

PERIODICALS
NOV 5 1978
PUBLIC LIBRARY OF
FT WAYNE & ALLEN COUNTY

CASHBOX

November 11, 1978

NEWSPAPER

\$1.95

ART AND RECORDINGS DEPARTMENT



Public Library of Ft. Wayne &
Allen Co.
Order Division - Periodical Sect.
900 Webster St. (Rear)
Ft. Wayne,
Indiana 46802

Journey

For
the person
who thought
they had
everything...

everything,
Volume 2.

You Don't Bring Me Flowers
(DUET WITH NEIL DIAMOND)

Love Theme From "A Star Is Born"
(EVERGREEN)

Love Theme From "Eyes of Laura Mars"
(PRISONER)

My Heart Belongs to Me
Songbird

The Way We Were

Sweet Inspiration/Where You Lead

All in Love Is Fair

Superman

Stoney End

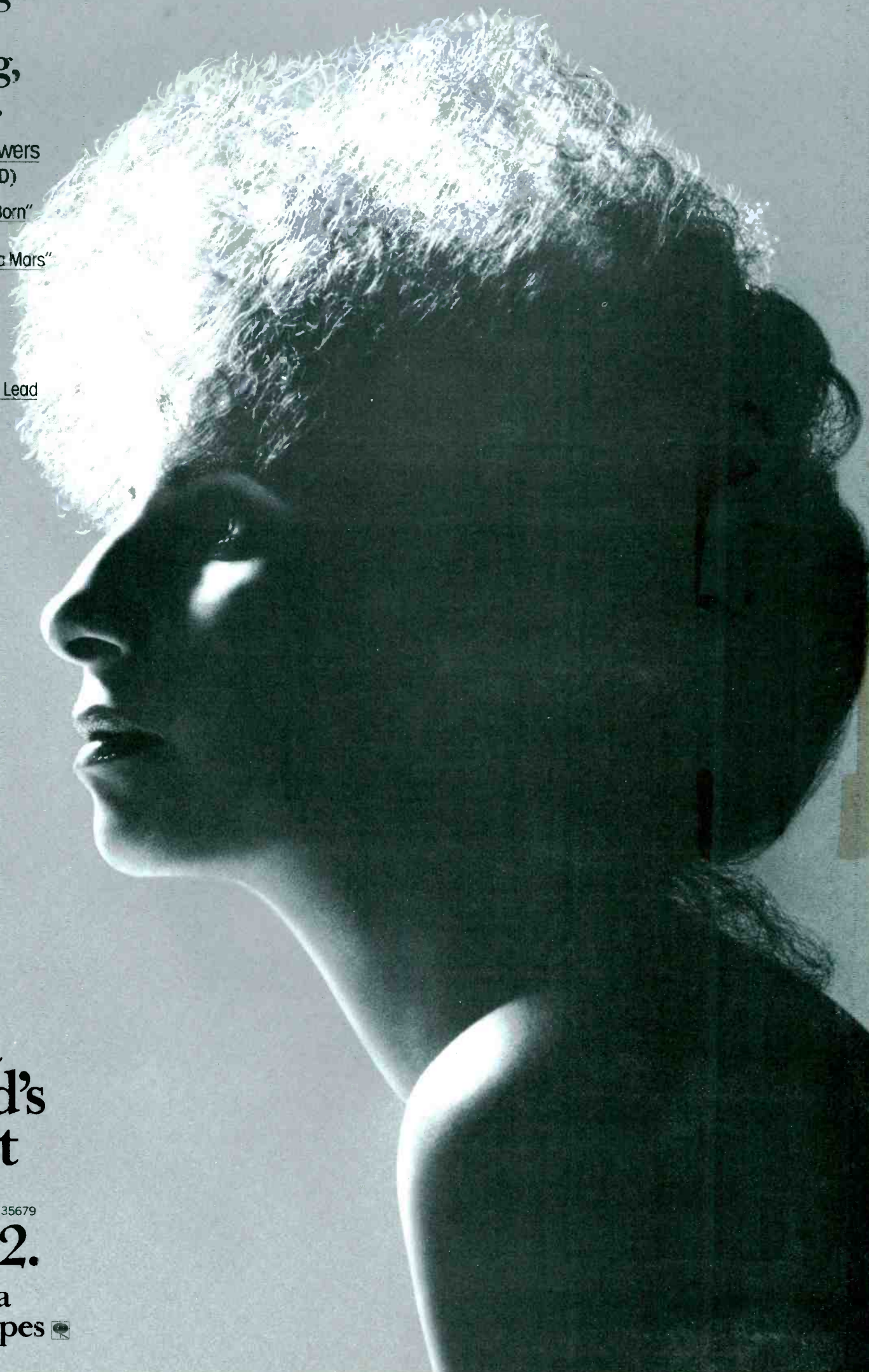

Barbra
Streisand's
Greatest
Hits FC 35679
Volume 2.

On Columbia
Records and Tapes 

CASH BOX

THE INTERNATIONAL MUSIC RECORD WEEKLY

GEORGE ALBERT
President and Publisher

MEL ALBERT
Vice President and General Manager

STAN MONTEIRO
Director of Marketing

DAVE FULTON
Editor In Chief

J.B. CARMICLE
General Manager, East Coast

JIM SHARP
Director, Nashville

PATRICK CLIFFORD, *Acct. Exec, East Coast*
CHUCK MEYER, *Acct. Exec, West Coast*

East Coast Editorial
KEN TERRY, *East Coast Editor*
CHARLES PAIKERT
LEO SACKS
AARON FUCHS

West Coast Editorial
ALAN SUTTON, *West Coast Editor*
RANDY LEWIS
JEFF CROSSAN
PETER HARTZ
JOEY BERLIN
RAY TERRACE
DALE KAWASHIMA
COOKIE AMERSON

Research
KEN KIRKWOOD, *Manager*
BILL FEASTER
LEN CHODOSH
HARALD TAUBENREUTHER
MARK ALBERT
J. PATRICK FAULSTICH
SEAN THOMAS
JACK CHIPMAN

Nashville Editorial/Research
BOB CAMPBELL
TIM WILLIAMS
KEN WOODS
DENISE MEEK

Art Director
LARRY CRAYCRAFT

Circulation
THERESA TORTOSA, *Manager*

PUBLICATION OFFICES

NEW YORK
119 West 57th, N.Y., N.Y. 10019
Phone: (212) 586-2640
Cable Address: Cash Box N.Y.
Telex: 666123

CALIFORNIA
6363 Sunset Blvd. (Suite 930)
Hollywood, Ca. 90028
Phone: (213) 464-8241

NASHVILLE
21 Music Circle East, Nashville, Tenn. 37203
Phone: (615) 244-2898

CHICAGO
CAMILLE COMPASIO, *Coin Machine, Mgr.*
1424 S. 61st Ct., Cicero IL 60650
Phone: (312) 863-7440

WASHINGTON, D.C.
JOANNE OSTROW
4201 Massachusetts Ave., NW
Washington, D.C. 20016

ENGLAND — JON DONALDSON
NICK UNDERWOOD
25 Denmark St., London WC 2
Phone: 01-836-1362/01-836-4188

ARGENTINA — MIGUEL SMIRNOFF
Belgrano 3252, Piso 4 "B"
Buenos Aires, Argentina
Phone: 89-6796

BRAZIL — H. GANDELMAN
Av. Rio Branco, 156 Sala 627
Rio de Janeiro RJ
Phone: 231-3231
Cable: COPIGAN

CANADA — KIRK LAPOINTE
56 Brown's Line
Toronto, Ontario, Canada M8W 359
Phone: (416) 251-1283

HOLLAND — PAUL ACKET
P.O. Box 11621 (Prinsessegracht 3)
The Hague
Phone: (70) 624621, Telex: 33083

ITALY — GUIDO HARARI
via Solari, 19
20144 Milan, Italy

AUSTRALIA — JOCK VEITCH
4/58 Ramsgate Avenue
Bondi, Sydney, NSW Australia

JAPAN — Adv. Mgr., SACHIO SAITO
Editorial Mgr., FUMIYO TACHIBANA
3rd Floor of Chuo-Tatemono bldg.
2-chome, 11-1, Shinbashi, Minato-ku,
Tokyo Japan, 105
Phone: 504-1651

FRANCE — CLAUDE EM MONNET
262 bis Rue des Pyrenees
Paris, France 75020
Phone: 361-8534
Telex: 612787F

WEST GERMANY — GERHARD AUGUSTIN
Herzog Rudolf Str. 3
8 Munich 22
Phone: 221363
Telex: 5-29378

SUBSCRIPTION RATES \$80 per year anywhere in the U.S.A. Published weekly by CASH BOX, 119 West 57th St., New York, N.Y. 10019. Printed in the U.S.A. Second class postage paid at New York, N.Y., and additional mailing offices. Copyright © 1978 by the Cash Box Publishing Co., Inc. All rights reserved. Copyright under Universal Copyright Convention. POSTMASTER: Send form 3579 to CASH BOX, 119 West 57th St., New York, N.Y. 10019.

EDITORIAL No Hype About Publicity

The record industry, like the movie world, operates on a star system. Not only are the recording artists stars, but also the personnel at the respective record companies. But there is one department that is consistently overlooked by both top-level executives and even many artists — and that is the under-staffed and overworked publicity department.

In this era of media saturation, press has become a valuable marketing tool for labels in an effort to expose and break new acts. Artists like Meat Loaf and The Cars have become "darlings of the press" and this has helped in their overall success. With the marketplace being flooded with new talent and albums, exposure through newspapers, magazines

and television has become as vital as live concerts and airplay. Every facet of exposure is necessary for new and growing artists to attain new sales levels.

While promotion staffs are usually flashy lots with slick lines and an aversion to the word "no," the publicity people are lower-keyed but with a similar dedication to success. But, because there is no way to gauge how ink sells records, the efforts of the publicity staff often go unnoticed.

As the competition becomes increasingly tough among record companies, let us hope that the status of publicity rises commensurately with that of other departments, and that the role of the publicity staffer is duly accepted as an integral function of selling records.

NEWS HIGHLIGHTS

- Music industry experiences resurgence in Detroit (page 7).
- 20th Century's Livingston reaffirms commitment to record division despite earnings dip (page 7).
- Indie promotion men benefitting from music business boom (page 7).
- TK making successful transition to full-fledged album label (page 8).
- First Gospel Week set for this week in Nashville (page 44).
- Ontario government contemplates subsidizing Canadian artists' LP sales (page 58).
- Eric Clapton's "Backless" and Kansas' "Two For The Show" are leading Album Picks of the week (page 17).
- Linda Ronstadt's "Ooh Baby Baby" and Hot Chocolate's "Every 1's A Winner" are leading Singles Picks of the week (page 19).

TOP POP DEBUTS

SINGLES 68

OOH BABY BABY Linda Ronstadt — Asylum

ALBUMS 85

LIVE BOOTLEG — Aerosmith — Columbia

POP SINGLE		POP ALBUM	
MACARTHUR PARK Donna Summer Casablanca		GREASE Various Artists — RSO	
R&B SINGLE		R&B ALBUM	
ONE NATION UNDER A GROOVE Funkadelic — WB		ONE NATION UNDER A GROOVE Funkadelic — WB	
COUNTRY SINGLE		COUNTRY ALBUM	
SLEEPING SINGLE IN A DOUBLE BED Barbara Mandrell — ABC		I'VE ALWAYS BEEN CRAZY Waylon Jennings RCA	
JAZZ		GOSPEL	
REED SEED Grover Washington Jr. Motown		FROM THE HEART Shirley Caesar — Hob	
		Donna Summer	

CASH BOX TOP 100 SINGLES

November 11, 1978

	Weeks On Chart		Weeks On Chart		Weeks On Chart
1 MACARTHUR PARK DONNA SUMMER (Casablanca NB 939)	11/4	34 THE POWER OF GOLD DAN FOGELBERG/TIM WEISBERG (Epic 8-50606)	11/4	68 OOH BABY BABY LINDA RONSTADT (Asylum E-45546-A)	1
2 HOT CHILD IN THE CITY NICK GILDER (Chrysalis CHS 2226)	1	35 SHE'S ALWAYS A WOMAN BILLY JOEL (Columbia 3-10788)	44	69 IN THE BUSH MUSIQUE (Prelude PRL 71110)	76
3 KISS YOU ALL OVER EXILE (Warner/Curb WBS 8589)	3	36 EASE ON DOWN THE ROAD DIANA ROSS/MICHAEL JACKSON ((MCA 40947)	27	70 CUZ IT'S YOU JAMES WALSH GYPSY BAND (RCA JH-11403)	74
4 YOU NEEDED ME ANNE MURRAY (Capitol 4574)	4	37 I'M EVERY WOMAN CHAKA KHAN (Tattoo/WBS 8683)	38	71 HERE COMES THE NIGHT NICK GILDER (Chrysalis CHS 2264)	80
5 DOUBLE VISION FOREIGNER (Atlantic 3514)	6	38 "LIKE A SUNDAY IN SALEM" (THE AMOS & ANDY SONG) GENE COTTON (Ariola 7723)	46	72 MY BEST FRIEND'S GIRL CARS (Elektra 45537)	79
6 HOW MUCH I FEEL AMBROSIA (Warner Bros. WBS 8640)	8	39 MY LIFE BILLY JOEL (Columbia 3-10853)	40	73 SO YOUNG, SO BAD STARZ (Capitol P-4637)	78
7 BEAST OF BURDEN ROLLING STONES (RS 19309)	8	40 BACK IN THE U.S.A. LINDA RONSTADT (Asylum-E-45519-A)	65	74 HOLD ME, TOUCH ME PAUL STANLEY (Casablanca NB 940)	84
8 WHENEVER I CALL YOU "FRIEND" KENNY LOGGINS (Columbia 3-10794)	7	41 PRISONER OF YOUR LOVE PLAYER (RSO 908)	20	75 BICYCLE RACE/FAT BOTTOMED GIRLS QUEEN (Elektra E-45541-A)	8
9 READY TO TAKE A CHANCE AGAIN BARRY MANILOW (Arista AS 0357)	11	42 HOLD THE LINE TOTO (Columbia 3-10830)	30	76 THE DREAM NEVER DIES THE COOPER BROS. (Capricorn CPS 0308)	83
10 YOU NEVER DONE IT LIKE THAT CAPTAIN & TENNILLE (A&M 2063)	10	43 RAINING IN MY HEART LEO SAYER (Warner Bros. 8682)	10	77 "I WAS MADE FOR DANCIN'" LEIF GARRETT (Scotti Bros./Atlantic SB 403)	86
11 I JUST WANNA STOP GINO VANNELLI (A&M 2072)	10	44 HOW YOU GONNA SEE ME NOW ALICE COOPER (Warner Bros. WBS 8695)	47	78 BLAME IT ON THE BOOGIE THE JACKSONS (Epic 8-50595)	89
12 SHARING THE NIGHT TOGETHER DR. HOOK (Capitol P-4621)	14	45 SEARCHING FOR A THRILL STARBUCK (United Artists UA-X1245-Y)	60	79 LOVE ME AGAIN RITA COOLIDGE (A&M 2090)	87
13 REMINISCING LITTLE RIVER BAND (Harvest P-4605)	15	46 DREADLOCK HOLIDAY 10cc (Polydor PD 14511)	8	80 DON'T HOLD BACK CHANSON (Ariola 7717)	90
14 I LOVE THE NIGHT LIFE (DISCO ROUND) ALICIA BRIDGES (Polydor PD 14483)	12	47 PROMISES ERIC CLAPTON (RSO 910)	7	81 DRIFTWOOD THE MOODY BLUES (London 5N-273)	88
15 WHO ARE YOU WHO (MCA 40948)	17	48 Y.M.C.A. VILLAGE PEOPLE (Casablanca NB 945)	58	82 EVERY 1'S A WINNER HOT CHOCOLATE (Infinity INF-50,002)	—
16 YOU DON'T BRING ME FLOWERS BARBRA & NEIL (Columbia 3-10840)	9	49 FOREVER AUTUMN JUSTIN HAYWARD (Columbia 3-10799)	5	83 DO YOU FEEL ALRIGHT KC & THE SUNSHINE BAND (TK 1030)	85
17 GET OFF FOXY (Dash/TK 5046)	31	50 NEW YORK GROOVE ACE FREHLEY (Casablanca NB 941)	64	84 I WILL STILL LOVE YOU STONEBOLT (Parachute RR 512)	43
18 TIME PASSAGES AL STEWART (Arista AS 0362)	3	51 RUN FOR HOME LINDISFARNE (Atco 7093)	8	85 A MAN I'LL NEVER BE BOSTON (Epic 8-50638)	—
19 ALIVE AGAIN CHICAGO (Columbia 3-10845)	18	52 FLYING HIGH THE COMMODORES (Motown 1452-F)	7	86 FIRE POINTER SISTERS (Planet P-45901)	—
20 SWEET LIFE PAUL DAVIS (Bang B-738)	25	53 INSTANT REPLAY DAN HARTMAN (Blue Sky/CBS ZS8 2772)	4	87 MARY JANE RICK JAMES (Gordy 7162F)	—
21 BLUE COLLAR MAN (LONG NIGHTS) STYX (A&M 2087)	24	54 LOVE IS IN THE AIR JOHN PAUL YOUNG (Scotti Bros./Atlantic SB 402)	5	88 GOT TO HAVE LOVING DON RAY (Polydor 14489)	49
22 RIGHT DOWN THE LINE GERRY RAFFERTY (United Artists X-1233-Y)	13	55 DON'T LOOK BACK BOSTON (Epic 8-50590)	18	89 YOUR SWEETNESS IS MY WEAKNESS BARRY WHITE (20th Century TC 2380)	—
23 ONE NATION UNDER A GROOVE FUNKADELIC (Warner Bros. WBS 8618)	13	56 LE FREAK CHIC (Atlantic 3519)	39	90 WHATEVER HAPPENED TO BENNY SANTINI? CHRIS REA (Magnet/U.A. X1252-Y)	—
24 DON'T WANT TO LIVE WITHOUT IT PABLO CRUISE (A&M 2076)	26	57 ON THE SHELF D&M (Polydor PD 14510)	3	91 WAVELENGTH VAN MORRISON (Warner Bros. 8661)	61
25 STRAIGHT ON HEART (Portrait 6-70020)	28	58 FUN TIME JOE COCKER (Asylum E-45540)	6	92 THIS IS LOVE PAUL ANKA (RCA JH 11395)	70
26 (OUR LOVE) DON'T THROW IT ALL AWAY ANDY GIBB (RSO RS 911)	29	59 HOT SUMMER NIGHTS WALTER EGAN (Columbia 3-10824)	9	93 SUBSTITUTE CLOUT (Epic 8-50591)	52
27 STRANGE WAY FIREFALL (Atlantic 3518)	32	60 CAN YOU FOOL GLEN CAMPBELL (Capitol P4638)	5	94 SOFT AND WET PRINCE (Warner Bros. WBS 8619)	95
28 BOOGIE OOGIE OOGIE TASTE OF HONEY (Capitol 4565)	33	61 PART-TIME LOVE ELTON JOHN (MCA 40973)	7	95 TAKE ME TO THE RIVER THE TALKING HEADS (Sire/WBS 1032)	96
29 CHANGE OF HEART ERIC CARMEN (Arista AS 0354)	19	62 I WILL BE IN LOVE WITH YOU LIVINGSTON TAYLOR (Epic 8-50604)	21	96 HOPELESSLY DEVOTED TO YOU OLIVIA NEWTON-JOHN (RSO RS 903)	54
30 EVERYBODY NEEDS LOVE STEPHEN BISHOP (ABC AB 12406)	35	63 JOSIE STEELY DAN (ABC AB 12404)	9	97 THREE TIMES A LADY COMMODORES (Motown M-1433-F)	68
31 TALKING IN YOUR SLEEP CRYSTAL GAYLE (United Artists UA-X1214-Y)	34	64 WE'VE GOT TONITE BOB SEGER & THE SILVER BULLET BAND (Capitol P-4653)	12	98 DON'T CRY OUT LOUD MELISSA MANCHESTER (Arista 0373)	—
32 DANCE (DISCO HEAT) SYLVESTER (Fantasy 827)	16	65 GREASED LIGHTNIN' JOHN TRAVOLTA (RSO 909)	3	99 SUMMER NIGHTS JOHN TRAVOLTA/OLIVIA NEWTON-JOHN (RSO 906)	71
33 IT'S A LAUGH DARYL HALL & JOHN OATES (RCA PB 11371)	25	66 THEMES FROM THE WIZARD OF OZ MECO (Millennium MN 620)	45	100 NEW YORK CITY ZWOL (EMI P-8005)	81
	12	67 THERE'LL NEVER BE SWITCH (Gordy 7G-159-F)	11		6

ALPHABETIZED TOP 100 SINGLES (INCLUDING PUBLISHERS AND LICENSEES)

A Man I'll (Pure Songs — ASCAP)	85	Get Off (Sherlyn/Lindseyanne — BMI)	17	Love Is In (Edward B. Marks — BMI)	54	So Young (Maximum Warp/Rock Steady — ASCAP) 73
Alive Again (Make Me Smile — ASCAP)	19	Got To Have (MTB — SESAC)	88	Love Me Again (Almo — ASCAP/Irving — BMI)	79	Straight On (Wilson's/Know — ASCAP)
Back In The Arc — BMI)	40	Greased (Edwin H. Morris — ASCAP)	65	MacArthur Park (Canopy — ASCAP)	1	Strange (Steven Stills/Warner Tamberlane/EI Suero — BMI)
Beast Of (Colgems/EMI — ASCAP)	7	Here Comes (Beachwood — BMI)	71	Mary Jane (Stone Diamond — BMI)	87	Substitute (Touch Of Gold — BMI)
Bicycle Race (Queen/Beachwood — BMI)	75	Hold The Line (Hudmar — ASCAP)	42	My Best Friend's (Lido — BMI)	72	Summer Nights (Edwin H. Morris — ASCAP)
Blame It On (Almo — ASCAP)	78	Hold Me, Touch Me (Kiss — ASCAP)	74	My Life (Impulse/April — ASCAP)	39	Sweet Life (Web IV — BMI)
Blue Collar (Almo/Stylian — ASCAP)	21	Hopelessly (Unichappell/John Farrar/Ensign — BMI J. Farrar)	96	New York Groove (Mother Tongue — ASCAP)	100	Take Me (Jec/AI Green — BMI)
Boogie Oogie (Conductive/On Time — BMI)	28	Hot Child (Beechwood — BMI)	2	New York Groove (April Blackwood/Russell Ballard — ASCAP)	50	Talking In (Roger Cook/Chriswood — BMI)
Can You (Royal Oak/Windstar — ASCAP)	60	Hot Summer (Melody Deux/Swell Sounds/Seldak — ASCAP)	59	On The Shelf (ATV — BMI)	57	Themes From The (Leo Feist — ASCAP)
Change Of Heart (Camex — BMI)	29	How Much I (Rubicon — BMI)	6	One Nation (Malbiz — BMI)	23	The Dream (Obob Mastro/Tamiami/Amin — Welbeck)
Cuz It's (Gypsy Family — BMI)	70	How You Gonna (Ezra/Jodrell — ASCAP/Candlewood Mountain — BMI)	44	Ooh Baby (Jobete — ASCAP)	68	The Power Of (Hickory Grove — ASCAP)
Dance (Disco Heat) (Jobete — ASCAP)	32	I Just (Ross Vannelli)	11	(Our Love) Don't Throw It All (Stigwood/Unichappell — BMI)	26	There'll Never (Jobete — ASCAP)
Do You Feel (Harrick — BMI)	83	I Love The (Lowery — BMI)	14	Part Time Love (Jodrell/Leeds — ASCAP)	61	This Is Love (Camerica — ASCAP)
Don't Cry Out (Irving/Woolnough/Jemava/Unichappell/Begonia — BMI)	98	I Was Made (Michael's/Scot Tone — ASCAP)	77	Prisoner Of (Touch Of Gold/Crowbeck/Stigwood — BMI)	41	Three Times A Lady (Jobete/Commodores — ASCAP)
Don't Hold (Kichelle/Jamerson/Cos-K — ASCAP)	80	I Will Be (Morgan Creek/Songs Of Bander-Koppelman — ASCAP)	62	Promises (Narwhal — BMI)	47	Time (DJM/Frabjous/Approxmate)
Don't Look (Pure Songs — ASCAP)	55	I'm Every Woman (Nick-O-Val — ASCAP)	37	Raining In (House Of Bryant — BMI)	43	Wavelength (Essential — BMI)
Don't Want (Irving/Pablo Cruise — BMI)	24	Instant Replay (Silver Steed — BMI)	53	Ready To (Ensign/Kamikazi — BMI)	9	We've Got Tonight (Gear — ASCAP)
Double Vision (Somerset/Evansongs/WB — ASCAP)	5	In The Bush (Division/Leeds/Phylmar — ASCAP)	69	Reminiscing (Screen Gems-EMI — BMI)	13	What Ever Happened (Magnet/Interworld — ASCAP) 90
Dreadlock (Man-Ken — BMI)	46	It's A Laugh (Hot-Cha & Six Continents — BMI)	33	Right Down (Hudson Zay — BMI)	22	Whenever I Call (Milk Money — ASCAP/Rumanian Pickleworks — BMI)
Driftwood (Bright — ASCAP)	81	I Will Still Love You (W.B. — ASCAP)	84	Run For (Crazy/Chappell — ASCAP)	51	Who Are You (Towser Tunes — BMI)
Ease On Down (Fox Fanfare — BMI)	36	Josie (ABC/Dunhill — BMI)	63	Searching For (Brother Bill's — ASCAP)	45	Y.M.C.A. (Greenlight — ASCAP)
Everybody Needs (Stephen Bishop — BMI)	30	Kiss You (Chinnichap/Careers — BMI)	3	Sharing (Music Mill/Alan Cartee — ASCAP/BMI)	12	You Don't Bring (Stonebridge/Threesome — ASCAP)
Every One Is A (Finchley — ASCAP)	82	Le Freak (Chic — BMI)	55	She's Always (Joel Songs — BMI)	35	You Needed (Chappell/Ironside — BMI)
Fat Bottomed (Queen/Beachwood — BMI)	75	Like A (United Artist — ASCAP)	38	Soft (Princess — ASCAP)	94	You Never (Kiddio Music/Don Kirshner — BMI)
Fire (Bruce Springsteen — ASCAP)	86					Your Sweetness (Sa-Vette/Rei Nel — BMI)
Flying (Jobete/Commodores — ASCAP)	52					
Forever Autumn (Duchess — BMI)	49					
Fun Time (Marsaint — BMI)	58					

⊖ = Exceptionally heavy radio activity this week

⊕ = Exceptionally heavy sales activity this week

L I N D A R O N S T A D T



“Ooh Baby Baby”

E-45546



THE NEW SINGLE FROM THE TRIPLE PLATINUM ALBUM:

“Living in the USA” PRODUCED BY PETER ASHER

6E-155

E N G I N E E R E D B Y V A L G A R A Y



JACKSON BROWNE
YOU LOVE THE THUNDER (E-45543)

FROM HIS TRIPLE PLATINUM ALBUM "RUNNING ON EMPTY"

Asylum Records & Tapes 

Produced by Jackson Browne/ Engineered by Greg Ladanyi/ Management: Peter Golden & Assoc., Inc.



PLATINUM PIECES — A&M recording group Styx was recently presented with a platinum album for "Pieces Of Eight" following its sold-out concert at L.A.'s Forum. Pictured (l-r) at the Forum club are: Judy Friesen; John Panozzo, James Young, Tommy Shaw, Chuck Panozzo and Dennis De Young of Styx; Jerry Moss, A&M chairman; Kip Cohen, vice president of A&R for A&M; and Gil Friesen, A&M president.

20th-Fox Music Earnings Dip During Corp.'s Best 9 Months

by Jeff Crossan

LOS ANGELES — Losses posted by the record division of 20th Century Fox Film Corp. were the sore spot in the company's recently released third quarter and nine month financial statements.

The record division posted a \$3.8 million loss for the quarter, compared to a \$2.3 million profit earned during the summer quarter of 1977. And nine month figures for the division reflected a \$5.9 million loss, against last year's \$1.5 million profit.

The contrast to last year's figures can largely be attributed to the release and sales success last summer of the soundtrack LP from the film "Star Wars" on 20th Century Fox Records.

'Star Wars' Felt

The effect of "Star Wars" was also felt in the overall corporate figures which reached a new high for the nine month period but dropped substantially in the third quarter when compared to the same period last year, which reflected the earnings gained from the film's release.

Third quarter income dropped 45 per-

Jukebox Petition Is Twice Refused

by Joanne Ostrow

WASHINGTON, D.C. — Five jukebox operators and the 1,100-member AMOA were turned down twice last week in attempts to obtain an injunction against the Copyright Royalty Tribunal's recently adopted jukebox regulations. First, Judge Aubrey Robinson Jr. denied the motion for a temporary restraining order and preliminary injunction in Federal District Court here Oct. 31. The plaintiffs then filed petition in Appeals Court to seek a stay on the lower court ruling and that, too, was refused.

The action shifts back to District Court for a hearing on a final injunction to be scheduled sometime after the CRT's hearing on Nov. 9.

Jukebox owners and operators had threatened to file suit against the Tribunal immediately after the CRT's regulations were announced (Cash Box, Sept. 16). The location listing requirement, adopted the CRT in September, was the major point of contention. The rule mandates that jukebox operators furnish the Tribunal with the name of each establishment where jukeboxes are placed and the number of machines at each site, plus updated annual reports.

Coin machine owners/operators bitterly opposed the ruling, arguing throughout the

(continued on page 54)

cent to \$18.4 million, or \$2.26 a share, from last year's \$31.6 million, or \$4.02 a share, in the same quarter. Total revenues fell 6 percent to \$161 million from \$171.5 million during last year's third quarter.

For the nine months ended Sept. 30, net income climbed 28 percent to \$51.4 million or \$6.43 a share from \$40 million, or \$5.16 a share in 1977. Revenues for the nine month period were up 30 percent for a record high of \$469.1 million, compared to last year's \$361.6 million figure.

Losses Examined

The losses posted by 20th Century Fox Records were examined Oct. 27 at a board of directors meeting.

"It was just a routine review," said Alan Livingston, 20th Century-Fox entertainment group president. "The record company has been showing some losses this year and it was just a discussion of what our projections are and whether or not we can look for a turnaround."

Livingston said he was optimistic that the record company would soon begin to offset its losses as the result of the label's fall program and stressed that the corporation has no plans to shelve its music operations.

"The corporate attitude is that the record industry is a three-and-a-half billion dollar industry domestically and eight billion internationally," Livingston said. "We are an entertainment company and it's a business we should be in. That attitude hasn't changed."

Selective Signing

Livingston said that the label would not

(continued on page 48)



BURNIN' — Epic recording group Heatwave appeared recently at Madison Square Garden, where they played selections from their latest album "Central Heating." Pictured backstage after the show are (l-r): Al DeMarino, vice president of artist development for Epic, Portrait and the Associated Labels; Lennie Petze, vice president of A&R for Epic; Johnnie Wilder, Jr., Mario Mantese, and Keith Wilder of Heatwave; Mike Bernardo, black music marketing northeast regional promotion for CBS Records; Russell Timmons, director of progressive music A&R for Epic; and Ernest Berger of Heatwave. Seated (l-r) are: Roy Carter of Heatwave; Jim Charne, director of merchandising for E/P/A; and Kalvin Duke and Billy Jones of Heatwave.

Changing Social Climate Aids Detroit's Musical Resurgence

by Aaron Fuchs

NEW YORK — Six years after the departure of the entire Motown operation from Detroit, Motor City gives every indication of re-establishing itself as a center of music industry activity.

Recent gold records for Detroit artists the Dramatics, the Floaters, and Enchantment, in addition to the R&B, pop, jazz and disco success locals Michael Henderson, C.J. and Company, Al Hudson & the Soul Partners, the Mike Theodore Orchestra, the ADC Band, and the Fantastic Four offer evidence that there is a resurgence of the Detroit sound that Motown built an empire with in '60s.

But, whereas the success of Detroit soul music in the '60s could be reasonably attributed to the genius of one man, Berry Gordy, the Detroit scene today is galvanized by a wide variety of factors and by a number of individuals. To some, responsibility for Detroit's musical resurgence can be seen in terms of the larger social climate of the city.

'Bad Publicity'

Tom Collins, operations manager for Detroit's WJLB, said, "Detroit had a lot of bad publicity for a while, the 'murder capital of the world' sort of thing, and Motown's departure corresponded to the city being in a very bad state. Five years ago you could walk down a street at 5:30 in the afternoon and it would be deserted. Now, there's more building, more employment and peo-

ple are getting back into music and getting down and boogieing."

Michael Henderson, a leading artist in the musical resurgence of Detroit whose "In the Night Time" album is charted jazz, pop, and black contemporary, said, "You have to give Detroit's mayor, Coleman Young, all the credit for holding Detroit together when Motown left. He fought hard to have the Renaissance built in Detroit, which is the largest hotel, bank, and business complex in the country, and was responsible for turning this city around, and the attitudes of people towards it. A lot of entertainers who were going to leave stayed when they saw that happen."

There have also been a number of other factors in the city's resurgence. J. Michael McKay, WJLB's program director, said, "The talent was always here. Detroit is like a sea full of fish, and for every group you find that's dynamite, there are two more that are better. But until recently, most of the local talent here did not have the knowledge to go to the people that could help them and say, "Hey, I'm dynamite, give me a shot. The attitude that prevailed was, 'let's be satisfied with making it big in Detroit.'"

Picking Up The Pieces

Bill Craig, vice president of field activities and A&R, special markets, for ABC Records, noted that "the music scene here started to pick up the pieces here about three or four years ago. Immediately after

(continued on page 48)

Business Is Booming For Independent Promotion Men

by Charles Paikert

NEW YORK — Despite the numerous problems that have plagued many small, independent businessmen within the music industry, most of the country's independent promotion men have benefited from a booming business, and have diversified their operations to include AOR, retail, and artist relations services.

According to Dick Kline, executive vice president and national promotion director for Polydor Records, the independent promotion man's continued success has been a result of the industry's rapidly accelerating growth and competition. "There's even more of a need for the independents now," Kline commented, "because, with all the competition out there, the record company is gaining another positive. The independents have a

history of being able to deliver, or else they wouldn't be there. Their credibility is well established in a market, and after the local man lays the groundwork for a record, they play an essential role in closing the project in key areas."

"They're specialists," stated Sammy Vargas, northeast promotion manager for MCA Records. "The independents are onto the pulse of the marketplace, and their expertise in specialized product is invaluable to a company." Vince Faraci, national pop promotion director for Atlantic Records, another company with a history of utilizing independents, added, "We plan to continue using them as a support tactic in the marketplace. Everybody's looking for that extra edge."

Personnel Changes

Independent promotion men themselves cite frequent company personnel changes as one reason for their own durability. "Let's face it," said Jerry Brenner, a veteran New England promotion man, "a good promotion man always moves up the ladder, and that leaves a void in the market. But the independent is always there, and knows what each station needs at a par-

(continued on page 54)

Lundvall To Receive Award From CPME

NEW YORK — Bruce Lundvall, president of the CBS Records Division, will be presented with the 1978 Humanitarian Award by the Conference of Personal Managers East at a luncheon Nov. 10 at the Pierre Hotel in New York City. Don Cornelius and Scott Muni will host the luncheon.

Lundvall will be honored for his "philanthropic efforts outside and within the recording industry," according to luncheon president Gerard Purcell. Portions of the luncheon proceeds will be contributed by the Conference of Personal Managers to the T.J. Marell Memorial Foundation for Leukemia Research, of which Lundvall is a charter member.



PLATINUM PRESENTATION — Frankie Valli (right) recently was presented with a platinum copy of his "Grease" single by RSO Records president Al Coury.

Bogart Honored As 'Man Of Year'; UJA Nets \$700,000

LOS ANGELES — More than 2,000 leaders of the music and motion picture fields gathered recently at the Americana Hotel in New York City to raise \$700,000 for the United Jewish Appeal's annual drive and to pay tribute to 35-year-old Neil Bogart, president of Casablanca Record & FilmWorks, who was named Man of the Year by the U.-J.A. Entertainment Division.

The program for the evening included Dick Clark as master of ceremonies; Midge Constanza, former assistant to the President of the United States, who brought personal greetings to Bogart from President Carter; a special performance by Donna Summer, which was highlighted by a slide presentation chronicling Bogart's career;

See Photos Pg. 20

and a segment during which three of Bogart's children — Jill, Timothy and Bradley — sang with Summer.

Other dais guests included Manhattan Borough president Andrew Stein; Kiss member Ace Frehley; Coen Solleveld, president, Polygram worldwide; Walter

(continued on page 54)

RCA To Release Elvis Picture Disc

NEW YORK — RCA Records' first commercial picture disc will be "Elvis, A Legendary Performer, Vol. 3." The limited edition disc, which will have two full-color likenesses of Presley, one on each side, will retail for \$15.98. A regular edition of the album will list for \$8.98.

The 13-cut album will include two songs that have never been released, six songs in versions that have never before been released, and a rare interview with Elvis and his manager, Colonel Tom Parker. Each LP will also contain a full-color poster and a 16-page fully illustrated booklet.

A highlight of RCA's merchandising campaign for the album will be an in-store video presentation with the theme, "His Music Says the Things You Feel."



GOLDEN CARS — Elektra/Asylum recording group The Cars was presented a gold record recently for the self-titled debut LP, following a performance at the Forum in Los Angeles. Pictured (l-r) are: Jerry Sharrell, E/A vice president/artist development; Elliot Easton, Ric Ocasek, Greg Hawkes, David Robinson and Ben Orr of the Cars; Mark Hammerman, west coast director/artist development; Mel Posner, vice chairman; Fred Lewis, The Cars' manager and George Daly, E/A A&R director.

Campaign To Transform TK Into Album Label Succeeds

by Ken Terry

NEW YORK — In one 90-day period this year, TK albums by Peter Brown, KC and the Sunshine Band, Betty Wright, and Foxy all went gold. This was no accident; TK, which had its first hits with singles, has finally become a full-fledged album label.

Among the 40 or so LPs that TK now has on the market are Bobby Caldwell's self-titled debut on TK/Clouds, T-Connection's "On Fire" on TK/Dash, Latimore's "Dig A Little Deeper" on TK/Glades, Eddie Daniel's "Street Wind" on TK/Marlin, the Ritchie Family's "American Generation" on TK/Marlin, "Phil Upchurch" on TK/Marlin, Ralph McDonald's "The Path" on TK/Marlin, "USA/European Connection" on TK/Marlin, "Dorothy Moore" on TK/Malaco, Gwen McCrae's "Let's Straighten It Out" on TK/Cat, Gregg Diamond's "Star Cruiser" on TK/Marlin, Jimmy Bo Horne's "Dance Across The Floor" on TK/Sunshine Sound, Michal Urbaniak's "Ecstasy" on TK/Marlin, and Michael Bloomfield's "Count Talent and the Originals" on TK/Clouds. In addition, TK has recently signed deals with Jimmy Castor and Joe Tex, and albums should be forthcoming from them shortly.

This proliferation of albums on a label that used to be considered singles-oriented is the result of a conscious campaign that was initiated by Henry Stone, TK's president and founder, two years ago. "In the record business, you have to change with the times," Stone commented. "I made a commitment about two years ago to become an album company, and now it's a pure album company."

Naturally, only a small percentage of TK's LP output can be expected to go gold or platinum. But Stone points out that a fair number of his current records (e.g., Voyage, U.S.A. European Connection) are selling in the 150-200,000 range. "It's not gold or platinum," he said, "but it sure adds up to a lot of sales when you have eight or ten of those things going. Now we're on the way to gold album with Bobby Caldwell, another new artist."

New artists have been the lifeblood of TK since its establishment in 1970. All of the original artists on TK, including Betty Wright, Beginning of The End, Timmy Thomas, Latimore, George and Owen McCrae, and KC and the Sunshine Band, were newcomers to the music business when they had hits with the Miami-based label. And it is still Stone's policy to look for new acts with hit potential — a policy that has recently paid off handsomely with such artists as Peter Brown and Foxy.

An increasing number of well-known names, however, are beginning to crop up on the TK roster, including Joe Tex and Jimmy Castor. According to Stone, signing these acts is part of his campaign to build a strong album company.



Henry Stone

Another part of that strategy is TK's recent expansion out of its R&B and disco base into jazz, rock and gospel music. TK's Clouds label, for example, specializes in rock, with Bobby Caldwell as the major artist and other acts to be signed early next year. The Roots, another TK-distributed label, features such blues artists as Jimmy Reed, Gene Barge and Wild Child Butler. Marlin is a jazz fusion/disco label, where Michael Urbaniak and Eddie Daniels brush shoulders with Gregg Diamond and the U.S.A. European Connection. There are also two TK-distributed labels that specialize in gospel, Malaco and Gospel Roots.

Expand Base

"I'm trying to keep my base very strong, which is the R&B-disco thing," Stone commented, "and there is a need for us to expand. We've done it with the jazz fusion thing, and rock, I guess, is the next thing to get into. But we have to do it very selectively and very cautiously, because you can't go in there and not actually compete with the majors in that."

"We'll build our own rock acts — that's the main thing. I'll use my promotion know-how. I mean, there's still nothing like hit product, you know? If it's in the grooves,

(continued on page 53)

Pic Disc Serves Notice To Alberti On Patent Issue

LOS ANGELES — Pic Disc, Inc., a picture disc manufacturing division of the Fitzgerald/Hartley Co., has put Alberti Record Mfg. on notice that its method of manufacturing discs may infringe on Pic Disc's exclusive patent.

The action came following the release of an Alberti-manufactured "Rocky Horror Picture Show" picture disc. A spokesperson for Alberti downplayed the written notice from Pic Disc and said that "we are breaking no law."

But Mark Hartley of Fitzgerald/Hartley said "with the popularity of picture discs, we are actively seeking to enforce our exclusive patents. The one in question with Alberti is U.S. patent no. 3,584,094 which was filed a while ago by Harold Dague. It covers the method which it appears upon examination is the method used by Alberti."

The notice from Pic Disc requires that Alberti immediately cease and desist from further infringement or provide proof that it has not and is not now infringing the methods of picture record manufacture covered by Pic Disc's patent.

John Alberti of Alberti Mfg. called the notice "a joke," and that Alberti was not in violation of patents. "We checked it out and we are not in violation of any patents held by them (Pic Disc)," Alberti said.

With Picture Records Inc. serving as an intermediary between Alberti and its clients, Alberti is currently working on a Linda Ronstadt picture disc.

Solleveld Affirms Commitment Of Polygram To U.S.

NEW YORK — Coen Solleveld, worldwide president of Polygram, recently sent out a letter to U.S. Polygram employees in which he explained his motivation for coming to America.

"My reason for coming is straightforward: to establish a strong and vigorous liaison and interchange among our rapidly growing U.S. businesses and our international operations," he noted.

"The growth and development of U.S. markets are key to Polygram's continued success. In turn, the expertise generated in making Polygram pre-eminent in the U.S. entertainment industry will be invaluable for Polygram elsewhere around the world."

Solleveld emphasized the fact that "while here as worldwide president of Polygram, it is my intention to maintain all existing management and reporting lines."

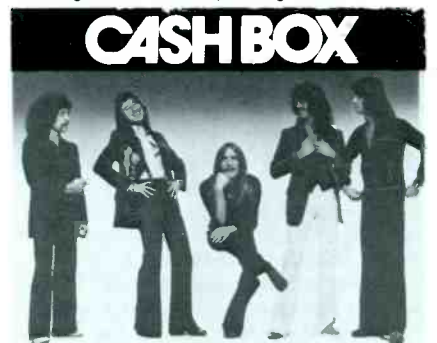

After three consistently successful albums for Columbia, Journey is standing on the threshold of ... "Infinity." The group's fourth album for the label, which has been certified platinum, is a marked departure for the San Francisco-based group. Produced by Roy Thomas Baker (Queen, The Cars), "Infinity" introduces a fresh new emphasis on vocals with the addition of singer Steve Perry.

But Perry is not the only new member of the band. Steve Smith recently joined the group as a replacement for drummer Aynsley Dunbar, who co-founded Journey along with bassist Ross Valory, pianist Gregg Rolie, and guitarist Neal Schon.

The members of Journey are no strangers to pop music fans. Valory is a veteran of the Steve Miller Band. Rolie was an integral part of the first four Santana albums, as was Schon, who joined Santana following their debut LP. Smith is a veteran of bands led by Jean-Luc Ponty and Ronnie Montrose, and Perry is a former member of ex-Vanilla Fudge bassist Tim Bogart's group.

With their combined experiences in all of these well-known bands, Journey's members are beginning to meld together into one of the premiere rock acts of the '70s and '80s. Their potential is truly infinite.

Index

Album Reviews	17
AMOA Special Section	56
Black Contemporary	50
Classified	57
Country News & Album Chart	36
Country Singles Chart	38
Disco	46
East Coastings/Points West	16
FM Analysis	22
Gospel	44
International News	58
Jazz	49
Latin	55
Looking Ahead	48
Merchandising	30
New Faces To Watch	10
Pop Album Chart	62
Pop Radio Analysis	28
Pop Singles Chart	4
Radio News	21
Regional Programming Guide	26
Singles Reviews	19

EXPO '78



**AMUSEMENT
& MUSIC**

AMOA

**OPERATORS
ASSOCIATION**

A CASH BOX SPECIAL EDITION



Welcome From Association President Don Van Brackel

AMOA's 30th year, 1978, is certainly an important milestone in the history of an association which, in my opinion, has done far more for this industry than most of us can possibly realize. AMOA has not only waged an unending battle on copyright legislation, but it has consistently developed services for the membership.

In January the new \$8 jukebox royalty became effective. We assisted in the implementation of the new law by distributing licensing information as a matter of service to members and cooperation with the U.S. Copyright Office. Prior to that, in May of last year, we strongly recommended to the Copyright Office the need for simplified methods of compliance. The members were advised of these recommendations. There is still much to be done on this problem, some of which will be costly, and we must ask the entire industry to help in this endeavor as well as our dues-paying members. We will not give up the fight for what we consider fair and equitable treatment.

This has been a year of growth and progress for AMOA. Because the exposition has become an international event, gaming equipment is being exhibited for the first time this year. Our audio visual slide program on the industry, which has been presented to state conventions and government agencies, has been praised as a valuable public relations tool. Last month we initiated a cost-of-doing-business survey the results of which will be a valuable service for all of us. Earlier this year we hired an assistant for the executive vice president because of the increased workload of administering the association. AMOA is on the move.

The exposition seminar this year will cover two important subjects: a discussion on the jukebox royalty with our legal counsel and the chief of the Licensing Division of the U.S. Copyright Office as panelists; and, second, a discussion on amusement centers with three leading authorities on the subject making up the panel. Further to AMOA's education programs, our Mechanics Schools will continue to be held wherever needed throughout the country. There will also be a management level seminar next March conducted by the University of Notre Dame. For convenience, this will be held at the O'Hare International Airport in Chicago, and I urge you to register during this exposition.

My warmest congratulations to the board of directors, to the exposition chairmen and committees, and to the staff of AMOA, for the tremendous job they have done in planning this year's exposition. There is nothing like it anywhere.

Don Van Brackel
National president



Don Van Brackel

Happy Birthday, AMOA

AMOA is celebrating its 30th anniversary; three decades of growth, progress and fulfillment, culminating in its present status of international significance. The annual AMOA convention in Chicago is noted the world over, and each year finds an increase in the number of foreign countries represented at the show. This was a contributing factor in the association's decision to permit coin-operated gaming equipment to be exhibited at the 1978 exposition.

At birth, AMOA (then MOA) was a 14-member committee, formed as a defense against adverse legislation and this remains a primary goal, with strong leadership and membership support providing a much more powerful defense mechanism, today. With the passage of the new copyright law, which imposes an \$8 per jukebox royalty fee, a long-standing legislative battle came to a partial end for the association. Partial, in that certain "regulations" of the law draw strong membership opposition and, while diligently assisting operators in complying, AMOA resumed its efforts towards securing a more simplified method of compliance.

Among the milestones in AMOA's history was the first national convention, held in Chicago in 1950 for an audience of less than 500. Not an impressive figure by today's standards but the event was the forerunner which established the annual trade show as a vital industry function. In the ensuing years, as the association progressed, numerous membership services were implemented, along with organizational programs commensurate with the association's internal growth. By 1977, AMOA had more than a thousand members and this past year the association increased its office staff.

As further evidence of the association's outstanding 30-year growth pattern, the 1978 annual exposition, Nov. 10-12, at the Conrad Hilton Hotel, will occupy three exhibit halls. The display of coin-operated amusement equipment, and related products, will be unsurpassed, according to association officials. American firms will be well represented in the ranks of convention exhibitors as they've been in previous years, but there'll also be a marked increase in the number of foreign firms exhibiting products at Expo '78. Attendance, on both the domestic and foreign level, is expected to reach an all time high. This year's convention should dramatically reflect the association's 30 years of achievement.

Happy birthday, AMOA.

20 Hours Of Exhibit Time Scheduled

This year we again use three large exhibit rooms — the East and West on the lower level and the Continental on the lobby level — to accommodate the greatest array of exhibitors in the association's history. Visitors may enter the exhibit area via the East Room on the lower level or via the Continental Room on the lobby level.

We have a distinguished roster of exhibitors . . . we urge you to visit the exhibit floors frequently and systematically. Make it a point to see all exhibits in all three rooms

Get The Most From The Show

by Fred M. Granger

AMOA's executive vice president Fred Granger has prepared a list of guidelines for visitors to follow in covering the annual convention. His suggestions are as follows:

1) Go to the exposition with the intent of learning as much as you possibly can, especially about new equipment. Attend educational sessions such as the AMOA Seminar. Visit AMOA service booths on the exhibit floor. Keep an open mind.

2) If possible, attend the exposition with someone from your own company. Then you will be able to discuss, on the spot, the merits of the products you see. Or you may wish, at least some of the time, to split up and each concentrate on different parts of the show and then compare notes later.

3) Use your AMOA Exposition Program and Directory of exhibitors complete with floor plans. Then you can check off names

of exhibitors you may have visited or may wish to visit again. Make sure to visit every exhibitor. The one you miss might be the one who could do you the most good.

4) Ask questions. Be inquisitive. Exhibitors cannot always display everything they have, nor can they publish all of their technical information and know-how. So, ask questions.

5) Discuss your particular problems with exhibitors. In this show most exhibitors will have technical people on hand to help you. Read the exhibitors' literature. Collect what you think will be helpful and take it home with you.

6) Get in the habit of taking notes. Amidst such a large display of coin-operated equipment you will find it impossible to remember everything. So carry a notebook in which you can jot down names, products, manufacturers, ideas — whatever might be helpful. Don't trust anything to memory.

7) Keep on the move. The AMOA Exposition is a wonderful opportunity to talk shop with others in the coin machine business. Sometimes informal conversations can yield a gold mine of valuable information.

8) Meet new people. Introduce yourself. Your badge gives you the right to approach new people, most of whom will be glad to meet you. Eat with someone different at

Artists Announced For AMOA Banquet

CHICAGO — Barbara McNair, Cristy Lane, Kenny O'Dell, Ed Raven, the Ritchie Walton Revue, Tommy Wills and emcee Billy Kelly are among the performers who will entertain at the annual AMOA banquet, to be held Sunday evening, Nov. 12, in the Grand Ballroom of the Conrad Hilton Hotel. Producer of this show, and the many before it, is Hirsh de la Viez.

every meal. Circulate at parties and receptions. The member you haven't spoken to may help you the most.

9) Ask for help. If you don't know who can aid you with a particular problem, consult one of the AMOA officers or directors. They will usually know who is most qualified or experienced to help you. Or consult members of the trade press who are very knowledgeable and will be glad to help you. If you are from another country, you can get help from AMOA's International Visitors Booth.

10) Finally, to get the most out of the show, work it systematically. Spend as much time on the exhibit floor as possible. Check the floor plan from the official directory, the trade magazines or the enlarged floor plan posted throughout the show. Work the show carefully, thoroughly. The AMOA Exposition is a very special, high quality show. It only happens once a year. Get the most out of it.

EXPO '78 SCHEDULE OF EXHIBIT HOURS AND EVENTS

(Advance registrants may pick up badges at registration desk, Thursday, Nov. 9, between 1:00 PM and 8:00 PM)

Friday, November 10	
8:30 AM to 5:30 PM	Registration Desk Open
8:00 AM to 9:00 AM	Continental Breakfast (Ballroom foyer)
9:00 AM to 12:00 Noon	AMOA Industry Seminar (Grand Ballroom)
12:00 PM to 6:00 PM	Exhibits Open
12:30 PM	Ladies Luncheon (Waldorf Room)
Hospitality Suites Open In Evening	

Saturday, November 11	
10:00 AM to 5:30 PM	Registration Desk Open
10:00 AM to 6:00 PM	Exhibits Open
11:30 AM to 1:00 PM	General Membership Bruncheon & Program (Boulevard Room)
Hospitality Suites Open In Evening	

Sunday, November 12	
10:00 AM to 3:30 PM	Registration Desk Open
10:00 AM to 4:00 PM	Exhibits Open
6:00 PM to 7:00 PM	Cocktail Hour (Boulevard Room)
7:00 PM to 1:00 AM	Banquet & Show (Grand Ballroom)

Mystic 478

A Pleasure Machine with
Three New Profit-Boosting Features.



For years, jukeboxes just played music. Today Rock-Ola's amazing Mystic 478 actively merchandises music and makes more money than ever before.

First, consider the exclusive Bonus Play feature. You can program each Mystic to offer the type and frequency of Bonus Play most profitable to the individual location. The flashing Bonus light stimulates added pay.

Because a jukebox sells more music when it's playing, Mystic has an optional Random Complimentary Play feature.



ROCK-OLA

ROCK-OLA Manufacturing Corporation
800 North Kedzie Avenue, Chicago, Illinois 60651

©1978-FMC, Chicago, IL

After a varying period of inactivity, Mystic will randomly select and play a complimentary record.

Only Rock-Ola micro-computes and displays the Top 3 Location Hits. This helps the uncertain player make popular selections. It also challenges players to push their favorites into the Top 3.

And Mystic 478 is crafted to uphold Rock-Ola's world recognized reputation for trouble-free operation. Put Mystic's power to work increasing profits. It's one machine you can really bank on.



Exhibitors

A-1 SUPPLY, INC.
P. O. Box 10580
Reno, Nevada 89510
(702) 329-6318
Booth #C-13

ABLOY SECURITY LOCKS
5603 Howard St.
Niles, Illinois 60648
(312) 647-9650
Booth #12-A

ALLIED LEISURE INDUSTRIES, INC.
245 W. 74th Pl.
Hialeah, Florida 33014
(305) 558-5200
Booth #P-13 & 14

AMERICAN SHUFFLEBOARD CO., INC.
210 Paterson Plank Rd.
Union City, New Jersey 07087
(201) 865-6633
Booth #126-129

AMERICON
700 W. Virginia St.
Milwaukee, Wisconsin 53204
(414) 272-4324
Booth #1 & 1-A

AMICO MARKETING INT'L. CORP.
350 Fifth Ave.
New York, N.Y. 10001
(212) 239-4145
Booth #C-89

AMUSEMENT EMPORIUM INC.
2075 S. Valentia St.
Denver, Colorado 80231
(303) 751-4851
Booth #116-117

ARACHNID, INC.
2500 N. Main St.
Rockford, Illinois 61103
(815) 962-3919
Booth #98-A

ARDAC, INC.
4860 E. 345th St.
Willoughby, Ohio 44094
(216) 951-3440
Booth #114-115

ASTRO GAMES, INC.
360 Scott St.
Elk Grove Village, Illinois 60007
(312) 364-7755
Booth #86-87

ATARI, INC.
1265 Borregas Ave.
Sunnyvale, Calif. 94086
(408) 745-2500
Booth #13-24, 25-36

AUTOMATIC PRODUCTS CO.
75 W. Plato Blvd.
St. Paul, Minnesota 55107
(612) 224-4391
Booth #101-102

AUTOMAVE S.S.
c/Fuencarral #101
Madrid 4, Spain
Booth #95

AUTO-PHOTO COMPANY
350 Lear Ave.
Costa Mesa, Calif. 92626
(714) 540-8082
Booth #P-4

BALLY MANUFACTURING CORP.
2640 W. Belmont Ave.
Chicago, Illinois 60618
(312) 267-6060
Booth #146-150 & 140

BELAM EXPORT CORP.
51 Madison Ave.
New York, N.Y. 10010
(212) 689-5632
Booth #187A-188

BIC PEN CORP.
Wiley Street
Milford, Connecticut 06460
(203) 878-9341
Booth #C-71, 72

BRUNSWICK CORPORATION — Consumer Division
One Brunswick Plaza
Skokie, Illinois
(312) 470-4700
Booth #64-66

CALER, JOHN W.
7506 Ciybourn Ave.
Sun Valley, Calif. 91352
(213) 765-1210
Booth #100B

CAROUSEL INTERNATIONAL CORP.
P. O. Box 307
Eldon, Missouri 65026
Booth #2-5

CENTURY GAMES LIMITED
1430 Koll Circle #105
San Jose, Calif. 95112
(408) 297-8202
Booth #C-58, 59

CHAMPION BILLIARDS, INC.
900 Andre
Bay City, Michigan 48706
(517) 686-4000
Booth #C-12

CINEMATRONICS, INC.
1466 Pioneer Way, Suite 6
El Cajon, Calif. 92020
(714) 440-2933
Booth #C-54, 55

COIN ACCEPTORS, INC.
4946 Daggett Ave.
St. Louis, Missouri 63110
(314) 664-5550
Booth #C-15, 16

COMPUTER KINETICS CORP.
31129 Via Colinas, Bldg. 701
Westlake Village, Calif. 91361
(213) 991-2199
Booth #68-69

CORPORACION SONATA S.A.
Apartado Postal 22036
Mexico City 22, Mexico
(905) 573-24-13, 57301-11
Booth #C-79

COUNTRY INTERNATIONAL RECORDS
1010 17th Ave. So.
Nashville, Tenn. 37212
(615) 254-1886
Booth #P-10

CURRIE DISTRIBUTING (CAMPBELLVILLE) LTD.
R.R. #2
Campbellville, Ontario, Canada LOP 1S0
(416) 854-2267
Booth #C-68

D&R INDUSTRIES, INC.
7111 N. Capitol Drive
Lincolnwood, Illinois 60645
(312) 677-3200
Booth #P-1 & 2

DEUTSCHE WURLITZER GMBH
Wurlitzerstr. 6,
Hullhorst Germany NRW 4971
5744-1001
Booth #P-5

DYNAMO CORPORATION
1805 S. Great Southwest Pkwy.
Grand Prairie, Texas 75051
(214) 641-4286
Booth #W-1-6

EMPIRE DISTRIBUTING, INC.
2828 N. Paulina St.
Chicago, Illinois 60657
(312) 871-7600
Booth #154-157

EXIDY, INC.
2599 Garcia Ave.
Mountain View, Calif. 94043
(415) 968-7670
Booth #44-47

FORBES MANUFACTURING
Faulkner St.
North Billerica, Massachusetts 01862
(617) 663-4689
Booth #93-A

J.F. FRANTZ MANUFACTURING CO.
1936 W. Lake St.
Chicago, Illinois 60612
(312) 829-2399
Booth #191-193

TONY GALGANO, INC.
4134 W. Armitage Ave.
Chicago, Illinois 60639
(312) 278-8300
Booth #P-11

GAME-A-TRON, INC.
923 W. Main St.
New Britain, Connecticut 06053
(203) 229-4839
Booth #C-62

GAME PLAN, INC.
140 Lively Blvd.
Elk Grove Village, Illinois 60007
(312) 437-6870
Booth #C-9, 10

GERINVEX S.A.
Longemalle No. 10
Renens, Switzerland 1020
(21) 341407
Booth #190

D. GOTTLIEB & COMPANY
165 W. Lake St.
Northlake, Illinois 60164
(312) 562-7400
Booth #C-81-86

GREMLIN INDUSTRIES, INC.
8401 Aero Drive
San Diego, Calif. 92123
(714) 277-8700
Booth 70-72, 88-90

IMPERIAL BILLIARD INDUSTRIES
550 Industrial Road
Carlstadt, New Jersey 07027
(201) 935-9330
Booth #48-49

INDER. S.A.
Poligono Industrial "COBO CALLEJA"
Felipe Asenjo 1
Fuenlabrada, Madrid, Spain
231 86 59
Booth #C-73-74

INNOVATIVE SYSTEMS, INC.
903 Talladega
P.O. Box 626
Muskogee, Oklahoma 74401
(918) 683-0387
Booth #C-66, 67

INTEC
1131 Lincoln Highway
No. Versailles, Pennsylvania 15137
(412) 824-8100
Booth #94

INTERFLIP S.A.
Rufino Gonzalez, 25
Madrid 17, Spain
(17) 204 99 10
Booth #C-51, 52

INTERNATIONAL BILLIARDS, INC.
2311 Washington Ave.
P.O. Box 7693
Houston, Texas 77007
(713) 869-3237
Booth #C-56

INTRAMAR MARKETING LTD.
801 York Mills Rd., Suite 201
Don Mills
Ontario, Canada M3B 1X7
(416) 447-0465
Booth #C-69

J-S SALES COMPANY, INC.
24 S. Third Ave.
Mt. Vernon, New York 10550
(212) 324-3830
Booth #40-41

IRVING KAYE COMPANY
48 Union St.
Stamford, Connecticut 06906
(203) 348-1800
Booth #158-165

KURZ-KASCH, INC.
1501 Webster St.
P.O. Box 1246
Dayton, Ohio 45401
(513) 223-8161

LETTER-ALL, INC.
(Dewey-Carter Company Div.)
242 Wood St.
Doylestown, Pennsylvania 18901
(215) 348-8880
Booth #99-A

LIBIN & ASSOCIATES
907 N. Hollywood Way
Burbank, Calif. 91505
(213) 845-7488
Booth #91

LITTLE GIANT INDUSTRIES
31 South 100 West
American Fork, Utah 84003
(801) 756-7656
Booth #C-41

LOWEN-AUTOMATEN GMBH & CO. KG
Im Tiergarten 20-30, P.O. Box 168
6530 Bingen/Rhein
West Germany
(6721) 15202
Booth #P-8

MEADOWS GAMES, INC.
181 Commercial St.
Sunnyvale, Calif. 94086
(408) 732-8110
Booth #37-38, 57-58

MECHANICS SCHOOLS
AMOA Mechanics School
35 E. Wacker Dr.
Chicago, Illinois 60606
(312) 726-2810

Cal's Coin College
P.O. Box 810
Nicoma Park, Oklahoma 73066
(405) 769-5343
Booth in Registration Area

MEYCO GAMES, INC.
650 Vaqueros Ave.
Sunnyvale, Calif. 94086
(408) 245-1603
Booth #97-A

MEYER & WENTHE
7220 W. Wilson
Harwood Heights, Illinois 60656
(312) 867-7575
Booth #39

MICRO-MAGNETIC INDUSTRIES, INC.
981 Commercial St.
Palo Alto, Calif. 94303
(415) 321-5520
Booth #186

MIDWAY MANUFACTURING CO.
10750 W. Grand Ave.
Franklin Park, Illinois 60131
(312) 451-1360
Booth #151-153

MIRACLE RECREATION EQUIPMENT CO.
P.O. Box 275
Grinnell, Iowa 50112
(515) 236-7536
Booth #67

MIRCO, INC.
10888 N. 19th Ave.
Phoenix, Arizona 85029
(602) 997-5931
Booth #134-135



THE CONRAD HILTON HOTEL • CHICAGO, ILLINOIS
FRIDAY, SATURDAY, SUNDAY - NOVEMBER 10-11-12

*AMOA's International Trade Show for Coin-Operated
Games, Music and Allied Products*



Exhibitors

MOBILE RECORD SERVICE CO.
2716 Penn Ave.
Pittsburgh, Pennsylvania 15222
(412) 391-8182
Booth #186-A&B

MONDIAL COMMERCIAL CORP.
350 Fifth Ave.
New York, N.Y. 10001
(212) 947-5659
Booth #C-87-88

MONSTER CORPORATION (THE)
307 E. Lincoln Way
Ames, Iowa 50010
(515) 232-2912
Booth #100-A

NAMCO LTD.
2-8-5 Tamagawa
Ohta-ku
Tokyo, Japan 146
(U.S.: (408) 756-7600)
Booth #81-83, 98-100

NATIONAL VENDORS
5055 Natural Bridg
St. Louis, Missouri 63115
(314) 383-3000
Booth #130-131

NEVADA GAMING SCHOOLS, INC.
3100 Sirius Road
P.O. Box 15407
Las Vegas, Nevada
(702) 873-2345
Booth #95-A

NU-LOOK PRODUCTS
P.O. Box 6255
Philadelphia, Pennsylvania 19136
(215) 673-3355
Booth #C-14

O.B.A., INC.
2522 Irving Blvd.
Dallas, Texas 75207
(214) 630-8004
Booth #7-8

O.K.F. S.p.A.
Via Masetti n. 56,
Ganaceto (Modena) Italy 41010
059-386042
Booth #9-10

OSBORNE COINAGE COMPANY
2851 Massachusetts Ave.
Cincinnati, Ohio 45225
(513) 681-5424
Booth #11

PEABODY'S INCORPORATED
P.O. Box 210
Virginia Beach, Virginia 23458
(804) 422-2900
Booth #12

PENN-RAY INTERNATIONAL CORP.
1705 Winchester Rd., P.O. Box 390
Cornwells Heights, Pennsylvania 19020
(215) 638-4720
Booth #112-113

PHOTO MACHINES, INC.
2927 Industrial Rd.
Las Vegas, Nevada 89109
(702) 732-3106
Booth #C-63, C-78

PLATT LUGGAGE, INC.
2301 S. Prairie Ave.
Chicago, Illinois 60616
(312) 225-6670
Booth #132

PLAY MASTER, INC.
5909 Paris Rd.
Columbia, Missouri 65201
(314) 474-8591
Booth #62-63, 76-77

POLAND MANUFACTURING CO., INC.
P.O. Box 1168
Forrest City, Arkansas 72335
(501) 633-2205
Booth #189

POLAROID CORPORATION
549 Technology Square
Cambridge, Massachusetts 02139
(617) 864-6000
Booth #C-80

RAMTEK CORPORATION
292 Commercial St.
Sunnyvale, Calif. 94086
(408) 738-4422
Booth #C-31-33; C44-46

R.J. REYNOLDS TOBACCO CO.
401 N. Main St.
Winston-Salem, No. Carolina 27102
(919) 748-4100
Booth #54-56

ROCK-OLA MANUFACTURING CORP.
800 N. Kedzie Ave.
Chicago, Illinois 60651
(312) 638-7600
Booth #P-9

ROWE INTERNATIONAL, INC.
75 Troy Hills Rd.
Whippany, New Jersey 07981
(201) 887-0400
Booth #P-6, C-2-3

RUBYROSE-COLUMBO
P.O. Box 3720
Beverly Hills, Calif. 90212
(213) 652-8093
Booth #93

SAFEGUARD COIN BOX
101 Clinton Rd.
Fairfield, New Jersey 07006
(201) 575-0040
Booth #43

SEGA ENTERPRISES, INC.
2550 Santa Fe Ave.
Redondo Beach, Calif. 90278
(313) 772-0833
Booth #P-15, 16-17

SEEBURG CORPORATION, THE
1500 N. Dayton St.
Chicago, Illinois 60622
(312) 642-0800
Booth #P-7

SKEE BALL INC.
8th & Maple Sts.
Lansdale, Pennsylvania 19446
(215) 362-0300
Booth #P-12

SKYHIGH AMUSEMENT OF CANADA LTD.
72c Brunswick Ave.
Dollard des Ormeaux
Quebec, Canada H9B 2C5
(514) 864-8422
Booth #C-43-44

SPINDEL INSURANCE AGENCY, INC.
3700 174th Court
#11A, Box 515
Lansing, Illinois 60438
(312) 895-1900
Booth #139

STANDARD CHANGE-MAKERS, INC.
422 E. New York St.
Indianapolis, Indiana 46202
(317) 639-3423
Booth #119-120

STERN ELECTRONICS, INC.
1725 W. Diversey Parkway
Chicago, Illinois 60614
(312) 935-4600
Booth #141-145

SUNBIRD CORPORATION
6949 Washington Ave. So.
Minneapolis, Minnesota 55435
(612) 944-1437
Booth #C-60, 61 & 64-65

SUTRA IMPORT CORPORATION
485 Brown Court
Oceanside, New York 11572
(516) 536-6770
Booth #103-105

SUZO TRADING COMPANY B.
Schoenebergerweg 85-89
Rotterdam, Netherlands 3023
010-760252
Booth #C-36

T.A.T. DEVICES LTD.
Elmer Dane Works
Gomersal, Cleckheaton
West Yorkshire, England BD19 4LE
0274-873942
Booth #C-11

T.J.M. CORPORATION
5 Walnut
Elgin, Illinois 60120
(312) 742-5620
Booth #C-35

TAITO AMERICA CORPORATION
233 N. Michigan Ave.
Chicago, Illinois 60601
(312) 565-0118
Booth #73-75

TAPE-ATHON
502 S. Isis Ave.
Inglewood, Calif. 90301
(213) 776-6933
Booth #P-3

TELMARK SYSTEMS, INC.
16902 El Camino Real, Suite 1C
Houston, Texas 77058
(713) 486-8641
Booth #C-37-40

TOMMY LIFT GATE MFG. CO.
Bus Brown Drive, P.O. Box 8
Woodbine, Iowa 51579
(712) 647-2050
Booth #111

TORNADO, INC.
5204 Airport Freeway, Hwy. 121
Fort Worth, Texas 76117
(817) 831-2231
Booth #C-28-29

TOURNAMENT SOCCER
7930 Occidental Ave. So.
Seattle, Washington 98108
(206) 763-1211
Booth #59-61; 78-80

TRU-CHECK COMPUTER SYSTEMS, INC.
250 E. Hartsdale Ave.
Hartsdale, New York 10530
(914) 472-9030
Booth #50

TWELVE SIGNS, INCORPORATED
3369 S. Robertson Blvd.
Los Angeles, Calif. 90034
(213) 553-8000
Booth #52-53

U.B.I., INC.
51 Progress St.
P.O. Box 37
Union, New Jersey 07083
(201) 686-7030
Booth #173-178

U.S. BILLIARDS, INC.
243 Dixon Ave.
Amityville, New York 11701
(516) 842-4242
Booth #169-172; 179-182

UNIVERSAL COMPANY, LTD.
1-12-3 Nihombashi
Horidome-cho
Chuo-ku, Tokyo 103, Japan
03-661-6003
Booth #C-4-8

UNIVERSE AFFILIATED INT'L., INC.
609 N. Union Ave.
Hillside, New Jersey 07205
(201) 686-5163
Booth #C-47-50; C-53

VALLEY COMPANY (THE)
333 Morton St., P.O. Box 656
Bay City, Michigan 48707
(517) 892-4536
Booth #106-110; 121-125

VECTORBEAM
33441 Central Ave.
Union City, Calif. 94587
(415) 489-2000
Booth #96-97

VIDEO RESEARCH CORP.
260 Sheridan Ave.
Suite 414
Palo Alto, Calif. 94306
(415) 321-6708
Booth #70-A

VIDEOTRON ENTERTAINMENT CORP.
22201 Ventura Blvd.
Suite 201
Woodland Hills, Calif. 91364
(213) 347-1841
Booth #C-30 & 118

VENGUARD (Div. of Vendo Co.)
10500 Barkley
Overland Park, Kansas 66212
(913) 341-1300
Booth #84-85

VENTURE LINE, INC.
2207 S. 48th St.
Tempe, Arizona 85285
(602) 967-5914
Booth #C-75-77

WICO CORPORATION
6400 W. Gross Point Rd.
Niles, Illinois 60648
(312) 647-7500
Booth #133 & 136-138

WILDCAT CHEMICAL CO., INC.
1349 E. Seminary Drive
Fort Worth, Texas 76115
(817) 924-8321
Booth #42

WILLIAMS ELECTRONICS, INC.
3401 N. California Ave.
Chicago, Illinois 60618
(312) 267-2240
Booth #166-168 & 183-185

ZILA CORPORATION
2103 S. Hathaway St.
Santa Ana, Calif. 92705
(714) 957-9371
Booth #6

ZURCON INDUSTRIES, INC.
280 Industrial Drive
Fredonia, Wisconsin 53021
(414) 255-2203
Booth #51

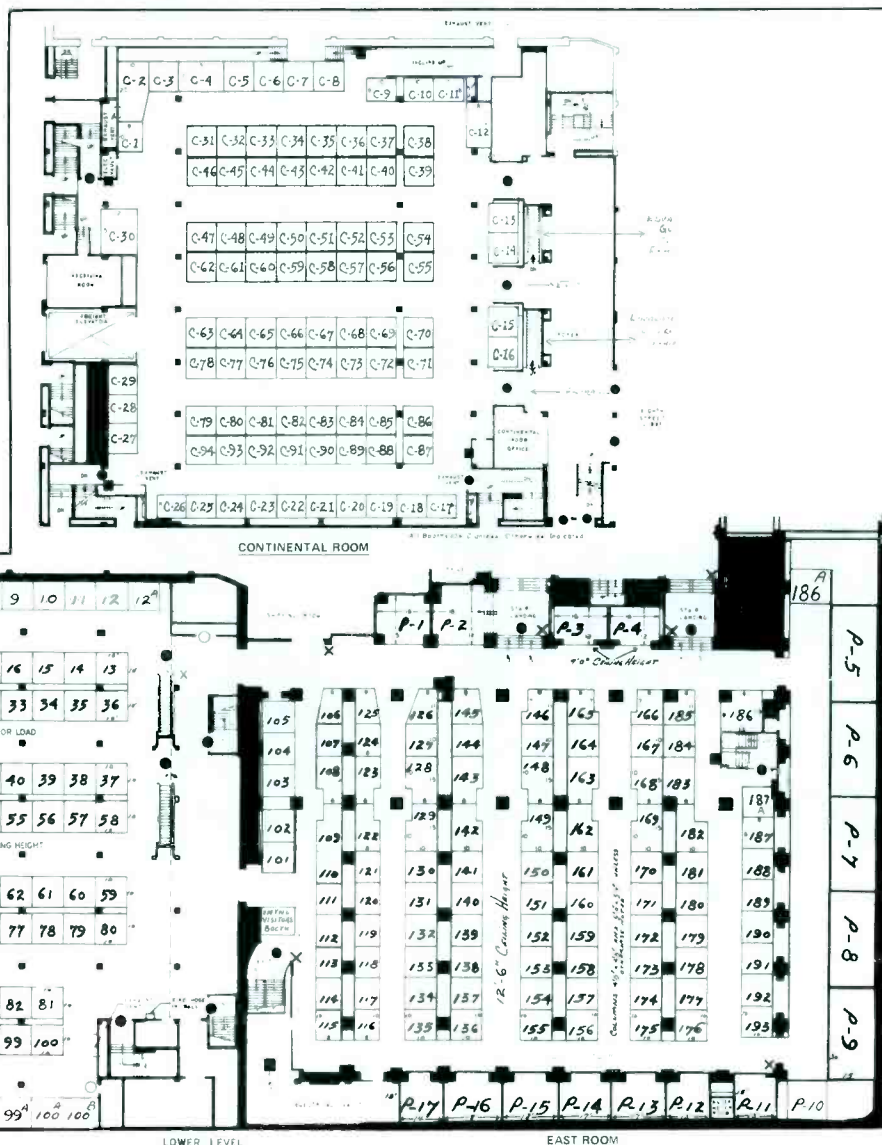



Distributors Speak Out On Significance Of AMOA Expo

by Alan Sutton

LOS ANGELES — "We go to the AMOA show to meet with the manufacturers and get a line on all the new equipment that is coming out."

"It's an opportunity to touch base with other distributors to exchange ideas about the direction the industry is taking."

"By attending the AMOA seminar, we

can pass the information along to operators in our area who are unable to attend the show."

Comments such as these vividly illustrate the importance of the annual AMOA Exposition to the nation's distributors of coin-operated amusement games and jukeboxes. From a distributor's point of view, it is the most important

business convention of the year; no other meeting attracts such a broad cross-section of industry representatives in one marketplace.

This year's convention, the association's 30th, will be held Nov. 10-12 at Chicago's Conrad Hilton Hotel.

See New Product

In a recent survey, distributor company

executives said the primary reason for attending the AMOA Expo is to view new product and discuss sales and promotion strategies with factory representatives. They also said AMOA is the ideal forum for comparing notes with fellow distribs on issues of mutual concern, such as price-per-play and location ownership of games. Finally, many distributors feel it is their duty to attend the show in order to keep customers apprised of the latest developments in the industry.

"I don't think there is a distributor in the country that doesn't attend AMOA," said John Scavarda, general manager of Circle International in Los Angeles. "It's the most important show in the industry."

"AMOA makes purchasing easier by giving us a preview of what's coming out in terms of new product. Also, it gives us a handle on adding new lines."

Ray Hibarger, president of Hanson Distributing, Bloomington, Minn., agreed that the show's primary function is to expose new equipment.

"AMOA is an excellent place to feel the pulse of the industry, where it is headed — specifically what we can expect in the coming months in the way of product," he said.

Enhance Marketing Capability

"It's an opportunity to meet with the manufacturers we represent in an attempt to enhance our capability to market their products, with particular emphasis on game concepts, service and promotion."

"Another important thing is it exposes us to new manufacturers with other new products."

Hibarger said it is also helpful to be able to see how operators respond to the new games.

"The environment at AMOA is very conducive to getting an idea of how our customers feel about the new pieces," he said. "Their reaction is much more candid because they are not in a sales environment."

Similarly, Ira Bettelman, vice president of C.A. Robinson & Co. in Los Angeles, said: "Although I may already be familiar with a new game, it's important to see the way 200, 300, 500 operators react to it. I may not be looking at the game as much as I'm looking at the people."

The executives stressed the importance of comparing notes on topics of mutual interest with other distributors attending AMOA.

"At any convention you go, number one, to see new products," said Art Warner, assistant sales manager at Betson Enterprises in New Jersey. "But it's equally as important to see other distributors and get a feeling for what's happening nationwide."

What sort of things do distributors discuss at AMOA?

"We talk about general trends and directions in the business — what inventories look like, location commissions, price-per-play, things like that," said Ira Bettelman.

As a result of these discussions, existing pieces are frequently reevaluated as to their earnings potential, said Hanson Distributing's Hibarger.

Reevaluate Equipment

"Oftentimes in exchanging ideas with other distributors we find that their customers have found a place for a particular piece that is generally not a good earner," he said. "And it helps us to know, for example, if a piece that does not do well in a bowling alley does very well in an arcade. Then we can recommend it to customers who have had a bad experience with the piece."

More than that, distributors say they are responsible for keeping their customers in-

(continued on page C-12)

SCORE<1> HI-SCORE SCORE

0000 0000 00

MIDWAY'S SPACE INVADERS

The electrifying new one or two player game in which the players match their skill and wits in defense of the planet Earth, against waves of attacking invaders from outer space.

The player must strategically position, then fire his laser missile launcher attempting to knock out the ever-attacking invaders before they can drop missiles destroying the defender's protective bunkers and missile launcher.

Two players play alternately for high scores and extended play time.

SPACE INVADER offers titulating sounds, dramatic play action and inviting cabinet graphics creating player appeal and high income.

SCORE<1> HI-SCORE SCORE<2>

0000 0000 0000

PLAY

SPACE INVADERS

SCORE ADVANCE TABLE

☹=7 MYSTERY

☹=30 POINTS

☹=20 POINTS

☹=10 POINTS

SCORING VALUES

Cabinet size: Height 68" (162.6 CM)
 Width 26½" (67.3 CM)
 Depth 34" (86.4 CM)

Weight: 260 lbs. (117 k)

Midway Grows as the World Plays

M — **MIDWAY MFG. CO.**
 A BALLY COMPANY
 10750 West Grand Avenue
 Franklin Park, Illinois 60131
 phone: (312)451-1360

PRINTED IN U.S.A.

BEATLES

"ARTISTS OF THE YEAR"

*Thank You
Amusement and Music Operators of America*



Records, Inc.

www.americanradiohistory.com

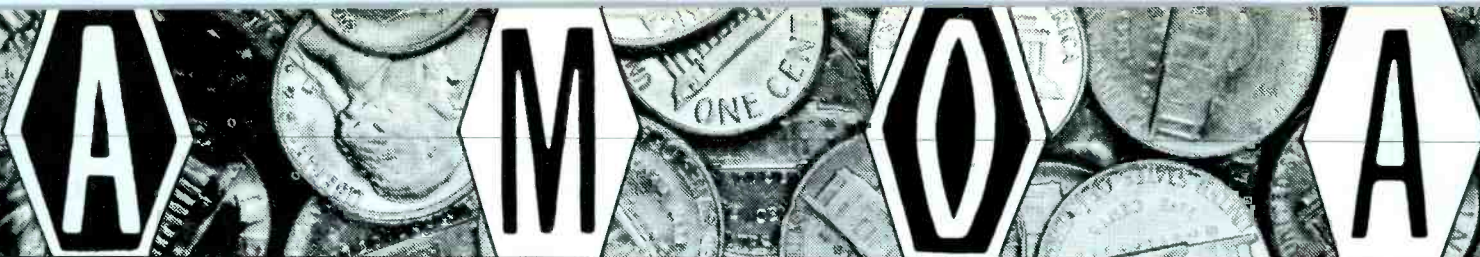

AMOA JUKE

SINGER FOR OP'S

The One-Stop for Ops!
Serving Jukebox Operators
Exclusively for Over 25
Years

OLDIES ARE OUR
SPECIALTY!

FREE TITLE STRIPS

ONE-DAY SERVICE

SINGER **ONE STOP** FOR OP'S

2130 WEST CHICAGO AVENUE

CHICAGO, ILLINOIS 60622

Phone: (312) 772-3450

BIGGER AND BETTER: Each issue contains more money-saving information for you . . . \$26.00 per year in the USA and \$31.00 overseas. ELECTRONIC AMUSEMENT REPORT, 7011 N. Atlantic Avenue, Cape Canaveral, Florida 32920.

A Full Line of
Coin Operated
Recreational
Tables from

American
SHUFFLEBOARD COMPANY
210 PATERSON PLANK ROAD
UNION CITY NEW JERSEY

"The House That
Quality Built"

Money in your pocket. New digital Sweet Shawnee. Distributors wanted. AMUSEMENT SYSTEMS CORPORATION, 7011 N. Atlantic Avenue, Cape Canaveral, Florida 32920, (305) 783-5763.



Bee Gees

Artist Of The Year

Twenty years ago few people around the world knew much about the Bee Gees, but 20 years from now they will still be talking about the "Bee Gees Fever of 1978."

In fact, when one looks at the 70s in contemporary music, no other group has made an impact on the scale of the Brothers Gibb — Barry, Robin and Maurice. Their ascension has been deceptive, but never more convincing than their history-making surge into 1978, the year the Bee Gees Fever truly captured the pulse and the hearts of the people.

The "Bee Gees Fever of 1978" not only represents the phenomenal chart successes of the Gibb brothers during the year, but it symbolically reflects the mood of the times. The stage was set last year when Barry, Robin and Maurice began working on the soundtrack album for "Saturday Night Fever," produced by Robert Stigwood for Paramount Films.

Almost simultaneously, the Bee Gees had just completed their "Here At Last . . . Bee Gees . . . Live" album, a million-selling two-record set that featured 22 of their greatest hits, and were preparing for a major tour of the same title. Their previous album, "Children Of The World" (1976), was nearing double-platinum, and "Main Course," the one before (1975), was still lingering as one of their most well-received albums ever.

They also had enjoyed three #1 hits; "How Can You Mend A Broken Heart" (1971), their first #1 in America; "Jive Talkin'" (1975); and "You Should Be Dancing" (1976). In between, hits like "Love So Right," "Boogie Child," "Run To Me" and "My World" kept them constantly in the Top 20.

While Stigwood sought their writing talents for the music in "Saturday Night Fever," he also engineered their first starring roles, in "Sgt. Pepper's Lonely Hearts Club Band," released this summer, co-starring the Bee Gees and Peter Frampton. The \$12 million RSO musical extravaganza, directed by Michael Schultz and produced by Robert Stigwood, oozes with plenty of glitter and musical excitement, making it one of the most anticipated and highly acclaimed film releases this year.

Amidst this wave of activity, the Bee Gees finally sat down, in Paris, to write the title song for "Saturday Night Fever." The song they delivered, "Stayin' Alive," drooled with the frenzy and fiery excitement that sparked John Travolta's memorable and academy-award-nominated performance as Tony Manero, Brooklyn's disco king.

The Bee Gees later wrote and co-produced, along with Albhy Galuten and Karl Richardson, the majority of the "Saturday Night Fever" soundtrack album. Within weeks of its release, the album spread a fever throughout America unlike any experienced since the Fabulous Four blitzed

(continued on page C-26)



Crystal Gayle

Record Of The Year

If the last year is any indication of the things to come for Crystal Gayle, then the sky's the limit for the lady from Nashville.

In 1977, Crystal was presented with the "Outstanding Female Vocalist" award by both the Academy of Country Music and the Country Music Association. In February 1978 NARAS presented Crystal with her first-ever Grammy for the country female vocal performance of the year. Also in 1978, both the Academy of Country Music and the Country Music Association named Crystal their "Outstanding Female Vocalist" for the second consecutive year.

Combining pop, country and blues, Crystal is an artist whose country feel is apparent, yet because of her varied musical tastes, her own style is hard to categorize.

Crystal was born in the small eastern town of Paintsville, Kentucky where singing immediately became a part of her life since all four brothers and three sisters were involved in music. At the age of four, Crystal and her family moved to Wabash, Indiana where she actually got her first taste of performing live. It was during her high school years that she performed in church, for charities and other civic organizations.

After graduation, Crystal signed her first recording contract with Decca Records, now MCA. Her first single, "I've Cried (The Blue Right Out Of My Eyes)," hit the top twenty on the country charts and when it was re-released in 1977, it moved high on the country charts again.

In January 1973, Crystal signed with United Artists Records. Her first UA single, "Restless," received heavy airplay and was a country chart item. Through the success of "Restless," Crystal found herself performing in many of the top nightclubs across the country.

Now she's working constantly, traveling from one city to the next. Crystal and her husband Bill, (who is studying law) now live in Nashville. Although Crystal is quite a homemaker, most of her spare time is spent writing songs and trying out new musical ideas.

Crystal's first album, "Crystal Gayle," contained three country hits, "Beyond You," "Wrong Road Again" and "This Is My Year For Mexico." Her second album, "Somebody Loves You," contained more of the same, including the hits, "Somebody Loves You" and her first #1 country hit, "I'll Get Over You."

Crystal's third work, entitled "Crystal," showed crossover activity to the pop market and included the hits, "One More Time," "Do It All Over Again" and "Never Miss A Real Good Thing."

Crystal's fourth album, "We Must Believe In Magic" is her best seller to date achieving platinum status in February 1978. Her recent success is due in part to a strong crossover into the pop stream of music. Her hit single off the album, "Don't It Make My Brown Eyes Blue," went platinum.



Debby Boone

Pop Record Of The Year

People who debate the importance of heredity versus environment in the parenting of talent will have a difficult time separating the genes from the upbringing in the case of 21-year-old Debby Boone. Daughter of rock 'n' roll patriarch Pat and granddaughter of country & western star Red Foley, one could easily say that Debby was 'to-the-manner-born.'

Debby was born in Hackensack, New Jersey, and moved with her family to the Los Angeles area when she was four. Shirley Boone dressed her four daughters alike (the others are Cherry, Lindy and Laury) and taught them to sing four-part harmony. As might be imagined, there was always a lot of singing going on in the Boone family, whether at impromptu home gatherings, at church or on tour. Debby's earliest memories of family sing-alongs center around her dad's career. Debby's "big break" occurred eight years ago when Pat headlined a bill in Japan with the then unknown Osmonds. It was decided that if the girls could come up with one song they could sing in the show, they could accompany him to Japan. The song they chose was "What The World Need Now Is Love," and the singing Boones have been a welcome staple on musical circuits throughout the world ever since.

With two of the daughters now married and one in college, the logistics of wide-ranging tours became more and more difficult. The time seemed right for Debby to step out on her own. Producer Mike Curb had been after Debby to record solo for the last three years. Her first Warner-Curb solo single "You Light Up My Life" (the theme song from the Columbia motion picture of the same name) was the longest running top-of-the-charts single in 23 years. Her debut album "You Light Up My Life," produced by Michael Lloyd, Mike Curb and Joe Brooks and released in September 1977, features Debby's sisters singing with her on several songs, including a few fine oldies such as Lennon-McCartney's "From Me To You." Although she claims she's more comfortable with ballads, like "End Of The World," her version of the upbeat "Hasta Manana" proves her versatility.

Thus far, the year 1978 has not only seen the continued expansion of Debby's creative horizons, but her emergence as a talent of major stature within the entertainment industry. At the 1978 Grammy Awards, Debby and "You Light Up My Life" won Best New Artist and Song of the Year, respectively. "You Light Up My Life" was an Academy Award winner as well, for Best Movie Theme Song, not to mention NARM awards for Best Selling Single and Best Selling LP By a New Artist.

Debby's second album is titled "Midstream" and highlights material perfectly suited to her distinctive vocal style. The LP was produced by Brooks Arthur and Joe Brooks.



BOX AWARDS



Bonnie Tyler

Country Record Of The Year

Within the past year, vocalist Bonnie Tyler has become one of the most popular recording artists on the international charts. Her latest single, "It's A Heartache," reached #1 in Austria, #3 in Germany, Holland and Belgium, #4 in England, #5 in Australia and Top 10 in South Africa. It's her fourth globe-spanning hit, but there's still a major goal to be reached — the American charts.

One sure indication of the enormous momentum Bonnie's career has achieved already is the race by several U.S. artists to cover her latest hit. But RCA Records, which now releases her discs throughout the world, has rushed out the original hit version of "It's A Heartache" in this country first.

Some European journalists have recently taken to describing Bonnie as a female Rod Stewart. At her record company's offices in London they refer to Rod Stewart as a male Bonnie Tyler. But Bonnie herself simply says flatly, "I hate the comparisons with anyone else. And if anyone thinks me a lightweight, instant success, I shall be around to remind them that my real success is only just starting . . ."

With her career being guided by Gordon Mills, one of the world's top managers, Bonnie is certain to be taking some giant steps. Color photos of the blonde singer with blue eyes appear frequently in Europe's pop music publications and with the success of each hit, particularly "It's A Heartache," her fame spreads to new corners of the world.

Bonnie Tyler was born in a small Welsh town just outside of Swansea. While working as an assistant in a candy shop, she used to sing into an imaginary microphone and dream of appearing on BBC-TV's Top Of The Pops. She had her first multi-nation smash with "Lost In France," which is included in her debut album "The World Starts Tonight" (released in the U.S. on Chrysalis). Other highlights of that initial LP include "More Than A Lover," another of her global hits, and a unique interpretation of the classic Janis Joplin number "Piece Of My Heart."

Her second album was the first to feature her new, fulltime band. Members are Kevin Dunn on bass, who's been with Bonnie for four years; drummer Mick Gibbons, who played with Badfinger; steel and rhythm guitar player Peter King; keyboard player Roger Bara, the band's only non-Welshman; and lead guitarist Taff Williams. The album contains "It's A Heartache," "Heaven" and a memorable version of "You Make Me Feel Like A Natural Woman."

Tyler's third release, recently recorded at London's Rak Studios contains 10 new tunes co-produced by Ronnie Scott, Steve Wolf and Robin Cable. As yet untitled, the new LP is slated for release by RCA in January of 1979.



Heatwave

Soul Record Of The Year

The most refreshing new band to emerge on the International pop scene in 1977 was Heatwave, the seven-piece group whose debut American single, "Boogie Nights," was one of only three singles to be certified platinum (two million records sold) in the United States by the RIAA over the course of the year. Significantly, "Boogie Nights" was the only one of those three platinum singles to be written by the act who performed it. Moreover, Heatwave's success didn't stop with that record, as their debut album, "Too Hot To Handle," has since been certified double-platinum (two million units sold) in the U.S. by the RIAA. Most recently (late March 1978) it was learned that the second single picked from that LP, namely "Always And Forever," had climaxed its dramatic Top 20-pop/Top 5-R&B chart run with RIAA gold certification (one million records sold) in the U.S. — that announcement coming just days before the release of Heatwave's long-awaited second album, "Central Heating."

Heatwave's leader and founder is Johnnie Wilder, Jr., a dynamic singer who has overseen every step of the band's career. A native of Dayton, Ohio, Johnnie's family includes five brothers, one of whom, Keith, has been the second lead vocalist of Heatwave since his joining the lineup in late 1975.

After attending Central State University in Wilberforce for a year, Johnnie enlisted in the Army, and was shipped out to "Strat-Com" headquarters in Heidelberg, West Germany, at the beginning of 1969. To point a finger at Heatwave's earliest origins, it would be the Cashmeres, a five-man a cappella vocal group that Johnnie organized to sing at service clubs on weekends. Soon he met a group of German musicians calling themselves the Soul Sessions, and they were able to achieve a sound emulating the Chi-Lites, Temptations, etc. When the Army's red tape took away a couple of the singers, though, Johnnie reorganized the group as the Noblemen, and eventually became its solo lead singer until his discharge in January, 1972.

Johnnie immediately returned home to Dayton, but in two months he was back in West Germany singing with Soul Sessions for another half-year. It didn't take long before Johnnie found countryman Tommy Harris, drummer-leader of the Upsetters, and they began practicing together at a small room in Zweibrücken — it was the percolating radiator in that room, which never stopped pouring on the heat 12 months a year, that gave them their new name: Heatwave.

Johnnie Wilder, Keith Wilder, Mario Mantese, Rod Temperton, Bilbo Berger, Roy Carter and Billy Jones — together in Heatwave as their second album, "Central Heating," again produced by Barry Blue, begins its reign on the charts.

Power Of Earnings Determines AMOA Jukebox Winners

CHICAGO — AMOA members annually vote for the association's coveted Jukebox Awards. The awards, which are based solely on a record's earning power in jukeboxes, are presented at the annual AMOA Banquet — the climax of the three-day exposition.

The following is a list of the AMOA Jukebox Award winners for the past few years:

- 1968**
 Record of the Year — **Honey** by Bobby Goldsboro (United Artists)
 Artist of the Year — **Glen Campbell** (Capitol)
 Record Company of the Year — **Epic Records**
- 1969**
 Record of the Year — **Harper Valley P.T.A.** by Jeannie C. Riley (Plantation Records)
 Artist of the Year — **Glen Campbell** (Capitol)
 Record Company of the Year — **MGM Records**
 Great Friend Award — **Boots Randolph** (Monument)
- 1970**
 Record of the Year — **Raindrops Keep Fallin' On My Head** by B. J. Thomas (Scepter Records)
 Artist of the Year — **Johnny Cash** (Columbia)
 Artists of the Year — **Creedence Clearwater Revival** (Fantasy)
- 1971**
 Record of the Year — **Rose Garden** by Lynn Anderson (Columbia)
 Artist of the Year — **Charley Pride** (RCA)
 Artists of the Year — **Dawn** (Bell)
 Record Company of the Year — **Columbia Records**
- 1972**
 Record of the Year — **Shaft** by Isaac Hayes (Stax)
 Soul Record of the Year — **Shaft** by Isaac Hayes (Stax)
 Country & Western Record of the Year — **Easy Lovin'** by Freddie Hart (Capitol)
 Pop Record of the Year — **American Pie** by Don McLean (United Artists)
 Artist of the Year — **Charley Pride** (RCA)
 Artists of the Year — **Sonny & Cher** (MCA-Kapp)
- 1973**
 Pop Record of the Year — **Tie A Yellow Ribbon Round The Old Oak Tree** by Dawn (Bell)
 Soul Record of the Year — **Killing Me Softly With His Song** by Roberta Flack (Atlantic)
 Country & Western Record of the Year — **Funny Face** by Donna Fargo
 Artist of the Year — **Helen Reddy** (Capitol)
 Artists of the Year — **Dawn** (Bell)
- 1974**
 Record of the Year — **Most Beautiful Girl in the World** by Charlie Rich (Epic)
 Pop Record of the Year — **Sundown** by Gordon Lightfoot (Reprise)
 Country & Western Record of the Year — **Let Me Be There** by Olivia Newton-John (MCA)
 Soul Record of the Year — **Show And Tell** by Al Wilson (Rocky Road Records)
 Artist of the Year — **Charlie Rich** (Epic)
- 1975**
 Record of the Year — **Before The Next Teardrop Falls** by Freddy Fender (ABC-Dot)
 Pop Record of the Year — **I Can Help** by Billy Swan (Monument)

(continued on page C-28)

COIN MACHINE TRAINING FOR REPAIR MAINTENANCE Trouble Shooting

- SLOTS
- PINBALLS
- ELECTRONIC AMUSEMENTS
- ARCADES
- BINGOS
- VIDEO ELECTRONICS
- MUSIC and VENDING

"Your future is our business."

Nevada Gaming Schools, Inc.

3100 Sirius Road
 Las Vegas, Nevada 89102
 Tel: 702/873-2345



Certified BALLY training school sixth year

NEW! BELITA

LIGHTWEIGHT PORTABLE COIN COUNTER

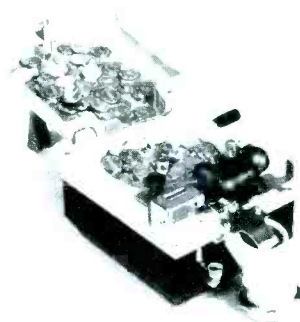

NEW! BELITA

LIGHTWEIGHT PORTABLE COIN COUNTER

- automatic stop
- inexpensive
- coin tray support
- bag holder
- fast
- only 9 pounds
- long lasting

R. H. BELAM CO., INC.
 51 Madison Ave.,
 New York, N.Y. 10010
 212/689-5633

DIDN'T SHE MAKE YOUR JUKEBOX SING?

“DON'T IT MAKE MY BROWN EYES BLUE”
AMOA RECORD OF THE YEAR.





1978 Jukebox/Games Route Survey

This survey was compiled from questionnaires sent to operating companies coast to coast. It is indicative of operating trends throughout the country but is in no way an absolute method of measuring these trends. This **Cash Box** feature cannot be reproduced in any way without the expressed permission of the editors of **Cash Box**.

Average number of coin-operated phonographs purchased annually by individual operating companies 15
(Compared to last year, this figure reflects a decrease in purchases of new phonographs. 65% of the responding operators said they bought "less" new machines this year than last year; 25% said they bought the "same" amount and 10% reported they had increased their purchases this year.)

Average weekly music gross \$40
(A slight increase over last year. Our survey also revealed taverns to be the most profitable locations for phonographs; with lounges considered a close second and such youth oriented spots as college campus centers and teen clubs reported sporadically.)

When asked how long a phonograph is kept on the route, the majority of reporting operators said seven years.

Fully 98% of the operators polled said they own furniture style phonographs (and this figure compares exactly to last year); however, when asked to indicate how many units were on location the individual figures

ranged from a low of four to a high of 50 and we were unable to determine an accurate average.

The predominant pricing on phonographs continues to be 2-25¢, as indicated by the majority of responding operators. In two instances, however, operators reported straight quarter play on 20% of their routes.

Weekly Record Purchases

Our poll revealed that operators purchase new records at the rate of three per machine, per week. Depending upon the number of machines on the route, this figure could range from between a total of 150 to 600 on a weekly basis, which serves to emphasize the operator's significance in the singles market.

Programming Singles

In programming their jukeboxes, operators rely on a routeman to select the singles for their machines, according to 40% of those polled, with the one-stop a close second; 20% said the responsibility is handled by an employee-programmer and 10% reported that they make the selections themselves.

We asked operators to list in order of importance the five most useful sources as guidelines in selecting new records. Here are the findings:

1. Trade magazines
2. One stops
3. Location requests
4. Personal selection by route personnel
5. Local radio station charts.

Trade magazine charts continue to play a major role in jukebox programming, as the poll revealed. One-stops, however, were elevated to the number two position (over last year's number four), surpassing location requests which dropped slightly to number three.

Operators were asked if phonograph collections this past year were more than last year, the same, or less. 55% reported collections to be the same as last year, 35% reported an increase, 10% reported collections to be lower than last year.

Promoting Phonograph Play

In response to the question "What do you do to promote more play on your phonographs?", one operator replied, "Program to the location . . . make every effort to get request records," and this eloquently sums up the feelings expressed by the majority responding. While some operators suggested colored title strips to call attention to new releases, spotlighting particular recording artists with high appeal, maintaining jukeboxes in clean, ship shape condition to encourage play, most felt that a jukebox stocked with records patrons want to hear will get the most play.

Location Commissions

50/50 continues to be the most widely used commission split, with 85% of the operators reporting it. 5% reported 60/40 (operator's favor); a small percentage use rentals and one operator applies a \$6 service charge.

Games

Estimated weekly gross on the following games was reported as:

Pool Tables	\$45
Pingames	\$42
Video Games	\$24
Shuffle Alleys	\$26
Soccer Tables	\$20

Popularity Chart

The most popular games in locations that are mainly in business to serve food are pinball machines and video games. Likewise, pinball machines and video games also rate high in arcades or other off street locations, according to our survey.

Play Pricing

Straight quarter play on flippers took a decided upturn in this year's survey, with 50% reporting it and 50% using 2-25¢ pricing. Shuffle alleys also reflected a departure from last year: 65% of the responding operators use straight quarter pricing on shuffle alleys and 35% 2-25¢. Video games were unanimously reported at straight quarter.

The Machine Purchase Graph

When asked about new game purchases this year 90% of the responding ops said they bought more new equipment this year than last, and only 5% said they bought less. This dramatic increase was similarly reflected in our 1976 survey; in 1977, however, only 30% reported buying more new machines.

When asked about used equipment
(continued on page C-12)

Serving successful operators with the highest earning equipment, backed by our 40-year reputation for service and reliability.

ALCA MIDWAY
ALLIED NAMCO
AMERICOIN POLAROID
ATARI-KEE PSE
BALLY RAMTEK
CINEMATRONICS SONIC
EXIDY STERN
FRANZ TOURNAMENT SOCCER
GREMLIN TAITO
GOTTLIEB VALLEY
MEADOWS COMPUTER KINETICS
MIRCO U.S. BILLIARDS

C.A. Robinson & Co.

2301 W. PICO BLVD., LOS ANGELES, Cal. 90006/Tel: (213) 380-1160

Combining experience and dynamic young ideas. Our staff is the finest, specialists in accomplishing the difficult today and the impossible tomorrow.



1978 Jukebox/Games Route Survey

(continued from page C-11)

purchases, 85% reported buying "less than last year" with two ops reporting buying "none."

Queried as to how long various machines are kept on the route, responses averaged out to: four years for pingames; 5-1/2 years for shuffle alleys; 5-1/2 years for pool tables and 2 years for video games.

Electronic Pinball Machines

The growing popularity of electronic pinball machines was evident in our survey: 95% of the responding ops have them and, what's more, 85% feel they are higher earners than their electromechanical counterparts. As to the number of units on the route — here again, an average was difficult to determine, since the figures ranged from a minimum of five to a total of 150 spread over an individual route. This is a far cry from "one 'being evaluated' to a total of 21" on a route, as reported in last year's survey. On the subject of servicing the electronic models a slightly larger percentage (than in '77) feel they are easier to service, but the majority of responding ops expressed an opposing view.

General Trade Information

When asked to report on new locations added to the route this year, 80% of the ops responded that new additions were "good" (as opposed to 15% last year); 10% reported they were "satisfactory" (as opposed to 85% in '77) and 10% said they "lost more than they gained."

In response to our queries on tournaments, 30% reported some participation, specifically in pool tournaments; the feeling being that, when properly handled, they do

stimulate increased earnings.

"Do you lease jukeboxes to locations" was another question we asked. 60% of the operators said "yes" and the financial arrangement averaged out to around \$33 per week.

Attesting to the merit of national and state associations, 90% of the operators polled said they are members of both AMOA and their local state association.

When posed the hypothetical question "If you could operate only one type of machine, which would it be?" the pinball got 50% of the vote, with pool tables a close second, jukeboxes as number three — and one op said "Sprint II."

"Cut throat competition" is one of the most irritating things about the operating business, according to one operator. Other comments on the subject included: "loans, bonus and poor distributor service;" "night

service and having to change a machine for lack of parts;" "high taxes and high cost of doing business;" "escalation of customer loans to impossible amounts;" "location demands in excess of income."

The following comments were made in response to the question "What can factories do to improve equipment and service to operators?": 1) sponsor more schools and provide better service manuals; 2) improve quality control so that machines will be fully operational when uncrated; 3) expedite parts shipments; 4) test equipment more rigorously at the factory; and 5) increase hot line service. Most of the comments dwelled on "quality control" and one operator suggested that "some game factory . . . make a good game that can be sold to the operator for \$995."

Here's a sampling of what operators feel distributors can do to improve their service:

1) maintain larger parts inventories; 2) hold more service schools; 3) provide good test equipment; 4) have more service information available; and 5) improve the quality of repair and provide faster service.

In forecasting what lies ahead for the music and games industry operators displayed mixed feelings, ranging from optimism to — "if game prices are not lowered, the games business will be dead in two years!"

One operator predicts "a bright future for the industry" and "many new opportunities;" another sees the "games business increasing over the next few years" and "more advance technology;" another said "inflation is a terrible threat to our pricing structure as exemplified in the conversion from 2-25¢ to 1-25¢ . . . where do we go from here;" while still another astutely observed that "business gets better and better each year" but predicts that "the large routes will ultimately dominate the industry."

The final question in our survey asked, "If there is room for improvement (in the industry) what improvements would you suggest." Here are some of the responses: "Less distributor credit to help keep the 'fly by nights' out of this business;" "Operators should recognize the fact that they are business people, in a flourishing industry, and act accordingly in the conduct of their own businesses;" "The high cost of operating should prompt us all to take a second look at our pricing;" "Let's take full advantage of the opportunities available to us for learning how to service today's equipment."

Distributors Speak Out On AMOA

(continued from page C-6)

formed about what is accomplished at the convention.

"We try to attend all the business meetings," said John Scavarda, "because what is of interest to the operator is also of interest to us. A lot of operators look to the distributor for information they don't get on their own — especially in Los Angeles where there are many mom and pop operators."

Chuck Farmer, vice president of sales at Shaffer Distributing, Columbus, Ohio, agreed that "the more we are familiar with the operators' problems, the better we can

serve them.

"We make it a point to attend the various meetings and pass the information we gather along to operators who didn't make the show."

Relay Information

While noting that only 5% of the operators in his area attend AMOA, Marty Cerin of Mountain Coin in Denver said, "I attend the seminar and the different manufacturer events because it's important for us to relay this information to the operators back home."

Hlbarger said he prepares a special

(continued on page C-24)

*We are grateful to distributors
and operators for their support
over this past year.*

Thank you. . . from all of us at Stern.

STERN ELECTRONICS, INC.

1725 Diversey Parkway • Chicago, Illinois 60614
(312) 935-4600, Telex 25-4657

**Toll Free Number For Service Only:
800-621-6424**

See our new "NUGENT" pinball machine at the AMOA convention.

*Would you like to see
the N.S.M Show surprise*



*of the world's biggest
coin machine exhibition?*

See it at

AMOA, booth 8



Exclusive world distributors: **LÖWEN-AUTOMATEN**
6530 Bingen/Rhein, Germany
Telephone: Germany 6721-15202
Telex: 04-2222

For the United States: **LOWEN-AMERICA, Incorporated**
Phone/Sales: 312-7875016
Phone/Service: 312-2975617



Atari To Feature 'Football' & 'Space Riders' At '78 AMOA

SUNNYVALE — A futuristic space cycle race, complete with space age electronic score sounds, is portrayed in the mirrored backglass art and design of the new four-player pinball game from Atari, Inc., which is called "Space Riders." It will be among the new models housed in the Atari exhibit at AMOA.

The "wide action" game has three "captive ball" drop targets to dramatize the central action of play and "Bike City" rollover lanes for double or triple bonus and these employ the carry-over memory for retaining the playfield status.

Reliability

Space Riders, while abundant in visual appeal and exciting play features, is built for reliability and easy care and maintenance, to further benefit the operator, as stressed by the factory. Atari's national sales manager Frank Ballouz pointed out that, in test, the game performed exceptionally well. "The high scoring strategy features and skill challenges make Space Riders a players' game," he said, "as evidenced by high collections."

The new game, currently available through Atari distributors, offers such operator options as: 16 coin/credit levels, three or five ball, optional match credit, replay or add-a-ball levels and varying special levels.

In producing "Football," its new video game, Atari, Inc. has captured the realism and thrills of a favorite American sport. The heated offense and defense action; running plays; pass plays; interceptions; the sounds of the cheering spectators and even the familiar whistle of the referee, are all contained in this exciting, new game, which will be displayed at the AMOA convention.

In the play process, offense (depicted by O's) controls the "man" with the ball; defense (depicted by Xs) controls the slightly larger and flashing "middle linebacker" and the computer controls the remaining players on each team. A unique Track Ball allows players full control over speed and direction of movement.

Add-A-Coin Feature

Operators can set the game for 90, 120, 150 or 180 seconds per coin and, by use of the special add-a-coin feature, players can determine their game time. A 30 second warning towards the end of the game

Traffic Grabbing Graphics Featured On Williams' 'Phoenix' Pinball Game

CHICAGO — "The dazzling, eye-appealing graphics on 'Phoenix' will lure the players, and once they begin to play, the action-packed playfield will bring them back again and again," said Ron Crouse, marketing manager for Williams Electronics, Inc., in announcing the introduction of the factory's new four-player pinball machine. "Phoenix" is currently in production and will be featured in the Williams' exhibit at AMOA.

The model's graphics, portraying the fiery theme of the half-man, half-bird figure from ancient Egyptian mythology for which the machine is named, showcases the creative talent of Constantino Mitchell, Williams' new in-house artist.

In addition to its many physical attributes, Phoenix is also equipped with the factory's noted dual sounds system, which enables operators to select either echoes and bleeps or musical tones, all triggered by the action on the playfield. The game's unique "Blazeway" ramp provides numerous scoring opportunities for the player, including bonus points and a five



'Space Riders'



'Football'

signals the player to add-a-coin for more time.

The game is encased in a height-adjustable cabinet which allows it to be either a stand-up pedestal model or a cocktail table. A specially designed 9" base which is bolted on to the bottom of the cabinet can be easily removed to change the game height to 40-inch or 31-inch, depending upon the needs of the location.



'Phoenix'

times bonus multiplier. Via the spinning target and drop targets, players can score additional points and bonuses up to the 145,000 point level.

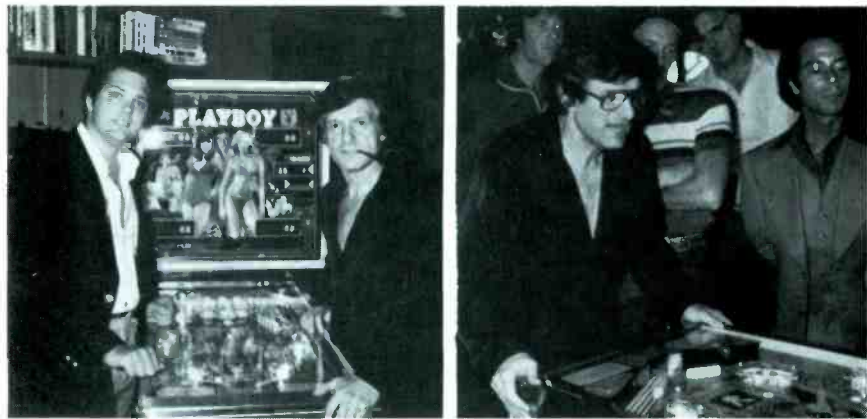

BALLY PRESENTS PLAYBOY — Tom Nieman of Bally Manufacturing Corp. recently made the official presentation of the first model of the new 'Playboy' Pinball machine to Hugh Hefner at the famed Playboy Mansion in California. In the first photo Nieman (l) makes the presentation to Hefner. In the second photo, Hefner tries out his new Playboy machine in the company of (l-r): Lance Rentzel of the L.A. Rams; actor James Caan; and Ira Bettelman of C.A. Robinson, Bally's Los Angeles distributor.

Bally Unveils New 'Playboy' Pinball At AMOA Expo '78

CHICAGO — Making its debut in the Bally exhibit at the 1978 AMOA exposition will be the factory's latest four-player flipper, the much heralded "Playboy." Dominating the machine's tantalizing backglass art is Playboy editor-publisher Hugh Hefner, surrounded by Playmates Patti McGuire and Sondra Theodore, along with the

New Gremlin Game Avoids Violence

"Frogs," a new game designed to take players out of troubled waters of battlefields into the enchantment of a pond fantasy, is here from Gremlin.

Designed to interest women who have drifted away from violent games, Frogs provides both men and women with a video challenge.

A three dimensional setting, created with mirrors and special effects, puts the player in control of a smiling green leaper, hungry for the mosquitoes which dart among the rushes.

For 90 seconds, a player uses the joystick to send Mr. Frog jumping from his lily pads and into the air after buzzing in-

(continued on page C-18)

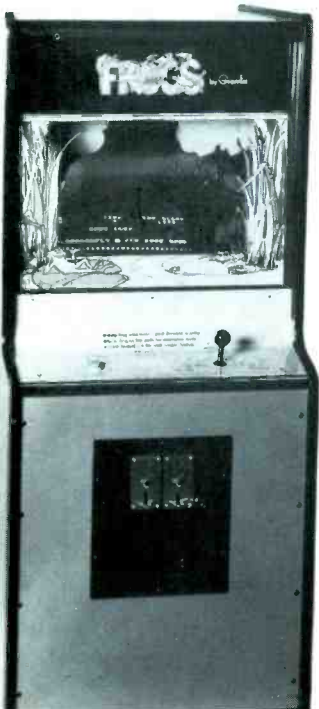

'Frogs'

magazine's popular cartoon characters "Granny" and "Little Annie Fanny."

The idea for Playboy was conceived at Bally two years ago and the finished product, in addition to its many appealing visual and technical features, is the third Bally game to contain the factory's synthesized sound package which creates music and futuristic sound effects.

When the machine is activated, a "wolf whistle" accompanies the opening play and, as scoring bonuses are tallied, the familiar strains of the "Playboy After Dark" television musical theme continuously recur. Among the game's unique play features is a kickback lane called "The Grotto," named after Hefner's subterranean swimming pool.

Playboy is the latest in a lineup of successful celebrity-themed pinball machines produced by Bally, joining the ranks of "Evel Knievel," Bobby Orr's "Power Play," Elton John's "Capt. Fantastic" and, most recently, "The Six Million Dollar Man," (TM) the factory's revolutionary new six-player flipper featuring television star Lee Majors. Latter piece will also be on display in the Bally exhibit.

Celebrity Theme

The celebrity theme and related mass media exposure have contributed significantly to the "rapid and unprecedented growth of pinball in the United States," as pointed out by Bally's Tom Nieman, and this latest model will further enhance the picture.

Bally has planned an extensive Playboy campaign which will include heavy trade advertising and various eye-catching posters and brochures. Patti and Sondra, the Playmates who posed for the Playboy backglass, will be making personal appearances at the Bally booth during AMOA and attractively designed backglass posters will be given away to convention visitors.

Slots On Display

Another "premiere" taking place at the Bally exhibit this year will be a display of various models in the factory's current slot machine line. Among the machines to be featured are two Dollar slots; two Classic slots and a Big Bertha model, the 7-1/2 foot tall Constellation. They will operate with a specially designed Bally token and be set to "pay out" on each handle pull.

The 1978 AMOA convention marks the first time gaming equipment has been allowed at the show, under special permission granted by the city of Chicago, and the sanction of the AMOA board of directors.

hot single

Lots of Bounce!



MOST DESIRABLE PLAYER

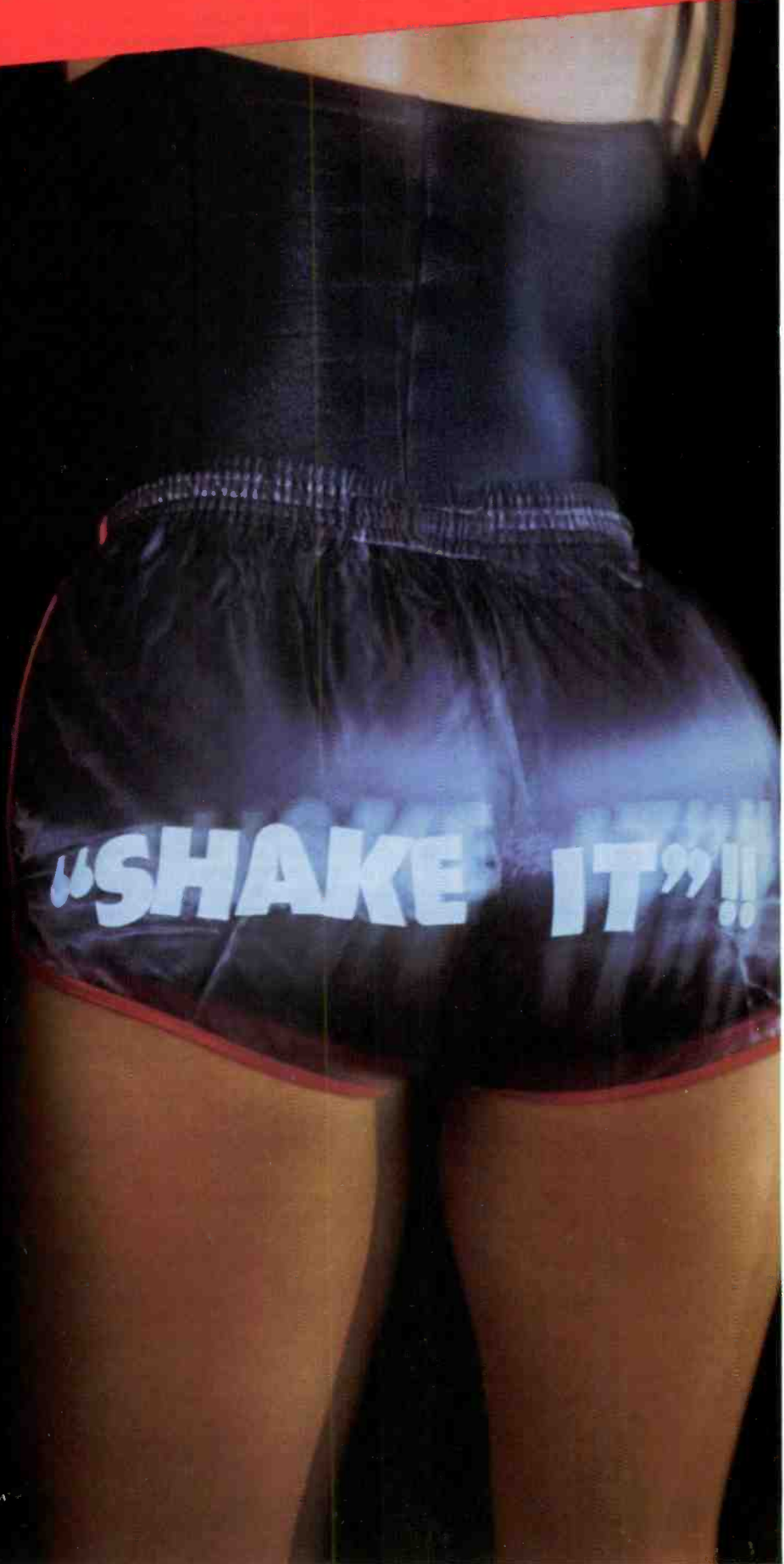

Jan Matthews

"Shake It" #7039

from the album Stealin' Home



Produced by Sandy Robertson & Jan Matthews

direction: Brain Arts Associates 206/634-1333

©1994 MCA RECORDS INC. LOS ANGELES, CA



Cheryl Lynn

After several years of singing and numerous, varied performances to her credit, Cheryl Lynn is finally beginning to feel some of the confidence in her talent that her manager Delbert Langston has had all along.

"Delbert always told me I could make it, but I never believed it. So he has been the one to do all the pushing," Cheryl says.

But after the last couple of years, having landed a role with the road production of "The Wiz," having taken the top prize on the "Gong Show" and subsequently having been signed to Columbia Records because of her "Gong Show" performance, now Cheryl is starting to believe Langston was right.

Her debut single, "Got To Be Real," is moving up the charts and her self-titled debut album is continuing that success.

For all the years she has been singing, Cheryl said only in the last few years did she seriously consider performing as a career. Before she made that decision, she says she was "really into school." It was only in 1976 that she quit her studies at USC, where she was studying to be a speech pathologist, to audition for "The Wiz."

Her first step toward a professional singing career, though, was taken when she tried out for a group called Happy Free & Easy.

"Delbert, who went to the same high school I did, called me up one day and asked me if I wanted to audition for a group," Cheryl says.

"He told me there would be other candidates and that I should show up precisely at my assigned try-out time. I got very nervous, figuring there would be a lot of other girls there. As it turned out, I was the only one.

"So I made it into the group, but I wasn't really serious. Delbert and Tommy Brown (who later joined Hues Corporation) always had to push me to get me to the rehearsals. I would have rather been at the basketball game or something," Cheryl says.

Later, it was Langston who convinced her to audition for "The Wiz," a role she also won. "I was understudy for the Wicked Witch of the West, and when we got to Chicago, I got to play the role." While still involved with the show, she auditioned for, and received, a spot on the "Gong Show." Chuck Barris later said of Lynn, "Of the 4,000 acts I've seen, Cheryl Lynn is the all-time great."

"After the show," she says, "we were getting calls from lots of record companies. But I got one call I just couldn't forget. It was from Bob Johnston at CBS. I picked up the phone and he said, 'Hello darlin'. You looked so innocent there on the TV, I just had to save you from the wolves.'"

That phone call, she says, was the turning point in her decision to go with Columbia. She has continued to work with Johnston, who is executive producer of the album.

Only after she was signed did she try to write songs, which she says is turning into another satisfactory venture for her. Her goal now is to continue to develop as a writer and performer as well as to get a band together so she can tour and promote the album.

"I want to keep writing, making records and maybe even start a production company with Delbert to produce other artists."



Wilton Felder

Throughout the 1960s, the Jazz Crusaders were esteemed by their peer group for their creativity and feeling for improvisation. But the group found that the connotation of the word jazz in those days was less than a viable commercial commodity. To broaden their sound and scope, the group became the Crusaders, and have since inhabited the pop charts on a regular basis.

During this transitional period, the group's founding members began to enjoy success as studio musicians, producers, and solo artists. Pianist Joe Sample was the first to strike out on his own with "Rainbow Seeker." And now tenor saxophonist Wilton Felder (who also lives a double life as an electric bassist) has emerged with his solo debut for ABC Records, entitled "We All Have A Star."

"Our intention has always been to establish the group as an entity first," Felder says. "But now we feel that the time has come for each member to express a side of himself that might not ordinarily develop as a Crusader. Ultimately, this kind of individual expression will enhance the unity of the Crusaders as a whole."

One of the factors that distinguishes Felder's new album from Sample's is the use of lyrics, since the Crusaders don't ordinarily sing on record. Felder explains that "I took a gamble in this respect because I wanted to surprise listeners with an approach that they might not expect from a member of the group." He attributes the direction of the LP to a "freeness the Crusaders has experienced in the last couple of years that has enabled each of us to grow more confident in our own abilities."

Felder notes that the titles of the songs on "We All Have A Star" parallel "the spiritual feeling that the album tries to convey. For instance, 'We All Have A Star' is an affirmation of the soul, while 'Ride On' tells the listener that everything is going to be all right. Honesty and sincerity are qualities that are very important to me, and the album is my way of saying that I care."

He emphasizes that the chart successes of melodic jazz composers like Chuck Mangione has proven that "the climate is right for songs and melodies. Musicians have gotten so sidetracked with vamps that they've forgotten the importance of conceptualizing beautiful melodies. That's why Billy Joel's 'Just The Way You Are' was so popular."

Though he won't accept an outside recording date, (which he strictly reserves for "the Crusaders' sound"), Felder asserts that session work has helped him to appreciate the fundamentals of "putting a song together instead of just playing over it." He had originally learned to play the bass when the Crusaders' long succession of bassists had to be shown what and how to play, and has since recorded with such pop artists as Joni Mitchell, Barry White, Steely Dan and Michael Franks.

Though the Crusaders are kept busy with their individual free-lance commitments, Sample, Felder and Stix Hooper recently found time to co-produce B.B. King's "Midnight Believer" LP. As aspiring musicians growing up in Houston, the group frequently listened to the guitarist's records. "You can imagine the thrill," he says, "of not only playing on his album but producing it and then coming up with a hit."

Popovich Finds Comfortable Home For Cleveland Int'l

LOS ANGELES — "To some people being based in Cleveland might seem like a disadvantage, but to me it's most important to be somewhere where I feel real comfortable."

Those are the feelings of Steve Popovich, president of Cleveland International Records, which has been headquartered in Popovich's Cleveland home since its inception in 1977. Popovich says he feels comfortable in Cleveland for a number of reasons.

"It's a good market to live in because it allows you to keep a perspective on the business," he says. "Cleveland has a great cross-section of radio, it's always been a great breakout market and it's always been behind new music."

It was in Cleveland, Popovich says, that his label's first release, Meat Loaf's "Bat Out Of Hell" LP, received initial airplay after its release last November. The album recently was certified double platinum.

Exposing New Talent

"I think a lot of radio people in some cities have gotten so far removed from new music that I would find it real uncomfortable to live there," Popovich says, "Cleveland radio is the best radio in the United States from the standpoint that the stations are into exposing new talent."

Popovich was no stranger to the Cleveland market when he opened offices there in March of 1977 after leaving CBS, where, after 14 years with the company, he was serving as A&R head at Epic Records. In 1963 Popovich took his first job in the music industry working in the CBS warehouse in Cleveland. And from 1967 to 1969 he worked local promotion in Cleveland for MCA and CBS Records. While at CBS Popovich met Stan Snyder and Sam Letterman, who worked in the

RSO Re-signs Clapton, Releases New Album

LOS ANGELES — Eric Clapton has renewed his contract with RSO Records and his personal manager Robert Stigwood. Clapton's new studio LP "Backless" is scheduled for release by RSO Nov. 6 and a European tour to support the album will begin Nov. 5.

"It gives me great pleasure, both personally and professionally to work with an artist as widely respected as Eric Clapton," said Stigwood. "He has long been one of rock and roll's premier performers and it is an honor for me to be involved with him, not only as his manager, but also as his friend. I am very much looking forward to the coming years as the most successful in our time together."



THE COSMIC MESSENGER AT ATLANTIC'S OFFICES — Atlantic recording artist Jean-Luc Ponty, whose newest album for the label is entitled "Cosmic Messenger," was recently honored by the label with a luncheon at Atlantic's offices. Shown at the luncheon are (l-r): standing, Jerry Greenberg, president, Atlantic Records; Perry Cooper, director of artist relations for Atlantic; and Judy Libow, associate director of national pop album promotion. Seated are Ponty and Tunc Erim (right), director of national pop album promotion for Atlantic.

sales department. In 1977 the three men left the company to form Cleveland International, which is distributed by CBS.

"We decided to leave the company and start our own label," says Snyder, the label's vice president, "primarily because the higher we were going up into the corporate structure the farther we were getting away from the actual music and the record business itself, which is street-oriented."

Back To Basics

At Cleveland International, with only six staffers and an artist roster which consists of five acts, Snyder, who is based in the label's New York offices with Letterman,

(continued on page 53)

Grammy Voters Hold Meet In L.A.

LOS ANGELES — Representatives from the recording industry gathered here Oct. 27-28 to screen several thousand entries for this year's Grammy Awards. More than two dozen producers, performers, writers, trade journalists and recording company and radio station personnel participated in the all-day sessions which were held in the national office of the Records Academy (NARAS) in Burbank.

The participants discussed numerous recorded performances submitted by academy members and record companies to make sure the entries were included in the correct musical categories.

Prior to the meeting, pre-screening sessions in selected fields had been held in Nashville and New York, where committees had reviewed entries in the country, gospel, inspirational, jazz, latin, children's, comedy and documentary fields. In addition, in New York, a committee of experienced classical record members, under the chairmanship of David Hall, had screened all classical entries.

Next Step

The next step in the Grammy procedures will be a review of the screening results in first draft form by the seven chapters' board of governors and the Academy's national trustees. Following their ratification, the lists will be mailed late in November along with first round ballots, to the Academy's 5000 active members. Their votes will determine the Grammy Awards finalists in all except craft categories which are being nominated by special committees in the various chapters. These will be announced Jan. 8 at press conferences in Los Angeles and New York.

A second round of voting will determine this year's winners, which will be announced Feb. 15 during the Academy's annual CBS-TV special.

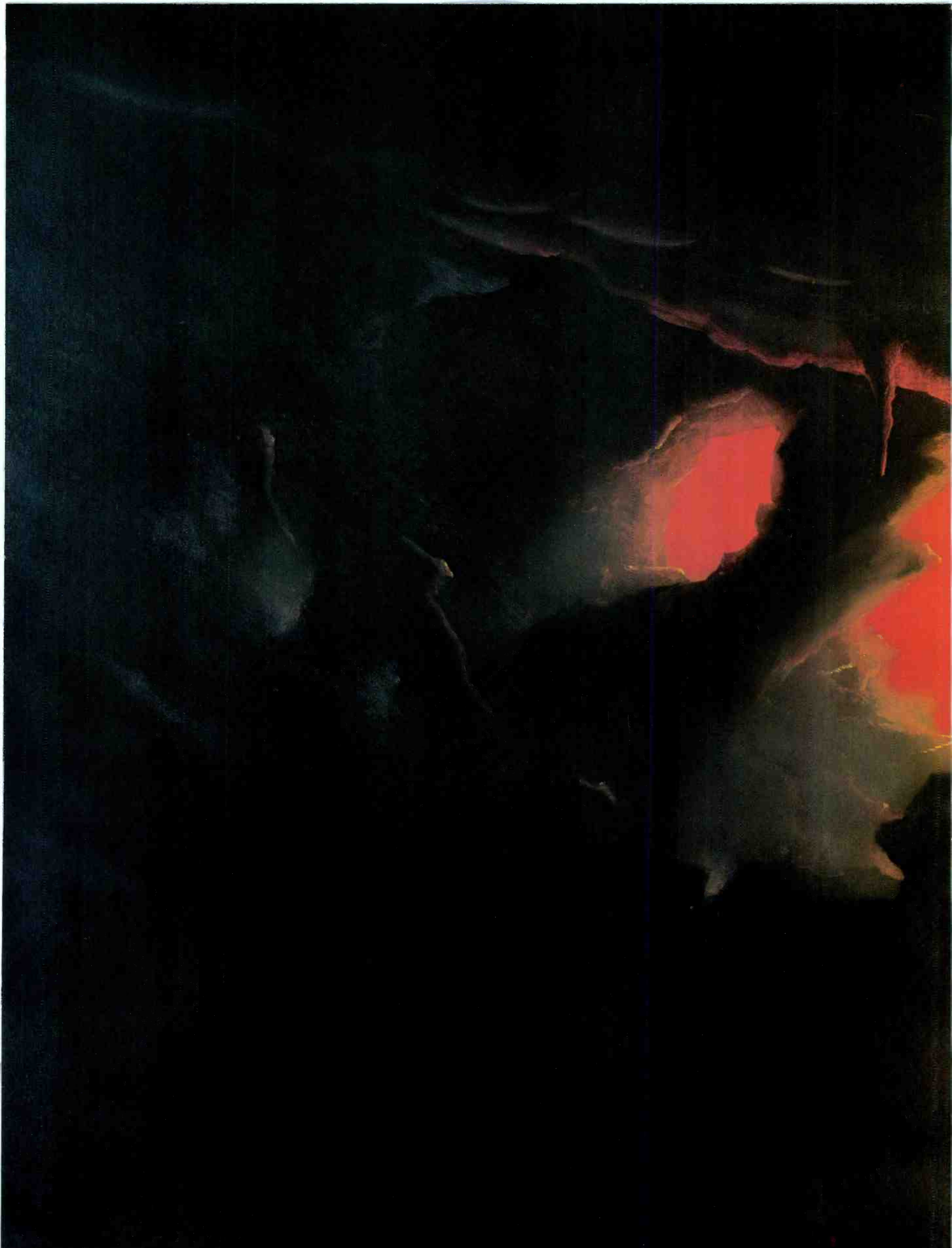

SOUNDTRACK ALBUM PRODUCED BY
LEONARD ROSENMAN AND SAUL ZAENTZ

Side 1

Theme from *The Lord of the Rings*
History of the Ring
The Journey Begins; Encounter with the Ringwraiths
Riders of Rohan

Side 2

Escape to Rivendell
Mines of Moria
The Battle in the Mines; the Balrog

Side 3

Mithrandir
Gandalf Remembers
Frodo Disappears
Following the Orcs
Attack of the Orcs

Side 4

Helm's Deep
The Dawn Battle; Theoden's Victory
The Voyage to Mordor;
Theme from *The Lord of the Rings*

A SAUL ZAENTZ PRODUCTION

A RALPH BAKSHI FILM

J.R.R. Tolkien's
THE LORD OF THE RINGS

Music by LEONARD ROSENMAN

Screenplay by

CHRIS CONKLING and PETER S. BEAGLE

Based on the novels of J.R.R. TOLKIEN

Produced by SAUL ZAENTZ

Directed by RALPH BAKSHI

A
FANTASY
FILMS
PRESENTATION

Released thru
United Artists
A TriStar Company

THE ORIGINAL MOTION PICTURE SOUNDTRACK RECORDING COMPOSED AND

L.R.R. Tolkien's

The
LORES
OF THE
RINGS

CONDUCTED BY LEONARD ROSENMAN  ON FANTASY RECORDS AND TAPES
TWO-RECORD SET LOR-1 AVAILABLE ON  TAPES



Dr. Hermann Franz

Dr. Franz Named As Senior VP, Polygram Group

NEW YORK — Dr. Hermann Franz has been named to the position of senior vice president of Polygram. Franz, who has served as a member of the management of Polydor B.V./GmbH since April of 1978, will be responsible for the areas of manufacturing, recording technology, and development. He succeeds Dr. Dick van Amstel, who is retiring.

Franz joined the Polygram management on April, 1978 after having served since 1969 as managing director of the Siemens subsidiary company, Vacuumschmelze GmbH.

BMA Garners Members

NEW YORK — WEA Distributing Corporation, music licensing organizations BMI SESAC; and Stanley Gortikov, president of the RIAA are among the prominent new members of the recently formed Black Music Association.

Also joining the organization were Chrysalis Records, Savoy Records, PIKS Corporation and Marc Gordon Productions.

Further details of the BMA's membership services division will be announced at the BMA Board of Director's Meeting, November 17-19 at the Cherry Hill Hyatt House in Cherry Hill, New Jersey.

Cornyn Adds Creative Services To His WB Duties; Somers Is Promoted

LOS ANGELES — Stan Cornyn, executive vice president of Warner Bros. and Adam Somers, director of merchandising for the label, have assumed new duties, according to an announcement by Mo Ostin, chairman of the company.

In addition to his current responsibilities, Cornyn will become director of creative services, a post left vacant with the resignation in September of Derek Taylor. Cornyn will have the departments of advertising, merchandising, art, editorial, product managers, operations, production and international reporting to him.

In making the announcement, Ostin said, "As Stan Cornyn and I studied the vacancy,

Columbia Pictures Publishing Names Holmes As VP

NEW YORK — Robert Holmes has been appointed vice president of the newly-formed Columbia Pictures Music Publishing Group. He will be responsible for managing the various business activities relating to music publishing and will act as the liaison between Columbia Pictures and Columbia Pictures Television in respect to business considerations regarding filmed and taped music.

"This appointment gives recognition to the importance of music in films," said Jim Johnson, vice president of administration for Columbia Pictures, in a joint announcement with Ed Masket, executive vice president of administration for Columbia Pictures Television. "We will now make major attempts to attract contemporary songwriters to compose music for films and television."

Holmes was formerly vice president of business affairs for the Arista Music Publishing Group. Prior to that he was general counsel for the Motown Record Corporation, which he joined after practicing entertainment law with Paul, Weiss, Rifkin, Wharton & Garrison, a New York-based law firm.

FCC Boosts Limit On Routine Fines

WASHINGTON, D.C. — The amount of the fine the FCC is allowed to impose on broadcasters has doubled, as has the authority of the FCC staff to act without consulting the commission before imposing a routine fine.

The amount Congress has authorized the FCC to fine a broadcaster for violation of commission rule or policies, or for violation of the Communications Act, is \$20,000. And the commission ordered that the staff be authorized to impose fines of up to \$4,000 without bringing the matter to the FCC for review. Previously, the staff was able to impose fines of up to \$2,000 without checking with the commission first.

The aim of the new policy is to delegate to the staff these routine matters which are governed by existing policy.

It became clear that the best choice was clearly to add Cornyn's talents again to this area. He developed the department and is, I believe, better than anyone else in the industry at maximizing results in the creative field. He is a great catalyst."

Additional Duties

Somers will assume immediately the post of national operations director in addition to being merchandising head. Somers' new duties will see him supervising a wide range of operational areas of the company, including personnel, administrative services and operations of the company's residences in Burbank, New York and Nashville.



Selsky

Mack

Rogan

Stephens

Infinity Appoints Corrison — Infinity Records has announced the appointment of Peter Corrison as director of creative services. Corrison, a designer of many familiar album covers (including the Rolling Stones' "Some Girls") was east coast director of creative services for AGI from 1972 through 1975. He was nominated for Grammy Awards in 1973, 1974 and 1975 for his design of covers for two albums by Cheech & Chong and one by Led Zeppelin.

Selsky Named At WB — Ira Selsky has been appointed director of business affairs for Warner Bros. Records. Prior to his appointment, he occupied the post of general attorney for ABC Records for a period of four and a half years.

Mack Appointed At Atlantic — Marty Mack has been appointed west coast regional promotion director, it has been announced by Atlantic Records. From January to May 1977 he had his own independent promotion firm M&M Productions. He served as Pacific Record & Tape's promotion representative in northern California. He joined Phonogram Records in January 1978, serving as west coast promotion manager until he joined Atlantic.

Rogan Named At 20th — Tom Rogan has been appointed as east coast promotion director for 20th Century-Fox Records. Prior to joining the label he was director of east coast pop promotion for Motown Records for three years, and for TK Records, both based in New York.

Stephens Appointed At TK — TK Productions has announced the appointment of Steve Stephens as eastern regional marketing and sales director, based in TK's New York office. Previous to this appointment, he was marketing director of Record Shack of New York.

Wolmark At Atlantic — Alan Wolmark has been appointed manager of national album promotion & special projects for Atlantic Records. He taught writing at Brooklyn College, his alma mater, for two years. A native of England, he also worked at Virgin Records in the U.K. during 1973.



Wolmark

Stebbins

Jeffries

Peale

Larkin Appointed At WB — Jim Larkin has been appointed Warner Bros. Records' midwest regional promotion manager. Prior to his appointment he worked at ABC Records as local and regional representative, and previously as operations manager for station WEBC in Duluth, Minn.

Stebbins Joins 20th — 20th Century-Fox Records has announced the appointment of Bud Stebbins as midwest regional sales manager. Prior to joining the sales department, he was 20th's central midwest regional promotion director for one year, responsible for all of Indiana, Illinois and Wisconsin.

Jeffries Upped At RCA — Nancy Jeffries has been appointed A&R producer for RCA Records. Prior to her promotion, she had served as manager of A&R administration for RCA Records, and had previously served as department A&R coordinator for R&B music at RCA.

20th Adds Peale — 20th Century-Fox Records has announced the appointment of Bob Peale as regional promotion director, responsible for all of Texas, Louisiana and Oklahoma. Before coming to 20th, he was local promotion manager in the Houston area with CBS Records for four years.

Voyage Ups Guess — Voyage Records has announced the promotion of George Guess to vice president in charge of national promotion. He formerly held the title of director, national promotion.

Chrysalis Ups Two — Chrysalis Records has announced the promotion of Toby Lubov and Fred Salzberg to the positions of manager, west coast and east coast publicity, respectively. In her new capacity, Lubov will be responsible for overseeing tour press and acting as trade liaison for Chrysalis and its artists; Salzberg, as east coast manager, will work in conjunction with east coast director Linda Steiner, coordinating tour publicity and consumer-oriented features.



Lubov

Salzberg

Pober-Cox

Shmerler

Kaye Ups Pober-Cox — Janice Pober-Cox has become executive assistant to Chuck Kaye, president of Almo/Irving/Rondor International Group of music publishing companies (the publishing division of A&M Records). Prior to joining Almo/Irving Music, she held the positions of tour coordinator for Steeleye Span and executive assistant to the president of Music Sales Ltd., both firms operating out of London, England.

Voyage Names Morrison — Voyage has appointed Rick Morrison as director of national disco promotion. He comes from Capitol where he was east coast disco promotion coordinator.

Shmerler Joins RCA — RCA Records has appointed Steven Shmerler as administrator, merchandising, Associated Labels. He joins RCA Records from a managerial position with The Paul Winter Consort and A&M Records, for whom he was creatively involved in album

(continued on page 48)



Adam Somers



Stan Cornyn

CASH BOX PRESENTS:

**THE BEST
OF**



TUNE INTO PAGES 22/24

Cream Momentum Building As Green Package Comes Out

by Joey Berlin

LOS ANGELES — A year-and-a-half ago when Cream Records was born, president Al Bennett and his associates drew up a five-year plan aimed at developing a strong, broad-based independent record company. Last week, Bennett looked at his company and pronounced it "right on schedule," with a major release days away, a second single from his top rock act getting good response and a couple of potentially strong acts waiting in the wings.

Set for release on Nov. 8 is one of Cream's most important albums to date, soul singer Al Green's "Truth In Time," along with the first single, a cover of Lulu's hit "To Sir, With Love," and a 12-inch disco cut, "Wait Here." Promotion vice president Don Graham says the LP-45-EP multi-release, which will be packaged together for promotional use, is an industry first. Cream is also releasing a second single from the debut LP from Snail and is planning a major push for recently-signed quintet Legs Diamond. A joint venture with singer Johnny Rivers is also reported to be in the works.

First Steps

The first steps in building the label were acquiring talent and building a strong financial base. The talent search resulted in the purchase of Hi Records whose roster includes Green, Ann Peebles and O.V. Wright, rock bands Snail and Legs Diamond, black-disco artists Brenton Wood and O'Mar, Canadian folkie Ian Tamblyn, Leon Russell protege Don Nix and the dozen acts on Don Schlitten's Xanadu jazz label. The financial base for Cream Records was solidified with the acquisitions of Hi Records and its publishing company and the 527 copyrights of East Memphis Music, including such titles as "Respect," "Dock of the Bay" and "Theme from Shaft."

With the initial goals met, Cream is now trying to build up sales and airplay momentum. Based on the successes of Green, Snail and O.V. Wright with their initial Cream releases and Green's grand prize award at the recent Tokyo Music Festival, the label feels it has established credibility with retailers and radio.

"We feel the momentum building," says Paul Culberg, Cream marketing vice president. "In less than two years we've got better than 70 percent of our distributors firmly on our side. After seven months the Snail LP is still selling and when we released the group's second single the reaction from radio was, 'Oh, a new Snail single,' not

Springsteen On Tour

NEW YORK — Bruce Springsteen and the E Street Band began a second tour of the U.S. on November 1 in support of their current platinum LP, "Darkness on the Edge of Town." The tour opened in New Jersey at Princeton University and concludes in Cleveland on December 31 at the Richfield Coliseum.

Springsteen played 86 dates in 70 cities during a four-month concert tour earlier this year.

'What's a Snail?' It's all very gratifying because those relationships are what's going to make us. We are going to be a hot record company soon."

With the release of "Catch Me," Snail's second single, Cream is optimistic that the LP, which has currently sold in excess of 125,000 copies, will catch fire. The company has backed the Santa Cruz quartet with an extensive marketing campaign and was lucky enough to have much of the band's poster material used on the set of this season's top-rated new television series, "Mork & Mindy." The cover art on the Snail album earned a certificate of distinction from Art Direction magazine.

Legs Diamond

Cream is scheduled to release "You've Lost That Lovin' Feeling," the company's first single from Legs Diamond, in two weeks. The Los Angeles-based band had two albums out on Mercury and were rediscovered by Cream A&R vice president Hal Winn. If the single does as well as expected the quintet's first Cream album will be released early next year, in keeping with the company's policy of staggering its releases so that each one can get maximum attention from the promotion and marketing staffs.

"You can't just throw stuff out and wait for it to hit, you've got to work all your product,"

(continued on page 20)



Joe Vias

RCA Opens Latin American Office, Headed By Vias

NEW YORK — RCA Records has opened a Latin American regional office in Miami. Joe Vias, Jr. has been selected to run the office as director of market development for the Latin-American region. Vias will report to Adolfo Pino, president of RCA Records in Brazil and Argentina.

"The establishment of this new office will undoubtedly strengthen RCA's overall position in this often-overlooked but extremely significant market area," noted Arthur Martinez, division vice president of RCA International. "The new office will centralize and consolidate our Latin-American operation in a city that is the gateway to the entire Latin-American area." The company currently maintains offices in Mexico and Brazil.

In his new position, Vias will have full responsibility for the acquisition of outside labels, artists and masters for exploitation in Latin America, and for the direction and administration of licensees there as well. Vias will also be responsible for the promotion of the exploitation of RCA catalogs from around the world, the promotion of Latin-American product within Latin-America and in Latin-American markets in the U.S., and for the initiation and coordination of RCA artist tours throughout Latin-America.

Vias previously served as director of in-

(continued on page 54)

EAST COASTINGS — NOTES FROM NEW YORK — Yes, L'Affaire Grace Jones at Roseland Halloween Night was appropriately outrageous. Police barricades had to be put up outside to contain long lines of folks dressed in costumes on par with the decadent theme set by Grace in her by-now-classic nude/animal invitation. Jones' visual flair onstage delighted her very special audience, who, Warner Brothers hopes, will propel her to the crossover status attained by fellow disco favorites Donna Summer and Village People. Judging by the Halloween excitement, WB's pop goal is definitely attainable... Ready for the "Manhattan Music Playoffs"? Well, Ron Alexenburg's Infinity Records is teaming up with Andrew Stein, the ambitious Manhattan Borough president, to offer a recording contract to the group who wins a borough-wide "battle of the bands" contest in January. The contest is part of Stein's "task force" (headed up by Ron Delsener and Sid Bernstein) to revitalize interest in New York as a music industry center. Applications for the playoffs, limited to Manhattan residents who are not signed with a label, are available from the Manhattan Borough president's Office, Room 2035, 1 Center Street, N.Y.C. 10007, or by calling 566-4976... Storytowne, the on-again, off-again 59th St. jazz club, is now on again, reportedly with a big band booking policy. Gerry Mulligan, now leading a 13 piece band, re-opens the club November 8... And Tramps, Terry Dunne's comfortable downtown nightspot, is expanding its professional showcase format as of November 12 to include four straight



THE COMMODORE, THE MAESTRO, AND THE DOCTOR — Columbia Recording artist Andre Kostelanetz recently recorded the Commodores' "Three Times A Lady." Offering the maestro congratulations are Lionel Ritchie of the Commodores (left) and Dr. George Butler, vice president of jazz/progressive a&r for Columbia Records.

nights, Sunday through Wednesday.

CASABLANCA STRIKES AGAIN — Despite an uncharacteristic lack of fanfare, it's becoming obvious that a key area of Casablanca's newly strengthened New York office is the recently formed BookWorks Division, headed up by publishing veteran Mel Sokolow. Sokolow sees the venture as proof of "Neil Bogart and Peter Guber's commitment to being major international entertainment company," and he's particularly excited about the opportunity to cross-market book and music ventures. As an example, he mentioned a hypothetical book-length version, with pictures, of a song theme by, say, Donna Summer. BookWorks will also work closely with Casablanca FilmWorks, and, Sokolow said, the five-month-old division is currently developing projects that will appear in book form in conjunction with other publishers, while bearing a Casablanca logo. Among the projects on the ever-expanding Casablanca roster — a new book by Joe Eszterhas, and "Yogurt," featuring 450 recipes for the stuff.

NAMES IN THE NEWS — Wally Bryson has left Fotomaker, and the ex-Raspberry is contemplating future moves from his Cleveland home base... Off to Japan, for the last 2 weeks in November — Stanley Clarke, Jeff Beck, Mike Garson and Simon Phillips... Also Japan bound in early December — Frank Marino & Mahogany Rush... Terry Garthwaite and Toni Brown, former Joy of Cooking vocalists, have each completed their solo albums. Garthwaite's is produced by Orrin Keepnews... Also due for a solo album, finally — Marcy Levy, vocalist with Eric Clapton of late... Andy Pratt is in the studio, recording his next LP... Jay Jacobs, of William Morris' music department, was shot Sunday before last while entering his apartment building. He's reported in stable condition... Remember Duane Eddy? Look for a new RCA compilation... Blondie's encore at a recent Long Island gig — T. Rex' "Bang A Gong"... The first group from Maine signed by a major label, The Blend, put on a successful showcase performance recently for the national press at the University of Maine in Portland. MCA's Denny Rosencrantz signed the group.

SCREEN SCENES — Planning on catching Sylvester Stallone's new flick, "Paradise Alley," to see Tom Waits as "Mumbles"? Forget it, Waits is great — but he's on screen less than five minutes. His big line, responding to Stallone's query "What are you saving it for?," was "I'm saving it for a big finish..." On the other hand, if you were planning to see Alan Rudolph's "Remember My Name," starring Tony Perkins and Geraldine Chaplin, to hear the Alberta Hunter soundtrack, by all means go — the music alone is worth it.

WATCH FOR — Watch for a spate of executive appointments at Polydor, as the first sign of Dick Klimes' clout... A bar-coded Elvis Costello album in January (\$7.98 list)... A National Public Radio special on "Rock and Roll" featuring Bob Seger, Robbie Robertson, and Patti Smith the week of December 17... Picture discs for the following Capitol

LEVON — If Levon Helm had his druthers, the Band would still be a working unit. But the philosophical Arkansas drummer is content to "let things fall together," and in the meantime is enjoying himself with the RCO All Stars, Duck Dunn, Levon reports, "has emerged as the leader" of that aggregation, which may be joined by Paul Butterfield on their next album. The All Stars are recording in Woodstock and have a gig lined up for the New Orleans Mardi Gras, followed by a Japanese tour.

charles palkert



CARN AND WONDER — During Jean Carn's recent performance at the Total Experience in Los Angeles, Stevie Wonder surprised the audience by doing a duet with Carn.

POINTS WEST — FOREIGNER'S FLING — Atlantic hosted a bash for Foreigner following the group's sold-out show at the Forum, but label president Jerry Greenberg, who flew out from New York for the show, didn't wait for the concert to end to join in the festivities. A professional drummer in his own right, Greenberg got up with the group while the band was still performing and sat in on drums for a while. Foreigner's recent tour has been an "Around The World In 42 Days" affair, so in keeping with that theme, the party after the show in the Forum Club was laid out in international motif, with food from 10 countries and several international flags lining the club. Decorations also featured ice carvings of the group's name and its train logo. As the band left the stage and headed toward the Forum Club, Greenberg presented the members with gold singles for "Double Vision" and "Hot

(continued on page 18)

Who is
MONKEY JOE

Ask Burl Ives...
or call 615-889-7100

BACKLESS — Eric Clapton — RSO RS-1-3039 — Producer: Glyn Johns — List: 7.98

On the heels of his top selling "Slowhand" album, this veteran guitarist/vocalist/composer has emerged with another striking work which spotlights his moderately-paced, refined rock numbers. Clapton several years ago largely shifted from his hard-rock stance to a more controlled yet resonant delivery, and this LP continues in this vein. Spearheaded by the charted single, "Promises," "Backless" also contains "Watch Out For Lucy" plus "Roll It," a stinging rocker which features the vocals of Marcy Levy.



FEEL THE NEED — Leif Garrett — Scotti Brothers/Atlantic SB 7100 — Producer: Michael Lloyd — List: 7.98

Leif Garrett bounds from teenage heartthrob to disco sensation with his first Scotti Brothers release. "Feel The Need" features "I Was Made For Dancing," which presents three minutes of frenetic dancing fun that is too engaging to worry listeners about its overly familiar hooks. Garrett and producer Michael Lloyd have created a solid collection of new and reworked favorites guaranteed to re-deliver hardcore Leifsters and capture older music lovers as well. Disco and pop 40.



MISS GLADYS KNIGHT — Buddah BDS 5714 — Producer: Tony Macaulay — List: 7.98

After many successful years with the Pips, Gladys Knight's first solo effort will most assuredly garner her extensive chart activity and airplay. Though the disco single, "It's A Better Than Good Time" did enjoy some chart success, it is the album's mood-making ballads which should be the most appealing to the songstress' mainstream, pop-oriented following. The gospel/MOR sound of "Sail Away/Freedom For The Stallions" and "I'm Comin' Home Again" are the outstanding cuts here.



SMOKIN' — Smokey Robinson — Tamla T9-363A2 — Producer: William "Smokey" Robinson — List: 9.98

Recorded last May at his Roxy engagement in Hollywood, this two-record set exquisitely captures the intense, soulful energy which Robinson delivers in concert. The album should please Robinson fans of all ages, because the material here features a solid sampling of both his classic Miracles numbers as well as his more recent solo tunes. Standout tracks on the LP include "I Second That Emotion," "The Agony And The Ecstasy," and "The Tears Of A Clown."

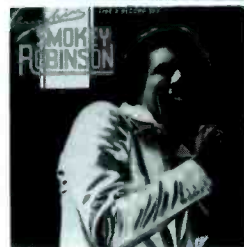

SARAH DASH — Kirshner JA 35477 — Producers: W. Gold, J. Siegel, G. Knight and G. Allan — List: 7.98

On her first solo since leaving the soul trio Labelle, Sarah Dash has concocted an album which should appeal to both a disco and pop audience. The key to this effort is the stirring, high-soaring vocals of Dash, plus the crisp arrangements of Leon Pendarvis. "Sinner Man" boasts a propelling dance beat, while other numbers such as "You" and "I Can't Believe" display Dash's ability to perform tender ballads. Overall, a promising, frequently satisfying endeavor.



LEGEND — Poco — ABC AA-1099 — Producer: Richard Sanford Orshoff — List: 7.98

Yes, Virginia, this is a brand-spankin' new Poco album and it is a good feelin' to know. Spearheaded by group veterans Rusty Young and Paul Cotton, "Legend" finds this year's Poco downplaying its trend-setting "city 'n' western" stance in favor of a truly beautiful, fragile MOR tonality which never bores as those Poco harmonies soar. A more than commendable return. "Boomerang," "The Last Goodbye" and "Legend" the top cuts featured on this splendid effort.



1969 — CREEDENCE CLEARWATER REVIVAL — Fantasy CCR-69 — Producer: John Fogerty — List: 9.98

Fantasy Records has re-issued this group's first six albums in the form of three two-record sets which should revive interest in the Creedence catalog. All three repackages contain top-notch material, ranging from such early hits as "Suzie Q" and "Proud Mary" to later classics like "Up Around The Bend" and "Have You Ever Seen The Rain." The "1969" set may possibly be the strongest, featuring the songs of "Green River" and "Willy And The Poor Boys."



PARTNERS IN CRIME — Bandit — Arlola SW 50042 — Producer: Matthew Fisher — List: 7.98

This is the type of rock 'n' roll music which some feel is specifically geared for instant acceptance by America's AOR outlets. Charlie, Prism, Fotomaker (its latest), Foreigner and countless others are cited as examples of this supposed trend. Bandit steals from all of these yet manages to fence their musical booty in such a way that it emerges as both innocuous and inoffensive to even, say, Elvis Costello fans. For FM formats.



PRONTO MONTO — Kate & Anna McGarrigle — Warner Bros. BSK 3238 — Producer: David Nichtern — List: 7.98

With its third album, the Canadian McGarrigles continue to evocatively perform its original pop/folk compositions. The twosome has received extensive critical praise since its debut album a while back, and "Pronto Monto" is sure to win acclamation as well as hopefully establish a wider pop audience for the duo. Evenly divided between intimate ballads and affectionate upbeat tunes, this LP includes "Oh My Heart," "Come Back Baby" and "Side Of Fries."



TWO FOR THE SHOW — Kansas — Kirshner PZ2 35660 — Producer: Kansas — List: 13.98

Due to the success of its last two albums ("Leftoverture" and "Point Of Know Return") this midwestern progressive rock outfit has established itself as a major recording attraction and concert draw. This live two-record set captures the group's energetic, hard-rocking onstage delivery, providing a power-packed souvenir for Kansas' legion of fans. Including such recent hits as "Carry On Wayward Son" and "Dust In The Wind," the LP also features lengthy renditions of many of Kansas' earlier compositions.

PLAYIN' TO WIN — Outlaws — Arista AB 4205 — Producer: Robert John "Mutt" Lange — List: 7.98

"Playin' To Win" expands upon the guitar-oriented progressive southern rock sound which helped establish this Florida band's stronghold on AOR and pop stations across the Union. On exhibit is the sextet's obvious love for playing and singing, particularly on "You Are The Show," where the Outlaws' acknowledge its loyal audience. Already the #2 Most Added album on FM this week, watch for that audience to acknowledge back with chart bullets.



READY TO ROLL — Thelma Houston — Tamla T7-361R1 — Producers: Hal David and Greg Wright — List: 7.98

Producer Hal David has most assuredly given this album his magic touch. The tight, elegant production compliments the fine vocal ability of Thelma Houston, taking her to the height of her artistic ability. From the smooth melodic ballads to the forceful uptempo tunes, this album spans the gamut of every radio format. Although Houston was beginning to be known primarily as a disco artist, this LP displays her versatile musical talent.



LOU REED LIVE TAKE NO PRISONERS — Arista AL 8502 — Producer: Lou Reed — List: 11.98

On the heels of his critically acclaimed album, "Street Hassle," and a highly successful tour, Lou Reed has released this two-record set which was recorded at the Bottom Line in New York. This LP includes such recent tracks as the controversial "I Wanna Be Black" and "Street Hassle," plus such early Reed classics as "Sweet Jane" and "Walk On The Wild Side." Unlike his previous two live albums, this LP displays a more sensual, unified sound that effectively captures the street-wise intensity of Reed's current band.



HIS BEST — Paul Anka — United Artists UA-LA922-H — Producers: Various — List: 7.98

Containing seven of his most famous studio compositions and three cuts recorded live in Japan, this greatest hits package reaffirms Paul Anka's creative skills as a contemporary pop-rock/easy listening singer/songwriter. "His Best" features such Anka standards as "My Way" and "(You're) Having My Baby," as well as such works as "The Times Of Your Life" and "Let Me Try Again." This LP should be a strong Christmas seller.

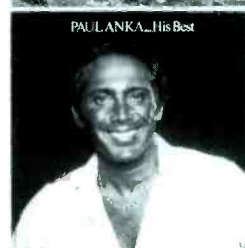

GREEN LIGHT — Cliff Richard — Rocket BXL1-2958 — Producer: Bruce Welch — List: 7.98

A pop hero from London to Lima since 1958 and a one-hit wonder in the U.S. since 1976, Cliff Richard now graces these shores again with his third Rocket album. Utilizing the composing and back-up vocal talents of Tarney/Spencer and ex-Shadow Bruce Welch once again as producer, Richard creates an album that deftly shifts from an intensity last heard via Roxy Music ("She's A Gypsy," and the title cut) to wonderfully uplifting ballads ("Start All Over Again").

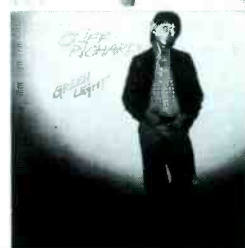

STREAMLINE — Lenny White — Elektra 6E-164 — Producers: Larry Dunn and Lenny White — List: 7.98

Ex-Return To Forever drummer Lenny White digs from a multi-format stockpile of rocking fusion chops on this Larry Dunn-produced release. Let the jazz traditionalists cringe as White works wonders on star tracks like "Lady Madonna" (guest vocal by Chaka Khan) and his unashamedly bashing "12 Bars From Mars," what matters most is that this music is good and will open the ears and minds of new listeners raised on mainstream rock, jazz, and R&B product.



WELCOME TO THE CLUB — Richard Kerr — A&M SP-4721 — Producer: Christopher Bond — List: 7.98

An established songwriter who has composed material for Barry Manilow, among others, Richard Kerr launches his solo recording career with this album. "Welcome To The Club" showcases Kerr's talents as an effective pianist, singer, and most importantly, as a composer of uplifting, accessible pop-rock selections. Backed by an array of studio musicians, this LP contains such tunes as "I Can't Afford That Feeling Anymore" and "I Feel It All." For MOR and pop formats.

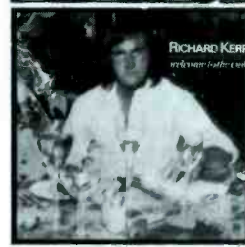

NEW MOON RISING — Lisa Lawalin — Monument MG7630 — Producer: Fred Foster — List: 7.98

"New Moon Rising" marks the debut of Lisa Lawalin, a former Miss Georgia and a skillful vocalist in the adult contemporary/pop vein. Lawalin possesses a caressing, pleasant voice which capably handles this collection of lush ballads and affectionate upbeat tunes. Produced by Fred Foster, this album includes such tracks as "Your Love," "Steppin' Stone" and a rendition of the '60s Motown classic, "Dancing In The Street."





Steve Katz

Katz Appointed VP Of A&R At Phonogram Inc.

NEW YORK — Steve Katz has been appointed vice president of A&R for Phonogram/Mercury Records. He joined the label in July as director of east coast A&R.

Katz's career began in 1963, when he was a member of the Even Jug Band with John Sebastian and Maria Muldaur. Three years later, he and Al Kooper formed the Blues Project, a seminal blues/rock band.

In 1968, Katz and Kooper founded Blood, Sweat & Tears, where Katz remained as guitarist, writer and vocalist until 1973.

After his stint with BS&T, Katz branched into producing, and produced Lou Reed's "Rock And Roll Animal" and Elliot Murphy's "Night Lights." Most recently, Katz completed production of the Horslips album on DJM.

Welk Signs Hieronymus

LOS ANGELES — Welk Music Group has signed composer Richard (Dick) Hieronymus to an exclusive publishing pact with the company. Hieronymus, who has scored nine feature films and TV pilots during the past few years, has composer and arranger credits with more than 30 artists. He will be assigned to the Hollywood division of the Welk Group and will work with Gaylon Horton, division manager along with Dean Kay.



GILDER GILDED — Chrysalis recording artist Nick Gilder recently was presented a gold copy of his "Hot Child In The City" single by label execs during a taping of the "Mike Douglas Show." Pictured (l-r) are: Billy Bass, vice president of promotion and creative services; Scott Kranzberg, national promotion director; guitarist James McCulloch; Jaime Herndon, guitarist/keyboardist; Douglas; Eric Nelson, bassist; Gilder; Lloyd Segal, manager; Terry Ellis, president of Chrysalis Records; drummer Craig Krampf and Sal Licata, senior vice president of Chrysalis Records.

Fotomaker Sets Visits To WEA Branches

NEW YORK — To coincide with the release of their second LP, "Vis-A-Vis," and the single "Miles Away," Atlantic recording group Fotomaker has embarked on a series of visits to WEA branches across the country. Two simultaneous itineraries have been scheduled, with some of the group members stopping in Philadelphia, Dallas and Atlanta, while others visit Boston, Chicago and Cleveland. The band will also make a trip to the Los Angeles WEA offices. Fotomaker is currently rehearsing for a planned winter tour.

Brownstein, Smith Open New Management Firm

LOS ANGELES — Brownstein/Smith Management has opened offices at 731½ North Croft Ave. here under the direction of Bob Brownstein and Clay Smith.

Brownstein previously was with Elektra/Asylum Records where he was coordinator of artist development. Smith is the former director of promotional activities and special events coordinator for Captain Jacques Cousteau.

Gene Parsons Signs To Sierra/Briar Records

LOS ANGELES — Gene Parsons, former member of the Byrds and the Flying Burrito Brothers, has signed with Sierra/Briar Records. Parsons' first solo LP since 1973 is slated for release next spring.

Parsons who is currently touring with the re-formed Flying Burrito Brothers, will continue to serve as A&R director for Sierra/Briar.

Halsey Signs Nelson

LOS ANGELES — Epic recording artist Rick Nelson recently signed an exclusive representation contract with the Jim Halsey Company. Nelson is the first artist to sign under the company's new contemporary division, Jim Halsey Contemporary, Ltd.

Summer Single Gold

LOS ANGELES — "MacArthur Park," Donna Summer's single on Casablanca Records has been certified gold by the RIAA.

(continued from page 16)

Blooded." Some of the celebrities in attendance included Cher, Kristy McNichol, Tatum O'Neal, Penny Marshall, Cindy Williams, Avery Schreiber, Paul Stanley, Judd Hirsch (of "Taxi"), Willie Ames ("Eight is Enough"), Leif Garrett, Shaun Cassidy, members of Tom Petty's band, The Heartbreakers, David Robinson, Jeff Conway (also of "Taxi"), Kenny Rankin, Robin "Mork" Williams, Bob Guillion ("Soap"), Linda Lavin ("Alice") and Eloise Laws, to name a lot . . . Kiss has been doing several promotions of the four members' solo albums, including some radio IDs for KHJ in Los Angeles, KFRC in San Francisco and KHSN in Coos Bay, Oregon, on that station's first anniversary.

CLASH CITY ROCKERS — Regarded by many rock critics as being the most talented and influential new wave band around, English punk group the Clash is finally ready to issue its first American album, entitled "Give 'Em Enough Rope," on Epic Records. Cash Box received an advance copy of the LP, which is actually the group's second effort, the first being "The Clash," released a year-and-a-half ago in England. Along with the Sex Pistols, the Clash spearheaded the British punk movement, and now with the Pistols gone, the responsibility of reaffirming the power and impact of the punk movement rests almost entirely upon the shoulders of the Clash.



TOLKIEN TWOSOME — Film composer Leonard Roseman (left) posed with film director Ralph Bakshi recently following the recording of the score for the upcoming full-length animated feature film "The Lord of the Rings." The soundtrack LP, on Fantasy Records, is scheduled for release soon.

"Give 'Em Enough Rope" lives up to all expectations, exhibiting the intense rock 'n' roll energy of the early punk sound combined with a fiercely determined working class stance, biting, highly imaginative lyrics, and the clean, crisp production of Blue Oyster Cult producer Sandy Pearlman. Featuring the compositions of lead vocalist/guitarist Joe Strummer and guitarist Mick Jones, the LP is scheduled to be released the third week of this month. Song titles include "Safe European Home," "All The Young Punks" (thematically similar to Mott The Hoople's "All The Young Dudes"), "Guns On The Roof" and "Julie's Been Working For The Drug Squad." . . . The female musical trio, Hot, has been cast to perform the lead roles in Harry Hope's 30th film, "We Can Be Strong Together." The group, which

features Gwen Owens, Cathy Carson and Juanita Curiel, will also record the soundtrack album: The film, which is directed by Dan Seeger, is due out next April.

BARBATA INJURED — John Barbata, drummer for Jefferson Starship, was seriously injured in a car crash early Saturday morning, Oct. 28. Driving through the town of Comptche in Mendocino County, CA, Barbata and his friend Terry Hill collided into a tree after Barbata swerved to miss a deer which was blocking the road. Hill died in the crash, and Barbata was taken to Santa Rosa Memorial Hospital, where he spent five hours in the operating room. The drummer suffered a fractured neck, right forearm and jaw, plus a concussion and he is expected to take six to eight months to recover. On a lighter note, the Starship is scheduled to appear on the "Star Wars Holiday Special" on Nov. 17 on CBS. For the show (taped before Barbata's accident), the group will perform without Grace Slick, and will introduce its forthcoming single, "Light The Sky On Fire," written by Craig Chaquico . . .

Last month Kendun Recorders in Burbank was the site of a mastering seminar conducted by Lella Greenstone, Kendun's director of creative services, Leah Bernstein, executive assistant to owner Kent Duncan, Jo Hansch, mastering engineer and Althea Mathis, traffic supervisor. The subjects discussed were "the language of mastering," "technical requirements" and "deadlines and shipping," among others . . . Warner Bros. recording group Funkadelic has started a national tour in support of its latest LP, "One Nation Under A Groove." The tour, which features the Brides Of Funkenstein as the opening act, consists of 33 dates, concluding in San Francisco on Nov. 19.

BUFFALO TALK — Capitol's Norton Buffalo took time out from his current national tour for a visit to the Cash Box offices recently. The harmonica ace is playing clubs and small halls now, with a new band that includes a couple of members of Clover who have backed Elvis Costello. "I like clubs a lot better than stadiums," reports the veteran of many 50,000+ seating dates with acts like Steve Miller. "Now I can play ballads and talk to the audience. It's like playing in your living room." In between gigs, Buffalo has been guesting with such artists as Bonnie Raitt, Judy Collins, the Doobie Brothers and David ("Hutch") Soul. Buffalo has also been exploring other media, appearing on Soul's "Starsky and Hutch" and as part of Bette Midler's band in her upcoming motion picture, "The Rose."

While playing the Roxy in Los Angeles right after his visit to Cash Box, Buffalo's chromatic harp was swiped. But unfortunately for the thief, both real and make-believe police were on the scene. Soul and Buffalo and some of his roadies took off with a description of the alleged pilferer. Unable to apprehend their suspect, Soul and Buffalo turned the case over to local authorities, who reportedly frisked every "longhair" on the Sunset Strip — and recovered the missing harp. . . . Rhino Records, an independent label based in L.A., is currently enjoying success with the outbreak of its release of "Whole Lotta Love" by the Temple City Kazoo Orchestra. Receiving steady airplay on such stations as WNEW and WBAL in New York, WMMS-Cleveland and KROQ-L.A., the record features the hilarious sound of kazooos (believe it or not) imitating Jimmy Page's guitar licks and the screeching vocals of Robert Plant. Among the Kazoo-ers is Harold Bronson, Rhino A&R director . . . ABC artists John Klemmer and Joe Sample are planning to record a direct-to-disc LP together . . . Rock quartet Cheap Trick is in L.A. recording its fourth album for Epic.

ALL IN THE FAMILY — Composer/arranger David Axelrod married Terry Hatton on Oct. 29 at the home of attorney James Tolbert in Van Nuys . . . The first wedding ceremony in a recording studio took place late last month at Eldorado Studios in Hollywood. George "Fidel" Bell married Nadya Gordon-Rae, who is the traffic manager at Eldorado. The wedding was recorded by the studio . . . Chris Huston, chief engineer for Far Out Productions, and wife Taran recently gave birth to a son, Jesse Michael, in L.A. . . . Black Oak manager Butch Stone and his wife Connie recently gave birth to a son, Justin Michael.

OPPOSING PROPOSITION 6 — This past weekend Casablanca recording acts Pattie Brooks, Love & Kisses, and Chocolate City artist Vernon Burch performed a benefit concert in support of the No On 6 committee at the Disco Room of Studio One in Los Angeles. The committee opposes California's Proposition 6 (The Briggs Initiative) which proposes the firing of any state school teacher who publicly endorses homosexual behavior . . . Also in support of the committee was a two-night Halloween monster party that was held at Trocadero's Transfer in San Francisco that featured performances by Deborah Washington, Denise McCann and others . . . Bay area punk group the Avengers is recording and mixing singles that will be part of its forthcoming album for Virgin Records.

(continued on page 54)

In This Issue: Recordmate Of The Year

FEATURE PICKS

LINDA RONSTADT (Elektra/Asylum E-45546)
Ooh Baby Baby (3:18) (Jobete Music — ASCAP)
 (W. Robinson/W. Moore)

This follow-up to "Back In The U.S.A." is likely to be a monster. A cover of the song by Smokey Robinson, this track has a simply beautiful feel of emotional affecting vocals and a fine evocative sax solo. Delicate guitar embellishments and piano chording make this killer of the week. Top 10 bound.



HOT CHOCOLATE (Infinity 50,002)
Every 1's A Winner (3:35) (Finchley Music — ASCAP) (E. Brown)

Remember "You Sexy Thing?" Well, the English band Hot Chocolate is back with an auspicious start on the new Infinity label. This record has the musical and vocal hooks to make a big splash. Errol Brown is a stunningly unique singer; the keyboard lick by Larry Ferguson is memorable; the beat carried by Tony Connors and Harvey Hinsley is dark and understatedly fierce.



BOSTON (Epic 8-50638)
A Man I'll Never Be (3:57) (Pure Songs — ASCAP)
 (T. Scholz)

The title track from the "Don't Look Back" album reached the Top 10 on pop lists. This second single opens with a piano ballad feel which quickly expands when Tom Scholz adds his princely guitar work. The beat remains moderate. Keyboards, which sound like a church harpsicord, provide a high melody line. Vocals are characteristically soaring. Top pop potential.



POINTER SISTERS (Planet P-45901)
Fire (3:41) (Bruce Springsteen — ASCAP) (B. Springsteen)

Robert Gordon did a dashing version of this Springsteen composition. The Pointer Sisters with the help of a sparkling arrangement and edgy guitars deliver a commanding performance. Produced by Richard Perry, this is the first release on the new E/A Planet custom label. Excellent vocals and perky delivery make this a good Top 40 add.

JACKSON BROWNE (Elektra/Asylum E-45543)
You Love The Thunder (3:57) (Swallow Turn Music — ASCAP) (J. Browne)

"Running On Empty" has been on the street for nearly a year now but interest is still there. This third single has a moderate pace, good lyrics and a strong hook. The slide guitar work and backing vocals are effective. Top 40 shot.



DAN HILL (20th Century TC-2392)
Let The Song Last Forever (3:15) (Welbeck Music — ASCAP/ATV Music and Mann & Weil Songs — BMI) (D. Hill/B. Mann)

Dan Hill is an elegant emotional balladeer and a perceptive analyzer of the pain of relationships. This second single from "Frozen In The Night" is a classy re-statement of the issues he has made his reputation exploring. Written with Barry Mann, the track features piano, strings and fluctuating beat. Top 40, MOR material.



CITY BOY (Mercury/Phonogram 74032)
What A Night (2:41) (Zomba/City Boy Music/Chappell & Co. — ASCAP) (Broughton)

"5.7.0.5." was one of the better turntable records of the year. Although a strong song, the track failed to make Top 40 inroads. This second single from the "Book Early" album has a fine rolling chorus that ought to appeal to pop lists. A moderate beat, electric piano backing, nice guitar fills and excellent vocal arrangement make this track a good shot for Top 40 action.



PHOEBE SNOW (Columbia 3-10856)
Every Night (3:32) (Maclen Music — BMI) (P. McCartney)

Phoebe's new album is called "Against The Grain" and this cover of the McCartney tune is one of the album's finest tracks. The clear high double-tracked "Oooo" hook is shimmering. A firm beat, nice guitar work and fine execution make this a good candidate for pop success.

SINGLES TO WATCH

CARLY SIMON (Elektra/Asylum E-45544)
Tranquillo (Melt My Heart) (3:45) (C'Est Music — ASCAP/Country Road Music — BMI) (C. Simon/J. Taylor/A. Mardin)

Taken from her "Boys In The Trees" album, this single ought to be of immediate interest to Top 40 stations. A funky arrangement of guitars, horns and strings follow a stepping beat. Simon's vocals are clean. Nice chorus.

KIKI DEE (Rocket JH-11413)
One Step (3:26) (Snow Music — BMI/Saint Basil Music — ASCAP) (T. Snow/G. Ballard)

"Stay With Me" is the name of Kiki Dee's brand new album. This first single opens with entwining guitar lines and piano work. Horns join in the merriment. Dee's vocals are excellent and the arrangement skillfully supports her efforts. This is a fine Top 40 add.

CHERYL LADD (Capitol P-4650)
Good Good Lovin' (3:44) (Screen Gems-EMI Music — BMI) (B. Mann/C. Weil)

Cheryl Ladd has been the subject of an intensive Capitol push. Her first single "Think It Over" made a respectable showing. This second single proves again that Ladd is a good singer and that with a well-arranged uptempo number, she can deliver a product worthy of Top 40 attention.

FOGHAT (Bearsville/WB BBS 0329)
High On Love (4:04) (Riff Bros. Music — ASCAP) (Peeverett/Price)

This follow-up to "Stone Blue" is no-holds-barred rock 'n' roll. With guitars flailing and the bass providing a rippling undercurrent, the vocals climb the mountain of love. If you like biting rock, try this one for size.

ROBERT JOHNSON (Infinity 50,000)
I'll Be Waiting (3:30) (Fuse Music — ASCAP) (R. Johnson)

Robert Johnson plays all the instruments — guitars, bass and drums — on this single from the much heralded new label Infinity Records. This track is straight ahead rock 'n' roll with an opening vocal lick reminiscent of "The Bird Is The Word" and a story of teenage love. Enthusiastic and driving, this track is a good Top 40 add.

FOTOMAKER (Atlantic 3531)
Miles Away (3:35) (Fotomaker Publ./Adrian Leighton Music — BMI) (F. Vinci)

This track from "Vis-A-Vis" has a hook which ought to stick to Top 40 and AOR programmers. Piano, keyboard texture and solid guitar work join the fine on-the-rise vocals for a strong performance.

SHAUN CASSIDY (Warner/Curb WBS 8698)
Midnight Sun (3:48) (American Broadcasting Music — ASCAP) (P. McCann)

Taken from "Under Wraps," this track has an elegant guitar opening and soft silky keyboard work. The chorus lifts the pace in this ode to that special one. Michael Lloyd's production features strings, easy beat and backing female vocals.

JOE SIMON (Spring/Polydor SP 190)
Love Vibration (3:09) (Possie Music/Teddy Randazzo Music — BMI) (T. Randazzo/J. Simon)

Produced by the Harris Machine, this track has a ticking rhythm guitar bottom and dashing string top. Simon gets down in the middle. Horns and backing singers add depth to the arrangement. With a funky groove, this is suited to R&B and disco play.

JIM CAPALDI (RSO 912)
Daughter Of The Night (3:15) (April Music — ASCAP) (M. Rickfors/H. Huss)

This title track from Capaldi's new RSO album is a majestic number which rides well-textured keyboard work, strings, punctuating rhythm guitars, moderate ballad beat and an interlocking rhyming lyric. Good lead and backing vocals. Suited to Top 40 play.

BLONDIE (Chrysalis CHS 2271)
Hanging On The Telephone (2:25) (Rare Blue Music/Monster Island Music — ASCAP) (J. Lee)

The first single from "Parallel Lines," "I'm Gonna Love You Too" failed to create substantial Top 40 interest. This second single, produced by Mike Chapman, features a fast clipping beat, varied guitar work and good lead vocals by Deborah Harry. Suited to AOR and adventurous pop lists.

TAVARES (Capitol P-4658)
Never Had A Love Like This Before (3:30) (Medad Music/Irving Music — BMI) (L.R. Hanks/Z. Grey)

"Madame Butterfly" is the name of Tavares' forthcoming album. This first single is a rich and funky track which soars on the fine lead vocals, strong chorus, tasty jazz guitar touches, conga backing and keyboard support. The vocals are pleasantly favored in the mix. Suited to R&B and Top 40 lists.

JOE WALSH (ABC 12426)
Turn To Stone (3:59) (ABC/Dunhill Music/Barnstorm Music/Belkin Music — BMI) (J. Walsh/T. Trebandt)

ABC has released a "Best Of Joe Walsh" album in anticipation of the Christmas season. This track from the "So What" album is a strong rocker with commanding guitar work and excellent vocals. Top 40 material.

CAROLE KING (Capitol 4649)
Morning Sun (3:25) (Colgems — EMI Music — ASCAP) (C. King)

"Welcome Home" is the name of King's latest LP and this second single has a steady beat and appealing acoustic guitar and piano work that ought to make the track appealing to Top 40 and AC lists. Good vocals and harmonies.

ENGLEBERT HUMPERDINCK (Epic 8-50632)
The Moment In Time (4:01) (Silver Blue Music — ASCAP) (A. Bernstein/R. Adams)

Englebert's latest effort is a warm MOR ballad which has an easy pace and string backing. Cheek-to-cheek material, this ballad has a mix which keeps Engelbert's voice in the foreground. Humperdinck fans will enjoy this one.

SNAIL (Cream CR-7830)
Catch Me (3:32) (Blue Ave./Churn Music — ASCAP) (K. Kraft/B. Aguirre)

Snail is a big priority for Cream Records and the album, although it has not yet broken into the Top 100, has demonstrated considerable tenacity. This second single has a nice upward move and an arrangement of strings, guitars and singing which is suited to Top 40 play.

(continued from page 14)

promotion, merchandising and artist development. Before that, he was director of marketing and operations for The Frank Kraus Company, Limited.

Lane Named At Cream — Barney Lane has been named eastern regional marketing director for Cream Records. Lane, who has been a Vista volunteer and taught TV-Radio Writing & Announcing at Syracuse University, comes to Cream from CTI where he held a similar regional position.

Brown-Powell Named At A&M — A&M Records has announced the appointment of Sharyn Brown-Powell as publicity manager/R&B. She joined A&M in 1972 as an administrative assistant in the A&R department, went on to serve as executive secretary to A&M chairman Jerry Moss. Prior to joining the company, she had served as production assistant on the syndicated "Black Omnibus" television show.

Williams Named — John Williams has been named as executive vice president of Black and White Sales Consultants Ltd. Williams, with over 20 years experience in the music industry, mainly with CBS Records, will be responsible for the day to day activities of Thunder Sound Studios, Markham Records and Tapes and Inter Global Music.

Holder Appointed At CBS — CBS Records has announced the appointment of Lori Holder as Associated Labels promotion manager in the CBS Records Los Angeles branch. She most recently held the position of local promotion manager for ABC in the Los Angeles marketing area. Prior to that, she worked at Radio & Records and also at KZOK in Seattle where she was music director.

Rocklin Appointed At A&M — A&M Records has announced the appointment of Stacey Rocklin as national television coordinator. She joined the label in April 1978 as assistant television coordinator. She was previously administrative assistant in the publicity department at Capitol Records and an account executive with Edye Rome Public Relations.

Conway Named At E/P/A — CBS Records has announced the appointment of Michael Conway as Epic/Portrait/Associated local promotion manager for the CBS Records Atlanta branch. His most recent position with CBS was as an inventory specialist for the Atlanta branch.

Mobley Named At CBS — CBS Records has announced the appointment of Curtis Mobley as black music marketing local promotion manager for the CBS Records Atlanta branch. His most recent position with CBS was as a black music marketing local promotion manager for the Dallas branch.

Bench Appointed At CBS — CBS Records has announced the appointment of Bruce Bench as single record coordinator for the CBS Records Atlanta branch. His most recent position with CBS was as an inventory specialist.

Changes At E/A — Tony Vino has been named Elektra/Asylum local promotion representative for Miami. For the past three years he has taught rock ensemble classes and guitar and piano labs at the Miami High School of Performing Arts. Also Ed Korte has been named Elektra/Asylum local promotion representative for St. Louis. Prior to joining E/A, Korte was a time salesman for radio stations KCFM, KATZ and KKSS in St. Louis, and KBEY (now KBEQ) in Kansas City. Previously he had worked for General Electric.

McCune And Culp Join Image — Linda McCune and Phil Culp have joined the staff of Image Marketing & Media in Los Angeles. McCune formerly with 12 by 12 magazine and Pickwick's North Hollywood rack operations, will be serving as a marketing representative. Culp, formerly buyer for Superior Music, in Glendale will be working in the capacity of operations liaison.

Cream Momentum Building As Green Package Comes Out

(continued from page 16)

says Culberg. "We give ourselves the opportunity to promote and work each act individually so that we give each act the exposure necessary to get it to the consumer's attention. We time our releases to keep our artists in the public eye — the more staying power the greater the sales."

Other upcoming Cream releases include a disco single from Brenton Wood, "Let's Get Crazy Together," and another disco effort, "Freaky Monstrosity," by O'Mar. Don Nix is mixing his label debut now and Ian Tamblin, a Canadian who Bennett believes has unlimited potential, is currently formulating his recording plans.

Xanadu

As part of its plan to build a broad-based company, last January Cream made a manufacturing, distribution, promotion and advertising deal with Don Schlitten's jazz label, Xanadu Records. Xanadu issues two series of jazz albums, a gold series of classics (mostly not previously released) and a silver series of new material. A Xanadu sampler released early this year sold out, and the new album by Rutgers music professor and jazz guitarist Ted Dunbar is doing well. Until now, all Xanadu releases have had gold or silver covers, depending on which series they were part of, but the label is planning to begin using color on its upcoming covers in an attempt to increase its sales appeal.

On the international front, Cream is rapidly concluding licensing, distribution and publishing agreements for the entire record-buying world, according to international division vice president Bob Weiss. A former European director for Capitol and the first Warner Bros. international vice president, Weiss personally visited all the countries Cream has made deals in and reports that Green, Snail, Wood, Peebles

and Wright are all viable international acts. He also indicates Cream is attempting to set up a two-way flow of talent that will see foreign acts record for Cream in the U.S. and the company is working toward simultaneous worldwide release of major artist product.

Independent Distribution

Bennett has firmly committed Cream to independent distribution. Despite the loss of much indie business to the majors, Bennett believes the long range outlook for independent distribution is good.

"Indies are healthier now than they were in the early '70s," says Bennett. "They are at the mercy of the indie labels, but if they get successful product they'll be successful. With some labels going with the majors I'm getting more concentration on my product, but the stronger the indie distributors the stronger the indie label, so now I'm hoping my competition does well."

Bennett also commented on two rumors concerning Cream that are making the rounds. One has former Bennett associate Johnny Rivers renewing their relationship; the other concerns a reported offer from the Polygram Group to buy out Cream Records.

"Johnny and I have been talking, but to date nothing has been consummated," reports Bennett. "But I know how to merchandise him and he knows it." Rivers' Soul City label was distributed by Bennett's Liberty Records in the '60s as a joint venture. A similar deal is reportedly in the works.

But on the subject of a possible sell-out to Polygram, or anyone else, Bennett is unequivocal. "The rumors are totally unfounded," insists Bennett. "There have been no such discussions. Cream Records is right where I wanted it to be and we are moving into our next phase."



UJA MAN OF THE YEAR — Neil Bogart, Casablanca Record & Filmworks president was recently honored by the Entertainment Division of the United Jewish Appeal as its Man Of The Year. Pictured (l-r) in the top row at the fundraising ceremony at the Americana Hotel in NYC are: Dick Clark, master of ceremonies; Morris Levy, president of Roulette Records and chairman of U.J.A.'s Entertainment Division; Bogart and his wife Joyce; Manhattan

borough president Andrew Stein presenting a proclamation from N.Y. Mayor Koch to Bogart; and Bogart addressing the attendees. Pictured (l-r) in the bottom row are: Timothy Bogart; Donna Summer; Jill and Bradley Bogart; Midge Constanza, former assistant to the President of the United States; and Bogart dancing with his daughter Jill. In his acceptance speech, Bogart urged sustained efforts to aid Israel.

AirPlay

STATION TO STATION — For the sixth consecutive year, **KSHE**/St. Louis is offering its listeners a heavy-duty rock 'n' roll show to celebrate its birthday. The station's 11th anniversary party is set for Nov. 15 at the Checkerdome, featuring **The Marshall Tucker Band**, **Trooper** and **Sea Level**. . . **Gene Simmons** of **Kiss** was at **Y100**/Miami-Ft. Lauderdale Oct. 27 for the giveaway of a "Kissmobile," a \$6,000 customized Firebird, supplied by Casablanca Record and FilmWorks. The "Kissmobile" is part of a \$75,000 cash and prize contest . . . The response to **WYNY**'s two weeks of All-**Beatles** programming was so positive that the station has decided to dedicate every Sunday to the acclaimed quartet. NBC's New York FM outlet will make every other Sunday song a Beatle song . . . **KRLA**/Pasadena's **Art Laboe** morning show has added four new featurettes, including an oldies feature with **Sha Na Na's Bowzer**. Bowzer recently co-hosted Laboe's show with fellow **Sha Na Naer Scott**. Another recent guest host was **Charo**. . . **RSO's Player** is set to perform a special benefit concert for "Toys For Tots" in association with **Z93**/Atlanta on Dec. 3 at the Omni . . . **WGN**/Chicago's **Wally Phillips** is getting a farm education this fall. Farmers in 42 counties in Illinois have donated 120 acres to Phillips in the hope that his on-air experiences as a grain producer will help the public understand the problems farmers deal with every year. The eventual sale of Phillips' 120 acres of corn will result in a large donation to the Neediest Children's Christmas Fund.

WFBR/Baltimore recently aired a 31-hour special, "A Chronology of American Music." The station played, in order, every record to reach #1 on the charts for the past 22 years . . . **14Q**/Worcester recently celebrated its second year on the air with a giant public birthday party. To further mark the occasion, Worcester Mayor Early proclaimed the day of the party "I Love 14Q Day." . . . CBS radio affiliates now have the option of carrying "Monday Night Football." **KY102**/Kansas City is one of the many music stations taking advantage of the service . . . **KRTH**/Los Angeles (**K-Earth**) is co-sponsoring the Nov. 12



EATING CROW — Morning men **Jim Quinn** of **13Q**/Pittsburgh and **John Lanigan** of **WGAR**/Cleveland made a friendly wager on the recent Pittsburgh Steelers-Cleveland Browns football game. After the Steelers' victory, Lanigan had to go to Pittsburgh and eat crow. He is pictured above with Quinn, doing just that.

"Hollywood 10K Run" in celebration of Hollywood's 75th anniversary. The 10-kilometer race, sanctioned by the AAU, is also co-sponsored by Warner Bros. Records . . . **WRKO**/Boston's fifth annual Londonderry Faire will take place Nov. 17-19.

NEW FORMATS AND OWNERS — **WLOB-AM-FM**/Portland, Me. have been purchased by Portland Radio Inc. The stations have also changed formats. The FM has gone AOR and is programmed by **Dave Ross**. The AM has switched to MOR, under the direction of **Nelson Gardner**. The stations would appreciate help in filling in holes in their libraries . . . Daytimer **KDJQ**/Mesa-Phoenix, formerly **KDKB**, has assembled almost 2,500 of the original hits of '50s, '60s and early '70s for its new golden oldies format. The station is being

programmed by **Bud Thomas** for a 25-40 target audience. . . **WACO** in Waco, Tx. has been purchased by the station general manager, **Robert Weathers**, at a reported cost of \$1.5 million. The contemporary music station has been on the air since 1922.

NEW JOBS — Air personality **George Michael** has signed a new long-term contract with **WABC**/New York. Michael worked as a jock at several Midwestern radio stations between 1962 and 1966, before he moved to **WFIL**/Philadelphia. He joined **WABC** in 1974 and is heard 6-10 p.m. When not on the air at **WABC**, Michael moonlights as a sportscaster . . . **WRVR**/New York has hired **Chuck Mitchell** as MD and assistant PD. . . Changes in the on-air lineup at **KPOL**/Los Angeles find the coed team of **Scott & Crunch** doing mornings (last teamed at **WCAR**/Detroit), **Paul Johnson** moving to middays, recent **KYA**/San Francisco arrival "**Natural**" **Nell Ross** taking over the afternoon drive slot and **Dave Steele** handling the evening show . . . **Michael Sarzynski** has joined **WNBC**/New York as 6-10 p.m. personality. A regular feature on his show will be visits from the **Allen**, a being of unknown origins with uncanny knowledge of UFOs. And speaking of UFOs, **WNBC** has added UFO researcher **Lee Spiegel** to its staff as science consultant. Spiegel has produced and narrated an 18-part documentary series on UFOs now airing on **WNBC**. The flying saucer specialist is also set to address the United Nations on the subject on Nov. 27 . . . Latest word out of **WAAF**/Worcester says **John Duncan** has moved from MD to PD, while assistant PD **Paul Lemieux** is now also MD . . . **Simone Geoffrion** is the new promotion coordinator for **Y100**/Miami-Ft. Lauderdale . . . **Beth Blakeman** has been appointed to the creative staff of **Drake-Chenault's** special features division. She will be in charge of maintaining the artist archives and working on development of new programs . . . Associated Press deputy director of broadcasting **Bob Benson** has been named vice president of ABC News, Radio . . . **Cynthia Harris** has been appointed news editor at **WOWO**/Ft. Wayne . . . The new general sales manager of **WNBC**/New York is former local sales manager **Virginia Tompkins**. . . **Michael Plumstead** is now general sales manager of **WFBR-WBKZ** in Baltimore. He had been with Rustcraft Broadcasting Group . . . **J. Michael Henderson** has been appointed general sales manager of **WPEZ**/Pittsburgh.

ODDS & ENDS — On behalf of **Alice Cooper's** new Warner Bros. single, "How You Gonna See Me Now?," Alive Enterprises (Cooper's management company) is preparing a 90-minute special featuring Cooper, lyricist **Bernie Taupin** and producer **David Foster**. Cooper and Taupin are currently on a radio promotion tour . . . The ABC American FM Radio Network has inaugurated a new lifestyle feature, "Rock Notes," produced and hosted by **Larry Jacobs** of **KLOS**/Los Angeles. The 90-second report covering a wide range of topics of interest to young adults will be scheduled at the discretion of the affiliate stations . . . Mushroom Records has released a limited-edition EP featuring four cuts off **Chilliwack's** "Lights From The Valley" album. The AOR sampler is pressed in clear vinyl and packaged in a round jacket . . . The Fall ARBs will be available one to three days earlier to stations that pay an extra \$25 for Federal Express delivery. Arbitron has also announced the establishment of a new Advance Ratings service for the Fall book. Advance Ratings will supply information from the local market report up to seven working days before the printed rating book arrives.

Joey Berlin



DIAMOND AT THE ROXY — MCA recording artist **Dyan Diamond** made her debut performance at the Roxy in Los Angeles recently. Pictured standing (l-r) after the show are: MCA's **Sam Passamano**, **Stan Bly**, **Santo Russo**, **Diamond** and **Denny Rosencrantz**; **Jay Harvey** of **Don Kelley Management**; MCA's **Jim Saltzman** and **Jeff Scheible**. Shown kneeling (l-r) are: producer **Kim Fowley** and **KNAC** program director, **Paul Fuhr**.

Browne Gets Top Honors From DIR

NEW YORK — Winners in DIR Broadcasting's second annual Rock Radio Awards have been announced. A two-hour radio special, featuring live performances, records and acceptance speeches, will be broadcast on DIR's group of 250 FM stations on Nov. 22. The show will be hosted by singer **Rita Coolidge** and **Scott Muni**, program director of **WNEW-FM**/New York.

The winners are: **Jackson Browne**, favorite male singer; **Linda Ronstadt**, favorite singer/songwriter; **Fleetwood Mac**, favorite female singer; **Fleetwood Mac**, favorite group; "Running On Empty" (**Jackson Browne**), favorite album; "French Kiss" (**Bob Welch**), favorite debut album; "Because The Night" (**Patti Smith**), favorite single and "Rumours" (**Fleetwood Mac**), favorite all-time album.

The **Tom Donahue Memorial Award**, named for the progressive rock radio pioneer, goes to "Walrus" publisher **George Meier**.

Loyola Holds Annual National Radio Confab

CHICAGO — The 9th annual Loyola National Radio Conference was recently held at the Marriott-Chicago Hotel and Loyola University.

Mike Englehaupt, assistant chief engineer for **WMET** and **Joe DeStefano** were the technical/engineering coordinators for this outing. This year's conference coordinators made a concerned effort to integrate the technical/engineering aspects of broadcasting into the conference activities.

Technical Seminars

This year's list of technical seminars include: Building A Radio Station, Recording Studio Techniques As They Relate To Radio Station Production, Remote And Special Broadcasts, Audio Console Technology, Transmitter & Related Systems Operation & Design, Going FM, and Cleaning Up Your Carrier Current Sound.

Meyer Wins WNBC's 'Hometown' LP Contest

NEW YORK — **Hester Meyer**, a 24-year-old art student from **Bergenfield, N.J.**, recently won **WNBC's** "Hometown" album art contest. Meyer's design won first prize over 1,000 entries.

KC College Radio Seminar Debuts

KANSAS CITY — The first "Kansas City College Radio Seminar" was held at the Radisson Hotel here Oct. 21 to help establish college radio as a viable medium in the area. Seminar coordinator **Chuck Lackner** reports that 50 students representing college stations in Missouri and Kansas took part in discussions on such topics as programming, promotions record service and broadcasting careers.

Lackner credits **WEA**, **Venture Records** and **Mushroom Records** with contributing to the success of the seminar through their sponsorship. Along with label representatives, other guests included **Al Casey**, program director at **WHB**/Kansas City; **Bob Laurence**, program director at **KBEQ**/Kansas City; **Khrist Favor**, music director at **KEWI**/Topeka and **Dave Fulton**, editor-in-chief of **Cash Box**.

"This was the first such seminar in the Kansas City area and as such it was a very successful one," says **Lackner**. "We are planning to repeat the seminar in the spring and again next fall. Support of college radio is excellent here and I look forward to next spring's seminar."

Capricorn, KZLA, KWST Offer Sea Level Promo

LOS ANGELES — Four lucky couples won a rock 'n' roll "Living In A Dream" evening, hosted by **Capricorn Records** and **L.A. rockers**, **KZLA** and **KWST**, Nov. 1, 1978 in honor of **Sea Level's** opening at the Roxy. The winners were selected by a drawing on both stations on Oct. 30 and they were chaperoned by **Jim La Fawn** of **KZLA**, **Pam May** of **KWST**, and **Rick Harold** of **Capricorn Records**.

Who is



Ask Burl Ives...
or call 615-889-7100

MOST ADDED F M L P s

#1 Most Added

#2 Most Added

#4 Most Added

#5 Most Added

#6 Most Added



AEROSMITH
Live Bootleg
Columbia



OUTLAWS
Playin' To Win
Arista



KANSAS
Two For The Show
Kirshner

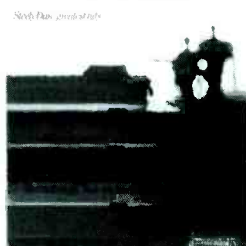

STEELY DAN
Greatest Hits
ABC



CINDY BULLENS
Desire Wire
United Artist

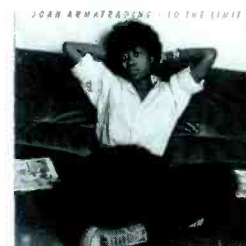

JOAN ARMATRADING
To The Limit
A&M

#1 Most Added

AEROSMITH — Live Bootleg — Columbia

ADDED THIS WEEK — KSJO, KWST, KSHE, WNOR, WLAV, WJKL, KEZY, WLVQ, WBLM, KMET, WGRQ, WAAL, KRST, WBAB, WQXM, WCCC, WMMS, KSN, C-101, WOUR, WXRT, WLIR, KYTX, ZETA-7, KOME, WBCN

HISTORY TO DATE — WYFE, KTXQ, WABX, WYDD, WMMS

#2 Most Added

OUTLAWS — Playin' To Win — Arista

ADDED THIS WEEK —

KSJO, KWST, WIOQ, WJKL, KWKI, WYFE, KMET, WAAL, WYDD, KZAM, WBAB, WQXM, WCCC, WMMS, KSN, WHFS, WLIR, WSN, KADI, ZETA-7, KOME

HISTORY TO DATE — None

#3 Most Added

KANSAS — Two For The Show — Kirshner

ADDED THIS WEEK — KSJO, KWST, WABX, KTXQ, WLAV, WYSP, WIOQ, KEZY, KWKI, WYFE, WLVQ, WBLM, KMET, WBAB, WQXM, WCCC, KZEW, WLIR

HISTORY TO DATE — None

#4 Most Added

STEELY DAN — Greatest Hits — ABC

ADDED THIS WEEK — WABX, WNOE, WIOQ, WYFE, WBLM, KMET, WGRQ, KINK, WBAB, WQXM, WCCC, KREM, KSN, WSN, KADI

HISTORY TO DATE — KSJO, WAAF, KEZY, WLAV, KMEL, KWST, ZETA-7, KRST, KFML, WMMS, WLIR, WZMF, KZAM, KBPI, WLVQ, WOUR

#5 Most Added

CINDY BULLENS — Desire Wire — United Artists

ADDED THIS WEEK —

KSJO, KSHE, WABX, WYSP, WBLM, WAAF, KRST, KKTX, WHFS, KZEW, WOUR, WLIR, ZETA-7

HISTORY TO DATE — WBAB

#6 Most Added

JOAN ARMATRADING — To The Limit — A&M

ADDED THIS WEEK — KNAC, KSJO, WNOR, WLAV, WAAL, KRST, WCCC, KKTX, KZEL, C-101, WXRT, WKLS

HISTORY TO DATE — WJKL, WIOQ, KLLO, WNEW, KINK, WBAB, WRNW, KZEW, WLIR, WBCN, WSN, KZAM, KSN, WOUR, WYSP, WBLM, WHFS

#7 Most Added

FOTOMAKER — Vis-A-Vis — Atlantic

ADDED THIS WEEK — WIOQ, KWKI, WYFE, WAAL, KRST, WBAB, WBCN, KKTX, KZEW, WLIR, ZETA-7

HISTORY TO DATE — KSJO, WBAB

#8 Most Added

TANYA TUCKER — TNT — MCA

ADDED THIS WEEK — KSJO, WYFE, WAAL, WBCN, WCCC, WMMS, KSN, WHFS, KZEW, WLIR

HISTORY TO DATE — None

#9 Most Added

JIMMY BUFFETT — You Had To Be There — ABC

ADDED THIS WEEK —

WNOR, WLVQ, WAAL, KRST, WBCN, WMMS, WHFS, C-101, WKLS, KOME

HISTORY TO DATE — WYFE, KEZY, WBLM, WNEW, WLAV, KNAC, WQXM, ZETA-7, KINK, WRNW, KZEL, WLIR, KZAM, KADI, WOUR

#10 Most Added

RUSH — Hemispheres — Mercury

ADDED THIS WEEK — KSJO, WABX, WLAV, WYFE, WGRQ, WAAL, KREM, KZEL, WLIR

HISTORY TO DATE — WYSP, WJKL, WIOQ, KTXQ, WQXM, KSHE, WBAB, KKTX, WMMS, KZEL, WZMF, C-101, WLVQ

FM Station Reports — New ADDS/Hot Rotation

WRCN-FM — LONG ISLAND — CHUCK MACKIN
ADDS: Gene Cotton, Jethro Tull, Ace Frehley, Queen (45)
HOTS: Ambrosia, Boston, Chicago, Firefall, Fogelberg/Weisberg, Foreigner, Hall & Oates, Heart, Billy Joel, Kenny Loggins, Rolling Stones, Linda Ronstadt, Al Stewart, Styx, Gino Vannelli, Who, Yes, Neil Young

KMET-FM — LOS ANGELES — JACK SNYDER
ADDS: George Thorogood, Kansas, Aerosmith, Outlaws, Steely Dan, Black Sabbath, Queen (45)
HOTS: Who, Rolling Stones, Foreigner, Aerosmith, Ted Nugent, Boston, Heart, Cars, Bob Seger, Molly Hatchet

KNX-FM — LOS ANGELES — MICHAEL SHEEHY
ADDS: Pointer Sister, Chris Rea (45), Rita Coolidge (45)
HOTS: Nicolette Larson, Richard Torrance, Linda Ronstadt, Elton John, Kiki Dee, Phoebe Snow, Al Stewart, Ian Matthews, Firefall, 10cc, Billy Joel, Fogelberg/Weisberg, Van Morrison, Toto, Cliff Richard, Santana, Al Jarreau

KWST-FM — LOS ANGELES — PAM MAY
ADDS: Greg Kihn, 1994, Pat Travers, Nicolette Larson, Kansas, Aerosmith, Outlaws, Eric Clapton, Robert Johnson (45)
HOTS: Neil Young, Chicago, Linda Ronstadt, Billy Joel, Who, Styx, Yes, Al Stewart

WNOE-FM — NEW ORLEANS — CAPT. HUMBLE
ADDS: Funkadelic, John Handy, Billy Joel (new), Steely Dan
HOTS: Gino Vannelli, Billy Joel (old), Bobby Caldwell, Bros. Johnson

WRNO-FM — NEW ORLEANS — SAM ROBERTS
ADDS: Dr. John, Billy Joel, Nicolette Larson, Ace Frehley, Wishbone Ash, Toto, Queen (45), Baby Grand
HOTS: Rollings Stones, Gerry Rafferty, Chicago, Santana, Lynyrd Skynyrd, Foreigner, Al Stewart, Fogelberg/Weisberg, Gino Vannelli, Ambrosia, Elton John, Tom Petty, Firefall, Styx, Linda Ronstadt

WNOR-FM — NORFOLK — RON REGER
ADDS: Nicolette Larson, Toto, Jimmy Buffett, Aerosmith, Joan Armatrading
HOTS: Kenny Loggins, Little River Band, Foreigner, Boston, Rolling Stones, Fogelberg/Weisberg, Linda Ronstadt, Firefall, Billy Joel, L. LeRoux, Neil Young, Heart, Lynyrd Skynyrd

ZETA-7 — ORLANDO — GARY BROWN
ADDS: Bandit, Outlaws, Cindy Bullens, Shawn Phillips, Wishbone Ash, Fotomaker, Aerosmith, Neil Larson, Tom Scott, Peter Tosh (45), Lindisfarne, Steve Martin
HOTS: Jimmy Buffett, Styx, Yes, Firefall, Jethro Tull, Santana, Stephen Stills, Billy Joel, 10cc, Heart, Van Morrison, Neil Young, Boston, Foreigner, Who, Rolling Stones, Molly Hatchet

WIOQ-FM — PHILADELPHIA — HELEN LEICHT
ADDS: Steve Forbert, Outlaws, Peter Criss, Starz, Fotomaker, Steely Dan, Kansas, Cheap Trick (radio edit), Robert Johnson (45)
HOTS: Billy Joel, Rolling Stones, Al Stewart, Heart, Neil Young, Foreigner, Boston, Blondie, Bryan Ferry, David Bowie, Stephen Stills, Joan Armatrading, Baby Grand, Bliss Band, 1994, Trevor Rabin, Styx, Van Morrison, Linda Ronstadt

WYSP-FM — PHILADELPHIA — STEPHEN JOHNSON
ADDS: Kansas, Pointer Sisters, Blondie, Bandit, Cindy Bullens, Steely Dan, Robert Johnson (45)
HOTS: Foreigner, Boston, Who, Styx, Pablo Cruise, Yes, Linda Ronstadt, Al Stewart, Chicago, Billy Joel, Elton John

WYDD-FM — PITTSBURG — STEVE DOWNES/JACK ROBINSON
ADDS: Outlaws, Pat Travers, Nicolette Larson, Cheap Trick (radio edit), Robert Johnson (45)
HOTS: Styx, Foreigner, Who, Chicago, Al Stewart, Linda Ronstadt, Kenny Loggins, Neil Young, Yes, Billy Joel, Fogelberg/Weisberg, Boston, Gino Vannelli, Heart, Ambrosia, Firefall, Toto

KINK-FM — PORTLAND — LESLIE SARNOFF
ADDS: Tom Scott, Steely Dan, Eric Clapton, Livingston Taylor (45)
HOTS: Al Stewart, Elton John, Linda Ronstadt, Billy Joel, Chuck Mangione, Toto, "War of the Worlds," Neil Young, Joan Armatrading, Ian Matthews, Jimmy Buffet, Nicolette Larson, Van Morrison, Sea Level, Mark-Almond, Heart, Stephen Stills, Geover Washington Jr., Richard Wright, Gino Vannelli, Pat Metheny, Dr. John, Neil Larson

WYFE-FM — ROCKFORD — ARMAND CHIANTI/BRAD HOFFMAN
ADDS: Kansas, Cheap Trick (radio edit), Rush, Outlaws, Steely Dan, Richard Wright, Ronnie Laws, Fotomaker, Lindisfarne, Tanya Tucker
HOTS: Jethro Tull, Neil Young, Who, Boston, Linda Ronstadt, Van Morrison, Al Stewart, Billy Joel, Fogelberg/Weisberg, Styx, Heart, Chicago, Gino Vannelli, Firefall, Hall & Oates, 10cc, Jimmy Buffett, Yes, Santana, Ted Nugent

KADI-FM — ST. LOUIS — PETER PARISI
ADDS: Paul Korda, Linda Ronstadt, Starz, Bandit, Outlaws, Nicolette Larson, Steely Dan
HOTS: Toto, Styx, Billy Joel, Fogelberg/Weisberg, 10cc, Ambrosia, Kenny Loggins, Firefall

KSHE-FM — ST. LOUIS — TED HABECK
ADDS: Aerosmith, Starz, Southside Johnny, Cindy Bullens, Queen (45), Alice Cooper (45)
HOTS: Boston, Yes, Who, Billy Joel, Golden Earring, Toto, Ted Nugent, Trevor Rabin, Robin Trower, Styx, Rush, David Coverdale, Trooper, Rolling Stones

KMEL-FM — SAN FRANCISCO — MARK COOPER
ADDS: Sea Level, Steve Martin, Alice Cooper (45), Justin Hayward (45)
HOTS: Who, Al Stewart, Linda Ronstadt, Van Morrison, Styx, Chicago, Neil Young, Yes, Hall & Oates, Toto, Firefall, 10cc, Heart, Player, Lynyrd Skynyrd

KSAN-FM — SAN FRANCISCO — KATE INGRAM
ADDS: Aerosmith, Firefall, Waylon Jennings, Billy Joel, Outlaws, Carl Perkins, Terry Reid, Phoebe Snow, Steely Dan, Tanya Tucker
HOTS: Joan Armatrading, Blondie, David Bowie, Cars, Cheap Trick, Devo, Dave Edmunds, Bryan Ferry, Hall & Oates, Greg Kihn, Van Morrison, Tom Petty, Ramones, Rolling Stones, Linda Ronstadt, Southside Johnny, 10cc, Who, Neil Young

KOME-FM — SAN JOSE — DANA JANG
ADDS: Outlaws, Aerosmith, Jimmy Buffett, Brand X, Happy The Man, Levon Helm, Elton John, George Thorogood
HOTS: Ambrosia, Blue Oyster Cult, Boston, Cars, Chicago, Fogelberg/Weisberg, Foreigner, Hall & Oates, Heart, Kenny Loggins, Van Morrison, Rolling Stone, Linda Ronstadt, Santana, Al Stewart, Styx, Talking Heads, Who, Yes, Neil Young

KSJO-FM — SAN JOSE — PAUL WELLS
ADDS: Rush, Dire Straits, Kansas, Spirit, FM, Cheap Trick (radio edit), Ian Gomm (imp), Fortune, Tanya Tucker, Joan Armatrading, Cindy Bullens, Lenny White, Fresh, Richard Torrance, Aerosmith, Blend, Axis, Outlaws, Paul Kossoff, Elvis Costello (imp 45), Robert Johnson (45)
HOTS: Santana, Ted Nugent, Dave Edmunds, Ramones, Hall & Oates, David Bowie, Heart, Pat Travers, Who, Lynyrd Skynyrd, Dyan Diamond, Styx, Yes, Bryan Ferry, Rory Gallagher, Jethro Tull, Blue Oyster Cult, Boston

KZAM-FM — SEATTLE — JON KERTZER
ADDS: Heath Bros., Dollar Brand, Pointer Sisters, Guy Clark, Dire Straits, Outlaws, George Thorogood, Lindisfarne, Richard Torrance, Kate & Anna McGarrigle, Cliff Richard, Gail Davies, Monty Alexander Seven, Poco, Jules & Polar Bears
HOTS: Billy Joel, Van Morrison, Al Stewart, Valerie, Carter, Neil Young, Bruce, Cockbutn, Bim, Linda Ronstadt, Fogelberg/Weisberg, Elton John, Janis Ian, Heart, Laura Nyro, Third World, Eric Clapton (45)

KREM-FM — SPOKANE — LARRY SNIDER
ADDS: Terry Reid, Levon Helm, Steely Dan, Rush, Ted Nugent, Grover Washington Jr., Weather Report, Starbuck, Caldera, Eric Clapton (45), Lindisfarne (45), Genesis (45)
HOTS: Foreigner, Styx, Boston, Who, Al Stewart, Santana, Neil Young, Firefall, Chicago, Linda Ronstadt, Fogelberg/Weisberg, Heart, Billy Joel, Van Morrison, Steely Dan

WQXM-FM — TAMPA — NEAL MIRSKY
ADDS: Ace Frehley, Steely Dan, Aerosmith, Outlaws, Kansas, David Bowie, Hall & Oates, Queen (45)
HOTS: Linda Ronstadt, Billy Joel, Foreigner, Kenny Loggins, Fogelberg/Weisberg, Jimmy Buffett, Rolling Stones, Styx, Firefall

WOUR-FM — UTICA — TOM STARR
ADDS: Ted Nugent, Jerry Kelly, Stillwater, Steve Forbert, Aerosmith, Cindy Bullens, Lindisfarne, Robert Johnson (45)
HOTS: Neil Young, George Thorogood, Billy Joel, Bruce Springsteen, Jethro Tull, Styx, Ambrosia, Dave Edmunds, Van Morrison, Ian Matthews, Firefall

WHFS-FM — WASHINGTON — DAVE EINSTEIN
ADDS: Outlaws, Cindy Bullens, Capt. Beefheart, Stillwater, Jimmy Buffett, Tracy Nelson, Matrix, Pointer Sisters, Tanya Tucker, Guy Clark, Bobby David
HOTS: Santana, Tom Waits, Dave Edmunds, Levon Helm, Van Morrison, Weather Report, George Thorogood, Neil Larson, Sea Level, Joan Armatrading, Terry Reid, Steve Forbert, Dr. John, Carl Perkins, Southside Johnny, "Woodstock Mtn. Revue", Gordon Payne, James Montgomery, Bryan Ferry, Nicolette Larson

WAAF-FM — WORCESTER — JOHN DUNCAN
ADDS: Bandit, Bliss Band, Cindy Bullens, Southside Johnny
HOTS: Boston, Fogelberg/Weisberg, Billy Joel, Kenny Loggins, Linda Ronstadt, Steely Dan, Al Stewart, Styx, Who

Nicolette Larson has sung
for Neil Young, Emmylou

Harris and Jesse Winchester.

And now she's singing for you.

Apparently, that's just fine

with stations up and down the

FM dial, from Boston to

Atlanta, Charlotte to Detroit

to San Francisco.

That's an unusual amount of
attention for a debut album to

generate. But then, this is

not an ordinary debut album.

This is *Nicolette*.

Nicolette/Nicolette Larson

Produced by Ted Templeman

On Warner Bros. records & tapes

Personal management:

Eddie Tickner Management

 (BSK 3243)



TOP FM ROTATION

	LW	WKS	TITLE	ARTIST	LABEL	TOP 200 POP	PRIME CUTS
1	1	6	Living In The U.S.A.	Linda Ronstadt	Asylum	2	Just One Look, Old To Dream, Alison, Ooh Baby, Title
2	4	3	52nd Street	Billy Joel	Columbia	4*	Big Shot, My Life, Title
3	3	7	Pieces Of Eight	Styx	A&M	7	White Hope, Message, Blue Collar, Title
4	2	7	Time Passages	Al Stewart	Arista	14*	Valentina, All Seasons, Timeless, Title
5	5	11	Who Are You	The Who	MCA	10	Sister Disco, New Song, Music Must, Guitar, 905, Title
6	7	11	Don't Look Back	Boston	Epic	6	Man I'll Never Be, Satisfied, Title
7	6	10	Twin Sons . . .	Fogelberg/Weisberg	Epic	12	Lazy Susan, Alley, Nocturne, Gold, Tell Me
8	8	7	Dog & Butterfly	Heart	Portrait	9	Cook, Hi Jinx, Straight On, Title, Mistral Wind
9	9	5	Comes A Time	Neil Young	Reprise	17*	Goin Back, Look Out, Human, Motorcycle
10	12	2	Elan	Firefall	Atlantic	63*	Strange Way, Get You Back, Winds Of Change
11	10	5	Wavelength	Van Morrison	WB	42*	Natalia, Santa Fe, Title, Checkin'
12	15	20	Double Vision	Foreigner	Atlantic	5*	Hot Blooded, Title, Blue Day, Children
13	14	22	Some Girls	The Rolling Stones	Rolling Stones	8	Miss You, Respectable, Beast, Whip, Shattered
14	11	5	Hot Streets	Chicago	Columbia	11*	Alive, No Tell Lover, Love Was New, Title
15	13	5	Tormato	Yes	Atlantic	13	Future Times, Onward, Circus
16	22	5	Brother To Brother	Gino Vannelli	A&M	20*	I Just Wanna Stop, River Must Flow, Evil Eye, Title
17	20	12	Life Beyond L.A.	Ambrosia	WB	31*	How Much I Feel, Title
18	18	3	Inner Secrets	Santana	Columbia	54*	Dealer, Well All Right, Stormy, Wham!, Move On
19	16	17	Nightwatch	Kenny Loggins	Columbia	18	"Friend," Easy Driver, Angelique, Title
20	17	3	A Single Man	Elton John	MCA	30*	Shine On, I Don't Care, Madness, Song For Guy, Part-Time Love
21	19	22	The Cars	The Cars	Elektra	50	All I've Got, Bye Love, Stereo, Mixed Up, Best Friend's
22	23	5	Bloody Tourists	10cc	Polydor	64*	Dreadlock, Mr. Time, Shock, Tokyo, Reds
23	21	9	Along The Red Ledge	Hall & Oates	RCA	25	It's A Laugh, Serious Music, Melody, Don't Blame
24	—	1	Toto	Toto	Columbia	133*	Hold The Line
25	—	1	Weekend Warriors	Ted Nugent	Epic	69*	Need You Bad, Title
26	27	5	Live Bursting Out	Jethro Tull	Chrysalis	28*	Lullaby, Skating, Hunting, Minstrel, Aqualung
27	29	25	Stranger In Town	Bob Seger	Capitol	19	Hollywood, Number, Final Scene, We've Got Tonight
28	26	3	Hearts Of Stone	Southside Johnny	Epic	169	Better Way Home, Talk To Me, Trapped, Title
29	—	1	Tracks On Wax 4	Dave Edmunds	Swan Song	199	Trouble Boys, Television
30	24	3	Thoroughfare Gap	Stephen Stills	Columbia	—	Dance Alone, Beaucoup, Fade Away, Booty, Title

FM Station Reports — New ADDS/Hot Rotation

KRST-FM — ALBUQUERQUE — BOB SHULMAN

ADDS: Aerosmith, Jimmy Buffett, Joan Armatrading, Pointer Sisters, Cindy Bullens, Bobby David, Stillwater, Shelter, Caldera, Fotomaker, FM, Gypsy, Ronnie Laws, Spirit
HOTS: Linda Ronstadt, Lynyrd Skynyrd, Fogelberg/Weisberg, 1994, Toto, Styx, Boston, Who, Neil Young, Firefall, Gino Vannelli

WSAN-FM — ALLENTOWN — RICK HARVEY

ADDS: Outlaws, Steeleye Span, Johnny's Dance Band, Ronnie Laws, Steely Dan, Elton John (45)
HOTS: Gino Vannelli, 10cc, City Boy, Styx, Firefall, Chicago, Al Stewart, Linda Ronstadt, Phoebe Snow, Fogelberg/Weisberg

KYTX-FM — AMARILLO — MAX MILLER

ADDS: 10cc, Aerosmith, Crawler, Mark-Almond
HOTS: Who, Rolling Stones, Boston, Firefall, Neil Young, Heart, Linda Ronstadt, Player, Styx, Al Stewart, Billy Joel, Eric Clapton (45), Van Morrison

KEZY-FM — ANAHEIM — LARRY REISMAN

ADDS: Aerosmith, Eric Clapton, Kansas, Queen (45)
HOTS: Kenny Loggins, Rolling Stones, Toto, Linda Ronstadt, Foreigner, Who, Chicago, Fogelberg/Weisberg, Al Stewart, Heart, Styx, Van Morrison, Ambrosia

WKLS-FM — ATLANTA

ADDS: Joan Armatrading, Jimmy Buffett, Steely Dan (45)
HOTS: Rolling Stones, Who, Boston, Foreigner, Firefall, Linda Ronstadt, Heart, Kenny Loggins, Gino Vannelli, Fogelberg/Weisberg

WAAL-FM — BINGHAMTON — SCOTT MICHAELS

ADDS: Outlaws, Poco, Joan Armatrading, Rush, Aerosmith, Fotomaker, Jimmy Buffett, Tanya Tucker, Queen (45)
HOTS: Heart, Billy Joel, Chicago, Styx, Neil Young, Firefall, Al Stewart, Fogelberg/Weisberg, Elton John, Linda Ronstadt, Van Morrison, Queen (45), Eric Clapton (45)

WBCN-FM — BOSTON — TONY BERARDINI

ADDS: Tanya Tucker, Terry Reid, Jimmy Buffett, Aerosmith, Richard T. Bear, Dane Donohue, Fotomaker, Starz
HOTS: James Montgomery, Southside Johnny, Cars, Devo, "Kiss", Van Morrison, Aerosmith, Billy Joel, Rolling Stones, Shirts

WGRQ-FM — BUFFALO — JOHN VELCHOFF

ADDS: Rush, Eric Clapton, Toto, Steve Martin, Steely Dan, Aerosmith, Queen (45)
HOTS: Billy Joel, Foreigner, Ace Frehley, Al Stewart, Gino Vannelli, Bob Seger, Rolling Stones, Fogelberg/Weisberg, Linda Ronstadt, Styx, Ted Nugent, Chicago, "Nat'l Lampoon", Heart, Pablo Cruise, Boston, Cars, Firefall, Ambrosia, Alan Parsons

WJKL-FM — CHICAGO — TOM MARKER/WALLY LEISERING

ADDS: Patrice Rushen, Ducks Deluxe, Paul Brett, Shawn Phillips, Bandit, Martin Bogen & The Armstrongs, Cheap Trick (radio edit), Tracy Nelson, Outlaws, Firefall, Aerosmith
HOTS: Joan Armatrading, Southside Johnny, Dave Edmunds, Van Morrison, Cars, Levon Helm, Third World, Santana, Genya Ravan, Ouray, Dr. John, Billy Joel, Waylon Jennings, George Thorogood, Mark-Almond, Fogelberg/Weisberg, David Sancious, Walter Horton, Jean-Luc Ponty, Jeff Lorber Fusion

WXRT-FM — CHICAGO — BOB GELMS

ADDS: Steve Martin, Joan Armatrading, Aerosmith, Tina Turner, Baby Grand, Chieftains, Queen (45)
HOTS: Van Morrison, Billy Joel, Neil Young, Linda Ronstadt, Tom Waits, 10cc, Al Stewart, Yes, Peter Gabriel, Jethro Tull, Rolling Stones, Gino Vannelli, Devo, Bryan Ferry, Elton John

WMMS-FM — CLEVELAND — KID LEO/JOHN GORMAN

ADDS: Tanya Tucker, Devo, Starz, Outlaws, Reggie Knighton, Kinzman Dazz, Jimmy Buffett
HOTS: Linda Ronstadt, Billy Joel, Cars, Neil Young, Al Stewart, Heart, Boston, Who, Yes, Styx, Foreigner, Toto, Blue Oyster Cult, Southside Johnny, Player

WLVO-FM — COLUMBUS — TOM TEUBER/STEVE RUNNER

ADDS: Aerosmith, Jimmy Buffett, Kansas, Eric Clapton, Gene Cotton, Queen (45)
HOTS: Styx, Kenny Loggins, Who, Boston, Foreigner, Fogelberg/Weisberg, Linda Ronstadt, Billy Joel, Rush, Ted Nugent, Neil Young, Yes, Heart, Cars, Al Stewart, Gino Vannelli

C-101-FM — CORPUS CHRISTI — MANDO CAMINA

ADDS: Joan Armatrading, Jimmy Buffett, Aerosmith, Bandit, Mark-Almond
HOTS: Linda Ronstadt, Yes, Al Stewart, Billy Joel, Styx, Bob Seger, Boston, Chicago, Firefall, Foreigner, Rush, Santana, Who, Elton John, Gino Vannelli, Fogelberg/Weisberg

KTXQ-FM — DALLAS — TIM SPENCER

ADDS: Eric Clapton, Kansas, Nicolette Larson, Shawn Phillips
HOTS: Toto, Billy Joel, Al Stewart, Eric Clapton, Firefall, Linda Ronstadt, Tom Petty, Ambrosia, Hall & Oates, Foreigner, Styx, Heart, Neil Young, Fogelberg/Weisberg, Santana, Aerosmith

KZEW-FM — DALLAS — MARK CHRISTOPHER

ADDS: Fotomaker, Starz, Pointer Sisters, Cindy Bullens, Poco, Tanya Tucker, Bliss Band, Dave Edmunds, Network, Kansas, Arlyn Gale, Ted Nugent, Queen (45), Robert Johnson (45)
HOTS: 1994, Hall & Oates, Chicago, Elton John, Billy Joel, Heart, Gino Vannelli, Van Morrison, Linda Ronstadt, Bob Seger

KBPI-FM — DENVER — JOHN BRADLEY

ADDS: Toto
HOTS: Linda Ronstadt, Firefall, Who, Chicago, Kenny Loggins
KFML-AM — DENVER — LARRY BRUCE/KEN KOHL

ADDS: Steve Martin

HOTS: Fogelberg/Weisberg, Billy Joel, Van Morrison, Al Stewart, Eric Clapton (45), Ambrosia, Firefall, Bob Seger, 10cc, Linda Ronstadt

WABX-FM — DETROIT — JOE KRAUSE

ADDS: Steely Dan, Rush, Kansas, Triumph, Cindy Bullens, Southside Johnny, Queen (45)
HOTS: Cars, Rolling Stones, Billy Joel, Ted Nugent, Styx, Chicago, Foreigner, Kenny Loggins, Boston, Who

KZEL-FM — EUGENE — STAN GARRETT

ADDS: Southside Johnny, Rory Gallagher, George Thorogood, Wishbone Ash, Rush, Chaka Khan, Nicolette Larson, Steve Forbert, Joan Armatrading, Eric Clapton
HOTS: Neil Young, Fogelberg/Weisberg, Boston, Ted Nugent, Santana, Norton Buffalo, Cars, Al Stewart, Billy Joel, Jethro Tull, Linda Ronstadt, Chuck Mangione

WLAV-FM — GRAND RAPIDS — DOC DONOVAN

ADDS: Bliss Band, Ace Frehley, Joan Armatrading, Kansas, Jack Tempchin, Aerosmith, Rush, Spirit, April Wine, Al Stewart (45), Hall & Oates (45), Firefall (45), Queen (45), Fotomaker (45)
HOTS: Styx, Boston, Who, Foreigner, Steve Martin, Rolling Stones, Kenny Loggins, Heart, Fogelberg/Weisberg, Yes, Linda Ronstadt, Billy Joel, Gino Vannelli, Ted Nugent, Ambrosia

WCCC-FM — HARTFORD — BILL NOSAL

ADDS: Tanya Tucker, Nicolette Larson, Ducks Deluxe, Aerosmith, Pointer Sisters, Joan Armatrading, Steely Dan, Kansas, Outlaws
HOTS: Linda Ronstadt, Who, Boston, Billy Joel, Al Stewart, Fogelberg/Weisberg, Foreigner, Kenny Loggins, Ambrosia, Chicago, Styx, Heart, Van Morrison, Firefall, Neil Young, Elton John, Hall & Oates, 10cc

KWKI-FM — KANSAS CITY — JIM ZEINER

ADDS: Starz, Outlaws, Ted Nugent, Kansas, Fotomaker, Jim Capaldi
HOTS: April Wine

KKTX-FM — KILGORE — JIM HODO

ADDS: Aerosmith, Devo, Lindisfarne, Joan Armatrading, Pointer Sisters, Dire Straits, Southside Johnny, Fotomaker, Cindy Bullens, Steve Martin, Bandit
HOTS: Linda Ronstadt, Billy Joel, Who, Styx, Yes, Firefall, Elton John, Al Stewart, Neil Young, Boston, Heart, Santana, Van Morrison, Eric Clapton (45), Rolling Stones, Fogelberg/Weisberg

WBLM-FM — LEWISTON/PORTLAND — JOSE DIAZ

ADDS: Aerosmith, Kansas, Steely Dan, Starz, Son Seals, Bandit, James Montgomery, Cindy Bullens
HOTS: Blend, Heart, Van Morrison, Cars, Billy Joel, Linda Ronstadt, Chicago, Bruce Springsteen, Pablo Cruise, Bill Chinnock, Neil Young, Al Stewart, Boston, Who, Hall & Oates, Ambrosia, 10cc, Gerry Rafferty, Bob Seger, Foreigner

KNAC-FM — LONG BEACH — PAUL FUHR

ADDS: Kansas, Outlaws, Jimmy Buffett, George Thorogood, Cindy Bullens, Joan Armatrading, Gene Simmons, Ace Frehley, Queen (45), Jesse Colin Young (45), Robert Johnson (45)
HOTS: Chicago, Yes, Styx, Billy Joel, Who, Al Stewart, Ted Nugent, Linda Ronstadt, Heart, Boston

WBAB-FM — LONG ISLAND — BERNIE BERNARD

ADDS: Poco, Kansas, Outlaws, Aerosmith, Jerry Kelly, Hero, Lindisfarne, Neil Larson, Dire Straits, Tilt, Steely Dan, Fotomaker
HOTS: Who, Van Morrison, Billy Joel, 10cc, Elton John, Al Stewart, Chicago, Linda Ronstadt, Yes, Stephen Stills, Styx, Boston, Cars, Ambrosia, Rolling Stones, Foreigner, Bob Seger, Neil Young, Santana, Southside Johnny

WLIR-FM — LONG ISLAND — DENIS McNAMARA/LARRY KLEINMAN

ADDS: Crawler, Aerosmith, Fotomaker, Outlaws, Bandit, Lindisfarne, George Thorogood, Tanya Tucker, Bryan Ferry, Rush, Dodgers, Ted Nugent, Kiki Dee, Cindy Bullens, Starz, Richard T. Bear, Kansas, Poco, Wishbone Ash

HOTS: Billy Joel, Dave Edmunds, Outlaws, Stephen Stills, Rolling Stones, Elton John, Cars, "Rocky Horror Picture Show", Jethro Tull, Van Morrison

THE CASH BOX EDITORIAL

April 30, 1955

There can be little doubt that the economy of the United States is on the verge of one of its greatest eras of prosperity. And the effects of this bright future on the music and record fields will be spectacular . . . The social changes which have occurred in the United States in the last two decades have all tended in the direction of greater productivity, greater distribution of wealth and greater leisure for the majority of the population. These changes . . . can only affect the music and record business favorably.

January 24, 1964

The success of the Beatles in America could change the whole thinking of American record companies toward all British product. Until recently, the British sound didn't fare very well in the States . . . Now, however, everything seems to be coming up British . . . It's quite obvious that the belief that "the British sound is too square for American teenagers" has been broken. And if our guess is correct, we'll be seeing more releases from the Isles on a regular basis.

September 9, 1972

Along with the boom in black music has come the increasing importance of black radio. It has reached the point where many of these outlets are competing effectively for share-of-audience with their Top 40 counterparts . . . There is, however, a basic difference between the two . . . (Black) stations are generally operating on a less restrictive programming schedule, offering more time to not only the established recordings, but new entries . . . We believe this development is something Top 40 radio should be weighing with considerable thought.

October 7, 1978

New artists are the lifeblood of the music business. This hackneyed phrase is certainly valid, but the practical application of this philosophy is not being developed to its fullest potential . . . We believe that there is a way to increase exposure and sales of records by these unknown artists . . . We propose a sliding scale of suggested retail list prices to cover the various career stages that artists pass through . . . The basic concept is to make the struggling artist a more attractive purchase.

A Cash Box tradition!

helping the industry make sound business decisions

REGIONAL PROGRAMMING GUIDE

northeast

WTRY — ALBANY/TROY — CHRIS BAILEY, MD

1-1 — A. Murray. JUMPS: 30 To 25 — J. Cocker, 29 To 24 — A. Stewart, 24 To 20 — Styx, 23 To 19 — D. Ray, 21 To 16 — Hall & Oates, 17 To 13 — Dr. Hook, 16 To 11 — G. Vannelli, 13 To 9 — A. Bridges, 12 To 10 — Rolling Stones, 11 To 8 — Foreigner, 10 To 7 — C. Gayle, 6 To 4 — D. Summer, Ex To 29 — Pablo Cruise, Ex To 27 — Firefall, Ex To 26 — A. Gibb, Ex To 22 — Barbra/Neil. ADDS: E. John, Fogelberg/Weisberg, B. Joel, Toto.

WGUY — BANGOR — MARK LAWRENCE, MD

1-1 — Ambrosia. JUMPS: 29 To 26 — Firefall, 28 To 21 — Barbra/Neil, 27 To 23 — A. Gibb, 25 To 22 — Chicago, 24 To 20 — Fogelberg/Weisberg, 22 To 19 — G. Vannelli, 21 To 17 — A. Stewart, 19 To 16 — C. Gayle, 18 To 13 — Stonebolt, 17 To 14 — B. Manilow, 13 To 8 — Dr. Hook, 11 To 9 — Rolling Stones, 10 To 5 — Foreigner, Ex To 30 — Queen, Ex To 27 — B. Joel. ADDS: 15 — Captain & Tennille, Chic, J. Hayward, P. Stanley.

WRKO — BOSTON — RICH WOODWARD, MD

2-1 — A. Murray. JUMPS: 29 To 26 — B. Joel, 28 To 24 — Dr. Hook, 26 To 20 — D. Hartman, 20 To 17 — E. Carmen, 19 To 16 — Pablo Cruise, 17 To 14 — Ambrosia, 16 To 13 — Van Morrison, 12 To 9 — Captain & Tennille, 4 To 2 — A. Bridges, Ex To 30 — L. Taylor, Ex To 28 — A. Stewart, Ex To 27 — Barbra/Neil, Ex To 21 — Chic. ADDS: Firefall, Village People, E. Clapton.

F105 — BOSTON — CHARLIE FERNANDEZ, MD

2-1 — D. Summer. JUMPS: 29 To 26 — D. Ray, 27 To 19 — Barbra/Neil, 26 To 23 — Chicago, 23 To 10 — Cars, 21 To 16 — B. Manilow, 19 To 11 — Ambrosia, 17 To 14 — A. Stewart, 15 To 12 — Captain & Tennille, 7 To 4 — A. Bridges, Ex To 30 — Dr. Hook, Ex To 29 — Pablo Cruise, Ex To 28 — D. Hartman. ADDS: C. Gayle, B. Joel, Village People.

WKBW — BUFFALO — JON SUMMERS, MD

1-1 — B. Manilow. JUMPS: 30 To 23 — A. Frehley, 25 To 20 — A. Stewart, 21 To 14 — Heart, 20 To 10 — Barbra/Neil, 16 To 13 — Foreigner, 10 To 6 — G. Vannelli, 9 To 3 — Ambrosia, 5 To 2 — D. Summer, Ex To 30 — J. Cocker, Ex To 28 — Village People, Ex To 25 — B. Joel. ADDS: Queen, Toto, B. Seger, Fogelberg/Weisberg.

WDRG — HARTFORD — JIM ENGLISH, MD

1-1 — A. Murray. JUMPS: 30 To 27 — Sylvester, 29 To 26 — G. Vannelli, 28 To 24 — C. Gayle, 27 To 22 — Dr. Hook, 23 To 20 — A. Bridges, 22 To 19 — A. Stewart, 19 To 14 — Hall & Oates, 13 To 10 — Rolling Stones, 12 To 8 — L. Ronstadt, Ex To 30 — E. Carmen, Ex To 29 — Chicago, Ex To 28 — Barbra/Neil. ADDS: A. Gibb, Firefall, Chic.

WAVZ — NEW HAVEN — CURT HANSEN, MD

1-1 — Ambrosia. JUMPS: 34 To 21 — Chic, 33 To 26 — Village People, 27 To 14 — Switch, 25 To 17 — Foreigner, 24 To 18 — G. Vannelli, 23 To 16 — Chicago, 21 To 10 — Musique, 20 To 15 — A. Stewart, 17 To 6 — Dr. Hook, 14 To 5 — B. Joel, 12 To 7 — Rolling Stones, Ex To 23 — B. White. ADDS: 32 — Queen, 31 — Rolling Stones, 30 — Barbra/Neil.

WABC — NEW YORK — SONIA JONES, MD

2-1 — A. Murray. JUMPS: 31 To 25 — G. Vannelli, 24 To 12 — B. Manilow, 19 To 16 — Ambrosia, 14 To 8 — Captain & Tennille, 4 To 2 — D. Summer. ADDS: 24 — A. Bridges, 6 — Exile.

99X — NEW YORK — BOBBY RICH, PD

2-1 — D. Summer. JUMPS: 29 To 23 — Barbra/Neil, 25 To 18 — D. Hartman, 23 To 20 — A. Bridges, 21 To 17 — Rolling Stones, 18 To 15 — Ambrosia, 17 To 11 — A. Frehley, 14 To 7 — B. Manilow, 13 To 9 — Rolling Stones, 7 To 5 — A. Murray, Ex To 30 — Dr. Hook, Ex To 29 — L. Ronstadt.

WFIL — PHILADELPHIA — GARY DE FRANCISCO, MD

1-1 — LRB. JUMPS: 24 To 21 — G. Vannelli, 23 To 20 — K. Rogers, 21 To 18 — B. Joel, 20 To 17 — P. Davis, 16 To 11 — Barbra/Neil, 14 To 9 — D. Summer, 9 To 7 — E. Carmen, Ex To 25 — A. Cooper, Ex To 24 — Chicago, Ex To 23 — A. Gibb. ADDS: S. Bishop, A. Bridges.

WIFI — PHILADELPHIA — JEFF ROBBINS, MD

1-1 — D. Summer. JUMPS: 30 To 16 — Barbra/Neil, 28 To 24 — Captain & Tennille, 25 To 21 — Sylvester, 24 To 20 — A. Gibb, 22 To 15 — Chicago, 21 To 17 — A. Bridges, 19 To 14 — Pablo Cruise, 18 To 9 — Ambrosia, 16 To 11 — Player, 11 To 7 — Foreigner, Ex To 30 — J. Cocker, Ex To 29 — A. Stewart, Ex To 27 — B. Joel, Ex To 18 — G. Vannelli. ADDS: Musique, Fogelberg/Weisberg, D. Hartman, A. Frehley.

WPRO-FM — PROVIDENCE — ALAN EDWARDS, MD

1-1 — D. Summer. JUMPS: 29 To 26 — L. Ronstadt, 28 To 21 — Styx, 27 To 22 — A. Cooper, 26 To 20 — D. Hartman, 25 To 19 — Barbra/Neil, 24 To 18 — P. Davis, 22 To 17 — A. Gibb, 20 To 15 — Dr. Hook, 19 To 16 — Captain & Tennille, 7 To 5 — K. Loggins, 6 To 4 — Foreigner, 5 To 2 — Ambrosia, Ex To 27 — Fogelberg/Weisberg, Ex To 25 — B. Joel, Ex To 24 — E. John, Ex To 23 — Meat Loaf. ADDS: Chic, Toto, Pablo Cruise.

WBBF — ROCHESTER — TOM NAST, MD

2-1 — G. Rafferty. JUMPS: 33 To 27 — A. Stewart, 31 To 25 — Steely Dan, 27 To 24 — Flyer, 20 To 12 — Chicago, 19 To 11 — Dr. Hook, 17 To 10 — Pablo Cruise, 15 To 9 — D. Summer, 11 To 7 — Foreigner, 6 To 2 — Ambrosia, Ex To 35 — L. Garrett, Ex To 32 — Firefall, Ex To 30 — Barbra/Neil. ADDS: A. Gibb, B. Joel, Toto, M. Manchester, Lindisfarne, Renaissance.

WTLB — UTICA — JIM REITZ, MD

2-1 — D. Summer. JUMPS: 30 To 27 — Chicago, 29 To 25 — A. Stewart, 27 To 18 — Sylvester, 25 To 22 — Player, 23 To 17 — Dr. Hook, 20 To 13 — G. Vannelli, 19 To 15 — D. Ray, 17 To 14 — Hall & Oates, 16 To 12 — Pablo Cruise, 11 To 6 — Foreigner, 9 To 7 — B. Manilow, 4 To 2 — Ambrosia, Ex To 29 — A. Gibb, Ex To 28 — Village People, Ex To 26 — Barbra/Neil. ADDS: B. Joel, Boston, E. John.

southeast

WANS — ANDERSON — BILL McCOWN, MD

1-1 — D. Summer. JUMPS: 34 To 29 — J. Cocker, 33 To 25 — Toto, 32 To 24 — Chic, 30 To 27 — E. Clapton, 29 To 23 — 10cc — 26 To 20 — Fogelberg/Weisberg, 24 To 19 — Ace, 23 To 18 — Chaka Khan, 20 To 15 — Chicago, 19 To 14 — Firefall, 16 To 12 — G. Cotton, 14 To 10 — A. Stewart, 13 To 9 — Styx, 10 To 7 — Funkadelic, 8 To 5 — G. Vannelli, 7 To 3 — Dr. Hook, 4 To 2 — Foreigner, Ex To 33 — Gypsy, Ex To 32 — E. John, Ex To 31 — Barbra/Neil. ADDS: B. Joel, Hot Chocolate, A. Cooper, Queen.

WAGQ — ATHENS — BRADY MCGRAW, MD

4-1 — D. Summer. JUMPS: 30 To 27 — Barbra/Neil, 29 To 21 — 10cc, 23 To 17 — A. Gibb, 18 To 15 — A. Stewart, 17 To 14 — E. Clapton, 16 To 5 — Funkadelic, 14 To 11 — Pablo Cruise, 10 To 7 — D. Hook, 7 To 4 — Ambrosia, Ex To 30 — Funkadelic, 14 To 11 — Pablo Cruise, 10 To 7 — Dr. Hook, 7 To 4 — Ambrosia, Ex To 30 — A. Cooper, Ex To 29 — E. John, Ex To 28 — Village People. ADDS: B. Joel, B. Seger, Chic, Sylvester.

Z-93 — ATLANTA — DALE O'BRIEN, MD

2-1 — Foreigner. JUMPS: 30 To 25 — E. Clapton, 29 To 21 — Chicago, 27 To 24 — Toto, 25 To 22 — C. Stanton, 24 To 10 — Barbra/Neil, 23 To 19 — B. Manilow, 21 To 12 — Heart, 20 To 16 — Hall & Oates, 12 To 8 — Firefall, Ex To 29 — B. Seger, Ex To 28 — B. Joel, Ex To 27 — L. Ronstadt. ADDS: 30 — E. Carmen, A. Gibb, J. Cocker, G. Campbell, D&M.

WQXI — ATLANTA — J.J. JACKSON, MD

1-1 — A. Murray. JUMPS: 30 To 27 — M. Manchester, 28 To 25 — A. Gibb, 27 To 23 — Firefall, 24 To 19 — Chicago, 22 To 14 — Barbra/Neil, 18 To 13 — B. Manilow, 15 To 12 — E. Carmen, 12 To 10 — Hall & Oates, Ex To 30 — E. Clapton, Ex To 29 — Fogelberg/Weisberg, Ex To 28 — Heart. ADDS: B. Joel, B. Seger, Village People.

WBBQ — AUGUSTA — BRUCE STEVENS, MD

3-1 — A. Bridges. JUMPS: 30 To 25 — Barbra/Neil, 29 To 26 — Styx, 27 To 19 — Firefall, 25 To 18 — Chicago, 21 To 13 — Toto, 19 To 15 — E. Carmen, Ex To 30 — E. John, Ex To 29 — E. Clapton, Ex To 28 — Heart. ADDS: Queen, Chic, A. Cooper, A. Frehley, N. Pointer, Hot Chocolate, L. Taylor.

WCAO — BALTIMORE — SCOTT RICHARDS, MD

1-1 — D. Summer. JUMPS: 30 To 26 — Chaka Khan, 29 To 25 — 10cc, 28 To 23 — E. Carmen, 27 To 24 — Toto, 26 To 22 — Chicago, 21 To 18 — A. Gibb, 20 To 17 — Heart, 19 To 16 — Pablo Cruise, 18 To 13 — G. Vannelli, 17 To 6 — Barbra/Neil, 16 To 12 — Sylvester, 13 To 10 — D. Hartman, 10 To 3 — Dr. Hook, Ex To 30 — J. Cocker, Ex To 29 — Fogelberg/Weisberg, Ex To 28 — B. Joel, Ex To 27 — A. Stewart.

WERC — BIRMINGHAM — WALT BROWN, MD

1-1 — Ambrosia. JUMPS: 28 To 25 — L. Ronstadt, 27 To 24 — A. Cooper, 26 To 17 — E. John, 24 To 21 — A. Gibb, 23 To 19 — Funkadelic, 21 To 18 — Village People, 19 To 12 — Barbra/Neil, 16 To 8 — G. Vannelli, 12 To 9 — Dr. Hook, 11 To 6 — Foreigner, 10 To 4 — Who, 9 To 7 — Captain & Tennille, 5 To 2 — A. Bridges, Ex To 28 — E. Clapton, Ex To 27 — B. Joel, Ex To 26 — J. Hayward. ADDS:

Fogelberg/Weisberg, B. Seger, J. Cocker, Queen.

WSGN — BIRMINGHAM — BILL THOMAS, MD

7-1 — Dr. Hook. JUMPS: 28 To 25 — Chicago, 25 To 15 — Barbra/Neil, 24 To 19 — C. Gayle, 23 To 16 — A. Gibb, 22 To 17 — Pablo Cruise, 18 To 14 — Firefall, 16 To 13 — Funkadelic, 13 To 9 — D. Summer, 11 To 8 — Captain & Tennille, 6 To 3 — A. Bridges, Ex To 30 — A. Cooper, Ex To 23 — B. Joel. ADDS: Sylvester, Fogelberg/Weisberg, L. Ronstadt, Village People.

WAYS — CHARLOTTE — SCOTT SLADE, PD/MD

1-1 — N. Gilder. JUMPS: 30 To 27 — Chicago, 28 To 25 — P. Davis, 26 To 22 — Fogelberg/Weisberg, 24 To 20 — A. Stewart, 21 To 11 — Barbra/Neil, 20 To 16 — Rolling Stones, 18 To 12 — Chic, 17 To 14 — G. Cotton, 12 To 9 — G. Vannelli, 11 To 7 — Foreigner, 4 To 2 — A. Murray, Ex To 30 — L. Ronstadt, Ex To 29 — R. James, Ex To 28 — Firefall, Ex To 26 — B. Seger. ADDS: Switch, A. Gibb, B. Joel, Village People.

WMFJ — DAYTONA BEACH — JOHN SCOTT, MD

1-1 — Dr. Hook. JUMPS: 44 To 39 — Switch, 43 To 36 — Fogelberg/Weisberg, 41 To 34 — E. Carmen, 39 To 33 — A. Gibb, 37 To 31 — J. Hayward, 36 To 30 — Toto, 33 To 28 — Who, 32 To 27 — E. Clapton, 31 To 25 — Chic, 30 To 22 — E. John, 29 To 24 — A. Frehley, 27 To 23 — Clout, 26 To 19 — Village People, 25 To 21 — D. Ray, 24 To 20 — L. Sayer, 23 To 7 — Ambrosia, 22 To 18 — B. Manilow, 21 To 16 — G. Cotton, 20 To 13 — Chicago, 17 To 14 — Lindisfarne, 12 To 10 — S. Bishop, 11 To 6 — Pablo Cruise, 10 To 8 — C. Gayle, Ex To 45 — P. Tosh, Ex To 44 — L. Taylor, Ex To 43 — L. Garrett, Ex To 42 — J. Cocker, Ex To 41 — B. Seger, Ex To 40 — Dennis, Ex To 29 — Barbra/Neil. ADDS: D. Hartman, C. King, A. Stewart, R. James, ELO, P. Stanley.

WJDX — JACKSON — DAVE KIMBRO, MD

1-1 — Exile. JUMPS: 30 To 9 — Barbra/Neil, 28 To 21 — A. Stewart, 27 To 24 — Village People, 23 To 17 — A. Gibb, 19 To 16 — Chicago, 15 To 10 — A. Bridges, 10 To 6 — G. Vannelli, 9 To 5 — Rolling Stones, 4 To 2 — B. Joel, Ex To 28 — A. Cooper. ADDS: Pablo Cruise, B. Joel, E. John.

WAPE — JACKSONVILLE — PAUL SEBASTIAN, MD

3-1 — A. Murray. JUMPS: 30 To 26 — Chaka Khan, 29 To 24 — Village People, 28 To 25 — R. James, 27 To 23 — D. Ray, 25 To 22 — Sylvester, 20 To 17 — Foreigner, 13 To 8 — Ambrosia, 9 To 7 — D. Summer, 8 To 6 — B. Manilow, Ex To 30 — A. Gibb, Ex To 29 — B. Seger, Ex To 28 — Barbra/Neil, Ex To 27 — Chicago. ADDS: D. Hartman, Chic, A. Cooper, Hot Chocolate.

WRJZ — KNOXVILLE — MARK THOMPSON, MD

1-1 — A. Bridges. JUMPS: 32 To 29 — E. Clapton, 31 To 18 — 10cc, 30 To 25 — Chicago, 29 To 22 — Toto, 28 To 24 — Pablo Cruise, 27 To 23 — Firefall, 26 To 19 — W. Egan, 24 To 21 — D. Hartman, 23 To 16 — Fogelberg/Weisberg, 18 To 12 — Foxy, 17 To 13 — A. Stewart, 15 To 8 — Dr. Hook, 8 To 4 — Captain & Tennille, 7 To 3 — D. Summer, Ex To 31 — J. Hayward, Ex To 27 — A. Gibb, Ex To 26 — Barbra/Neil. ADDS: J. Cocker, B. Joel, A. Cooper, E. John, L. Ronstadt.

WQPD — LAKELAND — JUDGE KRATER, PD

1-1 — D. Summer. JUMPS: 39 To 35 — Chicago, 37 To 33 — E. John, 26 To 23 — Firefall, 24 To 21 — E. Carmen, 23 To 20 — A. Frehley, 22 To 19 — Heart, 21 To 18 — S. Bishop, 9 To 7 — Foreigner, Ex To 40 — L. Garrett, Ex To 39 — Barbra/Neil, Ex To 38 — Cooper Brothers, Ex To 37 — Starbuck. ADDS: Lindisfarne, Moody Blues, B. Seger, C. Mangione.

Y-100 — MIAMI — COLEEN CASSIDY, MD

2-1 — A. Murray. JUMPS: 30 To 26 — P. Davis, 29 To 25 — B. Joel, 28 To 19 — Chic, 27 To 23 — Barbra/Neil, 25 To 22 — Meco, 22 To 18 — Rose Royce, 20 To 16 — Village People, 18 To 15 — B. Manilow, 17 To 13 — L. Garrett, 16 To 11 — Sylvester, 15 To 8 — Foreigner, 13 To 10 — K. Young, 9 To 6 — N. Gilder, 7 To 4 — Musique, Ex To 29 — D&M, Ex To 28 — P. Stanley. ADDS: 30 — Queen, 27 — G. Vannelli.

96X — MIAMI — LOU MEYER, MD

4-1 — Musique. JUMPS: 37 To 32 — Chicago, 36 To 31 — Dr. Hook, 35 To 29 — A. Stewart, 33 To 28 — D. Hartman, 31 To 26 — Goody, Goody, 30 To 27 — G. Vannelli, 29 To 22 — Captain & Tennille, 28 To 21 — Ambrosia, 26 To 23 — 10cc, 24 To 10 — Village People, 23 To 18 — A. Bridges, 22 To 13 — Chic, 20 To 14 — Foreigner, 17 To 6 — Sylvester, 7 To 4 — K. Young. ADDS: L. Ronstadt, Barbra/Neil, Pablo Cruise, Chanson.

WHYY — MONTGOMERY — RICH THOMAS, MD

1-1 — D. Summer. JUMPS: 30 To 21 — A. Stewart, 29 To 23 — Firefall, 28 To 20 — Chicago, 23 To 19 — E. Carmen, 21 To 15 — Hall & Oates, 20 To 17 — S. Bishop, 17 To 13 — Barbra/Neil, 16 To 9 — J. Hayward, 15 To 12 — Foreigner, 14 To 11 — Styx, 13 To 7 — B. Joel, 8 To 6 — Who, 7 To 2 — A. Bridges, Ex To 29 — Pablo Cruise, Ex To 27 — A. Gibb, Ex To 24 — C. Gayle, Ex To 22 — Funkadelic. ADDS: D. Hartman, Toto, Fogelberg/Weisberg, E. Clapton, Village People.

WLAC — NASHVILLE — EVA WOOD, MD

1-1 — A. Bridges. JUMPS: 39 To 36 — L. Ronstadt, 38 To 28 — D&M, 37 To 27 — Chicago, 35 To 32 — A. Gibb, 33 To 30 — G. Cotton, 30 To 23 — Sylvester, 29 To 22 — Firefall, 28 To 25 — Fogelberg/Weisberg, 22 To 19 — Styx, 21 To 18 — A. Stewart, 20 To 11 — Funkadelic, 17 To 14 — Ambrosia, 16 To 13 — G. Vannelli, 15 To 12 — Foreigner, 13 To 8 — Captain & Tennille, 9 To 7 — Dr. Hook, Ex To 33 — Barbra/Neil. ADDS: E. Clapton, Chaka Khan, J. Cocker, Village People, A. Cooper, C. Rea, Ian Matthews, Pointer Sisters.

BJ 105 — ORLANDO — TERRY LONG, MD

1-1 — N. Gilder. JUMPS: 40 To 34 — A. Gibb, 39 To 33 — G. Vannelli, 37 To 29 — Barbra/Neil, 36 To 30 — Chicago, 32 To 24 — Commodores, 31 To 26 — Pablo Cruise, 30 To 23 — Ambrosia, 28 To 19 — A. Bridges, 27 To 20 — W. Egan, 20 To 15 — Rolling Stones, 19 To 14 — Foreigner, 18 To 13 — Firefall, 15 To 9 — D. Summer, 13 To 10 — D. Gates, 12 To 8 — Who, 10 To 7 — St. Bishop, 8 To 6 — B. Seger, 7 To 2 — Dr. Hook. ADDS: 40 — Toto, 39 — Jacksons, 38 — Captain & Tennille, G. Campbell, P. Stanley, Matthew Moore.

WLEE — RICHMOND — KEN CURTIS, MD

9 To 1 — D. Summer. JUMPS: 27 To 11 — Barbra/Neil, 24 To 14 — D. Hook, 22 To 12 — Chaka Khan, 21 To 15 — A. Gibb, 16 To 10 — A. Bridges, 14 To 9 — Pablo Cruise, 12 To 8 — G. Vannelli, 11 To 7 — J.P. Young, 10 To 5 — Captain & Tennille, 7 To 4 — B. Manilow. ADDS: 30 — A. Cooper, 26 — E. John, 24 — Chicago.

WSGA — SAVANNAH — JIM LEWIS, MD

1-1 — Funkadelic. JUMPS: 30 To 26 — Firefall, 29 To 22 — Village People, 28 To 25 — A. Stewart, 23 To 19 — Prince, 22 To 16 — Barbra/Neil, 21 To 14 — A. Gibb, 20 To 17 — Chicago, 19 To 15 — Commodores, 17 To 12 — G. Vannelli, 16 To 11 — P. Davis, 13 To 6 — Dr. Hook, 12 To 8 — B. Joel, 10 To 7 — Ambrosia. ADDS: 30 — Fogelberg/Weisberg, 29 — L. Ronstadt, 28 — Chic, 27 — Pablo Cruise.

WPGC — WASHINGTON D.C. — JIM ELLIOT, MD

1-1 — D. Summer. JUMPS: 29 To 24 — B. Joel, 27 To 23 — Chicago, 25 To 16 — A. Gibb, 22 To 19 — D. Hartman, 18 To 15 — P. Davis, 16 To 13 — Sylvester, 13 To 8 — Dr. Hook, 8 To 6 — Barbra/Neil, 7 To 5 — A. Bridges, Ex To 30 — Heart, Ex To 28 — Pablo Cruise, Ex To 26 — Firefall. ADDS: Village People, Chic, E. Carmen, Chanson.

southwest

Z-97 — DALLAS — GARY MACK, PD

2-1 — LRB. JUMPS: 21 To 11 — C. Gayle, 11 To 7 — G. Rafferty, 7 To 2 — K. Loggins. ADDS: 23 — Heart, 21 — J.P. Young.

KLIF — DALLAS — STEVE SCOTT, MD

1-1 — K. Loggins. JUMPS: 36 To 32 — L. Ronstadt, 34 To 24 — Barbra/Neil, 32 To 29 — Player, 30 To 27 — Pablo Cruise, 27 To 22 — S. Bishop, 26 To 21 — Firefall, 23 To 18 — Dr. Hook, 21 To 15 — A. Stewart, 15 To 10 — Van Morrison, 12 To 8 — D. Summer, 11 To 7 — Ambrosia, Ex To 37 — R. Coolidge. ADDS: B. Joel, E. John, Toto.

KINT — EL PASO — JOHNNIE KAYE, MD

6-1 — D. Summer. JUMPS: 29 To 25 — Dr. Hook, 28 To 24 — G. Vannelli, 26 To 23 — Chicago, 25 To 22 — B. Joel, 24 To 20 — A. Bridges, 23 To 19 — Styx, 22 To 18 — B. Manilow, 20 To 17 — Who, 19 To 16 — P. Davis, 18 To 13 — Hall & Oates, 11 To 7 — D. Gates, 8 To 6 — Ambrosia, Ex To 26 — Barbra/Neil. ADDS: Pablo Cruise, A. Gibb, Chic.

KILY — HOUSTON — BILL YOUNG, PD

1-1 — Foxy. JUMPS: 40 To 20 — Barbra/Neil, 34 To 25 — Foreigner, 33 To 28 — Ambrosia, 32 To 24 — A. Gibb, 30 To 16 — B. White, 24 To 21 — A. Bridges, 23 To 17 — Styx, 22 To 19 — Heart, 18 To 12 — J. Hayward, 12 To 7 — G. Vannelli, 7 To 4 — P. Davis. ADDS: 40 — J. Cocker, 39 — B. Seger, 38 — R. James, 36 — B. Joel, 34 — D. Williams, 31 — S. Bishop, Pointer Sisters, Boston, Queen, L. Ronstadt.

KRBE — HOUSTON — CLAY GISH, PD

1-1 — D. Summer. JUMPS: 40 To 36 — E. John, 39 To 35 — J. Cocker, 36 To 26 — A. Gibb, 35 To 32 — Firefall, 34 To 30 — Chicago, 33 To 29 — Talking Heads, 32 To 25 — Starbuck, 30 To 20 — Foreigner, 27 To 24 — Chaka Khan, 24 To 18 — Styx, 23 To 12 — J. Hayward, 22 To 17 — Ambrosia, 13 To 10 — B.

REGIONAL PROGRAMMING GUIDE

Manilow, 12 To 9 — G. Vannelli, 10 To 4 — Dr. Hook, 8 To 6 — Rolling Stones, 7 To 5 — Captain & Tennille, 6 To 3 — P. Davis, 4 To 2 — N. Gilder, Ex To 39 — A. Fehley, Ex To 37 — B. Seger. ADDS: 40 — B. Joel, 28 — Funkadelic, 21 — Barbra/Neil, L., Ronstadt, N. Gilder.

WBHQ — MEMPHIS — HARRIETT LAPIDES, MD

1-1 — Funkadelic. JUMPS: 24 To 17 — G. Vannelli, 23 To 20 — Foreigner, 21 To 18 — Chaka Khan, 16 To 5 — L. Sayer, 13 To 7 — Ambrosia, 10 To 8 — D. Summer, Ex To 28 — A. Gibb, Ex To 27 — L. Ronstadt, Ex To 25 — Barbra/Neil. ADDS: A. Stewart, Firefall.

WTIX — NEW ORLEANS — TERRY YOUNG, MD

4-1 — D. Summer. JUMPS: 40 To 33 — Chaka Khan, 39 To 32 — Switch, 36 To 29 — A. Gibb, 34 To 22 — Firefall, 32 To 28 — Barbra/Neil, 32 To 21 — A. Cooper, 29 To 25 — A. Stewart, 21 To 18 — G. Vannelli, 20 To 17 — N. Gilder, 16 To 9 — Ambrosia, 15 To 12 — Sylvester, 14 To 8 — Funkadelic, 9 To 5 — Who, 8 To 4 — Styx, Ex To 40 — G. Cotton, Ex To 39 — D & M, Ex To 38 — 10cc, Ex To 37 — Fogelberg/Weisberg, Ex To 36 — Pablo Cruise, Ex To 35 — Boston. ADDS: Chicago, Chic, G. Campbell, L. Taylor, L. Garrett, W. Egan, L. Ronstadt.

WKY — OKLAHOMA CITY — SANDY JONES, MD

1-1 — A. Murray. JUMPS: 20 To 15 — G. Vannelli, 19 To 14 — Dr. Hook, 18 To 7 — Foreigner, 15 To 12 — C. Gayle, 12 To 9 — B. Manilow, 10 To 6 — Captain & Tennille, 4 To 2 — D. Summer, Ex To 20 — Chicago, Ex To 19 — A. Stewart, Ex To 18 — Hall & Oates. ADDS: Hot Chocolate, Firefall, A. Gibb.

KSLO — ST. LOUIS — R.J. REYNOLDS, MD

1-1 — A. Murray. JUMPS: 20 To 25 — Village People, 21 To 17 — A. Fehley, 19 To 16 — B. Manilow, 18 To 15 — Sylvester, 17 To 14 — Ambrosia, 15 To 12 — J. Hayward, 14 To 11 — Funkadelic, 12 To 6 — Foreigner, 10 To 4 — D. Summer.

KXOK — ST. LOUIS — LEE DOUGLAS, MD

4-1 — D. Summer. JUMPS: 35 To 27 — E. Carmen, 34 To 17 — Barbra/Neil, 31 To 26 — Dr., Hook, 27 To 24 — Firefall, 26 To 23 — Hall & Oates, 25 To 22 — D. Gates, 22 To 19 — G. Vannelli, 21 To 18 — A. Gibb, 19 To 12 — J. Hayward, 12 To 5 — Ambrosia, 11 To 9 — Steely Dan, 7 To 4 — K. Loggins. ADDS: 40 — B. Seger, 39 — S. Bishop, 38 — A. Cooper, 30 — Journey.

KEEL — SHREVEPORT — RANDY DAVIS, MD

3-1 — Ambrosia. JUMPS: 28 To 26 — Firefall, 27 To 23 — A. Stewart, 26 To 22 — Sylvester, 24 To 18 — G. Vannelli, 22 To 19 — C. Gayle, 21 To 17 — Chicago, 19 To 14 — Dr. Hook, 18 To 15 — Hall & Oates, 16 To 12 — A. Bridges, 13 To 9 — B. Manilow, 12 To 7 — Foreigner, 9 To 6 — Captain & Tennille, 6 To 3 — D. Summer, Ex To 29 — A. Gibb, Ex To 28 — Pablo Cruise, Ex To 25 — Barbra/Neil. ADDS: E. Carmen, Heart, Fogelberg/Weisberg.

KAKC — TULSA — CHARLEY DEREK, MD

2-1 — Ambrosia. JUMPS: 31 To 27 — 10cc, 29 To 21 — E. John, 24 To 19 — V. Morrison, 22 To 17 — Firefall, 21 To 18 — A. Gibb, 20 To 16 — Heart, 19 To 14 — Fogelberg/Weisberg, 18 To 15 — Toto, 15 To 10 — A. Stewart, 10 To 6 — A. Bridges, 7 To 5 — Foreigner, 6 To 2 — G. Vannelli, Ex To 31 — A. Cooper, Ex To 26 — B. Joel, Ex To 22 — Barbra/Neil. ADDS: Pointer Sisters, Hot Chocolate, Styx, Jacksons.

midwest

WCUE — AKRON — CRAIG JOHNS, MD

36-1 — Barbra/Neil. JUMPS: 31 To 26 — A. Gibb, 29 To 25 — Styx, 27 To 24 — Heart, 26 To 23 — A. Bridges, 12 To 9 — Captain & Tennille, 10 To 8 — Stones, 9 To 6 — Funkadelic. ADDS: 40 — Cars, 39 — B. Seger, 38 — D. Hartman, 37 — A. Cooper.

WBGW — BOWLING GREEN — GARRY MOORE, MD

1-1 — J. Hayward. JUMPS: 29 To 26 — Player, 28 To 25 — Village People, 26 To 23 — G. Cotton, 25 To 18 — A. Cooper, 23 To 20 — W. Egan, 22 To 19 — KC & Sunshine Band, 21 To 14 — B. Manilow, 20 To 15 — Foreigner, 19 To 13 — G. Vannelli, 18 To 12 — Firefall, 13 To 10 — Hall & Oates, 10 To 7 — Ambrosia, 7 To 5 — Dr. Hook, 6 To 2 — P. Davis, Ex To 30 — Chicago, Ex To 29 — A. Stewart. ADDS: Queen, Barbra/Neil, Boston, S. Bishop, E. Carmen.

WINW — CANTON — LINDA LONDON, MD

2-1 — D. Summer. JUMPS: 34 To 22 — Barbra/Neil, 33 To 28 — A. Stewart, 26 To 23 — Chicago, 22 To 18 — Village People, 21 To 12 — A. Bridges, 19 To 16 — E. Carmen, 18 To 14 — G. Vannelli, 11 To 7 — Captain & Tennille, 9 To 5 — Ambrosia, 8 To 6 — K. Loggins, 6 To 4 — Foxy, Ex To 35 — Styx, Ex To 34 — B. Joel, Ex To 32 — Sylvester. ADDS: Chic, Hot Chocolate, Musique.

WLS — CHICAGO — ALAN BURNS, MD

1-1 — Exile. JUMPS: 38 To 23 — Foreigner, 26 To 22 — G. Rafferty, 18 To 13 — Who, 12 To 10 — K. Loggins, 10 To 6 — D. Summer, 4 To 2 — N. Gilder.

WMET — CHICAGO — BOBBY CHRISTIAN, MD

3-1 — Foreigner. JUMPS: 31 To 27 — G. Vannelli, 25 To 22 — Barbra/Neil, 20 To 17 — B. Joel, 19 To 14 — Ambrosia, 12 To 8 — Chicago. ADDS: 33 — Queen, 32 — Dr. Hook, 31 — Fogelberg/Weisberg.

Q102 — CINCINNATI — MARK ELLIOT, MD

4-1 — N. Gilder. JUMPS: 32 To 25 — Barbra/Neil, 30 To 26 — Styx, 28 To 23 — E. Clapton, 26 To 22 — Chicago, 24 To 18 — Firefall, 23 To 19 — 10cc, 22 To 14 — B. Manilow, 20 To 17 — D. Summer, 19 To 12 — A. Stewart, 18 To 11 — Pablo Cruise, 15 To 10 — Fogelberg/Weisberg, 14 To 6 — Heart, 12 To 8 — A. Murray, 11 To 9 — L. Ronstadt, 7 To 4 — Ambrosia. ADDS: 35 — Queen, 34 — L. Ronstadt.

WGCL — CLEVELAND — JEFF GERBER, MD

5-1 — D. Summer. JUMPS: 28 To 15 — Firefall, 23 To 16 — Heart, 22 To 19 — Sylvester, 21 To 11 — Village People, 19 To 14 — Switch, 14 To 7 — A. Stewart, 13 To 9 — B. Manilow, 9 To 6 — G. Vannelli, Ex To 20 — Jacksons. ADDS: 30 — Cars, 29 — Chic, 26 — Barbra/Neil, Lindisfarne.

WZZP — CLEVELAND — CLEVELAND REYNOLDS, MD

1-1 — E. Carmen. JUMPS: 34 To 30 — B. Seger, 32 To 29 — L. Ronstadt, 31 To 27 — J. Cocker, 29 To 25 — A. Gibb, 28 To 19 — Firefall, 26 To 23 — 10cc, 24 To 20 — Heart, 23 To 18 — Chicago, 21 To 15 — S. Bishop, 20 To 10 — G. Vannelli, 18 To 13 — Dr. Hook, 17 To 9 — A. Stewart, 11 To 8 — Ambrosia, 6 To 3 — Foreigner, 5 To 2 — D. Summer, Ex To 35 — L. Garrett, Ex To 34 — Fogelberg/Weisberg, Ex To 33 — Lindisfarne, Ex To 32 — Village People. ADDS: 28 — B. Joel, 17 — Barbra/Neil, Chaka Khan, L. Taylor, G. Cotton, P. Stanley, Styx.

WNCI — COLUMBUS — STEVE EDWARDS, MD

1-1 — A. Murray. JUMPS: 20 To 17 — Styx, 17 To 13 — Barbra/Neil, 13 To 7 — Foreigner, 12 To 8 — C. Gayle, 11 To 5 — Ambrosia, 6 To 4 — B. Manilow, 4 To 2 — Foxy, Ex To 20 — Dr. Hook, Ex To 18 — P. Davis. ADDS: 21 — Hall & Oates, 19 — Rolling Stones, Chicago, B. Joel, Fogelberg/Weisberg.

WING — DAYTON — KEN WARREN, MD

1-1 — Ambrosia. JUMPS: 30 To 27 — A. Gibb, 29 To 26 — Elton John, 28 To 22 — Firefall, 23 To 18 — E. Carmen, 20 To 13 — Chicago, 17 To 6 — G. Vannelli, 14 To 11 — Hall & Oates, 10 To 7 — A. Stewart, 9 To 5 — Pablo Cruise, 6 To 4 — B. Manilow, 5 To 3 — D. Summer, Ex To 29 — Dr. Hook, Ex To 19 — Barbra/Neil. ADDS: Toto, Switch, 30 — Boston.

KIOA — DES MOINES — GARY STEVENS, PD/MD

3-1 — N. Gilder. JUMPS: 25 To 14 — Dr. Hook, 24 To 13 — G. Vannelli, 23 To 20 — Who, 21 To 16 — C. Gayle, 17 To 9 — J. Travolta, 11 To 5 — B. Manilow. ADDS: 25 — Pablo Cruise, 24 — Barbra/Neil.

CKLW — DETROIT — ROSALIE TROMBLEY, MD

1-1 — Exile. JUMPS: 24 To 18 — A. Stewart, 22 To 16 — Chaka Khan, 20 To 17 — E. Carmen, 18 To 9 — Chic, 17 To 4 — Barbra/Neil, 15 To 6 — Ambrosia, 6 To 2 — D. Summer, Ex To 30 — Cooper Bros., Ex To 29 — A. Bridges, Ex To 26 — Cars. ADDS: P. Davis, Firefall.

WDRQ — DETROIT — CHARITA DORAM, MD

1-1 — Exile. JUMPS: 34 To 27 — L. Ronstadt, 31 To 26 — A. Stewart, 30 To 21 — Chic, 28 To 25 — A. Cooper, 27 To 23 — Fogelberg/Weisberg, 26 To 22 — Ross/Jackson, 25 To 19 — Captain & Tennille, 24 To 13 — M. Johnson, 23 To 16 — Pablo Cruise, 18 To 11 — Ambrosia, 17 To 8 — Chicago, 13 To 5 — Cars, 8 To 4 — D. Summer, 7 To 3 — LRB, 4 To 2 — G. Vannelli. ADDS: 35 — B. Joel, 34 — Firefall, 33 — Dr. Hook, 31 — A. Bridges, 30 — Rose Royce.

KFMD — DUBUQUE — STEVE SESTERHEIN, MD

4-1 — Ambrosia. JUMPS: 24 To 10 — Chicago, 23 To 20 — Player, 22 To 17 — Heart, 21 To 9 — A. Stewart, 16 To 8 — D. Summer, 6 To 2 — Foreigner, Ex To 24 — Toto, Ex To 23 — Barbra/Neil, Ex To 22 — Firefall, Ex To 21 — Pablo Cruise. ADDS: Gypsy, I. Mathews, Elton John, B. Joel, A. Cooper.

WDBQ — DUBUQUE — CHUCK BAILEY, PD/MD

1-1 — N. Gilder. JUMPS: 30 To 26 — Styx, 29 To 25 — P. Davis, 28 To 19 — J. Travolta, 26 To 23 — Who, 22 To 17 — Ambrosia, 17 To 14 — D. Summer, 16 To 12 — B. Manilow, 15 To 11 — Captain & Tennille, 12 To 3 — Stonebolt, 11 To 7 — C. Gayle, Ex To 30 — E. Carmen, Ex To 29 — A. Bridges, Ex To 28 — Dr. Hook. ADDS: Elton John, A. Stewart, G. Cotton.

WEBC — DULUTH — STEVE OLIVER, MD

1-1 — D. Summer. JUMPS: 29 To 25 — Fogelberg/Weisberg, 27 To 22 — A. Gibb, 26 To 19 — Firefall, 25 To 16 — Dr. Hook, 23 To 15 — G. Vannelli, 20 To 17 — A. Stewart, 17 To 10 — Foreigner, 16 To 12 — Rolling Stones, 14 To 9 — B. Manilow, 13 To 8 — Player, 11 To 6 — B. Joel, 5 To 3 — J. Hayward, Ex To 29 — E. Carmen, Ex To 24 — Barbra/Neil. ADDS: 30 — B. Joel, Elton John, E. Clapton.

Z-96 — GRAND RAPIDS — JAY MICHAELS, MD

1-1 — Ambrosia. JUMPS: 30 To 25 — Pablo Cruise, 25 To 20 — Foxy, 22 To 19 — Hall & Oates, 18 To 13 — Chicago, 16 To 10 — G. Vannelli, 12 To 6 — B. Manilow, 10 To 4 — Foreigner, 4 To 2 — D. Summer. ADDS: Barbra/Neil, Styx.

WIFE — INDIANAPOLIS — JERRY STEELE, MD

1-1 — A. Murray. JUMPS: 34 To 30 — Lindisfarne, 31 To 26 — Firefall, 27 To 24 — E. Carmen, 24 To 15 — A. Bridges, 23 To 18 — Barbra/Neil, 20 To 17 — Rolling Stones, 19 To 11 — Ambrosia, 17 To 12 — G. Vannelli, 12 To 8 — Captain & Tennille, 10 To 6 — B. Joel, 6 To 2 — K. Loggins, Ex To 35 — Joey Travolta, Ex To 33 — P. Stanley, Ex To 31 — B. Seger, Ex To 28 — Village People, Ex To 25 — A. Gibb. ADDS: A. Stewart, Chic, P. Davis, Cooper Bros., Chaka Khan, Meat Loaf, Matthew Moore.

WNDE — INDIANAPOLIS — JEFF LUCIFER, MD

1-1 — A. Murray. JUMPS: 30 To 24 — G. Vannelli, 26 To 19 — Chicago, 21 To 18 — Firefall, 20 To 10 — A. Bridges, 19 To 15 — B. Manilow, 14 To 8 — D. Summer, 9 To 7 — Foxy, Ex To 29 — C. Gayle, Ex To 28 — A. Stewart, Ex To 27 — Pablo Cruise, Ex To 26 — Barbra/Neil. ADDS: Heart.

KBEQ — KANSAS CITY — KIM WELSH, MD

2-1 — A. Murray. JUMPS: 30 To 27 — 10cc, 29 To 26 — A. Stewart, 28 To 18 — Village People, 27 To 24 — P. Davis, 25 To 17 — A. Fehley, 23 To 20 — A. Cooper, 22 To 19 — C. Gayle, 21 To 4 — D. Summer, 20 To 16 — Fogelberg/Weisberg, 19 To 15 — D. Parton, 15 To 8 — G. Vannelli, 11 To 7 — Ambrosia. ADDS: 30 — Gypsy, 29 — Pablo Cruise, 28 — B. Joel, 2 — Barbra/Neil.

WHB — KANSAS CITY — DON BERNS, MD

1-1 — N. Gilder. JUMPS: 38 To 29 — A. Gibb, 37 To 31 — A. Stewart, 33 To 21 — A. Cooper, 31 To 27 — Pablo Cruise, 30 To 22 — Chicago, 29 To 19 — Village People, 25 To 18 — Firefall, 22 To 17 — Dr. Hook, 20 To 16 — Heart, 18 To 15 — Fogelberg/Weisberg, 16 To 11 — Rolling Stones, 11 To 9 — Ambrosia, 10 To 5 — G. Vannelli, 5 To 3 — D. Summer. ADDS: 40 — P. Stanley, 39 — 10cc, 38 — D. Hartman, 35 — B. Joel.

WKLO — LOUISVILLE — GARY MAJOR, MD

12-1 — D. Summer. JUMPS: 30 To 25 — J. Hayward, 29 To 23 — K. Rogers, 28 To 10 — Barbra/Neil, 27 To 24 — G. Cotton, 26 To 16 — G. Vannelli, 25 To 19 — A. Stewart, 21 To 12 — Ambrosia, 18 To 8 — Dr. Hook, 10 To 3 — Rolling Stones, Ex To 30 — Chicago, Ex To 29 — Pablo Cruise, Ex To 28 — Firefall, Ex To 27 — L. Sayer. ADDS: A. Bridges, A. Cooper, B. Seger, Hot Chocolate, Boston.

WISM — MADISON — JOHN LITTLE, MD

3-1 — D. Summer. JUMPS: 30 To 27 — Firefall, 29 To 25 — A. Gibb, 28 To 21 — Barbra/Neil, 26 To 16 — A. Stewart, 23 To 19 — Heart, 21 To 14 — Fogelberg/Weisberg, 20 To 15 — E. Carmen, 17 To 13 — Chicago, 14 To 10 — Dr. Hook, 12 To 7 — G. Vannelli, 10 To 8 — Rolling Stones, 8 To 6 — B. Manilow, Ex To 30 — Toto, Ex To 29 — A. Bridges, Ex To 28 — Pablo Cruise. ADDS: A. Cooper, G. Cotton, B. Seger, Hot Chocolate.

WOKY — MILWAUKEE — JEFF RYDER, MD

1-1 — B. Joel. JUMPS: 29 To 26 — Pablo Cruise, 28 To 21 — Dr. Hook, 18 To 14 — G. Vannelli, 15 To 12 — Ambrosia, 6 To 4 — Who. ADDS: 30 — Chicago, 29 — Heart, J. Hayward.

WZUU — MILWAUKEE — CHRIS CURTIS, MD

3-1 — D. Summer. JUMPS: 25 To 21 — Pablo Cruise, 24 To 18 — Dr. Hook, 23 To 19 — Firefall, 20 To 7 — B. Manilow, 18 To 11 — G. Vannelli, 11 To 9 — Heart, 7 To 4 — Who, 6 To 2 — Foreigner, Ex To 25 — A. Stewart, Ex To 24 — A. Cooper, Ex To 23 — Captain & Tennille, Ex To 22 — A. Bridges. ADDS: Queen, B. Joel, A. Gibb.

KDWB — MINNEAPOLIS — DAVE THOMPSON, MD

1-1 — N. Gilder. JUMPS: 26 To 23 — B. Joel, 21 To 18 — Dr. Hook, 20 To 17 — Pablo Cruise, 19 To 16 — Chicago, 18 To 14 — Fogelberg/Weisberg, 16 To 12 — G. Vannelli, 15 To 9 — A. Stewart, 13 To 10 — E. Carmen, 10 To 7 — Foreigner, 7 To 2 — B. Manilow. ADDS: 29 — B. Seger, 26 — Barbra/Neil, 24 — Firefall.

KSTP — MINNEAPOLIS — GREG AUSHAN, MD

1-1 — K. Loggins. JUMPS: 29 To 26 — G. Cotton, 28 To 24 — B. Joel, 25 To 18 — Barbra/Neil, 24 To 20 — Firefall, 19 To 14 — A. Stewart, 16 To 12 — E. Carmen, 8 To 5 — B. Manilow, 4 To 2 — Ambrosia. ADDS: 29 — Elton John.

WOW — OMAHA — ROGER DAVIS, MD

2-1 — N. Gilder. JUMPS: 30 To 21 — C. Gayle, 26 To 15 — P. Davis, 24 To 13 — Chicago, 21 To 11 — A. Stewart, 13 To 6 — Dr. Hook, 10 To 7 — Rolling Stones, Ex To 30 — Barbra/Neil, Ex To 29 — Player, Ex To 25 — Village People, Ex To 20 — A. Murray.

WPEZ — PITTSBURGH — MARK FRITZGES, MD

2-1 — D. Summer. JUMPS: 33 To 27 — Firefall, 32 To 28 — E. Carmen, 27 To 19 — Chicago, 24 To 21 — A. Stewart, 22 To 17 — Dr. Hook, 19 To 16 — A. Bridges, 16 To 12 — G. Vannelli, 13 To 9 — B. Manilow. ADDS: B. Joel, A. Gibb, Fogelberg/Weisberg, Barbra/Neil.

13Q — PITTSBURGH — JIM QUINN, MD

2-1 — D. Summer. JUMPS: 30 To 26 — P. Davis, 29 To 25 — E. Carmen, 28 To 24 — Styx, 27 To 23 — Chicago, 24 To 20 — Firefall, 23 To 7 — Barbra/Neil, 21 To 18 — Dr. Hook, 20 To 12 — A. Bridges, 18 To 15 — J.P. Young, 7 To 4 — Ambrosia, Ex To 30 — B. Joel, Ex To 28 — A. Gibb. ADDS: 29 — Heart, 27 — A. Stewart, 16 — Chic, Village People.

KKLS — RAPID CITY — MIKE KJAR, MD

1-1 — N. Gilder. JUMPS: 25 To 21 — E. Carmen, 22 To 18 — Dr. Hook, 20 To 17 — Styx, 19 To 14 — B. Manilow, 18 To 15 — Toto, 17 To 13 — D. Summer, 15 To 11 — G. Vannelli, 13 To 10 — Foreigner, 11 To 9 — Heart, 9 To 7 — Ambrosia, Ex To 25 — A. Stewart, Ex To 24 — J. Hayward, Ex To 20 — Chicago. ADDS: A. Cooper, A. Gibb, B. Joel.

WSPT — STEVENS POINT — PAT MARTIN, PD/MD

1-1 — Fogelberg/Weisberg. JUMPS: 29 To 25 — E. Clapton, 27 To 23 — 10cc, 26 To 17 — Barbra/Neil, 25 To 20 — Firefall, 24 To 21 — Heart, 23 To 18 — Chicago, 20 To 16 — G. Cotton, 18 To 14 — Hall & Oates, 16 To 13 — B. Manilow, 15 To 10 — Dr. Hook, 13 To 8 — A. Stewart, 9 To 5 — D. Summer, 4 To 2 — G. Vannelli, Ex To 30 — A. Cooper, Ex To 29 — Elton John, Ex To 26 — Pablo Cruise, Ex To 24 — B. Joel, Ex To 22 — A. Gibb. ADDS: L. Ronstadt, Steely Dan, M. Macgregor.

WKWK — WHEELING — JIM ROBERTS, MD

4-1 — B. Manilow. JUMPS: 40 To 31 — P. Davis, 36 To 23 — Barbra/Neil, 32 To 24 — A. Gibb, 30 To 27 — Starbuck, 28 To 21 — A. Stewart, 25 To 19 — G. Vannelli, 24 To 20 — Chicago, 22 To 14 — Firefall, 21 To 13 — Foreigner, 17 To 11 — Dr. Hook, 16 To 10 — D. Summer, 11 To 8 — Ambrosia, 9 To 6 — Hall & Oates, Ex To 40 — B. Joel, Ex To 39 — L. Ronstadt, Ex To 38 — E. Clapton, Ex To 37 — Pablo Cruise. ADDS: Hot Chocolate, B. Seger, L. Garrett, Eng. Dan & J.F. Coley.

KLEO — WICHITA — BOB LAWRENCE, MD

1-1 — A. Murray. JUMPS: 30 To 23 — P. Davis, 28 To 15 — Chicago, 25 To 19 — Styx, 24 To 20 — Stonebolt, 23 To 14 — B. Manilow, 22 To 17 — Heart, 17 To 8 — A. Bridges, 16 To 10 — Dr. Hook, 13 To 6 — G. Vannelli, 11 To 7 — Ambrosia, Ex To 30 — G. Cotton, Ex To 29 — Firefall, Ex To 28 — Who, Ex To 24 — Fogelberg/Weisberg, Ex To 21 — Barbra/Neil. ADDS: Village People, B. Seger, S. Bishop, Melba Moore, Elton John, B. Joel, Louisiana Le Roux.

west

KRKE — ALBUQUERQUE — CHRIS CAREY, MD

4-1 — D. Summer. JUMPS: 30 To 25 — Fogelberg/Weisberg, 29 To 23 — A. Bridges, 27 To 24 — C. Gayle, 26 To 22 — A. Gibb, 25 To 19 — Barbra/Neil, 24 To 17 — Styx, 22 To 18 — Firefall, 21 To 16 — Pablo Cruise, 19 To 15 — A. Stewart, 18 To 11 — Chicago, 14 To 10 — Dr. Hook, 12 To 9 — Foreigner, 9 To 6 — G. Vannelli, 7 To 4 — B. Manilow. ADDS: 30 — A. Cooper, 29 — Elton John, 28 — B. Joel, 27 — P. Davis.

KERN — BAKERSFIELD — PETE SHANNON, MD

3-1 — N. Gilder. JUMPS: 27 To 22 — Chicago, 25 To 21 — Pablo Cruise, 24 To 20 — S. Bishop, 23 To 19 — A. Bridges, 22 To 18 — B. Manilow, 21 To 17 — Firefall, 19 To 16 — Styx, 18 To 15 — Foreigner, 13 To 9 — Captain & Tennille, 12 To 10 — C. Gayle, 11 To 6 — D. Summer, 9 To 7 — G. Rafferty, 8 To 5 — A. Murray, Ex To 30 — G. Vannelli, Ex To 29 — G. Cotton, Ex To 24 — Elton John, Ex To 23 — Barbra/Neil. ADDS: A. Stewart, P. Davis, B. Seger.

(continued on page 48)

POP RADIO

A N A L Y S I S

REGIONAL ACTION

EAST

- Most Added**
1. MY LIFE — Billy Joel — Columbia
 2. PART-TIME LOVE — Elton John — MCA
 3. HOLD THE LINE — Toto — Columbia
 4. (OUR LOVE) DON'T THROW IT ALL AWAY — Andy Gibb — RSO
- Most Active**
1. YOU DON'T BRING ME FLOWERS — Barbra/Neil — Columbia
 2. SHARING THE NIGHT TOGETHER — Dr. Hook — Capitol
 3. I JUST WANNA STOP — Gino Vannelli — A&M
 4. HOW MUCH I FEEL — Ambrosia — Warner Bros.

SOUTHEAST

- Most Added**
1. HOW YOU GONNA SEE ME NOW — Alice Cooper — Warner Bros.
 2. LE FREAK — Chic — Atlantic
 3. Y.M.C.A. — Village People — Casablanca
 4. THE POWER OF GOLD — Fogelberg/Weisberg — Epic
- Most Active**
1. YOU DON'T BRING ME FLOWERS — Barbra/Neil — Columbia
 2. ALIVE AGAIN — Chicago — Columbia
 3. SHARING THE NIGHT TOGETHER — Dr. Hook — Capitol
 4. (OUR LOVE) DON'T THROW IT ALL AWAY — Andy Gibb — RSO

SOUTHWEST

- Most Added**
1. MY LIFE — Billy Joel — Columbia
 2. EVERY 1' IS A WINNER — Hot Chocolate — Infinity
 3. YOU DON'T BRING ME FLOWERS — Barbra/Neil — Columbia
 4. EVERYBODY NEEDS LOVE — Stephen Bishop — ABC
- Most Active**
1. I JUST WANNA STOP — Gino Vannelli — A&M
 2. MACARTHUR PARK — Donna Summer — Casablanca
 3. HOW MUCH I FEEL — Ambrosia — Warner Bros.
 4. YOU DON'T BRING ME FLOWERS — Barbra/Neil — Columbia

MIDWEST

- Most Added**
1. MY LIFE — Billy Joel — Columbia
 2. YOU DON'T BRING ME FLOWERS — Barbra/Neil — Columbia
 3. WE'VE GOT TONIGHT — Bob Seger — Capitol
 4. PART-TIME LOVE — Elton John — MCA
- Most Active**
1. I JUST WANNA STOP — Gino Vannelli — A&M
 2. TIME PASSAGES — Al Stewart — Arista
 3. SHARING THE NIGHT TOGETHER — Dr. Hook — Capitol
 4. ALIVE AGAIN — Chicago — Columbia

WEST

- Most Added**
1. HOW YOU GONNA SEE ME NOW — Alice Cooper — Warner Bros.
 2. MY LIFE — Billy Joel — Columbia
 3. OOH BABY BABY — Linda Ronstadt — Asylum
 4. PART-TIME LOVE — Elton John — MCA
- Most Active**
1. YOU DON'T BRING ME FLOWERS — Barbra/Neil — Columbia
 2. HOW MUCH I FEEL — Ambrosia — Warner Bros.
 3. I JUST WANNA STOP — Gino Vannelli — A&M
 4. (OUR LOVE) DON'T THROW IT ALL AWAY — Andy Gibb — RSO

MOST ADDED RECORDS

1. **MY LIFE — BILLY JOEL — COLUMBIA**
KTLK, KLIF, WNOE, KRBE, WZZD, WBBF, WNCI, WZUU, KBEQ, WPEZ, WAYS, KFRC, WQXI, WHB, WDRQ, KPAM, KLEO, WZZP, F-105, KILT, WAIR, KASH, WTLB, KRKE, WTRY, WANS, WKIX, WJDX, WAGQ, WEBC, KFMD, KYNO, KKLS, WRJZ, WFOM, WAUG.
2. **HOW YOU GONNA SEE ME NOW — ALICE COOPER — WARNER BROS.**
WAIR, WRFC, KRKE, WANS, KYNO, KENO, KKLS, WRJZ, WFOM, WAUG, WCUE, KJRB, KTAC, KCPX, KXOK, WKLO, WISM, WAPE, WLEE, Q 94, WLAC, WBBQ, KING.
3. **WE'VE GOT TONIGHT — BOB SEGER — CAPITOL**
KERN, KXOK, WKBW, WKLO, WISM, KDWB, WERC, WKXX, KING, WQXI, KLEO, KILT, KASH, WKIX, WQPD, WAGQ, KENO, KSLY, WCUE, WKWK.
4. **PART-TIME LOVE — ELTON JOHN — MCA**
B-100, Q102, KTLK, KLIF, WLEE, KPAM, KLEO, KSTP, WTLB, WDBQ, KAAV, WTRY, WKIX, WJDX, WEBC, KFMD, KOPA, WRJZ, WFOM, WGUY.
5. **THE POWER OF GOLD — FOGELBERG/WEISBERG — EPIC**
WTRY, WKIX, KCPX, KIMN, KEEL, WKBW, WIFI, WNCI, WCOL, WPEZ, WSGN, WERC, WSGA, Q94, WHHY, WMET, KPAM.
6. **FAT BOTTOM GIRLS/BICYCLE — QUEEN — ELECKTRA**
WNOE, WKBW, WZUU, Y100, WERC, WKXX, WBBQ, KHJ, WMET, Q102, KILT, WAVZ, WANS, KYNO, KOPA, WBGW, WAUG.
7. **LE FREAK — CHIC — ATLANTIC**
WTIX, WDRG, WGCL, 13Q, WAPE, WSGA, Q94, WBBQ, WPGC, WPRO, WRFC, WKIX, WAGQ, KINT, KOPA, WINW, WIFE.
8. **OOH BABY BABY — LINDA RONSTADT — ASYLUM**
KTAC, KJR, KGW, KCBQ, WTIK, KRBE, WSGN, WSGA, 96X, Q102, KILT, WSPT, WKIX, V-97, WRJZ, KRSP.
9. **EVERY 1'S A WINNER — HOT CHOCOLATE — INFINITY**
KJRB, KCPX, KJR, KEEL, WKY, WNOE, WKLO, WISM, WAPE, KING, KAKC, WAIR, WANS, KYNO, WINW, WKWK.
10. **YMCA — VILLAGE PEOPLE — CASABLANCA**
10Q, KJR, KTLK, 13Q, WSGN, WAYS, WHHY, WLAC, WPGC, WQXI, WRKO, KLEO, F-105, KOPA.
11. **YOU DON'T BRING ME FLOWERS — BARBRA/NEIL — COLUMBIA**
Z-96, WAVZ, KENO, WBGW, KNUS, KSLQ, KRBE, K10A, KDWB, WGCL, KBEQ, WPEZ, 96X, WZZP.
12. **(OUR LOVE) DON'T THROW IT ALL AWAY — ANDY GIBB — RSO**
10Q, KIMN, WKY, WDRG, WZZD, WBBF, WCOL, WZUU, WPEZ, WAYS, Z-93, KINT, KKLS.
13. **HOLD THE LINE — TOTO — COLUMBIA**
KTLK, KLIF, WKBW, WBBF, WHHY, BJ105, KPAM, WPRO, WING, WTRY, WKIX, V-97, KRSP.
14. **CHANGE OF HEART — ERIC CARMEN — ARISTA**
KTAC, KIMN, KEEL, WCOL, WKXX, WPGC, Z-93, KRSP, WBLI, WBGW.
15. **FUN TIME — JOE COCKER — ASYLUM**
WERC, WLAC, Z-93, KILT, WAIR, WRFC, WRJZ, WBLI, WAUG.

RADIO ACTIVE SINGLES

1. **YOU DON'T BRING ME FLOWERS — BARBRA & NEIL — COLUMBIA**
KHJ 25-13, KRTH 16-10, KTLK 32-20, KFRC 23-14, KTAC 30-19, KJRB 26-11, KJR 19-10, KGW 21-11, KCBQ 33-22, KCPX 27-22, KERN X-23, KING X-25, KPAM X-27, KILT 40-20, WNOE 21-15, KXOK 34-17, KLIF 34-24, WTIK 32-28, KEEL X-25, WHBQ X-25, KAKC X-22, WKBW 20-10, WFIL 16-11, WIFI 30-16, WPRO-FM 25-19, WZZD 17-12, 99X 29-23, F105 27-19, WRKO X-27, WBBF X-30, WDRG X-28, 13Q 23-7, WCOL 24-7, CKLW 17-4, WNCI 17-13, WOV X-30, WISM 28-21, WKLO 28-10, WMET 25-22, WHB 19-7, WNDE X-26, KLEO X-21, KSTP 25-18, WING X-19, WLEE 27-11, BJ105 37-29, WBBQ 30-25, WLAC X-33, WCAO 17-6, WHHY 17-13, Q94 X-21, WKXX 10-3, WSGA 22-16, WPGC 8-6, Z93 24-10, WQXI 22-14, Y100 27-23, WSGN 25-15, WAPE X-28, WERC 19-12, WAYS 21-11.
2. **I JUST WANNA STOP — GINO VANNELLI — A&M**
WABC 31-25, WKBW 10-6, WDRG 29-26, WZZD 11-4, WFIL 24-21, WIFI X-18, WING 17-6, WZZP 20-10, KLEO 13-6, WNDE 30-24, WHB 10-5, WDRQ 4-2, WMET 31-27, K10A 24-13, WKLO 26-16, WISM 12-7, KDWB 16-12, WGCL 9-6, WCOL 23-13, WOKY 18-14, WZUU 18-11, KBEQ 15-8, WPEZ 16-12, WLEE 12-8, BJ105 39-33, 96X 30-27, WLAC 16-13, WCAO 18-13, WSGA 17-12, WAYS 12-9, WERC 16-8, KILT 12-7, WHBQ 24-17, KRBE 12-9, WTIK 21-18, WNOE 8-5, KLIF 15-10, KXOK 22-19, WKY 20-15, KAKC 6-2, KEEL 24-18, 10Q 24-21, KJRB 11-6, KTAC X-25, KJR 16-13, KERN X-30, KCBQ 23-20, KGW 9-5, KHJ 29-24, KPAM 15-11.
3. **HOW MUCH I FEEL — AMBROSIA — WARNER BROS.**
WHBQ 13-7, KRBE 22-17, WTIK 16-9, KLIF 11-7, KXOK 12-5, KSLQ 17-14, KNUS 16-13, KEEL 3-1, KFRC 19-15, KRTH 9-7, KHJ 15-9, B100 8-6, KCBQ 10-6, KTLK 16-11, KIMN 10-6, KCPX 8-3, KTAC 12-9, KJRB 10-7, 10Q 8-6, WAPE 13-8, WSGA 10-7, Q94 6-4, WLAC 17-14, 96X 28-21, BJ 105 30-23, WKBW 8-3, WABC 19-16, WBBF 6-2, WIFI 18-9, 99X 18-15, WRKO 17-14, WPRO 5-2, F105 19-11, KBEQ 11-7, 13Q 7-4, WOKY 15-12, WCOL 8-6, CKLW 15-6, WNCI 11-5, WKLO 21-12, Q102 7-4, WMET 19-14, WDRQ 18-11, WHB 11-9, KLEO 11-7, WZZP 11-8, KSTP 4-2.
4. **SHARING THE NIGHT TOGETHER — DR. HOOK — CAPITOL**
10Q 23-15, KTAC Ex-26, KCPX 14-9, KJR 22-19, KCBQ 21-18, KING 15-11, KPAM 16-9, KEEL 19-14, KNUS 21-18, WKY 19-14, KXOK 31-26, KLIF 23-18, KRBE 10-4, WDRG 27-22, WZZD 12-7, WBBF 19-11, 99X Ex-30, WRKO 28-24, WPRO 20-15, F105 Ex-30, WPEZ 22-17, WZUU 24-18, 13Q 21-18, WOKY 28-21, WCOL 30-27, WNCI Ex-20, WOW 13-6, KDWB 21-18, WISM 14-10, WKLO 18-8, K10A 25-14, WHB 22-17, KLEO 16-10, WZZP 18-13, WING Ex-29, WLEE 24-14, BJ105 7-2, 96X 36-31, WLAC 9-7, WCAO 18-13, Q94 27-18, WKXX 14-11, WSGA 13-6, WERC 12-9, WSGN 7-1, WQXI 12-10, WPGC 13-8.

SECONDARY RADIO ACTIVE

Titles listed below are receiving strong radio support from key secondary stations around the country.

1. **YOU DON'T BRING ME FLOWERS — BARBRA/NEIL — COLUMBIA**
WAIR 34-23, KASH Ex-20, WTLB Ex-26, WRFC 29-25, KAAV Ex-23, KRKE 25-19, WMFJ Ex-29, WTRY Ex-22, WSPT 26-17, WANS Ex-31, WQPD Ex-39, WJDX 30-9, V-97 37-23, WAGQ 30-27, WEBC Ex-24, KFMD Ex-23, KINT Ex-26, KYNO Ex-25, KOPA Ex-26, KROY Ex-29, KSLY Ex-26, WRJZ Ex-26, KRSP Ex-25, WBLI Ex-19, WAUG 28-18, WFOM 24-19, WGUY 28-21, WIFE 23-18, WCUE 36-1, WINW 34-22, WKWK 32-23.
2. **ALIVE AGAIN — CHICAGO**
WTLB 30-27, WRFC 27-24, Z-96 18-13, KRKE 18-11, WMFJ 20-13, WAVZ 23-16, WSPT 23-18, WANS 20-15, WQPD 39-35, WJDX 19-16, V-97 Ex-36, KFMD 24-10, KINT 26-23, KYNO 27-23, KKLS Ex-20, KOPA Ex-27, KROY 23-20, KSLY 8-4, WRJZ 30-25, KRSP 20-16, WBLI Ex-26, WBGW Ex-30, WAUG Ex-26, WFOM 20-17, WGUY 25-22, WINW 26-23, WKWK 24-20.
3. **I JUST WANNA STOP — GINO VANNELLI — A&M**
KASH 16-10, WTLB 20-13, WRFC 10-5, Z-96 16-10, KRKE 9-6, WAVZ 24-18, WTRY 16-11, WSPT 4-2, WANS 8-5, WKIX 9-6, WJDX 10-6, WEBC 23-15, KINT 28-24, KYNO 23-17, KENO 15-11, KKLS 15-11, KOPA 16-11, KRSP 15-11, WBLI 24-16, WBGW 19-13, WAUG 5-3, WFOM 9-5, WGUY 22-19, WIFE 17-12, WINW 18-14, WKWK 25-19.
4. **SHARING THE NIGHT TOGETHER — DR. HOOK — CAPITOL**
WTLB 23-17, WDBQ Ex-28, WRFC 23-20, KRKE 14-10, WAVZ 17-6, WTRY 17-13, WSPT 15-10, WANS 7-3, WKIX 17-11, V-97 13-7, WAGQ 10-7, WEBC 25-16, KINT 29-25, KYNO 17-13, KKLS 22-18, KROY Ex-22, WRJZ 15-8, KRSP 4-2, WBLI 21-17, WBGW 7-5, WAUG 13-7, WKWK 17-11, WGUY 13-8, WFOM 10-6.
5. **TIME PASSAGES — AL STEWART — ARISTA**
WAIR 32-29, KASH 7-3, WRFC 22-17, KRKE 19-15, WAVZ 20-15, WTRY 29-24, WSPT 13-8, WANS 14-10, WJDX 28-21, WAGQ 18-15, WEBC 20-17, KFMD 21-9, KENO Ex-27, KKLS Ex-25, KROY Ex-28, WRJZ 17-13, KRSP 18-14, WBLI 25-20, WBGW Ex-29, WFOM 16-10, WGUY 21-17, WINW 33-28, WKWK 28-21.
6. **(OUR LOVE) DON'T THROW IT ALL AWAY — ANDY GIBB — RSO**
WAIR 20-9, KASH 25-22, WTLB Ex-29, KRKE 26-22, WMFJ 39-33, WAVZ 9-3, WTRY Ex-26, WSPT Ex-22, WKIX Ex-27, WJDX 23-17, WAGQ 23-17, WEBC 27-23, KYNO 26-20, KENO Ex-28, KSLY Ex-27, WRJZ Ex-27, KRSP 25-22, WAUG 30-24, WFOM 23-20, WGUY 27-23, WIFE Ex-25, WCUE 31-26, WKWK 32-24.
7. **STRANGE WAY — FIREFALL — ATLANTIC**
WRFC 24-19, KRKE 22-18, WTRY Ex-27, WSPT 25-20, WKIX Ex-26, WQPD 26-23, WEBC 26-19, KFMD Ex-22, KENO Ex-30, KOPA 25-21, KROY Ex-30, KSLY 31-25, WRJZ 27-23, KRSP 16-12, WBGW 18-12, WAUG 18-9, WFOM 21-18, WGUY 29-26, WIFE 31-26, WKWK 22-14.

MCA RECORDS

EXTENDS A WARM WELCOME TO



LOGAN H. WESTBROOKS · STANLEY BETHE

L · I · S · T · E · N

FOR THEIR INITIAL SINGLE RELEASES



**THE
VALENTINE BROTHERS**
"Sound Of Music"

SOR-40971

Produced and Arranged by Richard Evans



**CHUCK BROWN
& THE SOUL SEARCHERS**
"Bustin' Loose"

SOR-40967

Produced by James Purdie for Dancer Productions

MERCHANDISING



Pictured is the winning display by Great American Music in Bloomington, Minnesota.

Winners Named In 'Star Wars' Promo

LOS ANGELES — The Great American Music Store in Bloomington, Minnesota has been awarded the grand prize in a national "Star Wars" display contest sponsored by 20th Century-Fox Records. From a field of 350 national entries, the Great American Music outlet won the top prize of \$1,000, which will be shared by store manager Mickey Fisher and employees Mike Harris and Tim Whelan, who set up the winning display.

Jim Fisher, 20th Century national sales director, acknowledged the efficient efforts of Nancy Victor, merchandising coordinator for Pickwick/Minneapolis, who was instrumental in making the contest a success and creating a first prize winner.

Second place honors went to the Sound Warehouse in Houston, Texas. The Sam Goody outlet in Springfield, Pennsylvania placed third, followed by fourth place Eucalyptus in Tukwila, Washington and fifth place to the Sam Goody store in Woodbridge, New Jersey.

RCA Reactivates 'Nipper' Trademark

NEW YORK — RCA's "Nipper" trademark — the little fox terrier listening to "His Master's Voice" on an old phonograph player — will be reactivated during the coming months in a major corporate marketing campaign. Plans to incorporate the trademark into product division advertising will amount to over \$8 million annually, according to Mort Gaffin, director of corporate identification and exhibits for RCA.

Though the trademark has been primarily used on RCA records, album jackets and stereo tapes in recent years, a revised design of the symbol will be used in newspaper, magazine, and television advertising, as well as on the sides of approximately 3,000 company vehicles. The "Nipper" will also start appearing on a variety of point-of-sale materials, shipping cartons, and the company's entire line of color television sets.

Capitol Sets 5 Pic Discs

LOS ANGELES — Capitol Records will release in December and January special limited edition picture discs of five multi-platinum Capitol albums. Each disc will carry a SEAX prefix with a suggested list price of \$15.98.

Editions of 100,000 units will be issued for "Book Of Dreams" by the Steve Miller Band; "Band On The Run" by Wings; "Abbey Road" by the Beatles; "Dark Side Of The Moon" by Pink Floyd; and "Stranger In Town" by Bob Seger and the Silver Bullet Band.

Grey Pacts With Creative Image For Visual Records

LOS ANGELES — Lewis Grey, west coast concert promoter, has joined forces with Frank L. Touch, president of Creative Image Productions, to produce and market videotape performances of albums and concerts under the Visual Records label.

Creative Image will handle production, duplication, marketing and distribution for Visual Records. Grey, whose Lewis Grey Productions specialized in R&B concert promotions, is in charge of talent acquisition.

While noting that no acts have yet agreed to participate, Touch said he expects to have the first visual records on the market by Christmas. Retail price for the video cassettes is \$49.95.

72 Machines

Creative Image has 72 Beta and VHS format duplicating machines, capable of producing 50,000 units per month. Touch said that within six months production will be upped to 250,000 units monthly with 400 machines in operation.

At present, distribution is being negotiated with Photomat, Sears and Montgomery Ward. The video cassettes will be available through record and audio component stores. Plans for a visual tape club are also being discussed.

Capitol Set To Release \$132.98 Beatles Box

LOS ANGELES — On Nov. 13, Capitol Records will release "The Beatles Gift Box," a limited edition set containing all 12 Beatle studio albums as originally released in United Kingdom on Parlophone/Apple/EMI Records.

'Beatles Rarities'

In addition, an album titled "Beatles Rarities" containing 17 Beatles songs, including two never before released on an album in the U.S., "The Inner Light" and "You Know My Name (Look Up The Number)," will be included in the boxed set. Both songs did appear on 45s.

"The Beatles Gift Box" carries a prefix BC-13 and a suggested list of \$132.98. Only 3,000 sets will be available in the U.S.

Atlantic Releases Its First 12" Picture Disc

NEW YORK — Atlantic Records has released its first 12-inch picture disc featuring "Le Freak," the current disco single from the group Chic. The record, backed with "Savoir Faire," is currently available as a promotional item only. Both songs are taken from the group's second LP, "C'est Chic."

SINGLES BREAKOUTS

Camelot — National CHIC ALICE COOPER PAUL DAVIS DR. HOOK NICK GILDER DAN HARTMAN E.C. KING MCCOO/DAVIS TOM PETTY GINO VANNELLI	Harmony House — New Jersey DAN HARTMAN RICK JAMES BILLY JOEL CHAKA KHAN MOODY BLUES TALKING HEADS	Cactus — Houston MUSIQUE PEACHES & HERB DON WILLIAMS	Father's & Sun's — Indianapolis ERIC CLAPTON ALICE COOPER FOGELBERG/WEISBERG ANDY GIBB DAN HARTMAN CHAKA KHAN LINDISFARNE LEO SAYER LIVINGSTON TAYLOR	Licorice Pizza — Los Angeles ALICIA BRIDGES RICK JAMES DOLLY PARTON KAREN YOUNG	Richman Bros. — Philadelphia BARBRA/NEIL JOHN BELUSHI PAUL DAVIS FIREFALL FOGELBERG/WEISBERG FUTURES BILLY JOEL CHERYL LYNN	Western Merchandisers — Amarillo FIREFALL E.C. KING AL STEWART GINO VANNELLI	P.B. One Stop — St. Louis BILLY JOEL	Alta — Phoenix BOSTON ALICE COOPER PAUL DAVIS NICK GILDER LINDA RONSTADT VILLAGE PEOPLE	Record World, T.S.S. — New York BARBRA/NEIL BILLY JOEL	Spec's — Miami BARBRA/NEIL ERIC CLAPTON LEIF GARRETT	Sounds Unlimited — Chicago BILLY JOEL KENNY ROGERS AL STEWART	D.J.'s Sound City — Seattle ALICE COOPER JUSTIN HAYWARD BILLY JOEL VAN MORRISON BOB SEGER VILLAGE PEOPLE	Harmony Hut — Washington D.C. BOBBY CALDWELL CHIC NICK GILDER HERMAN KELLY	Tape City — New Orleans BARBRA/NEIL FOGELBERG/WEISBERG BILLY JOEL DON RAY AL STEWART	Record Theater — Cleveland BARBRA/NEIL BRIDES OF FUNKENSTEIN CARL ALICE COOPER GABRIEL	Music Plus — Los Angeles ELTON JOHN FIREFALL	Cavages — Buffalo ERIC CLAPTON ACE FRELLEY BILLY JOEL	Sound Warehouse — San Antonio CHIC MUNDO EARWOOD	Discount — St. Louis ALICIA BRIDGES ACE FRELLEY JAMES WALSH GYPSY BAND	King Karol — New York COMMODORES ROBERTA FLACK	Record Dept. Merch. — Memphis BARBRA/NEIL CHICAGO	Harmony House — Detroit DR. HOOK JIMMY MCKEE QUEEN BOB SEGER	Record Factory — San Francisco ALICE COOPER DR. HOOK ROSS/JACKSON STYX TOTO	Bee Gee — Albany BARBRA/NEIL AL STEWART	Radio Drs. — Milwaukee BARBRA/NEIL LEO SAYER
--	---	---	--	---	---	--	---	---	--	---	--	--	--	---	---	--	--	--	---	--	---	--	--	---	--

ALBUM BREAKOUTS

Camelot — National ERIC CARMEN CHICAGO FIREFALL BILLY JOEL STEVE MARTIN TED NUGENT LINDA RONSTADT STEELEY DAN (Hits) JOE WALSH (Hits) THE WIZ	Wherehouse — Los Angeles ALICIA BRIDGES CITY BOY WAYLON JENNINGS SEA LEVEL TOTO	1812 Overture — Milwaukee AEROSMITH BAR KAYS ELTON JOHN CHAKA KHAN STEVE MARTIN IAN MATTHEWS TED NUGENT TOM SCOTT PHOEBE SNOW PAT TRAVERS VILLAGE PEOPLE	Sound Warehouse — San Antonio AEROSMITH JIMMY BUFFETT CON FUNK SHUN KIKI DEE CHAKA KHAN JOHN KLEMMER IAN MATTHEWS SHAWN PHILLIPS LOU RAWLS STEELEY DAN (Hits)	Harmony Hut — Washington D.C. GIL SCOTT-HERON BOBBY CALDWELL ELTON JOHN HERMAN KELLY	Pickwick — National BLACK SABBATH DAVID BOWIE CAMEO PAUL DAVIS FIREFALL NICK GILDER JETHRO TULL BILLY JOEL ELTON JOHN RONNIE LAWS STEVE MARTIN TED NUGENT ELVIS PRESLEY SANTANA DONNA SUMMER GROVER WASHINGTON JR. JOHNNY GUITAR WATSON BARRY WHITE	D.J.'s Sound City — Seattle JIMMY BUFFETT CHICAGO COMMODORES (Hits) YES	Harmony House — Detroit ERIC CARMEN ELTON JOHN	Tape City — New Orleans FIREFALL FOGELBERG/WEISBERG AL JARREAU BILLY JOEL STEVE MARTIN SANTANA AL STEWART GROVER WASHINGTON JR. BARRY WHITE NEIL YOUNG	Tape City — New Orleans AEROSMITH JIMMY BUFFETT CHAKA KHAN MARSHALL TUCKER TED NUGENT STEELEY DAN (Hits) THIRD WORLD	Korvett's — National JETHRO TULL ELTON JOHN ANNE MURRAY TED NUGENT QUAZAR SWITCH VILLAGE PEOPLE BARRY WHITE THE WIZ	Independent — Denver HALL & OATES ISAAC HAYES LES MCCANN TED NUGENT STARGARD	Discount — St. Louis PETER CRISS GREG KINN TREVOR RABIN GENE SIMMONS PAUL STANLEY TOTO WISHBONE ASH ZWOL	Spec's — Miami JIMMY BUFFETT GENE COTTON ELTON JOHN STEVE MARTIN PETER, PAUL & MARY STARGARD	Record World, T.S.S. — New York AEROSMITH GENE CHANDLER CHANSON CAPTAIN & TENNILLE NICOLETTE LARSON TED NUGENT TOM SCOTT STEELEY DAN TOTO TOM WAITS THE WIZ J.P. YOUNG	Handleman — National ERIC CARMEN FIREFALL JETHRO TULL BILLY JOEL MARSHALL TUCKER DIANA ROSS SYLVESTER VILLAGE PEOPLE BARRY WHITE YES	Record Factory — San Francisco AEROSMITH CHAKA KHAN BILLY JOEL STEVE MARTIN	Sounds Unlimited — Chicago RORY GALLAGHER JETHRO TULL ELTON JOHN VAN MORRISON ANNE MURRAY TED NUGENT ROSE ROYCE SANTANA 10cc YES	Oz — Atlanta AEROSMITH JIMMY BUFFETT ISLEY BROTHERS ELTON JOHN TED NUGENT	Cavages — Buffalo GENE CHANDLER CHAKA KHAN TRIUMPH	Everybody's — Portland JIMMY BUFFETT FIREFALL JETHRO TULL ELTON JOHN BILLY JOEL STEVE MARTIN SANTANA STEPHEN STILLS 10cc	Father's & Sun's — Indianapolis AEROSMITH JIMMY BUFFETT DANE DONAHUE FIREFALL NICK GILDER CHAKA KHAN QUAZAR LOU RAWLS	Western Merchandisers — Amarillo JIMMY BUFFETT FIREFALL STEVE MARTIN	Record Bar — National AEROSMITH JIMMY BUFFETT TED NUGENT
---	--	---	---	--	---	---	--	--	---	--	---	--	--	--	--	---	--	--	---	---	---	---	---

TOP SINGLE BREAKOUT OF THE WEEK

YOU DON'T BRING ME FLOWERS — BARBRA & NEIL — COL.

TOP ALBUM BREAKOUT OF THE WEEK

LIVE BOOTLEG — AEROSMITH — COLUMBIA

Most Country music played on radio and most Country music hits are licensed by BMI.

Congratulations to these writers of
the 101 most performed Country songs
in the BMI repertoire
April 1, 1977 to March 31, 1978

Donald Addrisi
Richard Addrisi
Arthur Alexander Jr.
Peter Allen
Paul Anka-2 awards
Bill Anthony
James Banks
Max D. Barnes
Jeff Barry
Carl Belew
Chuck Berry
Rory Bourke
Roger Bowling-2 awards
Tommy Boyce
Bobby Braddock-2 awards
L. Russell Brown
Pete Brown (PRS)
Ed Bruce
Jack Bruce (PRS)
Patsy Bruce
Jimmy Buffett-2 awards
Hal Bynum
Wayne Carson
Eric Clapton (PRS)
Hank Cochran-2 awards
David Allan Coe
Sonny Curtis
Mac Davis
Steve Davis
Yves Dessca (SACEM)
Lew DeWitt
Bobby Emmons-2 awards
Bill Enis
Ahmet Ertegun
Donna Fargo
John Farrar (PRS)
Wes Farrell
Dick Feller
Claude Francois (SACEM)
Larry Gatlin-4 awards
Don Gibson
Ray Girado (SGAE)

Bobby Goldsboro
Cathy Gosdin
Roger Greenaway (PRS)
Merle Haggard-2 awards
Johanna Hall
John Hall
Tom T. Hall
Dallas Harms (PRO-Canada)
-2 awards
Bobby Hart
Alan Hawkshaw (PRS)
Jerry Hayes
Joe Hobson
Wayland Holyfield-3 awards
Jerry House
Mark James
Phillip Jarrell
Mike Kossler
Kris Kristofferson
Denise LaSalle
Alain Le Govic (SACEM)
Dickey Lee
Irwin Levine
Marcella Levy
Barry Mann
Eddie Marion
Timothy J. Marshall
Glenn Martin
Layng Martine Jr.
Barry Mason (PRS)
Ronald McCown
Bob McDill
Huey Meaux
Joe Melson
Frances Miller
Chips Moman-3 awards
Willie Nelson
Kenny O'Dell
Roy Orbison
Dolly Parton-3 awards

Michel Pelay (SACEM)
Ben Peters-3 awards
Maxime Piolot (SACEM)
Curly Putman
Eddie Rabbitt-2 awards
Jerry Feed
Don Reid
Roscoe Reid
Jacques Revaux (SACEM)
Allen Reynolds
George Richey-2 awards
Kent Robbins
Marty Robbins
Ronnie Rogers
Troy Seals
Billy Sherrill-5 awards
Shel Silverstein
Kenny Sower
Bobby Springfield
Even Stevens-3 awards
W.S. Stevenson
Donn Tankersley
James Taylor
George Terry
Henderson Thigpen Jr.
Sonny Throckmorton-4 awards
Mel Tillis
Allen Toussaint
Conway Twitty-2 awards
Rafe Van Hoy
Bobby Vinton
Wayne Walker-2 awards
Van Walls
Jimmy Webb
Cynthia Weil
Sterling Whipple
Benny Whitehead
David Wilkins
Lawton Williams
Dennis Wilson
Norro Wilson
Jimmy Work

BMI

What the world expects from
the world's largest music licensing organization.

COUNTRY

Upward Movement Reflected On Current Country Chart

by Bob Campbell

NASHVILLE — Activity on this week's **Cash Box** Country Singles' Chart reflects the heaviest upward movement of 1978.

Several singles by major artists in the top 25 show strong capabilities of moving into the top five or #1 position. As a result, competition in the next few weeks for prime slots will be stiff, and record sales will play a large role in determining which singles land prime spots during the next month.

On this week's singles chart, seven records moved upwards 20 or more positions, and five other records moved upwards at least 15 numbers. By comparison, only one song, Marty Robbins' "Please Don't Play a Love Song," moved 20 points or more last week. In the Aug. 12 **Cash Box** three months ago, Emmylou Harris' "Easy From Now On" was the only record which moved 20 spots, and only two records moved 20 points in the May 13 issue six months ago.

Williams Climbing

This week, "Tulsa Time" by ABC's Don Williams, moved 46 positions to #25 bullet. On the chart two weeks, "Tulsa Time" jumped more spots than any record ever on the singles' chart. It is also the most added record this week with 46 stations adding "Tulsa Time." John Conlee's ABC release, "Lady, Lay Down," moved 26 points to #27 bullet this week after only two weeks on the chart.

Five other records moved 20 positions. Jacky Ward's "Rhythm Of The Rain" on Mercury moved to #32 bullet after two weeks, Loretta Lynn's "We've Come A Long Way Baby" on MCA, moved to #36 bullet after two weeks; "Please Don't Play Me A Love Song" by Columbia's Marty Robbins, moved to #38 bullet after three weeks; Kenny O'Dell's "As Long As I Can Wake Up In Your Arms" on Capricorn, moved to #49 bullet after two weeks; and "Playin' Hard To Get" by Columbia's Janie Fricke, moved to #63 bullet after two weeks.

Five other records show unusually high chart movement this week. Joe Stampley's "Do You Ever Fool Around?" on Epic, moved 19 places to #40 bullet after only two weeks on the chart; "High and Dry" by Ovation's Joe Sun, moved 19 points to #53 bullet after two weeks; Stella Parton's "Stormy Weather," on Elektra/Asylum moved 17 places to #30 bullet after five weeks; Susie Allanson's "Back To The Love" on Warner Bros. moved 16 positions

to #34 bullet; and "Love Survived" by ABC's Roy Head, moved 17 points to #70 after two weeks.

"Sleeping Single In A Double Bed," by ABC's Barbara Mandrell, rides the #1 spot this week, but three records are in a close race for the top position next week. The Oak Ridge Boys' "Crying Again" on ABC is #2 bullet after 11 weeks, The Kendalls' "Sweet Desire" on Ovation sits at #3 bullet after eight weeks, and "I Just Want To Love You" by Elektra/Asylum's Eddie Rabbitt is close behind at #4 bullet after seven weeks.

Twelve records between the #10 and #25 positions carry bullets this week, and each of these records are by major artists. Bobby Bare's "Sleep Tight, Good Night Man" on Columbia is riding the #11 spot after six weeks, and Columbia's Moe Bandy, Capitol's Billy "Crash" Craddock, ABC's Tommy Overstreet, Warner Bros.' Con Hunley, Elektra/Asylum's Vern Gosdin and RCA's Charley Pride are lined up right behind Bare.

Other strong records which entered the top 25 this week are Johnny Paycheck's "Friend, Lover, Wife" on Epic, Willie Nelson's "All of Me" on Columbia, "Don't You Think This Outlaw Bit's Done Got Out Of Hand" by RCA's Waylon Jennings, Kenny Rogers' "The Gambler" on United Artist and Williams' "Tulsa Time."

Top Single Recorded At Woodland Studios

NASHVILLE — Woodland Studios, an independent "state-of-the-art" recording facility here which has been utilized by such artists and acts as Neil Young and Kansas, is also used by many country acts. And the top two songs on the **Cash Box** Country Singles' Chart this week were recorded at Woodland.

Barbara Mandrell's #1 song, "Sleeping Single In A Double Bed" and the Oak Ridge Boys' "Crying Again" were both recorded at and mastered at Woodland. And Ronnie Milsap's "Let's Take The Long Way Around The World," which hit the #1 position last week, was also recorded and mastered at Woodland.

Other songs on this week's chart recorded at Woodland include Billy "Crash" Craddock's #13 record, "Hubba Hubba," Con Hunley's "You've Still Got A Place In My Heart," which sits at #15; and Larry Gatlin's "I've Done Enough Dyin' Today," which debuts this week at #60 bullet.

TOP 75 ALBUMS

	Weeks On Chart		Weeks On Chart
	11/4		11/4
1 I'VE ALWAYS BEEN CRAZY WAYLON JENNINGS (RCA AFL 1-2979)	1 4	39 TAMMY WYNETTE'S GREATEST HITS, VOL. IV (Epic KE-35630)	— 1
2 LET'S KEEP IT THAT WAY ANNE MURRAY (Capitol ST 11732)	2 40	40 20 GOLDEN GREATS BUDDY HOLLY/THE CRICKETS (MCA 3040)	50 7
3 HEARTBREAKER DOLLY PARTON (RCA AFL 1-2797)	3 13	41 BANJO BANDIT R. CLARK/B. TRENT (ABC AY-1084)	41 5
4 STARDUST WILLIE NELSON (Columbia JC 353605)	4 28	42 LARRY GATLIN'S GREATEST HITS (Monument MG-7628)	— 1
5 WHEN I DREAM CRYSTAL GAYLE (United Artists UA-LA 858-H)	5 20	43 KENNY ROGERS (United Artists UA LA 689G)	44 3
6 EXPRESSIONS DON WILLIAMS (ABC AY 1069)	6 7	44 LIVE FROM THE STAGE OF THE GRAND OLE OPRY JERRY CLOWER (MCA-3062)	— 1
7 LOVE OR SOMETHING LIKE IT KENNY ROGERS (United Artists UA-LA 903-H)	7 17	45 WE MUST BELIEVE IN MAGIC CRYSTAL GAYLE (United Artists UA LA 771G)	55 4
8 TEAR TIME DAVE & SUGAR (RCA APL 1-2861)	8 7	46 REDHEADED STRANGER WILLIE NELSON (Columbia KC 33482)	43 6
9 LIVING IN THE USA LINDA RONSTADT (Asylum 6E-155)	9 5	47 OH! BROTHER LARRY GATLIN (Monument MG 7626)	25 22
10 WAYLON & WILLIE WAYLON JENNINGS & WILLIE NELSON (RCA AFL 1-2696)	11 40	48 RED WINE AND BLUE MEMORIES JOE STAMPLEY (Epic KE 35443)	28 11
11 ELVIS — A CANADIAN TRIBUTE ELVIS PRESLEY (RCA KKL 1-7065)	12 4	49 HONKY TONK HEROES CONWAY TWITTY/LORETTA LYNN (MCA 2372)	45 18
12 TEN YEARS OF GOLD KENNY ROGERS (United Artists UA-LA 835-H)	18 41	50 THE VERY BEST OF CONWAY TWITTY (MCA 3043)	39 23
13 MOODS BARBARA MANDELL (ABC AY-1088)	30 4	51 THE BEST IS YET TO COME JOHNNY DUNCAN (Columbia KC 35451)	42 6
14 ONLY ONE LOVE IN MY LIFE RONNIE MILSAP (RCA APL 1-2780)	10 17	52 THE BEST OF GENE WATSON (Capitol ST 11782)	47 19
15 THE BEST OF THE STATLER BROTHERS (Mercury SRM 1-1037)	22 47	53 BURGERS AND FRIES CHARLEY PRIDE (RCA APL 1-2983)	48 5
16 EVERY TIME TWO FOOLS COLLIDE KENNY ROGERS & DOTTIE WEST (United Artists UA-LA 864-H)	21 33	54 LOVE IS JUST A GAME LARRY GATLIN (Monument MG 7616)	57 4
17 ENTERTAINERS . . . ON AND OFF THE RECORD THE STATLER BROTHERS (Mercury ARM 1-5007)	14 31	55 CONWAY CONWAY TWITTY (MCA-3063)	— 1
18 WOMANHOOD TAMMY WYNETTE (Epic KE-35442)	13 19	56 COLLISION COURSE ASLEEP AT THE WHEEL (Capitol SW 11726)	58 4
19 VARIATIONS EDDIE RABBITT (Elektra 6E-127)	19 32	57 ROSE COLORED GLASSES JOHN CONLEE (ABC-AY-1105)	— 1
20 ROOM SERVICE OAK RIDGE BOYS (ABC AY 1065)	20 22	58 MARTY ROBBINS' GREATEST HITS, VOL. IV (Columbia KC-35629)	— 1
21 Y'ALL COME BACK SALOON OAK RIDGE BOYS (ABC/Dot DO 2093)	29 54	59 PLEASURE & PAIN DR. HOOK (Capitol SW-11859)	— 1
22 I'M ALWAYS ON A MOUNTAIN WHEN I FALL MERLE HAGGARD (MCA 2375)	24 14	60 DAVID A. COE'S GREATEST HITS (Columbia KC-35627)	— 1
23 OLD FASHIONED LOVE THE KENDALLS (Ovation OV 1733)	23 31	61 SIMPLE DREAMS LINDA RONSTADT (Asylum 6E-104)	61 2
24 HERE YOU COME AGAIN DOLLY PARTON (RCA APL 1-2544)	27 55	62 FACE OF A FIGHTER WILLIE NELSON (Lone Star LS 4602)	62 4
25 GREATEST HITS THE MARSHALL TUCKER BAND (Capricorn CPN-0214)	35 2	63 HANK COCHRAN WITH A LITTLE HELP FROM HIS FRIENDS (Capitol ST 11807)	60 4
26 THE WAY IT WAS IN '51 MERLE HAGGARD (Capitol ST-11839)	17 4	64 LINDA RONSTADT'S GREATEST HITS (Asylum 6E-106)	64 2
27 I BELIEVE IN YOU MEL TILLIS (MCA 2364)	15 20	65 I WOULD LIKE TO SEE YOU AGAIN JOHNNY CASH (Columbia KC 35313)	52 4
28 HEAVEN'S JUST A SIN AWAY THE KENDALLS (Ovation OV 1719)	33 4	66 IT WAS ALMOST LIKE A SONG RONNIE MILSAP (RCA APL 1-2439)	66 50
29 ELVIS SINGS FOR CHILDREN AND GROWNUPS TOO ELVIS PRESLEY (RCA CLP 1-2901)	16 13	67 DON'T BREAK THE HEART THAT LOVES YOU MARGO SMITH (Warner Bros. BSK 3173)	54 4
30 LOVE IS WHAT LIFE'S ALL ABOUT MOE BANDY (Columbia KC-35534)	26 5	68 OL' WAYLON WAYLON JENNINGS (RCA APL 1-2317)	63 4
31 TURNING UP AND TURNING ON BILLY "CRASH" CRADDOCK (Capitol SW 1153)	31 5	69 SON OF A SON OF A SAILOR JIMMY BUFFETT (ABC AA 1046)	65 29
32 REFLECTIONS GENE WATSON (Capitol SW 11805)	32 9	70 COUNTRY BOY DON WILLIAMS (ABC DO 2088)	67 14
33 THE OUTLAWS VARIOUS ARTISTS (RCA APL 1-1321)	34 6	71 BETTER ME TOMMY OVERSTREET (ABC AY-1066)	71 4
34 DARK-EYED LADY DONNA FARGO (WB BSK-3191)	36 5	72 QUARTER MOON IN A TEN CENT TOWN EMMYLOU HARRIS (Warner Bros. BSL 3141)	68 40
35 FALL IN LOVE WITH ME RANDY BARLOW (Republic RLP-6023)	38 3	73 LOVE ME WITH ALL YOUR HEART JOHNNY RODRIGUEZ (Mercury SRM 1-5011)	73 4
36 BEST OF DOLLY PARTON (RCA APL 1-1117)	40 4	74 MELLO MEL McDANIEL (Capitol ST 11779)	72 4
37 DAYTIME FRIENDS KENNY ROGERS (United Artists UA LA 754 G)	37 4	75 LET'S SHAKE HANDS AND COME OUT LOVIN' KENNY O'DELL (Capricorn CPN 0211)	75 4
38 JOHNNY PAYCHECK'S GREATEST HITS, VOL. II (Epic KE-35623)	— 1		



JOHNNY DUNCAN SIGNS — Columbia artist Johnny Duncan, who has had a long string of hit records recently signed a new, long-term recording contract with Columbia. Shown at the signing are (l-r): Jim Wagoner, president, American Management; Bruce Lundvall, president, CBS Records division; Jerry Lastelick, Duncan's attorney; Rick Blackburn, vice president, marketing, CBS Records, Nashville; and Duncan (seated).

COUNTRY

The Country Column

Ohio Gov. James A. Rhodes has proclaimed Nov. 4 as "**Ronnie Milsap Day**" throughout the state. Appearing in Columbus, the RCA artist was presented the proclamation by a representative of the governor's office. The proclamation was awarded Milsap "... in view of the large contribution he has made in entertaining the citizens of the state of Ohio, and for the major entertainment contribution he made to the state this past summer by his record-breaking appearance at the Ohio State Fair. Milsap has lined up several November concerts in Ohio. Milsap recently earned his second gold album award of this year. Currently #17 on the **Cash Box** Country Album Charts, "Only One Love In My Life" has been certified gold by the RIAA, and "It Was Almost Like A Song" earned gold status last spring. Milsap also recently won the 1978 Country Music Association Award for "It Was Almost Like A Song."



Ronnie Milsap

Artic Records artist **Norman Wade** fulfilled a lifelong dream recently when he was booked with **Don Helms** and the **Original Drifting Cowboys** in Slydell, La.

Epic Artist **Rick Nelson** has signed an exclusive representation contract with the Jim Halsey Co. of Tulsa, Okla. A veteran of over 20 years in entertainment with a number of million sellers, Nelson is the first artist signed under the company's new contemporary division, Jim Halsey Contemporary, Ltd. Nelson, who played a lead role for many years on the family oriented "Ozzie and Harriet" television show, works with his Stone Canyon Band and played

Nashville's **Exit/In** last spring. "We're in the process of exploring a wider audience, and Rick Nelson's talents will lead the way," said Diana Pugh, executive vice president of the Halsey Agency.

Minnie Pearl will be taping a television Christmas special at Opryland on Nov. 19-22 which will air Dec. 13 on ABC.

Epic's **Tammy Wynette**, who recently was kidnapped for nearly an entire day and was bruised badly during the episode, received a threatening note last week which was found on her front door. Police have no clues as to who kidnapped Tammy, but they believe this new note is connected with the kidnapping, and the police force is putting high priority on solving the harassment of Wynette. Tammy will appear at the Mill Run Theatre in Chicago, Ill. on Nov. 24 and 25. Her "Womanhood" LP sits this week at #18 on the CB Country Chart.

Epic's **Joe Stampley** will appear at the Cowtown Club in Dodge City, Ka. on Nov. 17.

Warner Bros.'s **Donna Fargo**, who seems to be recovering fast from multiple sclerosis, will appear at Orries Supper Club in Wheaton, Ill. on Nov. 21, and then she will fly to Georgia for two appearances there on Nov. 24-25.

Maria Kilroy has announced the formation of Person-to-Person Promotions, a Nashville-based promotion company which is designed to offer specialized services in the area of recorded singles and albums. A monthly newsletter providing industry information, suggestions and station comments will be a regular feature of the firm.

Scorpion Artist **R.W. Blackwood** and Southern Writers Group, USA are offering a "Dolly" Doll promotion to coincide with Blackwood's single of "Dolly," which sits this week at #77 with a bullet on the CB Country Chart. Dolly Parton dolls are being offered to country stations for give-aways in a trivia-quiz contest.

Mercury's **Jacky Ward** and **Reba McEntire** have just signed with the booking agency of Dick Blake International.

GATLIN GATHERING For the CMA Week celebration last week, People magazine took its 12 top advertisers to Nashville and before they left on the junket, the reps from the 12 firms were asked what they wanted to do while they were in Nashville. They offered standard responses such as "see the Grand Ole Opry House" and visit the Country Music Hall of Fame." They also asked to meet a famous country music personality and chose Mercury's **Larry Gatlin**. When Gatlin heard about their request, he not only consented to meet the Madison Ave. execs, but invited them all over to his house for a chili party. The heads of such companies as Eastman Kodak, Colgate-Palmolive and Eastern Airlines were highly pleased and came away with both their wish and their appetites fulfilled. . . . **Leo Sayer**, a person who wouldn't be an obvious subject in a country music-related item, nonetheless is gaining country as well as pop airplay with his new single "Raining In My Heart." In addition, he is broadening his country exposure even more since **Stella Parton** has recorded his "Stormy Weather," also from his latest album, "Leo Sayer."

Columbia's **Bobby Bare** has just signed a management contract with American Management of Encino, Ca. According to Jim Wagner, president of American Management, "We are all very happy to be associated with Bobby and his manager Bill Graham, and we look forward to a very happy and long relationship."

Chris LeDoux, who was the 1976 PRCA World Champion Bareback Bronc Rider, performed rather than rode broncs at the Oct. 26 Montana Rodeo Association Finals in Butte, Montana. With several authentic Western-Country albums under his belt on his own label, Chris plans to be in Nashville this month cutting tunes for a new album. And he recently wrote and recorded two songs for the upcoming Will Rogers Centennial Celebration in Oklahoma.



Roy Clark

MCA's **Loretta Lynn** is set to tape a segment of "The 21 Days of America." This television series on American heritage will be aired three times on a specific day between Flag Day and July 4.

Writer/singer **Tracy Nelson** recorded a live show at the **Exit/In** last week which will air on the syndicated college radio show, "Thirsty Ear." The show airs regularly in 70 markets. Nelson is also being considered for the part of **Patsy Cline** in the upcoming movie, "Coal Miner's Daughter," about the early life of Loretta Lynn. **Sissy Spacek** will play Loretta in the film. Tracy will also sing the title song for the new NBC-TV movie, "Amateur Night." And this month Nelson will appear with Columbia's **Bobby Bare** on "Austin City Limits." In addition, Tracy is one of the few artists in Nashville to have cut a direct-to-disc album. Titled, "Doing It My Way," the album was recorded here in Nashville.

ABC's **Roy Clark** recorded an album last week that also features **Clarence "Gatemouth" Brown** and Brazilian percussionist **Airto Moreira**. Produced in Tulsa, Okla. by Steve Ripley of the Jim Halsey Co., the album is mostly instrumental but Clark and Brown will do some vocal work. Brown is an underground legend who is widely respected by his peers for his guitar and fiddle work. Clark also will team up with **Tammy Wynette** for the first time and the two will headline the main showroom of the Frontier Hotel Nov. 9-22.

bob campbell

Jerry Wallace

Has Another #1'er



"I WANNA GO TO HEAVEN"

(5-1035)

CASH BOX BILLBOARD RECORD WORLD



Exclusive Mgmt:
Universal Mgmt.
(615) 259-3495

Dist. By: 4-Star
37 Music Square, East
Nashville, Tenn. 37203

For DJ Coples Call:
(615) 329-0444

CASH BOX TOP 100 COUNTRY

November 11, 1978

	Weeks On Chart	11/4		Weeks On Chart	11/4		Weeks On Chart	11/4
1 SLEEPING SINGLE IN A DOUBLE BED BARBARA MANDRELL (ABC AB-12403)	2	10	34 BACK TO THE LOVE SUSIE ALLANSON (Warner/Curb WBS-8686)	50	3	68 SMOOTH SAILIN' CONNIE SMITH (Monument 45-266)	73	3
2 CRYIN' AGAIN OAK RIDGE BOYS (ABC AB-12397)	3	11	35 I'M LEAVING IT ALL UP TO YOU FREDDY FENDER (ABC 12415)	40	5	69 TEAR TIME DAVE & SUGAR (RCA PB-11322)	33	13
3 SWEET DESIRE THE KENDALLS (Ovation OV-1112)	4	8	36 WE'VE COME A LONG WAY BABY LORETTA LYNN (MCA 40954)	56	2	70 LOVE SURVIVED ROY HEAD (ABC AB-12418)	87	2
4 JUST WANT TO LOVE YOU EDDIE RABBITT (Elektra E-45531)	7	7	37 THEN YOU'LL REMEMBER STERLING WHIPPLE (Warner Bros. WBS 8632)	42	6	71 MAYBE YOU SHOULD'VE BEEN LISTENING JESSI COLTER (Capitol P-4641)	76	3
5 LITTLE THINGS MEAN A LOT MARGO SMITH (Warner Bros. WBS 8656)	5	10	38 PLEASE DON'T PLAY A LOVE SONG MARTY ROBBINS (Columbia 3-10821)	58	3	72 THE SOFTEST TOUCH IN TOWN BOBBY G. RICE (Republic REP-031)	84	2
6 AIN'T NO CALIFORNIA MEL TILLIS (MCA 40946)	6	10	39 THIS IS A HOLD UP RONNIE McDOWELL (Scorpion SC 0560)	39	7	73 THE WAY IT WAS IN '51 MERLE HAGGARD (Capitol P-4636)	78	3
7 ON MY KNEES CHARLIE RICH (WITH JANIE FRICKE) (Epic 8-50616)	13	6	40 DO YOU EVER FOOL AROUND JOE STAMPLEY (Epic 8-50626)	59	2	74 I THOUGHT YOU WERE EASY RAYBURN ANTHONY (Mercury 55042)	77	3
8 DAYLIGHT T.G. SHEPPARD (WBS-8678)	8	8	41 ONE RUN FOR THE ROSES NARVEL FELTS (ABC AB-12414)	46	5	75 MINSTREL MAN REBECCA LYNN (Scorpion SC 0559)	75	5
9 WHAT HAVE YOU GOT TO LOSE TOM T. HALL (RCA PB-11376)	9	9	42 RAINING IN MY HEART LEO SAYER (WB WBS 8682)	45	5	76 IF I HAD TO DO IT ALL OVER AGAIN STONEY EDWARDS (JMI-47)	81	4
10 THAT'S WHAT YOU DO TO ME CHARLY McCLAIN (Epic 8-50598)	11	9	43 LOVE GOT IN THE WAY FREDDY WELLER (Columbia 3-10837)	48	4	77 DOLLY R.W. BLACKWOOD (Scorpion SC-0561)	88	3
11 SLEEP TIGHT, GOOD NIGHT MAN BOBBY BARE (Columbia 3-10831)	20	6	44 POISON LOVE GAIL DAVIES (Lifesong ZS8-1777)	49	4	78 LOVE AIN'T GONNA WAIT FOR US BILLIE JO SPEARS (United Artists UA-X-1251-Y)	—	1
12 TWO LONELY PEOPLE MOE BANDY (Columbia 3-10820)	14	9	45 FEET RAY PRICE (Monument 45-267)	57	3	79 TILL THEN PAL RAKES (Warner Bros. WBS-8656)	79	4
13 HUBBA HUBBA BILLY "CRASH" CRADDOCK (Capitol P-4642)	15	9	46 JUST OUT OF REACH LARRY G. HUDSON (Lone Star 702)	51	7	80 PROMISES ERIC CLAPTON (RSO RS910)	85	3
14 FADIN' IN, FADIN' OUT TOMMY OVERSTREET (ABC AB-12408)	16	7	47 ANYONE WHO ISN'T ME TONIGHT KENNY ROGERS/DOTTIE WEST (United Artists UA-1234-4)	10	11	81 SOMEBODY'S GONNA DO IT TONIGHT R.C. BANNON (Columbia 3-10847)	86	2
15 YOU'VE STILL GOT A PLACE IN MY HEART CON HUNLEY (Warner Bros. WBS-8671)	17	7	48 I WANNA GO TO HEAVEN JERRY WALLACE (4-Star 5-1035)	54	5	82 BLUER THAN BLUE BEVERLY HECKEL (RCA PB-11360)	41	10
16 BREAK MY MIND VERN GOSDIN (Elektra E-45532-A)	18	6	49 AS LONG AS I CAN WAKE UP IN YOUR ARMS KENNY O'DELL (Capricorn CPS-0309)	69	2	83 THE OTHER SIDE OF JEANNIE CHUCK POLLARD (MCA 40965)	89	2
17 BURGERS AND FRIES CHARLEY PRIDE (RCA PB-11391)	23	4	50 WHAT TIME DO YOU HAVE TO BE BACK TO HEAVEN RAZZY BAILEY (RCA PB-11338)	12	14	84 I'M GONNA FEED 'EM NOW PORTER WAGONER (RCA PB 11411)	—	1
18 HANDCUFFED TO A HEARTACHE MARY K. MILLER (Inergi I-310)	19	9	51 SHARING THE NIGHT TOGETHER DR. HOOK (Capitol P-4621)	62	9	85 ONE MORE TIME SANDRA KAYE (Door Knob WIG-DK-8-075)	91	5
19 FRIEND, LOVER, WIFE JOHNNY PAYCHECK (Epic 8-50621)	22	4	52 JUST HANGIN' ON MEL STREET (Mercury 55043)	55	5	86 YOUR LOVE HAD TAKEN ME THAT HIGH CONWAY TWITTY (MCA 40963)	—	1
20 ALL OF ME WILLIE NELSON (Columbia 3-10834)	25	4	53 HIGH AND DRY JOE SUN (Ovation OV 1117)	72	2	87 IN MEMORY OF YOUR LOVE DEBBY BOONE (Warner/Curb WBS-8700)	—	1
21 DON'T YOU THINK THIS OUTLAW BIT'S DONE GOT OUT OF HAND WAYLON JENNINGS (RCA PB-11390)	28	3	54 ONE SIDED CONVERSATION GENE WATSON (Capitol P-4616)	21	12	88 HEALIN' AVA BARBER (Ranwood RAN-1087)	96	2
22 THE GAMBLER KENNY ROGERS (United Artists UA-X1250)	30	3	55 LET'S BE LONELY TOGETHER DALE McBRIDE (Con Brio CBK-140)	60	5	89 DARLING POACHER (Republic REP-028)	94	4
23 LET'S TAKE THE LONG WAY AROUND THE WORLD RONNIE MILSAP (RCA PB-11369)	1	11	56 SAVE THE LAST DANCE FOR ME RON SHAW (Pacific Challenger PC-1631)	66	8	90 EVERYNIGHT SENSATION DURWOOD HADDOCK (Eagle Int'l EL-1148)	90	3
24 THINGS I'D DO FOR YOU MUNDO EARWOOD (GMC-104-A)	24	11	57 IT'S NOT EASY DICKY LEE (RCA PB-11389)	61	4	91 THERE'LL BE NO TEARDROPS TONIGHT WILLIE NELSON (United Artists UA-X-1254-Y)	—	1
25 TULSA TIME DON WILLIAMS (ABC AB-12425)	71	2	58 WILL YOUR REMEMBER MINE WILLIE NELSON (Lone Star 703)	63	4	92 GET BACK TO LOVIN' ME JIM CHESNUT (Hickory AH-54038)	—	1
26 CAN YOU FOOL GLEN CAMPBELL (Capitol P-4584)	29	8	59 TWO HEARTS TANGLED IN LOVE KENNY DALE (Capitol P-4619)	27	11	93 SHE NEVER SPOKE SPANISH TO ME JOE ELY (MCA 40956)	95	2
27 LADY LAY DOWN JOHN CONLEE (ABC AB-12420)	53	2	60 I'VE DONE ENOUGH DYIN' TODAY LARRY GATLIN (Monument 45-270)	—	1	94 LONESOME RIDER COODER BROWN (Lone Star 704)	—	1
28 THE BULL AND THE BEAVER MERLE HAGGARD/LEONA WILLIAMS (MCA-40962)	38	3	61 ANOTHER GOODBYE DONNA FARGO (Warner Bros. WBS 8643)	32	12	95 LOVE ME AGAIN RITA COOLIDGE (A&M 2090)	97	2
29 WHAT'CHA DOIN' AFTER MIDNIGHT, BABY HELEN CORNELIUS (RCA PB-11375)	31	8	62 OH, SUCH A STRANGER DON GIBSON (ABC/Hickory AH-54036)	65	4	96 HOW I LOVE YOU IN THE MORNING PEGGY SUE (Door Knob, DK-8-079)	—	1
30 STORMY WEATHER STELLA PARTON (Elektra E-45533)	37	5	63 PLAYIN' HARD TO GET JANIE FRICKE (Columbia 3-10849)	83	2	97 THE LOVE IN ME JIM NORMAN (Republic REP-030)	—	1
31 JULIET & ROMEO RONNIE SESSIONS (MCA 40952)	35	7	64 DOUBLE S BILL ANDERSON (MCA 40964)	—	1	98 LEAVE WHILE I'M SLEEPING MICKI FUHRMAN (Louisiana Hayride LH-785)	—	1
32 RHYTHM OF THE RAIN JACKY WARD (Mercury 55047)	52	2	65 AIN'T LIFE HELL HANK COCHRAN/WILLIE NELSON (Capitol P-4635)	67	5	99 HALF EMPTY BED FRANK MEYERS (Little Darlin' LD 7805)	99	2
33 WHAT'S THE NAME OF THAT SONG GLENN BARBER (Century 21 C21-100)	36	9	66 GIMME BACK MY BLUES JERRY REED (RCA PB 11407)	—	1	100 YOU CAN'T HURRY LOVE STACEY ROWE (Sabre ZSL-4507)	—	1
			67 LAST EXIT FOR LOVE WOOD NEWTON (Elektra E-45528)	74	3			

ALPHABETIZED TOP 100 COUNTRY SINGLES (INCLUDING PUBLISHERS AND LICENSEES)

Ain't Life Hell (Tree — BMI)	65	Handcuffed To A (Mandy Music — ASCAP)	18	Love Me Again (Almo-ASCAP/Irving — BMI)	95	That's What (Music City — ASCAP)	10
Ain't No California (Tree Pub. — BMI)	6	Healin' (Hall-Clement Pub. — BMI)	88	Love Survived (Jack & Bill — ASCAP)	70	The Bull And (Shade Tree — BMI)	28
All Of Me (Bourne/Marling — BMI)	20	High And Dry (Tree Pub. — BMI)	53	Maybe You (Screen Gems/EMI — BMI)	71	The Gambler (Writers Night — ASCAP)	22
Another (ATV/Mann & Weil/Frascotti — BMI)	61	How I Love (Lodestar — SESAC)	96	Minstrel Man (Fiddleback — BMI)	75	The Love In (Singletree — BMI)	97
Anyone Who Isn't (Bobby Goldsboro — ASCAP)	47	Hubba Hubba (Ray Stevens — BMI)	13	Oh, Such A Stranger (Acuff-Rose — BMI)	62	The Other Side (Paukie/Pollivan — BMI)	83
As Long As (House Of Gold/Hungry Mountain — BMI)	49	I Just Want (Briarpatch/DebDave — BMI)	4	On My Knees (Hi Lo Music — BMI)	7	The Softest Touch In Town (WUB — ASCAP)	72
Back To The Love (House Of Gold — BMI)	34	I Thought You (Hall-Clement — BMI)	74	One More Time (Door Knob — BMI)	85	The Way It Was (Shade Tree — BMI)	73
Bluer Than Blue (Let Me Be There — ASCAP)	82	I Wanna Go To (Fireweed — ASCAP)	48	One Run For The (Jerry Chesnut — BMI)	41	Then You'll Remember (Tree — BMI)	37
Break My Mind (Acuff-Rose — BMI)	16	If I Had To (La Debra — BMI)	76	One Sided (Joe Allen — BMI)	54	There'll Be No (Fred Rose — BMI)	91
Burgers And Fries (Pi-Gem — BMI)	17	I'm Gonna Feed (Four Star — BMI)	84	Playin' Hard To Get (Bobby Goldsboro — ASCAP)	63	Things I'd Do (Music West of the Pecos — BMI)	24
Can You Fool (Royal Oak/Windstar — ASCAP)	26	I'm Leaving It All (Venice — BMI)	35	Please Don't Play (Algee — BMI)	38	This Is A (Cristy Lane — ASCAP)	39
Cryin' Again (Tree Pub. — BMI/Cross Keys — ASCAP)	2	In Memory Of (Yatahey — BMI)	87	Poison Love (Unichappell — BMI)	44	Till Then (MCA/Warlock — ASCAP)	79
Darling (September — ASCAP)	89	It's Not Easy (Screen Gems — BMI)	57	Promises (Narwhal — BMI)	80	Tulsa Time (Bibo Music — ASCAP)	25
Daylight (Blue Lake — BMI)	8	I've Done Enough (First Generation — BMI)	60	Raining In My (House Of Bryant — BMI)	42	Two Hearts Tangled (Publicare — ASCAP)	59
Dolly (Buzz Cason/Let There Be Music — ASCAP)	77	Juliet & Romeo (Combine — BMI)	31	Rhythm Of The Rain (Warner-Tamerlane — BMI)	32	Two Lonely (Milene — ASCAP)	12
Don't You Think (Waylon Jennings — BMI)	21	Just Hangin' On (Maplehill/Vogue — BMI)	52	Save The Last (Rumbalero — BMI)	56	We've Come A Long Way (Twitty Bird — BMI)	36
Do You Ever (Rogan/Mullet — BMI)	40	Just Out Of (4-Star — BMI)	46	Sharing The (Music Mill — ASCAP/AI Cartee — BMI)	51	What Cha' (Dunhill — BMI)	29
Double S (Stallion/Tree — BMI)	64	Lady Lay Down (Tree Pub. — BMI)	27	She Never Spoke (Rainlight — ASCAP)	93	What Have You (Hallnote — BMI)	9
Everynight Sensation (Curtis Wood — ASCAP)	90	Last Exit For (Briar Patch/Deb Dave — BMI)	67	Sleep Tight, Good Night Man (Bobby Goldsboro Music — ASCAP)	11	What Time Do (House of Gold — BMI)	50
Fadin' In (Tree — BMI)	14	Leave While I'm (ATV — BMI)	98	Sleeping Single (Pi-Gem — BMI)	1	What's The Name (Glenn To Glenn — BMI/Merilark — ASCAP)	33
Feet (Blackwood/Fulnes — BMI)	45	Let's Be Lonely (Con Brio — BMI)	55	Smooth Sailer (Tree — BMI)	68	Will You Remember (Tree — BMI)	58
Friend, Lover, Wife (Algee — BMI)	19	Let's Take (Chess — ASCAP/Pi-Gem — BMI)	23	Somebody's Gonna Do It (Ben Peters — BMI)	81	You Can't Hurry (Stone Agate — BMI)	100
Get Back To (Milene — ASCAP)	92	Little Things Mean (Leo Feist — ASCAP)	5	Stormy Weather (Longmanor/Chrysalis — BMI)	30	Your Love Had (Twitty Bird — BMI)	86
Gimme Back (Sleepy Hollow — ASCAP)	66	Lonesome Rider (Window — BMI)	94	Sweet Desire (Terrace — ASCAP)	3	You've Still Got (Fred Rose — BMI)	15
Half Empty Bed (Dream City — BMI)	99	Love Ain't Gonna (Blackwood/Ben Peters — BMI)	78	Tear Time (Forrest Hills — BMI)	69		
		Love Got In The (Young World — BMI)	43				

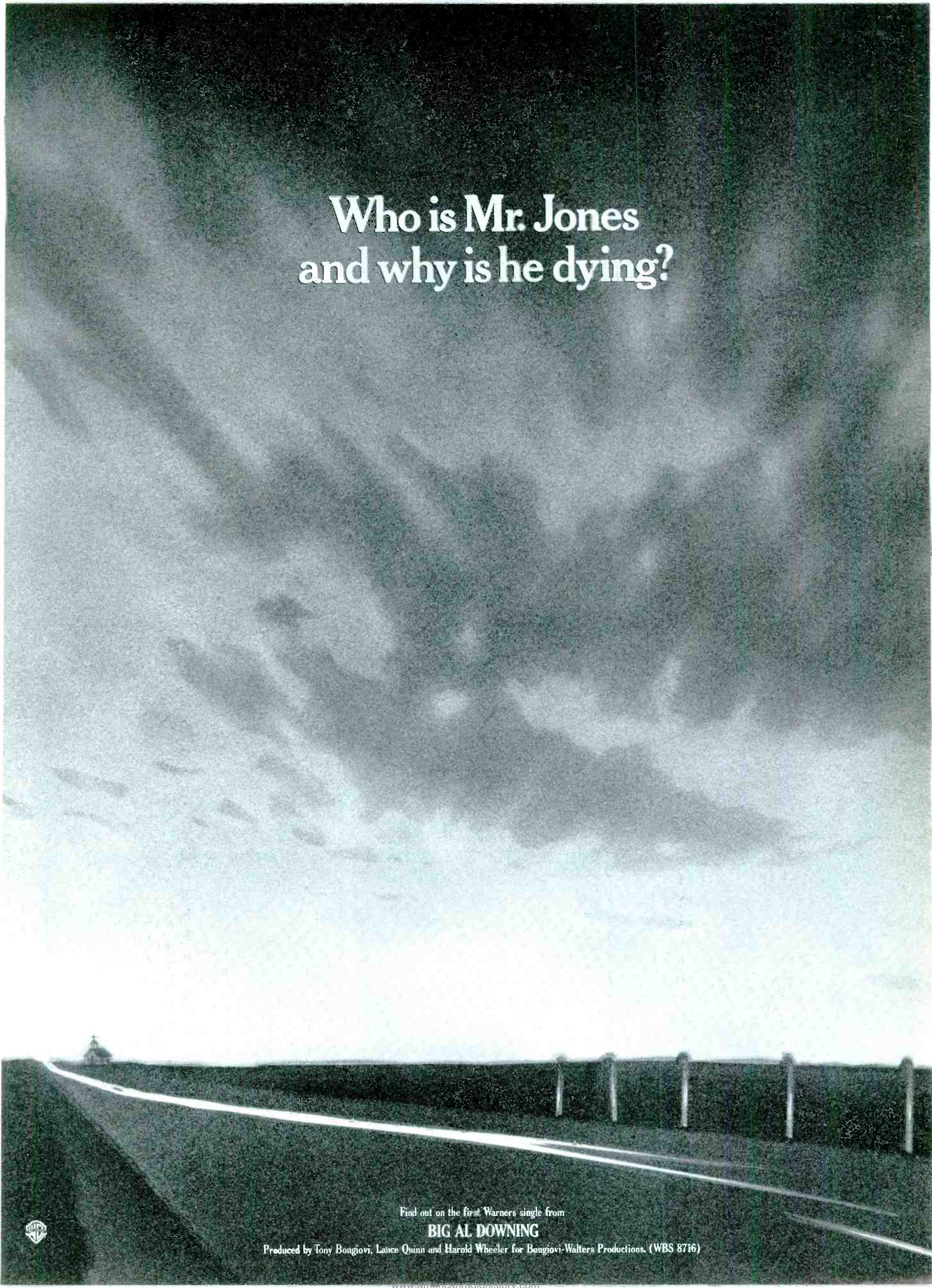

Who is Mr. Jones
and why is he dying?

Find out on the first Warners single from

BIG AL DOWNING

Produced by Tony Bongiovi, Lance Quinn and Harold Wheeler for Bongiovi-Walters Productions. (WBS 8716)



45 / REVIEWS / LP

JOHNNY RUSSELL (Mercury 55045)

How Deep In Love Am I? (2:47) (Hall-Clement — BMI) (Bob McDill)

To kick off Russell's new association with Mercury, producer Jim Vienneau has matched Johnny with a tune by one of Nashville's hottest writers, Bob McDill. The song is haunting, yet smoothly rolls into a driving beat which is sure to catch everyone's attention.

MICKEY GILLEY (Epic 8-50631)

The Song We Made Love To (2:12) (April Music/Widmont Music — ASCAP) (K. Wahle)

Gilley appears to be drifting further away from the Jerry Lee Lewis style and with this single you will see even less hot piano work and more mellow vocal style. This cut is sure to follow the Gilley stream of top 10 singles.

CONWAY TWITTY (MCA 40963)

Your Love Had Taken Me That High (2:35) (Twitty Bird Music — BMI) (Jack Dunham/Galen Raye)

With the rumors adrift that Conway is losing clout at country radio, he and producer Owen Brady released this spin-off of the giant "You've Never Been This Far Before." The tune is almost identical but only time will tell if the response is to be the same.

CRISTY LANE (LS 169)

I Just Can't Stay Married To You (2:49) (Chappell Music-ASCAP/Tri Chappell-SESAC) (Gillespie/Black/Bourke)

The sales and chart growth on Cristy Lane singles has been fantastic. Each release does better than the last. This single has tones of Patti Page and should set another level for LS Records.

SINGLES TO WATCH

MUNDO EARWOOD (GMC GMC-105)

Fooled Around And Fell In Love (3:26) (Music West Of The Pecos — BMI) (Mundo Earwood)

DON KING (Con Brio CBK-142)

You Were Worth Waiting For (2:30) (Wiljex Pub. — ASCAP) (Jeanie Walker)

LANEY SMALLWOOD (Monument 45-271)

Let's Fall In Love Again (2:50) (Tay-Son Music — ASCAP) (Ron Muir/Eddie Rhines)

O.B. McCLINTON (Epic 8-50620)

Natural Love (3:20) (Bobby Goldsboro Music — ASCAP) (R. Bailey)

TARA GRAHAM (12 Oaks 0011)

You Just Loved The Leavin' Out Of Me (2:27) (Beechwood Music/Window Music — BMI) (Linda Hargrove)

ASLEEP AT THE WHEEL (Capitol P-4659)

Texas Me & You (3:28) (Paw Paw Music/Asleep At The Wheel Music — BMI) (Ray Benson)

BELLAMY BROTHERS (Warner Bros. WBS-8692)

Lovln' On (3:07) (Ben Peters Music — BMI) (Ben Peters)

DONNIE ROHRS (AD-KORP ST-1258)

Hey Baby (3:07) (LeBill Music/Unart Music — BMI) (Cobb/Channel)



DAYLIGHT — T.G. Sheppard — Warner/Curb — BSK-3259 — Producers: Jack Gilmer and T.G. Sheppard — List: 6.98

T.G. Sheppard keeps getting better and better. One of his talents is recognizing which songs work best for him. For instance, the old Turtles song, "Happy Together," and "I'd Like To See Jesus On The Midnight Special" fit him perfectly. His voice is also growing deeper. Most of these songs are sophisticated, but still retain a deep country strain. "When Can We Do This Again" is also included.

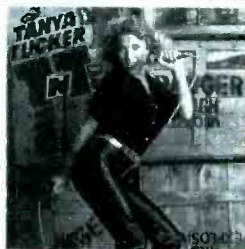

TNT — Tanya Tucker — MCA — MCA-3066 — Producer: Jerry Goldstein — List: 7.98

If country fans have raised an eyebrow at the changes Dolly Parton has made lately, they certainly aren't ready for the 'new' Tanya Tucker. Beyond a shadow of a doubt, the cover graphics are the most blatantly sexual of any album jacket ever released by a country artist. And the music inside is tough LA rock. Tanya does throw in a small dose of country, but this is in no way a country album. At any rate, it is a fine album and should garner airplay and sales in all markets.

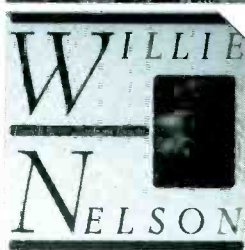

THERE'LL BE NO TEARDROPS TONIGHT — Willie Nelson — United Artists — UA-LA-930-H — Producer: unlisted — List: 6.98

It seems Willie Nelson has been on every major record label at one time or another. Now United Artists has polished up some old masters and packaged this collection of previously released and unreleased material. Willie Nelson fans will want this album because that unmistakable Nelson sound is evident even though these cuts are more than 10-years-old. "I'll Walk Alone," "Am I Blue" and "There'll Be No Teardrops Tonight" are the strongest cuts.

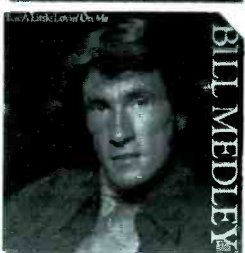

LAY A LITTLE LOVIN' ON ME — Bill Medley — United Artists — UA-LA-929-H — Producer: Larry Butler — List: 6.98

Bill Medley used to sing that deep bass part for The Righteous Brothers and here he is again, this time singing country music under the production reins of Larry Butler. These songs fit Medley's rich baritone, and he seems at home with country-pop material. If anything, Medley's vocals seem more controlled and smoother than years ago. Best songs here are "Statue Of A Fool," "Why Don't We Go Somewhere And Love" and the title cut.

More Highlights From DJ Week In Nashville



E/A, CON BRIO AND JMI DJ WEEK FUNCTIONS — During the whirlwind D.J. Week held in Nashville Oct. 15-21, Elektra/Asylum's Roy Acuff was honored Oct. 20 when Nashville Mayor Richard Fulton pronounced "Roy Acuff Day." Elektra/Asylum also held an informal reception at the Hyatt-Regency. Con Brio held its annual studio party at Columbia Studio B, and JMI Records gave a benefit showcase for the Humphreys Street School and Community Project at the Exit/In on Oct. 21. Shown at the Con Brio party in the first two photos on the **top row** (l-r) are: (first photo) Johnny K, Con Brio promotion director; Dale McBride, Con Brio artist; and Earle Faulk, WCMS Radio; (second photo) Laura Spoon, Ariola Records, LA; Ed Salamon, WHN Radio program director; Bill Walker, Con Brio Records president; and Terri Hollowell, Con Brio artist. In the third photo on the **top** right are JMI artist Stoney Edwards; Bill Williams, JMI national promotion director and

president of Concerts for People (benefit co-sponsors); and Aubrey Hornsby, director of Concerts for People. In the first photo of the **bottom row** (l-r), Mayor Fulton is presenting Acuff key to the city on Teddy Bart's "Noon Show." Shown are Ewell Roussell, E/A national country sales director; Acuff; Fulton; and Wesley Rose, president of Acuff-Rose Publishing Co. Shown in middle **bottom row** photo at the E/A party are (l-r): Ewell Roussell, E/A national country sales director; E/A recording artist Vern Gosdin; James Wood, E/A Atlanta sales representative; Jan Kurtis, Gosdin's manager and Norm Osborne, E/A national country promotion director. Shown at the Exit/In in the last photo on the **bottom row** are (l-r): Curt Allen, JMI engineer and assistant producer; Stoney Edwards, JMI artist; Rachel Peer, JMI artist; Jack Clement, JMI owner and president and E/A artist, Kathy Johnson, JMI artist (foreground); and Elliott Dolin, Clement's bass player.

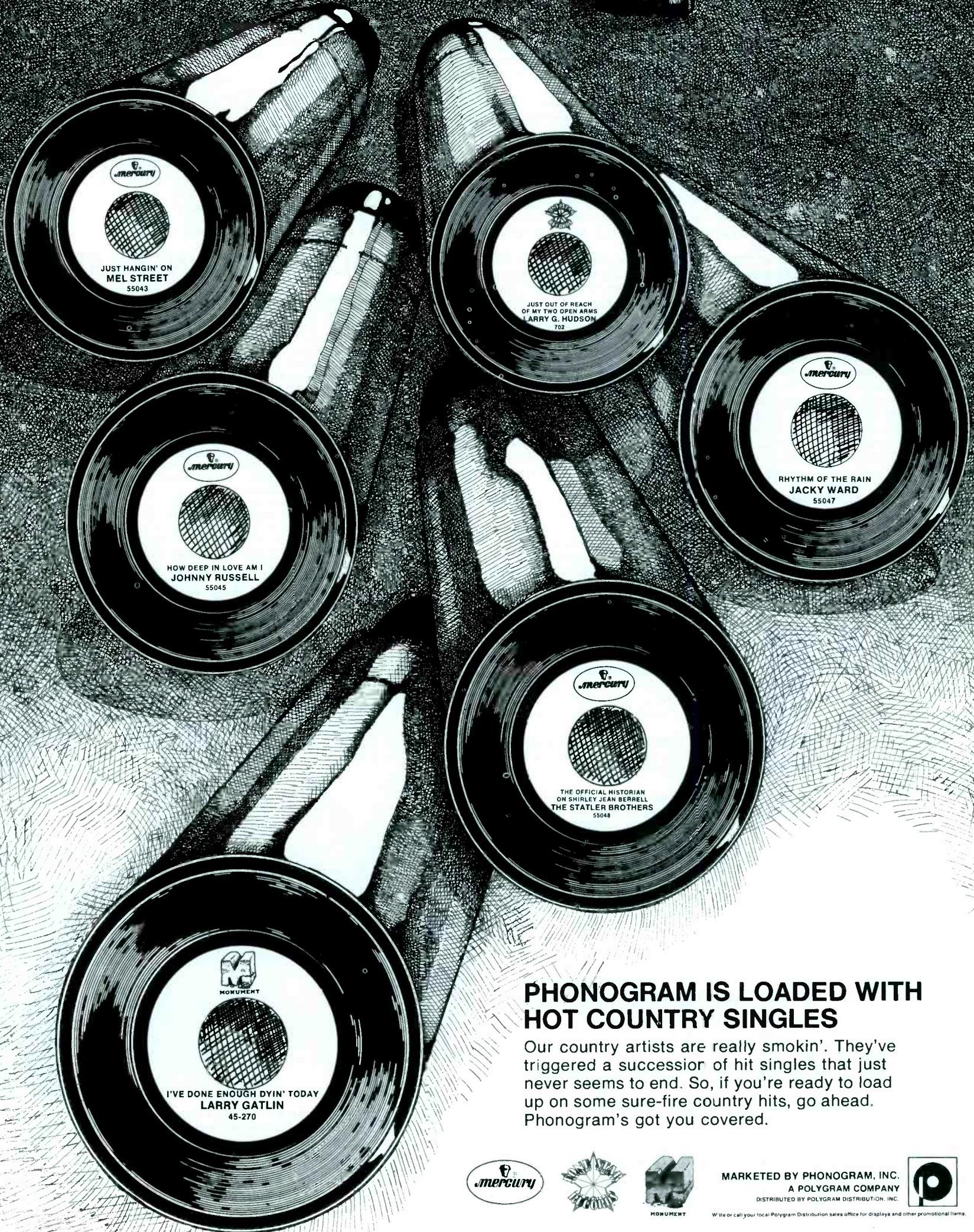
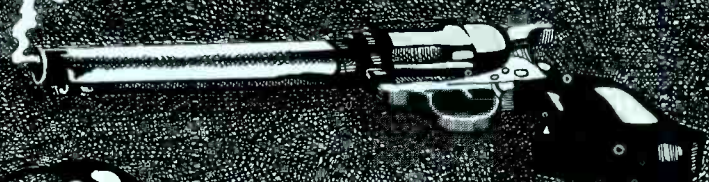

Mercury
 JUST HANGIN' ON
 MEL STREET
 55043

Mercury
 JUST OUT OF REACH
 OF MY TWO OPEN ARMS
 LARRY G. HUDSON
 702

Mercury
 RHYTHM OF THE RAIN
 JACKY WARD
 55047

Mercury
 HOW DEEP IN LOVE AM I
 JOHNNY RUSSELL
 55045

Mercury
 THE OFFICIAL HISTORIAN
 ON SHIRLEY JEAN BERRELL
 THE STATLER BROTHERS
 55048

M
 MONUMENT
 I'VE DONE ENOUGH DYIN' TODAY
 LARRY GATLIN
 45-270

PHONOGRAM IS LOADED WITH HOT COUNTRY SINGLES

Our country artists are really smokin'. They've triggered a succession of hit singles that just never seems to end. So, if you're ready to load up on some sure-fire country hits, go ahead. Phonogram's got you covered.



MARKETED BY PHONOGRAM, INC.
 A POLYGRAM COMPANY
 DISTRIBUTED BY POLYGRAM DISTRIBUTION, INC.



Write or call your local Polygram Distribution sales office for displays and other promotional items.

COUNTRY RADIO

THE COUNTRY MIKE

COUNTRY RADIO ECHO PREMIERS THIS MONTH — As mentioned last week in this column, a new tip-sheet, exclusively devoted to country music, will be on the streets later this month . . . it's called "Country Radio Echo." The "Echo" will be put together by **Judy Adams**, wife of RCA regional promotion director **Galen Adams**, with a little help from her friends. Judy plans to mail the first issue of the "Echo" in the latter part of this month . . . And she says that any country station can report its playlist to her. For information on how to subscribe and report call Judy Adams in Atlanta at 404-977-1011.

MUSIC DIRECTOR PROFILE — KLAC/Los Angeles music director **Cathy Hahn** describes herself as a Southern California gal who likes country music and country radio.



Cathy Hahn

Cathy was born in the LA suburb of Gardena, and began her career in the radio industry in 1972, when she worked in sales at XPRS/Los Angeles. At the time, XPRS had a syndicated country format. Before coming to KLAC three years ago, Cathy also worked for Alto Communications, a syndicated radio packaging firm, and she worked for entertainer **Billy Joel's** personal manager. In 1975, **Carson Schreiber** hired her to work for KLAC part-time in the music library. Later that year, she was promoted to full-time programming secretary under **Hal Smith**. In early 1976, Cathy replaced **Don Langford** as MD, when he became PD.

GET WELL SOON !!! — KKYX/San Antonio MD **Max Gardner's** wife, **Dorls**, is in the hospital undergoing surgery this week. She's in San Antonio's St. Luke's Lutheran Hospital if you'd care to drop her a get-well note . . . or send it to Max in care of KKYX . . . 8022 Bander Rd . . . 28228.

KHEY PROMOTES RUSSELL AND POTTER — KHEY/EI Paso has announced the promotion of **Charlie Russell** to operations director, and **Ray Potter** will take-over Russell's programming duties as the new PD. Potter will also continue to handle the music. Congratulations to KHEY for their superb recognition of talent. By the way . . . if you've had trouble getting chart information from KHEY in the past couple of weeks, Potter apologizes for the inconvenience. KHEY has been remodeling and the music line has been temporarily disconnected . . . so call their regular number for the next few weeks . . . 915-566-9301.

WSAI/Cincinnati is looking for one part-time and one full-time announcer. If you're interested . . . **Jonathon Fricke** at 513-251-5700 . . . or send a tape and resume to him at West 8th Street & Matson Place . . . Cincinnati . . . 45204. Women and minorities are encouraged to apply. WSAI is an Equal Opportunity Employer.

ARB PROMOTIONS IN MOTION — When the Arbitron surveys are in progress, it is customary for most radio stations to promote themselves more than usual . . . and the current ARB is no exception. In the next few weeks . . . **Country Mike** will be telling you what other country radio stations across the nation are doing to boost the book. If you have special promotions in progress . . . let us know at **Cash Box** . . . 21 Music Circle East . . . Nashville, Tennessee . . . 37203.

WUBE IS GIVING A HOUSE AWAY — A little more than a month ago, WUBE/Cincinnati kicked off what may be one of the most aggressive promotional campaigns of all time for a country radio station. WUBE's "Home In The Country" promotion will enable some contestant to win a \$78,000 package of prizes. The "Home In The Country" package consists of a new \$42,000 home, stocked with more than \$36,000 worth of goodies, including a new car, a new boat, and more than \$1,500 in carpeting. To be eligible, contestants must enter the contest at one of WUBE's sponsors, and then listen for their name on the air. When they hear their name, the contestant has to call the station within a certain time period to be entered in the contest. WUBE has been making the contest that much more exciting by broadcasting live from the giveaway home each weekend. RCA's **Ronnie Milsap** will give away WUBE's "Home In The Country" on the air November 18th. The live on-the-air giveaway will culminate a nine-week promotional campaign by the station.

WVOJ GIVES GROCERIES AND CARS — WVOJ/Jacksonville is gearing up for a good book this time by giving away a new Mustang and over \$2,000 worth of groceries each week. The station is backing up those giveaways with free albums each hour . . . and "Country" **Charlie White** says they're planning to create a "Double S" contest, in conjunction with **Bill Anderson's** new single.

PLEASE GET IT RIGHT — WHK/Cleveland MD **Terry Stevens** says that he's been missing some mail lately . . . he thinks you may have the wrong address . . . so here's WHK's correct mailing address . . . Cleveland Plaza . . . 12th & Euclid . . . Cleveland . . . 44115. Thank you, says Stevens.

SPEAKING OF WHK — Former WHK Local Sales Manager, **Rick Rambaldo**, has been named General Sales Manager, effective immediately . . . and after only four months as an account exec WHK's **Lonnie Gronk** has been promoted to National Sales Manager.

WRRD/St. Paul, (formerly WLOL) has a new phone number. Please make a note of it for future reference . . . 612-699-1330.

WYDE GETS LARRY JAMES AND GOES 24 HOURS — According to the vice president of Columbia Pictures Radio, **Wynn Alby**, WYDE/Birmingham has hired **Larry James** to fill its morning slot . . . beginning November 20. James is currently with WBT/Charlotte and was named this year's CMA D.J. of the Year. In a related announcement, Alby also confirmed that WYDE will begin broadcasting 24-hours a day on November 20. The new line-up features James in the morning; PD **Mike Malone**, 10-2; MD **Dave White**, 2-6; and **Ken Michaels** will jock from 6-midnight. WYDE is currently looking for a top-notch all night jock . . . if interested . . . send tapes and resumes to Wynn Alby . . . 2112 11th Ave. South . . . Birmingham . . . 35205.

country mike

WDEE Hosts Reception

DETROIT — WDEE and Eller Outdoor Advertising, both Combined Communications' properties, held a media reception and cocktail party here recently to get acquainted with local media representatives. The reception was hosted by WDEE vice president **Bill Johnson**. Combined Communications owns 13 radio stations in seven markets.

Rye Gets RCA Position

NASHVILLE — William C. Rye, Jr., has been named manager, merchandising administration for RCA Records in Nashville.

MOST ADDED COUNTRY SINGLES

- TULSA TIME** — **DON WILLIAMS** — **ABC**
WWOL, WHN, WTSO, WIRE, KRAM, KZIP, WMNI, WBAP, KLAQ, KSON, KCUB, KIKX, WSHO, KNEW, FM-97, WHOO, KSSS, WCMS, WSUN, WTMT, KLAC, KVOC, WKDA, WPNX, KFTN, KCKN, KCKC, WJJD, WDAF, KRAK, KXLR, WAME, WMP, KWMT, WWVA, KBBQ, KSOP, WAXX, WQQT, WXCL, WDOD, WJRB, WFAI, KFDI, KGA, WGTO.
- I'VE DONE ENOUGH DYIN' TODAY** — **LARRY GATLIN** — **MONUMENT**
WCMS, KSSS, KKYX, KRMD, KIKX, KCUB, WNRS, KRAM, WTSO, KFTN, WBAM, WUBE, KRAK, WDEE, WMP, WPLO, WWVA, WAXX, WQQT, WDOD, KWKH, WJRB, WFAI, KGA, WGTO, WIL.
- DOUBLE S** — **BILL ANDERSON** — **MCA**
WPNX, WKDA, WVOJ, WCMS, WHOO, WNRS, KRAM, WIRE, KCKC, WBAM, KLZ, WPLO, WWVA, KLIC, WAXX, WQQT, WXCL, KYNN, KWKH, WSDS, KBET, WFAI, KGA, KTTS.
- GIMME BACK MY BLUES** — **JERRY REED** — **RCA**
WPNX, KVOC, WVOJ, KSSS, KKYX, KNEW, KIKX, KZIP, KRAM, WUBE, WAME, WPLO, KLIC, KBBQ, KSOP, KYNN, KWKH, WSDS, KFDI, WGTO, KTTS, KIKK.
- PLAYIN' HARD TO GET** — **JANIE FRICKE** — **COLUMBIA**
KLLL, WVOJ, WCMS, KEBC, FM-97, KIKX, KJJJ, KXOL, KOUL, KFTN, KCKC, WDEE, KLIC, KSOP, WSDS, WJRB, KGA, WGTO, WIL.
- LADY LAY DOWN** — **JOHN CONLEE** — **ABC**
WPNX, KVOC, WSLR, WKMF, WSHO, WMAQ, WMNI, KZIP, KCKC, WBAM, WAME, KWMT, KSOP, WXCL, WDOD, KWKH, KBET, KWJJ.

MOST ACTIVE COUNTRY SINGLES

- BURGERS AND FRIES** — **CHARLEY PRIDE** — **RCA**
WKDA 48-22, KLAC 50-42, WTMT ex-40, WMC ex-23, WCMS 45-36, KSSS ex-26, KEBC 37-30, KRMD 35-29, FM-97 34-24, KNEW 39-32, KIKX ex-40, KCUB 34-24, KNOE 47-40, KXOL ex-35, WNRS 37-31, KMPS ex-27, WMNI ex-37, KZIP 49-39, WIRE ex-33, WTSO 39-28, WWOL 37-28, WIL ex-35, WUBE 39-34, KRAK ex-35, KLZ 39-26, KENR ex-33, KWMT ex-39, KLIC ex-37, KLLL 59-49, KERE 42-31, KSOP 39-32, KOKE ex-27, WAXX ex-31, WSDS 47-33, KBET 38-29, WFAI ex-37, WPNX ex-37, WSUN ex-25, KKYX ex-40, KLAQ ex-27, KRAM 36-24, WDAF 30-21, WAME ex-30, WWVA ex-38, KBBQ ex-25, WEMP 30-23, WDOD ex-27, KWKH 29-20, CCKN 23-8, WJRB ex-38, KGA ex-20, WGTO 45-36, KTTS 40-20, KIKK ex-38, KOYN 19-17.
- THE GAMBLER** — **KENNY ROGERS** — **UNITED ARTISTS**
WKDA 28-20, KVOC 23-12, KLAC 46-40, WMC ex-24, WCMS ex-40, KEBC ex-35, KRMD 39-34, WHOO 26-21, WKMF ex-29, FM-97 32-20, KNEW ex-39, KIKX ex-35, KCUB 38-29, KJJJ 36-29, KMPS ex-29, WMNI ex-35, KOUL ex-22, WIRE ex-38, WTSO 42-26, KFTN 36-25, WWOL 35-26, WUBE 33-26, WJJD ex-29, KLZ 33-22, WMP, 29-21, KENR 38-23, KWMT 36-30, KLIC ex-35, KLLL 65-55, KERE 43-32, KSOP ex-38, WAXX ex-32, WSDS ex-48, KBET 24-18, WFAI ex-38, WPNX ex-34, WSUN 23-10, WMAQ ex-40, WBAP ex-41, KRAM 37-25, WDAF ex-28, WPLO ex-27, WEEP 27-22, WWVA 37-28, WYDE ex-29, WHK 37-25, WEMP ex-30, WDOD ex-29, KWKH 30-21, CCKN 34-14, KGA ex-28, WGTO 39-29, KIKK ex-36, KOYN 28-16.
- SLEEP TIGHT, GOOD NIGHT MAN** — **BOBBY BARE** — **COLUMBIA**
KVOC ex-35, KLAC 47-39, KSSS ex-24, KRMD 30-23, KWJJ 39-31, KNEW 32-27, KIKX 26-17, KCUB 25-19, KJJJ 33-27, KXOL ex-39, WNRS 42-37, KMPS 23-16, WMNI 31-26, KZIP 63-35, KOUL 36-27, WIRE 41-35, WTSO 25-19, KFTN 27-18, WWOL 32-24, KCKC 25-15, WIL ex-37, WUBE 36-31, KRAK 34-27, KLZ 40-29, KXLR 27-20, WMP, 22-17, KENR ex-35, KWMT 29-24, KVOO ex-36, KLLL 46-28, KERE 34-25, KSOP 27-16, WAXX 26-18, WQQT ex-36, KYNN 27-15, WSDS 29-20, WFAI 36-26, WSUN ex-29, WMAQ ex-39, KLAQ ex-24, WAME ex-24, WPLO 23-18, KBBQ 31-24, WDOD ex-38, WJRB 34-25, KGA 29-19, WGTO 26-18, KIKK 40-34, KOYN 37-31.



BIFF COLLIE GETS FICAP AWARD — The Federation of International Country Air Personalities (FICAP) presents a worthy broadcaster with the Living Disc Jockey Hall of Fame Award each year. This year's award, presented during the FICAP banquet, went to long-time broadcaster and record executive **Biff Collie**. Congratulating Collie on the award in the above photo are (l-r): **Larry Scott**, PD at KJJJ/Phoenix; **Chuck Chellman**, Trustee of the D.J. Hall of Fame; in the background is **Mike Burger**, PD at WHOO/Orlando and President of FICAP; **Collie**; **Sharon Bell**, editor of the FICAP Voice; and **Charlie Douglas** with WWL/New Orleans.

Who is



Ask Burl Ives...
or call 615-889-7100

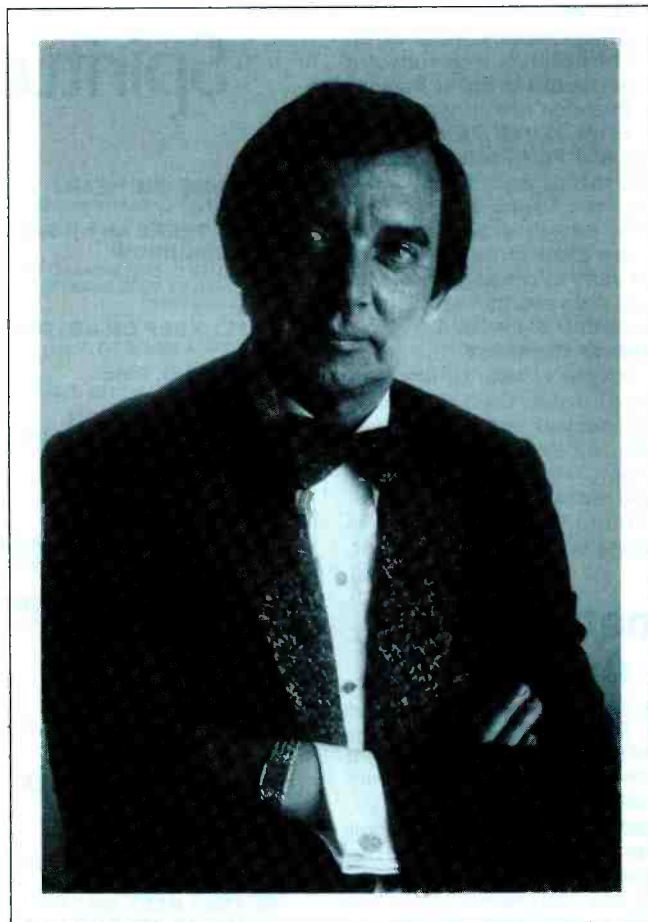

A warm HAND of friendship is extended to

RAY PRICE

as we welcome him to the Monument Family of Fine Artists.

Ray has long been renowned for putting HEART and SOUL
into every song interpretation. As a result he stands
HEAD and SHOULDERS above the crowd. His first Monument release is

FEET

(45-267)

which is already off and running to the top of the
charts. All of which has made us feel 10 FEET tall.

RAY PRICE, another reason why



Monument is Artistry

TWENTY ONE MUSIC SQUARE EAST, NASHVILLE, TENNESSEE 37203

GOSPEL

First Gospel Week Scheduled Nov. 5-8 At Opryland Hotel

by Bob Campbell

NASHVILLE — The 1st annual Gospel Music Week, sponsored by The Gospel Music Association (GMA), is set for this week (Nov. 5-8) at The Opryland Hotel here. The 10th annual Dove Awards Show will culminate Gospel Music Week Nov. 8 with a banquet/awards show in The Opryland Hotel.

Thirty-two instructional programs, including seminars, workshops and panel discussions, will highlight Gospel Music Week. In addition, six publishing companies will conduct six choral reading sessions on existing and new music.

Forty speakers will address such subjects as artist management, songwriting, motivation, sound equipment, contracts-copyrights, television, radio, marketability and development of talent, music publishing and record company's views. Speakers will include Mrs. Tex Ritter; "Hee Haw" producer Sam Lovullo; Jerry Clower, member of The Grand Ole Opry and humorist; Bill and Gloria Gaither, writers and artists; Tandy Rice, president of Top Billing; Irving Waugh, vice president of television production, Tree International and former president of WSM-TV; and Marijohn Wilkins, writer, artist, author and owner of Buckhorn Music Company.

17 Categories

Greentree artist Sharalee and former

professional basketball player Jerry Lucas will co-host the Dove Awards, which will be presented in 17 categories. A composer of gospel music and books as well as a pianist and violinist, Sharalee has appeared with such groups as the Johnny Mann Singers, the Spurrilows and Paul Johnson. Lucas, Sharalee's husband, also co-authored "The Memory Book," which stayed on the New York Times' best-seller book list for 50 weeks. "We are most fortunate to have Sharalee and Jerry Lucas as co-hosts for the 10th annual dove awards," said John T. Benson, III, president of the GMA.

Awards Presenters

Presenters for the 17 awards, which includes special awards for the Gospel Music Hall of Fame inductees and the Associate Award, are Senator Birch Bayh of Indiana, Jeannie C. Riley, Barry McGuire, Connie Smith, Larnelle Harris, Frances Preston, W. F. Myers, Dottie Rambo, Le Breska Hemphill, James Blackwood, Kurt Kaiser,

(continued on page 45)

Maranatha! Inks Word Agreement

SANTA ANA, Ca. — Beginning last week, all Maranatha! Music albums, tapes and songbooks will be distributed by word, Inc., Maranatha! Music president Chuck Fromm has announced

Fromm said Maranatha! Music will still operate under its present international distribution agreement, but Word will distribute the entire Maranatha! Music line throughout the United States. General advertising, public relations and radio relations will be conducted through Maranatha! Music, but trade advertising will be developed and placed through Word's advertising department.

Also remaining with Maranatha! will be responsibility for album and songbook selection, design and album production.

"We are very enthusiastic about linking our creative flow with the best sales force in the field," Fromm said. "This arrangement is something we have been praying about for a long time, and one which will allow Maranatha! to direct much time and energy toward the services it performs best — outreach ministries, including live concerts, television and the production of quality christian music."

TOP 20 ALBUMS

Spiritual

	Weeks On Chart	10/28
1 FROM THE HEART SHIRLEY CAESAR (Hob HBL 501 B)	1	8
2 (IS THERE ANY HOPE FOR) TOMORROW JAMES CLEVELAND AND THE CHARLES FOLD SINGERS VOL. 3 (Savoy 7020)	2	32
3 I'LL KEEP ON HOLDING ON MYRNA SUMMERS (Savoy 14483)	3	14
4 GOSPEL FIRE GOSPEL KEYNOTES (Nashboro 7202)	4	8
5 LIVE IN LONDON ANDRAE CROUCH & THE DISCIPLES (Light 5717)	5	18
6 DONALD VAILS CHORALEERS (Savoy 7019)	7	28
7 MAMA PRAYED FOR ME SENSATIONAL WILLIAMS BROS. (Savoy 14462)	11	36
8 TONIGHT'S THE NIGHT GOSPEL KEYNOTES (Nashboro 7187)	12	60
9 CHAPTER 5 INEZ ANDREWS (ABC/Songbird SB 269)	9	6
10 LOVE ALIVE WALTER HAWKINS & THE LOVE CENTER CHOIR (Light 5686)	6	70
11 WHEN JESUS COMES SARA JORDON POWELL (Savoy 14465)	8	44
12 JESUS IS COMING THE SENSATIONAL NIGHTINGALES (ABC/Peacock 29232)	13	4
13 VERY BEST OF THE MIGHTY CLOUDS OF JOY (ABC/Peacock AA 1091/2)	—	2
14 LIVE DOROTHY NORWOOD (LA DCP 1915)	14	10
15 FACE IT WITH A SMILE TESSIE HILL (ABC/Peacock PY 59233)	—	2
16 SINGING IN THE STREETS THE PILGRIM JUBILEE SINGERS (Nashboro 7198)	10	14
17 FIRST LADY SHIRLEY CAESAR (Hob HBL 500 B)	16	68
18 LOVE ALIVE II WALTER HAWKINS & THE LOVE CENTER CHOIR (Light LS 5735)	—	2
19 JOY! REV. MILTON BRUNSON & THOMPSON COMMUNITY CHOIR (Creed 3078)	19	4
20 LOVE AT CARNEGIE HALL JAMES CLEVELAND (Savoy 7014)	15	62

Inspirational

	Weeks On Chart	10/28
1 HAPPY MAN B.J. THOMAS (Myrrh MSB 6593)	1	10
2 MIRROR EVIE TOURNQUIST (Word WST 8735)	2	70
3 FOR HIM WHO HAS EARS TO HEAR KEITH GREEN (Sparrow 1015)	4	70
4 COSMIC COWBOY BARRY MCGUIRE (Sparrow SPR 1023)	14	4
5 HOME WHERE I BELONG B.J. THOMAS (Myrrh MSB 6574)	5	70
6 A LITTLE SONG OF JOY FOR MY LITTLE FRIENDS EVIE TOURNQUIST (Word WST 8745)	7	30
7 MUSIC MACHINE CANDLE (Birdwing BDWG 2004)	6	34
8 MANSION BUILDERS THE 2nd CHAPTER OF ACTS (Sparrow 1020)	3	26
9 PRAISE II VARIOUS ARTISTS (Maranatha 77-026)	10	6
10 GENTLE MOMENTS EVIE TOURNQUIST (Word WST 8714)	8	70
11 LIVE IN LONDON ANDRAE CROUCH & THE DISCIPLES (Light 5717)	13	12
12 AWAITING YOUR REPLY RESURRECTION BAND (Starsong SSR 0011)	—	2
13 TELL 'EM AGAIN DALLAS HOLM & PRAISE (Greentree R 3480)	—	2
14 PRAISE I VARIOUS ARTISTS (Maranatha 77-008)	17	4
15 EMERGING PHIL KEAGGY BAND (New Song NS 004)	11	20
16 COME BLESS THE LORD CONTINENTALS (New Life NL 77-76)	9	10
17 BETHLEHEM (Maranatha 77-040)	15	6
18 COMMUNION BIRDWING (BWR 2009)	12	10
19 FUN IN THE SON ISAAC AIR FREIGHT (Maranatha 77-039)	—	2
20 FIRST CLASS THE BOONE GIRLS (Lamb & Lion LL 1038)	16	8



GOSPEL MUSIC MONTH — Tennessee Gov. Ray Blanton recently proclaimed the month of November as "Gospel Music Month." Saying he was delighted with the steady growth of gospel music throughout the United States and the world, Blanton presented the proclamation to Don Butler (far left), executive director of the Gospel Music Association and Ed Shea (center), southern regional director of ASCAP.

Gospel Reviews

THE CREEK BANK SINGERS — "Dottie Rambo's Down By The Creek Bank" — Impact: R/3484 — Producer: Joe Huffman — List: 6.98.

Dottie Rambo and Dave Huntsinger deserve a special Dove award for this incredible "little" album. Kids from one to a hundred will love "Down By The Creek Bank." "The Creek Bank Singers" are 27 kids, directed by Floyd Parker, from Berea First Baptist Church in Greenville, S.C. They are Stars! And their performance is heavenly. Dottie's creative genius powers the project with masterpieces such as: "Germs," (a beautiful story inspired by daughter Reba's imaginary canine playmate) "I Am Adopted," "Love Is," and "Multiply" (written with Huntsinger). If the disenfranchised "children" of this world are heard, "Down By The Creek Bank," will fill radio playlists in both religious and secular markets.



LEN MINK — "Garment Or Praise" — Tempo: R-7218 — Producers: Jesse Peterson & Dan Posthuma — List: 6.98.

Len Mink and his producers have exquisitely tailored, "Garment Of Praise." Song selection is intelligent and chronologically cohesive. Production and arrangements are complimentary from the standpoint of song content. And the star of the package is Mink's baritone — smooth as his namesake and equally rich. Mink glides up and down the vocal staircase from the basement to the balcony. Most effective are "He Was There All The Time," (G.S. Paxton's classic) "Free At Last," Barry McGuire's "Communion Song," and the traditional "Power In The Blood." Mink is from the "Gaither school of music" and has graduated Phi Beta Kappa.

DOROTHY NORWOOD — "Live" — LA: LADCP 1915 — Producer: Lawrence Roberts — List: 6.98.

Remember? You were young and the pastor of the small congregation, of which your family was a member, announced an upcoming revival, complete with visiting evangelist and minister of music. And then the hallowed week arrived and you were sitting on your knees at the edge of an inside pew, clutching a mason jar of ice water, knowing full well that the tingle of excitement running through the air meant something special was happening. And when the music started and swept through the crowd like a tornado, you were entranced. That aura is precisely what Dorothy Norwood has captured. This album, recorded live at the First Baptist Church in Nutley, N.J., includes "A Mother Cries," "Have A Little Talk With Jesus," and "I Surrender All."

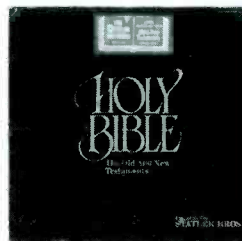

THE STATLER BROTHERS — "Holy Bible" — Mercury: SRM-2-101 — Producer: Jerry Kennedy — List: 10.98.

Recording an album, even a two-record set, concerning The Holy Bible, is an ambitious project to say the least. The Statler Brothers found this to be more than true. They spent eight years on this project. The two-record set, one side devoted to the old testament and the other the new testament, chronicles the creation, Moses, Samson, David, Solomon, and the prophets. The second record tells of Jesus' earthly reign. It also includes a superb interpretation of Stuart K. Hine's immortal, "How Great Thou Art." The Statlers, seven time winners of CMA group honors may add a Dove award to their collection.

GOSPEL

Gospel News

NASHVILLE — **B.J. Thomas**, who converted to Christianity a couple of years ago, has now written a book which tells of his rise to fame, his downhill ride with drugs and his eventual conversion. "Home Where I Belong," written along with **Jerry B. Jenkins**, graphically describes his self-destructive nine-year drug addiction in which he nearly died several times from excessive amounts of uppers, downers and cocaine. Thomas' Myrrh album, "Home Where I Belong," rides the #1 spot on **Cash Box's** Inspirational Album chart this week and won a 1978 Grammy for "Best Inspirational Performance."

Lamb & Lion Records is scheduling major recording projects for this fall and winter. **Dan Peek**, a founding member of the pop group, "America," is working on his first solo album for the label with **Chris Christian** doing the production work. **Pat Boone** has been in the studio working on a solo album using the production services of **Paul Johnson**. His first solo album since "Texas Woman," Boone's new LP is reportedly incorporating a big band, MOR feel. **Wendell Burton** and **DeGarmo & Key** will also record new albums this fall. **Dan Collins** will produce Burton, who will write, arrange and sing lead vocals on the entire album. Described as a straight ahead rock 'n' roll group with straight ahead Christian lyrics, "DeGarmo & Key" will roll into the studio in December for work on their second album.

Randall Hames of **The Hames Quartet** likes to buy old airplanes and rebuild them. Only 22-years-old, Hames first bought a plane five years ago when he purchased a 1946 Taylorcraft. He recently bought and rebuilt a two-place Pitts Special which had once belonged to a Georgia cropduster who was killed in an airplane accident. At one point, Hames owned three airplanes.

Myrrh Records, a division of Word, Inc. has announced the signing of the new Christian rock group **Glad**, and the release of its new album by the same name. **John Bolles**, **Bob Kaufflin** and **Ed Nalle** of the five-member group, have written all of the group's material for the album. "The word 'gospel' means good news," Bolles said. "But people frequently don't think the message of Christ is either good or is news. Changing that frame of mind is one thing we are trying to do."

Word's **Evie Tournquist** has become the first gospel artist who has ever received an accredited Gold Record Award in Australia, and Sacred Production in Australia (Word's Australian distributor) has released a special promotion on all of Evie's albums. Included in the promotion are car stickers, gold album stickers, special mailers, brochures and a life-size 4' 11" color stand up of Evie which will appear in Australian record stores. In honor of the "Gentle Moments" LP, the Evie promotional campaign will carry the theme, "Thank you Australia, Gentle Moments Is Gold."

The Christian management agency of Linda Miller and Associates has announced three additions to its staff. **Marlaine Yunt** is the new administrative assistant, **Norma Boyd**, who served for 10 years as executive secretary of the Gospel Music Association, will work as business manager and **Frances Fuqua** is the new artist representative.

Cynthia Clawson and **Ragan Courtney** will be the featured guests at **The Bill Gaither Praise Gathering** Nov. 16-19 in Indianapolis, Ind. Clawson and Courtney have also signed an exclusive writers' agreement with Triune Music, Inc.

Robert Hale and **Dean Wilder** have recorded a new album for Word, Inc. titled, "Shenandoah."

Triangle Records' **David Ford**, former bass soloist for the **Robert Shaw Chorale**, will be featured as **Elijah** in two special presentations of "Elijah" in Houston, Tx. on Oct. 27-29. Ford will also be involved in the fourth annual performance of the "Messiah" by the Mozart Club in Winston-Salem, North Carolina on Dec. 3.

Linda Miller and Associates and Limited Edition Talent, Inc. have announced the signing of writer **George Gagliardi** to an exclusive booking and management agreement. **Cynthia Clawson** and **David Ford** are among the gospel artists who have recorded the songs.

Buryl Red and **Ragan Courtney** have recently completed a new musical, "The Acts of the Apostles," which premiered last week at The Texas Baptist Convention in Austin, Tx. The musical is published by Triune Music, Inc. and will be released in January of next year. It will be programmed in all the Texas State Musical festivals in the spring of 1979.

Myrrh artist **David Meece** was the featured contemporary Christian performer at the recent Baptist World Youth Cog Congress in Manila, Philippines. Meece has been working on his third album under the production of **Brown Bannister**.

"A Christian Perspective on Halloween," a one-hour radio special hosted by **WFIL's Tom Dooley** and featuring **Mike Warnke**, has been made available for use around Halloween this year.

Chuck Gilard is nearly through with his fourth album for Good News Records. This new album will be lighter in vein than "Written On The Wind," his previous release.

The legendary **Blackwood Brothers** recently toured the Iron Curtain countries of Russia and Finland and found there are a handful of church-going Christians thriving in those communist countries. In spite of searches, The Blackwood Brothers also managed to smuggle many Bibles printed in Russian into the communist countries.

by bob campbell



EVIE GOES GOLD IN AUSTRALIA — Sacred Productions of Australia (Word's Australian distributor) has announced that **Evie Tournquist's** word album, "Gentle Moments," has become the first gospel album ever to receive a gold award by the Australian Record Industry Association. An Australian Gold Record represents sales in excess of 20,000 copies. Shown at the presentation are (l-r): **Stan Moulton**, joint managing director of Sacred Productions, Australia; **Dan Johnson**, Word Record promotion director; **Stan Moser**, Word vice president of marketing; **Evie**; **Lennar Sjöholm**, producer; and **Roland Lundy**, Word vice president of record sales.

First Gospel Week Scheduled Nov. 5-8 At Orpyland Hotel

(continued from page 44)

Paul and **Kathie Lee Johnson**, **Jarrell McCracken**, **Candy Hemphill**, **Cindy Cruse**, **Kelly Nelson**, **Amy Grant**, **Cam** and **Cher Floria**, **Gary McSpadden**, **Johnny Zell** and **Doug Oldham**.

Ralph Carmichael and orchestra will play a medley of the top 10 gospel songs of the year. Special entertainment will be provided by **The Couriers**, **B.J. Thomas**, **Dave Boyer**, **Cathedral Quartet**, **The Mighty Clouds of Joy**, **Reba Rambo**, **Evie Tournquist**, **Shirley Caesar** and **Johnny Zell** of **The Lawrence Welk Show**.

Categories include "Male Gospel Group," "Song of the Year," "Contemporary Gospel Record Album of the Year," "Traditional Gospel Album of the Year," "Inspirational Gospel Album of the Year," "Gospel Record Album of the Year by a Non-Gospel Artist," "Soul Gospel Record Album of the Year," "Male Gospel Vocalist," "Female Gospel Vocalist," "Gospel Songwriter of the Year," "Gospel Instrumentalist," "Gospel Disc Jockey of the Year," "Gospel Television Program," "Backliner Notes of a Gospel Record Album," "Graphic Layout and Design of a Gospel Record Album" and "Gospel Record Album Cover Photo or Record Album Cover Art."

Nominees for "Gospel Song of the Year" include "Born Again," "Free," "He's Alive," "I Believe He's Coming Back," "I'm Standing On The Solid Rock," "Learning To Lean," "Ordinary People," "Rise Again," "Sun's Coming Up" and "Your Love Broke Through."

Greentree Releases Andrus/Blackwood LP

NASHVILLE — Greentree Recording group **Andrus/Blackwood & Co.** has just released a new, double album "Following You," containing 18 songs. Produced by **Phil Johnson**, the album features material by gospel writers **Johnson**, **Tim Sheppard** and **Bruce Hibbard**.

Greentree is a division of **The Benson Co.**, and Benson plans a marketing and merchandising campaign in support of the album. A merchandising kit will be mailed to the top 500 accounts in the top 200 markets and will include posters, four window banners, taped 60-and-30-second radio spots, camera-ready ad slick, artist biography, artist itinerary and a co-op information sheet.

Nominees for "Male Gospel Vocalist" include **James Blackwood**, **Larnelle Harris**, **Dallas Holm**, **Rex Nelson** and **Doug Oldham**. Nominees for "Female Gospel Vocalist" include **Cynthia Clawson**, **Reba Rambo Gardner**, **Vestal Goodman**, **Janet Paschal** and **Evie Tournquist**.

"Contemporary Gospel Record Album of the Year" nominees include "Fresh Surrender" by **The Archers**; "Grand Opening" by **Andrus Blackwood & Co.**; "Tell Them Again" by **Dallas Holm** and **Praise**; "The Lady Is A Child" by **Reba Rambo Gardner**; and "Transformation" by **the Cruse Family**.

Nominees for the "Inspirational Gospel Album of the Year" include "Expressions" by **Walt Mills**; "Free" by **Larnelle Harris**; "Have A Nice Day" by **Lanny Wolfde**; "Pilgrim's Progress" by **The Bill Gaither Trio**; and "Somebody Like You" by **Phil Johnson**.

"Gospel Songwriter of the Year" nominees are **Chris Christian**, **Bill Gaither**, **Dallas Holm**, **Harold Lane**, **Gary S. Paxton** and **Dottie Rambo**.

ASCAP Holding Gospel Luncheon

NASHVILLE — The American Society of Composers, Authors and Publishers will hold its second annual Gospel Appreciation Luncheon Nov. 6 at **The Opryland Hotel**, announced **Ed Shea**, ASCAP southern regional director. The luncheon will be held in conjunction with **Gospel Music Week** festivities.



LIGHT RECORDS HOSTS LUNCHEON — In honor of **Walter Hawkins** and his wife, **Tramaine**, **Light Records** recently hosted a luncheon at the **Sheraton Universal Hotel** in Hollywood, Ca. **Hawkins'** new album is "Love Alive II", and his wife has just signed as a solo artist on the **Light Label**. Shown (l-r) are: **Ralph Carmichael**, **Light Records** president; **Tramaine Hawkins**; and **Bill Cole**, **Light Records A&R**.

GOSPEL MUSIC WEEK PROGRAM

	SUNDAY	MONDAY	TUESDAY	WEDNESDAY
		Eye Opener Coffee/Danish	General Membership Meeting Coffee/Danish Will Be Served	Eye Opener Coffee/Danish
8:30-9:30		Music To Start Your Day B. Benson		Music To Start Your Day B. Benson
9:45-10:45		M:9A—Artist Management T. Rice—J. Clower M:9B—On Stage: Lights, Sound, Presence J. Rosen—R. Coker M:9C—Song Writing C. Christian—P. Johnson M:9D—Choral Reading Session Broadman Press	T:9A—Motivation D. Johnson T:9B—Sound Equipment Presented by the Shure Company T:9C—Contracts—Copyrights D. Ludwig—B. Thompson—M. Milam T:9D—Choral Reading Session Benson Publishing Co.	W:9A—Marketability and Development of Talent D. Back—J. Moscheo—J. Sturdivant W:9B—Multi Media W. Buchanan W:9C—Music Publishing E. Benson—A. Brown—H. Spencer—B. Killen W:9D—Choral Reading Session Lilienas Publishing Co.
11:00-12:00		M:11A—Television; Syndication/Production S. Lovullo—R. Markowitz M:11B—Promotion: Colleges/Concerts/Fairs J. Sullivan—J. Norman—L. Peyton M:11C—Song Writing B. Gaither—G. Galtner M:11D—Choral Reading Session Gospel Publishing House	T:11A—Television J. Waugh T:11B—Radio D. McKinnan—G. Holmes— T:11C—Custom Recording J. Huffman—M. LeFevre—G. Ingram T:11D—Choral Reading Session Triune Music Co.	W:11A—Television: Ministry/Career J. Moss W:11B—Record Company's Views B. Mackenzie—S. Moser—S. Byrd—B. Garner W:11C—Sound Equipment Presentation by the Bose Company W:11D—Choral Reading Session Manna Music
12:15-1:45	Free Time	Free Time	Free Time	Free Time
2:00-3:00	Registration	M:2A—Opry House Tour Mrs. T. Ritter M:2B—A Visit With T.B.A.	T:2A—Opry House Tour Mrs. T. Ritter T:2B—A Visit With A. Orland	W:2A—Tour Opryland Mrs. T. Ritter W:2B—Ready, Set, Remember J. Lucus
3:30-5:00		Artist Showcase	Artist Showcase	Free Time
5:30-7:00	Free Time	Free Time	Free Time	
7:30-10:00	Gospel Music '78 Ballroom	Gospel Music '78 Ballroom	Jesus Music Festival Inc. In. Rgstr. Fee (\$1.50 To Gen. Public)	10th Annual Dove Awards Banquet

DISCO

Disco Breaks

CHECK YOUR MAILBOX — Invitations were mailed last week for the upcoming national meeting of regional record pool representatives, which will be held in Miami, Fla., Nov. 13-14. The **Coconut Grove Hotel** has been chosen as the site for these important meetings. For reservations call: 305-858-2500 (and don't forget to ask for the special rate). The tentative agenda contains three major sections: **Topic A** is a closed meeting of the elected regional pool heads in which the qualifications for membership and the formation of a national association of record pools will be discussed. Other pool heads may attend as observers. **Topic B** will concern relations with record companies and the formulation of a uniform feedback system to include both individual and composite responses. In the latter part of this meeting, record company spokespersons will be invited to air their companies' view of various feedback systems in addition to general remarks concerning the proposed national trade association. **Topic C** will be an open session to discuss relations with the trade papers. Representatives from the trades will be invited to speak.

GOING EARLY? — If you are in Miami on Nov. 10-11, check out the two-day event, "Disco Explosion," which is being staged by Project Masters and Y-100 at the 5,000 capacity Miami Expo Center. **Sylvester, Karen Young, Afro-Cuban Band** and **Cissy Houston** are scheduled to appear. Four local jocks will spin: **Bob Eckenwiler** from Uncle Charlie's in Miami, **John Terry** from Button in Ft. Lauderdale, **Carlos Nodal** from Honey For The Bears in Coconut Grove and **Barbara Jane Graham** from Pete And Lenny's in Ft. Lauderdale. In addition to partying, there will be 30 exhibition booths displaying the latest in sound equipment, dance instruction, clothes and hair styles etc. **Bo Crane** from the Florida Record Pool is acting as a consultant to the two-day affair.

PEOPLE IN THE NEWS — **Ray Cavlano**, vice president of special projects for TK, has resigned from his position, effective Nov. 3. This move is part of Ray's overall gameplan which is expected to reach fruition within four to five weeks. An informal listening party of projected product was held last week in NYC and **Judy Weinstein** reports the product is "incredibly hot." **Dan Joseph**, newly appointed director of national disco promotion, is standing in Ray's stead at TK. . . **Alan-Michael Mamber** who was national disco promotion for Salsoul has left the company. Alan reports that he is taking time to consider his next move. Prior to joining Salsoul four months ago, Alan was at West End for two years.

(continued on page 54)

~REVIEWS~

FIRST CHOICE — **Hold Your Horses** — **Gold Mind GG 401** — 12" — 5:50

Spinning at 33rpm with a new list of \$3.98, this track, produced by Tom Moulton and Thor Balursson, opens with a galloping conga beat for easy segueing. Strings, piano and guitars join and build to the chorus. Rochelle Fleming's lead vocals start low and funky and then climb the mountain. A piano break with overhead sawing strings is effective. Well-textured, this record ought to hold up well under repeated play.

DENISE MCCANN — **Tattoo Man** — **Butterfly BR-1245/2** — 12" — 5:16 — **Promo Only**

This first 12" taken from McCann's "Tattoo Man" album ("Midnight Madness" will be the second) is a new hybrid direct-to-disc disco recording. The bass tracks have an exciting vibrancy and instrument separation is well-achieved. Horns ride on top backing the upfront vocals. Tambourine and congas add texture. Cowbell and congas highlight a break. Backed by the perky R&B-influenced "I Don't Wanna Forget You." 45 rpm.

RADIO

DISCO

HIGHLIGHTS

WKTU — NEW YORK — MATTHEW CLENOTT

HOT ROTATION:

Keep On Jumpin'/In The Bush — Musique — Prelude
MacArthur Park — Donna Summer — Casablanca
Instant Replay — Dan Hartman — Blue Sky
Never Let Go — Eastbound Expressway — AVI
Victim — Candi Staton — Warner Bros.
I Love The Night Life (Disco Round) — Alicia Bridges — Polydor
#1 Dee Jay — Goody Goody — Atlantic
Only You — Teddy Pendergrass — Phila. Int'l.
YMCA — Village People — Casablanca
One Nation Under A Groove — Funkadelic — Warner Bros.

HIT BOUND:

Chains — Bionic Boogie — Polydor
Your Sweetness Is My Weakness — Barry White — 20th Century
Giving Up, Giving In — Three Degrees — Ariola
Workin' & Slavin' — Midnight Rhythm — Atlantic
A Little Lovin' (Keeps The Doctor Away) — The Raes — A&M
Dance To The Drummer's Beat — Herman Kelly — TK
Le Freak — Chic — Atlantic
Je Suis Music — Cerrone — Cotillion
Shoot Me With Your Love — Tasha Thomas — Orbit
Shake Your Groove Thing — Peaches & Herb — Polydor

WBOS — BOSTON — JANE DUNKLEE

HOT ROTATION:

MacArthur Park — Donna Summer — Casablanca
Le Freak — Chic — Atlantic
I Love The Night Life — Alicia Bridges — Polydor
Instant Replay — Dan Hartman — Blue Sky

Eyes In The Back Of My Head — Patti LaBelle — Epic

Freak With Me — Universal Robot Band — Red Greg
Victim — Candi Staton — Warner Bros.
Standing In The Shadows Of Love — Deborah Washington — Ariola
Cruisin' — Village People — Casablanca
Dancin' In My Feet — Laura Taylor — TK

HIT BOUND:

Giving Up, Giving In — Three Degrees — Ariola
Plug Me To Death/Love Disco Style — Erotic Drum Band — Prism
Chains — Bionic Boogie — Polydor
Shake Your Groove Thing — Peaches & Herb — Polydor
Workin' & Slavin' — Midnight Rhythm — Atlantic
Je Suis Music — Cerrone — Cotillion

WLYT-FM — CLEVELAND — FREDDIE JAMES

HOT ROTATION:

MacArthur Park — D. Summer — Casablanca
Instant Replay — Dan Hartman — Blue Sky
Keep On Jumpin'/In The Bush — Musique — Prelude
I'm A Man — Macho — Prelude
I Love The Night Life — Alicia Bridges — Polydor
Cruisin' — Village People — Casablanca
Victim — Candi Staton — Warner Bros.
Burnin' — Carol Douglas — MCA
Dance (Disco Heat) — Sylvester — Fantasy
#1 Dee Jay — Goody Goody — Atlantic

HIT BOUND:

Change — Zulema — London
I Wanna Make It On My Own — Evelyn Thomas — Casablanca
Never Let Go — Eastbound Expressway — AVI
Bring On The Love — Gloria Jones — Capitol
Standing In The Shadows Of Love — Fever — Fantasy

TOP 30 DISCO

	Weeks On Chart		Weeks On Chart
1	11/4	MACARTHUR PARK SUITE DONNA SUMMER (Casablanca — LP)	1 3
2		I LOVE THE NIGHT LIFE (DISCO ROUND)* ALICIA BRIDGES (Polydor 12")	2 3
3		AIN'T THAT ENOUGH FOR YOU* JOHN DAVIS & THE MONSTER ORCH. (Sam LP/12")	4 3
4		LE FREAK* CHIC (Atlantic — 12")	6 3
5		KEEP ON JUMPIN'/IN THE BUSH MUSIQUE (Prelude — 12")	5 3
6		INSTANT REPLAY* DAN HARTMAN (Blue Sky — 12")	3 3
7		DANCIN' IN MY FEET* LAURA TAYLOR (TK — 12")	9 3
8		MY CLAIM TO FAME/TRUE LOVE IS MY DESTINY JAMES WELLS (AVI — LP)	13 3
9		BEAUTIFUL BEND — (all cuts) BORIS MIDNEY (Marlin/TK — LP)	8 3
10		I'M A MAN MACHO (Prelude — LP/12")	10 3
11		CRUISIN' VILLAGE PEOPLE (Casablanca — LP)	14 3
12		MR. D.J. YOU KNOW HOW TO MAKE ME DANCE THE GLASS FAMILY (JDC — LP)	12 3
13		SUPERSTAR BOB MCGILPIN (Butterfly — 12" Remix)	7 3
14		YOU STEPPED INTO MY LIFE* MELBA MOORE (Epic — 12")	18 3
15		WORKIN' & SLAVIN'* MIDNIGHT RHYTHM (Atlantic 12")	20 3
16		QUEEN OF THE NIGHT (all cuts) LOLEATTA HOLLOWAY (Gold Mind — LP)	17 3
17		OUR MS. BROOKS (all cuts) PATTIE BROOKS (Casablanca — LP)	19 3
18		SHAKE YOUR GROOVE THING PEACHES & HERB (Polydor — 12")	26 2
19		CERRONE IV CERRONE (Cotillion — LP)	28 2
20		JUNGLE D.J. KIKROKOS (Polydor — LP)	21 3
21		A LITTLE LOVIN' (KEEPS THE DOCTOR AWAY) THE RAES (A&M — LP)	24 3
22		STARCRUISER (all cuts) GREGG DIAMOND (Marlin/TK — LP)	16 3
23		YOU MAKE ME FEEL (MIGHTY REAL)/DANCE (DISCO HEAT) SYLVESTER (Fantasy — 12")	15 3
24		STANDING IN THE SHADOWS OF LOVE DEBORAH WASHINGTON (Ariola — 12")	22 3
25		CHAINS/CREAM ALWAYS RISES BIONIC BOOGIE (Polydor — LP)	— 1
26		YOUR SWEETNESS IS MY WEAKNESS BARRY WHITE (20th Century — 12")	29 3
27		PLUG ME TO DEATH/LOVE DISCO STYLE EROTIC DRUM BAND (Prism — LP)	25 3
28		DOIN' THE BEST THAT I CAN BETTY LAVETTE (West End — 12" Remix)	— 1
29		STANDING IN THE SHADOWS OF LOVE* FEVER (Fantasy — 12")	30 2
30		ONE NATION UNDER A GROOVE FUNKADELIC (Warner Bros. — 12")	— 1

Compiled from audience response as reported from top Disco programming artists.

*12" available for sale

PROGRAMMERS PICKS

MUST SPIN

CAN'T MISS

Danae Joacvidis Boston	Instant Replay Dan Hartman — Blue Sky	Hold Your Horses First Choice — Salsoul
Tony Smith New York	Shake Your Groove Thing Peaches & Herb — Polydor	Contact Edwin Starr — 20th Century
Danny Krivit New York	In The Bush Musique — Prelude	You Saved My Day Cheryl Lynn — Columbia
Jack Olson Seattle	Plug Me To Death Erotic Drum Band — Prism	La Bamba Anthony Rodriguez — IGM
Earl Reed Chicago	Shake Your Groove Thing Peaches & Herb — Polydor	Sing Sing Gaz — Salsoul
Cosmo Wyatt Boston	Je Suis Music Cerrone — Cotillion	Giving Up, Giving In Three Degrees — Ariola
Steve Nader Detroit	Shake Your Groove Thing Peaches & Herb — Polydor	Standing In The Shadows Fever — Fantasy
Jim Knapp Tampa	MacArthur Park Donna Summer — Casablanca	Will They Miss Me David Simmons — Fantasy
Al Paez New Orleans	Cerrone IV Cerrone — Cotillion	Wonder Woman Wonderland Band — R.S. Int'l.
Bob Lombardi Miami	Le Freak Chic — Atlantic	Double Love Crackin' — Warner Bros.
Rusty Garner Los Angeles	I'm In You Samba Soul — RCA	Ready To Roll Thelma Houston — Tamla
Tim Rivers San Francisco	Feed The Flame Lorraine Johnson — Prelude	Music Is All We Need T.H.P. Orchestra — Butterfly
Manny Sllal Los Angeles	MacArthur Park Donna Summer — Casablanca	Feed The Flame Lorraine Johnson — Prelude
Frank Sesito Philadelphia	Ready To Roll Thelma Houston — Tamla	I Will Survive Gloria Gaynor — Polydor
Frank Lembo Philadelphia	C'est Chic Chic — Atlantic	Ready To Roll Thelma Houston — Tamla

8 Tough Acts to Follow,

but so easy to dance to...

1. EVELYN "CHAMPAGNE" KING—"I Don't Know If It's Right" PD-11415 From her album "SMOOTH TALK" APL1-2466
2. ODYSSEY—"Single Again" PD-11400 From their latest album "HOLLYWOOD PARTY TONIGHT" AFL1-3031
3. SHALAMAR—"Take That to the Bank" YD-11354 From their new album "DISCO GARDENS" BXL1-2895
4. LAKESIDE—"It's All the Way Live" YD-11382 From their debut album "SHOT OF LOVE" BXL1-2937
5. GREY & HANKS—"You Fooled Me" (Part I & II) PD-11347
6. SOLAR FLARE—"Boogie Fund" PD-11335
7. NYCC—"I'll Keep My Light in My Window" PD-11372 From "MAKE EVERY DAY COUNT" APL1-2782
8. BUFFALO SMOKE—"Stubborn Kind of Fella" PD-11368

Our latest array of disco
singles (12").

RCA



REGIONAL PROGRAMMING GUIDE

(continued from page 27)

KTLK — DENVER — PAULA MATTHEWS, MD

3-1 — A. Murray. JUMPS: 32 To 20 — Barbra/Neil, 27 To 23 — A. Stewart, 25 To 21 — Heart, 20 To 16 — A. Gibb, 16 To 11 — Ambrosia, 7 To 4 — K. Loggins, Ex To 35 — A. Cooper, Ex To 32 — P. Davis, Ex To 31 — Sylvester. ADDS: Toto, Elton John, B. Joel, Village People.

KIMN — DENVER — ED GREENE, MD

2-1 — A. Murray. JUMPS: 23 To 16 — C. Gayle, 16 To 13 — Stones, 14 To 8 — D. Summer, 10 To 6 — Ambrosia. ADDS: A. Gibb, Fogelberg/Weisberg, E. Carmen.

KASH — EUGENE — BILL DUDLEY, PD & MD

1-1 — Meat Loaf. JUMPS: 26 To 17 — A. Frehley, 25 To 22 — A. Gibb, 24 To 16 — Player, 19 To 15 — Toto, 16 To 10 — G. Vannelli, 14 To 9 — J. Hayward, 7 To 3 — A. Stewart, Ex To 30 — E. Carmen, Ex To 24 — Elton John, Ex To 20 — Barbra/Neil. ADDS: B. Joel, N. Gilder, B. Seger.

KYNO — FRESNO — CHRIS VAN CAMP, MD

1-1 — Exile. JUMPS: 27 To 23 — Chicago, 26 To 20 — A. Gibb, 25 To 21 — C. Gayle, 23 To 17 — G. Vannelli, 21 To 18 — Stones, 19 To 14 — K. Loggins, 17 To 13 — Dr. Hook, 15 To 11 — Foreigner, 13 To 9 — B. Manilow, 11 To 8 — D. Summer, 10 To 6 — Ambrosia, Ex To 25 — Barbra/Neil. ADDS: E. Clapton, A. Cooper, G. Campbell, Hot Chocolate, P. Tosh, Queen, Cars, B. Joel.

KENO — LAS VEGAS — STEVE SOMMERS, MD

4-1 — B. Joel. JUMPS: 30 To 22 — Styx, 29 To 21 — S. Bishop, 21 To 18 — Stones, 20 To 13 — Journey, 19 To 14 — Foxy, 18 To 10 — ARS, 16 To 8 — Pablo Cruise, 15 To 11 — G. Vannelli, Ex To 30 — Firefall, Ex To 29 — Toto, Ex To 28 — A. Gibb, Ex To 27 — A. Stewart. ADDS: P. Davis, Barbra/Neil, A. Cooper, B. Seger.

KRTH — LOS ANGELES — BOB HAMILTON, PD & MD

1-1 — N. Gilder. JUMPS: 30 To 24 — Hall & Oates, 27 To 22 — Village People, 24 To 20 — L. Ronstadt, 23 To 19 — A. Gibb, 21 To 15 — Toto, 20 To 17 — Chicago, 17 To 12 — Sylvester, 16 To 10 — Barbra/Neil, 11 To 9 — Stones, 9 To 7 — Ambrosia, 7 To 5 — D. Summer, Ex To 30 — L. Taylor, Ex To 29 — Chic. ADDS: 26 — Funkadelic.

KHJ — LOS ANGELES — STEVE CASEY, MD

1-1 — N. Gilder. JUMPS: 29 To 24 — G. Vannelli, 25 To 13 — Barbra/Neil, 15 To 9 — Ambrosia, 9 To 7 — B. Manilow, 7 To 4 — D. Summer, 6 To 3 — Foxy. ADDS: 30 — Queen, 29 — Pablo Cruise.

10Q — LOS ANGELES — GARY GREENBERG, MD

1-1 — N. Gilder. JUMPS: 30 To 20 — Toto, 29 To 23 — Pablo Cruise, 27 To 18 — Styx, 25 To 22 — A. Stewart, 24 To 21 — G. Vannelli, 23 To 15 — Dr. Hook, 18 To 14, Foreigner, 13 To 10 — B. Manilow, 9 To 7 — D. Summer, 8 To 6 — Ambrosia, 7 To 3 — Foxy. ADDS: 30 — Village People, 29 — Elton John, 28 — A. Gibb.

KOPA — PHOENIX — STEVE RIVERS, MD

3-1 — A. Murray. JUMPS: 30 To 24 — B. Joel, 29 To 22 — D. Hartman, 28 To 23 — Toto, 26 To 20 — B. Bridges, 25 To 21 — Firefall, 23 To 18 — Styx, 21 To 14 — A. Stewart, 19 To 15 — Pablo Cruise, 16 To 11 — G. Vannelli, 13 To 6 — Ambrosia, 10 To 3 — D. Summer, 9 To 5 — Who, 4 To 2 — Foreigner, Ex To 30 — V. Morrison, Ex To 29 — P. Davis, Ex To 28 — B. Seger, Ex To 27 — Chicago, Ex To 26 — Barbra/Neil. ADDS: Elton John, Village People, Queen, Chic.

KGW — PORTLAND — TERRY DANNER, MD

2-1 — Captain & Tennille. JUMPS: 23 To 20 — P. Davis, 21 To 11 — Barbra/Neil, 18 To 15 — E. Carmen, 17 To 8 — D. Gates, 9 To 5 — G. Vannelli, Ex To 25 — G. Campbell, Ex To 24 — A. Cooper, Ex To 23 — A. Joel. ADDS: L. Taylor, J. Hayward, L. Ronstadt.

KPAM — PORTLAND — MICHAEL O'BRIAN, MD

2-1 — Ambrosia. JUMPS: 28 To 23 — Pablo Cruise, 25 To 18 — A. Gibb, 20 To 17 — P. Davis, 19 To 12 — A. Bridges, 18 To 15 — C. Gayle, 16 To 9 — Dr. Hook, 15 To 11 — G. Vannelli, 12 To 7 — B. Manilow, 9 To 5 — Foreigner, 7 To 2 — D. Summer, Ex To 30 — E. Carmen, Ex To 29 — Firefall, Ex To 28 — A. Stewart, Ex To 27 — Barbra/Neil. ADDS: Fogelberg/Weisberg, Toto, E. Clapton, B. Joel, Elton John.

KROY — SACRAMENTO — CHRIS MITCHELL, MD

1-1 — N. Gilder. JUMPS: 30 To 27 — Styx, 29 To 23 — Sylvester, 27 To 21 — A. Bridges, 23 To 20 — Chicago, 16 To 12 — Captain & Tennille, 15 To 11 — J. Travolta, 14 To 9 — B. Manilow, 13 To 10 — Foreigner, 11 To 8 — Ambrosia, 8 To 4 — D. Summer, Ex To 30 — Firefall, Ex To 29 — Barbra/Neil, Ex To 28 — A. Stewart, Ex To 26 — Heart, Ex To 24 — P. Davis, Ex To 22 — Dr. Hook.

KCPX — SALT LAKE CITY — GARY WALDRON, MD

2-1 — K. Loggins. JUMPS: 30 To 26 — Styx, 29 To 25 — Lindisfarne, 27 To 22 — Barbra/Neil, 26 To 14 — B. Joel, 25 To 21 — Chicago, 23 To 20 — P. Davis, 19 To 13 — E. Carmen, 15 To 12 — A. Gibb, 14 To 9 — Dr. Hook, 12 To 7 — D. Summer, 10 To 8 — C. Gayle, 9 To 6 — Foreigner, 8 To 3 — Ambrosia, 7 To 5 — Who. ADDS: Fogelberg/Weisberg, Hot Chocolate, A. Bridges, A. Cooper.

KRSP — SALT LAKE CITY — LORRAINE WINNEGAR, MD

1-1 — Ambrosia. JUMPS: 27 To 19 — Elton John, 26 To 23 — P. Davis, 25 To 22 — A. Gibb, 20 To 16 — Chicago, 18 To 14 — A. Stewart, 16 To 12 — Firefall, 15 To 11 — G. Vannelli, 14 To 10 — Fogelberg/Weisberg, 4 To 2 — Dr. Hook, Ex To 26 — B. Joel, Ex To 25 — Barbra/Neil. ADDS: E. Carmen, L. Ronstadt, Toto, A. Bridges.

B-100 — SAN DIEGO — C.C. MCCARTNEY, MD

5-1 — Who. JUMPS: 30 To 27 — L. Taylor, 28 To 25 — W. Egan, 27 To 15 — Chicago, 24 To 21 — ARS, 18 To 14 — Stonebolt, 14 To 11 — Heart, 12 To 8 — Styx, 11 To 7 — B. Joel, 8 To 6 — Ambrosia, Ex To 30 — B. Seger, Ex To 29 — A. Stewart, Ex To 28 — Toto. ADDS: Elton John, ELO.

KCBQ — SAN DIEGO — NINA GOMEZ, MD

4-1 — Foreigner. JUMPS: 33 To 22 — Barbra/Neil, 32 To 29 — Fogelberg/Weisberg, 31 To 24 — A. Stewart, 30 To 27 — Funkadelic, 29 To 26 — Firefall, 28 To 25 — A. Gibb, 26 To 23 — Toto, 24 To 21 — W. Egan, 23 To 20 — G. Vannelli, 22 To 15 — Chicago, 21 To 18 — Dr. Hook, 20 To 17 — Captain & Tennille, 18 To 13 — B. Manilow, 12 To 9 — J.P. Young, 15 To 8 — C. Gayle, 14 To 10 — D. Summer, 11 To 7 — Styx, 10 To 6 — Ambrosia, 9 To 5 — Stones, 5 To 2 — N. Gilder. ADDS: 34 — L. Ronstadt, 32 — A. Bridges.

KFRC — SAN FRANCISCO — DAVE SHOLIN, MD

1-1 — Exile. JUMPS: 29 To 25 — Santana, 26 To 22 — A. Gibb, 24 To 20 — Cars, 23 To 14 — Barbra/Neil, 22 To 18 — Toto, 19 To 15 — Ambrosia, 15 To 12 — Sylvester, 14 To 10 — Stones, 9 To 6 — Foreigner, 5 To 3 — Journey, 4 To 2 — A. Murray, Ex To 30 — Firefall, Ex To 29 — A. Stewart, Ex To 28 — Styx. ADDS: B. Joel.

KSLS — SAN LOUIS OBISPO — JOHN TOBIN, MD

1-1 — A. Stewart. JUMPS: 32 To 28 — 10cc, 31 To 25 — Firefall, 30 To 23 — Devo, 29 To 24 — Talking Heads, 28 To 18 — Elton John, 27 To 17 — L. Ronstadt, 26 To 22 — Wings, 25 To 21 — J. Cocker, 24 To 20 — Toto, 23 To 13 — J.C. Young, 22 To 11 — E. Clapton, 20 To 16 — Moody Blues, 19 To 12 — W. Zevon, 18 To 14 — B. McGilpin, 16 To 10 — ELO, 11 To 9 — Ambrosia, 8 To 4 — Chicago, Ex To 32 — G. Kinn, Ex To 31 — Chaka Khan, Ex To 30 — Cars, Ex To 29 — P. Tosh, Ex To 27 — A. Gibb, Ex To 26 — Barbra/Neil. ADDS: B. Seger, E. Money, Clout, C. Santana, Pointer Sisters, I. Matthews, R. Johnson.

KJR — SEATTLE — TRACY MITCHELL, MD

5-1 — D. Summer. JUMPS: 25 To 22 — Fogelberg/Weisberg, 22 To 19 — Dr. Hook, 19 To 10 — Barbra/Neil, 17 To 14 — Toto, 16 To 13 — G. Vannelli, 10 To 8 — Who, Ex To 25 — G. Campbell, Ex To 24 — B. Joel. ADDS: L. Ronstadt, Hot Chocolate, Village People.

KING — SEATTLE — TOM MCKAY, MD

1-1 — Foreigner. JUMPS: 25 To 22 — Chicago, 22 To 19 — Toto, 16 To 13 — P. Davis, 15 To 11 — Dr. Hook, 13 To 9 — B. Manilow, 10 To 4 — C. Gayle. Ex To 25 — Barbra/Neil, Ex To 24 — Pablo Cruise, Ex To 23 — A. Stewart. ADDS: B. Seger, A. Cooper, Hot Chocolate, Carole King.

KJRB — SPOKANE — TOM HUTYLER, MD

2-1 — Foreigner. JUMPS: 30 To 25 — B. Joel, 26 To 11 — Barbra/Neil, 25 To 19 — Firefall, 24 To 21 — Chicago, 20 To 14 — A. Gibb, 19 To 16 — S. Bishop, 16 To 10 — A. Stewart, 12 To 8 — A. Bridges, 11 To 6 — G. Vannelli, 10 To 7 — Ambrosia, Ex To 30 — L. Ronstadt, Ex To 29 — N. Gilder, Ex To 17 — Village People. ADDS: Steely Dan, A. Cooper, Hot Chocolate, Queen.

KTAC — TACOMA — BRUCE CANNON, MD

1-1 — N. Gilder. JUMPS: 30 To 19 — Barbra/Neil, 27 To 22 — C. Gayle, 25 To 21 — Chicago, 24 To 20 — A. Bridges, 21 To 17 — Foreigner, 20 To 16 — Heart, 15 To 11 — D. Summer, 12 To 9 — Ambrosia, 8 To 6 — Captain & Tennille, 7 To 4 — B. Joel, 6 To 3 — Who, Ex To 30 — Pablo Cruise, Ex To 29 — A. Stewart, Ex To 28 — P. Davis, Ex To 27 — A. Gibb, Ex To 26 — Dr. Hook, Ex To 25 — G. Vannelli, Ex To 24 — B. Joel. ADDS: A. Cooper, L. Ronstadt, E. Carmen.

Changing Social Climate Aids Detroit's Musical Resurgence

(continued from page 7)

Motown left, the raw talent was here, but it was just so dissipated that the music scene appeared to have diminished. There was no longer the single entity like Motown to look towards."

In addition to discovering its untapped talent, Detroit stayed alive by retaining its musicians, the backbone of its sound. As Michael Henderson pointed out, "Motown left, but the sound stayed. Your best session men, like Earl Van Dyke on keyboards, James Jameson on bass, and Pistol on drums all stayed." Henderson, who played bass on many Motown sessions, explained why he stayed as well, "I just figured that the sound wasn't with Motown, it was with Detroit."

In addition to the musicians that stayed, the scene was further tapped by the return of musicians who had left earlier and returned. Armand Boladian, president of the Detroit-based Westbound label, said, "When Motown left, a lot of the musicians left, also, feeling that Los Angeles was where they had to go for work, but when they got there, the scramble and the competition was more than they had bargained for. A musician who was unchallenged in Detroit met his match in L.A., and one by one they started coming back."

Sustaining Momentum

Credit for sustaining the scene in the wake of Motown's departure is also freely given to veteran record men like Boladian and producer/studio owner Don Davis. Bill Craig stated, "I attribute the resurgence most to Armand Boladian. When Motown left, Armand came on like gangbusters with the Detroit Emeralds, Fantastic Four, and Funkadelic." Michael Henderson added, "I think Don Davis turned it around. He had Groovesville productions, and was producing hits at United Sound for Johnnie Taylor, Marilyn and Billy, and the Dramatics, and more than anyone else, he was giving local musicians work and a reason to stay."

Davis himself cited the number of professionally equipped studios, including his own United Sound, for giving the scene a certain backbone. But, if Boladian and Davis helped keep the Detroit music scene stable with their solidly professional approach, it was the entrepreneurial spirit of the new record men and their growing professionalism that were vitally reflected in the resurgence.

John Smith, vice president of promotion, special markets, for ABC Records, said, "Look at the growth of an Al Perkins in the studio. Look at the difference between the early records he produced on Al Hudson and the Soul Partners, and his new one, 'Spread Love.' The difference is like night and day." Bill Craig added, "I have to give credit to a Woody Wilson, who produced the Floaters while he was working as a maintenance man for Hertz Rent-a-Car. Now you know that a guy who works for Hertz can't afford to take off from work, and by no means can he afford to fly to California — he comes back home and he doesn't have a gig. People around here still know that Berry Gordy started Motown on \$600 and you're starting to get records cut here that are as good as any others on the country, by guys who have saved their \$700 to \$1,000."

Show Of Confidence

Along with the increasing professional-

ism of the record men has come a greater show of confidence from the major labels. A little over a year ago, for example, Atlantic Records took over the distribution of Westbound; and a couple of months ago, ABC Records disclosed that it would open an office in Detroit with Bill Craig heading it up.

More To Come

But many feel that the growth that has been shown so far is only the beginning of much more to come. For example, the music of George Clinton and his various P-Funk spinoffs is considered to be a Detroit-oriented music, by virtue of the fact that Clinton evolved Funkadelic from his Detroit-based vocal group, the Parliaments, and, in addition, does all of his recording at Don Davis' United Sound Studios. According to Davis, "The closest thing to a Berry Gordy that exists in Detroit today is the P-Funk organization. And God knows when it's going to stop, because they're getting better all the time. But they're really ushering in a new era of music, which is what Berry Gordy did. He saw that there was a need for a hybrid and he had the foresight to put the ingredients together. George has been recording a long time, and now the time has become right for him."

Davis' assessment of his role in Detroit's music and his plans for the future inspire still more confidence in Detroit's contemporary music scene. "I became primarily involved in my studio operation because I needed a 24-track machine to record with and there were none in town. So I looked at the stable of acts I was producing and figured that, for the amount of studio hours I was going to use in a year, it would pay for me to buy my own. But even as I was booking the time for acts I was not involved with, I noticed that their formulas for success were different from mine, and that suddenly, in the course of two years, the whole street scene was changing, and a style that I was successful with, for Marilyn and Billy (McCoo), and for Johnnie Taylor, was cold."

"But it's been to my advantage to work so closely with George, going back to the days when I used Bootsy to play bass on 'Disco Lady,' because if you look over to your right and you see that you're working right next to the people who are changing the sound of the street, it's that much easier to absorb what they're doing and free yourself from your own shackles of style. I have just recently made the decision to start putting together a stable of acts and to start grooming talent the way Berry used to."

20th Music Profits

(continued from page 7)

stop signing new acts but added that new artist acquisitions would be made "on a highly selective" basis. "We have a pretty good stable of artists," he said, "and we feel that we can only do justice to a limited number."

No replacement has yet been named to fill the vacancy created at the label by the departure in August of Harvey Cooper, vice president of A&R administration and Harvey Bruce, west coast A&R director.

Rick Sidoti has been named national singles promotion director at the label, Livingston announced. Sidoti fills the spot created when Toni Profera left the promotion post August 11.

Looking Ahead To The Top 100

SHAKE IT (Steamed Clam — BMI) IAN MATTHEWS (Mushroom M7039)

YOU TOOK THE WORDS RIGHT OUT OF MY MOUTH (Edward B. Marks/Neverland/Peg — BMI) MEAT LOAF (Cleveland Int'l./Epic 8-50634)

THE GAMBLER (Writers Night — ASCAP) KENNY ROGERS (United Artists UA-X1250)

WELL ALL RIGHT (MPL Communications — BMI) SANTANA (Columbia 3-10839)

(YOU GOT TO WALK AND) DON'T LOOK BACK (Jobete — ASCAP) PETER TOSH (Rolling Stones RS 19308)

JAZZ

TOP 40 ALBUMS

	Weeks On Chart			Weeks On Chart	
	11/4	Chart		11/4	Chart
1 REED SEED GROVER WASHINGTON JR. (Motown M7-910R1)	2	5	21 TROPICO GATO BARBIERI (A&M SP 4710)	18	16
2 CHILDREN OF SANCHEZ CHUCK MANGIONE (A&M SP 6700)	1	7	22 HEAVY METAL BE-BOP THE BRECKER BROTHERS (Arista AB 4185)	23	6
3 MR. GONE WEATHER REPORT (Columbia JC 35358)	3	4	23 THANK YOU FOR . . . F.U.M.L. (FUNKING UP MY LIFE) DONALD BYRD (Elektra 6E-144)	—	1
4 ALL FLY HOME AL JARREAU (Warner Bros. BSK 3229)	12	3	24 SOFT SPACE THE JEFF LORBER FUSION (Inner City 1056)	27	6
5 SECRETS GIL SCOTT-HERON & BRIAN JACKSON (Arista AB 4189)	5	10	25 INTIMATE STRANGERS TOM SCOTT (Columbia JC 35557)	—	1
6 FLAME RONNIE LAWS (United Artists UA-LA881-H)	16	3	26 PATRICE PATRICE RUSHEN (Elektra 6E-160)	—	1
7 IMAGES CRUSADERS (ABC/Blue Thumb BA 6030)	4	18	27 WEEKEND IN L.A. GEORGE BENSON (Warner Bros. 2WB 3139)	22	41
8 COSMIC MESSENGER JEAN-LUC PONTY (Atlantic SD 19189)	7	11	28 SUNBELT HERBIE MANN (Atlantic SD 19204)	31	4
9 CARNIVAL MAYNARD FERGUSON (Columbia JC 35480)	9	6	29 FRIENDS CHICK COREA (Polydor PD 1-6160)	25	14
10 YOU SEND ME ROY AYERS (Polydor PD-1-6159)	8	14	30 SIMPLICITY OF EXPRESSION BILLY COBHAM (Columbia JC 35457)	28	5
11 WHAT ABOUT YOU STANLEY TURRENTINE (Fantasy F-9563)	6	8	31 OUT OF THE WOODS OREGON (Elektra 6E-154)	29	4
12 FEELS SO GOOD CHUCK MANGIONE (A&M SP 4658)	11	54	32 LES McCANN THE MAN (A&M SP 4718)	34	2
13 LEGACY RAMSEY LEWIS (Columbia JC 35483)	14	5	33 A SONG FOR YOU RON CARTER (Milestone M-9086)	35	7
14 LARRY CARLTON (Warner Bros. BSK 3221)	13	14	34 NEW WARRIOR BOBBY LYLE (Capitol SW 11809)	32	6
15 SOUNDS . . . AND STUFF LIKE THAT! QUINCY JONES (A&M SP 4685)	10	21	35 LOVE SATELLITE RONNIE FOSTER (Columbia JC 35373)	36	3
16 TIME AND CHANGE CALDERA (Capitol SW 11810)	15	9	36 SUNLIGHT HERBIE HANCOCK (Columbia CJ 34907)	24	19
17 BEFORE THE RAIN LEE OSKAR (Elektra 6E-150)	17	9	37 TIMES SQUARE GARY BURTON (ECM 1-1111)	38	3
18 PAT METHENY GROUP (ECM 1-1114)	20	15	38 CAN YOU FEEL IT RAY BARRETTO (Atlantic SD 19198)	39	2
19 IN THE NIGHT TIME MICHAEL HENDERSON (Buddah BDS 5712)	19	19	39 DON'T STOP THE CARNIVAL SONNY ROLLINS (Milestone M 55005)	37	7
20 THE GREETING McCOY TYNER (Milestone M-9085)	21	4	40 MANHATTAN SYMPHONIE DEXTER GORDON QUARTET (Columbia JC 35608)	—	1

ON JAZZ

The most interesting development to come out of the annual NARAS screening committee meetings in Los Angeles (which determines placement of Grammy Award entries) was the problem of dealing with Clarence "Gatemouth" Brown and his LP on Music Is Medicine. The album, which was a pick on this page several months ago, shows Brown's total immersion in a wide variety of styles, including jazz, traditional blues, bluegrass and country. The committee thoroughly enjoyed each of the tracks, but where does one place an album which contains such diverse music? Since the artist has an acknowledged following in Nashville, has frequently appeared at jazz festivals, and is venerated by blues fans, it might be a good idea to have ABC delve into his classic Duke/Peacock performances of the 1950s, which have never appeared on LP.

"Opening Remarks" is the title of Ted Dunbar's initial Xanadu effort. Dunbar did all the writing for the quartet, which in-

cludes Tommy Flanagan, Sam Jones and Leroy Williams.

Inner City is very excited about the debut album of Richard Sussman ("Free Fall"), which features Tom Harrell, Larry Schneider and Mike Richmond. Classic Jazz, the IC sister label, has new releases by Tiny Grimes and Arnett Cobb. The former is a quartet date featuring Lloyd Glenn, while the latter is a nine-piece band including some Lionel Hampton alumni such as Wallace Davenport, Buster Cooper, Milt Buckner and Eddie Chamblee.

Lennie White, Donald Byrd and Patrice Rushen headline on new Elektra releases. White's album, "Steamline," may disappoint those looking forward to the further adventures of the "Astral Pirates" but should please lovers of progressive jazz-rock. The Byrd LP features his new group, The 125th Street Orchestra and The Uptown Singers and is titled "Thank You For Funking Up My Life."

bob porter



CARLTON AT THE ROXY — Warner Bros. recording artist Larry Carlton recently played the Roxy in Los Angeles, and following his show the jazz guitarist was greeted by friends and record officials. Pictured (l-r) backstage are: George Duke; Carlton; Greta Valenzuela, Warner Bros. jazz department; and Stanley Clarke.

JAZZ ALBUM PICKS

INTIMATE STRANGERS — Tom Scott — Columbia JC 35557 — Producers: Tom Scott and Hank Cicalo — List: 7.98

Tom Scott has established himself as a top studio arranger and performer, composer and support player, but with his first solo effort for Columbia it's time for his own career to blossom. Backed by some of the finest studio cats around, Scott's sax and lyric work is up to his usual highest-quality standards. Side one, a three-part, six-song suite that tells the story of a sax player's brief romantic encounter, is one of the most beautiful and challenging jazz pieces ever captured on vinyl.

PRE-RAHSAAN — Roland Kirk — Prestige 24080 — List: 8.98

Two diverse settings, recorded seven years apart, for the multi-talented/multi-reedman. The earlier date finds him in the company of organist Jack McDuff in a rather conservative, but thoroughly stimulating set, while the second album finds him in the company of Jackie Byard, Richard Davis and Alan Dawson in a wildly inventive display of virtuosity. Kirk was a remarkable musician, and this is some of his very finest work.

CHANGES & THINGS — Sam Jones — Xanadu 150 — Producer: Don Schlitten — List: 7.98

It's hard to imagine how veteran bassist Jones could have done any better on his latest for the Cream Records-distributed Xanadu label. From the choice of collaborators — including Blue Mitchell, Slide Hampton and Louis Hayes — to the distinctive material to the freshness of the solos, "Changes & Things" is one of the most solid mainstream offerings to come along in quite some time. Jones' percussive approach to the bass is best showcased on a track called "Sam's Things."

TOM SCOTT



Roland Kirk



JOHN KLEMMER • JOHN KLEMMER



CRY — John Klemmer — ABC AA-1106 — Producer: John Klemmer — List: 7.98

Klemmer has abandoned use of the echoplex in his band performances but on this very special project (which has concerned him for several years), Klemmer returns to the electronic device for solo improvisations. Mysterious, melodic and satisfying, these tracks evoke colors and images. Whether offering fast runs and popping low notes on "Intimacy" or the straight ahead blow of "Waterfalls," this album is a quintessential example of the solo saxophone statement.

DAVE PELL'S PREZ CONFERENCE

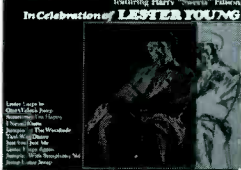

PREZ CONFERENCE — Dave Pell — GNP Crescendo 2122 — Producer: Dave Pell — List: 7.98

Saxophonist Pell with his group has created a tenor Super-Sax here in a program designed to honor Lester Young. Three tenors and baritone play harmonized (courtesy of Bill Holman) solos by Lester Young. Soloists are Sweets Edison (who has rarely sounded better) and Arnold Ross on piano. Ten tunes, mostly of pre-war vintage, encompass some of Young's most memorable solos. Well conceived, well executed and well worth a listen.

Benny Golson



BLUES ON DOWN — Benny Golson — Milestone 47048 — List: 8.98

These days, Golson plays disco for Columbia on soprano sax. But in the '50s and early '60s, he played great jazz on tenor for a variety of labels, including Riverside (the source of this music). Compatriots here include Kenny Dorham, JJ Johnson, Wynton Kelly and Barry Harris, and the music is among the best of its time.

BLACK CONTEMPORARY

Cooke Foundation Launched; Benefit To Be Held In Vegas

by Cooke Amerson

LOS ANGELES — Thelma Houston, Stevie Wonder, Natalie Cole and Martha Reeves are among artists who have made commitments to participate in the upcoming benefit awards show for the Sam Cooke Foundation, to be held in Las Vegas at the Aladdin Hotel Dec. 17.

The announcement of the awards show and performers came during a launching party for the foundation held at the Beverly Hills Hotel last week. Verlene Rogers and family of the late Sam Cooke founded the organization, whose purpose is to raise money for the fight against sickle cell anemia and establish a scholarship fund for disadvantaged youths pursuing a career in music.

Help From RCA

Rogers, director of the organization and two of the Cooke brothers, who are serving as president and vice president of the organization approached RCA Records last September for assistance with the project. Rogers explained, "George Abraham, director of special projects for RCA, was instrumental in assisting us in obtaining the help we got from RCA. They have furnished us with office space, telephones and also assisted us with our opening cocktail party."

Currently, the organization's five main

objectives are: 1) To immortalize the name of Sam Cooke; 2) To create an organization that will be active in raising funds for recognized charitable activities; 3) To present a Sam Cooke Memorial Awards of the Sixties Show; 4) To present awards to artists who have made great musical contributions to the recording arts during the Sam Cooke era; and 5) To round up additional major artists to participate in the awards show.

The overall game plan of the organization was discussed at length at last week's cocktail party. The party, which was held at the Beverly Hills Hotel, drew support from many entertainment personalities, including Janet Dubois, Raymond St. Jacques, Don Cornelius, Khaliah Ali, Calvin Lockhart and others.

Although it was previously announced that the Sam Cooke Foundation would be affiliated with the City of Hope, it has since been set up as a private organization.

TV Special Soundtrack Slated In Nov. On MCA

LOS ANGELES — MCA Records will release the soundtrack of "A Woman Called Moses," a television special starring Cicely Tyson this month. The soundtrack features singer Tommie Young. The program will air on NBC-TV Dec. 11-12.



BLUENOTES TO FANTASY — Fantasy Records recently signed the Bluenotes, who will be releasing a disco oriented single for the label shortly. Pictured (l-r) are: Lloyd Parks and Larry Brown of the Bluenotes; Hank Cosby, director of A&R at Fantasy; Ralph Kaffel, president of Fantasy; Herb Meyers, group manager; Ollie Woodson, Bernard Wilson and John Atkins of the Bluenotes.

THE RHYTHM SECTION

PICKETS — Rev. Jessie Jackson and Rev. Buster Soarles are preparing to picket the east and west coast offices of Atlantic Records and of Rolling Stones Records in protest of lyrics on current Stones album. Spokesperson from operation PUSH said, "We want to call attention to the fact that we will not allow artists to indiscriminately put anything before our children, we want a public apology, and will not stop until we get it."

REGGIE SMITH CELEBRITY BENEFIT — The first annual Reggie Smith Celebrity Tennis Classic benefitting the National Association of Sickle Cell Disease will be held in Los Angeles at the Mountain Gate Country Club Nov. 11 and 12. The event will be sponsored by Pepsi Cola, with Marilyn McCoo and Billy Davis, Jr. The Jacksons, Kellee Patterson and Fred Williamson among some of the celebrity participants. Representing the Los Angeles Dodgers will be Ron Cey, Steve Garvey, Tommy Lasorda, and Davey Lopes.

THE SUMMER TOUR — Donna Summer has embarked on her second major concert tour of the year. The tour, which debuted in Canada last week, has taken her to Buffalo, where she was the first entertainer to perform at the city's new Convention Center, and includes two benefit concerts in her hometown of Boston — one for her family church and the other to establish a Donna Summer Arts Scholarship Fund.

GREY & HANKS — Songwriting team of Grey and Hanks, who have penned hit tunes for L.T.D., Tavares, Jerry Butler and several others, have decided to sing some of their lyrics themselves, and currently have a tune out entitled "You Fooled Me," on RCA Records.

NEW IN MORNING — Dave Ford has taken on the duties of morning man at WMBM in Miami, in addition to being their production director.

cooke amerson

TOP 75 ALBUMS

	Weeks On Chart		Weeks On Chart
1	1 7/4	ONE NATION UNDER A GROOVE FUNKADELIC (Warner Bros. BSK 3209)	
2	3 9	LIVE AND MORE DONNA SUMMER (Casablanca NBLP 7119)	
3	2 10	IS IT STILL GOOD TO YA ASHFORD & SIMPSON (Warner Bros. BSK 3219)	
4	6 5	THE MAN BARRY WHITE (20th Century T-571)	
5	4 12	ROSE ROYCE STRIKES AGAIN (Warner Bros. WHK 3227)	
6	5 15	BLAM! BROTHERS JOHNSON (A&M SP 4714)	
7	8 13	SWITCH (Gordy/Motown G6-980R1)	
8	7 19	STEP II SYLVESTER (Fantasy F-9556)	
9	9 22	LIFE IS A SONG WORTH SINGING TEDDY PENDERGRASS (Phila. Int'l. JZ 35095)	
10	10 22	BETTY WRIGHT LIVE (Alston 4408)	
11	11 22	TOGETHERNESS L.T.D. (A&M SP 4705)	
12	19 6	REED SEED GROVER WASHINGTON JR. (Motown M7-019R1)	
13	12 25	COME AND GET IT! RICK JAMES (Gordy G7-981R1)	
14	13 20	GET OFF FOXY (TK/Dash 30005)	
15	25 5	CRUISIN VIL LAGE PEOPLE (Casablanca NBLP 7118)	
16	14 19	IN THE NIGHT TIME MICHAEL HENDERSON (Buddah BDS 5712)	
17	17 10	SECRETS GIL SCOTT-HERON & BRIAN JACKSON (Arista AB 4189)	
18	16 21	SUMMERTIME GROOVE BOHANNON (Mercury SRM 1-3728)	
19	15 24	A TASTE OF HONEY (Capitol ST 11754)	
20	20 25	NATURAL HIGH THE COMMODORES (Motown M6-902B1)	
21	21 19	SPARK OF LOVE LENNY WILLIAMS (ABC AA 1073)	
22	24 6	THE WIZ (MCA 2-14000)	
23	48 2	CHAKA CHAKA KHAN (Warner Bros. BSK 3245)	
24	23 14	YOU SEND ME ROY AYERS (Polydor PD 16159)	
25	18 14	SUNBEAM THE EMOTIONS (Columbia JC 35385)	
26	22 7	TAKE IT ON UP POCKETS (Columbia JC 35480)	
27	34 5	FUNK OR WALK THE BRIDES OF FUNKENSTEIN (Atlantic SD 19201)	
28	39 4	GIANT JOHNNY GUITAR WATSON (DJM/Phonogram DJM 19)	
29	41 4	FLAME RONNIE LAWS (United Artists UA-LA881-H)	
30	32 4	"ROSS" DIANA ROSS (Motown M7-907R1)	
31	35 11	KEEP ON JUMPIN' MUSIQUE (Prelude PRL 12158)	
32	31 27	SMOOTH TALK EVELYN "CHAMPAGNE" KING (RCA APL 1-2466)	
33	42 5	UGLY EGO CAMEO (Chocolate City/Casablanca CCLP 2006)	
34	38 6	BROTHER TO BROTHER GINO VANNELLI (A&M SP 4722)	
35	36 8	MOTHER FACTOR MOTHER'S FINEST (Epic JE 35546)	
36	44 4	ALL FLY HOME AL JARREAU (Warner Bros. BSK 3229)	
37	29 8	ROBERTA FLACK (Atlantic SD 19186)	
38	40 12	CHANSON (Ariola SW 50039)	
39	28 18	FIRED UP 'N' KICKIN' FATBACK BAND (Spring 16718)	
40	26 22	SOUNDS... AND STUFF LIKE THAT! QUINCY JONES (A&M SP 4685)	
41	33 13	FOR YOU PRINCE (Warner Bros. BSK 3150)	
42	27 23	LOVESHINE CON FUNK SHUN (Mercury SRM 1-3725)	
43	30 13	FOREVER YOURS THE SYLVERS (Casablanca NBLP 7103)	
44	57 2	CHERYL LYNN (Columbia JC 35486)	
45	37 10	BEFORE THE RAIN LEE OSKAR (Elektra 6E-150)	
46	55 2	MR. GONE WEATHER REPORT (ARC/Columbia JC 35358)	
47	58 2	THE GOLDEN TOUCH CERRONE (Cotillion/Atlantic SD5208)	
48	50 3	GOOD THANG FAZE-O (She/Atlantic SH 741)	
49	45 8	CHILDREN OF SANCHEZ CHUCK MANGIONE (A&M SP 6700)	
50	51 3	EVERYBODY'S DANCIN' KOOL & THE GANG (De-Lite DSR 9509)	
51	52 9	WELCOME TO MY ROOM RANDY BROWN (Parachute/Casablanca RRLP 9005)	
52	49 17	HOUSE OF LOVE CANDI STATON (Warner Bros. BSK 3207)	
53	46 16	ATLANTIC STARR (A&M SP 4711)	
54	56 27	HEADLIGHTS THE WHISPERS (Solar/RCA BXL 1-2274)	
55	— 1	FOR THE SAKE OF LOVE ISAAC HAYES (Polydor PD-1-6164)	
56	— 1	COMMODORES' GREATEST HITS (Motown M7-912R1)	
57	59 3	MELBA MELBA MOORE (Epic JE 35507)	
58	60 3	QUAZAR (Arista AB 4187)	
59	62 2	NOTHING SAYS I LOVE YOU LIKE I LOVE YOU JERRY BUTLER (Phila. Int'l./Columbia JZ 35510)	
60	— 1	WHAT YOU WAITIN' FOR STARGARD (MCA 3064)	
61	47 14	JASS-AY-LAY-DEE OHIO PLAYERS (Mercury SRM 1-3730)	
62	54 12	QUARTZ (Marlin 2216)	
63	61 4	HOLLYWOOD PARTY TONIGHT ODYSSEY (RCA AFL 1-3031)	
64	66 4	BOBBY CALDWELL (Clouds/TK 8804)	
65	69 2	ALICIA BRIDGES (Polydor PD-1-6158)	
66	43 35	MACHO MAN THE VILLAGE PEOPLE (Casablanca NBLP 7096)	
67	— 1	DISCO GARDENS SHALAMAR (Solar/RCA BXL1-2895)	
68	68 3	BARE BACK THE TEMPTATIONS (Atlantic SD 19188)	
69	70 3	THE GAMBLE HUFF ORCHESTRA MFSB (Phila. Int'l. JZ 35516)	
70	53 19	NATALIE... LIVE! NATALIE COLE (Capitol SKBL 11709)	
71	63 18	GET IT OU'CHA SYSTEM MILLIE JACKSON (Spring SP 6719)	
72	65 14	THE CONCEPT SLAVE (Cotillion DS 5206)	
73	64 18	IMAGES CRUSADERS (ABC AB 6030)	
74	73 7	UNLOCK YOUR MIND THE STAPLES (Warner Bros. BSK 3192)	
75	75 8	QUEEN OF THE NIGHT LOLEATA HOLLOWAY (Gold Mind/Salsoul GA 9501)	

CASH BOX TOP 100

November 11, 1978

	Weeks On Chart		Weeks On Chart		Weeks On Chart
1 ONE NATION UNDER A GROOVE FUNKADELIC (Warner Bros. WBS 8618)	11/4	35 YOU SHOULD DO IT PETER BROWN (TK/Drive 6272)	11/4	69 Y.M.C.A. VILLAGE PEOPLE (Casablanca NB 945)	11/4
2 DANCE (DISCO HEAT) SYLVESTER (Fantasy F-827)	3	36 PARTY LEON HAYWOOD (MCA 40941)	34	70 TIME SLIPS AWAY OHIO PLAYERS (Mercury 74031)	79
3 YOUR SWEETNESS IS MY WEAKNESS BARRY WHITE (20th Century TC 2380)	8	37 SWEET MUSIC MAN MILLIE JACKSON (Spring SP 185)	33	71 IT'S ALRIGHT (THIS FEELING I'M FEELING) VIVIAN REED (United Artists UA-X1239-Y)	71
4 MAC ARTHUR PARK DONNA SUMMER (Casablanca NB 939)	9	38 TAKE IT ON UP POCKETS (Columbia 3-10755)	35	72 HELP YOURSELF BRASS CONSTRUCTION (United Artists UA-X1242-Y)	73
5 I'M EVERY WOMAN CHAKA KHAN (Warner Bros. WBS 8683)	10	39 (I'M JUST THINKING ABOUT) COOLING OUT JERRY BUTLER (Phila. Int'l./Columbia ZS8-3656)	46	73 CHANGE ZULEMA (Le Joint/London 5N-34001)	81
6 THERE'LL NEVER BE SWITCH (Gordy 7G 159-F)	6	40 SAY A PRAYER FOR TWO CROWN HEIGHTS AFFAIR (DeLite DE 908)	39	74 SING A HAPPY SONG THIS FUNKY MUSIC WAR (United Artists UA-X1247-Y)	74
7 TONIGHT'S THE NIGHT BETTY WRIGHT (TK/Alston 3740)	7	41 I LOVE THE NIGHT LIFE (DISCO ROUND) ALICIA BRIDGES (Polydor PS 14483)	40	75 IS IT LOVE? LARRY GRAHAM & GRAHAM CENTRAL STATION (Warner Bros. WBS 8665)	78
8 IT SEEMS TO HANG ON ASHFORD & SIMPSON (Warner Bros. 86501)	2	42 WHOLE LOT OF SHAKIN' EMOTIONS (Columbia 3-10828)	49	76 DANCE TO THE DRUMMER'S BEAT HERMAN KELLY & LIFE (Alston/TK 3742)	80
9 BLAME IT ON THE BOOGIE THE JACKSONS (Epic 8-50595)	4	43 GOT TO GET YOU INTO MY LIFE EARTH, WIND & FIRE (Columbia 23-1079)	36	77 WE BOTH DESERVE EACH OTHER'S LOVE L.T.D. (A&M 2095)	85
10 I'M IN LOVE (AND I LOVE THE FEELING) ROSE ROYCE (Whitfield WHI 8629)	5	44 LONG STROKE ADC BAND (Cotillion/Atlantic 44243)	57	78 STAND UP ATLANTIC STARR (A&M 2065-S)	44
11 MARY JANE RICK JAMES (Motown G7-162)	30	45 TAKE THAT TO THE BANK SHALAMAR (Solar/RCA JH 11379)	55	79 JUST FREAK SLAVE (Cotillion/Atlantic 44242)	90
12 (OLIVIA) LOST AND TURNED OUT THE WHISPERS (Solar/RCA JH 11353)	15	46 SPECIAL OCCASION DOROTHY MOORE (Malaco 1052)	37	80 THINKIN' ABOUT IT TOO AL JARREAU (Warner Bros. WBS 8677)	88
13 HOLDING ON (WHEN LOVE IS GONE) L.T.D. (A&M 2057)	11	47 DANCING IN PARADISE EL COCO (AVI 203)	45	81 GET ON UP, GET ON DOWN ROY AYERS (Polydor PD1 4509)	89
14 DON'T STOP, GET OFF THE SYLVERS (Casablanca NB 938)	12	48 SMILE THE EMOTIONS (Columbia 3-10791)	42	82 "WELCOME TO HARLEM" GARY TOMS EMPIRE (Mercury 74023)	82
15 EASE ON DOWN THE ROAD DIANA ROSS & MICHAEL JACKSON (MCA 40947)	16	49 ANGEL DUST GIL SCOTT-HERON (Arista AS 0366)	60	83 "HOW DO YOU DO" AL HUDSON & THE SOUL PARTNERS (ABC AB 12424)	—
16 YOU FOOLED ME GREY AND HANKS (RCA JH 11346)	17	50 SHAKE AND DANCE WITH ME CON FUNK SHUN (Mercury 74008)	43	84 "WORKIN' OVERTIME" DENISE LaSALLE (ABC AB 12419)	87
17 I JUST WANNA STOP GINO VANNELLI (A&M 2072-S)	20	51 DON'T WANNA COME BACK MOTHER'S FINEST (Epic 8-50596)	51	85 GANGSTER OF LOVE JOHNNY GUITAR WATSON (DJM/Phonogram DJMS 1101)	—
18 DON'T HOLD BACK CHANSON (Ariola 7717)	22	52 RIDE-O-ROCKET THE BROTHERS JOHNSON (A&M 2086)	53	86 INSTANT REPLAY DAN HARTMAN (Blue Sky/CBS ZS3-2772)	—
19 DISCO TO GO THE BRIDES OF FUNKENSTEIN (Atlantic 3498)	23	53 WHAT YOU WON'T DO FOR LOVE BOBBY CALDWELL (Clouds/TK 11)	65	87 NOW THAT WE FOUND LOVE THIRD WORLD (Island/Warner Bros. IS 8663)	92
20 LET'S START THE DANCE HAMILTON BOHANNON (Mercury 74015)	14	54 GET DOWN GENE CHANDLER (20th Century TC 2386)	62	88 ALMOST LIKE BEING IN LOVE MICHAEL JOHNSON (EMI 8004)	93
21 GET OFF FOXY (Dash 4056)	19	55 BARE BACK THE TEMPTATIONS (Atlantic 3517)	54	89 LOVE VIBRATION JOE SIMON (Spring/Polydor SP 190)	—
22 FUNK 'N' ROLL (DANCIN' IN THE FUNKSHINE) QUAZAR (Arista AS 0349)	24	56 YOU STEPPED INTO MY LIFE MELBA MOORE (Epic 8-50600)	64	90 WONDER WORM CAPTAIN SKY (AVI 225-S)	95
23 UNLOCK YOUR MIND THE STAPLES (Warner Bros. WBS 8669)	28	57 VICTIM CANDI STATON (Warner Bros. WBS 8582)	52	91 HAVEN'T STOPPED DANCING YET GONZALEZ (Capitol P-4647)	—
24 FLYING HIGH THE COMMODORES (Motown 1452-F)	25	58 IN THE NIGHT-TIME MICHAEL HENDERSON (Buddah/Arista BDA 600)	69	92 LIVIN' IT UP (FRIDAY NIGHT) BELL & JAMES (A&M 2069)	96
25 ONLY YOU TEDDY PENDERGRASS (Phila. Int'l./CBS ZS8-3657)	29	59 DO WHAT YOU FEEL CREME D'COCOA (Venture V-102)	59	93 YOU THE McCRARYS (Portrait 6-70014)	56
26 IN THE BUSH MUSIQUE (Prelude PRL 71110)	32	60 SHAKE YOUR GROOVE THING PEACHES & HERB (Polydor PD 14514)	68	94 MR. DJ YOU KNOW HOW TO MAKE ME DANCE THE GLASS FAMILY (JDC 428-1)	—
27 LE FREAK CHIC (Atlantic 3519)	47	61 SO EASY CON FUNK SHUN (Mercury 74024)	63	95 LET ME (LET ME BE YOUR LOVER) JIMMY "BO" HORNE (TK 1005)	75
28 SOFT AND WET PRINCE (Warner Bros. WBS 8619)	18	62 "MIDNIGHT GIRL" LENNY WILLIAMS (ABC AB 12423)	70	96 MELLOW LOVIN' JUDY CHEEKS (Salsoul S7-2063)	91
29 I WANNA MAKE LOVE TO YOU RANDY BROWN (Parachute/Casablanca RR 517)	31	63 LOVE, I NEVER HAD IT SO GOOD QUINCY JONES (A&M 2084)	48	97 I LIKE GIRLS FATBACK BAND (Spring 181)	58
30 GOT TO BE REAL CHERYL LYNN (Columbia 3-10808)	38	64 "FREE ME FROM MY FREEDOM/TIE ME TO A TREE (HANDCUFF ME)" BONNIE POINTER (Motown M 1451F)	72	98 "COME FLY WITH ME" BOBBY BLAND (ABC AB 12405)	83
31 TAKE ME I'M YOURS MICHAEL HENDERSON (Buddah BDA 597)	13	65 LOVE DON'T LIVE HERE ANY MORE ROSE ROYCE (Whitfield/Warner Bros. WHI 8712)	77	99 "LOVE ATTACK" SHOTGUN (ABC AB 12395)	61
32 HOT SHOT KAREN YOUNG (West End WSS 1211)	26	66 "LOVE TO BURN" O.C. SMITH (Shadybrook SB 1045)	67	100 GOT TO HAVE LOVING DON RAY (Polydor 14489)	66
33 I DON'T KNOW IF IT'S RIGHT EVELYN "CAMPAGNE" KING (RCA PB 11386)	41	67 BOOGIE OOGIE A TASTE OF HONEY (Capitol 4565)	50		
34 ONLY YOU LOLEATTA HOLLOWAY & BUNNY SIGLER (Gold Mind G7-4012)	21	68 DON'T WEAR YOURSELF OUT THE McCRARYS (Portrait 6-70022)	76		

ALPHABETIZED TOP 100 R&B (INCLUDING PUBLISHERS AND LICENSEES)

Almost Like (United Artists — ASCAP)	88	Got To Have (MTB — SESAC)	100	Living It Up (Mighty Three — BMI)	92	Soft & Wet (Princess Music Co. — ASCAP)	28
Angel Dust (Brouhaha — ASCAP)	49	Haven't (Old "Eye"/Buckwheat — ASCAP)	91	Long Stroke (Woodsongs/Bus — BMI)	44	Special (Unichappell Music — BMI)	46
Bare Back (Good Life — BMI)	55	Help (Desert Rain/Big Boro — ASCAP)	72	Love Attack (ABC/Dunhill/Goblet/Funk Rock — BMI)	72	Stand Up (Almo/Newban/Audio — ASCAP)	78
Blame It On (Almo Music — ASCAP)	9	Holding On (Almo/McRouscod — ASCAP)	13	Love Don't (May 12th/Warner-Tamerlane — BMI)	99	Sweet Music (Jolly Rogers — ASCAP)	37
Boogie Oogie Oogie (Conduive/On Time — BMI)	67	Hot Shot (Scully — ASCAP)	32	Love, I (Yellow Brick Road/Bloody — ASCAP)	65	Take It (Pockets/Verdangel — BMI)	38
Change (Double Joint/Zu-Greco — BMI)	73	How Do (Perks — BMI)	83	Love To (Screen Gems/EMI — BMI)	63	Take Me I'm (Electrochord — ASCAP)	31
Come Fly (Capitol Dome — ASCAP)	98	I Don't Know (Six Continents/Mills and Mills — BMI)	33	Love To (Screen Gems/EMI — BMI)	63	Take That (Rosey — ASCAP)	45
Dance (Jobete — ASCAP)	2	I Just (Ross/Vannelli)	17	Mr. DJ (Callon — BMI)	94	There'll Never (Jobete — ASCAP)	6
Dance... (Dummock's/Sherlyn — BMI)	76	I'm Every (Nick-O-Val — ASCAP)	5	Now That (Mighty Three — BMI)	87	Thinkin' (Aljarreau/Desperate — BMI)	80
Dancing In (Equinox — BMI)	47	I'm Just (Mighty Three — BMI/Fountain — ASCAP)	39	(Olivia) Lost (Spectrum VII — ASCAP)	12	Time Slips (Unichappell — BMI)	70
Disco To Go (Rubber Band — BMI)	19	I Love (Lowery — BMI)	41	Only You (Lucky Three/Suemay/Six Strings — BMI)	25	Tonight's The (Sherlyn — BMI)	7
Don't Hold (Kichelle Jamersonian/Cos-K — ASCAP)	18	I'm In (May 12th/Warner-Tamerlane — BMI)	10	Only You (Mighty Three — BMI)	34	Unlock Your (Temporary-Secular — BMI)	23
Don't Stop (Rosy — ASCAP)	14	Instant (Silver Steed — BMI)	86	Party (Jim-Edd — BMI)	36	Victim (Dannmusic — ASCAP)	57
Don't Wanna (Satsong — ASCAP)	51	In The Bush (Pat Music Div./Leeds Music Corp./Phylmar — ASCAP)	26	Ride-O (Nick-O-Val — ASCAP)	52	We Both (Almo/McRouscod — ASCAP)	—
Don't Wear Yourself (Island — BMI)	68	In The Nighttime (Electrochord — ASCAP/Intense — BMI)	58	Shake And (Val-Joe — BMI)	50	Irving/McDotsbov — BMI)	77
Do What You Feel (Barcam — BMI)	59	I Like Girls (Ciita — BMI)	97	Shake Your Groove (Perren-Vibes — ASCAP)	60	Welcome To (Sumac — BMI)	82
Ease On (Fox Fanfare — BMI)	15	Is It Love (Nineteen Eighty-Foe — BMI)	75	Sing A Happy (Far Out — ASCAP)	74	What You (Warner-Tamerlane/May 12th — BMI)	53
Flying High (Jobete/Commodores — ASCAP)	24	It's Alright (Jays/Chappell — ASCAP)	71	Smile (Saggitfire — BMI/Steelchest — ASCAP)	48	Whole Lot (Saggitfire — BMI/Steelchest — ASCAP)	42
Free Me (Jobete — ASCAP/Stone Diamond — BMI)	64	It Seems (Nick-O-Val Music — ASCAP)	8	So Easy (Val-Le-Joe — BMI)	61	Wonder (Thom Thom — ASCAP/Upper Level — BMI)	90
Funk 'N' Roll (Jumpshot — BMI)	25	Just (Spur Tree/Cotillion — BMI)	79			Working (Warner Tamerlane/Ordena — BMI)	84
Gangster (Hermosa — BMI)	82	Le Freak (Chic — BMI)	27			Y.M.C.A. (Greenlight — ASCAP)	69
Get Down (Gaetana/Cachand/Cissi — BMI)	54	Let Me (Sherlyn/Harrick — BMI)	81			You (Island — BMI)	93
Get Off (Sherlyn/Lindseyanne — BMI)	21	Let's Start (Bohannon Phase II — ASCAP)	—			You Fooled (Irving/Medad — BMI)	16
Get On Up (Rich Fish/Adena — ASCAP)	81	Intersong-USA — ASCAP)	20			You Should (Sherlyn/Decibel — BMI)	35
Got To Be (Butterfly/Gong — BMI/Hudman/Cotaba — ASCAP)	30					You Stepped (Stigwood/Unichappell — BMI)	56
Got To Get (Maclen — BMI)	43					Your Sweetness (Sa-Vette/Six Continents/Rel Nel — BMI)	3

BLACK CONTEMPORARY

MOST ADDED SINGLES

- LONG STROKE — ADC BAND — COTILLION**
OK-100, KDIA, WLTH, WORL, WYLD, KMJQ, KPRS, WATV, WLOU, KGBC.
- WHAT YOU WON'T DO FOR LOVE — BOBBY CALDWELL — CLOUDS**
WJLB, WORL, WWRL, KKT, WGOK, WJMO, KPRS, WLOU, KYOK, WDAO.
- LOVE DON'T LIVE HERE ANYMORE — ROSE ROYCE — WHITFIELD**
KDKO, WRAP, WORL, WYLD, WJNR, WLOU, WEAL, WDAO, WXEL-FM.
- LE FREAK — CHIC — ATLANTIC**
OK-100, KKSS, WVOL, WGPR-FM, WDIA, WYLD, WJPC.
- I DON'T KNOW IF IT'S RIGHT — EVELYN "CHAMPAGNE" KING — RCA**
KDIA, KDKO, WVOL, KATZ, KKT, WVKO, KGBX.
- WE BOTH DESERVE EACH OTHER'S LOVE — L.T.D. — A&M**
WGPR-FM, KATZ, WWD, WAOK, KPRS, WLOU, WDAO.
- "HOW DO YOU DO" — AL HUDSON & THE SOUL PARTNERS — ABC**
WBMX, WLTH, WGPR-FM, WJLB, KATZ, WYBC, KYOK.
- GET DOWN — GENE CHANDLER — 20th CENTURY**
WUFO, WJLB, WYLD, WAOK, WVKO, WSOK.
- "MIDNIGHT GIRL" — LENNY WILLIAMS — ABC**
WLTH, WWRL, WGIV, WRBD, WJMO, WDAO.

MOST ADDED ALBUMS

- CHAKA — CHAKA KHAN — WARNER BROS.**
OK100, KDAY, KKSS, WWIN, WGPR-FM, WUFO, WORL, WGOK, KOKY, WJNR, WLOU, KYOK, WSOK.
- NOTHING SAYS I LOVE YOU LIKE I LOVE YOU — JERRY BUTLER — PHIL. INT'L.**
WLTH, WWIN, WEDR, WUFO, WRBD, WYBC, KSOL, KOKY, WLOU, KYOK, WMBM.
- FOR THE SAKE OF LOVE — ISAAC HAYES — POLYDOR**
WIGO, WWIN, WEDR, WGPR-FM, WUFO, WILD, WORL, WWRL.

SELECTED ALBUM CUTS

- WHAT YOU WAITIN' FOR — STARGARD — MCA**
Sensuous Woman, Never Take You Back.
- LOU RAWLS LIVE — PHILADELPHIA INTERNATIONAL**
Stay Awhile With Me, Send In The Clowns.
- PATRICE — PATRICE RUSHEN — ELEKTRA**
When I Found You, Music Of The Earth.
- THE GOLDEN TOUCH — CERRONE IV — COTILLION**
Rocket In My Pocket, Je Suis Music.
- WE ALL HAVE A STAR — WILTON FELDER — ABC**
Let's Dance Together, I Know Who I Am.

BLACK RADIO HIGHLIGHTS

WIGO — ATLANTA — TONY GRAY, PD — #1 — FUNKADELIC
JUMPS: 30 To 25 — Chic, 20 To 6 — G. Vannelli, 18 To 10. ADDS: El Coco, M. Henderson, High Inergy, B. Maupin, Mother's Finest, J. Butler, Afro Cuban Band, Musique, K. Young, Brass Construction. LP ADDS: Pablo Cruise, B. White, I. Hayes.

WWIN — BALTIMORE — DON BROOKS, MD
HOTS: Ashford/Simpson, Switch, Funkadelic, Grey & Hanks, Chaka Khan, Musique, Quartz, B. White, Chanson, C. Lynn, M. Moore, Brides of Funkenstein, R. James, Peaches & Herb, Quazar, Staples. ADDS: Shalamar, Ray Barretto. LP ADDS: I. Hayes, Latimore, Chaka Khan, J. Butler, C. Lynn.

WILD — BOSTON — SONNY JOE WHITE, MD — #1 — FUNKADELIC
ADD: Gonzalez, G. Vannelli, Zulema. LP ADDS: I. Hayes.

WUFO — BUFFALO — BYRON PITTS, MD — #1 — FUNKADELIC
JUMPS: 39 To 21 — ADC Band, 34 To 26 — Lakeside, 18 To 4 — Chic, 14 To 6 — C. Lynn. ADDS: Lakeside, J. Ray, Odyssey, Fatback Band, G. Chandler, S. Robinson. EXTRAS: R. Foster, Village People, Peaches & Herb, H. Hancock, Quartz, R. Flack, V. Burch, B. Pointer. LP ADDS: Chaka Khan, Stargard, Lakeside, J. Butler, Odyssey, I. Hayes, Cerrone, L. Rawls, Manu Dibango, E. Harris, N. Larson.

WGIV — CHARLOTTE — LEE MICHAELS, PD
HOTS: Funkadelic, G. Vannelli, B. White, T. Pendergrass, B. Wright, Chaka Khan, Bohannon, Chic, Mother's Finest, Grey & Hanks. ADDS: Brothers Johnson, G.S. Heron, L. Williams. LP ADDS: Cameo, Kool & The Gang, Ramsey Lewis, J.G. Watson, Double Exposure, Gary Toms Empire.

WJPC — CHICAGO — SANDRA ROBERTS, MD
HOTS: B. White, C. Lynn, Chaka Khan, Rose Royce, Emotions, Brides of Funkenstein, Funkadelic, Bohannon. ADDS: Chic. EXTRAS: Village People. LP ADDS: M. Moore, Ashford/Simpson, R. Lewis, R. Laws.

WBMX — CHICAGO — JAMES ALEXANDER, PD
ADD: C. Lynn, Chaka Khan, Captain Sky, Funkadelic, B. White, Brides of Funkenstein, G. Chandler, Prince. ADDS: A. Hudson, Stylistics, Taste of Honey. LP ADDS: Les McCann, P. Rushen, Free Life, Bell & James, W. Felder.

WJMO — CLEVELAND — LYNN TOLLIVER, PD — #1 — FUNKADELIC
JUMPS: 34 To 29 — Staples, 33 To 27 — E.C. King, 32 To 25 — Kinsman Dazz, 29 To 17 — M. Henderson, 26 To 18 — Rose Royce, 21 To 15 — Sylvester. ADDS: Chanson, R. Caldwell, Shalamar, L. Williams, J.G. Watson, Brothers Johnson. LP ADDS: Kinsman Dazz.

WJLB — DETROIT — TOM COLLINS, MD
JUMPS: 40 To 33 — J. McKee, 38 To 35 — E.C. King, 37 To 29 — C. Lynn, 36 To 30 — Quazar, 35 To 28 — R. James, 30 To 24 — Chaka Khan, 29 To 23 — Chic, 17 To 12 — Staples, 15 To 10 — ADC Band. ADDS: Rose Royce, M. Henderson, Al Hudson, G. Chandler. EXTRAS: D. Washington, Musique, H. Kelly, R. Ayers, O. Wright, B. Caldwell, Bell & James, K.C. & Sunshine Band, LTD. LP ADDS: Aquarian Dream, W. Felder, Sea Level.

WGPR-FM — DETROIT — GEORGE WHITE, PD — #1 — SWITCH
JUMPS: 34 To 22 — Quazar, 33 To 21 — Bell & James, 32 To 18 — Chanson, 30 To 27 — Brass Construction. ADDS: Rare Essence, Cloe Martin. EXTRAS: LTD, General Johnson, D. Washington, A. Hudson, Chic, Odyssey, Slave, Pleasure. LP ADDS: Chaka Khan, Glass Family, R. Laws, Captain Sky, Bar-Kays, I. Hayes, Les McCann.

WRBD — FT. LAUDERDALE — JOE FISHER, PD — #1 — FUNKADELIC
JUMPS: 15 To 6 — Bohannon, 14 To 5 — Sylvester, 9 To 4 — Switch. ADDS: R. Barreto, N. Connors, L. Williams, S. Robinson, M. Moore, Kool & The Gang, J. Simon, A Taylor. LP ADDS: Stargard, Peaches & Herb, L. Johnson, J. Butler, L. Rawls.

WEAL — GREENSBORO — TY MILLER, MD — #1 — H. KELLY
JUMPS: 26 To 19 — Quazar, 23 To 13 — B. White, 20 To 5 — Chic, 18 To 12 — Chaka Khan, Ex To 25 — G. Chandler. ADDS: Futures, Ohio Players, J.G. Watson, C. Jackson, Norfolk, Slave, Rose Royce.

KYOK — HOUSTON — RICH ROBERTS, MD — #1 — FUNKADELIC
JUMPS: 31 To 19 — Brides of Funkenstein, 26 To 11 — C. Lynn, 24 To 9 — Chic. ADDS: Quazar, B. Caldwell, Ohio Players, A. Hudson, J. Simon, Hot Chocolate. LP ADDS: Chaka Khan, Latimore, J. Butler.

KMJQ — HOUSTON — PAM WELLES, MD — #1 — B. WHITE
JUMPS: 38 To 33 — Switch, 31 To 23 — M. Moore, 23 To 12 — T. Pendergrass, 22 To 13 — Jacksons, 21 To 17 — G.S. Heron, 19 To 7 — R. Ayers. ADDS: ADC Band, G. Diamond, Double Exposure, Chanson, O.C. Smith. EXTRAS: Ex To 30 — B. Pointer, Ex To 29 — G. Knight. LP ADDS: W. Felder, P. Rushen, Stargard.

WTLC — INDIANAPOLIS — ROGER HOLLOWAY, MD
HOTS: Captain Sky, B. Wright, Switch, LTD, G. Vannelli, A. Starr, Pockets, T. Pendergrass, Quazar, Brides of Funkenstein, Mtume, Chaka Khan, Staples, Graham Central, J. Butler. ADDS: M. Henderson, G.S. Heron, B. Pointer, M. Jackson, J. Carn, Gonzalez, Ross/Jackson, Ashford/Simpson, D. Summer, R. James, B. White, Chic, Chanson, Ollie Baba, Brecker Brothers, W. Pickett, Shotgun, N. Connors.

KPRS — KANSAS CITY — DELL RICE, MD — #1 — FUNKADELIC
JUMPS: 40 To 30 — N. Cole, 39 To 32 — Village People, 38 To 31 — K. Barrow, 37 To 30 — L. Williams, 36 To 29 — R. Brown, 34 To 28 — McChrays, 33 To 27 — Shalamar, 32 To 26 — O.C. Smith, 31 To 25 — T. Pendergrass, 28 To 23 — M. William, 27 To 22 — Chanson, 25 To 21 — Temptations, 24 To 20 — K.C. & Sunshine Band, 23 To 19 — Quazar, 22 To 18 — Q. Jones, 21 To 17 — Chaka Khan. ADDS: LTD, V. Burch, A. Jarreau, B. Caldwell, ADC Band, Faith, Hope & Charity, Special Delivery, J. Butler, Ex To 36 — L. Garrett, Ex To 35 — Slave, Ex To 34 — Faze-O. LP ADDS: Stargard, D. Byrd, W. Felder.

KOKY — LITTLE ROCK — KELLY KARSON, MD — #1 — FUNKADELIC
HOTS: ADC Band, J.G. Watson, Chanson, E. King, Quazar, B. White, Ashford/Simpson, R. James. ADDS: G.S.-Heron, 7th Wonder, War. LP ADDS: J. Butler, Lakeside, Chaka Khan, A. Prysock, Stargard, J. Santana, S. Dash.

KKTT — LOS ANGELES — WALT LOVE, PD — #1 — R. JAMES
JUMPS: 28 To 17 — Whispers, 27 To 14 — Brides of Funkenstein, 25 To 18 — Ross/Jackson, 23 To 19 — Staples, 10 To 6 — Switch. ADDS: E.C. King, B. Caldwell, Latimore. LP ADDS: A. Jarreau, Sun, Village People, Mother's Finest.

KDAY — LOS ANGELES — STEVE WOODS, PD
HOTS: B. Wright, Bohannon, Jacksons, D. Summer, Funkadelic, Shalamar, Switch, Ashford/Simpson, R. James, Chaka Khan. ADDS: Village People, D. Hartman, Lakeside. LP ADDS: Odyssey, G. Diamond, D. Hartman, Village People, Chaka Khan.

WLOU — LOUISVILLE — NEAL O'REA, PD — #1 — BRIDES OF FUNKENSTEIN
JUMPS: 39 To 25 — L. Williams, 38 To 23 — G.S. Heron, 37 To 24 — R. James, 36 To 22 — J. Carn, 35 To 20 — Chic, 34 To 19 — A. Hudson, 30 To 21 — Quazar, 26 To 18 — Kool & The Gang, 25 To 16 — Temptations, 22 To 11 — E.C. King, 21 To 13 — J. Butler. ADDS: M. Henderson, LTD, Mtume, Fatback Band, B. Caldwell, Rose Royce, ADC Band, Slave, D. LaSalle. LP ADDS: Chaka Khan, J. Butler, L. Rawls, D. Byrd.

WDIA — MEMPHIS — JAYE MICHAEL DAVIS, MD — #1 — FUNKADELIC
JUMPS: 30 To 21 — P. Brown, 29 To 20 — Commodores, 28 To 24 — Crown Heights, 27 To 19 — K. Young, 24 To 18 — T. Pendergrass, 22 To 15 — Grey & Hanks, 19 To 12 — Chaka Khan, 15 To 9 — Sylvers, 11 To 8 — Ross/Jackson, 10 To 4 — Switch. ADDS: R. Brown, O.C. Smith, Emotions, Chic, O.V. Wright.

WEDR — MIAMI — JOHNNY DOLAN, MD
ADD: Sheila Hilton, Edwin Starr, A. Prysock, Wonderland Disco, 3 Degrees. LP ADDS: Ollie Baba, J. Castor, Booker T, I. Hayes, J. Butler, Double Exposure.

WYBC — NEW HAVEN — JAMES JORDAN, MD
HOTS: Switch, Jeffree, ADC Band, D. Pearson, G. Chandler, S. Dash, Chaka Khan, Chic, Lakeside, E.C. King. ADDS: V. Burch, A. Hudson, Gonzalez, Hot Ice. LP ADDS: L. White, Faze-O, L. Rawls, J. Butler, T. Houston, Major Harris, Caroline, J. Handy, P. Rushen, D. Byrd, Lamont Johnson.

WXEL-FM — NEW ORLEANS — REG HENRY, MD — #1 — FUNKADELIC
JUMPS: 35 To 28 — J. Butler, 28 To 22 — Chic, 24 To 21 — LTD, 23 To 18 — G. Vannelli, 20 To 15 — G.S. Heron, 17 To 9 — B. Caldwell, 15 To 10 — Jacksons. ADDS: Bros. Johnson, Rose Royce. LP ADDS: Cheryl Lynn, Phoebe Snow.

WNJR — NEWARK — JERRY LOVE, PD
HOTS: Funkadelic, Whispers, L. Williams, LTD, Ashford/Simpson, D. Moore, Quazar, D. Summer, T. Pendergrass, Chaka Khan, J. Gilliam, B. Caldwell, Zulema, B. Bland, Crown Heights Affair, B. Wright, Temptations, Commodores, B. White, Jacksons, Emotions, J. Cheeks, L. Heywood, G. Chandler, Switch, M. Moore, Sylvers, R. Brown, Shalamar, Peaches & Herb. ADDS: Rose Royce, E. Drennon, Art Wilson. LP ADDS: Chaka Khan, Temptations, Richard Groove Holmes, P. Rushen, E. Harris.

WWRL — NEW YORK — LINDA HAYNES, MD
HOTS: A. Bridges, Commodores, Funkadelic, D. Hartman, R. James, Chaka Khan, Musique, Peaches & Herb, Shalamar, G. Vannelli, Zulema. ADDS: B. Caldwell, L. Haywood, L. Williams, J. Butler, G.S. Heron. LP ADDS: Major Harris, I. Hayes, M. Moore, P. Rushen, L. White.

KDIA — OAKLAND — JERRY BOULDING, PD
HOTS: Ashford/Simpson, Switch, Funkadelic, Cheryl Lynn, B. White, R. Brown, Rose Royce, Chaka Khan, B. Caldwell, D. Moore. ADDS: McChrays, ADC Band, E.C. King. LP ADDS: G. Vannelli, Quazar, J. McGriffin.

WORL — ORLANDO — STEVE CRUMBLY, MD — #1 — B. WHITE
JUMPS: 40 To 35 — D. LaSalle, 39 To 22 — Chic, 38 To 21 — Musique, 37 To 23 — M. Henderson, 31 To 20 — Sho Nuff, 30 To 26 — E.C. King, 28 To 24 — L. Williams, 18 To 12 — Chaka Khan, 16 To 8 — D. Summer, 15 To 5 — Brides of Funkenstein, 7 To 3 — A. Bridges, Ex To 34 — Vivian Reed, Ex To 25 — Ross/Jackson. ADDS: Rose Royce, E. Williams, B. Pointer, ADC Band, B. Caldwell, Pablo Cruise, D. Hartman, Greg Diamond, M. Lamb. LP ADDS: Chaka Khan, I. Hayes, Chanson, Brides of Funkenstein, A. Jarreau.

WDAS — PHILADELPHIA — JOE TAMBURRO, PD — #1 — CHIC
JUMPS: 42 To 27 — LTD, 30 To 26 — Shalamar, 29 To 25 — R. James, 28 To 16 — ADC Band, 27 To 24 — Raw Sugar, 26 To 23 — B. Pointer, 25 To 22 — L. Haywood, 24 To 21 — Brass Construction, 23 To 20 — Ross/Jackson, 22 To 19 — Chanson, 21 To 18 — B. Wright, 20 To 17 — Staples, 19 To 13 — B. White, 18 To 15 — G. Vannelli, 17 To 12 — J. Butler, 9 To 6 — B. Caldwell. ADDS: C. Garrison, M. Henderson, Futures, Joe Simon, 7th Wonder.

WAMO — PITTSBURGH — EDDIE EDWARDS, MD — #1 — ASHFORD/SIMPSON
JUMPS: 40 To 32 — R. Lewis, 33 To 24 — Chaka Khan, 25 To 20 — War, 24 To 19 — Rose Royce, 20 To 13 — Chic, 13 To 8 — Brides of Funkenstein. ADDS: Musique, Joe Thomas, Gary Toms Empire.

WANT — RICHMOND — KIRBY KARMICHAEL, PD — #1 — C. STATON
JUMPS: LP To 9 — Rose Royce, LP To 8 — A. Hutson. ADDS: Lakeside, Gladys Knight, Whispers, Village People, D. Hartman, Phyrework. LP ADDS: Futures, Brass Construction, Sylvester, G. Vannelli, Latimore, Chaka Khan, I. Hayes.

KSOL — SAN FRANCISCO — J.J. JEFFRIES, PD — #1 — JACKSONS
JUMPS: 24 To 19 — Brides of Funkenstein, 23 To 17 — Chanson, 22 To 15 — Staples, 20 To 13 — Commodores, 16 To 12 — Quazar, 14 To 10 — Ross/Jackson, 13 To 6 — Chaka Khan. ADDS: G. Vannelli, R. Brown, T. Pendergrass, Bros. Johnson. LP ADDS: O.C. Smith, Maze, J. Butler, J.B. Horne, Rose Royce, G. Chandler.

KATZ — ST. LOUIS — EARL PERNELL, MD
JUMPS: 27 To 20 — L. Williams, 23 To 10 — Whispers, 22 To 15 — KC & Sunshine Band, 17 To 9 — Bros. Johnson, 16 To 6 — Chaka Khan, 15 To 13 — Chanson, Ex To 30 — General Johnson, HB To Pick — M. Henderson. ADDS: Cheryl Lynn, Grace Jones, E.C. King, A. Hudson, D. LaSalle, Sho Nuff, LTD, Gonzalez, Crown Heights Affair, Shalamar, M. Moore, Emotions, Musique, McChrays. LP ADDS: Funkadelic, Ashford/Simpson, G.S. Heron, Lonette McKee, Faze-O, Ronnie Laws.

KKSS — ST. LOUIS — WALT SUMMNER, MD
HOTS: Jacksons, D. Summer, Ashford/Simpson, G. Vannelli, Rose Royce, Cheryl Lynn, Chanson, Staples, Chaka Khan, Commodores. ADDS: Chic, Musique, Grey & Hanks. LP ADDS: W. Felder, L. White, L. Rawls, Chaka Khan, M. Moore, Bell & James, Phyrework.

OK100 — WASHINGTON — JOHN MOEN, MD
Funkadelic, C. Lynn, Mother's Finest, Chic, Brides of Funkenstein, C. Khan. ADDS: Emotions, Chic, ADC Band, G.S. Heron, Shalamar. LP ADDS: Cameo, C. Khan.

Campaign To Transform TK Into Album Label Succeeds

(continued from page 8)

you stand a better shot. We know how to merchandise it; we know how to sell it. I've been doing it for years. It's a matter of making the commitment, and I'll make the commitment."

West Coast Connection

One source of new rock acts for TK will be Inphasion Records, the West Coast-based label that was recently formed by Danny Kessler and Clancy Grass. Under terms of Inphasion's recently signed distribution deal with TK, the label will be distributed by TK in the U.S. and Canada, with Polydor taking care of worldwide distribution.

Another distribution deal has been signed between TK and Muscle Shoals Sound, which has just formed a new label. "We'll be drawing a lot of strength from Muscle Shoals, which has always been a tremendous wealth of talent and material," Stone remarked. "You know, a lot of acts have gone down to record at Muscle Shoals, but what they've done is they've picked up the material down there."

TK also has an office in New York, which accounts primarily for disco talent. But the center of TK's A&R operation remains Miami, and it is in the Miami area that Stone has discovered some of his top acts, including Betty Wright, Foxy and KC and the Sunshine Band.

KC now has his own TK-distributed label, Sunshine Sound, as well as a brand new studio. While his own group remains a TK Records act, Sunshine Sound includes Jimmy Bo Horne and Fire.

TK employs three in-house producers: Cory Wade, Ray Martinez, who specializes in disco, and Steve Alaimo, executive producer and Stone's partner in TK. In addition, they use many outside producers. But, whoever produces a TK album, there is usually a certain sound on the LP that identifies it as a TK product.

While Stone agreed that there is a "TK Sound," he stressed his hands-off policy in the studio. "We get involved with outside producers who do their own thing," he said. "They do realize that TK has sort of a funky, happy, nice dance music or whatever you want to call it — and they do their own thing and sort of integrate that into it. And it seems to work."

"I mean, I wouldn't go to a Gregg Diamond and say, 'Gregg, this is the way you have to do it.' But you listen to the album, man, and it's all groovin' and TKish, you know? And it still has Gregg Diamond all over the place."

Always A Record Man

Henry Stone has been in the record business for over 30 years, and he knows every phase of it. But his first love was always discovering and recording new talent, and TK Records has proven to be the perfect outlet for his creativity.

Stone came to Miami in 1946 after having played jazz trumpet and worked in publishing in Los Angeles. At that time, he



IF EVERYBODY HAD AN OCEAN — While in Miami working on a new Beach Boys album, Brian Wilson (l) was visited by Maurice Gibb (r) of the Bee Gees, who previewed a few new Bee Gees songs for Wilson. Pictured above, the pair relaxing on the beach.

remembers, there was "nothing but palm trees" in Miami. Stone discovered a warehouse in town that was filled with 50,000 78s on the Black and White label which the owner was trying to unload. Having peddled some records from the back seat of his car in California, Stone thought he could sell them; and so he found himself in the record distribution business.

For a time, Stone worked for Pan American distributors, then set up his own Seminole Record Distributors. Meanwhile, he was beginning to record a few acts on the side. "I always had a studio in the back of my pocket," he recalled in a previous **Cash Box** interview (**Cash Box**, March 27, 1976). "And around this time I recorded Ray Charles on Rockin' Records, my own label. I also recorded John Lee Hooker under a pseudonym."

In the early '50s, Stone went into partnership with Syd Nathan of King Records in Cincinnati. Together, they formed Deluxe Records, and Stone produced James Brown's classic, "Please Please Please," on Federal, another of Nathan's labels.

Stone founded Tone Distributors after parting ways with Nathan in the mid-'50s. At the same time, he had a label called Chart Records, "which put out a lot of those early Alan Freed-type (rock) groups." He also had several other small labels over the years, most of them distributed by Atlantic. In 1960, one of these ventures, Dade Records, had a hit with James Brown's "Mashed Potatoes."

Throughout the '60s, however, Stone concentrated mostly on building Tone, which at one time, he says, distributed nearly every independent label for the state of Florida. Today, Tone is still one of the biggest independent distributors in the Miami area. But Stone is no longer directly connected with the enterprise, which is now run by Lynda Stone Millman.

Stone credits Warner Bros., Elektra/Asylum and Atlantic with giving him the impetus to start TK Records. By forming WEA and pulling their lines from independent distribution in 1971, he says, they pushed him into doing what he really wanted to do: become a record manufacturer.

Independents Are Strong

How does Stone feel about independent distribution today? "I feel very strongly about it," he replied, "because I'm one of the major labels. There's A&M and TK and there's 20th Century and Arista — there are not that many (major independent) labels. So we get a tremendous amount of recognition at the independent distribution level." Stone added that, since the independent manufacturers have relatively few releases at any given time compared to a CBS or a WEA, they can work them better than the major branch outfits can. "That's a super advantage for TK and a few of the stronger independents. And that's why I believe that the independent network at this point is very, very strong."

At the same time, he noted, the very size of CBS, WEA and Polygram is working to the advantage of the indies from an A&R standpoint. "There's a situation out there now, which I'm feeling as a major independent, where people cannot get their product released. They just can't go to CBS right now. CBS has so many commitments, WEA has so many commitments, and Polygram is just committed up to their teeth. So people can't get their product out. And we're a growing, creative business. So what's going to happen? There are just going to be people springing up with product. A few of them are going to have a rough time, but it's going to expand. It's the creativity of our business: You just can't control it."



BITING THE APPLE — Columbia recording artists Jules and the Polar Bears recently appeared in New York at the Bottom Line, where they performed selections from their debut LP, "Got No Breeding." Pictured backstage after their set (l-r) are: group members David White, David Beebe, Richard Vredice, and Steve Hague; Peter Jay Philbin, associate director of talent acquisition for the label's west coast A&R department; Don Ellis, vice president of national A&R for Columbia; Jules Shear of the group; Jack Craigo, senior vice president and general manager for Columbia; Bruce Lundvall, president of the CBS Records Division; and manager Ed Reeves.

Popovich Finds Comfortable Home For Cleveland Int'l

(continued from page 10)

has been able to return to the basics of the business.

"As a small company you can oversee everything every step of the way, from the recording process to the artwork to getting the mastering approval from the artist," Snyder says.

Although he is based in New York so he can be close to CBS operations, Snyder echoes Popovich's sentiments concerning the decision to headquarter the label's three-man promotion staff in Cleveland.

"In Cleveland we have the biggest breakout radio market that I think exists," Snyder says. "And it's real tough to break a new act without radio."

New Acts

And new acts are what make up the Cleveland International roster, which consists of Meat Loaf, The Euclid Beach Band, Ellen Foley, Jesus Alvarez and The Boyzz. The Euclid Beach Band just finished recording its debut LP while Foley and Alvarez are currently in the studio working on their first efforts. The Boyzz LP has been out for about a month and a single, "Wake It Up. Shake It Up" recently was released.

All the acts were signed by Popovich, who assumes the lion's share of A&R responsibilities in addition to the role he plays directing the label's promotion staff out of Cleveland.

Popovich was tipped off to Meat Loaf by a long-time friend who was managing the rock artist. Ellen Foley was signed after Popovich heard her perform as a back-up singer in Meat Loaf's band. And the Euclid Beach Band was discovered by Popovich while he was out driving one afternoon.

"They had a local record here called 'There's No Surf In Cleveland' on Scene Records and I heard it about 13 times once on my car radio," Popovich says. "So I called Scene trying to track it down. We bought the single and agreed to do an album with the group."

Popovich says Cleveland's proximity to Chicago, which he considers a hotbed of undiscovered talent, is another advantage to his label's location. The Boyzz were playing in a Chicago club when Popovich first heard them.

"We've found that Chicago is full of clubs and new bands," says Snyder. "That environment doesn't exist in New York and it sure doesn't exist in Los Angeles, New York and L.A. clubs serve primarily a showcase function for the record companies."

But with five acts on the Cleveland International roster, Popovich says he has no plans to sign any new acts in the near future.

"We want to keep a small roster here for

the first couple of years so we can be totally committed to the people we have already signed," he says. "With this type of operation we're able to stick with an album for a year as we have with Meat Loaf."

Unlike many custom labels, which leave all promotional responsibilities to their distributor, Popovich says he attempts to get his records off the ground even before they are released to prove to CBS that they deserve to be priority items.

"Meat Loaf's first record shipped 100,000," says Snyder. "But it took six weeks of field work prior to the release of the album with cassettes we made. We called the CBS branch people, FM radio people and accounts and in effect, we pre-sold the album. We got instant airplay and sales in the Cleveland and New York markets."

Currently the label's promo staff is trying to get the ball rolling on the Boyzz LP, a new Meat Loaf single and The Euclid Beach Band's LP.

"With just three promotion men we can cover the whole country out of Cleveland," Popovich says. "For example, one guy drove to Buffalo this morning and he'll work that market today and go to every station there with the records. He'll also get together there with a tip sheet and the biggest account."

But even though Cleveland International may attempt to cover the whole country, the real muscle for marketing and promoting the label's product has to come from its distributor.

"I think our role in this whole thing is to first of all make hit records," says Snyder. "Next we go out and bring them to a certain level which will allow CBS and their tremendous marketing operation to move in and take it to whatever level it can reach. That's it in a nutshell."

Gene Parsons Signs To Sierra/Briar Records

LOS ANGELES — Gené Parsons, former member of the Byrds and the Flying Burrito Brothers, has signed with Sierra/Briar Records. Parsons' first solo LP since 1973 is slated for release next spring.

Parsons who is currently touring with the re-formed Flying Burrito Brothers, will continue to serve as A&R director for Sierra/Briar.

Atco Inks Lindisfarne

NEW YORK — Lindisfarne has been signed to a recording contract with Atco Records. The group's debut album for the label, "Back and Fourth," will ship this week. The LP was produced by Gus Dudgeon and includes the single, "Run From Home."



FOREIGNER'S WEST COAST WELCOMING — Atlantic recording group Foreigner was in Los Angeles recently for a performance at the Forum where the group was presented gold awards for their singles "Hot Blooded" and "Double Vision." After the show a party was held for the band, label execs and members of the press. While in California, the band traveled to San Diego where they were presented a certificate in appreciation of a benefit performance they gave to help rebuild the city's Aerospace Museum which was destroyed by fire. Pictured (l-r) are: (seated) Ed Gagliardi and Lou Gramm of the band and Jerry



Greenberg, Atlantic president; (standing) Tunc Erim, national pop album promotion director; Dennis Elliott of the band; John David Kalodner, director of west coast, A&R; Mick Jones of the band; Al Greenwood and Ian McDonald of the band; Bud Prager, Foreigner's manager; Kathy Schanker and Bob Greenberg, vice president and general manager of Atlantic; Mick Jones of Foreigner and Mayor Pete Wilson of San Diego who presented the certificate; and Judd Hirsch of Taxi; Candice Martinelli and Jones. During the group's show at the Forum, Jerry Greenberg sat in on drums.

Business Is Booming For Many Of The Independent Promotion Companies

(continued from page 7)

particular time. He's a fixture, in a constantly changing marketplace."

Another factor, according to Ken Kandell, a promotion man working with Joe Cash in the Washington, D.C. area, has been the "streamlined function of the independent. He doesn't," Kandell said, "have to be burdened with a lot of other company-related tasks, like filling out expense forms and sitting in on conference calls. His main concern is the program director, and he can concentrate on that."

Since the promotion man's relationship with a radio station program and music director has traditionally been crucial, most promotion men surveyed by **Cash Box** echoed Joe Cash's comment that "credibility is the key. We can afford to be honest, and we have to convince stations that we're the best tool they can use to decide what's right for them."

AOR Specialists

Another service that Cash and other promotion men have begun to provide has been that of an AOR specialist. According to Brenner, who has recently added album specialist Al Perry to his staff, "For an independent promotion man, AOR has probably become just as important as Top 40. And Top 40 is constantly watching AOR, a fact you can see on their playlists, which are about 70% similar."

Steve Leeds, a five-year promotion man with Atlantic Records who has just started his own northeast regional AOR company, stated, "It's still a new field, but the reality is that AOR radio is incredibly sophisticated, and they're subject to the same needs and pressures as Top 40. We're filling a vacuum that has emerged in the marketplace."

Another new AOR firm, Could Be Wild Promotion from Buffalo, has also, according to co-principal Bruce Moser, incorporated artist relations services into their structure. "We've set up live radio concerts and in-store appearances for artists," Moser stated. "Radio is just the first step. Then we have to concentrate on the retail accounts and any other vehicle which might be helpful to the artist and his record."

Among the problems facing the AOR promotion men are the limitations of budgets and competing consultancy services like Burkhart/Abrams. "AOR is an ad-

Vias Named Head Of RCA Latin Operations

(continued from page 16)

ditional budgetary problem for companies," Leeds said, "and smaller companies often can't afford to keep an album specialist."

Kandell viewed the consultancy problem "as an example of AOR radio degenerating itself into robot media. The Burkhart/Abrams format is unreceptive to new product, making it really hard for the human factor, which the promotion man provides, to break into the rotation. And the research that they claim is bullshit."

Cash added that many AOR formats have proved frustrating for Top 40-oriented promotion. "They seem to either have a liberal add list, which is great, but doesn't provide concentrated rotation. Or else they're as tight as AM and you don't get any rotation."

Aside from AOR, retail has become another key promotional target. Bill Harper, a longtime Philadelphia-based promotion man, stressed the importance of "convincing an account to buy with enthusiasm. 'Nowadays,' Harper said, "you have to develop a rapport with the buyer at key accounts, as well as with radio station programmers, in addition to providing display material or in-store promotion services, if necessary. In other words, you must treat (retail) accounts like stations."

Jukebox Petitions

(continued from page 7)

hearings that the location lists would be "unduly burdensome" and that they violate the businessmen's right to confidentiality. The performing rights societies, on the other hand, disputed those claims.

Nov. 9 Hearing

The CRT will go ahead with a hearing on Nov. 9, due to cover several jukebox items.

Among the points on the Tribunal's agenda is a request to reconsider the previous decision to adopt the jukebox rule. Also, several questions on the Freedom of Information Act and its application to the location list requirement are to be considered.

Finally, the Tribunal will look at BMI's suggestion that copyright owners be given further guidance on how claims should be submitted and how surveys should be conducted. As previously detailed, ASCAP and SESAC endorse a random sampling of actual performances on jukeboxes, while BMI believes royalties should be distributed according to information gathered from trade paper charts.

UJA Honors Bogart

(continued from page 8)

Yetnikoff, president of CBS Records; Joe Smith, president of Elektra Records; Jerry Moss, president of A&M Records; Irwin Steinberg, executive vice president of Polygram; Jeffrey Franklin, president of A.T.I.; Jeff Wald, president of Wald-Nanas management; Bill Aucoin, president of Aucoin management; and Steve Rubell and Ian Schrager of Studio 54, among many others.

East Coastings/Points West

(continued from page 18)

The LP is being produced by **Steve Jones**, formerly of the **Sex Pistols**.

ALL THE DUDES ON E STREET — Former **Mott The Hoople** leader **Ian Hunter**, recently signed to Chrysalis, is currently recording his new solo album in New York. The singer-songwriter is being backed by three members of **Bruce Springsteen's E Street Band (Max Weinberg, Roy Bittan and Garry Tallent)** plus former **David Bowie/Mott** mainstay **Mick Ronson**, who is producing the album and contributing guitar licks. Hunter's album, his first American release since the critically acclaimed "All-American Alien Boy" over two years ago, is due out next February. Hopefully, a concert tour will follow . . . The debut album by the **Euclid Beach Band** on Cleveland International will be issued next March. The LP is produced by **Eric Carmen** . . . First American Records will be expanding into the disco field with the release of "Introducing Danny Johnson," a solo album by the former lead singer of the **Chi-Lites** . . . **Dolly Parton**, currently in the midst of her first European concert tour, received an enthusiastic reception from her British fans during her visit to London . . . **Bonnie Sanders**, who co-wrote a tune for the soundtrack of the film "Black Pearl," is also writing material for **Dinah Shore's** upcoming LP on Sesame Street Records

SHORT TAKES — **Peter Tosh's** "Bush Doctor" album, which marks the first time **Mick Jagger** and **Keith Richards** (the Glimmer Twins) have produced an album other than by the Stones, will be issued by Rolling Stones/Atlantic Records on Nov. 14 . . . Interworld songwriter **Molly-Ann Leikin** has completed the lyrics to **Lee Holdridge's** "Moment By Moment" theme for the John Travolta/Lily Tomlin movie of the same name. The title song is being recorded by **Yvonne Elliman** . . . **Macey Lipman**, head of the Macey Lipman Marketing firm and a "closet painter" for many years, came out of the closet, so to speak, last week and hosted an invitational exhibition of his paintings at the Anhalt/Barnes Gallery in Los Angeles . . . Mushroom recording artist **Ian Matthews** has been the opening act for the current national tour by **David Gates** and **Bread**.

dale kawashima

Disco Breaks

(continued from page 46)

Rumors are flying at presstime about Alan's replacement — more next week . . . **Wes Bradley** who handled promotions for BADA has left that position to handle independent promotion projects with Caviano. At this time, Bradley's main efforts are concentrated on "Workin' & Slavin'" on Atlantic . . . **Michael Gormley** won the quarterly merit award of the Pocono Pool on Nov. 6. Gormley works at The Library in Bala Cynwyd, which sounds like a town in Wales but is actually a Philadelphia suburb . . . **Ken Jason**, who spins at Footloose And Fancy Free in Chicago, has become (as far as is known) the first DJ to have a computerized playlist. Once having programmed his computer, Jason enters updates and gets a print-out at the push of a button. He mails the sheet to labels as part of his feedback . . . **Jeff Broltman**, who used to spin at Stag and Doe in Montecello, N.Y. has moved to Texas to assist **Sam Meyer** at Disco-Texas . . . **George Ferren** who is a DJ at The Stud in San Francisco has joined the office staff of BADA.

UPCOMING PRODUCT — **Simone Soussan** recently signed a production deal with Polydor that calls for six albums over the next year to appear on the Harem label. The first release is "Let The Music Play" by Arpeggio which is slated for a Nov. 27 release along with many other new Polydor entries. Polydor, reportedly, is launching a major push of disco product this month with a promotion entitled "Step Into Our Disco" . . . The brand new label Infinity Records which is headed by **Ron Alexenburg** is releasing this week a 12" promo only which features "Every 1's A Winner" by **Hot Chocolate** with "You Can Do It" by **Doble Gray** on the flipside. Gray has an album due shortly titled "Midnight Diamond" . . . A&M is releasing a non-commercial 12" "Ain't We Funkin'" by the **Brothers Johnson** within several weeks. Also scheduled for mid-November is a 12" version of "Dancin' In The Halls Of Love" by **Alessi**. "Don't Want To Live Without It," 12" by **Pablo Cruise** came out last week with a remixed break by the LP's producer **Bill Schnee**. At the same time, A&M put out a jazzy uptempo 12" of "Just The Way You Are" by **Les McCann**. Recently out is a new **Bell & James** album. At this point, it is a toss up whether the 12" will be "Living It Up" or "I Love The Music" . . . Motown has issued "Smokin'" a live greatest hits package by **Smokey Robinson** . . . AVI is hush-hush about a Christmas disco album which is due next week . . . MCA is readying "Do The Samba" by **Van McCoy** . . . Atlantic is releasing in late November "Bring Your Own Funk" by the **Fantastic Four**. A 12" "Sexy Lady" with mix by **Issy Sanchez** will be out at the same time. Mid-month is the timing for the release of "Stairway To Heaven" by **The Wonder Band**. Issy is very excited about a track called "Disco Extravaganza" by **GB Experience And Speed**.

APPEARANCES — London's **Zulema** will appear at the Paradise Garage in Manhattan on Nov. 11. She will also be seen on the Soap Factory TV show which will air the week of Nov. 23. **Musique** will join Zulema on the show. In turn, the **Trammys** will join Musique on Nov. 24 at the Brooklyn Cotillion Terrace . . . HOT FLASH: Ariola has replaced disco promotion man **Randy Sillis** with **Jack Witherby** of the Southwest Record Pool.

peter hartz

TOP 20 ALBUMS

LOS ANGELES POP	LOS ANGELES SALSA
1 TE JURO QUE NUNCA VOLVERE LUPITA D'ALESSIO (Orfeon 021)	1 HOMENAJE A BENNY TITO PUENTE (Tico 1425)
2 DERRUMBES SALVADORS (Arriba 3005)	2 AQUI ESTOY YO OSCAR DE LEON (TH-2036)
3 SOLA LISSETTE (Coco 148)	3 TREMENDA DIMENSION DIMENSION LATINA (Velvet 8012)
4 LA VOZ RANCHERA CHELO (Musart 10638)	4 ESTO SI ES LO MIO ISMAEL RIVERA (Tico 1428)
5 CAMARON PELAO LOS POLIFA CETICOS (Latin Int. 5025)	5 INCONQUISTABLE DIMENSION LATINA (TH-2040)
6 DESNUDATE MIGUEL GALLERDO (Latin Int. 2042)	6 EDDIE PALMIERI (Epic JE-35523)
7 CANTA A JUAN GABRIEL ROCIO DURCAL (Pronto 1031)	7 LA COMEDIA HECTOR LAVOE (Fania 522)
8 LEO DAN (Caytronics 1504)	8 SALSA DISCO FEVER VARIOUS ARTISTS (Coco 152X)
9 SERENATA SIN LUNA LOS ANGELES NEGROS (International 925)	9 LA PRIMERISIMA TOMMY OLIVENCIA (Inca 1061)
10 RASGOS CAMILO SESTO (Pronto 1025)	10 SALSA ENCENDIDA TIPICA 73 (Inca 1062)
11 NUMERO 8 LOS TIGRES DEL NORTE (Fama 564)	11 ONLY THEY COULD HAVE MADE THIS ALBUM CELIA CRUZ/WILLIE COLON (Vaya 66)
12 LOS ALAMBRADOS LOS BUKIS (Mericana/Melody 5611)	12 CHARANGA 76 EN EL 78 CHARANGA 76 (TR 139X)
13 EL AMOR JULIO IGLESIAS (Alhambra 23)	13 SPANISH FEVER FANIA ALL STARS (Columbia C135336)
14 TU SONRISA LORENZO SANTAMARIA (Latin Int. 6920)	14 LOUIS RAMIREZ Y SU AMIGOS LOUIE RAMIREZ (Cotique 1096)
15 CON MARIACHI CHELO (Musart 10585)	15 SABOR SENTIMIENTO Y PUEBLO ISMAEL MIRANDA (Fania 530)
16 ESPECTACULAR JUAN GABRIEL (Pronto 1036)	16 OSCAR DE LA SALSA OSCAR DE LEON (Top Hits 2026)
17 BESITOS LOS HUMILDES (Fama 560)	17 SALSA MAYOR (Velvet 8011)
18 AMIGO ROBERTO CARLOS (Caytronics 1505)	18 NEW YORK CITY SALSA ORQUESTRA BWAY (Coco 140)
19 PAJARILLO NAPOLEON (Raff 9065)	19 SALUD DINERO Y AMOR ORQUESTR NOVEL (Fania 520)
20 VIVAN LOS MOJADES LOS TIGRES DEL NORTE (Fama 551)	20 EXPLORANDO LA SONORA PONCENA (Inca 1060)

Latin Picks

ARLEQUIN — Nydia Caro — Alhambra 155 — Producer: Manuel de La Clave

Nydia Caro is well known all over Latin America; she is an established superstar and no stranger to the Latin charts. In this album she excels vocally on every cut. Beautiful arrangements by R. Arcusa. The album consists mostly of ballads and soft rock. There are two outstanding songs done in English. The back up vocals are good. Best cuts are "Arlequin," "Keep On Moving," "Aqua de Manantial," "Isadora" and "Se Te Vas."

TRAIGO SABOR — Sonora Matancera — Orfeon — 16H-5134 — No Producer

Sonora Matancera has been the pioneer of Latin music for approximately 50 years. Salsa music of today was done many years ago, and this outfit needs no introduction. On this remarkable album most of the cuts are moving salsa numbers except for one slow bolero. The vocals are superb. The orchestra is very tight. The arrangements are great and there are a few good solos by the piano player and lead vocals.

VUELVE-LUISA MARIA GUELL — Alhambra Acs-43 — No Producer

Multi-talented Cuban vocalist Luisa Maria Guell excels in this album of love songs in her own romantic way. Her voice is superb throughout this LP which features some dazzling orchestrations. Great backing provided by string section and background vocalists. This album was recorded in Spain. The best songs are "Senor Amor," "No Me Vayas A Enganar," "El Viejo Bar," "Buelve," "Haz El Amor" and "Besame Mucho."



LATIN BEAT

The First Charanga World Festival reportedly took place in Caracas, Venezuela, Oct. 10 to 12, at Nuevo Cinco Coliseum. Representing Cuba was **Orq. Aragon**, regarded as a major musical force in Cuba. **Richie Bonilla** of the RMM booking agency in New York set up two bands for the festival, both representing Puerto Rico and New York; they were Charanga American and **Gene Hernandez** and **Novedades**. The festival was promoted by **Jesus Anton** of Producciones P.P.C.A., the same company that presented the First World Salsa Festival in Caracas in 1975. If you've wondered what **Alex Masucci** has been up to since he left big brother Jerry at Fania, here's the word: Alex is presently assistant to **Cris Blackwell**, owner of Island Records, whose stable includes **Bob Marley**, **Grace Jones**, and **Inner Circle**. Alex is playing a vital role in artist development, plus pushing the product once the recording is cut. Right now, Alex is putting his chips on a group called "**Third World**," who hail from Jamaica and already have a "Sure Shot" on WBLS, "Now That We've Found Love."

Beautiful Puerto Rican songstress **Nydia Caro** will be appearing at Alice Tully Hall in Lincoln Center Nov. 20. The event, sponsored by the Association Cardiovascular del Sur, marks Nydia's first concert appearance in New York.

Paquito Navarro claims that if Disco keeps growing, we could lose all our Latin youth. Although Paquito has moved over to WKTU's as a Disco disc jockey, he's still a Salsero. He feels that many of the clubs are catering to "a mature crowd" and there's no place for teenagers to see our music live. When the old Cheetah was around, the young crowd had a place to go. This guaranteed a new generation of Salsa lovers. This Cheetah crowd was labeled, "the sneaker crowd" and was discouraged by most club owners. Many club owners don't realize that the Cheetah crowd is now between 21 and 25 years old — the very people who go to their clubs today.

In other words, the Cheetah helped establish a group of Latin music lovers who today help sustain the Latin clubs. Like Paquito says, "We need clubs or certain nights for the new generation because they have no place to go. If we don't provide for them and expose them, our own youth will turn away from our music. It is our responsibility to lure and entertain our young if we are to survive as an industry."

Ramon Segura of Ariola, Spain, presented **Rocio Durcal** and **Juan Gabriel** gold records in Madrid, for the top sales reflected by the recordings of Rocio, interpreting **Juan Gabriel**... **Camilo Fernandez**,

associate of Quatro Records of Chile, sold his interests in the company to the remaining associates. This has brought about a complete structure in the creative-artistic sense in the company. A film titled "En Esta Primavera" starring **Juan Gabriel** was premiered in New York. Performances of **Salvador's** (Arriba) in the area of Chicago, during the month of September, have been quite successful. **Jose Jose** will attend the "50 Year Celebration" of professional life of **Don Pedro Vargas**, which will take place this weekend at the Miami Jai Alai and aired on the popular Mexican television show "Siempre En Domingo". **Juan Bau** will start his tour on November 12 in Chile. From there to Bolivia, Argentina, Peru and Colombia, then returning to Spain to record a new LP. In March he will start on another tour that will take him to Central America, Mexico and the United States. On December 14 he will be honored by Discos Orbe with a Gold Record in Bogota, Colombia.

Ralph Mercado and **Ray Aviles** will present the second Salsa International concert at Madison Square Garden Friday, Nov. 10, 1978 at 8 p.m. Their first Salsa International concert took place at the Garden last November.

Internationally known "Salsa" artists will star at the concert. From Puerto Rico and New York will be **Ismael Rivera Y Sus Cachimbos** making one of their rare concert appearances. Also appearing will be **Wilfrido Vargas Y Sus Beduinos** from Santo Domingo, **La Dimension Latina** with **Andy Montanez Y Rodrigo Mendoza** from Venezuela, Colombia's newest sensation **Fruko Y Sus Tesos**, and **Libre**, who will be making their first appearance at a **Mercado/Aviles** Garden Concert.

The following news is courtesy of *Extra Magazine*, Puerto Rico. **Alberto Maravi** from Infopesa, Peru, has been on the Island vacationing. **Natalie Cole** has been touring all of Puerto Rico. **Silvio Inglesias** has left his position at KQ-FM to become co-owner of Salsoul 98. **Willie Rosario** has finally finished his new album for Top Hits. The following singers **Gullio Rivera** and **Junior Toledo** were added to **Willie Rosario's** newest album. **Raphael** has been packing them in at Caribe Hilton. **Rota** has informed us that Orfeon will open again for business. **John Travolta** Saturday Night Fever Disco album is number 1 on the Island. The impact of disco music has Latin sales down. **Antonio Aquilar** Rodeo Show was a total disaster, the losses were estimated at \$60,000. **La Orquesta Aragon** and **Los Papines**, from Cuba, will be at the Roberto Clemente Coliseum in November.

ray terrace

Argentinian News

BUENOS AIRES — Raul Matas, emcee of two of the most popular TV programs in Chile, visited Buenos Aires to get in touch with the local scene. Matas is considered the creator of the popular disk jockey format in the Spanish speaking world, having started the format in 1942. Afterwards he lived many years in New York, Madrid and Buenos Aires, and returned to Chile three years ago for his current post as anchor-man in the evening news on the Chilean state TV network, which includes 74 stations, covering the entire country.

Leon Gleco, one of the leading rock-pop artists in this country, returning from a tour covering all Latin countries and the States. In Los Angeles he visited studios, radio and TV stations invited by WEA, which is represented in Argentina by Sicamericana, Gleco's company here.

Phonogram signed a contract with **Jalme**

Torres to release his production of the music of "De antiguas razas," his folk show staged at the Margarita Xirgu Theater. "De antiguas razas" has been reviewed as one of the best musicals of the season.

Vaiven Producciones is revamping its sales organization in the interior of the country and has a schedule of releases for the rest of the year, besides the contracting of foreign labels for representations. The diskery is currently managed by **Jorge Gomez Carrillo**, **Jorge Romero**, **Jose Goncalves** and **Miguel Angel Ivaldi**.

RCA has released two interesting Brazilian recordings: one of them is the latest LP cut by top star **Jorge Ben**, whose visit to Argentina was announced but postponed. The other one is tagged "The Brazilian sound of **Sarah Vaughn**" and features the famed chantress plus several top rated local musicians.

miguel smlrnoff

Only \$8 will make your juke box legal under the Copyright Law.

On January 1, 1978, a new copyright law went into effect.

Under the new law, writers and publishers are entitled to compensation for juke box performances of their music.

In order to assure this compensation, the law requires that juke box owners register every box they operate with the U.S. Copyright Office, and pay that Office an \$8 annual fee for each box. You'll receive a certificate for each juke box, which must be displayed on it.

It's an easy law to comply with.

But, failure to register and pay the required fees can make you a copyright infringer, liable for damages of at least \$250 per song infringed. And lawsuits against jukebox operators for copyright infringement are being brought.

Whether you own one box or 101 boxes, you must have a license and pay the appropriate fees.

If you haven't registered your juke boxes with the Federal Government yet, now's the time to do it.

Just contact the U.S. Copyright Office, Licensing Division, Washington, D.C., 20557, Tel. (703) 557-1394, and they will send you the simple forms you need.

After all, it scarcely seems worth risking so much for something you can get for only \$8.

ASCAP

American Society of
Composers, Authors and Publishers

New! The only pinball game with **6-player** earning power!

Bally THE SIX MILLION DOLLAR MAN™*

Bally, first in pinball, does it again. First in celebrity tie-ins, in electronic technology and in Memory & Recall, Bally is now first in 6-player earning power with THE SIX MILLION DOLLAR MAN™. Worldwide location tests have proven the popularity and massive money-making capability of this exciting game.



FEATURES:

- ELECTRONIC MEMORY & RECALL as popularized on *Eight Ball* and *Strikes and Spares*.
- SPACE-AGE SOUND EFFECTS & 6 TUNES that add extra excitement to game play.
- ATTENTION-GETTING GRAPHICS featuring TV's BIONIC MAN™* Colonel Steve Austin.
- FAMOUS FREE-BALL GATE & PLAY-MORE POST for more scoring and playing fun.
- NEW BIONIC™ POWER SCORE for greater special scoring power.
- 100% ELECTRONIC CIRCUITRY

So if you want to get with BIONIC™ earning power, get with Bally THE SIX MILLION DOLLAR MAN™. Contact your Bally distributor or write:

Bally® makes the games people play.

Bally Manufacturing Corporation
2640 W. Belmont Ave.
Chicago, IL 60618
312/267-6060

*A trademark of and licensed by Universal City Studios, Inc.

©1978 Universal City Studios, Inc. All Rights Reserved.



Seeburg's 'Disco 160' Shows New Microcomputer System

CHICAGO — "The jukebox will never be the same..." commented one operator upon viewing the new cylindrical shaped Seeburg "Disco 160" phonograph, with its new look and unique design concept. The visual impact of the new model is further accentuated by the dramatic cabinetry of brightly illuminated graphics, silvered chrome and glass.

Also outstanding, in the visual sense, is the "Cupolium Sphere" or "see-thru

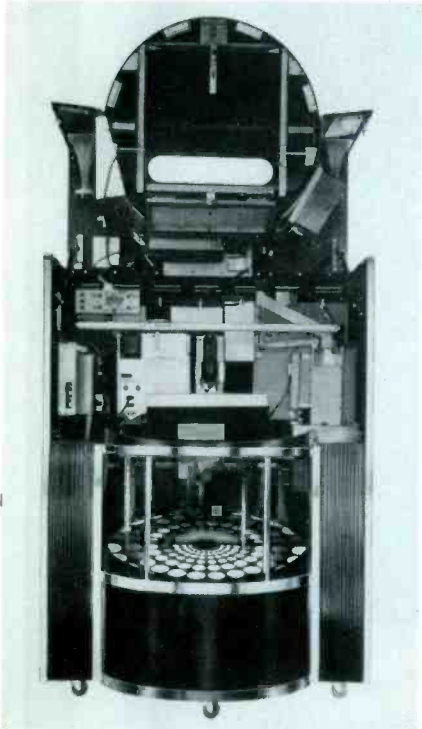

'Disco 160'

theater showcase," as Seeburg describes it, which allows the customer to observe the Seeburg Selec-O-Matic record mechanism in action. It appears to float across a disco floor surface, in an environment of flashing light and disco graphics, as it revolves, scans, makes record selections, etc., in full view.

The Customer Play Arena on the Disco 160 houses all of the machine's play features, including the innovative 8-Digit illuminated Microcomputer Display Panel, which reveals the number of the record selected and that of the record being played, as well as the amount of credits the customer has acquired for future play. Additionally, if a number is erroneously selected an illuminated "error" display is immediately signaled so that a reselection can be made.

Also contained in the Customer Play Arena are the 10-Button Electronic Digital Selector, Coin Slot, Dollar Bill Acceptor Accessory and Title Display.

Technological Advances

While the new model is designed to capture patron interest it has numerous technological advances for the benefit of the operator.

"Not only has the marvels of Seeburg microcomputerization improved communications between the phonograph and the music buying customer at the location, but it has afforded many advantages to the operator as well," commented William F. Adair, Seeburg board chairman. "The Seeburg Disco 160 features our exclusive operator oriented CPA Microcomputer Memory Bank. It's an entirely new system that offers a visual reportage of complete money and record audit in a matter of seconds," he added. "Here are features designed basically for the operator ...

features that will truly become important assets to the economics of his business."

The system also reveals the 15 least-played records, in numerical order, and offers continuous free play for testing or servicing purposes as well as a continuous free credit mode for use not only in testing but in non-coin or rental situations, as well.

The 10-Button Digital Selector on the new machine allows for simplified record selection and, by utilizing only three-digit numbers, eliminates the letter-number selection process. Seeburg's All Coin Accumulator permits patrons to deposit any combination of coins for music selection and may be supplemented with the factory's optional Dollar Bill Acceptor.

Columnar Speaker Modules

New columnar speaker modules have been incorporated into the Disco 160. Two matched exponential horns are mounted at ear level to achieve a wide angle dispersion of mid range and high frequency sounds. A 200-watt stereo amplifier, combined with the various other components, provide a sound that will surround the location and, in addition, to satisfy specific acoustical requirements, there are two amplifier controls which provide nine different audio combinations.

The upper lid assembly of the Disco 160 lifts up easily and is held in position by two pneumatic lid supports so that all major electronic components are at eye level. The lower front panel of the cabinet lifts out to give full accessibility to both the record mechanism and the 12-inch woofers.

The Seeburg Console, compact and only 5-1/2" deep, is available in two models: Chrome and Antique Bronze. Ideal for fast food locations where limited space prohibits console models, the unit occupies a minimum of wall space and is built for convenient front end servicing. The cash box lifts out easily which eliminates any additional slide-out space on either side of the unit.

Rowe Exhibit Will Spotlight Two Jukeboxes Designed For Different Location Settings

CHICAGO — The Rowe exhibit at AMOA '78 will be enhanced by the presence of the factory's new R-83 line, consisting of the starkly colorful "Fiesta" model, which is geared to the contemporary disco crowd; and the elegantly designed "Claremont" for the posh, more subdued environment. Both were featured at the factory's national distributors meeting in Chicago and subsequently shown by Rowe distributors at the



'Gee Bee'



'Clay Champ'

Namco's AMOA Exhibit Will Focus On Four Machines

LOS ANGELES — Namco Ltd. of Japan and its U.S. subsidiary, Namco America, Inc., will focus their AMOA exhibit on four games — "Shoot Away," "Clay Champ," "Gee Bee" and "Submarine" — according to Satish Bhutani, vice president of Namco America.

Bhutani called Submarine "one of the most realistic" games of its kind "ever put into a cabinet." Designed for a variety of locations, Submarine is an electro-mechanical game in which the player takes aim through a periscope and tries to sink enemy vessels.

When an enemy ship is hit, it explodes and points are scored. For maximum points, players aim at a smaller, black ship that when hit bursts into a fireball and sinks.

Gee Bee, as Bhutani pointed out, is a semi-pinball video game based on a com-

bat theme. It features colorful cabinet graphics and its compact size is suitable to any location.

Shoot Away, of course, is Namco's popular arcade-size skeet shooting game. Suitable for one or two players, its large screen monitor depicting a tree-lined outdoor scene will "beautify any game room," according to Bhutani.

Clay Champ is a compact version of Shoot Away, suitable for street locations as well as arcades.

Namco America, which opened a 10,000 square foot facility in Sunnyvale, Calif. Sept. 1, markets all Namco products in the United States and Canada as well as Central and South America. When fully equipped, the plant will have the capability to

(continued on page C-26)



'Fiesta'



'Claremont'

various territorial showings which were held across the U.S.

The styling of the new machines is similar to that of the previous models, Rowe's highly successful R-82 series, which contributed immensely to the banner sales year enjoyed by the factory over the past 12 months. The color schemes and graphics, however, have been re-designed to provide a different look.

Standard equipment on the R-83 series is a powerful 125-watt amplifier which delivers a deep, rich sound and Rowe is proud of the fact that by FTC standards it is rated as more powerful than many of the higher watt amplifiers currently advertised. Depending upon the location's requirements, however, the sound can be changed from true stereo to monaural, via a "mono-stereo switch, which is one of the flexibility features of this amplifier.

Memorec Computer

The new models also contain the noted Memorec computer which not only tallies each record that is selected but also determines the least and most popularly played records plus the total number of selections made; and the Playmaker which provides random selection play after a pre-determined period of no-play and serves as a merchandising tool for attracting attention and stimulating additional play.

The outstanding solid state system, introduced by Rowe three years ago, is also contained in the new line. Every component in the R-93, including the plug-in solid state modules, is accessible from the front door for quick and easy servicing.

Operators may contact Rowe distributors for further details on the new machines and the factory's full line of optional accessories.

NAMCO

the name that brings you most
profitable and reliable games

SUBMARINE

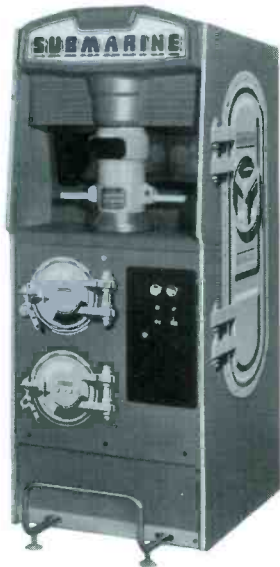

CLOSE ENCOUNTERS OF
THE BEST KIND
NAMCO'S FUTURE GAME
LINE UP

SHOOT AWAY



CLAY CHAMP



SEE US AT AMOA BOOTH NBR. 81, 82, 83, 98, 99 & 100 WEST ROOM.

NAMCO AMERICA INC.

343 GIBRALTAR DRIVE SUNNYVALE, CALIFORNIA 94086
HEAD OFFICE 408-745-7600 TELEX 171-163

Meadows

sends its sincere thanks to its fine distributors and customers for five years of friendship

...and its commitment that

the best is yet to come!

PAUL JACOBS
President

Meadows
GAMES, INC.

181 Commercial Street
Sunnyvale, CA 94086 • 408-732-8110

Wurlitzer Reveals New 1979 Phonograph Line In Germany

CHICAGO — The new line of Wurlitzer phonographs for 1979 were premiered by Deutsche Wurlitzer during the German factory's annual international conference, Oct. 2-3, at the Berline Hilton in West Berlin. A full representation of distributors from all over the world, including a contingent representing the factory's U.S. network, were present at the event.

Especially outstanding in the new line is the model X-200, distinguished for its

color and cabinetry of this model are completely new and it drew exceptional reaction at the presentation.

Also shown were the Niagara 160-selection, a popular U.S. model which is sporting some new color options; the Cabarina 160-selection (walnut cabinet) and Tarock 160-selection (oak cabinet) furniture style models, which also boast reduced dimensions for more flexibility on location; and the Lyric 100-selection, which



'Niagara'



'Cabarina'



'Lyric'



'Tarock'



'Atlanta IV'



'X-200'

microprocessor controlled system and the 200-selection feature. This is the first 200-selection machine built by Wurlitzer since 1974, when the 3800 model contained this feature.

The Atlanta IV is a 160-selection machine, which is slightly reduced in dimensions but big in style and design. The

is geared for installation in locations with limited space.

The new line will be displayed at the AMOA convention, in Parlor 5 at the Conrad Hilton, and several members of the Deutsche Wurlitzer executive staff will be in Chicago for the show.

Bally Will Sponsor Service Booth At AMOA Expo '78

CHICAGO — In addition to its elaborate product exhibit at AMOA, Bally Manufacturing Corp. will, for the first time, sponsor a separate booth primed exclusively for the disposition of service information and assistance. The Bally Field Service Booth will be under the direction of the factory's field service manager Bernie Powers whose entire staff will be available during exhibit hours to answer questions and provide service assistance on a one to one basis.

This accommodation is "another first in the Bally tradition," as noted by Powers, who pointed out that last year Bally sponsored a special service school in conjunction with the AMOA convention.

Training Aids

"We have noticed at past conventions," Powers said, "that a number of the owner operators who attend carry with them a list of questions. Many of these questions were submitted to them by their mechanics but in some cases operators are seeking information for themselves." These past queries and the feedback from Bally's longstanding school program provided a basis for the prepared information that will be available at the booth, along with training aids and related material.

During a convention of such magnitude it is difficult to give individual attention, in the environment of an active and very crowded exhibit, Powers stressed. "The Bally Field Service Booth will allow us to sit down and discuss specific topics, or service problems, without distractions," he said.

New Gremlin Game Avoids Violence

(continued from page C-14)

sects as the pond becomes alive with a myriad of insect noises.

Controlled by a button, the frog's tongue takes aim and snatches up the bugs as they fly above the pond. A stray jump plummets the frog into the pond and he must swim to the surface before an attack can be resumed, consuming valuable time.

In the final seconds, a bonus dragonfly appears as the most delectable treat for our frogs. His capture results in a free game.

The challenge is constant. As a player becomes more proficient, additional insects appear to tempt the chaser. High Score is displayed to keep interest mounting with each successive game.

Program 70



Tarock



Cabarina



Lyric



Niagara

X9
X9 electronic
X200 electronic



Atlanta

Ask your nearest agent

Lovell Company, 637 Broadway S. E., Albuquerque, N. Mex. 87102
 Pilotta Distributing Co., Route 31 East, Newark, N.Y. 14513
 Sensation International, R. Franke, 556 W. 3560 South, Salt Lake City, Utah 84115
 Carhex International Co., 4139 N.W. 132nd Str., Opa Locka, Fla. 33054
 Lew Jones Distr. Co., 1311 North Capitol Ave., Indianapolis, Ind. 46202
 Roth Novelty Comp., 333 North Pennsylvania Ave., Wilkes-Barre, Pa. 18701
 Southern Music Comp., 503 West Central Blvd., Orlando, Florida
 Central Distributing Co., 3814 Farnam Str., Omaha, Nebr. 68131
 Bay Coin Sales Inc., 1161 Rogers Ave., Brooklyn, New York 11226
 United Distributors Inc., 420 South Seneca, Wichita, Kansas 67203
 Wayne Napthal Distributors, Columbia Amusement, 12175 East Burnside, Portland, Oregon 97230

WURLITZER
 means Music to millions®

OR: Deutsche Wurlitzer GmbH · D-4971 Hüllhorst/W-Germany
 Postfach 1160 · Telefon (05744) 1001 · Telex 0972122



Daily Routine Of Free-Lance Mover Is Very Rarely Routine

by Frank Manners

The free-lance mover is a little noted and much maligned member of the coin machine business; a bone or a boon depending on the operator to whom you talk. At the least, they envision him as a necessary evil, a man in motion who, for a nominal fee, transports their machines between distributor and location, location and location, shop and location, and back again, ad infinitum.

At best, he is more than just a mover supplying only horsepower and manpower. He performs an invaluable service to the operator. Firstly, he does a burdensome job that frees the operator for other tasks, and he does it cheaper than if an operator rented a truck and did it himself. Secondly, he acts as the operator's unofficial public relations man at the location, listening to complaints and soothing the ruffled egos of location owners. Thirdly, he's part service man. He sets up the game, checks it out, puts on the operator's locks and licenses, and has it earning money before the operator even arrives. Some movers will change records in the juke box as part of their service. Ultimately a capable mover can virtually manage the route, and in certain cases, the operator does little more than collect, allowing the mover to make decisions about ordering new equipment and switching old.

Daily Routine

The average mover runs his business like a modest entrepreneurial effort. The

daily routine: out on the street in the morning by 8:30 or 9:00 and back in at 6:30 the earliest, 9:00 the norm. He works Saturday, and reserves Sunday for dire emergencies. The mover usually owns and operates two to four trucks. He may rent extra trucks during extraordinarily busy spells, with two men per truck, and he groups the deliveries by areas; first-north, south, west, and east, and then subdivided into neighboring streets. He spans a radius of 50 miles. Normally the operator must schedule a move a day in advance, but the trucker's reputation depends on efficient, rapid service so he attempts to squeeze in last minute requests. To increase speed and responsiveness, some use a radio paging beeper hooked to their belts so the operator can contact them directly with a fifteen second message. Others work from a central office manned by a woman, and the drivers constantly call her to pick up new moves.

The daily routine, however, is rarely routine. The unusual is usual, the bizarre, commonplace. Obstacles inevitably occur to derail the mover from his appointed rounds. Time is his nemesis. He may arrive at a location in the boondocks while it's closed or he arrives at lunch time, and they tell him to come back two hours later, thus destroying his schedule. At times, a location may refuse to accept a machine or to give one up. If they accept it, the machine may not fit through the door, and an insistent location owner demands that they remove the door and the screen and

possibly the transom so he can have his game. Often he must haul a game up or down flights of stairs which laboriously prolongs an apparently simple move, especially if it's a loaded can vendor or pool table. One time, a mover squandered three hours when the band holding juke box records in place popped loose. One hundred Spanish records tumbled all over, the non-bilingual mover had to put each one back in the correct slot.

The worst pitfall that can happen? Two nominees. Dropping a machine. The cost of the damages wipes out profits from several deliveries. Or getting to a location with a truck load of equipment, and hearing the owner roar, "I don't want these. Get them out of here. The operator promised me new stuff." Now the mover's squarely in the middle, a place he often finds himself. Whether or not he goofed, the trucker conveniently becomes the operator's scapegoat. If the game doesn't work, blame the mover. If the equipment is scratched, the mover did it.

Nevertheless, the free-lance mover often rises above these mundane setbacks, gloriously meets the challenge of the job, and ascends briefly to the rarefied atmosphere of earthly Olympus. One mover, alone, once strapped a juke box to his back, and, hunched over, carried it up a flight of stairs. Another trucker and his helper, stymied by an arcade's small front door and impossibly winding staircase, hauled thirty games up the rear fire escape and through the second floor emergency

door. Finally one legendary figure has been known to cart 20 football bowlers and pool tables singlehandedly into a location by walking them on end like an inanimate dancing partner. The same mover once found himself in a devilish dilemma. While he lugged a half-ton can vendor up a steep stairwell, an operator's helper on the bottom decided to let go and walk away because hauling machines wasn't his job. Stooped over the vendor, holding it tenaciously, the mover couldn't go up and he couldn't go down. He broke out in a cold sweat, he tasted salt in his parched mouth, burned with tension, and remained frozen in his own personal limbo.

Rewarding Business

Despite the tribulations and tests of true grit, the movers generally agree that the business is rewarding. If not, they would leave it. You meet people and make a buck, although you may have to chase an operator for it. You can function on a moderate level or grow boundlessly, like one trucker, from a humble \$150 pickup truck to a nine diesel fleet. You freely set your limits. You work in the great outdoors which possesses an undeniable attraction regardless of the heat and sleet, snowing and blowing. And once a year you may blissfully experience the mover's dream a week when everything goes smoothly. You hit all the locations when they're open, all machines are accepted, they all work, and you get paid on the spot. To the mover, nirvana is not half as blessed as this.

NOW—Public Liability Insurance

For
Coin Machines on Locations
SPECIAL LIFE INSURANCE RATES
to
DISTRIBUTORS & OPERATORS

All Risk Insurance for

Games—Music—Vending Machines
At Locations

All Other Forms of Insurance

SPINDEL INSURANCE AGENCY, INC.
P.O. Box 515—Lansing, Ill. 60438
Phone 312—895-1900

THE U.S. MARSHALL

The lowest priced coin-operated free play game.

On Display At AMOA
Booths #191 192



U.S. MARSHALL

J.F. FRANTZ MFG. CO.
1940 West Lake Street
Chicago, Illinois 60612
Telephone: (312) 829-2399

Be sure to visit our AMOA booth and pick up your key chain!

Now you win with both sides of our coin.



You know Gremlin for innovative electronic games and for reliable engineering that helps cut maintenance costs.

You know Sega for advanced electro-mechanical game research and development and for creative concepts proven in Sega's own trend-setting parks and arcades. Now, you should know that Gremlin is a Sega company. And that's really good news! Because Gremlin and Sega are putting their skills together to bring you the exciting, rewarding products you want. Gremlin

now is also the source for all Gremlin/Sega products and services in the U.S. and Canada. Gremlin and Sega will continue to do what each does best. Together, we'll do more for you and your customers. So you win both ways.

When you say Gremlin, say Sega. It's the best combination of names in the business.

Gremlin®

GREMLIN INDUSTRIES, INC.
8401 Aero Drive, San Diego, CA 92123
(714) 277-8700 • TWX 910-335-1621

A **SEGA**
COMPANY

SEGA ENTERPRISES, LTD.
A.P.O. Box 63, Tokyo, Japan,
TELEX 781 22357, SEGASTAR J22357



Some Tips About Bally Electronic Flippers With Sound

by B.M. Powers

With the advent of an electronic sound system in Ballygames, there have been a few significant changes. These changes effect not only the present games but, in some ways, effect the games prior to the introduction of electronic sounds. I will take the changes one at a time and discuss their significance and uses.

The first change that has taken place was the installation of the sound module itself. The part number for this module is AS2518-32. This module is divided into six circuit areas: power supply, tone date processor, programmable frequency generator, tone trigger generator, voltage controlled alternator, and audio amplifier.

The trouble shooting procedures for this module are no different from the other Bally modules and are included in our 'Bally Electronic Pinball Games Repair Procedures.' This manual is a new one and is identified as F.O. 560-1. It replaces F.O. 560 and is effective for all electronic flippers from Freedom through Lost World and future games.

It should be noted that F.O. 560 should be replaced with F.O. 560-1 in your files. F.O. 560-1 is included in all Bally games as was F.O. 560.

The next significant factor evolved around the electronic sound package is the ability to install it in electronic games that did not have electronic sounds, i.e., putting

it in a Night Rider or Eight Ball. This will not give the same exact sounds or tunes as a game like Lost World. It will give an electronic chime sound in place of the solenoid.

The sounds are different but not to the extreme interrelation of sounds on games like Lost World or The Six Million Dollar Man. It does give the ability to control the volume of the sound.

To make this conversion, order Bally Kit #525. The kit consists of the following:

Part No.	Quantity	Description
AS-2888	1	Sound P.C.B.
E-556-768	1	Cable
AS-2958-1	1	Speaker
P-6442-213	2	Mounting Brackets
M-1829-1	2	Mounting Clips
SFPP-832-1106	2	Screws
SAPR-600-1508	7	Screws
F.O. 608	1	Procedure for Installation

The next change that has taken place is the modification of our basic (without personality ICs) Micro Processor Module. The basic number has changed from AS 2518-17 to AS2518-35.

The AS2518-35 is adaptable to games prior to Lost World by changing the jumper requirements.

First, let's refer to Table I that will give us the common 'personality' or ROM combinations used on AS2518-17 MPU

Modules in games prior to Lost World.

As stated above, the jumper requirements change when using a new style or AS2518-35 Module in one of these games.

A jumper is a soldered wire between the two connections which are labeled on the faces of these boards.

Now, let's take a look at Table II which gives us the I.C. combinations and jumper requirements. Compare Table I to Table II.

Taking the opposite view — that is, using an old style or AS2518-17 MPU Module in a later game — Lost World or the Six Million Dollar Man is not quite as easy a procedure.

There are certain modifications that need to be made for adaptability. First, however, let's look at Table II, the IC combinations for these games, using the new style module AS2518-35.

The first thing to be discussed is how to use, say, a Night Rider MPU Module in a Six Million Dollar Man. This is in reference to using an old style or AS2518-17 MPU in a later model game which requires the base module to be an AS2518-35.

The AS2518-17 Module can be converted for use as an AS2518-35. In order to make this conversion, order Bally Kit #523 from a Bally distributor. This kit includes the following:

Description	Quantity
Terminal, 3 pronged	6
Insulated Wire, Black	4Ft.
Insulated Wire, Yellow	1Ft.

Insulated Wire	.5Ft.
Connector, Wafer, 5 Pin	1
Set of Labels	1 Set
Instruction, F.O. 597	1

This conversion will give you the ability to use it in the later games.

After the conversions are made, this module will be labeled with one of the labels in the kit as 'AS2518-17, modified per F.O. 597.'

This module still has the ability to be used in prior games which exclusively used the AS2518-17 Module and the later games using the later module, AS2518-35.

The only things that have to be watched now are the memory combinations and jumper requirements which change for the games that initially had this MPU. Let's now refer to Table IV, Memory Combinations and Jumpers, for use with MPU AS2518-17, modified per F.O. 597.

The changes sound more complicated than they are in actuality. The main thing that becomes more important than before is taking special notice of the jumper combinations.

In referring back to Table I, most of the jumpers were the same between modules and many times, during module replacement, a person did not even look and just changed the ROM packages successfully.

The ROM or personality IC combinations will continue to be published for both

(continued from page C-24)

TABLE I

MEMORY COMBINATIONS AND JUMPERS FOR USE WITH MPU AS2518-17

GAME	SOCKET LOCATION			JUMPER REQUIREMENTS
	U1	U2	U6	
FREEDOM	E720-8	E720-10	E720-7	E1-E2; E3-E4; E8-E9
	E720-8	E720-9	E720-7	E1-E2; E3-E4; E8-E9
	E720-1	E720-2	E720-7	E1-E2; E3-E4; E8-E9
NIGHT RIDER	E721-12	E721-13	E720-20	E1-E2; E3-E4; E8-E9
	E721-10	E721-11	E720-20	E1-E2; E3-E4; E8-E9
	E721-3	E721-7	E720-20	E1-E2; E3-E4; E8-E9
	E721-5	E721-6	E720-20	E1-E2; E3-E4; E8-E9
	E721-3	E721-4	E720-20	E1-E2; E3-E4; E8-E9
EVEL KNEIVEL	E722-17	E720-20	E720-20	E1-E2; E3-E4; E6-E7; E8-E9
	E722-11	E720-20	E720-20	E1-E2; E3-E4; E6-E7; E8-E9
EIGHT BALL	E723-17	E720-20	E720-20	E1-E2; E3-E4; E6-E7
	E723-20	E720-20	E720-20	E1-E2; E3-E4; E6-E7
POWER PLAY	E724-25	E720-20	E720-20	E1-E2; E3-E4; E6-E7
MATA HARI	E725-21	E720-20	E720-20	E1-E2; E3-E4; E6-E7
STRIKES AND SPARES	E740-16	E720-20	E720-20	E1-E2; E3-E4; E6-E7
BLACK JACK	E728-32	E720-20	E720-20	E1-E2; E3-E4; E6-E7

TABLE I - BMP/GDK 10/6/78

TABLE II

MEMORY COMBINATIONS AND JUMPERS FOR USE WITH MPU AS2518-35

GAME NAME	U1	U2	U6	JUMPERS REQUIRED
FREEDOM	E720-8	E720-10	E720-7	SAME AS NIGHT RIDER
NIGHT RIDER	E721-12	E721-13	E720-20	E1-E3; E2-E6; #9-E11; E12-E36; E13-E15; E16-E17; E31-E32; E33-E34.
EVEL KNEIVEL		E722-17	E720-20	E7-E8; E13-E15; E16A-E19; E9-E11; E12-E36; E31-E32; E33-E34; E1-E4; E2-E6.
EIGHT BALL		E723-17	E720-20	SAME AS EVEL KNEIVEL
POWER PLAY		E724-25	E720-20	SAME AS EVEL KNEIVEL
MATA HARI		E725-21	E720-20	SAME AS EVEL KNEIVEL
STRIKES & SPARES		E740-16	E720-20	SAME AS EVEL KNEIVEL
BLACK JACK		E728-32	E720-20	SAME AS EVEL KNEIVEL

TABLE II - BMP/GDK 10/6/78

TABLE III

MEMORY COMBINATIONS AND JUMPERS FOR USE WITH AS2518-35

GAME NAME	SOCKET LOCATIONS			JUMPER REQUIREMENTS
	U1	U2	U6	
LOST WORLD	E729-39	E729-40	E720-29	E1-E5; E2-E4; E7-E8; E10-E12; E13A-E14A; E16A-E18; E11-E19; E31-E32; E33-E35
	E729-34	E729-47	E720-28	E1-E5; E2-E4; E7-E8; E10-E12; E13A-E14A; E16A-E19; E11-E25; E31-E32; E33-E35
	E729-33	E729-48	E720-28	E1-E4; E2-E6; E7-E8; E9-E11; E12-E36; E12-E15; E16A-E19; E31-E32; E33-E34
SIX MILLION DOLLAR MAN	E742-9	E742-10	E720-30	E1-E5; E2-E4; E7-E8; E10-E12; E13A-E14A; E16A-E19; E11-E25; E31-E32; E33-E34
	E742-13	E742-14	E720-30	SAME AS ABOVE
	E742-15	E742-16	E720-30	SAME AS ABOVE
	E742-20	E742-18	E720-30	E1-E4; E2-E6; E7-E8; E9-E11; E12-E36; E13-E15; E16A-E19; E31-E32; E33-E34

TABLE III - BMP/GDK 10/6/78

TABLE IV

MEMORY COMBINATIONS AND JUMPERS FOR USE WITH MPU AS2518-17 (MODIFIED PER F.O. 597)

GAME NAME	SOCKET LOCATIONS			JUMPERS REQUIRED
	U1	U2	U6	
FREEDOM	E720-8	E720-10	E720-7	E1-E2; E3-E4; E12-E7; E14-E15
NIGHT RIDER	E721-12	E721-13	E720-20	SAME AS FREEDOM
EVEL KNEIVEL		E722-17	E720-20	E1-E2; E3-E4; E12-E13; E14-E11; E7-E6
EIGHT BALL		E723-17	E720-20	SAME AS EVEL KNEIVEL
POWER PLAY		E724-25	E720-20	SAME AS EVEL KNEIVEL
MATA HARI		E725-21	E720-20	SAME AS EVEL KNEIVEL
STRIKES & SPARES		E740-16	E720-20	SAME AS EVEL KNEIVEL
BLACK JACK		E728-32	E720-20	SAME AS EVEL KNEIVEL
LOST WORLD	E729-39	E729-40	E720-28	SAME AS EVEL KNEIVEL
SIX MILLION DOLLAR MAN	E742-5	E742-6	E720-30	SAME AS EVEL KNEIVEL

TABLE IV - BMP/GDK 10/6/78

Williams[®]

...a new generation of growth and profit, through
commitment to innovative excellence.

We're the Hot One!
And we've only just begun.

Williams[®] 
ELECTRONICS, INC.

An Xcor International Inc., Company
3401 N. California Ave., Chicago, IL 60618
Cable Address: WILCOIN, CHICAGO
AVAILABLE FOR IMMEDIATE DELIVERY
THROUGH YOUR WILLIAMS DISTRIBUTOR

WELCOME TO



See Atari's world of stars at "StarWorld '78", the Show of Shows at A.M.O.A.

Nothing else in the world even comes close. We've created games to a higher power. A Starclass line of games for the new era of operators and a new era of players.

Wild, exciting video and pinball attractions that challenge mind and skill like no other.

New Video Excitement.

There are video games that offer the experience and illusion of reality as never before. Sports challenges, space war competition, battle and motor sports action. And more.

New Pinball Adventure.

And new pinball games with advanced play action designs, with new electronics, reliability and graphic appeal that are ahead of the state of everybody's art. Implementing the themes of today for popular attraction and unlimited promotional tie-in possibilities.

More Industry Firsts.

Atari profit engineered firsts like the *Wipe Action™* pinball playfield, Atari-developed solid state electronics for pinballs, digital scoring, play attracting space-age sound effects built-in self test systems are all included as standard.

And more are on the way for 1978-1979 to enhance your profit potential even more.

See all the stars of your future at the A.M.O.A. Talk to your local Atari distributor about today's profit winners like *Super Breakout™* video and *Middle Earth™* pinball. He can even give you a glimpse into the future. He's previewing the sensational new *ORBIT™* space action video, new Atari *FOOTBALL™* video, and the out-sight *Space Riders™ 4 player* pinball. Or contact us for referral at Atari Inc., 1265 Borregas Ave., Sunnyvale, CA. 94086. (408) 745-2500.

Challenge the future at Atari's "StarWorld '78", exhibits 13 through 36 at the A.M.O.A.



Some Tips On Bally Solid State Flippers With Sound

(continued from page C-22)

style modules AS2518-17 and AS2518-35, as new games are produced.

With the inclusion of an additional module, the sound module, there are some other ramifications affecting the testing procedures. Refer to Figure 1 which shows the power distribution for a flipper with electronic sounds. This easily illustrates that there is an additional module (A8) that will also now be included during the diagnostic tests.

The self-diagnostic tests are approached in the same manner as prior games. Power-on sequences the MPU module until MPU operating condition is successfully obtained. Then, by the use of the self-test button located inside the front door of the game, the following diagnostic routine takes place.

1. Pressing the self-test button the first time cycles the switched lamps to flash on and off continuously.
2. Pressing the self-test button the second time cycles each digit on each display from 0 thru 9.
3. The next press of the button cycles the solenoids individually. This depicts an identification number on each display as the solenoid is energized.
4. Pressing the self-test button again causes the MPU to energize the sound module. A tune will be played repeatedly.
5. The last self-test causes the MPU to search each switch assembly for stuck or closed contacts. An identification number would be displayed on each display if the search encounters a stuck switch.

As can be seen, the only significant change is the inclusion of the sound module during the self-test sequence.

The next change evolves around the field test unit Kit #485. Kit 485 consists of two (2) Aid Units that are used in conjunction with the MPU. The Aid Units have been changed to accommodate the additional modules. The kit number had changed to Kit 485-1. These changes can be made to existing Aid Kits.

Kit 485 is good for games from Freedom through Strikes and Spares — those

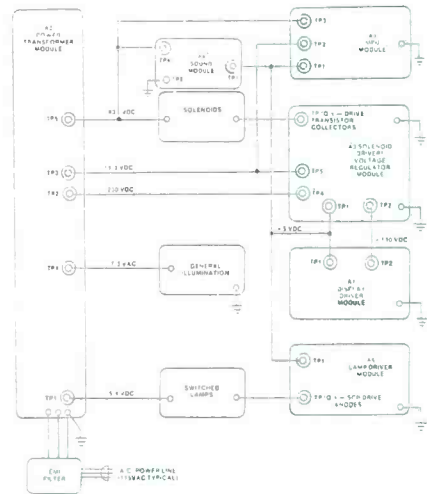

FIGURE 1 POWER DISTRIBUTION DIAGRAM

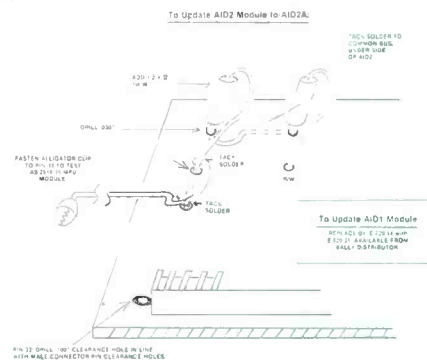

FIGURE 2 CONVERSION OF AID KIT #485 TO AID KIT #485-1

without sound modules. Kit 485-1 is good for all games, Freedom through the Six Million Dollar Man and future games.

To update the Aid 1 Module, replace integrated circuit U1, E-720-14 with E-720-31. E-720-14 is a plug-in ROM. The new E-720-31 ROM is available through a Bally distributor.

The other change is to the Aid 2 Module. This change includes the addition of 1.25 Ohms, 1/4W resistor, and the drilling of four holes. Refer to Figure 2 which gives a visual depiction of the change to Aid 2.

Atari AMOA Sweepstakes Set

CHICAGO — The Atari exhibit at this year's AMOA convention will carry a Starworld '78 theme, complete with futuristic motif plus the added attraction of a sweepstakes drawing for a multitude of valuable prizes, along with numerous other special events and prize giveaways.

The grand prize award in the Starworld Sweepstakes will be a Super Breakout (TM) machine. To be eligible, AMOA visitors need only fill out the appropriate entry forms which will be available at Atari's booths 13-36. Daily drawings for finalists will be held on Friday and Saturday (Nov. 10-11) at 2:00 p.m. and Sunday at 12:00 noon. Finalists present at the preliminary drawings will receive Atari belt buckles.

Prizes Offered

The grand prize drawing will be held on Sunday at 1:00 p.m. and winners do not have to be present to receive the top prizes. Among the prizes being offered, in addition to the Super Breakout (TM) are: a Betamax video recorder, a remote control color television, a set of Tumi all leather luggage, a Sony Swivelvision mini television, Seiko digital pocket alarm clocks and Seiko metal desk clocks.

As a further enhancement in the Atari

booth, there will be several new machines on display being premiered specifically for the AMOA audience and these include the "Football" and "Orbit" video games and the "Space Riders" wide action pinball machine.

Atari representatives will be at the booth to demonstrate the new products and there will be promotional tie-ins as well.

Distributors Speak Out On Value Of AMOA

(continued from page C-12)

AMOA Report for his customers that includes highlights of the show and commentary on new equipment. "It's sort of a preview before the pieces are released that gives them an idea of what is coming as well as what our feelings are," he explained.

Tom Portale, vice president of Portale Automatic Sales, Los Angeles and San Francisco, summed up distributor feelings toward AMOA.

"It's an absolute necessity for a distributor to attend," he said, "to meet your current suppliers, to get to know potential new suppliers and to see just in what direction the industry is heading."

THANK YOU
AMOA

RECORDS
AMERICAN
RADIO
US



Earnings Power Determines AMOA Jukebox Awards

(continued from page C-9)

Country & Western Record of the Year — **Thank God I'm A Country Boy** by John Denver (RCA)
Soul Record of the Year — **Kung Fu Fighting** by Carl Douglas (20th Century Records)
Artist of the Year — **Freddy Fender** (ABC-Dot)

1976

Record of the Year — **Wasted Days And Wasted Nights** by Freddy Fender (ABC-Dot)
Pop Record of the Year (tie) — **Love Will Keep Us Together** by Captain & Tennille (A&M) and **Feelings** by Morris Albert (RCA)
Country Record of the Year — **Convoy** by C.W. McCall (Polydor)
Soul Record of the Year — **That's The Way I Like It** by KC & The Sunshine Band (TK)
Artists of the Year — **Captain & Tennille** (A&M)

1977

Record of the Year — **Lucille** by Kenny Rogers (United Artists)
Pop Record of the Year — **Southern Nights** by Glen Campbell (Capitol)
Country & Western Record of the Year — **Lucille** by Kenny Rogers (United Artists)
Soul Record of the Year — **Car Wash** by Rose Royce (Whitfield)
Artist of the Year — **Kenny Rogers** (United Artists)

DOWN TIME Can Kill You!

Nation's oldest and largest component repair center can save you money. Logic repairs-all makes, all models of video and non-video P.C. boards, monitors and jukebox amplifiers. \$13.50 plus parts. **ASC Dist. Sales Co., 7011 N. Atlantic Avenue, Cape Canaveral, Florida, 32920 (305) 783-5763.**

NAMCO Shows 4

(continued from page C-16)

mass produce its own games.

Bhutani said Namco America customers are assured to prompt service and parts replacement. To this end, a toll free number — 800-538-1610 — has been installed directly to the company headquarters at 343 Gibraltar Drive, Sunnyvale, Calif. 94086.

Namco Ltd., whose president is Masaya Nakamura, was founded approximately 25 years ago.



'Shoot Away'



'Submarine'

Bee Gees Named Top Artist

(continued from page C-8)

the country 14 years ago.

It was a coup for the Brothers Gibb. In less than six months of its release, in November 1977, "Saturday Night Fever" had erased all previous record-holders as the biggest grossing album in the history of the recording industry.

At one point in February 1978, the album sustained peak sales of one million units in successive weeks. During the same period, the Bee Gees had written or produced five singles in the Top 5, and "Night Fever," released on the tail of "How Deep Is Your Love," and "Stayin' Alive," became their third No. 1 single in succession, a feat which had only been achieved once before in the seventies. Added to their previous number ones in the seventies, the Bee Gees total jumped to six, tying yet another record for the most No. 1 singles in the past decade. They also had the No. 1 and No. 2 singles ("Night Fever" and "Stayin' Alive") in the same week, marking the first time it has been done since the Beatles did it in 1964.

Younger brother Andy's "Love Is Thicker Than Water," written by Barry and Andy Gibb, and co-produced by Barry Gibb, Alby Galuten, and Karl Richardson, also became a No. 1. In addition, other Bee Gees songs and artists featured on the album were also affected by the fever. Their tunes (written by Barry, Robin and Maurice, and produced by Freddie Perren), "If I Can't Have You," performed by Yvonne Elliman, and "More Than A Woman," performed by Tavares, scored high in the charts.

The Bee Gees had become the No. 1 musical act in the world, leveling a final and decisive blow to any speculation that their future was in jeopardy. More important, the Bee Gees had conquered their own internal strife. They became pacesetters and shining symbols of what it takes to survive: determination, flexibility, raw talent, and creativity.

They first learned the essence of survival as youngsters in Brisbane, Australia, where their father, Hugh, a bandleader, took his five children in the fifties to escape the grimness of post-war England. Coached by their father, they first started singing at Ovals (speedway stadiums) in Australia, and in 1958 Barry, the eldest, and Robin and Maurice, non-identical twins, were christened The Bee Gees.

"Bee Gees First," their debut album gave the brothers their first potion of stardom before Barry had reached age 20. One of their first major tours featured a concert at

London's Royal Albert Hall. Still teenagers, the Bee Gees were augmented by a 60-piece orchestra, a huge choir, and the Royal Air Force Brass Band. Their second album, "Horizontal," and third, "idea," hit big in America, and singles like "Massachusetts," "I've Gotta Get A Message To You," and "I Started A Joke" found their way to the Top 10, to sustain the momentum.

The sixties were crazy days, and the Bee Gees, caught amidst the craziness and their meteoric rise to stardom, broke up early in 1969. Barry and Maurice continued to record together, while Robin pursued a solo career.

In late 1970 they rejoined, and the Bee Gees' second phase kicked off with their No. 3 hit, "Lonely Days." A string of others followed: "How Can You Mend A Broken Heart," "Don't Want To Live Inside Myself," "My World," and "Run To Me." "Two Years On" and "Trafalgar" followed as successful albums, but it wasn't until they teamed with ace producer Arif Martin that the Bee Gees really took off once again. With a fresh R&B twist to their music, their albums "Mr. Natural" and "Main Course" opened new horizons and proved that the Bee Gees were on their way to the top again. Their self-produced "Children Of The World" album finally revealed a well-defined Bee Gees style, and the most powerful and memorable sound thus far in the 70s.

Says Barry, "We've been through all the stages, struggling and then hitting it big. We've split and reformed, had number ones and toured the world. We're proud of the music we've created, and we hope to keep on doing it."

"We've all got the same brain wave now," Robin explains. Says Maurice, "Our music has always been based around melodies — 'classical pop.' It's our songwriting that has kept us going, and in a sense we were the first group to use an orchestra on record, with bass and drums, to fit in rhythmically."

The Bee Gees' influence on the world of music has been remarkable. No other three voices harmonize with the distinguishing qualities of the Brothers Gibb, and their songs possess that delicate lyrical and musical balance that makes them timeless and precious gems. They have been survivors and purveyors, and one can't help but believe that the "Bee Gees Fever of 1978" could well be the fever of '79, '80, '81, and of many, many years to come.

Welcome, AMOA and visitors from abroad!

Pay us a visit and see why

WORLD WIDE is foremost in equipment reconditioning expertise — world-wide!

We handle all makes: music, games, full line vending.

Equipment available As Is — clean, complete.

EXPORT SPECIALISTS SINCE 1945

Special export packing, documentation, etc.



FLIPPER GAMES

Reconditioned - Guaranteed.

\$395 and up

WORLD WIDE distributors co.

A DIV. OF AMERICAN RECREATION GROUP

2730 W. FULLERTON AVE., CHICAGO, IL 60647

Phone: 312/384-2300

Cable: GAMES-CHICAGO

CASH BOX Subscription Blank

119 WEST 57TH ST. • NEW YORK, N.Y. 10019 • 586-2640
USA

- 1 YEAR (52 ISSUES) \$80.00
 2 YEAR SPECIAL \$140.00
 1 YEAR FIRST CLASS/AIRMAIL, \$140.00
Including Canada and Mexico

OUTSIDE USA FOR 1 YEAR

- AIRMAIL \$145.00
 1st Class Steamer Mail \$115.00

NAME _____

COMPANY _____

ADDRESS BUSINESS HOME _____

CITY _____ STATE _____ PROVINCE _____ COUNTRY _____ ZIP _____

NATURE OF BUSINESS _____ PAYMENT ENCLOSED

DATE _____ SIGNATURE _____

Please Check Classification

- DEALER RECORD CO.
 ONE-STOP DISC JOCKEY
 DISTRIBUTOR JUKEBOXES
 RACK JOBBER AMUSEMENT GAMES
 PUBLISHER VENDING MACHINES

OTHER _____



**OH, WHAT A
SPIN WE'RE IN.**

Thanks and Best Wishes
AMOA '78

 **RECORDS AND TAPES**

DYNAMITE!!

A Must For All Juke Boxes!

**"I JUST CAN'T STAY MARRIED
TO YOU"** LS 169



Cristy Lane

**Could Be The Record of Year
For The Juke Boxes!**

 **RECORDS**

Continuity, The Important Ingredient

Five years ago, on our 25th anniversary, I wrote that there was one characteristic of the founders of MOA (later AMOA) that stood out above all else: persistence. These early founders saw the need for a national trade association and they were not about to be put off by anyone or anything or any combination thereof. Despite problems along the way, they pursued their goal with single-minded persistence, and that's one of the reasons why we have a national association today.

Until now, our 30th year, succeeding leaders have never lost that characteristic which has served the association so well from the very beginning. But they — the successors — have added another important ingredient to our 30-year story: continuity. AMOA has arrived at its present success with the inspired guidance of these later and present day leaders who saw the

need for continuing a strong national association. It is this strong continuity, so important in the life of an association, that has built block by block the AMOA we celebrate today.

The man who led AMOA during this 30th year was president Don Van Brackel, who grew up in the business, who was a boy of 10 when the association was founded, and who holds a college degree in accounting. He has brought his long experience, his education and his informed interest in the business to bear on all aspects of the organization agenda. So let us give President Don Van Brackel a resounding vote of thanks for his very real contribution to the success of this fine association on its 30th birthday.

Frederick M. Granger
Executive vice president

1979 State Association Calendar

Jan. 14-15; Music Operators of Minnesota; annual conv.; Holiday Inn (downtown), Minneapolis.
Jan. 19-21; Oregon Amusement & Music Operators Assn.; annual conv.; Valley River Inn, Eugene.
Feb. 2-4; South Carolina Coin Operators Assn.; annual conv.; Carolina Inn,

Columbia.
May 11-12; Ohio Music & Amusement Assn.; annual conv.; Columbus Hilton Inn, Columbus.
May 25-27; Music & Amusement Assn., Inc.; annual conv.; Stevensville Country Club, Swan Lake, N.Y.

THE JUKE BOX PROGRAMMER

TOP NEW POP SINGLES

- 1 YOU DON'T BRING ME FLOWERS BARBRA & NEIL (Columbia 3-10840)
- 2 Y.M.C.A. VILLAGE PEOPLE (Casablanca NB 945)
- 3 ALIVE AGAIN CHICAGO (Columbia 3-10845)
- 4 MY LIFE BILLY JOEL (Columbia 3-10853)
- 5 HOW YOU GONNA SEE ME NOW ALICE COOPER (Warner Bros. WBS 8695)
- 6 LE FREAK CHIC (Atlantic 3519)
- 7 I WILL BE IN LOVE WITH YOU LIV TAYLOR (Epic 8-50604)
- 8 WE'VE GOT TONIGHT BOB SEGER (Capitol P-4653)
- 9 YOU TOOK THE WORDS RIGHT OUT OF MY MOUTH MEAT LOAF (Cleve. Int'l/Epic 8-50634)
- 10 PART-TIME LOVE ELTON JOHN (MCA 40973)

TOP NEW COUNTRY SINGLES

- 1 ALL OF ME WILLIE NELSON (Columbia 3-10834)
- 2 DON'T YOU THINK THIS OUTLAW BIT'S DONE GOT OUT OF HAND WAYLON JENNINGS (RCA PB-11390)
- 3 FRIEND, LOVER, WIFE JOHNNY PAYCHECK (Epic 8-50621)
- 4 THE GAMBLER KENNY ROGERS (United Artists UA-X1250)
- 5 WE'VE GONE A LONG WAY BABY LORETTA LYNN (MCA 40954)
- 6 TULSA TIME DON WILLIAMS (ABC AB-12425)
- 7 I'VE DONE ENOUGH DYIN' TODAY LARRY GATLIN (Monument 45-270)
- 8 PLEASE DON'T PLAY A LOVE SONG MARTY ROBBINS (Columbia 3-10821)
- 9 YOUR LOVE HAD TAKEN ME THAT HIGH CONWAY TWITTY (MCA 40963)
- 10 LOVE SURVIVED ROY HEAD (ABC AB-12418)

NEW R&B SINGLES

- 1 LE FREAK CHIC (Atlantic 3519)
- 2 LOVE DON'T LIVE HERE ANYMORE ROSE ROYCE (Whitfield/Warner Bros. WHI 8712)
- 3 LONG STROKE ADC BAND (Cotillion/Atlantic 44243)
- 4 WHOLE LOTTA SHAKIN' EMOTIONS (Columbia 3-10828)
- 5 (I'M JUST THINKING ABOUT) COOLING OUT JERRY BUTLER (Phila. Int'l 2S8 3656)
- 6 WHAT YOU WON'T DO FOR LOVE BOBBY CALDWELL (Clouds/TK 11)
- 7 FREE ME FROM MY FREEDOM/TIE ME TO A TREE (HANDCUFF ME) BONNIE POINTER (Motown M-1451F)
- 8 Y.M.C.A. VILLAGE PEOPLE (Casablanca NB 945)
- 9 IN THE NIGHT-TIME MICHAEL HENDERSON (Buddah/Arista BDA 600)
- 10 YOU STEPPED INTO MY LIFE MELBA MOORE (Epic 8-50600)

TOP NEW MOR SINGLES

- 1 YOU DON'T BRING ME FLOWERS BARBRA/NEIL (Columbia 3-10840)
- 2 (OUR LOVE) DON'T THROW IT ALL AWAY ANDY GIBB (RSO RS 911)
- 3 HOW YOU GONNA SEE ME NOW ALICE COOPER (Warner Bros. WBS 8695)
- 4 I WILL BE IN LOVE WITH YOU LIV TAYLOR (Epic 8-50604)
- 5 I JUST WANNA STOP GINO VANNELI (A&M 2072)

Push Button Pleasure

"FLYING HIGH"^{M-1452F}
Commodores

"FREE ME FROM MY FREEDOM"^{M-1451F}
Bonnie Pointer

"SHOE SOUL"^{T-5429F}
Smokey Robinson

"THERE'LL NEVER BE"^{G-7159F}
Switch

"MARY JANE"^{G-7162F}
Rick James

MOTOWN SINGLES



© 1978 MOTOWN RECORD CORPORATION

CLASSIFIEDS

CLASSIFIED AD RATE 25 CENTS PER WORD

Count every word including all words in firm name. Numbers in address count as one word. Minimum ad accepted \$6.25. CASH OR CHECK MUST ACCOMPANY ALL ORDERS FOR CLASSIFIED ADVERTISING# If cash or check is NOT enclosed with order your classified ad will be held for following issue pending receipt of your check or cash. NOTICE — \$158 Classified Advertisers (Outside USA add \$78 to your present subscription price). You are entitled to a classified ad of 40 words in each week's issue for a period of one full year, 52 consecutive weeks. You are allowed to change your Classified each week if you so desire. All words over 40 will be billed at the rate of 25c per word. Please count words carefully. Be sure your Classified Ad is sent to reach Hollywood publication office by Wednesday, 12 noon, of preceding week to appear in the following week's issue.

Classified Ads Close WEDNESDAY

Send all copy to: CASH BOX, 6363 Sunset Blvd., Hollywood CA 90028

COIN MACHINES WANTED

WANTED: Used and new Bally Slot machines, Bally Bingos. Contact: WILMS DISTRIBUTING CO. 87 Booms Steenweg, 2630 Aarstelaar — Belgium Tel: 031/876800 — Telex: 31888

WANTED: Atari Indy 4's, Indy 8's Star Ship, Drag Races, Midway Wheels II. THE MAGNA FUN COMPANY, 400 Jacksonville Road, Hatboro, Pennsylvania, 19040. Tel: (215) 674-5560.

COIN MACHINES FOR SALE

CONVERSION CARTRIDGES — Play stereo records on Seeburg monaural phono B thru 201. No adjustments required — just plug in — eliminate sound distortion, needle skipping, excessive record wear. \$24.95 POSTPAID# Satisfaction guaranteed. Quantity discounts. C.A. THORP SERVI, 1520 Missouri, Oceanside, Ca. 92054.

FOR SALE: 200 units used pinball games, Gottlieb, Williams and Bally available, all in working order. FOB Hong Kong U.S. \$1007/740. Please write to SUN MONG CO., LTD., 1st floor, 50-56 Mongkok Road, Kowloon, Hong Kong.

FOR SALE: North Carolina Vending and Amusement business in full operation. Will sell complete or separate. Vending \$150,000, Amusement \$400,000, or complete \$499,000. Reply in confidence to Box 105 Cash Box, 6363 Sunset #930, L.A. Calif. 90028.

FOR SALE: Lotta fun converted to Barrel O Fun \$1200 & up; Shoot A Line \$1300 & up; National 222 Console \$225; Midway Wild Kingdom Gun \$150; Brunswick Rebound Air Hockey \$300; GUERRINI VENDING 1211 W. 4th Street, Lewiston, Pa. 17044.

FOR SALE: Used and New Bally Bingos, Bally Slot machines, Flippers, Bowlers (new) Genuine Bally parts. Contact: WILMS DISTRIBUTING 87 Booms Steenweg, 2630 Aarstelaar — Belgium Tel: 031/8768000 — Telex: 31888

GAME SPECIALIST: We have a large inventory of games. Big price reduction on Drag Races, Triple Hunt, S-1s, Pool Shark, Atarians, Guided Missile, Circus. Call today. Coin Machine Distributors, Inc. 21 N. Division St., Peekskill, N.Y. 10566. Phone (914) 737-5050.

FOR SALE: Bally: Captain Fantastic (4pl) \$695, Bow & Arrow (4pl) \$595, Amigo (4pl) \$295, Old Chicago (4pl) \$595, Flicker (2pl) \$495, Air Aces (4pl) \$595; Williams: Pat Hand (4pl) \$495; Gottlieb: "300" (4pl) \$495; Midway: Road Runner \$795, Check Mate (cocktail) \$595, Maze (cocktail & upright) \$495. MICKEY ANDERSON, INC., P.O. Box 6369, Erie, PA 16512. (814) 452-3207.

FOR SALE: Fireball — Near mint condition, location ready, sale or trade for new digital; \$1800 — make offer. ANTHONY AMUSEMENTS, 3609 N. Forestdale Ave., Dale City, Virginia. (703) 670-2681.

NATIONAL WHITENBURG MODEL 400 FOOD VENDER 1 National 21CE candy machine — Vendo Visi-Vend Rowe cigarette machines 20 700 \$175 or 7 for \$1000 — Rowe 20 800 \$295, crating extra. Arcade equipment. Motor Cycle, Funland, Pennant, Sami, Sea Raider and Dune Buggy, pool tables, pinballs and many other items. VATHIS VENDORS. Call (214) 792-2806, 793-3723 or 792-1810.

FOR SALE: Have available a great quantity of second hand electro-mechanical pinball games — Gottlieb and Williams. Price on request. Write to: SOVODA, S.A., Export Dept., 51 Rue de Longvic, 21300 Chenove, France. Tel: 16 80/473 8001. Telex 350018 SOVODA CHENO.

FOR SALE: Silver Sails, Red Arrows, Ticker Tapes, Blue Chip and Stock Markets. Also Sweet Shawnees, Bally Jumbos and Super Jumbos, Big Threes, Blue Spots, Mt. Climbers, Mystic Gates and Bonanzas. Antique slots for legal areas. Call WASSICK NOVELTY, Morgantown, W. Va. (304) 292-3791.

FOR SALE: Rock-Ola 504 wallbox \$100; Rock-Ola Receivers, 1725-8-2, 1765, 1721, 1769 \$65 each. WESTERN DISTRIBUTORS, 1226 SW 16th Avenue, Portland, Ore. 228-7565

AVAILABLE NEW Sweet Shawnee, Sweet Shawnee Hold and Draw-Twin Knight, Black Dragon. Used Trailblazer, Super Wild Cat, Red Arrow. Also available, used Como Hollycranes, and assorted Holly Parts. Antique slots for legal states. LOWELL ASSOC., P.O. Box 386 Glen Burnie, Maryland 21061, (301) 768-3400.

SEEBURG LPC 150, AMI 200, N 150. Johnson coin sorter & counter 295, Tennis Tourney 200, Electro Dart 100. BROWSER, 2009 Molt Ave., Far Rockaway, N.Y.

FOR SALE: *Jet Spin \$510, Big Hit \$475, Royal Flush \$600, "Three Hundred" \$525, Surf Champ \$595, Spirit of '76 \$575, Gridiron \$475, Power Play (s.s.) \$950, Night Rider (s.s.) \$800, Wizard \$650, Night Rider (e.m.) \$650, Capt. Fantastic \$695, Bow & Arrow (s.s.) \$510, Stars (s.s.) \$1145, Atarians (s.s.) \$650, Airborne Avengers (s.s.) \$875, Speakeasy \$495, Out of Sight (unshopped) \$350, Hot Shot (unshopped) \$295, Duitron (unshopped) \$325, Boomerang (unshopped) \$375, Oxo (unshopped) \$250, Pat Hand (unshopped) \$465, Racer \$550, Guided Missile \$600, M-4 Tank \$675, Double Play \$825, Sea Wolf \$1075, Lemans \$825, Ultra Tank \$750, Breakout \$765, Steeplechase \$425, M-79 Ambush \$1050, Trivia \$325, Circus \$525, Safari \$725, Depth Charge \$695, Blasto \$895, BiPlane 4 \$750, BiPlane 2 \$395, Bazooka \$500, Gypsy Juggler \$925, Dozer \$925, Kiddie Auto Racer (like new) \$500, Kiddie Boat (like new) \$500, Kiddie Boat (unshopped) \$200, Sandy Pony (unshopped) \$225, Air Hockeys (used) \$325, Air Hand Ball \$395, Foosball (in original crate) \$575, Strike (in original crate) \$895, Strike (used) \$725. Call or write. NEW ORLEANS NOVELTY CO., 1055 Dryades, New Orleans, Louisiana, 70113 Tel: (504) 529-7321.

SALE: Route in Puerto Rico, 700 assorted cigarette and music netting operator more than \$150,000 per annum. Contact United States Amusements, 2W. Northfield Road, Livingston, New Jersey, 07039, (201) 992-7813.

FOR SALE: 32 Bally High Flyers Brand New — 5 Bally Mystic Gates Brand New — 5 Bally Bonanza Brand New. Also Blue Chips, Wallstreet, Stockmarkets, Tickettapes, Balis, Other Bingos. UNITED STATES AMUSEMENTS, 2 W Northfield Rd., Livingston New Jersey 07039 (201) 992-7813.

ALL TYPES OF COIN-OPERATED EQUIPMENT. Flippers, shuffle alleys, guns, TV games, Williams, Gottlieb, ChiCoin, Ramtek, Allied, Natting Phonographs (large selection) Wurlitzer, Seeburg, AMI, Rock-Ola, Rock-Ola vending. Cigarettes, candy, cold drink. Nationaling. Cigarettes, candy, cold drink. National Smokeshop, Rock-Ola. All kinds shipped to perfection or buy as-is and save. We have the right price and equipment on hand to serve your needs. Write or call: FLOWER CITY DISTRIBUTORS, INC., 389 Webster Ave., Rochester, N.Y.

FOR SALE: New York State Add-A-Balls Pin Games. Call (315) 788-5130. BRENON'S COIN MACHINES, INC. 110 Main, Brownville, New York 13615

FOR SALE: Bally's Bingo "Bally Bali," new 10 units and used 9 units, prices negotiable. OVERSEAS LIAISON & TRADING, LTD., 1-20, Tsukiji 4-chome, Chuo-ku, Tokyo 104, Japan. Telex: J25362.

FOR SALE: Seeburg Cs jukeboxes. Gottlieb: Target Alpha, Abra Ca Dabra, Spin Out, Atlantis. Williams: Stratoflight, Triple Strike, El Dorado, Super Star. Bally: Hokus Pokus, Capt. Fantastic. D&L DISTRIBUTING CO., INC., 6691 Allentown Blvd., Harrisburg, Pa. 17112. (717) 545-4264.

FOR SALE: Florida Music & Game route on Gulf Coast. Well Established medium route in fast growing area. Priced right to sell. Mr. Warren, Box 1404, Sarasota, Florida 33577.

National Cig-222-100MM-1ACMR \$350, National Cig-Crown-222-100MM-ACMR-\$1 \$400, National Cig-Crown-800-100MM-ACMR-\$1 \$475, Rowe Riviera/B/F Console Electric-100MM-\$1 \$325, Call or Write for price on Load 75 machines. AMUSEMENT SERVICE 908 E. DeRenne Ave. P.O. Box 22547 Phone (912) 354-4881.

FOR SALE: 50 Seeburg 160 selection wall boxes \$25 each; 20,000 used 45 rpm records 1000 or less 10c each, over 1000, 9c each. Walling 200 scale \$200; Rock-Ola Lowboy \$60. One-third down balance C.O.D. CENTRAL MUSIC CO., Box 284, Killeen, Texas 76541.

bingos for export market, or legal territories. Golden Gates, Bountys, Bikinis, Can Cans, Circus Queens, Roller Derby's, Laguna Beachs, Magic Rings, Big Wheels, Folies Bergers, Venices Bonus 7, Zodiacs, and Orients. Write for prices. D&P MUSIC CO., 658 W. Market St. P.O. Box 243 York Pa. 17405.

SERVICES COIN MACHINE

ACE LOCKS KEYS ALIKE: Send locks and the key you want them mastered to: \$1.25 each, 10% D/C in lots of 100 or more. RANDEL LOCK SERVICE, 61 Rockaway Ave., Valley Stream, N.Y. 11580. (516) 825-6216. Our 38th year in vending.

WE'VE MOVED: Look forward to a faster turnaround on your repairs. All logic boards \$13.50 plus parts. Jukebox amplifiers \$15.00 plus parts. NRI validators \$25. Monitors, BO/ACS, changers and more. Our expertise saves you money. ASC, 7011 N. Atlantic Ave., COAPE Canaveral, Fla. 32920.

LEGAL

NEED A LAWYER? Call Law Offices of L. Rob Werner. (213) 705-0555, 462-1722. 6255 Sunset Blvd., 20th Floor, Hollywood, CA 90028 or 18075 Ventura Blvd., Encino, CA 91436. We desire to serve the legal needs of entertainers, managers, songwriters and producers.

EMPLOYMENT SERVICE

SCHOOL FOR GAMES AND MUSIC, one to three week course. Phonos — video, electro-mech. and logic flippers. By schematics! CAL'S COIN COLLEGE, P.O. Box 810, Nicoma Park, Oklahoma 73066. Telephone: (405) 769-5343.

YOUNG WRITER-PRODUCER with sources for artists and material desires association with a progressive record company needing same and prepared to make offers. Write C.K. Aspinwall of 652 Azalea Drive in La Grange, Ga. 30240.

JO-BAR MUSIC PUBLISHING CORPORATION and BAR-JO Records, Inc. needs investors and stockholders to re-open music business. Write BAR-JO at 83-45 Vietor Ave., Suite 2B, Elmhurst, NY 11373 or call (212) 898-1628 or 243-5668.

CONCERT PACKAGER/COORDINATOR seeking a gig as an assistant road manager or advance person for Christian artists, or production co. Write Chris Ringer at 3333 West 2nd St., Building 56, Apt. #122, Los Angeles, CA, 90004.

BMI SONGWRITER-COMPOSER who has written for Tavares, Righteous Bros., Grass Roots and others now auditioning soulful keyboard players for composing-collaborating. Also have contemporary soul and disco catalog for A&R men and producers. Willie H. Wilson (213) 299-6649.

MIDWEST GROUPS, CHICAGO SERVICE offers complete promotional package: includes prestige loop address, confidential telephone, mail, secretarial service; advertising, personalized promotion. Ideal for new groups. Low start-up rates. Heyworth Service, 29 E. Madison St., Chicago, IL 60602. Phone (312) 782-4741.

GAME TECHNICIAN — Expanding established organization located northern New Jersey seeks 1st class mechanic. Fully capable of on street repair, solid-state and electro-mechanical pin games. This is a unique opportunity to join rapidly growing company. Salary open, many benefits. Reply in confidence to Box 624, Cash Box, 6363 Sunset Blvd., #930, Hollywood, CA 90028.

SERVICE SCHOOL FOR GAMES AND MUSIC. Ten-week night course teaches practical theory, schematics. \$575 full price. COMMIT, 2115 Beverly Blvd., Los Angeles, la. 90057 (213) 483-0300.

RECORDS-MUSIC

HOUSE OF OLDIES: World headquarters for out of print 45's and LP's, catalog is \$1.50. Specials: First American EP & Cover of the Beatles in mint condition — \$20 Vee Jay EP 903 (2). Beatles Christmas Lp on Apple SBC100 — Sealed \$12. HOUSE OF OLDIES 276 Blecker St., N.Y., N.Y. 10014.

FOR SALE: The Music Industry Series by attorney Walter Hurst. Record Industry book \$25. Publishers Office Manual \$25. Copyright \$10. Music/Record Business and Law \$10. How To Be A Music Publisher \$10. SEVEN ARTS PRESS, INC., Box 649, Hollywood, CA 90028.

LEADING RECORD AND TAPE DISTRIBUTORS of all labels. Will sell current & cut-out merchandise, accessories & blank tapes at lowest prices. Member of NARM. Send for free catalogues. CANDY STRIPE RECORDS, INC., 371 South Main Street, Freeport, New York 11520. (212) 895-3930. Telex 126851 Canstripe Free.

SUCCEED IN THE ENTERTAINMENT FIELD! Let professional marketing communications firm handle your promotional work. 8 years experience. Call (312) 787-3715 or write Corinne Carpenter Communications, 1636 North Wells, Suite 2307, Chicago, IL 60614.

WANT: 45s/ALL TYPES 1955-1976 (Pop, R&B, C&W, MOR). Will deliver cash if you got enough of what we want. Call Martin Cerf/Phonograph Record Magazine, P.O. Box 2404, Hollywood, CA 90028.

INTERNATIONAL RADIO STATIONS, MUSIC PUBLISHERS, discotheques and fanclubs subscribe to our Automatic Airmail Service for all singles and LPs from the charts. The fastest and most dependable service in the world. AIRDISC SPECIAL SERVICES, Box 835, Amityville, New York 11701.

WALLACE LEAVES BMA: I Jerry Wallace, am no longer associated with BMA RECORDS and am free to record with whom I desire due to violation of BMA Recording Contract by BMA.

SONG LYRICS WANTED: exciting proposition. For details write: 30 Sneyd Hall Road, Bloxwich, Staffordshire, England.

WANT RECORDS & TAPES, 45s AND LPs, surplus returns, overstock cut-outs, etc. Call or write Harry Warriner at KNICKERBOCKER MUSIC CO., 101 Gedney St., Nyack, N.Y. 10969 (914) 358-5086.

Looking for the best ADULT/CONTEMPORARY music supply service at the lowest possible price? Your problems with record service are over when you join us. Stereo or mono. THE MUSIC DIRECTOR PROGRAMMING SERVICE, Box 103, Indian Orchard, Massachusetts 01651.

NAME CHANGE? MUSIC BUSINESS PEOPLE: If you want a professional name, the new name MUST be in harmony to your original name, or the results in you life will be super disastrous. Contact numerologist, BISHOP DEAN, Nashville tennessee, (615) 331-3508, or write Box 110881, Nashville, Tennessee 37211.

FREE CATALOG: New York's largest and most complete One-Stop specializing in OLDIES BUT GOODIES. Retail stores and chains only. Write to: Paramount Records Inc., 1 Colonial Gate, Plainville, New York 11803.

KING OF MUSIC RECORDS is looking for masters. Send copies to KING OF MUSIC RECORDS, 806-16th Avenue South, Suite 217, Nashville Tenn. 37203, or call (615) 242-2023.

FOR SALE: 5,000 jukebox 45s, 100 different \$8.50; foreign \$13. Choose Rock, Disco, Polka, Country. AL'S 2249 Cottage Grove, Cleveland Heights, Ohio 44118.

OPERATORS — We buy used records not over 1 year old — 10c each plus postage. JOHN M. AYLESWORTH & CO. 9701 Central Ave., Garden Grove, Calif. 92644 (714) 537-5939.

RARE RECORD SHOPS AND FINDER. List of 31 United States shops. Up to date list personally compiled \$2. MACLEAN'S, 312 Belanger St., Houma, La. 70360.

FOR EXPORT: All labels of phonograph records, cartridges, cassettes. Also excellently priced selections of close-outs. Nearly 30 years of personalized service to importers world over. Wholesale only. DARO EXPORTS, LTD. 1468 Coney Island Avenue, Brooklyn, N.Y. 11230. Cable: EXPDARO, NEW YORK.

HUMOR

DEEJAYS! Here's top drawer comedy for you! 11,000 one-line gags for radio; only \$10! Unconditionally guaranteed! Catalog of one-liners, funny stories, putdowns, trivia, breaks, and lots more, free on request Edmund Orri., 41171-C Grove Place, Madera, Calif. 93637.

ATTENTION ANNOUNCERS! Let our total comedy service unlock bigger ratings for you! Established professionals offering subscription gagletter, Dee Jay Handbooks, career-boosting Monologues, individualized Custom Gags and much more. Send for FREE INFORMATION PACKAGE. PETER PATTER P.O. Box 402-C, Pine-dale, Calif., 93650.

CLASSIFIED POWER!

Got machines to sell? Is there something you're looking to buy? Maybe you'd like to move some used 45's or need a route mechanic? See ad rates above.

Classified Ads Close WEDNESDAY

Send all copy to: CASH BOX, 6363 Sunset Blvd., Hollywood CA 90028

Make sure your check is enclosed

INTERNATIONAL



BETTE MIDLER HITS GERMANY — Singer Bette Midler (second from right) undertook a successful debut concert tour of Germany. Following her sold-out show at the Hamburg Music Center, Midler was greeted by WEA-Germany officials and friends, and presented with a cake by WEA-Germany managing director Siegfried Loch (far left).

International Dateline

Germany

MUNICH — **Fleetwood Mac** is going to be awarded with a platinum record for over 500,000 sold copies of the album "Rumours" in Germany. Siegfried E. Loch, managing director of WEA Germany, will present the award to the group in Los Angeles.

In its issue of Oct. 15 Musikmarkt published single and LP statistics for the three quarters of 1978, showing that in the singles chart Ariola-Eurodisc has gained top position with 33.8 percent, followed by EMI-Electrola with 18.9 percent and closely followed by DGG/Polydor with 17.0 percent. Phonogram is in fourth place with 10.3 percent and Siggie Loch's WEA shows 6.3 percent which is an indication of the rapid growth this company has gained in 1978.

On the LP chart EMI-Electrola is still in the top slot with 22.4 percent, Ariola-Eurodisc number two with 17.5 percent, followed by Phonogram with 13.8 percent, DGG/Polydor and CBS.

The biggest album in the first quarter of 1978 was **Abba's** "The Album," while **Pink Floyd's** "Wish You Were Here" takes the second position, followed by "Saturday Night Fever" soundtrack.

Phonogram is featuring two sales campaigns for this autumn. Under the slogan "A Barrel Full Of Music" specially-priced music cassettes are being offered. The product includes artists like **Vic Leandros**, **Chuck Berry**, **The Platters** and **Los Incas**.

A special campaign for **Ullrich Heep's** 14th LP, "Fallen Angel," is being initiated. Special posters, window-displays and stickers are being offered to the shops and TV support has been arranged. . . . Chrysalis' office in Hamburg was closed down Oct. 15, since **Teddy Meire**, European promotion manager, left

Chrysalis to go back to Switzerland, where he is expected to return to EMI Electrola, his employer previous to Chrysalis. Meire had been handling the interests of the company since Sept. 1977 in Hamburg.

This October was "**Travolta Month**" for Germany. Most of the teenage music magazines were featuring stories for the new movie "Grease," putting **John Travolta** on their front covers. Also, Spiegel magazine issued a headline story on the "Disco Fever" in Germany with Travolta on the cover. In Hamburg, Frankfurt and Munich discos in the style of "Studio 54" are being opened, thus confirming the importance of disco music in Germany.

gerhard augustlin

England

LONDON — English band **Showaddywaddy** has been chosen to appear in the Royal Variety show on Nov. 13 in the presence of **Queen Elizabeth**. A debut album has been issued from American singer/writer **Jack Tempchin**, on Arista. Tempchin in the past, has written such classics as the **Eagles'** "Peaceful Easy Feeling" and "Already Gone."

CBS Records is currently claiming literary credibility for its new signing, street/punk poet **John Cooper Clarke**. Cooper Clarke's debut LP, released this week, features 40 minutes of aesthetic banality. To help promote his verse-on-vinyl, Clarke spent an afternoon on a soap box at London's famed Speakers' Corner, only to be swooped upon by the police for using a megaphone (by English law — only natural voices are allowed to be heard in public at Speakers' Corner). Among the crowd supporting Clarke was **Elvis**

(continued on page 58)

Ontario Govt. May Subsidize Canadian LP Sales In 1979

by Kirk LaPointe

TORONTO — The Ontario provincial government is contemplating an indirect subsidization plan for the Canadian record industry which would make Canadian albums less expensive to purchase in 1979. If implemented, the plan would allow consumers to purchase Canadian albums with used Wintario lottery tickets, each of which would be worth 50 cents for a maximum two dollar discount towards LPs retailing over three dollars.

The government proposal still being deliberated by the provincial cabinet could take effect by January 1979, said Reuben Baetz, the minister in charge of overseeing the operation of the Wintario lottery draw.

The draw, which takes place every other week, has historically used its profits for

CBS Canada Displays Strong Sales Increase

TORONTO — CBS Records Canada enjoyed a third quarter consolidated sales increase of 30.1% over a similar period in 1977, and an overall 28% increase in comparison with the 1977 company fiscal year, according to Arnold Gosewich, chairman and chief executive officer of the label.

"The so-called 'third-quarter doldrums' were not in evidence at CBS Records Distribution (up 44%), All Records Supply (the company's rack-jobbing outlet, up 16%), A & A's (the company's retail franchise chain, up 38%) or Custom Factory Sales (up 29%)," Gosewich said. "What is particularly gratifying is that strong sales results have occurred within every major profit center of CBS Canada."

Despite an ongoing cost increase, Gosewich noted that record sales for the company continued to grow. The firm has had a total of 56 gold and platinum record awards from January to September of this year, an increase of 57% over 1977.

CBS-England Launches Disco Pool Department

LONDON — CBS-England's Disco promotions department is unveiling plans for a new disco department at the label. Under the banner of CBS Disco Pool, the aim of this new venture is to establish a closer working relationship with the disco fraternity, with emphasis towards the disco disc jockeys. It is hoped the new department will increase sales of the catalog of dance-oriented product available through CBS.

Believing that disco promotion should always remain an integral part of company marketing, promotion and sales activity, the CBS Disco Pool will be used to integrate disco promotion within the total marketing strategy of the company.

direct subsidization of culture and recreation within the province of Ontario. In addition, it has been allowing ticket purchasers to partake in its "half-back" program, which allows them to use their old one-dollar lottery tickets as fifty-cent vouchers towards the purchase of Canadian books and magazines. Since the half-back program took effect last year, Canadian book sales have risen by one-third in the province.

"No matter how you look at it," says Brian Robertson, president of the Canadian Recording Industry Association, "it will benefit the Canadian music business. It is going to encourage people to listen to more bands here, and give us a competitive edge over records from competing countries."

The Wintario half-back program is also going to be extended to Canadian movies, and is likely to also be used in the theatre industry by mid-1979.

All of the industry personnel surveyed by **Cash Box** hailed the government's proposal as "extremely beneficial" to the growth and development of the music business in Canada. Ross Reynolds, executive vice president of WEA Music Canada Ltd., said the move will "be an immense help to the promotion of Canadian music in this province. I expect that more Canadian albums will go gold and platinum as a result."

Need Clarification

Retailers are indicating that they will not increase their prices to reap rewards from the new plan. But as a spokesman for A & A's retail chain said, "We're going to have to have more clarification as to what exactly constitutes a Canadian record. Likely we'll also have to attach "CanCon" stickers to the right discs so both consumers and retailers know what disc qualifies under the program."

Wintario is also attempting to put money directly into the pockets of upstart Canadian music groups, by sponsoring cross-provincial tours for them, although their efforts have been received reluctantly by the Canadian music industry. As one spokesman for GRT Records put it, "a government body should only go so far in the interference of an artist's career."

Virgin Signs Publ. Pact

LONDON — Virgin Music has signed an agreement with Shelter Records publishing companies for UK representation. The Shelter roster includes such artists as Tom Petty, JJ Cale, Phoebe Snow, as well as song titles by Peter Tosh, Bunny Wailer and Leon Russell. The deal was secured for Virgin by Carol Wilson and for the Shelter group by Don Williams. Virgin's first aim will be to place some unrecorded Tom Petty songs with several major British artists.

INTERNATIONAL BESTSELLERS

Brazil

- TOP TEN 45s**
- 1 **Wuthering Heights** — Kate Bush — Odeon
 - 2 **Automatic Lover** — Dee Jackson — RGE/Fermata
 - 3 **Get Off** — Foxy — CBS
 - 4 **Boogie Oogie Oogie** — A Taste Of Honey — Capitol
 - 5 **Sosiego** — Tim Maia — WEA
 - 6 **Stayin' Alive** — Bee Gees — Phonogram
 - 7 **It's A Heartache** — Bonnie Tyler — RCA
 - 8 **Night Fever** — Bee Gees — Phonogram
 - 9 **Macho Man** — Village People — RCA
 - 10 **The Closer I Get To You** — Roberta Flack — WEA

TOP TEN LPs

- 1 **Alerta Geral** — Alcione — Phonogram
- 2 **Disco Baby** — As Melindrosas — Copacabana
- 3 **Excelsior A Maquina Do Som Vol. 7** — Various — Som Livre
- 4 **Saturday Night Fever** — Soundtrack — Phonogram
- 5 **Te Contel? "International"** — Various — Som Livre
- 6 **Dancin Days "National"** — Various — Som Livre
- 7 **Amigo** — Roberto Carlos — CBS
- 8 **16 Temas Romanticos De Novelas** — Various — K-Tel
- 9 **Discoteca Papagalo** — Various — Som Livre
- 10 **De Pe No Chao** — Beth Carvalho — RCA

Australia

- TOP TEN 45s**
- 1 **Black Is Black** — LaBelle Epoque — EMI
 - 2 **Are You Old Enough** — Dragon — CBS
 - 3 **Dancing In The City** — Hain Marshall — EMI
 - 4 **Three Times A Lady** — Commodores — AST
 - 5 **Hopelessly Devoted To You** — Olivia Newton-John — Polydor
 - 6 **Oh, Carol** — Smokie — EMI
 - 7 **Dreadlock Holiday** — 10cc — Polydor
 - 8 **You're The One That I Want** — J. Travolta/O. John — Polydor
 - 9 **Love Will Find A Way** — Pablo Cruise — Festia
 - 10 **Grease** — Frankie Valli — Polydor

TOP TEN LPs

- 1 **The War Of The Worlds** — Jeff Wayne's Musical Version — CBS
- 2 **Grease** — Soundtrack — Polydor
- 3 **Living In The U.S.A.** — Linda Ronstadt — WEA
- 4 **O Zambesi** — Dragon — CBS
- 5 **It's A Long Way There** — Little River Band — EMI
- 6 **Bat Out Of Hell** — Meat Loaf — CBS
- 7 **Comes A Time** — Neil Young — WEA
- 8 **Worlds Away** — Pablo Cruise — Festia
- 9 **Some Girls** — Rolling Stones — EMI
- 10 **Don't Look Back** — Boston — CBS

Germany

- TOP TEN 45s**
- 1 **Substitute** — Clout — Carrere/Polydor
 - 2 **Mexican Girl** — Smokie — EMI
 - 3 **Rasputin** — Boney M — Ariola
 - 4 **You're The One That I Want** — J. Travolta/O. John — RSO
 - 5 **You're The Greatest Lover** — Luv' — Polydor
 - 6 **Dancing In The City** — Hain Marshall — EMI
 - 7 **Lucky** — Bernie Paul — Ariola
 - 8 **Lovemachine** — Supermax — Atlantic
 - 9 **Summer Nights** — J. Travolta/O. John — RSO
 - 10 **Summer Night City** — Abba — Polydor

TOP TEN LPs

- 1 **Grease** — Soundtrack — RSO
- 2 **Nightflight To Venus** — Boney M — Ariola
- 3 **20 Welthits im Gitarrensound** — Ricky King — Epic
- 4 **World Of Today** — Supermax — WEA
- 5 **20 Diamant Hits** — Neil Diamond — Phonogram
- 6 **Saturday Night Fever** — Soundtrack — RSO
- 7 **Von Tag zu Tag** — Milva — Metronome
- 8 **Pyramid** — The Alan Parsons Project — Arista
- 9 **...Then There Were Three...** — Genesis — Phonogram
- 10 **Nimm mich mit, Freddy** — Freddy Quinn — Polydor

— Kent Music Report

— Der Musldmarkt

**MEXICO
GUATEMALA**

**HONDURAS
PERU**

**ECUADOR
COSTA RICA**

**CHILE
BOLIVIA**

**ARGENTINA
URUGUAY**

**BRAZIL
NICARAGUA**

**VENEZUELA
EL SALVADOR**

**COLOMBIA
PANAMA**

**DOMINICAN REPUBLIC
PUERTO RICO**

**VIAS
MIAMI**

The Best Way to
Reach the
Latin American
Market!

OPERATOR

Meet Joe Vias,
the pro in our new Miami Office.
He's the man to call when you need to
make fast and firm contacts in Latin America.
He has the facility at his fingertips
to reach any market from Argentina
to the Dominican Republic.

It's simple to remember:
when you think of Latin America...
think of RCA and Joe Vias.

Our new office is located at:
7220 N.W. 36th Street
Miami, Florida 33146
Telephone: (305) 591-9600
Telex: 264016



RCA INTERNATIONAL

INTERNATIONAL

International Dateline

(continued from page 57)

Costello, who later disappeared on the back of an aging Vespa scooter . . . **Peter Skellern** is to make his first ever London headlining appearance at the London Palladium on Nov. 8.

MCA Records has entered into a new licensing agreement with Do It Records, the provincial-based independent record company. First release under the new deal is the single "Modern Man" by "M" . . . **Tibor Serly**, the distinguished American composer, teacher and musical theorist, died, age 76, after being knocked down by an automobile in London on Sunday, Oct. 9. He had been enroute to Hungary where he was to have been honored with a Serly Festival of his compositions in Budapest. Serly was an official member of ASCAP since 1945.

Rob Cooksey (ex-manager of **Deep Purple**) and **Martin Birch** have formed a production company, Christy Productions, and in association with Curzon Sound, a new record label, Christy Records. First release from Christy is a single entitled, "Who Do You Love," by **Mainland**.

Parliament/Funkadelic has added an extra London date to its two nights at the Hammersmith Odeon, which have already sold out. The extra date is Thursday, Dec. 14.

Black Sabbath's 10th anniversary album, "Never Say Die," has charted in the first week of release. The band is currently taking a break from its American tour to do dates in Germany and France . . . Ariola Records recently hosted an informal lunch at London's Churchill Hotel to show a video presentation of Ariola acts: **Yvonne Keeley/Steve Flanagan, John Paul Young, Three Degrees** and **Child**.

Riva Records has set the release date of the new **Rod Stewart** LP for Nov. 17. Stewart will begin a world tour at the end of next month. Entitled "Blondes Have More Fun," the new LP will ship gold . . . London's Capital Radio, the biggest U.K. commercial station, is expanding its interests, with the purchase of the Duke of York's theater and a new promotional push behind their popular symphony orchestra, **The Wren Orchestra**.

nick underwood

Argentina

BUENOS AIRES — The CBS Sales Convention was the top event of the week, with the full sales & promo staff of the label gathering in Buenos Aires for business plus an evening of entertainment at the Nogaro Hotel with a show by top level artists. Also invited to the convention were the leading distributors, retailers and journalists.

Phonogram's promo people have been busy with the arrival of disco chanteuse **Gloria Gaynor**, who is appearing this week at the Buenos Aires Bauen Hotel theatre.

RCA also had its sales convention on

Oct. 26-27, discussing promo and sales issues and unveiling the product for the year-end season. Following the convention here, creative director **Marlo Pizzurno** traveled to Miami for the RCA International convention in that city.

Microfon's **Los Pasteles Verdes** has arrived in Argentina for a new series of appearances in Buenos Aires and other cities, including Montevideo in Uruguay. The group records for Infopesa of Peru, represented here by Microfon, which is now promoting its new single "Mar" and an LPA titled "Lo Mejor." The group has obtained good sales in the U.S. Latin markets, where it is also distributed by the Kaminsky brothers' company.

EMI Odeon reports good results for its Coleccion Musical budget series, formed with a wide selection of evergreen albums. The label is also working on the cassette market, which has been growing steadily in Argentina despite an overall sales slump.

"The Last Waltz" by **Martin Scorsese**, with the **Band** and **Bob Dylan** among others, may be the next link in the series of musical films being shown in Buenos Aires, after "Saturday Night Fever," "Grease" and "Thank God It's Friday." Although "Fever" was a big success, "Grease" was labeled "Forbidden for minors under 18 years old," which took away most of its appeal for the market and affected greatly the sales of the soundtrack album. The latest Stigwood epic, "Sgt. Pepper," will also be premiered soon.

miguel smirnoff

A&M Undertakes Promo Carpenters Campaign

LONDON — A&M Records is undertaking an extensive promotional campaign next month surrounding the release of the Carpenters, "Singles 1974-78". The album, the follow-up to "Singles 1969-73", will be launched with a 300,000 pound national advertising campaign on Nov. 10.



MANILOW IN LONDON — After his opening night at the London Palladium, singer/composer Barry Manilow was greeted by Clive Davis, president of Arista Records U.S. at a party hosted by Arista UK. Pictured (l-r) are Davis and Manilow.



ROCK 'N' ROLL THUNDER — New York's John Thunders flew into London recently to play a sold-out show at the Lyceum. The former New York Doll singer/guitarist was here to promote his debut album for Real Records entitled "So Alone." Pictured after the show (l-r) are: Dave Hill, managing director of Real Records; Thunders; Bill Fowler, WEA director of promotions; and Terry Ork, Ork Records of New York.

CHUM Will Broadcast 10 Concerts In TV-FM Simulcast By Oct. 1979

TORONTO — As part of its agreement with the CRTC when it purchased CITY-TV in Toronto, CHUM Limited announced it will broadcast 10 concerts with television-FM radio simulcasting by Oct. 31, 1979.

The first of 10 shows will be a Murray MacLauchlan concert from the El Mocambo club Nov. 4 at 11:00 p.m., Eastern time. CHUM-FM program director Warren Cosford stated that the concerts, featuring Canadian talent exclusively in its initial stages, will be held at intervals of one month over the next year.

Moses Znaimer, president of CITY-TV, said at a press gathering at the El Mocambo Oct. 19, that he envisions the broadcasts as "a potentially enormous step in the right direction for the music and television business" towards the alignment of rock and television industries in this country. "Television has done a bad job in trying to capture the essence of a rock performance in this country. We want to develop this program into a state-of-the-art presentation utilizing the highest standards available."

It is felt that CITY-TV will likely attempt to syndicate the live broadcasts to other markets. "We are going to spend large sums of money in presenting these performances," Znaimer told **Cash Box**. "We will have a two-day set-up time, and will be using over 60 people in the presentation. While we will keep the show to CITY-TV initially, we hope that it will be a worthy syndication product before too long."

The program will help fill a void in Canadian television, which has historically snubbed rock music to a large degree. While pop stars Patsy Gallant and Rene Simard have successful network shows, the music

presentations have not been realistic rock performances. "We don't think that we'll be interfering at all in the musical performance," says Znaimer, who added that commercial interruptions will be minimal throughout the one-hour show.

Cosford intimated that the program will also expand its perimeters by late 1979, and feature international performers. "We've already had inquiries from two big-name American artists for such a program," he added.

CBS/True North national publicity director Joe Owens, the label for which Murray MacLauchlan records in Canada, said that the label was proud to be a part of the first of many such simulcast performances.

Polydor Records-UK Merges Two Depts.

LONDON — Polydor Records-England has merged its existing promotion division with an overseas exploitation division to form a new unit, according to A.J. Morris, Polydor managing director.

The new division will be headed by Tony Bramwell, who has previously been working as an independent promotion man for Polydor for the past seven years. His function will now be full-time. Deputy head of promotion goes to Adrian Rudge, who is currently overseas exploitation manager. Rudge will maintain his overseas responsibilities, but will merge his activities into the new division.

Other members of the new promotion division include John Howson, Bob White, Chris Withers-Green, Joe Reddington, Theo Loyla, disco promotion, and Maurice Gallagher, artist liaison manager.

INTERNATIONAL BESTSELLERS

Argentina

TOP TEN 45s

- 1 **Stayin' Alive** — Bee Gees — RSO
- 2 **Para Vivir Un Gran Amor** — Cacho Castana — Microfon
- 3 **It's A Heartache** — Bonnie Tyler — RCA
- 4 **Si Fuera Como Ayer** — Tormenta — Microfon
- 5 **Por Ti** — Sergio Denis — Philips
- 6 **Cumparsita Dance** — Jinny & The Flamboyants — Music Hall
- 7 **Sera Varon, Sera Mujer** — Trio San Javier — CBS
- 8 **Cella** — Pomada — RCA
- 9 **Rivers Of Babylon** — Boney M — RCA
- 10 **Rindete Al Amor** — Luisa Fernandez — Music Hall

TOP TEN LPs

- 1 **Exitos En Primavera** — Selection — Microfon
- 2 **Saturday Night Fever** — Soundtrack — RSO
- 3 **Hit Sounds** — Selection — EMI
- 4 **En Castellano** — Demis Roussos — Philips
- 5 **Amor Con Ritmo Vol. 2** — Selection — Music Hall
- 6 **Piramide** — The Alan Parsons Project — Arista
- 7 **Musica Con Todo** — Selection — RCA
- 8 **A Mis 33 Anos** — Julio Iglesias — CBS
- 9 **Los Maximos** — Selection — CBS
- 10 **Studio 57** — Studio 57 Group — Arfon

— Prensario

Great Britain

TOP TEN 45s

- 1 **Summer Nights** — J. Travolta/O. John — RSO
- 2 **Rasputin** — Boney M — Atlantic/Hansa
- 3 **Sandy** — John Travolta — Midsong International
- 4 **Lucky Stars** — Dean Friedman — Lifesong
- 5 **MacArthur Park** — Donna Summer — Casablanca
- 6 **Sweet Talkin' Woman** — Electric Light Orchestra — Jet
- 7 **Rat Trap** — Boomtown Rats — Ensign
- 8 **Love Don't Live Here Anymore** — Rose Royce — Whitfield
- 9 **Blame It On The Boogie** — Jacksons — Epic
- 10 **I Can't Stop Loving You** — Leo Sayer — Chrysalis

TOP TEN LPs

- 1 **Grease** — Soundtrack — RSO
- 2 **The Big Wheels Of Motown** — Various — Motown
- 3 **Nightflight To Venus** — Boney M — Atlantic/Hansa
- 4 **Images** — Don Williams — K-Tel
- 5 **War Of The Worlds** — Jeff Wayne's Musical Version — CBS
- 6 **Classic Rock** — London Symphony Orchestra — K-Tel
- 7 **Strikes Again** — Rose Royce — Whitfield
- 8 **Brotherhood Of Man** — Brotherhood Of Man — K-Tel
- 9 **Bloody Tourists** — 10cc — Mercury
- 10 **Sat'n City** — Various — CBS

— BMRB

Italy

TOP TEN 45s

- 1 **You're The One That I Want** — J. Travolta/O. John — RSO
- 2 **Wuthering Heights** — Kate Bush — EMI
- 3 **Triangolo** — Renato Zero — Zerolandia
- 4 **Una Donna Per Amico** — Lucio Battisti — Numero Uno
- 5 **Una Donna . . . Una Storia** — Walter Foini — Polydor
- 6 **Automatic Lover** — Dee Jackson — Durium
- 7 **Love Is In The Air** — John Paul Young — Derby
- 8 **Grease** — Frankie Valli — RSO
- 9 **No** — Gianni Bella — CGD
- 10 **Liu'** — Alunni Del Sole — Ricordi

TOP TEN LPs

- 1 **Saturday Night Fever** — Soundtrack — RSO
- 2 **Una Donna Per Amico** — Lucio Battisti — Numero Uno
- 3 **Grease** — Soundtrack — RSO
- 4 **Zerolandia** — Renato Zero — Zerolandia
- 5 **Step II** — Sylvester — Fantasy
- 6 **The Kick Inside** — Kate Bush — EMI
- 7 **Nuntereggae Piu'** — Rino Gaetano — It
- 8 **Liu'** — Alunni Del Sole — Ricordi
- 9 **Rimini** — Fabrizio De Andre' — Ricordi
- 10 **Tu** — Umberto Tozzi — CGD

Cash Box Top Albums/101 to 200

November 11, 1978

	Weeks On Chart	11/4	Chart		Weeks On Chart	11/4	Chart		Weeks On Chart	11/4	Chart
101 DARKNESS ON THE EDGE OF TOWN BRUCE SPRINGSTEEN (Columbia JC 35318)	7.98	96	22	134 STUDIO TAN FRANK ZAPPA (DiscReet DSK 2291)	7.98	135	5	168 MOVE IT ON OVER GEORGE THOROGOOD & THE DES MOYERS (Rouner 3024)	7.98	—	1
102 YOU HAD TO BE THERE JIMMY BUFFETT (ABC AK-1008/2)	11.98	—	1	135 CHAMPAGNE JAM ATLANTA RHYTHM SECTION (Polydor PD-1-6134)	7.98	132	33	169 HEARTS OF STONE SOUTHSIDE JOHNNY AND THE ASBURY JUKES (Epic JE 35488)	7.98	175	3
103 Q: ARE WE NOT MEN? A: WE ARE DEVO!!! DEVO (Warner Bros. BSK 3239)	7.98	114	6	136 LOU RAWLS LIVE (Phila. Intl. PZ2 35517)	13.98	—	1	170 ZWOL (EMI/America SW 17005)	7.98	172	5
104 YOU SEND ME ROY AYERS (Polydor PD 1-6159)	7.98	91	13	137 IMAGES THE CRUSADERS (ABC Blue Thumb BA 6031)	7.98	122	18	171 THE GOLDEN TOUCH CERRONE IV (Cotillion/Atlantic SD5208)	7.98	198	2
105 "BUT SERIOUSLY, FOLKS" JOE WALSH (Asylum 6E-141)	7.98	101	24	138 CHANSON (Ariola SW 50039)	7.98	144	5	172 NICOLETTE NICOLETTE LARSON (Warner Bros. BSK 3243)	7.98	177	2
106 UGLY EGO CAMEO (Chocolate City/Casablanca CCLP 2006)	7.98	120	4	139 REUNION PETER, PAUL AND MARY (Warner Bros. BSK 3212)	7.98	143	5	173 BLUE VALENTINE TOM WAITS (Asylum 6E-162)	7.98	186	2
107 PYRAMID THE ALAN PARSONS PROJECT (Arista AB 4180)	7.98	103	20	140 ATLANTIC STARR (A&M SP 47111)	7.98	128	11	174 THE GARDEN OF LOVE DON RAY (Polydor PD 1-6150)	7.98	176	7
108 HEARTBREAKER DOLLY PARTON (RCA AFL 1-2797)	7.98	86	14	141 EDDIE MONEY (Columbia JC 34909)	7.98	130	54	175 GOOD THANG FAZE-O (SHE/Atlantic SH 741)	7.98	179	3
109 GREATEST HITS STEELY DAN (ABC AK-11707/2)	11.98	—	1	142 GREATEST HITS COMMODORES (Motown M7-912R1)	7.98	—	1	176 THE BRIDE STRIPPED BARE BRYAN FERRY (Atlantic SD 19205)	7.98	178	4
110 MOTHER FACTOR MOTHER'S FINEST (Epic 35546)	7.98	115	9	143 ROAD TO RUIN RAMONES (Sire RRK 6063)	7.98	149	5	177 MOLLY HATCHET (Epic JE 35347)	7.98	182	2
111 SESAME STREET FEVER THE MUPPETS (Sesame Street CTW 79005)	7.98	102	12	144 M.I.U. ALBUM BEACH BOYS (Brother/Reprise MSK 2268)	7.98	148	5	178 WHEN WE ROCK, WE ROCK AND WHEN WE ROLL, WE ROLL DEEP PURPLE (Warner Bros. PRK 3223)	7.98	181	3
112 SUNBEAM THE EMOTIONS (Columbia JC 35385)	7.98	106	14	145 THOROUGHFARE GAP STEPHEN STILLS (Columbia JC 35380)	7.98	150	3	179 BOBBY CALDWELL (Clouds/TK 8804)	7.98	—	1
113 AGAINST THE GRAIN PHOEBE SNOW (Columbia JC 35456)	7.98	124	5	146 STRANGERS IN THE WIND BAY CITY ROLLERS (Arista AB 4194)	7.98	147	4	180 OUT OF THE BLUE ELECTRIC LIGHT ORCHESTRA (Jet/CBS KZ2-35467)	11.98	183	51
114 BEFORE THE RAIN LEE OSKAR (Elektra 6E 150)	7.98	95	9	147 A CANADIAN TRIBUTE ELVIS PRESLEY (RCA KKLI-7065)	8.98	169	2	181 LEGACY RAMSEY LEWIS (Columbia JC 35483)	7.98	187	2
115 LOVESHINE CON FUNK SHUN (Mercury SRM 1-3725)	7.98	107	22	148 SOUNDS... AND STUFF LIKE THAT QUINCY JONES (A&M SP 4685)	7.98	123	22	182 LET'S GET SMALL STEVE MARTIN (Warner Bros. BSK 3090)	7.98	188	60
116 NOT SHY WALTER EGAN (Columbia JC 35077)	7.98	109	28	149 FROZEN IN THE NIGHT DAN HILL (20th Century-Fox T-558)	7.98	113	9	183 WHO DO YA (LOVE) KC AND THE SHINSHINE BAND (TK 607)	7.98	141	13
117 HEAT IN THE STREET PAT TRAVERS BAND (Polydor PD 1-6170)	7.98	129	5	150 QUAZAR (Arista AB 4187)	7.98	—	1	184 PHOTO-FINISH RORY GALLAGHER (Chrysalis CHR 1170)	7.98	190	3
118 NEXT OF KIHN GREG KIHN BAND (Beserkley/GRT JBZ 0056)	7.98	121	11	151 THE BEST OF DAVID CROSBY AND GRAHAM NASH (ABC AA 1102)	7.98	163	2	185 HOTEL CALIFORNIA EAGLES (Asylum 6E-103)	7.98	184	99
119 TO THE LIMIT JOAN ARMATRADING (A&M SP 4732)	7.98	134	2	152 FOR THE SAKE OF LOVE ISAAC HAYES (Polydor PD-1-6164)	7.98	—	1	186 FM VARIOUS ARTISTS (MCA 2-12000)	7.98	152	28
120 ON THE EDGE SEA LEVEL (Capricorn CPN 0212)	7.98	125	4	153 SPARK OF LOVE LENNY WILLIAMS (ABC AA 1073)	7.98	142	18	187 THEIR GREATEST HITS EAGLES (Asylum 6E-105)	7.98	189	139
121 ROBERTA FLACK (Atlantic SD 19186)	7.98	105	8	154 GIANT JOHNNY GUITAR WATSON (DJM/Phonogram-19)	7.98	167	3	188 INTIMATE STRANGERS TOM SCOTT (Columbia JC 35557)	7.98	—	1
122 SONGBIRD BARBRA STREISAND (Columbia JC 35373)	7.98	112	23	155 BOSTON (Epic JE 34188)	7.98	157	9	189 NO SMOKE WITHOUT FIRE WISHBONE ASH (MCA-3060)	7.98	195	2
123 PARALLEL LINES BLONDIE (Chrysalis CHR 1192)	7.98	110	8	156 STREET LEGAL BOB DYLAN (Columbia JC 35453)	7.98	131	19	190 NIGHT MOVES BOB SEGER (Capitol ST 11557)	7.98	191	106
124 BOOK EARLY CITY BOY (Mercury SRM 1-3737)	7.98	108	10	157 HEAVEN TONIGHT CHEAP TRICK (Epic JE 35312)	7.98	137	24	191 HERE AT LAST... BEE GEES... LIVE! (RSO 2-3901)	11.98	194	76
125 GOIN' COCONUTS DANNY & MARIE (Polydor PD-1-6169)	7.98	138	4	158 SIMPLE DREAMS LINDA RONSTADT (Asylum 6E-104)	7.98	162	61	192 OBSESSION UFO (Chrysalis CHR 1182)	7.98	154	17
126 FUNK OR WALK THE BRIDES OF FUNKENSTEIN (Atlantic SD 19201)	7.98	151	3	159 WHAT YOU WAITIN' FOR STARGARD (MCA-3064)	7.98	—	1	193 LIVE BARRY MANILOW (Arista AB 8500)	11.98	196	75
127 SHAUN CASSIDY (Warner/Curb BS 3067)	6.98	116	74	160 ALL 'N ALL EARTH, WIND & FIRE (Columbia JC 34905)	7.98	145	50	194 SO FULL OF LOVE THE O'JAYS (Phila. Intl. JZ 35355)	7.98	156	31
128 OCTAVE MOODY BLUES (London PS 708)	7.98	119	20	161 DREAMBOAT ANNIE HEART (Mushroom 5005)	7.98	168	138	195 THE ALBUM ABBA (Atlanta SC 19164)	7.98	173	40
129 SMOOTH TALK EVELYN "CHAMPAGNE" KING (RCA APL 1-2466)	7.98	117	21	162 STEALIN' HOME IAN MATTHEWS (Mushroom MRS-5012)	7.98	174	2	196 YOU'RE GONNA GET IT TOM PETTY & THE HEARTBREAKERS (Shelter/ABC DA 52029)	7.98	160	24
130 THE BEST OF JOE WALSH (ABC AA-1083)	7.98	146	4	163 JASS-AY-LAY-DEE OHIO PLAYERS (Mercury SRM 1-37330)	7.98	133	14	197 CRY JOHN KLEMMER (ABC AA-1106)	7.98	—	1
131 ANIMAL HOUSE ORIGINAL MOTION PICTURE SOUNDTRACK (MCA 3046)	7.98	136	9	164 BOYS IN THE TREES CARLY SIMON (Elektra 6E-128)	7.98	140	21	198 THAT'S WHAT FRIENDS ARE FOR JOHNNY MATHIS & DENIECE WILLIAMS (Columbia JC 35435)	7.98	161	16
132 INFINITY JOURNEY (Columbia JC 34912)	7.98	127	34	165 WET DREAM RICHARD WRIGHT (Columbia JC 35559)	7.98	126	5	199 TRACKS ON WAX 4 DAVE EDMUNDS (Swan Song SS 8505)	7.98	180	5
133 TOTO (Columbia JC 35317)	7.98	153	4	166 SGT. PEPPER'S LONELY HEARTS CLUB BAND THE BEATLES (Capitol SMAS 2653)	7.98	139	13	200 LOVE ME AGAIN RITA COOLIDGE (A&M SP 4699)	7.98	192	22

ALPHABETIZED TOP 200 ALBUMS (BY ARTIST)

Abba	195	Chanson	138	Gallagher, Rory	184	Martin, Steve	24,182	Rafferty, Gerry	51	Toto	133
Aerosmith	85	Cheap Trick	157	Gayle, Crystal	99	Marshall Tucker	81	Ramones	143	Travers, Pat	117
A Taste Of Honey	41	Chicago	11	Gibb, Andy	62	Meco	90	Rawls, Lou	136	Trower, Robin	97
Ambrosia	31	City Boy	124	Gilder, Nick	38	Matthews, Ian	162	Ray, Don	174	UFO	192
Armatrading, Joan	119	Cocker, Joe	66	Hall & Oates	25	Math/Will	198	Rolling Stones	8	Van Halen	77
Ashford & Simpson	21	Commodores	37,142	Hayes Isaac	152	Meat Loaf	36	Ronstadt, Linda	2,158	Vannelli, Gino	20
Atlanta Rhythm Section	135	Con Funk Shun	115	Heart	9,161	Molly Hatchet	177	Rose Royce	40	Village People	35,61
Atlantic Starr	140	Coolidge, Rita	200	Henderson, Michael	95	Money, Eddie	141	Ross, Diana	89	Waits, Tom	173
Ayers, Roy	104	Criss, Peter	68	Hill, Dan	149	Moody Blues	128	Santana	54	Walsh, Joe	105,130
Bay City Rollers	146	Crosby, David — Graham Nash	151	James, Rick	58	Morrison, Van	42	Scott, Tom	188	War Of The Worlds	100
Beatles	166	Crusaders	137	Jarreau, Al	80	Mother's Finest	110	Scott-Heron, Gil	74	Washington, Grover	46
Beach Boys	144	Deep Purple	178	Jennings, Waylon	60	Muppets	111	Sea Level	120	Watson, Johnny Guitar	154
Bee Gees	191	Devo	103	Jethro Tull	28	Murray, Anne	26	Seeger, Bob	19,190	Weather Report	45
Bishop, Stephen	53	Dylan, Bob	156	Joel, Billy	4,16	Musique	75	Simmons, Gene	48	White, Barry	39
Black Sabbath	87	Eagles	185,187	John, Elton	30	Nelson, Willie	86	Simon, Carly	164	Who	10
Blondie	123	Earth, Wind & Fire	180	Jones, Quincy	148	Nugent, Ted	69	Snow, Phoebe	113	Williams, Lenny	153
Blue Oyster Cult	44	Edmunds, Dave	199	Journey	132	Ohio Players	163	Southside Johnny	169	Wishbone Ash	189
Bohannon, Hamilton	76	Egan, Walter	116	KC & Sunshine Band	183	O'Jays	194	Springsteen, Bruce	101	Wright, Betty	52
Boston	6,155	Electric Light Orch.	180	Khan, Chaka	56	Oskar, Lee	114	Stanley, Paul	65	Wright, Richard	165
Bowie, David	67	Emotions	112	Kihn, Greg	118	Osmond, Donnie & Marie	125	Stargard	159	Yes	13
Brides of Funkenstein	126	Exile	27	King, Evelyn	129	Pablo Cruise	29	Steady Dan	70,109	Young, Neil	17
Bridges, Alicia	98	Faze-O	175	Klemmer, John	197	Parsons, Alan	107	Stewart, Al	14	Zappa, Frank	134
Brothers Johnson	59	Ferry, Bryan	176	Larson, Nicolette	172	Parton, Dolly	108	Stills, Stephen	145	Zwol	170
Brownie, Jackson	71	Firefall	63	Laws, Ronnie	82	Pendergrass, Teddy	78	Streisand, Barbra	122		
Buffett, Jimmy	102	Fleck, Roberta	121	Lewis, Ramsey	181	Peter, Paul & Mary	139	Styx	7,79		
Caldwell, Bobby	179	Fleetwood Mac	93	Little River Band	49	Petty, Tom	196	Summer, Donna	3	SOUNDTRACKS	
Cameo	106	Fogelberg/Weisberg	12	Loggins, Kenny	18	Player	72	Switch	34	Animal House	131
Carmen, Eric	91	Foreigner	5,167	L.T.D.	82	Pockets	88	Sylvester	33	FM	186
Cars	50	Foxy	55	Lynyrd Skynyrd	32	Ponty, Jean-Luc	83	Talking Heads	73	Grease	1
Cassidy, Shaun	96,127	Frehley, Ace	47	Mangione, Chuck	22,94	Presley, Elvis	147	10cc	64	Saturday Night Fever	23
Cerrone IV	171	Funkadelic	15	Manilow, Barry	84,193	Quazar	150	Thoroughgood, George	168	Sgt. Pepper's	43
										The Wiz	57

CASH BOX TOP 100 ALBUMS

November 11, 1978

		11/4	Weeks On Chart		11/4	Weeks On Chart		11/4	Weeks On Chart		
1 GREASE	12.98		26	35 CRUISIN'	7.98	51	5	68 PETER CRISS	7.98	71	6
VARIOUS ARTISTS (RSO 2-4002)				VILLAGE PEOPLE (Casablanca NBLP 7118)				(Casablanca NBLP 7122)			
2 LIVING IN THE U.S.A.	7.98	2	6	36 BAT OUT OF HELL	6.98	34	54	69 WEEKEND WARRIORS	8.98	97	2
LINDA RONSTADT (Asylum 6E 155)				MEAT LOAF (Cleve. Int'l./Epic PE 34974)				TED NUGENT (Epic FE 35551)			
3 LIVE AND MORE	12.98	3	9	37 NATURAL HIGH	7.98	25	25	70 AJA	7.98	54	57
DONNA SUMMER (Casablanca NBLP 71119)				COMMODORES (Motown M7-902R1)				STEELY DAN (ABC AA 1006)			
4 52nd STREET	8.98	10	3	38 CITY NIGHTS	7.98	43	8	71 RUNNING ON EMPTY	7.98	63	46
BILLY JOEL (Columbia FC 35609)				NICK GILDER (Chrysalis CHR 1202)				JACKSON BROWNE (Asylum 6E 113)			
5 DOUBLE VISION	7.98	6	19	39 THE MAN	7.98	55	4	72 DANGER ZONE	7.98	52	10
FOREIGNER (Atlantic SD 1999)				BARRY WHITE (20th Century T-571)				PLAYER (RSO RS 1-3036)			
6 DON'T LOOK BACK	8.98	5	11	40 ROSE ROYCE STRIKES AGAIN	7.98	31	10	73 MORE SONGS ABOUT BUILDINGS AND FOOD	7.98	76	15
BOSTON (Epic FE 35050)				(Warner Bros. WHI 3227)				TALKING HEADS (Sire SRK 6058)			
7 PIECES OF EIGHT	7.98	7	7	41 A TASTE OF HONEY	7.98	32	24	74 SECRETS	7.98	79	11
STYX (A&M SP 4724)				(Capitol ST 11754)				GIL SCOTT-HERON & BRIAN JACKSON (Arista AB 4189)			
8 SOME GIRLS	7.98	8	21	42 WAVELENGTH	7.98	50	5	75 KEEP ON JUMPIN'	7.98	84	9
ROLLING STONES (Rolling Stones Records/Atlantic COC 39108)				VAN MORRISON (Warner Bros. BSK 3212)				MUSIQUE (Prelude PRL 12158)			
9 DOG & BUTTERFLY	8.98	9	7	43 SGT. PEPPER'S LONELY HEARTS CLUB BAND	15.98	28	15	76 SUMMERTIME GROOVE	7.98	80	11
HEART (Portrait FR 35555)				VARIOUS ARTISTS (RSO RS 2-4100)				HAMILTON BOHANNON (Mercury SRM 1-3728)			
10 WHO ARE YOU	7.98	4	10	44 SOME ENCHANTED EVENING	7.98	47	7	77 VAN HALEN	7.98	65	38
THE WHO (MCA 3050)				BLUE OYSTER CULT (Columbia JC 35563)				(Warner Bros. BSK 3075)			
11 HOT STREETS	8.98	12	5	45 MR. GONE	7.98	49	5	78 LIFE IS A SONG WORTH SINGING	7.98	61	22
CHICAGO (Columbia FC 35512)				WEATHER REPORT (ARC/Columbia JC 35358)				TEDDY PENDERGRASS (Phila. Int'l./JZ 35095)			
12 TWIN SONS OF DIFFERENT MOTHERS	7.98	11	10	46 REED SEED	7.98	59	6	79 THE GRAND ILLUSION	7.98	73	67
DAN FOGELBERG & TIM WEISBERG (Epic JE 35339)				GROVER WASHINGTON JR. (Motown M 7-910R1)				STYX (A&M SP 4637)			
13 TORMATO	7.98	13	5	47 ACE FREHLEY	7.98	60	6	80 ALL FLY HOME	7.98	90	5
YES (Atlantic SD 19202)				(Casablanca NBLP 7121)				AL JARREAU (Warner Bros. BSK 3229)			
14 TIME PASSAGES	7.98	18	7	48 GENE SIMMONS	7.98	53	6	81 GREATEST HITS	7.98	98	5
AL STEWART (Arista AB 4190)				(Casablanca NBLP 7120)				MARSHALL TUCKER BAND (Capricorn CPN 0214)			
15 ONE NATION UNDER A GROOVE	7.98	15	7	49 SLEEPER CATCHER	7.98	38	23	82 TOGETHERNESS	7.98	70	22
FUNKADELIC (Warner Bros. BSK 3209)				LITTLE RIVER BAND (Harvest SW 11783)				L.T.D. (A&M SP 4705)			
16 THE STRANGER	7.98	16	56	50 THE CARS	7.98	42	21	83 COSMIC MESSENGER	7.98	62	11
BILLY JOEL (Columbia JC 34987)				(Elektra 6E 135)				JEAN-LUC PONTY (Atlantic SD 19189)			
17 COMES A TIME	7.98	20	4	51 CITY TO CITY	7.98	41	31	84 EVEN NOW	7.98	78	38
NEIL YOUNG (Reprise MSK 2266)				GERRY RAFFERTY (United Artists LA 840-G)				BARRY MANILOW (Arista AB 4164)			
18 NIGHTWATCH	7.98	14	18	52 BETTY WRIGHT LIVE	7.98	39	21	85 LIVE BOOTLEG	13.98	—	1
KENNY LOGGINS (Columbia JJ 35387)				(Alston 4408)				AEROSMITH (Columbia PC2 35564)			
19 STRANGER IN TOWN	7.98	17	25	53 BISH	7.98	37	9	86 STARDUST	7.98	87	28
BOB SEGER & THE SILVER BAND (Capitol SW 11698)				STEPHEN BISHOP (ABC AA 1082)				WILLIE NELSON (Columbia JC 35305)			
20 BROTHER TO BROTHER	7.98	24	7	54 INNER SECRETS	8.98	77	3	87 NEVER SAY DIE	7.98	92	4
GINO VANNELLI (A&M SP4722)				SANTANA (Columbia FC 356000)				BLACK SABBATH (Warner Bros. BSK 3186)			
21 IS IT STILL GOOD TO YA	7.98	19	10	55 GET OFF	7.98	46	20	88 TAKE IT ON UP	7.98	89	7
ASHFORD & SIMPSON (Warner Bros. BSK 3219)				FOXY (Dash/TK 30005)				THE POCKETS (Columbia JC 35480)			
22 CHILDREN OF SANCHEZ	14.98	23	8	56 CHAKA	7.98	94	2	89 "ROSS"	7.98	100	4
CHUCK MANGIONE (A&M SP 6700)				CHAKA KHAN (Warner Bros. BSK 3245)				DIANA ROSS (Motown M7-907R1)			
23 SATURDAY NIGHT FEVER	12.98	22	49	57 THE WIZ	14.98	68	6	90 THE WIZARD OF OZ	7.98	93	8
BEES GEES & VARIOUS ARTISTS (RSO RS 4001)				MOTION PICTURE SOUNDTRACK (MCA 2-14000)				MECO (Millennium MNL 8009)			
24 A WILD AND CRAZY GUY	8.98	56	2	58 COME GET IT!	7.98	44	24	91 CHANGE OF HEART	7.98	104	4
STEVE MARTIN (Warner Bros. HS 3238)				RICK JAMES (Gordy G7-981R1)				ERIC CARMEN (Arista AB 4184)			
25 ALONG THE RED LEDGE	7.98	26	10	59 BLAM	7.98	48	15	92 FLAME	7.98	118	4
DARYL HALL & JOHN OATES (RCA AFL 1-2804)				THE BROTHERS JOHNSON (A&M SP 4714)				RONNIE LAWS (United Artists LA-881-H)			
26 LET'S KEEP IT THAT WAY	7.98	30	13	60 I'VE ALWAYS BEEN CRAZY	7.98	64	5	93 RUMOURS	7.98	82	89
ANNE MURRAY (Capitol SW 11743)				WAYLON JENNINGS (RCA AFL 1-2979)				FLEETWOOD MAC (Warner Bros. BSK 3010)			
27 MIXED EMOTIONS	7.98	21	15	61 MACHO MAN	7.98	58	35	94 FEELS SO GOOD	7.98	69	55
EXILE (Warner Bros. BSK 3205)				VILLAGE PEOPLE (Casablanca NBLP 7096)				CHUCK MANGIONE (A&M SP 4658)			
28 BURSTING OUT	11.98	33	5	62 SHADOW DANCING	7.98	57	22	95 IN THE NIGHT TIME	7.98	74	20
JETHRO TULL (Chrysalis CHR 1201)				ANDY GIBB (RSO RS 1-3034)				MICHAEL HENDERSON (Buddha BDS 5712)			
29 WORLDS AWAY	7.98	29	22	63 ELAN	7.98	88	3	96 UNDER WRAPS	7.98	83	14
PABLO CRUISE (A&M SP 4697)				FIREFALL (Atlantic SD 19183)				SHAUN CASSIDY (Warner/Curb BSK 3222)			
30 A SINGLE MAN	7.98	45	2	64 BLOODY TOURISTS	7.98	75	6	97 CARAVAN TO MIDNIGHT	7.98	85	12
ELTON JOHN (MCA 3065)				10cc (Polydor PD 1-6161)				ROBIN TROWER (Chrysalis CHR 1189)			
31 LIFE BEYOND L.A.	7.98	36	15	66 PAUL STANLEY	7.98	67	6	98 ALICIA BRIDGES	7.98	111	4
AMBROSIA (Warner Bros. BSK 3135)				(Casablanca NBLP 7123)				(Polydor PD1-6158)			
32 SKYNYRD'S FIRST AND ... LAST	7.98	27	9	66 LUXURY YOU CAN AFFORD	7.98	66	10	99 WHEN I DREAM	7.98	81	20
LYNYRD SKYNYRD (MCA 3047)				JOE COCKER (Asylum 6E 145)				CRYSTAL GAYLE (United Artists LA 858-H)			
33 STEP II	7.98	35	16	67 STAGE	11.98	72	5	100 THE WAR OF THE WORLDS	13.98	99	17
SYLVESTER (Fantasy F-9556)				DAVID BOWIE (RCA CPL 2-2913)				JEFF WAYNE/VARIOUS ARTISTS (Columbia PC2-35290)			
34 SWITCH	7.98	40	12								

STEVE MARTIN "A WILD AND CRAZY GUY" IS HERE

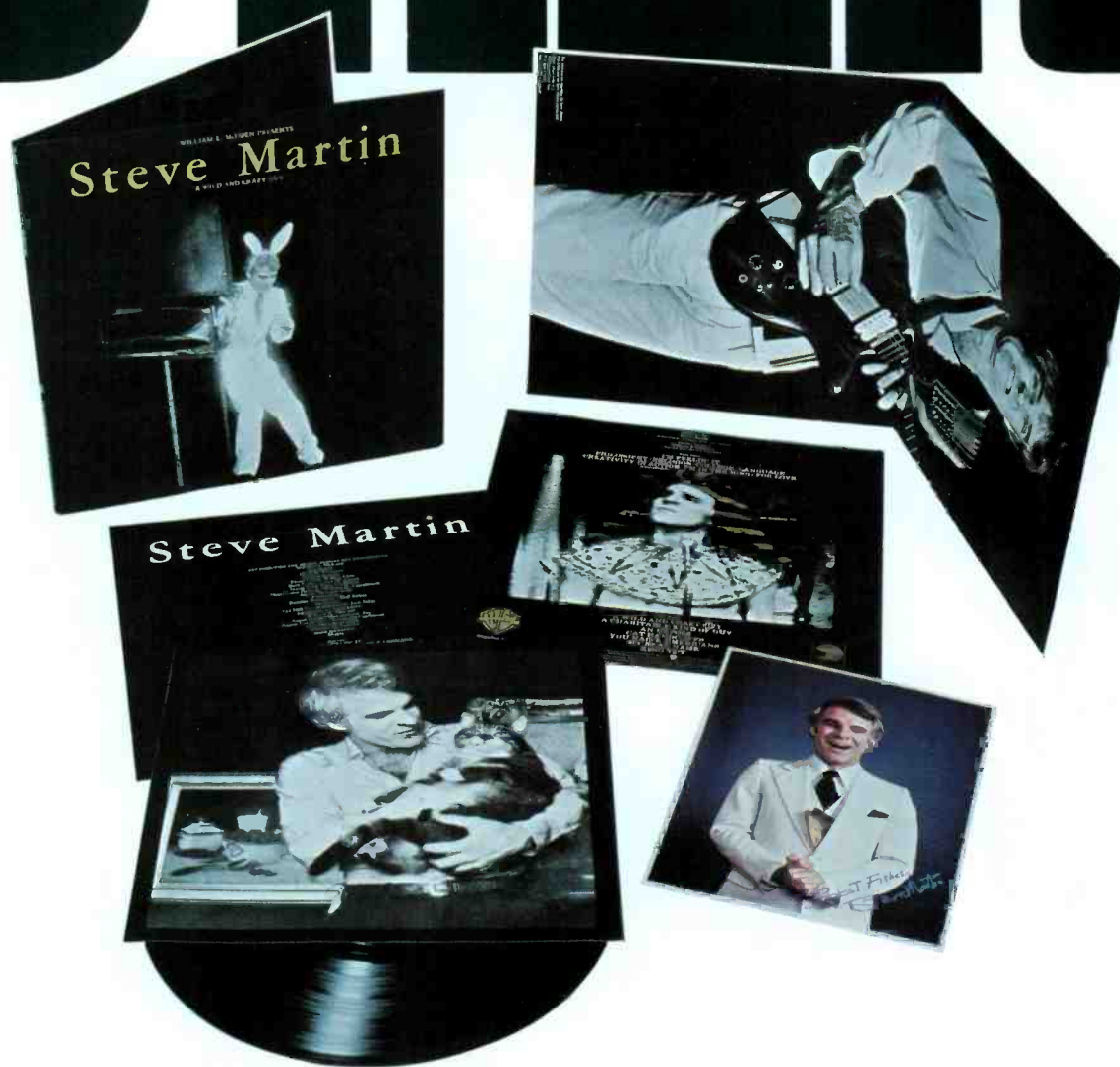

Millions of Steve Martin fans have been waiting for it. And his *new* album is (excuse us) another masterpiece by a comedian who is becoming a legend.

Like all the greats before him, Steve's career is multi-faceted.

There will be movies.

And a lot more television.

But, like all the greats, it is the comedy he presents on stage that really gets to the heart of his talent.

Side one of "A Wild And Crazy Guy" was recorded at The Boarding House in San Francisco. Side two was recorded at a recent concert attended by 9,000 people at Red Rocks, an outdoor amphitheater near Denver, Colorado.

Like his Grammy Award winning first album, "Let's Get Small," we can assure you that "A Wild And Crazy Guy" is THE album for your wild and crazy record collection.

We're having some fun now.



Produced by William E. McEuen
Aspen Recording Society
On Warner Bros. Records and Tapes
BSK 3238



A N A M E R I C A N P R A Y E R

JIM MORRISON

MUSIC BY

THE DOORS



FINALLY.



PRODUCED BY JOHN HAENY

CO-PRODUCED BY COLUMBUS COURSON, JOHN PAUL DENSMORE, ROBERT KRIEGER, FRANK LISCIANDRO AND RAYMOND MANZAREK

©1978 Elektra/Asylum Records • A Warner Communications Co.

www.americanradiohistory.com