

The Cash Box

VOLUME XVIII—NUMBER 38

JUNE 8, 1957



"Start Movin'" says Sal Mineo, teenage idol, Arnold Maxim, A&R head of Epic Records, and Bill Nielsen, national sales director—and that's just what happened to the hit disk of the same name. On the market only a few weeks, the record has already become a national best seller. This is a triumph for all three since it is Mineo's first release, a smash hit for Maxim who has been holding Epic's A&R reins only a couple of months, and it means lots of sales for Nielsen, who guides the destiny of the label.

YOU'LL HIT
A NEW HIGH
IN SALES

ORIGINAL CAST
RECORDING

RCA VICTOR 



Gwen Verdon
Thelma Ritter
in the New Musical

New
Girl in
Town

WITH
NEW
GIRL
IN TOWN

THE RCA VICTOR ORIGINAL-CAST ALBUM OF
BROADWAY'S NEWEST MUSICAL SMASH-HIT!

NEW GIRL IN TOWN is getting the biggest send-off of the season! Just look:

- Consumer ads in *Esquire*, *The New Yorker*, *Saturday Review*, and the catalogs (*Schwann*, *Long Player*, *Forty-Fiver*, *This Month's Records*) plus inclusion in "New Sensations In Sound" ad in *High Fidelity*.

- Timely ads in 5 editions of *Playbill*, running for 4 weeks during the height of the vacation season—when thousands of people will see the show in New York.

PLUS: • DeeJay contest with fabulous prizes • Ad mats in 2 sizes • Shipping to radio stations on Pop Album Release Service • Special coverage on new DeeJay Album Program • Full-color point-of-sale piece • Special cut-out to clip on albums on display or in the rack • Mounted album covers to use as displays • Feature spot in "Save-On-Records" June Bulletin.

Now... while everybody's talking about NEW GIRL IN TOWN... it's time for you to start talking about her, too! Contact your RCA VICTOR Distributor today!

And don't forget to order these RCA Victor pop singles featuring songs from the show:

(47/20-6913) EDDIE FISHER:
Sunshine Girl c/w Did You Close Your Eyes?
(47/20-6889) HUGO WINTERHALTER:
Theme From New Girl in Town c/w It's Good To Be Alive
(47/20-6888) TONY MARTIN: Look At 'Er
(ERA-302) ARTHUR FIEDLER:
Music From New Girl in Town



RCA VICTOR
RADIO CORPORATION OF AMERICA





FOUNDED BY BILL GERSH

The Cash Box

Volume XVIII—Number 38

June 8, 1957

Publishers

BILL GERSH JOE ORLECK

The Cash Box Publishing Co., Inc.

1721 Broadway, New York 19, N. Y.
(All Phones: JUdson 6-2640)
Cable Address: CASHBOX, N. Y.
JOE ORLECK

CHICAGO OFFICE

32 West Randolph St., Chicago 1, Ill.
(All Phones: DEarborn 2-0045)
BILL GERSH
Howie Freer Chuck Peele

HOLLYWOOD OFFICE

6272 Sunset Blvd., Hollywood 28, Cal.
(Phone: HOLlywood 5-2129)
JACK DEVANEY
Bob Martin

BOSTON OFFICE

80 Boylston St., Boston 16, Mass.
(Phone: HANcock 6-8386)
GUY LIVINGSTON

LONDON OFFICE

17 Hilltop, London, N.W. 11, England
(Phone: Speedwell 2596)
MARCEL STELLMAN

ADVERTISING STAFF

BOB AUSTIN, General Mgr., Music Dept.
JERRY SHIFRIN, Music Dept.

EDITORIAL STAFF

SID PARNES, Editor-In-Chief
NORMAN ORLECK, Editor
MARTY OSTROW, Editor
IRA HOWARD, Associate Editor
IRV LICHTMAN, Assistant Editor
CISSIE GERSH, Woman's Editor
POPSIE, Staff Photographer
BRUNO DUTKOWSKY, Art Director

A. MARINO, Office Manager

T. TORTOSA, Circulation

ADVERTISING RATES on request. All advertising closes Friday at 12 Noon preceding week of issue. Advertisements subject to approval of publishers.

SUBSCRIPTION RATES \$15 per year anywhere in the U. S. A. Published weekly. Second class mailing privileges authorized at New York, N. Y.

THE CASH BOX covers the entire music industry, ranging from retail record and music stores to disk jockeys, music publishers, recording artists, record manufacturers, music composers and arrangers, radio and TV stations, and all others allied to the music industry throughout the world.

THE CASH BOX covers the entire coin machine industry all over the world. Operators, jobbers, distributors, manufacturers and suppliers of automatic music, vending, service and amusement machines are covered.

THE CASH BOX coverage extends to finance firms, loan organizations, factors, banks, and other financial institutions, expressly interested in the financing of coin machines of all kinds.

"THE CASH BOX PRICE LISTS" (a combination of The Cash Box' former 'Confidential Price Lists' and The Cash Box' former 'C. M. I. [Coin Machines Industry] Blue Book') are the one and only officially recognized price quotations guide for all new and used machines in the United States and all over the world where American made machines are used. "The Cash Box Price Lists" are an exclusive and copyrighted feature of The Cash Box. "The Cash Box Price Lists" are recognized officially by cities and states throughout the country as the "official price book of the coin machines industry." "The Cash Box Price Lists" are officially used in the settlement of estates, for buying, selling or trading of all types of coin operated equipment and are also officially recognized for taxation purposes. "The Cash Box Price Lists" are used by finance firms, factors, loan companies, bankers, and all other financial institutions to guide them in the making of loans to members of the coin machines industry. "The Cash Box Price Lists" have been legally recognized in courts in the United States, Canada, and many foreign countries. Entire business transactions and legal cases are based upon the quotations appearing in "The Cash Box Price Lists."

Copyright under the International Copyright Convention. All rights reserved by the Pan American Copyright Convention. Copyright 1957 by The Cash Box Publishing Co., Inc.

Teenage Market Points Way To New Prosperity Heights!

It's an acknowledged fact that teenagers buy a great many of the pop records produced in this country. And as the record industry has come to realize the potency of this teenage market and to cater to it, sales of records have expanded beyond all expectations, and indications point to an even brighter future.

It is obvious, for instance, from the age of the audiences that it attracts that the entire Rock and Roll movement, which is today the dominant force in the pop record field is almost exclusively devoted to teenagers. It provides a beat to which teenagers in particular enjoy dancing and the lyrics of most of the songs with that beat are aimed at subjects which have meaning to the teenage level. Yet despite the fact that Rock and Roll has been limited for the most part to this age group, record sales in general have continued to mount, indicating that today the teenage market is so important in the entire pop single picture, that this age level alone is capable of increasing sales.

It is not hard to understand this when we examine some of the figures available to us. Statistics reveal that teenagers' earnings and allowances last year amounted to over nine billion dollars. The average U.S. teenager is reported to have either from earnings or allowances or both \$10.55 a week. He or she saves \$4.05 of this and spends the other \$6.50. And if you want to look ahead, the sixteen million teen-

agers will increase to twenty-four million by 1965, and their income will then be fourteen billion dollars.

For the record industry, this is an extremely encouraging picture. As teenagers increase in numbers and their income goes up, it can only mean that they will purchase more and more of the records to which they are so attracted.

It means also that the record industry in general will have to keep paying special attention to teenagers' needs. This age group is buying records in large quantities today because the record firms are producing records which are in many ways specifically designed for them. But we must never lose sight of the fact that tastes change and that what a teenager likes today, he may not necessarily like next month. We must constantly be on the lookout therefore for indications of taste changes and hints of new likes and dislikes.

Fortunately, the record industry has shown itself to be attuned to the needs of the public of all ages, able to adjust to changing conditions and desires and to meet the needs of the day. We are certain that the industry will be able to meet the challenge of an increasing teenage population and provide the kind of music wanted by that age group in order for them to enjoy the records they want and in order for the record industry to go on to new heights of prosperity.



THE NATION'S
Top Ten
JUKE BOX TUNES

(PLUS THE NEXT 25)

		Pos. Last Week
1	ALL SHOOK UP ELVIS PRESLEY AL-3359—David Hill	1
	VI-6870—Elvis Presley	
2	LITTLE DARLIN' THE DIAMONDS EX-2101—The Gladiolas	2
	ME-71060—The Diamonds	
3	SCHOOL DAY (RING RING GOES THE BELL) CHUCK BERRY BR-55007—Big Tiny Little	3
	CH-1653—Chuck Berry	
4	SO RARE JIMMY DORSEY FR-755—Jimmy Dorsey	6
5	A WHITE SPORT COAT MARTY ROBBINS CO-40864—Marty Robbins	7
	CR-61835—Johnny Desmond	

6	COME GO WITH ME DEL-VIKINGS DE-30231—Sunny Gale DL-6112—Federals	4
	DO-15538—Del-Vikings	
7	LOVE LETTERS IN THE SAND PAT BOONE DO-15570—Pat Boone DO-15578—Mac Wiseman	—
	VP-1003—Vivienne	
8	ROUND AND ROUND PERRY COMO DA-2121—Walter Solek O.	5
	VI-20/47-6815—Perry Como	
9	DARK MOON GALE STORM — BONNIE GUITAR (Tie) DO-15550—Bonnie Guitar DO-15558—Gale Storm	10
	VI-6910—Hawkshaw Hawkins	
10	GONE FERLIN HUSKY CA-3628—Ferlin Husky CO-40852—Joan Weber	8
	ME-71070—Bobby Wayne	

11) I'M WALKIN' 12) FOUR WALLS. 13) ROCK-A-BILLY. 14) PARTY DOLL. 15) FABULOUS. 16) FREIGHT TRAIN. 17) START MOVIN'. 18) PLEDGE OF LOVE. 19) VALLEY OF TEARS. 20) WHY BABY WHY. 21) EMPTY ARMS. 22) MAMA LOOKA BOOBOO. 23) BUTTERFLY. 24) IT'S YOU I LOVE. 25) YOUNG BLOOD. 26) MY LITTLE BABY. 27) THE GIRL WITH THE GOLDEN BRAIDS. 28) WONDERFUL! WONDERFUL! 29) IT'S NOT FOR ME TO SAY. 30) ROCK YOUR LITTLE BABY TO SLEEP. 31) BYE BYE LOVE. 32) I'M SORRY. 33) LOVE IS A GOLDEN RING. 34) BERNARDINE. 35) YES TONIGHT JOSEPHINE.

CODE

AB—Abbott	CH—Chess	EL—Eldorado	GR—Groove	MO—Modern	SE—Seeco
AL—Aladdin	CK—Checker	EP—Epic	HE—Herald	NG—Norgran	SP—Specialty
AO—Apollo	CM—Cameo	ER—Era	IM—Imperial	OK—Okeh	SU—Sun
AP—ABC—Paramount	CO—Columbia	EX—Excello	JU—Jubilee	PE—Peacock	TI—Tico
AT—Atlantic	CR—Coral	FB—Fabor	JZ—Josie	PR—Prestige	UN—United
BR—Brunswick	DA—Dana	FE—Federal	KA—Kapp	RA—Rainbow	UQ—Unique
BT—Bethlehem	DE—Decca	FI—Fiesta	KI—King	RE—Regent	VE—Verve
BY—Bally	DL—DeLuxe	FR—Fraternity	LI—Liberty	RM—Rama	VI—RCA Victor
CA—Capitol	DO—Dot	4 Star—Four Star	LO—London	RO—Roulette	VJ—Vee-Jay
CD—Cadence	DT—Dooto	G—Gee	ME—Mercury	RP—RPM	VK—Vik
	DU—Duke	GL—Glory	MG—MGM	SA—Savoy	VP—Vip

IT'S UTOPIA (Translation) THE MOST!

“SHANGRI-LA”

by THE FOUR COINS



9123

• Breaking in Chicago, Cleveland, Pittsburgh, Detroit and spreading

“Only those records best suited for commercial use are reviewed by THE CASH BOX”

Her



1st Release on *Dot*

AN OVERNIGHT
TWO SIDED SMASH!

Margaret
Whiting
sings...

**"SPEAK FOR
YOURSELF JOHN"**

and

**"KILL ME
WITH KISSES"**

Dot 15583

Dot

RECORDS, Inc. • Sunset and Vine • Hollywood, Calif. • Phone HO 3-4181
THE NATION'S BEST SELLING RECORDS

The Fontane Sisters

with their Newest Release

"FOOL AROUND"

and

"WHICH WAY TO YOUR HEART"

Dot No. 15581



Dot RECORDS, Inc. • Sunset and Vine • Hollywood, Calif. • Phone HO 3-4181
 THE NATION'S BEST SELLING RECORDS

In Canada - Quality Records

"Only those records best suited for commercial use are reviewed by THE CASH BOX"

The brightest New Star of 1957!

Bonnie Guitar

**"IF YOU SEE
MY LOVE DANCING"**

and

**"HALF
YOUR
HEART"**

Dot No. 15587



Dot RECORDS, Inc. • Sunset and Vine • Hollywood, Calif. • Phone HO 3-4181
THE NATION'S BEST SELLING RECORDS

In Canada — Quality Records

"It's What's in THE CASH BOX That Counts—INTERNATIONALLY"

HERE IS HOT "ICE" - THE NO. 1 SINGING GROUP

**THE
DIAMONDS**



With Another Double Smash Follow Up To "Little Darlin'"

DON'T SAY GOODBYE

AND

WORDS OF LOVE

MERCURY 71128

Just Appeared June 2nd On The Steve Allen TV Show

On Location For Universal Pictures

Also Chalking Up Big Grosses On One Nite Stands-Backed By
Jimmy Palmer And His Orchestra



"It's What's in THE CASH BOX That Counts—INTERNATIONALLY"



Record Reviews

A DISK & SLEEPER

B VERY GOOD

C FAIR

B+ EXCELLENT

C+ GOOD

D MEDIOCRE

ALAN DALE
(ABC-Paramount 9828)

B+ "HEARTLESS HEART" (2:22) [Hawthorne ASCAP — Tobias, Altman] A sure-handed heavy beat delivery by Alan Dale gives this wailing rocker an interpretation highly qualified for strong juke play, and overall sales reaction. Don Costa adds greatly to the sturdy Dale reading. Keep tabs on the side. It's a great first showing for Dale on ABC-Paramount.

B "CRY, CRY, CRY" (2:53) [Golden State BMI—Shuler, Willridge, Guidry] Dale is blues-inclined in this doleful item expressively related by the artist. Top half has the commercial edge.

LENNY PERNA
(Dot 15582)

B "CALYPSO GIRL" (2:30) [Debmar ASCAP—Marcucci, Angeles] For customers still stuck on calypso items, they'll find a typically colorful and rhythmic calypso number in this pressing featuring to good advantage Lenny Perna with male chorus and ork accompaniment. The waxing grows on the listener.

B "I HOPE YOU FIND A SWEET-HEART" (1:48) [Debmar ASCAP — Marcucci, De Angeles] A bouncy hint of old fashioned harmony is imaginatively conceived by Perna, the ork and chorus. Easy-going effort.

DOLORES VENTURA
(President 1016)

B "PORTO FINO" (2:35) [Piccadilly BMI—Edwards] Miss Ventura is the lead voice in this lush chorus and ork production dressed up in a delightful latin environment. Vivid display of an attractive melody.

C+ "THE HANDY MAN FROM PERU" (2:30) [Dorchester BMI —Martinelli] A calypso-flavored creation is fashioned in sparkling style by the same members as on the top deck.

CLEVE LYONS AND HIS TRIO
(Vik 0276)

B "OUT OF THE CLOSET" (2:17) [Raleigh BMI—Jackson] A driving combo piece presented by the Cleve Lyons Trio makes snappy use out of Lyons' lively organ work, and Al Dobbins' unrelenting sax antics. High-flying jumper.

C+ "FANTASTIC MOOD" (2:07) [Raleigh BMI—Lyons] A mellow organ from Lyons leads the crew in this provocative, easy-going mood number.

JO STAFFORD
(Columbia 40926)

B+ "I'LL BE THERE (WHEN YOU GET LONELY)" (2:48) [Golden West BMI—Burgess] Few female vocalists command the warmth and sincerity of Jo Stafford, and her way with this melody bringing back memories of "You Belong To Me". Jo gets to the heart of the matter with ease and conviction. Fine deejay disk.

B "UNDERNEATH THE OVERPASS" (1:56) [Paramount ASCAP —David, Burt, Bacharach] A train-tempo ditty is invitingly performed by the lark in this multiple-racking feat. Swinging side.

The Cash Box Disk of the Week

"WORDS OF LOVE" [Nor-Va-Jak BMI—Halley]

"DON'T SAY GOODBYE" [Pure BMI—Stevens, Goodman, Stone]

THE DIAMONDS (Mercury 71128)

● The sensational Diamonds, well over the million mark with their current smasheroo "Little Darlin'", follow-up with a fabulous new side that stands a great chance of extending their string to two gold disks in a row. The tune is titled "Words Of Love" and features many of the hit characteristics present in "Little Darlin'". Great latin beat, wonderfully commercial harmony, a recitation that the kids'll be wild about and some ace guitar work. All out hit for the rock and roll market. Flip, "Don't Say Goodbye" is a jumpin' R & R item that makes your toes tap. Strong coupling that could be a big chart rider too.

"SWEET STUFF" (2:13) [Hawthorne ASCAP—Schroeder, Weisman]

"IN THE MIDDLE OF A DARK, DARK NIGHT" (2:22)
[Oxford ASCAP—Merrill]

GUY MITCHELL (Columbia 40940)

● Guy Mitchell, with three consecutive smashes under his belt ("Singing The Blues," "Knee Deep In The Blues," and his current hit "Rock-A-Billy") should have no trouble making it 4-in-a-row with the two excellent sides coupled on his latest platter. "Sweet Stuff" is a potent rocker with a torrid beat and a great teenage lyric. Guy is in top vocal form and should thrill his fans both here and abroad with this one. Equally delighting is the companion deck "In The Middle Of A Dark, Dark Night". Charming shuffler with a beautiful melody. Smooth, easy listening. This half could win out in the long run. Another double-decker for the Guy.

"SOMETHING WONDERFUL HAPPENS"
[Sands ASCAP—Bushkin, DeVries]

"YOU'RE CHEATIN' YOURSELF" [Barton ASCAP—Hoffman, Manning]

FRANK SINATRA (Capitol 3744)

● The amazing Mr. Sinatra, who zoomed into the number one spot on the album best seller list in a matter of days with his great new "Swingin' Affair" LP, has a fabulous new single that should enjoy the same reaction. Titled "Something Wonderful Happens", the tune is one of the best legit ballads to hit the wax scene in many months. It's a tender and melodic song about summer romance penetratingly presented in Sinatra's inimitable manner. Frankie's best romantic deck since "Young At Heart". Dee jays will wear the grooves off of this one. Great song with standard qualities. Flip is a free swinging love opus dubbed "You're Cheatin' Yourself". Keep an eye on the top portion. It'll climb at a steady pace.

"FALLEN STAR" (2:21) [Tree BMI—Joiner]

"PRIZE POSSESSION" (2:20) [Geronimo BMI—Hill]

FERLIN HUSKY (Capitol 3742)

● Ferlin Husky, the high riding country star who became a prominent figure in the pop recording field with his tremendous waxing of "Gone", follows-up with another big song out of the country market that could repeat the success "Gone" achieved. The tune is titled "Fallen Star" and features the ace vocalist with a heart-felt delivery of a tender romantic lyric. Husky has a natural tear in his voice that gives a special meaning to whatever he sings. The coupling "Prize Possession" is a rhythmic jumper that should have the youngster's hoppin'. Good rock-a-billy deck. Husky has a hot coupling for his millions of new admirers.

"JENNY, JENNY" (2:00) [Venice BMI—Johnson, Penniman]

"MISS ANN" (2:05) [Venice BMI—Johnson, Penniman]

LITTLE RICHARD (Specialty 606)

● Little Richard has another powerful coupler that should have no difficulty in racking up a huge sale in the pop dept. (See R & B Reviews).

THE SECRETS
(Decca 30350)

B "QUEEN BEE" (2:00) [Monument BMI—Hunter, Fisher, Johnson] This is a fast-moving "calypso-rock," a combination of both a calypso and rock 'n roll styling, performed infectiously by a new group labeled the Secrets. Cute buzz of the bee gimmick is used throughout the snappy session. Solid debut. Group has potential.

C+ "SEE YOU NEXT YEAR" (2:43) [Kahl BMI—Briggs, Ray-sor] A conventional rock 'n roll ballad number is presented with polish by the group.

THE NORMAN PETTY TRIO
(Columbia 40929)

B+ "THE FIRST KISS" (2:42) [Dominion BMI—Petty] Norman Petty and His Trio may have pulled another "Almost Paradise" out of the hat with this beautiful melody played and sung by the group. The theme of a first kiss makes the pressing extremely applicable to the teen market as well as the adults. En-trancing presentation of a first-class song. Watch this carefully.

B+ "THE FIRST KISS" (2:45) [Dominion BMI — Petty] The same Petty melody is strictly an instrumental on this side. The number still retains its melodic pull power, and will probably vie for sales honors with the top deck.

JACKIE AND ROY
(ABC-Paramount 9821)

B "I'M FOREVER BLOWING BUBBLES" (2:13) [Remick ASCAP—Kenbrovin, Kелlette] This new outlook on an old favorite is from a new album by the jazz-inspired vocal team of Jackie and Roy. The two seem to have great vocal jazz invention fun, as they rollic through the tune. The listener will also enjoy the refreshing Jackie and Roy atmosphere. Great disk jockey platter.

B "WHISPER NOT" (2:51) [Silhouette ASCAP—Goldson] The two play the role of "instruments" as they imaginatively react to a bluesy opus. Slick side.

LOU STEIN
(RKO Unique 403)

B+ "THE LITTLE SPINET" (2:17) [Veronique A S C A P — Leahy] Piano ace Lou Stein, who clicked recently with "Almost Paradise", should have another big money-maker in this contagious bounce instrumental. Light and colorful piano novelty with a most inviting melody. Watch this sleeper. It's loaded with potential.

B "SONG OF THE EAST" (2:53) [Weiss & Barry BMI—Stein] Here the artist fashions one of his own compositions. A haunting, moody item set against a slow, steady beat. Side builds in intensity and a chorus joins in making the side extremely exciting. Strong coupling.

FRANKIE AVALON with
ROCCO & HIS SAINTS
(Chancellor 1004)

B "CUPID" (2:28) [Debmar ASCAP — Marcucci, DeAngelis] Frankie Avalon makes a strong first showing on Chancellor as he shuffles thru a catchy rock and roll romancer. Lad has the kind of voice the kids want. Good arrangement, delivery and material.

C+ "JIVIN' WITH THE SAINTS" (1:58) [Ram-Bed BMI—Chesler, Kekalos] Frankie and the boys go instrumental on this half and belt out a torrid rocker that'll keep the kids hoppin'. Strong jumper in the "Honky Tonk" category.

"Only those records best suited for commercial use are reviewed by THE CASH BOX"

Sailing To The TOP!



The
**FOUR
ACES**
TWO SIDED HIT..



"THREE SHEETS TO THE WIND"

and

"YES SIR, THAT'S MY BABY"

DECCA-9-30348 (30348)



A NEW WORLD OF SOUND

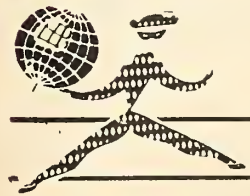

"It's What's in THE CASH BOX That Counts—INTERNATIONALLY"



Record Reviews

A DISK & SLEEPER

B VERY GOOD

C FAIR

B+ EXCELLENT

C+ GOOD

D MEDIOCRE

THE RHYTHMETTES

(Brunswick 55012)

B+ "MIND READER" (2:02) [Larry Spier ASCAP—Wayne, Frisch] This is a "Mr. Sandman"—flavored piece all done up in a happily inventive harmonic blend by the rhythmettes assisted by a deep-voiced bu-boom-bu-bu boom male. A catchy novelty. Could break wide open.

C+ "MISTER LOVE" (2:45) [Acuff-Rose BMI—R&D Kershaw] A pop version of the hit country and western wailer is convincingly read by the girl group and the bass gentleman.

SID GOULD

(Coral 61841)

B "SID GOULD'S INITIAL GAME" [Opus BMI—D. Jacobs] A "game" that involves audience participation results in a hilarious side by comedian Sid Gould. Gould's request for the initials of silent film stars gives the comic lots of room for wild guesses and side comments sure to provide many howls. Excellent comedy platter.

C+ "MORRIS" [Monmar ASCAP—Bass] A comedy sketch in song and rhyme is good for several laughs from Gould.

LES BAXTER ORCH.

(Capitol 3728)

B "RUBY LIPS" (2:31) [Fred Raphael ASCAP—Thompson] A string filled latin mood item is attractively styled by Les Baxter and the ork. Pretty theme with voices neatly woven into the string presentation.

C+ "THE LONELY WHISTLER" (2:18) [Leeds ASCAP—Norman, Baxter] A blues theme combining whistling and strings is interestingly fashioned on this end. Heavy theme from the Swedish flicker, "The Vicious Breed."

BARBARA GORMAN & SISTER VIV

(Arrow 715)

B "WAS IT JUST FOR FUN" (2:32) [Abe Olman ASCAP—Dyess, Parnum] The Arrow label could have a big money-maker in this commercial rock and roll ballad introduced by the Gorman Sisters, ages 12 and 6. Gals have a feel for the music teenagers want and could do big things with this love tune.

B "8 O'CLOCK DATE" (2:17) [Twin EE Music BMI—Zane] Another excellent commercial ditty by the gals. Strong rock and roller with a slightly faster tempo than the top side. Good lyric with great teen appeal. If these sides get a fair share of the play, they'll make noise.

JACK HANSEN

(Plaza 5007)

B "CALYPSO HORN" (2:08) [Darl BMI—Hansen, Hansen] The label introduced the recent noise-maker, "Seven Days In Barcelona." This is a tuneful calypso inspired item making very effective use out of a trumpet, string instruments and a chorus. It's one of those novel things that could catch on.

B "SWEET CHACOUN" (2:07) [Calypso BMI—Attaway] Another calypso side, a tenderly pretty melody, is fashioned with warmth by Jack Hansen backed by a chorus and ork. Good calypso attraction.

The Cash Box Sleeper of the Week

"SEND FOR ME" (2:35)

[Winneton BMI—Jones]

"PERSONAL POSSESSION" (2:56)

[Roosevelt BMI—Singleton, McCoy]

NAT "KING" COLE (Capitol 3737)

● The "King," Nat Cole, currently enjoying tremendous success with his fabulous album "Love Is The Thing," should meet with the same good fortune on his latest single. One side, "Send For Me" features Nat in the rock and roll idiom. Terrific reading of a smooth sailing romantic jumper the youngsters will find tailor-made for their dancing needs. Commercial stuff for today's market. Equally delighting is the companion deck "Personal Possession." Here the ace lends his dulcet tones to a superbly written romancer with class. Rich and rewarding performance that should enjoy a long and successful run on the charts. Big money-making coupler.

"SHENANDOAH ROSE" (2:05)

[Planetary ASCAP—Webster, Livingston]

"SHENANDOAH ROSE" (2:18)

[Planetary ASCAP—Webster, Livingston]

"ROCKABILLY PARTY" (2:28)

[Planetary ASCAP—Hoffman, Manning]

"CONSIDERATION"

(2:17)

[Desmo ASCAP—Desmond]

HUGO & LUIGI (Roulette 4012)

JOHNNY DESMOND (Coral 61846)

● A few years ago "Yellow Rose Of Texas" sent the music business on a recording spree of Civil War tunes. Two great new recordings of another thrilling marcher dubbed "Shenandoah Rose" could turn the trick again. The two powerful waxings feature Hugo & Luigi on Roulette and Johnny Desmond on Coral.

Hugo & Luigi work with a spirited chorus and come up with an inspiring recording featuring flutes, share drums and the works. The Coral disk features Desmond's voice in the spotlight, also neatly showcased by a full choral accompaniment. The time is ripe for a new march hit and both of these should make the grade.

Roulette teams its version with a commercial novelty that could also step out. It's a rockin' ditty loaded with teen appeal and titled "Rockabilly Party." Clever item with lyrics that mention the name of many of today's prominent recording stars. Desmo's companion piece is a contagious calypso ditty with a rockin' beat.

"GRADUATION RING" (2:41)

[Compton ASCAP—Leonard, Carroll]

"YOU, YOU ROMEO" (2:23)

[Planetary ASCAP—Elton]

JAYE P. MORGAN (RCA Victor 6938)

● Jaye P. Morgan bounces back into the disk spotlight with two great new sides that'll splash her name all over the charts in the coming weeks. They're both outstanding and both will keep the jockeys' turn tables spinning. "Graduation Ring" is a wonderful romantic ballad with a beat, perfectly timed for the current graduation season. Lyrics have great teen appeal and Jaye's delivery is from the heart. "You, You Romeo" is a very clever novelty with a brilliant arrangement and orchestration by Hugo Winterhalter. Unusual romancer with a great beat. Superb change of pace number for any jock's daily programming. Two money-making sides for dealers and ops. Take your pick.

"SUSIE-Q" (2:08) [Arc BMI—Hawkins, Lewis, Broadwater]

"SUCH A SHAME" (2:30) [Meridian BMI—Hill, Stevenson]

THE CREW-CUTS (Mercury 71125)

● The Crew-Cuts put two exciting sides back-to-back for their most powerful release in quite some time. Both items are aimed directly at the younger set and should meet with great approval in this area. "Susie-Q" is a fast-rising rock and roller treated to an exciting pop reading by the quartet. Swinging arrangement with heaps of guitar and rhythm to keep the side swinging from beginning to end. The coupler is a fascinating new tune called "Such A Shame." An emotional love song with an exciting galloping tempo backdrop. Here again the boys excell. Upper half has the edge.

LU ANN SIMMS

(Columbia 40937)

B "RUN, DON'T WALK" (2:20) [Hecht-Lancaster & Buzzell ASCAP—Roberts, Jacobson] After a short "Here Comes The Bride" opening, Lu Ann Simms gives out with a bright, hillbilly-flavored composition in bubbling style. Jimmy Carroll, the ork and chorus trace Miss Simms' vocales technics with enthusiasm. Happy effort.

B "THE STILL SMALL VOICE" (2:46) [Blackwood BMI—Walker] The lark is on a straight ballad here, and does a distinctively soft vocal performance on the listenable melody. A pressing deejays will find solid programming.

VIVIENNE

(Vip 1003)

B+ "LOVE LETTERS IN THE SAND" [Bourne ASCAP—N. & C. Kenny] This is Vivienne's second effort for Vip, a version of the Nick Kenny oldie, which is currently enjoying great popularity on the charts. After the warm opening, the thrush offers a swinging approach. Delightful side worthy of a share in the song's sales prize.

B "LIGHT A CANDLE" [Scherer BMI—Oneil, Howe] A strong inspirational number is handled with conviction by the artist.

VIC STEVENS

(Styletone 101)

C+ "LOVE ME BABY" (2:15) [J. B. L.&V. BMI—Wellington, Cobb] Vic Stevens gets a group assist as he drives thru a powerful rocker that really moves. Swinging dance item aimed at the teenage market.

C+ "100 CUPS OF COFFEE" (2:37) [Hill & Range BMI—Tepper, Bennett] Another enthusiastic vocal effort by Stevens on a solid jumper for the rock and roll market.

MITZI MASON

(Vik 0278)

B+ "FOR THE LAST TIME" (2:03) [Peer Int'l BMI—Heather] Mitzi Mason hands in a dynamic delivery on a tune with a big melody and a good lyric that contrasts the past with the present thanks to her new love. Elliot Lawrence with his ork and chorus do a bang-up job. This one bears watching.

B "HICKORY DICKORY DOCK" (2:04) [E. B. Marks BMI—Ebb, Klein] An inviting play on the familiar children's rhyme gets a rock 'n roll fling from Miss Mason. The thrush gives the tune a bright run-through.

BERT CONVY

(Mercury 71100)

B "TWO HEARTS" (2:29) [Argo BMI—Convy, Emenegger] A sentimental romancer set to a quick shuffle beat is performed with admirable vitality by Bert Convy and the Cheers. Catchy number, performed with zest.

C+ "YOU NEVER HAVE TIME" (2:05) [Argo BMI—Williams] A hand clappin' affair is read with authority by Convy and the Cheers. A rock 'n roll romp.

"Only those records best suited for commercial use are reviewed by THE CASH BOX"



ROSEMARY CLOONEY

Sing, Little Birdie,
Sing b/w
Who Dot Mon, Mom?
4-40917



CATHY JOHNSON

My Johnee b/w
Please Come Back to Me
with Ray Ellis
4-40930



GENE AUTRY

Johnny Reb and
Billy Yank
(from the Herald Tribune
cartoon) b/w
Happy Little Island
4-40931



TONY RAND

Seven Come Eleven b/w
It Can't Be True or Can It
4-40925

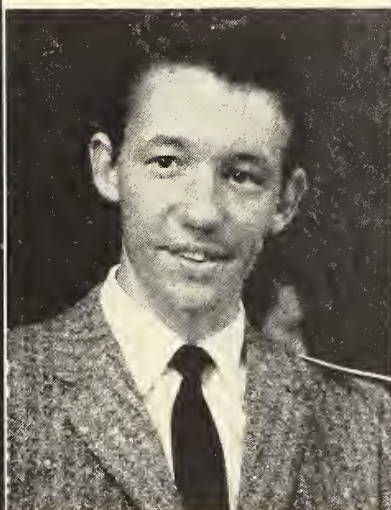

BOBBY LORD

Just Wonderful b/w
High Voltage
4-40927



THE COLLINS KIDS

Hop, Skip and Jump b/w
Young Heart
Larry and Lorrie Collins
featuring Larry on
the guitar
4-40921-c

THE SURE-FIRE HITS ARE ON THE HOTTEST COMPANY IN THE BUSINESS

COLUMBIA  **RECORDS**

A DIVISION OF CBS
© "Columbia"          

A Note from Archie Bleyer



London Lowdown

Eddie Fisher and Debbie Reynolds arrive in London on June 4. She'll depart a few days before Eddie starts his week's appearance at the London Palladium. Heading the bill at the moment is Howard Keel.

Week-end TV was highlighted by appearances by Frankie Laine on the Palladium Show and Les Compagnons de la Chanson on the BBC's Winifred Atwell show. The Goofers are to be one of the main attractions in the new summer Palladium show starting June 17th and will probably stay for a minimum of twelve weeks. Although this act has played the Lido in Paris, this is the first time they appear in London.

At long last that talented thrush Peggy Lee makes her appearance in the best sellers over here with her waxing of "Mr. Wonderful" and my guess is that Jeri Southern may very well make a surprise entry in the charts with her recording of "Fire Down Below". It is a pleasure to see these two girls at last in the top sellers where they rightly deserve to be.

This Week's Best Selling Pop Singles (Courtesy "New Musical Express")

- 1) Butterfly—Andy Williams (London)
- 2) Rock-A-Billy—Guy Mitchell (Philips)
- 3) Yes, Tonight Josephine—Johnnie Ray (Philips)
- 4) When I Fall In Love—Nat "King" Cole (Capitol)
- 5) Too Much—Elvis Presley (HMV)
- 6) Cumberland Gap—Lonnie Donegan (Pye-Nixa)
- 6) Freight Train—Chas. McDevitt Group (Oriole)
- 8) I'll Take You Home Again Kathleen—Slim Whitman (London)
- 9) Ninety-Nine Ways—Tab Hunter (London)
- 10) Mr. Wonderful—Peggy Lee (Brunswick)
- 10) Around The World—Gracie Fields (Columbia)
- 12) Chapel Of The Roses—Malcolm Vaughan (HMV)
- 13) Around The World—Ronnie Hilton (HMV)
- 14) Baby Baby—Teen-Agers (Columbia)
- 15) I'm Sorry—Platters (Mercury)
- 16) Around The World—Bing Crosby (Brunswick)
- 17) Butterfly—Charlie Gracie (Parlophone)
- 18) Butterfingers—Tommy Steele (Decca)
- 19) Banana Boat (Day-O)—Harry Belafonte (HMV)
- 20) Young Love—Tab Hunter (London)
- 21) I'm Walkin'—Fats Domino (London)
- 22) Little Darlin'—The Diamonds (Mercury)
- 23) Heart—Max Bygraves (Decca)
- 24) Mangos—Rosemary Clooney (Philips)
- 25) Why, Baby Why?—Pat Boone (London)
- 26) Look Homeward Angel—Johnnie Ray (Philips)
- 27) We Will Make Love—Russ Hamilton (Oriole)
- 28) She's Got It—Little Richard (London)
- 29) Around The World—Mantovani (Decca)
- 30) White Sport Coat—King Brothers (Parlophone)



Record Reviews

A DISK & SLEEPER **B** VERY GOOD **C** FAIR
B+ EXCELLENT **C+** GOOD **D** MIOCRE

The Cash Box Sleeper of the Week

"EIGHTEEN" (2:12) [Meridian BMI—Boobis, Nephew]
 "FADED ORCHID" (2:15) [Roosevelt BMI—Stone]
 CONNIE FRANCIS (MGM 12490)

● Connie Francis, a talented lark destined for stardom, has hit upon the piece of material that should send her over the top. The number that should establish her as a big name is tagged "Eighteen." It's an exciting rock and roller describing the thoughts and feelings of young lady who's just turned eighteen. Extremely unusual side presented with great emotion against a stirring R & R rhythm accompaniment excellently supplied by a chorus and Sid Bass' Orchestra. Potent side sure to have a special meaning to millions of teenagers. Flip, "Faded Orchid" is a lovely romancer displaying the lark's outstanding multiple voicing.

"SOMEBODY'S BEEN ROCKING MY BABY" (2:02)
 [Smash BMI—Thompson]
 "OLD MAN MOSE" (2:27) [Santly-Joy ASCAP—Randolph, Armstrong]
 ROD WILLIS (Chic 1010)

● The Chic label, which introduced "Freight Train" and Nancy Whiskey, has an exciting new talent in Rod Willis—a thrilling rock-a-billy songster who could zoom into the spotlight with his waxing of "Somebody's Been Rocking My Baby." It's a swinging affair chock-full of all the gimmicks that have started the kids dancing again. And the melody sticks after just one listen. Rod has a bright future to look forward to and this waxing should start him on the road. Bottom deck "Old Man Mose" is another rhythmic jumper handled with verve. Solid oldie brought up to date. Keep an eye on the "Baby" side.

"AT OUR HOUSE" (2:06) [Monument BMI—Regney, Regney]
 "JOHNNY COME KISS ME" (2:45) [Melody Lane BMI—Gilbertson, Harrison]
 CLARE NELSON (Epic 9220)

● Epic Records has hit upon a charming and versatile new songstress who can sing along with the best of 'em. Her name is Clare Nelson and she debuts with a wonderful new two-sider that could establish her as a name to be reckoned with. One half "At Our House" displays the songstress with a pert, little girlish novelty about a teenager who's thrilled with the fact that her boy friend is coming for dinner at her house. Refreshing ditty with clickability. Miss Nelson sings in a more mature romantic vein on the equally outstanding companion deck "Johnny Come Kiss Me." Beautiful arrangement of an excellently written romancer. Both sides are standout and both could make big noise for Clare.

"NEXT STOP PARADISE" (1:48) [Prentice ASCAP—Dreyer, Diamond]
 "HOW COULD YOU KNOW?" (2:14) [Regent BMI—Randazzo, Colacrai]
 TEDDY RANDAZZO (Vik 0277)

● Teddy Randazzo, who's become a teenage idol as the lead voice of the Three Chuckles, makes his debut on Vik as a soloist, and from the sound of his first solo effort, it looks as tho he'll have a big hit. The lad is right in line with the best of the rock and rollers as he belts out a torrid swinger tagged "Next Stop Paradise." Great performance that'll have the kids flippin'. Watch this lad, he's headed for the big time. The coupling features the tender tones of Teddy on a touching love tune dubbed "How Could You Know?" Lovely romancer with great teenappeal. Big debut disk.

"WHOLE LOT OF SHAKIN' GOING ON" [Marlyn BMI—Williams, David]
 "I'LL BE ME" [Knox BMI—Clement]
 JERRY LEE LEWIS (Sun 267)

● Jerry Lee Lewis, who indicated that he's of star calibre with his rockin' record of "Crazy Arms," has in his latest release the material that will skyrocket him into the spotlight in the pop, country and rhythm & blues fields. The lad is a sensational performer out of the rock-a-billy school. He hands in an ultra commercial job as he belts out a house-rockin' side tagged "Whole Lot Of Shakin' Going On." Side has a great beat. It should be on the charts in all fields. Flip is another exciting side presented against a skiffle beat. Lewis has a great style the kids'll love.

- Right On Top
- THE EVERLY BROS.
 "BYE BYE LOVE" #1315
- Andy's greatest
 ANDY WILLIAMS
 "I LIKE YOUR KIND OF LOVE" #1323
- THE BOBBSEY TWINS
 THE BOBBSEY TWINS ARE CAROL & JANET OF THE CHORDETTES
 "PART TIME GAL"
 "A CHANGE OF HEART" #1324
- Climbing fast
- THE CHORDETTES
 "ECHO OF LOVE" #1319
- From The Strange One
 ARCHIE BLEYER
 "JOCKO'S THEME" #1313
- THREE NATURALS
- JOYCE HAHN
 "GONNA FIND ME A BLUEBIRD"
 "I SAW YOU, I SAW YOU" #1318
- KENYON HOPKINS
 "ROSEBUD" #1322
- MARTY FRANKLIN
 "MAMA LOOK A BOOBOO"
 "JAMAICA FAREWELL" #1321
- NEW RELEASE
- THE CAPRI SISTERS
 "CALL ME MUTTON CHOPS"
 "TIPPY TOE" #1314



"Only those records best suited for commercial use are reviewed by THE CASH BOX"



Record Reviews

A DISK & SLEEPER **B** VERY GOOD **C** FAIR
B+ EXCELLENT **C+** GOOD **D** MEDIOCRE

The Cash Box Best Bets

- ★ "HEARTLESS HEART" Alan Dale ABC Paramount 9828
- ★ "THE FIRST KISS" Norman Petty Trio Columbia 40929
- ★ "TEN LITTLE WOMEN" Sam Butera Prep 105
- ★ "THE LITTLE SPINET" Lou Stein RKO-Unique 403
- ★ "FOR THE LAST TIME" Mitzi Mason Vik 0278
- ★ "AFRAID" Lee Young Par 231
- ★ "LOVE LETTERS IN THE SAND" Vivienne Vip 1003
- ★ "MIND READER" Rhythmettes Brunswick 55012

JERI JORDON

(Bally 1037)
B "SEA SHELLS" (2:25) [Tannen BMI—Long, Russell] A slow-paced waltzer reminiscent of "Tennessee Waltz" is touchingly caressed by thrush Jeri Jordan. The chorus and ork under Lew Douglas softly back Miss Jordan effectively. Very listenable side.
C+ "THE ARCHITECT" (2:05) [Valleydale BMI—Menziez, Gettinger] A powerful, semi-inspirational composition is performed with authority by Miss Jordan and Lew Douglas' chorus and ork.

THE BLOCKBUSTERS/ EDDIE BEAL COMBO

(Antler 4006)
B "FULLTIME BABY" (2:35) [Argo BMI—Miles] The top side of the deck is a rocker from a pic., "Carnival Rock," and features the Blockbusters in a torrid instrumental touch with a solo voice plying the lyrics. Pro R&R issue the kids will find solid listening.
B "TONI'S TUNE" (1:56) [AMC ASCAP—Ram] The Eddie Beal combo takes over things on the bottom half with a novel change-of-pace. "Toni's Tune" is neat little melody the group plays with a clean, and class touch. Easy-going disk fare.

THE MADHATTANS

(Atlantic 1142)
B "WOWIE" (2:14) [Progressive BMI—Hester, Shaw] The Madhattans bow on Atlantic with a delightful pop novelty that brings the listener back to the roaring '20's. Lively charleston cornballer tailor-made for the juke boxes. Happy item easy-on-the-ears. Excellent change-of-pace side for jockeys.
C+ "A BASKETFUL OF BLUE-BERRIES" (2:14) [Progressive BMI—Hester, Apolinar, Parker] This half is a contagious calypso ditty pleasantly handled by the crew. Group has a good sound.

SAM BUTERA

(Prep 105)
B+ "TEN LITTLE WOMEN" (2:09) [Southern ASCAP — Noland] Sam Butera and his boys tear thru an exciting rock and roller loaded with teenappeal. Exciting hard-driver with a strong vocal and ace sax work by Butera. Commercial side to watch closely.
B "LOVE CHARM" (2:26) [Sherman BMI—Stanley] Another exciting arrangement of a rock and roller that's starting to show some action. When tune clicks, this rhythmic treatment will bite off a good share of the sales.

CAROL RICHARDS

(RCA Victor 6940)
B "COME TO MAMA, PAPA DO" (2:50) [Peer International BMI—Gaze, Gordon] The song has a tender touch, and with sweet voiced Carol Richards at the vocal helm it comes across nicely. Part of the lyrics are sung in German. Warm side.
C+ "DADDY" (2:10) [Republic BMI—Troup] Miss Richards, in a totally opposite approach from the top half, purrs through the oldie with intimate charm.

LEE YOUNG

(Par 231)
B+ "AFRAID" (2:14) [Robert Mel-lin BMI—Johnston, Johnston] A dramatic ballad with a heavy rock 'n roll beat is unleashed with formidable vocal emotion by Lee backed by a male chorus, and rockin' ork. The stint and the melody linger on. Excellent juke-box side. Watch this side.
C+ "I'M PLEADING" (2:22) [Al Dexter BMI — Dexter] Young takes the rock 'n roll path again, this time in the more exciting rockin' vein. Good work-out for teen dancers.

RAY COLEMAN

(Arcade 147)
B "ROCK, CHICKEN ROCK" (2:40) [Valley Brook ASCAP—Keefer, Keefer, Haley] A sizzling rocker is energetically belted by Ray Coleman and the Skyrockets. This no-holds barred release is tailor-made for the kids.
C+ "JUKEBOX ROCK AND ROLL" (1:50) [Jack Howard BMI—Coleman, Zario, Costello, Roccia] Just as the title implies, this is a wide open juke box creation done with lots of vigor by Coleman and the combo.

ELLA FITZGERALD

(Verve 10050)
B "MANHATTAN" (2:47) [E. B. Marks ASCAP—Rodgers, Hart] Taken from her 2 LP package devoted to the songs of Rodgers and Hart, Ella Fitzgerald offers a sprightly vocal on the witty classic about New York. Sure to keep deejay turntables very active.
B "LET'S FALL IN LOVE" (3:00) [Harms ASCAP—Porter] Ella Slyly recites the extraordinarily clever lyrics of Cole Porter's "Let's Do It." The side is taken from another 2 disk set, the music of Porter.

MAY 27, 1957

THE BILLBOARD'S

• *Review Spotlight on . . .*

POP DISK JOCKEY PROGRAMMING

MANTOVANI ORK. . . . London 1746 AROUND THE WORLD (Young, ASCAP)

Other versions of the movie theme have already grabbed extensive jockey play, but this one rates spins on basis of quality performance and excellent trumpet solo. Lush, richly orchestrated instrumental programming material. Flip is "The Road to Ballingarry" (ASCAP).



The Magic of

MANTOVANI

makes this film theme a HIT!

Around the World

from "Around the World In 80 Days"

1746

A trumpet triumph by
Stan Newsome

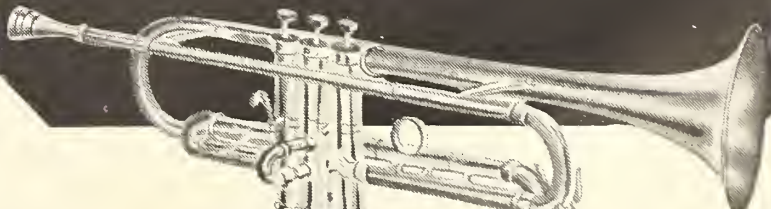

LONDON

RECORDS

539 West 25 St., New York 1, N. Y.



MGM Records

Joni James



BREAKING BIG!
SUMMER LOVE
and
I'M SORRY FOR YOU, MY FRIEND

K12480 • MGM 12480

Connie Francis



HIT OF MOA CONVENTION!
EIGHTEEN
and
FADED ORCHID

K12490 • MGM 12490



Marvin Rainwater

GONNA FIND ME A BLUEBIRD

K12412 • MGM 12412

Dick Hyman Trio

SWEET GEORGIA BROWN

and
TOKYO ALLEY
K12476 • MGM 12476

Robbin Hood



FOR THE LOVE OF MIKE
and
WOULDN'T CHA LIKE TO KNOW

K12486 45 RPM ONLY

Ron Hargrave

HOLD ME
and
THE SONG OF THE MOONLIGHT

K12475 45 RPM ONLY

NEW SOUND TRACK ALBUM SELLSATON
Featuring Fred Astaire, Cyd Charisse, Janis Paige, Carol Richards



MGM Studio Orchestra And
Conducted By Andre Previn

E3542 ST



Round The Wax Circle

NEW YORK:

Guy Lombardo has broken the all-time Roseland Dance City record. In a two week engagement, just ended, Lombardo grossed slightly over \$80,000. . . . Bernie Nee and the Four Voices performed at the Ambassador's Ball in honor of Abba Eban last Sunday at the Essex House Hotel in Newark. Art Ford acted as emcee. . . . CBS Radio is preparing a weekly nighttime half-hour program to star Stan Freberg. . . . Joe Reisman will conduct and perform on the "RCA Victor Galaxy Of Stars" to be telecast over NBC Saturday night June 15. . . . Joe Candullo and his orchestra are supplying the music at Guy Lombardo's East Point House restaurant in Freeport, Long Island this summer. . . . English publisher Jack Heath picked up European rights to several songs while he was here. They included "Shenandoah Rose" and "You, You, Romeo" from Phil Kahl, "Graduation Ring" from Compton Music, and "Shish-Kebab" from Pure Music. He plans to return to the States at least once every year. . . . The music theme from the motion picture "Saint Joan," recorded by Capitol, employs a most unusual instrument—a shepherd's pipe. . . . The Richard Maltby Orchestra, currently on a nationwide tour, was two years old on May 27. . . . Judy Scott into the Mapes Hotel in Reno for two weeks starting June 27. . . . Fred Waring returns to television on a regular basis, after a three year absence, as the summer replacement of "The Garry Moore Show." . . . Irv Jerome, president of Prexy Records, is taking to the road to visit all his Southern distribbers. He's kicking off the new Al Berry release, "King Of The Blues" in that area and stimulating action of the Cues' "Crazy, Crazy Party." . . . Louise Carlyle expects to become a mother in a couple of days. She also has a new record out on the MOSS label, "The Real McCoy" and "Welcome Back Into My Heart." . . . The Versatones on RCA Victor are currently crowding them in at the Gothic Room of the Hotel Duane in Manhattan.

CHICAGO:

This past week saw the '56-'57 season of Chi Automatic Phonograph Bowling League draw to a rousing close as ops and record distribbers met at annual banquet. Distrib, Tony Galgano, received the winning trophy from Cash Box' Bill Gersh for his team while Coral's Ed Walker collected the last place booby prizes. . . . Dauntless International's Audio Fidelity starting to beat the big drum with lotts promotion via Galgano Record Distribbers for Duks Of Dixieland LP just out. . . . Reports in that Buddy DeFranco Casino Ballroom concert netted profitable gate. . . . Epic teen sensation, Sal Mineo, had his deejay tour cut short by an eye infection. "But it didn't cut his record short," advises United Distrib's Ernie Leaner. "Start Movin' has really taken off," he added. . . . Salem's Shirley Forwood (like in golf) stopped by with a big Michigan Howdy for Ray Rayner's teen TV audience. Kids seemed to go for Shir's "Good Night." . . . Jim Lewis, WEMP, Cream City deejay, writes about a rising talent out his way, Bobby Dean. "Kid promises to be one of the biggest record talents to come," advises Lewis. . . . Our deepest condolences to Midwest Mercury's Henry Freidman on the passing of his father. . . . Says Joe "Singer" Sipiora, Singer One-Stop, "Except for a cloud now and then, business has been great." . . . Thanks to Chuck Miller for the card and lyrics to "tender" "Rang Tang Ding Dong." So that's what you've been saying all this time? . . . Standard Radio Transcription Service's Milton Blink planed into NYC for ten-day stay and session of recordings for SRTS's standard collection. . . . Howard Miller to present another big show from stage of Opera House. Bill to include Tab Hunter. . . . Columbia's Jerry Mazzara still keeping after Don Cherry's (fore) "April Age" and beginning to see success with Johnny Mathis' "It's Not For Me To Say." By the way, the speed at which this Mazzara rushes around makes us think someone spiked his Wheaties. . . . Stan Pat all excited over his bosses' first Roulette recording, Hugo and Luigi's big surprise release. . . . Forster's Phil Miller on the road with "Cattle Call" by Dinah Shore. Busy guy has been thru Chi, Cleveland, Detroit, and Philly.

HOLLYWOOD:

Dot Records going all out on a promotion campaign with the release of their original sound track album of "The Ten Commandments." Tom Mack, who produced the album, and Bob Wilhem will supervise the campaign. . . . Frank Evans of KDAY acting as master of ceremonies for the Friday night dance contests held at the Hollywood Palladium during Harry James' four week stand. Winners receive copies of James' Capitol albums. . . . Dot Records artist Molly Bee has been signed to play the Evansville Indiana Fair in August. . . . MGM singer-actor, Dean Jones, has been signed to a featured role in MGM's "Jailhouse Rock" starring Elvis Presley. Jones was also recently signed to sing the title song of the forthcoming picture, "Gunpoint Ridge." . . . Eddie Baxter, whose organ albums on the Rendezvous label have been doing very well nationally, currently appearing at The Plush Horse. . . . Capitol Records launched its own company magazine, The Capitol World this month. Vic Rowland, manager of press relations, is editor of the house organ, with Merrylin Hammond named associate editor. . . . The Dream Records label bowed on Peter Potter's Juke Box Jym with its first release tagged a hit. Disk features Annita Ray singing "Frankie's Song," written by eden abbez, the writer of "Nature Boy." . . . Maze Records doing well with "Oh Well," written by June Cook and Kirby Allan and sung by Johnny Gable. . . . Bob Denton's "On My Mind Again" on the Dot label, originally from the country field, has been stepping out for a pop hit.



EDDIE BAXTER



**TERESA
BREWER**
sings-

the **FIRST**
POP VERSION
Of One Of The
Greatest Country Standards

**"TEARDROPS
IN MY
HEART"**

CORAL
RECORDS
9-61850 (61850)

published by
SOUTHERN MUSIC PUB. CO.
Gen. Prof. Mgr. MURRAY DEUTCH

"It's What's in THE CASH BOX That Counts—INTERNATIONALLY"



The Records Disk Jockeys Played Most

A SUMMARY OF REPORTS RECEIVED FROM THE NATION'S DISK JOCKEYS

		Pos.	Last Week
1	LOVE LETTERS IN THE SAND PAT BOONE (Dot)	2	
2	ALL SHOOK UP ELVIS PRESLEY (RCA Victor)	1	
3	A WHITE SPORT COAT MARTY ROBBINS (Columbia)	5	
4	SO RARE JIMMY DORSEY (Fraternity)	4	
5	LITTLE DARLIN' DIAMONDS (Mercury)	3	
6	SCHOOL DAY (RING RING GOES THE BELL) CHUCK BERRY (Chess)	7	
7	FOUR WALLS JIM REEVES (RCA Victor) JIM LOWE (Dot)	11	
8	DARK MOON GALE STORM (Dot) — BONNIE GUITAR (Dot)	6	
9	OLD CAPE COD PATTI PAGE (Mercury)	13	
10	FREIGHT TRAIN NANCY WHISKEY (Chic) RUSTY DRAPER (Mercury) MARGIE RAYBURN (Liberty)	16	
11	START MOVIN' SAL MINEO (Epic)	24	
12	IT'S NOT FOR ME TO SAY JOHNNY MATHIS (Columbia)	17	
13	I'M WALKIN' RICKY NELSON (Verve) FATS DOMINO (Imperial)	12	
14	BYE, BYE LOVE EVERLY BROTHERS (Cadence)	25	
15	TEENAGER'S ROMANCE RICKY NELSON (Verve)	18	
16	COME GO WITH ME DEL-VIKINGS (Dot)	9	
17	ROUND AND ROUND PERRY COMO (RCA Victor)	8	
18	GONE FERLIN HUSKY (Capitol)	10	
19	THE GIRL WITH THE GOLDEN BRAIDS PERRY COMO (RCA Victor)	31	
20	FABULOUS CHARLIE GRACIE (Cameo) STEVE LAWRENCE (Coral)	30	

21) I JUST DON'T KNOW. 22) ROCK YOUR LITTLE BABY TO SLEEP. 23) TALKIN' TO THE BLUES. 24) WITH ALL MY HEART. 25) AROUND THE WORLD. 26) LITTLE WHITE LIES. 27) MANGOS. 28) I LIKE YOUR KIND OF LOVE. 29) PLEDGE OF LOVE. 30) EMPTY ARMS. 31) YOUNG BLOOD. 32) GOIN' STEADY. 33) GONNA FIND ME A BLUEBIRD. 34) DON'T CALL ME SWEETIE. 35) SEARCHIN'. 36) WONDERFUL! WONDERFUL! 37) ONE FOR MY BABY. 38) SHISH-KEBAB. 39) ISLAND IN THE SUN. 40) VALLEY OF TEARS. 41) ROCK-A-BILLY. 42) IT'S YOU I LOVE. 43) PARTY DOLL. 44) LOVE IS A GOLDEN RING. 45) BERNARDINE. 46) MY LITTLE BABY 47) PROMISES, PROMISES. 48) MAMA GUITAR. 49) MY DREAM. 50) OVER THE MOUNTAIN. 51) I'M GONNA SIT RIGHT DOWN AND WRITE MYSELF A LETTER. 52) 1492. 53) WHY BABY WHY. 54) CAN'T WAIT FOR SUMMER. 55) QUEEN OF THE SENIOR PROM. 56) WONDERING. 57) BUTTERFLY. 58) PEACE IN THE VALLEY. 59) LOOK AT 'ER. 60) YES, TONIGHT, JOSEPHINE; DON'T CRY, MY LOVE.

"YOUNG LOVE"
sold over a million!

"FIRST DATE, FIRST KISS, FIRST LOVE"
still climbing!

NOW another GOLD RECORD maker by...



SONNY

JAMES

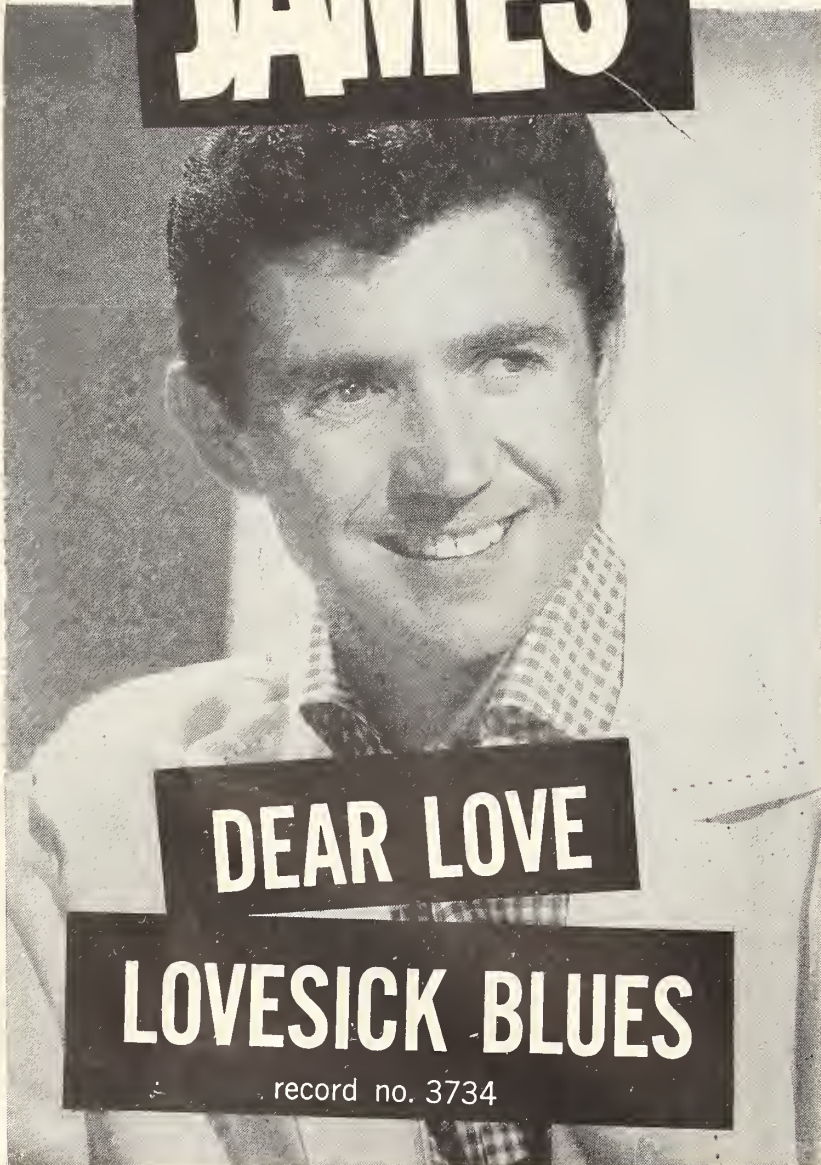

DEAR LOVE

LOVESICK BLUES

record no. 3734

LOOK!

312,000 SHIPPED IN 4 DELIRIOUS DAYS!

"Shenandoah Rose"

lyric by
Paul Francis Webster
music by
Jerry Livingston

"ROCK-A- BILLY PARTY"

words and music by
Al Hoffman and Dick Manning



by

HUGO & LUIGI

with Orchestra & Chorus
ROULETTE # 4012

Spin a Winner



ROULETTE

659 Tenth Ave.
New York, N. Y.

"It's What's in THE CASH BOX That Counts—INTERNATIONALLY"

OPERATORS RETAILERS DEEJAYS

In Order To Have Your Top Ten Represented In THE CASH BOX Charts,

Fill In The Coupon Below (Or Put Them On Your Own Letterhead)

And Mail To THE CASH BOX 1721 BROADWAY NEW YORK 19, N. Y.

List Your Top Ten Pop Tunes Here

NAME OF RECORD HERE	ARTIST OR BAND HERE
1.
2.
3.
4.
5.
6.
7.
8.
9.
10.

List Your Top Ten Country Tunes Here

NAME OF RECORD HERE	ARTIST OR BAND HERE
1.
2.
3.
4.
5.
6.
7.
8.
9.
10.

List Your Top Ten Rhythm 'N Blues Records Here

NAME OF RECORD HERE	ARTIST OR BAND HERE
1.
2.
3.
4.
5.
6.
7.
8.
9.
10.

NAME

FIRM

ADDRESS

CITY STATE



Platter Spinner Patter

ALL ABOUT DISK JOCKEYS

The disk that deejay Mike Secrest (WTIX-New Orleans, La.) cut for MGM, "The Gift," is reported to be making noise. . . . Gerry Myers (CKOY-Ottawa, Ont.) has added a new daily from 4 PM to 5 PM for the younger set to his schedule. The stint is called "Club 1310," and Gerry would appreciate more

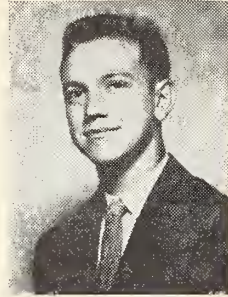

MIKE SECREST
(WTIX—New Orleans, La.)

platters from the various companies. . . . Stan Douglas (WTWN-St. Johnsbury, Vt.) has initiated a segment of his "Stan Mans Matinee" whereby local talent is given a chance to try their skills at being Program Director, disk jockey or Music Librarian. Given 15 minutes of air time during the 2 hour show, those who have tried their hand at the gimmick have ranged in age from 9 to 26. . . . The radio listeners of Dewey Phillips' "Phillips' Pop Shop," (simultaneously on TV) get to hear Phillips and the engineer going through the routine of getting the radio commercial straight. . . . Station KTKT-Tucson, Ariz. has become strictly a music and news operation as of May 15th. . . . Dick Biondi (WHOT-Youngstown, Ohio) recently had an air interview with Sai Mineo (Epic) over the telephone. . . . Station WBRB-Detroit-Mt. Clemens began its operation on May 18th. The deejay staff of WBRB includes Dick Drury, Dave McLaughlin, Johnny Russell and Johnny Osborne. . . . Sid Parnes, Editor-In-Chief of The Cash Box was interviewed on tape over station KDTH-Debuque, Iowa while he was attending the recent MOA convention in Chicago. KDTH Program Director Bob Gribben handled the interview. . . . Album Covers That Tell The Story: Gene Piatt (KELO-Soiux Falls, S. D.) writes that such albums as "Alone" with Judy Garland (Capitol); "A Swingin' Affair!" with Frank Sinatra (Capitol); "Bergen Sings Morgan" with Polly Bergen (Columbia); and "The Gilded Hawk" with Coleman Hawkins (Capitol) all rate praise for covers, and contents.

* * * * *

Cal Milner and Larry Brown of WPEN (Philadelphia, Pa.), who were honored a short while ago by the Delaware County Lodge 27, Fraternal Order of Police, will be similarly honored June 6th by the Poplar Area Community Council with the first annual Payac Award for outstanding service to youth and the community. . . . The modernization of its music library to LP's, resulted in 2,000 27 rpm 12 inch classical records of KYW-Cleveland, given



AL RADKA
(KFRE—Fresno, Calif.)

free to various non-profit organizations. . . . Unanimous Choice: Ed Baker (KWFR-San Angelo, Tex.) says that all the deejays at KWFR, including himself, agree that the Steve Lawrence pressing of "Can't Wait For Summer," on Coral will soon be high on the charts. . . . Archie Hignett is a policeman who also conducts a deejay show over WCFL-Chicago, Ill., which combines music with tips on traffic safety. . . . Stan Z. Burns has returned to WINS-New York with a program that will salute a star vocalist or musical show. Burns, who is heard 10 to 11 AM on weekdays, and 6 to 9 AM Saturdays, opened his new stint with the hits from the singing career of Perry Como (RCA Victor). . . . David Herman, (WEEX-Easton, Pa.) is honeymooning with his bride, Jane, at Grossinger's in New York. . . . Long-time banjo-player, Eddy Peabody (Dot), guested on the Al Radka (KFRE-Fresno, Calif.) TV show a short while ago. . . . Station WKCR-Columbia University, New York concluded its season's broadcasting Friday, May 17th, and will return to the air in September. WKCR deejay Bernie Bond will return to the outlet in the Fall. . . . Rocky Foxx is the rock 'n roll deejay of WFOX-Milwaukee, Wis. Foxx has a show on every night from 6 to 8:15 PM and is broadcast from the Fiesta drive-in, an idea the platter spinner likes as it lets him meet more of his listeners.

* * * * *

Myles Foland (WCPO-Cincinnati, Ohio) will do a TV remote from a local swimming pool every Sunday from 3 to 5 with the aid of Bob Smith. The two will interview guests and spin the top disks. . . .



WALTER POWELL, JR.
(WBVL—Barbourville, Ky.)

Walter Powell (WBVL-Barbourville, Ky.) did an hour program on WBVL in honor of Randy Wood and Dot records. Powell told how Wood started the company, and related the success stories of Dot artists. The deejay used the October 13th edition of The Cash Box, and liner notes from Dot albums for his material. . . . Bob Lyons (WQAM-Miami, Fla.) received hundreds of get-well cards for Jimmy Dorsey after an on the air request for cards for the ailing bandleader. . . . New morning man, and Chief Engineer at WKXL-Concord, N. H. is Britt Belyea. WKXL's afternoon deejay is Jim Reid. The station would appreciate taped station breaks from the stars. . . . June 5th will see a get-together of the WPEN-Philadelphia, Pa. staff and W.T. Grant Dept. store as part of the store's anniversary celebration.

"Only those records best suited for commercial use are reviewed by THE CASH BOX"

Everybody is covering Tommy...

THE ORIGINAL!
THE ORIGINAL!
THE ORIGINAL!
THE ORIGINAL!
THE ORIGINAL!

THE ORIGINAL!
THE ORIGINAL!
THE ORIGINAL!
THE ORIGINAL!
THE ORIGINAL!



BUT

Tommy Prisco

has the **ORIGINAL HIT!**

"TEARDROPS IN MY HEART"

b/w

"MAYBE SOMEDAY"



5-9219

"It's What's in THE CASH BOX That Counts—INTERNATIONALLY"

From the Sol C. Siegel Production
"MAN ON FIRE"
 an M-G-M presentation

MAN ON FIRE

ROBBINS MUSIC CORPORATION

ATTENTION
 watch for
FACE IN THE CROWD
 &
MAMA GUITAR

REMICK MUSIC CORP.

IT'S A DANDY FOR
Gene Nash
"DANDY LION"

Jubilee 5285

Jubilee Records
 1650 Broadway, New York City

Dean Martin
 CAPITOL
 Leny Eversong
 CORAL

I CAN'T GIVE YOU ANYTHING BUT LOVE

Jo Ann Campbell
 ELBORADO
 Doris Allen
 JADE

MUSIC FROM THE GREAT CATALOG OF MILLS

A Hot Novelty!
"FRANKIE'S SONG"
ANITA RAY
 and The Nature Boys
 # 1300

DREAM RECORDS
 1486 NO. FAIR OAKS AVE.
 PASADENA CALIFORNIA

FALSE HEARTED GIRL

Tennessee Ernie Ford
 CAPITOL

AMERICAN MUSIC, INC.
 9109 SUNSET BLVD., HOLLYWOOD, CALIF.

Her Father's In The Record Business



CHICAGO—"Gee it's swell to have a dad in the record business", says Joyce Talmadge, whose father is Art Talmadge, vice president of Mercury Records. Here she is with (left to right) Johnny Perkins of the Crew-Cuts; Dave Somerville of the Diamonds; Ray Perkins of the Crew-Cuts; Bill Reed, Phil Leavitt and Ted Kowalski of the Diamonds; and (rear) Rudy Mangeri of the Crew-Cuts. Occasion was opening night for the Crew-Cuts at the Empire Room of Chicago's Palmer House.

WMGM Tests Single Band Transmission

NEW YORK—With permission from the Federal Communications Commission, Station WMGM is testing and introducing a new system of broadcasting which makes possible improved fidelity with average-priced receivers, it was announced last week by Arthur Tolchin, Vice President and Director of the 50,000-watt Metro-Goldwyn-Mayer facilities.

Both the Federal Communications Commission and radio engineers throughout the country are watching closely the experimental single band tests. Should the reports be of an encouraging nature, it is possible the Federal Communications Commission might then authorize the single side band system on a more extensive basis so that further public reaction could be obtained.

Known technically as the Kahn System of Compatible Single Side Band Transmission, it is the development of Leonard R. Kahn, president of the Kahn Research Laboratories, Freeport, L.I. Kohn's system, it is reported, can reduce the effects of both interference and fading, without the listener having to adapt his receiver in anyway whatever.

Oriole To Release Salem Disks In England

CHICAGO—Mort Hillman, prexy of Salem Records, last week announced that in a Trans-Atlantic telephone conversation with J. G. Shestapol and other executives of Oriole Records in London, England, arrangements were concluded for Oriole Records to lease the Bobby Christian record of "Crickets On Parade". Oriole will handle this record for England and all of Western Europe.

It was also announced that an agreement would shortly be concluded with Oriole Records to handle the complete Salem catalog for the same area. The Salem catalog, though the company is only seven months old, includes 8 singles and 2 albums released, with 2 other albums to be released in the near future.

RCA Talent Showcase At Grossinger's

GROSSINGER, N.Y. — RCA-Victor held a talent showcase Monday evening (May 27) at Grossinger's in the Catskills. Purpose of the event was to let some of the top talent-buyers see and hear RCA-Victor's newest songsters perform before a live audience so that the production chiefs and other impresarios would be able to judge whether they could use the singers in television, radio, night clubs, and other entertainment fields.

Recording artists who sang for the experts in the Grossinger Terrace Room were the Lane Brothers, Leni Barteri, Bobby Brooks, Martha Carson, Bob Jaxon, Mitzi Mason, and Jim Reeves.

On hand for the talent show were many NBC execs including Manie Sacks, V. P. in charge of TV programming; Robert Lewine, V. P. in charge of daytime TV programming; Mort Werner, V. P. in charge of night-time TV programming; Perry Cross, director of daytime TV programming; Michael Dann, V. P. in charge of network TV programs; George Heinemann, program director of NBC-owned-and-operated stations, and Dan Russell and Sue Salter of "Monitor."

Among the producers in the audience were William Bachor of the Ray Bolger Show; Garth Dietrich, and Jack Hein of the "Today" show.

Also present were Larry Kanaga, president of GAC; Harry Kalcheim of the William Morris Agency; and director Barry Shear.

Hosting the group were RCA-Victor's Jack Burgess, general manager of the single record department; William Bullock, general manager of albums; Joe Carlton, A. & R.; Edward Heller, musical director of albums, and Bernie Miller, administrator of artist exploitation.

Quinn Leaves Bethlehem

NEW YORK — It was announced last week that Joe Quinn of Bethlehem Records had resigned from his post with the LP record company. Quinn is leaving for the Coast where he will join another diskery, as yet unannounced.

Quinn will not be replaced at Bethlehem.

20 To 25 Welk Albums Planned For This Year

HOLLYWOOD—This may be the most successful recording year in the history of Lawrence Welk and his Champagne Music Makers, with an all-time total of 20 to 25 LP Welk Albums scheduled to be released during 1957 under the Coral and Brunswick labels.

Credited with more than 4,700,000 individual record sales during the past two years according to Coral, three new Welk albums have been released by Coral so far during 1957, with two more, "Champagne And Roses," and "World's Greatest Music" scheduled for nationwide distribution within the next 90 days. Also, a special album of Dixieland music, highlighting jazz clarinetist Pete Fountain, enlisted from New Orleans and now a regular in the Champagne Music aggregation, is being readied for July release.

"Waltzing with Lawrence Welk," "Show Time," and "Madison Square Garden," the latter a recording of the special one-night performance in New York by the Champagne Music Makers before a full house, are currently enjoying record album sales nationally, it is reported by Sam J. Lutz, Welk's personal manager.

Planned are Brunswick-label solo albums of 12 tunes each for Alice "Champagne Lady" Lon, Tiny Little, Jr., Pete Fountain, Larry Dean, Larry Hooper, Dick Dale, Jerry Burke and Dick Kesner, plus a special album featuring Miss Lon and Dale in 12 duoharmony numbers. Additional albums by Aladdin and Bob Lido also are under consideration.

The Lennon Sisters, now firmly established as one of the mainstays of the Welk television group, will record a minimum of three Brunswick albums this year totaling 36 numbers.

"World's Greatest Music," a selection of 12 of the most popular semi-classical melodies, has been completed, for which Welk helms a full orchestra of 80 pieces, emphasizing the use of string instruments. Coral plans to release this as a "special" in late July or early August.

To keep abreast of the 1957 recording plans, Welk's present schedule of two television programs weekly (Saturdays and Mondays—ABC-TV Network) plus weekend appearances (Fri.-Sat.-Sun.) at the Aragon Ballroom, has now been augmented by Welk-men weekly recording sessions each Tuesday afternoon and Thursday night.

Ernie Ford Magazine Out

HOLLYWOOD—A 100-page "one shot" magazine, called "Tennessee Ernie Ford" by the Hollywood writer, Ted Hilgenstuhler, was being distributed to the nation's news-stands last week.

Ford's recording activities at Capitol are covered in a section called "16 Tons' of Recording Success" which appears on pages 58 through 65 of the illustrated book.

Subscription — THE CASH BOX

52 Issues	\$15
First Class	\$20
Airmail	\$30
52 Issues + Free Weekly Classified Ad	\$48

"Only those records best suited for commercial use are reviewed by THE CASH BOX"



DELLA CHIESA (KEY-A-SA)

(from the 20th Century Fox Film BERNADINE)

B/W

LIGHT A CANDLE

(say a prayer)

VIP-1003

VIP DISTRIBUTORS

- MILWAUKEE, WISC. •
RECORDS UNLIMITED, INC. 2107 W. Aver Ave.
- LOS ANGELES, CAL.
UNIVERSE RECORD DIST. 2524 W. Pico Blvd.
- CINCINNATI, OHIO
HIT RECORD DISTRIBUTORS 1043 Central Ave.
- PHOENIX, ARIZONA
DESERT SANDS ENTERPRISES 11 West Adams St.
- E. HARTFORD, CONN.
EASTERN RECORD DIST. 26 Clark St.
- BALTIMORE, MD.
GIMBEL BROTHERS 3521 Belair Rd.
- PITTSBURGH, PENNA.
EAST COAST DIST. 633 Liberty Ave.
- CHICAGO, ILL.
FRUMKIN SALES CO. 2007 S. Michigan Ave.
- PHILADELPHIA, PA.
LESCO DISTRIBUTORS 17 S. 21st Street
- SAN FRANCISCO, CAL.
NEW SOUND 50 Julian Avenue
- BOSTON, MASS.
TRANSDISC CORP. OF BOSTON 285A Huntington Ave.
- NEW YORK CITY
PORTEM DISTRIBUTING CO. 733 11th Avenue
- OKLAHOMA CITY, OKLA.
B & K DISTRIBUTING CO. 608 N. Hudson
- DETROIT, MICHIGAN
S & S DISTRIBUTING CO. 3955 Woodward Ave.
- MIAMI, FLORIDA
BINKLEY DISTRIBUTORS 301 S.W. SIXTH
- JACKSONVILLE, FLA.
BINKLEY DISTRIBUTORS 58 Riverside
- UTICA, N. Y.
MID-STATE DISTRIBUTORS 420 Varick St.
- DALLAS, TEXAS
CENTURY DISTRIBUTORS, INC. 137 Glass St.
- MEMPHIS, TENN.
ONE STOP RECORD DIST. 1087 Union Ave.
- NASHVILLE, TENN.
MUSIC CITY RECORD DIST. 80 Lafayette St.
- ALBANY, N. Y.
SEABOARD DIST. COMPANY 1004 Broadway
- DENVER, COLORADO
ZION DISTRIBUTING CO. 2056 Champa St.
- ST. LOUIS, MO.
GAY MUSIC CO. 1722 Washington St.
- MINNEAPOLIS, MINN.
SANDELL COMPANY 42 Glenwood Ave.
- MADISON, WISCONSIN
TELL MUSIC DIST. COMPANY 2702 Monroe St.
- TORONTO, CANADA
QUALITY RECORDS, LTD. 380 Birchmount Rd.



BILLY BRANDO

Love Me Again

B/W

One Sided Love

VIP-1002



Al Conte Quartet

AL CONTE
the hottest pianist of our times."

Now available for immediate delivery
12" long play—\$3.98

VIP-2001



RUSS MILLER

I SIT IN MY WINDOW

B/W

WAIT FOR ME, MY LOVE

(Look Away - Look Away)

VIP-1006

One Fifty Seven West Fifty Seventh Street, New York City



Prep Shifts A & R Dept. To New York

HOLLYWOOD—The Artists and Repertoire operation of Prep Records has been transferred to New York City it was announced last week by President Glenn Wallichs.

Andy Wiswell repertoire executive in New York will head Prep's A & R operation and handle all new recordings. In the selection of recorded masters submitted for consideration for a Prep release, Wiswell will be assisted by Irv Jerome, Sales Manager of Prep and Manny Kellem, District Sales and Promotion Manager, New York, who, with Wiswell as chairman, will comprise a review committee.

Wallichs further stated that the initial success of Prep has been gratifying, and through the combining of sales and A & R in New York, accelerated development is anticipated.

Fujita Cited For LP Covers

NEW YORK—S. Neil Fujita, Director of Design and Packaging for Columbia Records has been honored with a Gold Medal by the Art Directors Club of New York. The award was conferred in the category titled, "Point of Sale, Record Album Covers, Book Jackets." The Gold Medal signifies "outstanding contributions to the field of graphic art."

Fujita is widely known in designing and packaging circles. His newest medal is added to a collection of awards, including the New York, Philadelphia and Chicago Art Directors Clubs. An artist as well as designer, Fujita has received numerous exhibitions of his paintings throughout the country.

Earlier this month seventeen Columbia LP covers, were chosen for inclusion in the American Institute of Graphic Arts' selection of fifty superior designs in the category.

Liberty Rep. Opens N.Y. Office

NEW YORK — Jane Gibbs east coast representative for Liberty Records, will open new offices in this city, Monday, June 3.

The offices will be located at the Shelton-Towers, Lexington Ave. & 49th St.

Contest Winner Meets Star



HOLLYWOOD—Woody Hinderling of Bullseye and Candlelight has announced that Barbara Ann Davies of Vancouver, B.C. was the winner of the Jesse James lyric contest. She won a free trip to Hollywood and received the V.I.P. treatment. Red Robinson, a D.J. in Vancouver was the sponsor of Barbara Ann and the recipient of a \$100 prize.

Above film star Jeff Hunter greets Miss Davies, one of his many fans.



Juke Box Regional Record Report

The Top Ten Records—City by City

New York, N. Y.

1. Come Go With Me (Del-Vikings)
2. Little Darlin' (Diamonds)
3. It's Not For Me To Say (J. Mathis)
4. All Shook Up (E. Presley)
5. Wonderful! Wonderful! (J. Mathis)
6. So Rare (J. Dorsey)
7. A White Sport Coat (M. Robbins)
8. Start Movin' (S. Mineo)
9. Love Letters In The Sand (P. Boone)
10. With All My Heart (J. Sands)

Philadelphia, Pa.

1. Little Darlin' (Diamonds)
2. Love Letters In The Sand (P. Boone)
3. All Shook Up (E. Presley)
4. School Day (C. Berry)
5. Four Walls (J. Reeves)
6. Dark Moon (G. Storm)
7. Start Movin' (S. Mineo)
8. With All My Heart (J. Sands)
9. Fabulous (C. Gracie)
10. A White Sport Coat (M. Robbins)

San Antonio, Tex.

1. Love Letters In The Sand (P. Boone)
2. Come Go With Me (Del-Vikings)
3. Talkin' To The Blues (J. Lowe)
4. Little Darlin' (Diamonds)
5. School Day (C. Berry)
6. A White Sport Coat (M. Robbins)
7. Gone (F. Husky)
8. So Rare (J. Dorsey)
9. All Shook Up (E. Presley)
10. It's You I Love (F. Domino)

Kansas City, Mo.

1. Love Letters In The Sand (P. Boone)
2. So Rare (J. Dorsey)
3. School Day (C. Berry)
4. All Shook Up (E. Presley)
5. Rock-A-Billy (G. Mitchell)
6. Teenager's Romance (Nelson)
7. Dark Moon (G. Storm)
8. I'm Stickin' With You (J. Bowen)
9. Too Late (G. Austin)
10. I'm Sorry (Platters)

Atlanta, Ga.

1. Come Go With Me (Del-Vikings)
2. Four Walls (J. Reeves)
3. Searchin' (Coasters)
4. Little Darlin' (Diamonds)
5. Dark Moon (B. Guitar)
6. Pledge Of Love (M. Torok)
7. A White Sport Coat (M. Robbins)
8. All Shook Up (E. Presley)
9. Love Letters In The Sand (P. Boone)
10. Young Blood (Coasters)

Pittsburgh, Pa.

1. A White Sport Coat (M. Robbins)
2. All Shook Up (E. Presley)
3. Love Letters In The Sand (P. Boone)
4. Wonderful! Wonderful! (J. Mathis)
5. So Rare (J. Dorsey)
6. Little Darlin' (Diamonds)
7. Round And Round (P. Como)
8. Queen Of The Senior Prom (Mills Bros.)
9. Teenager's Romance (Nelson)
10. Gone (F. Husky)

Seattle, Wash.

1. Teenager's Romance (Nelson)
2. All Shook Up (E. Presley)
3. I'm Walkin' (R. Nelson)
4. A White Sport Coat (M. Robbins)
5. Lucille (L. Richard)
6. Over The Mountain (Johnnie & Joe)
7. Gone (F. Husky)
8. School Day (C. Berry)
9. Love Letters In The Sand (P. Boone)
10. Start Movin' (S. Mineo)

Chicago, Ill.

1. So Rare (J. Dorsey)
2. Love Letters In The Sand (P. Boone)
3. Dark Moon (B. Guitar)
4. All Shook Up (E. Presley)
5. I'm Walkin' (Nelson/ Domino)
6. School Day (C. Berry)
7. With All My Heart (J. Sands)
8. Little Darlin' (Diamonds)
9. Gonna Find Me A Bluebird (M. Rainwater)
10. Rock-A-Billy (G. Mitchell)

Minneapolis, Minn.

1. Love Letters In The Sand (P. Boone)
2. So Rare (J. Dorsey)
3. School Day (C. Berry)
4. Dark Moon (Storm/Guitar)
5. He's Mine (Platters)
6. All Shook Up (E. Presley)
7. Four Walls (Lowe/Reeves)
8. I Like Your Kind Of Love (A. Williams)
9. Goin' Steady (T. Sands)
10. Little Darlin' (Diamonds)

Cleveland, Ohio

1. Love Letters In The Sand (P. Boone)
2. Bye Bye Love (Everlys)
3. I'm Walkin' (R. Nelson)
4. All Shook Up (E. Presley)
5. A White Sport Coat (M. Robbins)
6. I Like Your Kind Of Love (A. Williams)
7. Dark Moon (G. Storm)
8. Start Movin' (S. Mineo)
9. So Rare (J. Dorsey)
10. Little Darlin' (Diamonds)

New Orleans, La.

1. Dark Moon (G. Storm)
2. All Shook Up (E. Presley)
3. So Rare (J. Dorsey)
4. Valley Of Tears (F. Domino)
5. Talkin' To The Blues (J. Lowe)
6. Four Walls (Lowe/Reeves)
7. Love Letters In The Sand (P. Boone)
8. Teenager's Romance (Nelson)
9. C. C. Rider (C. Willis)
10. Come Go With Me (Del-Vikings)

Houston, Tex.

1. Searchin' (Coasters)
2. Isabella (R. Tan)
3. C. C. Rider (C. Willis)
4. A White Sport Coat (M. Robbins)
5. Love Letters In The Sand (P. Boone)
6. Young Blood (Coasters)
7. Come Go With Me (Del-Vikings)
8. Little Darlin' (Diamonds)
9. All Shook Up (E. Presley)
10. Bad Boy (Jive Bombers)

Boston, Mass.

1. It's Not For Me To Say (J. Mathis)
2. Little Darlin' (Diamonds)
3. Love Letters In The Sand (P. Boone)
4. All Shook Up (E. Presley)
5. Dark Moon (B. Guitar)
6. So Rare (J. Dorsey)
7. A White Sport Coat (M. Robbins)
8. Rock-A-Billy (G. Mitchell)
9. Old Cape Cod (P. Page)
10. Queen Of The Senior Prom (Mills Bros.)

Milwaukee, Wis.

1. Dark Moon (B. Guitar)
2. I'm Walkin' (R. Nelson)
3. Love Letters In The Sand (P. Boone)
4. Little Darlin' (Diamonds)
5. All Shook Up (E. Presley)
6. So Rare (J. Dorsey)
7. Four Walls (J. Reeves)
8. School Day (C. Berry)
9. With All My Heart (J. Sands)
10. A White Sport Coat (M. Robbins)

Los Angeles, Calif.

1. Love Letters In The Sand (P. Boone)
2. All Shook Up (E. Presley)
3. So Rare (J. Dorsey)
4. Little Darlin' (Diamonds)
5. Dark Moon (G. Storm)
6. Round And Round (P. Como)
7. School Day (C. Berry)
8. Party Doll (B. Knox)
9. Come Go With Me (Del-Vikings)
10. A White Sport Coat (M. Robbins)

Detroit, Mich.

1. Love Letters In The Sand (P. Boone)
2. Rosie Lee (Mello-Tones)
3. Young Blood (Coasters)
4. Start Movin' (S. Mineo)
5. Bye Bye Love (Everlys)
6. All Shook Up (E. Presley)
7. I'm Walkin' (R. Nelson)
8. School Day (C. Berry)
9. Over The Mountain (Johnnie & Joe)
10. So Rare (J. Dorsey)

Baltimore, Md.

1. Dark Moon (B. Guitar)
2. Love Letters In The Sand (P. Boone)
3. School Day (C. Berry)
4. Wonderful! Wonderful! (J. Mathis)
5. A White Sport Coat (M. Robbins)
6. All Shook Up (E. Presley)
7. Four Walls (J. Reeves)
8. Young Blood (Coasters)
9. Empty Arms (T. Brewer)
10. Bernardine (P. Boone)

St. Louis, Mo.

1. Teenager's Romance (Nelson)
2. Love Letters In The Sand (P. Boone)
3. Little Darlin' (Diamonds)
4. Freight Train (N. Whiskey)
5. Start Movin' (S. Mineo)
6. Dark Moon (G. Storm)
7. Fabulous (C. Gracie)
8. Goin' Steady (T. Sands)
9. All Shook Up (E. Presley)
10. Can't Wait For Summer (S. Lawrence)

Cincinnati, Ohio

1. School Day (C. Berry)
2. I'm Walkin' (R. Nelson)
3. All Shook Up (E. Presley)
4. Gone (F. Husky)
5. Love Letters In The Sand (P. Boone)
6. Little Darlin' (Diamonds)
7. A White Sport Coat (M. Robbins)
8. Dark Moon (G. Storm)
9. Teenager's Romance (Nelson)
10. Fabulous (C. Gracie)

San Francisco, Calif.

1. All Shook Up (E. Presley)
2. Come Go With Me (Del-Vikings)
3. Gone (F. Husky)
4. So Rare (J. Dorsey)
5. A White Sport Coat (M. Robbins)
6. School Day (C. Berry)
7. Dark Moon (B. Guitar)
8. Little Darlin' (Diamonds)
9. Searchin' (Coasters)
10. Rang Tang Ding Dong (Cellos)

Denver, Colo.

1. All Shook Up (E. Presley)
2. School Day (C. Berry)
3. Gone (F. Husky)
4. A White Sport Coat (M. Robbins)
5. Dark Moon (G. Storm)
6. So Rare (J. Dorsey)
7. I'm Walkin' (R. Nelson)
8. Love Letters In The Sand (P. Boone)
9. Little Darlin' (Diamonds)
10. Teenager's Romance (Nelson)

BILL DOGGETT

DING DONG

KING 5058

RAM - BUNK - SHUS

KING 5020

CHLOE

b/w

NUMBER THREE

KING 5044

ANNIE LAURIE

IT HURTS TO BE IN LOVE

DE LUXE 6107

IT MUST BE YOU

DE LUXE 6135

DONNIE ELBERT

WHAT CAN I DO

b/w

HEAR MY PLEA

DE LUXE 6125

THE "5" ROYALES

THINK

b/w

I'D BETTER MAKE A MOVE

KING 5053

LITTLE WILLIE JOHN

I'VE GOT TO GO CRY

b/w

LOOK WHAT YOU'VE

DONE TO ME

KING 5045

THE MIDNIGHTERS

OH, SO HAPPY

b/w

IS YOUR LOVE FOR REAL

FEDERAL 12299

NEW RELEASE

EARL BOSTIC

SHE'S FUNNY THAT WAY

b/w

EXERCISE

KING 5056

KING
RECORDS



Best Selling Sheet Music

		LAST WEEK
1	DARK MOON Dandelion BMI—Miller	2
2	A WHITE SPORT COAT Acuff-Rose BMI—Robbins	4
3	ROUND AND ROUND Rush BMI—Stallman, Shapiro	3
4	LOVE LETTERS IN THE SAND Bourne ASCAP—Kenny, Kenny, Coats	10
5	LITTLE DARLIN' Excellorec BMI—Williams	5
6	ALL SHOOK UP Shalimar-Presley BMI—Blackwell, Presley	1
7	FOUR WALLS Sheldon BMI—Moore, Campbell	6
8	SO RARE Robbins ASCAP—Herst, Sharpe	15
9	COME GO WITH ME Gil & Phoebe BMI—Quick	11
10	WHY BABY WHY Winneton BMI—Dixon, Hanson	12
11	ALMOST PARADISE Peer International BMI—Petty	7
12	IT'S NOT FOR ME TO SAY Korwin ASCAP—Stillman, Allen	—
13	EMPTY ARMS Ivory BMI—Hunter	9
14	BUTTERFLY Mayland & Presley BMI—September	14
15	GIRL WITH THE GOLDEN BRAIDS Roncom ASCAP—Kahan, Snyder	—

first "GONE"...now even greater!

a new smash single by

FERLIN HUSKY



A FALLEN STAR PRIZE POSSESSION

record #3742



Peatman List

SONGS WITH LARGEST RADIO & TV AUDIENCE

The top 30 songs of the week on radio and TV based on the Copyrighted Audience Coverage Index & Audience Trend Index—A National Survey of Popular Music Heard Over Network Broadcasts. Published by the Office of Research, Inc., Dr. John G. Peatman, Director.

RADIO (LISTED ALPHABETICALLY) TV

A Face In The Crowd	Remick	A White Sport Coat	Acuff-Rose
A White Sport Coat	Acuff-Rose	All Shook Up	Shalimar
Almost Paradise	Peer	Around The World	Young
Around The World	Young	Best Way You Know How	Glenbrook
Bernardine	Palm Springs	Butterfly	Mayland & Presley
Can't Wait For Summer	Southern	Chantez, Chantez	Chantez
Do I Love You (Because You're Beautiful)	Williamson	Dark Moon	Dandelion
Don't Cry My Love	B. F. Wood	Do You Love Me	Valley
Empty Arms	Ivory	Empty Arms	Ivory
Endless Love	Mills	Fool's Errand	Planetary
Four Walls	Sheldon	Gone	Hill & Range
Girl With The Golden Braids	Roncom	I Can't Give You Anything But Love	Mills
Gunfight At The O.K. Corral	Paramount	I'll Never Cry	Sunbeam
I Can't Give You Anything But Love	Mills	I'm Sorry	Algonquin
I Could Have Danced All Night	Chappell	I'm Walkin'	Reeve
Italiano	Harms	It's You I Love	Travis
It's Good To Be Alive	Valyr	I've Grown Accustomed To Her Face	Chappell
It's Like Gettin' A Donkey To Gallop	Bregman-Vocco-Conn	Let's Keep The Dodgers In Brooklyn	Famous
Little Darlin'	Excellorec	Liberty Tree	Disney
Little White Lies	Bregman-Vocco-Conn	Little Darlin'	Excellorec
Look At 'Er	Valyr	Love Letters In The Sand	Bourne
Love Letters In The Sand	Bourne	Marianne	Montclare
Old Cape Cod	Pincus	Ninety-Nine Ways	Mayland
One For My Baby	E. H. Morris	Only One Love	Bentley
Round And Round	Rush	Round And Round	Rush
So Rare	Robbins	School Day (Ring Ring Goes The Bell)	Arc
Stars Fell On Alabama	Mills	So Rare	Robbins
Twelve O'Clock Tonight	Chas. N. Daniels	Teen Age Waltz	Champagne
Underneath The Overpass	Paramount	Too Late	Alamo
When Rock 'n Roll Come To Trinidad	Marvin	Valley Of Tears	Travis

"It's What's in THE CASH BOX That Counts—INTERNATIONALLY"



Album Sure Shots

★ Also Available in EP

BERGEN SINGS MORGAN
POLLY BERGEN
(Columbia CL 994)



Top Selling Records

Reported by

Retail Outlets

From Coast to Coast

ALAMO PIANO CO.
San Antonio, Tex.

1. Love Letters In The Sand (P. Boone)
2. Calypso Melody (D. Rose)
3. Talkin' To The Blues (J. Lowe)
4. Empty Arms (T. Brewer)
5. So Rare (J. Dorsey)
6. Till (P. Faith)
7. It's Not For Me To Say (J. Mathis)
8. Round And Round (P. Como)
9. Coconut Woman (H. Belafonte)
10. White Sport Coat (Robbins)

GILLETTE MUSIC
Chicago, Ill.

1. So Rare (J. Dorsey)
1. I'm Walkin' (R. Nelson)
3. Love Letters In The Sand (P. Boone)
4. All Shook Up (E. Presley)
5. Dark Moon (B. Guitar)
6. Don't Cry My Love (V. Lynn)
7. With All My Heart (J. Sands)
8. Come Go With Me (Del-Vikings)
9. Gonna Find Me A Bluebird (M. Rainwater)
10. I Just Don't Know (4 Lads)

BURK'S MUSIC SHOP
St. Paul, Minn.

1. School Day (C. Berry)
2. Love Letters In The Sand (P. Boone)
3. Freight Train (R. Draper)
4. Those Brown Eyes (Tarriers)
5. Trust In Me (C. Conner)
6. Gonna Find Me A Bluebird (M. Rainwater)
7. I Like Your Kind Of Love (A. Williams)
8. So Rare (J. Dorsey)
9. He's Mine (Platters)
10. I Just Don't Know (4 Lads)

CALIFORNIA MUSIC CO.
Los Angeles, Calif.

1. So Rare (J. Dorsey)
2. All Shook Up (E. Presley)
3. Love Letters In The Sand (P. Boone)
4. White Sport Coat (Robbins)
5. Little Darlin' (Diamonds)
6. Gone (F. Husky)
7. My Little Baby (P. Como)
8. Freight Train (R. Draper)
9. Dark Moon (G. Storm)
10. Start Movin' (S. Mineo)

RICHLOY ONE STOP
Philadelphia, Pa.

1. All Shook Up (E. Presley)
2. Love Letters In The Sand (P. Boone)
3. White Sport Coat (Robbins)
4. I'm Walkin' (R. Nelson)
5. My Secret Love (Carterays)
6. School Day (C. Berry)
7. Four Walls (J. Reeves)
8. Start Movin' (S. Mineo)
9. Little Darlin' (Diamonds)
10. So Rare (J. Dorsey)

AMERICAN MUSIC CO.
Houston, Tex.

1. Searchin' (Coasters)
2. C. C. Rider (C. Willis)
3. Isabella (R. Tan)
4. Little Darlin' (Diamonds)
5. Valley Of Tears (F. Domino)
6. Dark Moon (G. Storm)
7. Talkin' To The Blues (J. Lowe)
8. Love Letters In The Sand (P. Boone)
9. Bad Boy (Jive Bombers)
10. Young Blood (Coasters)

Mineo Starts Fans Movin'



DETROIT—18 year old Movie Star, Sal Mineo was mobbed by wildly enthusiastic fans Saturday May 18th at Edgewater Park in Detroit.

Mineo appeared on the "Bobbin' with Robin" show on WKMH. Robin Seymour told reporters Mineo was due to arrive at 4:00 P.M.—the crowd arrived at three. "I returned to the broadcast trailer just before the Tiger baseball game went off the air," said Seymour, "and it took me about ten minutes to get from the edge of the crowd to the door of the trailer.

I must say there was no intentional violence or vandalism in the crowd, everyone was in a holiday mood. The trouble came because those in the rear were pressing forward to get a better look. It took 16 policemen, a dozen park employees and several volunteers from the crowd almost an hour to clear a path fifteen feet from Mineo's car door to the trailer door. In the meantime the pressure from the crowd knocked us off the air twice, broke two windows in the trailer, broke the tail lights on the trailer. Several teen-agers had their friends boost them atop the trailer. About a half dozen were forced into the trailer itself by the pressure of the crowd—there was no way possible to get them out so we let them stay—it was like canoing in a sieve. Several times I was sure the trailer was going to get tipped over. All this time we were on the air. Each time the crowd snapped our broadcast lines Russ Betz, our engineer, would plunge into the crowd, find the trouble and fix it. He did a terrific job—he kept us on the air with spit and baling wire. It was hilarious. It was raining off and on all afternoon and everyone was drenched but happy.

"Very little advance promotion was given—we mentioned it on the air several times a day beginning Tuesday. It seems to me that this demonstrates a very important fact—radio is bigger today than it ever was. It is obvious that if you want to reach the people of America you've got to use radio".

Above, the cameraman catches some of the afternoon's action. Mineo's first Epic disk "Start Movin'" is currently in the nation's top ten.

THE RECORD SHOP
Hartford, Conn.

1. Bye Bye Love (Everly Bros.)
2. Start Movin' (S. Mineo)
3. Love Letters In The Sand (P. Boone)
4. When Rock N' Roll Came To Trinidad (N. Cole)
5. White Sport Coat (Robbins)
6. Around The World (Crosby)
7. Freight Train (C. Devitt)
8. Rockin' Rollin' Rover (Haley)
9. Gone (F. Husky)
10. Goin' Steady (T. Sands)

GARDEN CITY MUSIC CTR.
Garden City, L. I., N. Y.

1. Bye Bye Love (Everly Bros.)
2. Little Darlin' (Diamonds)
3. Wonderful! Wonderful! (J. Mathis)
4. One For My Baby (Bennett)
5. All Shook Up (E. Presley)
6. Come Go With Me (Del-Vikings)
7. Teenage Romance (R. Nelson)
8. School Day (C. Berry)
9. White Sport Coat (Robbins)
10. Dark Moon (G. Storm)

BOSTON RECORD DIST.
Boston, Mass.

1. It's Not For Me To Say (J. Mathis)
2. Little Darlin' (Diamonds)
3. All Shook Up (E. Presley)
4. Rock-A-Billy (G. Mitchell)
5. Dark Moon (B. Guitar)
6. So Rare (J. Dorsey)
7. Harem Dance (Armenian Jazz Sextet)
8. White Sport Coat (Robbins)
9. School Day (C. Berry)
10. Empty Arms (T. Brewer)

SUPER ENTERPRISE
Washington, D. C.

1. Bye Bye Love (Everly Bros.)
2. So Rare (J. Dorsey)
3. School Day (C. Berry)
4. Four Walls (J. Reeves)
5. Young Blood (Coasters)
6. Valley Of Tears (F. Domino)
7. Dark Moon (G. Storm)
8. All Shook Up (E. Presley)
9. Love Letters In The Sand (P. Boone)
10. White Sport Coat (Robbins)

G. SCHIRMER MUSIC CO.
Cleveland, Ohio

1. Rosie Lee (Mello Tones)
2. Love Letters In The Sand (P. Boone)
3. Over The Mountain (C. Berry)
4. So Rare (J. Dorsey)
5. I'm Walkin' (R. Nelson)
6. All Shook Up (E. Presley)
7. Dark Moon (G. Storm)
8. Young Blood (Coasters)
9. School Day (C. Berry)
10. Start Movin' (S. Mineo)

THE MUSIC BOX
Spokane, Wash.

1. All Shook Up (E. Presley)
2. School Day (C. Berry)
3. Love Letters In The Sand (P. Boone)
4. Four Walls (J. Reeves)
5. White Sport Coat (Robbins)
6. Little Darlin' (Diamonds)
7. Dark Moon (B. Guitar)
8. Bye Bye Love (Everly Bros.)
9. I'm Walkin' (F. Domino)
10. Talkin' To The Blues (J. Lowe)

SPRUCE RECORD SHOP
Scranton, Pa.

1. Love Letters In The Sand (P. Boone)
2. Start Movin' (S. Mineo)
3. School Day (C. Berry)
4. Good Morning Captain (J. D. Gibson)
5. Bye Bye Love (Everly Bros.)
6. Gonna Find Me A Bluebird (M. Rainwater)
7. All Shook Up (E. Presley)
8. My Little Baby (P. Como)
9. Star Dust (N. Cole)
10. Fabulous (C. Gracie)

BELL SALES CO.
Knoxville, Tenn.

1. Rang Tang Ding Dong (Cellos)
2. Young Blood (Coasters)
3. Searchin' (Coasters)
4. All Shook Up (E. Presley)
5. Dark Moon (G. Storm)
6. Rock Your Little Baby To Sleep (B. Knox)
7. Four Walls (J. Reeves)
8. Love Letters In The Sand (P. Boone)
9. C. C. Rider (C. Willis)
10. Empty Arms (I. J. Hunter)

ONE STOP RECORD SERVICE
Kansas City, Mo.

1. Love Letters In The Sand (P. Boone)
2. So Rare (J. Dorsey)
3. School Day (C. Berry)
4. I'm Sorry (Platters)
5. I'm Stickin' With You (J. Bowen)
6. Too Late (G. Austin)
7. After School (R. Starr)
8. Dark Moon (G. Storm)
9. Rock Your Little Baby To Sleep (B. Knox)
10. Teenage Romance (R. Nelson)

ALBEE MUSIC CENTER
Brooklyn, N. Y.

1. It's Not For Me To Say (J. Mathis)
2. Come Go With Me (Del-Vikings)
3. Little Darlin' (Diamonds)
4. Wonderful! Wonderful! (J. Mathis)
5. With All My Heart (J. Sands)
6. Start Movin' (S. Mineo)
7. White Sport Coat (Robbins)
8. Over The Mountain (Johnnie & Joe)
9. So Rare (J. Dorsey)
10. Love Is A Golden Ring (F. Laine)

THE GROOVE RECORD SHOP
Norfolk, Va.

1. Johnny's House Party (J. Heartsman & Gaylarks)
2. Searchin' (Coasters)
3. School Day (C. Berry)
4. Lucille (L. Richard)
5. Rang Tang Ding Dong (Cellos)
6. All Shook Up (E. Presley)
7. I'm Sorry (Platters)
8. Party Doll (R. Brown)
9. Let The Four Winds Blow (R. Brown)
10. Next Time You See Me (L. J. Parker)

LYRIC NEWS & REC. SHOP
Indianapolis, Ind.

1. So Rare (J. Dorsey)
2. Gone (F. Husky)
3. Mama Looka Booboo (H. Belafonte)
4. Dark Moon (G. Storm)
5. Almost Paradise (R. Williams)
6. Wonderful! Wonderful! (J. Mathis)
7. Goin' Steady (T. Sands)
8. China Gate (N. Cole)
9. My Dream (Platters)
10. Love Letters In The Sand (P. Boone)

CAMPUS RECORD SHOP
Detroit, Mich.

1. Love Letters In The Sand (P. Boone)
2. Start Movin' (S. Mineo)
3. I'm Walkin' (R. Nelson)
4. Young Blood (Coasters)
5. Bye Bye Love (Everly Bros.)
6. Rosie Lee (Mello Tones)
7. School Day (C. Berry)
8. Baby She's Gone (J. Scott)
9. So Rare (J. Dorsey)
10. Over The Mountain (Johnnie & Joe)

DEW MUSIC CO., INC.
Monroe, La.

1. Searchin' (Coasters)
2. All Shook Up (E. Presley)
3. Talkin' To The Blues (J. Lowe)
4. So Rare (J. Dorsey)
5. Come Go With Me (Del-Vikings)
6. He's Mine (Platters)
7. Dark Moon (G. Storm)
8. Fabulous (C. Gracie)
9. Bernadine (P. Boone)
10. C. C. Rider (C. Willis)

BERGENFIELD MUSIC, INC.
Bergenfield, N. J.

1. It's Not For Me To Say (J. Mathis)
2. Love Letters In The Sand (P. Boone)
3. White Sport Coat (Robbins)
4. Start Movin' (S. Mineo)
5. Dark Moon (G. Storm)
6. All Shook Up (E. Presley)
7. Bye Bye Love (Everly Bros.)
8. So Rare (J. Dorsey)
9. Yes Tonight Josephine (Ray)
10. Little Darlin' (Diamonds)

All reports are
So Great for
"SO YOUNG"
by
Clyde Stacy
Candlelight #1015
CANDLELIGHT RECORDS
1650 BROADWAY
(Phone: Circle 7-5947)

"Only those records best suited for commercial use are reviewed by THE CASH BOX"



Best Selling Pop Albums

★ Also Available in EP

		Pos. Last Week
1	★A SWINGIN' AFFAIR! FRANK SINATRA (Capitol W 803 * EAP-1-803, 2-803, 3-803, 4-803)	1
2	★MY FAIR LADY BROADWAY CAST (Columbia OL 5090 * A 5090)	3
3	★LOVE IS THE THING NAT "KING" COLE (Capitol W-824 * EAP-1-824, 2-824, 3-824)	2
4	AROUND THE WORLD IN EIGHTY DAYS MOVIE SCORE (Decca DL 9046)	4
5	★STEADY DATE TOMMY SANDS (Capitol T 848 * EAP-1-848, 2-848, 3-848)	5
6	MANTOVANI FILM ENCORES MANTOVANI AND HIS ORCHESTRA (London LL-1700)	8
7	★HYMNS TENNESSEE ERNIE FORD (Capitol T 756 * EAP-1-756, 2-756, 3-756)	6
8	★CALYPSO HARRY BELAFONTE (RCA Victor LPM 1248 * EPA 1248)	7
9	★ROGER WILLIAMS: SONGS OF THE FABULOUS FIFTIES ROGER WILLIAMS (Kapp KXL 5000 * KE-714, 15, 16, 17, 18) (2—12" LP)	9
10	★AN EVENING WITH BELAFONTE HARRY BELAFONTE (RCA Victor LPM 1402 * EPA 1402)	10
11	★THE KING AND I MOVIE CAST (Capitol W 740 * EAP 740)	12
12	★SPIRITUALS TENNESSEE ERNIE FORD (Capitol T-818 * EAP-1-818, 2-818, 3-818)	11
13	★DANCE TO THE MUSIC OF LESTER LANIN (Epic LN 3340 * EG 7185)	20
14	★CLOSE TO YOU FRANK SINATRA (Capitol W 789 * EAP 789)	13
15	★OKLAHOMA MOVIE CAST (Capitol SAO 595 * SDM 595)	15
16	★'S WONDERFUL RAY CONNIFF (Columbia CL 925 * EPA 925)	18
17	BERGEN SINGS MORGAN POLLY BERGEN (Columbia CL 994)	—
18	★THE EDDIE DUCHIN STORY MOVIE SCORE (Decca DL 8289)	14
19	WALTZ WITH LAWRENCE WELK (Coral CRL 57119)	17
20	IT'S POLKA TIME STAN WOLOWIC (ABC-Paramount ABC 151)	19
21	CINDERELLA ORIGINAL TV CAST (Columbia OL-5190)	16
22	★ELLA FITZGERALD SINGS THE RODGERS AND HART SONG BOOK (2—12" LP) (Verve MG V 4002 * EPV-5027, 8, 9, 30, 31, 32, 33, 34, 35)	24
23	★ELVIS ELVIS PRESLEY (RCA Victor LPM 1382 * EPB 1382)	21
24	PAT PAT BOONE (Dot DLP-3050)	25
25	★SUDDENLY IT'S THE HI-LO'S (Columbia CL 592 * B-9521, 2, 3)	23

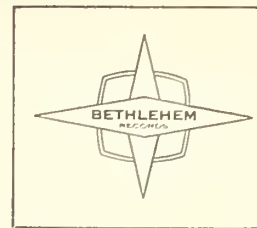

Sallie Blair



Sallie Blair

SQUEEZE ME — SALLIE BLAIR

Bethlehem Records: BCP 6009

"SHE IS SEX
WITH A CAPITAL X"
... Walter Winchell

Sallie Blair sings like no one has ever sung before. Orchestrations by Richard Wess.



DON'T MISS IT!

BETHLEHEM
New York Hollywood



An example of a 4 color cover printed by us will appear here every week.

AMAZING

NEW LOW PRICES FOR PRINTING
4 COLOR PROCESS ALBUM COVERS
New facilities enable us to Beat Competition and Meet Schedules!

WRITE—WIRE OR PHONE
For immediate quotations on any job

PILGRIM PRESS

124 White St.
N. Y.

Phone:
WOrth 6-0755-
Peter Strauss

"It's What's in THE CASH BOX That Counts—INTERNATIONALLY"



Album Reviews

POPULAR

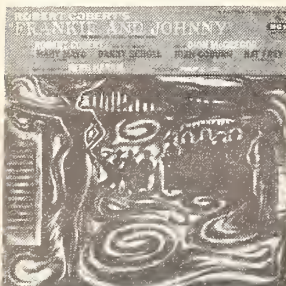

"FRANKIE AND JOHNNY" — An American Legend In Two Acts—MGM E3499 (1-12" LP)

"Frankie And Johnny" is a musical drama with a score and book by Robert Cobert, and lyrics by Dion McGregor. Based on the classic he-done-her-wrong tale, the score contains both the techniques of musical comedy and opera. It is effectively performed by a cast headed by Mary Mayo (Frankie); Danny Scholl (Johnny); Joan Coburn (Nelly Bly) and Nathaniel Frey (Bartender). The show music coterie is the big market here.



"ALICE IN WONDERLAND" — "MANY MOONS" — "THE EAGER PIANO"—Jane Powell—Columbia CL 986 (1-12" LP)

Jane Powell is heard in a musical-narrative presentation of Lewis Carroll's classic "Alice In Wonderland." Miss Powell warmly relates Alice's adventures nicely aided by Carmen Dragon's delicate musical score and a supporting cast. Two other children's tales, previously available on a Columbia 10 inch disk, on the set are James Thurber's delightful "Many Moons" and Michael Morris' clever adventures of a piano, "The Eager Piano." Outstanding presentation for youngsters.



"FRANCES FAYE SINGS FOLK SONGS" — Bethlehem BCP 6017 (1-12" LP)

Miss Faye displayed an adventurous singing spirit in the unique, and in this corner well-done, Bethlehem "Porgy And Bess" package. Many folk songs lend themselves admirably to a jazz treatment, and the stylist proves it in this fine release. "Frankie And Johnny," "St. James Infirmary" and "Lonesome Road" are more obvious examples on disk; but listeners can marvel at the sensitivity (and jazz sensitivity) Miss Faye imparts on such items as "Greensleeves" and "Johnny Has Gone For A Soldier" with throaty conviction. Bethlehem and Frances Faye have another interesting, and successful experiment.



"SONGS BY MARVIN RAINWATER" — MGM E3534 (1-12" LP)

Rainwater's C&W and pop stock rose considerably with his current smash, "Gonna Find Me A Bluebird," and this collection of his single stints for MGM (including "Bluebird") ought to be eyed with enthusiasm by dealers facing both a country and/or pop market. Rainwater has a soothing, and highly versatile delivery with a warmth and sparkle of considerable means. Notable examples from talented artist.



"DESIGNED FOR DANCING"—Jan Garber And His Orchestra—Decca DL 8484 (1-12" LP)

Garber has been dishing up the sentimental fox-trot beat for many years, and this experience is brought out in every bounce and sax solo. The tunes include a list of unchallenged evergreens ("All The Things You Are," "Pagan Love Song," "Love Walked In"). This is reliable work for the more mature folks from Decca.

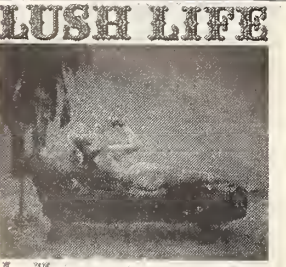

"LUSH LIFE" — Joe Mooney's Songs—Atlantic 1255 (1-12" LP)

This Atlantic release features singer-organist Joe Mooney in a collection of rare items ("Polka Dots And Moonbeams," "Lush Life," "Have You Met Miss Jones") sung and played with a distinguished taste for describing the "plot" of each tune with conviction, and understanding. Milt Hinton on bass and Osie Johnson on drums are the bright backing. Unusually fine disk appearance.



"BITS AND PIECES"—Jackie And Roy—ABC-Paramount ABC 163 (1-12" LP)

Jackie and Roy, the delightful jazz-inspired vocal team, are at their inventive best in their second LP effort for ABC-Paramount. On a program of 8 originals and 2 evergreens ("Darn That Dream" and "I'm Forever Blowing Bubbles"), the team romps through most of them with sometimes only a boop-pah-doo against the snappy ork support ("Aura"). Smart, gay and totally delectable vocal jazz waxing.



"THE GILDED HAWK" — Coleman Hawkins, Tenor Sax—Capitol T 819 (1-12" LP)

This could be just good mood music, but with Coleman Hawkins doing the solo tenor sax work here, there is purpose and good mood music. Hawkins, on a program of indestructables ("I Didn't Know What Time It Was," "Autumn Leaves," "Every Thing Happens To Me") sensitively caresses the melodic strains of each selection. Glenn Osser directs the lush string backing. Excellent jazz-mood attraction.

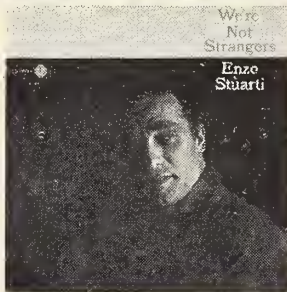

"WE'RE NOT STRANGERS"—Enzo Stuarti — Jubilee JLP 1041 (1-12" LP)

Stuarti is the Italian-born singer making his first LP appearance in a program nicely flavored with melodies suggesting Italian foundations ("I Have But One Heart," "Santa Lucia," "O' Sole Mio"). The artist is perfectly at home in the warmth and soaring quality of the material, which he sings in both Italian and English. Fine vocal efforts.



"MEYER DAVIS CORDIALLY INVITES YOU..." — Meyer Davis And His Orchestra — ABC-Paramount ABC-176 (1-12" LP)

The Davis crew is one of the leading orks specializing on "society" functions, and disks utilizing the efforts of such an outfit usually fare very well, sales-wise. The 9 bands contain a total of 25 melodies ("This Can't Be Love," "Blue Skies," "Just In Time"), including "full-length" versions of such favorites as "Blue Danube" and "Siboney," all dressed up in a skillful, familiar society beat. This is strong chart potential.



"BAMBI"—Music From The Original Motion Picture Sound Track—Disneyland WDL-4010 (1-12" LP)

"DUMBO"—Music From The Original Motion Picture Sound Track — Disneyland WDL-4013 (1-12" LP)

Two further charming LP sound-tracks from Disneyland, the memorable "Bambi," and "Dumbo," are now available, and dealers are advised to make lots of room for them on their kiddy shelf. The "Bambi" pressing is highlighted by 2 lovely songs, "Love Is A Song" and "I Bring You A Song" plus witty scoring. A circus atmosphere is expertly caught in "Dumbo" with such delights as "Look Out For Mr. Stork" and "Pink Elephants On Parade" plus, once again, a sparkling orchestral score. Major childrens' stock.



"HAWAIIAN MEMORIES" — The Hawaiian Troubadors—Mercury MG 20217 (1-12" LP)

This is Hawaiian music, played by Frenchmen for American consumption. On the collection of exotic Hawaiian melodies ("The Hawaiian Serenade," "Song Of The Islands," and "Pagan Love Song"), the boys, on guitars and celeste, whip through them with a fine touch for authenticity and affection. Good mood stuff for those caught in the lure of the islands.



"CALYPSO FOR DANCING"—JC. Heard—Epic LN 3348 (1-12" LP)

For those still hep to calypso, this Epic issue ought to fill the bill. Singer-drummer JC. Heard, one time performer for Duke Ellington, Cab Calloway, and Benny Goodman and others, has cut 12 easy-going, slickly portrayed calypso compositions designed for a dance step, but, as most of the set's purchasers will regard as more important, also very listenable. Good calypso fun.



"NEARER MY GOD TO THEE"—The Louvin Brothers—Capitol T 825 (1-12" LP)

The Louvin Brothers are one of the most familiar, and accomplished interpreters of religious music in the country and western field. With warmth, rhythm and sincerity, the team presents 12 inspirational songs, half of them written by the boys. Selections from the program: "Nearer My God To Thee," "Praying," "Last Chance To Pray," and "Wait A Little Longer, Please Jesus." Must C&W stock.



Album Reviews



"NOSTALGIA IN HI-FI" — Golden Crest CR 4002 (1-12" LP)

From Golden Crest's "Lab Series" comes this hi-fi collection of sounds from the musical machine of yesteryear. The brassy tinkle of these mechanical music makers is quaint, and so are the tunes ("Dark Town Strutters Ball," "Peg O' My Heart,"). Accurately recorded sound. Hi-Fi buffs will be this set's most enthusiastic market.



"JOE LOCO PLAYS THE CLASSICS" — Joe Loco And His Orchestra—Seeco CELP 406 (1-12" LP)

Latin ork leader Joe Loco, in somewhat of a recess from his cha-cha-cha and mambo doings, has transcribed 12 classical selections to an up tempo and frothy South-Of-The-Border beat. The material includes such familiar pieces as Chopin's "Polonaise Op. 35"; Rimsky-Korsakoff's "Song Of India"; and Schubert's "Serenade." Classy renditions of melodic numbers.

JAZZ

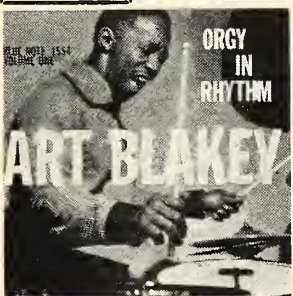

"ORGY IN RHYTHM"—Art Blakey, Drums — Blue Note 1554 (1-12" LP)

This is one of the most ambitious and creative steps into the afro-jazz relationship. First-rate drummer Art Blakey, working with a number of percussion instruments (conga, timbales, tree logs), formal jazz devices (piano, flute, bass) plus occasional chants by one Sabu and Blakey himself, has created 7 penetrating and quite striking sessions that have an unrelenting vitality and expressiveness. Excellent sound. An always interesting waxing.



"THE AUSTRALIAN JAZZ QUINTET + 1" — Bethlehem 6015 (1-12" LP)

The group is a prime source of dealer jazz revenue. One side of the disk is devoted to a 3 movement jazz opus by Bill Holman, "Jazz In D Minor," a smartly swinging work with a haunting middle movement. The flip side, on standards ("I'll Be Around,") and originals ("Cubano Chant"), is highlighted by the skillful touch of Dick Healey on flute and Jack Broken-sha on vibes. Excellent jazz material.

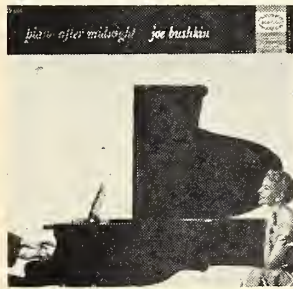

"PIANO AFTER MIDNIGHT"—Joe Bushkin — Epic LN 3345 (1-12" LP)

Bushkin is a blend of society and jazz pianist with the latter approach usually, and effectively, getting the upper hand. The set features Bushkin, assisted at times by Buck Clayton (trumpet), Jo Jo Jones (drums) and either Eddie Safranski and Sid Weiss on bass, on 10 standards ("Here In My Arms," "Once In A While") and 2 Bushkin originals ("High Cotton," "Everyday Is Christmas") played with a light, relaxed attack. Slick artistry for jazz or mood listening.

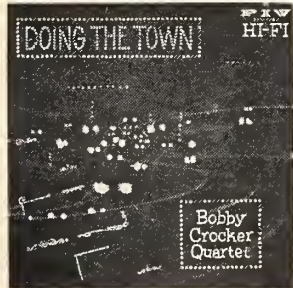

"DOING THE TOWN"—Bobby Crocker Quartet — Piv 5000 (1-12" LP)

As the group is doing New York town, its urban and polished approach to the bill ("42nd Street," "Lullabye Of B'way," "Street Of Dreams") fits neatly into the general atmosphere associated with the place. The big guns in the Crocker (drums) are pianist Ray Rasch and guitarist Howard Roberts. Some fine sophisticated jazz punches here.



"JAZZ MESSAGE #2"—Featuring Hank Mobley (Tenor Sax)—Savoy MG-12092 (1-12" LP)

The disk is divided into 2 groups, with Mobley and bassist Doug Watkins the only musicians on both sides of the pressing. Though Mobley's effervescent tenor does most of the featured playing here, greatly aiding the flighty and happy mood of the affair are such stellar performers as Lee Morgan (trumpet); Donald Byrd (trumpet); Kenny Clark and Art Taylor on drums; and Hank Jones and Barry Harris on piano. Original pieces. Terrific show of names, and they perform beautifully. Fine sessions.



"LATIN KICK"—Cal Tjader — Fantasy 3250 (1-12" LP)

There is a growing disk relationship between Latin rhythms and jazz, and previous to this Fantasy release, jazz vibist Cal Tjader turned a similar trick with an issue labeled, "Mambo With Tjader." This package cover the Latin beat with smoothness, directing itself, at times, to the cha cha beat ("Moonlight In Vermont") or to more formal jazz ("Will You Still Be Mine"). Brew Moore on tenor does some of the neatest jazz tricks. Relaxed Jazz-Latin offering.



"NICE DAY WITH BUDDY COLLETTE" — Featuring Collette Playing Clarinet, Alto Sax, Flute And Tenor Sax — Contemporary C3531 (1-12" LP)

This is Collette's second pressing for Contemporary, the first being a similar approach. The 10 sessions feature Collette in 1 of 4 instruments (clarinet, flute, alto and tenor sax) on several evergreens ("Over The Rainbow," "I'll Remember April") and Collette compositions ("A Nice Day," "Fall Winds"), playing briskly with 2 exceptions: the haunting and tender flute work on "Over The Rainbow" and "Fall Winds."

CLASSICAL



MOZART: Concerto No. 21 In C Major For Piano And Orchestra (K. 467)—Concerto No. 27 In B-Flat Major For Piano And Orchestra (K. 595)—Rudolf Serkin — The Columbia Symphony Orchestra Under The Direction of Alexander Schneider—Columbia ML 5013 (1-12" LP)

Pianist Rudolf Serkin measures up beautifully to these two brilliant Mozart concertos, each of whom is fairly well represented in the LP catalogue. Serkin's command of both the colorful Concerto No. 21 and the contrasting soul-searching of the Concerto No. 27 is one of great virtuosity and insight. Excellent orchestral support from Alexander Schneider and the Columbia Symphony Orchestra. Here's the versions of the two works the classical coterie will want.



SURINACH: Second Symphony—**TURINA:** Rapsodia Sinfonica For Piano And Orchestra—Sondra Bianca, Piano—With Arthur Winograd Conducting The Philharmonia Orchestra Of Hamburg—MGM E3510 (1-12" LP)

Composer-conductor Carlos Surinach's "Second Symphony" is highly rhythmic orchestral composition strongly associated with the musical qualities of his native Spain, and Joaquin Turina's "Rapsodia Sinfonica" evokes with a fiery passion and tenderness the composer's own Seville. Sondra Bianca provides the commendable keyboard artistry on the latter work. Fine disk.

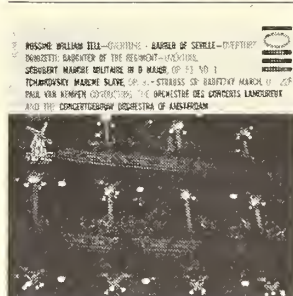

ROSSINI: William Tell Overture — Barber Of Seville Overture — **DONIZETTI:** Daughter Of The Regiment Overture — **SCHUBERT:** Marche Militaire, Op. 51. N. 1—**TCHAIKOVSKY:** Marche Slave, Op. 31—**STRAUSS, SR:** Radetsky March, Op. 228 Paul Van Kempen conducting The Orchestre Des Concerts Lamoureux And The Concertgebouw Orchestra Of Amsterdam—Epic LC 3349 (1-12" LP)

The rousing and melodic nature of these familiar overtures and marches make them convenient companion pieces for a hi-fi treat. This is just what the listener receives from conductor Paul Van Kempen.



FRANCAIX: Symphony For Strings—**IBERT:** Divertissement—Carlos Surinach Conducting The MGM Orchestra—MGM E 3514 (1-12" LP)

This MGM release provides an abundance of musical laughs, one from Jean Francaix and his adroit and clever "Symphony For Strings," the other from Jacques Ibert, who goes even further than Francaix's work in its delightful kidding of musical conventions. Carlos Surinach, whose work for MGM has most often been on rarely recorded items, does a sparkling orchestral stint with the MGM orchestra. Fine sound. Two witty orchestral creations, well performed.



J. S. BACH: 12 Chorale Preludes From The Orgelbuchlein Toccata, Adagio And Fugue In C Major—Andre Marchal — Zodiac LP-335 (1-12" LP)

Marchal is the sightless organist of the Church of St. Eustache in Paris, and in this Zodiac release Marchal performs 12 lovely religious Chorale preludes from Bach's "Orgelbuchlein" on one side, and Bach's famed "Toccata, Adagio, And Fugue In C Major." The performance on both counts is organ work of the first order, wonderfully expressive in feeling, astonishingly skillful in its technical attack. Superb sound. Outstanding Bach reading.

On The MOA Convention Floor



- | | | | |
|--|--|--|--|
| 1) Bob Austin and Charlie Hall. | 7) Betty Johnson and Joe Carlton. | Nancy Whiskey, Harold Pounds, Al Kallman and Rita Carlyle. | 18) The Four Freshmen. |
| 2) Henry Droz, Jack Scott, Larry Newton, Frankie Avalon, Bob Mareucci and Lenny Garmisa. | 8) Al LeFleur and record model. | 14) Sonny Cox and Nancy Whiskey. | 19) Pee Wee King, Ivory Joe Hunter and Don Cherry. |
| 3) Jerry Mazzara and Carol Lamb. | 9) Abner, Chuck Peele and Calvin Carter. | 15) Mike Maitland and Margaret Whiting. | 20) Joe Deane, Cathy Carr and Ed Bonner. |
| 4) Goldie Goldmark and Joe Carlton. | 10) Li'l Wally. | 16) Sandy Singer, Betty Johnson, Reed Farrell and Spider Webb. | 21) Mel Schlank and Diane Payne |
| 5) Nick Alexander and the Coquettes. | 11) Marvin Rainwater and Sol Handwerker. | 17) Don Cherry and Herb Oettinger. | 22) Paul Cohen and Miss Wong. |
| 6) Lou Boorstein, Hal Fine, Mrs. Hal Fine, Jerry Baline and Jack Burgess. | 12) Jimmy Hilliard and Glory Fox. | | See other photos on page 31 and 48 |
| | 13) Chic Records model, Bill Varley, | | |

TAKING OFF!
EDDIE COCHRAN
"Mean When I'm Mad"
 # 55070

LIBERTY
 RECORDS, INC.

ANOTHER BMI "PIN-UP" HIT
SCHOOL DAY (RING! RING! GOES THE BELL)
 Recorded by **CHUCK BERRY . . . Chess**
"BIG" TINY LITTLE . . . Brunswick
 Published by **ARC MUSIC CORP.**

Dot Records Ships "Ten Commandments" Albums

HOLLYWOOD—Dot Records' prexy Randy Wood last week announced that first shipments of the label's deluxe LP of Elmer Bernstein's original music score from Cecil B. DeMille's "The Ten Commandments" already were being received by retail outlets.

"The Ten Commandments" album is the culmination of four months of preparation by Dot album chief Tom Mack, represents his first assignment since joining Dot Records in February, and is the label's first LP from a motion picture sound track.

The original music score for "The Ten Commandments" was considered by DeMille as an important, integral part of the picture, and came under his close personal supervision. It was composed by Elmer Bernstein, who considered it his "challenge of a lifetime", and required a year and a half to write.

An ancient, unusual musical instrument, the sistrum, in use over three thousand years ago and re-created by modern experts with detailed correctness according to thorough museum research, was employed by Bernstein to achieve a musical framework of Biblical times, along with the shofar or ram's horn, equally ancient but still used today. Certain modern but rare instruments such as the

theremin and novachord, tiple, Indian drum, finger cymbals, and bass flute were used by Bernstein for musical effects related to the Biblical period. One of Bernstein's minor problems was to teach a modern musician how to play the sistrum.

By working out possible tonal ranges and likely combinations of sounds and notes which could come from these odd instruments, Elmer Bernstein's score includes fanfares, processions and ballet music, as well as music for awesome sequences like Moses before the Burning Bush on Mount Sinai; the Exodus to freedom of the Children of Israel; the parting of the Red Sea; the destruction of the Pharaoh's chariots; the wild worship of the Golden Calf; and the giving of the Commandments.

The two-pocket cover of "The Ten Commandments" album, designed by Jerome Gould and Associates, winner of many national awards in all fields of design, features multi-color photographs of actual scenes from the picture, with captions of authentic Biblical reference. The editorial liner contains copy written by Cecil B. DeMille, a brief biography of Elmer Bernstein, with direct quotes from the composer concerning the complexities of the problems in scoring a picture of

the magnitude of "The Ten Commandments", a listing of the unusual musical instruments used, and titles of the musical excerpts from the score. With the final approval of Cecil B. DeMille, who remained personally interested in the album, Dot's album chief Tom Mack, working closely with Randy Wood, selected 18 pieces from the wealth of available material as being most representative musically of the scope and meaning of the picture itself.

Side 1 of the album contains four bands: 1. Prelude; 2. In the Bulrushes; 3. The Bitter Life; 4. Love and Ambition. Side 2 has six bands: 1. The Hard Bondage; 2. Egyptian Dance; 3. The Crucible of God; 4. And Moses Watered Jethro's Flock; 5. Bedouin Dance; 6. I Am That Am. Side 3's four bands are: 1. Overture; 2. Thus Says The Lord; 3. The Plagues; 4. The Exodus. The final Side 4 is composed of four pieces: 1. The Pillar of Fire; 2. The Red Sea; 3. The Ten Commandments; and 4. Go, Proclaim Liberty!

Active public interest in the music from "The Ten Commandments" is evidenced by advance orders which began to come in before actual work on the album even started the diskery reported.

"Only those records best suited for commercial use are reviewed by THE CASH BOX"

At The MOA Convention Banquet



CHICAGO—Shown seated at the dais are: (Front Row L. to R.) Lt. Com. Bishop; Lt. Com. Spearman; Capt. Waliszewski; Hon. Cong. George P. Miller; Guest of Honor G. Norman Ditchburn, London, Eng.; Frank Fabiano; James Hutzler; Ralph Ridgeway, Max Hurvich and Willie Blatt. (Rear Row L. to R.) Lloyd Cramer, Ted Nichols, Gordon Stout, John A. Wallace, Norman Gefke, Larry Marvin, Lou Casola, Howard Ellis, Harlan Wingrave, Sidney Levine, George A. Miller, Clinton S. Pierce, Harry Snodgrass, Martin Britz, Tom Winthrow, Wm. Hullinger, Les Montooth, James Tolisano, Lewis Ptacek, Jr., and Victor Ostergren.



23) Seated at The Cash Box table are: (clockwise) Bob Austin, Bill Gersh, Cissie Gersh, Mrs. Howie Freer, Marcia Hillman, Mrs. Chuck Peele and Chuck Peele, Howie Freer.

24) On stage, Hirsh de la Viez.
25) Somethin' Smith and the Red-heads.
26) Jodie Sands.
27) The Diamonds.

28) Jimmy & Virginia Hilliard.
29) Eddy Arnold and Don Cherry.
30) Margaret Whiting.
31) Roger Williams.
32) Betty Madigan.

33) Georgia Gibbs.
34) Tony Bennett.
35) Bonnie Guitar.
36) Little Brenda Lee.
37) Dean Jones.

Columbia Announces Winners Of Mozart Contest

NEW YORK—Winners have been announced for Columbia Records' National Mozart Bicentennial Contest.

The objective of the contest was to stimulate student interest in the music of Mozart, and provide incentive for teachers to develop a creative study unit. During 1956-57, the year marking the 200th anniversary of Mozart's birth, eighth-graders across the country were delving into encyclopedias, dictionaries and music libraries, producing scrapbooks, radio scripts and even color sound films.

First prize (100 LP records and a high fidelity phonograph equipped with headset earphones for classroom use) was awarded to St. Edwards School, Waterloo, Iowa. This ambitious group of eighth-graders filmed in color and with sound their conception of the life of Mozart. Entitled "Mozart the Wonder Boy", the film was written, produced, staged and dramatized by the youngsters themselves.

Portraying Mozart in his amazing childhood, the script required a juvenile thespian to perform on the piano, organ and violin, as well as trip over the feet of a suspiciously youthful looking Austrian Emperor. In his untimely death scene, Mozart was shown frantically composing his last major work, coughing dramatically, adjusting his cotton wig and finally slumping lifelessly in his chair, his right hand remembering to drop a quill pen to the floor. The group's teacher is Sister Mary Lolita, O. S. F. Principal

at St. Edwards School is Sister Mary lone.

Second prize (75 LP records and a high fidelity phonograph) went to Akiba Jewish Day School, Chicago, Illinois, for its film version of Mozart's life, handled with the use of flashback incidents, and ending with a segment of the Mozart Requiem. Teacher-Supervisor was Abraham Buchman.

Third prize (50 LP records and a high fidelity phonograph) was awarded to St. Vincent De Paul School, Milwaukee, Wisconsin, for their entry: a complete Mozart puppet show, as well as a scrapbook filled with research information, mobiles and wallpaper designs. Their teacher is Sister Mary Josette. Principal at St. Vincent De Paul is Sister Mary Simonetta.

Fourth prize (50 LP records) went to Jack Yates School, Houston, Texas. The 29 students of this eighth grade class wrote and taped an original play titled "Much Ado About Mozart". Within this dramatization were performances of Mozart songs and arias, as well as some of his keyboard music. Teacher: Mrs. Gloria Duke. Principal at Jack Yates: William S. Holland.

Fifth prize (25 LP records) was awarded to Lincoln Jr. High, Meriden, Conn. These 20th Century Mozart fans chose to use the modern medium of radio, and with fine technique produced an adaptation of the CBS Television program "You Are There." They set up inquiring microphones at

the site of the premiere performance of Mozart's "Don Giovanni." Among the opening-night celebrities in attendance were Beethoven, who confided to the reporter that "the performance was terrible; the music was superb", Benjamin Franklin, who when asked what he thought of the work, said: "... better to ask me what I thought of 'Don Giovanni'. There was a man! As to the music, I have a tin ear". Their teacher is Miss P. McLaughlin. Principal at Lincoln Jr. High is T. Mason Brown.

Other prizes were awarded for Runners-up, Honorable Mention, and Special Mention.

Capitol Appointment

HOLLYWOOD—The appointment of Ronald C. Beyl as Special Analyst has been announced by Daniel C. Bonbright, Vice President, Administration and Finance Division, Capitol Records, to whom Beyl will report.

Before joining Capitol, Beyl had been actively engaged in systems and methods studies with the Universal Pictures Co. Previously, he was a staff assistant to the general manager and treasurer of American Aeronautics Corp., and was a fiscal and statistical specialist in the armed forces. He is a graduate of USC, Los Angeles, where he received his B. S. degree in Business-Finance and engaged in graduate work.

12 Top Name Motion Picture Stars
"HOLLYWOOD SINGS"

Soon To Be Released
on

ZEPHYR
RECORDS

BUTTERFLY

recorded by

Charlie Gracie—Cameo Records
Andy Williams—Cadence Records

Mayland Music Publishing Co.
and Elvis Presley Music, Inc.

GONE

recorded by

Ferlin Husky—Capitol Records
Dallas Music Co., Inc.

TOO MUCH

recorded by

Elvis Presley—Victor
Elvis Presley Music, Inc.
and Southern Belle Music.

ALL SHOOK UP

recorded by

Elvis Presley—Victor
Shalimar Music Corp. and
Elvis Presley Music, Inc.

HILL AND RANGE SONGS, INC.



Disk Jockey

REGIONAL RECORD REPORTS



Disk Jockey

REGIONAL RECORD REPORTS

Bill Reifel

- WSHS—Floral Park, N. Y.
- All Shook Up (E. Presley)
 - Come Go With Me (Del-Vikings)
 - Love Letters In The Sand (P. Boone)
 - Little Darlin' (Diamonds)
 - So Rare (J. Dorsey)
 - Wonderful! Wonderful! (J. Mathis)
 - Bernardine (P. Boone)
 - Start Movin' (S. Mineo)
 - School Day (C. Berry)
 - A White Sport Coat (Robbins)

Bill Balance

- KFWB—Hollywood, Calif.
- Harem Dance (Armenian Jazz Sextet)
 - Love Letters In The Sand (P. Boone)
 - Promises, Promises (Shore)
 - Rosebud (K. Hopkins)
 - Talkin' To The Blues (Lowe)
 - My Little Baby (P. Como)
 - Old Cape Cod (P. Page)
 - Fabulous (S. Lawrence)
 - Empty Arms (T. Brewer)
 - Island In The Sun (H. Belafonte)

Jack Gavin

- WCCM—Lawrence, Mass.
- Love Letters In The Sand (P. Boone)
 - Imagination (King Sisters)
 - Trust In Me (C. Connor)
 - I Need You Tonight (Burke)
 - Old Cape Cod (P. Page)
 - Out In The Cold Again (Teenagers)
 - Fabulous (G. Gracie)
 - Start Movin' (S. Mineo)
 - Goin' Steady (T. Sands)
 - It's Not For Me To Say (J. Mathis)

Ken Johnston

- WNRC—New Rochelle, N. Y.
- With All My Heart (J. Sands)
 - Don't Cry My Love (Lynn)
 - Echo Echo Echo (D. Lee)
 - Love Letters In The Sand (P. Boone)
 - Little White Lies (Johnson)
 - Gonna Find Me A Bluebird (M. Rainwater)
 - Start Movin' (S. Mineo)
 - A Face In The Crowd (Hi-Lo's)
 - I Just Don't Know (4 Lads)
 - Freight Train (Rayburn/Whiskey)

Earl McDaniel

- KPOP—Los Angeles, Calif.
- Animals Rock 'N Roll (C. Rhubarb)
 - I Just Don't Know (4 Lads)
 - Valley Of Tears (F. Domino)
 - My Dream (Platters)
 - I Like Your Kind Of Love (A. Williams)
 - My Little Baby (P. Como)
 - Old Cape Cod (P. Page)
 - Start Movin' (S. Mineo)
 - Freight Train (N. Whiskey)
 - Baby, Baby Wait For Me (P. Lee)

Gordon Hamilton, Bob Perry, Dan Gillette

- WCAP—Lowell, Mass.
- Love Letters In The Sand (P. Boone)
 - Little Darlin' (Diamonds)
 - A White Sport Coat (Robbins)
 - All Shook Up (E. Presley)
 - So Rare (J. Dorsey)
 - Teenager's Romance (Nelson)
 - Dark Moon (B. Guitar)
 - It's Not For Me To Say (J. Mathis)
 - Little Billy Boy (Three D's)
 - School Day (C. Berry)

Ira Cook

- KMPC—Los Angeles, Calif.
- All Shook Up (E. Presley)
 - Round and Round (P. Como)
 - So Rare (J. Dorsey)
 - Butterfly (A. Williams)
 - Dark Moon (G. Storm)
 - Mangos (R. Clooney)
 - Empty Arms (T. Brewer)
 - Love Letters In The Sand (P. Boone)
 - Almost Paradise (Williams)
 - Harem Dance (Armenian Jazz Sextet)

Al Meltzer

- WHEN—Syracuse, N. Y.
- Love Letters In The Sand (P. Boone)
 - School Day (C. Berry)
 - Dark Moon (G. Storm)
 - Come Go With Me (Del-Vikings)
 - So Rare (J. Dorsey)
 - Freight Train (N. Whiskey)
 - All Shook Up (E. Presley)
 - A White Sport Coat (Robbins)
 - Almost Paradise (R. Williams)
 - Gone (F. Husky)

Hal Ball

- WTUS—Tuskegee, Ala.
- All Shook Up (E. Presley)
 - Little Darlin' (Diamonds)
 - I'm Walkin' (F. Domino)
 - Empty Arms (I. J. Hunter)
 - Four Walls (J. Reeves)
 - Love Letters In The Sand (P. Boone)
 - Let It Be Me (J. Corey)
 - Fools Fall In Love (Drifters)
 - Dark Moon (G. Storm)
 - Drowning My Sorrows (T. Brewer)

Jim Blaine

- KCSB—San Bernardino, Calif.
- All Shook Up (E. Presley)
 - School Day (C. Berry)
 - So Rare (J. Dorsey)
 - Dark Moon (B. Guitar)
 - Little Darlin' (Diamonds)
 - Love Letters In The Sand (P. Boone)
 - Mangos (R. Clooney)
 - Talkin' To The Blues (Lowe)
 - It's Not For Me To Say (J. Mathis)
 - Shish-Kebab (R. Marterie)

Howard Clark

- KCIJ—Shreveport, La.
- All Shook Up (E. Presley)
 - School Day (C. Berry)
 - Love Letters In The Sand (P. Boone)
 - A White Sport Coat (Robbins)
 - It's You I Love (F. Domino)
 - Susie-Q (D. Hawkins)
 - Gone (F. Husky)
 - Goin' Steady (T. Sands)
 - It's Not For Me To Say (J. Mathis)
 - Around The World (V. Young)

Bill Sheridan

- WADK—Newport, R. I.
- Love Letters In The Sand (P. Boone)
 - So Rare (J. Dorsey)
 - All Shook Up (E. Presley)
 - Little Darlin' (Diamonds)
 - Round and Round (P. Como)
 - A White Sport Coat (Robbins)
 - Dark Moon (B. Guitar)
 - It's Not For Me To Say (J. Mathis)
 - Little White Lies (B. Johnson)
 - Mama Guitar (D. Cornell)

Del Parks

- WDRF—Chester, Pa.
- Love Letters In The Sand (P. Boone)
 - Wondering (P. Page)
 - Shish-Kebab (R. Marterie)
 - Round and Round (P. Como)
 - A Rose And A Prayer (B. Whalen)
 - Empty Arms (T. Brewer)
 - Butterfly (C. Gracie)
 - 40 Cups Of Coffee (B. Haley)
 - Poor Butterfly (S. Vaughan)
 - I Need Your Lovin' (Twitty)

Rudy Paolangeli

- WTKO—Ithaca, N. Y.
- All Shook Up (E. Presley)
 - Round and Round (P. Como)
 - Party Doll (S. Lawrence)
 - I'm Walkin' (F. Domino)
 - Butterfly (A. Williams)
 - My Little Baby (P. Como)
 - Imagination (King Sisters)
 - Shish-Kebab (R. Marterie)
 - Wonderful! Wonderful! (J. Mathis)
 - A White Sport Coat (Robbins)

Sam Babcock

- WHB—Kansas City, Mo.
- School Day (C. Berry)
 - All Shook Up (E. Presley)
 - So Rare (J. Dorsey)
 - Rock-A-Billy (G. Mitchell)
 - Love Letters In The Sand (P. Boone)
 - Dark Moon (G. Storm)
 - Pledge Of Love (Copeland)
 - Gone (F. Husky)
 - I'm Sorry (Platters)
 - Too Late (G. Austin)

Bob Elliott

- KENT—Shreveport, La.
- Searchin' (Coasters)
 - A White Sport Coat (Robbins)
 - Little Darlin' (Diamonds)
 - Susie-Q (D. Hawkins)
 - All Shook Up (E. Presley)
 - School Day (C. Berry)
 - It's Not For Me To Say (J. Mathis)
 - Gone (F. Husky)
 - Lucille (L. Richard)
 - Empty Arms (I. J. Hunter)

Tom Johnson

- WSYL—Sylvania, Pa.
- All Shook Up (E. Presley)
 - Little Darlin' (Diamonds)
 - Round and Round (P. Como)
 - So Rare (J. Dorsey)
 - A White Sport Coat (Robbins)
 - Gone (F. Husky)
 - Dark Moon (G. Storm)
 - Party Doll (B. Knox)
 - Love Letters In The Sand (P. Boone)
 - Rock-A-Billy (G. Mitchell)

Tom Harvey

- CKEY—Toronto, Ont., Can.
- All Shook Up (E. Presley)
 - Little Darlin' (Diamonds)
 - Round and Round (P. Como)
 - Gone (F. Husky)
 - Come Go With Me (Del-Vikings)
 - School Day (C. Berry)
 - Party Doll (B. Knox)
 - So Rare (J. Dorsey)
 - Butterfly (A. Williams)
 - Why Baby Why (P. Boone)

Myles Foland

- WCPO—Cincinnati, Ohio
- Teenager's Romance (Nelson)
 - Four Walls (J. Reeves)
 - I Just Don't Know (Four Lads)
 - So Rare (J. Dorsey)
 - Shangri-La (Four Coins)
 - Jamie Boy (K. Starr)
 - Bernardine (P. Boone)
 - All Shook Up (E. Presley)
 - A White Sport Coat (Robbins)
 - School Day (C. Berry)

Chris Charles

- WGAW—Gardner, Mass.
- Love Letters In The Sand (P. Boone)
 - A White Sport Coat (Robbins)
 - It's Not For Me To Say (J. Mathis)
 - Dark Moon (Storm/Guitar)
 - Little Darlin' (Tazmen)
 - Gone (F. Husky)
 - So Rare (J. Dorsey)
 - Just Because (L. Price)
 - Fabulous (C. Gracie)
 - I Just Don't Know (4 Lads)

Chuck Phillips

- WEMP—Milwaukee, Wisc.
- I'm Walkin' (R. Nelson)
 - Old Cape Cod (P. Page)
 - I Like Your Kind Of Love (A. Williams)
 - Start Movin' (S. Mineo)
 - Easy Pickin' (Tazmen)
 - Love Letters In The Sand (P. Boone)
 - A White Sport Coat (Robbins)
 - Look At 'Er (Young/Martin)
 - One For My Baby (Bennett)
 - Rock Bottom (McGuire)

Ed Bell

- WIVY—Jacksonville, Fla.
- All Shook Up (E. Presley)
 - School Day (C. Berry)
 - A White Sport Coat (Robbins)
 - Little Darlin' (Diamonds)
 - So Rare (J. Dorsey)
 - Come Go With Me (Del-Vikings)
 - Round and Round (P. Como)
 - Four Walls (J. Reeves)
 - Love Letters In The Sand (P. Boone)
 - Dark Moon (B. Guitar)

Paul "Sonny" Hanover

- CHML—Hamilton, Ont., Can.
- Little Darlin' (Diamonds)
 - All Shook Up (E. Presley)
 - Dark Moon (G. Storm)
 - Love Letters In The Sand (P. Boone)
 - So Rare (J. Dorsey)
 - A White Sport Coat (Robbins)
 - Gonna Find Me A Bluebird (J. Hahn)
 - School Day (C. Berry)
 - Fabulous (C. Gracie)
 - Round and Round (P. Como)

"Uncle John" Brunell

- WSKI—Montpelier, Vt.
- Little Darlin' (Diamonds)
 - A White Sport Coat (Robbins)
 - Come Go With Me (Del-Vikings)
 - Round and Round (P. Como)
 - Gone (F. Husky)
 - Four Walls (J. Reeves)
 - Pledge Of Love (D. Contino)
 - Butterfly (A. Williams)
 - Teen Age Crush (T. Sands)
 - Gonna Find Me A Bluebird (M. Rainwater)

Eddie Dillon

- KVOR—Colorado Springs, Colo.
- Old Cape Cod (P. Page)
 - Love Letters In The Sand (P. Boone)
 - All Shook Up (E. Presley)
 - Freight Train (R. Draper)
 - School Day (C. Berry)
 - Young Blood (Coasters)
 - He's Mine (Platters)
 - Rosie Lee (Mello-Tones)
 - So Young (Clovers)
 - Rock Your Little Baby To Sleep (B. Knox)

Bob Salter

- KNEW—Spokane, Wash.
- Teenager's Romance (Nelson)
 - All Shook Up (E. Presley)
 - Rock Your Little Baby To Sleep (B. Knox)
 - Love Letters In The Sand (P. Boone)
 - Start Movin' (S. Mineo)
 - A White Sport Coat (Robbins)
 - Peace In The Valley (Presley)
 - I'm Walkin' (R. Nelson)
 - Gone (F. Husky)
 - Goin' Steady (T. Sands)

Chuck Blore

- KELP—El Paso, Texas
- Little Darlin' (Diamonds)
 - Somebody Else Will (Lewis)
 - Till (P. Faith)
 - Old Cape Cod (P. Page)
 - Crazy Love (F. Sinatra)
 - Everything But Love (Rodgers)
 - Evangeline (R. Arms)
 - Shish-Kebab (R. Marterie)
 - I Just Don't Know (4 Lads)
 - My Dream (Platters)

Martin Tobin

- KLAN—Seattle, Wash.
- Teenager's Romance (Nelson)
 - School Day (C. Berry)
 - All Shook Up (E. Presley)
 - Girl With The Golden Braids (P. Como)
 - So Rare (J. Dorsey)
 - Bernardine (P. Boone)
 - Little Darlin' (Diamonds)
 - Cattle Call (D. Shore)
 - Start Movin' (S. Mineo)
 - Dark Moon (B. Guitar)

Doug Burrows

- CKY—Winnipeg, Man., Can.
- Dark Moon (G. Storm)
 - So Rare (J. Dorsey)
 - Freight Train (R. Draper)
 - I Need Your Lovin' (Twitty)
 - School Day (C. Berry)
 - Little Darlin' (Diamonds)
 - A White Sport Coat (Robbins)
 - Pledge Of Love (Contino)
 - All Shook Up (E. Presley)
 - Four Walls (J. Lowe)

Don Straus

- KXLL—Missoula, Mont.
- So Long, My Love (F. Sinatra)
 - Round and Round (P. Como)
 - Party Doll (S. Lawrence)
 - Butterfly (A. Williams)
 - When I Fall In Love (N. Cole)
 - Gone (F. Husky)
 - I'm Sorry (Platters)
 - Teen Age Crush (T. Sands)
 - Little Darlin' (Diamonds)
 - A White Sport Coat (Robbins)

Bob Engel

- WJW—Cleveland, Ohio
- Love Letters In The Sand (P. Boone)
 - Dark Moon (B. Guitar)
 - Love Is A Golden Ring (Laine)
 - So Rare (J. Dorsey)
 - It's Not For Me To Say (J. Mathis)
 - Haunting Me (The Kings IV)
 - Talkin' To The Blues (Lowe)
 - Old Cape Cod (P. Page)
 - You're A Heavenly Thing (L. Armstrong)
 - Freight Train (N. Whiskey)

Nick Nickson

- WBBF—Rochester, N. Y.
- Round and Round (P. Como)
 - All Shook Up (E. Presley)
 - Around The World (V. Young)
 - Love Letters In The Sand (P. Boone)
 - A White Sport Coat (Robbins)
 - Pledge Of Love (K. Copeland)
 - Can't Wait For Summer (S. Lawrence)
 - Shish-Kebab/Harem Dance (Marterie/Armenian Jazz Sextet)
 - Mangos (R. Clooney)
 - Mama Guitar (D. Cornell)

Joe Silver

- WICK—Scranton, Pa.
- Bye Bye Love (Everly Bros.)
 - Little Darlin' (Diamonds)
 - School Day (C. Berry)
 - Arrow Of Love (Six Teens)
 - Valley Of Tears (Domino)
 - Start Movin' (S. Mineo)
 - Bernardine (P. Boone)
 - I Trusted You (J. Bowen)
 - Rock Your Little Baby To Sleep (B. Knox)
 - I'm Gonna Sit Right Down & Write Myself A Letter (B. Williams)

Don Caldwell

- WHLL—Wheeling, W. Va.
- Teenager's Romance (Nelson)
 - Love Letters In The Sand (P. Boone)
 - School Day (C. Berry)
 - Gone (F. Husky)
 - My Dream (Platters)
 - All Shook Up (E. Presley)
 - Young Blood (Coasters)
 - Dark Moon (Storm/Guitar)
 - So Rare (J. Dorsey)
 - It's Not For Me To Say (J. Mathis)

George Fennell

- WHIL—Medford, Mass.
- It's Not For Me To Say (J. Mathis)
 - Dark Moon (B. Guitar)
 - All Shook Up (E. Presley)
 - Fabulous (C. Gracie)
 - School Day (C. Berry)
 - Rock-A-Billy (G. Mitchell)
 - So Rare (J. Dorsey)
 - Don't Call Me Sweetie (E. Rodgers)
 - Yes Tonight Josephine (Ray)
 - Rock Your Little Baby To Sleep (B. Knox)

Bill Dwyer

- WHAM—Rochester, N. Y.
- Love Letters In The Sand (P. Boone)
 - Mama Guitar (D. Cornell)
 - Mangos (R. Clooney)
 - Shrine Of St. Cecilia (Young)
 - Shish-Kebab (R. Marterie)
 - It's Not For Me To Say (J. Mathis)
 - Freight Train (N. Whiskey)
 - Love Is A Golden Ring (Laine)
 - Bye Bye Love (Everly Bros.)
 - Don't Call Me Sweetie (E. Rodgers)

Lonny Starr

- WNEW—New York, N. Y.
- It's Not For Me To Say (J. Mathis)
 - How Many Stars Have To Shine (C. McRae)
 - I Just Don't Know (4 Lads)
 - Can't Wait For Summer (S. Lawrence)
 - Wonderful! Wonderful! (J. Pearce)
 - Around The World (E. Fisher)
 - Passing Strangers (Vaughan & Eckstine)
 - I'm Gonna Sit Right Down & Write Myself A Letter (B. Williams)
 - I'm Walking The Floor Over You (G. Gibbs)
 - Hickory Dickory Dock (Mason)

Bob Ellis

- KOY—Phoenix, Ariz.
- Love Letters In The Sand (P. Boone)
 - Sittin' In The Balcony (D. Cornell)
 - Around The World (V. Young)
 - Talkin' To The Blues (Lowe)
 - Crazy Love (F. Sinatra)
 - Old Cape Cod (P. Page)
 - Beginning To Miss You (McGuire)
 - I'm Gonna Sit Right Down & Write Myself A Letter (B. Williams)
 - Twelve O'Clock Tonight (Day)
 - Ninety-Nine Ways (T. Hunter)

Tom Hopkins

- WDLG—Port Jervis, N. Y.
- Stay As Sweet As You Are (N. Cole)
 - Fabulous (S. Lawrence)
 - Girl With The Golden Braids (P. Como)
 - I Like Your Kind Of Love (A. Williams)
 - Mangos (R. Clooney)
 - It's Not For Me To Say (J. Mathis)
 - I Never Had A Chnce (Martin)
 - Old Cape Cod (P. Page)
 - Gonna Move To The Outskirts Of Town (J. Ray)
 - Shake Hands With A Guy In Love (D. Olson)

Marty Faye

- WAAF—Chicago, Ill.
- With All My Heart (Sands)
 - Close Your Eyes (H. Lance)
 - One For My Baby (Bennett)
 - Your Kisses Kill Me (Gorme)
 - Crickets On Parade (B. Christian)
 - Passing Strangers (Vaughan & Eckstine)
 - It's Not For Me To Say (J. Mathis)
 - When Rock And Roll Come To Trinidad (N. Cole)
 - Hi, Ho Stevo (L. Nye)
 - I Like Your Kind Of Love (A. Williams)

Bob Ancell

- WPOW—New York, N. Y.
- Come Go With Me (Del-Vikings)
 - Little Darlin' (Diamonds)
 - All Shook Up (E. Presley)
 - School Day (C. Berry)
 - It's Not For Me To Say (J. Mathis)
 - With All My Heart (J. Sands)
 - Start Movin' (S. Mineo)
 - Mama Looka Booboo (Belafonte/Franklin)
 - Round and Round (P. Como)
 - Love Letters In The Sand (P. Boone)

John Leban

- WCAE—Pittsburgh, Pa.
- Teenager's Romance (Nelson)
 - All Shook Up (E. Presley)
 - Freight Train (R. Draper)
 - A White Sport Coat (Robbins/Desmond)
 - So Rare (J. Dorsey)
 - Wondering (P. Page)
 - Love Letters In The Sand (P. Boone)
 - Over The Mountain (Johnnie & Joe)
 - My Dream (Platters)
 - Can't Wait For Summer (S. Lawrence)

ATTENTION DEEJAYS, PROGRAM DIRECTORS, LIBRARIANS—Please keep us constantly informed of any changes in call letters or title.

ATTENTION DEEJAYS, PROGRAM DIRECTORS, LIBRARIANS—Please keep us constantly informed of any changes in call letters or title.

"Only those records best suited for commercial use are reviewed by THE CASH BOX"



Disk Jockey

REGIONAL RECORD REPORTS

Jimmy Paul Mahoney
KDEF—Albuquerque, N. M.

1. All Shook Up (E. Presley)
2. Dark Moon (Guitar/Storm)
3. A White Sport Coat (Robbins/Desmond)
4. Little Darlin' (Diamonds)
5. School Day (C. Berry)
6. So Rare (J. Dorsey)
7. Come Go With Me (Del-Vikings)
8. Four Walls (Lowe/5 Keys)
9. Round And Round (P. Como)
10. Love Letters In The Sand (P. Boone)

Jerry Nesler
KSDO—San Diego, Calif.

1. So Rare (J. Dorsey)
2. Dark Moon (B. Guitar)
3. Love Letters In The Sand (P. Boone)
4. Talkin' To The Blues (Lowe)
5. Four Walls (D. Collins)
6. Mangos (R. Clooney)
7. Bernardine (P. Boone)
8. Charm Bracelet (Lancers)
9. Wonderful! Wonderful! (J. Mathis)
10. I Saw You, I Saw You (Hahn)

Jim Mendes
WICE—Providence, R. I.

1. It's Not For Me To Say (J. Mathis)
2. Love Is A Golden Ring (Laine)
3. All Shook Up (E. Presley)
4. Little Darlin' (Diamonds)
5. Start Movin' (S. Mineo)
6. Suddenly (J. Adams)
7. My Little Baby (P. Como)
8. A White Sport Coat (Robbins)
9. Mangos (R. Clooney)
10. Coconut Woman (Belafonte)

Bill Atkins
KDOK—Tyler, Texas

1. Searchin' (Coasters)
2. Old Cape Cod (P. Page)
3. School Day (C. Berry)
4. Suzie-Q (D. Hawkins)
5. Little White Lies (Johnson)
6. White Silver Sands (Gardner)
7. A White Sport Coat (Robbins)
8. Talkin' To The Blues (Lowe)
9. Rock Your Little Baby To Sleep (B. Knox)
10. Love Letters In The Sand (P. Boone)

Don Burford
KBSF—Springhill, La.

1. All Shook Up (E. Presley)
2. A White Sport Coat (Robbins)
3. School Day (C. Berry)
4. Party Doll (B. Knox)
5. So Rare (J. Dorsey)
6. Gone (F. Husky)
7. I'm Walkin' (F. Domino)
8. Round and Round (P. Como)
9. Little Darlin' (Diamonds)
10. Come Go With Me (Del-Vikings)

Scott Muni
WAKR—Akron, Ohio

1. He's Graduating (Mamselles)
2. Love Letters In The Sand (P. Boone)
3. School Day (C. Berry)
4. My Beautiful Dream (Coronados)
5. Next Stop Paradise (Randazzo)
6. I Like Your Kind Of Love (A. Williams)
7. So Rare (J. Dorsey)
8. Steady Date (T. Sands)
9. Wonderful! Wonderful! (J. Mathis)
10. Like A Baby (V. Nelson)

Josh Brady
WBBM—Chicago, Ill.

1. I Just Don't Know (4 Lads)
2. Gonna Find Me A Bluebird (J. Hahn)
3. Face In The Crowd (Cornell)
4. Four Walls (J. Lowe)
5. Speak For Yourself John (Carr)
6. Dark Room (B. Guitar)
7. So Rare (J. Dorsey)
8. Around The World (Crosby)
9. Little White Lies (Johnson)
10. Italiano (P. Faith)

Bob Fuller
WNBP—Newburyport, Mass.

1. Love Letters In The Sand (P. Boone)
2. One For My Baby (T. Bennett)
3. A White Sport Coat (Robbins)
4. My Dream (Platters)
5. So Rare (J. Dorsey)
6. My Little Baby (P. Como)
7. It's Not For Me To Say (J. Mathis)
8. Without Him (F. Laine)
9. Queen Of The Senior Prom (Mills Bros.)
10. Four Walls (J. Reeves)

Lou Dennis
WBRY—Waterbury, Conn.

1. Love Letters In The Sand (P. Boone)
2. School Day (C. Berry)
3. So Rare (J. Dorsey)
4. Don't Call Me Sweetie (E. Rodgers)
5. Around The World (Haskell)
6. With All My Heart (Sands)
7. I Just Don't Know (4 Lads)
8. A White Sport Coat (Robbins)
9. Freight Train (N. Whiskey)
10. My Little Baby (P. Como)

Tom Wallace
KTKT—Tucson, Ariz.

1. Little Darlin' (Diamonds)
2. All Shook Up (E. Presley)
3. Come Go With Me (Del-Vikings)
4. School Day (C. Berry)
5. A White Sport Coat (Robbins)
6. Party Doll (S. Lawrence)
7. I'm Walkin' (F. Domino)
8. Gone (F. Husky)
9. Butterfly (A. Williams)
10. Why Baby Why (P. Boone)

Dave Walshak
KCTI—Gonzales, Texas

1. All Shook Up (E. Presley)
2. Love Letters In The Sand (P. Boone)
3. Dark Moon (G. Storm)
4. Valley Of Tears (F. Domino)
5. My Dream (Platters)
6. A White Sport Coat (Robbins)
7. I Like Your Kind Of Love (A. Williams)
8. Fabulous (S. Lawrence)
9. Don't Cry My Love (V. Lynn)
10. I Just Don't Know (Four Lads)

Len Ross
KDB—Santa Barbara, Calif.

1. I Just Don't Know (4 Lads)
2. Angelia (A. Wayne)
3. Calypso Melody (D. Rose)
4. Round and Round (P. Como)
5. Snake Charmer (N. Kaye)
6. 1492 (B. Johnson)
7. Love Is A Golden Ring (Laine)
8. Yes Tonight Josephine (Ray)
9. Wonderful! Wonderful! (J. Pearce)
10. True Love Gone (Madigan)

Joe Buerry
WJWL—Georgetown, Dela.

1. Love Letters In The Sand (P. Boone)
2. I Just Don't Know (4 Lads)
3. It's Not For Me To Say (J. Mathis)
4. Little White Lies (Johnson)
5. Mangos (R. Clooney)
6. Old Cape Cod (P. Page)
7. Girl With The Golden Braids (P. Como)
8. 1492 (B. Johnson)
9. Oh Pain! Oh Agony! (G. McKenzie)
10. My Little Baby (P. Como)

Fred Lowery
WISH—Indianapolis, Ind.

1. So Rare (J. Dorsey)
2. Round And Round (P. Como)
3. Dark Moon (B. Guitar)
4. A White Sport Coat (M. Robbins)
5. Crickets On Parade (B. Christian)
6. Around The World (Young)
7. I'm Walkin' (R. Nelson)
8. Good Night (S. Forwood)
9. Empty Arms (T. Brewer)
10. Grasshopper Jump (Watts)

Perry J. Brown
WTAO—Boston, Mass.

1. Queen Of The Senior Prom (Mills Bros.)
2. It's Not For Me To Say (J. Mathis)
3. Fabulous (C. Grayco)
4. All Shook Up (E. Presley)
5. With All My Heart (J. Sands)
6. Your Kisses Kill Me (Gorme)
7. Love Letters In The Sand (P. Boone)
8. Goin' Steady (T. Sands)
9. Little Billy Boy (Three D's)
10. Little Darlin' (Diamonds)

Bruce D. Farnsworth
WHYN—Springfield, Mass.

1. Little Darlin' (Diamonds)
2. It's Not For Me To Say (J. Mathis)
3. So Rare (J. Dorsey)
4. On Forgotten Street (Rondo)
5. Love Letters In The Sand (P. Boone)
6. Empty Arms (T. Brewer)
7. Four Walls (J. Reeves)
8. Evangeline (R. Arms)
9. Old Cape Cod (P. Page)
10. Graduation Day (T. Sands)

Bob Gotsch
KMOX—St. Louis, Mo.

1. Little Darlin' (Diamonds)
2. School Day (C. Berry)
3. A White Sport Coat (Robbins)
4. Fabulous (C. Gracie)
5. Start Movin' (S. Mineo)
6. Valley Of Tears (F. Domino)
7. The Girl With The Golden Braids (P. Como)
8. Four Walls (J. Reeves)
9. Goin' Steady (T. Sands)
10. One For My Baby (T. Bennett)

Norm Pringle
CKDA—Victoria, B. C., Can.

1. A White Sport Coat (Robbins)
2. All Shook Up (E. Presley)
3. Rock-A-Billy (G. Mitchell)
4. I'm Walkin' (R. Nelson)
5. Yes Tonight Josephine (Ray)
6. Gone (F. Husky)
7. School Day (C. Berry)
8. Love Letters In The Sand (P. Boone)
9. Rock Your Little Baby To Sleep (B. Knox)
10. Little Darlin' (Diamonds)

Hank Goldman
WANN—Annapolis, Md.

1. Bernardine (P. Boone)
2. Angelia (A. Wayne)
3. A White Sport Coat (Robbins)
4. Freight Train (N. Whiskey)
5. School Day (C. Berry)
6. Mama Guitar (D. Cornell)
7. Wonderful! Wonderful! (J. Mathis)
8. Billy Goat (B. Haley)
9. Wowie (Madhattans)
10. Rock Bottom (McGuire)

Stan Douglas
WTWN—St. Johnsbury, Vt.

1. All Shook Up (E. Presley)
2. Love Letters In The Sand (P. Boone)
3. I'm Walkin' (R. Nelson)
4. School Day (C. Berry)
5. Pledge Of Love (Copeland)
6. Freight Train (R. Draper)
7. Party Doll (B. Knox)
8. Rock Your Little Baby To Sleep (B. Knox)
9. So Rare (J. Dorsey)
10. Little Darlin' (Diamonds)

Dick Pike
WNOP—Newport, Ky.

1. Teenager's Romance (Nelson)
2. Fabulous (C. Gracie)
3. Four Walls (Reeves/Lowe)
4. Crickets On Parade (B. Christian)
5. It's Not For Me To Say (J. Mathis)
6. Goin' Steady (T. Sands)
7. Love Letters In The Sand (P. Boone)
8. Like A Baby (V. Nelson)
9. With All My Heart (Sands)
10. That's Life (J. Pleis)



Sure Shots

The Cash Box "Sure Shots" highlight records which reports from retail dealers throughout the nation indicate are either already beginning to sell in quantity or else give every sign of doing so.

"ONE FOR MY BABY"

The Cash Box Disk of the Week 4/20

Tony Bennett Columbia 40907

"QUEEN OF THE SENIOR PROM"

Mills Brothers Decca 30299

"SHANGRI-LA"

The Cash Box Best Bets 5/11

Four Coins Epic 9213

It's Tops! It's Pop!

Marty Robbins'
A WHITE SPORT COAT
(AND A PINK CARNATION)
COLUMBIA 40864 (4-40864)

THE ORIGINAL — THE HIT
"SEVEN DAYS IN BARCELONA"
by **HENRI DE PARI**
RKO Unique # 394

RKO UNIQUE RECORDS 1440 Broadway New York, N. Y.

Breaking Big **Johnny Cash**
"NEXT IN LINE"
b/w **"DON'T MAKE ME GO"**
Sun 266

SUN RECORD CO. 706 UNION ST. MEMPHIS, TENN.

D.J.'s HERE IT IS
Chris Conners.....
"MIXED EMOTIONS"
Atlantic 1138
\$ \$ \$
ROGER MUSIC
1790 Broadway
N. Y., N. Y.

Oldest **ONE-STOP** record service
ALL LABELS • ALL SPEEDS
45 RPM 55¢
• Free title strip service
THE MUSICAL SALES COMPANY
140 W. MT. ROYAL AVE. BALTIMORE, MD

ATTENTION DEEJAYS, PROGRAM DIRECTORS, LIBRARIANS— Please keep us constantly informed of any changes in call letters or title.



Everly Brothers Join Grand Ole Opry

NASHVILLE—Riding high on the wings of their hit Cadence record, "Bye, Bye Love," the Everly Brothers became Grand Ole Opry "regulars" Saturday night, June 1.

Grand Ole Opry Director W. D. Kilpatrick signed Don Everly, 20, and Phil Everly, 18, to a contract May 29. Signing came 10 days after the boys staged a sensational guest debut that brought thunderous applause from jampacked Ryman Auditorium.

"It means fulfillment of our life's ambition," said Don. He recalled his father, Ike Everly, and two uncles, Leonard and Charlie had hoped to reach these heights in their careers—and had passed on to the boys a similar goal.

Don and Phil began singing with their parents 12 years ago in a family group, appearing all over the nation on tour and on radio. Their parents retired from the music profession two years ago and the boys began to work on their own.

Don graduated from West High School in Knoxville, Tenn., and Phil is finishing high school by correspondence.

The brothers are also song writers. When Don was 16 they turned out "Thou Shalt Not Steal," recorded by Kitty Wells. They also wrote "Here We Are Again," recorded by Anita Carter; and "It Takes A Lot of Heart" and "That's The Life I Have To Live," sung by Justin Tubb.

Both boys were born in Brownie, Ky., near Central City. Their parents live in Hammond, Ind. but plan to move to Nashville soon. Wesley Rose of Acuff-Rose signed them to exclusive songwriting contracts 4 months ago.

Hold 5th Jimmie Rodgers Memorial Festival

MERIDIAN, MISS. — As the strains of Jimmie Rodgers' matchless yodel lingered in the still, sunshiny air—hundreds of devoted followers bowed their heads in prayer for the most lasting feature of the Fifth Annual Jimmie Rodgers' Memorial Festival here May 21-22.

Other events, a daytime parade, a dance, and a night of song, drew greater crowds. But no event was so meaningful as the priceless memorial moment—when wreaths were placed at the foot of the marble rest under which rests the body of the founder of modern Country music.

Mississippi Lieut. Gov. Lynn Gardin gave a brief address—paying tribute to Rodgers for his most lasting memorial—songs in the hearts of mankind—establishing more firmly a "great tradition" for America.

Mrs. Rodgers, the widow, Mrs. Anita B. Court of Corpus Christie, Tex., his only surviving daughter, and Mrs. Lottie Mixon of York, Ala., a sister, were present.

An hour-long concert of Rodgers' records preceded the brief ritual during which tribute was paid to Ernest Tubb and Hank Snow as founders and moving spirits for the occasion.

Both Tubb and Snow received the Jimmy Rodgers Achievement Awards, top honors of the celebration, at the Night of Song in Ray Stadium, attended by 11,000 — concluding the festival.

Marty Robbins was awarded the "Country Music's Man of the Year" trophy and Kitty Wells was acclaimed "Queen of Country Music" for the festival. These awards were made by Tennessee Gov. Frank G. Clement, special guest.

Mississippi Gov. J. P. Coleman, who led the daytime parade, presented the Ralph Peer trophy to Jim Denny of Nashville for his contribution to country music, on a radio broadcast preceding the memorial day program.

Singing on the stadium program, opened by Tubb and Snow with their band members, were Johnny & Jack and Kitty Wells, Justin Tubb, Gordon Terry, Billy Walker, the Wilburn Brothers (Teddy and Doyle), Porter Wagoner, Sleepy McDaniel, Jim Reeves, Johnny Cash, Melvin Endsley, Jimmy Newman, Carl Smith, Mimi Roman, Ronnie Self, Goldie Hill, Jimmy Swann, Rod Brasfield, Hawkshaw Hawkins, Jean Shepard, Audrey Williams, Carl Perkins, Jimmie Rodgers Snow, Jerry Jericho, Curtis Gordon and others.

Emceeding was Eddie Hill, assisted by Bob Gallion and C. R. Smith.

Columbia Reports 50,000 "Bergen Sings Morgan" LP's Sold In 1st Week

NEW YORK — Columbia Records reports record-shattering sales of 50,000 of the "Bergen Sings Morgan" LP in the first week following the "Playhouse 90" production of "The Helen Morgan Story." Columbia Album Sales Manager Stan Kavan cited the coordinated, "extra-TV" promotion saturation as a forceful factor responsible for the album's success.

In the months before the release of the album, promotion plans of Columbia, CBS-TV, and MCA were coordinated to mount steadily toward a culmination the night of the TV performance plug. In addition to easel figures of Polly Bergen prepared for in-store display, Columbia produced special "now in stock" posters, accorded full disk jockey service prior to the show, and prepared dealers and field salesmen with a running account of the promotional tools being forged for their use. Miss Bergen devoted unusual time and energy in cooperation with an intensive magazine and newspaper publicity campaign designed to continue unsubsidized for a period after the TV presentation.

This is the third TV originated album Columbia has recently released and in each of the three, the elements have been significantly different. "Cinderella," the first Rodgers and Hammerstein TV spectacular original, was executed as other TV and Show albums have been in the past, being a "record version" of the enormously successful program. "Drum Is A Woman" was the first instance of a TV show based on an album creation, the album having been on sale in stores before the final U.S. Steel Hour script was completed. In this case, Irv Townsend was armed with nothing more than the Columbia Record when he presented the TV idea to the show's Producer Marshall Jamieson, who was convinced on this evidence. The Bergen album, on the other hand, did not undertake to reproduce the TV show at all. It was conceived and produced as an arresting idea, irrespective of the TV connection. That the television program offered exciting possibilities for attention for the star's debut on Columbia Records was, as the promotion campaign reveals, a subject of lively awareness.

The Big Ones Come from Valleybrook

"HOOK, LINE AND SINKER"

recorded by
BILL HALEY
and his Comets
DECCA 30214

Valleybrook PUBLICATION, Inc.
129 E. 5th Street
Chester, Penna.
New York Office: 224 W. 49th St., Suite 407 • Cl 6-5252

Fast climbing the charts . . .

DON'T CRY MY LOVE

A great vocal rendition by
VERA LYNN

on London Records (# 1729)

THE B.F. WOOD MUSIC CO., INC.

Desmond In 2nd Film

NEW YORK—Coral recording star Johnny Desmond, who recently completed his motion picture debut in a starring role in the Columbia musical "Calypso Heat Wave", starts shooting another film for Columbia on June 4th. Producer Sam Katzman signed the vocalist for a starring role in a dramatic film this time. The picture, "Escape From San Quentin," is based on an actual incident of a San Quentin break several years ago. Coral, incidentally, reports excellent initial reaction to Desmond's latest album, "Johnny Desmond Goes Calypso," which includes tunes from his first Columbia film.

Fields Forms Flack Firm

CHICAGO—Barney Fields, Chicago promoter, last week announced his resignation from Bally Records to head up his own public relations and record promotion office to be located at 54 W. Randolph St.

Fields, who for some time has been handling Tony Bennett's p.r. and record promotion along with his Bally position, says he will now be in a position to give artists heavy concentration.

Chancellor Signs Avalon

PHILADELPHIA, PA. — Frankie Avalon, young trumpet star, has signed a long term pact with Chancellor Records, according to the company's presidents, Marcucci and DeAngelis.

Avalon, who at one time was a trumpet protege of Jackie Gleason and Paul Whiteman, performs as a vocalist on his first Chancellor recording "Cupid".

For the past five years, Avalon has been devoting his time to studying trumpet and has been playing with a local group known as Rocco and his Saints. It has been only in the past few months that he has been taking singing lessons.

COMPLETE RECORD PRESSING SERVICE

7" — 10" — 12"

all speeds
from tape to finished records

A-N-L RECORDING CORPORATION

4465 N. LINCOLN CHICAGO, ILL. RAvenswood 8-6552

— THE MUSIC BOX —

1301 W. 79th St.

(ALL PHONES . . .

AMERICA'S MOST

ORDER SHIPPED

CHICAGO 20, III.

. . . Aberdeen 4-3600)

COMPLETE ONE-STOP!

SAME DAY RECEIVED—FREE TITLE STRIPS

Headed For A National Smash!

Pat Kelley

"THE STRANGER DRESSED IN BLACK"

"She's A Devil"

Chic 1009



"Silk Stockings" To Be MGM's 50th Sound Track

NEW YORK — MGM Records is scheduling its 50th sound track album with the release of "Silk Stockings" in early June. The sound track set, a 12" LP, features Fred Astaire, Cyd Charisse, Janis Paige, Peter Lorre, Joseph Buloff, Jules Munshin and Carol Richards. The MGM Studio Orchestra is conducted by Andre Previn except for the "Silk Stockings" production number which is conducted by Johnny Green.

MGM Records is flooding Norfolk, Va., with advance copies of the album in time for the world premiere of the MGM picture in Norfolk on June 8. Window posters, dummy album covers, co-op mats, and special disk jockey albums at \$1.00 each are being made available to distributors.

"Only those records best suited for commercial use are reviewed by THE CASH BOX"

Raymond Scott Develops New Electronic Musical Instrumental



NEW YORK—Composer-conductor Raymond Scott has obvious reasons for smiling proudly as his 2½ year old daughter Debbie assumes a Helen Morgan-esque pose atop the Scott Clavivox, a new electronic musical instrument he has just developed.

The Clavivox is a keyboard instrument (Piano-type keyboard) that has two unusual features: first, its ability to slide smoothly in pitch from any note on the keyboard to any other without a break and without hesitation, slowly or quickly, as interpretation may require. Second, the use of two foot pedals makes possible a human-like vibrato control. One pedal varies the speed of the vibrato; the other the depth of pitch of the vibrato.

This is the first time that this combination of effects has been accomplished on a keyboard-type instrument. The sound of the Scott Clavivox is especially close to that of the human voice, hence the name.

Raymond Scott, currently musical director of NBC's "Your Hit Parade", is, in addition to being a composer-conductor, well known for his interest along creative musical engineering lines. He has a number of patents on other electronic devices.

He is also known for the Raymond Scott Quintet, which recorded many of his own compositions. He has composed a number of works for the Broadway stage, including "Lute Song".

Capitol To Add HMV Classics To Release Schedule Next Fall

HOLLYWOOD — Capitol Records will, in the near future, add to its line of classical recordings selections from prominent international artists now appearing on "His Master's Voice", or HMV, the label of England's Electric and Musical Industries, Limited. The announcement was made by Glenn E. Wallichs, Capitol's president.

In recent years, "His Master's Voice" recordings have been released in this country by RCA Victor.

Scheduled for late fall release by Capitol will be recorded performances by the world renowned violinist, Yehudi Menuhin. High ranking artists to follow include Artur Rodzinski, Louis Kentner, Shura Cherkassky and many others.

Wallichs further stated that Capitol would augment its program of FDS domestic recording of classical artists, with Fall releases of Leopold Stokowski, Nathan Milstein, the Hollywood Bowl Symphony and other leading artists and orchestras scheduled.

Additions To Production Staff of Mitchell Show

NEW YORK — Additions to the production staff of Guy Mitchell's show over ABC-TV next fall were announced last week.

Kevin Joe Johnson will direct, Earl Sheldon will be the musical director and Ted Cappy, formerly with the Sid Caesar Show, will handle the choreography. Phil Cohan was previously announced as the producer.

Writers for the show are now being screened, and it is expected that a top team of two will be signed shortly.

The entire package is under the supervision of Edward Joy Productions, with Eddie Joy the executive producer.

The program will make its debut on Saturday, September 21, 10-10:30 P.M., E.S.T., following the Lawrence Welk Show.

Meeting The Bye Bye Boys



WORCESTER, MASS.—The Everly Brothers, Phil (left) and Don (right) currently the proud possessors of one of the hottest singles in the record business, "Bye, Bye Love," visited with Worcester dee jay Jack O'Rourke (WNEB) while passing through the city. "Bye, Bye Love," the brothers' first Cadence waxing was originally issued as a country disk but instantaneously hit in both pop and country. The tune is #9 in the pop best seller list and #8 in country.

E. B. Marks Buys Cugat's Alameda Music Catalog

NEW YORK — The entire catalog of Alameda Music, Inc., Xavier Cugat's Latin-American music publishing firm, has been purchased by the Edward B. Marks Music Corporation. It will be operated by Marks as a separate concern and it will be affiliated as regards performing rights with BMI, as is Marks. Alameda has published a number of Latin-American popular compositions; new ones will be added from time to time.

At the same time, Cugat, as a writer, entered into a publication agreement with Marks Music, which has published his still popular theme song, "My Shawl," as well as such compositions of his as "Nightingale," "Mambo Ay Ay," "Night Must Fall" and many others. The first three songs to be published under the new agreement which is one entirely aside from the Alameda purchase, are "Learning," which Cugat adapted from a theme by Tchaikovsky and for which Ben Raleigh has written English lyrics, "Very, Very Satisfied," and "Pan Amor Cha Cha." The last named is the title and theme song of a new Italian film and is to be the name, as well, of a new Cugat album.

Cugat and his wife, Abbe Lane, leave shortly for Europe where they will continue to make foreign films. They will return here early in September, at which time they will resume their television and recording activities, Cugat for Columbia Records and Miss Lane for Victor Records.

Special Gleason EP

HOLLYWOOD — A new EP by Jackie Gleason called "To A Sleeping Beauty", was released by Capitol Records on May 27.

The new album spotlights Gleason in a new role, a dramatic presentation of emotional monologues with instrumental accompaniment, "To A Sleeping Beauty" and "Apology At Bedtime." "To A Sleeping Beauty," written by Gleason and Larry Markes, was introduced by Gleason on his CBS-TV program June 1. "Apology At Bedtime" was co-authored by Gleason and Harlan Miller.

Still Climbing Higher on the Charts!

"C. C. RIDER"

CHUCK WILLIS

ATLANTIC 1170

ATLANTIC RECORDING CORP.
157 West 57 St., N.Y.C.

PAT BOONE . . . Love Letters In The Sand (DOT 15570)
FOUR ACES . . . Yes Sir, That's My Baby (DECCA 30348)
DAVID SEVILLE . . . Camel Rock (LIBERTY)
THE KENTUCKIANS . . . 'Way Out There (BRUNSWICK)
EYOIE GORME . . . I'll Take Romance (ABC-PARAMOUNT 9780)
THE KING SISTERS . . . Imagination (CAPITOL)
BIG MAYBELLE . . . All Of Me (SAVOY 1512)
BOURNE, INC. — ABC CORP.

"BLUES DON'T MEAN A THING"

b/w "IF I HAD A TALKING PICTURE OF YOU"

Savoy 1513

The JIVE BOMBERS

SAVOY RECORD CO
56 MARKET ST
NEWARK, N J

Tommy Sands

"Fantastically Foolish"

CAPITOL 37403

CENTRAL SONGS, INC.
6308 SUNSET BOULEVARD HOLLYWOOD 28, CALIF.
HOLLYWOOD 1-9347

The Princess And The Dee Jay



CHICAGO—Dee jay Jim Lounsbury, who recently joined Chicago's ABC-TV station WBKB-TV, meets "Little Princess Blue Echo," a young Cherokee lass who visited local jockeys to promote Dot Records' waxing of the tune "Blue Echo" cut by Danny Welton.



R & B Ramblings

NEW YORK:

Everyone in New York still talking MOA and now settling down to a more active selling period. Whether it was the MOA meeting that started things going again, or a natural surge in business is hard to determine, but the general consensus is that sales have shown a decided increase and the Spring slack seems to be over. . . . Lots of good records now springing forth—and one that should provide a good hypo is the new Little Richard platter, "Jenny, Jenny" and "Miss Ann." Both sides were taken from his album after a reaction showed they were getting tremendous acceptance. . . . Morty Palitz, Jubilee Records, keeping his fingers crossed as he talks about the new Cadillacs "My Girl Friend." "This will be a great seller in pop and r & b," says Palitz. . . . Don Robey, Duke and Peacock, speaks of his labels as "rhythm headquarters." He is especially high on his new twosome, Brooks and Brown. Robey says, "Their debut dinking, "They Call Her Rosie Lee" and "Sleeping On An Ocean Of Tears," is really creating a heat-wave around the offices as orders keep coming in." Another the Duke fellas are excited about is Leo Baxter's "No Longer Wanted." . . . Otis Williams and his Charms have a new one out on DeLuxe, "Talking to Myself" and "One Kind



SENSATIONS

Word From You." . . . Jerry Winston Mardi Gras Records, announces the signing of Joe Cuba, formerly with Rainbow Records, to his Latin label. Jerry also in high spirits as he tells of two great sessions this week with The Pearls and The Velours for his Onyx label. . . . Mel Turoff, Roulette, Rama, Gee and Tico promotion chief, takes to the road this Monday for two weeks in the mid-west. Mel will primarily work on the newest Roulette single, "Shenandoah Rose" by Hugo and Luigi. The Roulette bunch are really flipping about this plate 'cause they feel they could have one of the big disks of year. . . . Turoff, discussing the new LP line, tells of the great reaction the distribbers have given its introduction—just from the portfolios sent out. . . . Sol Rabinowitz, Baton Records, in with the next Ann Cole release. The gal has two great sides which could make her a big star. . . . Apollo Records continues to build in new areas with The Cellos' "Rang Tang Ding Dong." Already in the Top Sixty, a little push could make this a biggie. . . . Al Silver, Herald Records, happily exclaims about the upsurge in business and says he has three great decks to take advantage of it. His "Tonight, Tonight" by the Mello-Kings has taken off in the local New York-New Jersey area; the new 5 Satins' "To The Aisle" and "Wish I Had My Baby," just going out, has excited the distributors who have heard it; and the current Charlie and Ray, "Sweet Thing," is building very nicely. . . . Woody Hinderling of Candlelight excitedly tells of the action on "So Young" by Clyde Stacey in Buffalo. George Lorenz (Hound Dog) has started a contest—"How Old is Clyde Stacey and How Young is Hound Dog?" Woody's one of the young fellas in the record biz, but his unassuming, modest approach is so refreshingly different that we think a lot of jockeys are likely to pitch in and help. . . . George Goldner's Gone label out with three new disks. He introduces three newcomers in Gary Dale with "Pretty Baby" and "Love Is Dynamite"; Al Wood and The Wanderers with "My Lady Chou Coumme" and "Mask Off"; and Jackie Dee with "I'll Be True" and "How Wrong I Was." "I'll Be True" is the old Faye Adams hit. . . . The Mesners at Aladdin Records have issued a special release of the Kent Cigarette commercial, titled "The Kent Song." The Mesners are pretty high on this deck as they feel that the publicity that the record will get should be big. They plan to send thousands of sample records to the deejays around the country with a package of Kent Cigarettes enclosed. The release features "For Love," the vocal version of the jingle, and "The Kent Song" which is an instrumental version.

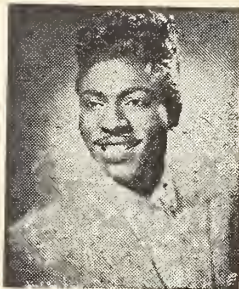

LITTLE RICHARD



THE PEARLS

Three Beas and A Beep handle the vocal and Buddy Weed and Orchestra the instrumental. The Sensations' "You Made Me Love You" on Atco getting scattered reaction in several areas, and could break out soon.

CHICAGO:

Our hats off to two swell guys who have won the admiration and respect of all musicdom with their rapid climb to the top in their particular field. Len and Phil Chess officially moved into swank new offices on Boul Mich this past week with darn near everyone trying to make some excuse to get in and take a tour thru the gleaming white studios and stock rooms. "Even got my hair cut for the occasion," quipped Len Chess as bro Phil supervised finishing touches. . . . Fast Domino stopping off enroute for many one-niters as he heads into Hollywood's Mocambo for extended engagement. . . . Stan Lewis, New Orleans, was in town to catch his fast travelling boy, Dale "Susy Q" Hawkins, before he took off for more deejay promo. . . . Local deejays picking up on Par recorder Lee Young and his first swinger, "I'm Pleading". WAAF's Jesse Owens says the tune has a lot of merit. . . . Over at M.S. Distribbers, things are bouncing right along with Cadence duo Everly Bros. (Don-20, Phil-18) and "Goodbye Love". Tune has taken off like a house-a-fire and promises to be really big for the Blyer crew. . . . Jim Fleming, Shaw, finding Cream City better and better for booking of weekend band dates. "We've had full houses for Charles Brown, Al Smith, Chuck Willis, B. J. McNeely and Muddy Waters," cheers Fleming. . . . Chuck Berry "knocking 'em dead" in Philly with Chess smasher "School Day". . . . Herb Kole

jumping for joy over new Bill Doggett deck, "Ding Dong" and Five Royales' "Think". Herb claims these will be big-big-big for King. Still climbing for the King Distribbers happy sales mgr. is Herb Lance's "Close Your Eyes". "The thing just won't quit," Kole exclaims. . . . Ruth Brown closed a reportedly rousing two weeker at Roberts Show Club. Requests were so heavy to have her back she's skedded for return in early August. . . . Bill Doggett one-niting Fla. circuit. . . . Blue Chip's "Echo, Echo, Echo" by Dan Lee said to be one of the hottest R&B numbers to grace Garmisa Distribbers' roster in quite some time. Says Myron Schulz, "The deck is being shipped with every order." . . . Big J. McNeely collecting verra heavy applause from Detroit audiences. . . . Muddy Waters and Little Walter crossing each others paths as they one-nite thru-out south'n area. . . . The Mongloows' brand new release, "Please Send Me Someone To Love" predicted by Phil Chess to be the biggest thing group has produced to date. . . . Argo LP's, to come include another set by The Dick



CHUCK BERRY

Layne Quartet, Chubby Jackson's Band, and vocalist, John Young. . . . Vee-Jay has recently signed The Harmony 4 and released their new spiritual "All Things Are Possible". "Looks real big", promises Abner. Biggest thing around Vee-Jay camp is The Spaniels' rocker, "Everyone's Laughing" and heading right up there along side The Spaniels is Jimmy Reed's brand new opus "The Sun Is Shining". Says Ab, "Reed was never better". . . . Kae Williams stopped by to shout hello and introduce us to his boy, Solomon Burke. Burke has a new one on Apollo entitled "You Are My One Love" b/w "For You And You Alone". . . . Ace comes on the scene with blues sound, "Blow Wind Blow", by Junior Gordon. . . . Chuck Willis one-niting local area while Charles Brown heads east in preparation for quick trip back to Chi for 6/14 Crown Propellor opening. . . . Stan Pat finally got the rest he lost over MOA week and got back to his first loves, Rama-Gee-Roulette. Big for the well liked fellow is "I Want To Know" on Rama by The Heartbeats, "Ten Pairs Of Shoes" by The Clefstones on Gee and Rama's "Teenage Blues" by Roc LaRue. We've got a hot op tune on Roulette", confided Pat. "It's called '49 Juke Boxes' by Alfie Weatherbee and promises to be a top seller". . . . George and Ernie Leaner, United Distribbers, report Atco's "Young Blood" beginning to collect a lot of pop spins hereabouts. Chief spinner, "The Pajama Song", by The Serenades also promising big things. . . . Muddy Waters stopped off in Chi enroute south for one-niter tour. . . . Phil Chess planed into Detroit for weekend visit with Charlie Gray of Cosnat Distribbers. . . . WAAF deejay, Jesse Owens, running clever birthday promotion with his listeners. Jess plays a birthday request for the listner and then mails off a card and record as a little gift from him. . . . Way up on the sales and hit list of All-State Distribbers is Fats Domino's "Valley Of Tears" on Imperial, Buddy Knox's "Don't Make Me Cry" on Roulette and Jimmy Bowen's "Warm Up To Me". . . . Imperial LP "Here Stands Fats Domino", Specialty LP "Little Richard" and Atlantic LP "The Clovers" doing real well so says Paul Glass of All-State. . . . Count Basie and Joe Williams followed Woody Herman into the Blue Note. . . . Lillian Offitt in town with her new Excello swinger, "Miss You So". . . . Clifton Chenier dropped into



HEARTBEATS



JIMMY REED

town for two weeks at Crown Propellor after closing "swinging date" in Pittsburgh. . . . Clyde Stacy, Candlelight, getting tremendous reception via Chi air with "So Young". . . . Larry Wyn, WSBC, threw dance-show this past week with Willie Dixon, The Spaniels, Harrold Burrage, Annie Laurie, and Otis Rush appearing.

LOS ANGELES:

Louis Jordan and his Tympany Five just completed a series of college dates in the East, and head for New York to be guest starred on the Jackie Gleason show on CBS-TV this Saturday night, June 8. Louis and the band will perform selections from his best-selling Mercury album, "Somebody Up There Digs Me". . . . Faye Adams has a big record in her initial release of "Keeper Of My Heart" for Imperial Records. . . . Lowell Fulson, Checker Records artist headlining the show at the 54 Ballroom this weekend. . . . Ed Townsend, formerly heard on the Aladdin label with his recording of "Every Night" in negotiating with Dot Records for the purchase of some masters of the vocalist singing his original tunes. . . . Class Records opening new offices on 'record row' on Pico Boulevard. Latest release on the label to take off is "Moze!" by Paul Clifton. . . . Mike Kasino to Las Vegas where Personality Production' artist Mr. Domingo is currently appearing at the El Rancho Vegas. . . . The Colts were made members of The Saints and Sinners Club after a recent appearance before the members. The group joins a list of other honorary members which includes, Nat Cole, Herb Jeffries, Sammy Davis, Jr., and Billy Daniels. . . . John Barnette signed vocalist Honey Brown during a recent trip to Chicago, and plans to bring her to Hollywood for a recording session in the near future.



FAYE ADAMS

"Only those records best suited for commercial use are reviewed by THE CASH BOX"



Territorial Tips

The Cash Box "Territorial Tips" chart highlights Rhythm and Blues records showing regional action, which have not yet appeared in the national top 20.

(Listed Alphabetically)

* Indicates first appearance on Territorial Tips

- AFTER HOURS
Lloyd Glenn (Aladdin 3346)
- ALL OF ME
I DON'T WANT TO CRY
Big Maybelle (Savoy 1512)
- A WHOLE LOT OF SHAKING GOING ON
Jerry Lee Lewis (Sun 267)
- COCOANUT WOMAN
Harry Belafonte (RCA Victor 6885)
- DEAREST
Mickey & Sylvia (Vik 0267)
- DIANE
Ba Rhamba (Cash 452)
- DING DONG
Bill Doggett (King 5058)
- DON'T ASK ME TO BE LONELY
Dubs (Gone 5002)
- EVERYBODY NEEDS SOMEBODY
Little Walter (Checker 859)
- EVERYONE'S LAUGHING
Spaniels (Vee-Jay 246)
- FABULOUS
Charlie Gracie (Cameo 107)
- FLORENCE
Paragons (Winley 215)
- *GET ON THE RIGHT TRACK BABY
Ray Charles (Atlantic 1143)
- GONE
Ferlin Husky (Capitol 3628)
- GROANIN' THE BLUES
Otis Rush (Cobra 5010)
- HERE COMES ROMANCE
Clovers (Atlantic 1129)
- HE'S MINE
Platters (Mercury 71032)
- HEY BO DIDDLEY
MONA
Bo Diddley (Chess 1652)
- HONEY, WHERE YOU GOING
LITTLE RAIN
Jimmy Reed (Vee-Jay 237)
- I'M SO EXCITED
John Lee Hooker (Vee-Jay 245)
- I'M WALKIN'
Rickey Nelson (Verve 10047)
- IN THE DOORWAY CRYING
Midnighters (Federal 12293)
- ISABELLA
Roy Tan (Dot 15551)
- I'VE GOT TO GO CRY
Little Willie John (King 5045)
- I WANT TO GET MARRIED
B. B. King (RPM 492)
- I WOULD LIKE TO KNOW
Bobby Mitchell (Imperial 5440)
- JENNY, JENNY
MISS ANN
Little Richard (Specialty 606)
- JOHNNIE'S HOUSE PARTY
John Heartsman & Gaylarks (Music City 807)
*Jimmy Beasley (Modern 1021)
- *JOY RIDE
Doc Bagby (Okeh 7080)
- JUNGLE HOP
Don & Dewey (Specialty 599)
- LET THE FOUR WINDS BLOW
Roy Brown (Imperial 5439)
- *LITTLE BILLY BOY
WHAT MADE MAGGIE RUN
Del-Vikings (Dot 15571)
- LITTLE BILLY BOY
Three D's (Paris)
- LOOBY DOO
Bobby Byrd (Zephyr 70-018)
- LOVABLE
*FOREVER
Dale Cook (Specialty 596)
- *LOVE LETTERS IN THE SAND
Pat Boone (Dot 15570)

- LOUIE LOUIE
YOU ARE MY SUNSHINE
Richard Berry & Pharohs (Flip 321)
- MESSED UP
Harrold Burrage (Cobra 5012)
- MIDNIGHT
Googie Rene (Class 205)
- MISS YOU SO
Lillian Offitt (Excello 2104)
- MY DREAM
I WANNA
Platters (Mercury 71093)
- MY HEART IS CRYING
Billy Boy (Vee-Jay 238)
- ONE HUNDRED YEARS FROM TODAY
Alice Jean (Rhythm 102)
- OUT IN THE COLD AGAIN
Lyman & Teenagers (Gee 1036)
- PLEDGE OF LOVE
Ken Copeland (Imperial 5432)
Penguins (Atco 1132)
- PRETEND
Tab Smith (Unltd 205)
- RAKIN' AND SCRAPIN'
Dean Beard (Atlantic 1137)
- RANG TANG DING DONG
Cellos (Apollo 510)
- ROCK ALL NIGHT
Shirley & Lee (Aladdin 3380)
- ROCK ME
Muddy Waters (Chess 1652)
- *ROCKIN' PNEUMONIA AND
BOOGIE FLU
Huey Smith (Ace)
- ROCK YOUR LITTLE BABY TO SLEEP
Buddy Knox (Roulette 4009)
- ROSIE LEE
Mello-Tones (Gee 1037)
- SIDE TRACK
Googie Rene (Class 208)
- SHOULD I EVER LOVE AGAIN
Wynona Carr (Specialty 589)
- SO RARE
Jimmy Dorsey (Fraternity 755)
- START MOVIN'
Sal Minea (Epic 9216)
- STRANGE WORLD
Gene & Eunice (Aladdin 3374)
- SUZIE-Q
Dale Hawkins (Checker 863)
- SWEET AND EASY TO LOVE
Roy Orbison (Sun 265)
- TALKIN' TO THE BLUES
Jim Lowe (Dot 15569)
- THE GAME OF LOVE
Lavern Baker (Atlantic 1136)
- THE SUN IS SHINING
*BABY, WHAT'S ON YOUR MIND
Jimmy Reed (Vee-Jay 248)
- TRUE LOVE GONE
Enchanters (Caral 61756)
- UNITED
Love Notes (Holiday 2605)
- WARM UP TO ME BABY
Jim Bowen (Roulette 4010)
- WHY DO YOU HAVE TO GO
Dells (Vee-Jay 236)
- WHAT CAN I DO
HEAR MY PLEA
Donnie Elbert (DeLuxe 6125)
- WHAT DO YOU KNOW ABOUT LOVE
Wynona Carr (Specialty 600)
- WHEN I GET YOU BABY
Ruth Brown (Atlantic 1140)
- YOU MADE ME LOVE YOU
Sensations (Atco 6090)
- *ZOOZ
Charts (Everlast 5001)



THE NATION'S R & B TOP 20

		Pos. Last Week
1	SCHOOL DAY Chuck Berry (Chess 1653)	1
2	ALL SHOOK UP Elvis Presley (RCA Victor 6870)	2
3	C. C.-RIDER Chuck Willis (Atlantic 1130)	3
4	LITTLE DARLIN' Diamonds (Mercury 71060) Gladiolas (Excello 2101)	4
5	COME GO WITH ME Del-Vikings (Dot 15538)	5
6	VALLEY OF TEARS Fats Domino (Imperial 5442)	9
7	YOUNG BLOOD Coasters (Atco 6087)	10
8	OVER THE MOUNTAIN AND ACROSS THE SEA Johnnie & Joe (Chess 1654)	13
9	SEARCHIN' Coasters (Atco 6087)	15
10	I'M WALKIN' Fats Domino (Imperial 5428)	6
11	LUCILLE Little Richard (Specialty 598)	11
12	JUST TO HOLD MY HAND Clyde McPhatter (Atlantic 1137)	12
13	LOVE'S A HURTIN' GAME Ivory Joe Hunter (Atlantic 1128)	8
14	TROUBLES, TROUBLES, TROUBLES B. B. King (RPM 492)	14
15	JIM DANDY GOT MARRIED Lavern Baker (Atlantic 1136)	7
16	NEXT TIME YOU SEE ME Little Jr. Parker (Duke 164)	16
17	IT HURTS TO BE IN LOVE Annie Laurie (DeLuxe 6107)	18
18	EMPTY ARMS Ivory Joe Hunter (Atlantic 1128)	17
19	IT'S YOU I LOVE Fats Domino (Imperial 5442)	19
20	SEND ME SOME LOVIN' Little Richard (Specialty 598)	20

Hitting Big Nationally!

(No. 7 Shreveport, La.
The Cash Box R & B Retail Outlets)

"Chicken Baby Chicken"

"I'll Forever Love You"

Tony Harris

No. 104

New Releases Looking Big!

"Look What You've Done To Me"

"Misery"

Professor Longhair

No. 106

"What Is Life Without A Home"

"Ooh Little Girl"

Floyd Dixon

No. 105

4523 south western avenue
los angeles 62, california
AXminster 5-3124

"It's What's in THE CASH BOX That Counts—INTERNATIONALLY"



R & B Sure Shots

**"JENNY, JENNY"
"MISS ANN"**

Little Richard

The Cash Box
Award o' the Week 6/8

Specialty 606

"MY DREAM"

The Platters

The Cash Box
Disk of the Week 5/18

Mercury 71093

The Original!
**"JOHNNY'S
HOUSE PARTY"**

John Heartsman
and The Gaylarks

MUSIC CITY # 807

MUSIC CITY RECORDS
1815 Alcatraz Ave., Berkeley, Calif.

BEGINNING TO BREAK!
"HERE I AM"
Oscar McLollie
CLASS # 206

Class RECORDS
1107 El Centro • Hollywood, Calif.

ON THE CHARTS!
Heading For The Top
GENE & EUNICE
"STRANGE WORLD"
3374



**LABELS WANTED
FOR DISTRIBUTION!**
LINK DISTRIBUTING CORP.
156 West 44th St.
New York 36, N. Y.

Thorough background in business will enable us to concentrate on your line. Contact: Danny Anello at above address or phone Circle 6-7381.

**Ops! Dealers! DeeJays!
Watch Us Grow!**

**"EVERYONE'S
LAUGHING"**

— BY —
THE SPANIELS

246

Vee-Jay RECORDS, INC.
2129 S. Michigan Avenue
Chicago 16, Illinois

The Cash Box

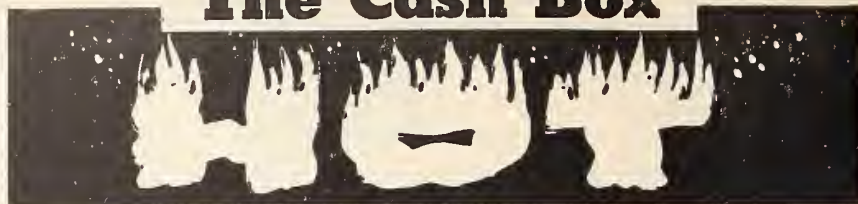

NEW YORK

CHICAGO

NEW ORLEANS

1 COME GO WITH ME
Del-Vikings
(Dot 15538)

2 LITTLE DARLIN'
Diamands
(Mercury 71060)

3 ALL SHOOK UP
Elvis Presley
(RCA Victor 20-6870)

4 SEND ME
SOME LOVIN'
Little Richard
(Specialty 598)

5 OVER THE MOUNTAIN
AND ACROSS THE SEA
Johnnie & Joe
(Chess 1654)

6 EMPTY ARMS
Ivory Joe Hunter
(Atlantic 1128)

7 OUT IN THE
COLD AGAIN
Lyman & Teenagers
(Gee 1036)

8 JUST TO HOLD
MY HAND
Clyde McPhatter
(Atlantic 1137)

9 SO RARE
Jimmy Dorsey
(Fraternity 755)

10 JUST BECAUSE
Lloyd Price
(ABC-Paramount 9792)

ALL SHOOK UP
Elvis Presley
(RCA Victor 20-6870)

IT HURTS
TO BE IN LOVE
Annie Laurie
(DeLuxe 6107)

NEXT TIME
YOU SEE ME
Little Jr. Parker
(Duke 164)

SCHOOL DAY (RING
RING GOES THE BELL)
Chuck Berry
(Chess 1653)

LOVE'S A
HURTIN' GAME
Ivory Joe Hunter
(Atlantic 1128)

C. C. RIDER
Chuck Willis
(Atlantic 1130)

TROUBLES, TROUBLES,
TROUBLES
B. B. King
(RPM 492)

LITTLE DARLIN'
Diamands
(Mercury 71060)

COME GO WITH ME
Del-Vikings
(Dot 15538)

MISS YOU SO
Lillian Offitt
(Excello 2104)

WHAT CAN I DO
Dannie Elbert
(King 5045)

VALLEY OF TEARS
Fats Domino
(Imperial 5442)

C. C. RIDER
Chuck Willis
(Atlantic 1130)

OVER THE MOUNTAIN
AND ACROSS THE SEA
Johnnie & Joe
(Chess 1654)

ALL SHOOK UP
Elvis Presley
(RCA Victor 20-6870)

TROUBLES, TROUBLES,
TROUBLES
B. B. King
(RPM 492)

GET ON THE
RIGHT TRACK BABY
Ray Charles
(Atlantic 1143)

EMPTY ARMS
Ivory Joe Hunter
(Atlantic 1128)

LOVABLE
Dale Cook
(Specialty 596)

JENNY, JENNY
Little Richard
(Specialty 606)

ST. LOUIS

NEWARK

DALLAS

1 C. C. RIDER
Chuck Willis
(Atlantic 1130)

2 ALL SHOOK UP
Elvis Presley
(RCA Victor 20-6870)

3 JUST TO HOLD
MY HAND
Clyde McPhatter
(Atlantic 1137)

4 SCHOOL DAY (RING
RING GOES THE BELL)
Chuck Berry
(Chess 1653)

5 TROUBLES, TROUBLES,
TROUBLES
B. B. King
(RPM 492)

6 LOVE'S A
HURTIN' GAME
Ivory Joe Hunter
(Atlantic 1128)

7 THE SUN IS SHINING
Jimmy Reed
(Vee-Jay 248)

8 LITTLE DARLIN'
Diamands (Mercury 71060)
Gladiolas (Excello 2101)

9 NEXT TIME
YOU SEE ME
Little Jr. Parker
(Duke 164)

10 YOUNG BLOOD
Coasters
(Atco 6087)

C. C. RIDER
Chuck Willis
(Atlantic 1130)

SCHOOL DAY (RING
RING GOES THE BELL)
Chuck Berry
(Chess 1653)

NEXT TIME
YOU SEE ME
Little Jr. Parker
(Duke 164)

OVER THE MOUNTAIN
AND ACROSS THE SEA
Johnnie & Joe
(Chess 1654)

JUST TO HOLD
MY HAND
Clyde McPhatter
(Atlantic 1137)

DON'T ASK ME
TO BE LONELY
Dubs
(Gone 5002)

LUCILLE
Little Richard
(Specialty 598)

OUT IN THE
COLD AGAIN
Lyman & Teenagers
(Gee 1036)

WHAT CAN I DO
Dannie Elbert
(King 5045)

ALL SHOOK UP
Elvis Presley
(RCA Victor 20-6870)

COME GO WITH ME
Del-Vikings
(Dot 15538)

SCHOOL DAY (RING
RING GOES THE BELL)
Chuck Berry
(Chess 1653)

YOUNG BLOOD
Coasters
(Atco 6087)

IT'S YOU I LOVE
Fats Domino
(Imperial 5442)

LITTLE DARLIN'
Diamands
(Mercury 71060)

ALL SHOOK UP
Elvis Presley
(RCA Victor 20-6870)

HE'S MINE
Platters
(Mercury 71032)

A WHOLE LOT OF
SHAKING GOING ON
Jerry Lee Lewis
(Sun 267)

TROUBLES, TROUBLES,
TROUBLES
B. B. King
(RPM 492)

JENNY, JENNY
Little Richard
(Specialty 606)

"Only those records best suited for commercial use are reviewed by THE CASH BOX"

The Cash Box



PHILADELPHIA

LOS ANGELES

DETROIT

- 1 OVER THE MOUNTAIN AND ACROSS THE SEA
Johnnie & Joe
(Chess 1654)
- 2 C. C. RIDER
Chuck Willis
(Atlantic 1130)
- 3 LITTLE DARLIN'
Diamonds
(Mercury 71060)
- 4 ALL SHOOK UP
Elvis Presley
(RCA Victor 20-6870)
- 5 SCHOOL DAY (RING RING GOES THE BELL)
Chuck Berry
(Chess 1653)
- 6 JUST TO HOLD MY HAND
Clyde McPhatter
(Atlantic 1137)
- 7 NEXT TIME YOU SEE ME
Little Jr. Parker
(Duke 164)
- 8 LUCILLE
Little Richard
(Specialty 598)
- 9 JIM DANDY GOT MARRIED
Lavern Baker
(Atlantic 1136)
- 10 WHAT CAN I DO
Donnie Elbert
(King 5045)

- 1 OVER THE MOUNTAIN AND ACROSS THE SEA
Johnnie & Joe
(Chess 1654)
- 2 LITTLE DARLIN'
Diamonds (Excello 71060)
Gladiolas (Excello 2101)
- 3 ALL SHOOK UP
Elvis Presley
(RCA Victor 20-6870)
- 4 VALLEY OF TEARS
Fats Domino
(Imperial 5442)
- 5 SCHOOL DAY (RING RING GOES THE BELL)
Chuck Berry
(Chess 1653)
- 6 JUST BECAUSE
Lloyd Price
(ABC-Paramount 9792)
- 7 TROUBLES, TROUBLES, TROUBLES
B. B. King
(RPM 492)
- 8 COME GO WITH ME
Del-Vikings
(Dot 15538)
- 9 JOHNNY'S HOUSE PARTY
Heartsman & Gaylarks
(Music City 807)
- 10 STRANGE WORLD
Gene & Eunice
(Aladdin 3374)

- 1 ALL SHOOK UP
Elvis Presley
(RCA Victor 20-6870)
- 2 SCHOOL DAY (RING RING GOES THE BELL)
Chuck Berry
(Chess 1653)
- 3 YOUNG BLOOD
Coasters
(Atco 6087)
- 4 SO RARE
Jimmy Dorsey
(Fraternity 755)
- 5 ROSIE LEE
Mello-Tones
(Gee 1037)
- 6 I WANT TO GET MARRIED
B. B. King
(RPM 492)
- 7 JOHNNY'S HOUSE PARTY
Heartsman & Gaylarks
(Music City 807)
- 8 LITTLE DARLIN'
Diamonds
(Mercury 71060)
- 9 OVER THE MOUNTAIN AND ACROSS THE SEA
Johnnie & Joe
(Chess 1654)
- 10 JOY RIDE
Doc Bagby
(Okeh 7080)

ATLANTA

MEMPHIS

SAN FRANCISCO

- 1 SEARCHIN'
Coasters
(Atco 6087)
- 2 COME GO WITH ME
Del-Vikings
(Dot 15538)
- 3 JUST TO HOLD MY HAND
Clyde McPhatter
(Atlantic 1137)
- 4 C. C. RIDER
Chuck Willis
(Atlantic 1130)
- 5 LITTLE DARLIN'
Gladiolas (Excello 2101)
Diamonds (Mercury 71060)
- 6 JENNY, JENNY
Little Richard
(Specialty 606)
- 7 WHAT CAN I DO
Donnie Elbert
(King 5045)
- 8 YOUNG BLOOD
Coasters
(Atco 6087)
- 9 SO RARE
Jimmy Dorsey
(Fraternity 755)
- 10 LUCILLE
Little Richard
(Specialty 598)

- 1 C. C. RIDER
Chuck Willis
(Atlantic 1130)
- 2 I WANT TO GET MARRIED
B. B. King
(RPM 492)
- 3 MISS YOU SO
Lillian Offitt
(Excello 2104)
- 4 COME GO WITH ME
Del-Vikings
(Dot 15538)
- 5 IN THE DOORWAY CRYING
Midnighters
(Federal 12293)
- 6 JUST TO HOLD MY HAND
Clyde McPhatter
(Atlantic 1137)
- 7 GOT MY MOJO WORKING
Ann Cole
(Baton 237)
- 8 YOUNG BLOOD
Coasters
(Atco 6087)
- 9 IT'S YOU I LOVE
Fats Domino
(Imperial 5442)
- 10 LITTLE DARLIN'
Gladiolas (Excello 2101)
Diamonds (Mercury 71060)

- 1 ALL SHOOK UP
Elvis Presley
(RCA Victor 20-6870)
- 2 ONE HUNDRED YEARS FROM TODAY
Alice Jean
(Rhythm 102)
- 3 SCHOOL DAY (RING RING GOES THE BELL)
Chuck Berry
(Chess 1653)
- 4 SEARCHIN'
Coasters
(Atco 6087)
- 5 NEXT TIME YOU SEE ME
Little Jr. Parker
(Duke 164)
- 6 JOHNNY'S HOUSE PARTY
John Heartsman & Gaylarks
(Music City 807)
- 7 RANG TANG DING DONG
Cellos
(Apollo 510)
- 8 LOUIE LOUIE
Berry & Pharohs
(Flip 321)
- 9 IT HURTS TO BE IN LOVE
Annie Laurie
(DeLuxe 6107)
- 10 C. C. RIDER
Chuck Willis
(Atlantic 1130)

He's Sensational!



New Teen Smash...
DALE HAWKINS
"SUSIE-Q"

CHECKER 863

YOU ASKED FOR THEM...



MOONGLOWS

"PLEASE SEND ME
SOMEONE TO LOVE"

CHESS 1661

CHESS & CHECKER
2120 S. MICHIGAN AVE.
CHICAGO 16, ILL.

ALL PHONES: CALUMET 5-2770



R & B Reviews

A AWARD & SLEEPER

B VERY GOOD

C FAIR

B+ EXCELLENT

C+ GOOD

D MEDIOCRE

EARL BOSTIC
(King 5056)

B+ "SHE'S FUNNY THAT WAY" (2:25) [Robbins A S C A P—Daniels, Whiting] On this side Bostic turns in his usual top-flight performance on the standard lovely. Dreamy, melodic, and beaty the way the kids demand it. The big side that should grab lots of attention.

B "EXERCISE" (2:38) [Earl's BMI—Bostic] The swinging horn specialists treats his big audience to a Bostic-written tune. A lively middle beat jumper instrumental with Bostic's big sax away out front. Happy wax that should draw action.

BROOKS AND BROWN
(Duke 172)

B+ "THEY CALL HER ROSALIE" (2:39) [Lion BMI—Brooks and Brown] Brooks and Brown wail a slow blues "about a gal called Rosalie and what she did to me". Dramatic slow beat treatment with some moving blues singing. Deck's a stopper and bears close watching.

B "SLEEPING IN AN OCEAN OF TEARS" (2:50) [Lion BMI—Brown, Brooks] Slow beat dramatic item with rolling drums and eerie feeling. Startling in mood—but definitely something you'll listen to. Good debut for the duo.

TOMMY MOSLEY
(Peacock 1678)

B "I'LL WALK WITH YOU" (2:15) [Lion BMI—Cobb, Kay] Tommy Mosley sings a pop styled pretty with good effects. His lovely vocaling, given a choral backdrop, comes through a stirring wax. Definitely for the pop market.

B "WHAT WOULD YOU DO" (2:17) [Lion BMI—Robey] Mosley turns to a middle beat bouncer and gives it a sprightly but effortless reading. Good warm weather item in its light, bouncy feeling. Happy pleaser.

THE COLONAIRS
(Ember 1017)

B+ "CAN'T STAND TO LOSE YOU" (2:45) [Angel BMI—Francis, Williamson] The Colonairs turn about with a "big" performance styled offering. Sweet, "Ink-Spot" type treatment, complete with recitation. Deck is commercial and bears close watching.

B "SANDY" (2:15) [Angel BMI—Francis, Dames] The Colonairs skip tidily about with a quick beat jumper all about a gal named Sandy. Cute peppery item with the beat, romantic interest, and the fem name, that seems so important commercially these days.

JAMES (SUGARBOY) CRAWFORD
(Imperial 5441)

B+ "MORNING STAR" (2:15) [Reeve BMI—Crawford, Bartholomew] Crawford turns tender on the flip, with a slow, rhythmic ballad. Tuneful item sold in good style. Feeling filled deck that finds a receptive ear.

B "I DON'T NEED YOU" (2:29) [Reeve BMI—Smith, Bartholomew] Quick beat honky tonk tune rocked out by Crawford with an appealing vocal. Crawford skips, in flighty style, backed with a rolling instrumental support. Ok deck.

The Cash Box Award o' the Week

"JENNY, JENNY" (2:00) [Venice BMI—Johnson, Penniman]

"MISS ANN" (2:05) [Venice BMI—Johnson, Penniman]

LITTLE RICHARD (Specialty 606)

● Here's two pre-tested items taken from Little Richard's hot selling album—"Jenny, Jenny" and "Miss Ann". Both decks are given the individualized shouting of the sensational coast singer. Tho we lean ever so lightly to "Jenny, Jenny", Little Richard rocks out both decks with his numerous vocal tricks that make any of his etchings so stand-out. "Jenny, Jenny" is reminiscent of his former hit, "Slippin' and Slidin'". It is a quick beat rocker in which the atomic shouter shows off best. The coupling, "Miss Ann", is the more restrained of the two. It is a middle beat rocker that has to get plenty of attention. It is very possible that Richard has not "one"—but "two" hits here.

"MY GIRL FRIEND" (1:55) [Benell BMI—Powell, Navarro]

"BROKEN HEART" (2:46) [Benell BMI—Powell, Navarro]

THE CADILLACS (Josie 820)

● The Cadillacs rock out what could be their strongest release yet in a quick beat racer titled, "My Girl Friend". The deck takes off from the opening note, grabs your attention immediately and keeps a head-lock on it until they sign off one minute fifty-five seconds later. An effervescent, bubbly tune—it is given a standout treatment by The Cadillacs complete with all their interjected Cadillacisms. This deck looks like a big summer hit. The coupling, "Broken Heart", is a straightaway treatment of a lovely, slow beat ballad. Delightfully and tenderly done. Pleasing and relaxing listening—but for the sales action we look to "My Girl Friend".

"WHOLE LOT OF SHAKIN' GOING ON" (2:39)
[Marlyn BMI—Williams, David]

JERRY LEE LEWIS (Sun 267)

● Looks like another hit out of the Sun label. See pop reviews.

CLYDIE KING
(Specialty 605)

B+ "OUR ROMANCE" (2:30) [Venice BMI—Franklin] Clydie King does a delightful bit of vocaling, etching a slow rhythmic love ballad. Tender teen-age tune handled with one eye on the charts. Two good decks to introduce the new talent.

B "WRITTEN ON THE WALL" (2:05) [Venice BMI—Franklin] Clydie King jumps lightly through the quick beat lilter. Happy romancer told with a cute reading. Infectious item with a strong rhythmic backing. Deck could start something going.

RIFF RUFFIN
(Ebb 103)

B "IF YOU PLEASE" (2:14) [Ebb BMI—R. Ruffin] Riff Ruffin delivers a slow beat blues ballad with a cozy reading that comes through well. Ruffin sells the song well. Easy to listen to wax.

B "NO MORE" (2:20) [Ebb BMI—R. Ruffin] Ruffin about faces completely as he rocks out a quick beat jumper with an enthusiastic reading. Deck is a lively wax that gets the spirit jumping. Happy and driving wax.

TONY HARRIS
(Ebb 104)

B+ "I'LL FOREVER LOVE YOU" (2:05) [Ebb BMI—O. Harris] Harris turns in the stronger performance on a middle beat blues bouncer. Love lyric with emotion and good individual styling. Deck moves and Harris could have something here.

B "CHICKEN, BABY, CHICKEN" (2:20) [Ebb BMI—O. Harris] Gravel voiced Tony Harris shouts out a quick beat jumper with a teen-age lyric. Enthusiastic exhauster given a real swinging reading. Kids should like it.

CHARLIE SINGLETON
(Atlas 2700)

B "FRENCH SWEET SONG" (2:49) [Salvadora] Charlie Singleton and his band dish up an appealing instrumental quick beat. Flavoury item melodically. Ok programming.

C+ "PYRAMID" (2:38) [MacAvery BMI—Mahones] Oriental spiced item. Flute solo gives it the proper touch. Two interesting decks.

The Cash Box R & B Best Bets

- ★ "SHE'S FUNNY THAT WAY"..... Earl Bostic..... King 5056
- ★ "THEY CALL HER ROSALIE"..... Brooks and Brown..... Duke 172
- ★ "OH SO HAPPY"..... The Midnighters..... Federal 12299

THE MIDNIGHTERS
(Federal 12299)

B+ "IS YOUR LOVE FOR REAL" (2:17) [Jay & Cee BMI—Ballard, Green] The Midnighters rock out a quick beat jump in great style. Lead is very strong and the resulting wax. Could grab lots of action.

B+ "OH SO HAPPY" (2:40) [Real McCoy BMI—Owens, McCoy, Glover] The Midnighters have another side that bears close watching. This is a middle beat bouncer with a treatment and piece of material that is different. This one is quite a hunk of wax and it could turn out to be the best the group has turned out in quite a while. Somethink to watch 'cause it has that certain something Two excellent sides, either of which could be "big"—but we think this is the stronger deck.

CRAWFORD BROTHERS
(Aladdin 3375)

B "MIDNIGHT MOVER GROOVER" (1:54) [Aladdin BMI—Crawford Bros.] The Crawford Brothers turn out a slow, rhythmic instrumental with some great sounds. Exciting dim lights blues that should grab lots of attention.

B "MIDNIGHT HAPPENINS" (2:34) [Aladdin BMI—Crawford Bros.] Similar offering with a slightly faster tempo. Dramatic, moody and exciting. Both sides offer moving music.

THE PALMS
(United 208)

B "TEAR DROPS" (2:30) [Pamlee BMI—Marshall] The Palms offer a dramatic slow beat ballad. Tenderly and emotionally told. Good lead handles his chores well. Moving treatment and story.

B "EDNA" (2:45) [Pamlee BMI—Marshall] Another dramatic ballad blues told with touching softness. Pretty melody and engaging arrangement. Strong night club material.

THE CHARTS
(Everlast 5001)

B "ZOOP" (2:21) [Everlast BMI—Cooper, Johnson] The Charts team on a sprightly quick beat bouncer. Infectious joyous bouncer with a couple of gimmicks that give the tune something extra. Deck deserves a good look. Exposure could create some action.

B "DESERIE" (2:38) [Everlast BMI—Cooper, Johnson] Slow beat, rhythm ballad on which The Charts work well. Romancer with a falsetto lead giving the number an attention getting quality. Right in the vein of what the kids want. Two effective sides that should be watched.

THE ISLEY BROTHERS
(Teenage 1004)

B "THE COW JUMPED OVER THE MOON" (2:33) [Jeepster BMI—Isley, Gordon] The Isley Brothers jump with quick beat enthusiasm as they tell of the cow that jumped over the moon. Driving, hard hitting reading that the kids can exhaust themselves to.

B "ANGELS CRIED" (2:20) [Monument BMI—Canton, Kosloff, Petrillo] The Isley's make a complete about face and blend on a slow paced ballad pretty. Tender story told against a rhythmic background.

"Only those records best suited for commercial use are reviewed by THE CASH BOX"



R & B Reviews

A AWARD & SLEEPER B+ EXCELLENT B VERY GOOD
C+ GOOD C FAIR D MEDIOCRE

The Cash Box

R & B Sleeper of the Week

"IT MUST BE YOU" (2:49)
 [Chappell ASCAP—Benjamin, Marcus, Gibson]

"PLEASE, HONEY, DON'T GO" (2:34)
 [Men-Lo BMI—Watkins, Bell, Mendelsohn]

ANNIE LAURIE (DeLuxe 6135)

● Annie Laurie follows "It Hurts To Be In Love" with another strong chart possibility, "It Must Be You". It is a slow beat rhythm blues ballad handled by Miss Laurie in her usullay great style. The lass gives it all the feeling and warmth she can muster and the result is a top flight wax that should be her second straight hit. The flip, "Please, Honey, Don't Go" is an intriguing slow beat bouncer blues again done in excellent manner. Good mood effort. This girl really sings these two sides. Keep an alert eye on "It Must Be You".

"HYPNOTIZED" (2:35) [Nor-va-jak Music BMI—Terry Noland]

"TEN LITTLE WOMEN" (2:38) [Nor-va-jak Music BMI—Terry Noland]
 TERRY NOLAND (Brunswick 9-55010)

● Terry Noland dishes up a rock-a-billy treatment of a Noland written quick beat jumper, "Hypnotized". An infectious beaty bouncer that swings along in happy fashion. Noland handles the cute number with a foot-tappin' arrangement and the deck comes off with real commercial strength. This is one that looks like a biggie in coming weeks. Keep close tabs on it. The coupling, "Ten Little Women", is a similar hunk of cloth dished up with an enthusiastic vocal. Quick beat jumper with a novelty arrangement. Strong backer-upper—but we think "Hypnotized" is slightly up front.

"RUN RUN LITTLE JOE" (2:10) [Excellorec BMI—M. Williams]

"COMIN' HOME TO YOU" (2:53) [Excellorec BMI—M. Williams]

THE GLADIOLAS (Excello 2110)

● The Gladiolas, who offered the original and a big selling version of "Little Darlin'", now come up with an infectious quick beat calypso item, "Run Run Little Joe". The deck seems to have all the ingredients. Happy quick beat tune with a great reading by the talented group. The tune is a delightful joyous lilter with the calypso flavor—but not the overdone melodies that have been coming out on every label. This one stands on its own merit—calypso notwithstanding. It looks like a big hit for The Gladiolas. The flip, "Comin' Home To You", is a slow beat change of pace. A lovely ballad tenderly told. Moving, pleasing but not as strong as "Run Run Little Joe".

JIMMY McCRACKLIN

(Irma 107)

B "I'M THE ONE" (2:38) [B Flat BMI—McCracklin] Jimmy McCracklin wails a slow beat blues with that down home feeling. McCracklin tells in good style his story of a successful love affair.

C+ "SAVOY'S JUMP" (2:37) [B Flat BMI—McCracklin] McCracklin backs with a quick beat wax. Deck moves with a sprightly mood. Infectious jump that'll induce foot tappin'.

JIMMY WILSON

(Irma 108)

B "OH RED" (2:31) [B Flat BMI—J. Wilson] Jimmy Wilson turns in a good reading of a quick beat bouncer with a touch of "Shake Rattle & Roll". Sprightly effort that gets you. Happy wax that should get itself some attention.

C+ "BLUES IN THE ALLEY" (2:33) [B Flat BMI—J. Wilson] Wilson gets down to a slow beat deep south blues in which he wails his tormented tale. Should get a good reception in the down home market.

SUGAR PIE & PEE WEE

(Rhythm 1007)

B+ "LET'S GET TOGETHER" (2:33) [Argee BMI—Parham, Barksdale] Sugar Pie & Pee Wee team delightfully on a quick beat skipper. Happy treatment of a light, tuneful item. Theme of the lyric is a marriage proposal. Deck is an appealing one in sound, melody and treatment. Could grab off a nice piece of action.

B "IF YOU TAKE AWAY YOUR LOVE" (2:35) [Argee BMI—Parham, Barksdale] The youthful team tries its hand at a slow, rhythmic ballad. This duo has an appealing and refreshing sound, and it comes forth on both decks. Good wax—but we like the upper waxing for the action.

IKE TURNER

(Federal 12297)

B "DO YOU MEAN IT" (2:14) [Armo BMI—Ike Turner] Ike Turner wails a rhythmic middle beat jump with a gusto filled projection. Good Lindy hopper material.

B "SHE MADE MY BLOOD RUN COLD" (2:20) [Armo BMI—Ike Turner] Novelty slow beat rocker with an air of mystery. Dramatic performance that makes for good programming. Turner handles it well.

De Paris Tours Africa



NEW YORK — Atlantic Records' jazz star Wilbur De Paris is shown arriving in the recently founded state of Ghana. De Paris toured Africa under the sponsorship of the President's Special International Program for Cultural Presentations administered by the American National Theatre and Academy for the State Department. The famous jazz performer went over to take part in the festivities incidental to the founding of Ghana. He was in Ghana for twelve days and then went on to Nigeria, Ethiopia and other countries. While in Ethiopia, Emperor Haile Selassie presented him with a gold medal.

Capitol Issues "Face In The Crowd" Album

HOLLYWOOD — Capitol Records, on May 27, released its exclusive high fidelity album of music from the sound-track of the Elia Kazan production of Budd Schulberg's "A Face In The Crowd." Making his motion picture debut as star of "A Face In The Crowd" is Andy Griffith, Capitol recording artist.

Included in the new set are "Main Title" ("A Face In The Crowd"), "Free Man In The Morning," a calypso number titled "Fruit Salad Ferryboat," "Old Fashioned Marriage," "Just Plain Folks," a piano medley of "Free Man In The Morning" and "Just Plain Folks," and "Mama Guitar" on Side 1. On flipside are "Rock-A-Billy Rock," "Just A Closer Walk With Thee," "March Montage," "Vitajex Jingle," "Rain Fever" and "Elevator" and "A Face In The Crowd." Griffith sings the latter song plus "Free Man In The Morning," "Mama Guitar," and "Just A Closer Walk With Thee."

Wilson & Astaire On Morrow Show

NEW YORK—Stylist Julie Wilson and Fred Astaire are due for Edward R. Murrow's "Person To Person" TV'er Friday, June 7th on the CBS network.

Miss Wilson will be interviewed from her New York apartment, while Astaire will tackle Murrow's queries from his Beverly Hills home in California.

Both Miss Wilson and Astaire were born in the same city, Omaha, Nebraska.

"JOHNNY'S HOUSE PARTY"
 Part 1 & 2
JIMMIE BEASLEY
 And The Rockers
 Modern #1021

Modern RECORDS
 9317 W. Washington Blvd., Culver City, Calif.

BREAKING IN
 THE NEW YORK AREA

"TONIGHT, TONIGHT"
 by THE
Mello-Kings
 HERALD # 502

Herald RECORDS
 1697 B'way,
 New York City, N.Y.

GOING, GOING, REAL GONE!

The Dubs
"DON'T ASK ME"
 b/w
"DARLING"
 GONE # 5002

GONE RECORDS
 1650 BROADWAY NEW YORK CITY
 Circle 6-4710

A HIT ON DUKE!

DUKE'S DARE DEVILS RHYTHM
 OF
BROOKS and BROWN
 (THE BLUES TOPPERS)

"They Call Her Rosia Lee"
 B/W
 "Sleeping In An Ocean Of Tears"
 DUKE # 172

DUKE RECORDS, INC.
 2809 ERASTUS ST.
 HOUSTON 26, TEX.

A SLEEPER!!

"Let Me Cry"
WILLIE HEADEN
 # 410

DOOTO RECORDS

DON'T BE ALL
 MESSED UP
 ORDER

"MESSED UP"
 COBRA # 5017

HARROLD BURRAGE

COBRA RECORD CORP.
 3346 W. ROOSEVELT CHICAGO 12, ILL.
 (All Phones: NEVada 8-2325)

Climbing Fast!

Fats Domino
 No. 5442

"It's You I Love"
 and
 "Valley Of Tears"

Imperial Records

Pointing Out The Tune



OAKLAND, CALIFORNIA — Pictured backstage at one of the Grand Ole Opry road shows held in the Oakland Auditorium is Faron Young showing Curley Gold his new song book and folio.

Decca Pacts Two Groups

NEW YORK — The Decca artist roster last week was augmented by the signing of two new groups. The company has pacted The Westernaires Orchestra, and a vocal quintet called The Five Secrets.

The Westernaires, a Milwaukee aggregation, make their bow on the label with "Sweet Talk" and "Walking Alone In A Crowd". Personnel of the group are Curly Williams, Bobby Steel, Ralph Hanzel, Billy Wood and Jimmy Allen.

The Five Secrets personnel includes Dave Concepcion, Steve Murphy, Pat Russo, Vincent Santorelli and Frank Del Corvo. The group hails from Staten Island, N.Y. Their initial release couples "See You Next Year" and "Queen Bee".

Celestial Records In Stereo

SEATTLE, WASH.—Nelson Alexander, vocalist hailing from Vancouver, B.C., and currently at The Patio in Denver, has just recorded 12 original songs for Celestial Tapes and Celestial Records. All done in stereo, the songs include calypso, folk, rhythm numbers and ballads to show the versatility of this new song stylist. Nine of the compositions were composed by tunesmith Art Benson, and are being cleared thru Grosvenor House Music, an ASCAP affiliate.

Other new recording artists on the Celestial roster include Marge Whaley, honky-tonk pianist, and Gay Jones, piano stylist, formerly arranger for Lionel Hampton, Ernie Fields and the Freddie Slack orchestra, in addition to E'lan, Celestial's original hi-fi girl.

Distribution for Celestial for the Pacific Northwest has just been taken over by the newly-formed distributor Paramount Audio Sales, Inc.

Victor Signs Milton Allen

NEW YORK — Milton Allen is RCA Victor's newest addition to the Country roster. He is 19, and has had formal voice training. Allen recorded for the first time in Nashville with Steve Sholes on May 24th, and Sholes is very excited about him. "Milton sings straight but with a fine beat", Steve says, "and his style is very individual. With his looks and talent he is bound to be popular with the younger set".

Mayer Upped At Capitol

HOLLYWOOD—The assignment of Pery Mayer to the Promotion Department of Capitol Records in Hollywood, to coordinate album program presentation material, disk jockey album excerpt records, and all other material required to announce each release to Capitol's sales force and record dealers, was announced last week by Dick Rising, National Sales Promotion Manager.

Mayer moves to the Promotion Department from Capitol's Editorial Department. Prior to his Capitol affiliation, Mayer served several years as an account executive with the McCarty Advertising Company and Western Advertising Company (advertising agencies) in Los Angeles. Mayer reports directly to Bill Muster, who is responsible for the coordination and execution of all direct single record and album promotion.

Song Plugging Cowgirl



NEW YORK—Paramount Pictures undertook to focus disk jockeys' attention on Frankie Laine's Columbia "45" recording of the Dmitri Tiomkin-Ned Washington ballad, "Gunfight at the O. K. Corral," by having cowgirl Barbara Adkins call on the gentlemen at their respective stations. Each jockey received a badge signifying his appointment as a deputy sheriff of O. K. Corral where, according to the songsmiths, the Earps and Clantons shot it out in them thar outlaw days. Toy guns and a pressing of the disk completed the presents the gal had for the fellers. Paramount's angle? It's the title song of upcoming rough Western saga starring Burt Lancaster and Kirk Douglas.

Jack Lacy of WINS didn't scare Barbara one bit with that toy gun.



R & B

Disk Jockey

REGIONAL RECORD REPORTS

<p>MIKE GAVIN WCCM-Lawrence, Mass.</p> <ol style="list-style-type: none"> 1. Jungle Hop (Don & Dewey) 2. It's You I Love (F. Domino) 3. Young Blood (Coasters) 4. Game Of Love (L. Baker) 5. A Whole Lot Of Shakin' (J. L. Lewis) 6. Rang Tang Ding Dong (Cellos) 7. Little Billy Boy (Three D's) 8. Atom Bomb Baby (Five Stars) 9. My Dream (Platters) 10. Billy Goat (B. Haley) 	<p>TOM JOHNSON WSYL-Sylvania, Ga.</p> <ol style="list-style-type: none"> 1. All Shook Up (E. Presley) 2. School Day (C. Berry) 3. Little Darlin' (Diamonds) 4. Come Go With Me (Del-Vikings) 5. I'm Walkin' (F. Domino) 6. Just Because (L. Price) 7. Empty Arms (I. J. Hunter) 8. Party Doll (B. Knox) 9. Young Blood (Coasters) 10. Jim Dandy Got Married (L. Baker) 	<p>HAL BALL WTUS-Tuskegee, Ala.</p> <ol style="list-style-type: none"> 1. Little Darlin' (Diamonds) 2. I'm Walkin' (F. Domino) 3. Dearest (Mickey & Sylvia) 4. Empty Arms (I. J. Hunter) 5. Fools Fall In Love (Drifters) 6. Come Go With Me (Del-Vikings) 7. School Day (C. Berry) 8. Lucille (L. Richard) 9. I'm Sorry (Platters) 10. Searchin' (Coasters)
<p>JIM REID WKXL-Concord, N. H.</p> <ol style="list-style-type: none"> 1. Come Go With Me (Del-Vikings) 2. Little Billy Boy (Three D's) 3. Chopstick (Four Esquires) 4. It's You I Love (F. Domino) 5. After School (R. Starr) 6. Out In The Cold Again (Lymon & Teenagers) 7. All Shook Up (E. Presley) 8. Game Of Love (L. Baker) 9. Lucille (L. Richard) 10. Jim Dandy Got Married (L. Baker) 	<p>DEL PARKS WDRF-Chester, Pa.</p> <ol style="list-style-type: none"> 1. I'm Walkin' (F. Domino) 2. Pledge Of Love (Copeland) 3. Rock On (B. Johnson) 4. Just Because (L. Price) 5. Send Me Some Lovin' (L. Richard) 6. Love's A Hurtin' Game (I. J. Hunter) 7. Valley Of Tears (F. Domino) 8. Calypso Rock 'N Roll (Deep River Boys) 9. C. C. Rider (C. Willis) 10. School Day (C. Berry) 	<p>HOWARD CLARK KCIJ-Shreveport, La.</p> <ol style="list-style-type: none"> 1. All Shook Up (E. Presley) 2. Jenny, Jenny (L. Richards) 3. Young Blood (Coasters) 4. Come Go With Me (Del-Vikings) 5. Just Because (L. Williams) 6. It's You I Love (F. Domino) 7. Susie Q (D. Hawkins) 8. Over The Mountain (Johnnie & Joe) 9. Dearest (Mickey & Sylvia) 10. I Would Like To Know (B. Mitchell)
<p>WAYNE HANNAH WMAK-Nashville, Tenn.</p> <ol style="list-style-type: none"> 1. Searchin' (Coasters) 2. Susie Q (D. Hawkins) 3. See You Next Year (Cletones) 4. A Whole Lot Of Shakin' (J. L. Lewis) 5. Rang Tang Ding Dong (Cellos) 6. C. C. Rider (C. Willis) 7. Rosie Lee (Tunedrops) 8. Over The Mountain (Johnnie & Joe) 9. Miss Ann (L. Richard) 10. When I Get You Baby (R. Brown) 	<p>JIM BROWNELL WQOK-Greenville, S. C.</p> <ol style="list-style-type: none"> 1. Little Darlin' (Diamonds) 2. Come Go With Me (Del-Vikings) 3. C. C. Rider (C. Willis) 4. Just To Hold My Hand (C. McPhatter) 5. Jim Dandy Got Married (L. Baker) 6. Let The Four Winds Blow (R. Brown) 7. Valley Of Tears (F. Domino) 8. Just Because (L. Price) 9. Pledge Of Love (Penguins) 10. Love's A Hurtin' Game (I. J. Hunter) 	<p>SCOTT MUNI WAKR-Akron, Ohio</p> <ol style="list-style-type: none"> 1. School Day (C. Berry) 2. What Made Maggie Run (Del-Vikings) 3. Rosie Lee (Tune Drops/Mello-Tones) 4. Like A Baby (V. Nelson) 5. Leap Frog (C. Alaimo) 6. Tonight Tonight (Mello-Tones) 7. Dearest (Mickey & Sylvia) 8. I'm Walkin' (Nelson/Domino) 9. A Whole Lot Of Shakin' (W. Smith) 10. Empty Arms (I. J. Hunter/Game Of Love (L. Baker)

Top Selling Records

Reported by

R & B

Retail Outlets

From Coast to Coast



<p>LYRIC RECORD SHOP Indianapolis, Ind.</p> <ol style="list-style-type: none"> 1. All Shook Up (E. Presley) 2. Little Darlin' (Diamonds) 3. It's You I Love (F. Domino) 4. I'm Walkin' (R. Nelson) 5. A White Sport Coat (M. Robbins) 6. Rock-A-Billy (G. Mitchell) 7. You Are My Sunshine (R. Berry) 8. School Day (C. Berry) 9. Over The Mountain (Johnnie & Joe) 10. Lucille (L. Richard) 	<p>RECORD CENTER Cleveland, Ohio</p> <ol style="list-style-type: none"> 1. School Day (C. Berry) 2. I'm Walkin' (F. Domino) 3. Valley Of Tears (F. Domino) 4. Game Of Love (L. Baker) 5. Send Me Some Lovin' (L. Richard) 6. Empty Arms (I. J. Hunter) 7. He's Mine (Platters) 8. Rosie Lee (Mello-Tones) 9. Johnny's House Party (J. Seasley) 10. Rang Tang Ding Dong (Cellos) 	<p>MUSIC BOX Spokane, Wash.</p> <ol style="list-style-type: none"> 1. School Day (C. Berry) 2. Lucille (L. Richard) 3. C. C. Rider (C. Willis) 4. Come Go With Me (Del-Vikings) 5. Young Blood (Coasters) 6. Just To Hold My Hand (C. McPhatter) 7. Empty Arms (I. J. Hunter) 8. I'm Walkin' (F. Domino) 9. All Shook Up (E. Presley) 10. Over The Mountain (Johnnie & Joe)
<p>BLUEBIRD PHONO. CO. Chicago, Ill.</p> <ol style="list-style-type: none"> 1. All Shook Up (E. Presley) 2. The Next Time You See Me (L. J. Parker) 3. It Hurts To Be In Love (A. Laurie) 4. C. C. Rider (C. Willis) 5. School Day (C. Berry) 6. Love's A Hurtin' Game (I. J. Hunter) 7. Send Me Some Lovin' (L. Richard) 8. Little Darlin' (Diamonds) 9. Come Go With Me (Del-Vikings) 10. Empty Arms (I. J. Hunter) 	<p>MELODY MUSIC Brooklyn, N. Y.</p> <ol style="list-style-type: none"> 1. With All My Heart (T. Sands) 2. Start Movin' (S. Mineo) 3. Send Me Some Lovin' (L. Richard) 4. Zoop (Charts) 5. School Day (C. Berry) 6. Out In The Cold Again (Lymon & Teenagers) 7. Over The Mountain (Johnnie & Joe) 8. Come Go With Me (Del-Vikings) 9. Jim Dandy Got Married (L. Baker) 10. Rang Tang Ding Dong (Cellos) 	<p>RECORD SHACK New York, N. Y.</p> <ol style="list-style-type: none"> 1. Come Go With Me (Del-Vikings) 2. Just To Hold My Hand (C. McPhatter) 3. Little Darlin' (Diamonds) 4. Send Me Some Lovin' (L. Richard) 5. So Rare (J. Dorsey) 6. Valley Of Tears (F. Domino) 7. Just Because (L. Price) 8. Get On The Right Track (R. Charles) 9. When Rock And Roll Come To Trinidad (N. Cole) 10. It Hurts To Be In Love (A. Laurie)
<p>GRAMAPHONE SHOP Los Angeles, Calif.</p> <ol style="list-style-type: none"> 1. Over The Mountain (Johnnie & Joe) 2. Let Me Cry (W. Headon) 3. Troubles, Troubles, Troubles (B. 8. Kings) 4. Don't Want No Woman (B. 8. Bland) 5. Love's A Hurtin' Game (I. J. Hunter) 6. Arrow Of Love (Six-Teens) 7. It Hurts To Be In Love (A. Laurie) 8. I Smell Trouble (B. 8. Bland) 9. Next Time You See Me (L. J. Parker) 10. Heartbeats 	<p>ONE STOP MUSIC New Orleans, La.</p> <ol style="list-style-type: none"> 1. Rocking Pneumonia & Boogie Flu (H. Smith) 2. All Shook Up (E. Presley) 3. Valley Of Tears (F. Domino) 4. Over The Mountain (Johnnie & Joe) 5. So Young (C. Stacey) 6. No Buts, No Maybes (Prof. Longhair) 7. Teenager's Romance (R. Nelson) 8. My Dream (Platters) 9. Jungle Hop (Don & Dewey) 10. What Can I Do (D. Elbert) 	<p>KING RECORDS Dallas, Tex.</p> <ol style="list-style-type: none"> 1. Come Go With Me (Del-Vikings) 2. Young Blood (Coasters) 3. School Day (C. Berry) 4. All Shook Up (E. Presley) 5. He's Mine (Platters) 6. It's You I Love (F. Domino) 7. Lucille (L. Richard) 8. Troubles, Troubles, Troubles (B. 8. Kings) 9. So Rare (J. Dorsey) 10. 30 Second Lover (S. Royales)

America's Leading ONE STOP Record Service

LESLIE DISTRIBUTORS

639 TENTH AVE. 2231 FIFTH AVE. 377 WINDSOR ST. 221 FRELINGHUYSEN AVE.
NEW YORK 36, N.Y. PITTSBURGH, PA. HARTFORD, CONN. NEWARK, N. J.
PLaza 7-1977 GRant 1-9323 JAcKson 5-1147 Blgelow 3-1155

"Only those records best suited for commercial use are reviewed by THE CASH BOX"



Country Big 10 JUKE BOX TUNES

	Pos. Last Week
1 A WHITE SPORT COAT Marty Robbins (Columbia 40864)	1
2 FOUR WALLS Jim Reeves (RCA Victor 6874)	5
3 GONE Ferlin Husky (Capitol 3628)	3
4 ALL SHOOK UP Elvis Presley (RCA Victor 6870)	2
5 GONNA FIND ME A BLUEBIRD Marvin Rainwater (MGM 12412)	4
6 FRAULEIN Bobby Helms (Decca 30194)	8
7 HONKY TONK SONG Webb Pierce (Decca 30255)	7
8 WALKIN' AFTER MIDNIGHT Patsy Cline (Decca 30221)	6
9 BYE BYE LOVE Everly Brothers (Cadence 1315)	—
10 THERE YOU GO Johnny Cash (Sun 258)	10

Inspiration



NEW YORK—Publicist-personal manager Arthur Pine and Captain Allen Swift, master of ceremonies of the "Popeye TV Show," are seen above with the inspiration for the "Official TV Popeye Record Album" which they produced for Associated Artists Productions and on which Swift is featured. The album has proven to be such a strong seller that follow-up Popeye albums are being planned by Associated.

W & G Reps Esoteric & Motif In Australia

MANCHESTER, N.H.—In an effort to offer national distribution to more independent American labels in "The Land Down Under", James N. Parks of Manchester, N.H., the American Representative of W & G Record Processing Company, Pty., Ltd., with headquarters in Melbourne, Australia, announced the completion of agreements with William Fox of Esoteric Records of New York City and Milton W. Vedder of Motif Records Corporation of Hollywood, California, whereby W & G will have exclusive rights to Esoteric and Motif masters for manufacture and distribution in Australia and New Zealand.

First releases from Esoteric masters will include two 12" LP's of that label's "Siena Pianoforte" series, five 12" LP's of various classical selections and two 10" LP's "Jazz Off-The-Air" volumes one and two.

Motif will be represented with its first LP release in Australia via its jazz album titled "Mood For Max" to be followed by other Motif single and LP releases.

W & G, is the distributor for the ABC-Paramount label in that territory.

Jimmy Dean Show Adds Saturday Evenings To Schedule

NEW YORK—In addition to its regular early morning schedule, "The Jimmy Dean Show," CBS Television's popular country music program, goes nighttime every Saturday, 10:30-11:00 PM, EDT, beginning June 29, it was announced last week.

"Two For the Money," formerly in this time period, will switch to an earlier hour, 8:30-9:00 PM, EDT, on that same date.

The decision to put "The Jimmy Dean Show" on in the new Saturday night slot was based upon the initial success of the morning series. On the air since April 8 "The Jimmy Dean Show" right from the start received high ratings in early morning television for that time period.

In addition to special guest stars each week, the show will spotlight the regular Dean troupe, Jan Crockett, the Texas Wildcats, Jo Davis, Mary Klick, Alec Houston and the country lads.

"The Jimmy Dean Show" will continue to originate from WTOF in Washington, D.C. The CBS production is in association with Connie B. Gaye, Executive producer for CBS Television is Edwin S. Friendly, Jr.

It is broadcast Mon.-thru-Fri., 7:00-7:45 AM, EDT, and rebroadcast 7:00-7:45 AM, CDT.



Country Best Sellers

IN RETAIL OUTLETS

	Pos. Last Week
1. A WHITE SPORT COAT Marty Robbins (Columbia 40864)	2
2. FOUR WALLS Jim Reeves (RCA Victor 6874)	3
3. GONE Ferlin Husky (Capitol 3628)	1
4. ALL SHOOK UP Elvis Presley (RCA Victor 6870)	4
5. GONNA FIND ME A BLUEBIRD Marvin Rainwater (MGM 12412)	6
6. HONKY TONK SONG Webb Pierce (Decca 30255)	5
7. FRAULEIN Bobby Helms (Decca 30194)	7
8. BYE BYE LOVE Everly Brothers (Cadence 1315)	11
9. WALKIN' AFTER MIDNIGHT Patsy Cline (Decca 30221)	8
10. THERE YOU GO Johnny Cash (Sun 258)	9
11. A FALLEN STAR. 12. NEXT IN LINE. 13. FIRST DATE, FIRST KISS, FIRST LOVE. 14. I'LL BE THERE. 15. AM I LOSING YOU. 16. OH, SO MANY YEARS. 17. YOUNG LOVE. 18. I MISS YOU ALREADY. 19. MR. LOST. 20. DON'T MAKE ME GO.	

Decca Signs Andy Bey

NEW YORK — Decca Records last week announced the first release by a newcomer to the label, Andy Bey. Bey, an eighteen-year-old vocalist, hails from New Jersey. He is the younger brother of The Bey Sisters (Salome and Gerry), who made their debut on the Decca label several months ago. Andy Bey, although he has been professionally inactive for several years, is no newcomer to the business. As a youngster he was featured as one of TV's "Startime Kids," and only went into semi-retirement while his voice was changing. Bey's first Decca release couples "My Personal Possession" and "The Meaning Of The Blues".



The Country Records Disk Jockeys Played Most

A SUMMARY OF REPORTS RECEIVED FROM THE NATION'S DISK JOCKEYS

1. FOUR WALLS	Jim Reeves (RCA Victor)
2. GONNA FIND ME A BLUEBIRD	Marvin Rainwater (MGM)
3. GONE	Ferlin Husky (Capitol)
4. A WHITE SPORT COAT	Marty Robbins (Columbia)
5. BYE BYE LOVE	Everly Brothers (Cadence)
	Webb Pierce (Decca)
6. ALL SHOOK UP	Elvis Presley (RCA Victor)
7. FRAULEIN	Bobby Helms (Decca)
8. HONKY TONK SONG	Webb Pierce (Decca)
9. A FALLEN STAR	Jimmy Newman (Dot)
10. OH, SO MANY YEARS	Wells & Pierce (Decca)
11. WALKIN' AFTER MIDNIGHT. 12. NEXT IN LINE. 13. I'LL BE THERE. 14. AM I LOSING YOU. 15. I MISS YOU ALREADY. 16. THERE YOU GO. 17. THE SHRINE OF ST. CECILIA. 18. FIRST DATE, FIRST KISS, FIRST LOVE. 19. DON'T MAKE ME GO. 20. MONEY. 21. YOUNG LOVE. 22. TEARS BEHIND THE SMILE. 23. PLEDGE OF LOVE. 24. DARK MOON. 25. SOMEDAY. 26. GIRL IN THE NIGHT. 27. THREE WAYS. 28. MR. LOST. 29. A CHANGE OF HEART. 30. I'M SETTIN' YOU FREE; QUICKSAND; THE WOMAN I NEED; MR. LOVE; LOVE LETTERS IN THE SAND; HE WAS THERE.	

MAE and SHORTY WHITSON SING

RAMBLE RECORDS "THE OLD MOON IS GUILTY NOT MY HEART"

b/w
"I WISH I COULD KISS
YOU GOODNIGHT"

White Oak Music — BMI



Country Reviews

A BULLSEYE **B** VERY GOOD **C** FAIR
B+ EXCELLENT **C+** GOOD **D** MIEDIOCRE

NEWCOMB-RAYNER CANNONBALLERS
 (Co-Ed 049-094)

B "JEANIE" [Sorority-Fraternity BMI—Mayhams] Here's a mighty catchy tale in which many country wax stars are asked to help locate a lost gal dancer who loves c&w music. It's a fetching, up tempo ditty that the Newcomb-Rayner Cannonballers fashion in ear-pleasing style.

C+ "RUN AWAY HEART" [Sorority Fraternity BMI—Mayhams] Here the group, Eddie, Bill and Mac, appealingly grooves a tearful, quick beat love affair.

BAILIN' WIRE BOB
 (Fee Bee 208)

B "HILLBILLY LOVIN'" (2:18) [Fee Bee BMI—E. Morris] The label that introduced Del-Vikings with "Come Go With Me" debuts KIMO-Independence, Mo. deejay, Balin' Wire Bob on two tunes already kicking up some dust on the jocks' turntables. This half is an engaging, quick beat refresher that Bob decks out in spirited style.

B "ANYPLACE I HANG MY HAT" (2:20) [Fee Bee BMI—Strack, Linn, Dallas] Here the chanter spins a moderate paced, sentimental affair in warm, sincere fashion. Two good showings.

JIMMY DEAN
 (Mercury-Starday 71120)

B+ "LOSING GAME" (2:35) [Starrite BMI—J. O'Gwynn] Jimmy Dean, star of his own CBS-TV show, sends up a penetrating vocal performance on a poignant, moderate paced lover's weeper. Powerful wax. Could step out and climb way up the sales ladder.

B "HAPPY CHILD" (2:10) [Starrite BMI—R. Miller] Under lid is happy-go-lucky, up beat novelty that Dean wraps up in most attractive style. Strong coupling.

RUSTY WELLINGTON
 (Arcade 144)

B "I AIN'T A-MOVIN' ON NO MORE" (2:00) [Valley Brook ASCAP—A. R. Keefer] Rusty Wellington steps up to bat out a tantalizing, fast moving ditty that's gonna latch on to a heap of sales and spins.

C+ "CONVICT AND THE ROSE" (2:25) [Shapiro-Bernstein ASCAP—Chapin, King] Wellington displays his persuasive vocal-yodel style on this quick paced, Latin-flavored, prisoner's lament.

LEON McAULIFFE
 (Cimarron 4282)

B "LITTLE GIRL GO AND ASK YOUR MAMA" [Hill & Range BMI—McAuliffe] Here's a two-sided instrumental treat that the deejays should find to their liking. The swinging music is supplied by "Take It Away Leon" McAuliffe and his Cimarron Boys.

B "CARROL COUNTY" [Cimarron Pub. BMI—Arr: McAuliffe] This half is the wonderful old-timer done up anew with a sparkling McAuliffe arrangement.

DICK HART
 (Cowtown Hoedown 778)

B "EVERYBODY'S SWEET-HEART, NOBODY'S FOOL" (2:49) [Cowtown Hoedown BMI—Hart] Dick Hart comes through in first class style as he intros on the label with an expressive portrayal of a slightly up tempo romantic affair.

B "TIME OUT FOR THE BLUES" (2:28) [Cowtown Hoedown BMI—Hart] Under biscuit is a toe-tappin' lover's lament that Hart projects convincingly. The Cowtown Hoedowners ably back up both sides.

THE CASH BOX BULLSEYE



"SWEET INNOCENCE" (2:30) [Amber ASCAP—D. Lampert, J. Gluck, Jr.]

"WHY ASK FOR THE MOON" (1:47)
 [Shapiro, Bernstein ASCAP—L. Martin, W. Myers]

RED FOLEY (Decca 30334)

● The "Old Redhead," Red Foley, who certainly needs no introduction to ops, dealers or deejays sends across a great new coupling that could very well develop into a double-barreled smash. And the chanter's readily recognizable vocal stylings are pleasingly evident as he brightly knocks out the delightful, quick beat love cutie "Why Ask For The Moon" and "Sweet Innocence," a beautiful, slow paced romantic lament that he renders with the utmost sincerity. Superb choral assist by the Anita Kerr Singers on this twin-threat for the pop-country market.

"MINE ALL MINE" (2:15) [Starrite BMI—B. Barnes, M. Singleton]

"NICKEL'S WORTH OF DREAMS" (2:20)
 [Starrite BMI—B. Barnes, E. Aycock]

BENNY BARNES (Mercury-Starday 71119)

● Benny Barnes, who took "Poor Man's Riches" and turned it into a click, comes up with two more potent items, either of which can follow suit. On the top lid the nasal-voiced songster distinctively styles an up tempo, sentimental waltzer labeled "Nickel's Worth Of Dreams." On the under portion he engagingly romps over a most appealing, fast paced romantic entry tagged "Mine All Mine." Splendid instrumental backdrop on this two-sided winner.

"BOP BOP BABY" [Knox BMI—W. Moore, D. Penner]

"DON'T NEED YOUR LOVIN' BABY" [Knox BMI—W. Moore, P. Penner]

WADE & DICK (Sun 269)

● The rockin' Sun label continues to keep in step with the teen-age demands as it turns out another solid pair of chart contenders tailor-made for the dancin' set. The stars, this time, are two talented newcomers Wade & Dick, "The College Kids." On one side they belt out an exciting house-rocker labeled "Bop Bop Baby." On the flip they infectiously spin a rockin' Latin beat, blues item titled "Don't Need Your Lovin' Baby." Sensational background and beat on both ends. Take your pick.

"A FALLEN STAR" [Tree BMI—Joiner]

"PRIZE POSSESSION" [Geronimo BMI—Hill]

FERLIN HUSKY (Capitol 3742)

● Ferlin Husky follows up his gold waxing of "Gone" with a thrilling pairing that should easily find its way into the 'magic circle'. (See Pop reviews).

"SOMEBODY'S BEEN ROCKING MY BABY" [Smash BMI—C. Thompson]

ROD WILLIS (Chic 1010)

● Rod Willis, another great Chic talent, serves up one with the potential to develop into a smash pop and country disk. (See Pop reviews).

"WHOLE LOT OF SHAKIN' GOING ON" [Marlyn BMI—Williams, David]

JERRY LEE LEWIS (Sun 267)

● Jerry Lee Lewis has a sensational all-market pile-driver. (See Pop reviews).

THE WINTERS BROTHERS

(Columbia 40913)

B+ "NO ONE BUT YOU" (2:10) [Cedarwood BMI—F. Robinson] A potent, quick paced love ditty with a South-of-the-border flavoring is excellently executed by the Winters Brothers, Don & Floyd. Stellar mountain harmony and instrumental work on a deck with hit potential.

B "WHAT DO YOU SEE IN HIM" (2:30) [Golden West BMI—D. Winters, E. Hill, J. Winters] Another grade "A" reading, this time on a tear-compelling, moderate beat opus.

DAVE RICH

(RCA Victor 6926)

B+ "RED SWEATER" (2:12) [Gaylord BMI—D. Rich] Dave Rich's polished tones are heard to full advantage as he races over this pop-styled fast paced, teenage weeper with a "White Sport Coat" flavoring. Socko choral and ork assist.

B "THE KEY TO MY HEART" (2:14) [Tree BMI—G. Vandell, P. Strecker] This end Rich and chorus prettily lilt over a heartfelt romantic opus. Both sides are aimed at the pop-country market.

THE FARMER BOYS

(Capitol 3732)

B+ "FLASH, CRASH AND THUNDER" (2:06) [Central Songs BMI—A. Owens, R. Weber] A clever, fast paced, crying-towel opus is treated to a fabulous 'pure country' vocal effort by the Farmer Boys. It's by far their best side to date. Could be a smash.

B+ "SOMEONE TO LOVE" (2:36) [Beechwood Music BMI—A. Owens, J. Simpson] Lower slicing, a touching middle beat weeper, features some more expert 'down home' vocal and instrumental sounds. Tremendous double-decker for the ops, dealers and deejays.

WILEY BARKDULL

(Hickory 1065)

B+ "TOO MANY" (2:14) [Acuff Rose Pub. BMI—F. & B. Bryant] A rockin' musical backdrop showcases Wiley Barkdull's captivating rendition of a hard-hitting blues item that can hit hard on the popularity lists. Watch it.

B "NO ONE WILL EVER KNOW" (2:30) [Milene Music ASCAP—Rose, Foree] This end spotlights Barkdull's intriguing vocal mannerisms on a middle beat, romantic tear-jerker. Two strong contenders for the charts.

BILL HALL

(Mar-Vel 1001)

B "LET ME LOVE YOU" (1:56) [Hits of Tomorrow BMI—D. Sims, B. Hall, J. Mattingly] A light and appeling romantic ditty that gallops along at top speed is delivered with gusto by the smooth-voiced Bill Hall. Sparkling musical support for the chanter's initial performance.

C+ "WHAT HAPPENED TO YOUR HEART" (2:22) [Hits of Tomorrow BMI—D. Sims, B. Hall, D. Coleman] Hall sings right from the heart on this easy-goin' tearful love affair. An easy-on-the-ears offering that merits the airplay.

KING STERLING

(Starday 298)

B "WHAT WILL YOUR ANSWER BE" (2:15) [Starrite BMI—Sterling, Jenkins] King Sterling pours his heart out on this dramatic, middle beat lover's opus. A highly effective reading that could stir up a heap of attention.

B "NOT MUCH" (2:15) [Starrite BMI—D. Marais] Sterling's mel-low tones come across with telling effect on this moderate paced romantic heartbreaker. Top notch offerings.

"Only those records best suited for commercial use are reviewed by THE CASH BOX"



Country Round Up

KRKD-Los Angeles, Calif. deejay, Joe Allison, currently with the "Town Hall Party" TV Show, seen on Channel 11, Sat. nites in L.A., notes that he has a TV 'first' in connection with promoting c&w music. The "Town Hall Party" is a 3-hour TV show with three 10-minute intermissions. During the intermissions Joe conducts the "Party Line," the "Startime" and the "Information Booth" backstage for the benefit of the TV audience. "Party Line" sez Joe is TV's 1st and only TV newscast devoted entirely to the c&w field of entertainment. The "Startime" portion features the "Town Hall" star of the week in an informal interview. "Information Booth" is the segment where the viewing audience is allowed to call Joe while he is on the air to ask questions pertaining to their favorite c&w entertainers. Incidentally, Joe, who was formerly with WSM in Nashville, and his wife, Audrey, who was a singer and dancer in the same city, are the writers of many hit tunes, which include "Teen Age Crush", "Live Fast, Love Hard, Die Young" and "It's A Great Life".



JOE ALLISON

Wax artist, Rusty Wellington, into New York recently making the rounds with his latest Arcade slicing, "Convict And The Rose" and "I Ain't A-Movin' On No More".

Officials of the California Country Music Convention, to be held on Aug. 23rd and 24th in Salinas, have chosen Jeani Mack, 16-year-old thrush with Spade Cooley's all-girl band, to be "Miss Country Music Of Southern California". Jeani will serve as hostess for the country music fans and the entire field and will appear on TV shows, radio spots and personals to plug the convention. She will compete in the finals at the convention for the title of "Miss Country Music Of The West Coast" for which the prize will be a recording contract and session which will be cut at the convention. She was presented the award on the "Search For Talent" show on KOCS in Ontario, California, by station manager Pete Odom.

Producers Roy Glenn and Pee Wee Reid announce the addition of Bob Shelton, a top comedian from the Southwest, to the cast of their Saturday night, "Red River Jamboree", Paris, Texas. Bob is a veteran showman, formerly with WFAA-Dallas, "Shindig" and "Early Birds", and for many years worked with the Bob & Joe Shelton-Sunshine Boys group. He also appears on the Saturday afternoon live broadcast from the Coliseum, which is aired by remote from KFTV-Paris.



RUSTY WELLINGTON

Jerry Newcomb, of Co-Ed's Newcomb-Raynor Cannonballers, infos that two boys from the outfit have left for military service. The boys' latest Co-Ed slicing, reportedly kicking up the dust in Tennessee, is tagged "Jeanie" and "Runaway Heart".

"Ole" Uncle Charlie Babcock, CKLB-Oshawa, Ont., Can., types that "Ramblin' Lou", WJL-Niagara Falls, N. Y., and all his Twin Pine Mountaineers played the big show and dance at the "Red Barn" in Oshawa on May 21st. Babcock, who booked the show, notes that, as usual, Lou had 'em hangin' from the rafters.

"Cuz'n" Larry Lane, who is now spinning three hours of c&w wax a day at WKTS-Brooksville, Fla., is in need of a heap of gospel, in addition to the regular country platters.

Jim Reeves, heading in the direction of a gold disk for his pop-country, RCA Victor smash, "Four Walls", has been set by Mgr. Herb Shucher for a June 9th appearance on the Steve Allen NBC Network TV'er. While continuing negotiations for additional network TV shots, Shucher announced that Jim'll commence a 10-day swing through the Southwest.

Slim Wilson and Goo-Goo Rutledge, the inimitable "song-butcherer" team of Flash & Whistler, are undoubtedly the travelin'est act in the "Ozark Jubilee" gang. Having just wound up three weeks of work with their supporting troupe in Wisconsin, Minnesota, Wyoming, Montana and Idaho, they headed into Ohio for a 4-day Harry Riddle promotion which took them into Toledo on May 30th, Cincinnati May 31st, Columbus June 1st and Troy June 2nd. The all-Jubilee cast on the Ohio dates included Smiley Burnette, Marvin Rainwater and Uncle Cyp. During the following week, Flash & Whistler move on to Plotka, Gainsville, Ocala and Daytona Beach, Florida.



BOB SHELTON

With the close of school in Springfield Fri., on May 24th, Brenda Lee was promoted to the seventh grade. On June 15th she'll headline DJ Howard Miller's presentation at Chicago's Civic Theatre.

Back home from his Eastern deejay swing on June 1st, Billy Walker sings "On My Mind Again" on Dow Chemical's "Red Foley Show" over 275 ABC Radio Network affiliates and 23 additional stations.

Bill Wimberly's Country Rhythm Boys cut their latest Mercury-Starday session on May 23rd in Houston. . . . Famed conductor Richard ("Moritat") Hyman did the arrangements for Marvin Rainwater's MGM session in New York. . . . Red Foley returns to his emcee chores on Ozark Jubilee on June 8th and, incidentally, celebrates a birthday June 17th. . . . Via ABC Publicity, "Uncle Cyp String

Bow Ties" are being sent to numerous TV and radio columnists, together with Uncle Cyp's own "instructions" for tying the tie.

Tom Edwards, WERE-Cleveland, Ohio writes in his newsletter that he's starting a new country music series on WEWS-TV featuring live local talent and occasional name talent when available. It's a low budgeted show, paying scale, and will be viewed on Thursday nites at 10:00 P. M. Any artist working the area is invited to drop in on the show.



JEANI MACK

George T. Popkins who runs "Pop's Country Store" on WXGI-Richmond, Va., types that altho his listeners have taken to the new country music sounds, most of the requests on the new releases have been for the more traditional tunes such as Starday's "Flowers On The Hillside" by Bill Clifton and "Your Old Stand-by" by Jim Fanes. Also, he predicts a hit for Louise Duncan's Capitol recording of "I'm Already Married To You In My Heart". George wants everyone to know that his new mailing address is at WXGI, 300 German School Rd., Richmond, Va.

Murray Nash's "Ad Libs & Intros" newsletter is back on the scene again after a short absence.

With the maple sugar season in full swing across Canada, Canadian old tyme fiddler, Ward Allen is enjoying an exceptionally good re-run in plays of Sparton disking of "Maple Sugar" as well as big sales on his later release, "Back To The Sugar Camp". Ward is still holding forth at CFRA, Ottawa, Ontario and touring the Ottawa Valley on personals. He was in Toronto recently plugging his numbers with local D. J.'s.

Wade Birchfield pens from Detroit that Jimmy Martin's new Decca release, "I'm The Boss Of This Here House" and "Dog Bite Your Hide", can be had by the deejays by dropping a line to Jimmy at 532 Parkview Drive, Detroit 14, Mich. Jimmy, incidentally, headlines the "Lazy Ranch Barn Dance" at 12101 Mack Ave. in Detroit.

"Uncle" Jim Christie, widely known c&w disk jockey, who for the past seven years has been spinning the wax for the 150,000 watter XEG, is taking over duties as Production and Promotion manager for radio station WISK in St. Paul, Minnesota. Jim will still continue to do his shows for XEG and XERB. Sez Jim, WISK is the twin-cities' oldest c&w station and they hope to make it the most listened to c&w station in the great northwest. Artists are invited to contact him at Radio Station WISK, 158 White Bear Ave., St. Paul, Minnesota. Jim can use all country and gospel records.



JIM REEVES

KIMO-Independence, Mo. sent out a cute gimmick promoting deejay, "Balin' Wire" Bob Strack. Bob's likeness is printed on a KIMO, \$5.00 Bonus bill. Bob infos that KIMO DJ, "Tiny," is opening his "Tiny's Hillbilly Park" at Happy Hollow Lake, about 20 miles southeast of Kansas City, on about June 1st. Tiny has some sides out on MGM under the name of Hal White. Strack, incidentally, has a pair of sides out on the FeeBee label and notes that FeeBee prexy, Matt Furin, says there is very encouraging reaction to both sides, "Anyplace I Hang My Hat" and "Hillbilly Lovin'".

Gene Boyd infos that Bill Moss, c&w DJ at WDRF-Chester, Pa., is currently packing them in nightly at "Dominick's Rainbow Room" in Lynnwood, Pa. On Sundays, Bill and his band, the Melody Pals are the sensation of "Sunset Park," an outstanding western music haven in the area. Bill can also be heard daily on WDRF from 12:10 till 1:00 P.M., every week day, and every Saturday on the big c&w show from 2:30 till 5:00 P.M.

KLRA-Little Rock, Ark. deejay Ken Parsons types that "the recent Jimmie Rodgers day in Meridian was one of the highpoints of his life . . . a thrill no one in country music should miss next year." Ken tells jocks to be on the lookout for two great items: James O'Gwynn's next Mercury-Starday, "Do You Miss Me" . . . and the projected Johnny Cash Album. Ken heard both artists preview these . . . and he thinks they are bound to hit hard. One of Cash's album numbers, "Give My Love To Rose" is a weeper of the old style, and will undoubtedly become a standard through the years, sez Ken.



FLASH & WHISTLER

A full week of dates will keep Leon McAuliffe and His Cimarron Boys busy in the home state of Oklahoma. On May 24th the band played for the yearly grand opening of the Shadow Lake Ballroom at Noel, Missouri. This is one of the favorite resort retreats for people living in and around the Ozarks. Leon and the boys have not limited their efforts to ballrooms this spring. Many prom dates, theatre appearances, and country club dates have hardly given the boys in the band a chance to rest. His latest release on the Cimarron Label is tagged "Little Girl, Go And Ask Your Mama" and "Carroll

County."

Attention: Please address any information concerning Country Music and talent to Ira Howard, Country Editor, The Cash Box, 1721 Broadway, New York 19, N. Y.

Seeburg..

ALWAYS FIRST

WITH MAJOR ADVANCEMENTS!

...the exclusive

Tormat memory unit

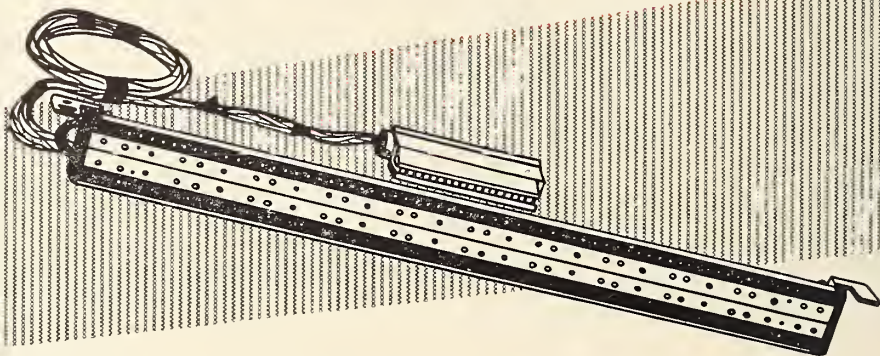
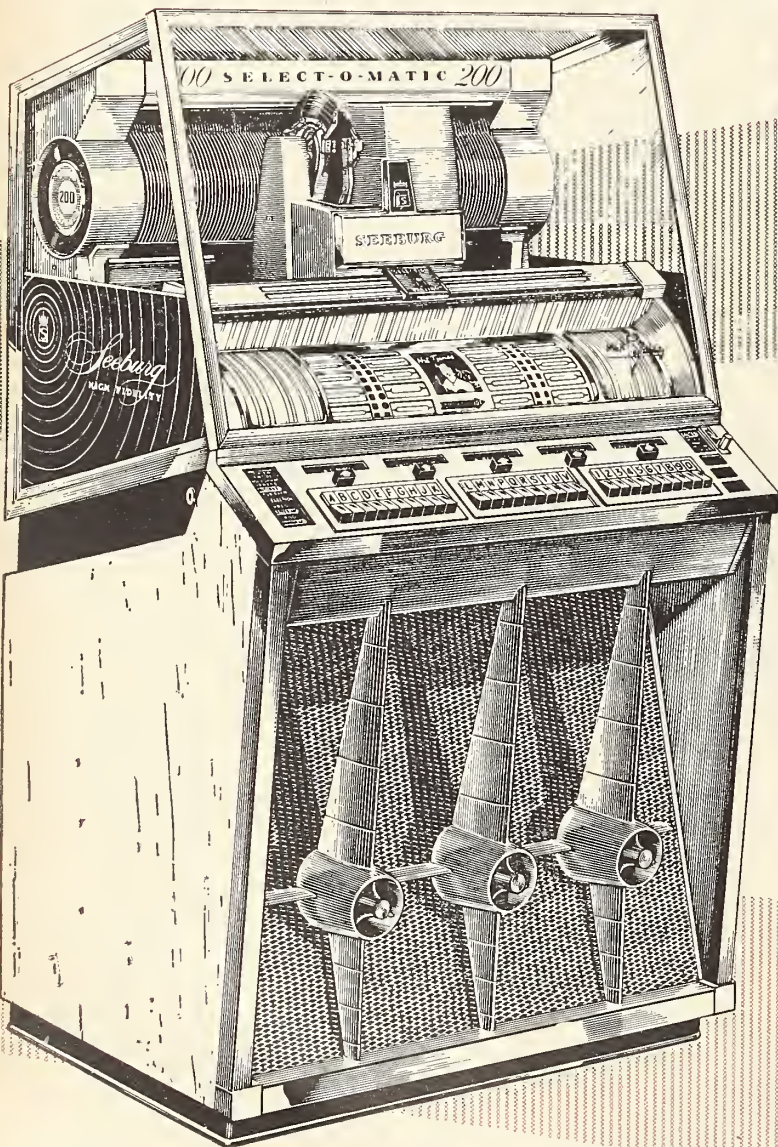

Another Seeburg exclusive. Until the development of the Seeburg Tormat Memory, all such previous assemblies involved *hundreds of moving parts*. With the Tormat Memory Unit *there are no moving parts*. That's because there is a tiny Toroid with an individual "memory" to control the play of each of the 200 record sides.

Completely Sealed! Guaranteed 5 Years!

Tiny Toroid enlarged many times. This is the first commercial application of Toroids other than for "memories" of giant computing machines.

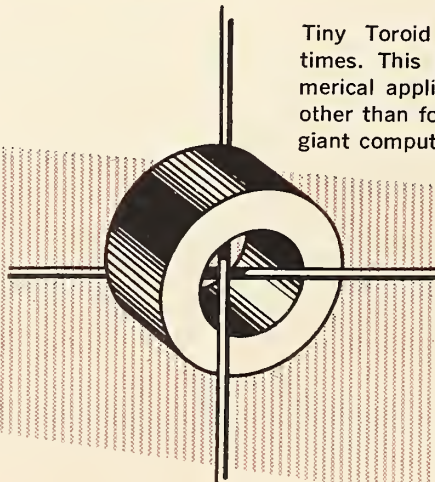

Seeburg

DEPENDABLE MUSIC SYSTEMS SINCE 1902

J. P. SEEBURG
Chicago 22, Illinois

Division of Fort Pitt Industries, Incorporated

*America's Finest and
Most Complete Music Systems*



Here and There

NEW YORK—Charles M. Sievert, financial editor and columnist of the *New York World Telegram and Sun*, in a column last week, wrote about the wide assortment of appraisals and predictions for the nation's economy which continually flows across his desk. He's puzzled by the number of pessimistic viewpoints injected. "What puzzles us," he writes, "is that with basically the same set of facts, and reliable sources of information, the outlook can be painted with either somber or bright hues. The answer seems to lie in who does the painting." Sievert refers to a professor of economics of a Midwestern university who seems to have gotten into a rut. "He begins every year with a forecast that we're headed for a depression," reports Sievert. "... it seems there are some in this era who feel some kind of fame can be obtained if the wheel stops on their blue note . . . Anyway, the odds are awfully heavy against the pessimist winning this year." To strengthen this claim, Sievert quotes Prentice-Hall's latest bulletin which begins with "underlying strength of the boom continues to confound the pessimists" and then continues with "there are no signs of actual or impending decline in the final take of the customers of industry and trade—particularly when services as well as goods are considered."

NORTH TONAWANDA, N. Y.—In his annual report to stockholders, R. C. Roling, president, The Rudolph Wurlitzer Company, this city, made a very interesting and pertinent statement. Looking ahead at prospects for 1957-1958, Roling said: "As we consider the year ahead it seems to be the general opinion of the Government and most informed business men and economists that, barring some unfavorable international situation, business generally should be good. Favorable factors are: constantly rising personal incomes and the desire of people everywhere to have products such as we make. The unfavorable factors are: rising labor and material costs and our inability, in many cases, to pass these costs on to our customers because of the highly competitive situation in the music industry. Since we are an organization for profit it is imperative for the future welfare of Wurlitzer that we make a reasonable profit on our sales. This we hope to accomplish by an aggressive and forward-looking program."

GET UP! GET OUT! GET DOING!

Get up!

Get out of that nice, big, soft, easy, pillowy office chair.

Get back into real, honest-to-goodness, aggressive, promotional, showmanship action once again.

Get out of that beautiful, modern office.

Get away from that cool, relaxing air-conditioner and that tempting bar.

Get out and meet your customers face to face once again.

Get doing.

It's a lot later than you think.

The time has arrived when no operator, regardless of how well he thinks he has his established and recognized business in hand and, further, regardless of how well he thinks he has his employees trained, and regardless of how loyal his employees are to him, can afford to spend his time in a luxurious, air-conditioned office, seated 'way deep down in a soft, pillowy, comfortable office chair and believe, by so doing, that he is overcoming the kind of fierce competition he is faced with today.

The fact remains that, unless the operator who built up the business he now prides himself on being his, gets up, gets out and gets doing, he's going to find that inflation, plus the fiercest competition in all the history of American business, can make him one of the abnormal and continually growing number of bankruptcies being reported every week.

There isn't an operator, today, who can afford to do anything else but—get up—get out—get doing!

The employees who comprise the operator's organization, if he's a big operator, will tell him this is the truth.

If he's a small operator, he absolutely needs every single ounce of energy, intelligence and business acumen he can summon unto his aid, just to remain in business on a somewhat profitable basis.

These are the facts:

1) Machines featuring nickel play are actually bringing their owners but 2½¢ per play.

2) Machines featuring dime play are actually bringing their owners but 5¢ per play.

This is due to constant, creeping inflation. Inflation that has already downed the value of the American dollar this year of 1957 to but 50.8¢. Just half of what the dollar was worth in 1939.

And what's happened these past 18 years? Overhead expenses have zoomed up over 450%. Cost of new equipment is up over 350%. All this since 1939 when the U. S. dollar was worth a full, honest-to-goodness 100 American cents.

What does this mean to the average operator? The operator who is paying 350% more for an amusement machine, and charging only a nickel per play, is actually obtaining but 2½¢ per play, compared to what he used to get 18 years ago, in 1939 and, at the same time, is paying 450% more for overhead expense.

The operator who buys a brand new juke box and is still charging only a nickel per play, well, in his case only the Good Lord can help him to remain in business. Unless, of course, there's no TV, radio, or any other sort of amusement or music in his area. Or unless he has so much money he can afford to lose great, big chunks of it daily.

Operators agree that *The Cash Box*' "10¢ Play Plus" plan is the answer. They admit that *The Cash Box* is a million percent right when it urges them to obtain an equitable return from the gross intake of all their equipment.

They also agree that the average location owner is an understanding human being. He isn't an ogre. Or a man from Mars. He is enough of a businessman and enough of an understanding human being to accept facts. Especially when these facts are clearly, calmly and correctly presented to him.

The operator, today, must arrange for a separation of expenses from gross intake between himself and his locations. Then, and only then, can he divide what is actually profit. The operator will then be in a position to, once again, enjoy a decent return on his investment in new equipment as well as in his business generally.

The average operator is an intelligent and astute businessman. He is a supersalesman of a very definite sort. Or else how could he ever have climbed to his present exalted position in the toughest of all industries—the entertainment field?

The operator will admit that he, and only he, the owner of his business, the man who made his business what it is today, the man who worked so hard each daylight hour and practically every night to instill loyalty and respect and understanding in his employees and to, at the same time, stimulate his employees with the need to protect their livelihood so as to be able to continue their lucrative positions and their futures with his firm. He is still the one, and only the one man who can assure himself, as well as his employees, continued future success.

There is only one way in which he can do this.

Get out and, once again, meet his location owners face to face.

Get better acquainted with them. Especially the new locations whom he hasn't yet met and whom he doesn't even yet know.

Sell them all over again on himself and his organization. The way he used to sell when he started. When he was fighting to just break even. When he wanted that little, extra slice of bacon with his eggs.

He must immediately get doing these things because, unless he does so, he is going to find himself among the losers. The losers who are facing the roughest, toughest, fiercest competition that this industry, and all American industry for that matter, has yet had to face.

He, the operator . . . the one man who built his business . . . the one man who caused his business to become so well recognized and so well accepted by all the public . . . the one man who gained so fine a standing in his community—this one man, the operator, must get doing again!

George A. Miller Re-elected President And Managing Director For Next Three Years

MOA Board of Directors Give George A. Miller Rising Vote of Thanks for Great Work Already Accomplished Past Nine Years and Unanimously Re-elect Him President and Managing Director for '57 to '61.

Miller Also Re-elected State President and Managing Director for 26th Consecutive Year by the California Music Merchants Association.

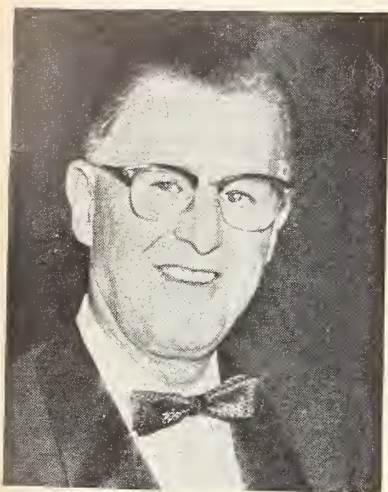

GEORGE A. MILLER

"I'm going back to California to work harder than ever. I'm going to try my very best to double and even redouble our membership, if that is at all possible. I'm going to keep in touch with every single member of MOA all during the year. I want everyone to call on me for whatever their problem.

"When we come back here in 1958 to attend our 8th annual convention I am of the sincere belief that it will be greater and even more illustrious than this record-breaking past convention.

"I want to take this opportunity to thank each and every member of MOA and every single one of the Board of Directors for their confidence, their belief and their faith in my leadership."

Miller remained on in this city until the following week after the seventh annual convention. Meetings of the Board of Directors were in progress for two days after the convention. The first meeting is reported to have lasted until 5 A.M. the next morning.

"One tremendously great thrill to me and to all the Board of Directors", George A. Miller reported, "was the fact that, immediately after the convention closed, exhibitors came up to our official suite and signed up for the 1958 convention, leaving cash deposits for booths.

"Already", Miller concluded, "and for the first time in our history, twelve booths have been sold for next year's (1958) convention which will again be held here in Chicago."

Other officers elected were: J. Harry Snodgrass, Albuquerque, N. M., secretary; Martin C. Britz, Great Falls, Mont., treasurer; Clinton Pierce, Brodhead, Wis., 1st vice-president; Albert S. Denver, New York City, vice-president; Hirsh de LaViez, Washington, D. C., vice-president; William Hurlinger, Delphos, O., vice-president; Les Montooth, Peoria, Ill., vice-president; Howard Ellis, Omaha, Neb., vice-president; and Tom Withdraw, Midland, Texas, sargeant-at-arms.

Elected to serve on the Board of Directors were: James Tolisano, Hartford, Conn.; Larry Marvin, Sacramento, Calif.; William Blatt, Miami, Fla.; Lewis Ptacek, Manhattan, Kan.; Max Hurvich, Birmingham, Ala.; Victor Ostergren, Gary, Ind.; Norman Gefke, Sioux Falls, S. D.; Dave Baker, Arlington, Mass.; John Wallace, Oak Hill, W. Va.; Pete Weyh, Havre, Mont.; Gordon Stout, Pierre, S. D.; Ralph Ridgeway, Springfield, Mass.; Harlan Wingrave, Emporia, Kan.; James Hutzler, Martinsburg, W. Va.; Ted Nichols, Fremont, Neb.; Lou Casola, Rockford, Ill.; Lloyd Cramer, Ottumwa, Iowa; Frank Fabiano, Buchanan, Mich.; K. A. Carmney, Richmond, Ky.; Joe Lederman, New-

More MOA Convention Pictures



CHICAGO—Here are a few more pictures taken at the MOA Convention, held at the Morrison Hotel, which arrived too late for our last issue.

- 1) Lou Nemes, Sylvia and Joe Brilliant.
- 2) Having fun—Ted Bush, Johnny Bilotta, Joe Mangone, Herb Oettinger, "Big Bill" Rodstein, Stanley Levine, Joe Robbins, and the girl is Jodi Sands.
- 3) Charles "Little Jimmy" Johnson brings to the show, Fire Commissioner Quinn and Chiefs Riley and Murphy. Bill O'Donnell and Fred Mills, Jr. join the group.
- 4) Sarkis Anthony and Fred Beshara with a model.
- 5) Marty Tuchow and Mrs. Joe (Sylvia) Brilliant.
- 6) J. T. Auton, Betty Johnson and J. R. (Pete) Pieters.
- 7) Herman Pollock, former coinman, and now head of Arrow Record Company.
- 8) Anthony DeGutis with a model.

(BANQUET PICS and OTHERS on PAGES 30 & 31)

ark, N. J.; Carl Pavesi, White Plains, N. Y.; Stan Bremer, St. Louis, Mo.; George J. Morgan, Peru, Ind.; Ralph L. McMichaels, Denver, Colo.; Jake Friedman, Atlanta, Ga.; and Joe Silla, Sr., Oakland, Calif.

"It's What's in THE CASH BOX That Counts—INTERNATIONALLY"



Be an early bird

Production facilities are rapidly expanding at United to meet the terrific demand for the sensational new, simplified United Phonograph, featuring many new major engineering developments that put more profits in the operator's pocket. It will pay you to keep informed. Write directly to United for the very latest information and earliest delivery dates. Your early action will bring faster delivery to you. Write today.

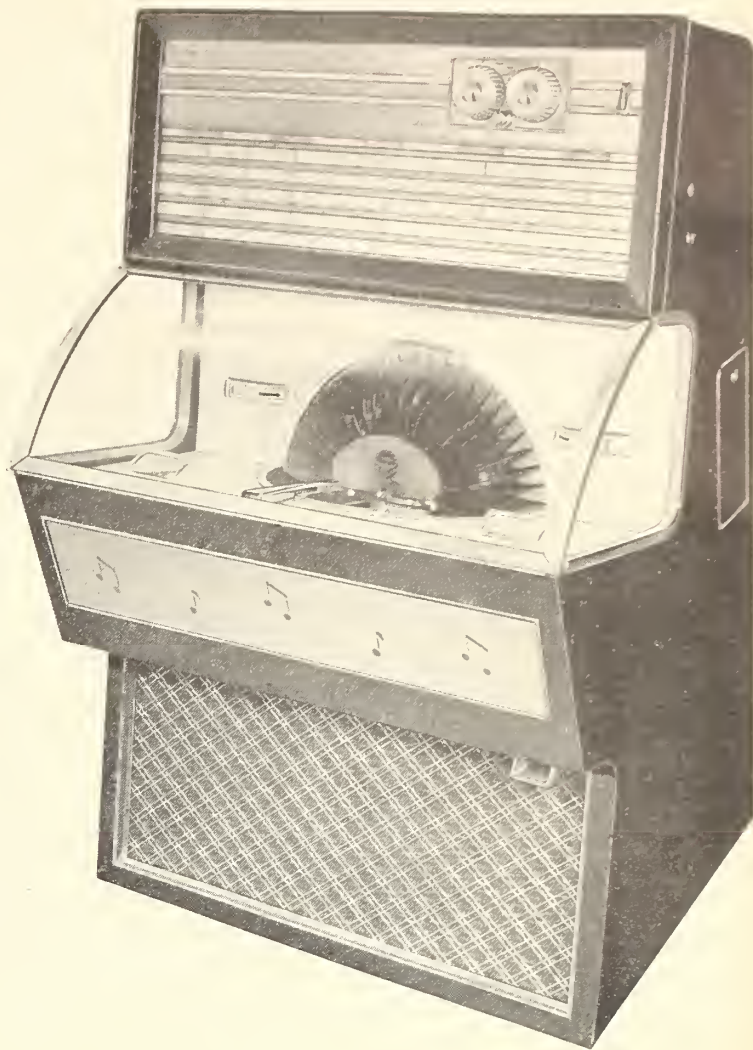

UNITED MUSIC CORPORATION
 3401 NORTH CALIFORNIA AVENUE
 CHICAGO 18, ILLINOIS
 CABLE ADDRESS: UMCORP

Services Locations Via Airplane

GREENFIELD, MASS.—Servicing by plane is the unusual type operation of Mohawk Music Service, this city, and is in keeping with trend to speed up in business methods, which may soon be commonplace among music ops throughout the country. As it stands now, Arthur K. Strahan is the only op in New England who services his customers by airplane. However, some of the other coinmen in Mass., taking a tip from Arthur, are looking into the feasibility and some are already taking lessons in flying, among them Dick Mandell, gen. mgr., Associated Amusements, Boston.

Strahan covers his 80-mile territory with a Luscomb airplane, and if a customer some 25 miles away calls, Arthur may walk into his location 20 minutes later.

Besides the airplane, this high speed op, uses two Thunderbirds and a Volkswagon for his ground operations.

Operating a six man outfit in an area with widely separated towns, Strahan gets around by air and land transportation in unique fashion. The Thunderbird is used to carry tools, disks and spare parts. The plane is used to pick up phonos and parts from distrib in Boston a 35 minute trip by air, but a two and one-half hour drive by auto.

Using his systems of transportation alternatively, he can hop in and out of locations at such a rapid rate that he's cut service calls in-coming down to less than one per month per location. By making the location calls in rapidity, he prevents locations from cluttering up service calls in a sort of preventive service technique.

Use of sports cars has cut gasoline costs and some \$1,300 has been saved in using the speedy little wagons in the course of a year, he estimates. Besides the time saving factors, the advertising and sales promotion of the airplane gimmick accounts for much

24 Hour Hot Water Test For J. H. Keeney Venders



PAUL HUEBSCH

CHICAGO—"We know of only one sure way to make certain that our hot coffee and combination coffee-hot chocolate venders will operate per-

fectly on location," reported Paul Huebsch, general sales manager of J. H. Keeney & Company.

fectly on location," reported Paul Huebsch, general sales manager of J. H. Keeney & Company. "That is to put the machine thru the very same operation as if it were on location. "One of the final testing procedures we use at the end of the production line is time-consuming," Huebsch explained "It takes an extra twenty four hours. "What's more, we don't merely spot-check the Keeney hot drink machines. Every single vender coming off the line is checked thoroly from an electro-mechanical standpoint. "Results prove this one test to be well worth the extra twenty four hours." Huebsch continued to describe the test as starting with pumping pre-heated water into the tanks of the hot coffee and the coffee-hot chocolate venders. Temperature of the water is noted every hour for 24 hours to make sure the heating elements keep temperatures constant, as set on the thermostat. If there is any variation in temperature during the 24 hours, the machine is rejected. A new tank or new thermostat, or both, are installed. Coincident with the hot water test, inspectors check inlet and outlet solenoids, which let water in and out of the tank. Huebsch pointed out that the 24-hour hot water test is one of a series to which each vender is subjected before being packed for shipment. "We want every Keeney vending machine to operate consistently and constantly on location," he concluded.

new business and keeping old customers satisfied. He takes prospective location spot operators up for a plane ride to discuss business, and who can say "no" up in the clouds? Then, there is the unique method of collections, based on the telephone company's collection system. Money is picked up once every 30 days, with the customer receiving a monthly statement. Majority of location owners get their commissions once a year, with a few on a six months' basis. This saves money on bookkeeping, too. Mohawk operates music, pins, arcade equipment and around 40 cigarette vending machines. All locations are on 10¢ play, even in areas where nickel play is still in evidence.

ALL GAMES CLEANED AND IN WORKING ORDER

Bally VICTORY	\$ 55.00
Bally ROCKETS	75.00
Bally ABC	285.00

United CLIPPER	\$125.00
RING-A-BELL (in crate)	100.00
Keeney SPEEDLANE	75.00
SUPER FRAME	35.00
FLASH BOWLER	70.00
TRIPLE STRIKE	110.00
Williams SKEE BALL (6-player)	375.00
Bally SPACE SHIP	200.00

WIRE—WRITE or PHONE HE 1-7577.
 1/3 Deposit Required On Each Order.

We are exclusive factory distributors for:

**BALLY-WILLIAMS-ROCK-OLA
 LAKE CITY AMUSE. CO.**
 4533 PAYNE AVE., CLEVELAND, O.
 (Tel.: HE 1-7577)

RE-CONDITIONED REPLACEMENTS

Wurlitzer Model 1800	\$795
Wurlitzer Model 1900	875
Wurlitzer Model 2000	1020
Seeburg Model 100-G	795
Seeburg Model V-200	875

CULP DISTRIBUTING COMPANY

614 West Grand Avenue
 OKLAHOMA CITY, OKLAHOMA
 (Phone: CEntral 2-8084)

Us Gals by Cissie Gersh



Meeting Dates

Music Operators' Associations

- June 3—California Music Merchants' Association
Place: 311 Club, 311 Broadway, Oakland, Calif.
- 3—United Music Operators of Michigan
Place: Fort Wayne Hotel, Detroit, Mich.
- 4—Westchester Operators Guild, Inc. (6th Annual Banquet)
Place: Holiday Inn, Scarsdale, N. Y.
- 6—Phonograph Merchants' Association, Cleveland, Ohio
Place: Hollenden Hotel, Cleveland, Ohio (General)
- 6—California Music Merchants' Association
Place: Sacramento Hotel, Sacramento, Calif.
- 6—Eastern Ohio Phonograph Operators' Association
Place: 4104 Rush Blvd., Youngstown 12, Ohio (General)
- 7—North Carolina Automatic Music Assn.
Place: Cape Fear Hotel, Wilmington, N. C.
- 10—Tri-County Juke Box Operators' Association
Place: Elum Music Offices, Massillon, Ohio
- 11—California Music Merchants' Association
Place: Fresno Hotel, Fresno, Calif.
- 11—Western Massachusetts Music Guild
Place: DeMarco's Restaurant, West Springfield, Mass.
- 12—California Music Merchants' Association
Place: Bakersfield Inn, Highway 99, Bakersfield, Calif.
- 12—New York State Operators Guild
Place: Palatine Hotel, Newburgh, N. Y.
- 13—California Music Merchants' Association
Place: U. S. Grant Hotel, San Diego, Calif.
- 13—Eastern Massachusetts Music Operators' Association
Place: Beaconsfield Hotel, Boston, Mass.
- 17—Wisconsin Music Merchants' Assn.
Place: Beaumont Hotel, Green Bay, Wisc. (12:00 Noon)
- 17—Westchester Operators' Guild, Inc.
Place: American Legion Hall, 57 Mitchell Place, White Plains, N. Y.
- 19—Automatic Equipment and Coin Machine Owners' Assn. Inc., Indiana
Place: Room 24, 550 Broadway, Gary, Ind.
- 20—Eastern Ohio Phonograph Operators' Association
Place: 4104 Rush Boulevard, Youngstown 12, Ohio (Executive Board)
- 20—Phonograph Merchants' Association, Cleveland, Ohio
Place: Hollenden Hotel, Cleveland, Ohio (Executive Board)
- 24—Central States Music Guild
Place: 805 Main Street, Peoria, Ill.
- 27—West Virginia Music Operators' Association
Place: McLure Hotel, Wheeling, W. Va., 6:00 P.M. (W. Va. M.O.A. Executive Board)
- 28, 29—3rd Annual State Convention of W. Va. Music Ops
- July 20, 21—Music Guild of Nebraska
Place: Clark Hotel, Hastings, Neb.

I'm sure that all of us gals were just as thrilled as I was over the creation of the MOA Ladies Auxiliary and the fact that, next year, we'll have our very own Hospitality Suite and an even bigger and better Fashion Show Luncheon. . . . My sincerest thanks to Marie (Mrs. Clinton S.) Pierce my Co-Chairwoman of this year's MOA Fashion Show Luncheon. And thanks to Mrs. Wm. Hullinger, Mrs. Norman Gefke, Mrs. Howard Ellis, Mrs. Martin Britz, Mrs. Howard Freer, Mrs. Gordon Stout and Mrs. Les Montooth, who also served on the committee to help make this first MOA Fashion Show Luncheon so outstanding.

Immediately after the MOA convention I attended the big annual banquet of the Chicago Automatic Phonograph Bowling League this past Saturday night. A marvelous time was had by all. . . . Congratulations to Carol Priebe and Rene Gallet. They've just tied the knot. Carol works for Chicago Coin. Rene, of course, is with Paschke Phono Service. . . . Mrs. Ray Gallet told me she celebrated her birthday last week. Ray bought her a new car. "He had to", she said, "my old car just wouldn't run anymore". . . . Mrs. Ursula Galgano looked absolutely ravishing at the bowling banquet and proved to her hubby, Tony, how much he needed her by her great bowling skill. . . . Maggie Kraft of Decca is so tired. She planted flowers in her garden Saturday morning. "And that's hard work", quoted Maggie. (Aside: Thanks for the record, Maggie)

Saw Eve (Mrs. Nate) Feinstein. She was all excited about the new baby just born to Gail and Gene Waldman, children of Mr. and Mrs. Maurice Ginsburg. By the way, just

have to mention how glamorous Eve looked. I'm sure her trip to California had something to do with it. This gal is just a living doll. . . . Isabel Oomens had a laughing good time this past Saturday nite. . . . Sorry to hear about that terrible accident Kathy Pieri had last March. Altho surgery was necessary it just didn't affect her beautiful looks at all.

Was so very happy to see Edith Davis at the bowling league banquet. Edith is not feeling too well these days. But a little patience and time will cure all her woes. A wonderful person like Edith has absolutely no right to be on the sick list. Not even for a day. Edith is a very sincere and charming person. I consider her one of the nicest people. She looked lovely Saturday night. . . .

Thanks to Mrs. Mildred Lynch Lillard for her very, very beautiful letter. I only hope I can live up to all the nice things she said. . . . That Nicky O'Donnell just seems to get more attractive each day. And what a lady of fashion she has become. . . . Was so happy to see Edna (Mrs. Ray T.) Moloney at the big MOA banquet. She looked her very beautiful, charming self. Soooo attractive. . . . Sylvia (Mrs. Joe) Brilliant of Detroit all upset because Joe didn't bring her in for the MOA Ladies Fashion Luncheon where she would have been happy to serve on the committee. . . . Met Mrs. David C. Rockola and learned she is a golfer par excellence. At least that's what Mr. Rockola told me. We'll just have to get together for 18 holes of golf. . . . Welcome to Chicago to Sadie (Mrs. Jack) Mitnick who has moved her home to our mid-western Windy City. I'm sure she'll like it here.

SANDY MOORE... Offers Operators... A ONE-STOP SERVICE

for
EVERY POSSIBLE NEED
RECORDS—NEW and USED MACHINES—PARTS—PREMIUMS
• WE SHIP ALL OVER THE WORLD •
Complete Your Shopping ALL AT ONE TIME AT ONE PLACE.
Anything You Want—WE HAVE ON HAND

SANDY MOORE'S RECORD CENTER
240 E. MERRICK RD., FREEPORT, L. I., N. Y. (Phone: MAnyfair 3-2472)

SEE FISCHER'S NEW ULTRA-MODERN "IMPERIAL" SIX-POCKET POOL ON DISPLAY AT OUR SHOWROOM

PRICED RIGHT — IMMEDIATE DELIVERY

BINGOS		ARCADE	
Key West	\$565	Brazil	\$375
Big Show	525	Monaco	335
Double Header	445	Stardust	245
Nite Club	415	Starlet	195
Broadway	375	Pixies	185
Beach Beauty	295	Triple Play	145
Miami Beach	215	Tropicana	115
SHUFFLES		5 BALLS	
Ex. Ringer Ball	\$195	4-Pl. Register	\$345
Genco Skill Ball	225	4-Pl. Score Board	265
Un. DLX Comet	95	2-Pl. Sea Belles	325
Un. DLX Targette	85	2-Pl. Toreador	275
C.C. Hollywood	185	2-Pl. Duette	195
Bally Victory	75	C.C. Blondie	245
Un. Team Bowler	75	Bally Balls-A-Poppin'	255
		Rainbow	\$295
		Harbor Lites	210
		Sweet Add-A-Line	175
		Sluggin' Champ	175
		Regatta	145
		C. C. Capri	165
		Jockey Club	125



Phone: EVerglade 4-2300

Chicago 47
2330 N. Western Ave.

Attention: Operators' Associations

Associations desiring listings in this column, please write to THE CASH BOX, 1721 Broadway, New York 19, N. Y.

Service-free days mean ... Care-free days Ahead



when you **BUY**

ROCK-OLA

the Phonograph that proves itself on location with

Proven time-tested mechanism

Proven time-tested ^{the original} rotating magazine

Proven time-tested ^{the original} rotating program

Proven profits with ^{the only} single button selection system

Proven service reliability

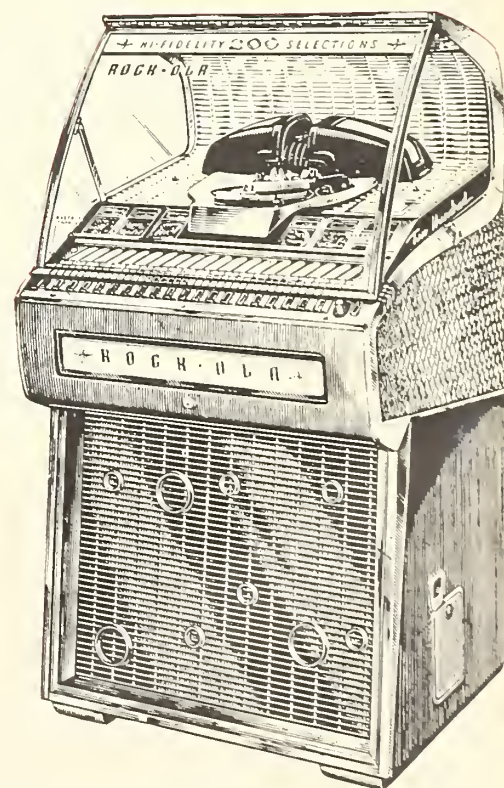

200, 120, 50 Selections

ROCK-OLA MANUFACTURING CORP.
800 N. KEDZIE AVENUE • CHICAGO 51, ILLINOIS

Chicago Automatic Phonograph Bowling

Bowling Teams Enjoy Big Night of Entertainment Closing '57 Season. 32 Entries To Compete Next Year — Double Present Teams. Look Forward to Tremendous '58 Season of Play and Double Attendance at Banquet

Edith Davis and Bob Gnarro Get Surprise Gifts for League Achievements. The Cash Box to give '58 City Bowling Champ Award



Bob Gnarro, who was elected president for the 5th time, makes opening welcome address.



Bill Gersh, publisher of THE CASH BOX, who acted as mc, presents Bob Gnarro award in honor of his being elected president for 5th straight year.



League Banquet Best Of All Time

CHICAGO—The finest party ever held by the 16 teams that comprise the Chicago Automatic Phonograph Bowling League took place this past week, Saturday evening, at Allgauer's famous restaurant in this city.

"This was without any doubt," stated Robert E. (Bob) Gnarro, president of the league, "the grandest and most entertaining banquet we have held in all our existence."

Next year's banquet will probably be double the size, due to the fact that there will be double the number of teams in action. A southside team, which will be known as the "American Team," and a northside team, which will be called the "National Team."

As Bill Gersh, publisher of The Cash Box, who emceed the banquet for the 5th straight year, ever since the league's inception, stated:

"Tho the banquet is sure to be bigger next year it is doubtful whether it will ever be homier and happier than it is today and has been for the four past years."

The Cash Box has agreed to donate the award for the Championship Team for the forthcoming 1957-1958 season.

Bill Gersh then plunged right into the activities and called up, first of all, the team captains who were awarded their prize money for the season:

Eddie Walker, Coral Records; Julius Mohill, Star Music; Paul Brown, Western Automatic Music; Morrie Minkus, Atlas Music; Joe Moss, Mercury Records; Les Taylor, ABC Music No. 2 team; Ray Gallet, Paschke Phono Service; Al Rice, ABC No. 1 team; Robert Holl, Gillette Distributing; Charles Pieri, Coven Music; Tony Ignoffo, Decca Records; Red Lossaso, Singer; Ralph Kick, M. S. Distributing; Marino Pieroni, B & B Novelty; Peter Oomens, Walter Oomens Sons and Tony Galgano, Galgano Distributors.

Following this, awards were made. High Series Scratch to Myrtle Sochacki of Star Music with a score of 527. She also had the high game for the year—205. And was also awarded the WIBC (Women's International Bowling Congress) pin to wear from now on. For the men the winner was Harry Julian of Singer One-Stop with 627.

There was a tie for High Game Scratch between Carol Gallet of Paschke and Ursa Galgano of Galgano Distribs with 201. Dick Laga won for the men with 241.

Jane Minter of Gillette Distributing won the ladies' award for High Series Handicap with 627. Bob Gnarro of

As in all past banquets, the festivities were divided into two parts—the awarding of prizes and trophies to individuals and teams; and the enjoyment of a sumptuous meal. Photographs on the preceding page picture both phases. Photos from 1 thru 27 cover the presentation of prizes, with Bill Gersh seen on most of them handing out the awards; photos from 28 thru 41 show members of the teams with their guests at the dinner tables.

- 1) Mary Gillette with Bill Gersh.
- 2) Gil Lossaso flashing his "crying towel."
- 3) Bob Gnarro making an award to Edith Davis, who retires as League Secretary.
- 4) Last Place Champs—Team composed of Eddie Walker; Mary Ann

ABC Team No. 1 won for the men with a total of 710.

Loretta Oomens, even tho this was her first time in the league, came up with an award for High Game Handicap with 237. Morrie Pomerantz of ABC team No. 1 won for the men with 272.

For First High Individual Average, Flo Shapman of Decca Records won with 142. For the men, Harry Julian of Singer, with a score of 170.

Second High Individual Average was awarded to Myrtle Sochacki of Star Music whose score was 141 and for the men, Ray Gallet of Paschke Phono Service, whose score was 167.

For the best increased averages during the year—Josephine Swider of ABC team No. 2 with a gain of 4 points and for Joe Moss of Mercury with 8 points.

The "last place champs" this year were George Holl, who has held this dubious honor for the past four years. Mary Ann Walker was the ladies winner.

Something new was added this year with a "Triplicate Award" going to Julie Gallet for bowling three games with identical scores of 117. She was given a chevron from WIBC for this honor and also a year's subscription to the Women's Bowling magazine by her teammates as a gift.

The last place championship team came up for their awards this year. Captain Eddie Walker and his mates: Mary Ann Walker, Dick Laga, Jack Reiling and Rudy Zelina.

Second Place Team awards went to Walter Oomens Sons. Peter Oomens, captain. Loretta, Isabel and Johnny Oomens and Cass Kalas making up this team.

The "Championship Team" was that of Galgano Distributors, captained by Tony Galgano and featuring Ursa Galgano, Charley Alesi, Ed Teske and Wally Maslo.

Bob Gnarro, president of the league, then made a surprise presentation to Edith Davis who left the position as secretary of the league this year. All the league pitched in to give her this beautiful gift.

Before Bob Gnarro could walk away from the mike, Bill Gersh called him back and made another surprise presentation to him of engraved gold watch cuff links from The Cash Box and all the league for being elected president of the league for the 5th consecutive year.

In fact, Bob Gnarro has been president of the Chicago Automatic Phonograph Bowling League ever since its inception.

- Walker; Dick Laga and Jack Reiling.
- 5) Walter Oomens & Sons' 2nd Place Team, composed of Pete Oomens, capt.; Loretta Oomens; Isabel Oomens; Johnny Oomens and Cass Kalas.
- 6) Championship Team composed of Tony Galgano, capt.; Ursa Galgano; Charley Alesi; Ed Teske and Wally Maslo.
- 7) Best Increased Average During The Season—Joe Moss, Mercury; Josephine Swider, ABC #2 Team.
- 8) 1st High Individual Average—Flo Shapman, Decca.
- 9) High Game Handicap—Morrie Pomerantz; Loretta Oomens.
- 10) High Score Handicap—Jane Minter, Gillette; Bob Gnarro, ABC #1 Team.
- 11) Paul Brown, Western Automatic Music.
- 12) Robert Hall, Gillette Distributors.
- 13) Joe Moss, Mercury.
- 14) High Game Scratch—Carol Gallet; Ursa Galgano.
- 15) High Game Scratch—Dick Laga.
- 16) 2nd High Individual—Myrtle Sochacki; Ray Gallet.
- 17) Special Triplicate Award—Julie Gallet.
- 18) Last Place Champs—George Holl; Mary Ann Walker.
- 19) Al Rice, ABC Music #1 Team.
- 20) Eddie Walker, Coral.
- 21) Julius Mohill, Star Music.
- 22) Ray Gallet, Paschke Phono Service.
- 23) Tony Ignoffo, Decca; Charles Pieri, Coven Music; Red Lossaso, Singer.
- 24) Tony Galgano; Galgano Distributors; Peter Oomens, Walter Oomens & Sons.
- 25) Morris Minkus, Atlas Music.
- 26) High Series Scratch—Outstanding Woman Bowler: Myrtle Sochacki, Star Music.
- 27) Les Taylor, ABC #2 Team; Marino Pieroni, B & B Novelty; Ralph Kick, M. S. Distributors.
- 28) thru 41—Tables of bowlers and their guests enjoying dinner.

*If you are reading
someone else's copy of
The Cash Box
why not mail this coupon
today!*

THE CASH BOX
1721 BROADWAY
NEW YORK 19, N. Y.

Enclosed find my check.

\$15 for a full year (52 weeks) subscription

\$30 for a full year (outside United States)

\$45 for a full year (Airmail outside U.S.)

NAME

FIRM

ADDRESS

CITY ZONE ... STATE

"It's What's in THE CASH BOX That Counts—INTERNATIONALLY"

AMI Production Departments On Two Full Shifts, says Haddock



Through The Coin Chute

CALIFORNIA CLIPPINGS

GRAND RAPIDS, MICH.—John Haddock, president AMI, Inc., this city, reports that the AMI plant here is a busy place these days with production departments on two full shifts. "In this way", explains Haddock, "we hope to meet the unprecedented demand for the three new model 'H' machines."

"New production and inspection efficiencies insure a steady flow of completed units that meet every rigid standard of performance for trouble-free service in the field."

The plant photos herewith show manufacturing and inspection procedures: (Top) Assembly, testing and inspection of "H" mechanisms are performed on a conveyor line that circles one floor of the plant, past ten adjustment and inspection booths, providing a smooth, orderly flow of equipment to and from each work station. Further along the line, the decorative and functional trim is installed before the mechanisms are automatically lowered to the floor below where they join other sub-assemblies that make up the music machine; 2) Here a pulse converter is given a line run-in duplicating its

actual operation in the field. Control panel lights keep the inspector constantly informed of progress and signal any adjustments which may be necessary: 3) Here on the final run-in line every precision part must fit perfectly and operate faultlessly to insure trouble-free performance in the field. This group of machines is undergoing final crediting and sound checks.



Lucille and Paul Laymon, Paul A. Laymon, Inc., report they are shipping out Bally's fourteen foot ABC "Bowling Lanes" as fast as they are received. Ed Wilkes says sales of the Rock-Ola "200" remain at a steady level. Jimmy Wilkens busy on the floor taking orders for Bally's "Show-Time" in-line game which is proving very popular with the operators. . . . Dick Hall, Oxnard operator, taking time off to enjoy some fishing in the high Sierras. . . . Norty Beckman and his wife, Clarice, telling the staff at Norty's Music Center about their enjoyable evening at The Coconut Grove seeing The McGuire Sisters. Norty told the girls he believed the big side of their new Coral release would be "Beginning To Miss You". Jan Graham says a record that should take off is Jodi Sands "With All My Heart" on Chancellor. Harold Goldfine reports Little Richard has another big one with "Jenny, Jenny" on Specialty. The operators are keeping Ana Martinez busy supplying them with "Old Cape Cod" by Patti Page on Mercury. . . . Before returning to St. Paul after a two week stay, Herman Pastor congratulating his partner, Bill Happel, on the efficiency of the staff at Badger Sales Company, Inc. Don Ames phoning in orders for the AMI "H-200" phonograph from the San Diego area. Dave Yates doing double duty in the Parts Department while Jack Leonard is taking a well deserved week's vacation at his home in Reseda. Marshall Ames busy writing up orders for Keeney's "Bowl-O-Rama" which has caught on with the operators. . . . Lou Dunis, AMI and Bally Distributor in Portland and Seattle, visiting Pico Boulevard on his way home from the MOA Convention.

Frank Davis reported to Wayne Copeland, on his return from the MOA Convention, that every piece of new and used equipment had been sold out at Sierra Distributors for three days, but two carloads of Wurlitzer "2150" phonographs and many pieces of used equipment had been received and were being processed to handle the orders. Frank had to take equipment out of the show windows to fill orders. Pete Ley returned from the Bakersfield-San Joaquin area to join Ed Wisler in sales in the showroom. Ed reports a great increase in sales of the "Ranger" six-pocket pool table. Jim Crosby greatly relieved to receive word that his home in Kansas City was by-passed by the tornado. . . . Bob Shuck of Bob's Music, Redondo Beach, driving to Kentucky from the MOA Convention in Chicago where he will visit relatives before returning to the Coast. . . . Tex Williams dropped in Leuenhagen's Record Bar to play his new Decca release of "Talking To The Blues" for the Solle Sisters, Mary, Kaye and Claire. The girls have completed all arrangements to attend the graduation exercises of their niece, Barbara Chandler in Marysville on June 14th. Barbara will again help out at the Bar through the summer months. Mary has had to special order The Mulcays' record of "My Happiness" and "Near You" on Cardinal because of the many requests from the operators. Kay believes "Goodnight Waltz" by Jack Pleis on Decca will take off. . . . Hank Tronick returned to his desk at C. A. Robinson & Company after a stay in San Diego and reported to Charley Robinson on how United's "Team" Bowling Alleys had taken off in that area. Charley is looking forward to the arrival of United's "UPA-100" phonograph and is hoping his new showrooms will be ready for the big showing. Al Bettelman reports two arcades are contemplating banks of four and ten United "Team" Bowling Alleys to handle the increasing play. Ray Powers says the music business is increasing more and more with used equipment arriving in the rear door and being delivered out the front.

Jack Simon returned to Simon Distributing Company after a successful trip through Nevada and Northern California. John Freeman reports there has been an influx of out of town operators coming to pick up pieces of equipment. Sonny Lomborg busy preparing a large overseas shipment. . . . Many operators have dropped in to wish the Lanzy Brothers, Bill, Andy, Nick and Vinny, continued success with the American Coin Machine Service Company. The rush of route and overhaul work is keeping the entire staff on their toes. Two new members will join the crew in the next few weeks. . . . At California Music Company, Sammy Ricklin busy setting up the vacation schedule for his employees and realized he scheduled everyone but himself. Gabe Orland reports the operators acceptance of the new title strips with the reduced center space has been so great he has had to re-order the first week to handle the demand. Buddy Robinson says a hot one in the R & B field is Shirley & Lee's "Rock All Night" on Aladdin. Martha Delgado reports the teenagers are going for Sil Austin's Mercury release of "Dues Day". Val Zuniga reports that after her appearance on television in "The Helen Morgan Story", Polly Bergen's album of "Polly Bergen Sings Helen Morgan" took a big jump in sales. . . . George Mahlum will be away from his desk at Minthorne Music Company for two weeks more after his recent surgery. Wayne Davis closed another large order for the Seeburg "200" phonographs. Wayne reports they completely sold out Chicago Coin's "Bowling League" and are awaiting another shipment. Paul Vogel busy turning out used equipment at the Minthorne Used Equipment Department and reports there is a great demand for all used Seeburg equipment.

than twice the space formerly occupied.

"Over the many years in the business" stated the Koepfel brothers, "we have supplied the operators, both local and out-of-town with the finest reconditioned music machine equipment. With the added space and finer facilities now available, we will now be in a position to give our customers better and faster service."

"The best coin machine magazine—THE CASH BOX".

Kiyo Nakamoto
MAIN OFFICE: TOKYO, JAPAN
Naha Okinawa, R.I.

Koepfel Distrib Moves

NEW YORK—Harry and Hymie Koepfel moved their Koepfel Distributing Company this week to new quarters at 607 Tenth Avenue, this city.

Forced to move from its previous quarters due to the demolition of the buildings on the entire block to make room for a parking lot, Koepfel Distributing moved its equipment and tools across the street temporarily. After one week, the new location at 607 Tenth Avenue became available and the firm is now almost completely set here, except for a few minor details.

Offices, showrooms and shop at new quarters are all new and modern, and in addition, the firm will have more

Remember for **EXPORT** it's

International Scott Crosse Co.
SCOTT CROSSE COMPANY
1423 Spring Garden Street, Philadelphia 30, Pa.
Rittenhouse 6-7712
Branch: 819-821 Lackawanna Ave., Scranton, Pa.

SEEBURG 100-R	\$725
ROCK-OLA 51-50	150
ROCK-OLA FIREBALL	275
A.M.I. G-120	695
A.M.I. D-80	295
WURLITZER 1700	595

New Keeney BOWL - O - RAMA
Team Scoring! Team Marks! Gutters!

New 6 - POCKET POOL GAMES
IMMEDIATE DELIVERY

Phonographs Reconditioned and Refinished Like New
Exclusive Seeburg Distributors

ATLAS MUSIC COMPANY

A Quarter Century of Service

2118 N. WESTERN AVE., CHICAGO 47, ILL., U. S. A. ARmitage 6-5005

TERMS: 1/3 Dep., Bal. C.O.D.

We Have New Deluxe **FISHER IMPERIAL** 6-Pocket Pool
Hit of M.O.A. Show

We Have New **EXHIBIT TRUE BOWLER** 6-Pocket Pool
Hit of M.O.A. Show

MUSIC

WURLITZER
2000—1900—1800—1700—1500A
1500—1250—1100

AMI
G-200—F-120—M-120—E-80—D-80

SEEBURG
V-200—J—R—C
B—BL—100A

WANTED—

WILL PAY CASH \$\$\$\$ for
WURLITZER 1800—1700—1500—1500A
BALLY & UNITED BINGOS
GOTTLIEB & WILLIAMS 5 BALLS

KIDDIE RIDES

BALLY CHAMPION HORSE \$450
MERRY-GO-ROUNDS
(Lane, Lee, etc.) 400
BALLY SPACE SHIP 225
SEE SAW 195
SCIENTIFIC TV RIDE 195
BOATS 225

Redd DISTRIBUTING CO.

WRITE — WIRE — CALL

CLOSEOUTS: New POOL TABLES... \$50

298 Lincoln St., Allston 34, Mass.

ALgonquin 4-4040

Exclusive distributors for
WURLITZER—BALLY—EXHIBIT—CHICAGO COIN

WE WILL SHIP ANYWHERE



Through The Coin Chute

NEW ENGLAND NIBBLES

Biz continues at an unabated torrid pace in New England, with ops clamoring for new equipment. . . . Big impetus was due in part to the official opening of the fun spots, parks, beaches, etc. on Memorial Day when Hampton Beach, N. H.; Old Orchard, Me.; Revere, Norumbega, Nantasket and Salisbury in Mass., observed traditional season opening day festivities. . . . More coin equipment is evident in beach locations this year than ever before.

At Trimount Automatic Sales Corp. (Seeburg), Donald Murray, head shipping clerk, is back from honeymoon trip. Biz is on the upsurge on everything from phonos to guns. Arcade equipment is moving daily and staff is hard put to keep up with demand. . . . At Associated Amusements (Rock-Ola), Ed Ravreby in Conn. on extended sales trip. Bowlers are going big. Gen. Mgr. Dick Mandell and Mrs. Mandell off to Manhattan for Memorial Day weekend. . . . At Atlas Distributors (AMI), Louis Blatt reports heavy action on new AMI models. Brother Barney Blatt is still recuperating at home. . . . At Redd Distributors (Wurlitzer), Bob Jones, genial sales mgr. here, reports plant is oversold on pool tables and Wurlitzer "half-dollar" phonos. Al Levine of sales is out ill. Games, guns, arcade equipment moving at rapid pace and export biz is up. . . . Ben D. Palastrant resigns as of June 1 as regional rep for Apco, Inc. "You can look forward to an announcement from a reputable manufacturer and myself which will be of utmost interest to you as a vending machine specialist," Ben wrote in letters announcing his resignation. "A new idea in vending equipment which opens up a new field and a real door opener for old and new locations," the letter continued. "It has a terrific market and will greatly add to your earnings as the item vended has public acceptance, fast turnover".

Ops in visiting distribs this week included: Guy Durgin, Presque Isle, Me.; Joe Ferris, Madison, Me.; Joe Viana, Fitchburg; Sol Robinson, Newton; Dave Baker, Arlington; Harry Deshowitz, Chelsea; Steve Pielock, Worcester; Bill Hamel, Concord, N. H.; Ray Shea, Worcester; Tom Libbey, Haverhill; Ralph Lackey, West Roxbury; Al York, Middlebury; Al Dolins, Hyannis; Denny Dolvin, Springfield; Martin Oliver, Portland, Me.; Joe Assad, York Beach, Me.; Peachy Cassanta, Milford; Sam Podensky, Lynn; Mike Paskevich, Nashua, N. H.; John Lazar, Manchester, N. H.; Arthur Strahan, Greenfield; Gerald Waterhouse, Fall River; Ken Ghearse, Brockton; Stan Skop, Waranoco, Me.; Jerry Balboni, Springfield; Art Rhode, Bristol, Conn.; Roger Ferrato, Willimantic; Peter Ruharston, Springfield; Russell Maudsley, Holyoke; Frank Watkin, Springfield; Bill Arrison, Chester, Vt.; Dave Campagna, Springfield, Me.; Paul Carrizia, Beverly; D. J. Halle, Berlin, N. H.; Don Foote, Randolph; Cy Jacobs, Allston; Pat D'Amico, Methuen; George Traster, Oxford; Bill Alekel, Lawrence; Walter Adams, Woonsocket, R. I.; Lawrence Bettencourt, Danvers; Earl Graham, Salisbury; Ben Ross, Boston.

Boston Licensing Board has collected \$24,250 for 633 pins in Boston in 1956. A total of 690 applications were made for pin games in 1956, but 57 applications were rejected, leaving the 633 figure. . . . WHDH music librarian Jerry Diamond will soon be cataloguing his own record. Atlantic Records has released "Sunburned Lips" with Diamond as vocalist. . . . John McLellan, who hosts WHDH's program on jazz, "Top Shelf" has done the cover notes for the Pacific Jazz Enterprises' new LP release, "Flute 'n Oboe, Bud Shank, Bob Cooper, Pacific Jazz, 1926". . . . Disk jockey Bob Clayton travels his "Boston Ballroom" to New York week of June 17 when he will guest host for vacationing Martin Block on the "Make Believe Ballroom" over WABC, New York. . . . Thelma Baker, half of the Baker Sisters, is recuperating in St. Clare Hospital, New York, from major surgery. The Baker Sisters open at the Frolic in Revere on June 23 for two weeks. . . . Johnny Mathis, Columbia disk artist, had big opening at Blinstrub's May 27, where he was in for week, and was feted at big press party at WNAC studios Wednesday, May 29. . . . Eileen Rodgers, Columbia diskster, at Ranch House in Providence, R. I., May 31, and is booked for White City Park, Shrewsbury, June 7, 8, 9. Singer is on N. E. deejay tour June 5 and 6 promoting her platter, "Don't Call Me Sweetie."

Marvel Mfg. Provides Positive Single Ticket Dispensing For "Lucky Horoscope"

CHICAGO — Ted Rubenstein of Marvel Manufacturing Company, this city, advises that the firm's new double-thick tickets for the "Lucky Horoscope" vender provides positive dispensing of one ticket at a time.

"The heavier cardboard stock we now use for our numbered tickets", Rubenstein stated, "is double the thickness of the original.

"This assures operators of accurate, one-ticket-per-play vending for all models of 'Lucky Horoscope', and eliminates loss of revenue."

Rubenstein also reported that he is very pleased with "the outstanding repeat business we are enjoying for both horoscope venders and tickets.

"It proves beyond all doubt," he said, "that the operators are getting wonderful earnings from our horoscope machines.

"As a matter of fact", Rubenstein added, "they tell us that 'Lucky Horoscope' takes in more the first week than they pay for it. And that the

second and third weeks keep going better and better."

Honeymoon Or First Prize?

CHICAGO — What's more important?

Go on a honeymoon, or— Remain in town and cinch first prize in the Chicago Phonograph Bowling League.

Such was the decision that faced Carol Priebs, pretty secretary at Chicago Coin Machine Company, when she married René Gallet.

At the time, Carol was well in the lead for first prize in "High Games Scratch".

Although torn between two loyalties, Carol chose the honeymoon.

As it turned out, Carol got the prize, too.

She tied for first place with Ursula Galgano, with a score of 201.

Genco Intros New 2-Player Roll Down Game, "Sweet Twenty One"

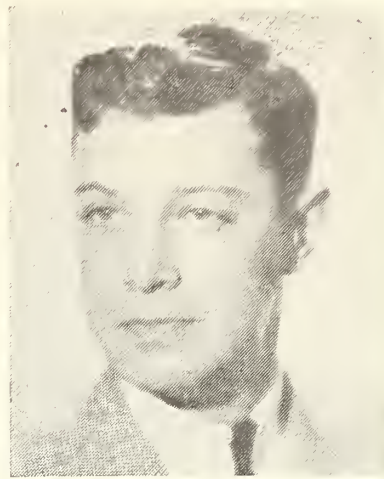

AVRON GENSBURG

CHICAGO—Avron Gensburg, vice-president of Genco Manufacturing & Sales Company, announced this past week that the firm is shipping a new two-player roll down game, "Sweet Twenty One", to its distributors.

"In this game", Gensburg stated, "the popularity of the card game '21' is combined with skillful handling of each ball as the player attempts to guide it into the hole that will give him the score he wants.

"In addition, we have added exciting bonus features to provide more competitive play-appeal than any

other such game we have ever produced in the past."

Action on "Sweet Twenty One" starts with the "Frame Score". There are four frames. Game can be played by a single player, or two can shoot alternately as indicated on the backglass.

Players roll 2 1/2" wood balls by hand over slightly slanted formica playfield, aiming for one of the desired holes numbered 1 to 11.

By landing the balls into the numbered holes on the playfield, player attempts to tie the "Frame Score" with any lit pennant from numbers 16 to 21, adding bonus score values of 10 to 60 points.

Player gets highest total score registered automatically on the backglass as he ties the highest lit pennant score.

On the last or fourth frame, player shoots until he earns "Double Bonus" score for 21. If he goes over "21", player gets no bonus.

"Sweet Twenty One" is quickly adjustable for replay or straight novelty. It is equipped with slug rejector coin mechanism for dime play.

Avron Gensburg concluded by stating, "To become quickly convinced of the tremendous profit possibilities of this great new game of skill, we suggest to all operators that they call at their Genco distributor and play 'Sweet Twenty One'."



LIKE MAGIC!

An Amazing 20-Foot Bowling Alley from your old Shuffle Game!

EXHIBIT'S

TRU-BOWLER

BIG! BIG! BIG! 2-lb. genuine Brunswick Duck Pin Bowling Balls. 4 1/2" diameter. Closest thing to real bowling!

FIRST Has It—FIRST!

Exclusive EXHIBIT Distributors for Illinois—Indiana



COIN MACHINE EXCHANGE, INC.

Wally Finke & Joe Kline

1750 W. NORTH AVE. • CHICAGO 22, ILLINOIS • Dickens 2-0500

5-BALL GAMES

GOTTLIEB

Fair Lady, 2-Pl.	\$375
Gladiator, 2-Pl.	295
Easy Aces	215
Harbor Lights	215
Derby Day	225
Stuggin' Champ	190
Shindig	120
Guys & Dolls	95
Chinatown	75
Skill Pool	75

WILLIAMS

Race The Clock	210
Grand Champion	90
Silver Skates	80
Four Corners	80
Disc Jockey	75

WANTED

Will pay CASH or TRADE!

SEEBURG M100A, B, BL, C, G, & R
GOTTLIEB and WILLIAMS PIN GAMES
GUNS OF ALL TYPES

SPECIAL CLOSEOUT

1 AMI G200	\$695
3 AMI G120	600
1 AMI F120	500
1 AMI E120	375

ALL MACHINES EXCEPTIONALLY CLEAN.

Exclusive Gottlieb, Williams, Seeburg, Genco and International Mutoscope Distributors



Remember IN NEW ENGLAND IT'S TRIMOUNT!

40 WALTHAM STREET
BOSTON 18, MASS.
Tel. Liberty 2-9480

CIAA Meets June 4

Plan All Day Golf Outing for Members. Many Important Matters to be Reviewed at Meeting



SAM GREENBERG

which relate to our business and plan for the future.

"Our interest is solely in building a better industry for all", he continued, "and this can only be accomplished by all of us planning and working together and by getting all operators to join with us so that we will have real unity."

Greenberg went on to say that an all day golf outing had been suggested by many of the members for a day in August.

He emphasized the fact that, since there had been no meeting in May, that everyone be sure to attend this meeting on Tuesday evening, June 4.

"We urge you", Greenberg advised all members, "to make every effort to be at this meeting."

"Our purpose in holding these meetings is to benefit our business", he emphasized.

"Members and all non-members should attend", he said. "This", he added, "is going to be one of the most important meetings of the year."

Charles Pieri of Monarch Coin and Fred Minter of Gateway Distributing are sharing in dispensing refreshments to the entire membership immediately after the meeting.

CHICAGO—Sam Greenberg, president of Chicago Independent Amusement Association, this city, advised the membership that the monthly meeting would be held in the Pine Room of the Congress Hotel at 9 P.M., Tuesday, June 4.

"In addition to the many matters we wish to review", Greenberg stated, we must also discuss issues

TERRIFIC TEXAS TRADE-INS

Wurlitzer Model 1700 \$695
 Wurlitzer Model 1900 875
 Seeburg Model V-200 895

Re-conditioned in our Shop and Backed by our Guarantee

COMMERCIAL MUSIC COMPANY, INC.

1550 Edison Street
 DALLAS, TEXAS

(Phone: Rlverside 1-6381)

Williams

Now Delivering:

- 1957 BASEBALL
- CROSSFIRE GUN GAME
- SIX POCKET POOL TABLE

See Your Williams Distributor

Williams

MANUFACTURING CO.
 4242 W. Fillmore St., Chicago 24, Ill.

Better Tone at Less Cost!

NEW CoMco HI-FI SPEAKERS
 The Only True Low-Priced High Fidelity Speaker!

Hi Fi Wall Model \$19.95 Hi Fi Corner Model \$23.95

CoMco Extended Range SPEAKERS
 Wall... \$11.95 Corner... \$15.95 Ceiling... \$11.95

COVEN MUSIC CORP.

3181 NO. ELSTON AVENUE, CHICAGO 18, ILLINOIS
 (Phone: INdependence 3-2210) Cable Address: COVENMUSIK.

THE HITS OF THE MOA SHOW!!

AQUATIC'S "SQUOITS"
 and
 DALE'S "BURP GUN"
 ("COPS & ROBBERS")

2 NEW ACTION-PACKED AMUSEMENT MACHINES
 SUITABLE FOR TAVERNS, ARCADES and ALL LOCATIONS

CONTACT YOUR DISTRIBUTOR—or WRITE, WIRE, PHONE:

★ **MIKE MUNVES CORP.** ★

577 - 10th AVE.,
 NEW YORK 36, N. Y.
 (Phone: BRyant 9-6677)

ATTENTION !

If you are seeking information on any coin operated machines of American manufacture, write: "The Cash Box"—the authority of the coin operated machines industry.

OJO !

Si desean informes respecto a máquinas accionadas por monedas fabricadas en los Estados Unidos, escriban a "The Cash Box"—la firma más competente en la industria da máquinas accionadas por monedas.

ACHTUNG !

Falls Sie Auskunft über jede Art von Münzautomaten amerikanischer Herstellung wünschen, schreiben Sie doch bitte an "The Cash Box"—die Sachverständigen der Münzautomatindustrie.

ATTENTION:

Si vous avez besoin de renseignements sur n'importe quelle machine a distribution automatique, de fabrication américaine, écrivez a "The Cash Box"—qui font autorité dans l'industrie de la machine à distribution automatique.

THE CASH BOX

1721 BROADWAY
 NEW YORK 19, NEW YORK

"It's What's in THE CASH BOX That Counts—INTERNATIONALLY"

United Music Announces Initial List Of Distributors

Others to be Named as Production Steps Up, and New Factory 15,000 Sq. Ft. Addition Completed

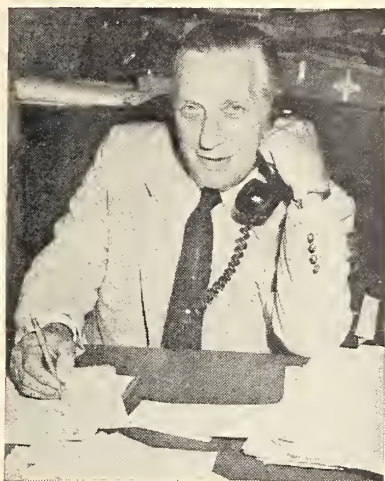

JACK MITNICK

CHICAGO—Jack Mitnick, sales director of United Music Corporation, this city, released the first official listing of distributors for the firm's new UPA-100 automatic phonograph.

Mitnick advised, with release of these names:

"This is only the first and only a partial list of our distributors.

"The fact is", he continued, "and as I have already advised everyone, we will add on more distributors as our production steps up.

"This", he stated, "would come into being just as soon as our new 15,000 square foot factory addition is completed.

"At that time", he added, "I hope to be able to issue a more complete list of distributors."

Heinrich Hecker of Paderborn, West Germany, is distributor for Western Germany.

Suren Fesjian of Mondial Commercial Corporation of New York, N. Y., has been named distributor for France, Algeria, Tunisia and Morocco.

Fred Cuendet and Michel Verdier of Padorex of Lausanne, Switzerland, has been appointed distributor for all Switzerland.

Frans Simons of Antwerp, Belgium, has been named distributor for Belgium, Holland and Luxembourg.

I. H. Rothstein and Al Rodstein of Banner Specialty Company, Philadelphia, Pa., have been appointed distributors for the state of Pennsylvania and a portion of Southern New Jersey.

Harry Rosenberg and Sam Weisman of Double-U Sales Corporation, Baltimore, Md., have been named distributors for Delaware, Maryland, Virginia and Washington, D. C.

Gil Kitt of Empire Coin Machine Exchange, Chicago, Ill., is distributor for Wisconsin and northern Illinois area.

T. B. Holliday and W. H. Richardson of T. B. Holliday Company, Inc., Charlotte, N. C., have been named distributors for the states of North and South Carolina.

Charles A. Robinson of C. A. Robinson Company, Los Angeles, Calif., was appointed distributor for southern California area.

Dave Simon of New York, N. Y. has become distributor for New York, Connecticut and the northern New Jersey area.

Great Op Reaction To Two Munves Amusement Games

Acquatic's 'Squoits' and Dale's 'Burp Gun' Highlight of Munves Display at MOA Show

NEW YORK—Joe Munves, Mike Munves Corporation, this city, back from exhibiting at the MOA Convention, reported that the two amusement machines, for which the firm is national distributors, were received enthusiastically by the visiting coinmen in Chicago.

"Both games, Acquatic's 'Squoits' and Dale's 'Burp Gun' ('Cops & Robbers')" stated Joe, "were accepted by arcade owners, and what particularly pleased us, by coinmen with regular routes covering the tavern and general location. Altho we wrote numerous orders while in Chicago, since

we've returned to New York, the phone has been ringing continuously with requests for immediate shipments of both machines. And, not only from those present at the show, but from others who saw our advertisements, or were informed by men who were at the show. Mike and I have every confidence that both these games will bring operators of all types of locations exceptionally fine collections."

Munves stated that the firm has appointed a number of distributors thruout the country to handle the two machines.



This man is looking into your future

How does it look? Rosy? Free of cancer? You hope! But hoping isn't enough. Of every 6 Americans who get cancer this year, 3 will die because science still has no cure for them. It will take research . . . lots of research . . . to find that cure. And research, let's face it, takes money. Pitch in and help. Send a generous check . . . right now . . . to "Cancer" in care of your local Post Office.

American Cancer Society

ROSEN Gives You REAL Buys!

SHUFFLE ALLEYS

All Star Team Bowler	\$395.00
14 Ft. Bowling League	795.00
Chief	75.00
Clover	35.00
Criss Cross Bowler	95.00
Criss Cross Target	75.00
Crown Bowler	75.00
Delight	25.00
Double Score	35.00
Feature Bowler	95.00
Fireball	150.00
League	100.00
Match Pool	95.00
Miami Shuffle	100.00
Ringer Ball	350.00
Royal	75.00
United 6 Player	35.00
Skee Ball	295.00
Star Bowler	35.00
Starlite	100.00
Super Frame Alley	100.00
United Targette	95.00
Ten Frame Bowler	35.00
Ten Frame Double Score	45.00
Chicago Coin Tournament Ski Ball	Write
Triple Score	25.00
Triple Strike	175.00
Rainbow	125.00
Roll-A-Ball	475.00
Skill Ball, 2 Players	350.00
Blinker Bowler	225.00
United 14 Ft. Bowling Alleys	795.00
Championship Bowlers, new	475.00
Derby Pool, deluxe	125.00
United 11th Frame	125.00
Flash Bowler	125.00
Hollywood Bowler	175.00
Clipper	175.00

1/3 With Order, Balance C.O.D.
WRITE — PHONE — WIRE
SEND FOR COMPLETE LISTS.

DAVID ROSEN

Exclusive AMI Dist. Ea. Pa.
855 N. BROAD STREET, PHILA. 23, PA.
PHONE—STEVENSON 2-2903

Illinois' Phono Ops Plan Statewide Organization

Heads of Four Top Associations to Meet in Chicago to Discuss Plans For Forming Organization to Benefit All Ill. Music Ops

CHICAGO — Phil Levin, president of Recorded Music Service Association, this city, has agreed to meet with Lou Casola of the Illinois Amusement Association, Les Montooth of the Central Illinois Amusement Association and Bob Lindelof of the Northern Illinois Music Operators Association in his offices here in Chicago.

The association heads met with Phil Levin during the MOA convention. Levin agreed to meet with these men to discuss plans for the formulation of a statewide organization to benefit all the music operators in Illinois.

Any other organization heads who may wish to attend this meeting which, it is expected, will take place in the very near future at the Chicago offices of the Recorded Music Service Association, should contact any of the above mentioned men.

It is understood that the state organization will not, naturally, affect the efforts of the local organizations thruout the state.

Rather its purpose will be to help all the music operators thruout the state of Illinois on all state matters.

Such an organization has long been wanting, the men stated, and all are of the opinion that it can be formed and can also become very successful in helping all Illinois' music operators.

"This is something we needed for a long time", stated Louis E. Casola of Rockford, Ill., president of the Illinois Amusement Association, "and its formulation is an absolute necessity today.

"We most sincerely hope", he added, "that every music operator everywhere in the state of Illinois will join in to help us plan and form this statewide organization."

NICKEL & DIME DISPENSERS

TO BUILD YOUR PROFITS!!

\$12.95 EA.

COIN CHANGE QUICKLY MADE TO SATISFY CUSTOMERS. NO DELAY IN COUNTING COINS OR JAMMING OF OLD DISPENSERS.

TOUCH THE LEVER AND FIVE COINS DROP IN YOUR HAND.

THE MOST DURABLE AND ACCURATE COIN DISPENSER ON THE COIN MACHINE MARKET.

AVAILABLE IN 1c, 5c, 10c, 25c MODELS

EXCLUSIVE FACTORY REPRESENTATIVE

DUNIS DISTRIBUTING COMPANY

100 ELLIOTT AVE., W., SEATTLE 99, WASH.

PHONE: MURdock 7740



GENCO'S "SWEET TWENTY ONE"

SENSATIONAL NEW ROLL-DOWN GAME for 1 or 2 Players

EXCITEMENT, SUSPENSE GALORE! NOTHING LIKE IT IN THE ENTIRE COIN GAME FIELD

Hits a new high in BUILT-IN competitive challenge—a thrill in every play. Ideal for every location.

- National Coin Rejector Coin Chute
- 2 1/2" Wooden Balls
- Durable Formica Playfield
- Easy Servicing — All mechanics in back rack
- 4 exciting frames—adjustable to 3
- Bonus and double bonus features

ADJUSTABLE FOR REGULAR OR REPLAY

KEEP "ON THE GO" WITH GENCO

CABINET 6 FT. LONG, 2 FT. WIDE
FITS ALL LOCATIONS

SEE YOUR GENCO DISTRIBUTOR TODAY!

STILL GOING STRONG! **"CIRCUS"** Rifle Gallery

Featuring Mysterious "CRAZYBALL" and "SAD SAM" Targets

GENCO MFG. & SALES CO. 2621 N. Ashland Avenue Chicago 14, Illinois

HAVE YOU BEEN ACTIVELY ENGAGED IN THE INDUSTRY FOR TEN YEARS?

If you have been actively engaged in the industry for ten years or more, but not yet 20 years, you are now eligible to become an "Alternate Member" of the "20 Year Club". As an "Alternate Member" you enjoy all the privileges of the "20 Year Club" and will automatically be transferred into the "20 Year Club" on reaching your 20th year in the industry. If you are eligible for membership as an "Alternate Member" of the "20 Year Club" fill out the application and mail today!

(PLEASE PRINT)

ENTERED THE INDUSTRY _____ MONTH _____ DAY _____ YEAR

BORN _____ (MONTH—DAY—YEAR)

NAME IN FULL _____

FIRM NAME _____

ADDRESS FOR 'CLUB' MAIL _____

CITY _____ ZONE _____ STATE _____

MAIL TODAY TO:

THE CASH BOX' "20 YEAR CLUB"
32 WEST RANDOLPH STREET, CHICAGO 1, ILLINOIS



Through The Coin Chute

EASTERN FLASHES

Not many coinmen making personal visits to coinrow this week, but every wholesaler reported no let-up in orders. Plenty of phone business, and mail orders keep on coming in. At some wholesalers, execs and sales personnel kept glued to the phone, with customers demanding immediate action so equipment would be on location for the big holiday week-end. If it comes up sunny and warm, there'll be plenty of smiling faces.

What might look like bad news sometimes turns completely into the best possible break. Take the case of Harry and Hymie Koepfel of Koepfel Distributing Co. Because a syndicate bought up the property on 10th Ave., from 44th to 45th St., and plan to turn it into a parking lot, the Koepfels had to move out of a very desirable location on the row. They moved all their machines and equipment across the street into their other store, but the space was small and dismal. This week they were able to lease and move into a large, recently renovated, clean and modernized quarters on the corner of 44th St. and 10th Ave. And it's on the West side of the street, just what the doctor ordered. Now the Koepfels expect more biz than ever. . . . Joe Munves, who ran the MOA exhibit booth for Mike Munves in Chicago, back in the office, real excited over the reception given to Aquatic's "Squirts" and Dale's "Burp Gun" ("Cops & Robbers"), two new amusement machines. Munves is national distributor for both these items, and Joe advises distributors have been appointed thruout the nation. . . . Meyer Parkoff, Atlantic New York Corp., tells us he's relaxing this week, recuperating from the excitement of his UJA testimonial dinner. "I just didn't realize how much work I put in, and how tired I was until I relaxed" said Meyer. "After the holiday week-end I'll check with the boys to see how business is, altho I haven't anything but good news 'til now." . . . "Senator" Al Bodkin, makes the rounds on coinrow, with the usual big smile, particularly when he tells of the fun and excitement which percolated at the MOA show.

The New York State Department of Labor reported that the State Employment Service filled 50,734 jobs in New York City during April, the highest for the month since the height of the Korean War. Demand for workers was at an extremely high level, with employers here placing requests for 73,000 jobs during the month. . . . Barney (Shugy) Sugerman and Irv (Kempy) Kempner, Runyon Sales, paid a visit to ops in the upper area of their New York territory. "Came back with plenty of orders for both AMI's model 'H' phones, and games of Bally," smilingly reported Shugy. . . . Al Simon and Al D'Inzillo, Albert Simon, Inc., eagerly awaiting delivery of Genco's new roll-down game "Sweet Twenty One." "Stick around a few minutes" requested Simon, "it should be arriving any minute." . . . Joe Young, Abe Lipsky and Allie Goldberg, Young Distributing, all out when we dropped in. "Visiting music ops," we were informed. However, shipping dept. seemed plenty busy, preparing Wurlitzer phonos for delivery to ops. . . . We created quite a stir on the row this week when we showed the trade several old-time photos. The one which created the greatest interest was taken at an opening party of Mike Munves. Concensus was that the picture was taken around 1938, 39 or 40, and the location was on 10th Ave. and 43rd Street. In the picture were such well known men as: Mike Munves, Joe Munves and his wife; Carl Pavesi, Sol Silverstein, Hymie Budin (deceased); Sue Gasparro; Harry Koepfel; Willie Gaines (still with Munves); Jack Semel; Jack Firestone; Rosy Rosenberg (deceased); Harry Hoppe, the English coinman (deceased); Charlie Katz; Jack Fitzgibbons (deceased); Meyer Parkoff; and naturally, Bill Gersh and Joe Orleck. . . . Many here getting ready to attend the 6th Annual Dinner of the Westchester Operators Guild, being held at the Holiday Inn, Scarsdale, N. Y., on Tuesday night, June 4. The Westchester party is always a happy event, with everyone having a wonderful time.



Through The Coin Chute

UPPER MID-WEST MUSINGS

Twin City distributors complaining of business dropping off the past week. Very little action around Minneapolis. With fishing season opening last Saturday operators are still out after the big ones. . . . John Seglem, of Duluth, Minn., drove in to Minneapolis for the week end to visit relatives and made the rounds, picking up some parts and records for the route. . . . Mr. and Mrs. Ike Sundem of Montevideo, Minn., in town for the day—Mrs. Sundem to see her doctor for a check up. . . . Forrest Dahl, of Fergus Falls, Minn., in town for the day buying equipment for his resort spots. . . . Pete Vanderhyde of Dodge Center, Minn., also in town for the day visiting the distributors looking for something new in equipment. . . . Glen Bichel and the Mrs. in town for the day, Glen making the rounds while Mrs. Bichel busy making the rounds of the department stores. (Chippewa Falls, Wisc.) . . . Harry Nold of Cambridge, Minn., in Mpls. for the day picking up his record supply for his route. . . . Bruce Windhurst, of Aberdeen, S. C., in Mpls. for the day making the rounds. Mainly to try and trade in his Cadillac for a new one. . . . Greg Wagner and Syl Wiederholt of the W. & W. Novelty Co. Miesville, Minn., in town on a hurry up trip to pick up some parts and records for their route. . . . Elmer Gredin of Winona, Minn., in town for the day making the rounds. . . . Eugen Hearth, of Harried, S. D. seen at the MOA show in Chicago having himself a good time. . . . Joe Weber of Blue Earth, Minn., in town visiting the distributors. With him was his son Darrell, who is attending the College of St. Thomas in St. Paul. Darrell is taking his pre-med, and finals next week and then home for the summer and working on the route during his vacation. . . . Operators in the resort areas in Minnesota are getting caught up, getting their equipment all set up in the resorts, before the resorts open up for the Summer. Operators in the resort areas in Wisconsin are expecting the biggest tourist business this year.

"It's What's in THE CASH BOX That Counts—INTERNATIONALLY"



Through The Coin Chute

CHICAGO CHATTER

This was one Memorial holiday everyone looked forward to this year. With the MOA convention out of the way, many here felt they needed some relaxation. In fact, some were just dog-tired from entertaining the many who came to town and, as others said, "With long distance phones buzzing away and with a convention under way and one million other things to do, looks like this summer season will be the industry's greatest. A rest right now, before the summer business boom, is sure most welcome". . . . Mr. and Mrs. Ed Ratajack and their son, Mark, thrilled to see their pictures in *The Cash Box* and asking for a copy. . . . Also Arthur Aloysius Garvey phones first thing this past Monday and advises, "Save that picture of me and my two grandchildren for me, please. In fact", he adds, "tell Joe Orleck I'll be in New York on Monday morning and will call around at *The Cash Box* offices to

pick it up". . . . Zeke Wolf putting more of his time and attention to the export field. Zeke has been getting letters from all over the world for his Auto-Bell products and feels he was neglecting a big chunk of business.

Bill O'Donnell cracked, "It isn't more business. It's how are we going to fill the orders we have on hand already. And," he adds, "with more orders coming in, well, that's the problem." As someone told Bill, "Wish we had the same complaint". . . . Jack Mitnick in New York helping the movers pack his tea pot and pans and make sure that these will arrive at his new apartment in Chicago in perfect condition. "Yes", said Jack, "Sadie and I are going to become Chicagoans. We both love this town." (So welcome Jack and Sadie Mitnick to our Windy City. We know you'll love it). . . . Many a guy at the MOA show got a thrill shaking hands with Fred Mills, Jr. Looking at Fred they recalled back to the days when they used to shake hands with his late Dad. And everyone remarking afterwards about the fact that, "There's a Fred Mills in the industry again". . . . Mel Binks and Joe Beck strolling down Randolph Street arm in arm, busily and completely engaged in conversation. Mel clicked with his newest and looks like a big season ahead for him.

Pat Buckley, Jerry Haley and Fred Morris devoting themselves completely to the export market these days. . . . Talk about busy, busy men—Sam Wolberg just thrilled at the results Chicago Coin enjoyed from this MOA convention. This was one time, he remarked, when entire groups of ops were able to see their latest products attractively grouped together. And Ed Levin along with Mort Secore and Phil Robinson nod their heads in agreement. ChiCoin booth was most attractive. . . . Sam Lewis driving along the outer drive completely lost in thought. At last, awakened by persisting honking of the car alongside of his, Sam looks up, smiles, and says, "Brother, I'm so busy trying to figure how to ship 20 to 50 that I didn't even know I was driving." This can happen when a firm clicks with a new one. . . . John Frantz strutting about with his chest looking like that of a pouter pigeon and pointing to the pic in *The Cash Box* of himself and his two most beautiful dotters. Said John, "They're worth every minute of all the hard work". . . . Anybody seen Clarence Schuyler around? . . . That Harry Brown doing more business than ever with his advertising specialties. And some very outstanding novelties.

Avron Gensburg, Ralph Sheffield and Al Warren all talking at once. Offering one suggestion right after the other. For a new name for a grand game. The boys have come up with one that looks like a long, long run machine. . . . The Gottliebs getting ready for their summer trek up to the northwoods where the fishing is just fine. . . . Paul Huebsch phones to ask, "Say, what happened to the headline in our ad?" The only answer, Paul, rush, rush, rush will do this everytime. But, Paul so happy over biz pickup, he just smiles away and adds, "I'll call you back. I'm in conference with some buyers here and looks like we're starting off the summer at top speed". . . . Ted Rubenstein one happy guy these days as he surveys the business the firm has enjoyed so far this year. Says Ted, "Believe it or not we're moving ahead faster than we ever expected to." . . . That picture of David C. Rockola and John Watling caused a real stir with many asking for copies. "There", said one old timer, "are two real Daddies of our business. Two men who helped the industry to go places with great products".

C. T. (Mac) McKelvy and Tom Herrick plenty busy ever since the day they officially presented the new Seeburg. Both men constantly on the telephone as orders come flooding into this giant plant. . . . Jerry Kuklin said, "Well, our metal typer sure brought plenty of visitors out here to our place, even tho we didn't display at the MOA show". . . . Longdistance phone call from Habana, Cuba, Leon Sapochnik advising, "Bill, be sure to put my ad in your 15th Anniversary issue". (For which we most sincerely thank Senor Léon). . . . Herb Oettinger will play golf over the holiday weekend. Bill DeSelm will play golf over the holiday weekend. Ray Riehl, Hank Dabek and everyone else at United will probably play golf over the holiday weekend. Just to relax from the hustle and bustle and noise of these past ten days. . . . Sam Stern expected back from Paris this past week and the plant ready to double all production runs to meet the orders he's sure to return with. At least, so says Art Weinand, and Art should know.

Vince Shay and Stan Levin get into a double telephone conversation with two customers and between the yelling, sell the same machines twice over again. Laments Stan, "Now where'll we get all those machines?". . . . Maurice Ginsburg became a gran'pa for the second time. Says he, "Wait'll it happens to you. You'll find that it's all you want to live and work for." (Can this be Maurice speaking? Eddie's brother?). . . . Seems the rumor is true. There won't be a Walter Oomens Sons firm—after 24 years in Chicago's automatic music biz. . . . Two guys doing a grand job—Phil Weisman and

Mike Spagnola with the new AML. . . . Ben Coven just simply beaming at the attention his charming missus, Trudy, getting from his table. . . . Joe Robbins



SAM WOLBERG



JOEL STERN



WALLY FINKE



BILL O'DONNELL



This Is Your **LUCKY Day!**

New **LUCKY HOROSCOPE**
5c, 10c or 25c PLAY

- ✓ NATIONAL COIN REJECTOR in each chute
- ✓ NOW has TWO coin returns and other new features

GAME HOLDS 1,000 numbered tickets.



EASY TO LOAD • SIZE: 18" x 8" x 6" • Shipping Wgt. 20 lbs. • Write for details

MARVEL MANUFACTURING CO.
2849 W. FULLERTON CHICAGO 47, ILL.
TEL.: DICKENS 2-2424

NOW ON DISPLAY!

UNITED'S Hi-Fidelity "UPA-100" MUSIC SYSTEM

Empire COIN MACHINE EXCHANGE

1012-14 MILWAUKEE AVE., CHICAGO 22, ILL. Phone: EVERGLADE 4-2600

now back to his first love. The phono business. Telling the world all about United's "UPA-100" phono. . . . Wally Finke looking like a young, handsome devil and, of all things, at last making up his mind. That it's time to wed. (won't someone please warn him quick). . . . Fred Mintner all excited over the fact that his firm getting such nice compliments on the phonos they've shipped to buyers around and about.



FRED MILLS, JR.

George A. Miller interrupts, as this column is being typed, to advise that 18 booths already sold for MOA's 1958 convention. Says he, "I'm so thrilled, I don't know how to thank all these marvelous people". . . . Nicest thing Charles (Little Jimmy) Johnson could ever have done was to bring those very important personages from Chicago's Fire Dept. to see the MOA convention. . . . Joe Schwartz highly pleased with the export biz his firm has done this year. Says he, "We've exceeded any year so far on exports. Only wish we had all the machines we need to fill orders", he added. . . . Herb Perkins still walking around in a daze because of the marvelous reception Keeney products got at his booths. Next year, Herb claims, Keeney'll have the biggest and best exhibit yet. . . . Those who met young Joel Stern of World Wide much impressed with the energy and good common sense reasoning of this son of Al Stern. And the way Joel gets that business, domestic and export, is something to truly marvel at. Keeps his whole organization on their toes all of the time. Yep, like someone said, it sure takes young blood.

HAPPY BIRTHDAY THIS WEEK TO: Edward Blumenfeld, Michigan City, Ind.; Mike Rice, Oklahoma City, Okla.; Harry Goldberg, Miami, Fla.; Russell J. Coon, Chicago, Ill.; Frank Bartnik, Milwaukee, Wis.; Alfred Rade, New Brunswick, N.J.; M. W. Arnold, Hannibal, Mo.; George A. Brown, San Francisco, Cal.; Alan Dibble, Kelso, Wash.; Fred C. Crawford, Kirksville, Mo.; Timothy McGraw, Champaign, Ill.; Senator Homer E. Capehart, Washington, D.C.; A. L. Durand, Green Bay, Wis.; Ben DeFazio, Moosic, Pa.; Morris Liedeker, Corpus Christi, Tex.; Howard B. Newcomb, Oklahoma City, Okla.; Wm. G. Liske, Kinston, N.C.; Ben Gordon, New Britain, Conn.; John S. Colucci, Waterbury, Conn.; Owen J. Mullinix, Jr., Savannah, Ga.; Henry Zeichner, New York, N.Y.; Vincent Genna, Galveston, Tex.; James V. Stone, Dallas, Tex.; Charles M. Rishor, Peterborough, Ont., Canada; Paul Golden, Chicago, Ill.; Sam Pullaro, Pueblo, Colo.; R. C. Walter, Dayton, O.; Daniel Heilicher, Minneapolis, Minn.

"It's What's in THE CASH BOX That Counts—INTERNATIONALLY"

For biggest pool profits operate new improved

Bally® Official 6 POCKET Pool

New Visual-Totalizer Ball-Sorter speeds up play, increases earnings

No time lost shuffling chips to keep score. No time wasted in arguments. Result is more coins through the chute per hour, bigger profits for you.



DOUBLE DIME OR SINGLE QUARTER CHUTE

PATRONS CAN PLAY

- Basic Pool
- Rotation Pool
- 15-Ball Pool
- 9-Ball Pool
- 8-Ball Pool
- Kelly or Pea Pool
- 10-Ball Pool
- 10-Ball Rotation Pool
- 10-Ball Kelly Pool

76½ IN. BY 43½ IN.

Sturdy construction, simple mechanism insure years of trouble-free profitable performance. Warp-proof pressed-wood playfield upholstered with genuine green billiard cloth, as are live-rubber cushions. Cabinet luxuriously finished in 2-tone browns to harmonize with fixtures in all types of locations.

LOOK
what you get to promote play

- Finest quality imported cue-ball
- 15 highest quality imported numbered pool-balls in official colors and striping
- 4 accurately balanced cue-sticks
- Polished wood triangle
- Cue-chalk
- Complete set of tally-balls or peas for Kelly Pool
- Pea-Shaker Bottle
- Complete rules for 9 different games and glossary of pool-terminology
- Cue Repair Kit
- Accurate spirit-level

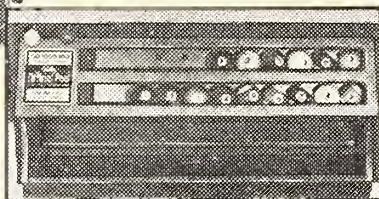

New Visual-Totalizer Ball-Sorter—exclusive feature of Bally OFFICIAL POOL—speeds up play, boosts earnings. Players are not required to shuffle tally-chips to keep score, never waste time in arguments. Ball-Sorter automatically separates each player's pocketed balls from opponent's pocketed balls. And, because pocketed balls are always in view, players follow progress of game merely by glancing at Visual-Totalizer. Balls cannot be removed from Ball-Sorter until coin is deposited, when balls drop into ball-delivery rack.

BALLY MANUFACTURING COMPANY
2640 BELMONT AVENUE, CHICAGO 18, ILLINOIS, U. S. A.

6 Point Plan For Selling Dime Play

BOSTON, MASS.—One of the foremost exponents of 10¢ play, Jim Geracos, operator of National Music Company, has a 6-point plan for selling and keeping the dime on the juke box route following a location survey to be made by the op:

1. All new disks.
2. Participation in programming by owner and employees.
3. Request cards for customer participation.
4. Sound system checks and improvements.
5. Equipment rotation.
6. Location advertising within the location.

Geracos feels that "if a music op believes his phono service is good enough to warrant the dime, he'll have no trouble establishing it."

Jim Geracos has waged the battle for ten cent play in radio addresses, at meetings of the Mass. Music Operators Assn., of which he was first president, in newspaper articles and on practically every front on which he can bring the proposal to the attention of the public and the industry.

"Don't be negative," he cautions ops preparing to switch to the dime. Too many ops are "negative," he contends.

"Avoid explanations of technical details and higher costs, but concentrate on service," he advises. "Remember that the location owner is not interested in the operator's troubles—he has plenty of his own. What he wants is more profit!"

Geracos carries his program into his own operation in fine style. First he leaves cards with location owners for special platter requests, polishes the equipment, improves speaker locations, adds new records to the phono, and talks the dime switch over and over with the employees—all this is after the location owner has been sold on the conversion.

Making the employees feel they have a stake in the operation is important and they, the waitresses, etc., can do more to help the switch become a success than practically any other group, he feels. The Boston operator predicts that it will be an absolute must for all ops to get the dime in the very near future and that it is high time that all those ops still on the old time nickel deal smarten up and create a master conversion plan. He contends that too many ops feel they cannot risk going to the dime and this is holding the industry back.

A. B. T. RIFLE SPORT
3 and 6 Gun Models



- Pace Aristo Scale
- Kicker & Catcher
- A.B.T. Guesser Scale
- A.B.T. Challenger

Manufacture and Sales

J. F. FRANTZ MFG. CO.

1940 W. LAKE STREET, CHICAGO 12, ILL.
(Tel.: TAyor 9-2399)

● Full Line of Parts at all times. We Repair and Recondition all A.B.T. equipment.

George A. Miller, Pres. MOA, Expresses Appreciation To Cissie Gersh



CHICAGO — With the 1957 MOA Convention successfully written into history, George A. Miller, president of MOA had time to acknowledge his appreciation to those who assisted in

making the Convention a success.

To Cissie Gersh, who co-chaired the first MOA Ladies Fashion Show Luncheon, Miller wrote:

"May I take this means of thanking you personally for your wonderful cooperation and assistance at the MOA convention and especially for the wonderful way in which you handled the Fashion Show and Sightseeing Trip.

"You ladies may not have realized it, but you took a great amount of responsibility off my shoulders right at a time when I was so busy, and I don't know how I could have handled it if it were not for you nice ladies.

"Everyone here has been so nice to me this year that there are just not words in my vocabulary to express my deep appreciation. Thanks seems so inadequate when one wants to say so very very much, but it is the only word that I can think of at this time."

4 Locations On Dime Better Than 7 on Nickel

LITTLE FALLS, MINN. — "On one trip, changing over to 10¢ play, we lost 3 out of 7 locations in one town", reports Stanley C. Woznak of Little Falls Music, this city.

"But", he adds, "that's why we recommend that operators, on losing a location on account of changing to dime play, leave the owner with a friendly feeling.

"The four spots we had now put on dime play took in more than the seven spots we had in this one town on nickel play.

"Not only that", adds Woznak, "but due to the word spreading around the locations two of the three spots we lost are back with us and are on 10¢ play.

"We get a better percentage from these spots and, what's more, we are using older equipment.

"The answer, as far as we are concerned", Woznak concludes, "is due to the service and programming we give. This is our best weapon."

"It's What's in THE CASH BOX That Counts—INTERNATIONALLY"

SILVER MIRRORED BACKGLASS

KEENEY GIVES YOU THIS FANTASTIC NEW MONEY MAKER THAT DEFIES COMPARISON IN THE BOWLING FIELD!

**6-PLAYER
REGULATION
BOWLER**

BOWL-O-RAMA

**TOTAL TEAM SCORING!
TOTAL TEAM MARKS!**

IMPROVED
PIN RE-SET
MECHANISM

"FEATHER-LIFT" PLAYFIELD

EASY TO SERVICE!

FEATURING:

- ☆ Jam-Proof Ball Lift
- ☆ Actual Gutters
Also available without gutters
- ☆ Colored Reels for Team Scoring
- ☆ Black and White Reels for Team Marks

Keeney is First with Regulation Bowling at its very best in

"BOWL-O-RAMA"

HAND-HIGH BALL RETURN BUTTON!

National Slug Rejector Coin Mechanism

Order FROM YOUR
KEENEY DISTRIBUTOR NOW!

J. H. *Keeney* & CO., INC.
2600 W. FIFTIETH STREET • CHICAGO 32, ILLINOIS

Two Lengths: 14 ft. and 11 ft.

**HINGED
INSERT!**



Loosen 2 clips to swing open the picture frame moulding of life-box — then entire insert with reels and wiring folds forward

**VENDING
MACHINE
OPERATORS!**

It will PAY you to build today for a secure tomorrow with

**KEENEY
VENDERS**

CIGARETTE • SOUP 300 cup • COFFEE 300 cup
COFFEE-CHOCOLATE combination 500 cup • SNACK

"Greatest Game In Ten Years," Says Nate Gottlieb

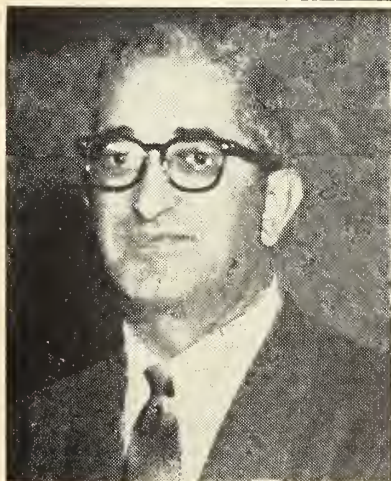

NATE GOTTLIEB

CHICAGO — "The talk among the trade this week is that 'Royal Flush'

has proved itself our most outstanding five ball game in ten years", proudly stated Nate Gottlieb of D. Gottlieb & Company.

"The only pinball that ever made a bigger hit with players was 'Humpty Dumpty', which first presented flippers to the public. The record of sales and production we set at that time has never yet been reached.

"However", Nate continued, "'Royal Flush' will come the closest to that record of any five ball game, judging from the way orders are now pouring in.

"For the first time in many years, we find ourselves forced to go beyond our limited production schedule and continue shipping 'Royal Flush' to meet the demands of all Gottlieb distributors."

Nate went on to explain how the

current Gottlieb game takes full advantage of the magnetic appeal of playing cards by using two new and outstanding features.

He remarked, "One is the use of our holdover feature, which challenges the player to complete a royal flush on his very next try, or the game after.

"The other exciting new feature that stimulates repeat action at the coin chute is our 'Roto-Target' idea. The rotating targets have captured the approval of pinball players everywhere.

"But", Nate continued, "don't forget the many other fast action and scoring features that also combine to put 'Royal Flush' in a class all by itself.

"In view of the pressure put on us by our distributors, the only thing we can do this once is to help increase their sales by extending our production run of 'Royal Flush' for a few more weeks."

Nate Gottlieb concluded by saying, "It certainly is a thrilling and gratifying feeling to all of us at the fac-

READY FOR LOCATION

Wurlitzer Model 1250	\$ 75
Wurlitzer Model 1400	125
Wurlitzer Model 1700	575
Wurlitzer Model 1800	675
Wurlitzer Model 1900	800
Wurlitzer Model 2000	900

CRUZE

DISTRIBUTING COMPANY, INC.

1101 West Washington Street

CHARLESTON, W. VA.

(Phone: Dickens 4-4566)

tory to provide the trade with a game they all acclaim as 'The greatest in ten years'."

"It's What's in THE CASH BOX That Counts—INTERNATIONALLY"



GOTTLIEB'S ROYAL FLUSH

PRESENTING

A Terrific New Idea to Attract and Hold Player Interest...

ROTO-TARGETS!

Hitting Roto-Targets lites cards in lite box for Royal Flush. Complete Flush lites targets for special score. Holdover feature carries lighted cards from game to game.

- ♠ Scoring Rollovers 1-2-3-4-5 Relights One of 5 Rollovers for Special.
- ♥ All New Match Feature for Extra Play.
- ♣ Super-Powered Flippers Shoot Ball Up Field at Roto-Targets.
- ♦ Available with Twin Chutes.
- ♠ High Score to 7,900,000.
- ♥ Plus All the Standard Gottlieb Play Features!

Subject to AMUSEMENT TAX Only!

Amusement Pinballs
as American as Baseball and Hot Dogs!

D. Gottlieb & Co.
1140.50 N. KOSTNER AVENUE • CHICAGO 51, ILLINOIS

ALL GOTTLIEB MACHINES ARE EQUIPPED WITH NATIONAL SLUG REJECTORS

Now...
SHOWING
and
DELIVERING

AMI "H"

PHONOGRAPHS
AT ALL OFFICES

RUNYON
SALES COMPANY

Factory Representatives for:

AMI, Inc., Bally Manufacturing Co.,

J. H. Keeney & Co., Permo, Inc.

593 10th Ave., New York 18, N. Y., LO 4-1880

221 Frelinghuysen Ave., Newark 8, N. J., BI 3-8777

231 Windsor St., Hartford, Conn., JA 7-4470

SEE THE ALL-
LOCATION LINE BY
WURLITZER
PIONEERS OF
50 CENT PLAY

Teenages Of AMI, Inc., Sponsored Group Win Awards

Banquet Signals Completion Of Eight Months Of Practical Experience in Business Operation

GRAND RAPIDS, MICH. — Teenage members of a Junior Achievement group sponsored by AMI, Incorporated, won a number of awards at a banquet, May 9, signaling completion of eight months of practical experience in business operation. The 18 members of the JAMI Novelty Company were presented with two Company awards and three individual awards, including recognition for sales excellence and a business school scholarship valued at \$850.00.

The JAMI Novelty Company was one of 17 groups of teen-agers sponsored by an equal number of leading Grand Rapids firms to give first-hand experience in the American free enterprise system. The Junior Achievement program, extended to Grand Rapids for the first time this year, is a nationwide movement that permits teen-agers to participate realistically in every phase of business. The Youngsters handle details of forming and running an actual company, including formal incorporation, selling stock, keeping complete business records, manufacturing and selling a product of their choice and finally handling all phases of orderly liquidation to experience a complete business cycle in eight months.

Each JA company met on schedule one night each week throughout the season for production in a building maintained by Junior Achievement. Selling their products was done primarily door-to-door in free time after school or work. In addition to financial support necessary to carry out the program, AMI and the other companies furnished four volunteer advisers who attended the young people's meetings and work sessions and were available at all times for advice and guidance on sales, production and business matters.

The JAMI Novelty Company ended the year with a substantial net profit after paying wages, rent, operating costs and other typical Company obligations. From these profits, the Company paid stockholders a ten percent dividend, a sales bonus to each member based on hours worked and donated an arbor press to Junior Achievement of Grand Rapids for use at the JA work center in years to come.

AMI will again sponsor a group when the program is reactivated this Fall.

Make The Other Man See Your Problem

VICKSBURG, MISS.—“If you can make the other man see your problem”, says Joe Farris II of this city, “he’ll usually go along with any suggestion you have to make.”

Farris was speaking of how to get location cooperation when he made the above statement.

“Locations are people”, he continued, “and, therefore, some will be amenable to sensible suggestions. Others don’t care what the suggestion is—they’re ‘again’ it’ regardless.”

“It’s unfortunate”, Farris adds, “that we have to have the latter type, but, we do.”

“The only positive suggestion I’d care to make”, says Farris, “is that the operator do business just like he would in any other field of endeavor.”

“There are certain people’s business you seek. There are others you feel you can do without. It may hurt some to give up additional revenue but, in the long run, the anguish and uncertainty such people will cause you will outweigh what little financial good they do you, if any.”

“I have a competitor here”, Farris reports, “who’s independent as hell. I admire him for it. So I’m taking a leaf from his book. I don’t intend to let anyone play me against my competitor for his own selfish ends.”

“After all”, Farris points out, “my problems are closer aligned to those of my competitor than they are to those of the location owner and so, as far as that goes, are my interests.”

“I don’t know whether this is the proper place”, concludes Farris, “but that’s the strongest argument there is for operator cooperatives.”

“It’s What’s in THE CASH BOX That Counts—INTERNATIONALLY”



BERT BENDER AT THE PIANO

WHERE DO YOU SELL YOUR MUSIC?

This is the Queen's Gambit Club in Chicago. It's a private key club. It has a custom high fidelity sound system. It has a piano bar—and live entertainment. *It also has an AMI "G-200" juke box.* Why? Why does this private, prestige location want the "G"? Because the "G" fits—*anywhere*. Because club members *wanted a juke box*. Because—if you have the right juke box—you can sell your music *in all kinds of locations*. Why should AMI advertise the "G"—now that the new "H" is out? Because

every AMI juke box is designed to give operators a longer investment life . . . and a longer earning life in all kinds of locations.

AMi Incorporated 1500 Union Avenue, S. E., Grand Rapids 2, Michigan

Originator of the automatic selective juke box in 1927 . . . known by operators for coin-operated music instruments of unrivaled dependability since 1909.
LICENSEE, Jensen Music Automates—building the IMA-AMI Juke Box sold through Oscar Siesbye, A/S, 5 Palatsgade, Copenhagen K., Denmark.

"It's What's in THE CASH BOX That Counts—INTERNATIONALLY"

CLASSIFIED ADVERTISING SECTION

WANT

WANT—12 ft. American Bank Shuffleboards; 22 Ft. Rock-Ola Shuffleboards; Targettes; Derby Rolls; Juke Boxes. Write or wire. STATE AMUSEMENT CO., 1531 BROADWAY, TACOMA 2, WASH. (Tel.: Fulton 2282).

WANT — Rock-Ola 120 Wall Boxes and 1438 Comets. H & H MUSIC AND DISTRIBUTING, 1626 THIRD AVE., MOLINE, ILL. (Tel.: 4-6703).

WANT—Miami Beach; Beach Beauty; Broadway; Nite Club; Parade; Big Show; Key West. JJ PARKER CO., 1308 SO. MAIN ST., LAS VEGAS, NEVADA (Tel.: Dudley 4-6086).

WANT—Your used or surplus records all speeds. 45's our specialty. We buy all year round and pay top prices. No lot too large or too small. No more than 10% blues. We pay freight. BEACON SHOPS, 821 NO. MAIN STREET, PROVIDENCE, R. I. (Tel.: Union 1-7500).

WANT—Late Model 2 Player Pins, Big Time, Broadways, other late models, cash or will trade 6 slightly used Popperette 10c Pop Corn Venders, 4 Wall type Shuffleboard Electric Scoreboards. PACIFIC KIDDIE RIDE DIST. CO., 1212 S. TACOMA AVE., TACOMA, WASH. (Tel.: MA 2317).

WANT—AMI 80, 120, 200 selection Wall Boxes, Hideaway units, Phonographs. Late 2 Player Pinballs. Write stating condition, number and best cash price. ST. THOMAS COIN SALES LTD., ST. THOMAS, ONT., CANADA (Tel.: 2648).

WANT—Used American 12 ft. Rebound Shuffle Boards also overhead units for same. Please advise best price. WESTERN DISTRIBUTORS, 3126 ELLIOTT AVE., SEATTLE, WASH. (Tel.: Garfield 3585).

WANT—45 RPM Records, new or used. No quantity too large or small. Highest prices paid. Write stating quantity on hand. TONY CALGANO, CALGANO DIST. CO., 4142 W. ARMITAGE, CHICAGO 39, ILL. (Tel.: Dickens 2-7060).

WANT—Used records, 45's or 78's. All types—Pop, Hillbilly, Blues. We buy year round, any quantity. We can provide shipping cartons if needed. Write or phone. JALEN AMUSEMENT CO., INC., 14 E. 21st STREET, BALTIMORE 18, MD. (Tel.: Belmont 5-2881).

WANT—Will Pay \$\$\$\$\$\$ Cash. Entire Inventory, Large Operators, Distributors. Please send complete list Bally, United Bingos, Guns, Arcade, Music, Shuffle. REDD DIST. CO., INC., 298 LINCOLN STREET, ALLSTON, MASS. (Tel.: ALgonquin 4-4040).

WANT—Phonograph records made before 1940. Dealers or juke box stock. I will pay the highest prices. Some labels wanted are Brunswick, Vocalion, Paramount, Gennett, Meletone. JACOB S. SCHNEIDER, 109 WEST 83rd ST., NEW YORK, N. Y. (Tel.: TRafalgar 7-9147).

WANT—Broadways, Night Clubs, Parades, Big Shows and Key West. Highest cash prices paid in the Middle West. T & L DISTRIBUTING CO., 1663 CENTRAL PARKWAY, CINCINNATI 14, OHIO (Tel.: Main 1-8751).

WANT—To Report Baritone Michael Anthony Sings Four Great Russ Colombo Ballads, including "You Call It Madness" and "Time On My Hands". Post Card for Free Michael Anthony Sample Record. H. R. C. ENTERPRISES, 2145 HOLLYWOOD WAY, BURBANK, CALIF.

WANT—To Buy. Wurlitzer 1500A—1550A—1600—1650; All Late Gottlieb 5 Balls; All Kinds Bally Bingos; Muto. Drive yourself Drive-mobile. CLEVELAND COIN MACHINE EXCHANGE, INC., 2029 PROSPECT, CLEVELAND, OHIO. (Tel.: Tower 1-6715).

WANT—Round The World Trainers—Drivemobiles, Other Arcade Equipment. Quote lowest price and condition. DONAN DIST. CO., 5007 N. KEDZIE AVE., CHICAGO 25, ILL. (Tel.: JU 8-5211).

WANT—Late model Shooting Galleries; Round World Trainers; Drive Mobiles; other late arcade machines. State condition and lowest price first letter. ECONOMY SUPPLY CO., 577 TENTH AVE., NEW YORK, N. Y. (Tel.: CHickering 4-8628).

WANT—Literature on any type of coin machine — Merchandising, Amusement, Skill, Rides, Music — anything that takes a coin for any purpose. WITHAM ENTERPRISES AND ASSOCIATES, 20-22 CUNNINGHAM AVE., GLENS FALLS, N. Y.

WANT—For export: 25 Wurlitzer 1600's at \$225 ea.; 25 Wurlitzer 1400's at \$125 ea. Will trade against other equipment, or pay cash. Call, write, wire. YOUNG DISTRIBUTING, INC., 575 11th AVE., NEW YORK 36, N. Y. (Tel.: CHickering 4-5050).

WANT—Attention Everyone in the Coin Business. We want Arcade Equipment and All the Bally and United Bingos you have. Plenty of \$\$\$\$ waiting. Don't Write or Wire but call us collect—LOcust 4-4415. BELGIAN AMUSEMENT CO., 334 NORTH BROAD ST., PHILADELPHIA, PA.

WANT—Used Bally Bingos; Gottlieb and Williams Pins; Guns and Phonographs. Send complete list. Highest prices paid. Representatives of Wurlitzer and Gottlieb Games. GABE FORMAN OR SANDY MOORE, YOUNG DISTRIBUTING L. I. CORP., 240 E. MERRICK RD., FREEPORT, L. I.

WANT—Used Records. High prices paid for 78's and 45's. No quantity too large or too small. We buy brand new LP's (33-1/3 RPM) in quantity. Write or phone. FIDELITY DISTRIBUTORS, 666 10th AVE., NEW YORK 36, N. Y. (Tel.: JUDson 6-4568).

WANT—Used Bingo games reconditioned or not, also Seeburgs M100A, M100B. Are also interested in agencies for new games for Belgium and Luxembourg. Airmail offers including seaworthy packing f.a.s. New York and catalogues to: ETS. SONBEL, 30, AVE. DU PORT, BRUSSELS, BELGIUM.

CLASSIFIED ADVERTISING SECTION

WANT—Used 45 Records not over 6 months old. I pay 13¢ and the freight. No Blues. H. BAUER, 4224 W. 99th PLACE, OAKLAWN, ILL. (Tel.: GArden 4-9485).

WANT—Any quantity of Chicago Coin Ski Bowls, Genco Official Skill Balls, Genco DeLuxe 6-player Skill Balls; Williams Roll-A-Balls. Must be new, in original crate. Contact Our Detroit Office For Best Results. Cash Waiting MILLER-NEWMARK DISTRIBUTING CO., 42 FAIRBANKS STREET, N.W., GRAND RAPIDS 2, MICH. (Tel.: GL 606807).

WANT—Latest model music machines. Quote price in first letter. KOEPEL DISTRIBUTING CO., 607 TENTH AVE., NEW YORK 36, N. Y. (Tel.: LOngaere 3-3343).

WANT—Used Gottlieb and Williams 5 Ball Pins. High prices paid for Model 1954 on. Call collect—UNION 3-8574—UNION 3-8627. H. BETTI & SONS, 1706 MANHATTAN AVE., UNION CITY, N. J.

FOR SALE

FOR SALE—1 Post War Photomat. Will trade for Bingos or Phonographs. LIEBERMAN MUSIC CO., 257 PLYMOUTH AVE., NO., MINNEAPOLIS, MINN. (Tel.: FEderal 9-0031).

FOR SALE—Bally Back Glass for the older machines. Right price. TOLEDO COIN MACHINE EXCHANGE, 814 SUMMIT, TOLEDO, OHIO (Tel.: CH 3-4005).

FOR SALE—Locks of all kinds. Bally pinball locks, Wall Box locks, Music Box locks, like new, 75c ea. AUTOMATIC MUSIC CO., 703 MAIN ST., BRIDGEPORT, OHIO. (Tel.: NE 5-1444).

FOR SALE—Used machines of all models, as is or shopped and ready for location. AUTOMATIC MUSIC DISTRIBUTORS, INC., 900 NORTH WESTERN, OKLAHOMA CITY 6, OKLA. (Tel.: FOrrest 5-3456).

FOR SALE—Music and Game Route with Bingos, Located in Booming Texas Industrial Area. Excellent Return for '56 and '57 is even better. \$35,000—One-Half Cash with Excellent Reference. P. O. BOX 2051, FT. WORTH 1, TEXAS.

FOR SALE—Records!!! 5¢ over wholesale, and label. Free title strips. Quick service. New accounts, token deposit with order. We also purchase surplus records now unused only. RAYMAR SALES CO., 170-21 JAMAICA AVE., JAMAICA 32, N. Y. (Tel.: OLYmpia 8-4012, 4013).

FOR SALE—ChiCoin Flash Bowler, \$100; ChiCoin Playtime, \$100; United Chief, \$75; United Official, \$25; 1 ChiCoin Band Box Speaker, \$75. WANT—Late Bally Bingos. AUTOMATIC AMUSEMENT CO., INC., 1000 PENNSYLVANIA ST., EVANSVILLE 8, IND. (Tel.: HA 3-4508).

FOR SALE—United and Chicago Coin Shuffles, 10th Frame and later models; Wurlitzer 1500's, 1400's, 1250's, 1015's; all type Bingos; Coon Hunt, as is or shopped. CANYON STATES DIST. CO., 301 E. 7th, TUCSON, ARIZONA. (Tel.: 3-8688).

FOR SALE—Or Trade. Two Practically new Capitol Pamorama with Film, \$395 ea.; 5 Small Pools, 5 Jumbo, \$75 ea. Will Trade for Bingo or Novelty Games, Kiddie Rides on equal basis. MELODY MUSIC CO., 201 LAWRENCE STREET, LAKE CHARLES, LA. (Tel.: HEMlock 6-5916).

FOR SALE—Bingos in quantities. In stock. Big Shows; Double Headers, Parades, Night Clubs, Broadways, Miami Beach, Big Times. GLOBE DISTRIBUTING CO., 1623 N. CALIFORNIA AVE., CHICAGO 47, ILL. (Tel.: ARmitage 6-0780-81).

FOR SALE—All types of used Pool Tables, jumbo and regular. Also late Shuffle Alleys. Will trade for AMI Jukes or Seeburg. Special price on ultra modern speaker and Baffle (8 inch speaker), \$7.50. GATEWAY DISTRIBUTING CO., 3622 W. NORTH AVE., CHICAGO 47, ILL. (Tel.: Dickens 2-1214).

FOR SALE — The best buy in used Bally Bingo Games. Just buy one and you will see why you pay a little more and be glad you did. Your money back if not completely satisfied. 1/3 deposit with all orders. Write or call: ALLAN SALES, INC., 937 MARKET ST., WHEELING, W. VA. (Tel.: CEDar 2-7600).

FOR SALE—New modern wall speakers, \$11.95 ea.; C.C. Band Box (used), \$95; 5206 (48 sel.) Wall Boxes, \$29.50; Seeburg 100 sel. Wall Boxes, \$49.50. BILOTTA DIST. CO., 224 N. MAIN STREET, NEWARK, N. Y. (Tel.: Newark 598).

FOR SALE—Guns: Genco's State Fair; Exhibit's Sportland Shooting Gallery. Bingos: United's Pixie, Singapore and Cabana. SALINA MUSIC AND AMUSEMENT CO., 121 NORTH 7th, SALINA, KANSAS.

FOR SALE—United Hawaii's, \$45; Chicago Coin Tournament Ski-Bowls (Like New), \$395; Blondie (Like New), \$250. J. ROSENFELD CO., 4701 WASHINGTON BLVD., ST. LOUIS 8, MISSOURI (Tel.: FOrrest 7-6730).

FOR SALE—One Double Header, like new, A-1 condition, \$475. LEWIS & FOLLETT MUSIC CO., SOUTH 180 HOWARD ST., SPOKANE 4, WASH. (Tel.: MA 8585).

FOR SALE—Bally Broadway, \$345; Night Club, \$395; Parade, \$405; Big Show, \$495; Key West, \$545; United Tropics, \$45; Nevada, \$65; Manhattan, \$115; Pixie, \$185; Bally King Pin Bowlers, \$295; Gold Medal, \$195; Jet, \$105; Champion, \$95; United Team, \$95; 11th Frame, \$125; Imperial, \$75; also other Bingos and Bowlers—Write or Call. MICKEY ANDERSON, 314-316 E. 11th ST., ERIE, PA. (Tel.: 5-7549).

FOR SALE — Hi-Speed Super Fast Shuffle Board wax. 24 one-pound cans per case, \$8.50 f.o.b. Dallas, Texas. Sold on money back guarantee. Distributor for D. Gottlieb, ChiCoin, J. H. Keeney. STATE MUSIC DISTRIBUTORS, INC., 3100 MAIN ST., DALLAS, TEXAS.

CLASSIFIED ADVERTISING SECTION

FOR SALE—Millions of extra coins are taken from clean machines. Clean Right With Lemonite. Wolfe Distributing Co., Birmingham Vending Co., Birmingham, Ala. Use and Sell Lemonite. Try Lemonite Electric Contact Cleaner. Write GRACO SALES CO., RFD 1, BOX 403, ARLINGTON, TENN.

FOR SALE—We have a large stock of reconditioned Five Balls, Shuffle Games and Bingo. Write for list. WESTERHAUS CORP., 3726 KESSEN AVE., CINCINNATI, OHIO. (Tel.: MONTANA 1-500).

FOR SALE—Jumbo, \$275; ABC, \$275; Rockets, \$65; Victory, \$55; Champion, \$75; Bally Space Ship, \$235; Bally Boat, \$195; Williams Race The Clock, \$125; Williams Four Bagger, \$285; Williams 6 Player Roll-A-Ball (Used), \$375; Williams Crane (New), Write; Ring-A-Ball (in crate), \$100. For quantity wholesale prices Write—Wire or Phone HE 1-7577. 1/3 Deposit Required On Each Order. We are exclusive factory distributors for: Bally—Williams—Rock-Ola. LAKE CITY AMUSEMENT CO., 4533 PAYNE AVE., CLEVELAND, OHIO (Tel.: HE 1-7577).

FOR SALE—Comco—Extended Range Speakers and Baffles. Quantity at modest prices. Engineered for heavy duty use. Satisfaction guaranteed or money will be refunded. Finished in Lined Oak, Natural or Mahogany. Packed two to a carton, \$11.95 ea. COVEN MUSIC CORP., 3181-3 ELSTON AVE., CHICAGO 18, ILL. (Tel.: INDEPENDENCE 3-2210).

FOR SALE—AMI F-120, \$675; AMI E-80, \$400; Seeburg, M100C, \$545; Seeburg M100G, \$695; Wurlitzer, 1700, \$575; Wurlitzer, 1800, \$695. MONROE COIN MACHINE EXCHANGE, INC., 2423 PAYNE AVE., CLEVELAND 14, OHIO (Tel.: SUPERIOR 1-4600).

FOR SALE—Exporters and Wholesalers, Attention. We have 30 V-200 Seeburg Phonographs For Immediate Delivery. Wire Best Offer. SHELDON SALES, INC., 881 MAIN ST., BUFFALO, N. Y. (Tel.: LINCOLN 9106).

FOR SALE—200 Seeburg, Write; AMI Model A's No broken plastics, \$75; Seeburg 20 Selection Boxes changed over 10c, 3 for 25c; \$10; Wurlitzer 3020, \$5; Two Vendor Coin Changers, \$65; 1717 Rock-Ola Steppers, \$30; Gold Star, \$145; Stage Coach, \$155; Gypsy Queen, \$165. H & H MUSIC AND DISTRIBUTING, 1626 THIRD AVE., MOLINE, ILL. (Tel.: 4-6703).

FOR SALE—Reconditioned, Gwaranteed, Wurlitzer 24 Record Hideaway Cellar Units, complete with Packard Adaptors, price \$80. Wallboxes, clean, \$6; Wurlitzer 1080's \$75. FEDOR MUSIC CO. c/o GEORGE THAYER & CO. 47 STATE ST., BINGHAMTON, N. Y.

FOR SALE—Export Buyers Attention! In-Line Games, \$35 & up; Pool Tables, \$50 & up; Pin Games, \$25 & up; Music, \$75 & up; Kiddie Rides, \$100 & up. ASSOCIATED AMUSEMENTS, INC., 8 RUGG ROAD, ALLSTON 34, MASS. (Tel.: STADIUM 2-4010).

FOR SALE—Flag Ship, \$295; Marathon, \$250; Score Board, \$225; Balls-A-Poppin', \$295; Classic Bowler, \$225; Diamond Lil, \$115; Regatta, \$120; Big Ben, \$100; Quartette, \$50; Lovely Luck, \$50; Saddle & Turfs, \$165. All games are near new. CROWN NOVELTY CO., INC., 920 HOWARD AVE., NEW ORLEANS, LA. (Tel.: CANAL 7137).

FOR SALE—New and Used Phonographs, 5 Balls, Bingos, Shuffle Alleys and Arcade Equipment. Distributors for AMI, United, Williams and Auto-Photo. CENTRAL DISTRIBUTORS, 2315 OLIVE ST., ST. LOUIS, MO. (Tel.: Main 1-3511) or 2805 MAIN ST., KANSAS CITY, MO. (Tel.: HARRISON 1-4747).

FOR SALE—Seeburg V-200, \$749.50; Seeburg R, \$649.50; Seeburg C, \$469.50; Seeburg B, \$349.50; Wurlitzer 2000, \$895; Wurlitzer 1900, \$795; Wurlitzer 1800, \$695; Wurlitzer 1650, \$325. UNITED DISTRIBUTORS, INC., P.O. BOX 1995, 920 W. SECOND ST., WICHITA 12, KANSAS. (Tel.: HO 4-6111-4-3504).

FOR SALE—Surf Rider, \$235; Starfire, \$254; Stardust, \$225; Wonderland, \$135; Peter Pan, \$125; Thunderbird, \$75; Smoke Signal, \$145; Snafu, \$135; Hot Diggity, \$225; Race The Clock, \$125. All in stock. GLOBE AUTOMATIC VENDING CO., 291 WATER ST., QUINCY 69, MASS. (Tel.: MAYFLOWER 9-0010).

FOR SALE—Williams 4 Bagger, \$350; Genco Champion Baseball, \$250; Hi Fly Baseball, \$275; State Fair Gun, \$350; Rifle Gallery, \$150; Keeney Sportsman, \$175; Marathon, \$275; Easy Aces, \$195; Hawaiian Beauty, \$105. UNIVERSITY COIN MACHINE EXCHANGE, 858 N. HIGH ST., COLUMBUS 8, OHIO. (Tel.: AXMINSTER 4-3529).

FOR SALE—Bowling Alley Conversion, "Do It Yourself" Kit, Ball Lift, Ball Return. Rollovers, Rubber Balls. Fast Easy Installation. Send for picture. 8 Foot Game, \$169.50; 8½ Foot Game, \$174.50. Prompt shipment made. Send 1/3 deposit, balance COD. WEST SIDE DIST., 612 TENTH AVE., NEW YORK, N. Y. (Tel.: CIRCLE 6-8464).

FOR SALE—America's finest reconditioned phonographs and music accessories. Every one of our reconditioned machines guaranteed beautiful condition regardless of price. Tell us what you need. Get our prices before you buy. ANGOTT DISTRIBUTING CO., INC., 2616 PURITAN AVENUE, DETROIT 21, MICH. (Tel.: UNIVERSITY 4-0773).

FOR SALE—Model 1438 120 Selection 45 RPM Rock-Ola "Comet" Phonographs, \$465; Model 1546 120 Selection Chrome Rock-Ola Wall Boxes, \$50; AMI Model E120, \$425; Wurlitzer Wall Boxes: Model 3020, \$7.50; Model 4820, \$12.50; Model 4851, \$15. O'CONNOR DISTRIBUTORS, INC., 2320 WEST MAIN, RICHMOND 20, VA. (Tel.: 84-3264).

CLASSIFIED ADVERTISING SECTION

FOR SALE—Large stock of Bingos, Shuffle Alleys, Pool Games; Phonographs. If we don't have what you want, we will make an honest effort to get it. Distributors for United, Exhibit, Rock-Ola and Williams. Write for jobber's discount. DAN STEWART CO., 140 EAST 2ND SOUTH, SALT LAKE CITY 11, UTAH. (Tel.: DAVIS 2-2473).

FOR SALE—New Six Pocket Pool Table, 41x74". Write. 1st Grade 48" Cue Sticks, \$1.69 ea.; \$18 doz.; Rails with Live Rubber, Quality Cloth, 32x48", \$11.95 set; 3" Marbelized Rubber Balls, \$1.49 ea. CHAMPION DIST. CO., 3833 W. DIVISION ST., CHICAGO, ILL. (Tel.: ALBANY 2-3272).

FOR SALE—AMI F120, Like New, \$565; AMI E120, \$375; AMI A, 49.50; AMI C, \$95; Wurlitzer 1800, \$765; Wurlitzer 1700, \$645; 4851 Wurlitzer Wall Boxes, Like New, \$12.50; Telequiz, \$65; Oxygen Machine, Like New, \$95. Shuffleboards: United Imperial, \$65; United Banner, \$135; United Leader, \$100; United Rainbow, \$95; Chicago Coin Triple Score, \$45; Seeburg C, \$475; Seeburg B, \$395; Seeburg Wall Boxes, \$47; Large stock of 5 Balls and Bingo Machines. LEW JONES DISTRIBUTING CO., 1301 N. CAPITOL AVE., INDIANAPOLIS 2, IND. (Tel.: MELROSE 5-1593).

FOR SALE—Williams, United and Chicago Coin Electric Front Pool Tables, \$50 ea. Write. PENNSYLVANIA VENDING CORP., 1826 E. CARSON ST., PITTSBURGH 3, PA.

FOR SALE—Beach Beauty, \$299.50; Nite Club, \$365; Miami Beach, \$175; Pixie, \$150; Starlet, \$199.50; Variety, \$100; Beach Club, \$60; Wurlitzer Model # 1100, \$70; Model # 1015, \$50. Terms One-Third Deposit, Balance Sight Draft. GENERAL DISTRIBUTING CO., 1609 NEW ORLEANS AVE., NEW ORLEANS, LA. (Tel.: TULANE 6729).

FOR SALE—Complete line of used Phonographs, Shuffle Games, Cigarette Machines and various types of all other games and equipment. Lowest prices. Best merchandise. One letter, wire or phone call will convince you. We are factory representatives for United, Williams, Bally, DeGrenier and Genco. TARAN DISTRIBUTING, INC., 3401 N.W. 36th ST., MIAMI 42, FLA. (Tel.: NEWTON 5-2531).

FOR SALE—Muto-Scope K.O. Champ, \$350; Williams DeLuxe B. B., \$100; King Of Swat, \$275; Rock and Roll, \$85; Gladiator, \$265; Marathon, \$285; Broadway, \$325; Nite Club, \$400; Wurlitzer, 1800, \$625. NEW ENGLAND EXHIBIT CO., NEWTON, MASS. (Tel.: DE 2-1500).

FOR SALE—All types used AMI, Wurlitzer and Seeburg equipment. Clean and shopped or as is. Factory Distributor for Seeburg. DICKSON DISTRIBUTING CO., 631 W. CALIFORNIA, OKLAHOMA CITY, OKLA. (Tel.: REGENT 6-3691).

FOR SALE—Or Trade for Kiddie Rides: Genco State Fair, \$295; Genco Davy Crockett, \$225; United DeLuxe Bonus Gun, \$200; United Pirate Gun, \$325; Williams Polar Hunt, \$200; Williams Sidewalk Engineer, \$100; Chicago Coin Steam Shovel, \$135; Chicago Coin Twin Hockey, \$185; Genco Hi-Fly Baseball, \$200. RELIABLE COIN MACHINE CO., 184 WINDSOR ST., HARTFORD, CONN. (Tel.: CHAPEL 9-6556).

FOR SALE—Special. Bally: Big Shows, \$475. United: Monacos, \$385; Pirate Guns, \$375; Pool Alleys, \$175. Genco: Sky Raider Gun, \$215; Champion 2-player Baseball, \$165. International Mutoscope: Voice-O-Graphs, \$275; Rock 'n Roll, \$37.50. Williams: Fun House, \$225; Red-White-Blue, \$139.50. NEW ORLEANS NOVELTY CO., 115 MAGAZINE ST., NEW ORLEANS, LA. (Tel.: CANAL 5306).

FOR SALE—King Arthur, \$35; Twenty Grand, \$55; Disc Jockey, \$75; Grand Slam, \$85; Four Corners, \$85; Gypsy Queen, \$185; Gayety, \$119.50; Miami Beach, \$235. Make offer on Bright Lights, Bright Spots, 3-4-5's, Long Beach, Circus, Stars. WANT—Big Times. NOBRO NOVELTY CO., 142 DORE ST., SAN FRANCISCO, CALIF. (Tel.: MA 1-5438).

FOR SALE—3 Keeney Speedlanes, Chicken Sam Rifle, Shuffle Bowlers, Guns. Also Pool Tables—all makes and models. For best buys, write or call: HY POLO AMUSEMENTS, INC., 1969 W. WILSON AVE., CHICAGO 40, ILL. (Tel.: LONGBEACH 1-3378).

FOR SALE—18 foot Rock-Ola Shuffle Board \$149.50; Shuffle Board game wax (12 cans) \$3.50; Fast wax ease 12 cans) \$4.50; Pucks (set of 8) \$12; Fluorescent Lights pair \$22.50; Adjusters \$18.50. PURVEYOR DISTRIBUTING CO., 4322 N. WESTERN, CHICAGO 18, ILL. (Tel.: JUNIPER 8-1814).

FOR SALE—Slate Top Pool Table Replacement, any size holes wherever you want them, ¾ in. Gennine Slate, Best Cloth and Large Lively Bumpers. Lowest Price. Ball for Bumper Games, 2½ in. Size, Red or White, 50¢ per ball. Will trade for any merchandise, what have you? SEACOAST DIST., INC., 1200 NORTH AVE., ELIZABETH 4, N. J.

FOR SALE—Lowest prices Thunderbolts, Lightnings, \$229.50 ea.; Hollywood Bowlers, \$269.50; Chicago Coin Super Home Rnn, \$179.50; Bingos, Pool Tables, trade for Kiddie Rides, Arcade Equipment or write best cash offer. Ready for location. ALLIED DISTRIBUTING CO., 786 MILWAUKEE AVE., CHICAGO, ILL. (Tel.: CANAL 6-0293-4-5).

THE CASH BOX

"The Industry's Market Place"

PUBLISHES MORE CLASSIFIED ADS EACH WEEK THAN ALL OTHER MAGAZINES IN THIS INDUSTRY PUBLISH IN A MONTH — PROVING THAT THE ENTIRE INDUSTRY RECOGNIZES THE CASH BOX' CLASSIFIED AD SECTION AS "THE INDUSTRY'S MARKET PLACE."

WANT

FOR SALE

CHECK OFF WHICH YOU DESIRE

CLASSIFIED AD RATE 10 CENTS PER WORD

Count every word including all words in firm name. Numbers in address count as one word. Minimum ad accepted \$1.00. CASH OR CHECK MUST ACCOMPANY ALL ORDERS FOR CLASSIFIED ADVERTISING. If cash or check is not enclosed with order your classified ad will be held for following issue pending receipt of your check or cash.

Notice to 52x Special Classified advertisers. You are entitled to a classified ad in each week's issue containing no more than 40 words, which includes your firm name, address and telephone number. All words over 40 will be charged to you at the regular rate of 10c per word. Please count words carefully.

ALL CLASSIFIED ADVERTISING CLOSSES WEDNESDAY NOON AT THE CASH BOX, 1721 Broadway, New York 19, N. Y.

Use This Convenient Form For Your Classified Ad

START HERE



FIRM _____

ADDRESS _____

CITY _____ ZONE _____ STATE _____

TELEPHONE NUMBER _____

ENCLOSE YOUR CHECK—AIRMAIL TO:

THE CASH BOX

1721 BROADWAY, NEW YORK 9, N. Y.

CLASSIFIED ADVERTISING SECTION

MISCELLANEOUS

FOR SALE—Wurlitzer 2000, \$900; Wurlitzer 1900, \$825; Seeburg M-100A, \$225; United Handicaps, used, \$435. WANT—All 45 rpm phonographs, especially Seeburg B's, C's, R's, G's, and J's. NATIONAL NOVELTY CO., 640 W. MERRICK ROAD, VALLEY STREAM, L. I., N. Y. (Tel.: LOcust 1-6770 and 6771).

FOR SALE—Bally Big Show, \$485; Bally Key West, \$525; Bally Beach Beauty, \$280; Bally Beach Club, \$60; United Triple Play, \$150; Keeney's Deluxe Challenge Bowler, \$275. NASTASI DISTRIBUTING CO., 912 POYDRAS STREET, NEW ORLEANS, LA. (Tel.: MA 6386).

FOR SALE—Reconditioned Seeburg 100 Selection Wall-O-Matics, Model 3W1, Chrome Covers, New Selection Buttons, New Aluminum Instruction Plates, \$57.50. Telephone or wire collect. SYracuse 75-1631. DAVIS DISTRIBUTING CORP., 738 ERIE BLVD., E., SYRACUSE 3, N. Y.

FOR SALE—Seeburg MI00A, \$225; MI00C, \$575; MI00G, \$700; MI00W, \$700; M100R, \$800; 3W1 Chrome, \$55; Wurlitzer 1800, \$750; 1900, Write, AMI D80, \$300; 40, \$175; Evans Century, \$275. MUSICAL SALES, 2334-36 OLIVE STREET, ST. LOUIS 3, MO. (Tel.: CH 1-8561).

FOR SALE—"Arcade Equipment." Genco Quarterback, \$200; Genco State Fair, \$395; Seeburg Shoot The Spook, \$75; Exhibit Rifle Gallery, \$125. W. B. DISTRIBUTORS, INC., 1012 MARKET ST., ST. LOUIS 1, MO. (Tel.: CEntral 9292).

FOR SALE—United: Derby Roll, \$135; Fifth Inning, \$150. Bally: Gold Medal and Blue Ribbons, \$175 each; Baseballs—Super Slugger, \$225. MOHAWK SKILL GAMES CO., 67 SWAGGERTOWN ROAD, SCHENECTADY 2, N. Y. (Tel.: FRanklin 7-2162).

FOR SALE—AMI Model "B", "C" and "G-200" Shopped or in "as is" condition. Right off the route and ready for immediate delivery . . . Call today. RUNYON SALES CO., 593 10th AVE., NEW YORK, N. Y. (Tel.: LOngacre 4-1880).

FOR SALE—14 and 11 foot Bowler Parts Specials; Back glass protector, \$11.95 ea. Plexiglas Pin Panel protector, 12½"x23", \$5.95 ea. Non-scut rubber balls, 3", \$1.95 ea. WICO CORP, 2913 N. PULASKI RD., CHICAGO 41, ILL. (Tel.: MULberry 5-3000).

FOR SALE—100 Telequiz, with film. Reconditioned, refinished, ready for location. 5c or 10c play. Special price, \$99.50. Write for quantity prices and list of other equipment. G O R SALES, 5216 N. LECLAIRE AVE., CHICAGO, ILL. (Tel.: AVenue 3-6818).

NOTICE—Salesmen. Leading coin-machine manufacturer offers excellent opportunity for capable experienced salesmen contacting distributors and operators. Unlimited possibilities; car essential. Give full details regarding yourself first letter. Our sales force knows of this advertisement. BOX # 403, THE CASH BOX, 32 W. RANDOLPH ST., CHICAGO, ILL.

NOTICE—Diversification with no investment! Our program has already proven itself to leading operators. Make hundreds of dollars each week with our "Especially made for the 'profit' trade merchandising approach" in the specialty food field. A.B.C. MFG. CO., 3441 W. NORTH AVE., CHICAGO 47, ILL.

NOTICE—That idea you have can become a new coin operated device. Contact Bob Young for Development and Engineering advice. BOB YOUNG'S SERVICE, 3427 BEN LOMOND PL., LOS ANGELES 27, CALIF. (Tel.: NO 2-3254).

NOTICE—Attention Operators: It pays to diversify your source of income! Place Latex, Comb, Ball Point Pen machines and others in your present or new locations. Write for free catalog. NATIONAL SANITARY SALES, INC., 6640 N. WESTERN, DEPT. CB, CHICAGO 45, ILL.

NOTICE—Louisiana & Southern Mississippi Operators. Your authorized Rock-Ola Distributor is HUEY DISTRIBUTING CO. Write, wire or phone. 3760 AIRLINE HIGHWAY, NEW ORLEANS 20, LA. (Tel.: VERNon 5-7976).

NOTICE—It's your business to KNOW THE FACTS! How can operator-cooperatives affect you? How can you get your locations' cooperation? How can "10c Play Plus" help you? What percentage of the nation's juke boxes feature 10c play? What percentage of U. S. amusements feature 10c play? All this and more appeared in *The Cash Box*. In addition to "The Cash Box Price Lists" which, for over 18 years since their inception, have been internationally recognized and officially accepted *The Cash Box* is the publication that conceived the idea for MOA (Music Operators of America). *The Cash Box* originated and has constantly crusaded for: "National Public Relations Bureau," "Dime Play," "National Credit Bureau," "National Board of Trade," "National School for Mechanics," "2-Minute Recordings," "Equalized Record Tone Level." *The Cash Box* "Quarterly Export Edition" has won world wide recognition and international acclaim. *The Cash Box* Annual Encyclopaedic Edition plus its Anniversary Issue is accepted as "The Year Book of the Industry." When you send \$15 for a full year's (52 weeks) subscription to *The Cash Box* (just about two bits a week) you are getting what has been acclaimed by all as: "The BIBLE of the Industry." Send your \$15 check today to: THE CASH BOX, 1721 BROADWAY, NEW YORK 19, N. Y.

THIS WEEK'S USED MACHINE QUOTATIONS 18th YEAR OF PUBLICATION 922nd CONSECUTIVE WEEK'S ISSUE

How To Use "THE CASH BOX PRICE LISTS"

[Also known as the "C. M. I. (Coin Machine Industry) BLUE BOOK"]

FOREWORD: Many times, wide differences appear in the quotation of high and low prices of certain equipment. Like any true reporter "The Cash Box Price Lists" can only feature the market prices as they are quoted. "The Cash Box Price Lists" act exactly the same as the market quotation board at the Stock Exchange—posting the prices as they are quoted for the past week, regardless of how much they may seem to be out of line. Some prices do not change for months. "The Cash Box Price Lists," rather than show no price, retain the last known quotations for such equipment so that the subscriber at least has the last known prices as a basis to work with. Prices may be very widely divergent. Someone on the West Coast may feel a certain machine worth \$150.00 whereas someone on the East Coast may think it worth but \$75.00. Of course, serial, appearance, demand, territory, quantity, and condition of equipment must be taken into consideration. (Some equipment offered by outstanding firms, having a reputation for shipping completely reconditioned machines, will be offered at higher prices than others, due to the added cost of reconditioning.) "The Cash Box Price Lists" reports each quotation exactly as it is made and depends on the subscriber to make average price adjustments to fit the peculiarities of his territory.

METHOD: "The Cash Box Price Lists" should be read as follows: First price listed is lowest price quoted for the week; Second price listed is highest price quoted.

FOREIGN BUYERS: To cover cost of packing, crating, shipping, etc., figure an additional \$20 to \$25 on Pin Games—and \$25 to \$30 on Phonographs.

CODE

- | | |
|-----------------------------|------------------------------------|
| 1. Prices UP | 5. No quotations Last 2 to 4 Weeks |
| 2. Prices DOWN | 6. No quotations 4 Weeks or Longer |
| 3. Prices UP and DOWN | 7. Machines Just Added |
| 4. No change from Last Week | * Great Activity |

REGARDING SELLING PRICES

IMPORTANT!

Reports received indicate that, in some cases, purchasers become upset due to the fact that they cannot, many times, buy equipment listed in the lower price brackets. Sometimes sellers of machines listed at from \$10.00 to \$25.00 ask from \$50.00 up to \$75.00 and even more for these very same machines. Purchasers of such equipment must realize that machines in the very low priced categories are much worn to be priced at these low figures. To completely recondition such machines, the reconditioner must add onto his price the cost of transportation to obtain these machines, the labor, parts and supplies needed to recondition the machines, plus the cost of cartons, crates and labor for packing and shipping of the machines, in addition to a decent profit which will, in most cases, raise the price of a \$10.00 to \$20.00 machine to anywhere from \$50.00 to \$75.00 and up. In the case of arcade and kiddie ride machines these may even be higher due to the fact that many of the parts have to be made by hand or contracted for at some machinist shop, since manufacturers of many of the old arcade machines and kiddie rides are no longer in business and it is impossible to obtain parts for reconditioning. Purchasers of such equipment should take these facts into consideration and, at the same time, should also realize that many buyers today have their own repair and reconditioning departments as well as experienced mechanics, such buyers will purchase machines "as is", at prices quoted by the trade at large, and recondition the machines themselves to meet their own operating standards.



PHONOGRAPHS

LISTED ALPHABETICALLY

AMI

4* Model A, '46, 40 Sel., 78 RPM	45.00	125.00	2* Model G-120, '55, 120 Sel., 45 RPM	695.00	795.00
1. Model B, '48, 40 Sel., 78 RPM	75.00	130.00	2. Model G-200, '56, 200 Sel., 45 RPM	690.00	825.00
1* Model C, '50, 40 Sel., 78 RPM	85.00	140.00	4. WM Wall Box	5.00	10.00
4* Model D-40, '51, 40 Sel., 78 RPM	145.00	225.00	4. SM or SL Stepper	10.00	15.00
2* Model D-80, '51, 80 Sel., 45 RPM	275.00	325.00			
4. Model E-40, '53, 40 Sel., 45 RPM	290.00	375.00			
4. Model E-80, '53, 40 Sel., 78 RPM	345.00	400.00			
4* Model E-120, '53, 120 Sel., 45 RPM	375.00	495.00			
2. Model F-80, '54, 80 Sel., 45 RPM	520.00	650.00			
4* Model F-120, '54, 120 Sel., 45 RPM	550.00	675.00			
4. Model G-80, '55, 80 Sel., 45 RPM	525.00	725.00			

EVANS

4. Mills Constellation, '47 Model 951, 40 Sel., 78 RPM	25.00	45.00
4. Constellation, '49, Model 135, 40 Sel., 78 RPM	65.00	95.00
4. Jubilee, '52, Model 245, 40 Sel., 45 RPM	100.00	150.00
4. Century, '52, Model 2045, 100 Sel., 45 RPM	200.00	275.00

ROCK-OLA

6. 1422, '46, 20 Sel., 78 RPM	25.00	60.00
6. 1424, '46, Playmaster Hideaway, 20 Sel., 78 RPM	30.00	60.00

(PHONOGRAPHS—Continued)

4. 1426, '47, 20 Sel., 78 RPM	35.00	65.00	2* V200, '55, 200 Sel., 45 RPM	695.00	875.00
4. 1428, '48, Magic-Glo, 20 Sel., 78 RPM	35.00	75.00	4. W1-L56 Wall Box 5c	3.00	5.00
4. 1432, '50, Rocket '50-51, 50 Sel., 78 RPM	75.00	100.00	4. 3W2 Wall-a-Matic	3.00	5.00
4. 1432, Same as above Converted to 45 RPM	90.00	135.00	4. W4L-56	5.00	10.00
4. 1434, '51, Rocket '51-52, 50 Sel., 78 RPM	120.00	180.00	4. 3W5-L56 Wall Box 5c, 10, 25c	5.00	10.00
2. 1434, Same as above, Converted to 45 RPM	135.00	190.00	4. W6L-56 5/10/25 Wire-less	5.00	10.00
4. 1436, '52, Fireball, 120 Sel., 45 RPM	145.00	275.00	4. 3W7-L-56	5.00	12.00
4. 1436A, '53, Fireball, 120 Sel., 45 RPM	165.00	295.00	4* 3W1 Wall-a-Matic	40.00	60.00
2. 1438, '54, Comet, 120 Sel., 45 RPM	385.00	465.00			
4. 1446, '54, Hi-Fi, 120 Sel., 45 RPM	485.00	650.00			
4* 1448, '55, Hi-Fi, 120 Sel., 45 RPM	600.00	675.00			

SEEBURG

4. 146S, '46, Standard, 20 Sel., 78 RPM	20.00	40.00
2. 146M, '46, Master with Remote Attach., 20 Sel., 78 RPM	20.00	40.00
2. 147S, Standard, 20 Sel., 78 RPM	20.00	50.00
2. 147M, '47, Master with Remote Attach., 20 Sel., 78 RPM	20.00	55.00
2. 148S, '48, Standard, 20 Sel., 78 RPM	20.00	60.00
4. 148M, '48, Master with Remote Attach., 20 Sel., 78 RPM	20.00	70.00
4. 148ML, '48, Light Cab. Master with Remote Attach., 20 Sel., 78 RPM	20.00	75.00
1* M100A, '49, 100 Sel., 78 RPM	175.00	225.00
4* M100B, '51, 100 Sel., 45 RPM	345.00	425.00
2. M100BL, '51, 100 Sel., 45 RPM, Light Cab.	385.00	440.00
1* M100C, '53, 100 Sel., 45 RPM	445.00	575.00
2* HF100G, '54, 100 Sel., 45 RPM	545.00	700.00
4* HF100R, '54, 100 Sel., 45 RPM	645.00	800.00

WURLITZER

2. 1015, '46, 24 Sel., 78 RPM	25.00	60.00
2. 1017, '46, 24 Sel., 78 RPM	25.00	65.00
4. 1080, '46, 24 Sel., 78 RPM	35.00	75.00
2. 1100, '47, 24 Sel., 78 RPM	65.00	110.00
4. 1217, '50, Hideaway, 48 Sel., 45 or 78 RPM	65.00	130.00
2* 1250, '50, 48 Sel., 45 or 78 RPM	75.00	145.00
4* 1400, '51, 48 Sel., 45 or 78 RPM	135.00	185.00
2. 1450, '51, 48 Sel., 45 or 78 RPM	150.00	195.00
2. 1500, '52, 104 Sel., 45 & 78 Intermix	195.00	250.00
2. 1500A, '53, 104 Sel., 45 & 78 Intermix	225.00	295.00
4. 1600, '53, 48 Sel., 45 & 78 Intermix	225.00	325.00
2. 1650, '53, 48 Sel., 45 RPM	250.00	365.00
4. 1650A, '54, 48 Sel., 45 or 78 RPM	275.00	375.00
4* 1700, '54, 104 Sel., 45 RPM	525.00	650.00
2* 1800, '55, 104 Sel., 45 RPM	595.00	795.00
4* 1900, '56, 104 Sel., 45 RPM	675.00	895.00
2* 2000, '56, 200 Sel., 45 RPM	795.00	995.00
4* 3020 Wall Box	4.00	8.00
4. 3048 (Conv. of 3020)	5.00	8.00
4. 3031 Wall Box	3.00	5.00
4. 3045 Wall Box	4.00	10.00
4* 4820 Wall Box	10.00	20.00
4. 4820 Wall Box	10.00	20.00



PINBALL GAMES

Manufacturers and date of game's release listed. Code: (B) Bally; (CC) Chicago Coin; (Ev) Evans; (Ex) Exhibit; (Ge) Genco; (Got) Gottlieb; (Ke) Keeney; (Un) United; (Wm) Williams.

4. ABC (Un 3/52)	20.00	40.00	4. Classy Bowler (Got 7/56)	230.00	265.00
4. Ace High (Got 2/57)	275.00	375.00	4. C.O.D. (Wm 9/53)	50.00	90.00
4. Across the Board (Un 9/52)	20.00	45.00	4. Colors (Wm 11/54)	110.00	150.00
4. All Star Basketball (Got 1/52)	20.00	30.00	2. Coney Island (B 9/52)	20.00	50.00
4. Arabian Knights (Got 12/53)	85.00	125.00	4. Control Tower (Wm 3/51)	15.00	25.00
4. Arcade (Wm 11/51)	25.00	35.00	4. Coronation (Got 11/52)	30.00	75.00
2. Army-Navy (Wm 10/53)	35.00	65.00	4. County Fair (Un 9/51)	15.00	30.00
4* Atlantic City (B 5/52)	25.00	60.00	4. Crossroads (Got 5/52)	45.00	70.00
4. Auto Race (Got 9/56)	250.00	295.00	4. Crosswords (B 1/56)	195.00	295.00
4. Balls-A-Poppin' (B 11/56)	200.00	350.00	4. Cue Ball (Wm 2/57)	275.00	300.00
2. Beach Beauty (B 11/55)	275.00	350.00	4. Cyclone (Got 5/51)	25.00	40.00
4. Beach Club (B 2/53)	40.00	60.00	4. Daffy Derby (Wm 8/54)	75.00	135.00
4. Beauty (B 11/52)	40.00	70.00	2. Daisy May (Got 7/54)	135.00	165.00
2. Big Ben (Wm 9/54)	75.00	130.00	4. Dealer "21" (Wm 2/54)	35.00	85.00
4* Big Show (B 9/56)	475.00	570.00	4. Derby Day (Got 5/56)	175.00	225.00
2. Big Hit (CC 7/52)	20.00	35.00	4. Diamond Lill (Got 12/54)	110.00	165.00
4* Big Time (B 1/55)	150.00	225.00	4. Disk Jockey (Wm 11/52)	35.00	75.00
4. Blondie (CC 8/56)	250.00	295.00	2. Domino (Wm 5/52)	25.00	50.00
4. Brazil (Un 10/56)	375.00	450.00	4. Double Action (Ge 1/52)	15.00	30.00
2. Bright Lights (B 5/51)	25.00	45.00	4. Double Feature (Got 12/50)	15.00	30.00
4* Bright Spot (V 11/51)	35.00	65.00	4* Double Header (B 7/56)	400.00	475.00
4* Broadway (B 12/55)	320.00	395.00	2. Dragonette (Got 6/54)	125.00	155.00
4. Cabana (Un 3/53)	30.00	70.00	2. Dude Ranch (B 9/53)	50.00	75.00
4. Capri (CC 10/56)	195.00	240.00	2. Duette (Got 4/55)	165.00	195.00
4. Caravan (Un 2/56)	245.00	320.00	4. Easy Aces (Got 12/55)	175.00	220.00
4. Caravan (Wm 6/52)	30.00	55.00	4. Eight Ball (Wm 1/52)	30.00	50.00
4. Chinatown (Got 10/52)	35.00	75.00	4. Fairway (Wm 6/53)	40.00	60.00
4. Circus (Un 8/52)	35.00	55.00	4. Five Star (Univ 5/51)	25.00	40.00
2. Circus Wagon (Wm 10/55)	185.00	265.00			

(PINBALL GAMES—Continued)

4. Flying High (Got 2/53)	50.00	80.00
4. Four Bells (Got 10/54)	135.00	160.00
4. Four Corners (Wm 12/52)	45.00	85.00
4. Four Horsemen (Got 9/50)	20.00	35.00
2. "400" (Upright) (Ge 10/52)	30.00	50.00
4. Four Stars (Got 6/52)	40.00	60.00
4. Frolics (B 10/52)	40.00	95.00
4. Frontiersman (Got 11/55)	120.00	185.00
2. Fun House (Wm 10/56)	225.00	275.00
4. Futurity (B 3/51)	20.00	35.00
3* Gay Times (B 6/55)	150.00	200.00
4* Gayety (B 3/55)	75.00	120.00
4. Georgia (Wm 7/50)	20.00	30.00
4. Gladiator (Got 1/56)	225.00	265.00
4. Glamour (Got 7/51)	10.00	20.00
4. Globe Trotter (Got 11/51)	20.00	30.00
4. Golden Nugget (Upright) (Ge 2/53)	35.00	50.00
4. Gold Star (Got 8/54)	125.00	160.00
2. Grand Champion (Wm 3/53)	45.00	75.00
2. Grand Slam (Got 4/53)	40.00	85.00
4. Green Pastures (Got 1/54)	60.00	120.00
4. Gun Club (Wm 11/53)	35.00	75.00
4. Guys-Dolls (Got 5/53)	30.00	95.00
4. Gypsy Queen (Got 2/55)	135.00	175.00
2. Handicap (Wm 6/52)	30.00	50.00
2. Happy Days (Got 7/52)	35.00	60.00
4. Happy-Go-Lucky (Got 3/51)	20.00	30.00
2. Harbor Lites (Got 2/56)	165.00	195.00
4. Harvey (Wm 5/51)	25.00	40.00
4. Havana (Un 2/54)	35.00	90.00
3. Hawaii (Un 6/54)	45.00	90.00
4. Hawaiian Beauty (Got 4/54)	100.00	130.00
4. Hayburner (Wm 6/51)	25.00	50.00
4. Hi-Fi (B 6/54)	50.00	95.00
2. Hit 'N Run (Got 4/52)	30.00	50.00
4. Holiday (Ke 12/51)	25.00	35.00
4. Hong Kong (Wm 9/51)	25.00	35.00
4. Horsefeathers (Wm 1/52)	20.00	35.00
4. Horse Shoe (Wm 12/51)	15.00	25.00
7. Hot Diggity (Wm 8/56)	225.00	250.00
4. Ice-Frolics (B 1/54)	40.00	95.00
4. Jalopy (Wm 8/51)	35.00	70.00
4. Jockey Club (Got 5/54)	70.00	135.00
4. Jolly Joker (Un 11/55)	70.00	120.00
4. Jubilee (Got 5/55)	230.00	275.00
2. Jumping Jacks (Upright) (Ge 12/52)	20.00	40.00
3* Key West (B 12/56)	525.00	575.00
2. King Pin (CC 12/51)	20.00	40.00
4. Knockout (Got 1/51)	15.00	25.00
2. Lady Luck (Got 9/54)	85.00	150.00
2. Lazy "Q" (Wm 2/54)	45.00	100.00
4. Leaders (Un 10/51)	25.00	50.00
2. Lite-A-Line (Ke 6/52)	35.00	50.00
2. Long Beach (Wm 7/52)	35.00	55.00
4. Lovely Lucy (Got 2/54)	55.00	125.00
4. Lucky Inning (Wm 5/50)	20.00	30.00
4. Lulu (Wm 12/54)	125.00	180.00
4. Mad. Sq. Garden (Got 6/50)	20.00	30.00
4. Majorettes (Wm 4/52)	20.00	35.00
4. Manhattan (Un 4/55)	75.00	140.00
4. Marathon (Got 10/55)	250.00	285.00
4. Marble Queen (Got 8/53)	60.00	95.00
2. Mermaid (Got 6/51)	20.00	35.00
4. Mexico (Un 3/54)	40.00	100.00
4* Miami Beach (B 9/55)	175.00	235.00
4. Minstrel Man (Got 3/51)	25.00	40.00
4. Monaco (Un 8/56)	325.00	425.00
4. Mystic Marvel (Got 3/54)	100.00	145.00
4. Nevada (Un 8/54)	30.00	85.00
4. Niagara (Got 12/51)	25.00	50.00
4. Nifty (Wm 12/50)	15.00	25.00
4* Night Club (B 4/56)	345.00	455.00
2. "9" Sisters (Wm 1/54)	50.00	100.00

4. Olympics (Wm 5/52)	30.00	50.00
2. Palisades (Wm 7/53)	40.00	65.00
4. Palm Beach (B 7/52)	40.00	70.00
4. Palm Springs (B 11/53)	40.00	80.00
2* Parade (B 6/56)	350.00	465.00
4. Paratrooper (Wm 8/52)	20.00	40.00
4. Peter Pan (Wm 4/55)	125.00	165.00
4. Piccadilly (Wm 5/56)	200.00	285.00
4. Pin Bowler (CC 6/50)	10.00	20.00
2. Pin Wheel (Got 11/53)	65.00	100.00
2* Pixie (Un 10/55)	135.00	190.00
4. Play Ball (CC 1/51)	15.00	25.00
4. Poker Face (Got 9/53)	60.00	95.00
4. Quartet (Got 2/52)	45.00	70.00
4. Queen of Hearts (Got 12/52)	50.00	80.00
4. Quintet (Got 3/53)	45.00	90.00
2. Race The Clock (Wm 5/55)	125.00	175.00
1. Regatta (Wm 11/55)	125.00	180.00
4. Register (Got 10/56)	325.00	375.00
4. Rio (Un 11/53)	35.00	75.00
4. Rocket (Ge 5/50)	15.00	25.00
4. Rockettes (Got 8/50)	20.00	30.00
4. Rodeo (Un 2/53)	35.00	85.00
2. Rose Bowl (Got 10/51)	25.00	45.00
4. Saddle and Turf (Ev 10/53)	145.00	195.00
2. (Club Model)	160.00	200.00
4. Scoreboard (Got 4/56)	235.00	300.00
4. Screamo (Wm 4/54)	50.00	110.00
4. Sea Belles (Got 8/56)	255.00	325.00
2. Sea Jockeys (Wm 11/51)	30.00	50.00
4. Select-A-Card (Got 4/50)	15.00	25.00
4. Shindig (Got 10/53)	55.00	110.00
4. Shoot The Moon (Wm 11/51)	30.00	65.00
4. Show Boat (Un 12/52)	50.00	90.00
4. Silver Chest (Upright) (Ge 4/53)	55.00	85.00
4. Silver Skates (Wm 2/53)	30.00	65.00
4. Singapore (Un 10/54)	50.00	100.00
4. Skill Pool (Got 8/52)	35.00	50.00
4. Skyway (Wm 8/54)	65.00	135.00
4. Slugfest (Wm 3/52)	25.00	45.00
2. Sluggin' Champ (Got 4/55)	150.00	175.00
4. Smoke Signal (Wm 10/55)	135.00	175.00
4. Snafu (Wm 12/55)	135.00	185.00
4. Southern Belle (Got 6/55)	155.00	185.00
2. South Seas (Un 5/56)	270.00	365.00
2. Spark Plugs (Wm 9/51)	20.00	30.00
4. Spitfire (Wm 2/55)	65.00	125.00
4* Spot Lite (B 1/52)	35.00	65.00
2. Sportsman (Wm 2/52)	20.00	30.00
4. Springtime (Ge 3/52)	15.00	30.00
2. Stage Coach (Got 11/54)	135.00	165.00
4. Stardust (Wm 3/56)	225.00	310.00
7. Star fire (Wm 1/57)	254.00	285.00
4* Starlets (Un 12/55)	175.00	235.00
2. Star Pool (Wm 10/54)	85.00	150.00
4. Stars (Un 6/52)	30.00	45.00
2. Starlite (Wm 3/53)	35.00	50.00
4. Steeple Chase (Un 1/52)	25.00	50.00
2. Struggle Buggies (Wm 12/53)	40.00	80.00
4. Sunshine Park (B 12/52)	25.00	35.00
4. Super Jumbo (Got 10/54)	250.00	295.00
7. Super Score (Wm 9/56)	225.00	255.00
4. Surf Club (B 3/54)	37.50	75.00
7. Surf Rider (Wm 12/56)	235.00	265.00
4. Sweepstakes (Wm 1/52)	50.00	75.00
4. Sweet-Add-A-Line (Got 7/55)	145.00	185.00
4. Tahiti (Un 8/53)	25.00	75.00
4. Three Deuces (Wm 8/55)	165.00	190.00
4. Three Four Five (Un 6/51)	15.00	25.00
4. Thunderbird (Wm 5/54)	70.00	125.00
4. Tim-Buc-Tu (Wm 1/56)	140.00	195.00
2. Times Square (Wm 4/53)	50.00	75.00
4. Toreador (Got 6/56)	275.00	320.00
4. Touchdown (Un 1/52)	20.00	30.00

(PINBALL GAMES—Continued)

4. Tournament (Got 8/55)	210.00	265.00
4. Triple Play (Un 8/55)	125.00	175.00
2. Tropicana (Un 1/55)	55.00	130.00
4. Tropics (Un 7/53)	25.00	65.00
4. Twenty Grand (Wm 12/52)	25.00	55.00
4. Twin Bill (Got 1/55)	120.00	165.00
4* Variety (B 9/54)	65.00	135.00

2. Watch My Line (Got 9/51)	20.00	30.00
4. Whizz Kids (CC 3/52)	30.00	45.00
4. Wild West (Got 8/51)	30.00	50.00
2. Wishing Well (Got 9/55)	155.00	175.00
4. Wonderland (Wm 5/55)	125.00	175.00
4* Yacht Club (B 6/53)	45.00	80.00
4. Zingo (Un 10/51)	25.00	75.00



2. Bally Victory Bowler (5/54)	55.00	130.00
2. Bally Champion Bowler (5/54)	60.00	140.00
2* Bally Jet Bowler (8/54)	65.00	150.00
2. Bally Rocket Bowler (8/54)	65.00	160.00
4* Bally Mystic Bowler (12/54)	90.00	175.00
4* Bally Magic Bowler (12/54)	95.00	185.00
4* Bally Blue Ribbon (3/55)	175.00	250.00
4* Bally Gold Medal (3/55)	175.00	260.00
2. Bally ABC Bowler (7/55)	275.00	365.00
2. DeLuxe model	285.00	375.00
2. Bally Congress (7/55)	365.00	395.00
4. DeLuxe model	375.00	400.00
4. Bally Jumbo Bowler (9/55)	275.00	425.00
4. Bally King Pin Bowler (9/55)	275.00	435.00
4. ChiCoin 6-Player (8/51)	35.00	65.00
4. ChiCoin 6-Player DeLuxe (5/52)	35.00	65.00
4. ChiCoin Match Bowler (6/52)	35.00	65.00
4. ChiCoin Bowl-A-Ball (10/52)	35.00	80.00
4. ChiCoin Match Bowl-A-Ball (11/52)	35.00	80.00
4. ChiCoin 10th Frame Special (12/52)	35.00	80.00
4. ChiCoin Name Bowler (1/53)	35.00	85.00
4. ChiCoin 10th Frame Double Score Bowler (2/53)	35.00	90.00
2. ChiCoin Crown (4/53)	35.00	100.00
2. ChiCoin Crown, Giant Pins (4/53)	40.00	100.00
4. ChiCoin Triple Score (6/53)	25.00	110.00
4. ChiCoin Gold Cup (7/53)	50.00	115.00
4. ChiCoin High Speed Crown (7/53)	50.00	120.00
4. ChiCoin High Speed Triple Score (8/53)	60.00	125.00
4. ChiCoin Advance (10/53)	65.00	135.00
4. ChiCoin King (10/53)	75.00	140.00
4. ChiCoin Criss Cross Bowler (12/53)	50.00	145.00
4. ChiCoin Super Frame (3/54)	50.00	155.00
4. ChiCoin Starlite (5/54)	65.00	160.00
4. ChiCoin Feature (7/54)	65.00	170.00
2. ChiCoin Holiday (9/54)	95.00	185.00
2. ChiCoin Flash (10/54)	95.00	190.00
4. ChiCoin Playtime (10/54)	95.00	200.00
4. ChiCoin Fireball (11/54)	95.00	200.00
4. ChiCoin Thunderbolt (12/54)	150.00	210.00
4* ChiCoin Triple Strike (2/55)	150.00	225.00
4. ChiCoin Arrow (2/55)	160.00	225.00
4. ChiCoin Criss Cross Targette (1/55)	35.00	150.00
4. DeLuxe model	50.00	160.00
4. ChiCoin Bonus Score (4/55)	175.00	265.00
4. ChiCoin Big League (5/55)	175.00	270.00
2* ChiCoin Hollywood (5/55)	175.00	270.00
2. ChiCoin Blinker (8/55)	225.00	275.00
4. ChiCoin Score-A-Line (9/55)	235.00	285.00
4. ChiCoin Bowling Team (10/55)	235.00	290.00
4. ChiCoin Miami Shuffle (10/56)	65.00	195.00
4. Exhibit Twin Rotation (5/52)	50.00	80.00
4. Genco Shuffle Target (7/51)	20.00	30.00

4. Genco 8-Player Rebound (9/51)	20.00	35.00
4. Genco Shuffle Pool (11/53)	25.00	65.00
4. Genco Match Pool (2/54)	50.00	85.00
4. Gottlieb Bowlette (3/50)	15.00	25.00
4. Keeney Super DeLuxe League Bowler (3/52)	25.00	70.00
4. Keeney High Score League (5/52)	25.00	75.00
4. Keeney Team (10/52)	25.00	80.00
4. Keeney Team (10/52)	25.00	90.00
4. Keeney Club (4/53)	25.00	90.00
2. Keeney Domino (5/53)	30.00	95.00
4. Keeney Carnival (5/53)	40.00	100.00
4. Keeney Pacemaker (9/53)	45.00	100.00
4. Keeney Mainliner Bowler (1/54)	60.00	150.00
4. Keeney Bonus Bowler (3/54)	70.00	160.00
4. Keeney Diamond Bowler (5/54)	75.00	165.00
2. Keeney Bikini (6/54)	75.00	170.00
4. Keeney Century (6/54)	90.00	185.00
4. Keeney American (9/54)	90.00	195.00
4. Keeney National (9/54)	90.00	195.00
4. Keeney Speedlane (4/55)	95.00	250.00
4. United 6-Player Super (3/52)	20.00	65.00
4. United 4-Player Official (5/52)	25.00	50.00
4. United 6-Player Super (7/52)	30.00	60.00
4. United 10th Frame Star (9/52)	35.00	60.00
4. United Manhattan 10th Frame (9/52)	35.00	75.00
4. United Manhattan (9/52)	35.00	85.00
4. United 10th Frame Super (10/52)	35.00	85.00
4. United Cascade (2/53)	35.00	85.00
4. United Clover (2/53)	35.00	85.00
4. United Liberty (2/53)	35.00	85.00
4		

Now Available In Super FREE-PLAY Model

NEW COLORS! NEW PLAY! NEW BIGGER PROFITS! NEW REALISTIC STRIPED PLAYFIELD!

*Tops in EXTRA FEATURES!
Tops in EXTRA PROFITS for YOU!*

chicago coin's BOWLING LEAGUE



**NEW!
ALL METAL
ROLLER CHAIN
AND SPROCKET
BALL LIFT**

**(ELIMINATES
BALL JAMS)**

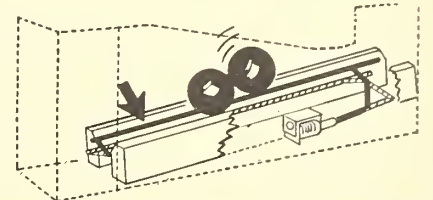
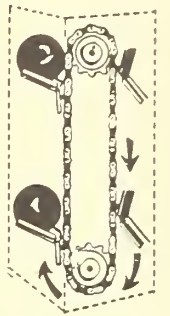

**BALLS FEEDING ON TO CHAIN ELEVATOR GET
AGITATED IN THE TROUGH, PREVENTING
JAMMING OR BALL HANG-UPS**

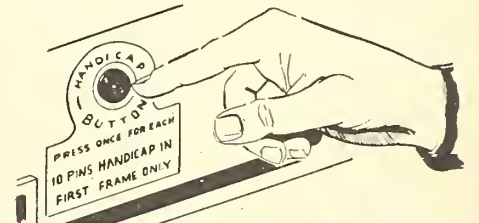

SCORING HANDICAP CONTROL

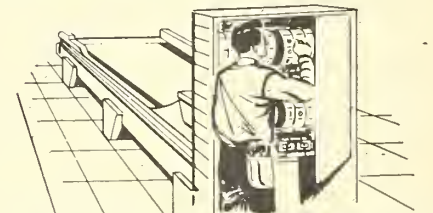

ALL MECHANISM IN THE BACK RACK

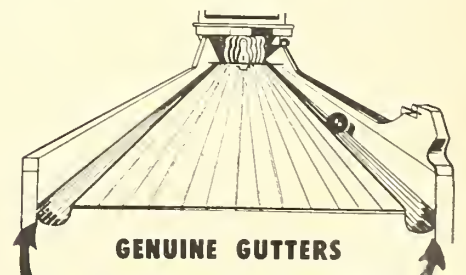

**GENUINE GUTTERS
NEW REALISTIC STRIPED PLAYFIELD!**

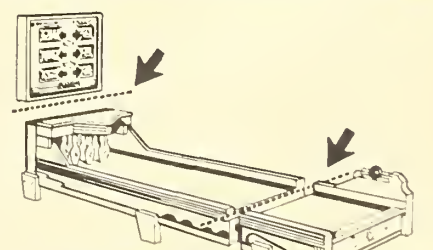

**3 SECTIONS FOR EASY HANDLING!
Custom Built For A Perfect Fit**

Available In **20 ft. 8 in.
Length**

(Convertible to 14 ft. 8 in.)
2 GAMES IN ONE



Order Now For Early Delivery

Your Choice Of
3 Size Cabinets!

- 20 ft. 8 in. Length
- 14 ft. 8 in. Length
- 12 ft. Length

29 Inches Wide
18 Inches High

Equipped With National Slug Rejector!

**chicago
coin
MACHINE COMPANY**

1725 W. DIVERSEY BLVD. CHICAGO 14, ILLINOIS

"It's What's in THE CASH BOX That Counts—INTERNATIONALLY"

(SHUFFLE GAMES—Continued)

1. Un. Super Bonus (9/55)	180.00	265.00	4. Top Notch Special	295.00	375.00
4. DeLuxe model	195.00	275.00	4. Un. Regulation (11/55)	295.00	385.00
4. Un. Top Notch (10/55)	295.00	365.00	4. DeLuxe model	325.00	390.00



KIDDIE RIDES

1. Bally Champion Horse	300.00	465.00	4. Chicago Coin Super Jet	195.00	345.00
1. Bally Moon Ride	150.00	295.00	2. Chicago Round The World Trainer	350.00	500.00
1* Bally Space Ship	160.00	325.00	4* Clown See Saw	125.00	250.00
2. Bally Speed Boat	195.00	300.00	4. Decco Merry-Go-Round	225.00	325.00
1* Bert Lane Merry-Go-Rd	285.00	400.00	4. Exhibit Big Bronco	250.00	395.00
4. Bert Lane Miss America Boat	225.00	350.00	4. Exhibit Mustang	300.00	395.00
2. Bert Lane Fire Engine	295.00	400.00	4. Exhibit Space Patrol	150.00	295.00
			4. Scientific Television	195.00	300.00



ARCADE EQUIPMENT

4. ABT 6 Gun Rifle Range	500.00	595.00	4. DeLuxe model	160.00	195.00
4. Air Football	195.00	295.00	4. Keeney Ranger (3/55)	225.00	250.00
4. Amus. Boomerang	30.00	75.00	4. DeLuxe model (3/55)	235.00	260.00
2. Bally Big Inning	65.00	100.00	4. Lite League	45.00	75.00
4. Bally Heavy Hitter	30.00	50.00	4. Mills Panorama Peek (11/54)	175.00	325.00
4. Bally King Pin	20.00	50.00	4. Mills Conv. for Panoram Peek	10.00	20.00
2. Bally Rapid Fire	65.00	100.00	4. Muto. Atomic Bomber	65.00	125.00
4. Bally Undersea Raider	75.00	125.00	4. Mutos. Ace Bombers	95.00	140.00
4. Capitol Midget Movies	95.00	195.00	4. Mutoscope Dr. Mobile (Prewar)	95.00	160.00
4. Champion Hockey	45.00	125.00	2. Mutos. Fly Saucers	90.00	140.00
2. ChiCoin Basketball Champ	100.00	150.00	4. Mutos. Photo (Pre-War)	125.00	295.00
4* ChiCoin 4-Player Derby	99.50	150.00	2. Mutos. Photomatic (DeLuxe)	250.00	325.00
4* ChiCoin Goalee	40.00	90.00	4. Mutoscope Silver Gloves	125.00	200.00
4. ChiCoin Hockey	50.00	75.00	4. Mutoscope Sky Fighter	60.00	140.00
4. ChiCoin Midget Skee	60.00	125.00	4* Mutos. Voice-O-Graph 35¢	175.00	350.00
4. ChiCoin Pistol	30.00	95.00	4* Mutoscope K.O. Chmp	275.00	375.00
4* ChiCoin Home Run, 6 Player (3/54)	85.00	165.00	4. Mutos. Drive Yourself	450.00	550.00
2* Super model	85.00	175.00	4* Mutoscope Rock n' Roll (7/56)	35.00	100.00
4* ChiCoin Twin Hockey (5/56)	150.00	275.00	4. QT Pool Table	50.00	70.00
4* ChiCoin Steam Shovel (5/56)	135.00	250.00	4. Quizzer	50.00	75.00
4. Edelco Pool Table	20.00	35.00	4. Rockola World Series	35.00	75.00
4. Evans Bola Score	40.00	70.00	4. Scientific Baseball	20.00	35.00
4. Evans Bat-A-Score	40.00	105.00	4. Scientific Basketball	20.00	40.00
4. Evans Ski Roll	35.00	75.00	4. Scientific Batting Pr.	30.00	60.00
2. Evans Super Bomber	60.00	115.00	4. Scientific Pitch 'Em	50.00	150.00
4. Evans Play Ball	30.00	50.00	2. Seeburg Bear Gun	75.00	150.00
4. Evans Ten Strike '46	30.00	60.00	4. Seeburg Chicken Sam	50.00	100.00
4. Evans Tommy Gun	30.00	75.00	4. Seeburg Shoot the Chute	45.00	90.00
4* Exhibit Dale Gun	35.00	75.00	4* Seeburg Coon Hunt	85.00	175.00
2. Exhibit Gun Patrol	50.00	100.00	2. Set Shot Basketball	135.00	250.00
2. Exhibit Jet Gun	50.00	125.00	4* Telequiz	75.00	100.00
2. Exhibit Space Gun	50.00	125.00	4. Un. Team Hockey	25.00	50.00
2. Exhibit Pony Express	70.00	125.00	2. United Jungle Gun	75.00	175.00
4* Exhibit Silver Bullets	35.00	125.00	2. DeLuxe model	75.00	180.00
4. Exhibit Six Shooter	50.00	125.00	2* Un. Carn. Gun (10/54)	125.00	185.00
4. Exhibit Vitalizer	40.00	70.00	2. DeLuxe model	125.00	190.00
4. Exhibit Shooting Gal. (6/54)	85.00	175.00	2. Un. Bonus Gun (1/55)	200.00	250.00
4. Exhibit Star Shooting Gallery (9/54)	85.00	195.00	2. DeLuxe model	200.00	260.00
4* Exhibit Sportland Shooting Gallery (11/54)	125.00	210.00	4. United Super Slugger (7/55)	225.00	325.00
4. Exhibit "500" Shooting Gallery (3/55)	150.00	275.00	4* United Star Slugger (4/56)	275.00	365.00
4. Exhibit Treasure Cove Shooting Gallery (6/55)	225.00	325.00	4. Wilcox-Gay Recordio Series (4/51)	20.00	75.00
4. Games Inc. Hunter (1/56)	225.00	285.00	4. Wms. DeLuxe World Series (2/52)	35.00	80.00
4. Genco Sky Gunner	75.00	145.00	4* Wms. DeLuxe Baseball (4/53)	65.00	125.00
4. Genco Night Fighter	75.00	145.00	4. Wms. Pennant Baseball (12/53)	80.00	135.00
4* Genco 2-Player Basketball	110.00	225.00	4. Wms. Super Pennant Baseball (12/53)	84.50	150.00
3* Genco Rifle Gal. (6/54)	125.00	225.00	4. Williams Super Star Baseball (12/53)	90.00	165.00
4. Genco Big Top Rifle Gallery (6/54)	235.00	300.00	4. Williams Major League Baseball (2/54)	99.50	175.00
4. Super Model (12/55)	325.00	375.00	4. Wms. All Star Baseball (2/54)	125.00	180.00
2. Genco Wild West Gun (2/55)	245.00	300.00	4. Wms. Big League Baseball (2/54)	125.00	185.00
2. Genco Sky Rocket Rifle Gal. (5/55)	215.00	300.00	4. Williams Jet Fighter (10/54)	125.00	225.00
2* Genco Champion Baseball (9/55)	195.00	310.00	4. Williams Safari (2/54)	195.00	295.00
2* Genco Quarterback (10/55)	175.00	315.00	4. DeLuxe model	200.00	300.00
4* Genco Hi-Fly Baseball (5/56)	200.00	325.00	2. Wms. Polar Hunt (3/55)	200.00	310.00
4* Genco State Fair Rifle Gal. (6/56)	295.00	395.00	2* Wms. Sidewalk Engineer (4/55)	100.00	175.00
4. Jack Rabbit	50.00	75.00	4* Wms. King Of Swat (5/55)	195.00	275.00
4. Jungle Joe	45.00	65.00	4* Williams Four Bagger (4/56)	285.00	395.00
4. Keeney Air Raider	65.00	140.00	4. DeLuxe model	310.00	395.00
4. Keeney Sub Gun	70.00	125.00			
2. Keeney Texas Leaguer	20.00	40.00			
4* Keeney Sportsman (11/54)	150.00	195.00			

Manufacturers New Equipment

Products listed here are currently in production. Prices are manufacturers' list prices, F.O.B. factory.

AMI, INCORPORATED

- H-200 200-sel. phonograph
- H-120 120-sel. phonograph
- H-100 100-sel. phonograph
- HAB-200 Selective-play Hideaway
- HBB-200 Continuous-play Hideaway
- WQ-200 200-sel. Wallbox
- WQ-120 120-sel. Wallbox
- Bargrip Wallbox Bracket
- Recessed Ceiling Speaker
- Wall Speaker
- Corner Speaker

No List Price Authorized for Publication

J. H. KEENEY & CO., INC.

- Bowl-O-Rama (6 Player) 14 Foot
- 11 Foot
- True-Score (6 Player) 14 Foot
- Super Big Tent
- Snack Vender
- Soup Vender
- DeLuxe Hot Coffee Vender
- DeLuxe Hot Coffee & Hot Chocolate Combo Vender
- Various Models of above ...

No List Price Authorized for Publication

ROCK-OLA MFG. CORP.

- Model 1455, 200 Sel.
- Model 1454, 120 Sel.
- Model 1452, 50 Sel.
- Model 1450—Playmaster, 120 Sel.
- Model 1546, Chrome Wall Box, 120 Sel.
- Model 1548, 50 Sel. Wall Box
- 1617—Hi-Fi Wall Speaker
- Model 1906, Remote Volume Control
- Model 1927, Remote Volume Control with Cancel Button

No List Price Authorized for Publication

AUTO-PHOTO CO.

- Studio Model "II" \$3,245.00

BALLY MFG. CO.

- Official Pool \$ 395.00
- Show-Time 837.00
- ABC Bowling Lanes (6 Player) 18 Foot 1,330.00
- 14 Foot Model 1,245.00
- 11 Foot Model 1,225.00
- Bike (Kiddie Ride) 835.00
- Model T (without Record Changer) 705.00
- Model T (with Record Changer) 755.00
- The Champion (with new all-metal cabinet) 835.00

CHICAGO COIN MACHINE CO.

- Super Bowling League (6 Player) 14 Foot
- Bowling League (6 Player) 20 Foot-8 In.
- 14 Foot-8 In.
- 11 Foot-11 In.

No List Price Authorized for Publication

EXHIBIT SUPPLY CO.

- Six-Pocket Pool
- 6 Peek Barrels, with base
- Nudist Colony (Ant Colony)
- 5 See-A-View Houses
- Card Vender, with base
- Single Column
- Double Column

No List Price Authorized for Publication

J. F. FRANTZ MFG. CO.

- Kicker & Catcher (Counter Game)
- ABT Challenger Pistol (Counter Game)
- ABT Guesser Scale
- ABT Rifle Sport (Shooting Gallery)
- Aristo Scale

No List Price Authorized for Publication

GENCO MFG. & SALES CO.

- Sweet Twenty One (2 Player Roll Down Game)
- Rotation Pool
- Gypsy Grandma Fortune Teller
- Circus Rifle Gallery Regular Model
- Match Model
- Davy Crockett (Rifle Gallery)

No List Price Authorized for Publication

D. GOTTLIEB & CO.

- Royal Flush (Single Player, 5-Ball)

No List Price Authorized for Publication

INTERNATIONAL MUTOSCOPE CORP.

- Bang-O-Rama \$ 325.00
- Voice-O-Graph, 45-78 RPM With musical unit 1,850.00
- Without musical unit 1,750.00
- Lord's Prayer Vender 390.00

J. P. SEEBURG CORP.

- KD200 Phonograph
- L100 Phonograph
- D3WA-Wall-O-Matic 200
- MRVC-Master Remote Volume Control
- HFCV2-8-High Fidelity Wall Speaker
- HFCV3-8-High Fidelity Corner Speaker
- HFCV1-12-High Fidelity Recessed Speaker
- PS6LZ-Power Supply
- HFA1-L6-Power Amplifier

No List Price Authorized for Publication

UNITED MFG. CO.

- Bowling Alley (6 Player) 11 Foot \$1,170.00
- 14 Foot 1,195.00
- 18 Foot 1,315.00
- Team Play Bowling Alley (6 Player) 11 Foot \$1,240.00
- 14 Foot 1,265.00
- 18 Foot 1,385.00

Available in 25¢ Play, also available in 2 Plays—25¢ with Credit Unit—Price on Request.

- Pirate Gun \$ 645.00
- Handicap Shuffle Alley (Without Match Feature) Single Chute 760.00
- Double Chute 780.00
- DeLuxe Handicap Shuffle Alley (With Match Feature) Single Chute 810.00
- Double Chute 830.00

WILLIAMS MFG. CO.

- DeLuxe 1957 Baseball
- 6-Pocket Pool Table
- Crossfire (Regular Model)
- DeLuxe Crossfire (Match Model)
- Peppy, The Clown
- Crane

No List Price Authorized for Publication

THE RUDOLPH WURLITZER CO.

- Model 2100 Phonograph, 200 Sel.
- Model 2104 Phonograph, 104 Sel.
- Model 2150 Phonograph, 200 Sel.
- Model 5210 Wall Box, 200 Sel., 3-Wire
- Model 5207 Wall Box, 104 Sel., 3-Wire
- Model 257 Stepper, 104 Sel.
- Model 5115 Hi-Fi Corner Speaker, 4"5" Matched Cones
- Model 5116 Hi-Fi Corner Speaker, 8" Heavy Duty with Extended Range

No List Price Authorized for Publication

**HOW THEY ARE
DOING AT AL GOODMAN'S
PLAYTIME ARCADE**

**WITH
UNITED'S
BOWLING
ALLEY**

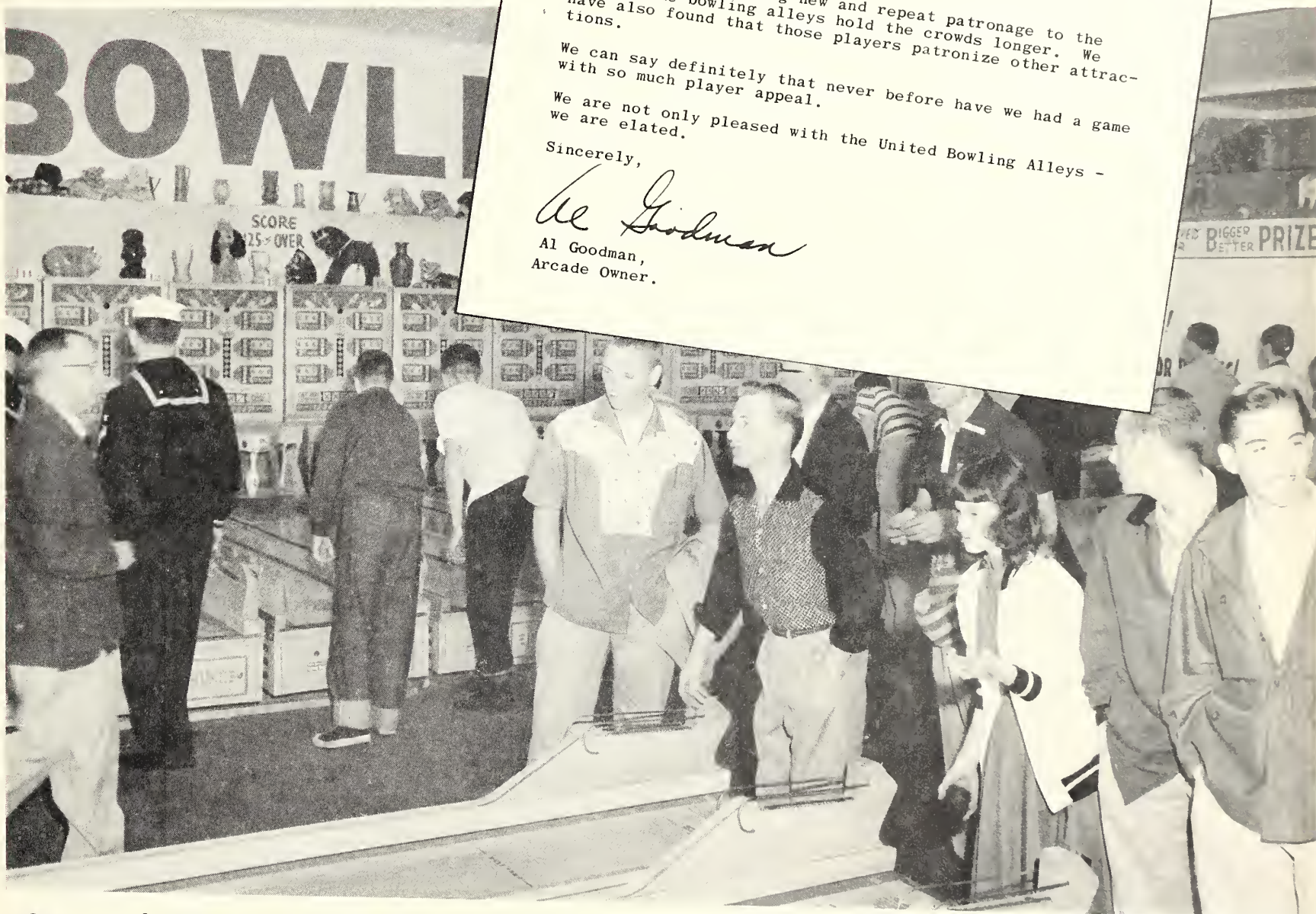

A. & B. Coin

400 West Pike

Long Beach, Calif.
May 12, 1957

United Manufacturing Company
3401 North California
Chicago 18, Illinois.

Gentlemen:

You will be interested to know that we are operating a battery of 21 United Bowling Alleys at the Playtime Arcade on the Pike here in Long Beach. They are doing sensational business.

We are highly pleased with the reception given these machines. I am sure that you will be interested in the story behind their installation.

About two months ago, upon the advice of the Simon Distributing Company of Los Angeles, we purchased six of the United Bowling Alleys and immediately put them on location. They attracted an unusually large number of players. It was common to see 14 or more players at the six machines. This clearly indicated that we could most profitably use more of them. Because of the tremendous popularity of the machines, we removed some older equipment. We purchased 15 additional alleys. This was all that we could fit into the remaining arcade space. We could use several more United Bowling Alleys - if the space permitted.

In addition to drawing new and repeat patronage to the arcade, the bowling alleys hold the crowds longer. We have also found that those players patronize other attractions.

We can say definitely that never before have we had a game with so much player appeal.

We are not only pleased with the United Bowling Alleys - we are elated.

Sincerely,

Al Goodman

Al Goodman,
Arcade Owner.

Get United's BOWLING ALLEY On Location Now! Available in Regular and Team Models... Operates Everywhere!



UNITED MANUFACTURING COMPANY

3401 N. CALIFORNIA AVENUE, CHICAGO 18, ILLINOIS



SIZES

11 FT. LONG
14 FT. LONG
18 FT. LONG

SECTIONAL
CONSTRUCTION
FOR EASY INSTALLATION
AND HANDLING

SEE YOUR DISTRIBUTOR

Bally SHOW-TIME

**EXTRA time is EXTRA fun,
earns EXTRA cash for you**

Extra earning-power of Extra Time is profit-proved in greatest Ballygames. Now SHOW-TIME gives players 4 WAYS TO PLAY FOR EXTRA TIME . . . and the extra play-appeal insures extra profits to you. Get SHOW-TIME from your Bally Distributor today.

New Style **MAGIC SQUARES**
plus New **MAGIC LINE**

TRIPLE-DECK ADVANCING SCORES
CORNER SCORES — BALLYHOLE
EXTRA BALLS



ABC Bowling Lanes

PLAYED WITH 3 IN. BALLS

SCORES AUTOMATICALLY TOTALIZED BY

**OFFICIAL
BOWLING RULES**

STRIKES — SPARES — SPLITS

STRAIGHT BALL • HOOK BALL • BACK-UP BALL

6 CAN PLAY

3 POPULAR SIZES

11 ft., 14 ft., 18 ft. long

18 IN. HIGH ALLEY • SECTIONAL CONSTRUCTION

ORDER FROM YOUR BALLY DISTRIBUTOR

BALLY MANUFACTURING COMPANY, 2640 Belmont Avenue, Chicago



Free
**TOURNAMENT
PROMOTION KIT
WITH EACH GAME**