

# COMMUNICATIONS QUARTERLY

THE JOURNAL OF  
COMMUNICATIONS  
TECHNOLOGY

Summer 1993

\$9.95

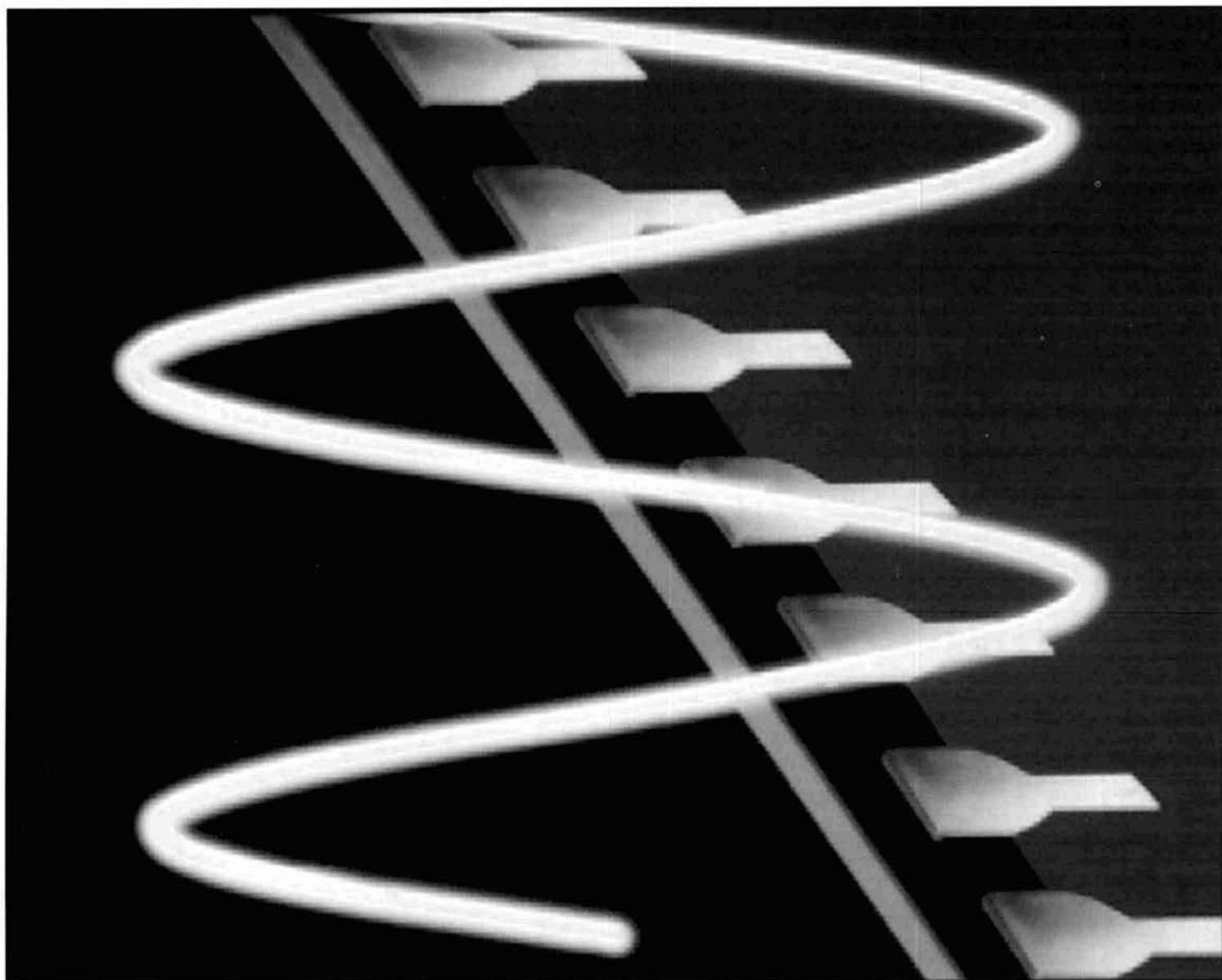

- Wavelength Division Multiplexing
- The Frequency Tunable Crystal Filter
- The Excalibur DAP and the Digital Data System
- Transmitting Short Loop Antennas for the HF Bands: Part 1

- 12:1 Baluns
- Receiver Performance
- Direct Digital Synthesis
- HF MOSFET Linear Amplifier

# Depend on the #1 Handheld in the World



## Incredibly Tough!



DJ-580 Dual Bander

Photo for Demonstration only-  
Abuse to the Transceiver will void  
the warranty

For Brochures, Mod Sheets, Operation  
Manuals And Service Manuals, Try Our  
New 24 Hour Hot Line.  
**Telephone: 310-618-9017**

## Model DJ-580T

The DJ-580T gives new meaning to the word "Versatility" This Super-compact radio offers great sound, excellent sensitivity, and a comfortable ergonomic design that puts it in a class by itself.

### The Right Features, Right Now:

Alinco's DJ-580T has Full-Duplex Cross Band operation and cross Band Repeater functions with real world power and excellent sensitivity. Airband receive with simple modification.

This unit has built in DSQ for paging, CTCSS encode and decode standard, various scanning functions, 3 power level selections for each band, bell function, and an illuminated keypad.

New MCF function allows you to set the 40 memory channels regardless of which channels you want for VHF or UHF. Any combination is possible.

If the battery is depleted to less than 5 volts, Alinco's Patented Low Battery Function is automatically

activated. You can continue to operate the radio all the way down to 3.5 volts. This feature will also indicate when the battery is getting low.

*Check out the affordable technology of the 90's.  
Check out ALINCO.*



**ALINCO**  
ELECTRONICS INC.

ALINCO ELECTRONICS INC.

438 Amapola Avenue, Unit 130, Torrance, CA 90501

Tel: (310) 618-8616 Fax:(310) 618-8758

Specification and feature are subject to change without notice or obligation.

**NEW**

**HERE NO MAN  
HAS GONE  
BEFORE**



Shown with optional  
TA100S antenna—Actual  
frequency measurement shown  
(not simulated).

**OPTOELECTRONICS' New  
HandiCounters® are Light Years Ahead!**

**Only Our New 3000A & M1  
HandiCounters® Can Give  
You *THESE* Numbers!**

- 15 Gate Times selectable from 100 micro sec. to 10 sec.
- 7 Hour Battery Life (3000A)
- 6 Hour Battery Life (M1)
- 10 Digit LCD Display
- 16 Segment Bargraph
- 3 Data Storage Registers
- 13 Mili Second (1.3% of a second) Measurement Rate
- 1 Hz Resolution in 1 Second for frequencies below 250MHz
- 2 Wire Serial Output for Data Logging
- 19 Years of Dependability & Service
- 10 Hz Resolution in .4 seconds for frequencies below 1GHz
- 10 MHz Industry Standard Time Base



**Plus all these incredible features:**

- OE10 INSIDE  
Ultra Reliable—Ultra Fast Counter IC
- DIGITAL FILTERING *pat. pend.*  
Fastest Method to Reduce False Counts—No Loss of Sensitivity
- DIGITAL AUTO CAPTURE *pat. pend.*  
Auto Holds & Stores—Works Even Near Strong RF Fields

LCD BACK LIT DISPLAY  
Day/Night Visibility

FULL RANGE COUNTER  
Includes High Impedance 50ohm Amplifier for 10Hz and up Coverage

HI-TECH EXTRUDED ALUMINUM CABINETRY  
No Sheet Metal

ENVIRONMENTALLY SAFE  
No Soldered in NiCads

MADE IN THE USA



PC Data Logging with optional CX12 RS232 Converter (\$89.)

	3000A	M1
Digital Filter	•	•
Digital Auto Capture	•	•
Computer Interface (Serial TTL)	•	•
10 Digit LCD	•	•
Multi Function	•	•
Back Light	•	•
Battery Life	6-7 hrs	5-6 hrs
Range	10Hz - 3GHz	10Hz - 2.4GHz
Size	5.4' x 4'	3' x 5'
<b>OPTIONS</b>		
Back light	standard	standard
TCXO ± .2ppm	\$100.	\$100.
<b>PRICE</b>	<b>\$329.</b>	<b>\$229.</b>

**OPTOELECTRONICS**

Factory Direct Order Line  
**1-800-327-5912**

305-771-2050 • Fax 305-771-2052  
5821 NE 14th Ave, Ft. Lauderdale, FL 33334  
5% ship/ Handling (Max \$10) U.S. & Canada. 15% outside continental U.S.  
Visa, Master Card, C.O.D., Cash or Money Order only.

# KENWOOD

...pacesetter in Amateur Radio

# Venture

A new realm in HF communications



## TS-950SDX HF Transceiver

Offering superb TX/RX performance plus exceptional signal purity, Kenwood's TS-950SDX establishes a new benchmark for HF communications.

- Built-in DSP (digital signal processor)
- Dedicated Power MOS FET final section
- User-friendly menu system
- Automatic antenna tuner built-in
- AIP (Advanced Intercept Point) system
- Ultra-fine (1Hz) tuning

### • Super stability with reliability

The Power MOS FET final section is conservatively rated at 150W (40W in AM mode). This increases reliability and lowers distortion.

### • Wideband general coverage receiver

The TS-950SDX covers all Amateur bands from 160 to 10 meters. The receiver covers 100kHz to 30MHz.

### • 100 memory channels with multi-scan functions

Enabling independent storage of TX and RX parameters, the 100 memory channels may be scanned with such conveniences as programmable memory channel lock-out and continuous control of scan speed.

### • Built-in DSP

The digital signal processor replaces conventional analog circuitry for processing the TX signal in the SSB, CW, AM, and FSK modes. Reception is also enhanced: digital PSN detection and digital audio filtering help to eliminate interference and improve audio quality.

### • Power MOS FET final section

The TS-950SDX ranks as the first Amateur Radio transceiver to feature an FET final section. Superior linearity results in greatly improved TX performance.

### • Dual-frequency receive

The TS-950SDX can simultaneously receive two frequencies within 1MHz of each other. To facilitate split-frequency operations, front panel controls include M/S (main/sub) select and an RX • SUB key for instantly swapping the two frequencies. A 500Hz CW filter is included in the sub receiver.

KENWOOD COMMUNICATIONS CORPORATION  
AMATEUR RADIO PRODUCTS GROUP  
P.O. BOX 22745, 2201 E. Dominguez Street  
Long Beach, CA 90801-5745

KENWOOD ELECTRONICS CANADA INC.  
6070 Kestrel Road, Mississauga, Ontario, Canada L5T 1S8

©1995 KENWOOD

# COMMUNICATIONS QUARTERLY

THE JOURNAL OF  
COMMUNICATIONS  
TECHNOLOGY

## CONTENTS

Volume 3, Number 3

Summer 1993

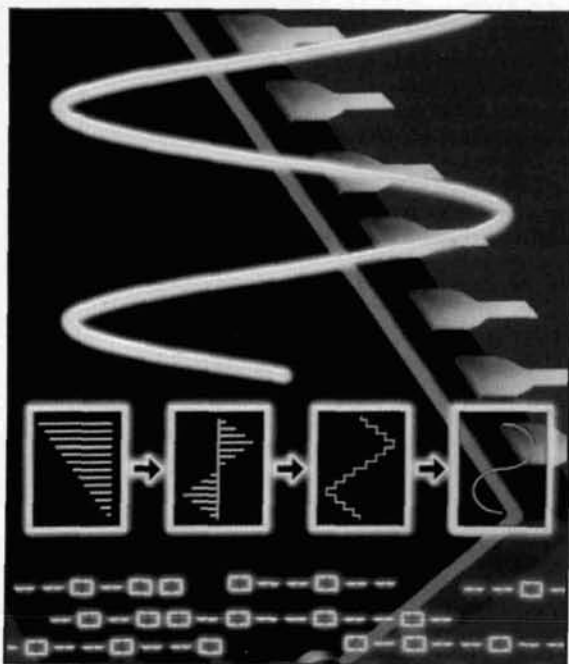

Bergeron, page 13

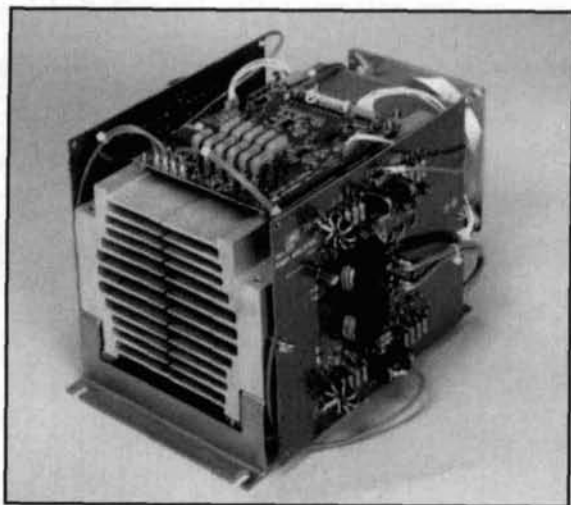

Tozawa, Sakaue, Takada, Furukawa, Takemura, page 53

- 13 Direct Digital Synthesis**  
*Bryan Bergeron, NU1N*
- 29 The Frequency Tunable Crystal Filter**  
*John Pivnichny, N2DCH*
- 36 The 12:1 Balun**  
*Jerry Sevick, W2FMI*
- 39 Wavelength Division Multiplexing**  
*Dr. H. Paul Shuch, N6TX*
- 43 The Excalibur DAP And The Digital Data System**  
*Rich Erlichman, ND4G*
- 49 The Solar Spectrum**  
*Peter O. Taylor*
- 53 HF MOSFET Linear Amplifier**  
*Yoji Tozawa, Hiroyuki Sakaue, Ken-ichi Takada, Koji Furukawa, Shinichiro Takemura*
- 63 Transmitting Short Loop Antennas For The HF Bands: Part 1**  
*Roberto Craighero, I1ARZ*
- 70 Technical Conversations**  
*Paul Jagnow, K0RLT; Albert E. Weller, WD8KBW; and Peter Bertini, K1ZJH*
- 73 Receiver Performance**  
*Jon A. Dyer B.A., G4OBU, VE1JAD*
- 89 Quarterly Devices**  
*Rick Littlefield, K1BQT*
- 99 Tech Notes**  
*Ron Badman, ZL1AI; Tom Powell, ZL1TJA; and Trevor King, ZL2AKW*

Cover photo: Enter the DDS zone—where frequency, phase, and waveform amplitude are defined digitally. Photo by Bryan Bergeron, NU1N.

## Getting Into The Loop

In the six years I've been editing amateur radio magazines, I have never received as many articles on loop antennas as I have in the past six months. Loops seem to be gaining popularity in the amateur community. Perhaps this is because more and more amateurs are being forced to find ways around community restrictions of more visible dipoles and beam antennas, or maybe it's because we now have a greater understanding of how to build them.

Compact HF transmitting loop antennas and active receiving loops are used widely in professional and military communications. Single and multi-turn transmitting loops are found in low-profile HF embassy and marine installations. During the Vietnam war, the U.S. Army also used a mobile loop for ground operations.<sup>1</sup>

In the amateur radio community, loop receiving antennas have been most popular over the years for use in radio direction finding activities. Such antennas have been used on hidden transmitter hunts, to locate pirate radio stations and jammers, and to track down sources of RFI or TVI. However despite the popularity of loops for reception of radio signals, amateurs are only just beginning to realize the value of loop antennas for transmitting purposes.

A loop is a closed-circuit antenna. It's made up of a conductor that's formed into one or more turns with the ends close together. There are two general classes of loop antennas: (a) those in which both the total conductor length and the maximum linear dimension of a turn are very small compared with the wavelength, and (b) those in which both the conductor length and the loop dimensions begin to be comparable with the wavelength.<sup>2</sup>

Electrically small loops are high-Q antennas with very narrow effective bandwidths. This high-Q characteristic, makes an excellent front-end filter for today's broadband receiver—reducing intermodulation distortion (IMD) from strong off-frequency signals. On transmit, these filtering properties reduce harmonic radiation dramatically.

Of course, most great ideas also present us with challenges. The loop antenna is no exception. It is very important when constructing a loop to overcome ohmic losses that will reduce efficiency. Poor-quality welds or the use of mechanical connectors between sections will lead to lossy outcomes. A single piece of tubing bent to the desired shape will provide a better antenna than several sections connected together as they are in square or octagonal loops.

A second challenge one faces when building

a loop antenna is to design a control system to tune it. Because the Q is so high, it's necessary to have a user-friendly tuning mechanism that can resolve 1000 or more settings over the tuning range of the antenna. Otherwise, it will be difficult to obtain accurate retuning for even small changes in frequency. Also, in order to prevent RF burns from the high RF voltage across the tuning capacitor, it is very important to use an automatic or remote-control tuner.

But these challenges notwithstanding, loop antennas can be excellent performers. Roberto Craighero, I1ARZ, whose work appears in this issue of *Communications Quarterly*, has been experimenting with small transmitting loops since 1985. In the February 1989 issue of *Radio Communications*, Roberto comments: "...a well-constructed loop at ground level can have a radiation efficiency close to that of a dipole antenna a half-wave above ground, and significantly better than a dipole less than a half-wave above ground." To generate more interest in loops, I1ARZ describes a transmitting short loop antenna for the HF bands. He has used this antenna successfully for the last few years, and has even made some record contacts while operating QRP.

For optimum efficiency and performance, Roberto used a rather expensive vacuum capacitor when building his antennas. However, he offers alternative designs using split-stator and butterfly capacitors for those who want to reduce their cost. Rick Littlefield, K1BQT, our "Quarterly Devices" author, found a third alternative made by a company in New Rochelle, New York—the PTFE dielectric tunable capacitor. See his column in this issue for details.

For those who want to try a loop, but don't want to build one, models are available from at least two amateur radio manufacturers. Although I haven't seen any of these antennas in action, I've heard reports indicating that they are highly efficient and easy to use. Should one come my way, I'll pass along my opinions. You see my shack doesn't sport a loop antenna...yet!

**Terry Littlefield, KA1STC**  
Editor

#### REFERENCES

1. Roberto Craighero, I1ARZ, "Electrically Tunable HF Loop," *Radio Communications*, February 1989, pages 38-42.
2. Gerald Hall, K1TD, Editor, *The ARRL Antenna Book*, American Radio Relay League, Newington, Connecticut, page 2-27.

#### EDITORIAL STAFF

**Editor**  
Terry Littlefield, KA1STC  
**Consulting Technical Editor**  
Robert Wilson, WA1TKH  
**Senior Technical Editor**  
Peter Bertini, K1ZJH  
**Assistant Editor**  
Nancy Barry

#### EDITORIAL REVIEW BOARD

Forrest Gehrke, K2BT  
Michael Gruchalla, P.E.  
Hunter Harris, W1SI  
Bob Lewis, W2EBS  
John Marion, W1QM  
Walter Maxwell, W2DU  
Jim McCulley, P.E.  
William Orr, W6SAI

#### BUSINESS STAFF

**Publisher**  
Richard Ross, K2MGA  
**Advertising Manager**  
Arnie Sposato  
**Sales Assistant**  
Tracy Walsh  
**Controller**  
Frank Fuzia  
**Circulation Manager**  
Catherine Ross  
**Data Processing Manager**  
Melissa Kehrwieler  
**Data Processing**  
Carol Licata  
**Customer Service**  
Denise Pyne

#### PRODUCTION STAFF

**Art Director**  
Elizabeth Ryan  
**Asst. Art Director**  
Barbara Terzo  
**Artist**  
Susan Reale  
**Electronic Composition Manager**  
Edmond Pesonen  
**Production Manager**  
Dorothy Kehrwieler  
**Photographer**  
Pat Le Blanc  
*A publication of*  
**CQ Communications, Inc.**  
76 North Broadway  
Hicksville, NY 11801-USA

**Editorial Offices:** P.O. Box 465, Barrington, NH 03825. Telephone/FAX: (603) 664-2515.

**Business Offices:** 76 North Broadway, Hicksville, NY 11801. Telephone: (516) 681-2922. FAX: (516) 681-2926.

*Communications Quarterly* is published four times a year (quarterly) by *CQ Communications, Inc.* Subscription prices: Domestic—one year \$29.95, two years \$56.95. Foreign—one year \$39.95, two years \$76.95. Foreign Air Mail—one year \$60.95, two years \$118.95. Contents copyrighted CQ Communications, Inc. 1993. *Communications Quarterly* does not assume responsibility for unsolicited manuscripts. Allow six weeks for change of address.

Second-class postage paid at Hicksville, NY and additional mailing offices.

**Postmaster:** Please send change of address to *Communications Quarterly*, CQ Communications, Inc., 76 North Broadway, Hicksville, NY 11801. ISSN 1053-9344.

# Get a Grip on Antenna Performance!

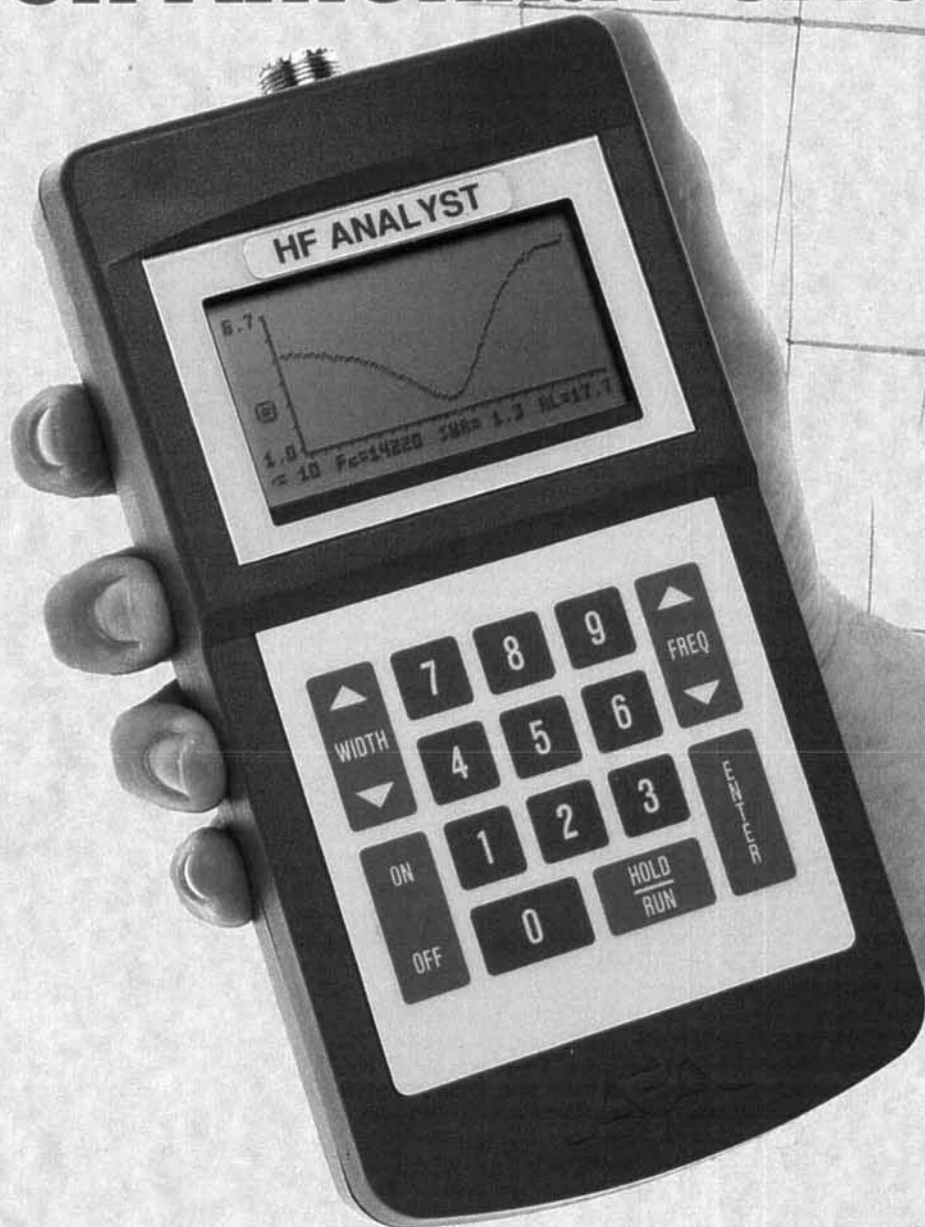

Better antenna performance is **finally** within reach! Now, with the SWR-121 Antenna Analyzer, you can see how your antenna is performing. Graphic display shows what's happening with your antenna's SWR over any frequency from 1 MHz to 32 MHz. Use the SWR-121 HF Antenna Analyst anywhere—up the tower, at a Field Day site, helping out a friend! Got a piece of co-ax

that you would like to test? Use the SWR-121 to measure the return/loss...no more guessing!

Optional software lets you view, save, and print SWR plots on your IBM compatible PC.

For more information on the SWR-121, call AEA's Literature Request Line at (800)432-8873 or contact your favorite ham radio equipment dealer.



*Connect with us*

# LETTERS

## On publishing program listings

Kudos: I just received my winter 1993 *Communications Quarterly*—a truly excellent issue. Particularly good: Bill Carver's "High-Performance Crystal Filter Design," Bob Brown's "Long Path Propagation," Jerry Sevick's latest balun article, Joe Carr's piece on small loops, Rick Littlefield's column on Collins filters, Peter Taylor's "The Solar Spectrum," Garry Shapiro's article on PK-232 filters, and Lloyd Butler's piece in "Tech Notes."

Opinion: I consider publishing program listings a waste of space. Magazines have done it since the dawn of the personal computer age, of course, yet typing in an error-free listing is tedious and difficult at best. One usually faces hours of debugging. I'll bet most fail to get the first one they try working, and never try again.

A spreadsheet program is a far easier to solve all but recursive problems. I'm not referring to spreadsheet macros, which is just another form of programming. I mean keeping it simple—just putting equations in cells.

Consider the program in Bill Carver's LC tester article. It's short enough to list in a magazine, but long enough to be tedious. Also, although Pascal is a fine, structured computer language, I'll wager not more than a few percent of your readers use it regularly. If so, assuming they even have Pascal on their computers, they'll do "nose-in-manual time." A few cells in a spreadsheet could produce the same results with a lot less strain and spreadsheets never crash, run out of memory, or have any problem printing.

Is use of a spreadsheet for technical calculations rare? If so, it might be a good article topic. If not, perhaps it's time to try spreadsheet listings instead of programs. Apart from being more "user-friendly," the practice would save space in the magazine.

**Dave Barton, AF6S**  
San Jose, California

## Look us up in Sweden

I'd like to congratulate your magazine, which publishes the highest high-tech ham radio related articles in the world. Last January, I visited the Swedish Space Physics Institute (Institutet för Rymdfysik, or IRF) in Kiruna, Sweden. Kiruna is located above the Arctic Circle, which is an ideal location for accessing polar orbit satellites. The researchers at IRF often relay information on satellite technology. I went there to assist a U.S. researcher, who is also a ham, KL7YR, and was investigating polar stratospheric clouds in relationship to the "thinning ozone layer." When I browsed the IRF's well-furnished technical library for something to read in English, it surprised me to find a current issue of *Communications Quarterly* on the shelf among the technical journals. However, there were no other ham radio magazines!

You've proven that your magazine has the same quality as professional technical journals. Please, keep up the good work.

**Nobuyuki Fujita, WB1Y**  
Hudson, Massachusetts

## Too much huffing and puffing

The article in the Spring 1993 issue on Yagi wind loads is interminable huffing and puffing about the obvious. In the worst case, which is equal element and boom drags, the standard method gives loads forty percent high. Fine with me. By standard methods, a real-life antenna like a TH6DXX has loads twenty percent high. That's fine, too.

Overestimation of loads is the aim of the game in conservative design. Who wants to come up short? Think about it: 17-odd pages to prove that the standard method does what it is supposed to do—overestimate. This result was known to start with and could have been shown in a page.

**Fred Grant, AA4NG**  
Newport News, Virginia

## Any comments?

With respect to Bob Vernal's, ZL2CA, method of estimating the total resistance of small radiating systems (*Communications Quarterly*, Spring 1993, "Tech Notes") it appears to me that the described method measures the total circuit resistance including the internal resistance of the generator as transformed by the matching network.

Consequently the transformed internal resistance of the generator is assumed to be equal to ("matched" to) the remaining circuit resistances, then the measured resistance is actually twice the true loss of the matching network and antenna system.

Could you or your readers comment?

**Albert E. Weller, WD8KBW**  
Columbus, Ohio

## An excellent article

"Determination of Yagi Wind Loads Using the 'Cross-Flow' Principle" (Spring 1993) was an excellent article, covering a subject which has created a lot of confusion both in the amateur community and the professional structural engineering fraternity.

Mr. Weber's remarks under the headings "The Challenge" and "Establishing the Standard" did not go unnoticed!

The article contained a lot of good information which we can all use. We shall use it to recalculate and restate our wind loads on our data sheet, at their next printing. Thanks for a task well done.

**Peter Onnigian, PE,**  
W6QEU  
Ham Pro Antennas  
Sacramento, California





CQ's new videos  
bring the exciting world of  
amateur radio into your  
living room!

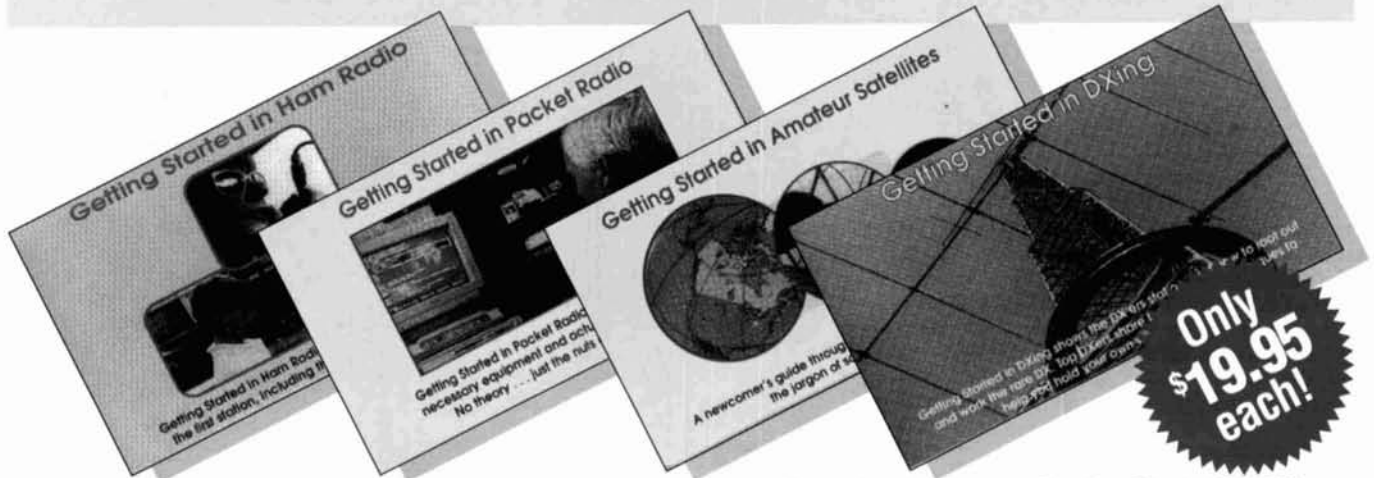

**Getting Started in Ham Radio.** The authoritative fast paced video introduction to the fascinating world of ham radio. Shows how to select equipment and antennas. How to use repeater stations for improved VHF coverage. The importance of grounding and the basics of soldering. How to get the most out of your station, whether it's home-based, mobile or hand held!

**Getting Started in Packet Radio.** This video will help de-mystify the exciting but sometimes confusing world of packet radio. Shows you how to get started in using your computer on the radio. Includes step-by-step instructions on making packet contacts and using packet bulletin boards, networks and satellites.

**Getting Started in Amateur Satellites.** Shows you how veteran operators set up their satellite stations and how to find and track ham satellites with ease. How to access current satellites and contact far ranging countries around the world. This video is filled with easy to understand advice and tips that can't be found anywhere else.

**Getting Started in DXing.** Top DXers share their experience on equipment, antennas, operating skills and QSL-ing. See hams work rare DX around the world. If you're new to DXing this video is for you. All the valuable information presented here may well give you the competitive edge you need to master the exciting world of DXing.

## The New CQ Video Library!

Now, for the first time, CQ brings you all our experience in an exciting new format. Our videos will help you get started and improve your existing skills in amateur radio with our informative, helpful and easy-to-follow instructional videos.

Whether you're a new ham or just getting started in Packet, Satellite or DXing we've got your video. Each tape gives you first-hand tips from hams who are on the air. You'll get advice from some of our hobby's most experienced users. They take you under their wing and show you just what it takes to get on the air!

Filled with step-by-step tips in setting up your first station, operating satellites, using packet radio, maximizing your DXing potential, these videos offer insights for beginners and experienced operators alike. You can order just the ones you want, or all four. It's up to you.

Send for your first video today and start growing now in the exciting and adventurous world of amateur radio!

**CQ Communications**  
76 North Broadway, Hicksville, New York 11801  
For Faster Service Call 516-681-2922 or FAX 516-681-2926

**NEW!**

# HAL Announces the PCI-4000 PC-CLOVER System

For Fast, Bandwidth-Efficient HF Data

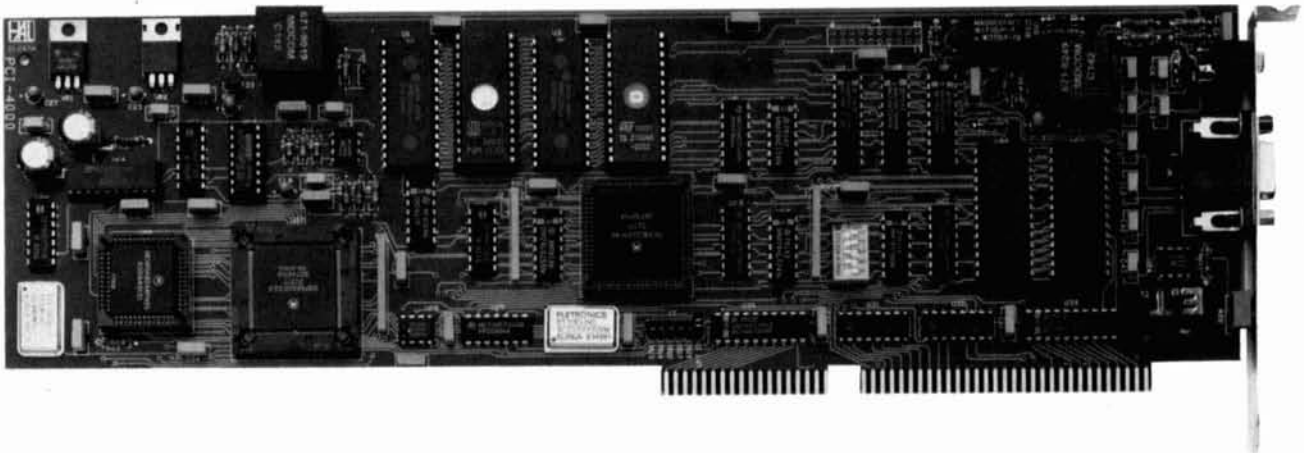

The PCI-4000 uses the latest development in HF data transfer methods—CLOVER-II. CLOVER-II is designed to maximize the amount of data which can be transferred in a narrow bandwidth over HF radio frequencies. It uses a combination of four tone frequencies with phase and amplitude modulation to achieve data transfer rates as high as 60 characters per second—about ten times faster than AMTOR. The PC-CLOVER system incorporates Reed-Solomon error correction, not simply a retransmission scheme. The PCI-4000 is a full-sized PC card which operates in a 80286-based PC or higher.

## The PCI-4000 PC CLOVER system features:

- ♣ Higher throughput than RTTY, AMTOR, Packet, or PACTOR on similar HF channel
- ♣ Simple pull-down menu operation
- ♣ Signal bandwidth of 500 Hz (@50 dB down)
- ♣ Plugs into your PC (286, 386SX, 386, or 486 machines)
- ♣ Easy interface to your transceiver
- ♣ Automatically adapts to HF band conditions
- ♣ Error correcting using Reed-Solomon error correction

You've read about it in the articles. Now you can operate CLOVER!  
Order your PC-CLOVER system today from HAL Communications Corp.

**PCI-4000 PC-CLOVER System      Only \$995.00**



HAL Communications Corp.  
P.O. Box 365  
Urbana, IL 61801  
Phone (217) 367-7373  
FAX (217) 367-1701



# When we talked to technicians about servicing radios, they told us they were too busy to talk.

Now the new HP 8920A RF Communications Test Set solves test problems in less time, so you have more.

- Easy-to-use front panel
- Optional full-feature spectrum analyzer
- Rugged portable package
- Built-in computer with optional software for FM, cellular mobile and base station testing.
- Price \$13,800



**Keeping you ahead in communications.**

For more information call: **1-800-344-3802** and ask for Charlie or Ken.



## Announcing . . . The Latest Additions to CQ's Book Library

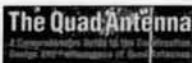

**The Quad Antenna**, by Bob Haviland, W4MB. This is *the definitive* technical book on the design, construction, performance and application of Quad Antennas. Take advantage of over 20 years of research with this practical volume.

Only \$15.95 each



**Packet Radio Operator's Manual**, by CQ columnist and Amateur Radio Packet authority Buck Rogers, K4ABT. This new guide to packet operation is ideal whether you're an advanced user or just starting out. Wiring schematics for nearly every combination of controller/radio/computer are also included.

Only \$15.95 each



**Ham Radio Horizons**, by Peter O'Dell, WB2D. This book is the ideal introduction to amateur radio. You'll quickly learn about ham radio in simple terms that everyone can understand. It's a perfect complement to your club's amateur licensing programs and makes a great gift for the would-be ham.

Only \$12.95 each

CQ's new books are a fantastic addition to your amateur library. Whether you want to learn more about packet radio, discover the trade-offs between quads and yagis, or introduce someone to ham radio, we have the book for you.

**SEND FOR YOUR BOOKS TODAY!**

Please add \$3.50 shipping & handling for each book.

**For fastest service, call our order department at (516) 681-2922!  
Or Write: CQ Communications, 76 North Broadway, Hicksville, New York 11901  
FAX: 516-681-2926**

## ASTRON POWER SUPPLIES

• HEAVY DUTY • HIGH QUALITY • RUGGED • RELIABLE •



MODEL VS-50M

### SPECIAL FEATURES

- SOLID STATE ELECTRONICALLY REGULATED
- FOLD-BACK CURRENT LIMITING Protects Power Supply from excessive current & continuous shorted output
- CROWBAR OVER VOLTAGE PROTECTION on all Models except RS-3A, RS-4A, RS-5A, RS-4L, RS-5L
- MAINTAIN REGULATION & LOW RIPPLE at low line input Voltage
- HEAVY DUTY HEAT SINK • CHASSIS MOUNT FUSE
- THREE CONDUCTOR POWER CORD except for RS-3A
- ONE YEAR WARRANTY • MADE IN U.S.A.

### PERFORMANCE SPECIFICATIONS

- INPUT VOLTAGE: 105-125 VAC
- OUTPUT VOLTAGE: 13.8 VDC ± 0.05 volts (Internally Adjustable: 11-15 VDC)
- RIPPLE Less than 5mv peak to peak (full load & low line)
- All units available in 220 VAC input voltage (except for SL-11A)

### SL SERIES



### • LOW PROFILE POWER SUPPLY

MODEL	Colors		Continuous Duty (Amps)	ICS* (Amps)	Size (IN) H x W x D	Shipping Wt. (lbs.)
	Gray	Black				
SL-11A	•	•	7	11	2 3/4 x 7 3/8 x 9 3/4	12
SL-11R	•	•	7	11	2 3/4 x 7 x 9 3/4	12
SL-11S	•	•	7	11	2 3/4 x 7 3/8 x 9 3/4	12
SL-11R-RA	•	•	7	11	4 3/4 x 7 x 9 3/4	13

### RS-L SERIES



### • POWER SUPPLIES WITH BUILT IN CIGARETTE LIGHTER RECEPTACLE

MODEL	Continuous Duty (Amps)	ICS* (Amps)	Size (IN) H x W x D	Shipping Wt. (lbs.)
RS-4L	3	4	3 1/2 x 6 1/8 x 7 1/4	6
RS-5L	4	5	3 1/2 x 6 1/8 x 7 1/4	7

### RM SERIES



MODEL RM-35M

### • 19" RACK MOUNT POWER SUPPLIES

MODEL	Continuous Duty (Amps)	ICS* (Amps)	Size (IN) H x W x D	Shipping Wt. (lbs.)
RM-12A	9	12	5 1/4 x 19 x 8 1/4	16
RM-35A	25	35	5 1/4 x 19 x 12 1/2	38
RM-50A	37	50	5 1/4 x 19 x 12 1/2	50
RM-60A	50	55	7 x 19 x 12 1/2	60
• Separate Volt and Amp Meters				
RM-12M	9	12	5 1/4 x 19 x 8 1/4	16
RM-35M	25	35	5 1/4 x 19 x 12 1/2	38
RM-50M	37	50	5 1/4 x 19 x 12 1/2	50
RM-60M	50	55	7 x 19 x 12 1/2	60

### RS-A SERIES



MODEL RS-7A

MODEL	Colors		Continuous Duty (Amps)	ICS* (Amps)	Size (IN) H x W x D	Shipping Wt. (lbs.)
	Gray	Black				
RS-3A	•	•	2.5	3	3 x 4 3/4 x 5 3/4	4
RS-4A	•	•	3	4	3 3/4 x 6 1/2 x 9	5
RS-5A	•	•	4	5	3 3/4 x 6 1/8 x 7 1/4	7
RS-7A	•	•	5	7	3 3/4 x 6 1/2 x 9	9
RS-7B	•	•	5	7	4 x 7 1/2 x 10 3/4	10
RS-10A	•	•	7.5	10	4 x 7 1/2 x 10 3/4	11
RS-12A	•	•	9	12	4 1/2 x 8 x 9	13
RS-12B	•	•	9	12	4 x 7 1/2 x 10 3/4	13
RS-20A	•	•	16	20	5 x 9 x 10 1/2	18
RS-35A	•	•	25	35	5 x 11 x 11	27
RS-50A	•	•	37	50	6 x 13 3/4 x 11	46
RS-70A	•	•	57	70	6 x 13 3/4 x 12 1/2	48

### RS-M SERIES



MODEL RS-35M

MODEL	Continuous Duty (Amps)	ICS* (Amps)	Size (IN) H x W x D	Shipping Wt. (lbs.)
• Switchable volt and Amp meter				
RS-12M	9	12	4 1/2 x 8 x 9	13
• Separate volt and Amp meters				
RS-20M	16	20	5 x 9 x 10 1/2	18
RS-35M	25	35	5 x 11 x 11	27
RS-50M	37	50	6 x 13 3/4 x 11	46
RS-70M	57	70	6 x 13 3/4 x 12 1/2	48

### VS-M AND VRM-M SERIES



MODEL VS-35M

- Separate Volt and Amp Meters • Output Voltage adjustable from 2-15 volts • Current limit adjustable from 1.5 amps to Full Load

MODEL	Continuous Duty (Amps)			ICS* (Amps)	Size (IN) H x W x D	Shipping Wt. (lbs.)
	@13.8VDC	@10VDC	@5VDC			
VS-12M	9	5	2	12	4 1/2 x 8 x 9	13
VS-20M	16	9	4	20	5 x 9 x 10 1/2	20
VS-35M	25	15	7	35	5 x 11 x 11	29
VS-50M	37	22	10	50	6 x 13 3/4 x 11	46
• Variable rack mount power supplies						
VRM-35M	25	15	7	35	5 1/4 x 19 x 12 1/2	38
VRM-50M	37	22	10	50	5 1/4 x 19 x 12 1/2	50

### RS-S SERIES



MODEL RS-12S

- Built in speaker

MODEL	Colors		Continuous Duty (Amps)	ICS* Amps	Size (IN) H x W x D	Shipping Wt. (lbs.)
	Gray	Black				
RS-7S	•	•	5	7	4 x 7 1/2 x 10 3/4	10
RS-10S	•	•	7.5	10	4 x 7 1/2 x 10 3/4	12
RS-12S	•	•	9	12	4 1/2 x 8 x 9	13
RS-20S	•	•	16	20	5 x 9 x 10 1/2	18
SL-11S	•	•	7	11	2 3/4 x 7 3/8 x 9 3/4	12



**The new R-2550.**  
COMMUNICATIONS SYSTEM ANALYZER

**SPECIAL INTRODUCTORY PRICE**

## At only \$8695, it produces like a money tree.

In today's economy, your shop needs maximum value – top performance at lower cost.

Motorola introduces the R-2550, with the combination of performance features you need – variable level duplex generator

- auto calibrated spectrum analyzer
- auto calibrated field strength meter
- large (7" diagonal) CRT
- digital storage oscilloscope
- dozens of additional features – all at a price that will make you think you planted a money tree.

For information, call:

**1-800-235-9590**

Or write P.O. Box 2606  
Scottsdale, AZ 85252



**MOTOROLA**

*Quality means the world to us.™*



# JRL-2000F

## Fully Automatic MOSFET HF LINEAR AMPLIFIER

- 1 kW NO-TUNE POWER AMPLIFIER
- 48 MOSFET'S SINGLE ENDED PUSH-PULL (SEPP) DESIGN
- BUILT-IN AUTOMATIC ANTENNA TUNER
- HIGH-EFFICIENCY SWITCHING POWER SUPPLY



The JRL-2000F is the world's first MOSFET HF linear amplifier, designed using the same high technology found in JRC's professional high-power radio transmitters. Featuring a heavy-duty power amp that incorporates 48 RF power MOSFETs to ensure low distortion and clean output up to 1,000 watts (100% duty cycle, 24 hour) SSB/CW, plus a

high-speed automatic antenna tuner with memory capacity of 1820 channels for instant QSY. Plus a high efficiency switching power supply (80V-264V) with power factor correction to suppress AC line currents, an automatic antenna selector for up to four antennas and a wireless remote control unit.



*Japan Radio Co., Ltd.*

430 Park Ave, 2nd Floor New York, NY 10022

Phone: (212)355-1180 Fax: (212)319-5227

Telex: 961114 JAPAN RADIO NYK

# DIRECT DIGITAL SYNTHESIS

## *An introduction*

---

Communications involves the exchange of information. Communications engineers and amateur radio enthusiasts share a common goal in striving for systems that are compact, affordable, and provide ergonomic features. The modern communications transceiver is indicative of this trend. In most of these transceivers, the digital processing tasks are performed by analog hardware; however high-end systems are increasingly dependent on digital techniques, because of the superior performance and flexibility they provide.<sup>1</sup> In addition, the use of digital hardware, often in a hybrid design that also uses analog hardware, promises cost savings due to a reduced component count and easier assembly. The absolute repeatability from unit to unit is a major advantage of digital techniques. Furthermore, the move from analog to digital promises greater versatility, because circuit functionality can be redefined in software. In many instances, digital methods can be used to provide features not practical with purely analog electronics. Some examples are real-time video and speech coding and compression.<sup>2</sup>

Although an affordable all-digital communications transceiver is still some way off, virtually all modern transceivers are analog and digital hybrids. Microprocessor control of transceiver operation is now common on all but the most inexpensive units. User-definable audio and IF filters, based on digital signal processing (DSP) techniques, have also become popular.

Direct digital synthesis, or DDS, is perhaps the most exciting digital technology to filter down to the level of communications equipment. DDS is a method by which the frequency, phase, and amplitude of a waveform are defined digitally. In this article, I'll examine Direct Digital Synthesis in light of current competing and complementary analog technologies,

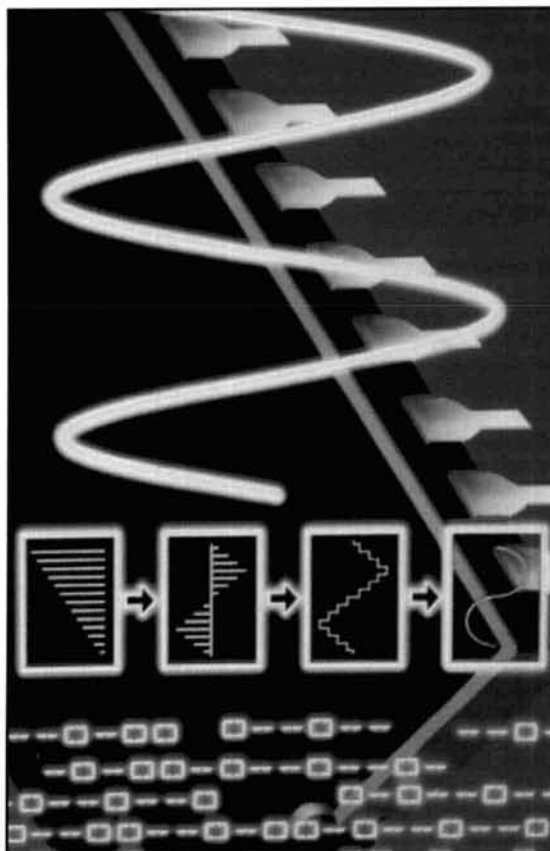

and explore the promise DDS holds for the future of communications.

## Frequency synthesis

Carrier generation is a fundamental feature of virtually all RF communications. For example, superheterodyne receivers rely on a variety of oscillators or synthesizers for their operation, as do the simplest RF transmitters. In order to evaluate the relative merits of DDS, it may be

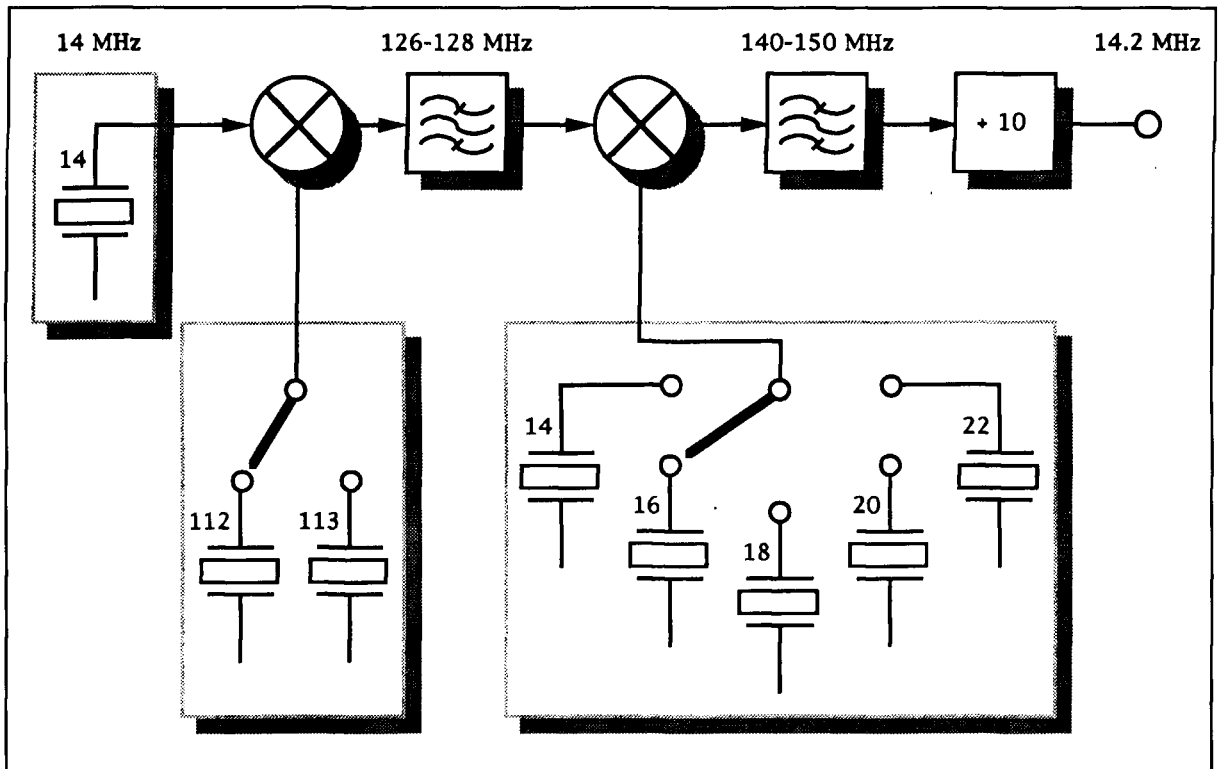

Figure 1. Direct analog synthesis (DAS) relies on a combination of mixing, filtering, and dividing to generate a particular output frequency. With the 112 and 16-MHz crystal oscillators selected, the output frequency is  $(14 + 112 + 16) \text{ MHz}/10$  or 14.2 MHz. All values are shown in MHz.

useful to review the characteristics of the more conventional methods of generating an RF carrier. These include: physical size, cost, stability, spectral purity, tuning capability, switching speed, and circuit complexity.

## LC oscillators

LC oscillators provide excellent tuning capabilities, and can generate any frequency within their tuning range. Unfortunately, these analog oscillators have generally poor mechanical, temperature, and long-term stability.<sup>3</sup> Although the spectral purity of an LC oscillator can be relatively good, it's limited by the Q of the tuned circuit. A high Q is difficult to attain at HF with miniature components; a Q on the order of 100 is good. Spectral purity can be excellent at VHF and above if cavity resonators with Qs of thousands are used.

## Crystal oscillators

In contrast to LC oscillators, crystal oscillators exhibit good stability and generally excellent spectral purity. The penalties for these features include increased cost and a fixed output frequency. The frequency of a crystal oscillator

can be adjusted *slightly*, as in a variable-frequency crystal oscillator, or VXO, but stability will suffer.

The spectral purity of crystal oscillators can be attributed to their Qs, which can approach  $10^6$ . The output frequency of crystal oscillators tends to decrease continuously with time, on the order of 0.1 to 10 parts per million (ppm) per year. This aging, due to the gradual relief of strains on the crystal, is most pronounced during the first few months of service. Once a crystal oscillator has gone through the initial aging, frequency stability is generally on the order of a few ppm when operated over normal temperature ranges with a stable supply voltage.

The long-term stability of crystal oscillators can be enhanced by operating the crystals in a constant temperature oven. Temperature compensated crystal oscillators or TCXOs can deliver stabilities of 0.1 ppm over the range of 0°C to 50°C.<sup>3</sup> Both TCXOs and uncompensated crystal oscillators are available in compact modules, ranging in size from DIP packages to standard transistor cans.

## Variable frequency oscillators

Variable frequency oscillators (VFOs) share many of the traits of LC oscillators and VXOs.



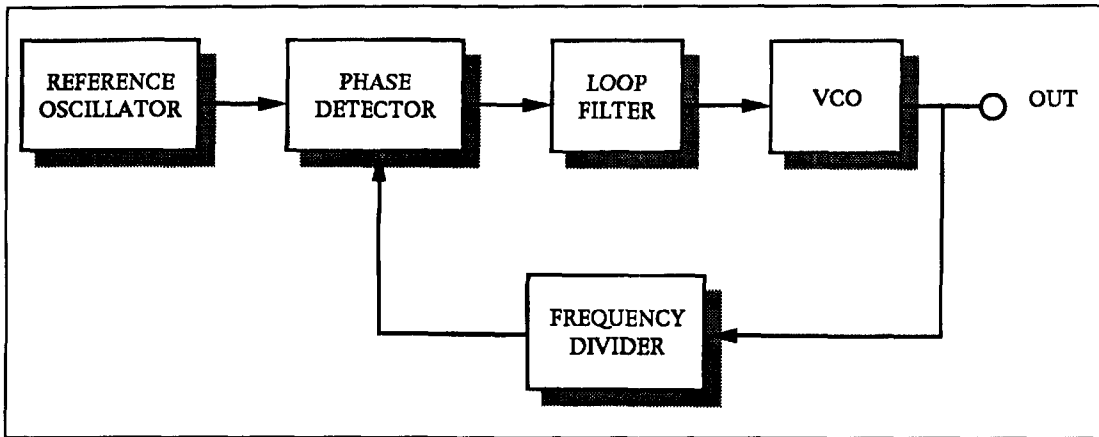

Figure 2. Components of a basic PLL synthesizer include a reference oscillator, phase detector, loop filter, voltage-controlled oscillator (VCO), and frequency divider.

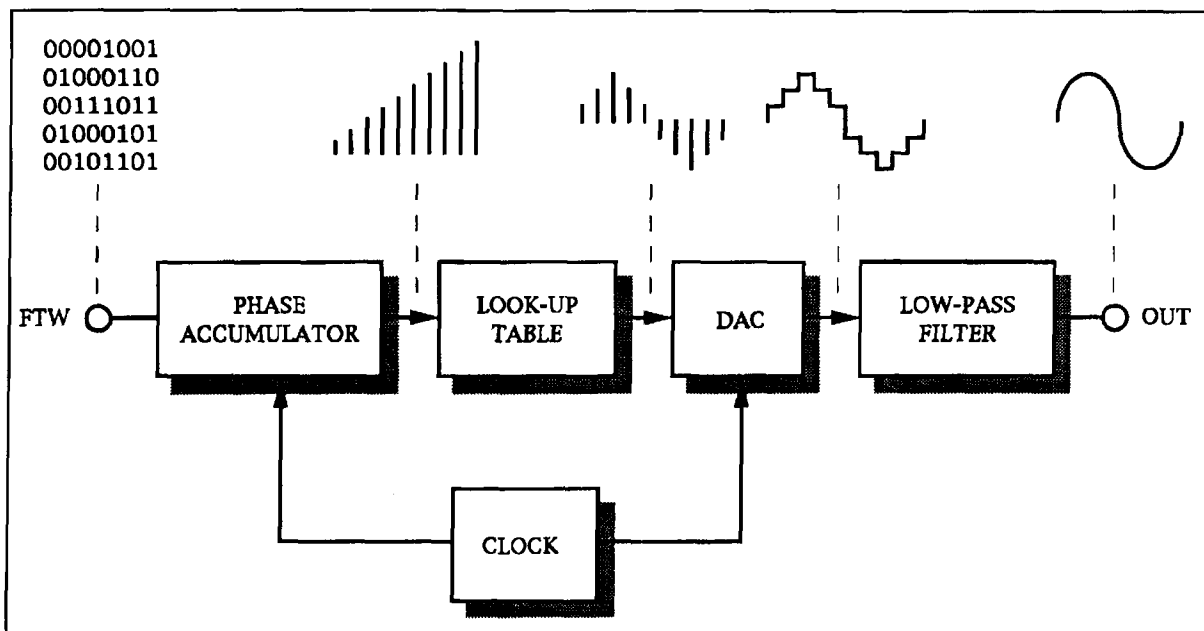

Figure 3. A basic DDS synthesizer consists of a stable clock source, a phase accumulator, a sine look-up table, a digital-to-analog converter (DAC), and a low or bandpass filter. The digital frequency tuning word (FTW) defines the linear phase increment to be output by the phase accumulator that's translated into an amplitude change by the look-up table. The digital amplitude change data is converted into an analog waveform by the digital-to-analog converter (DAC). Noise and harmonics in the DAC output are suppressed by the output filter.

This is partly because VFOs resemble VXOs in which the crystals have been replaced by inductors and capacitors. Although VFOs can provide relatively broad frequency coverage, they are susceptible to instabilities arising from mechanical, thermal, and electrical stresses. Because any change in VFO component spacing or shape results in a frequency shift, VFOs must be built to withstand the vibration, temperature variations, and chassis stress associated with routine operation. All components must have substantial inherent rigidity, and must be mounted securely to avoid frequency shifts. Materials used to construct the VFO must be

selected to minimize thermal instability.

The electrical stability of a VFO is a function of the components used in the construction of the unit. For example, ordinary disc ceramic capacitors have no place in VFO design. However polystyrene capacitors are often used in VFO design because their thermal characteristics tend to cancel those of the inductors, resulting in excellent frequency stability. VFOs are also sensitive to load variations, and require a buffer stage to isolate the VFO from a load that may vary and cause phase shifts. VHF parasitic oscillations also plague VFOs. This common source of VFO noise can be minimized by

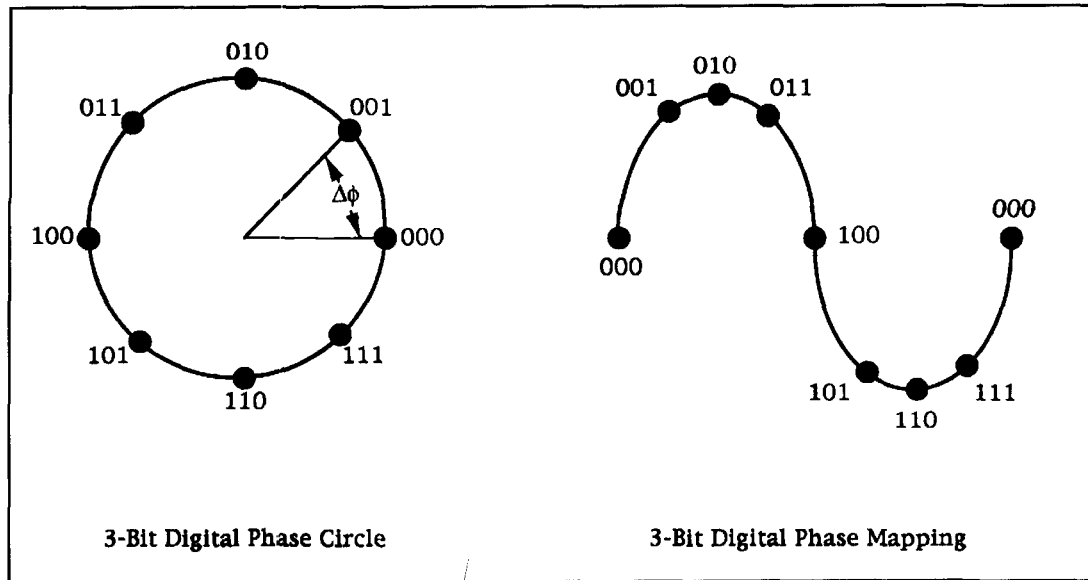

Figure 4. As shown in the phase circle (left), the phase change for a sinewave of fixed frequency is a linear function of time. In this example, the granularity of phase change mapping is limited by the 3-bit binary representation to 8 points along the sinewave. For a given clock frequency, a phase accumulator with a bit size greater than 3 bits would provide greater frequency resolution (see Figure 5).

judicious filtering and using the shortest possible signal leads.

## Direct analog synthesis

Direct analog synthesis (DAS) is an early attempt at realizing the tuning capabilities of LC oscillators, together with the stability and spectral purity of crystal oscillators, albeit in a brute-force fashion. As Figure 1 illustrates, DAS relies on a combination of mixing, filtering, and dividing in order to generate a particular output frequency. The system is called direct synthesis because ultimately the output frequency is obtained directly from one master crystal oscillator.

If you look at Figure 1, you'll notice that the DAS output frequency is virtually the same as the input frequency, but resolution has been increased by a factor of ten. This makes 100-kHz steps possible. In this example, the use of the 112-MHz crystal oscillator in the first crystal bank provides output frequencies of 14.0, 14.2, 14.4, 14.6, and 14.8-MHz, depending on the crystal oscillator selected in the second crystal bank. Using the 113-MHz crystal oscillator in the first crystal bank, outputs of 14.1, 14.3, 14.5, 14.7, and 14.9 MHz are possible. With the settings shown, the output frequency is  $((14 + 112 + 16)\text{MHz}/10)$ , or 14.2 MHz.

The addition of a second, identical block of crystal oscillators, filters, and mixers that accepts as its input the output of the block shown in Figure 1, would increase frequency output resolution again by a factor of ten. This

configuration would provide an output range of 14.00 to 14.90 MHz in 10 kHz increments. Any desirable resolution can be attained by cascading additional blocks. The divide by 10 stage at the DAS output not only provides the proper output frequency, but also reduces spurious noise generated by the mixing process.

A variant of DAS, single crystal synthesis, relies on a single crystal oscillator to generate, through frequency multiplication and division, all the frequencies used in the mixing process. Although this design only provides for a relatively small number of output frequencies, frequency changes are on the order of milliseconds and, as in DAS, these changes can be computer controlled.

Direct synthesis offers high spectral purity—frequency switching times on the order of only a few microseconds, at whatever frequency resolution is required. For example, commercial DAS signal generators can provide signals with a 1-Hz resolution over a 1-GHz range, with spurious output 100 dB down from the main output. The penalties for such impressive specifications include size and, of course, cost.

## Phase-locked loop (PLL) synthesizers

Not only is the phase-locked loop (PLL) system of frequency synthesis the most often used method of carrier generation in communications equipment, but it also has a variety of other uses. These range from tone decoding to demodulation of both AM and FM signals and

pulse synchronization. The PLL synthesizer's popularity stems from a number of features: synthesizer output frequency can be defined digitally, the output is available in linear frequency steps, and the output frequency accuracy mirrors that of the highly stable crystal reference oscillator. The digital frequency control of PLL synthesizers allows a number of desirable user-interface features, including automated scanning and tuning, as well as the provision for memory channels. Furthermore, the traditional manual control characteristic of analog VFOs can be reproduced through the use of rotary optical encoders.

As illustrated in **Figure 2**, a basic PLL synthesizer consists of a reference oscillator, phase detector, loop filter, voltage-controlled oscillator (VCO), and frequency divider. The reference oscillator is most commonly based on a crystal oscillator for maximum accuracy and long-term stability. The phase detector compares two input signals, and generates an output based on their phase difference. The output of the phase detector is filtered by the loop filter, typically a simple RC low-pass filter, before being fed to the VCO control port. This phase-error signal is used to vary the frequency of the VCO so it deviates in the direction of the input frequency. The goal is to adjust the output of the frequency divider so it's on the same frequency as the reference oscillator. With proper PLL design, this feedback loop locks the VCO into maintaining a fixed phase relationship between the VCO output and the reference oscillator output. The output of this locked VCO serves as the synthesizer output.

The tradeoffs associated with PLL synthesizers include relatively poor frequency resolution, extended settling or lock-up time, and sometimes poor spectral purity. In addition, these three factors are closely interrelated. For example, channel frequency spacing is limited

to the reference oscillator frequency. In other words, the frequencies available at the PLL synthesizer output are  $f_r N$ , where  $f_r$  is the reference oscillator frequency and  $N$  is the integer value of the frequency divider, within the operating range of the VCO. For small channel spacings, the reference oscillator can be fed through a second fixed divider before being applied to the phase detector. However, corrections at the output of the phase detector are generated just once every cycle of the reference oscillator signal, so there is a practical limit to the lowest usable reference oscillator frequency. In the simple PLL synthesizer design in **Figure 2**, settling time is inherently related to the frequency resolution. More complex variations of this PLL synthesizer design (mixer PLLs and two-loop synthesizers, for instance) can be used to provide output with adequate resolution in the HF through VHF range.<sup>4</sup>

Although the long-term stability of a PLL synthesizer is essentially equal to that of the reference oscillator, the short-term stability is a function of the VCO and loop filter designs. VCO stability is critical. A VCO with poor inherent stability will produce phase noise around the VCO output frequency. Phase noise can be reduced by increasing the  $Q$  of the VCO (e.g., by using a crystal as the VCO resonator element) and by reducing the time constant of the loop filter. Unfortunately, using a crystal to increase stability, as in a voltage controlled crystal oscillator (VCXO), severely limits the range of possible output frequencies. Also, it may not be possible to shorten the time constant of the loop filter in an attempt to decrease acquisition and settling time. The time constant of the loop filter must be long enough to attenuate the two input frequencies and the sum frequency from the phase detector. In general, actions aimed at reducing PLL phase noise tend to compromise the overall PLL design. For

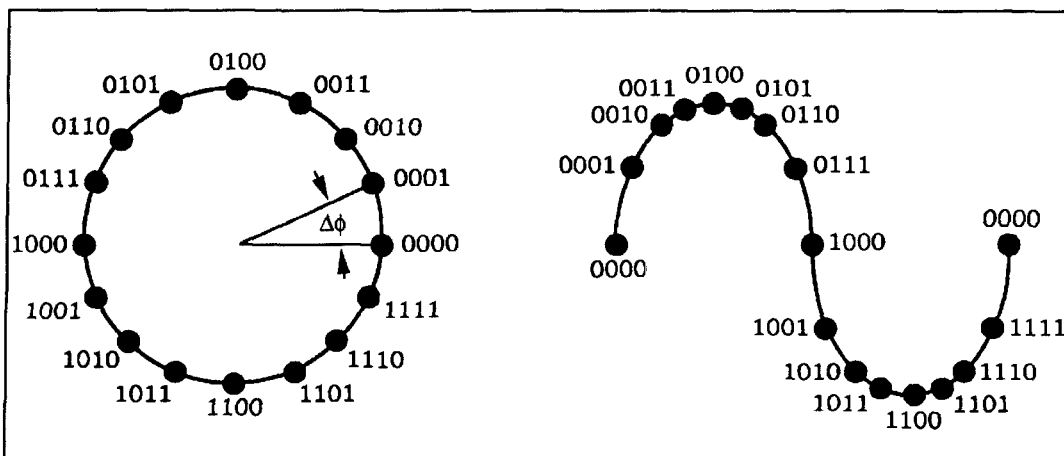

**Figure 5.** A phase accumulator with a bit size of 4 can represent a sinewave with twice the frequency resolution of an accumulator with a bit size of only 3 bits, assuming identical clock frequencies (see *Figure 4*).

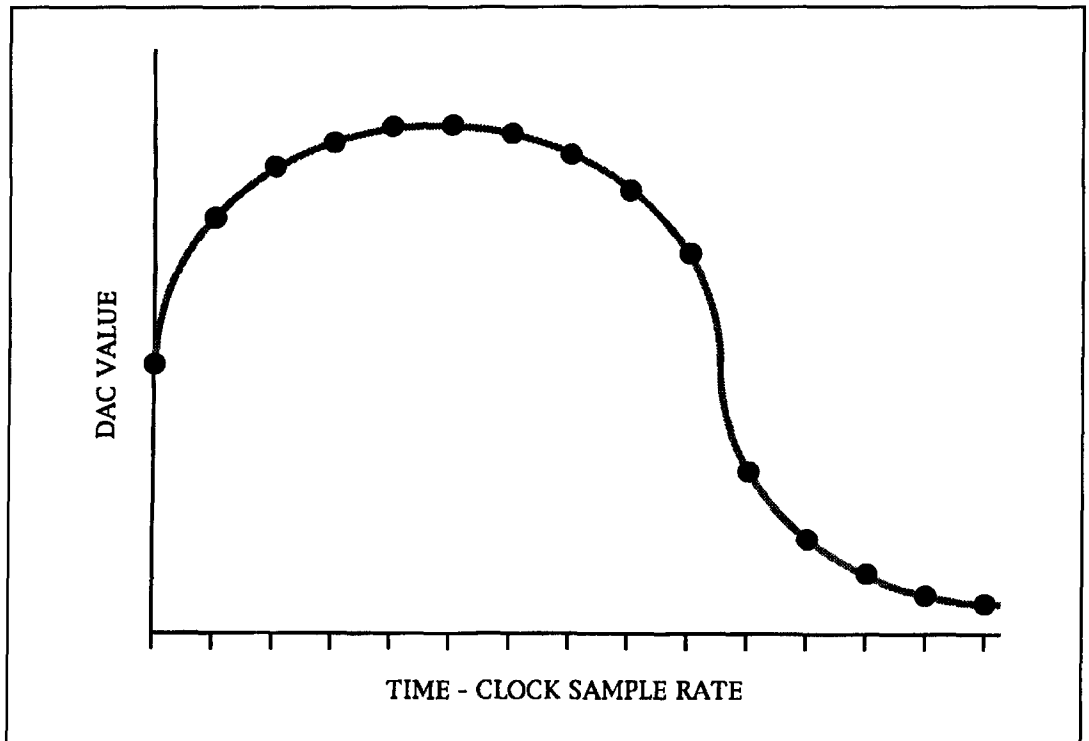

Figure 6. For a given clock frequency and phase accumulator bit size, taking fewer (larger) phase jumps increases the synthesizer output frequency. Similarly, taking more (smaller) phase jumps decreases output frequency. In this example, taking relatively frequent, smaller phase jumps, results in a relatively low DAC output frequency. Compare with Figures 7 to 9. Note that, for the sake of clarity, these figures show the digital DAC input values, and not the raw phase accumulator output values.

example, lower phase noise can be realized by accepting either longer settling times or coarser frequency resolution.

Synthesizer noise, which is a limitation of PLL synthesizers, appears both as unwanted sidebands close to the desired output signal and as broadband noise that may extend some distance from the output frequency. Some noise can be attributed to the various oscillators in the synthesizer. This source of noise can be minimized by careful shielding, filtering of the power and control leads, and judicious selection of the mixing frequencies. Also troublesome is the phase noise generated by the random difference of the phase between the synthesizer output and a sinewave of the same frequency. For example, it's difficult to prevent some of the comparison frequency signal from reaching the VCO, where it produces sidebands on the VCO output at the reference frequency and its harmonics.<sup>4</sup>

Because of the interrelated limitations of settling time, frequency resolution, and spectral purity associated with PLL synthesizers, engineers have looked to other technologies. This brings us to the next step in the evolutionary path of carrier frequency generation—an all-digital scheme that may be realizable on a single chip—direct digital synthesis.

## Direct digital synthesis

A direct digital synthesizer (sometimes referred to as a numerically controlled oscillator, or NCO) minimally consists of a circuit that generates the output frequency directly from a stable system clock and digital input data. As shown in Figure 3, the components of a basic DDS synthesizer include a stable clock source, a phase accumulator, a sine look-up table, a digital-to-analog converter (DAC), and a low or bandpass filter. Some manufacturers produce DDS chips that contain all but the clock and low-pass filter; others require an external DAC as well. Provision for an external DAC gives the designer more flexibility. For instance, a cheaper DAC may be substituted for a more expensive one if the synthesizer will only be used at low frequencies. However, for VHF and above work, external DACs aren't feasible due to the delays and skew that would be produced by the longer data lines.

DDS involves the stepped, digital integration of a phase increment to produce a sinewave output at a given frequency, as suggested by the data samples along the top of Figure 3. This phase increment determines how many clock cycles elapse for every cycle of the output frequency. The integration involves adding the

phase increment via an accumulator at each cycle of the clock frequency. The continuously increasing phase is transformed to a digital representation of a sinewave, usually by a look-up table in ROM, and this representation is converted to an approximation of a sinewave by a DAC. A low or bandpass filter is required to smooth the output into a continuous sinewave. Armed with this brief, high-level description of DDS, let's examine each component of a typical system in more detail.

## System clock

As in virtually all digital systems, the system clock in a DDS synthesizer limits the throughput of the system; that is, the status of the system can change only on the rise or fall of the clock signal. The basis for the system clock is generally a crystal oscillator because of the simplicity, compactness, and, most importantly, stability it affords. The stability of the system clock is a major factor in the generation of spurious responses, especially phase noise.

Because the output frequency is ultimately generated from the system clock, the Nyquist limit dictates that the clocks in DDS systems operate at no less than twice the output frequency. Additional practical constraints, such as the need to minimize the spurious output of the system, necessitate even higher clock fre-

quencies—for instance, three times the desired output frequency.

## Phase accumulator

The phase accumulator is a digital counter with memory that defines the instantaneous phase point of the signal to be synthesized. On every clock cycle, the accumulator adds a value, defined by the frequency tuning word (FTW), to the value already stored in the accumulator's memory. Normally, the FTW is changed only when the output frequency is to be changed. When the bit size capacity of the accumulator is exceeded, the phase accumulator overflows and the count begins again.

The output of the phase accumulator represents the instantaneous *phase values* for the synthesized signal. As illustrated in **Figures 4** and **5**, the phase change for a sinewave of fixed frequency is a linear function of time. This phase linearity is most obvious in the phase circle depictions.

As described by the relationship in **Equation 1**, the output frequency of a DDS system is a function of the clock frequency, the phase accumulator bit size, and the phase jump size—as defined by the FTW.<sup>5</sup>

$$\text{frequency} = \frac{\text{phase jump size} \times \text{clock frequency}}{2^{(\text{accumulator bit size})}}$$

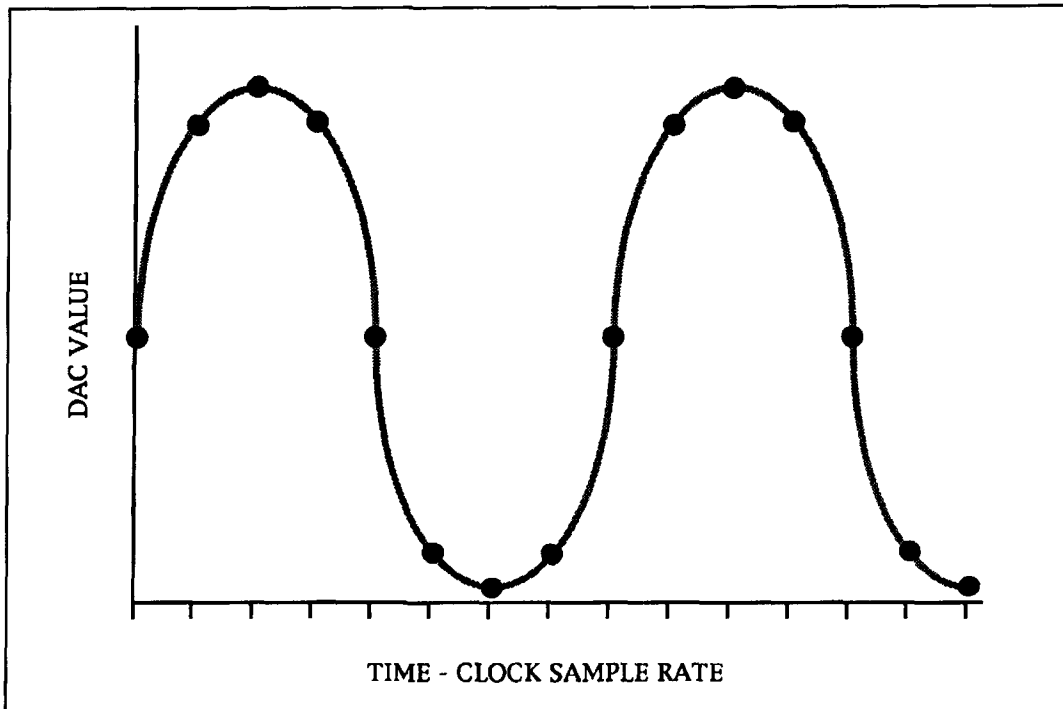

Figure 7. Increasing the relative size of DAC phase jumps (and therefore making jumps less frequently) results in a relatively higher output frequency. Compare with *Figure 6*.

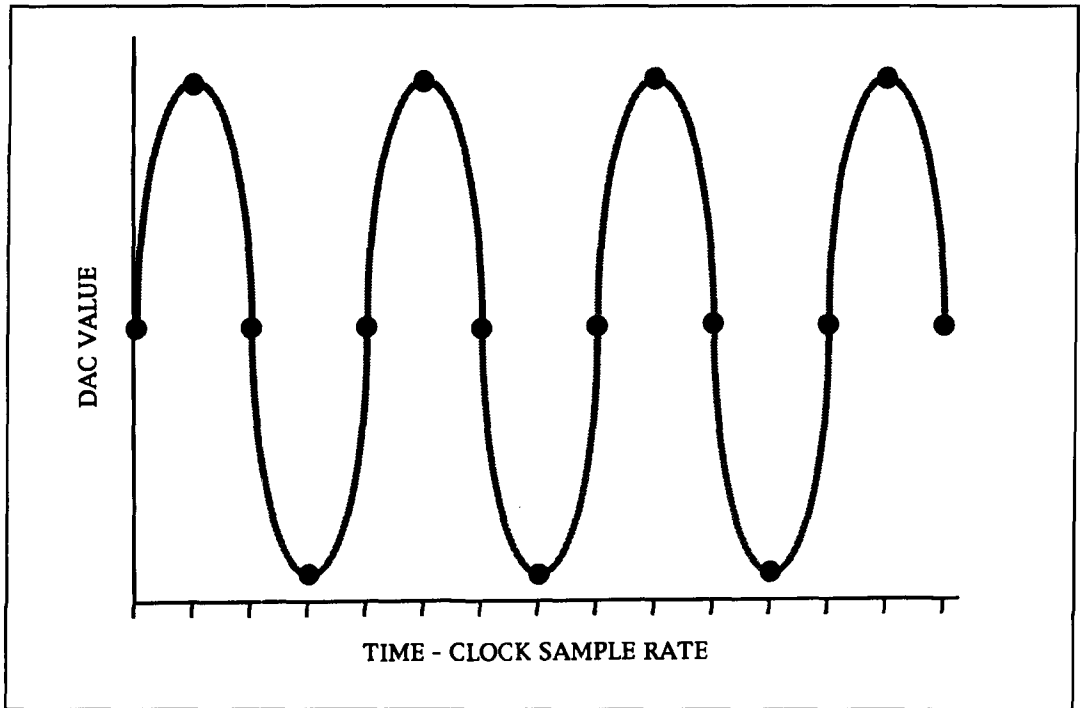

Figure 8. Further increasing the relative size of DAC phase jumps, and decreasing jump frequency, results in a relatively higher output frequency. Compare with *Figures 6 and 7*. Note that the size of DAC phase jumps cannot be increased indefinitely, but only to the point that at least two points are defined on each sinewave. That is, the maximum DAC output frequency is one half of the clock frequency.

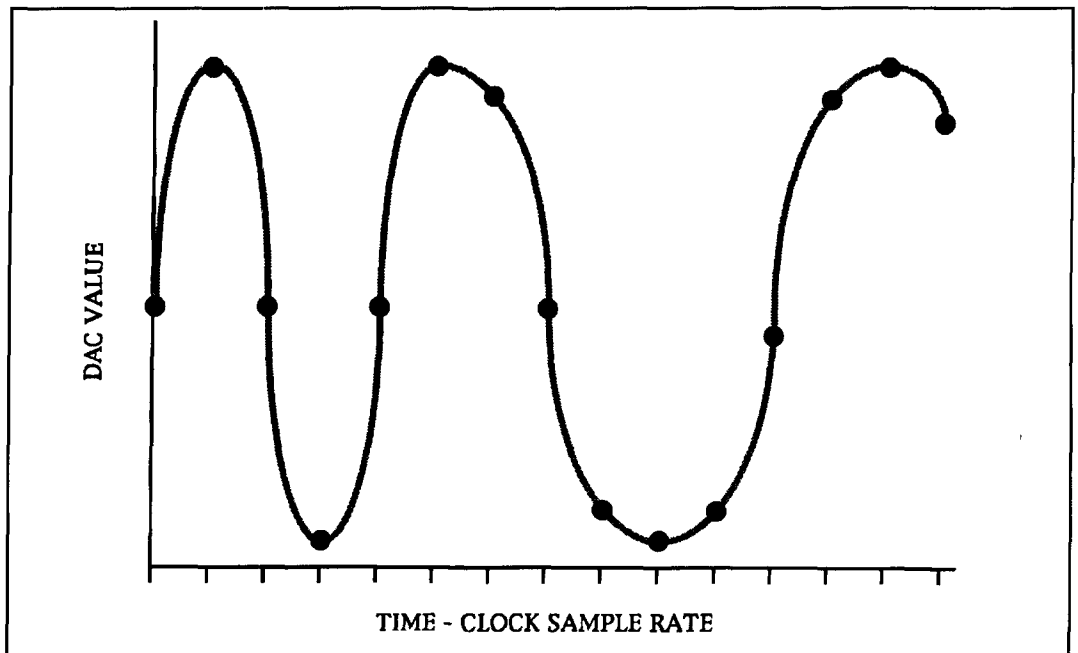

Figure 9. The DAC output is not limited to fixed-frequency sinewaves. In this example, the output frequency has been dynamically altered by shifting the phase jump size.

As this equation indicates, the output frequency of the synthesizer is always some fraction of the clock frequency, and that fraction is defined by the ratio of the phase jump size to the accumulator bit size. That is, for a given clock frequency and accumulator bit size, tak-

ing fewer phase jumps (larger phase jump size) increases the synthesizer output frequency. Similarly, taking more phase jumps (smaller phase jump size) decreases output frequency (see **Figures 6 through 9**).

From **Equation 1**, we can also determine the

BINARY INPUT	OUTPUT VOLTAGE
000	$0/8 \times V_r$
001	$1/8 \times V_r$
010	$2/8 \times V_r$
011	$3/8 \times V_r$
100	$4/8 \times V_r$
101	$5/8 \times V_r$
110	$6/8 \times V_r$
111	$7/8 \times V_r$

Figure 10. A 3-bit DAC can accept eight distinct binary input values, ranging from 000 to 111 (left), providing eight discrete output voltages. DAC resolution can be described as  $V_r/2^N$ , where  $V_r$  is the reference voltage and  $N$  is the number of bits. In this example, the resolution is  $V_r/8$ .

frequency resolution of the synthesizer output. For a given clock frequency and accumulator bit size, and the minimum phase jump possible (i.e., a phase jump size of 1), the relationship becomes:

$$\text{frequency resolution} = \frac{\text{clock frequency}}{2^{(\text{accumulator bit size})}}$$

Frequency resolution is therefore directly proportional to the clock frequency and inversely proportional to 2 raised to the power of the number of the accumulator bit size. For example, if the instantaneous phase values, as output from a phase accumulator clocked at 10 MHz are defined by a 3-bit binary word, then

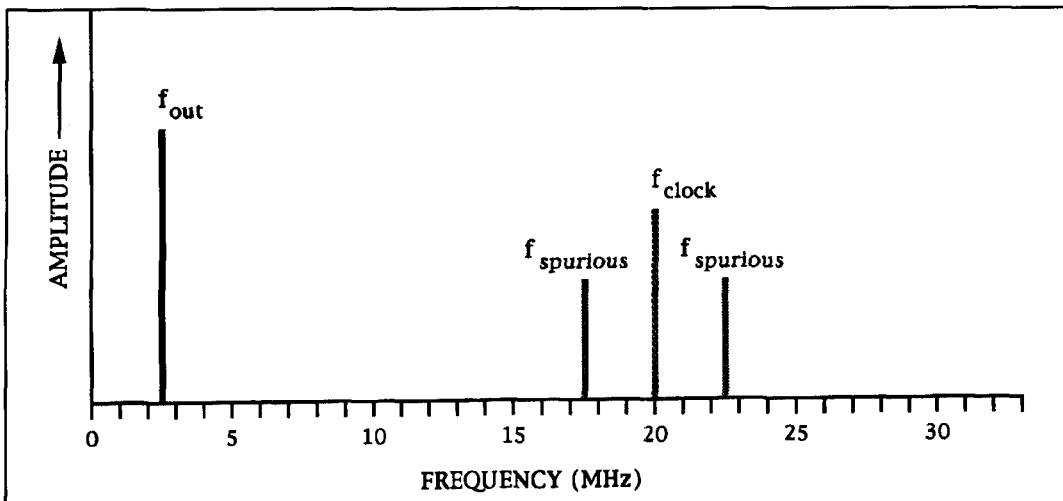

Figure 11. Unfortunately, DDS synthesizers produce spurious signals that appear on either side of the clock frequency and harmonics of the clock signal, in addition to the desired or fundamental frequency. In this example of a DDS synthesizer operating at 20 MHz with an output frequency of 2.5 MHz, the first pair of spurious signals appear at 17.5 and 22.5 MHz ( $20 \text{ MHz} \pm 2.5 \text{ MHz}$ ). Relative amplitude values have been assigned for clarity.

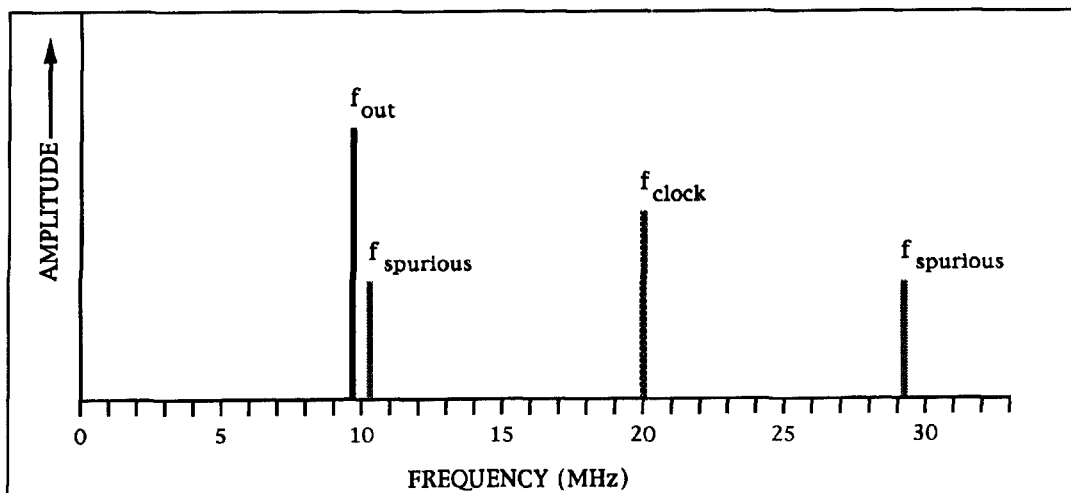

Figure 12. As the DDS synthesizer output frequency approaches  $f_{clock}/2$ , the frequency of spurious signals related to the clock and main output becomes closer to that of the output frequency. In this example, a DDS synthesizer operated at 20 MHz with a 9.75 MHz output frequency, generates a spurious signal at 10.25 MHz ( $20 \text{ MHz} - 9.75 \text{ MHz}$ ), only 750 kHz removed from the main output frequency. Compare with Figure 11. Relative amplitude values have been assigned for clarity.

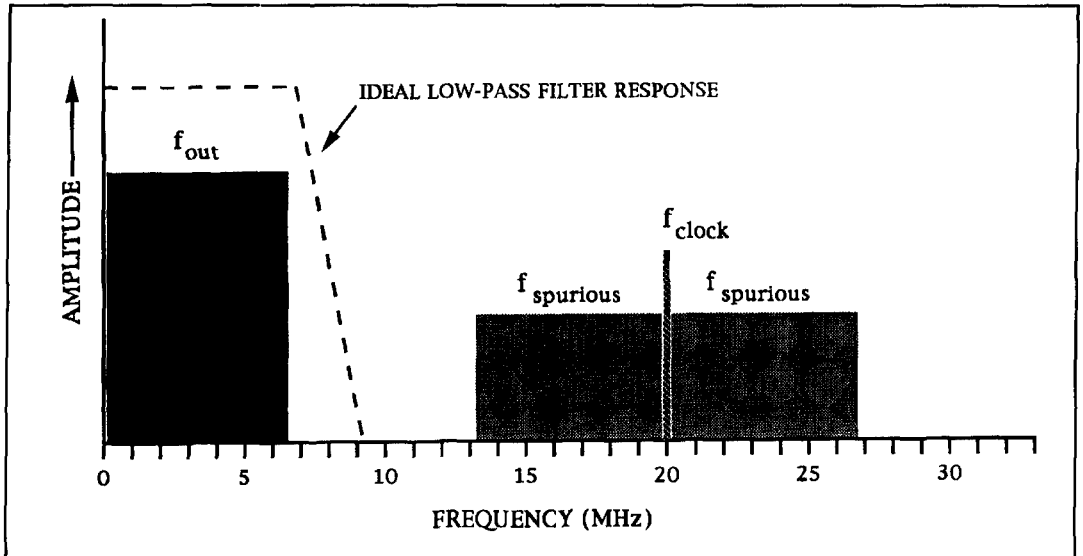

Figure 13. DDS synthesizers are generally designed to provide a maximum output frequency of  $f_{\text{clock}}/3$ , which allows the use of a low-pass filter with a cutoff slightly above  $f_{\text{clock}}/3$ . In this design, the effect of spurious signals resulting from the mixing of the clock and output signals can be minimized by the low-pass filter (aliases aren't considered here). For example, a DDS synthesizer operated in this manner at 20 MHz provides a maximum output frequency of about 6.67 MHz. The possible frequency of the spurious signal(s) is far enough removed from the output frequency so as to be easily handled by a low-pass filter with a cutoff of about 7 MHz. Relative amplitude values have been assigned for clarity.

the frequency resolution is  $10 \text{ MHz}/(2^3)$ , or 1.25 MHz. Similarly, a 4-bit accumulator would provide a resolution of  $10 \text{ MHz}/(2^4)$ , or 0.625 MHz. In a practical HF synthesizer system with a system clock operating at 10 MHz, a bit size on the order of 20 might be selected,

providing a usable resolution of  $10 \text{ MHz}/(2^{20})$ , or roughly 10 Hz.

A DDS synthesizer clocked at 450 MHz with an output at 150 MHz and a 5-kHz channel spacing requires a phase accumulator with a bit size of:

$$\begin{aligned} \text{frequency resolution} &= \frac{\text{clock frequency}}{2^{(\text{accumulator bit size})}} \\ 2^{(\text{accumulator bit size})} &= \frac{\text{clock frequency}}{\text{frequency resolution}} \\ \text{accumulator bit size} &= \log_2 \left\{ \frac{\text{clock frequency}}{\text{frequency resolution}} \right\} \\ \text{accumulator bit size} &= \log_2 \left\{ \frac{450,000,000 \text{ Hz}}{5,000 \text{ Hz}} \right\} \\ \text{accumulator bit size} &= \log_2 (90,000) \\ \text{accumulator bit size} &\approx 16.5 \end{aligned}$$



Rounding up to the nearest integer value, an accumulator with a bit size of at least 17 would fulfill our requirements. In practice, an accumulator with a bit size of 18 would probably be the most readily obtainable. Figures 4 and 5 also illustrate the effect of accumulator bit size on the resolution with which the output frequency waveform can be defined.

## Look-up table

Up to this point, all we have is a digital representation of the linear phase changes with time at the phase accumulator output. The output of the phase accumulator must be translated into amplitude changes with time in order to be useful in generating a signal at a given frequency. This translation could be realized by performing a mathematical operation on each value output from the phase accumulator; for example, evaluating  $(\sin)X$ , where  $X$  is the accumulator output. However, evaluating each value output from the accumulator in this manner would not only be computationally intensive, but more importantly, it would require numerous clock cycles to perform (prolonging synthesizer settling time). A more efficient method of translating phase to amplitude values is to use a look-up table, generally stored in ROM, that can provide the necessary translation as quickly as possible. The look-up table provides an *approximate* mapping of the linear phase changes output from the accumulator to the nonlinear amplitude changes with time that

represent the final output signal.

The mapping of phase to amplitude is less than perfect because the actual amplitude values must be rounded to the nearest value that can be represented in binary, within the limitations of the bit resolution of the look-up table. In spite of these truncation errors, the approximations provided by the look-up table are generally sufficient, as long as the bit resolution of the look-up table is compatible with the rest of the DDS system. For example, the bit resolution of the look-up table should be at least as great as the bit resolution of the digital-to-analog converter it feeds. Some advocate using a look-up table with a couple of extra bits above the minimum required by the DAC in order to minimize spurious output.<sup>5</sup> This would mean that the input for a look-up table feeding an 8-bit DAC should be able to handle 9 or 10 bits.

## Digital-to-analog converter (DAC)

The digital-to-analog converter, or DAC, accepts the digital amplitude words from the look-up table and generates a corresponding time-varying analog voltage. In effect, the DAC modulates a reference analog voltage by the digital amplitude words to produce an analog voltage. The full-scale value of the reference analog voltage is multiplied by the fraction represented by the digital word to produce the analog output voltage—a 3-bit DAC, for instance.

In operation, each of the binary input values

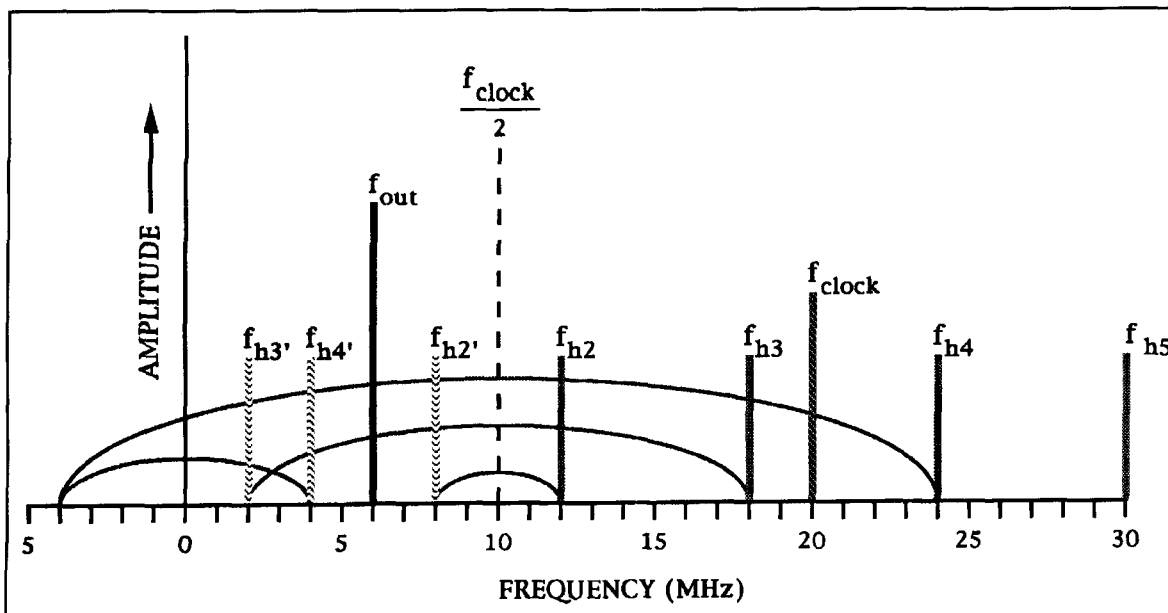

Figure 14. Spurs harmonically related to the DDS synthesizer output frequency appear between  $f_{\text{clock}}/2$  and DC in predictable locations. As illustrated here, the location of these spurs can be calculated graphically.  $f_{\text{clock}} = 20$  MHz.  $f_{\text{clock}}/2 = 10$  MHz.  $f_{\text{out}} = 6.0$  MHz. The first four harmonics of the synthesizer output ( $f_{h2} - f_{h5}$ ) are expected at 12, 18, 24, and 30 MHz, but appear as aliases ( $f_{h2'} - f_{h5'}$ ) at 8, 4, and 0.1 MHz. Relative amplitude values have been assigned for clarity.

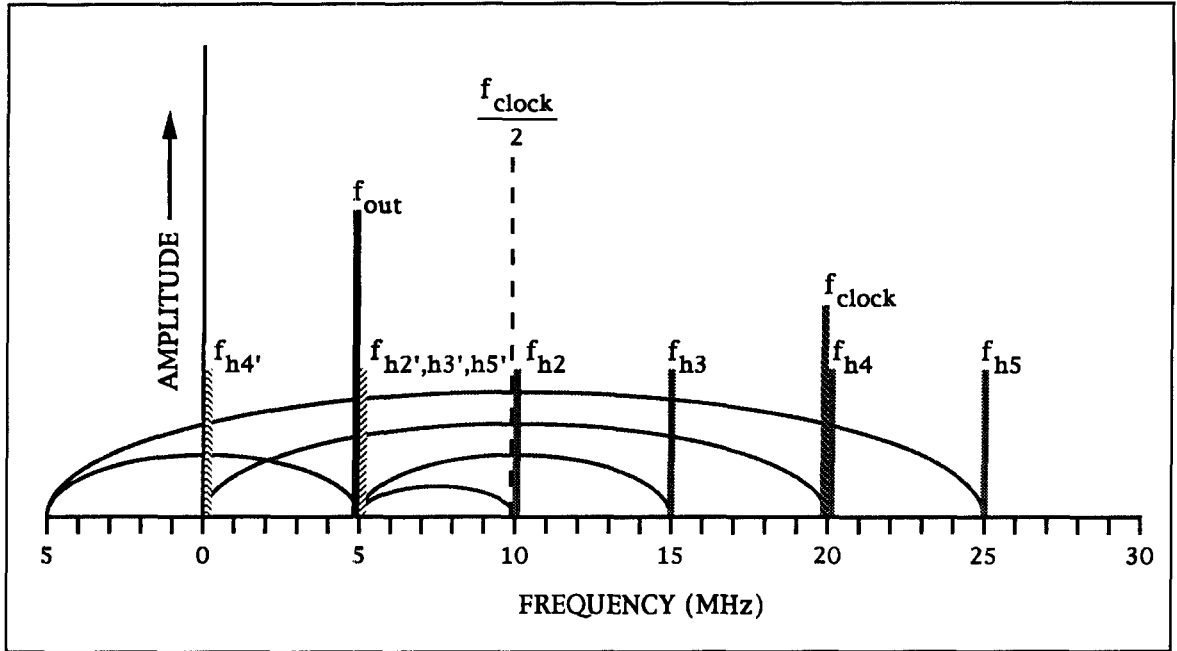

Figure 15. A DDS synthesizer output frequency of  $f_{\text{clock}}/4$  is considered a “good” frequency because spurs are virtually absent in the output. Aliases ( $f_{h2'} - f_{h5'}$ ) either appear at  $f_{\text{out}}$  or as a DC offset error. Relative amplitude values have been assigned for clarity.

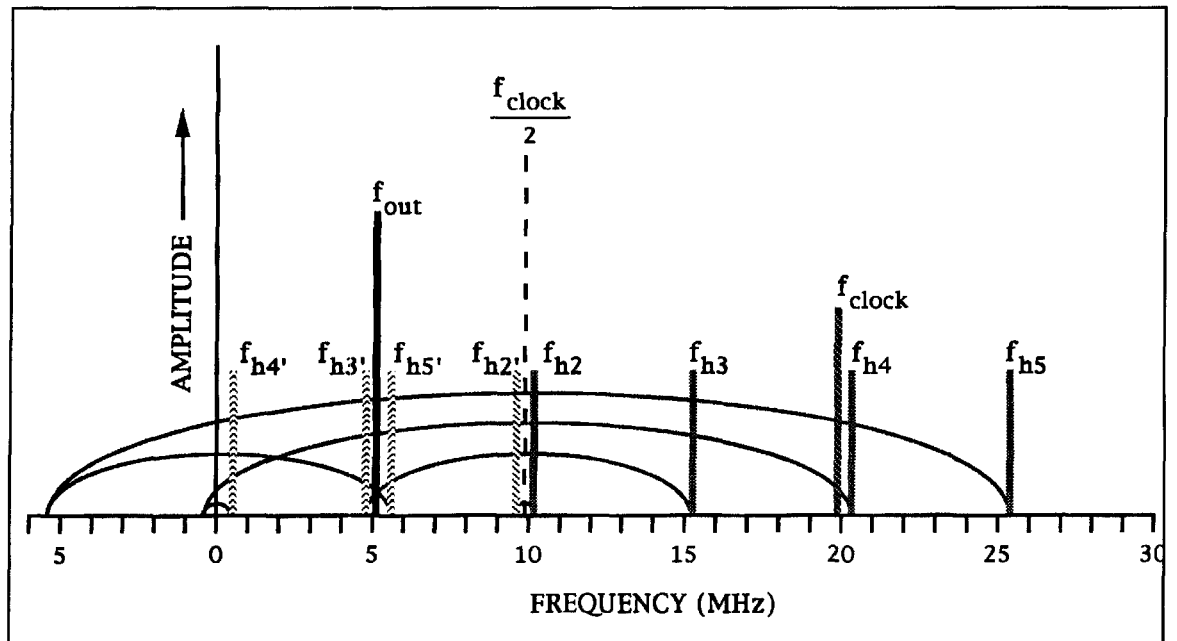

Figure 16. As the DDS synthesizer output frequency is shifted slightly above  $f_{\text{clock}}/4$  to 5.1 MHz, aliases of odd-order harmonics accumulate around the output signal (alternate odd-order harmonics fall on opposite sides of the output frequency). Compare with Figure 15. Relative amplitude values have been assigned for clarity.

to the DAC is treated as the numerator of a fraction that has  $2^N$  as the denominator, where  $N$  is the number of bits handled by the DAC. As illustrated in Figure 10, assuming a reference analog voltage of  $V_r$ , and a 3-bit DAC, which can accept eight distinct binary input values ranging from 000 to 111, eight discrete

voltage outputs are possible ( $N=3$ ). Note that the output voltage is always less than the reference voltage. The resolution of a DAC is  $V_r/2^N$ , where  $V_r$  is the reference voltage and  $N$  is the number of bits, as was defined. For a 3-bit DAC, the resolution is  $V_r/8$ . In comparison, the resolution of a 12-bit DAC is  $V_r/2^{12}$ , or

$V_r/4096$ . DAC bit size or resolution is a major factor in determining DDS spectral purity. Greater bit resolution allows a DAC to more closely approximate the desired output amplitude, and reduces spurious signal generation.

In addition to resolution, DAC specifications relevant to DDS synthesizer spectral purity include linearity error, differential linearity error, and stability.<sup>6</sup> The linearity error of a DAC is a measurement of the deviation of the DAC's actual output from a line fitted to the measured end points—for example, the values associated with 000 and 111 for a 3-bit DAC. Differential linearity error refers to the maximum difference between each analog output step and the ideal step size of one least significant bit. Like many electronic components, the stability of a DAC is also a function of time, temperature, and power supply voltage variations.

## Low-pass filter

No matter how great the bit resolution of the DAC, the amplitude of the DAC output will change abruptly because of the manner in which the analog output is generated from a digital signal. The stair-step waveform output from the DAC contains spurious signals that appear on either side of the clock frequency and harmonics of the clock signal, in addition to the desired or fundamental frequency of the synthesizer. These abrupt changes manifest themselves as high-frequency noise that must be removed by filtering in order to obtain a sinewave signal from the DDS synthesizer. The frequencies of the spurious signals that occur at multiples of the clock and output frequencies are identified by:

$$f_{\text{spurious}} = N \times f_{\text{clock}} \pm f_{\text{out}} \quad (3)$$

where  $f_{\text{spurious}}$  is the frequency of the spurious signal,  $N$  is an integer (for example, 0, 1, 2, 3),  $f_{\text{clock}}$  is the system clock frequency, and  $f_{\text{out}}$  is the synthesizer output frequency.<sup>7</sup> For example, as shown in **Figure 11**, with a clock frequency of 20 MHz and an output frequency of 2.5 MHz, the first pair of spurious signals will appear at 17.5 and 22.5 MHz (20 MHz  $\pm$  2.5 MHz).

As the theoretic upper frequency limit of the synthesizer is approached ( $f_{\text{clock}}/2$ , the Nyquist frequency), the frequency of the lower spurious signal approaches that of the output frequency. This means that, with a 20-MHz clock and 9.75-MHz output frequency, the first lower spurious signal will appear at 10.25 MHz (20 MHz—9.75 MHz), only 750 kHz up from the desired output frequency (see **Figure 12**).

Removing spurious signals from the DDS

synthesizer output is more difficult when the frequencies of the output and spurious signals differ little in frequency. For this reason, the maximum output frequency from a DDS system is generally limited to  $1/3$  of the clock frequency, and a low-pass filter with a cutoff slightly above  $1/3$  of the clock frequency is used. As illustrated in **Figure 13**, with a 20-MHz clock frequency, the maximum output frequency is 20 MHz/3 or 6.67 MHz, and the closest the lower spurious signal of the first pair can approach the desired output frequency is 13.33 MHz (20 MHz—6.67 MHz). Filtering the 13.33-MHz signal from the desired output signal, which could have a frequency as great as 6.67 MHz, should not be a problem.

Unfortunately, in addition to the spurious signals produced by the mixing of clock and output signals, there are a variety of other mechanisms in DDS capable of producing spurious signals in the output. These mechanisms and the nature of the spurious signals generated are described in more detail in the next section.

## DDS design challenges

Before DDS can become the technology of choice for all frequency synthesis applications, DDS engineers must determine how to best eliminate, reduce, or avoid the spurious signals in the synthesizer output. It is the discrete sideband noise or spurs, both amplitude modulated (AM) and phase modulation (PM), that presents the greatest problem, as opposed to broadband noise that plagues PLL synthesizers. In most cases, these spurs are harmonically related to the synthesizer output frequency.

A major component of DDS noise can be attributed to the amplitude truncation resulting from the finite word size of the DAC and look-up table; for example, the value 0.2838449582147 might be represented as 0.284.<sup>8</sup> Imperfections in the DAC, including those resulting in a variety of nonlinearities and glitches, also contribute to spurious output. Part of the problem is that fast and accurate DACs are simply difficult to construct. Current IC fabrication techniques limit component matching accuracy to only about 9 or 10 bits. In addition, the requirement for fast DDS settling favors the use of shorter word lengths. Oversampling, running the DDS system clock at more than two times the output frequency, can help improve things—but only up to the accuracy limit of the DAC. As described earlier, a properly designed low or bandpass filter can be used to remove spurs from the synthesizer output, as long as the spurs are sufficiently removed from the output frequency.

When considering DDS spurious noise generation, it's useful to examine the two extreme

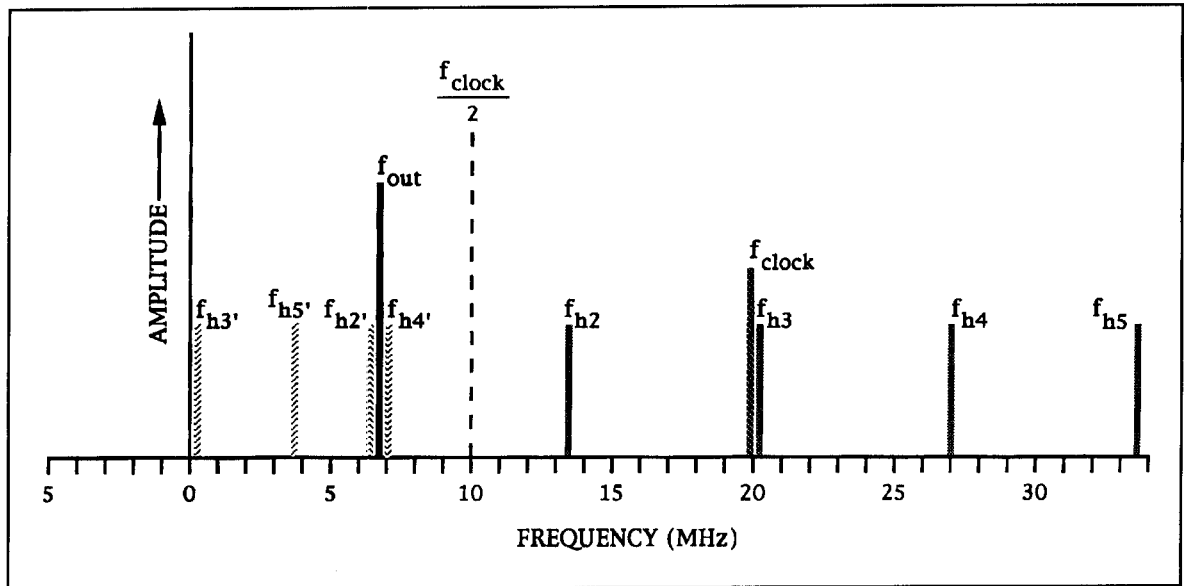

Figure 17. Particularly “bad” DDS synthesizer output frequencies, like those near  $f_{\text{clock}}/3$ , are associated with high-energy, close-in spurs. Note the close-in even and odd-order aliases of this DDS synthesizer operating at 20 MHz with an output at 6.75 MHz (just above  $f_{\text{clock}}/3$ ).

cases of operation. In the first, the synthesizer is operated so there is no close-in common multiple between the system clock and synthesizer output frequencies. The noise generated in such a system has a uniform probability distribution; that is, white noise. Because this white noise is the result of an AM process, it can be suppressed with a hard limiter following the low-pass filter, at the expense of generating odd harmonics of the wanted output frequency.

In the second case, the synthesizer output frequency is an integer submultiple of the system clock frequency. In this scenario, the noise is concentrated in several discrete AM spurs. As in the first case, this noise can also be suppressed by noise reduction circuitry; for example, hard limiting following the low-pass filter. It's important to note that the *total* power in the discrete spurs is approximately equal to the power in the white noise generated in the first case. As a general rule, the more complicated the output to clock frequency ratio, the more lines of spur energy are distributed over, and the lower their general level.<sup>9</sup>

The spurs generated in DDS that are harmonically related to the synthesizer output frequency appear between the Nyquist frequency ( $f_{\text{clock}}/2$ ) and DC in predictable locations. These spurs are mirrored between  $f_{\text{clock}}/2$  and DC because the sampling process causes the harmonics of the output frequency to appear as lower frequencies in the DAC output; that is, the spurs are aliases. Recall that aliasing can occur whenever the sampling rate is less than twice the highest frequency in the original analog signal.

Consider a DDS system with a system clock frequency of 20 MHz, and an output frequency of 6 MHz. As illustrated in **Figure 14**, the Nyquist frequency of  $f_{\text{clock}}/2$  is 10 MHz, and the first four harmonics of the DDS output appear at 12 MHz ( $f_{h2}$ ), 18 MHz ( $f_{h3}$ ), 24 MHz ( $f_{h4}$ ), and 30 MHz ( $f_{h5}$ ). The second harmonic of the output ( $f_{h2}$ ) is expected at 12 MHz, or 2 MHz higher than the Nyquist frequency. However, it is mirrored back to 8 MHz ( $f_{h2'}$ ), 2 MHz lower than the Nyquist frequency. Similarly, the presence of the third harmonic ( $f_{h3}$ ) appears at 2 MHz ( $f_{h3'}$ ). The alias of the fourth harmonic ( $f_{h4'}$ ) appears at 4 MHz; aliases may not appear below DC or 0 MHz, but are folded back again from that point. To test your understanding of this mechanism, use this graphic approach to verify that the frequency of the spur due to the fifth harmonic ( $f_{h5}$ ) should appear at 100 kHz.

In DDS work, there is a concept of “good” and “bad” frequency combinations. An output at  $f_{\text{clock}}/4$  is considered one of the good frequency combinations because spurs are virtually absent in the output. As **Figure 15** shows, when a synthesizer is operated with a system clock frequency of 20 MHz and an output of 5 MHz ( $f_{\text{clock}}/4$ ), the spurs virtually disappear. Aliases either fall on the fundamental output frequency (odd-order harmonics), the Nyquist frequency (even-order harmonics), or appear as a DC offset error (even-order harmonics).

Consider what happens to the spur distribution when the DDS output frequency is increased slightly to 5.1 MHz. As illustrated in **Figure 16**, the odd-order harmonics accumu-

late around the output signal. If you were to carry out this evaluation to include higher-order harmonics, you would find that alternate odd-order harmonics fall on opposite sides of the output frequency.

The amount of spur energy near the output frequency gets even greater as we approach an output frequency of  $f_{\text{clock}}/3$ . Bad frequency combinations like this can have spurs up to  $6N$  dB below the carrier, where  $N$  is the number of effective DAC bits.<sup>10</sup>

**Figure 17** depicts the spur energy distribution for a DDS synthesizer operating at 20 MHz with an output at 6.75 MHz—just above  $f_{\text{clock}}/3$ . Note that even-order harmonics are now close-in to the main output frequency, as well as the fifth harmonic.

The spurs that appear around the DDS output frequency may be both AM and PM, sometimes at the same modulating frequency.<sup>9</sup> PM spurs, due to phase truncation in the DDS, are the most troublesome. PM can occur in DDS when the output is not a binary submultiple of the clock frequency (that is,  $f_{\text{clock}}/2N$ , where  $N$  is an integer), because there is drift on the output phase relative to an ideal sinewave of the same frequency. For example, if for most of the time a DDS is generating an output frequency

that is just slightly too high, its phase advances relative to the ideal. Every so often, in an attempt to get in sync, the phase accumulator output will not advance on a particular clock cycle. The result is that the DAC delivers the same output voltage as on the previous clock cycle, delaying the phase of the output.

When the phase increment sent to the look-up table by the phase accumulator is the same on each and every cycle of the output, there's no phase truncation and no generation of PM spurs. The smallest phase increment is determined by the number of bits sent from the accumulator to the ROM, and not by the number of bits in the FSW.

PM spurs can be suppressed by frequency division. Dividing the direct digital synthesis output frequency by two will reduce PM sidebands by 6 dB, by halving the modulation index.<sup>9</sup> Recall that PM is simply FM in which the deviation is directly proportional to the modulation frequency. In FM, the deviation is independent of the modulation frequency and proportional to the signal amplitude. Although the frequency division results in reduced synthesizer frequency coverage, it does provide for finer output frequency resolution.

Another way to avoid spurs is to use two dif-

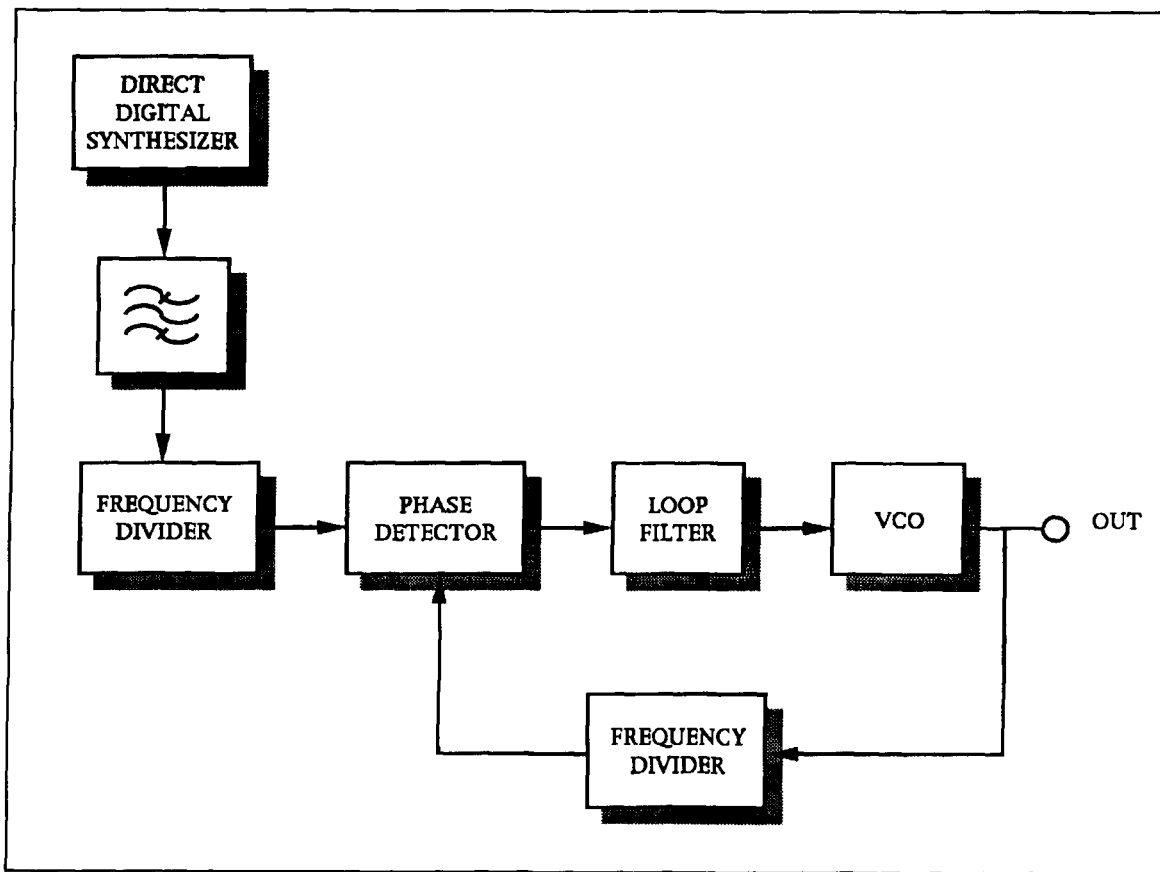

**Figure 18.** In this hybrid design, a DDS synthesizer is operated as the reference oscillator of a single-loop PLL synthesizer. This design provides fine frequency resolution without the compromises of a traditional PLL synthesizer. The result is a synthesizer with excellent frequency agility, low close-to-carrier noise levels, and freedom from spurious output.

ferent clock frequencies. The clock that provides the most complicated output frequency to clock frequency is selected, dispersing the spurious energy among many lower level spurs instead of in a few large ones.

## The future of direct digital synthesis

DDS promises to be the ideal solution to a variety of signal generation needs. Not only can this technology provide regular, small frequency increments directly from a single clock signal, but it can do so with a minimum of discrete components. In addition, the frequency stability delivered by DDS approaches that of a crystal-controlled oscillator, while allowing electronic control of frequency and modulation.

DDS has come to be viewed as a viable supplement to, and in some instances, a replacement for, the ubiquitous PLL synthesizer. In DDS, not only are the major tradeoffs associated with PLL synthesizers addressed (i.e., phase noise, frequency resolution, and settling time), but these factors are mutually independent. In addition, the design lends itself to methods not practical with other synthesizer techniques—including numeric modulation.

Phase noise isn't a problem in a well-designed DDS system. For example, the phase noise is generally less than the phase noise of the reference oscillator. Two factors account for this. First, the phase linearity of the DDS is the same as the clock time linearity, given the translation from linear phase change to amplitude change that occurs in the system. Second, the reference clock frequency is divided by some number greater than two (and usually three), further reducing the effective phase noise by a factor of  $20 \log_{10} N$ , where  $N$  is the divisor.<sup>5</sup>

The settling time of a DDS synthesizer, typically measured in nanoseconds, is generally superior to that of PLL synthesizers. Factors that affect DDS settling time include the bandwidth of the low or bandpass output filter, the phase accumulator bus architecture and bit size, as well as the delays associated with data transfer rates between the accumulator and look-up table, the look-up table and DAC, in addition to the throughput of the DAC. For example, the delays associated with loading the phase accumulator are greater when a serial interface is used instead of a more efficient parallel bus, and this delay is more pronounced with greater accumulator bit size. However with proper design and matching of component capabilities, DDS system settling times do not present a practical limitation.

DDS lends itself to direct digital modulation

(numeric modulation) because the frequency, phase, and amplitude of the synthesizer output can be defined by the FTW. For example, FM can be achieved by simply adding or subtracting from the FTW (see **Figure 9**). Additional modulation schemes are also possible with a look-up table held in RAM. For instance, the instantaneous output frequency and amplitude can be defined by dynamically altering the translation values stored in the look-up table. DDS obviously lends itself to experimentation.

In some commercial HF communications systems, hybrid designs have been used to take advantage of DDS, while retaining the benefits of current tried-and-tested technology. In one hybrid design, a DDS synthesizer is operated as the reference oscillator, at say 10.7 MHz, of a PLL synthesizer (see **Figure 18**). This design provides fine frequency resolution without the compromises of a traditional PLL synthesizer. By using a DDS synthesizer as a stable, variable reference in place of a fixed crystal oscillator, a simple, single-loop PLL synthesizer design can be used. Frequency settling between PLL steps is achieved quickly by adjusting the reference frequency by a few tens of Hz.<sup>9</sup> Because the reference frequency varies relatively little, inexpensive but highly selective crystal filters can be used at the DDS synthesizer output. The end result of this hybridization is a synthesizer with excellent frequency agility, low close-to-carrier noise levels, and freedom from spurious output.

As experimenters and engineers gain experience and familiarity with DDS, and as newer and more powerful DDS chips come to market, there will be an explosion in the use of this promising technology. The early hybrid DDS designs now appearing, much like the early transistor-tube hybrids, foreshadow the time when virtually all communications devices will rely on DDS, together with DSP and other digital techniques.

## REFERENCES

1. Ulrich Rohde, "Recent Advances in Shortwave Receiver Design," *QST*, 76(11): 45-56, 1992.
2. Pat Hawker, "Digital Signal Processing Yields New Hardware," *Electronics and Wireless World*, 97(1677): 674-5, 1992.
3. P. Horwitz and W. Hill, "Active Filters and Oscillators," *The Art of Electronics*, 1980, Cambridge University Press, Cambridge.
4. William I. Orr, "Frequency Synthesis," *Radio Handbook*, 1987, Howard W. Sams & Company, Indianapolis, Indiana.
5. Robert Zavrel, "Radio Frequency Oscillators and Synthesis," *The ARRL Handbook for Radio Amateurs*, Schetgen, editor, 1993, The American Radio Relay League, Newington, Connecticut.
6. M. Baltrush, "Digital-to-Analog and Analog-to-Digital Converters," *Handbook of Modern Electronics and Electrical Engineering*, Belove, editor, 1986, John Wiley & Sons, New York.
7. I. Hickman, "Direct Digital Synthesis: Part 2," *Electronics and Wireless World*, 97(1678): 746-8, 1992.
8. I. Hickman, "Direct Digital Synthesis," *Electronics and Wireless World*, 97(1677): 630-4, 1992.
9. I. Hickman, "Genuine Solutions to Spurious Arguments," *Electronics and Wireless World*, 97(1679): 842-5, 1992.
10. P. Saul, "Direct Digital Synthesis," *QEX*, (March): 7-10, 1991.

# THE FREQUENCY TUNABLE CRYSTAL FILTER

*An experimental crystal filter with a continuously adjustable center frequency.*

---

The piezoelectric crystal filter is now a standard part of almost all shortwave and amateur receivers and transceivers. Indeed many receivers contain several crystal filters with bandwidths corresponding to the requirements of CW, SSB, and AM modulated signals accessible via a front panel switch.

Other receivers include sophisticated high frequency oscillator and BFO frequency shifting controls (called passband tuning or IF shift).<sup>1,2,3</sup> This control gives you the feeling that the signals within the receiver passband are fixed while the crystal filter center frequency is being shifted. In actuality, the filter is fixed and the signals are shifted.

Some of the more advanced receivers take this oscillator shifting idea one step further to include an adjustable variable bandwidth feature.<sup>4,5,6,7</sup> In essence, two fixed frequency crystal filters with widely different center frequencies—for example, 8 MHz and 455 kHz—are used. Signals pass through one filter, are heterodyned to a second IF frequency and pass through the second filter. The apparent “overlap” of the two filters is adjusted by carefully controlling the heterodyne oscillator frequency shift simultaneously with the high frequency oscillator shift and BFO shift. (This really gets complicated as a later description will show.)

I'll describe the operation of an experimental crystal filter in which the center frequency is actually (not apparently) adjustable. This

adjustment is continuously tunable over a limited but useful range of frequencies while the filter is operating; that is, passing and/or rejecting signals. As a bonus, the bandwidth of the filter is also continuously and independently adjustable (without interaction with the center frequency adjustment).

## The ladder filter

Piezoelectric crystals can be represented in the region of their fundamental frequency by an equivalent circuit consisting of a series resonant arm and a shunt “holder” capacitance in place of the contacts, leads, and case enclosing the piezoelectric element (see **Figure 1**).

It is well known that the series resonant frequency of the crystal element given by

**Equation 1:**

$$f_x = \frac{1}{2 \times \pi \times \sqrt{L_x C_x}}$$

is very stable over long periods of time and through temperature excursions. Narrowband filters built using these crystals depend on this stability and are fixed frequency filters.

The adjustable frequency filter uses a ladder type circuit with several crystals of an identical and fixed series resonant frequency,  $f_x$  (see **Figure 2**). The circuit may include any number

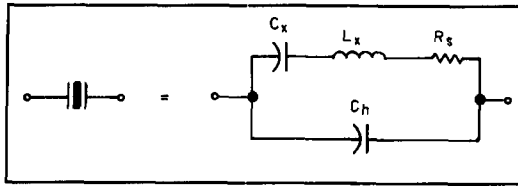

Figure 1. Crystal equivalent circuit.

of crystals with the addition of elements consisting of a crystal, a parallel capacitor,  $C_p$ , a series capacitor,  $C_s$ , and a shunt capacitor,  $C_n$ , in the position indicated by the three dots, (...). Practical filters usually contain from 3 to 12 such elements depending on the ultimate stop-band rejection and the steepness of the pass-band skirts desired.

All of the parallel capacitors,  $C_p$ , have the same value. Series capacitors,  $C_s$ , shunt capacitors,  $C_n$ , and end capacitors,  $C_{end}$ , all have different values. However by virtue of input/output symmetry, the capacitor values occur in pairs with each capacitor in a pair having the same value. The two inductors,  $L$ , whose function is described later, also have the same value by symmetry.

Just like many filters, for proper operation the frequency tunable filter must be terminated in a fixed resistance at the output. Likewise, it must be driven by a signal source with a fixed resistance. Neither of these resistors are shown in **Figure 2**.

It is essential that the crystals' series resonant frequencies,  $f_x$ , remain fixed to within 0.0001 percent or better. This requirement is easily satisfied by most common crystals. However, the capacitor and inductor values aren't nearly so critical in the operation of the filter, so normal  $\pm 5$  percent tolerance of these components, for example, is satisfactory. Note that the inductors,  $L$ , aren't resonant with the other circuit elements anywhere in the vicinity of the crystal frequencies,  $f_x$ .

Although inductors,  $L$ , are not absolutely necessary, their inclusion allows for a greater frequency shift than would be possible without them. Adjustment of the capacitors in a specific pattern yields the desired tuning of the pass-

band center frequency. It isn't necessary to adjust the crystals or inductors. The bandwidth and terminating resistances are not affected.

## An example

A filter using three 8-MHz crystals, as shown in **Figure 3**, with a bandwidth of 500 Hz is shifted from a calculated center frequency of 8000375 Hz to 8001375 Hz by adjusting the capacitors between the values shown in **Table 1** (see **Photo A**). This shift may be checked analytically by entering the component values into a circuit simulator computer program. Frequency response sweeps with the capacitors set to each group of values in **Table 1** show the shift in center frequency.

Terminating resistors of 2000 ohms and inductors of 15  $\mu$ H are used in this example of a CW filter. I verified the filter experimentally by building up the circuit of **Figure 3** using fixed capacitors of the values shown in the left-hand column of **Table 1**. After completing passband measurements, I unsoldered the capacitors and replaced them with fixed capacitors of the values shown in the right-hand column. Indeed, the center frequency shifted 1 kHz to the right while the bandwidth at the 3 dB points remained constant. **Figure 4** shows the measured results. For this filter, the crystals actually used had  $f_x = 8005800$ , rather than the assumed value of exactly 8 MHz.

Although I only measured two points, it is possible to set the center frequency to any value between these two points by proper selection of capacitor values. The procedure for computing these values is provided in **Appendix A**.

If you have a way to smoothly adjust capacitor values, then it's possible to smoothly adjust the center frequency to any value between these two columns, or even beyond the two points. Furthermore, the center frequency could be adjusted while the filter is operating.

## Capacitor adjustment

Capacitor values are most readily adjusted using voltage variable capacitors—a semicon-

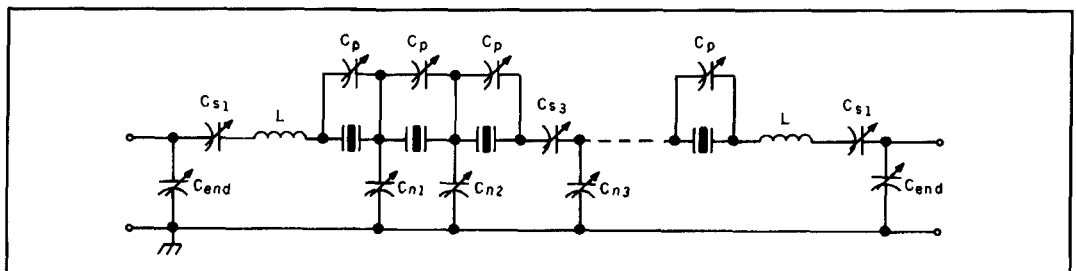

Figure 2. Frequency tunable crystal filter circuit.



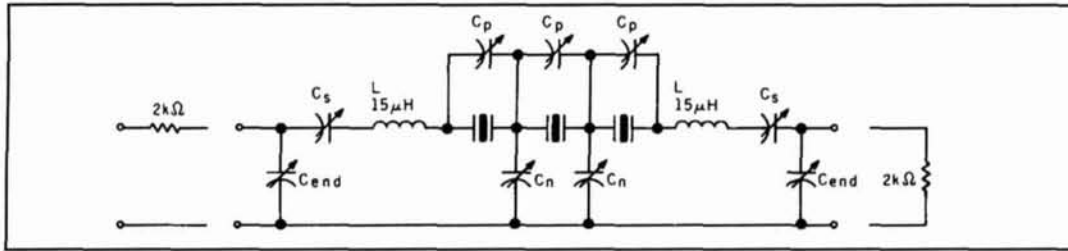

Figure 3. Simple frequency tunable filter with three crystals.

ductor device having the properties of a capacitor whose value depends upon the value of an applied direct-current voltage. Each capacitor in Figure 2 is replaced by the network of Figure 5A. The 0.01 μF capacitors and 100-k resistors are used to isolate the direct current from the radio frequency currents. In the case of Cn and Cend, where one end of the original capacitor is connected to ground, the simplified circuit of Figure 5B is used.

It is also theoretically possible to use mechanically adjustable variable capacitors. In practice, their use would be unwieldy due to the need to make their values track to specified calculated capacitances. Specially shaped plates would be required.

Another possibility would be to use the "programmable resistor," a device which has just come on the market, to drive a tuning varactor. This resistor would let you make precision adjustments of capacitance over the varactor's range by sending digital data to programming pins. I haven't yet tried to use such a device in a tunable crystal filter.\*

### A bonus: bandwidth control

Another useful feature of this voltage vari-

\*For more information on this and other programmable devices, see "Quarterly Devices" on page 65 of the Spring 1993 issue.

Center Frequency	8000375	80013785	Hz
Cp	84	56.4	pF
Cs	57.9	17.9	pF
Cn	203	17.4	pF
Cend	36.4	4.8	pF

Table 1. Capacitor values for 1-kHz shift.

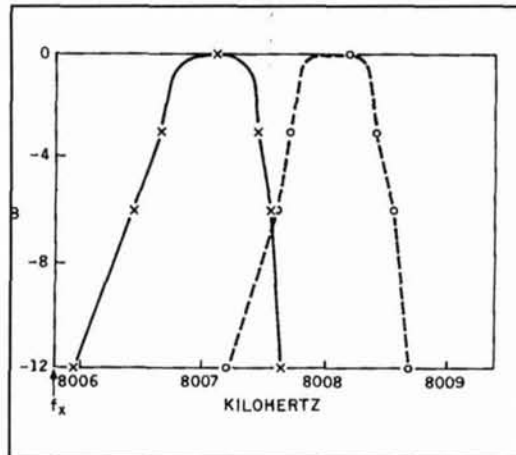

Figure 4. Measured passband of simple filter with fixed capacitors for bandwidth = 0.5 kHz.

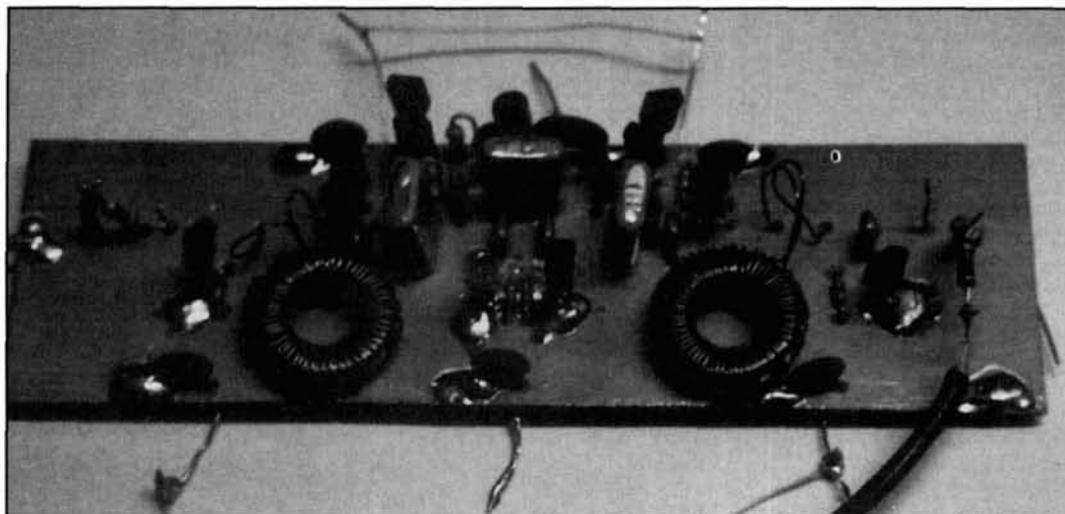

Photo A. The simple tunable filter of Figure 3.

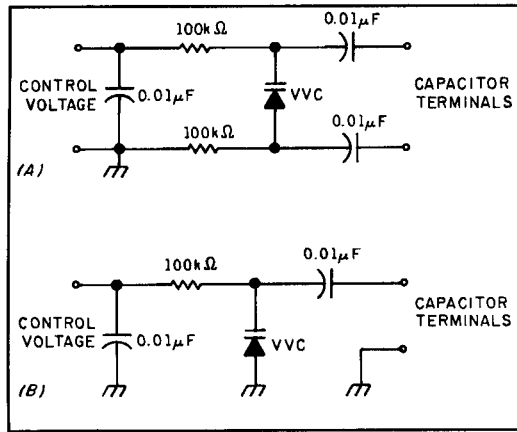

Figure 5. Voltage variable capacitor (VVC) isolation circuits.

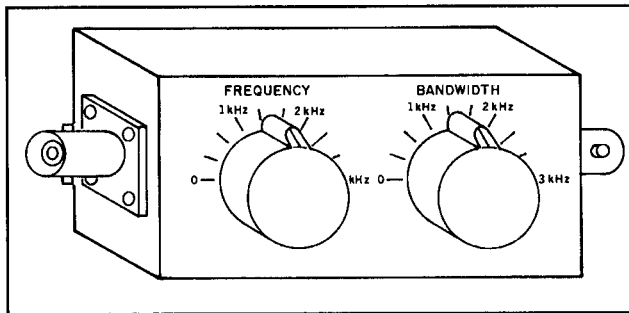

Figure 6. Filter with tuning controls.

able capacitor approach is that the bandwidth of the filter can be independently adjusted, also through proper adjustment of capacitor values. Although the capacitors must be adjusted in a specific way, the filter consists of a stable crystal filter with a single knob to change its center frequency and another knob to change the bandwidth. This concept is shown in **Figure 6** for clarity. There is no interaction between the two knobs.

An implementation of the voltage variable capacitor approach is described in the following section.

### Capacitor adjustment strategy

Using the simple 3-crystal filter of **Figure 3**

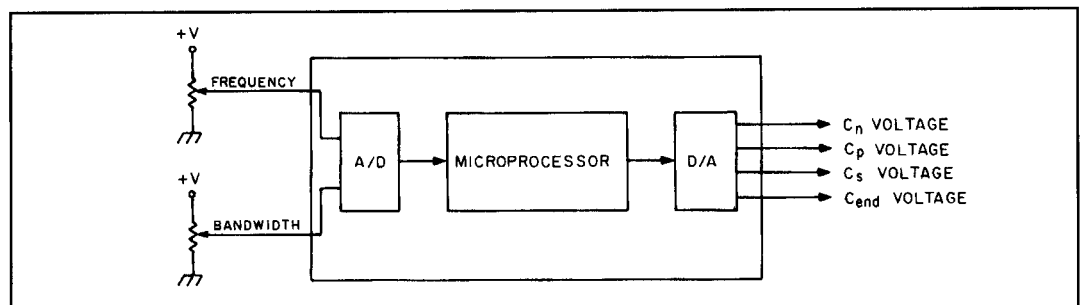

Figure 7. Microprocessor control.

as an example for any desired center frequency and bandwidth, you'll note there are nine capacitors which require simultaneous adjustment to four different values. Each additional pair of crystals requires six additional adjustable capacitors of two additional values: Therefore, it is unlikely that any random or experimental adjustment will result in a satisfactory response. You must solve a set of equations in real time or use a table look-up procedure to obtain values previously calculated from the equations. **Appendix A** gives the equations for a simple 3-crystal filter.

Either of these two methods can be developed using the microprocessor strategy of **Figure 7**. Many practical microprocessor devices are available. Some include the analog-to-digital and/or digital-to-analog converters (A/D and D/A) and program storage. These typically cost less than a few good quality crystals, so a microprocessor-controlled crystal filter is practical. The remaining components, resistors, capacitors, voltage variable capacitors, and inductors are readily available at low cost. Speed of calculation should be fast enough to follow manual adjustment of the center frequency and bandwidth controls.

### Additional measurements

I ordered a supply of voltage variable capacitors from the Newark catalog for use in the simple 3-crystal circuit previously measured with fixed capacitors.

I chose the Motorola MVAM115 for  $C_n$  and the Motorola MV209 for  $C_{end}$  using the circuit of **Figure 5B**. These are rated as 440 to 560 pF with a minimum 15:1 capacitance ratio and 26 to 32 pF with a 5 to 6.5:1 capacitance ratio, respectively. I placed the two MV209s in parallel for each  $C_p$  and  $C_s$  using the isolation circuit of **Figure 5A**. Because of the wide tolerances, I sorted the devices into three bins for each type based on their actual capacitance versus voltage curves. I found the voltage required to set a particular capacitance could differ by as much as 1 volt from one device to another. The actual DC voltages applied to the filter depend-

	Lower Center Frequency		Upper Center Frequency	
Cn	243 pF	4.4 volts	27 pF	12.6 volts
Cend	40.1	2.1	9.5	10.0
Cp	14.8	12.0	39.9	7.4
Cs	54	5.0	40.6	6.5

Table 2. Capacitor and voltage values.

ed on which bin the particular devices came from, as I selected them and soldered them into the circuit.

The diodes draw only leakage current during operation, so I used a simple voltage box with four potentiometers to set the required DC voltages (see **Figure 8**). The actual voltages used for two frequency settings with a 1-kHz bandwidth are shown in **Table 2**. The two center frequencies are spaced 1 kHz apart.

The actual measured passbands are shown in **Figure 9**. Note that after taking the readings at the lower center frequency, I shifted the filter to the upper frequency merely by adjusting the four potentiometers to the output voltages given in the right-most column of **Table 2**. Readjustment to the original location produced the lower passband. No soldering or unsoldering was required (see **Photo B**).

## Conclusion and discussion

The microprocessor can set voltages, just as I did manually using values from **Table 2**, so I have demonstrated the principle of a tunable center frequency crystal filter. Voltage settings for any intermediate frequency or a different bandwidth can be calculated via the microprocessor, using the equations in **Appendix A**. This filter then provides passband tuning and adjustable bandwidth features, but in a very different way than is done in today's receivers. Only one filter is required to provide both features.

The amount of frequency tuning (shift) of the filter's center frequency is limited with this approach to some large fraction of the spacing between the series and parallel resonant frequencies of the crystals. This is similar to "pulling" the frequency of a crystal oscillator with a series or parallel variable capacitor. Since it is possible to increase this "pulling" in a VXO by adding a series inductance, perhaps this filter tuning can be extended in a similar way by the addition of series inductances. I haven't yet tried to analyze or understand that situation. Note that the inductors of **Figures 1 and 3** perform a different role. They are there to allow the termination resistance to remain

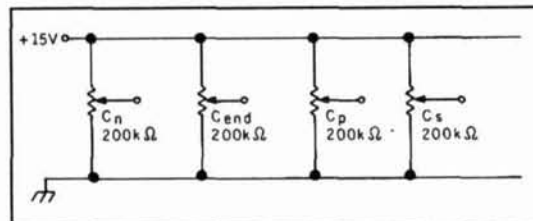

Figure 8. Circuit for setting capacitor voltages.

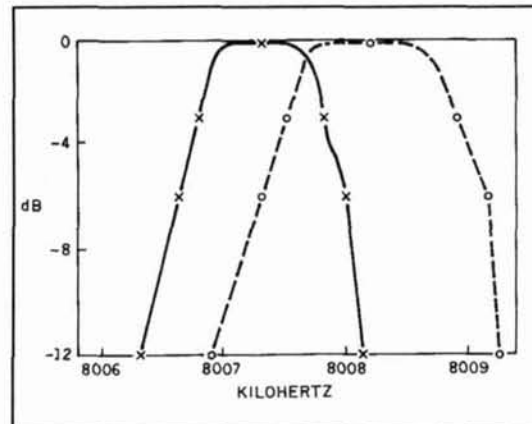

Figure 9. Measured passband of simple filter with voltage variable capacitors for BW = 1 kHz.

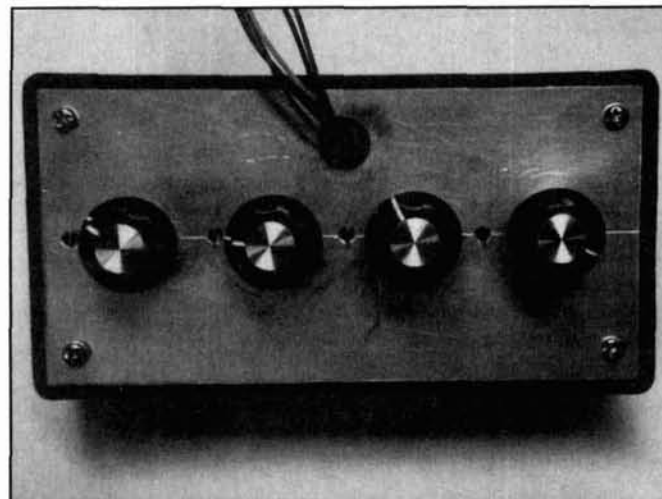

Photo B. Tuning box to set the voltage across the voltage variable capacitors.

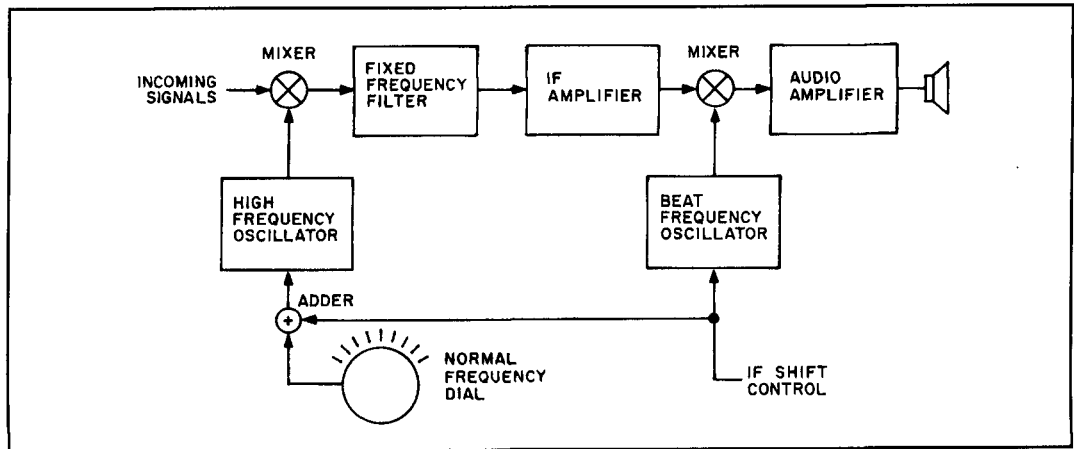

Figure 10. IF shift feature block diagram.

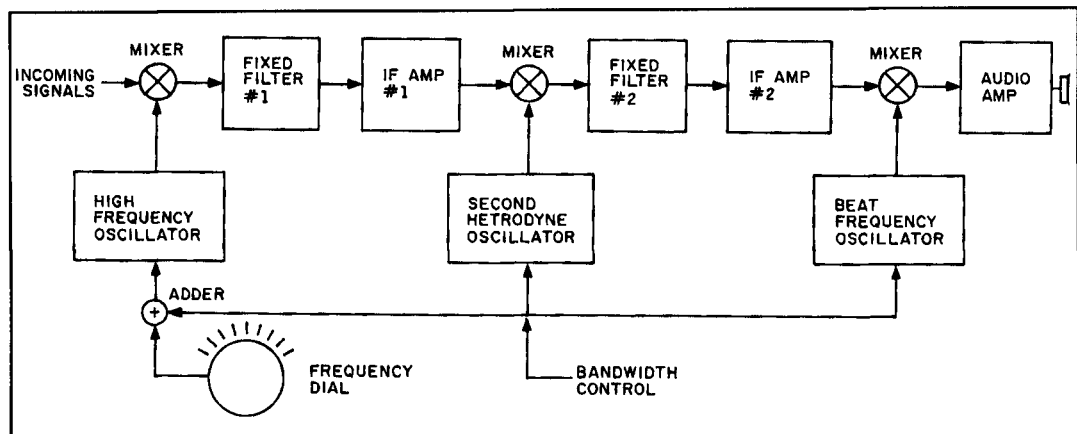

Figure 11. "Apparent" bandwidth adjustment block diagram.

constant over a larger tuning range than would be possible with adjustment of Cend alone.

It should be possible to tune the center frequency of an upper sideband ladder crystal filter with crystals in a shunt rather than series connection by shifting the values of the series capacitors. I haven't tried to work out the details of this configuration either.

A good source of more tightly specified (better matched) voltage variable capacitors would eliminate the need to sort them by measuring the C versus V curve for each one.

Independent separation of multiple closely spaced signals is possible using a separate frequency adjustable crystal filter to track and pass each signal. There would be no interaction with the other signals.

I hope this information gets some experimenters thinking about tunable crystal filters and their many possibilities. Because we all consider crystals frequency stable elements, all crystal filters built to date appear to be fixed frequency devices. Now that the tuning potential has been demonstrated, I expect to see more work in this direction.

#### REFERENCES

1. G.C. Collins, "Receiver Features that Help You Beat Interference," *QST*, February 1983, pages 43-47.
2. D. Newkirk, "Transceiver Features that Help You Beat Interference," *QST*, March 1991, pages 16-21.
3. "Frequency-Synthesizer Type Transceiver," US Patent #4,097,805, June 27, 1978 by Motoyuki Fujii, Koji Yokota, and Hajime Yashita all of Tokyo, Japan and assigned to Trio Kabushiki Kaisha (Kenwood).
4. C.P. Clark, "Variable-Bandwidth Filters-Irish Style," *QST*, March 1978, page 35.
5. T.P. Hulick, "Add Variable-Bandwidth Tuning to Your Fixed-Bandwidth Receiver," *QST*, September 1977, pages 19-23.
6. J. Pelham, "Putting Variable-Bandwidth Tuning Back Into Late-Model ICOM IC-751A Transceivers," *QST*, April 1991, pages 47-48.
7. "Interference Eliminator in Communication Receivers," US Patent #4,267,605, May 12, 1981 by Mitsuo Matsuzawa and Hajime Yashita of Tokyo, Japan and assigned to Trio Kabashiki Kaisha (Kenwood).

## Appendix A.

### Calculation of Capacitor Values for the Filter of Figure 3.

Select three crystals with parameters  $C_x$ ,  $L_x$ ,  $C_h$ , and  $R_s$ . (Note: parameter  $R_s$  is not used in the calculations.)

Calculate  $f_x$  from **Equation 1**.

For any bandwidth and frequency, calculate intermediate variables:

$$I = \frac{2\sqrt{2F-B}}{2F-\sqrt{2B}}, \quad Q = f_x / B$$

where B is the 3 dB down bandwidth, F is the frequency difference between the filter center frequency and  $f_x$ . F is positive; i.e., center frequency is above the crystal series resonant frequency.

Calculate:

$$C_p = C \times Q \left[ \frac{1-\sqrt{2}}{1-I} \right] - C_h$$

must be positive

$$C_n = \sqrt{2}C \times Q \frac{(1-\sqrt{2}/I)^2}{1-(1/I)^2}$$

and intermediate variable

$$R1 = \frac{1}{\omega C \times Q} \times \frac{1-(1/I)^2}{(1-\sqrt{2}/I)^2}$$

where:  $\omega = 2 \times \pi \times f_x$

Select  $R > R1$  for the entire range of desired F and B. R is the termination resistance—a fixed value.

Calculate:

$$C_{end} = \frac{1}{\omega R} \sqrt{R/R1 - 1}$$

and intermediate variable

$$C_t = \frac{1}{\omega^2 R^2 C_{end}} - C_{end}$$

Choose an inductor L, large enough so Cs

(below) is positive for the entire range of desired F and B.

$$C_s = \frac{1}{1/C_n - 1/C_t + N^2 L}$$

Use the three crystals, two inductors, L, and terminating resistors, R, for the filter. Adjust voltage variable capacitors to produce capacitances of the calculated values for  $C_p$ ,  $C_n$ ,  $C_{end}$ , and  $C_s$ .

## Appendix B. Receiver features.

Present-day shortwave radios use elaborate heterodyne schemes to achieve an apparent shift using a fixed frequency filter (see **Figure 10**). This feature is known as "IF shift," and involves the adjustment of the high frequency oscillator to shift signals within the fixed passband, while simultaneously adjusting the beat frequency oscillator to cancel out the effect of the signal shift on the audio tone of the received signal. This action makes it appear that the signal has remained steady in an adjustable filter passband.

More advanced shortwave radios use an even more elaborate double heterodyning scheme to achieve an apparent bandwidth adjustment (see **Figure 11**). Two fixed frequency crystal filters at different IF frequencies are required. By simultaneously adjusting the high frequency oscillator, second heterodyne oscillator, and beat frequency oscillator, the effective overlap of the two filter passbands is adjusted creating an apparent bandwidth adjustment.

Combination of the bandwidth feature and the IF shift feature, though elaborate, provides the full capability available in the most sophisticated radio designs. ■

## PRODUCT INFORMATION

### Philips ECG Expands Semiconductor Replacement Line

Philips ECG has expanded their ECG® Replacement Semiconductor product line.

The expansion features 60 new modules and ICs used in VCRs, TV, audio, PC and industrial equipment applications. Functions include voltage regulators, motor drivers, signal processors, decoders, AFPOs, small signal sub systems, deflection circuits and electronic attenuators. Also added to the newly expanded semiconductor line are discrete transistors, rectifiers and diodes.

Additions to the line are described in a new Master Replacement Guide supplement which cross references over 8,000 additional industry

part numbers to the ECG types that replace them. The ECG Semiconductor line has approximately 4,000 solid state devices that replace over 270,000 industry part numbers.

The complete cross-reference section from the Master Guide merged with that of Supplement 1 is also now available in an updated version of a floppy disk program for IBM PCs and compatibles.

All ECG products, literature and software are available through authorized Philip ECG distributors. To locate the nearest distributor, consult "Electronic Equipment & Supplies" in the telephone directory yellow pages or call toll-free, 1-800-526-9354.

# THE 12:1 BALUN

*Information on high and medium-power versions of this balun*

Over the years, the broadband, 12:1 balun has been of special interest to users of rhombic and V antennas. With this balun, the following advantages over multielement arrays can be fully exploited. Rhombics and Vs are simpler to construct both electrically and mechanically, and there are no particularly critical dimensions or adjustments. Furthermore, they give satisfactory gain and directivity over a 2-to-1 frequency range. They have also been found to be more effective in reception. Because their designs can present input impedances of 600 ohms, and very long lengths of highly efficient 600-ohm open-wire line can be used between the shack and the antenna, an efficient and broadband 12:1 balun is a natural for use with these antennas. But, to my knowledge, satisfactory baluns have not been available for this use.

\* Kits and finished units available from Amidon Associates, Inc., 2216 East Gladwick Street, Dominguez Hills, California 90220.

I will present two versions\* of a series-type balun designed to match 50-ohm cable to a balanced load of 600 ohms. One is a high-power unit designed to handle the full legal limit of amateur radio power over a bandwidth of 7 MHz to 30 MHz. The other is a medium-power unit capable of handling about one-half the legal limit of amateur radio power from 3.5 MHz to 30 MHz. Both baluns use a 1:1.33 unun in series with a 1:9 Guanella balun (hence the term series-type balun).

As you will see, these baluns are not especially easy to design and construct. The major difficulties lie in trying to obtain sufficient choking reactances in the coiled windings to meet the low-frequency requirements, and large enough characteristic winding impedances to meet the high-frequency requirements. Since a coiled winding with a characteristic impedance of 200 ohms (the objective) is practically impossible to obtain with any reasonable size

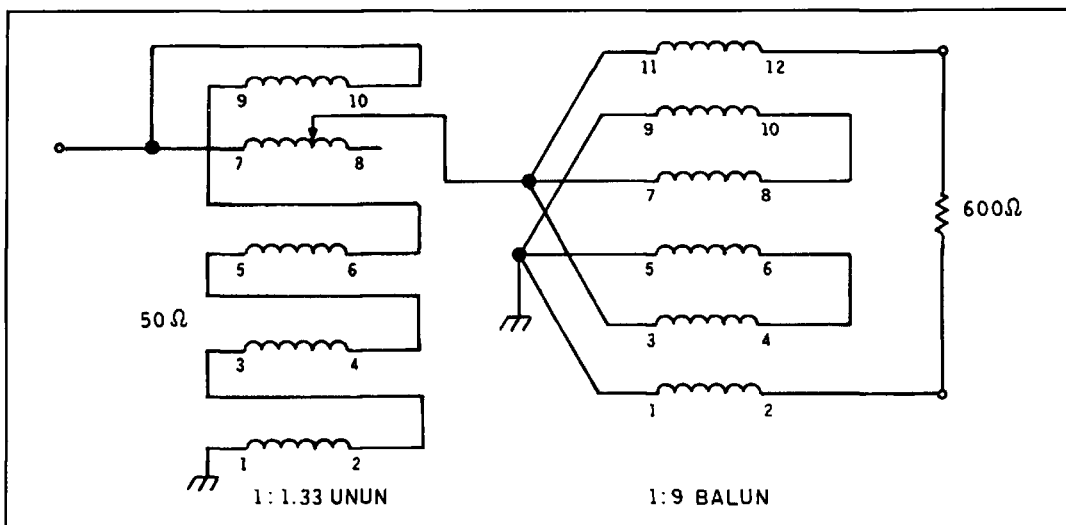

Figure 1. Schematic diagram of the series-type 12:1 balun using a 1:1.33 unun in series with a 1:9 Guanella balun.

of wire and number of turns, I used the compensating technique first described in my book.<sup>1</sup> Because the characteristic impedances of the 9:1 Guanella balun are somewhat less than 200 ohms, a compensating effect (and hence higher frequency response) can be obtained by having a higher (than the normal objective) characteristic impedance of the windings in the 1:1.33 unun. Earlier work (also described in my book) presented a 12:1 balun using a 1:3 unun in series with a 1:4 Ruthroff balun. The baluns presented here, using a 1:1.33 unun in series with a Guanella 1:9 balun, are much improved designs.

## A high-power 12:1 balun

**Figure 1** shows the schematic diagram of the series-type 12:1 balun used in both the high and medium-power versions. **Photo A** shows a top view of the high-power balun; **Photo B** shows a side view.

The 1:1.33 unun<sup>2</sup> has 5 quintufilar turns on a 1.5-inch OD ferrite toroid with a permeability of 250. Winding 7-8 is no. 14 H Thermaleze wire and the other four are no. 16 H Thermaleze wire. Winding 7-8 is also tapped at 3 turns from terminal 7.

The 1:9 Guanella balun has 8 bifilar turns of tinned no. 16 wire on each of the three toroids. Each wire is covered with Teflon™ tubing and further separated by two additional Teflon tubings. The characteristic impedance of the windings is about 190 ohms (the objective is 200 ohms). The ferrite toroids have an OD of 2.4 inches and a permeability of 250. The spacing between the toroids is 1/2 inch.

In matching 50-ohm cable to a balanced load of 600 ohms, the response is literally flat (within a percent or two) from 7 MHz to 30 MHz. Within this bandwidth, this balun is capable of handling the full legal limit of amateur radio power. In a matched condition, the expected insertion loss is about 0.25 dB.

## A medium-power 12:1 balun

**Photo C** shows the top view of the medium-power 12:1 series-type balun and **Photo D** shows the side view. This balun also has the same 1:1.33 unun described earlier.

The 1:9 Guanella balun has 11 bifilar turns of no. 18 hook-up wire on each toroid. The wires are further separated by two no. 18 Teflon tubings. The characteristic impedance of each winding is about 170 ohms. The toroids have an OD of 2.4 inches and a permeability of 250. The spacing between the toroids is also 1/2 inch.

In matching 50-ohm cable to a balanced load of 600 ohms, the response varies less than 5

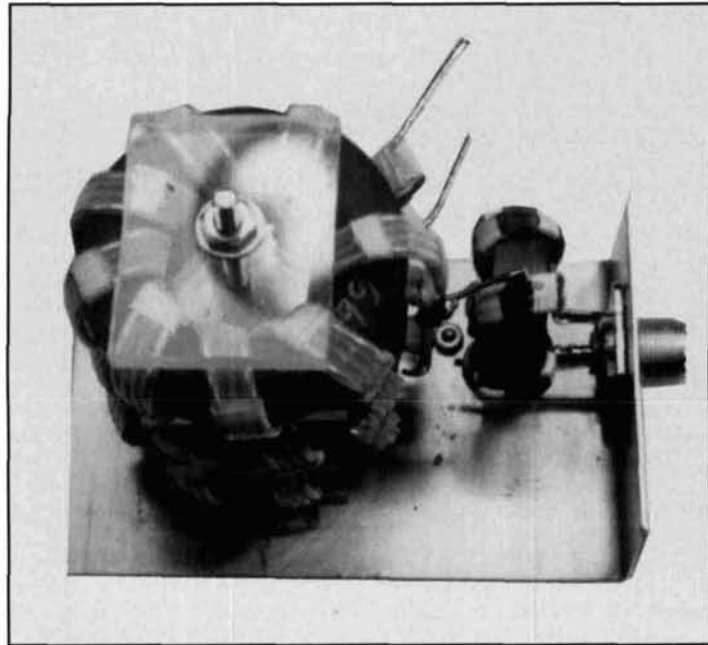

Photo A. Top view of the high-power 12:1 balun.

percent from 3.5 MHz to 30 MHz. Within this bandwidth, the balun can handle about one-half the legal limit of amateur radio power. As with the high-power version, the expected insertion loss is also 0.25 dB.

## Closing comments

In closing, I would like to make the following comments.

First, high-impedance baluns like the ones in this article are sensitive to metallic enclosures.

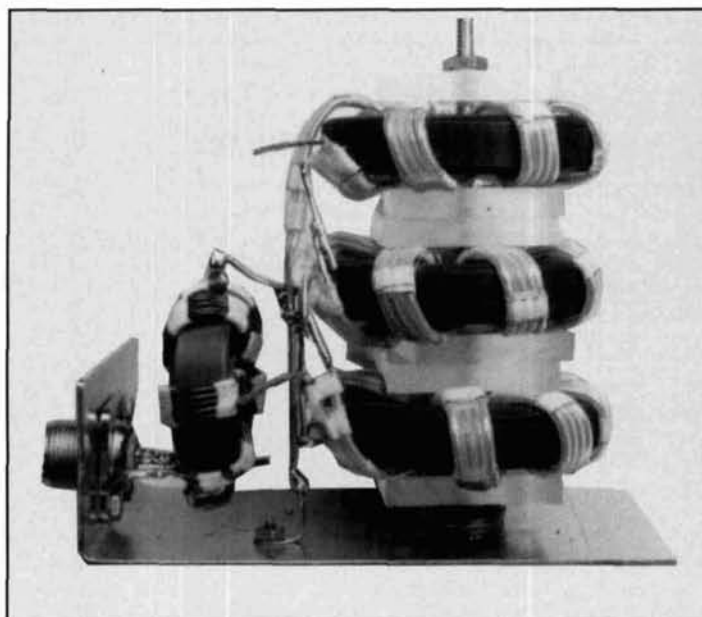

Photo B. Side view of the high-power 12:1 balun.

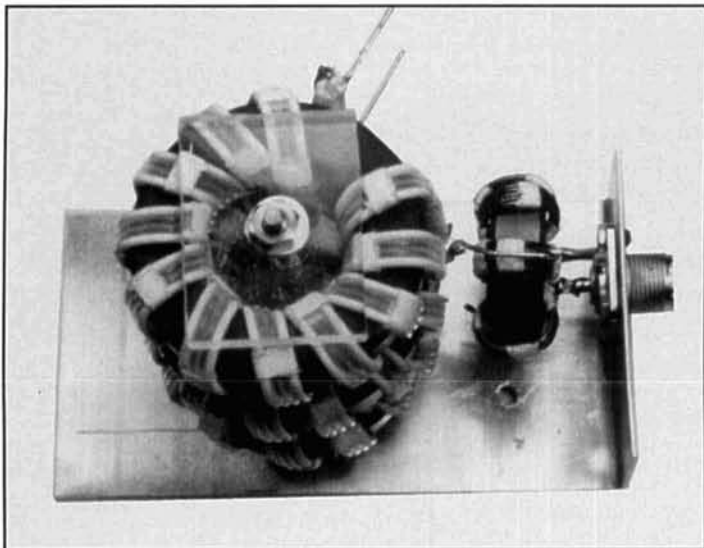

Photo C. Top view of the medium-power 12:1 balun.

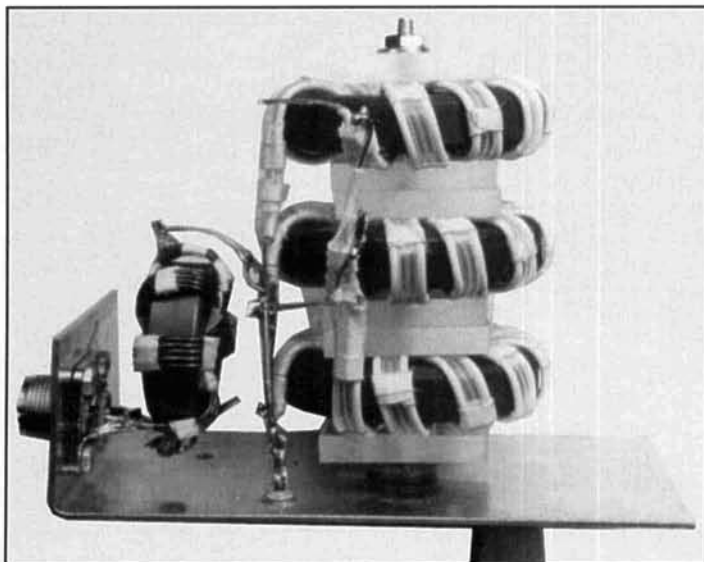

Photo D. Side view of the medium-power 12:1 balun.

If a minibox were to be used, I would suggest one with proportions 6 inches long by 5 inches wide by 4 inches high. Smaller metallic enclosures would reduce the characteristic impedances of the windings and thus effect the high frequency response. The subchassis shown in the photos were used because they provided the necessary electrical and mechanical support.

Second, the baluns described here also make excellent ununs, but with some compromise in the low-frequency response. I would suggest using the high-power unit only between 14 MHz and 30 MHz and the medium-power unit only between 7 MHz and 30 MHz.

Third, for readers interested in VHF operation, I would suggest the parallel-type approach described in my two previous articles.<sup>3,4</sup> In this case, a 9:1 Guanella balun is connected in series-parallel with a 1:4 Guanella balun. This would produce a broadband ratio of 12.25:1. By using 170-ohm twin-lead (about 10 inches long) threaded through ferrite beads with a permeability of 125, it appears that it is possible to match 50-ohm cable to a balanced load of 612.5 ohms throughout the VHF band.

And fourth, by using 125 permeability toroids in the 1:9 Guanella baluns, the insertion loss would be reduced by about one-half (0.12 dB). The trade-off would be in low-frequency response. The high-power unit would now cover about 10 MHz to 30 MHz and the medium-power balun, about 7 MHz to 30 MHz.

#### REFERENCES

1. Jerry Sevick, W2FMI, *Transmission Line Transformers*, 2nd edition, Amateur Radio Relay League, Newington, Connecticut, 1990.
2. Jerry Sevick, W2FMI, "The 1.5:1 and 1.33:1 Ununs," *CQ*, November 1992, pages 26-30.
3. Jerry Sevick, W2FMI, "6:1 and 9:1 Baluns," *Communications Quarterly*, Winter 1993, pages 43-51.
4. Jerry Sevick, W2FMI, "1.5:1 and 2:1 Baluns," *Communications Quarterly*, Spring 1993, pages 39-44.

## PRODUCT INFORMATION

### Spectrum Analyzer Selection with the New Tektronix Selection Guide

The new high-performance Spectrum Analyzer Selection Guide is available from Tektronix.

Detailed specification and application information on Tektronix Spectrum Analyzers is included in the selection guide. A handy "Spec at a Glance" reference chart helps you readily select the best solution for your application.

For a copy of the selection guide, request Tektronix literature #25A-8527-0. Or by calling 1-800-426-2200, Ext. 181.





# WAVELENGTH DIVISION MULTIPLEXING

*Without fuss or filters*

Just as RF multiplexers generally employ LC filters, and microwave multiplexers usually include cavities, fiber optic multiplexers have traditionally used simple optical filters to combine and separate signals. My students and I have been exploring an alternative technique that involves combining sound engineering practice with good old ham ingenuity. The result promises to simplify equipment, increase reliability, and improve both spectral and power efficiency.

## Introduction

Ever since Claude Shannon<sup>1</sup> first quantified the relationship between bandwidth and infor-

mation content, communications engineers have been vying to develop the most spectrally efficient modulation scheme. Most contenders have incorporated some form of multiplexing, where multiple communications channels share a common RF, microwave, or optical link.

Time division multiplexing samples a number of different information channels sequentially for transmission on a single carrier. Frequency division multiplexing generally involves summing a multitude of independent subcarrier frequencies, each with its retinue of modulation sidebands. In polarization division multiplexing, two different information signals are modulated onto carriers of the same frequency, which are propagated with their elec-

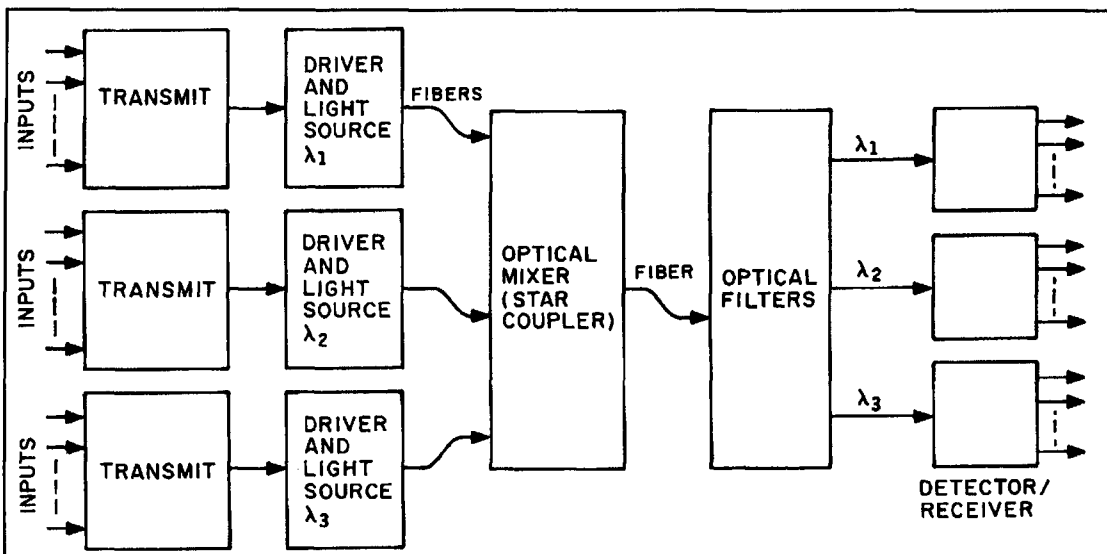

Figure 1. Typical wavelength division multiplexing scheme.

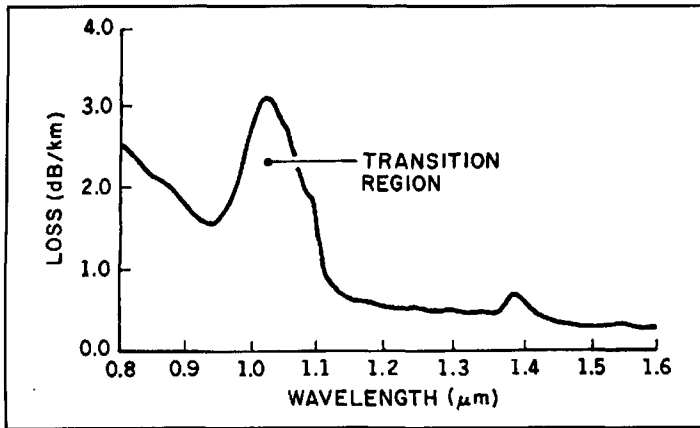

Figure 2. Attenuation versus wavelength for typical single-mode glass fiber.

trostatic fields oriented orthogonally. Wavelength division multiplexing incorporates independently modulated carriers of different frequencies sharing a common transmission medium. It is this latter technique to which the present study directs itself.

### Prior art

Figure 1 from Reference 2 depicts a traditional fiber optic wavelength division multiplexing scheme. Three infrared sources (lasers or light emitting diodes—LEDs) of different wavelengths are modulated independently with their respective channel intelligence. Although any number of optical carrier frequencies might be used, common practice is to generate carriers at wavelengths typically near 850, 1300, and 1550 nm. As you can see in Figure 2,<sup>3</sup> these wavelengths represent low loss windows for typical single-mode glass fiber.

Optical star couplers combine the three modulated carriers onto a single glass or plastic light pipe. At the receive end of the fiber, couplers split the output beam into three identical components, each containing elements of all three signals. Bandpass filters at the coupler outputs let each of three photodetectors “see” and respond to a single carrier frequency. Demultiplexing could be achieved as readily using wavelength selective couplers. In fact,

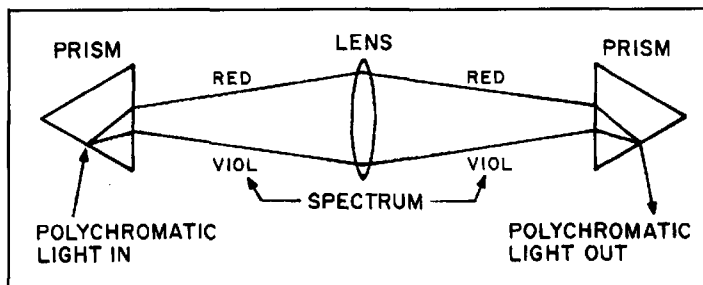

Figure 3. Prisms can both combine and separate spectral components.

Hecht<sup>4</sup> indicates that the “major use of wavelength-selective couplers is in WDM.”

The system just described, though effective, suffers from a number of drawbacks. The band-pass characteristics of the individual filters or wavelength selective couplers limit the modulation bandwidth, hence data rate, of the three channels. A filter narrow enough to reject the adjacent channels is likely to exhibit considerable insertion loss at the intended passband wavelength. Additionally, any three-way signal splitter will, even neglecting dispersion and reflective losses, attenuate the desired signal by at least 5 dB. For that matter, the coupler used to combine the signals at the transmit end will similarly contribute to system losses.

Consequently, the recovered optical amplitude will, for each channel, be at least an order of magnitude below what might have been accomplished over the same fiber, under single channel conditions.

Palais<sup>5</sup> notes that “wavelength division multiplexer designs can be based upon either of two mechanisms: angular dispersion or optic filtering.” He acknowledges the limitations of filter-type multiplexers, as noted, and then identifies two devices for achieving angular dispersion—the prism and the blazed reflection grating. He presents an application example using a combination of a GRaded INdex (GRIN) rod lens and a reflective diffraction grating, but leaves implementation of a prism multiplexer to the imagination of the reader. The present project represents an attempt to reduce to practice a multiplexer using prisms to achieve angular dispersion.

### The proposed solution

The ability of a triangular dispersing prism to separate polychromatic light into its constituent spectral components has been well known for three centuries, and was well documented by Newton. Dating from the same period, application of Huygens’ Principle<sup>6</sup> tells that such a prism should also be able to combine monochromatic light sources into a polychromatic beam (see Figure 3). Beam splitters are one such application of prisms. Hecht<sup>4</sup> states that “many optical systems use devices called beam splitters to separate (sic) light of different wavelengths into a single beam.” Why not apply prisms to the task of combining and separating modulated carriers of diverse wavelengths, eliminating the signal couplers and filters shown in Figure 1, and with them, their attendant limitations?

The solution proposed to my Fiber Optic Principles class at the Pennsylvania College of Technology in April 1992 is depicted in Figure 4. Here three modulated light sources (laser

diodes or LEDs) producing carriers of differing wavelengths are mounted on one face of a triangular prism, with spacing selected so a single polychromatic beam emerges. Said beam is in turn coupled into a glass fiber (a lens will doubtless be required to launch the resulting beam within the acceptance cone of the fiber). At the receive end of the fiber (where again a lens may be used to couple between fiber and prism), a second prism separates the wavelength multiplexed signal into its constituent parts, with a separate photodetector mounted at each of three appropriate spots on the prism's output face. As a result, wavelength division multiplexing and demultiplexing can be achieved without the use of couplers, filters, or their attendant loss.

The next step is to determine in the laboratory whether such a scheme can actually be reduced to practice.

## Reduction to practice

Although the intended application will likely involve the use of infrared carriers, prototyping the system with visible sources facilitates direct observation of the system's optical properties. Initial implementation of the proposed wavelength division multiplexing scheme was attempted with red, green, and blue coherent sources. (It is little coincidence that the television primary colors were selected for initial analysis.) The red source used was a small Helium-Neon laser, operating at its familiar 632.8 nm primary visible transition. For blue light, a 488 nm Argon Ion laser was chosen. A tunable Helium-Neon laser provided a green output at 543 nm.

Initial attempts to converge the three sources into white light through a dispersive 60-degree glass prism have been unsuccessful, due to the

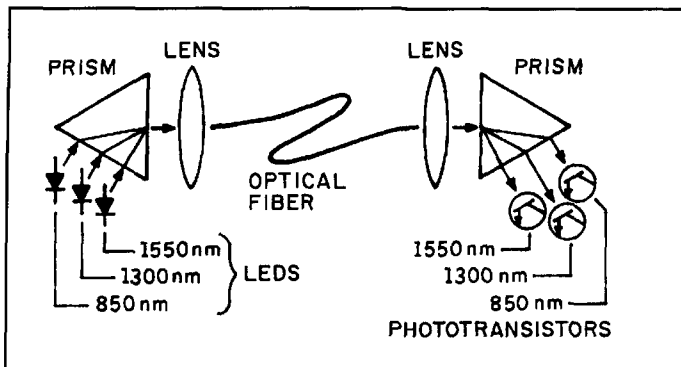

Figure 4. Use of prisms for wavelength division multiplexing.

critical angular and lateral alignment required of the three laser sources. It turned out to be far easier to combine the three carriers in a beam splitter constructed from four 45-degree reflective glass prisms, as shown in Figure 5.

Despite relatively high combining losses, a bright white beam emerged. By blocking combinations of laser beams, it was possible to crudely approximate the RGB Television secondary colors (yellow, magenta, cyan). A more precise rendering of secondary colors would require carefully balancing the amplitudes of the three primary sources.

In the demonstration system, polychromatic light emerging from the beam splitter was focused into a 10-meter length of 125-micron diameter multi-mode step index glass fiber, the ends of which were well cleaved and polished. A beam expander collimated the fiber's output, focusing it into a 60-degree dispersive glass prism. Three spatially distinct primary colors were clearly projected from the prism's output face. No attempt was made to modulate the three carriers, or to couple light from the prism into three independent photodetectors.

Nevertheless, I feel this breadboard system has

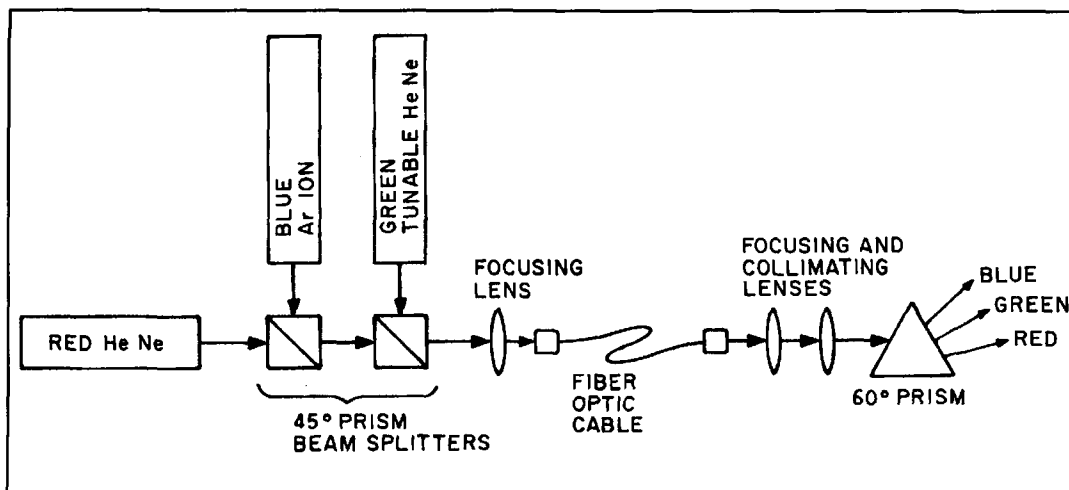

Figure 5. Prototype system demonstrated in the laboratory at the Pennsylvania College of Technology.

demonstrated the key features of wavelength division multiplexing.

## Implications for further study

The use of a dispersive prism for combining three laser sources into a monochromatic beam remains to be demonstrated. As was mentioned, the position of the three laser beams is critical. The beam splitters demonstrated are workable, but highly inefficient. It is important to solve the alignment problem if the system is to achieve its potential for power efficiency.

It's not clear how best to position photodetectors to recover the individual carriers efficiently. Mounting the detectors directly on a prism face is appealing in its simplicity, but again, physical positioning is highly critical. Once these problems have been addressed, the next logical step will be to modulate the individual sources and measure system risetime. This will allow for the quantification of the overall bandwidth limitations.

## About the institution

The Pennsylvania College of Technology is a subsidiary of the Pennsylvania State University, offering undergraduate technical training in 79 different specialties, including lasers, fibers optics, and electronic communications. Associate degree and, more recently, Baccalaureate studies feature relatively small classes, with emphasis on practical hands-on

experience. The investigation just described is typical of the kinds of projects in which our students are involved. Inquiries from students and industry are always welcome.

## Acknowledgments

I am indebted to the Spring 1992 Fiber Optic Principles class at the Pennsylvania College of Technology for acting as a sounding board for their Professor's ruminations on the concepts presented here. Three of my students in particular—Brett Shelton, Dennis Grace, and Brad Hilbish—showed great initiative in prototyping the proposed system. Thanks are also due to an enlightened colleague, laser instructor Karl Markowicz, for bringing some coherence to our analysis.

This manuscript first appeared in *Proceedings of Microwave Update 1992*, published in October 1992 by the American Radio Relay League, Newington, Connecticut. It is reprinted here with their kind permission.

## REFERENCES

1. C.E. Shannon, "A Mathematical Theory of Communication," *Bell System Technical Journal*, (27): pages 379 and 623, 1948.
2. H. Zanger and Cynthia Zanger, *Fiber Optics—Communications and Other Applications*, Macmillan, New York, 1991, page 116.
3. D.J. Sterling, *Technician's Guide to Fiber Optics*, Delmar, New York, 1987, page 63.
4. J. Hecht, *Understanding Fiber Optics*, Sams, Indianapolis, 1987, page 196.
5. J.C. Palis, *Fiber Optic Communications*, Prentice Hall, Englewood Cliffs, New Jersey, 1992, pages 230-235.
6. F.A. Jenkins and Harvey E. White, *Fundamentals of Physical Optics*, McGraw-Hill, New York, 1937, pages 52-53.

## PRODUCT INFORMATION

### **Tektronix introduces their new 2707 External Tracking Generator.**

The new 2707 External Tracking Generator from Tektronix provides a flexible, high-performance solution for swept-frequency measurements with the Tektronix 2711, 2712 and 2714 Spectrum Analyzers. The 2707's swept-frequency coverage is from 100 kHz to 1.8 GHz, and output level adjustments can be made in 0.1 dB steps. The 2707's capabilities can be shared among multiple 271X Spectrum Analyzers to make frequency-response or SWR measurements, check duplexers or cables, or characterize filters. It can also be used to characterize EMI test site attenuation.

The dynamic range of at least 100 dB allows the 2707 and associated spectrum analyzer to check duplexer isolation and filter rejection. You can set the 2707's output level from 0 dBm to -48 dBm (-1.2 dBmV to 46.8 dBmV) in 0.1 dB steps to maximize control over amplifier compression tests; and a frequency

offset capability provides correct spectrum analyzer/tracking generator alignment, even when testing very long cables or other devices that introduce significant delay.

Probe power is also provided in the new 2707 External Tracking Generator. This allows use of an active probe to couple signals to the spectrum analyzer input.

The 2707 is connected to a 2711, 2712 or 2714 Spectrum Analyzer via an umbilical cable. This allows easy setup and operation via menus displayed on the spectrum analyzer screen. The cable also provides a computer control path to the 2707 allowing the unit and spectrum analyzer to be controlled as a single instrument via GPIB or RS-232 for automated test applications.

For more information on the Tektronix 2707 External Tracking Generator and its options, please write on company letterhead to Tektronix, Inc., Test & Measurement Group, P.O. Box 1520, Pittsfield, MA 01202, or call 1-800-426-2200.

# THE EXCALIBUR DAP AND THE DIGITAL DATA SYSTEM

*Two facets of the world of commercial digital communications*

---

User demand for improved error rates and higher speed transmission has transformed the world of data communications. We have witnessed the analog market decline as it is replaced by more reliable and more accurate digital service.

Commercial digital communications started in the early 1970s with AT&T's DDS™. This was a service unlike any other AT&T had ever offered, based on end-to-end digital transmission to the user. The process avoided the conversion from the computer's digital signal to analog and back to digital again, thus eliminating noise and distortion. DDS is still the only service for which AT&T offers a performance guarantee.

The DDS, or Digital Data System, is a service furnishing digital access to a user via a private leased line into the Public Switched Telephone Network (PSTN). This access is provided for the transmission of digital data, using digital transmission facilities exclusively. The service supplies point-to-point and multi-point connections at synchronous data rates of 2.4 Kbps, 4.8 Kbps, 9.6 Kbps, 19.2 Kbps, and 56 Kbps, and point-to-point service at 64 Kbps. Synchronous means that the data is available with a clocking signal that is provided by the network.

To interface to the network, the customer must have a Data Service Unit/Channel Service Unit (DSU/CSU) connected between his Data Terminal Equipment (DTE) and the DDS line. The DSU/CSU is responsible for translating the signal level and format from the customer's DTE to the required level and shape for trans-



Photo courtesy of Racal Data Communications, Inc..

mission on the DDS network. An analogy for this would be a modem.

The PSTN has an interconnected network of facilities or *trunks* that run at very high data rates between the telephone companies (TELCOs) or carriers. AT&T term T1 describes a digital carrier facility running at 1.544 Mbps for short-haul transmissions in North America.

The signal carried by the T1 facility is called the Digital Signal Level 1 (or DS-1). A DS-1 is structured into frames of 193 bits each, repeated at a rate of 8,000 frames per second, or 193 bits per frame x 8,000 frames per second = 1.544 Mbps (see **Figure 1**). Each frame consists of 24 8-bit time slots plus 1 framing bit. Each time slot, when repeated over many

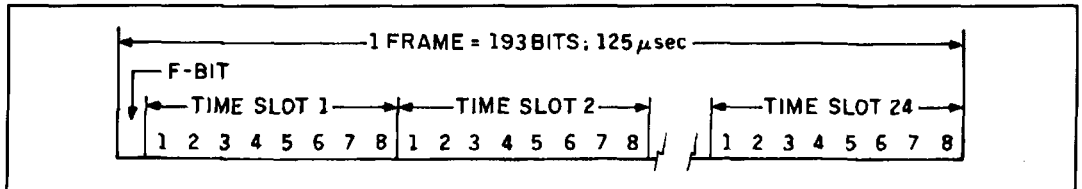

Figure 1. Interface at 1.544 Mbps.

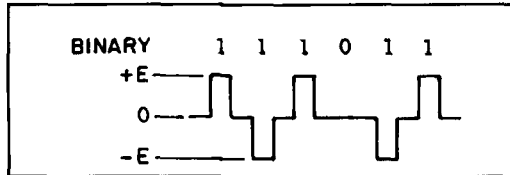

Figure 2. Bipolar Return-to-Zero signal (Alternate Mark Inversion).

frames, represents a “channel” referred to as a Digital Signal Level 0 (or DS-0). Each of these channels consist of a “standard” bandwidth of 64 Kbps, or 8 bits per frame x 8,000 frames per second. Note that a DS-0 can be further defined as a DS-0A or DS-0B. More on this later.

A process called Time Division Multiplexing or TDM combines all the channels to create the aggregate T1. This technique divides a circuit into a series of channels for simultaneous data transmission by assigning different time slots to each channel input. Multiplexing is the combining of all the channels; demultiplexing is the technique of stripping out or separating each channel (as needed) at the particular time slot(s) for accessing the data for a given channel. The number of channels times the bandwidth per channel equals the total bandwidth of the circuit.

Not all users (customers) require the full bandwidth of a standard DS-0 channel (64 Kbps). Fifty-six Kbps is a commonly available high-speed service. This is formatted into 8-bit bytes that include a C-bit (for control), giving 7 data bits x 8,000 frames per second = 56 Kbps. The channel can be further subdivided into smaller time slots using a technique called “byte stuffing.” This method is called Subrate Data Multiplexing, or SDM, by TELCOs. (AT&T calls it “fractional T1.Ed.)

Subrate is a generic term referring to any data rate under 56 Kbps. The DS-0 channel can be divided into 20 slots of 2.4 Kbps, 10 slots of 4.8 Kbps, or 5 slots of 9.6 Kbps, or 3 slots of 19.2 Kbps. Say a customer has his equipment running at an aggregate rate of 9.6 Kbps. In order to use the bandwidth properly and prevent data from skewing across the time slot or byte boundaries, the network’s equipment must repeat or “stuff” 4 identical bytes of data for every one byte of data that the customer’s DSU/CSU sends out. This works to maintain a

user-aggregate rate of 9.6 Kbps. At the receiving end of the network, the network will throw away 4 out of 5 bytes, delivering only 1 byte per slot time, thus maintaining the same 9.6 Kbps line rate on the local loop.

“But that only adds up to 48 Kbps in the time slot,” you comment. “What happened to the rest of the bandwidth?” At subrates the data is formatted into 8-bit bytes, including an F-bit (for framing) and a C-bit, leaving 6 data bits per frame x 8,000 frames per second = 48 Kbps available. This byte stuffing redefines the DS-0 into a DS-0A. The DS-0A designation means that only one customer or application still owns the time slot (or 64 Kbps channel) on one local loop. In this case, the C-bit is always set to 1.

The speeds can be mixed, however, with the highest speed determining the maximum number of available subchannels within the DS-0, calling it a DS-0B. For example, assume the DS-0 is divided into 5 subchannels of 9.6 Kbps (because of one customer’s requirements). Another customer’s application is running at 4.8 Kbps and is assigned another of the subchannels in the same time slot. The network’s SDM equipment provides the DS-0B format, where each subchannel is treated independently from different customers or different local loops. The network only uses one byte of 9.6 Kbps from customer one in the first slot, “byte stuffs” two bytes of customer number two’s single byte of data (at 4.8 Kbps) into slot 2, and fills the other 3 slots (at 9.6 Kbps each) with binary ones as filler—rounding out to 64 Kbps.

Now that I’ve defined some of the terms, let me explain how the data or signaling are actually handled in the transmission media. The local loop or interface to the user is similar to a phone line, but consists of 4 wires terminating in a modular type RJ-48 connector. One pair represents the Transmit Data and the other the Receive Data, giving a full duplex path. The pairs are annotated in a fashion similar to a standard phone line as: T, R, T1, and R1. Receive Data are called TIP and RING; Transmit Data designations are TIP1 and RING1. The signal format or baseband waveform is a *bipolar return to zero* signal with a 50 percent duty cycle, at an amplitude (dependent on line rate) from about 0.75 volts peak to almost 1.5 volts peak, when terminated with 135 ohms resistive impedance.

The actual wave form used in DDS service is called Return-to-Zero Alternate Mark Inversion or RZ-AMI (see **Figure 2**). With an AMI-type signal, the binary ones are represented by equal-amplitude pulses alternating in polarity. The zeros are represented by the absence of pulses. The net DC energy is eliminated, allowing the signal to be transformer coupled. The DDS network also requires that you be synchronized to the incoming bipolar bit stream. A network rule dictating that there be sufficient data pluses (binary ones) present in the bit stream, ensures timing recovery (or clock) from the signal.

Certain control signals have been defined to allow the network to signal a customer, or the customer to signal the network, regarding status, equipment, or other network conditions. These are special signals that can not be misinterpreted as customer data. To create these control sequences, an intentional violation to the AMI rule is transmitted. To maintain the required 0 volts DC component on the line, these violations (especially if there are two or more consecutive violations) are required to alternate in polarity. A few of these are described here:

Please note that the following notations apply:

- 0 Denotes zero volts transmitted (Binary Zero).
- B Denotes  $\pm E$  volts with polarity determined by bipolar rule (Binary One).
- V Denotes  $\pm E$  volts with polarity in violation of bipolar rule (Binary One).
- X Denotes 0 or B, if the number of Bs since the last V is Odd or Even, respectively.
- N Denotes that the bit value is disregarded, and 0 or 1 is acceptable.

**Out-of-Service signal or OOS.** A signal the network provides to the customer when the "other end" of the circuit is out of order. OOS is coded as 00BX0V at subrates, or N00X0V at 56 Kbps.

**Control Mode Idle or CMI.** A signal the network will send to a customer when no data is available. This condition should cause the customer unit to drop DCD (Data Carrier Detect). CMI is also what a customer's unit will send out to the network in the absence of data from his own DTE (i.e., RTS down). CMI is coded as BBBX0V at subrates, or BBBBX0V at 56 Kbps (see **Figure 3**).

**Zero Suppression Sequence or ZS.** To ensure clock recovery, there is a maximum limitation on the number of consecutive zero bit times that may be sent (6). To prevent exceeding this condition, the ZS control sequence is sent, and when it is received, a unit is required to replace the sequence with zeros—pre-

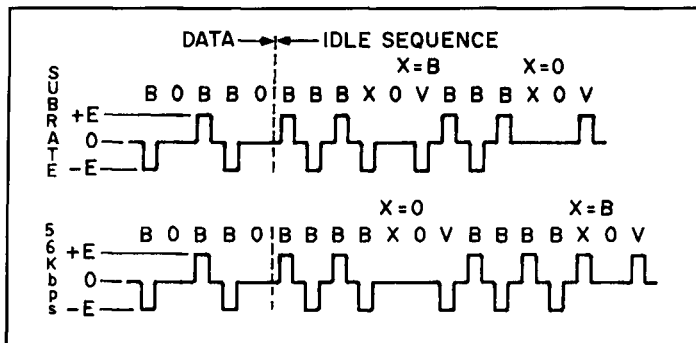

Figure 3. Control mode idle sequence.

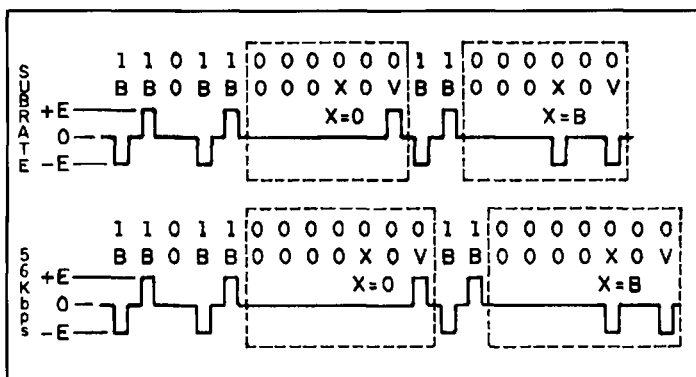

Figure 4. Zero suppression code and bipolar violation code sequence.

servicing the original data stream. ZS is coded as 000X0V at subrates, or 0000X0V at 56 Kbps (see **Figure 4**).

The primary advantage to having a digital signal is the ease with which it can be regenerated compared to an analog signal<sup>2</sup>. In **Figure 5**, a binary digital pulse is shown as it propagates along a transmission line. Note how the shape of the pulse becomes distorted by normal attenuation due to line length, noise, and/or other types of interference that is normal on a transmission line. Also note, however, that at a point on the line where the TELCO places a digital amplifier, or repeater, the pulse is recovered, reshaped, and then retransmitted.

Amplifiers of this type are put at regular intervals along the transmission line and are called "regenerative repeaters." In contrast, an analog signal by nature is required to be amplified and reproduced as is. That includes any noise and distortion that the signal may pick up along the way. All this noise gets amplified and accumulates right along with the original signal. The probability of errors in the data increases along with the length of the line and/or the number of times the signal is recovered and reamplified.

Two other advantages of digital circuits are their high reliability and the fact that they can be produced more inexpensively than analog circuits. Higher reliability can be had in the net-

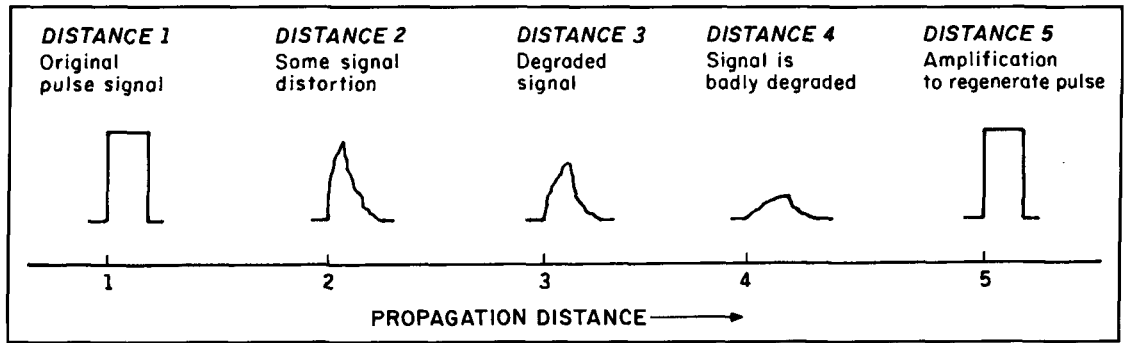

Figure 5. Pulse degradation and regeneration.

work because signals need not be converted as many times in digital systems as they must using analog modems. For modems, the conversion sequence goes from digital (at the customer's terminal) to analog (customer's modem), back to digital (the network does a conversion for T1 transmission), back to analog (the network converts again for the local loop to the customer's modem), and once more back to digital (at the customer's terminal). It is obvious that with each conversion there is a likely probability for equipment breakdown, or at the very least, for noise or interference to cause a high enough error rate to make the data rate or throughput drop significantly.

The quality of the DDS service is designed to average, on a daily basis, a minimum of 99.5 percent error-free seconds at 56 Kbps and up. A better rate is expected at the lower speeds. Keep in mind, quality is a measure of error performance *while the system is in use* (available). Availability shall average on an annual basis at least 99.9 percent. That is, annual down time is less than 0.1 percent.

To ensure the high quality of service and low

error rates, the TELCOs have built a series of diagnostic tests into the network that are available to the customer. The diagnostics consist of a series of loop-backs, and the Bit Error Rate Test (BERT). The loop-back command sequence is sent by the network to the customer's equipment (DSU) to check out the availability of the line (service) or to pinpoint the source of a problem. The command is sent to the customer as a control code or Bipolar Violation 0B0X0V (at subrates) or N0B0X0V (at 56 Kbps) as was described earlier. The customer's equipment is required to recognize this signal, stop sending its customer data, and instead loop back whatever data is received from the network. Another way the TELCO puts the DSU into a loop-back is to reverse the current flow in the loop from the TELCO's central office to the customer's unit. The customer's unit is required to identify this current reversal and transition into loop-back mode. Once in the loop-back mode, a BERT can be initiated to ensure the quality of the data being transmitted and received.

A major tradeoff or disadvantage of digital

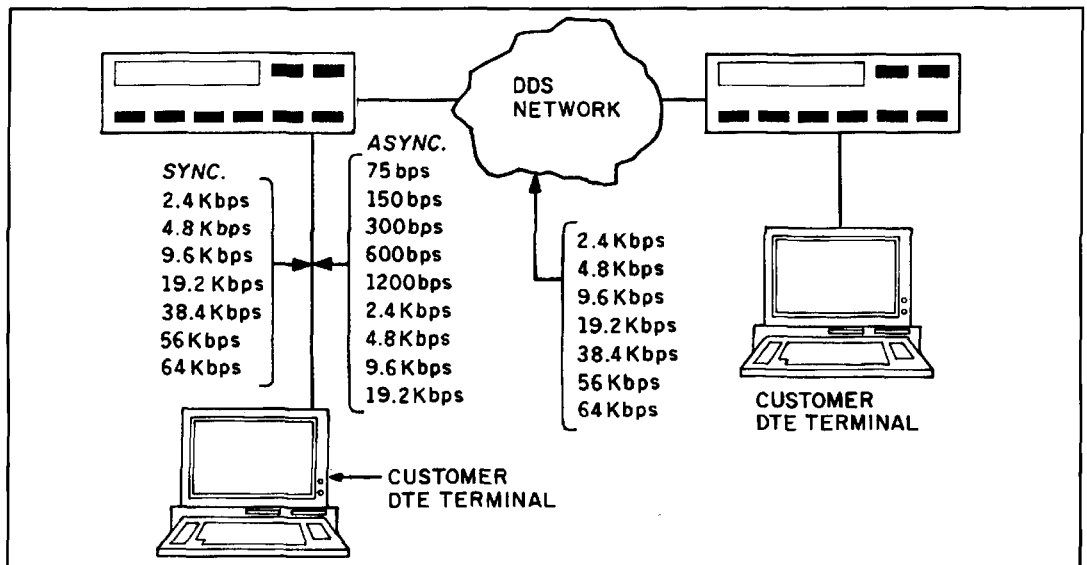

Figure 6. Point-to-point network.



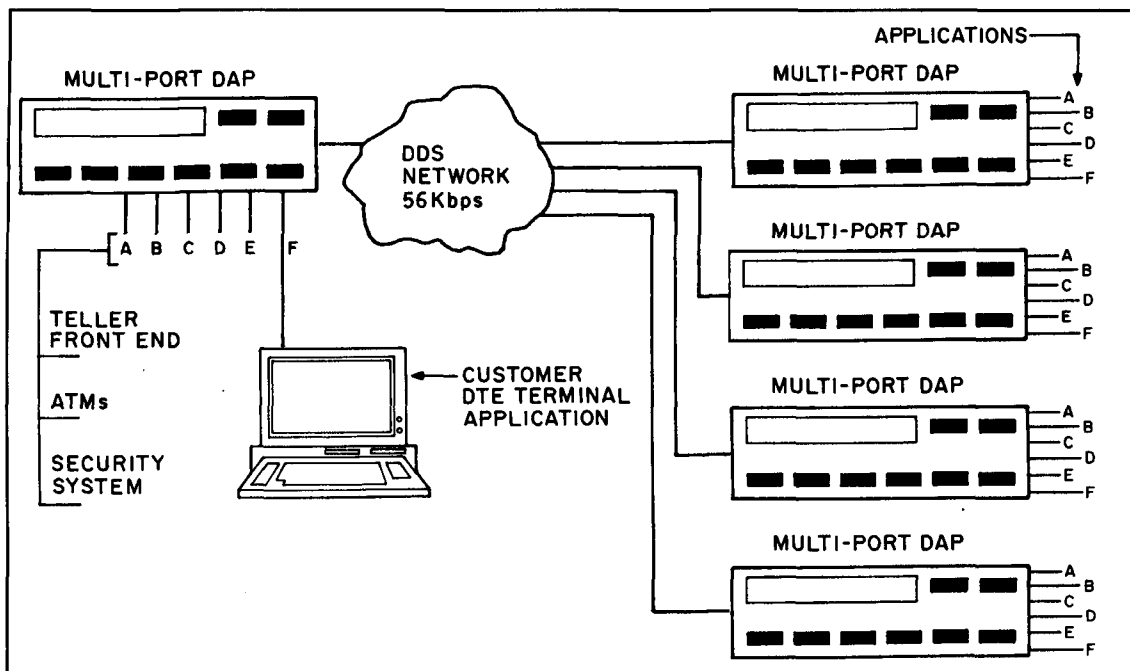

Figure 7. Multi-point network.

transmission is that a much greater bandwidth is required for communicating the same information in digital form than is required in analog form. Because an analog signal doesn't need to be synchronized to be detected and recovered, the necessity of synchronization for the detection of a digital signal can be listed as a disadvantage of digital transmissions.

## The Excalibur DAP

The Excalibur™ Multirate Digital Access Product (DAP) is a DSU/CSU that provides a versatile, user-friendly interface between the customer's DTE and all digital data services. Efficient and economical performance is provided in both point-to-point and multi-point network configurations. It operates at synchronous speeds of 2.4, 4.8, 9.6, 19.2, 38.4, 56, and 64 Kbps. It also can operate at all asynchronous speeds from 75 bps up to 19.2 Kbps. **Figures 6 and 7** are examples showing point-to-point and multi-point networks. The "Single-Port" DAP is used in the point-to-point circuits, and can be used as single application or single drop on a multi-point network. The "Multi-Port" DAP is used in the multi-point (also known as "multi-drop") circuits, and can also be strapped to operate in a point-to-point circuit as well.

The DAP provides a 48-character menu-driven front panel display for ease in monitoring, configuring, and testing. Prompts guide the user through each operating procedure. Control of remote unattended DAPs from the front panel of the local unit is easy. By simply enter-

ing the remote DAPs address (within a customer's network), you can perform any operating procedure as if you were at that remote site. Diagnostic tests such as loop-backs and bit-error rate tests can be started and monitored from the front panel using the menus.

The Excalibur DAP offers the versatility to change services as a customer's needs and/or the tariffs (from the TELCO) change. The DAP can run in many different modes of operation. Select a "basic digital service" and the customer can have "interruptive diagnostics." Under a second digital service, the carrier provides a "noninterruptive secondary channel." The DAP can also provide its own "noninterruptive secondary channel" on the carrier's "basic service." The customer, however, must be able to give up a small amount of bandwidth for this mode. A "Network Management System" called Communications Management Series (CMS®) is available, too. Using CMS, the DAPs can be configured, tested, and/or reconfigured as required using a personal computer.

"Interruptive diagnostics," as the name implies, means that the main channel customer data is stopped, or interrupted, while diagnostic testing is executing—using a portion of the main channel bandwidth. Noninterruptive diagnostics use a secondary channel allowing diagnostics to be performed independently, without affecting main channel customer data.

A point-to-point network would consist of two Excalibur DAPs connected directly together, with no intermediate processing nodes or computers. They may have as many switching facilities (i.e. phone line, network) linking the

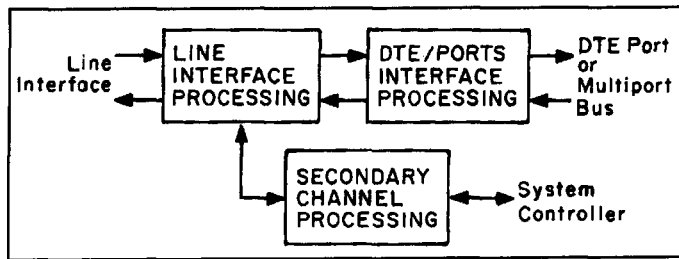

Figure 8. Data pump data flow.

two end points as needed, depending on the distance between them. On initial installation, the DAP needs to be configured for the DDS rate and type of service. These parameters are maintained in a nonvolatile section of memory, so this install process need not be performed again.

Depending on the rate at which the DTE is running, both RS-232D and V.35 interfaces are provided. The V.35 interface is for rates greater than 19.2 Kbps. Only one of the interfaces can be used at a time. The "data-pump" provides an async-to-sync converter built in supporting asynchronous DTEs operating at port speeds below 19.2 Kbps. If the DTE rate is lower than the minimum DDS line rate of 2.4 Kbps, or different than the DDS line rate in general, the "data-pump" provides "rate adaption" as necessary (Figure 8).

As you can see in Figure 8, the "data-pump" is a software module that services the DTE port(s) and the DDS line for both the transmit and receive functions. The data is read from the appropriate hardware register and stored in a buffer; then, when required, it is written to the appropriate register for transmission. The secondary channel data is stripped off (DDS receive) or merged into the data stream (DDS transmit) as part of the processing from the system controller. The secondary channel path can lead to the front panel or out to another port where the CMS is connected, if the unit is the main or central site. It is the subsystem controller's responsibility to execute any commands received via this secondary channel.

The Excalibur DAP also provides, as an option, an "Integral Dial BackUp." This option can be a 2-wire analog dial backup (up to 14.4 Kbps) or 4-wire (DDS style) switched 56 Kbps<sup>3,4</sup>. The switched 56 K is unique in that there is no connection before backup, and the customer is only paying for the local loop termination—just as with a normal dial-up modem. To establish a connection, the unit dials the number of the remote unit by "pulse dialing." When the connection is made by the remote unit answering the call, both units transfer their data path over to the newly established link. The DAPs monitor the dedicated DDS line continuously, and if the DDS line

comes back up, can decide when to terminate the dial backup call, and switch back over to the dedicated lines.

## The future

The future for digital communications is solid. Phone company technological advances in the area of fiber optics are making more and more bandwidth available. To take advantage of this, many customers are coming up with more complex applications needing the extra bandwidth, and with it higher speeds. These higher speeds are making conventional analog modems more and more obsolete because they can't run at speeds much higher than 19.2 Kbps.

The future for digital communications is also assured because of the extremely high reliability rate provided by the equipment and the network, combined with a very low error rate. As more customers transfer their services to the digital environment, the phone companies will lower tariffs to make it even more attractive.

The DDS network will eventually be absorbed by the Integrated Services Digital Network (ISDN)<sup>5</sup>. The DSU/CSU will be replaced by the switched digital modem, or Terminal Adapter, with speeds up to 2 x 64 Kbps = 128 Kbps. *Basic rate ISDN* provides 144 Kbps of bandwidth on one 2-wire circuit, divided into two 64 Kbps "B" channels and one 16 K "D" channel. The "B" channels allow either voice or data transmission; the "D" channel is used for TELCO signaling and X.25 packet switching data. The ISDN can combine a voice line and data line for simultaneous use—eliminating the cost of multiple lines, installation, and monthly fees. With ISDN, the customer will be able to combine a variety of unique telephone services provided by the TELCO within the office or home. Since ISDN will not peak for another 3 to 5 years, this seems to guarantee the continued success of DDS and the Excalibur DAP.

## Notes

Excalibur is a trademark and Communications Management Series (CMS) is a registered trademark of Racal Data Communications, Inc. Dataphone Digital Service (DDS) is a registered trademark of AT&T.

### REFERENCES

1. "Digital Data System, Channel Interface Specification." *AT&T Technical Reference PUB #62310*, November 1987.
2. Bernard Sklar. *Digital Communications, Fundamentals and Applications*. Prentice Hall, 1988.
3. "Special Access Connections to the AT&T Communications Network for New Service Applications." *AT&T Technical Reference PUB #41458*, October 1985. *Addendum to PUB #41458A*, February 1987.
4. "Switched 58 KB/S Data Service Unit." *US Sprint Technical Specification TS-0046*, Issue 4, April 1989.
5. William Stallings. *ISDN: An Introduction*. Macmillan Publishing Company, 1989.

# THE SOLAR SPECTRUM

## *Understanding the total solar irradiance*

---

In the Spring 1992 issue of *Communications Quarterly*, I briefly alluded to “total solar irradiance”—the sum of all solar energy received at the Earth outside its atmosphere—and its importance in determining systematic changes in the Sun’s diameter. This issue, I thought some amplification on this interesting topic would be in order.

Most of us have heard the term, “solar constant,” a not very fitting phrase (since it varies slightly) for what is more appropriately named the solar irradiance. During the first half of this century, a number of measurements of this quality were made from ground-based observatories; chief among them the long series of observations under the direction of C.G. Abbot of the Smithsonian Institution.

Actually, the first measurements of solar irradiance were obtained in 1837 by the Frenchman, C.S.M. Pouillet, using a simple device consisting of a blackened container filled with water. A thermometer inserted into the liquid recorded changes in the rate of temperature increase when the instrument was moved from the shade to sunlight. Pouillet determined a value of 1260 watts per square meter with his experiment—quite good in the light of modern observations, which show a value nearer 1368 W/m<sup>2</sup>.

Such instruments, called “pyrheliometers,” were eventually improved upon with electronic devices that operate by comparing the heat generated by the Sun with that of a fixed electrical current. The Smithsonian program, begun by S.P. Langley in 1902 and directed by Abbot until 1960, employed similar instrumentation; in this case the “bolometer” developed by Langley and calibrated by a special pyrheliometer built by Abbot. A recent analysis of the Smithsonian measurements show a mean value of 1353 W/m<sup>2</sup> for the irradiation component.

Abbot’s data indicated that the irradiance seemed to be constant, at least within an uncer-

tainty of about 1 percent. Unfortunately, even though these data were acquired at mountain-top sites, they still suffered from atmospheric absorption—mainly by ozone and water vapor—so that relatively large, and variable, corrections to the measurements were required to make the data useful. These problems have now largely been overcome through the use of spacecraft and similar vehicles that place monitors well above the densest portion of the Earth’s atmosphere.

When solar energy reaches the terrestrial environment it heats the atmosphere, surface, and oceans. Most of the infrared radiation is absorbed by carbon dioxide and water vapor as it traverses the atmosphere, and a portion escapes into space. It is interesting to note that if the atmosphere did not absorb such radiation, the Earth’s temperature could not support most forms of life.

Of course, there are large differences in the averaged amount of solar energy that is received at any one location of the Earth’s surface (this is known as the solar “insolation”); it is far less, some 20 percent on the average, than the total solar irradiance. The more pronounced of these variations occur because of latitude differences and time effects. For example, the annual amount of solar energy received in equatorial regions is over twice as great as at the poles where the Sun is below the horizon for a portion of the year.

Time effects are mainly seasonal. During the summer, any location receives more energy because the Sun is higher in the sky and daylight is longer. The effect is somewhat complicated by other conditions like the dissimilarity in energy storage capability between land and sea (water has the greater capacity). According to Kenneth J.H. Phillips,<sup>1</sup> this phenomenon more than compensates for additional radiation received during January when the Earth is closer to the Sun than it is in July.

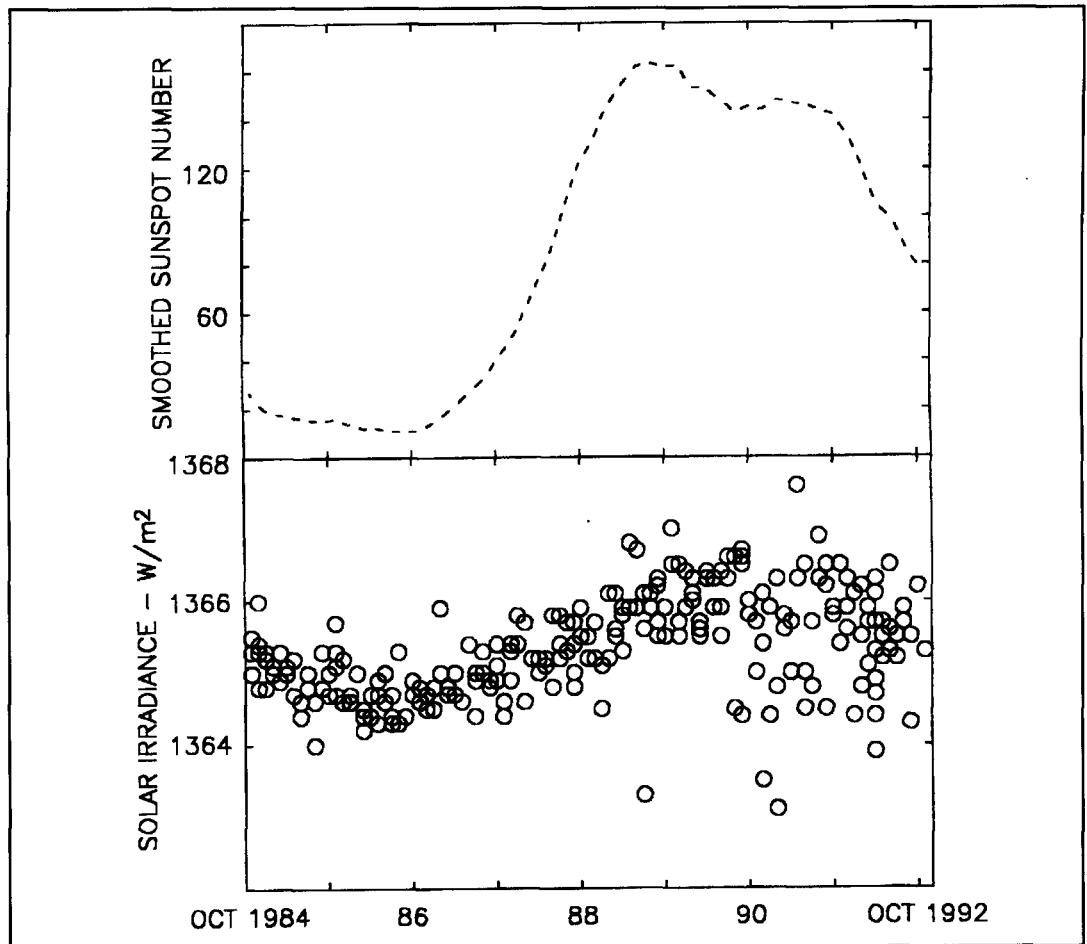

Figure 1. A comparison of smoothed relative sunspot number (upper) and solar irradiance as gathered by NASA's Earth Radiation Budget Satellite from October 1984 through October 1992.

More recent measurements of the solar irradiance are obtained with devices such as "active cavity radiometers," which typically consist of two identical, blackened, cone-shaped cavities and an electronic servo-system. The electrical system is usually designed to keep one of the cavities—the primary—at a slightly higher temperature than the secondary, or reference cavity. Sunlight enters the primary cavity through a shutter, causing it to heat up. Differing power requirements between open and closed conditions provide a good estimate of solar irradiance.

Figure 1 shows measurements gathered by monitors that operate on the same principle. The instrumentation was placed into Earth orbit during October 1984 aboard NASA's Earth Radiation Budget Satellite (ERBS). According to a description of this device presented in a recent issue of *Solar-Geophysical Data*,<sup>2</sup> information is collected and processed by the ERBS system in the following way:

"Individual total solar irradiance values represent instantaneous measurements that are cosine corrected and normalized to the mean Earth/Sun distance. Once each two weeks the

Sun is observed by the monitor for several 64-second intervals, each separated into two 32-second periods. During the first period the Sun drifts across the field of view, and its radiation is measured.

"During the second period a low-emittance shutter, representative of a near-zero irradiation source, is cycled into the field of view and its radiation field measured. The resulting measurements from the two periods are used to define the irradiance. Measurement precision is approximately 0.01 percent with an accuracy near 0.02 percent."

Similar monitoring systems are currently operating on the NOAA-9 and NOAA-10 spacecraft platforms as well as on ERBS, and have flown on Solar Maximum Mission, Nimbus-7, and other spacecraft.

Now all of this is well and good, but is the solar irradiation truly constant? The answer is no . . . and no! In the first instance—over the short term—it has been found that the transit of a large sunspot group across the Sun's disk produces a conspicuous decline in radiation emitted from the photosphere. Conversely, when sunspot activity is low, and few, if any spot

groups are present on the visible hemisphere, irradiation rises to relatively high levels. Moreover, when an intensity-corrected, total sunspot area is compiled over time, it is possible to determine an "irradiance deficit" that is directly attributable to sunspot presence. The resulting index is well correlated with the measured irradiance.

Why does the passage of a large sunspot group produce this effect? Because it is highly unlikely that energy generation deep within the Sun is mimicked precisely by photospheric activity (it takes radiation several million years to rise from the solar interior to its surface, and any variations would be smoothed together in the process), the energy blocked by the relatively cooler spot-group must reappear in some form in the future.

Some explanations of this effect suggest that the energy is stored within the group's magnetic field and reradiated later, while others propose that it is otherwise redirected, perhaps into magnetic wave motion. (The latter phenomenon would be temporary; as the waves deteriorate, energy would be reradiated.) Several investigators suspect that faculae—the large, bright appearing areas frequently associated with sunspots—play a role in this process.

Over the longer term it appears that irradiance rises and falls with the solar cycle (Figure 1), as it does show a certain small long-term variation as well. In fact, after allowance for spot-group effects, satellite measurements like those depicted in the diagram can be fitted to a sinewave with a period of about 10.95 years, in good agreement with the 11-year sunspot cycle. These and other investigations (e.g., Reference 3) have associated the irradiance ( $I$ ) with the sunspot number ( $R$ , Equation 1), and with the solar 10.7 centimeter radio flux ( $F$ ) as shown by Equation 2.

$$I = 1366.82 + 7.71 \times 10^{-3}R \quad (1)$$

$$I = 1366.27 + 8.98 \times 10^{-3}F \quad (2)$$

## Notes concerning Arthur Stokes' new VLF receiver design

Joseph J. Carr, K4IPV, whose fine articles concerning various types of small loop antennas appear in the Winter and Spring 1993 issues of *Communications Quarterly*, provides the following sources for the toroid inductors described in this column in the Spring issue (both companies publish catalogs):

Ocean State Electronics  
P.O. Box 1458  
Westerly, Rhode Island 02891  
1-800-866-6626

Maplins Electronics  
P.O. Box 3  
Rayleigh, Essex  
England SS6 8LR

Mr. Carr is currently engaged in developing Arthur Stokes', N8BN, new receiver, with an eye towards simplifying its construction by using a printed circuit board and smaller inductors with trimmer capacitors in place of the toroid coils (see Figure 2 and the associated parts list). We look forward to learning the results of these experiments.

## Recent solar activity and short-term forecast<sup>4</sup>

In a recent issue of the *AAS Solar Physics Division Newsletter*,<sup>5</sup> R. White and G. Rottman of the SOLSTICE science team, and their colleagues at the National Solar Observatory and Solar Research Corporation, report that a sud-

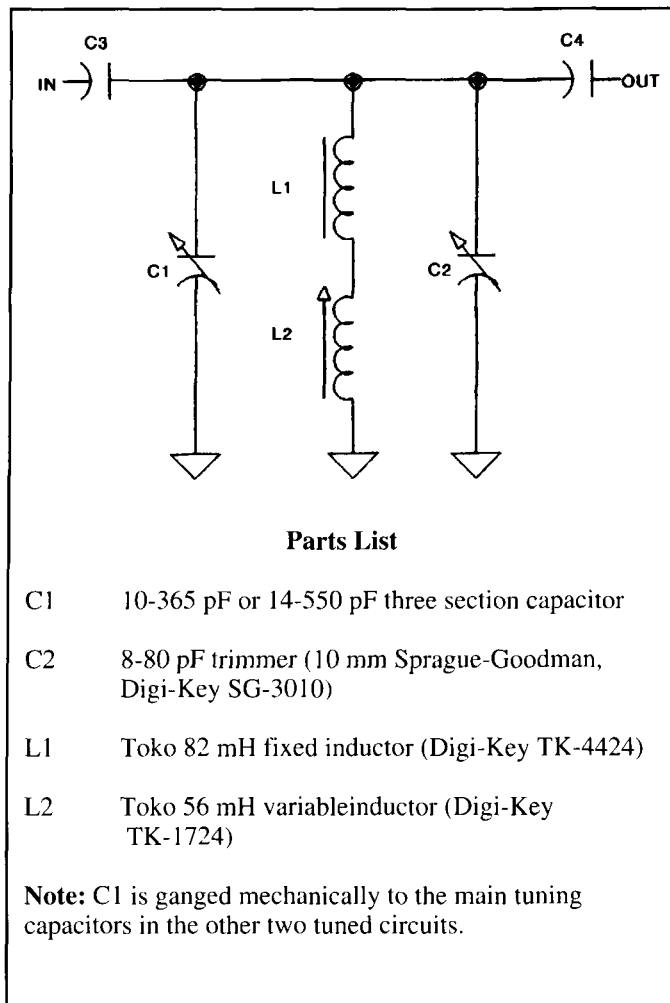

Figure 2. One possible modification of the new Stokes VLF receiver design. (From a drawing supplied by Joseph J. Carr.)

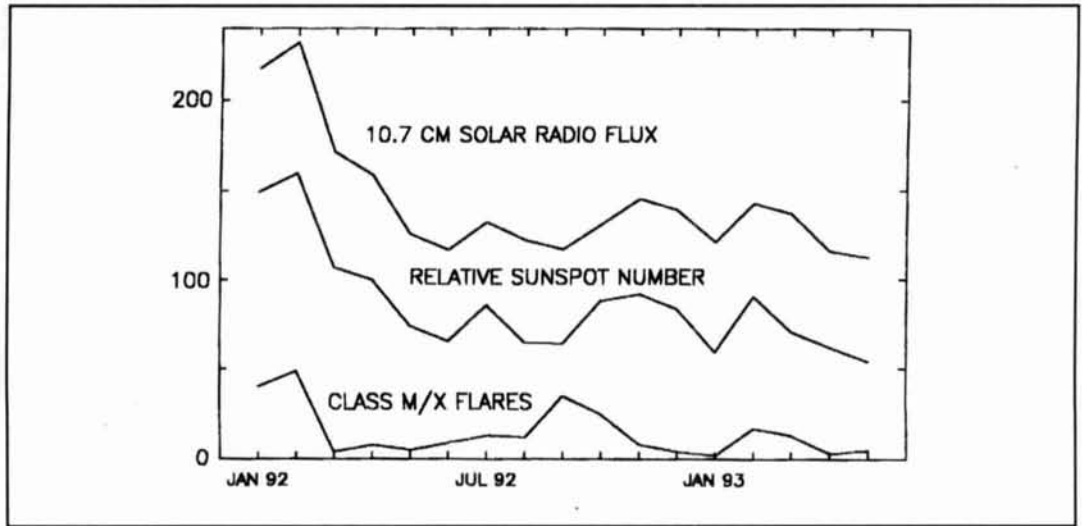

Figure 3. Monthly sunspot, solar 10.7 centimeter radio flux, and class M/X solar flare production indices between January 1992 and May 1993. Note the sudden decline and stabilization at a lower activity plateau.

den, steep decline occurred in a number of solar activity indices beginning February 1992. The sharp decrease ended in mid-1992, with the Sun at a considerably lower activity level which continues through May 1993.

In their article, these researchers report the decline appeared in Lyman- $\alpha$ , 10.7 centimeter radio flux, and 1-8Å X-ray flux, among other indices. According to White and his cohorts, the cause of this change arises principally from the level of activity in the Sun's Southern Hemisphere. They point out that a similar decrease in radio flux preceded the burst of activity in 1972 that spawned the potent August 1972 flare activity. **Figure 3** shows the 10.7 centimeter radio flux from January 1992 through May 1993, along with sunspot and class M/X flare production indices.

Otherwise, solar activity was mainly low between mid-February 1993 and June 1. As

expected, the geomagnetic field storm level increased around the vernal equinox (March 21), but in general only occasional periods of major or severe disturbances have occurred since then. Similar activity is expected to continue during the next few months as solar cycle 22 continues to decline to a predicted 1996 minimum. The next solar cycle, number 23 in the series of recorded cycles, is expected to exceed the current cycle in maximum intensity, and may be of shorter duration than the average.

#### REFERENCES

1. Kenneth J.H. Phillips, *Guide to the Sun*, Cambridge University Press, Cambridge, England, 1992.
2. *Solar-Geophysical Data*, Part II, Number 581, January 1993.
3. J.K. Hargreaves, *The Solar-Terrestrial Environment*, Cambridge University Press, Cambridge, England, 1992.
4. Portions of this information were taken from the SELDADS data base.
5. *AAS Solar Physics Division Newsletter*, 1993, Number 1 (submitted February 1993 by Dick White).

## PRODUCT INFORMATION

### Surface Mount Glass Models Added To Sprague-Goodman Pistoncap® Trimmer Line

Sprague-Goodman, Inc. has expanded its Pistoncap® trimmer capacitor line to include new surface mount glass models.

These new trimmers are surface mount adaptations of Sprague-Goodman's existing line of Pistoncap trimmer capacitors. They are available in vertical and horizontal mount types, in standard and extended capacitance ranges, both sealed and unsealed.

All Pistoncaps permit high resolution, by means of precision, multiturn adjustment. In addition to surface mounting, Pistoncaps are available in a variety of standard mounting

styles for panel and printed through-hole mounting. All capacitors in the line meet applicable MIL-C-14409D requirements.

For additional information, contact Sprague-Goodman Electronics, Inc., 134 Fulton Avenue, Garden City Park, NY 11040-5395.

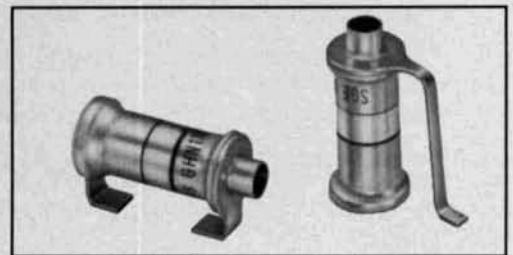

Yoji Tozawa  
Hiroyuki Sakaue  
Ken-ichi Takada  
Koji Furukawa  
Shinichiro Takemura  
JRL-2000F Design Team  
Japan Radio Co. Ltd.  
Reprinted with  
permission from  
*JRC Review*

# HF MOSFET LINEAR AMPLIFIER

*The JRL-2000F linear uses solid-state technology designed for high-power transmitters*

Some 1 kW-class HF transmitters use bipolar transistors in their final-stage power amplifier. However, solid-state amplifiers have their disadvantages: a low margin of output power, sensitivity to excessive currents, outputs and thermal stresses, high intermodulation distortion (IMD), and low efficiency.

To solve these problems, Japan Radio Co. Ltd. (JRC) has developed 2, 3, 5, and 10 kW HF transmitters with power amplifier modules that use power MOSFETs for their final stage devices.

This article describes an HF linear amplifier developed for amateur radio stations, which incorporates new solid-state technology designed for the high-power transmitters used for the GMDSS and coastal radio stations. The new HF linear amplifier was created with an eye to superior performance and ease of operation. It features a low IMD, a high margin of output power, a highly efficient MOSFET full-bridge switching regulator or power factor improvement, and an instantaneous switching antenna tuner.

## Introduction

The development of semiconductor technology has already replaced transmitting tubes with



Photos in this article appear courtesy of Japan Radio Co., Ltd.

solid-state circuits for the final-stage power amplifiers in transmitters and broadcasting equipment.

All solid-state units with bipolar transistors have become popular for large HF transmitters of up to 1 kW output. Using semiconductors in the final stage has provided many advantages, including: low voltage for the power supply, adjustment-free operation, reduced size, and so

**Table 1. Specifications.**

Operating frequency bands:	1.9, 3.5, 3.8, 7, 10, 14, 18, and 21-MHz amateur bands (24, 28-MHz band: antenna tuner only)
Rated output power:	SSB, CW, RTTY, 1 kW PEP
Output impedance:	50 ohms unbalanced, VSWR < 3.0 (16.7 ~ 150 ohms)
Unwanted radiation:	-60 dB or less (below PEP)
IMD:	-35 dB or less (below PEP)
Input impedance:	50 ohms unbalanced
Excitation power:	100 watts maximum
Frequency switching time:	less than 0.1 second
Power supply voltage:	180 to 264 volts AC, single phase, 50/60 Hz
Power consumption:	2.5 kVA or less (at 1 kW output)
Temperature range:	-10 to +40°C
Protection items:	excessive PA current, PA overheat, PA abnormal load, excessive AC power supply voltage, power supply overheat, PA failure, excessive antenna VSWR, excessive excitation power, and antenna matching anomaly
Dimensions:	430 W x 300 H x 420 D mm (excluding projections)
Weight:	approximately 2 kg

on. However, power amplifiers incorporating bipolar transistors have some disadvantages. These include: a low margin of output power, susceptibility to thermal stress and reflected power, low input/output linearity, and high IMD. Therefore, it has not been generally recognized that the solid-state amplifier is superior to the vacuum-tube type.<sup>1,2</sup>

As was stated above, the HF linear amplifier described here has been designed for amateur radio stations, making use of the solid-state technology intended for professional transmitters. Development has concentrated on achieving improvements in basic performance and ease of operation by focusing on a PA module using MOSFETs with low IMD and sufficient output margin. Also included are a switching power supply with a power factor corrector to

meet home power service conditions and a built-in instantly switchable antenna tuner.<sup>3</sup> **Table 1** gives unit specifications. **Photo A** shows an inside, overhead view of the unit.

## Problems of conventional devices

Most HF linear amplifiers on the market have an output range of 500 watts to 1.5 kW. Most use vacuum tubes and must be tuned manually to a desired frequency. They also have other problems like bulkiness and weight, loud cooling fans, large AC input current, and the absence of an output power meter. Some fully solid-state devices designed to solve these problems have appeared on the market, but they are unpopular due to their low margin of output power and low input/output linearity.

## Design criteria

Before developing the JRL-2000F, JRC set basic policies to follow in solving the problems of conventional amplifiers.

(1) To take advantage of the power MOSFET circuit technology to achieve improved input/output linearity and a sufficient margin of output power.

(2) To use a fully automatic tuner with a multi-channel memory to enable instantaneous frequency switching.

(3) To incorporate a compact, light switching power supply unit to meet a variety of supply voltages worldwide.

(4) To enable the connection and selection of two or more antennas.

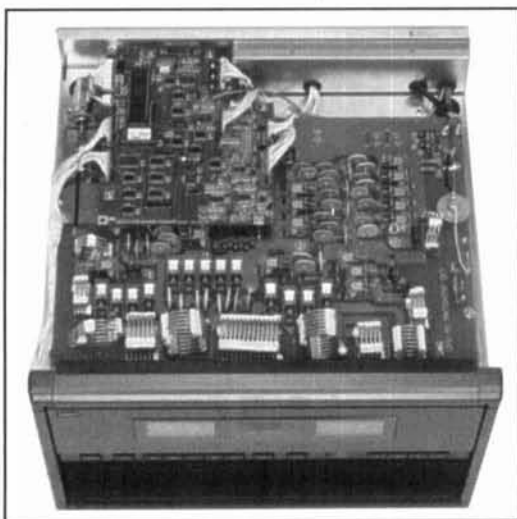

**Photo A.** Inside the JRL-2000F.



Figure 1. Block diagram for HF linear amplifier.

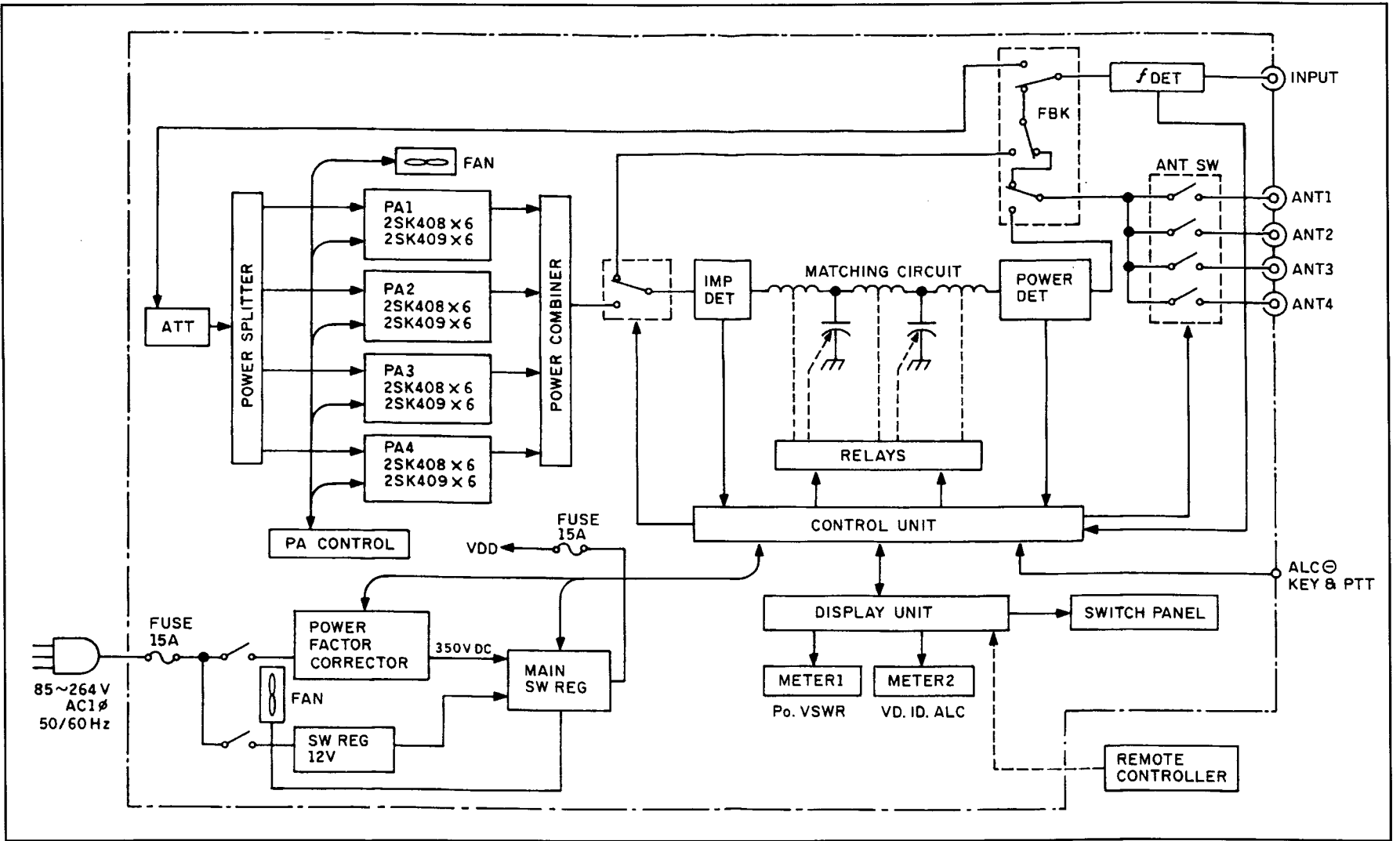

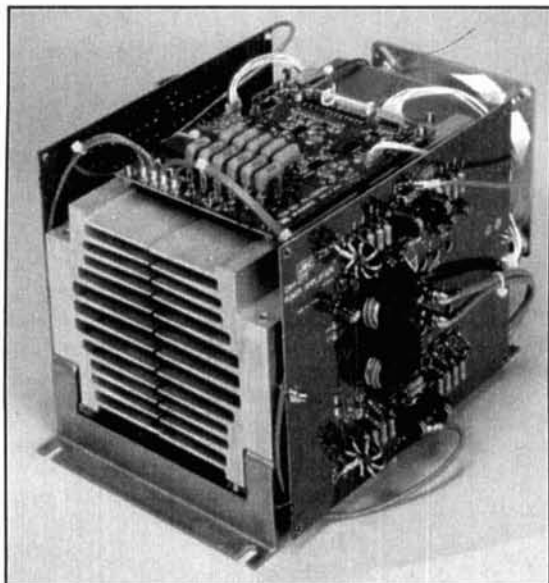

Photo B. The PA unit.

- (5) To enable full break-in operation (QSK).
- (6) To reduce the noise of cooling fans and relays.
- (7) To produce an interface applicable to any type of exciter.
- (8) To create a sophisticated appearance.

### Configuration

The JRF-2000F block diagram is shown in **Figure 1**. It consists of a PA unit, a matching unit, an antenna switching unit, a control unit, a display unit, and a power supply unit.

### The PA unit: PA with 48 power MOSFETS

The PA unit (see **Photo B**) is equipped with four wideband power amplifier circuits of 250

watts output (PA1 to PA4), each incorporating 12 VHF power MOSFETs, six 2SK 408s, and six 2SK 409s. The rated output of 1 kW is obtained by combining the outputs from these circuits.

The class AB linear power amplifier using MOSFETs has excellent linearity and a low high-order IMD. Balanced operation without thermo-runaway is possible in a parallel combination because the MOSFET has a negative temperature coefficient.<sup>4</sup>

### SEPP wideband power amplifier circuit

The HF wideband power amplifier circuit is commonly configured as a transformer-coupled push-pull circuit (**Figure 2**). In this circuit, the two power waveforms, respectively amplified in half cycle by two transistors, are mixed by combining transformer T2 to obtain an output waveform. However, this process yields output waveform distortion due to the output capacitances of the transistors and the transmission delay of transformer T2, thus degrading the input/output linearity.<sup>5</sup> When bipolar transistors are used, the input impedance between the base and the emitter is 1 ohm or less, and shows nonlinearity characteristic of a diode. Therefore, it is quite difficult to match this impedance to the input impedance of 50 ohms for the power amplifier circuit in wideband mode. It is also impossible to obtain excellent characteristics in all the bands because of insufficient impedance matching in the amplifier circuit, as shown in **Figure 2**. The PA circuit of the JRL-2000F uses a current combining Single Ended Push-Pull (SEPP) circuit to compensate for the deficiency of the transformer-coupled push-pull circuit, so an output waveform with less distortion component is obtained. Thus,

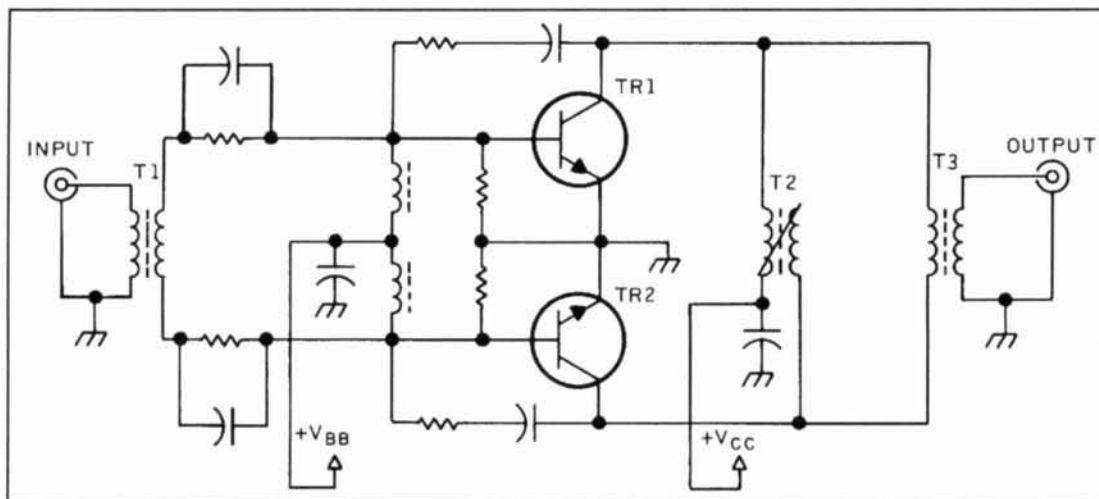

Figure 2. Transformer-coupled push-pull PA circuit.

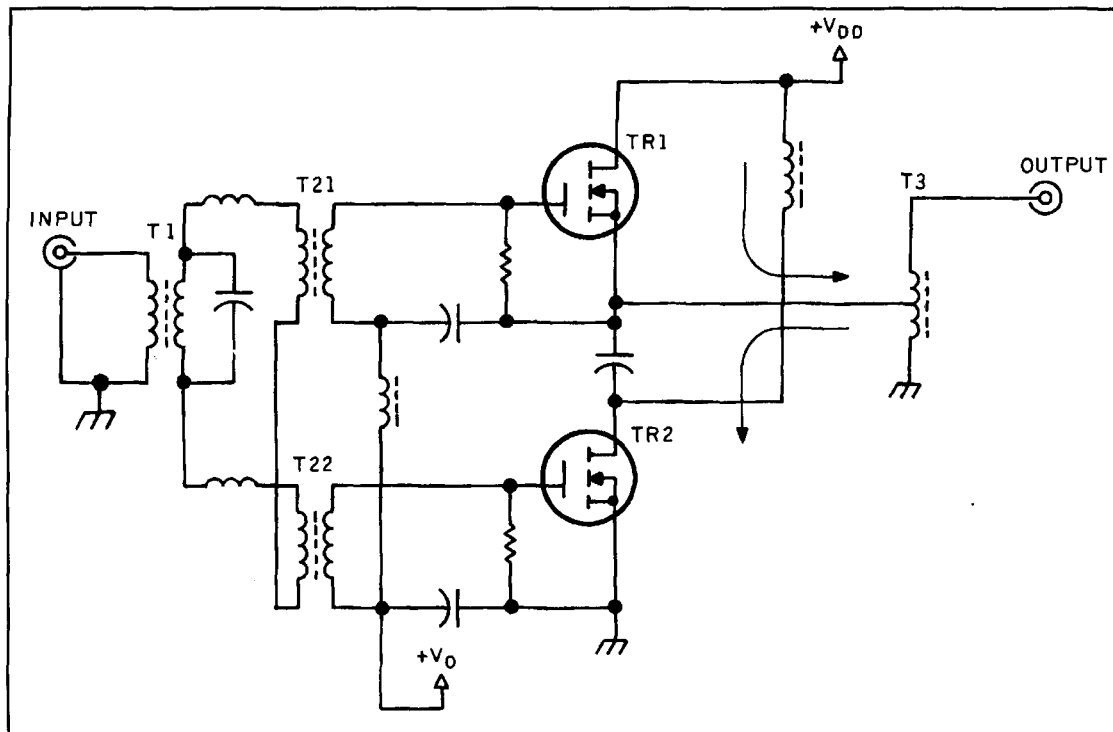

Figure 3. SEPP PA circuit with MOSFET.

low distortions like the second-order higher harmonics of  $-40$  dB and the third-order of  $-30$  dB can be obtained for the combined output of the four PA circuits.<sup>6</sup>

The PA circuit is shown in **Figure 3**. As for the impedance matching at the input circuit, an excellent input impedance characteristic is obtained by forming a circuit in which the input capacitance of the insulated gate MOSFET is included as part of the low-pass filter network. **Figure 4** shows an equivalent input circuit. C1 and C2 are MOSFET input capacitances, R1 and R2 are terminating resistances and with L1, L2, and L3 comprise a  $\pi$ -type low-pass filter. T1 is a step-up transformer that converts the impedance of the low-pass filter to 50 ohms. This network achieves the VSWR value of less than 1.2 in all bands at the input terminal.

As has been described, the PA circuit is designed with a focus on impedance matching in the input/output circuits. As a result of two-tone tests, the constant gain in all the bands of 1.6 to 30 MHz, and the intermodulation distortion of  $-35$  dB or less (below PEP) were achieved at rated output. The MOSFET features a low high-order IMD, as shown in **Figure 5**, in contrast to the bipolar transistor which shows a high IMD in the 11th and higher order.

### Bias control circuit

When a class AB linear power amplifier circuit is constructed with MOSFETs, the operat-

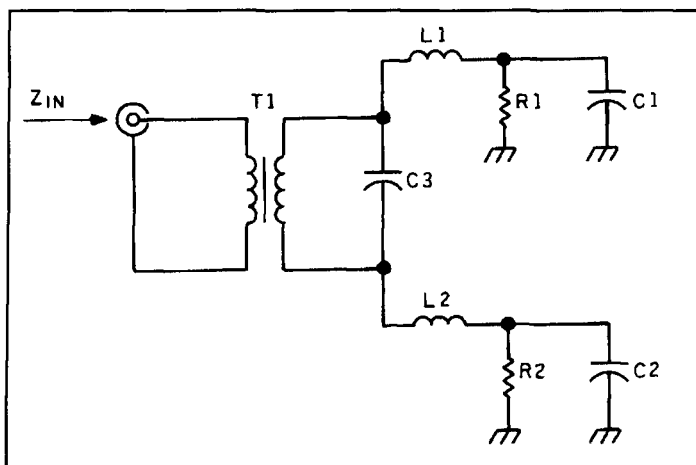

Figure 4. Equivalent input circuit in SEPP PA.

ing-point gate voltage is relatively high and the drain idle current is also high because the rise of the gate-source voltage ( $V_{GS}$ ) versus drain current ( $I_D$ ) curve of the MOSFET is not as sharp as that of the bipolar transistor. This characteristic results in a low high-order IMD and the operating point of the bias voltage is not critical. Adjusting the bias voltage on which the excitation voltage is overlapped is apparently equivalent to adjusting the gain of the power amplifier. The JRL-2000F linear amplifier takes advantage of this characteristic to achieve operational stability by controlling the bias voltage  $V_{GS}$  according to its operating condition.

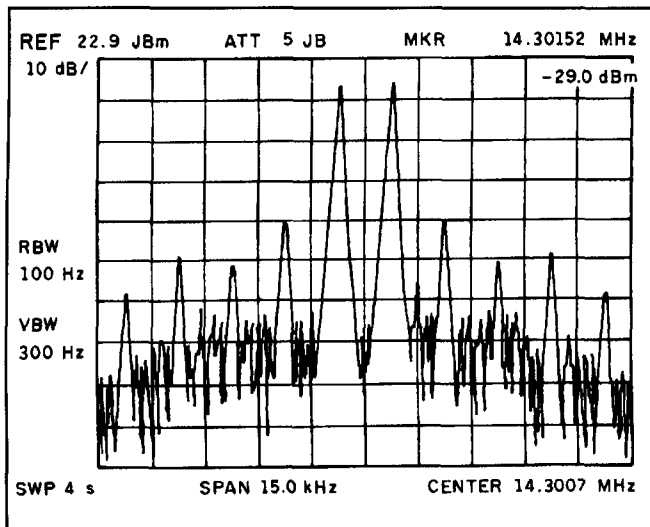

Figure 5. IMD characteristic at two-tone test.

## Radiating system

For a PA system that provides a large output with a small number of power transistors, forced cooling with quick-response thermal radiators is required because heat concentrates in the radiator. In this case, a radiator with heat pipes or high-density fans is needed; however, this would be costly and create a noise problem caused by overuse of cooling fans.

Forty-eight heat-resistant MOSFETs are used in the PA to radiate heat separately—enabling the use of a radiator with a large thermal time constant. Because it takes the radiator a relatively longer time to reach a high temperature,

FREQUENCY	ANTENNA			
	1	2	3	4
1.600 ~ 1.610	DATA	DATA	DATA	DATA
1.610 ~ 1.620	DATA	DATA	DATA	DATA
1.620 ~ 1.630	DATA	DATA	DATA	DATA
1.630 ~ 1.640	DATA	DATA	DATA	DATA
⋮	⋮	⋮	⋮	⋮
⋮	⋮	⋮	⋮	⋮
⋮	⋮	⋮	⋮	⋮
⋮	⋮	⋮	⋮	⋮
⋮	⋮	⋮	⋮	⋮
⋮	⋮	⋮	⋮	⋮
⋮	⋮	⋮	⋮	⋮
⋮	⋮	⋮	⋮	⋮
⋮	⋮	⋮	⋮	⋮
⋮	⋮	⋮	⋮	⋮
29.44 ~ 29.67	DATA	DATA	DATA	DATA
29.67 ~ 29.99	DATA	DATA	DATA	DATA

Figure 6. Memory map.

it is possible to delay the operation of cooling fans actuated when a high-temperature is detected in the radiator. This is convenient for intermittent operation in SSB or CW mode frequently used at amateur stations, because the fans are slow to begin operation and, when operated, their rotation time is short. Low-noise fans, located in the rear to alleviate noise problems, are used in the JRL-2000F.<sup>13</sup>

## Output matching circuit

The output matching circuit receives a wide-band output from the power amplifier unit and matches the antenna load (VSWR < 3.0) to a load impedance of 50 ohms of the power amplifier unit. At the same time, it attenuates undesired harmonics. The large power circuit in the matching circuit consists of capacitors with high voltage ratings, coils, and the relays to switch them. The relays are controlled by a microcomputer in the control circuit and all the relays operate automatically. An outline of the automatic tuning system follows.

First, the circuit receives a high-frequency output from the exciter and obtains frequency information through the frequency counter incorporated in the control circuit. When the high-frequency output from the exciter is fed into the PA unit, it is not applied to any antennas because the bias voltage is negatively controlled. The relays are preset in a standard state according to the information received.

Second, the high frequency output from the exciter bypasses the PA unit and is applied to the L- $\pi$ -L matching circuit. The absolute value, Z, and phase  $\phi$  of the impedance vector are detected by the impedance detecting circuit, converted to digital signals, and then sent to the control circuit. In the control circuit, the relays are switched according to the information of Z and  $\phi$ , and the input impedance is adjusted to be  $Z = 50 + j0$  ohms. In addition, the control circuit has a memory matrix for 1820 channels consisting of four antenna numbers 1 to 4 and 455 HF sub-bands. When matching is obtained, the states of all the relays are stored in memory. The memory map is shown in Figure 6. Once stored, a matching state is recalled by immediately switching each relay when one frequency or antenna is changed to another. If the frequency or antenna number selected is one for which matching has not been provided, the frequency indicator on the front panel flickers indicating the absence of stored data.

The forward/reflected current to/from the antenna is detected in the output detecting circuit, and the output power and the VSWR value of the antenna are indicated by the meters on the front panel.

The output of the PA unit in the JRL-2000F

has a small harmonic component, so the Q value of the tank circuit can be reduced and the matching circuit can be realized with a small amount of loss. A high-speed, compact, and lightweight matching circuit can also be designed because fewer high-voltage parts are employed due to the low impedance matching and the use of relays for switching.

### Antenna switch unit

The JRL-2000F incorporates an antenna switch unit to connect up to four antennas.

### Automatic antenna switching

At most amateur radio stations, a frequency decides the antenna type. The JRL-2000F adopts the automatic antenna switching function to automatically select the antenna whose data is stored in the output matching circuit memory, and to reproduce the memorized relay state in the circuit based on the frequency information obtained.

The antenna number last used is also stored in the memory in case two or more data exist for one frequency.

### Full break-in operation

The antenna switch unit incorporates small high-speed relays for changing between receive and transmit in order to realize full break-in operation. The block diagram of a receive-transmit changer is shown in **Figure 7**. When receiving, the receive signal is applied to K5 and sent to the receiver via K3, K2, and K1. The receive signal flows only within the shielded antenna switch unit, so noise caused by the CPU and power supply is suppressed to its minimum level. The relay switching noise is reduced because all relays are contained in the switch unit. When transmitting, there are three operating modes according to the linear amplifier state. They are as follows:

(1) Operation as an antenna switch only. The transmitting signal from the exciter is sent to the antenna via K1, K2, K3, and K5.

(2) Operation as an automatic tuner. The transmitting signal from the exciter is sent to the antenna via K1, K2, K4, MU, K3, and K5.

(3) Operation as a linear amplifier. The transmitting signal from the exciter is sent from K1 to PA where the signal is amplified and then sent to the antenna via K4, MU, K3, and K5. K1, K2, and K3 are high-speed small relays. The relays are connected in parallel with K3 to withstand a large amount of power.

K4 is a comparatively large slow-speed relay

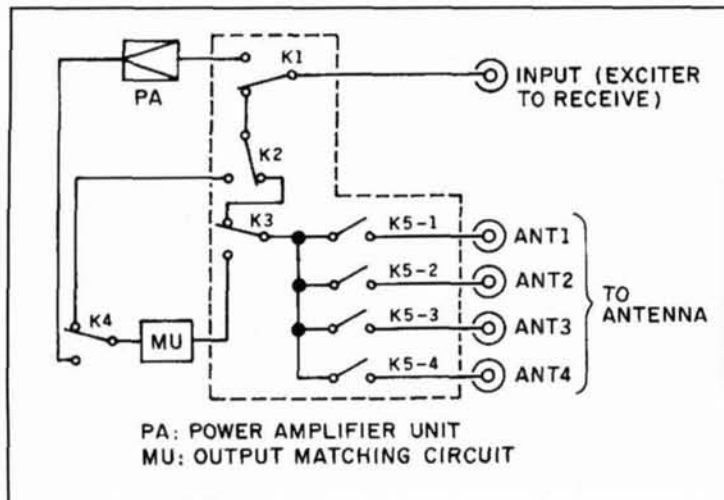

Figure 7. Block diagram of receive-transmit changer.

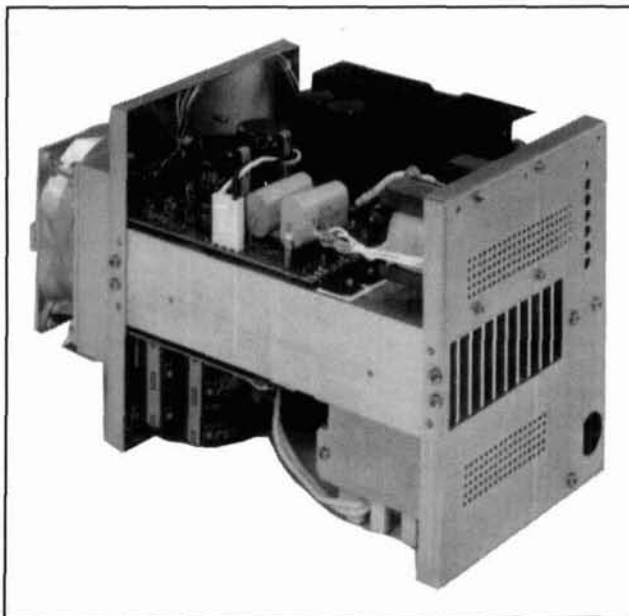

Photo C. The power supply unit.

because it does not switch whenever receive-transmit changeover is performed.

### Power supply unit: outline

The power supply unit, shown in **Photo C**, is a switching supply that receives the commercial AC single-phase power of 200 to 240 volts and provides a stabilized output of +80 volts DC, 30 A maximum, and +12 volts DC, 4A and -12 volts DC 0.5 A for the control circuit. In the capacitor-input power supply unit, a sharp pulse-shaped current containing many harmonics to charge the capacitors flows through the line. Therefore, the power factor is so small as to be about 0.5 to 0.7, requiring a large VA in a linear amp that needs a large input power of 2

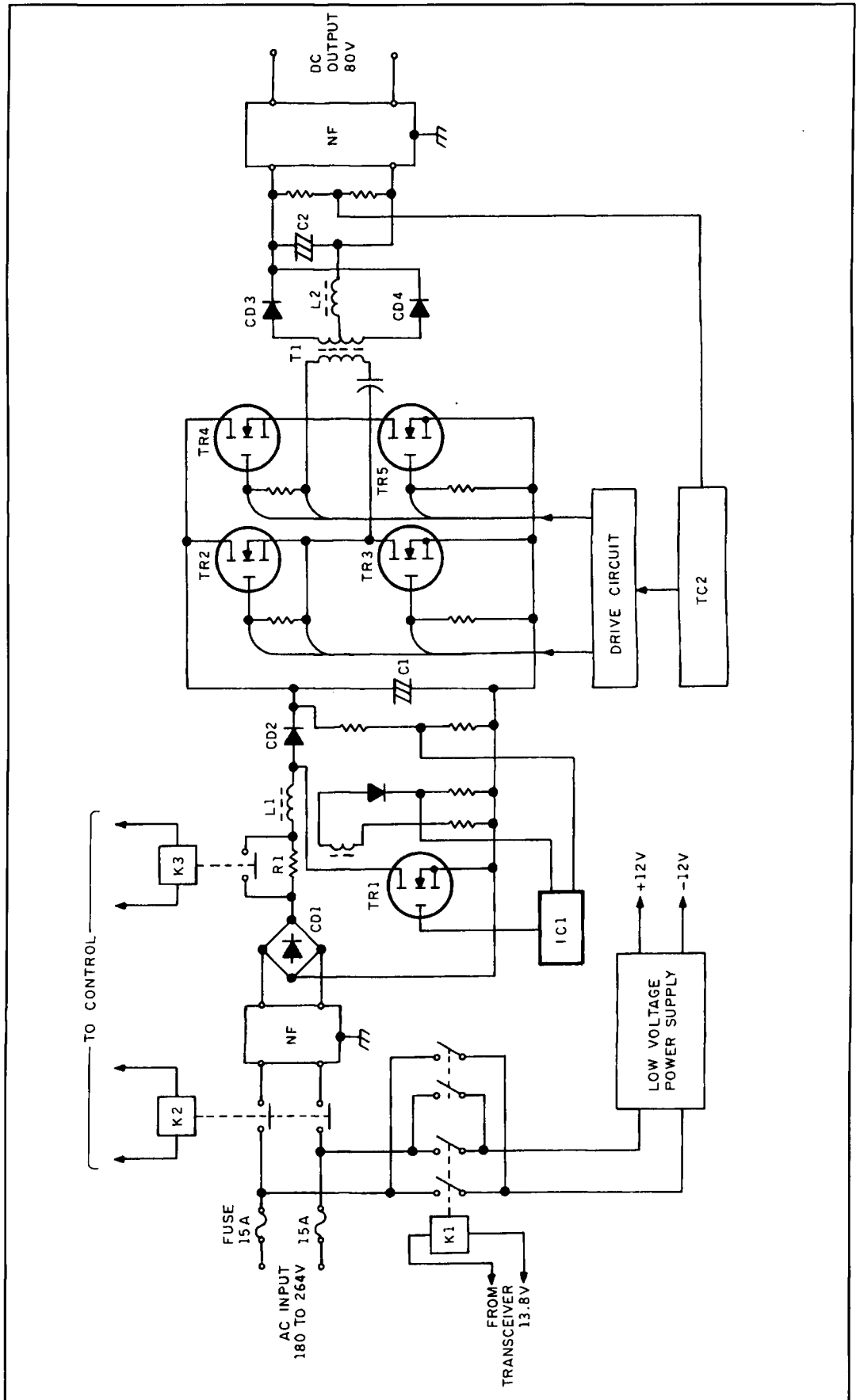

Figure 8. Block diagram of power supply unit.

kW or more. To solve this problem, a power factor corrector circuit is arranged in the preceding stage of the switching regulator circuit. As a result, a power factor of approximately 1 is obtained and the line current is reduced to about 11 to 12 A when obtaining a stabilized output of 2 kW from the single-phase 220 volts AC line. This happens because the total operating efficiency of the power supply unit is 90 percent or more.

In addition, the margin of current for the primary parts is increased due to the small input peak current—ensuring enhanced reliability. In the meantime, harmonic noise is drastically reduced because the current fed into the input line is not pulse-shaped.

The dimensions of the power supply unit are 215 mm H x 175 mm W x 250 mm D (excluding projections). The weight is approximately 9 kg. It is possible to reduce the size and weight of a power supply unit of this class by paying special attention to structure design and available space.

## Configuration

The newest power MOSFETs and fast recovery diodes are used as switching elements in the switching regulator and power factor corrector circuit to meet the requirement for “low-loss switching,” “wide-range safe operation,” and “quick response of switching elements” in high-power operation. The required performance is achieved by controlling these elements appropriately. Protection is provided to prevent the circuits from excessive input line voltage, output terminal short-circuit, overload, and overheating. The forced cooling system (heat sink temperature detection) with a DC fan is adopted in the power supply unit. These features, as well as the electrical circuit design will allow continuous operation at 2.4 kW maximum. The configuration of the unit is shown in **Figure 8**.

## Power factor corrector circuit

The operation of the power factor corrector is as follows:

A DC/DC converter is inserted into a smoothing circuit, and line current waveforms are corrected to sine waveforms by appropriate converter control.

The power factor corrector circuit receives an input of 180 to 264 volts AC and provides the subsequent stage, the main switching regulator, with 350 volts DC output. The circuit uses the ML 4812 produced by Micro Linear Co. Ltd. The ML 4812 is a control IC with a built-in oscillator. The oscillator is a separately excited type that supplies an inductor, L, with a continuous current. This continuous method of sup-

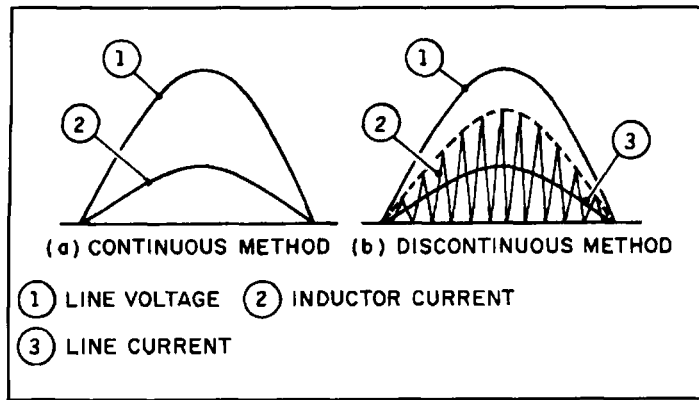

Figure 9. Current waveforms of inductor in power factor corrector circuit.

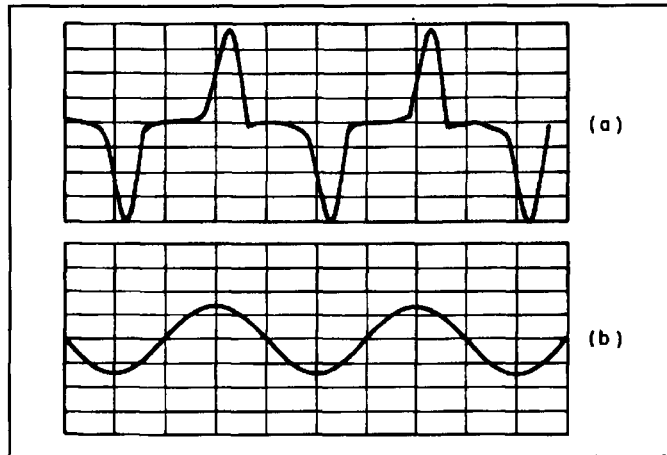

Figure 10. Current waveforms of AC input circuit. (A) Without power factor corrector circuit. (B) With power factor corrector circuit.

plying current with a fixed switching frequency is different from the conventional discontinuous method used in a control IC without an oscillator. The advantages of the continuous method over the conventional discontinuous one are:

- (a) Low noise level
- (b) Small ripple current to the inductor in switching.

These advantages facilitate simplification and high power incrementation of the input line filter. The current waveforms in the continuous and the discontinuous methods are shown in **Figure 9**. The input line current waveforms with and without the power factor corrector circuit in a capacitor-input type power supply unit are shown in **Figure 10**.

## Main switching regulator circuit

The main switching regulator circuit of the power supply unit is a DC/DC converter which receives 350 volts DC output from the power factor corrector circuit in the former stage, and provides a stabilized output of 80 volts DC, 30 A maximum and 2.4 kW maximum. The circuit

consists of a full bridge circuit with switching frequency of 150 kHz using four high-speed, large power 2SK 1250 MOSFETs (500 volts, 20 A). The full bridge circuit is more complicated than others, but the voltage availability and power compatibility are high. When the power factor corrector circuit—a step-up converter—is used in the previous stage in the unit, the full bridge circuit is preferable because the input voltage is high. The JRL-2000F employs this circuit in order to correspond to a variety of voltages.

For a long time, JRC has been working on high-efficiency, high-power MF (0.6 to 1.6 MHz) transmitters using this switching method. All the high-frequency amplifier circuits of the transmitters use full bridge switching circuits. The JRL-2000F power supply unit has been developed based on this switching technology. When the load fluctuates considerably in a short time, the switching regulator may sometimes cause a control delay resulting in unsuitable output response. This is because the switching regulator is, in general, a control circuit using a closed loop. The power supply unit with an improved control system sufficiently adapts to intermittent operation with the power supply load (no load to 30 A) in CW mode at its maximum output. The output voltage regulation of the unit with maximum load is within  $\pm 1.5$  per cent of that without load.

## Structure

The cabinet consists of a main chassis, a front panel, a rear panel, and top and bottom

covers—made mainly of aluminum to make it light. The front panel uses aluminum extrusion for a rugged framework and a sophisticated appearance.

## Conclusions

We have described the configuration and outline of the JRL-2000F HF linear amplifier. The linear has been designed based on the power MOSFET PA technology developed for professional large HF transmitters and also on the high frequency switching technology used in large high-efficiency MF transmitters. The switching power supply unit with a power factor corrector can be applied to other fields.

Recently, many kinds of FETs and SITs have been developed, and the power electronics for power supply and power amplifier circuits have been advancing rapidly. In the future, power devices will increase in efficiency and decrease in size along with the emergence of other new devices and a new circuit design technology.

## REFERENCES

1. M.J. Close, "HF Communications Transmitters—All Solid or Valved?", *HF Radio System and Techniques*, IEE, April 1985.
2. Helge Granburg, "Power MOSFETs Versus Bipolar Transistors," *Motorola RF Device Data Book*, Volume 2, 1988, AN860.
3. Y. Tozawa, "JRL-2000F MOSFET HF Linear Amplifier for Amateur Radio," *CQ Ham Radio Japan*, No. 536, February 1991.
4. Helge Granburg, "Four MOSFETs Deliver 600 Watts of RF Power," *Microwaves and RF*, January 1983.
5. S. Abe and Y. Tozawa, "All Solid-State 1 kW HF Transmitter," *JRC Technical Review*, Volume 16, 1981.
6. Y. Tozawa, "Design of Low-Distortion HF Transmitter with Power MOSFETs," *HF Radio System and Techniques*, IEE, July, 1991.

# PRODUCT INFORMATION

## 270 Vdc, 10 Amp Power Switching Relay

Kilovac Corporation introduces a new 270 Vdc, 10A multi-purpose power switching relay for the Military, Space and Commercial Aerospace industries. Kilovac's new AP10A relay is rated from  $-55^{\circ}\text{C}$  to  $85^{\circ}\text{C}$ , and can be used for 270Vdc applications as well as 155Vdc for submarines and ships, 120Vdc battery operated systems like the space station, and a variety of other applications.

The AP10A is 1.7 cubic inches in size and

can provide over 2000 volts of isolation across open contacts for system safety. It can switch at up to 1000Vdc at lower currents without damage, and dissipates less than 3 watts at 10A, eliminating the need for heat sinks and fans or de-rating for temperature.

The AP10A also offers mounting options including through the chassis, PC board, and panel mounting.

For more information contact Kilovac Corporation, P.O. Box 4422, Santa Barbara, CA 93140 or call 805-684-4560.

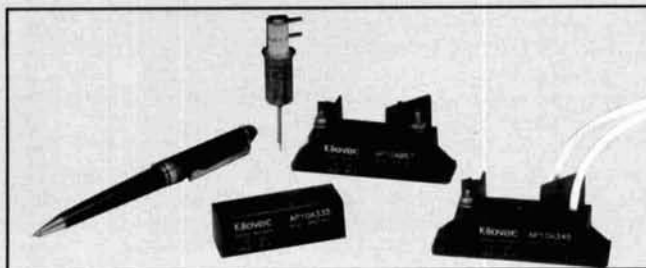



# TRANSMITTING SHORT LOOP ANTENNAS FOR THE HF BANDS: PART 1

## *Basics on working with loop antennas*

---

**T**ransmitting short loop antennas (also improperly called “magnetic” loops) have been around a long time, but only in the last few years have they been developed for amateur use with significant improvements. It is now possible to build a very effective and compact antenna of this configuration.

I will describe the construction of a short loop antenna for the HF high bands, providing alternatives to simplify construction. However, before I begin, I will outline some historical notes and follow them with the theory of this radiating system.

### A brief history

It seems that the first attempt at using a transmitting short loop antenna in the amateur field was made by Lewis McCoy, WIICP, when he was a member of the ARRL technical staff. McCoy’s tests on his experimental antenna were reported in the March 1968 issue of QST. The project was inspired by a military antenna of the same type used by the United States Army in Vietnam. The results of this test were rather sparse, most probably due to the heavy ohmic losses caused by the junction of the sides of the octagonal-shaped frame. The following years showed only rare and tentative attempts on the part of American and English amateurs

at building and using loops. The first extensive study on short loop antennas was presented by Hans Wuertz, DL2FA in CQ-DL during 1983. Wuertz also presented several methods for matching the loop to a 50-ohm coax cable feed-line. Some of these methods are presently used in amateur and commercial loops.

In 1985, Ted Hart, W5QJR, published a booklet dedicated to loop antennas. The booklet contained formulas for calculating the main parameters of a short loop and a detailed building project (also reported in QST in June of 1986). Hart introduced the concept of using split stator or butterfly capacitors in series with the loop to tune the antenna, leaving the rotor contact disconnected. This eliminated the ohmic losses caused by the rotor sweeping contact in conventional variable capacitors. He obtained a very effective radiating system tuned remotely by a small motor. A few pages on W5QJR’s work are also published in the latest issues of *The ARRL Antenna Book*.

### A general description

A short loop antenna can be considered a single-turn inductor where the circumference has a length between  $1/3$  and  $1/8$  wavelength. If a variable capacitor is placed in series, it is possible to resonate the loop at the required frequen-

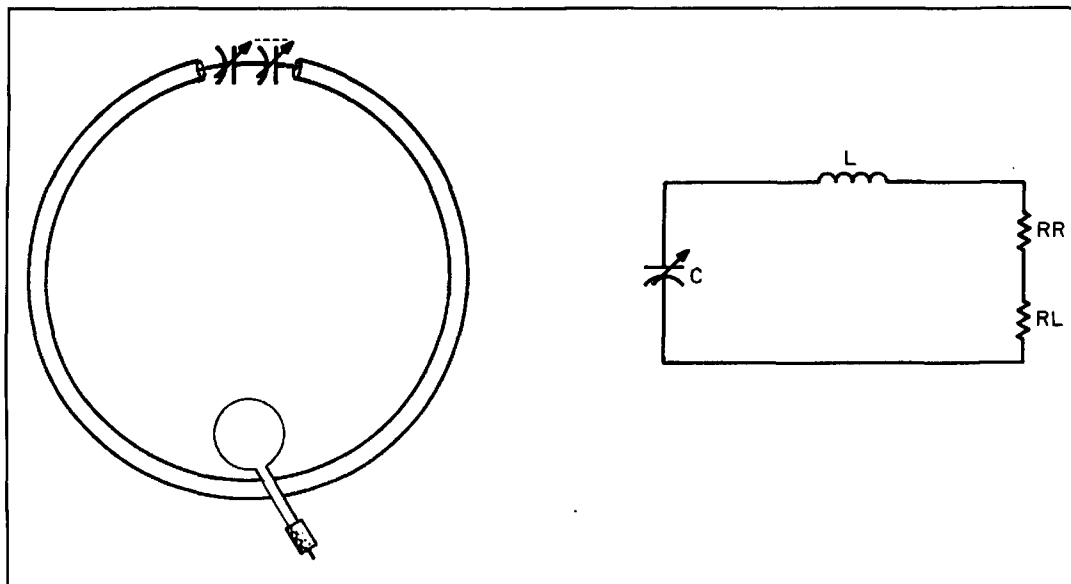

Figure 1. The electrical diagram of a short loop antenna.

cy. In such a situation, the loop radiates and the prevailing component of the radiated electromagnetic near-field is magnetic. (This is why the short loop is also called a “magnetic” loop.) Note that the magnetic component of the field is much less affected by earth dielectric losses and nearby objects; therefore, in principle, it is less important to elevate the antenna above ground. In some circumstances, the short loop can be used indoors with very good results; however, for safety reasons, I would not recommend that you do this unless you are using very low power.

If the circumference length exceeds  $\frac{1}{3}$  wavelength, the loop becomes self resonant and acts as an “electric” antenna of the same family as the quad or delta loop, but with lower radiation efficiency. To obtain a high level of efficiency, the circumference must be 1 wavelength and the loop must be elevated above ground. The short loop radiates in the plane containing the loop, while the quad or delta radiates at 90 degrees off the plane containing the loop. The circulating current in the loop is constant, while in a quad it is sinusoidal.

The short loop radiates with a nearly constant path from 0 to 90 degree elevation angles and can be used successfully in short, medium, and long-range contacts. When mounted vertically, the radiation diagram at 0 degrees elevation shows two deep nulls on both sides of the loop. These nulls can be used to reject local QRM and QRN when receiving weak signals. A small TV rotator can be employed to rotate the loop. On higher elevation angles, directivity is reduced and the antenna is nearly omnidirectional. A completely omnidirectional pattern can be obtained by mounting the antenna horizontally, but in this case the loop must be ele-

vated above ground to be reasonably effective.

Due to the very narrow bandwidth, the short loop acts as a sharp filter, reducing the transmission of harmonics that can cause TVI or BCI. In receive mode, the short loop performs extremely well. Due to the magnetic properties already mentioned, the antenna is much less sensitive to the electrical components of the field; consequently, manmade and atmospheric noise, all with prevailing electrical components, are greatly reduced. On low bands the reception is significantly improved. You can hear very weak signals that, due to noise, are impossible to receive with conventional antennas. Another big advantage is the antenna’s selectivity, which can reduce splatter and intermodulation distortion caused by strong off-frequency signals. You will appreciate this advantage even more on the low bands where QRM level is high.

### Radiation resistance and radiation efficiency

The formula that Ted Hart, W5QJR, developed to determine the radiation resistance of a short loop antenna is shown in **Equation 1**:

$$RR = 3.38 \times 10^{-8} \times F^4 \times A^2 \quad (1)$$

where: F = frequency in MHz, A = loop area in square feet.

Two main assumptions can be made:

- 1) The radiation resistance is directly proportional to the area enclosed in the loop.
- 2) The resultant value of the radiation resistance in a short loop is extremely low (on the order of a few milliohms).

We know from the theory that to obtain a good radiation efficiency from any antenna, the value of the radiation resistance must be high. This is also true in the case of the short loop antenna. The only way to obtain the best radiation resistance is to consider the area of the loop. From geometry, we know that a circle is the figure with the largest enclosed area with a given perimeter. This is why the short loop is generally round.

For a multiband loop, it is preferable to have frequency coverage with a ratio of 1:2. In other words, the frequency coverage should be 28 to 14 MHz or 14 to 7 MHz, and so on. However "magnetic" radiation is obtained only when the loop circumference is less than  $\frac{1}{3}$  wavelength, therefore the loop size should be calculated for the highest frequency of the bands covered.

Now let's consider the equivalent electrical diagram of a short loop (**Figure 1**). The two resistances represent:

RR = the radiation resistance (which is not a real resistance, but a conventional measure in ohms expressing the ability of the antenna to dissipate the applied RF power and therefore to radiate).

RL = the resistive losses of the antenna expressed in ohms.

L = the loop inductance.

C = the tuning capacitance.

The formula to determine the efficiency of any antenna in percentage is expressed by the ratio:

$$E = \frac{RR}{RR + RL} \times 100 \quad (2)$$

If RL approaches the value of RR, efficiency drops markedly. Therefore, every effort must be made to keep the resistive losses to a minimum. It is necessary to use a large diameter conductor to carry the high RF current present in the loop. If a small diameter conductor is used a large percentage of the power will be lost as heat. Therefore copper tubing of large diameter is essential to obtain good results. It is also very important to use a high-quality tuning capacitor. Vacuum variable capacitors are best, but you can also obtain good performance with transmission type split-stator or butterfly capacitors. Make sure the loop ends and capacitor are carefully welded together.

Remember that additional losses are present in the system. These include: insulation losses, capacitor losses, feed losses, and losses from metallic masses near the antenna lying in the same plane of the loop (fences, pipes, wires, etc.). True efficiency can be calculated using the measured bandwidth as a reference. For practical purposes, it is possible to obtain a reliable indication of the real antenna efficiency by comparing the calculated bandwidth with the measured bandwidth. If an appreciable difference is found, the antenna is lossy and needs

some troubleshooting. The most common problems are: bad capacitors, weak welds, and poor mounting locations.

Using the formulas adopted by Ted Hart, W5QJR, and published in *QST* in June of 1986, it is possible to calculate all the main parameters of a short loop. To simplify the calculation, I prepared a short GWBasic program adaptable to all types of computers (see **Listing 1**). With such a program it is possible to obtain all data necessary to project a short loop of different shapes (circle, octagon, square). You can optimize the loop that best suits your requirements. The efficiency calculated with these formulas is based only on the conductor loss and can be quite high. In some conditions, it is possible to obtain over 90 percent efficiency, but remember what I said earlier. Additional losses will greatly reduce the real radiation efficiency of the antenna, but with a careful selection of materials and accurate construction the loop performance will be excellent. If you decide to build a short loop antenna, it is essential to use high quality material.

The loop conductor should be copper tubing no less than 0.9 inches in diameter.

It is preferable to use the circular shape when making the loop. This shape enables you to build the antenna in a single piece, or in two pieces joined at the bottom if the loop is large. The octagonal loop has an efficiency very close to the circular loop, but losses are introduced when you weld the eight sides of the frame together. The square-shaped loop is the worst case, but is still a good compromise between efficiency and easy construction.

All efforts must be made to use a high quality tuning capacitor. If you choose split-stator or butterfly capacitors, make sure there are no spacers between the stator and rotor plates. The plates must be welded directly to the supporting bars and shaft.

The capacitance value calculated with the formulas used in this article is referenced to a conventional capacitor and can only be used for a vacuum capacitor. If split-stator or butterfly capacitors are used as the two sections in series with the loop, the value of each section must be doubled to obtain the required capacitance. As an added benefit, this will double the capacitor's voltage rating. In other words, if you find from the calculation that a 50-pF capacitor with a rating of 5 kV is needed to resonate the loop at the required frequency, the split-stator or butterfly capacitors used must have a capacitance of 100 pF per section with a rating of 2.5 kV. Do not use a conventional capacitor or significant losses will be introduced by the sweeping contact of the rotor shaft, leading to poor antenna performance.

It is important to know the residual capacitance (capacitor fully open) of the tuning

```

5   CLS
10  PRINT "CALCULATION OF MAIN PARAMETERS OF A SHORT LOOP
    ANTENNA"
20  PRINT "(copper conductor)"
50  PRINT "Loop conductor length (max. 1/3 lambda)          feet:":INPUT S
60  PRINT "Loop conductor diameter                          inches:":INPUT D
70  PRINT "Frequency                                         megahertz:":INPUT F
80  PRINT "Power                                             watt:":INPUT P
90  PRINT "For circular shape loop, type 1"
100 PRINT "For octagonal shape loop, type 2"
110 PRINT "For square shape loop, type 3"
125 INPUT Z$
130 IF Z$="1" GOTO 160
140 IF Z$="2" GOTO 190
150 IF Z$="3" GOTO 210
160 A=7.900001E-02 * S^2
170 PRINT "loop area                                         sq. feet:":PRINT A
180 GOTO 240
190 A=.069 * S^2
200 PRINT "loop area                                         sq. feet:":PRINT A
205 GOTO 240
210 A=.062 * S^2
220 PRINT "loop area                                         sq. feet:":PRINT A
240 RR=3.38 * 10^-8 * F^4 * A^2 * 100
250 PRINT "Radiation Resistance                             milliOhms:":PRINT RR
260 RL=9.96 * 10^-4 * SQR(F) * (S/D) * 100
270 PRINT "Loss Resistance                                     milliOhms:":PRINT RL
280 E=RR/(RR+RL) * 100
290 PRINT "Radiation Efficiency (basis ohmic loss)          %":PRINT E
300 DB=LOG (E/100)/LOG(10) * 10
310 PRINT "Efficiency expressed in dB dB:":PRINT DB
320 L=1.9 * 10^-8 * S * (7.353 * LOG((96 * S)/(3.1416 * D))
    /LOG(10)-6.386) * 10^6
330 PRINT "Loop Inductance                                    microHenry:":PRINT L
340 XL=2* 3.1416 * F * L
350 PRINT "Inductive Reactance                               Ohms:":PRINT XL
360 Q=XL/(RR+RL)/2 * 100
370 PRINT "Quality Factor                                         Q:":PRINT Q
380 DF=F/Q * 1000
390 PRINT "Bandwidth                                             kHz:":PRINT DF
400 VC=SQR(P * XL * Q)/1000
410 PRINT "RF Voltage across capacitor                          kiloVolts:":PRINT VC
420 CT=1/(2 * 3.1416 * F * XL) * 10^6
430 PRINT "Tuning Capacitance                                       picoFarads:":PRINT CT
440 CD=.82 * S
450 PRINT "Distributed Capacitance                             picoFarads:":PRINT CD

```

CALCULATION OF MAIN PARAMETERS OF A SHORT LOOP ANTENNA  
(copper conductor)

```

Loop conductor length (max. 1/3 lambda)          feet: ? 10
Loop conductor diameter                          inches: ? 1
Frequency                                         megahertz: ? 14
Power                                             watt: ? 100
For circular shape loop, type 1
For octagonal shape loop type 2
For square shape loop, type 3
? 1
loop area                                         sq. feet: 7.900001
Radiation Resistance                             milliOhms: 8.103696
Loss Resistance                                 milliOhms: 3.726691
Radiation Efficiency (basis ohmic loss)          %: 68.499
Efficiency expressed in dB                       dB: -1.643158
Loop Inductance                                 microHenry: 2.258547
Inductive Reactance                             ohms: 198.6726
Quality Factor                                   Q: 839.6709
Bandwidth                                        kHz: 16.6732
RF Voltage across capacitor                      kiloVolts: 4.084356
Tuning Capacitance                             picoFarads: 57.22068
Distributed Capacitance                         picoFarads: 8.2
Ok

```

Listing 1. Short program for calculating the main parameters of a short loop.

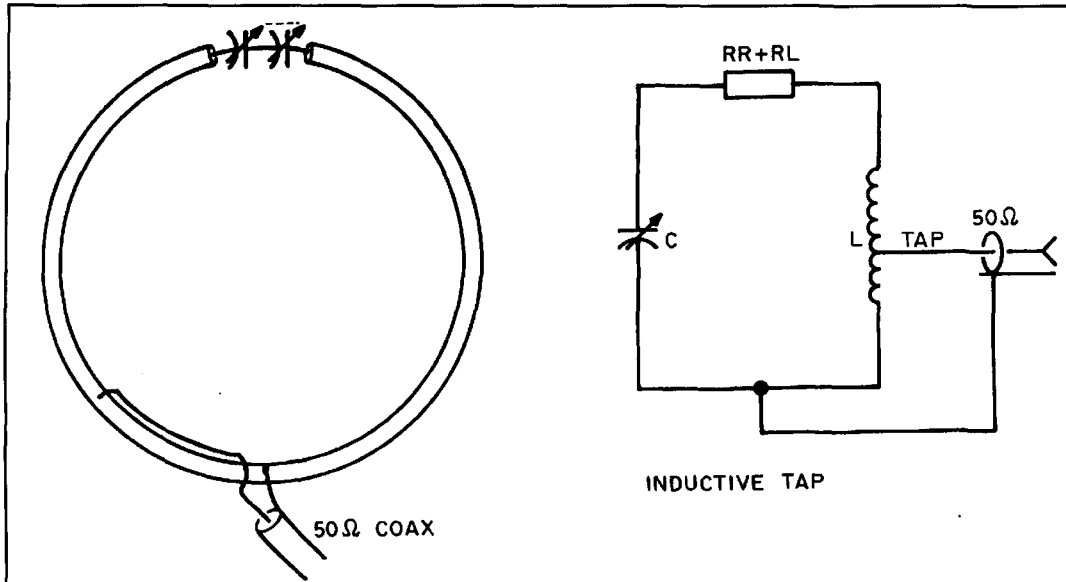

Figure 2. The tapped matching circuit.

capacitor. In fact, when the loop length is at its maximum ( $1/3$  wavelength), a very small capacitance will resonate the antenna at the highest frequency of the selected bands. Residual capacitance also plays a role in the distributed capacitance of the loop itself. If the residual capacitance is too high, it will be impossible to resonate the antenna to the required frequency. To obtain resonance it is necessary to shorten the length of the loop, unless one or two plates of the capacitor can be removed without affecting the lower frequency coverage of the selected bands.

### The feed system

There are several ways to couple a 50-ohm

coax feed line to the loop. The most popular are the tapped matching and transformer coupling methods shown in **Figures 2 and 3**.

The tapped match is the simplest way to feed and match a short loop antenna. (see **Figure 2**). The approximate length of the "gamma match-like" conductor is equal to the loop circumference multiplied by 0.125. When this conductor is raised slightly from the central portion of the loop, it is possible to obtain a good match to the 50-ohm feed coax cable over a rather limited frequency range. Note, however, that the loop is fed asymmetrically and this can affect the radiation pattern and also the effectiveness of the antenna. In fact, during my experiments, I found a lower overall rate of performance when I compared this method with the transformer

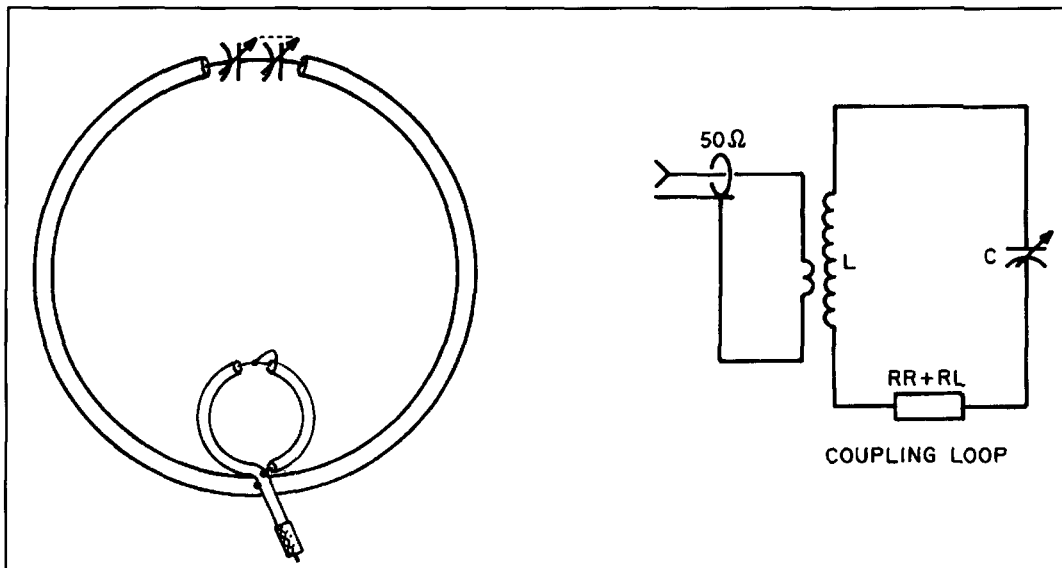

Figure 3. The transformer coupling circuit.

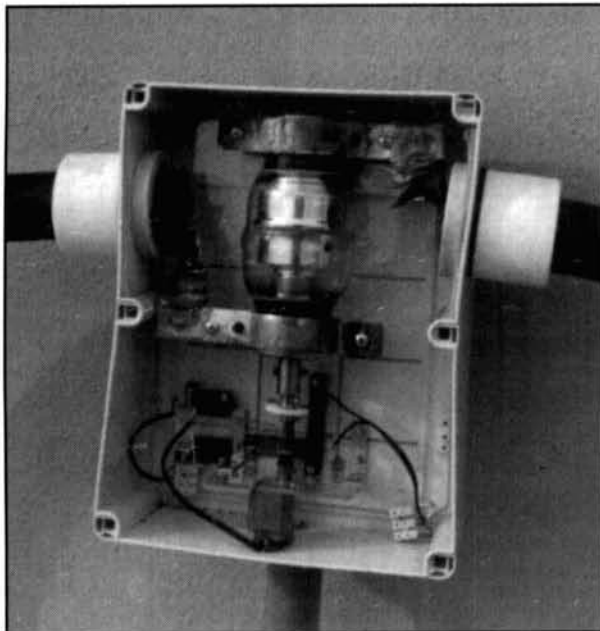

Photo A. Details of the remote tuning system.

coupling method. But despite its reduced efficiency, the tapped match is very simple to build and adjust.

The preferred matching method is the transformer coupling circuit in **Figure 3**. It is somewhat more complicated from a mechanical standpoint, and is more difficult to adjust for the lowest SWR; however, it is possible to keep the SWR low over a wide range of frequencies. Of the two circuits, transformer coupling provides best overall performance.

The small loop is made with coax cable such as RG-8 or RG-212 and is constructed to provide symmetry at the centerline of the system. The feed loop is approximately 1/6th the size of the main loop, but the proper dimensions must be found experimentally. The antenna is adjusted after it is mounted in its operating position, using very low input power. A VSWR bridge is connected at the input side of the feed loop. The coax cable must have a vertical run of about 3 feet, or it will be difficult to obtain a low SWR due to possible coupling with the loop. Do not use an antenna tuner.

### The tuning motor and remote control

The very narrow bandwidth of a short loop makes it necessary to retune the antenna every time you change frequency. This is quite a nuisance and requires the construction of a remote tuning control system. It is not advisable to place the loop near the transceiver and tune the antenna by hand. Manual tuning is difficult to perform and is influenced by one's proximity to

the loop. It is also dangerous due to the very high RF voltage on the loop conductor. Hand tune the antenna only when doing experimental work and always use low RF power.

There are two practical remote tuning systems. The first uses a stepper motor with an appropriate step angle to obtain an accurate tuning. Resolution should be approximately 10 kHz or less.

The second system can be constructed using a normal DC motor of good quality with built-in reduction gear and shaft turning speed not to exceed 5 revolutions per minute (see **Photo A**). It is possible to further reduce the speed to the required maximum speed of 1 rpm or less using an external reduction gear of the type once used in old receivers. It is also possible to reduce the rotation speed electronically with an integrated circuit especially designed for this application. I will describe this system later.

Pay special attention to the motor feed line and how it is routed from the lower end of the loop to the motor. Do not allow the motor control wire to become coupled to the small coaxial loop. Despite RF chokes and bypass capacitors, RF energy will be coupled to the line and antenna performance will be reduced. Route the motor line through the electrically neutral middle section of the loop, along the supporting mast. Make sure the motor line is shielded. Shielded two-conductor wire works well. Connect two 10-nF ceramic bypass capacitors to each motor contact and to the wire shield and motor body. At the bottom, the shields must be grounded to the supporting mast or to the central bottom point of the loop. Normal two-wire cable can be used from here to the shack. See **Photo B** for details.

You could also mount the motor at the bottom of the loop and use a long plastic rod to drive the tuning capacitor at the top. This is more complicated mechanically, but it will avoid any possibility of RF coupling to the motor feed line and, consequently, provides better antenna performance.

### Practical performance of a short loop antenna

The empirical method of antenna comparison is the simplest technique amateurs can use to evaluate an antenna. I built a half-wave dipole for the 20-meter band. This dipole was made with aluminum tubing and was perfectly resonant on midband. The feedline was coupled to the dipole by a gamma match; the SWR was 1:1. The dipole was placed on top of a telescopic mast with rotator; the antenna height was 10 meters over the flat roof of the building where I live. The roof is about 15 meters above street level. I prepared a short loop antenna of 1

meter diameter made of copper tubing of 0.9 inches and resonant in the 20 meter band. This loop was fixed in an upright position to a Black & Decker working table far from the dipole mast. The elevation of the loop from the floor was about 1 meter. The 50-ohm coax feed lines of both antennas were about the same length. In the shack, the two lines were connected to the two output sockets of an antenna tuner; the tuner was isolated from the antennas. The RF power applied was about 50 watts. I was able to alternate between the two antennas instantly by using the switch on the antenna tuner. The dipole was maintained with the same orientation for the maximum radiation pattern of the loop. Using this setup, I made tests for about three months at different hours of the day and night under varying propagation conditions. During my experiments, I did not disclose the type of antenna under test. I wanted to avoid a "psychological" influence on my correspondent. The average of the reports received from the loop were almost the same as the reports received from the dipole. At times the dipole performed slightly better; at other times the loop took the lead. Most of the differences originated with the different polarization of the two antennas. The polarization used by the correspondent also had some influence. This type of test is certainly not a scientific method to measure the performance; however, it is possible to obtain a good indication of how the antenna is working.

At the end of my tests, I concluded that the two antennas could be considered equivalent. I can also confirm that if the dipole is lower than a half wave over the ground, the short loop definitely performs better. I worked DX stations from all over the world several times with very good reports. My record was a VK station worked with a QRP SSB transceiver (2 watts PEP). On medium distance contacts, reports obtained were always between S9 and S9 + 10/15 dB. Really outstanding!

I can confirm that the short loop is an excellent antenna for people unable to erect good conventional antennas. It is evident that the loop presents mechanical difficulties during construction, but if care is exercised and good



Photo B. The complete antenna showing the connections from the remote tuning to the shack.

materials are used, the results are really outstanding and will reward your efforts. I can honestly attest to this after a few years of activity using a very small radiating system. In my next article, I will give details on constructing such a system. ■

## PRODUCT INFORMATION

### HP Announces Major Advancement In Test Technology

Hewlett-Packard Company announces a breakthrough testing technique called HP TestJet technology. It incorporates the HP TestJet Technology into a board-test system. The technology tests for open solder joints on complex digital parts such as application spe-

cific integrated circuits (ASIC) and very large scale integrated (VLSI) circuits. This test can help avoid surface-mount failure caused by open solder joints. The TestJet also eliminates the need for programming patterns or libraries.

For more information contact Hewlett-Packard Company, Direct Marketing Organization, P.O. Box 58059, MS51L-SJ, Santa Clara, CA 95051-8059.

# TECHNICAL CONVERSATIONS

*The article "Building the Perfect Noise Bridge," in the Spring 1993 issue of the Quarterly brought us these comments.*

## Dear Editor:

I found Popodi's, AA3K/OE2APM, article "Building the Perfect Noise Bridge" (*Communications Quarterly*, Spring 1993) interesting and informative. Two points, however, deserve further discussion.

The simplest of these is the treatment of the load connector. If the bridge is (as usual) equipped with a coaxial cable connector (e.g., SO 239) the bridge is intended to measure impedances on coaxial lines. Thus, the connector should be treated as a short section of coaxial line having (hopefully) the characteristic impedance of the coaxial system in use. The plug on the cable (e.g., PL 259) is usually a part of the system that is being measured. The additional cable length of the jack is only about one half inch, or a shunt capacitance of about 1 pF for 50-ohm systems.

If a bridge with a coaxial connector is used to measure lumped components, Popodi's method of compensation is reasonable, but errors will occur when the bridge is used with coaxial cable. If the bridge is intended for measurement of lumped components, binding posts, or a double banana jack and plug should be used. The shunt capacitance and series inductance of these terminals must be accounted for or compensated in accurate work.

The second point is more serious and challenges Popodi's conclusion that the admittance form of the bridge is inherently more accurate than the impedance form. Popodi neglects the series inductance associated with the variable capacitor. The effective capacitance (the capacitance seen at the capacitor terminals) is:

$$C_e = C_0 / (1 - \omega^2 LC_0) = C_0 / (1 - \omega^2 / \omega_r^2)$$

where the designation  $C_0$  is the low frequency capacitance,  $L$  is the series inductance,  $\omega$  is the operating frequency, and  $\omega_r$  is the resonant frequency of the capacitor.

If  $C_e$  is to differ from  $C_0$  by no more than 1 percent, then the resonant frequency of the capacitor must be at least ten times the measurement frequency—280 MHz for measurement at 28 MHz. For a 140 pF capacitor set at half mesh (70 pF) the series inductance cannot exceed 4.6 nH. This is a very stringent require-

ment. Practical capacitors are apt to exceed this by a factor of three.

The series inductance of the variable capacitor, which is nearly independent of the mesh, and other series inductances can be exactly compensated in an impedance (series form) bridge by the technique described. But I know of no way to compensate the inductance of the variable capacitor in an admittance (parallel form) bridge. As the inductance may cause errors in the measured susceptance approaching 10 percent at 28 MHz, the admittance bridge can hardly be considered as accurate to approximately 1 percent at this frequency.

**Albert E. Weller, WD8KBW**  
Columbus, Ohio

*A reader had these comments on Joe Carr's article: "Small Loop Antennas, Part 1." Joe passed them along to us.*

## Howdy Joseph,

Your article on small loops was quite interesting, and the program makes preliminary calculations very easy. I thought you might be interested in a modification of your code that runs on monochrome machines, and leaves input data on the screen for several iterations so previous parameters and results can be viewed without having to print, or copy, results from the screen.

When I started reorganizing the program, I realized that the whole thing was one in-line process with one jump at the end if the user desired to repeat the process. So that's what the modified code does.

The loop antenna diagram was done with PAINT.COM from *PC Magazine*, and was copied to the text file using SNIPPER.COM (or DOSCLIP) also from *PC Magazine*. All of those are public domain programs.

To make the screen more informative, I suggested a limit on the size of the loop, and then added a calculation for the wavelength at the operating frequency so users could figure out what 0.1 wavelength is without having to grab their calculators.

I'm looking forward to reading the second part of the article.

**Paul G. Jagnow, K0RLT**  
Iowa City, Iowa

*The modified program listing appears in Listing 1. Ed.*



```

1000 'PROGRAM TO CALCULATE INDUCTANCE OF SMALL LOOP ANTENNAS
1010 'Communications Quarterly Winter 1993 By Joseph Carr (K4PIV)
1020 'Major reorganization of code by Paul Jagnow (KORLT) 13 Feb 93
1030 'Equations for loop inductance from F. W. Grover (1946)
1040 'No special display requirements. All output is plain text.
1050 '
1060 'Initialization
1070 KEY OFF: CLS: PI=3.14159
1080 'Draw Loop Antenna Picture
1090 LOCATE 4,1
1100 PRINT " (<----- A ----->)"
1110 PRINT " "
1120 PRINT " "
1130 PRINT " "
1140 PRINT " "
1150 PRINT " "
1160 PRINT " "
1170 PRINT " "
1180 PRINT " "
1190 PRINT " "
1200 PRINT " "
1210 PRINT " "
1220 PRINT " "
1230 PRINT " "
1240 PRINT " "
1250 PRINT " "
1260 PRINT " "
1270 PRINT " "
1280 PRINT: PRINT
1290 INPUT "Enter desired operating frequency in KHz: ",FKHZ
1300 F=FKHZ*1000
1310 PRINT "At operating frequency, 1 wavelength, in cm = "; 3E+10/F
1320 'Get loop shape
1330 INPUT "Loop shape: (T)riangle, (S)quare, (H)exagon, (O)ctagon ? ", T$
1340 K1=0
1350 'Interpret shape input and set K1..K4
1360 IF T$="T" OR T$="t" THEN K1=.006: K2=1.1547: K3=.65533: K4=.1348
1370 IF T$="S" OR T$="s" THEN K1=.008: K2=1.4142: K3=.37942: K4=.3333
1380 IF T$="H" OR T$="h" THEN K1=.012: K2=2.0: K3=.65533: K4=.1348
1390 IF T$="O" OR T$="o" THEN K1=.016: K2=2.613: K3=.75143: K4=.07153
1400 IF K1=0 THEN 1330 'Repeat if input not valid
1410 'Get input on loop dimensions
1420 INPUT "What is the LENGTH of each loop side in cm ? ", A
1430 INPUT "What is the WIDTH of each loop side in cm ? ", B
1440 INPUT "How many TURNS are to be used for the loop ? ", N
1450 'Calculate inductance of loop antenna - from Grover
1460 NN = N+1: XA=K1*N^2*A
1470 XB = ((K2*A*N)/(NN*B))
1480 XB = LOG(XB)
1490 XB = XB+K3+(K4*NN*B)/(A*N)
1500 L = XA*XB
1510 'Calculate C needed for resonance
1520 LA = L/10^6: C =(1)/(4 * PI^2 * F^2 * LA): C=C*10^12
1530 'Display results
1540 PRINT: PRINT USING "&####.#&";"Inductance:";L;" uH. ";
1550 PRINT "C to Resonate at";FKHZ;"KHz = ";
1560 PRINT USING "#####.#&";C;" pF"
1570 'Ask user what's next - do it again or quit
1580 PRINT: INPUT "Enter Q to Quit, any other key to do it again: ",B$
1590 IF B$="Q" OR B$="q" THEN SYSTEM ELSE 1320 'It ends here

```

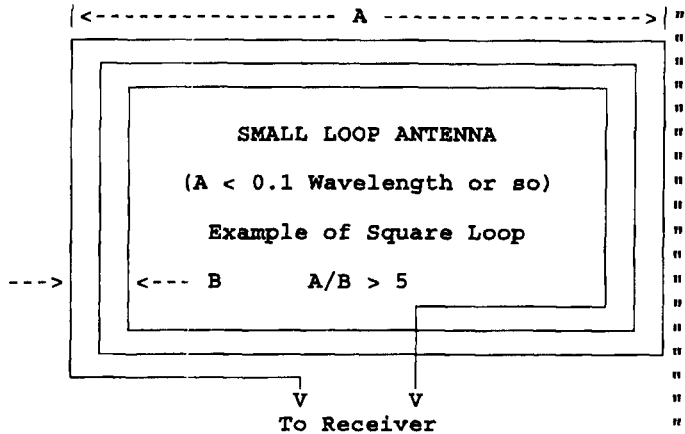

Listing 1. Program to calculate inductance of small loops with modifications by KORLT.

*Parts sources located for VLF receiver project*

In our Spring 1993 issue, Art Stokes, writing in Peter Taylor's column "The Solar Spectrum," laments the growing scarcity of once common components he used in the

updated version of his VLF solar flare receiver.

With some effort, I have found two sources for the 365-pF tuning capacitors. Antique Electronic Supply and Antique Audio are two companies that cater to the antique radio enthusiast. Both carry single-section 365-pF capaci-

tors, as well as other components that are not commonly available. Antique Audio currently lists a three-section 450-pF unit for under six dollars. This three-section capacitor, when used with adjustable inductors and capacitive trimmers for tracking alignment, might even allow for single-knob tuning on the TRF LF receiver for our more experimentally inclined readers.

Mouser Electronics offers economical plastic tuning capacitors. These capacitors are similar to those used in miniature transistor AM radios, thus, some method of adapting them to a 1/4-inch shaft is needed.

Eighty-eight millihenry loading coils were once popular in many radio-teletype demodulators in the audio filters and in the discriminator circuits. These coils came in two flavors, both as 88 and 44-mH versions were available surplus. The only way to tell them apart was by the color-coded spaghetti leads, or by measuring the inductance—so be sure to check the values of any found in the junkbox or at a flea market before attempting to use them.

RC based op-amp filter and discriminator circuits have long eclipsed the popularity of the 88-mH loading coil designs, and these coils are now hard to find. A possible alternative is to investigate the pot-core forms available from Amidon Associates, and winding your own coils using the technical information that is also available from Amidon. The pot-core materials may also perform better at VLF than the iron-core loading coils.

Antique Electronic Supply may be reached at 6221 South Maple Avenue, Tempe, Arizona 85283; their telephone number is (602) 820-5411. Antique Audio is located at 5555 North Lamar, suite H-101, Austin, Texas 78751, or via telephone at (512) 467-2944. Mouser Electronics has several distribution centers nationwide, and customer service and sales information may be obtained by calling (800) 346-6873.

**Peter Bertini, K1ZJH**  
Senior Technical Editor

## PRODUCT INFORMATION

### **PCMCIA prototyping card**

The IBM Endicott Functional Design Center announces the PCMCIA prototyping card. The PCMCIA credit card-sized package is used for many types of memory as well as interfaces to LANS, 3270 terminals, radios, FAX machines, etc. and can be used for early experimental use in lab environments.

The card contains front and back pad arrays for manual or mechanized component attachment, internal power planes for low noise—directly tied to the standard power pin, peripheral power busses, and cable attach pads at the far end. They come with the standard 68 pin connector and Type I compatible frame for insertion in existing PCMCIA slots.

The price, including connector and frame, is currently \$25 and can be ordered from stock in single quantities.

Microchannel, AT Bus, and VME/VXI bus prototyping cards priced at \$110, \$75, and \$120 each in single quantities are also available.

For more information, or to place an order, contact John Pivnichny or Julie Barnes at IBM Corporation, 1701 North Street, T17/004-3, Endicott, NY 13760; or call 607-755-6565 or 607-755-6566 or FAX to 607-755-6562.

### **EMC Measurement Solutions**

A brochure, "EMC Measurement Solutions—Affordable and Effective", is available from Tektronix.

The pamphlet provides an overview of world-wide EMI regulations, the sources and nature of EMI signals, and specific information on Tektronix measurement solutions. A synopsis of national regulations is presented and various regulatory agencies are discussed as well as such topics as preventing EMI from becoming a problem, the origin of EMI signals and the regulatory basis for controlling interference. Also discussed are the four steps to EMI compliance. A range of hardware and software-based EMI measurement solutions are presented. RF spectrum analyzers, personal Fourier transformers, antennas, line impedance stabilization networks (LISNs) and other devices are listed and described.

For your free copy of the EMC solutions brochure, write on company letterhead to Tektronix, Inc., Test & Measurement Group, P.O. Box 1520, Pittsfield, MA 01202 and request Tektronix literature #29W-8793-0 or call 1-800-426-2200, Ext. 181.

# RECEIVER PERFORMANCE

## *Descriptions and definitions of each performance parameter*

---

**A**lmost everyone who has endeavoured to communicate on the radio spectrum has taken at least a passing interest in receiver performance. For many, this curiosity may well have been confined to the “three Ss”—sensitivity, selectivity, and stability—as it is easy to be discouraged by the relative complexity of any comprehensive receiver specification. This is rather a pity, as the whole subject of receiver performance is not only very revealing, but also quite fascinating. Improvements to receiver design and increased activity on the radio bands has meant that traditional ways of specifying performance are no longer sufficient. It is the “dynamic” performance parameters that really tell us how good a receiver is!

In this article, I try to cut through the haze of misunderstanding that seems to surround the topic by providing clear descriptions and definitions of each performance parameter, what it means to the user, and why it’s important. I’ve placed particular emphasis on the all-important “dynamic” performance parameters. With this information under his or her belt, the reader will be able to make sense of even the most exhaustive performance specification, which (of necessity) can be quite complex. It is important to specify all parameters accurately and completely if confusion or misinterpretation is to be avoided. Bland statements in glossy advertisements of, for example, “sensitivity 0.5µV” can in fact be quite misleading.

### Noise

One of the fundamental concepts underlying

receiver performance is that of noise. So before I examine performance parameters, I’ll take a brief look at the physics of noise.

Thermal noise is due to the random movement of charged particles in the effective impedance at the input to the receiver. This noise is proportional to temperature,\* and cannot be avoided except by cooling the whole antenna system to near absolute zero! It is even present if a shielded 50 or 75-ohm resistor representing the antenna impedance is plugged into the receiver input. Thermal noise is also proportional to the resistance/impedance, and to the bandwidth. This is illustrated in the expression for noise shown in **Equation 1**:

$$V_{N_{EMF}} = \sqrt{4kTBR} \quad (1)$$

where:

$V_{N_{EMF}}$	is RMS thermal noise voltage (EMF)
k	is Boltzmann’s Constant ( $1.38 \times 10^{-23}$ )
T	is temperature in °Kelvin
B	is bandwidth in Hz
R	is resistance in ohms

We can easily plug some real-life numbers into the expression to calculate the thermal noise developed on a typical 50-ohm antenna system. For the 50-ohm impedance, ambient temperature of 300°K (about 27°C), and a

---

\*That’s what temperature is—the average speed of the particles jiggling around in a solid, liquid, or gas. If the particles are charged (e.g., electrons), we get noise.

bandwidth of 3 kHz, **Equation 1** works out as:

$$\begin{aligned}V_{N_{EMF}} &= \sqrt{4kTBR} \\ &= \sqrt{4 \times 1.38 \times 10^{-23} \times 300 \times 3000 \times 50} \\ &= 0.05 \mu\text{V (EMF)} \\ &= -26 \text{dB} \mu\text{V}_{EMF}\end{aligned}$$

Rather than use a specific bandwidth, it's often helpful to normalize the calculation to 1 Hz. If we repeat the calculation for 1 Hz (or just divide 0.05 by  $\sqrt{3000}$ ), we get 0.91 nV<sub>EMF</sub>—which translates to -61 dB $\mu$ V, or -174 dBm. (See the sidebar, "Units Used in this Article," for an explanation of dB $\mu$ V and dBm.)

The expression in **Equation 1** is very useful and revealing. For example, it tells us that for a given antenna impedance and a nominal ambient temperature, the only way to reduce the thermal noise is to reduce receiver bandwidth. Although specifically a formula for thermal noise, it is also generally true that any random noise (as produced in an electronic circuit) will also be proportional to (the square root of) temperature, bandwidth, and resistance.

## Traditional performance parameters

Armed with this little bit of physics, let's get down to an examination of each of the performance parameters, what they mean, how they are specified, why they're important, and how they can be improved.

## Sensitivity

Sensitivity is the measure of a receiver's ability to pick up and amplify the smallest of signals without losing any of the "intelligence" carried by that signal. We might think that all we need to do to increase sensitivity is to increase gain indefinitely; but we soon run into the real limiting factor—noise. All electronics circuitry produces some noise, and once the signal level falls to a value close to the receiver noise level (normally expressed as a signal-to-noise ratio (S/N)), no further reduction can be tolerated because intelligibility would be lost—

\*As an alternative to S/N, it is quite commonplace to quote signal+noise to noise (S+N/N) or even signal+noise+distortion to noise+distortion (SINAD), as these are easier to measure. However, the difference between all three is only about 0.5 dB, and for most purposes can be ignored for S/Ns of 10 dB or more.

\*\*On FM, an alternative definition is sometimes used, called the quieting sensitivity. This is defined as the input level required to reduce the output noise by, say, 20 dB (squelch off).

\*Most communications receivers have a number of different filters, so now we need a sensitivity figure for each of the filter bandwidths!

and this is what sets the sensitivity. (Note that even if the receiver were hypothetically perfect—noiseless—you would still run into the thermal noise of **Equation 1**!)

Sensitivity is defined as the signal voltage required to give a specific signal to noise ratio (S/N),\* in a particular receiver bandwidth, for a particular receiver mode (e.g., AM, SSB, etc.). In the case of AM, the modulation level must also be stated, and is often quoted at the 30 percent level. For FM, sensitivity is defined as the signal voltage required for a specific S/N, in a particular bandwidth and receiver mode, to give a specific modulation deviation.\*\* Bandwidth must be taken into account when we define sensitivity (and many of the other performance parameters) because noise is involved. Remember that noise is proportional to bandwidth. (The receiver's input resistance/impedance and operating temperature range are usually defined elsewhere in the specification.)

In the days of noisy tubes (valves), good sensitivity was hard to achieve without compromising other performance aspects. Now with bipolar transistors and FETs, sensitivities of 0.5  $\mu$ V<sub>EMF</sub> for a 10-dB S/N ratio in a 3-kHz bandwidth can easily be achieved on HF for an SSB or CW signal. On FM, a similar figure will be obtained. As AM is usually specified at 30 percent modulation level in a 6 or 8-kHz bandwidth, the figure will be approximately 9 or 10 dB (about 3 times) worse than the SSB/CW figure—in this case about 1.6  $\mu$ V<sub>EMF</sub>. On VHF and above, receiver sensitivities are often even better, but there is a good reason for this (more later).

## Noise Factor

The sensitivity figure for a receiver is a very intuitive way of describing how sensitive (or deaf) a receiver is but, as we have seen, is a rather complex definition involving the particular bandwidth of interest,\* the temperature, receiver mode, S/N ratio, and input impedance. It would seem much more convenient to be able to express a receiver's sensitivity in a way that is independent of all these variables. The noise factor is just such a measurement. With a single number, it tells us everything we need to know about a receiver's sensitivity. The noise factor (NF) can be defined as the ratio of the S/N of a hypothetically perfect (noiseless) receiver to that of a real receiver, which adds its own noise to that of the thermal noise. Because it is the ratio of two ratios, it is indeed independent of bandwidth, temperature, mode, S/N, and impedance. A noise factor of 10 dB is typical for an HF receiver, while factors of 5 dB or less are quite common at VHF/UHF. The noise factor for the hypothetically perfect

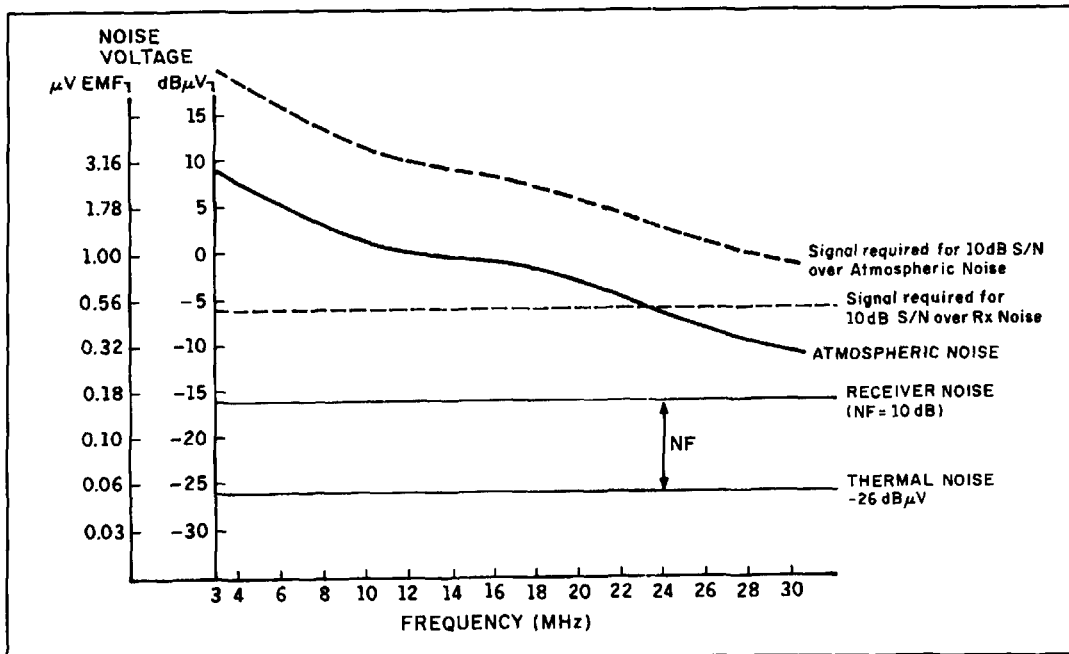

Figure 1. Noise on HF in a 3 kHz bandwidth.

receiver would be 0 dB. The next paragraph illustrates the inter-relationship between sensitivity and noise factors.

## Noise on HF

All this may seem very theoretical, and you may wonder what happens in real life. **Figure 1** shows typical HF spectrum noise voltages as received on a wideband antenna system using a 3-kHz receiver bandwidth at a quiet location. We can see the thermal noise (as calculated earlier) at  $-26 \text{ dB}\mu\text{V}$ . If we have a receiver with a noise factor (NF) of 10 dB, then its noise floor will be as shown at  $-26 + 10 = -16 \text{ dB}\mu\text{V}$ . For most modes in use on HF (SSB, AM, CW, etc.), a signal to noise ratio of 10 dB is considered adequate by many users. To achieve this S/N of 10 dB, a signal must be 10 dB above the receiver noise floor, which in this case is at  $-16 + 10 = -6 \text{ dB}\mu\text{V}$ , or  $0.5 \mu\text{V}_{\text{EMF}}$ , shown in **Figure 1** as the horizontal dashed line.

This establishes the well-known relationship that an NF of 10 dB is equivalent to a sensitivity of approximately  $0.5 \mu\text{V}_{\text{EMF}}$  for a 10 dB S/N in a 3 kHz bandwidth. The sensitivity or noise factor for any other bandwidth and S/N can be calculated in a similar way using the following expression:

$$\text{Sensitivity}_{(\text{dB})} = \text{NF}_{(\text{dB})} + V_{\text{N}(\text{dB})} + S/\text{N}_{(\text{dB})} \quad (2)$$

**Figure 1** also shows us something of even greater significance: the typical atmospheric noise for a quiet area at a quiet time. This is

between 5 and 25 dB above our receiver noise. Consequently, under real operating conditions on HF, our receiver, with its published sensitivity of  $0.5 \mu\text{V}_{\text{EMF}}$  for 10 dB S/N, will need a signal of between  $1 \mu\text{V}_{\text{EMF}}$  (at 30 MHz) and  $10 \mu\text{V}_{\text{EMF}}$  (3 MHz) to give a 10 dB S/N ratio—and this is for a quiet atmosphere (and no QRM)!

Thus, perhaps the most significant conclusion to be drawn from **Figure 1** is the realization that for a receiver with a sensitivity of  $0.5 \mu\text{V}_{\text{EMF}}$  (10 dB NF) it is the atmospheric noise, not the receiver noise, that dominates and limits receiver performance on HF. Indeed the sensitivity could be reduced to  $1 \mu\text{V}_{\text{EMF}}$  (15 dB NF) without loss of performance, except perhaps at 20 to 30 MHz. This means that for an HF receiver using a wideband antenna, there is little point in reducing the NF below 10 dB—especially as sensitivity can only be obtained at the expense of dynamic effects like intermodulation performance.

It's also worth noting that claims of  $0.15 \mu\text{V}_{\text{EMF}}$  for 10 dB S/N (seen advertised for an SSB transceiver) are quite impossible! Even a perfect receiver with a 0 dB NF needs  $0.16 \mu\text{V}_{\text{EMF}}$  ( $-16 \text{ dB}\mu\text{V}$ ) to achieve 10 dB S/N due to the thermal threshold of  $-26 \text{ dB}\mu\text{V}$ .

## VHF and above

Above 30 MHz, as the frequency increases, the level of background noise (now mainly cosmic noise) received by the antenna continues to fall, and above about 120 MHz drops below thermal noise. Thus at quiet locations (away

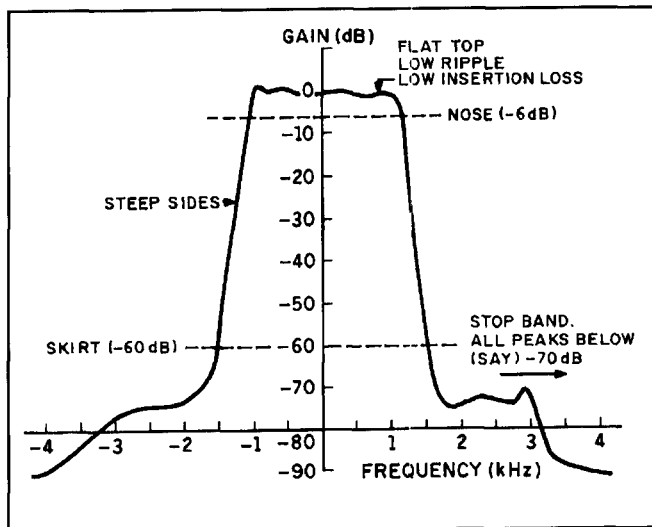

Figure 2. Ideal filter response.

from manmade noise), VHF and UHF receivers can benefit from NFs of less than 10 dB. The challenge here is to achieve figures as close to the magic 0 dB as possible. Figures of 2 to 5 dB or less are quite achievable using careful circuit design.

The overall NF of any receiver is usually determined by the NF of the first amplifying stage in the receiver—normally an RF amplifier (but sometimes a mixer). RF amplifiers nowadays invariably use low-noise FETs, and careful attention must be paid to the circuit that couples the antenna to the first stage. “Noise matching” is a technique sometimes used on VHF/UHF equipment. Instead of matching receiver input impedance to the antenna impedance, noise matching deliberately mismatches the two impedances in a way that optimizes the NF.

## Why CW will never die

The discussions on sensitivity concentrated mainly on noise voltage in a 3-kHz receiver bandwidth, suitable for an SSB transmission. However, don't forget that noise is proportional to the square root of the bandwidth. Consequently, if bandwidth is reduced from 3 kHz to 300 Hz, all noise voltages (thermal, receiver, manmade, and atmospheric) drop by a factor of  $\sqrt{10} = 3.16$  times, or 10 dB. This means that sensitivity for the same (10 dB NF) receiver referred to above, while having a sensitivity of  $0.5 \mu\text{V}_{\text{EMF}}$  in 3 kHz, can also be described as having a sensitivity of  $0.5/3.16 = 0.16 \mu\text{V}_{\text{EMF}}$  for 10 dB S/N in a 300 Hz bandwidth. All this explains the continuing use of

CW in the HF bands; a CW signal can still be copied when SSB would be lost in the noise! In fact, some CW operators can copy a CW signal with a S/N of close to 0 dB,\* so the advantage over SSB can be as much as almost 20 dB.

## Selectivity

The selectivity of a receiver is its ability to tune to one signal while rejecting other close-in signals. Good selectivity was traditionally achieved by means of distributed tuned circuits in the IF strip. To obtain good selectivity, a low second IF was required—usually less than 1 MHz, and typically 455 to 470 kHz.

Nowadays the required selectivity is usually obtained by using one or more block filters—either crystal, mechanical, or ceramic. The old constraint of a low second IF no longer applies; in fact, it is easier to design crystal filter frequencies higher than 1 MHz. Standard IFs have been established at 1.4, 1.6, 9.0, and 10.7 MHz—although the 455 kHz IF using ceramic filters is still very commonplace. In addition to the “main selectivity” filters, block filters are also used as “roofing filters” in the first IF of HF receivers (see Reference 1). These are commonly in the VHF region, and crystal filters in the 40 to 90 MHz range have been developed for this purpose. VHF and UHF receivers may have a first IF of many hundreds of MHz, and surface acoustic wave (SAW) filters are often used in this application.

The ideal filter response has a flat top with low ripple, steep sides going down to a -80 dB (or greater) stopband, which extends a long way out (see Figure 2). Selectivity is usually quoted at the nose bandwidth (6 dB down), and the skirt bandwidth (at 60 dB down). Good values for an 8-pole SSB filter are 2.7 kHz and 4.4 kHz, respectively. One convenient measure of filter performance often quoted is the shape factor (SF), which is the ratio of the skirt bandwidth to the nose bandwidth. The ideal SF is 1:1; anything less than 2:1 for a 3-kHz SSB filter is considered good. Sometimes the nose bandwidth is quoted for the 3 dB points, rather than the 6 dB level. This makes little difference for some filters, but a great deal of difference for others!

Mechanical and crystal filters can be quite close to the ideal (at a cost), and some less expensive ceramic filters give surprisingly good results. Impedance matching into and out of a filter is of great importance, and insertion loss (the loss caused by the filter in the middle of the passband—usually less than 10 dB) must be made up for by amplification. A typical “suite” of filters of a high grade HF communications receiver might be 8 kHz for AM, 2.7 kHz for SSB (often with two asymmetrical fil-

\*I can remember watching an old-timer copying a ZL station (that I could hardly even hear) through all kinds of QRM and QRN and getting perfect copy!

## Units Used In This Article.

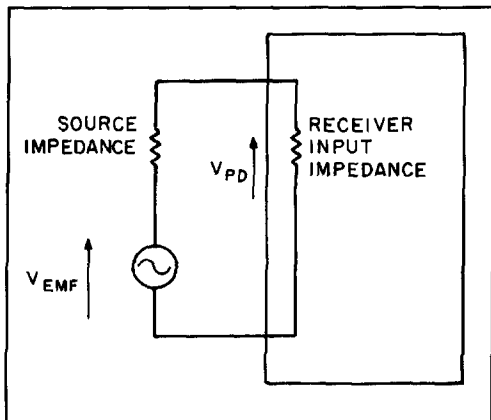

The dB $\mu$ V is a dB relative to 1  $\mu$ V $_{EMF}$ . The dBm is a dB relative to 1 mW into the system's impedance, normally 50 ohms. Zero dBm (50 ohms) works out at 224 mV $_{PD}$ , or 113 dB $\mu$ V; thus to convert from dB $\mu$ V to dBm (50 ohms) simply subtract 113. (For example, 0 dB $\mu$ V = 1  $\mu$ V $_{EMF}$  = 0.5  $\mu$ V $_{PD}$  = -113 dBm). To convert between any other units see **Appendix 2**.

Note that RF voltages in this article are EMF (electro-motive force) unless otherwise stated. Recently, it has become common for manufacturers to specify sensitivities and other parameters using PD (potential difference) instead. Some people prefer to use PD, others EMF. It really doesn't matter which is used as long as the distinction is made clear. Often it is not, which usually implies that PDs are intended. Of course, the use of PDs makes many parameters (e.g., sensitivity) look twice as good (6 dB better) because, in a matched impedance system, PD is always half EMF!

ters—one for USB, one for LSB), and 1.0 kHz, 300 Hz, and 100 Hz for CW, RTTY, and other narrowband data transmissions. The trend in amateur equipment is for the tightest possible SSB filter (2.4 kHz); often 600 or 300 Hz are used for CW. A VHF/UHF receiver may have any of the above plus wider filters, perhaps 12 and 50 kHz—or even wider for FM. (Hi-Fi FM tuners need a 200-kHz filter!)

Note that the discussion on selectivity refers to what could be called the “static selectivity” of the receiver, or the selectivity to a single signal only. For a discussion on dynamic selectivity, see the section on reciprocal mixing.

As an interesting aside, consider the audio CW filter, often used by the amateur fraternity in lieu of a good CW filter at the IF. The best filter of all is the human computer (otherwise known as a brain), and a good operator can pick out and copy a weak CW signal in company with numerous other signals because of the difference in tone. (Many experienced CW operators prefer to listen in a wide bandwidth and do their own filtering even when sharp CW filters are available.) However, the audio image frequency (see **Figure 3**) will also give an output of exactly the same tone, and even the “human filter” will find it impossible to differentiate. Unfortunately, this is exactly the frequency that the audio filter cannot differentiate either! Also, unless AGC voltage is at least partially audio-derived, strong unwanted signals in the IF passband will reduce the IF gain, reducing post-filter dynamic range.

Nevertheless a good (multi-pole) audio filter can be beneficial, especially if a linear detector is being used. (A product detector is linear; an envelope detector is not!) Also, if a steep-sided

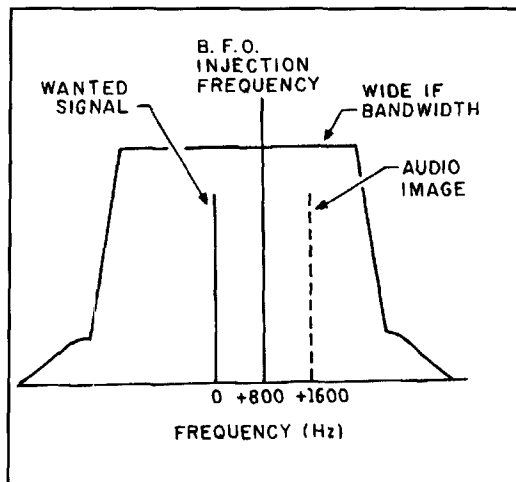

Figure 3. Rejection of audio image.

SSB filter is available, the audio image can be rejected if the BFO injection is made to coincide with the edge of the passband.

### Image (second channel) rejection

In the normal superheterodyning process, a desired signal ( $f_s$ ) beats in the mixer with the local oscillator (or synthesizer output) frequency ( $f_{LO}$ ), and one of the resultant products of the mixing process, usually  $f_{LO} - f_s$ , at the intermediate frequency (IF), is passed by the IF selectivity filter.

However, another frequency called the image or second channel frequency ( $f_{LO} + f_{IF}$ ) also beats with the local oscillator to produce a product at the IF. This frequency must be

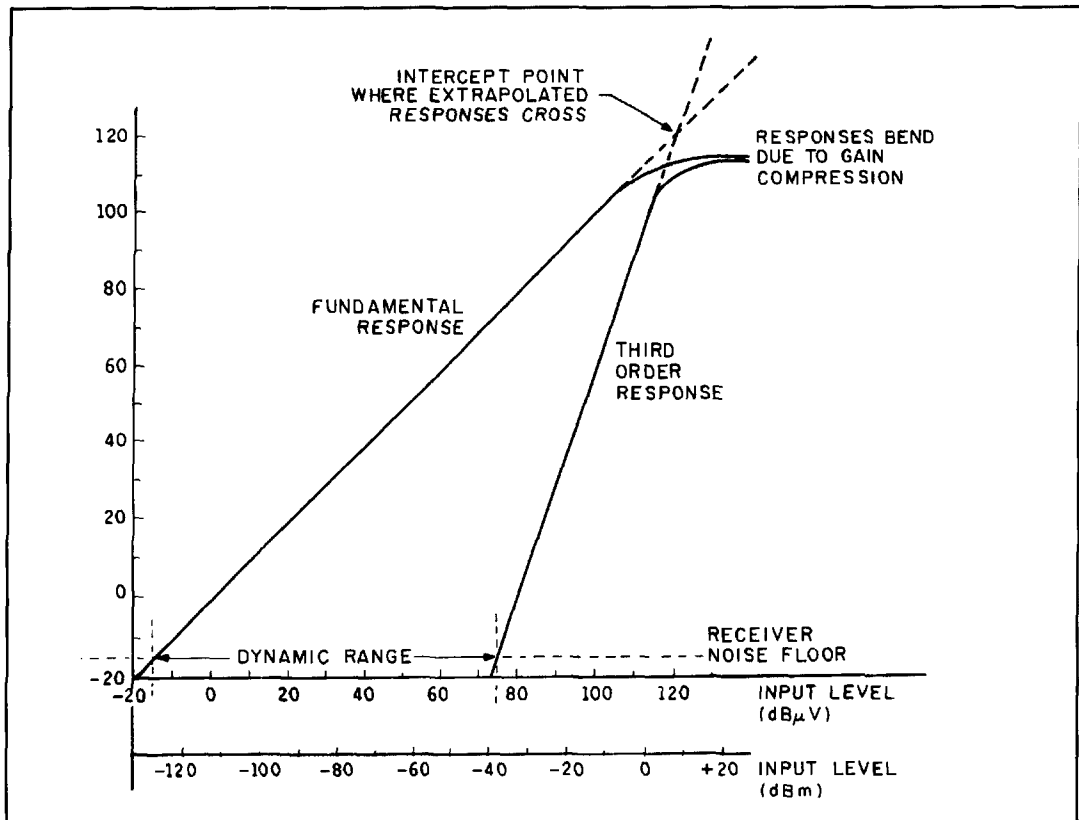

Figure 4. Intercept point.

rejected by some form of RF tuning—either ganged to the “tuning” control or using a separate “pre-selector” control—or by means of switched bandpass filters, usually automatically switched on synthesized receivers.

As the image frequency is equal to  $f_s$  plus twice the IF, the higher the first IF, the further away from  $f_s$  will be the image frequency, and the easier it will be to reject. If up-conversion techniques are used on an HF receiver, the first IF will be in the 40 to 90 MHz range (see **Reference 1**) and the image frequency will also be at VHF and thus can be rejected by a simple 35-MHz low-pass filter at the receiver input.

Image frequency rejection is specified as the ratio in dB of an unwanted signal above  $1 \mu\text{V}_{\text{EMF}}$ , to give the same output as a wanted (on-tune)  $1 \mu\text{V}_{\text{EMF}}$  signal. Sixty dB of rejection is a poor performance, while 90 dB or more is considered good.

## IF rejection

Intermediate frequency (IF) interference occurs when a strong signal at a receiver IF directly breaks through the early receiver stages and into the IF amplifier. IF rejection is specified in the same manner as image rejection with 90 dB or more being a desirable number. This number should be quoted for all the intermedi-

ate frequencies in a receiver; sometimes in a double conversion receiver the figure for the second IF is paradoxically worse than that for the first IF! Good screening is necessary between IF and RF stages, and IF traps in early pre-IF stages can be used to reduce IF breakthrough. Taken together, IF and image rejection are sometimes referred to as “rejection of external spurious signals.”

## Internal spurious responses

Internal spurious responses (spuri or spurs) are receiver responses to signals generated within the receiver itself—in other words, self-generated noises and whistles. These internally generated signals can be fixed (e.g., reference frequencies, etc.) or can move when the receiver tuning is changed. Internal spurious responses cause problems when they occur at the signal frequency or an IF. Such signals are generated by any oscillators and mixers within the receiver or, as is common these days, by digital circuitry like synthesizers and frequency counters—especially the drive lines to multiplexed displays! Other causes of spurious signals are power supply harmonics, parasitic oscillations in amplifiers, and even subharmonics of any up-conversion IFs!

Frequency synthesizers and other digital cir-



uits produce large numbers of frequencies, and most waveforms are digital square waves with fast rise-times rich in harmonics. (CMOS and LSI—for example, N-MOS—is usually better in this respect than TTL, which has faster rise-times.) Normally, signals internal to the chips don't cause a problem; it's the signals on the pins and tracks that usually cause the grief! Typically tens or even hundreds of frequencies are produced, and very effective shielding is necessary. Careful circuit design is important, with adequate low-pass and bandpass filtering. With a good design, it's possible to keep spurious outputs 100 dB down on the main output level. This standard of performance should ensure that all spurious responses are no more than 3 dB above the receiver noise floor in a 3 kHz bandwidth. In some cases, as an economic compromise, a specification may state that all spurious responses are below a certain level, with a number of (stated) exceptions. It will then list the few (maybe five or so) exceptions with their frequencies and levels.

### Stability

Stability is the measure of the frequency drift of a receiver with time and temperature. A fully synthesized receiver can have a stability approximately equal to that of its temperature-controlled frequency reference source. (See **Reference 1** for a more detailed discussion). If an oven-controlled temperature stabilized crystal oscillator is used, a stability of less than 1 part in  $10^8/^\circ\text{C}$  ( $0.1 \text{ Hz}/^\circ\text{C}$  at 10 MHz) can be achieved over the operating temperature range of the receiver. Sometimes stability is specified in terms of a short-term (temperature) drift plus a long-term (crystal aging) drift. With partial synthesis the stability is normally governed by the stability of the VFO, but with cool, buffered solid-state designs it is possible to achieve short-term drift (after a three-hour warm-up) of 50 Hz/hour. The latter is probably adequate for normal SSB/CW/RTTY/AM communications, but more exotic systems like Lincompex, Kineplex, and Piccolo need the stability provided by full synthesis.

### Dynamic performance

All of the performance parameters mentioned so far refer to what might be called the "static" performance of the receiver, or the performance of the receiver to a single (test) signal. In the real world, we must deal with a band full of signals—some of which are very large. In this section, we'll look at this more realistic "dynamic" situation, and just what it means to receiver performance.

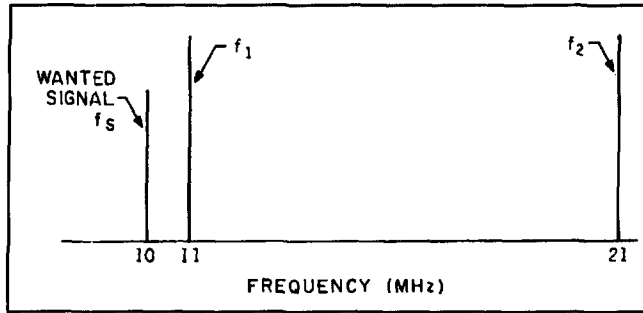

Figure 5. Second order IMPs.

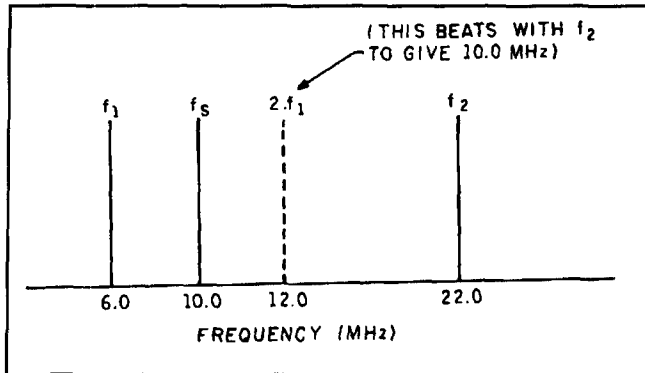

Figure 6. Third order IMPs.

In general (with the exception of reciprocal mixing), dynamic effects are caused by large off-tune signals that cause the receiver to operate in a nonlinear manner. Two of these large unwanted signals can intermodulate with each other, producing a product at the same frequency as the desired signal (intermodulation); or modulation from an unwanted signal can be transferred to the required signal (cross modulation); or an unwanted signal can reduce the sensitivity of (or block) the required signal (blocking). These dynamic interference effects of intermodulation, cross-modulation, and blocking, have been largely ignored in the past. Only in the last ten to fifteen years has their true importance been understood. For example, in the late '60s it became fashionable to market receivers based on previous designs where tubes (valves) were replaced by bipolar transistors. This resulted in a smaller (and cooler) receiver with lower power consumption. However many aspects of receiver performance, particularly dynamic effects, suffered at this time due to the fundamental nonlinearity of transistors as compared to tubes (or FETs).

There are two reasons why dynamic effects are so important. The traditional performance parameters of sensitivity, selectivity, and stability (the "three Ss") have undergone many improvements over the years, and develop-

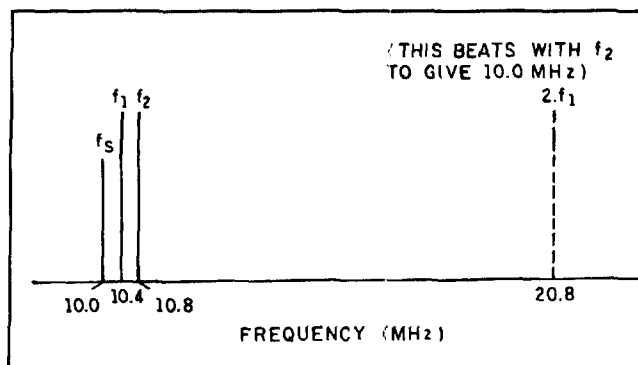

Figure 7. Close-in third order IMPs.

ments in technology such as low noise FETs, block filtering, and frequency synthesis mean that we can more or less design to the performance level required. On the other hand, activity on the bands (especially on HF and VHF) has increased to such an extent that there are always many large off-tune signals present at the receiver's input stages. Thus, it is these dynamic effects, rather than the traditional "three Ss," that largely determine the performance of the communications receiver under real-life operating conditions.

### Intercept Point

Before we talk about intermodulation, cross-modulation, and blocking in more detail, I'd like to introduce two very useful concepts—that of the intercept point and dynamic range. As mentioned, large unwanted signals produce products due to any nonlinearity in the front-end of a receiver. There are many causes of these nonlinearities, some of which can be quite surprising. For example, they can even be produced by dissimilar metals in the antenna (the "rusty bolt" effect)! Any nonlinearity will cause these products to be produced. Don't forget that a mixer is just a nonlinear circuit and, just as for any mixer, a number of different products will be produced—including second-order and third-order products.

It's these second and third order products\* that cause intermodulation, cross modulation, and blocking. This is because the receiver responds to these products at a greater rate than it responds to the fundamental signal input (see **Figure 4**). Second-order products cause the output to increase as the square of the input—twice as many dB, and third-order products as the cube of the input—3 times as many dB. Of course, fourth, fifth, and higher order intermod-

\*Without going too deeply into the mathematics, suffice it to say that the mixing process produces a number of frequency products in accordance with a mathematical equation containing a number of terms. The equation includes a squared term that corresponds to the second-order product, and a cubed term corresponding to the third-order product.

ulation products are also produced, but they are normally ignored as second and third order effects predominate.

The intercept point, arguably the single most useful performance parameter of all, occurs where two extrapolated responses cross. As third-order effects are generally more significant than second-order effects (more on this later) it is usual to consider only the third-order intercept. This can be seen in **Figure 4**, where the third-order response crosses the fundamental response (extrapolated) at 120 dB $\mu$ V or +7 dBm. Note that while most amplitude measurements are defined using voltages ( $\mu$ V, mV, dB $\mu$ V, etc.), the intercept point is usually specified as a power ratio, the dBm, where a dBm is a dB relative to a power of 1 mW into the receiver input impedance. See the sidebar on units for more details.

The third-order intercept is important because, with just a single number, it gives a very good indication of the intermodulation, cross-modulation, and blocking performance of a receiver! Values of +5 to +35 dBm are considered good. The second-order intercept, which occurs where the second-order response crosses the fundamental response (extrapolated), will generally be at a higher level than the third-order intercept, but as was mentioned is generally of lesser importance.

### Dynamic range

Now let's consider the second of our "useful" concepts, that of dynamic range. The dynamic range of a receiver is the range of signal amplitudes, from the smallest to the largest, to which the receiver can respond. The "single signal" dynamic range is limited at the low end by noise, and at the upper end by a phenomenon known as gain compression. Basically, the amplifier outputs start hitting the supply rails and the outputs can't increase any further. One definition of dynamic range uses the above limiting factors and defines dynamic range as the range of signals from the sensitivity level (as defined earlier) to the level required to produce a given level of distortion in the output. Another definition uses the blocking performance level as the upper limit; this is known as the "blocking" dynamic range.

However, these definitions are of limited value in the real "dynamic" situation of a great number of signals, some of which are very large in amplitude. It's these large signals that really limit the dynamic range (again due to the receiver's nonlinearities) and we must therefore derive a definition that takes this "dynamic" situation into account. We can thus loosely describe dynamic range as the range of input signals over which dynamic interference effects produce outputs that are not significant; that is,

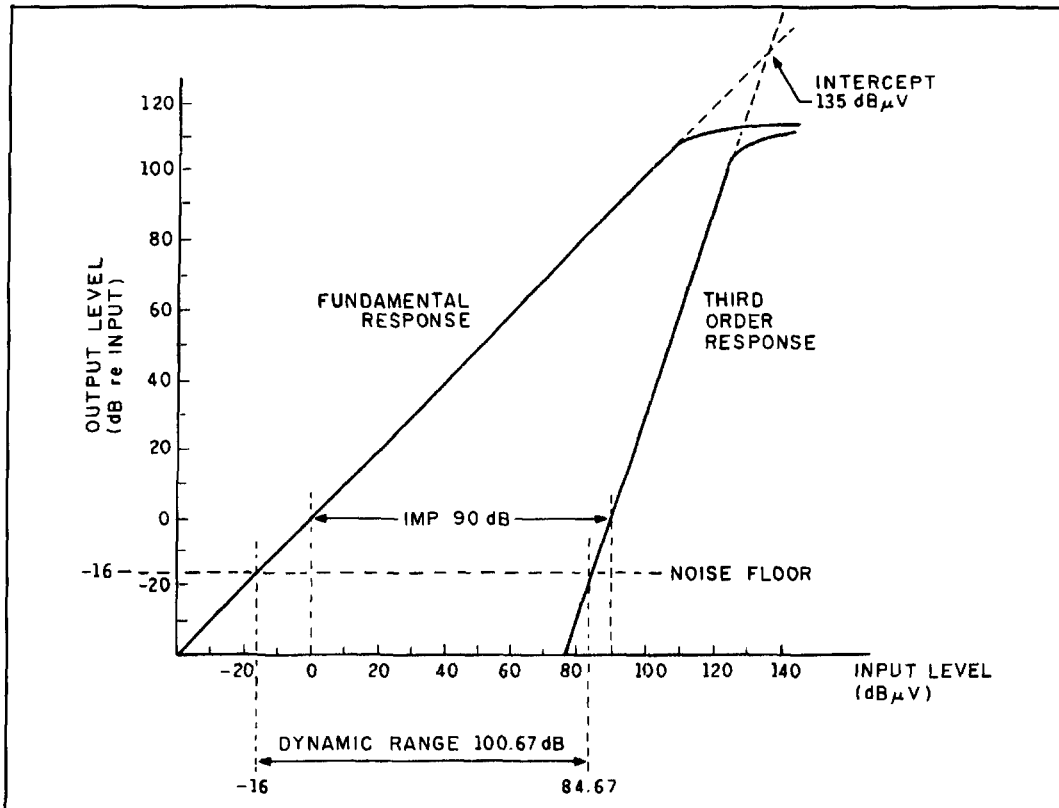

Figure 8. Intermodulation of 90 dB.

which are at or below the noise floor. A useful working definition of dynamic range may be expressed as follows:

Dynamic range is two-thirds of the difference in level between the noise floor and the intercept point in a 3-kHz bandwidth. Or, alternatively, dynamic range is the difference between the fundamental response input level and the third-order response input level as measured along the noise floor\* in a 3-kHz bandwidth (see **Figure 4**). Because the definition involves noise, a particular receiver bandwidth must be specified and, of course, if the bandwidth is reduced the dynamic range improves!

Using the above "preferred" definition, the dynamic range for the receiver depicted in **Figure 4** is 90 dB. Using our first rough "single signal" definition it would be more like 130 dB! These are by no means the only methods of specifying dynamic range, and clearly great care must be taken in interpreting manufacturer's figures. Using our preferred method of definition, a dynamic range of 90 to 110 dB for 3 kHz bandwidth with an intercept point of 120 to 150 dBμV (+7 to +37 dBm), can be considered good.

## Intermodulation

Intermodulation interference products occur when two large unwanted signals beat together

(intermodulate) in a nonlinear receiver stage, such as the RF amplifier or mixer, to produce a product at the desired frequency. These two unwanted signals will generally be far enough removed from the desired signal so that individually they would not normally be heard. (That is, when converted by the normal receiver's heterodyning process, these signals are outside the IF passband or are "off-tune" or "off-channel.") It is only when these signals are present together that they intermodulate or mix to produce interference.

Second-order intermodulation products are simply equal to  $f_1 \pm f_2$ , where  $f_1$  and  $f_2$  are the two unwanted frequencies. For example, refer to **Figure 5**, where the two unwanted signals are at 11 and 21 MHz—causing a beat at 10 MHz. Other pairs of signals at (say) 6 and 16 MHz, or 3 and 7 MHz, would produce a similar product at 10 MHz. One point to note about second-order intermodulation is that at least one of the unwanted signals must be outside the passband of any reasonably tight RF tuning. This includes the passband of any octave or suboctave block front-end filter, currently fitted to many modern communications receivers (see **Reference 1**). However, great care must be taken to ensure good input/output isolation around these filters, or second-order intermodu-

\*Sometimes it's defined at a level 3 dB above the noise floor, rather than right at the noise floor!

lation may be a real problem. A number of recently introduced inexpensive general coverage HF receivers are evidence of this situation. In these receivers, third-order intermodulation performance is quite good, but second-order performance is poor if you are using a wideband antenna without an antenna tuning unit (ATU).

Third-order intermodulation products are generally equal in frequency to  $2f_1 \pm f_2$ . In **Figure 6**, the second harmonic of a 6-MHz signal (at 12 MHz) beats with a 22-MHz signal to produce a 10-MHz third-order product at the desired frequency. In this example, front-end tuning should easily reject both signals, but consider the example of **Figure 7**. Here the second harmonic of a 10.4-MHz signal (at 20.8 MHz) intermodulates with a 10.8-MHz signal to produce the 10-MHz interfering signal. In this example, both unwanted signals are very close to the desired signal, and well within the RF passband—regardless of the type of RF tuning in use.

It is for this reason that, third-order intermodulation is normally considered more important than second-order. In a well designed receiver, second order intermodulation should be easily rejected by the front-end tuning, and a very high performance achieved. Consequently, many performance specifications only specify third-order intermodulation.

Intermodulation performance (IMP) is typically specified as the levels of two unwanted signals not less than (say) 20 kHz off tune to give a 0 dB $\mu$ V (1  $\mu$ V<sub>EMF</sub>) response. A good receiver will have a third-order intermodulation performance of 80 to 100 dB $\mu$ V or more. Second-order intermodulation performance should be similar to that for third-order but it is often not stated, which can be misleading. A statistical analysis based on data relating to the actual signals received over the whole HF band using wideband (rhombic) antennas indicates that at least 90 dB of third-order intermodulation performance is required. (See **References 2 and 3** for details.) It's easy to see why such a figure is needed. Ninety dB $\mu$ V corresponds to 32 mV<sub>EMF</sub>, and at almost any time, there will be tens of broadcast (and other) stations putting

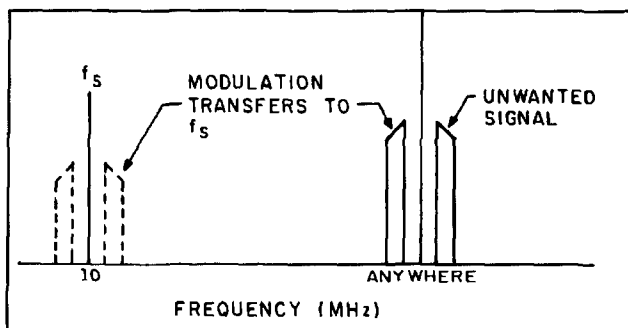

**Figure 9.** Cross modulation.

between 10 and 100 mV<sub>EMF</sub> onto a wideband HF antenna, with hundreds of others in the range 1 to 10 mV<sub>EMF</sub>!

If this all seems a bit mind boggling, the following example should help to put everything into perspective. Referring to **Figure 8**, with our 10-dB NF receiver, we see the receiver noise floor, again for a 3-kHz bandwidth as previously calculated at -16 dB $\mu$ V. For this example, we will consider a receiver with a good intermodulation performance (IMP) of 90 dB. Using the earlier definition for intermodulation, this 90-dB performance is indicated by the line at the 0 dB $\mu$ V level. The third order response for this receiver is also shown. This will have a slope three times that of the fundamental response, with its position defined by the 90-dB IMP line. The intercept point occurs at 135 dB $\mu$ V, or +22 dBm (50 ohms), where the extrapolated responses cross. (In practice, the actual responses bend over before crossing, as shown, due to gain compression.) The dynamic range can be determined using our "preferred" definition, and turns out to be 100.67 dB. This is also shown in **Figure 8**.

For those interested in the math, we can calculate (rather than draw) the intercept point and dynamic range as follows:

The fundamental response is a graph of the form  $y_1 = x$ .

The third order response is a graph where  $y_3 = mx + c$ ,  $m$  is the order (in this case 3) and  $c$  is minus the IMP times the order (i.e.,  $-90 \times 3 = -270$ ). Thus  $y_3 = 3x - 270$ .

At the intercept point  $y_1 = y_3 = x = 3x - 270$ , thus  $2x = 270$ , and  $x = 135$ .

Thus the intercept point is 135 dB $\mu$ V.

Dynamic range = IMP minus two thirds of the receiver noise floor, which in this case is  $90 - (0.67(-16)) = 100.67$  dB.

**Table 1** shows the results of these calculations of intercept point and dynamic range (in a 3-kHz bandwidth) for typical IMP levels.

## In-band intermodulation

In-band intermodulation occurs when two signals within the IF passband intermodulate to produce extra products. It's normally of little significance except where multichannel "Voice Frequency Telegraphy (VFT)" systems such as "Piccolo" are in use. In-band intermodulation is normally specified as the level of an unwanted intermodulation product relative to two equal wanted in-band signals. A typical level of performance for a good receiver is for a product 40 dB or more below the level of two equal in-band signals.

## Cross modulation

Cross modulation occurs when modulation

**Table 1. Relationship of IMPs, dynamic range, and intercept point.**

IMP (dB)	Intercept point (dBμV) (dBm)		Dynamic range: NF=10 dB, Bandwidth=3 kHz dB
70	105	-8	80.67
80	120	+7	90.67
90	135	+22	100.67
100	150	+37	110.67
110	165	+52	120.67

from a single unwanted amplitude modulated signal transfers itself across, and literally modulates the desired signal (see **Figure 9**). This transfer of modulation again occurs due to the nonlinearities in the early receiver stages, and sometimes the same modulation may reappear on each adjacent signal tuned in. Cross modulation may be specified as the level required in dBμV for a 30 percent modulated carrier greater than (say) 20 kHz off-tune, to cause an interfering signal 20 dB below a desired signal greater than some specified level, in a (say) 3 kHz bandwidth.

Cross modulation is a third-order effect, so good third-order intermodulation performance will tend to mean good cross modulation performance. In fact, the level of an interfering signal will normally have to be higher than that for intermodulation. The interfering signal will be within the front-end tuning bandwidth of the receiver, so it will typically be in the same or adjacent broadcast band to the band being received. A level of 100 to 120 dBμV can be considered good.

## Blocking

Blocking, or desensitizing, is similar to cross modulation in that a single strong interfering signal is involved; however, in this case the large off-tune signal causes a reduction in desired signal output. This reduction is due to a product, again produced in the nonlinearities of the receiver front-end, which subtracts from the desired signal's fundamental power term. It is specified as the level of an unwanted signal, removed from the desired channel by at least (say) 20 kHz, required to reduce a desired output (of specified level) by 3 dB. In some recent receiver designs, blocking performance is so good that a 3-dB reduction does not occur, and a 1-dB reduction must be specified! Blocking can often be induced by a strong CW signal, causing gain to fluctuate up and down with the keying. Ninety to 110 dBμV for a 3-dB reduction is considered a good performance for a desired 1-mV<sub>EMF</sub> signal.

Note that we have specified a value of "at

least 20 kHz" for our off-channel interfering signal for this, and other, dynamic performance parameters. This value is usually chosen to ensure that the unwanted signal will be outside the passband of the receiver IF stages, and while 20 kHz is suitable for a HF receiver with a good roofing filter (which might have a nose bandwidth of 12 kHz or so), a figure of 50 kHz might be used for a VHF or UHF receiver.

## Causes and cures of nonlinearity effects

As we have seen, intermodulation, cross modulation, and blocking are caused by large off-tune signals driving the receiver into nonlinearity. There are three fundamental methods of improving performance: (a) reducing the level of all signals, large and small alike, (b) preventing the off-channel signals from getting into the receiver, and (c) improving the linearity of the early stages of the receiver, before and including the roofing filter. (A roofing filter is inserted into the first IF and used to reduce the number of strong signals passing through the IF chain. It is almost as narrow as the widest main selective filter, and it is the point in the receiver path beyond which nonlinear effects generally do not cause a problem.\*)

The first method (a) works because the response to the unwanted (large) signals falls off at a faster rate than that of the desired signals (see **Figure 4**). It is implemented by a front-end attenuator or a wideband AGC loop (separate from the main AGC loop) that operates on the RF amplifier on large signals only, and thus can be thought of as being an automatic attenuator. Both methods have the disadvantage of reducing receiver sensitivity, often when good sensitivity is most needed, and therefore other solutions must be found.

Method (b) typically involves the use of sub-octave filters or some sort of preselector tuning, and can be very effective in reducing second-order effects. However, as mentioned previous-

\*With the minor exception of in-band intermodulation.

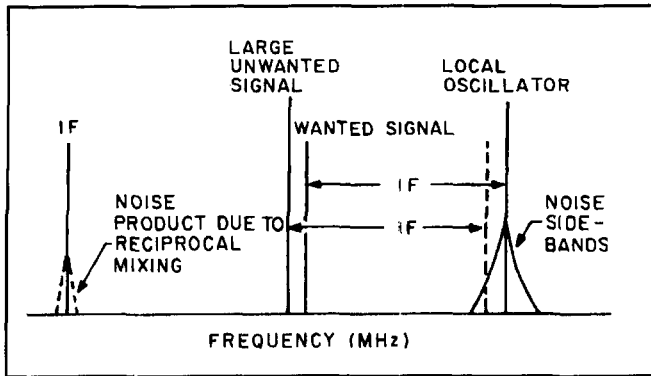

Figure 10. Reciprocal mixing.

ly, interfering signals that produce third-order products can be very close indeed to the desired signal—too close for even the tightest RF tuned circuits to have an effect.

Thus, the only really effective solution is to improve front-end linearity—method (c). Before we look at (c), let's consider the linearity of the active devices used in RF amplifiers and mixers. Bipolar transistors are particularly poor in this respect, but FETs are approximately square-law devices and are therefore very good in terms of third-order effects, but not quite so good for second-order products. Thus modern designs invariably use FETs (often MOSFETs) for good third-order performance, with sub-octave front-end filters to ensure good second-order performance.

Linearity can be further improved by using high voltage supplies, and by keeping pre-roofing filter gain down to a minimum consistent with the required sensitivity; this can thus be achieved by keeping noise levels down. Taken to the extreme, this could mean that the RF amplifier could be completely dispensed with, and the signals fed directly to a low-noise mixer via the front-end filters. This isn't such a drastic step as might appear, as a NF of 10 dB is more than adequate on HF, and can be achieved without an RF amplifier.

The mixer may be a double-balanced switching-type diode mixer using high levels (volts) of local oscillator injection to switch hard and thus improve linearity. As was mentioned, almost anything imaginable can be a cause of nonlinearity, and all components normally considered to be linear, passive, and reciprocal must be carefully checked to ensure that they really are. This especially applies to ferrite cores used for RF coils and transformers, and crystal filters—which are often nonlinear and nonreciprocal; i.e., having different characteristics if connected the “wrong” way round.

The practice of fitting protection diodes at the receiver input (often found on marine-band main receivers) may also cause nonlinearity, as

can diodes used to switch front-end filters, etc., if not designed carefully. If all these points are carefully considered, very good linearity can be achieved with an intercept point of 140 dB $\mu$ V (+27 dBm) or better. This level of performance ensures that intermodulation and cross modulation products are below atmospheric noise on HF, and therefore will not be heard!

## Reciprocal mixing

Reciprocal mixing is due to high levels of unwanted signals mixing with the noise sidebands of the local oscillator/synthesizer, and thus producing unwanted products at the desired frequency (see **Figure 10**). It is another phenomenon which until fairly recently had been more or less ignored—partly because tube (valve) local oscillators were inherently “cleaner” than many of the solid-state frequency synthesizers that appeared in receivers in the '60s and '70s.

Reciprocal mixing is important because it reduces the *selectivity* of the receiver in the presence of large close-in signals, in a way not revealed by reference to the “selectivity” figures quoted in the receiver specification! It does this by introducing off-tune signals into the IF at levels proportional to the distance they are away from the desired signal, effectively reducing the selectivity of the receiver. This is illustrated in **Figure 11**, where the response curves indicate the dynamic selectivity of the receiver; i.e., the selectivity of the receiver in a “real-life” situation of a band full of signals, and not just a single test frequency. As can be seen, it's the stopband of the filter response that has been changed, and with 50 dB of reciprocal mixing, a considerable loss of performance occurs. However, when the reciprocal mixing has been improved to 70 dB, its effect on filter response can be considered fairly minor.

Reciprocal mixing is specified as the level in dB of an unwanted signal at (say) 20 kHz off-tune, above a desired signal, to produce a noise product 20 dB down on the desired signal level, in a specified bandwidth (usually 3 kHz). The unwanted signal will be fairly close to the desired signal, and cannot be rejected by front-end filtering and, as this effect is *not* caused by front-end nonlinearity, any of the “cures” described above will have no effect! The only solution is to design oscillators with very low noise outputs—especially with regard to the close-in phase noise.

Oscillator noise can be reduced by employing high “Q” in the oscillator circuit, and also by using high powers in the oscillator, thus improving S/N. Phase locked loops (PLLs) in frequency synthesizers can be very poor in this respect, especially single-loop designs which,

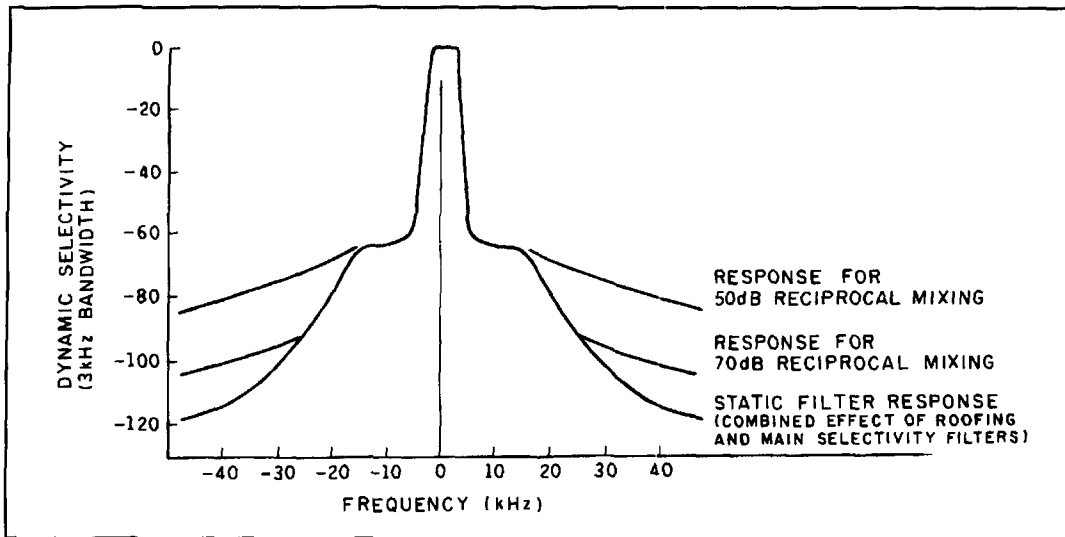

Figure 11. Dynamic selectivity.

because of the high division ratios used, have low loop gain resulting in high levels of noise. Also, PLLs frequently use low “Q” and low power VCOs in the output. The noise produced is phase modulated and cannot be removed by limiting. However, with good design a frequency synthesizer output noise of 90 to 100 dBc\* can be obtained, while a good FET crystal oscillator can give 110 dB or better. This should ensure a reciprocal mixing performance of 70 dB or better. (Sometimes reciprocal mixing is specified in terms of a 3-dB reduction of SINAD of the desired signal, rather than a product 20 dB down on the desired signal. In this case the figure will look almost 20 dB better, at around 90 dB or so for a good receiver.

### Other miscellaneous parameters

Various other performance parameters and operational features also form an important part of a receiver specification. A few are mentioned below (those that require further explanation) but most are self-explanatory—see the “typical” performance specification of **Appendix 1** for a complete listing of these parameters and other operational features.

### AGC performance

Communications receivers must handle signals with an amplitude range of about 120 dB (1,000,000 to 1!), so some form of automatic gain control (AGC) is invariably included. For maximum operator convenience the AGC should keep the output almost constant over the very large range of input signals. Thus the AGC performance is stated as a change in output level for a given change in input level

above (say)  $1\mu\text{V}_{\text{EMF}}$ . A very good performance might be 2 dB output change for 110 dB change in input level. In addition, the AGC system will usually have a variety of different attack and decay times to suit different modes and conditions. These should be stated in the current receiver design specifications.

### BFO range

When a receiver is fitted with a variable BFO for CW reception (as all receivers should be!) the adjustment range should be specified.

### Outputs

Most communications receivers have a number of audio outputs, including outputs for speaker, phones, and sometimes a line output unaffected by the audio gain control. All these outputs should be listed, together with nominal output levels (and total harmonic distortion). Some receivers also provide IF (and other) outputs; again, these should be listed with the nominal signal levels.

### Conclusions

Although the traditional performance parameters of sensitivity, selectivity, and stability (the “three Ss”) are still important, with modern receiver design it is the dynamic parameters of intermodulation, cross modulation, blocking, and reciprocal mixing that really define receiver performance. Other parameters such as

\*The dBc is a dB referenced to the carrier output—in this case to the oscillator output level.

dynamic range (if defined adequately) and third-order intercept point are also extremely useful pointers to overall receiver performance. Receiver performance specifications must be comprehensive to avoid confusion and misinterpretation. In any event, great care should be taken when interpreting specifications.

The performance of the communications receiver has increased over the years (with one or two ups and downs) and it is now possible to design receivers that provide excellent performance at reasonable cost. As activity on the bands has constantly increased (especially on HF and VHF), this improvement in performance has been of vital importance in maintaining the ability to communicate. Although in the area of top "professional" equipment the cost has gone up in proportion to its complexity, at the amateur level the real cost (verses performance) has in some cases actually gone down! There are now a large number of general coverage receivers available (from overseas) that offer very high performance and complexity in relation to their cost.

This reduction in real cost is due, in part, to the availability of relatively low cost complex ICs, crystal filters, and FETs, as well as to tremendous improvements in design techniques. Trends include more extensive use of ICs, perhaps with a single chip full-synthesizer,

and microprocessor control of the receiver. Digital processing techniques employing high speed A/D and D/A converters will find increasing usage, but direct conversion (a sort of superhet with an IF of zero frequency) remains, as ever, on the horizon. It seems likely that more extensive use will be made of remote control of receivers via data link, and that in communications centers a central microcomputer will be linked to each operating position—performing a variety of useful functions. On the domestic scene, the home computer can be linked to the receiver via an RS232 line, and can be used to decode RTTY and SSTV signals, etc. It could also be used as a big "memory" to store channels (frequencies/modes/filters and a channel ident) for instant recall. Receivers available now offer performance that ten years ago could be obtained only from professional receivers costing ten times as much, and which twenty years ago could not be obtained at all!

#### REFERENCES

1. J.A. Dyer, "HF Receiver Design," *Communications Quarterly*, Summer 1992, page 81.
2. R.F.E. Winn, "Synthesized Communications Receiver," *Wireless World*, October 1974, pages 413-417.
3. R.F.E. Winn, "Effects of Receiver Design in Communications Systems," *IERE Proceedings of the Conference on Radio Receivers and Associated Systems*, 4-6 July 1972, pages 193-204.

### Appendix 1: A Typical Receiver Performance Specification

This detailed typical specification indicates the performance required for a "very good" HF receiver. Additional parameters not mentioned in the main body of the article, such as frequency range, receiver modes, etc., have been added for completeness. Note that specifications like this should state worst-case figures (i.e., maximum or minimum test limits used while the receiver is being tested.) In some specifications, however, "typical" figures are used instead. At first sight, this will make the receiver seem considerably better: for example, a worst-case (test limit) NF of 10 dB will often "typically" be 7 dB. It is therefore important to establish whether a true specification or a list of typical values is meant. The specification below uses worst-case (test limit) figures. Note that as before the dB $\mu$ V is a dB relative to 1  $\mu$ V<sub>EMF</sub>.

#### Specification

Frequency Range	50 kHz to 30 MHz (continuous coverage)				
Frequency Display	7 digit, resolution 10 Hz				
Receiver Modes	CW, FSK (RTTY), SSB (USB and LSB), ISB, AM, NBFM				
Input Impedance	50 Ohms				
Sensitivity (500 kHz to 30 MHz)	SSB, CW, ISB:	0.5 $\mu$ V <sub>EMF</sub> for 10 dB SINAD in a 3 kHz bandwidth			
	AM:	2.2 $\mu$ V <sub>EMF</sub> for 10 dB SINAD in a 8 kHz bandwidth, modulation 30%			
	FM:	0.6 $\mu$ V <sub>EMF</sub> for 10 dB SINAD in a 15 kHz bandwidth, deviation 2.1 kHz <sub>RMS</sub>			
Noise Factor	10 dB				
IF Selectivity	<b>filter</b>	<b>available on</b>	<b>-6dB</b>	<b>-60dB</b>	<b>shape factor</b>
	15 kHz	FM	15.00	33.00	2.2
	8 kHz	AM	7.80	14.00	1.8
	2.7 kHz	SSB,ISB,CW	2.70	4.30	1.6



	<b>filter</b>	<b>available on</b>	<b>-6dB</b>	<b>-60dB</b>	<b>shape factor</b>		
	1 kHz	CW	1.00	2.00	2.0		
	300 Hz	CW	0.28	0.75	2.7		
Dynamic Range	104 dB in 3 kHz bandwidth						
Third Order Intercept	+27 dBm (50 Ohms) = 140 dBμV						
Third Order Intermodulation	94 dBμV. The levels of two unwanted signals both greater than 20 kHz off tune must be 94 dBμV [-19 dBm (50 Ohms)] to give a 1 μV (0 dBμV) response.						
Second Order Intermodulation	95 dBμV. The levels of two unwanted signals both greater than 20 kHz off tune must be 95 dBμV [-18 dBm (50 Ohms)] to give a 1 μV (0 dBμV) response.						
In-band Intermodulation	-40 dB. Two in-band signals of equal amplitude will produce a product greater than 40 dB down.						
Cross Modulation	110 dBμV. For a wanted signal greater than 300 μV <sub>EMF</sub> in a 3 kHz bandwidth, a 30% modulated carrier greater than 20 kHz off frequency must be 110 dBμV [-3 dBm (50 Ohms)] to produce a signal 20 dB below the wanted signal.						
Blocking	110 dBμV. A signal greater than 20 kHz off frequency will be 110 dBμV [-3 dBm (50 Ohms)] to cause a 3 dB reduction of a wanted 1 mV <sub>EMF</sub> (60 dBμV) signal.						
Reciprocal Mixing	75 dB. An unwanted signal greater than 20 kHz off frequency will be 75 dB above the level of a wanted on-frequency signal in a 3 kHz bandwidth to produce a noise product 20 dB below the wanted signal.						
Image Rejection	90 dB. The image frequency must be 90 dBμV [-23 dBm (50 Ohms)] to give a 1 μV <sub>EMF</sub> (0 dBμV) response.						
IF Rejection	90 dB. For the first and second IF the level of an unwanted signal will be 90 dBμV [-23 dBm (50 Ohms)] to give a 1 μV <sub>EMF</sub> (0 dBμV) response.						
Crosstalk (ISB)	-50 dB. On ISB mode the crosstalk between two equal 0 dBm (600 Ohms) outputs shall be less than -50 dB relative to the output at 1 kHz.						
Internal spuri	All internally generated spurious signals are less than 3 dB above receiver noise, in a 3 kHz bandwidth.						
Stability	After 10 minute warm-up, better than 1 part in 10 <sup>8</sup> /°C. Long term crystal aging less than 1 part in 10 <sup>9</sup> per day.						
Antenna Radiation Protection	Less than 20 μV <sub>EMF</sub> into 50 Ohms. (= -87 dBm, or 2pW)						
AGC Performance	Receiver can withstand 30 V <sub>PD</sub> at antenna input continuously. A spark gap is provided.						
AGC Time Constants	For all input levels greater than 2 μV <sub>EMF</sub> an input level change of 100 dB will result in and output change of less than 3 dB.						
		<b>SLOW</b>			<b>FAST</b>		
	<b>Mode</b>	<b>attack</b>	<b>hang</b>	<b>decay</b>	<b>attack</b>	<b>hang</b>	<b>decay</b>
	ISB,SSB,CW	10 ms	2s	200 ms	5 ms	200 ms	50 ms
	AM,FM	20 ms	-	20 ms	5 ms	-	5 ms
BFO Range	±3 kHz						
AF Outputs	Main Output:	2 watts into 8 ohms at <3% total harmonic distortion (THD)					
	Headphones:	20 mW into 600 ohms					
	Line Output:	600 ohms balanced line independent of AF Gain control, internally settable to -10 to +10 dBm (600 Ohms)					
Muting	Ground return (0V) on mute terminal to mute. Mute level at least 60 dB down.						
Metering	Meter reads signal strength in dBμV, or AF line level in dBm (600 Ohms).						
Power Requirements	200 to 250, or 100 to 120 volts AC, 45 to 65 Hz, at 50 VA (Volt-Amperes).						
Environment	Operating temperature range -10 to +40°C (+14 to +104°F).						
	Storage temperature range -40 to +70°C (-40 to +158°F).						
	Relative Humidity up to 95% at 40°C (104°F), non condensing.						
MTBF	8000 hours						
Dimensions	350 mm wide, 180 mm high, by 250 mm deep.						
Weight	14 Kg (31 lbs)						

## Appendix 2: Voltage and Power Relationships

Figure 12 is very useful for making quick conversions between the many units in common use. It shows the relationships between voltage levels as specified in  $V_{EMF}$ ,  $V_{PD}$ , and  $\text{dB}\mu\text{V}(\text{EMF})$ , and power levels in  $\text{dBm}$  (50 ohms), and watts (50 ohms). It also shows the S-meter response recommended by the International Amateur Radio Union (IARU). This specifies that S9 should be at  $100 \mu\text{V}_{EMF}$  ( $50 \mu\text{V}_{PD}$ ) and that each S-point should be at 6 dB intervals. Also shown are thermal noise levels for various bandwidths from 1 Hz to 10 kHz.

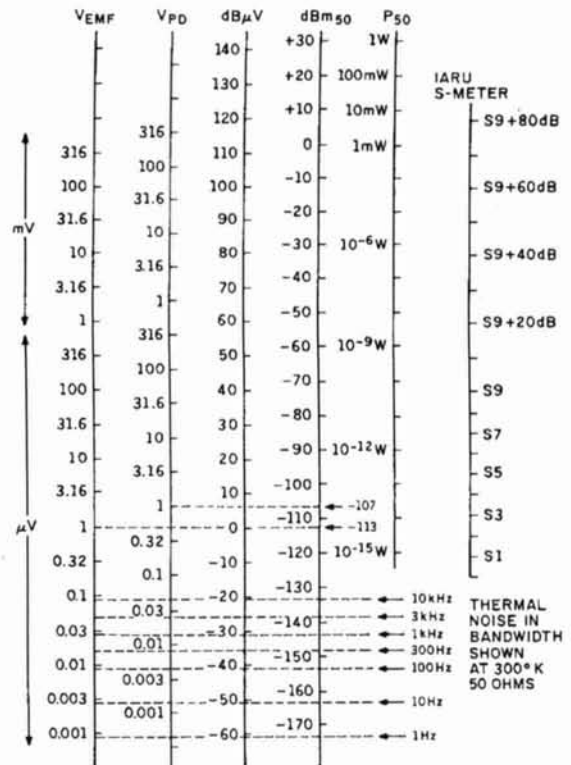

Figure 12. Voltage and power relationships.

## PRODUCT INFORMATION

### New Universal Counter from Hewlett-Packard

Hewlett-Packard Company introduces the HP 53131A universal counter, which allows test engineers to optimize testing for bench applications in manufacturing and the lab. For applications in which frequency resolution is paramount, the counter can provide 10 digits of resolution per second.

The HP 53131A is based on technology developed for HP's modulation-domain analyzers to provide high-frequency resolution with high test speeds.

Key features include 225 MHz bandwidth (an optional Channel 3 provides frequency measurements up to 3 GHz); 500-ps single-shot time-interval resolution; 200 full formatted measurements per second Hewlett-Packard Interface Bus throughput; standard measurements such as frequency, period, ratio, time interval, pulse width, phase angle, duty cycle, totalize, peak voltage and rise time; and limit testing allows the user to set upper and lower limits for any measurement; analog-display mode allows interactive device tuning; statistics can be computed for all measurements or only for measurements that fall within limits;



and single-key setup recall allows users to create and store up to 20 setups.

The HP 53131A counter can be used for stand-alone bench or computer-controlled systems applications. The standard HP-IB (IEEE-488.2) port provides full Standard Commands for Programmable Instruments (SCPI) compatible programmability. The standard RS-232-C port (talk only) provides printer support or data transfer to a computer through a terminal-emulation program.

To receive more information on the HP 53131A counter, contact Hewlett-Packard Company, Direct Marketing Organization, P.O. Box 58059, MS51L-SJ, Santa Clara, CA 95051-8059.

# QUARTERLY DEVICES

## *New devices for loops and linears*

In this issue of *Communications Quarterly*, Roberto Craighero presents a comprehensive guide for designing a practical 14 to 30-MHz HF loop antenna. Because of its compact size and high radiating efficiency, the HF loop antenna is currently receiving a lot of attention from builders and manufacturers alike. To date, most versions rely upon wide-spaced split-stator air-variable capacitors for tuning. Mr. Craighero introduces an alternative tuning method—a motor-driven vacuum-sealed variable capacitor. In this edition of “Quarterly Devices,” I’ll introduce the PTFE-dielectric variable, a relatively new type of capacitor to enter the RF marketplace, as a third alternative. PTFE-dielectric variables appear especially promising for this application.

Additionally, we’ll look at some powerful new opportunities for linear amplifier designers from Svetlana Electron Devices, Inc. Svetlana offers a line of tetrode RF-power tubes that could change the way we think about linear amplifiers in the United States.

### Loop antenna tuning capacitor—special requirements

As Mr. Craighero’s article explains, loop antennas are really extremely high-Q LC circuits especially designed to radiate RF energy. In order to work, the L portion must exhibit very low ohmic loss, and the C portion must handle extremely high RF voltages. When choosing a variable capacitor to work in this regime, special qualities are needed:

1. The capacitor must provide a low dissipation factor and a very high unloaded Q. Any dielectric loss through the capacitor will severely compromise antenna Q and radiating efficiency.
2. The capacitor’s RF breakdown voltage rating must be high. By way of example, a 3-foot

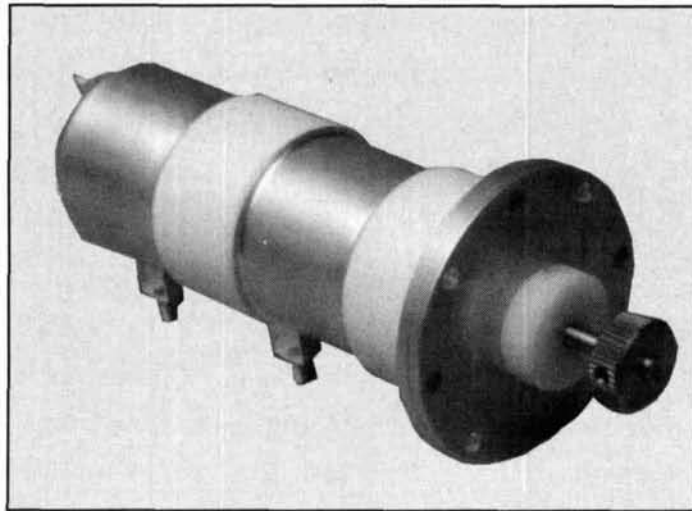
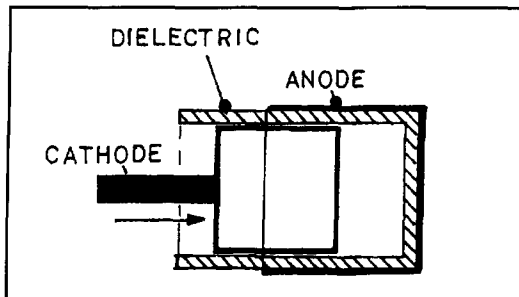

Photo A. Split-anode PTFE capacitor.

diameter loop operating at 14 MHz with a power input of 100 watts will develop nearly 4 kV across its capacitive element. Arcing can become a serious problem at these voltages.

3. Excellent fine-tuning resolution is required. Loops, which typically exhibit a usable VSWR bandwidth of around 15 kHz, can be extremely sensitive to even a small amount of capacitor backlash or mechanical roughness.
4. The capacitor mechanism must be easy to motor-drive (i.e., require low torque). It must also withstand the wear and tear of constant retuning without deterioration.
5. The capacitor should be symmetrically shaped for easy insertion into the loop. Attachment points must be suitable for welding or silver-soldering to the element, because mechanical fasteners will cause excessive ohmic loss.
6. Wipers or sliding contacts cannot be used. The capacitor must use a bellows-loaded movable element, or a split stator tuned by an isolated common element such as a rotor or piston.



**Figure 1.** Basic structure of a PTFE-dielectric capacitor. The capacitor body is isostatically molded virgin Teflon dielectric with a copper anode electroplated to the outer surface. The cathode, a brass piston, moves within the center portion of the assembly to vary capacitance.

7. All capacitor plates must be welded or silver-soldered to their mounting structure; spacer or friction-fit construction will not work because of resistive losses.

This shopping list of special requirements virtually eliminates the possibility of using low-cost mass-produced capacitors in loop antennas. Presently, most amateur and commercial manufacturers use welded or extruded air-variables that have been custom-fabricated to fit the specific application. These capacitors are quite large and must be encased in a housing to keep environmental contaminants like water, air pollution, bugs, and organic debris from reaching exposed plates.

Vacuum variables, as described in Mr. Craighero's article, offer an attractive alternative to air-variables from a technical standpoint; unloaded Q and voltage ratings are very high, and the capacitor elements are environmentally sealed. However, on the negative side, new vacuum-variables are extremely expensive and surplus units are increasingly difficult to find. Also, there is some evidence that constant

retuning may cause premature cracking of the internal bellows structure.

## Electroplated PTFE RF tuning capacitors

For over 30 years, Polyflon Company of New Rochelle, New York has produced a wide range of electroplated PTFE products for RF applications ranging from HF to microwave service. Recently, Polyflon announced a line of high-power PTFE dielectric piston-type variable capacitors to support manufacturers building MRI amplifier and plasma generating equipment. This new line offers capacitance ranges and breakdown voltages that should also be attractive to designers of loop antennas, antenna tuning networks, and tube-type high-power HF and VHF linear amplifiers.

**Figure 1** shows the basic structure of the PTFE-dielectric piston-type variable. Capacitance is developed between anode and cathode across a pure Teflon™\* dielectric. Because the dielectric constant of Teflon is 2.13, PTFE capacitors require significantly less plate area than air-variable equivalents. Plate area is further reduced because Teflon's superior high-voltage insulating properties allow much closer anode-cathode spacing.

Arcing due to structural irregularities or sharp edges is always a possibility in high-voltage RF circuits. To combat this, Polyflon uses a proprietary electroplating process that deposits copper directly onto isostatically molded PTFE components. This technique virtually eliminates the potential for generating edge corona from sharp corners or arcing from trapped air pockets.

Virgin PTFE capacitors offer very high unloaded Qs. Teflon dielectric provides a dissipation factor of less than 0.0001 at frequencies

\*Teflon is a trademark of the Dupont Corporation.

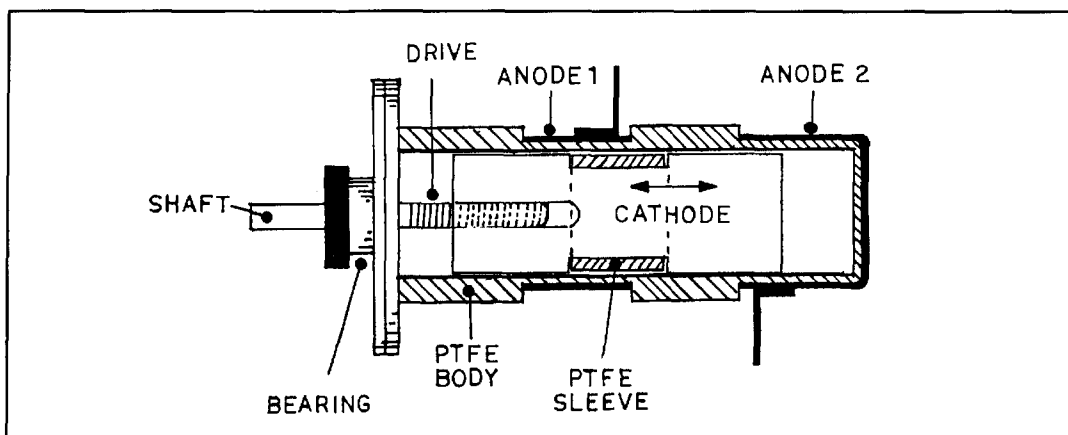

**Figure 2.** PTFE-dielectric capacitor with split anode. Split-anode PTFE piston capacitor is suitable for tuning HF loop antennas. Like a split-stator air-variable, this design has no wiper or slip-ring assembly to introduce unwanted ohmic resistance into the antenna LC circuit.

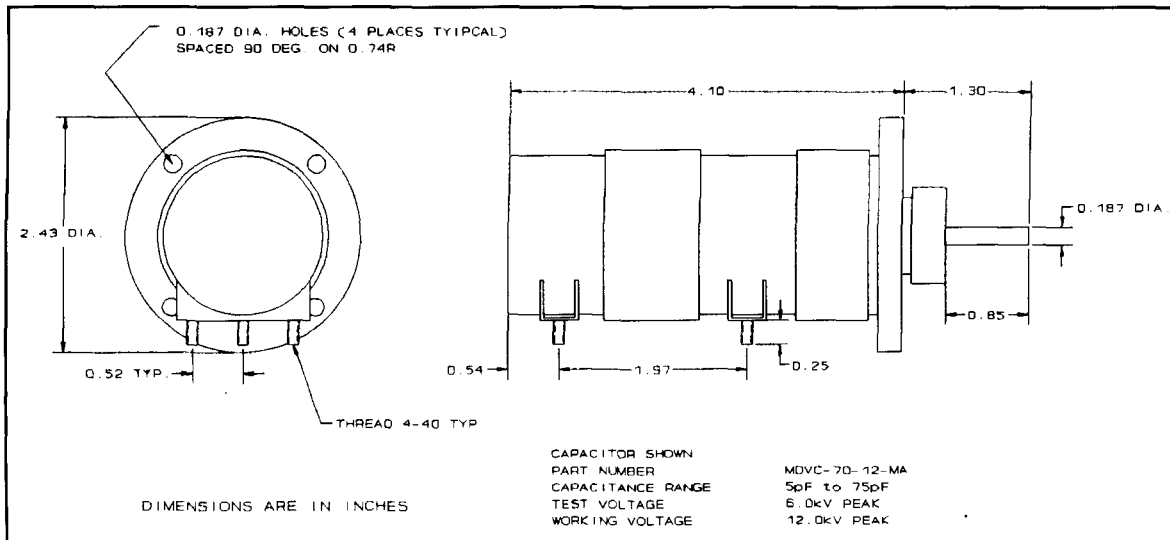

Figure 3. Dimensional drawing of a 75-pF 6.0 kV Polyflon split-anode variable capacitor.

below 50 MHz, allowing these capacitors to attain unloaded Qs of 5000 or better under dry conditions. Teflon insulation also makes for a very stable capacitor. PTFE is impervious to corrosive chemicals and has no known long-term failure modes. Moisture absorption is typically less than 0.01 percent. Although Teflon capacitors should be protected from direct exposure to weather, external dehydration is not required in most HF applications.

A split-anode capacitor design suitable for use in RF loops is shown in **Figure 2** and **Photo A**. The main body of the capacitor consists of a piece of shaped Teflon dielectric with two anode elements electroplated in place. An electrically isolated brass piston is mounted internally on a drive-screw assembly. This piston moves through the center of the capacitor, providing mutual coupling between the two anodes. As with split-stator designs, the split anode configuration eliminates the need for a mechanical wiper or slip-ring contact. Because the two capacitive elements are effectively connected in series via the piston, each section must develop twice the desired end-to-end capacitance. This requires more anode area per section, but also doubles the overall voltage rating of the device.

Typically, a 3-foot diameter loop antenna will require a C range of approximately 5 to 70 pF to tune from 14 to 30 MHz. To handle 100 watts RF input over this range, the capacitor's end-to-end voltage rating should be at least 6 kV (or 3 kV per section). **Figure 3** illustrates the mechanical configuration of a Polyflon PTFE-dielectric capacitor that meets this general requirement. Note that the overall package size is considerably smaller than comparable open-frame or vacuum-sealed devices.

Although the stud-mounting hardware shown on this particular drawing was specified for a different RF application, it is important to mention that Polyflon sells on a customer-direct basis and any unit in their line may be altered to suit customer preference. For example, if your use happens to be for a loop antenna, you can specify 180-degree opposing solder-tabs instead of stud mounting.

As previously noted, superior fine-tuning resolution is vital for capacitors used in loop applications. The "typical" loop profiled in this article has a continuous tuning range covering more than 15 MHz, and exhibits a usable bandwidth of only 15 kHz. This means the tuning capacitor must be able to resolve a minimum of 1000 points between C-min and C-max to be minimally functional! Fortunately, Polyflon's tuning mechanism seems especially well suited for this task.

Refer back to **Figure 2** to visualize how the Polyflon tuning drive mechanism works. The cathode tuning element rides on a threaded drive screw through the center of the capacitor. Two factors—screw pitch and distance of travel—determine the number of turns required to move this element from C-min to C-max. If a 40-pitch screw is installed and the distance of travel is 1.5-inches, 60 full shaft revolutions are needed to tune the capacitor through its range. A comparable 1/2-turn air variable would need an external 120:1 drive to achieve equivalent drive reduction. Because loops are notoriously tricky to tune with the small reduction-drive type DC motors commonly used in this application, any added mechanical advantage and turns reduction provided by the capacitor itself will be beneficial.

In addition to inherent drive reduction, PTFE

## General Characteristics

### Electrical

Cathode:	Oxide-coated
Voltage	12.6 ± 0.7 V
Current, at 12.6 volts	3.6 ± 0.3 A
Voltage cathode-heater, max.	± 100 V
Warm-up time	2.5 minutes
Amplification factor, grid-to-screen	6.5 ± 2
Direct interelectrode capacitance (grounded cathode):	
Input	51 ± 5 pF
Output	11 ± 2 pF
Feedback	0.9 pF
Frequency for maximum ratings	150 MHz

### Mechanical

Maximum overall dimensions:	
Length	90 mm (3.51 in.)
Diameter	72 mm (2.81 in.)
Net weight	550 g (1.21 lb.)
Operating position	Any
Cooling	Forced air
Maximum operating envelope temperature	200°C
Recommended socket	Svetlana SK-1A

### Radio Frequency Linear Amplifier Class AB<sub>1</sub>

#### Maximum ratings

DC plate voltage	2.5	kV
DC screen voltage	350	V
DC grid voltage	-150	V
DC Plate current	0.8	A
Plate dissipation	800	W
Screen dissipation	15	W
Grid dissipation	2	W

#### Typical Operation (grid, driven, single tone)

Frequency	60	60	MHz
Power output	550	780	W
DC plate voltage	2	2.2	kV
DC screen voltage	300	350	V
Bias voltage*	-37	-47	V
Zero-signal plate current	300	360	mA
DC plate current	465	630	mA
DC screen current	30	30	mA
Peak rf grid voltage	30	35	V
Plate dissipation	380	600	W
Intermodulation distortion measured by two tone method at 1 MHz:			
3rd order		-30	dB
5th order		-40	dB

\* Approximate value adjusted to specified zero-signal plate current

Figure 4. Specifications for the 4CX800A.

### 4CX800A Outline Drawing

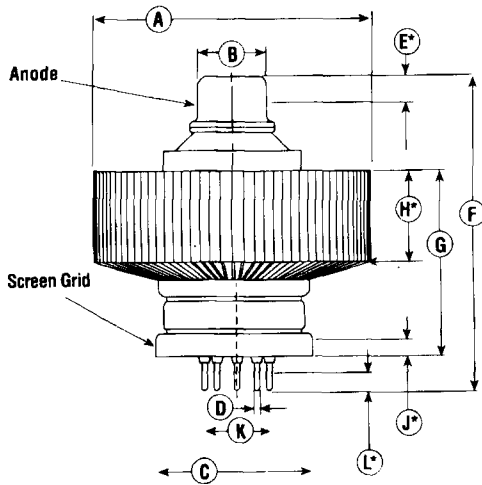

\*Contact Surface

Dimensional Data						
Dim.	Inches			Millimeters		
	Min.	Max.	Ref.	Min.	Max.	Ref.
A	2.756	2.835		70	72	
B	0.669	0.748		17	19	
C	1.988	2.028		50.5	51.5	
D	0.053	0.060		1.34	1.53	
E	0.394	—		10	—	
F	—	3.543		—	90	
G	2.008	2.126		51	54	
H	0.747	0.860		20	22	
J	0.197	—		5	—	
K	—	—	0.7	—	—	175
L	0.3	0.37		7.6	9.4	

Note:  
Ref. dimensions are for reference only and are not for inspection purposes.

### Typical Operation, Linear with Cathode Resistance

	Grid Driven		Cathode Driven		
DC plate voltage	2200	2200	2200	2200	V
Bias voltage	-56	-57	-57	-63	V
Zero signal plate current	160	150	100	70	mA
DC plate current	550	520	590	490	mA
Plate input power	1200	1150	1300	1100	W
Driving voltage	75	77	52	64	V
DC grid current	0	0	0	0	mA
Driving power	56 <sup>1</sup>	59 <sup>1</sup>	27	41	W
Power output	750	750	750	750	W
Intermodulation distortion					
3rd order	30 <sup>2</sup>	30 <sup>2</sup>	32 <sup>2</sup>	32 <sup>2</sup>	
5th order	43 <sup>2</sup>	42 <sup>2</sup>	40 <sup>2</sup>	35 <sup>2</sup>	
Efficiency	63	65	58	68	%
Zero-signal plate dissipation	352	330	200	154	W
DC screen voltage	350	350	300	300	W
DC screen current	24	24	20	17	mA
Cathode resistance	24 <sup>4</sup>	33 <sup>4</sup>	0	24 <sup>4</sup>	ohms

#### Notes:

1. The drive power is determined with a 50 ohm resistance input circuit.
2. The intermodulation distortion level does not deteriorate with decreasing drive voltage.
3. The level of intermodulation distortion with decreasing drive voltage does not deteriorate to less than -28 dB and -35 dB respectively corresponding to a driving voltage of 50 V.
4. Increasing the resistance in the cathode circuit decreases the zero-signal plate current and increases the drive power required.

<b>General Characteristics</b>	
<b>Electrical</b>	
<i>Cathode:</i>	<i>Oxide-coated</i>
<i>Voltage</i>	<i>12.6 ± 0.6</i>
<i>Current, at 12.6 volts</i>	<i>4.4 ± 0.3 A</i>
<i>Voltage cathode-heater, max.</i>	<i>± 100 V</i>
<i>Warm-up time</i>	<i>2.5 minutes</i>
<i>Transconductance</i>	<i>50 mA/V</i>
<i>Direct interelectrode capacitance (grounded cathode):</i>	
<i>Input</i>	<i>86 pF</i>
<i>Output</i>	<i>12 pF</i>
<i>Feedback</i>	<i>0.15 pF</i>
<i>Frequency for maximum ratings</i>	<i>250 MHz</i>
<b>Mechanical</b>	
<i>Maximum overall dimensions:</i>	
<i>Length</i>	<i>95 mm (3.51 in.)</i>
<i>Diameter</i>	<i>72 mm (2.81 in.)</i>
<i>Net weight</i>	<i>600 g (1.21 lb.)</i>
<i>Operating position</i>	<i>Any</i>
<i>Cooling</i>	<i>Forced air</i>
<i>Maximum operating envelope temperature</i>	<i>200°C</i>
<b>Radio Frequency Linear Amplifier, Class AB<sub>1</sub></b>	
<b>Maximum ratings</b>	
<i>DC plate voltage</i>	<i>2.5 kV</i>
<i>DC screen voltage</i>	<i>350 V</i>
<i>DC grid voltage</i>	<i>-150 V</i>
<i>DC Plate current</i>	<i>1.4 A</i>
<i>Plate dissipation</i>	<i>1.6 kW</i>
<i>Screen dissipation</i>	<i>20 W</i>
<i>Grid dissipation</i>	<i>0.1 W</i>
<i>*Approximate value adjusted to specified zero-signal plate current</i>	

Figure 5. Specifications for the 4CX1600A.

transmitting variables incorporate ball-bearing shaft mounts to ensure smooth low-friction operation over a prolonged life of continuous use.

## The bottom line

Given what we've covered, let's review how the Polyflon wiperless design stacks up against our original criteria for loop resonating capacitors. The PTFE-dielectric variable:

1. Offers low dissipation, high Q.
2. Meets voltage breakdown requirements.
3. Is easy to motor drive with good tuning resolution.
4. Has a long mechanical life with no flexible connections.
5. Is small and light weight, easy to mount.
6. Has no wipers or movable contacts.

7. Is solderable with no mechanical fasteners in the RF path.

In short, the Polyflon PTFE-dielectric variable appears to be a natural candidate for this somewhat demanding RF application.

## Product availability

Currently, Polyflon PTFE-dielectric variables are only available on a made-to-order basis; they are not stocked in inventory for individual sales. This makes single-lot procurement of customized units convenient, but a setup charge is required with each order. As quantities increase, pricing drops rapidly—to roughly one half the cost of a comparable sealed-vacuum unit.

For additional product information you may call Polyflon Company at (914)636-7222; the



### 4CX1600A Outline Drawing

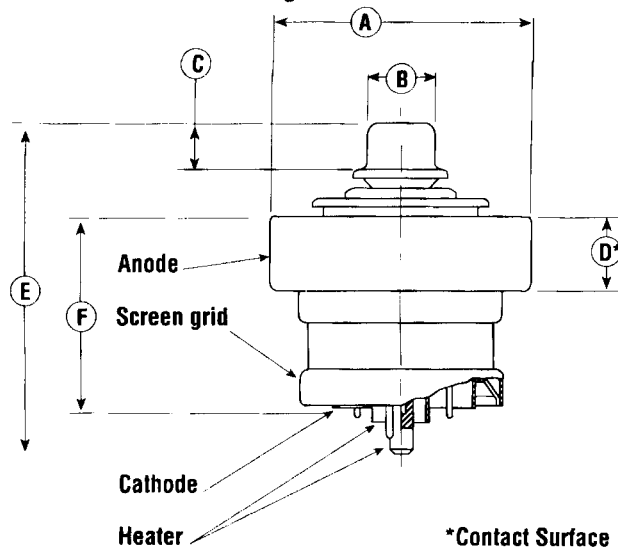

Dimensional Data				
Dim.	Inches		Millimeters	
	Min.	Max.	Min.	Max.
A	3.76	2.83	70	72
B	0.67	0.75	17	19
C	0.394	—	10	—
D	0.787	0.866	20	22
E	—	3.740	—	95
F	1.968	2.155	50	55

Note:  
Ref. dimensions are for reference only and are not for inspection purposes.

### Typical Operation, Grid Driven, Single Tone

Frequency	75	75	MHz
Power output	1600	1500	W
DC plate voltage	2400	2400	V
DC screen voltage	350	350	V
Bias voltage <sup>1</sup>	-53	-70	V
Zero-signal plate current	500	200	mA
DC plate current	1100	870	mA
DC screen current	20	48	mA
DC grid current	0	0	mA
Driving voltage	50	88	V
Driving power <sup>2</sup>	25	77	W
CW plate input power	2640	2068	W
Intermodulation distortion <sup>3</sup>			
3rd order	-36	-30	dB
5th order	-58	-34	dB
Efficiency	61	72	%
Cathode resistance	0	24	ohm

Notes:

1. Approximate value, adjust to specified zero-signal plate current.
2. The driving power is determined with the 50 ohm resistance input circuit.
3. Intermodulation distortion measured by two-tone method at one MHz.

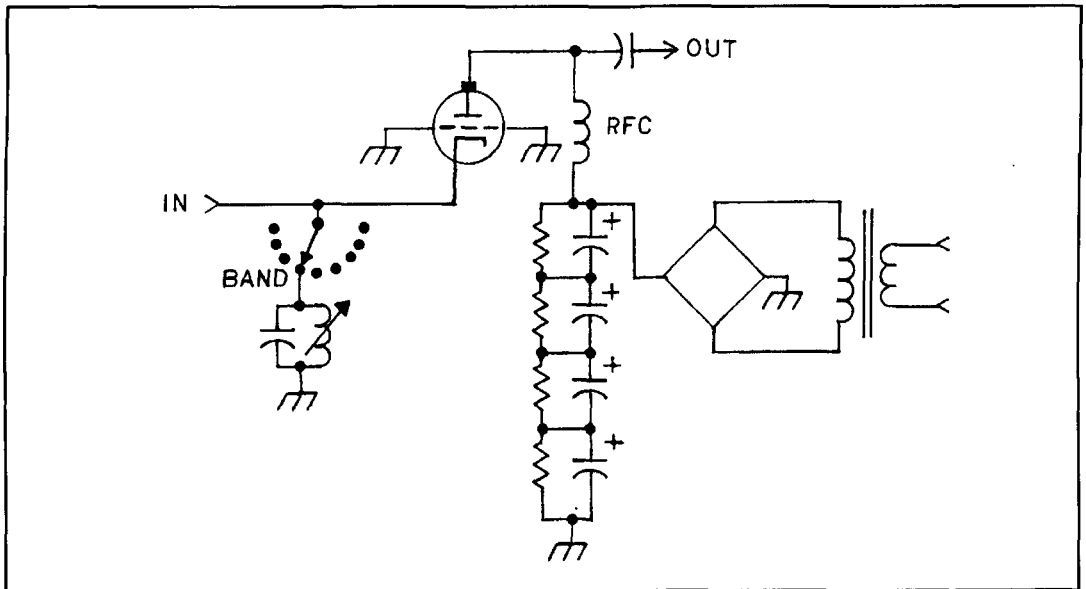

Figure 6A. Simplified schematic of a cathode-driven grounded-grid triode amplifier. Grounded-grid triode requires bandswitched 50-ohm matching network for each band.

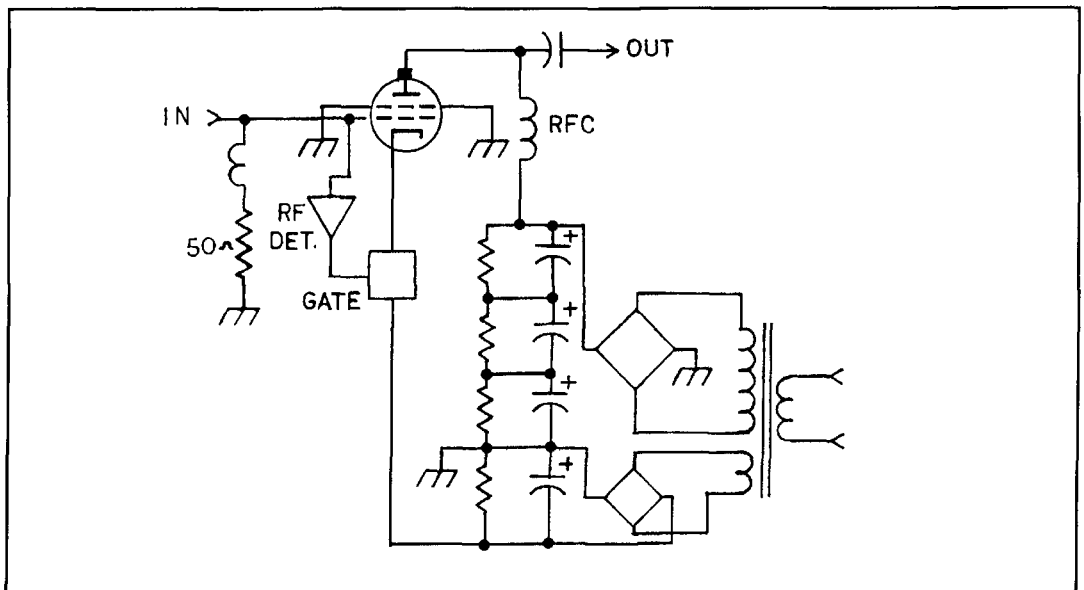

Figure 6B. Simplified schematic of a terminated-grid AB1 tetrode amplifier. Tetrode circuit uses no input bandswitching, only a 50-ohm resistor and small inductor (to cancel grid capacitance on 12 and 10 meters). RF-sensing gate cuts off tube when no signal is present to reduce plate dissipation in SSB and keyed CW operating modes.

FAX number is (914)633-3664. Their product capability covers a broad range of Teflon-based RF products. Initial consultation and custom-product design services are offered at no charge. Polyflon is a division of Crane Co.

### Svetlana ceramic tetrodes—a new breed of import

Svetlana of St. Petersburg, Russia, is one of the world's leading designers and producers of

power-grid tubes. Recently privatized, this major power-tube manufacturer now has worldwide marketing and distribution capability through U.S.-based Svetlana Electron Devices Inc. of Huntsville, Alabama. Marketing Director George Badger, W6TC, has offices in Portola Valley, California.

Svetlana offers power-grid tubes at all power levels up to—and exceeding—one megawatt. Some of these tubes will be of particular interest to designers and builders in the amateur radio community. For example, two Russian-

made ceramic power-grid tetrodes that are especially well-suited for amateur radio service were introduced at the Dayton Hamvention® this spring. The Svetlana 4CX800A is rated at 750 watts PEP and 750 watts keydown CW. The Svetlana 4CX1600 is rated at 1500 watts PEP and 1500 watts keydown CW. Both tubes are conservatively rated and may be operated in grid-drive, grid-driven passive input, or cathode-driven modes.

Although the 4CX800A and 4CX1600A will operate in grounded-grid service, the recommended mode is passive grid-driven service with a 50-ohm resistive untuned input. This eliminates the need for multiple input tuned circuits and neutralization. See **Figure 4** and **Figure 5** for complete tube specifications and operating data.

Because Svetlana specializes in power-grid tetrodes, they do not offer direct plug-in replacements for the triodes used in most existing U.S.-built linear amplifiers. However, the availability of economical power-grid tetrodes in the United States could change the way we design amplifiers.

## Some historical reasons why U.S. manufacturers use triodes

From a technical standpoint, the question of which style tube actually makes a better amplifier has pros and cons on both sides. National Radio's NCL-2000 was the last popular tetrode linear to be sold in the United States. After that, virtually all manufacturers settled on the cathode-driven triode as their design of choice.

Several factors contributed to this preference. Among them was the availability of relatively inexpensive tubes like the 811A, 572B, and 3-500Z (all more rugged than the delicate 8122A used in the NCL-2000). Drive power was not a problem then; most tube-type exciters could muster 120 or more watts to push a low-gain cathode-driven amplifier to the 1200-watt legal limit. Tuned input circuits weren't needed; virtually all exciters had adjustable pi-networks that could provide a conjugate match with the amplifier's cathode circuit. For the triodes, power supplies were easier and cheaper to build because no separate screen supply was required. Finally, grounded-grid linears were considered to have lower intermodulation distortion (IMD) and better damage immunity; operators didn't need to worry about driving the grids positive and destroying the tubes!

## Some reasons to reconsider the tetrode

Later on, when solid-state exciters became

the norm, many of the original reasons for using grounded-grid triodes became less valid. For one thing, linear manufacturers had to install bandswitched 50-ohm tuned-input networks into their amplifiers (with WARC and high-power authorization on 160-meters, there are now nine HF bands to cover instead of five). This added significantly to complexity and cost. Also, most solid-state exciters were internally ALC-limited at 100 watts; not enough power to drive some existing linears to full rated output. To complicate matters, the U.S. legal power limit was redefined upward to 1500 watts PEP. This pushed the industry to adopt the more efficient—but now very expensive—ceramic triodes like the 3CX800A7 and 3CX1500A7 to deliver full legal output on less drive. At the same time, the cost of older-style glass triodes seemed to skyrocket, increasing manufacturer and owner-replacement costs.

In the present market, domestic triode prices have risen to the point where solid-state high-power amplifiers are becoming cost effective and manufacturers are looking off-shore for cheaper sources of glass triode tubes. Given all of this, Svetlana hopes United States designers will take a long hard look at tetrode designs and consider their inherent advantages. Some of the technical reasons being cited for building a 1990s-style tetrode amplifier are listed below. Also, **Figures 6A** and **B** present a simplified schematic comparison of triode and tetrode designs:

1. New tetrode designs can use a split-secondary transformer and state-of-the-art power supply techniques to reduce supply costs on a par with existing triode amplifiers.
2. Gain is high; virtually any 80 to 100 watt exciter can develop sufficient voltage swing across the grid termination to drive a tetrode amplifier to full legal output.
3. No bandswitched tuned-input circuit is required; the exciter looks into a flat 50-ohm resistive load on all nine bands.
4. Terminated grid amplifiers operating in class AB1 do not require driver regulation or neutralization. They are inherently stable over the full amplifier operating range.
5. Russian-style power-grid tetrodes, new to the West, are more rugged and less subject to destruction from mistuning.
6. RF-gating of the bias circuit can dramatically lower average power dissipated by idle current, allowing class AB1 amplifiers to run cool while providing superior IMD.

## The bottom line

While the technical reasons for using tetrodes have renewed merit, perhaps the most com-

elling reason to use them may be price. Svetlana claims power-grid tetrodes currently sell at about half the cost of comparable U.S.-made ceramic triodes. Because amateur radio is a recreational service and tube budgets must come out-of-pocket, this may prove to be a powerful motivator to give them a try in your next amplifier project.

In addition to the 4CX800 and 4CX1600,

Svetlana Electron Products also offers 4X150, 4X250B, 4X350A, 5CX1500, and 4CX5000 power-grid tubes for sale in the United States. For technical assistance, data sheets, product-line updates, and pricing information, contact George Badger, W6TC, at Svetlana Electron Devices Inc., 3000 Alpine Road, Portola Valley, CA 94028; telephone (415) 233-0429 or FAX (415) 233-0439. ■

## PRODUCT INFORMATION

### **Tektronix introduces digital scope with oversampling capability.**

Tektronix, Inc. introduced the first "low cost" 100 MHz digital real-time oscilloscope on the market that uses a technique called "oversampling" to boost single-shot bandwidth to the full analog bandwidth of the scope. The latest addition to the popular TDS (Tektronix Digital Scopes) family, the TDS 320 is designed primarily for the service market, as well as the education and design markets.

The TDS 320 offers two channels that digitize at the rate of 500 million times-per-second (500 MS/s). This oversampling capability, made possible by a Tektronix-proprietary mixed-signal technology, eliminates the potential for aliasing of the input signal. The TDS 320 gathers two and a half times the number of samples needed to reconstruct the signal. It provides a reproduction of the waveform up to the full bandwidth of the scope, even for single-shot waveforms.

The TDS 320's intuitive interface reflects the simplicity of the traditional analog interface—while supporting a wide range of digital functionality and offers a choice of a dot or vec-

tored display. The TDS 320 also delivers a continuous display similar to an analog scope's display.

The TDS 320's communications option, including GPIB and Centronics-type interfaces, enables the user to have hardcopy at the push of a button. Hardcopy options include landscape or portrait, Thinkjet, Deskjet, Laserjet, Epson, Interleaf, TIFF, PCX, BMP and EPS Image. This option also lets users download waveforms for documentation or analysis purposes or to program the scope for automated testing.

In addition to over 20 waveform measurements, the TDS 320 offers four acquisition modes—sample, peak detect, envelope and average. With edge and basic video triggering, the TDS 320 can capture waveforms the service technician or digital designer needs to see.

The TDS 320 is being sold through authorized Tektronix stocking distributors, sales representatives and Tek Direct—Tektronix' direct order catalog featuring 24-hour shipping.

For more information, contact Tektronix Inc., Test and Measurement Group, P.O. Box 1520, Pittsfield, MA 01202, or call 1-800-426-2200.

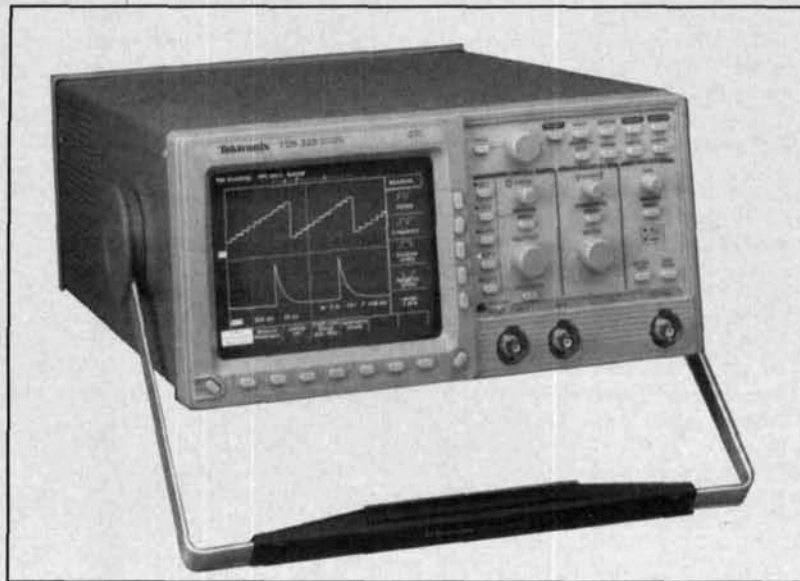

# TECH NOTES

## Sharing information from abroad

*One of the many benefits of being on the staff of Communications Quarterly—besides associating with our fine authors and other staff members—is the opportunity to peruse a multitude of foreign amateur and electronic publications. Because these magazines are seldom seen by our American readers, the “Tech Notes” column seems to be an ideal way to share the best of the short technical articles we discover in these publications. In this issue, we are featuring two pieces selected from “Break In”—the official journal of the New Zealand Association of Radio Transmitters (Inc.). Peter Bertini, K1ZJH, Senior Technical Editor*

## The ZL Packet Radio Modem (Packet Radio on a Small Budget)

*Ron Badman, ZL1AI, and Tom Powell, ZL1TJA  
Reprinted with permission from the November 1992 issue of “Break In”.*

“**Packet radio**—I can’t afford it!” How many times have I heard that, and often from active hams with IBM clones sitting idle alongside their 2-meter rigs? As many Commodore-64 owners discovered years ago, packet radio doesn’t have to cost a packet. “Digicom” software was written to turn the C-64 into a Terminal Node Controller (TNC), which did all the hard work. Only a simple Bell 202 was required to operate packet radio. Now TNC emulating software is available for the IBM compatible computer from at least three different sources. These software packages are “Poor Man’s Packet” (PMP), “Baycom,” and “Graphic Packet” (GP).

This article describes a simple and inexpensive Bell 202 modem, which can be used with any suitable software, such as the above to provide 1200 baud packet radio operation with an IBM compatible computer. The unit has provision to connect to either the printer port or the RS-232 port of your computer, depending on the software used. Computer connections are given for PMP, Baycom, and GP software, and it should be a simple matter to work out the connections required for other software.

## How it happened

We started out to make up some modems for

ourselves and friends and ended up some seven or eight board iterations later, with this one. First we made a simple board with a minimum of components to run PMP on the parallel port. Then we added an RS-232 chip to run Baycom on the serial port. Then we made a board which accommodated both; and thought we had finished the job. Then we realized that a transmitter PTT timeout was required, so we added that. Then we added receive audio protective diodes and an optional audio load resistor. After that I tried it with an ICOM IC-2A, and finding a combined PTT and microphone circuit, made an addition to cater for this type of handheld. Finally, after screwing my neck around to view the tiny LED on the IC-2A while testing it out with the modem, we added a transmit LED to the board. This article describes the final product. Friends who have earlier versions of the board may not have all these features.

## The modem chip

The modem uses the Texas Instruments TCM3105 asynchronous FSK modem chip. This chip is a rather smart piece of silicon, incorporating a frequency synthesized FSK transmitter, a frequency-to-voltage conversion FSK receiver, and switched-capacitor filters for both sending and receiving. It meets both Bell 202 and CCITT V23 specifications, and can operate over a range of baud rates. The external connections required for packet radio are, however, very simple.

## Circuit description

Referring to the schematic diagram **Figure 1**, the modem uses a PAL color-burst crystal on 4.433 MHz. (These can be obtained from old color TV sets which have been scrapped.) The CLK output from pin 2 of IC1 is inverted by section E of the 4049 and fed into pin 5. With this connection, and pins 12 and 13 grounded, the chip is set up for Bell 202 standard at 1200 baud send and receive. Audio from the receiver is fed via C8 into the receive pin (pin 4) of the modem chip. Resistor R4 is an optional load, which can be used if you wish to take audio from a loudspeaker outlet, without the speaker connected. This should be 8.2 ohms for most base and mobile sets, but some handhelds may use 16 or 22-ohm speakers. Consult your handbook for the correct load value. If you keep the internal speaker connected, or wire in an exter-



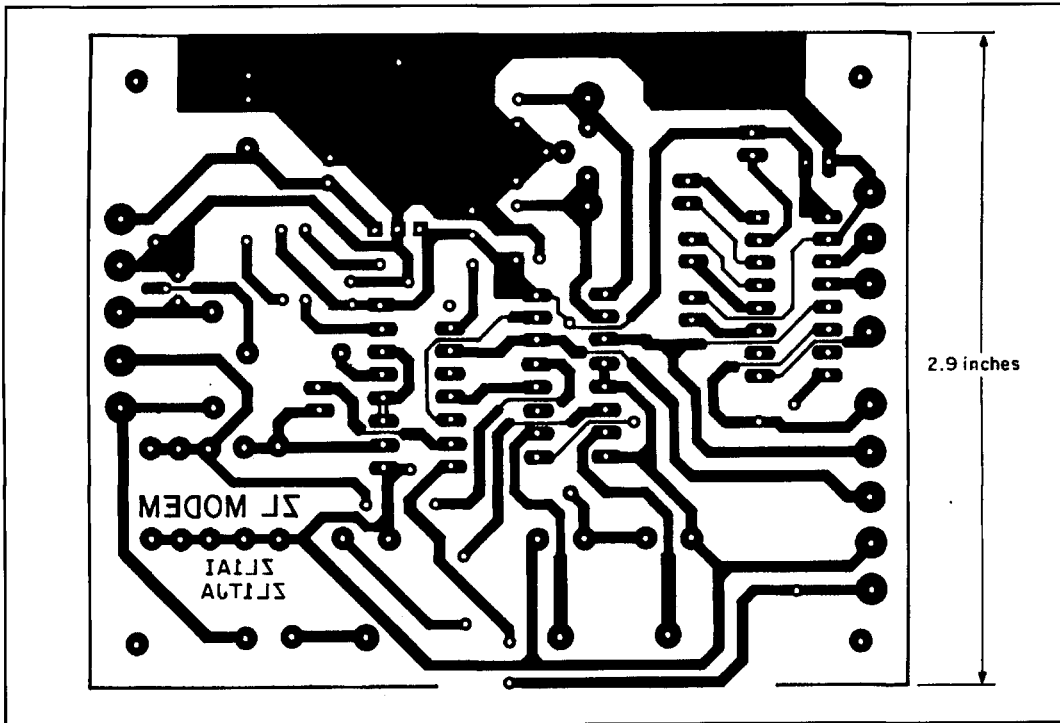

Figure 2. PC board artwork.

nal one, then omit R4. Likewise, if your transceiver has a low level audio output jack which you can take the audio from, then omit R4. Diodes D2 and D3 are used to protect the 3105 from excessive audio voltages. FSK transmit

tones from the modem appear on pin 11 and are output via C9, the level control trimpot VR3, and C16 to the microphone input or linepatch input on your transmitter.

Pin 3 (carrier detect output) is fed to pin 11

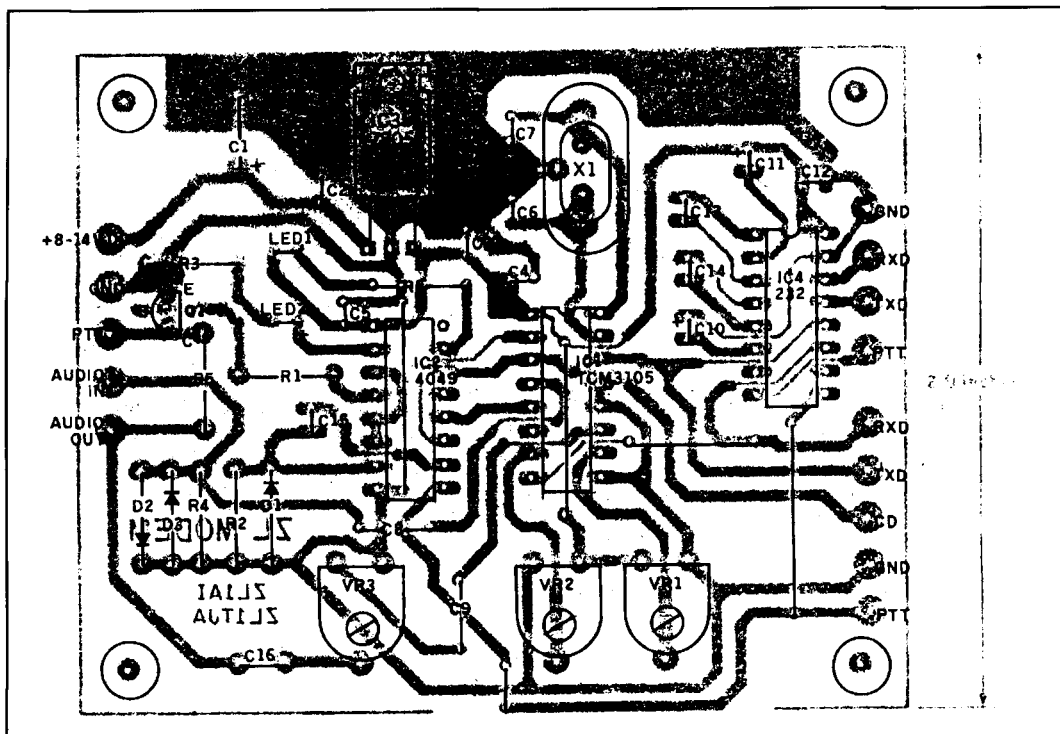

Figure 3. Component layout.

on the printer port for PMP. It is buffered by section F for the 4049, and fed to "carrier detect" LED1. The CD output is not used by Baycom or GP, but the LED is still handy to have on the modem, to indicate incoming data. Trimpot VR1 sets the carrier detect threshold, and VR2 is the receive bias adjustment for minimizing bias distortion.

Sections B, C, and D of the 4049 and transistor Q1 activate the transmitter PTT function when commanded by the computer. Sections C and D together with C15, R2, and D1 form a time-out circuit which ensures that the transmitter PTT must release after 18 seconds maximum. This prevents the frequency from being inadvertently jammed by a computer error, or by running some other program while the radio and modem are powered up. The transmit PTT line is buffered by section A of the 4049 and fed to "transmit" LED2 to indicate when a packet is being transmitted.

With PMP software, IC4 is not used, and it must not be on the board because it would interfere with signals between the modem chip and the computer. Connections for PMP are made as shown, to the lower set of terminals on the board. The pin numbers shown here are pins on the computer parallel printer port. This is the 25-pin female connector on the rear of the machine.

With software which requires connection to the serial port, such as Baycom or Graphic Packet, IC4 is required, but beware, connections are not the usual serial pins. IC4 converts between the TTL voltages (0 to 5 volts) to its left, and the RS-232 voltages ( $\pm 10$  volts) to its right. This chip generates its own + and - voltages from the +5 volt supply. Note carefully the polarity of the four electrolytics connected to it, especially C11, which has its negative to the +5 volt rail. The pin numbers shown to the right of IC4 are pins on the serial computer port.

R5 is an optional resistor that is required on some handhelds (e.g. IC-2A) where the PTT line and the microphone line are combined. ICOM shows 20 to 30 k for triggering the IC-2A PTT line, but I found that with 22 k, audio from the modem could interfere with the PTT operation. A value of 10 k worked satisfactorily. If you have a separate PTT line, do not install this resistor.

Current drain of the modem is only 15 mA. A 7805 regulator is used so it may be powered from a range of DC voltages, as indicated. In most cases a suitable voltage can be obtained from the radio equipment.

## Construction

The PC board artwork is shown in **Figure 2** for those who wish to make their own.

Assembly of the modem on the printed circuit board is straightforward, and will take an experienced constructor less than 30 minutes. The component layout is shown in **Figure 3**. I recommend that you socket the TCM3105 and the ICL232. Do not fit IC4 if you intend to use only the PMP software.

Start the PCB assembly by soldering the five wires shown on **Figure 3**. These must be done first as some ICs fit over the top of them. Everything else is straightforward, just as shown on the diagram. The resistors and diodes are all 0.4 inch long, so you can pre-bend these. C2, C3, C4 are the little 0.1 inch spaced monolithic capacitors used for bypassing in digital circuits. C8, C9, and C16 are greencaps or similar—there is plenty of room on the board for them. The LEDs may be mounted directly on the board, or they may be fitted to the box, and wires run to them.

## Connecting cords

Connect the radio wires to the pads on the left-hand side of the board.

To use Baycom or Graphic Packet software, connect the serial port from the computer to the pads on the top right of the board. Stick to the pin numbering shown on **Figure 3**, as this software uses nonstandard connections to the serial port. The pin numbers shown under the DB25 label refer to the 25-pin serial connector used on most PCs and XT's. The pin numbers alongside in brackets refer to the 9-pin serial connector used on more recent machines.

To use PMP, connect the computer parallel port wires to the pads on the lower right-hand side of the board. Make sure that the ICL232 chip is *not* on the board.

If you wish to try both PMP and Baycom, you may connect both lots of cords to the modem. However, to use Baycom or GP you *must remove the parallel cord from the computer, and to use PMP you must remove the ICL232 IC from the board*. No provision has been made for switching between these two options as I believe most hams will want to select one software package, and stick with it.

## Checking the modem out

Switch on and verify +5 volts on the 5-volt rail. If you have an oscilloscope you should see clock signals (19,200 kHz) on pins 2 and 5. If using IC4, you should have -10 volts on pin 6 and +10 volts on pin 2.

## Adjustments

The adjustments do not seem critical. I recently assembled one of these modems, and



with the trimpots set to half way, connected it up to a computer and ICOM IC-260A. Then I (Ron) turned round to get a screwdriver to adjust them, and when I turned back I found that Tom, ZL1TJA, had switched on and connected to the ZL1UX bulletin board.

I would however recommend that you make some preliminary adjustments before trying it on air. Connect to your computer and 2-meter rig. Set the receive volume control so you can hear the packet transmissions clearly, but not loudly. With the receiver muted, adjust VR1 so the CD LED just turns off. It should then turn on with signal and off in absence of signal. Set the receive bias adjustment VR2 for 2.7 volts on pin 7 of IC1, and received distortion should be sufficient to get you on the air.

The setting of the transmit audio level control VR3 depends on the audio input circuit in your transmitter. Start with it about 90 degrees from the counter-clockwise (minimum audio) end. Now transmit a series of packets and monitor the transmissions with a separate receiver. Adjust the audio modulation level with RV3 so that it is well below overload point. This can generally be found by increasing the level until the received audio shows no further increase in volume, and then backing it off until a small drop in audio volume results.

If you are not receiving 100 percent copy, you may need to adjust VR2 using a test program such as that supplied with the PMP software, or by slow careful adjustment for best copy while monitoring a busy data channel.

## Software

I found many interesting features in the different software packages, including quite extensive instructions, but a discussion of packet software is beyond the scope of this article.

Good luck with packet radio, and do drop one of us a line via the BBS at ZL1UX, to let us know how you're getting on, or if you have any questions.

## Build Your Own Direct Reading Capacitance Meter

Trevor King, ZL2AKW

Condensed for publication by Peter Bertini, K1ZJH

Reprinted with permission from the September 1992 issue of "Break In"

Grab bags of surplus unused capacitors become an attractive proposition provided you can fathom out what they are. You may possess polystyrene capacitors that the marking ink (used to

show the values and working voltages) has rubbed off.

This instrument saves you trying to recall myriads of condenser value codings. You will find other uses, for example the ability to check the settings obtained with a variable capacitor used to tweak alignment. The reading obtained by the Direct Reading Capacitance Meter gives the value needed for a substitute fixed capacitor.

This instrument has the facility to transfer capacitive reactance, in linear fashion, to the scale of an analog direct reading meter. The analog meter is equally happy with fixed or variable capacitance readings.

## Theoretical

The design of cheap and accurate direct reading capacitance meters became a lot easier with the availability of solid-state integrated circuits, which did not rely on earlier technology such as gaseous discharge devices and the special voltages necessary to operate them. The simplest designs settled on the use of the 555 timer IC operated as a monostable oscillator.

The definitive work was done by A. Wilcox for the English magazine *Television* in the early 1970s. Construction projects subsequently appeared in *Electronics Australia* in October 1976, and in *QST* in January 1983. The design used for this project begins with the *QST* circuit, but takes cognisance of the earlier efforts and then sets out to overcome many of the perceived limitations (see **Figure 1**).

An explanation is provided for the technical reader. To make the theory aspects clearer, please refer to the circuit.

The 555 is used as a monostable oscillator and the test capacitor, which we will call  $C_x$ , is first charged and then discharged. The meter indicates the average discharge current.

The formula is:

$$I_{ave} = \frac{V \times C_x}{(R_b + 2R_b)C_1} \times K$$

where:

V = voltage to which  $C_x$  is charged

K = a constant, depending on the charge and discharge time of the 555 circuit—including contributions made by the IC internal structure, as well as the exterior resistance ratios and  $C_1$ .

It can be deduced from the formula that big capacitors need to be tested on the big capacitor's range, otherwise the current will be enormous and probably bend the meter pointer. This can be proven empirically, but turns out to be expensive!

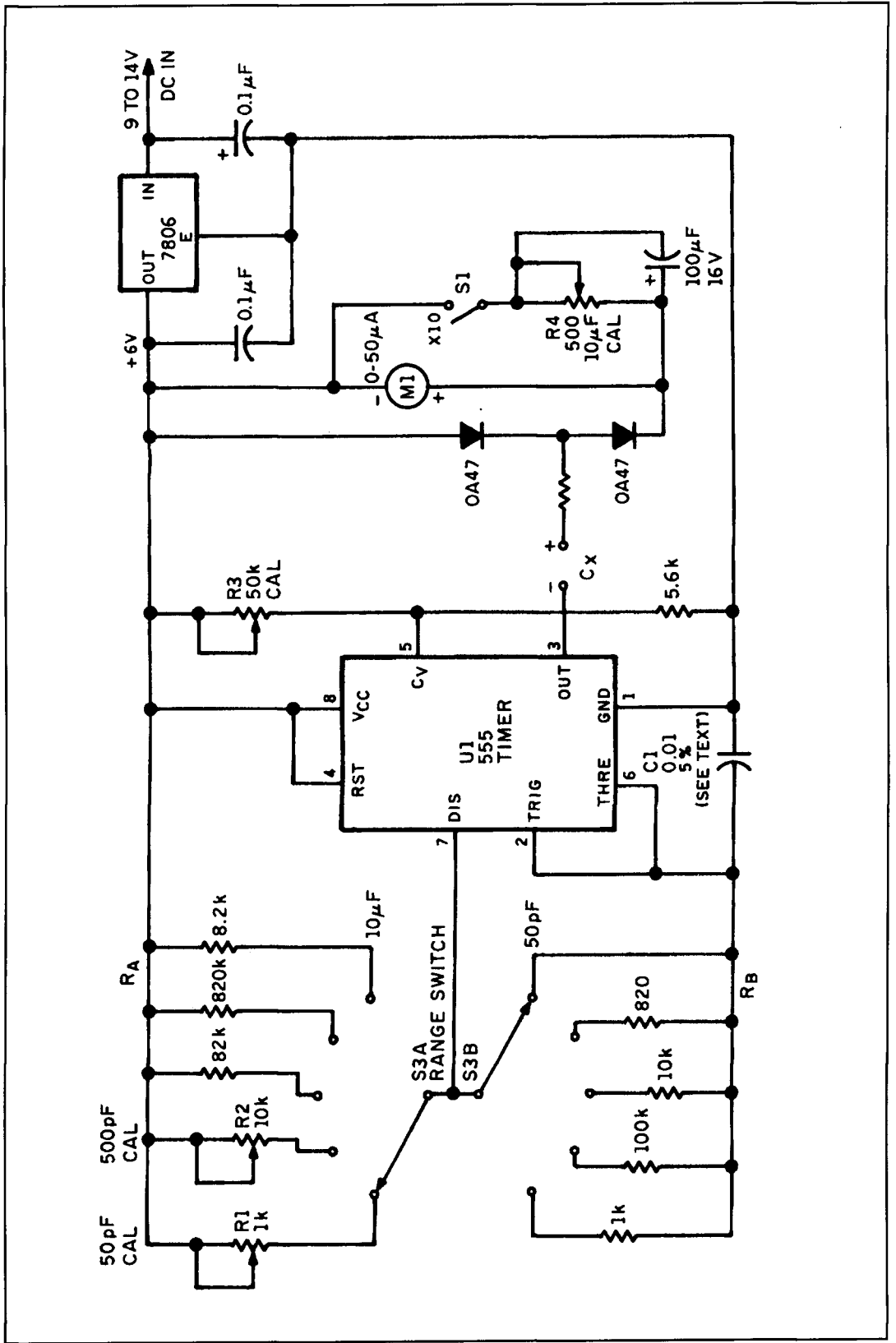

Figure 1: Direct Reading Capacitance Meter schematic diagram. Resistances  $R_A$  and  $R_B$  correspond to the resistors selected by the range switch (S3). S3A selects the value of  $R_A$ , while  $R_B$  is selected by S3B. All fixed resistors are 5-percent, 1/4-watt carbon types. Polarized capacitors are electrolytic. Numbered components not listed here are for text reference only.

R1—1-k PC-mount trimmer    R2—10-k PC-mount trimmer    R3—50-k PC-mount trimmer  
 S1 —SPST switch    S3 —2-pole, 5-position rotary switch    U1—555 timer IC

## Construction begins

There are various approaches possible, via the junkbox, at little or no cost at all.

### Front panel

The specification calls for a 50  $\mu\text{A}$  meter mounted on a plastic box. The bottom range reads 50 pF full scale. A switch provides five rotary switch positions, extending the ranges by a decade factor each time.

### Range extender

We now have, at position 5 of the switch, a full scale direct reading of 0.5  $\mu\text{F}$ . At this point, the meter needle starts to flicker visibly at the frequency achieved by the 555 oscillator. To extend the range further, a ten times shunt is paralleled across the basic 50- $\mu\text{A}$  meter movement. This extends all ranges by a ten times factor, and the maximum becomes 5  $\mu\text{F}$ . As the meter flicker is unacceptable, an auxiliary switch also brings in a 100  $\mu\text{F}$  smoothing capacitor across the meter movement.

### Applied voltage

Applied voltage is about 2 volts on the terminals, which is unlikely to harm even the most delicate components.

### Stabilization

The *Electronics Australia* (October 1976) design by Ian Pogson gives 50 pF on the low range. Harry M. Neben, W6QB, who described the unit featured in *QST* (January 1983) reported difficulties encountered in achieving good stability and settled for 200 pF.

If the Australians can do it, 50 pF ought to work in New Zealand, so the stability aspect was explored in some depth, and various time-consuming solutions were investigated. The successful outcome may be of interest and provides for:

1. A 5.6-k resistor from pin 5 to ground,
2. A 6-volt three-terminal voltage regulator (instead of a temperature and current sensitive Zener),
3. A plastic cabinet body (to avoid stray capacitance provided by a metal front panel),
4. The timing resistor on the 50-pF range is adjusted for the individual 555 after the other ranges have been preset, so as to provide a customized correct full scale reading,
5. It is also convenient, although not essential, to have an adjustable resistor for the 500 pF range.

## Construction details

Short internal wiring is preferable and the IC PCB is mounted right at the test terminals. Additionally, the 555 timer IC is socketed for peace of mind.

### Calibration

Use a good 0.047  $\mu\text{F}$  capacitor on range three to set the 50 k calibrator to produce a reading of 47  $\mu\text{A}$ . Then set the x10 range (using the appropriate switch settings) with its preset to read 5  $\mu\text{F}$  full scale. Next adjust the 50 and 500 pF controls. You are now able to accurately see the difference between 2.7 and 3.3 pF.

### Low-cost operation

The unit has a small mains power supply, and needs a secondary winding able to provide anything between 9 and 14 volts DC (after rectification) to the regulator input. If you do not like to wire mains-operated accessories, a 9-volt alkaline battery can be used, but do not omit the voltage regulator.

### Sources of components

The plastic cabinet enclosing the unit measures 195 x 115 x 60 mm. It is not the type with internal ribbing and has a smooth inside to make hole cutting easier. The 50  $\mu\text{A}$  meter used is a 3500-ohm internal resistance Micronta. You can make a substitution; there are still some good quality Japanese-made meters to be had.

Professional quality instrument terminals are hard to find. Some inferior offerings have inserts and terminal binders made to different clearances, and slop up and down the threads. Belling-Lee instrument terminals are a joy to use and can be found occasionally. Most electronics suppliers stock a range of 5-percent resistors, but (should you decide to use them) 1 or 2 percent values are usually only available on special order. The 0.01  $\mu\text{F}$  polystyrene timing capacitor is the heart of the 555 circuit, so it is worth finding a really good component. Get a 250 volt, or more, full-size one if at all possible, as the miniatures have less area and thinner polystyrene.

Do not neglect the power supply. Use a good quality mains-rated switch in the phase line and a mains-rated tie-point for any other connecting points; a proper cord-grip should be used in preference to the traditional Ham-knot and a pilot light or neon is worthwhile. The prototype had bridge rectification using a single 9 volts AC secondary winding. The voltage regulator needs 0.1- $\mu\text{F}$  capacitors mounted directly on the pins to keep radio frequency energy from the station equipment out and guarantee stability for

the internal operation of the regulator's high gain devices. The filter capacitor is on the input side of the regulator, and as the current drawn is very small, a 16 volt 220  $\mu$ F is adequate.

### Conclusion

There is great satisfaction to be had in building up reliable and accurate test equipment. Spend some time on the cosmetics; try to obtain matching knobs, give consideration to using brass flat-head machine screws where they appear on the outside, and, if silk screening is out of the question, you can use dymo-tape labels. Rubber stick-on feet ensure the case does not scratch anything and stops it sliding off the bench.

With a few known 2-percent calibration capacitors used from time to time as a reference source, this meter has been found to provide

consistent and quite accurate measurements. The "ZL2AKW Direct Reading Capacitance Meter" prototype has been in regular use for several months and performs consistently well.

### CORRECTION

In "Tech Notes" in the spring 1993 issue, the captions for **Figure 1** on page 81 and **Figure 1** on page 83 were reversed. The caption for **Figure 1** of "Practical Estimation of Electrically Small Antenna Resistance" should read: Diagram showing test arrangement and components of system resistance. The caption for **Figure 1** of "Measurement of Velocity Factor on Coaxial Cables and Other Lines" should be: Test setup for measuring the velocity for coaxial cable or transmission line. Ed.

## PRODUCT INFORMATION

### Real-Time Spectrum Analysis

Tektronix introduces the 3054 DSP System. The 3054 uses a bank-of-filters analyzer and newly designed processing to provide spectral frame update rates as fast as 12.5  $\mu$ S. New memory processing and data compression methods expand stored capture time coverage to a range covering 0.8 seconds to more than 26,000 seconds. These new capabilities, combined with a 10-MHz real-time input bandwidth and spans from 100 Hz to 10 MHz, offer flexibility and resolution in time-frequency signal analysis.

The transform size is selectable from 32 to 1024 frequency bins (26 to 801, displayable). A tunable center frequency allows any frequency within the DC to 10 MHz range to be viewed at reduced spans and higher resolutions.

Individual spectral frames can be displayed as power or phase versus frequency. Frames can also be displayed in a time-frequency series (spectrogram) with color-coded amplitude. Displays can be full screen for highest viewing resolution, or they can be split screen for visual comparisons of data.

The 3054 DSP System is fully programmable via a built-in C compiler and Unix operating system. It includes a trigger input for precise timing of spectral output with time-domain events and other standard features such as a GPIB interface, a real-time interface, and color printer compatibility. The system can be rack-

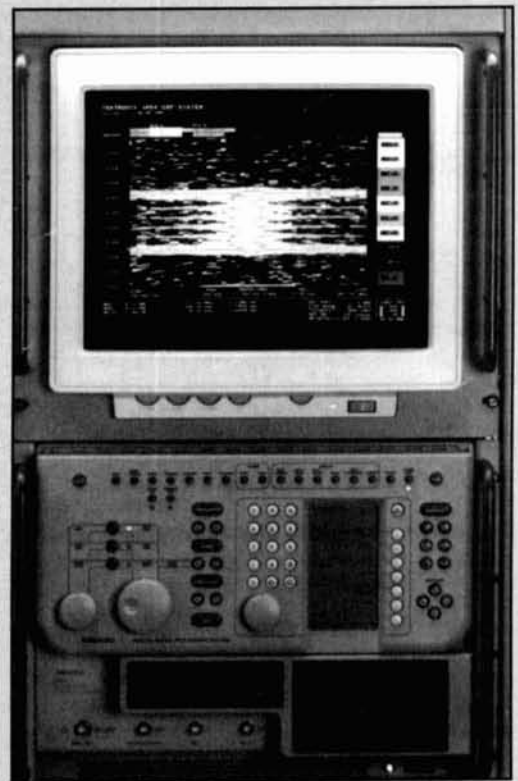

mounted or used in a desktop configuration.

For more information on the Tektronix 3054 DSP System, please write on company letterhead to Tektronix Federal Systems, Inc., P.O. Box 4495, MS 38-386, Beaverton, OR 97076-4495, or call 1-800-TEK-WIDE.

# VERSATILITY PLUS +



L.L. Grace introduces our latest product, the **DSP-12 Multi-Mode Communications Controller**. The DSP-12 is a user programmable, digital signal processing (DSP) based communications controller.

## FEATURES

- Multi-tasking operating system built in
- PC-compatible (V40) architecture allows development of custom applications using normal PC development tools and languages
- Motorola DSP56001 DSP processor
- Serial interface speeds from 110 to 19200 bps
- Optional 8-channel A-to-D & DAC for voice and telemetry applications
- 12-bit conversion architecture
- V40 source code and schematics available
- RAM expandable to one megabyte. Useable for mailbox feature, voice mail and development
- EPROM expandable to 384k bytes
- Low power requirements: 10-15vdc, 750ma
- 3 analog radio connectors. RX & TX can be split in any combination. Programmable tuning outputs are available on each connector
- Many modems available in the basic unit, including Packet, RTTY, ASCII, and PSK modems for high speed packet and satellite work
- Both V40 and DSP programs can be down-line-loaded from your PC or a bulletin board. You can participate in new development!
- Built in packet mailbox
- V40 and DSP debuggers built in
- Open programming architecture
- Free software upgrades
- Low cost unit
- Room for future growth

## APPLICATIONS

- HF Packet
- HF RTTY & ASCII, including inverted mark/space and custom-split applications
- VHF Packet
- 400bps PSK (satellite telemetry)
- 1200bps PSK (satellite & terrestrial packet)
- V26.B 2400bps packet
- 9600bps direct FSK (UO-14)
- Morse Code

## CUSTOM APPLICATIONS

- Voice compression
- Telemetry acquisition
- Message Store-and-Forward
- Voice Mail

## COMING ATTRACTIONS

(Remember, software upgrades are free!)

- WEFAX and SSTV demodulators
- NAVTEX
- AMTOR and SITOR
- Multi-tone Modems
- ARINC ACARS

Commercial inquiries are welcomed. We offer rapid prototyping of custom commercial, civil, and government applications including intelligent radio, wireline, and telephone modems.

DSP-12 Multi-mode Communications Controller .....	\$ 595.00
One Megabyte RAM Expansion Option .....	149.00
Date/Time Clock Backup Option .....	29.00
8-Channel A-To-D Telemetry/Experimentation Option .....	49.00
Wall-Mount Power Supply for DSP-12 (110 vac) .....	19.00

We accept MasterCard & VISA and can ship C.O.D. within the USA. All orders must be paid in US Dollars. Shipping & Handling: \$5 (\$20 International).

### L. L. Grace Communications Products, Inc.

41 Acadia Drive, Voorhees, NJ 08043, USA

Telephone: (609) 751-1018

FAX: (609) 751-9705

CompuServe: 72677,1107

1/91

L. L. Grace also manufactures the Kansas City Tracker family of satellite antenna aiming systems. Call or write for more information.



## VARI-NOTCH® DUPLEXERS

FOR 2 METERS

The TX RX Systems Inc. patented Vari-Notch filter circuit, a pseudo-bandpass design, provides low loss, high TX to RX, and between-channel isolation, excellent for amateur band applications. TX RX Systems Inc. has been manufacturing multicoupling systems since 1976. Other models available for 220 and 440 MHz, UHF ATV and 1.2 GHz.

### MODEL 28-37-02A

144-174 MHz  
92 dB ISOLATION AT 0.6 MHz SEPARATION  
400 WATT POWER RATING

### TX RX SYSTEMS INC.

8625 INDUSTRIAL PARKWAY, ANGOLA, NY 14006  
TELEPHONE 716-549-4700 FAX 716-549-4772 (24 HRS.)



19" RACK MOUNT

Looking to challenge your building skills?  
Want to explore beyond Amateur communications?

Well here's the publication for YOU!

*COMMUNICATIONS QUARTERLY*, the journal of communications technology. You are invited to become part of an elite group of Radio Amateurs and technical professionals as a subscriber. Circulation will be strictly limited.

Each quarterly has approximately 100 pages of technical material; advertising is limited. Articles flow from page to page, without the interruption of ads placed in the middle. The open layout accentuates each author's work and lets you make notes, calculations, or comment for alter reference. Graphs, photos, computer program listings, and charts are presented in an easy-to-use format. In fact over time, you'll find much of what is presented in *COMMUNICATIONS QUARTERLY* will become the standard in the Amateur and professional communications field.

Act now. Subscribe today!

1 year-\$29.95  
2 years 56.95

Foreign-1 year \$39.95  
2 years 76.95

Foreign Air Mail-1 year \$ 60.00  
2 years 110.95

MasterCard/VISA/American Express accepted

CQ Communications, Inc., 76 North Broadway, Hicksville, NY 11801  
Phone: 516-681-2922/FAX: 516-681-2926

## DIGITAL METER & LCR METER



### DMM 2360

\$129.95

DMM + LCR Meter  
Very Versatile DMM

- Inductance: 1µH - 40H
- Capacitance: 1pF - 40 µF
- Temperature: -40 - 302°F using diode-type temp. probe TP-DO5 \$7.00
- Frequency: 1Hz - 4MHz
- Logic test: 20MHz
- Diode test
- Continuity beeper
- Volt, current, ohm
- 3999 count display
- Peak hold
- Auto power off
- 10 MΩ input impedance
- Complete with test leads, soft case, 9 V battery, spare fuse and manual



### LCR 814

\$199.95

Best Handheld  
LCR Meter

- Inductance: 0.1 µH-200H
- Capacitance: 0.1 pF-20,000 µF
- Impedance: 1 mΩ-20MΩ at 1kHz
- Dissipation Factor / Q Factor measurements
- Zero Adjustment to compensate for parasitics
- Test frequency 1kHz
- Best for small component for high frequency application
- Tweezer type test fixture for surface mount component \$25.00
- Padded deluxe case \$5.00

**ALFA ELECTRONICS**  
P.O. BOX 8089, PRINCETON, NJ 08543  
(800) 526-ALFA / (609) 275-0220  
FAX: (609) 275-9536

QUALITY DMM, GOOD RELIABILITY  
15 DAY MONEY BACK GUARANTEE  
1 YEAR REPLACEMENT WARRANTY  
WRITE OR CALL FOR FREE CATALOG  
Visa, MasterCard, American Express C.O.D. Purchase Order Welcome

## Surplus Sales of Nebraska

"Where The Hard To Find Parts Are Found"

Collins - RF - High Voltage - High Power - Transmitting - Switches - Relays - Loads - Attenuators - Terminations - Roller Inductors - Toroids - Capacitors, Oil, Mica, Doorknob, Vacuum, Chip, Trimmer, Air - Tubes - Transistors, Diodes, PIN Diodes - IC's - Microwave - Meters - Fingerstock - Heatsinks - Chokes - Copper Braid - Filters - Waveguide - Test Equipment - Wire - Coax - Connectors, All Types - Resistors, All Types - Transformers - Fans - Coiforms - Knobs - Feet - Fuses - Breakers

Call or write for flyer 6A

## Surplus Sales of Nebraska

1502 Jones Street  
Omaha, NE 68102  
402-346-4750  
FAX: 402-346-2939

## DOWN EAST MICROWAVE



### MICROWAVE ANTENNAS AND EQUIPMENT

- Loop Yagis • Power Dividers • Dish Feeds
- Complete Antenna Arrays • Linear Amps
- Microwave Transverters & Kits • GaAs FET Preamps and Kits • Microwave Components
- Tropo • EME • Weak Signal • OSCAR • FM
- Packet • ATV
- 902 • 1269 • 1296 • 1691 • 2304 • 2400 • 3456 • 5760 • 10,368 MHz

### ANTENNAS

2345 LYK	45 el	Loop Yagi Kit	1296 MHz	\$95
1345 LYK	45 el	Loop Yagi Kit	2304 MHz	\$79
3333 LYK	33 el	Loop Yagi Kit	902 MHz	\$95
1844 LY	44 el	Loop Yagi Assembled	1691 MHz	\$105
3B Feed	Tri Band	Dish Feed 2.3, 3.4, 5.7 GHz		\$15

Many others and assembled versions available. Shipping extra.

### LINEAR AMPS AND PREAMPS

2303 PA	1.2 to 1.3 GHz	3w out	13.8 VDC	\$130
2318 PAM	1.24 to 1.3 GHz	20w out	13.8 VDC	\$205
2335 PA	1.24 to 1.3 GHz	35w out	13.8 VDC	\$325
2340 PA	1.24 to 1.3 GHz	high gain 35w out	13.8 VDC	\$355
2370 PA	1.24 to 1.3 GHz	70w out	13.8 VDC	\$695
1302 PA	2.2 to 2.5 GHz	3w out	13.8 VDC	\$430
13 LNA	2.3 to 2.4 GHz	preamp	.6 dB NF	\$140
23 LNA	1.2 to 1.3 GHz	preamp	.6 dB NF	\$95
33 LNA	900 to 930 MHz	preamp	.6 dB NF	\$95
1691 LNA WP	1691 MHz	mast mounted preamp	.8 dB NF	\$140

Kits, Weatherproof Versions and other Frequencies Available

### NO-TUNE TRANSVERTERS AND TRANSVERTER KITS

SHF 902K	902 MHz Transverter	40mW, 2m IF	Kit \$139
SHF 1296K	1296 MHz Transverter	10mW, 2m IF	Kit \$149
SHF 2304K	2304 MHz Transverter	10mW, 2m IF	Kit \$205
SHF 3456K	3456 MHz Transverter	10mW, 2m IF	Kit \$205

OSCAR and other frequencies available, also Amps and package versions wired and tested.

Write for more information. Free catalog available.



### DOWN EAST MICROWAVE

Bill Olson, W3HQT

RR1 Box 2310, Troy, ME 04987  
(207) 948-3741 Fax: 207-948-5157



# ELNEC

## Advanced Antenna Analysis Program

Fast to learn and easy to use, ELNEC lets you analyze nearly any type of antenna in its actual operating environment. Describe your antenna with ELNEC's unique menu structure and spreadsheet-like entry system and watch it make azimuth and elevation plots, report beamwidth, f/b ratio, takeoff angle, gain, and more. Save and recall antenna files. Print plots on your dot-matrix or laser printer.

ELNEC uses the full power of MININEC code but makes description, analysis, and changes worlds easier and faster. With ELNEC there's no messing with "pulses" - just tell it where on a wire you want a source or load to go, and ELNEC puts it there. And keeps it there, even if you change the antenna. ELNEC has a host of other features to make analysis fast and easy. The MaxP option extends ELNEC's capability to very complex antennas (up to 260 "pulses").

ELNEC runs on any PC-compatible computer with at least 512k RAM, CGA/EGA/VGA/Heracles, and 8/9 or 24 pin Epson-compatible or HP LaserJet/DeskJet printer. (The MaxP option requires a hard disk, coprocessor, and 640k RAM.)

There's no copy-protection hassle with ELNEC - it's not copy protected. And of course there's extensive documentation.

ELNEC is only \$49.00 postpaid. MaxP is \$25.00. (Please add \$3.00 per order for airmail outside N. America.) VISA and MasterCard orders are accepted - please include card number and expiration date. Specify coprocessor or noncoprocessor type. Order or write for more information from:

Roy Lewallen, W7EL  
P.O. Box 6658  
Beaverton, OR 97007

## ATV CONVERTERS • HF LINEAR AMPLIFIERS

DISCOVER THE WORLD OF FAST SCAN TELEVISION



### AMATEUR TELEVISION CONVERTERS

ATV3 420-450 (GaAs-FET) \$ 49.95 Kit  
ATV4 902-928 (GaAs-FET) \$ 59.95 Kit

### 2 METER VHF AMPLIFIERS

35 Watt Model 335A \$ 79.95 Kit  
75 Watt Model 875A \$ 119.95 Kit  
Available in kit or wired/tested

For detailed information and prices, call or write for our free catalog.

### HF AMPLIFIERS per MOTOROLA BULLETINS

Complete Parts List for HF Amplifiers Described in the MOTOROLA Bulletins.

AN758 300W	\$154.15	AR313 300W	\$366.00
AN762 140W	\$ 95.15	AR305 300W	\$346.82
AN791 20W	\$ 83.79	EB63 140W	\$ 89.65
AN779H 20W	\$ 93.20	EB27A 300W	\$136.80
		EB104 600W	\$371.65

### New!! 1K WATT 2-50 MHz Amplifier

POWER SPLITTERS and COMBINERS  
2-30MHz  
600 Watt PEP 2-Port \$ 69.95  
1000 Watt PEP 2-Port \$ 79.95  
1200 Watt PEP 4-Port \$ 89.95

100 WATT 420-450 MHz PUSH-PULL LINEAR AMPLIFIER - SSB-FM-ATV  
KEB67-K (Kit) \$159.95  
KEB67-PCB (PC Board) \$ 18.00  
KEB67-1 (Manual) \$ 5.00

### UNIVERSAL DIGITAL FREQUENCY READOUT

TK-1 (Wired/tested) \$149.95

### HEAT SINK MATERIAL

Model 99 Heat Sink (6.5 x 12 x 1.6) \$ 22.00  
CHS-8 Copper Spreader (8 x 6 x 1/4) \$ 20.00  
We also stock Hard-to-Find parts

### CHIP CAPS-Kemet/ATC

METALCLAD MICA CAPS-Unelco/Semco  
RF POWER TRANSISTORS  
Mini-Circuit Mixers  
SBL-1 (1-500Mz) \$ 6.50  
SBL-1X (10-1000Mz) \$ 7.95

### ARCO TRIMMER CAPACITORS

VK200-20/4B RF Choke \$ 1.20  
56-590-65-3B Ferrite Bead \$ 2.00  
Broadband HF Transformers

### Low Pass Filters

For Harmonics (Up to 300W)  
10m, 15m, 20m, 40m, 80m & 160m



Add \$4.00 for shipping and handling

## CCI Communication Concepts Inc.

508 Millstone Drive • Beavercreek, Ohio 45434-5840  
(513) 426-8600 • FAX (513) 429-3811



## 24 HOUR SHIPPING ELENCO • HITACHI • B&K PRODUCTS

TO ORDER CALL TOLL FREE  
1-800-292-7711  
1-800-445-3201 (Can.)

### AFFORDABLE - HIGH QUALITY 2 YEAR WARRANTY



STANDARD SERIES  
S-1325 25MHz \$349  
S-1340 40MHz \$495  
S-1365 60MHz \$849

- Features:
- High Luminance 6" CRT
  - 1mV Sensitivity
  - X-Y Operation
  - Voltage, Time, + Frequency differences displayed on CRT thru the use of cursors (S-1365 only)
  - Plus much, much more
  - TV Sync
  - 2 - x1, x10 Probes
  - Complete Schematic

### ELENCO OSCILLOSCOPES



DELUXE SERIES  
S-1330 25MHz \$449  
S-1345 40MHz \$575  
S-1360 60MHz \$775

- Features:
- Delayed Sweep
  - Automatic Beam Finder
  - Z Axis Modulation
  - Built-in Component Test
  - Plus all the features of the "affordable" series
  - Dual time base
  - Illuminated internal graticule

### Hitachi Compact Series Scopes

V-212 - 20MHz Dual Trace	\$399
V-525 - 50MHz, Cursors	\$995
V-523 - 50MHz, Delayed Sweep	\$949
V-522 - 50MHz, DC Offset	\$895
V-422 - 40MHz, DC Offset	\$795
V-222 - 20MHz, DC Offset	\$649
V-660 - 60MHz, Dual Trace	\$1,149
V-665A - 60MHz, DT, w/cursor	\$1,325
V-1060 - 100MHz, Dual Trace	\$1,395
V-1065A - 100MHz, DT, w/cursor	\$1,649
V-1085 - 100MHz, QT, w/cursor	\$1,995
V-1100A - 100MHz, Quad Trace	\$2,495
V-1150 - 150MHz, Quad Trace	\$2,895

### B&K OSCILLOSCOPES

2120 - 20MHz Dual Trace	\$389
2125 - 20MHz Delayed Sweep	\$539
1541B - 40MHz Dual Trace	\$695
2160 - 60MHz Dual Trace, Delayed Sweep, Dual Time Base	\$949
2190 - 100MHz Three Trace Dual Time Base, Delayed Sweep	\$1,395
2522A - 20MHz / 20MS/s Storage	\$875

Digital Capacitance Meter  
CM-1550B by Elenco  
Big 1" Display  
\$58.95  
9 Ranges  
1pF-20,000pF  
3% basic accy  
Zero control w/ Case

Digital LCR Meter  
LC-1801  
\$125  
Measures:  
Caps. 1pF-2000pF  
Res. 0.1-20M  
by Elenco

Digital Multimeter  
DVM-838  
\$39.95  
11 Functions with Case

FLUKE MULTIMETERS  
(All Models Available Call)

Model 93	\$1,225.00	70 Series	
Model 95	\$1,549.00	Model 70II	\$65.00
Model 97	\$1,795.00	Model 77II	\$149.00
10 Series		Model 79II	\$169.00
Model 10	\$62.95	80 Series	
Model 12	\$79.95	Model 87	\$289.00

Digital Triple Power Supply  
Elenco XP-765  
\$289  
0.20V @ 1A  
2.00V @ 1A  
5V @ 5A  
Fully regulated, Short circuit protected with 2 limit control, 3 separate supplies XP-660 with Analog Meters \$195

Video Head Tester  
Elenco HT-200  
\$44.95  
Tells you if VHS head is defective or worn.

Digital Multimeter w/ Inductance & Capacitance  
LCM-1850  
\$75.00  
Ten Functions  
by Elenco

Color Convergence Generator  
Elenco SG-250  
\$89.95  
Kit \$69.95  
Finest in the industry  
10 rock steady patterns  
RF and video output

12A DC Power Supply  
B-K 1586  
\$169.95  
3-14V @ 12A  
Fully regulated & protected  
Separate volt & current meters  
with current limiting, low ripple

Quad Power Supply XP-580  
by Elenco  
\$79.95  
2-20V @ 2A  
12V @ 1A  
5V @ 5A  
Fully regulated and short circuit protected

B&K 390  
\$139  
3-3/4 Digi DMM  
Bar graph  
9 Functions  
Including Temp, Freq  
Rubber Foot

Dual-Display LCR Meter  
w/ Stat Functions  
B-K 878  
\$239.95  
Auto/Manual Range  
Many Features  
w/ Q Factor  
High Accuracy

Sweep/Function Generator  
with Freq. Counter  
Elenco GF-900  
\$239  
GF-8026  
Int/Ext operation  
Sine, Square, Triangle, Pulse, Ramp  
2 to 2MHz, Freq Counter 1-10MHz

Audio Generator  
Elenco GF-900  
\$99  
20Hz-150KHz  
Sine/Square  
Waves  
Handheld

2MHz Function Generator  
\$219.95  
B-K 3011B  
LED Display, Sine, Square, Triangle, Ramp  
& Pulse Waves. TTL & CMOS

Digital Multimeter Kit  
with Training Course  
Elenco M-2655K  
\$49.95  
Fun & Easy to Build  
Full Function 34 Ranges, Includes  
Capacitance, Transistor/Diode Testing  
20Amp AC/DC, Extra Large Display, Ideal  
School Project M-2661 (assembled) \$55

Learn to Build and Program  
Computers with this Kit  
Includes: All Parts, Assembly and Lesson Manual  
Model MM-8000  
\$129.00  
by Elenco

Elenco Wide Band  
Signal Generators  
\$119  
SG-9000  
RF Freq 100K-450MHz AM Modulation  
of 10KHz Variable RF output  
SG-9500 w/ Digital Display & 150MHz built-in counter \$239

TELEPHONE PRODUCT TESTER  
\$499.95  
B-K 1045A  
Provides basic operation tests for corded & cordless telephones, answering machines and automatic dialers.

Multi-Function Counter  
Elenco F-1200  
1.2GHz  
\$229  
Measures Frequency, Period, Totalize  
8 LED digits, Crystal oven oscillator,  
5ppm accuracy

## TOROID CORES



- Iron Powder
- Ferrite
- Shielding Beads
- Ferrite Rods
- Split Beads

Small orders welcome. All items in stock for immediate delivery. Low cost experimenter's kits: Iron Powder, Ferrite. The dependable source for toroidal cores for 25 years.

Call or write for free catalog and tech data sheet.

## PALOMAR ENGINEERS

Box 462222, Escondido, CA 92046  
Phone: (619) 747-3343  
Fax: (619) 747-3346

WE WILL NOT BE UNDERSOLD  
URS SHIPPING - 48 STATES 5% OTHERS CALL  
IL RES add 7.75% TAX  
PROBES INCL. ALL SCOPES & METERS

C&S SALES INC.  
1245 ROSEWOOD, DEERFIELD, IL 60015  
FAX: 708-520-0085 • (708) 541-0710

15 DAY MONEY BACK GUARANTEE  
FULL FACTORY WARRANTY  
WRITE FOR FREE CATALOG  
Prices Subject to Change

## 1691 MHZ WEATHER SATELLITE SYSTEM

- 1691 MHz HEMT Pre-amp.  
model TS-1691-P Amp.....\$450
- 1691 MHz Receiver  
model TS-1691-Recvr.....\$450
- Decoder Board & Software  
Model TS-VGA-SAT4.....\$399
- Low Loss (microwave) Coaxial Cable  
(65ft) with connectors  
model 1691-coax ass'y.....\$65
- Track If IBM Satellite Orbital  
Program Tracks All Satellites,  
World Map, Print Out.....\$99
- 1691 MHz Loop-Yagi Antenna  
model 1691-LY(N).....\$99
- 1691 MHz Loop-Yagi Extention  
Model 1691-LY-XTN.....\$85
- Demonstration Disc (IBM-PC VGA  
compatible) of signals recorded from  
WX-SAT system.....\$3

## J-BEAM'S AND LOOP YAGIS

### ANTENNAS

137 MHz	2XY-137-C	\$95.00
137 MHz	5XY-137-C	135.00
1691MHz	1691LY:N:	99.00
1691 MHz	1691 LY EXTN.	85.00
70/MBM48		115.00
70/MBM88		160.00
1268 MHz	1268LY:N:	99.00
1268 MHz	1268 LY EXTN.	85.00
1296 MHz	1296 LY:N:	99.00
1296 MHz	1296 LY EXTN.	85.00

### HARNESSE KITS

PMH 2-70.....	29.00
PMH 4-70.....	55.00

### LOOP YAGI ACCESSORIES AVAILABLE

Prices Subject to Change Without Prior Notice.  
All Antennas include 50 ohms Balun.  
Write for detailed specs.



**Spectrum International, Inc.**  
P.O. Box 1084 Dept. Q  
Concord, MA 01742 U.S.A.  
Phone: 508-263-2145  
FAX: 508-263-7008

# ORGANIZE AND PROTECT YOUR COPIES OF *Communications Quarterly*

Now there's an easy way to organize and keep copies of your favorite magazine readily available for future reference.

Designed exclusively for *Communications Quarterly* by Jesse Jones Industries, these custom-made titled cases and binders provide the luxury look that makes them attractive additions to your bookshelf, desk or any location in your home or office.

Whether you choose cases or binders, you'll have a storage system that's durable and well organized to help protect your valuable copies from damage.

- Cases and binders designed to hold a year's issues (may vary with issue sizes).
- Constructed of reinforced board, covered with durable maroon leather-like material.
- Free personalization foil for indexing year.
- Cases V-notched for easy access.
- Binders have special spring mechanism to hold individual rods which easily snap in. This allows magazines to be fully opened for easy readability.
- Title hot - stamped in gold.

Communications Quarterly  
Jesse Jones Industries, Dept. COMM-Q  
499 East Erie Avenue,  
Philadelphia, PA 19134

Quantity	Cases	Binders
One	\$ 7.95	\$ 9.95
Three	\$21.95	\$27.95
Six	\$39.95	\$52.95

Please send \_\_\_\_\_ cases; \_\_\_\_\_ binders

Add \$1 per case/binder postage and handling. Outside USA \$2.50 per case/binder. (U.S. funds only)

Enclosed is \$ \_\_\_\_\_

Charge my: (Minimum \$15)

American Express

Visa

Mastercard

Diners Club

Card # \_\_\_\_\_ Exp. Date \_\_\_\_\_

Signature \_\_\_\_\_

Print Name \_\_\_\_\_

Address \_\_\_\_\_

No P.O. Box Numbers Please

City/State/Zip \_\_\_\_\_

Zip \_\_\_\_\_

*PA Residents add 7% sales tax*  
**Call TOLL FREE 7 days,**  
**24 hours 1-800-825-6690**



# ANTENNA OPTIMIZERS

**AO 6.0** automatically optimizes antenna designs for best gain, pattern, impedance, SWR, and resonance. AO optimizes cubical quads, phased arrays, interlaced Yagis, or any other arrangement of wire or tubing. AO uses an enhanced, corrected MININEC algorithm for improved accuracy, assembly language for high speed, and protected mode for high capacity. AO features stunning 3-D radiation patterns, 3-D geometry and wire-current displays, 2-D polar and rectangular plots with overlays, automatic wire segmentation, automatic frequency sweep, symbolic dimensions, symbolic expressions, skin-effect modeling, current sources, polarization analysis, near-field analysis, up to 450 pulses, and pop-up menus. AO 6.0, \$100. AO-Pro 6.0 (5700 pulses), \$600. 386+387 or 486DX and VGA required. MN 4.5 (256 pulses; any PC; no optimizer, 3-D patterns, or assembly language), \$50. GUY 1.0 (guy-wire modeler), \$25.

**YO 5.0** automatically optimizes monoband Yagi designs for maximum forward gain, best pattern, and minimum SWR. YO models stacked Yagis, dual driven elements, tapered elements, mounting brackets, matching networks, skin effect, ground effects, and construction tolerances. YO optimizes Yagis with up to 50 elements from HF to microwave. YO runs hundreds of times faster than MININEC. YO is calibrated to NEC for high accuracy and has been extensively validated against real antennas. YO is intuitive and highly graphical. YO 5.0, \$75. YOC 5.0 (assembly language, much faster), \$100. NEC/Yagis 1.0 (professional accuracy reference), \$50.

YOC and NEC/Yagis require a math coprocessor; MN and YO come with both coprocessor and noncoprocessor versions. All except AO run on any IBM PC compatible with graphics. All programs include extensive documentation. Add 7.25% CA, \$5 overseas. Visa, MasterCard, U.S. check, cash, or money order. 3.5" or 5.25" disk.

Brian Beezley, K6STI  
507 1/2 Taylor, Vista, CA 92084  
(619) 945-9824, 0700-1800 Pacific Time

CALL

## NEMAL FOR RF



- Connectors
- Adapters
- Cable Assemblies
- Coaxial Cable

Manufacturer Of Custom  
Electronic Wire And Cable.

- Low Minimums • Quick Delivery

CALL US AT  
1-800-522-2253  
OR FAX YOUR REQUIREMENTS TO  
1-305-895-8178

Call for your copy of our new 44-page  
Cable & Connector Selection Guide.  
More than 2,500 commercial and QPL  
cable and connector products in stock.

**NEMAL ELECTRONICS, INC.**  
12240 N.E. 14th AVE., N. MIAMI, FL 33161  
(305) 899-0900

Come to the 1993

## AMSAT Space Symposium

La Quinta Inn & Conference Center  
Arlington, Texas

October 8, 9 & 10

Your BEST chance to learn how to work

### Amateur Satellites:

The high orbit DX satellites:

OSCARs 10 & 13

The "easy birds":

RS 10 & 12

Store & forward PACKET spacecraft

AO 16, LU 19, UO 22, KO 23

and more coming SOON!

Now building:

Phase 3D (The satellite for ALL amateurs)

SEDSAT (Easy to use 2 to 10 meter transponder + digital)

PANSAT (An experiment in amateur spread spectrum)

RS 15 (A new Russian 2 to 10 meter satellite)

More PACKET satellites



Majorie Swain with Grand Prize won at 1992 Symposium - a Kenwood TR-751A all-mode 2 meter transceiver. OM Carroll W7DU seems pleased with her good fortune

For more information  
write or call



PO Box 27  
Washington, DC 20044  
301-589-6062

## AMATEUR TELEVISION

GET THE ATV BUG



New 10 Watt

Transceiver  
Only \$499

Made in USA  
Value + Quality  
from over 25 years  
in ATV...W6ORG



Snow free line of sight DX is 90 miles - assuming 14 dBd antennas at both ends. 10 Watts in this one box may be all you need for local simplex or repeater ATV. Use any home TV camera or camcorder by plugging the composite video and audio into the front phono jacks. Add 70cm antenna, coax, 13.8 Vdc @ 3 Amps, TV set and you're on the air - it's that easy!

TC70-10 has adjustable >10 Watt p.e.p. with one xtal on 439.25, 434.0 or 426.25 MHz & properly matches RF Concepts 4-110 or Mirage D1010N-ATV for 100 Watts. Hot GaAsfet downconverter varicap tunes whole 420-450 MHz band to your TV ch3. 7.5x7.5x2.7" aluminum box.

Transmitters sold only to licensed amateurs, for legal purposes, verified in the latest Callbook or send copy of new license. Call or write now for our complete ATV catalog including downconverters, transmitters, linear amps, and antennas for the 400, 900 & 1200 MHz bands.

(818) 447-4565 m-f 8am-5:30pm pst.

Visa, MC, COD

**P.C. ELECTRONICS**

Tom (W6ORG)

2522 Paxson Lane Arcadia CA 91007

Maryann (WB6YSS)

How to put MORE power into your antenna and get better and higher signal strength ???

- Use the all new **OUTSTANDING, HIGHEST EFFICIENCY (97% TO 99%),** and the **BEST BROADBAND UNUN (unbalanced to unbalanced) and BALUN (balanced to unbalanced) TRANSFORMERS** exclusively designed and optimized by **DR. JERRY SEVICK W2FMI.** Amidon Associates, Inc. now offers the widest selection of the W2FMI Baluns and Ununs to meet all your requirements for better and more consistent communication. Also available in do-it-yourself kits.

Use **UNUN** transformers for matching 50-ohm cable to:

- (1) Vertical antennas, inverted L's and ground fed slopers (all over good ground systems),
- (2) 75-OHM cable,
- (3) A junction of two 50-OHM cables,
- (4) Shunt-Fed towers performing as vertical antennas, and
- (5) The output of a transceiver or class B linear amplifier when an unfavorable VSWR condition exists.

Use **BALUN** transformers for matching:

- (1) Half-waves dipoles and inverted V's
- (2) Quad antennas
- (3) Folded dipoles
- (4) Rhombic and V antennas
- (5) Yagi beams



All designs, when used according to instructions, are guaranteed to give outstanding performances. Comparisons with other matching transformers are invited.

**POWER RATING:** at least 2KW continuous from 1MHz to 40 MHz.

W2FMI HIGH POWER UNUNS	IMPEDANCE MATCH	COMPLETE UNIT PRICE
2.25-1HU50	50:22.22-OHMS	\$34.95
2-1-HU50	50:25-OHMS	\$34.95
2:1-HDU50	50:22.22-OHMS	\$49.95
	50:25-OHMS	
2.25-1-HU112.5	112.5:50-OHMS	\$34.95
2:1-HU100	100:50-OHMS	\$34.95
2:1-HDU100	112.5:50-OHMS	\$49.95
	100:50-OHMS	
1.78-1-HU50	50:28-OHMS	\$34.95
1.5-1-HU50	50:32-OHMS	\$34.95
1.5-1-HU75	75:50-OHMS	\$34.95
4:1-HRU50	50:12.5-OHMS	\$49.95
4:1-HCU50	50:12.5-OHMS	\$49.95
9:1-HRU50	50:5.56-OHMS	\$49.95
9:1-HU50	50:5.56-OHMS	\$34.95
1.78-1-HDU50	50:28-OHMS	\$49.95
	50:18-OHMS	
1.56-1-HDU50	50:32-OHMS	\$49.95
	50:18-OHMS	
HMMU50(5 diff ratios) MULTIMATCH UNUN		\$69.95
1.78-1-HMMU50 (8 different ratios) MULTIMATCH UNUN		\$69.95

W2FMI HIGH POWER BALUNS	IMPEDANCE MATCH	COMPLETE UNIT PRICE
4:1-HB50	50:12.5-OHMS	\$39.95
1:1-HBHS0	50:50-OHMS	\$39.95
1.5:1-HB75	75:50-OHMS	\$59.95
2:1-HB100	100:50-OHMS	\$59.95
4:1-HBM200	200:50-OHMS	\$39.95
4:1-HB/U200	200:50-OHMS	\$59.95
4:1-HBHT200	200:50-OHMS	\$59.95
6:1-HB300	300:50-OHMS	\$59.95
6:1-HB/U300	300:50-OHMS	\$119.95
9:1-HB450	450:50-OHMS	\$119.95
12:1-HB600	600:50-OHMS	\$199.95

NOTE: OTHER BALUN & UNUN TRANSFORMERS AVAILABLE. PLEASE CALL OR WRITE FOR ADDITIONAL DETAILS.  
BOOKS: 1) "Transmission Line Transformers Design Handbook" by Jerry Sevick, W2FMI, Amidon Associates, Inc., 1991, \$6.00 ea. 2) "Transmission Line Transformers" by Jerry Sevick, W2FMI, APRIL, 1996, \$20.00 ea.

**ALSO AVAILABLE:**  
**Iron Powder and Ferrite Products**  
Millions of Parts in Stock for Immediate Delivery.  
Low Cost Experimental Kits.  
**Call for our FREE tech. flyer.**  
Toroidal Cores • Shielding Beads • Shielded Coil Forms • Ferrite Rods • Pot Cores • Baluns • Etc.

**AMIDON Associates, INC.**  
Fast reliable service since 1963  
2216 East Gladwick Street, Dominguez Hills, CA 90220  
TEL: (310) 763-5770 • FAX: (310) 763-2250

Unconditional money back guarantee for 1 year on completed unit.

**SPECIAL KIT PRICE \$28.00!  
CALL TODAY!**

## ROANOAK DOPPLER DF!

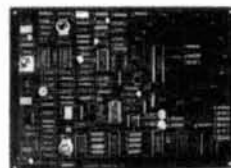

Ready to assemble board and component kit ...\$87.50

"Transmitter Hunting" TAB Books 323 ppg ....\$19.95

(The calibration procedure for this unit can only be found in this book.) Add \$2.90 per unit for shipping.

## TS352 B/U Multimeter

20,000 ohms per volt sensitivity up to 5,000 volts!  
Depot Overhauled!  
Complete with test leads.



**ONLY \$39.95**

Add \$5.00 each for shipping, California

residents add 7.75% sales tax

**Douglas RF Devices, (916) 688-5647  
Box 246925, Sacramento, CA 95824**

## Measure Up With Coaxial Dynamics Model 83550 Digital Wattmeter

The "Generation Gap" is filled with the "new" EXPEDITOR, the microprocessor based R.F. AnaDigit System.

The EXPEDITOR power computer...you make the demands, it fills the requirements.

- Programmable forward AND reflected power ranges.
- Can be used with the elements you now have.
- Compatible with all Coaxial Dynamics line sizes and power ranges.
- 18 scales from 100 mW to 50 kW.

Contact us for your nearest authorized Coaxial Dynamics representative or distributor in our world-wide sales network.



**COAXIAL DYNAMICS, INC.**

15210 Industrial Parkway  
Cleveland, Ohio 44135  
216-267-2233 1-800-COAXIAL  
FAX 216-267-3142

Service and Dependability... A Part of Every Product



**NEW Peak Power Added**

## ADVERTISER'S INDEX

AEA/Adv. Elec. Applications.....	5
Alfa Electronics .....	108
Alinco Electronics .....	Cov.II
Amidon Associates .....	112
AMSAT.....	111
Astron Corporation .....	10
Beezley, Brian, K6STI.....	111
C & S Sales .....	109
Coaxial Dynamics .....	112
Communications Quarterly.....	108
Communications Concepts .....	109
CQ Videos.....	107
CQ Books.....	9
Douglas RF Devices .....	112
Down East Microwave.....	108
HAL Communications.....	8
Hewlett Packard.....	9
Japan Radio, JRC.....	12
Jesse Jones Industries.....	110
Kenwood .....	Cov.IV, 2
L.L. Grace Comm. Products .....	107
Lewallen, Roy, W7EL .....	109
Motorola.....	11
Nemal Electronics.....	111
OPTOelectronics.....	1
Palomar Engineers .....	109
PC Electronics.....	111
Spectrum International, Inc.....	110
Surplus Sales of Nebraska .....	108
TX RX Systems Inc .....	108
Yaesu.....	Cov.III

We'd like to see your company listed here too. Contact Arnie Sposato, N2IQO, at (516)681-2922 or FAX at (516)681-2926 to work out an advertising program to suit your needs.

"200 watts, real cross band receive, even two flywheel-weighted main knobs!"

"Yaesu did it again!"



"Right, there's only one real performer – the FT-1000."

## FT-1000 All Mode HF Transceiver

- RF Power Output: Up to 200 Watts
- True Cross-band Dual Receive: Two Large Tuning Knobs
- Front Panel RX Antenna Switch: For Beverage or Loop
- Direct Digital Synthesis (DDS)
- Automatic Antenna Tuner: Built-in, 30 Memories
- Frequency Range: 100kHz-30MHz (RX), 160-10 meters (TX)
- 100 Memories: Independent ATU and Mode/IF Filter Memory
- CW Spot and Two CW Key Jacks for Maximum Convenience
- Dynamic Range: 108 dB
- Optional Digital Voice Recorder (DVS-2): 16 Seconds Each RX/TX
- Accessories:
  - SP-5 External Desk-top Speaker
  - LL-5 Phone Patch Unit
  - MD-1C8 Desktop Microphone
  - YH-77ST Stereo Headphones
  - FL-7000 500W Linear Amplifier
  - DVS-2 Digital Voice Recorder

# Hear signals you've never heard before.



You're a competitor. You want optimum receiver performance and you want "muscle" on transmit. First with 200 watts – more power than any competing transceiver – and "hand warm" at maximum RF. It's easy to see why the FT-1000 has been judged "best overall" by top DX'ers worldwide.

For elite-class contesting and DX operation, exclusive features maximize your score. Dual Receive – Watch a multiplier or new country on one frequency, run QSOs on another. Diversity Reception – Use two antennas at different heights or opposite polarization. Extensive Cascaded IF Filtering – For "low end" battles.

Dramatic front panel design features two flywheel-weighted tuning knobs, RX antenna selector and two large displays.

A perfect blend of electronics and human engineering, the FT-1000 is the Best of our Best!

To hear signals you've never heard before and get the competitive edge, see your Yaesu dealer today.

# YAESU

Performance without compromise.<sup>SM</sup>

© 1993 Yaesu USA, 17210 Edwards Road, Cerritos, CA 90701 (310) 404-2700

Specifications subject to change without notice. Specifications guaranteed only within amateur bands. Some accessories and/or options are standard in certain areas. Check with your local Yaesu dealer for specific details.

# KENWOOD

...pacesetter in Amateur Radio

# Compact Milestone

Kenwood unveils the world's smallest HF transceiver

HF is going places—thanks to the smallest transceiver of its kind offering high-performance communications wherever convenience, the freedom. And whether used for DX-peditions, or in a fixed installation, this rig packs a powerful punch. Maximum output is 100W, and there's a full range of advanced features—including 100 memory channels, DDS with innovative "fuzzy" control, and AIP for superior dynamic range IF shift and CW reverse mode help reduce interference, while a noise blanker improves clarity. For user-friendly operation on the move, there's a multi-function microphone and powerful menu system. And the TS-50S is fully equipped for split-frequency operations. Test drive one today.

**TS-50S**  
HF TRANSCEIVER

to Kenwood's new TS-50S, its kind in the world. Providing communications with go-anywhere, the TS-50S is your passport to for mobile operations and a powerful punch. Maximum output is 100W, and there's a full range of advanced features—including 100 memory channels, DDS with innovative "fuzzy" control, and AIP for superior dynamic range IF shift and CW reverse mode help reduce interference, while a noise blanker improves clarity. For user-friendly operation on the move, there's a multi-function microphone and powerful menu system. And the TS-50S is fully equipped for split-frequency operations. Test drive one today.



**NEW**

KENWOOD COMMUNICATIONS CORPORATION  
AMATEUR RADIO PRODUCTS GROUP  
P.O. BOX 22745, 2201 E. Dominguez Street  
Long Beach, CA 90801-5745

KENWOOD ELECTRONICS CANADA INC.  
6070 Kestrel Road, Mississauga,  
Ontario, Canada L5T 1S8

93-ARD-0599