

# CATJ

OFFICIAL JOURNAL OF THE COMMUNITY ANTENNA TELEVISION ASSOCIATION  
JULY 1983

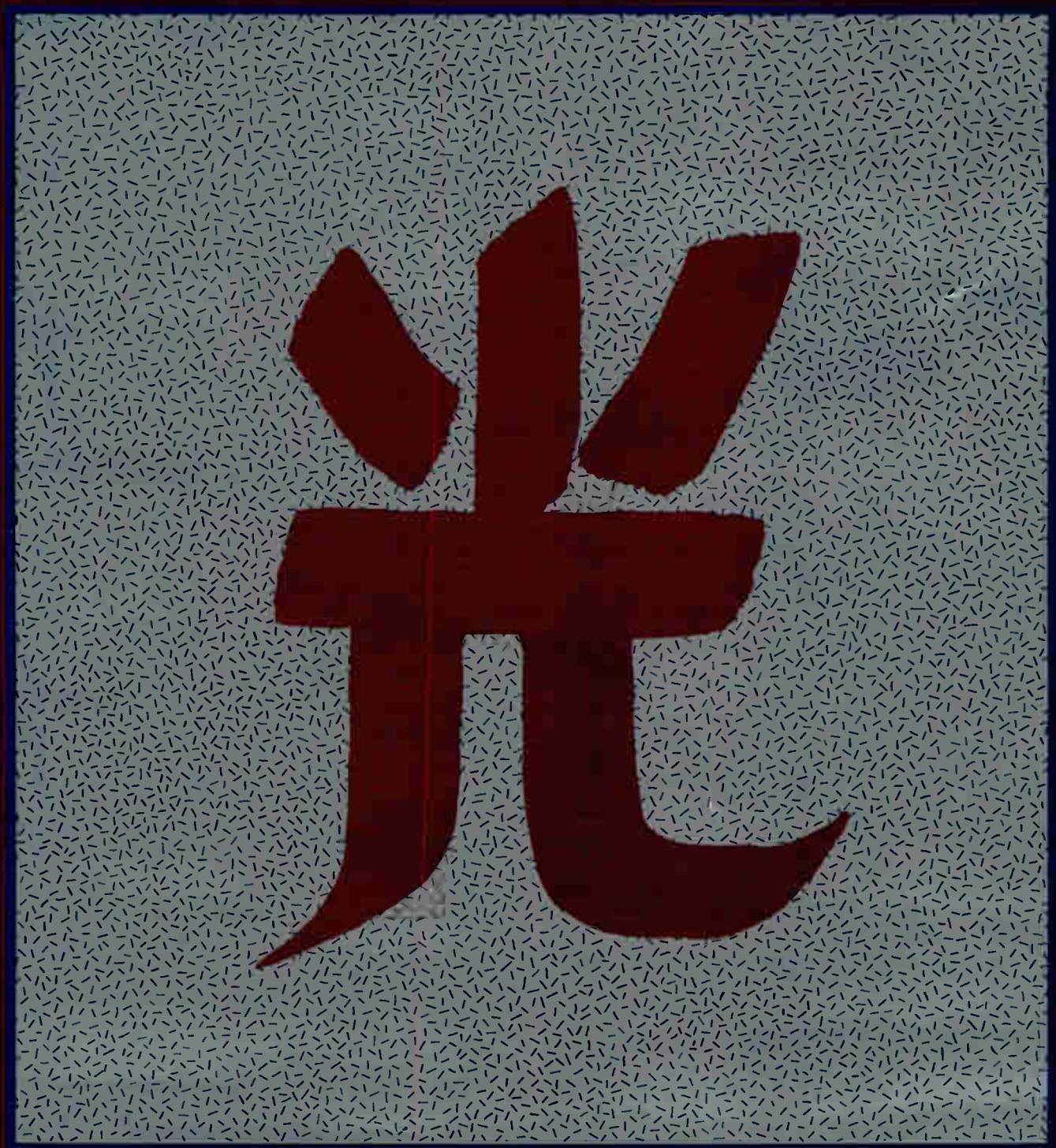

WorldwideHistory

MULTIMODE OPTICAL FIBERS

---

# THE TRACERS™

---

## Find signal leakage before the FCC fines you.

---

RF signal leakage is not a new concern for cable system operators.

Loose connectors, hairline cracks in expansion joints, loose or corroded covers on equipment housing can all lead to signal leakage problems.

What is new is the crackdown on violators of the FCC regulations.

Vitek can help you avoid costly penalties and repairs with the Tracers. Both the compact TR-1 and TR-2 RF Detection Receivers locate and measure leakage and determine whether radiation exceeds FCC limits.

These easy-to-use units operate with any specified cable TV video or pilot carrier. And no separate transmitter is required.

Other features include a crystal controlled local oscillator, front panel frequency trim adjustment, meter display and audible warning tone.

And since they are made by Vitek, you know they will stand up to hard knocks out in the field for a long time to come.



Tracer Model TR-1

Tracer Model TR-2

If you want to find signal leaks before they can put a drain on your financial resources, call Vitek today, and ask for the Tracers.

**AUGAT® VITEK**  
Quality and Innovation

Vitek Electronics, Inc., 4 Gladys Court, Edison, New Jersey 08817 (201) 287-3200

# maximum security

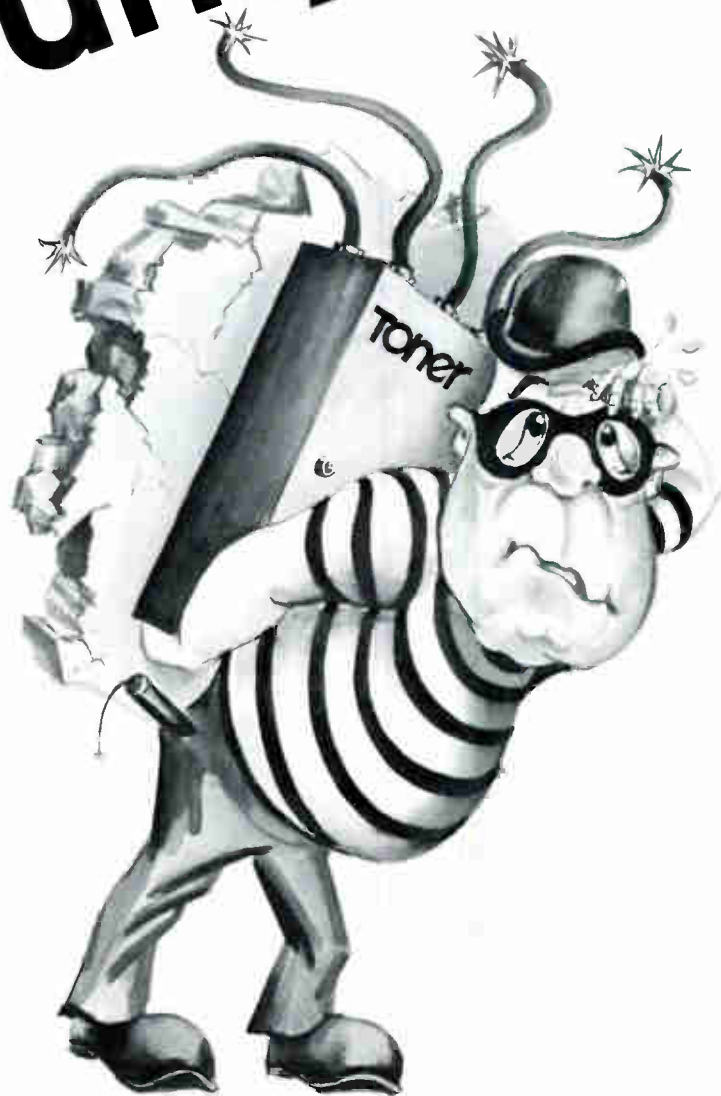

against theft,  
weather, and  
RF radiation

...with security cabinets from  
**TONER**

You get more protection value for your money with TONER lockable apartment house cabinets. Constructed of 14 and 16 gauge steel with  $\frac{3}{8}$ " plywood backboards. Shipped fully assembled. Indoor and outdoor models in five sizes. Now available in 4", 6", and 8" depths.

TONER has the cabinets you need in stock and ready to ship — today!

## TONER

cable equipment, inc.

969 horsham rd. • horsham, pa. 19044

**800-523-5947**

(In pa. 800-492-2512)



CATJ, The Official Journal for the Community Antenna Television Association is published as a service for Association Members and other providing services to the industry.

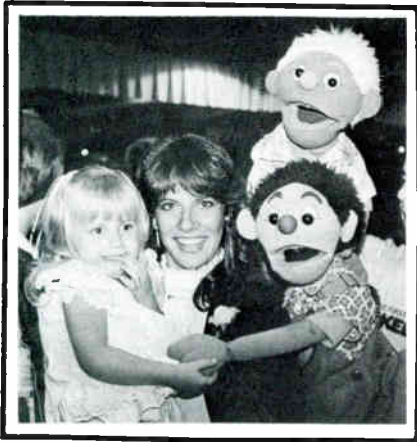

See Page 10

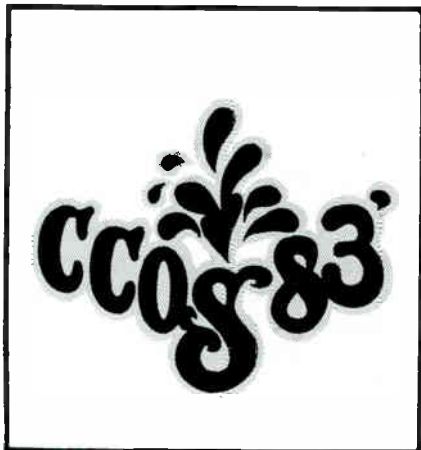

See Page 36

### ABOUT THE COVER:

Featured in this month's CATJ is a combined presentation, edited by KAZUD NEMOTO, an audio-visual Technician at Centelope Valley College, Lancaster, California, on the Development of VHF Multichannel Television System studied in Japan at the NHK using Multimode Optical Fibers. The symbol featured on the cover is the Japanese version of OPTICAL.

## TABLE OF CONTENTS

4	CATA-TORIAL — <i>This month's editorial carries a copy of a letter written to Dan Ritchie, who is responsible for the newly formed "Consortium For Cable Information", with the CATA suggestions for the image of cable television that needs to be projected.....</i>
6	S.J. BIRKILL ON EXPERIMENTAL TERMINALS — <i>a discussion on Noise Figure and Noise Temperature .....</i>
10	A PICTORIAL REVIEW OF THE RECENT NCTA EXHIBITS.....
16	DEVELOPMENT OF VHF MULTICHANNEL TELEVISION TRANSMISSION SYSTEM USING MULTIMODE OPTICAL FIBERS — <i>by Kazuo Nemoto, Audio Visual Technician, Antelope Valley College, Lancaster, CA. and owner of Nemoto's Video and Computer Sales Co. ....</i>
28	THE FILTERED EARTH STATION #14 — Terrestrial Interference Avoidance — This segment, by Glyn Bostick Microwave Filter Co., discusses the Purchased Professional Survey.....
36	PLANS FOR CCOS '83 BEING FINALIZED — INFORMATION CONCERNING THE TECHNICAL AND MANAGEMENT SESSIONS .....
	DEADLINE FOR PRE-REGISTRATION FEE IS JULY 15th!! After that date, ALL registration is \$150.
40	WASHINGTON UPDATE — <i>A bulletin from CATA Executive Director, Steve Effros, concerning the recent voting on S.66....</i>
42	NEW PRODUCT REVIEW — CATA Associate Member, Ben Hughes Communication Products Co., <i>discusses their product line designed for the preparation of coaxial cable for CATV, MATV, and STV applications .....</i>
45	ASSOCIATES' ROSTER .....
48	CLASSIFIED .....

S.J. BIRKILL on  
EXPERIMENTAL TERMINALS

# Noise Figure

# Noise Temperature

With increasing numbers of Ku-Band satellite systems entering service, and the tendency for 12 GHz receiving system noise performance to be specified by Noise Figure (dB) rather than Noise Temperature (K), it seems opportune to review these two terms.

Returning briefly to fundamentals, we remember the equation for available noise power  $P_n$ , the power dissipated in a matched load as a result of a thermal noise voltage generated across a resistor at absolute temperature  $T$ , measured in bandwidth  $B$ :

$$P_n = kTB,$$

where  $k$  represents Boltzmann's constant,  $1.374 \times 10^{-23}$  joules/Kelvin.

Applying this to a receiving system with reference to the "receiver" input port (LNA flange), the antenna acting as noise source  $kTB$ , then if we had a "perfect" LNA, contributing no noise of its own, the noise power at its output would just be  $kTB$  multiplied by the LNA's gain factor  $G$ . (Remember here we are still considering numerical ratios, not dB — the standard 50 dB gain LNA has a numerical power gain of 100,000 times.)

But, sadly, the LNA generally contributes more noise than the antenna. Let us call its actual output noise power  $N_1$ . The thing we call Noise

Figure is simply the ratio of this actual output noise power (with  $T = T_0$ , the reference temperature of 290K) to that value which a noise-free LNA would give:

$$F = \frac{N_1}{kT_0BG}$$

For the hypothetical perfect amplifier, no noise would be added, so noise output would equal noise input, and  $F$  would have a value of 1.

The LNA's noise output naturally includes the  $kTBG$  term, as well as its own contribution which we shall call  $N_r$ . So  $N_r$  is the difference,

$$N_r = N_1 - kT_0BG$$

$$= (F - 1) kT_0BG$$

But we can consider  $N_r$  itself to be the result of a  $kTB$  equation, where here  $T = T_r$ , the receiver (amplifier)'s effective noise temperature, referred to the input port. This noise power is also amplified by  $G$ , so we can say:

$$kTrBG = (F - 1) kT_0BG$$

The  $kBG$  terms are common to both sides, so we are left with:

$$Tr = (F - 1) T_0$$

This we can rewrite:

$$F = 1 + Tr/T_0$$

Remembering that  $T_0$  is (almost) always taken as 290K we have the ability to convert directly between values of noise figure and noise temperature. Customarily noise figure is expressed in decibels, so:

$F(\text{dB}) = 10 \log F(\text{ratio})$   
Here are some useful values:

Tr(k)	F(ratio)	F(dB)
65	1.22	0.88
70	1.24	0.94
75	1.26	1.00
80	1.28	1.06
85	1.29	1.12
90	1.31	1.17
100	1.34	1.29
120	1.41	1.50
150	1.52	1.81
170	1.58	2.00
226	1.78	2.50
290	3.00	3.00
359	2.24	3.50
438	2.51	4.00
527	2.82	4.50
627	3.16	5.00
870	4.00	6.00

Fig. 1 is a plot of noise figure against equivalent noise temperature, over the range of greatest interest.

Note that noise temperatures may also be expressed in dB, usually relative to absolute zero, as in the logarithmic derivation of earth terminal receive figure of merit,  $G/T$ . Here we may have a system noise temperature of (say) 104K, combined with an antenna gain of 44.25 dB(dBi). It is convenient to convert the  $T_s$  factor to 20.17 dB(K). Subtraction from the gain figure then gives the  $G/T$ , 24.08 dB(/K).

In cascading RF amplifiers we need

CATJ, The Official Journal for the Community Antenna Television Association is published as a service for Association Members and other providing services to the industry.



See Page 10



See Page 36

### ABOUT THE COVER:

Featured in this month's CATJ is a combined presentation, edited by KAZUD NEMOTO, an audio-visual Technician at Centelope Valley College, Lancaster, California, on the Development of VHF Multi-channel Television Transmission System studied in Japan at the NHK using Multimode Optical Fibers. The symbol featured on the cover is the Japanese version of OPTICAL.

## TABLE OF CONTENTS

4	CATA-TORIAL — <i>This month's editorial carries a copy of a letter written to Dan Ritchie, who is responsible for the newly formed "Consortium For Cable Information", with the CATA suggestions for the image of cable television that needs to be projected.</i> .....
6	S.J. BIRKILL ON EXPERIMENTAL TERMINALS — <i>a discussion on Noise Figure and Noise Temperature</i> .....
10	A PICTORIAL REVIEW OF THE RECENT NCTA EXHIBITS .....
16	DEVELOPMENT OF VHF MULTICHANNEL TELEVISION TRANSMISSION SYSTEM USING MULTIMODE OPTICAL FIBERS — <i>by Kazuo Nemoto, Audio Visual Technician, Antelope Valley College, Lancaster, CA. and owner of Nemoto's Video and Computer Sales Co.</i> .....
28	THE FILTERED EARTH STATION #14 — Terrestrial Interference Avoidance — This segment, by Glyn Bostick Microwave Filter Co., discusses the Purchased Professional Survey .....
36	PLANS FOR CCOS '83 BEING FINALIZED — INFORMATION CONCERNING THE TECHNICAL AND MANAGEMENT SESSIONS .....
	DEADLINE FOR PRE-REGISTRATION FEE IS JULY 15th!! After that date, ALL registration is \$150.
40	WASHINGTON UPDATE — <i>A bulletin from CATA Executive Director, Steve Effros, concerning the recent voting on S.66.</i> . . . .
42	NEW PRODUCT REVIEW — CATA Associate Member, Ben Hughes Communication Products Co., <i>discusses their product line designed for the preparation of coaxial cable for CATV, MATV, and STV applications</i> .....
45	ASSOCIATES' ROSTER .....
48	CLASSIFIED .....

# catatorial



Peter Athanas  
President of CATA

**President's Note:** The following letter was sent by CATA to Dan Ritchie CEO of Group W and the newly-named head of the "Consortium For Cable Information".

Mr. Daniel L. Ritchie  
Chief Executive Officer  
Group W Cable  
888 7th Avenue  
New York, N.Y. 10107

Dear Dan:

Congratulations on your assumption of the post of "first steward" of the new venture in cable television aimed at "improving cable's public image". There is no question that such an undertaking is needed. However, before plans get developed in stone, there are a few suggestions we would like to offer.

As I am sure you know, the Community Antenna Television Association has maintained for a long time that one of the most serious problems facing our membership is the rampant misperception of what the cable television business really is. CATA represents both large and small systems. Our membership spans the spectrum from very small "mom and pop" systems to the largest MSO in the United States. Our members run "traditional" "CATV" reception systems and are also involved in some of the most innovative experiments in broadband communications such as the efforts now going on in Boston. Our members provide cable television service to over 6 million subscribers, and that number is growing rapidly. The one unifying factor, however, is that CATA works with and represents the workers at the system level. We focus on the practical, day to day problems of the individual owner or manager and try to deal with those problems rather than focus on the board rooms of the large corporations as some other associations do. Both types of focus are important and they complement each other. That is why many major corporations are joining CATA — to assure that the input of the local owner or manager is attended to as well as the CEO. Having worked on that level for several years I can assure you that we are very sensitive to the "image" of cable television.

If the trade press reports are accurate, the NCTA and some of the major cable companies have decided to fund



---

an effort to “improve” that image. But what image of cable television are you going to project? CATA believes that the problems we are all facing today regarding renewals and franchise promises stem in great part from unrealistic projections of cable’s image in the past. This view, and its consequences, are apparently shared by many influential members of the cable community. I would recommend that you take a look at some of the recent comments of Tryg Mehren regarding recent franchise requests and promises for corroboration of that view.

The evidence is unfortunately all around us that the “popular” perception of what cable television is does not really comport with reality. Witness the ongoing struggle we face on Capitol Hill to get some reasonable stability in the regulatory process of cable. The debate has shifted to one that pictures cable as presenting such a threat to that Bell System’s local telephone rates that, so the argument goes, our massive data transmission and “enhanced services” capabilities should be strictly regulated, or we should be put on an “equal” regulatory footing with the telephone industry! This is all happening at a time when less than one percent of all cable homes have the technical capacity for two-way interactive data transmission! The perception of what cable could be, or what it might be in the future, or what it has the technical capability for has far outstripped the reality of what cable is, and what services have been proved to be economically viable.

The popular perception of cable is that it is an extremely “rich” industry and the new “money machine” for big companies in the telecommunications business. The fact that the industry is over 5 billion dollars in debt is seldom mentioned. We are perceived as the technological solution to many urban ills — thus we see the demands for access, training, studios, mobile vans, etc. Very little is mentioned about the massive amount of equipment already purchased by cable systems around the country that has lain dormant after the initial thrill of the technology wore off. We are perceived as the purveyors of pornography but are seldom noted for the delivery of the unique, quality programming such as that provided by C-SPAN. But I’m sure you are aware of the litany of perceptual problems we face.

What are the solutions? One, to be sure, is the initiation of an effort such as the one you are now heading to “correct” some of our “image” problems. However, before you do so CATA would encourage you to engage in widespread dialogue with all segments of the industry to assure that the image which is ultimately projected is accurate.

We have gotten into the problems mentioned above in no small part due to our own actions. The “bells and whistles” perception of the cable industry has served very well to promote the stock of some major companies. It served very little purpose in the middle of a franchise battle or an effort to impress Wall Street for some companies to focus on the economic realities of those technological wonders — the fact that they theoretically could be done was enough to create the desired excitement — the reality of whether the technology could be translated into services that consumers really wanted was left for later. The same is true of the major cable television trade show/media events. They are “sexy”, they attract attention to the industry, but do they give an accurate picture of an industry that still has a majority of systems with 12 channel capacity or less? And speaking of “sex”, is our problem with constantly getting “bad press” about “porn” a true picture of cable or is it really a reflection on the popular press — both television and newspapers, which find it useful for their purposes to stress such issues because it sells their products?

All of these issues must be analyzed and dealt with in a truthful and open manner in any effort to correct the misperception of the cable industry that is now so prevalent. We must all seek to portray what the cable industry as a whole really is — the good and the bad, the traditional and the experimental if we ever hope to be treated by the public, the financial community and the government in any sort of rational way. CATA stands ready to aid in any way we can in that effort.

We trust that you recognize that any effort to present the “image” of the cable television industry must be broad based. Consultation and cooperation with all segments of the industry will be necessary. A “PR” campaign designed and run by a few corporate giants will be recognized for what it is, and will dilute the effectiveness that could be attained. Of course the principal source of funding for any such campaign will have to come from companies such as yours — however we urge you to plan and execute your efforts in cooperation with the entire industry to assure that it succeeds, as it must, for the sake of the entire cable television industry.

I look forward to hearing from you regarding this innovative initiative, and again, congratulations and our deep appreciation for your willingness to take on what may be one of the most difficult and important assignments in the cable television business today. We are glad to see that “operation reality” is finally under way. □



S.J. BIRKILL on  
EXPERIMENTAL TERMINALS

# Noise Figure Noise Temperature

With increasing numbers of Ku-Band satellite systems entering service, and the tendency for 12 GHz receiving system noise performance to be specified by Noise Figure (dB) rather than Noise Temperature (K), it seems opportune to review these two terms.

Returning briefly to fundamentals, we remember the equation for available noise power  $P_n$ , the power dissipated in a matched load as a result of a thermal noise voltage generated across a resistor at absolute temperature  $T$ , measured in bandwidth  $B$ :

$$P_n = kTB,$$

where  $k$  represents Boltzmann's constant,  $1.374 \times 10^{-23}$  joules/Kelvin.

Applying this to a receiving system with reference to the "receiver" input port (LNA flange), the antenna acting as noise source  $kTB$ , then if we had a "perfect" LNA, contributing no noise of its own, the noise power at its output would just be  $kTB$  multiplied by the LNA's gain factor  $G$ . (Remember here we are still considering numerical ratios, not dB — the standard 50 dB gain LNA has a numerical power gain of 100,000 times.)

But, sadly, the LNA generally contributes more noise than the antenna. Let us call its **actual** output noise power  $N_1$ . The thing we call Noise

Figure is simply the ratio of this **actual** output noise power (with  $T = T_0$ , the reference temperature of 290K) to that value which a noise-free LNA would give:

$$F = \frac{N_1}{kT_0BG}$$

For the hypothetical perfect amplifier, no noise would be added, so noise output would equal noise input, and  $F$  would have a value of 1.

The LNA's noise output naturally includes the  $kTBG$  term, as well as its own contribution which we shall call  $N_r$ . So  $N_r$  is the difference,

$$\begin{aligned} N_r &= N_1 - kT_0BG \\ &= (F - 1) kT_0BG \end{aligned}$$

But we can consider  $N_r$  itself to be the result of a  $kTB$  equation, where here  $T = T_r$ , the receiver (amplifier)'s effective noise temperature, referred to the input port. This noise power is also amplified by  $G$ , so we can say:

$$kT_rBG = (F - 1) kT_0BG$$

The  $kBG$  terms are common to both sides, so we are left with:

$$T_r = (F - 1) T_0$$

This we can rewrite:

$$F = 1 + T_r/T_0$$

Remembering that  $T_0$  is (almost) always taken as 290K we have the ability to convert directly between values of noise figure and noise temperature. Customarily noise figure is expressed in decibels, so:

$F(\text{dB}) = 10 \log F(\text{ratio})$   
Here are some useful values:

Tr(k)	F(ratio)	F(dB)
65	1.22	0.88
70	1.24	0.94
75	1.26	1.00
80	1.28	1.06
85	1.29	1.12
90	1.31	1.17
100	1.34	1.29
120	1.41	1.50
150	1.52	1.81
170	1.58	2.00
226	1.78	2.50
290	3.00	3.00
359	2.24	3.50
438	2.51	4.00
527	2.82	4.50
627	3.16	5.00
870	4.00	6.00

Fig. 1 is a plot of noise figure against equivalent noise temperature, over the range of greatest interest.

Note that noise temperatures may also be expressed in dB, usually relative to absolute zero, as in the logarithmic derivation of earth terminal receive figure of merit,  $G/T$ . Here we may have a system noise temperature of (say) 104K, combined with an antenna gain of 44.25 dB(dBi). It is convenient to convert the  $T_s$  factor to 20.17 dB(K). Subtraction from the gain figure then gives the  $G/T$ , 24.08 dB/(K).

In cascading RF amplifiers we need

to know the way in which noise figures of subsequent stages modify the first stage noise figure to determine the overall receiver sensitivity. This applies both between stages (as in an LNA) and between blocks (say the interface between LNA and receiver).

Right at the front end there is additional thermal generated by any lossy component, for example the waveguide run between feed and LNA, or even (especially at 12 GHz) the downpath through the earth's atmosphere. This loss-related noise is given (as a noise temperature) by  $T_0(1-\alpha)$ , where  $\alpha$  is the transmission coefficient, the inverse of the loss factor as a numeric ratio. Alternatively if  $L$  is the antilog of  $0.1 \times$  (loss in dB), then noise temperature contribution  $T_L$  is given by:

$$T_L = T_0 (L-1)/L$$

As an example, consider a ferrite polarization rotator inserted between feed and LNA. These are becoming popular in home TVRO systems on account of their instant current-controlled selection of vertical or horizontal, and their absence of moving parts. However, unlike the mechanical type (e.g. "Polarotor") the ferrite device can introduce significant loss. Good ones 0.15 dB or less, not-so-good ones as much as 0.5 dB.

On a warm day up near the antenna's prime focus the temperature of

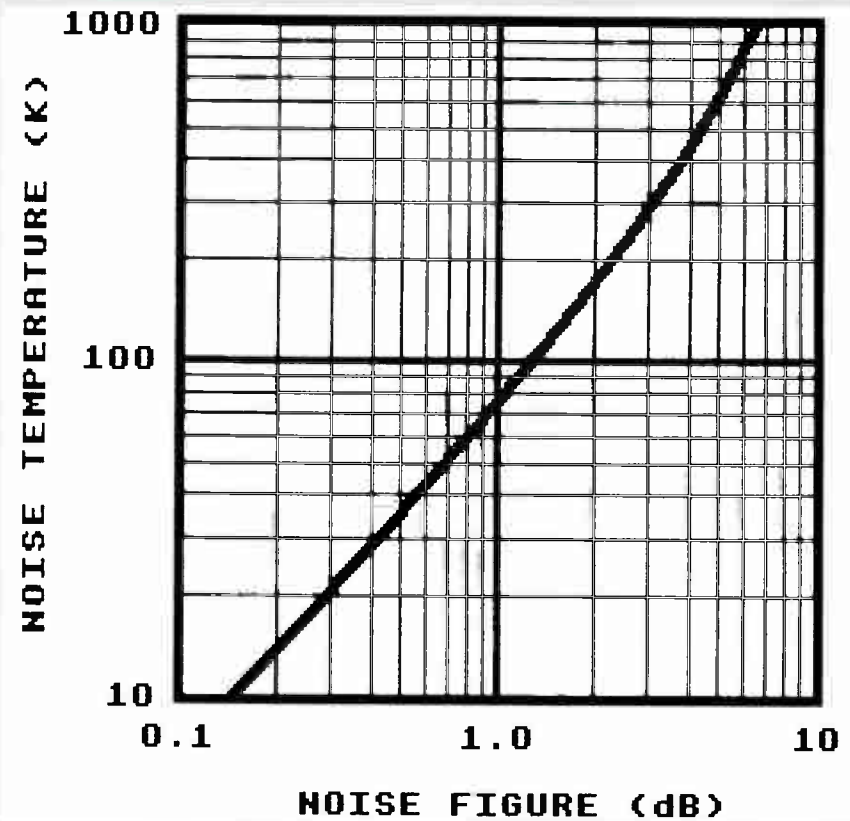

such a polarizer could easily reach 104° F, that's 40°C, or 313 Kelvin. Here's a case where we cannot assume  $T_0$  to be 290K. With 0.5 dB insertion loss, the polarizer will not only attenuate the signals by that amount, but will also add its own noise contribution amounting to

$$T_L = 313 (\text{antilog}(0.1 \times 0.5) - 1) / \text{antilog}(0.1 \times 0.5) = 34.04 \text{ K}$$

This noise temperature is referred to the polarizer's input port. It suffers its own attenuation in passing through the device, so the additional noise presented to the LNA flange is 0.5 dB less, at a noise temperature of 30.34

K. Given the G/T example quoted above, effective gain  $G$  is reduced by 0.5 dB, noise temperature  $T$  is increased by 30.34 K, so  $G/T$  becomes

$$44.25 - 0.5 - 10 \log(104 + 30.34) = 22.47 \text{ dB/K}$$

This represents a not insignificant reduction in sensitivity of 1.61 dB, from the original value of 24.08 dB/K. It should be noted that this simple analysis neglects the effect of the additional attenuation on the antenna noise temperature, a factor which offsets the damage by a small amount, typically no more than 3 K. ▶

In considering cascaded networks, we can apply the same considerations of input and output noise power to each stage, as we did when defining figure. Without examining its derivation in detail, here is the general equation for system noise figure:

$$F_S = F_1 + \frac{(F_2 - 1)}{G_1} + \frac{(F_3 - 1)}{G_1 G_2} + \dots + \frac{(F_n - 1)}{G_1 G_2 \dots G_{(n-1)}}$$

and likewise for effective noise temperature:

$$T_e = T_1 + \frac{T_2}{G_1} + \frac{T_3}{G_1 G_2} + \dots + \frac{T_n}{G_1 G_2 \dots G_{(n-1)}}$$

Interstage (or feedline) loss may be allowed for by considering it to be a gain of less than 1. All gain terms here are numerical ratios, not dB.

A 4 GHz LNA design might include a first stage of 11 dB gain, 65 K noise temperature, and a second stage

of 13 dB, 100 K. Input isolator loss is 0.15 dB, all figures worst case. Imagine the designer can choose between a third stage of 120 K (NF = 1.5 dB) at \$25, 290 K (NF = 3.0 dB) at \$10, or 438 K (NF = 4.0 dB) at \$5.

In each case the input isolator contributes 9.85 K to the LNA noise

temperature (take  $T_0 = 290$  K). For the first system,

$$\begin{aligned} T_{LNA} &= 9.85 + 65 + (100/12.59) \\ &\quad + (120/(12.59 \times 19.95)) \\ &= 9.85 + 65 + 7.94 + 0.48 \\ &= 83.27 \text{ K} \end{aligned}$$

For the second system,

$$\begin{aligned} T_{LNA} &= 9.85 + 65 + (100/12.59) \\ &\quad + (290/(12.59 \times 19.95)) \\ &= 9.85 + 65 + 7.94 + 1.15 \\ &= 83.94 \text{ K} \end{aligned}$$

And for the third system,

$$\begin{aligned} T_{LNA} &= 9.85 + 65 + (100/12.59) \\ &\quad + (438/(12.59 \times 19.95)) \\ &= 9.85 + 65 + 7.94 + 1.74 \\ &= 84.53 \text{ K} \end{aligned}$$

The designer would be well advised to go for the cheapest stage 3 option, as its noise contribution is effectively masked by the gain (24 dB or 251 times) of stages 1 and 2. In practice the LNA's noise temperature would also be modified by the effect of subsequent stages, but so long as stage 3 realised a useful amount of gain (8 dB or more) their noise contribution can be ignored. □

#### OFFICERS

Peter Athanas, President  
Carl Schmauder, Vice President  
Clarence Dow, Secretary/Treasurer

#### DISTRICT DIRECTORS

One	Clarence Dow (Maine)
Two	Michael J. Rigas (Pennsylvania)
Three	David Fox (West Virginia)
Four	John Rhinehart (Tennessee)
Five	Joe Bain (Oklahoma)
Six	Wayne Sheldon (California)
Seven	Carl Schmauder (Oregon)
Eight	Virgil Mehus (Minnesota)
Nine	Peter Athanas (Wisconsin)
Ten	Jim Hays III (Kentucky)

#### VICE DIRECTOR

Lee Holmes (Guam)

#### ASSOCIATES' DIRECTORS

Raleigh B. Stelle III, Texscan/Theta Com  
Ernie Larson, Larson Electronics

#### DIRECTORS EMERITUS

Gene Edwards (Ohio)  
Chuck Kee (Oregon)  
William Ridsen (Kentucky)

#### CATJ STAFF

**President and Publisher**  
G.H. Dodson

**Business and Managing Editor**  
Celeste Rule Nelson

**Executive Assistant to the Editor**  
Diane Howard

**Circulation Manager**  
Lori Biggers

**Contributing Editors**  
S.J. Birkill, Stephen Effros,  
Ralph Haimowitz

**Art Director/Marketing**  
Phyllis Crumpler

**Assistant Art Director**  
Dianna Johnson

#### OFFICES

National Headquarters  
CATA/CATJ  
Celeste Rule Nelson, Managing Editor  
4209 N.W. 23rd, Suite 106  
Oklahoma City, Ok. 73107  
(405) 947-7664; 947-4717

CATA (Washington Office)  
Stephen R. Effros, Executive Director  
3977 Chain Bridge Rd.  
Fairfax, Va. 22030  
(703) 691-8875

CATA (Engineering Office)  
Ralph Haimowitz, Director  
518 21st Street S.W.  
Vero Beach, Fl. 32960  
(305) 562-7847

The Community Antenna Television Association, Inc. is a nonprofit organization formed under Chapter 19, Title 18 of the Statutes of the State of Oklahoma. As such, no part of its assets or income shall be the property of its members, such assets and income shall be devoted exclusively to the purposes of the Corporation.

The Community Antenna Television Journal (CATJ)—ISSN-0194-5963—is published monthly by Television Publications, Inc., 4209 N.W. 23rd, Suite 106, Okla. City, OK 73107. Subscription price: \$18.00 per year, \$22.00 per year Canada, Mexico, and foreign is \$25.00 per year. Second class postage paid at Oklahoma City.

**POSTMASTER:** Send address change to 4209 N.W. 23rd, Oklahoma City, OK. 73107.

CATJ is a Copyright © 1983 by the Television Publication, Inc. All rights reserved. Qudean reservados todos los derechos. Printed in U.S.A. Permission to reprint CATJ published material must be given by Television Publications, Inc., prior to republication.

*Thanks Multichannel News!*

# On-Time News

The Newspaper for the New Electronic Media

## **News Ain't News When It's Old News**

News is a time-based commodity. Old news just isn't news anymore.

At **Multichannel News**, we take "timeliness" seriously. If you don't get us on-time, you stand to lose, to miss something, to not know. That's why we "drop-ship" **Multichannel News** to U.S. Post Office entry points all over the United States ... including Manhattan, Washington, D.C., Los Angeles, Atlanta and other cities.

**Multichannel News** is delivered within one day of our cover date (a *real* date, not a Monday later than we publish so you might think an old copy is current) to over 90% of our subscribers. Our informal surveys of media in our field show nationally-distributed on-time rates ranging from our 90% to a dismal 15% for some magazines ("on-time" for the weeklies means within one working day of the *real* cover date; for bi-weeklies and semi-monthlies "on-time" means within 3 working days; for monthlies it means within the first week of the cover date month).

Here's how well the magazines and newspapers get their information to you:

### "On-Time" Performance Rates

Publication	On-Time Rate
Cable Age	40%
Cable Marketing	15%
Cable TV Business (TVC)	45%
Cablevision	70%
CATJ	80%
CED	70%
Electronic Media	60%
Multichannel News	90%
SAT-Guide	60%
View	18%

(Study conducted over three months at five locations)

Some of these publications talk about their "shelf life" value to advertisers and readers. At **Multichannel News**, we think timely delivery of accurate news is most important.

Our format, too, is geared for timely use by busy executives. We know that to over 80% of readers, the latest news is **most important**. And by a margin of almost 5 to 1, multichannel industry executives pick **Multichannel News** as the best source for the most up-to-date news.\*

\*Survey available upon request

*When You Gotta Know...*

**Multichannel News**

The Newspaper for the New Electronic Media



# KNOWING YOU HAVE THE BEST

in cable technical information



Name \_\_\_\_\_

Company \_\_\_\_\_ Title \_\_\_\_\_

Address \_\_\_\_\_

City \_\_\_\_\_ State \_\_\_\_\_ Zip \_\_\_\_\_

## CATA MEMBER

(Must Furnish System Name)

- \$14.00 Enclosed for 1 Year
- \$40.00 Enclosed for 3 Years

## NON MEMBER

- \$18.00 Enclosed for 1 Year
- \$50.00 Enclosed for 3 Years

CANADA/MEXICO SUBSCRIBERS: Add \$4.00 per year to rates given above. All other Foreign Countries add \$7.00 per year to rates given above. Special handling arranged upon request. U.S. CURRENCY ONLY.

Mail to: CATJ Magazine  
Suite 106, 4209 N.W. 23rd  
Oklahoma City, Okla. 73107

# Get the ASTI Handbook And Kiss TI Goodbye!

*Glyn Bostick and his team of microwave interference fighters have incorporated the ongoing FILTERED EARTH STATION articles into a 200 page reference manual. Available now, for the first time, the ASTI HANDBOOK shows in detail how to avoid and/or suppress terrestrial interference—even at "hopeless" TVRO sites! ASTI works, and it can save you money. Order now and take advantage of pre-publication price!*

## What Is ASTI?

Terrestrial interference (TI) is fast becoming a major economic consideration for the installers and operators of TVRO earth terminals. Thousands of dollars, even hundreds of thousands, may be at stake when the earth station is turned on—only to discover that TI is degrading or altogether preventing reception of desired satellite signals.

The purpose of this volume is to introduce ASTI — the avoidance/suppression approach to eliminating TI — to the 3.7-4.2 GHz TVRO industry. Conscientious application of ASTI will reduce the possibility that TI will be encountered at turn-on, increase the probability that unavoidable TI can be suppressed, and enhance the effective operating quality of the TVRO system.

The authors, as designers of microwave filter networks and other TI-suppression techniques, have had ample opportunity to test ASTI — it works! Measured over a period of time, the costs are substantially lower than any alternative, especially in terms of dollars saved when the initial or only site can be made operable. Furthermore, both cost and complexity of filtering to eliminate TI are lowered considerably when the essential aspects of ASTI are employed.

## About the Authors:

**Glyn Bostick** is the founder, president and chief engineer of Microwave Filter Company, Inc. Mr. Bostick, who writes CATJ's monthly "Filtered Earth Station" articles, has been designing filters to suppress interference at CATV systems and TVRO earth stations since 1967.

**John Fannetti** is MFC's senior technical consultant and head of the company's Field Service Division. He has 30 years of engineering and earth station troubleshooting experience.

**William Johnson**, chief engineer of R&D, has de-

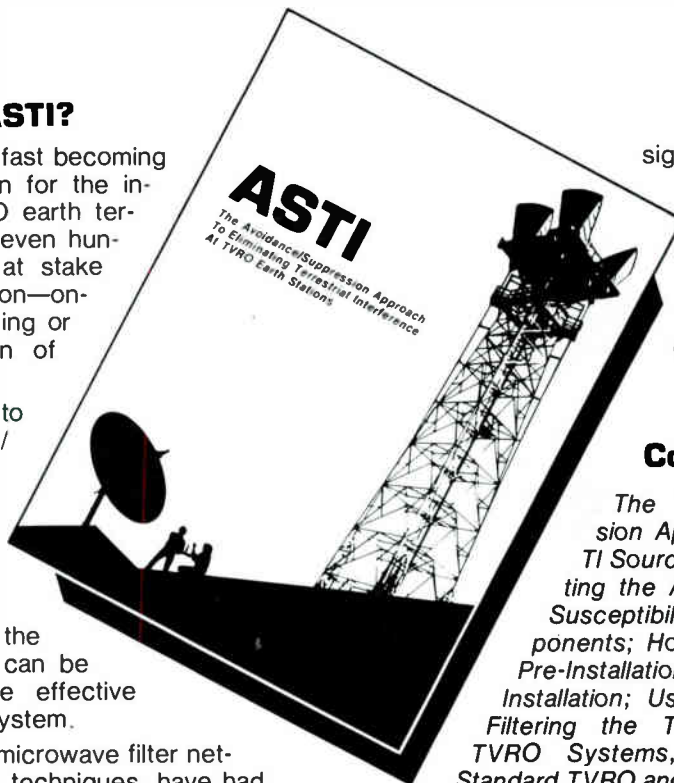

signed many of MFC's CATV and TVRO products. Mr. Johnson earned his BSEE at Syracuse University and is currently engaged in graduate studies there.

## Contents Include:

*The TI Avoidance/Suppression Approach; Why Satellites; TI Sources; TI Symptoms; Selecting the Antenna for Least TI; TI Susceptibility of Other TVRO Components; How to Select a Site; The Pre-Installation Site Survey; Defensive Installation; Use of Artificial Shielding; Filtering the TVRO; Filtering Special TVRO Systems, SMATV Techniques; Standard TVRO and Satellite Data; Formulas and Derivations...*

## Order Form

Mail to: CATJ Magazine,  
4209 NW 23rd, Suite 106, Oklahoma City, OK 73107

- Pre-publication special \$99\* (before 1 July):
- Post-publication \$125\* (after 1 July):

**PAYMENT MUST BE ENCLOSED**

NAME \_\_\_\_\_

COMPANY \_\_\_\_\_

STREET \_\_\_\_\_

CITY, STATE, ZIP \_\_\_\_\_

PHONE \_\_\_\_\_

\*Outside U.S.A., Draft Drawn  
On U.S. Bank

# NCTA SHOW

Photo Essay

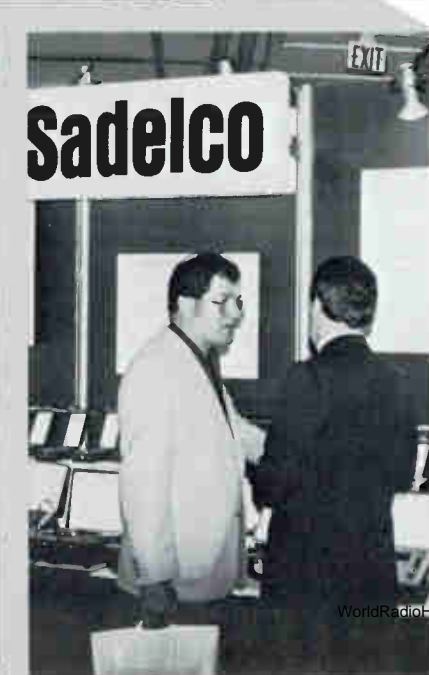







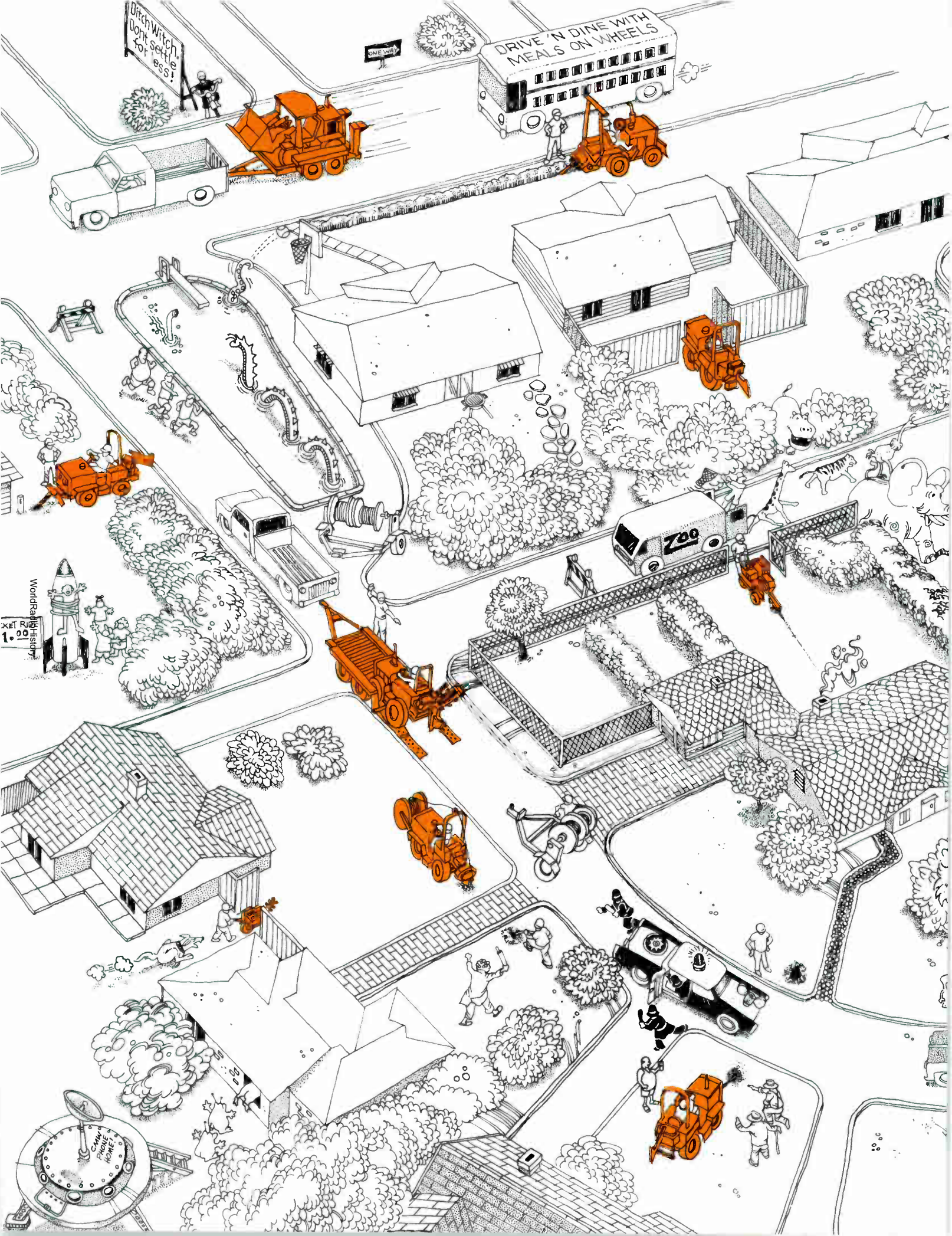

Ditch Witch  
Don't settle  
for less!

ONE WAY

DRIVE 'N DINE WITH  
MEALS ON WHEELS

Zoo

Wordsearch  
1.00

DANCE WITH ME  
PLEASE



# Count the ways Ditch Witch® equipment can bury cable.

No one can install underground cable more ways than Ditch Witch. You'll find more CATV crews in more neighborhoods putting more cable in the ground with Ditch Witch equipment than with any other make of machine.

Compact trenchers and vibratory plows that can go through a 36-inch yard gate. Lawn plows with trenching accessories. Larger four-wheel-drive riding trenchers. Combo™ machines that can trench *and* plow. Earth Saw™ equipment for cutting trench in streets. And utility backhoe and hydraulic boring units that let one machine do more jobs.

And for a limited time, Ditch Witch is offering a 10% special discount offer. See the details below!

The Charles Machine Works, Inc.  
 P.O. Box 66 Perry, Oklahoma 73077  
 (405) 336-4402

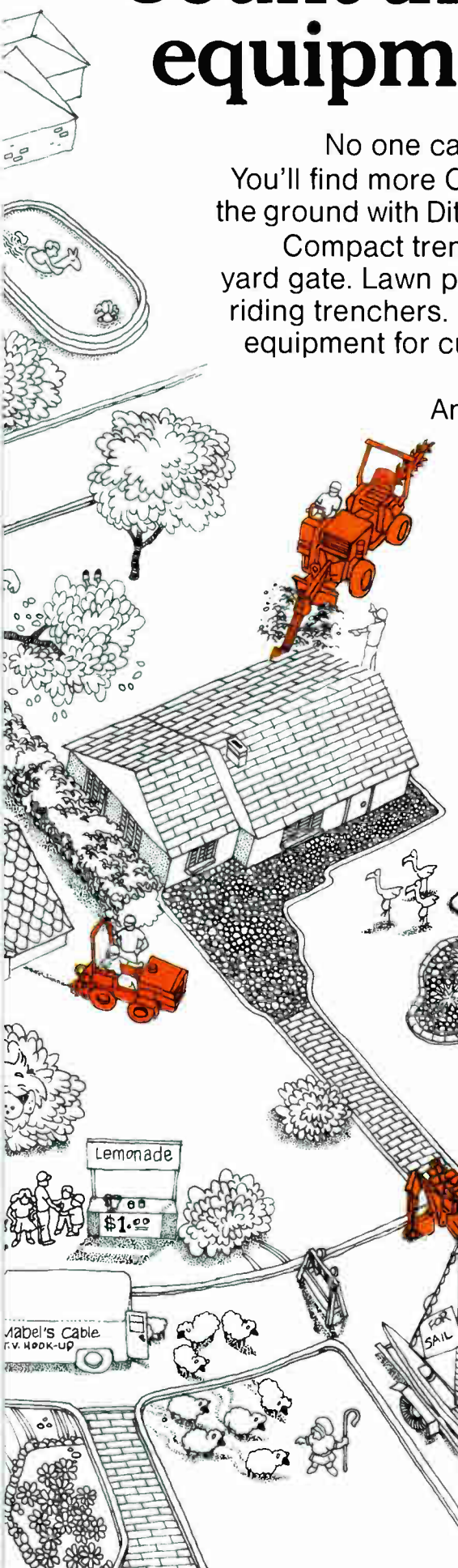

Don't Settle for Less!

**10% DISCOUNT OFFER**

This Ditch Witch coupon is good for a 10 per cent discount off the purchase of a piece of new Ditch Witch equipment or 10 per cent discount off Ditch Witch parts orders of \$500 or more. Complete the coupon and leave it with your Ditch Witch dealer when you make your purchase. Offer good at participating dealers. Offer expires August 30, 1983.

Company Name \_\_\_\_\_

Purchaser Name \_\_\_\_\_

Address \_\_\_\_\_

City \_\_\_\_\_ State \_\_\_\_\_ Zip \_\_\_\_\_

Telephone \_\_\_\_\_ Date of Purchase \_\_\_\_\_

WorldRadioHistory

# NCTA

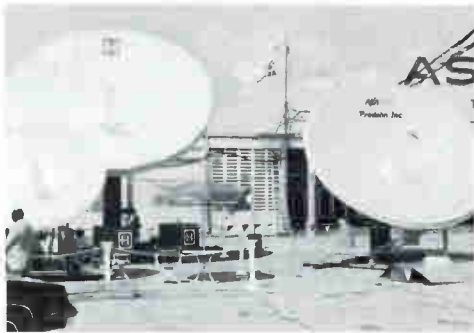



# ***Speedy Recovery***



***Here's your handle  
on fast repair...***

**COMSONICS, INC.**

**If you're stuck with equipment failure . . .  
stick a label on it and send it to us!**

We're ComSonics. And unsurpassed response times are the special ingredients we've added to the quality repair service the cable industry has come to expect from us for over a decade.

**2-Day Turnaround** — Your damaged equipment is repaired to perfection and on its way back to you in a matter of hours.

**5-Day Turnaround** — We'll get your equipment working through our line, so you can get it back on line, fast.

**14-Day Turnaround** — Even our normal repair time is a priority, because we know in an emergency you can't afford to be left standing by.

Send us satellite receivers, headend, line and test equipment and field strength meters. We repair them all from our extensive inventory of parts.

When your cable equipment is down you don't need sympathy — you need results. You'll be relieved to know the "get well quick" message ComSonics delivers is a guarantee, not a wish!

***Watch your  
equipment repair  
problems  
dissolve!***

Call for your FREE handle on Fast Repair kit today.  
In VA call collect: 1-703-434-5965

**1-800-336-9681**

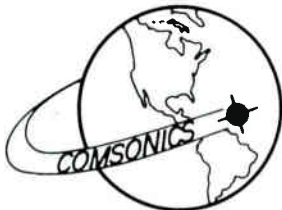

*An Employee Owned Corporation*

**COMSONICS<sup>®</sup>, INC.**

P.O. Box 1106      Harrisonburg, VA 22801  
UPS address — ComSonics Lane at Port Republic Road

WorldRadioHistory



# Development of VHF Multichannel Television Transmission System Using Multimode Optical Fibers

*Editor's Note:*

*This report, prepared by Kazuo Nemoto, Audio Visual Technician at Antelope Valley College, Lancaster, California and owner of Nemoto's Video and Computer Sales Co., was precipitated from several visits to Japan when Mr. Nemoto had occasion to visit the facilities. He found that the NHK (Japanese Broadcasting Corporation) working through Mr. Takizawa and his staff, had begun research on optical fiber seven years ago. As a result, laser diode development has made it possible to use optical fiberglass for multichannel TV transmission in VHF systems. The NHK has installed this system in Hakone, Japan, and has had successful results with the equipment. It was also reported by Mr. Nemoto that in visiting with Mr. Yamaura of the Hitachi Cable Company, who worked in*

*in conjunction with the NHK Technical Research Division, he observed additional material about optical fiberglass multichannel VHF TV transmission systems, which was in the production stage at the time of the article preparation.*

*Mr. Yamaura wrote Mr. Nemoto: "All equipment in Hakone has been checked out for testing performance after one year. The result of the test was excellent. They did not have any problems since they installed the Optical Fiber Transmission System."*

*In accepting this material, CATJ felt that the information concerning Japanese fiber optics used in cable television would be of great benefit to its readers. The material is thus presented and reprinted in its entirety for the information of our readers.*

# チャンネル多重伝送システムの開発

## TV Signal Transmission System Using An Optical Fiber

BY: Kazuo Nemoto  
43315 Edson Street  
Lancaster, CA 93534

Instead of coaxial cables, optical fibers are now attracting public attention for an analog transmission system of VHF TV signals like a CATV.

For the transmission of TV signals in base band, optical fibers have been already utilized. But, for that of TV signals in VHF band, they have not been utilized yet.

We had been involved in studying an analog and multi-channel transmission system of VHF TV signals using optical fibers and laser diodes, and finally obtained the following system performances under the conditions: transmitting TV signals are on 7 channels arranged in the frequency range from 90 MHz to 222 MHz.

System performances { Signal to noise ratio; 44 ~ 46 dB  
Intermodulation; -50 ~ -54 dB  
Crossmodulation;  
less than -62 dB

Here, you can see the experimental arrangement of the system, and its details are as follows;

Optical fiber { type; graded index  
diameter of clad; 195  $\mu\text{m}$   
diameter of core; 120  $\mu\text{m}$   
fiber length; 2 km  
transmission loss; 3 dB/km  
type; laser diode

Optical transmitter { wave length; 0.83  $\mu\text{m}$   
average optical output; 5 mW

Optical receiver { type; avalanche photo diode

In order to complete the transmission system, we had to solve two important problems.

One was the reduction of multi-path distortion generated in a fiber with a small diameter. At first, we thought of picking up a single mode fiber. But, its light coupling loss was so large that we had to adopt a multi-mode fiber. Although 'graded index curve' should be made ideal, in multi-mode transmission, it is difficult to realize it in manufacturing process. Accordingly, we adopted a large diameter fiber to reduce multi-path distortion.

The other was the reduction of noise generated in a laser diode. The noise occurs when the emission wave length skips discretely, depending on the temperature of the laser diode. This is not an avoidable phenomenon in its basic properties. Finally, we put the laser diode package on a Peltier Thermo-element to reduce the noise.

NHK has developed an optical transmission system of VHF multi-channel TV signals in cooperation with Hitachi Cable Ltd.

Hitherto, it has been considered that an analog wide-band transmission system using a multi-mode fiber, a laser diode and a photo diode was impractical because of the following problems:

- 1) the distortion generated in the laser diode with non-linearity,
- 2) the noise caused by the fluctuation of emission wave-length when the temperature of the laser diode drifts,
- 3) the noise caused by the interference in the laser diode between emission wave and reflection wave which reflects from optical connectors and other discontinuous points,
- 4) the modal noise and distortion generated in the fiber by the multi-mode propagation.

Then, theoretical and experimental studies were made to solve these problems.

For problem 1), we have developed a new type of laser diode which has a large optical output power and excellent linearity. (HITACHI Type 3000)

For problem 2), we put the laser diode on a Peltier thermo-element and controlled the temperature of it within  $\pm 0.1^\circ\text{C}$ .

For problem 3), we cut the ends of the fiber with oblique angle at optical connectors and other discontinuous points.

For problem 4), we adopted an optical fiber with a large core diameter and a small numerical aperture.

As a result, the optical transmission system, which transmits seven channel TV signals in VHF band, have been realized through a multi-mode fiber in length of 2 km, as shown in Photo 1.

The system performances are as follows:

Signal to noise ratio; 43 dB  
Intermodulation; -50 dB  
Crossmodulation; -60 dB

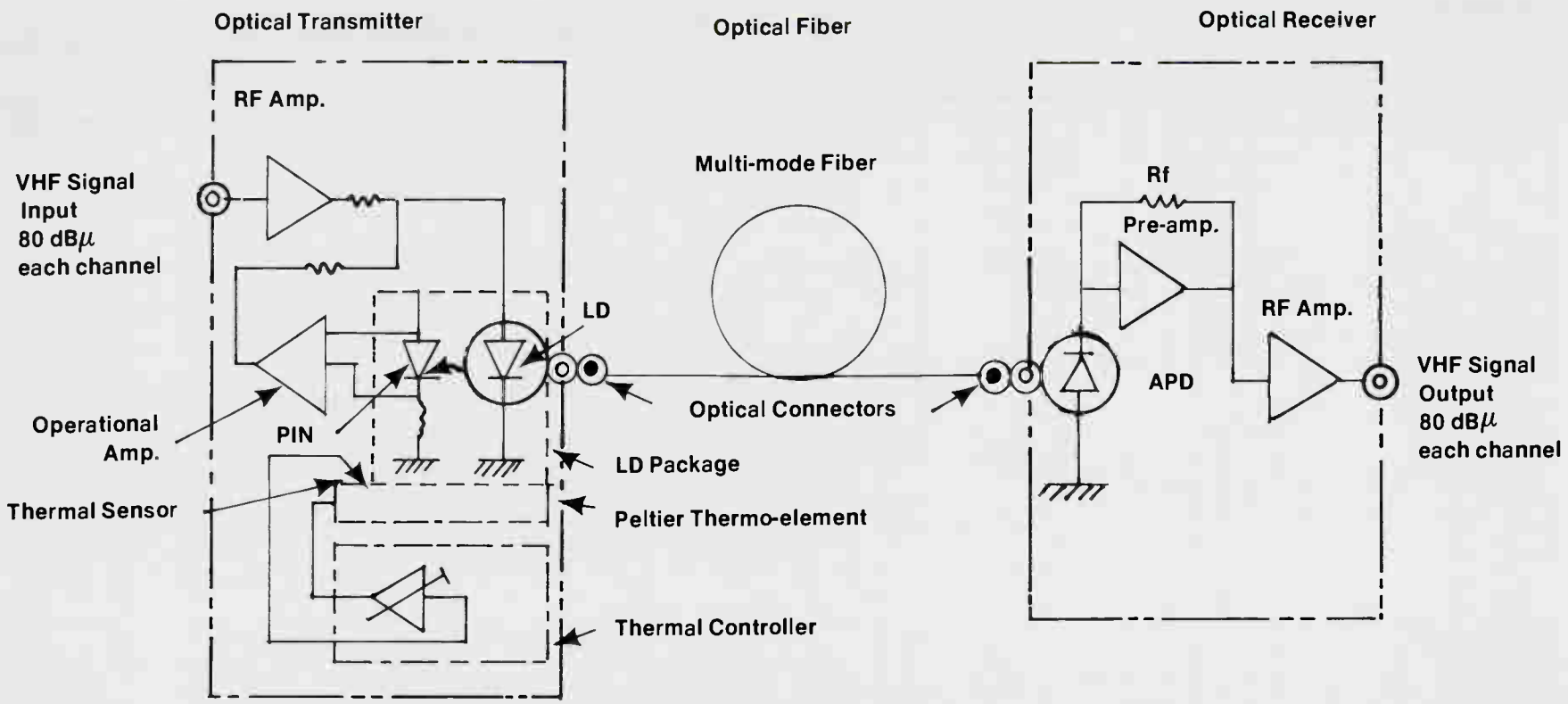

LD: Laser Diode,

PIN: PIN Diode,

APD: Avalanche Photo-diode

Experimental Arrangement

**Figure 1**

# First In Reliability

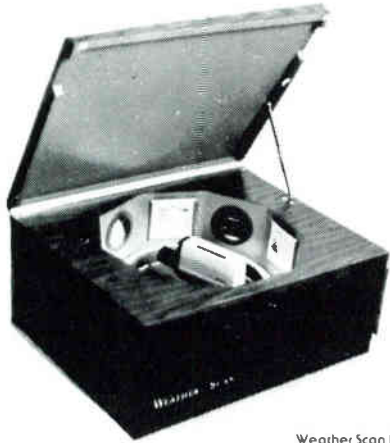

Weather Scan III

**Impressive quality . . . surprisingly low price. Just \$3295 for the most reliable unit available (at any price!).**

We have been in the cable television business for 23 years . . . and providing weather information systems for the past 16 years. We know what you need and we know how to manufacture it. For reliability and performance.

The Weather Scan III comes complete with Sony AVC-1400 camera with separate mesh vidicon and 2:1 interlace sync. Includes Time, Temperature, Barometric Pressure, Wind Velocity, Wind Direction, plus four card holders. Compact cabinet is just 28" wide, 23" deep and 14" high. For complete information call or write.



## Weather Scan, Inc.

An R.H. Tyler Enterprise

Loop 132 and Throckmorton Hwy. Olney, Texas 76374 Ph. 817-564-5688

# SMALL SYSTEM SPECIALISTS

At Triple Crown — small is BIG! Our products are designed and manufactured specifically to suit small system applications. We built our first 36 channel system almost a decade ago. Since then we have provided the expertise and top quality equipment for hundreds of systems around the globe.

From Guam to Greenland, from Peru to Pennsylvania, we have established an impressive list of satisfied Triple Crown owners. We

would be proud to introduce you to one . . . his testimony may make you one too!

Our extensive experience in the field of television reception and distribution systems coupled with our constant dedication to engineering excellence, makes Triple Crown an industry leader. We can give you big system performance with a small system price tag. If you are in the market for equipment or even some friendly advice, call us first . . .

because we are!

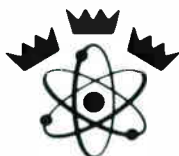

## TRIPLE CROWN ELECTRONICS INC.

4560 Fieldgate Drive, Mississauga, Ontario, Canada L4W 3W6 Tel.: (416) 629-1111 Telex: 06-960456

JULY, 1983

CATJ

19



# VHS Multichannel TV Transmission using multimode fibers

## ABSTRACT

In VHF multichannel TV transmission systems, the influence of a reflected wave from the fibers and multimode propagation are identified as the causes of the deterioration of the transmission properties. The use of optical isolation devices and larger core/small NA fibers is one of the solutions which enables short haul transmission.

### 1. Introduction

Improvement of laser diode linearity enables VHF multichannel TV transmission. [1] However, problems noise and distortion generated in light sources and transmission lines have occurred and many of them are unsolved. [2]-[4] This paper describes the measured noise and distortion characteristics of experimental systems using multimode GI fibers and also the measured results with regard to the dependence of fiber parameters on IM distortion, clarifying the causes of degradation.

### 2. Optical transmitter and receiver

The configurations of the transmitter and receiver are shown in Figure 2. As a light source, a HITACHI BH laser diode is used, which has excellent linearity. [5] The

laser diode is packaged together with a pigtail fiber and a PIN photodiode, monitoring not only the average emitted power but also the RF signals. Average optical output is 5 mW and the modulation index is fixed at 10%/CH in all experiments of this paper. At the receiver an APD is used as the photodetector. Its output current is amplified through a low noise transimpedance amplifier. (equivalent input noise current =  $10 \text{ pA}/\sqrt{\text{Hz}}$ )

### 3. Experimental results

Measured C/N and second order IM distortion are shown in Figures 3 and 4 respectively, after transmission through 1 Km of a conventional GI fiber (core diameter =  $60 \mu\text{m}$ , NA = 0.2), including two optical connectors at both ends and three splices. C/N shown in Figure 2 has fluctuations, which can be explained by the influence of the reflected optical signal from the transmission line. [6] However Figure 5 demonstrates that both the low frequency noise and the RF peak noise disappear by using isolation devices.

Figure 4 shows the IM as a function of the laser bias current at the TR MONITOR terminal and the REC OUT terminal. In Curve 2 (REC OUT), an increase of the distortion is observed, compared with Curve 1 (TR MONITOR). The slow variation in IM is also attributed to the interference of the reflected wave. ▶



Streamline Your Cable  
Operation

**DRAMATIC  
HARDWARE  
PRICE BREAKTHROUGH**

Announcing the  
**NEW TRS-80 Model 12 Microcomputer  
And  
CATV Billing-Accounts Receivable Systems,  
Version 5.0**

for systems up to 6,000 subscribers:	for systems up to 20,000 subscribers:
TRS-80 Model 12 \$3,999	TRS-80 Model 12 \$6,893
with two 1.25 meg disk drives	with 12 meg hard disk drive
DMP 500 Printer 1,795	DMP 500 Printer 1,795
CATV 5.0 B-A/R Software 2,800	CATV 5.0-HD B-A/R Software 3,300
	\$11,988



**Radio  
Shack**  
(207)-496-2281

Associate Store  
P.O. Box 749  
Caribou, Maine 00736

**EXCEPTIONAL VALUES\* IN PROFESSIONAL QUALITY**

# TOOLS

Choose from a wide range of precision-made, longlasting hand-  
tools for most electronic assembly and repair work.

Soldering Irons & Accessories • Electronic Shears & Scissors

## Weller® • Wiss® • Xcelite®

Electronic Pliers • Screwdrivers • Nutdrivers • Strippers • Cutters

Most are in stock and ready to go. We ship within one workday  
of receiving your order.



\*VALUES LIKE THIS

Call today for pricing and free  
catalog detailing our complete  
line of tools and other CATV  
products & services.

Weller® Controlled-Output  
Soldering Station  
Model WTCPN

\$7150

Broadband Engineering  
211 Commerce Lane  
Jupiter, Florida 33458

**Toll Free: 800-327-6690**  
Florida: (305) 747-5000



Quality and Innovation

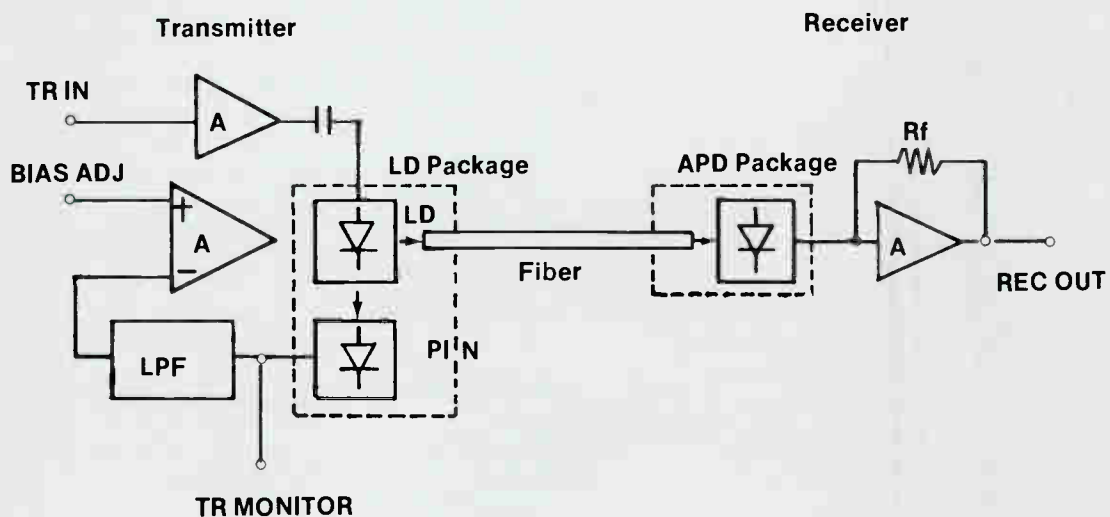
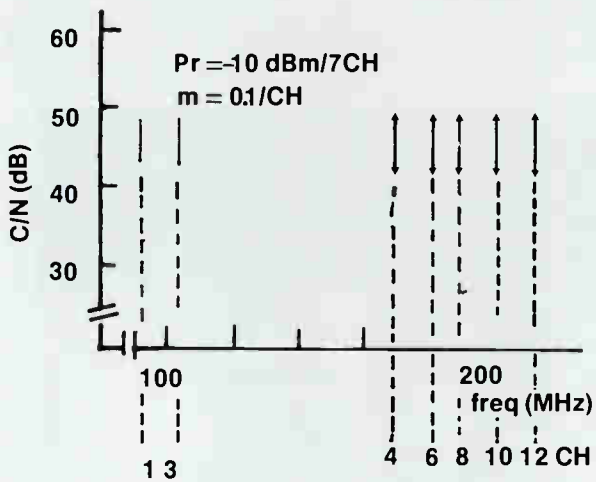
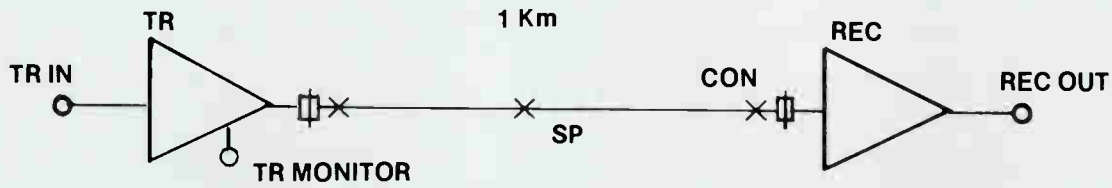

**Figure 2**  
**Configurations of optical transmitter and receiver**

Figure 6 shows experimental results using 2 Km GI fiber (core diameter =  $60 \mu\text{m}$ ,  $\text{NA} = 0.2$ ). Curve 1 shows the measured IM at TR MONITOR, and Curve 2 demonstrates the effect of isolation devices. Even in this case, serious degradation is observed at REC OUT terminal, as is shown by Curve 3. Therefore excess IM is generated when optical signals propagate through multimode fibers.

Based on this experimental result, several types of GI fiber were fabricated in order to investigate the dependence of fiber parameters on IM distortion

characteristics. Figure 8 shows the relative IM as a function of fiber length for different fiber types. IM degradation decreases with increasing core diameter and decreasing NA. By optimizing the fiber parameters, the IM will not increase even after a transmission through 2-3 Km long fibers. It is known that the distortion characteristics depend considerably on such transmission parameters as the mode dispersion and the bandwidth etc. In addition to this, fibers of larger core diameter and smaller NA are favorable with regard to coupling with sources.



**Figure 3**  
C/N for each TV channel

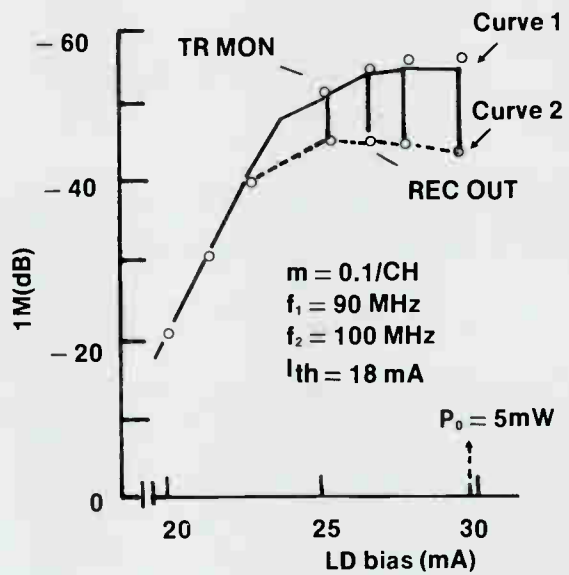

**Figure 4**  
IM as a function of LD bias

#### 4. Conclusions

In VHF multichannel TV transmission systems, using laser diodes and multimode fibers, the deterioration of transmission characteristics is attributed to the feedback from the line and also to multimode propagation. Isolation devices are effective for the former, and the

use of larger core/small NA fibers is one of the solutions to the latter. Hereby short haul transmission can be realized. Further studies with regard to fiber excitation must be made to obtain improved transmission characteristics. ▶



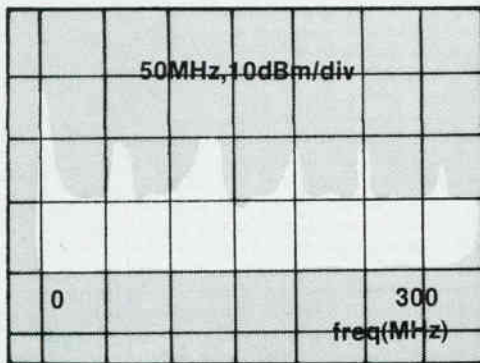
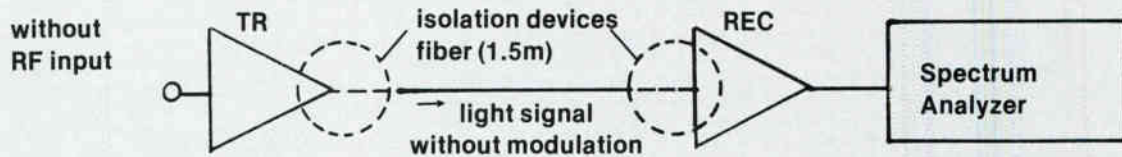

(1) without isolation devices

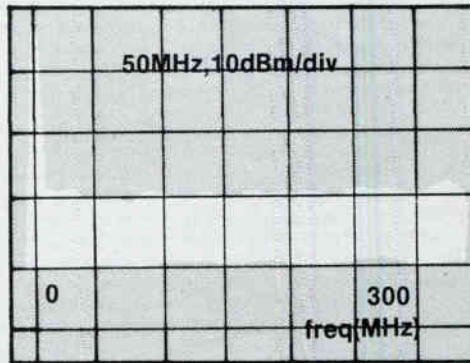

(2) with isolation devices

FIGURE 5  
NOISE SPECTRA AT RECEIVER OUTPUT

Super Savings on Sensational Selection!

# PARTS SALE!

Featuring Big Reductions in:

Hybrids • BMK's • Lightning Arrestors • MOV's  
RF Transistors • Bridge Rectifiers • Quads

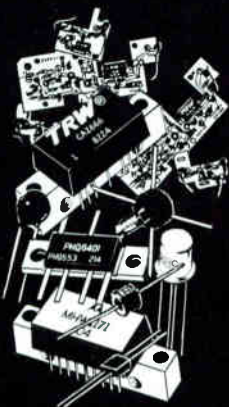

- Guaranteed Performance
- In stock and ready to go. We ship within one workday of receiving your order.
- Reduced prices are in effect June through September and apply to our current inventory. Orders will be filled on a first come-first served basis.

See details and prices in our "Summer Specials" mailer. Make sure you get a copy by calling us today.

Toll Free: 800-327-6690  
Florida (305) 747-5000

Broadband Engineering, Inc.  
211 Commerce Lane  
Jupiter, Florida 33458

**AUGAT BROADBAND**  
Quality and Innovation

Interest in New  
U.S. Savings Bonds  
is growing daily  
at Singer  
in Stanford.



Leola Elliott  
"I buy Savings Bonds for my daughter. This is one way I can help her with her financial future."

Ernest E. Felago  
"The Payroll Savings Plan is a convenient way for me to save for my retirement and also take advantage of the tax-savings option."

Director of Sales  
Department of the Treasury  
U.S. Savings Bonds Division  
Washington, D.C. 20226

Yes, please send me Free information about the Payroll Savings Plan.

Name \_\_\_\_\_  
Position \_\_\_\_\_  
Company \_\_\_\_\_  
Address \_\_\_\_\_  
City \_\_\_\_\_ State \_\_\_\_\_ Zip \_\_\_\_\_



NEW  
VARIABLE RATE BONDS  
MAKE IT  
SMART TO  
**Take stock  
in America.**

# Microdyne Satellite Receiving Equipment is backed by the Most Responsive Service Policy in the Industry

Microdyne equipment is designed to the highest achievable standards of reliability and we are very successful in meeting these standards.

But even Microdyne products fail on occasion. So we provide our customers with this assurance.

If your Microdyne equipment fails, ship it to our service depot. Within 48 hours of our

receiving it, it will be repaired and on its way back to you. If we cannot repair it within 48 hours, we ship a new replacement unit.

If your equipment is in warranty, there is no charge for this service.

If the equipment is out of warranty, you pay only our published flat repair charge which is quoted prior to your

returning the equipment. There are no surprises, no delays.



If it becomes necessary to ship a new replacement unit, there is no additional charge.

**This is an exceptional service policy.  
It's from Microdyne.  
An exceptional company.**

***Microdyne Corporation***

P.O. Box 7213 • Ocala, FL 32672 • (904) 687-4633 • TWX: 810-858-0307



Curve 1

(1) IM at TR MONITOR, without isolation devices



Curve 2

(2) IM at TR MONITOR, with isolation devices

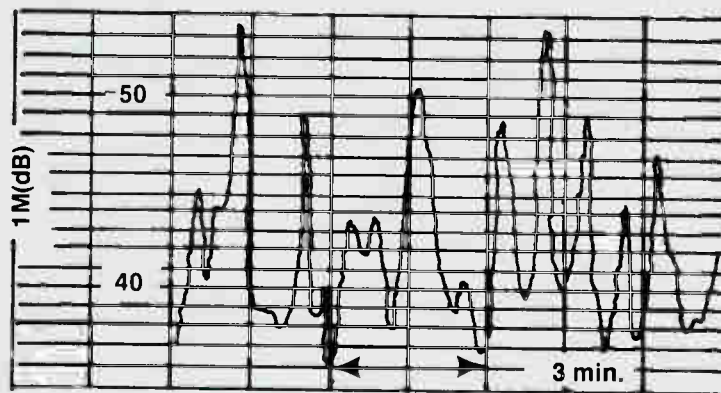

Curve 3

(3) IM at REC OUT, with isolation devices

**Figure 6**  
IM degradation by multimode propagation  
via 2 km GI fiber

#### Acknowledgement

The authors would like to express their thanks to the members of Central Research Laboratory, HITACHI Ltd., for valuable advice, and also to NHK (Japan Broadcasting Corp.) for their encouragement. The author gratefully acknowledges the cooperation of the following in the preparation of this report:

Mr. Takizawa - NHK Technical Consultant  
 Mr. Ikeda - NHK Technical Consultant  
 Mr. M. Yamaura - Hitachi Cable, Head Engineer  
 Mr. F. Roberts - President, Mono County TV Inc.,  
 Dean of Technical Department at Antelope Valley  
 College



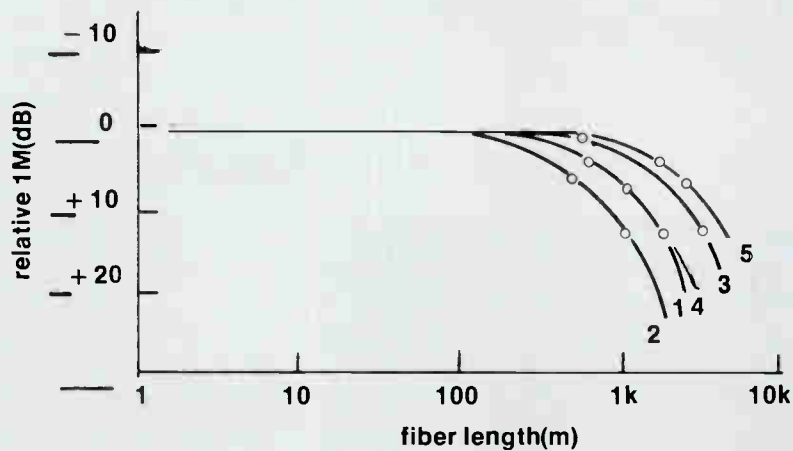

	core dia.	NA	bandwidth
1	60 $\mu\text{m}$	0.20	0.7 GHz. km
2	"	"	0.4
3	"	0.13	1.0
4	120	0.20	0.4
5	"	0.13	1.5

**Figure 7**  
**IM as a function of fiber length**  
**for different fiber types**

### References

1. K. Nagano et al., "Optimizing optical transmitter and receiver for transmitting multichannel broadcasting TV signals using laser diode", 5th Eur. Conf. on Opt. Comm. (1979)
2. K. Stubkjaer, "Distortion of light signals transmitting via multimode graded-index fibers", Electron. Lett., 15, 797 (1979)
3. R. Epworth, "The phenomenon of modal noise in analog and digital optical fiber systems", 4th Eur. Conf. on Opt. Comm. (1978)
4. K. Petermann, "Wave length-dependent transmission at fiber connectors", Electron. Lett., 15, (1979)
5. M. Maeda et al., "Buried-heterostructure lasers for wideband linear optical sources", 3rd Eur. Conf. on Opt. Comm. (1977)
6. O. Hirota and Y. Suematsu, "Noise properties of injection lasers due to reflected waves", J. Quantum Electron. QE-15, 142 (1979) □

Return of  
**THE FILTERED EARTH STATION #14**  
Terrestrial Interference Avoidance

# *A Comprehensive Approach*

By: Glyn Bostick  
William P. Johnson  
David Skevel  
Microwave Filter Co.

## The Purchased Professional Survey



data to decide the exact location of the TVRO is properly called the **siting**, an operation to be discussed later on in this series.

The objective of the survey is to identify every **potential** source of TI and determine its frequency, polarization, azimuth and intensity.

Properly equipped, TVRO owners and installers can identify **operational** microwave transmitters, but it is usually not feasible for them to investigate and discover the locations of new microwave facilities in the planning or building stage. The professional frequency coordinator can do both, and his services are recommended for commercial installations where quality operation into the indefinite future is essential.

While this series is mainly addressed to the CATV-TVRO engineer, residential earth station installers should seriously consider purchasing some of the services offered by frequency coordination firms. The rapid growth of the transcontinental microwave relay network will eventually make the present "install, then test" mode of TVRO installation unprofitable. Hence, every installer should learn how to test for TI prior to installation.

### Last Time

In part #13, it was shown how to compute the probable TI/Satellite signal ratio as seen at the downconverter, given the relative locations and beam pointings of the interference and TVRO antennas.

### This Time

We discuss the result of visits with the leading frequency coordinating

houses and illustrate and describe the services available from them to increase, by an order of magnitude, the accuracy of site analysis over do-it-yourself methods.

### The Survey Defined

Strictly speaking, the survey is the intelligence gathering stage of the TVRO project. Applying gathered

### TVRO Frequency Coordination

**Frequency coordination** is the complete process of "clearing" a proposed TVRO site. It includes testing the site for acceptable TI levels, notifying current microwave users of the TVRO operator's plans, requesting that microwave users disclose any future plans which may impact on the proposed TVRO, and finally, consolidating this effort into legal protection by filing for license with the FCC.

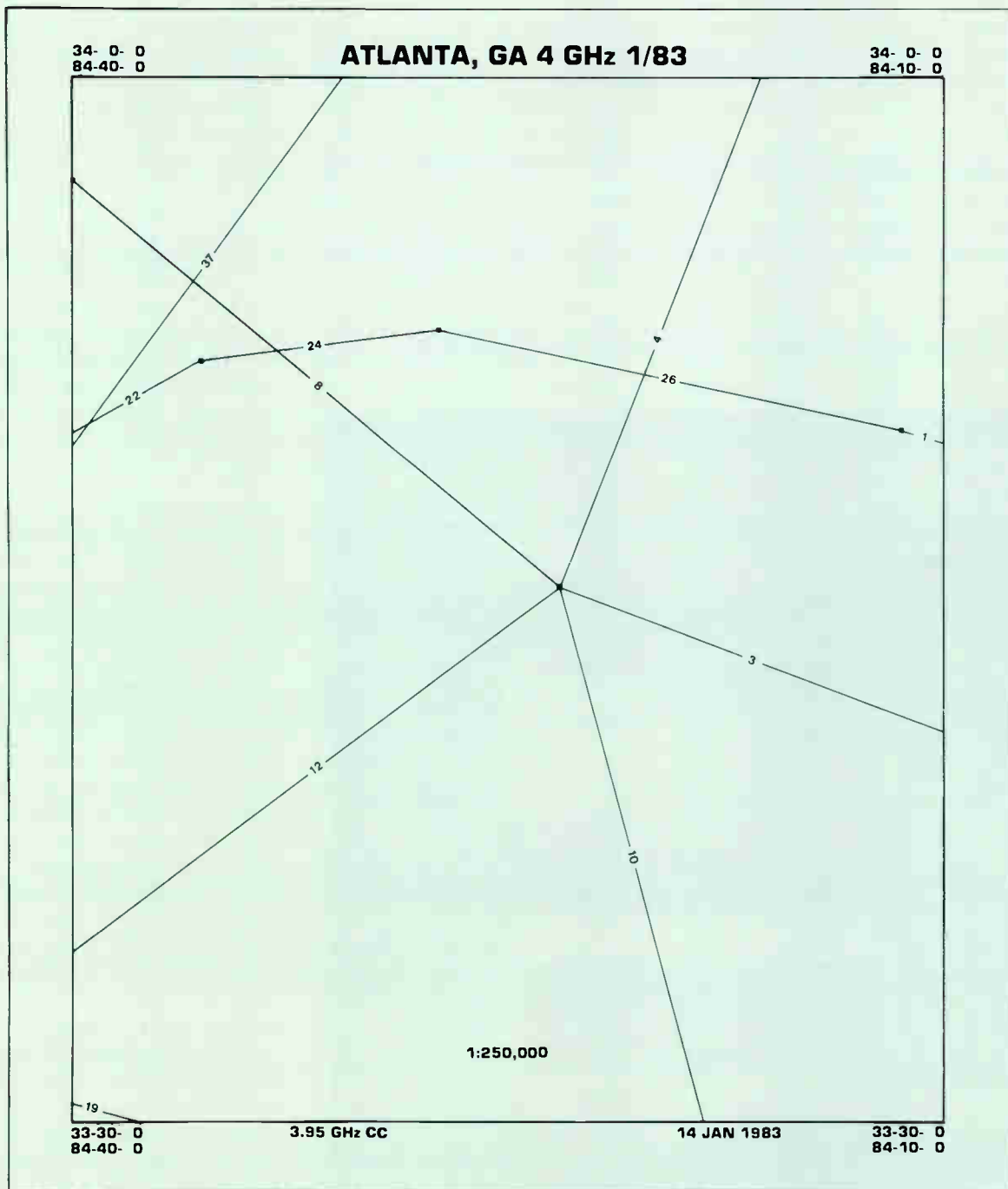

*This route map connects microwave towers, indicating microwave antenna beam pointing. Route segment distance is shown in miles. (Courtesy SPECTRUM PLANNING, INC.)*

### Why Do It?

If it is very important that the TVRO operate without trouble, the TVRO planner must test the site for TI and analyze the results. This is called the **interference analysis**. If it is economically important that quality TVRO operation continue into the future, then it is vital that the planner notify all present microwave users of

his plans and request that they disclose new installations in the planning stage and facilities in the building stage. This is called a **coordination notice**.

These steps are the minimum acceptable for such revenue-generating TVROs as are used by CATV systems, for example. But what about

future microwave facilities which are neither in the building or planning stage? After the TVRO is designed and constructed to include features to deal with **current** TI, what happens in the more distant future when a **new** microwave transmitter comes on?

If the TVRO system is unlicensed, the answer is simple: more TI might



be expected and the only viable course of action is to perform more work on the installation. This may involve redesign of the TVRO or, in extreme cases, relocating it.

As implied, protection against such a contingency is afforded through licensing the TVRO with the FCC. Although not mandatory, FCC licensing gives legal protection against "surprise" microwave transmissions. Licensing places the installation on the public record and the planners of

new microwave facilities must find and notify the TVRO owner of their plans — just as he had to notify all licensed microwave facilities of his plans. He is thus given a forum for formal objection, if necessary.

Where the investment is substantial and the TVRO operates as revenue-gathering capital equipment, serious thought must be given to obtaining maximum legal protection. Accordingly, the frequency coordination process should be mounted as a

formal project — and this should include licensing. Considering what is at stake, the licensing process does not represent a major inconvenience for a substantial TVRO facility.

### Who Does It?

Doing the analysis work relating to the licensing of TVRO earth stations is the **exclusive** business of a number of professional frequency coordination firms. They routinely handle all phases of the work, including filing the license application. If desired, they will even notify the TVRO owner when a new microwave facility is proposed and advise him on its potential impact on the TVRO.

These firms operate from a large computer data base which includes the location, beam pointing, emitted power and many other factors pertaining to microwave transmitting stations. These data bases are continually updated to include FCC licensing and frequency coordinating notices.

While there are no legal structures preventing a TVRO owner or installer from performing any or all phases of the frequency coordinating process, it is hard to compete with professionals: because of their investment to complete computerized data bases, their work is swift and surprisingly modest in cost. The detailed services offered by the professional frequency coordinator are available individually, or as standard or custom packages.

### Who Are The Coordinators?

Some leading professional frequency coordinators are listed at the end of this article. The list is not exhaustive as some coordinators carry on this activity as an adjunct to their principal business and do not use a business title indicative of this service.

The authors have investigated the specific services of three of the leading coordinators (**COMPUCON**, **COM-SEARCH**, and **SPECTRUM PLANING**), samples of whose work are illustrated. All three seem extremely customer-oriented, and they freely disclosed all details of their operations to permit their description here. Space restrictions would not allow complete descriptions of all three services, but the services illustrated here are thought to be representative of all three.

**Broadband's great little MDA:**

**Now — a 35-channel, 300 MHz hybrid apartment amplifier for as low as \$89.95\*!**

8 dB Noise Figure  
Minimum Input: -2 dBmV

Cross-Mod @ 48/43 dBmV  
35 Channels: -63 dB

Broadband Engineered & Guaranteed

50-300 MHz Bandwidth  
50-440 MHz Bandwidth (not shown)

Push-Pull Hybrid Circuitry

Finned Aluminum Housing

Plug-in Pad

Equalizer (Available at extra cost)

Variable Slope Control (0-8 dB)

Capable of full channel loading at designated bandwidth.

\*Price for 50 units (MDA-300-30-T).

Designed for use in apartment house, hotel and motel CATV or MATV distribution systems, our Multiple Dwelling Amplifier (MDA) also comes in a 54-channel, 440 MHz model at an equally attractive price.

Try as we might, we can't think of a better deal on the market. Traditional Broadband excellence inside and out. Tough and durable. A high quality, dependable performer, the MDA is the cost effective answer to your distribution system's basic needs. It is ideal for multiple dwelling sites requiring a maximum of 30 dB gain.

We don't think you can beat the price — we know you can't beat the performance.

Model	Bandwidth	Gain	Output Capability*
MDA-300-30-T	50-300 MHz	30 dB	+ 49/44 dBmV
MDA-440-40-T	50-440 MHz	30 dB	+ 47/42 dBmV

\*Output specified at -50 dB CTB @ 54-channel loading for 440 MHz units and 35-channel loading for 300 MHz units.

For additional information on specifications or pricing, call us toll-free at 800-327-6690, or write Broadband Engineering, Inc., P.O. Box 1247, Jupiter, Florida 33468.

**AUGAT BROADBAND**  
Quality and Innovation

### The Preliminary Computer Analysis

This is sometimes called the **free space interference analysis** because it is an analysis based on free space transmission, of the probable impact on the earth station of each microwave transmitter within a prescribed radius of the TVRO site.

This analysis does not take into account the attenuating effect of intervening terrain or other obstacles between pertinent microwave transmitters and the TVRO. It does take into account the gain of the transmit antenna **toward** the microwave transmitter. It is therefore a pessimistic analysis: almost invariably, less TI will actually be measured at the site because of the above-mentioned attenuating factors. The usefulness of the preliminary computer analysis lies in the speed of delivery (overnight express, in many cases), and in the fact that the site can be cleared for licensing purposes, if the data indicates that TI will not prevent trouble-free operation of the proposed TVRO.

This type of analysis can be initiated by telephone simply by telling the frequency coordinator the latitude and longitude of the proposed earth station. The coordinator has instant access to detailed maps for any locality.

One of the outputs is an estimate of the TI/Satellite signal ratio seen at the downconverter. Interference is proportional to this ratio. The computer print out identifies microwave transmitters by many characteristics, including the frequency, polarization and level of **operating and planned** sources, their azimuth and distance to the proposed TVRO site.

### The Detailed Computer Interference Analysis

This analysis is similar to the preliminary analysis but is more detailed: using computerized topographical maps of the TVRO location, it takes into account the attenuation of TI by intervening terrain. Almost invariably, the TI levels predicted by the detailed computer analysis will be lower than those predicted on the preliminary analysis. If the preliminary analysis will not clear the site for con-

struction or licensing purposes, the detailed analysis will often do so. This service is also available on short notice, and although is somewhat more costly than the preliminary analysis, can be considered economical when weighed against the possibility of being surprised by TI at turn-on.

### Ancillary Reports Derived From the Interference Analysis

The computers used by the coordinators are programmed to supply a

number of different types of final readouts derived from the preliminary and detailed computer interference analyses. These readouts include a breakdown of operational and planned TI sources (as well as a differentiation between the two), an indication of which TVRO channel will be affected by each individual carrier, a polarization analysis, a polar plot with the TVRO at the center, indication of the azimuth, and strength of each carrier considered to be a threat to the TVRO. The latter is very useful

---

# Knowing what it is does not tell you how to use it.



A paintbrush in the hands of a Sunday painter is an amusement. But in the hands of a master, it is an expressive medium. The difference is more than talent and reputation, it is creativity and expertise.

Heller-Oak's experience in lending money to the communications industry is why we feel "Professionalism is Priceless." We bring to each meeting the willingness and the flexibility to make things work. If you need this kind of professionalism, call Chris Flor at 312/621-7665 or Matt Breyne at 312/621-7638.

## "Professionalism is Priceless"

*finance is more than lending at*

**Heller-Oak Communications Finance Corp.**

105 West Adams Street, Chicago, IL 60603

MICROWAVE INTERFERENCE ANALYSIS FOR EARTH STATION PLACEMENT

SITE NAME: SYRACUSE N. Y. COORDINATES: 43- 5-27 N LATITUDE ELEVATION: 0 FEET AMSL  
 76- 4-46 W LONGITUDE CENTERLINE: 0 FEET AGL

COMPANY: MICROWAVE FILTERS DATE THIS RUN: 05/04/83 1538 HRS INTERFERENCE CRITERIA:  
 TOPOGRAPHIC MAP(S): -137.0 DBW/1 MHZ SHORT TERM  
 (0.01 PERCENT OF THE TIME)

AGENT: E. S. ANTENNA F. C. C. -147.0 DBW/1 MHZ LONG TERM  
 (20.0 PERCENT OF THE TIME)

COMPUCON PATTERN USED: 32-25 LOG(THETA)

ENGINEER: GARY W LOPEZ

BASED ON LINE-OF-SIGHT CONDITIONS, THE FOLLOWING EXISTING AND PROPOSED 4 GHZ MICROWAVE PATHS WITHIN 126 MILES CREATE INTERFERENCE INTO THE PROPOSED EARTH STATION EXCEEDING THE OBJECTIVES STATED ABOVE:

*Exceeds long term criteria by 19.4 db*

C A S E N O	TRANSMITTER COMPANY - CALL SIGN - FCC ANTENNA CODE ANTENNA MODEL	LATITUDE LONGITUDE ELEVATION- CENTERLINE	RECEIVER COMPANY - CALL SIGN PATH STATUS - CHANNEL LOADING - EQUIPMENT	A AZIMUTH TO E. S.	B ANTENNA DISCRIM	C TRANSMIT GAIN	INTF. SOURCE DISTANCE	AZIMUTH FROM EARTH STATION TO TX	INTF LEVEL INTO E. S.	SMOOTH EARTH LOSS	TERREST. TX POWER	E X C E E D S O B J E C T I V E	
												SPACE LOSS	HORIZON GAIN
1	NORTH SYRACUSE, NY ATTN -KEE85 -853200 KS-15640	43- 7-21 76- 6- 3 420'- 79'	AMBOY CENTER, NY ATTN - KEE74 OP-2S-2PYY01	31.9 153.7 121.8	37.6DB 46.0DB -8.4DB	2.4MI 3.9KM 116.30B	333.7 -10.0DB	-127.6DBW	7.0DBW	9.4	19.4		
2	SYRACUSE, NY ATTN -KEB31 -842800 KS-15676B	43- 2-55 76- 8-51 400'-215'	PHOENIX, NY ATTN - KEE75 OP-VS-2PYY01	325.5 49.7 84.2	39.5DB 55.9DB -16.4DB	4.5MI 7.3KM 121.6DB	229.8 -1.5DB	-132.5DBW	7.0DBW	4.5	14.5		
3	SYRACUSE, NY ATTN -KEB31 -842800 KS-15676B	43- 2-55 76- 8-51 400'-215'	SULLIVAN, NY ATTN - KEA93 PC-45D-2PYY02	101.4 49.7 308.4	39.5DB 63.0DB -23.5DB	4.5MI 7.3KM 121.6DB	229.8 -1.5DB	-139.6DBW	7.0DBW	0.0	3.4		
3	SYRACUSE, NY ATTN -KEB31 -842800 KS-15676B	43- 2-55 76- 8-51 400'-215'	SULLIVAN TOWNSHI, NY ATTN - KEA93 OP-VS-2PYY01	101.4 49.7 308.4	39.5DB 63.0DB -23.5DB	4.5MI 7.3KM 121.6DB	229.8 -1.5DB	-139.6DBW	7.0DBW	0.0	3.4		
3	SYRACUSE, NY ATTN -KEB31 -842800 KS-15676B	43- 2-55 76- 8-51 400'-215'	SULLIVAN, NY ATTN - KEA93 PC-45D-2PYY02	101.4 49.7 308.4	39.5DB 63.0DB -23.5DB	4.5MI 7.3KM 121.6DB	229.8 -1.5DB	-139.6DBW	7.0DBW	0.0	3.4		

*Exceeds objective*

*Vertical Polarization*

*Future Carrier with Vertical Polarization*

*Type of transmission (VS = Stabilized Video)*

05/04/83

POLAR PLOT OF TERRESTRIAL INTERFERENCE CASES  
 CRITICAL CASES: COMPUTER PREDICTED  
 4 GHZ

CLIENT : MICROWAVE FILTERS LATITUDE : 43- 5-27  
 SITE : SYRACUSE N. Y. LONGITUDE : 76- 4-46  
 CRITERIA : -147.0 DBW / 1 MHZ FOR 20.0 PERCENT (LONG TERM)  
 ANTENNA : F. C. C. 32-25 LOG(THETA) (F40022)  
 AZIMUTH : 165.5 - 255.2 FOR GEOSTATIONARY SATELLITE ARC OF 66. - 145.

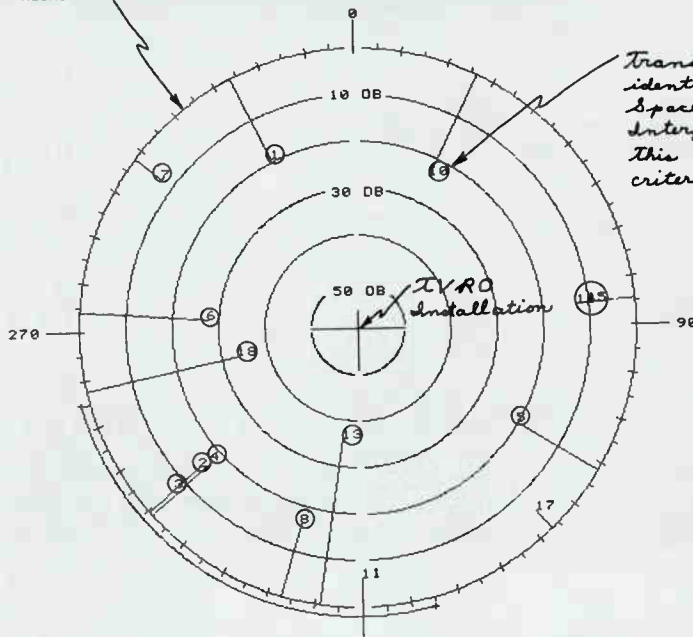

*Transmitter #10 identified on "Free Space Microwave Interference Analysis" This signal exceeds criteria by about 21 db*



◀ Preliminary computer interference analysis. Calculations are made on free-space basis with no allowance for attenuation of intervening terrain. The detailed computer interference analysis takes terrain attenuation into account by use of the applicable computerized propagation path model. (Courtesy of COMPUCON, INC.)

▶ The Polar Plot is one of the many ancillary print-outs available with the computerized interference analysis. Here all interference carriers which exceed the agreed criteria are plotted in azimuth and intensity as a guide to augmenting and/or taking advantage of natural shielding. (Courtesy of COMPUCON, INC.)

to the operator — it gives him a guide to spotting local obstructions which might aid in placing the TVRO in a “quiet zone” .

#### The Route Map

This is a map of the TVRO's designated area showing the location of microwave transmit stations. Lines connect these stations indicate their beam pointing. This is an extremely useful device for the regional professional TVRO installer or operator as it permits swift identification of microwave facilities most likely to product TI.

#### The Intensity Overlay

This is another specialized map of the TVRO's designated region showing approximate intensities of interference at various locations in that region. This computer generated map takes into account applicable microwave transmitters and the specific regional terrain. This map is especially useful to the regional installer as it indicates “good” and “bad” areas, and alerts him to the advisability of making a thorough pre-installation survey in the troubled areas.

#### The Professional Site Survey

This service consists of a personal visit to the proposed site by a frequency coordination field team. The field team measures actual TI levels, especially those signals indicated as unacceptably high by either the preliminary or detailed computer

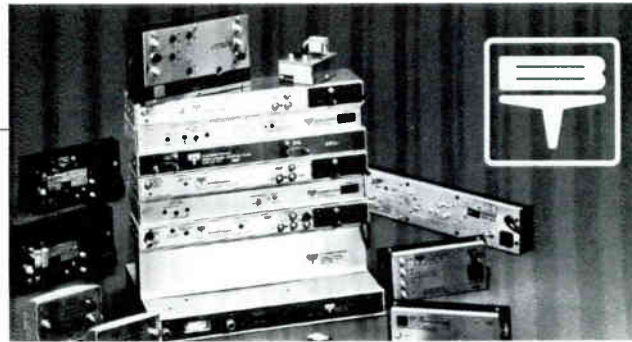

## Look to us for high quality B-T no-wait CATV equipment.

We have it in stock for immediate delivery.  
Or pick-up.

Blonder-Tongue stock items include: antennas, amplifiers, modulators, converters, filters, headend accessories, traps, processors, preamps, and more. Call us for what you need.

## Davco, Incorporated

America's Oldest CATV Distributor

- Same day shipment
- Help when you need it
- Everything you need in one stop
- In business since 1949!



Authorized  
Blonder-Tongue  
Stocking  
Distributor

P.O. Box 2456

Batesville, Arkansas 72501

(501) 793-3816

# SOLD

## MOULTRIE COUNTY CABLEVISION, INC.

Cable Television System Serving  
Sullivan, Illinois

*The seller was represented  
by the undersigned.*

**AMCOM, INC.**

Charles Greene, President  
Building E, Suite 200  
5775 Peachtree-Dunwoody Road, N.E.  
Atlanta, Georgia 30342  
(404) 256-0228

*This notice appears as a matter of record only. June, 1983*

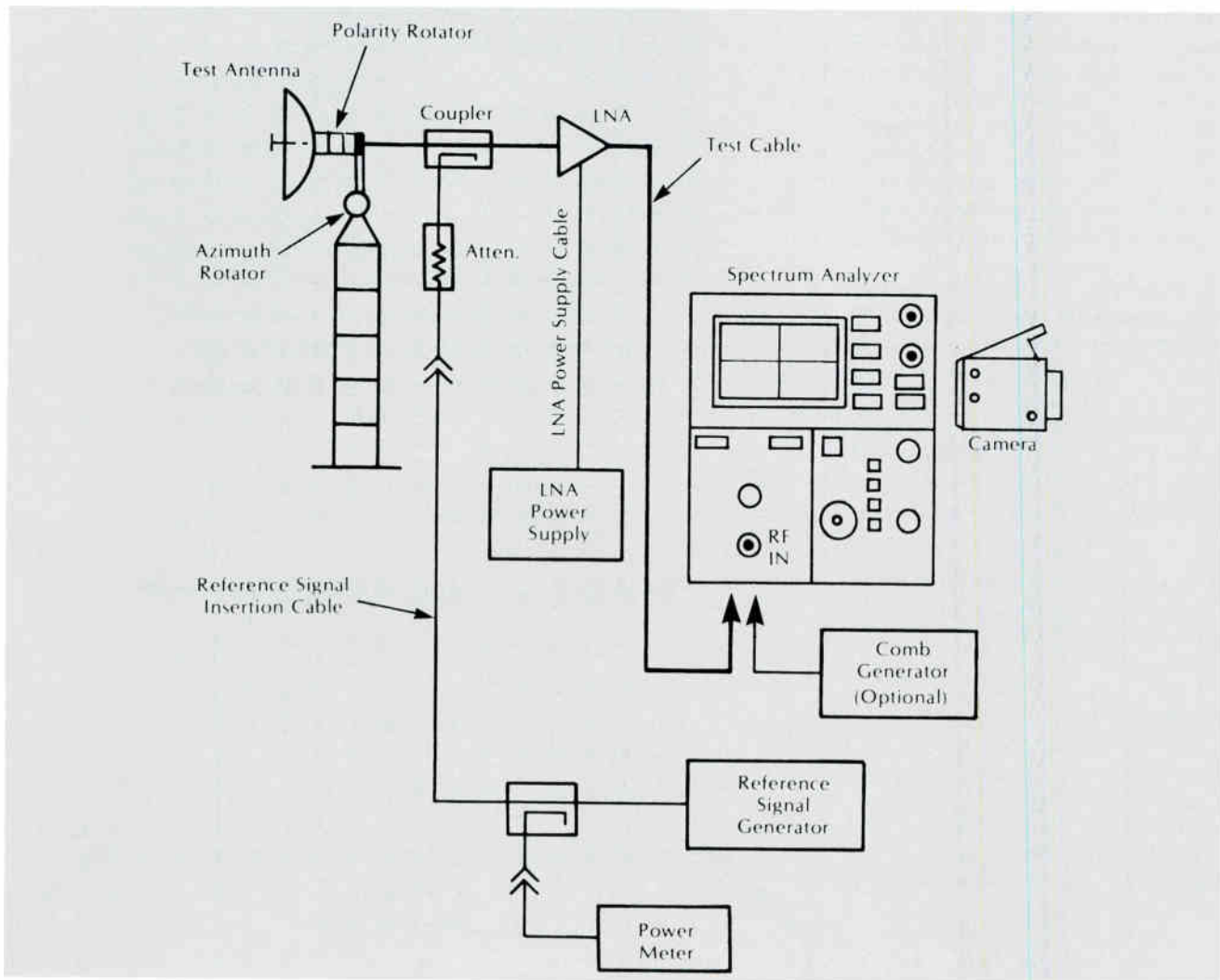

*Typical Field Survey Equipment of the Frequency Coordinator. The basic equipment is the calibrated test antenna and wide-band, microwave spectrum analyzer. Other equipment shown is necessary to calibrate the basic equipment to high accuracy. (Courtesy of SPECTRUM PLANNING, INC.)*

analysis. The team is equipped as shown in the illustrative block diagram. Essentially, the equipment consists of a spectrum analyzer and a calibrated test antenna-amplifier. The remainder of the tools are used to field calibrate the team's equipment to a high degree of accuracy. The team measures and charts each TI signal, and computes its degradation effect on the satellite signal as received by the proposed TVRO.

This team usually includes an experienced microwave engineer familiar with available electronic interference filters, the construction of microwave barriers, and signal reflection analysis. The team will make

detailed recommendations as to the best location for the TVRO and suggest means to reduce unacceptable levels of TI.

#### **The Coordination Notice**

The frequency coordinator will act as the agent for the TVRO planners in locating (by computer) and notifying all owners of operational microwave facilities of the proposed TVRO installation, and requesting that they notify you (through him) of any planned (not-yet-operational) facilities.

#### **License Applications**

The frequency coordinator will prepare and file the application for

licensing the TVRO. To support the application he will use the results of the preliminary or detailed computer interference analysis, and if necessary, the results of the on-site analysis as evidence that the proposed site is acceptably clear of TI. Also necessary in the licensing process are the results of the coordination notice.

#### **Future Protection Service**

For an annual fee, the frequency coordinator will automatically notify the TVRO owner when a new microwave facility is proposed, evaluate the potential threat, and take steps on his behalf to reduce the conflict.

## Minimum Survey Strategy Using Professional Services

The wide range of services available from the typical frequency coordination firm makes affordable TVRO planning strategies possible. This is true whether the TVRO being planned is a costly commercial installation or a less expensive residential system.

At the very least, those involved in planning and installing commercial systems should obtain a preliminary interference analysis before quoting the customer a total cost. The ancillary polar plot should be obtained at the same time. In case unacceptable levels of TI are predicted by the analysis, the polar plot can aid in eliminating the threats which are obviously blocked by intervening structures or terrain. If a study of these two documents induces doubt, it is recommended that a detailed analysis should be obtained. If a study of this third document does not resolve all doubt, then an on-site survey should be done, either by a professional frequency coordination firm or by the contractor himself, using the appropriate equipment. Prior to this costly last step, the customer's agreement should be obtained. Consistently applied, this strategy will preserve estimated profit in the average case.

Installers of residential TVROs can benefit from the same strategy, when it is affordable under their specific circumstances. As the typical installer operates within a relatively small regional area, his minimum investment for a typical site should include a preliminary analysis and a microwave route map. A simple survey kit (described in the next installment) is also preferable to the "demo" style of survey.

### Next Time

Part #15 will show how to do your own TI measurement survey, using readily available and affordable equipment.

### Acknowledgements

The authors wish to thank Bernadette Andaloro for reducing a great mass of material into a reasonable manuscript and David Bostick for the expert document stat work which



## Checking response flatness?

It's easy with Sadelco's  
SC 450 Spectrum Calibrator

**1/4 dB  
ACCURACY  
4.5-450 MHz  
MHz Ratio: 100 to 1**

Covers the complete  
CATV range, present  
and future.



## Checking signal levels?

do it accurately with Sadelco's  
FS 3D-VS Signal Level Meter

**450 MHz  
60 Channels**

PLUS . . .

the FS 3D-VS Professional SLM  
has Built-in Quality Features . . .

- ± 1.0 dB Accuracy
- Electronic Auto. Shut-off
- New High-Impact case
- AC/Battery Operation:  
3 types of Battery Options:  
Nicads, Alkaline or  
Carbon Zinc

## Sadelco, Inc. 75 West Forest Ave., Englewood, N. J. 07631 201-569-3323

General Rep. for Europe: Catec AG Luzern/Switzerland, Habsburgerstr. 22. Tel. 041-23-90-56 Telex: TELFI 78168

### Distributors in U.S.A.:

**ANIXTER COMMUNICATIONS**  
Alaska:  
Anchorage 907-274-8525  
Fairbanks 907-456-1815  
California:  
Los Angeles (Irvine) 714-556-6270  
Colorado:  
Denver (Englewood) 303-741-2900  
Florida:  
Tampa 813-626-7115  
Georgia:  
Atlanta 404-449-6533  
Illinois:  
Chicago (Elk Grove Village)  
82-640-1156  
Skokie (Headquarters) 312-667-2600  
New Jersey:  
Uniontown 201-328-0980  
Missouri:  
St. Louis 314-423-9555  
Ohio:  
Cleveland 216-349-0323  
Oregon:  
Portland 503-285-2245  
Texas:  
Houston 713-674-8035  
Washington:  
Seattle 206-251-6760  
**CABLE TV SUPPLY CO.**  
California:  
Los Angeles 213-204-4440  
Georgia:  
Decatur 404-981-9220  
Illinois:  
Addison 312-543-9800  
Massachusetts:  
Woburn 617-938-1221  
New Jersey:  
Cinnaminson 609-829-0100  
Ohio:  
Circleville 216-526-0919  
Texas:  
Grand Prairie 214-988-1841  
Houston 713-681-6141  
**DAVCO ELECTRONICS CORP.**  
Arkansas:  
Batesville 501-793-3816  
**ELECTROTEX**  
Texas:  
Houston 713-526-3456  
**GULF ELECTRONIC SUPPLY INC.**  
Florida:  
Miami 305-592-6583

**HURLEY ELECTRONICS INC.**  
California:  
Inglewood 213-678-7644  
Long Beach 213-537-5375  
Oceanside 714-722-7694  
San Bernardino 714-885-0721  
San Diego 714-235-6245  
Santa Ana 714-971-2203  
Van Nuys 213-781-8410

**KLUNGNESS ELECTRONIC SUPPLY**  
Michigan:  
Iron Mountain 1-800-582-7140  
All other States 1-800-338-9292

**MIDWEST CATV SYSTEM**  
West Virginia:  
Clarksburg 304-622-4700

**MIDWEST CORP.**  
Florida:  
Miami 305-592-5355  
Indiana:  
Indianapolis 317-251-5750  
Kentucky:  
Lexington 606-277-4994  
Louisville 502-491-2888

Maryland:  
Lanham 301-577-4903  
Michigan:  
Troy 313-689-9730  
Ohio:  
Cincinnati 513-651-1904  
Cleveland 216-871-3116  
Columbus 614-476-2800  
Virginia:  
Virginia Beach 804-464-6256  
West Virginia:  
Nitro 304-722-2921

**NELSON ELECTRIC SUPPLY CO.**  
Texas:  
Dallas 214-741-6341

**NORTH SUPPLY CO.**  
Kansas:  
Lenexa 913-888-9800

**POLELINE CORP.**  
Subsidiary of RMS Electronic Corp  
New York:  
Bronx 212-829-1070

**S.A.L. COMMUNICATIONS**  
California:  
Chattsworth 213-741-9100  
Georgia:  
Decatur 404-981-0050  
Indiana:  
Indianapolis 317-244-2477  
New York:  
Melville 516-694-7110  
Texas:  
Dallas 214-348-8811

**TELE-WIRE SUPPLY CORP.**  
Florida:  
Sarasota 813-371-3447  
Michigan:  
Three Rivers 800-253-2069  
New York:  
Great Neck (Headquarters)  
516-829-8484  
Pennsylvania:  
Simpson 717-282-2340  
Texas:  
Grand Prairie 800-527-1646

**THE DROP SHOP LTD.**  
California:  
Hayward 415-887-7474  
New Jersey:  
Roselle 201-241-9300

**TONER CABLE EQUIPMENT**  
Pennsylvania:  
Horsham 800-523-5947  
Pennsylvania Only 800-492-2512

**TVC SUPPLY CO. INC.**  
Pennsylvania:  
Hersey 800-482-2398  
East of Mississippi:  
800-233-2147

### Distributors in Canada:

**ANIXTER-MICRO SAT**  
Pickering, Ontario 900-265-4655  
**INCOSPEC ELECTRONICS, INC.**  
Montreal-Nord, Quebec 514-322-5540  
**R.F. COMMUNICATIONS LTD.**  
Ontario 416-475-1030  
**TECH COMM SALES, INC.**  
Burnaby, British Columbia 604-437-6122

Continued on Page 40





## MORE INFORMATION ABOUT THE SESSION . . .

### Management



#### **CREATING AN EFFECTIVE AND PROFITABLE LOCAL AD SALES FORCE —**

This session will demonstrate the ways and means to enter into the field of local advertising . . . how to prepare your office personnel to sell local advertising on your local origination channel . . . how to use satellite program ad sports as additional source of income (even for small cable system).

#### **TO KNOW CABLE IS TO LOVE CABLE —**

This session will illustrate the value of effective training . . . a program that gets into the specifics of various training programs and methods of training cable personnel to achieve the greatest potential and effectiveness from your cable system.

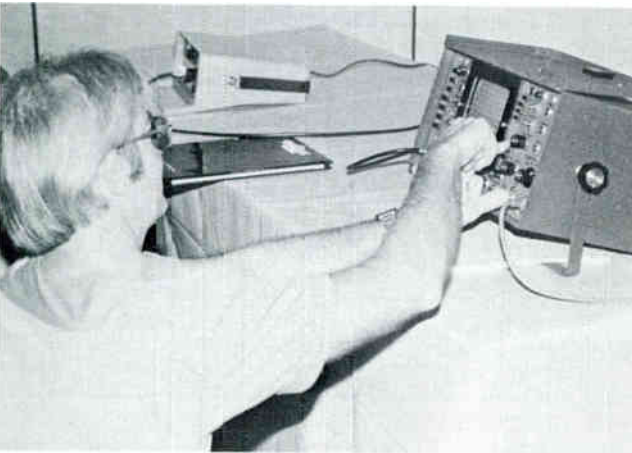

#### **ADULT ENTERTAINMENT — HOW IT AFFECTS CABLE TELEVISION**

The panel presenting this session will represent programming representatives from several adult programming sources . . . what is the future of adult entertainment on cable systems . . . what are the benefits and what are the problems? Sure to be a hot topic at CCOS '83.

#### **WASHINGTON UPDATE**

A presentation in the very latest information on what's going on in Washington . . . how is legislation going to affect cable television . . . what legislation is in the Senate and House of Representatives . . . what's going on at the FCC. All cable operators need this one!!

#### **TIERING AND PACKAGING CABLE SERVICES**

A presentation on the various methods of tiering and packaging satellite programming . . . how to use this to increase subscriber base for more profits.



#### **GET YOUR DAILY PAPER ON CABLE**

Leasing cable channels to the local newspaper — lots of discussion about this one — a new way to provide the daily newspaper electronically.

## MAKING A CLEAN SWEEP OF IT

The Engineering Team from Wavetek will explain all the methods of cable television sweep generator tests, from system sweeping and balancing to bench testing of cable and components. Theory includes sweeping amplifiers, measuring return loss, measuring port-to-port isolation, and much, much more. This session will include a hands-on laboratory position to allow more cable technicians and engineers to perform the tests and measurements. Seating will be limited to 30 people each session (three are scheduled) and we would encourage you to reserve your space with the CATA office as soon as possible to insure your spot.

## CABLE ANTENNA FOR LESS

Wayne Sheldon, Chairman of CATA's Engineering Committee, will give a "back to basics" session on how to adapt inexpensive rooftop type television antennas for use in cable systems. Included will be hints on how to "build your own" antennas. Another opportunity for a Sheldon presentation you won't want to miss.

## EVERYTHING YOU WANTED TO KNOW ABOUT THE FCC, BUT WERE AFRAID TO ASK

Chris Pappas, FCC Field Specialist (see CATJ, January 1983, for his article on Signal Leakage and FCC Technical

Standards) will have the FCC Field Test Van at the site of the Arlington Hotel for cable operators to tour. In the seminar presentation, procedures used when the FCC Field Test Van appears at a cable television system will be discussed, demonstrating the tests and measurements taken to determine if the cable system meets FCC technical standards. Ample time will be allowed for a full question and answer session, and the cable operators will be definitely invited to tour the van. Should be an interesting on-site tour.

## NEW TECHNOLOGY ON FIBER OPTICS

How are fiber optics being used today? What is the new fiber optic hub technology being used for rural cable systems? What's coming tomorrow in fiber optics?

## CONVERTERS

A session all about converters . . . problems . . . proper use . . . All of It!!

## COMMON CABLE SYSTEM PROBLEMS

Common cable system problems plague operators consistently . . . this will help to identify cable problems and faults . . . such as co-channel, cross-modulation, inter-modulation, hum, ghosting, etc.

## TEST EQUIPMENT

What do you need? When do you need it? □

# We've Got The Filter You Need For Your Cable TV System...



## Or We'll Build It, Fast.

Catalog C/80, a 40-page pillar of the cable TV industry, features filters and traps currently being used in hundreds of CATV, MATV and CCTV systems. Delivery time for most standard products is 10 days or less.

But if you need a one-of-a-kind special and you can't afford to wait, we've still got you covered—we'll design and build exactly what you need for your installation, and we'll work around the clock to deliver it when you need it.

Use our toll free number and talk to the RF or microwave engineer who will design your special filter. He'll give you a prompt, on-line analysis of your specifications, and he'll quote price and delivery time. Before you hang up, you'll know what you need, when you'll have it and how much it will cost—all with just one phone call!

Once you've placed an order, our unique QRC (quick reaction capability) begins to work for you: QRC combines the efficiency of computer-aided design with a dedicated model shop and test labs to insure that your filter will be what you need when you need it.

When you need a filter to do a job exactly as you want it done, and you need it now, Call MFC!

**MFC**  
MICROWAVE FILTER COMPANY, INC.

6743 Kinne St., East Syracuse, NY 13057  
Toll Free 1-800-448-1666 — TWX 710-541-0493  
NY/HI/AK/Canada (Collect) 315-437-3953

PROPAGATION PATH GEOMETRY

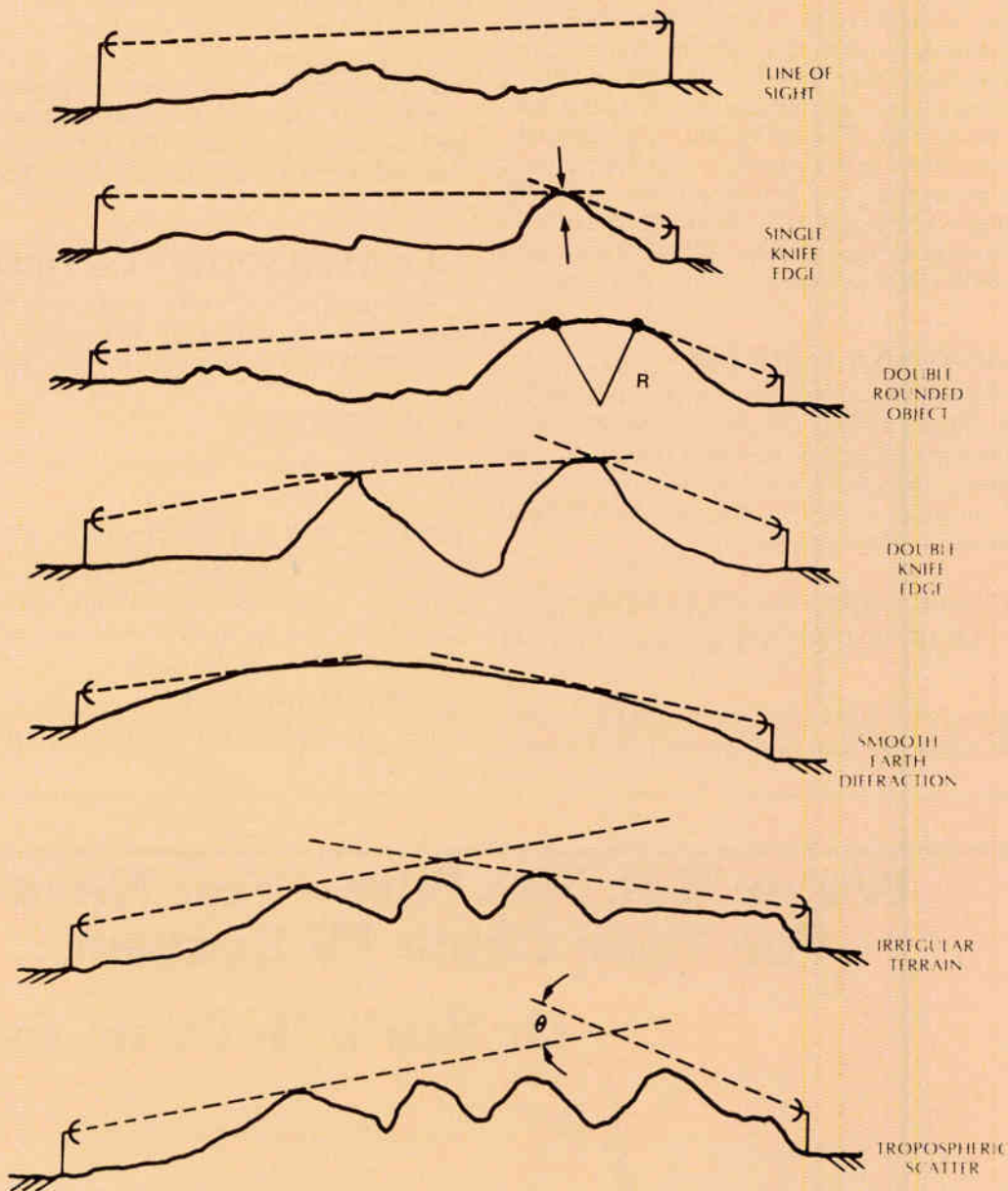

*Propagation models defined in National Bureau of Standards Technical Bulletin #101. These models are among those which have been computerized by some frequency coordinators for use in detailed computer interference analyses. (Courtesy of SPECTRUM PLANNING, INC.)*

made clear illustration of professional survey services possible. Our thanks, also, to Donna Kaiser who carefully reconstructed our dog-eared "dead sea scrolls" into neatly annotated exhibits. Special thanks go to the personnel of the frequency coordinators listed below. Their characteristic southern hospitality and their enthusiastic and frank discussion of their operation made this a very plea-

sant and fruitful learning experience, both for the authors and, we hope, the readers.

COMSEARCH, INC.  
11503 Sunrise Valley Drive  
Reston, Virginia 22091  
703-620-6300  
Jerry SCHULMAN,  
V.P. Marketing

COMPUCON, INC.  
P.O. Box 401229  
Dallas, Texas 75240  
214-233-4830  
Becky SHIPPAN

SPECTRUM PLANNING  
P.O. Box 1360  
Richardson, Texas 75080  
214-699-3536  
Debbie MEAD, Jerry ARMES

□



# DON'T DELAY . . . REGISTER NOW FOR PRE-CONVENTION RATES HOT SPRINGS ARKANSAS – THE ARLINGTON



## PLEASE CHECK

- CATA MEMBERS\* ..... 75.00
- NON CATA MEMBERS ..... 100.00
- SPOUSES ..... 25.00
- CHILDREN OVER 16 ..... 25.00

\*MUST FURNISH SYSTEM NAME BELOW

ENCLOSED IS \$ \_\_\_\_\_ to cover registration for;

### PLEASE PRINT

NAME \_\_\_\_\_

SYSTEM \_\_\_\_\_

ADDRESS \_\_\_\_\_

CITY \_\_\_\_\_ STATE \_\_\_\_\_ ZIP \_\_\_\_\_

TELEPHONE (\_\_\_\_\_) \_\_\_\_\_

### PLEASE LIST

NAME of Spouse \_\_\_\_\_

NAMES of Children (and AGES) \_\_\_\_\_ AGE \_\_\_\_\_

\_\_\_\_\_ AGE \_\_\_\_\_

\_\_\_\_\_ AGE \_\_\_\_\_

\_\_\_\_\_ AGE \_\_\_\_\_

\_\_\_\_\_ AGE \_\_\_\_\_

**SEND TO: CATA CCOS 83 4209 N.W. 23rd, Suite 106, Oklahoma City, Ok. 73107  
AFTER JULY 15th, ALL REGISTRATION WILL BE \$150.**

# CATA CATV TECHNICAL TRAINING SEMINAR

## HOTEL INFORMATION

A block of hotel accommodations has been set aside for each seminar at the hotels indicated. Please make your own reservations directly with the hotel by completing and mailing in the hotel reservation form below to the appropriate hotel. For telephone reservations, be sure to include the information that you are attending the CATA CATV Technical Training Seminar to receive the special room rates as indicated.

### BASIC

#### LAKE WORTH, FLORIDA AUGUST 1-3

**COUNTRY SQUIRE INN**  
7859 LAKE WORTH ROAD  
LAKE WORTH, FLORIDA 33463  
PHONE: (305) 968-5000

Take exit 36 off the Florida Turnpike.  
S - \$33.00  
D - \$35.00

Sponsored by the SCTA

#### ATLANTA, GEORGIA NOVEMBER 7-9

**MASTER HOST INN MIDTOWN**  
1152 SPRING ST. N.W.  
ATLANTA, GEORGIA 30309  
PHONE: (404) 875-3511

Located at I-75/85 at 14th Street in Atlanta.  
S - \$28.00  
D - \$32.00

Sponsored by the SCTA

### ADVANCED

#### RICHMOND, VIRGINIA JULY 11-15

**MASSAD HOUSE HOTEL**  
11 N. FOURTH STREET  
RICHMOND, VIRGINIA 23219  
PHONE: (804) 648-2893

S - \$26.00  
D - \$32.00

Sponsored by the SCTA

#### SAN ANTONIO, TEXAS OCTOBER 3-7

**LA QUINTA MOTEL**  
333 NORTH EAST LOOP 410  
SAN ANTONIO, TEXAS 78216  
PHONE: (512) 828-0781

Located just on the east side of the airport.

S - \$31.00  
D - \$37.00

Sponsored by the Texas Cable Association

#### REVERE, MASSACHUSETTS DECEMBER 5-9

**HOWARD JOHNSONS MOTOR LODGE**  
407 SQUIRE ROAD  
REVERE, MASS. 02151  
PHONE: (617) 284-7200

Located at the junction of Rts. C-1 and 60, 18 minutes from Logan Airport.

S - \$47.00  
D - \$53.00

CATA wishes to extend their appreciation to the Southern Cable Television Association (SCTA) and the Texas Cable Association, for their cooperation in sponsoring the above indicated seminars.

CUT HERE

### HOTEL RESERVATION FORM

Please reserve the following room requirements in the name of the company or individual shown:

NAME: \_\_\_\_\_ TELEPHONE: \_\_\_\_\_  
(Company or Individual) Area Code

ADDRESS: \_\_\_\_\_  
(P.O. Box or Street No.) (City) (State) (Zip)

NUMBER OF ROOMS: \_\_\_\_\_ OCCUPANCY: SINGLE DOUBLE

ARRIVAL: \_\_\_\_\_ DEPARTURE \_\_\_\_\_  
(Date) (Time) (Date)

**SEND DIRECTLY TO HOTEL CATA CATV TECHNICAL TRAINING SEMINAR**

# SENATE ADOPTS S.66 -

## Now The Real Fight Begins!

### Washington Update

by Stephen R. Effros  
CATAs Executive Director

By now you have already read the news. The United States Senate has adopted S.66. The cable television industry was successful in its lobbying efforts to keep the bill relatively free from incapacitating amendments, including the primary one, offered by Senator Abdnor, which would have resulted in cable being regulated at the State level under common carrier status. To our knowledge, this is the first time that an amendment or bill fully backed by AT&T and the local telephone companies has been defeated in a roll-call vote in the Senate. We have a lot to be proud of. It took a lot of work. A big "thank you" should be spread around the industry to all of you who helped us in this fight. The letters, telegrams, telephone calls and quick fights to Washington paid off. It could not have been done without the entire cable industry working together. We proved once again that having several different groups, looking at the issues from different viewpoints, but agreeing on the end result, created a synergistic force. A great deal of credit must be given to Jim Mooney of the NCTA who coordinated the effort of, not only the NCTA, but all the other players, including CATA. We all worked together, and we won. Now the question is — what did we win? The answer is that we won the opportunity to work even harder on the House side in an effort to get favorable deregulation of the cable industry.

We are not going to spend the time and space in this issue to go over the details of the bill as ultimately passed. Suffice it to say that the main outlines of the bill regarding rate deregulation and franchise renewal remain. The details, in many cases, are different. Throughout the consideration of the bill on the Senate floor, amendments were suggested in order to satisfy individual Senators. Some of those amendments were accepted, and some were rejected. The final package, from CATA and NCTA's perspective, still accomplishes the goal of substantial deregulation. However, it is not worthwhile to go into all the details here because a different bill will be written in the House of Representatives. Should we be successful in getting that bill passed, then a "conference committee" will have to clear up the differences between the two bills. Only then will it really be worth your learning all the legalistic details since, until then, you won't have to worry about complying with those details and neither will the cities.

Where do we go from here? Well, the negotiations have already begun with Rep. Wirth and his Communications Subcommittee staff regarding the drafting of companion legislation. A first round of hearings, at which CATA President Peter Athanas testified, has already taken place. And hopefully, in the not too distant future, in a month or two, we will see the first draft of a bill introduced in the House of Representatives that will become the focus of all of our attention for the remainder of this political year! Well, not exactly. We also have two, and soon to be three, copyright bills floating around Capitol Hill as well. Of course we will be working on those as well.

In any event, there is no question that when the "cable bill" does finally appear on the House side it will be a tough, bitter fight to get it through! Why? For starters, AT&T has already let it be known that it intends to fight passage of the bill. The telcos lost a

major battle in the Senate — a battle that they put a lot of money and effort into. They lost it because they simply did not have the facts on their side. The "Big Lie", didn't work. Try as they might, they could not convince the Senate that the reason local telephone rates will be going up is because of competition caused by the cable television industry. Also, they did not get the response that they had hoped for from the argument that all providers of a similar service must be regulated in a similar manner. There are numerous examples of large companies being regulated in a different manner from their small "rivals". Independent oil producers pop to mind, and the Senate knew that if ever there was a "dominant" industry participant, it would have to be telcos with regard to data services. The telcos also know that they do not have much of a chance of convincing Tim Wirth's very knowledgeable subcommittee members that they are not dominant! So efforts to get their "amendments" added in the House are going to be very difficult. Thus, since they don't want this bill to ever get into a conference committee with the Senate, they will now focus their efforts on killing the bill outright. How? First, they will continue to spread the "Big Lie". There is no question that increased local telephone rates are a potent political club — even if that club is aimed at an industry, cable, that has nothing to do with the increases. Another likely move on the part of the telcos is to assist the dissident cities who have been fighting against the NCTA/National League of Cities compromise which was the basis for S.66. The reason this cable bill will be so much harder to win in the House is that House members are much more subject to the political pressures of local mayors. And in this case, the local mayors still don't understand the issues involved in this debate. They are being swayed by the rhetoric of some dissident cities, and they are being given incorrect information as well. As an example, a list was circulated of alleged "concerned cities" with regard to S.66. Yet when we checked with some of the city cable administrators on that list, they did not indicate that they were opposing S.66!

This is where you come in. If you thought the going was tough in the Senate, you have a big surprise coming! What we are going to have to do in very short order is make sure that our Congressmen really know what the issues are in cable television regulation. We are going to have to make sure they know the fact, the reality of cable television. This is something that CATA has been focusing on for some time now, and our first job on Capitol Hill will be to make sure that the members of the House Commerce Committee understand cable reality. You can help by being sure your Congressman or woman knows. You **MUST** start contacting their offices now as part of an overall educational campaign about cable. We must not lose the momentum! Again, thanks for the great work you have done already, and be prepared to do a lot more! You did it to build your system in the first place. Now it's up to you to protect your investment. If anyone has any questions about what they should do, or can do, or needs help explaining cable issues to either your local authorities or your Representatives, give Steve Effros or Ellen Adams in the CATA Washington Office a call — they'll help you out (703/691-8875). □



# NEW PRODUCT REVIEW

Ben Hughes Communication



By: Diane Hughes, President  
Ben Hughes Communications,  
Products Co.

## CABLE-PREP<sup>®</sup>ARATION

Following the introduction of Cable Television service over thirty years ago, the need for proper coupling of cable and connector eventually became more apparent. We all became aware that only through the proper preparation of the cable end, and the assembly of the connector, could we insure a sound connection to an appropriate signal device, as well as eliminate future costly service calls. As technology has increased in the cable industry, so has the development of hand tools.

The products manufactured by Ben Hughes Communication Products Company, Inc. revolve around the preparation of coaxial cable. Our product line consists of a Stripping/Coring Tool, and a Coring Tool for solid sheath aluminum cable, and Hex Crimp Tools for CATV, MATV, and STV applications. We also produce custom-designed crimp tools for special industry applications. Accessory tools, such as conductor cleaners, carpet cutters and drill guides, and cable forming tools are available too.

Ben Hughes Communication Products Company, Inc. is located in Old Saybrook, Connecticut. The company was founded in 1979 by Benjamin W. Hughes,

Jr., who had worked in many facets of the industry since 1953. The products manufactured are promoted under the trademark of **CABLE-PREP<sup>®</sup>** and are distributed in the United States, Canada, and across Europe. The company's continuous concern is to provide effective, high quality hand tools which are used to prepare the appropriate cable and connector.

### PREPARATION OF SOLID SHEATH ALUMINUM CABLES

With the development of the two-piece sleeve and integral mandrel connector, it became necessary to manufacture a tool which would remove the dielectric foam from the cable.

The **CABLE-PREP<sup>®</sup>** Stripping/Coring Tool (SCT) combines both the stripping of the aluminum sheath, and the coring of dielectric from the cable. This combined operation results in a fast, cost-effective cable preparation which eliminates the need for two separate tools. Sliding the Guide Sleeve of the SCT over a pre-cut cable and rotating the tool in a clockwise direction results in removal of the cable dielectric. By positioning a Stop Clamp on the cable, the distance from the end of

# CATV, MATV & STV APPLICATIONS

MODEL NO.	CONNECTOR SERIES	RG-/U CABLE TYPES	MAJOR HEX	MINOR HEX
Standard Single Braid and Single Tape Cables				
HCT-659	"F"	RG-59 RG-6	.324	.262
HCT-911	"F"	RG-11 RG-59	.410	.262
HCT-611	"F"	RG-11 RG-6 RG-59	.410	.324
Double Braid and Double Tape Cables†				
HCT-6QS	"F" (LRC Connectors)	RG-6 Double Braid & Double Tape RG-59 Double Braid & Double Tape (also RG-6, 59 Single Braid, Single Tape)	.359	.324
HCT-660	"F" (Gilbert Connectors)	RG-6 Double Braid & Double Tape RG-59 Double Braid & Double Tape (also RG-6, 59 Single Braid, Single Tape)	.384	.324
HCT-211	"F"	RG-11 Double Braid & Double Tape 32-375CX (Scientific-Atlanta)	.475	.100

\*Connectors for RG-59/U with separate crimp rings use .262 hex. Attached crimp rings for RG-59/U use .324 hex. RG-6/U connectors with separate or attached crimp rings use .324 hex.

†HCT-6QS and HCT-660 may be used on standard cable when attached crimp rings are used on F-59 connectors.

Table 1

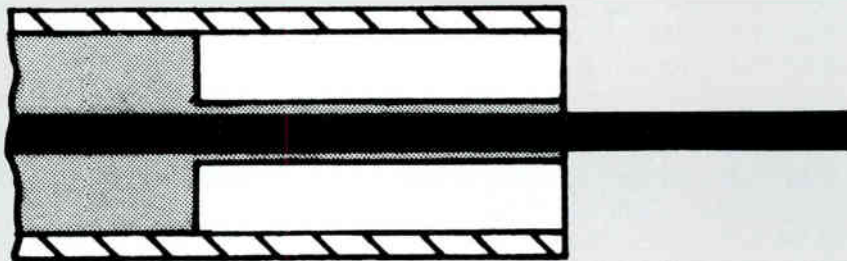

Figure 1

the Guide Sleeve to the Stop Clamp will determine the length of the exposed center conductor, and continuing to rotate the tool will strip back the aluminum sheath until the tool turns freely against the Stop Clamp. Excess dielectric material must now be removed from the exposed center conductor. By using our Part #4010 Center Conductor Cleaner, designed out of high strength plastic, the conductor is scraped clean without marring the copper cladding. The aluminum sheath now has a squared and slightly flared end with a clean, exposed center conductor, ready for easy sleeve and connector body insertion. (See Figure #1).

The SCT has a high alloy tool steel blade. This insures longer blade sharpness, as well as the ability of re-sharpening the cutting edges. This virtually eliminates the need for any future blade replacement. All SCT's are color-coded for easy identification to appropriate cable size. The SCT's are constructed of a high strength polymer, which offers impact resistance and added strength, as well as being insulated for use on activated system splices. The SCT is also readily adaptable for use with a 3/8" power drill if so required.

Although the Stripping/Coring Tool is relatively new, we have tested our product through field testing, under adverse conditions, to insure trouble-free operation. Our testing results show installation time is reduced by more than 50 percent due to our dual operation characteristics. In addition, with proper usage, repair/replacement of the SCT is almost nonexistent, which is why we back the tool with a One Year Full Warranty.

#### APPLICATION OF HEX CRIMP TOOLS FOR RG-/U CABLE

The most advanced design of "F" connectors requires a hex compression crimp. Once the connector has been compressed by a hex crimp tool, it exhibits both mechanical and RF improvement over the conventional 1/8" wide ring type "F" connector application. This crimping process of connector installation calls for a high compressive force, and a light-weight and easy-to-operate tool for the installer to use.

The CABLE-PREP® Hex Crimp Tool (HCT) manufactured by Ben Hughes Communication Products Company, Inc. stresses the simplicity of design while also offering a 14-to-1 mechanical advantage from the tool's toggle action, and the ability to compensate for wear of these toggle joints by using an adjustable eccentric pin.

Presently the concept of the 1/2" long ring and/or one-piece sleeve connector is the most effective "F" connector in use today, with respect to holding power (connector pull-out resistance) and RF integrity. In order to implement these two design requirements, one must select the proper connector for its intended cable design and finally select the proper hex crimp tool for that connector. The result of the proper connector and cable grouping will be an easy, efficient assembly with maximum RF integrity and holding power. Table 1 describes our HCT tools and which models are to be

used with various RG Cable configurations along with the hex sizes of each particular model.

The operation of the CABLE-PREP® Hex Crimp Tool is quite simple; the hand force required to compress the connector sleeve is multiplied via a toggle clamping design. This particular design is eventually subject to wear at its critical toggle pin points, if not properly maintained by periodic cleaning and oiling. This wearing condition and high compressive force necessitated the design and implementation of a toggle adjusting feature. This adjusting feature clearly assures increased longevity, while also increasing the overall quality and utilization of the tool. The compression (toggle) adjustment allows for the reinstatement of the Positive Homing Action (PHA), which slowly deteriorates through normal usage. When normal usage tends to wear (loosen) the factory pre-set toggle action, an adjustment can easily be made to duplicate its original feel. In order to do so, one must remove the "clip ring", which retains the starred adjustment wheel, and rotate this adjusting wheel one or two positions in a counter clockwise direction until the correct toggle action is achieved. Reassemble the clip ring back onto its adjusting "D" pin, and the HCT is now ready for use again. For even longer life of the HCT, a field Maintenance Kit (MK-1050) is available. This kit consists of replacement pins, retaining rings, links, clip rings, and adjustment wheel. With these parts, you can easily rebuild the specific stress points designed in the HCT. Once the MK-1050 kit has been installed, the HCT is brought back to its original condition.

Each HCT model is specifically sized for two RG-/U size cables. Table 1 can be used for easy reference when determining which Hex Crimp Tool to use with which RG-/U cable size and construction type. Over the last few years, with an influx of new cable designs and connector recommendations, the most recent application being used on Double Braid and Double Tape cables, some confusion has occurred. When ordering, please specify the HCT with the hex dimensions recommended by your connector supplier. A proper crimp is achieved with mechanical strength and prevention of R.F.I. only when the cable connector and crimp tool's hex size are in accord with each other.

#### CABLES, CONNECTORS, ET AL.

In the last thirty years, equipment employed during the installation of cable has evolved to where precision tools are now available to facilitate quality construction. Our hand tools are also designed to be as cost-effective as possible. Cable, connector and tool manufacturers, and those directly involved in the installation, are realizing the importance of working together to determine the job requirements without having to deal with avoidable problems and down-the-line non-profitability. Ben Hughes Communication Products Company, Inc. continues to research the development of new tool ideas and concepts, which will result in effective, high quality hand tools necessary in the industry. □



Distributors	Manufacturers	Service Firms
D1—Full CATV equipment line	M1—Full CATV equipment line	S1—CATV contracting
D2—CATV antennas	M2—CATV antennas	S2—CATV construction
D3—CATV cable	M3—CATV cable	S3—CATV financing
D4—CATV amplifiers	M4—CATV amplifiers	S4—CATV software
D5—CATV passives,	M5—CATV passives	S5—CATV billing services
D6—CATV hardware	M6—CATV hardware	S6—CATV publishing
D7—CATV connectors	M7—CATV connectors	S7—CATV drop installation
D8—CATV test equipment	M8—CATV test equipment	S8—CATV engineering
D9—Other	M9—Other	S9—Other

# Associate Roster

Note: Associates listed with \* are Charter Members.

**ADT Security Systems,**  
One World Trade Center,  
92nd Fl.,  
New York, NY 10048  
212—558-1444  
(M9 Security Equipment)

**Alpha Technologies,**  
1305 Fraser St. D-G,  
Bellingham, WA 98225  
206—671-7703  
(M9, Standby Power  
Supplies)

**AMCOM, Inc.,**  
Bldg. E, Suite 200,  
5775 Peachtree-  
Dunwoody Rd., N.E.,  
Atlanta, GA 30342  
404—256-0228  
(S9, Brokering &  
Consulting)

**Amplica, Inc.,**  
950 Lawrence Dr.,  
Newbury Park, CA 91320  
805—498-9671  
(M4)

\* **Anixter Communications**  
4711 Golf Road,  
Skokie, IL 60076  
312—677-2600  
(D1)

**Apple/Store**  
Rte. #1, Box 156,  
Beaver Dam, WI 53916  
414—885-6249

**The Associated Press,**  
50 Rockefeller Plaza,  
New York, NY 10020  
212—621-1513  
(S9 Automated News  
SVC)

**Automation Techniques,**  
1846 N. 106th E. Ave.  
Tulsa, OK 74116  
918—836-2584  
(M9)

**Avantek, Inc.,**  
481 Cottonwood Dr.,  
Milpitas, CA 95035  
408—946-3080  
(M8, 9 TVRO  
Components)

**Av-Tek, Inc.,**  
Box 188,  
Aurora, NE 68818  
402—694-5201  
(M8)

**BEI**  
P.O. Box 937,  
Olathe, KS 66061  
800—255-6226  
(M9 Character  
Generators)

**Ben Hughes  
Communications**  
P.O. Box AS,  
Old Saybrook, CT 06475  
203—388-3559  
(M6, 9)

**Blonder-Tongue Labs, Inc.,**  
1 Jake Brown Rd.,  
Old Bridge, NJ 08857  
201—679-4000  
(M1, 2, 4, 5)

**Broadband Engineering,  
Inc.,**  
P.O. Box 1247,  
Jupiter, FL 33458  
1-800—327-6690  
(D9, M4, S9)

**Budco, Inc.,**  
4910 East Admiral Place,  
Tulsa, OK 74115  
1-800—331-2246  
(D9, Security &  
Identification Devices)

**CATEL,**  
4800 Patrick Henry Dr.,  
Santa Clara, CA 95054  
408—988-7722

\* **C-COR Electronics, Inc.,**  
60 Decibel Rd.,  
State College, PA 16801  
814—238-2461  
(M1, 4, 5, S1, 2, 8)

**CCS Cable**  
P.O. Box 14710,  
Phoenix, AZ 85063  
602—272-6855  
(M3)

**CWY Electronics,**  
405 N. Earl Ave.,  
Lafayette, IN 74904  
1-800—428-7596  
(M9, D1)

**CableBus Systems,**  
7869 S.W.  
Nimbus Avenue,  
Beaverton, OR 97005  
503—543-3329  
(M1)

**Cable Graphic Sciences,**  
7095 N. Clovis Ave.,  
Clovis, CA 93612  
209—297-0508  
(M9 Character  
Generators)

**Cable Health Network,**  
2840 Mt. Wilkinson Pkwy.  
Atlanta, GA 30339  
404—436-0886  
(S4)

**Cable-Text Instruments,  
Div. of Telpar, Inc.**  
P.O. Box 796  
Addison, TX 75001  
214—233-6631  
(M9 Generators)

**Century III Electronics, Inc.**  
610 Neptune Ave.,  
Brea, CA 92621  
714—671-2800  
(M1, 3, 4, 5, 7, 8,  
S1, 2, 8)

**Capscan, Inc.**  
P.O. Box 36,  
Adelphia, NJ 07710  
1-800—CABLETV or  
222-5388  
(M1, 3, 4, 5)

**Channel Master,**  
Ellenville, NY 12428  
914—647-5000  
(M2, 3, 4, 5, 6, 7)

**Comm/Scope Company,**  
Rt. 1, Box 199A,  
Catawba, NC 28609  
1-800—438-3331  
(M3)

**Communications Equity  
Associates,**  
851 Lincoln Center,  
5401 W. Kennedy Blvd.,  
Tampa, FL 33609  
813—877-8844  
(S3)

**Comprehensive Cable  
Enterprises**  
206 Westminster Ct.  
Madison, WI 53714  
608—249-3442  
(S1, 2, 4, 5, 7, 8, 9)

**Computer Video  
Systems, Inc.,**  
3678 W. 2105 S. Unit 2,  
Salt Lake City, UT 84120  
1-800—453-8822  
(M9)

**COMSEARCH INC.,**  
11503 Sunrise Valley  
Drive,  
Reston, VA 22091  
703—620-6300  
(S8, S9, Earth station  
placement frequency  
coordination)

**ComSonics, Inc.,**  
P.O. Box 1106,  
Harrisonburg, VA 22801  
1-800—336-9681  
(M8, 9, S8, 9)

**DF Countryman Co.,  
Div. of Telpar, Inc.**  
St. Paul, MN 55104  
612—645-9153  
(D1, S1, 8)

**The Disney Channel**  
500 S. Buena Vista,  
Burbank, CA 91521  
213—840-5080  
(S4)

**Ditch Witch,**  
P.O. Box 66,  
Perry, OK 73077  
1-800—654-6481  
(M9)

**The Drop Shop Ltd., Inc.**  
Box 284,  
Roselle, NJ 07203  
1-800—526-4100 or  
1-800—227-0700 (West)  
(D3, 4, 5, 6, 7, 8, 9,  
M5, 6, 7, 8, 9 Plastics)

**Durnell Engineering Inc.,**  
Hwy 4 So.  
Emmetsburg, IA 50536  
712—852-2611  
(M9)

**Eagle Com-Tronics, Inc.,**  
4562 Waterhouse Rd.,  
Clay, NY 13041  
1-800—448-7474  
(M9 Pay TV Delivery  
Systems & Products)

**Eales Comm. &  
Antenna Serv.**  
2904 N.W. 23rd  
Oklahoma City, OK 73107  
405—946-3788  
(D1, 2, 3, 4, 5, 6, 7,  
S1, 2, 7, 8)

**Eastern Microwave, Inc.,**  
3 Northern Concourse,  
P.O. Box 4872,  
Syracuse, NY 13221  
315—455-5955  
(S4)

**Electroline TV  
Equipment, Inc.,**  
8750-8th Ave.,  
St. Michel,  
Montreal, Canada  
H1Z 2W4  
514—725-2471  
(M4, 5, 7, 9, D7, 9)

# Associate Roster

**Electron Consulting Associates,**  
Box 2029,  
Grove, OK 74344  
918-786-5349  
(M2, D1, S1, 8)

**Elephant Industries,**  
P.O. Box 3626  
N. Ft. Myers, FL 33903  
813-995-7383  
(M9)

**ESPN,**  
ESPN Plaza,  
Bristol, CT 06010  
203-584-8477  
(S9)

**Franey & Parr of Texas, Inc.,** (Formerly Doherty & Co.),  
One Turtle Creek Village,  
Suite 524,  
Dallas, TX  
214-528-4820  
(S9, Insurance)

**GTE Products Corp.,**  
**Sylvania CATV Div.,**  
1790 Lee Trevino Drive,  
Suite 600  
El Paso, TX 79936  
1-800-351-2345  
(D7, M1, 4, 5, 9,  
Converters, S4, 8)

**Gardiner Communications Corp.,**  
3506 Security St.,  
Garland, TX 75042  
214-348-4747  
(M9 TVRO Packages, S1, 2, 8)

**General Cable Corp.,**  
1 Woodbridge Center,  
P.O. Box 700  
Woodbridge, NJ 07095  
1-800-526-4385  
(M3)

**Gilbert Engineering Co.,**  
P.O. Box 23189,  
Phoenix, AZ 85063  
1-800-528-5567 or  
602-245-1050

**Group W Satellite Communications,**  
41 Harbor Plaza Dr.,  
P.O. Box 10210,  
Stamford, CT 06904  
203-965-6219  
(S4)

**H & R Communications,**  
Rt. 3, Box 102G,  
Pocahontas, AR 72455  
1-800-643-0102  
(M2, D1, S2, 3, 8)

**Harris Corporation,**  
P.O. Box 1700,  
Melbourne, FL 32901  
305-724-3401  
(M2, 9, S2)

**Heller-Oak Communications,**  
105 W. Adams St.,  
Chicago, IL 60603  
1-800-621-2139 \* 7600  
(S3)

**Home Box Office, Inc.,**  
12750 Merit Dr.  
Dallas, TX 75251  
214-387-8557  
(S4)

\* **Hughes Microwave Communications Products,**  
3060 W. Lomita Blvd.  
Torrance, CA 90505  
213-517-6233  
(M9)

**Ind. Co. Cable TV, Inc.,**  
P.O. Box 3799  
Hwy. 167 N,  
Batesville, AR 72501  
501-793-4174  
(D1)

\* **Jerry Conn Associates, Inc.,**  
P.O. Box 444,  
Chambersburg, PA 17201  
1-800-233-7600  
1-800-692-7370 (PA)  
(D3, 4, 5, 6, 7, 8)

**KMP Computer Services, Inc.,**  
703 Central Ave.,  
Los Alamos, NM 87544  
505-662-5545  
(S4, 5)

**Karnath Corporation,**  
2001 Westridge,  
Plano, TX 75075  
214-422-7981 or 7055  
(S1, 2, 8, 9)

**Katek, Inc.,**  
215 Wood Ave.,  
Middlesex, NJ 08846  
201-356-8940

**Klungness Electronic Supply,**  
P.O. Box 547,  
107 Kent Street,  
Iron Mountain, MI 49801  
1-800-338-9292  
1-800-682-7140 (Mich)  
(D1, 8, S2, 8)

**LRC Electronics, Inc.,**  
901 South Ave.,  
Horseheads, NY 14845  
607-739-3844  
(M7)

**Lash-Ade Company,**  
P.O. Box 147,  
Guntersville, AL 35976  
205-582-6333  
(M9 Cable Protector,  
S9 Equipment Repair)

**Larson Electronics,**  
311 S. Locust St.,  
Denton, TX 76201  
817-387-0002  
(M9 Standby Power)

**Lemco Tool Corporation,**  
Box 330A,  
Cogan Station, PA 17728  
1-800-233-8713  
(M8, 9 Tools)

**Lindsay Specialty Products, Ltd.,**  
50 Mary Street West,  
Lindsay,  
Ontario, Canada K9V 4S7  
705-324-2196  
(M1, 2, 4, 5, 7, 9)

**Magnavox CATV Division,**  
100 Fairgrounds Drive,  
Manlius, NY 13104  
1-800-448-5171 or  
1-800-522-7464 (N.Y.)  
(D4, 5, 7, M4, 5, 6, 7, S3, 8)

**McCullough Satellite Equipment,**  
Route 5, Box 97,  
Salem, AR 72576  
501-895-3167  
(M2, 9, D3, 4, 6, 7)

**Microdyne Corporation,**  
471 Oak Road,  
Ocala, FL 32672  
904-687-4633  
(M9 Satellite TV  
Receivers)

\* **Microwave Filter Co.,**  
6743 Kinne St., Box 103,  
E. Syracuse, NY 10357  
1-800-448-1666  
(M9 Bandpass Filter)

**Midwest Corp.,**  
P.O. Box 226,  
Clarksburg, WV 26301  
1-800-624-3845  
(D1, 2, 3, 4, 5, 6, 7, 8)

**Modern Cable Programs,**  
5000 Park St. N.,  
St. Petersburg, FL 33709  
(S4)

**Mullen Communications Construction Co., Inc.,**  
P.O. Box 1387A,  
Green Bay, WI 54305  
414-468-4649  
(S2)

**National Farmers Union Property & Casualty Co.,**  
12025 E. 45th Ave.,  
Denver, CO 80251  
303-371-1760  
(D9, Insurance Service)

**North Supply Company,**  
600 Industrial Pkwy.,  
Industrial Airport, KS  
66031  
913-791-7000  
(D1, 2, 3, 4, 5, 6, 7, 8)

**Oak Industries, Inc.,**  
Crystal Lake, IL 60014  
815-459-5000  
(M1, 9 Converters, S3)

**Octagon Scientific, Inc.,**  
476 E. Brighton Ave.,  
Syracuse, NY 13210  
315-476-0660  
(M9)

Distributors	Manufacturers	Service Firms
D1—Full CATV equipment line	M1—Full CATV equipment line	S1—CATV contracting
D2—CATV antennas	M2—CATV antennas	S2—CATV construction
D3—CATV cable	M3—CATV cable	S3—CATV financing
D4—CATV amplifiers	M4—CATV amplifiers	S4—CATV software
D5—CATV passives	M5—CATV passives	S5—CATV billing services
D6—CATV hardware	M6—CATV hardware	S6—CATV publishing
D7—CATV connectors	M7—CATV connectors	S7—CATV drop installation
D8—CATV test equipment	M8—CATV test equipment	S8—CATV engineering
D9—Other	M9—Other	S9—Other

Note: Associates listed with \* are Charter Members.

**Phasecom Corp.**,  
6365 Arizona Circle,  
Los Angeles, CA 90045  
213—641-3501  
(M1)

**Power and Telephone  
Supply Company, Inc.**,  
530 Interchange Drive  
N.W.,  
Atlanta, GA 30336  
1-800—241-9996  
(D1)

**M/A Com Prodelin, Inc.**,  
P.O. Box 100  
Claremont, NC 28610  
704—459-9762  
(M2, 3, 7, S2)

**Pyramid Industries, Inc.**,  
P.O. Box 23169,  
Phoenix, AZ 85063  
1-800—528-4529  
(M7, 8)

**Quality RF Services, Inc.**,  
825 Park Way, Suite 3,  
Jupiter, FL 33458  
305—747-4998  
(M4, S9)

**RMS Electronics**,  
50 Antin Place,  
Bronx, NY 10462  
1-800—223-8312  
1-800—221-8857 (Poleline)  
(M4, 5, 6, 7, 9)

**Reuters**,  
1212 Avenue of the  
Americas, 16th Floor,  
New York, NY 10036  
212—730-2715  
(D9)

**Rockwell International**,  
M.S. 402-101,  
Dallas, TX 75207  
214—996-5954  
(M9, Microwave/Satellite)

**S.A.L. Communications,  
Inc.**,  
P.O. Box 794,  
Melville, NY 11747  
1-800—645-9062  
(D1)

**Sadelco, Inc.**,  
75 West Forest Ave.,  
Englewood, NJ 07631  
201—569-3323  
(M8)

**Scientific Atlanta, Inc.**,  
3845 Pleasantdale Rd.,  
Atlanta, GA 30340  
404—449-2000  
(M1, 2, 4, 8, S1, 2,  
3, 8)

**Showtime Entertainment,  
Inc.**,  
1633 Broadway,  
New York, NY 10019  
212—708-1600  
(S4)

**Southern Satellite  
Systems, Inc.**,  
P.O. Box 45684,  
Tulsa, OK 74145  
918—481-0881  
(S9)

**Superior Electronics  
Center**,  
2010 Pine Terr.,  
Sarasota, FL 33581  
813—922-1551  
(M4, S9)

**TVC Supply Co., Inc.**,  
1746 E. Chocolate Ave.,  
Hershey, PA 17033  
717—533-4982  
(D1, 2, 3, 4, 5, 6, 7, 8)

**Teledac, Inc.**,  
1575 Taschereau Blvd.,  
Longueuil,  
Quebec, Canada J4K 2X8  
514—651-3716  
(M9 Character  
Generators)

**Tele-Wire Supply Corp.**,  
7 Michael Ave.,  
East Farmingdale,  
NY 11735  
516—293-7788  
(D1, 2, 3, 5, 6, 7, 8, 9)

\* **Texscan Corp.**,  
2446 N. Shadeland Ave.,  
Indianapolis, IN 46219  
1-800—528-4066  
(M9 Bandpass Filters)

\* **Theta-Com CATV**,  
2960 Grand Avenue,  
Phoenix, AZ 85061  
602—252-5021  
(M1, 4, 5, 7, 8)

\* **Times Fiber  
Communications**,  
358 Hall Avenue,  
Wallingford, CT 06492  
1-800—243-6904  
(M3)

**Tocom, Inc.**,  
P.O. Box 47066,  
Dallas, TX 75247  
214—438-7691  
(M1, 4, 9 Converters)

\* **Toner Cable  
Equipment, Inc.**,  
969 Horsham Rd.,  
Horsham, PA 19044  
1-800—523-5947  
In PA. 1-800—492-2512  
also 1-800—523-5947 (PA)  
(D2, 3, 4, 5, 6, 7)

**Triple Crown  
Electronics, Inc.**,  
4560 Fieldgate Dr.,  
Mississauga, Ontario,  
Canada L4W 3W6  
416—629-1111  
Telex 06-960-456  
(M4, 8)

**Turner Broadcasting  
System**,  
1050 Techwood Dr.,  
Atlanta, GA 30318  
404—898-8500

**Tyton Corp.**,  
P.O. Box 23055,  
Milwaukee, WI 53223  
414—355-1130  
(M6, 7)

**United Press International**,  
220 East 42nd St.,  
New York, NY 10017  
212—682-0400  
(S9 Automated News  
SVC.)

**United Video, Inc.**,  
3801 South Sheridan Rd.,  
Tulsa, OK 74145  
1-800—331-4806  
(S9)

**Video Data Systems**,  
205 Oser Ave.,  
Hauppauge, NY 11787  
516—231-4400  
(M9)

**Viewstar, Inc.**,  
705 Progress Ave.,  
Unit 53,  
Scarborough,  
Ontario, Canada M1H 2X1  
416—439-3170  
(M9 Cable Converter)

**Vitek Electronics, Inc.**,  
4 Gladys Court,  
Edison, NJ 08817  
201—287-3200

**Warner Amex Satellite  
Entertainment Corporation**,  
1211 Avenue of the  
Americas,  
New York, NY 10036  
212—944-4250  
(S4)

\* **Wavetek Indiana**,  
5808 Churchman,  
Beech Grove, IN 46107  
1-800—428-4424  
TWIX 810—341-3226  
(M8)

**Weatherscan**,  
Loop 132,  
Throckmorton Hwy.,  
Olney, TX 76374  
817—564-5688  
(D9, Sony Equip. Dist.,  
M9 Weather Channel  
Displays)

**Western Towers**  
Box 347,  
San Angelo, TX 76901  
915—655-6262/653-3363  
(M2, 9 Towers)

**Winegard Company**,  
3000 Kirkwood Street,  
Burlington, IA 52601  
1-800—523-2529  
(M1, 2, 3, 4, 5, 7)

**Zenith Radio Corp.**  
1000 N. Milwaukee Ave.  
Glenview, IL 60025  
312—391-8195  
(M1, 6) □



# Classified

## OPPORTUNITIES

### VICE PRESIDENT OF ENGINEERING POSITION

- Do you have extensive experience in all phases of upgrading and rebuilding older plants?
- Have you experience in addressable systems?
- Do you have a proven track record in analyzing capital costs and developing accurate capital expenditure budgets?
- Does your experience include plant and headend maintenance of larger, older systems?

If you can answer "yes" to all of these questions and can provide excellent references, you might be the person we are looking for to become part of our management team. Ideal Florida location and entrepreneurial atmosphere make this an excellent opportunity for a knowledgeable, experienced professional whose associates recognize the importance of the technical aspects of our business.

Please reply with your resume and compensation history, which will be held in confidence to:

CATJ, 4209 N.W. 23, Suite 106  
Box 683  
Okla. City, OK 73107

## FOR SALE

### Promo Encoder - Channel 6

400 Traps (300 good - 100 need retuning). Used three times for pay per view. Have now installed addressables.

Call:

Ken or Johnny  
Avenue TV Cable Service, Inc.  
PO Box CN, Ventura, Ca. 93002  
(805) 643-9971

## FOR SALE OR TRADE

1000 Oak Descrambler Econocode 2 and one Oak Scrambler. Contact Harlan Community Television Inc. 121 South First Street, Harlan, Kentucky, Tel. (806) 573-2945.



## ATTENTION! SYSTEM MANAGERS — TECHNICIANS NEEDED

Excellent opportunity for system managers and technicians for our systems in Colorado, Texas, and Oklahoma. Need qualified personnel for these Southwestern locations; good working conditions and opportunity for the right people who want to work and stay actively involved in the cable business. These systems have good equipment to work with and offer excellent situations to grow in the cable business. If interested, send resume to the box number indicated below.

Box 71080  
c/o CATJ  
4209 N.W. 23rd  
Suite 106  
Okla. City, OK 73107

## Your company can help us prevent child abuse.

**Help us get to the heart of the problem.**

**Write: National Committee for Prevention of Child Abuse  
Box 2866, Chicago, Illinois 60690**

- Please send us information on how we can help.
- We want to start helping right now. Enclosed is a check for \$\_\_\_\_\_.

NAME \_\_\_\_\_

TITLE \_\_\_\_\_ COMPANY \_\_\_\_\_

ADDRESS \_\_\_\_\_

CITY \_\_\_\_\_ STATE \_\_\_\_\_ ZIP \_\_\_\_\_



**National Committee for  
Prevention of Child Abuse**

A Public Service of This Magazine  
& The Advertising Council.



CATJ classified advertising is offered as a service by CATA for its membership.

ANY member of CATA may advertise in the CATJ classified section FREE of CHARGE (limit of 50 words per issue — 3 issues per year.)

CATA offers three types of memberships:

- 1.) Systems — paying regular monthly dues based on number of system subscribers.
- 2.) Associate Members — pay an annual fee.
- 3.) Individual Members — pay an annual fee.

NON MEMBERS may also use the Classified section at the rate of 50 cents per word with a minimum charge of \$20.00. Add \$2.00 for blind-box. Non-members should include full payment with the ad insertion.

Deadlines for all Classified Advertising is the 1st of the month for the following month's issue.

Address all Classified material to: CATJ, Suite 106, 4209 N.W. 23rd, Oklahoma City, Okla. 73107.

# ADD UNLIMITED PAY CHANNELS TO YOUR SYSTEM WITHOUT LOSING YOUR INVESTMENT IN CONVERTERS.

## Now, That's The Ticket!



If you're like most cable systems, you've spent almost \$225,000 on converters. Don't throw away that investment! With Eagle's Descrambler, you can add 15 tiers of service and unlimited channels to your system using your present converter.

### Write Your Own Ticket!

Whether you're adding one pay channel, 15 pay channels, or 15 tiers of service with 120 channels, Eagle's Descrambler can handle it all. Select only what you need. In the future, channels can be added to the headend scrambler with our simple plug-in module. The headend unit integrates with all manufacturer's modulators and processors and is compatible with all Standard/HRC/ICC configurations.

### The Best Show In Town

Eagle's Descrambler is compatible with all single channel output converters and is factory tuned for channel 2, 3, or 4. The descrambler

has no information on the audio making it ideal for AML transmission.

### Private Audiences Only

There are no subscriber controls with Eagle's Descrambler and our unique sync suppression scrambling insures maximum security. In addition, we've developed a tamperproof identification matrix to eliminate concerns about theft of service.

### Future Attraction

Addressability? It's coming. Eagle's Descrambler will be ready for addressability when you are . . . and the descrambler will be perfectly compatible with our addressable unit. Across the board, we're working to protect your investments.

Add pay channels . . . maximize your converter investment . . . prepare for addressability . . . Eagle's 15 Tier Descrambler Now, That's The Ticket!



OFFICE ADDRESS: 4562 Waterhouse Road, Clay, N.Y. 13041 (315) 622-3402  
MAIL ADDRESS: P.O. Box 2457, Syracuse, N.Y. 13220  
IN CANADA: Deskin Sales • Montreal • Toronto • Vancouver (416) 495-1412  
77D Steelcase Road West, Markham, Ontario L3R2M4

CALL TOLL FREE TO ORDER WorldRadioHistory 800-448-7474





# The connection cable systems have waited for POLELINE CORP. & OMNI-SHRINK™

Exclusive to the CATV industry through Poleline Corp., a new patented "state-of-the-art" heat shrink tubing.

**Offering 8 Unique Advantages**

- **Dripless Sealant**—hot melt sealant flows to encapsulate, but does not drip.
- **Superior Moisture Barrier**—lower moisture vapor transmission rate.
- **Excellent Abrasion and Cut Through Resistance.**
- **Self Sealing**—no migration of pinholes and splits.
- **Minimized Longitudinal Shrinkage.**
- **Superior Weatherability**—flexible from:  $-40^{\circ}$  F. to  $200^{\circ}$  F.
- **High UV Resistance**—no breakdown due to sun's U.V. rays.
- **Clean Peel Off**—patented butyl sealant removes quickly and easily. Leaves no mastic residue on cable connectors.



**Old Type**—Adhesive drips-propagation of pinholes and splits during shrinkage. **Not** clean stripping.



**Omni-Shrink™**—Non-drip sealant. Pinholes and splits self-seal. No propagation.

**PoleLine Corp.**

SUBSIDIARY OF RMS ELECTRONICS, INC.

**OMNI - SHRINK™**

by RADIATION DYNAMICS, INC.  
a wholly owned subsidiary of Monsanto Company

20 Antin Place, Bronx, N.Y. 10462 - TOLL FREE (800) 221-8857 (Continental U.S.A., Puerto Rico, U.S. Virgin Is.) Call Collect (212) 829-1070 (N.Y. State Only)  
WESTERN OPERATIONS: 2901 W. Garry Ave., Santa Ana, California, 92704 Call Collect (714) 662-1041

© Copyright 1983 RMS Electronics, Inc.