

CATV

OFFICIAL JOURNAL OF THE COMMUNITY ANTENNA TELEVISION ASSOCIATION
DECEMBER 1982

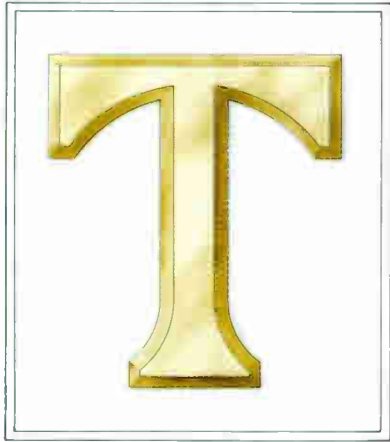



he gold standard

in service, innovation and technology.

For almost a decade, Triple Crown has been designing and producing the best cable equipment you can buy. We've also been offering service designed to meet your individual needs and you've shown us your approval through loyalty.

Thanks to your support, we've increased our staff and expanded into larger facilities to supply more of the high technology, cost-effective equipment you need.

We are still dedicated to providing system operators with the same personal service that has been the foundation of our reputation...

A reputation that you've helped us build and we intend to keep.

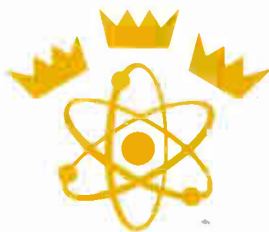

**Triple Crown
— We set our standards high.**

**TRIPLE CROWN ELECTRONICS INC.
4560 Fieldgate Drive, Mississauga, Ontario, Canada L4W 3W6 Tel.: (416) 629-1111 Telex: 06-960456**



**We have more
Blonder-Tongue CATV
equipment in stock
than Blonder-Tongue.
Or anyone else.**

On hand for immediate delivery, we keep an enormous stock of such Blonder-Tongue items as modulators, amplifiers, converters, filters, headend accessories, traps, processors, preamps and more.

So, whenever you need something in CATV—equipment or answers—write or call Toner toll-free, 800-523-5947. In Pennsylvania 800-492-2512.

Call us toll-free. Get same-day shipment plus advice from people you can trust.

TONER
cable equipment, inc.
969 horsham road
horsham, PA 19044

CATJ, The Official Journal for the Community Antenna Television Association is published as a service for Association Members and other providing services to the industry.

TABLE OF CONTENTS

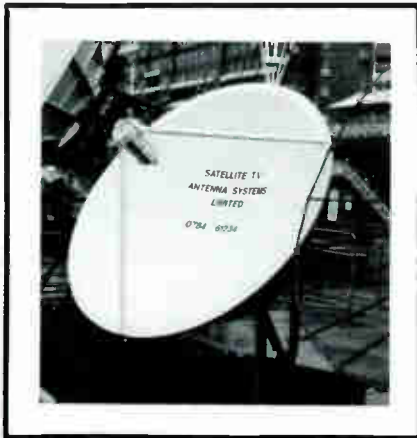

See page 6

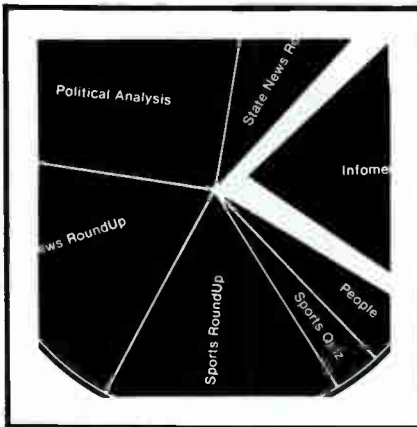

See page 44

ON THE COVER

As the season approaches for holiday greetings and exchanges, CATJ greets all our friends with wishes for a happy holiday.

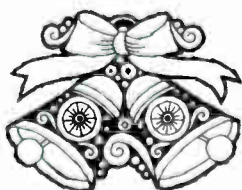

4	CATA-TORIAL — <i>This month, Peter Athanas, CATA President, presents his editorial concerning the CRT reimposition of the old FCC distant signal rules</i>
6	BIRKILL ON EXPERIMENTAL TERMINALS — <i>Ku-Band Reception Techniques are discussed this month by Steve Birkill as more interest is now being generated in the higher frequency band</i>
18	YOUR COLUMN — <i>interesting problems presented with relatively simple solutions presented</i>
20	CABLE TECH'S COOKBOOK — <i>Glyn Bostick continues on his filter series and discusses Band-Splitters with cross over frequencies</i>
22	MICROWAVE DATA TRANSMISSION USING AML TECHNIQUES — <i>A.H. Sonnenschein of Hughes Aircraft Company, Microwave Communications Products, in cooperation with I. Rabowsky and W.C. Margiotta, prepared this paper, discussing the transmission of various forms of data via AML microwave systems</i>
26	WASHINGTON UPDATE — <i>There are a lot of things in the forefront of the cable industry news. Steve Effros, CATA Executive Director, brings CATJ readers up to date</i>
36	LETTERS TO THE EDITOR — <i>This month's collection indicates that people are reading and paying attention. There was an error in the Cable Tech's test answers, and the mistake was called to our attention. You'll want to check this and the other letters out for additional information</i>
41	ASSOCIATES SHOWCASE
44	NEW PRODUCT REVIEW — <i>This month CATJ is featuring UPI CABLE NEWS the new customized news format</i>
49	ASSOCIATES ROSTER
52	CLASSIFIED

BITING THE BULLET ON DISTANT SIGNALS

It had to happen sometime, and don't say CATA hasn't been warning you! The Copyright Royalty Tribunal (CRT) has, in essence, re-imposed the old FCC distant signal rules. The result will be that larger systems all over the country will be restricted from carrying as many distant independent television signals as they want. The question for today : **is that all bad?**

I won't go into all the details here, you can get them by reading the December Washington Update (page 26). In short, however, the CRT has decided that, because the FCC eliminated the "distant signal" rules, they were required to judge how much the additional signals that cable systems added after the elimination of those rules would be worth. What they decided was that each independent signal that was added was worth **3.75% of basic subscriber revenue!** Now that is a fantastic number! To give you some sort of "ball-park" feel for it, it means about **50 cents per subscriber per month.** No other signal that we carry which is advertiser supported comes even close to that fee.

What did the CRT really do? Well, the head of the Tribunal, Tom Brennan, said it best when he told reporters that the CRT did not really think that cable systems would pay that inflated fee — rather they would simply **drop** the channels! So, in essence, the CRT intentionally set an artificially high fee for added distant signals with the intention of forcing those signals off the air and forcing the cable industry back to 1980 and the FCC distant signal rules. As things stand right now they will succeed.

Is it fair? **No.** To begin with, you should remember that the distant signal rules were written to protect broadcasters. The smaller the market the more restrictive the FCC was in allowing other signals in — the reasoning being that in the smaller market the broadcaster was having a hard time anyway, to limit the amount of competition that was allowed. Of course the thought that there may be a restriction on the First Amendment rights of television viewers never entered the minds of the FCC Commissioners and the fact that all viewers outside the top 100 markets were being relegated to second class citizen status also did not seem to bother them.

Then, finally in 1980, the cable industry got its point across and the Commission eliminated the restrictive rules. They did so not because they finally agreed that cable viewers had rights (although they did admit that all of the logic behind their original rules were wrong) but

because they found that the restrictions did not really help the broadcasters anyway!

Now, in 1982, the CRT has reimposed that second class status. They have done it economically instead of by rule, but the effect will be the same: distant independent signals will be taken off of cable systems. Unless, that is, a Court Appeal is successful, or we can get Congress to understand how unfair this entire decision is with regard to certain systems.

Who gets hurt the most? Systems in smaller markets with approximately 4000 or more subscribers. The decision does not affect any system that does not make more than \$214,000.00 per half year. That lets out the smaller systems. It also does not seriously impact any system in the top 100 markets since they are allowed to import at least two distant independent signals in the first place. That may mean that only two satellite delivered signals will survive, but at least there will be two! So the larger systems in the smaller markets are the ones that will suffer the most. The suffering will come from the fact that a lot of those systems added signals after the Commission eliminated its rules and that action was affirmed in the "Malrité" case. They added the signals even though CATA put out numerous warnings at the time that the CRT was capable of doing what it has just done — and that great caution should be exercised in the decision to add any additional distant signals.

One other group that could potentially be harmed is the large operators in the major urban areas who have promised the world in their franchise bids, including all sorts of distant signals. If those promises are enforced by the cities, and the 3.75% rate is sustained, a lot of red ink is going to flow! Of course some of these same operators are also program suppliers, and with that hat on, they must be cheering this decision since it will mean more room on the systems for their programming. It must be tough to cry out of one side of your mouth while you laugh on the other!

What should we do about all this? Well, of course, there will be an appeal. But the Courts generally are reluctant to substitute their judgment for that of a Tribunal unless there is a showing that the Tribunal was totally unreasonable or illegal in the way it made its decision. While we have many good arguments for why the decision is no good, it will be tough to convince a Court that the Tribunal exceeded its authority in making the decision. The appeal is worth taking, however, because the decision is so extreme it may fall of its own weight.

Another possible recourse is legislation. Since it does not look like cable copyright legislation will get through Congress this year, it may be that the cable industry has to go back next year and seek corrective legislation for what the CRT has just done, which is to eliminate the economic ability of cable operators to carry distant independent signals that Congress clearly intended for us to carry — if they had not, we would not have gotten the compulsory license in the first place!

It should be noted that either of these courses will not result in protecting us from making some hard decisions. The CRT rates go into effect on Jan. 1, 1983. Even if a Court test is started, it certainly will be several years before it is resolved, and a "stay" of the effectiveness of the new rates would not protect us from ultimately having to pay them if we lost in Court. Similarly, Congressional legislation is not even possible before the first of next year. So we will have to decide now what to do — we will have to bite the bullet.

Would it be so bad to eliminate some distant independent signals? Certainly our subscribers will scream (**tell them to contact their congressman immediately!**). But what about giving them other programming in place of those signals — C-SPAN, or CNN, USA, Daytime, SNC etc. Not only may we be

able to replace the programming lost, but we may be able to make some advertising dollars as well!

Naturally, we would like to offer all the programming we can to our subscribers. They should have the right to see the signals that are about to be denied to them. Make sure they know that you are not the one to blame for the reduction in service and that, if they want those signals back, they had better make that very clear to Congress — we do have a political power base regarding this issue that can be used, if we make sure it is properly directed!

In the meantime, look closely at your alternatives. Look not only to eliminating the signals, but to restructuring your "basic" package. Always remember that the new fees **ONLY** apply to "basic" subscribers. There was speculation many years ago that eventually we would give away "basic" for free. Indeed, some of the big urban systems are planning to do just that — or almost, with \$2.00 rates and so on. There are ways to deal with this new problem. While CATA will continue to work for all operators to assure our continued right to import as many distant signals as our subscribers want to watch, you should not look on the current situation with total despair. "**Biting the bullet**" sometimes strengthens the jaw. □

OFFICERS

Ben V. Willie, Chairman of the Board
Peter Athanas, President
Carl Schmauder, Vice President
Clarence Dow, Secretary/Treasurer

DISTRICT	DIRECTORS
One	Clarence Dow (Maine)
Two	
Three	David Fox (West Virginia)
Four	
Five	Joe Bain (Oklahoma)
Six	Wayne Sheldon (California)
Seven	Carl Schmauder (Oregon)
Eight	
Nine	Peter Athanas (Wisconsin)
Ten	Jim Hays III (Kentucky)

VICE DIRECTOR

Lee Holmes (Guam)

ASSOCIATES' DIRECTORS

Raleigh B. Stelle III, Texscan/Theta Com
Ernie Larson, Larson Electronics

DIRECTORS EMERITUS

Gene Edwards (Ohio)
Chuck Kee (Oregon)
William Ridsen (Kentucky)

CATJ STAFF

President and Publisher
G.H. Dodson

Business and Managing Editor
Celeste Rule

Executive Assistant To The Editor
Diane Howard

Circulation Manager
Carolyn McCray

Contributing Editors
S.J. Birkill, Stephen Effros,
Ralph Haimowitz

Art Director/Marketing
Phyllis Crumpler

Assistant Art Director
Dianna Johnson

OFFICES

National Headquarters
CATA/CATJ
Celeste Rule, Managing Editor
4209 N.W. 23rd, Suite 106
Oklahoma City, Okla. 73107
(405) 947-7664; 947-4717

CATA (Washington Office)
Stephen R. Effros, Executive Director
3977 Chain Bridge Rd.
Fairfax, Va. 22030
(703) 691-8875

CATA (Engineering Office)
Ralph Haimowitz, Director
518 21st Street S.W.
Vero Beach, Florida 32960
(305) 562-7847

The Community Antenna Television Association, Inc. is a nonprofit organization formed under Chapter 19, Title 18 of the Statutes of the State of Oklahoma. As such, no part of its assets or income shall be the property of its members, such assets and income shall be devoted exclusively to the purposes of the Corporation.

The Community Antenna Television Journal (CATJ) — ISSN-0194-5963 — is published monthly by Television Publications, Inc., 4209 N.W. 23rd, Suite 106, Okla. City, OK 73107. Subscription price: \$18.00 per year, \$22.00 per year Canada, Mexico, and foreign is \$25.00 per year. Second class postage paid at Oklahoma City.

POSTMASTER: Send address changes to 4209 N.W. 23rd, Oklahoma City, OK. 73107.

CATJ is a Copyright © 1982 by the Television Publications, Inc. All rights reserved. Quedan reservados todos los derechos. Printed in U.S.A. Permission to reprint CATJ published material must be given by Television Publications, Inc., prior to republication.

Steve J. Birkill

Ku-Band Reception Techniques

It was the May 1979 issue of CATJ when I last went into any detail on this topic. There has been no change in the physics of microwaves or semiconductors since then, but a lot more people are taking a lot more interest in the higher frequency band, for a variety of reasons.

Ku-Band satellites have advanced a long way since 1979, as a glance at last month's chart will reveal. Then we had the "Hermes" Communications Technology Satellite for North America, the "Yuri" experimental broadcasting satellite doing a similar job for Japan, and OTS and

Sirio providing more modestly-powered services to Europe. Anik B was about to enter operational service for Canada, and the first Intelsat V was being readied for launch. Today there are five Intelsat V satellites in orbit, but of the other pioneering Ku-Band birds only OTS and Anik B remain operational.

Instead we have talk of high power satellites for direct television broadcasting, and medium power fixed service satellites for new business and cable services and for "early entry" or "interim" DBS, all operating in Ku-Band. The domestic medium power satellite (EIRPs to

around 50 dBW maximum) include SBS, Spacenet, and Anik C. Already 2 SBS (Satellite Business Systems) birds are in use; a third should be joining them by the time you read this, given a successful launch, along with the first Anik C aboard the fifth Shuttle flight scheduled for November 11.

Then in the upper part of the downlink band the high power (60 dBW or more EIRP per channel) satellites for true DBS, promised for the second half of this decade both in the USA and elsewhere. In the United States, these are known by the names of the DBS applicants; in

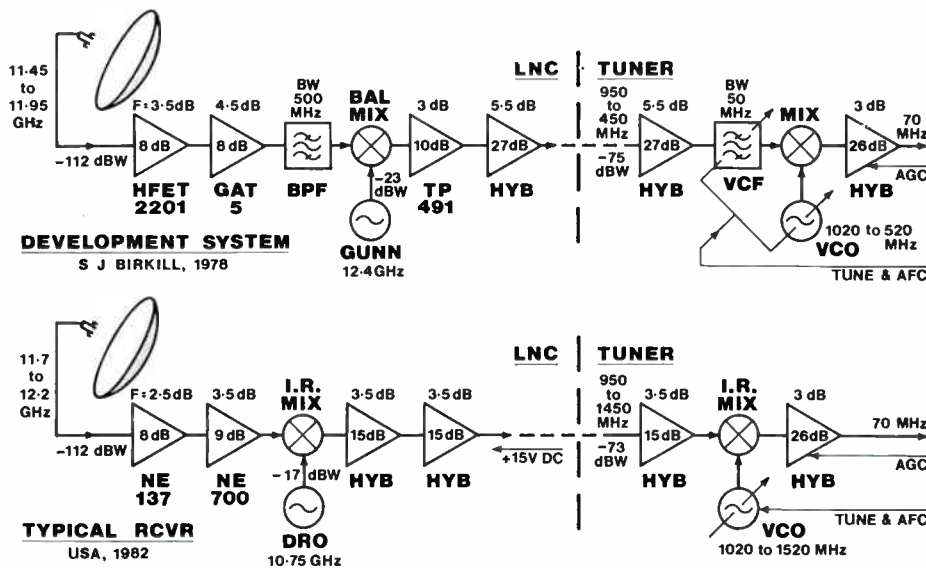

FIG.1: 11/12 GHz RF/IF SCHEMATICS

How to stretch available frequencies.



Build the muscle you need with Hughes AML™ Systems.

When your downstream and upstream traffic has used up all your allocated microwave frequencies, it's time to expand your capabilities with a Hughes AML frequency reuse system. There's no need to top off your operation at 70 or 80 channels when you could use a hundred or more. No need to struggle with the CARS band or hope additional channel allocations are made available. You can look to Hughes now.

Re-exercise your frequencies.

A Hughes AML system employing

signal discrimination techniques allows you to reuse the frequencies you have already been allocated. It can boost your system to 160 channels or more. And when compared to super trunks or multiple headends, Hughes AML advantages include faster implementation, better quality signals, and higher reliability.

Go with the AML decathlon champ.

A Hughes AML system is versatile as well as powerful. It can offer two-way transmission of video or data from as far as 30 miles away. Hughes AML can support single or dual cable systems, and can handle multiple-

tier and addressable scrambling systems. It permits multi-system sharing of CARS band frequencies within the same community without interaction.

For more information on Hughes AML systems, write or call:

Hughes **MICROWAVE™
COMMUNICATIONS
PRODUCTS**

P.O. Box 2999, Torrance, CA 90509, (213) 517-6233. After hours emergency service (213) 534-2170. In Canada: Anixter-MicroSat Communications, 970 Brock Road South, Pickering, Ontario Canada L1W 2A1, (416) 839-5182.

AML
Any
Amplitude
Modulation
Link

Creating a new world with electronics

HUGHES

HUGHES AIRCRAFT COMPANY

©1982

NOW

SPECTRUM ANALYZERS

for monitoring, service and testing communication equipment
100 kHz - 2 GHz

The Model 632B-1 is well suited for wide range distortion and noise measurements, test

equipment calibration, EMC tests, and other frequency domain applications up to 2.0 GHz.



Send for our new catalog.

arad polarad polarad

Polarad Electronics, Inc. 5 Delaware Dr., Lake Success, N.Y. 11042 TEL 516-328-1100 TWX 510-223-0414

the rest of the world, it is in general one satellite system, with five channels, per country. By 1990 there could easily be 20 DBS birds operating worldwide, each with millions of viewers per channel, as well as say 25 domestics in the fixed satellite service, plus about a dozen Ku-Band satellites in the global system.

That makes for a lot of receiving hardware over the next seven years. I guess there isn't such a variety of reasons for folks to take an interest after all. If DBS takes off there will be fortunes to be made. How well it will take off in any given location is the subject of much speculation. Just as some expect cable to fail in Great Britain, others predict DBS will bomb in America. One thing's for sure: the Japanese will get a big slice of the cake, wherever the sales go!

It is up to the home industry to come up with competitive product in the right quantity, to minimize the foreign slice. A few microwave companies are going it alone, developing the technology in-house to meet the DBS challenge. That technology had better be good because it must be reliable and it must be cheap — to look at 500 as the absolute maximum end-user price for a DBS terminal does not seem unreasonable. Indeed some in the industry are aiming towards half that value.

Most visible right now are those operations with established 4 GHz product, but perhaps without the "sharp end" microwave technology to produce their own 12 GHz receivers, at least not yet. A number of companies have chosen to handle imported equipment as their 12 GHz line, units such as that shown here from the DX Antenna Company of Japan. These are sold under a variety of names and make up a large proportion of current 12 GHz receiver sales.

A third approach is that of ALCOA-NEC. The ALCOA-NEC Communications Corporation, or ANCOM, as the new venture is called, draws on ALCOA's experience in aluminum fabrication and the giant Japanese Nippon Electric Company's pre-eminence in micro-

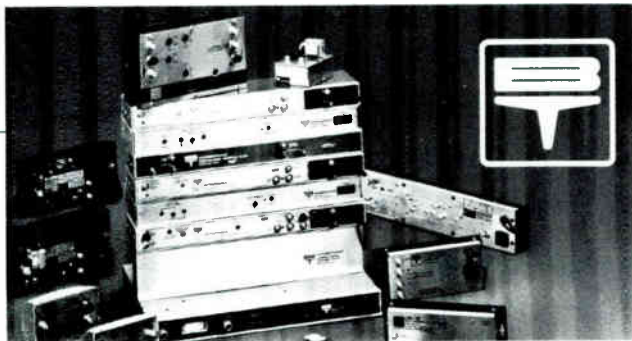

Look to us for high quality B-T no-wait CATV equipment.

We have it in stock for immediate delivery. Or pick-up.

Blonder-Tongue stock items include: antennas, amplifiers, modulators, converters, filters, headend accessories, traps, processors, preamps, and more. Call us for what you need.

Davco, Incorporated

America's Oldest CATV Distributor

- Same day shipment
- Help when you need it
- Everything you need in one stop
- In business since 1949!



Authorized Blonder-Tongue Stocking Distributor

P.O. Box 2456

Batesville, Arkansas 72501

(501) 793-3816

wave solid-state circuitry, to become a very serious contender for domination of the DBS receiving hardware market. Majority ownership in American, so avoiding any import barriers. The metal antennas will be fabricated in the USA, and plans are to import the electronics from Japan initially, with the establishment of American manufacturing facilities at a later date.

Receiver demands for fixed and broadcast satellite services are similar. DBS specs require a lower G/T (figure of merit), but low noise performance continues to be more cheaply available each year, and it seems unlikely that full advantage of current techniques will not be taken with DBS, as well as FSS, receivers. The downlink bands are contiguous, and with the future of the "early entry" contenders unknown, there may well develop two parallel DBS strains, with high power and medium power downlinks. The receiver manufacturers have the option of tackling this with an extended band receiver tuning 11.7 to 12.7 GHz. Teamed with a steerable dish, inevitably larger than DBS alone would require, the user could access both classes of service.

So what is required of the 12 GHz DBS receiver? For its baseline specification, Comsat's Satellite Television Corporation (STC) selected the combination of 4.5 dB receiver noise figure with an antenna of 0.75 m aperture, giving a G/T of some 9 dB/K. Satellite EIRP will be determined according to area, with the use of shaped beams delivering higher clear weather power flux densities into regions of heavy annual rainfall, to achieve the required protection against rain outage, as a percentage of the worst month. A typical minimum EIRP value over a coverage area (time zone) is 57 dBW, rather lower than the value fixed for Europe at WARC-77. The STC plan also allows for antenna apertures of 0.6 and 0.9 meters to be used.

The 9 dB/K is a clear sky value. It must be noted that there are limits to the antenna/LNC combinations that can be used to achieve this. Antenna beamwidth is not an important consideration, as DBS spac-

Power off? keep going... with alpha standby power



**OVER 10000 UNITS
OPERATING AND FIELD
PROVEN COAST TO COAST**

**New Franchise or Rebuild?
ALPHA offers you
unsurpassed reliability
along with these features:**

- Automatic battery cycling.
- Extended battery life due to temperature compensated float and equalize charging.
- Less than 1 cycle transfer time.
- Inverter crystal controlled and line synchronized. 20-30 second time delay before synchronized retransfer to utility.
- Epoxy coated aluminum enclosure for maximum durability.
- All batteries on top to keep vapours and corrosive emissions away from electronics.

**And for state-of-the-art systems
these options:**

APM (Automatic Performance Monitor)
Performs selftesting and monitoring functions.
Saves costly maintenance time.
For even better operating economy,
talk to us about the new Micro
Processor Status Monitoring
and Control.



**ALPHA
TECHNOLOGIES**
1305 Fraser St., D-6
Bellingham,
WA 98226
(206) 671-7703

Scottsdale, Arizona
(602) 948-4484
Napa, California
(707) 255-2010
Marietta, Georgia
(404) 971-1021

Indianapolis, Indiana
(317) 849-7572
Burnaby, B.C.
(604) 430-1476
Pickering, Ontario
(416) 839-5182

Cable TV Brokerage

AMCOM, INC.

CHARLES GREENE

(404) 256-0228

5775 Peachtree-Dunwoody Road, N.E.
Building E, Suite 200 Atlanta, Georgia 30342

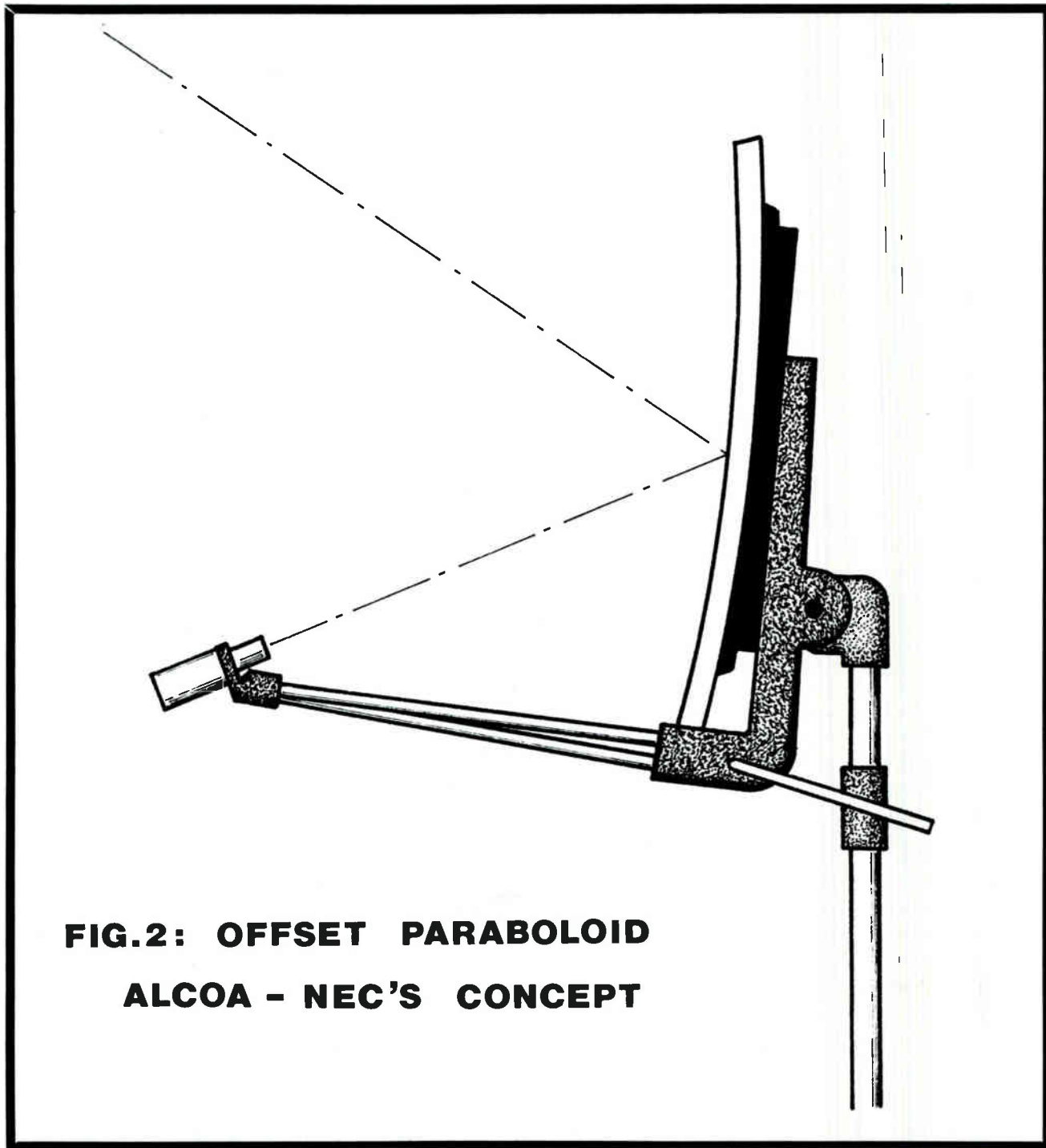

**FIG.2: OFFSET PARABOLOID
ALCOA - NEC'S CONCEPT**

ing is planned at 20° - even a 20 cm dish has a beamwidth of 9°. But reducing receiver noise temperature to permit use of a smaller antenna brings extra penalties during rain attenuation conditions. Not only does the signal fade, but the sky temperature increases under these conditions, causing relatively more degra-

dation at the terminal with lower clear sky noise temperature. Still, 3 dB receiver noise figure is now quite achievable, leading to specification performance with an antenna of 60 cm or less.

So how are receiver designs shaping up? Back in 1979 I described the fin-line ("planar circuit in wave-

guide") mixer developed by Dr. Konishi of NHK Labs in Japan. This was one of the first attempts at a 12 GHz DBS receiver design for truly low cost volume production. A stamped or etched metal plate forms an E-plane septum in rectangular

continued

RECEIVE 48 CHANNELS FROM TWO SATELLITES WITH JUST ONE DISH.

Now cable operators can double their programming options at a fraction of the previous cost and bring the savings to their bottom line. The dual beam TVRO modification means you can receive signals from two adjacent satellites without going to the expense of installing a second dish.

Dual beam means you can add more service tiers, and that means an increased profit potential.

Satcom III-R

Time Inc.
Warner Amex
Times Mirror Satellite
Programming
Viacom International
Turner Broadcasting System
Southern Satellite Systems
PTL
ESPN
Christian Broadcasting
Network
USA Network
United Video
Community Service Network
Reuters
Landmark Communications
Modern Satellite Network
C-SPAN

Galaxy I

Time Inc.
Group W Broadcasting
Company
Times Mirror Satellite
Programming
Viacom International
Turner Broadcasting System
SIN Television Network
C-SPAN



Satcom III-R
(131° W)

Galaxy I
(135° W)

With the dual beam modification, you can receive Galaxy I and Satcom III-R simultaneously. These are the only two major cable satellites to be placed in adjacent orbital slots, and their transponders will be packed with the leading programmers in the cable industry. With dual beam, you won't be forced to choose between competing satellites ever again.

Here are just a few reasons why you will want the dual beam TVRO modification:

No purchase and installation costs for a second dish

No new real estate required

No perceptible loss of signal quality

Diversified programming and expanded service tiers

Reception of both Galaxy I and Satcom III-R, featuring the strongest programmers in the industry

To receive programming from these two cable birds, all that is required is a modification of the existing feed system. Reflectors from 4.5 to 7.0 meters in diameter with focal length to diameter ratio (f/d) from 0.3 to 0.5 can be accommodated. The modified feed system utilizes a limited offset from the paraboloid focal point to restrict the range between beams to less than 5 degrees and maintain high efficiency.

Once modified, the dual beam feed system will receive signals from 3.7 to 4.2 GHz. The loss of gain due to the production of two beams is on the order of 0.5 db.

Remember, other birds just can't match up to the Galaxy I/Satcom III-R package that you can receive with the dual beam modification. Get the most attractive mix of quality cable programming available. Save on the cost of upgrading your system. Get the dual beam TVRO modification and see what the skies have to offer.

For additional technical specifications and test data, contact these leading manufacturers:

M/A-COM VIDEO SATELLITE, INC.
Duke Brown
National Sales Manager
32 3rd Ave.
Burlington, Massachusetts 01803
(617) 272-3100

MICRODYNE CORPORATION
Earl Currier
Sales Manager
491 Oak Road
Ocala, Florida 32672
(904) 687-4633

SCIENTIFIC ATLANTA
Pat Miller
Marketing Manager
P.O. Box 105027
Atlanta, Georgia 30348
(404) 925-5000

For additional information contact:

Cindi S. Whalen, HUGHES COMMUNICATIONS, P.O. Box 92424, Los Angeles, California 90009 (213) 615-1000

HUGHES COMMUNICATIONS

HUGHES

HUGHES AIRCRAFT COMPANY

Hughes Communications, Inc., a wholly owned subsidiary of Hughes Aircraft Company, TELEX 664480

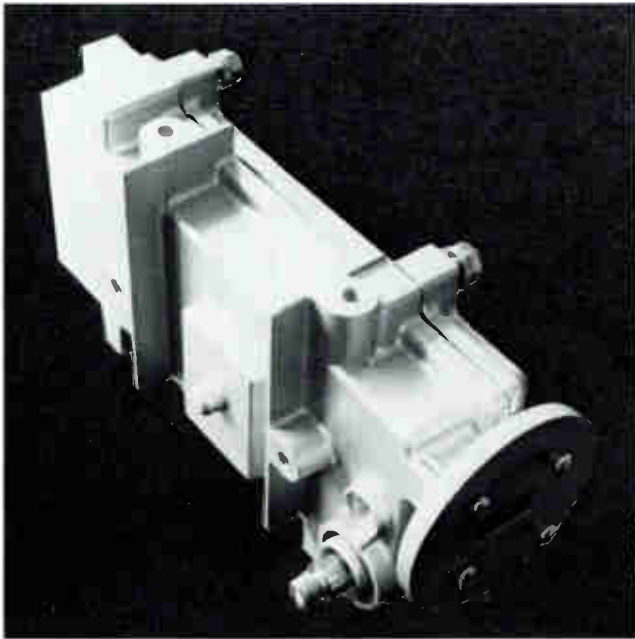

PHOTO 1

DX Antenna Company 11/12 GHz LNC type DSA-501 converts a 500 MHz block down to a UHF first intermediate frequency. This is a popular item in several low cost American 12 GHz terminal packages.

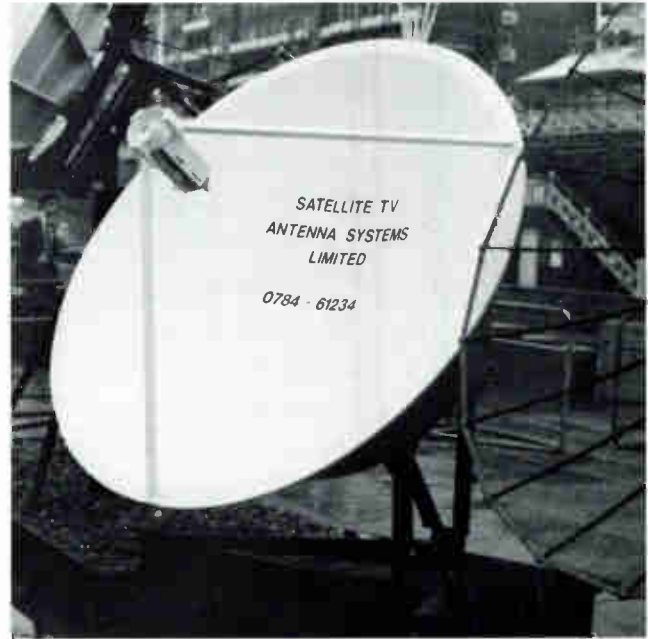

PHOTO 2

1.8 meter plastics composite antenna by Britain's Satellite TV Antenna Systems Ltd with DX LNC provided high quality reception from OTS on the Racal-Oak stand at Brighton's International Broadcasting Convention in September.

continued

SNIFFER THE ORIGINAL RF LEAKAGE DETECTION SYSTEM

Internally Calibrated Detector

Signal Source

U.S. & Foreign Patents 4072899, 853942

Near Field Probe

Field Proven
Successful
In Heavy
FM Off-Air
Market

NEW

High Selectivity Front End
Rejects Off-Air Interference,
Offers Pinpoint Accuracy

An Employee Owned Corporation

COMSONICS, INC.

P. O. Box 1106 Harrisonburg, VA 22801

1-800-336-9681

INVA. 703-434-5965 COLLECT

IN CANADA

INCOSPEC
ELECTRONICS INC

4651, boul. des Grandes Prairies,
St-Léonard (Québec), H1R 1A8
Tél: (514) 322-5540
Télex: 05-829713

Steve J. Birkill

Ku-Band

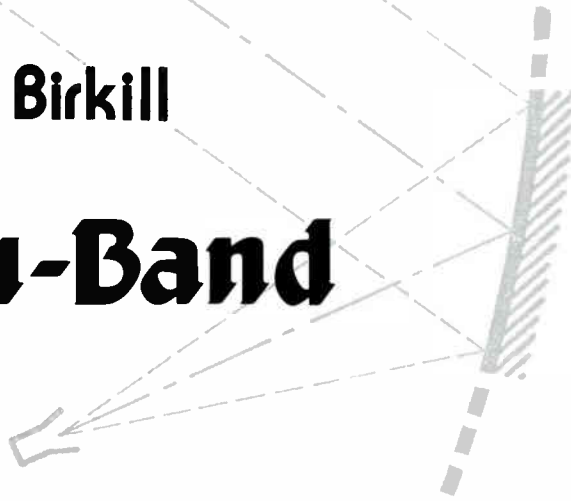

waveguide, and carries all the microwave circuitry of the LNC, including Gunn-effect local oscillator and image-recovery mixer. Image recovery is a technique which uses a signal bandpass filter at the input to act as a mismatch at first image frequency. The phase of this mismatch is set by its distance from the mixer, such that noise power at the image frequency is rejected, and conver-

sion loss reduced. This way a noise figure of 4.5 dB maximum (3.8 dB typical) can be achieved over the DBS band, without an LNA.

But surely this approach has been superseded by more recent advances in GaAs technology? Don't you believe it! Take a look inside the DX Antenna's unit shown in the photo, and you find the old Konishi mixer. The Gunn device has gone, to be

replaced by a frequency multiplier diode pumped by a FET oscillator of exceptional stability, thanks to a dielectric resonator inside a diecast cavity. But the mixer is straight out of NHK's application note, right down to its 3.8 dB typical noise figure.

The remainder of DX's head unit consists of an IF head amplifier covering the 0.9 to 1.4 GHz first intermediate frequency (block down-conversion is standard at 12 GHz), the whole being powered by 12 volts DC sent up the cable from the indoor tuner/demodulator unit. The latter performs the tuning function in its second downconversion, and the demodulator is a standard limiter discriminator type with a sharply defined 'knee' to the S/N vs C/N curve at threshold. IF bandwidth is nominally 20 MHz, but can be specified to suit the transmission system (20 MHz for USA, 30 MHz for Europe).

Waveguide input flange is Japanese WRJ-120, equivalent to US WR-75 or British WG-17, and 75-ohm IF output is via the screw-type F jack, universal in the USA but virtually unknown anywhere else. First IF gain seemed in short supply, with a maximum specified cable loss of 10 dB at 1 GHz being a little restrictive. At a recent demonstration at IBC-82, Brighton, England, the antenna was situated 400 meters from the exhibition hall, and I had to provide 40 dB additional IF gain to overcome cable loss and swamp the second converter's own noise. For use with the Oak 'Orion' encrypted signals of Satellite Television PLC the video clamp had to be disabled, but apart from slight truncation sparklies in red and cyan of the PAL color bar waveform, caused by the 20 MHz IF bandwidth of the sample unit, the DX receivers performed admirably. The Orion digital audio was passed without audible errors, even on the 1.8 meter plastics composite antenna of Satellite TV Antenna Systems Ltd of Staines, England, to whom thanks for supplying the review unit. The combination is to be recommended for OTS reception in Europe, at a worthwhile saving over the traditional 3-meter terminal.

**Compare Cost • Compare Performance
Then Buy Gillaspie**

**Gillaspie 5500
Satellite Receiver**



- Receiver frequency range: 3.7 to 4.2 GHz
- Full audio subcarrier agility: 5 to 8 MHz
- Better than 8 dB C/N threshold
- LNA power through coax or rear panel connector
- 10 MHz unfiltered baseband video w/ audio subcarrier on rear panel
- Loop through 70 MHz IF between downconverter and IF strip
- Video output: (2) 1v PP, 75 adjustable
- Unfiltered video output: .25v PP, 75
- Audio output: 10 dBm 600 adjustable
- Built-in polarization switching available as option
- Remote audio and video tuning available as option

The Model 5500 Satellite Receiver from Gillaspie. Delivery stock to 30 days. Line amplifiers, coax switches and signal splitters available. Application assistance upon request, *we understand cable!*

Get The Last Word First!

Gillaspie & Associates
365 San Aleso Ave., Sunnyvale, CA 94086 (408) 730-2500

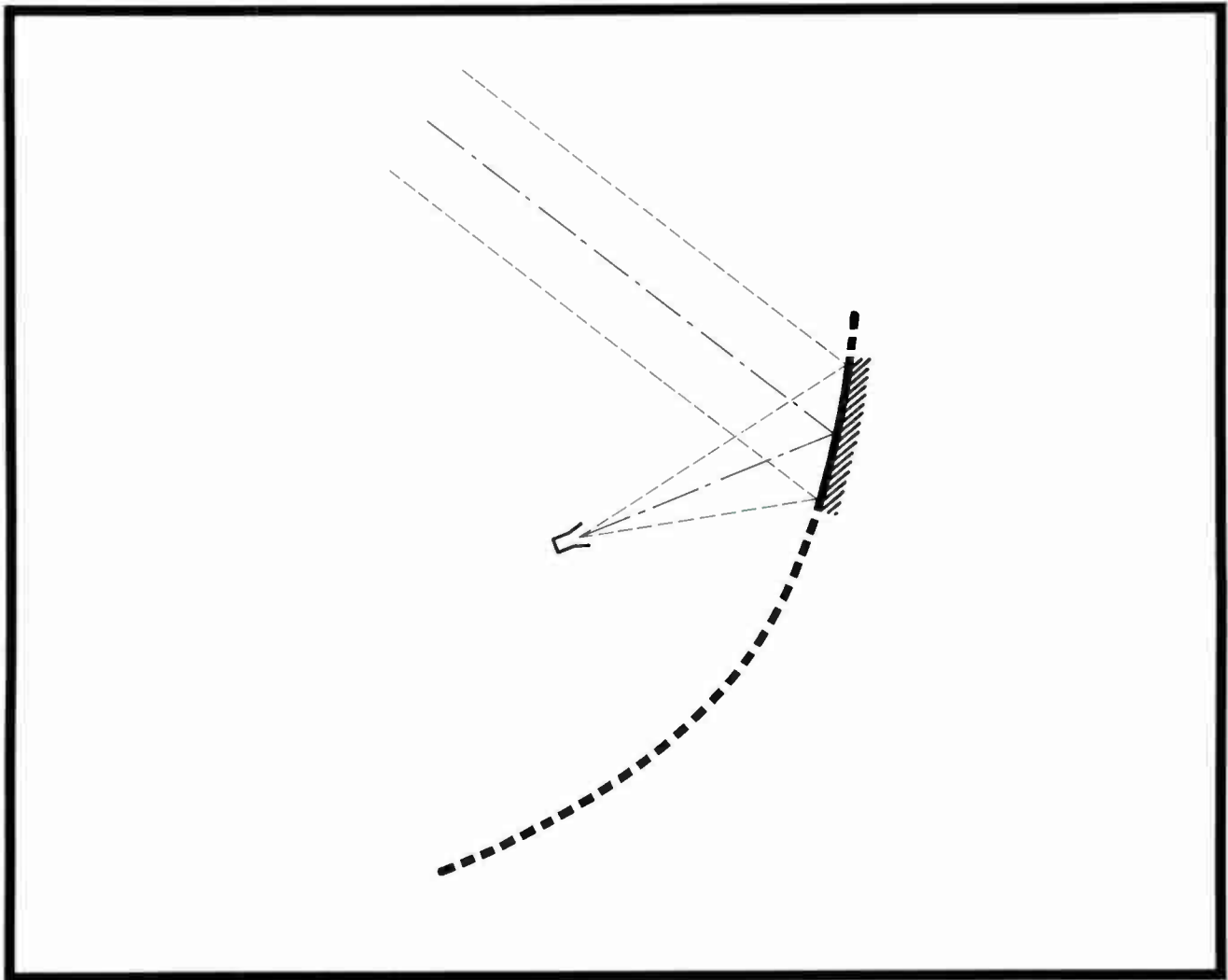

FIGURE 3
OFFSET PARABOLOID — RAY GEOMETRY.

continued

But what of the GaAsFET LNA? Certainly it appears unlikely that a non-converting head unit will find much of a place in 12 GHz terminals. But alternative architectures integrating stages of RF amplification are appearing. Figure 1 shows a block schematic of my own experimental 11/12 GHz head unit, built for OTS in 1978. Two stages of FET amplification before a single-balanced Schottky-diode mixer give a noise figure in the region of 4 dB. The local oscillator is a commercial (Mullard) cavity-stabilized Gunn, on the high side of signal, giving an inverted first IF in the UHF range. The second schematic shown is intended to represent the type of

Equipment &
 Supplies for
 Cable TV
 MDS & STV

405 N. Earl Avenue
 Lafayette, Indiana 47904

Call Toll Free 800-428-7596
 Indiana 800-382-7526

design now being favored, rather than to represent any one manufacturer's approach. Two of the newer half-micron recessed-gate GaAsFETs are used before an image-rejection mixer to achieve a noise figure in the 3 dB region. The local oscillator is a GaAsFET design on microstrip, stabilized by a dielectric resonator puck in the feedback path. The remainder of the receiver is quite conventional, tuning taking

place at the second conversion to a standard IF. Alternatively a UHF phase-locked loop may be used.

The GaAsFETs available continue to improve, though more slowly than in earlier years. Latest and best are the Mitsubishi MGF-1403 with a noise figure of 1.8 dB at 12 GHz (0.7 dB at 4 GHz) and Nippon Electric's new NE673, claiming 1.5 dB at 12 GHz and 0.6 dB at 4 GHz. (For comparison, that

last figure translates to 43°K!) So we may soon be seeing uncooled 12 GHz front ends with 2 dB or better noise figures. Roll in the 40 centimeter dish!

On the antenna front, thoughts have been turning to ways of making the home antenna more acceptable in the domestic environment. A good low noise electronically slewable flat panel antenna has yet to emerge (and there are plenty working towards it) but one angle being pursued in the offset paraboloid. By placing the feed below the reflector and angling it upwards (see Figure 2) not only is aperture blockage eliminated, but antenna noise temperature is reduced (feed spill-over sees more sky, less ground) and accumulation of ice and snow is discouraged. This is the type of antenna being developed by ALCOA-NEC.

Figure 3 shows the ray geometry of the offset system. It is as if the reflector were a portion of a much larger paraboloid. The feed is located at the focus of this imaginary dish (whose boresight is towards the satellite) but because only a portion of the reflector exists, the feed is designed just to illuminate this portion. It then performs just as it would as a part of the larger dish, and directs its beam the same way. So we can reconfigure the required antenna aperture as a flatter, more nearly vertical reflector, with the added advantage of pointing the feed skywards. Fabrication is not complicated, as a metal dish of this size will be pressed or stamped, a plastics reflector will be molded, and there is no need for circular symmetry.

Beyond the next five years, it seems inevitable that a flat panel array of suitable characteristics will be developed. The receiver electronics revolution will come with the MMIC (Monolithic Microwave Integrated Circuit), a complete LNC on a single chip of Gallium Arsenide. Wherever that comes from it is likely to be an OEM deal, much as happens with the UHF tuners in today's TV sets, where the TV manufacturer buys in the 'clever' bits ready-made. □



The PHASECOM MODULATOR & The SAW FILTER. A perfect match.

They're a natural. The Phasecom 2000 Series Modulator and the new solid state SAW (Surface Acoustic Wave) Filter.

Top technical performance. Exceptional reliability. It's what they're both all about. We had to put them together.

So now, every Phasecom Modulator has a SAW Filter at IF. For a perfectly shaped vestigial sideband signal. For flat group delay. Without tuning or

maintenance.

And better yet...at no increase in price. It's all part of our ongoing efforts to bring you the best value in headend electronics in the industry today.



PHASECOM CORP.
The Headend Experts
6365 Arizona Circle
Los Angeles, CA 90045
Tele: (213) 641-3501



Our 'oddballs' mean "No Sweat" Apartment Installations

For wiring apartment buildings for cable, you need more than coax and converters. You also need the 'oddball' items — like reverse transformers. Drive rings. Wall plates. Cable ties. Voltage and continuity testers. Stripping tools. Security sleeves and locking terminators. Taps. Traps. TV/FM splitters. Riser/fault locators. Security boxes. Matching transformers. Attenuator pads. Installation molding. Parental control key locks. UHF/VHF splitters. Right-angle "F" connectors. Marking devices. And a hundred other hard-to-find items. You need The Drop Shop. Because we stock *all* these oddballs and more. So we can ship the same day. For complete one-stop shopping. And no sweat installations.

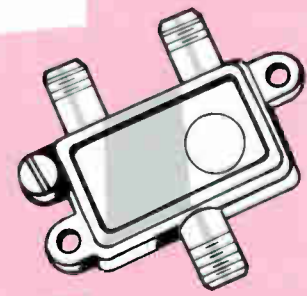
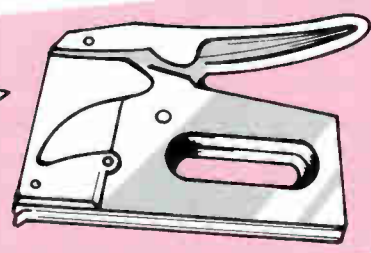
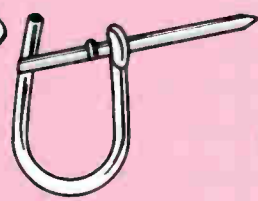
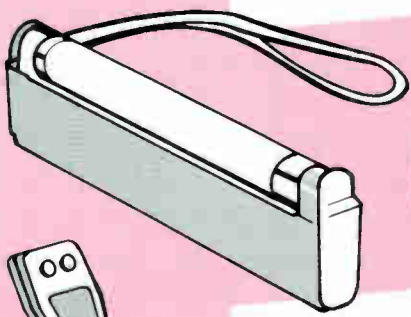
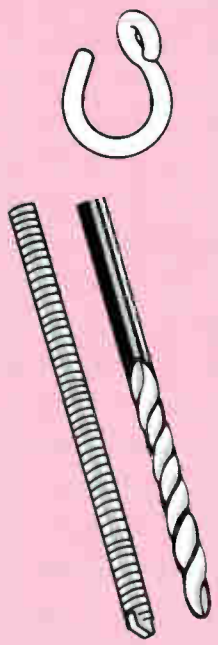

THE DROP SHOP LTD

The Apartment Specialists—
We deliver what others promise.

NEW JERSEY
• P.O. BOX 284, ROSELLE, N.J. 07203
• (201) 241-9300
• TOLL FREE 800-526-4100

CALIFORNIA
• P.O. BOX 4771, HAYWARD, CA 94540
• (415) 887-7474
• TOLL FREE 800-227-0700

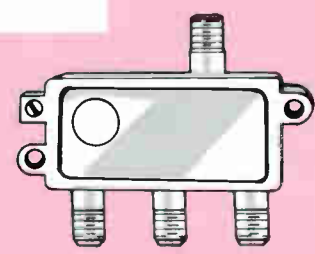
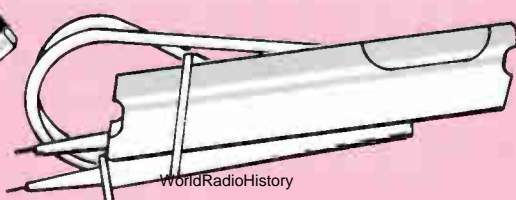
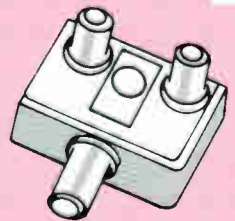
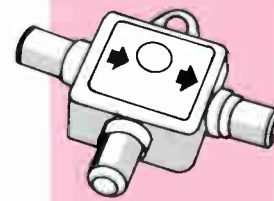
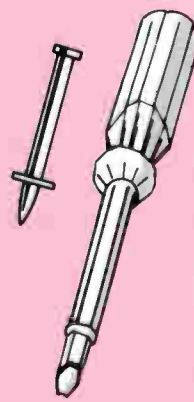

Your Column

Keep Heat Shrink Tubing Clean Inside

PROBLEM: Because it is a low turnover item, the heat shrink tubing that is hauled around in the service trunk for several days or weeks gets full of lint and dirt. It soon becomes unusable and must be thrown away as it will not seal properly. We buy it in long pieces and cut off whatever is needed for each repair job, so losing a whole piece is several dollars of extra cost.

SOLUTION: After my grumbling for several years about the amount of tubing being wasted this way, one of my men suggested the simplest solution in the world: simply squeeze the ends flat and tape it shut with electrical tape, thereby keeping it clean inside. Makes one feel foolish to overlook such a simple solution!

Portable Fuse

A while back we had an intermittent problem that nearly drove us wild. On a section of system that was about three years old and had



given no previous problems, everything would work normally for days, sometimes weeks, and then the fuse would blow in a power supply. We would replace the fuse, and then everything would work normally again and we could find no reason for its blowing. After several trips out, we finally decided that it was definitely a problem that needed special attention. We even

thought that maybe somebody was playing games with us.

After some deliberation, we decided to make a "portable fuse" to put in the line. We took a small die cast housing from an old splitter, put two cable size fittings in it, and connected the center pins with a fast blow fuse. We let both the signal and the power go through the fuse. This did not cause any serious problem with signal degradation.

We opened the line at a tap or splitter and installed the device. At each specific location, the value of the fuse was chosen to be slightly larger than the power passing through it. This way when the short occurred, if it blew the portable fuse, we knew it was still beyond the location, and, if the power supply fuse blew, we were past it. By picking mid-points and halving the remaining part of the system each time, we found it on about the sixth try.

It turned out to be a defective fitting that had a machining whisker left inside. I have no explanation as to why it didn't short and stay shorted, but it didn't. We probably would never have found it without our portable fuse. □

... An exchange of ideas and suggestions from cable operators!! Got an idea or suggestion? Send it in!! Got a problem? Submit it too and perhaps we can get a solution for you! It's yours — use it!

KEEP PACE with the Industry All New 1982

Subscribe

Name

Address

City

State

Zip

CATA MEMBER

NON-MEMBER

* \$14.00 Enclosed for 1 Year

\$18.00 Enclosed for 1 Year

* \$40.00 Enclosed for 3 Years

\$50.00 Enclosed for 3 Years

NOTE: CANADA/MEXICO SUBSCRIBERS: Add \$4.00 per year to rates given above. All other Foreign Countries add \$7.00 per year to rates given above. Special handling arranged upon request. U.S. CURRENCY ONLY.

* MUST FURNISH SYSTEM NAME:

Mail to: CATJ Magazine

Suite 106, 4209 N.W. 23rd

Okla. City, Okla. 73107

WorldRadioHistory

CATJ

COMMUNITY ANTENNA TELEVISION JOURNAL

CBIC

CITIZENS BAND INTERFERENCE COMMITTEE DIAGNOSTIC WALL CHART

Diagnostic Wall Chart Instructions

This Diagnostic Wall Chart is intended to help you identify the cause of CBIC. It contains a list of symptoms and their possible causes. It also includes a flow chart to help you narrow down the possibilities.

Interference is caused by the presence of a transmitter operating in the same frequency band as the receiver. The transmitter may be a radio, a television set, or a mobile phone. The receiver may be a radio, a television set, or a mobile phone. The interference may be caused by the transmitter or the receiver. The chart provides a list of symptoms and their possible causes. It also includes a flow chart to help you narrow down the possibilities.

FCC COMPLIANCE TESTS SUBJECTIVE EVALUATION SYSTEM WALL CHART

HEAD END SIGNAL QUALITY EVALUATION COMPARISON CHART

COMMUNITY ANTENNA TELEVISION JOURNAL FM VIDEO TRANSMISSION WALL CHART

Possible Video Distortions



Excessive Video Level



Low Video Level



Inverted Video



Typical Video



Loss of Low Frequency Response (Preemphasis Gulp)



Loss of High Frequency Response (Microphonic Gulp)



Loss of Color Distortion (Phase Lock)



Impulse Noise (Non-Modulated Video Receiver)

FM VIDEO TRANSMISSION WALL CHART

This chart gives you a basic introduction to FM transmission, helping you to recognize particular distortions or set up problems, whether observed with a waveform monitor or a video monitor.

HEADEND/INTERFERENCE WALL CHART — has more than 20 off-the-screen photos of typical (and not so typical) off-air headend type problems. Each is identified, and with this chart you can zero in on headend problems in one big hurry. Explains what headend interference looks like and leads you to solutions to eliminate it.

FCC TESTS WALL CHART — is the industry's best training tool for teaching system employees how to recognize everything from cross-mod to HumMod. Has more than 60 off-the-screen photos of typical plant problems; things like Hum Mod (with calibration), signal to noise, co-channel and more.

CB INTERFERENCE WALL CHART — leads you quickly and painlessly to cures to CB interference.

COST FOR EACH IS: \$10.00 or \$35.00 set of 4.

NAME _____

ADDRESS _____

CO. NAME _____

ADDRESS _____

CITY _____ **STATE** _____ **ZIP** _____

I am enclosing a check for \$ _____ for the items marked below.

- A — F.M. Video Transmission Chart**
- B — CBIC — Citizens Band Interference Committee Diagnostic Chart**
- C — FCC Compliance Tests Subjective Evaluation System Chart**
- D — Head End Signal Quality Evaluation Comparison Chart**

Mail to: CATJ Magazine
Suite 106, 4209 N.W. 23rd
Okla. City, OKla. 73107

GENERAL COOKBOOK NOTE
 Cookbook designs are selected for their general purpose applicability and for quick construction, using easy-to-get parts. Explicit theory is avoided and is implicit in the simple formulas for circuit elements. We will present each design in "stand alone" form: no need to go to any other technical references!

Power Passing Part 7

General Purpose Bandsplitter CABLE TECH'S

SPLITTER PERFORMANCE

This procedure allows you to design a bandsplitter having low loss pass bands beginning at plus or minus ten percent of the crossover frequency (F_p) and 3DB within plus or minus five percent of the crossover frequency.

As can be seen from the skematic diagram of Figure 1, it consists of a low-pass and high-pass filter properly combined at a common input junction.

DESIGN PROCEDURE

- (1) Select your crossover frequency and call this F_p .
- (2) Compute the inductance and capacitance values using the formulas of Figure 1.
- (3) Select capacitors from standard values (See Figure 1). If calculated values are non-standard (not within five percent of standard value), parallel two or more capacitors which will add up to the correct value.
- (4) Wind your coil inductors. See the formula on Figure 2. Compute the number of turns required and round up to the nearest half turn, to make the circuit layout easier: You can always stretch the coil to reduce the inductance value.
- (5) Circuit layout. Position the coils for low mutual coupling: Adjacent coil axes should be at right angles to one another, if possible. Layout for minimum

lead length on capacitors C_2 , C_3 and C_4 .

TUNING UP

- (1) Peak the crossover. Sweeping insertion loss, obtain as deep a notch as possible at F_p by adjusting coils L_1 and L_5 .
- (2) Adjust return loss in the low band. Sweeping for return loss

maximize return loss in the low band by adjusting coils L_2 and L_3 .

- (3) Maximize return loss in the high band. Adjust coils L_4 and L_5 . Many times it is helpful in obtaining the best return loss for the high band to have two C_4 (the capacitor at the common terminal) adjustable.

Design for 75 ohm Bandsplitter

$L_1 = 40.5/F_p$	$C_1 = 624/F_p$
$L_2 = 21/F_p$	$C_2 = 3658/F_p$
$L_3 = 31.3/F_p$	$C_3 = 786/F_p$
$L_4 = 7.16/F_p$	$C_4 = 1180/F_p$
$L_5 = 43/F_p$	$C_5 = 585/F_p$

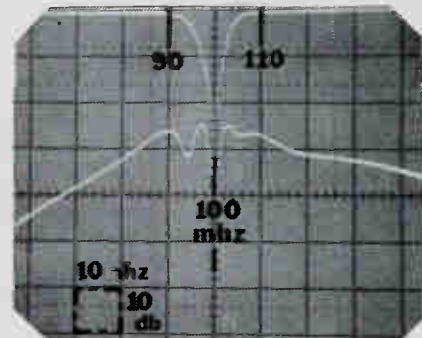

Spectrum Sweep of Completed Filter

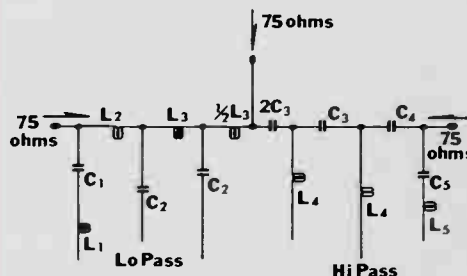

STANDARD CAPACITANCE VALUES			
Primary standard values are:			
1.0	2.7	5.0	MULTIPLY THESE BY 10, 100, etc. AND GET OTHER STANDARD VALUES
1.2	3.0	5.6	
1.5	3.3	6.8	
1.8	3.9	7.5	
2.2	4.7	8.2	

Figure 1
Design for 75 ohm Bandsplitter



FILTER COOKBOOK

by: Glyn Bostick
Jean Dickinson
Microwave Filter Company, Inc.

DESIGN EXAMPLE

We want to split the low band (Channels 2-4) from mid and high band (120 to 216 mhz).

The FM band is not important to us in this case so we chose a crossover frequency (Fp) of 100 Mhz.

(2)/(3)/(4) Using 100 Mhz as our Fp, we compute the capacitance and inductor values required. We select the capacitors from the standard capacitance value table and we wind the coils per Figure 2. The table below shows the computed element values including calculated turns together with final values used in this design.

COIL	Computed Inductance (uh)	Computed #Turns	Final Used
L1	.405	7.28	7
L2	.21	4.59	5
L3	.313	6.05	6
1/2 L3	.157	3.77	5
L4	.0716	2.31	2
L5	.43	7.61	8



Figure 2
Design of 75 Ohm Bandsplitter

CAPACITOR	Computed Capacitance (PF)	Final Used
C1	6.24	6.8
C2	36.58	3.9
C3	7.86	8.2
2C3	15.72	12.0
C4	11.8	12.0
C5	5.85	5.6

Figure 1 is a spectrum sweep of the completed filter.

NEXT TIME

By request, we will go back to the simple shot trap and show how to build it for good return loss even at the notch frequency. We understand that there are times when you want to dissipate an interfering carrier at the trap: You don't want it reflecting back into delicate electronics.

ACKNOWLEDGEMENTS

Many thanks to John Greatrex for Line Art, Dave Skeval for Photography, and to Denise Dickinson for Mechanical Assembly. □

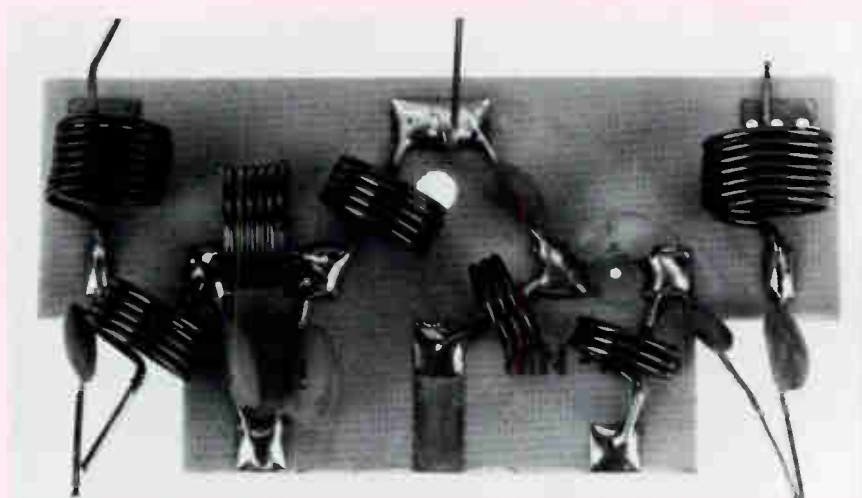

Figure 3
Picture of Completed Circuit
W/Elements from Example Mounted

Microwave Data Transmission Using AML Techniques

By: A.H. Sonnenschein P.E., I. Rabowsky,
and W.C. Margiotta
HUGHES AIRCRAFT COMPANY
MICROWAVE COMMUNICATIONS
PRODUCTS

This paper discusses the characteristics and relative merits of some of the alternate signal modulation methods which are employed to transmit various forms of data and voice over AML microwave systems.

AML systems have during the past 10 years become widely accepted as the dominant means for

the local distribution of multiple video signals in the CATV industry. The reasons for this extensive use of more than 20,000 video channel paths worldwide are tabulated in Figures 1 and 2. In a nutshell, these reasons are that AML systems are more cost effective, spectrum efficient, and reliable than any of the available alternatives.

The trend towards the use of AML hub distribution systems has further accelerated in recent years, as a direct consequence of the dramatic increase of channel capacity of major market franchises. This increase in channel loading has the following effects: 1 - A shortening of permissible amplifier cascades, 2 - A major increase in the cost of

- ECONOMICAL FOR MULTIPLE CHANNELS
- SPECTRUM EFFICIENT — HIGH CHANNEL CAPACITY
- CABLE COMPATIBLE — VHF IN/OUT
- GOOD PERFORMANCE
- HIGH RELIABILITY

Figure 1. Why AML?

- INCREASED CHANNEL CAPACITY REQUIREMENTS & DUAL CABLE SYSTEMS
- SHORTER AMPLIFIER CASCADES (MORE HUBS)
- ESCALATING COST OF HEADENDS
- FREQUENCY RE-USE TECHNIQUES
- ACCELERATING CASH FLOW BY LEAPFROGGING TO PROFITABLE AREAS

Figure 2. Further Reasons For Recent Proliferation of AML in Major Urban Markets.

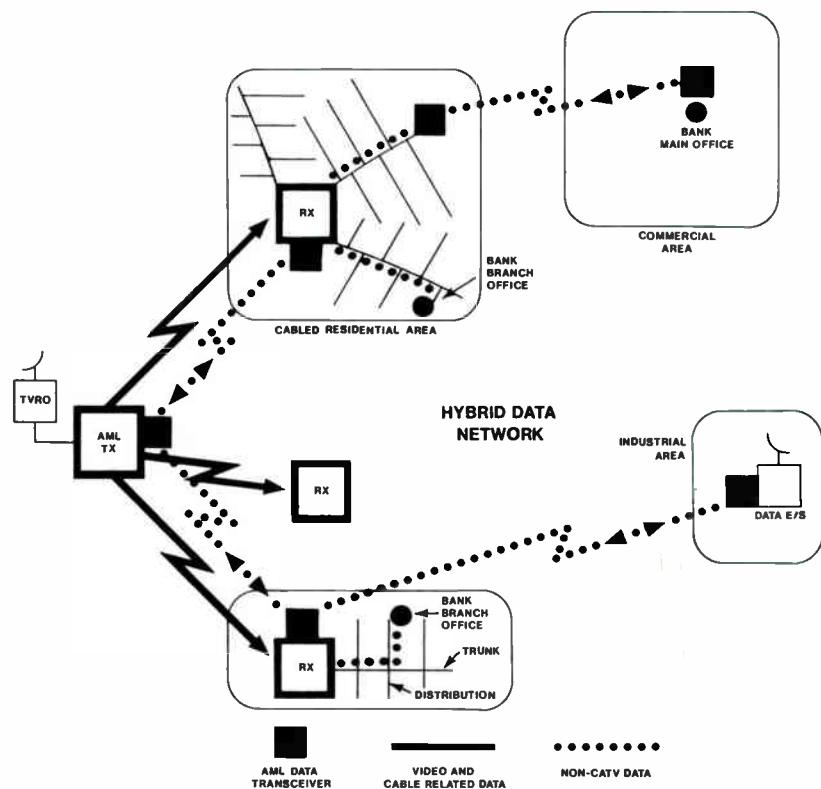

Figure 3. Hybrid Data Network.

sophisticated headends to an extent that the cost of duplicating headends at various hubs becomes prohibitive, and 3 - A further strain on limited frequency allocations. All the factors have intensified the necessity for the use of AML systems in suburban as well as rural areas. Channel capacities as high as 160 channels are frequently necessary to accommodate all upstream as well as downstream transmission requirements.

More recently, various forms of data transmission requirements have been added to the prior video and FM broadcast traffic requirements. Some of these new requirements are CATV related, for instance security alarm signals, subscriber addressable control signals, interactive service signals, etc. An even larger growth area however is represented by opportunities for carrying signals for unrelated non-CATV entities on a leased channel basis. Potential customers include various kinds of institutions as well as commercial and industrial establishments.

Thus there are two major reasons why we have had to implement the data transmission capabilities of AML systems. First is the obvious fact that where the AML system forms the backbone of a CATV system, it must be capable of transmitting all required cable related as well as all leased channel data traffic. More importantly however is the fact that many potential commercial and industrial customers for data transmission services are in non-residential areas that are not cabled now, and that will be the last to be cabled — if they are ever cabled. Thus, a hybrid transmission system, as illustrated in **Figure 3** is the only practical means of serving such potential data transmission customers. As the illustrations indicate, microwave relays are used to complement the CATV system, extending service to uncabled areas.

Before proceeding on to the various different data modulation methods, it is useful to briefly summarize the principle of operation of an AML system, from a broader perspective than is common in normal CATV video usage (see **Figure**

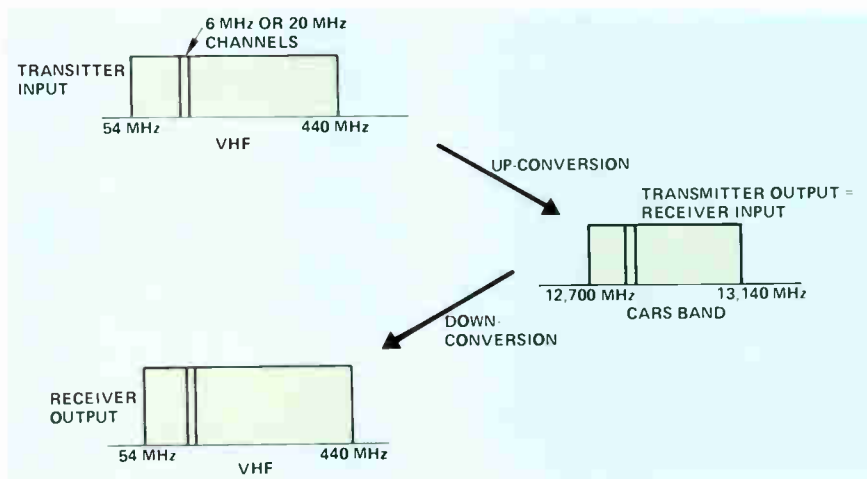

Figure 4. AML - Principle of Operation.

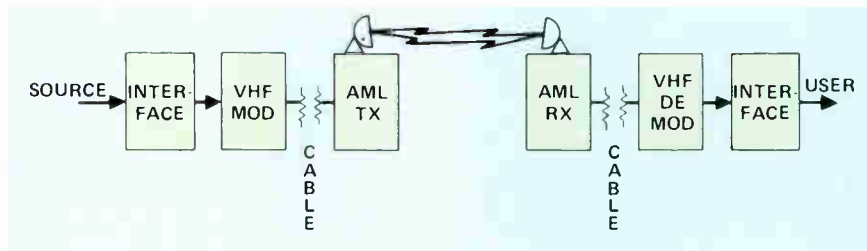

Figure 5. Block Diagram.

MODULATION	TECHNIQUE	APPLICATION
VSB	VESTIGIAL SIDEBAND AM	VIDEO/DATA
FM	FREQUENCY MODULATION	VIDEO/VOICE & DATA
SSB	SINGLE SIDEBAND SUPRESSED CARRIER AM	VOICE & DATA
FSK	FREQUENCY SHIFT KEYING	VOICE & DATA
QPSK	QUADRATURE PHASE SHIFT KEYING	VOICE & DATA

Figure 6. Modulation Techniques for Data Transmission.

4). It can be seen that the AML system is essentially a frequency translating device. It simply up-converts any signals that lie in the VHF band to the 12 GHz band, transmits these signals from one place to another and then down-

converts the received signals back to VHF again. In this process, it fully preserves all incoming modulation forms and spectral relationships. Thus the acronym AML no longer

continued

only denotes an "Amplitude Modulated Link" for VSBAM video signals, but rather a faithful and transparent microwave transmission system for any or all modulation forms, be they digital or analog. It has only half jokingly been suggested that AML really means "Any Modulation Link" and it is with this broadened scope that we wish to deal with here, bearing in mind that all the previously mentioned cost and bandwidth saving attributes of AML systems recognized for video traffic apply equally well to data transmission.

As illustrated in Figure 5 a typical block diagram of an AML one-way data link consists of an appropriate interface with the transmitting data equipment followed by a modulator which provides a modulated VHF carrier at its output. The VHF modulator output is connected to the input of an AML transmitter which then upconverts the VHF signal to the authorized microwave frequency. The signal received at a remote site by the AML receiver is downconverted to VHF and fed to a VHF demodulator. The output of the demodulator provides the appropriate interface with the receiving data communications equipment. Two-way communications is obtained by duplicating the equipment shown, with the exception of the antenna systems, at each data communications site and by providing frequency distinction between the upstream and downstream paths.

The modulators and demodulators may be remote from the AML equipment, being interconnected with standard CATV cable links.

There are a number of standard data communications interfaces which may be required to interconnect the data equipment to the modulator-demodulator (modem) equipment. Data processing standard interfaces such as RS-232C, RS422 and V.35 are readily available. Bell standard interfaces such as DS1, DS2 are also available.

There are five modulation methods that are being widely used for transmission of voice and data. They are tabulated in Figure 6. As

APPLICATIONS	SIGNAL RANGE	ADVANTAGES	DISADVANTAGES
• VIDEO & PROGRAM AUDIO	NTSC STANDARD COMPOSITE VIDEO 6 MHz BANDWIDTH	• SPECTRUM EFFICIENT • CABLE COMPATIBLE • ECONOMICAL	NO FM IMPROVEMENT
• LOW SPEED DATA	3 CHANNELS 600 b/sec	• INEXPENSIVE	VERY LOW DATA RATE
• LINE SYNC MULTIPLEX	ANY COMBINATION OF NTSC VIDEO, OR DATA TO A TOTAL OF 6.3 Mb/sec	• POTENTIALLY LOW COST IN LARGE VOLUME • TDMA • FREQUENCY SHARED • TELETEXT COMPATIBLE	NOT YET COMMERCIALY AVAILABLE

Figure 7. VSB.

APPLICATION	SIGNAL RANGE	ADVANTAGES	DISADVANTAGES
• VIDEO & PROGRAM AUDIO	STANDARD NTSC VIDEO & AUDIO	FM IMPROVEMENT OF SIGNAL TO NOISE	REQUIRES 20 MHz
• BROADCAST AUDIO FM	16 CHANNELS @ 15 KHz AUDIO @ 75 KHz DEVIATION	LOW COST, FM IMPROVEMENT	REQUIRES 20 MHz
• VOICE ANALOGUE	600 CHANNELS OF FDM @ 4 KHz EA	MODERATELY HEAVY DENSITY	REQUIRES 20 MHz
• VOICE DIGITAL	192 VOICE CHANNELS T1 COMPATIBLE	COMPATIBLE WITH DIGITAL SWITCHING	SPECTRUM INEFFICIENT, COMBINED ON ONE STREAM
• DATA ANALOGUE	600 FDM CHANNELS EACH CHANNEL 14.4 Kb/s	FM IMPROVEMENT EDP COMPATIBLE	LIMITED DATA RATES, REQUIRES DATA MODEMS
• DATA DIGITAL	12 Mb/sec IN T1 FORMAT	FM IMPROVEMENT, T1 COMPATIBLE.	EXPENSIVE MULTIPLEXERS, SELECTIVE FADING SENSITIVE

Figure 8. FM (20 MHz).

APPLICATION	SIGNAL RANGE	ADVANTAGES	DISADVANTAGES
VOICE	< 960 CHANNELS OF FDM @ 4 KHz EA	• SPECTRUM EFFICIENT	NO FM IMPROVEMENT
DATA	< 960 CHANNELS @ < 14.4 Kb/s	• COMPATIBLE WITH STANDARD EDP INTERFACES. • SPECTRUM EFFICIENT	NO FM IMPROVEMENT

Figure 9. SSB (6 MHz BW).

APPLICATION	SIGNAL RANGE	ADVANTAGES	DISADVANTAGES
DATA	< 56 CHANNELS @ 56 Kb/s	LOW COST CABLE COMPATIBLE	VERY SPECTRUM INEFFICIENT

Figure 10. FSK (Frequency Shift Keying).

APPLICATION	SIGNAL RANGE	ADVANTAGES	DISADVANTAGES
VOICE	144 T1 COMPATIBLE VOICE CHANNELS	• SPECTRUM EFFICIENT. • CABLE COMPATIBLE • PARTIONABLE USING FDM TECHNIQUES	REQUIRES HIGH C/N RATIOS FOR LOW BER COMPARED TO FM OR FSK
DATA	10 Mb/s IN A 6 MHz BANDWIDTH SLOT	• SPECTRUM EFFICIENT • CABLE COMPATIBLE • PARTIONABLE USING FDM TECHNIQUES	REQUIRES HIGH C/N RATIOS FOR LOW BER COMPARED TO FM OR FSK

Figure 11. QPSK (Quadrature Phase Shift Keying).

you can see from the table, the familiar VSB and FM modulation methods can be used for either video or data transmission.

Each form of modulation has its own particular advantages and disadvantages to be considered when designing a data communications system for a particular application and for transmission through a broadband cable system.

Figures 7, 8, 9, 10 and 11 tabulate some of the characteristics of VSB, FM, SSB, FSK and QPSK modulation in relationship to the transmission of voice and data. These charts describe the applications and relative merits of the various modulation methods for different types of message traffic requirements.

Upon review of a specific application, it should be possible to narrow down the selection of equipment to a preferred choice. For example, if you are to transmit data during daylight hours and entertainment video at night, you would most likely choose VSB and use line sync multiplex equipment to transmit the data. Line sync multiplex equipment is designed to convert standard data formats into teletext format and to transmit up to 525 lines of data at the rate of 9600 BPS for each line.

If the application calls for subdividing a 6 MHz channel into many standard 4 KHz voice channels and thus serve many users of voice and data, then you will use Frequency Division Multiplex (FDM) equipment together with a single sideband modulator.

If the application calls for a data network to connect a few hundred data terminals to a computer center, and if available spectrum on the cable is not in short supply, you will use an economical FSK data communications systems.

Finally, if you have a mix of high speed data requirements such as 1.544 MBPS T1 lines for digital telephone switching systems, or 1 MBPS lines for high speed graphics terminals, then you will use the QPSK RF data modems. Because a 1.544 MBPS data modem requires a bandwidth of about 1.1 MHz it is possible to subdivide the 6 MHz channel

and by utilizing FDM techniques isolate T1 data streams from one another, thus providing security between applications and preventing intersymbol interference from interrupting the entire data transmission in the channel.

The data communications network designer should become thoroughly familiar with each of the modulation methods listed above, and the wide variety of interfacing data communications equipment. This information together with the knowledge that the AML microwave link is equivalent to a short length of broadband coaxial cable makes it possible to design cost effective, reliable data communications networks.

In conclusion, we would like to reiterate the following points.

1. Message traffic in general, and data traffic in particular, offer one of the most promising and profitable enhanced service opportunities for CATV operators.

2. Data transmission requirements consist of CATV related traffic (such as interactive services or station monitoring) as well as traffic for institutional, commercial and industrial customers.

3. Such data traffic requires high transmission reliability and spectral utilization efficiency.

4. Commercial and industrial customers are frequency not in cabled areas and can only be reached by hybrid systems combining cable compatible microwave and cable elements.

5. AML microwave techniques offer advantageous means of accommodating virtually any analog or digital signal capable of being carried on conventional cable systems. In such applications, the AML system becomes a virtually transparent link which completely avoids the distortions and other technical and financial costs inherent in microwave systems that require demodulation of the cable-carried signals to baseband and subsequent remodulation to cable compatible formats. □

(Publication in NCTA's 1982 Technical Papers)

TO-packaged Mixer and IF Gain Modules for TVRO... From Avantek

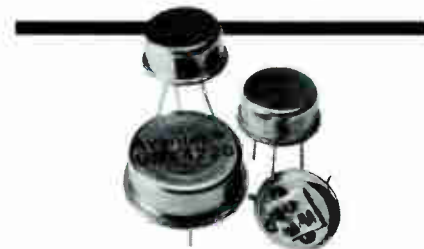

UMX-4220 TVRO Mixer (TO-8 package):

- 3.7–4.2 GHz RF, 2.4–5.5 GHz LO, DC–1.3 GHz IF
- 6 dB Maximum SSB Noise Figure
- Low R-port VSWR for low passband ripple
- Low L-port VSWR minimizes oscillator pulling
- Low LO Leakage prevents interference

UTO and GPD Series IF gain modules:

- 0.1–1500 MHz (TO-12), 5–2300 MHz (TO-8)
- Use in conventional microstrip PC board
- Cascadable without performance loss
- UTO Series: High Performance, GPD Series: Low Cost
- Eliminates amplifier design problems

Avantek's UMX-4220 and IF gain modules simplify TVRO design, assure excellent performance and minimize customer returns. They're perfect complements to the TVO-8370, a voltage-tuned local oscillator designed and priced for TVRO applications. Contact Avantek for the address and phone number of your nearest stocking distributor, who will provide detailed information on performance and on our competitive pricing for all these TVRO components.

the vertically integrated company

Avantek

3175 Bowers Avenue
Santa Clara, California 95051
(408) 496-6710

DECEMBER, 1982 CATJ 25

CATJ

wishes to take this opportunity to extend the warmest of wishes for a very happy holiday season to all of its readers, advertisers, and supporters.

At this time of year, feelings for our fellow-man mellow and flow into those of cheer and goodwill, and we welcome this holy time to reflect on our many blessings. We live in a land where the blessings number freedom, opportunity, and abundance, and we wish to join with you at this happy time to share the joy of the season.

G.H. Dodson
Publisher

Celeste Rule
Managing Editor

Diane Howard
Executive Assistant

Phyllis Crumpler
Art Director

Dianna Johnson
Assistant Art Director

Carolyn McCray
Circulation



all of their "intuitive logic" was wrong! The importation of distant signals did not in fact have an adverse economic impact on local broadcasters — so the Commission dropped the distant signal rules.

Why have we gone through this piece of history? Because it is important to understand what happened before in order to appreciate how wrong-headed the current CRT decision is! You see, the CRT is supposed to deal with the value of copyrighted signals, not the protection of broadcast stations. Somehow those two things have gotten totally balled up in this decision. For what the CRT has actually done is reimpose the distant signal rules, but they have done so by the use of economics instead of federal "carriage rules".

The amount of money we pay for the distant signals we carried in the past, under the FCC's old rules, was set by Congress. The CRT can make adjustments to those fees for inflation, etc. but they cannot change the basic formula. Congress made it clear in setting the formula that the intention was to assure that cable subscribers would get to see the programming in question. What the CRT appears to have done is intentionally to set the rates that they have power over so high that cable subscribers will not get to see those signals! We think that the CRT has violated its own mandate.

The price they have set is 3.75 percent of gross basic subscriber revenue for each additional DSE that is carried in excess of those that were allowed to be carried prior to the Commission eliminating its distant signal rules. You should keep in mind that each distant independent television signal counts for one "DSE" and each educational or network signal counts for a quarter of a "DSE". For the sake of simplicity, we will talk about independent signals here, since that is the

real point of contention, but remember that the decision applies to networks and educational stations as well.

Let's take an example to see how this decision works. Let's say you operate a system with 4000 subscribers. Your basic subscriber rate is \$9.00/month. That means you gross \$432,000 per year on basic revenues alone, or \$216,000 per half year. Any cable operator grossing over \$214,000 per half year must file copyright payments based on the "long form", and therefore you calculate "DSE's", thus the new rates will apply to you.

Let's assume the system is in a smaller market, one that under the old FCC rules was only allowed to import one distant signal. So you "imported" WGN from Chicago since it was available on a microwave loop that went near your system. For the first time, the subscribers in your home town were able to watch programming other than from the networks. They loved it. Then the Commission dropped its distant signal rules, and, of course, in the meantime you had installed a small earth terminal to pick up programming via satellite. Now you could serve your subscribers even better. For a charge of ten cents per subscriber per month delivery charge you could, and did, bring in not only WGN, but WOR and WTBS — all distant independent broadcast television signals. Now, for the first time, your subscribers had a choice! They loved it even more!

Now comes the CRT decision. Those two "extra" distant signals have arbitrarily been assigned a "value" by the CRT. That "value" is supposed to approximate the marketplace, but let's see if it really does. Those two signals will cost you 3.75 percent of gross basic revenue EACH as of January 1, 1983! That means, in our example, that you will have to pay a copyright fee of \$16,200 per

Upgrade your SLE line extenders with push-pull hybrid electronics - Broadband now offers the BMK-53 in ready-to install modules.*

With our BMK-53 now in ready-to-install modules, it's a relatively simple matter to upgrade your Jerrold® SLE-1, 20 2P line extenders to 300 MHz push-pull hybrid electronics. Another cost effective option from Broadband, it features:

- Push-pull hybrid electronics
- 300 MHz - 35 channel capacity
- 30 or 60 volt powering options
- 28 dB gain (standard module)
- 32 dB gain (high gain module)
- Three levels of surge protection
- 12 to 20 dB of equalization at 300 MHz

Pricing as low as \$99.50 for more than 50 pieces.

*Also available as a replacement assembly ready to install in your existing module.

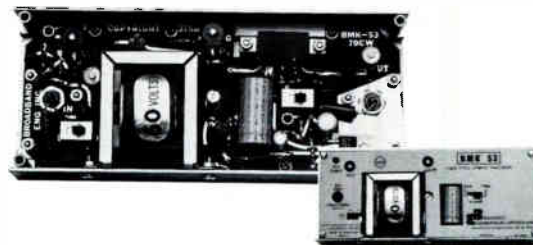

For free specification sheets and pricing, call our toll-free number (800-327-6690) or write Broadband Engineering, Inc., P.O. Box 1247, Jupiter, Florida 33458.

BROADBAND™
A SUBSIDIARY OF **AUGAT**

year for each additional signal. That comes out to about \$.35 cents per month per subscriber. And of course that does not count the delivery cost, which is another \$.10 per month per subscriber. A total of almost \$.50 per month per subscriber! There are no other advertiser supported programs even offered to cable television operators that come even close to that cost. It will be interesting to hear how the CRT justifies that rate as a so-called "marketplace value"!

In fact, what they have done is pretty clear. They have made a communications policy decision, not a copyright decision. In fact the head of the Tribunal, in talking to reporters about the decision, acknowledged that they did not really expect cable operators to pay the fee, they expected us to drop the signals! That is about as strong a showing as can be made that they did not really make a "marketplace" decision! There are very good grounds for an appeal.

But what about right now? The appeal won't do us much good by the time we have to make up our minds as to whether to continue to carry these signals or not. **Remember, any signal in the class we have just discussed that you carry on Jan. 1, 1983 will cost you 3.75 percent of gross subscriber revenue!** Even if there is a court appeal and a "stay" of the effectiveness of the rules, you will still have to pay that much if the appeal is unsuccessful. So a decision will have to be made now as to whether you want to carry those signals for that price or not.

How much is a distant signal worth? That has been a question we have discussed many times on these pages. It is something only you can decide in your own community. Since there are now lots of alternative sources of programming it may be that the sensible route is to drop the extra distant signals and add something like ESPN or CNN or C-SPAN, SPN, DAYTIME, USA or one of the others. Why you could even start looking at the possibility of selling your own ads! This is one of the ironies of this decision. Once again in an effort to "protect" the broadcaster, we are being forced to go into direct competition with him for local advertising dollars, something we would not have done if he had just supported our importation of distant signals! If we were local broadcasters we would be fighting against this decision as hard as we could!

WHO GETS HURT THE MOST?

The subscriber. As usual, our customers will be the ones to suffer. They will have lost the ability to choose among the competitive programming channels. The impact will be felt most in two different places — first, as we noted, in the smaller market, larger system. Why? Because the increase does not apply to the smaller market, smaller system and in the larger markets the

operators were already allowed to import two distant signals, so they will not feel the loss as much (they may have to drop one independent, rather than two). Another group that may get hit hard is the large urban systems. In the franchise wars they have all promised to import usually three and sometimes more distant signals. Those signals, or at least some of them, will now cost 3.75 percent of gross basic subscriber revenues! Now anyone who has been reading the CATACable knows that we have serious doubts about whether those urban promises can be met in the first place, let alone with another 3.75 or 7.50 or 11.25 percent taken off the bottom line! Of course the cable operators will have a very good reason to go back to the cities and ask to renegotiate, but the cities have not been too keen on that idea lately!

One possible saving grace for the urban promise operators is that in many cases the "basic" revenue will be low — based on \$2.00 or \$3.00 "basic" service. Naturally we expect a lot of court suits to develop challenging what the "basic" rate really is, but we can also see a clear justification for operators of any size to re-think the "packaging" of their services. It may very well be that the time has now come to "give away" "basic" service in order to entice subscribers to get the enhanced services — after all, that is where the

continued

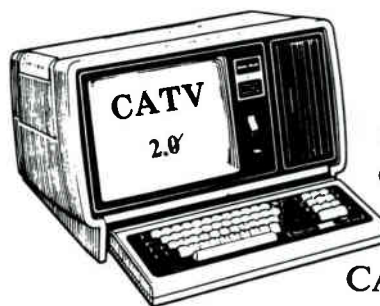

Streamline Your Cable
Operation With _____

CATV BILLING, ACCOUNTS RECEIVABLE, AND CASH RECEIPTS SYSTEM

up to 2,500 subscribers		up to 5,000 subscribers	
TRS-80 Model II	\$3,499	TRS-80 Model II	\$3,499
2 Disk Expansion	1,750	8.5 MB Hard Disk	4,500
DMP 500 Printer	1,795	DMP 500 Printer	1,795
CATV 2.0 Software	1,750	CATV 2.0-HD Software	2,000
	\$8,794		\$11,794
up to 5,000 subscribers		up to \$10,000 subscribers*	
TRS-80 Model 16	\$5,798	TRS-80 Model 16	\$5,798
DMP 500 Printer	1,795	8.5 MB Hard Disk	4,500
CATV 4.0 Software	2,550	DMP 2000 Printer	3,795
	\$10,143	CATV 4.0-HD Software	2,800
			\$16,893

*20,000 with extra equipment

**Radio
Shack**
(207)-496-2281

Associate Store
P.O. Box 749
Caribou, Maine 00736

operator can make incremental increases in income — such as through pay, or advertising, or whatever. What if we gave “basic” away free for any subscriber who ordered the “enhanced basic” package of advertiser supported cable originated channels? Suffice it to say that it is going to be interesting to watch!

SYNDICATED EXCLUSIVITY

The CRT also added to the fees of certain operators because they no longer have to black out syndicated programming under the FCC rules. These additional fees apply only to operators filing the “long form” copyright accounting form based on “DSE’s” (just as in the case of the distant signal rules mentioned above) who are also in either the “top 50” or “second 50” television markets. They did that because those are the only places to which the old syndicated exclusivity rules applied. You can see the rate increases in the chart printed in this issue. In short if you are in the top 50 markets and your DSE rate increases by 75% and if you are in the second 50 markets it increases by about 38%. All in all not an overwhelmingly bad increase considering the amounts that were being demanded by the other side in the hearings.

There were, by the way, some other pieces of good news coming out of the CRT decision. By

the way, as this is being written the formal written decision of the CRT has yet to be published, so there may be some technical changes later on. Anyway, you should appreciate the fact that the CRT theoretically could have applied the distant signal rate increases retroactively to the day the FCC dropped its rules (June 24, 1981). They decided against that, in favor of giving cable operators the chance to get rid of any additional signals they don't want to have to pay extra for before Jan. 1, 1983. Also, the CRT could have imposed another “cost of living” increase on all the rates. They decided against that too.

NOW WHAT?

Well, by Jan. 1, 1983, if you operate a system that is affected by the rate increases, you will have to decide whether you want to pay those rates, (or whether your subscribers are willing to pay the extra fee for them) or not. If the answer is no, then you have to be sure the signals are not carried after Dec. 31, 1982. No court challenge that we can mount now will successfully work before that decision must be made. The same is true of any action we might seek on Capitol Hill.

Yes, much as we hate to say it, this decision will probably mean that we will have to go through at least one more year of battling over copyright in

SADELCO

PRINTING SIGNAL LEVEL METER SYSTEM

FEATURES:

- VLSI controlled miniature printer
- Use with SADELCO Digit Level Series Meters
- ASCII Parallel Computer Interface available
- Custom Systems available on request

CT 1007	= +04.4 dB
CT 1008	= -10.6 dB
CT 1047	= +06.3 dB
CT 1048	= -10.3 dB
CT 1087	= +04.6 dB
CT 1088	= -10.6 dB
CT 1107	= +04.6 dB
CT 1108	= -10.6 dB
CT 1117	= +04.6 dB
CT 1118	= -10.6 dB

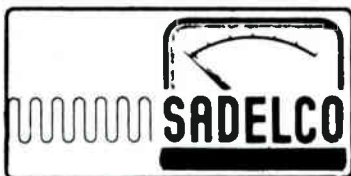
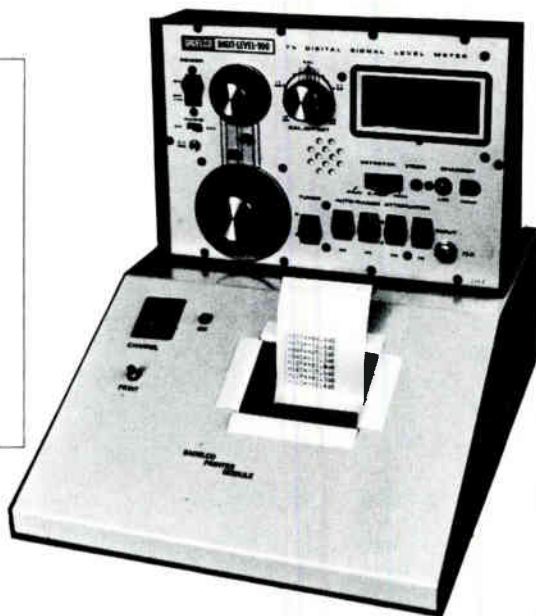

FOR INFORMATION
 CONTACT: JOE SADEL
 5053 San Lorenzo Dr., Santa Barbara CA 93111
 tel. (805) 964-8909

CATA — GLANCE: THE COPYRIGHT RATE INCREASE

Who Does it Apply To?

All systems which calculate copyright payments using copyright accounting form CS/SA 3 (the "long form") — that is, those systems with gross subscriber revenue in excess of \$214,000 per half year. If you do not calculate your copyright fees based on "Distant Signal Equivalents" (DSE) then NONE of these increases apply to you.

When?

The fees will apply to all signals carried as of the first accounting period of 1983.

Distant Signal Increase:

For each "DSE" (either a full DSE for each independent signal or 1/4 DSE for each educational or network signal imported) you continue to carry as of Jan. 1, 1983 that you were not allowed to carry when the FCC's distant signal rules were in force you will have to pay 3.75 percent of basic subscriber revenue.

Syndicated Exclusivity Rate Increase:

Because syndicated exclusivity is no longer applied, the CRT has determined that the value of signals already carried in the top 100 markets has increased by the following amounts;

Top 50 Markets —

	old fee	+	add	=	new fee
1st DSE	.799		.599		1.398
2/3/4 DSE	.503		.377		.880
5th or more	.237		.178		.415

Second 50 Markets

1st DSE	.799		.300		1.099
2/3/4 DSE	.503		.189		.692
5th or more	.237		.089		.326

continued

*New
Low Prices*

\$500.00
\$600.00

(1-24)
110°K NOISE TEMPERATURE

(1-24)
100°K NOISE TEMPERATURE

- IMMEDIATE DELIVERY
- MILITARY QUALITY: MIL-I-45208
- 12 MONTH GUARANTEE
- FACTORY REPAIR SERVICE

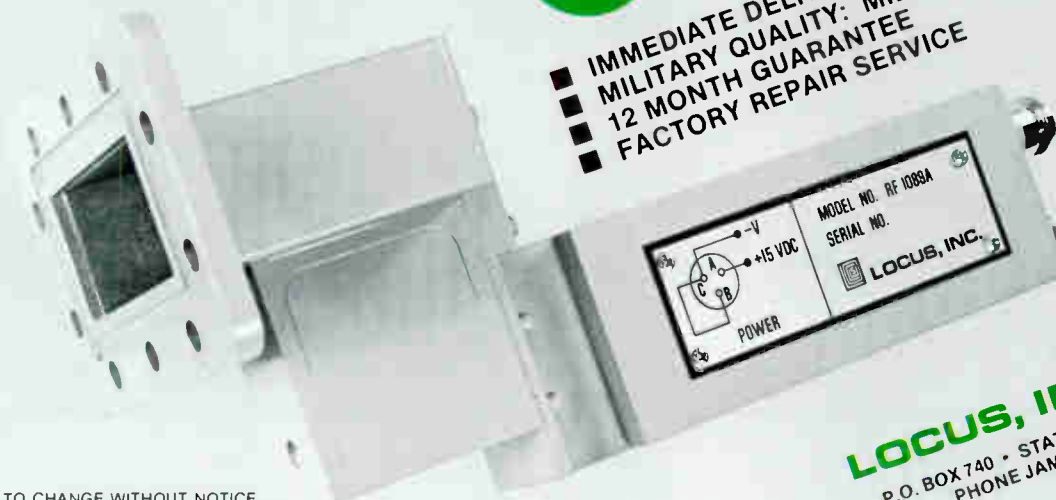

LOCUS, INC.
P.O. BOX 740 • STATE COLLEGE, PA 16801
PHONE JAMES HESS (814) 466-6275

PRICES SUBJECT TO CHANGE WITHOUT NOTICE
ALL SHIPMENTS C.O.D. WITH PRIOR ARRANGEMENT

WorldRadioHistory

The character generator that plugs into an Apple. Marquee 800.

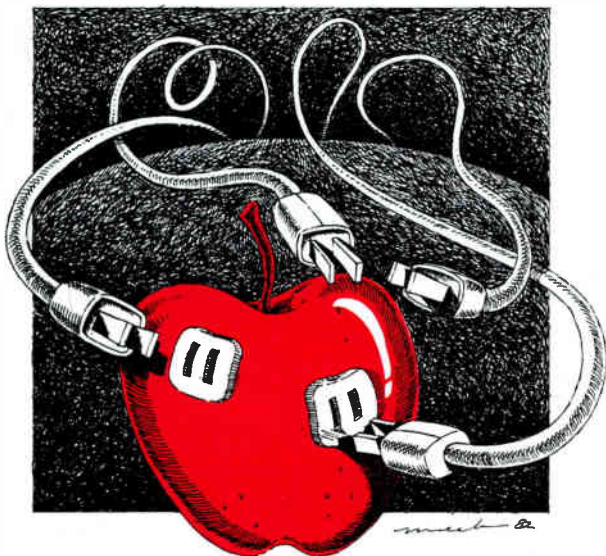

Now you can program and control an unlimited number of Marquee 800 character generators, local or remote, with one Apple II* computer.

The Marquee/Apple Sequence System makes it possible to format display pages and crawl messages, and send them at specified times to any number of Marquee character generators.

The system allows virtually unlimited storage of pages and crawl messages, and accommodates sending on either wire pair, or automatic dial-up systems.

Marquee 800. The character generator that can interface with an Apple. Call us today for more information about this system.

TOLL FREE: 1-800-255-6226

In Kansas: 913 764-1900

TWX: 910 749-6401

WRITE: P.O. Box 937

Olathe, KS 66061



Serving the television industry since 1967

*Apple is a registered trademark of Apple Computer Inc.

Congress. The decision, combined with the court reversal recently of the "EMI" case has resulted in H.R. 5949 not being the "final solution" to the copyright issue that we had all hoped. The odds are now that it will not be adopted during the "lame duck" session of Congress. Thus, we will start over again next year — possibly with a bill that will correct the mess the CRT has just created!

Of course any "solution" may really be too late. This decision will have an impact on all systems well before there is any new legislation or court reversal. We expect to see a lot of systems drop at least one distant independent signal. That, in turn, will mean that there may not be enough support to pay for three distant independent signals on satellite. Further, the "superstations" that were counting on carriage in the major urban markets may not be able to count so completely on that carriage any more.

Needless to say, there are lots of complications with this new decision and lots of individual cases that have to be worked out. As usual, CATA's Washington Office will be glad to try to help you out to the degree we can — just give us a call, that is what CATA is all about.

REALITY IS COMING! REALITY IS COMING!

As you all know, CATA has been mounting a campaign for some time now to try to get folks to see the cable television industry in a realistic fashion. This is particularly important for city officials who are in the process of granting franchises or are in the refranchising process, but it is also important for the industry itself. All indications are that, at least so far as the industry itself is concerned, reality is coming as somewhat of a shock!

It was less than three months ago that we wrote on these pages about all the fantastic new announcements of programming aimed at the American consumer. There was the imminent start-up of DBS service, the explosion of LPTV, and numerous new programmers announcing their wares. What are the lead stories now? Well, the headline in the New York Times read "Losses Doom CBS's Cable TV Arts Service". In the Wall Street Journal: "ESPN Says Losses for Year Could Reach \$20 Million as Advertising Sales Falter". Again the Journal: "Warner Amex's Aggressive Cable Strategy Is Dealt Some Setbacks as the Losses Grow". In Television Digest: "Three Cable programmers — Disney Channel, ARTS cultural service and women-oriented Daytime — announced layoffs in last 2 weeks . . ." And finally, again back to the Wall Street Journal: "Oak Industries Delays Start-Up in Sending Pay-TV via Satellite."

The "blue sky" is finally falling on cable, and it is about time! Don't misunderstand, we do not wish ill on anyone. We are not in favor of com-

panies failing, of programmers going out of the business, of promises being reniged. However all of these things were predictable, and predicted in these pages as the hype over cable television development got so super-heated that all reason was left on the sidelines by the big players in the big game.

Since that hype has adversely effected, and will continue to adversely effect the whole industry, we are very much against it, and we are doing our best to let everyone know that our best long term strategy for the future of this business is to be honest about what it can and cannot do, and then strive to do what we can do well.

Given the long article in this issue on what has just happened to our ability to import distant independent television signals, it might be good to focus, for a moment, on what the alternatives are. Yes, we have many. But what shape are they in? One of the most popular advertiser-supported cable program sources is ESPN. But now ESPN admits that the ad dollars are not enough to cover the increasing product costs. What will happen? Well the \$.05 per subscriber compensation program to cable operators is being eliminated, and the odds are that cable operators will have to pay some money in the future to get the programming. Advertising revenue alone is not enough at this early stage of cable programming development. ESPN's primary owner, Getty Oil, is denying rumors that they want to sell the service, but they are not denying that if it does not look like a winner in the near future, they may want to bail out. Some options may be expanding the subscriber base by offering ESPN to local broadcast stations as well as cable systems, or shifting over to a pay service. Getty and ABC already have a deal to produce some ESPN programming in the pay-per-view mode so we will have to wait and see. But it should give you a hint as to the true state of the programming industry for cable that one of the most popular and "successful" channels is on the ropes!

If that is true of ESPN, what about The Weather Channel and the Cable Health Network? Both acknowledge that they are going through growing pains — let's hope they are not terminal! One, of course, that has already succumbed is CBS Cable. We have discussed that case already so we won't go into detail here, but one quote is worth noting. CBS Broadcast Group President Gene Jankowski, when questioned about the recent failure, said that CBS Cable had met CBS's expectations in quality, subscribership, and cost of services, but that it did not bring in enough revenues. He attributed this development to misinformation about the overall revenue situation in the cable industry from outside consultants! Now how's that

continued

FCC TESTING

and more.



DIAL TOLL FREE
1-800-336-9681
IN VA., 703-434-5965 COLLECT

SYSTEM SERVICES

FCC TESTING

PROOF OF PERFORMANCE TESTS

MICROWAVE PATH SITINGS

SIGNAL SURVEYS (UHF & VHF)

**HEAD END EQUIPMENT
REALIGNMENT & REPAIR**

SYSTEM REMEDIAL WORK

SYSTEM FREQUENCY RESPONSE SWEEPS

STRAND MAPPING

SYSTEM DESIGN (NEW OR REBUILD)

- On-Site Capability
- Progressive Engineering Services
- Proven Technical Procedures
- Most Up-To-Date Equipment
Used in All Test Phases
- Printed Test Results Packaged
For Your Convenience
- Completion Period for FCC Testing
Is Average of One Long Day

An Employee Owned Corporation



COMSONICS, INC.
P. O. Box 1106 Harrisonburg, VA 22801

EAS ELECTROLINE'S ADDRESSABLE SYSTEM

A cost-effective system offering maximum security with ease of control for multi-unit buildings.

EAS Designed to control access or premium service to subscribers in multidrop buildings. The system is modular in design. Security is maintained by means of continuous scanning. EAS is ideal for apartments, hotels, hospitals or other such location where constant control is needed and to provide visual audit of each subscriber's status.

ADDRESSABLE SYSTEM

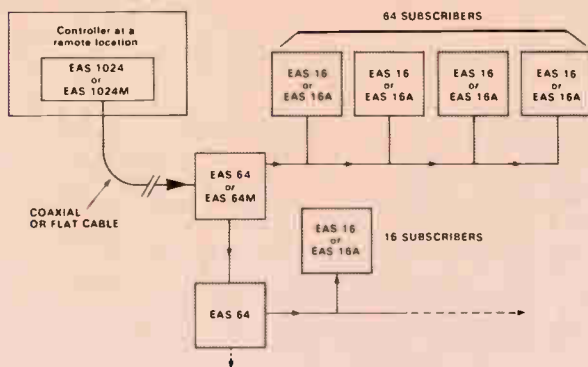

EAS The above system is composed of 3 units — a microprocessor control (EAS-1024); a decoder (EAS-64); and a wide-band, multitap switch assembly (EAS-16). The system can be installed in 2 alternative configurations and is most compatible with other systems.
Illustrated folder with specifications upon request.



ELECTROLINE Television Equipment Inc.

8750, 8th Avenue . St-Michel
Montreal, Que. H1Z 2W4

or phone collect
(514) 725-2471

Representatives across
Canada and the U.S.A.

- TAPS
- FILTERS
- COUPLERS
- SPLITTERS
- SPECIAL AMPLIFIERS
- SWITCH-TRANSFORMERS

for an incredible statement. Who was CBS listening to? They certainly weren't reading their CATA-cables very carefully! It appears that they are still surprised that the cable industry still has a majority of 12 channel systems! They didn't realize that all those promises in the big cities are still on paper, not in the streets! If an organization as supposedly sophisticated as CBS can make such a massive error and attribute it to "outside consultants", can you imagine what is going on elsewhere? It's frightening.

Is it all doom and gloom? No, of course not. What is basically going on with the employee cut-backs and the retrenching of plans is that a lot of folks are finally taking a close look at what the cable television industry really is as opposed to what they want it to be. We may indeed be a broadband two-way interactive highway in the urban centers in the future, but that future is still some time off, and for those who are trying to cash in on that future today, the bottom line is going to be very rough.

Another division of CBS probably said it best. The CBS Vice President of technology, Harry Smith, who is working on a videotex experiment with AT&T, said that telephone delivery was chosen over cable because there is not enough two-way cable plant in the country right now. He said cable **MAY** be viable for videotex in the 1990's, but not today. Let's hope that more people begin to distinguish cable's promise from its present reality. If we don't, we will be regulated based on that theoretical promise rather than what we really are — and then we may never get where we might be going!

WE MAY ALL BE GOING TO COURT!

The latest trend in the continuing saga of the cable television franchising battles is disheartening. The battles are moving into the courtroom. It has always been our view that, when you go to court, you have already lost the battle. The lawyers wind up to be the only winners.

The latest round of law suits may be the most important to hit the cable television industry in a long time. Basically, from one side or the other, the challenge has been mounted against the entire franchising process. The trouble with that sort of challenge is that no one seems to know what would happen if it actually turned out to be successful!

On one side, we have several cable companies who for one reason or another are having trouble with franchise renewals. Cities are going out for RFP's and seeking competitive bids instead of renewing options granted in original franchises, or they are simply denying renewals to the original operator. The other variation is a cable operator who has lost a franchise competition but still wants to compete in the community on a head to

WITHOUT THE INDEX VOLUME, YOUR LIBRARY IS INCOMPLETE

The 1981 Supplement to CATJ's INDEXED VOLUME is now available!

Included in this group are the articles on:

- UPGRADING YOUR SYSTEM
- CATV BILLING AND FINANCING
- 3 METER ANTENNAS
- AML DISTRIBUTION
- INTERFERENCE STUDIES AND SATELLITE
- STATION FREQUENCY COORDINATION
- PREVENTIVE MAINTENANCE OF SYSTEM
- DEGRADATION
- SMALL OPERATOR SURVIVAL AND HELP FOR
- THE RURAL SYSTEMS
- SATELLITE COMMUNICATION
- CONVERTERS
- AND . . . the regular monthly
- STEVE BIRKILL ARTICLES and
- WASHINGTON UPDATE

Separated by subject matter, this addition is designed to fit into the tabbed sections of the INDEXED VOLUME, a compilation of the major articles since the inception of CATJ (May 1974 through 1979). Completing this library, the 1980 CATJ Supplement is still available.

If you don't have your INDEXED VOLUME and the 1980 and 1981 SUPPLEMENTS, your library isn't complete.

Order today!!

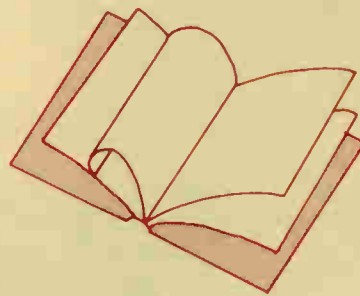

**A
VALUABLE
WORKING
REFERENCE**

YES!

I WANT TO
KEEP UP WITH
THE CURRENT INNOVATIONS
IN THE FIELD!
SEND ME:



Item	
_____ Index Volume with 1980 & 1981 supplement	\$150
_____ Index Volume with 1980 supplement	\$120
_____ Index Volume	\$100
_____ 1981 supplement	\$ 30
_____ 1980 supplement	\$ 30

I am enclosing a check for \$ _____ for the items marked above.

Name _____

Address _____

City _____ State/County _____ Zip _____

MAIL TO: CATJ 4209 N.W. 23rd Suite 106 Okla. City, Okla. 73107

STANDARDIZE

WITH THE NATIONAL STANDARDS FOR CATV SYSTEMS — GRAPHIC SYMBOLS

In order to help you standardize your grid and map preparation Television Publications is now offering a brochure of National Standards for CATV systems Graphic Symbols.

The symbols in this publication present cable television systems operators and engineers with a uniform means of schematic and system map design throughout the Cable Television Industry. Order one for each of your operators and engineers and get standardized!

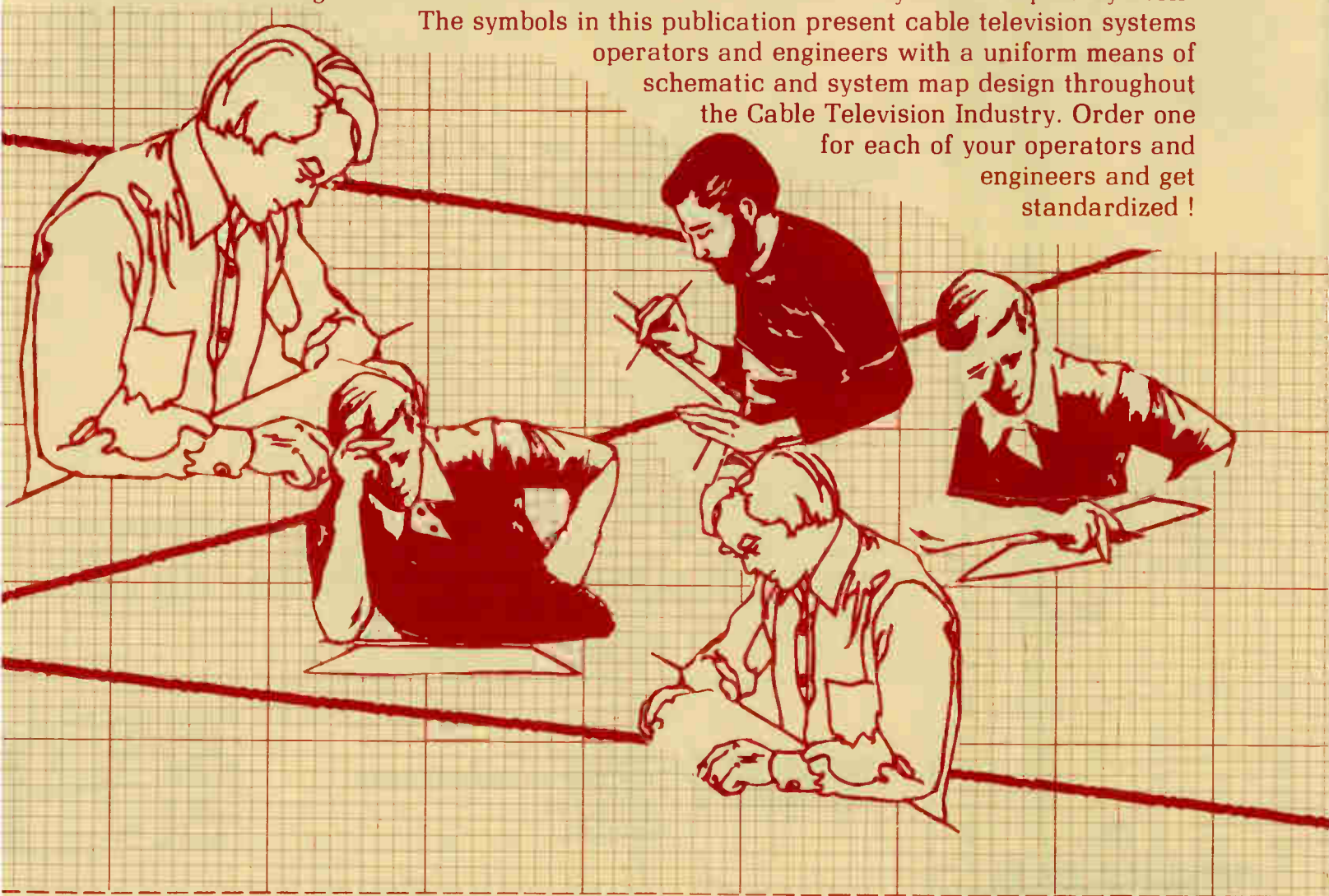

YES! I WANT THE NATIONAL STANDARDS FOR CATV SYSTEMS — GRAPHIC SYMBOLS GUIDE
SEND TO:

NAME

SYSTEM NAME

ADDRESS

PHONE

CITY

STATE

ZIP

PRICES

5.00 each

40.00 for 10 guides

90.00 for 25 guides

PLEASE SEND _____ SYMBOLS GUIDES. ENCLOSED IS \$ _____ FOR MY ORDER.

MAIL TO: TELEVISION PUBLICATIONS, INC. SUITE 106 4209 NW 23 OKLA. CITY OKLA. 73107 405/947-7664

WorldRadioHistory

head basis with the winner. In both cases, the courts are being asked to find out that the franchising process violates the antitrust laws because it limits competition. One lawyer who has brought cases of this type is now even arguing that existing cable operators in a city should not even participate in any bidding process that the city might design — he claims the whole process, and those who support and promote it, such as the consultants at CTIC, Associates are violating the law by “selling” the franchise to the highest bidder and by participating in schemes that amount of “extortion” of cable operators. As an added measure, the claim is made that a cable operator cannot be thrown out of a city and cannot lose a franchise, because it would violate his First Amendment rights.

On the other side of the coin, a public interest group is now suing the city of Denver claiming that it has violated the antitrust laws and the First Amendment by granting only one franchise. The irony here is that the cable operator, who may agree with the public interest group that some of the provisions in the franchise really exceed the power of the city (we all tend to agree with that premise in one way or another) is now going to be forced to pay to defend the city position — because the franchise says the operator will bear all legal expenses that might be incurred by the City because of the grant of the franchise!

So the lines are now drawn: is the franchising process legal? Can a city throw out an operator after his franchise has expired without violating the First Amendment? Is it a violation of the antitrust laws to conduct competitive bidding for cable television franchises? All of these questions will now be answered by the Courts unless Congress acts first. In a way we hope that Congress does act, because no one really knows what would happen if the Courts decided that the challengers were right!

Let's say, for instance, that the Court decided that the whole franchising process was illegal — that it violated both the antitrust laws and the First Amendment. Would it mean that anyone could build anywhere? Would it mean that whoever was rich enough to overbuild and wipe out the competition would win? What would happen in the legislatures as the cities pressed their claims to regain their “right” to regulate? Would there be a move in Congress to give that power back? We have checked that possibility and the answer is probably no, but that may not be the case at the State level. In short, there are a lot of “what ifs” and we don't have enough time or space to deal with them this month — we will focus again on this issue next month. Suffice it to say for now that it may be in the best interests of both the cities and the cable operators to come to an agreement among ourselves now, rather than be forced into it later. □

FCC TESTING and more.

ACT NOW.

Dial 1-800-336-9681 and schedule your system today.

STRAND MAPPING—SYSTEM DESIGN

- Mapping available across entire U.S.
- Field foremen check
- Accuracy of $\pm 2\%$
- Field notes applied to your base maps or new
- Special system specs available at extra cost



ON-SITE SERVICE

- FCC Testing and Proof of Performance
- Radiation Audits
- System Remedial Work
- Headend Realignment and Repair
- Frequency Response



An Employee Owned Corporation

COMSONICS, INC.

P. O. Box 1106 Harrisonburg, VA 22801

1-800-336-9681

IN VA., 703-434-5965 COLLECT

Letters

Mr. Ralph Haimowitz
Engineering Director
CATA
518 21st St. S.W.
Vero Beach, Florida 32960

Dear Ralph:

Just a couple of comments in regard to the "TechTest" questions that appeared in the September issue of CATJ, and the answers which were published in October.

I think there may have been a typo or two, and in a couple of cases, perhaps some practice rather than standard answers appear to have been supplied. In any case, here are my comments:

1. While 0 dbmV is the correct answer, it should be referenced to 75 ohms, since the measurement is often made after the matching transformer, and could be misread. I will agree that almost any SLM in current

use will accept only 75 ohm input, and therefore the reading becomes almost automatic with regard to impedance, but this answer should have been as specific as was the answer to question 4.

2. Most construction specifications that I see require system grounding at the first, last, and every tenth pole in a given run, plus a ground at each amplifier, power supply, and line extender. Some systems also ask for grounds at the pole each side of an amplifier, but typically this is needed only in severe lightning areas. The National Electrical Code definitely requires a ground at the house, at the point of entry (or as near thereto as practical), but unfortunately many operators, even today, do not observe this rule.

3. Correct.

4. Okay - strictly speaking, the answer is unknown. With the facts as given, the answer is 40 db - but you didn't ask for the absolute or corrected value - even though you are right - without the other factors the actual number cannot be reached.

5. Correct.

6. + 26 dbmV equals 20,000 microvolts, not 20. I thought maybe the sign had been printed wrong, but - 26 dbmV is 50 microvolts, so that didn't check either.

7. Correct, except strictly, the statement should be 45 dbmv (without the plus sign), or higher.

8. Correct.

9. As in the question regarding grounding, it's difficult to argue with overkill, but experience with most of the good-quality SLM's available today indicates their reliability to be such as not to require every-day calibration - depending on what is meant by "calibration". If calibration means only checking a few representative channel readings against a meter that is known (or more likely, assumed) to be accurate, then everyday checking is probably not overkill. If, though "calibration" means what it should, and requires a full-channel run-through against a calibrated standard, with a correction chart prepared for each channel, I would believe that not only is this depth not necessary, it requires so much time that few techs, even those who realize the value, will take the time. This is certainly a judgment call, but

my own feeling is that once a week for a routine spot-check, with a full run-through once a month should be sufficient.

10. Correct.

Ralph, I'm not trying to be nit-picking - these are just my reactions to the questions and answers. I think the idea is great, but obviously, the answers need to be completely accurate.
Sincerely,

Bill Karnes
Karnath Corporation
Plano, TX.



Dear Bill:

Thanks for your letter of October 14th. Thought you might appreciate a response so that you know we listen.

1. 0dBmV is the correct answer. According to the FCC Rules,

Subpart K - Technical Standards, Paragraph 76.605 (4): "The visual signal level, across a terminating impedance which correctly matches the internal impedance of the cable system as viewed from the subscriber terminals, shall not be less than the following appropriate value:

Internal Impedance	Visual Signal Level
75 ohms	1 millivolt
300 ohms	2 millivolts

I am certain you are aware that 1 millivolt across a 75ohm impedance termination is 0dBmV, and 2 millivolts across 300ohms is also 0dBmV.

2. I have to agree with your comments in principle. The answers should have read, "at every pole or pedestal where an amplifying or passive device is installed in the cable run". As you know, there are no "required"

standards for bonding and grounding, and many company specifications only call for the first, last, and every tenth pole of a given run. However, the use of common bonding at each device installed in the system will reduce the problems encountered by sheath currents. True, every house drop should be bonded to the electrical ground at the house. Expect to see this as a standard requirement in the near future.

4. I stand by my answer on this question. We should not be in the habit of providing readings that are not correct. After all, the FCC would not accept "ballpark figures." The purpose here was to make technicians aware that the meter indications shown on their meters are not necessarily accurate and we do teach the proper procedures in our seminars, including how to formulate correction factors for

continued

10 DAYS FACTORY REPAIR SERVICE

Send your Sadelco Meters direct to the factory for repair.

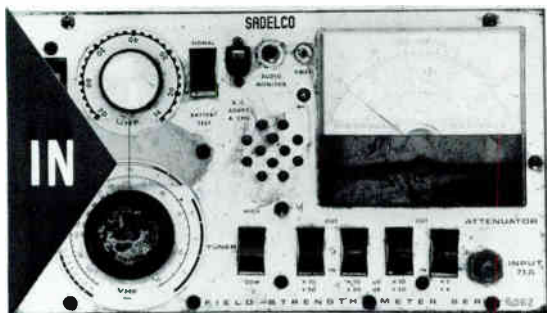

REPAIR
HOT-LINE
201
569-3323

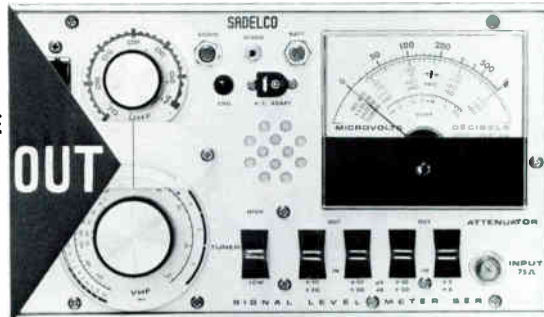

■ 10 work-days, in-out service

■ Repair cost-estimate on request

Trade-in any make SLM . . . we will allow a liberal discount towards the purchase of any new Sadelco Signal Level Meter.

Sadelco, Inc. 75 West Forest Avenue, Englewood, New Jersey 07631 201-569-3323
General representative for Europe: Catec AG Luzern/Switzerland, Habsburgerstr 22. Tel. 041-23-90-56 Telex: TELFI 78168.

meter bandwidths and noise floor of the meters.

6. You are absolutely correct. The answer should be "20,000 microvolts (19,950 to be exact)."
7. 45dB is correct.
9. Calibration in this instance refers to checking the technicians meters to a known source daily (meter calibrator, pilot generator, etc.). Although the quality of meters today is greatly improved, the technicians abuse their equipment dreadfully, and this causes them to lose their accuracy. Daily local calibration, such as I have described, prevents the problem of several plant technicians from making inaccurate adjustments to plant levels causing the levels to be different at various locations throughout the system which affects several important factors such as carrier-to-noise and cross modulation. Also, daily meter calibration will frequently alert

the technician that he needs to recharge or replace the batteries in his meter. Many technicians have been caught adjusting amplifier levels with a meter with weak batteries and found that after increasing output levels at a number of locations that their batteries were going and the meter readings were erroneous.

It is really great to hear from people in the industry like you. You really help keep us on our toes and cause others to think about what they read in the trade magazines. It also helps us to find errors and insure that the right answers are given. Sincerely,

Ralph A. Haimowitz

Ms. Celeste Rule, Managing Editor
CATA/CATJ
4209 N.W. 23rd St., Suite 106
Oklahoma City, OK 73107

Dear Ms. Rule:

I am writing in response to the letter from Charles W. Gentry published in your September issue in which he comments on my article "The Gravelization of Spinach".

As any writer must, I enjoyed obtaining a reaction, particularly one as positive and constructive as his. In general, I agree with the comments he makes, and could easily write a twenty-page letter in response! I'll try instead to limit this to something short enough to appear in one issue!

First allow me to dispose of a few trivial points. One of the hazards of printing numerical examples is the risk of making mistakes, and in this case my calculator done me wrong. Unless I'm in error again, the three numbers that appeared in my article should have been 113 dB, 62 (?), and 164 (?). Between your typesetter (who needs a little training in algebraic notation) and the terminology used, Gentry's equations

First In Reliability

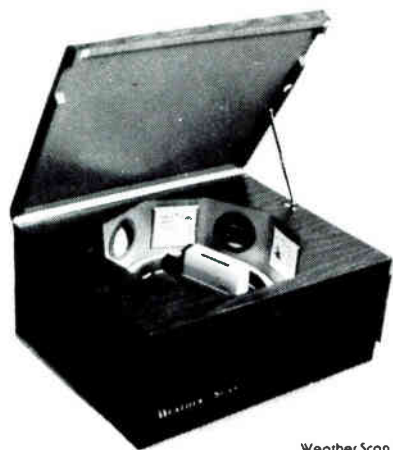

Weather Scan III

Impressive quality . . . surprisingly low price. Just \$3295 for the most reliable unit available (at any price!).

We have been in the cable television business for 23 years . . . and providing weather information systems for the past 16 years. We know what you need and we know how to manufacture it. For reliability and performance.

The Weather Scan III comes complete with Sony AVC-1400 camera with separate mesh vidicon and 2:1 interlace sync. Includes Time, Temperature, Barometric Pressure, Wind Velocity, Wind Direction, plus four card holders. Compact cabinet is just 28" wide, 23" deep and 14" high. For complete information call or write.



Weather Scan, Inc.

An R.H. Tyler Enterprise

Loop 132 and Throckmorton Hwy. Olney, Texas 76374 Ph. 817-564-5688

came out rather badly. The symbol "dB" appeared in the wrong place. A dB is not a quantity that can be used in an equation, like "%o" it is a symbol that indicates that a certain mathematical operation has been performed. His last equation, for example, should be written like this (and please, Mr. Typesetter, put the I's and the R's a half line above and below the line!):

$$\text{Power Gain} = \left[20 \times \text{LOG} \left(\frac{I_{\text{out}}}{I_{\text{in}}} \right) + 10 \times \text{LOG} \left(\frac{R_{\text{out}}}{R_{\text{in}}} \right) \right] \text{dB}$$

Unfortunately, although I agree with Mr. Gentry that the "complete formula" should be used in all cases where the input and output impedances differ, almost the entire rest of the technical world doesn't! I labeled as Myth #6 the incorrect and confusing practice of finding the decibel gain of an amplifier by taking 20 times the log to the base 10 of its voltage gain, without regard to its input and load impedance. This ridiculous practice is almost univer-

sally used in the electronics industry. To cite one example in thousands, the published specs. for the National LH201 OP amp (1) state, in the printed text, that the voltage gain is 160 "volts per millivolt" (i.e. 160,000 times), and the graph showing gain vs. frequency shows it to be a little over 100 dB at low frequencies. My undependable calculator says that $20 \times \text{LOG}(160,000) = 104.1$ (and I refuse to

say "dB", although it apparently doesn't bother National!).

I'm afraid a great many of us who grew up in this century, using electrical units and language, have an inadequate appreciation of the work that went into creating these technical standards in the first place. Hundreds of scientists on the committees of organizations like the ISO (International Standards Organization) and IEC (International Electrotechnical Commis-

sion) devoted endless hours of effort covering more than a century to arrive at the standards we now take for granted, the volt the ohm, and all the other accepted units that make it possible for one engineer or scientist to communicate with another. Unfortunately, at just about the time when all of this work was reaching an end and the SI (Metric) system had very nearly evolved, the Bell Labs introduced the decibel. Since that time, for more than 50 years, the dB has never been recognized by these official organizations, and as a result, there simply are no standards governing its use. The telephone people have one set of customs, the acoustics people have theirs, CATV committees further confused the issue, and the satellite experts developed a dB jargon that only they can understand!

In short, complete chaos reigns in the use of dBs. Mr. Bruce B. Barrow expressed the feelings of one who understands the importance of

continued

We've Got The Filter You Need For Your Cable TV System...

Or We'll Build It, Fast.

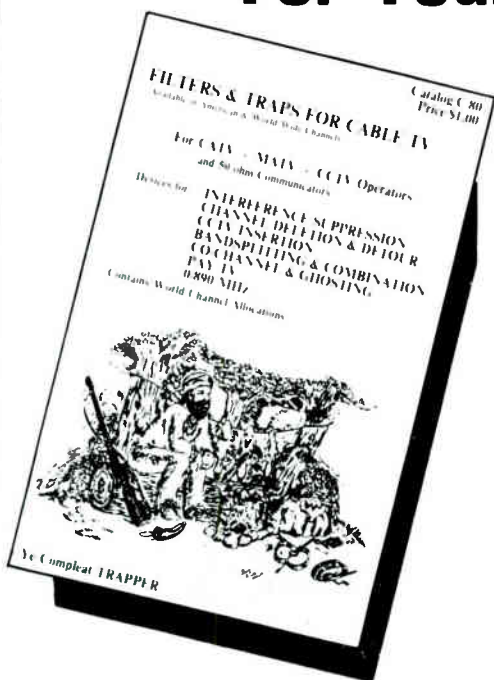

Catalog C/80, a 40-page pillar of the cable TV industry, features filters and traps currently being used in hundreds of CATV, MATV and CCTV systems. Delivery time for most standard products is 10 days or less.

But if you need a one-of-a-kind special and you can't afford to wait, we've still got you covered—we'll design and build exactly what you need for your installation, and we'll work around the clock to deliver it when you need it.

Use our toll free number and talk to the RF or microwave engineer who will design your special filter. He'll give you a prompt, on-line analysis of your specifications, and he'll quote price and delivery time. Before you hang up, you'll know what you need, when you'll have it and how much it will cost—all with just one phone call!

Once you've placed an order, our unique QRC (quick reaction capability) begins to work for you: QRC combines the efficiency of computer-aided design with a dedicated model shop and test labs to insure that your filter will be what you need when you need it.

When you need a filter to do a job exactly as you want it done, and you need it *now*, Call MFC!

We are now represented by Jerry Conn Associates in Penn., Ohio, NJ, Va., W. Va., Md., Del. and Washington, D.C.

MFC
MICROWAVE FILTER COMPANY, INC.

Jerry Conn Associates
P.O. Box 444
Chambersburg, PA 17201

6743 Kinne St., East Syracuse, NY 13057
Toll Free 1-800-448-1666 — TWX 710-541-0493
NY/HI/AK/Canada (Collect) 315-437-3953

standardization when he wrote (2) "The decibel jargon that Ward displays in his last paragraphs does not prevent one from arriving at right answers most of the time, especially when used by competent engineers who have a good feel for what the right answer should be." After spending a good part of my life trying to find some way through this muddle, I am beginning to suspect that dB "jargon" is, and always will be, just that! (Mr. Webster defines "jargon" as "A special vocabulary or idiom fashionable in a particular group or clique.") In other words, decibels have about the same relationship to International Standards

as Preppy Talk, or the gibberish of the Valley Girls has to the English language!

In an attempt to accomplish something along constructive lines, I have recently published a description of "N-Logs" (3) which have all the advantages of dBs, and the further advantage of being carefully defined so that they can be used to state, as an integer, the number resulting from any measurement, with any degree of precision. Having a new name they might perhaps replace the "dB Anything", without running the risk it faced of conflicting with the well-established bad practices associated with the dB.

Yours Truly
 Keneth A. Simons
 Consultant
 WAVETEK

References

1. 1980 Linear Databook, National Semiconductor Corp., pp 3-66 and 3-67.
2. W.W. WARD and B.B. Barrow, "Another view of dimensions and dB." Proc. IEEE (Lett.), Vol. 60, p. 473, June 1972
3. K.A. Simons "N-Logs: A New Number Language for Scientific Computers", Dr. Dobbs Journal, Vol. 5, Issue 10, Nov.-Dec. 1980, p.4. □

A Step Forward

IS A MINI-SIZED STEP ATTENUATOR

75 OHM Model

FREQUENCY RANGE
 .1-1000 MHz



SHOWN ACTUAL SIZE

ATTENUATION RANGE
 0-102.5dB
 in 1/2 dB steps

- Power Blocked
- RF High Frequency Proven Switches
- 100% Shielded
- RF Gasket on Base to Prevent Signal Leakage
- Power (.5 WATTS)
- Type F Connectors

STEP VALUES	TYPICAL PER STEP ACCURACY		
	FREQUENCY RANGE		
	1-250MHz	250-500MHz	500-1000MHz
0-10.9dB	±0.01dB	±0.05dB	±0.2dB
10-10dB	±0.1dB	±0.3dB	±0.5dB
20 and 30	±1%	±1.5%	±2%
Max @ 102.5dB Attenuation	±1.0dB	±1.5dB	±2.0dB
VSWR	1.2:1	1.2:1	1.4:1
Insertion Loss	0.1dB	0.2dB	0.4dB

1-800-336-9681

IN VIRGINIA
 703-434-5965
 COLLECT

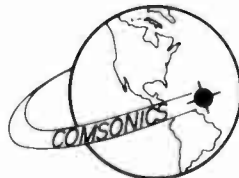

COMSONICS, INC.

P. O. Box 1106 Harrisonburg, Virginia 22801
 An Employee Owned Corporation

Showcase

CABLE GRAPHICS SCIENCES INTRODUCES INSTANT GRAPHICS!!

Cable Graphic Sciences, has introduced a low cost display generator with an 'Instant Graphics' feature for under \$3000. Designed for local access and advertising applications, it employs a unique microcomputer-based design that allows the user to create graphic displays in seconds.



The Cable Graphic System 800/A features: Six Formats — Videotex like graphics — A Unique Instant Graphics feature that allows users to instantly store and retrieve graphic pictures and designs — floppy disk storage — an accurate clock — 375 to 750 lines of memory depending on whether you choose 40 or 20 character lines — a crawl line — power failure protection — a built-in Color Bar generator for adjusting monitors — Worldwide Service — and much more. Each system is environmentally tested and burned-in for a minimum of 100 hours prior to shipment for added reliability. And, it is available in either NTSC or PAL versions.



Displays created on the System 800/A may be copied to multiple floppy diskettes, thus allowing MSO's to prepare advertising or public access announcements at a central location well in advance of actual need. Floppy disks can

then be distributed to local systems via U.S. Mail if desired.

Ken Doyle, General Manager of Cable Graphic Sciences, said: "The System 800/A is a result of our own experiences in constructing and operating a small system in the California foothills. We wanted to provide a local, advertiser-supported, information channel that projected the 'High Technology' image of our system. But, there simply wasn't anything available to do that at a price

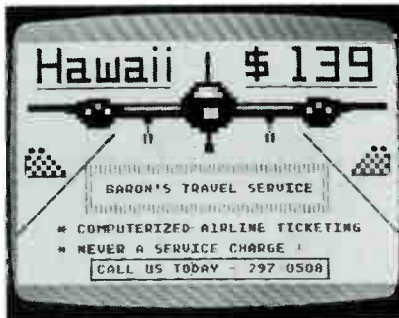

Actual raster photographs of displays created with the CABLE GRAPHIC SYSTEM 800/A. Its VIDEOTEX graphics make it ideally suited for local advertising applications.

we could afford". Doyle continued: "Graphics is the real key to selling advertising services to local merchants. But, most character generators are still 10 years behind the times in this area." So, Doyle, with some 20 years of communications and electronic experience under his belt, went on to design his own system!

The price for the System 800/A is \$2895 complete including floppy disk drive and a library of instant graphic designs. Delivery is 1 to 3 weeks ARO.

Under development are System 800/A options including: Temperature Display — Expanded Memory — Real-Time control of external devices — Real-Time Scheduling — and a Telephone Interface for remote operation. Special customized versions are also available upon request.

For further information, please contact: Cable Graphic Sciences, 7095 N. Clovis Ave., Clovis, Ca. 93612, or call (209) 297-0508.

MA/COM PRODELIN INTRODUCES NEW 3.7 METER ANTENNA SYSTEM

(Claremont, N.C.) — M/A-COM Prodelin's newest introduction is a 3.7 meter (12') Earth Station Antenna System designed specifically for today's market offering fast, easy and

economical installation.

Featured for ease of assembly and rapid installation is the new T-Bar azimuth/elevation mount. The mount achieves a pointing accuracy within .2° at 65 mph winds and can withstand 125 mph winds. This configuration also ensures excellent performance at 12 GHz and offers low cost antennas for audio, video and digital receive-only applications at 4 and 12 GHz.



Prodelin's Earth Station Antenna System utilizes compression-molded fiberglass to further facilitate ease of handling and reduce shipping costs. Ten (10) segmented lightweight petals self-align and are easily transported in standard elevators for rooftop installations.

The 12' Antenna System with the new T-Bar mount is price competitive and available from Prodelin for immediate delivery.

FOR FURTHER INFORMATION CALL:
George Gilbert
Director of Marketing
MA/COM Prodelin, Inc.
(704) 459-9762

LOW COST CHARACTER GENERATORS PRICING FROM \$2725.

Teledac is pleased to introduce their new junior/senior Model T-1016 JR and T-1016 SR. By integrating a new memory compression technique, it provides up to 68 pages of memory. Other features include clock, Spanish characters, graphic text separators, bar charts and lots more

REPS:

continued

Showcase

WESTEC COMMUNICATIONS INC.
Scottsdale, AZ (602) 948-4484
Napa, CA (707) 255-2010

MICROSAT s/e INC.
Marietta, GA
(404) 971-1021

UNITED VIDEO: BEING "GOOD GUYS" GIVES THEM NCAA BLACK EYE

TULSA, Okla. — "All we did was provide cable television systems with the programming they asked for and we ended up as a whipping post for an NCAA and Texas University football fray," United Video's Executive Vice President Roy Bliss responded to inferences that the company illegally provided a live cable TV feed along its central U.S. microwave route.

The dispute erupted when United Video, at its microwave customers' requests, carried KXAS's (Dallas NBC affiliate) broadcast of the Oklahoma University and Texas University fall Cotton Bowl football classic. The live feed was approved by the NCAA two days before the game, and United Video customers immediately began pressing the company for the microwave feed so they could provide it to their cable TV subscribers according to Bliss.

"We don't even know which cable systems carried the game for their subscribers since we are a common carrier responding to the requests of our customers. Our customers, the cable companies, asked for transmission of the game, and we obliged as we always do in these circumstances," Bliss continued.

United Video owns more than 8,000 channel miles of microwave in eight central-U.S. states, and provides television and other transmission services to cities along the route that would never be able to get TV stations from other cities or as clear reception of the signal if they depended on off-air antennas instead of the point-to-point microwave relay system. The Oklahoma-Texas game was carried by a portion of the United system that serves 50 cable systems in Texas, Oklahoma, Arkansas and southern Missouri.

According to Jack Riley, Director of Microwave Development at United Video, the legal responsibility of whether to show the game or not was the burden of the individual cable system, not United Video's. The only way United could have halted carriage of the game was by receiving a court injunction prohibiting the transmission, but according to United officials, the company has

never received an injunction, threat of law suit or written request to withhold transmission even though it has been alleged in local newspaper articles.

"We sure didn't get any complaints from the Longview, Texas system or any other cable system when they picked the game up off our Arkansas system. And the fact that there were no previous announcements about the carriage leads me to believe that a unique service was provided to viewers that would never otherwise get to see such an outstanding football classic," Riley explained. "Believe me, we had numerous requests and total support for the transmission from the cable systems."

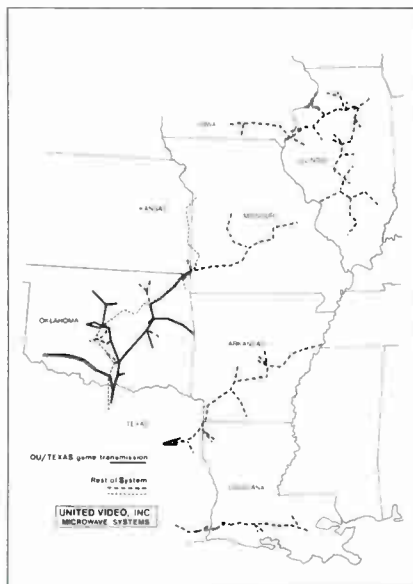

I think its more than coincidence that a Texas official waited to call United Video on the telephone at 1 p.m. on Saturday, less than an hour before game time, talked to someone with no pertinent official capacity at United Video, and waited only 15 minutes for an official response from us," Riley continued. "That, with the lack of an injunction, leads me to believe that the telecast is exactly what everyone wanted, but because of the complexity of proper NCAA rules interpretation, some people wanted to cover their responsibilities first in case a legal question later arose."

Bliss pointed out that United Video, one of the nation's largest common carriers with microwave and satellite transmission customers nationwide, has been in the business since 1965, and has always worked cooperatively with the NCAA, athletic organizations and teams. "We are customer-oriented but are very cognizant of the need for organizations to protect their members and players," he continued. "I guess what irritates me is that all we did was provide what our

customers requested and because of some individual interests we became a scapegoat on an issue that should have never involved us at all. I almost feel slandered," he said.

Riley said that the microwave system is now carrying an increasing load of special sporting events. This month it will provide four live Sportsvision events free to cable systems in Illinois and Iowa as a viewer response experiment to determine the popularity of specialized telecasts throughout its entire system.

United Video also operates satellite uplink facilities near Chicago and is the carrier for popular cable satellite services including WGN television, the Chicago SuperChannel, EPG, a customized cable electronic program guide, WFMT fine arts stereo radio, Seeburg Music, Satellite Music Network, Bonneville easy listening music, Moody Bible, Audio Express and the VISIT data transmission service.

CONTACT: Roy L. Bliss or Jack Riley, United Video, 918-665-6690, Tulsa

ANIXTER INTRODUCES NEW 58 CHANNEL CORDLESS REMOTE CONVERTOR

Anixter Communications has begun marketing a new cordless handheld remote 58 Channel Hamlin convertor, the CRX-5000, it was announced by Ferris Peery, Vice-President of Convertor Sales. The CRX-5000 features a frequency synthesized first local oscillator. It is available with built-in descrambling, and an internal A/B switch for dual cable operation.



The remote handheld channel selector operates on infra-red wireless remote control, and features instantaneous frequency selection, scan up-down channel select, and "favorite channel" memory. Hamlin products have been field-proven and are widely recognized for their reliability because of a negligible failure rate.

FEATURES OF HAMLIN'S CRX CONVERTORS

1. Frequency synthesized first local oscillator.
2. Will operate in frequency offset

systems.

3. Automatic centering control on front panel.

4. 58 channel capacity.

5. NTSC or HRC frequency configurations.

6. LED channel indicator.

7. Available with built-in descrambling.

8. Scan up-down channel select.

9. Available with internal A/B switch for dual cable operation.

10. Infra-red wireless remote control

a. instantaneous frequency selection

b. on/off control

c. will operate in frequency offset systems

d. scan up-down channel select

e. favorite channel memory

The CRX-5000 is now being stocked for immediate delivery throughout Anixter Communication's network of distribution centers in the U.S. and Canada. For more information, contact Anixter at One Concourse Plaza, Skokie, Illinois 60076 or call (312) 677-2600.

HARRIS INTRODUCES 6.1 METER EARTH STATION ANTENNA

Harris introduces the Easily Transportable (E.T.) 6.1 Meter Earth Station Antenna. This high-gain Intelsat Qualified Antenna is highly transportable and quickly erected. An experienced crew of three men can have the antenna operating in 24 hours. The pedestal is a cross elevation over elevation type that provides a limited motion coverage of ± 10 cross elevation and full 90° coverage in elevation. The E.T. Earth Station Antenna, when equipped with the properly polarized feed subsystem, can operate with any Domsat or Intelsat Geostationary Satellite from any location in the world. The antenna achieves full elevation coverage with no field adjustments. The antenna is completely erectable in the field without cranes or hoists.

SUMMARY ELECTRICAL SPECIFICATIONS

Gain	4 GHz	46 dB
	6.1 GHz	49 dB



Antenna Temperature @ 20° Elevation Angle = 46° K

Typical G/T at 4 GHz with a 50° K LNA System, Elevation Angle $20^\circ = 26.1$

Axial Ratio 0.5 dB (Intelsat IV A and V)

All antenna sub-assemblies are packaged for loading on a 2-1/2 ton truck or loaded in the cargo bay of either a C-141 or a C-130 aircraft.

This product is another Harris First, joining the complete product line of 6.1 Meter to 32 Meter Satellite Earth Station Antennas.

For more information, contact Rod Hurlbut (214) 984-0555, or write P.O. Box 1277, Kilgore, Texas 75662.

APPLE/STORE OFFERS SMALL-SYSTEM BILLING SERVICE

BEAVER DAM, WI — Apple/Store Computer Services here has developed a cable TV billing program tailored to the needs of the small cable operator. It provides in-house billing and accounts receivable record keeping for cable systems with 300-10,000 subscribers, and is available now to operators nationwide.

The Apple/Store System was designed for the Apple II micro-computer and stores a variety of information.

The system is customized by Apple/Store for every company. It provides for the simple creation of customer account files, easy entry of manual invoices and payments, and automatic billing of all recurring monthly charges for each customer.

Upon command, the Apple/Store Billing System prepares monthly statements for customers, showing past due balances, installation charges, and recurring monthly charges for up to ten different service categories. The system is completely automatic.

Management reports from the Apple/Store System can include a complete accounts receivable aging of every customer, one-line or complete customer master records, payment histories, current subscriber totals of all services, and a variety of other kinds of information.

The Apple/Store System also makes mailing of pay TV guides a simple function and it prints rolodex cards with complete customer information.

A final feature of the system is a copy function, which automatically provides multiple copies of all stored information.

The Apple/Store Cable TV Billing System was designed by a cable operator, with 18 years' experience operating small cable systems, and two professional computer programmers. Originally designed for the operator's own use, the system was developed over a period

of one year. It was then tested and debugged over a number of additional months, in three systems ranging in size from 360 to 1100 subscribers. It has already been successfully marketed in Wisconsin, Michigan, and Illinois.

The billing system requires the Apple II to be equipped with a minimum of 48K of RAM, an auxiliary fan and a 10-key data entry pad. In addition, a video monitor and a minimum of two disk drives are required. The type and quantity of disk drives needed depends on the total number of subscribers the operator wants to process as one system.

For operators already owning an Apple Computer, the Apple/Store Billing System can be installed for \$1,500. Operators not owning the Apple can purchase it locally at the best price, or can purchase it from Apple/Store, with the billing system software. A complete system for 2,750 subscriber is listed at \$7,500. Other systems are available starting at \$6,500 for 350 subscribers.

Included in the cost of the Apple/Store System is set up and delivery, on-site training, and de-bugging of each individual system. Further, a maintenance service at \$25 per month offers telephone hot-line trouble-shooting, and loan of replacement parts whenever required.

For more information, contact Renee Rosado, Apple/Store Computer Services, P.O. Box 692, Beaver Dam, Wisconsin 53916 or call (414) 887-7964.

NCS ANNOUNCES SATELLITE RECEIVER REPAIR

NCS Industries, formerly National Com-Serv is pleased to announce a new service for repair of satellite receivers.

According to Richard Grasso, President and Chairman of the Board, "With the addition of our new on-site earth station, we have the capability of dynamic testing of receivers with the actual satellite signals including complete alignment to manufacturer specification. This new capability is in addition to NCS Industries extensive service and repair facility for all CATV equipment."

NCS Industries has been serving the CATV and MATV industry since 1974 with sales and service of new and used equipment. Corporate headquarters are located at 2255-E. Wyandotte Rd., Willow Grove, PA 19090. □

UPI BREAKTHROUGH:

Customized News Service

United Press International (UPI) has announced the launch of a totally new UPI CABLE NEWS format, a unique ultra-high-speed alphanumeric cable news service that will allow cable TV systems and other electronic media to custom design programming tailored to the needs and interests of each community. The new service was first demonstrated at the Western Cable Show in Los Angeles in November, and will be demonstrated at upcoming shows in the future.

The UPI CABLE NEWS format is a one-of-a-kind customized news service that provides a menu of categories, offering you the opportunity to program them into your own 60 minute, 24 hour a day cycle, according to the discretion of the cable operator based on the community dictates and needs. As they have said, what's right for Walla Walla may be altogether wrong for Corpus Christi. Is what you want 6 minutes of sports, or 10? 7 or 17 minutes of international news? 12 minutes of national news or just 2? 32 minutes of state and regional news or more? Whatever you think you need and your subscribers want, you can pick the subjects and the time spent on each category.

The new service, designed and produced by UPI, is the most advanced in its field. It will offer hundreds of information categories, in variable time formats from one to

30 minutes in one-minute increments, including coverage of all top national and international news and sports events; individual news reports from each of the 50 states, state sports, state weather, state farm news and state business reports. In addition, there will be extensive coverage of financial news, commodities, Wall Street and money markets; Canadian news and a host of general and feature categories for specific interest

groups. Keep in mind that each news category is updated every hour, as news breaks, by UPI correspondents reporting from the 243 bureaus around the world.

All categories are edited and formatted exclusively for the TV screen: 32 characters per line, eight lines per page — not computerized reprogramming of newspaper or broadcast wires. The amount of information offered is so extensive and flexible that cable systems can

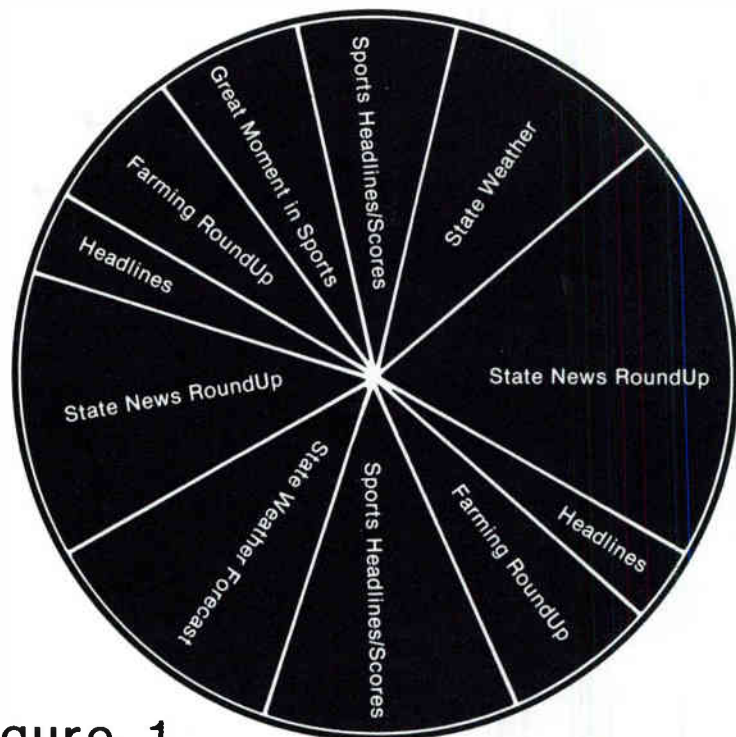

Figure 1

NEW PRODUCT REVIEW



program multiple channels, using UPI's unique coding system.

As the categories are updated around the clock, the fully customized service is downline programmable and can be changed upon request from subscribing cable systems. The built-in flexibility and choice of categories make the new service an ideal vehicle for local advertising sponsors, since time of segment and sequence of segments can be planned, making specific

shows available for sponsorship by selected advertisers, geared to the specific interests of local viewers.

The unique UPI hardware for the new service was designed to be fully compatible with all existing newspaper front end systems. This will allow newspapers which program local cable news channels to interface directly with the local cable systems. Joint cable-newspaper ventures using the new service will begin shortly in several selected markets.

A NATURAL FOR LOCAL ADVERTISERS

As was stated above, this news service is an ideal vehicle for local advertising.

Since the time of segment and sequence can be planned in advance, a cable system can offer specific shows for sponsorship by selected advertisers. It would make the operation then a natural for local retailers and for products and brands in search of cost-efficient local markets. Special daily features that could complement local advertising include:

- Lifestyles . . . People . . . Science . . . Consumer Corner . . . Entertainment . . . Horoscopes . . . TV highlights . . . the Lighter Side

Special weekly features include:
 Analysis of major domestic issues . . . Business week in review . . . Best selling books . . . Religious news . . . Travel tips and vacation information.

Let's take a look at a sampling of what's available on the new service . . . and refer to **Figure 1** and **Figure 2** for a sample one-hour repeating weekend and weekday program . . .

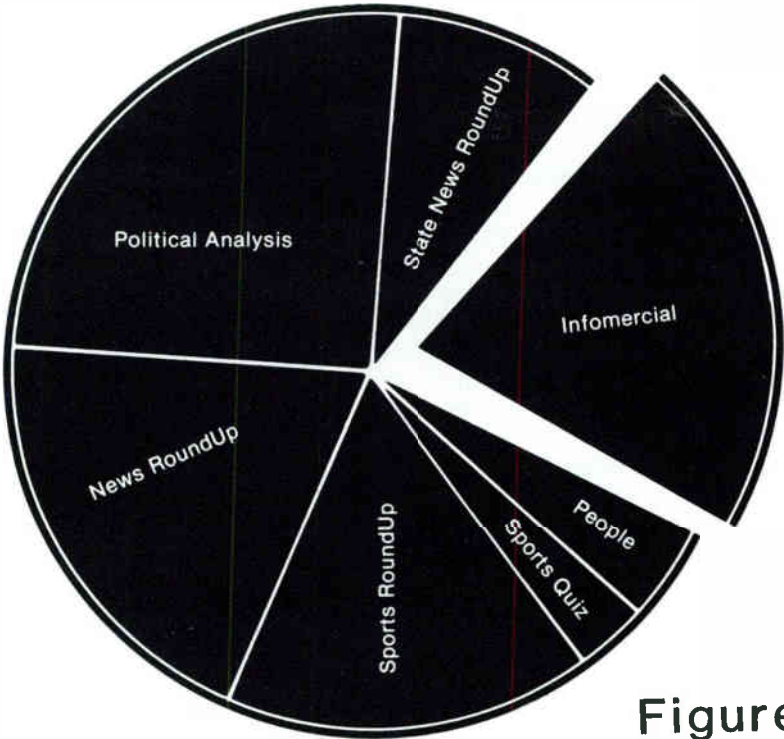

Figure 2

UPI CABLE NEWS

UPI

One Up on the System

BULLETINS

Less than one minute on major developments in news, sports and weather.

NEWS

Headlines: Around two minutes. Updated hourly.

News Roundup: Up to 17 minutes. Capsule wrap-up of the day's major stories. Updated throughout the day.

Domestic News: One to two minutes devoted to one story. Number of stories varies.

International News: One to two minutes devoted to one story. Number of stories varies.

Energy Wrap-up: Around two minutes. Updated daily, Monday through Friday.

WEATHER

National Forecast: Up to two minutes. Updated for times daily.

National Weather Summary: Up to three minutes. Updated four times daily.

Domestic Temperature Lists: Up to two minutes. Updated throughout the day.

Foreign Temperature Lists: One minute. Updated daily.

CANADA

Canadian News Roundup: Up to 10 minutes. Updated throughout the day.

Canada Weather: Around three minutes. Updated throughout the day.

FEATURES

Horoscopes: Updated daily. Around five minutes.

Each approximately two minutes:

Daily Almanac: Updated daily.

Lifestyles: Monday through Friday.

People: Updated daily.

Science: Monday through Friday.

Consumer: Monday through Friday.

Entertainment: Monday through Friday.

Lighter Side: Monday through Saturday.

WEEKLY FEATURES:

Analysis: Around five minutes. Analysis of a major domestic issue. Available Sunday morning.

Business Week in Review: Around five minutes. Available Friday evening.

Books: Around two minutes. The week's best sellers. Available Saturday afternoon.

Religion: About five minutes. Review of major religious news of the week. Available early Sunday.

Travel: About five minutes. Available early Saturday.

STATE

Headlines: About two minutes. Updated throughout the day.

News Roundup: About 15 minutes. Updated throughout the day.

State News: Individual stories, about one minute each. Updated throughout the day.

State Sports Roundup: Up to 15 minutes. Updated daily.

State Sports Scores: Up to 16 minutes, depending on season.

State Weather: Forecasts, current conditions. Around six minutes. Updated throughout the day.

FINANCIAL

Financial News: Business stories throughout the day, averaging one minute each Monday through Friday. Around 30 daily.

Farming: Four minutes. Roundup of major farm news. Daily.

Business News: About four minutes. Wrap-up of top business and financial news. Available every evening, Sunday through Thursday.

European Money Report: About three minutes, available 6 a.m. Eastern time, updated around 2:30 p.m. Eastern. Dollar and gold reports

from abroad. Monday through Friday.

Market at a Glance: Available 8 a.m. Eastern, updated hourly until 7 p.m. Up to seven minutes. Report on major market indexes, including Dow Jones and closing OTC, plus NYSE and AMEX most actives. Monday through Friday.

Financial News Headlines: Two minutes, available at 8 a.m., Eastern, updated hourly until 7 p.m. Monday through Friday.

Currency: Two minutes, updated five times daily. Domestic-foreign gold, dollar, prime rate, CDs, Treasury Bills. First available 9 a.m. Eastern. Monday through Friday.

Coin Quote: Two minutes, available 10 a.m. Eastern time, Monday through Friday.

NYSE Selected Stock List: 13 minutes. First available 11 a.m. Eastern, updated throughout trading day.

AMEX Selected Stock List: Two to three minutes. First available 11 a.m. Eastern, updated throughout trading day.

Meat Futures: Three minutes. Chicago Mercantile Exchange report. Open available around 11 a.m. Eastern, closing around 2 p.m. Monday through Friday.

Grain Futures: Four minutes. Chicago Board of Trade report. Open available about 11 Eastern, updates at mid-session and close. Monday through Friday.

Cotton, Sugar, Coffee and Cocoa Futures: Two minutes, first available 11 a.m. Eastern time, updated midday and close. New York futures exchange report. Monday through Friday.

Gold, Silver and Copper Futures: About four minutes. First available 11 Eastern, updated once more before close. Monday through Friday.

Twenty Most Widely Held Stocks: One minute. First available noon, updated at close. Monday through Friday.

Midwest Livestock: Four minutes. USDA report of major Midwest markets. Available around noon, Eastern, Monday through Friday.

New York Foreign Exchange: Two minutes. Available around 6 p.m. Eastern. Monday through Friday.

Farm Market Summary: Maximum 14 minutes. Wrap-up on livestock, carlot meat, national grain market summary as provided by USDA. Available around 6 p.m. Monday through Friday.

Value Line Stock Index Futures: One minute. Available around 7 p.m. Monday through Friday.

Daily Market Summary: Around 14 minutes. USDA breakdown on activity at major Midwest terminals and auctions. Available around midnight, Eastern time. Monday through Friday.

Weekly USDA Reviews of Midwest Livestock, Feedstuffs, Grain and Wool: Up to 25 minutes. Available Friday around midnight, Eastern time.

Most Active Stocks of the Week: 20 NYSE and 10 AMEX. About two minutes. Available Friday evening.

SPORTS

Sports Headlines: One to two minutes. Major sports scores, brief items on major sports news stories. Updated throughout the day.

Sports Roundup: Around 10 minutes. Wrap-up of top sports news, results. Updated throughout the day.

Sports News: Sports stories throughout the day, averaging one to two minutes each. Updated throughout the day.

Scoreboard: Around 10 minutes. Major sports standings. Available after completion of day's major sporting events.

Sports Calendar: Day's schedule of major sporting events. Two to three minutes. Available around midnight, Eastern time.

Sports Quiz: One minute. Sports quiz question of the day in one display, followed by the answer. Available by 11:30 a.m. Eastern time.

Sports Figure Birthday or Sports Anniversary: One minute. Available by 4 a.m. Eastern time.

continued

UPI CABLE NEWS

UPI

One Up on the System

continued

SPORTS FEATURES

Speaking of Sports: About six minutes. An in-depth look at a sports issue or event. Daily except Sunday. Available around midnight Eastern time.

Great Moments in Sports History: Five to six minutes, Monday through Friday. Available around 9 p.m.

Sports Preview: Up to eight minutes. A look ahead at a sporting event. Available Sunday morning.

SEASONAL SPORTS

NOTE: All in the following "Sizing Up" series sub for the daily speaking of sports and provides an advance look at their particular sporting event. All except the pro football run about six minutes.

Sizing Up the Superbowl: In two parts.

Sizing Up the College Bowls: 15 parts.

Sizing Up Pro Football: Eight parts. Each about 12 minutes.

Sizing Up College Football: Nine parts.

Sizing Up Baseball: 28 parts.

Sizing Up the Masters: Eight parts.

Sizing Up the Derby: Three parts.

Sizing Up the Indy: Five parts.

Sizing Up the U.S. Open: Eight parts.

Sizing Up the PGA: Eight parts.

Sizing Up the World Series: Two parts.

Ratings: About two minutes. Rankings of top 20 college football or basketball teams. Available Tuesdays by 6:30 a.m. Eastern time.

Fared: About two minutes. How the top 20 college football or basketball teams fared for the week. Available Sunday morning.

Probable Pitchers: Pitchers and records for following day baseball games. Available 6 p.m. daily.

Pro Football Odds: About four minutes. Available Wednesdays.

Pro Prophet: Up to 15 minutes. Picking the winners in pro football. Subs for daily speaking of sports. Available early Friday morning.

College Prophet: Up to 24 minutes. Subs for daily speaking of sports. Early Thursday.

Ski World: Up to 17 minutes. Roundup of ski conditions around the country. Subs for daily speaking of sports. Early Friday.

College Basketball Results: Up to 30 minutes.

College Football Results: Up to 30 minutes.

Major League Leaders: Leaders in hitting, pitching and stolen bases. Updated daily in season. Around five minutes.

ACCESS SIMPLY ACCOMPLISHED

UPI CABLE NEWS service is being delivered nationwide, using the vertical blanking interval (VBI) of SATCOM-3. Transponder 6 (the WTBS channel) and WESTAR 3 (Transponder 1). Almost every cable system in the U.S. can have access to the UPI service by simply plugging the newly designed UPI hardware into the output port of their existing satellite receiver (channel 6) and connecting it to existing character generators.

The editorial content of UPI's high-speed newswire has been designed so that it is virtually universal with the accepted teletext and videotex formats. The unique controller engineered for the custom cable service was built so that it can also be adapted easily to teletext and videotex systems.

The CABLE NEWS format is an outgrowth of UPI's plans made during the 1960's for an exclusive news service for cable clients. At its inception, it began as a 10 minute scroll display punched into paper tape by a teletype operator. From that computer terminals came into use, to the page display with added codings to permit operators to display commercials within the news report. Then came the regional news being added precipitating this development of a totally news concept.

Sum it up to say that UPI has developed a customized cable news . . . for your system . . . for your market . . . for your viewers.

For more information on this service, we would suggest that you contact Jack Klinge, "our" man at UPI in Dallas. Jack, as the UPI Director of Affiliate Relations, represents UPI at the many conventions and state meetings across the country. As a long time supporter of CATA, CATA's CCOS, and CATJ, most of you probably know and recognize Jack as a leader in this business. We feel certain that a conversation with Jack will convince you of the appeal and useability of this news service for your system. Call him at 214-980-8350.

UNLIMITED PROGRAMMING POTENTIAL

Because of the abundance of categories and the sheer volume of news at a cable operator's disposal, programming can be formulated to suit the viewers' need. For example you can put together:

* A 9 a.m. to 5 p.m. daytime segment with news and features geared to daytime audiences.

* A 5 p.m. to 9 a.m. overnight segment for the times when the more news-hungry viewers are watching.

* A 24 hour weekend segment that can be used for extended sports coverage and features.

Program more than one channel . . . use one for sports, another for state news, and yet another for national news. Also included is the Spanish language news, which would be a strong consideration in many areas, and the Washington news report. This service is definitely a way to give the viewers all the news they want programmed in a way that is right for a specific system.

Distributors	Manufacturers	Service Firms
D1—Full CATV equipment line	M1—Full CATV equipment line	S1—CATV contracting
D2—CATV antennas	M2—CATV antennas	S2—CATV construction
D3—CATV cable	M3—CATV cable	S3—CATV financing
D4—CATV amplifiers	M4—CATV amplifiers	S4—CATV software
D5—CATV passives	M5—CATV passives	S5—CATV billing services
D6—CATV hardware	M6—CATV hardware	S6—CATV publishing
D7—CATV connectors	M7—CATV connectors	S7—CATV drop installation
D8—CATV test equipment	M8—CATV test equipment	S8—CATV engineering
D9—Other	M9—Other	S9—Other

Associate Roster

Note: Associates listed with * are Charter Members.

ADT Security Systems,
One World Trade Center,
92nd Fl.,
New York, NY 10048
212—558-1444
(M9 Security Equipment)

Alpha Technologies,
1305 Fraser St. D-G,
Bellingham, WA 98225
206—671-7703
(M9, Standby Power
Supplies)

AMCOM, Inc.,
Bldg. E, Suite 200,
5775 Peachtree-
Dunwoody Rd., N.E.,
Atlanta, GA 30342
404—256-0228
(S9, Brokering &
Consulting)

Amplica, Inc.,
950 Lawrence Dr.,
Newbury Park, CA 91320
805—498-9671
(M4)

* **Anixter Communications**
4711 Golf Road,
Skokie, IL 60076
312—677-2600
(D1)

Apple/Store,
Rte. #1, Box 156,
Beaver Dam, WI 53916
414—885-6249

The Associated Press,
50 Rockefeller Plaza,
New York, NY 10020
212—621-1513
(S9 Automated News
SVC)

Automation Techniques,
1846 N. 106th E. Ave.,
Tulsa, OK 74116
918—836-2584
(M9)

Avantek, Inc.,
481 Cottonwood Dr.,
Milpitas, CA 95035
408—946-3080
(M8, 9 TVRO
Components)

BEI
P.O. Box 937,
Olathe, KS 66061
800—255-6226
(M9 Character
Generators)

**Ben Hughes
Communications**
P.O. Box AS,
Old Saybrook, CT 06475
203—388-3559
(M6, M9)

Blonder-Tongue Labs, Inc.,
1 Jake Brown Rd.,
Old Bridge, NJ 08857
201—679-4000
(M1, 2, 4, 5)

**Broadband Engineering,
Inc.,**
P.O. Box 1247,
Jupiter, FL 33458
1-800—327-6690
(D9, replacement parts)
(M4, S9, Repair)

Budco, Inc.,
4910 East Admiral Place,
Tulsa, OK 74115
1-800—331-2246
(D9, Security &
Identification Devices)

CATEL,
4800 Patrick Henry Dr.,
Santa Clara, CA 95054
415—969-9400

* **C-COR Electronics, Inc.,**
60 Decibel Rd.,
State College, PA 16801
814—238-2461
(M1, M4, M5, S1, S2, S8)

CBS Cable,
1211 Avenue of the
Americas, 2nd Floor,
New York, NY 10019
1-800—528-3341
(S4)

CCS Hatfield/CATV Div.,
5707 W. Buckeye Rd.,
Phoenix, AZ 85063
201—272-3850
(M3)

CWY Electronics,
405 N. Earl Ave.,
Lafayette, IN 74904
1-800—428-7596
(M9, D1)

CableBus Systems,
7869 S.W.
Nimbus Avenue,
Beaverton, OR 97005
503—543-3329
(M1)

Cable Graphic Sciences,
7095 N. Clovis Ave.,
Clovis, CA 93612
209—297-0508
(M9 Character
Generators)

Cable Health Network,
2840 Mt. Wilkinson Pkwy.
Atlanta, GA 30339
404—436-0886
(S4)

Cable-Text Instruments,
705 Avenue K, Suite #4
Plano, TX 75074
214—422-2554
(M9 Generators)

Century III Electronics, Inc.
3880 E. Eagle Drive,
Anaheim, CA 92807
630-3714
(M1, M3, M4, M5, M7, M8,
S1, S2, S8)

Capscan, Inc.,
P.O. Box 36,
Adelphia, NJ 07710
1-800—CABLETV or
222-5388
(M1, M3, M4, M5)

Channel Master,
Ellenville, NY 12428
914—647-5000
(M2, 3, 4, 5, 6, 7)

**Collins Commercial
Telecommunications,**
MP-402-101,
Dallas, TX 75207
214—690-5954
(M9, Microwave)

CommScope Company,
Rt. 1, Box 199A,
Catawba, NC 28609
1-800—438-3331
(M3)

**Communications Equity
Associates,**
851 Lincoln Center,
5401 W. Kennedy Blvd.,
Tampa, FL 33609
813—877-8844
(S3)

**Computer Video
Systems, Inc.,**
3678 W. 2105 S. Unit 2,
Salt Lake City, UT 84120
1-800—453-8822
(M9)

COMSEARCH INC.,
11503 Sunrise Valley
Drive,
Reston, VA 22091
703—620-6300
(S8, S9, Earth station
placement frequency
coordination)

ComSonics, Inc.,
P.O. Box 1106,
Harrisonburg, VA 22801
1-800—336-9681
(M8, M9, S8, S9)

DF Countryman Co.,
1821 University Ave.,
St. Paul, MN 55104
612—645-9153
(D1, S1, S8)

Ditch Witch,
P.O. Box 66,
Perry, OK 73077
1-800—654-6481
(M9)

The Drop Shop Ltd., Inc.,
Box 284,
Roselle, NJ 07203
1-800—526-4100 or
1-800—227-0700 (West)
(D3, 4, 5, 6, 7, 8, 9,
M5, 6, 7, 8, 9 Plastics)

Durnell Engineering Inc.,
Hwy 4 So.
Emmetsburg, IA 50536
712—852-2611
(M9)

Eagle Com-Tronics, Inc.,
4562 Waterhouse Rd.,
Clay, NY 13041
1-800—448-7474
(M9 Pay TV Delivery
Systems & Products)

**Eales Comm. &
Antenna Serv.,**
2904 N.W. 23rd,
Oklahoma City, OK 73107
405—946-3788
(D1, 2, 3, 4, 5, 6, 7,
S1, 2, S7, 8)

Eastern Microwave, Inc.,
3 Northern Concourse,
P.O. Box 4872,
Syracuse, NY 13221
315—455-5955
(S4)

Associate Roster

Electroline TV Equipment, Inc.,
8750-8th Ave.,
St. Michel,
Montreal, Canada
H1Z 2W4
514-725-2471
(M4, 5, 7, 9, D7, 9)

Electron Consulting Associates,
Box 2029,
Grove, OK 74344
918-786-5349
(M2, D1, S1, 8)

Elephant Industries,
P.O. Box 3949
N. Ft. Myers, FL 33903
813-995-7383
(M9)

ESPN,
ESPN Plaza,
Bristol, CT 06010
203-584-8477
(S9)

The Entertainment Channel,
1133 Avenue of the Americas,
New York, NY 10036
212-930-4900
(S4)

Ferguson Communications Corp.,
P.O. Drawer 1599,
Henderson, TX 75652
214-854-2405
(S1, 2, 7, 8, 9)

Franey & Parr of Texas, Inc., (Formerly Doherty & Co.),
One Turtle Creek Village,
Suite 524,
Dallas, TX
214-528-4820
(S9, Insurance)

GTE Sylvania,
10841 Pellicano Dr.,
El Paso, TX 79935
1-800-351-2345
(D7, M4, M5, M6, S4, S8)

Gardiner Communications Corp.,
3506 Security St.,
Garland, TX 75042
214-348-4747
(M9 TVRO Packages, S1, S2, S8)

General Cable Corp.,
1 Woodbridge Center,
P.O. Box 700
Woodbridge, NJ 07095
1-800-526-4385
(M3)

Gilbert Engineering Co.,
P.O. Box 23189,
Phoenix, AZ 85063
1-800-528-5567 or
602-245-1050

Group W Satellite Communications,
41 Harbor Plaza Dr.,
P.O. Box 10210,
Stamford, CT 06904
203-965-6219
(S4)

H & R Communications,
Rt. 3, Box 102G,
Pocahontas, AK 72455
1-800-643-0102
(M2, D1, S2, S3, S8)

Harris Corporation,
P.O. Box 1700,
Melbourne, FL 32901
305-724-3401
(M2, M9, S2)

Heller-Oak Communications,
105 W. Adams St.,
Chicago, IL 60603
1-800-621-2139 * 7600
(S3)

Home Box Office, Inc.,
7839 Churchwill Way,
Suite 133, Box 63,
Dallas, TX 75251
214-387-8557
(S4)

* **Hughes Microwave Communications Products,**
3060 W. Lomita Blvd.,
Torrance, CA 90505
213-517-6233
(M9)

* **Jerry Conn Associates, Inc.,**
P.O. Box 444,
Chambersburg, PA 17201
1-800-233-7600
1-800-692-7370 (PA)
(D3, D4, D5, D6, D7, D8)

KMP Computer Services, Inc.,
703 Central Ave.,
Los Alamos, NM 87544
505-662-5545
(S4, 5)

Karnath Corporation,
2001 Westridge,
Plano, TX 75075
214-422-7981 or 7055
(S1, 2, 8, 9)

Katek, Inc.,
134 Wood Ave.,
Middlesex, NJ 08846
201-356-8940

Klungness Electronic Supply,
P.O. Box 547,
107 Kent Street,
Iron Mountain, MI 49801
1-800-338-9292
1-800-682-7140 (Mich)
(D1, D8, S2, S8)

LRC Electronics, Inc.,
901 South Ave.,
Horseheads, NY 14845
607-739-3844
(M7)

Larson Electronics,
311 S. Locust St.,
Denton, TX 76201
817-387-0002
(M9 Standby Power)

Lemco Tool Corporation,
Box 330A,
Cogan Station, PA 17728
1-800-233-8713
(M8, 9 Tools)

Lindsay Specialty Products, Ltd.,
50 Mary Street West,
Lindsay,
Ontario, Canada K9V 4S7
705-324-2196
(M1, 2, 4, 5, 7, 9)

Magnavox CATV Division,
100 Fairgrounds Drive,
Manlius, NY 13104
1-800-448-5171 or
1-800-522-7464 (N.Y.)
(D4, 5, 7, M4, 5, 6, 7, S3, 8)

McCullough Satellite Equipment,
Route 5, Box 97,
Salem, AR 72576
501-895-3167
(M2, 9, D3, 4, 6, 7)

Microdyne Corporation,
471 Oak Road,
Ocala, FL 32672
904-687-4633
(M9 Satellite TV Receivers)

Microwave Associates Communications Co.,
777 S. Central Expwy.,
Suite 1G,
Richardson, TX 75080
214-234-3522
(M9 Microwave Radio Systems)

* **Microwave Filter Co.,**
6743 Kinne St., Box 103,
E. Syracuse, NY 10357
1-800-448-1666
(M5 Bandpass Filter)

Midwest Corp.,
P.O. Box 226,
Clarksburg, WV 26301
1-800-624-3845
(D1, 2, 3, 4, 5, 6, 7, 8)

Modern Cable Programs,
5000 Park St. N.,
St. Petersburg, FL 33709
(S4)

Mullen Communications Construction Co., Inc.,
P.O. Box 1387A,
Green Bay, WI 54305
414-468-4649
(S2)

NCS
2255-E Wyandotte Rd.,
Willow Grove, PA 19090
1-800-523-2342
1-800-492-2032 (PA)
(D1, 2, S8, 9 repair service)

National Farmers Union Property & Casualty Co.,
12025 E. 45th Ave.,
Denver, CO 80251
303-371-1760
(D9, Insurance Service)

Distributors	Manufacturers	Service Firms
D1—Full CATV equipment line	M1—Full CATV equipment line	S1—CATV contracting
D2—CATV antennas	M2—CATV antennas	S2—CATV construction
D3—CATV cable	M3—CATV cable	S3—CATV financing
D4—CATV amplifiers	M4—CATV amplifiers	S4—CATV software
D5—CATV passives	M5—CATV passives	S5—CATV billing services
D6—CATV hardware	M6—CATV hardware	S6—CATV publishing
D7—CATV connectors	M7—CATV connectors	S7—CATV drop installation
D8—CATV test equipment	M8—CATV test equipment	S8—CATV engineering
D9—Other	M9—Other	S9—Other

Note: Associates listed with * are Charter Members.

North Supply Company,
10951 Lakeview Ave.,
Lenexa, KS 66219
1-800-255-6458
1-800-332-1073 (Kansas)
(D1, 2, 3, 4, 5, 6, 7, 8)

Oak Industries, Inc.,
Crystal Lake, IL 60014
815-459-5000
(M1, M9 Converters, S3)

Octagon Scientific, Inc.,
476 E. Brighton Ave.,
Syracuse, NY 13210
315-476-0660
(M9)

Phasecom Corp.,
6365 Arizona Circle,
Los Angeles, CA 90045
213-641-3501
(M1)

**Power and Telephone
Supply Company, Inc.,**
530 Interchange Drive
N.W.,
Atlanta, GA 30336
1-800-241-9996
(D1)

Prodelin, Inc.,
1350 Duane Avenue,
Santa Clara, CA 95050
408-244-4720
(M2, M3, M7, S2)

Pyramid Industries, Inc.,
P.O. Box 23169,
Phoenix, AZ 85063
1-800-528-4529
(M7, 8)

RMS Electronics,
50 Antin Place,
Bronx, NY 10462
1-800-223-8312
1-800-221-8857 (Poleline)
(M4, M5, M6, M7, M9)

Reuters,
1212 Avenue of the
Americas, 16th Floor,
New York, NY 10036
212-730-2715
(D9)

Rockwell International,
M.S. 402-101,
Dallas, TX 75207
214-996-5954
(M9, Microwave/Satellite)

**S.A.L. Communications,
Inc.,**
P.O. Box 794,
Melville, NY 11747
1-800-645-9062
(D1)

Sadelco, Inc.,
75 West Forest Ave.,
Englewood, NJ 07631
201-569-3323
(M8)

Scientific Atlanta, Inc.,
3845 Pleasantdale Rd.,
Atlanta, GA 30340
404-449-2000
(M1, M2, M4, M8, S1, S2,
S3, S8)

Shafer Associates, Inc.,
9501 Briar Glen Way,
Gaithersburg, MD 20760
301-869-4477
(S9, consultant)

**Showtime Entertainment,
Inc.,**
1633 Broadway,
New York, NY 10019
212-708-1600
(S4)

**Southern Satellite
Systems, Inc.,**
P.O. Box 45684,
Tulsa, OK 74145
918-481-0881
(S9)

TVC Supply Co., Inc.,
1746 E. Chocolate Ave.,
Hershey, PA 17033
717-533-4982
(D1, 2, 3, 4, 5, 6, 7, 8)

Teledac, Inc.,
1575 Taschereau Blvd.,
Longueuil,
Quebec, Canada J4K 2X8
514-651-3716
(M9 Character
Generators)

Tele-Wire Supply Corp.,
122 Cutter Mill Rd.,
Great Neck, NY 11021
1-800-325-4868
(D1, 2, 3, 5, 6, 7, 8, 9)

* **Texscan Corp.,**
2446 N. Shadeland Ave.,
Indianapolis, IN 46219
1-800-528-4066
(M8 Bandpass Filters)

* **Theta-Com CATV,**
2960 Grand Avenue,
Phoenix, AZ 85061
602-252-5021
(M1, M4, M5, M7, M8)

* **Times Fiber
Communications,**
358 Hall Avenue,
Wallingford, CT 06492
1-800-243-6904
(M3)

Tocom, Inc.,
P.O. Box 47066,
Dallas, TX 75247
214-438-7691
(M1, M4, M5, Converters)

* **Toner Cable
Equipment, Inc.,**
969 Horsham Rd.,
Horsham, PA 19044
1-800-523-5947
In Penna. 1-800-492-2512
also 1-800-523-5947 (PA)
(D2, D3, D4, D5, D6, D7)

**Triple Crown
Electronics, Inc.,**
4560 Fieldgate Dr.,
Mississauga, Ontario,
Canada L4W 3W6
416-629-1111
Telex 06-960-456
(M4, M8)

**Turner Broadcasting
System,**
1050 Techwood Dr.,
Atlanta, GA 30318
404-898-8500

Tyton Corp.,
P.O. Box 23055,
Milwaukee, WI 53223
414-355-1130
(M6, 7)

USA Network,
208 Harristown Rd.,
Glen Rock, NJ
201-445-8550
(S4)

United Press International,
220 East 42nd St.,
New York, NY 10017
212-682-0400
(S9 Automated News
Svc.)

United Video, Inc.,
3801 South Sheridan Rd.,
Tulsa, OK 74145
1-800-331-4806
(S9)

Video Data Systems,
40 Oser Avenue,
Hauppauge, NY 11787
516-231-4400
(M9)

Viewstar, Inc.,
705 Progress Ave.,
Unite 53,
Scarborough,
Ontario, Canada M1H 2X1
416-439-3170
(M9 Cable Converter)

Vitek Electronics, Inc.,
4 Gladys Court,
Edison, NJ 08817
201-287-3200

**Warner Amex Satellite
Entertainment Corporation,**
1211 Avenue of the
Americas,
New York, NY 10036
212-944-4250
(S4)

* **Wavetek Indiana,**
5808 Churchman,
Beech Grove, IN 46107
1-800-428-4424
TWIX 810-341-3226
(M8)

Weatherscan,
Loop 132,
Throckmorton Hwy.,
Olney, TX 76374
817-564-5688
(D9, Sony Equip. Dist.,
M9 Weather Channel
Displays)

**Western Communication
Service,**
Box 347,
San Angelo, TX 76901
915-655-6262/653-3363
(M2, Towers)

Winegard Company,
3000 Kirkwood Street,
Burlington, IA 52601
1-800-523-2529
(M1, M2, M3, M4, M5, M7) □

Classified

TECHNICAL OPPORTUNITIES

PROJECT ENGINEER

Excellent opportunity for experienced hands-on tech with fast growing MSO in Tennessee (20,000 subs.). Minimum 7 years CATV experience, willing to travel Middle and East Tennessee. Second class phone preferred. Must have references and knowledge of all phases of CATV engineering, including design and construction supervision, with the ability to stay within budgets and complete projects on time. This position will report directly to the regional manager.

An equal opportunity employer.

Send resume to:

Bob Pace, Regional Manager
National TV Cable Company
P.O. Box 328
McMinnville, Tenn. 37110



ATTENTION! SYSTEM MANAGERS — TECHNICIANS NEEDED

Excellent opportunity for system managers and technicians for our systems in Colorado, Texas, and Oklahoma. Need qualified personnel for these Southwestern locations; good working conditions and opportunity for the right people who want to work and stay actively involved in the cable business. These systems have good equipment to work with and offer excellent situations to grow in the cable business. If interested, send resume to the box number indicated below.

Box 71080
c/o CATJ
4209 N.W. 23rd
Suite 106
Okla. City, OK 73107

Your company can help us prevent child abuse.

One of the tragic aspects of child abuse is that it doesn't have to happen.

The National Committee for Prevention of Child Abuse knows how child abuse can be prevented.

But we need your company's help to do it. We need help in two ways.

The first involves educating your employees to the causes and prevention of child abuse—through literature which we can make available.

The second way involves helping us set up additional prevention facilities—through the donation of money in your company's name.

The National Committee for Prevention of Child Abuse is a private, charitable organization. In the last seven years we've made great strides in the prevention of child abuse.

But the problem is still enormous. We need your help. Please mail the attached coupon today.

And help us put an end to child abuse.

Help us get to the heart of the problem.

Write: National Committee for Prevention of Child Abuse
Box 2866, Chicago, Illinois 60690

Please send us information on how we can help.

We want to start helping right now. Enclosed is a check for \$ _____

NAME _____

TITLE _____ COMPANY _____

ADDRESS _____

CITY _____ STATE _____ ZIP _____



National Committee for
Prevention of Child Abuse

A Public Service of This Magazine
& The Advertising Council.



CATJ classified advertising is offered as a service by CATA for its membership.

ANY member of CATA may advertise in the CATJ classified section FREE of CHARGE (limit of 50 words per issue — 3 issues per year.)

CATA offers three types of memberships:

- 1.) Systems — paying regular monthly dues based on number of system subscribers.
- 2.) Associate Members — pay an annual fee.
- 3.) Individual Members — pay an annual fee.

NON MEMBERS may also use the Classified section at the rate of 50 cents per word with a minimum charge of \$20.00. Add \$2.00 for blind-box. Non-members should include full payment with the ad insertion.

Deadlines for all Classified Advertising is the 1st of the month for the following month's issue.

Address all Classified material to: CATJ, Suite 106, 4209 N.W. 23rd, Oklahoma City, Okla. 73107.

THE ENDURING SYMBOL OF QUALITY



The American Eagle. Lasting symbol of strength and independence. Subject to attack . . . but always the standard of leadership, endurance and survival.

For over 5 years, Eagle Comtronics has maintained its strength, independence, and course through periods of growth, change and challenge.

We've grown from a four person operation to among the leading privately held companies in the CATV business employing over 600 people.

Why do Eagles endure? Ask us.

Or ask cable operators who have purchased over 10,000,000 of our traps. In 1977, Eagle introduced cost efficient security to the CATV industry with the first reliable, stable, anti-corrosive trap in the business.

Ask over 1,000 cable operators who are now using our 500 MHz tap. Eagle's tap led cable into the world of 440 + MHz capability and our tap continues to lead the industry with its unique mechanical features and the lowest insertion loss of any tap available in the market.

Ask 8 of the top 10 MSO's who are now using our programmable descrambler. Developed through engineering expertise and with a unique and practical approach to securing multi-tiered service, our programmable descrambler is the ticket for systems needing to expand service without depleting capital.

Ask about our new addressable descrambler. A plain and simple product that eliminates the concept that addressability is

"too complex" or "too much too soon" for today's cable systems.

Ask our twenty-one member engineering team that is at the leading edge of cable technology. Eagle is investing over 60 man years in the research and development of products for your future. Projects in progress include interactive two way communications systems, communications data security, MDS, STV, Satellite DBS, and Direct Satellite Transmission.

It's the largest ongoing research and development effort in Eagle Comtronics' history. It's common sense telling us to pay as much attention to the wants and needs of our customers as we do to the quality of products we manufacture.



EAGLE QUALITY PRODUCTS: Addressable Descramblers, Programmable Descramblers, Traps, Taps, Splitters, Home Terminals, Converters.

OFFICE ADDRESS: 4562 Waterhouse Road, Clay, N.Y. 13041 (315) 622-3402 MAIL ADDRESS: P.O. Box 2457, Syracuse, N.Y. 13220
IN CANADA: Desklin Sales • Montreal • Toronto • Vancouver 77D Steelcase Road West, Markham, Ontario L3R2M4 (416) 475-1412
IN EUROPE: Siemens S.A. • Brussels, Belgium (02) 536.21.11 Telex 21.347

CALL TOLL FREE TO ORDER 800-448-7474

WorldRadioHistory

Descrambler-16D

Descramble 1 to 16 Tiers
Unlimited Channels

An Entirely New Concept in the Security Marketplace



Model 16D



Scrambler-1000
"For Unlimited Scramble Capability"



RMS ELECTRONICS, INC./CATV DIVISION • 50 ANTIN PLACE, BRONX, N.Y. 10462
TOLL FREE: (800) 223-8312 (Continental U.S.A., Puerto Rico, U.S. Virgin Islands) • CALL COLLECT: (212) 892-1000 (N.Y. State)
WESTERN OPERATIONS: 2901 W. GARRY AVE., SANTA ANA, CALIF., 92704 • TEL. (714) 662-1041 • CALL COLLECT
SOUTHWEST OPERATIONS: 1401 FRANKLIN DRIVE, SAN MARCOS, TEXAS, 78666 • TEL. (512) 396-5432 • CALL COLLECT

WorldRadioHistory