



RADIOWORLD

OCTOBER 12, 2011

In-Depth Technology for Radio Engineers

\$2.50

RADIOWORLD.COM



Sam Wallington's Engineering Team Builds a Network at EMF

Educational Media Foundation is one of the largest radio networks in the United States, with approximately 700 signals serving markets in nearly every

NEWSMAKER

state. With two contemporary Christian music formats, K-Love and Air1, it has grown from a single radio station in 1982 to a network serving a weekly cum of roughly 9 million listeners. The network comprises some 328 full-power radio stations and 340 FM translators. Though noncommercial, most of these stations are owned and operated by EMF.

Radio World Engineering Extra's Technical Editor talked to Sam Wallington, vice president of engineering for Educational Media Foundation. Wallington has an AS degree in electronics technology from Pacific Union College in California and began his career in interest in sound systems. He has been with EMF for some 18 years. He joined in 1993 as its only engineer. He



now oversees a staff of 30 engineers, plus a team that specializes in new site construction.

How did you make your way into the radio broadcast industry?

Like most engineers, technical things have always been fun for me, starting as a toddler when I'd take things like a music box apart, figure out how it worked, play with it a bit and put it back together — so often that the fasteners wouldn't hold any more. At 13, I became fascinated by the electronics involved in sound systems, and started volunteering at church under a very talented and creative elderly man, Barney LeDuc, who

(continued on page 8)

International Broadcasters Know DCC

BY ERNIE FRANKE

The author, WA2EWT, is a broadcast consultant in St. Petersburg, Fla.

The FCC has formally approved a "green" technique for AM radio stations that want to reduce their operating costs. The technique is known as

WHITEPAPER

Modulation Dependent Carrier Level, or MDCL. Public notice was issued on Sept. 13, extending what had been an experimental program in Alaska to all U.S. AM stations.

International broadcasters have been familiar with the concept for many years under the name of Dynamic Carrier Control. The purpose of this article is to explain to U.S. AM stations a technology already familiar to their colleagues abroad.

With escalating power bills, controlling electricity usage is especially important to the international broadcaster. Dynamic Carrier Control, offering significant savings in power bills for high-power broadcast transmitters, was proposed more than 75 years ago. It took the power of the integrated circuit digital signal processor (DSP) and pulse-step modulation (PSM) to bring

(continued on page 4)

#####AUTO#3-DIGIT 604
00181 RMEA 0025185 E1102
STBM 012
THOMAS BRAXTON
SENIOR ENGINEER
SHURE INC
201 BULL LN
BOLINGBROOK IL 60490-1520

4G Simplicity

ACCESS 2USB



IP • 3G • Wi Fi • 4G • BGAN / VSAT • PSTN • DSL

Learn more at comrex.com/promo and take advantage of a special offer valued at \$500.



comrex.com

Tel: 978-784-1776 • Toll Free: 800-237-1776 • e-mail: info@comrex.com

World Radio History

E-6

The flagship of our E-Series consoles, the E-6 does it all. Its intuitive interface gives you all the power you need for an on-air or production studio.

SIDEBOARD

Perfect for newsrooms, guest talent, interviews, the SIDEBOARD's tiny footprint lets you put it exactly where you need it.

E-1

With its small footprint, the E-1 can be a self-contained console when paired with our ip88cb Console Audio BLADE. It also becomes a full function station on our WheatNet-IP AoIP Network.



DO A LOT MORE THAN JUST SCRATCH THE SURFACE(S)...

Let's face it, your console IS your desktop. Wouldn't it make sense to use one that knows how you work and makes your job not only easier and faster, but better in every way?

Wheatstone's **E-6**, **E-1** and **Sideboard** control surface consoles do just that.

They're intelligent with virtually limitless routing capabilities, letting you control what's around you as well as sources in other studios. These are pure "RADIO" inside and out – not someone's glorified idea of what a starship helm should look like – so you're immediately at home with their form and function.

Featuring an intuitive layout that never leaves you guessing, as well as smart control over on-screen functions, these are truly world class consoles, right down to the feel and reliability of real P+G faders.

So what's behind them? Our WheatNet-IP AoIP network – the most powerful, flexible and fastest AoIP network available to broadcast. Self-aware, self-configuring, self-healing and ten times faster through the ENTIRE network. And they're made right here in the USA in our New Bern, NC facility! The cost? A whole lot less than you might think.



Download the FREE white paper "The Technical Case for the Intelligent Network" at WheatIP.com



THE INTELLIGENT NETWORK™

phone 1.252.638-7000 | WheatNetIP.com | sales@wheatstone.com



Let's Explore the Promise of IP Remotes

Tests of Wireless 4G for Broadcast Tantalize, Delight and Frighten

BY MICHAEL LECLAIR

It is sheer curiosity that led me to some recent experiments with 4G wireless Internet.

For some time now, it has been a commonplace amongst certain groups that our old standby technology for remote broadcasts, ISDN, is dead. Well, if not quite dead, then on its back, limbs flailing helplessly. It's time to bury it and convert all our audio to packets that travel through the cloud.

It sounds appealing, like the early days of jet travel before the seats shrank.

Although I may regret this, I'll admit that I was there with other engineer dinosaurs at the dawn of the ISDN era. I remember a sales representative at a broadcast conference standing on stage and yelling out the number toll-free number 1-800-GET-ISDN so you knew who to call to get it.

For those of us without a Marti RPU, who previously had been confined to either plain telephone lines or equalized broadcast loops, ISDN was nothing short of miraculous. With a limited lead time you could get almost any of the Bell Operating Companies to install a digital circuit that would pass clean and clear audio (assisted by an audio codec, of course) to and from almost anywhere in the United States and much of Europe.

ISDN quickly became a radio favorite.

PLAN FOR THE FUTURE

Fast-forward 10 years. Entire national networks of ISDN-equipped studios fed a surge in talk and information programming that is still with us. ISDN remains the gold standard of studio interconnections when audio quality is desired and the distance is further than the horizon.

Sadly, few other data customers followed suit in adopting ISDN. In the quest for faster connections, data technologies progressed from the analog modem to DSL and high-speed data over consumer cable networks. By stripping off precise timing and packetizing the content, data transfer speeds could be accelerated radically.

Lowly old ISDN fell far behind. It remains what could be only termed a "niche" service. There are still many radio and studio ISDN customers, and they use a lot of long-distance time, but the growth is limited. The fear of someday finding ISDN unavailable is a valid one. Some of the regional telephone companies have openly threatened to abandon all their copper lines.

At my day job, working for WBUR in Boston, I have the responsibility of



Hacked Linksys WRT54 router and Verizon MiFi. The Linksys receives a signal from the MiFi and connects to the codec via a CAT-5 cable.

planning for remote broadcasts. Since the days of ISDN may be numbered, I have made investments in audio codecs that support both ISDN and what has come to be known as "IP" connections.

We have printed articles in Engineering Extra that describe the special requirements for an IP codec: It must have the ability to buffer packets to account for the sometimes bursty nature of Internet data transfer, and it must be able to provide good quality at low data rates for when the Internet connection is not good. IP codecs must be able to handle the non-synchronous delivery of data where bits show up whenever they can and must then assembled back into the correct order and timing to pass real time audio.

From a manufacturing perspective, it seems fairly cost-effective to combine the operations of an ISDN codec with the IP part. The encoding and decoding process remains essentially the same. The trick is to get the ones and zeroes back into order in a synchronous stream, error-free, after they have gone hurtling through the public Internet. That's the IP part of an IP codec.

INTO THE WILD

With equipment in hand, it became hard for me to resist trying it out. Perhaps this was a technology that could save me money on remotes and even improve the quality. Coincidentally, Verizon Wireless began to offer 4G data services in the Boston area in January of 2011. Karl Voelker, our manager of information systems, picked up a MiFi device from Verizon to test it out.

The wireless modem in the MiFi connects to Verizon's 700 MHz band 4G

data services. In turn it wirelessly provides a connection to a 802.11b/g/n-enabled device like a laptop computer.

In a neat reverse hack, Karl turned a surplus consumer Linksys wireless router into the interconnection device for our codecs, which do not have 802.11 adapters. Instead of taking in a wired Internet connection and creating a wireless signal for a computer, as I do with mine at home, this router connects wirelessly to the MiFi and outputs a wired connection to the codec.

If you think about the previous sentence a second, you'll see that it runs exactly backwards.

It took a bit of fiddling with the IP codecs to get them to connect to the router correctly. For some reason they would not DHCP properly, meaning that when they asked to be connected to the network, they would not get a valid address and directions on how to see the public Internet. Once I had figured out

(continued on page 14)

THIS ISSUE

OCTOBER 12, 2011

Sam Wallington's Engineering Team Builds a Network at EMF	1
International Broadcasters Know DCC	1
Let's Explore the Promise of IP Remotes	3
It's Showtime for the New EAS	16
A Difference in Protection	19
Why You Should Practice the Art of Writing	22

E-mail: rwee@nbmedia.com
 Website: www.radioworld.com
 Telephone: (703) 852-4600
 Business Fax: (703) 852-4582
 Editorial Fax: (703) 852-4585

For address changes and subscription renewal, please visit radioworld.com and click on the "Subscription" button. To submit letters or story proposals, to request writer's guidelines, or for other editorial matters, e-mail the editor radioworld@nbmedia.com.

EDITORIAL STAFF

EDITOR IN CHIEF, U.S. Paul J. McClane
 TECHNICAL EDITOR, RWEE Michael LeClair
 PRODUCTION EDITOR, RWEE Karen Lee
 NEWS EDITOR/WASH. BUREAU CHIEF Leslie Stimson
 AD & TECHNOLOGY EDITOR Brett Moss
 TECHNICAL ADVISER Thomas R. McGinley
 CONTRIBUTING EDITOR John Bisset
 INTERNATIONAL EDITOR IN CHIEF T. Carter Ross
 LATIN AMERICA EDITOR IN CHIEF Rogelio Ocampo
 EUROPE EDITOR Karina Gerardi
 MANAGING EDITOR, WEB Brian Smith

EDITORIAL CONTRIBUTORS

C. Alexander, Barry Blesser, James Careless, Harry Cole, Ken Deutsch, Mark Durenberger, Charles Fitch, Ty Ford, Harold Hallikainen, Craig Johnston, Paul Kaminski, Peter King, Mark Lapidus, Daniel Mansergh, John Merli, Laura Mir, Jim Peck, Mark Persons, Sharon Rae Pettigrew, Stephen M. Poole, Carl Lindemann, Ted Nahil, James O'Neal, Tom Penkowsky, Rich Rarey, Tom Ray, John Schneider, Randy Stine, Richard Strickland, James G. Withers, Tom Vernon

ADMINISTRATION & PRODUCTION

PUBLISHER John Casey
 EDITORIAL DIRECTOR T. Carter Ross
 PRODUCTION DIRECTOR Davis White
 PRODUCTION PUBLICATION COORDINATOR Karen Lee
 ADVERTISING COORDINATOR Caroline Freeland

CIRCULATION

ASSOCIATE CIRCULATION DIRECTOR,
 AUDIENCE DEVELOPMENT Tracey Dwyer
 CIRCULATION MANAGER Kwentyn Keenan
 CIRCULATION COORDINATOR Michele Fonville

SUBSCRIPTIONS

Radio World, P.O. Box 282, Lowell, MA 01853
 TELEPHONE: 888-266-5828 (USA only 8:30 a.m.-5 p.m. EST)
 78-667-0352 (Outside the US) FAX: 978-671-0460
 WEBSITE: www.myRWNews.com
 E-MAIL: newbay@computerfulfillment.com

CORPORATE

NewBay Media LLC
 PRESIDENT AND CEO Steve Palm
 CHIEF FINANCIAL OFFICER Paul Mastrorandi
 CONTROLLER Jack Liedke
 GROUP CIRCULATION DIRECTOR Denise Robbins
 VICE PRESIDENT OF WEB DEVELOPMENT Joe Ferrick

VIDEO/BROADCAST GROUP

EXECUTIVE VICE PRESIDENT Carmel King
 VICE PRESIDENT / SALES DIRECTOR Eric Trabb

ADVERTISING SALES REPRESENTATIVES

U.S. EAST & LATIN AMERICA: John Casey, jcasey@nbmedia.com
 T: 212-378-0400, ext. 512 | F: 330-247-1288
 U.S. WEST & CANADA: David Carson, dcarson@nbmedia.com
 T: 212-378-0400, ext. 511 | F: 866-572-6156
 SOUTHERN EUROPE, AFRICA, MIDDLE EAST:
 Raffaella Calabrese, rcalabrese@broadcast.it
 T: +39-02-9288-4940 | F: +39-02-7004-36999
 U.K. & IRELAND, CENTRAL & NORTHERN EUROPE:
 Graham Kirk, g.kirk@audiomedia.com
 T: +44-1480-461555 | F: +44-1480-461550
 JAPAN: Eiji Yoshikawa, callers@world.odn.ne.jp
 T: +81-3-3327-5759 | F: +81-3-3322-7933
 ASIA-PACIFIC: Wengong Wang, wwg@imaschina.com
 T: +86-755-83862930/40/50 | F: +86-755-83862920
 CLASSIFIEDS: David Carson, dcarson@nbmedia.com
 T: 212-378-0400, ext. 511 | F: 866-572-6156

Radio World Founded by Stevan B. Dana

Radio World (ISSN: 0274-8541) is published bi-weekly with additional issues in February, April, June, August, October and December by NewBay Media, LLC, 28 East 28th Street, New York, NY 10016. Phone: (703) 852-4600, Fax: (703) 852-4582. Periodicals postage rates are paid at New York, NY 10079 and additional mailing offices. POSTMASTER: Send address changes to Radio World, P.O. Box 282, Lowell, MA 01853.

REPRINTS: For custom reprints & eprints, please contact our reprints coordinator at Wright's Media: 877-652-5295 or JewBay@wrightsmedia.com

© Globe Graphic © iStockphoto.com / Edward Grajeda

Copyright 2011 by NewBay Media, LLC.
 All rights reserved.
 Printed in the USA



DCC

(continued from page 1)

it to fruition.

Today, all modern super-power (output power greater than or equal to 100 kW) shortwave, and most medium-wave (AM band) transmitters, incorporate DCC capability. Total power consumption typically is reduced by 15 to 30 percent, and the effects are virtually undetectable to the listening audience.

As a benchmark, the average household in the U.S. consumes about 11,000 kilowatt-hours of electricity each year. Assuming an average power savings of 25 percent with DCC, a *single* modern 250 kW transmitter, operated 12 hours per day, saves 342,000 kilowatt-hours per year, or the equivalent of powering 30 average homes.

If we multiply this by the over 1,000 short-wave, super-power transmitters positioned around the world, we save enough electrical energy to power over 30,000 homes, a small city.

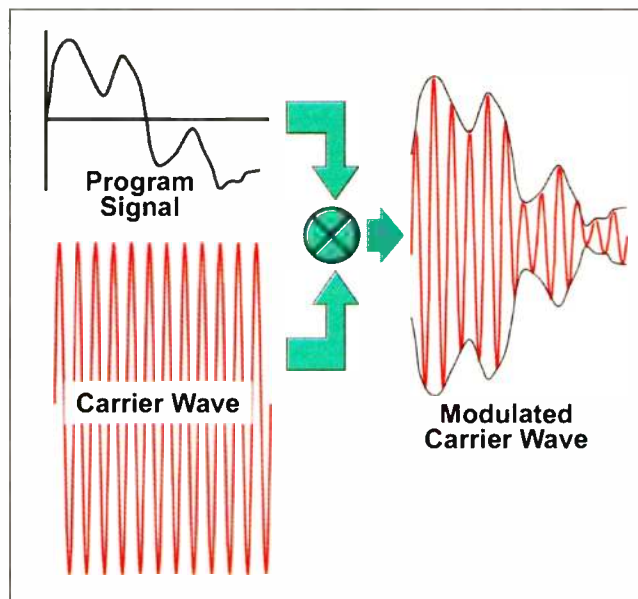

The AM modulator impresses the program onto the high-frequency radio wave.

consumes 75 to 80 percent of the total output power, making AM a very inefficient mode of transmission.

This raises the question: "How can the transmitted waveform be modified to reduce power without reducing received quality in simple AM receivers?"

WHAT DOES THE CARRIER DO FOR US?

The carrier in any AM system has two functions: to translate the information signal to a higher frequency that is suitable for transmission and to suppress static noise and interference during silent intervals in the program. When the amplitude of the audio signal is significantly less than that required for 100 percent modulation, it is possible to save on the power consumption of the transmitter by reducing the amplitude of the carrier, without affecting demodulation of the sidebands. Power savings of 15 to 30 percent (depending on program material) are feasible if carrier power is reduced 3 to 6 dB (carrier reduced one-half to one-fourth) of

the rated output power when modulation is low, with little or no effect on reception of the signal. DCC is designed to keep the carrier at sufficient amplitude to achieve 100 percent modulation, even during the low-level portions of the audio program.

WHAT IS DCC?

Traditionally, AM systems have provided a fixed carrier level and applied modulation up to 100 percent (or +125 percent positive). Using DCC, during periods of low or no modulation, power consumption can be significantly lowered by automatically reducing the carrier level and restoring the carrier level when modulation later increases.

The transmitter is adjusted for full carrier power output when the audio input appears at 100 percent modulation. If the audio input level falls, the carrier level will dynamically adjust itself to maintain modulation at 100 percent. If modulation is totally removed, the carrier level will fall to a pre-selected minimum level (-3 dB to -6 dB). Typically a front-panel switch or remote control offers selectable levels and types (different transfer curves) of DCC. With a typical 0.1 ms attack and 200 ms release time, DCC retains the ability to modulate to positive 125 percent as we do now. At +125 percent modulation, the carrier remains at the same level corresponding to 100 percent modulation.



Power savings are impressive when DCC is added to 100, 250 and 500 kW transmitters.

BACKGROUND ON AMPLITUDE MODULATION

Amplitude modulation occurs when a voice or music signal's varying voltage (f_m) is applied to a carrier frequency (f_c). The resultant AM signal consists of the carrier frequency, plus upper and lower sidebands, known as double sideband amplitude modulation (DSB-AM), more commonly referred to as plain AM.

When a carrier is amplitude-modulated, only one-third of the total RF power is contained in the information-bearing sidebands. The other two-thirds of the RF output power is contained in the carrier, which does not contribute to the transfer of information. The intelligence is in the sidebands, and the carrier is aptly named for its purpose of merely carrying the modulation.

With a complex modulating signal, such as voice or music, the sidebands generally contain only 20 to 25 percent of the overall signal power; thus the carrier

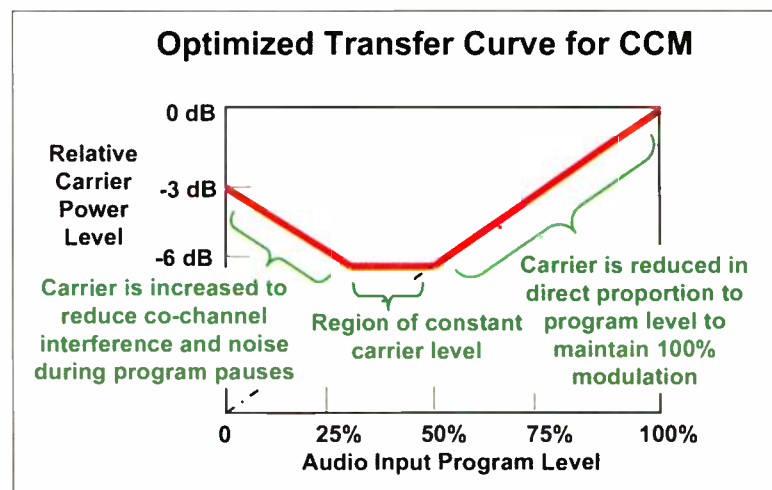

The transfer function between the program audio and the actual level of the carrier has evolved to a curve that reduces the carrier power by a factor of four in the mid-volume range, but retains half-power at low audio moments.

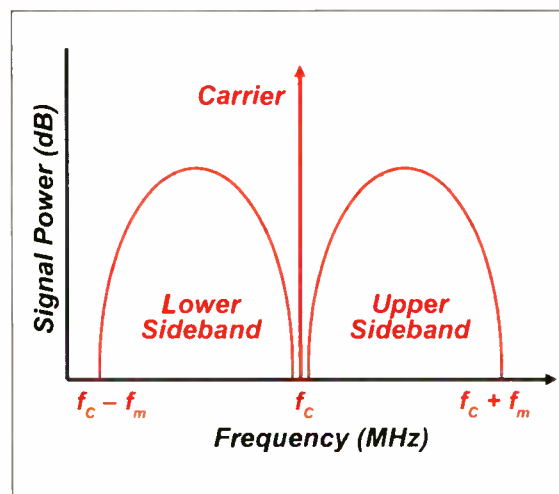

The spectrum of AM signal shows the wasteful carrier power compared to the information-bearing sideband power.

ORIGIN OF DCC

This amplitude modulation energy-saving mode was devised in the late 1930s. DCC was not implemented in transmitter designs until the 1980s, because of the complexities of the control circuitry. If we journey back in time to the 1930s to the village of Gliesmarode in Germany, we find the first trace of DCC with Professor Pungs, who was involved in the development of broadcasting technology. His system was known as "HAPUG" Modulationsverfahren, incorporating the last name of each of the three inventors: Harbich, Pungs and Gerth. This system never made it beyond the experimental stage, due to a lack of computing and processing technology.

PULSE STEP MODULATION

The advent of PSM in the 1980s and DSPs in the 1990s allowed the implementation of DCC in all modern, high-power transmitters today. Using signal process-

(continued on page 6)



WHY MORE BROADCASTERS are choosing Nautel

MORE Innovation



More than 1,100
AUI capable
transmitters
shipped.

MORE Control



AUI: Advanced User Interface

Nautel invented the AUI system with its advanced control and instrumentation to help engineers **SAVE TRIPS, SAVE TIME** and **SAVE MONEY**.

MORE Support

Nautel has never discontinued support for any product. Ever. That's just one reason why Nautel support is renowned in the industry. New innovations like the AUI not only help you but help us support you when you need us most.

MORE To Count On

#1 Nautel has emerged as one of the world's largest manufacturers of Radio Broadcast transmitters.

ZERO debt

Nautel is a conservatively managed company free of debt.

Four Decades of consistent ownership.

10,000+ Nautel transmitters shipped.

Making Digital Radio Work.

nautel.com

DCC

(continued from page 4)

ing, we can readily break the modulation voltage waveform into a large number of steps. These small increments are used to turn a series of switches on or off. Thus modulation losses are now reduced to very low switching losses, increasing the efficiency of the modulator itself to better than 95 percent.

The modulator typically consists of 48 series-connected modules, mimicking the sampling levels, which are switched into and out of operation to superimpose high-level audio onto the high-voltage DC anode (plate). The switching is accomplished with insulated gate bipolar transistors (IGBTs). A low-pass filter follows the series-connected modules, which removes the switching signals and allows the DC and audio signals to pass to the RF amplifier. To further refine the linearity, each power supply step is pulse-width modulated, creating a smooth transition from one step to the next.

PROGRAMMING TYPE AFFECTS POWER SAVINGS

As might be expected, actual power saving over that of non-DCC usage is highly affected by audio program content, with talk programs giving more power-saving than most music programming. Even the short blank spaces between spoken words allow the carrier to be reduced in conjunction with the decrease in modulation power.

Popular music programming dwells longer at modulation peaks, as evidenced by the higher degree of modulation index. Audio processing, which artificially increases the average level of modulation, tends to reduce power savings and increases the total power consumption. Tests using processed music programs consistently produced a power saving of 18 percent, whereas talk programs produced power-savings in excess of 22 percent.

DOES DCC AFFECT THE LISTENERS?

In AM transmission systems, the signal-to-noise ratio (SNR) is largely determined by sideband power, not by carrier power. Thus, if an AM transmitter is modulated at 50 percent, a listener will have to turn the volume up 6 dB (x4) to get the same loudness as a transmitter modulated at 100 percent, consequently bringing up the background noise level by the same amount. If the carrier level of the same transmitter is lowered to obtain 100 percent modulation, no change in sideband power will occur. A receiver's automatic gain control (AGC) circuitry will bring the volume up much as a volume control does, and background static noise will also increase by the same amount. Thus

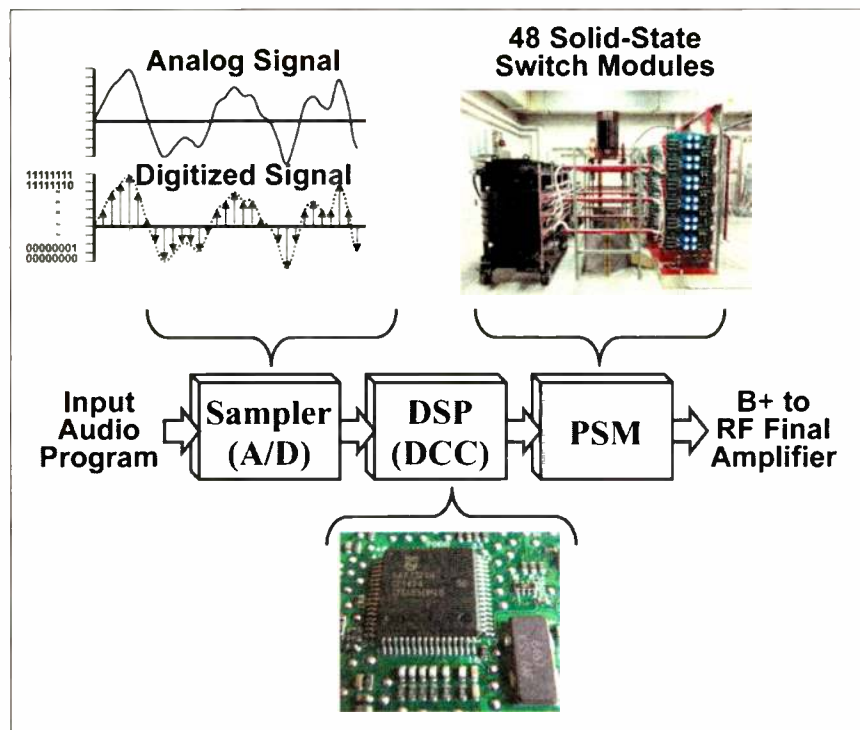

The advent of the digital signal processor (DSP) and the solid-state pulse-step modulator (PSM) have allowed DCC to emerge as a 'green' technology.

the SNR remains constant.

When folks seriously discuss the quality of the received signal over audio, they are most likely talking about local AM or FM, where small imperfections are readily noticed. The quality of audio over shortwave or international medium-wave is inherently low, due to atmospheric, fading and noise. Laboratory tests on subjective listening quality using DCC, even with co-channel interference, showed no degradation.

Today, with so many Web-controlled, remote monitoring receivers, it is easy for a broadcaster to access their signal audio via the Internet. This allows the broadcaster to monitor their signal and make their own assessment of DCC under real-world propagation effects when transmitting to remote areas on shortwave. DCC tends to have little effect on listener perception because of slow receiver AGC. Experience has shown that when running a transmitter with DCC, response time is best set to fast attack/slow decay (0.1 ms attack / 200 ms release) and carrier suppression, with no modulation, is set to -6 dB for first-hop targets and -3 dB for third-hop targets.

HOW DOES DCC AFFECT THE TRANSMITTER?

DCC extends the life of transmitter components because the transmitter operates below its design capability. One first notices that the power amplifier (PA) current meter now starts to wiggle with DCC energized. PA current will decrease with low-level audio as the carrier level is dynamically in accordance with the average modulation. Without DCC, the majority of PA current was needed just to produce the

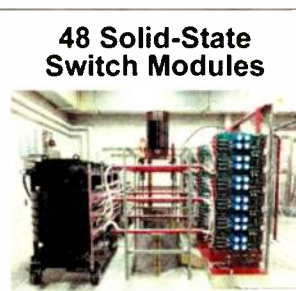

evidenced an overall efficiency of only 70 percent. With the use of switch-mode Class D and pulse-step modulation, the overall (AC power-to-RF power) efficiency has improved to nearly 80 percent for high-power shortwave and nearly 90 percent for high-power medium-wave transmitters.

FOLLOW THE MONEY TRAIL

DCC's appearance can be linked to NATO nations trying to save energy as a result of the ripple effects of OPEC-related oil supply crises. Eastern European manufacturers of shortwave transmitters never adopted DCC because Russia, in particular, had no energy crises due to its abundant supply of oil.

International broadcasters are indeed interested in "going green," and even more so in the future as power bills continue to escalate. Not only do all the manufacturers of high-power transmitters offer DCC, but all the broadcasters use it to help contain expenses. DCC was pioneered by the broadcasting giant British Broadcasting Corp. (BBC) and AEG Telefunken in the late 1980s.

Tests using processed music programs consistently produced a power saving of 18 percent, whereas talk programs produced power-savings in excess of 22 percent.

large constant-amplitude carrier power.

This variable power-line loading can cause audio modulation on the AC mains if the power lines are exceptionally long to the broadcast station. This is especially true at large transmitting centers, where two or more transmitters are simultaneously broadcasting over different bands, but using the same audio program. When powered by diesel generators, feedback control circuitry in the generators must be modified to handle these increased load swings on the AC power line.

WHO OFFERS DCC?

DCC's effectiveness and acceptance by broadcasters is indicated by the fact that all of the super-power shortwave transmitter manufacturers — Continental Electronics in Dallas, RIZ-Transmitters in Croatia, Thomson Broadcast & Multimedia in Switzerland and Nautel in U.S./Canada — offer it as built-in or optional. Nautel has long offered DCC on its NX series of high-power medium-wave models. Harris Corp. offers DCC in its line of high-power AM transmitters.

The addition of DCC can pay for itself in as little as a few months, based on the broadcast power level and the price of oil. Transmitters more than 30 years old

As the cost of electricity steadily increased, others such as Voice of America (VOA), Trans World Radio (TWR), HCJB (Voice of the Andes), Radio France Internationale (RFI), Deutsche Welle (DW), Radio Canada International (RCI), Far East Broadcasting Co. (FEBC), Australian Broadcasting Corp. (ABC Radio Australia), Radio New Zealand (RNZ) and Radio Netherlands Worldwide (RNW) quickly joined the fray. As a simple matter of economics, it is to be expected other broadcasters will add to the numbers, as they are able to make the switch.

In April 2011, the FCC authorized the use of DCC on non-commercial AM stations in Alaska as long as notification was given to the commission. The high cost of electricity in the state was a factor in the decision to allow stations to use DCC experimentally. Power reductions of 30 to 35 percent were reported, with no deterioration of received sound and no complaints about reception from listeners.

The experimental operation appears to have been a success, confirmed by the recent FCC action to allow DCC for all U.S. AM stations.

Comment on this or any other story to rwee@nbmedia.com

Sale

ARC console family



\$1,599
ARC-10U

\$3,495
ARC-158P

\$5,495
MARC-15-12

Sale

Whether stand-alone or networked, the Arrakis ARC and MARC series consoles are feature laden, high performance, and professionally reliable. Ideal for On Air, production, or Internet Radio !!!

Stand-alone ..or.. Networked !

NEW

ARC-8

Intro Sale

\$799



8 channels
Stereo Program output
2 mic, 4 stereo line, PC, Phone in
USB interface for play & record from a PC
Mix-minus in-out for an external Telephone Hybrid
BDTH balanced and unbalanced inputs and outputs for flexibility

What more need be said ?

Innovative & cost effective Radio products from Arrakis Systems

Read what our users say...

KJDL, Lubbock, TX

" I like (Xtreme) a lot! Once we got things together we never have any problems. (Xtreme) is a 9 out of 10 for usability. It didn't take me long to figure out. I picked up most of the major (features) in the first day. (The Xtreme) is user-friendly for all involved."

Jessie Walker, Program Director

DMS Broadcasting, San Francisco, CA

" When we started, we were jumping into something we knew nothing about! We called your tech support & within a day they had a solution. It was miraculous. They helped us get wired up & set up. (Tech Support) had a positive & upbeat attitude. They went above & beyond!"

David Trudrung, General Manager & Co-owner

KSMZ, Alexander, AR

" Xtreme has more flexibility, sounds better & has fewer problems then our stations running (other automation systems). It's easier to program & a 9 compared to other programs out there."

Scott Gray

Join the hundreds...

... of others on air with Digilink-Xtreme, the best automation system in Radio. Full featured, it is easy to install, use, and maintain. Best of all, it is easy to buy. Choose from either the no contract \$100 per month 'Solutions Program' from Arrakis Systems or buy 'Xtreme-Complete' outright for only \$6,500 from Broadcast Supply Worldwide (BSW)

WHY PAY A FORTUNE FOR AUTOMATION ?



Digilink-Xtreme

only \$100 per month
support, training, upgrades
the best automation in Radio, period !

www.arrakis-systems.com

970-461-0730

WALLINGTON

(continued from page 1)

became my mentor. He encouraged me to continue to pursue interests in electronics and anything else mechanical, electrical or otherwise techie.

Just before I graduated from college, the campus radio station KCDS changed direction after some financial challenges and I somehow talked my way in the door as a volunteer and was able to help Bill Lyons, the chief engineer, finish wiring some new studios. Before I knew it — OK, it was seven months — my volunteering turned into a paying job.

A few years later, the victim of some budget cuts, I bounced from job to job before joining a friend to work as contract engineers in California's North Bay Area. Educational Media Foundation became a client after a 1988 firestorm on Geyser Peak destroyed their only station's transmitter site, then KCLB, and we helped in the emergency reconstruction of the station on a nearby mountain. That "emergency" mountain turned out to be the right place to be to begin feeding programming to other signals.

As contracting work dried up somewhat in the tight economy of 1993, I joined EMF as its sole staff engineer.

What kinds of duties do you have on a daily basis?

Originally, I was responsible for anything even vaguely technical ... from facilities, such as toilets and air conditioners, to telephones and copiers, to studios and transmitters. As EMF has grown, my duties have changed, gradually splitting off various functions such as telecom, IT, studios, software development and physical plant.

At this point, I am responsible for everything between the satellite uplink input and where it comes out of listener's speakers. That means I primarily

run an RF shop, though with obvious audio needs such as EAS and other emergency programming sources.

I lead an amazing team who can figure out a solution to just about any problem imaginable, usually under tight timelines and budget restrictions. Other than that, I get to help develop new technologies, such as the Wegener iPump store-forward audio system; train technical and operational staff; and help shape the future of the organization as a whole.

In a typical year, EMF builds, upgrades or makes significant changes at about 100 signals. By necessity, therefore, we have a site development group that manages these projects in cooperation with our engineers and acquisition/legal/application folks.

Due to changing circumstances, we frequently have to adjust our processes to compensate for new zoning and permitting laws, suddenly escalating rent rates, lack of access to power, or any number of other variables. In the "good old days" we could just put up an antenna on a tower most of the time. Now it's appropriately necessary to confirm structural, zoning and other legal compliance in addition to the fun of building a transmitter facility. This is a constant source of entertainment.

What is your most interesting recent project?

One of the challenges we constantly face is the need to do everything several hundred times. For example, if a new box needs to go in at every signal, that means we're installing about 700 boxes. Anything times 700 is expensive. Further, it's essential that everything we buy or build is very stable, robust and reliable.

Recently, like many, we've just completed the rollout of the new Common Alert Protocol EAS. Honestly, the

most challenging part was providing IP connectivity at all stations, since mountain-top IP isn't always available, or anything resembling reliable.

Fortunately, thanks to the foresight of one of my engineers, Alan Guthrie, we had been building an in-house satellite-based IP system for a couple years before CAP-EAS became required, so we were a long ways down the road. It turned out that what we originally envisioned as just a good way to gain secure remote visibility and access into our individual stations turned out to be a huge help in CAP-EAS.

Another project we've started has been the three-year rollout of the Worldcast Relio remote control system at all our stations. Worldcast developed this system in cooperation with Clear Channel, so we have been able to stand on the shoulders of others to gain knowledge of the amazing capabilities of this "smart" remote control system, and have had the fun of contributing some of our own ideas. For example, Alan Guthrie spec'd a new I/O interface box that Worldcast was kind enough to have Sealevel build for us.

Like most stations, we're constantly looking for ways to be more efficient. One of our blessings is an on-staff programmer, Paul Swagerty, who has developed software that helps us manage everything from where stuff is to signal routing through the network.

For example, he's built software that allows our news team to instantly go on the air live at any facility or combination of facilities to air breaking news stories, all without engineering's intervention in routing the signal. This is particularly useful at 3 a.m. It's also relatively "bullet-proof" to avoid the unintended consequences of a typographical error causing the wrong commands to be sent to some or all stations.

Recently we completed construction on a backup network facility in Indianapolis with complete uplink capabilities. For some time, there was concern about our ability to continue to operate in the event of a catastrophic failure or disaster at our main uplink facility in Rocklin; this second location gives us the ability to continue to serve our audience even if we lose the main uplink completely, and provides the studios for our morning shows.

How do you handle the national distribution of your program audio for K-Love and Air1?

EMF has used Ku-band satellite distribution since 1992, and in some cases

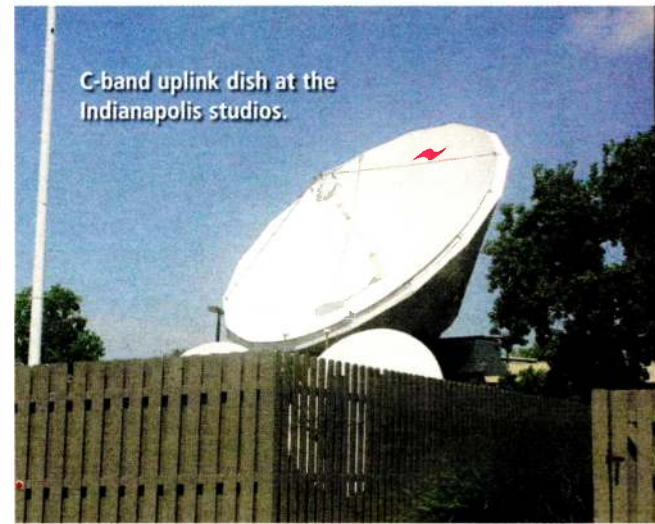

C-band uplink dish at the Indianapolis studios.



Equipment racks at the Indianapolis uplink.

such as translators, off-air feed from a regional signal. In 2002, we added Multiple Channel Per Carrier capabilities to allow flexibility in programming. Currently, we are building a C-band MCPC system to eliminate rain-fade issues, and expect to deploy the first downlink sites late this year. With the existing, fully-redundant Ku system, we are able to remotely switch any satellite receiver to another channel, which, as I mentioned, is handy for breaking news. But this capability also allows us to "cover" for some equipment failures in a way that's transparent to the audience. Some facilities are "hardened" with backup generators, transmitters and/or auxiliary antennas. The depth of redundancy is typically based on the audience size of the station, market by market.

EMF seems to use a fair number of translators. What is your thinking about why to use them instead of fully power stations?

EMF has been utilizing translators since long before they became controversial, the first being constructed in

(continued on page 10)

Alan Guthrie at KLRD's solar-powered site in San Bernardino/Yucaipa, Calif.

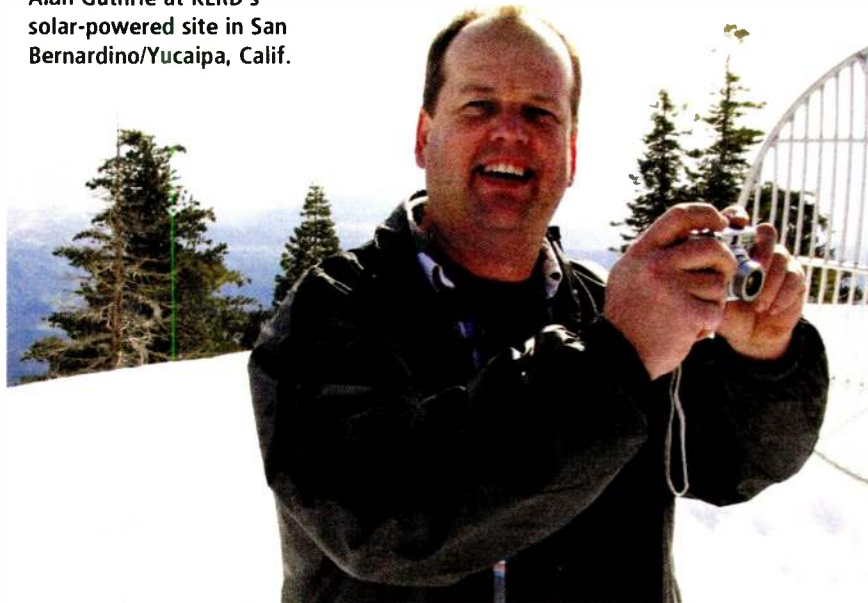

Itching for a new console? This one's half the scratch.

So, it's time to upgrade your studio. Hey, let's be real - it's way past time. You knew those analog consoles were only good for 10 years when you bought them... 15 years ago. They need resuscitation so often, you keep a defibrillator in your tool kit.

Still, your GM says it'll cost too much to replace them. That's when you make like MacGyver and whip out your secret weapon: Radius, the new IP console from Axia. You show him the pictures. You tell him what Radius can do, with its 4 program buses, automatic mix-minus, instant-recall console snapshots, one-touch Record Mode, convenient talkback and rugged machined-aluminum construction. You show him the built-in Ethernet ports you'll use to eliminate the miles of expensive cable in your ceilings, and you can tell he's already counting the money he'll save.

Then you hit him with the haymaker: at just \$5,990, Radius costs less than you'd expect to pay for some flimsy, stripped-down, feature-free board with less brainpower than your wireless mouse. After he picks his jaw up off the floor, you get to tell the jocks about their cool new Axia consoles. And go home a bonafide money-saving, airstaff-pleasing Engineering hero, smiling with the knowledge of the envious looks you'll get at the next SBE meeting...

- » One-touch Options control. Push and rotate to select source, adjust pan, trim gain and more.
- » Sexy, multi-segment LED meters with switchable VU / PPM ballistics and peak hold.
- » Time of day clock can slave to your NTP server.
- » Do it yourself or do it automatically. Event timer has manual or auto reset option.
- » One touch lets you talk back to phone callers, codecs or any source with a backfeed.
- » Silky smooth, side-loading 100mm, conductive-plastic faders beg for your touch.
- » Rugged anodized machined aluminum surface has laser etched markings that can't rub off. Backed with our 5-year warranty.
- » Avionics-grade switches with LED lighting.
- » Full-featured monitor section even lets you control Guest studio monitors.
- » You've always wanted a convertible? Remove bumpers, swing meters back and voila! you can rack-mount your Radius.
- » Razor-sharp OLED source / options display with audio confidence meter on every fader.
- » Plenty of professional, balanced mic, analog, AES and Livewire I/O in a fan-free 2RU chassis.
- » It doesn't just look cool it stays cool thanks to beefy heat sinks and fan free design.
- » Rugged, built-in super-duty power supply. No line-lumps or wall-warts on Axia gear.
- » Built-in Ethernet switch lets you network devices and studios easily.

www.AxiaAudio.com/Radius



Available in the U.S. from BGS: (352) 622-7700

WALLINGTON

(continued from page 8)

mid-'80s. They are an excellent tool to reach underserved areas, and since we are listener-supported, there has to be a clear community interest to justify constructing and operating these signals. Though we filed for a number of translators in the 2003 filing window, we constructed a very large percentage of the ones that were granted to us, the exceptions being those that were unbuildable due to circumstances beyond our control or were no longer considered necessary due to the passage of time and the addition of other EMF signals in an area.

We continue to operate those that have survived the inevitable encroachment of new or upgraded stations, with thousands of people benefitting from their presence every day.

What do you think of the proposed compromise that is pending at the FCC for the resolution of the frozen translator applications from 2003?

We do have more applications pending from that filing window, and our position on them is fairly evident in the various filings we've made since.

We are partially in support of, and partially opposed to, the FCC's proposed compromise, and we've filed comments in the proceeding.

As a bit of an aside, when the FCC was initially contemplating the LPFM

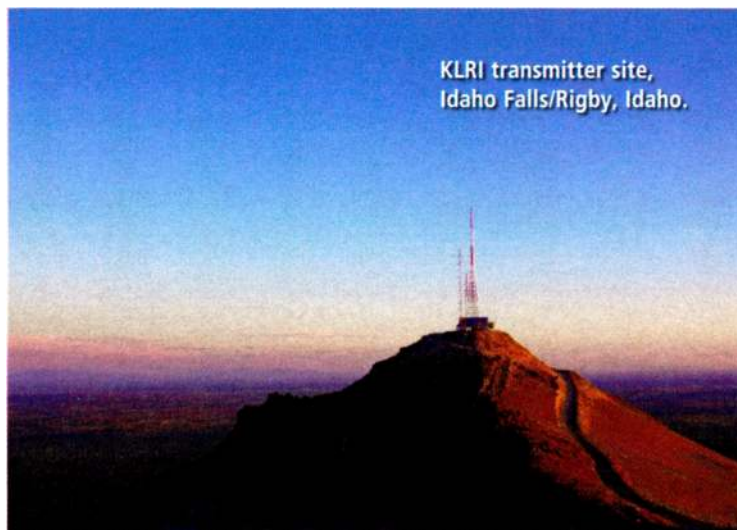

KLRI transmitter site, Idaho Falls/Rigby, Idaho.

service, I had hoped they would simply tweak the existing translator rules for LPFM operators, adding only the capability of local program origination when combined with the ownership and program-type requirements that are in the current LPFM rules. That would have maintained a relatively level playing field for these secondary services, avoiding many of the challenges faced today by both sides of the argument.

Does EMF have AM as well as FM stations?

We have a few AM stations. Because we mostly air music, and AM receiver quality has declined significantly since AM stereo "died," we have found that listenership has been markedly less on AM. If the facility reasonably could be financially viable, we would consider

it, but we do have lower listenership expectations from AMs. If we operated a talk format, we would probably feel differently, depending on the station, as many regional AMs have an enviable coverage area, especially at night. I share the frustration of many engineers, since AM can sound really good on well-made receivers.

How do you see the future of the radio industry?

There have been naysayers that have predicted complete and absolute doom for radio. According to one I remember from a few years back, we should be done by now.

Though radio faces unprecedented competition and distraction, content still remains king. Whether one operates a blog, a TV network, a radio station, or preaches in a small church, it is quality and innovative content that will bring — and keep — audience.

As an industry, radio has frequently done itself a disservice by placing the bottom line ahead of programming, which often translates as automation or syndicated programming without real concern for what the audience actually thinks or wants.

Unfortunately, some stations don't really care what listeners think. For example, I know of a station where the program director regularly deletes the content of the listener comments answering machine — without ever listening to the comments.

If the listener's opinion isn't important enough to even hear, it's not surprising that radio listenership is declining. Auditorium testing and ratings have their value, but only as part of a bigger equation. Bottom line and complaining aside, what are we as an industry doing



All in a day's work: Wallington en route to antenna repair.

to ensure that listeners actually want what we provide?

On the technical side, I think the industry is ready for some innovations. As the economy recovers, perhaps some have the creativity to come up with better ways of doing radio.

Is there a version of digital radio that would be markedly better than analog? Can we reduce the latency on HD Radio, especially on HD2 or HD3 channels?

What new ways can we find to improve reliability of all systems involved in generating a radio signal? How about transmitter or antenna designs that honestly improve overall efficiency, thereby cutting costs? What about technical ideas creating income innovation?

How could broadcasters, including TV, partner with telecommunication companies to relieve some of their download bandwidth squeeze? If we're talking about putting a radio in a phone, why not use that radio to deliver IP content, freeing telco bandwidth and making money at the same time? As the original "streaming" providers, broadcasters should be good at it — it's just sending bits instead of waves, right?

EMF isn't perfect, but, like many broadcasters, intends to continue to improve. If we all do our part, the industry can have a bright future.



Digital Alert Systems
A DIVISION OF MONROE ELECTRONICS

DASDEC-11

CAP/EAS is Serious Business

You Need a Serious Compliance Partner you need Digital Alert Systems

Only Digital Alert Systems gives you....

- Flexible hardware/software to fit current and future requirements
- Full web-browser operation with multiple simultaneous user access and tiered security.
- More serial, USB, and Ethernet (IP) ports for interfacing options
- Secure internal AM/FM/WX receivers to save space and wiring
- Full EAS/CAP compliance at the lowest cost-per-stream
- Base units starting at just \$1995

It's time to get serious about CAP/EAS compliance and there's no better company than Digital Alert Systems with award winning products that can be customized to fit your application. Combined with world class service you can't find a better long term partner.

Digital Alert Systems

585-765-1155

www.digitalalerts.com

Call or click to see why so many broadcasters have selected Digital Alert Systems as their CAP/EAS partner.

GET.IT.NOW.

Free 2011 Catalog from Telos, Omnia and Axia.



www.telosalliance.com/now

© 2011 The Telos Alliance, TLS Corp.

World Radio History



NETWORK...HEAL THYSELF

No matter how well you maintain your life, there are bound to be ups and downs. Of course, just by selecting WheatNet-IP, you're already practicing the best possible regimen of preventative medicine. Its robust architecture and hyper-intelligence ensure that it's out there racing to the finish line, every minute of every day. Each BLADE (what we call our super smart nodes) knows the full configuration of its network, ensuring there is no single point of failure. And while all networks have a backup system, we go way beyond that: WheatNet-IP offers as many points of recovery as you have BLADES in your system.

But, every now and then, something MAY happen that might call for the replacement of a BLADE. In the exceptionally unlikely event that a BLADE should fail, just plug an alternate in and you are up and running. Since each BLADE has the entire WheatNet-IP Intelligent Network's configuration embedded in its DNA, the new BLADE inherits its function immediately and you are back up and running. Pretty cool, eh?



THE INTELLIGENT NETWORK™

phone 1.252.638-7000 | WheatNetIP.com | sales@wheatstone.com

IS YOUR ADIP NETWORK AN INTELLIGENT NETWORK?

Download the **FREE** white paper "The Technical Case for the Intelligent Network" at WheatIP.com

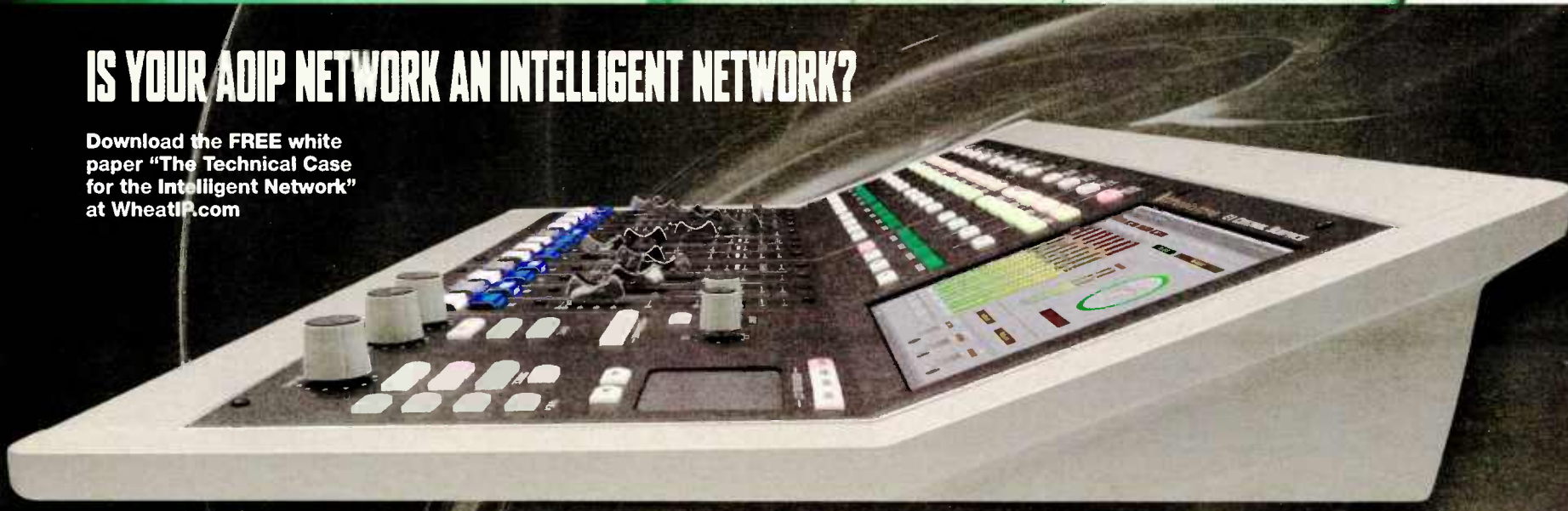

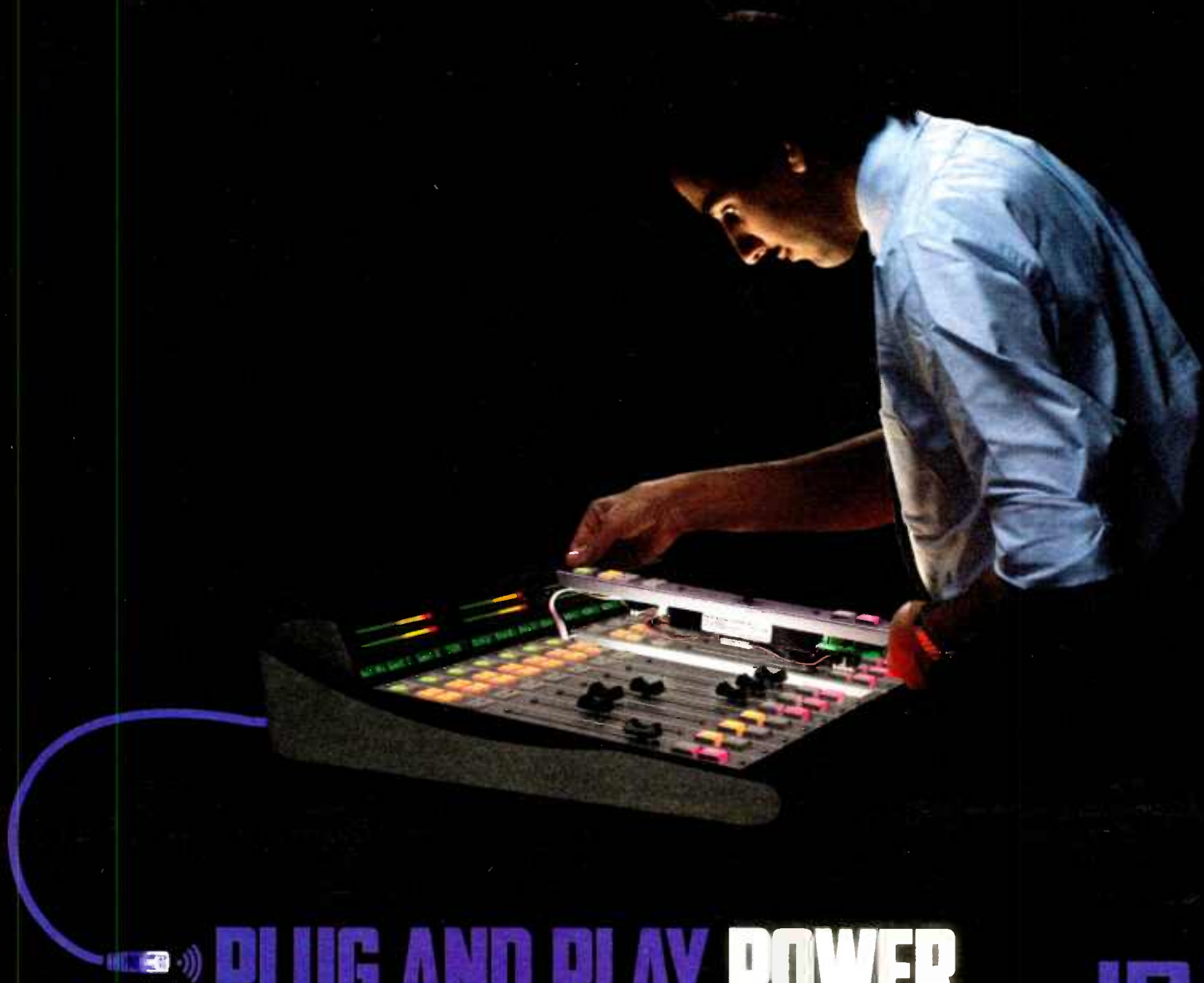

PLUG AND PLAY POWER **IP-12**

AUDIOARTS MODULAR WHEATNET-IP NETWORKABLE CONSOLE

Here's how easy it is to setup the new IP-12 console: Unbox it. Plug it in. You're ready to go. But don't let its simple setup fool you. It's one very powerful little console...

First, its modern, modular design moves all audio, logic and control outside the control surface and into a single rack-space audio interface/mix engine (called a BLADE). This gives you much greater mixing/processing capabilities as well as the ability to network when you have more than one console. Imagine simply calling up any audio sources on any of your consoles anywhere in your facility. And, if you've already got the WheatNet-IP Intelligent Network, it fits right in.

Got automation? IP-12 is hardware-ready. We offer a software driver that works seamlessly with the most popular automation platforms to give you control right from the console!

Contact your Audioarts dealer, give us a call or visit us on the web today to learn more about the power, flexibility and affordability of the IP-12.

FLEXIBLE. AFFORDABLE. BUILT TO LAST.

phone 1.252.638-7000 | audioartsen지니어링.com | sales@wheatstone.com



IP REMOTES

(continued from page 3)

how to get that working we tried our first connections.

Sure enough, I could enter the public IP address of our studio codec and it would connect right up. For this first test I was in my shop connecting to a codec down the hall but in real terms it was flying out to a 4G tower somewhere, connecting to the public Internet, routing its way to our university network and then directly to my uniquely named device. Seeing it frame for the first time was one of those purely geeky moments that the engineer in me loves. Cool.

SEE DAD, I TOLD YOU

Next I tried to use my home DSL connection. This worked easily, but I learned pretty fast the connections required for real-time audio have to be, well, pretty fast. Sadly my home DSL wasn't up to the task. Though I could create a connection at 128 kilobits per second that delivered good audio quality, it would not hold stable for very long. About every three to four minutes it would mute for a few seconds. By lowering the data rate down to 64 kbps and adjusting the buffer I could get it to stay longer but it would still fail.

Undoubtedly this was in no small part

due to the fact that I have two teenage sons whose social lives consist largely of their Internet use. They have been telling me for years that we have "lousy Internet" at my house. With chagrin I have to acknowledge they are probably right.

Note there is only so much buffer storage that can be applied for a typical remote broadcast before conversation between the studio and remote site become strained beyond usable. While heroic levels of buffering (like 20 seconds worth) might have given me stability it would not have worked for a broadcast.

We had tested the performance of the 4G MiFi and found it to deliver download and upload speeds in excess of 20 Mbps at times. This was much faster than a typical home DSL, so for our next test we tried using the IP codec at an outdoor event on the Esplanade along the Charles River. The main link was an ISDN but we also built a backup link using the 4G.

I'm happy to say that the 4G worked pretty well. With a modest buffer and a data rate of 64 kbps we could hold a good connection for most of an hour. There was still the occasional mute but I feel that with some further experimentation or perhaps an antenna we could eliminate this.

HEAD SHOT

Our final test was at a remote from

a function room at the Marriott Hotel near Copley Square. The event was a conference dedicated to Web journalism. Our initial walkthrough and tests showed the 4G to have good signal strength and excellent upload speed. Again, we contracted for an ISDN circuit to be the main feed but we planned to use the 4G as a backup service.

While we had some initial problems with the MiFi, we solved them early on the morning of the remote, and connected up around two hours before the broadcast. From the studio I ran a stream monitor to gather statistics on this link, and it was fabulous for those two hours, with no dropouts, and high-quality audio passing both ways without a single mute or packet loss.

I suppose the part about the conference being aimed at Web journalism should have been a warning sign, but it wasn't until later that we thought about that. Precisely eight minutes into our live broadcast, the wireless connection dropped out hard, and we did not get a reliable connection for the entire time of the remote. It was able to connect for perhaps one minute at a time before dropouts. We tried adjusting the buffer, moving the MiFi and dropping the data rate but no dice. There just were too many devices competing with ours for data and it did not work. At all.

MAKE SURE THERE'S A PLAN B

From my experience I would say that right now it takes the truly brave to enter this New World of IP audio, particularly when it comes to wireless remotes.

We found to our delight that 4G has more than enough bandwidth to handle audio with excellent quality. We also discovered that there isn't really a way to know for sure if a particular site will work or not at the exhilarating moment the remote site goes live. Even after two flawless hours before the broadcast, it took just eight minutes for the crowd to get going and turn our wireless connection from framed to folly.

My advice is to keep on ordering those ISDN lines if you can, because right now they remain the most reliable way to cover high-quality remotes without a radio link. The uncertain popularity of a particular event can determine if too many users are present to reliably use wireless systems.

But by all means go out there and experiment. For short, newsy feeds, this service is flexible, comes in small packages and is reasonably easy to use. It takes newsgathering just about anywhere you can get a signal. That's a first step on what we all expect to be the eventual future of audio. Just be careful out there.

Have success story of an IP remote? Send me a note at rvwe@nbmedia.com and let us know how it went.

The Best FM/HD Exciter - Period! 802E^x

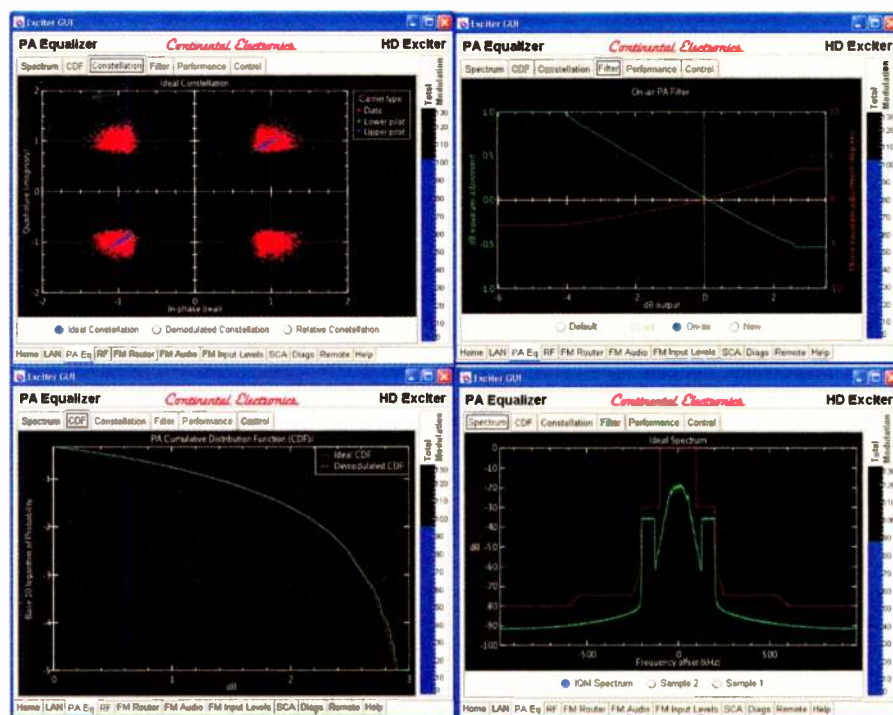

Only Continental's 802E^x gives you
"Insight" - IBOC performance at a glance

HD Radio
Licensed Manufacturer



Continental Electronics

www.contelec.com

sales@contelec.com

(214) 381-7161

MINSTRUMENT MATRIX

Sophisticated Minstruments from NTI give you comprehensive test capability... and these flexible audio instruments fit in the palm of your hand

DL1 Digilyzer Digital Audio Analyzer

A handheld digital audio analyzer with the measurement power & functions of more expensive instruments, the DL1 Digilyzer analyzes and measures both the digital carrier signal (AES/EBU, SPDIF or ADAT) as well as embedded digital audio. In addition, the DL1 functions as a smart monitor and digital level meter for tracking down signals around the studio. Plugged into either an analog or digital signal line, it automatically detects and measures digital signals or informs if you connect to an analog line. In addition to customary audio, carrier and status bit measurements, the DL1 also includes a comprehensive event logging capability.

- ▶ AES/EBU, SPDIF, ADAT signals
- ▶ 32k to 96k digital sample rates
- ▶ Measure digital carrier level, frequency
- ▶ Status/User bits
- ▶ Event logging
- ▶ Bit statistics
- ▶ VU + PPM level meter for the embedded audio
- ▶ Monitor DA converter and headphone/speaker amp
- ▶ Audio scope mode



DR2 Digirator Digital Audio Generator

The DR2 Digirator not only generates digital audio in stereo & surround, it is a channel transparency and delay tester as well, all condensed into a handheld package. Delivering performance & functionality challenging any digital audio generator made today, it produces all common audio test signals with sampling frequencies up to 192 kHz and resolution up to 24 bit. The Digirator features a multi-format sync-input allowing the instrument to be synchronized to video and audio signals. In addition to standard two-channel digital audio, the DR2 can source a comprehensive set of surround signals.

- ▶ AES3, SPDIF, TOSLink, ADAT outputs
- ▶ 24 bit 2 channel digital audio up to 192 kHz SR
- ▶ Sine wave with stepped & continuous sweeps; White & Pink Noise; Polarity & Delay test signals
- ▶ Dolby D, D+, E, Pro-Logic II, DTS and DTS-HR surround signals
- ▶ Channel Transparency measurement
- ▶ I/O Delay Measurement
- ▶ Sync to AES3, DARS, word clock & video black burst
- ▶ User-generated test signal files



AL1 Acoustilyzer Acoustics, Audio & Intelligibility Analyzer

The AL1 Acoustilyzer features extensive acoustical measurement capabilities as well as analog audio electrical measurements such as level, frequency and THD+N. With both true RTA and high resolution FFT capability, the AL1 also measures delay and reverberation times.

With the optional STI-PA Speech Intelligibility function, rapid and convenient standardized "one-number" intelligibility measurements may be made on all types of sound systems, from venue sound reinforcement to regulated "life and safety" audio systems.

- ▶ Real Time Analyzer
- ▶ Reverb Time (RT60)
- ▶ Delay measurements
- ▶ High resolution FFT with zoom
- ▶ Optional STI-PA Speech Intelligibility function
- ▶ Automatic Distortion analyzer (THD+N)
- ▶ Frequency, RMS Level, Polarity measurements
- ▶ Requires optional MiniSPL microphone
- ▶ Includes MiniLINK USB interface & Windows PC software for storing tests and PC transfer



MR-PRO Minirator High performance Analog Audio Generator + Impedance/Phantom/Cable measurements

The MR-PRO Minirator is the senior partner to the MR2 below, with added features and higher performance. Both generators feature an ergonomic instrument package & operation, balanced and unbalanced outputs, and a full range of signals.

- ▶ High (+18 dBu) output level & <-96 dB residual THD
- ▶ Sine waves & programmable swept (chirp) and stepped sweeps
- ▶ Pink & white noise
- ▶ Polarity & delay test signals
- ▶ User-generated custom test signals & generator setups
- ▶ Impedance measurement of the connected device
- ▶ Phantom power voltage measurement
- ▶ Cable tester and signal balance measurement
- ▶ Protective shock jacket



ML1 Minilyzer Analog Audio Analyzer

The ML1 Minilyzer is a full function high performance audio analyzer and signal monitor that fits in the palm of your hand. The comprehensive feature set includes standard measurements of level, frequency and THD+N, plus VU+PPM meter mode, scope mode, a 1/3 octave analyzer and the ability to acquire, measure and display external response sweeps generated by a Minirator or other external generator.

Add the optional MiniLINK USB computer interface and Windows-based software and you may store all tests on the instrument for download to your PC, as well as send commands and display real time results to and from the analyzer.



- ▶ Measure Level, Frequency, Polarity
- ▶ Automatic THD+N and individual harmonic distortion measurements k2 - k5
- ▶ VU + PPM meter/monitor
- ▶ 1/3 octave analyzer
- ▶ Requires optional MiniSPL microphone for SPL & acoustic RTA measurements
- ▶ Frequency/time sweeps
- ▶ Scope mode
- ▶ Measure signal balance error
- ▶ Selectable units for level measurements



MR2 Minirator Analog Audio Generator

The MR2 pocket-sized analog audio generator is the successor to the legendary MR1 Minirator. It is the behind-the-scenes star of thousands of live performances, recordings and remote feeds.

- ▶ Intuitive operation via thumbwheel and "short-cut" buttons
- ▶ New higher output level (+8 dBu) & low distortion
- ▶ Programmable Swept (chirp) and Stepped sweeps
- ▶ Sine waves
- ▶ Pink & White noise
- ▶ Polarity & Delay test signals
- ▶ Illuminated Mute button



PO Box 231027
Tigard, Oregon 97281 USA
503-684-7050
www.minstruments.com
info@ntiam.com

It's Showtime for the New EAS

CAP-Enabled System Is the Culmination of Years of Effort — Will It Improve the Old?

BY GUY WIRE

The overdue revamped EAS system unofficially kicks off a new era in coming months.

Your masked rebel of radio renewal has railed against EAS for years as a relic of the cold war. Except for tornado alley, few areas of the country have benefited from meaningful EAS activation. Instead, the public has become numb to the incessant testing of digital duck farts.

Right after 9/11, we challenged EAS leaders to step up and find ways to make the system a valuable resource when Mother Nature and civil emergencies threaten public safety. In 2004, the effort to fix EAS officially was launched, with the Federal Emergency Management Agency, Department of Homeland Security, National Oceanic and Atmospheric Administration, National Alliance of State Broadcasting Associations, Society of Broadcast Engineers and the FCC all getting together to craft the massive overhaul.

National Weather Service monitoring has since become required in most state EAS plans along with the valuable Amber Alerts. Common Alerting Protocol and the Internet now have been introduced into the scheme. Fast-forward seven years, and we appear to have what should be a significantly improved EAS.

The original Sept. 30 deadline for all broadcast and cable outlets to have purchased and installed the new CAP-enabled EAS equipment was extended at the last minute to June 30, 2012. Most stations have deployed the new gear and were ready to go in September, but it's welcome relief for those that haven't. All stations also are prepping for the first-ever nationwide EAN test on Nov. 9; this will test the effectiveness of the Federal Primary Entry Point system, although it will not involve CAP.

NOT QUITE READY

FEMA and the FCC undoubtedly realized the deadline extension was necessary since so many pieces of the new EAS puzzle were not in place. FCC Part 11 rules covering CAP-related changes for EAS and other details have not yet been finalized. Several of the key EAS hardware makers encountered manufacturing delays and weren't even shipping their new units until this spring. A lot of smaller stations are not yet compliant.

The vast majority of state and local 911 centers, NWS stations and other origination facilities also do not have CAP-enabled encoding hardware installed. State and local government budgets have been slashed almost everywhere, with no money to buy replacement encoders or CAP servers.

Some form of state governor "must-carry" provision will be part of the new rules, with the details at the state level still under construction. Those are sure to foster even more confusion and dysfunction until each state works out the wrinkles.

It's a good thing the Sept. 30 deadline was postponed. The new system simply wasn't ready. FCC enforcement of the new equipment rule just didn't make sense had it not been extended.

LOTS OF TESTING

Attention is now focused on the upcoming EAN activation on Nov. 9. A nationwide EAN is when the president is handed the biggest microphone govern-



ment can make available to speak to the nation on every media outlet at the exact same time. We understand that President Obama will not be speaking on Nov. 9 but will leave the practice test message delivery to a FEMA official.

A few states like Washington jumped into the EAS upgrade early, deploying the new CAP boxes first at state-supported and other public stations, along with LP-1 and PEP facilities. As with most government mandates, the law of unintended consequences has precipitated a few issues and unanswered questions.

According to reports from a number of markets, stations have endured mistaken and/or out-of-area activations, missing audio messages and the EAS robot voice mispronouncing words and names of towns, to name just a few.

To be fair, any new nationally mandated system like this will need shake-out time to fix the bugs and start working reasonably well.

SCARY TIMES

Since 9/11, our country, indeed the entire world has become a very different place. Not only have threats of terrorism increased, the instances of extreme weather events seem to be occurring more often. Catastrophic hurricanes like Ivan, Charley, Katrina and Irene, the massive California and southwestern wildfires, and the many devastating tornadoes like those in Joplin and Birmingham have been costly and destructive in recent years. And let's

not forget a rare East Coast earthquake this August, which caused substantial disruption in Washington.

These events heightened our collective awareness about the importance of adequate early warning and public safety.

SERVE COMMUNITY WITHOUT EAS

Since weather forecasting went high tech with satellites, Doppler radar and a host of other advanced atmospheric analysis tools, the ability to make accurate predictions about storms of all kinds has gotten very good. Broadcasters have tapped into that information resource directly and have been alerting the public without needing EAS to play middleman.

With the addition of the Internet, cell phones and social networking, additional warning mechanisms are now available that the public is using on a massive scale to stay in close touch with friends and family. Even before any serious weather event looms on the horizon, almost everybody knows it's coming ... except of course in the case of fast-forming tornadoes.

Stations that are heavily engaged in their communities place high importance on broadcasting breaking emergency news and severe weather information. Long ago most of them established reliable local sources to receive that information directly from government agencies without relying on EAS or a NOAA weather radio.

Certainly the stations that still maintain a good news department or have a sister TV station with staff meteorologists do this well. They can and often do switch directly to a local government agency or spokesman who has been tracking an impending event and put them on the air within a news bulletin without relying on an EAS alert message to convey the relevant information. EAS is almost an unnecessary annoyance for these stations. It could disappear tomorrow and the vast majority of those living in their service areas would still get their emergency news and alerts just fine.

WHO'S PAYING ATTENTION

The problem we have in this business, however, is that since ownership consolidation and the economic downturn, a large majority of radio stations rely on automation for significant portions of their broadcast schedule with no live operators on duty. Without EAS auto-forwarding the serious alerts, listeners to those stations could remain uninformed of an impending event.

Many radio listeners "get their news" from music stations; yet many of those stations run automated voice-tracked hours and don't maintain a news department or partnership with an all-news station or TV outlet.

Radio stations are licensed as stewards of a public resource and regulated by the government to serve the convenience and necessity of the public trust. Reporting and conveying vital information about serious weather threats and other emergencies to safeguard the public is perhaps the most fundamental tenet of that trust. Stations that short-change their mandate are simply failing to fulfill their obligations as licensees.

It could be argued that before automation and fewer live operators became commonplace, broadcasters were a lot more responsible about paying attention. Delivering the news about breaking emergencies and incoming severe weather to their service areas was a priority.

(continued on page 18)

Drops jaws. Not audio.



Broadband Internet is everywhere. Which makes it ideal for live remotes.

Unfortunately, the internet is also notoriously erratic. Even if you're lucky enough to get a good connection, it might deteriorate during your show. So you dial back the bitrate, sacrificing sound quality to play it safe.

There is a better way.

Meet the amazing new Z/IP ONE codec.

Telos and Fraunhofer collaborated to develop a unique coding algorithm that adapts to changing network conditions on-the-fly.

If your connection quality drops, the Z/IP ONE uses error concealment, elastic buffers, and bitrate adjustments to keep audio flowing at maximum quality.

The Z/IP ONE now makes it possible to use the internet for great sounding remotes.

The convenience of the Internet. The sound of Telos.

AUDIO | NETWORKS
www.telos-systems.com

BROADCAST TELEPHONY



Telos is the trusted World Leader in single-line hybrids and multi-line phone systems.

ZEPHYR IP & ISDN CODECS



With more than 20,000 in daily use around the world, Zephyr is The Best Way to Hear from Everywhere.

World Radio History

STREAMING AUDIO



Hardware and software products for processing, encoding and streaming your audio content.

AUDIO LOGGING



PC Software for archiving and logging all of your stations audio.

EAS

(continued from page 16)

It seems only the “big stations” do this reliably anymore. Too many others are content to let a pre-programmed PC run their stations with a hard drive full of tunes or syndicated shows via satellite.

This is where EAS actually “comes to the rescue.”

NEW HARDWARE SETUPS

Like every other chief engineer responsible for a cluster of stations, I’ve been working diligently to get up to

speed with my new EAS CAP boxes and see how the new scheme functions in my area. There have been a number of snafus, but as more folks on both sides get better acclimated to the changes, EAS operations will get smoother over time. Let’s make sure all the new folks coming in get fully trained.

Operationally, dealing with the new full-featured EAS boxes is delightfully easier than their predecessors. The Web GUI interface with Ethernet and LAN connectivity is a godsend. Reviewing which events you want to filter and forward to air with an appropriate amount

of delay time for live operators to control execution must be done carefully. Installing and programming the new CAP boxes gives all of us a good opportunity to rethink how EAS is handled at our stations.

A few colleagues at smaller stations have asked me about the CAP “add-on” boxes. Those would allow continued use of the legacy encoders and supposedly save money. From what I have seen and read, choosing that option will likely be short-sighted. EAS is not going away. If anything, it’s liable to gain more importance as the future becomes more

unpredictable.

Strict EAS compliance is a religion for most broadcast groups, because the FCC wields the threat of stiff fines for violations. Sometimes EAS enforcement seems to have become a convenient income generator for the Portals to help defray operating expenses. Will impending government spending cuts ramp up the pressure on this “funding” opportunity even more?

Q&A ON THE NEW RULES

FEMA has held a series of ongoing EAS Q&A webinars that offer a wealth of additional information about how the new system and specifically the Nov. 9 EAN are supposed to operate. Their website features a “national dialogue” on the new EAS with tips and suggestions on best operating practices for hardware installation, event filtering and many other topics. Check it out at <https://nationaldialogue-emergencyalertsystem.ideascale.com/>

There are a few remaining holdover rules that do nothing to enhance the effectiveness of EAS. The most obvious one is the RWT that must be transmitted by all participating stations once a week, even if no other station is assigned to monitor that station.

Since the RMT effectively tests a station’s EAS equipment and the ability for operators or auto-forwarding to place alerts on the air every month, RWTs are simply not needed. Almost every other item in the rules requiring periodic compliance checks specifies a monthly or quarterly schedule.

All that RWTs really accomplish is making listeners “tune out” and become more immune to real alerts. A few of my colleagues also suggest canning the RWT in the recent public comments filed in the Docket 04-296 proceeding. Hopefully the FCC will give us relief here in the final rulemaking.

KUDOS

As a government-mandated requirement, EAS has struggled in many areas to become truly effective and relevant as a primary warning system to protect the public. But with the initiatives to update an aging system originally designed for Soviet ICBM attacks, I’ve got to tip my hat to the efforts by all the groups and agencies that took on this challenge. Even with the rules not yet finalized, getting bureaucrats with different agendas to agree and then act on anything nowadays is remarkable.

It’s now up to the folks in charge of originating the real alerts to make timely and proper decisions and then for all broadcast and cable outlets to get them on the air. The new EAS has a better chance than ever before to deliver on its promise.

Guy Wire is the pseudonym for a veteran radio broadcast engineer.

131ST

CONFERENCE
October 20-23, 2011

EXHIBITS
October 21-23, 2011

Jacob K. Javits Convention Center
New York, NY

AES Audio Engineering Society

www.aes.org

A Difference in Protection

Which Class of Station Gets Just a Bit More?

BY CHARLES S. FITCH

SBE certification is the emblem of professionalism in broadcast engineering. To help you get in the exam-taking frame of mind, Radio World Engineering Extra poses a typical question in each Certification Corner. Although similar in style and content to test questions, these are not from past exams nor will they be on future exams in this exact form.

Frequency-modulated (FM) radio has gone through a number of changes since Major Armstrong and his supporters pressed to get this revolutionary radio service into existence back in the 1930s.

FM had many "fathers," but no one was more of a driving proponent than Armstrong. He said his motivation was spawned when he was attempting to listen to and enjoy a classical music broadcast at his home in the Yonkers area, north of New York City. A passing lightning storm was wiping out AM reception. Armstrong was a person who

made his best efforts working from a defined problem. The high-fidelity, static-free performance of FM today is the historic result of his work.

Before World War II the FM band was in the 42 to 50 MHz region. Wartime advances in components, improved VHF receiver performance and expanding demand for spectrum (mainly from TV agitators) mandated a move for FM services into higher frequencies.

Around 1946, stations started migrating to our present FM band of 88 to 108 MHz. By 1948, everyone was located in the "new" band.

FAIR ALLOCATIONS

The dominance and simplicity of AM, the band move, the cost of receivers, consumer apathy and postwar economic factors almost put the kabosh on early FM.

Even so, the FCC, visionary broadcasters and discriminating elements of the public knew the intrinsic value of FM and persevered. Today FM is the

dominant radio medium. In 2002, for example, Entravision bought a cluster of Los Angeles FMs and paid roughly \$10,000 per watt. While the long-term future of radio is a popular debate topic, FMs today are seen as extremely valuable, almost unique broadcast assets.

The grand vision of Congress and the FCC is that an FM broadcast station is a valuable *community service and resource*. Not wanting to duplicate the relatively chaotic development of the AM band, various schemes were developed to assign FM facilities equitably across the United States. Starting in the 1950s, a table of community assignments was generated in the attempt to distribute FM spectrum evenly by population and community.

Since there was no spectrum squeeze, facilities were treated on a case-by-case basis with the result that stations as varied as WHO's 400,000 watt ERP monster existed on the same dial with little Class D 10 watters. Power and height restrictions were put in place in 1962.

As the number of applications, con-

Class Distinction

(Exam level: CBRE)

In the April 13 issue of RWEE, we asked:

All stations in the commercial part of the FM band are protected to their 1 mV/m contour except for:

- a. Class A and full Class C
- b. Class B and Class D
- c. Class B and Class C2
- d. Class B and Class B1
- e. Class B1 and C1

struction permits and licenses grew, more order was needed. This led to the adoption of sophisticated "class" descriptors with more exact facility specifications. An enlarged table of community allocations was adopted that for years guided the growth and station distribution on the FM dial.

A population density concept also was added. FM stations in highly populated areas were allowed to cover a marketing footprint of sufficient population to be economically successful, but some-

(continued on page 20)

1 GREAT CODEC TWO GREAT SOLUTIONS

1) Ultra-Portable Live Remotes

Report-IT to Bridge-IT for News, Sports and Talkshows



2) Affordable STLs

Bridge-IT for Studio to Transmitter Links

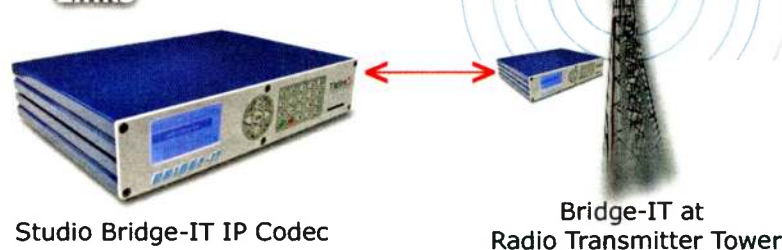

Call your favorite dealer today

Tieline
www.tieline.com

317-845-8000

www.tieline.com

* iPhone and App Store are trademarks and/or registered trademarks of Apple Inc., registered in the U.S. and other countries.

CLASS

(continued from page 19)

what limited to allow more allocations. Elsewhere, broadcasters were allowed to cover more area with bigger and more powerful signals to serve isolated areas as well as accumulate enough of a population to make an economic go of it. Hence the class difference where we have maximum coverage Class Bs for mainly the dense eastern areas and Class Cs elsewhere.

WITH SOME RESERVATIONS

A notable feature on the FM dial is the distinction between the "reserved section" that lies between 88 and 92 MHz and the commercial portion between 92 and 108 MHz.

The Reserve Band was a critical component in the creation of the FM broadcast service. Generally attributed to Major Armstrong, the fundamental concept was to provide communities with a vehicle for programming outside of the usual commercial sources. The vision was to give the arts, education and religion the opportunity for broadcast carriage without commercial necessity.

In the commercial band, all initial allocations are done by minimum spacing. The spacings have been designed to minimize interference without having to complete a detailed engineering study.

However, in the Reserve Band the FCC rules allow allocations to be done by interference method (somewhat similar to AM methodology). This means that if a proposed station can demonstrate that it causes no new interference to any existing stations, it is allowed.

Interference for Reserve Band allocation purposes is calculated according to charts developed by the FCC in the 1950s. The protected service contour (the 1 mV/m contour) is first determined using the FCC's 50/50 graph (or formulas that emulate that graph) on a specific azimuth toward the potential interfering station

FM Station Class	Reference (Maximum) Facilities for Station Class (see 47 CFR Section 73.211) ERP (in kW) / HAAT (in meters)	FM Protected or Primary Service Contour		Distance to Protected or Primary Service Contour (km)	Distance to 70 dBu (or 3.16 mV/m) City Grade or Principal Community Coverage Contour (see 47 CFR Section 73.315) (km)
		dBu	mV/m		
Class A	6.0 kW / 100 meters	60 dBu	1.0 mV/m	28.3 km	16.2 km
Class B1	25.0 kW / 100 meters	57 dBu	0.71 mV/m	44.7 km	23.2 km
Class B	50.0 kW / 150 meters	54 dBu	0.50 mV/m	65.1 km	32.6 km
Class C3	25.0 kW / 100 meters	60 dBu	1.0 mV/m	39.1 km	23.2 km
Class C2	50.0 kW / 150 meters	60 dBu	1.0 mV/m	52.2 km	32.6 km
Class C1	100.0 kW / 299 meters	60 dBu	1.0 mV/m	72.3 km	50.0 km
Class C0 (C-zero)	100.0 kW / 450 meters	60 dBu	1.0 mV/m	83.4 km	59.0 km
Class C	100.0 kW / 600 meters	60 dBu	1.0 mV/m	91.8 km	67.7 km

being considered. The interfering station's signal level on the reverse azimuth is calculated using the FCC's 50/10 graph. If the two contours overlap, interference is assumed and the allocation would not be permitted.

B SPECIAL

Originally, Class B FM stations were allowed a maximum of 20,000 watts ERP, as these were expected to parallel the allocation and service areas of "regional" class AM stations. Around 1975, a change in the perception of what constituted the service contours of these allocations moved up the maximum ERP to 50,000 watts.

In rationalizing this new power and the intended service area, it was determined that Class Bs would be protected to their 0.5 mV/m predicted service contour. I have identified no technical reason for this Class B exception other than the reasonable anticipation of existing FMs to maintain their established service area and audience. All other classes received 1 mV/m protection.

Thus the correct answer to the question posed at the beginning of this article is "d."

MORE AND MORE

At the suggestion of noted consulting engineer

Serge Bergen, some small changes in required spacing allowed hundreds of new FM stations to be accommodated under the famous Docket 80-90 rulemaking. Bergen and other proponents noted that improvements in FM receivers, especially adjacent-channel rejection, would allow reduced spacing to other stations within 600 kHz. The goal was to allow hundreds of unserved communities to have their first radio service.

With this new spacing criterion and in a sort of "AM-ization" of the FM band, in-between classes of FM stations were created with appropriately adjusted spacing values so that more stations and an overall maximization of the FM band was achieved. You can see the table of minimum separations for the range of station classes at www.fcc.gov/mb/audio/spacing/73215e.html.

Shown here is the commercial coverage and contour table directly from the FCC website. As you can see, all classes except for Class B and B1 are protected to their 1 mV/m contour.

The other contour listed, 3.16 mV/m (70 dBu) is important because this is the coverage that is required over the city of license.

Actually, these classic signal levels are very high, corresponding to typical receiver performance in 1950. The F(50,50) graphs predicted FM service would be present 50 percent of the time at 50 percent of the locations within the service area. With today's receivers, full quieting FM reception can be had at a fraction of these signal levels.

Charles "Buc" Fitch, P.E., CPBE, AMD, is a frequent contributor to Radio World. Missed some SBE Certification Corners or want to review them for your next exam? See the "Certification" tab under Columns at radioworld.com.

Strong in Your Field

Question for next time
(Exam level: CBRE)

What factor(s) most affect the predicted or measured far-field signal strength of a nondirectional AM station?

- Transmitter power
- Antenna power input, antenna height
- Antenna power input, antenna height, radial count
- Antenna power input, antenna height, radial count, top loading
- All other factors being equal, ground conductivity

PRODUCTS & SERVICES SHOWCASE

DYNAMAX MX SERIES

Easy to Operate
Easy to Install
Easy to Service

- 6 to 18 channel configurations
- 24 or 36 inch wide frames
- 2" or 3" wide modules options
- 4 Output Buss (two Stereo and two Mono)
- Metering for all 4 Outputs
- 2-4X1 Auxiliary inputs standard
- Mic preamp on first two channels
- 20 Configurations available

MODEL 343



MODEL 340 SERIES



NEW!





SANDIES

WWW.SANDIESUSA.COM
215-547-2570

WRITING

(continued from page 22)

of clarity, hooking, fun, etc. When I do this, I often notice that there are good sentences scattered among bad sentences in the four versions. I then pick and choose, and again rewrite the paragraph.

The key to practice is the emotional freedom to critique your own work. I had to learn this when I wrote my first and probably only book. After the initial three years of effort, I had nine versions of the book manuscript! And then the publisher's copy editor rewrote 50 percent of my final text.

The editor was afraid that I would be very upset about all the changes. However, I was delighted with how much the new version improved the book. When I write these Radio World articles, I always generate an early draft and send it to our honorable editor, Michael LeClair, who comments on the draft (especially this one because he has a special interest in writing). Sometimes a single comment forces me to rethink a full paragraph or conclusion. In fact, some articles were completely rewritten when I saw that that Michael became confused or could not figure out the point.

WRITE WELL TO GET THE BEST JOB

While we are often pressured to

write memos for business managers or articles for trade publications, writing a cover letter for a job application can have a dramatic impact on your career. A good cover letter can be worth thousands of dollars in increased income.

From my experiences as a career coach, I have observed the difference between a good and bad cover letter. Most people do not understand its pur-

Engineers often make the mistake that relevance should be obvious – it isn't.

pose and they write a lot of facts about their skills and experience: "I did this and I did that." Such letters are so dry, they fail in their single purpose.

This poses the question: What is the purpose of a cover letter? It has only one purpose. It must make the candidate come alive as a person who would be a welcome member of the company.

Having been an interviewer who helped companies sort through hundreds of applicants, I know that each

applicant gets about 60 seconds of attention. I will never invest time to figure out the candidate's qualifications if that process takes too much work. Life is not fair. The writer of a cover letter has to create a mental model that I can easily recognize. The writer needs to make my life easier because I am looking for a candidate who understands how to make the life of colleagues and manager function better.

Let me illustrate this with a concrete example of a candidate who was applying for a graduate program in health policy. I was helping her convert a boring application into one that would get attention. I knew that she had to sell herself in the first sentence. If the reader was emotionally captivated in that opening, the rest of the application would serve to reinforce the emotional decision to want her in the program. Notice both the first and last sentences in the paragraph below and the absence of facts about the candidate.

Crisis is opportunity. Newspapers regularly highlight exploding health care costs, striking unionized workers or diminishing quality of care. In addition to inducing anxiety and selling newspapers, these articles prepare society and its political leaders to invest in meaningful change and improvement in

our national health care system. I want to be part of the process that transforms an archaic system into one that will match the current needs of society.

Using this paragraph, she was admitted with full funding to all of the top schools in her field. Her professor confirmed that the opening paragraph got her admission. The rest of the application and interviews were consistent with the mental model that the cover letter created in just 70 words. She was *showing not telling* him who she was.

My high school English teacher proved to be right: Learning to write is important even (especially) if you want to be an engineer. My engineering career was made by my writings. Yes, I had something to say, but lots of others had the same knowledge that I had. The difference is that readers wanted to read what I wrote.

As my final argument for learning to write, consider that you have unique skills and experiences that are important for executives and managers. If you want to be taken seriously and paid as a valuable contributing resource, those executives need to understand your message.

Barry Blesser is director of engineering for 25-Seven Systems. Contact him at www.blesser.net.

AM Ground Systems Co.

www.amgroundsystems.com

1-888-GROUND0

eng@amgroundsystems.com

PHYSICAL
AM SITE SERVICES

- CONSTRUCTION
- EVALUATION
- REPAIR
- SAMPLE, FEED & CONTROL LINE LOCATION, REPLACEMENT & REPAIR
- MOM MODELING PREPARATION WORK

SERVING THE TECHNICAL AND CONSTRUCTION NEEDS OF AM BROADCASTERS FOR OVER 25 YEARS

- Complete Ground System Construction, Evaluation and Repair Services.
- Fast, Efficient Full Site Construction Services.
- Firm quotes



AMGROUNDSYSTEMS.COM
888-476-8630
888-GROUND0



9/11/2001
WE STILL REMEMBER

Has your AM site been vandalized or damaged by unauthorized construction?

Has your coverage or site stability declined over time?

Contact us today for a no obligation quote on any of our services.

Reliable,
On-time Installation
Firm Quotes
Quality Workmanship

Why You Should Practice the Art of Writing

The Communication Is Successful When Your Ideas Appear in the Mind of a Reader

BY BARRY BLESSER

Throughout much of my life, I hated to write.

Not only was it painful, but I lacked the skills to formulate a coherent sentence or paragraph. This deficiency was a severe tax on my career. Yes, I forced myself to write when absolutely required. With lots of time, I eventually could create acceptable text.

My writing improved over the years, but without confidence or proficiency. Then, about 10 years ago, I decided to write my first book for MIT Press, and I knew that I needed to become better at the craft of written communication. I would like to share my learning experience.

As I was struggling to learn, my daughter recommended a book that proved to be infinitely better than the other zillions of books on how to write. Get a copy of William Zinseer's book "On Writing Well." I read it at least a dozen times.

Unlike books that teach the mechanics of writing, this book teaches the "psychology" of writing. Many of the principles for written communications are equally valid for oral presentation. I use these principles in meetings, public addresses and discussions.

BRAIN-TO-BRAIN CONNECTIONS

Let me start with the fundamental principle: Communication is successful when the ideas in the head of the writer appear in the mind of the reader. Thus oral and written communications make many similar assumptions.

The channel between the two people must be open so that the message can flow. This implies that both parties have the energy to devote cognitive resources to both sending and receiving messages. One or both parties may be distracted with

unrelated issues, such as recently learned bad news. Either party may be tired.

Wait for the channel to be open. You can always ask if this is a good time to communicate. And respect the answer, especially if it is no. Pushing a message through a closed window frustrates both sender and receiver.

Nobody wants to spend time with a long article or lecture if in the end they are not interested in the content. If you start with the details, the receiver has no idea if they should invest the time.

One solution is to begin with a one-sentence summary of the scope, which answers the question why should you want to continue reading. This leads to the concept of the "hook," getting the receiver interested in the content to follow. Grab the listener in the first sentence such that he or she wants to read more. One way to hook the reader is to personalize the opening, rather than being dry and academic.

Even the driest technical writing and oral presentations benefit from personal references since they appeal to emotions. Facts by themselves are not meaningful unless we know the relevance of the information. Engineers often make the mistake that relevance should be obvious — it isn't. In a report about testing a transmitter an engineer could start with a comment about being nervous about how the station would handle a weather disaster. He is making a statement about the relevance of the content to follow.

DROWNED IN WORD FLUFF

Communications should be fun for both the sender and receiver, and the pleasure gets both parties to invest in the process. Zinseer has a wonderful article on page 26 about chickens, written by the author E.B. White at the height of World



War II. I personally have little interest in chickens; but the article was a delight.

The opening sentence illustrated the hook: "Chickens do not always enjoy an honorable mention among city-bred people, although the egg, I notice, goes on and on." At least for me, I wanted to read the next sentence. Reread the opening paragraph of this article; that was a pure hook that (I hope) grabbed your attention.

It's important to raise the efficiency of communicating because the reader will get bored with too many useless words.

In general, adjectives and adverbs detract rather than adding to clarity. Word fluff kills communications.

In one classroom exercise, Zinseer describes a teacher who assigned each student the task of writing an essay. The next assignment was to reduce the size of that essay by a factor of two without removing any content. The result was actually an improvement in readability and interest.

Which of the following two sentences works best? (a) "I very much enjoyed the dramatic and illuminating presentation of your well-thought-out, high-impact discussion and analysis." Or (b), "I enjoyed your presentation." Both sentences are saying that you enjoyed the presentation. One version required 19 words. The other took four, and less time to read.

KNOW YOUR READER

Know the background and language of your audience. Writing for a colleague is not the same as writing for a manager, an investor, your kids or a general newspaper. If you assume knowledge that is not present, your communication will not make sense. Conversely, if you begin with the basics to an expert reader, he will be instantly bored and shut down the channel.

In writing this article, I created a mental model of you the reader as a broadcast engineer who loved engineering classes but who found English classes boring. For this reason, I chose to use a broadcast model to represent writing, which has a transmitter (writer), a listener (reader), a channel (paper) and a program (message). Listeners will stay tuned to the station if they (a) find the content personally relevant, (b) have a clear channel without noise and (c) do not have to work hard to comprehend the program. Learning to write is similar to learning to set up a broadcast facility.

Communicating is an art that is learned; none of us were born with the ability. How then do you improve your ability?

The conventional answer is practice and feedback. Try this experiment: Write four versions of a paragraph. Then critique the differences using the concepts

(continued on page 21)

ADVERTISER INDEX

This listing is provided for the convenience of our readers. Radio World assumes no liability for accuracy.

PAGE	ADVERTISER	WEB SITE/URI
21	AM Ground Systems Co.	www.amgroundsystems.com
7	Arrakis Systems Inc.	www.arrakis-systems.com
9	Axia - A Telos Alliance Company	www.axiaaudio.com
1	Comrex Corp.	www.comrex.com
14	Continental Electronics Corp.	www.contelec.com
10	Digital Alert Systems	www.digitalalertsystems.com
5	Nautel Ltd.	www.nautel.com
15	NTI Americas, Inc.	www.ntiam.com
20	Sandies	www.sandiesusa.com
17	Telos - A Telos Alliance Company	www.telos-systems.com
11	Telos Alliance Company	www.telos-systems.com
19	Tieline	www.tieline.com
2, 12, 13, 24	Wheatstone Corporation	www.wheatstone.com



Rebuilt Power Tubes 1/2 the cost of New!

Se Habla Español

ECONCO

Se Habla Español



Tel: 800-532-6626 Web: www.econco.com
 Intl +1-530-662-7553 Fax: +1-530-666-7760

VSoft THE LEADER IN BROADCAST ENGINEERING SOFTWARE!
 Winner of Radio World Newspaper's Cool Stuff Award!

Probe4 Create stunning "real world" coverage maps and interference studies using Longley-Rice, FCC, PTP, Cost-231-Hata, Okamura/Hata, and others.
AM Bro Prepare AM skywave and groundwave allocation studies and map FCC contours.
FM Commander Perform FM allocation studies under spacings and contour-to-contour protection.

• www.v-soft.com • +1-319-266-8402 •

Do Something Really Crazy!

...like...conserve some cash!

- FM Transmission Systems
- FM Studio Gear

Get Crazy! Get Our Low Prices Today!

Toll-Free: 1-866-282-9061 www.mainsource.us
sales@mainsource.us

main source

Commercial FM, Non-Commercial FM LPFM Specialists

AM Modeling Software

- AM Allocations
- Contour Protection
- Coverage
- DA Design
- DA Proof Tools
- FM Allocations
- PCN Coordination Tools
- Population Studies
- Phasor/ATU Design
- Diplexer Design

Au Contraire Software, Ltd.
www.aucont.com
 (303) 489-3454

TUNWALL RADIO

AM/FM/MULTI-SWITCH AND CUSTOM CONTROLLERS
 330.995.9642 www.tunwallradio.com

GRAHAM BROCK, INC.

BROADCAST TECHNICAL CONSULTANTS
 Full Service From Allocation to Operation AM/FM/TV/AUX Services;
 Field Work; Antenna and Facilities Design

Over 45 years engineering and consulting experience

912-638-8028
 202-393-5133
www.grahambrock.com

"God Protect & Guide the USA to Victory"
 Serving Broadcasting Since 1948

Mullaney Engineering, Inc.
 Member AFCCE

Mullaney Engineering, Inc.
 9049 Shady Grove Court
 Gaithersburg, MD 20877
Mullaney@MullEngr.com
www.mullengr.com ♦ 301-921-0115 Voice ♦ 301-590-9757 Fax

RF PARTS™ CO.
 Se Habla Español We Export

EIMAC • TAYLOR • SVETLANA
 New & Rebuilt Tubes - Same Day Shipping

Motorola • Toshiba • SGS • Thomson & Mitsubishi Semiconductors

800-737-2787 760-744-0700
rfp@rfparts.com www.rfparts.com

- AM, FM and TV coverage predictions and upgrade studies
- Broadcast transmission facility design
- FCC applications preparation
- Contact *Clarence M. Beverage* or *Laura M. Mizrabi* for additional information

Communications Technologie, Inc.
 Radio Frequency/Broadcast Engineering Consultants

P.O. Box 1130, Marlton, NJ 08053
 Tel: (856) 985-0077 Fax: (856) 985-8124
www.comtechrf.com

525 AM Modulation Monitor*

See and hear everything.

INOVONICS BROADCAST
www.inovonicsbroadcast.com
 1-800-733-0552

*Outdoor loop antenna included.

CLEANUP

YOUR ON-AIR SOUND & IN THE RATINGS

AirAura's 31-Band Limiter Delivers FAR More Clean Sound Detail than ANY Other Limiter on the Market. Here's Why This Is Important...



In a traditional processor with 5-band limiting, selecting 3 bands results in 60% of the audio being affected. It's clear to see how such a coarse adjustment can adversely affect the overall audio.



In the AirAura, with 31-band limiting, only the narrow bands that need limiting are affected (just 9.5% of the audio spectrum). This allows MUCH more natural sound and the ability to tune-in your audio with near surgical precision.

In a side-by-side listening comparison, you'll hear that this difference is HUGE. 31-Band Limiting is also relevant because it's a natural division – each band represents one third-octave of the audio spectrum. This makes processing more natural and more musical.

AirAura has a lot of other tricks up its sleeve, all of which reduce or refine the amount of processing to reduce distortion, artifacts and overblown sound. All we ask is that you listen...we know you'll be blown away.

GET THE RADIO CLEAN MACHINE

AIRAURA IS THE BEST ON-AIR PROCESSOR YOU CAN BUY

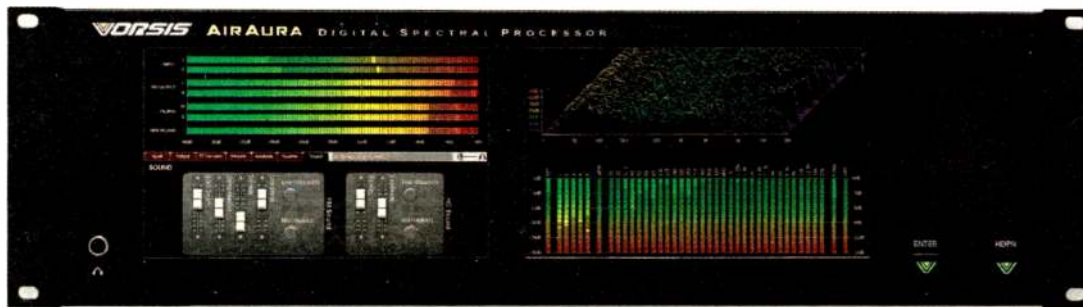

Put the Vorsis CleanUp Crew to Work In YOUR Studio. You Won't Believe The Difference In Your On-Air Sound Or Listenership.



WHEATSTONE
VORSIS

phone 1.252.638-7000 | vorsis.com | sales@wheatstone.com

AIRAURA
THE RADIO CLEAN MACHINE

Download a FREE whitepaper or watch video about AirAura at RadioCleanMachine.com