

*****3-DIGIT 857
 J750970 D08 9203 5232 251
 TOM MILLER
 ASST CE
 KTZR
 2033 S AUGUSTA PL
 TUCSON AZ 85710

RadioWorld®

For **Production** and
Broadcast services, see
Buyers Guide,
 pp. **39-56**

Vol 17, No 18

Radio's Best Read Newspaper

September 22, 1993



Studio Sessions

Equipment and Applications for Radio Production and Recording. AES Preview begins on page 27.

AM Stations Vie for New Frequencies

by John Gatski

WASHINGTON Nearly 1,000 AM stations have applied for migration to the expanded AM band (1605 kHz to 1705 kHz) for various reasons, such as nighttime operation and escape from low-band congestion.

Judging by the large number of applicants, computing the allotment scheme will take "several months," according to the FCC. About 87 Class C stations that applied were ineligible and an additional 28 stations filed after the deadline.

Under Docket 87-267, known as the "AM improvement docket," the FCC intended to use the expanded band as one of the methods to relieve congestion and interference on the lower band.

Successful applicants will be allowed 10 kW daytime and 1 kW nighttime power authorizations. They also will be encouraged to go AM stereo. (Most of the applicants on the FCC's initial list are stereo.) Protection parameters also are changed from the lower band including a 800 kilometer co-channel and 200 kilometer first adjacent protection ratios (except for stations next to the high-frequency channels on the existing AM band).

Jim Burtle, AM Branch chief for the FCC, said the final station selection process will not be completed until early 1994 at the earliest. About 200-250 stations can be accommodated in the expanded band, based on the criteria, he said.

continued on page 6 ▶

Industry Reacts to 'Super' Show

by Randy Sukow

WASHINGTON Exhibitors and broadcasters likely to participate in the first four-association joint fall broadcast equipment exhibition next year appear to favor the consolidation plan.

As expected, the National Association of Broadcasters (NAB) officially announced late last month that it had completed an eight-year contract to combine its annual fall Radio Show exhibit with the Radio-Television News Directors (RTNDA) and Society of Broadcast Engineers (SBE) exhibitions. The Society of Motion Picture and Television Engineers (SMPTE) signed on as a surprise, late addition to the group.

The first joint show will be in Los Angeles, Oct. 12-15, 1994. New Orleans tentatively is penciled in for the 1995 show.

"I think it makes economic sense," said Jim Thompson, president and CEO, Liberty Radio Group, and chairman of NAB's Radio Show Committee.

There is a feeling among some NAB members that a combined exhibition could threaten the radio-only focus of the fall show, Thompson said, but "I think its up to us (in the radio industry) to make sure it doesn't happen."

Some members of the other groups also worried that the "integrity" of their own conferences would be compromised by time and space constraints at the joint convention centers. RTNDA members were said to be especially wary of the possible effects to its conference. Most fears have been allayed, RTNDA President David Bartlett said.

"In the balance of the arrangement... RTNDA's organizational integrity and independence and the independence and integrity of the RTNDA conference are maintained," Bartlett said.

"NAB is not interested in taking over RTNDA. That is not where we're coming from," said NAB Joint Board Chairman Wayne Vriesman, vice president of Tribune Broadcasting's radio group, who also served briefly as RTNDA chairman in the late 1970s.

The other two groups, SMPTE and SBE are similarly safe from absorption into NAB, representatives for the associations said.

Under the terms of the agreement, the groups will share exhibit space only.

Conference registrations will remain separate. NAB staff will organize the exhibitions all eight years.

The groups did not disclose how revenues from the exhibitions will be divided. "We're not a competitive organization. The society is a group of individuals that are interested in technology," said SMPTE President

Irwin Young, when asked whether overlap attendance could lead to lower revenues for his group.

A joint exhibition may, in fact, be a financial benefit to each organization. A combined show would reduce overhead for each group while perhaps attracting new members. "All four organizations had flat or declining profits from these conventions," said John Abel, NAB executive vice president, operations, who was acknowledged as the prime mover behind the joint agreement.

"NAB has been unsuccessful in attracting radio engineers to the fall show. In 1991, I believe nine (registrants) said they were radio engineers," Abel said. Bringing engineers from SBE and SMPTE into the same building could help boost the Radio Show's attendance, he said.

Total attendance for all four 1994 conferences and the equipment exhibition could be between 25,000 and 30,000, assuming some overlap. The projected attendance of the four individual 1993 shows is: SMPTE, 15,000-20,000; NAB, 6,500; RTNDA, 2,500, and SBE, 1,000.

The first joint exhibition is projected at about 400 exhibitors covering 124,000 square feet of exhibition space. But other factors could swell those numbers.

NAB's spring show, by far the world's largest convention for broadcasters, maintains a long waiting list of exhibitors. in

continued on page 6 ▶

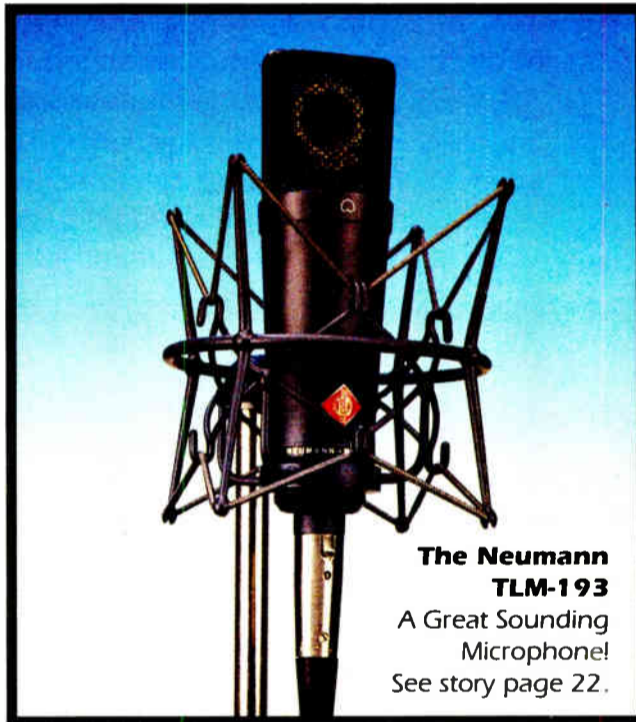

The Neumann TLM-193
 A Great Sounding Microphone!
 See story page 22.

TOWER OF POWER

38.5 KW ■ GROUNDED GRID

SINGLE CABINET ■ SMALL FOOTPRINT

NEW!
 FM3500G

CCA TRANSMITTERS

P.O. Box 426 • Fairburn, Georgia 30213 • USA

(404) 964-3530 • FAX: (404) 964-2222

CCA

Circle (59) On Reader Service Card

NEWSWATCH

CCA To Hold Transmitter School

FAIRBURN, Ga. CCA Electronics will hold its Semi-Annual Service School, Oct. 22 and 23, at its Fairburn facility.

The school will cover CCA's AM, FM and solid state broadcast transmitters. Cost is \$259, including some meals, certificate and owner's manual of your choice.

For more information, contact Cheryl Kaufman at CCA, 404-964-3530. The fax number is 404-964-2222, and the address

is 360 Bohannon Road, P.O. Box 460, Fairburn, Ga. 30213.

'New Ears' Available

SYRACUSE, N.Y. The second edition of "New Ears: The Audio Career and Education Handbook" is now available from New Ears Publishing.

Designed to assist students interested in studying sound engineering, music recording and music technology, "New Ears" is a comprehensive reference to audio career and education,

according to the publisher.

Subjects include radio/TV broadcasting, music recording, live sound, and audio engineering.

Book price is \$24.95 post paid. For more information contact New Ears Publishing, at 315-425-0048.

NABET Clears Last Contract Hurdle

WASHINGTON Last month's New York Publicists' ratification of a proposed NABET/ AFL-CIO contract with Cap-Cities

ABC clears the way for signing a "master agreement" contract.

The master agreement had been agreed to by bargaining parties of the union and ABC last spring, but some NABET chapters were not happy with it, and sent negotiators back to the bargaining table.

Ratification bonuses, which had been delayed by the contract snag, will now be forthcoming, once the master contract is signed, according to NABET.

Study Group Formed

WASHINGTON The National Radio Systems Committee, a

joint group of the Electronic Industries Association (EIA) and the National Association of Broadcasters (NAB), has formed a study group to investigate high speed FM subcarrier technologies.

The group is inviting individuals or companies that have proven and tested subcarrier technologies compatible with 57 kHz RDS (RBDS) subcarriers to participate in the group. The study group's work could lead to a future NRSC standard.

For more information, contact John Marino at the NAB, 202-429-5391; or Tom Mock at the EIA, 202-457-4976.

DECK II Offers 'NuBusless' Editing

SAN FRANCISCO OSC announced that its new DECK II software provides four-track, CD quality, direct-to-hard disk recording on the new Macintosh Quadra 840AV and Centris 660AV.

continued on next page ►

Only AUDIOARTS Has It...

WHEATSTONE'S STRENGTH! With Wheatstone's professional experience, engineering know-how, support capability and corporate stability behind it, this AUDIOARTS console design is the right choice.

The A-50 is cost effective through clever engineering and the latest advances in CAD design and electronic assembly procedures. It was developed by the same design team that creates Wheatstone's high end equipment. This console's performance is light years beyond the competition.

Naturally, it has all of the most important features: machine control functions, programmable channel logic, and three busses (Program, Audition, and Telephone). It also has the monitors you need: control room, studio and headphone—each with its own level control. It's designed so you can expand or add accessory modules as your needs grow.

You can benefit from our major market experience. Take advantage of Wheatstone's expertise and reputation; call us today for immediate action.



AUDIOARTS ENGINEERING
7005 Performance Dr., Durham, N.C. 27702 / (919) 452-6000 / fax 315-452-0160

Circle (88) On Reader Service Card

World Radio History

Index

FEATURES

Don't Neglect Your Personal Computer	10
by Tom Vernon	
Sometimes You Just Have to Fight THE BIG ONE	13
by Al Peterson	
Getting on the Cyber-Radio History Train	14
by Barry Mishkind	
AM Kept Flooded Midwest Informed	15
by Dee McVicker	
Old Commission Business Will Get Older	38
by Harry Cole	
Workbench	38
by John Bisset	

STUDIO SESSIONS

SADiE Impresses Canadlan Producer	19
by Edward Marshall	
Neumann Targets Radio for TLM-193	22
by Ty Ford	
Producer Embraces Multichannel Sound	23
by Frank Beacham	
Product Guide	24
AES to Showcase Production Gear	27
by John Gatski	
AES Exhibitor Directory	28
A Good Ground Can Alleviate Hum	34
by Bruce & Jenny Bartlett	
Examining the Magneto-Optical Option	36
by Mel Lambert	

BUYERS GUIDE

USER REPORTS

Sports Show Enters Digital Satellite Age	39
by Ken Van Prooyen	
Holland Brings Music to Talker KGO	41
by Stephen Taylor	
DataWorld Puts Signals on the Map	42
by Kevin T. Fisher	
BP Offers One-Stop Library Shopping	44
by Tom Benson	
NSN's 'Eye in the Sky' Tends To Colorado Public Radio Network	44
by Robert Hensler	
Bonneville Libraries Help Put WAVV on Top	45
by Norman Alpert	
ComStream Delivers with Digital Uplink	47
by Paul Donahue	
Canary Brings 'Something' to WETN	50
by Chris Lang	
FirstCom Gives WJMN a Winning Impression	51
by Gordon McAdams	

TECHNOLOGY UPDATES

Omni Music
Valentino
National Public Radio (NPR)
Radio Computer Services (RCS)
International E-Z Up
Manhattan Production
ABC Satellite Services

by Christopher H. Scherer

CLEVELAND Sometimes an ordinary thunderstorm can have a longer-than-anticipated effect on radio broadcasters. During a recent thunderstorm in northeastern Ohio, most stations experienced only brief power outages. Three stations, however, were not so lucky.

The high winds caused many power outages all over Cuyahoga and Geauga counties on July 28. Even though some areas were without power for four days or more, only three radio stations experienced major power interruptions. Most stations had outages lasting only a few minutes.

The three Cleveland stations that did not escape the storm's wrath were WRMR (AM), WDOK (FM) and WENZ (FM). WDOK and WRMR lost power for 24 hours in their downtown studios starting at 6:30 p.m. The stations gave the local power company some time to restore downtown power, but after an hour gave up and started taking matters into their own hands.

After a quick fix (a CD player put directly on the air from the transmitter room), temporary studios were established at each transmitter site using portable mixers and some studio equipment. This allowed as close to "normal" operations as possible.

The temporary studios were up in time for the morning shows. Because the transmitter was located in its old studio building, WRMR used a control room that was used by WJW(AM) (WRMR's former call letters). It had not been used for broadcast in nearly 15 years.

WRMR used a stereo Ramsa P.A. mixer, two cart machines, two CD players, and two microphones to maintain

programming. The engineers said they were proud that they maintained the AM stereo signal during the entire outage.

WDOK, however, leases space for its transmitter site, and had to use an employee's house as the temporary studio. The equipment included two cart machines, a CD player, a microphone and a Marti RPU for a temporary STL. This studio was used until 7 p.m. the next day, when the main studio's power was restored.

Downtown power outages are too rare to justify a permanent backup generator for WDOK, engineers said. Provisions are being made for suitable temporary backup studio power, as well as a permanent reel-to-reel at each transmitter site as backup music sources.

WENZ had power at its studio, but at 7 p.m. on Wednesday, July 28, lost power at its transmitter site in Newbury, Ohio. (At the time, the station had plans for a backup generator for the transmitter site, but had not yet installed it, due to several "red-tape" hurdles, including local zoning ordinances.)

A search for a rental unit (which were, of course, in high demand), yielded a temporary generator, which was installed on Thursday morning (July 29) and ran until Tuesday night (August 3).

Even though local power had been restored after three days, the power company work crews were so busy that its dispatch office had no indication that power had been restored to the area.

A power crew was finally sent on Tuesday to turn power off at the pole so that commercial power could be re-connected to the building.

□ □ □

Christopher Scherer is chief engineer for WRMR(AM)-WDOK(FM) Cleveland.

Storm Forces Impromptu Broadcasting

NEWSWATCH

► continued from previous page

Previous 16-bit recording on a Mac was available only with additional NuBus cards, but with Macintosh's new Apple Real Time Architecture, the DECK II software can run without the additional cards.

For more information, contact OSC at 800-343-DECK.

FCC Preempts Local Ban on Amateur Radios

WASHINGTON The FCC will overrule certain state and local ordinances prohibiting amateur radio transceivers when these laws are enforced based on the incidental reception.

The ruling affects amateur radio broadcasters whose transceivers are outlawed because they are capable of receiving public safety, special emergency, or other radio service frequencies.

The American Radio Relay League asked the FCC to preempt such laws because amateur radio transceivers typically allow for the incidental reception of adjacent frequencies in order to insure the adequate reception of the entire amateur radio service band.

ARRL contended that the amateur operators have "special needs for out-of-band reception" and the FCC concurred.

In its decision, said that state and local

laws that preclude the possession in vehicles or elsewhere of amateur radio service transceivers that are not forbidden by federal law, "are inconsistent with federal objectives of facilitating and promoting amateur radio service..."

Stations Fined For Howard Stern Broadcasts

NEW YORK Stations licensed to Infinity Broadcasting and several of its subsidiaries including WXRK (FM) New York, WYSP (FM) Philadelphia, and WJFK-FM Manassas, Va. (Washington) were fined \$125,000 each last month for broadcasting "indecent material" during segments of the Howard Stern Show.

KFBI (FM) Pahrump, Nev., was fined \$73,750 for airing the same material from nine Stern broadcasts between Nov. 10, 1992 and Jan. 13, 1993. With the action taken on Aug. 12, the stations have until Sept. 13 to respond to the fines.

Station Totals

WASHINGTON FCC totals reveal, as of July 31, there were 11,484 radio stations licensed in the U.S.

Included in the count were: AM commercial, 4,951; FM commercial, 4, 903 and FM educational, 1,630.

Your Station Operates 24 Hours a Day So Do We

Meet the Continental Service Team. They are available 24 hours a day, 365 days a year to assist you with solutions to any technical service questions. These people have many years experience troubleshooting equipment in the field and are knowledgeable about all Continental transmitters and accessories. **Continental offers the best service in the broadcast industry.**

Dave Chenoweth

Dave Chenoweth

Ken Branton

Ken Branton

John Hutson

John Hutson

Jan Aerts

Jan Aerts

Service 214-388-5800



Continental Electronics Corporation

P.O. BOX 270879 DALLAS, TEXAS 75227-0879 214-381-7161 TELEX: 73-398 FAX: 214-381-4949

HIGH Q FILTERS NOTCH AND BANDPASS

- Low loss
- Broad frequency range 30-950 MHz
- Single, double & triple cavities for spot or wider band attenuation
- Excellent power handling & temperature stability
- Field tunable

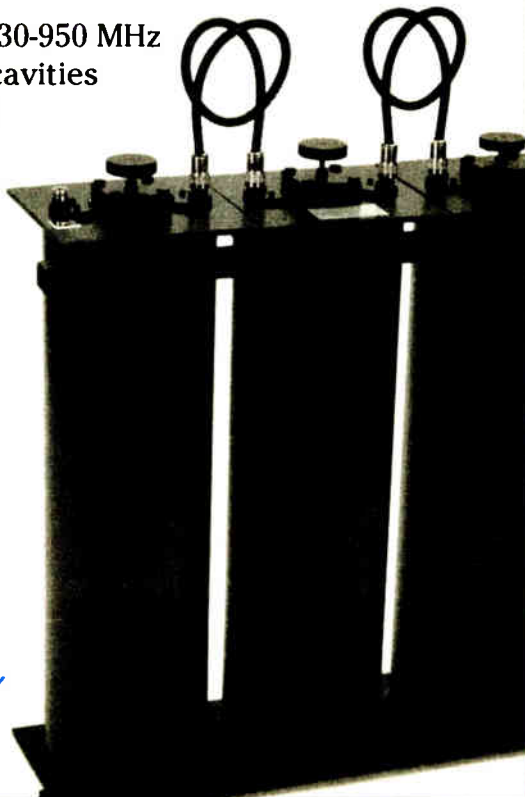

For more information, request our data sheets for HIGH Q FILTERS.



MICROWAVE FILTER COMPANY
6743 KINNE STREET
EAST SYRACUSE, NY 13067
800-448-1866 • 315-437-3953
FAX: 315-463-1467

Circle (216) On Reader Service Card

Circle (92) On Reader Service Card

Technology a Powerful Programming Tool

by Lucia Cobo

WASHINGTON A couple of issues ago, I wrote about my trip to Oriole Park at Camden Yards and how things aren't what they used to be. One of the things I said was that the programming content of radio is what will carry it forward into the next century.

After I sent that column off to press, I thought about that statement and decided that perhaps I came across as dismissive of the technical side of things. I didn't mean it that way.

By now, the NAB Fall Radio Show has come and gone. Computers and compression technology were evident everywhere and the impact they have on broadcasting will be felt for a long time. Technical



developments seem to be geared toward station automation—or at least partial automation and the integration of many aspects of a station's operations into one central system.

The bottom line at the show was obvious: Digital technology offers broadcasters a variety of ways to make life easier, faster and more cost-effective.

There are manufacturers of radio gear, however, who would like to invite managers and programmers to think of technology as more than just boxes and gadgets. Why else would so many of these manufacturers display their gear at a convention traditionally associated with programming and management?

The answer, according to many of them,

is that "knowledge is power." Although digital technology is being used today to replace existing technologies at a fraction of the cost, over time, the broadcaster that will succeed will be the one that can harness the power of the technology and use it to create better radio.

"People will realize the power of a dial-up, high power, high fidelity connection anywhere in the world," says Telos Systems' Steve Church. "I do think it is a whole new paradigm. The power has been with the people who own the distribution channels.

Church outlined a world where ad hoc networks can appear on demand—and only for as long as needed. Church can foresee a day when record companies will debut records on the air using some digital transmission system or device rather than sending out hundreds of demo discs. Or even a use for the technology devised by creative programmers that we can't even imagine yet.

"Over time," he prophesies, "it has the power to revolutionize the programming aspect of our business."

With the introduction of the Harris Allied Digit™ Digital FM exciter earlier this year and the new Sony line of digital gear for stations, including the PMD-C1 and PMD-C1P MiniDisc cart machines; the CDK-3600 360-disc compact disc changer; and the CDP-3100 broadcast CD player, the all-digital radio station is a reality.

And the rate of conversion from analog to digital is accelerating. Arrakis Systems' Jon Young sees a "pressing need for automation. That move has started to heat up significantly."

And whether your station broadcasts live or fully automated, Young believes: "Those people who have got it and know how to use it are going to win."



VOLUME 10 SEPTEMBER 1993 NUMBER 9

In this issue...



Tower
Radio Speakers

A.R.C. — THE NATIONAL PUBLICATION FOR BUYERS AND SELLERS OF OLD RADIOS AND RELATED ITEMS — PUBLISHED MONTHLY

Hours can be spent perusing Antique Radio Classified.

The number of companies displaying new or recently introduced products on the show floor this year grew. This too benefits the broadcaster, says Young, bringing production equipment and expertise into the reach of a

majority of broadcasters.

"Digital systems designed for broadcast are as affordable as the cart machines they replace—and are as easy to use," said Young. "The technology delivers a capability that was never there."

By now you've all heard or read about compression stacking. At the NAB '93 Convention held in April, Herb Squire, chief engineer of WQEW(AM)-WQXR-FM in New York presented the results of a "dueling algorithm" test he had conducted. He found that the combining of two or more data compression schemes in a broadcast audio chain can result in severe sonic degradation of overall audio quality.

In time, the issues will be resolved by cost. Says Steve Church: "In my perspective, over time, compression will only be used where bandwidth is expensive—for example, digital phone lines. Hard disk systems are less expensive.

"Manufacturers will test algorithms jointly to ensure that various pieces can connect without degradation. People are becoming more judicious, too, about how and where they use algorithms in the chain."

★ ★ ★

If you don't already know about the Antique Radio Classified, check out a subscription to this little booklet of treasures. The 100-page monthly booklet lists hundreds of "for sale" items that include old radios, broadcasting gear, hi-fi equipment, televisions, ham/CBs and test equipment. Folks who want to buy or trade items also advertise quite freely, as do service and parts providers. This may be the way to find that old Catalin tube you have been looking for.

Editor John Terry, a radio collector, also solicits informative "old equipment and how to fix it" articles for the publication.

Subscriptions are \$29.95 (second class) \$44.95 (first class) in the U.S. Subscribers placing a classified ad can get their first 20 words free. The address is Antique Radio Classified, P.O. Box 2 (V-67), Carlisle, Mass. 01741, or call 508-371-0512.

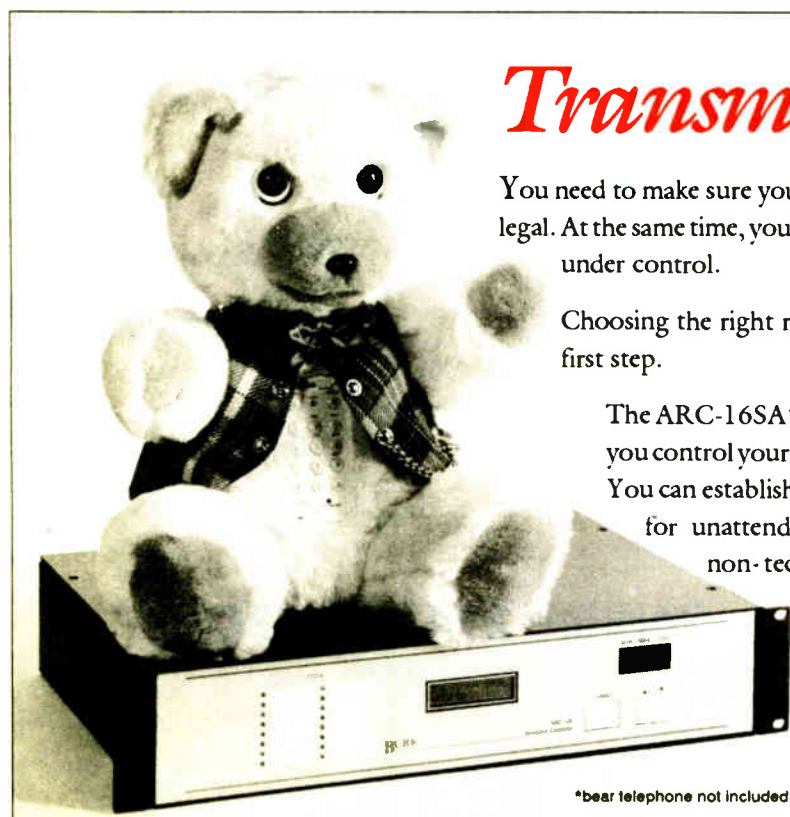

Transmitter Control can be a Bear

You need to make sure you can stay on the air and stay legal. At the same time, you need to keep operating costs under control.

Choosing the right remote control system is the first step.

The ARC-16SA* from Burk Technology lets you control your transmitter from any phone. You can establish off-premises control points for unattended operation, or supervise non-technical operators by phone. The annual savings can be thousands of dollars.

The ARC-16SA is part of a modular system. For full-time control, add a studio unit. Multi-site options make it easy to control several transmitter sites or even control studio equipment such as program automation.

Call now for your copy of our new catalog, then ask us to show you how we can improve your operation and your bottom line.

Call TOLL FREE
1-800 255-8090

BURK
TECHNOLOGY

7 Lomar Drive, Pepperell, MA, 01463 (508) 433-8877

Circle (142) On Reader Service Card

World Radio History

READERS FORUM

If you have comments for Radio World, call us at 800-336-3045 or send a letter to Readers Forum (Radio World, Box 1214, Falls Church, VA 22041 or MCI Mailbox #302-7776). All letters received become the property of Radio World, to be used at our discretion and as space permits.

More on DOS

Dear RW,

After reading the latest article regarding MS-DOS 6.0 and its DoubleSpace compression utility (RW, July 28), I thought I'd offer a comment.

In five years of operating my program consulting business, we have experienced four major computer failures. One occurred while installing an additional hard drive. Another file glitch resulted in the loss of a 2,000-station database. (The backup also wrote to a flawed disk and would not restore data.) One resulted from another computer's hard disk failure and the other came from problems using the Stacker program. I must say that with computers, more than any other piece of equipment, if it ain't broke, don't fix it.

After your columns, I am satisfied that my fears of using a compression program, while possibly unwarranted, are not unfounded. I agonized for months about upgrading from DOS 3.3, which came installed, because of horror stories I'd heard.

We run a very lean computer. Unless it is something like Windows, requiring tedious installation, we keep only about eight programs on the HDs.

I'm running a business. I don't want hours of backup time or hours to restore. All I want to do is type a letter or generate a report for a client without delay. Anything that might even remotely cause my computer to hit a tree is avoided like the plague.

J.R. Russ, president
J.R. Russ Programming &
Research, Philadelphia

Classical error

Dear RW,

I'm always pleased to see an article about classical music radio, but James Wold's Aug. 11 article ("Classical Grand Past Resonates") was in error.

In his first example, Wold confused WFMT(FM) and WEFM(FM). WFMT,

not WEFM, was sold to the Tribune Corp. WEFM was sold to Woody Tanger (who now owns commercial classical stations in Detroit, Miami and Philadelphia). He, in turn, sold the station to another company which changed the format from classical to rock.

WFMT was "given" by the Tribune Company to noncommercial WTTW(TV) Chicago. WFMT has always been a commercial station, although its present owner is a public broadcaster.

In both the WFMT and WEFM cases, there were listener committees concerned that the new owners would drop the classical format. However, it was eventually ruled that the FCC could not require a licensee to maintain a given format.

Mr. Wold is correct that classical music continues to play on. It is the longest running and most stable radio format. Today there are some 40 commercial classical music stations, most of which have been in the format continuously for decades. Our station will celebrate its 31st anniversary in November. And, of course, there are some 300 noncommercial stations that present significant schedules of classical music.

Robert Conrad, president
WCLV(FM) Cleveland

Editor's note: Several readers caught the WEFM/WFMT mix up, which seems to be even more evidence of how seriously classical music broadcasters and listeners follow the subject and the loyalty they feel for their very durable format. RW is glad there is neither decrescendo nor coda to this affection.

Barry boosters

Dear RW,

I cannot disagree more with reader Quentin Powell ("Readers Forum," Aug. 25) who claims Barry Mishkind's computer column is a "waste of space." In the same issue of RW, there are many ads for broadcast computer hardware or software products. Computers are revolutionizing broadcasting as we know it.

The more we as engineers know about computers, how they operate and how to make them work (which frequently requires a better understanding of the software than the hardware), the better off we are and the more secure our jobs will be in the future.

Whether it's writing a letter to a vendor with WordPerfect, preparing an equipment budget for the GM with a spreadsheet, plotting points with topographical mapping software, every engineer should be computer literate.

This does not mean we must become "computer geeks," but to be successful, we do need to understand the technology. Computers may have first been used in radio as traffic/billing/logging systems, where they were out of our realm of responsibility. But lately, they have moved into the newsroom, the production studio and the control room. This makes them part of our domain, and we must know how to support these systems and the networks that connect them as well as we know our cart machines and studio wiring.

There are many good computer magazines, but not all your readers subscribe to

Technologies Merge At AES

The reality of "CD quality" broadcasting creeps closer with every digital development. Given the wherewithal, today's radio broadcaster could construct an all digital radio station, including all digital transmission.

That reality is not without its challenges, however. Now more than ever, broadcast engineers and producers need to stay aware of developments in audio engineering in general. The Audio Engineering Society convention, to be held Oct. 7-10 in New York, is just the place to acquire this information.

Digital transmission and digital studio gear necessitate programming that can stand the scrutiny. The advent of digital technology in the recording studio has not only changed the recording industry, but the production of advertising messages, liners, IDs, promos, and long- and short-form programming for radio. The distinction between the two realms of engineering—recording and broadcast is increasingly difficult to distinguish.

For many recording studios, radio production is the bread and butter of existence—sustaining them between recording artist projects. Conversely, for many radio stations, even in smaller markets, production rooms have become an alternate source of revenue. In many cases, those production rooms have changed from simple setups with two-track reel-to-reels for dubbing carts to four- or even eight-track recording setups.

The explosion in the market of digital audio workstations will be evident on the AES exhibit floor. The ease with which these tools can be implemented and used to enhance your station grows every day.

What all this translates into is a need to stay informed about new challenges, like the perils and advantages of stacking compression algorithms. All of these will be discussed at the AES show. To deny the importance of this and similar technology to broadcasting is to deny the chance to gain a competitive edge. And in some markets, it has become more a necessity than an edge.

—RW

them or have the time to digest the profusion of information available. I feel that Barry's column is well-written and relevant to our role as broadcast engineers.

If Mr. Powell wonders what "MS-DOS 6.0 has to do with radio," I hope he has a good understanding of how to use the "undelete" feature the next time the sales manager calls to say he has accidentally erased his station's total sales figures for the year and wants to recover them.

Computers will play a large role in our future. Get with the program.

Alan Clarke, chief engineer,
KSAU(FM) Nacogdoches, Texas

Dear RW,

The letter questioning the attention Barry Mishkind pays to computers must have been intended to be tongue-in-cheek. Virtually every piece of equipment has some form of microprocessor and many use personal computers as controllers.

As director of a satellite-delivered talk radio network, I speak to hundreds of stations every month. Dozens of these conversations include references to the digitization of their plants. Digital systems interface with their operators through personal computers. The newest program automation systems use computers running DOS or Macintosh operating systems. Our digital production system uses a Macintosh.

Our engineering department is spending a great deal of time researching our digital future. Our next addition to the engineering staff will be someone with a computer rather than a broadcast electronics background.

Any station that ignores computers will do it at their own peril. Morse Code thinking in an age of satellites, fiber and megabytes will lead to a future block-

buster move: "Jurassic Engineers."

Rich Wood, director,
WOR Radio Network,
New York

Dear RW,

I just wanted to write and let you know that I not only enjoy Barry Mishkind's articles, but I hope to see many more in the future. The recent ones about MS-DOS 6.0 are of great value.

In response to Quentin E. Powell's letter, I believe he is missing something very important that could well affect him too. In this day and age, computers are the common denominator of most radio stations. Automation in its various forms would not exist without computers.

Could you imagine billing your clients without a computer system? Traffic departments would be crippled without computers. Has Mr. Powell ever done a payroll by hand? Try to get financing without a spreadsheet.

MS-DOS 6.0 has problems, which are very real and can bring a computer to a halt faster than you can say, "So what?" I used the RW articles and letters to demonstrate to people that the MS-DOS 6.0 problems are not a rumor, but have already had a negative impact on broadcasters.

RW is a trade magazine with the mission to inform us, and Mr. Mishkind's articles are exactly what's needed. Most CEs and CEOs don't have time to sort through 12 magazines for information.

What Mr. Powell overlooks is that many station engineers are computer literate. By calling a whole class of technically able people "geeks," he is not in intimate touch with reality. Mr. Powell needs to wake up and smell the floppy.

John Morehouse,
engineer/programmer
KAVA(AM) Burney, Calif.

Radio World
Vol. 17, No 18 September 22, 1993

Editor Lucia Cobo
Managing Editor Randy Sukow
News/Studio Sessions Editor John Gatski
Assistant Editor Mary Ann Dorsie
Contributors Frank Beacham/N.Y.
Bruce Ingram, Pamela Watkins, Nancy Reist
Technical Editor John Bisset
Technical Advisor Tom McGinley
Editor (International) Alan Carter
Managing Editor (International) Charles Taylor

Radio World (ISSN 0274-8541) is published semi-monthly by Industrial Marketing Advisory Services, Inc., 5827 Columbia Pike, Suite 310, Falls Church, VA 22041. Phone: 703-998-7600, Fax: 703-998-2966. Second-class postage rates are paid at Falls Church VA 22046 and additional mailing offices. POSTMASTER: Send 3579 forms and address changes to Radio World, P.O. Box 1214, Falls Church VA 22041. Copyright 1993 by Industrial Marketing Advisory Services, Inc. All rights reserved.

—PRINTED IN THE USA—

**Next Issue of
Radio World
October 13, 1993**

Industry Reacts to Fall 'Super' Show

► continued from page 1

spite of recent expansion of the Las Vegas Convention Center, where the spring show is booked until beyond 2000. "We are expecting some exhibitors from the spring show to perhaps migrate to the fall show," Abel said, at least until additional renovations planned for the Las Vegas facility are completed.

The size of the new joint show will require NAB and its partners to choose exhibition sites with greater care.

The Los Angeles Convention Center, which has housed several SMPTE fall conferences, is expected to easily accommodate

the four conferences, as promised, without affecting the size or length of the individual conferences. The New Orleans facility also is expected to have ample space for the joint show, especially by 1995, when an expansion (to match the current size of the Las Vegas Convention Center) is expected to be complete, Abel said.

The joint agreement extends what had already become a well-established consolidation trend. SBE, the smallest of the four groups, merged its convention's equipment exhibition with RTNDA for the 1992 and the upcoming 1993 conference in Miami. The SBE will continue its "SBE Day" sessions at the NAB spring convention.

But not all of those contacted by RW thought the trend would serve SBE well. "I don't believe the RTNDA and the SBE have enough in common to where they should have a joint conference," said Steve Claterbaugh of Continental Electronics, Dallas, a regular Radio Show and SBE exhibitor.

Claterbaugh called next year's joint exhibition "a bastardization" of the groups and said SBE was most in danger of losing its identity to NAB.

SBE President Richard Farquhar said consolidation will help the society in the long run, allowing it to focus on its certification and education functions and leaving the expensive and time-consuming details of the exhibition to NAB.

"NAB manages exhibits well," Farquhar said.

"We're glad to see the show coming together," said Martha Rapp, a spokeswoman for Harris Allied, Quincy, Ill., which will be exhibiting at eight different shows during September and October 1993, including the Radio Show, SMPTE and RTNDA/SBE. "From a manufacturer and equipment-supplier standpoint, it's going to be a lot more manageable to focus on one big effort."

"I think it's probably a help," said Tim Bealor, sales manager, Broadcast Electronics, another prominent Radio Show exhibitor. "It's just an expense to do trade

shows. If we don't alienate any segment of the customer base, it's a big advantage for us."

SMPTE exhibitors will benefit from the

deal with lower booth rates: \$17 per square foot for joint-show exhibitors, compared to \$19 for the 1993 SMPTE exhibition. The \$17 rate will be a slight increase for Radio Show exhibitors paying \$16.50 per square foot this year (\$21.50 for non-members), and for RTNDA/SBE exhibitors paying \$15.

Expanded AM Band List

► continued from page 1

The FCC has a complex computer program seeking the "ideal" allotment of stations based on ranking. Rankings are based on the "interference factor."

"The interference factor is a total interference area caused over the total interference-free service area," Burtle said.

That ranking also is combined with other preference criteria, such as full time stations having preference over daytimers, Burtle said. "There is more improvement in moving the full time stations than there is moving the daytimers."

No matter which station gets a preference, stations have their own reasons for applying to the expanded band. Some want to get out of the crowded spectrum confines of their market. Others, who have been unsuccessful in trying to secure nighttime service (or increase nighttime power) by the normal application process, also have applied.

Still, there are applicants who are said to have applied to enhance the values of their stations in the resale marketplace, according to several industry analysts.

Apparently, at least one station is willing to give up a lot of signal to get a nighttime authorization. Religious broadcaster KXEN St. Louis, would be giving up a 50 kW daytime signal to broadcast at night. KXEN's Managing Partner Burt Kaufman said the station is willing to trade 50 kW for 10 kW daytime and a 1,000 kilowatt nighttime omni-directional signal—depending on how the allotment of other stations on 1010 kHz are positioned on the new band.

Kaufman said his station has a construction permit pending with the FCC for a 500 watt nighttime directional pattern, but "obviously a 1,000 kW signal would be a lot better."

Once a station gets an allotment it does not mean the transition will be perfect.

Stations migrating from lower frequencies to the higher frequencies will face certain laws of physics. Upper frequencies can't deliver as much signal with the same power as the lower frequencies do.

"Typically the propagation is better on the lower AM frequencies," NAB Engineer John Marino said. But with fewer stations on the expanded band, he added, "the tradeoff will be that you may be able to hear the station as far out as you did on the lower band."

Marino said there will be some equipment investment for stations that want to get on the expanded band including transmitters, diplexer network and AM stereo exciter and related gear for those not already AM stereo.

All eligible stations that applied for the expanded band will eventually be informed by the FCC whether they make the final cut, Burtle said. Those that do will be sent Form 301 for engineering analysis, and a final determination will then be made.

For more information about the FCC's expanded band process, contact the FCC's AM Branch at 202-254-9570.



LMA/DUOPOLY CONTOUR MAPS

The DATAWORLD LMA/DUOPOLY Market Survey Contour maps present a precise electronic verification of overlapping and intersecting contours.

AM 5 mV/m and FM 3.16 mV/m City Grade contours are shown in full color, including transmitter site indicator. The map is supported with a printout showing all of the stations which appear on the map. Daily updating of DATAWORLD'S AM and FM databases protects against errors and omissions.

OTHER MAP OPTIONS

- SHADOWING (TERRAIN SHIELDING)
- CONTOUR COVERAGE
- POPULATION DENSITY
- ZIP CODE BOUNDARIES
- RECEIVED SIGNAL LEVEL
- SPECIAL REQUIREMENTS

1990 CENSUS

WHO ARE YOUR LISTENERS?

1990 BUREAU OF CENSUS POPULATION COUNTING

- Comprehensive Ethnic and Demographic Data
- Ethnic/Demographic Data Available for Each Zip Code Within Coverage Area
- Age Analysis Reflected in Ethnic Breakout
- Resolution Increased to Block Level
- Percent of County Coverage Shown

ETHNIC PIE-CHART DISPLAY

- Projects Ethnic Population in Multi-Color Pie Chart Form

dataworld®

800-368-5754 FAX: 301-656-5341

ELIMINATE PODIUM CLUTTER.

PB2X8 Pressbox/Microphone Distribution System MICROAMP SERIES



CALL OR WRITE FOR A FREE DETAILED BROCHURE.

ATI AUDIO TECHNOLOGIES INCORPORATED

Eliminate the usual press conference microphone clutter with just a single or a back-up pair of microphones.

Feed each of eight transformer isolated channels from either input or both Mic/Line inputs mixed.

Drive a high level XLR and a medium or low level TRS line simultaneously from each output.

Use as a 2X8 DA, stereo 1X4 DA or two input mixer.

Studio grade performance, field proven ruggedness.

328 Maple Ave., Horsham, PA 19044, USA

- Rack or desk mount
- Two low noise Mic/Line inputs
- Phantom power, low cut filter
- Loop thru expansion inputs
- Calibrated test oscillator
- Switchable bargraph VU meter
- XLR, 1/4" and 3.5mm TRS jacks
- Headphone output

(215) 443-0330 FAX: (215) 443-0394



Touch & Go.

ENCO's DAD486x Digital Audio Delivery System is the true cart machine replacement. With a touch screen, it really performs at your fingertips.

Designed to streamline and simplify the tasks of producing, recording and distributing audio, the DAD486x is the most user-friendly system you'll ever love to operate.

The DAD will do more than just improve your audio. It will improve your bottom line. Eliminate the expense of operating and maintaining traditional, endless-loop cartridge machines while providing power, versatility and

flexibility. And, get high quality audio.

DAD's advanced production and operating features are so intuitive and easy to understand that your system investment will begin to pay for itself as soon as it is installed.

This system was planned for use in the real world. DAD's graphic user interface emulates a standard analog audio cartridge machine's controls. Push PLAY and DAD plays the cut shown in the Playback "slot." The number of playlists you can store in DAD's memory is unlimited. And its powerful ARRAY feature puts 144 audio

events at your fingertips for instant playback.

In order to meet your specific needs, a DAD486x system can be configured to precisely match your budget and operational needs. And it's expandable. Start with a single channel DAD system. Add additional channels and workstations as your needs grow. Expand it to a multiple user, multiple channel system to allow simultaneous production, recording, and playback so you can operate at maximum efficiency.

Because the DAD system is designed for use on a standard 486 PC

platform, you can choose to purchase a complete system including hardware and software or select your own hardware platform and let ENCO provide the DAD486x software.

More than just a radio automation system, DAD can be found in use at WJBK-TV2, The Dallas Mavericks, and The Weather/Travel Channel.

Add the friendliest digital audio delivery system to your station. Simply touch & go... with DAD from Harris Allied.

1-800-622-0022

Fax 317-966-0623

HARRIS
ALLIED

Germans Listen to More Private Radio

by Michael Lawton

COLOGNE, Germany There is more than one revolution occurring in Germany. A new annual radio listener survey found that new local commercial stations in the nation show marked increases in their audience, while public stations continue a gentle downward trend.

But despite the arrival of more private radio stations over the last year, the ARD, the German federation of regional public radio authorities, can still boast that public stations are way ahead in audience figures. An average 39.05 million Germans listen to ARD stations every weekday, compared to the 21.33 million listening to private stations.

Both sides can take comfort in statistics that reveal 84.1 percent of the population "listened to the radio yesterday" and that the average period of listening is nearly three hours.

Media analysis '93

The figures come from Media Analysis '93, a national listening poll conducted just once a year in Germany, which creates great anticipation among those in the broadcast industry and its proponents.

Among them, of course, are advertisers measuring radio's usefulness as a medium. According to one report, advertising revenues increased by 20 percent in the first three months of this year alone. These figures help convince them their money was well spent.

The survey is designed to benefit stations that accept advertising, as most of the more popular public stations and the private stations here do. The non-commercial stations, mostly classical music and cultural formats, are left out of the findings, which makes little difference to the total, because most have small audiences.

The findings do not separate individual, local private stations, but include them

under the regional advertising distributors—the "Kombis"—through which they gain all but their local advertising.

So who is winning and who is losing? In percentage terms, the champion is a classical music station in Hamburg, Klassik Radio, which increased its audience by 100 percent after getting better frequencies and changing its program content.

Another small station, Berlin's Energy 103.4, raised its audience by 40 percent after cutting down its speech content drastically.

General agreement

The real value of the annual figures for many is what they say about listener trends, although generally accepted inter-

hour daytime" results show the private stations pulling away.

Public radio stations seem to be especially vulnerable when they meet with an effective private-station competitor, especially private stations aimed at youthful target audiences.

Radio NRW, for example, which offers music and information programming aimed at the 20-49 age group to local stations in the state of North Rhine Westphalia, can claim that its stations increased their audience by 8.6 percent to 850,000 listeners per average hour. Its nearest equivalent, public radio station WDR2, lost 6.1 percent with

WDR's marketing subsidiary WWF, however, said that the WDR2 figures give no cause for alarm. Last year, the

Advertising revenues increased by 20 percent in the first three years.

number of private local stations in the state increased by 60 percent, so their 8.6 percent increase in listenership is not much of an achievement.

Nationally, listeners seem to appreciate the local dimension offered by private stations, which the regionally organized public stations cannot offer.

High-quality programs

Holger Peterson of RMS, a national advertising distributor, said people choose local radio when it offers professional, high-quality programs. He said the gains of the past year are a reward for the stations' focus on improved professionalism.

But according to WDR, listeners are starting to move back from the private local radio station to the public regional station. More detailed regional audience research published at the same time as the national figures indicate that WDR stations are enjoying a slight renaissance in areas where local radio is well-established, WDR said.

All the same, local relevance seems to be important to German listeners. People in former East Germany once listened to Bavarian radio stations instead of local stations airing Communist propaganda. New stations—both local and regional—that reflect native interests are burgeoning. Private and public Bavarian stations have suffered somewhat.

As usual, Berlin seems to be an exception to the rest of the nation. Listenership has decreased substantially. One popular theory is that Berliners cannot keep up with the increasingly large number of stations in the city.

□ □ □

Michael Lawton, a free-lance journalist and broadcaster, covers the radio industry in Germany for RW.



Enthusiasm for commercial radio can be seen in the elaborate studios of OK Radio, as well as in the increased levels of listenership posted in Germany.

pretations are rare.

The "listeners yesterday" numbers suggest that public stations are maintaining their hold. The "listeners per average

650,000 listeners, even though its news service is considered superior, with the strength of the ARD correspondents behind it.

WDR4, the area's public station aimed at older listeners, does not suffer from private competition. It outdraws both Radio NRW and WDR2 with 1.3 million listeners, in spite of its six percent drop.

Ludger Lausberg, marketing director of

A Broadcast Industry
BEST BUY

Mono Play **\$920**
Stereo Play **\$1000**

F.O.B. Factory

Reliable / Rugged / Professional Design

- All Metal Housing with Cast Aluminum Front Panel
- Half Inch Thick Aluminum Deck with Stainless Steel Overlay
- Air-Damped Solenoid with Telfon™-Coated Plunger
- Direct-Drive Capstan Motor
- Three-Point Adjustable Head Mounts
- Output Transformers
- CMOS Logic
- Straightforward / Serviceable Design
- Compact Size (1/3 Rack Width)
- 30-Day Guarantee of Satisfaction / 1-Year Warranty



DL Series

AUDI-CORD CORPORATION

1845 West Hovey Avenue, Normal, Illinois 61761 USA
Phone 309-452-9461 - Fax 309-452-0893

Available Through Your Regular Distributor

TXL-110, TXL-210

Transmission Limiters

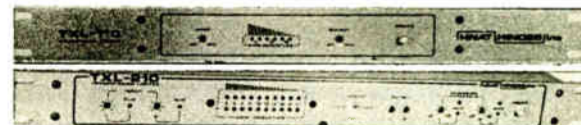

ENVIRONMENTALLY SAFE... NO EAR POLLUTION...
Just CLEAR, BIG DIMENSION SOUND.

Today's digital audio imposes a new requirement on broadcast transmission systems, particularly audio processors.

The TXL series Transmission Limiters are designed to preserve your program resource and deliver it intact to the transmission system, without the familiar processing residue that cost rating points.

The TXL series limiters are also safe to your FINANCIAL ENVIRONMENT... (No slick, multicolor full page ads to pay for).

CALL TODAY...For more on the TXL-110 & TXL-210 capabilities.

HNAT HINDES Inc

42 ELAINE ST., THOMPSON, CT 06277
203-935-9066 / 9242 FAX 203-935-9919

**OTARI'S NEW R-DAT:
PROFESSIONAL QUALITY WITHIN YOUR REACH.**



When you've had enough of unreliable "warmed-over" consumer decks, we've got a *professional* R-DAT for you at an affordable price.

Our new DTR-90 delivers the rock-solid reliability and superb sound that have made Otari audio machines the choice of professionals everywhere, and at the same time delivers all the performance and features you'll ever need.

For example, so you can make changes fast and easily, the DTR-90 is the only R-DAT available with individual record insert on Ch. 1, Ch. 2, and time-code channel. And its user-friendly front panel features an LCD screen that gives you powerful functions often relegated to DIP switches in other R-DATs—you can even detach the control section of the front panel and use it as a remote unit!

You'll also appreciate the optional Time-code Card with its chase synchronizer for tight lock with VTRs and ATRs, as well as features like read-after-write and punch-in, punch-out.

And if you need a complete electronic editing system, you can't do better than couple the DTR-90 with Otari's CB-149 editor for flawless digital editing.

For the complete story on this quality-built and affordable R-DAT, call Otari at (415) 341-5900.



Otari Corporation
378 Vintage Park Drive
Foster City, CA 94404
U.S.A.
(415) 341-5900
Fax: (415) 341-7200

Otari Corporation
U.S.A.
(415) 341-5900
Fax: (415) 341-7200

Otari Inc.
Japan
(0424) 81-8626
Fax: (0424) 81-8633

Otari
(UK) Ltd.
United Kingdom
(0753) 580777
Fax: (0753) 542600

Otari
Deutschland GmbH
Germany
02159/50861-3
Fax: 02159/1778

Otari Singapore
Pte., Ltd.
Singapore
(65) 743-7711
Fax: (65) 743-6430

STATION SKETCHES

Don't Neglect Your Personal Computer

by Tom Vernon

HARRISBURG, Pa. To the engineer trained on audio and RF circuits, the station's personal computer can be an intimidating black box. Nevertheless, the day will probably come when he or she is called on to fix one, or connect several together in a network.

You can learn your PCs at a

low-stress pace by adding them to your station's regular preventive maintenance schedule.

Dusting

The best place to begin is inside the main cabinet, where dust tends to accumulate. Air flow is restricted, increasing the chance of thermal intermittents or failures.

Remove the cover and give

the inside a good cleaning. A vacuum cleaner and crevice tool work, but a mini-vac is gentler and allows for easier access to tight spots. (If you don't have one, a mini-vac is a worthwhile and inexpensive addition to your tool kit.)

Pay particular attention to the area around the fan and power supply. Be careful not to loosen any boards or edge connectors,

and to return any cards that were removed to the correct slots.

Check the backup battery. This device keeps the system clock running on time and also powers the CMOS circuitry that maintains configuration information. They are usually lithium-type batteries with two-to-three-year life spans. If you decide to replace the battery,

have a printout of the configuration file in hand to save yourself from searching through manuals for the correct scheme.

Replace the cover and give the outside of the machine a thorough going over with a damp cloth and mild cleanser. This won't affect the computer's performance, but gives people the perception that your equipment is clean and orderly. By all means, give them that perception.

Hard and floppy drives

The most vital part of your computer system is the hard drive and the information it stores. You can replace any part of your system for much less time than it takes to restore or replace lost data from a faulty hard drive.

You can get a written report on your hard drive's health with the DOS CHKDSK command. It tells you the amount of memory used and free and lists the directories and files.

Be aware of any messages that tell of file allocation problems, damaged sectors or lost chains. If your drive has any of these problems, you must run CHKDSK again with the /F option. DOS will then attempt to repair the damage. Details on how to use CHKDSK are included in your DOS documentation.

The speed of a hard drive will gradually decrease as files that were once together are fragmented. Specialized software, such as Norton Utilities SD (Speed Disk), will restore files to their original configuration and greatly improve speed.

If you're not already doing so, institute a regular back up of hard-drive data to floppy disks. While this may be done with the DOS BACKUP command, more elegant and efficient programs are available from other manufacturers. You may also purchase an internal tape backup for either Macintosh or IBM compatibles for around \$200. These devices automatically back up a hard drive overnight, even if you're not around.

Like cart machines, computer disk drives have heads that get dirty and can impair proper operation. Floppy disk head cleaners are available in 5.25 and 3.5 inch formats, and should be part of the regular maintenance schedule.

Disk head cleaners contain a porous, mildly abrasive material which is usually moistened with special fluid. It can be cycled through the drive a few times by typing the DIR command. The cleaner will evaporate after a few minutes.

Monitors

Clean the screen of the monitor with a damp rag and glass cleaner. Always spray the cleaner on the rag, and never directly on the screen. Spraying the screen causes excess cleaner to

continued on page 37 ►

Be Quiet!



The original Shure FP32 set the standard in field production for portable stereo mixers. Now, with the new FP32A, you can count on getting even less. Noise, that is...30dB less! In fact, the FP32A is so quiet and improved that it's perfect for use with DAT and other digital recording media.

Professional Mixing You Can Take Anywhere.

The Shure FP32A is a 3-input, 2-output portable mixer specifically designed for:

- remote audio recording
- electronic field production
- electronic news gathering
- location film production

The FP32A weighs just 3.5 lbs and is only 2-1/4" H x 6-3/8" D x 7-1/4" W in size.

With 8 hours use from two 9V alkaline batteries — or powered by any 12 to 30 VDC source — the FP32A goes wherever you do. And since it's from Shure, you can count on its durability and ruggedness.



So Many Features In So Little Space.

You get all the features of the original FP32 plus:

- 48V phantom power
- pop-up pan pots
- input level LED indicators
- mix bus jack and cable
- headphone mode switch
- mixer/monitor switch
- adjustable peak output LEDs
- stereo link for inputs 2 and 3
- more than 30 other new features and improvements

So go to your nearest dealer and pick up an FP32A. Once you use it, you'll see why we're making so much noise about something so quiet.

For the Shure FP dealer nearest you, call 1-800-25-SHURE.

SHURE®

The Sound of The Professionals®...Worldwide.

Circle (116) On Reader Service Card

World Radio History



The **NEW** AudioVAULT 100™ digital audio storage system



AV-100 is a PC board used in conjunction with IBM-compatible computers to record, store and play back audio material such as commercials, tags, liners and jingles, or satellite programs. Each PC can accommodate up to four AV-100 boards, each capable of running independently. The AudioVAULT 100 digital audio storage system brings incredible capabilities to your station...at an incredible price.

Operating in Microsoft Windows — with a software platform adapted from the popular AudioVAULT 90™, which has been field-proven over the past two years in all size markets — AV-100 is a system that gives you easy command over your audio inventory, improved signal quality, lower maintenance costs and higher profits.

Consider these features:

▲ Select one of five sampling rates.

▲ Import/export capability for traffic and billing functions.

▲ Compression ratios from 1:1 (uncompressed) to 12:1, applied by cut.

▲ Stand-alone operation of satellite-delivered material with cross fade, ducking and real-time delay.

Introductory price starting at \$2,995!

Call Broadcast Electronics for the full story on the incredible AV-100.

Ask for Dave Buck or Ted Lantz.

DON'T SETTLE FOR LESS!



© Circle (124) On Reader Service Card
BROADCAST ELECTRONICS INC.
 4100 N. 24th St. P.O. Box 3606 Quincy, IL 62305-3606

**In a typical
broadcast day,
DigiCart/II
prepared and
played more
audio than its
predecessors
did in a week.**

DigiCart/II goes far beyond cart machines and reel-to-reel decks—and even most digital machines. It's a uniquely powerful digital audio recorder, with software tools that bring color and interest to your work. ■ In production, use DigiCart/II to make mistake-proof edits, precise fades, and seamless back-to-back cuts. ■ On-the-air, get instant access to music and effects loops, voice-overs, delayed news feeds, and QuickStack™ playlists. ■ DigiCart/II supports an eight hour hard drive, and three new high capacity cartridges—ideal for playing current inventory and moving audio between machines. ■ DigiCart/II is attractively priced and available now.

DigiCart/II

A MINI WORKSTATION. A CART MACHINE.
A WELL VERSED DIGITAL AUDIO RECORDER.

360 Systems

PROFESSIONAL DIGITAL AUDIO

Sometimes You Just Have To Fight 'THE BIG ONE'

Dear Luci,

Hope you don't mind if I take a serious slant this time. We just defused a potentially earth-shaking event.

Let me preface it by asking you: Would you put THE BIG ONE on the air?

You know, THE BIG ONE. The one word you save until the end of the argument. One-seventh of George Carlin's dirty word list. The one that nets you five Hail Marys in confession. The reason Eventide builds delay lines.

Of course you wouldn't. But what if you were paid to put it on the air?

One of those back-to-school clothing commercials came to me for production last month. Nestled in with Bill-A-Bong, Guess and other brands of jeans was a new one: Fuct.

Say it out loud. Again. Louder. How did you just feel?—perhaps the same as I did laying a cold read down on tape.

C'mon. They can't be serious. Does anybody really believe the clothing company came up with such a name for any reason other than to tick off parents or to legitimize use of that word:

"Hey, what kind of jeans should I get?"
"Get__!"

I've heard all the arguments to support airing this ad:

"After all, look at it. It's a 't,' not a 'k.' It's not the same thing."

How can you possibly air such a spot based on spelling? Audiences don't spell what they hear, they listen.

"But it's the client's message. We have no right to censor that minute he's paying for!"

Amazingly, this defense was once offered after I objected to a case of improper language in an agency dub. (I was overturned that time—the cash was too pretty.) Sure, it's his message, but it's our station. We are the ones who have to answer to the community, not the clothing store. We set the standards for our part of the dial.

"The customer is always right."

A food store chain in New England uses this as its slogan. If that store were to sell me a side of beef, do you think I'd be allowed to process it in aisle three? Nope, because they have standards.

"Two other stations in the market are airing the spot the way it is."

Ya-stinkin'-hoo. Billy-off-the-Brooklyn-Bridge time, so let's all jump. Maybe that's why we're beating them in the ratings.

"It's about time radio grew up. Newspapers and magazines use the word all the time."

Man, that's important to you, get out of radio now and get a job at one of those publications. Write whatever you want.

"How can you make such an arbitrary rule governing your commercials?"

Arbitrary? Does the weather guy say what a great @\$%ing day it's going to be? Does the sweeper/liner guy promo

the next \$%*&ing music sweep? Put it on the air just once and I'll meet you under "Positions Wanted" in Simone's back pages.

These are all sound, legitimate defenses in behalf of the client. I can't ignore that. It is his money and he has all these pants to sell and wants to do it on my station. Saying "no" to any business these days is hazardous.

We reached a compromise and it all worked out quite well. The client got his message, we kept our reputation intact and the awesome honor of being the first

FROM THE TRENCHES

by Alan Peterson



station to begin using THE BIG ONE legitimately (in spots or otherwise) must fall to someone else.

Would I put THE BIG ONE on the air for money? Let me just say I don't intend to be the first to do so. Free speech, censorship and commerce aside, I'll quote Bob Dylan and say, "It Ain't Me Babe." Let someone else

blaze the trail. I'll wait in my 501s. The other brand doesn't fit me.

—Al

□□□

Al Peterson is production director for WNNK-FM Harrisburg, Pa. He'd like your opinion on this subject. Call him at 717-238-1041 or by EMAIL on CompuServe 73122,312.

AN EXCLUSIVE EVENT.

There are moments in the course of a manufacturing Company's life that become historical milestones, not only for the Company itself, but for the whole industry. EXCLUSIVE FM, AEV's newest FM broadcasting processor, represents one of such milestones.

It's an event. A truly extraordinary event, setting a faster pace in the evolution of FM broadcasting.

To emphasize only some of EXCLUSIVE FM's features would be like diminishing it. AEV is pleased to invite Radio and TV Broadcasters the world over to contact its Dealers for detailed information, as well as to verify, in the course of a hands-on demonstration, the meaning of the word "extraordinary".

GOLDEN SERIES

Precious TOOLS

AEV ELECTRONIC BROADCAST EQUIPMENT

Phone 39 + 51 + 950249 / 950350 Fax 950201

KEYBOARD CONNECTION

Getting on the Cyber-Radio History Tour

by Barry Mishkind

TUCSON, Ariz. Some months ago, I demonstrated how infobases can be used to pull together data for quick indexing and searching of all sorts of information (RW, March 24).

Newsrooms, for example, can easily compile all of their news scripts for later retrieval. Salesmen can develop leads and client lists. Programming departments can save lists of callers, requests and data on music and artists. The uses are limited only by the imagination.

Now here's a twist for those interested in the early days of radio.

Historical bases

I have created an infobase—OLDRADIO—from the listing of stations on the air in 1928, when the Federal Radio Commission made a major reassignment of frequencies. The late 1920s was an interesting period following the original surge of license applications (many of which lasted as little as three months), and just before the Depression.

This first version lists all stations licensed as of November 11, 1928, their frequencies, power, ownership and frequency-sharing arrangements, where applicable. Fellow RW columnist George Riggins aided the project with information provided through the FidoNet BROADCAST echo (more on that later). I have traced many stations to their modern call letters and frequencies.

In some cases, a station can be traced to three, four or five former frequencies, or to three stations that were later combined into one. Some of this information was stunning.

Today we consider frequency allocations to be relatively stable. It wasn't always so. WTOP(AM) Washington, for example, was born in Brooklyn as WTRC (Twelfth assembly district Republican Club). It was sold to the publishers of the "Fellowship Forum," a Klux Klan publication, and moved to Virginia under the calls WTFF. The calls later changed to WJSV (after the station's manager J.S. Vance), and finally WTOP when the station was moved to Washington.

In the 1920s, C.L. Carrell had a "mobile license" to broadcast from sites in Illinois, Michigan, Indiana, Wisconsin and Ohio. The mobile part of the license eventually ran out and the station came to rest.

Another interesting "mover," KYW(AM), started in Chicago, and shut-

led to Philadelphia and Cleveland, eventually going back to Philadelphia to stay.

Reasons for starting stations varied widely. Sometimes stores used them to sell products. A Seattle bootlegger built stations to communicate with his fleet.

OLDRADIO has been produced using FOLIO VIEWS and askSam, two fine

To give you an idea of the range of topics, recent discussions included transmitter tuning, dealing with the FCC, the mechanics of network news production, historic radio call letters and broadcast history. A number of working engineers, from large markets to small, air personnel, network executives, manufacturers,

In some cases, a station can be traced to three, four or five former frequencies. Some of this information is stunning.

infobases. If you are interested in receiving a copy OLDRADIO version 1, contact me for details.

I am still adding information to the infobase, and corrections, additional information, and suggestions are always welcome. Further information on early broadcast history, biographies of broadcast stations and frequently asked questions about the industry are also available on request.

Broadcasting via computer

As I said, much of the OLDRADIO information was gathered by participants on the FidoNet BROADCAST echo. This is one of the international networks you can access from your computer modem. In fact, by dialing a local number, you can read and send messages to engineers all over the world.

Several networks are available for broadcasters. Some, like CompuServe, charge by the minute. Others (FidoNet, MediaNet BPCN and RIME) are run by hobbyists around the world and operate on donations.

I am currently the moderator on the FidoNet BROADCAST echo, which offers information-sharing of broadcast-related issues. Users can ask questions of fellow professionals or offer feedback to RW.

lawyers, and others all participate.

Ask your local BBS to pick up BROADCAST. Often one of the broadcasters on line can point you to a local participating BBS. If you can't find a local BBS carrying BROADCAST, try one of these from around the country:

National Supervisory Network, Avon, Colo., 303-949-3253; SPPE, St. Petersburg, Fla., 813-525-2326; Communications Specialties, New York, 212-645-8673; Coconino County, San Francisco, 415-861-8290; L.A. Valley College, Los Angeles, 818-985-7150; DFW Amateur Radio, Dallas, 214-226-1181.

Broadcasters BBS, Phoenix, 602-872-9148; The Lighthouse, Lansing, Mich., 517-321-0788; Terry's Place, Connecticut, 203-732-0575; Borderline!, North Carolina, 704-938-6207; Country Club, Toledo, Ohio, 419-843-5801; and Boardwalk, Federal, Wash., 206-941-3124.

Further information on FOLIO VIEWS is available at 1-800-54-FOLIO, and on askSam at 1-800-800-1997.

□ □ □

Barry Mishkind, can be reached on FidoNet at 1:300/11.3 or "barry@coyote.datalog.com" on Internet (on CompuServe use your CIS Mail to Internet service), or write 2033 S. Augusta Place, Tucson, Ariz. 85710.

Why Your AM Station Should Install The
LBA TUNIPOLE™
ANTENNA SYSTEM



BETTER THAN SERIES FED IN EVERY WAY!

PERFORMANCE

- Super bandwidth and efficiency - even at low frequencies.
- Improved impedance match - reduces tuning unit loss and complexity.
- Identical radiation pattern to series fed.
- Power capacity to 1,000,000 watts.

ECONOMY

- Up to 3 AM frequencies on one tower - without multicouplers.
- Reduces tower height and ground system requirements.
- Mount FM, TV, or communications antennas - without isocouplers or stubs.
- No base insulators or lighting transformers.
- Fast installation - one day typical.

LIGHTNING PROTECTION

- Direct tower ground - diverts lightning strokes to protect transmitters, tuning units, and other antennas.
- Lightning dissipators available for even greater protection.

RELIABILITY

- Hundreds of LBA systems in use since 1963 - the world leader in folded unipole technology.
- Heavy duty components give stable, long life operation from the tropics to the arctic.
- Unequaled support with 30 years of worldwide RF experience.
- One year warranty on parts and workmanship.

OPTIONS AVAILABLE

- Enhance operation with PowerTopper™ top loading systems and BaseMax™ base efficiency systems. Full line of tuning units and RF components available.

For More Information About the World's Best AM Antenna System, Contact us at:
919-757-0279
919-752-9155 FAX
 or our representatives worldwide



LBA TECHNOLOGY, INC.
 Broadcast & Communications Antenna Products
 P.O. Box 8026 Greenville, NC 27835 USA

Additional LBA Group services include Engineering Consulting Services in all aspects of Radio, TV, Microwave, Cable TV, Cellular Telephone, System Design and Equipment Procurement.

An LBA Group Company ©1993

THE SIMPLE SOLUTION FOR DIGITAL AUDIO TRANSPORTATION

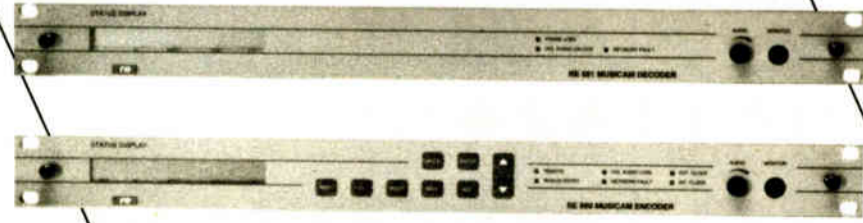

- ▲ MUSICAM ISO/MPEG Layer 2, 2A
- ▲ Switched 56, 64 kbit/s, ISDN, Fractional T-1
- ▲ User data channel from 300-9600 baud
- ▲ Easiest set-up locks to network or internal clock
- ▲ Fully automatic decoder reduces operator set up

- ▲ Multiplex or redundant two times 56/64 for 112/128 kbit/s
- ▲ Mono, Dual Mono, Stereo, Joint Stereo operation
- ▲ AES/EBU and SPDIF digital interface *included*
- ▲ Two-times V.35, X.21 or RS 422 interface *included*
- ▲ Headphone monitor *included*

The RE 660/661 MUSICAM Digital Audio Codec was developed to enhance MUSICAM technology, providing up to 20 kHz of audio bandwidth. From satellite networks to switched 56 telephone lines, the full-featured RE 660/661 is completely bit rate flexible up to 384 kbit/s. Applications range from network program distribution to remote pick-ups for sports, concerts, special events, news gathering, STL back-up, audio backhaul, recording and post production studios. When it comes to digital audio transportation, nothing comes close to the RE 660/661 for providing quality audio with hassle free set up. Backed by 55 years of experience in analog and digital audio products, the RE 660/661 is the simple MUSICAM solution for all your digital audio transmission needs.

Available through Harris Allied and Broadcasters General Store



RE AMERICA, INC.
 31029 Center Ridge Rd. ▲ Westlake, Ohio 44145
 Phone: (216) 871-7617 ▲ Fax: (216) 871-4303

Circle (167) On Reader Service Card

Circle (35) On Reader Service Card

OFFBEAT RADIO

AM Kept Flooded Midwest Informed

By Dee McVicker

QUINCY, Ill. Along one section of the swollen Mississippi River, there's a radio station that people know they can count, on come hell and high water.

When high waters hit during the worst flood of the century, WGEM(AM) Quincy, Ill., became a vital conduit of information for nearby listeners in Illinois, Missouri and Iowa.

"We were like a giant two-way radio," said WGEM-AM-FM-TV's director of operations, Leo Henning, who opened the station's phone lines and frequency to listeners during continuous, live coverage of the disaster.

For over a month, the station was heard along the flood zone—from Burlington, Iowa, to Hannibal, Mo.—marshalling evacuations one moment and calling for help to find someone's lost family pet the next. The station became the central exchange for "everything from requests for sandbags to requests for volunteers, brownies and suntan lotion," Henning said.

The decision

The phone never quit ringing with reports in the field from listeners, some on cellular phones. "We used no relay. We used no producer. We used no call screening. It went straight to air," Henning said. "That was a real dicey

move on our part, but it went surprisingly well."

In the first 21 days of the month-long coverage, WGEM had taken over 35,000 phone calls, including a call from President Clinton from Air Force One. The President, on his way to St.

"We were like a giant two-way radio."

—Leo Henning
WGEM-AM-FM-TV

Louis to address the governors of the flooded states, took the time to tell WGEM: "Your station has done such a wonderful job coordinating things. I really respect that."

The decision to abandon regular talk/news programming for around-the-clock flood information was made on the morning of July 1, when Henning went down to the basement to get a shirt from the dryer. He found himself standing in a pool of river water.

"I ran down to the station and said, 'Guys, this is '73 all over again. Get

ready, because when that six inches of rain fall hits that river, it's going to rise like a rocket.'"

Henning's words proved prophetic. The Mississippi rose to eventually break through 10 of the 13 surrounding levees. The damage far surpassed the historic 1973 flood.

From high on a bluff in Quincy, WGEM began its "Floodwatch '93" vigil with the help of co-owned WGEM-FM and WGEM-TV. The decision to go with the AM instead of the FM for fulltime coverage was based on the area's large concentration of elderly listeners, who would know

to tune to the AM dial.

As the rains poured with no relief in sight, WGEM-FM switched to fulltime automated programming and shifted personnel to help with the continuous AM coverage. Help also arrived from the area's two major broadcast equipment manufacturers, Harris Allied and Broadcast Electronics.

"Because of Harris and BE, WGEM is one of the most technically advanced radio stations in the country," said Henning, whose stations are equipment testing sites for both manufacturers.

Both the AM and FM use Broadcast Electronics automation and Harris transmitters, and received on-the-spot technical support from both manufacturers. "We were able to devote our energies to providing information on the air

continued on page 37 ▶

**Dalet runs the system
you run the show**

Dalet gives broadcasters the freedom to get creative

- Satellite automation, cartridge replacement, non destructive audio editing
- Inexpensive unlimited storage using standard PC networks
- True multitasking under **WINDOWS**
- Real time recording of mixes makes music automation sound **better than live!**

Find out why leading radio stations around the world have chosen Dalet. Call our US distributor:

RF Specialties Group

WASHINGTON	(206) 546-6546
CALIFORNIA	(805) 682-9429
MISSOURI	(816) 635-5959
TEXAS	(806) 372-4518
	(214) 771-4235
PENNSYLVANIA	(412) 733-1994
	(215) 322-2410
FLORIDA	(904) 678-8943

dalet

Going For The Gold

Affordable Recordable CD

The Marantz CDR600 Compact Disc Recorder is a complete standalone CD recording and playback system featuring stop/start recording, state of the art A/D and D/A converters, digital I/O, and full CD compatibility.

Because the CDR600 can create and read a temporary table of contents, recording can be stopped and then resumed at a later time.

All of the necessary hardware and software fits into three rack spaces, so no external computer is required.

The Marantz CDR600, now with a new reduced price, represents a breakthrough in price and performance for compact disc recording. Go for the gold. Call Harris Allied.

8:00 a.m. to 8:00 p.m. EST
1-800-622-0022
Fax 317-966-0623

HARRIS ALLIED

COLE'S LAW

Old Commission Business Will Get Older

by Harry Cole

WASHINGTON As summer 1993 closed, the commission was focusing on several pieces of old business, so here are some timely updates.

First, all you AMers who let the commission know of your interest in "migrating" to the expanded portion of the AM band can take heart. The FCC has issued a list of everybody who filed such an "expression of interest."

Unfortunately, that's all it issued. Basically, it is a list of responding stations, ordered alphabetically by state, and then alphabetically by city of license within each state. The primary, if not sole, purpose of the list is to let you know whether or not the FCC is aware of your application.

The real nitty gritty won't happen for several months. The next step will be to run that list through a complex computer program designed to "calculate the allotment plan" for the expanded band. Notwithstanding the miracles of modern computer technology, that program is expected to "run for several months" before achieving "a complete solution."

(Apparently the allotment program involves "optimization routines" that "continually change a station's allotted frequency," thus requiring all frequencies to be allotted before any results are announced.)

Once the computer arrives at the "complete solution," there will be a public notice and individual notifications to each applicant. The lucky ones will then get to file for specific frequencies (FCC Form 301).

AMers anxiously awaiting the phone call (or the visit from Ed McMahon) advising

them that they are the lucky ones, should not hold their breath. We're still easily months away even from the first real cut, and that estimate takes the commission's own estimate at face value, without including such pesky roadblocks as petitions for reconsideration of the selection process, petitions to deny individual applications and appeals of any or all of the above.

Modulation matters

A coincidental illustration of the kinds of bureaucratic delays possible in the expanded-band proceeding, is the August 1993 Notice of Inquiry on how to define "overmodulation" and how best to implement any

proposed limits on modulation levels. (The mere fact that a notice is out should not be interpreted as a sign of imminent resolution. To the contrary, the comment/reply period won't close until the end of this year (unless it gets extend-

able engineering session at the spring 1991 National Association of Broadcasters convention.)

The commission attempted to sidestep the modulation question in 1991 by telling everybody that it was on the front burner and that an inquiry (or possibly even a rule making) was in the works and likely to be issued shortly. That inquiry now begins some 30 months later. So much for front-burner treatment.

The modulation inquiry offers few insights into the commission's thinking on the modulation issue. It does suggest some consideration of eliminating specific limits on modulation. Those limits would be replaced by a new emission limitation or standard designed to prevent harmful adjacent-channel interference.

As for "instrumentation," the FCC acknowledges that "the equipment needed to determine compliance with emission limitations may be more expensive than that used to make traditional modulation measurements," even though the commission reiterates its long-held position that it does not intend to type-approve monitoring equipment or to specify what type of equipment licensees must use.

To the extent that the notice at least gets

the ball rolling, it is probably a good thing. Any of you who have any thoughts at all on the issues of modulation and modulation measurement should respond.

Fine time

Finally, for those of you who occasionally worry about what happens if you don't keep your nose clean, the commission has clarified and updated its system for issuing fines and forfeitures, which was adopted about two years ago. The system was revised slightly last month, reducing the base fines for some violations, but leaving most at 1991 levels.

Perhaps the most interesting aspect of the new version is the list of fine "adjustment criteria." Once a violation has been established, the commission first looks to the list to determine the base fine for a particular violation. That base fine can then be adjusted up or down. Historically, the standards for adjustment have been, shall we say, fuzzy. Not anymore.

At last the commission will provide reasons for adjustments. Upward-adjustment criteria include: egregious misconduct (50-90 percent); ability to pay versus relative disincentive (50-90 percent); intentional violation (50-90 percent); substantial harm (40-70 percent); prior violations of same or other requirements (40-70 percent); substantial economic gain (20-50 percent), and repeated or continuous violation (varies).

Downward-adjustment criteria include: minor violation (50-90 percent); good-faith or voluntary disclosure (30-90 percent); history of overall compliance (20-50 percent), and inability to pay (varies).

Of course, these are all pretty broadbrush categories leaving the commission a lot of room to fudge. But we should probably be thankful that it provides at least some guidance.

If you have any questions about any of these matters, or would like to chip your two cents worth into the modulation proceeding, contact your communications counsel.

□□□

Harry Cole is a partner in the Washington-based law firm of Bechtel & Cole, Chartered. He can be reached at 202-833-4190.

AMers anxiously awaiting the phone call advising them that they are the lucky expanded-band winners should not hold their breath.

proposed limits on modulation levels.

Comments in that proceeding are due November 5, and replies are due December 15. The dates are emphasized here for a reason.

Faithful readers with long memories may recall early 1991, when there was a flap at the commission over proper techniques for measuring overmodulation. The FCC responded with a cryptic public notice acknowledging the existence of a controversy. The notice seemed to address part of the issue, but wimped out before answering all questions.

(FCC representatives were repeatedly asked for straight answers, and repeatedly declined to provide any during a memo-



You can measure... with the best monitor and the most accurate test set.

The FMM-2/FMS-2 series monitors provide an even greater degree of precision measurement than ever before... **You can measure S/N below 90 dB, You can measure crosstalk below 85 dB, You can measure separations of better than 70 dB, You can measure frequency response to better than 0.25 dB, You can measure distortions to lower than 0.01%, and much more...** Our uncluttered panels and autoranging voltmeters make these measurements a dream.

BELAR ELECTRONICS LABORATORY, INC. (215)687-5550
LANCASTER AVENUE AT DORSET, DEVON, PENNSYLVANIA 19333
Call or write for more information on Belar AM, FM, Stereo, SCA and TV monitors.

Circle (85) On Reader Service Card

ARE YOU LOOKING FOR A COST EFFECTIVE ALTERNATIVE TO MANUFACTURER SERVICE?

IN CASE OF EMERGENCY

We can help get you back on the air with our STL Loaner Program. We have STL's available that will be set to your frequency prior to shipping.

We also provide over-the-phone technical assistance.

SERVICE, REPAIR & CALIBRATION

› STL's › RPU's › TSL's › Exciters
› AM/FM Broadcast Monitors
› Remote Control Systems

SPECIALIZING IN EQUIPMENT BY

› Belar › Marti › Moseley
› McMartin › TFT › And others...

An authorized TFT service center

SQUARED TECHNICAL SERVICE
2198 Hubbard Lane
Grants Pass, OR 97527
(503) 471-2262

Circle (44) On Reader Service Card

High-Quality, Full-Duplex Digital Audio...

 **CYLINK**

- *Full-Duplex Audio*
- *Highest Quality Sound*
- *No Licensing Required*
- *Alternative Or Back-up STL*
- *Quality Remotes From ANY Location*

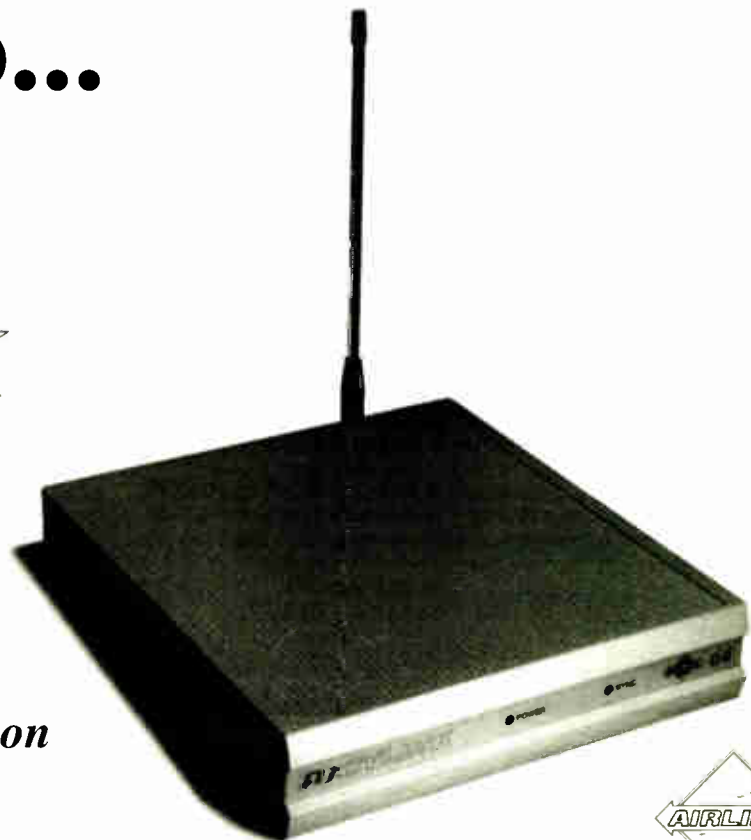

...Anywhere You Want It!

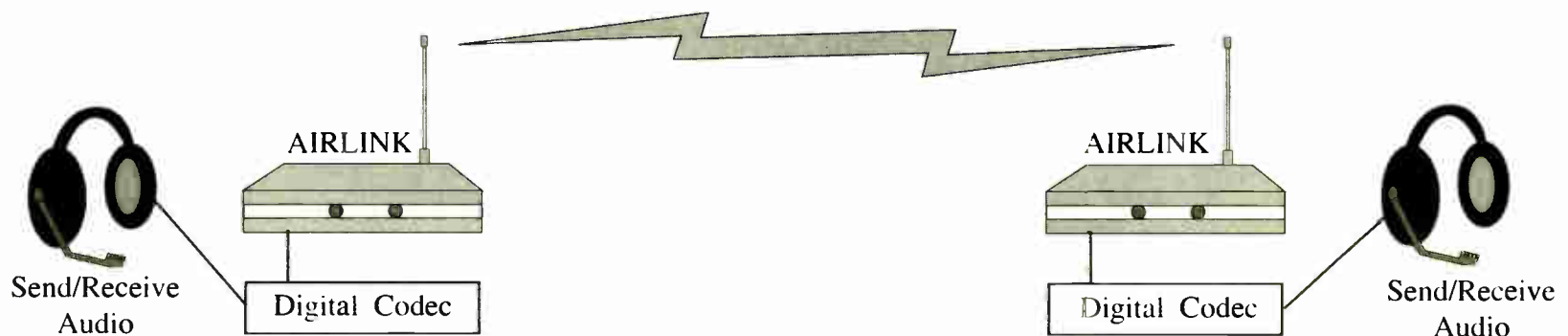

Used in conjunction with digital audio codecs, the AirLink digital wireless modems from Cylink can convey your audio signal from 10 to 30 miles in full duplex without sound degradation. AirLinks can be installed in minutes, with no carrier intervention or licensing requirements, since they operate in an FCC-designated spread spectrum frequency band (902 - 928 MHz). AirLink provides a high quality, interference-free, remote audio link for areas where RPU frequencies, STL frequencies and phone lines are difficult to obtain. Call BSW for more information.

Call Toll Free 800-426-8434 or Fax 800-231-7055

Equipment Solutions To Keep You Number One

BSW[®]

BROADCAST SUPPLY WORLDWIDE

7012 27th Street West Tacoma, Washington 98466

Circle (152) On Reader Service Card

World Radio History



Come to grips with audio production that makes sense.

Now's the time to get your hands on SoundLink — the first Random Access Digital Audio Multi-Track system with all the critical functions you need at a price you can live with.

An all-in-one system, SoundLink provides hard disk recording, mixing, non-destructive editing, signal processing and MIDI recording in one comprehensive and affordable package.

If you want a whole new feeling about digital audio production, please call Korg Professional Audio at 800-645-3188 Ext: 280. In NY, call 516-333-9100.



**See Us At
AES Demo Room 1E05**

SoundLink
KORG
PROFESSIONAL AUDIO

©1993 Korg U.S.A.

Circle (210) On Reader Service Card

World Radio History

Studio Sessions

AES Preview
Coverage,
see page 27.

Equipment and Applications for Radio Production and Recording

USER REPORT

SADiE Impresses Canadian Producer

by Edward Marshall

TORONTO My job as a recording engineer at the Canadian Broadcasting Corporation's new Broadcast Centre in Toronto means I am exposed daily to all the wonderful new digital equipment from companies such as Sony, Sonic Solutions, Neve/AMS and so on.

Because I also am the operator of a busy free-lance company, Marshall Arts Productions, I am faced with a dilemma. After being spoiled rotten at my "day job," what equipment can I purchase for my own production work that will satisfy my high-tech habit and still fit into my "home studio" size budget?

I discovered a relatively new digital workstation and am pleased to report after a few months of continuous use, that it completely answers my needs. The system

right half of the panel are two 1/4-inch phone jacks for LTC In and Out, a BNC connector for Video Sync and three 5-pin DIN connectors to accommodate MIDI In, Thru and Out.

Operating SADiE

But enough about nuts and bolts. If most of you are in any way like the recording engineers I know, computers are something to be tolerated only in an attempt to create music and sounds and programming. In contrast, the SADiE has proven to be extremely helpful, quick and friendly.

Always displayed on the bottom half of the screen are two windows: showing the basic "transport" controls on the right and "level" sliders and meters on the left.

Three different windows are used in the operation. The most prominent is the PLAYLIST window that gives a very simple but clear display of

your project as it is being assembled. The EDIT window in which recorded clips are further refined, and the TRIM window, which is used to finely adjust edit points.

To start work, simply connect your DAT machine to the Digital AES ports (or your analog source to the XLR inputs). SADiE uses the well known system of pull-down menus along the top of the screen. Simply choose the menu from which you

source from the want to record.

Windows convenience

Again, using the pull-down menu labeled SETUP, we find the function called RECORD SETUP. Bingo! Up comes a box that asks questions such as mono or stereo, what would you like to title this recording, and it lets you know how much time is left on the hard drive.

(I'm using a Fujitsu 1GB drive that provides 3 hours, 24 minutes of track time or 1 hour, 42 minutes of stereo storage space.)

Next, just click on the RECORD button on the transport control panel, monitor your source coming in, and, at the appropriate spot, click on the FORWARD arrow and SADiE is recording. The STOP button stops recording, and by returning to the record setup box, you are ready for the next recording.

After you have recorded your material into SADiE, you can carry out other familiar tasks, such as "topping and tailing," by simply using the EDIT window and selecting the clip you want to work on. As in ancient days when you would rock the tape back and forth against the tape heads, you now rock the displayed waveform back and forth.

the mouse or trackball—just place it at the top of the screen in the PLAYLIST window. Each clip is displayed like a piece of tape but in alternating colors and with its title displayed.

Easy order changes

Changed your mind about the order of clips? Easy to fix. Just click on the clip

continued on page 35 ▶



The SADiE system is a low-cost, IBM-platform audio editor with a user-friendly edit display.

also would fit nicely in radio production suites. It is called SADiE, Studio Audio and Video Ltd. of Cambridge, England, and has just arrived in North America.

The hardware

Contrary to recent trends, the SADiE Disk Editor is based on an IBM platform (486 processor and at least 4MB RAM required along with a suitable size and speed SCSI hard drive for storage of audio data) and MS DOS and Windows software. Either a mouse or trackball can be used in the operation of SADiE and a standard VGA adaptor and monitor display the unusually user friendly and colorful graphics.

To this readily available computer equipment, SADiE adds an X-S card that takes care of the DSP functions, an X-ACT card that provides the digital/analog conversions and timecode interfacing, and a breakout panel.

The breakout panel gives the first indication of SADiE's capabilities. From left to right, there is a single female XLR next to two male XLR connectors labeled as Digital AES In and AES Out 1 and 2. Next, there are analog connections (also on 3-pin XLR) for Input 1 and 2 and Outputs 1, 2, 3 and 4. On the

DIGITAL EVOLUTION

Technology evolves. The market develops.
DIC Digital excels.



As one of the original suppliers of DAT tape to the professional, DIC Digital recognized industry demands. As a result, we were the first DAT supplier to offer a truly professional DAT cassette.

Once again DIC Digital is leading the way by introducing recordable CD's. Our discs are fully compatible and bear the "compact disc" logo. DIC Digital's CD-R's are readily available in 18, 63 and 74 minute lengths. Call today for the name of your nearest DIC Digital dealer.

THE ULTIMATE IN SOUND

DIC DIGITAL™

Glen Pointe Centre West
500 Frank W. Burr Blvd., Teaneck, NJ 07666
Phone: 201-692-7700 Fax: 201-692-7757
Circle (126) On Reader Service Card

Why not get everything professional

Digital Audio Workstations have to offer?

Create your best part out of 10 recordings and use it in five different places... record 100 takes in the same place, on the same track... synchronize sound FX to a picture in less than a second... erase a word and bring it back a week later... and do all this on a machine that gives you instant access with incredible editing speeds, the sound quality you want, and the reliability you can count on, project after project.

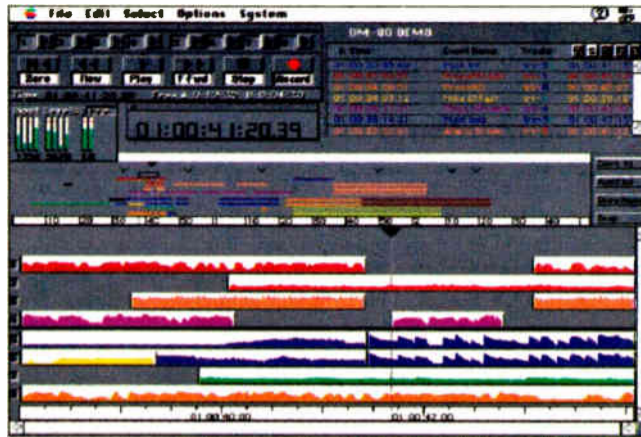

Optional DM-80-5 Multitrack Manager control for the Macintosh®— easy to learn, fast to use.

the Word.

Problem is, many DAWs just can't give you all of these things.

Here's why:

Problem: Some systems use a single computer for graphic user interface *and* for audio information processing. This slows the whole system down, and makes you wait.

The Answer: A workstation that separates the hardware "engine" from the user interface computer. This way, audio information processing is not slowed down by the user interface, and the interface computer operates without the load of additional tasks. And you save time and money.

Problem: A system crash in the middle of a complicated project could cost you as much in time lost as some of the less professional DAWs are worth. You should expect reliability you can count on from your DAW, and get it.

The Answer: First, call around. Check the reputation of DAWs. We have DM-80s working every day all over the world in high volume production environments. Our customers will tell you they're reliable.

Problem: Some systems don't give you a user interface that's familiar and easy-to-use.

The Answer: Buy a DAW that lets you choose either a dedicated hardware remote that gives you familiar tape recorder controls, or computer software control that is simple to understand and easy to operate.

Problem: Some DAWs are the weakest link in the audio chain. The DAW you buy should deliver sonics as good or better than any piece of audio equipment you own.

The Answer: Choose a DAW from a company that knows professional audio, not just a company that knows computers. But most of all, ask audio professionals who own one.



We believe you'll find all these answers and more in the Roland DM-80 Digital Audio Workstation. Call us at (213) 685-5141, ext. 337, or FAX (213) 722-0911 for a brochure. Or better yet, schedule a demo. You're going to like what you hear.

"The thing is just impossible to screw up! The DM-80's non-destructive editing is the only way to go—revisions are extremely easy, and very quick."

— DAVID ESCH
DIRECTOR OF COMMERCIAL PRODUCTION
WPNT CHICAGO



"Edits fast, sounds great, and doesn't break. The DM-80's multilayering capabilities and simultaneous recording on all tracks gives us the flexibility to do whatever we want."

— JOEL VALENTINE
PRESIDENT
21ST CENTURY SOUND DESIGN, HOLLYWOOD
("NORTHERN EXPOSURE")

the Word on the street.

"The first DM-80 paid for itself in two months, so we bought a second one... I like the editing ease—no waiting. It's my 'word processor' for audio."

— MICHAEL STANTON
COMPOSER/ARRANGER
AUDIO PRODUCTIONS, INC., NASHVILLE



"The DM-80 is our secret weapon! It's a very enabling technology."

— MAZ & KILGORE
GRAMMY NOMINATED PRODUCERS
NEW YORK

"What goes in... comes out! And the sound is wonderful. Easy editing, plus easy sync to video lets me concentrate on the creative aspects of the production."

— RICHARD FREITAS
EMMY AWARD NOMINATED AUDIO PRODUCER
THE DOVETAIL GROUP, CONNECTICUT

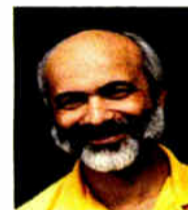

"Operational speed and ease of editing make the DM-80 the greatest thing since sliced bread! We use it for all our production."

— VINCENT FUMO
SENIOR EDITOR
INDEPENDENCE BLUE CROSS, PHILADELPHIA

"The DM-80's power and speed allow me to complete a half-hour television documentary every week. As an investment, the DM-80 has proven to be a very smart choice."

— JIM HEFFERNAN
EMMY AWARD WINNING SOUND DESIGNER/PRODUCER
VIDEOSMITH, INC., PHILADELPHIA
("1ST FLIGHTS WITH NEIL ARMSTRONG")



PRODUCT EVALUATION

Neumann Targets Radio for TLM 193

by Ty Ford

BALTIMORE Through the late 1980s and early 1990s, adverse changes in the exchange rate between the German Mark and the U.S. Dollar pushed the price of Neumann's U87, U89 and TLM170 studio mics into the \$2000-plus range—a range beyond the budget boundaries of many U.S. broadcasters and studios.

The vacuum that was created was quickly filled by studio condenser mics that hovered around \$1000 (Audio Technica, Gefell, AKG). It became obvious that Neumann needed a contender with similar features and performance in

the same price range.

The company introduced that contender at the 1993 NAB spring show: the transformerless TLM 193. The \$1,295 list price includes the mic, a swivel mount and a wooden jeweler's case. A custom suspension mount also is in the works. For this article, Neumann USA provided me with a pre-production sample of the TLM 193 that was so new it was minus one of the three layers of capsule screen.

So the first question you're probably asking is, "For about a thousand dollars less than a U87, what is the TLM 193 missing?" Certainly not sound quality (more about the specs and sound in a

minute), but there are a few deletions that allowed Neumann to keep the price down.

Solid cardioid design

The TLM 193 is a large diaphragm, double-membrane cardioid condenser microphone. Unlike the U87, TLM 170 and U89, which are multi-pattern mics, the TLM 193 is cardioid only. If you don't need or rarely use a mic with a

about 3 dB hotter. It also had a slightly smaller sweet spot than the U87. The TLM 193 exhibited more proximity effect and presence than the U87 when worked at a distance of 3-5 inches. However, at a distance of six inches the U87 produced a slightly greater bass response. At a distance of one foot, it was almost impossible to distinguish which mic was which. The TLM 193 is less peaky in its response than the U87, and its response extends further to both the low and high-frequencies.

The noise comparisons provided an interesting challenge. Although the TLM 193 obviously was quieter through the

With the TLM 193, Neumann has achieved excellence at a competitive price. Expect the mic to catch on quickly in both the project studio and production studio markets.

number of different patterns, you don't have to pay for patterns you don't need.

As another cost-saving feature, Neumann left out the 10 dB mic pad. If your mic preamps don't require padding, or if they have active gain stages that allow you to vary the gain of the mic without changing the impedance that the mic "sees," you'll be fine. However, if your mic inputs use less-expensive resistive pads that increase the impedance that the mic "sees" when it's connected to the console, be forewarned that this can degrade the quality of the signal a mic like the TLM 193 has to offer.

Finally, the TLM 193 has no bass roll-off. If you've got a poorly insulated studio that's next to a railroad yard, you'll have to roll off the bottom with some sort of equalization.

But don't get the idea that this "austerity program" has negatively affected the quality and performance of the TLM 193—it hasn't. The TLM 193 is a very quiet, great sounding mic in the time-honored tradition of the Neumann.

According to Neumann's Jeff Alexander, the TLM 193 is smaller than the U87, but of similar proportions. It uses the same capsule as the U89i and TLM 170 and has electronics similar to the transformerless FET 100 circuitry of the KM 100. The size, however, is reduced due to the use of hybrid electronics.

The TLM 193 requires 48V phantom powering. If your present console doesn't provide phantom power, you can get a separate power supply from Neumann or other suppliers.

Our tests were conducted at four different studios in the Washington area, using the same male voice (mine) as the audio source. We swapped mic cords and preamps whenever noise was heard to insure that the noise was not coming from other bad preamps or cables.

Because the TLM 170 and the TLM 193 share the same capsule, they sounded quite similar. The sweet spot of the TLM 193 was a bit larger, primarily due to the fatter body of the TLM 170 that gets in the way as you move higher. Their output levels were nearly identical. The TLM 193 had a wider cardioid pattern and was slightly hotter around 5 kHz.

When compared to a U87 (not the U87Ai), the TLM 193 proved to be

monitors, the level meters on the AMS AudioFile that we were monitoring contradicted what we were hearing. It showed that the TLM 193 was 4-5 dB noisier than the U87.

Bass-sensitive

After close scrutiny, it was apparent that the noise from the TLM 193 was low frequency room resonance, or from the passage of truck traffic half a block away, but not from the mic itself.

In another studio, the Gefell M71 (single-pattern cardioid) was perhaps a dB hotter than the TLM 193, but it was also noisier. While noise in both mics was very low, cranking up the monitors allowed us to determine that what noise we could hear from the Gefell was mostly low frequency (120-180 Hz).

The TLM 193's noise was more mid- and high-frequency in content. This seemed to contradict the experience we had with the TLM 193 in the previous studio, where the TLM 193 exhibited no mid- or high-frequency noise to speak of. The cardioid pattern of the Gefell was noticeably larger on the Gefell than on the TLM 193.

When comparing the TLM 193 with an AKG C-414 EB, both mics provided almost identical output level. The 414 had a tighter pattern than the TLM 193, and the 414 provided a slight bump in the lower frequency bass and was slightly brighter than the TLM 193 in the 6-8 kHz range—a comparison similar to that which I've observed between the U87 and the 414.

In conclusion

With the TLM 193, Neumann has achieved excellence at a competitive price. I expect the mic to catch on quickly in both the project studio and production studio markets.

If you've had trouble integrating high-output condenser mics into your system, check out the sidebar in the next *Studio Sessions* for some helpful tips.

□ □ □

For more information on the Neumann TLM 193, call Jeff Alexander at Neumann, (203) 434-5220, or circle Reader Service 151.

Ty Ford's new book, "Advanced Audio Production Techniques," was recently published. For more information, call 800-366-2665.

THE PROFESSIONAL'S CHOICE



Featured:

K7 proPHILE
High Performance Power Amplifier

Internationally renowned manufacturers
and distributors of professional amplifiers
and speaker systems



Australian Monitor

AUSTRALIAN MONITOR U.S.A.
TEL:215-380-1394
FAX:215-380-1358

AUSTRALIAN MONITOR
TEL:416-693-0300
FAX:416-691-7193

AUSTRALIAN MONITOR
FAR EAST
TEL:65-742-9131
FAX:65-742-8103

AUSTRALIAN MONITOR
LATIN AMERICA
TEL:55-21-866-7922
FAX:55-21-286-1445

AUSTRALIAN MONITOR
EURO
TEL:49-7248-4446
FAX:49-7248-4447

53 College Street
Gladesville NSW 2111

AUSTRALIAN MONITOR
PTY LTD
AUSTRALIA

TEL:61-2-816-3544
FAX:61-2-817-4303

Circle (42) On Reader Service Card

SIGNAL-TO-NOISE

Producer Embraces Multichannel Sound

by Frank Beacham

NEW YORK It's refreshing, in this smoke and mirrors audio world, to discover that rare practitioner of the recording arts who breaks away from the conventional path to pursue a unique vision of his own. Such a person is Brad S. Miller, a man with a lot to say about surround sound and how it can be made better than it is today.

Miller heads Mobile Fidelity Productions of Nevada, a production company specializing in the recording of multichannel digital soundfields. If you suspect the company has a connection with Mobile Fidelity Sound Lab, the audiophile record label, you are right. Miller founded the label, sold it and today licenses the name back to the company.

Four-channel recording

In an earlier column we noted that it was Miller, in 1984, who commissioned the building of a very high quality digital recording system known as Colossus. Now being offered as a commercial product, Colossus is a 16-bit PCM digital audio processor that allows the recording of four discrete audio channels on a professional NTSC video recorder.

Invented by Lou Dorren, father of the four-channel FM radio broadcast standard, Colossus has been used to make over 100 compact discs ranging from live music and sound effects to archival A-D conversions and multitrack mix downs.

Miller uses Colossus to create an eclectic series of meticulously-recorded sound vignettes featuring trains, storms, gunfire, car chases, gentle surf with gulls and the like. Don't, however, confuse these recordings with traditional sound effects. "They are designed for home entertainment," Miller says. "These are little sound vignettes without picture. A whole scene usually unfolds as you listen."

Though currently released on compact disc in two-channel stereo, each of these sonic stories was recorded in the discrete

four-channel Colossus format with a phase coherent "soundfield" microphone that replicates the 360-degree symmetry of the original acoustical space. The idea is that the microphone and the human ear/brain functions become interchangeable and mirror each other with regard to the perception and localization of sound.

As dazzling as these recordings are on a stereo CD, Miller notes that none of today's home formats can deliver the full impact of the original four channel masters. And, don't even suggest to Miller that his recordings be released in any of today's matrixed surround formats.

"I come from the quadraphonic era," Miller says proudly. "I've always thought it was nonsense to combine discrete multitracks into two channels and then try to get them back. It doesn't work....never has worked. This is the reason motion picture directors do not permit real surround soundfields.

"Many in Hollywood who process sound forget how sensitive our ears are and how easy it is to confuse them," he continues. "The more they try to downplay the surround channels as a necessary evil, the worse it gets."

Pure quadraphonic

A key to Miller's thinking on sound can be found in what is NOT done in the recording process. That philosophy is summed up in an ad for Colossus: "No signal processing, matrix encoding, DSP manipulations, phase steering schemes, fakery, quackery, or psychoacoustical babble has been employed."

Soundfields that are recorded correctly, Miller says, do not favor a "best seat" inhibitor. When listening to a discrete four channel system, one can wander about the soundfield on foot, or turn the chair or head in any direction, at any time.

Rejecting today's stereo surround schemes as "simply special effects," Miller is a staunch proponent of a four-channel compact disc format. He plans to

re-release all of his discrete four-channel recordings when such a format is a reality. "The protocol has been written for a four-channel CD format," he says. "It's contained in the red book standard."

However, a limitation of the four channel CD format—one that is a key to holding up its deployment—is a lack of adequate program capacity. A four-channel CD will hold only about 30 minutes of program material, as opposed to the hour-plus capacity of a stereo CD. This could soon change, Miller notes, with the development of new lasers that will allow doubling of the CD packing density.

For fixed installations, however, it is not difficult to install discrete four-channel playback systems today. The minimum requirements for properly listening to pre-recorded soundfields, Miller says, are four discrete I/O reproduction channels, equal power to all channels, identical or similar loudspeakers and a subwoofer with each speaker. The digital multitrack ADAT and Tascam DA-88 machines offer reasonably-priced playback capability for such installations, according to Miller.

(Brad Miller can be reached at 702-831-4459. His CDs are distributed by Bainbridge Entertainment Co., P.O. Box 8248, Van Nuys, CA 01409-8248.)

□ □ □

Frank Beacham is a writer, director, producer and consultant. His address is 163 Amsterdam Ave. #361, New York, NY 10023.

CD AUTOMATION WITH DIGILINK ONLY \$9,490*

- Play over 2000 songs on 144* CD's (option up to 1100 CD's)
- Music Scheduling system standard
- 10 hours of stereo hard disk storage (20 hours mono)
- 4 standard switcher external inputs (11 optionally avail.)
- Schedule up to one week in advance
- Simultaneously play a Commercial and record a Spot

No matter how you add it up, it quickly becomes obvious why Digilink is #1 in digital audio for Radio. Features, price, and customer satisfaction have made Digilink the choice of broadcasters from Russia to Japan to your own back yard. Whether for live on air, satellite-CD- tape automation, or multitrack production, Digilink fills your needs now and in the future. For practise, price your system on the form below and then write, call, or FAX Arrakis for more information.

VOICE (303) 224-2248 , FAX (303) 493-1076

ARRAKIS

DIGILINK ORDER FORM

Name- _____

Call letters- _____

Address- _____

Telephone- _____

10 hour system, stereo (20 hours mono).....\$7,995

CD Controller (for up to 8 Pioneer 18 disk players)..\$1,495
(the CD players must be supplied locally-\$3,500)

Options-

16 hour system, stereo (32 hours mono).....\$9,995

Add 7 more switcher inputs (Total 11).....\$444

2nd switcher w 7 inputs for timed recording.....\$295

Network Board plus software.....\$495
(for 2 or more Digilinks or a scheduling computer)

Video Doubler.....\$1,395
(control a Digilink from two places- up to 100')

Add a Second Studio-

Add a Production studio to your Air studio.....\$8,490
(2nd 10 hours system w Network Card)

Trak*Star 8 Track Editing Software.....\$1,995
(add an 8 track editor for ultimate production)

Total List Price- \$ _____

1993 Arrakis Systems inc. 2619 Midpoint Drive, Fort Collins, CO. 80525

Clark Listens...

Clark listens to its customers and designs its complete line of audio/video cable accordingly. Now you can listen to Clark's new 700 Series snakes that are designed, as usual, with the customer in mind.

Why not give Clark a listen?



Cables available cut to length and terminated to your specs.

CLARK WIRE & CABLE

1-800-CABLE-IT!

1801 Holste Road • Northbrook, IL 60062

Listen to Clark!

Circle (191) On Reader Service Card

Circle (203) On Reader Service Card

AES PRODUCT GUIDE

The following is a sample of products planned for display at the 1993 AES Convention. Due to the large number of companies exhibiting, all products could not be listed. For future Product Guide submissions send to: Radio World, c/o Studio Sessions Editor, 5827 Columbia Pike, Suite 310, Falls Church, Va. 22041



Valley Model 730 Digital Dynamics Processor

The Model 730 is Valley's new digital processor that combines compression, expansion/gating, high frequency compression/limiting, digital level control, and peak limiting all in one unit.

Parameters added to the traditional threshold, attack, release, ratio and gain controls include setpoint, slope, range, pre-delay, delay hold, mix, and stereo spread. Other features include 99 user programmable storage registers and multiple analog/digital I/Os.

For more information, contact Valley Audio at 800-800-4345, or circle **Reader Service 183**.



Neumann Strategy 2002 Studio Mixing System

The Neumann Strategy 2002 is a new studio mixing desk system that features separate digitally controlled operation and separate sound signal processing sections.

The 2002 features include motor driven fader, static or snapshot automation or dynamic automation, graphic control, optional multitrack switching option, and channel slide-in modules.

For more information, contact Jeff Alexander at Neumann at 203-434-3148, or circle **Reader Service 39**.

Alesis ADAT Eight-track Recorder

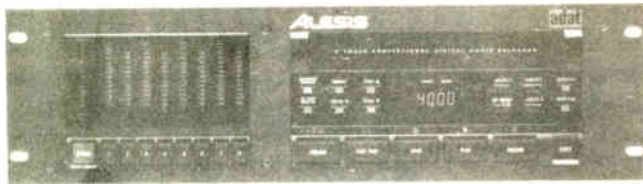

Now aimed at broadcasters and radio production studios, the Alesis ADAT is a low-cost, S-VHS-based digital audio recorder providing eight audio tracks.

The unit will record 40 minutes of linear digital audio on the eight tracks at a 48 kHz sampling rate, or multiple ADATS can be slaved (up to 16) for a total of 128 tracks. Other features include the optional BRS controller, and multichannel optional digital interface.

For more information, contact Gary Lynn at Alesis, 800-5-ALESIS, or circle **Reader Service 72**.

Sony PCM-E7700 DATStation



Expected to ship at the end of the year, Sony's new PCM-E7700 is a dual DAT editor.

The unit features non-destructive editing, real-time digital jog, automatic-assemble editing from EDL and digital cross fades.

For more information, contact Sony Professional at 800-635-SONY, or circle **Reader Service 127**.

TRUE BLUE FOR THE VIEWS.



Talk radio pros expect the unexpected, but there's one thing they can always depend on—the reliability of true blue.

audiopak
BROADCAST CARTRIDGES

P.O. Box 3100 • Winchester, VA 22601
Tel: (800) 522-CART or (703) 667-8125
Fax: (703) 667-6379

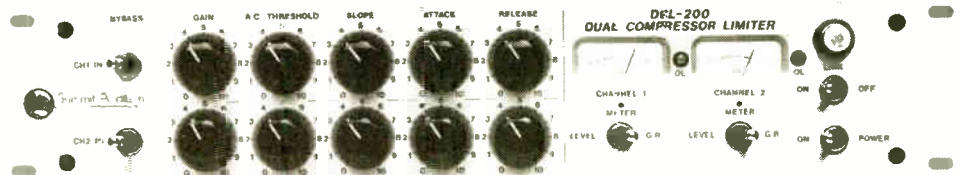

Summit Audio Model DCL-200 Tube-Type Compressor/Limiter

The Summit Audio DCL-200 dual compressor/limiter is a hybrid design tube/transistor unit said to offer the "tube" sonics with solid state reliability.

Designed for broadcast and recording studio facilities, the unit includes variable attack/release times, "soft knee" transition, output gain control, and balanced/unbalanced inputs and outputs.

For more information, contact Summit Audio at 408-395-2448; or circle **Reader Service 170**.



Mackie MicroSeries 1202 12-Channel Audio Mixer

The economical MicroSeries 1202 mixer features the same performance of the reputable Mackie CR-1604, but in a more compact configuration.

The features list includes four mic inputs, 48V phantom power, balanced/unbalanced mono and stereo inputs, two AUX sends per channel, and 12-LED peak meter display.

For more information, contact Mackie at 800-258-6883, or circle **Reader Service 155**.

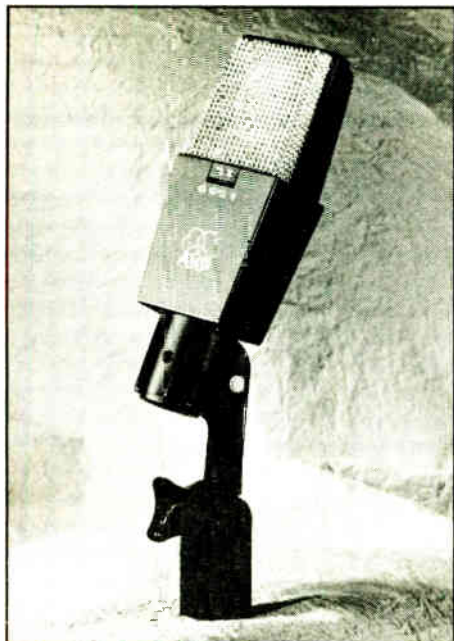

AKG Vintage TL Microphone

To be unveiled at AES, AKG has based its Vintage TL microphone on the electronics of the C414, but with the sound and look of the classic C12 tube mic, according to the company.

The Vintage TL is a 1-inch dual diaphragm pressure gradient microphone that offers four polar patterns: cardioid, hypercardioid, omnidirectional and figure eight. Other features include 12dB/octave bass cut and switchable pre-attenuation pad.

For more information, contact Joey Wolpert at AKG, 510-351-3500, or circle **Reader Service 81**.

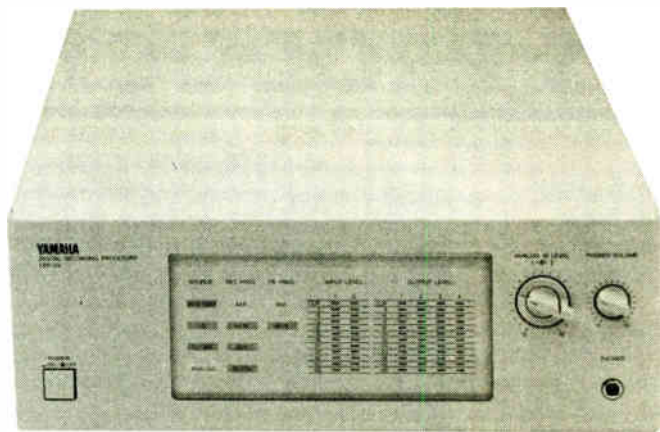

Yamaha Digital CBX-D5 Digital Recording Processor

The Yamaha CBX-D5 is designed to handle the processor functions of multitrack recording, leaving the com-

puter for computing and storage.

Utilizing a four-track system with two simultaneous recording and four-track CD quality playback, the CBX-D5 can be used with low-cost computers such as the Macintosh Classic II, SE 30, Atari ST, and any Windows 3.1 compatible computer.

Used with a 100MB hard drive, the systems can record 10 minutes of stereo audio. With more hard drive space, the time increases. Other features include on-board DSP and EQ.

For more information, contact Yamaha of America at 714-522-9011, or circle **Reader Service 196**.



Rane SM82 Line Level Stereo Mixer

The Rane SM82 stereo mixer is designed to expand existing consoles by eight stereo inputs without having to purchase another console.

Features include stereo balance controls, stereo AUX send and RETURN, and 98 dB signal-to-noise ratio.

For more information, contact Ellen Allhands at Rane, 206-355-6000, or circle **Reader Service 86**.

Denon DTR-80P Portable DAT Recorder

The Denon DTR-80P is a portable DAT that allows analog input sources to be recorded at the same sampling frequency as a CD (44.1 kHz).

Other features include SCMS, 18-bit D/A conversion, 3.5-hour record time/4-hour playback and optional DE-50 one-point stereo microphone.

For more information, contact Mike Stelts at Denon, 201-575-7810, or circle **Reader Service 212**.



Lexicon Model 2400 Time Compressor/Expander

The Lexicon Model 2400 is well-suited for the commercial production facility. The unit enables users to make program material fit into fixed time constraints, such as sound effects.

For more information, contact Jon Durant at Lexicon, 617-736-0300, or circle **Reader Service 55**.

continued on page 26 ▶

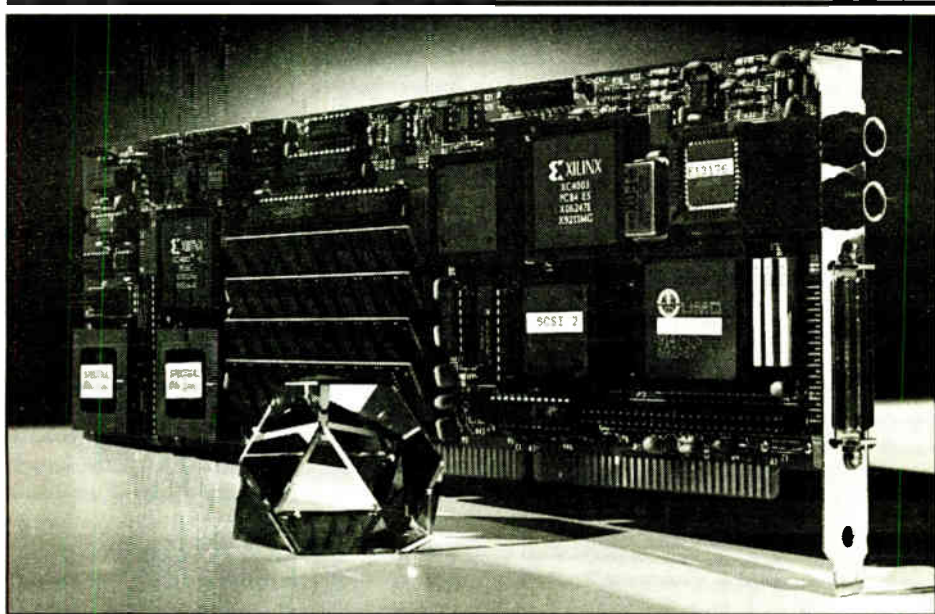

Spectral Synthesis PRISMA

The PRISMA is a low-cost random access, multichannel digital audio workstation card that works with any ISA bus-compatible computer. The PRISMATICA also is available for Windows users.

The PRISMA records, mixes and plays twelve simultaneous digital audio segments on 64 virtual tracks. It also includes multi-band parametric EQ on active channels and can connect to a variety of external products via AES/EBU, S/PDIF or SPECTRAL Multi-I/O protocols.

For more information, contact Spectral Synthesis at 206-487-2931, or circle **Reader Service 30**.

Fostex RD-8 Multitrack Recorder

Fostex will show its low-cost, new RD-8 (eight-track) multitrack recorder, based on the S-VHS tape Alesis ADAT platform.

The RD-8's modular design and internal synch enable the user to build sample-accurate 16, 24 or larger number of tracks by "stacking" more RD-8 units. Also, the RD-8 features a built-in time code reader and generator.

For more information, contact David Orin at Fostex, 310-921-1112 or circle **Reader Service 13**.

All CD, All the Time.

Marantz has put recordable CD technology and blank CDs within reach of your budget. End the confusion and

clutter of endless carts, cassettes and the occasional record by transfer to CD. Gain the advantage of rapid random access and unparalleled digital audio performance for everything you put on the air.

Today most music goes on air from CD; why not consider transferring your IDs, commercials, and sweepers to CD as well. You can also create custom CDs from music libraries, and your sales staff will love to present new spots

to clients on CD.

marantz®
The affordable recordable



Marantz Professional Products • 1000 Corporate Blvd., Aurora, IL 60504
phone: 708.820.4800, fax: 708.820.8103

Who's running the ship?

Unattended operation is one way to keep your station profitable, but you still have to mind the store.

The acclaimed Burk Technology ARC-16 Remote Control System is the first step. You can control transmitter and studio from any phone.

But wait. There's more!



Introducing AutoPilot™ from Burk Technology.

AutoPilot is break-through computer software that makes automatic operation of your studio/transmitter facility a dream come true.

- Automatic power changes
- Automatic pattern changes
- Automatic site changes
- Automatic power trim
- Automatic fault recovery
- Automatic logging

Now your imagination is the only limit.

The new FCC fine schedule is imposing. Why risk a big penalty when AutoPilot can help you stay within the rules?

Call us at 508-433-8877
or toll free at
1-800 255-8090
for more information
and a FREE DEMO.

BURK

TECHNOLOGY

Circle (63) On Reader Service Card

AES PRODUCT GUIDE

▶ continued from page 25



Sennheiser MKH80 Condenser Microphone

The MKH80 is a multi-pattern condenser microphone, designed to meet the rigors of digital recording.

As part of the transformerless MKH line, the unit's radio frequency tuned circuit contributes to the mic's high immunity to humidity and low inherent noise (10dB-A), (20dB-CCIR). The capsule measures 26mm x 176mm.

For more information, contact Joe Ciaudelli at Sennheiser, 203-434-9190, or circle Reader Service 26.

Apogee Professional DAT

Apogee has teamed up with KAO Corp. of Japan and developed a DAT tape engineered to last up to 30 years, according to the company.

Every aspect of the tape has been designed to rugged specifications including the shell, which has been awarded 15 patents.

For more information, contact Angie Orduno at Apogee, 310-915-1000, or circle Reader Service 201.



Akai DR4d Hard Disk Recorder

Although intended as an inexpensive (\$2,000) studio, hard-disk based digital recorder, broadcaster studio professionals have expressed interest in the Akai DR4d.

The unit is a four-in, four out recorder with 18-bit, 64x oversampling A/D and 18-bit, 8x oversampling D/A. A total of seven SCSI hard drives can be used with the DR4d.

For more information, contact James Martin at Akai, 817-336-5114, or circle Reader Service 117.



CCS PACE MUSICAM Editor

Designed for newsrooms and radio studios, the CCS PACE editor provides easy use for technical and non-technical users.

Features include four MUSICAM decoders, four analog inputs, two MUSICAM encoders, two four-channel mixers, analog outputs and monitors speakers.

The PACE editor connects to an out-

board equipment via an internal digital routing switcher, allowing, for example, the recording of two separate events while editing a third at the same time.

For more information, contact David Lin at 908-946-3800, or circle Reader Service 56.

STUDIO SERVICES

427 SOUND EFFECTS
\$89.00

For a 5-CD set with a 30-day money-back guarantee.

Take an extra \$10 off if you mention this ad!

Send \$79 to Ghostwriters
2412 Unity Ave. N., Dept. RW
Minneapolis, MN 55422

For credit card orders call
(612) 522-6256



and the all new
Rodeo Trails

These two programs bring your listeners the latest news, interviews and feature stories from the world of professional rodeo. Plus, complete coverage of the National Finals Rodeo this December. Call today to get more information.

(503) 276-8233

Available on barter basis.

ATTENTION:

ALL MAJOR RADIO NETWORKS

OR ANY PARTY INTERESTED!!!

KU BAND UPLINK FROM LAS VEGAS
DIGITAL MUSICAM 20 KHZ AUDIO
702-649-9126

THE JERRY L. HECKERMAN
LAS VEGAS TELEPORT

Doing Business without Advertising is Like Winking in the Dark...You Know What You're Doing, But Nobody Else Does

ATTENTION PROVIDERS!

Promote your services to **Radio World's** 22,000+ readers. Reach Radio Station and Recording Studio owners/managers and engineers with your message. For information on affordable advertising call **Simone** at **1-800-336-3045**.

AT&T DISQ Digital Mixer Core

The AT&T DISQ Digital Mixer Core is a digital mixing option for the Solid State Logic E and G Series consoles.

The AT&T system connects to the Neve VR or SSL Series G. The boards knobs, faders and switchers then become encoders that generate signals to control the digital processing.

For more information, contact David Arneke at AT&T, 919-279-7680, or circle Reader Service 100.

Australian Monitor Opal 2802 Amplifier

From "down under," the Australian Monitor Opal 2802 is a professional amplifier capable of supplying up to 280 watts per channel.

The amp features buffered 21 position front panel-stepped attenuators, balanced XLR and barrier strip inputs, binding post outputs, bridge switching, and HP-1/LP-1 filter cards and limiter cards. Specifications include: .005 percent or less harmonic distortion and 100dB signal-to-noise ratio.

For more information, contact Australian Monitor USA at 215-380-1394; Australian Monitor Canada, 416-693-0300; or circle Reader Service 27.

AES CONVENTION

PREVIEW

AES To Showcase Production Gear

by John Gatski

NEW YORK The 1993 Audio Engineering Society (AES) show will showcase new audio technologies with an emphasis on multimedia equipment and techniques.

The convention will be held October 7-10 at the Jacob Javits Convention Center, providing more room for the exhibits and meetings. More than 200 companies will show new equipment that can enhance radio production suites and independent recording studios. (See Product Guide for a sampling of new and established products to be shown at AES).

Besides the multimedia sessions, which will focus on audio for High Definition Television (HDTV) and multichannel sound and other applications, diverse topics such as digital music, DSP, and perceptual encoding should be of interest to audio professionals.

Besides the multimedia sessions, diverse topics such as digital music, DSP, and perceptual encoding should be of interest to audio professionals.

The following are *some* of the highlighted sessions (a full schedule will be available on the AES show floor).

The Digital Music session, 9 a.m., Thursday, Oct. 7; includes presentations on: a multiple digital signal processor-based music synth, new interfaces for interactive control of real-time signal processing, a time-domain format corrected pitch-shifting algorithm and the new Synthkit algorithm designed by Korg.

The Test, Measurement and Specifications session, 9 a.m., Thursday, Oct. 7; will include presentations on common specifications for digital audio interface jitter, and a BBC study outlining transparency testing using a new test signal.

The DSP: Theory and Applications sessions (Parts I, II, III) begin at 1:30 p.m., Thursday, Oct. 7. Subjects will focus on several related topics including one-bit processing, error spectrum shaping, effects of DAC nonlinearity on noise-shaped signals, a single chip stereo audio codec for PC multimedia applications, dither in the production studio, and DAW DSP development.

A session of particular interest to RW readers will be the Perceptual Coding sessions. Part I is 2:00 p.m., Friday, Oct. 8, and Part II is 1:00 p.m., Sunday, Oct.

10. Subjects will include attack processing to optimize temporal characteristics of low bit-rate audio coding, reports on MUSICAM and ISO/MPEG I and II, variable data rate recording on a PC using MPEG Layer III, lossless audio data compression for real-time applications, real-time PC-based implementation of Dolby AC-2 compression, and a report on Dolby's AC-3 multichannel encoder.

The Microphones and Loudspeakers sessions, Parts I and II, are scheduled for 9 a.m. and 1:30 p.m., Saturday, Oct. 9. Subjects to be addressed include adaptive beam steering microphones, peakless diaphragm, and control of listening room resonances.

Besides the technical papers, audio workshops and seminars will be presented. The list includes computer control of sound systems, professional practices

and job strategies in the 1990s and beyond, audio and multimedia, auralization, the art of audio mixing, perceptual encoding demonstrations, and grounding, shielding and interconnections in analog/digital audio.

Several tours of area radio, TV and production facilities are scheduled as well. Facilities will include WQEW(AM)-WQXR-FM, Rodgers and Hammerstein Archives of Recorded Sound, the Vinyl Record Plant (DMM LPs) and Clinton Recording Studios.

For more information about the 1993 AES show, call 212-661-8528.

Strategy 2002

Innovation and Ergonometry

- Flexible assignment of operating groups to audio channels and individual configuration of control elements per channel.
- Multifunctional output meter with simultaneous display of two inline levels and one dynamic function.
- Unlimited dynamic and static automation of all functions. Ultraconvenient scene management.
- Practice-proven optimum number of rotary controls and displays per channel for direct access to live mix.
- Audio signal processing independent of fully digital control desk.
- Easy editing of settings and configurations via controllable screen graphics if required.
- Ergonomically functional and attractive design.

Strategy 2002:
Signposting the future
in every way.

Georg Neumann GmbH Berlin

Charlottenstr. 3 • D-10969 Berlin • Tel.: 0049-30/2 59 93-0 • Fax: -108

Circle (128) On Reader Service Card

World Radio History

The following are the booth numbers/demonstration rooms of the companies exhibiting at the 1993 AES Convention.

COMPANY	BOOTH #	COMPANY	BOOTH #	COMPANY	BOOTH #
AB International Electronics	341	Audiotechniques/Tube Tech	632	Desper Products Inc.	500
Ace Label Systems Inc.	459	Augan Instruments BV	350	DGS Pro Audio	1240
Acme	1217	Aurasound	871	Dialog4 System Engineering GMBH	356
ACO Pacific Inc.	1125	Australian Monitor Pty. Ltd.	1127	DIC Digital	338
Acoustical Supply International	1235	Automatic Inspection Devices Inc.	1251	Digidesign	650
Adamson Systems Engineering	966	Avalon Design	971	Digital Audio Labs	1070
AGM Digital	769	Avid Technology	1045	Digital Designs	1216
Akai/IMC	736	AVR-Audio Video Research Inc.	344	Digital Expressions Inc.	455
AKG Acoustics, Inc.	318	B.B.C. Speakers Spa Italy	567	Digitech	236
Albrecht GMBH Studiogerate	500	Bag End Loudspeakers	1051	DOD Electronics Inc.	236
Alesis Corp.	444	BASF Corporation	400	Dolby Laboratories Inc	414
Allen & Heath	234	BEC Technologies Inc.	1218	Doremi Labs Inc.	1060
Alpha Audio Acoustics/Acoustical	645	Belden Wire and Cable	855	Dorough Electronics	1028
AMEK/TAC U.S. Operation	332	beyerdynamic	519	Drawmer Distribution Ltd.	156
AMI Publishing	1206	BGW Systems Inc.	232	Dan Dugan Sound Design	853
Ampex Recording Media Corp.	512	BNK Electronis Inc.	1400	Dynaudioacoustics	1156
Analog Devices Inc.	166	Brainstorm Electronics Inc.	500	E & E'lectronix/	
Apex Machine Company	445	BSS, A Division of AKG	318	Anthony Demaria Labs	561
Aphex Systems	138	CAD	333	E-MU Systems Inc.	458
API Audio Products	518	Cadac Electronics Ltd.	466	Eastern Acoustic Works Inc.	319
Apogee Electronics	1015	Carver Corporation	137	Emerald Technology Inc.	1246
Apogee Sound Inc.	1044	CCS Audio Products	1160	Ensoniq/EMagic	1056
Apollo Masters Corporation	722	Circuit Research Labs Inc.	1214	Entertainment Digital Network	870
Applied Research & Technology	1219	Circuits Maximus Co. (CMCI)	707	ETA Lighting	563
APRS	768	Clark Wire & Cable Co. Inc.	1128	Euphonix	1138
Arch-Rep Associates	1167	Cliff Electronic Components Inc.	873	Eventide Inc.	701
Ariel Corporation	461	CM Automation	660	Fairlight/DSG	371
ARX	1157	Community Prof. Sound Systems	418	Ferrofluidics Corporation	1055
AT&T (Demo—3D05)		Concept Design Electronics Mfg	135	F.I.L.P. SPA	957
Athan Corporation	134	Connectronics Corporation	339	First Light Technology Inc	460
Audex	1052	Cooper Sound Systems	853	Fostex Corp. of America	235
Audio Accessories Inc.	1248	Countryman Associates Inc.	1033	(Demo—1E01)	
Audio Exchange International Inc.	1156	Creation Technologies Inc.	838	Frazier	348
Audio Logic	236	Crest Audio Inc.	614	Full Sail Center	
Audio Precision	326	Crown International	741	for the Recording Arts	848
Audio Processing Technology	661	(Demo—2D02)		Furman Sound Inc	756
Audio Teknology Inc. (ATI)	707	Crystal Semiconductor Corp.	737	Futters Ltd. (Deltron)	1240
Audio-Technica U.S. Inc.	600	CSIRO Div. of Radiophysics	172	G Prime Limited	571
Audio/Digital	263	CST Manufacturing & Sales	1169	Gefen Systems	750
AudioControl Industrial	473	Cubicon Corporation	666	Genelec Oy (Demo—1E03)	
		Cyberlogic Inc.	366	General Music Corporation	1259
		D & R Electronics USA Inc.	559	Geppo International Inc.	1224
		D-Cart	760	G.M.L. Inc.	503
		Dateq-QMI	154	Gold Line/Loft	337
		DB Magazine/Sagamore Publ.	368	Gotham AG	1240
		DBX-A Division of AKG	318	Great Valley Products Inc.	
		DDrum Inc.	972	(Demo—2D03)	
		Demeter Amplification	1250	Group One Ltd.	958
		Denon America Inc.	944	Hafler Professional	569
				Harmonia Mundi Acustica GMBH	604
				Harrison GLW Inc.	118
				Heino Ilsemann GMBH	346
				Hewlett-Packard Co.	1262
				HHB Communications Ltd.	271
				Home & Studio Recording	1159
				Hush Systems (Demo—2D04)	
				Image Communications	1154
				Innovative Electronic Designs	1228
				Intersonics Inc.	754
				Intertec Publishing	451
				IRT Institut Fur Runfunktechnik GMBH (Demo—2D06&7)	
				JBL Professional	244
				Jeanius Electronics	354
				JL Cooper Electronics	501
				The John Hardy Company	1155
				Josephson Engineering	1150
				JRF Magnetic Sciences	134
				JVC Professional Products Co.	160
				KABA	940
				Klipsch Professional	647
				Korg USA (Demo—1E05)	
				KRK Monitoring Systems (Demo—2D05)	
				Kurzweil/Young Chang America	608
				KW Control Systems Inc.	367
				Leonardo Systems Inc./DBA Adams-Smith	1059
				Lester Laboratories	938
				Lexicon Inc	144
				Live Sound	1256
				Lone Wolf Inc.	1038
				Mackie Designs	1266
				Mag-Zon Inc.	372
				Malcolm Toft Associates Ltd.	1258
				Manley Laboratories	1208
				Marantz Professional Products	1151
				Mark IV Pro Audio Group	452
				Mark of the Unicorn Inc.	463
				Marshall Electronics Inc.	1118
				Martin Audio Ltd./Martin America	851
				Media Technologies Ltd.	700
				Mercenary Audio	1255
				Metro Magnetics USA Inc.	1166
				Meyer Sound Laboratories Inc. (Demo—3D03)	
				Michael Stevens & Partners Ltd.	1254

continued on page 30 ▶

Products & Services Showcase

For more information on the products shown below, circle the appropriate Reader Service No.(s) on the enclosed Subscription/Reader Service card or contact the advertiser directly.



The CELLCAST RBS-400 1.8 offers complete portability and flexibility for remotes. Complete with a 4-channel mixer, frequency extender, cellular transceiver and landline capabilities, 600 ohm line out, and Vu meter. It is powered by 10 Ni-Cad rechargeable batteries, 12v adaptor, and AC power supply. 24 hour product support standard.

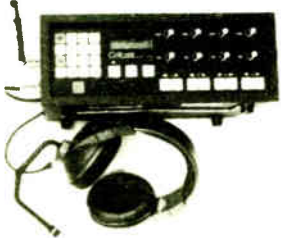

Call Bridget Taylor today for our \$195.00 2 week trial at

1-800-852-1333

READER SERVICE NO. 28

NEW FROM TITUS TECH LABS

THE SIMPLE TRUTH



COMPOSITE AUDIO MONITOR

Very Fast—Wideband—Precision
Baseband FM Stereo Level Measurements

- Accurately measures audio limiting and composite clipping levels
- Pilot and SCA injection levels
- Balanced, bridging, floating inputs
- scope, freq counter, peak hold outputs

AND MUCH MORE... CALL FOR DETAILS



77 Kreiger Lane Glastonbury, CT 06033
(203) 633-5472

READER SERVICE NO. 140

Call for your FREE copy of the new



Focal Press

Electronic Media Catalog

Get the Best Possible Audio

Advanced Audio Production Techniques

Ty Ford

Especially written for folks without an engineering background who want to learn how to listen, how to connect equipment, and how to use it to achieve the best sound. By using visual language, charts and graphs, the book offers a multi-dimensional approach to get across the practical concepts that are the basis of good audio.

1993 • 160pp • 240-80082-6 • \$24.95

Call Focal Press: 1-800-366-2665 8:30-4:30 ET
or write: Electronic Media Catalog
80 Montvale Ave. Stoneham, MA 02180

READER SERVICE NO. 97

Full function RDS for only \$1750



When you're ready for RDS, Modulation Sciences is ready for you. You already know us as the world's largest supplier of subcarrier equipment for radio and TV, with more Sidekick® SCA generators in use worldwide than all other brands combined.

Now we've made it easy and affordable for you to enjoy *all* the

benefits of broadcasting an RDS signal. Our RDS generator plugs right into your PC. And our included software gives you access to the entire CENELEC or U.S. RDS or RBDS Standard feature set.

So why buy an RDS coder offering only part of the RDS standard when, for even less money, you can have the whole thing?

Modulation Sciences is a worldwide supplier of ModMinder® FM modulation monitors, StereoMaxx™ spatial image enlargers, composite audio processors and distribution amplifiers, Sidekick® subcarrier generators and receivers for FM and TV, Wired STL™ line drivers & receivers, TV stereo generators, SAP and PRO channel generators, and the remarkable new PROceiver™

For details on the RDS-1 System or any MSI product, contact your MSI dealer or

modulation sciences, inc.

12 A World's Fair Drive • Somerset, NJ 08873 USA

Toll Free (800) 826-2603 • FAX (908) 302-0206 • Outside USA (908) 302-3090

STUDIO SESSIONS

► continued from page 28

Michelex Industrial Group	1210
Micro Technology Unlimited	1066
Madah-Com Inc./Blue Noise	170
Millenia Media	1270
Mix & Electronic Musician/Act III	151
Motorola, DSP Division	260
Nady Systems Inc.	335
Nagra/Phi Technologies	918
National Semiconductor	470
Neotek Corporation	914
Network Music Inc.	954
Neumann	1014
Neutrik USA Inc.	544
Night Technologies International	973
Now! Recording Systems Inc./Sonocraft	266
NVision Inc.	955
OAP Audio Products	457
Omnimusic	948

Opcode Systems Inc	131
Optical Laser	1212
Orban-A Division of AKG	318
Otari Corporation	824
Oxmoor Corporation	1017
P.A.S.T. Professional Audio System	1255
Pacific Radio Electronics	1273
Panasonic Broadcast & TV Sys.	744
Peavey Electronics Corp.	714
Penny & Giles Inc.	1124
Philips	1144
Plitron Manufacturing, Inc.	735
Ponica Industrial Co. Ltd.	759
Pro Sound News	752
Pro-Bel Inc.	1267
Professional Audio Design, Inc.	1156
Professional Audio Systems	854
Professional Sound	1252
Professional Sound Services Inc.	175

QMI	154
QSC Audio Products Inc.	1032
(Demo—3D06)	
Quested Monitoring Systems	572
Radian Audio Engineering Inc.	758
Rane Corporation	1037
Rean Products Inc.	859
Renkus-Heinz Inc.	155
R E P Magazine	1253
Roland Pro Audio/Video Group	1100
Rorke Data Inc.	866
RPG Diffusor Systems Inc.	169
RSP Technologies (Demo—2D04)	
Sabine Musical Mfg. Co.	1232
Sam Ash Professional	1268
Samson Technologies Corp.	1000
Sanken Microphones/Dev. Tech	500
Sascom Marketing Group	560
Scharff Weisberg Inc.	770
Schoeps/Posthorn Recordings	267

SCV Electronics	1170
Selenium Loudspeakers/M & P	
Sellmark Elect./Audiomation	552
Sennheiser Electronics Corp.	1014
Shape Inc.	733
Shure Brothers Incorporated	506
Siemens Audio Inc.	724
Sig Tech	1050
Solid State Logic	800
Sollas Corp.	766
Sonex Acoustical Products Div.	1134
Sonic Science	270
Sonic Solutions	844
(Demo—2D08)	
Sony Corporation of America	432
Sound Ideas	916
Sound Tech	1069
Soundcraft	251
SPARS	1204
Spatializer Audio Laboratories, Inc.	500
Spectral Synthesis Inc.	732
Stage Accompany USA	150
Stage Tec GMBH	1168
Stewart Electronics Corp.	1129
Studer Revox America Inc.	624
Studio Audio Digital Equipment Inc.	1173
Studio Sound	1116
Studio Techniques	369
Studio Technologies Inc.	158
Success Specialty Sales Corp.	1114
Summit Audio Inc.	932
Symetrix Inc.	1215
Systems Wireless Ltd.	1054
Sytek Audio Systems Corp.	1238
T.C. Electronic of Denmark	360
T ² (Tactile Technology, Inc.)	761
Tannoy-TGI North America, Inc.	644
Tascam	424
TCI, Theatre Crafts International	1152
TDK Electronics Corp.	860
Tech 21 Inc.	1231
Technical Audio Devices	3D01
Techron-TEF Products	218
Tektronix Inc.	867
Deutsche Bundespost Telekom	
(Demo—1E02)	
Telex Communications Inc.	1236
Telos Systems	658
That Corporation	936
3M Co. Pro Audio	708
360 Systems	872
Timeline Vista Inc.	1024
TOA Electronics Inc	653
(Demo—3D04)	
Tomei/Quali Source	1061
Toroid Corporation of Maryland	268
Total Media Inc	863
Transco	773
Trident Audio USA	832
Turbosound-Audio Independence Ltd.	572
Turtle Beach Systems	566
UREI	261
Valley Audio Products Inc.	558
VEAM, div. of Litton Systems	1068
Vega Wireless Systems	469
The Virtual Mixing Co./California	659
Walters-Storyk Design Group	934
Weisberg Audio	1057
(Demo—2D01)	
Westlake Audio Inc.	1039
Whirlwind	222
White Instruments	1035
Wireworks Corporation	1200
Wright Microphones & Monitors	1255
Xedit Corporation	1402
Yamaha Corporation of America	124
(Demo—3D02)	
Yamaha CBXD5	226
Yorkville Sound	962
Z-Systems	1244
Zoran	672

From San Francisco to Singapore From New Zealand to New York

CCS Audio Codecs Connect the World



CDQ2000 Family

- 20 kHz Stereo Codec
- CD Quality Transmission
- ISO MUSICAM[®] Compression

New **CDQ1000**



- 10 kHz Mono
- Universal Compatibility
- G.722 or MUSICAM



MICRO FAMILY

- 7.5 kHz Audio Codec
- Broadcast Quality Transmission
- CCITT G.722 Compression

Discover Crystal Clear Digital Audio[™]

Discover CCS



CCS Audio Products
33 West Main Street
Holmdel, NJ 07733, USA
908-946-3800 FAX: 908-946-7167



CCS Europe GmbH
Obere Hauptstraße 52
D-8050 Freising, Germany
49 8161 12222 FAX: 49 8161 12280

Which type of CD player is right for your station?



Denon

With its hugely successful DN-970 and DN-950 CD Cart™ Players, Denon helped make CDs the broadcast media of choice. Given the success of these industry-standard players, there were only two things Denon could do: 1. Make a CD Cart player that is smaller, faster, smarter and better; 2. Make a pro CD player that is *not* a Cart player. Denon did both.



ACD-56 CARTRIDGE WITH ATS BAR CODE.

The new DN-961FA Drawer-Loading CD Player is Denon's answer to the many broadcasters who *formerly* had to choose between the drawer-type player they needed and the Denon performance they wanted.

Its Eject-Lock during play adds another most-wanted feature to its list of attractions. Meanwhile, the new DN-951FA CD Cart™ Player dramatically improved functionality

with its Auto Track Select (ATS) system, which reads bar-coded carts to *lock-in*, *lock-out* or *auto-cue* to a specific track.

That's not all; three-in-a-rack mounting, true instant start, and end-of-message signals with selectable time-to-end are just a few more key features of these cost-effective new players.

The DN-961FA and DN-951FA. Denon just made it twice as easy to decide which CD player is right for you.

DENON
The first name in digital audio.

TM Century[®]
Inc.

PRESENTS OUR NEWEST

fully INTEGRATED AUTOMATION AND LIVE ASSIST SYSTEM

Ultimate[™]
Digital
Studio!

THE NEXT GENERATION

NEW FEATURES AND ENHANCEMENTS OF ULTIMATE Digital Studio II include:

NEW BARGRAPH display
SHOWS AT A GLANCE
HOW MUCH TIME IS LEFT
IN YOUR SONG, COMMERCIAL,
JINGLE, ETC.

NEW COUNTDOWN
clock WARNS
OPERATOR THAT END
OF EVENT IS NEAR!

Full WALKAWAY OR LIVE
CONTROL WITH JUST
ONE KEYSTROKE!



NEW AUDIO CONTROLLER
WITH SOFTWARE-CONTROLLED
AUDIO LEVELS AND MIXING.

NEW SUPPORT FOR TIME-SCHEDULED
EVENTS, INCLUDING REAL-TIME NETWORK JOINS.

- ◆ NEW AUDIO CONTROLLER USES DIGITAL TECHNOLOGY FOR SOFTWARE CONTROL OF AUDIO LEVELS AND CROSS-FADES
- ◆ POP-UP WEATHER, CALENDAR, PSA, AND LINER WINDOWS
- ◆ ENHANCED REAL-TIME FUNCTIONS, INCLUDING REAL-TIME NETWORK JOINS
- ◆ ENHANCED SUPPORT FOR SECOND-GENERATION COMPACT DISC CHANGERS
- ◆ ENHANCED SUPPORT FOR LOCAL-AREA NETWORKS
- ◆ INCLUDES ALL THE FEATURES THAT MADE THE ORIGINAL UDS FAMOUS, INCLUDING TM CENTURY'S EXCLUSIVE AUTOSEQUENCE TECHNOLOGY, AND SUPPORT FOR ALL INDUSTRY-STANDARD MUSIC-SCHEDULING AND TRAFFIC SYSTEMS

FOR MORE INFORMATION CALL (800) TM CENTURY

A Good Ground Can Alleviate Hum

by Bruce Bartlett
with Jenny Bartlett

ELKHART, Ind. In this segment in our ongoing discussion of hum prevention, we'll look at power wiring, earth ground, safety ground, and safety ground wiring.

Power the audio system on its own circuit, separate from lighting, air-conditioning, etc. This equipment can put noise spikes on the AC line. All the audio equipment should be on the same phase of the power line to prevent hum.

Here are four ways of powering the audio system. The first is most effective—and most expensive; the last is least effective but costs the least:

- Power the audio system from its own power transformer on a telephone pole outside the studio.
- Get power from an independent breaker box.
- If you have 3-phase power wiring, put the audio system on a different phase of the incoming AC mains than other equipment is connected to.
- Power the audio system from its own circuit breaker with an adequate amperage rating.

In any case, it helps to use "AC isolation transformers" between the AC power outlets and the audio-equipment power cords. These transformers remove RFI made by lightning, computers,

motors, and other sources.

The planet earth is the ultimate sink for hum and RF fields picked up on cable shields. So a low-resistance connection to the earth is the best ground. This is called an earth ground. Examples are the steel framework of a building, or a copper rod, stake, or pipe driven into the earth.

True Earth ground

Why not just use the safety ground (power ground) in the wall outlets? It may not connect to the earth with low resistance. If the wall-outlet ground doesn't drain away all your hum and RFI, install your own earth ground, and

use that to ground your audio system.

For adequate hum prevention, many radio stations need a large, multi-rod grounding system. It should be installed by a grounding specialist. In cities, you may need to ground to your building's steel frame, which extends into the earth.

Sometimes you can get by with a single 8-foot copper rod or pipe (available at electrical supply stores). Drive this rod into moist earth outside the studio. Then get some No. 4 gauge, or larger, stranded insulated cable, and securely bond this ground wire to the ground rod with a pipe clamp (available at hardware stores). In areas with RFI, use a copper strap or braid 4-to-12 inches wide and as short as possible.

Run the cable (or strap) up to the single ground point in your system—the system ground. This might be the console ground bus (a terminal or plate). Or it might be the ground-bus bar in your circuit-breaker box.

Grounding to a cold water pipe is not recommended. The pipe may have plastic sections, or may create a shock hazard for water-mains workers.

In most buildings, the safety ground wire is "daisy-chained" or connected from one outlet to the next. This arrangement can cause hum because each outlet's ground terminal is at a different resistance to earth ground. So, hum currents may flow between two pieces of audio equipment that are plugged into separate outlets. Here are some ways around this problem.

Add your own ground system

If you're installing a system in a building which is already wired for AC power, put in your own safety-ground wires with the following procedure. Use low-resistance insulated wire—whatever gauge your local code requires for a safety ground.

1. Ground the chassis of each major piece of equipment separately to the system ground.
2. Connect each chassis of rack equipment separately to the rack ground bus.
3. Connect each rack ground to the system ground.
4. To remove the extra safety-ground connections, put electrical 3-to-2 adapters on the 3-prong power cords.

If you're installing new power wiring, use AC outlets with isolated ground terminals. That is, use special wall outlets that float (isolate) the ground terminal from the wall box; the wall box will be grounded through the conduit instead. These outlets are available from electrical supply houses.

Typical AC outlets with modern wiring contain three wires: hot (black), neutral (white), and ground (bare or green). The ground wire goes to the U-shaped hole in the outlet. You'll be substituting your own ground wire for the bare or green one.

Follow this procedure:

1. Run a low-resistance insulated wire from each outlet's ground receptacle back to the ground bus bar in the circuit-breaker box. Follow code! Try to keep the lengths of all the ground leads about equal for equal resistance to earth ground. These ground wires should never short to the conduit, or you'll get ground loops.
2. Plug the rack equipment into the rack's AC outlet strip.
3. Plug in each rack's AC outlet strip,

continued on next page ▶



*Perfect tools for professionals:
CD and CD-R
players from
STUDER*



The new professional D730 and D731 CD players hold several trump cards. The operating concept is identical on both the desktop and rack-mount version. Not only are the RED book standards implemented, but also important parts of the ORANGE book standard. A special scan function allows the user to play CD-Rs on which the TOC has not yet been written: Once the TOC has been created, coded skips are correctly processed. In addition, the remaining time is displayed with great accuracy. This is of special benefit in the intro mode with its high-precision count down.

Safety features are an integral part of both models: The status preservation which guarantees that even after a «power down», the laser is repositioned exactly on the last address; a quality indicator that provides information on the CD playability; program-controlled customization of all operating procedures, comprehensive remote facilities, integrated optional interfaces for special functions, and, what is more, access to all CD sub-code information via the AES/EBU output for advanced data processing.

STUDER
PROFESSIONAL AUDIO EQUIPMENT

STUDER REVOX AMERICA, INC.
1865 AirLane Drive, #12
Nashville, Tennessee 37210
(615) 391-3399/Fax (615) 391-5974
New York (212) 626-6734
Los Angeles (818) 703-1100

STUDER REVOX CANADA
1947 Leslie Street
Toronto, Ont M3B 2M3
(416) 510-1347/Fax (416) 510-1294

SADiE Workstation Impresses Producer

► continued from page 19

in question and drag it somewhere else. Want more space between some clips? Click on and move them.

Even easier! Tell SADiE how many seconds or minutes you want between the clips, and it will do it for you. Want to use the same material two, three or four times, or more? No problem. Even if you have assembled a group of several clips and want to repeat it without having to do all the edits over again, one key stroke and a click of the mouse, and you're in business.

To really polish up joins between two clips such as in fine editing for music

and CD assembly, just drag the cursor across the join in question and access it in the TRIM window. Here the two clips can be manipulated in several ways such as timing, levels and cross-fades.

Crossfades come in a choice of 14 shapes—varying from linear, to logarithmic, to equal power, to exponential, to whatever else you can think of. Crossfade times are limited only by the length of the clip and are heard instantly.

Instead of entering cumbersome numbers such as 50 or 75 milliseconds, you only have to click on the cursor to the shaded part of the waveform and drag it to whatever point you would like the fade to go to. There is never any doubt or confusion as to what you are working on at the time, because the piece being manipulated is highlighted in bright red.

In the TRIM window, you can play to your heart's content without any real concern because it is only when you have achieved true happiness with the edit that you then click on the WRITE-BACK button to transfer your decisions back to the PLAYLIST window. At any time, while you are in the TRIM window, you can simply exit and return back to where you were when you started. If you have second thoughts after writing your new edit, SADiE provides not only one but several levels of UNDO.

One reassuring feature of SADiE is that it is nearly impossible to lose anything. In the event of a power interruption or the "unlikely" possibility of a computer crash, the SADiE reboots to the exact place it was before the interruption with all EDL information intact. This is not always the case on some high-dollar systems that I have worked on and is truly remarkable for a product of this kind.

Conclusions

I could go on about all the amazing features such as 24-bit, chase sync and gen

sync capability, SMPTE interfacing, 64 times oversampling sigma delta conversions and so forth, as well as the new software that just arrived (software updates are completely free by the way) with digital compression/limiting/gates, time compression, eight-track PLAYLIST display and built in 8x4, 8x2 or 8x1 mixer.

There is an amazing correlation between the operation of SADiE and the good old days of tape editing. It seems obvious to me that the guys who put this system together actually did record and edit tapes in the real world.

The bottom line is the system works great, sounds great and the support of SADiE and J-Mar Electronics in Toronto lets you sleep well at night.

For more information about the SADiE system, contact Jonas Berzanskis at 313-572-0500; or circle **Reader Service 6**.

□□□

Edward Marshall is a staff recording engineer for CBC Radio in Toronto where he has worked for 27 years. In this capacity, as well as in his freelance work, he has more than 400 LPs, cassettes, and CDs to his credit. He can be reached at 416-622-3533.

Good Ground Reduces Hum

► continued from previous page

and each major piece of equipment, into an isolated-ground AC outlet.

You may want to enclose the power wiring in grounded metal conduit to prevent hum radiation from the power lines into audio circuits.

A proper grounding scheme resembles a tree. This is called a "star" or "single-point" grounding system. There's a single common ground point for the whole studio: the ground bus bar or console ground bus. You connect all the equipment chassis individually to that single ground—not to each other.

Portions of this article were excerpted from the authors' book, "Practical Recording Techniques," published by Howard W. Sams.

□□□

Bruce Bartlett is a microphone engineer and technical writer for Crown International. Jenny Bartlett is a technical writer. Bruce can be reached at 219-294-8388.

MODULUX & TRAK*STAR STUDIO FURNITURE ARE THE BROADCASTERS CHOICE

- ☐ Select from among several Modulux and Trak*Star lines.
- ☐ Complete systems start at under \$1,000.
- ☐ Rugged and attractive design for professional use.
- ☐ Video monitor and computer compatible systems.
- ☐ Complete, modular, off the shelf studios for fast delivery.
- ☐ Total in house design capability for any custom studio.

Modulux studio furniture systems can be found from Moscow, to Italy, to the savannas of Nigeria, to the high mountains of the Andes in Paraguay, in dozens of other countries around the world, and of course in hundreds of stations across the United States. Precision manufacturing to metalworking tolerances, use of the finest in high quality materials throughout, and an attractive design have made Modulux the largest selling furniture system and the choice of broadcasters around the planet.

Consoles
Modulux
Trak*Star
Digilink
Modulink

For more information, call or write
ARRAKIS,

(303) 224-2248

the premier broadcast manufacturer of consoles, furniture,
Digilink and Trak*Star digital audio products.

ARRAKIS

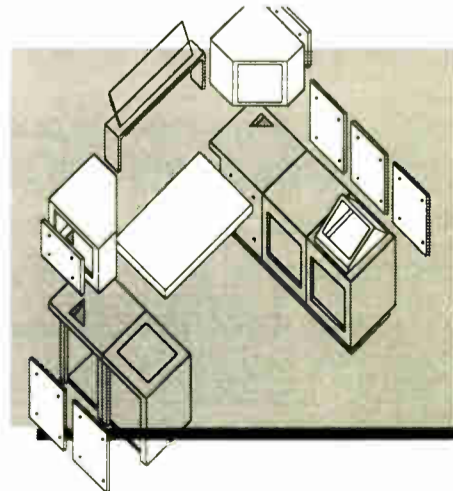

© 1993 Arrakis Systems inc. 2619 Midpoint Drive, Fort Collins, CO. 80525

do you want it to do?

The HPT Series from BEXT is everything you've heard it is: it can be an exciter, a transmitter, a translator and a booster in one high performance, fully featured package. From \$3,695 to \$3,985.

BEXT

739 5th Ave. • San Diego, CA 92101
619-239-8462 • FAX: 619-239-8474

Circle (158) On Reader Service Card

Circle (135) On Reader Service Card

DIGITAL DOMAIN

Examining The Magneto-Optical Option

by Mel Lambert

LOS ANGELES It cannot have escaped the attention of RW readers that we now have available to us an increasing selection of data-storage options.

Ranging from conventional DAT recorders, hard disk systems to the newer optical-based devices, we can now more rationally match the recording medium to the selected task. Stir into the equation a range of data-reduction formats, and we begin to appreciate the alternatives.

Of particular interest are the various new, erasable magneto-optical (MO) recorder/editors that often incorporate some form of data compression to provide several hours of record capacity.

Setting aside for one moment the question of multiple generations of digital audio data compression, we are immediately struck by the user convenience of such systems. Because, in addition to a high data capacity per cubic inch (a standard 128MB MO cartridge can hold around 90 minutes of mono, 4:1 compressed material) such systems offer another benefit: instant access to recorded material as soon as we load the storage media.

Convenience of MO

In contrast to a DAT tape, we can remove an MO cartridge from a field recorder, place it into a production studio's

waveform editor, and begin the editing process within a couple of seconds. Contrast this situation with conventional tape-based systems, where the material to be edited first has to be transferred to the storage media—either hard disk or optical—and then often off-loaded to another type of media for replay to air.

By its very nature, the same MO cartridge, of whatever capacity we deem necessary, can serve multiple duty as a recording, edit storage, and replay medium. I cannot think of another format that offers such versatility.

And even if we decide to use different capacities of optical media for various

Of particular interest are the various new, erasable magneto-optical (MO) recorder/editors.

stages in the broadcast-production process (for example, maybe smaller, 3.5-inch 128MB MOs for field recording and news applications, 1GB drives in the waveform editors, and 20MB "flopticals" for airplay), high-speed data transfers at multiple playback speeds will take care of transferring material around the station.

The point is that at no time in the

process do we need to wait for the sound files to become available; as soon as the media is inserted into the appropriate recorder, editing system or playback device, it is instantly ready.

Which is not to say that conventional hard-disk systems cannot be incorporated into the process. For example, we might decide to use MO-based field recorders, linked via digital I/Os to an existing PC- or Mac-based editing system. While the material is being inloaded in real time, we might begin the auditioning process on the first sound segments, assuming that the editing software allows concurrent access to

the audio files being recorded to hard disk.

And, lest we forget, there now exist several floppy-based recorder/players that do an excellent job in the on-air or production studio of providing the type of user convenience we might expect from the digital equivalent of our familiar analog NAB cartridge machines, with storage capacities to match.

Pro MiniDisc

In addition, several companies are now offering MiniDisc recorders and players that feature what we might refer to as professional rather than consumer features (more rugged construction, full AES/EBU digital interface, enhanced use controls, etc.). Again, their inclusion into the broadcast chain provides instant access to recorded material, and enhanced operator convenience.

Currently, because of our need to ensure reasonable record capacities from existing size drives, we are pretty much forced to use some type of data-compression scheme in field recorders and replay systems. (Editing systems, by their very nature, can be connected to a virtually limitless number of high-capacity drives, to provide storage of multiple jingles, promos, IDs, commercials and other material.)

While this may change in the medium future—as record capacities of affordable MO drives rise from their current 128/256MB for 3.5-inch MOs and 650 MB/1.2GB for larger size media to perhaps two or even three times these capacities—we are still faced with limit-

ed data-transfer rates. The latter are dependent upon the physical nature of the magneto-optical or phase-change recording process, and the type of computer interface used to connect the MO drives to the host PC controller.

Because of these and other related reasons, for field recorders we are pretty much dependent upon data compression to provide sufficient recording capacity in a reasonable sized package. And to limit the size of the physical package that DJs and on-air staff need to manipulate, we might expect to restrict the size of digital cartridges to 3.5-inch MOs or floppy disks (dependent, once again, on the material they hold and the intended application).

Again, to provide reasonable storage capacities, some form of data compression will be required on the replay side. All of these various elements already exist in one form or another. Their integration into the broadcast environment should prove to be simple, cost effective and reasonably painless. Provided, of course, that we pay attention to one or two important operational rules.

Be aware of compression

First, we should be aware of the types of data-compression schemes being used at each stage in the process from field acquisition: through editing and mixing, to the replay to air and the subsequent broadcast chain. Aside from attempting to reduce the number of encode/decode stages to an essential minimum, and seeking out digital interfaces that enable us to transfer data-compressed materials between compatible systems, we can minimize any minor sonic artifacts by utilizing the same compression scheme at intermediate stages.

Secondly, we need to ensure that if we do need to accommodate several different compression schemes—maybe MUSICAM for a remote or field recordings, followed by Dolby AC-2 within an editing system, and then APT's apt-X100 for on-air replay—we are fully aware how they interact with one another, and also how post-processing equalization and other signal manipulation might cause sonic anomalies.

Investigations of the sonic impact of various data compression algorithms will allow us to take full advantage of magneto-optical data storage systems as part of our growing arsenal of digital broadcast systems.

□ □ □

Mel Lambert has been intimately involved with the production and broadcast industries on both sides of the Atlantic for more than 15 years. Now principal of Media&Marketing, a Los Angeles-based consulting service for the professional audio industry, he can be reached at 818-753-9510.

COUNTRY

CD MUSIC
LIBRARY FROM
HALLAND!

NEW COUNTRY LIBRARY!...FEATURING THE BEST COUNTRY HITS FROM 1985 TO PRESENT

There will be over 650 songs, all original versions by the original artists.

Library content is being programmed by Joe Patrick, of Joe Patrick Broadcasting Consulting. This music list is used by Patrick-consulted stations, virtually all of which are #1 in their markets.

The library is now in production, for release during the 4th quarter of 1993.

For information, call
1-800-HALLAND
or (818) 963-6300



Halland Broadcast Services, Inc.
1289 East Alost Avenue,
Glendora CA 91740



Conex Electro-Systems
AS-101 AUDIO SWITCHER

AS-101 Audio Switcher

- Illuminated and legendable control buttons
- Instant or overlap switching
- Front panel accessible level controls
- Options include: RS-232 interface, remote control, relay-follow-switch outputs
- Network proven quality and reliability

10 Stereo In - 1 Stereo Out

P.O. Box 1342 Bellingham, WA 98227
1-800-645-1061 FAX (206) 676-4822

Conex Electro-Systems, Inc.

Writing Your PC Upkeep Checklist

► continued from page 10

run inside the monitor, possibly resulting in short circuits and ruining PC boards.

If you have a serious dust problem, consider purchasing special anti-static screen cleaners. They are available through most computer supply houses.

Keyboards and printers

Keyboards usually receive the brunt of use and abuse. Depending on the circumstances, cleaning may require wiping the exterior with a damp cloth and vacuuming under the keys, or complete disassembly and washing to clean spilled drinks and other grunge. Some keyboards may require careful disassembly and burnishing of the contacts with an eraser to remove oxidation.

One important precaution: never plug in or unplug a keyboard while the computer is running. Some keyboards have a micro-processor chip inside, and you'll invariably end up destroying it. Replacement ICs may be expensive and hard to find.

Before cleaning your dot matrix print-

er, unplug it and allow the print head to cool. Use a vacuum cleaner and damp cloth to remove all the fine paper dust from inside the machine and along the paper feed path. Remove the ribbon and clean ink debris from around the print head. Then install a new ribbon.

Run the built-in self test to verify print quality and operation. This is done on many printers by holding down the line feed button while turning the power on, although this procedure varies from machine to machine. A white line running through the printout indicates a broken pin or pins on the print head, and it will have to be replaced.

Laser printers need regular attention too. As with dot matrix printers, unplug it and allow it to cool down before going over it with a mini-vac and damp cloth to remove the fine white dust in the paper feed.

Follow the manufacturer's instructions for disassembly to clean the transfer corona wire. This is typically done with a swab dipped in alcohol. The transfer guide and registration assembly also need to be cleaned per directions in owner's manual.

The final step is to close the printer, power up and run the self-test to check the print density. Most laser printers

have a density control you can adjust to compensate for gradual loss of toner.

Finally, document your entire computer system in the same manner you do studio wiring. Use adhesive wire markers on cables and equipment. Make a block diagram of what goes where as the system expands.

Computer systems have become so reliable that we tend to take them for granted. Downtime or the loss of a hard drive is almost as bad as being off the air. You can reduce system failures, while familiarizing yourself with normal PC operation by adding your computers to the maintenance routine.

□ □ □

Tom Vernon divides his time between consulting and completion of a Ph. D. He can be reached at 717-367-5595.

WGEM's Aid to Flooded Towns

► continued from page 15

and almost no energy to the operation of the stations," Henning said.

Continuous, live coverage proved to be draining. Although WGEM(AM) is not the primary EBS station for the area, people tuned in for vital information. During one particularly crucial levee break, Henning and his staff made the risky decision to continue full, 5 kW power at night.

"There was no time to call the FCC. We got the rule book out, read through the rules, called an attorney and said we're going to do it," Henning said.

Later, after checking with the FCC and getting approval, Henning was glad they made the decision. Nighttime power of 1 kW would surely have been too little to maintain the information link between National Guard personnel and levee commissioners during one of the largest water spills since the flood began.

Elsewhere people tuned into WGEM to keep track of flood events much as they had watched CNN during the Gulf War. The nation's television stations and news bureaus suddenly tuned to 1440 kHz as clouds kept emptying rain on drenched farm land.

By the time the sun broke through in early August, WGEM(AM) gained celebrity status, appearing in articles in the "New York Times," "People," and "USA Today," "ABC World News Tonight," "Today" and National Public Radio.

Henning praised the courage of WGEM's listeners: "There was a village, Niota, Ill., which is north of here, and had been fighting the river for several days. A lady called when her last line of defense broke. Her last phone call from her house was to the radio station, saying that Niota was gone."

□ □ □

Dee McVicker has been covering the broadcast beat for five years as a regular contributor to *RW* and as a freelance writer for the industry. She can be reached at 602-545-7363.

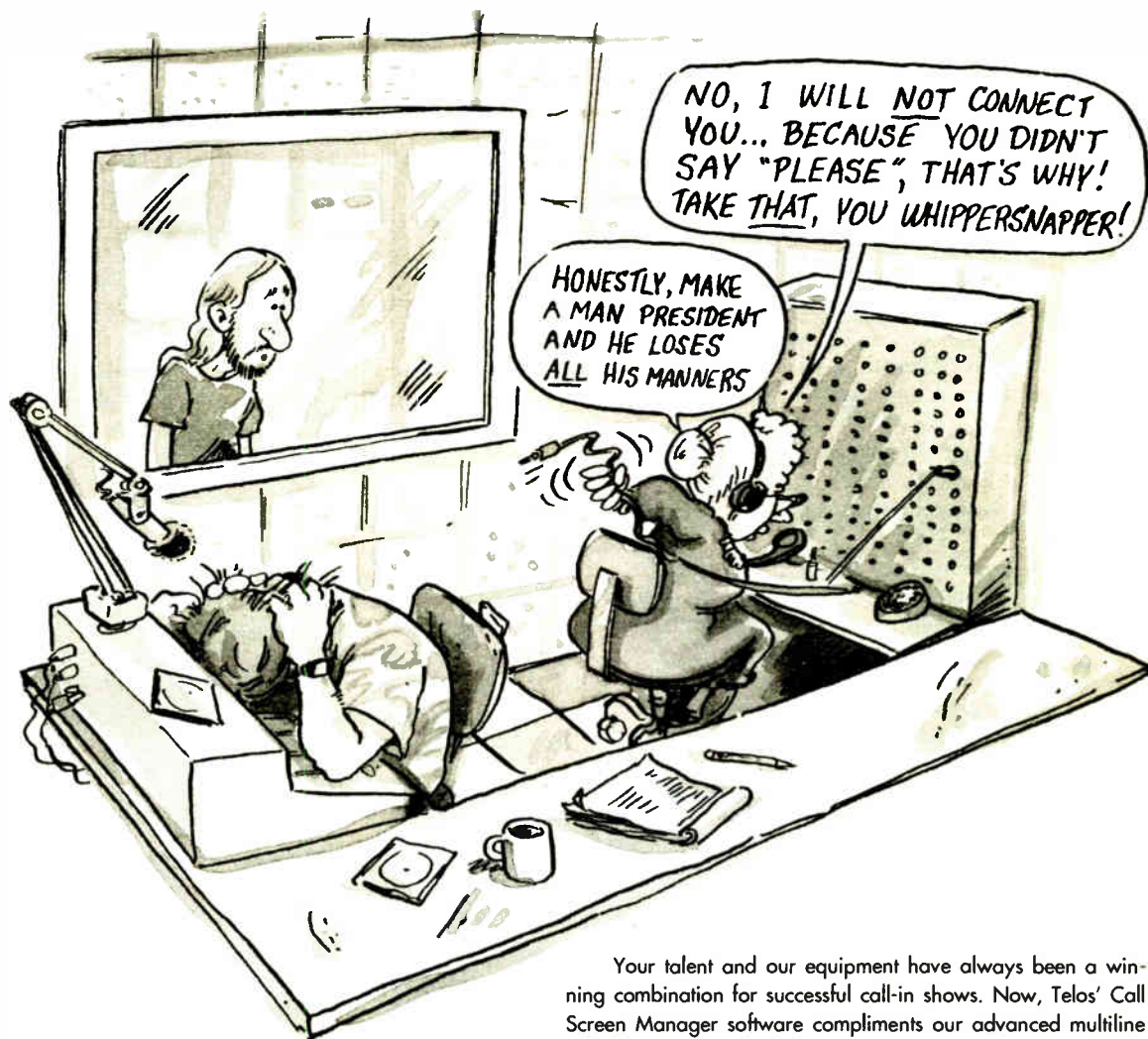

Call Screen Manager

Talk Show Management Software



Your talent and our equipment have always been a winning combination for successful call-in shows. Now, Telos' Call Screen Manager software compliments our advanced multiline talk show systems by helping your screener/director provide your talent with information on each caller.

Call Screen Manager uses inexpensive IBM-compatible PCs and peripherals and you can choose two different screen views, so information is always displayed in the most useful, easy-to-interpret format. Features include real-time display of line status; full page and quick messages that may be stored and sent with simple keystroke combinations; a caller information database module with modifiable data fields and report and export capabilities; and the ability to accomplish most critical screener functions from the computer keyboard.

Two versions of Call Screen Manager are available. Host Software provides for a director position and any number of talent positions using a single PC. Remote Software allows communications between the studio and talent located at a remote site via modem.

So hire the best and give them the tools they need. Isn't it time you experienced the pleasure of great phones?



2101 Superior Avenue • Cleveland, Ohio 44114
216.241.7225 • FAX: 216.241.4103

WORKBENCH

Simplifying Access to Your Trim Pots

by John Bisset

FALLS CHURCH, Va. A recent *Workbench* (Sept. 8), dealt with ways to get easier access to trim pots on the Otari MX-5050. Putting a screwdriver into the pot slot isn't a problem with these machines. You drill the small access holes to permit easier adjustment of the SRL levels and the pots are mounted on the board immediately beneath the cover.

Access on Belar modulation monitors, however, is not as simple. The pots or trimmers are located far behind the cover plate, and looking for the screwdriver slot can be a tedious task. The "frequency adjust" trimmer on the FM monitor, for example, is placed on the front panel for easy frequency meter calibration. The only problem is that the trimmer is placed far enough behind the front panel hole to make any tweaking difficult.

Chic Leyh from WGMS-FM Washington showed me a solution to this frustrating problem. He uses a piece of black shrink tubing and cuts it to fit the distance between the front panel and the trimmer. He then chooses a piece big enough to fit over the protruded end of the trimmer, yet with a diameter large enough for a greenie or similar narrow-blade screwdriver.

A heat gun is used to shrink the end of the tubing around the trimmer cap and hold it in place. The opposite end is cut just as it exits the front-panel adjustment hole. If you want, a drop of contact cement or glue can further stabilize the tubing where it meets the front panel.

This 15-minute modification makes monitor calibration a breeze.

The Belar AM monitor, which has a number of adjustment holes in the rear, can be similarly modified. Unfortunately, most of these adjustments are single-turn pots, and there is no way to shrink the tubing over them. Each piece must be physically aligned using a wooden swab stick. Sparingly apply contact cement on the inside-rear panel where each piece of tubing ends. This technique is particularly useful on equipment that has been

Ed stores them in large metal film cans, available at most photo supply stores.

The cans are inexpensive and provide superb protection. The cans are large enough for the seven-inch alignment tapes, plus any paperwork, special instructions, or forms you want to store as well. Chic and Ed can be reached at 301-468-1800.

★ ★ ★

Arizona is known for its desert critters—the kind that like to attack transmitters. Art Crane, a contract engineer there,

has a client station with a CCA 20,000-watt transmitter on top of a mountain in nearby Nevada. The transmitter's main circuit breaker would occasionally trip, making it impossible to get back on the air using the remote control.

Bits of mouse, lizard or large insect would often be found near some component tied to the 8kV plate supply. The critter would disintegrate, tripping the breaker, but leaving the transmitter otherwise undamaged.

Art soon tired of traveling to the mountain-top just to reset a breaker. He couldn't find any electronic-reset circuit breakers in the catalog (they're probably too expensive anyway), so Art devised a solution on his own.

He mounted a large 120VAC solenoid several inches above the circuit breaker handle and linked them with a length of nylon cord (see photo). With the circuit breaker "on" and the solenoid de-ener-

gized, gravity extends the solenoid plunger one and a quarter inches. This leaves the nylon cord slack, and the breaker free to trip.

Circuit breakers meeting the UL and CSA requirements cannot be forced "on"

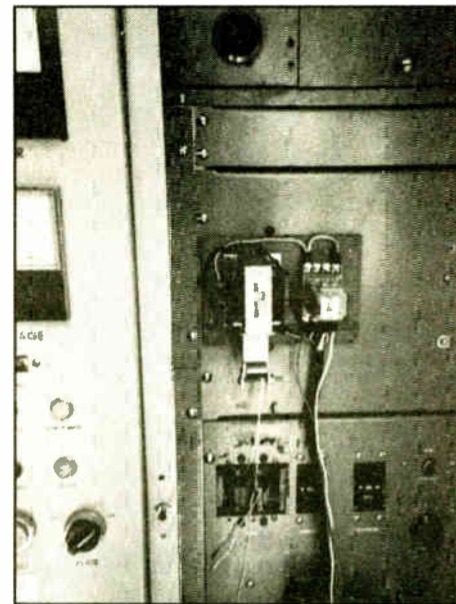

By tying a short piece of nylon cord to the solenoid plunger, the plate breaker can be reset by remote control.

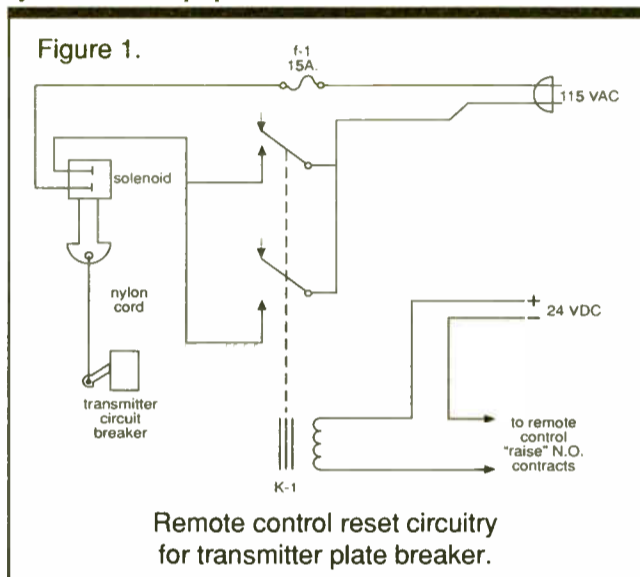

engineered in such a way that the trim pot doesn't align with the adjustment hole.

While I was over at WGMS-FM, Chic's assistant, Ed Channel, showed me his alignment tape collection. They were standard MRL/STL alignment tapes, but

AES 95th Convention
AUDIO IN THE AGE
OF MULTIMEDIA

October 7-10, 1993
 Jacob K. Javits Convention Center • New York

Science emphasizes detached observation, objectivity, and logical deduction, but most who come away from the AES 95th and New York City this fall will find themselves feeling anything but detached—the combined dynamics of this city and this event simply won't allow it.

Circle (206) On Reader Service Card

dataworld[®] MAPS

DO YOU KNOW YOUR MARKET?
YOUR COMPETITION DOES!

DATAWORLD MAPS CAN

- Depict your coverage!
- Market orient your sales people!
- Target your ethnic/demographic markets!
- Identify marginal signal areas!
- Plot any special requirements!

MAP OPTIONS

- SHADOWING (TERRAIN SHIELDING)
- CONTOUR COVERAGE
- POPULATION DENSITY
- ZIP CODE BOUNDARIES
- RECEIVED SIGNAL LEVEL
- SPECIAL REQUIREMENTS

dataworld[®]
 A Service of DW, Inc.

(301) 652-8822 (800) 368-5754

Circle (53) On Reader Service Card

by restraining the handle during overload. They will trip internally anyway. Once the circuit breaker trips, the slack in the nylon cord is taken up, allowing the one-and-a-quarter-inch stroke of the solenoid plunger to reset the breaker.

The solenoid exerts a maximum pull of 16 pounds, which is more than adequate for resetting the breaker. It pulls 12 amps at maximum extension, so it is powered through a DPDT relay with paralleled 10-amp contacts (see Figure 1).

The nylon cord, a sixteenth of an inch in diameter, is sold by Ace Hardware for chalk lines. It is somewhat elastic, yet strong enough to absorb the shock delivered by the solenoid without breaking.

Art bought the solenoid, relay and socket through the Grainger catalog. He used a Dormeyer Model 3000-M-1 (Grainger 2X242), a DPDT 24 VDC GP Relay (Grainger 1A485) and an eight-pin octal socket (Grainger 5X852).

Both the solenoid and relay were mounted on a 5x7.5x0.25-inch piece of Micarta, drilled and tapped for component mounting screws. No screws were allowed to protrude through the back of the Micarta, thus keeping the surface flat.

The entire assembly was mounted to the transmitter using pieces of double-sided adhesive foam tape (Radio Shack 64-2343) applied to the entire back surface.

All the critter-access holes may be finally located and sealed one day, but until then it's nice to be able to remotely reset the breaker when normal transmitter restart procedures fail. Art Crane can be reached at Desert RF Engineering, 602-453-3546.

□ □ □

John Bisset is a principal with the contract engineering group Multiphase Consulting. He can be reached at 703-764-0751. Submissions to *Workbench* can be sent to his attention, in care of RW, or faxed to 703-998-2966. Published submissions qualify for recertification credit for all SBE certification levels.

USER REPORT

Sports Show Enters Digital Satellite Age

by Ken Van Prooyen
Technical Services Manager
Radio Bible Class

GRAND RAPIDS, Mich. Not too long ago, our sports talk show support staff, based in Grand Rapids, Mich., traveled 3 1/2 hours every Saturday morning to Moody Broadcasting Network in Chicago.

Whether it was warm or cold, clear or icy, we made the trip to air "Sports Spectrum," a production of Radio Bible Class. The host, Chuck Swirsky, Sports Director of WGN(AM) Chicago, lives in Wheaton, Ill., and works in Chicago.

"Sports Spectrum" is a live, 55-minute sports program featuring scores, news and information with both live and recorded interviews. Guests include athletes, coaches and sports personalities.

Listeners are given the opportunity to

call in and ask athletes or Chuck questions from the world of sports. Currently, "Sports Spectrum" airs on more than 200 stations in North America and U.S. territories. Its companion, Sports Spectrum magazine, has a readership of about 60,000 nationwide.

The challenge

From the beginning, the production team's challenge was getting the program on the air with the highest quality (both in content and technology) and the least cost. This meant moving the production to Grand Rapids while leaving the host in Chicago.

But how could quality audio be transported between Grand Rapids and Chicago? How could the team produce the program in the Radio Bible Class Studios and present it to the stations and listeners of the Moody Broadcasting Network?

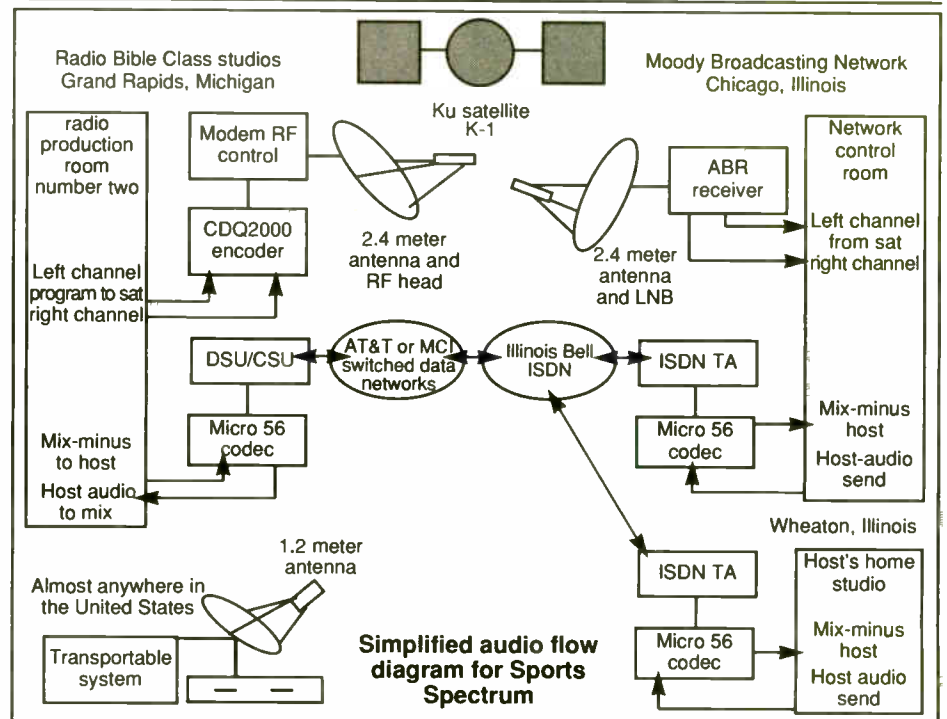

During the first year of the program, various telephone and satellite schemes were investigated. But the production team was never happy with the prospective results: not-so-great audio at a high cost or great audio at an even higher cost with minimum flexibility.

Considering this was three years ago,

radio broadcasters were just learning that "digital" spelled audio transmission. It was then that Dick Becvar of California Digital Audio Systems Inc. entered the picture.

As head of the production staff, I explained our programming challenge.

continued on page 41 ▶

5 out of 5 cassettes prefer the TASCAM 122 for tension headaches.

Temperature. Humidity. Stress. Just another day in the life of today's cassette tapes. And one more reason to choose the industry standard: the 122 MKIII stereo cassette recorder from TASCAM.

The 122 MKIII is uniquely designed with an advanced servo control system that assures back tension remains the same throughout the entire reel and is unaffected by other elements such as temperature or humidity. So even on the worst of days, you'll always find relief with the TASCAM 122 MKIII.

Truly, the three head MKIII is a workhorse. With its Cobalt Amorphous heads and rugged construction, it's built to withstand relentless play and extreme conditions while



delivering the industry's finest cassette performance day after day. Choose the 122 MKIII.

It not only cures tension headaches, but may eliminate your heartburn, as well.

The full-featured industry standard 122 MKIII is the finest and most durable three head deck you can buy for today's production studio.

TASCAM

Take advantage of our experience.

Products & Services Showcase

For more information on the products shown below, circle the appropriate Reader Service No. (s) on the enclosed Subscription/Reader Service card or contact the advertiser directly.

SOUND YOUR BEST ON THE AIR!



CART MACHINE SERVICES:

CART MOTORS REBUILT to quiet flutter-free perfection-shafts resurfaced
Single \$120.00 Triple \$140.00

CART HEADS RELAPPED guaranteed to perform like new

Same day turnaround

Replacement heads and motors available

REEL TO REEL SERVICES:

HEADS RELAPPED and precise digital/optical

ASSEMBLY ALIGNMENTS

performed for maximum response & head life



CAPSTAN & REEL MOTORS REBUILT for MCI, OTARI and more

For peak performance from your recording equipment, call The Audio Magnetic Professionals



224 Datura Street, Suite 614, West Palm Beach, FL 33401
Call 1-800-826-0601 for "Same Day Service" in Florida (407) 659-4805
Authorized Parts Dealers for: MCI • OTARI • TEAC/TASCAM

READER SERVICE NO. 193

Central to:

- Customer Needs
- Engineering
- Quality
- Fabrication
- Installation
- Specialized Services



Central to All Your Tower Needs

2855 Hwy. 261 • Newburgh, IN 47630-8642
800-264-0595 • FAX 812-853-6652

READER SERVICE NO. 211

FREE COMPUTERS!

Get it all! Pick either our new Simple-CD[®] automation with the DJ-Pro[®] production system OR our DJ-Lite[®] Satellite automation system with the DJ-Pro[®] production system. Get two computers, two monitors, two hard disks, a full LAN network and assembly, free!

\$9,995.00

Lease as low as \$229.00 per month

Plug n' Play

Package system price includes either a Simple-CD control system with a 16 unit Pioneer[™] CD six-pack interface OR a DJ-Lite satellite music system controller with I/O cards and software. Either system is connected by a fast LAN network to a DJ-Pro production workstation. Wire to your console audio and you're on the air.

Package system includes two premium apt-X[™] audio cards, two fast 386 SX-33 computers each with 340 meg hard disks (5+ hours mono recording), two VGA color monitors, two LAN cards & software, 15' LAN cable and Manuals.

Full Backup for Safety - Easy Production

Use DJ-Pro for fast spot production, then send by LAN to Simple-CD or DJ-Lite. Relax! Your spots are backed up and safe.

The Management

1-800-334-7823 1-817-625-9761
P.O. Box 1-36457 Ft. Worth, TX, 76136
1600+ Stations - Our 13th year

READER SERVICE NO. 54

Take Control...

The Jr. Audio Director provides output source selection between **Left Only, Right Only, Mono, Stereo, and Stereo Reverse**. Installation is easy, using the plug-in Euro-style barrier strip.



\$390.00

BENCHMARK MEDIA SYSTEMS, INC.
315/437-6300 800/262-4675 FAX 315/437-8119

Features/Functions

- Stereo (normal)
- Mono
- Left Only
- Right Only
- Stereo Reversed
- Right Channel Polarity Inversion
- Rackmountable
- Built in mono mode gain reduction
- LED Indicators
- Balanced I/O's

Benchmark
...the measure of excellence![™]

READER SERVICE NO. 82

Attention Advertisers!

Reach 22,000 + Readers worldwide. RADIO WORLD's Product Showcase provides a perfect medium for test marketing your products and services. It's an efficient, effective and affordable advertising option.

For more information, including rates and deadlines, Fax SIMONE at

1-703-998-2966

or Call

1-800-336-3045

Shape Up!

Coverage. Saturation. DBk contours. In FM broadcasting, the "bottom line" is always based on your pattern.

More than any other manufacturer, Shively has the experience and reputation for providing crucial pattern solutions for critical propagation problems. On any tower. At any power level. Remember, *it pays to be heard*.

A good pattern. The shape you need. Talk to your consultant. And contact us.

Shively Labs

A Division of Howell Laboratories, Inc.
19 Harrison Road, Bridgton, ME 04009
207-647-3327 FAX 207-647-8273

READER SERVICE NO. 45

"ITC" The Only Affordable Spectrum Analyzer

THREE FULL FUNCTION ANALYZERS TO CHOOSE FROM 600 MHz - 1000 MHz - 1800 MHz

80 dB ON SCREEN DYNAMIC RANGE.

With ITC's Exclusive EFPLA Log Amp. (pat. pend.)

-110 dBm SENSITIVITY AT ALL SPAN WIDTHS.

ITC Analyzers have -110 dBm .7uv. sensitivity at all Resolution Band & Span widths.

HIGH STABILITY (<1KHz per Hr. after warm up)

FEATURES Baseline Clipper, Video Filter, 5" CRT, Preset plus variable Dispersion settings from 0 - 50 Mhz per/div, 100:1 tuning ratio for easy Center Frequency selection, & More.

ITC INSTRUMENTS

9222 Chesapeake Dr. Suite A
San Diego Ca. 92123 USA

MADE IN THE USA

TERMS: M/C, VISA, AE, CHECK, MO, COD, P.O. (OAC)

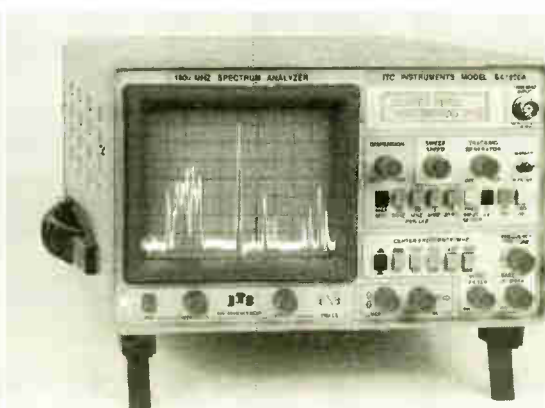

SA600A 600 MHz \$1295.00 Opt.1 50 MHz marker \$200.00
SA1000A 1000 MHz \$1595.00 Opt.3 +/- 5 KHz Filter \$350.00
SA1800A 1800 MHz \$1895.00 Opt.5 Tracking Gen. \$250.00
Opt. 6 Center Frequency Display \$275.00

**FOR MORE INFORMATION & INTRODUCTORY OFFER
CALL 1-800-232-3501 619-277-4619 FAX-277-6736**

PRICES START AT
\$1295.00
MODEL SA600

A MUST FOR:

- AM-FM-SW-TV Stations-CATV
- CHECKING SUB-CARRIES
- SATELLITE FEEDS
- UP LINKS, DOWN LINKS
- AUDIO-VIDEO-SIGNAL LEVELS
- HEAD-IN SYS. & MODULATORS
- CHECK FCC REQUIREMENTS

ITC Analyzers are the perfect low cost choice for All AM, FM Broadcast-VHF, UHF TV maintenance depts., and FCC compliance testing. You will save time & money with a ITC low cost Spectrum Analyzer.

READER SERVICE NO. 164

USER REPORT

Halland Brings Music to Talker KGO

by Stephen Taylor
Production Director
KGO(AM)

SAN FRANCISCO What use would a news or talk or "news/talk" station have with the top 40 hits of 1955 through 1992? That all depends on the station's target audience and how the station tries to relate to them.

KGO(AM) Newstalk 810, aims to sound like a well-rounded station that communicates with listeners of the same

Halland's latest library contains over 700 AC/CHR hits of 1980 through 1992.

generation(s). **Halland Broadcast Services'** "Rock & Roll Graffiti," "The 70s," and "The Eighties Plus" are wonderful tools in pursuit of that goal.

Reaping the benefits

A couple years ago, I read that Halland Broadcast Services was releasing 1,700-plus top hits of the 1950s, 1960s and 1970s. After some discussion, everyone agreed that acquiring the libraries would be beneficial.

One of the advantages of the libraries is the amount of time saved by the news reporters and producers. If a certain theme or artist is needed to musically illustrate or enhance a news story or feature, the news staff doesn't have to run off to the music store.

Someone just visits the CD library and dubs off the "hook" or instrumental passage needed. And when recording artists visit during our "talk" programming, we may actually have some of their work right on CD.

After obtaining the Halland libraries,

we installed CD players in the control rooms. (If we suddenly decide to change format after 17 years of news/talk, we could.)

The talk personalities, news anchors, reporters, producers and the production staff all began to realize that new doors were opened. If Chubby Checker or Dion shows up as a guest, we're ready with their hits.

The thing that some people in "non-music" radio may forget, or not believe, is that music is "shorthand" for messages that don't need to be verbalized. And just because some listeners like "voice-radio," it's no reason to believe they don't have full knowledge and appreciation of popular music.

The only negative about the Halland package is that it's taking some people so long to move forward a decade or two in utilizing "The Eighties Plus." News producers will, for example, ask to play a song that has been overused.

Current track

I now suggest they consider something more current. Halland's latest library contains over 700 AC/CHR hits of 1980 through 1992. It's fun to watch them discover that we're no longer locked into "oldies." Maybe it's just me, but most of the hit songs from the last few years seem fresh, especially within the context of news/talk radio.

A few weeks ago, I did a promo for our reporter in Bosnia. I thought "Land of Confusion" by Genesis had the appropriate feel and lyrics. One can only hope the listeners agreed. UB-40's "Red, Red Wine" worked for the station-sponsored Sonoma Art & Wine Festival.

And Steely Dan is coming to town after 19 years of absence from the concert trail. It was good to hear "Hey Nineteen" in the news story, as well as older material like "Do It Again."

News and talk radio don't operate in separate universes. The acknowledgment/enjoyment of music is just another

Bible Class applied for two licenses: one for a 2.4 meter fixed earth station in Grand Rapids and another for a transportable 1.2 meter antenna.

As a result, the first program using the new system aired from Grand Rapids on December 19, 1992. Utilizing the new technology, Chuck can deliver the sportscast, interview a guest or answer listener questions from his home or MBN studio via ISDN from Chicago.

In Grand Rapids, we integrate the actualities, guest or listener calls, bumpers, opens and closes, and deliver them to Moody with MUSICAM™ quality.

The new system also provides the flexibility for "Sports Spectrum" to go on the road. This year, at the NCAA Final Four, Chuck interviewed coaches and officials from the National Association of Basketball Coaches Fan Jam and took listener comments and calls.

We're thankful for the flexibility and quality these facilities provide and are pleased with the full service and cost effective solutions California Digital brought to "Sports Spectrum."

□ □ □

For information, contact Caryn Beemer in California at 805-523-2310; fax: 805-523-0480; or circle Reader Service 204.

facet of our lives. When we skillfully utilize popular music to support and illustrate a point or to deliver our messages, it works beautifully.

There are two types of promos that feature pop music. One uses the title or lyrics in a very obvious way to underscore the message. The second is a more subtle use of familiar instrumental passages. These may not immediately receive notice, but they will gradually sink into the listeners' awareness by the third or fourth listening.

Halland's "Rock & Roll Graffiti," "The 70s," and "Eighties Plus" series have

pleased me, and at times surprised me, with the depth and quality of sound. I've also found the catalog on computer disc—categorized by title, artist, and year—easy to use. I have it installed right in my digital editor for quick access while I'm mixing and editing.

There are other songs I wish were included, but I'm generally extremely enthusiastic about Halland. Customer service is terrific, and the company willingly replaces damaged CDs, even if your own clumsiness is the cause.

Try Halland out—see and hear if it's what you want. So far, it works for me.

□ □ □

For information, contact Steve Steinberg in California at 818-963-6300; fax: 818-963-2070; or circle Reader Service 10.

CAT-LINK Digital STL :

TOP 25
MARKET SWEEP

It's no wonder 50 stations in the Top 25 markets are sold on

QEI's CAT-LINK, the DIGITAL STL problem solver:

- Uses T1 data circuits or 23 GHz radio
- The only digital FM composite link*
- **NO COMPRESSION and NO DELAY**
- Full bi-directional capability
- Multiple discrete channel capability
- Ideal for LMAs

And that's why more savvy stations in the Top 25 and markets of every size are turning to CAT-LINK. Call QEI toll-free at 800-334-9154 and be swept away.



*U. S. Patent # 5,054,070



QEI Corporation
One Airport Drive P.O. Box 805 Williamstown, N.J. 08094 USA
800 334-9154 FAX: 609 629-1751 INTERNATIONAL: 609 728-2020

Circle (120) On Reader Service Card

Sports Show Enters Digital Satellite Age

► continued from page 39

We required the following: program audio traveling to and from Chicago, the flexibility of Chuck broadcasting from Chicago or his home, or the possibility of taking the whole program on remote.

I knew a little bit about BPSK, QPSK, SCPC and FM-Squared and a little more about Switched 56 and ISDN. But I didn't know enough to make good decisions regarding gear purchases. Through telephone calls, faxes and letters, Dick counseled us on how to make the best use of technology and financial resources.

Finding the answer

With a detailed plan and approval from the leadership at Radio Bible Class, we contracted with California Digital for the purchase and installation of a Ku band uplink system, receivers and Switched 56 modems and codecs.

Because of our varying needs, Radio

USER REPORT

DataWorld Puts Signals on the Map

by Kevin T. Fisher
Broadcasting Consultant
Smith and Powstenko

WASHINGTON Since the days of the prehistoric Neanderthal, man has used graphic illustrations to communicate information. In the broadcast industry, maps are commonly used to depict various situations regarding a station's signal.

Whether used as a promotional tool, a rate card map or a complex exhibit in an FCC filing (such as a comparative cover-

age analysis), a map is an important tool that can quickly convey messages to readers.

DataWorld provides a tremendous number of map services to consulting engineers, communications attorneys and radio stations. In selecting the right map for the job, users must decide the elements that best depict the pertinent information.

Selecting a map

Typically, the process begins by determining which station or stations to

include. Obviously, a rate card map will depict the salesman's station. On the other hand, an interference study requires the showing of one station's service contour and the interfering contour of the problem station.

A comparative coverage analysis or a duopoly typically has numerous station contours shown on one map. DataWorld maintains databases containing the operating parameters of all authorized and proposed broadcast facilities in the United States.

DataWorld also maintains three-second and 30-second terrain databases for most of the United States. One convenient aspect of DataWorld's mapping services is that contour determinations are performed in-house once you know the stations to be included on the map.

With a variety of user-specified options, the map can be as simple or as detailed as you wish.

The DataWorld maps are quite accurate. Although the FCC requires a station's contours to be determined along a minimum of eight or nine radials, the DataWorld computer normally computes these contours along 72 radials, resulting in a more accurate depiction of a station's contours.

In instances where an independently derived determination of a station's contour is required, I turn to DataWorld to perform this sometimes difficult task.

Every station in a multi-station study (such as a comparative coverage or duopoly analysis) has contours prepared in different manners and by different consultants. The DataWorld service calculates all stations in a given study in a like manner, eliminating discrepancies.

A broadcast facility has a myriad of contours to describe its coverage and interference capabilities. Depending on the type of showing desired, one or more of these contours will be shown for each station in the project.

Is more better?

While many believe that "more is better" in this regard, I feel a map is a more effective communication tool when it's least cluttered by extraneous information. For instance, I typically won't add a "city-grade" contour to a rate card map, because a potential advertiser is usually only interested in the most distant signal that can be received by the audience.

Another option on the DataWorld map is background data. Obviously, a contour alone doesn't mean anything without reference to geographic data.

DataWorld map selections include state and county boundaries, zip code boundaries, cities, rivers, lakes and other geographic references. With regard to cities,

you can opt to show only those meeting certain population criteria (such as any city with a population of 10,000 or greater).

Here again, I recommend that you choose only those references needed to make the map readable. It's the contours that must stand out in the showing.

DataWorld can also provide the contours on mylar, a clear plastic, which can then be placed over a base map, such as one from the U.S. Geological Survey. In this case, it's important to inform DataWorld of the scale of the map you plan to use so the contour can be drawn to the same scale.

Details, details

DataWorld can add extremely detailed data within any station contour. Population density, demographic, terrain shadowing and received signal level information are just a few of the options available.

DataWorld's plotter is state-of-the-art. It produces contours and background data in a host of colors. In addition, you can choose to show the contours in a variety of broken patterns and line thickness.

One of the most awesome maps I've ever seen is hanging on my wall. It's a DataWorld map depicting more than 200 station contours throughout the United States. (Just the calculation of each station's contour is impressive.)

The contours are for eight clients, each with their own color. Each contour is labeled with the station's call sign and the city of license. DataWorld prepared this map from a simple list of call signs.

DataWorld can tailor a map to any need. With a variety of user-specified options, the map can be as simple or as detailed as you wish. The only complaint I have with DataWorld is that someday the company may put my draftsman out of work.

□ □ □

For information on DataWorld's maps, contact John Neff in Maryland at 800-368-5754; fax: 301-656-5341; or circle Reader Service 123.

DIGILINK SATELLITE AUTOMATION \$7,995

- 10 hours of stereo storage (20 hours mono)
- 4 switcher external inputs standard, for up to 4 networks
- Logic inputs for station ID, 4 liners, & commercial break
- Program up to 40 Clocks and 40 Jocks
- Schedule up to one week in advance
- Simultaneously play a Commercial *and* record a Spot

No matter how you add it up, it quickly becomes obvious why Digilink is #1 in digital audio for Radio. Features, price, and customer satisfaction have made Digilink the choice of broadcasters from Russia to Japan to your own back yard. Whether for live on air, satellite-CD-tape automation, or multitrack production, Digilink fills your needs now and in the future. Price your system on the form below and then write, call, or FAX Arrakis for more information.

VOICE (303) 224-2248, FAX (303) 493-1076

ARRAKIS

DIGILINK ORDER FORM	
Name- _____	
Call letters- _____	
Address- _____	
Telephone- _____	
10 hour system, stereo (20 hours mono).....	\$7,995 <input type="checkbox"/>
Options-	
16 hour system, stereo (32 hours mono).....	\$9,995 <input type="checkbox"/>
Add 7 more switcher inputs (to Total 11).....	\$444 <input type="checkbox"/>
2nd switcher w 7 inputs for timed recording.....	\$295 <input type="checkbox"/>
Network Board plus software.....	\$495 <input type="checkbox"/>
(for 2 or more Digilinks or a scheduling computer)	
Video Doubler.....	\$1,395 <input type="checkbox"/>
(control a Digilink from two places- up to 100')	
Add a Second Studio-	
Add a Production studio to your Air studio.....	\$8,490 <input type="checkbox"/>
(2nd 10 hours system w Network Card)	
Trak*Star 8 Track Editing Software.....	\$1,995 <input type="checkbox"/>
(add an 8 track editor for ultimate production)	
Total List Price- \$ _____	

1993 Arrakis Systems inc. 2619 Midpoint Drive, Fort Collins, CO. 80525

Circle (147) On Reader Service Card



FM STUDIES

- **SPACING/INTERFERENCE SEARCHES** to locate a channel
- **DETAILED INTERFERENCE STUDIES** optimizing site location and directional antenna designs (calculates allowed ERP on all 360 bearings)
- **TERRAIN ELEVATION RETRIEVAL** determines HAAT for 8 or more radials
- **DISTANCE TO CONTOURS** plots projected coverage
- **POPULATION COUNTING** to determine potential listening audience
- **COVERAGE MAPS AND OVERLAYS** depicts signal coverage, zip code boundaries, received signal level, terrain shadowing and more

dataworld
A Service of DW Inc

(301) 652-8822 (800) 368-5754

Circle (11) On Reader Service Card



Introducing ADX, the first digital production system designed for the real world of broadcasting. A world where time is of the essence, change is the rule, last-minute is routine, and creativity is the competitive edge!

ADX is a fully integrated system which combines the creative flexibility of digital recording with the speed and intuitiveness of a fully automated production mixer. Instead of simply storing audio elements and their edit decisions, ADX also recalls and recreates the mixing and processing talent of the producer.

Just imagine having the ability to precisely replay complex multitrack production work the way you mixed and equalized it yesterday, last week or last month! Think of the creative time saved when a change or update is requested in an otherwise perfect mix.

Plus, the ADX is unencumbered by the architectural limitations of first-generation workstations and is designed to grow and expand with your needs. Even the basic system has more standard features than anything before.

And like all PR&E products, ADX is a powerful tool optimized for the fast and furious demands of broadcasting and backed by world-famous PR&E support. Call today for information on ADX, the next generation of digital.

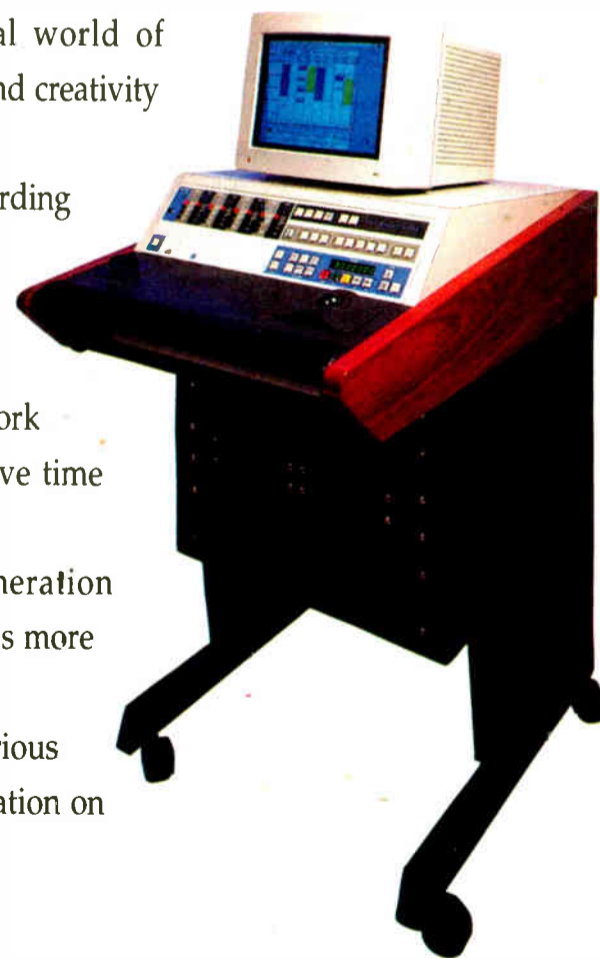

Pacific Recorders & Engineering Corporation, 2070 Las Palmas Drive Carlsbad, CA 92009
 Tel: 619-438-3911 Fax: 619-438-9277 GSA Contract: GS-03F-2057A

DESIGNS THAT MAKE THE DIFFERENCE

USER REPORT

BP Offers One-Stop Library Shopping

by Tom Benson
Group Program Director
Dame Media Consultants

HARRISBURG, Pa. Dame Media operates eight stations in markets of all sizes, top 100 to below 200. **Broadcast Programming** deserves much of the credit for our ratings success, while still helping our bottom line.

BP's expertise saves our personnel time by actually performing specific tasks, such as compiling daily music logs or knowing who to call for a new piece of equipment or a fresh marketing concept.

Today, Broadcast Programming is more

than just yesterday's automated programming service.

Moving up

All our music FM stations are "live," and with BP's consultants, we're working with some of the best in the industry.

Jay Albright is one of the top country experts today. With his help, we recently switched our WMTZ-FM in Johnstown, Pa., to BP's Digital Country in less than five days during a holiday week. WMTZ-FM is Johnstown's first FM country station, and Jay is the reason we hit the air "running."

BP's Jim LaMarca guides The River, WRVV(FM) in Harrisburg, Pa. Using a custom version of the "Heart of Rock" format, WRVV(FM) has evolved from a niche rock/AC to a popular, mass appeal lifestyle music station. And in today's radio world, even the smallest markets face stiff competition.

There are 13 stations "above-the-line" in Williamsport, Pa., and WKSB(FM), a 1960s/1970s-based gold/AC, just scored a 24.7 for adults aged 25-54 (Spring 1993 Arbitron Total Week) with the help of BP's Mike Bettelli.

These knowledgeable national programmers bring their expertise and "fresh ears" to our markets two or three times a year. Plus, BP has the support staff to work with us daily, if necessary.

All of our stations receive customized

scheduled music with BP's "Playlist Plus." We do the music adds locally each week with help from BP's research resources, which are just a toll-free phone call away, and BP does the rest.

Music director

I like to think of the service as each station's music director, as it frees up a lot of time for our operations directors. Playlists are sent to our station on floppy or by actual hard copy, depending on our requirements.

Consultants, playlists and marketing ideas from BP help our music stations win, but Broadcast Programming even helps our news/talk stations. BP's Sentry

System digital automation package is the workhorse of our unique service on the AM dial in Harrisburg.

One system helps run WKBO(AM), on 1230 kHz, an all-news station, and soon another system will be running news/talk WHP(AM) on 580 kHz.

Music, news, live, automated, even satellite, Broadcast Programming can help stations in any size market sound better. But it can't replace your local per-

BROADCAST PROGRAMMING

2211 FIFTH AVENUE • SEATTLE, WA 98121 • (206) 728-2741 • (800) 426-9082 • FAX (206) 441-6582

sonnel. Station workers execute the format and make it happen, while BP helps them be more productive.

BP also offers a customized voice-over service for client stations and pre-packaged music formats for every possible demographic (each format is guided by its own specialist). In addition, the "Share Points" newsletter gets the creative juices flowing every Monday.

If you want value-added services, I suggest the one-stop shopping mega-store for radio: Broadcast Programming.

□ □ □

For information, contact Jim LaMarca in Washington at 800-426-9082; fax: 206-441-6582, or circle Reader Service 95.

At Your Fingertips!

Find the information you need in Radio World's 1993 Directory.

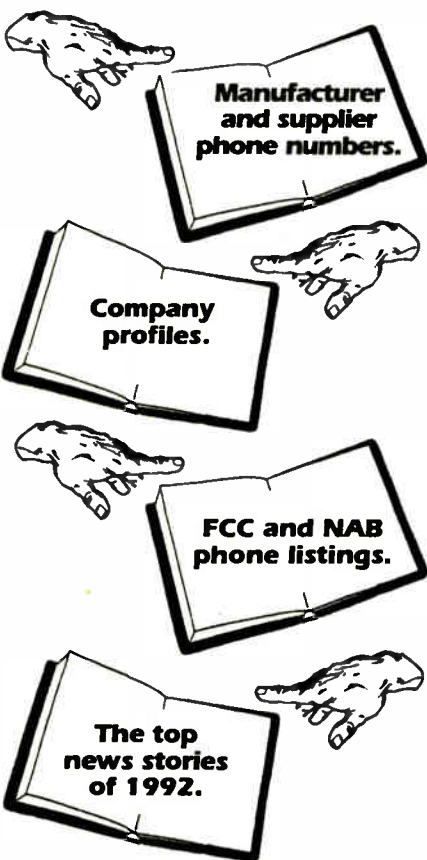

...And more.

We have a limited number available at \$14.95 each.

To order, call



1-800-336-3045

USER REPORT

NSN's 'Eye in the Sky' Tends To Colorado Public Radio Net

by Robert Hensler
Technical Director
Colorado Public Radio

DENVER The merger of KCFR(FM) in Denver and KPRN(FM) in Grand Junction formed Colorado Public Radio. It meant KCFR, the primary station, was responsible for the operation of the second station 250 miles away, on the other side of the Rocky Mountains.

KPRN has a staff of three people plus a contract engineer. It is walkaway, and we monitor it from Denver. Our problem involved economically running both stations with one full-time engineer. As a hub station for a system of over 10 translators, KPRN needed to be kept in a running and operational status.

Continuous monitoring

Fortunately, we heard about **National Supervisory Network (NSN)**, which just came into existence. Using a satel-

lite, NSN continuously monitors all operating limits and EBS, and has control of the transmitter.

There is still positive control of the transmitter at KPRN, so the contract engineer, Norm Price, can take over operation at any time. We also receive

The true beauty of the system is its flexibility.

weekly reports and graphs showing the overall operation of the transmitter. This is very helpful to Norm, who only goes to the station several times a week.

The true beauty of the system is its flexibility. If Norm is at one of his other stations or on vacation, NSN will call Denver. At this point I can ask questions like: Is the audio still on? Is there a thunderstorm in the area (NSN has the National Weather Service radar for the entire country)? Is the power on? What happens when you recycle the transmitter?

Asking these questions allows me to decide whether or not to drive across the mountains or stay home. Norm can also call NSN from anywhere in the country and get an update on how the transmitter is running—not just the current readings.

We gave NSN a list of all the procedures to follow if there is a problem, including lowering the power during a thunderstorm. This makes us feel better, as the transmitter is on a mountain top. As Norm says, he still receives phone calls at 3 a.m., but it's always a true problem, not a perceived problem by a disk jockey.

NSN monitors EBS by logging the tests and notifying Denver if there's an activa-

tion. At this point, NSN can just log the event, activate the EBS and broadcast the message, or we can originate it at the head-end. In addition, NSN can originate our weekly EBS test.

Real world

All the staff at NSN was involved in radio broadcasting and understands broadcasting in the real world. Through the years, I've found this to be of great value. It's like having another engineer on staff whose job is to just watch the transmitter.

The following example illustrates how valuable NSN can be. During Memorial Day holiday, Norm Price and I was in Denver. The transmitter rang. It was NSN.

"Your Grand Junction station's power dropped to 24 percent power, but your plate voltage is normal." I asked them to turn off the transmitter for 10 minutes, turn it back on and let me know what happened.

In the meantime, I started making preparations to go to Grand Junction. NSN called back 15 minutes later and told me the transmitter came back up at full power, but then slowly dropped back to 24 percent.

With this information and other readings, I decided the problem was probably a weak tube. We hadn't received any complaints about our signal, so I decided to stay in Denver. Norm came back the next day and that night replaced the tube.

Part of the reason management may balk over the service is cost. We needed satellite equipment for the interconnect, and we chose a three-year lease purchase.

Along with this cost is the normal monthly fee of about \$525. Once you have the necessary satellite equipment, NSN maintains it. As NSN says, "It is in our best interests to keep you up and running."

□ □ □

For information on NSN, contact Muffy Montemayor in Colorado at 800-345-8782; fax: 303-949-9620; or circle Reader Service 174.

AEV

a leading Italian and European manufacturer of audio broadcasting equipment, particularly aimed at FM radio studios, is looking for dealers willing to market its products all over the US territory.

AEV Snc
via Saviolo, 1/E
I-40017 Le Budric di Persiceto, Italy
tel. +39-51-950249 +39-51-950350
fax +39-51-950201

Circle (22) On Reader Service Card

USER REPORT

Bonneville Libraries Help Put WAVV on Top

by Norman Alpert
President/GM
WAVV(FM)

FORT MYERS, Fla. We've used the Bonneville Ultra Contemporary Music Library for about nine months and are happy to report its success at WAVV(FM) in Naples/Marco.

According to the latest Fall 1993 Arbitron, we ranked number one for persons aged 35+ and 45+. WAVV(FM), an Easy Listening station, also had some listeners in the 25-34 and 18-24 age groups. This allowed us to build enough total audience for the number one spot in the 25+ and 18+ grouping, and to hold the lead position in the persons 12+ measurement.

Bonneville helps us create an easy listening sound that is both fresh and contemporary.

But our experience with Bonneville goes well beyond nine months. We also worked with Bonneville Programming from 1971 to 1982 in northern New England. We established a solid audience during those 11 years on WHOM(FM) in Mount Washington, N.H.

Bonneville played a great part in the success of that station, which we sold in 1982. In fact, from 1976 to 1982, WHOM(FM) delivered more listeners than any other station north of Boston. Admittedly, this was helped by the station's massive FM signal, but it hadn't occurred prior to that time.

WHOM(FM) was a 48,000 W station, but it was approximately 6,288 feet above sea level in Portland, Maine. The tower, situated on Mount Washington, boomed a one mV/m signal into Portland, Maine, located about 70 miles away.

We're most impressed with the size of Bonneville's music library. There are more than 2,500 selections available in the Ultra Contemporary format, which contributes a great deal toward avoiding repetition.

We're even more impressed with the support staff at Bonneville. There is a dedication and desire to produce a superior product, which flows down from the top. John Patton, the CEO and President of Bonneville, was personally concerned about a hardware and software problem we initially encountered when setting up our music system.

Walter Powers, Bonneville's vice president/operations, is a technical wizard in setting up a music system. Walter came to Naples and worked at an unbelievable pace in setting up our system for our programming launch date of Thanksgiving Day last November.

I collapsed about 11:30 p.m., but Walter continued to pound away. His pounding kept me awake, so I had to continue working beyond midnight with him.

Bud Stiker, who is in charge of sales for Bonneville, is not the type of person who forgets you after signing a Bonneville contract.

This is really the way all radio should

be sold—based on the uniqueness of the audience delivered by a particular format. However, in the real world, agencies and a number of accounts demand to see the latest ratings and point levels, and so it goes.

Our system is now operating almost flawlessly. We have an Arrakis Digi-Link controlling 32 Pioneer PDM501 compact disc players. The technical quality of the

Bonneville compact disc library is absolutely superb.

The large size of this library also allows us unending combinations, so the rotation is kept new and fresh with the help of the RCS Selector Music scheduling system. The Arrakis accepts data from RCS Selector and the DARTS Traffic System, producing a smooth interface.

We highly recommend the Bonneville Broadcasting team, as we're very pleased with the performance of the entire system.

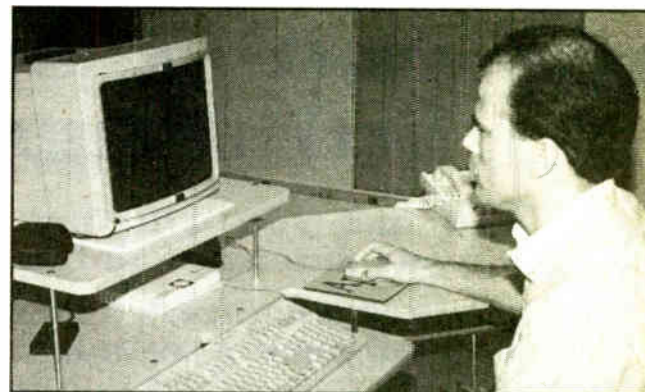

Roger Wolski, Bonneville Broadcasting program producer, at work on the Sonic Solutions digital editing and CD pre-mastering workstation.

For information, contact Bud Stiker in Illinois at 800-631-1600; fax: 708-291-0841; or circle Reader Service 107.

the unity 2000i
the world's best sounding fm processor

CUTTINGEDGE

2101 SUPERIOR AVENUE, CLEVELAND, OHIO 44114 • TEL: (216) 241-3343 • FAX: (216) 241-4103

Circle (83) On Reader Service Card

World Radio History

There are just a couple of things we can't supply to broadcasters... buildings and voice talents.

Call AEQ and you will find almost everything you need for your local radio station or for your international broadcast network.

Our talented engineers can provide you with Systems Engineering Design, state of the art equipment, technical advice and, most of all, the expertise obtained through the set up of over a hundred radio stations using our own designed equipment over the last ten years.

Do not hesitate. Choose somebody who knows. Choose AEQ.

AEQ MP-10 Portable Mixer. Allows program production and news report from anywhere with an available telephone line.

AEQ SYSTEL-3000 Multipoint Multiconference System. Allows full duplex simultaneous intercommunication of up to 9 people. Controlled via PC or through AEQ CR-01 remote control console.

AEQ TH-02 Digital Hybrid. The ultimate solution to talk show problems.

AEQ BC-2000 Broadcast Mixing Console. Complete Modular design. 18, 25 or 35 module versions.

- ❖ Power Amplifiers
- ❖ Digital Telephone Hybrids
- ❖ Frequency Line Extenders
- ❖ Distribution Amplifiers
- ❖ Broadcast Mixing Consoles
- ❖ Broadcast Portable Mixers
- ❖ Self Powered Monitors
- ❖ Line Amplifiers
- ❖ Line Equalizers
- ❖ "Turn-key" Projects
- ❖ ...and much more !

 aeq

C/ Rey Pastor, 36 Pol. Ind. Leganés 28914 - Leganés (Madrid) ESPAÑA Tel.: + 34 1 686 13 00 Fax: + 34 1 686 44 92
 AEQ-America 2211 South 48th Street, Suite H - Tempe, AZ USA 85282 Tel.: (602) 431-0334 Fax: (602) 431-0497

Circle (37) On Reader Service Card

World Radio History

USER REPORT

ComStream Delivers with Digital Uplinks

by Paul Donahue
Technical Consultant
California Digital

MOORPARK, Calif. The business of radio involves delivering audio to listeners after it has wound its way from studio source, through studio equipment, over a microwave link and through the transmitting equipment and the station's antenna.

Before the advent of digital audio VSAT Satellite technology, stations had limited sources for programming, with either national network feeds or locally-generated programming as the main options.

As a result of new satellite technology, stations have many programming source options to improve their product and operating budgets. With the emergence of new digital radio satellite technology, the economics of radio will continue to improve.

Before 1990, radio stations never considered owning their own satellite uplink to deliver shows or programming to other stations because of the high cost of the equipment and satellite transmission space.

On the job

In 1990, Tom Joyner, "the fly jock," was rated No. 1 in Dallas on KKDA-FM with a daily morning show, and No. 1 in Chicago on WGCI-FM with a daily afternoon show. Tom was flying between cities on a daily basis to entertain listeners in both cities, but the travel was beginning to take its toll.

To solve the problem, California Digital and Gannett engineers met with ComStream engineers to design the next generation of satellite technology by marrying two critical technologies: compressed digital audio and low-cost digital data VSAT satellite transmission technology.

Compressed digital audio, as used in the Eureka-147 DAB and USA Digital DAB systems, the Panasonic Digital Cassette and the Sony Mini Disc, permit-

ted Gannett to use low-cost and reliable digital data VSAT systems from ComStream to transmit the Tom Joyner show with no loss in audio quality or entertainment value.

Tom continued to be No. 1 in both Dallas and Chicago without traveling so much. And the digital satellite technology sounded so good, local station personnel often couldn't tell the difference between cities.

California Digital and Comstream have provided the system solution to many broadcasters and networks. . .

Immediately, other Gannett radio stations, including KIIS-FM in Los Angeles, had ComStream and California Digital engineers design and build systems that could transport digital audio between owned stations. KIIS-FM in Los Angeles required a flyaway system for morning personality Rick Dees. It was needed to provide daily audio for KIIS-FM and for his Weekly Top 40 show from any location in the world.

Rick Dees often scouts out interesting events around the world for morning show remotes. Rick uses the ComStream digital audio satellite system at lower costs than analog phone lines.

Rick Dees does his daily morning radio show from many diverse locations, on just a few hours notice. And because he receives a CD-quality feed from KIIS-FM, complete with local phone calls, the show always sounds as good as it does from his L.A. studio.

Sharing resources

How do you reduce the cost of programming while enhancing value of your on-air sound without sounding canned? Many progressive radio groups are quietly starting their own networks and sharing programming and production resources among stations, to lower operating costs while developing new

revenue streams.

California Digital regularly provides proprietary technology with ComStream digital audio VSAT equipment to build regional, national, and international networks for the sharing of morning talent, production and other programming day-parts at low operating costs.

When Paxson Broadcasting began buying stations in Florida, California Digital helped design a system linking its four

the Hispanic community with a Spanish-language network, it faced the near-impossible task of erecting a C band digital audio uplink in downtown Manhattan.

California Digital engineers provided a low-cost solution by delivering the New York-originated audio to the CBS-owned Teleport Minnesota in Minneapolis. CBS now uses digital phone lines and CCS CDQ2000 MUSICAM™ encoders to send the New York-originated audio to the digital audio uplink in Minneapolis.

The digitized audio is then beamed to the United States, Canada and Mexico by satellite ASC-1, using a small portion of a CBS video transponder to affiliates with ComStream ABR200 MUSICAM digital audio receivers for CD-quality sound. The project meets all expectations and fits in the desired budget. Affiliates can sign on by installing a receiver at their station.

When Promosat, a Hispanic Programming Network, wanted to improve audio quality for its satellite affiliates, the solution was to save money by bypassing a middleman satellite teleport operator. Promomedia now operates its own ComStream digital audio satellite uplink in Guadalajara, Mexico and sends two CD-quality stereo signals of music programming directly to affiliates across the

continued on page 52 ▶

markets in a program-sharing arrangement.

For example, Paxson Broadcasting now sends news programming from Miami to any owned and operated station, or to any affiliates that may be added. The newly-syndicated "Ron and Ron" show is uplinked from Tampa to several affiliates and to Paxson's own stations, even though it isn't heard in Tampa due to a non-compete agreement. The modular design of the technology allows the Paxson group to continue growing without becoming outdated.

When CBS Radio wanted to superserve

MARTI

Don't wait 8 weeks to get your new STL system. We've been selling FCC approved STL systems since 1970, and we've got them in stock, ready to ship.



STL-15C Composite Transmitter

Frequency synthesized * Unexcelled narrow band performance * Digital ready (with external modems)

For more information call:

MARTI Electronics, Inc.

PO Box 661

Cleburne TX 76033-0661

Phone: (817) 645-9163 • FAX: (817) 641-3869

SUBSCRIPTION/READER SERVICE FORM	
<p>FREE Subscription/Renewal Card</p> <p>I would like to receive or continue receiving Radio World FREE each month. <input type="checkbox"/> Yes <input type="checkbox"/> No</p> <p>Signature _____ Date _____</p> <p>Please print and include all information:</p> <p>Name _____ Title _____</p> <p>Company/Station _____</p> <p>Address _____</p> <p>City _____ State _____ ZIP _____</p> <p>Business Telephone () _____</p> <p>Please circle only one entry for each category:</p> <p>I. Type of Firm</p> <p>D. Combination AM/FM station F. Recording Studio</p> <p>A. Commercial AM station G. TV station/teleprod facility</p> <p>B. Commercial FM station H. Consultant/ind engineer</p> <p>C. Educational FM station I. Mfg. distributor or dealer</p> <p>E. Network/group owner J. Other _____</p> <p>II. Job Function</p> <p>A. Ownership G. Sales manager</p> <p>B. General management E. News operations</p> <p>C. Engineering F. Other (specify) _____</p> <p>D. Programming/production _____</p>	
<p>Reader Service</p> <p>Sept. 22, 1993 Issue Use Until Dec. 22, 1993</p> <p>Please first fill out contact information at left. Then check each advertisement for corresponding number and circle below.</p> <p>Purchasing Authority</p> <p>1. Recommend 2. Specify 3. Approve</p> <p>001 023 045 067 089 111 133 155 177 199</p> <p>002 024 046 068 090 112 134 156 178 200</p> <p>003 025 047 069 091 113 135 157 179 201</p> <p>004 026 048 070 092 114 136 158 180 202</p> <p>005 027 049 071 093 115 137 159 181 203</p> <p>006 028 050 072 094 116 138 160 182 204</p> <p>007 029 051 073 095 117 139 161 183 205</p> <p>008 030 052 074 096 118 140 162 184 206</p> <p>009 031 053 075 097 119 141 163 185 207</p> <p>010 032 054 076 098 120 142 164 186 208</p> <p>011 033 055 077 099 121 143 165 187 209</p> <p>012 034 056 078 100 122 144 166 188 210</p> <p>013 035 057 079 101 123 145 167 189 211</p> <p>014 036 058 080 102 124 146 168 190 212</p> <p>015 037 059 081 103 125 147 169 191 213</p> <p>016 038 060 082 104 126 148 170 192 214</p> <p>017 039 061 083 105 127 149 171 193 215</p> <p>018 040 062 084 106 128 150 172 194 216</p> <p>019 041 063 085 107 129 151 173 195 217</p> <p>020 042 064 086 108 130 152 174 196 218</p> <p>021 043 065 087 109 131 153 175 197 219</p> <p>022 044 066 088 110 132 154 176 198 220</p>	
<p>Copy & Mail to: Radio World, PO Box 1214, Falls Church, VA 22041, or FAX to: 703-998-2966</p>	

Products & Services Showcase

For more information on the products shown below, circle the appropriate Reader Service No.(s) on the enclosed Subscription/Reader Service card or contact the advertiser directly.

NEW!!! from AVCOM
PSA-65A Portable Spectrum Analyzer & SCPC-2000E Single Channel Per Carrier Receiver

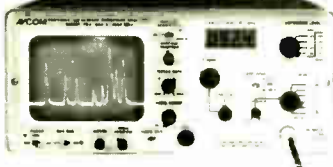

PSA-65A Portable Spectrum Analyzer - \$2855
 AVCOM's PSA-65A Portable Microwave Spectrum Analyzer covers a frequency range from less than 2 MHz to 1000 MHz. The broad frequency coverage and high sensitivity of the PSA-65A make it ideal wherever a low cost, compact spectrum analyzer is needed. The light weight, battery or line operated PSA-65A Portable Spectrum Analyzer from AVCOM is the perfect instrument for field testing of RF systems, classroom instruction, satellite system alignment, electronic countermeasures, cable TV maintenance, cellular and production use.



SCPC-2000E SCPC Satellite Receiver - \$1875
 AVCOM's Single Channel Per Carrier Receiver, model SCPC-2000E, has been developed for the reception of FM SCPC signals from satellites operating in the 3.7 to 4.2 GHz band. The SCPC-2000E is a complete receiver that can tune up to 4 specific crystal controlled audio or data channels from a given transponder and adapt to a variety of de-emphasis requirements. The SCPC-2000E is available in either wide or narrow band models and may be used with the SS-1000 (\$1027) Slave for simultaneous reception of additional channels.

AVCOM OF VIRGINIA 500 Southlake Blvd. Richmond, VA 23236 U.S.A.
 Bringing High Technology Down to Earth Phone 804-794-2500 / Fax 804-794-8284

READER SERVICE NO. 130

CONSOLE UPGRADE WITHOUT THE BIG EXPENSE



COST COMPARISON

Approach digital quality with your yesteryear audio console by using BDI plug-in retrofit electronics. If the cost of a new console is depriving you of a competitive air sound then BDI electronics are the answer. Better headroom, lower noise, lower distortion, dynamic range approaching 90dB and improved reliability are just some of the advantages of our easy to install upgrades. Call us today direct for a competitive air sound tomorrow!

Our retrofit electronics currently support most:

*Gates/Harris Consoles
 RCA Consoles
 McMartin Consoles
 McCurdy Consoles*

bdi Broadcast Devices, Inc.
 5 Crestview Avenue
 Peekskill, NY 10566 **(914) 737-5032**

READER SERVICE NO. 8

Obstruction Lighting That's Not Sky High

ElectroFlash™ Aviation Lighting Systems

- Medium and High Intensity Obstruction Strobe Lighting
- ETL Certified, FAA, Transport Canada and ICAO Approved
- Compatible with Dual Installations—Auto Restart
- Available with AC, DC or AC/DC Combination Input Voltage
- Installation and Service Maintenance Available
- Equipment Warranted for 24 Months—Includes Flash Tube

P.O. Box 329
 Nashua, NH 03060
 Tel: (603) 883-6500
 Fax: (603) 883-0205



READER SERVICE NO. 19

Tired Of Replacing Expensive Headphones?

Designed to provide vivid sound reproduction when used with today's digital sources, these stereophones feature high-performance 40 mm drivers. The maximized power handling capability ensures full, accurate reproduction of the wide dynamic range found in digital program material.

The soft leatherette earpads and adjustable headband provide for hours of comfortable listening while the closed-back design of the earpieces allows for privacy and prevents unwanted outside sounds from interfering with your listening enjoyment. The 3.0 m (9.8 ft.) cable is terminated in a 3.5 mm mini plug, ideal for portable systems, and a 1/4" plug adapter is included for home use.



Only \$29⁹⁵

2342 S. Division Avenue
 Grand Rapids, Michigan 49507
1-800-999-9281

200 Fareway Drive - Suite 2
 Smithfield, North Carolina 27577
1-800-369-7623

AUDIO BROADCAST GROUP

READER SERVICE NO. 64

EXPANDABILITY

Expandable Digital Remote Control.
 As your station metering requirements grow to additional sites and channels, the DRC 190 from Hallikainen & Friends grows with you. By its inherent, modular-expansion design, the DRC 190 can accommodate a single transmitter or grow to manage up to 100. Reliable firmware includes a multiple access, anti-contention data packet system allowing any site to communicate with any other site over wireline, sub-carrier or half-duplex UHF radio. The same firmware allows expanding the system by adding additional sites or channels at any time. For a system to grow with, not out of, expand with the DRC 190.

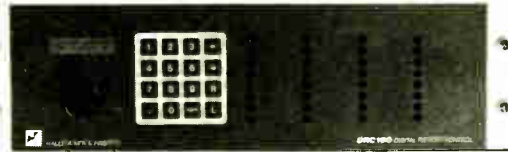

PROGRAMMABLE EXPANDABLE AFFORDABLE DRC 190

HALLIKAINEN & FRIENDS
 141 Suburban E4, San Luis Obispo, CA 93401-7590 USA
805-541-0200

READER SERVICE NO. 106

the Desk Jockey™
Digital Automation That Makes Sense

Have you noticed that automation ads these days are filled with nothing but gee-whiz technobabble?

*Investment in technology is good.
 Return on investment is better.*

Call us today to learn about real broadcasters who've made real money real fast using genuine Desk Jockey automation systems.

RB Rodman \ Brown & Associates, Inc.
Advanced Technology Studio Systems
(708) 983-0977

READER SERVICE NO. 220

Affordable Custom Broadcast Furniture



TEL: 1-800-676-0216
FAX: 215-640-5880

STUDIO TECHNOLOGY

4 Pennsylvania Avenue, Malvern, PA 19355

READER SERVICE NO. 68

Manufacturers

Is your company or product featured in our pages? Distribute extra copies of **Radio World** articles to your customers with **Radio World's** reprint service.

Print as many copies as you want for **one low price.**

For information, call Simone Mullins at **1-800-336-3045**

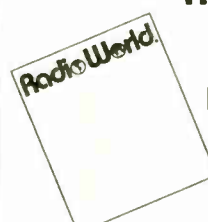
Products & Services Showcase

For more information on the products shown below, circle the appropriate Reader Service No.(s) on the enclosed Subscription/Reader Service card or contact the advertiser directly.



Econco REBUILT POWER TUBES



Approximately One Half
the Cost of New

3,000 Hour Unconditional Guarantee
Call for Our Price List

Econco 1318 Commerce Ave. Woodland, CA 95695
Phone: 916-662-7553 Fax: 916-666-7760 Telex: 176756
Toll Free: 800-532-6626 From Canada: 800-848-8841

READER SERVICE NO. 61



CD100 · X Compact Disc Adapter-Amplifier

Matches any consumer compact disc player or cassette deck to broadcast console input. Only \$89.00 FOB factory or from any broadcast dealer.

Russ Friend & Associates

342 N. Sunnyside
Clovis, CA 93611

Phone 209-298-6838 FAX 209-298-8270

Turntable Parts/Felts
Russco, Collins TT-200, Sparta

READER SERVICE NO. 205

PORTABLE OFF SITE EBS MONITOR \$350⁰⁰

Tuneable AM/FM Receiver and
FCC Certified Decoder Model C.D.



Ideal for use during hours of unattended operation at the studio and transmitter site. With modern remote control equipment the alert message can be put on the air with a telephone.

Decoder in a minibox (price \$250⁰⁰) is available for use with receiver of your choice, or the decoder can be driven by phone line audio.

Gorman Redlich Mfg. Co.

257 W. Union St. Athens, Ohio 45701
FAX 614-592-3898 · Phone 614-593-3150

READER SERVICE NO. 24

DIELECTRIC... your "RF Source."

- * Antennas (TV & FM)
- * Transmission Line & Waveguide
- * Switches
- * Filters
- * Combiners
- * Loads



With over 40 years of engineering and manufacturing excellence, Dielectric supplies standard and custom RF products *built to last*. Call and let us help...

DIELECTRIC COMMUNICATIONS 
1-800-341-9678 P.O. Box 949
Fax 207-655-7120 Raymond, Maine 04071

READER SERVICE NO. 77

The CircuitWerkes AC-2 Autocoupler



More Features. Better Price.

- Auto-connect and disconnect.
- FCC Pt.68 registered.
- Two-Year limited warranty.
- LED Indicators for audio clipping, incoming rings and line status.
- Answers on user selectable number of rings.
- Momentary or latching dry contacts at pickup.
- Momentary open collector output at pickup.
- Defeatable pickup inhibit function for cart decks, etc..
- Can be combined with CircuitWerkes DTMF decoder board to form a dial-up DTMF remote control.
- Optional ComboLok provides for secured access.

CircuitWerkes

6212 SW 16th Place
Gainesville, Florida 32607
(904) 331-5999
fax (904) 331-6999

READER SERVICE NO. 182

Byte it with



A Digital Recorder specifically designed to record phone calls and play them back quickly and easily.

Fast nondestructive editing.

Easy access and fast stacking of bits.

The most powerful way to record and air phone-bits.

The Blue Group

1001 Ridge Avenue
Clearwater, FL 34615
TEL 813. 442.1665

READER SERVICE NO. 213

Efficient & \$
Economical \$
\$\$\$ \$\$\$\$\$

Radio World's Products & Services Showcase reaches over 22,000 radio station owners, managers, engineers and consultants every month.

To advertise your product or service, contact your sales representative or Simone Mullins at
1-800-336-3045

Excalibur Electronics CD-1 Interface Amp



The industry's favorite unidirectional interface amplifier is designed to match IHF output standards (10kΩ unbalanced, -10dBV) to broadcast input standards (+4dBm, balanced). DC coupling, <0.006% THD & IMD, and >90dB S/N make the CD-1 appropriate for use with the highest quality CD players, as well as with monitor tuners, cassette and tape playback, DAT playback, and ENG equipment. Table-top mounting or, using the included angle brackets, may be attached to a rack panel, your cabinetry, or anywhere convenient. A dual version, the CD-2, is also available.

EXCALIBUR ELECTRONICS, INC., CHANTILLY, VIRGINIA
Please circle our bingo number for a data sheet and a dealer list

READER SERVICE NO. 15

AUTO-ANSWER TELEPHONE COUPLER

Ideal for unattended situations such as listen lines, IFB feeds, dial-up networks, remote transmitter sites & satellite links.

- Clean connection to phone line
- Easy to install
- Send or receive program
- F.C.C. registered



COMREX[®]

Comrex Corp., 65 Nonset Path, Acton MA 01720
Tel: 1-800-237-1776 Fax: 508 635-0401

READER SERVICE NO. 176

USER REPORT

Canary Brings 'Something' to WGTN

by Chris Ling
General Manager
WGTN-AM-FM

GEORGETOWN, S.C. Radio broadcasters are constantly trying to keep up with the ever-changing demands of competition and technological advancement. The key, of course, is to do it cost-effectively.

Every once in a while, something comes along to improve our stations dramatically, while not hindering our out-of-pocket expenses. The Canary Production Library is one of those

"somethings."

The backbone of a radio station is its ability to produce good, quality production, both for itself and clients. When investing in a production library, stations hope to select one that stands the test of time and doesn't sound outdated.

It must be flexible enough to accomplish many tasks. What if you could acquire such a library and have it cost you a little unused inventory and no cash? Would you get it?

We did, and have been using the Canary Production Library for the past

three months. To say we're pleased is an understatement. Because a major portion of my background has been in programming, I know what pleases programmers and clients.

This is one of those fabled "Win, Win, Win" scenarios. Your clients win, your station wins, and a national client wins (because he'll be running spots on your station).

With the Canary Production Library, you get tremendous variety and flexibility. You'll get the typical 60-second and 30-second beds, but you also receive extended beds. Some are as long as 3.5 minutes, which is perfect for special programming segments.

Your production director won't need to splice beds together, and you'll be pleased with the varieties of styles and production cuts to fit any situation or business. From classic to alternative, domestic to international, or subtle to

shear power, the library has it all.

And with today's tight budgets, the price couldn't be better. You can receive the entire library on a barter basis. The barter program allows great flexibility as to when spots run. If you're in need of a great production library (when are we not?), consider the Canary Production



Canary Production Libraries

Library before your competition does. It's a great product at a great time at a great price.

□ □ □

For information, contact Canary Productions in Pennsylvania at 215-825-1254, or circle Reader Service 122.

FROM MOSCOW TO NEW YORK MORE STATIONS BUY ARRAKIS

Arrakis Systems is a world leader in radio studio technology. In Japan, Digilink is a brand name for hard disk audio for radio. For use around the world, the United States Air Force chose the 10,000 series console from among all competitors as its console of choice. When the United Nations needed 6 entire studios with consoles and furniture for a rush shipment to Cambodia early this year, they chose Arrakis 10,000 consoles and Modulux furniture. In Jamaica, Tahiti, and elsewhere, entire factory assembled and tested Arrakis studios are on the air. Around the world and of course in the United States... more stations buy Arrakis for their digital audio, console, and furniture needs !!!!!

Digilink is the #1 selling digital audio hard disk system in radio today. You can replace your cart machines for live On Air and have an automation system for walk away at the same time! For more information, call or write ARRAKIS,

(303) 224-2248

the premier broadcast manufacturer of consoles, furniture, Digilink and Trak*Star digital audio products.

ARRAKIS

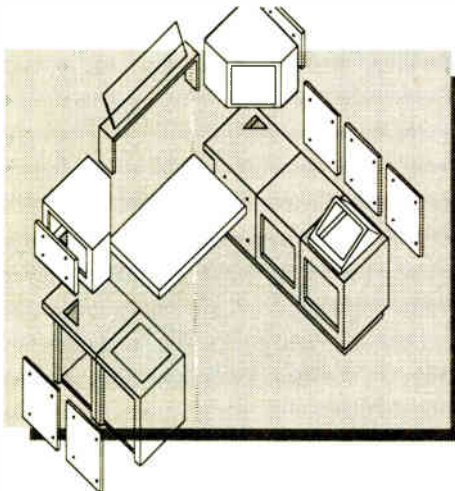

© 1993 Arrakis Systems inc. 2619 Midpoint Drive, Fort Collins, CO. 80525

Circle (132) On Reader Service Card

INDUSTRY ROUNDUP

Ku Band Offers New Alternatives To Satellite Delivery Services

by Mary Ann Dorsie

WASHINGTON It sounds local, it appears local, and it even feels local. But the newest and most affordable in satellite-delivered programming often originates thousands of miles away, without listeners ever knowing the difference.

With the technology to deliver audio transmission on the Ku band, a slew of new possibilities are opening to radio stations, especially the smaller ones without the big-city budgets, according to some delivery service companies.

The newly-discovered audio uplink allows some stations to say: "For \$300, I can have 24-hour-a-day programming for my radio station," said Kelly Hethcote, sales manager for National Supervisory Network.

Finding the link

The expensive C band uplink was the only option for satellite services even as late as a couple years ago, Hethcote said. In the past, the Ku band was only used for data transmission, he said. The band is still turning analog transmission into digital feed, but through encoding and depressing, audio is the end product on the other end.

Hethcote said religious stations and other niche markets are taking full advantage of this programming. "There's definitely a rush toward the front of the stage with niche programming," he said.

And even though the platform may cost around \$20,000, "in comparison with \$45,000 or \$50,000, it makes the product much more attainable," he said. Some packages cost as little as \$200 to \$300, without clearing any spots for time seg-

ments, Hethcote said.

One of National Supervisory Networks' clients is an adult rock station in Fayetteville, N.C. For 12 hours of the service, the cost is \$200, and for full usage, which will be implemented in October, the cost is \$300, Hethcote said.

One of the first to put a Ku band audio network together was Cliff Gardiner at Rocky Mountain Radio—KZYR(FM)—in Colorado. The station cuts its own liners and fills 20-second spots with local events and upcoming happenings.

"The quest of network delivery is to sound like it is happening locally," he said.

Local talent

The significant cost of hiring high-powered talent is another reason stations are opting for satellite networks, said Linda Donahue, President of California Digital.

"It gives an opportunity for owners of small stations to get programming at a low cost," Donahue said.

California Digital is just introducing a Digital Storage System for networks. It allows programs to be delivered, yet provides the local sound with local spots.

"It localizes the national programming in such a way, the audience doesn't ... consciously feel they're listening to some New York guy," she said.

She said comparable systems cost around \$16,000, but feels it can be accomplished for around \$6,000.

In the next few years, Hethcote foresees a direct-to-home digital audio transmission, something he predicts could be a threat to radio.

"You will have new competitors vying for time spent listening to the radio," Hethcote said.

USER REPORT

FirstCom Gives WJMN a Winning Impression

by Gordon McAdams
Production Director
WJMN(FM)

BOSTON First impressions can tell you a great many things. And from the direct, no-nonsense, personable approach of **FirstCom**, you get the impression that its production libraries are more than a rehash of the same old thing.

The FirstCom team in Dallas is first rate. The people understand your needs and speak your language (they can even translate it to your business office). More importantly, whatever sound you're looking for, they have you covered.

FirstCom's Sound Designer series is the one select collection you'd pack away and take to that desert island.

If you're not a subscriber to FirstCom's production libraries, you know the frustration of limited resources. Cutting that restaurant or shoe spot with one of the same six cuts you've beaten to death can be a real challenge.

FIRSTCOM BROADCAST SERVICES

Most libraries feature two or three cuts per disc that you like, and another 27 or so that never get past the "bad club" background muzak.

Here at WJMN(FM), we use the Techsonics library for our promos, IDs and sweepers (the new House Jamz library may soon be added to the mix), but when it comes to spots that don't fall into the nightclub, aerobics, or tractor pull category, we reach for FirstCom.

FirstCom features two extensive music libraries: "Maximum Impact" and "Sound Designer." The Sound Designer series comprises the bulk of our library, as it's coded for easy reference. Need the perfect background for "Wangs Wok?" Grab the brown "Foreign Discs" and head down to cut 29, "Shanghai." Almost all the cuts are good.

Categories such as Novelty, Rock, Specialty and Urban supplement the "Underscore" section (the core of our library). Yours could be different. The

best part about this library is getting to pick and choose.

FirstCom sent us about 50 different discs, and we sat down and listened to all of them. We kept the ones we wanted and returned the ones we didn't want.

Through this pick-and-choose process, you can tailor a library to your own specific needs. Need a good seasonal library? Grab the black discs. Don't need the jazz? Send it back. Need a lot of really good medium tempo, rich sounds? Grab the blue "Underscore" discs.

Of course, it really wouldn't matter

which discs you selected if they weren't worth selecting. This is not the case with FirstCom. In an ocean of available music libraries, FirstCom's Sound Designer series is the one select collection you'd pack away and take to that desert island.

Payment and terms most likely can be negotiated, a feature your business office can't refuse. For sound service and first class follow-up, FirstCom is first rate.

□□□

For information, contact *Andrea Bergeron* in Texas at 800-858-8880; fax: 214-404-9656; or circle **Reader Service 49**.

People, Promotions And Appointments

FWT Inc. recently hired **Jerry Mulder** as director of technical projects. His main responsibilities include developing new projects, streamlining FWT's marketing methods and negotiating equipment and materials cost quotes.

APOGEE ELECTRONICS hired **Greg Laney** as the new Sales Engineer. Laney has worked with Luther Vandross, Soul II Soul, Paula Abdul and Randy Travis, and has extensively used **APOGEE CONVERTERS** in recording sessions.

In addition, the company hired **Angie Orduno** to support the sales and marketing department.

Mark W. Pohlman joined **Moffet, Larson & Johnson (MLF)** as senior network engineer. Pohlman, formerly with GTE Mobile Communications in Atlanta, will handle networking and interconnection of telecommunications systems for the firm.

Company News

John Fluke Mfg. Co. Inc. has changed its corporate name to **Fluke Corporation**. In addition, the company changed its stock exchange symbol from "FKM" to "FLK."

Antenna Technology will provide two Simulcast multibeam satellite earthstations as downlinking antennas for the United States Satellite Broadcasting's (USSB) Digital Satellite Systems (DSS™) uplinking facility.

KRNA(FM) in Iowa City/Cedar Rapids, Iowa has installed the **Harris Digit™**, a digital FM exciter. The units provides 32-bit direct digital synthesis precision for signal quality.

Otari recently established a direct Sales Office in New York City. The office will have direct end-user sales responsibility for the company's "high tech" products, including the DTR-900, MTR-100, MTR-90, ProDisk 464 and all console/automation products.

Tape machine and studio console support will be handled by **Greg Hanks**, New York Technical Support Inc., 35 Hardscrabble Hill Rd., Chappaqua, N.Y.

10514; phone: 212-246-0227; fax: 914-238-6823.

ProDisk and post production console support will be handled by **Laslo Katona** and **Vince Mosdar**, Film-Tek and Associates Inc., 26-07 Broadway, Suite 24, Fair Lawn, N.J. 07410; phone: 201-797-4999; fax: 201-797-7274.

An Inmarsat-B telephone call from a commercial user terminal was made by **ViaSat Technology Corporation**. The call was made through COMSAT Mobile Communications' Land Earth Station (LES) in Southbury, Conn., using Inmarsat's Atlantic West satellite, from a ViaSat Technology LYNXX™ Terminal in Hauppauge, N.Y.

RF Specialties of California opened a new office in the San Francisco bay area. **Bill Newbrough**, Northwest regional sales manager, will head the office at 4480 Treat Blvd., Suite 238, Concord, Calif., 94521; phone: 510-687-9990; fax: 510-687-9991.

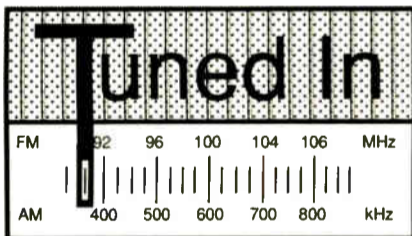

THE INDUSTRY'S RDS/RBDS LEADER HAS JUST CRUSHED THE COMPETITION

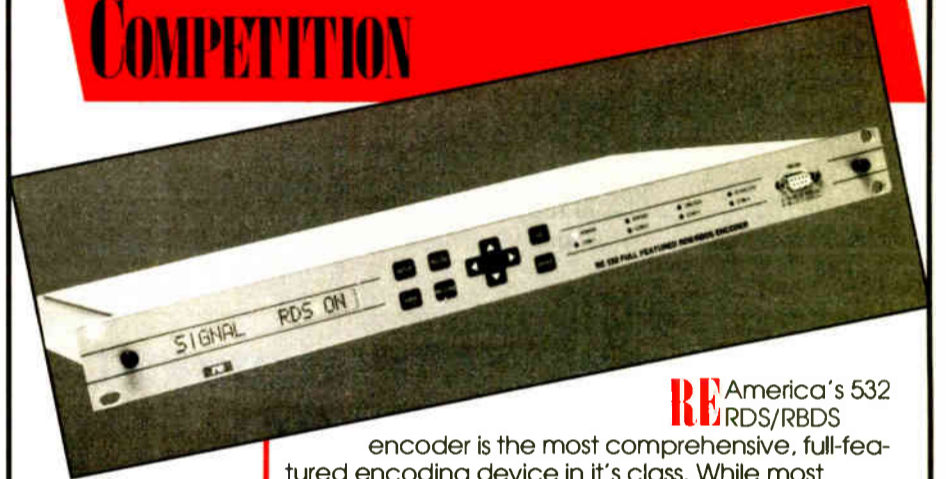

RE America's 532
RDS/RBDS

encoder is the most comprehensive, full-featured encoding device in its class. While most American RDS/RBDS encoder manufacturers are building their first product, the RE 532 represents RE's third-generation RDS/RBDS encoder. The RE 532 provides five data ports to enable broadcasters to take full advantage of the revenue potential that RDS/RBDS offers.

Ancillary RDS/RBDS data services such as Paging and Differential Global Positioning (DGPS) are now emerging as major revenue sources for broadcasters. The RE 532 will intelligently manage these services as well as maintain the integrity of the stations RDS/RBDS data, such as call signs, format and radio text.

The RE532 comes complete with its own proprietary PC control software which enables the unit to be set up and programmed quickly. Remote data control and phone-line communications can be accomplished with any Hayes compatible modem.

Without a doubt, the RE 532 is the most cost-effective, revenue-generating, piece of equipment your station could ever purchase. Now that a U.S. standard for the Radio Broadcast Data System exists, it promises to provide broadcasters with new and exciting opportunities for increasing the bottom line.

- ▲ Full-featured RDS/RBDS encoder in a compact single rack space
- ▲ Includes Paging and DGPS capability
- ▲ Five data ports for main and ancillary data usage
- ▲ Front panel keypad for easy setup adjustments
- ▲ Backlit LCD displays menu of all parameters
- ▲ Two discrete pilot sync inputs for main and back-up transmitters
- ▲ 16 data records may be programmed and sequenced automatically
- ▲ PC control program is included
- ▲ Operates as a stand-alone RDS/RBDS subcarrier generator plus loop-through mode

re

RE AMERICA, INC.
31029 Center Ridge Rd. ▲ Westlake, Ohio 44145
Phone: (216) 871-7617 ▲ Fax: (216) 871-4303

TECHNOLOGY UPDATES

OMNIMUSIC

CD Libraries Cover News, Sports and Documentaries

HOLLYWOOD, Calif. OMNIMUSIC supplies 86 CDs containing over 3,000 tracks for almost any broadcast media situation.

Over 450 tracks are edited in 29- and 59-second lengths, specifically for use in commercials or promos. Tracks are also provided for news, sports, documentaries and drama programming.

The OMNI library has "short cuts" for logos, station IDs, intros and outros, and stings, sweeps, orchestral hits, bumpers, zaps, whooshes, etc.

The company offers flat-rate, unlimited-use annual blanket licensing. Multi-year discounts are also available.

Annual blanket rates include: the OMNIMUSIC Broadcast Blanket (includes full library and updates) for \$2,500; the OMNIMUSIC educational blanket (includes full library and updates) for \$1,500; and OMNI SELECT 50 Broadcast Blanket (includes 50 CDs) for \$1,800.

For information, contact Jerry Burnham in California at 800-828-6664; fax: 213-962-4556; or circle Reader Service 43.

NPR SATELLITE SERVICES

Audio Transmission Covers Range of Situations, As Galaxy IV Targets U.S. and Parts of Caribbean

WASHINGTON NPR Satellite Services, a longstanding provider of satellite interconnection services for radio broadcasters, accommodates virtually any type of audio transmission ranging from a multi-station live remote to a full-time satellite radio network.

NPR recently switched from Galaxy VI to Galaxy IV (located at 99 degrees), Transponders 1 and 3. Galaxy IV's "footprint" covers all 50 states and parts of the Caribbean. The space segment NPR Satellite Services offers on Galaxy IV is backed-up and non-preemptible.

Although NPR Satellite Services has provided C band analog audio transmission service to radio broadcasters for the past 14 years, recent developments in digital technology make it possible to combine digital equipment with our C band system. This new method of transmission combines digital technology and audio compression.

This enables a stereo transmission to be put on a single carrier, so leasing a full-time satellite channel is more affordable than ever before. Costs that previously ranged from \$5,000 to \$8,000 per month



for stereo service now cost \$1,000 to \$2,000 per month. Moreover, a stereo transmission that once provided 15 kHz frequency response is now capable of CD-like, 20 kHz frequency response.

For information, contact Miriam C. Lenett in Washington, D.C. at 202-822-2613; fax: 202-822-2679; or circle Reader Service 90.

VALENTINO

Music and Sound Effects Libraries Set to Include Worldwide Broadcasters

ELMSFORD, N.Y. The Valentino Production Music and Sound Effects libraries on compact disc include both musical selections and sound effects produced for professional broadcast industries. The libraries were recently expanded to satisfy the requirements of foreign-based broadcast organizations.

The Music Library, which now has almost 100 CDs, and the Sound Effects Library, which has almost 50 CDs, meet the daily needs of broadcasting.

The Music Library has more than 2,500 selections of musical compositions with musical cuts, bridges, themes, backgrounds, openings, closings and titles for television and radio producers in an audio studio setting.

Included are national anthems of more than 40 countries, and individually-titled CDs such as "Horror and Suspense," "Elevator Music," "Disco" and "Christmas."

Each CD in the Sound Effects Library addresses a specific category of effect, such as cars, people, aircraft, ships, military, animals and the environment.

The libraries can save broadcasters time and money, with the ability to produce better programming.

Valentino is exhibiting the libraries in England, the Netherlands, France,

Switzerland, Brazil, Argentina, Mexico, Singapore and Japan.

For information, contact Valentino in New York at 914-347-7878; fax: 914-347-4764; or circle Reader Service 114.

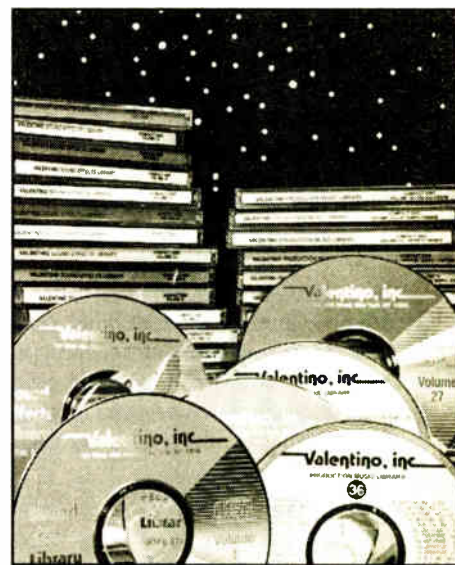

For the world's strongest AM transmitters, look to Nautel

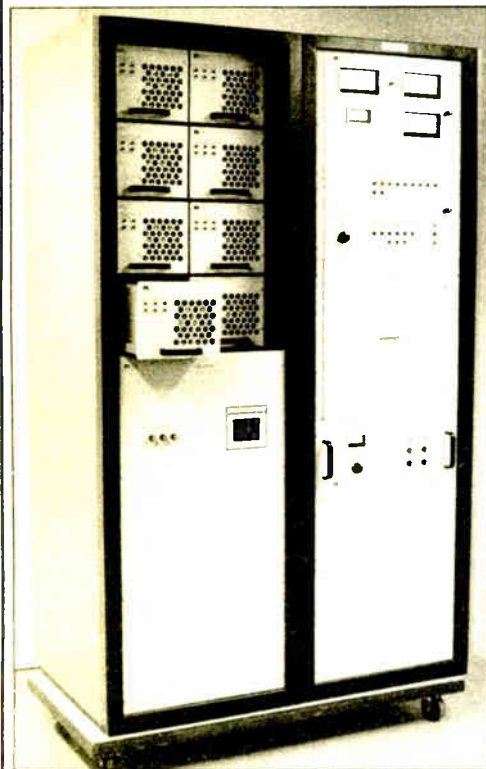

Totally solid state AMPFET ND 10 10kW AM

Nautel AM transmitters keep you on the air with an unmatched combination of value, performance and reliability

Low cost of ownership - with typical efficiency ratings up to 80 percent, a totally solid state Nautel transmitter pays for itself in tube replacement and utility

Superior audio transparency - Nautel AM transmitters utilize inherently linear digital Pulse Duration Modulation for the cleanest sound you can broadcast. Audio is ruler-flat throughout the range and distortion is typically less than 0.5%

Field-proven reliability - Nautel transmitters give you multiple protection systems for both power line and lighting transients, VSWR protection, soft failure design, reserve cooling and safe on-air servicing

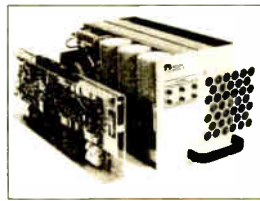

Removable AM Power Module

Make a strong transmitter choice. Call us today for all the facts on our totally solid state AM and FM transmitters.



Nautel Maine Inc.
201 Target Industrial Circle
Bangor, Maine 04401 USA
Phone: (902) 823-2233

Nautel
(Nautel Electronic Laboratories Limited)
R.R. #1, Tantallon, Halifax County,
Nova Scotia, Canada B0J 3J0
Fax: (902) 823-3183

Circle (105) On Reader Service Card

ComStream Delivers Programming With Digital Satellite Technology

► continued from page 47

United States and Mexico at one-tenth the cost of the previous teleport-provided channel.

There are many regional network satellite applications, including Rollings Communications, which shares programming among owned stations in Central Illinois using a California Digital-designed network with ComStream VSAT digital audio equipment.

Noble Broadcasting sends audio to its Mexican transmitters via satellite, and has added affiliates in a LMA arrangement to expand coverage.

KPFA(FM) in Berkeley, Calif., provides full-time programming of its Pacifica Network to KFCF(FM) in Fresno, Calif., with help from our network designs, proprietary technology and ComStream satellite equipment.

When Premiere Radio Networks decided to syndicate No. 1 country music morning man, Gerry House, California Digital designed the network. We built ComStream equipment into the system to distribute the show nationally by satellite with localized elements.

Aside from sounding good, the econom-

ics of distribution is astounding. Stereo digital audio Ku band satellite uplinks covering the entire United States with stereo audio programming can be installed for less than \$35,000. And stereo digital audio satellite channels covering the entire United States with programming range in cost between \$1,200 to \$3,000 a month.

California Digital and ComStream have provided the system solution to many broadcasters and networks wishing to share talent, dayparts, programming and costs.

California Digital has worked with NASA and JPL engineers to develop proprietary artificial intelligence Ku band power controllers and other digital audio satellite, phone line, and fiber optic line systems to develop reliable and effective networks with local, regional, national or international reach. ComStream builds digital audio satellite equipment for radio networking and point-to-point applications.

□ □ □

For information, contact Bob Meisterling in California at 619-458-1800; fax: 619-552-0488; or circle Reader Service 80.

To Make Money in Radio Advertising, You've Got to Push the Right Buttons.

Since 1990, radio stations in every music market have been more creative, more efficient and more profitable with the



DSE 7000. In order to increase profits in the competitive

radio environment of the '90s, general managers have been asking more from their production directors, who in turn have had to do things faster and cheaper. Clearly, the trusty 8-track recorder wasn't going to lead radio stations through this new era.

Since it was impossible to become more efficient at tape splicing, astute production types contemplated digital technology. They found out



about a company with over 40 years experience manufacturing professional audio products, who was already shipping a digital sound editor for radio production. Not coincidentally, this system had many of the same controls and functions they were used to.

They tried a demo of the DSE 7000 and realized they



could produce spots in one-third the time. Which meant they had time for a certain luxury called creativity.



The DSE's UNDO button gave them room to experiment. And its audio quality raised their standards to an entirely new level.

Today, hundreds of radio stations are making more money producing radio commercials, because they're pushing buttons on the DSE. Now it's time to push some buttons

on your telephone and call AKG.



DSE 7000 • THE NEW SPEED OF SOUND™



AKG Acoustics, Inc. 1525 Alvarado Street, San Leandro, California 94577, USA, Tel: (510) 351-3500, Fax: (510) 351-0500

AKG is a registered trademark of Akustische u. Kino-Geräte Ges.m.b.H., Austria. ©1993 AKG Acoustics, Inc.

Circle (166) On Reader Service Card

World Radio History

RADIO COMPUTING SERVICES INC.
Master Control Allows Storing and Playing Of Music and Commercials with Digital Quality

SCARSDALE, N.Y. RCS Works! by Radio Computing Services Inc. is a completely integrated digital station system, incorporating a user's Selector music log with the full line of RCS products.

The system allows users to store and play music and commercials with digital quality directly from the computer's hard drive. Instant access to sound effects, drop-in carts and jingles is available with the press of a button.

Master Control interfaces with CD

jukeboxes and satellite network services, and can be live-assist or fully automated.

The Master Control studio system has three video screens: one for the electronic copy book; one for the display status of upcoming digital events such as songs, spots or drop-in carts; and a third for past, present and future log events.

For information, contact Tom Zarecki in New York at 914-723-8567; fax: 914-723-6651; or circle Reader Service 160.



Clearly Digital.

Moseley's DSP 6000 Digital Transmission System...
the clear solution to your STL problems is now a reality.

- ▼ Convey up to four 15 kHz audio channels with CD quality specifications over a single STL.
 - ▼ Interface to any composite STL, preserving the capital investment of your existing STLs.
 - ▼ 25 dB system gain improvement over analog STLs reduces new antenna & transmission line costs.
 - ▼ Low coding delay of 3.8 ms keeps the air talent happy.
 - ▼ Fade and co-channel intermod problems have no effect on SNR, so even quiet passages remain crystal clear and noise free.
 - ▼ A built-in V.35/RS-422 interface opens the door for utilizing the DSP 6000 with Fractional T1 digital Telco circuits.
 - ▼ AES/EBU digital I/O allows direct digital interface to other digital hardware.
- To learn more about the digital transmission advantage, call today for our free color brochure.

Moseley

MOSELEY ASSOCIATES INC. • 111 CASTILIAN DRIVE • SANTA BARBARA, CA 93117 • (805) 968-9621 • FAX (805) 685-9638

INTERNATIONAL E-Z UP
Instant Shelters Provide Portable, On-Site Protection

ONTARIO, Calif. The E-Z UP Instant Shelters by International E-Z UP Inc. are designed to help keep you cool at on-site remotes, promotions and other outdoor events in the broadcast industry.

The shelters can be set up in less than 60 seconds, and are useful for placing attention-grabbing call letters and station colors. Available with a reproduced silk screen of the station logo, the shelters also come in many different colors.

Sidewalls, halfwalls, rail skirts and bug screens are also available. E-Z UPs range from 8 x 8 to 10 x 20 feet and fold down easily and compactly to fit in storage bags after use.

For information, contact International E-Z UP in California at 909-466-8333; fax: 909-944-2884; or circle Reader Service 41.

MANHATTAN PRODUCTION
Libraries Feature More Than 46 CDs of Varied Music Genres

NEW YORK Manhattan Production Music consists of over 46 CDs, each with over 60 minutes of original copyrighted music. MPM features musical genres such as pop, jazz, country and classical. Specialty categories include sports, news and comedy.

The library features over 500 short (10 seconds or less) music beds for stingers, about 200 cuts of short sweepers/IDs and about 600 themes for spots. MPM uses a simple "blanket licensing" system, giving the producer a full musical spectrum without any licensing hassles.

Manhattan Production Music's new sound effects library, The Audiophile Sound Effects Series, is produced with 128 times over-sampling and in stereo.

It features 495 of the most popular sound effects usable for radio, television and motion pictures, and other unique effects.

For information, contact Ron Goldberg at 800-227-1954; in New York state at 212-333-5766; fax: 212-262-0814, or circle Reader Service 141.

ABC
Programming Distribution Via Satellite Takes Off

NEW YORK ABC Satellite Services distributes radio programming via satellite for a wide range of networks and programmers throughout the industry.

ABC maintains space segment on a variety of satellites. The primary distribution medium is Satcom C-5, transponder 23 (a fully protected, digital, wide-band DATs transponder). Virtually all distribution on Satcom C-5 is done using 20 kHz SEDAT technology, one of the finest audio quality available via satellite today.

This method reaches thousands of commercial radio stations, especially in the major markets, across the United States.

ABC Satellite Services also provides digital and analog automation cueing. Clients have the value of ABC engineering expertise and experience behind them.

For information, contact Joe Busch in New York at 212-456-5606; fax: 212-456-5622, or circle Reader Service 143.

MARKETPLACE

A compendium of new and recently introduced radio broadcast products

Digital Audio Control Center

Digital Domain™ introduced the VSP™, a digital audio control center, featuring a record and monitor selector, external processor loop, sample rate converter, digital patchbay, distribution amplifier, hardware and software format converter and crystal-locked jitter eliminator.

The rack-mount unit, which is available in two models, is 1 3/4" x 19" x 6". The VSP reclocks digital audio signals with a crystal oscillator, eliminating jitter. It helps minimize or eliminate sonic differ-



ences between CD transports, DAT machines and jittery digital signal processors.

It accepts AES or S/PDIF format signals through six digital inputs, via RCA, XLR, Toslink optical and ST (AT&T) optical connectors. The unit converts impedances and software between all

standard formats and cleans up external D/A and A/D converters, digital recorders, work stations, CD players and other digital sources for better sound.

For information, contact Digital Domain in New York at 212-369-2932; fax: 212-427-6892; or circle Reader Service 78.

Patch Panels with Push-Pull Connectors

Lemo USA Inc. introduced patch panels designed with LEMO's push-pull connectors. A space-saving alternative to traditional patch panels, they're ideal for applications where many connectors are fitted into a small amount of space.

The connectors disengage simply and smoothly with an axial pull on the connector's outershell, requiring finger clearance on just two sides of the connector. This self-latching design assures signal continuity by preventing connector disconnection

caused by accidental pulling on the cable.

The patch panels measure 19" in length and accommodate connector designs from 50 or 75 ohm single or multicoaxial/triaxial inserts to a variety of signal or mixed insert variations.

The internal patch panel linking can be direct or made with microswitched adapters assuring signal normalization in coaxial and triaxial connectors.

For information, contact LEMO USA, Inc. in California at 800-444-5366; fax: 707-578-0869; or circle Reader Service 137.

Programmable Logic Controller

SMC Wireless introduced the Sprint 7010 Programmable Logic Controller. The unit is ideal for locations where remote control and data acquisition are needed.



The Sprint 7010 incorporates 16 analog input ports and 16 relay or transistor outputs. The unit, fully programmable, enables the user to customize the system to specific applications.

Alarm and other messages can be sent directly to an alphanumeric pager. Communication with the unit is accomplished through a standard RS232 serial port.

The unit operates from 12 volts DC with a standard 19-inch rack mount design.

For information, contact SMC Wireless in Texas at 800-527-1079; fax: 713-259-7801; or circle Reader Service 144.

Automation System

The EDAAS™ (Extensible Distributed Architecture Automation System) is a computer system designed for Radio/TV broadcast networks and other large broadcasting facilities.

It allows distribution of operator control, routing/switching, machine control and monitoring functions between multiple computers and workstations. The HDL audio storage system allows up to 32 simultaneous I/O channels and

storage of 480 hours of DC quality audio.

In addition, its CD-quality audio, precision networking and powerful command structure virtually eliminate errors and audio degradation. Operating under the Microsoft Windows™ environment and interconnecting via a high-speed Ethernet™ bus, EDAAS can control up to 200 simultaneous automated networks and feeds in the various applications.

Clark & Associates was chosen to deliver the EDAAS system to the



Time Delay Relays

The Power-Time KRD Series is a new line of compact, encapsulated, low-cost time delay relays designed for OEM machine and appliance applications.

The unit features a 10 amp rated miniature relay, combined with a digital solid state timing circuit and onboard adjustment. It comes in a 2" x 2" x 3/4" mold-epack package.

The design of the KRD Series eliminates the need for a separate mounting/connection socket. It is designed for automated assembly, and mounts with a single No. 8 or No. 10 screw, using 1/4 quick connect for electrical connection.

The Series is available in three modes of operation: Delay on Make, Interval or Recycling. Time delays from 200 milliseconds to 100 minutes are divided into five ranges. The time delay is adjustable with an onboard knob or ordered factory fixed. Its repeat accuracy is ±0.5 percent.

For information, contact Gary L. Weeks in New York at 315-638-1300; fax: 315-638-0333; or circle Reader Service 21.

Westwood One/Mutual/NBC Radio Networks for use in their Washington area network facilities.

For information, contact Bill Clark in Illinois at 309-837-2244; fax: 309-833-5175; or circle Reader Service 121.

ISDN Terminal Adapters

The TelePower ITA-2000 series of Intelligent Terminal Adapters consists of digital type data "modems" for high speed data transmissions over the Basic Rate Interface (BRI) (2B+D) ISDN tariffed telephone lines.

These standalone dual port TAs provide access over a single telephone line to two each 64 kbps "B" channels for circuit switched data calls, plus an additional 16 kbps "D" channel for call control and X.25 packet switched data applications.

The TAs accommodate a range of data terminal equipment to provide direct ISDN connections for one or two data terminals to the S/T interface of an NT-1 Network Termination Unit.

TelePower's TA can be used for Wide Area Network applications such as remote PC to PC, PC to LAN, or LAN to LAN



type connections, Group 4 FAX transmissions, and videoconferencing.

For information, contact Bob Schaaf in California at 818-587-5540; fax: 818-587-5546; or circle Reader Service 60.

AFFORDABLE FM1C

1 kW SOLID STATE FM STEREO TRANSMITTER



- Industry acclaimed FX50 Exciter.
- Reliable solid state design.
- 2 RF Power Modules for soft failure.
- Broadband design-no tuning.
- Internal Low Pass Filter.
- Reliable CMOS Controller.
- Compact, easy to install, rack mountable.
- Self-protected RF Modules.
- Integral Reject Load.
- Two year warranty.
- Meets IEC-215 safety requirements.
- Low cost of \$16,500 includes FX50 Exciter.



BROADCAST ELECTRONICS INC.
4100 N. 24TH ST. P.O. BOX 3606
QUINCY, IL 62305-3606 U.S.A.
PHONE (217) 224-9600
FAX (217) 224-9607
TELEX 250142



+



+



or



or

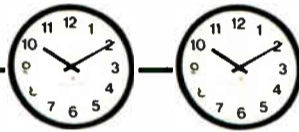

or



=

Our summer console sale

This summer save \$500.00 on a Radio Systems RS-12 or RS-18 console plus get your choice of a stereo DA, phone interface, impulse clock system, or phase fixer for free!

It's a great way to save on broadcast's most popular console, plus get the accessory you need.

The Products

- RS-12 12 channel stereo broadcast console
- RS-18 18 channel stereo broadcast console
- TI-101 Phone hybrid with equalization
- DA-16 Stereo eight output distribution amp
- AMD-1 Impulse master driver with two analog clocks
- PH-2 Stereo phase correction system

The Deal

Contact your authorized Radio Systems dealer for your \$500.00 console discount and to choose your free product. Call Radio Systems for the name of your local dealer or for more product information. Offer expires September 30th, 1993.

RADIO SYSTEMS INC.

110 High Hill Road • P.O. Box 458 • Bridgeport, NJ 08014-0458 • (609) 467-8000 • FAX (609) 467-3044

Circle (31) On Reader Service Card
World Radio History

RadioWorld

Broadcast Equipment Exchange

"Broadcast Equipment Exchange" accepts no responsibility for the condition of the equipment listed or for the specifics of transactions made between buyers and sellers.

NEW! NEW! NEW!
We now buy & sell pre-owned video equipment!

RADIO RESOURCES
1201 S. Sharp St.
Baltimore, MD 21230

DO YOU HAVE EXCESS EQUIPMENT TO SELL? Let us help you turn your excess equipment into CASH.

Some of our equipment needs are:
AM/FM TRANSMITTERS
FIELD STRENGTH METERS
MARTI VHF/UHF RPU EQUIPMENT
MARTI STL EQUIPMENT
OTARI MX 5050 REEL TO REEL DIGITAL SATELLITE EQUIPMENT
CONSOLES
ORBAN OPTIMODS

If there is a piece of pre-owned equipment you are looking for, give us a call, we can help!

THE INDUSTRY'S BEST NEW & PRE-OWNED EQUIPMENT DEALER
Ask for Steve or Chuck for Radio Products or Bob or James for Video Products

Call 1-800-54-RADIO
"The only # you need to know!"

FAX: 1-410-783-4635

Circle (32) On Reader Service Card

ACOUSTICS

Want to Sell

STUDIOFOAM
SOUND ABSORBENT WEDGES
TESTS 18% BETTER THAN SONEX!
COSTS LESS! BETTER COLORS!

1-800-95-WEDGE

AMPLIFIERS

McIntosh A-116-B pwr amp; Marantz 7 pre amp; Dynakit stereo 70 pwr amp; (2) Ampex 620 speaker amps. Kinura Records, Box 660236, Miami Springs FL 33166. 305-887-5329.

Ramko SMA-1000E stereo mon amp (2), gd cond, BO. P Guello, KUWS, 1800 Grand Ave, Superior WI 54880. 715-394-8187.

Ramko DA-16BR-E dist amp, \$150. J Vavricek, KSYZ, Grand Island, NE. 308-382-0108.

Rane HC-6 headphone amp in great cond, \$200. S Wytas, SWP, 165 Linden St, New Britain, CT 06051. 203-280-3913.

LPB DA1 16 dist amp, new. J Gelo, J&H Music Programming, POB 1697, Marco Island FL 33937. 813-642-6899.

New 250 W solid state amp, \$1800. Call for details. Bill Hoffman, 518-583-9490.

McMartin MX5 pro mixer pre-amp, bal/unbal, 2 mic, 2 phono, aux input w/rack ears, \$175. J Hayes, Radio Free New York, 1748 70th St, Brooklyn NY 11204. 718-234-9374.

Want to Buy

Tube Amplifiers. 612-866-6183.

Crown D-75; Gentner SPH-3, 3A or 4 phone interface, must be in gd cond. D Koehn, KKPR, 403 E 25th St, Kearney NE 68847. 308-236-9900.

Any tube type audio amplifiers such as Marantz, McIntosh, Fisher, Altec, WE, RCA, etc. John, 708-391-8828.

Looking for schematic of Eclipse Series ESS-500 A-542 power amp. Mail copy to R. Strange, 5208 W Acapulco Ln, Glendale AZ 85306.

ANTENNAS & TOWERS

Want to Sell

Andrew HJ9-50 5' cable, 500' with connectors on spool in Midwest, 1/2 new price. R Henry, WPIO, 505 Josephine St, Titusville FL 32796. 407-267-3000.

Phelps-Dodge 3-bay tuned to 107.1, avail early August, \$1200. D Sports, WCLA, POB 427, Claxton GA 30417. 912-739-3035.

Andrew 5' Helix w/connectors, 500' on spool, BO. J Rosebuck, 515-280-1350.

Rohn 55 300' tower, ERI 3-bay antenna tuned to 96.7, Cablewave 300' Helix, all for \$11,000; ERI GPCP 8-bay antenna, needs work, \$4000. M Howard, WYKZ, POB 5406, Valdosta GA 31603. 912-333-0755.

Helix 500', 1-5/8". L Kilday, WYKZ, POB 5406, Valdosta GA 31603. 912-333-0755.

Gates FM-4A cycloid 4-bay HP FM antenna, 91.3 MHz, 10 kW, BO. P Guello, KUWS, 1800 Grand Ave, Superior WI 54880. 715-394-8187.

Andrew 190' 1-5/8" coax foam dielectric, \$150/BO. J Morris, WFHB, POB 1973, Bloomington IN 47402. 812-824-4085.

ERI 1991 2-bay, tuned to 103.7, excel cond, BO. D Thornhill, WHHT, POB 457, Glasgow KY 42142. 502-651-6060.

Andrew 1/2" Helix, 650', brand new, \$1.75/ft/BO, will sell shorter lengths. R McDaniel, KJRG, Box 567, Newton KS 67114. 316-283-5150.

Andrews 1861 3-1/8"-1-5/8" reducer & (2) 81GF 3-1/8" EIA female connectors with gas barrier; Cablewave 1-5/8" air-dielectric coax, 180' with EIA connector one end. C Frodsham, KVSU, POB 7, Beloit KS 67420. 913-738-2206.

Decibel Products DB-224 antenna for Marti RPU system; Andrews 3" transmission line, 56', new; Cablewave 1-5/8" transmission line, 20', new; Cablewave 1/2" transmission line, 50', 100', 250', used. FB Nienow, WYTE, POB 1030, Stevens Point WI 54481. 715-341-8838.

200' 6" hard line low loss 72 ohm for FM/TV with hangers & elbows, BO. K Crosthwait, WTNN, 13206 Buttermilk Rd, Knoxville TN 37932. 615-531-2297.

Andrew 500' 5" air dielectric Helix w/connectors, BO. J Kosobucki, Saga Comm, 1416 Locust, Des Moines IA 50313. 515-280-1350.

FM - ANTENNAS

Designed and built for your frequency. Choose from 1 to 12 bays and five power levels. Financing available. Call Jimmie Joynt at S.W.R. 214-335-3425

Low power 6-bay HP FM antenna. K Diebel, KTJC, 1207 Louisa St, Rayville LA 71269. 318-728-5852.

Want to Buy

Andrew 7/8" Helix, 400-600' and clamps. J Viele, WHOT, 161 Fox St, Hubbard OH 44425. 216-783-1000.

6 bay around 92.1 MHz. J Hansen, WYRQ, 70SE 1st Ave, Little Falls MN 56345.

Low or medium power 3-bay CP FM antenna that operates on or near 99.5 MHz; also a low or medium powered 6-bay CP FM antenna on or near 92.3 MHz. K Diebel, KTJC, 1207 Louisa St, Rayville LA 71269. 318-728-5852.

Phase monitor, 5 tower or more. George, WNQM, 1300 WWCR Ave, Nashville TN 37218. 615-255-1300/1377.

AUDIO PRODUCTION

Want to Sell

Smartcaster, computer, digital audio: live or automated. D Nelson, 619-758-0885.

Correlation / Phase Indicator

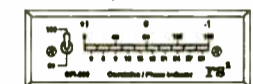

A compact alternative to XY displays for Stereo / Mono Compatibility Checks
Tape Head Azimuth Adjustment
Transmission Path Evaluation
Stereo / Mono Identification
Signal Polarity Testing
CPI-300 — \$ 265

recording studio services
PO Box 3004
Hendersonville, TN 37077
615-824-9303
Compuserve: 75366,311

Circle (14) On Reader Service Card

ADC 48 patchbay phone jack. D Nelson, 619-758-0888.

ADC 144 Pt TT patchbays, excellent condition, 1 rack space, 3 rows of 48, top 2 rows normalised, \$129 (you remove old wiring) or \$199, we totally refurbish with new front panel, ready to install. TT cords at cost with purchase! Also 1/4" PB's. Audio Village, POB 2902, Palm Springs CA 92262. 619-320-0728, or Fax 619-320-2454.

EMT 266 compressor, \$3400/BO; Fairchild 602 Conax high frequency clipper, \$400; Shure M-267, \$150. Russ Spice, 706-263-6400.

UREI 537 27 band graphic EQ's (3), \$200 ea; Eventide BD 955 bdc delay, 6.4 sec, 15 kHz, \$1000. C Scherer, WDOK, One Radio Ln, Cleveland OH 44114. 216-696-0123.

Fairchild Conax 600; Nagra-III w/neo pilot. Kinura Records, Box 660236, Miami Springs FL 33166. 305-887-5329.

dbx 155 4 chnl encode/decode type I NR (2), \$200 ea/\$350 both. P Cibley, Cibley Music, 138 E 38 St, NY NY 10016. 212-986-2219.

Shure FP-31 3 chnl mono mixer w/case in gd cond, BO. I Raider, Raider Prod, 1006 Stoneham Dr, W Chester PA 19302. 215-889-9565.

UREI 537 27-band graphic EQ's (3), \$200 ea; Eventide BD 955 bdc delay, 6.4 sec, 15 kHz, \$1000; C Scherer, WDOK, One Radio Ln, Cleveland OH 44114. 216-696-0123.

Shure SE30 3 chnl mixer w/gated comp, AC/DC, gd remote unit, excel cond, \$200. N Alexander, Alexander Productions, 514 Goodwin Dr, Richardson, TX 75081. 214-690-9777 or 214-913-2323 voice mail.

ADC 144 point TT bay wired to 50 pin Telcos, \$75/BO. S Wytas, SWP, 165 Linden St, New Britain, CT 06051. 203-280-3913.

Digital Music MX-28S powered MIDI patch bay, 2 in 8 out, mint, \$60. J Hayes, Radio Free New York, 1748 70th St, Brooklyn NY 11204. 718-234-9374.

SAVE \$300 ON T T 144 POINT PATCH BAYS

brokers of fine and coarse used equipment
audio village 619/320-0728



Shure SE-30 comp mixers (2), (4) mic/line inputs, vg, \$150/ea or \$250/both or BO. B Strapko, Strapko Resources, 40 Fillmore Ln, Streamwood IL 60107. 708-830-0701.

Want to Buy

Fairchild 600 conax or 602 Conax high freq limiters. J Gangwer, 942 32nd St, Richmond CA 94804. 415-644-2363.

Record cutting machines, tube amps, SME-3012 & other 16" arms, Firchild 602/670 limiters, omate mics. Kim, 612-866-6183.

MERCENARY AUDIO

WANTS TO BUY YOUR:

NEVE-SSL-TRIDENT-AMEK
UREI-TELETRONIX-FAIRCHILD
PULTEC-LANG-LEXICON
UNIVERSAL AUDIO-NEUMANN
AKG-TELEFUNKEN-AMS

ANYTHING THAT IS OF EXCEPTIONAL AUDIO QUALITY!

"this is not a problem"
(508)543-0069 TEL
(508)543-9670 FAX

AUTOMATION EQUIP

Want to Sell

ABC Radio Networks tone decoders (2) 2 digit LED readout w/reset button. \$100 ea. C Scherer, WDOK, One Radio Ln, Cleveland OH 44114. 216-696-0123.

SMC automation cntrir, works, MSP unit. B Ladd, WNRD, 108-1/2 E Main, Bellevue OH 44811. 419-483-2511.

Microprobe 100MP 24 event programmer w/25 Hz tone generator, \$600. T Parks, WOWU, POB 592, Kankakee IL 60901. 815-939-5089.

SMC 350 w/452 Carousels (4) w/452 MSP-1 programmer, (3) audio card, A Series cart player in racks, will sell all or separate. BO. J Baint, KKMO, POB 1277, Tacoma WA 98401. 206-922-3345.

TM Century Ultimate Digital Studio for live-assist or total walkaway operation, with UDS software, 8 Pioneer PD-Tm1 18-disk CD players, 360 Systems DigiCart with 200 MB hard drive plus all interface cards, cables & manuals, entire system can be operated by any 386 computer, currently on-air in Cleveland, MS, selling due to upgrade. L Fuss, WDTL, POB 1436, Cleveland MS 38732. 601-846-0927.

FM Transmitters have never offered this much for so little!



HENRY RADIO FM AMPLIFIERS offer these standard features:

- Single tube grounded grid output with solid state IPA
- Modular construction using quality standard components
- CD quality audio
- Power levels from 100 watts to 15 kW
- Full 1 year warranty

We at Hall Electronics understand RF however large or small the need.

We'll be glad to help with all your RF needs!

(804) 974-6466 • FAX: (804) 974-6450
1305-F Seminole Trail
Charlottesville, VA 22901

HALL Electronics

COMARK Antennas

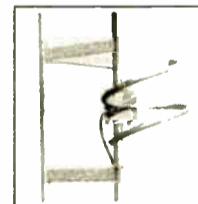

FM Broadcast Antennas
Circularity & Horizontally Polarized antennas available
Multiple bays available

Marti STL 15-C Composite STL System



Composite FM Stereo with 2 subcarriers
140 - 960 Mhz freq. range available
Digital Stereo Audio (with external Modems)

SINE SYSTEMS



RFC 1-B Dial Up Remote Control
Automatic Transmitter power control
Alarm dial out for 6 numbers
Timed functions for day/night power levels etc.
Optional RS-232 computer interface
Up to 64 channels of control and metering

SINE SYSTEMS

DAI-1 Dial up Audio Interface



Avoid Heavy Fines for EBS Non-Compliance
Easily handles EBS requirements for "walk away" Operations
Allows direct access to the air chain
Remote Broadcasts (no one at the station)

AUTOMATION EQUIPMENT...WTS

Schafer 800-T automation controller, will accept up to 12 audio sources, \$1500/BO. J Bahr, WVIS, Box 487, Frederiksted, St Croix VI 00840. 809-773-2220.

Sentry Systems Format Sentry to sell or trade, has controller, (2) 48-slot Instacarts, (3) R-R's, BO. R Carr, KXLE, 1311 Vantage Hwy, Ellensburg WA 98926. 509-925-1488.

Stereo 350 Carousels (4), random access; (4) equip racks, like new, 74" high & one 66" high; 10 assorted rack panels. FB Nienow, WYTE, POB 1030, Stevens Point WI 54481. 715-341-8838.

SMC Carousels (5), sterep and (2) 48-tray Instacarts, make offer. John Lackness, KAYD-FM, 409-833-9421.

SMC Carousel 350 stereo w/oak grain cabinet, vgc, \$400. D Koehn, KKPR, 403 E 25th St, Kearney NE 68847. 308-236-9900.

SMC MSP-12 automation system with 3 Carousels, 3 carts, DAS-12 audio switcher, screen, operational with all wiring, power packs, racks & manuals, \$6500. M Jarvis, KORC, POB 1419, Waldport OR 97394. 503-563-5100.

ABC Radio Networks tone decoders (2), 2 digit LED readout w/reset button, \$100 ea. C Scherer, WDOI, One Radio Ln, Cleveland OH 44114. 216-696-0123.

SMC 350 stereo Carousels (6), 3 in each rack, gd cond, sell one or all, \$400 ea or each rack, \$1000. P Swint, KIXQ, 2620 Dogwood Rd, Joplin MO 64804. 417-624-1310.

Shaffer 901 needs work, w/all parts, \$1400. S McGrath, WGNV, 429 Little B Rd, Newburgh NY 12550. 914-561-2131.

IGM RAM stereo automation controller w/4096 events of memory, clock, silent sense, 9 audio inputs, 4 random access Carousel cards, manuals. FB Nienow, WYTE, POB 1030, Stevens Point WI 54481. 715-341-8838.

SMC automation complete w/MSP-12 sat controller, DAS-12 audio switcher, (3) 452 Carousels, 350 Carousel, (2) video mon & complete set of cabinets, excel cond, still in operation, \$9995/firm. K Austin, KFXI, 1101 Hwy 81 N, Marlow OK 73055. 405-658-9292.

BUSINESS OPPORTUNITIES

Want to Sell

Two top quality music formats ready for partnership or sell outright, potential unlimited. J Gelo, J&H Music Programming, POB 1697, Marco Island FL 33937. 813-642-6899.

CART MACHINES

Want to Sell

BE 5300C tripledeck, stereo, PB, mint less than 50 hrs, BO. R Kaufman, Pams Prods, POB 462247, Garland TX 75046. 214-271-7625, after 3PM CDT.

Tapecaster XP5 stereo PB w/new heads, \$500/BO. J Bahr, WVIS, POB 487, Frederiksted, St Croix VI 00840. 809-773-2220.

CART MACHINES:

For Sale: \$395 & UP
Repairs: \$100 per deck + parts
Recondition: \$150 per deck + parts. Call Mark @ 619-598-3311

ITC Delta plyrs w/tones & fast cue, gd cond, mono (4), \$675; ITC Delta rcd, gd cond, mono, \$1100. K O'Malley, WTKR, 720 Boush St, Norfolk VA 23510. 804-446-1328.

Pacific Recorder Micro-Maxx, w/standard heads & speeds, rack-mountable metal casing, manuals & power cords, like new, \$1500/pr. K Rosato, Sound Broadcasting, 914-645-1626.

Spotmaster 505/BS stereo R/P lever type w/new heads, \$850/BO. J Bahr, WVIS, POB 487, Frederiksted, St Croix VI 00840. 809-773-2220.

BE Dura-Trak 90 stereo cart player, \$1000/BO. C Stalnaker, KDDK, POB 100, Little Rock AR 72203. 501-372-7740.

Carousels, (4) 250s plus one RS-50 random selector, working when removed, \$400 plus pkg/ship. J McAulay, KAPL, 10207 Ave R-12 East, Littlerock CA 93543. 619-247-1111.

Great Prices on original equipment tape heads for ITC, BE, Fidelipac, Otari, Tascam & others!
HALL Electronics
(804) 974-6466 • FAX 6450

Tapecaster 700P stereo player w/150 Hz decode, works fine w/manual, \$100. B Tidwell, WAFT, POB 338, Valdosta GA 31603.

ITC triple deck play units (2), one record unit, less than 2 yrs old, like new, \$5000/all, K Paul, WKXD, 259 S Willow Ave, Cookeville TN 38501. 615-528-6064.

Audicord TDS Series dual deck stereo play only w/connectors & manual, \$300. T Parks, WOWU, POB 592, Kankakee IL 60901. 815-939-5089.

ITC PD2 (2) mono PB, excel w/manual & 50 carts, \$250. J Hayes, Radio Free New York, 1748 70th St, Brooklyn NY 11204. 718-234-9374.

No matter how you stack it...
Nobody reconditions tape heads like JRF.

- Heads restored to new performance spec at a fraction of new cost
- Cart machines and all open reel formats
- Full line of replacement heads for all manufacturers

Experience the difference experience makes. Ask around. Nobody treats you or your heads better than JRF.

JRF MAGNETIC SCIENCES
249 Kennedy Rd., Greendell, NJ 07839
(201) 579-5773 Fax (201) 579-6021

Gates CPR-2, CAR-2 stereo cart machine (2) with one external recording amp, rack mount, BO; Gates 6702, 6708 stereo cart machines (2) with one external recording amp, good condition, BO. P Guello, KUWS, 1800 Grand Ave, Superior WI 54880. 715-394-8187.

Ampro CT2507 audio cart players, mono, cue tones, fast fwd, BO. Dave, Allmake Prod, 6130 S Dehmel Rd, Frankenmuth MI 48734. 517-652-6863, leave message.

ITC single play stereo cart decks (2); ITC R/P stereo cart deck, \$375 ea. J Vavricek, KSYZ, Grand Island NE. 308-382-0108.

Want to Buy

Audio, control and tone cards for UMC cartridge PB's and R/P that need repairs. B Hoisington, WKH Engr, 904-678-8943.

Telex Copier 1 & Copier 2, mono cassette, 16 speed, \$150. P Russell, Bowdoin College, Sills Hall, Brunswick ME 04011. 207-725-3066.

Tascam 42B (6) R/R w/rollaround frames; (3) Otari MX5050 B11, (6) Dynamax CRT-10 cart machines; (2) Tascam T-2640MS cassette duplicator & slave; (3) Dynamax ESD-10 eraser splice-finder, BO. J Phillips, WZOM, 414 Washington Ave, Defiance OH 43512. 419-782-8591.

STUDER SERVICE SPECIALIST
Thousands Serviced • Unbeatable Rates
Precision Capstan Resurfacing
Audio Advancing
Tel (615)742-3834 FAX (615)254-8826
PRICE-QUALITY-SERVICE
Let Us Prove It

Want to Sell

16 trk 2", \$3450; Otari 1" 8 trk, \$2450; 5050 III-8, \$1950; Ampex ATR800 mono, \$750; Tascam 25-2, \$750; Tascam 52 mint, \$1200; MCI Locator III, \$1195; Ampex AG350 solid st electr, \$100/ch. W Gunn, 619-320-0728.

Scully 280 1/2" 4-trk. D Nelson, 619-758-0888.

Recorder heads, used Scully mono & 2 trk, \$25-50, ATR100's, 3M M79-16 & 8's, Otari 1/2" 8 trks, \$495. W Gunn, 619-320-0728.

Ampex ATR100 taperecorders for parts. Circuit cards, heads, motors, machine parts, or electronic parts. Call 818-907-5161.

Ampex 440B 1/2 & 1/4 trk, \$425; Fostex E2, \$1750; Studer Revox B214, \$1000; Otari MX5050 2 SHD-rem, \$1000; Otari MX5050 MKIII 8 trk, \$3200. Russ Spice, 708-263-6400.

HEAD RELAPING/REPLACEMENT

All tape and film formats
30 years experience



350 N. Eric Drive
Palatine, IL 60067
708-358-4622

MCI JH-110B reel, play only, low chassis, (2) BO; MCI JH-110B reel, R/P, low chassis, (2) BO; MCI JH-110B reel, play only, tall chassis (2), BO; Ampex 2 trk ATR-100, BO; Inovonics electronics for mono repro, \$200; Otari MX5050BQII 1/4" 4 trk, excel cond, \$2000. C Scherer, WDOI, One Radio Ln, Cleveland OH 44114. 216-696-0123.

Ampex 440 B 1/2" 4-trk in original console, excel cond, \$1350. M Tail, Tait Recording Svc, 1347 S Capitol St SW, Washington DC 20003. 202-488-3905.

Ampex 350, excel cond; Crown 800, 7.5 & 15 ips, excel cond; Uher 4400 3 speed, gd cond; Roberts recorder 3.75 & 7.5 ips plus 8-trk R/P, dual R/P in both modes. F Reagan, Special Bct Srvs, 203 Westville Ave Ext, Danbury CT 06811. 203-743-7433.

Tascam 38 1/2" 8-trk open reel machine w/8 chnls of dbx Type I encode/decode NR, \$1500, w/o dbx, \$1200. P Cibley, Cibley Music, 138 E 38 St, NY NY 10016. 212-986-2219.

Metrotech/Scully 400L 4-trk logger w/rec amp/monitor, \$125. G Hoppe, WVVA, 1010 2nd St N, Sauk Rapids MN 56379. 612-252-6200.

Marantz field recorder, vari-speed, battery operated AC/DC, rarely used, \$200. R Edwards, Spinner, 1750-30th St #222, Boulder CO 80301. 719-630-1452.

REVOX PARTS/SERVICE
Cassette-CD-Open reel
Rebuilt A77s, \$800
Capstan resurfacing, ALL BRANDS.
JM TECHNICAL ARTS
30 Music Sq. W. #156
Nashville, TN 37203 (615) 244-6892

Ampex 350/440 parts transport & electronics parts, some new, most used, in super condition, motors, headstacks, guides, etc, also parts for Scully 280s & complete Inovonics electronics for 350s & 440s, all reasonably priced; Ampex MM 1100 16-trk 15/30 ips in superb cond, very little use, heads gd, all electronics have been checked out, has updates, counter, MDA fans, AC stabilizer card, mods, BO; Scully 280 1/2" 4-trk, vgc, 7 1/2/15 ips, \$750. 415-469-0136.

Telex Copier 1 & Copier 2, mono cassette, 16 speed, \$150. P Russell, Bowdoin College, Sills Hall, Brunswick ME 04011. 207-725-3066.

Tascam 42B (6) R/R w/rollaround frames; (3) Otari MX5050 B11, (6) Dynamax CRT-10 cart machines; (2) Tascam T-2640MS cassette duplicator & slave; (3) Dynamax ESD-10 eraser splice-finder, BO. J Phillips, WZOM, 414 Washington Ave, Defiance OH 43512. 419-782-8591.

Ampex 440C 2 trk w/rec elect, low hrs after rebuild w/manual, \$450; Ampex 350 2 trk play w/tube elect, \$150. Inovonics avail at \$50 ea; Schafer RPU-8 25 Hz encoder & remote control for Ampex 440 w/manual, \$75. B Tidwell, WAFT, POB 338, Valdosta GA 31603.

Sansui MR-6 6 trk cassette deck w/built in Dolby C NR, high speed, 70 db SN ratio w/high bias cassette, pitch control, memory return, punch in, rack mount or table top, 2 yrs old, few hours hrs, nice meters, \$300. J Hayes, Radio Free New York, 1748 70th St, Brooklyn NY 11204. 718-234-9374.

Tascam MS-16 16 trk 1" in excel cond, full locator, dbx NR & rollabout stand, avail 9/15/93, \$4500. J Block, Production Block, 906 E 5th St, Austin TX 78702. 512-472-8975.

Audio Technica RMH64 4 trk P/R, 6 chnl mixer/recorder 6 in 4 out, 2 cue sends, lanthom power, low/high speed R/P, parametric EQ & shelving, \$995 w/schematics. Gary, Fitzgerald Music Prod, 37-75 63rd St #B29, Woodside NY 11377. 718-446-3857.

Otari MC 5050. J Vavricek, KSYZ, Grand Island NE. 308-382-0108.

Studer Dyaxis w/I/O cables 30 mm storage, \$5000; DSP card & software, \$1200; 60 min Studer drive, \$2000 or all for \$6500. G Blood, Blood Pro Audio Srvs, 16E Johnson St #10, Philadelphia PA 19144. 215-848-2040.

Otari ARS1000 (4) R-R's interfaced to SMC system, gd cond, \$1000/all or \$400 ea. P Swint, KIXQ, 2620 Dogwood Rd, Joplin MO 64804. 417-624-1310.

Pioneer RE701, new heads, \$300; Ampex ATR700, gd cond, \$700; Tapesonic TR70, gd cond, \$250; Telex 235 w/(2) RP110 electr, \$200; TVC MC 1636 Mark II, new in box, \$300. J Parsons, Parsons Snd Srvc, 2781 Faysor Circle, Deltona FL 32738. 904-532-0190.

Teac A-3440 4 chnl multi trk deck, Simul-sync, 7.5 & 15 ips, pitch control, 7 & 10" reels, excel cond, plus dbx 155 4 chnl NR, \$550. J Hayes, Radio Free New York, 1748 70th St, Brooklyn NY 11204. 718-234-9374.

Otari QXD5050 4 trk w/separate balanced line & mic in/out, 7.5 & 15 ips, 1/4" tape, 10-1/2" NAB reels, wired remote, 1 kHz test oscillator, excel cond, \$1000/BO plus shpg. R Maier, RMA, 8908 Centreville Rd, Manassas VA 22110. 703-361-7508.

EMPLOYMENT

To place ads in this section, use the ActionGram form. To respond to box numbers write Radio World, PO Box 1214, Falls Church, VA 22041. Attn: _____

POSITIONS WANTED

Exper PD/GM w/impressive 20 yr trk rcd, successful programming bkgnd w/start-ups & turnarounds. WHB/KSLQ/WTNT/WETJ/Cromwell Group. Chip Douglas Mosley, 217-774-2958.

Nine Years audio production w/semester on-air seeking pos, will relocate, all offers considered. Andrew, WHB/KSLQ/WTNT/WETJ/Cromwell Group. Chip Douglas Mosley, 217-774-2958.

On-air & management, 17 years exper, format flexible, small market a must, dedicated leader/player, use to long hours. Mike, 703-994-5555 after 3 PM ET.

Exper radio personality seeks FT pos, 8 yrs as DJ & reporter, team player, nice guy, nice voice, solo or sidekick, NE or SE. Peter, 349 Franklin Rd, Denville NJ 07834. 201-361-1634.

Experienced, accountable AM/FM CE, excel troubleshooting skills, SBE certified, FCC general degree. Currently employed, desire NE. Write to: Radio World, POB 1214, Falls Church VA 22041. Attn: Box #09-22-01RW.

Sports reporter seeking full-time work at radio station; including play-by-play and/or analyst, can do it all. All sports, five years experience. Write to: Radio World, POB 1214, Falls Church VA 22041. Attn: Box #93-22-02RW.

Trained individual seeks entry-level employment in radio, willing to relocate, not afraid of hard work & willing to start out on ground floor. Doug, 405-527-6066.

Young man w/business degree w/exper in mgmt, radio announcing, news, talk shows & sales looking for the right opportunity, write to 417 South Story St, Boone IA 50036 or 515-432-1741.

AAS grad, electronic engineering, board operating exper needing opportunity to get into the electronics field, leave message. Kerry, 405-622-2781.

Available now, Gulf Coast, music format experienced, affordable air/production/promotions/audio engineering, deep voice, good appearance, single, references. Steve, 806-385-3888.

Rick Savage also known as Rockin Rick Allen from Akron, Ohio is seeking a FT CHR, Hot AC, or Rock gig. 216-773-1549.

Seeking FT announcing, programming gig, not sales, don't overlook what you haven't tried, Janet's no pricey, air-headed personality, PT announcing, computer literate, marketing experience. Janet, 502-895-5888.

Are you looking for someone w/several yrs exper in on/off air prod/promo/traffic/computer automated programming, then call Meg, 603-434-7928.

HELP WANTED

BROADCAST EMPLOYMENT WEEKLY

New professional positions in the broadcast industry available weekly from coast to coast. Stations report job announcements to us daily from all departments. Information is updated weekly & available to you fresh. No more "cold" calls and large phone bills to find out who's hiring. Radio stations & job seekers leave job opening & job wanted info FREE! Call for more info.
1-800-922-JOBS.
"We take the *hassle* out of your career moves!" Local Better Business Bureau participant!

Four Seasons Communications, located in suburban Washington, DC, is seeking a qualified Chief Engineer for its Richmond, Virginia stand alone FM, WMXB. The successful candidate will have strong FM transmitter & studio maintenance skills & good communications skills. He or she will be self-motivated & hands-on; in short, a results-oriented engineer. FCC General Class Radiotelephone Permit or SBE Certification preferred. If you want to be part of a thriving team, & work in a well-equipped radio station, send your resumé & salary requirements to:
Chip Fetrow
Director of Engineering, WXTR
5210 Auth Road
Marlow Heights, MD 20746
or FAX to 301-899-6011. EOE.

ABOUT OUR EMPLOYMENT SECTION

HELP WANTED: Any company or station can run "Help Wanted" ads for \$1.50/word or buy a display box for \$55/column inch. Payment must accompany insert, use your MasterCard or VISA; there will be no invoicing. Blind box numbers will be provided at an extra charge of \$10. Responses will be forwarded to listee, unopened, upon receipt. Call 800-336-3045 for details.

POSITIONS WANTED: Any individual can run a "Position Wanted" ad, FREE of charge (25 words max), and it will appear in the following 2 issues of Radio World. Contact information will be provided, but if a blind box number is required, there is a \$10 fee which must be paid with the listing (there will be no invoicing). Responses will be forwarded to the listee, unopened.

Mail to: BROADCAST EQUIPMENT EXCHANGE
PO Box 1214, Falls Church, VA 22041
Attn: Simone Mullins

CASSETTE & R-R...WTS

Scully 100 16 trk; Scully 280B 2 trk recorders. J Grill, Grill Studios, 619 Melwood Ave, Pittsburgh PA 15213.

STUDER/REVOX

Factory Authorized Service
"Superlative Service"

STUDIO-SONICS

450 W. Rand Road
Mt. Prospect, IL 60056
708-670-0025

Magnecord 728; Kenwood KW5066; Sony TC355; Sony 464CS, all work. BO. Gary, Fitzgerald Music Prod, 37-75 63rd St #B29, Woodside NY 11377. 718-446-3857.

Akai GX3650 1/2 trk R-R, 3 speeds, auto reverse, 7" NAB reels & remote, \$500/BO plus shpg. R Maier, RMA, 8908 Centreville Rd, Manassas VA 22110. 703-361-7508.

Tascam 34 4 trk in great cond w/manu- al, \$1200. C Downs, WVIK, Augustina College, Rock Island IL 61201. 309-794-7500.

SCULLY TAPE RECORDERS PARTS AND SERVICE

SEQUOIA ELECTRONICS

4646 Houndshaven Way
San Jose, CA 95111
(408) 363-1646

MCI JH-110B (2), play only, low chassis, BO; (2) MCI JH-110B, R/P, low chassis, BO; (2) MCI JH-110B, play only, tall chassis, BO; Ampex ATR-100 2 trk, BO; Inovonics electr for mono repro, \$200; Otari MX5050BQII 1/4" 4 trk, excel cond, \$2000. C Scherer, WDOK, One Radio Ln, Cleveland OH 44114. 216-696-0123.

Revox PR 99 MK II, 2 trk, mint cond, w/service manuals & carton, auto loc, remote, sel sync, \$875. R Cannata, Cantrax Recd, 2119 Fidler Ave, Long Beach CA 90815. 310-498-6492.

Want to Buy

Scully '100' recorders, record/play amplifiers, 8, 16, 24 track heads. Sequoia Electronics, 4646 Houndshaven Way, San Jose CA 95111. 408-363-1646.

Revox PR99 prefer MKII or III, must be in gd cond. D Koehn, KKPR, 403 E 25th St, Kearney NE 68847. 308-236-9900.

Need extender cord for Magnecord 1021-1022 or 1024. C Smith, KREK, POB 1280, Bristow OK 74010. 918-367-5501.

CD's/PLAYERS

Want to Sell

Denon DN-950FA in excel cond, \$750. R Michaels, KQFX, pOB 7762, Amarillo TX 79114. 806-355-1044.

COMPUTERS

Want to Sell

NEC P6 24 pin dot matrix printer w/8 internal fonts, \$100. P Cibley, Cibley Music, 138 E 38th St, NY NY 10016. 212-986-2219.

Want to Buy

Austrad PCW-9512 word processors (2), \$150 ea. G Arroyo, 407-830-0800.

CONSOLES

Want to Sell

Ramko DC5AR 5 channel mixers, 14 available, very good condition, \$225 each. 916-334-9449.

Consoles, \$500 & up. Call Mark at 619-758-0888.

Harris Stereo 80 solid state audio 8 mixer, 11 inputs w/tech manual & matching shelf, \$900. J Hall, WND A, 2407 9th Ave SW, Huntsville AL 35805. 205-539-9643.

Ampex AM-10 mixers (2). Kinura Records, Box 660236, Miami Springs FL 33166. 305-887-5329.

BE 45-50 stereo 4 console, 12 input, just removed from service, \$400. T Parks, WOWU, POB 592, Kankakee IL 60901. 815-939-5089.

Pacific Recorders LS-4 audio mixer/switcher; Pacific Recorders LS-10 monitor switcher, cue amplifier; (8) Audiometrics stereo distribution amplifier, 8x2 or 16x1, BO. J Phillips, WZOM, 414 Washington Ave, Defiance OH 43512. 419-782-8591.

TAC Scorpion-22 mono, 2 stereo inputs, 16 buss, \$5000; Tascam M-3700 automated, new, never used, 24 inputs, 8 buss, on board automation, \$11,000. L Thompson, 4631 Insurance Ln, Dallas TX 75214. 214-559-4000.

ASI M52C w/15 inputs, 4 outputs, plus 2 lines & two speaker outputs. F Reagan, Special Bdct Srvs, 203 Westville Ave Ext, Danbury CT 06811. 743-7433.

Shure FP-32 stereo location mixer, 3 pannable balanced mic or line inputs, 2 stereo outputs, tone gen, lo-cut filters, lit VU meters, slate mic, AB pwr & modified for 48V phantom pwr, reliable, battery pwr & suitable for ENG, EFP & radio remotes, \$625. D Brown, 813-895-9595.

BE 8-M100-A 8 chnl, 16 input board, very clean, never on-air, used in off-line video edit suite w/manual, \$800. A Dunkin, WAGA TV, 1551 Briarcliff Rd, Atlanta GA 30306. 404-491-0580.

Ramko 5-chnl stereo mixer brd Mo#Dc-55, 2 inputs per mixer except #5 which offers 5 inputs, \$325. R Chambers, 916-257-2121.

Radio Shack Realistic DJ mixer, 8 inputs, 4 outputs, great for beginner musicians, \$70 plus shpg. D Pulwers, Dave's Price Audio Prod, 310 N Howard St #103, Alexandria VA 22304. 703-751-9346.

Daven • SHALLCO
Rotary Step Attenuators for Console Upgrades

Gates	Langevin
Harris	Continental
Autogram	LPB
Collins	RCA
Cetec	McMartin
Broadcast Electronics	
Sparta and others	

Shallco, Inc.
308 Components Drive
PO Box 1089 Smithfield, NC 27577
919 934-3135 info
800 876-3135 orders
VISA and Mastercard Accepted

LPB Signature II S-20 30 inputs, stereo, 10-chnl former air board, upgraded studio, works great, BO. K Lincoln, WIZN, POB 1067, Burlington VT 05402. 802-860-2400.

Wheatstone 32x24, full patchbay & producers desk, like new cond, \$20K; Otari MTR-90 II, mint cond, \$31K. L Walkup, Grace Recdng, 159 Pelham Ave, Hamden CT 06518. 203-288-9771.

Auditronics 110A 18 in, 4 out, 3 band EQ, 2 aux sends, 8 meters, \$2600. Gary, Pranava, 1226 Sierra Alta Way, Los Angeles CA 90069. 310-271-3235.

Russco Mono 505 rack mount, 5 chnl, \$300; Ramko DC5AR 5 chnl mono, \$300; Grommes Precision M15 6 chnl mono tube type, \$275. J Parsons, Parsons Snd Srvc, 2781 Faysor Circle, Deltona FL 32738. 904-532-0190.

Autogram IC-10, \$3395 & AC-8 8 chnl & 10 chnl, \$2995, stereo, currently in use. B Ryan, KVIC, Box 5511796, Dallas TX 75355. 214-771-1008/4235.

Yamaha RM-1608 16 input studio console w/sweepable EQ, phantom power & on board patchbay, talkback & tone gen, excel cond, avail 9/15/93, \$2250. J Block, Production Block, 906 E 5th St, Austin TX 78702. 512-472-8975.

Want to Buy

Arakis 10 to 12 chnl slider console, must be in gd cond. D Koehn, KKPR, 403 E 25th St, Kearney NE 68847. 308-236-9900.

Harris M-90 or Auditronics 110 series console w/wo studio cabinetry & patching capability, will pick-up, any combination of modules considered. D Doelitzsch, WDDD, Marion IL. 618-997-8123.

Altec 250 Series knobs, keys, manuals & schematics. D Walker, WLW-A, 1111 St Gregory, Cincinnati OH 45202. 513-241-9597.

Russco 505S stereo console. J Parsons, Parsons Snd Srvc, 2781 Faysor Circle, Deltona FL 32738. 904-532-0190.

DISCO & SOUND EQUIPMENT

Want to Sell

Excellent quality mobile DJ syst incl JBL, Crest, Technics gear, plus music, call for equip list. J Hunter, KBRE, POB 858, Cedar City UT 84720. 801-586-5273.

Micro Trak mobile dual turntable unit remote console w/2 Russco Studio Pro Mdl B turntables, Micro Trak 6455B console, mono 5 pot, 8 input, fold out legs w/equip shelf, \$300. G Hoppe, WVVA, 1010 2nd St N, Sauk Rapids MN 56379. 612-252-6200.

Lexicon 224 reverb version 4.4, perfect shape, \$1875; Sennheiser Infrared Stereo wireless headphones & xmtr, \$225. Rick, Super Duper Audio Duplicating, 503-228-2222.

Fostex 3180 stereo reverb unit, rack mtable, 3 sec delay time, 24 MS, pre-delay time, will swap for UREI Cooper Time Cube Mdl 920-16. J Roper, Imperial Sound, 383 N Studio St, Terre Haute IN 47803. 617-877-2663.

UREI 539 1/3 oct EQ, (4), \$395/ea; dbx 20/20 real time analyzer/automatic equalizer, new, \$595; UREI 815C studio monitors, 3 woofers per cabinet, new, \$3500. Rick, Super Duper Audio Duplicating, 503-228-2222.

Realistic 10 band EQ (2) mint cond w/spectrum display, \$50. J Hayes, Radio Free New York, 1748 70th St, Brooklyn NY 11204. 718-234-9374.

Korg DW8000 w/heavy duty case, \$500; Arp Omni (2), \$450; Roland TR707 drum machine, \$250; Casio CZ101, \$175. Gary, Fitzgerald Music Prod, 37-75 63rd St #B29, Woodside NY 11377. 718-446-3857.

Numarck DM1775 4-chnl DJ mixer w/sampling, echo, delay, reverb, EQ, \$860. S Evans, Evans Technologies, 755 E Main, Greenwood IN 46142. 317-889-6969.

Want to Buy

Speakers needed, Altec, Tannoy, JBL. John, 708-391-8828.

FINANCIAL SERVICES

FINANCING ON ALL

RADIO EQUIPMENT

- Easy to qualify
- Fixed-rate, long-term leases
- Any new or used equipment & computers
- 100% financing, no down payment
- No financials required under \$50,000
- References available

Call Mark Wilson
(800) 275-0185

EXCHANGE NATIONAL FUNDING

Use Our Experience For Your Business

Call Mark Wilson
(800) 275-0185

EXCHANGE NATIONAL FUNDING

Use Our Experience For Your Business

LEASING AVAILABLE

SALE/LEASE BACKS, Sell your equipment to Carpenter for CASH. Carpenter LEASES your equipment back to you. You WRITE OFF the monthly payments and put the CASH to work. Carpenter & Associates, Voice 501-868-5023 Fax 501-868-5401.

LIMITERS

Want to Sell

Aphex 250 type III aural exciter, new cond, '93 mdl, all papers, invoice, manual etc, original carton, \$695. J Masters Ying, Ariel, 140A Bellevue Ave #5, Newport RI 02840. 401-846-9743.

Harris/Gates M-6543 FM mono limiter w/manual, \$75. T Rosen, KBCC, 1129 Acacia Ave, Bakersfield CA 93305. 805-871-6094.

dbx 164 stereo one knob limiter, \$150. T Parks, WOWU, POB 592, Kankakee IL 60901. 815-939-5089.

Air Corp Pro Announcer 500 mic compressor/EQ, excel cond, \$450/BO. M Osborne, WKSQ, POB 9494, Ellsworth ME 04605. 207-667-7573.

Gates M6467 stereo top end limiter, great cond, \$200 plus UPS. G Kirby, Gray Fox Video, 13613 US 36, Marysville OH 43040. 614-261-8871.

Orban 8000A Optimod, gd cond, BO. P Guello, KUWS, 1800 Grand Ave, Superior WI 54880. 715-394-8187.

McMartin BFM-1514-15 mono & stereo audio processors, priced to sell. Goodrich Ent, 11435 Manderson St, Omaha NE 68184. 402-493-1886.

Want to Buy

Compression limiting device for lw pwr AM mono travelers info radio service in useable cond. 813-933-6009.

Extender card for Harris MSP 100 servicing needed urgently; also looking for FM limiter modules for same. J Fink, WLAD, 198 Main St, Danbury CT 06810. 203-792-4266.

BUY-SELL-TRADE
OPTIMOD 8000 & 8100
414-482-2638

Composite clipper, any make. B Ladd, WNRP, 108-1/2 E Main, Bellevue OH 44811. 419-483-2511.

MICROPHONES

Want to Sell

Gefell Neumann UM57 tube mics, New capsules for SM2 & many others, New AC701 tubes for Neumann mics, \$275. W Gunn, 619-320-0728.

AKG 414's, \$695, original D12 like the Beatles used, \$295, Sony ECM54, \$150, Beyer M500 Ik new, \$300, Demeter 4-ch tube DI rack mt Ik new, \$875. W Gunn, 619-320-0728.

Electro-Voice RE16, \$250; Electro-Voice RE 20, \$300; Neumann U-67, \$2200; Altec 626A, call for price; Sennheiser MD 421, \$325; Sony ECM-50, \$175. Russ Spice, 708-263-6400.

EV DS 35; (2) EV RE 16; EV RE 20; Shure SM-5B studio, \$150 ea or \$600/all or BO. R Edwards, Spinner, 1750-30th St #222, Boulder CO 80301. 719-630-1452.

AKG 451-E (2) w/batt supply; (2) AKG C-60 w/AC supply. Kinura Records, Box 660236, Miami Springs FL 33166. 305-887-5329.

Audio Technica 811 bi-directional mic, new, BO; Gitzo 14' fishpole, internally wired w/AT mic mount, BO; I Raider, Raider Prod, 1006 Stoneham Dr, W Chester PA 19382. 215-889-9565.

Altec mics (2) w/power supplies. F Reagan, Special Bdct Srvs, 203 Westville Ave Ext, Danbury CT 06811. 743-7433.

Shure M267 pro mic mixer, industry standard, 4 inputs, limiter, low pass filter, battery & A/C operation, \$300; Shure M67 pro mic mixer w/rack ears, \$150. J Hayes, Radio Free New York, 1748 70th St, Brooklyn NY 11204. 718-234-9374.

Sennheiser 441, new w/all papers & response curves, \$450. R Payne, 313-786-1767.

Shure SM 82 mic w/line level output, \$275/BO. J Daniels, WRAV, 333 Delaware Ave, Delmar NY 12054. 518-439-0945.

Want to Buy

77-DX's, 44-BX's, KU-3A's On-Air lights. Top price paid. Fast response. Bill Bryant Mgmt, 2601 Hillsboro Rd, G12, Nashville TN 37212. 615-269-6131.

RCA 77DXs/44BXs ribbon, chrome/TV grey, gd cond, BO. R Kaufman, Pams Prods, POB 462247, Garland TX 75046. 214-271-7625, after 3PM CDT.

Mics needed, AKG, Shure, John, 708-391-8828.

PHONE: 703-998-7600 FAX: 703-998-2966



Call Simone Mullins, Classified Ad Manager, to reserve space in the next issue. Use your credit card to pay, we now accept VISA and MASTERCARD.

RadioWorld

5827 Columbia Pike, 3rd Floor
Falls Church, VA 22041

Select from these categories for best ad positioning:

Acoustics	Consoles	Software
Amplifiers	Disco-Pro Sound Equip.	Stations
Antennas & Towers & Cables	Financial Services	Stereo Generators
Audio Production (Other)	Leasing	Tapes, Carts & Reels
Brokers	Limiters	Tax Deductable Equipment
Business Opportunities	Microphones	Test Equipment
Cart Machines	Miscellaneous	Transmitter/Exciters
Cassette & R-R Recorders	Monitors	Tubes
CD Players	Receivers & Transceivers	Turntables
Computers	Remote & Microwave Equip.	Positions Wanted
	Satellite Equipment	Help Wanted

Classified Advertising Rates Effective January 1, 1993

	1x	3x	6x	12x
1-9 col inch (per inch)	\$55	53	50	45
10-19 col inch (per inch)	50	48	45	40
Distributor Directory	90	85	80	75
Professional Card	60	55	50	45
Classified Line Ad		\$1.50 per word		
Blind Box Ad		\$10 additional		

To compute ad costs: Multiply the number of ad inches (columns x inches) by the desired rate schedule for your per unit cost. Example: a 3" ad at the 1x rate is \$165, at the 3x rate \$159, at the 6x rate \$150, at the 12x rate \$147, etc.

DISTRIBUTOR DIRECTORY

The following distributors serving the broadcast industry would be glad to help you with any of your requirements.

... Canada, the Caribbean, Shannon to Shanghai, the dynamite Fifty ...

RADIO! The beat goes on!

CROUSE-KIMZEY OF ANNAPOLIS

tops in broadcast equipment
1-800-955-6800
ask for Kathleen

CORNELL-DUBILIER MICA CAPACITORS

FROM STOCK

JENNINGS VACUUM CAPACITORS

FROM STOCK

JENNINGS VACUUM RELAYS

SURCOM ASSOCIATES
2215 Faraday Ave., Suite A
Carlsbad, California 92008
(619) 438-4420

MICROPHONES...WTB

CBS or NBC call-ltr plate & antique floor mic stand for RCA 44 mic. M Harrington, POB 7619, Little Rock AR 72217. 501-223-9056.

MISCELLANEOUS

Want to Sell

INVENTORY REDUCTION SALE! Over 500 item list (fax or mail). Call Mark at 619-758-0888.

ComDial solid-state telephone syst, perfect for RF environ, 4 wire analog syst w/plenty of bells & whistles, 5 yrs old, great cond, cap of 24 extensions x 8 lines, 17 extensions currently, interfaces easily to bdct, \$2000. D Doelitzsch, WDDD, Marion IL. 618-997-8123.

Altec 15095 input transformers, 150/600 ohm inputs, 15 K ohm outputs, 8 pin octal base, (4), \$15/ea; Altec 1579A RIAA equalized solid state amp for magnetic phono pickup, input 47K ohm output 600 ohm sensitivity 5 mV for 70 mV @ 1kHz, power 12V @ 11 mA, 5 pin octal base, \$25. S Lawson, KAK Prod, 928 Hyland Dr, Santa Rosa CA 95404. 707-528-4055.

Clark Cortez motor & travel studio. F Reagan, Special Bdct Srvs, 203 Westville Ave Ext, Danbury CT 06811. 743-7433.

Switchcraft 36 point balanced patch bay. T Parks, WOWU, POB 592, Kankakee IL 60901. 815-939-5089.

R-R racks (2) to fit a Otari MX 5050, gd cond w/wheels, \$200/BO. J Roberts, Illinois News Network, 430 W Erie #505, Chicago IL 60610. 312-943-6363.

ESE MasterClock w/WWW rcvr; (7) analog slave clock displays, (4) ESE digital slave clock displays; (2) S2 position Switchcraft patch bays, BO; (4) Valley 400 mic processors; (3) Conex UM-33 monitor switchers; dbx 160X compressor-limiter; Orban 672A equalizer, BO. J Phillips, WZOM, 414 Washington Ave, Defiance OH 43512. 419-782-8591.

Broadcast Products 1988 Super Roving Radio remote bdct trailer equipped w/console, mast, amps & speakers, w/1979 Chevy Blazer w/5 kW gen for towing & pwr, \$15000/BO. G Fullhart, WVKS, 4665 W Bancroft St, Toledo OH 43615. 419-531-1681.

Radio sales training tapes, 30 topics covered on 16 VHS tapes, exc cond, current, \$2500. R Trumbo, 800-397-4146.

Eventide BD910 delay unit, lk new, \$3000. S McGrath, WGNY, 429 Little B Rd, Newburgh NY 12550. 914-561-2131.

Tie/Northcom telephone system, 6 line, 12 telephones, manuals. FB Nienow, WYTE, POB 1030, Stevens Point WI 54481. 715-341-8838.

AKG BX20 spring reverb. J Grill, Grill Studios, 619 Melwood Ave, Pittsburgh PA 15213.

Electro-Voice RE16, \$250; **Neumann U-67**, \$2200; **Altec 626A**, call for price; **Sennheiser MD 421**, \$325; **Russ Spice**, 708-263-6400.

Want to Buy

Jazz record collections, 10" LP/12" LP be-bop, swing, dixie, highest prices paid. B Rose, Program Recdgs, 228 East 10th, NUNY 10003. 212-674-3060.

Ampex tube recorders and mixers. W Gunn, 619-320-0728.

Radio transformers by Chicago, UTC, Triad, Peerless, Freed, Sola, send list. J Gangwer, 942 32nd St, Richmond CA 94804. 415-644-2363.

Pre-50's Bell System bakelite or metal telephones & ringer boxes. J Newman, Box 1211, Newport RI 02840. 401-847-0455.

45 RPM record shucks (protective sleeves). C Frodsham, KVSU, POB 7, E Highway 24, Beloit KS 67420. 913-738-2206.

Daven Step att 11061-KU, stereo w/cue, need two, F Cresce, Oxon Hill MD, 301-567-2012 evenings.

Copy of schematic for Collins 300 J-2 xmtr. Joe Eck, 913-263-7111.

MONITORS

Want to Sell

McMartin TBM-4500A FM stereo mod mon, BO. P Guello, KUWS, 1800 Grand Ave, Superior WI 54880. 715-394-8187.

McMartin TBM-3000A freq mon, needs neons, \$50. B Tidwell, WAFT, POB 338, Valdosta GA 31603.

Harris AM stereo STM-1 mod monitor, lk new, BO. J Baine, KKMO, POB 1277, Tacoma WA 98401. 206-922-3345.

Belar RF amp tuned to 106.1 MHz to drive Belar FMM1 & FMM2 monitors, \$400. J Bahr, WVIS, POB 487, Frederiksted, St Croix VI 00840. 809-773-2220.

Rust SFM-19 deviation monitor for 19 kHz, BO; **Indesys FM** mod monitor, BO; **Collins FM** mod monitor for parts, BO. C Scherer, WDOI, One Radio Ln, Cleveland OH 44114. 216-696-0123.

Want to Buy

McMartin (buy & sell) any model. C Goodrich, 11435 Manderson, Omaha NE 68164. 402-493-1886 or fax 402-493-6821.

AM modulation monitor, used, but in gd wrkg order; studio xmtr link, mono or composite 2-chnl stl. R Chambers, 916-257-2121.

RECEIVERS & TRANSCEIVERS

Want to Sell

AM STEREO RECEIVERS From \$34.95 Portable, Home, Auto **RRADCO** Phone/FAX 708-513-1386

Johnson Ranger II, \$75/BO. M Starin, WGOT, 457 Varney St, Manchester NH 03102. 603-625-1165.

Professional SCA demod card with excellent crosstalk rejection, \$20; **Superadio III** with SCA, \$85, performance guaranteed. 1-800-944-0630.

SCA receivers, (9) Johnson electronic ST-4A SCA tuners, Seven Systems 851, all less than 1 yr old, BO/all. P Boone, Village Sports Radio Network, POB 3300, Chapel Hill NC 27515. 919-968-4811.

Want to Buy

Marti SCG-10 92 kHz sub-carrier gen, SCD-10 92 kHz sub-carrier demodulator. R Rynders, Columbia School of Bdctg, 613 fourth St, #203, Santa Rosa CA 45404. 707-576-7542.

RECORDING SERVICES

CD 1-off copies from your DAT master. 48 hour turnaround. Integrated Digital Systems 310-478-4264 fax: 310-444-9224

REMOTE & MICROWAVE EQUIPMENT

Want to Sell

Gentner digital phone hybrid I, gd cond, \$650; **Hewlett Packard** audio osc & various AC voltmeters. K O'Malley, WTKR, 720 Boush St, Norfolk VA 23510. 804-446-1328.

Marti RPT 40 dual frequency; TFT 7610; Moseley TCS-2. D Nelson, 619-758-0888.

Moseley 505/L xtr, upgradable & gd for back up, \$2600 plus shpg. J Bahr, WVIS, POB 487, Frederiksted, St Croix VI 00840. 809-773-2220.

Moseley TRC-15 wire type remote control, BO. P Guello, KUWS, 1800 Grand Ave, Superior WI 54880. 715-394-8187.

TFT 9200 STL syst (2) 9200/9205 tuned to 944.875 & 945.025, new in factory sealed cartons, \$5600. G Levites, WEVD, 770 Broadway, NY NY 10003. 212-777-7900.

Broadcast Products Super Roving Radio 1988 remote bdct trailer, equipped w/console, mast, amps & spkrs w/1979 Chevy Blazer w/5 kW gen for towing & pwr, \$15,000/BO. G Fullhart, WVKS, 4665 W Bancroft St, Toledo OH 43615. 419-531-1681.

COMREX RENTALS

1, 2 and 3-Line Extenders Switched 56 Systems Call Steve Kirsch for details **Silver Lake Audio (516) 623-6114 FAX: 377-4423**

Sine Systems dial-up remote cntrl, in box, never used, \$1200; **Belar stereo** monitor, RF amp, FMM2, FMMS, \$2500. R Michaels, 806-355-1187.

TFT 7601 wireless remote control w/110 kHz SCA return in fair cond, \$1500/BO plus shpg. J Bahr, WVIS, Box 487, Frederiksted, St Croix VI 00840. 809-773-2220.

Colo Mag Satcuc 400 w/fan out card, \$350. D Koehn, KKPR, 403 E 25th St, Kearney NE 68847. 308-236-9900.

RENTALS RENTALS RENTALS

COMREX 3-line extender Frank Grundstein 215-642-0978 Audio/Video Consultants

Symetrix telephone interface, \$200. J Vavricek, KSYZ, Grand Island NE. 308-382-0108.

Kreco SC 155AC VHF 152-171 mHz 6 db gain base antenna. C Frodsham, KVSU, POB 7, Beloit KS 67420. 913-738-2206.

SATELLITE EQUIPMENT

Want to Sell

Wegener 3" satellite cards and mainframes. Call Mark at 619-758-0888.

Wegener 1601 mainframe, Microdyne 1100-FFC, 70 MHz downconverter, Colorado Magnetics TZF-100 time zone switch, California Amplifier 3.7-4.2 GHz LNA, California Amp 20 dBA amp, all cards needed for Unistar format 41, all 1 year old, \$4000/BO. A Baxa, WAVV, 11800 Tamiami Tr E, Naples FL 33962. 813-775-9288.

Macom/Prodelln 161-6 10' satellite dish w/mount & feed, 8 fiberglass sections, \$350. B Dickerson, WEAG, 1421 S Water St, Starke FL. 904-964-5001.

Wegener 1601, exc cond oldies format cards, time zero control, net switcher with all manuals, Best Offer over \$3500. Norm, WICE, 101 John St, Cumberland RI 02864. 401-725-9000.

SCPC sat rcvr, exc cond, tuned to G-2, transponder 3, single chnl carrier, audio 85.9 & 87.0, complete w/manual for \$900. M Jarvis, KORC, POB 1419, Waldport OR 97394. 503-563-5100.

Microdyne 1100 PCDR(5) receiver in excellent condition, down converter or stable 70 mHz input required, \$1200. C Damon, KWST, POB 1890, Flagstaff AZ 86002. 602-774-5559.

Want to Buy

Need feedhorn assy for Harris delta gain antenna mdl 5115. D Drago, WMAM, POB 609, Marinette WI 54143. 715-735-6631.

Advertise in **Radio World** and your ad will reach 22,000 subscribers.

SERVICES

REMOTE EQUIPMENT RENTALS
COMREX and GENTNER
 1, 2 & 3-Line Extender Systems Now With The New GENTNER EFT-3100
MARTI VHF/UHF RPU Systems
 Switched-56 Systems
 Call or FAX Dwight Weller
WELLER AUDIO-VISUAL ENGINEERING
 Baltimore, MD
 Phone: (410 or 800) 252-8351
 FAX: (410) 252-4261

ROHN Broadcast Towers
Furnished & Installed
 Guyed or Self-Supporting
 Solid or Tubular
20 Year Warranty!
 Call Mike Fleissner toll free
1-800-225-ROHN

E.T.S.
 Strobe Installation & Repair
 6 Mo. Labor & Parts Warranty
 Complete Tower Erection & Maint.
 "Our Business is Climbing to New Heights"
419-424-0020
 FLASHTECH - E.G.G. - T.W.R.

Space Available
 for more information, call
1-703-998-7600

Where In The World Are You?
 Reach radio professionals worldwide by advertising in **Radio World's** international edition.
 Call Simone for more information.
1-800-336-3045

Teletech, Inc.
 BROADCAST CONSULTANTS AND ENGINEERS
 • FCC Applications & Field Engineering
 • Frequency Searches & Coordination
 • Tower Erection & Maintenance
 • Facility Design & Construction
 CONTACT:
Kenneth W. Hoehn
 23400 Michigan Ave
 Dearborn, MI 48124
 (313) 562-6873

T. Z. Sawyer
Technical Consultants
1-800-255-2632
 • FCC Applications & Exhibits
 • Frequency Studies - Class Upgrades
 • Directional Antennas - AM/FM/TV
 • High Power Antenna Arrays
Telefax: (301) 913-5799
 6204 Highland Dr. Chevy Chase, MD 20815

PC - SOFTWARE
 AM FM TV Search Programs
 Contour Mapping-STL Paths
 RF HAZ-1990 POP Count
 FAA Tower-Draw Tower
Doug Vernier
 Broadcast Consultant
 1600 Picturesque Dr
 Cedar Falls, IA 50613
800-743-DOUG

Contact Radio World Newspaper for availabilities
P.O. Box 1214 Falls Church VA 22041
1-800-336-3045

SOFTWARE/DATABASES

Want to Sell

Ron Balonis' Broadcast Engineer's Computer Toolbox makes a computer a technical assistant for an engineer. For details, write **COMPUTER TOOLBOXES**, 118 Rice Street, Trucksville, PA 18708 or call 1-717-696-1490 <300/1200/8/N/1>.

STATIONS

Want to Sell

5kW day/29W nite w/new tower/ground system, w/4 acres in Jacksonville, FL metro market. Beautiful historic beach town. Best cash offer over \$200,000. Bill, 205-238-0281 or Mark, 205-236-6484.

DON'T BULLDOZE A TAX WRITEOFF

Our non-profit 501(C) (3) organization is acquiring AM/FM Radio Stations and wants to know about your property. Will consider purchase if no write-off available. Donations of equipment or towers also accepted. All situations considered. All information will be held in strictest confidence. Address all correspondence to **Chuck Harder**, People's Network Inc., 2nd Floor West Wing, 3 River Street White Springs, FL 32096

Full C FM in Sunbelt, priced for immediate sale, currently on air, for information & terms, call 1-405-878-1803.

Major Southwestern Market, full 100,000 W Class C FM CP, signal will cover close to million people, hot growth area, \$95,000. Craig, 914-643-9235.

Middle Tennessee 2500 W AM w/studios & 3 1/2 acres of land on AL/TN state line, owner would like to make a deal. Ernie, 615-374-3206.

PROFITABLE AM FOR SALE

Covering 5 counties, this 500 watt full-time AM station in Central Ohio, home of Honda of America, will go quickly! Some terms available, all offers considered. For more info contact:

Chamberlain

P.O. Box 69, Bellefontaine, OH 43311 513-592-8606

KJJJ FM in Southeastern Arizona market, 18 mos old w/positive cash flow, \$325,000 w/excel terms. S Greeley, KJJJ, POB 1726, Lake Havasu City AZ 86403. 602-855-1051.

250W daytimer near Springfield MO, \$50,000/BO. J Cooper, KMRP, POB K, Marshfield MO 65706. 417-866-5757 after 9:30 PM.

Want to Buy

Small to mid-size AM/FM or combo in trouble, dark, distress, poorly performing or bankrupt. Call or FAX JR at 717-421-8343.

STEREO GENERATORS

Want to Sell

Bauer 682 stereo generator. D Nelson, 619-758-0888.

Wilkinson SG1E solid state stereo gen, \$500/BO. J Bahr, WVIS, POB 487, Frederiksted, St Croix VI 00840. 609-773-2220.

Motorola AM stereo mdl 1300 exciter & mdl 1310 monitor, in use & in gd cond, going talk, \$1000/ea. D Doelitzsch, WDDD, Marion IL. 618-997-8123.

Dorrrough 80B stereo gen, \$200. J Danials, WRAV, 333 Delaware Ave, Delmar NY 12054. 518-439-0945.

Hnat-Hindes UM2000 Ultra Mod w/stereo gen, \$2250; Comp-Roc composite limiter, \$900. J Danials, WRAV, 333 Delaware Ave, Delmar NY 12054. 518-439-0945.

TAPES/CARTS & REELS

Want to Sell

Pams Jingles ref tapes, 1951-1976, BO. R Kaufman, Pams Prods, POB 462247, Garland TX 75046. 214-271-7625.

3M Scotch Cart II (300), mostly 3.5 & 4.5 min in length, like new, \$2.60 each or \$630 for all. Dave, Allmake Prod, 517-652-6863.

Scotch carts (1000), music lengths, \$2 ea; (2) 500 wire rack cart Carousels, \$150 ea. J Vavricek, KSYZ, Grand Island, NE. 308-382-0108.

Fidelipac Red & Aristocart Blue carts, 528 :40 & :70; Fidelipac TR-96 cart storage rack; Aristocart AW-20 plastic cart storage racks (25), new. FB Nienow, WYTE, POB 1030, Stevens Point WI 54481. 715-341-8838.

Ampex 406 10" reel tape, new, only \$11.95 each. Call Mark at 619-758-0888.

Want to Buy

Urgent need records, tapes, carts, CDs, automation, syndication, etc, fire burnt down massive library, insurance didn't cover, so please don't trash away those tapes, records, CDs, etc, we will take them any yr or format. S Stevenson, Stevenson Corp, POB 1288, Blaine WA 98231. 604-531-4576.

TAX DEDUCT EQUIP

Tax-deductible equipment donations sought by Penn State School of Comm bdct/cable major, need R-R's, cart machines, audio mixing boards, mics, engrg test equip, TBC's, consoles, studio-xmtr links, traffic computers/software & air monitor equip. D Macaluso, Penn State, 814-865-8801.

Educ non-profit radio needs low power FM or AM xmtr; also need studio equip, will pay shpg & give receipt. Dr Newcomb, Grand River Radio. 216-548-2053.

MARATHON PRODUCTS COMPANY

Audio Cartridge Rebuilding Division

Rebuilding/reloading, like new, all brands, any length up to & including 3.5 minutes, \$1.95 ea. FOB out plant, 48 hrs delivery. (New rate effective 9/1/93)

New NAB Marathon cartridges prices on request.

35 Years professional experience!

Lifetime member AES R.D. MYERS Sr.

Manufacturers of Audio Devices, Continuous Tape Mag.

69 Sandersdale Rd. Charlton, MA 01507

1-508-248-3157 or 1-508-853-0988

Circle (96) On Reader Service Card

Polyester/mylar tape, hundreds of 7" reels, all in boxes, some original, unopened, some recorded on, have 1200, 1800, 2300 & 3600' reels. BO. M Shlank, POB 850, Orange CT 06477. FAX 203-937-5961.

High school radio station in Washington DC looking for tax deductible donation of 1 kW Am xmtr or amp, will pay shipping or pick up. M Jeakins, JSC Corp/Metcon, 13102 New Parkland Dr, Herndon VA 22071. 703-709-9084.

TEST EQUIPMENT

Want to Sell

Crown RTA-2 real-time audio spectrum analyzer, \$1400/BO; Klark-Teknik DN60 real time audio analyzer w/calibrated mic, \$1850. Rick, Super Duper Audio Duplicating, 503-228-2222.

We Have RENTAL EQUIPMENT available to SAVE YOU MONEY

Spectrum Analyzer
Potomac Field Strength Meters
Impedance Bridges
Receiver/Generator
Audio Test Set

ALSO

Other Equipment Available
RADIO RESOURCES
Ask for STEVE, BILL or Chuck
1-800-54-RADIO

HP 4815A RF vector impedance meter, needs probe, \$800. G Arroyo, 407-830-0800.

HP 120B X-Y oscilloscope; Tektronix 602 X-Y-Z scope, BO. Dave, Allmake Prod, 6130 S Dehmel Rd, Frankenmuth MI 48734. 517-652-6863, leave message.

Want to Buy

AUL Instruments 6207-1, AN/URM-213B, instruction & service manuals. S Swanson, KBNL, Box 2425, Laredo TX 78044. 210-724-9211.

TRANSMITTERS

Want to Sell

HV P.S oil capacitors, 4.0MFD-10KV \$50, 8.0MFD-5KV \$60. Electrolytic 2100MFD-400VDC \$7 each. Emerald, 714-964-3912.

McMartin B-910 FM exciter on 91.3 MHz, gd cond, BO; Gates FM250C 250 W FM xmtr w/M6095 exciter & M6146 stereo gen on 91.3, BO. P Guello, KUWS, 1800 Grand Ave, Superior WI 54880. 715-394-8187.

Collins 205J-1A RF Linear Amplifier, 45KW, 2-30MHz, auto-tuned, \$8,500. Emerald, 714-964-3912.

CCA FM3000D vgc, no exciter, \$7500. D Sports, WCLA, POB 427, Claxton GA 30417. 912-739-3035.

Gates TE-3 on 104.1, \$650/BO. J Bahr, WVIS, Box 487, Frederiksted, St Croix VI 00840. 809-773-2220.

Harris FM5K, \$16,500; CSI FM3K, \$13,500; Harris MX-15, excel cond, \$1800; Energy-Onix SST-30 (30 watt), \$2500. R Michaels, KQFX, 3639-B Wolfun Ave, Amarillo TX 79102. 806-355-1044.

CSI 3 kW in excel cond, \$13,800. R Michaels, KQFX, 3639-B Wolfun Ave, Amarillo TX 79102. 806-355-1044.

TRANSMITTERS

1.0 kW	AM 1990	Gates	One
10.0 kW	AM 1977	Continental	316F
500 watts	FM 1984	OEI	675T500
1.0 kW	FM 1971	Collins	830-DIA
2.5kW	FM 1977	Harris	2.5H3
PMA MARKETING, INC. "TRANSMITTING SAVINGS TO YOU" 414-482-2638 FAX 414-483-1980			

Continental Electronics 814R 2.5 kW xmtr, \$11,000. M Howard, WYZK, POB 5406, Valdosta GA 31603. 912-333-0755.

Gates 1967 FM 1G w/o exciter, fully operational when removed, tuned to 102.3 FM w/harmonic filter adapting to 97.7 FM, many spare parts, new & used, crating, labor, shipping extra, \$3200. D Curley, WCXU, RR2, 2100 East Greenridge, Caribou ME 04736. 207-473-7513.

DEMOED EQUIPMENT

BEXT Inc. has a few demoed excitors, amplifiers and STL's for sale. All demoed systems are sold first come first served and have the same 2 year warranty as BEXT's new equipment. For information:

619-239-8462

RCA BTA-10U2 AM, ready for 5 kW, vgc, used as spare, \$10,000/firm. G Arroyo, 407-830-0800.

Gates BC1G to sell of trade, nds work, BO. R Carr, KXLE, 1311 Vantage Hwy, Ellensburg WA 98926. 509-925-1488.

Nautel AMPFET P400 xmtr; 400 W AM bdct xmtr, revised manual, NAX57A surge arrester, \$4000. G Hoppe, WVVAL, 1010 2nd St N, Sauk Rapids MN 56379. 612-252-6200.

Collins 830E-1A 5 kW FM w/new Econco spare final, gd cond, \$5800. J Schuler, WSCH, 6857 Salem Ridge Rd, Aurora IN 47001. 812-438-2777.

FM - TRANSMITTERS

Factory new not used. Why buy a used Transmitter when you can own a new FM Transmitter for about the same cost? Call JIMMIE JOYNT at 214-335-3425.

Harris TE-3 solid state FM exciter, \$500. C Frodsham, KVSU, POB 7, Beloit KS 67420. 913-738-2206.

Wilkinson FM exciter, like new cond, BO. C Politosia, New Horizon Bdctg, 200 D Main, Roysce City TX 75789. 214-636-9332.

Gates BC-5P 5K AM in service on 1220 kHz, \$5700. S McGrath, WGNY, 429 Little B Rd, Newburgh NY 12550. 914-561-2131.

Tepeco J317(M) FM in excel cond, \$1455, also has mod card for local 30 sec/hr announcements, \$480. C Damon, KWST, POB 1890, Flagstaff AZ 86002. 602-774-5559.

NEW 3 kW FM transmitters

for under \$14,000.

Call for details

Bill Hoffman

518-583-9490

10 watt PA for Harris TE-1 or TE-3, updated version, never used, \$450. P Ryan, KYMC, 2122 Marconi Ave, St Louis MO 63110. 314-664-7080.

Compression/limiting device for low power AM mono travelers info radio station in useable cond. A Anello, 813-933-6009.

RCA BTA-5T on-air at 590 kHz with spare parts & manuals, avail 10/1/93, \$5000. K Harvey, KAQQ, E 300 Third Ave, Spokane WA 99202. 509-459-9800.

TRANSCOM CORP.

Serving the Broadcast Industry Since 1978

Fine Used AM & FM Transmitters and Also New Equipment

For the best deals on Celwave products, Andrew cable and Shively antennas.

1 kW FM 1978 Collins 831C2	2.5 kW AM 1982 CCA 2500D
2.5 kW FM 1978 CCA 2500R	2.5 kW AM 1976 McMartin BA2.5K
3 kW FM 1975 CCA 3000D	5 kW AM 1977 RCA BTA 5L
3 kW FM 1974 Harris FM3H	
3.5 kW FM 1979 Syntronics SI-F-3	50 kW AM 1977 CCA AM50,000D
10 kW FM 1970 Collins 830F2	50 kW AM 1979 Harris MW50B
15 kW FM 1971 AEL 15KG	
25 kW FM 1981 Harris FM25K	
30 kW FM BE FM30	

1077 Rydal Road #101
Rydal PA 19046

800-441-8454 • 215-884-0888 • FAX No. 215-884-0738

Circle (73) On Reader Service Card

World Radio History

Circle (153) On Reader Service Card

Post... Big Savings!

PRICE BREAK-THROUGH

SOLID STATE FM TRANSMITTERS

100 Watt	\$4995
300 Watt	\$5995
500 Watt	\$7995

SOLID STATE FM AMPLIFIERS

100 Watt	\$2995
300 Watt	\$3995
500 Watt	\$5995

MADE IN U.S.A.

"The Transmitter People"

Energy-Onix

752 Warren Street, Hudson, New York 12534
(518) 828-1690 FAX (518) 828-8476
A Wise Enterprise

TRANSMITTERS...WTS

McMartin BA-1K 1 kW AM xmtr tuned to 1450 kHz, was on air until 3/93, currently kept in AC'd room, great cond, \$6000. R Vega, WOCN, 350 NE 71st St, Miami FL 33138. 305-759-7280.

Gates FMSH, rblt 11/90, 95.9 mHz, no PCBs w/McMartin BFM 8000 exciter, curr on air, avail 9/93, \$14,000. R Miller, Miller Media Group, 111 W Main Cross, Taylorville IL 62568. 217-824-3395.

Gates BC5-P 5 kW AM for parts, will sell any or all parts, very low price. Goodrich Ent, 11435 Manderson St, Omaha NE 68164. 402-493-1886.

CCA Electronics has the following equipment for sale: CSI-3000E 3KW FM transmitter w/EX-20F exciter; HJarris FM2.5K 2.5 KW FM transmitter w/MX-15 exciter. Contact Steve or Howard, 404-964-3530.

CSI 5000E FM xmtr, rebuilt in 1990 due to lightning damage, has been in perfect service until 3/93 when we upgraded, \$8000. H Beam, WAEY, POB 5588, Princeton WV 24740. 304-425-2151.

TTC/Wilkinson 2500E 1983 FM w/exciter, stereo gen & spare final, avail mid Sept, \$5000/BO. G Blum, KOLV, Box 6, Olivia MN 56277. 612-523-1017.

Want to Buy

McMartin AM/FM transmitter, any model, exciter or stereo modules. Goodrich Enterprises, 11435 Manderson, Omaha NE 68164. 402-493-1886.

AM 15 W for overnight operation; AM 1000 W for daytime operation. M Jarvis, KORC, POB 1419, Waldport OR 97394. 503-563-5100.

Service/owners manual needed for Wilkinson FME-10 exciter. J Fink, WLAD, 198 Main St, Danbury CT 06810. 203-792-4266.

Xmtrs 10-50 W for TIS. 813-933-6009.

Broadcast/Shortwave 1-3 kW AM needed such as Gates HF-1M, BC-1G or similar Collins equipment in working cond. G Lee, Radio KE6MS, HT Inc, 6345 Balboa Blvd, #111 Ste 270, Encino CA 91316. 818-774-9497.

50 watt carrier current xmtr, metered line coupler & power splitters. P Ryan, KYMC, 2122 Marconi Ave, St Louis MO 63110. 314-664-7080.

10 kW AM. George, WNQM, 1300 WWCR Ave, Nashville TN 37218. 615-255-1300/1377.

TUBES

Want to Sell

4-1000A, 8877, 4CX250B, 4CX1500B, 4CX3000A & more. We carry large inventory all major brands, Eimac, Amperex, RCA, etc. Call Stew 1-800-842-1489.

Eimac 4CX5,000A, new \$1195, used \$795. Eimac SK-300 Socket, new \$395, used \$295. Emerald, 714-964-3912.

Eimac 3CX3000A1, new, \$200; 3CX3000A7, BO. R Ness, Media Ventures, 6070 W Minooka Rd, Newark IL 60541. 815-942-2839.

Eimac 3CX1000A7/8283, need several to complete scientific project, full output polls OK. R Stankus, Mid-Lo Broadcasting, 10616 Savoy Rd, Richmond VA 23235. 804-320-1130 after 5.



Quality* Power Tubes

- 4X150A
- 4CX250B
- 4CX250BC
- 4CX350A
- 4CX15,000A
- 5CX1500A
- 5CX1500B

- Watch this list grow.
- Manufactured in Russia's largest power tube factory.
- Generous* warranty based on high quality.
- Honest prices based on quality at low cost.
- Shipment from USA stock.

Broadcasters
Call: 800-239-6900
FAX: 205-880-8077

OEMs, Distributors,
Volume Purchasers
Call: 415-233-0429
FAX: 415-233-0439

Circle (3) On Reader Service Card

ECONCO

Quality Rebuilt Tubes
Approximately 1/2 the Cost of New

Call for Our Price List

800-532-6626

916-662-7553

FAX 916-666-7760

Circle (181) On Reader Service Card

Want to Buy

WANTED!
Transmitting Tubes

We BUY & SELL all types of transmitting/receiving tubes.

C&N Electronics
Harold Bramstedt
6104 Egg Lake Road
Hugo, MN 55038

(612) 429-9397 ext.23
(800) 421-9397 ext. 23
FAX (612) 429-0292

Circle (38) On Reader Service Card

WANTED: TUBES

I pay cash or trade for all types of transmitting or special purpose tubes.

Nobody pays more or faster than us!

Mike Forman
1472 MacArthur Blvd.
Oakland CA 94602

(510) 530-8840
FAX: 510-530-0858

Need KT88, KT66, EL34, 6CA7, 211, 845, WE300B, WE350B. John, 708-391-8828.

TURNTABLES

Want to Sell

Technics direct drive TT's (2). F Reagan, Special Bdct Srvs, 203 Westville Ave Ext, Danbury CT 06811. 743-7433.

Keith Monks rcrd cleaner, perfect shape. \$750; Keith Monks anti-static Lp sleeves, never opened, \$24/box of 300. Rick, Super Duper Audio Duplicating, 503-228-2222.

JVC 4-DD-5 CD-4 quadrophonic disc demodulator, v. low hrs, \$75 plus shpg, no COD's. D Pulwers, Dave's Price Audio Prod, 310 N Howard St, #103, Alexandria VA 22304. 703-751-9346.

Technics SP25 (2) w/QRK arms, very low hrs w/never used bases, \$175 ea. B Tidwell, WAFT, POB 338, Valdosta GA 31603.

Presto 6N lath, 500 ohm cutter, \$200; Presto M8 cutter, complete in case, \$120. J Parsons, Parsons Snd Srvc, 2781 Faysor Circle, Deltona FL 32738. 904-532-0190.

Want to Buy

16" tonearm, record cutting machines, 45/78 records. 612-866-6183.

Eimac 3CX1000A7/8283 tubes. R Stankus, Mid-Lo Bdctg, 10616 Savoy Rd, Richmond VA 23235. 804-320-1130.

Space Available!
contact Simone at
1-800-336-3045

NOTICE!

To all buyers and sellers of used broadcast equipment including AM/FM/TV/shortwave transmitters, antennas, STLs and studio equipment—To better serve you, we have moved to our new location with over 40,000 square feet of warehouse and service facilities. For transmitter sales, parts, service and technical assistance, please make a note of our new address and phone number.

ARMSTRONG TRANSMITTER CORPORATION
4835 North Street Road
Marcellus, NY 13108
TELEPHONE: 315-673-1269
24 HOUR FAX: 315-673-9972

ADVERTISER INDEX

This listing is provided for the convenience of our readers. Radio World assumes no liability for inaccuracy.

Page No.	Advertiser	Reader Service No.	Page No.	Advertiser	Reader Service No.
12	360 Systems	17	49	Escalibur	15
46	AEO	37	48	Flash Technology	19
38	AES	206	28	Focal Press	97
44	AEV SNC	22	27	Georg Neumann GMBH-Berlin	128
13	AEV SNC	74	49	Gorman Redlich	24
40	AMP Services	193	57	Hall Electronics	219
6	ATI	208	36	Holland Broadcast Services	102
35	Arakis	135	48	Holkainen & Friends	106
23	Arakis	203	7	Harris-Albed	98,180
42	Arakis	147	15	Harris-Albed	51,190
50	Arakis	132	8	Hinat-Hindes	12
8	Audi-Cord	163	40	ITC Instruments	164
48	Audio Broadcast Group	64	14	J Squared Technical Service	44
2	Audiarts/Div. of Wheatstone Corp.	88	18	Korg	210
24	Audiopak	172	14	LBA, Inc.	167
22	Australian Monitor	42	25	Marantz	20
48	Avcom of Virginia	130	61	Marathon	96
17	BSW	152	47	Mart	115
16	Belar	85	3	Microwave Filter	216
40	Benchmark Media Systems	82	29	Modulation Sciences	110
35	Bext	158	54	Moseley	70
48	Broadcast Devices	8	52	Nautek	105
55	Broadcast Electronics	93	53	Orban/AKG/dbx	166
11	Broadcast Electronics	124	9	Otan Corp.	104
4	Burk Technology	142	43	Pacific Recorders	177
26	Burk Technology	63	41	OEI	120
62	C & N	38	51	RE America	119
1	CCA Electronics	59	14	RE America	35
28	Cellcast	28	57	Radio Resources	32
40	Central Tower	211	56	Radio Systems	31
49	Circuits Werkes	182	57	Recording Studio Service	14
23	Clark Wire and Cable	191	48	Rodman/Brown Associates	220
49	Comrex	176	20,21	Roland Corp.	108
36	Conex	18	49	Russ Friend & Associates	205
3	Continental Electronics	92	40	Shively Labs	45
30	Corporate Computer System (CCS)	214	10	Shure Brothers	116
45	Cutting Edge	83	34	Studer	146
19	DIC Digital	126	48	Studio Technology	68
15	Dalet	33	32,33	TM Century	187
6	Dataworld	76	39	Tascam	40
38	Dataworld	53	37	Telco Systems	112
42	Dataworld	11	49	The Blue Group	213
31	Denon America	149	40	The Management	54
49	Dielectric	77	28	Titus Technologies	140
49	Econco	61	61	Transcom Corp.	73
62	Econco	181	63	Wheatstone	161
61	Energy-Onix	153	64	Wheatstone	29

PublisherStevan B. Dana
Associate PublisherCarmel King
Marketing ConsultantAl Leon
Marketing AssistantAnnette Deutscher
Production DirectorKim Lowe
Production ManagerJulianne Stone
ProductionVicky Baron, Lisa Lyons, Lisa Mamo
Ad CoordinatorRegan Deatherage
Ad Coordination ManagerSimone Mullins
Circulation DirectorTiana Hickman
Circulation ManagerRebecca Seaborg
Accounts ReceivableSteve Berto

Advertising Sales Representatives
U.S. East: Skip Tash703-998-7600 Fax: 703-998-2966
U.S. West: Dale Tucker916-721-3410 Fax: 916-729-0810
International: Stevan B. Dana+1-703-998-7600 Fax: +1-998-2966
Europe: Dario Calabrese+39-2-753-0274 Fax: +39-2-753-2697
Japan: Eiji Yoshikawa+81-3-3327-2688 Fax: +81-3-3327-3010

Free Subscriptions are available upon request to professional broadcasting and audiovisual equipment users. For address changes, send current and new address to RW a month in advance at P.O. Box 1214, Falls Church, VA 22041. Unsolicited manuscripts are welcomed for review: send to the attention of the appropriate editor.

ACTION-GRAM

Equipment Listings

Radio World's Broadcast Equipment Exchange provides a FREE listing service for radio stations and recording studios only. All other end users will be charged. Simply send your listings to us, following the example below. Please indicate in which category you would like your listing to appear. Mail your listings to the address below. Thank you.

Please print and include all information:

Contact Name _____ I would like to receive or continue receiving Radio World FREE each month.
 Yes No

Title _____ Signature _____ Date _____

Company/Station _____ Please Circle only one entry for each category:

Address _____

City/State _____

Zip Code _____

Telephone _____

I. Type of Firm
D. Combination AM/FM station F. Recording studio
A. Commercial AM station G. TV station/teleprod facility
B. Commercial FM station H. Consultant/ind engineer
C. Educational FM station I. Mfg. distributor or dealer
E. Network/group owner J. Other _____

II. Job Function
A. Ownership G. Sales Manager
B. General management E. News operations
C. Engineering F. Other (specify) _____
D. Programming/production

Brokers, dealers, manufacturers and other organizations who are not legitimate end users can participate in the Broadcast Equipment Exchange on a paid basis. Line ad listings & display advertising are available on a per word or per inch basis.

WTS WTB Category: _____
Make: _____ Model: _____
Brief Description: _____
Price: _____

*Closing for listings is the first and third Fridays for the next month's issue. All listings are run for 2 issues unless pressed for space or otherwise notified by listee.

Broadcast Equipment Exchange
Phone: 703-998-7600 PO Box 1214, Falls Church, VA USA 22041 FAX: 703-998-2966

Give Your Production People Some POWER!

THE SP-6 IS LOADED WITH FEATURES! Like a powerful equalizer section that gives your talent greater creative freedom; four auxiliary sends that can be used for special effects, headphone feeds, or IFB mixes; both 8-track and stereo bus assigns for multi-track and dubbing work; plus a choice of mono mic/line or stereo input channels. And, to keep things fast and productive, it even includes full machine control logic, control room and studio mutes, plus tally systems—just like you'd expect on an on-air console. The SP-6 provides independent headphone, control room and multiple studio monitors, and (of course) an automatic stereo cue/solo

system. Our unique track monitor section will speed your production pace, allowing simultaneous stereo mixdown during the multi-track bed session.

A powerful group of accessory modules will increase your production control, like a 7-station intercom module that links this console with other Wheatstone consoles and talent stations throughout your complex; a full-function tape recorder control panel; an 8-position source selector to enhance input capability; additional studio modules to accommodate multi-studio installations; and finally, a digital event timer and a precision clock.

So contact Wheatstone, the company with the integrity and experience you can count on.



 Wheatstone® Corporation

SP-6

6720 V.I.P. Parkway, Syracuse, NY 13211 (tel 315-455-7740 / fax 315-454-8104)

Circle (161) on Reader Service Card

Wheatstone Has It!

Super Performance – Great Price!

OUR NEW A-300 CONSOLE HAS ALL THE RIGHT STUFF: Performance right at the limits of technology, the features you want, and a fresh clean look your clients will admire. It's got all the busses you'll need. It's got the crosstalk and bus off isolation you HAVE to have for LMAs and FM/AM combos. Its small footprint and low profile let you conserve valuable studio real estate. Its virtual audio bus™ architecture lets you place any module anywhere in the console—no dedicated slots!

Talent will love our easy-to-learn superphone module and the automated cue system that makes monitoring confusion-free. Our integrated intercom system lets them communicate with any other Wheatstone console or talent location—handsfree.

Your program director will really like the sound of this console: no VCA distortion—just flawless specs. And, because of its ultra-flexible architecture, it can be easily adapted to any format, anytime.

The A-300 has what engineers want: first class documentation, gold switches, gold connectors, a hinged meterbridge for easy re-lamping, straight-forward reliable logic technology, and the best I/O connection and tooling system in the industry.

The A-300 is the console that has followed the evolution of radio. Benefit from Wheatstone's experience and total commitment to your satisfaction. Contact us.



 Wheatstone® Corporation

A-300

7305 Performance Drive, Syracuse, NY, 13212 (tel 315-452-5000 / fax 315-452-0160)

Circle (29) On Reader Service Card

World Radio History