

\*\*\*\*\*3-DIGIT 857  
 J750970 D08 9203 8916 1018  
 TOM MILLER  
 ASST CE  
 KTZR  
 2033 S AUGUSTA PL  
 TUCSON AZ 85710

# Radio World

**Build a  
 Winning Sound**  
 Part I of a Series in  
**Running Radio,**  
 pp. 30-39

Vol 16, No 11

Radio's Best Read Newspaper

June 10, 1992

## LA Riots Spur KFI Remote

*Editor's note: The following is a first-person account of events leading up to and including a marathon KFI/KOST remote from CE Marvin Collins' suburban home during the worst rioting in U.S. history.*

by Marvin Collins

**LOS ANGELES** It was about 10:20 a.m. Thursday, April 30. As I drove south on Alvarado Boulevard to the Hollywood Freeway, I got a sinking feeling watching a large column of smoke rising from the area of the University of Southern California and the Los Angeles Coliseum. This was my evidence of the LA rioting which began following verdicts the day before in the trial of officers accused of beating

motorist Rodney King.

Driving onto the Hollywood Freeway, I noticed that traffic was lighter than usual and flowing very well. It was 10:30 a.m. when I pulled into my parking space at the KFI/KOST office building on S. Ardmore.

At first it seemed business as usual at the station. KFI Program Director David Hall and I discussed the possibility of doing the Tom Leykis afternoon show as a remote broadcast from the KFI traffic airplane circling South Central Los Angeles.

The morning's calm, however, was interrupted as we noticed a large fire that appeared to be east of our building, about four blocks away on Third Street. It became apparent that the situation in the vicinity of the KFI/KOST studio was deteriorating rapidly.

### Fire, looting nearby

It was close to noon. Smoke and flames from additional fires were clearly visible as a result of looting on Vermont Avenue at First and Third Streets.

It was difficult to imagine that conditions could turn from normal to disastrous so rapidly. Most buildings on my route from the Hollywood Freeway down Vermont and West on Third Street were either burned or pillaged, I found out later.

Because the situation at the KFI/KOST

Devastation just blocks from KFI's studio (below) prompted the station to broadcast from CE Marv Collins' living room (right).



studios was becoming worse, it was decided that personnel needed to be moved for safety reasons. Howard Neal, the general manager, told the employees they were excused from work.

At a meeting with Neal, Hall, and Mark Thomas, the KFI news director, we decided that KFI would keep only a minimum staff

at the studio: a board operator and a call screener. The talk show talent and news staff were to broadcast from a remote location.

continued on page 9 ►

## NEWSWATCH

### FM Revamp Plan Center of Debate

**WASHINGTON** The NAB's effort to institute an FM freeze while revamping allotment proceedings for the band drew mixed reaction from the sparse group of commenters who filed their opinions with the FCC.

Comments were made on two separate rulemaking proceedings: RM-7932 (the temporary suspension or freeze provision) and RM-7933 (the overhaul of station allotment practices). The NAB claimed that the band was oversaturated with radio outlets and that signal interference among stations has worsened; "prompt, comprehensive and remedial action" was called for to correct current allocation policies.

Among supporters of the NAB plan were KVEN Broadcasting, Jacobson Broadcasting, Capitol Broadcasting Corp., Group M Communications and the New Jersey Broadcasters Association. A comment typical of the support came from Bob Fox of KVEN, who wrote, "The marketplace cannot support existing stations and absolutely cannot support an increase in the number of stations."

The filing goes on to call for suspension of allocations and authorizations while reviewing the process by which they are granted.

Opposing comments were filed by E. Harold Munn, Jr. & Associates, Hamon Broadcasting Corp., John R. Furr and Troy Broadcasting Corp. Some of this opposition was based on

continued on page 2 ►

## NEW FROM GENTNER

### THE DIGITAL HYBRID 1

List Price \$995.00

- Cost Effective
- Easy Set-Up
- Clear Telephone Audio
- Available Now

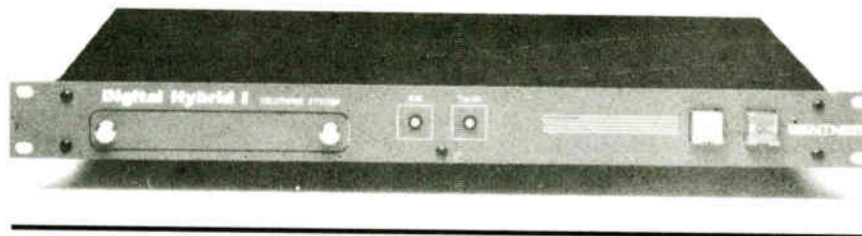

## NORTHEAST BROADCAST SYSTEMS

Broadcast Equipment Sales and Systems

Main Office (800) 227-1093

Southwest Office (800) 729-0494

Baltimore-Washington Office (800) 643-6325

## New UL Class for Broadcast

by Dee McVicker

**MELVILLE, N.Y.** Underwriters Laboratories (UL) is making its mark on the industry with a new product category specific to broadcasting.

According to reports from within the not-for-profit organization, which evaluates and certifies products in the interest of public safety, requirements for new UL category 1419 are expected to be published in June.

This event follows a UL meeting with 22 industry members, and likely will result in an American National Standards Institute (ANSI) standard. The ANSI standard will provide a national set of fire, electrical shock and casualty safety requirements for broadcast equipment.

Prior to the new category, broadcast equipment certified by UL was listed under commercial or household UL categories, for which the requirements are more stringent and the evaluation costs higher.

Already, more than 20 broadcast equipment manufacturers have listed more than 300 products under UL 1419, which specifies safety requirements for broadcast video and audio equipment, including RF products.

continued on page 10 ►

Circle (15) On Reader Service Card

World Radio History



# NEWSWATCH

► continued from page 1

motives peculiar to the particular commenter, but in general centered around the argument that a freeze would not protect FM stations.

John Furr wrote, "If the NAB really wants to protect its members from devaluation, it had better take an active role in promoting in-band DAB."

## Kautz Sentenced to Jail, Restitution

**OMAHA, Neb.** Jerry Kautz of Imperial Transmitters is headed for prison.

On May 1, Kautz pleaded guilty to mail fraud in U.S. District Court for the District

of Nebraska. A number of broadcasters had accused him of defrauding them by accepting payments in advance for broadcast equipment that was never delivered.

After gathering more than \$250,000 dollars in this manner, Kautz disappeared briefly before being apprehended by federal agents outside St. Louis several months ago.

Kautz was sentenced to 21 months in jail, with a three-year probationary period. He also is required to make restitution of \$256,965 to 48 victims.

Assistant U.S. Attorney Alan Everett told RW that the FBI to date has seized only \$5,000 of the money Kautz had accumulated. He added, however, that "we think we can

get our hands on almost all the money." Any amount still owed after that will be paid by Kautz in installments agreed to by the courts, Everett said.

The case of *The United States v. Jerrel E. Kautz* never actually went to trial, Everett explained. Kautz had originally been charged with several counts of mail and wire fraud. To avoid facing each count, he pleaded guilty to one, according to Everett.

The district attorney's office agreed to that arrangement, provided that the entire body of charges still would be considered by the court in determining Kautz's sentence.

For more information, contact the U.S. Attorney's office at 402-437-5241.

## MUSICAM via Phone

**TAMPA** Using the European MUSICAM digital compression technology, the "Ron & Ron Show," broadcast from

WYNF(FM) here, also is now being heard on WDIZ in Orlando.

The four-hour, live "Ron & Ron Show," known for its mix of irreverent humor, news and information and caller participation, is the first to use MUSICAM technology for stereo programming in the U.S., according to the CBS-owned WYNF.

The broadcast is the result of using two Switch 56 digital phone lines, a Corporate Computer Systems CDQ 2000 MUSICAM encoder at WYNF and a decoder at WDIZ.

According to WYNF Program Director Charlie Logan, the CDQ 2000 compresses the 15 kHz stereo audio sufficiently to be transmitted via the phone lines.

## Bigger Role for SBE?

**LAS VEGAS** With the success of SBE Day at NAB '92, the word is that an expansion of SBE's role in the highly popular engineering sessions during the convention seems imminent.

According to SBE and NAB officials, discussions are ongoing regarding how to increase SBE's role in the technical sessions. Several SBE members told RW on the show floor that perhaps SBE eventually would take over the sessions.

NAB and SBE officials gave no indication whether the involvement would go

continued on next page ►

# A Little Bit of MAGIC...

**SOMETIMES** all you need is one small high quality console. No complicated features—just crisp reliable performance. The **R-10** is that console; it has the features you need and all the performance and componentry that you could wish for. And by **PERFORMANCE** we mean a dynamic range of 113dB, a frequency response of ±1.4dB (20Hz-20KHz) and a THD of .002%!

**THE R-10** is just the console for small stations in small markets—or BIG stations chasing down remotes—or ANY station needing a reliable small format console.

So, put the magic to work for you. Contact **AUDIOARTS**.



**AUDIOARTS ENGINEERING**

6720 V.I.P. Parkway, Syracuse, NY (tel 315-455-7740/fax 315-454-8104)

# Index

## FEATURES

### Simple Steps to Pin-Point AM Radiation Problems

by W.C. "Cris" Alexander

16

### Workbench

16

### What No One Tells You about Contracting

by Barry Mishkind

17

### FCC's Revised Forfeiture List Is Another Fine Mess

by Harold Hallikainen

18

### Line Amps: Some Assembly Required

by Jim Somich

19

### Survival Strategy in Today's Tough Times

by John "Q" Shepler

20

### Marconi's Early Experiments Set Stage for Future Empire

by George Riggins

20

### The Importance of Labeling Digital

by Mel Lambert

22

### A Beginner's Guide to Digital Editing

by Bruce Bartlett with Jenny Bartlett

27

### N.C. Trilmulcasting Venture Relies on Marti "Plan A"

by Dee McVicker

29

## RUNNING RADIO

### Laying a Foundation for Your On-Air Sound

by Jeff Loughridge

30

### Top 40 Techniques for the 1990s

by Charles Taylor

31

### Today's Jazz: A Rewarding Challenge

by Mark Medicus

32

### A History of Modern Jazz

32

### Understanding Satellite Affiliation

by Karl Baehr and Harry Nelson

33

### Return to the Cradle of Educational Radio

by James T. Wold

34

### Simple Steps to Making Better Sales

by Shane Fox

36



► continued from previous page that far.

NAB Science and Technology spokesman Andy Butler said negotiations are underway with SBE and a decision would be finalized by early summer. When asked to what degree SBE will be involved in technical sessions, Butler said only that the organization's role would be "expanded in some way."

**Revised Broadcaster Fees**

**WASHINGTON** The FCC has proposed a revised fee collection program that will affect radio and television broadcasters, based on congressional legislation proposed but never passed in 1991.

The proposed fees are: Class A AM, \$550 (77 licensees); Class B AM, \$125 (1,776 licensees); Class C AM, \$125 (1,018 licensees); Class D AM, \$125 (2,081 licensees); Commercial I FM, \$550 (2,268 licensees); and Commercial II FM, \$125 (2,439).

On the TV side, the fees will range from \$125 (low power) to \$4,000 (VHF stations in the top 50 markets).

**Tax Court Allows License Write-Off**

**WASHINGTON** The U.S. Tax Court ruled in April that a value could be assigned to broadcast licenses for tax purposes.

Stemming from Jefferson Pilot's purchase of three stations in the early 1970s and subsequent attempt to write off the value of the license, the tax court overruled the IRS contention that the licenses were not subject to tax deductions.

The tax court's decision can be appealed, but there seems to be growing support for assigning a value to broadcast licenses in Washington.

**Clear Channel Gets Waiver**

**WICHITA, Kansas** The FCC has waived its one-to-a-market rule and allowed Radio Management Services to assign KQAM and KEYN-FM to Clear Channel Communications.

Since Clear Channel owns 100 percent of KSAS-TV in Wichita, the company had to request a waiver of the one-to-a-market rule to acquire the radio stations. Clear Channel requested the waiver under the "failed station" standard, which allows suspension of the

ownership rule if a station has gone dark or is in bankruptcy, but is considered vital to its community.

**Video Radio Service Expanded**

**WASHINGTON** The FCC has issued a Notice of Proposed Rulemaking (NPRM) that would allow video producers as well as the motion picture industry to use radio frequencies for interpersonnel communications.

The motion picture industry has had FCC authorization for many years to utilize radio communications among its production staff. In the rulemaking, No. 91-62, the service has been renamed the Video Production Radio Service.

**Brooklyn Pirate Nabbed**

**NEW YORK** The FCC shut down a pirate radio station in late April that was broadcasting on 1260 kHz from Brooklyn.

The station, known as "Radio Guinan," was operated by Jeane Lucien Borges of the Guinan Community Information Center. In November 1991, WADO and WFME complained to the FCC about the pirate broadcaster and the owner was issued a warning.

According to the FCC, that warning was ignored; the matter then was turned over to the U.S. Justice Department. The owner can be fined up to \$100,000 and/or one year in prison.

**Radio NRW Is Popular in Germany**

**OBERHAUSEN, Germany** Radio NRW is fast becoming one of the most successful private radio stations in Germany.

In the country's federal radio system, Radio NRW helps resolve the conflict between the two main German radio concepts: local radio, which mostly does not make money, and state radio, which offers very little local identification.

Broadcasting in Germany comes under the control of the state governments, which have set up different models for private radio. In some, one or two powerful stations broadcast statewide. In others, the state is divided up into small areas, each having its own station. Still other models are based on something approaching a free-for-all, with several stations competing in the same market.

In Germany's most populous state, North

Rhine Westphalia (NRW), where private radio began only two years ago, it was decided to go for a system that combined the power of a statewide network with the local identification possibilities of small city and rural area stations.

The state was divided into 46 areas, each with its own station, most of which have now gone on air. All but three of them decided to take Radio NRW, based in the industrial city of Oberhausen, as their sustaining network. To increase the identification of the listeners with "their" station, Radio NRW is never mentioned on air, although it provides the lion's share of the programming.

Each of the local stations is under contract to Radio NRW to take its news bulletin at the top of the hour, together with a four-minute block of statewide advertising (half the legally permitted hourly dose) just before the news. In addition, each station may use Radio NRW programs when it is not broadcasting its own.

But Radio NRW's control does not end there. Stations are required to follow hourly playlists provided by Radio NRW.

Radio NRW offers a pan-European adult contemporary (AC) format, with two German titles an hour, and around 30 percent speech content.

**New Books From NAB**

**WASHINGTON** Several new books from the NAB tackle such topics as station operations, future technologies, legal issues and sales promotions.

"The Engineering Handbook" is a definitive guidebook and training resource for broadcast engineers. Last updated in 1986, the new version is 1,345 pages and costs \$195 for members (\$235 for non-members).

"Advanced Media/Broadcast Technologies" is a "futurist" look at new broadcast technologies. The 149-page book examines some recent technologies for both radio and TV. The cost is \$20 for members (\$40 for non-members.)

"Broadcasters' Law and Regulation Conference Papers" is a compilation of session papers presented at the NAB '92 Law and Regulation Conference. The cost is \$45 for members (\$70 for non-members.)

**KXGO Stays On-the-Air**

**EUREKA, Calif.** KXGO-FM was the only station to remain on the air the entire time during the recent series of Northern California Earthquakes in late April.

The station remained on the air during the initial quake and after shocks using the DigiSat II automation system. According to KXGO owner Harold Holzapfel, the station operated in the automated mode until the station personnel could get to the station to take over operations.

**Gill Gross on CBS**

**NEW YORK** CBS Radio will launch its first network talk program later this summer with "The Gill Gross Show."

The three hour broadcast will air Monday through Friday and will be hosted by Gross, a noted journalist and substitute host of the syndicated "Paul Harvey News" since 1988.

The format will include radio guests and a 800 call-in phone number for listeners around the country. According to Robert Kipperman, VP and GM of CBS Radio Networks, Gross' "presence adds a new dimension to the CBS Radio Networks programming schedule, and we look forward to a long series of interesting and informative broadcasts."

BROADCAST EQUIPMENT AND HUMAN ENGINEERED STUDIO SYSTEMS

**Studio Systems**  
for AM • FM • TV audio

OVER 100 EQUIPMENT LINES SERVING THE BROADCAST INDUSTRY FOR OVER 30 YEARS

PRE-WIRES & TURNKEY NOBODY CAN MATCH OUR 30-YEAR REPUTATION FOR EXCELLENT SERVICE

• Delivered on time  
• Within budget  
• Outstanding workmanship  
• Stunning performance  
• Pre-wires, turn-key

**AUDIO BROADCAST GROUP**  
2342 S. Division  
Grand Rapids, MI 49507  
FAX 616-452-1652

Let's get our heads together!

**Call 1-800-999-9281.**

OVER 180 SYSTEMS DELIVERED & INSTALLED YOU'LL LIKE THE WAY WE DO BUSINESS

**Comrex Digital**

**Features:**

- 56/64 Kb/s Switchable
- Built-in Power Supply
- Portable or Rack Mount
- Complies with CCITT G.722
- 7.5 KHz Full Duplex Audio
- Ideal for Studio-to-Studio Links

**COMREX DIGITAL CODECS** provide wideband, two-way audio to put listeners right at the scene for sports, news, weather and more. The Comrex Codec allows broadcasters to take advantage of the new digital telephone services which are fast becoming an excellent low-cost alternative to satellite links or dedicated lines.

Our codecs can be used with switched 56 Kb/s and 64 Kb/s (ISDN) services as well as dedicated digital lines. The versatility and intelligence built into the Codec assure compatibility with virtually any digital telephone network, so all you have to do is plug it in and turn it on.

Call or fax us for complete information plus our useful notes on "How to Order and Use Digital Phone Service."

**COMREX**

Comrex Corporation  
65 Nonset Path, Acton, MA 01720  
800-237-1776 508-263-1800  
Fax 508-635-0401

Comrex (UK) Ltd.  
75 The Grove, Ealing  
London W5 5LL, UK  
081-579-9143 Fax 081-840-0018

Comrex Digital Audio Excellence



## Who's running the ship?

**U**nattended operation is one way to keep your station profitable, but you still have to mind the store.

The acclaimed Burk Technology ARC-16 Remote Control System is the first step. You can control transmitter and studio from any phone.

But wait. There's more!



**I**ntroducing AutoPilot™ from Burk Technology.

AutoPilot is break-through computer software that makes automatic operation of your studio/transmitter facility a dream come true.

- Automatic power changes
- Automatic pattern changes
- Automatic site changes
- Automatic power trim
- Automatic fault recovery
- Automatic logging

Now your imagination is the only limit.

The new FCC fine schedule is imposing. Why risk a big penalty when AutoPilot can help you stay within the rules?

Call us at 508-433-8877  
or toll free at  
1-800 255-8090  
for more information  
and a FREE DEMO.

**BURK**  
TECHNOLOGY

Circle (133) On Reader Service Card

## A Format Kickoff with a Bang (Almost)

by Alex Zavistovich

**WASHINGTON** It was just another day at WPHR(FM) in Cleveland, except for the police and the camera crew . . . and the hand grenade.

That's right, a hand grenade. Barry Thomas, CE at WPHR, suspects it was delivered as a prank by the competition, but it made for some tense moments around the station on May 11.



According to Thomas, WPHR had just launched into the promotion for its new format, "The End," which he describes as "Rock 40 with an alternative edge." The station kicked things off by playing 24 hours of nothing but "It's the End of the World as We Know It (And I Feel Fine)" by R.E.M., over and over. And over. (Hey, I like R.E.M., but that alone could push somebody over the brink.)

The promo generated the expected number of hate calls, and the police called and dropped by a couple times during that morning to make sure everything was OK. But it wasn't until mid-day that things got weird.

Apparently, some young guy dropped off a mailing envelope at the station, and seemed really eager to leave. That, coupled with the fact that the addressee's name—PD Lyndon Abell—was misspelled made folks around WPHR a little suspicious.

What would you do if, like Thomas, you peeked into that envelope and saw part of a hand grenade with the pin attached! Being nobody's fool, he moved the package to an isolated room and contacted the police.

The bomb squad showed up and a sweat-soaked shirt or two later they determined the hand grenade was a dud, and hadn't been rigged to blow. As Thomas put it, it was more like a brick through a window than anything else.

About that same time, a camera crew from one of the local TV stations showed up to interview WPHR staff about the format change.

Here's where the gang at WPHR showed themselves to be real pros. Their main concern was to downplay the bomb scare to reporters, because they didn't want to dilute the impact of their on-air exploits.

Now *that's* what I call being focused! "Hey, forget about that bomb in the conference room! We've got a radio station to run here!" Errol Flynn couldn't have handled it any smoother than these guys.

In the end, the police labeled the incident "criminal mischief: delivery of a suspected bomb." Things went back to normal pretty quickly after that, and "The End" has been on the air ever since.

Good luck with the format, WPHR. But you might want to lay off that R.E.M. song for a while—I don't think it tested very well.

★★★

WRCQ(FM) in Fayetteville, N.C. wanted to show its appreciation to the clients advertising on its station. So the management rented out a couple of parlor rooms at the local hotel, provided free cocktails and hors d'oeuvres, and treated everyone to a casino night party.

Each guest got \$5,000 in play money with which to test his or her luck and skill. At the end of the evening the winnings were used to bid on door prizes.

**"Hey, forget about that bomb in the conference room! We've got a radio station to run here!"**

I remember the "Monte Carlo Nights" sponsored by the local Lion's Club where I grew up. People loved them, they always did well for the charities, and they were good publicity. It may not be a bad idea to take a page from this lesson book and sponsor a similar casino night as a station promotion.

Of course, it would be best to hook up with the Jaycees, Lion's Club or other service organization in your area. Not only will you be helping your community, you'll find that these folks may be willing to act as dealers, croupiers or whatever, so no one can cry foul. Just keep in mind that some counties have strict ordinances about gambling, even for play money. Make sure you check with the authorities in your area.

In general, though, the casino night idea gives you a chance to stage a flashy, upscale-type promotion that lets your listeners feel like real high rollers for a night—and maybe even walk away with a prize to remind them of the fun they had at your party.

★★★

I thought it was a real sign of progress at the FCC when they announced a change-over to computers for storing the various comments, replies, petitions and other le-

gal paperwork attached to dockets before the Commission.

After all, they had very informative glossy "Before" and "After" photos showing how nice and tidy everything was without all those folders of documents lying around, cluttering up the place. Ah, I said to myself, the FCC has entered the computer age. How good for them. Things will go so much easier.

How wrong I was.

My very next trip to the FCC Public Reference Dockets Room brought me in direct conflict with the dreaded RIPS computer, in which the FCC has stored the texts of all proceedings initiated this year.

They tell me RIPS stands for "Record Image Processing System," but it could just as easily stand for "Really Irritating Patience Sapper" as far as I'm concerned. Don't get me wrong, I'm sure the system is just fine for those among us with the time to read Every. Page. One. After. The. Other. In. Page. Order.

Not many people work that way in the dockets room, though. They skip

around, read the summaries, scan the conclusions, get a feel for the filing. If it's not pertinent, they move on. The RIPS machines, while they have great, easy-to-read screens, aren't designed for someone to jump around freely in read-

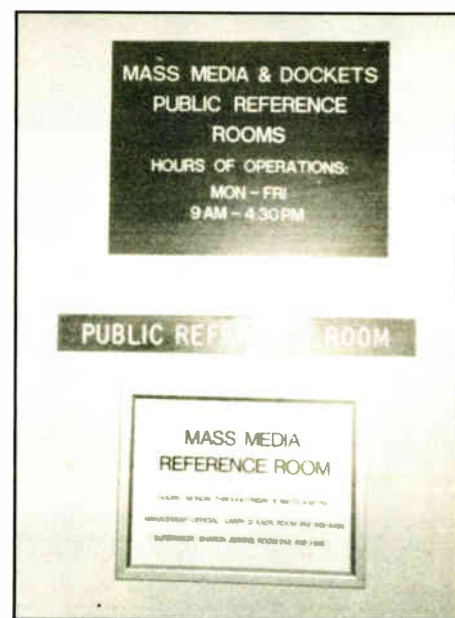

Abandon hope, all ye who enter here . . .

ing the document. You can order up copies of filings right from the computers, but they won't help you wade through the worthless ones to get down to business.

What that means is that the paralegals, engineering assistants, journalists and other folks who use the FCC Public Reference Room on a daily basis have to spend more time doing the same job. In this case, computers have made things more complicated, not easier.

Another example of Your Tax Dollars at Work.

That's it for now. Tune in next time,

*Alex*

Clipping creates **LOUDNESS** . . . Composite clipping is the **LOUDEST**

The trick is to keep distortion low . . .

Introducing

### SE-1 LOW DISTORTION COMPOSITE PROCESSOR

Distortion-canceling circuitry allows more clipping (loudness) with less distortion. Simple Installation & Setup. Only **\$395.00** Complete!

The PL-1 allows you to increase your loudness up to 6 db over using no composite clipping. Distortion is negligible up to 3 db of clipping with a gentle rise at 6 db.

There is no finer composite processor on the market today.

**SE**

**SOMICH ENGINEERING** . . . Loudness WITH Quality

**800-334-3925**

Processing Tools for Competitive Broadcasters

Circle (12) On Reader Service Card

World Radio History



# READERS FORUM

If you have comments for **Radio World**, call us at 800-336-3045 or send a letter to Readers Forum (Radio World, Box 1214, Falls Church VA 22041 or MCI Mailbox #302-7776). All letters received become the property of Radio World, to be used at our discretion and as space permits.

## Interlock interlocutor

Dear RW,

As manager of Harris Allied's Broadcast Technology Training Center, I applaud RW's ongoing efforts to provide broadcasters with helpful information.

However, I feel I must respond to John Bisset's April 22 *Workbench* article regarding cheating interlocks with a spade lug—particularly as a suggestion of Harris engineers. This is an incorrect statement. Harris does not encourage, condone or demonstrate how to cheat interlocks for any reason. In fact, we make every effort to seriously address safety issues with our customers. We demonstrate how to take measurements properly in a high voltage environment with all transmitter doors closed—not by bypassing interlocks.

While I am sure Mr. Bisset's intentions were good as evidenced by his cautionary statements, again I emphasize that Harris does not endorse any type of interlock cheating.

David C. Kobe, manager  
Harris-Allied Broadcast  
Technology Training Center  
Quincy, Ill.

## The right spin on the AM ratchet

Dear RW,

I have been following your articles on the ratchet clause regarding cutback of AM power by ten percent when a change of facilities takes place. While you don't come right out and say it, you are making it sound like the end of the world for broadcasters who fall into this cutback.

Let me remind you that if you are an AM directional, licensed to 5000 W, the actual power fed to the phasor is 5400 W. As you may remember, this power must be maintained within +5 percent (5670 W) or -10 percent (4860 W).

Let me also remind you of another well-known fact. In order to half signal strength at a given point, power must be reduced by 6 dB, or to 1350 W!

The dB difference between 5400 W and

4860 W is -0.4575 dB. This small change would cause signal strength at a point that measured 10 millivolts to be reduced to 9.487 millivolts or a drop of about 500 microvolts. I don't think this would cause any change in coverage, or even have any effect on radiated interference. Am I alone in my thinking?

Dick Kruse  
Contract engineer  
Brooklyn Park, Minn.

*Editor's note: We passed this letter on to Tom McGinley, RW's technical advisor and DE of Cook Inlet Partners. Mr. McGinley responds:*

*You are not alone in your thinking; however, your letter brings up a common misunderstanding about the ratchet clause. It refers to a 10 percent reduction in signal, which does not mean a 10 percent reduction in power, but rather in field strength, usually measured in millivolts per meter (mV/m). That means a 19 percent reduction in power, which is a bit more significant than your calculation suggests.*

*This reduction applies only in the direction towards a station whose RSS night limit under the old rules already includes a contribution from your station. If you propose a change in facilities, you will be obligated to reduce your transmitted field strength toward that station by 10 percent, using the 50 percent exclusion RSS calculation method.*

*For example, if your unattenuated field strength towards that station is now 190 mV/m (1000 W of power), you would have to modify your pattern or reduce ERP to a level of 171 mV/m (810 W of power), or about 1 dB. Remember that 1 dB is the threshold of the human ear being able to hear the difference. Many stations are unwilling to give up even that much, especially in a direction towards an important part of their coverage area.*

## Classical debate flip-side

Dear RW,

Shame on Barry Mishkind (*Eclectic Engineer*, RW, May 6) for spreading the myth that stations are abandoning the classical format because they can't generate cash flow!

Commercial classical stations are well and healthy—and growing. The Concert Music Broadcasters Association Directory last year showed a 13 percent increase in numbers in only three years. Broadcasting Yearbook, which includes non-commercial stations as well, shows a three-year growth of 23 percent. And fully half of the commercial classical music stations on the air have been classical for 20 years or more—and more than a quarter of them for 40 years or more!

Every survey has shown that classical music audiences lead every other format in income, education, and professional and executive occupations. Listeners to commercial classical music stations grew 5.5 percent from 1990 to 1991, according to Mediarmark Research. Their loyalty to their stations and their resistance to format changes are legendary, as WNCN, WEFM, KFAC, WRR, and many others have found out.

Those who deem the format "not capable of generating sufficient spot loads and cash flow" should talk to our members

## Creativity In Adversity

The verdict in the trial of police officers charged with the beating of LA motorist Rodney King sparked some of the worst rioting since the 1960s. In the aftermath of one of this nation's darkest hours, however, the broadcast industry is reminded again of its own adaptability in the face of the unexpected.

During the early hours of the rioting, management of KFI/KOST—which is only blocks from the center of the unrest—made the decision to pack up essential broadcast equipment and transmit from CE Marvin Collins' home in the suburbs of Los Angeles. RPU equipment and a 12-element yagi antenna provided the connection, and Collins' own home computer was pressed into service for news.

In that way, the station was able to continue to provide news and information to the public without interruption, and without risking the safety of its personnel.

As has happened in numerous emergency situations before, radio carried the day with creative problem solving. And again, the importance of being prepared for such contingencies has been underscored.

Remote broadcasts, especially those based on unforeseen circumstances, can only work if the necessary equipment is on the shelves at the station, ready to go. Without it, a station cannot fulfill its pledge to serve the public interest.

What's more, the KFI situation points out the value of having a chief engineer at the studio, rather than using a contract engineer exclusively. Contract engineers are an affordable solution for some stations' budgetary problems, but a person whose attention is spread among several stations may not be available at a moment's notice, as was required during the Los Angeles riots.

KFI/KOST was not the only station in LA to rise above the difficulties posed by the civil unrest. Many other stations have similar stories of courage and quick wit. They all serve as examples of radio at its best, prepared with state of the art technology and superior technical competence to respond quickly to whatever this rapidly-changing world throws in its path.

—RW

reporting revenue increases of 30 percent and more over last year!

John K. Major, President  
KCMA(FM)  
Tulsa, Okla.

## Birds with a bad rep

Dear RW,

It was refreshing to read an honest article written about stations that go to satellite automation (RW, April 8). Patrick Delaney did an excellent job of touching on some of the issues and concerns expressed when stations switch to the bird.

I've been with WKGH Allegan/Kalamazoo for a year now. We've been using the satellite full time on Unistar's country format with a Digital DJ hard disk automation system. The operation pulls better numbers than some of the live operations.

Since joining WKGH and going to fulltime satellite operations, I can honestly say that for most smaller to medium stations, going to the bird actually saves the jobs of those who are progressive enough to learn how to effectively use the new technology. As I write this letter, I'm getting prepared to travel to another station that I consult that will be going to satellite fulltime. We will be saving the jobs of employees who would have otherwise been let go.

But, as Mr. Delaney explains, the satellite is not just to be used as a last-ditch effort. Think of how your station operates. How many of the people you employ could you be putting out in the field by using satellite? How many could be meeting the public, doing remotes, doing PR, news, SELLING?! Is your small or medium market station operating with a bottomline orientation?

With all the benefits that satellite automation offers, and the fact that most people don't realize it is off the bird, doesn't it make sense to consider it as an option?

The one thing that gives satellite a bad reputation is the shoddy, "back-room" operators that don't bother with calls, liners, covering breaks, promotion—not to mention poor technical plants. Satellite isn't the cure-all. The only way it works is with

a small amount of effort from operators.

I not only call on operators of stations, but the networks themselves to do something about satellite's reputation. What would McDonald's do if one of its franchises was blowing off the format, not making the employees wear uniforms, not making the burger the way other franchisees do, not keeping the place clean? It would be bad for the company and the industry. It doesn't happen with McDonald's. It shouldn't happen with any network, either.

There are a ton of stations with potential. A smart operator somewhere should take the initiative to give 'em the bird.

Jeff A. Meyers  
WKGH Radio  
Allegan/Kalamazoo, Mich.

## DAT recording question

Dear RW,

A few thoughts on DAT recording. I purchased a Technics SV-DA10 recorder about six months ago and have been having good results. One thing kind of bugs me. I've been using it to master analog material for compact disc release. Now we all know that DATs run at 48 kHz sampling, and CDs run at 44.1 kHz. I'm also aware that a conversion is done at the CD pressing plants to U-Matic 1630 format and some magical 48-to-44.1 translation is taking place.

Here's the point: There has to be some degradation caused by the conversion. Interpolation is its own form of distortion, albeit a minor one. If only I could record at 44.1 to begin with, I'd be set.

What bugs me is the SV-DA10 will record at 44.1 but only if the source is a 44.1 digital signal. This is the question: Does anyone know if the circuitry of the A/D section is hardwired to 48 kHz or is there a modification that can be done that will resolve the problem and allow 44.1 recording? I'd be glad to look into the nuts and bolts further if I had a schematic. Is there anyone out there interested in working on this with me?

Mike Sokol  
JMS Productions  
Hagerstown, Md.

**Radio World**  
Vol 16, No 11 June 10, 1992

Editor ..... Alex Zavistovich  
Managing Editor ..... Lucia Cobo  
International Editor ..... Alan Carter  
Associate Editor ..... Charles Taylor  
News Editor ..... John Gatski  
Contributors ..... Frank Beacham/N.Y.,  
Bruce Ingram, Pamela Watkins, Nancy Reist  
Technical Editor ..... John Bisset  
Technical Advisor ..... Tom McGinley

**Radio World** (ISSN: 0274-8541) is published semimonthly by Industrial Marketing Advisory Services, Inc., 5827 Columbia Pike, Suite 310, Falls Church, VA 22041. Phone: 703-998-7600, Fax: 703-998-2966. Second-class postage rates are paid at Falls Church VA 22046 and additional mailing offices. POSTMASTER: Send 3579 forms and address changes to Radio World, P.O. Box 1214, Falls Church VA 22041. Copyright 1992 by Industrial Marketing Advisory Services, Inc. All rights reserved.

Next Issue of  
**Radio World**  
June 24, 1992



**HARRIS  
ALLIED**  
70th ANNIVERSARY

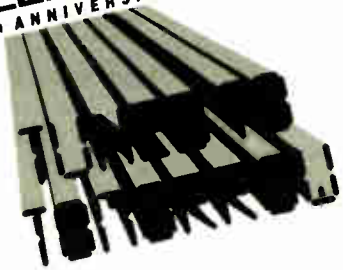

Due to circumstances within its control,  
the features of this new mini mixer...

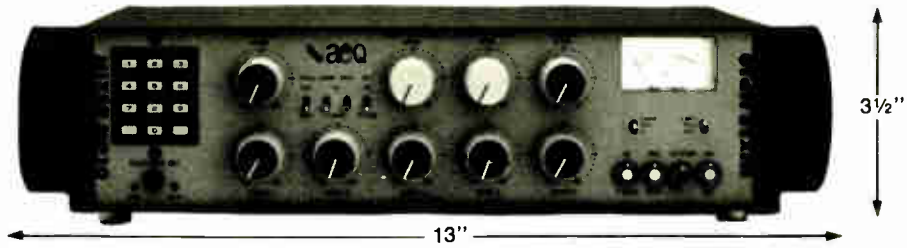

... prompt it to act like a mixer

**THIS BIG**

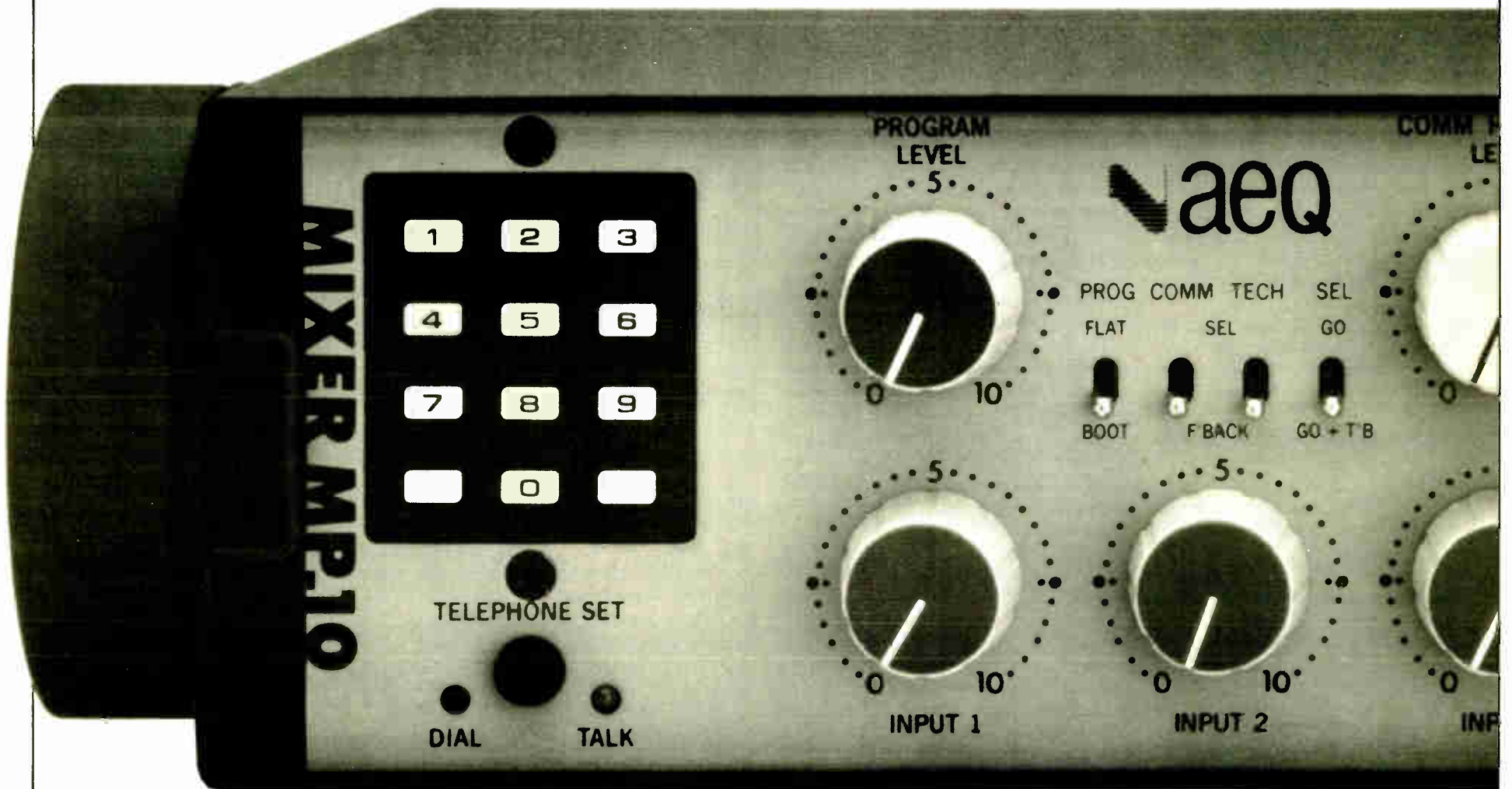

**Features:**

- Mix-minus capable for remote talk shows
- Two hybrids in-built
- Digitally stores up to 32 seconds of repetitive messages such as station IDs, etc.
- Universal dialing system (pulse & DTMF) for communications using standard telephone line exchanges

***It's loaded!***

**It's the Model MP-10 by AEQ. Available from Harris Allied.**

**HARRIS  
ALLIED**  
BROADCAST EQUIPMENT

**800-622-0022**

Fax (317) 966-0623 • In Canada (800) 268-6817



# Suspicious Fire Destroys Vegas FM Transmitters

## Continental Gets Stations Back On Air in 24 Hours

by John Gatski

**LAS VEGAS** A "suspicious" fire destroyed a transmitter/combiner building that housed equipment of three Las Vegas radio stations April 24. Quick work by Continental Electronics and station engineers, however, got all three stations back on the air within 24 hours.

The blaze destroyed the transmitter/combiner building and contents on 8,000-foot Mt. Potosi. The equipment was

owned by KJUL, KUDA and KEYV, and a two-way communications company. The total loss was estimated at \$1 million. The antenna/combiner system was made by ERI.

The blaze apparently started in the area of the two-way communications equipment and was called "suspicious" by fire officials. Forest rangers let the fire burn itself out.

KJUL CE Dan Peluso said the fire started about 3 a.m. and by the time that he, other station engineers and fire fighters got to the mountain peak location, it was a major blaze. No arrests have been made in connection with the fire, according to Peluso.

Since KJUL had temperature monitoring capability from the transmitter site back to the studio, Peluso said the records indicate that the fire must have spread very quickly. The temperature at the transmitter only increased about five degrees before the fire alarm was sounded, he said.

Continental was able to ship three 1 kW transmitters to the three stations' studios so they could go back on the air and at least transmit to their basic coverage areas, Peluso explained.

Peluso credits Continental for moving quickly to help the stations restore service. KUDA GM Scott Seidenstricker also praised Continental. "Well, when you have a fire and you have new transmitters there the same day—that's pretty doggone good. They were able to respond faster than anyone else."

All three stations erected one-bay antennas and used the 1 kW transmitters for about two weeks from their studios. Later, KJUL and KEYV took their transmitters and went back to Mt. Potosi to resume broadcasting at a lower power while KUDA moved to Black Mountain temporarily. KJUL used its 1 kW, while KUDA and KEYV purchased 3.8 kW



The fire left only debris and the charred remains of two 25 kW Continental transmitters.

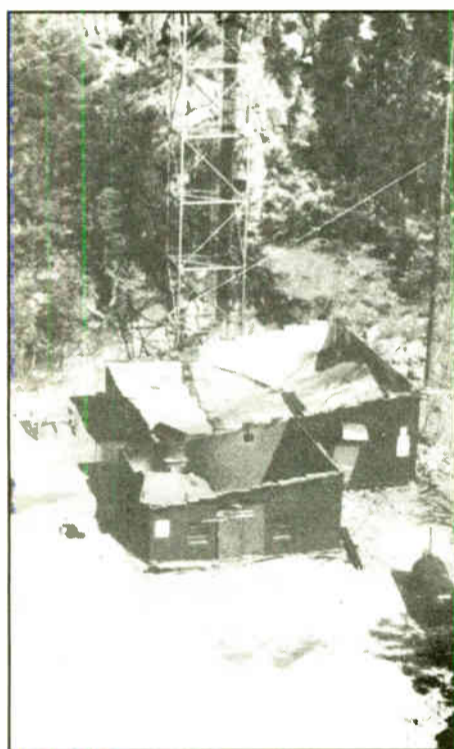

An aerial view of the transmitter site shows the extent of the fire damage.

transmitters for interim use.

All three stations have ordered separate higher power Continental transmitters to

replace the destroyed ones for use on Mt. Potosi, but Peluso said the stations may not return to a combiner system.

## SWEET & LOW.

If you're into audio for video, our message is short and sweet: The Tascam BR-20T is the lowest priced 1/4" professional centertrack timecode deck on the market.

The BR-20T is a professional audio-for-video recorder specifically designed for 2-track mastering and video post playback. Its center timecode track employs Tascam's innovative in-line head and timecode optimization system, neatly eliminating the need for timecode level monitoring and adjustments.

Other pro features of the BR-20T include full servo-controlled transport for quick, accurate response and gentle tape handling while under external synchronizer control. Easy, front-panel accessibility to all major audio calibration controls. And gapless/seamless punch in/out and spot erase.

The \$2,999\* BR-20T. The sweetest little audio-for-video machine you'll ever see. At the lowest price you'll ever hear.

Check it out, post-haste, at your nearest Tascam dealer.

## TASCAM®



© 1990 TEAC America, Inc., 7733 Telegraph Road, Montebello, CA 90640. 213/726-0303. \*Manufacturer's Suggested Retail Price.

## Emph'asize it!



WITH THE

## Emph'asizer™ AUDIO PROCESSOR

- DJ Personality Processor
- Production Tape Processor
- Gated Recovery Compressor
- Four Parametric Equalizers
- Phone Line EQ and Noise Suppressor
- Room Equalizer and Gated Mike Control
- Unobtrusive Background Noise Gate
- Mike and Line Level Inputs and Outputs

Free Detailed Brochure Available



**AUDIO TECHNOLOGIES INCORPORATED**  
328 Maple Avenue, Horsham, PA 19044 • (215) 443-0330  
Fax: 1-215-443-0394

Circle (71) On Reader Service Card

Circle (53) On Reader Service Card



# California EBS Scrutinized at CalCom

by Pamela Watkins

**LOS ANGELES** In recent years the Emergency Broadcast System (EBS) has been heavily scrutinized for ineffectiveness—especially in California.

Such disasters as the 1989 San Francisco earthquake and 1991's Oakland Hills fire have revealed problems with the EBS in the country's most populous state.

Based on comments at the recent CALCOM conference, an educational seminar sponsored by the Los Angeles chapter of the Society of Broadcast Engineers, EBS officials have decided to take advantage of this tenacious scrutiny by offering some of their own improvements.

During the conference, EBS officials said many of the system's problems are the result of human factors, stemming from radio and television stations' less-than-enthusiastic reactions to EBS and its format. For instance, it was pointed out, some broadcasters object to interrupting their programming for the 20-25 second attention tone the present system requires.

## Reducing the tone duration

One proposed improvement to the EBS is reduction of the alert tone to eight to 10 seconds. No decision has yet been reached.

Donald Root of the California Office of Emergency Services presented a report on an improved national EBS with a shorter tone. In essence, the entire emergency

broadcast need not take any longer than 30 seconds, he said.

Instead of using social security numbers, private codes and just an array of authentication techniques to verify authorization, EBS has devised a number/word challenge system.

For instance, when the National Weather Service calls an originating station, the station will give the weather forecaster a designated number. The forecaster then will peruse his or her checklist and give the station an answer, which is the word that corresponds to the number.

The standardized authentication system allows a substitute who might be on duty, whose social security number might not appear on the authorization list, to handle the emergency information.

## Capturing attention

Once identification is set, the engineer/operator at the Common Program Control Station (CPCS) captures the attention signal; the forecaster then announces the type of warning to be read and whether it is for immediate broadcast.

At this point, the engineer determines whether the warning pertains to his area and whether the station serves the affected area. A cue and five-second gap allow the engineer to drop program audio and bring up the CPCS audio. Then the CPCS repeats the attention signal and proceeds with the full announcement, including

reading the forecaster's entire announcement. The announcement might end with: "This completes the tape from the National Weather Service."

That of course is the station's cue to say: "This concludes this broadcast of the Emergency Broadcast System."

The tape can be repeated as necessary. The announcement—which could go live, but is more controllable when taped—is in effect made twice: once to the engineer to identify whether the warning pertains to the station's coverage area, and then again for live broadcast or taping.

However, even this system can not cure California of its particular EBS problems—especially with weather-related emergencies, EBS officials conceded. "One of the problems we find in California," Root said, "is that broadcasters have a very lackadaisical attitude, probably because no real weather has happened in six years."

Root is investigating the problem on the governmental level and among the local broadcast operation area committees.

## Making the system better

The Telecommunication Advisory County Preparedness committee, with KFWB(AM) CE Richard Rudman as its chairman, is mandated to evaluate the national EBS and to suggest changes to make it better.

Rudman said the EBS has often been looked at as the enemy. However, the local committee's goal is to change that perception, and have the state and local—as well as the national emergency system—looked upon as a tool.

Besides shortening the test tones, Rudman also suggested creating an Emergency News Network using audio and data channels.

"It would be friendly to broadcasters and a path to get plenty of information out, such as shelter access, and the EBS wouldn't even have to be used," Rudman said.

Thus, the Emergency News Network becomes a warning system and a source, he added.

In addition to national EBS improvements that are already underway, others have been proposed (including an automatic system) that are not dependent on the "daisy chain" of individual station operators. One of those new technologies is the Radio Data System (RDS).

California has done some of its own EBS improvements: The EDIS (Emergency Digital Information System) was created as a direct result of the 1989 California earthquake. During the San Francisco quake, if a hearing-impaired person saw the tremendous destruction on television, he or she had no idea where it was located.

Even if the hearing-impaired person figured out which areas the disaster affected, they still had no information regarding services. After the earthquake, the California legislature drafted a bill requesting the state Office of Emergency Services to develop a method which would solve this problem.

"Our challenge," Root said, "was to make it simple and not to tie up the origination station." Simply put, EDIS is a data delivery to television. Television stations plug the data into their character generators, which produce a crawl across the bottom of the screen. No manual intervention is required with the content of the message.

# AfriSpace Is Pleased with WARC Pact

by John Gatski

**WASHINGTON** A company that plans to provide broadcast DAB service to Africa and the Middle East by 1993 is pleased with the recent World Administrative Radio Conference (WARC) decision to reserve spectrum in the L-band for satellite DAB.

AfriSpace, a subsidiary of WorldSpace Inc., was granted an experimental license in 1991 to broadcast on S-band through Dec. 31 because the U.S. did not favor use of L-band spectrum for satellite DAB. Several countries at the WARC conference created a consensus for DAB at L-band (in the spectrum range of 1452-1492 MHz), but the agreement also allowed other countries, such as the U.S., to pursue S-band (2300 MHz) DAB.

Nonetheless, the International Telecommunications Union (ITU) decision at WARC allows AfriSpace to return to its original plan to broadcast on L-band, according to WorldSpace CEO Noah Samarra.

Originally, in late 1990, AfriSpace had indicated it wanted L-band, but the U.S. government had not yet hardened its pre-WARC, anti-L-band position. When the government's intentions on L-band were made clear later in 1991, AfriSpace had to apply for S-band on an experimental basis.

"It is especially gratifying that the ITU decided to allocate to our service the best available frequencies, those in the valuable L-band," Samarra said.

AfriSpace plans to offer satellite capacity for digital broadcasting to low-cost portable receivers in Africa and the Middle East. The satellite delivery would be provided by "lightsats," a low-cost system spun off from military technology that places each unit in a geostationary orbit.

AfriSpace claims it has developed a "unique digital coding technology" that permits dozens of audio channels (digital and analog) to be transmitted with the satellite power usually required for only three channels.

The receivers, to be priced at about \$100 U.S. dollars, are to be manufactured by Eufaula, Alabama and Lucky Goldstar in Korea, according to AfriSpace.

Although AfriSpace will act only as the conduit for programming service, Samarra said programming is likely to include news, music, public service, education and the World Health Organization (WHO) information. CNN and WHO already have agreed to provide service, he added.

The satellite uplink and some programming facilities will be based in the U.S. and then beamed to the satellite. Programmers from within Africa and the Middle East also will be able to uplink with the satellite and beam back to countries in those regions.

# PROOFS IMPROVED

**FM and TV-BTSC AUDIO PROOF TESTING** is reduced from hours to minutes with System One from Audio Precision... Automatic proofs run properly at constant deviation, plotting the required generator amplitude... and when finished, the results are stored in graphic form for your records.

**SPLIT SITE** proofs are simple with System One's available separate generator and analyzer configuration. With immediate capability to view and control both instruments, it's like being in two places at once.

**THE REST OF THE TIME** System One is the universal audio test set for maintaining any audio device or channel... STLs, consoles, carts, cassettes and RDATs, digital recorders and workstations... System One is the only product that can completely test both your analog and digital audio.

Call 800/231-7350 for our 36 page color catalog... and when you're ready our representative will arrange for an on-site demonstration.

**Audio precision**

PO.Box 2209, Beaverton, OR 97075  
503/627-0832, 800/231-7350  
FAX: 503/641-9806  
TELEX: 283957 AUDIO UR



Circle (111) On Reader Service Card



# Rioting Forces KFI Remote Broadcast from LA Hills

► continued from page 1

Plans for the Tom Leykis broadcast from the airplane were scrapped. It was necessary to do a longer remote broadcast than just one program from the airplane. We decided to broadcast from my house, which is about 15 miles away from the city and at an elevation that permitted a direct radio path for the KFI remote pickup unit (RPU).

## A homemade remote

At about 12:20 p.m., the adrenalin was really flowing. The smoke and fire appeared to be spreading with each minute. A lot remained to be done to get this impromptu remote broadcast on the air by 3

**Our first task was to mount the 12-element Yagi about half way up my ham antenna tower and point it in the direction of the studio.**

p.m. Fortunately, another member of the engineering staff, Bob Demont, drove his pickup truck to work that morning.

Almost all of the KFI remote equipment was loaded into Bob Demont's truck and we hastily departed. Bob drove the truck, and I was to meet him at the house in my car. The light traffic of early morning had turned into a snarl. Most businesses had let their employees leave early. I lost sight of Bob's truck as we drove north on Normandie Avenue.

While waiting for the signal to change at Third and Normandie, I observed groups of youths crossing the streets against the red light. I was nervous. It appeared that something was about to happen. It did happen soon after: The businesses on the northeast and southwest side of Third Street and Normandie were burned while businesses on the southeast and northwest side were ransacked.

I finally arrived home at 12:50 p.m., but Bob had not made it yet. I worried that he might have encountered a problem, but he arrived 10 minutes later.

Our first task was to mount the 12-element Yagi about half way up my ham antenna tower and point it in the direction of the studio. We then routed the coax cable down the tower and into the garage. The RPU transmitter was placed on the clothes dryer in the laundry room. That was as far as the cable reached.

## Point-to-point

Before leaving the studio, the 12-element Yagi antenna on top of the studio building was aimed in the direction of my house. I hoped the path was a good one and a full quieting signal would be received at the studio.

This path had never been tested before, and a lot was depending on it. I turned on the RPU transmitter and tried to call the studio on the telephone to see how well the signal was being there.

"All circuits are busy, try again later," the telephone recording said. Several attempts later, I did get through to Larry Metzler, the board operator on duty at the studio. It was a relief to hear him say it was a full quieting signal of good audio quality.

Bob laid out two microphone cables into the front room and hooked up two micro-

phones on the dining table. A Shure headphone amplifier was wired into the telephone line of my residence telephone. This became the listen-back line for KFI pre-delay audio. Because we were to take calls from listeners, it was necessary to use our 10-second delay.

Almost 3 p.m., and Tom Leykis had not yet arrived. He finally arrived at 3:03 p.m., casually sat down at the mic and went on the air as the 3 p.m. newscast ended.

Newsman Ken Gallacher arrived before Tom, but we had no source of news. I turned on my Apple IIGS computer and using my modem telephone line, I called the KFI newsroom computer. Now we had a source of news. News operations from the studio were terminated, and the newsroom was vacated to further reduce the risk of danger to KFI personnel.

## An Impromptu newsroom

Tom finished his show at 7 p.m. Ken Gallacher broadcast the 7 p.m. news using stories received remotely from the newsroom computer via my computer in the living room. By this time, the only people remaining in the KFI studio were Howard Neal, David Hall, Producer Marc Germain, and Promotions Director Bill Lewis. They were taking turns screening calls or operating the mixing console. KFI reporters were out in the field giving live reports by two-way radio or cellular telephones.

After the 7 p.m. newscast, Barbara Whitesides commenced her program from my living room table. About five minutes into the show she was interrupted by GM Howard Neal, sitting in front of a microphone back at the studio. Neal announced on KFI that the situation was too dangerous and the time had come to sign off—at about 7:10 p.m.

From my house, we stayed in communication with the small staff at the studio via the RPU and the listen-line telephone connection. Finally, they received word at the studio that National Guard protection would soon be provided. (It didn't arrive until 24 hours later).

Based on that information, we decided to sign back on the air and resumed with a special Barbara Whitesides show co-hosted by Howard Neal. As soon as we signed back on the air, however, the listeners were back on the telephone lines.

Bill Handel and Bill Press took over the living room airwaves after Barbara's show finished. Later in the evening, News Director Mark Austin Thomas kept busy with reporters on the three cellular telephones that also were positioned on the clothes dryer.

I took a nap and was awakened by Thomas at 4 a.m. to fix a problem with the headphone amplifier. I replaced its battery with a spare I had put out to be used when needed.

I was surprised to see that at 4 a.m. we had a staff of six people working in my living room. I was number seven. Terry-Rae Elmer and Jerry Wallace were handling the announcing duties after Bill Handel and Bill Press finished their program. Tracy Miller and morning show producer Bill Smith arrived to join the morning show team.

The morning show continued through the 10:00 a.m. newscast read by Terry-Rae Elmer. Programming was transferred back to the studio after it appeared to be safe to do so.

Several other stations also were affected by the Los Angeles riots including KKB, KLSX, KGFG, and KABC.

We are pleased to announce a solution to your capital budget problems with the

**BROADCAST SERVICES/EME**  
**Priority Lease Plan**

a nationwide offering with  
**\$25,000,000**  
in available funding

Funds up to \$50,000 available on credit application only — no financial statements required in most cases.

Convert capital expenditures into fully deductible operating expense by leasing. Leasing does not affect your borrowing power, and leaves your capital free for investment. Terms and payments can be structured to fit your cash flow situation, and you get the equipment you need immediately. Our leasing program accommodates amounts from \$5,000 up to the largest facility packages.

Another reason why people are calling us...

**The Preferred Source**  
**for audio and video equipment**

Here are just a few of our product lines:

Abco	EFXX	Otari
Adams-Smith	Electro-Impulse	Priority Leasing
ADC	Electro-Voice	Pro Products
AIR Corp.	Enberg	QEI
AKG	ESE	Radio Design Labs
A-Line Furniture	Eventide	Radix
Alps Furniture	Express Group	Ramko
Andrew	Fidelipac	Rane
Aphex	Gentner	Revox
ATI	Gepco Wire	Ruslang
Atlas	Hedco	Russco
Audi-Cord	Henry Engineering	Samson
Audio Animation	Hnat-Hindes	Scala
Audio-Digital	HOME Racks	Sennheiser
Audiometrics	Inovonics	Shure
Audio-Technica	ITC	Siemon
Audiopak	JBL	Somich Engineering
Auditronics	Kintronics	Stanton
Autogram	Klark-Teknik	Sonex
Azonic	Koss	Sony Pro Audio
B & B Systems	Lexicon	Soundcraft
Belar	Logitek	STL
Beyer Dynamic	Luxo	Symetrix
Broadcast Audio	Marantz	Tapecaster
Broadcast Electronics	Mark Products	Tascam
Burke Technology	Marti	Technics
Cablewave	Middle Atlantic	Telex
Celwave	Modulation Sciences	Telfax
Comark	Monroe	TFT
Compu-Temp	MTS	360 Systems
Comrex	MTU	3M/Scotch
CRL	Murphy Studio	Titus
Crown	Furniture	TMD/Will-Burt
DAC	Nakamichi	Valley Intl.
dbx	NEC	Vega
Di-electric	Neutrik	Viking
Denon	O. C. White	Wegener Comms.
Dictaphone	Omni-Mount	West Penn Wire
Dorrough	Orban	Zercom

**BROADCAST SERVICES/EME**

The Davis Communications Group, Inc.

Mid Atlantic 800/345-7112  
Southeast 800/525-1037  
West Coast 800/523-1037  
Video Sales 800/942-6005



Circle (1) On Reader Service Card



# State-of-the-Art, Support Key for BE

**QUINCY, Ill.** Over the past year and a half, Broadcast Electronics has introduced three solid state AM transmitters, a solid state FM transmitter, two digital audio products and a floppy disk "cart machine." Diversified? Yes, but according to BE's new owner Howard Crow, that's all part of the company's responsiveness to the market it serves.

In May 1990, Crow—with the management team of BE and the BankAmerica venture capital group—formed Cirrus Technologies to acquire the company from Larry Cervon.

With an MBA from New York University, Crow's career includes 16 years with

the Singer Company and five years as VP for the specialty electronics group at Dynatech. At the latter company, Crow's own specialty became acquisitions. During his time at Dynatech, he acquired eight companies, which helped build his group to some \$100 million in sales per year, according to Crow.

When he decided to strike out on his own, Crow turned to the broadcast industry, looking for companies with an international reputation for high quality. His search ended with Broadcast Electronics.

In time, the Cirrus Technologies holding company will purchase other firms. For now, however, Crow and BE President Jack

Nevin have focused their attention on further developing BE. In particular, both men are enthusiastic about the company's place in the international market.

"The overseas market is the fastest-growing segment geographically," Crow said. Latin American countries are especially interested in outfitting their new radio stations with state-of-the-art broadcast technology, he added.

According to Crow, that state of the art includes an increase in live-assist technology and digital products in the audio chain. To that end, he said, BE is heading into digital systems for station operation.

The company manufactures automation and hard disk storage devices such as the CORE and AudioVAULT; it also markets the 3.5-inch floppy disk "cart machine," the Disc Trak. These products represent a "major effort" toward the systems concept

that Crow says will account for much of the company's future growth both overseas and domestically.

BE also recently introduced three AM transmitters, each equipped with the power-efficient class E amplifier and a C-QUAM AM stereo exciter. "C-QUAM is the de facto standard," Crow explained. "We're just recognizing what customers have decided is the future of AM stereo." A solid state FM product also is available from BE, Crow added.

As important as BE's advanced technology developments are, Crow also places a strong emphasis on supporting its customers after the technology is in place.

That aspect of extensive product support also played a part in the Cirrus group's acquisition of BE. "It takes a fairly large company to provide ongoing product development and support. BE has always done that very well.

"Broadcast Electronics is a world-wide company," Crow said. "And we provide the kind of support that people can expect from a world-class company."

## We Make Digital Satellite Easy To Own



**Comtech 3.8 Antenna**  
The perfect antenna for reception of any format audio network.



**Fairchild Dart 384 Digital Audio Receiver w/Audio Card**  
Switchable digital audio receiver for program material broadcast via satellite using digital technologies.

**Lease for ONLY \$219 per month**  
(excludes freight & tax)

Call the Harris Allied satellite professionals.



**317-962-8596**

Fax (317) 962-8961 • In Canada (800) 268-6817

**HARRIS ALLIED**  
70th ANNIVERSARY  
TUNED TO TOMORROW

## UL Creates New Category

► continued from page 1

According to UL Engineer Tony Bodetti, who worked with broadcast manufacturers and broadcasters to draw up the requirements for UL 1419, the new category cuts UL evaluation costs by 50 to 70 percent for those broadcast manufacturers who want their products to be UL listed.

### Cutting cost standard

Moreover, he said, the new category "bridges the gap between the users and any problem they have with regulatory agencies."

Radio and TV broadcasters have complained in the past that local inspectors would not pass electrical inspection of broadcast facilities because equipment was not safety certified by UL or a similar organization.

Whether or not such a mark is required can vary according to inspector, city, or even if there has been a precedent of similar products listed with UL or a comparable organization.

In Los Angeles, for example, Gene Rubin, acting chief of the city's electrical inspection division, confirmed that all broadcast products used within Los Angeles city limits are subject to UL or similar safety certification.

Rubin, however, does consider FCC type-accepted equipment exempt from this requirement.

### Type acceptance is not UL

That is not the case, Bodetti noted. "But obtaining FCC approval does not also mean that your product complies with UL 1419," he said. "The UL mark is related to safety with respect to fire, shock and casualty hazard. Not with respect to emissions interference, (or) noise interference."

UL 1419 is expected to become an ANSI standard as early as six months from UL publication, following an ANSI approval process.

"In order for us to approach ANSI and tell them we want to get ANSI approval on this document, we have to go through what we call due process, where we have to make sure we get general consensus from a good portion of the industry," Bodetti said.

In the fall of 1991, UL invited industry manufacturers and broadcasters to participate in a two-day meeting held in Las Vegas. Twenty-two industry members showed up to respond to the new category. As a result, UL made modifications to the

category's requirements. Of significance, Bodetti said, "We made some changes to our standard specifically so we can harmonize with the general IEC requirements."

IEC (International Electrotechnical Commission) safety codes are considered by many broadcast manufacturers to be the

### Broadcast equipment used to be listed under commercial or household UL categories

preeminent standard for marketing products globally, primarily because governments worldwide specify IEC.

### ANSI and IEC

Unfortunately, as of yet, ANSI and IEC safety codes do not concur. But, as of the modification, UL 1419 requirements now parallel IEC general requirements wherever possible.

UL Associate Managing Engineer Steve Brown said, "The intent really was to have UL 1419 accepted and ANSI approved in the U.S. and then possibly bring it to the IEC and promote it there."

For this process to work, he added, it needs to be industry motivated.

But with ANSI approval of UL 1419 category nearing, several broadcast companies have voiced concern that although UL and other such third-party safety certification is voluntary, it will add to the cost of broadcast products.

"In an industry already fraught with cost-conscious purchases, (safety certification is) one of the things nobody wants to incur the expense on," QEI's Jeff Detweiler said.

Moreover, others argue, the national safety standard will serve as the catalyst for more and more local inspectors to insist on safety certification of broadcast gear.

But, Brown countered, "because there was no professional equipment standard, (some local inspectors) look for the closest ally, (and) were actually applying consumer requirements to some of the equipment."

UL 1419 is satisfying this need at a lower cost to broadcasters, he said.

To find out more about the new category, contact Tony Bodetti or Steve Brown at Underwriters Laboratories: 516-271-6200, extension 537 or 420.



# REVOLUTIONARY,

**Take total control of your programming with the revolutionary new CORE 2000...**the ultimate digital automated control system. You'll get the advantages of digital without having to learn a new system "language", because CORE 2000 has standard PC compatibility and is driven by the kind of database-supported programming you're probably already using. And CORE 2000 is incredibly flexible, with independent "smart" sourcing, and machine and audio control for up to 36 different source inputs. There's no limit to this revolution, either, because CORE 2000 is fully compatible with all present and future source equipment.

It's affordable. It's amazingly versatile. It's CORE 2000. Join the revolution!

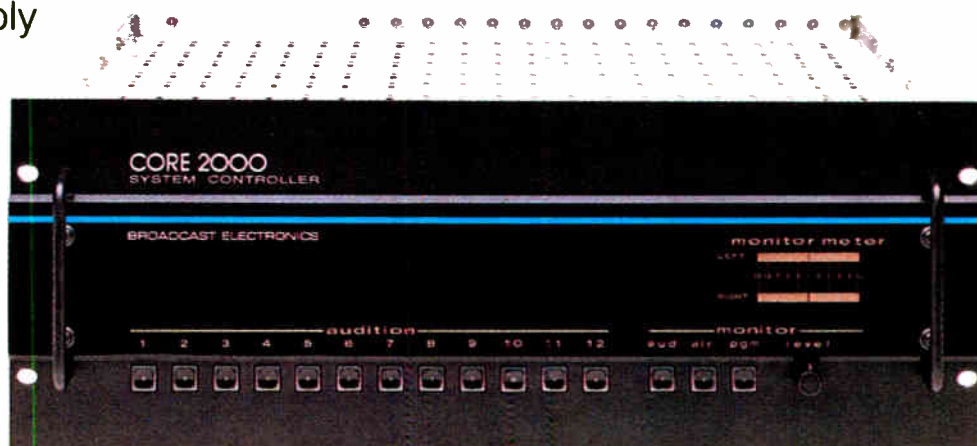

# EVOLUTIONARY

**AudioVAULT...It's the ultimate evolution of the cart machine.** Just imagine a digital source system that features multi-user tasking (four at once), simultaneous record/playback capabilities, stand-alone compatibility with most satellite systems, instant access to stored materials, and the flexibility to operate automatically or interactively as a part of virtually any control system.

Now imagine those features in an easy-to-use package that is operated like a standard cart machine. And imagine getting all the speed and clarity of digital without having to learn a new system "language".

It's economical. It's flexible. It's AudioVAULT. The ultimate evolution!

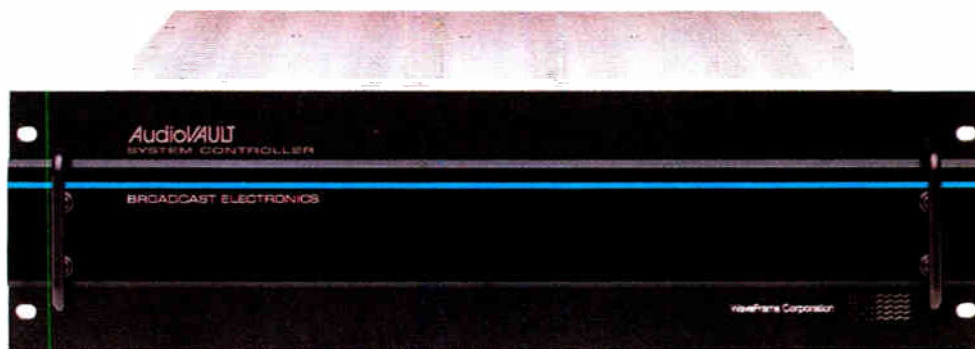
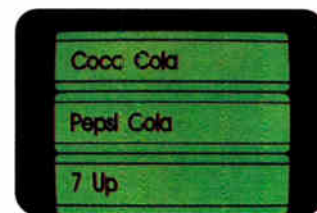

# DIGITAL.

For over thirty years, Broadcast Electronics has been the one company dedicated to radio broadcast technology. So, is it any surprise that we'd be among the first to put the power, efficiency and clarity of digital to work for the radio industry?

Contact us for more information on our revolutionary, evolutionary digital systems, plus our full line of transmitters, cart machines, studio consoles, stereo exciters and monitors.



®

**BROADCAST ELECTRONICS INC.**

4100 N. 24th St., P.O. Box 3606

Quincy, IL 62305-3606 USA

Phone (217) 224-9600, Telex: 250142, Fax: (217) 224-9607



# Processing Presented at NAB '92

by Thomas R. McGinley

**LAS VEGAS** NAB '92's Sunday afternoon engineering session concentrated on three separate areas in which the audio transmission process can be manipulated and conveyed through digital signal processing.

The areas are: audio bit-rate compression techniques to conserve bandwidth; audio processing in the digital domain for peak control and optimized modulation level; and broadcasting with the telephone company's ISDN (integrated services digital network) system.

With bit-rate reduction processing, John Stautner of Aware Inc. opened the session with an overview of the development of compressed audio standards and how they have become implemented.

There are three types of coding schemes used for low bit-rate compression: sub-band, transform, and multirate time and frequency. All make use of audio masking, in which quantization noise is always kept just below the threshold of audibility. Multirate coding is the most advanced and complex. It optimizes the coding requirements of lower frequencies versus higher frequencies so that noise is always fully masked.

Stautner also demonstrated the difference between a 386 PC equipped with an audio decoding board reproducing 8-bit 6 kHz audio versus a 486 PC playing the same bitstream at 16 bits and 20 kHz response with a decoder board using the Motorola DSM 56000 CPU.

## AC-2 and MUSICAM

Marina Bosi of Dolby presented the paper on the AC-2 digital audio coding for broadcasting and storage. Bosi is a researcher from Italy now working as manager for the Dolby Laboratories AC-2 system project. The AC-2 compression system is a transform-based, independent channel, fixed block scheme providing bit-rate reduction from 4:1 (192 kbps) up to 12:1 (64 kbps).

These rates are proposed CCIR standards for various type services, including HDTV, DAB, disk storage, cable TV, as well as studio and radio/TV production. The newer more complex AC-2A system is a multirate-based, adaptive block system which is more efficient at handling the coding for masking requirements at higher compression rates. At present, Dolby claims that decoder chips for DAB receivers using AC-2 at 192 kbps per channel can be produced in quantity for under \$10 each.

This could make AC-2 easier to implement for DAB than the European developed-MUSICAM because of the decoder cost and complexity issue. Bosi indicated that Dolby is continuing to work

on even more aggressive compression rates which could support high quality audio.

Gerhard Stoll from the German Institute for Radio Techniques traced the beginnings of MUSICAM, first known as MASCAM, and first demonstrated to the world at WARC '88 in Geneva. The International Standards Organization (ISO) picked MUSICAM as the best audio bit-rate compression algorithm from four other systems in a "sound-off" listening contest held in Stockholm in 1990.

MUSICAM became the choice for the Eureka project and has since undergone additional development and improvement. It is now known more accurately as ISO/MPEG Audio Layer II.

## Subjective listening tests

MPEG is the Motion Pictures Expert Group. Joined by ASPEC, the runner-up system in Sweden, the best of both systems along with even more technological improvement has created a new algorithm known as ISO/MPEG Audio Layer III.

Layer II was thoroughly tested at Swedish Radio in May, 1991 and performed to an average level of 4.8 on a 5.0 perfect scale using 10 reference sources on an A/B comparison to the original. Stoll then played a series of demonstration comparisons at 192 kbps down to 64 kbps compression with Layer II. Some nuance high end loss is detectable by some listeners at 64 kbps, especially with female solo voice, harpsichord and glockenspiel sources.

However, it was pointed out during the question and answer session that some independent groups have been conducting new

and extremely careful listening tests and have apparently identified new artifacts even at the 192 kbps standard heretofore not recognized.

## Program audio processing

Digital audio with stereo generation processing hardware for FM is now in its second year. Two of the system designers of the four available digital processors on the market addressed this session: Frank Foti of Cutting Edge Technologies (Unity 2000) and Bob Orban of AKG/Orban (Optimod 8200).

In his presentation titled "Digital Audio Processing: Knee Deep in the Hoopla," Foti attempted to step out of the mire of misapprehension with an overview of the advantages and disadvantages of digital versus analog.

He gave analog its due as a time-honored method for achieving loudness, but noted that it is prone to "gain cell" induced distortion artifacts and is not as accurate, flexible, or upgradeable. Digital processors, on the other hand, can be easily programmed for a wide range of capabilities, including instantly repeatable systematic changes for format or day-part programming and processing.

The old feedback gain cell topology of analog operates after the gain of the waveform has changed. The new "feedforward" digital controlled design actually looks at the signal before any change and optimizes the waveform before the gain is changed.

Foti conceded, however, that it is still a matter of choosing the right combination of compromises to achieve both "loud and clean."

While the best digital processing today is probably a little better than the best analog, the more important benefits to be gained from digital are yet to come from new design breakthroughs, Foti said.

Bob Orban gave a quick block diagram system overview of the Optimod 8200 and pointed out that digital processors should be placed at the transmitter rather than the studio to ensure that the composite signal is completely free of overshoot and bounce for tight modulation control.



MONDAY, APRIL 13—THURSDAY, APRIL 16, 1992  
LAS VEGAS CONVENTION CENTER

Orban stressed that if the industry is to take full advantage of the benefits digital can deliver, we will need to keep the audio completely in the digital domain all the way through from CD player to exciter. But there remain several roadblocks in the way, he noted.

There is still no sampling rate or interface standard. While Orban strongly supports the AES/EBU standard, three sampling rates (32, 44.1 and 48 kHz) are being used by different hardware manufacturers. As of yet, there is still no cheap chip for a sample rate converter.

## The weakest link

Orban said the weakest link in a digital processor is the input A-to-D converter. The 16-bit format currently being used may not be good enough for the total digital chain. An 18-bit format would yield a 103 dB signal-to-noise ratio, but would be expensive. Orban said he is sticking with the

analog stereo generator in the 8200 until those questions can be answered.

Tomorrow's digital radio studio may be like a TV studio with external boxes having to generate time base signals for all equipment, along with time base correctors, rate converters, etc.

Orban cited perhaps the most common complaint with any of the fully digital processors as excessive signal processing delay. This causes headphone monitoring to become slightly hollow and bothersome and is caused by simple comb filtering with bone conduction mixing and cancelling inside the head, particularly with male voices.

The best fix for this is to extract only headphone monitoring with its own processing, if necessary, prior to the digital air chain processing. Orban touched on the evils of composite clipping throwing garbage into the SCA region, but conceded that when it is used, analog clipping is better than digital for tighter peak control. He also offered the consolation that with the Walsh function stereo decoder chip appearing in most new car radios, most of the composite clipping artifacts occurring in the SCA region do not get decoded anyway.

## ISDN tutorial

Michael Smyth of Audio Processing Technology, Ltd. in Belfast, North Ireland, offered an ISDN tutorial, citing the development of this early digital audio transmission method many years ago by Bell Labs and other telephone companies.

Some broadcasters are starting to use ISDN in the US where phone companies are making it available as STL and satellite uplink backup circuits. Other applications include studio to studio linking.



# Set It And

**INTRODUCING THE SHURE FP410; THE "HANDS OFF" MIXER THAT DELIVERS PERFECT SOUND AUTOMATICALLY.**

The new Shure FP410 is not just another pretty face. It's a whole new concept in portable mixing; one that forever solves the nagging problems of multiple open microphones. By automatically keeping unused microphones turned down, the FP410 dramatically improves your audio quality.

The secret: Shure IntelliMix — the patented operational concept behind the revolutionary FP410. It thoroughly shatters existing standards for portable mixer performance and ease of operation.

Just set your levels and flip the switch to "Automatic." Shure IntelliMix does the rest.

□ Its Noise Adaptive Threshold activates microphones for speech but not for constant room noise, such as air conditioning.



## Booster Uses Detailed

by Nancy Reist

**LAS VEGAS** The use of FM boosters to improve signal coverage was the topic of two papers in an NAB '92 engineering session titled, "Maximizing Broadcast Signal Coverage."

The FCC loosened its restrictions on the use of FM boosters in 1987. Booster coverage still may not extend beyond the predicted contour of the primary station, but boosters may operate at power levels of up to 20 percent of the maximum permissible effective radiated power (ERP) of the full-service station they rebroadcast.

Stanley Salek, an engineer with Hammett & Edison Inc., explained that this new freedom has brought a penalty to many stations that use boosters.

In areas where the primary signal and the booster signal overlap, the two unequally delayed signals create significant amplitude modulation artifacts, leading to increased audio distortion and signal disruption. Salek called this "self-generated multipath."

He described the results of a laboratory study designed to evaluate the success of carrier synchronization, carrier and modulation synchronization, and carrier delay at reducing self-generated multipath when stations use boosters. The study was based on a hypothetical flat terrain model to simplify analysis.

The model's main station was defined as an omnidirectional Class B facility with an (ERP) of 50 kW, a height above average terrain (HAAT) of 492 feet, and a 54 dBu class contour of approximately 40 miles. The model's omnidirectional booster site was placed at two-thirds of this distance with 500 W ERP at 314 HAAT. The booster's 54 dBu contour extended about 13 miles.

This model produced a large interference zone which was then evaluated under conditions of unsynchronized operation, carrier synchronization, and carrier and modulation synchronization. During the synchronized modes, a variable delay unit was connected to the first translator to set a range of delay times for each RF signal level ratio measured. Distortion was measured through the outputs of an FM modulation monitor and an automotive receiver.

The results indicated that carrier and modulation synchronization provided the best balance, but boosters using any of the synchronization methods—including no synchronization at all—can operate without significant distortion in areas where the RF signal level ratio remains above 15 dB. In areas where distortion is a problem, synchronizing the time of the arrival of the main and booster signals also can significantly reduce distortion.

Salek recommended that station engineers evaluate the boundaries of the coverage problem area and use terrain sensitive computer analysis techniques to determine the optimum booster site and antenna system. Using a 15 dB signal level ratio as the indicator for significant interference, they can then determine areas where self-generated multipath may be a problem.

## Papers Address Concerns in RF

by Paul Rebmann

**LAS VEGAS** Engineering conferences at the NAB conventions offer unique learning opportunities that many engineers do not normally have. It is not only the presentations that are educational, but also the question and answer sessions following that expose what is on engineers' minds.

Here is a brief look at five NAB '92 engineering sessions.

R. Richard Bell of Dolby Laboratories presented an extensive look at RF design considerations in the development of high-spectral efficient, multichannel, all-digital STLs. After going over some of the advantages of a digital STL (DSTL), Bell went into detail on the components of such equipment and their requirements to meet the desired performance levels.

One of the main considerations covered in the presentation was the linearity of the radio frequency circuits in the DSTL. This was required to provide the spectral efficiency desired in the finished product.

The session began with the announcement that Dolby had received FCC Type Notification for its digital STL in March. Field tests at KKSF, San Francisco and KUSC, Los Angeles were described and demonstrated how the DSTL could remedy some common problems, such as adjacent channel and fresnel zone interference.

The fresnel zone interference problem at KUSC was especially interesting, as several tall buildings in the STL path created a 40 kHz wide notch in the STL signal. The DSTL carrier frequency

was increased by 100 kHz using the frequency agility feature to move the RF envelope out of the problem area.

The question and answer period indicated that the DSTL might be able to reduce the number of hops in long paths, since it exhibits a greater fade margin and shows substantial immunity to interference from adjacent channel, out of band—particularly 931 MHz paging—and aircraft flying through the path.

### Interface standards

The need for digital audio interface standards was explained by Robert R. Weirather of Harris Allied's Broadcast Division. A group of volunteers representing equipment manufacturers met in San Francisco during Radio '91 to begin developing such standards, according to Weirather. He outlined the purposes of the group, noting that any standards which might be developed would be voluntary and that if the group concluded that no standards were needed they would do nothing.

It was also noted that there may be several different interface standards—for example, a studio audio standard and another for a digitized composite signal to link stereo generators and excitors. The idea of an identification bit to designate the data compression scheme may help deal with the proliferation of different systems and allow some kind of connection in the digital domain. Current standards mainly used in recording studios and consumer gear also were mentioned.

Another session reviewed changes in the structural standards for communications towers. John

Windle of Stainless Inc. outlined the various versions of the EIA 222 standard, pointing out that before 1987 it did not have national recognition, nor was it in compliance with the Uniform Building Code. This created instances where towers built to EIA specifications did not meet the requirements local building or zoning commissions demanded.

Windle stated that the most significant effect on a tower is the wind load, and that the EIA standard relating to this was changed with revision D in 1987 and revision E in 1991. The most recent version provides a county-by-county listing of the maximum wind speed that can be expected in a 50-year period. Because ice creates the next most significant load after wind, many of the questions from the audience related to tower icing.

It was pointed out that it is better to spread appurtenances, such as transmission lines and conduit, around the tower instead of bunching them together. Windle responded to the query on where broadcasters could find the new standards by giving the address for EIA (2001 Pennsylvania Ave. NW, Washington, D.C. 20006).

### BAS concerns

Richard Rudman, chairman of the SBE National Frequency Coordinating Committee, outlined the problems facing the Broadcast Auxiliary Service (BAS) bands and proposed some workable solutions to some of those problems. In comparing the situation where many transmitters are operated at maximum power, Rudman called for a de-escalation in the BAS bands.

This voluntary proposal, which has already been implemented at KFWB Los Angeles, calls for a maximum transmitter power on mountaintop repeaters of 30 W and a 5 W maximum on airborne equipment. The de-escalation also asks for lowering mobile repeaters used in IFB operations to 1 W or less.

Also mentioned were equipment deficiencies such as inadequate output circuitry on solid state transmitters, illegally modified amateur radio gear, lack of maintenance and failure to properly identify stations, problems in both BAS and nearby land mobile bands. Rudman predicted that with the current economic situation and the increasing use of "zero-based budgets" that cheating will increase in an effort to save money. He showed slides of the Mt. Lukens repeater site, and a video showing efforts at tracking down an interference problem with a spectrum analyzer.

There were some positive notes in the session, with Rudman complimenting the local frequency coordinators across the country

continued on page 15 ►



FP410 Mixer shown actual size.

## Forget It.

□ Its MaxBus limits the number of activated microphones to one per talker.

□ And its Last Mic Lock-On keeps the most recently activated microphone open until a newly activated microphone takes its place.

With Shure IntelliMix, you'll get a "seamless" mix that's as close to perfect as you'll find. Providing the cleanest, clearest sound you've ever heard from a portable mixer. And freeing you from the tedious

task of turning microphones on and off.

For a closer look at the world's first portable automatic mixer, call for more information including the article "Why Use An Automatic Mixer?"

We think you'll agree: The Shure FP410 is automatically a classic.

Call 1-800-25-SHURE. The Sound Of The Professionals®..Worldwide.

**SHURE**



# PROPHET SYSTEMS, INC.

## AUDIO WIZARD

CONTROLS  
UP TO 16  
AUDIO STATIONS

### MINI-MAINFRAME COMPUTER

Over 10 Times  
the Power of Our  
486/33 System.

Over 100 Times  
the Power of a  
286 Based System.

*The  
Magical  
Digital Audio  
Broadcast  
System*

### D.A.T. BACKUP AND AUDIO STORAGE TAPE MACHINE

—PLUS—  
A STANDBY HARD  
DRIVE.

Backs up  
the main hard drive  
with their own power.

CONTROLS  
UP TO 32  
B&W STATIONS

### HOT STANDBY MINI MAINFRAME BACKUP COMPUTER

Controls  
Your Station  
In the Event Of  
A Failure of the  
Mainframe.

### 64X64X16 DIGITAL AUDIO SWITCHER

Controls up to  
64 Stereo Balanced  
Inputs. Up to 64  
Stereo Outputs.

Can run up to  
16 Audio Stations.  
Uses Dolby AC-2  
Audio Compression.

### MULTI GIGABYTE TOWER HARD DRIVE

Storage Unit  
with its own  
power supply up  
to  
25,000 minutes  
stereo

*Audio Wizard features...*

#### DIGITAL EDITING

- **Real Time Mixing**  
Allows listening to the spot as it is mixed.
- **Cut and Paste**  
Can mark a section of a track to erase or copy to another track.
- **Real Time Level Adjustment**  
While the spot is mixing you can adjust the levels of each track.
- **Library Storage**  
Can save tracks into a library for retrieval.
- **Record Screen with Real Time Display of Graphic Waveform**  
The audio record screen actually displays the waveform while you are recording.
- **Standard Broadcast VU Meters**  
The VU Meter looks just like an actual broadcast VU meter with needles.
- **Individual Left/Right Channel Controls**  
Can adjust the left and right channel audio level individually.
- **Stretch/Squeeze Tracks**  
Can adjust the length of tracks.
- **Add Tracks to the Mix Track**  
Can incremental mix a spot. Mix two tracks together and then add a new one in.

#### CONTROL ROOM

- **Immediate Access to All Spots**  
All Spots are stored in one place so there is no transfer time.
- **Manual, Satellite, Auto**  
The System can either be run manually or be put into auto mode to run a satellite music delivery station or to start and stop external devices.
- **Remote Control**  
Can modem into the control room and run it from a remote computer.
- **Fully Redundant**  
Each system includes an extra mini-mainframe computer to take over in the event of a failure of the main computer.
- **Overlap**  
Marks can be entered into the finished spot to set the overlap point for the control room.
- **Traffic Interface**  
Interface exists for most major traffic systems including: CBSI, Datacount, Profit Plus, RDS, Decision, ABC and many more.

#### COPY EDITOR

- **Sales People/Copy Writers can write copy and the production department can pull it up in the production room.**  
Removes the need for copy to be printed out. The Sales or copy department writes the copy on the system. When the production department wants to produce a spot they bring it up on the screen in the production room.

Deliveries Start July 15th. Reserve Your Delivery Spot Soon!

**Call 1-800-658-4403 or (308) 284-3007**



# Bidding a Fond Farewell to The Do-It-Yourself Heathkits

by Frank Beacham

**NEW YORK** When I saw the story on the front page of the New York Times my heart sank. It was like reading about the death of an old friend. There was the headline: "Plug is Pulled on Heathkits, Ending a Do-It-Yourself Era."

After 45 years, the Heath Company is closing out not just a line of assemble-your-own electronic kits, but a nostalgic era of American life. It seems the age of the computer and the integrated circuit has spelled doom for us "kitchen table" engineers.

The electronic kit business, a Heath official said, ran head-on into the "instant-gratification society." Declining interest in kit building and increased costs finally killed the line of products which introduced a generation of Americans to the miracle of electronics.

I've lost track of how many Heathkits I've built in my 44 years. The first, I think, was a simple radio. The last, about five years ago, was a Hi-Fi amplifier. I always went for the small stuff, never

having the nerve to tackle that big, imposing color TV kit in the catalog.

Building a Heathkit meant staking out a piece of family turf—usually the kitchen table—and commandeering every available muffin pan and small dish to hold the dozens of resistors, capacitors, screws and washers that came with every kit. Then there was the cord to the soldering pencil—always too short—which my little brother continually tripped over, causing burn marks on the linoleum floor, or, sometimes, his skin.

For me, the great excitement of building a Heathkit was that moment of truth when I plugged it in and first switched on the power.

I always backed away from the kit, fully expecting it to blow up in my face the moment the surge of electricity hit those parts. But you know, those kits always worked the first time. The fire and smoke never came. In fact, I don't remember a Heathkit ever failing for any reason throughout the years that I owned them.

Few things have been as well written in technical literature as a Heathkit manual. That is one piece of American technical ingenuity the Japanese have never come close to duplicating.

Once you mastered Soldering 101, it took a lot to go wrong. Step by step, check by check, the Heathkit builder was led meticulously though that sea of parts. Failure to successfully build a Heathkit usually revealed flaws in the kit builder's patience and temperament, rather than the kit itself.

My favorite kits had tubes and very basic parts. Electronic circuits seemed understandable back then, even to a novice, and the warm glow of the tubes brought far greater satisfaction than those plain black "solid state" parts that invaded the kits in later years.

When I recently called the Heath Company in Benton Harbor, Mich., to ask about the demise of the Heathkit, I was referred to the public relations office at Zenith Data Systems, Heath's corporate parent. I was told there was no news release about the sad event and William E. Johnson, Heath's president, was too busy to take press inquiries. Heath now wants to emphasize the sale of its line of home improvement and educational products, a spokeswoman said.

But as much as today's Heath Company may want to downplay this historic transition, the kit was the basis for the company that former barnstormer Ed Heath began in 1926. The first Heath products were airplane kits. But after Mr. Heath died in a crash on a test flight, the company was reorganized and moved into the electronic kit business. The first Heathkit was a five-inch oscilloscope, introduced in 1947 at a price of \$39.95.

The day after my call to Heath headquarters, a copy of the new Heath catalog arrived via overnight delivery. Inside was a smattering of kits still available. Among those were a few computers, some test equipment, DC power supply, a mini burglar alarm, an infrared motion sensor and an electronic "fish caller."

But I think I'll order a couple of those remaining kits and stash them away. Maybe a few years down the road I'll pull one out and introduce the right kid to a simple pleasure of my generation.

## RF Addressed At NAB Show

► continued from page 13

on all the work they have put into their "thankless task."

### Squeezing more out of tubes

How to obtain the greatest number of tube life hours was presented by John Sullivan of Econco. An extremely interesting slide show accompanied the session, showing the insides of power tubes and some of the workings of the Econco plant. Factors of tube life were reviewed and the importance of filament voltage in extending useful hours was stressed in both the session and the question and answer period.

Running the tube initially (soon after it is received) for a couple hundred hours at rated filament voltage, and then turning the filament voltage down to one- or two-tenths of a volt above where the power drops off, is the key to maximizing tube life, according to Sullivan. He reminded engineers to turn the filament voltage back up while retuning the transmitter, or else you could end up running the filaments too low and retuning to compensate.

The question and answer period brought out the fact that stations that are off at night but leave the filaments on can greatly extend tube life with a circuit that cuts the filament voltage in half during this time. Also, leaving the blower on when the transmitter is off will prevent rusting.

Sullivan said that many problems with tube oxidation are due to environmental problems, usually various airborne chemicals from nearby factories, and that there is no minimum filament voltage after the initial burn-in period.

One engineer commented that he averaged out the monthly cost of rebuilding a tube and kept track of transmitter efficiency and power costs, replacing the tube when increased power due to inefficiency exceeded the monthly cost of a rebuilt tube.

## Are You Getting the Kind of Service That You Expect?



**K-FOX 103**  
KTFX - FM 103.3  
8107 E. Admiral Place  
Tulsa, Oklahoma 74115 (918) 836-XXXX

January 1, 1992

The President  
Continental Electronics Corporation  
P. O. Box 270879  
Dallas, Texas 75227-0879

Dear Sir:

I am the owner of a 100,000 watt FM station in Tulsa, Oklahoma. I got into the FM business back in 1962 when FM wasn't anything!

I want to thank you for such wonderful employees like Cliff Koch (in the past), Ken Branton and Dave Chenoweth. I cannot begin to tell you how important their re-assuring voices on the other end of the phone have been when we were "off the air." I THANK YOU FOR YOUR 24 HOUR SERVICE!

As we move into 1992, I assure you that I would not consider buying any other product than Collins or Continental. YOU BACK UP WHAT YOU SELL AND I CAN NEVER FORGET THAT!

I hope you will suggest that others call me. I have nothing to gain by recommending CONTINENTAL. I recommend you only because you are REAL 24 hrs. a day. Your response time has always been a LIFESAVER.

Thanks for Steve, Dave, and Ken who really care about me and my old 835G.

Yours Truly,  
*Bill*  
William H. "Bill" Payne  
President & Chief Engineer  
Senior Broadcast Engineer

**SOUND BROADCASTING**  
356 FURBY ST., WINNIPEG, CANADA R3B 2V5 (204) XXXX-XXXX

January 9, 1992

Mr. Steve Claterbaugh,  
Continental Electronics  
P.O. Box 270879  
Dallas, Texas  
75227

Dear Steve:

It is always nice to communicate with Continental and particularly when it is to say "Thank you!"

Christmas Day proved to be an eventful day for Sound Broadcasting when our client, CIFX, was suddenly in dire need of an exciter loading resistor. As you are aware this is a part that NEVER needs replacing and a spare was nowhere to be found in the immediate area. A phone call to your parts department put me in touch with Bill Cooke, who performed beyond the call of duty. Within hours he had the right component on a plane to us. A little fancy footwork with the customs office and we were back in business before Boxing Day was over.

I would appreciate you passing my personal thanks on to Bill, and of course a very Happy New Year to you and everyone at Continental.

Best regards,  
*Sheila R. East*  
Sheila R. East  
General Manager.

**24 Hour Service**  
Technical Service  
**214-388-5800**  
Service Parts  
**214-388-3737**

 **Continental Electronics Corporation**  
P.O. BOX 270879 DALLAS, TEXAS 75227-0879  
214-381-7161 TELEX: 73-398 FAX: 214-381-4949

Circle (183) On Reader Service Card



# WORKBENCH

## How to Screw Up Your Studio Gear

by John Bisset

**FALLS CHURCH, Va.** Not long ago, I was called in to assist with the construction of a temporary studio. The main control room was to be gutted and a temporary studio was to be constructed in an office. Because the walls were going to be moved in the main control room, the Sonex® was pulled off the walls. A decision was made to install the Sonex® in the temporary studio.

I was all set with my caulk gun filled with a tube of construction adhesive, when the station chief walked over with an electric screwdriver and a handful of drywall screws. Placing a screw every couple of feet adequately secured the Sonex®.

When it came time to remove the foam and re-glue in the new studio, a can of spackling compound took care of the few dozen holes in the drywall. Can you imagine scraping all that construction adhesive off?.

★★★

George Nicholas at KHAK-AM-FM in

Cedar Rapids, Iowa, had an antenna fail recently. He was all set to clean out the interbay sections with that old standby, isopropyl alcohol. His tower crew showed up with a can of M.E.K. (for the chemists in our crowd, that's methyl ethyl ketone). M.E.K. is sold as a paint thinner, and can be found in most paint stores.

M.E.K. *must be used outside where there is plenty of ventilation.* The fumes are not healthy for you to breathe, nor do they smell very good. According to George, M.E.K. runs circles around isopropyl in its ability to cut grease and clean out dirt and soot.

As you may have experienced using isopropyl to clean a transmitter, the carbon dirt is smeared with an alcohol-soaked rag. The M.E.K. does such a thorough cleaning job that only a few passes are necessary before the rag comes out clean.

For those readers who have never had the pleasure of cleaning a failed antenna, after the antenna is disassembled and on the ground, the center conductor is removed

and a rag is wrapped around a pole (or even the inner conductor) and soaked with cleaner. It is then inserted into one end of the line, and worked as a sort of "ram-rod."

The procedure is repeated with a clean rag, until all the carbon is removed. It's an experience you'll never forget—especially if you don't have an aux FM antenna, and the GM is breathing down your neck.

★★★

Have you ever wondered what to do with a pair of broken headphones? Mike Sokol

single earphone on a wire.

The singer "cups" the mono-phone to one ear when he wants to hear his vocal. It's a natural motion for a singer, and he can hear the band with his other ear. There's also another benefit—the singer can't hang the mono-phone over the mic and cause feedback!

Mike added 100 ohm summing resistors on the two stereo lines to guarantee a mono signal. Though other brands of headphones can be used, the sealed, low-impedance type work best. Mike Sokol can be reached in Hagerstown, Md., at 301-791-2568.

□□□

Editor's note: Field modifications to

### FEED LINE

## Simple Steps to Pin-Point AM Radiation Problems

by W.C. Alexander

**DALLAS** The FCC has put directional AM stations on notice lately that directional antenna parameters and monitor points had better be in tolerance. I received one such letter myself.

The last time I checked the DA parameters and monitor points at any of our stations, they were "bracketed" right between the limits. But what if they had not been? What does one do when a monitor point (MP) goes high?

The first thing to do is determine what, if anything, has changed. This means environmentally, electrically, internal or external to the station. For instance, has there been any local construction that might affect the monitor point reading, such as a new water tower or power line supports? What about in the antenna field itself? Did you make any adjustments to the phasing and coupling equipment since the last in-tolerance reading?

### Check sampling loops

Whenever there is a problem with a monitor point, the first thing to do is look at the sampling loops, connectors, and lines. In most cases, sampling loops are mounted on a tower leg with the loop perpendicular to the opposite face of the tower. Stand under the sampling loop and look up; it should be lined up with the guy wires.

Loops mounted parallel to the tower face should be checked to ensure that all loops are in their normal positions with respect to the towers. Check all the loops in the same way—then, even if they are not the problem, at least you will know that you

are not chasing a loop alignment problem. Sampling lines, current transformers, connectors, etc. should be checked for security, watertightness, and the like.

Back in the transmitter building, set the loop reference current on the reference tower and, one at a time, connect the sample lines from the other towers to the reference tower input and see if the loop current indication is the same as it is on the tower's own channel.

I often have seen relay problems in antenna monitors that would cause a 10 percent change in the loop current reading for one tower. Without knowing, one can adjust the phasor to compensate, and just like that, the MPs are out. By swapping sample lines around on the monitor, you can verify that the monitor is working properly.

By the same token, if you leave the reference tower connected to its input channel and then swap the other towers around to one other input channel, you can be sure the phase detector is working right for each channel.

Assuming tower number one is the reference tower (0 phase), disconnect tower number two from its antenna monitor input and connect the other towers' sample lines there in turn, noting the phase reading on tower two's channel. They should all indicate the same phase as they do on their own channels. If there is a question about the tower two input channel, do the same thing using one of the other channels.

Once you are certain the antenna sampling and monitoring system is 100 percent reliable, make sure all the phases and ratios are what they should be.

continued on page 17 ▶

Figure 1.

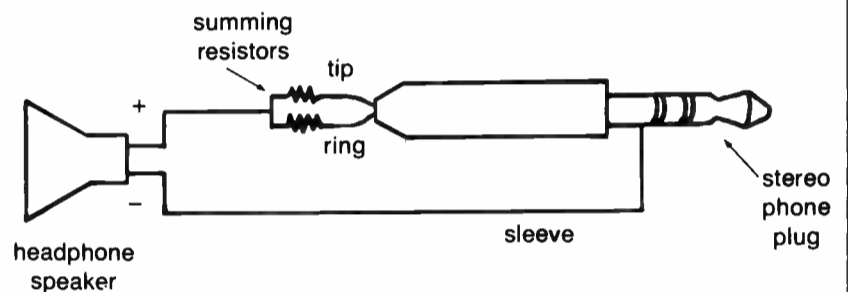

of JMS Productions came up with a cheap trick that is useful for both studio and live recording. While recording a rock band recently, Mike ran into a problem. When he turned down the monitors to reduce leakage, the singer couldn't hear himself; when he gave the singer the headphones, he couldn't hear the band.

His solution was the "mono-phone." In his junk box, Mike found a set of Koss Pro 4AAA headphones with a broken earpiece holder. A few minutes with his Swiss Army Knife and soldering iron, and Mike had a

equipment may invalidate the manufacturer's warranty. Before attempting any repairs or modifications, consult the manufacturer for advice and guidance.

Always use the utmost care and follow good engineering practices when working with or around electrical equipment or chemicals. RW will not assume responsibility for any loss or injury.

John Bisset is a principal with Multiphase Consulting, a contract engineering and projects company. He can be reached at 703-379-1665.

### Belden® audio cables can make a difference.

Be honest. If you had the big guy on-mic, would he sound a little... thin? The problem could be your audio cables, particularly if you're not connected with the broadcast industry's No. #1 choice, Belden.

Belden is preferred for quality,

reliability, and availability by broadcast professionals who know what they're getting when they buy Belden. We offer the industry's most complete line of cables, with immediate availability through our extensive distributor network. Digital audio cables. Snake cables. Flexible mic cables. Audio multi-conductor and paired cables. You name it.

If you had Pavarotti here,



Copyright ©1992 Cooper Industries, Inc.



# Pin-Pointing AM Radiation Problems

► continued from previous page  
Usually, they should be adjusted for the licensed values, but it is possible that they should be adjusted to some other value that is slightly off the licensed value (but still within tolerance).

## Check and recheck the system

This might be the case if some engineer in the past adjusted the antenna to get the MPs within tolerance and found that the altered values were needed to do so. With the DA parameters "bracketed," go check the monitor points again. If they are all "in," stop, write everything down (including turn counter readings on all the phasor controls), and go home. If not, read on.

Once it has been established that everything in the antenna system is working properly, the next step is to look outside the antenna field. If there are new structures about that you suspect of causing MP problems, you may need to take steps to eliminate them as re-radiators.

To find out, a simple first step is to go to the monitor point and rotate the field strength meter for a null. Look down the electrostatic break in the top of the antenna. The groove should be pointed directly at the transmitter site. If not, there is likely to be radiation coming in from some other direction.

Before we go off hunting for re-radiation, we need to determine whether just one or all the monitor points are out. If re-radiation is truly the culprit, chances are good that more than one monitor point will be affected. This is because the re-radiating element will produce a field at each of the monitor points that will vary with the fields from all the other towers and cause the field strength to be higher or lower than it should be.

## Re-radiating neighbors

If just the one MP is out, there is a good chance a local disturbance is causing the problem. The next step in this case is to run a partial proof of performance on the one radial. If it is the same season (winter, spring, summer, or fall) as the last full proof of per-

formance, read the field strength at 10 of the proof measurement locations on the radial between 3 and 16 km from the site.

Ratio these values to the DA values from the last full proof and average them. If the ratio is equal to or less than 1:1, the antenna is working properly and some local disturbance is making the MP unstable. If the ratio is greater than 1:1, there is a problem with the pattern that will probably require a consultant's help to fix.

If the season is different than that in which the last full proof was run, put the antenna system in the non-directional mode, detune all the unused towers, and read the same 10 points on the MP radial in the ND and DA modes. Towers above quarter-wave must go through a series inductance to ground.

Ratio the DA to the ND values at each point, average them, and multiply by the non-directional inverse distance field for that radial from the last full proof. If the value is less than the standard pattern value for that radial, the antenna is OK and the

disturbance is local. Otherwise, call your consulting engineer.

What if the partial proof shows the radial is OK? The MP is still high, and that's a violation, right? That's right, but the FCC has a way to deal with the problem. Just follow the steps outlined in

**I often have seen relay problems in antenna monitors that would cause a change in the loop current reading for one tower**

§73.158 of the FCC's rules.

In short, you must:

- Select a new monitor point. It must be one of the points used in the last full proof of performance, and generally must meet all the FCC's requirements for monitor points.
- Submit a partial proof of performance on

right, your station license will be modified to specify the new monitor point as the official MP, and a new limit will be set for it.

□ □ □

*Cris Alexander is director of engineering for Crawford Broadcasting. He can be reached at Box 561307, Dallas, TX 75356.*

## ECLECTIC ENGINEER

# What No One Tells You about Contracting

by Barry Mishkind

**TUCSON, Ariz.** The economics of broadcasting have put a lot of pressure on the bottom line. With the tremendous increase in competition over the last several years, most stations must count every dollar twice before spending.

Therefore, it's difficult to quarrel with the station manager who looks at the engineering department to see whether there is some way to trim the budget. He's only doing his job.

## Some correct responses

The engineer can respond in several ways. He can get angry, of course, and

walk. The manager rolls his eyes and looks for someone else to fill the position . . . at a lower salary.

Another way for the engineer to respond is by defending the current budget as the minimum necessary to operate the facility. Accurate records presented in a report showing the amounts saved and deferred over the past year will prevent further cuts.

One other alternative has presented itself to many stations: hiring a contract engineer. Several benefits are perceived. First, the station reduces the cost of the engineer. Since the contract engineer isn't considered an employee, payroll taxes and benefits are reduced.

The engineer can see this as a liberation. He's not forced to spend 40 hours in the office each week, and can do additional work for other facilities, gaining further income. Also, having several clients can provide more security from layoffs.

So, if you're in a station going through financial difficulties, you may feel this is a good time to consider becoming a contract engineer.

## On your own

Of course, part of the price that must be paid for such advantages is the need to pay for the taxes and benefits personally. The self-employment tax runs roughly 15 percent, as you end up paying both halves of the FICA contribution.

When the costs of personal tools and equipment, transportation and health insurance are added in, the additional gross income offered by the station suddenly begins to shrink before your very eyes.

I'm not trying to discourage you from considering going out on your own. I just want to be realistic in viewing contract engineering like any other business, with all its advantages and disadvantages.

## Don't forget Uncle Sam

Are there any other factors to consider regarding contract engineering? Certainly, and RW continues to provide information and tips to assist those engaged in contract engineering to be successful.

While I'm talking about the IRS, there are several areas I'd like to highlight.

One major consideration is whether you actually are a contract engineer or not. While you might figure that you can set your own title, the IRS has its finger here, too.

The IRS came up with some 20 factors used in determining whether you're really an "independent contractor." For example, if you are *required by your contract* to comply with company instructions on when, where and how work is done, the IRS may declare you an employee. This can cost a bundle at the end of the year.

Other factors that can cause the IRS to classify you as an employee and cause you severe problems as a contract engineer are: essentially working for only one company; not being allowed to use other people to do the work; being trained by the company; being reimbursed for all business and travel expenses by the company; having no significant investment in your tools, or using exclusively those provided by the company; having risk of loss, or being summarily dismissed by the company.

These are not the only factors, nor are they individually necessarily the determining factor on the part of the IRS. However, if you think you might be in a gray area, you would be well advised to visit a tax accountant.

## Other concerns

Two other areas where you need to check things out are insurance and legal matters. Not health insurance, which you and your family need, but liability insurance. And since you're thinking of being a contract engineer, shouldn't there be a real contract?

Suppose you're working on the transmitter late one night, and accidentally blow up the output tube. Who pays for the lost morning drive airtime? This can be quite expensive, and if an angry client comes after you, you'll be glad you bought insurance.

Even if you helped get a station back up at low power after some problem, there are managers who will accuse the engineer of

continued on page 19 ►

In fact, with over 60% of our line new in the last few years, we can probably offer you same day delivery on products the competition hasn't even heard of. All developed in cooperation with leading equipment manufacturers to guarantee compatibility, and assure you of Belden's renown reliability and signal integrity.

No wonder we're a match for the maestro! Call 1-800-BELDEN-4 for your FREE copy of our catalog, and see for yourself. Because, if it sounds too good to be true, it's probably Belden.



wouldn't you want Belden® here?

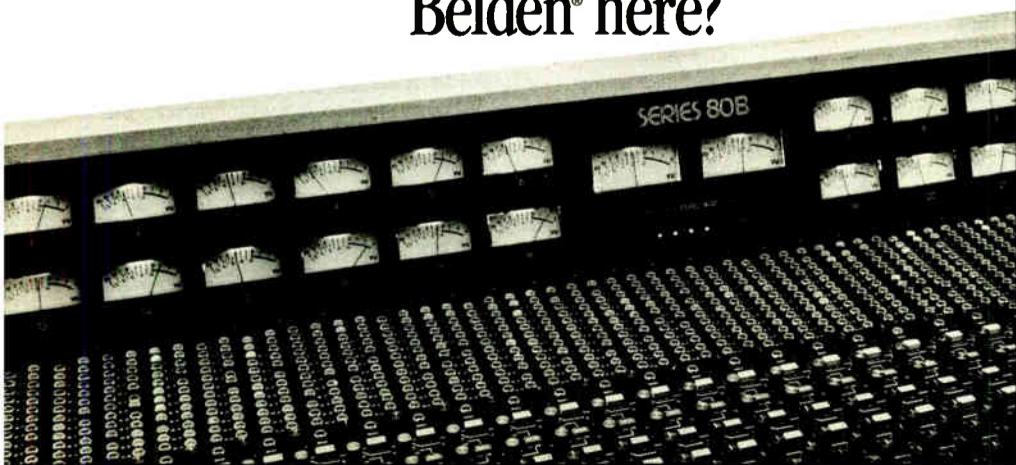

Circle (47) On Reader Service Card



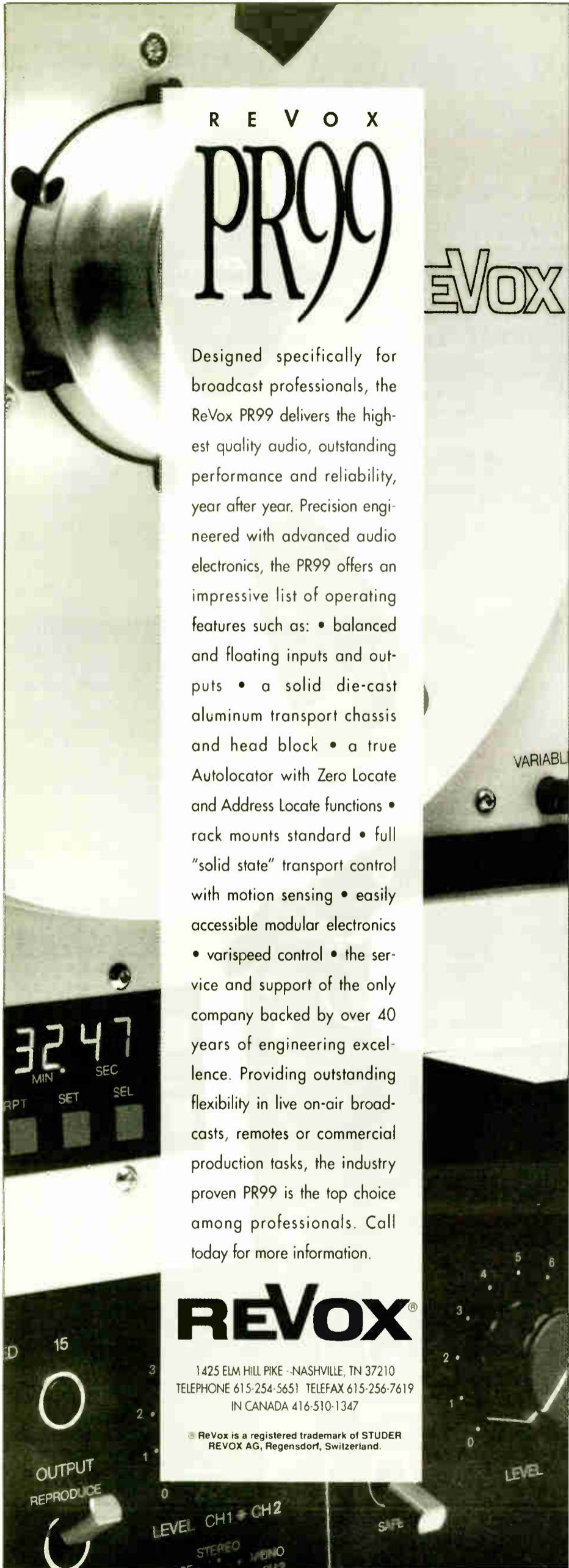

REVOX  
PR99

REVOX

Designed specifically for broadcast professionals, the ReVox PR99 delivers the highest quality audio, outstanding performance and reliability, year after year. Precision engineered with advanced audio electronics, the PR99 offers an impressive list of operating features such as: • balanced and floating inputs and outputs • a solid die-cast aluminum transport chassis and head block • a true Autolocator with Zero Locate and Address Locate functions • rack mounts standard • full "solid state" transport control with motion sensing • easily accessible modular electronics • varispeed control • the service and support of the only company backed by over 40 years of engineering excellence. Providing outstanding flexibility in live on-air broadcasts, remotes or commercial production tasks, the industry proven PR99 is the top choice among professionals. Call today for more information.

**REVOX®**

1425 ELM HILL PIKE - NASHVILLE, TN 37210  
TELEPHONE 615-254-5651 TELEFAX 615-256-7619  
IN CANADA 416-510-1347

ReVox is a registered trademark of STUDER  
REVOX AG, Regensdorf, Switzerland.

Circle (125) On Reader Service Card

INSIGHT ON RULES

# FCC's Revised Forfeiture List Is Another Fine Mess

by Harold Hallikainen

**SAN LUIS OBISPO, Calif.** A news-group has been started on Internet—Usenet News. This group is dedicated to the discussion of broadcasting issues. Discussion topics have included broadcast band DX, all-news radio on AM, digital audio broadcasting, SCA, AM band expansion, and the AMAX radio.

Those of you without local access to Internet might want to get a *free* account on the Cleveland Freenet (courtesy of Case Western Reserve University). You can register on-line by calling via modem, 216-368-3888. Those with Internet telnet access can reach Freenet at [freenet-in-a.cwru.edu](mailto:freenet-in-a.cwru.edu), [freenet-in-b.cwru.edu](mailto:freenet-in-b.cwru.edu) or [freenet-in-c.cwru.edu](mailto:freenet-in-c.cwru.edu).

There are over 1,000 newsgroups on Usenet News, covering almost everything. Freenet users can post to these groups. The postings are then distributed internationally.

### News about forfeitures

Last year, the FCC issued a table of standards for issuance of forfeitures (see FCC Policy Statement FCC 91-217, adopted July 11, 1991). The FCC has been

each of these violations. Some imagination was required to get the violation type in the Denver FCC report to match the types listed in the policy.

For example, "EBS logs" was considered a violation of the technical log requirements; EBS transmit test violations were considered to be a violation of the EBS equipment installation requirement. The musical embellishment of EBS was considered another EBS equipment violation—for lack of a better category in the policy.

The operator and remote control violations were considered failures to do required monitoring.

### EBS equipment certification

As we continue our review of the FCC's proposed AM station self-inspection form, we get to questions regarding EBS equipment. FCC regulation 73.932(a) requires all stations to operate a receiver capable of receiving the emergency attention signal and programming of other broadcast stations.

This section requires the equipment to be installed in such a way that the station staff is alerted "instantaneously" on reception of the emergency attention signal. Furthermore, 73.942(b) requires the decoder

Table 1.

Violation	Low Fine	High Fine	Avg. Fine	Policy
Public File	\$1,000	\$7,500	\$3,040	\$7,500
EBS Logs	\$1,000	\$2,500	\$2,250	\$5,000
EBS Tx Tests	\$1,250	\$5,000	\$3,125	\$12,500
EBS Music*			\$1,376	\$12,500
Unlic Op*	\$17	\$2,845	\$1,431	\$2,500
Remote Control*			\$5,112	\$2,500

\*These fines were derived from totals

issuing the "new and improved" fines.

Recently I received the FCC Denver FY1992 Broadcast Inspection Summary. Although it does not give exact details of the violations, it does give us some idea of which violations are most common and what the typical fine is. This report only covers inspections made by the Denver office between Oct. 1, 1991 and March 31, 1992.

The report states the FCC's national goal is 90 percent compliance (a particular rule is violated by 10 percent or less of the stations). The violation rates in various categories varied between 0 percent and 43 percent. Twenty-five stations were fined a total of \$87,250 for an average fine of \$3,490. Table 1 summarizes these results.

Individual fines are reported for violations of the requirements for public file, EBS logs and EBS test transmission. These individual fines were averaged. Several stations were listed as being fined for more than one violation.

In general, it appears that stations are fined roughly 74 percent of the total of the individual fines when several are combined. From these "combined fines" and the 74 percent factor, approximations were made for fines on the use of unlicensed operators, "musical embellishment of EBS" and remote control problems.

The "policy" column of the table shows what the FCC forfeiture policy suggests for

to be FCC-certified.

The FCC certification requirements, 15.132, require a label with the FCC certification number be permanently attached to the equipment. One station was fined \$300 (reduced to \$180) because the label fell off the equipment.

The FCC self-inspection report asks for the make, model number, serial number and FCC certification number for the EBS decoder and generator. The form goes on to ask whether "the equipment capable of generating the EBS Attention Signal" is located at all control points and/or studio locations as required by Section 73.932(b).

### Off-premise control

This point is of special concern to those stations using "off-premise control." Can the operator at that control point properly respond to EBS receive tones and emergency programming instantaneously? Put required tones, scripts and emergency programming on the air?

The form goes on to direct EBS questions to Mr. William Browning at 202-632-3906.

With the FCC's new ownership limits for radio (whatever final form they take), and their implications for LMAs, we may see a different approach to off-premise control. Stations under common ownership or involved in an LMA could share the expense

continued on page 23 ►



**BOTTOMLINE BROADCASTER**

# Line Amps: Some Assembly Required

by Jim Somich

**BROADVIEW, Ohio** This month's *Bottom Line Broadcaster* will combine what we have learned in the last two columns and some basic opamp building block theory: We'll design a simple line amplifier. A balanced input-output line amplifier can be one of the most useful building blocks you can construct.

Not only can it be used stand-alone as a remote amplifier, but a balanced line driver can also be handy wherever you have to make up "a few dBs." The amplifier described will ultimately be used in our console-rebuild plans.

Fig. 1 is a schematic/block diagram of our universal line amplifier project. It has a balanced input stage using the PMI SSM-2141 line receiver and a balanced output using the PMI SSM-2142 line driver chip.

**You know the schematics**

The schematics of the PMI chips were covered in a previous column. A volume control has been inserted between the 2141 and the opamp gain stage. I used a 10K pot, but the value is not critical. The use of a pot with an audio taper will provide a more linear action.

You will recognize the schematic portion as a standard non-inverting opamp gain stage. In this configuration, the input impedance is very high and the output impedance quite low. Gain is the ratio between  $R_1$  and  $R_2$ . Voltage gain equals  $R_2/R_1$ .

To help you gain familiarity with opamp circuit design, let's go over the line amplifier design step by step.

**Designated driver**

First, select your opamp. If you are going to drive a 600 ohm line with any ap-

Next, determine the maximum gain required in your application. In our example, 20 dB was chosen—that's a voltage ratio of 10 ( $\text{dB}=20 \text{ Log}_{10} E/E$ ). Therefore, the ratio between  $R_1$  and  $R_2$  must be 10. We chose 10K for  $R_1$  and 100K for  $R_2$ . The values are not critical;

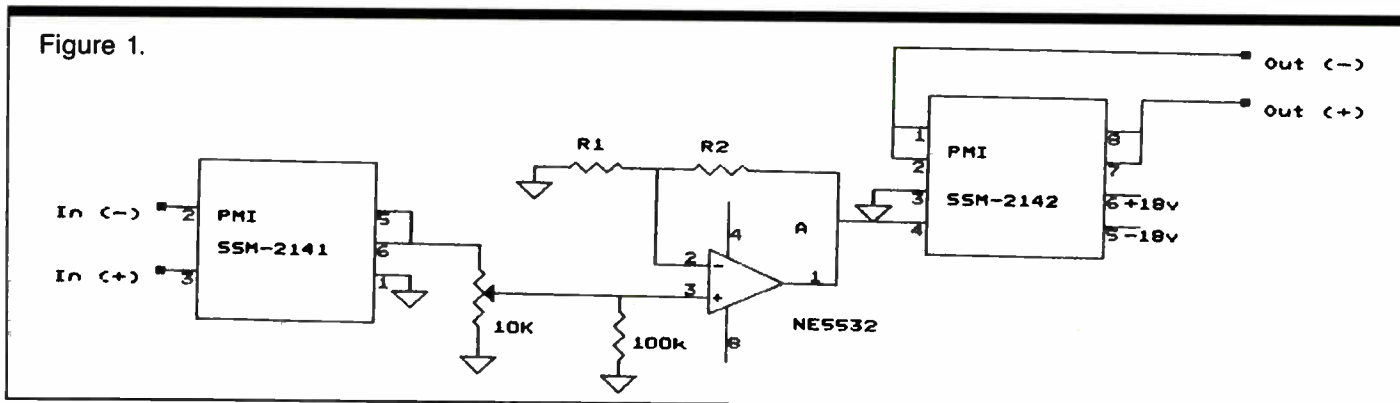

The line amplifier can be constructed on a small piece of perf board with a dedicated power supply, or you can power several amplifiers from an external supply.

The circuit shown is just a starting point for your own ideas. The beauty of opamps is that you can tailor the parts you have to your particular application.

preciable level, and you are not using a balanced line driver, choose an opamp designed for the purpose, such as the NE5534, manufactured by Signetics. If you are going to feed a high impedance load such as a line driver, you have a much wider choice since the opamp specified is not as critical.

Look for a low noise spec and high slew rate. A wide gain-bandwidth spec will allow you to run higher gains without running out of steam. Most modern opamps perform very well at audio frequencies with moderate gain. Don't be afraid to experiment with what you have on hand.

the ratio determines gain.

With most medium- to high-performance opamps, it is best to limit gain to 30 dB per stage . . . 20 dB is even better. If you need more gain, consider two stages. Using an input pot will allow you to reduce the input level for the required output level.

An alternative is to use a pot in the feedback loop in place of  $R_2$ . In some applications this will result in a better signal to noise ratio because the gain of the circuit is being tailored to your requirements rather than running while wide open at all times.

continued on page 23 ►

# CCA

## Evolution.

CCA has delivered more than 3,000 Broadcast Transmitters over the past 25 years. For 25 years our designs have been refined and improved. The result is the Evolution of the world's most perfected, most tested, most reliable, Radio Transmitter.

- \* Grounded Grid Triode
- \* Longest Tube Life
- \* Auto Power Control
- \* VSWR Power Foldback
- \* Single Phase Optional

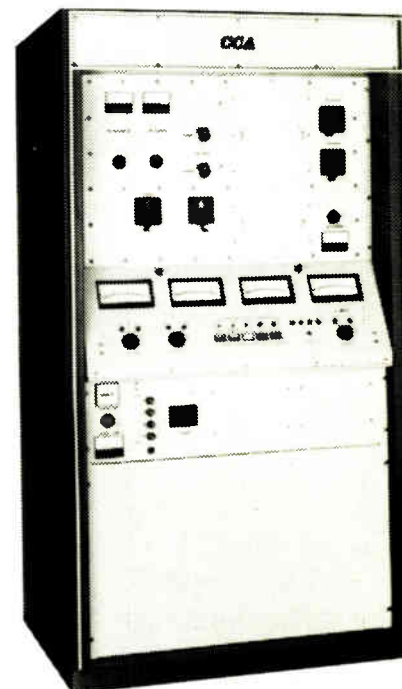

**CCA Electronics, Inc.**  
 P.O. Box 426  
 Fairburn, GA 30213  
 (404)964-3530 FAX (404)964-2222

Circle (91) On Reader Service Card



# Who's running the ship?

**U**nattended operation is one way to keep your station profitable, but you still have to mind the store.

The acclaimed Burk Technology ARC-16 Remote Control System is the first step. You can control transmitter and studio from any phone.

But wait. There's more!



**I**ntroducing AutoPilot™ from Burk Technology.

AutoPilot is break-through computer software that makes automatic operation of your studio/transmitter facility a dream come true.

- Automatic power changes
- Automatic pattern changes
- Automatic site changes
- Automatic power trim
- Automatic fault recovery
- Automatic logging

Now your imagination is the only limit.

The new FCC fine schedule is imposing. Why risk a big penalty when AutoPilot can help you stay within the rules?

Call us at 508-433-8877  
or toll free at  
**1-800 255-8090**  
for more information  
and a FREE DEMO.

# BURK

TECHNOLOGY

Circle (19) On Reader Service Card

## Q-TIPS

# Survival Strategy in Today's Tough Times

by John "Q" Shepler

**ROCKFORD, Ill.** The toughest situations to deal with are those that affect you directly. Any threat to your own or your family's well-being is far more devastating than mere broken equipment or belligerent customers. In these bleak economic times you do indeed need to take care of Number One.

No need to feel selfish. How can you possibly take care of other people's needs if you're worried all day about your own survival? Take care of Number One and you'll be far better able to take care of numbers two on down.

It's important to first figure out what you have going for you and what is making you feel insecure. It's possible that you may have caught the blues from somebody who's own disastrous situation has nothing to do with yours.

### Realistic assessment

How stable is your company? Is the station really nearing bankruptcy? If billing is steady or growing, then perhaps the cost-cutting measures are simply a precaution, or an opportunity to reduce waste and thus raise profits.

If the company is doing well, then how about your job? Remember the previous columns? Unless you're dealing with somebody out to clean house or they're after you personally, there is a good chance you can influence the situation to your advantage.

Most managers, even remote corporate types, don't have a personal vendetta against engineers or anybody else. They're simply trying to ensure their own survival and prosperity by cutting what makes sense to cut. So, change the equation. Become more valuable by becoming more versatile and convince them you're an asset, not a liability.

Once you've done what you can at the station, consider bolstering your own personal financial security. You'll sleep bet-

ter if you can squirrel away a rainy day fund, a few dollars at a time.

You have more control over your income than you think. You might get bold and convince your management that since you will do two or three jobs around the station, you should get half again as much as now. That's pretty gutsy, but might work in some situations.

### Other revenue streams

A better approach is to find out what extra income possibilities are available. Can you pick up residuals cutting commercials? How about fees for remotes, live appearances, or DJ music shows at school events?

Will anybody pay to hear a presentation about radio at a school or business dinner? Mull that one over. Lots of people are paid to speak an hour or less—and they often

get fed, too.

Look around town. Could the community college or trade school use another part-time instructor in the evening? Surprisingly, you don't need a degree to teach electronics, marketing, advertising, announcing, computers, or other specialized topics. All you need is expertise and energy. Here's another surprise—the hourly pay can be equal to or higher than what you now earn.

How about other stations in the area, radio or TV? Can you help out for vacations, emergencies, staffing problems, or other needs that won't affect your present work?

You may feel squeamis about moonlighting or doing something that looks like a conflict of interest. If you feel there is an ethical problem involved then pass on that

continued on page 28 ►

# Marconi's Early Experiments Set Stage for Future Empire

by George Riggins

**LONG BEACH, Calif.** In our last in-

from "home made" batteries.

Marconi continued to fine-tune his wireless equipment, always striving for more



**DO YOU KNOW YOUR MARKET?  
YOUR COMPETITION DOES!**

### DATAWORLD MAPS CAN

- Depict your coverage!
- Market orient your sales people!
- Target your ethnic/demographic markets!
- Identify marginal signal areas!
- Plot any special requirements!

### MAP OPTIONS

- SHADOWING (TERRAIN SHIELDING)
- CONTOUR COVERAGE
- POPULATION DENSITY
- ZIP CODE BOUNDARIES
- RECEIVED SIGNAL LEVEL
- SPECIAL REQUIREMENTS

**dataworld®**  
A Service of DW, Inc.

(301) 652-8822

(800) 368-5754

Circle (157) On Reader Service Card



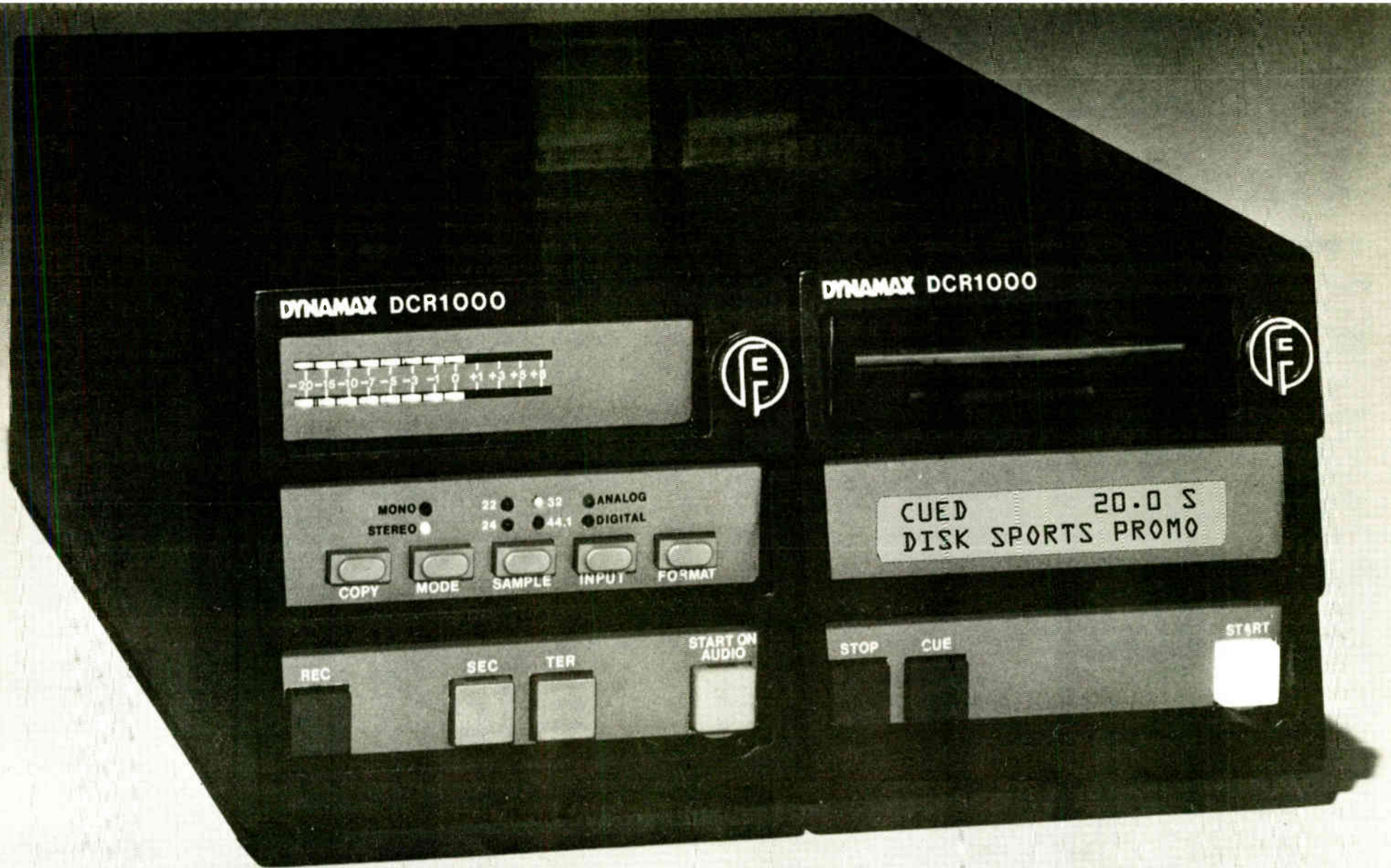

# DYNAMAX DCR1000 Digital Cartridge Recorder

## The Recorder

- Selectable sampling rates
- Secondary and Tertiary cues
- Extended scale peak metering
- AES/EBU digital input
- Start on audio
- Direct digital dubbing from CD
- PC keyboard for titling

## The Reproducer

- Simple cart-like operation
- No on-air personality training
- Just three front panel buttons
- Instant start and cue
- Maintenance-free design
- No head cleaning or alignment
- Awesome audio quality

## The Media

- Standard low cost floppy disks
- 2MB holds 60 second commercials
- 10MB stores over 5 minutes stereo audio with 15kHz bandwidth and 15 minutes mono with 10kHz

Call your nearest RF Specialties office  
for more information or to schedule a demonstration.  
The remarkable new DCR1000 is available now,  
and it's priced like an analog cart machine.

**A. NORTHWEST**  
Seattle, WA  
Phone (206) 546-6546  
FAX (206) 546-2633  
John Schneider

**B. WEST COAST**  
Santa Barbara, CA  
Phone (805) 682-9429  
FAX (805) 682-5170  
Sam Lane

**C. MIDWEST**  
Kearney, MO  
Phone (816) 635-5959  
FAX (816) 635-4508  
Chris Kreger

**D. SOUTHWEST**  
Amarillo, TX  
Phone (806) 372-4518  
FAX (806) 373-8036  
Don Jones & Tim Hawks

**E. NORTHEAST**  
Pittsburgh, PA  
Phone (412) 733-1994  
FAX (412) 327-9336  
Tom Monahan

**F. SOUTHEAST**  
Niceville, FL  
Phone (904) 678-8943  
FAX (904) 729-2744  
Bill Hoisington & Bill Turney

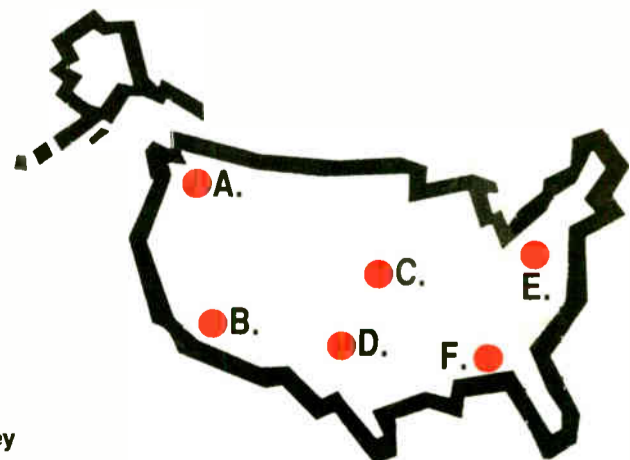

 **RF Specialties®  
Group**

Circle (39) On Reader Service Card



## DIGITAL DOMAIN

# The Importance of Labeling Digital

by Mel Lambert

**STUDIO CITY, Calif.** In addition to improved sound quality, digital technology offers many peripheral advantages. During routine transfers over short and long distances—from dubbing a DAT master to regional DAB hops—digital does not suffer from noise build-up, nor does it add increased wow and flutter distortion via the recording or transmission media. In just about every technical and operational respect, digital storage and playback offers significant advantages over analog techniques.

One advantage that might not be so obvi-

ous, however, is that the majority of digital media in a broadcast facility are capable of carrying integral labeling and ID information within the storage or transfer material. Examples are obvious. Compact discs, for example, contain ID and track information in the PQ codes recorded as part of the bitstream.

The codes appear both as a series of lookup tables recorded on the first few inner spirals, and also interleaved within the data that is encoded as series of pits upon the metallized surface. In this way, as soon as a CD is inserted into the player and spun up to speed, we are presented with a display of the number of tracks that the CD contains, and the duration of each cut.

In addition, the CD format provides standardized descriptions of alphanumeric labels that can be used to describe each of the individual audio cues.

## Timely information

The majority of broadcast CD players simply display the initial data of total cuts; some display the duration as well. During playback of a selected cut we will be presented with the normal choice of cut number, count up/count down, total time elapsed and time remaining (plus one or two other timing variations). This information can prove extremely useful during on-air and production assignments, if only because these timings will be extremely accurate.

If the CD player doesn't know to within a

fraction of a subframe where the laser pickup is located in the CD spiral—either by calculating the relative address, or reading the actual data bitstream passing beneath the detector—there would be no way that it could provide virtually instantaneous search to a selected track of index ID.

In fact, several of the currently available, serially-controlled CD multiplayers allow various data from the CDs loaded into their internal trays to be accessed from a Mac or IBM-compatible controller. Such data can be automatically entered into the master database that forms part of the external microprocessor-based automation system, and used during search and replay sequences. The software can confirm that the correct CD has been loaded into the appropriate tray, and is available to the automation system.

For systems that offer sufficient capacity to house several hundred CDs in a single chassis, we might set the software to first check through the available selections and re-assign the slots accordingly. It could then inform the operator that certain CDs are missing and should be inserted into the remaining slots, and then checked to ensure that the requested discs were, in fact, loaded correctly into the system.

Of course, such options are not restricted to CD. The coming generation of floppy-disk and Bernoulli-based players will offer more than 16-bit record/replay quality and high-speed cuing. Once again, auxiliary data

recorded into a simple "table of contents" somewhere on the disk can be accessed by the controlling microprocessor.

Such information can either be displayed in a small front-panel window—providing the operator with details of, for example, the cut name, duration and (maybe) play dates and other restrictions—or accessed by the controller software to confirm that the appropriate cut is loaded and ready for relay.

Some more advanced designs use the Bernoulli drive as an "inload gateway" to the system's internal high capacity hard drive. Now, of course, the track descriptions and timing information for the possibly several hundred gigabytes of digitized audio cuts can be fully catalogued and cross-indexed within a sophisticated database.

## DATs index, too

The humble DAT machine can also provide a degree of self-labeling data. As many chief engineers are already aware, the use of IEC 958 Type II digital I/Os, while dubbing from a non-copyright protected CD to a DAT recorder allows track/index IDs to trigger the automatic recording of start IDs and program numbers (PNOs). In addition, the dubbing of master DAT recordings via the same format of I/O ensures that the clone also contains PNOs in the same locations.

Unfortunately, the A-time count will be restarted from the head of the tape, but the minor differences between master and slave should not prove too troublesome. The ability to access identical PNO locations speeds up operations on the air or in the production studio. Beyond such functions, however, few DAT machines are capable of outputting data that can provide unique information about the actual DAT tape currently loaded.

A useful way of identifying a particular DAT reel to a computer-based automation controller might involve something as simple as a barcode reader and label-printing software. Having prepared a number of small labels for the DAT's top surface or front edge (very small labels!), the operator could simply move the barcode wand across its surface before loading the tape into the DAT transport. Affixing the label to the front panel of each DAT machine might even provide a unique indication of both DAT tape and the slot into which it was loaded.

I would be interested in hearing from any RW readers who have ideas of their own regarding labeling of digital media, or successful techniques they've used to identify DAT tapes. If appropriate, I'll include details in an upcoming issue.

□□□

Mel Lambert has been intimately involved with the production and broadcast industries on both sides of the Atlantic for many years. Now principal of Media&Marketing, a consulting service for the professional audio industry, he can be reached at 818-753-9510.

## WHEN YOU WANT MORE THAN JUST AN ANTENNA

JAMPRO has been providing the broadcasting industry with state-of-the-art antennas for over 35 years, longer than any other US antenna manufacturer. With over 3000 antenna systems delivered, at JAMPRO you don't just buy an antenna, you invest in experience.

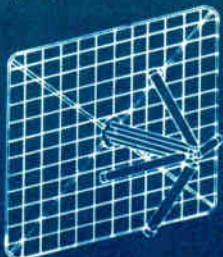

JAHDCP  
Arrowhead  
Screen Dipole

### THE LEADERS IN ANTENNA TECHNOLOGY

- Complete line of FM & TV broadcast antennas
- RF components, Filters & Combiners
- Modern 7000 ft FULL SCALE test range
- Directional antennas and pattern studies.

Call or fax us your needs today.

(916) 383-1177  
Fax (916) 383-1182



6340 Sky Creek Drive  
Sacramento, CA 95828

Circle (130) On Reader Service Card

## TRUE BLUE FOR THE NEWS.



For top reliability, put your news cuts on the cart more stations count on.

**audiopak**  
BROADCAST CARTRIDGES

P.O. Box 3100 • Winchester, VA 22601  
Tel: (800) 522-CART or (703) 667-8125  
Fax: (703) 667-6379

Circle (30) On Reader Service Card

World Radio History

Oh-Oh!

Call  
**CORTANA**

For Affordable Lightning Protection  
**505-325-5336**

P.O. Box 2548, Farmington, N. M. 87499  
FAX 505-326-2337

Circle (7) On Reader Service Card



# Line Amps: Some Assembly Required

► continued from page 19

After choosing gain and a method of controlling it, devise the input and output interfaces required. If you can run unbalanced, a single device will often suffice. In most cases, you will require some sort of matching, such as a balanced input or output. Select a packaged interface device such as the SSM-2141 input interface or SSM-2142 line driver to complete your circuit.

You may choose to AC couple the input or output using high quality film capacitors. If you require a stereo line amp, consider a dual or quad opamp package. This will simplify

your construction and make for a smaller package.

### Be direct

When designing with wide bandwidth opamps, it is important to keep leads short and direct. Always bypass the power leads at each device.

At the very least you should use a 10  $\mu$ F tantalum cap. For best bypassing add a small ceramic (.001  $\mu$ F typically). The tantalum will bypass best at low frequencies and the ceramic at high frequencies. If you do not etch a small PC board, keep your grounds direct and low impedance.

Establish a ground plane on your board if you can, as this is the best possible ground. If your circuit oscillates, you can be certain that you have not followed these instructions.

The best source for information can be application books available from all chip manufacturers. These are often available free of charge from the local distributors. The application books give all pinouts, specifications and typical circuits.

Remember, regardless of the amp you select, the basic design theory is the same. The next time you need a little gain, why not reach for your soldering iron and assemble a little line amplifier for just a few

dollars? Performance can equal or exceed commercially-built units.

Next month we will design a simple mic preamp. When combined with a line amplifier and power supply, you can build a single channel amplifier for simple remotes.

□□□

*Editor's note: Always use the utmost care and follow good engineering practices when working with or around electrical equipment. RW will not assume responsibility for any loss or injury.*

*Jim Somich is president of Somich Engineering. He can be reached at 216-526-4561.*

## Another Fine Mess

► continued from page 19

of transmitter operators. This would allow a single operator at a common control point to handle up to six radio stations—or whatever the final limits for local overlapping coverage may be.

This operator would have immediate access to both transmitter and audio control of all stations. A similar approach could work for stations that are not operating under LMA or common ownership by merely co-locating control and studio facilities. A community "broadcast center" could house several stations.

It would be a simple matter for one of the stations to provide transmitter control and emergency program control (EBS), because all facilities are in the same building. Some stations in this area are sharing operator responsibilities under LMA (where they also share studio/control facilities). One of the stations in a local LMA is also providing transmitter and emergency programming control for another station.

These stations are not sharing studio facilities, but do have a common transmitter site. Emergency programming control is handled by remote control of the composite stereo feed to each FM exciter at the site. In an emergency, each station is switched to the STL receiver of the station in control, allowing simultaneous broadcast of the emergency script, tones and programming.

### Next time

We'll continue our discussion of the FCC Self-Inspection Report in my next installment of *Insight on Rules*. In the meantime, if you'd like a copy of a 46-page "compliance package," including the FCC Self-Inspection Report, an FAA Obstruction Light Outage form, some FCC correspondence regarding inspections and compliance, FCC broadcast inspection forms, and the FCC Denver Broadcast Inspection Summary, contact me at Hallikainen & Friends, 141 Suburban Road, San Luis Obispo, CA 93401-7590.

□□□

*Harold Hallikainen is president of Hallikainen & Friends, a manufacturer of transmitter control and telemetry systems. He also teaches electronics at Cuesta College, San Luis Obispo and is learning Contra dancing. He can be reached at 805-541-0222. He can also be reached on internet at ap621@cleveland.freenet.edu or hhallika@pan.calpoly.edu or through CompuServe at INTERNET: ap621@cleveland.freenet.edu.*

# SEE SPOTS RUN.

**On-screen traffic log display**

**"Gas Gauge"**. Indicates what percentage of the system is available for recording.

**The Play Line**. Shows what's currently playing on-the-air, with a count-down timer.

**Record Line**. Shows what DCS is currently recording.

**Queue Window**. Just click on a listing, to place recordings in the queue for playing.

**Filler Window**. This special pop-up window gives you quick access to PSAs, jingles, promos and other fillers.

### ADVANCED FEATURES ENGINEERS DEMAND...

- **Digital Audio Editing.** The quickest and most flexible real-time editing function available makes editing news stories and commercial cuts simple.
- **Satellite /Live-Assist Operation.** Total support, including automatic back-fill of breaks.
- **Support of multi-cut "carts"**
- **Complete audit of all DCS activity -- airplay of audio, relays, etc.**

### ...PLUS FEATURES OTHERS DON'T OFFER!

- **Simultaneous Play/Record features.** Handle three stereo sources simultaneously -- overlap two spots for a tight segue, and record from another source at the same time.
- **High quality data reduction, without distortion**
- **No pre-allocation of disk space required.**

### Replace the chaos of carts with the speed and precision of the Digital Commercial System (DCS) from Computer Concepts.

By combining a standard industrial-grade PC with an advanced stereo audio board, DCS lets you program a day, a weekend, even entire weeks!

**AUTOMATE EVERYTHING, FROM PRODUCTION TO BILLING.**

**Production Studio.** DCS simplifies board work and replaces the muddy sound of analog tape with crisp CD sound quality.

**Control Room.** No more manual logs! DCS handles all your paperwork automatically, posting a commercial's actual airtime next to that listing. And DCS interfaces with traffic!

**DESIGNED BY RADIO PEOPLE FOR RADIO PEOPLE.**

Computer Concepts is one company you can count on—we've provided automated business systems to the radio industry for over seventeen years. We know how radio stations work and how to make them work more efficiently. That's why the DCS interface is so easy to learn, so simple to use.

**ASK ABOUT OUR AFFORDABLE ENTRY-LEVEL SYSTEM.**

To find out more about our entry-level system, or to receive a free DCS demo disk, call or FAX us today. You'll soon see one thing very clearly. You just can't manage as well without us.

**FREE UPDATED DEMO DISK!**  
**(800) 255-6350**  
**OR FAX (913) 541-0169**

**Computer Concepts CORPORATION**  
**8375 MELROSE DR. LENEXA, KS 66214**

**Our new Digital Audio Editing eliminates tedious "cut-and-splice" tape editing**



# DIGILINK

*...a revolution in radio studio technology .....*

## **THE DIGITAL AUDIO ADVANTAGE...**

Introduced in April of last year, Digilink is a digital audio workstation that saves your station money. There is no more routine maintenance, it has a 15 year average life, *and* you have total automation capability for nights... weekends... or whenever you need it. It comes complete in a 5 1/4" high, rack mounted cabinet that converts ordinary analog audio to CD quality digital audio which is stored on a computer hard drive. It does this just like you would store a business letter on your home computer. Digilink can then call up and play any digital audio file in milliseconds off its internal hard drive. Basically, you can think of Digilink as a huge multideck cart machine or cart carousel where you can line up and play thousands of carts or audio cuts sequentially. A single Digilink can therefore replace all of your cart machines in production, On Air, or in automation.

## **Digilink is a perfect cart or reel machine replacement...**

Digilink is the perfect replacement for magnetic tape based cart or reel machines. With Digilink, you can replace your cart machines with CD quality digital audio that requires no calibration, no maintenance, and the media has a 15 year average life. You can replace your reel to reel machines, razor blades, and tape with fast, nondestructive, CD quality, on screen waveform editing. You can cue virtually instantaneously. Digilink even costs less than comparable analog cart or reel machines. Digilink is the perfect audio record and play system for professional radio broadcast applications.

## **Digilink performs ALL types of automation...**

With Digilink you can operate fully live or mix various automation types into your daily programming. You can store all of your audio on hard disk at an incredible price or you can use hard disk for only commercial material recording. Digilink has an internal audio switcher with machine logic control. Digilink therefore supports satellite automation, reel and DAT tape automation, CD automation, and full hard disk automation all out of one compact box. Because Digilink is a computer, you can print out a log of what you have scheduled to play or print out a log of what really did play. With Digilink, you can be live on the air with full CD quality audio or program the system and walk away forever. Digilink even interfaces with all major traffic and billing systems through a Digilink import-export routine.

## **Digilink is engineered and manufactured by Arrakis...**

Digilink is not simply a hardware package assembled from parts built by *other* computer manufacturers and run under our software. Arrakis is the *only* manufacturer to build nearly all parts of the digital system in-house. We build our own *Arrakis* DSP board, SCSI board, I-O board, switcher board, cabinet, and cabling. Because Arrakis builds the system and doesn't simply mark up someone else's hardware, Arrakis can offer you Digilink with broadcast features and performance unmatched by anyone *and* at a truly remarkable price !!!

2619 Midpoint Drive, Fort Collins, CO. 80525



..... *at an incredible price. !!!!!!!!!!!!!!!*

whether you lease for under \$300 a month or buy, with Digilink you can literally make money by ...

- reducing maintenance,
- reducing staff demands,
- improving On Air sound,
- improving Production,  
*and improving all areas of your station performance !!!*

under **\$10,000**  
*for a COMPLETE 6 hour stereo system*



## FEATURES

- Simultaneous record- play !!!
- Uncompressed CD quality audio  
*or mix 2:1 or 4:1 compression*
- Use keyboard, mouse, trackball,  
or even a touchscreen
- Digital Waveform Editing
- Mix mono and stereo files
  
- Live Cart Machine replacement
- Reel to Reel machine replacement
- Satellite Automation
- Tape Based Automation
- CD Automation
- Hard Disk Based Automation
- Traffic and Billing Interface
- supports digital networks

## SPECIFICATIONS

*all tests performed at 1:1 compression*

### Digital Signal Processing System (DSP)

Sampling System- 16 bit linear PCM, 2 channels  
Sampling Rates- 44.1,32,22kHz, fixed filter on routing switcher  
Compression- 0,2,4...adaptive differential PCM

### Controller -

Floppy Disk- 3 1/2" 1.44M capacity, System Hard Disk- 40MB  
Printer Support- IBM compatible, parallel port

### Audio Performance- Digital Record playback

THD- .008%, Dynamic Range >85dB,  
Freq Response- (+)(-).5dB 10Hz-15kHz

### Physical Specifications

Dimensions- 19" Rack mounted- 19"W x 5 1/4" (3RU)H x 16"D  
Weight- 60lb's , Power- 110/220VAC, 50/60Hz, 100W

### Audio Performance- Routing Switcher

THD- .005% typ, S/N < 100dB below +4dBm  
Dynamic Range- >120dB,  
Freq. Response- (+)(-).1dB 20Hz-20kHz

**by** **ARRAKIS SYSTEMS inc.**

Voice (303) 224-2248, FAX (303) 493-1076



# PRODUCTS & SERVICES SHOWCASE

For more information on the products shown below, circle the appropriate Reader Service No.(s) on the enclosed Subscription/Reader Service card or contact the advertiser directly.

## PRECISION BROADCAST CABLES

### NEC CL2



#### AUDIO

- One pair, 22-gauge
- Flexible jacket
- Available in 7 colors
- One-step stripping



#### VIDEO

- Low loss .7 db @ 10 MHz
- Flexible jacket
- Same size as RG-59



#### SNAKE

- 2-24 pair
- Each pair numbered

Complete line of broadcast interconnect products, connectors, custom panels and cable preparation tools.

### NEMAL ELECTRONICS, INC.

12240 N.E. 14 AVE., NO. MIAMI, FL 33161  
OFFICES IN NEW YORK & FLORIDA

Please call or fax for your copy of our 44-page Cable & Connector Selection Guide  
US: (800)52-CABLE (522-2253) • Fax: (305)895-8178 • Intl.: (305)899-0900

READER SERVICE NO. 143



4CX35000C

Made in U.S.A. by EIMAC

Socket and Chimney Available

*Davilyns* CORPORATION



20<sup>th</sup> ANNIVERSARY SPECIAL

SALE PRICE

**\$4800<sup>00</sup>**

Regular Price \$6000.

Warranted to EIMAC Original Manufacturer's Specifications

Limited Availability. This offer expires 9/30/92. Offer limited to Broadcast Customers Only.



Call *Davilyns* for All Your Electron Tube Requirements.

(818) 787-3334 • (800) 235-6222 • FAX (818) 787-4732  
13406 Saticoy Street • No. Hollywood, CA 91605

READER SERVICE NO. 121

## COMET PRECISION VACUUM CAPACITORS

Voltages from 3 to 100 kv  
Currents from 30 to 1100 A  
Capacitance from 3 to 6600 pF  
Variable and Fixed Versions

Large variety of fixed capacitors for couplers and phasers. Broad range of voltages and capacitances to fit most transmitters. Outstanding quality and workmanship.

Inmark Corporation  
4 Byington Place  
Norwalk, CT 06850

Tel: 203-866-8474  
800-899-7947  
Fax: 203-866-0918

TRY US!!

READER SERVICE NO. 170

## WHY LEAVE THEM IN THE DARK...

...when you can reach over 18,000 radio professionals with your product showcase ad? Gain valuable exposure for your products or services at minimal cost.

For more information

**1-800-336-3045**  
or  
**FAX 1-703-998-2966**

## Products & Services Showcase

appears in each issue of

### Radio World

Radio World reaches 18,000+ radio station owners, managers, engineers and consultants.

To advertise your product or service in **Products & Services Showcase**, contact your sales representative

East Coast... Skip Tash..... 800-336-3045  
West & Midwest... Dale Tucker... 510-935-1470

## WireReady<sup>TM</sup>

Offering a real choice for today's radio news

**STOP WASTING PAPER**

**SAVE TIME & MONEY**

**COMPUTERIZE YOUR NEWS**

- Print just what you need
- Split-Screen editing
- Easy-to-Install
- Simple-to-Use

Manages: AP, UPI, Reuters, ABC, CBS, NBC, NOAA, CNN, and many others.  
Hundreds of Users: AM/FM music, AM news/talk, State Networks, U.S. Gov't agencies.



WireReady Newswire Systems Inc. 31-H Union Ave., Sudbury MA 01776 USA  
(508) 443-8181 (800) 833-4459 FAX (508) 443-5988

READER SERVICE NO. 184



## Econco REBUILT POWER TUBES



Approximately One Half the Cost of New

3,000 Hour Unconditional Guarantee  
Call for Our Price List

Econco 1318 Commerce Ave. Woodland, CA 95695  
Phone: 916-662-7553 Fax: 916-666-7760 Telex: 176756  
Toll Free: 800-532-6626 From Canada: 800-848-8841

READER SERVICE NO. 40



LINE OUT

# A Beginner's Guide to Digital Editing

by Bruce Bartlett  
with Jenny Bartlett

**ELKHART, Ind.** There's a new tool for audio production, light years ahead of tape editing, that may make you want to throw out your old razor blade and splicing block: It's a digital audio editor. If your station already has a personal computer, you can turn it into a digital editor for as little as \$1,500.

Basically, a digital audio editor is a high-capacity sampler. The editing system includes a computer circuit card, interface

them. In this example, each event is a different sound effect—door slam, crowd cheer, guitar solo, etc.

The playlist tells the disk drive where the events are in the soundfile, and when to play them. The read/write heads in the disk drive play the events by jumping from one part of the disk to another. Thanks to a memory buffer, events can play one after another without any glitches or clicks.

**List of essentials**

Following is a list of the equipment you'll need. The first four pieces come as a package.

- *Digital Signal Processor*—a circuit card that plugs into a slot in your computer.
- *Digital Audio Interface*—a box with connectors for digital audio, SMPTE and MIDI.
- *Cable*—connects the interface box to the circuit card.
- *Software*—for digital audio editing. You run this on your computer.

- *Personal computer*—IBM-compatible or Macintosh. Usually 640 kilobytes (640KB) of memory is enough. You'll also need a mouse.

- *Hard disk drive*—with 28 milliseconds or less random access time and at least 500KB per second data-transfer rate (throughput). A SCSI-type drive is recommended for speed. You'll need at least 11 megabytes per minute of stereo audio.

- *DAT recorder*—with digital inputs and outputs, or an analog/digital converter.

You might also want to add a pair of small, powered monitor speakers near your computer.

How do you use the editor? First, you'll

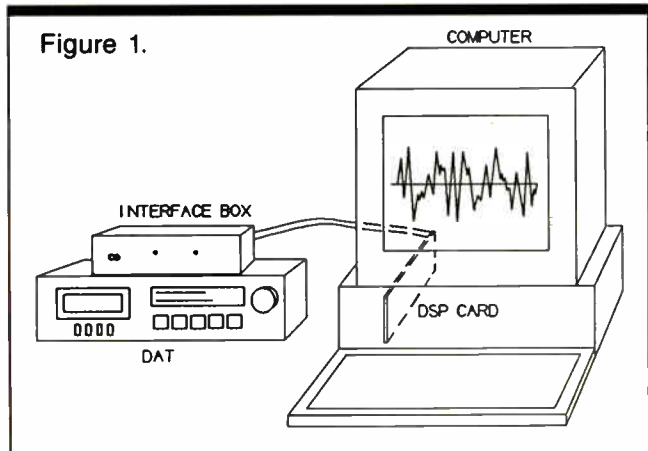

box and software.

With this system, you can record CD-quality digital audio—from your DAT machine or CD player—onto your computer's hard disk. Then you edit the program on screen with a mouse. You play the edited recording and record it back onto your DAT.

Some companies making digital editors are Turtle Beach, DigiDesign, Micro Technology Unlimited and Digital Audio Labs.

**Activated by mouse**

How might you use this system? Suppose you're producing a spot containing dialogue and sound effects. You could record the sound effects from a CD library onto your hard disk. Then, while recording the dialogue onto a DAT tape, you mix in the sound effects. You trigger each one at the right time by pressing a mouse button.

Or suppose you're producing a promo for a concert. You want to edit together short pieces of several songs, which will be heard under dialogue. Just record the songs onto your hard disk. Then use your mouse and computer

screen to define each segment of music. Assemble these segments into a list and then play the list.

The edits are non-destructive. That is, you can try several types of edits without changing the recording on the hard disk. Let's define some terms used with digital audio editors.

The *soundfile* is the digital audio data that you record onto hard disk. For example, the soundfile might be a series of sound effects. Within the soundfile, you define *events* (*zones* or *regions*). These are sections of the recording, such as individual sound effects.

You also set up a *playlist*: a list of the sound events in the order you want to play

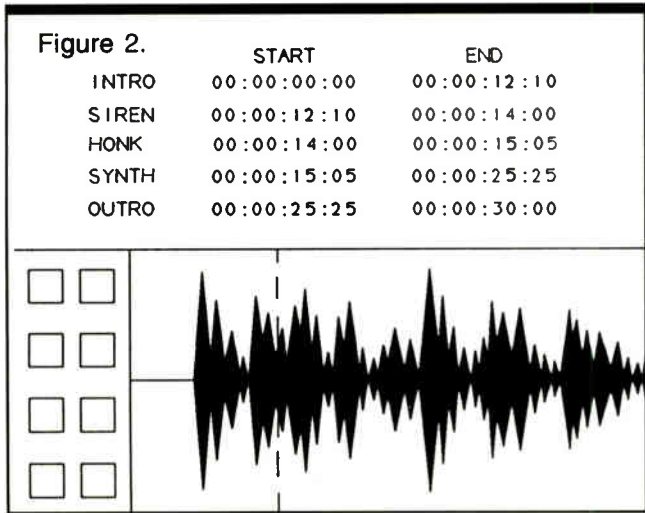

record an audio program—a selection of samples, songs and sound effects—onto your hard disk. Name the recording or soundfile, then click on the record-button icon. Next, hit play on your DAT machine. You'll be copying the DAT recording onto your hard disk. When done, hit the spacebar to stop.

A soundtrack (waveform) of your stereo program appears on the screen (Fig. 2, bottom half). You can quickly move around to various parts of the program and audition each part.

**Directory assistance**

Using your mouse, highlight the region of sound you want to define as an

event (for example, a particular sound effect). Trim the beginning and end points of this region with your mouse and the cursor on-screen. Once you define the region, go to other regions, and trim and define them.

Next, go to a playlist screen (Fig. 2, top half). Assemble the events you defined into a playlist. This is a list of the sound effects, song pieces, etc. in the order you want to play them.

If you play the entire list, the effects or songs are read off the hard disk according to your playlist. The transition from one event to another is seamless.

You can also play each event on cue, either manually or from a MIDI note, or at a specified SMPTE time.

If you wish, you can insert silence or cross-fades between events. You can even do digital signal processing, such as equalization, mixing, time compression, and so on.

As the playlist plays, you record the audio onto a DAT. There's your finished, edited tape, of CD quality. We'll have more on digital audio editing in future columns.

□□□

Bruce Bartlett is a microphone engineer and technical writer for Crown International, and the author of Stereo Microphone Techniques published by Focal Press. Jenny Bartlett is a technical writer. Bruce can be reached at 219-294-8388.

**Harris HT Series FM Transmitters From 3.5–35 kW.**

HT Series transmitters are engineered to give you high efficiency and unsurpassed performance. HT FM transmitters have proven their reliability and exceptional lightning survival capabilities in installations around the world. Here's why HT Series transmitters are the choice of demanding broadcasters:

- 55 Watt THE-1 FM Exciter with ultra-linear VCO operates at final carrier frequency with inaudible noise and distortion
- Quarter-wave cavity offers twice the bandwidth of folded half-wave designs to pass more of the FM signal without distortion
- Low velocity, high-efficiency direct drive cooling system
- Modular solid-state IPA and conservatively operated final tetrode PA
- High overall efficiency lowers AC power bills
- Broadband solid state RF driver uses FETs for highest reliability
- Solid state controller with automatic RF power control, proportional VSWR foldback, auto-restart
- Opto-isolated remote control/status interface, fully transient protected
- Exclusive FLEXPatch™ design allows easy bypassing of low-level stages to keep you on the air during emergencies

Call Harris Allied today at 800-622-0022 for more information on rugged, reliable, efficient HT Series FM transmitters.

Also available: 100% solid state 250 W, 500 W and 1kW HT Series transmitters.



800-622-0022

Tel (217) 222-8290 • Fax (217) 224-2764 • Telex 650-374-2978 HARRIS UR

© 1992 Harris Corporation

Circle (147) On Reader Service Card



# Surviving Tough Times

► continued from page 20

opportunity or talk it over with your boss. In these devastating times, your own management might be happy to see you pick up a few non-competitive bucks if it takes the pressure for raises off them.

Whatever you do, never forget the importance of protecting your primary job. Those major meal tickets are harder to come by these days.

## Non-radio opportunities

With that in mind, how about some more ideas? Can you fix electronic equipment? Try the TV, audio, and other consumer electronics service centers. They might be glad

to have somebody for a short peak load or permanent part-time. Somebody with your background is certainly capable of selling equipment at the stereo emporiums, discount stores, or perhaps Radio Shack.

How about installing or trouble-shooting alarm systems, car audio equipment, cellular telephones, two-way radios, avionics, industrial controllers, or home computers? Your potential employers are all in the Yellow Pages. Don't rule out anybody too soon.

I'm not suggesting giving up your first love of radio. I am suggesting ways to stay in the business and survive despite the poor economy or anemic sales at a particular station. Tough situations can be dealt with by tough

people who aren't afraid to put in some extra effort.

Here's something that might cheer you up. The hunker-down survival steps that you may need to take now can pay off even more when things pick up. How so? Your efforts at becoming more valuable to your employer can result in a raise or promotion when they get back into the black and can afford to show some appreciation.

Your search for extra income sources could also lead to part-time work for years to come. What pays the bills today buys extras tomorrow. You may even find that you like the variety of doing different jobs and decide to keep of mixture of primary and secondary jobs permanently.

What can you do today? Take a few dollars out of your billfold and stick them in a

dresser drawer—or better yet, into a savings account. Walk into the program director's or station manager's office and ask what extra work you could pitch in to do. Call your friends at other stations to ask whether they need part-time or vacation relief help. Get out that telephone book and circle any business that could use somebody with your skills. Make a few calls. Make some more tomorrow.

Yes, you have more control than you think. Let me know what works for you and we'll spread the ideas around. I'm sure there's more than enough for everyone.

□□□

*John Shepler is an engineering manager, writer and longtime RW columnist. He can be reached at 5653 Weymouth Drive, Rockford, IL 61111.*



**TUNED TO TOMORROW**

## We're Looking For...

- Optimods
- Type accepted STLs
- Stereo consoles
- Remote pick-up gear

**Call Now...**  
Let us know if you have any of these items. We selectively buy used gear and deal on trade-ins. We'll make the best deals to help upgrade your station economically.



*Chuck Yount*

## We Have Several...

- Used carts
- ITC 99B cart players
- Moseley SCA generators
- Studer cassette decks

**Don't Wait Around...**  
This stuff doesn't last long. So, call right away for these deals. But, because our inventory changes everyday, we'll always have great buys ready for you.



*Darrin Warner*

*Call Darrin or Chuck for buy, sell and trade of broadcast equipment.*



**317-962-1471**

Fax (317) 966-6321

## Marconi's Early Experiments

► continued from page 20

discovery by Marconi was that longer waves needed more power to cover the same distance.

Marconi achieved greater distance by placing the receiving end—or resonator—at a considerable height above ground on a hill and noted that the signals became significantly stronger. At this point the range of a useable signal was about a kilometer. By 1895 and with more development, the distance was increased to about two miles.

There was one problem—it took something to dislodge the mixture after the current was removed. Initially, the coherer was just shaken. Then, by adding a lodestone, a natural magnet, a little device that became known as a *tapper* was activated after the current was removed to restore the detector.

After proving that he could send signals over a hill at a distance of about two miles, Marconi felt he had a workable method of communication. He continued to make modifications that increased the distance even further.

Marconi offered his invention to the Italian government, but was turned down. Both Guglielmo and his mother envisioned many uses for his invention, including communication with ships. This led them to travel to England, as it was at that time the reigning maritime power of the world.

The year was 1896 and the month was June when Marconi registered his invention with the London Patent Office. The invention was listed as a "System of Telegraph, Using Hertzian Waves at High Frequency." The invention was assigned British Patent number 12039.

### Thicker than water

At this point, the family came into the picture. Marconi's mother, through her nephew Henry Jameson Davis, a milling engineer with Irish connections, helped introduce Marconi to the people who would set up the appointments for him to demonstrate the invention to the proper authorities.

Before one demonstration, while Marconi was assembling his equipment on the roof of a General Post Office Building, he was asked by a man on the street what he was doing. The men became acquainted and the questioner—George Stevens Kemp—became one of the small group of assistants that stayed with Marconi and the British Marconi Company for many years.

□□□

*George Riggins has experience in radio and electronics dating back to the 1930s. He also is a licensed ham radio operator and has had his own broadcast sales and service company, Riggins Electronic Sales, for more than 20 years. He can be reached at 213-598-7007.*

**SUBSCRIPTION/READER SERVICE FORM**



June 10, 1992 Issue    Use until September 9, 1992

**FREE Subscription/Renewal Card**

I would like to receive or continue receiving **Radio World** FREE each month.     YES     NO

Signature \_\_\_\_\_

Date \_\_\_\_\_

Please print and include all information:

Name \_\_\_\_\_

Title \_\_\_\_\_

Company/Station \_\_\_\_\_

Address \_\_\_\_\_

City \_\_\_\_\_

State \_\_\_\_\_

ZIP \_\_\_\_\_

Business Telephone ( ) \_\_\_\_\_

Please circle only one entry for each category:

**I. Type of Firm**

D. Combination AM/FM station

A. Commercial AM station

B. Commercial FM station

C. Educational FM station

E. Network/group owner

F. Recording studio

G. TV station/teleprod facility

H. Consultant/ind engineer

I. Mfg, distributor or dealer

J. Other \_\_\_\_\_

**II. Job Function**

A. Ownership

B. General management

C. Engineering

D. Programming/production

E. News operations

F. Other (specify) \_\_\_\_\_

**III. Purchasing Authority**

1. Recommend

2. Specify

3. Approve

**Reader Service**

Please first fill out contact information at left. Then check each advertisement for corresponding number and circle below. NOTE: Circle no more than 15 numbers, otherwise card will not be processed.

001 023 045 067 089 111 133 155 177

002 024 046 068 090 112 134 156 178

003 025 047 069 091 113 135 157 179

004 026 048 070 092 114 136 158 180

005 027 049 071 093 115 137 159 181

006 028 050 072 094 116 138 160 182

007 029 051 073 095 117 139 161 183

008 030 052 074 096 118 140 162 184

009 031 053 075 097 119 141 163 185

010 032 054 076 098 120 142 164 186

011 033 055 077 099 121 143 165 187

012 034 056 078 100 122 144 166 188

013 035 057 079 101 123 145 167 189

014 036 058 080 102 124 146 168 190

015 037 059 081 103 125 147 169 191

016 038 060 082 104 126 148 170 192

017 039 061 083 105 127 149 171 193

018 040 062 084 106 128 150 172 194

019 041 063 085 107 129 151 173 195

020 042 064 086 108 130 152 174 196

021 043 065 087 109 131 153 175 197

022 044 066 088 110 132 154 176 198



OFFBEAT RADIO

# N.C. Trimulcasting Venture Relies on Marti "Plan A"

by Dee McVicker

**HENDERSONVILLE, N.C.** It was not long ago that WTYN(AM) of Polk County, N.C., was dark. In nearby Transylvania County, the lights were also out on station WPNF(AM). Like many small-market stations across the nation, the chances of these AMs lighting up the airwaves again were dim.

Then, something happened. On Oct. 8, 1990, WTYN(AM) began receiving its programming from WHKP(AM) of neighboring county Henderson. Within a year, WPNF(AM) had also linked programming with the Henderson County station—and the trio lit up the state's tri-county area with what the stations' general manager calls "trimulcasting."

This alternative to fulltime programming enabled WPNF, a 1,000 W facility licensed to Brevard in Transylvania County, and WTYN, a 10 kW daytime and 540 W nighttime facility licensed to Tryon in Polk County, to significantly reduce operating costs and once again service their local markets.

### Extending your reach

For Radio Hendersonville, Inc., which purchased the two dark stations for the purpose of sharing programming with flagship station WHKP, the arrangement is the best of all possible solutions. "We are now able to reach the three-market area, compared to the one-market area before," said Radio Hendersonville's GM Art Cooley.

Compared to WHKP's county population of 70,000 and retail sales of \$600 million, he added, combining all three stations has extended Radio Hendersonville's advertising reach to a population of over 113,000 and retail sales of more than \$800 million.

This is just one of the reasons why program sharing between small-market AM or FM stations has become so popular lately, commented Dan Rau of Marti Electronics, which provided the STL system for Radio Hendersonville's trimulcast.

"It is extremely difficult to run a small-market station with a staff of six or seven when you only have \$10,000 worth of revenue each month," observed Rau. Without the financial burden of a large staff to run separate programming fulltime, WTYN and WPNF—and other AMs or FMs in similar situations—can profit from small-market revenues.

Rau calls this alternative to conventional programming "Plan A," a concept intended to address the economic woes of small-market AMs and Class A FMs through networking of satellite stations, time brokering formats for financial compensation, and other strategies. Plan A "works in a lot of markets," said Rau. "But the concept has more application for local radio in the small market."

### STLs route trimulcast

Marti's Plan A for Radio Hendersonville, which combines the company's three stations into a tri-county superstation network via STL links, is what made it possible to return WTYN and WPNF to the airwaves and to North Carolina listeners.

As Radio Hendersonville's flagship station, WHKP originates most of the pro-

gramming for the trio. The exception is in the early hours, between 8 a.m. and 11 a.m., when the three stations originate separate programming from their respective studios and air commercials appropriate for their markets. As FCC regulations require, each station maintains separate studios and fulltime—albeit streamlined—staffs.

To segue into local programming, announcers from each station are joined together in a two-hour roundtable discussion between 6 a.m. and 8 a.m. To accommodate this, programming originated at WTYN and WPNF studios makes the trip to WHKP's studio in Hendersonville and then is routed back to the local studios to be aired using the stations' respective transmitters.

For example, said Radio Hendersonville CE Norman Lyda, "If they originate (programming) at the studio in Tryon, it comes back to Hendersonville and is processed and sent back to (WTYN's) Tryon studio on the same link." Furthermore, he said, both WTYN's and WPNF's STL paths to WHKP are multi-hops.

Whereas WTYN's Tryon studio requires a simple STL relay on White Oak Mountain to link up with the flagship station's studio, WPNF's Brevard studio requires several points of relay before connecting with WHKP's studio in Hendersonville.

For the WHKP linkup to WPNF, said Lyda, "We have an RPU location on a mountain called Bearwallow Mountain. So we shoot from Hendersonville on up to Bearwallow—that's about a 12-mile hop—and then we go from Bearwallow to a mountain close to Brevard called Rich Mountain, and that's about a 22-mile hop. And, then from Rich Mountain we shoot to WPNF."

Including the STL links between each studio and their transmitters, the Marti system has nine points of relay, linking WHKP with the two stations some 22 miles in each direction. The STLs are bi-directional 950 MHz Marti systems, with primary remote control of the Brevard and Tryon sites handled through ARC-16 Burk Technology units.

### A little creativity

Setting up the system, said Lyda, required research, time and some engineering creativity. "I spent months trying to find these relay points," he said, adding that installation, done by himself and Ed McDade of Blue Ridge Consulting, also took considerable time. Lyda doesn't recommend Plan A for every station, but he is optimistic that many AMs and FMs can benefit from it.

GM Art Cooley agrees. "We looked at a satellite service at one time. (But) we didn't want to encumber ourselves with the holes in the window that they give you to fill (for advertising spots)."

Besides, he continued, "What we are trying to do with these outlying stations is to breathe life back into them. That's the idea behind this, to give them strength until they can once again become independent facilities in their own marketplace."

After all, he said, "That's what AM is all about, is localism."

□□□

Dee McVicker is a free-lance writer and regular contributor to RW. To inquire about her writing service, call 602-899-8916.



## WHY QEI?

### 24 Hours.

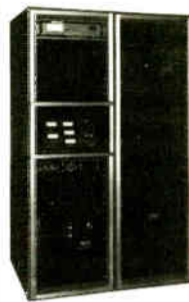

Our 24 hour service hotline number is 609-728-2020.

Call us toll free at 800-334-9154 for all the facts on QEI

"New Reliabilities" FM transmitters from 1kw to 30 kw.

### Power Up.



With our FMQ 3.5/5/10 kW or 20/30 kW FM transmitters, you can upgrade power in the field.

Call us toll free at 800-334-9154 for all the

facts on QEI "New Reliabilities" FM transmitters from 1kw to 30 kw.

### No Extras.



We never charge you extra for single phase power. Not on our FMQ 10000 or our FMQ 20000B—not even on our 30 k FMQ 30000B.

Call us toll free at 800-334-9154 for all the facts on QEI "New Reliabilities"

FM transmitters from 1kw to 30 kw.

### Less is More.

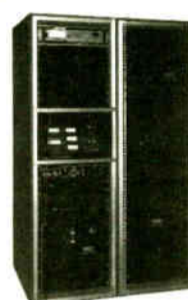

All of QEI's FM transmitters have no plate blockers or sliding contacts.

Call us toll free at 800-334-9154 for all the facts on QEI

"New Reliabilities" FM transmitters from 1kw to 30 kw.

### Free.



Our FREE spares kits include every solid state component of the transmitter, exciter and remote control.

Call us toll free at 800-334-9154 for all the facts on QEI "New Reliabilities" FM transmitters from 1kw to 30 kw.

### The Longest.



Our PA tube warranty is the longest in the business — 15,000 hours.

Call us toll free at 800-334-9154 for all the facts on QEI "New Reliabilities" FM transmitters from 1kw to 30 kw.

### Single Phase 30 kW.

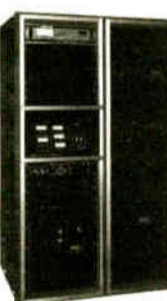

Our new FMQ 30000B is the only 30 kW transmitter available with a single phase power supply.

Call us toll free at 800-334-9154 for all the facts on QEI "New Reliabilities" FM transmitters from 1kw to 30 kw.

### Built-in Backup.



QEI's constant 50 Ohm interstage impedance lets you bypass the IPA or PA in the unlikely event of a problem.

Call us toll free at 800-334-9154 for all the facts on QEI "New Reliabilities" FM transmitters from 1kw to 30 kw.

QEI CORPORATION  
ONE AIRPORT DRIVE • P.O. BOX D • WILLIAMSTOWN, N.J. 08094  
TEL (800) 334-9154 • (609) 728-2020 • FAX (609) 629-1751

QUALITY • ENGINEERING • INNOVATION

Circle (42) On Reader Service Card







USAIRPLAY

# Top 40 Techniques for the 1990s

by Charles Taylor

**WASHINGTON** A lot of ink has been spilled over the last year trying to determine why the contemporary hit radio (CHR) format is in decline. Top 40 stations in a number of markets are in a tailspin as ratings consistently drop.

Here in Washington, when Christian-oriented Salem Broadcasting recently purchased Top 40 WAVA(FM) and then changed it to a religious format, no established station in the market—not even those with bottom-of-the-barrel ratings—considered making a play for the niche.

Much of the turmoil surrounds deep fragmentation of what now fits traditional Top 40 parameters. Those hungry for Amy Grant and Phil Collins likely cringe at hearing L.L. Cool J or Salt-N-Pepa on the same station. Likewise, fans of Guns N' Roses will probably turn the dial before enduring three minutes of Enya.

All of these artists have mass appeal—but not enough among the 18-34 demographic for one station to serve as a catch-all. Face it, music has changed in the last 10 years. While Bruce, Michael and Madonna may have served the demographic spectrum in 1984, today we also must contend with the extremes



Not enough mass-appeal

of heavy metal, rap and a myriad of ballads.

Still, CHR can thrive in the 1990s. It requires engraining your station into the minds of your target audience.

The following checkpoints offer ways to remain competitive in the frenzied 1990s, whether you are a struggling Top 40 or the market leader:

✓ *Know your market.* Go to clubs and see what packs the dance floor. Answer the phones and keep tabs on requests—then play them. Check with record stores and find out what people are buying; if there is a major Top 40 seller that you're not playing, you most likely should be.

What are high school kids talking about; who is cool at local universities? And what are the other stations in town playing?

✓ *Identify your music.* Tell listeners about an artist, where they are from and—how many times has this been said?—the name of the song, if it's new. It matters.

✓ *Hand in hand.* Encourage your sales department to establish creative links with the community. Stage a show with popular acts you air, then offer phone-ins to have listeners win the tickets. Have listeners bail air personalities out of imaginary prisons to raise money for local charities. Work remotes

wherever people go.

✓ *Take a chance.* Try out new music. Trust your listeners to let you know what they want to hear; don't decide for them. If the sound fits the market but the name is new, tell them who it is, let it spin and wait for the phones.

✓ *Listen before you play it.* So what if the last six songs by a performer were hits? If this one offers nothing new, hesitate. Award the slot to that promising new artist that might end up giving your station an edge over the other guys in town.

✓ *Let's hear them.* Put listeners on the air. Let them introduce songs, let them brag about their favorite station (as long as it's yours). Their voice is your voice.

✓ *Live your listeners' lifestyle.* When your audience clubs, club with them. Most major market CHRs already play dance music on weekend nights.

Also, hire young. Your staff should like the music you play, not shrug it off as trendy or crazy kid stuff. To sound "cutting edge," your talent must be able to talk about the music from the heart.

✓ *Wake them up.* An old standard that holds true: Your morning show should be dynamic and vital, the strongest hook of the day. If listeners tune in first thing, you have a better chance at holding onto them all day.

✓ *Make the morning man a household name.* Work to get your on-air personalities in the

news (preferably not the police report page). Slap their pictures on billboards and the sides of buses. Name recognition is the key to making the station feel like a friend.

✓ *Advertise.* Television, bumper stickers, sponsorships, charity drives, billboards, and of course, your own airwaves.

And while you are talking, why not mention the title of that last song?

✓ *Do not overprocess.* Power and volume should come from your talent, not your modulation. Electronic overprocessing is said to make listeners weary.

✓ *Know your niche.* Top 40 will never be everything to everybody. Work to remain true to 25-year-olds, but ride the hell out of musical trends for your 15-year-olds, too.

I do not accept Top 40's decline. Ratings are dependent on station promotion and an active relationship with the community. Become an extension of their voice and they cannot help but listen.

## GO ALL-DIGITAL. NOW.

### BP DIGITAL DELIVERY AND SENTRY SYSTEMS ONLY BROADCAST PROGRAMMING OFFERS IT ALL...

#### FULLY-RESEARCHED FORMAT CHOICES

BP mainstream and niche formats, based on the latest research, directed by the nation's most respected programming experts.

AC  
Soft AC  
Country  
CHR  
Classic Rock  
Adult Rock  
Oldies  
Urban  
Easy Listening

#### PROVEN ALL-DIGITAL CD TECHNOLOGY

Your *BP Digital Delivery™* format is delivered on custom compact discs, the industry's most widely used digital music source.

Use your present studio CD players for live operation or automate with Sentry Systems' *Format Sentry™*, one of the top-selling controllers on the market.

Sentry Systems' hard disk audio completes the package, providing an all-digital local sound at a surprisingly low cost.

### ALL-LIVE OR ALL-DAY WALKAWAY

Operate live, with our song-by-song hour-by-hour playlists, or automate your station for all the walkaway time you need...nights, weekends, or 24 hours a day.

WE STAY ON TOP OF THE MUSIC.  
YOU STAY ON TOP OF YOUR MARKET.

## STAYING POWER

# BROADCAST PROGRAMMING

AMERICA'S LEADING PROGRAMMING COMPANY (800)426-9082

Circle (63) On Reader Service Card



# Today's Jazz: A Rewarding Challenge

by Mark Medicus

**BALTIMORE** Jazz music of all varieties—traditional, avant garde, contemporary—is enjoying a renaissance these days. Artists like Harry Connick Jr., Natalie Cole and Dave Grusin have successfully introduced a whole new generation of listeners to an established musical form. And radio stands to gain the most from this interest in jazz music: Apart from record stores and night clubs, radio is the only venue listeners have to catch the latest from Dave Sanborn or Kenny G.

Among radio stations there seems to be no shortage of names to identify this type of pro-

gramming. Adult alternative is one generic label, with contemporary jazz, new age, and new adult contemporary (NAC) also commonly used.

Jamie Kartak, program director at Denver contemporary jazz outlet KHIH(FM), thinks the problem with identifying the format stems from the broad scope of the music. "It encompasses such a large amount of eclectic music that trying to find one word to describe it is impossible," she said.

## A rose by any other name

Program directors agree the music is slick but accessible to the listener. It can effortlessly approach the finest-crafted rock, then shift to the sensually melodic and change again to an easy-going Brazilian rhythm.

Kartak agrees. "It's very high quality music," she said. The one drawback to the format, she added, is lack of listener familiarity with the music. People tend to form an opinion of it before they hear it, she said. "To someone that doesn't know anything about it,

they describe you as the jazz station, and people have their own idea of what jazz is—swing or bebop or Dixieland. But once they get into it, then it's hard for them to turn to something else."

Among some of the stations having success with contemporary jazz are KIFM(FM) San Diego, KTWV(FM) "The Wave" Los Angeles, KHIH Denver and WNUA(FM) Chicago. Their programming formulas vary, but the music is largely instrumental, relying most heavily on contemporary jazz with lesser amounts of new age, jazz vocals and AC cross-overs.

The format is virtually in the basement of total format share—in the low single digits. This is due in part to ACs that program jazz-oriented music but list themselves only as AC. For a format with such an attractive demographic makeup, the largest obstacle to its growth may very well be preconceived perceptions and a simple unfamiliarity with the music.

"People have to be educated about it," says

Kartak. "There is no other way to be exposed to it other than the radio. There is MTV and country music on TV, but there is no other way to learn about this music except to tune in a radio station.

The education is paying off, however, especially in the larger markets where the format is coming of age. "You've got a base of listeners that have lived with it for a while—people who have been buying David Sanborn or Kenny G albums for 10 years," said Art Good, veteran jazz programmer and host of the syndicated "Jazz Trax" program.

The show itself is at least partially responsible for increasing contemporary jazz listenership. It airs on weekends in some 35 markets. Art continues "It's not something brand new anymore."

## Desirable demos

The terminology associated with the format is what needs to change the most, according to program directors. KIFM(FM) GM and PD Bob O'Connor agrees that the term "New Age" conjures up images of crystals, seances and other-worldliness.

WLQR(FM) Toledo, Ohio PD Steve Kendall agrees. "They link it all to that kind of lifestyle, and that isn't necessarily the case at all.

The contemporary jazz audience, however, has been described as hip, educated, sophisticated, upwardly mobile, active and environmentally aware, with an above average household income.

Operators will tell you that contemporary jazz is not a quick-fix format. "It's a format that grows," explained Art Good. "If you want a quick fix, Top 40 will get much faster ratings. With NAC/contemporary jazz it takes time to do it right."

The trend in popular music, of a leaning more toward jazz, is encouraging to programmers working in the area. KIFM(FM)'s O'Connor said, "Natalie Cole doing the music her father did 30 years ago hasn't hurt us. With Harry Connick Jr., and the recent Dave Grusin release—the trend shows no sign of letting up."

Encouraging signs can also be seen in the decreasing number of beautiful music stations and in the overabundance of AC-formatted ones. "We'll see an increase in the number of stations carrying the NAC, contemporary jazz, adult alternative labels," O'Connor said. "Its best days have yet to come."

□□□

Mark Medicus is a free-lance writer presently residing in Baltimore, Md., with a background in radio and a special interest in broadcast formats and world-band radio.



## NEW AM RULES

### AMSTUDY

#### DAYTIME ALLOCATION STUDY

- Both Dataworld and FCC Databases Studied
- Utilizes NEW (Corrected) Groundwave Curves
- NEW Adjacent Channel Protection Ratios Employed

### AMNIGHT

#### NIGHTTIME INTERFERENCE STUDY

- Utilizes NEW FCC Skywave Propagation with Greatly Improved Accuracy
- Calculates Extent of Nighttime Interference Received (Detailed Individual Night Limit)
- Provides Allowable Vertical Radiation to All Pertinent Stations (AM Night Permissible Radiation)
- Includes All Co-Channel and First Adjacent Records

### GWAVE

#### GROUNDWAVE (Daytime) COVERAGE CONTOUR STUDY

- Utilizes NEW (Corrected) Groundwave Curves
- Allows Input of Measured Soil Conductivity Data
- Counts Population Within Coverage Area Using 1980, 1986 and 1990 Census Data

### SKYWAVE

#### SKYWAVE (Night) COVERAGE CONTOUR STUDY

- All AM Nighttime Coverage Contours Have Changed Size and Shape
- Utilizes NEW FCC AM Skywave Propagation Model
- Counts Population Within Contours Using 1980, 1986 and 1990 Census Data

## dataworld®

P.O. Box 30730, Bethesda, Maryland 20824

FAX (301) 656-5341

(301) 652-8822 (800) 368-5754

## A History of Modern Jazz

**BALTIMORE** Much of the interest in contemporary jazz can be traced to a musical evolution that took place in the seventies. Rock artists experimented successfully with elements borrowed from areas like folk, country, classical and jazz. Bands like the Beatles, who launched their U.S. careers with songs like "Love, Love Me Do," scored even bigger commercial and critical success with breakthrough albums like "Sergeant Pepper's Lonely Hearts Club Band." Barriers were being removed between musical forms. Musical tastes had been educated.

Jazz seemed as though it was going through its share of expansion as well. Lighter and more accessible jazz had always been around to some degree, but with the release of George Benson's 1976 "Breezin'" LP—the first jazz album to go platinum—the flood gates to contemporary jazz were opened.

By the 1980s, eighties, contemporary jazz was making it to the commercial airwaves, no longer limited to college or public stations. AC and AOR programmers started seeing familiar names com-

ing across their desks—names that could easily fit into their formats. Names like Larry Carlton (a major contributor to the Steely Dan sound), David Sanborn and Tom Scott.

About this same period, there was an even newer kid on the block: New Age. Taking full advantage of digital recording technology, the softer, more contemplative sound of new age was a natural addition to contemporary jazz libraries. Programmers were more willing to test and play the music, as they became more accustomed and comfortable with their newfound cutting edge status.

Some stations chose to use contemporary jazz and new age in a mix with more conventional offerings. Stations like San Diego's KIFM(FM) chose to highlight the new music a few hours in the evenings and on weekends.

As audiences warmed to the new sounds, contemporary jazz and new age got more time to grow as formats. As more and more stations scored economic and ratings successes, the current crop of new AC and adult alternative stations appeared throughout the country.

## HAVE THE BEST SOUNDING STATION IN TOWN... FOR A LOT LESS MONEY!

J.R. Nelson is offering his services to your radio station on a  
**market exclusive basis** now at **an incredible price!!**

**ID/SWEEPERS/STAGERS PACKAGE (25 cuts) from \$300.\***  
**new 1992 BEDS & EFX PACKAGES FROM \$75.\***

*J.R. Nelson*  
PRODUCTIONS

**30% DISCOUNT FOR MULTIPLE STATION ORDERS. MONTHLY RETAINERS.**

**CALL/FAX FOR DEMO & RATE CARD:**  
**(216) 239-2752 FAX: (216) 239-1359**

\* = market size 100+



UPLINK

# Understanding Satellite Affiliation

by Karl Baehr and Harry Nelson

**ALBUQUERQUE, N.M.** Welcome to *Uplink*. Every month in this column, we will explore the very special needs of satellite programming affiliates. There are currently over 3,000 such radio stations, and this universe is expanding rapidly.

In the coming months, we will address such topics as: selling a satellite format; localizing effectively; operational structures; equipment and engineering; promotions; how to work with the networks for support negotiating a rate for services, and getting more from your format supplier.

Today let's start with three issues critically important to the satellite decision making process: network size, local versus satellite-delivered programming, and market size and use of services.

**A brief history**

It wasn't always so, but satellite companies now work with large numbers of stations. A mere decade ago, Satellite Music Network (SMN) had just a handful of affiliates. It was a day-to-day gamble with no assurances.

Today SMN continues to grow and boasts over 1,000 affiliates. And it is no longer alone. There are several networks now, each offering a variety of formats and growing rapidly.

In the wake of this growth stands the single station operators. They comprise the bulk of stations operating with satellite. Some utilize 100 percent satellite programming, others less.

The original decision to go with the network may have been predicated solely on cost. If the average station paid wages to on-air personalities in the range or \$4,000 to \$6,000 per month, it could now afford "better" talent for far less.

Others were attracted by the convenience of satellite. Fewer man hours and headaches. By buying into a collective approach, an operator became more effective—with greater marketing tools, more experienced programmers and stronger talent than they could otherwise afford—saving money and time.

**Out of your hands**

But the PD and the air staff weren't a few steps down the hall anymore, they were hundreds or thousands of miles away. The owner handed over the programming of the station to people he wouldn't recognize if they passed him on the street.

The owner would deal with an entire company charged with expediting successful programming decisions with the "good of the whole" in mind rather than benefit of the individual station.

Many affiliate stations say the trade-off in control is outweighed by the economic benefits, expertise and support systems offered by the networks. Unfortunately, not all affiliates are as comfortable with a network. There are some affiliates that remain silent and suffering.

The answer to this is a commitment to service by the networks, and understanding of the network by its affiliates.

**Is it live or local?**

The battle over this issue continues to rage. Many satellite affiliates strive to sound localized while the networks need to put a national face on their programming.

The first thing a newly signed satellite affiliate can expect to hear on the street in his market is the competition telling potential ad-

vertisers, "WXXX is not local." Stations carefully monitor network programming for the slightest hint of national bias, and seek assurance from their network salespersons and programmers.

Initially, networks must find new ways to assist their affiliates with sales training, promotional development, production and programming support beyond the initial "honeymoon" period. They must abandon the "business as usual" approach and openly discuss an affiliate's needs in the individual market. Networks must explain in detail the advantages of being a truly "national" station.

Local affiliates must re-orient their thinking to secure all the information they need to

successfully integrate what the network is doing. Both sides need to stay in step with each other—it is a two-way street.

Is it the size that counts? Too often the smaller market stations (the bulk of the affiliates) are dictated to by their big brothers in larger cities. When Snodgrass, Alabama expresses concern, the networks respond in a certain fashion. Realizing that most of their affiliates are of the Snodgrass class, should real changes be afforded them when faced with potential gains in larger cities like Houston or Milwaukee?

There is a cure for this schizophrenic decision making. Networks need to grow into larger, more competitive arenas while meet-

ing the requirements of small market America. If the networks continue to avoid creative solutions for the "little guys," they will have trouble keeping their smaller market base and lose the war fought on major market battlegrounds as well.

**Thinking ahead**

We tell clients frequently that by using satellite programming they are in an excellent position for the 1990s. In the wake of brutal competition for ad dollars, more station licenses (some 2,000 in the last decade) and other compelling industry factors, satellite stations can be lean and mean. Survivors.

A station can become successful by utilizing satellite, but it can't just go on the bird, sit back and expect its agenda to be met. "The networks, meanwhile, cannot present themselves simply as a lifeboat for "sinking" broadcasters. They must be champions to

continued on page 36 ▶

# Improve the Sound of Your Station!

...Control Commercials from Hard Disc

...Control Music from Compact Discs

...Improve DJ Content

## "Ultimate Digital Studio™" Controls Compact Disc Juke Boxes & "DigiCart" Hard Disc Digital Audio Recorders

**Only \$23,995**  
with 7½ hours  
of commercials,  
3 juke boxes  
and computer!



**Imagine...**  
having a *great* sounding radio station, where songs, commercials, talk, promos, and jingles come together perfectly. You'll have a station where where *creativity* thrives, yet announcers couldn't "forget" commercials or tags if they tried. Your studio'll be a clean, clutter-free showplace.

**Enjoy...**  
playing the *right* music from NoNOISE™ Compact Discs and sounding terrific. Your commercials will be *right* on the money from DigiCart™ digital audio hard drive. Logs automatically print out every spot to the second and every song by title and artist.

**Perfection Can Be Yours**  
with the *ultimate* in mistake-free, clutter-free, paper-free creative programming. It's affordable, with computer, three Sony CDK-006 industrial juke boxes, DigiCart™ HD-400 storing \*7½ hours of mono (or 3¾ hours of stereo) spots, jingles and songs for only \$23,995! A DigiCart for your production room adds only \$3,995. Call "(800) TM Century" for details. (Storage at 44.1 kHz \*with Dolby AC-2 6:1 data compression.)

# TM century

Inc.

**14444 Beltwood Parkway, Dallas, Texas 75244**  
**Phone: (800) TM Century - FAX: (800) 749-2121**

Yes! I want to know how TM Century's "Ultimate Digital Studio™" can help my station sound better! Mail to: TM Century, Inc., 14444 Beltwood Parkway, Dallas, TX 75244-3228, or FAX toll-free to (800) 749-2121.

Name \_\_\_\_\_ Title \_\_\_\_\_

Station \_\_\_\_\_ Phone (\_\_\_\_) \_\_\_\_\_

Address \_\_\_\_\_

City \_\_\_\_\_ State \_\_\_\_\_ Zip \_\_\_\_\_



# Return to the Cradle of Educational Radio

by James T. Wold

**MINNEAPOLIS** Broadcasting with an educational timbre has existed almost as long as the medium itself. In the Midwestern region of the U.S., three stations started by three institutions of higher learning gave the area's earliest broadcasting a strongly educational slant. This area could easily be called "the cradle of educational radio."

The earliest educational radio station was 9XM at the University of Wisconsin at Madison (later licensed as WHA on Jan. 13, 1922). The license for 9XM was held by Professor Earl M. Terry, who began sending out weather reports by Morse code as early as 1917 for nearby farmers.

During the war, when radio operations were banned, 9XM had a special permit from the Navy to conduct transmission experiments on the Great Lakes. When wartime restrictions were removed in 1919, Terry resumed his Morse Code broadcasts. He was eager to begin voice transmissions, but the necessary vacuum tubes were unavailable. Terry and his students built their own and began voice tests.

## Wireless experimentation

Wireless experimentation began early at the University of Minnesota at Minneapolis. Operation of an experimental station dates back to 1912, when the station was first installed in the old Electrical Engineering Building.

Early experimentation was conducted using a small transmitter operated by the engineering department of the university as a

lab for students. The University had an experimental license assigning it the call sign 9XI. Wireless broadcast at that time was entirely a lab project and transmission consisted of sending impulses or code short distances.

When the United States entered World War I in early 1917, President Woodrow Wilson declared that all licenses were revoked for the duration. The University station was dismantled and stored.

The next important development at the university radio station happened under the guidance of Professor C.M. Jansky Jr. Jansky arrived in Minnesota in 1920. Before becoming an instructor in the electrical engineering department, he had been at the University of Wisconsin experimenting with a new type of radio transmitter using thermionic vacuum tubes to generate oscillations. When Professor Jansky arrived in Minnesota, the university radio station was using a 1 kW transmitter tuned to 200 meters.

By January 1921 the daily reports were voice transmissions. Other colleges clamored for broadcasting facilities. By the end of 1922, 74 had licenses; their stories are told in S.E. Frost's book on early educational radio, "Education's Own Stations."

The second early educational radio station was WCAL(AM) Northfield, Minn. WCAL, which went off the air in late 1991, could trace its beginnings to the physics class of Erick Hettle, an early professor at St. Olaf College in Northfield. In the winter of 1916, several earnest students undertook an ambitious project in which they were to assemble radio equipment and attempt to transmit radio signals.

Before the students were able to finish their project, however, World War I intervened in the Spring of 1917. All wireless transmitting equipment was impounded and the project was dismantled. When the U.S. entered World War I, the Navy took over the operation of all wireless stations and amateur experimentation was forbidden.

## War-time hiatus ends

When Armistice was declared on Nov. 11, 1918 the ban on wireless radio transmission was lifted and the department of physics at St. Olaf College was able to continue its experiments in the wireless field. In July 1919, Hector R. Skifter, one of the more enterprising students, took out a station operator's license. The early call letters were 9AMH. The power used was five watts.

The culmination of the work at St. Olaf's came with the assignment of the call sign

WCAL on May 6, 1922. The station was authorized to operate on 360 meters (834 kilohertz) with 100 watts of power, for "unlimited time."

Parallel to the development of the other educational stations, 9XI embarked upon regular schedules and established itself in January, 1922. The station was a pioneer in the field of education on the air and was officially licensed by the Department of Commerce as WLB. In 1923 the Electrical Engineering Department moved to another building and WLB was housed in a suite of rooms on the third floor.

In 1937, WLB changed to 760 kHz and began to share daylight time with WCAL. The university's call letters were changed from WLB to KUOM in 1945.

□□□

*James T. Wold is a freelance writer based in Minnesota. His soon-to-be published book, Minnesota Microphones, will be published by Northstar Press. Wold can be reached at 1106 South Seventh Street, Minneapolis, MN 55415.*

## Laying a Sound Foundation

► continued from page 30

diligent, unrelenting attention to detail, we can achieve a compromise that will satisfy most every listener in any environment on any system, and that will produce a positive impact on ratings and revenue.

In this first column, it is also important to put audio processing in perspective. If we look at the big picture, processing is the icing on the cake. If your programming excels and you have a consistent, high quality sound, processing can help deliver those extra quarter-hours or that additional cume and make the difference between ranking number one and being an "also ran."

Although this may sound harsh, it is a fact: Audio processing will not cure or make invisible inferior programming or inconsistent, low quality sound. In fact, it will emphasize it. "Garbage in, garbage out" has never been more accurate than when aggressively processing audio.

In other words, spending tons of money on a top-notch system, then spending countless hours twisting and tweaking knobs, won't guarantee success if the rest of the picture is ignored.

## Consider the real world

Later on in this series we will discuss communication between you, the engineer and the PD. To successfully program a station, you have to identify your listeners and target them with your presentation. To suc-

cessfully process, you must consider the listener as well as his listening environments.

Who he is is as important as where he listens. Many dollars and hours are spent on logo design, music beds, production, and on-air presentation to create the station identity or its "personality." It is important to view the station "sound" as a part of this personality, to think about *how* it is heard as well as *what* is heard.

Because of this, all parties involved in the design of the station's sound must have the same clear understanding of its identity. As I said, we will discuss this in greater detail in a future column.

One fundamental issue common to all stations and all formats is consistency. The key to a superior sound—one that wraps itself around your listeners and compels them to listen longer and more often—is consistency. Cart to cart, CD to CD, spot to spot, source to source, the sound *must* be consistent if it is to be aggressively processed and give us predictable results.

To achieve that consistent sound, you have to keep one thing foremost in your thinking: *quality control*. That's where we'll pick up next time.

□□□

*Jeffrey Loughridge is president of Audio Concepts & Engineering, a technical consulting firm that designs and renovates studios. He can be reached at 1-800-777-4172.*



Over the years I've purchased literally hundreds of thousands of stickers from Communication Graphics because they're positively the best! I see

stickers on cars today that were put out ten years ago and they still look good! You can't beat 'em!



Harley Drew  
General Manager  
SUNNY 105/WZNY

**Communication  
Graphics Inc**

**RADIO IS LISTENING TO US.  
1-800-331-4438**

313 N. REDBUD • BROKEN ARROW, OK 74012 • IN OK (918) 258-6502 • FAX 1-918-251-8223

Circle (98) On Reader Service Card

Ever wish you could do your  
traffic and billing  
on a  
**Macintosh?**

You can...

Nordic Software, Inc.

917 Carlos Drive • Lincoln, Nebraska 68505-2059  
402-488-5086

Circle (107) On Reader Service Card



# TOTALLY TRANSPARENT TRANSMISSION PROTECTION.



## TRANSMISSION LIMITER 4000

### Pure Sound.

Protecting transmission systems from peak overload without audible artifacts—while stringently preserving natural sound quality—is the primary objective of many of the world's finest broadcast operations. That is why so many facilities around the world are choosing the Orban Transmission Limiter 4000. The 4000 provides the peak control they need, without audibly adding, subtracting or interfering with their signal in any way.

### Don't Take Our Word for It.

The 4000 provides transparent limiting with any source. Blind tests confirm that the sound of the Orban Transmission Limiter 4000 is virtually indistinguishable from the original source when driven as much as 15dB into limiting—even to trained listeners. Try it for yourself and hear what your facility can deliver when it is protected, not just restricted.

### Sophisticated, Easy to Use.

Orban engineers took years to develop the complex algorithms which permit the 4000 to protect inaudibly. Yet, they kept the front panel of the 4000 clean, clear and businesslike. The precision LED displays indicate any action of the compressor or HF limiter circuitry. The only adjustments are for INPUT level and OUTPUT level. The built-in tone generator and test mode permit rapid system setup and alignment.

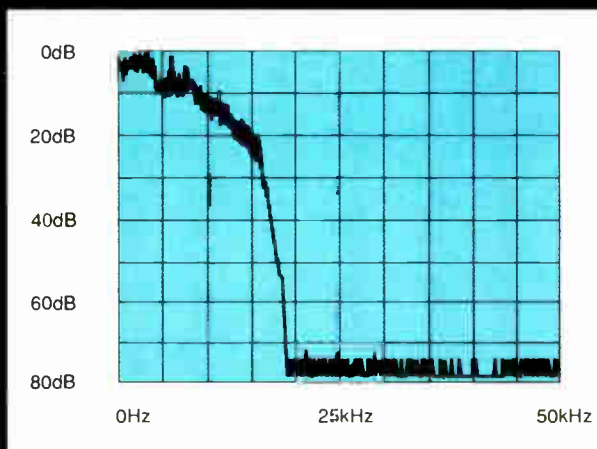

Power spectral density, at the 4000's output using "maximum peak hold" measurement. (10kHz/div. horizontal; 10dB/div. vertical)

### Orban Signature Quality.

The Transmission Limiter 4000 is one of a family of reliable, quality Orban products designed for demanding broadcast applications. Call your local Orban dealer

for a hands-on demonstration of the Orban Transmission Limiter 4000—another breakthrough product from the leaders in broadcast audio processing.

**orban**

© 1992 AKG Acoustics, Inc. Orban is a registered trademark of AKG Acoustics, Inc. AKG is a registered trademark of Akustische u. Kino-Geräte Ges.m.b.H., Austria.

a division of AKG Acoustics, Inc.  
1525 Alvarado Street, San Leandro, CA 94577 USA  
Tel: (1) 510/351-3500 Fax: (1) 510/351-0500

Circle (74) On Reader Service Card

World Radio History



# Simple Steps to Making Better Sales

by **Shane Fox**  
Chief Operating Officer  
Maxagrid International

**IRVING, Texas** Over the last several years, there have been a number of dynamic changes in the way sales commissions are viewed and calculated. These changes were due to different environmental circumstances facing the broadcast industry, such as deregulation, increased competition, and different economic cycles; as well as the continued implementation of sound yield management principles by broadcast management within the industry.

This article will address some new and innovative ways in which broadcast managers

are changing their commission plans, so as to ensure that adequate incentives exist for their people to *sell better, not just sell more*.

Most traditional commission plans for sales executives and management base compensation on selling *volume*. Volume was the answer if you wanted to make more money.

## Adjust the volume

Most salespeople in broadcasting do exactly that. They have figured it out. The way to make more money is to sell volume.

The fastest way to sell volume is to sell *cheap ads*. Management knows that volume selling will not maximize station revenues and yields. Managers practicing yield management recognize that volume selling

compromises station yields at different times of the year by various advertiser groups.

Commission structures are being modified to reflect this present day fact of yield management. For broadcast yields and revenues to be maximized, sales incentives and commission structures must be designed to compensate and reward individuals on selling *better, as well as selling more*.

Consequently, an interesting transformation is taking place within the broadcast industry regarding. New and different commission structures are being used to reconcile the traditional incongruities of volume selling by the salespeople, at the expense of adequate station yields as needed by management.

The broadcast industry realizes it is not al-

ways best to blindly reward volume business. Compensation based upon selling better is at least as important as selling by volume.

## Better sales

What does selling *better* mean? Let's look at a non-broadcast example.

You and I are selling cars for a guy named Jim. Jim designs what he thinks is a good commission structure to sell as many cars as possible.

For every \$10,000 worth of cars we sell, Jim will pay us \$2,500. He also tells us that we can sell all of the makes and models of his cars at a price that *we think reasonable*.

I sell a \$12,000 car for \$10,000, and you sell an \$8,000 car for \$10,000. We both made \$2,500, but who made the better sale, you or me?

This commission plan, like a lot of traditional ones in broadcast, succeeds in but one area. It will virtually guarantee that yields, margin and profitability from the sale will not be considered.

In this example, Jim's dealership sold \$20,000 worth of cars but, in aggregate Jim probably lost money. Both you and I as salespeople made \$2,500 each, but who really deserved to make more?

## Station yield

There are some examples of new broadcast commission structures. Many of these plans are designed around understanding customer buying behavior patterns associated with the advertiser, as well as categorizing the make-up of the account.

Once this is completed, a commission matrix is generated which results in a compensation structure which *balances* the better versus more scenario.

First, let's look at two of the most common buyer behavior profiles in broadcast. One buyer profile, which we will call the "Green" Group" has certain general characteristics

continued on page 38 ►

## Understanding Affiliation

► continued from page 33  
their affiliates.

With the 30/30 ruling and an ever-increasing number of LMAs, the networks should hear warning bells, and increase the level of service to their affiliates. The affiliates should be compelled to maximize their relationship with the network to put the best possible product on the air and on the street in their markets, no matter how large or small.

In coming installments of *Uplink*, we will talk with network executives, affiliate owners, consultants, equipment and service providers, and others in the industry who can help the satellite programming community continue to grow. Please write us in care of RW with your questions, comments or experiences regarding satellite broadcasting. We may select your letter for inclusion in future installments of *Uplink*.

□□□

Karl Baehr is president of KBE Broadcasting By Design, a consultancy offering a variety of services to satellite affiliates. Baehr is a former programmer and air personality. Harry Nelson is president of Harry Nelson & Associates, a satellite consultancy and an Operations Manager at Satellite Music Network for nearly a decade, programmer and former air personality of the year. Harry Nelson can be reached at 800-67-RADIO and Karl Baehr can be reached at 505-264-0450.

# LOG 14 DAYS OF AUDIO ON ONE DAT, PLAY IT BACK WHILE STILL RECORDING!



MDL-14



RCS TRACKER

The RCS TRACKER records up to 3 stations simultaneously, and provides random access to any logged time segment - even by phone - without interrupting the recording.

The RCS TRACKER consistently sounds better, costs less to operate, and is easier to use than any other logging technology.

The RCS TRACKER is a complete hardware-software system.

**RCS**

2 Overhill Road, Suite 100, Scarsdale, NY 10583  
Voice (914) 723-8567 Fax (914) 723-6651





# The Auditronics 800 Clean Air Policy.

What we surround ourselves with says a lot. The Auditronics 800 series says you won't settle for anything less than pure, seamless audio. More standard features than the others. Tomorrow's technology with the freedom to add options. The 800 says you know that when you own the best, the sky's the limit. Write or call for a free brochure.



*The Sound Of Perfection*

 **AUDITRONICS**

3750 Old Getwell Road, Memphis, TN 38118  
901-362-1350, FAX: 901-365-8629  
Circle (173) On Reader Service Card



# A Few Simple Steps to Making Better Sales

► continued from page 36 outlined below.

The other buyer profile, which we will call the "Red Group," has a much different buyer pattern. Those are found below as well. Take a few moments to read the profile make-up from these two broadcast groups, and then let's compare the two.

## Two kinds of buyers

**Red Group.** Typically, this advertiser group has the following profile: (1) There is no third party intermediary involved in any stage of the placement, negotiation, billing or invoicing process; (2) The advertiser is billed directly; (3) This tends to be

high-margin business, and (4) The station has very good information about the advertiser's needs, as station personnel initiate the communication.

**Green Group.** Typically, this advertiser group has the following profile: (1) A third party intermediary is involved in the initial placement, negotiations, and/or in the billing or invoicing process; (2) A third party is billed on behalf of the advertiser; (3) This tends to be Low Margin Business, and (4) The station has very poor information about the advertiser's needs, as the selling cycle is initiated by the third party intermediary.

Based on the above profiles, a station

should try to secure as many Green accounts as possible. However, commission structures

less profitable, lower yielding, and more price sensitive business.

Commissions that should be used for these two groups can be calculated quite easily given the margin or net yield per buyer group. For instance, if a salesperson has the

Figure 1.

Buyer Group	Time of Year and/or Amount of Order		
	Lowest Billing Quarter	Average Billing Quarter	Highest Billing Quarter
% Commission	\$10,000 or more	\$5,000-\$9,999	\$5,000 or less
Red Group	20	15	12.5
Green Group	50	40	25

traditionally have only concentrated on the Red Group advertiser, which is clearly the

same \$10,000 order from both groups, what is the net contribution to the station?

For the Green Group, the net contribution to the station, assuming one 15 percent commission, would be \$8,500. For the Red Group the net contribution to the station, assuming two commissions of 15 percent, would be roughly \$7,225.

However, if collections and payment from the Red Group run distinctively slower than the Green Group then the contribution towards the station would fall to about \$6,000.

A salesperson would be paid roughly the same amount on both accounts. However, the contribution margin from the Green Group is 30 percent greater than from the Red Group.

## Payment options

A station has a few options to change the payment structure. First, it could modify its overall pricing for the Green Group, enabling the station to stimulate demand from this sector of business. Second, the station could raise the commission structure for this group to accomplish the same goal. Or lastly, use a combination of both.

In our example from above, if the station lowered pricing only for the Green Group by 30 percent, then a balance would exist from both buyer groups in terms of *net margin and contribution*.

Presumably, this would stimulate demand and sales from the Green Group, both from the advertisers and salespersons perspective. More incentive now exists for the salesperson to focus on this segment. It would be *easier* to sell to this group because unit pricing is now lower.

Second, the station can hold its pricing the same for both groups, and give the salesperson much more of an incentive to sell *better* to this group because of the higher compensation structure. In fact, in our example, the station could give the salesperson a commission of 35 percent on this order and still realize an equal return as from a similar amount from a Red Group advertiser.

Finally, management could use a combination of both one and two above to ensure that incentives exist for salespeople to market high yield business on a regular basis enabling them to be rewarded on selling *better*.

A sample commission matrix would look like Fig. 1, using the examples above. The framework and concept presented here would apply for your station, even though the commission percentages and volume amounts would change for your individual situation.

As one can see from this schedule, incentives exist for the salesperson to focus just as much on the high margin business, selling *better*. This represents just as much profit contribution for the station as from the Red Group, however.

The important point is that the station and salesperson will make more money in the long run using this concept structure for broadcast commissions.

“CBSI's InterAcct accounting system delivers everything we were promised. The installation process was well-planned and coordinated. Our financial history was all pre-loaded for us. Our CBSI training specialist was extremely competent. The changeover occurred without any problems or delays.

“The InterAcct system has exceptionally strong internal control features, the menus are logical and easy to understand. The overall system is extremely fast and very flexible.

“Using InterAcct, we reduced the time it takes to process payables by several hours per week. InterAcct is up and running successfully in all of our locations.”

## STRAIGHT TALK FROM WTMJ ABOUT CBSI



**RON KURTIS**  
Vice President  
& Controller  
WTMJ, Inc.  
Milwaukee, Wisconsin

**KTNV-TV**  
Las Vegas, Nevada  
**WSYM-TV**  
Lansing, Michigan  
**WSAU/WIFC**  
Wausau, Wisconsin  
**KRVK-FM**  
Kansas City, Missouri  
**WTMJ Radio**  
Milwaukee, Wisconsin

**cbsi**

Custom Business Systems, Inc.

STRAIGHT TALK FROM THE BIG NAME IN BROADCAST SOFTWARE - 1-800-547-3930



# STATION SERVICES

News and Services for Business, Programming & Sales

## CD Libraries Available

**ENGLEWOOD, Colo.** Jones Satellite Audio, Inc. (JSA) adult contemporary and country CD libraries will be developed and distributed by Radio Programming and Management (RPM). In addition to distributing a complete JSA library to each affiliate, RPM will provide CDs of additional, new titles that will be included in JSA's satellite-fed radio formats.

Under terms of the agreement, RPM will provide libraries of two of JSA's five satellite formats during the next six months. The two companies are considering the development of CDs for the other three JSA formats and the customization of CD packages.

For more information, contact Tom Krikorian at RPM: 313-681-2660, or Andrea Montoni at JSA: 303-792-3111; or circle Reader Service 145.

## Tyler, Texas Metro Expands

**TYLER, Texas** The Tyler, Texas metro market (Smith County), formerly ranked 205 in the U.S., has been expanded to include Gregg and Cherokee Counties and has been renamed the Tyler-Longview Metro, rank number 138. The decision

is a result of a proposal submitted by several area radio stations.

The radio stations hope to attract a larger share of national advertising dollars to the market, as well as to compete more effectively with the area television stations. For information contact Thom Mocarisky at 212-887-1314, or circle Reader Service 136.

## Radio Input Sought for Fall Show

**WASHINGTON** The NAB Radio Show Programming Subcommittee is seeking input from stations that program niche formats for possible inclusion in the new, niche format session. NAB is also inviting Radio Show attendees to submit questions they would like addressed in the format forums, scheduled during the September 9-12 Radio '92 show, to be held in New Orleans.

The NAB asks that attendees help program the forums by providing planners with the questions to be incorporated into the forums' agenda. Speakers and panelists will formulate their remarks around issues raised by attendees.

For information on the Radio '92, or to submit questions, contact the NAB at 202-429-5350.

## Production Company Launched

**SAN FRANCISCO** Radio producer, programmer and on-air personality Ben Manila, is striking out on his own with the formation of the Ben Manila Productions company. The fully-equipped eight-track facility can accommodate production, music programming and consultation needs.

Manila's background includes stints at WOR(AM) New York; RKO Radio Networks and the Progressive Radio Network. Current clients include the ABC Radio Networks, Digital Planet, KFOG(AM) San Francisco and Radio MTV. For information, contact Ben Manila at 415-421-1220, or circle Reader Service 65.

## IBN Offers Digital Delivery

**CLEARWATER, Fla.** The Independent Broadcasters Network is now offering digital delivery of its 24-hour two-way talk programming, in addition to its two analog feeds. The IBN digital feed is on Satcom C-5, transponder 15, 10.1, 7.5

kHz, Digital-Dats.

Stations choosing the analog feeds can receive IBN on Satcom C-1, transponder 20, 7.38 video subcarrier, or on Galaxy 2, transponder 3, 77.2 SCPC.

For information contact Steve Weigner at 813-573-4402, or circle Reader Service 94.

## Motor Sports Radio Show

**JOHNSON CITY, N.Y.** Race-Talk, a program dealing with national and international car racing, is returning to the airwaves. Hosted by veteran network journalist Paul Kaminski, Race-Talk previews and reviews auto racing action.

The program is produced in Sportcom Associates' studios and on-site at the NASCAR Winston Cup, IndyCar™, NHRA Drag Racing, SCCA and IMSA Sports Car series and FISA Formula One events. Sportscom transmits the programming via a Comrex single-line frequency extender.

For information, contact Paul Kaminski at Sportscom Associates at 607-770-9165, or circle Reader Service 110.



The purchase of a radio station is a dream come true. We wanted to do it right from the start. Our logo design had to be first class; presenting just the right image. Communication Graphics came highly recommended to us. They lived up to their reputation.

**K98.3**

Arlene Bohach  
Arlene Bohach  
President/General Manager  
Bohmar Communications Inc.

**Communication Graphics Inc**

**RADIO IS LISTENING TO US.  
1-800-331-4438**

313 N. REDBUD • BROKEN ARROW, OK 74012 • IN OK (918) 258-6502 • FAX 1-918-251-8223

Circle (122) On Reader Service Card



## Clearly The Best.

The RPL 4000 Remote Pick-up Link, From Moseley. Planning on using quality remote broadcasts for revenue generation and station promotion? Moseley's RPL 4000 is the clear choice for today's crowded UHF RPU channels. The RPL 4000 delivers clear studio-quality audio so your next remote won't be a compromise.

- Lightweight: the RPL 4010 Transmitter is only 12.5 lbs •
- Three microphone inputs, one switchable to line •
- Frequency-agile two-frequency operation: wide or narrowband •
  - 20 Watts power output, AC or DC operation •
  - Excellent receiver sensitivity and selectivity •
- Built-in noise reduction, 27 Hz oscillator, Fully metered •

**Moseley**

111 Castilian Drive • Santa Barbara, CA 93117 • (805) 968-9621

Circle (56) On Reader Service Card



# Broadcast Equipment Exchange®

"Broadcast Equipment Exchange" accepts no responsibility for the condition of the equipment listed or for the specifics of transactions made between buyers and sellers.

## AMPLIFIERS

### Want to Sell

Crutchfield CR2x30 car stereo amp, 30 W/chnl, excel cond, \$50; Shure M-64 line amp w/tape, line/phono EQ switch, \$40. R Hardy, Richardy Prods, 3239 S 90th E Ave, Tulsa OK 74145. 918-627-2937.

Viking RP10-22 (2) tape head preamp to 600 ohm bal line, solid state, like new, \$35 ea. E Davison, 217-787-0800.

Amplidyne (2) controls, \$50 ea; Gates M6108, monitor, \$50; Macintosh 30 W; ADC Sound-shaper 1 EQ, \$75, all in gd cond. B Williamson, 914-858-2941.

Crown Micro Tech 1200 stereo, 320 W/ch 8 ohms, 495 W/ch 4 ohms, 1315 W mono 4 ohms, new, 3 yr xfer warranty. B Fisher, KPOK, Box 829, Bowman ND 58623. 701-523-3883.

New 250 W solid state amp, \$1800. Call for details. Bill Hoffman, 518-583-9490.

RCA, Altec tube mic pre's & tube amps & mixers; Langevin AM-16's, sale or trade. Tracy Eaves, 615-821-6099 (evenings before 10PM EST).

## ANTENNAS & TOWERS

### Want to Sell

Vector Tech phaser, 5 kW, set for 1470 AM, \$5000/BO, you pick up. P Ware, 805-947-3107.

Harris Dual Cycloid II pair of FM bays, gd shape w/mounting hardware, tuned to 104.1. G Brown, WJBM, 1010 Shipman, Jerseyville IL 62052. 618-498-2185.

Comark 5-pole patch panel, 2 link for 3 1/8" line, new, \$2500. S Karwan, KPSI, 2100 E Tahquitz Way, Palm Springs CA 92262. 619-325-2582.

Nems Clarke phase monitor, analog for 4-tower amateur array on 3.5 MHz. K Ericson, Cellular One, 1001 16th St, Denver CO 80265. 303-573-3261.

Large collection of AM phasing capacitors & inductors, great prices. T McGinley, WPGC, 6301 Ivy Lane, Greenbelt MD 20770. 301-441-3500.

Dielectric 50000 3 1/8", 4-port motorized coaxial xfer switch, excel cond w/local control panel, \$2800. R Sharkey, WAMO, 411 7th Ave, Pittsburg PA 15219. 412-456-4070.

Potomac AM14 3-tower AM, \$950. A Brobar, WHLI, 1055 Franklin Ave, Garden City NY 11530. 516-294-8400.

Dielectric DCVS-6B FM w/radomes, 9 yrs old, BO. R Cleveland, Radio One Ltd, 206 Rockwood Ave, Fredericton, NB, E3B 2M2, Canada.

ERI G4CPL-3 3-bay FM tuned to 98.3, 1 5/8" end input, you ship, avail 5/4/92, \$3500. W Kafka, KNOT, 116 S Alto, Prescott AZ 86303. 602-445-6880.

Cablewave (2) end for 3" flex cable #738355, like new, \$300 both; Andrew HJ8-50B 3" flex line, (1) 140'+(1) 20' section, \$200; Andrew 582A, (3) 3" hardline, 20' ea, \$400. J Cunningham, KEOR, Rt 2 Box 113B, Stonewall OK 74871. 405-265-4496.

Mark (2) 6' grids, parabolic for STL, BO. D Kelley, KCEM, 303 Ash St, Aztec NM 87410. 505-334-7558.

ERI 37CPS 6-bay FM tuned to 102.1 MHz w/deicers. J Church, WLUM, 2500 N Mayfair, Milwaukee WI 53226. 414-771-1021.

RF Coils, Contactors, TCTs, Hot Line Jacks, Complete Phasors:

## GELECO

Electronics, Ltd.

2 Thorncliffe Pk. Dr. U28

Toronto, Ont M4H 1H2

— Since 1960 —

Ph: 1-416-421-5631

Fax: 1-416-421-3880

Radio Systems CP-15 (12), excel cond, wired w/6' 3-phase cable & 3-phase disc plug, \$90 ea; misc lengths Saxton wire & low-loss RG-8 coaxial, estimated 3000 feet, most have PL-259 connectors on both ends, excel cond, \$0.10/foot+removal costs. R Rossman, WEHR, 103 Daniel Bldg, 2766 W College Ave, State College PA 16801. 814-863-0072.

FM Antenna, RCA BFC-14B w/heaters, 89.3 MHz, just removed from service, \$1650. 816-635-5959.

### Want to Buy

ERI/Collins FML-3E 3-bay, near 1980 vintage, close to 95.9 MHz, 1 5/8 fittings. D Rose, KAAA, 2534 Hualame Mtn Rd, Kingman AZ 86401. 602-753-2537.

EG&GLS-158A & LS-159 strobe lights, if not working, repairable. D Davis, KMOS, CMSU Wood 11, Warrensburg MO 64093. 816-543-4413.

## AUDIO PRODUCTION

### Want to Sell

Ampex 1000 one master maker, 10-chnl. E Kazmark, KAZZ, POB 1369, Deer Park WA 99006. 509-276-8816.

Yamaha SPX 90 dig multi-effect proc w/natural reverb, \$595. Erway, KKSBB, 1330 Cacique, Santa Barbara CA 93103. 805-568-1444.

dbx F900-A player w/(3) 902 de-essers, para-EQ & (3) 904 noise gates, \$2000; (2) dbx-160x comp/limiters, \$225 ea; Symetrix 525-dual gates comp/limiter, 7 mos old, \$250; Aphex type B aural exciter, \$200. D Crepps, IBS, 225 W Lookerman St, Dover DE 19901. 302-678-4420.

**SAVE \$300 ON T T 144 POINT PATCH BAYS**  
brokers of line and coarse used equipment  
audio village 619/320-0728

Belar Audio Sentry Silence Sense, \$275; Burwin 1201A proc, \$150; (2) EV Sentry 1A spkrs, \$300 ea; Mod Sci Stereo Maxx enhancer, \$1800; Orban 111 reberb, \$500; Ramko DA 1658R/E dist amp, \$150. B Williamson, 914-858-2941.

Eventide H910 Harmonizer, gd cond w/manual, \$350. J Addie, WFMT, 303 E Wacker Dr, Chicago IL 60601. 312-565-5033.

Orban 245E stereo synthesizer, BO. J Hansen, WYRO, 62 E Broadway, Little Falls MN 56345. 612-632-2992.

## CASSETTES • CARTS • REELS

### J & I AUDIO/VIDEO

A wholesaler in the Radio and Television market.

Now running SPECIALS on audio and video:

BASF CASSETTES-AMPEX R-Rs

AUDIOPAK, FIDELIPAC & ITC CARTS

For more information call Kris Elliot at

1-800-942-1711

or write to: J&I Audio/Video

20899 Kelvin Pl. Woodland Hills, CA 91367

### Circle (6) On Reader Service Card

Panasonic SV-255 portable DAT w/all access, 3 mos old, less than 25 hrs use, warranty, \$1800. J Martin, 213-876-7820.

### Want to Buy

Sports headset gd cond, prefer Sennheiser, Telex. Budd, 413-783-4626.

Sports headset gd cond, pref Sennheiser, Telex but will consider others. Budd, 413-783-4626.

AMCO 10 or 20 position stereo audio/video switch boxes. TKV, 301-445-5450.

## WANTED DEAD OR ALIVE! PULTEC EQ'S

Fairchild & Teletronix Limiters; Neumann, Telefunken, AKG, RCA, & Schoeps microphones. Tube McIntosh or Marantz amps & pre-amps. Sontec, ITI, & Lang EQs. Neve or API equipment. Boxes of old tubes; Urei, Orban, United Audio, DBX, & other outboard gear. Ampex ATR102s or 104s. Parts for MCI JH110/114 recorders. Altec 604s/crossovers/Tannoy speakers, JBL 2231; Altec 288h drivers; Misc. equipment of all types.

### Please Call:

Dan Alexander Audio  
5935 Market St.  
Oakland, CA 94608  
1-(415) 644-2363  
FAX: 1-415-652-4022

## AUTOMATION EQUIP

### Want to Sell

Cetec 7000 w/brain, 3 Audiofiles, 250 & 350 Carousel, Cetec load & dump unit, (4) video monitors, \$5500/BO/trade, you pick up. P Ware, 805-947-3107.

Schafer, old, BO. J West, 406-388-3337.

SMC auto control unit: DAS 6/12 dig audio switcher, MSP-12, ch4 programmer, computer mon, BO. P Berger, WNAM, POB 707, Neenah WI 54957. 414-727-2040.

IGM (2) Go-Carts, 24-tray, 1 42-tray, rack mounted w/Harris interface cards, gd cond, \$1700. G Faltus, WZMX, 10 Exec Dr, Farmington CT 06066. 203-677-6700.

Schafer 903 controller w/4 decks in 2 racks, works gd, BO. P Delaney, WOSX, Box 921, Marshfield WI 54449. 507-895-2065.

Automated Bdct Control tone gener, \$150; Gates time pulse mod, \$75; Gates ATC logging encoder, \$75; Sonomag 250 (3) cart Carousels, \$200; ATC cart player, parts, \$50. B Williamson, 914-858-2941.

Sonomag TS-25 (2) 25 Hz dual sensors, \$180 ea/\$350 both. B Tidwell, WAFI, POB 338, Valdosta GA 31603. 912-244-5180.

Insta-Cart 48-tray w/Sentry interface, recently recond w/manual, \$2600/trade. Ron, KPIK, 108 Dewitt Henry Dr, Beebe AR 72012. 501-882-3331.

Schafer 7000 control unit w/Audiofile source cards in racks, \$3000; IGM Instacart (2) 48-tray mono units in rack, \$2000 ea/\$3500 both. F Burke, WKRM, POB 308, Bath ME 04530. 207-443-6671.

SMC TG-25 tone gener w/manual, \$30. J Feasel, W64BG, 13549 Morse Rd, Pataskala OH 43062. 614-927-2592.

Cetec 7000 w/4 ITC R-R, (9) Audiofiles, (2) Beehive terminals, all options, gd working cond. C McCarthy, 916-244-9700.

Ampex 440B recently refurbished, new brakes, \$1000/BO. M Tupper, Alana Prods, 4197-11 Chasseral NW, Comstock Park MI 49321. 616-784-9215.

Systemation X-7 (12) cass decks w/X-7 brain, prod system, factory updated 1 yr ago, \$4000/BO. S Greeley, KZUL, POB 1866, Lake Havasu AZ 86403. 602-855-1051.

SMC 350RS Carousel, \$350; RSC-100 Random Access Selector, \$350, both w/manuals. R Miller, WRVI, 815 W Dean, Virden IL 62690. 217-965-3388.

IGM Instacart 48-tray, may need work, BO. D Kelley, KCEM, 303 Ash St, Aztec NM 87410. 505-334-7558.

Otari ARS 1000 25 Hz tone detector, new. J Phillips, WZOM, 408 Clinton, Defiance OH 43512. 419-784-1059.

Instacart (2) 48-hole w/Sentry firing systems & IBM-PC software; Otari, NationWide Talk Radio, POB 680888, Oak Grove OR 97268. 503-774-0459.

### Want to Buy

TM Century Auto Seque gd cond, 21 system. J Amburn, KTUE, POB 1260, Tulia TX 79088. 806-995-3531.

Sonomag 452 Carousel, gd cond. B Udytko, 717-477-3688.

## CAMERAS (VIDEO)

### Want to Sell

Hitachi FP-50 (2) studio w/Fujinon A10+11 CCU, cable, viewfinder, 200m, focus grip w/control cable & manual, \$3000 ea/BO. Frank, KCEA, POB 2385, Atherton CA 94027. 415-321-6049.

Canon-Quasar UC40-A w/stereo mic & title gener, Quasar VHS VCR Hi-Fi stereo, used twice, excel cond, \$800. J Diamond, Blue Diamond, Box 102C Chubbick Rd, Canonsburg PA 15317. 412-746-3455.

## CART MACHINES

### Want to Sell

Fidelipac CTR 100 Dynamax rec w/tones, splice find erase function, gd shape, stereo. G Brown, WJBM, 1010 Shipman, Jerseyville IL 62052. 618-498-2185.

Telex/Viking NAB mono players, \$50 ea; Sony TC228 8-trk R/P w/16 blank carts, clean & working, \$50. E Davison, 217-787-0800.

ATC (2) mono players, \$75 ea; Collins recorder, \$750. B Williamson, 914-858-2941.

Fidelipac 292 (3) & (1) 294 stereo cart w/3 tones & rapid cue, new, trade for 5/6 mono machines of similar value. R Wells, KSRQ, POB 1598, Santa Rosa CA 95402. 707-545-3313.

ITC RP (2) excel cond, wrack mounts \$15 extra, \$800 ea. F Lauerman, WMAM, POB 609, Manette WI 54143. 715-735-6631.

RCA (4), old & rec amp, OK cond, BO; Harris Criterion compact, stereo, BO. R Wells, KSRQ, POB 1598, Santa Rosa CA 95402. 707-545-3313.

ITC RP mono single-deck, new heads, motor, rack mount, gd cond, \$450. B Fogal, KDBX, 57400 S Morse Rd, Warren OR 97053. 503-397-0337.

**ITC CART MACHINES**  
**99B STEREO REPRO**  
**NEW UNITS. IN BOXES**  
8 units available  
**\$1900 Each**  
Jim Addie - WFMT  
312-565-5033 / 708-579-0729

Gates mono recorder, \$75; (2) players, \$75 ea; ATC player, \$750. B Williamson, 914-858-2941.

ITC Omega mono player, \$800; Premium mono recorder, \$850; WP mono player, \$500. B Williamson, 914-858-2941.

ITC-SP (3) stereo/1 tone, recently refurbished, \$525 ea/\$1300 all; Dynamax CTR-100 R/P mono. D Crepps, IBS, 225 W Lookerman St, Dover DE 19901. 302-678-4420.

BE/Spotmaster 1000/2000 series, gd cond, BO. Keefe, ALI, Box 313, Keene NJ 03431. 603-352-8461.

BE 5304B 3-slot stereo player, \$650; Audiocord E series stereo cart, PB, \$450. M Huffman, 800-455-9105.

Fidelipac CTR-92 (2) players; 1 CTR-94 R/P stereo cart w/3 tones & rapid cue, new, trade 5/6 mono of similar value. R Wells, 707-545-3313.

Tapecaster X700RPS, \$595; (1) R/P; (2) P, \$395. A Ishkanian, 804-752-6942.

Harris (4) mono, gd cond, \$400 ea. J Hansen, WYRO, 62 E Broadway, Little Falls MN 56345. 612-632-2992.

Tapecaster X-700 R/P unit, working cond, \$250. Karen, KYKA, 1109 W Chestnut, Yakima WA 98902. 509-453-6296.

RCA (4) ancient & record amp, OK cond, BO; Harris Criterion compact, stereo, BO. R Wells, 707-545-3313.

Audiocord DL P/R & 4 PB units. D Brook, WNLB, POB 602, Rocky Mount VA 24151. 703-483-7011.

Ampro 4500 mono cart player, \$200. D Rose, KAAA, 2534 Hualame Mtn Rd, Kingman AZ 86401. 602-753-2537.

Audi-Cord Modu-Cart 100 reproducer; Audiocord A-Series reproducer; ITC Series 99B recorder; ITC Delta 1 stereo w/Delta IV recorder amp (4) ITC ESL-IV splice finder; (2) BE cart winder; Tentelometer T2-H7-AC (for carts); (5) unused STL alignment carts. Call TM Century, 800-299-0021 X64.

### Want to Buy

Tapecaster X700, poor cond. A Ishkanian, 804-752-6942.

## CASSETTE & REEL-TO-REEL RECORDERS

### Want to Sell

Otari ARS 1000 stereo reel player, \$750; same nds nubs & pr, \$650; same nds nubs, \$700. B Williamson, 914-858-2941.

## TABER

— SPECIAL —  
AMPEX or SCULLY  
Capstan or Reel Motor Rebuild  
**\$18500**  
1880 Embarcadero Rd. Palo Alto, CA  
415-493-3811

MCI JH-110 2-chnl transport & elect in roll around console, nds work. Bill, WBMJ, 1409 Ponce de Leon #420, Santa Juan PR 00936. 809-724-1190.

Scully 270 (2), fair cond, \$200, FOB. A Crane, Desert RF Eng, 2099 Chip Dr, Lake Havasu AZ 86403. 602-453-3546.

## EXPERT REVOX REPAIRS

Fast Turnarounds — Competitive Rates  
Rebuilt A77s \$800  
Capstan shaft resurfacing, \$35.  
JIM TECHNICAL ARTS  
30 Music Sq. W. #5  
Nashville, TN. 37203 (615) 244-6892

Scully 280 for parts. R Robinson, 203-469-4465.

Otari MX-5050 MKIII-8 1/2" 8-trk recorder, low hrs, \$3000; Soundcraft 200B 16x4x2, very quiet, low hrs, \$1800. C Lallo, PYR, 465 W Anderson St, Hackensack NJ 07601. 201-646-0277.

## Sine Systems Dial Up Remote Control

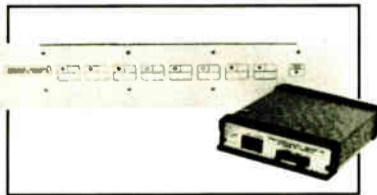

Complete 8 channel expandable system costs less than \$1,500!

THE SMART CHOICE!

**HE HALL**  
Electronics

Mastercard & Visa Welcome

### New Features For 1992!

- ☆ Automatic transmitter power control
- ☆ Alarm dial out for six telephone numbers
- ☆ Timed functions for PSA, PSSA or other uses
- ☆ Optional RS-232 computer interface
- ☆ Software update for older units available for less than \$100!

1305-F Seminole Trail  
Charlottesville, VA. 22901  
(804) 974-6466

Circle (84) on Reader Service Card

## ITC REPAIR — REFURBISHMENT

Direct Factory Cartidge Machine Repair Service  
Upgrades or Refurbishment  
All Work Warranted

Call The ITC Technical Service Department  
Toll-Free at



(800) 447-0414  
(309) 828-1381



International Tapetronics Corporation  
2425 South Main Street  
Bloomington, IL 61704





**CASSETTE . . . WTS**

Metrotec 400 logger recorder, 4-trk, works, BO. R Wells, KSRO, POB 1598, Santa Rosa CA 95402. 707-545-3313.

Schafer AL330 logging, 10 1/2" 1/6"-1/3", BO; Tapesonic 70-TRS 10 1/2", rack mount, stereo, BO; Revox A-77 for parts, BO. J West, 406-388-3337.



**CLEAN PATCH BAYS  
NO DOWN TIME**

**VERTIGO BURNISHERS AND INJECTORS RESTORE ORIGINAL PERFORMANCE TO YOUR PATCH BAYS**

**\$34.95 Ea.** Please write for additional information and order form today.

**VERTIGO RECORDING SERVICES**  
12115 Magnolia Blvd. #116 818-907-5161  
North Hollywood, CA 91607 fax: 818-784-3763

Akai CR 80D-SS quad 8-trk cart rec, BO/trade for other audio equip; BE Spotmaster 505, mono fair cond, BO/trade, J Roper, Imperial Sound, 383 N Studio St, Terre Haute IN 47803. 812-877-2663.

TEAC 1230, \$175; 7030SL recorder, \$200; X-3 MK II stereo reel, \$150; X300, \$150. B Williamson, 914-858-2941.

Tape-A-thon RR (2) bi-directional players, 3.75 ips 1/2-trk, auto rev, port 7" & 10 1/2", 1 rack mount 10 1/2", all working w/spare parts, \$50 ea. E Davison, 217-787-0800.

**HEAD RELAPPING/  
REPLACEMENT**  
All tape and film formats  
30 years experience

350 N. Eric Drive  
Palatine, IL 60067  
708-358-4622

Sony PCM-F-1 dig proc w/Apogee 944G filters in & out, \$1250; Sony SL-2000 port BETA, \$350. J Vanore, Acoustical Concepts, 708 Ashland, Ecdystone PA 19022. 215-328-6772.

AKAI 1722II portable stereo, \$175; B & H, \$50; ITC 750 stereo, \$475; Omnilib, \$75; Omnilib (2) 4-trk recorders, \$100 ea; Pioneer RT909, \$200; Revox A77 (2) recorders, 1 stereo, \$250 ea. B Williamson, 914-858-2941.

MCI JH110A 1/2", 9 yrs old, 7.5, 15, 30 ips, gd cond, will ship, \$2500. J Church, WLUM, 2500 N Mayfair, Milwaukee WI 53226. 414-771-1021.

Revox A-77 R/PB, gd cond w/wood case, \$300; PR-99 PB only, tone decoder stereo, gd cond, \$900; B-77 MKII, gd cond, \$300. M McVey, KKS1, 416 E Main, Ottumwa IA 52501. 515-684-0014.

Otari/SMC (5) w/25 Hz detectors, excel cond, \$1000 ea/BO: (1) Programmer 3A, live assist sequencer for 4 R-Rs, \$650/BO. J Hansen, WYRQ, 62 E Broadway, Little Falls MN 56345. 612-632-2992.

**SOUND YOUR BEST ON THE AIR!**

**CART MACHINE SERVICES:**  
**CART MOTORS REBUILT** to quiet flutter-free perfection—shafts resurfaced  
Single \$110.00 Triple \$130.00

**CART HEADS RELAPPED** guaranteed to perform like new  
Same day turnaround  
Replacement heads and motors available

**REEL TO REEL SERVICES:**  
**HEADS RELAPPED** and precise digital/optical  
**ASSEMBLY ALIGNMENTS** performed for maximum response & head life  
**CAPISTAN & REEL MOTORS REBUILT** for MCI, OTARI and more.

For peak performance from your recording equipment, call The Audio Magnetic Professionals.

224 Datura Street, Suite 614, West Palm Beach, FL 33401  
Call 1-800-826-0601 for "Same Day Service" in Florida (407) 659-4805  
Authorized Parts Dealers for: MCI • OTARI • TEAC/TASCAM

Circle (114) on Reader Service Card

## HEAD RECONDITIONING

Restore your worn heads to original (new) performance specifications at a fraction of the replacement cost. Our laboratory services include:

- Digital/Optical & Electrical inspection
- Precision recontouring of heads
- Complete digital/optical alignment of assembly
- Exclusive "Audio Magnetic Head Test Report"™ & Data Sheets

We also carry a full line of replacement heads and parts. Our 25 years of experience and reputation are unmatched in the industry.

**AMP MAGNETIC SCIENCES**  
249 Kennedy Road  
P.O. Box 121 • Greendell, NJ 07839  
Tel (201) 579-5773  
Fax (201) 579-6021

Circle (101) on Reader Service Card

Uher 106GA (3) gain amps for Mdl 4000 recorders, BO/trade for Akustomat F411; Uher Z162 Andusk 663 12 volt batt chrgs for Mdl 4000 recorders, BO/trade for Mdl Z124 mains unit. E O'Brien, Imperial Sound, 383 N Studio St, Terre Haute IN 47803. 812-877-2663.

MCI JH110B (4) 2-trk w/roll about variable profile cabs, remote controls and FTZs, \$2500 ea; Scully 280B full-trk mono rack mount, \$700; Studer Revox PR99 MKII (2), 2-trk, rack mount, \$2500, all in very gd cond. G Foldessy, WAKR, 1735 S Hawkins Ave, Akron OH 44320. 216-869-9800.

Metrotec 400 4-trk logger recorder, BO. R Wells, 707-545-3313.

**OTARI MX5050 . . .**  
MK III 8 track 1/2 inch tape recorder. (4) dbx 150 type 1 noise reduction units. Signiture Production Music Library, 2 CD's.  
**1-312-280-7723**

Otari ARS 1000 (4) 2-chnl w/25 Hz tone sensor & cue tone relays, \$875 ea. R Chambers, KSUE, 3015 Johnstonville Rd, Susanville CA 96130. 916-257-2121.

Revox A77 (2) 7 1/2 & 15 ips, stereo, R/P, excel cond, \$700; Tascam 34B, 7 1/2 & 15 ips, 4-trk, R/P, excel cond w/new heads, \$1998. Mark, Rod Page Prods, 1748 Mission Cliff Dr, San Diego CA 92116. 619-543-9727.

Scully 2848-8 1" 8-trk, 3 3/4-30 ips w/VS76 var spd mod, manuals, perfect cond, \$3000. T Sherry, 408-244-3848.

Pioneer SL4700 (4), rack mount, 6 disc CD players, \$100 plus shipping or all for \$300. E McCoy, KZEN, Box 100, Central City NE 68826. 308-946-3816.

ITC 856-7532 (2) P/B, very gd cond, \$425 ea. Karen, KYKA, 1109 W Chestnut, Yakima WA 98902. 509-453-6296.

**METROTECH  
DICTAPHONE  
LOGGERS**

PARTS AND SERVICE

**SEQUOIA  
ELECTRONICS**  
1131 Virginia Ave.  
Campbell, CA 95008  
(408) 866-8434

Ampro Scully Music System half track 270, auto rev, rack & 2 decks; Metrotec 3000 music system w/rack & (4) #500 auto rev, 1/2-trk decks. E Donze, KSGM, 410 Merchant St, St Genevieve MO 63670. 314-883-2981.

Ampex AG440C 2-trk rec/reproducer w/console, remote, manual, great cond, low use, \$1800/BO. J Rudisill, Audio Independence, POB 746, Aptos CA 95001. 408-684-0605.

Tascam 112 gd cond, modified for use w/Systemation automation, new capstan motors, \$350. R Horsley, Breck Tech Eng, POB 57, Garfield KY 40140. 502-756-2840.

**PHONE: 703-998-7600 FAX: 703-998-2966**



Call Simone Mullins, Classified Ad Manager, to reserve space in the next issue. Use your credit card to pay, we now accept VISA and MASTERCARD.

**RadioWorld®**  
5827 Columbia Pike, Ste 310  
Falls Church, VA 22041

**Select from these categories for best ad positioning:**

- |                            |                           |                         |
|----------------------------|---------------------------|-------------------------|
| Acoustics                  | Consoles                  | Stereo Generators       |
| Amplifiers                 | Disco-Pro Sound Equip.    | Switchers (Video)       |
| Antennas & Towers & Cables | Financial Services        | Tapes, Carts & Reels    |
| Audio Production (Other)   | Furniture                 | Tax Deductible Equip    |
| Automation Equip.          | Limiters                  | Test Equipment          |
| Brokers                    | Microphones               | Transmitters/Exciters   |
| Cameras (Video)            | Miscellaneous             | Tubes                   |
| Cart Machines              | Monitors                  | Turntables              |
| Cassette & R-R Recorders   | Movie Production Equip.   | TV Film Equip.          |
| CATV-MATV Equip.           | Receivers & Transceivers  | Video Production Equip. |
| CD's                       | Remote & Microwave Equip. | Video Tape Recorders    |
| CD Players                 | Satellite                 | Positions Wanted        |
| Computers                  | Software                  | Help Wanted             |
|                            | Stations                  |                         |

**Display Rates for Classified Advertising Effective January 1, 1991**

	1x	3x	6x	12x
1-9 col inch (per inch)	\$55	53	50	45
10-19 col inch (per inch)	50	48	45	40
Distributor Directory	90	85	80	75
Professional Card	60	55	50	45
Classified Line Ad		\$150 per word		
Blind Box Ad		\$10 additional		

To compute ad costs: Multiply the number of ad inches (columns x inches) by the desired rate schedule for your per unit cost. Example: a 3" ad at the 1x rate is \$165, at the 3x rate \$159, at the 6x rate \$150, at the 12x rate \$147, etc.

ITC 750/850 many, stereo, BO. D Kelley, KCEM, 303 Ash St, Aztec NM 87410. 505-334-7558.

Marantz PMD-420 port pro deck w/warranty, \$330; PMD-430 deluxe super portable pro deck, \$425. Ali, 603-352-8460.

Technics RS1500 2-trk; Sony/MCI JH110C on roll around metal cabinet, both excel cond; Dynafex NR system D2B. J Gelo, 813-642-6899.

MCI JH-110B reproduce only R-R's (2); MCI JH-110-2 in console; Sony TC-840 1/4-trk stereo R-R. Call TM Century, 800-299-0021 X64.

3M M79 24-trk, excel cond, \$9950. W Gunn, POB 2902, Palm Springs CA 92263. 619-320-0728.

Otari MX-70 16-trk 1", mint cond, \$10,500. W Gunn, POB 2902, Palm Springs CA 92263. 619-320-0728.

Scully 100-16 w/8-trk heads, \$2900. W Gunn, POB 2902, Palm Springs CA 92263. 619-320-0728.

**Want to Buy**

Otari MX 5050 (2), B series preferred. R Wells, KSRO, POB 1598, Santa Rosa CA 95402. 707-545-3313.

Otari 5050 gd cond; Sony ECM 50 mic, \$1000 both/BO. G Macsai, 202-223-0663.

Sony TC-D5M parts. J O'Leary, O'Leary Tech Svcs, 1717 Euclid St NW, Washington DC 20009. 202-332-8377.

Otari MX 5050 (2) B series pref. R Wells, 707-545-3313.

RCA RT-21 manuals, especially pinout for xport-to-elect connector. S Dorsey, WCWM, 173-7 Merrimac Tr, Williamsburg VA 23185. 804-229-1547.

Ampex 351 mono/stereo pair; svc book for Ampex 3200 duplicator slave or late model Ampex 300. D Dirlenfass, Transcription Svc, 7549 27th Ave NW, Seattle WA 98117. 206-784-4803.

Ampex ATR100 taperecorders for parts. Circuit cards, heads, motors, machine parts, or electronic parts. Call 818-907-5161.

Ampex PR10 electronic, mono or stereo. Joe Tippmann, POB 3007, Rapid City SD 57709. 605-348-7240.

Scully '100' recorders, record/play amplifiers, 8, 16, 24 track heads. Sequoia Electronics, 1131 Virginia Ave, Campbell CA 95008. 408-866-8434.

**ACTION-GRAM**

**Equipment Listings**

Radio World's Broadcast Equipment Exchange provides a FREE listing service for all broadcast and pro-sound end users. Simply send your listings to us, following the example below. Please indicate in which category you would like your listing to appear. Mail your listings to the address below. Thank you.

Please print and include all information: I would like to receive or continue receiving Radio World FREE each month.  YES  NO

Contact Name: \_\_\_\_\_ Title: \_\_\_\_\_  
Company/Station: \_\_\_\_\_ Signature: \_\_\_\_\_ Date: \_\_\_\_\_  
Address: \_\_\_\_\_  
City: \_\_\_\_\_ State: \_\_\_\_\_ Zip: \_\_\_\_\_  
Phone Number: \_\_\_\_\_  
Please circle only one entry for each category:

**I. Type of Firm**

D. Combination AM/FM station	F. Recording studio
A. Commercial AM station	G. TV station/teleprod facility
B. Commercial FM station	H. Consultant/ind engineer
C. Educational FM station	I. Mfg, distributor or dealer
E. Network/group owner	J. Other _____

**II. Job Function**

A. Ownership	D. Programming/production
B. General management	E. News operations
C. Engineering	F. Other _____

WTS:  WTB:  Category: \_\_\_\_\_  
Make: \_\_\_\_\_ Model #: \_\_\_\_\_  
Brief Description: \_\_\_\_\_  
Price: \_\_\_\_\_

WTS:  WTB:  Category: \_\_\_\_\_  
Make: \_\_\_\_\_ Model #: \_\_\_\_\_  
Brief Description: \_\_\_\_\_  
Price: \_\_\_\_\_

\*Closing for listings is the first and third Fridays for the next month's issue. All listings are run for 2 issues unless pressed for space or otherwise notified by listee.

**Broadcast Equipment Exchange**  
PO Box 1214 • Falls Church VA • 22041 • 703-998-7600 • FAX: 703-998-2966



### CASSETTE . . . WTB

MCI/Sony capstan & reel motors, any cond., recdg heads, most mfgs, machines, new, used. Relapped then sold. Amp Services, 224 Datura St No 614, W Palm Beach FL 33401. 800-826-0601, in FL 305-659-4805.

### CATV-MATV EQUIPMENT

#### Want to Sell

Century 21 country library, gd cond, complete. J Amburn, KTUE, POB 1260, Tulia TX 79088. 806-995-3531.

### CD's

#### Want to Sell

Audiometrics AMCD5-1000A (4) jukeboxes, holds 100 CDs, program via RS-232 port, very gd cond, \$2000 ea/BO. R Irwin, KSAC, 1021 2nd St, Sacramento CA 95814. 916-446-2294.

Sony CDP-3000 controller & transport, excel cond, \$750. G Kern, KQQL, 100 Washington St, Minneapolis MN 55401. 612-333-8118.

Tascam CD-501 several, need some work, BO. J Walker, WUVA, Charlottesville VA 22904. 804-924-3194.

Sony CDP-3000/CDS-3000 player system w/spare deck & all cables, \$2500. G Foldessy, WAKR, 1735 S Hawkins Ave, Akron OH 44320. 216-869-9800.

#### Want to Buy

Denon (2) units, excel cond. C Arnold, KIPR, 415 N McKinley #920, Little Rock AR 72205. 501-663-0092.

### COMPUTERS

#### Want to Sell

Wang terminal, CPU, hard drive, ran CBSI w/Control Data printer, works. BO. M Martindale, KVON, 1124 Foster Rd, Napa CA 94558. 707-252-1440.

ALR-SX16 1 meg RAM, 44 meg hard drive, 5/253.5 disk drives, VGA video interface, mon extra, \$695. D Crepps, IBS, 225 W Lockerman St, Dover DE 19901. 302-678-4420.

### Want to Buy

IBM compatible or better for educ FM, will pay for s/h. R Starliper, WMSS, 214 Race St, Middletown PA 17057. 717-942-9136.

### CONSOLES

#### Want to Sell

Langevin AM-301 (3), 2 in gd cond, 8-slider, dual mono, BO; Ramko custom 16-pot rotary mono, in 2 sections, BO. R Wells, KSRO, POB 1598, Santa Rosa CA 95402. 707-545-3313.

RCA BC-19/A 4-pot stereo board w/ or w/o plug ins. M Harris, KOOK, POB 1330, Tyler TX 75710. 913-393-2519.

Shure M67 4-input mixer, \$250. E Davison, 217-787-0800.

LPB Signature III 6-chnl mono, new, 2 yrs old w/books, \$1500+s/h. D Kasey, WROD, Box 991, Daytona FL 32115. 904-252-0677.

RCA BC-19/A 4-pot stereo board w/ or w/o plug-ins. M Harris, KOOK, POB 1330, Tyler TX 75710. 913-393-1519.

CCA Futura Six mono audio, nds work, 1 stereo pot. Erway, KKS, 1330 Cacique, Santa Barbara CA 93103. 805-568-1444.

Gates Gateway refurb, 10-chnl w/Q on all faders, new paint, Opamp labs & color pic, \$800; Gates Stereo Yard less pots, clean, gd parts, \$250. B Mayben, WXXJ, POB 71, S Pittsburg TN 37380. 615-837-5544.

Sparta (2) EQ mods, \$150 ea; Centurion II frame w/ps, \$600; Centurion IV frame, \$300. B Williamson, 914-858-2941.

Gates Studioette, \$75; Shure M68 mixer, \$100; Sony MX-650 6-chnl mixer, \$100; Collins 21221 portable, \$175; Shure 675, \$125. B Williamson, 914-858-2941.

Wheatstone/Audioarts A-50 12-chnl stereo bdct, prewired w/XLR cables, 8 mos old, \$5000. D Crepps, IBS, 225 W Lockerman St, Dover DE 19901. 302-678-4420.

Tascam M-320 20x4x8x2 configured, great cond, w/Calzone case, \$2199. S Wytas, SWP, 165 Linden St, New Britain CT 06051. 203-224-1811.

Ramko XL41S 4-chnl, stereo, 16 inputs, 2 yrs old, wired to custom punch block, works fine w/manual & amp, \$800/BO; 11-chnl, mono w/rack mount, I/O amps & pwr supply, no control cable, BO. M Martindale, KVON, 1124 Foster Rd, Napa CA 94558. 707-252-1440.

Langevin AM-301 (3), 8-slider, dual mono, BO; Ramko custom 16-pot rotary, mono, 2 sections, BO. R Wells, 707-545-3313.

Soundcraft RW 1897 (2) mono mic/line mods for SAC 200 console, \$200 ea. K Wooley, KAIM, 3555 Harding Ave, Honolulu HI 96816. 808-735-2424.

Trident 65 32in-16out w/pedestal base, wiring harness, mod extender card, excel cond, \$1000. J Diamond, Blue Diamond, Box 102C Chubbick Rd, Canonsburg PA 15317. 412-746-3455.

Yamaha MR1242 12 chnl, 4 subgroups, 3-band EQ, 12 tape returns, 3 aux buses, balanced ins/outs, talkback system, mint cond, less than 1 yr old, all documentation, \$1000. C Yengst, WAWZ, POB 37, Zarephath NJ 08890. 908-469-0991.

McMartin B-502 5 chnl stereo, gd cond w/manual, \$450. E McCoy, KZEN, Box 100, Central City NE 68826. 308-946-3816.

Autogram AC-8 8-chnl stereo board, gd cond, \$2700. M McGaha, KIZN, 9400 Fairview Ave, Boise ID 83704. 208-378-9200.

Ramko DC5RA 5-chnl stereo. J Phillips, WZOM, 408 Clinton, Defiance OH 43512. 419-784-1059.

Ramko DC-SM touch pad controls, fair cond, \$350. Karen, KYKA, 1109 W Chestnut, Yakima WA 98902. 509-453-6296.

Sony MX16 8 in, 4 out, gd shape; Pyramid PR8800 Echo, 8 in, 2 out w/new Echo in box, \$400. J Parsons, 2781 Fayson Cir, Deltona FL 32738. 904-532-0192.

Wheatstone 8X 16x8x2 rec/prod, mint cond, expandable to 24 chnl. J Lee, J Lee Prods, 208 Hampton Cir, Jupiter FL 33458. 407-575-1828.

MCI 428 28x24, 336 pt patchbay, prod desk, \$7500. W Gunn, POB 2902, Palm Springs CA 92263. 619-320-0728.

#### Want to Buy

Howe 10000 modules & parts. S Haynes, WHOU, North Rd Box 40, Houlton ME 04730. 207-723-4714.

Altec model 9300 parts & manuals. Joe Tippmann, POB 3007, Rapid City SD 57709. 605-348-7240.

Langevin AM4A w/documents. J Gangwer, 942 32nd St, Richmond CA 94804. 415-644-2363.

### DISCO & SOUND EQUIPMENT

#### Want to Sell

DJ & sound reinforcement system & pro light show w/mixer, strobes & spec lights, tri-amped Peavy DH 2's & 3's, 24-chnl Peavy mixer, effects, EQ & more; CD's, cass, turntables, mics & cords, road cases+150' 16-chnl snake for live sound reinforcement, perfect cond, \$25000/BO. E Miller, WZZY, POB 427, Winchester IN 47394. 317-584-2800.

ROH card cage w/ps, \$75; 201/218TA main-frame w/mods, \$300; Tapco 2200 stereo EQ, \$200; Tascam RS20 spring reverb, \$100; UREI 533 (2) mono EQs, \$200 ea; UREI 533 (2) EQs in rack mount, \$400 ea. B Williamson, 914-858-2941.

SuperSonic C1 dual-chnl compressor, self-contained, compress/recover active controls w/full data, \$175; Q1 dual-chnl semi-parametric EQ, 4 controls per chnl splits spectrum in 2, sweepable overlapping bands per chnl, \$195, both w/active balanced in/out, 1 owner, like new, black rack mount & full data. H Davis, 803-276-0639.

Symetrix SE-400 2-chnl 4-band parametric EQ, light use, \$175; Aphex Type C aural exciter, 2-chnl, light use, \$165; dbx 118 (2) compressor/expanders, unbalanced, stereo & dbx 119, \$60 ea/BO. J O'Leary, O'Leary Tech Svcs, 1717 Euclid St NW, Washington DC 20009. 202-332-8377.

dbx 120XDS sub harmonic synthesizer, gd cond, BO. S Wytas, SWP, 165 Linden St, New Britain CT 06051. 203-224-1811.

Soundcraftsmen TG-2209-600 graphic EQ, stereo, IO band, rack mount, balanced in/out, excel, \$100; Aphex C aural exciter #103, rack mount, excel cond, \$100. B Fogal, KDBX, 57400 S Morse Rd, Warren OR 97053. 503-397-0337.

Community CSX 57 pair of mobile DJ spkr cabinets w/dual 15" woofers, Titanium mid-horn & Piezo tweeter, carpet covered, as new, 5 yr warranty. B Fisher, KPCK, Box 829, Bowman ND 58623. 701-523-3883.

EV DL 15X (4) spkrs, removed from baseball park system, nds new cones, \$400/BO. B Mayben, WXXJ, POB 71, S Pittsburg TN 37380. 615-837-5544.

JBL 4312 1 pair 12" 3-way, warranty, perfect cond, \$600, will ship. Keefe, ALI, Box 313, Keene NJ 03431. 603-352-8461.

Dolby 361 (4) NR units, \$550 ea. W Gunn, POB 2902, Palm Springs CA 92263. 619-320-0728.

### FINANCIAL SERVICES

#### Want to Sell

#### EQUIPMENT FINANCING "LOANS BY PHONE"

- NO FINANCIALS REQUIRED FOR TRANSACTIONS UNDER \$35,000
- NEW OR USED EQUIPMENT
- \$2,000 to \$200,000
- NO DOWN PAYMENT
- SALE-LEASEBACK EQUIPMENT FOR WORKING CAPITAL

WE DO START UP BUSINESS TO APPLY OR REQUEST ADDITIONAL INFORMATION CONTACT MARK WILSON

**ENF** EXCHANGE NATIONAL FUNDING (800) 275-0185 FAX: (214) 235-5452

### LIMITERS

#### Want to Sell

Harris M-6543 Solid Statesmen FM w/manual, \$150. T Rosen, KBLI, 1129 Acacia Ave, Bakersfield CA 93305. 805-871-6094.

Howe Elect 2100 working cond, 4-5 yrs old, Phase Chaser, \$2000; Mod Sci MYB-2 Stereomax in working cond, 4-5 yrs old, \$2100. E Swanson, WZTR, 520 W Capitol Dr, Milwaukee WI 53212. 414-964-8300.

Altec 436 B compressor, tube type, working, BO; CBS 4440 compressor, Audimax, BO; CBS 4000 limiter, volumax, BO; CBS 450 dynamic presence EQ, BO. R Wells, KSRO, POB 1598, Santa Rosa CA 95402. 707-545-3313.

UREI 1178 dual peak, little use, \$500. B Fogal, KDBX, 57400 S Morse Rd, Warren OR 97053. 503-397-0337.

Gregg FM, \$4500; AM proc, \$3500; Optimod 8000A, \$1500. C Haynes, WJMI, 1850 Lynch St, Jackson MS 39203. 601-948-1515.

CBS 400 Audimax, \$150; CBS 444 Volumax, \$150; Gates Solid Statesmen, \$350; Harris MSP-90 AGC, \$600; UREI LA 3H (2) compressors, \$175 ea. B Williamson, 914-858-2941.

CBS Labs Audimax 4440A, \$500; 4450A, \$500; Volumax 4300, \$450; 410 (2), \$125 ea. C Arnold, KIPR, 415 N McKinley #920, Little Rock AR 72205. 501-663-0092.

Altec 436B tube type compressor, BO; CBS 4440 Audimax compressor, BO; CBS 4000 Volumax limiter, BO; CBS 450 dynamic presence EQ, BO. R Wells, 707-545-3313.

Harris/Gates M-6629 Solid Statesman AGC amp. C Brescia, WNBZ, Box 211, Saranac Lake NY 12983. 518-891-1544.

CRL SCA-2, Processor and Generator, never used, (2), \$2500 each. TFT Inc. EBS, never used, \$1275. David Wengierski, 214-328-0290.

## DISTRIBUTOR DIRECTORY

The following distributors serving the broadcast industry would be glad to help you with any of your requirements

## EMPLOYMENT

To place ads in this section, use the ActionGram form. To respond to box numbers, write Radio World, PO Box 1214, Falls Church, VA 22041, Attn:\_\_\_\_\_

### POSITIONS WANTED

Univ of MD campus celebrity Gary Allen graduates soon, over 2 yrs at WMUC, currently hosting live remotes & taping parodies. 2126 Hagerstown, College Pk MD 20742. 301-314-4590.

DJ seeks pos in LA, CA area, any shift/format except rap/R&B, prom & prod skills, fun, friendly. M Hart, 4107 Conrad Rd, Alexandria VA 22312.

Talented unemployed morning man, newsman, copy, PD, prod, 23 yrs exper, team player, prefer mgmt post, limited announcer duties. Larry, 717-653-2500.

PD/MD w/1000 CDs designed for AOR interested in helping you, any mkt. N Shearer, 817-387-8090.

College grad seeks employment, CH/URBAN/CHR radio/recorders, comm major, resume, ref, outgoing, will work & relocate. T Stein, POB 1498, Central Pella IA 50219. 515-628-7523.

Experienced, friendly highly motivated adult communicator w/great prod skills seeks stable opportunity, solid airwork, team player, AC/oldies/country. Dave, 712-262-7954.

Looking for Chiefs pos exper in all phases, high power AM directional & FM, audio, 20 yr vet, major & top 100 mkt exper, prefer warm climate anywhere, will consider 2 companies in single mkt on contract basis. Peter, 207-645-3019.

Quick fix solution for troubled stations, AM/FM, instant cash flow+ratings. B Elliott, 813-849-3477.

Marketable pro seeking air talent pos, skilled, responsible, personable team-plyr w/creative quality, AOR/AC/CHR/N/T. Randy, 919-294-2608.

### HELP WANTED

Accepting resumes for D/FW, Texas opportunities. FM CE, assistant CE, announcers with your format experience. Write to Radio World, POB 1214, Falls Church VA 22041. Attn: Box RW06-10-1.

### Equipment Sales

Professional Audio Supply is accepting applications for Sales Positions. Audio knowledge and sales experience are desired, Spanish a plus. Resumes to Lee Edwards, P.A.S., 5700 E Loop 820 South, Ft Worth, TX 76119. EOE

Working Chief Engineer for 100kW FM and DA AM in medium southern market. Previous DA AM experience required. Will maintain transmitters, STLs, satellite receivers, all studio equipment. Must have leadership skills and ability to interact with other staff members on a daily basis. Group owned. Excellent benefits. Send resume to Radio World. POB 1214, Falls Church, VA 22041. Attn Box 06-10-2RW.

**RADIO WORLD** reaches over **18,000** radio professionals twice monthly. **1-800-334-3045**

... getting tired of the price/quality/performance puzzle? ...  
 ... That's our game.  
**RADIO!** The beat goes on!  
**CROUSE-KIMZEY OF ANNAPOLIS**  
 tops in broadcast equipment  
**1-800-955-6800**  
 ask for Kathleen

**CORNELL-DUBILIER MICA CAPACITORS**  
 FROM STOCK  
**JENNINGS VACUUM CAPACITORS**  
 FROM STOCK  
**JENNINGS VACUUM RELAYS**  
**SURCOM ASSOCIATES**  
 2215 Faraday Ave., Suite A  
 Carlsbad, California 92008  
 (619) 438-4420

**SWR INC.**  
 SYSTEMS WITH RELIABILITY  
**FM-Antennas**  
 Outstanding performance and quality you can be sure of. All antennas are completely tested on SWR's test range. Custom directional patterns are available.  
**Contact JIMMIE JOYNT**  
**800-279-3326**

**SPENCER BROADCAST**  
 Supplying Radio Stations Nationwide. Call us for SAVINGS and SERVICE  
**CALL 602-242-2211**  
**FAX 843-2860**  
 Serving Radio Since 1979

## EMPLOYMENT SECTION

**HELP WANTED:** Any company or station can run "Help Wanted" ads for \$1.50/word or buy a display box for \$55/column inch. Payment must accompany insert, use your MasterCard or VISA; there will be no invoicing. Blind box numbers will be provided at an extra charge of \$10. Responses will be forwarded to listee, unopened, upon receipt. Call 800-336-3045 for details.

**POSITIONS WANTED:** Any individual can run a "Position Wanted" ad, FREE of charge (25 words max), and it will appear in the following 2 issues of Radio World. Contact information will be provided, but if a box number is required, there is a \$10 fee which must be paid with the listing (there will be no invoicing). Responses will be forwarded to the listee, unopened.

Mail To: **BROADCAST EQUIPMENT EXCHANGE**  
**PO Box 1214, Falls Church, VA 22041**

**THE SOURCE**  
 CALL US FOR ALL YOUR NEW BROADCAST EQUIPMENT NEEDS  
**Toll free: 800-HOT-AMFM (800-468-2636)**  
**305-651-5752**  
**FAX: 305-654-1386**  
 18620 N.E. 2nd Ave.  
 Miami FL 33179

Transmitters FM-TV-LPTV  
 Translators FM-TV-LPTV  
 STL Transmitters  
 Receivers and Antennas  
 Exciters-TV & FM  
 Stereo Generators  
*- Financing Available -*  
**Factory Direct Sales**  
**CALL 719-531-0124**



**LIMITERS . . . WTB**

**Optimod 8000 and 8100  
Buy—Sell—Trade  
414-482-2638**

**Want to Buy**

Orban 8100A gd & clean w/zero card. T McGinley, WPGC, 6301 Ivy Ln, Greenbelt MD 20770. 301-441-3500.

Optimod 8000A/8100A, gd cond. B Updyke, 717-477-3688.

**MICROPHONES**

**Want to Sell**

Shure SM-7 (4), 7 mos old, \$250 ea/\$900 all; (2) EV-RE-18's, \$125 ea/\$200 both; EV-635A, \$75. D Crepps, IBS, 225 W Lookerman St, Dover DE 19901. 302-678-4420.

AKG D110 lavalier dyn, new, \$35; (2) metal screen #W17 windshields that also fits Altec M20, new, \$10 ea; Altec 169A shock mtg, new, 7/8" dia mics, \$20; Mdl 571 lavalier, new, \$45; Shure SM56 & 546, mint, \$65. E Davison, 217-787-0800.

**SPACE  
AVAILABLE  
Call Simone Mullins  
at 1-800-336-3045**

Sennheiser MD421 U-5 w/case & clamp, excel cond, \$200. B Fogal, KDBX, 57400 S Morse Rd, Warren OR 97053. 503-397-0337.

B+K 2801 tube-type condenser, pwr supply, BO/trade for Sony CP-3 pwr supply. J Roper, Imperial Sound, 383 N Studio St, Terre Haute IN 47803. 812-877-2663.

EV RE-20 (2), gd cond, \$325 ea. C Kanz, PSI, N 27901 Sr 2, Reardan WA 99029. 509-796-5550.

Neumann U-67 & pwr supply, \$3000. F Virtue, Virtue Studios, 8807 Rising Sun, Philadelphia PA 19115. 215-763-2825.

Shure SM-57 (6), \$75 ea; (1) SM-58, \$100, \$525 all, all new. J Diamond, Blue Diamond, Box 102C Chubb Rd, Canonsburg PA 15317. 412-746-3455.

EV 664 dynamic cardioid, works well, on/off switch, \$830+s/h; EV 655C wide-range dynamic 50/150/250 ohm output choice, \$30+s/h; Shure omnidirectional dynamic SM50 50/150 ohm dual impedance, \$40+s/h; Shure isolation shock mount A55M for SM57, will work w/any mic of similar diameter, \$15+s/h; Realistic FM wireless system w/cvr & 3 lavalier xmtrs, works well, \$30+s/h. R Zimmer, Sound Enhancement Specialist, 2430 N Dodge Blvd Ste 134, Tucson AZ 85716-2639. 602-326-2080.

Desk mics (hiZ), EV-Shure mic stands, also baby booms (3); tubes, new (32) RCA, GE, Sylvania; Sams tube sub books #8 & #6; RCA tube manual; Sony head demagnetizer (new); jack female connectors; EV 502 transformer primary/secondary. Mr. Oliver, 212-874-7660/0274. Call afternoons till 10PM.

Telefunken U-47, Neumann U-67, KM-54 mint; RCA ribbon mics (2) KU3A's 10,0001, (3) 77-DX, (1) 44-BX, (2) BK-5; Altec tube mics M-11, M-20, M-30; 639 film version mic ect. Trade or sale. Tracy Eaves, 615-821-6099 (evenings before 10PM EST).

**Radio  
Control Service**

24-hour Transmitter Site Monitoring  
Licensed Operators

**Save Money & Keep  
Your Walk-Away  
Station FCC  
Legal with R.C.S.**

- Power/Pattern Change
- Nightly Tower Light Check
- EBS Activation and Receive
- Transmitter readings logged as often as you request

And more, all for  
one low monthly fee.

**Call RCS.  
915-675-8373**

**Want to Buy**

Neumann TLM 170 new cond, \$1950. A Marchesan, 416-665-2660.

Neumann U89, mint, \$1800. G Cork, 416-665-2542.

RCA Jr-Velocity ball-swivel mounting only. T Heathwood, Heritage Radio, POB 16, Boston MA 02167. 617-969-9966.

HP any lab ref mics, 1" versions. S Dorsey, WCWM, 173-7 Merrimac Tr, Williamsburg VA 23185. 804-229-1547.

**MISCELLANEOUS**

**Want to Sell**

Deep racks (2), \$50 ea; 36" table top rack, \$25; McMartin TG-2 EBS tone gener, \$375; WE KS19645-L2 (2) recorder couplers, \$50 ea. B Williams, 914-858-2941.

AKG R-25 remote control, BO/trade for Tascam remote. J Roper, Imperial Sound, 383 N Studio St, Terre Haute IN 47803. 812-877-2663.

Heathkit O-12 5" oscilloscope kit, circa 1955, new w/manual, never built, \$150. A Crane, Desert RF Eng, 2099 Chip Dr, Lake Havasu AZ 86403. 602-453-3546.

Patch bays (4) 2x24 2-conductor (tip & sleeve 1/4" w/solder blocks & whormal thru contacts. David, Prod House, 6130 S Dehmel Rd, Frankenmuth MI 48734. 517-652-6863.

TIE E300C 10-button phone, TT dial, new, \$50; WE field phones, magneto w/modern handset, excel cond, \$50 pr; music on hold interface to 1A2 phone systems up to 5 lines, \$25 per phone; Plantronic mini operators headsets (2) w/289B DBL plug, \$25 ea. E Davison, 217-787-0800.

ESE ES-400 10-min dig timer, modified for remote test, \$30. R Hardy, Richardy Prods, 3239 S 90th E Ave, Tulsa OK 74145. 918-627-2937.

111-C coils, \$35 ea/23-A EQa (8 kHz), \$25 ea, (2) 11-C & (1) 23-A, \$85 both, we pay s/h. W Florian, WNIB, 1140 W Erie, Chicago IL 60622. 312-633-9700.

Onan 5 kW natural gas gener, used 4 hrs, excel cond, \$4000. C Arnold, KIPR, 415 N McKinley #920, Little Rock AR 72205. 501-663-0092.

West Elec 24 V pwr supply, heavy & bulky. R Wells, 707-545-3313.

## CONSULTANTS

**Huntsville Antenna  
Engineering**

There is hope for AM radio!  
AM station unipole antennas with  
circular polarization & beam tilt.  
Broadband your present  
AM tower Series R shunt fed.  
205-353-6747

**Kenneth Casey  
Consulting Radio Engineer**

**MIRKWOOD  
ENGINEERING**

Rural & Remote Site  
Field Engineering

50 Park Ave.  
Claremont, NH 03743

**603/542-6784**

**T.Z. Sawyer  
Technical Consultants  
1-800-255-AMDA**

AM Directional Antenna Proofs  
AM-FM-TV-LPTV  
FCC Applications & Exhibits  
Station Inspections

6204 Highland Drive  
Chevy Chase, MD 20815-6610  
Telefax 301-913-5799

*Congratulations! You've  
found  
THE CARD!*

**Radio Systems Engineering  
"For all your Engineering Needs"**

AM - FM - TV - Translators - LPTV  
FCC Applications - Design - Installation

Call, fax, or write **today!**  
**(800) 551-1667**  
fax: (702) 898-8731  
4289 Roanridge - Las Vegas, NV 89120

**MULLANEY ENGINEERING, INC.**  
Consulting Engineers

- Design & Optimization of AM Directional Arrays
- Analysis for New Allocation, Site Relocation, And Upgrades AM FM TV LPTV Wireless Cable (MDS/MMDS/ITFS/OFS)
- Environmental Radiation Analysis
- Field Work
- Expert Testimony

9049 Shady Grove Court  
Gaithersburg, MD 20877  
Phone: (301) 921-0115  
Fax: (301) 590-9757

**Moffet,  
Larson &  
Johnson, Inc.**

Consulting Telecommunications  
Engineers

**Two Skyline Place  
5203 Leesburg Pike # 800  
Falls Church VA 22041  
703-824-5660  
800-523-3117**

Member AFCCE

**Consulting Communications  
Engineers**

- FCC Data Bases
- FCC Applications and Field Engineering
- Frequency Searches and Coordination
- AM-FM-CATV-ITFS-LPTV

**OWL ENGINEERING, INC.**

1306 W. County Road. F,  
St. Paul, MN 55112  
(612)631-1338 "Member AFCCE"

**W. LEE SIMMONS  
& ASSOC., INC.**

BROADCAST  
TELECOMMUNICATIONS  
CONSULTANTS

1036 William Hilton Pkwy  
Ste 200F  
Hilton Head Is., SC 29928

**1-800-277-5417  
803-785-4445  
FAX: 803-842-3371**

**EVANS ASSOCIATES**  
Consulting Communications Engineers

FCC Applications, Design  
& Field Engineering  
Broadcast Engineering Software

216 N. Green Bay Rd.  
Thiensville, WI 53092

**(414) 242-6000**  
Member AFCCE

**PC — SOFTWARE**

AM/FM/TV Search Programs  
Contour Mapping — STL Paths  
RF HAZ — 1990 POP Count  
FAA Tower — Draw Tower  
Broadcast Engineering

**Doug Vernier  
Broadcast Consultant  
1600 Picturesque Dr  
Cedar Falls, IA 50613**

**800-743-DOUG**

**Don't  
gamble  
with your  
advertising dollars.**

Advertise in Radio World  
and reach 18,000 +  
subscribers. Call  
1-800-336-3045 today!

**C.F. Ellis, P.E.**  
*Communications and  
Electromagnetic Consulting*

Applications, Propagation,  
Safety, System Design  
0.5 MHz—50 GHz  
30 years experience — Cost sensitive

1103 LaNeuville  
Lafayette, LA 70508  
Phone: 318-984-2420  
FAX: 318-989-8037

## SERVICES

**Tower Sales & Erection**

Turnkey Site Development  
Installation & Maintenance  
AM/FM Broadcast, TV,  
Microwave Systems,  
Antennas & Towers

**TOWERCOMM  
Communications Specialists**

**Ben Wall  
President**

6017 Triangle Dr.  
Raleigh, NC 27613  
(919)781-3496  
Gen. Contractor #25891 Fax (919)781-6454

Real World Propagation™ Studies  
Real World Propagation™ Workstation  
1990 Population Data on CD-ROM

**RE ENGINEERING TOOLS™**

3 Arc Second Terrain Data on CD-ROM  
Land Use and Land Cover Data on CD-ROM  
Online/Remote Access Services  
FCC & FAA Databases for PC

Richard P. & Richard L. Biby,  
Principals

**Communications Data Services, Inc.**  
6105-E Arlington Blvd. • Falls Church, VA 22044  
(703) 534-0034 • (800) 441-0034 • FAX (703) 534-7884 root@comm-data.com

**BROADCAST  
DESIGN &  
CONSTRUCTION, INC.**

- Facility Relocation
- R.F. Systems
- Soundproof/Acoustical
- Custom Cabinetry

24 HOUR EMERGENCY SERVICE  
**(313) 465-3226**

*When cost and  
quality count!*

**NORTH  
STAR  
TOWER**

Tower Construction  
& Maintenance

**Canton, NY  
315-386-4932  
FAX: 315-379-0951**

**Where In  
The World  
Are You?**

Reach radio professionals  
worldwide by advertising in  
Radio World's international  
edition. Call Simone for  
more information.

**1-800-336-3045**

**RENTALS**

For your next remote event rent the:  
**GENTNER EFT-3000**  
— or —  
**COMREX 3XP/3XR**  
3-line frequency extender package  
w/Shure SM-7 studio mics.

*Dwight Weller*  
**WELLER AUDIO-VISUAL  
ENGINEERING**  
Baltimore, Maryland  
**301-252-8351**

**SPECIALIZING IN ERECTION,  
REPAIRING, PAINTING  
AND MAINTENANCE  
RADIO, TWO-WAY, TV, TOWERS  
AND FLAG POLES**

**A STEEPLEJACK CO.**  
PAINTING AND STEEPLEJACK  
CONTRACTORS

FULLY INSURED FOR YOUR PROTECTION

**DON HIGLEY** 3722 ROMA  
713-462-6105 HOUSTON, TEXAS 77080

**THIS SPACE  
AVAILABLE**

**CALL  
1-703-998-7600**

FROM STOCK  
**Low Pass Filters  
Directional Couplers**  
CONNECTICUT

**MICROWAVE  
CORPORATION**

10 B Trackside Business Park  
Cheshire, Connecticut 06410  
203-250-9678 fax: 203-250-9688

**TENCO  
TOWER**

Lic. No. 357096

Installation & Maintenance of  
Broadcast & Communications  
Towers & Antennas

**Donald J. Tenns**

(916) 362-6846  
(916) 638-8833  
7923 Folsom Blvd. Suite A  
Sacramento, CA, U.S.A. 95827 FAX: (916) 638-8858

**Contact Radio World Newspaper for availabilities.  
P.O. Box 1214 • Falls Church VA • 22041**

**1-800-336-3045**





MISCELLANEOUS . . . WTS

## TRADE IN YOUR RE-20 AND \$149.00 AND GET A NEW EV RE-27N/DYM

The RE-27N/DYM microphone offers some great benefits over the legendary RE-20

- wider frequency response
- 6 db higher output
- greater sensitivity
- 3 switchable filters

Don't have an RE-20 to trade in? **CALL NOW** for a great price on the EV RE27N/DYM! EV 309 shock mount on sale for just \$75.00

**Boynton Studio Inc.**

Melody Pines Farm Morris NY 13808

SALES: (607) 263-5695 FAX (607) 263-2373

1955 Bristol Coach Bus award winning remote system w/30' ant, photos on request, \$3200. B Eberline, Eberline Broad, 1413 6th St., Bay City MI 46708. 517-892-6530.

Weather radar Raytheon 4804C w/60-mile range, \$3500/BO. M Berry, KGWY, POB 1179, Gillette WY 82716. 307-686-2242.

Signal splitters (1) 75%, 9%, 9%, 7%; (1) 32%, 29%, 22%, 17%; (1) 33%, 29%, 20%, 18%; (1) 33%, 28%, 25%, 14%; (1) 54%, 46%, excel cond, \$40 ea. R Rossman, WEHR, 103 Daniel Bldg, 2766 W College Ave, State College PA 16801. 814-863-0072.

**Rotron Blowers for Elcom, CCA, CSI, McMartin, Harris, rebuilt & new.**  
Goodrich Enterprises Inc.  
11435 Manderson St., Omaha, NE 68164  
402 493 1886 FAX 402 493 6821

Dielectric 2410 dummy loads, (10kW FM) air cooled w/3-1/8 input, Dielectric 5 kW w/3-2/8 input/1-5/8. Bird 1000W w/N input, Bird 2500W/UHF input, Bird 1200W/3-1/8 input. Goodrich Ent, 11435 Manderson, Omaha NE 68164. 402-493-1886 FAX 402-493-6821.

ABC 2500G 25-Hz generator; Orban 622B stereo parametric EQ. Call TM Century, 800-299-0021 X64.

**Want to Buy**

West Elec REP-111C telco repeat call. R Yaw, KQJM, Box 7000, Havre MT 59501. 406-265-7841.

Keith Monks or similar record cleaning mach. R Thompson, ASCO, Rt 1 Box 268, Timberville VA 22853. 703-896-8148.

Schematic for Western Electro condenser mic complement (pwr supply). R Robinson, 203-469-4465.

UTC LS type xformers. R Robinson, 203-469-4465.

SEDAT card to fit Fairchild DART rcvr; West Elec 24 V pwr supply, heavy, bulky and may blow-up. R Wells, KSRO, POB 1598, Santa Rosa CA 95402. 707-545-3313.

RCA 9-AX MI-4519 rack, will pick up in New Eng/NY. C Brescia, WNBZ, Box 211, Saranac Lake NY 12983. 518-891-1544.

Jazz record collections, 10" LP/12" LP bebop, swing, dixie, highest prices paid. B Rose, Program Recdgs, 228 East 10th, NYNY 10003. 212-674-3060.

**MONITORS**

**Want to Sell**

Gates GTM 885 stereo mod, \$400; HP HP3358 FM mod/freq, \$200; HP HP500A freq, \$100. B Williamson, 914-858-2941.

McMartin AMR 1 (2) AM tuners, 770 kHz, \$275 ea; STR400 SCA rcvr on 101.5 & 104.7, \$50; TBM 2500B RF amp, \$75; TBM 2200A stereo, \$650; TBM 3500B FM, \$650; TBM 4500A stereo mod, \$1100; TR 66 SCA rcvr, \$40. B Williamson, 914-858-2941.

Motorola 1410 (2) C-Quam AM stereo mod, tuned to 1240 kHz, \$3000/BO. R Irwin, KSAC, 1021 2nd St, Sacramento CA 95814. 916-446-2294.

TFT AM modulation monitor, \$300. R Chambers, KSUE, 3015 Johnstonville Rd, Susanville CA 96130. 916-257-2121.

Gen Radio 457A mod mon, RCA Radiola-33 TRF rcvr, working. E Duellman, WOMT, POB 1385, Manitowoc WI 54221. 414-682-0351.

**Want to Buy**

Any older McMartin mod monitors. C Goodrich, 11435 Manderson, Omaha NE 68164. 402-493-1886.

**RECEIVERS & TRANSCEIVERS**

**Want to Sell**

Kenwood 599 twins, matching xmtr & rcvr + spkr w/Hamtronics/VIC 20 for RTTY, high spd code, TX uses 2-6146 in final, \$300. B Mayben, WKXJ, POB 71, S Pittsburg TN 37380. 615-837-5544.

Avcom ACPC 3000E freq agile SCPC rcvr & Avcom 500-70 downconverter, both rack mount, in svc 7 mos, \$2100 both. D Crepps, IBS, 225 W Lookerman St, Dover DE 19901. 302-678-4420.

**AM STEREO RECEIVERS**  
Portable, Home/Studio, Auto  
**RRADCO GROUP**  
708-513-1386

Johnson IC-20 & RM-10 background. E Donze, KSGM, 410 Merchant St, St Genevieve MO 63670. 314-883-2981.

SCA decoder, high quality micro-miniature 6792 kHz, wired & ready to install, \$15. D Jackway, Background Music Eng, 5742 Fair Oak, Springfield MO 65810. 417-881-8401.

**REMOTE & MICROWAVE EQUIP**

**Want to Sell**

Telos 1 (2) dig hybrid telephone interfaces, 8 mos old, \$850 ea/\$1600 both; Symetrix SX-203 tele interface, \$100; Eventide BD-955 dig bdct delay, \$800; Rane HC-6 stereo head-phone console, \$150; ESE 194A 24-hr master clock, \$175; Custom Built U-shaped prod console, \$500+s/h. D Crepps, IBS, 225 W Lookerman St, Dover DE 19901. 302-678-4420.

Marti STL-8 mono system, on 946.0, not composite, like new, BO. D Payne, WZPL, 1440 N Meridian, Indianapolis IN 46202. 317-637-8000.

**COMREX RENTALS**  
1, 2 and 3-Line Extenders  
Switched 56 Systems  
Call Steve Kirsch for details  
**Silver Lake Audio**  
(516) 623-6114

Musicom CDQ-2000 encoder/decoder pair, 20 kHz digital STL, in svc 6 mos, \$6990, Datedel-T1 chnl bank equip, \$9900. D Crepps, IBS, 225 W Lookerman St, Dover DE 19901. 302-678-4420.

Moseley TPT-2 STL xmtr, excel cond, \$500. G Kern, KQOL, 100 Washington St, Minneapolis MN 55401. 612-333-8118.

TFT 7610C&R, 7630 dig w/chnl expander, \$1300. George, WWCR, 1300 WWCR Ave, Nashville TN 37218. 615-255-1300.

Motorola Tough Talker cell phone, interface & telfax mixer, 3 hrs continuous talk time, 1 yr old, \$900. G Violet, KSQB, 331 Lookout Pt, Hot Springs AR 71913. 800-676-1736.

**RENTALS RENTALS RENTALS**

**COMREX**  
3-line extender  
Frank Grundstein 215-668-6434  
Audio/Video Consultants 215-642-0978

Moseley TRC-15A, excel cond, \$900/BO. J Hansen, WYRQ, 62 E Broadway, Little Falls MN 56345. 612-632-2992.

Marti RPO 450-455 MHz, (2) RPT25 xmtr, (2) RPT 2 W port, (2) R-R rcvrs, (2) rcvrs, all dual freq, (2) Yagi ants, 2 duplex; Zercom Z-82 phase console, 4 chnls, rotary dial, \$700/BO. M Berry, KGWY, POB 1179, Gillette WY 82716. 307-686-2242.

Moseley 1600 RFS 4/1/92 complete system, \$2000. W Geesman, CGN, 6310 16th E, Tacoma WA 98424.

Burk Tech TC-8 remote & studio control units w/manual, 8 metering sources on easy to read dot matrix array, push button set up, \$1795. R Chambers, KSUE, 3015 Johnstonville Rd, Susanville CA 96130. 916-257-2121.

Marti studio xmtr link/dual system; Marti STL-8 xmtrs & R-200 rcvrs, FCC approved, excel cond, \$3950. R Chambers, KSUE, 3015 Johnstonville Rd, Susanville CA 96130. 916-257-2121.

Marti RPT-15/2, 161.67, used 6 mos. J Phillips, WZOM, 408 Clinton, Defiance OH 43512. 419-784-1059.

Moseley TRC-15A remote control, working, \$650. E Duellman, WOMT, POB 1385, Manitowoc WI 54221. 414-682-0351.

Moseley TRC-15 AW for wire-line, gd cond, \$800/BO. G Fulhart, WVKK, 4665 W Bancroft St, Toledo OH 43615. 419-531-1681.

**Want to Buy**

TFT 7770. D Payne, WZPL, 1440 N Meridian, Indianapolis IN 46222. 317-637-8000.

SEDAT card for Fairchild DART rcvr. R Wells, 707-545-3313.

**SATELLITE EQUIPMENT**

**Want to Sell**

Systemation Superswitch for Sat Music Ntwk, 1 1/2 yrs old, \$300. S Beeny, KRMS, Box 225, Osage Bch MO 65065. 314-349-2772.

Adcom 7550 mainframe/card cage w/pwr supply & remote cue card, \$50+s/h. G Fal-tus, WZMX, 10 Exec Dr, Farmington CT 06066. 203-677-6700.

Quik Disk 1 computer animation w/hard drive for R/PB in mono, 2 yrs old, excel cond, \$6000. D Brook, WNLB, POB 602, Rocky Mount VA 24151. 703-483-7011.

## Satellite Systems

**We Buy & Sell Used Satellite Receivers:**

Wegener, Adcom Fairchild DART Scientific Atlanta Microdyne & Others

**Spare Cards Satcue 400's**

**We support most formats.**

**We Need Inventory!**

**\*WE SAVE YOU THOUSANDS ON A NEW UNIT! \*30 DAY GUARANTEE! \*CASH FOR YOUR USED RECEIVER!**

(719) 634-6319 <sup>8-5</sup> MDT  
(719) 635-8151 Fax

Sci Atlanta 7300 & 7325 w/75k, 15k, VoiceCue, RFS 4/1/92 recent svc, \$7500. W Geesman, CGN, 6310 16th E, Tacoma WA 98424.

**SOFTWARE & DATABASES**

**Want to Sell**

FOR SALE: Ron Balonis' Broadcast Engineer's Computer Toolbox for IBM compatible computers. Send for details to COMPUTER TOOLBOX, 118 Rice Street, Trucksville, PA 18708-1628.

**STATIONS**

**Want to Sell**

Complete facility set up for talk, news & music, late, high quality equip, 14'x30'; 2-axle mobile studio w/AC & restroom. NationWide Talk Radio, POB 680888, Oak Grove OR 97268. 503-774-0459.

10000 W now silent, low down, assumption. J Milligan, 904-682-6638.

Suburban Atlanta AM lic/equip w/gd long-term lease on studios & land, \$150000. POB 52682, Atlanta GA 30355.

AM/FM Combo in Eastern Wyoming. Nice community support, nice small station, \$90,000 cash. Serious inquires only. 307-358-3636 ask for Brett.

AM Radio Station for sale, small college town, Central Virginia, \$245,000, financing available. Call 804-253-0143 or 804-825-1771.

AM/FM Combo, \$100,000 down and assume. Real estate and building included. Great opportunity for owner operator. Call 216-331-8012 or 305-296-7575.

**Want to Buy**

Troubled/dark stations welcome, owner financing. B Kidd, Airwaves Co, 510 W 2nd, Rayville LA 71269. 318-728-4574.

LPTV in SE, little/no money down, also CPs. N Davis, TV24, POB 5180, Defunak Sprgs FL 32438. 904-892-4038.

10 year GM, highly successful sales background. Experienced in turnarounds. Looking to buy FM or AF in large small-market. Some cash, mostly terms. 319-365-6830.

**STEREO GENERATORS**

**Want to Sell**

Motorola 1400 C-Quam AM stereo exciter, tuned to 1240 kHz, excel cond, \$3500/BO. R Irwin, KSAC, 1021 2nd St, Sacramento CA 95814. 916-446-2294.

# TRANSCOM CORP.

Fine Used AM & FM Transmitters and Also New Equipment

For the best deals on Celwave products, Andrew cable and Shively antennas.

1 kW FM	1964 Gates FM1C	1 kW AM	1982 Cont. 314R1
1 kW FM	1978 Collins 831C2	1 kW AM	1974 Harris BC1H1
2.5 kW FM	1978 CCA 2500R	1 kW AM	1968 Harris BC1G
3 kW FM	1975 CCA 3000D	2.5 kW AM	1982 CCA 2500D
20 kW FM	1974 RCA BTF 20E1	2.5 kW AM	1976 McMartin BA2.5K
25 kW FM	1988 TTC 25,000	5 kW AM	1968 Harris BC5H
30 kW FM	1981 BE FM-30	5 kW AM	1972 CCA AM5000D
		5 kW AM	1977 RCA BTA 5L
		10 kW AM	1972 RCA BTA 10U
		50 kW AM	1977 CCA AM50000D

1077 Rydal Road #101

Rydal PA 19046

800-441-8454 • 215-884-0888 • FAX No. 215-884-0738

## ARMSTRONG TRANSMITTER

World Leaders in rebuilt transmitters!

### AM-FM-TV TRANSMITTERS, FM ANTENNAS, STL'S

**TRANSMITTERS are available:**

- Tuned & Tested on YOUR Frequency
- Guaranteed
- Parts and technical support with every purchase
- Expedited Service Available

**TRADE INS GLADLY ACCEPTED**  
See your transmitter **WORKING** in our showroom **BEFORE** you take it home!

**NO ONE ELSE OFFERS YOU MORE**

**ARMSTRONG TRANSMITTER**  
Corporate Office  
5046 Smoral Rd.  
Syracuse, NY 13031  
PHONE (315) 488-1269  
FAX (315) 488-1365

**Over 500 customers in 30 countries**

**ARMSTRONG INTERNATIONAL**

<b>ARMSTRONG SOUTHWEST</b> Phone 512-599-0789 Fax 512-599-0799 San Antonio, TX	<b>HABLO ESPANOL</b> Phone 305-471-1175 FAX 305-471-1182 Miami FL	<b>ARMSTRONG SOUTHEAST</b> Phone 615-822-0256 FAX 615-826-0082 Hendersonville, TN.
---	--	---



**STEREO . . . WTS**

Moseley SCG-9 (4), \$750 ea; Dolby 361 A-Type (4), \$400 ea; Dolby 334(330) B-Type (2), \$700 ea. This equipment has not been put into regular service. Also, Teac 22-2 2-track ATR L/N, \$400. John Zwart, 212-355-7540.

7" boxes empty, gd cond, used. J Reed, Voice Svcs, POB 74, Westmoreland NY 13490. 315-768-0210.

**TAX DEDUCT EQUIP**

Gulf Elem School welcomes donation of any disco/sound/remote equip, video & AV too. M Mesch, Gulf Elem School, 3400 SW 17th Pl, Cape Coral FL 33914. 813-549-2726.

Consider tax deductible donation, make donations of funds/bdct equip to Charitable Bdct Training Svc. F Smith, CBTS, 615-624-7126.

DJ, CD, A/V equip needed, rcpt provided. M Mesch, Gulf Elem School, 3400 SW 17th Pl, Cape Coral FL 33914. 813-549-2665.

Monte Vista Christian School, would appreciate any donations of used TV broadcast equipment. T Quinn, 408-475-0233.

**SWITCHERS (VIDEO)**

**Want to Sell**

360 Systems AM-16B audio, 16x16 cross-point, \$800. J Church, WLUM, 2500 N Mayfair, Milwaukee WI 53226. 414-771-1021.

**TAPES/CARTS & REELS**

**Want to Sell**

Amos & Andy (20) private collection of radio shows on top grade cass, 20 tapes/40 programs, \$75/BO. H Davis, 803-276-0639.

**MARATHON PRODUCTS COMPANY**

**Audio Cartridge Rebuilding Division**

Rebuilding/reloading, like new, all brands, any length up to & including 3.5 minutes, \$1.75 ea. FOB out plant, 48 hrs delivery.

New NAB Marathon cartridges prices on request.

35 Years professional experience!

Lifetime member AES R.D. MYERS Sr.

Manufacturers of Audio Devices, Continuous Tape Mag.

69 Sandersdale Rd.  
Charlton, MA 01507

1-508-248-3157 or 1-508-853-0988

Circle (35) On Reader Service Card

Lite AC library wlover 1100 songs on Scotch Cart II, recorded in stereo from Century 21 Gold Disc CDs w/2 mobile cart racks holding 660 carts. G Frischling, WLTV, 7 Pkwy Ctr, Ste 780, Pittsburgh PA 15220. 412-922-9290.

3M carts over 2000 w/racks, used, great shape. BO. D Hall, KWYO, 215 4th St Ste A, Eureka CA 95501. 707-445-8104.

Telex 300' & 600' carts, used up to 1200', extra parts, \$25 to pack & ship; R-R 10 1/2", 7", 5", mostly Scotch, all size MT reels, some LT & boxes, \$100. E Davison, 217-787-0800.

Eng student desiring donation of old bdct equip (anything) in repairable cond, will pay all shipping charges. EE student at Purdue. C Gill, POB 371, Indianapolis IN 46206. 317-923-2800.

**TEST EQUIPMENT**

**Want to Sell**

EICO 377 audio signal gener, tube type, works very well, \$30. R Hardy, Richardy Prods, 3239 S 90th E Ave, Tulsa OK 74145. 918-627-2937.

Sencore DVM-32 multimeter, dig, like new, \$35; Leeds & Northrup resistance decade box 0.01 ohm to 20K ohms precision, 10 switches, \$50. E Davison, 217-787-0800.

General Radio Type 736-A wave analyzer, coll item, excel cond, \$300+s/h. Scott, WMRI, 820 N LaSalle, Chicago IL 60610. 312-329-4068.

Tek 2710 spec analyzer, 10 kHz, 1.8 GHz w/2704 DC inverter, batts, manual & users guide, 2 yrs old, great shape, \$10000. S Karwan, KPSI, 2100 E Tahquitz Way, Palm Springs CA 92262. 619-325-2582.

HP 201C tone oscillator, \$200; 330 dist analyzer, \$300; 206A audio gener, \$100. B Williamson, 914-858-2941.

HP 5245L freq counter, to 50 MHz, no plug ins, \$100; Radio Freq Labs 531 crystal impedance meter, 10-100 MHz, \$50. M Starin, WGOT, 457 Varney St, Manchester NH 03102. 603-625-1165.

GR1606A rf bridge, excellent condition, \$350. F Spaulding, 415-961-5018.

**RADIO RESOURCES**

We can save you \$ on your next equipment or supply purchase

Ask for our current list of quality pre-owned equipment

- Equipment available to rent for a day or a month
- Field strength meters
  - Audio test system
  - Impedance bridge
  - Telephone frequency extender
  - Spectrum Analyzer

1-800-54-RADIO

1-800-547-2346

FAX

1-301-783-4635

9am-6pm EST

Circle (3) On Reader Service Card

Potomac Instr AA-51 audio analyzer, used little w/book, \$2280/BO; Delta OIB-1, gd shape, recalibrated, \$2000. A Crain, WAVN, 1336 Brookhaven, S Haven MS 38671. 601-393-8056.

US Navy CKB 74028 freq meter, 125-20000 kHz, clean, gd cond w/ pwr supply & book, \$30. J Cunningham, KEOR, Rt 2 Box 113B, Stonewall OK 74871. 405-265-4496.

Patch bays (4) ADC single inputs (24) rack mount; Dynakit pre-amp PAS 2; manuals for Ampex recorders 601, 351, 350 also for Gotham PBF 150 W amp & Neuman lathe 131 disc cutter. Mr. Oliver, 212-874-7660/0274. Call afternoons till 10PM.

**Want to Buy**

Spectrum analyzer; HP/Boston FM signal gener. L Martin, Musiplex, 7610 Burlington, Ralston NE 68127. 402-331-2632.

**TRANSMITTERS**

**Want to Sell**

Collins 20 V-3 1 kW, nds reconditioning, \$1500+s/h. Erway, KKSBB, 1330 Cacique, Santa Barbara CA 93103. 805-568-1444.

Spares for RCA BTA5H. G Wilson, WWTC, 5501 Excelsior, St Louis Pk MN 55416. 612-926-1280.

Exciters: McMartin B-910 tuned and calibrated to your frequency, guaranteed: Mono, stereo, SCA. Goodrich Ent. Inc. 11435 Manderson St., Omaha NE 68164. 402-493-1886 FAX: 402-493-6821

Gates M-6095 FM exciter, 88.1 w/manual, 10 W, \$300. T Rosen, KBLL, 1129 Acacia Ave, Bakersfield CA 93305. 805-871-6094.

RCA 250 W BTA 250-L on 970 kHz w/new tubes, \$1500; tuned & tested at your freq w/new tubes, \$2550; various rblt rectifiers. D Jones, WRCC, 2052 Watson Blvd, Warner Robins GA 31099. 912-922-2222.

Harris MW-1A gd cond, nds some repair, \$13000. B Kidd, Airwaves Co, 510 W 2nd, Rayville LA 71269. 318-728-4574.

Harris 3.5 K, excel cond, spare final, tuned to 92.3 in ND. R Frisch, CERM Bdcty, 6300 Variel Ave #D, Woodland Hills CA 91367. 818-887-4246.

Sparta 625 25 kW removed from svc 12/91, \$27500+frt. K La Rue, Gen Comms, 2171 Ralph Ave, Stockton CA 95206. 209-462-6059.

McMartin B-910 reg mod reg & PA mods, works, 92.1 MHz, stable, BO. J Houts, KAAA, 2534 Hualapai Mtn Rd, Kingman AZ 86401. 602-753-2537.

B-910 FM, \$1000+s/h; Gates-Harris FM-10B 10 kW FM, partial rebuilt, 230 V single phase pwr, BO/will trade. M Benson, KWTV, 916-893-8737.

Harris HT 5-FM 3 yrs old, excel cond, tuned to 99.9, \$20000. D Brook, WNLB, POB 602, Rocky Mount VA 24151. 703-483-7011.

**CAPACITORS OVERNIGHT**

- Power Supply computer grade: up to 450 VDC
- Transmitting-MICA Sangamo, Cornell-Dubilier
- Oil Filled Non-PCB Oval, Rectangular

1-800-323-0460

FAX 1-802-425-3664

Kellner Electronics, Inc.

Charlotte, VT 05445

Circle (8) On Reader Service Card

Harris TE-3 tuned to 99.1, working when removed, \$400. G Violet, KSQB, 331 Lookout Pt, Hot Springs AR 71913. 800-676-1736.

RCA BTE-15A w/2 SCA generators, extender board & book. NationWide Talk Radio, POB 680888, Oak Grove OR 97268. 503-774-0459.

RCA BTF 3B 3 kW, working when removed, \$350. Karen, KYKA, 1109 W Chestnut, Yakima WA 98902. 509-453-6296.

LPB LA-25 25 W AM RF linear (14), tuned for 1100 kHz, excel cond, \$380 ea. R Rossman, WEHR, 103 Daniel Bldg, 2766 W College Ave, State College PA 16801. 814-863-0072.

**TRANSMITTERS**

30 watt	FM	BE	FX-30 Exciter
250 watt	FM	1979	Wilkinson 250E
1 kW	FM	1975	Harris 1H3
2.5 kW	FM	1972	Collins 831-D1
3 kW	FM	1975	Harris 3H3
5 kW	FM	1969	Visual 5KB
20 kW	FM	1972	RCA BTF-20E1
20 kW	FM	1990	BE 20B
25 kW	FM	1977	AEL 25KG

**PMA Marketing, Inc.**  
"Transmitting Savings to You"  
**414-482-2638 FAX 414-483-1980**

AEL 25 kW on air, \$9700. J Morton, KIOP, PO Drwr P, Durango CO 81302. 303-247-4464.

McMartin 2500 AM, 1979, clean w/manual & spares. J Phillips, WZOM, 408 Clinton, Defiance OH 43522. 419-784-1059.

TTC for XLFM xlator, TVK code keyer board for subaudible ID & audio board for spot injection, \$200 ea. D Rose, KAAA, 2534 Hualapai Mtn Rd, Kingman AZ 86401. 602-753-2537.

LPB AM-25 25 W AM, 1100 kHz, gd cond, \$500. R Rossman, WEHR, 103 Daniel Bldg, 2766 W College Ave, State College PA 16801. 814-863-0072.

Harris MW-1 w/spares & manual, gd cond, \$8200. C Arnold, KPR, 415 N McKinley #920, Little Rock AR 72205. 501-663-0092.

**NEW McMARTIN BF-5K**

Lowest priced tube replacements

5500 W FM, broadband grounded grid output circuit, VSWR protection, excellent efficiency 75-80% automatic recycling & overload status. Fully remote controlled. FCC approved to 5500 watts.

Harris FM-20 kW transmitter, 1981-82, excellent condition with MS-15 exciter. Being sold by station owner. Call Mr. Clayton at 314-721-1247.

**Goodrich Enterprises Inc.**  
11435 Manderson Street  
Omaha, NE 68164  
402-493-1886  
FAX: 402-493-6821

Used & New Transmission Line, many sizes & lengths, many like new. 412-733-1994.

RECTIFIERS: molded replacements and open assemblies available. Upgrade kits for older transmitters. DEALERS WELCOME. Repairs on open assemblies. Plastics Technology Inc, 205-633-6277 or FAX 205-633-3202.

Dielectric 2410 dummy loads, (10kW FM) air cooled w/3-1/8 input, Dielectric 5 kW w/3-2/8 input/1-5/8. Bird 1000W w/N input, Bird 2500W/UHF input, Bird 1200W/3-1/8 input. Goodrich Ent, 11435 Manderson, Omaha NE 68164. 402-493-1886 FAX 402-493-6821.

Andrew 3" Heliax 820', gd cond on 8' spool, \$1500. 816-635-5959.

**Want to Buy**

Collins 30K5 250 W AM 300 CW shortwave. W Reese, KPH, Box 630, Bolinas CA 94924. 415-868-1403.

Any 60/100 W AM, used, tunable, 530-1610 kHz. F Smith, 615-624-7126.

Low power AM for post-sunset use, 60 W, solid state pref. T Alexander, WELW, POB 826, Willoughby OH 44094. 216-953-1330.

Student needs working FM exciter to learn, no more than \$100. C Webb, 402-330-1645.

Harris FM 3.5 5 kW 1980-85 w/MX-15 exciter, close to 95.9 MHz. D Rose, KAAA, 2534 Hualapai Mtn Rd, Kingman AZ 86401. 602-753-2537.

**WE BUY**  
MOSELEY PCL-303, 505, & 606's  
414-482-2638

McMartin AM/FM xmtr, any model, exciter or stereo modules. Goodrich Ent., 11435 Manderson, Omaha NE 68164. 402-493-1886.

**FM BROADCASTERS!!**

We can meet all your FM transmitter needs!!



**SOLID STATE**

Amplifiers and transmitters are available at the popular levels of 25, 100, 300, 500, 1000, 1500, 2000, 2500, 3000, 4000 and 4500 watts. All units are broadbanded and designed for local and remote operation.

**ZERO BIAS GROUNDED GRID TRANSMITTERS**

**SINGLE TUBE—MEDIUM POWER**

Offered at 1.5, 3.5, 5.5, 7.5 and 12KW. These transmitters include a broadbanded solid state IPA, which can be used as emergency transmitters and a single zero biased grounded grid triode in their PA.

**TWO TUBE—HIGH POWER**

These transmitters utilize two grounded grid triodes and are available at standard outputs of 15, 22, 25, 30, 40 and 50KW.

"The Transmitter People"

**Energy-Onix**

752 Warren Street, Hudson, New York 12534  
(518) 828-1690 FAX (518) 828-8476

A Wise Enterprise

**PETER DAHL CO.**

Save \$\$

Heavy Duty Replacement Transformers, DC Filter chokes and capacitors for AM & FM transmitters manufactured by: AEL, CCA, CSI, COLLINS, CONTEL, CONTINENTAL, BAUER, GATES, GE, HARRIS, ITA, McMARTIN, RAYTHEON, RCA, SINGER, SINTRONIX, WILKINSON. Many other models also available.

**FAST Delivery and FREE Technical Support.**

5869 WAYCROSS AVENUE EL PASO, TEXAS 79924  
(915) 751-2300 TELEX: 76-3861 PWDCO  
FAX: (915) 751-0768

Circle (120) on Reader Service Card

Circle (49) on Reader Service Card



**TRANSMITTERS ... WTB**

**USED TV TRANSMITTERS,**  
antennas, cable, rigid line, etc.  
one watt to 110 kW.  
Best FM Line  
BUY — SELL

**BROADCASTING SYSTEMS**  
602-582-6550  
FAX: 602-582-8229  
Kenneth Casey

**TUBES**

**Want to Sell**  
Eimac 5 CX 1500 B new w/warranty, \$825.  
P Delaney, WOSX, Box 921, Marshfield WI  
54449. 507-895-2065.

Eimac 4CX250B (3) new, \$270/\$100 ea. R  
Swan, WROY, 101 N Church, Carmi IL  
62821. 618-382-4161.

**For the Best Prices**  
& 24 Hr service on transmitting tubes call  
402 493 1886 day or night. FAX 402 493 6821.  
TELEX 940103 WU PUB TLX BSN

4-1000A, 8877, 4CX250B, 4CX1500B,  
4CX3000A & more. We carry large inventory  
all major brands, Eimac, Amperex, RCA,  
etc. Call Stew 1-800-842-1489.

**ECONCO**  
Quality  
Rebuilt Tubes  
Approximately 1/2 the  
Cost of New

Call for Our Price List  
**800-532-6626**  
**916-662-7553**  
FAX 916-666-7760

Circle (9) On Reader Service Card

**FACTORY NEW TUBES**

3CX10000A3, 3CX1500A7,  
3CX2500A3, 3-500Z,  
4CV10000C, 4CX1000A,  
4CX1500B, 4CX10000D,  
4CX250B, 4CX300A,  
4CX35000C, 4CX350A,  
4CX5000A, 4-400A, 4-400C,  
572B, 6146B, PL328/TH328,  
PL347/TH347, 807, 813,  
833A, 833C, and more...

**CALL**  
**1-800-783-2555**

JoLida Tube Factory  
Annapolis Junction, MD

Audio generator, TE22 (Lafayette), Sencore  
translator tester (portable); Cannon plugs,  
male & female 3 prong (new); new & used  
cable w/Cannons or without. Mr. Oliver, 212-  
874-7660/0274. Call afternoons till 10PM.

**REBUILT ELECTRON TUBES**

Partial List: 6623, 23791,  
TH150, 6425F, 5604, 6696,  
6697, 5681, 5682, 5671,  
7804, 3CX10,000H3,  
3CX20,000H3, 4CX5000A,  
4CX35,000C

**Vacuum Tube Industries, Inc.**

**1-800-528-5014**  
**508-584-4500 X75**

**Want to Buy**  
RCA 6161/6181 used in TTU-1B, no shorts  
but weak. N Davis, TV24, POB 5180, Defu-  
nak Sprgs FL 32438. 904-892-4038.

**ELECTRON TUBES**  
**Vacuum Tube Industries, Inc.**  
**1-800-528-5014**  
**508-584-4500 X75**

ML 6623 & 6427 rebuildable duds. G Pro-  
ctor, Sat Cable, POB 5386, Galveston TX  
77554. 409-737-2142.

**TUBE REBUILDING**  
**FREELAND PRODUCTS**

Since 1940  
**SAVE ABOUT 50%**  
**—We buy dud tubes—**

**800-624-7626**  
**504-893-1243**  
**FAX 504-892-7323**

**TURNTABLES**

**Want to Sell**  
Audio Technica ATP-12 tonearm w/681 cart,  
\$225; QPK rim drive, \$75; Sparta/Micro-  
trak/Stanton (2) 500 carts, \$300 ea; Tech-  
nics SP25, \$225. B Williamson, 914-858-  
2941.

Technics SP15 & SP10 w/A+I tonearm &  
base, preamps, BO. B Brinizer, WDNC, 1000  
Park Forty Plaze Ste 120, Durham NC 27713.  
919-361-1051.

Technics SP10 MKII electronic, gd cond,  
\$400. B Glenn, KOTY, 830 N Col Cir Blvd,  
Kennewick WA 99336. 509-783-0783.

Scully/Westrex System record mastering  
lathe, updated, VP-131, \$35000. F Virtue,  
Virtue Studios, 8807 Rising Sun, Philadel-  
phia PA 19115. 215-763-2825.

Rek-o-Kut B12H 3-spnd w/S-120 tonearm &  
2 head shells, \$100. J Parsons, 2781 Fay-  
son Cir, Deltona FL 32738. 904-532-0192.

Technics SL-1200 almost new, \$400/BO; SP-  
25 (2) w/tonerms, light use, \$350 ea/BO.  
G Fullhart, WVKs, 4665 W Bancroft St, Tole-  
do OH 43615. 419-531-1681.

**Want to Buy**  
16" & tonearm. G Moor, Bromo Comm, POB  
M, St Simons Island GA 31522. 912-638-  
5608.

16" SME tonearm. D Dintenfass, Transcap-  
tion Svc, 7549 27th Ave NW, Seattle WA  
98117. 206-784-4803.

RCA 70-C/D transcription, will pick up in  
New Eng/NY. C Brescia, WNBZ, Box 211,  
Saranac Lake NY 12983. 518-891-1544.

**Details on  
space availability**  
Call  
**1-800-336-3045**

**VIDEO PROD EQUIP**

**Want to Sell**  
Sony RM-430 auto video editor, excel cond  
w/cables, \$525. M Johnson, Westhampton  
Video, POB 195, Nutting Lake MA 01865.  
508-582-6381.

**Want to Buy**  
Sony RM 580. Also AMCO 10 or 20 posi-  
tion stereo audio/video switch boxes. TKV,  
301-445-5450.

**This Month's Crossword**  
by Steve Walker

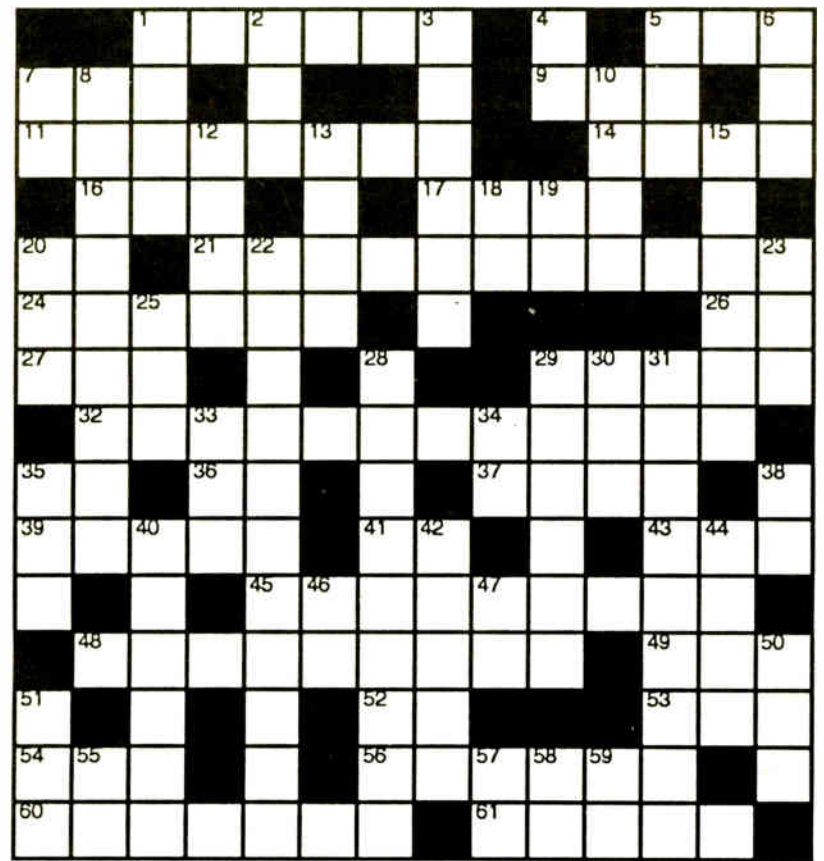

solution in next issue of RW.

**ACROSS**

1. Power surge
5. Mother
7. Pair, duo
9. "More than just great plates and panels"
11. Digital cart machine with built-in phone interface
14. Town in Somerset, England known for medicinal springs
16. Type of memory
17. Used to hang curtains
20. Degree
21. Expand\*Ability
24. Attempt
26. Therefore
27. Big boss
29. Assert
32. CD 10
35. Spot
36. Pronoun
37. Style or manner
39. Overactive
41. TV horse, Mr. \_\_\_\_\_
43. Spinning toy
45. The ones with the purse strings
48. LPB console
49. Charge
52. \_\_\_\_\_ LA, \_\_\_\_\_ SD, etc.
53. In a pen
54. Data rate
56. Change out certain parts
60. Make happy
61. Plate

**DOWN**

1. 1960's Dancing girl
2. Tax collector
3. HT Series transmitters
4. Annum; abbv.
5. Military term; abbv.
6. Rate of speed
7. Six-point score
8. Print only the news you need
10. "The big name in broadcast software"
12. CompuServe abbv. for "in my humble opinion"
13. Incline
15. Proposition or reasoned argument
18. Approved
19. Distribution amp, that is
20. Et cetera
22. "The Sound of Perfection"
23. Name; Fr.
25. Not me
28. Ultimate Digital Studio
29. \_\_\_\_\_ - Kimzey
30. Top
31. Made acidic or vinegar-like
33. Dice (singular)
34. Abbv for a relaxation technique using a mantra
35. Exclamation uttered on burst of insight
38. Toward the top
40. Cleric
42. Playing card
44. Not shut
46. The Evergreen State
47. Abbv for a form of transportation
50. Measures cardiac muscle activity
51. Turner station
55. Steeler state
57. Chinese pagoda
58. Negative
59. "\_\_\_\_\_ knows baseball."

# ADVERTISER INDEX

This listing is provided solely for the convenience of our readers.  
Radio World assumes no liability for inaccuracy.

Page No.	Advertiser	Reader Service No.	Page No.	Advertiser	Reader Service No.
41	AMP Services	114	40	Hall Electronics	84
7	ATI	71	6	Harris-Allied Bdct Equip.	25,186
24,25	Arrakis	117	10	Harris-Allied Bdct Equip.	—
3	Audio Broadcast Group	160	28	Harris-Allied Bdct Equip.	—
8	Audio Precision	111	27	Harris-Allied Radio RF Product	147
22	Audiopak	30	26	Inmark	170
37	Auditronics	173	40	J&I Audio	6
16,17	Belden Division, Cooper Ind	47	41	JRF Magnetic	101
11	Broadcast Electronics	140	32	J.R. Nelson	166
31	Broadcast Programming Inc.	63	22	Jampro	130
9	Broadcast Services	1	45	Kellner Electronics	8
19	Broadcast Svcs/Henry Engineering	163	45	Marathon Products	35
4	Burk Technology	133	39	Moseley	56
20	Burk Technology	19	26	Nemal Electronics International	143
38	CBSI	37	34	Nordic Software	107
19	CCA Electronics	91	1	Northeast Broadcast Labs	15
30	Communications Graphics	154	35	Orban/AKG/dbx	74
34	Communications Graphics	98	45	Peter Dahl	120
39	Communications Graphics	122	14	Prophet Systems	26
23	Computer Concepts Corp.	75	29	OEI	42
3	Comrex	33	36	Radio Computing Service (RCS)	137
15	Continental Electronics	183	30	Radio Mail	192
22	Cortana	7	45	Radio Resource	3
20	Dataworld	157	12,13	Shure Brothers	60
32	Dataworld	58	4	Somich Engineering	12
26	Davilyn	121	18	Studer Revox	125
26	Econco	40	33	TM Century	180
46	Econco	9	7	Tascam	53
45	Energy Onix	49	44	Transcom	150
20	FM Technology	72	2	Wheatstone	67
21	Fidelipac	39	47	Wheatstone	73
26	Gerstman Software	184	48	Wheatstone	132

Publisher .....Stevan B. Dana  
Associate Publisher .....Carmel King  
Marketing Consultant .....Albert Leon  
Production Director .....Kim Lowe  
Production Manager .....Julianne Stone  
Production .....Lisa Roach, Lisa Stafford  
Ad Coordinator .....Regan Deatherage  
Ad Coordination Manager .....Simone Mullins  
Circulation Director .....Tiana Hickman  
Circulation Manager .....Rebecca Seaborg

Accounts Receivable .....Valerie Mason

**Advertising Sales Managers:**  
East Coast .....Skip Tash  
800-336-3045, Fax : 703-998-2966  
West/Midwest.....Dale Tucker  
510-935-1470, Fax: 510-937-2280  
Headquarters  
1-800-336-3045, Fax: 703-998-2966

Free subscriptions are available upon request to professional broadcasting and audiovisual equipment users. For address changes, send current and new address to RW a month in advance at the above address. Unsolicited manuscripts are welcomed for review; send to the attention of the appropriate editor.



# *The New Wheatstone Production – Air Console*



## *In Fact, a Whole New Console Family...*

These consoles give you full multitrack production capability while at the same time providing familiar program and audition busing so your production room can double as a back-up on-air facility. They free up your primary Air studio for routine calibration and maintenance sessions. They are a perfect solution for complex talk or news formats.

Beyond its on-air capability the SP-4 is a powerful production console offered in 2, 4 and 8-track formats. Production crews will love the smooth sounding equalization, the auxiliary send buses, and, of course, the full on-air type machine and console logic. There's also plenty of room for those special functions: like a phone module that can handle multiple callers, yet

doesn't tie up your line inputs: an intercom module that lets you communicate with other Wheatstone consoles and rackmount locations throughout your facility; plus a studio control module, line preselectors, tape controllers, and automatic timers.

And, of course, there's the componentry: all gold contact switches for the ultimate in reliability, gold bus connectors, gold I/O connectors, solid state on/off lamps, and triple burned-in ICs. Naturally, each console is also triple-tested.

**The fact is.** Wheatstone's got the features, the componentry, the reliability, the performance and the reputation you can depend on.

Call us.

*SP-44/4-Track*



# The Closer You Get...

**WE MEAN IT**—we really DO provide the quality, performance, technical support, and innovation we promise!

Our model A-500 is a thoroughly engineered on-air console: it delivers the level of performance your clients now expect, and DAB demands. All components are selected for long life—gold bus connectors, gold I/O connectors, all gold contact switches, gas-filled relays, triple burned-in integrated circuits, solid state ON/OFF lamps, and precision laminated Lexan control surfaces for a lasting, wearproof finish. And we back that up with a 3-year parts and labor warranty, complete with

factory support from a technically competent and responsive staff.

We've also handled your special requirements as well with a super family of accessories, including a choice of three different telephone modules, an intercom module, an off-line mixer module for your remote feeds, talent control stations, accessory panels, failsafe power supplies, and auto cart and CD sequencing options.

**So take a close look:** we've got the quality, we've got the innovations, and you've got our commitment to top-notch support.

# The BETTER We Look!

 Wheatstone® Corporation

6720 V.I.P. Parkway, Syracuse, NY, 13211 (tel 315-433-7740/ fax 315-454-8104)

Circle (132) On Reader Service Card