

\*\*\*\*\*5-D101 65710  
J750374 D08 9004 3420 430  
BARRY MISHKIND  
CE  
KFXK  
2033 AUGUSTA PL  
TUCSON AZ 85710

# Radio World®

Vol 14, No 19

Radio's Best Read Newspaper

October 10, 1990

## DAB Draws Radio Show Crowd

by Judith Gross

**Boston MA** Reactions ran the gamut from enthusiasm to dread as Radio 1990 attendees packed several sessions on Digital Audio Broadcasting during the convention.

Their aim was to try and answer the question posed by one panel discussion: *DAB: Friend or Foe?*

By the end of a full day of digital information at the NAB's third Digital Radio Station Seminar and two other ses-

sions on the emerging technology—one of which was repeated—it was not clear how most station GMs and owners would answer that question.

What was certain is that interest in DAB is running high even among non-technical attendees and that the NAB intends to pursue its continued policy of localism for all future discussions of digital transmission.

The path toward discussion of DAB was paved early the day before the show opened with the all-day digital seminar.



(l-r) David Hicks, Alan Box, John Abel and Mike Rau tackle the question, "DAB: Friend or Foe?" at Radio 1990.

## Digital Technology Aids California EBS

by Frank Beacham

**San Francisco CA** A new digital emergency information system, designed to supplement the aging and cranky Emergency Broadcast System (EBS), is now operational and undergoing tests in the Bay area and Sacramento Valley in Northern California.

California's Emergency Digital Information System (EDIS), born less than a year after the devastating earthquake that killed 67 people here, utilizes inexpensive digital radio equipment to link local governments to the news media during disasters. The tests are being conducted by the Telecommunications Division of the California Office of Emergency Services (OES) and several key Bay Area broadcasters.

A digital radio relay located on Mount Diablo (east of San Francisco) now delivers EDIS messages to receivers in the San Francisco-Oakland-San Jose area and the Sacramento Valley, said Art Botterell, EDIS project coordinator at OES.

(continued on page 9)

The entire afternoon agenda focused on DAB, beginning with an overview of the technology by NAB staff engineer Stan Salek.

The Christian Science Monitor's Bill Spurlin discussed compression technology used in the two systems which have been vying to become the international standard for DAB transmission (see related story, this issue).

And NAB Senior VP of Science and Technology Michael Rau, addressed allocations considerations with coverage

area calculations based on the Eureka 147 system.

But the strongest viewpoint was expressed by Steven Edwards of Canada's Rogers Communications, who outlined results of tests of the Eureka system which took place this summer in Canada.

Edwards urged caution when considering the various DAB systems that either have been or will be proposed, especially, he noted, satellite systems which

(continued on page 7)

## Digital Group Meets

by Alan Carter

**Washington DC** Engineers from leading radio groups studying digital audio broadcasting (DAB) are formalizing their work and appear unconcerned about duplicating efforts of an NAB engineering advisory group with a similar mission.

Paul Donahue, Gannett Radio engineering VP and chairman of the Committee for Digital Radio Broadcasting, said the committee is different from NAB's in that it is "unencumbered by the political process—so far." NAB has formed a task force comprised of radio management to study DAB, and named engineers to an advisory group, several of whom who are members of the digital committee including Donahue.

Donahue and several other committee members met with reporters after a

meeting here in early September at National Public Radio. NPR Senior Engineer Mike Starling was elected vice chairman.

After returning from NAB Radio '90 in Boston, Starling said reaction to the committee is positive. One of the first issues he said the group will study is spread spectrum vs. single channel per carrier (SCPC).

The committee also said it will investigate systems that would be compatible with current FM broadcasting, although no such systems have yet been proposed.

At the press conference, Shamrock Broadcasting's Bert Goldman said that overall the group will examine compression techniques, modulation schemes and spectrum set-aside. "It's not a single

(continued on page 3)

**NEW**

### DYNAMAX CTR90 SERIES

- Superior Audio Quality, Dolby HX Pro™ Headroom Extension, DNR® Dynamic Noise Reduction
- Real Time Timer
- Extended Scale VU/PPM Metering
- Active Balanced Differential Inputs and Outputs
- Rugged Construction
- DC/PLL Drive

**DYNAMAX**  
BROADCAST PRODUCTS BY FIDELIPAC®  
Fidelipac Corporation  
P.O. Box 808 • Moorestown, NJ 08057 • USA  
TEL: (609) 235-3900 • FAX: (609) 235-7779

Contact Your Fidelipac Dealer for full specifications and prices.  
See the CTR90 Brochure in this issue.

Circle 111 On Reader Service Card



# Afrispace Plan Launched

by John Gatski

**Washington DC** By 1993, the world's first international, commercial digital audio transmission system will take CD-quality audio broadcasting to Africa and the Middle East via direct broadcast satellite (DBS), through a venture known as Afrispace Inc., a partnership of American and Japanese companies.

Company partners include Washington, DC-based Marcor, a financial backer of Satellite CD Radio Inc., a commercial digital

radio broadcast service proposed for the US; Defense Systems, a small satellite manufacturer based in the Washington suburbs; and Techno-Venture Co. of Japan.

Afrispace President Noah Samara said the delivery system's first phase will be in place by 1993 on a nine-channel "light satellite." The plan calls for Afrispace signals to be transmitted via satellite and received on digital receivers in continental Africa and Middle East countries.

"Our objective is to provide a

DBS audio transmission service to Africa and the Middle East," Samara said during a recent International Broadcaster Conference, hosted here by the Voice of America. "We don't intend to provide television broadcasts."

## An Afrispace odyssey

By 2000, the company plans to have launched a series of satellites to broadcast up to 100 channels, which would allow transmission of various audio qualities including AM (48 kBit/s data rate) FM (64 kBit/s)

and CD-quality audio (256 kBit/s). Each satellite channel will have 300 kHz bandwidth.

Afrispace will invest about \$35 million in start-up money into the project, and eventually end up with a 10-year \$350 million investment, according to the company. Earnings are expected to eventually generate an estimated \$1 billion annually.

Afrispace has filed for FCC permission to locate satellite control and tracking facilities in the US. Samara said he expects FCC approval sometime in 1991.

The system will use 1470-1530 MHz frequencies (L-band) for Afrispace broadcasts, the same frequencies as the proposed Satellite CD Radio. Samara said

the FCC has no reason not to approve the venture because there are few users of those frequencies in Africa or the Middle East.

The expected programming will include news, music, African super station programming, health information, education and special (miscellaneous) channels. Others options for Afrispace service include the ability for some African and Middle East ground stations to uplink with one of the satellites and transmit systemwide.

## Satellite system

Preliminary Afrispace plans show programming uplinked to a ground station in West Virginia, converted to digital data and then beamed to satellites on Ka-band. The digital signals would then be downlinked to L-band receivers.

Samara said no particular digital system has been chosen yet, but the technology is available and many companies are interested in the project.

The proposed Satellite CD Radio system, which currently has a petition pending with the FCC, is one digital technology that is being considered, according to Samara. That system would use a combination of satellite and terrestrial transmitters for US service.

To listen to Afrispace, special L-band digital receivers will have to be built, according to Samara. He envisioned portables initially costing \$100-\$200, but becoming less expensive as sales increase. Afrispace is actively discussing production of the receivers with several unnamed companies, Samara added.

For more information about Afrispace, contact Noah Samara at Afrispace, 202-408-8071.

# WE SURPRISED OURSELVES!



## AUDIOARTS® A-50 RADIO CONSOLE!

We wanted to know if it really was possible to build a high quality low-cost radio console. We found the answer to be quite exciting! We've come out with the A-50 console and even given it its own trade name: AUDIOARTS. This console comes complete with machine control functions; individually programmable channel logic; program, audition and telephone outputs; control room and studio monitors; as well as headphone and cue power amplifiers. It's also designed so you can expand or add accessory modules as your needs grow.

The A-50 is cost effective through clever engineering and the latest advances in electronic assembly procedures. It was developed by the same design team that creates our other high end equipment. Its performance is light years beyond the competition.

Imagine the benefit that our major market experience can bring to your station. Take advantage of Wheatstone's expertise and reputation. Call us today for immediate action!

 Wheatstone Corporation

6720 V.I.P. Parkway, Syracuse, NY 13211 (TEL 315-455-7740 / FAX 315-454-8104)

## INDEX

<b>When a Station Goes Too Dark</b> by Harald Hallikainen	12
<b>M-S Miking Creates Orangeburg</b> by Frank Beacham	15
<b>Workbench</b>	17
<b>The Hot Topics at Radio '90</b> by Lex Felker	18
<b>The Strange Case of The Tuckerton Tower</b> by Russell Roberts	19
<b>UL Makes Its Mark in Pro Audio</b> by Dee McVicker	20
<b>Common Sense Budget Planning</b> by Barry Mishkind	26
<b>A Guide to Mastering on DAT</b> Bruce Bartlett	27
<b>Stress Reduction for Engineers</b> by John "Q" Shepler	29
<b>Exploring Software Solutions</b> by Mel Lambert	30
<b>A Look at Amp Characteristics</b> by Ed Mantgamery	31
<b>The Continuing W and K Debate</b> by George Riggins	35



# Strother Tweaks DAB Proposals

by Alan Carter

**Hammond LA** Louisiana broadcast entrepreneur Ron Strother continues to fine tune his digital audio broadcasting (DAB) proposals, reducing the amount of bandwidth and revealing plans for possible experiments in New York and San Francisco.

In a supplement to his petition before the FCC for spectrum allocation filed in early September, Strother said that only 40 MHz—rather than 48 MHz—is needed for each market. The terrestrial DAB band would consist of ten 4 MHz channel groups, each of which could accommodate up to 12 or 16 separate audio signals, depending on what DAB system is selected as a national standard.

Strother also recommended that an additional 16-20 MHz be allocated for international satellite-based digital audio services, such as Voice of America, that currently are transmitted by shortwave and desperately need more reliable and better quality signals, and for other international telecommunications applications.

### Call for more spectrum

Finally, he called for additional spectrum for domestic satellite-based audio services that would compliment terrestrial DAB by providing service for underserved or rural areas and innovative

national and regional services such as reading services for the blind, slow-scan video, and nationwide EBS and public service programming.

In a separate filing on his request for permission to experiment with DAB over the air, Strother noted he is looking at New York City and San Francisco.

He originally proposed tests in Washington DC and in Boston, for which the new filing requests alternate channels because of potential conflict. Instead of channel 14 in Washington, he suggested channel 40, and in Boston, he requested channel 32 or 15.

The demonstrations in New York and San Francisco would test the effectiveness of DAB's ability to reduce multipath because the propagation conditions are much more severe than in Washington or Boston.

Strother said he has outlined a scenario for implementing DAB in New York, where each existing station would receive a channel.

### Market evaluation

Using the standard Consolidated Metropolitan Statistical Area (CMSA) for the New York radio market, he found an extreme demand would be placed on the technology and result in inefficient spectrum use.

As an alternative, Strother suggested that the FCC establish two separate DAB

service area classifications for CMSAs. The "Primary DAB Service Area" would consist of the entire CMSA. A "Secondary DAB Service Area" would consist of those counties that make up a secondary market in the CMSA.

For example, WPLJ-FM, licensed to New York City and serving the metro area, would be assigned the primary service area. But stations licensed to communities on Long Island would be assigned DAB channels licensed to cover

the Secondary Nassau-Suffolk DAB service area.

Based on this configuration, Strother determined that ten 4 MHz channel groups would be sufficient to convert New York to DAB. He also said the channel groups would permit future expansion of commercial and public DAB service.

All of Strother's proposals are pending before the FCC while the Commission completes a Notice of Inquiry into DAB.

## DAB Group Formalized

(continued from page 1)

issue and it may take a lot of work in different areas before there is any consensus," he said.

The committee heard a demonstration of the MUSICAM compression technique that is used with the European-developed Eureka 147 DAB transmission scheme. Other issues the group discussed were consumer demand for compact discs and the design of receivers with limited bandwidth.

The committee said it will file comments at the FCC on the DAB inquiry and it also adopted a formal state-

ment of purpose noting the goal is "to provide the listening public with radio broadcasts having a sound quality comparable to compact discs in a cost effective manner."

The group, which is open to all interested parties, had its beginning early this year when communications attorney Bob Mazer of Nixon, Hargrave, Devans and Doyle held a seminar on DAB. Engineers met as an *ad hoc* group until this meeting where they became a formal group.

For information, contact Paul Donahue at 213-466-8381 or Mike Starling at 202-822-2484.

## Going Our Way?

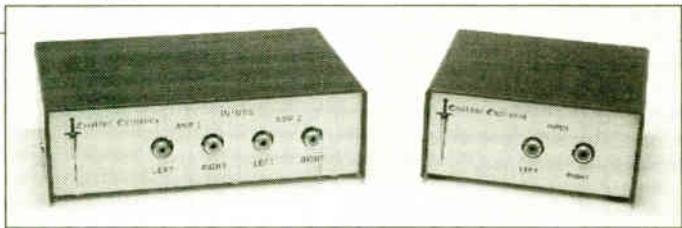

Interfacing semi-pro, IHF (-10dBV) to professional (+4dBm) equipment is on everyone's list of the ten worst nuisances. Now Bradley and Excalibur ease the pain with the CD-1, which amplifies one stereo source, and the CD-2, which handles two stereo sources. Input is via phono jack and the barrier strip output may be adjusted to levels up to +22dBm. Audio performance matches your best digital sources. Frequency response is 10Hz to 25kHz, ±0.25dB; THD is 0.006% and noise is 90dB below +4dBm. When you need to go "one way," Excalibur is the best way to go.

CD-1 \$99.00  
CD-2 \$165.00

Effective March 5, Bradley's sales offices will be open from 9 AM until 8 PM Eastern time, Monday through Friday. Whether you're in Portland, Maine or Portland, Oregon, Bradley's professional advice is closer than ever.

Open Until  
**8:00pm**

# Bradley

B R O A D C A S T

8101 CESSNA AVENUE • GAITHERSBURG, MARYLAND 20879  
TOLL FREE: 800-732-7665 • MD & DC: 301-948-0650 • FAX: 301-330-7198

Where Service and Engineering Make the Difference

Circle 81 On Reader Service Card

## DURA TRAK 90™

# Forget it.

Install a Dura Trak™ 90 cart machine, then forget about it. BE engineers made these new decks the simplest, most reliable and best-performing machines in their class.

- Clean audio performance with accurate cart guidance system, Phase Lok V head block and rugged direct drive motor.

- Designed to eliminate on-air mistakes with Cart-not-cued and Cart-previously-played lockouts, automatic muting and auxiliary start pulse.

- Fast Forward and three tone cue sensing standard.

- Engineered for durability with 1/2" aluminum deck plate, gold-to-gold contacts, solid cast front panel.

Simplicity, reliability, quality, affordability—Dura Trak 90 has them all. So you really will be able to forget about it. Just remember to contact your Broadcast Electronics distributor or call Bob Arnold at (217) 224-9600.

\* 115 VAC, 60 Hz, F.O.B. Quincy, IL: Exclusive of sales or use tax.



4100 North 24th Street • P.O. Box 3606 • Quincy, IL 62305  
Tel: (217) 224-9600 • Fax: (217) 224-9607 • Tlx: 250142



DURA TRAK 90 STEREO PLAYBACK: \$1795\* / STEREO RECORD/PLAYBACK: \$2695\*

Circle 5 On Reader Service Card



# Just Spell the Name Right, OK?

by Judith Gross

**Falls Church VA** Self-promotion is the name of the game, don't you know. At least that's becoming a truism in the DAB game.

Now I'm not going to spill the beans about the **Radio Show**. Let's save it for next time while I continue to get myself dizzy on the show circuit.



But in Boston it was interesting to see two of the proponents of DAB systems with petitions pending at the FCC find some very interesting ways of getting their message across to the radio station execs who happened to be around.

**Ron Strother**, who owns Strother Communications Inc. and who would like to test out the **Eureka DAB system** in New York, Boston, DC and San Francisco, wasted no time in getting his word out via his own newsletter.

If you didn't know better and you were handed one of these things as you walked into the convention center (as I was, although I do know better) you'd think it was a legit expounding of news on the subject of digital broadcasting—"digicasting"—as Strother calls it.

Then there was Radio Satellite Corp's **Gary Noreen**. He was so eager to show folks that satellite is do-able in car reception that he got up during the question segment of both the Digital Radio Station seminar and the "DAB: Friend or Foe?" (which I like to call, fondly, the **Fiend or Foe** session) and presented the latest gizmo.

You can see from the pix that it's a little round disc, metallic, slightly larger

than the mouth of your average styrofoam coffee cup. What the heck is it? Believe it or not, Gary says it's an antenna for car reception of satellite signals.

Gary, by the way also has a petition pending to offer radio services via satellite. He has advertised that stations can use his service for "superstation" status and says he's talking to some stations about the possibility.

One of those is **WCCO**, which has made no secret of the fact that it would like to be beamed up (Scotty) via satellite as a super AM.

I'm gonna tell you all about the rest of the Radio Show, and how nice it was to be in **lobstah territory**, next time. Promise. Let me just say a thing or two more about some tidbits from the show.

One concerns **AM stereo**. I think it came up during a session on RDS, talking about AM stereo compatibility with an RDS-like system for AM which could be used for special traffic alerts.

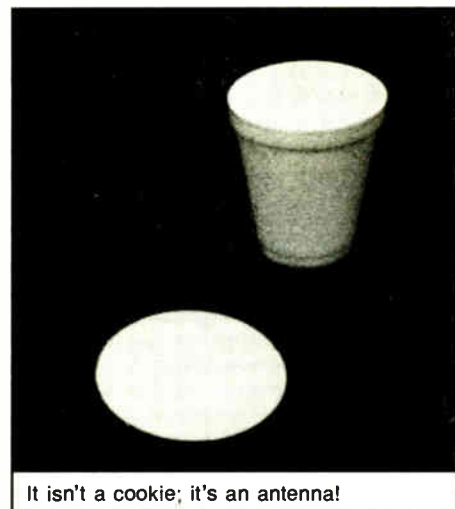

It isn't a cookie; it's an antenna!

Apparently there's some doubt about this.

**Gerry LeBow**, who is promoting RDS technology through his **Sage Alerting** systems, said he's having a tough time getting a straight answer from its European developers about the technology's compatibility with AM stereo.

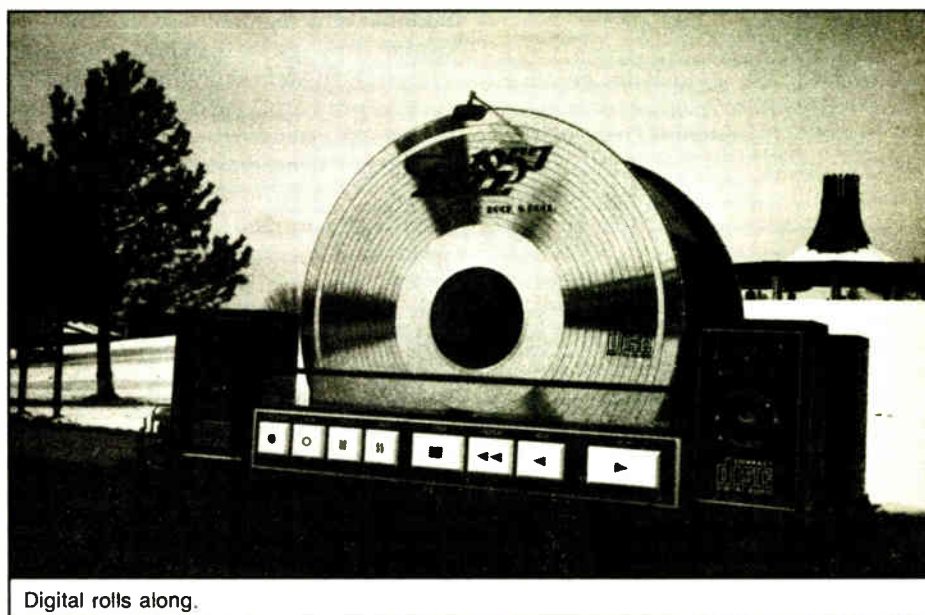

Digital rolls along.

Reason? AM stereo is **non-existent** in Europe.

Hmmmm. Well, I guess they've been busy with DAB and all... But on the stereo front, other countries are still interested. According to a FAX from Mexico's **CIRT** received (in Spanish) by NAB Science & Technology, the Mexican secretary of commerce and transportation has authorized AM stereo with the **C-QUAM** system.

The **CIRT** is also interested in the **NAB super radio** and wants to know if it could be manufactured in Mexico.

Here in the US, we'll be waiting to see what kind of comments the FCC gets on its **massive AM docket** concerning whether to encourage or mandate stations to go stereo.

Oh yeah. And one more thing I noticed up in Beantown, at the show. There was a "hidden" hot story, somewhat product related. It was the quantum leaps that have taken place in **data compression** for quality audio.

Now we already know all about the **MUSICAM** technology in the **Eureka** system. But products using quite advanced **compression algorithms** are beginning to proliferate and you can expect to see more, for transmission systems

and other audio applications.

I wondered why we've seen the technology take such a forward jump. But you probably already know. It's the chips. **DSPs**. They've come a long way, baby.

By the way there were no humongous **pseudo-boom-boxes** at the entrance to the show this year. But rolling discs, **Batman**, the **Dynamite Promotions** folks of Salt Lake City, Utah, sent me this nifty glance of a CD on wheels. It had to happen, didn't it?

And we all know that radio is everybody's **companion**. I guess our troops in the Persian Gulf are no exception. A campaign called **Air/Lift** has been launched by our very own radio industry to raise money to buy receivers for our men and women stationed there.

Don't know about you. But if I were thousands of miles from home in a tense part of the world, the radio is probably the **only thing** that could make me feel a little more secure. Like I really do have a friend.

Heard a juicy tidbit? Spill your guts to **Earwaves** by faxing JG at 703-998-2966, writing to PO Box 1214, Falls Church VA 22041, or calling 703-998-7600. Who knows, you could win a coveted **RW mug**.

## Transmitter Control can be a Bear

You need to make sure you can stay on the air and stay legal. At the same time, you need to keep operating costs under control.

Choosing the right remote control system is the first step.

The **ARC-16SA\*** from Burk Technology lets you control your transmitter from any phone. You can establish off-premises control points for unattended operation, or supervise non-technical operators by phone.

The annual savings can be thousands of dollars.

The **ARC-16SA** is part of a modular system. For full-time control, add a studio unit. Multi-site options make it easy to control several transmitter sites or even control studio equipment such as program automation.

Call now for your copy of our new catalog, then ask us to show you how we can improve your operation and your bottom line.

Call TOLL FREE  
1-800 255-8090

**BURK**  
TECHNOLOGY

7 Lomar Drive, Pepperell, MA, 01463 (508) 433-8877



## READERS FORUM

If you have comments for *Radio World*, call us at 800-336-3045 or send a letter to Readers' Forum (Radio World, Box 1214, Falls Church VA 22041 or MCI Mailbox #302-7776). All letters received become the property of Radio World, to be used at our discretion and as space permits.

### We have the tools to help AM

Dear RW:

Most consumers don't care whether their audio has .001% distortion or 1% distortion, or if their system is flat to 10 kHz or 20 kHz. As long as the audio is reasonably clean and solid, they'll listen to it (and yes, stereo is important).

From that point of view, at least, it would indeed seem that AM radio has a chance to be competitive.

But there are three things to remember about this.

The first is that, once the listener has been exposed to higher audio quality, and becomes acclimated to it, he/she generally won't be happy with anything less. Telephones get away with horrible sound because there's no real alternative; on the other hand, look at what the CD has done to the vinyl LP.

Second, AM/FM radios allow instant switching between bands; the listener can perform an A/B comparison at will. Unless AM sounds as good as FM under all conditions of reception, in the wee hours of the morning, while driving under bridges and power lines, the listener isn't going to be fooled.

Third, what the audio lover hates most is *non-musical* noise. He or she might put

up with limited high-end, but will *not* put up with static and hiss and popping in the music.

Sure, not having stereo has hurt AM; and the lousiness of most AM receivers is the nail in the coffin. But the coffin itself is AM's susceptibility to interference.

I have read and re-read your recent article on Docket 87-267, and I fail to see where it's that earth-shattering. Save for tightening overlap requirements and a few other tweaks, it does little if anything for AM's problems.

That docket is a case of too little too late. We've devoted a lot of attention to co- and adjacent-channel, but have almost ignored man-made and atmospheric interference. The only ways to address the latter involve improving the basic DSB-AM technology that we've been using since the 1920s.

As an engineer, of course I'm in favor of broadbanding. But the fact is, if we just broadband receivers given the current state of things, my poor little small-market AMs may very well go under. Out here "in the sticks," the key concern is, and always has been, coverage area. We don't have an urban audience to concentrate on; we have to cover a large area with low power to accumulate a significant audience.

In short, AM needs a complete technical overhaul, not just a good PR campaign and a little high end! Just requiring broadbanded AM stereo on all receivers will revive AM about as quickly as requiring that a turntable be sold with each CD player would revive the LP!

How did we get into this sorry state of affairs?

A lot of it has to do with the style of management that's being championed right now. We technical-types are given three minutes to present complex technical matters to kids-in-business-suits, who then give us a patronizing pat on the head and a treat, and ask us to leave the room while they make the *real* decisions.

(One need only look at the NAB's DAB panel—which includes not one engineer—for proof of this.)

Engineering types make them nervous; we live in a different world. We want to test stuff to make sure it works, to learn its limitations and then make our decisions based on that objective research. Unfortunately, that takes time and patience.

The current catch-phrase for decisive management, on the other hand, is that "ANY decision—even a bad one—is better than indecision." While decisiveness is certainly important, that dictum has to be applied with extreme caution to matters technical.

Not too long ago, a small group of engineers warned that a certain machine was unsafe; another group argued that it was fine. Management listened for a few moments, then tired of the nerds arguing with one another. They started pressuring for a definite Go or No Go. The small group was overruled, and the decision was made to proceed as planned.

Shortly thereafter, the shuttle Challenger exploded, killing everyone on board.

No one likes arguments, and certainly the Stereo Wars were getting nasty. Certainly a long, drawn-out debate was in

Continuing problems during times of catastrophes point to the need for an overhaul of the Emergency Broadcast System.

The system was built on premises and certain facts of life which have changed in recent times. The apparent demise of the Cold War has made the threat of nuclear attack from the Soviet Union or Eastern Bloc nations unlikely.

And the decline of AM listening has forced changes on a system designed for centralized control and set up to accommodate early radio technologies, before the rise of FM and even TV.

Disasters like the San Francisco earthquake, the Santa Barbara fires and hurricanes and tornadoes that afflict numerous regions of this country at various times of the year have given the EBS system more importance as a local, rather than a national system.

Discrepancies in jurisdiction in various counties and states, as well as uncertainty on the part of station personnel have caused confusion and kept EBS from being an effective warning tool.

In addition, routine on-air tests of the system, mandated by the FCC, have created a tune-out factor which could precipitate disaster when a real emergency occurs.

Currently a number of approaches are being tested in several states in an effort to create more useful emergency alerting networks. Many of these involve newer, digital technologies such as RDS.

The FCC, FEMA and broadcasters themselves should keep an open mind to changes in EBS and should encourage experimentation with new proposals.

If possible, a large-scale reevaluation of the system should be undertaken with the aim of assessing the experiments and setting up new guidelines that consider not only current circumstances but the changes radio will face in the future as well.

Broadcasting's extensive reach makes it an ideal medium at times when alerting the largest number of people, locally or nationally, is crucial to safety and survival.

A fresh approach to an aging system would restore its effectiveness and reassure everyone that the system will work when we need it most.

—RW

## Overhaul For EBS

**Radio World**  
Vol 14, No 19 October 10, 1990

Editor, Judith Gross

Associate Editor, Alex Zavistovich

News Editor, Alan Carter

Reporters, Charles Taylor, John Gatski

Benn Kobb, Frank Beacham/L.A.

Editorial Assistant, Marissa Friedman

Technical Advisor, Tom McGinley

Production Director, Kim Lowe

Chris Freter, Lisa Roach, Julianne Stone

Ad Production Coordinator, Jeanne Pearson

Publisher, Stevan B. Dana

Associate Publishers, Arthur Constantine

Carmel King

Ad Coordination Manager, Simone Mullins

Circulation Manager, Tiana Hickman

Accounts Receivable, Valerie Mason

Advertising Sales Representatives:

East & Midwest, Art Constantine

800-336-3045, Fax: 703-998-2966

West Coast, Pat Macsata

415-786-2198, Fax: 415-786-2754

**Radio World** (ISSN: 0274-8541) is published semimonthly (except February, which has 3 issues) by Industrial Marketing Advisory Services, Inc., 5827 Columbia Pike, Suite 310, Falls Church, VA 22041. Phone: 703-998-7600, Fax: 703-998-2966. Second-class postage rates is paid at Falls Church VA 22041 and additional mailing offices. POSTMASTER: Send 3579 forms and address changes to Radio World, P.O. Box 1214, Falls Church VA 22041. Copyright 1990 by Industrial Marketing Advisory Services, Inc. All rights reserved.

Free subscriptions are available upon request to professional broadcasting and audiovisual equipment users. For address changes, send current and new address to RW a month in advance at the above address. Unsolicited manuscripts are welcomed for review; send to the attention of the appropriate editor.

**Next Issue**  
**Radio World**  
**October 24, 1990**

no one's interest. But was the answer to cede the entire AM stereo market to one system just because a single manufacturer—Delco—decided to include it in some of its receivers?

I can say that honestly, because I was a C-QUAM supporter until recently. And in the mid '80s, I agreed with those industry leaders who said that C-QUAM was on its way to becoming the "de facto" standard, and that there was no point in continuing the Stereo Wars.

I have recently come to regret that acquiescence deeply. The fact is, a blind allegiance to C-QUAM is what is preventing this industry from taking decisive action to truly save AM radio.

Am I trying to restart the Stereo Wars? Heaven forbid! I'm trying to make a point.

The engineering community has recommended a number of innovative solutions for AM, including single-sideband (which would allow 10 kHz bandwidth in a single allocated channel, as well as other well-documented benefits), synchronous reception (which is far superior to an envelope detector—even cheap B/W TV receivers use them now!), and even Yazell's "NFR" (which would provide greater resistance to interference).

So why aren't these ideas given serious consideration?

It's simple: These proposals are basically incompatible with C-QUAM stereo and/or the C-QUAM receivers currently in service. Because we've bought onto the C-QUAM/NRSC bandwagon hook, line and sinker, we can't even consider alternatives.

This is especially incomprehensible when you consider that C-QUAM is in use in less than 20% of all US AM stations (considerably less, depending on those figures you read), and in less than 2% of all AM receivers.

Winning even 20% of electorate confers a mandate only to those who engage in wishful thinking.

If I sound a little cynical, I can't help it. The fact is, we've had the technology to "save" AM for years and the leadership of this industry simply refuses to implement it.

For example, if we were to use SSB,

along with a "locked companding" system—one in which the expander's control voltage is transmitted to the receiver, for precise complementary expansion regardless of reception conditions—AM would be competitive with FM, FMX and even DAB.

Yes, AM needs to be saved. But in our mad rush to save it, we're just going to kill it once and for all. Call me a prophet and be forewarned and thus forearmed: we're getting ready to spend a ton of money on a solution that—at best—will "save" AM for a few years, and little more.

For heaven's sake, can't we at least *consider* some alternatives?

Stephen M. Poole

Engineer-at-Large

Raeford, NC

### Good receivers are possible

Dear RW:

I agree with Powell Way from Columbia, South Carolina. He stated my feelings concerning the continuing controversy about receiver quality better than I could.

I own a couple of mid 1960s GM cars with original Delco AM/FM radios. One of the pleasures I derive from driving these vehicles is listening to the radio. AM quality is superior to FM. Signal to noise ratio, static rejection, audio fidelity and sensitivity all are superior.

This is not because the FM is poor but the AM is simple, with a front end that works.

The modern day receiver problem has a solution, we just need to fix it.

Richard L. Edwards, VP/DE

Guy Gannett Broadcasting Services

Miami, FL

## Correction

Sales for the first nine months of Continental's fiscal year were inaccurately reported in the 12 September issue of *Radio World*. The correct amount is \$31 million.

*Radio World* regrets the error.



**GET IT  
RIGHT**  
FROM HARRIS ALLIED

# THE BEST DEAL YOU'LL EVER WALK AWAY FROM

**1**

## 7 days of "walk away" time.

An automated broadcaster's dream? It's reality for AUDISK owners. AUDISK stores more than cart-based systems, and costs less. Your entire commercial inventory—plus PSAs, liners and IDs, and more—can be online at once. AUDISK's "smart audio" software will automatically play your liners and IDs in random rotation, substitute a PSA for a past-killdate commercial, switch ID calls in time with the satellite jocks, etc.



**2**

## AUDISK delivers the promise of automated digital audio.

Until now, digital systems only gave you part of the automation solution. AUDISK does it all—digital automation *and* digital storage—in one compact, convenient, easy-to-use system. For satellite formats, live-assist or any combination, nothing's easier to use than AUDISK. Even a computer novice can manually schedule an entire weekend of commercial stopsets in under 15 minutes. Or use the optional traffic system software interface for even greater convenience.

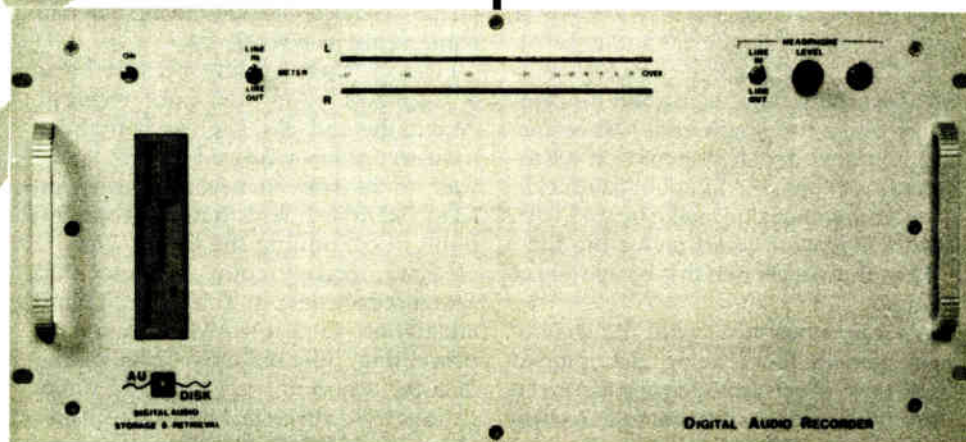

**3**

## The first digital audio hard disk system that's as easy to own as it is to use.

The wait for an affordable digital audio hard disk system is over. AUDISK actually costs less than cart-based automation. And it's designed by radio people for radio people. So the balanced XLR inputs and outputs, standard remote contact closures, even the optional traffic system interface, all fit the systems you already have installed. AUDISK makes digital audio storage and automation easy in every way.



**4**

## All the backup you could ever need.

In an emergency, AUDISK stands alone. With options like "disk mirroring" and fully redundant systems, you can walk away with total confidence. And AUDISK comes with another important kind of backup—the unmatched resources of Harris Allied Broadcast Equipment, including the service, installation support and custom configuration capabilities of Harris Allied Systems.

**5**

## Take the first step.

Call your Harris Allied representative toll-free at 800-622-0022 for more information on the digital audio automation system that does it all, so you can walk away—AUDISK.

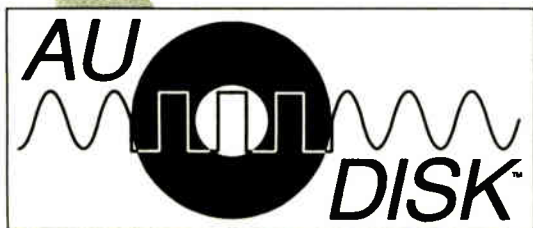

**HARRIS  
ALLIED**  
BROADCAST EQUIPMENT

**800-622-0022**  
Canada 800-268-6817

STUDIO EQUIPMENT • HARRIS RF PRODUCTS • SATELLITE GEAR • TRADE-INS • TURNKEY SYSTEMS

© 1990 HARRIS/ALLIED

"Call me, I'm interested." Circle 26.

World Radio History

"Send me literature." Circle 8.



# ISO Selects Compression

by Alan Carter

**Stockholm SWEDEN** The International Standards Organization (ISO) has determined that the MUSICAM and ASPEC compression algorithms should combine in some areas to set an international audio coding standard.

The decision, which one engineer called the selection of "a winner and a winner" was reached after extensive tests—which included listening—of four original systems which were eventually narrowed down to MUSICAM and ASPEC. Both systems use bit rate reduction algorithms to compress audio.

The ISO standard is designed for storage and retrieval in moving pictures and sound but sets the stage for selecting a compression standard to accompany a digital audio broadcasting (DAB) trans-

mission scheme—such as the European developed Eureka 147 system, which currently uses the MUSICAM algorithms.

Greg Urbiel, director of CBS Radio mid-west technical operations and the only North American broadcaster participating in tests this summer at the Swedish Broadcasting Corp. in Stockholm, said demonstrations showed the extreme advancements in compression technology in five years. "Some of it was awfully good."

A first draft of the ISO standard will be available by year end, according to Dr. H.G. Musmann, a professor at the University of Hanover in Germany who chairs the subgroup working on the standard.

The test results showed ASPEC superior in certain areas and MUSICAM in others, Musmann said. MUSICAM, however, reached "a little higher" score, he said.

"Since the basic structure of both algorithms is also the same," he said, "we agreed to combine the best components of both algorithms into the coding standard."

MUSICAM is a sub-banding coding on 32 sub-bands, developed by a group including the Centre Commun d'Etudes de Telediffusion et Telecommunications (CCETT) of France, the Institut fur Rundfunktechnik (IRT) of Denmark, Philips of the Netherlands and Matsushita of Japan.

ASPEC is a transform coding, overlapping blocks system developed by AT&T Bell Labs of the US, Centre National d'Etudes des Telecommunications of France, and Deutsche Thomson Brand and Fraunhofer-Gesellschaft FhG-AIS, both of Denmark.

However, not all reactions after the completion of the ISO selection process agreed on the outcome as stated by Musmann. The difference in the interpretation of the ISO between spokesmen for both developers showed the conflict within the process.

While AT&T termed the results a "merger" of the algorithms, the CCETT challenged the statement and said MUSICAM "won" with the final standard based on it.

Both camps, however, agreed that ASPEC scored higher in quality and MUSICAM higher on implementation, due to the simplicity of the encoder and decoder.

Nikil Jayant, head of signal processing for Bell Labs, admitted there is some controversy but said, "The decision of ISO is to come up with a merged algorithm with ASPEC and MUSICAM. In overall performance," he continued, "the total performance of the two was close enough to be merged."

As Y.F. Dehery of the CCETT explained, the standard at any bit-rate will be a sub-banding coding with psychoacoustical assistance as described in MUSICAM. The standard at 128 kBit/s

and 96 kBit/s will use the MUSICAM specifications.

Where work remains, Dehery said, is to provide a stereo program of acceptable quality within a total bit-rate of 128 kBit/s for two channels, for example, on the average 64 kBit/s per audio channel.

"It is clear after the ISO tests that at this low bit-rate, it will be very difficult to create stereo programs of high quality and additions must be made to the standard in order to improve the existing technique," Dehery said.

One solution is to introduce an additional layering to MUSICAM, which would use a technique called "run length coding" found in ASPEC.

The CCETT opposed that option, Dehery said, but the solution suggested by CCETT was rejected as too advanced and not easily comparable to a monaural encoding.

## DAB Key at Radio '90

(continued from page 1)

may be costly and less spectrum efficient.

And, noting the extensive research and dollars poured into the Eureka system, and the fact that its developers have "correctly identified every optimum feature of a digital system," Edwards went so far as to ask: "Is there any point in waiting for someone to develop another system or should we just get on with the next generation of radio?"

At the "Friend or Foe" session 500 radio executives packed an auditorium to hear NAB executives give their assessment of DAB developments.

Executive VP of Operations John Abel gave a history of DAB's development and emphasized the competitive threat to broadcasters from such services as CDs, digital cable radio and digital radio satellite services.

Alan Box, chairman of the NAB's DAB Task Force said broadcasters are "trying to decide whether to reach out and embrace

DAB without knowing how current FM and AM station holders will be affected."

Box wondered if all DAB facilities should be equal, under future allocations plans, and stressed that NAB views the new technology as "an enhancement, like HDTV." He urged broadcasters to stick together on policy decisions.

Questions from attendees showed concerns over such issues as whether DAB would be a boon to ailing AM stations or another obstacle in the path of AM's survival.

Asked about the time frame for DAB implementation, Abel estimated it would be late into the 1990s before stations began broadcasting DAB and ten years beyond that for full acceptance.

A German broadcaster asked why the NAB favors a terrestrial system over DAB via satellite. Abel answered with a reaffirmation of NAB's consistent policy of supporting localism and received a rousing round of applause from the audience.

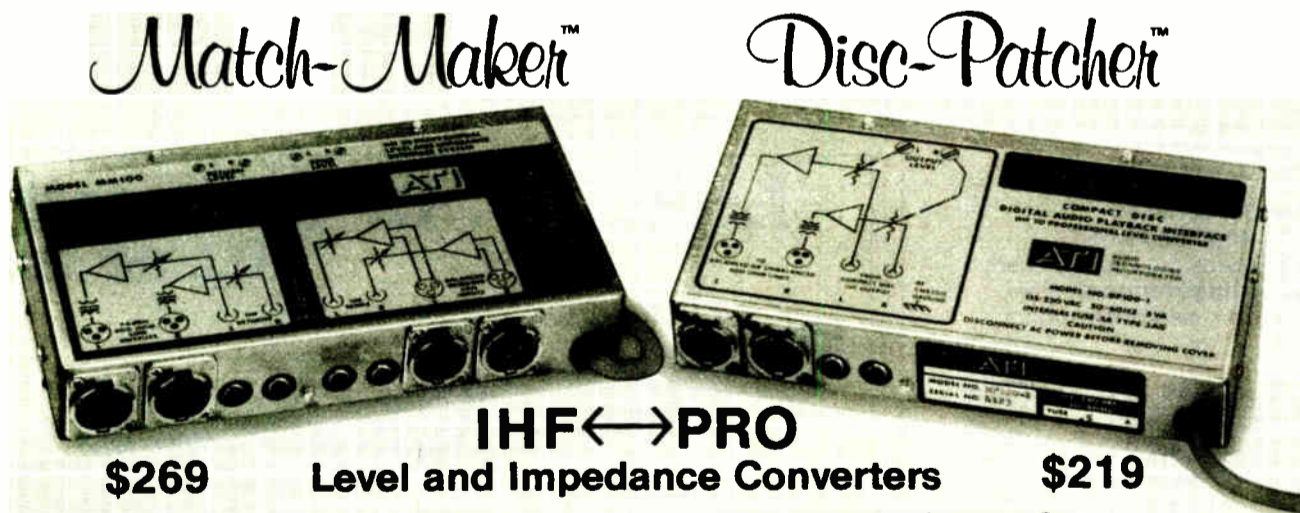

\$269

**IHF ↔ PRO**  
Level and Impedance Converters

\$219

**BI-DIRECTIONAL FOR**

- Reel to Reel and Cassette Recorders
- Graphic Equalizers and Noise Reducers
- Audio Effects Processors and Digital Reverb
- Dual Line Amp, DA, Splitter or Combiner

**UNI-DIRECTIONAL FOR**

- Digital Compact Disc Players
- ENG Cassette Dubbing
- Off-Air Monitor Tuners
- Console Audition Outputs

Interface consumer/industrial IHF (-10db) stereo source equipment and signal processing devices into professional studio +4dBm, 600 ohm systems without loading distortion, crosstalk, hum, response roll-off or RF pick-up.

True transformer output isolation, balance and protection with less than .01% THD even at 20Hz and +22dBm peak output!  
102 db dynamic range...greater than a Compact Digital Disc system!  
Self contained power supply, Velcro™ and dual rack mounting.  
Free Detailed Brochure and Specifications Available

**AUDIO TECHNOLOGIES INCORPORATED**  
328 Maple Avenue, Horsham, PA 19044  
(215) 443-0330



## For Excellence In Antennas

- A complete line of TV and FM Broadcast Antennas
- Modern 7,000 ft. test range facilities
- Innovative Engineering Careful construction
- Two Year Warranty on Product and Workmanship

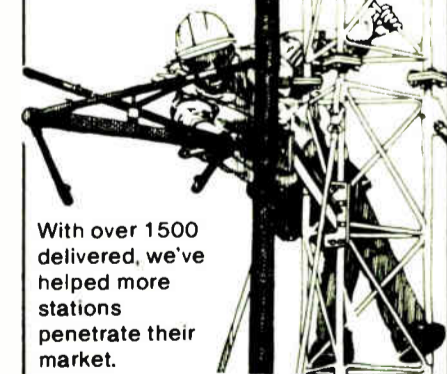

With over 1500 delivered, we've helped more stations penetrate their market.

FCC Directionals  
Pattern Studies  
Multi-Station Arrays  
Full Scale Measurement

**JAMPRO ANTENNAS, Inc.**  
6939 Power Inn Road  
Sacramento, CA 95828  
(916) 383-1177 TELEX 377321



# IEEE Symposium Looks Ahead

by Charles Taylor

**Washington DC** The 40th annual IEEE Broadcast Symposium focused on the future, offering engineers a look at modern technologies and those on the forefront, including digital audio broadcasting (DAB).

FCC Chairman Al Sikes, who spoke at a conference luncheon, stressed the Commission's forward-aimed goals—particularly with DAB—and its ongoing commitment to uphold broadcast standards.

"The fact is that the attitude of this Commission reflects an understanding that high standards are essential if broadcast media are to remain vital and continue to serve the important responsibilities which are a fundamental part of our broadcast culture," Sikes said.

## No AM stereo standards

He criticized the FCC's past stance on AM, claiming that as a result of rejecting proposals to create AM stereo standards, the Commission "consciously chose to establish an inferior radio service." Today, Sikes said, the Commission is taking steps to improve AM.

On DAB, he said, "I cannot tell you . . . what percentage of the population will expect compact disc quality and in what year, but I can tell you that the radio world is moving in that direction," he said.

Digital modulation is a "hot topic"

across the board at the FCC, said Bill Hassinger, assistant chief for engineering in the Mass Media Bureau. The issue is not limited to radio, but also in television and cellular telephone technology, he said. Hassinger noted that some experts believe all telecommunications services will become digital.

The FCC is preparing a Notice of Inquiry on spectrum for satellite sound and high definition television by satellite to develop a position for the 1992 World Administrative Radio Conference (WARC), Hassinger said. The Commission is "ambivalent" on what position to take. "The big one is broadcast satellite sound," he said.

A paper presented by NAB Science and Technology VP Michael Rau focused on terrestrial coverage considerations of the technology. NAB, in past discussions of DAB, has made clear that DAB applications by satellite delivery are contrary to its support of localism.

## Eureka coverage factors

In the paper, Rau said that practical implementation of a terrestrial DAB service would require a system-level examination of technical factors ranging from receiver technology and propagation characteristics to reliability of service.

Estimations completed by NAB Science & Technology were based on the Eureka 147 model, developed in Europe. The calculations were plotted for 50/50 service

(the current FM allocation coverage definition: 50% of the service area covered 50% of the time) as well as for 90/90 and 99/99 service.

The calculations concluded that at 1 kW ERP, at 100 MHz, a DAB broadcasting system would provide a maximum coverage of about 43 miles. At 500 MHz, the coverage is estimated to be a maximum of 31 miles.

"Obviously, there are a great many difficult policy decisions that confront the industry," Rau commented. "It is critical that the industry have as much technical information as possible about how a DAB system could be implemented and the nature of its performance characteristics."

Gary Noreen, chairman and CEO of Radio Satellite Corp., which has an application before the FCC for satellite radio

delivery, also made a presentation at the symposium.

Noreen said his company could offer 10 channels of audio to automobiles by the 1993 launch of a mobile satellite he will be using. Receivers, with AM/FM and his L-band reception, are expected to be on the market for the year end holiday season of 1993, he noted.

## Anti-skywave plan

In a session on addressing AM antennas, Timothy Cutforth, director of engineering for Vir James Consulting Radio Engineers, outlined specifications for implementation of anti-skywave antenna technology by extreme top loading of short antennas in a directional array.

He discussed applications at stations in California and Alaska. At KNWZ in Thousand Palms, CA, top loading from 93° physical height to 216° electrical height provided high angle skywave suppression while increasing gain for the KNWZ array, Cutforth said.

# DBS Due for Japan

by Bryan Harrell

**Tokyo JAPAN** Satellite-delivered digital radio is slated to go on-air here in 1991.

Satellite Digital Audio Broadcasting Inc. (SDAB) will offer direct broadcast satellite (DBS) radio beginning in April, blanketing Japan with a scrambled signal that consumers will receive using a decoder attached to existing home electronics.

A second service, for which the Japanese Ministry of Posts and Telecommunications (MPT) is outlining regulations, could begin in the fall by telecommunications satellites.

SDAB will share a channel on a DBS satellite launched 24 August with Japan Satellite Broadcasting Inc. (JSB), which will use only half of its audio portion for a TV signal.

The system will use A mode digital broadcasting, which has a sampling rate of 32 kHz, enabling a frequency response that tops out at 15 kHz and a dynamic range of 80 dB. While A mode is digital, it is not quite CD quality, which has frequency response to 20 kHz and dynamic range somewhat higher than 90 dB.

The satellite, BS-3a, making DBS radio possible, is expected to reach a final or-

bit position by November and will be tested for about three months, then phased in to replace a failed satellite, BS-2a that was launched in 1986.

Initial reports, however, said one of four solar panels on the satellite is not working because of a short in a power cable. It can still operate normally on three panels, but this development shortens the life span because the panels deteriorate.

When power drops, probably some time in 1991, only two channels on the satellite will operate. To accommodate the situation, Japan plans to launch a backup satellite.

SDAB and JSB will share one channel on BS-3a; the other two will be used by the Japan Broadcasting Corp. (NHK).

The second service would utilize empty transponder space on existing telecommunications satellites for genuine CD quality B-mode broadcasting that has 48 kHz sampling, response to 22 kHz, and 90+ dB dynamic range.

Not all the programming would be listener paid, suggesting that decoders for free programming would be standard product sold by electronic manufacturers. However, no details on this are yet available.

# PROOFS IMPROVED

**FM and TV-BTSC AUDIO PROOF TESTING** is reduced from hours to minutes with System One from Audio Precision... Automatic proofs run properly at constant deviation, plotting the required generator amplitude... and when finished, the results are stored in graphic form for your records.

**SPLIT SITE** proofs are simple with System One's available separate generator and analyzer configuration. With immediate capability to view and control both instruments, it's like being in two places at once.

**THE REST OF THE TIME** System One is the universal audio test set for maintaining any audio device or channel... STLs, consoles, carts, cassettes and RDATS, digital recorders and workstations... System One is the only product that can completely test both your analog and digital audio.

Call 800/231-7350 for our 36 page color catalog... and when you're ready our representative will arrange for an on-site demonstration.

**Audio precision**

P.O. Box 2209, Beaverton, OR 97075  
503/627-0832, 800/231-7350  
FAX: 503/641-9806  
TELEX: 283957 AUDIO UR



Circle 76 On Reader Service Card

## Live! . . . in concert! ALL the Time

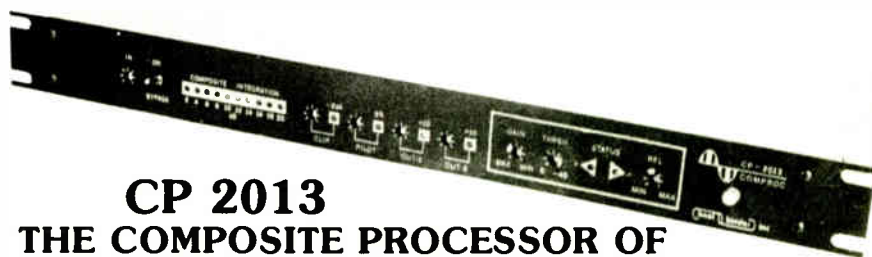

### CP 2013 THE COMPOSITE PROCESSOR OF THE FUTURE HERE TODAY

- ★ Low second harmonic clipper — flat to 420KHz!
- ★ Separation exceeding 60 dB
- ★ Ultra smooth, fast acting AGC, builds stereo image without the grunge!
- ★ 1½ dB louder than any other composite clipper
- ★ Multiple outputs plus remote control

AVOID THE RUSH — CALL NOW

**hnat hinders inc**

42 Elaine Street • R.R. 1 • Thompson, Connecticut 06277 • (203) 935-9066 • (203) 935-9242

Circle 35 On Reader Service Card



# EDIS to Assist California EBS

(continued from page 1)

The first EDIS digital receivers have been installed by KGO-TV and KCBS Radio in San Francisco and KFBK Radio in Sacramento. The Associated Press and Bay Cities News wire services and the "Traffic Central" traffic reporting service have also expressed interest in installing the receivers, Botterell said.

### Used by NWS

The National Weather Service already has originated several emergency messages that were transmitted successfully over the EDIS system, Botterell said. Others who can originate messages are the OES, state and federal agencies and

**EDIS uses digital radio transmission to deliver messages to receivers at media outlets.**

authorized county and local public-safety and emergency-management offices.

EDIS uses digital radio transmission to deliver messages to receivers at media outlets. "This application of inexpensive "packet radio" technology ensures that EDIS can survive emergencies which would sever underground cables and block telephone net-

works," Botterell said.

The State Warning Center's existing digital message processing system is the heart of EDIS. This system accepts messages from various input networks, screens them for proper format, packages them for transmission and drives the digital radio transmitter which controls the relay station on Mt. Diablo.

A portable backup relay system now is being assembled for quick deployment should the main relay fail, Botterell said. The primary control transmitter at the State Warning Center in Sacramento will also be backed up with a spare ready for immediate deployment.

### Message processing computer

A message processing computer is a key advantage of the system, Botterell said. During an emergency it is common for several agencies or jurisdictions to release information simultaneously. The EDIS message processor accepts multiple simultaneous inputs and sequences them into a single stream of messages for dis-

Figure 1.

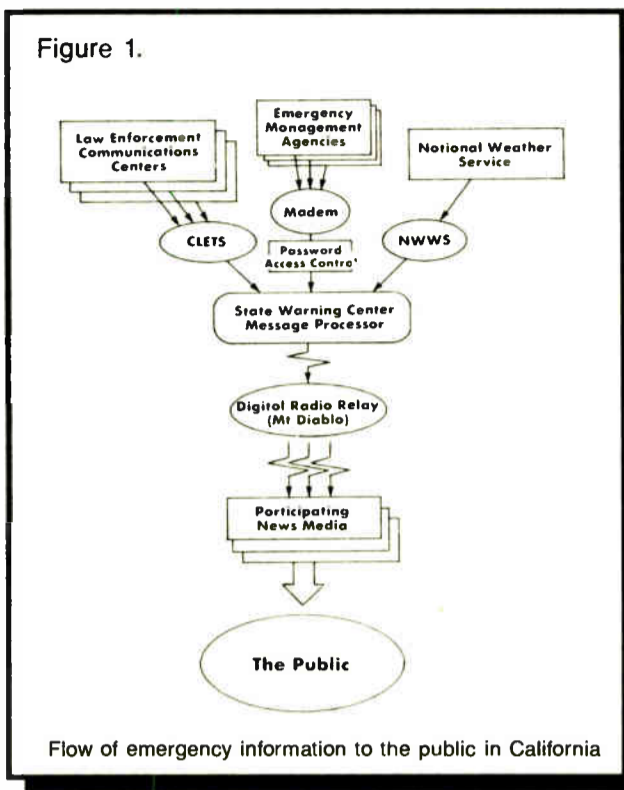

Flow of emergency information to the public in California

semination to the media.

Receivers, Botterell said, cost about \$500 and have so far been built by the individual stations from readily available components since no suitable pre-assembled receiver is available on the market. Most receivers feed their digital output directly to a printer for hard copy printout. In television applications, EDIS messages can be fed directly to newsroom computers and character generators for instantaneous on-screen captions.

EDIS owes much to the "groundbreaking work" on packet radio transmission of public information done by the Los Angeles County and City Emergency Preparedness Commission and Southern California broadcasters and to the experimenters of the Amateur Radio Service who developed packet radio technol-

ogy, said Botterell. He said he hopes the Northern and Southern California systems can soon be tied together to form the first links of a statewide network.

After the two cities are tied together, OES hopes to integrate EDIS into an emergency satellite communications network. Satellite links would distribute EDIS messages into the local digital radio relays in metropolitan areas. This architecture would also permit installation of direct satellite receivers to serve more isolated areas of the state.

The new California system was developed in light of widespread criticism of the performance of the existing EBS in California (see accompanying story on Santa Barbara fire) and the failure to provide visual displays for hearing-impaired television viewers. Its development and testing to date have been accomplished under existing state funding for the OES and individual broadcasters have paid for their own receivers.

In response to the EBS criticism, the California legislature approved a bill which authorized \$100,000 in funding to create a digital system but, due to the state's current budget crunch, the bill was vetoed by Gov. George Deukmejian. A new bill, requiring the OES to prepare a feasibility study of a digital system but without providing funding to build it, passed the legislature and is expected to be signed by the governor.

Ironically, the legislation without funding has widespread support ranging from the OES to the California Broadcasters Association.

Vic Biondi, executive director of the association, predicted that much of the digital system can be implemented without expenditure of tax dollars because of existing digital systems owned by the state. He predicted broadcasters would readily purchase receivers when the system is fully implemented.

## EBS Fails in Wildfire

by Frank Beacham

**Sacramento CA** In what is being described as another major failure of the Emergency Broadcast System (EBS) in a California disaster, state officials are questioning whether local government is even capable of providing useful information to the public during an emergency situation.

The latest EBS failure occurred during this summer's disastrous wildfire in Santa Barbara, officials said, and key emergency information was relayed to the public, not by government officials, but via talk radio station KTMS through its reporting staff. A similar EBS breakdown occurred in last year's San Francisco earthquake.

In an internal report by Art Botterell, assistant chief of telecommunications for the California Office of Emergency Services, several factors were cited for the EBS breakdown.

The equipment to activate the EBS system existed in the county emergency operations center and "the one individual familiar with its operation was otherwise occupied. Thus, when another county staffer finally tried to use the system, the required activation tones were not sent properly" so that the receiver at radio station KTMS, the common program control station (CPCS-1), never was activated.

Decisions about evacuation of threatened neighborhoods were made, not at the county emergency operations center,

but at a tactical command post. There were no provisions at the command post to transmit EBS messages.

(continued on page 10)



## ITC Cart II

Long recognized as the industry's premium cartridge, the ITC Cart II features less wow and flutter, less tape noise, less head and tape wear, less phase jitter and simply superb sound quality. Every millimeter of tape in every cartridge is 100% laser inspected to eliminate drop outs.

Call us for complete information on the ITC Cart II, and on our other high-quality broadcast products, all available

from  
**The Preferred Source.**

**BROADCAST SERVICES/EME**

The Davis Communications Group, Inc.

**Authorized Distributor**  
International Tapetronics Corporation

RADIO PRODUCTS DIVISION

**800/525-1037**

Four Oaks, NC 27524  
FAX 919/934-1537



# CA Fire Points Out EBS Flaws

(continued from page 9)

The county emergency operations center itself was evacuated for over an hour due to smoke and the impending fire and there was no alternative site from which EBS could be activated.

"The same thing happened in the San Francisco earthquake. If we had really needed the (EBS) system the last people who seem to know what's going on is government," said Jim Gabbert, state EBS coordinator, president of the California Broadcasters Association and owner of KOFT-TV in San Francisco.

"Santa Barbara had its plan and it totally fell apart on the government level," said Gabbert.

Gabbert voiced strong criticism last year when a snafu caused an EBS failure after the San Francisco earthquake that resulted in 67 deaths. At the time he called the EBS a relic from World War II days and said "it did not work then and it won't work in any city in the country the way it is currently set up."

Botterell's OES report praised Santa Barbara news/talk radio station KTMS for filling the void left by the lack of EBS information. "The local broadcast media were able to do such an outstanding job serving the public that the lack of EBS was hardly noticed," Botterell said.

"In fact, their (KTMS) performance

calls into question the traditional model of warning and public information as being a one-way street from government to the media," Botterell continued. "In fact the opposite was closer to the truth during the first few hours of the emergency."

Even when official information became available, Botterell said, it lagged behind KTMS. "For example, the official notice that U.S. 101 had been closed by the flames came over an hour after that news had been aired by a KTMS reporter," he noted.

Santa Barbara television station KEYT carried KTMS's audio with a slide through the night after their regular sign-off time and KCBS Radio in San Francisco carried large portions of KTMS's program live by telephone feed. KTMS chief engineer J.D. Straller said his station simulcast AM emergency programming on FM to reach a broader audience in the Santa Barbara area. He said it was the station's first simulcast in over 15 years.

Straller echoed Gabbert's comments about the lack of useful emergency information from government officials but praised local fire fighters and other field personnel with helping his station's reporting staff get needed information to the public. He said cellular telephones, which continued to operate when land lines failed, also helped his reporters get information to

the station.

Rather than rely on EBS information, Botterell said the evacuation of Santa Barbara citizens from their endangered homes "was mainly spontaneous, with sheriff's deputies using PAs and going door-to-door where they could. EBS was never a significant factor in the response or the recovery."

As a result of the Santa Barbara fire, Botterell said he drew two main lessons.

Government needs better facilities for listening to the media, as well as talking with them. And, the separate functions of warning, information, and reassurance should not be lumped together in-

discriminately in government public-information planning.

Both Gabbert and Botterell are aggressively promoting a new digital emergency information system for California (see accompanying article.)

But both also see a problem with the source of the information for any such system. "The problem we have found in post disaster areas is the government officials don't have the foggiest idea what's going on," said Gabbert.

"The real information is being gathered by the news media. The whole concept must change so that the news media is part of this system. I suggest a combination of media and government information be provided the system. I will try to steer our task force in that direction."

## Duggan Talks Tough

by Benn Kobb

**Washington DC** "We're all the victims" of the FCC's top-down decision making, according to FCC Commissioner Ervin Duggan.

Reflecting on his first few months in office at an informal public lecture 6 September, the newest commissioner praised FCC staff while he criticized the agency's processes in vivid words.

Sunshine Act laws that strictly govern a commissioner's role have turned deliberations into a rigid, artificial "Kabuki theater," Duggan said.

Regulations don't permit more than two commissioners to meet outside formal, recorded official Commission meetings. This suppresses the "robust clash of ideas, the group dynamics," he said.

Duggan complained that he is often asked merely to approve decisions handed down from FCC Chairman Al Sikes.

"I often feel like a member of the Hungarian parliament, or a Soviet citizen before reform (in those nations)," he said. "I'm asked to give my obedient paw print on the one option presented, and

not to make my imprint on substantial proposals before the FCC."

Duggan does not hold Sikes responsible for this procedure, which he said the chairman inherited from the past.

When asked about his goals, the commissioner said he will "rehabilitate the public interest across-the-board. I want to break open the process, to make it genuinely open. The consumer must be represented at the policy making table. The beleaguered consumer is always in danger of being ignored."

Also asked about his philosophy on spectrum allocations, especially in light of prior FCC pronouncements that the spectrum is no longer scarce because there are so many sources of information and entertainment, Duggan had a few more words of wisdom.

"Who in the world came out with the idea that spectrum is not scarce?" he replied. "A day does not pass that I'm not confronted with spectrum scarcity. This is a scarce, precious national resource. We should be as jealous of its protection as we are of Yosemite or the Grand Canyon."

### FILTERS FOR ANY BROADCAST APPLICATIONS

*Channel Combining, Combining Service Bands, TVRO Interference*



UHF/Microwave Diplexers & Triplexers Combine Service Bands, VHF-UHF Radio, STL & ENG Bands At The Tower

UHF Diplexer

**"We Make Filters In A Hurry For Customers In Trouble!"**



Professional TVRO Interference Filters C and Ku-Band

Multiple Carrier Notch Filter



Transmitter & Receive Filters, Combiners & Diplexers For VHF-UHF, LPTV & FM Stations

LPTV UHF 4 Channel Combiner



Call NOW For Fast Help Or To Receive Any Of Our FREE Catalogs



Combiners/Group Combiners & Filters For ITFS/MMDS/MDS "Wireless Cable"

Low Loss Channel Combiner

**Microwave Filter Company, Inc.**  
 6743 Kinne Street • East Syracuse, NY 13057  
 Toll Free(US/Canada): 1-800-448-1666 • Collect(NY/AK/HI): 315-437-3953  
 FAX: 315-463-1467 • Telex: 249-613

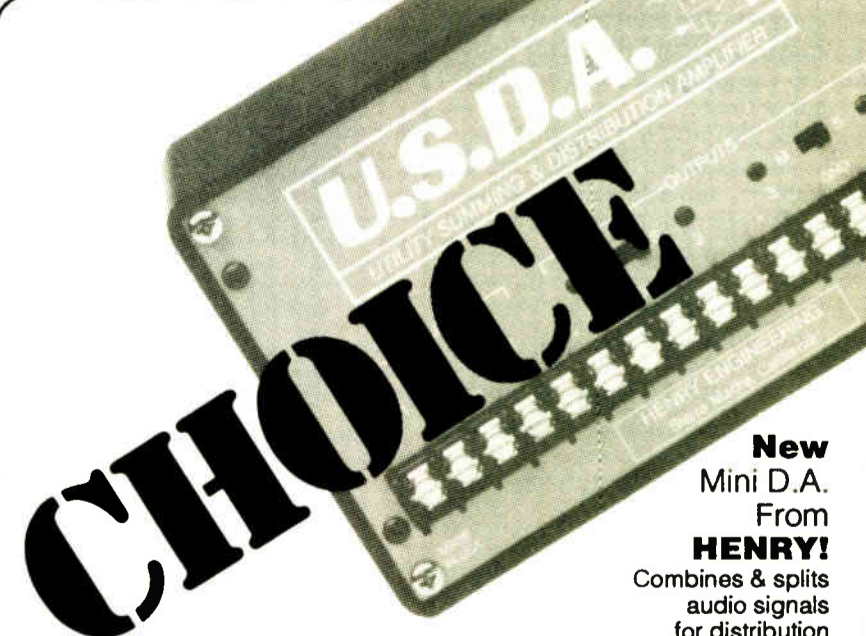

CHOICE

**New Mini D.A. From HENRY!**  
Combiner & splits audio signals for distribution

**FOR THE FULL PICTURE**  
 CALL TOLL FREE 1-800-356-5844  
**Consultation**  
 (608) 271-1100  
 5618 Odana Road  
 Madison, WI 53719





# #1 FOR ALL

Which cart machines do you put in your racks? Everyone has a different preference. Which carts do you put in your machines? The clear favorite is the genuine Audiopak broadcast cartridge, the

world's best selling tape cartridge. The #1 choice of demanding broadcasters across the country and around the world.

No matter what brand of machine they play them in, broadcasters know they can always count on Audiopak. That's because only bona fide Audiopak carts are loaded with real Audiopak tape. You expect consistency, reliability and unsurpassed audio performance. You

get them all with every batch of Audiopak carts —“workhorse” A-2s, “stereo” AA-3s and “digital-ready” AA-4s. Just as you have for years.

That's a record no “lookalike” cart will ever be able to match. So if you want all the clarity and phase stability your cart machines were designed for, don't take chances. Make sure they're playing “the only blue that's true”— genuine Audiopak carts. Look for our new Quality Assurance seal and the molded-in Audiopak logo on black A-2s as well as blue AA-3s and AA-4s. They're your guarantee of genuine Audiopak performance.



**audiopak**<sup>®</sup>  
BROADCAST CARTRIDGES

The cart the world  
counts on, cart after  
cart after cart.

P.O. Box 3100  
Winchester, VA 22601  
Tel: (800) 522-CART or  
(703) 667-8125  
Fax: (703) 667-6379

Circle 50 On Reader Service Card

World Radio History



# When a Station Goes Too Dark

## Tower Light Violations Carry High Price Tags

by Harold Hallikainen

**San Luis Obispo CA** Recently a dark AM station went a little too dark. It allowed its tower lights to go out. In June, the FCC fined the station \$10,000.

I have not yet seen the paperwork on this, but I did talk to people at the FCC field office. I found a similar case in the 2330 pages of 1989 violation notices and related correspondence I just received from the FCC under a Freedom of Information Act request (special thanks to Larry Clance at the FCC for all the work!).

## INSIGHT ON RULES

In that case, the power company cut the transmitter site power due to non-payment. The station convinced the power company to reduce the required deposit to restore power, because only the lights would be run.

It's quite sad that most of the violations I'm finding are at AM stations that have utilized "deferred maintenance" as a method of breaking even. These stations

often have no chief operator, or appear to have an unqualified chief operator (sometimes the program director).

### An expensive example

In the FOIA material I just received was an interesting tower light case that got a lot of publicity (see FCC Public Notice 3631, 17 July 1989). Here, a station was fined \$8000 for not having operating tower lights and another \$1000 for falsely indicating on the station logs that the tower lights were operating properly.

The station owner claims the previous owner said (in 1979) that no tower lights were required. The FAA called the station in 1984 and 1987 regarding the tower lights, so the station claimed that the FAA had been "notified" as required by 17.48.

The FCC responded that FAA notification is to be followed by repair of the required lighting as soon as possible (10 years is probably not satisfactory). Further, it appears that the tower lights could not be repaired due to the severe deterioration of the towers, making them dangerous to climb.

The case gets a bit more interesting. The FCC has always given larger fines (although generally in the \$1000 area) for interference problems (overpower, DA problems, etc.) and safety problems (inadequate AM fences, EBS problems and bad tower lights).

In this case, after the FCC inspection, the station received a determination from the FAA that the towers need not be lit because of their proximity to higher lit towers.

### Safety or paperwork?

At this point, it becomes an interesting question as to whether the fine is for a safety problem or a paperwork problem. The station should have gotten the FAA determination prior to disconnecting the lights (over 10 years ago), or, per-

been inspected and were operating properly? The FCC inspector thought so, the station argues not. Was the operator properly instructed in making log entries? Did the chief operator make adequate log reviews?

The station in September 1989 requested that the full FCC review the fine. In August 1990, the FCC affirmed the \$8000 fine (required tower lights not functioning). The proper procedure must be followed. The FAA notification, FAA determination and FCC application

## The Commission is taking tower lighting very seriously. Make sure that your operators are completing required daily tower light inspections.

haps within a short time after the lighting failure with appropriate notification of the FAA.

Further, once the FAA determines that lights are not required, a station needs to file with the FCC to modify the lighting requirements on the license. Many stations are cited for not having lights the FAA does not require but the FCC does, since the license was never modified.

Finally, the station was fined \$1000 for falsely indicating on logs that the lights were operating. At some point, the station changed forms for the station log. The old log form had a space marked: "TOWER LIGHTS ON: OFF:"

It appears the operators were to log the on and off times for the tower lights. When a new form was adopted, the "ON:" and "OFF:" spaces were deleted. The operators then wrote in "ON/OFF", dated and signed the entry, apparently in an attempt to make the new log match the old log form.

Did this indicate that the lights had

must be done (or at least in process) before the FCC inspects.

### How about your station?

The Commission is taking tower lighting very seriously. Make sure that your operators are completing required daily tower light inspections. Can they detect the failure of any light in the system?

I'd suggest logging the results of the inspection, although 17.49 requires the logging of only tower light failures, adjustments or repairs. Make sure your lighting matches that specified on the station license exactly. An Ohio station was cited for not having the tower lighting match that on the license, because the tower lighting included a lighted cross.

■ ■ ■

Harold Hallikainen is president of Hallikainen & Friends, a manufacturer of transmitter control and telemetry systems. He also teaches electronics at Cuesta College, San Luis Obispo. He can be reached at 805-541-0200.

## THIS MARTI REMOTE PACKAGE COULD BE YOURS FOR LESS THAN . . .

# \$5.00\*

A DAY

### MARTI PACKAGE INCLUDES . . .

- Two Frequency 30Watt transmitter
- Two Frequency receiver
- Magnetic mount mobile antenna
- Yagi directional antenna w/20 ft cable
- Omni-directional base antenna w/100 ft cable
- Contact your nearest Northeast Sales Office for all the details

\* Based on 36 month lease. Taxes and freight not included. Prior credit approval required.



**NORTHEAST BROADCAST LAB, INC.**

Serving the Broadcast Industry Since 1961

#### Main Office

P.O. Box 1179  
S. Glens Falls, NY 12803  
Tel: 518-793-2181  
FAX: 518-793-7423

#### Mid-Atlantic

P.O. Box 565  
Southampton, PA 18966  
Tel: 215-322-2227  
FAX: 215-953-0523

#### New England

P.O. Box 406  
Auburn, NH 03032  
Tel: 603-483-1002  
FAX: 603-483-2352

#### Southwest

P.O. Box 867717  
Plano, TX 75086  
Tel: 214-612-2053  
FAX: 214-612-2145

Circle 116 On Reader Service Card

## fm TRANSMITTERS FROM CONTINENTAL

- COMPACT AND EFFICIENT
- SOLID-STATE DRIVER
- EXCLUSIVE SOFT START™
- AUTOMATIC POWER CONTROL
- TOTALLY SELF CONTAINED
- TRANSTAT™ READY

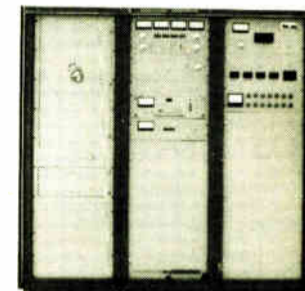

**varian**®

continental electronics division



P.O. Box 270879 Dallas, Texas 75227 • (214) 381-7161 FAX: (214) 381-4949

2061

Circle 66 On Reader Service Card





HE SAID,

*“You can write almost anything you want about this machine and put my name under it.”* SO WE DID.

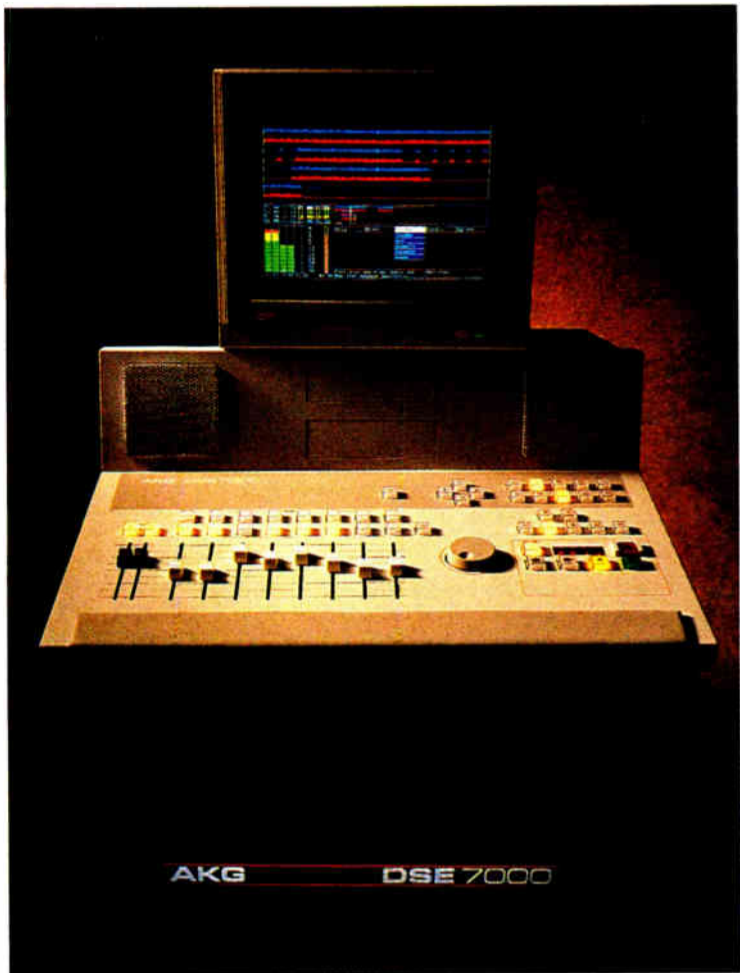

THE DIGITAL SOUND EDITOR. STATIONS FROM BOSTON TO SAN DIEGO ARE MAKING IT THE HOTTEST BOX IN RADIO.

Dan McCoy was the first production director in radio to use the DSE 7000, and he saw it revolutionize the way production is done at



WZOU-FM, one of the top stations in Boston. A spot that used to take an hour to produce now takes 20 minutes. Without tape.

Without razors. Without a single dB of generation loss. Even agency dubs now go right to the

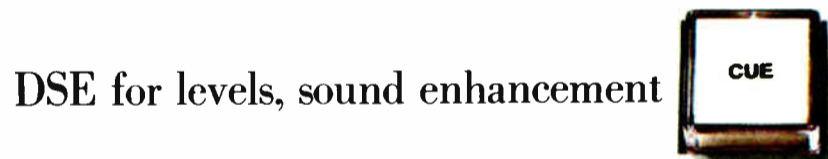

DSE for levels, sound enhancement

and tags; then onto carts. Creativity has exploded, too. With the DSE's instant UNDO feature,

the fear of trying new things is gone. You simply try another take, assemble a different edit,

or test a new effect. If you don't like the results, UNDO it instantly. No wonder WZOU has

designed their production facility around the DSE.

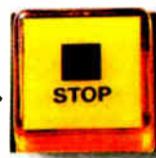

And no wonder Dan McCoy calls

this machine “the most impressive thing that's ever happened to radio.” His words, not ours.



1525 ALVARADO STREET, SAN LEANDRO, CALIFORNIA 94577, USA. (415) 351-3500. FAX: (415) 351-0500



DSE 7000 ♦ THE NEW SPEED OF SOUND





# POWER. PERFORMANCE. AND PROFIT.

What do you really need in a digital audio hard disk system? Simple operation, total creative control, a high level of recording and editing power, and lower cost?

Yes, Studer Dyaxis exactly.

**The New Dyaxis 2 + 2.** Now providing 4-channel simultaneous playback, Dyaxis is the ideal tool for production and post facilities where multichannel applications are required. New advanced features include overdub, multi-take record and programmable in/out, faster time-scaling, EQ and level change. (Original Dyaxis owners can upgrade!)



**Synchronization Is Easy.** With the System Synchronizer and Timecode option, Dyaxis (and Dyaxis 2 + 2) is a master of sample accurate timecode-based slave applications. With a click of the mouse, Dyaxis locks to SMPTE, EBU, VITC, video, and film tach.

**Superb Audio Quality.** Through Studer Editech Corporation's own proprietary A-D/D-A convertor implementation, anti-aliasing filter and analog circuit designs, Dyaxis has achieved a reputation for outstanding sound quality.

**RDAT Backs Up More.** Dyaxis' integrated data RDAT subsystem stores all soundfiles along with their precise editing instructions.

**Digital Compatibility.** Dyaxis communicates with and transcodes between all major digital audio formats such as DASH, AES-EBU, SPDIF, PD, SDIF, 601 and more.

**Studer Dyaxis—Designed For You.** Discover digital technology that's flexible, powerful and easy to use—all the right stuff at a price that might pleasantly surprise you. With Studer's legendary technical support and financial capabilities, Dyaxis is a sound investment in your future. Call us at 800-366-4900 for our free 12-page color brochure on Studer Dyaxis, or call any of our regional offices for an immediate demonstration.

**Picture your sound. On Dyaxis.  
From Studer, a name you can trust.**

## STUDER REVOX

Studer Revox America, Inc.  
1425 Elm Hill Pike • Nashville, TN 37210  
Tel: 615/254-5651 Fax: 615 256-7619  
New York 212.255-4462 • Los Angeles 818.780-4234  
Studer Revox Canada Ltd., Toronto 416.423-2831

Circle 45 On Reader Service Card

World Radio History



# M-S Miking Creates Orangeburg

by Frank Beacham

**Hollywood CA** It was about a year ago when I decided that I wanted to create a radio drama about a civil rights struggle that had occurred in my home state of South Carolina during the 1960s.

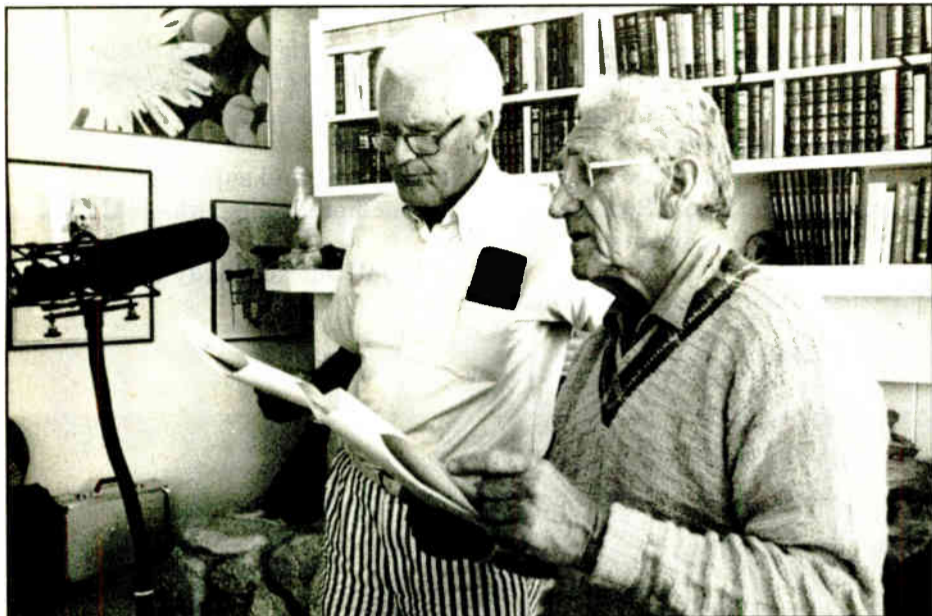

Actors Robert Rockwell (as SC Attorney General Dan McLeod) and James Whitmore (as Governor Robert McNair) record scenes for *The Orangeburg Massacre*.

Going in I knew I wanted big, powerful and sometimes violent stereo sound images. I wanted the riot scenes and gunshots to be startlingly real. I wanted to record the actors on locations in order to get gritty, realistic sound and thus avoid the sterile feeling one gets in a studio.

## A radio drama

The play, which I would write and direct, was well suited to bigger-than-life audio. In a nutshell, here's what happened:

On 8 February 1968, three black South Carolina college students were killed and 27 others wounded by a group of white highway patrolmen firing into a supposedly rioting crowd. Most were shot from the rear—some in the back and in the soles of their feet. None carried weapons.

After the shooting, South Carolina's top government officials engaged in a coverup to hide the true story from the nation. The story became known as The Orangeburg Massacre.

As far as sound recording was concerned, I wanted a system that would allow minimum set-up and as much control in post production as possible. In short, I wanted to concentrate on the actors and their performances, not the recording process.

## M-S miking

A technology as old as stereo itself seemed to fit the bill: the mid-side (M-S) microphone technique. M-S offered a simple, almost foolproof way to capture the desired stereo images on location. And it allowed me to vary the stereo width and perspective during editing.

The M-S recording technique came out of early experiments with stereophonic sound by Alan Blumlein and his colleagues at Electric and Musical Industries Ltd. (E.M.I.) in Great Britain in the early 1930s. Though it mostly has been used as a technique to record acoustic musical performances, it seemed well

suited to deliver the effect I wanted for the drama project.

An M-S microphone utilizes two fixed position capsules inside a single body (or it can be two microphones mounted together). A cardioid or hypercardioid capsule faces the front and is pointed

directly toward the sound source while a bi-directional, or figure eight capsule, is positioned at right angles to the sides. The outputs of the two microphones are then routed through an adjustable sum-and-difference matrix, which extracts two-channel, left and right, con-



Actor Blair Underwood (r) plays student activist John Stroman in the civil rights radio drama. Actor Joseph Burton (l) is also pictured.

ventional stereo.

Since my drama was being recorded for broadcast, good mono, as well as stereo, was an important consideration. Again, M-S fit the bill. M-S provides perfectly accurate monaural audio, something not so easily attained with other stereo recording techniques.

## Production aspect

For the production we chose a Neumann RSM 191 M-S stereo microphone equipped with a Neumann shock

mount, Rycote blimp windscreen and Windjammer high wind cover. As with all Neumann mics, the sound was simply exquisite. We recorded the capsules discretely onto a portable DAT recorder in the field and used the decoding matrix control later during the editing process. Though the results with M-S were quite satisfactory, several observations about using the process in our application should be considered:

*Observation # 1:* M-S works best for dialogue recording when there is natural ambience you want heard on the location. If you are recording dialogue in a studio or in a quiet room with no ambience and plan to add stereo effects behind the dialogue later, I would suggest recording in mono to start with.

One of our best stereo scenes was recorded in a very live acting studio with lots of outside traffic and street noise. I wanted the sound of a hot, sweaty southern courtroom during a trial. The Neumann RSM 191 was very effective in picking up the actors from the front and the coughs, fidgeting and whispers of the courtroom spectators from behind. Other dialogue scenes recorded in quiet offices or rooms without ambience were less effective or often took a lot of extra time to deal with in the editing process.

*Observation # 2:* A few things to know. When using the Neumann 191, with its hypercardioid front capsule, sound diminishes at 30% off axis from front of microphone.

To avoid the comb filtering effect, up the sensitivity of the side capsule when working actors off the front of the microphone. Note that when you up the sensitivity of the side capsule, the stereo image shrinks. To increase the width of the stereo image, lower the level of the side capsule.

Short of binaural or one of the new 3-D sound techniques, M-S recording is a good way get realistic stereo images in a quick and efficient manner. Though the hypercardioid front capsule of the Neumann 191 was sometime restrictive when we had a larger number of actors working a scene, the sound was sonically rich.

The 191 model was designed for news gathering applications and perhaps one of the studio models with varying pickup patterns might have been more suitable for radio drama applications. But the bottom line is this: M/S stereo recording is highly effective and easy to deal with in field recording situations.

Though it has worked well with music recording and radio drama, one hopes it will find a wider application, perhaps in daily news coverage where it would add a new dimension to the experience of "being there."

# Reality on The Radio

**Hollywood CA** Even as I was writing *The Orangeburg Massacre* radio play, I knew it could never be done in the confines of a recording studio. To get the realism I wanted, the walls would have to come down.

I was determined to go for the same level of reality. Since the story was set in South Carolina in the late 1960s, I wanted to capture, through sound, some feel for the time and place.

The play had two courtroom scenes and I sought the sweaty, electric fan reality of the un-airconditioned Southern courthouse of the period. I found it in an acting studio in Santa Monica.

The huge room had a wooden floor and hard walls and was very "live." It faced a busy street so that traffic noise was continuous. I told the owner it had the worst acoustics I had ever heard and I wanted to rent it for recording immediately!

By seating the "courtroom spectators" behind the stereo microphone and having the actors work the front capsule, the room magically gained the courtroom ambience I wanted.

I heard the spectators coughing and squirming in their seats as they reacted to testimony and the outside traffic noise gave the room an "open window" feel. The result was so perfect, in fact, that no further processing or equalization was required on the scene in post-production.

The show called for a series of civil rights marches and demonstrations at a bowling alley. All the outdoor scenes were recorded on a Sunday on the rooftop of an empty parking structure at Sunset-Gower Studios in Hollywood. On this day, *LA Law's* Blair Underwood played the student leader of the demonstrations and veteran character actors Parley Baer and Ford Rainey portrayed the Sheriff and bowling alley owner.

As director, I took the actors through a long list of actions ranging from marching and singing to being beaten and shot by the police. Underwood made a civil rights speech to the crowd of students and Baer used a powered megaphone to order the students to disperse.

Baer, a veteran of 15,000 network radio shows, 1500 television shows and 60 feature films, had played "Chester" on the original radio version of *Guns-moke*. Here he was, nearly 50 years later, playing the quintessential "red-neck" sheriff on a show I was directing.

"It had a very realistic quality ... a modern sound," Baer told me after hearing the program and giving his nod of approval. If it had been Orson Welles himself, I couldn't have been happier passing muster with such a tough critic.

Frank Beacham, *Radio World's* Los Angeles-based correspondent, also writes, produces and directs programs for radio, television, film and the stage. His program, *The Orangeburg Massacre* starring David Carradine, Blair Underwood and James Whitmore, is being distributed nationally to public radio stations.



# INTRODUCING

# RS CART 2000.

## A great *new* cart machine.

With so many good cart machines on the market today, how do you make a new one better?

Begin by including every important cart machine feature: 3 cue tones, fast forward, XLR connectors, active phase correction, front panel azimuth adjust, LED VU and phase meters, full logic, remote control, and more. You'd have to buy every other machine available to assemble all these features.

Next, build it to last. That means long life heads, 1/2" thick deck plate, direct drive Nidec motor, massive toroidal power supply, newly designed positive cart hold-down and guidance systems, and precision head-block assembly.

Finally, distinguish it with features no other unit has. The RS-2000 is the first cart machine to offer flutter correction, splice finder, and timer on all models.

But features aren't important if the engineering isn't top-notch. The RS-2000 was created by industry-renowned design engineer Mike Sirkis. So this "new" machine carries more than a decade of cart machine experience.

One last note: since the RS-2000 is built, sold and supported exclusively by Radio Systems, it carries one more trademark—**VALUE**. Every RS-2000 model is very affordable.

Call toll-free today for details.

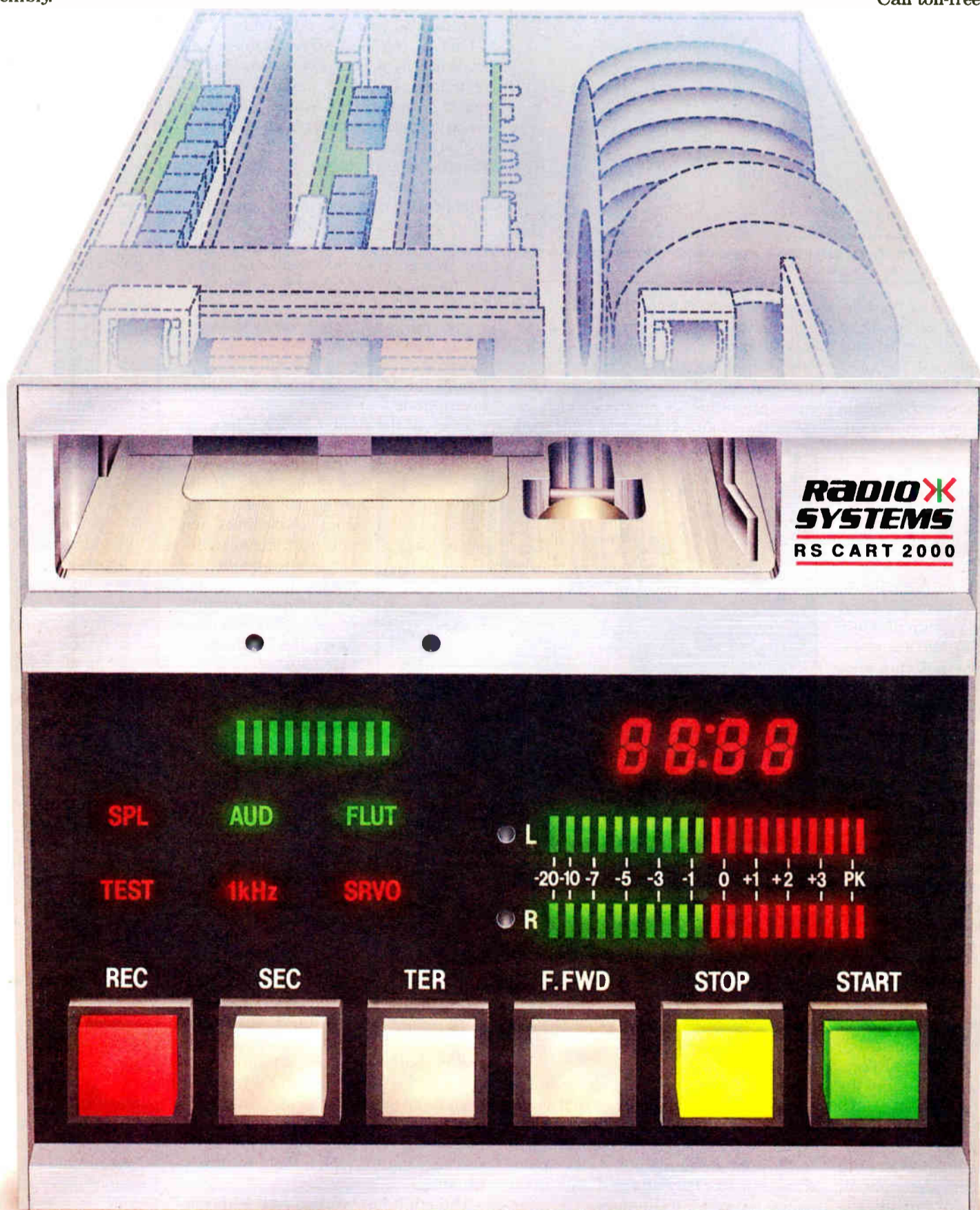



# WORKBENCH

## Tips for LDRs and Multimeters

by Jim Wenstrom, CE  
KFLS/KKRB

**Klamath Falls OR** Here are two useful tips for small market engineers or for those in larger markets who just like the idea of saving some dollars.

I'm not sure what life and budgets are like in the larger markets, but here every \$30 I can save is a large amount. About the only problem I have with my Harris 9001 automation is when the Vactrol LDRs burn out. They are easy to replace as they just plug in from the back of the automation.

What hurts the engineering budget is the \$35 bucks apiece from Harris to get

**... in the Sencore DVM37, I finally found a compact, portable, rugged multimeter. . .**

replacements. Several years ago, I even tried to get them direct from Vactrol but they make them under contract to Harris and could not sell them to me direct. I finally took one apart and found that the bulb had burned out. The bulb and three photo resistors are all that is in that little can.

For a while, I would take 328 bulbs apart and use that as a replacement, but they are actually a 6 V bulb and are difficult to remove. I finally opened my Mouser catalog and selected a T-1 type #715 wire lead bulb. At 59¢ each, my budget looks much better.

When you have a source on the Harris 9000 series automation go out (either program or audition), remove the LDR for that source (top row is program and bottom row of LDRs are audition). With an ohm meter, see if pins 2 and 8 are open or closed. If they are closed, your trouble is elsewhere.

If it shows open, then the bulb is blown. Carefully pry the lip of the can away from the base of the plug and pull them apart. With a low wattage solder-

ing pencil, replace the old bulb with a #715. Put it back together using contact cement or super glue. You just want to make sure the fit is fairly light tight. If after you reinstall it, you get some bleed over from program to audition or vice-versa, some light is bleeding in, so make the seal tighter.

In the past four years, this has saved the station over \$800. Just remind your GM every three or four rebuilds.

### Multimeter solution

Now here's another tip based on my own experience with multimeters in the dead of night.

It is frustrating enough to have to troubleshoot a dead transmitter at two in the morning, or fine-tune it after Sunday night (Monday morning) sign-off, but in either case you finally get enough power to the tower and you start to take a voltage measurement to compare with the spec sheet.

You grab your Simpson and DMM and you see that even without connecting it to anything it is reading 137 V! What do you know? I have been known in the past to rewire the transmitter's voltmeter to the points I need to read, but that is very time consuming. But what's a guy to do?

Your choices are limited, and they all cost. You can try to find a surplus RF voltmeter and try to pack it around or you can pay the big bucks for a fancy meter to do the job.

In the past two years, I have purchased several pieces of test gear from Sencore, and it has all worked out better than I would have ever hoped. So, I called my Sencore sales rep—Dave Opls—and he said he would send me a meter to try.

When he told me that the price tag was about \$400 I wasn't too sure that I wanted to even look at it, but what the heck, it wasn't going to cost me anything to try.

### Pleasantly surprised

It arrived just in time to make my weekly trip to the FM site for some "tweaking and peeking." I couldn't wait to get to the building to see what the meter would read with open leads—the first test.

When I got into the building, even before I poured my first cup of coffee, I turned the meter on and set it to its most sensitive voltage scale.

I was amazed when I looked at the display and it read "00.2" volts. My first thought was that the board-op had already turned the transmitter off. But the output meter was resting on 95% (19 kW) into five bays less than 75 feet away. This little meter was not showing any affect of being in an RF field of over 50,000 W! I was one happy small market engineer.

I was not surprised the next night when it also performed well at my AM site.

I sent my check off to Sencore the next day because in the Sencore DVM37, I finally found a compact, portable, rugged (they say that you can swing the thing around by the test leads) multimeter that works when and where you most need it.

Jim Wenstrom, who has quite a few technical tricks up his sleeve, can be reached at KFLS/KKRB: 1338 Oregon Ave., Klamath Falls, OR 97601.



## WHY QE1?

### 24 Hours.



Our 24 hour service hotline number is 609-728-2020.

Call us toll free at 800-334-9154 for all the facts on QE1 "New Reliables" FM transmitters from 1kw to 30 kw.

### Power Up.



With our FMQ 3.5/5/10 kW or 20/30 kW FM transmitters, you can upgrade power in the field.

Call us toll free at 800-334-9154 for all the facts on QE1 "New Reliables" FM transmitters from 1kw to 30 kw.

### Single Phase 30 kW.

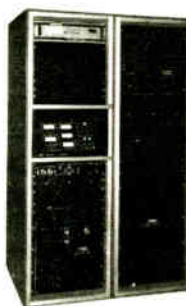

Our new FMQ 30000B is the only 30 kW transmitter available with a single phase power supply.

Call us toll free at 800-334-9154 for all the facts on QE1 "New Reliables" FM transmitters from 1kw to 30 kw.

### Less is More.

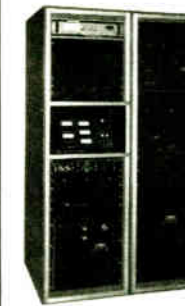

All of QE1's FM transmitters have no plate blockers or sliding contacts.

Call us toll free at 800-334-9154 for all the facts on QE1 "New Reliables" FM transmitters from 1kw to 30 kw.

### Free.



Our FREE spares kits include every solid state component of the transmitter, exciter and remote control.

Call us toll free at 800-334-9154 for all the facts on QE1 "New Reliables" FM transmitters from 1kw to 30 kw.

### The Longest.



Our PA tube warranty is the longest in the business — 15,000 hours.

Call us toll free at 800-334-9154 for all the facts on QE1 "New Reliables" FM transmitters from 1kw to 30 kw.

## NRSC-2 Dilemma? No Problem.

We deliver the simple, effective, and inexpensive solution to your compliance with the mandatory NRSC specification.

Easily installed in only minutes, our product utilizes digital techniques for full asymmetrical peak control, self-regulating pre-emphasis and no-overshoot lowpass filtering. It works with any existing processing, or can even stand alone as the only processor you really need!

INOVONICS' MODEL 222 - \$590

**Inovonics Inc.**

CALL: 1-800-733-0552  
FAX: (408) 458-0554





# The Hot Topics at Radio '90

by Lex Felker

**Boston MA** The crowd's spirits were high at the National Association of Broadcasters' Radio '90 convention in Boston.

But three things were clearly on broadcasters' minds as they browsed through the impressive equipment displays and listened intently at the well-attended panel discussions: digital radio, political advertising and spectrum fees.

## DAB's bark worse than "byte"?

There is little question that the one issue most on the minds of the broadcasters with whom I spoke in Boston is digital radio. As was evident by the exhibits at the convention, digital audio

## FELKER'S FORUM

technology is not some pipe dream. Concepts and hardware are already reasonably well developed, with rival encoding schemes competing for broadcasters' attention.

The prospect of digital technology being deployed in a new high-end radio service was juxtaposed frequently against the FCC's efforts to improve the

quality of the AM broadcast service. Many broadcasters found a disturbing irony in such a comparison and the logic of pursuing both policy objectives was questioned on several occasions.

But it wasn't so much the prospect of a new technology or service that seemed to bother most broadcasters. Rather, it was the possibility that they would not be invited to the party that seemed most frightening. From where I sit I find such an outcome most unlikely.

Obviously, the Commission has yet to render any final judgments on this issue. The hints it has left in both the digital radio Notice of Inquiry and in the work it is doing in preparing for WARC-92, however, lead me to believe that the FCC will find some way to provide local broadcasters with a means of keeping pace technically.

## Political broadcasting

Turning to the political arena, the Communications Act requires that, during certain time periods prior to primary and general elections, broadcasters charge political candidates the lowest rate being charged of commercial advertisers for the same class and time of spot.

To establish how well licensees have been complying with this requirement, the FCC audited the political advertising practices of some 30 radio and television

stations several weeks ago. A report offering what now appear to be preliminary results of these audits was released by the Commission the Friday before the

## ... it is certain that we have not yet heard the last of digital radio or political broadcasting...

start of the convention.

Among other things, the report seemed to imply that some broadcasters are charging political candidates too much for advertising time. With a new pre-general election advertising window just beginning, many broadcasters were understandably edgy about the FCC's report and wondered whether their operations were in compliance.

The matter was a topic of conversation at a number of panel discussions and hallway meetings, and I heard lots of grumbling that the Commission had not properly interpreted the data it had gathered.

FCC General Counsel Bob Petit tried to comfort those attending one session by indicating that detailed analysis of the

audit data would have to be completed before it could be established whether any of the 30 stations had violated the law.

Nevertheless, for this year at least, many licensees seemed resigned to erring on the safe side by charging political candidates a little less than their commercial accounts and thereby avoiding a fight with either the FCC or political candidates over this issue.

## Spectrum fees

Given the potential hardships they could impose on licensees, and the possibility that some stations could go silent, the President's proposed spectrum fees were (cussed and) discussed at most events I attended in Boston. Under the Bush administration's plan, a tax of 5% of gross revenues would be levied on all stations with annual receipts greater than \$100,000.

As this article is being written, congressional and administration budget "summitteers" continue to try and haggle out some compromise on the budget, and spectrum fees are among the revenue concepts still on the table.

By the time this article is published and read, perhaps the fight over spectrum fees will be finished. But it is certain that we have not yet heard the last of digital radio or political broadcasting, and these issues may remain hot topics for many radio conventions to come.

■ ■ ■

*Lex Felker is a technology/engineering consultant with the law firm of Wiley, Rein & Fielding, Washington, DC. He may be reached at 202-429-7000.*

## It's Not Just A Phase We're Going Through.

The tremendous success of the Tannoy PBM series of reference monitors is by no means coincidental. Since the introduction of the world renowned NFM-8 nearfield monitor, much time and effort has been spent on discerning the needs of the mixing engineer and the applied requirements of "playback monitors". The PBM Line exemplifies this commitment to excellence in reference studio monitoring. These compact loudspeakers sport robust poly cone mid-bass transducers utilizing efficient long-throw, high power voice coils. The low frequencies are carefully controlled by optimally tuned ports located on the rear of the loudspeakers. Hi frequencies are provided by Hi Power ferro fluid cooled polyamide dome tweeters which extend H.F. bandwidth beyond 20KHZ. The driver accompaniment is knitted

together by means of a precision hardwired crossover unit, utilizing robust low loss components, and heavy-duty input terminals which will accept standard 3/4" spaced banana plugs and the majority of high quality, specialist audio cables. Transducers and crossover assemblies are neatly housed in a stylish, high density, partial wrap cabinet, specially designed to minimize unwanted cabinet resonance, and high frequency reflection. In summarizing, we have left the best feature of all for last "price versus performance."

**TANNOY**  
Professional Products

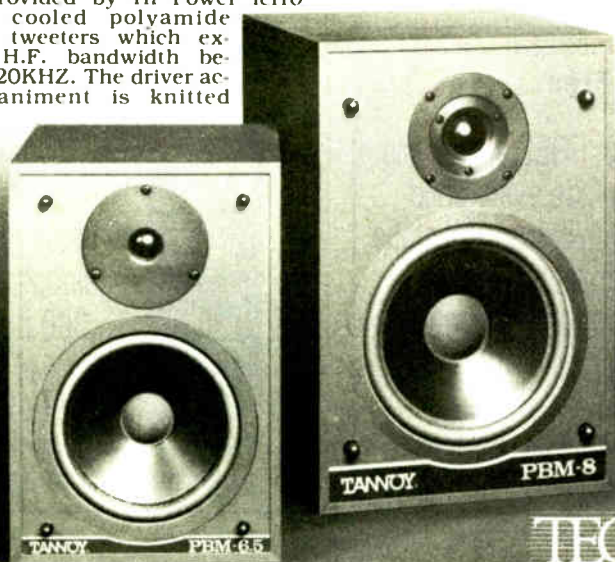

TEC AWARD WINNER

**TANNOY**

Tannoy North America, Inc. 300 Gage Ave., Unit 1, Kitchener, Ont., Canada, N2M 2C8  
Telephone (519) 745-1158 Telex 069-55326 Fax (519) 745-2384

Circle 130 On Reader Service Card



## Rugged Performer.

### Harris HT Series FM Transmitters From 3.5-35 kW.

HT Series transmitters are engineered to give you high efficiency and unsurpassed performance. HT FM transmitters have proven their reliability and exceptional lightning survival capabilities in installations around the world. Here's why HT Series transmitters are the choice of demanding broadcasters:

- 55 Watt THE-1 FM Exciter with ultra-linear VCO operates at final carrier frequency with inaudible noise and distortion
- Quarter-wave cavity offers twice the bandwidth of folded half-wave designs to pass more of the FM signal without distortion
- Low velocity, high-efficiency direct drive cooling system
- Modular solid-state IPA and conservatively operated final tetrode PA
- High overall efficiency lowers AC power bills
- Broadband solid state RF driver uses FETs for highest reliability
- Solid state controller with automatic RF power control, proportional VSWR foldback, auto-restart
- Opto-isolated remote control/status interface, fully transient protected
- Exclusive FLEXPatch™ design allows easy bypassing of low-level stages to keep you on the air during emergencies

Call Harris Allied today at 217-222-8200, Ext. 3408 for more information on rugged, reliable, efficient HT Series FM transmitters.

Also available: 100% solid state 250 W, 500 W and 1 kW HT Series transmitters.

**HARRIS ALLIED**

Harris Allied Broadcast Equipment  
Radio RF Sales • P.O. Box 4290  
Quincy, IL USA 62305-4290

© 1990 Harris Corporation

Circle 17 On Reader Service Card



# The Strange Case of The Tuckerton Tower

by Russell Roberts

**Trenton NJ** Did radio transmissions from the gigantic Tuckerton Tower play a role in the sinking of the British passenger liner Lusitania on 7 May 1915?

Was this incredibly powerful radio transmitter the site of a German Espionage operation during the early months of World War I? The historical debate rages.

## Across the waters

The Tuckerton Tower was the brainchild of Dr. Rudolph Goldschmidt, a brilliant German scientist. He conceived the idea of a transoceanic wireless.

The site he chose for his "super wireless" was Hickory (now Mystic) Island on the New Jersey coast, located on Great Bay, three miles south of the small community of Tuckerton. The firm, level ground offered an unobstructed view of the Atlantic Ocean in an extremely desolate setting.

On 21 May 1912 work crews began assembling the Tuckerton Tower. Everything was built, assembled and tested in Germany; then dismantled and shipped to America.

Triangularly-shaped in girth, the tower was 20' wide and 820' high—the second-tallest structure ever built by man. Cable junctions were spaced every 250'; four cables on each of the tower's three sides were connected to three 1100 ton concrete blocks set on the ground 600' from the base of the structure.

At the top of the tower was a 60' high wooden pole that held the antenna. The tower maintained 500,000 volts—the highest voltage of any radio tower in the world—and could receive an astounding 100 words per minute.

But while all of Tuckerton knew about the massive structure, the United States government did not. Thanks to an effective shroud of secrecy by Germany, it wasn't until May, 1913—one year later—that the US learned of the project.

Even though the tower was in a strategic location overlooking major Atlantic shipping lanes, and war clouds were rapidly gathering in Europe, it took another year—May, 1914—until a US Naval Inspector checked the tower and found nothing amiss. The station then received the call letters WGG.

## Weapon of espionage?

In June, 1914, the station was declared fully operational and a world that still used letters as the primary form of communication realized that the increasingly-militaristic German nation could send messages hurtling across the Atlantic (between Tuckerton and a sister station at Eilvese, Germany) at astounding speed.

One month later war erupted in Europe. Almost immediately England and France protested to the US that Tuckerton was communicating with German ships at sea, in violation of international treaty.

On 5 August 1914, President Woodrow Wilson declared America neutral in the war. Tuckerton was ordered closed because of alleged neutrality violations. Yet

since all other American communications to Germany had been cut by the war, Tuckerton was allowed to continue operations as the sole link to that nation.

Wilson's neutrality proclamation forbade wireless stations on American soil to communicate "messages of an unneutral nature." Yet it was soon discovered that the German crew operating Tuckerton had communicated military information to German cruisers in the North Atlantic.

This disclosure caused a US naval censorship team to be sent to Tuckerton, with orders to oversee operations—but not to take over the equipment. Station Manager Emile E. Mayer, a member of the German Army Reserve, remained on the job, as did other German nationals working at the station.

Despite the censorship team's presence, England and France continued to protest that Tuckerton was sending military messages. Wilson, however, felt that keeping Tuckerton open as the sole communications link with Germany was vital. Censorship at the station was tightened when American naval personnel were ordered to handle all transmis-

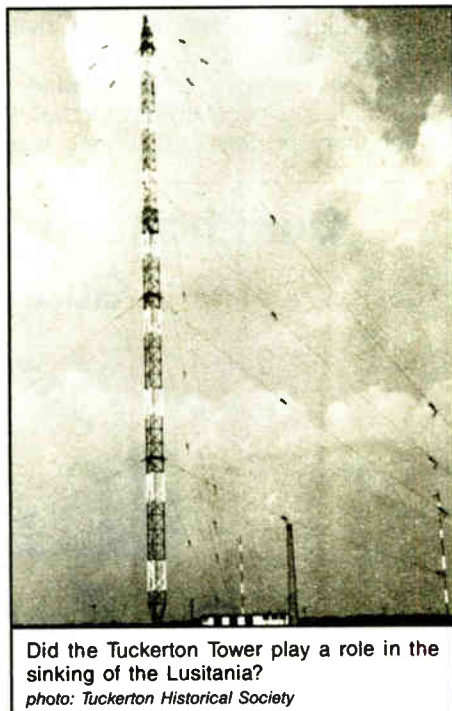

Did the Tuckerton Tower play a role in the sinking of the Lusitania?  
photo: Tuckerton Historical Society

sions. But German employees remained in charge of maintenance and also reportedly still received messages.

## House light codes

Thus, despite what seemed to be strict censorship measures, espionage could possibly have occurred at Tuckerton. Some Tuckerton residents seemed certain of it.

Dr. F. Lee Terry, who lived near Tuckerton as a boy, revealed years later that he had read many of the station's "coded" messages by watching the lights of his home. Every time the station transmitted, the tremendous electrical power drain caused house lights in the area to flicker. Terry said that by "reading" the dimming, flickering lights in his home, he could decode the messages telegraphically. He believed that the tower was used for German espionage activities.

Tuckerton was still under censorship (continued on page 22)

# High Yield CD



## The Technics SLP170

When it comes to receiving a great return on your investment, look to the SLP170 CD player from BSW and Technics. No other machine offers so much for so little...such as: Durable linear motor transport for accurate tracking, Auto-cue-to-music for fast and sure cueing at the beginning of audio, and Technics exclusive MASH digital-to-analog converter that dramatically improves sound quality.

Maximum yield from minimum investment...get it all with the SLP170 from BSW.

**Special Sale Price \$159.00**

Expires 10/31/90

# BSW®

BROADCAST SUPPLY WEST

America's Full-Time Broadcast Supplier

**1-800-426-8434**

ORDERS • INFORMATION • SPECIFICATIONS

BSW • 7012 27th Street W • Tacoma, WA 98466 • FAX 206-565-8114

Circle 120 On Reader Service Card



# UL Makes Its Mark in Pro Audio

by Dee McVicker

**Santa Clara CA** If you have ever tangled with a flame-throwing rack of equipment, consider this: UL is now making its mark on broadcasting gear.

This "marksmanship" by the notable Underwriters Laboratories should eventually lead to better equipment safety for broadcast engineers.

A not-for-profit, non-government organization dedicated to testing and certifying products according to safety merits, UL recently has shown an interest in broadcast equipment. So much interest that now there's a new UL cate-

gory, listed as 1419, specifically for evaluating and testing professional audio and video equipment.

## OFFBEAT RADIO

UL-1419, reported Murlin Marks, UL associate managing engineer of the electrical department, is a relative newcomer to the organization's category listings. "It's only been in the last three years that we've focused our resources into writing a set of requirements that responds to

the needs of this particular industry."

The result of UL's interest in broadcast equipment safety is a 100-page document reflecting investigation and testing of some 50 to 100 broadcasting products.

The type of broadcast equipment that has found its way to the UL testing bench, according to Regina Davis, UL's

than that of need. "In the early '70s we used (safety) requirements (for broadcast equipment) that existed for household commercial products, and those requirements didn't really apply. From a safety standpoint, this is a unique niche."

### Nudged into action

UL listing categories usually get their start because of prodding by manufacturers or customers inquiring about a particular product. "Then as more products are submitted, we try to com-

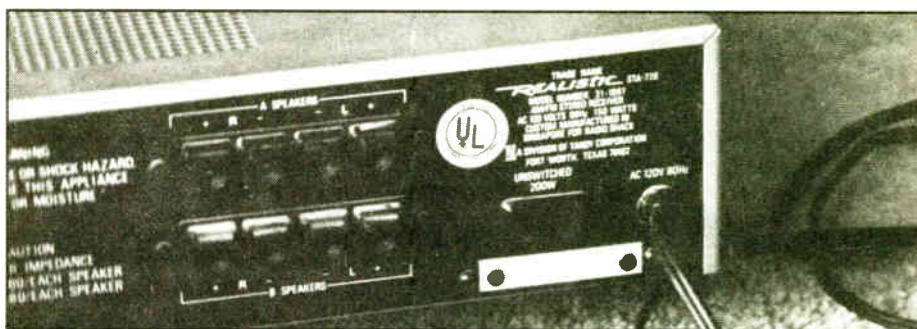

Underwriters Laboratories is now showing an interest in broadcasting equipment.

engineering group leader, is "a lot of signal processing at this point, (as well as) tape decks, monitors, mixing consoles."

Still in draft form and not yet finalized by Underwriters Laboratories, the document outlines tentative safety requirements for broadcast equipment under the new category. The published UL standard for UL-1419 will follow an open comment process whereby, said Marks, "we're going to have an industry meeting and after everybody that's interested looks at the proposal and gives their comments, then we'll publish a standard."

What took so long? According to Marks, it was more a matter of waiting for the UL evolutionary process to take its course

pile a set of requirements for that product," informed Marks.

In the case of UL-1419, prodding could have very well come about because of a misunderstanding of one city's safety code. According to some interpretations of Los Angeles' city codes, all equipment—including broadcast gear—residing in the city's jurisdiction needs to be safety-certified by a third party, such as UL or some other independent organization.

But, according to Los Angeles Chief Electrical Inspector Bill Greenwell, "I wouldn't say every piece of broadcast equipment (needs to be third-party cer-

(continued on page 22)

**GET IT RIGHT**  
FROM HARRIS ALLIED

**We Can Design Your System From The Ground Up.**

Rely on the team that has proven its ability on projects of all sizes for broadcasters worldwide. From concept and design through final sign-on and documentation.

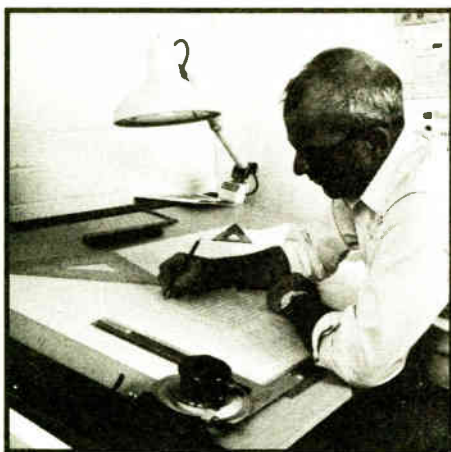

**HARRIS ALLIED SYSTEMS**  
217-222-8200  
FAX 217-224-2764

P. O. BOX 4290 • QUINCY, IL 62305-4290

©HARRIS/ALLIED 1990

## Our Phono Preamp Sounds Best! Guaranteed!

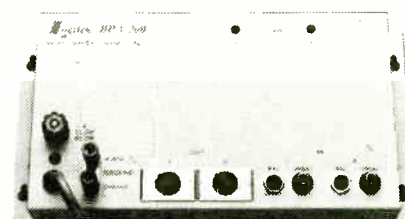

### The Logitek BPA-200 Balanced-Input Phono Preamp

Only the BPA-200 has:

- Isolated, passive equalization
- Dip-switch input capacitance settings
- Fully balanced outputs and inputs
- Low-hum toroidal power transformer
- 5-year parts/labor warranty
- Full refund if it doesn't sound better than what you're using now! (15-day approval)

**Call 800-231-5870**

(Texas, Alaska, Canada 713-782-4592 collect)

for full information, or call your Logitek Instant Action Dealer.

**Logitek** Electronic Systems, Inc.

When it has to work right

Circle 139 On Reader Service Card

"Call me, I'm interested." Circle 114.

"Send me literature." Circle 101.

World Radio History



# WHY YOU SHOULD PAY MORE FOR LESS.

**New Name-  
Same Great Cart!**  
The ITC Cart II Cartridge, formerly ScotchCart® II

*Less phase jitter caused by poorly tracking tape, because the naturally lubricated concave guides gently position the tape and allow the cartridge machine to perform critical guidance.*

*Less tape noise and signal loss with our 100% laser-inspected, high output, low noise tape which delivers better frequency response and keeps signal-to-noise ratio high, harmonic distortion low.*

*Less wow and flutter or stop cue overshoot, because there's no rotating hub to wear out, warp or rattle.*

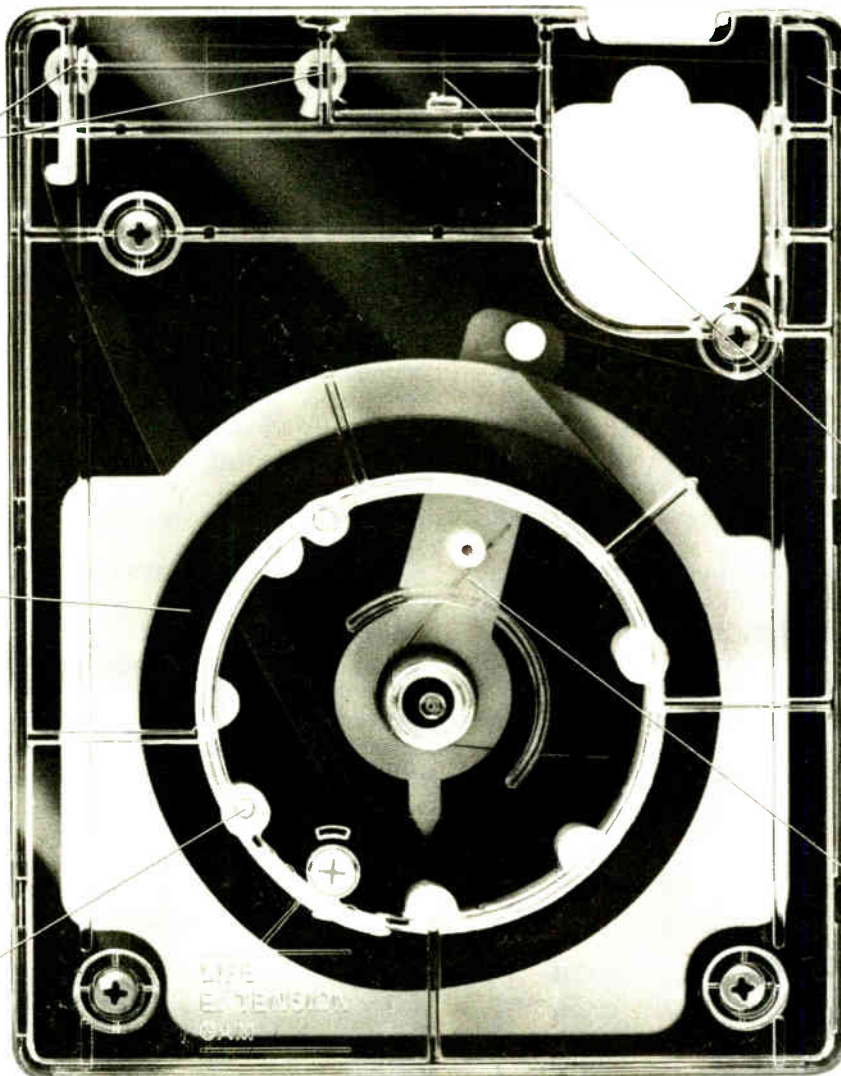

*Less chance of the cartridge cracking or breaking, because the tough polycarbonate cover withstands repeated use and abuse.*

*Less head wear, tape steering and modulation noise, because there aren't any pressure pads to add friction.*

*Less chance of tape destruction, because our patented dynamic tension control system ensures proper tape-to-head contact, and provides constant tension to control looping and prevent twisting.*

The ITC Cart II Cartridge, formerly ScotchCart® II

With broadcast cartridges, like everything else, you get what you pay for. With ITC Cart II cartridges, you get a revolutionary design that delivers trouble-free operation, superb sound quality and a life expectancy that's second to none.

We have renamed the cartridge due to trademark considerations, but only the name has changed, the cartridge and tape are the

same. New name, same great cartridge and performance.

For a complete listing of ITC Cart II dealers, call ITC toll-free at 800-447-0414 (in Illinois, call collect 309-828-1381.) Or write to ITC at P.O. Box 241, Bloomington, IL 61702-0241.

Because a cheaper cartridge may be more trouble than you can afford.

ScotchCart® II is a registered trademark of 3M



Circle 142 On Reader Service Card

World Radio History



# UL's Pro Audio Marksmanship

(continued from page 20)

tified for safety), because you have some equipment that is strictly regulated by the Federal Communications Commission. It gets kind of iffy; it's really something you've got to see one-on-one to make a determination."

Greenwell admitted that there has been some misunderstanding regarding the city's code. This, speculate some, could have initiated the prodding into UL certification of broadcasting equipment.

## Distinct from consumer

"This category is defined as professional audio/video, which means that (the equipment) is under supervision of technically qualified people at a broadcast station," said Marks, who pointed out that it is in-field maintenance and repair of equipment that divides this category from its consumer counterpart.

A credit to the industry, stated Marks, is that "the products seem to have a pretty good field record, so we're trying to work (safety) requirements around good, solid constructions which have proven satisfactory in the field."

Although the FCC and UL generally do not jointly arrive at safety standards, the requirements for category 1419 will conform to FCC regulation. For instance, said Davis, "radiation emission hazards will conform to its (the FCC's) requirements."

In addition, equipment volunteered—and it is a voluntary process—for UL certification will run through a series of tests, including input tests, temperature tests, dielectric voltage-withstand tests and abnormal operation tests.

Said Marks, "(UL requires) a pretty rigorous set of tests to evaluate that the performance of the product wouldn't cause

any particular hazards. Many of the well engineered products, at least well engineered as far as safety goes, don't have any problem passing these tests."

But, stressed Davis, equipment performance according to published specifications is entirely up to the manufacturer. "We don't check to see that frequency response is such and such, or anything like that. We're really looking at the safety features of the equipment," said Davis. Hazards such as casualties, fire and electrical shock are primary UL concerns.

That's not to say, however, that UL certification doesn't benefit product performance. In some cases it does. "To a certain extent there's a little bit of quality assurance built into safety evaluation," said Davis.

"For example, plastic materials will need to meet minimum criteria as far as flammability and so forth. And that tends to raise the quality assurance throughout the industry if all are required to meet the minimum criteria. Someone can't come along and use something that's real substandard."

## Won't add expense

Will this new interest in safety escalate equipment costs? Not likely. According to Marks, "The process that UL uses is to try to be reasonable and flexible in an evolutionary, integrative fashion, so you develop a set of requirements which aren't going to force you to change your product to fit the requirements."

Nor is it likely that third-party safety certification of all broadcast equipment will be federally mandated. Ultimately, most safety regulations fall under local state, county or city jurisdiction.

However, commented Marks, "The problem from the standpoint of the inspector is that he looks at all this equip-

ment and he or she doesn't know if it's safe. And the (stations) are under extreme pressure to get this equipment up and running. The inspector feels an obligation to get some sort of certification." This, he said, is one of the benefits of the UL mark.

Manufacturers that do elect to have their products UL certified will find the process relatively simple. Said Marks, "What has proven effective, at least for this category, is we sit down with the engineers—either design engineers, safety engineers or the people that are aware of various options in the design of the product. They explain what their product does, and we go over how our requirements would apply.

# Tale of Tuckerton Tower

(continued from page 19)

on 7 May 1915, when the Lusitania was sunk off the Irish coast by the German submarine U-20. It is one of the tenacious legends of history that U-20 commander Walther Schwieger received a terse message to "Get Lucy"—a command to attack the Lusitania. There is no documented evidence that Schwieger ever received such a command.

Yet the suspicion that Tuckerton might have sent such a message prompted the United States to investigate the possibility shortly thereafter. Interestingly, the government has never officially confirmed or denied the "Get Lucy" story.

## Violations commonplace

It was known that messages in violation of the neutrality guidelines were sent from Tuckerton. Messages of a non-neutral nature were constantly being submitted for transmission at Tuckerton in the hopes that some would slip through the censorship guidelines.

Unfortunately, since much of the data connected with the Tuckerton Tower concerns wartime/national security, in-

"We essentially do a preliminary evaluation before we actually get the sample and run tests. So far that's proven pretty effective in having the basic investigation run smoothly." A fee to cover engineering expenses is required to have products UL certified.

Depending on industry demand, the new category could become a UL published standard by late 1991. "I'd expect an industry meeting winter next year, and then six months or so later the standard would be published," said Marks.

Those interested in the new UL category can call Murlin Marks at Underwriters Laboratories, Inc., at 408-985-2400, extension 2353. Or FAX him at 408-296-3256.

■ ■ ■

Dee McVicker is a free-lance writer and regular contributor to RW. To inquire about her writing service, call 602-899-8916.

formation that might prove or disprove the "Get Lucy" story remains classified.

There is evidence that Germany may have intended the tower to be used for espionage. According to the *New York Times* of 8 August 1914, the German government had worked out a plan of radio communication, using warships as well as "super stations" like Tuckerton, designed to allow Germany to communicate in total secrecy anywhere in the world.

One day after America declared war on Germany on 6 April 1917, the entire German staff at Tuckerton was arrested. Since all had links to the German Army, they were considered prisoners of war, and no espionage charges were filed. The government ran the tower throughout the rest of the war.

On 28 December 1955, having outlived its usefulness, the Tuckerton Tower was demolished. But although the giant structure itself is no more, the questions about it remain as unyielding as the gigantic concrete foundation blocks that still exist on Mystic Island—perpetual reminders of the strange case of the Tuckerton Tower.

■ ■ ■

Russell Roberts is a free-lance writer who writes advertising and public relations material for radio stations in his hometown area of Trenton, NJ. He can be reached at 609-298-9652.



**You can measure... with the best monitor and the most accurate test set.**

The FMM-2/FMS-2 series monitors provide an even greater degree of precision measurement than ever before... **You can measure S/N below 90 dB, You can measure crosstalk below 85 dB, You can measure separations of better than 70 dB, You can measure frequency response to better than 0.25 dB, You can measure distortions to lower than 0.01%, and much more...** Our uncluttered panels and autoranging voltmeters make these measurements a dream.

**BELAR** CALL ARNO MEYER (215) 687-5550  
**ELECTRONICS LABORATORY, INC.**  
 LANCASTER AVENUE AT DORSET, DEVON, PENNSYLVANIA 19333  
 Call or write for more information on Belar AM, FM, Stereo, SCA and TV monitors.

Circle 48 On Reader Service Card



**DATAWORLD MAPS®**

**DO YOU KNOW YOUR MARKET? YOUR COMPETITION DOES!**

DATAWORLD MAPS CAN

- Depict your coverage!
- Market orient your sales people!
- Target your ethnic/demographic markets!
- Identify marginal signal areas!
- Plot any special requirements!

MAP OPTIONS

- SHADOWING (TERRAIN SHIELDING)
- POPULATION DENSITY
- CONTOUR COVERAGE
- SPECIALS

**dataworld®**  
 A Service of DW, Inc.

Fax (301) 656-5341  
 (301) 652-8822 (800) 368-5754

Circle 39 On Reader Service Card



Oh-Oh!

**Call CORTANA**

**STATI-GAT** The Affordable Lightning Prevention System

- Charge dissipation with 1/8" type 304, sharpened stainless steel rods
- Won't bend from ice/severe weather
- Provide a continuous low-resistance discharge path for static electricity

**Cortana Corporation**

Write for a Free Brochure.  
 P.O. Box 2548, Farmington, N. M. 87499  
 Call (505) 325-5336

Circle 79 On Reader Service Card



# PHASE TRAK 90™

## The perfect cart machines for an imperfect world.

PHASE TRAK 90 PLAYBACK &  
PHASE TRAK 90 RECORD/PLAYBACK



**D**o you really need a cart machine as good as Phase Trak 90? In a perfect world, perhaps not. After all, there'd be no tape skew or phase error in an ideal universe. So, you wouldn't need the continuous non-encoded phase correction circuitry\* we developed for Phase Trak 90 cart machines. This BE-exclusive process is so effective, it actually cleans up stereo carts that sound dull on ordinary machines, while assuring consistently clear mono performance. In a perfect world, tape formulation and performance

would be consistent from batch to batch and brand to brand. There'd be no need for the Record/Playback Phase Trak 90's Automatic Tape Analysis system with Learn Mode.

On a fault-free planet, all audio formats would be created equal. Then you wouldn't need Phase Trak 90's superior cartridge guidance system, Phase Lok V head block and CD-quality sound, including our Dynafex® noise reduction system that audibly improves stereo signal-to-noise performance.

And of course, in a perfect world DJs would always treat

cart machines with care and respect. So you could get by without Phase Trak 90's robust, fully modular design featuring a solid die-cast front panel, machined 1/2"-thick aluminum deck plate, cool DC servo motor drive, Hall effect switches and gold-to-gold interconnects. Phase Trak 90: Quite simply, the best cart machine ever made for the real world. If that's where you live and work, call Bob Arnold at (217) 224-9600, or ask your Broadcast Electronics distributor for more information.

\* Patent Pending  
Dynafex is a registered trademark of Circuit Research Labs, Inc.

**BE**® **BROADCAST  
ELECTRONICS INC**

4100 North 24th Street • P.O. Box 3606 • Quincy, IL 62305  
Tel: (217) 224-9600 • Fax: (217) 224-9607 • Tlx: 250142

Circle 106 On Reader Service Card

World Radio History







**NEW NEW NEW**

# **SERIES CONSOLES**

**S – \$6,499 /18 CHANNELS – \$8,893**

## **FEATURES**

- Totally Modular Console-Input modules, Output modules, Option modules
  - Ease of Service
  - Ease of Installation
  - Ease of Expansion
- Three Mainframe Sizes-8 channels, 18 channels, 28 channels
  - Full Metering
  - Timer on All models
  - Talkback to "2" studios
- Ultrahigh Quality Construction and design
  - Penny and Giles 3000 Series slide faders
  - VCA's
  - ITT Schadow switches
  - Gold connectors-IC's socketed-regulated power supply
- 3 Stereo Output Buses
- 2 Internal Mix-minus Buses for 'Telephone'
- Option Modules-D.A.'s, Mono Mixes, Remote Selectors, Etc.
- Comprehensive Logic system
  - Start and stop sources by isolated internal reed relays
  - Remote channel On and Off control with Tally lamps for turrets
  - Flashing OFF switches for cart machine status
  - Three muting buses for Control room and two studios
  - Timer reset selectable on each module
  - Monitor DIM function during cue and talkback



24-2248



**arrakis**  
**SYSTEMS, INC.**

Circle 31 On Reader Service Card

**NEW  
NEW  
NEW  
NEW  
NEW**

**NEW  
NEW  
NEW**



# Common Sense Budgets

by Barry Mishkind

**Tucson AZ** One of the most difficult matters and greatest causes of friction between station managers and engineers is the technical budget.

Too many managers see the engineering department simply as an expense. And, in truth, en-

gineering is an expense. After all, few engineers are out on the street selling air time.

Still, every business has its costs of operation and radio is no exception. Thus, the goal is to get the most for each dollar of expense. Wasted dollars mean lost profit.

The engineer, on the other

hand, has to balance the desire to keep costs low while providing a cost efficient department that does not slap the manager with "surprises."

If that weren't enough, these days of highly leveraged radio stations have created additional pressure to reduce spending until absolutely necessary. It's the

current month's P&L, not what will be needed six months down the road, that has become the business focus.

And perhaps that is the greatest frustration for the small to medium market engineer: trying to plan for future needs without undue hassles for either the air staff or the manager—who, after all, is the money tree.

There are reports of stations out there where the engineer is given a blank check to deal with the technical needs of the facility.

Let's face it, we'd all love to work under such a situation.

But the reality for most of us is somewhat less cash available than we need. In fact there are too many stations that have *no budget for maintenance or replacement whatsoever*. The engineer must find a time and way to plead for each need that arises.

In the middle are those stations that ask the engineer to prepare a proposed engineering budget of necessary purchases for planning purposes. Some managers make it as easy as possible by telling the engineer what money will be available ( $\pm 2\%$ ), and seeking an order usage of that cash.

Other engineers find themselves only a few steps above those with no budget: The manager takes the proposed budget and uses that as a starting point for cuts.

Most engineers are already aware of the need to deal with the other departments of the station as allies, not adversaries.

## ECLECTIC ENGINEER

In handling the department's requirements this is critical. The engineer that simply surprises the manager with budget requests will rarely get cooperation. The typical response is more like resentment.

On the other hand, a few minutes spent periodically in preparing a report on the condition of the station will go a long way to open communication and pave the way for granted budget requests.

For example, long before you want to replace the transmitter, you should be preparing reports on its age and the maintenance problems it is beginning to present.

Is your current transmitter now out of production? Are parts getting hard to acquire and more and more expensive? Does the unit use a lot of electricity or tubes that are becoming more expensive?

Giving six months' or a year's notice of your recommendations will allow the manager to plan for the expense, assuming there is agreement with your assessment.

Are there any options to the purchase of a new unit? If the problem is aural, can a new exciter keep the transmitter humming for another year or two, or more? If it is an RF problem, which is more important, the transmitter or the antenna?

Answering these questions will go a long way to putting proposed purchases in perspective. Of course, we'd like to be able to buy all new equipment every other year. The reality though, is that our job entails keeping everything running.

Let's face it: Unless a new owner comes in with a fat check-book, you can't fix everything at once. Not only that, but you don't have enough time to install

(continued on page 32)

Picture if you will...  
**The Sound Gremlins.**  
 Lurking in your signal...  
 wreaking havoc...leaving  
 in their wake a barren  
 landscape of sound. Flat, lifeless  
 audio haunted by tape and  
 equipment noise...  
 plagued by **erratic**  
 levels...tortured by  
 uncontrolled **sibilance**  
 End the torment—  
 call dbx now.



A division of  
 AKG Acoustics, Inc.  
 1525 Alvarado Street  
 San Leandro, CA 94577  
 Tel: 415/ 351-3500  
 Fax: 415/ 351-0500

**INDUSTRY STANDARD**

**COMPRESSOR/LIMITERS • NOISE REDUCTION SYSTEMS • EQUALIZERS • MODULAR PROCESSORS**

© 1990 AKG Acoustics, Inc.  
 dbx® is a registered trademark of Carillon Electronics Corporation.



# A Guide to Mastering on DAT

**In the Studio or On Location, this Fast-Growing Medium Captures the Flavor of Your Live Signal**

by Bruce Bartlett

**Elkhart IN** Have you considered mastering to DAT? It's becoming a popular alternative to open-reel tape.

DAT sound quality is higher than open reel and DAT recorders can be light and portable. In addition, now that consumer DAT recorders are "legal," many more are available at lower prices.

In last month's column we reviewed the basics of DAT recorders: benefits and drawbacks, sampling rates, features and indicators. Let's continue describing the hardware, then we'll get into techniques for mastering to DAT.

## DAT controls

The following controls are found only on professional units.

**Sampling frequency.** This sets the recording sampling frequency to 44.1, 48, or 32 kHz. A rate of 44.1 is preferred if you intend your master tape to be duplicated on compact disc. That's because the compact disc uses a 44.1 sampling rate, so no rate conversion will be necessary if your DAT is set to 44.1.

## LINE OUT

Note that current consumer decks cannot record at 44.1, but future consumer decks equipped with SCMS copy protection will be able to record at 44.1.

The 32 rate lets you record more than two hours on a single tape, but provides a less-extended high-frequency response.

**Emphasis.** This active preemphasis control boosts high frequencies during

recording and attenuates them during playback for lower noise.

**Copy inhibit.** This prevents dubbing any material that is copy protected. A DAT deck will identify data that has been recorded with a copy-inhibit flag in its

around -3 dB maximum. (A reading of 0 dB means you have no headroom left.)

When your mix is perfected, you're ready to record it. Cue the multitrack tape to the beginning of the program. Set the DAT tape counter to 00:00.

Play the multitrack tape. Just before the program starts, tap the Pause button on the DAT recorder to start recording. The Pause button is a toggle switch: Tap

grams, hit Pause, wait three seconds, and hit Pause again.

Play the multitrack tape. Just before the program starts, hit Pause on the DAT machine to release it and start recording the mix.

Using Pause and Stop sometimes makes slight noises on the DAT tape, but you'll have to live with them. Some DAT machines are quieter than others in this regard.

If the multitrack tape has noises just before the program starts, you'll have to leader the multitrack tape. That is, mark the multitrack tape with a grease pencil

(continued on page 28)

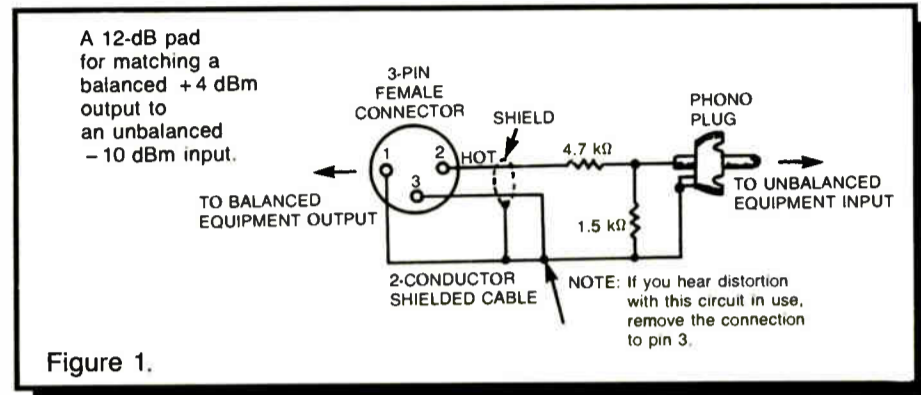

subcode and will not digitally copy that recording. If you want your DAT duplicated digitally on CD, be sure copy inhibit is off!

## Recording mixdowns on DAT

Once you understand the DAT's features and controls, mastering on DAT is simple. First connect your mixer output to the DAT analog line inputs. If your mixer output is XLR-type with a +4 dBm signal, but your DAT input is a phono jack designed for a -10 dBV signal, you'll need to construct a 12 dB pad to interface the two units (Figure 1).

To record your mixes onto DAT tape, search your multitrack tape for the first program you want to appear on the DAT master tape. Play the multitrack tape several times to practice the mix.

Set the DAT machine in record and pause mode, play the multitrack tape and set the DAT recording level to peak

once to pause, tap again to release pause and start recording.

When the program is done or fades into silence, hit Pause on the DAT machine to stop recording.

If you have another program to mix to DAT, now you can add a silent space between programs. If you want three seconds of silence, press Pause, wait three seconds and press Stop. This procedure is imprecise, so you'll need to experiment.

Repeat this procedure for all the programs you want to mix to DAT.

## Re-recording a mix

If you have to re-record a mix, follow this procedure, first find and play the end of the last mix you recorded on DAT. As soon as the program stops, hit Pause. Hit Record and Play while in pause mode.

For a three-second space between pro-

## Our STL's give you one distinct advantage.

### Front panel programmability

Engineers who rely on BEXT STL's as backups because of their easy frequency selection have learned two more significant facts: First, that our STL's outperform expensive competitors, and second, that our field response is quick, accurate and thorough.

Both the high value LC Series and the high performance SD Series offer the unique convenience of front panel programmability.

Both are modular systems: in the rare event that you need more than the standard 15W to reach your transmitting site, it is easy to add our 15W amplifier.

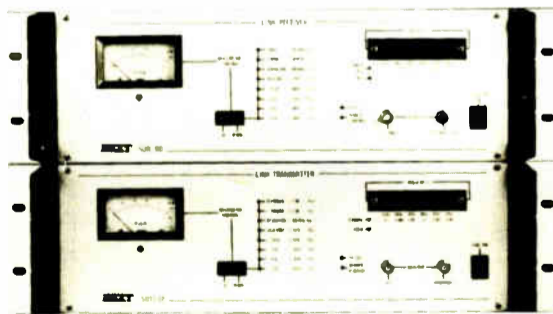

The LC Series is so affordable, even small stations can justify a backup system (remember — backup composite means full stereo redundancy.) It handles main program and subcarrier frequencies up to 100 kHz.

The SD Series offers top performance, and supports all subcarrier frequencies up to 200 kHz. The SD receiver's RF bandwidth is adjustable to optimize reception in your environment.

These reliable STL's are available with prompt delivery, direct from our San Diego offices. Call today for more detailed information.

Suite 7A  
739 Fifth Avenue  
San Diego, CA 92101 USA  
619-239-8462



## Fishing For A Phone Number?

Catch it in the  
**1990 Radio World Annual**

—The Industry Source for Manufacturer, Supplier, NAB and FCC Phone Listings, as well as Product Information, Company Profiles, Buyers Guide Reprints, RW's 1989 Editorial Index, Reference Material, and More ...

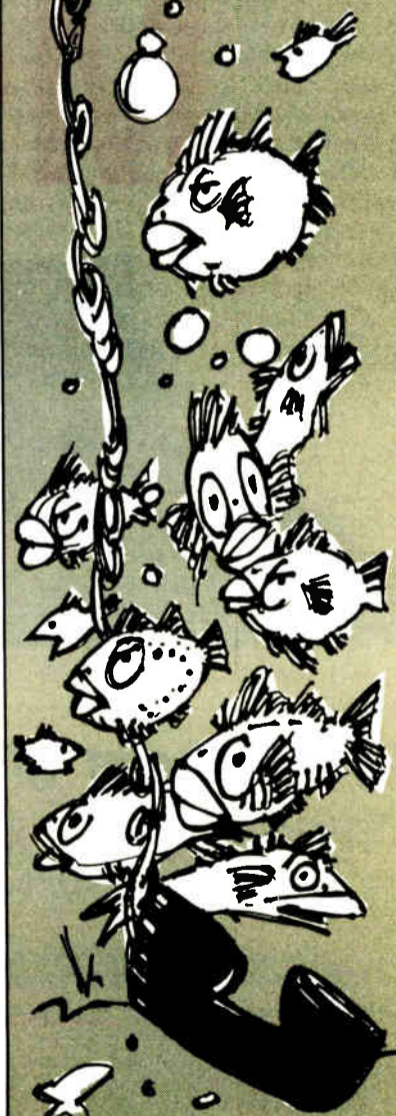

Send \$14.95 for each Annual to:

RW 1990 Annual  
P.O. Box 1214  
Falls Church, VA 22041



# Mastering to Digital Audio Tape

(continued from page 27)

at the playback head gap at the point where the music starts. Put the tape in a splicing block and cut it just to the right of the mark. This eliminates the noises. Then splice leader tape to the multitrack tape at the beginning of the song.

As an alternative, patch a noise gate between your mixer and the DAT machine. Set the noise gate threshold so that it removes noises before the program, but gates on reliably when the program starts. Once the program is in progress, bypass the noise gate or set its threshold to minimum (if this

can be done inaudibly). Turn the gate back on just before the end of the program.

## Recording live to 2-track

In some studio productions, the multitrack recording process is eliminated in favor of mixing everything live to the DAT machine. To do this, follow the same procedure as you did with the multitrack mixdown, except hit Pause (to start recording) a few seconds before the program starts. When the program is done, hit Pause again.

This method isn't always convenient. You might find it easier to record the pro-

gram non-stop, then copy from one DAT to another, editing and re-sequencing as you go. If possible, copy digital-to-digital for best sound quality.

When recording live to 2-track on location, a good procedure is to record the event non-stop. No tape swapping is necessary because DAT tapes run for two hours. If you record a concert, for example, you can edit the tape later to remove long applause and noises between songs. You do this by dubbing desired segments from one DAT to another.

Several DAT manufacturers are working on electronic editing capabilities so eventually you will be able to edit a DAT

tape much the way video editing is now done. But for now, it takes machine to machine dubbing.

As this article is written, only the Fostex D-20 DAT machine records SMPTE time code. It has SMPTE in and out connectors, and records the SMPTE time code in the DAT subcode area.

## Duplicating your DAT master

Once you have the DAT master tape completed, make a safety copy. Or, run two DATs in parallel during the mastering session.

You might want to duplicate your DAT master tape on a broadcast cart, DAT, compact disc, LP or cassette. For small runs of cassettes, simply dub the DAT tape to a stereo cassette deck. For larger runs, you'll need to use an outside cassette duplicator.

DAT is a new technology, however, so not all duplication houses have DAT machines from which to master. Check to see whether the duplicating house can handle DAT tapes. If not, you might take your DAT machine to the house's plant for them to use, or pay them to rent one.

Before sending your tape out, rewind it fully and set the counter to 00:00. Play the tape and write down the start and stop times for each selection. You might want to manually enter a Start ID at the beginning of each selection.

Be sure to write a tape log describing everything on the DAT master: title, client, engineer, producer, start/stop times for each selection, which cuts go on side A and which on side B and the counter time of the loudest part of the program.

No calibration tones are needed because the mastering engineer sets the recording level from the peak level of the program. Also, a DAT tape plays with the same flat frequency response on any machine, so you don't need to record tones at various frequencies.

## CD considerations

If you plan to have your DAT tape duplicated on compact disc, leave about 20 seconds of silence between selections for easier editing by the CD mastering house. You'll get cleaner results if you let them edit the spaces between selections.

Also, let the DAT machine get up to speed for a few seconds before playing the multitrack tape that you're mixing to DAT. If you record original material on a consumer DAT machine, you can digitally duplicate the DAT tape. SCMS does not prevent digital copying of original programs.

A compact disc can be mastered directly from a DAT tape. But the disc must contain PQ subcode information that tells the CD player where to locate each track on the disc. To generate this information, start with an edited, sequenced DAT master tape. Stripe the DAT tape with SMPTE time code.

Play the DAT tape and note the SMPTE times when each selection starts and stops. The CD mastering engineer will enter these times as PQ subcodes in the CD laser mastering machine, then will play the DAT tape while cutting the CD.

By following the suggestions given here, you should be able to create top-quality masters on DAT tape, or prepare your DAT masters for duplication. It's a joy to hear a master tape that sounds as clean as the live signal.

■ ■ ■  
Bruce Bartlett is a microphone project engineer and technical writer with Crown International. He can be reached at 219-294-8000.

**\$175.00**  
per  
**MONTH.**



RS-12 Console Shown. Similar Savings on RS-6 and RS-18.

## You can own this RS-12 Console.

For two years, RS Series consoles have brought top-dollar performance to broadcasters at affordable prices.

Many of you have asked for financing. Now it's possible at competitive rates and with no hassle.

You might say, "But let's see the small print." Here it is... and we think you'll like it:

- One dollar buy-out
- No financial statements if you've been in business for two years or more
- You'll have your answer within 48 hours
- Simple one-page application
- No filing fees
- Terms of one to five years
- Rates are subject to change, but you'll get a low monthly payment ... and a superb broadcast console from a company that cares.

**RADIO SYSTEMS INC.**

110 High Hill Road • P.O. Box 458 • Bridgeport, NJ 08014-0458 • 609/467-8000 • 800/523-2133 • FAX 609/467-3044

Call today and ask for information about financing plans for any of our equipment.



# Stress Reduction for Engineers

## A Stitch in Time Really Does Save You Nine

by John "Q" Shepler

**Rockford IL** It seems like everybody is tense these days. Maybe you've noticed this tension in yourself. You turn on the car radio just in time to hear the top rated song be devoured by cart #3 ... again! Your neck gets a little stiff. You push down on the accelerator a little harder.

As soon as you get through the front door, the receptionist shoves a dozen mail messages in your hand. The program director blocks your path down the hall. He's mad about the cart. He's even more teed-off about the dead battery in the remote van. Seems the weekend weenie left the two-way on ... again!

Now you're past him and rushing by the studio toward the transmitter room. A few more seconds and you'll be safely in the shop. Hmmm ... maybe you can lock the door for a bit. Nope. Not fast enough. The morning joker's running to catch up. His headphones are crackling ... again. He had to use the greasy ones from the weenie's production basket. Disgusting. It's all your fault his timing was off today.

Before this day is over, you will have nailed two carnivorous cart machines, punched the FM transmitter back on three times, dealt with the irate doctor who is picking up your station on his satellite dish, put new drivers in the headphones, gulped lunch, had indigestion all afternoon, driven 30 miles to show the sales manager how to turn on the remote pickup transmitter, called the receptionist a bad name, apologized three times because it wasn't her fault she told the FCC inspector to get lost. You told her specifically that all pests were supposed to get lost today.

Finally, at 7 PM you crawl home, gulp down a quick supper, and re-hash the day's events in your mind until it's time to go to bed. Of course, tomorrow is another day. But, it will probably be a lot like today.

### How to stop the pain

It doesn't have to be like this. You can make your life a lot easier.

Wait a minute, you say. What am I supposed to do? I'm getting beat up every day by all these other people. I have no control over them. They're all tense and hostile and taking it out on me. It's their fault, not mine.

Nope, it's your fault. Sit back and think a second. This isn't the first time

those cart machines ate tapes. You should have cleaned the gunk off those pinch rollers a week ago. It would only have taken five minutes.

How about the dead battery in the van? If you had wired the two-way through the key switch and not directly to the battery, it would have been shut off automatically. You should have thought that one through better.

The 30 mile drive? Sales managers don't get paid to be engineers. Either fix the front panel power switch, or put a sticker on that transmitter showing where your substitute toggle switch on the rear is located.

## Q-TIPS

The transmitter? Off three times? Shame, shame. Come in tonight and put in a new breaker. Otherwise, you'll be pestered every day from now on.

As for headphones ... about all you can do is buy a bunch of spares and rotate them through. Maybe put a resistor in line to limit the power from the phones amp. It's worth the bother to try.

Are you beginning to see a pattern here? Yes, you could have prevented every one of these disasters. None of these problems came out of the blue. You had at least a little warning the first time there was trouble.

People are generally understanding the first time something breaks. It's having to deal with the same headaches recurring day after day that gets their blood boiling over. Once that happens, they're out of control and you're in big trouble.

The point is that you have a lot more control than you think you have. A lot of the stress makers you deal with day to day can be subdued. Of course

things will still go wrong, but imagine how much less tense you'd be if there were three problems a day to solve instead of 30.

Start now to figure out how to make things run so smoothly that you can be a problem solver, not a scapegoat. Here's some help getting started.

### Six simple steps

**Make a list.** Get a ruled notebook and make a daily schedule. Before you go home, list the top five things that must get done tomorrow. Then list a couple of things you'd like to do, time permitting.

Tomorrow morning, jump on the first five items and check them off as they get done. If other problems pop up, add them to the list. Tomorrow night, create the next day's schedule, starting with what didn't get done and adding a couple of new items. Pretty soon, you'll have only a couple of "must do" and several "would be nice to do" items on each day's list.

**Label everything.** Nobody else thinks like an engineer, so spoon feed 'em. Do it with simple labels and directions. I learned this early on, when one of the DJs invented transmitter-by-numbers. Frustrated with forgetting the right sequence, he put dots with numbers on each of the main switches. In the morning, he just followed along: 1-2-3. Wish I could claim that idea.

**Train people.** If they call you because they don't know how to work something, make sure they can do it themselves the next time. Train people to be self-sufficient and they won't be bugging you so often.

**Buy spare parts.** You can't afford them all, so keep notes on which ones have failed, and make sure you have those. Also, keep one of each stay-on-the-air item on hand—like replacement tubes, fuses and the like.

**Routinely maintain.** Your daily schedule should have at least one maintenance item on it. You can hum along to the tunes while you clean and align those cart machines on your own schedule. If they crash during a rating period, you'll be jumping to somebody else's tune.

**Make sure everything is covered.** You can take a vacation in peace if you trade vacation coverage with another engineer. Make sure your friend has little to do but reassure the staff that all is well. Of course, you'll reciprocate.

Yes, life is tough. But we make it a lot tougher than it has to be. The best way to dissipate that unhealthy tension is to get things under control so that you are the master ... not a slave to avoidable misfortune.

■■■

John Shepler is an engineering manager, broadcast consultant, writer and regular RW columnist. He can be reached at 815-654-0145.

**RK-RACK SYSTEM  
AUDIO SIGNAL PROCESSING**



**COMMON FEATURES**

- THREE RACK UNITS OF SPACE INPUTS & OUTPUTS HAVE AUDIO TRANSFORMERS
- COMMON POWER SUPPLY- 100, 120, 240, 50/60 Hz
- REDUNDANT POWER SUPPLY FOR SAFETY
- SCREW TERMINALS FOR INPUTS & OUTPUTS

**10 MODULES FOR AUDIO NEEDS**

RK-PA	RK-AGDA
RK-VCADA	RK-DAADJ
RK-MLD	RK-ALC
RK-DA	RK-SC
RK-LA	RK-SB

SEND FOR FREE CATALOG

**SESCOM INC.**  
2100 WARD DR.  
HENDERSON NV 89015 U.S.A.  
702-565-3400, 800-634-3457, FAX 702-565-4828

**RF SPECIALTIES GROUP**  
LEADERS IN RF SYSTEMS FROM COAST TO COAST

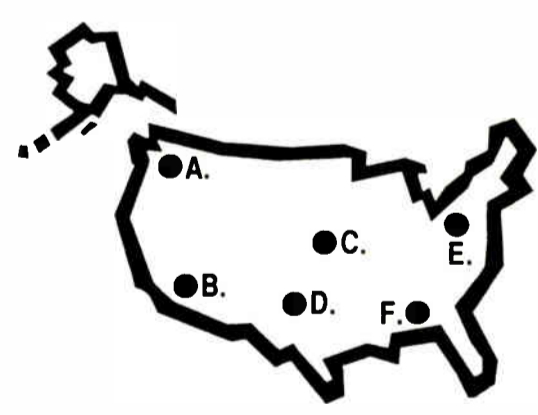

**A. RF Specialties of Washington, Inc.**  
19237 Aurora Avenue N.  
Seattle, WA 98133  
Phone (206) 546-6546  
FAX (206) 546-2633  
John Schneider

**B. RF Specialties of California**  
3463 State Street, Suite 229  
Santa Barbara, CA 93105  
Phone (805) 682-9429  
FAX (805) 682-5170  
Sam Lane

**C. RF Specialties of Missouri**  
R.R. #2, Box 152H  
Kearney, MO 64060  
Phone (816) 635-5959  
FAX (816) 635-4508  
Chris Kreger

**D. RF Specialties of Texas**  
P.O. Box 7630  
Amarillo, TX 79114  
Phone (806) 372-4518  
FAX (806) 373-8036  
Don Jones & Tim Hawks

**E. RF Specialties of Pennsylvania, Inc.**  
121 Conneaut Drive  
Pittsburgh, PA 15239  
Phone (412) 733-1994  
FAX (412) 327-9336  
Tom Monahan

**F. RF Specialties of Florida**  
P.O. Box 397  
Niceville, FL 32578  
Phone (904) 678-8943  
FAX (904) 729-2744  
Bill Turney

FOR ALL YOUR BROADCAST EQUIPMENT NEEDS, CALL THE SPECIALIST NEAR YOU

SYSTEM DESIGN COMPETITIVE PRICING

**RF Specialties® Group**

Each Office is Independently Owned and Operated

**Stay Ahead of the Competition**



**orban**



# Exploring Software Solutions

by Mel Lambert

**Studio City CA** As digital technology of one persuasion or another makes further inroads into the radio-broadcasting industry, it cannot have escaped the attention of many a chief engineer that certain digital solutions may not yet be carried by your favorite hardware supplier.

While the palette of available technologies includes CD decks, DAT recorders, workstations and a virtual cornucopia of signal processors, not so freely available—currently, at least—are integrated designs that fulfill the specific requirements of day-to-day radio broadcasting.

Consider, for example, the implementation of an automated, random-access recording and playback system, possibly designed to augment an existing satellite music service, or as a standalone function in a newsroom, for example.

As many as a dozen viable commercial designs exist that will meet the need of the majority of their targeted customers, but what about customized functions? What about such functions as integrating the system with an existing traffic and billing format? Or possibly serially linking the device to a planned workstation?

And what about a front-end controller

that has been designed to fulfill the specific needs of regular operators and which is configured to speed up the random selection of music cuts, commercials, station IDs, promos, PSAs and the virtually hundreds of discrete sound elements that are needed during any broadcasting day?

## Ways around the shortfall

Four alternatives immediately suggest themselves:

1. Try to convince a manufacturer to modify existing hardware/software for your specific needs.
2. Purchase an existing product and attempt to modify the hardware and/or software yourself to suit your specific applications. (Assuming that the manufacturer will provide you with sufficient access to the operational software and schematics of the analog/digital circuits.)
3. Develop custom software to run on a computer-based platform that houses or is connected to commercially available add-on hardware.
4. Develop proprietary hardware and software to handle the assigned tasks.

The first route is easy to determine; you simply need to outline your requirements and hope that sufficient other customers will be looking for the types of features and functions particular to your requirements. If so, perhaps the manufacturer can recover its often costly development time and effort from the enhanced market.

(We'll put aside for a moment the types of symbiotic relationships that more innovative firms might form with radio stations and under which the latter will act as a valuable R&D source and initial alpha/beta test site for new workstation offerings.)

Defining the enhancements and additional features you might need for an existing piece of hardware can be easier than actually implementing them in a commercial unit. Developers of hard disk-based automation and replay systems have invested considerable dollars and man hours in innovating a product and, perhaps not surprisingly, are reluctant to provide too many details of their

operating systems and other proprietary operational features.

Aside from letting the manufacturer's competition see any of its important design ideas, how can the developer of such systems continue to offer after-sales service and warranty support if the customer is freely modifying system functions and otherwise fooling with the controller software that's running the unit?

## Door number three

The fourth option, quite frankly, is almost certainly beyond the scope of all but the most technically proficient network technical department. Design and hand assembly of digital controller boards is a costly process, not to mention the implementation of hybrid analog/digital PCBs and support hardware.

(If you think that designing good-sounding analog line amps and other circuitry is difficult, try to do the same thing within a few inches of digital converters or filter circuits that are radiating square-wave hash well into the multiple-MHz range!)

## DIGITAL DOMAIN

A far more realistic solution, at least to my mind, would be to opt for the third compromise, and develop custom front-end software to drive commercially available A-to-D/D-to-A converter hardware and hard-drive storage devices.

Unfortunately, while the majority of the current hardware is capable of delivering the necessary sonic quality expected from digital, we quickly discover that linking together the various components is not as easy as one might at first have thought.

Not that any of the firms making discrete analog-to-digital and D-to-A converter systems have anything to hide; the majority of them are more than willing to provide details of the basic programming calls to their add-ons or plug-in boards, and the best ways in which to integrate them into a PC- or Mac-based platform.

## A formidable goal

The primary problem seems to be finding suitable staff to develop, write  
(continued on page 32)

**GET IT RIGHT**  
FROM HARRIS ALLIED

**BUY**

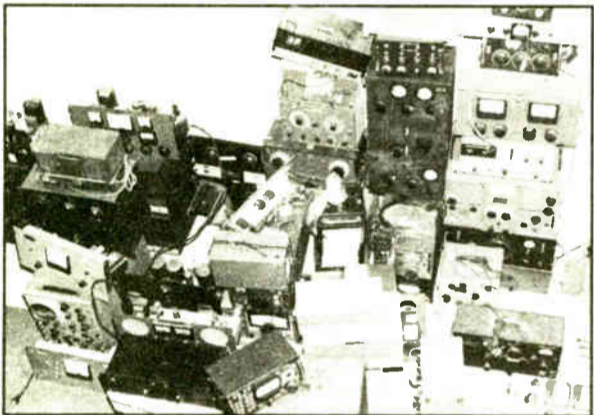

**SELL**



**TRADE**





**HARRIS ALLIED**  
EQUIPMENT EXCHANGE

317-962-1471  
FAX 317-966-6321

635 SOUTH E ST. • P.O. BOX 1487 • RICHMOND, IN 47374  
©HARRIS/ALLIED 1990

We selectively buy used radio equipment, sell new and used gear, and accept trades of broadcast equipment. Call Jim or Chuck today!

**SUBSCRIPTION/READER SERVICE FORM**

## Radio World

October 10, 1990 Issue    Use until January 10, 1990

**FREE Subscription/Renewal Card**

I would like to receive or continue receiving **Radio World** FREE each month.     YES     NO

Signature \_\_\_\_\_ Date \_\_\_\_\_

Please print and include all information:

Name \_\_\_\_\_ Title \_\_\_\_\_

Company/Station \_\_\_\_\_

Address \_\_\_\_\_

City \_\_\_\_\_ State \_\_\_\_\_ ZIP \_\_\_\_\_

Business Telephone (    ) \_\_\_\_\_

Please circle only one entry for each category:

**I. Type of Firm**

D. Combination AM/FM station

A. Commercial AM station

B. Commercial FM station

C. Educational FM station

E. Network/group owner

F. Recording studio

G. TV station/teleprod facility

H. Consultant/ind engineer

I. Mfg, distributor or dealer

J. Other \_\_\_\_\_

**II. Job Function**

A. Ownership

B. General management

C. Engineering

D. Programming/production

E. News operations

F. Other (specify) \_\_\_\_\_

**III. Purchasing Authority**

1. Recommend                      2. Specify                      3. Approve

**Reader Service**

Please first fill out contact information at left. Then check each advertisement for corresponding number and circle below. NOTE: Circle no more than 15 numbers, otherwise card will not be processed.

001	023	045	067	089	111	133
002	024	046	068	090	112	134
003	025	047	069	091	113	135
004	026	048	070	092	114	136
005	027	049	071	093	115	137
006	028	050	072	094	116	138
007	029	051	073	095	117	139
008	030	052	074	096	118	140
009	031	053	075	097	119	141
010	032	054	076	098	120	142
011	033	055	077	099	121	143
012	034	056	078	100	122	144
013	035	057	079	101	123	145
014	036	058	080	102	124	146
015	037	059	081	103	125	147
016	038	060	082	104	126	148
017	039	061	083	105	127	149
018	040	062	084	106	128	150
019	041	063	085	107	129	151
020	042	064	086	108	130	152
021	043	065	087	109	131	153
022	044	066	088	110	132	154

"Call me, I'm interested." Circle 47.

"Send me literature." Circle 11.



# A Look at Amp Characteristics

This is the third in a 12-part series called Amplifier Fundamentals. Northern Virginia Community College will offer 1.2 CEUs (continuing education units) to registered students who successfully complete the course and an examination mailed at its conclusion.

Successful completion of the course and the final exam will also earn 1.3 professional credits toward recertification under the maintenance of certification provisions of the SBE Certification Program. To register, contact the Director of Continuing Education, Annandale Campus, 8333 Little River Turnpike, Annandale, VA 22003, or call 703-323-3159. The fee for the course is \$35.

by Ed Montgomery

## Part III of XII

**Annandale VA** An amplifier usually has several stages to bring a signal up to a desired level. Audio consoles usually

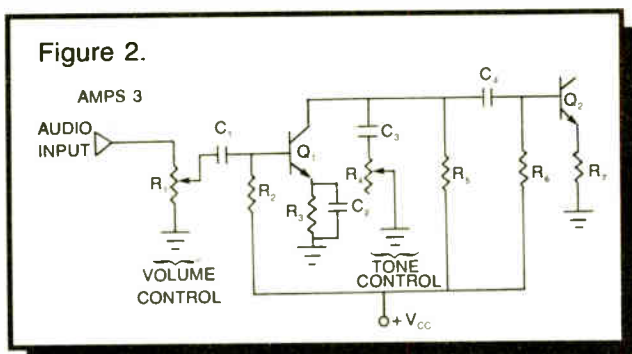

of pre-amplification, a driver stage and power output. An operational amplifier can contain all of this within one "chip." Most level setting or tone adjustments are made at the pre-amplifier stages and not in the power amplifier. A simplified illustration of this is found in Figure 2.

The tone control in this illustration is simply a resistive-capacitive circuit. The lower the value of  $R_4$  the more high fre-

quencies are bypassed to ground, resulting in only low frequencies being passed to the next amplifier stage.

quencies are bypassed to ground, resulting in only low frequencies being passed to the next amplifier stage.

quencies are bypassed to ground, resulting in only low frequencies being passed to the next amplifier stage.

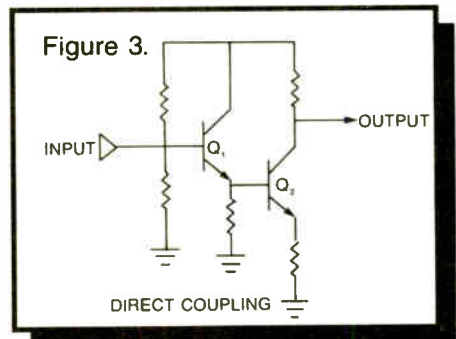

quencies are bypassed to ground, resulting in only low frequencies being passed to the next amplifier stage.

quencies are bypassed to ground, resulting in only low frequencies being passed to the next amplifier stage.

quencies are bypassed to ground, resulting in only low frequencies being passed to the next amplifier stage.

quencies are bypassed to ground, resulting in only low frequencies being passed to the next amplifier stage.

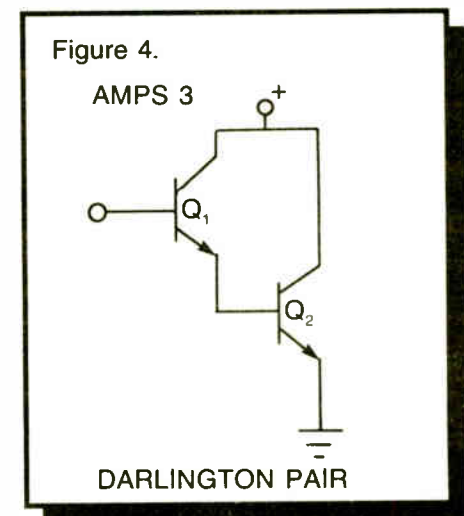

quencies are bypassed to ground, resulting in only low frequencies being passed to the next amplifier stage.

quencies are bypassed to ground, resulting in only low frequencies being passed to the next amplifier stage.

quencies are bypassed to ground, resulting in only low frequencies being passed to the next amplifier stage.

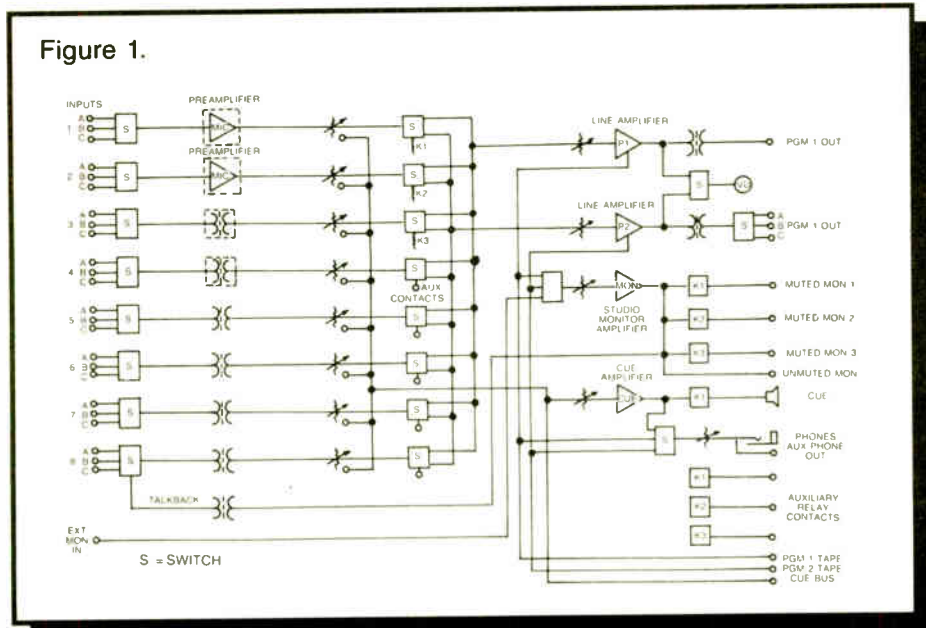

quencies are bypassed to ground, resulting in only low frequencies being passed to the next amplifier stage.

quencies are bypassed to ground, resulting in only low frequencies being passed to the next amplifier stage.

### Coupling

quencies are bypassed to ground, resulting in only low frequencies being passed to the next amplifier stage.

quencies are bypassed to ground, resulting in only low frequencies being passed to the next amplifier stage.

quencies are bypassed to ground, resulting in only low frequencies being passed to the next amplifier stage.

quencies are bypassed to ground, resulting in only low frequencies being passed to the next amplifier stage.

quencies are bypassed to ground, resulting in only low frequencies being passed to the next amplifier stage.

quencies are bypassed to ground, resulting in only low frequencies being passed to the next amplifier stage.

quencies are bypassed to ground, resulting in only low frequencies being passed to the next amplifier stage.

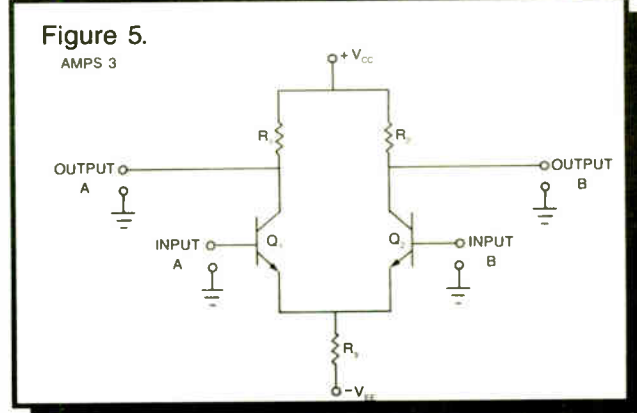

quencies are bypassed to ground, resulting in only low frequencies being passed to the next amplifier stage.

quencies are bypassed to ground, resulting in only low frequencies being passed to the next amplifier stage.



## Grab the Comrex and run...

Would you believe—a live talk show, broadcast from the back seat of an on-duty police cruiser... from a nude bar... or from the scene of a street crime? These are just some of the ways WNWS Talk

*"Spontaneity is the best marketing tool you can use!"*  
Lorri Sheffield, PD, WNWS Miami  
A Jefferson Pilot Station

Radio PD Lorri Sheffield puts her listeners *directly* in the middle of issues they care about.

At a moment's notice, WNWS puts its talk show talent where the action is. How? With cellphones and Comrex frequency extenders. The cellphone gives them immediate connection between the studio and the story—and the Comrex turns the telephone sound into broadcast quality.

"While other stations may do a quick 60 second bit at station breaks, we put a whole crew of producers and news people on the scene and cover it *live* during our talk show," says Sheffield. "There's strong emotional appeal. And we get right to the core!"

There's no need to depend on expensive dedicated phone lines or overcrowded RF links. The WNWS team can just grab the gear and go—doing the creative en route. And transmit great sounding audio from virtually anywhere.

Call today to hear what Comrex can do for *your* programming.



**COMREX**  
Specialists in Remote Broadcast Audio Transmission

Comrex Corporation  
65 Nonset Path, Acton, MA 01720  
1-800-237-1776 / (508) 263-1800 / Fax: (508) 635-0401



# Planning a Practical Budget

(continued from page 26)

everything if it were to arrive all at once, anyway!

So, look at your existing inventory. What are the replacement parts that you will be needing over the next year? Consider tubes, cart machine heads, turntable styli, replacement tape carts, etc.

All too often, when buying new gear, a station will neither budget for, nor purchase any replacement parts, so that when cart heads start to wear, for example, the engineer is back on the defensive, trying to justify what should already be on hand.

Starting with a relatively modest monthly amount, a lot of parts can be

stocked against future needs, reducing the need for large purchases.

The next project is to take the periodic reviews mentioned earlier and develop a balanced flow of needed acquisitions. Yes, the manager may reject it out of hand. But, as time goes by, and your predictions prove correct, that attitude should shift.

On the other hand, if you work for a manager who absolutely refuses to "budge" on the budget, maybe you ought to look for another station at which to work. Ulcers and 3 AM phone calls are not a fair feature of a secure job!

Now, here is the trickiest part of the

process. As you develop these preplanned budgets, don't start leaving things out. Yes, the temptation is to get what you can because the checkbook may be closed in future. But, time and time again, you'll find that if you don't specify the spare parts kit, it will *never* get bought.

Likewise with test gear. It's easy to make do with that old VOM. But today's studios and transmitters need a good scope and audio test gear to keep it running cleanly. And that is at minimum.

Remember, eventually everything is going to need maintenance. Having the impedance bridge on the shelf for a year or so may seem like a luxury, but the first time you lose a capacitor in a lightning storm and need to rebalance the phasor, you'll be glad it was there.

We could go on and on about the time lost when common replacement parts are not on hand, necessitating time consuming adjustments to keep worn parts useable, while ordering them from the supplier. A few pressure rollers and cart heads *will* eventually save you time and effort even if now they're just sitting on the shelf.

Sure, emergencies and unforeseen things cause strange failures. It is not possible to stock everything. Yet a tube on the shelf is worth 10 at the supplier's warehouse.

And the bonus is that you will never have to go to the boss and say, "If we want to get back on the air, I've got to order this FedEx, and you'll need to have a check ready tomorrow for several thousand dollars."

■ ■ ■

Barry Mishkind, aka RW's "Eclectic Engineer," is a consultant and contract engineer in Tucson. He can be reached at 602-296-3797, or on FidoNet 1:300/11.

## Tackle Your Fall Sportscasting with Microdyne



1100-FFC-X1 RDC(L)  
Downconverter



1100 PCDR-5  
Demodulator

The proven reliability leader in SCPC audio satellite reception.

Microdyne's downconverter is first draft choice in C-band downconverters. High stability and performance.

Running out in front is Microdyne's agile and flexible audio demodulator. Competition still can't compete.

Get the SCPC action for as little as \$150/mo. Call the Harris Allied satellite team!

**HARRIS ALLIED**  
SATELLITE EQUIPMENT  
317-962-8596

FAX 317-962-8961

3712 NATIONAL RD. WEST • P.O. BOX 1487 • RICHMOND, IN 47375

©HARRIS/ALLIED 1990

## Software in Digital Times

(continued from page 30)

and debug the necessary controlling software. While many of us are "computer literate," and more than familiar with the user interface and operational modes of some of the high-power IBM, Apple and Amiga systems, there can be no denying that the development of specific software is often something of a daunting task.

I have been engaged in putting together a series of design briefs for a PC-based recording and playback system designed to automate the replay to air of music, jingles, ad breaks, IDs, promos, PSAs, etc. Time and again I realize how rusty is my knowledge of higher-level languages, such as Pascal, Enhanced BASIC and the various forms of "C" that now exist, not to mention machine-code routines for the popular microprocessors and DSP chip sets.

Without a reasonable familiarity of such vernacular, and the common ways in which front-end screen drivers and

keyboard/mouse/keypad input routines translate into system requests and record/replay commands—not to mention optimizing data throughput via SCSI-equipped hard drives—the task can be pretty daunting.

But I am also finding that knowledgeable design engineers do exist, who can quickly write a fully functional I/O and graphics display shell for a PC or Mac, with high-speed calls to the ancillary hardware via standard buss architectures. The main problem seems to be that too few of these talented individuals are connected with the radio industry, and that it can take quite a while to bring them fully up to speed with our specific and often whimsical requirements.

### Insider information

I am discovering, however, that the more time I spend with software developers, the more knowledgeable I become in the types of functions that are relatively easy to implement, while others—maybe because of hardware limitations—will be more difficult and/or expensive to include within the proposed design.

Such insider information is invaluable, I find, simply because I can now be more specific in my design and function requests, having seen into the mind of an individual who considers software solutions more objectively than possibly you or I might see them.

■ ■ ■

Mel Lambert has been intimately involved with the production and broadcast industries on both sides of the Atlantic for the past dozen years. Now principal of Media&Marketing, a consulting service for the professional audio industry, he can be reached at 818-753-9510.

"Doing things for successful FM translators"



**FM TECHNOLOGY ASSOCIATES, INC.**

Talk with Howard Enstrom, veteran broadcast consultant who, in the 70s switched to FM translators as a specialty.



**FMTA services:** Feasibility studies, frequency searches, system design-engineering, FCC applications. Publisher of *The SIGNAL SOURCE*, bi-monthly newsletter all about FM translators. **BEST EQUIPMENT PRICES.**

**FM TECHNOLOGY ASSOCIATES, INC.**

30925 Vista Vista  
Mount Dora, FL 32757

(904) 383-3682 FAX (904) 383-4077

## SA 990 OP AMP

FOR HIGH PERFORMANCE AUDIO

- HIGH RELIABILITY
- VIBRATION TESTED
- HIGH QUALITY COMPONENTS
- FROM STOCK
- APPLICATION NOTES

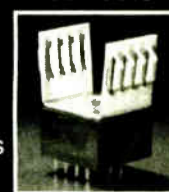

**Summit Audio Inc.**

P.O. Box 1678, Los Gatos, California 95031 U.S.A.  
408-395-2448 FAX 408-395-1403



# Satisfaction is not a luxury.

When you've handled the tough situations and made them look easy. When you've built a solid record of excellence. That's the time to appreciate the satisfaction of real achievement. It's also the time to acknowledge the tools that helped you do the job a little better than it might have been done. For many of today's leading broadcast professionals, a BMX Series III on-air console is right on top of that list.

That's because Pacific Recorders engineers aren't satisfied with a console design unless it meets all of your requirements. The BMX III handles complex programming, acquisition and communication tasks simultaneously—and brings superb audio performance to all

of them. The exceptionally broad range of mainframe sizes and module types lets you configure the board for your particular applications. Yet the functional layout is always easy to understand and learn.

At PR&E, we build consoles for the long term. So while you will certainly be pleased with your purchase of a new BMX III, you're likely to be even more satisfied with each passing year. Which is one more reason so many station groups and networks specify BMX III on-air consoles—time after time.

For more detailed information on the many advantages of owning a BMX Series III on-air console, call PR&E direct at 619-438-3911.



This satisfied BMX III user is Herb Squire, Chief Engineer at WQXR-FM/AM, New York, N.Y.



**Pacific  
Recorders &  
Engineering Corp.**  
2070 Las Palmas Dr.  
Carlsbad, CA 92009  
Tel 619-438-3911  
Fax 619-438-9277

©Pacific Recorders & Engineering Corp.





# The DAT Standard.

We all know it: broadcasters are a cautious lot.



So, despite DAT's great promise, at first most Radio stations, TV stations, and production houses took a wait-and-see attitude toward the new format.

But today, five years after the format was unveiled, two years after the RS-1000 was developed, and on the brink of a consumer DAT introduction, RS-DAT has emerged as the Pro DAT Machine. This means that over 300 units are now in use at such prestigious institutions as



ABC, CBS, the U.S. Navy, BBC, Muzak, Canadian Broadcasting Corporation, KIIS in LA, WQCD in NY, Greater Media, and hundreds of others.



RS-DAT is the perfect automation machine. Because it's the only one with end-of-message cues and broadcast standard remote control, it easily connects to all existing systems. And random cut access adds a whole new creative dimension to automation programming.

RS-DAT is the perfect automation



In fact, all of the prestigious automation companies whose logos appear on this page have integrated RS-DAT into their automation systems and recommend it to their customers for the best DAT performance.



RS-DAT is tested and ready for

automation, or as a live source in your air studio, or for DAT archiving.



The world is going DAT—RS-DAT—the one that works. Call today, or contact these fine companies directly about RS-DAT for automation.

**RADIO SYSTEMS INC.**

110 High Hill Road • P.O. Box 458 • Bridgeport, NJ 08014-0458  
609/467-8000 • 800/523-2133 • FAX 609/467-3044



# The Continuing W and K Debate

by George Riggins

**Long Beach CA** I've received a couple of interesting replies in response to the comments about the misplaced "W" and "K" calls. As mentioned in July, a few of these misplaced calls were left unchanged despite alterations in the station's "personality."

## Old Timer

Howard McDonald of KKMT/KKMT-FM sent quite a list of "W" calls that are still in use west of the Mississippi River, and "K" prefixes still active east of the Mississippi River. It may take some study to collect their histories.

Nonetheless, there's still a lot to be said about misplaced calls. A source of mine, *Radio News for June 1923*, carried the following paragraph, headlined "Mississippi River Is Limit Between W and K Calls":

"The Mississippi River is now the dividing line between the 'K' calls of the West and the 'W' calls of the East, as far as broadcasting stations are concerned. All new calls issued to broadcasting stations east of the Mississippi will begin with 'W' and those west with 'K,' so the stations can be immediately identified as Atlantic or Pacific when the initial letter is heard. The stations already listed under 'K' including KDKA will retain their original calls."

Two states—Louisiana and Minnesota—are divided by the Mississippi River. In a cursory check of the stations in Louisiana, there do not seem to be any misplaced prefixes. In going over a 1928 station list from the Federal Radio Commission, I had to wonder whether someone at the Commission failed seventh grade geography. Many "W" calls were issued in both Missouri and Kansas after 1923.

Another state that seemed to be misplaced was Iowa. As for Minnesota, additional study is necessary to get a feel for whether the line actually followed the Mississippi River which runs between St. Paul and Minneapolis, and then north. Stay tuned—more to follow.

One of the early "W" prefix stations now west of the Mississippi is WIBW. First licensed to Logansport, IN—on the banks of the Wabash—in 1923, the call was reissued to Topeka, KS by 1931. The station operated at 580 kc; power, 1000 W.

### Quest for the farthest west

Howard McDonald has also asked whether Rapid City,  $\pm 103^{\circ}13'10''$  west longitude, or El Paso,  $\pm 106^{\circ}28'50''$  west, was the western-most. El Paso is south of the southeastern corner of New Mexico in the extreme western finger of Texas. The western border of South Dakota is just a few miles west of the same longitude as Pecos, TX. El Paso is only a few minutes east of the longitude of Albuquerque, NM,  $\pm 106^{\circ}39'30''$ .

There is no contest! El Paso still

takes the prize for the "Lower 48" for having a misplaced prefix. If we include what presently constitutes our 50 states, then the call issued to the American Expeditionary forces in WW II—WVCX-Sitka, AK—is the record.

Now, do we include American possessions, territories and the trust territories? I, for one, have been trying to deal with radio in the continental US as it was known up to the time of WW II, or about 1946.

There are some very interesting calls and locations in the US if we want to include more than standard broadcast. We open ourselves to police, weather, aircraft, maritime stations and the American possessions, territories and trust territories of pre-World War II.

The latter possibilities were brought to my attention by Paul Swartzendruber, the CE for KVOH, an international short-wave station. Paul has done construction and maintenance on several stations in the Pacific.

Turning now to old-time radio, the Stix Baer and Fuller department store in St. Louis, MO started a unique operation in 1926. The store applied for and was issued a station license—WSBF—which featured an all-female staff of announcers in the period of 1927 and 1928. The station studios were located in the area of the store where receivers were displayed, demonstrated and sold.

Bob Nicholas, who grew up in the St. Louis area and was an avid broadcast DX chaser, says he remembers the operation because it was different and operated for the explicit purpose of

selling receivers. Perhaps this was one of the early "House Organs."

Two other interesting calls are WACO and WARE. These two stations seem to be the only two issued calls that both identify the city of license and spell the city name. WACO-Waco, TX,

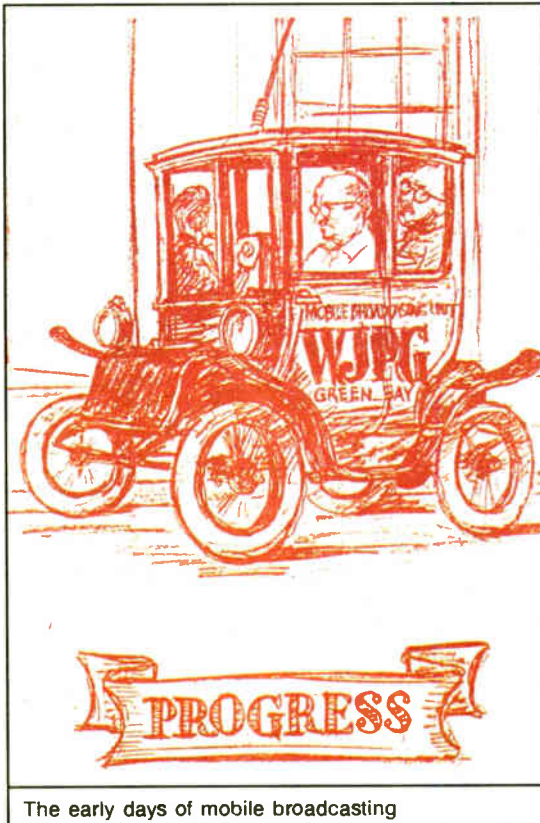

The early days of mobile broadcasting

was issued between 1929 and 1931, frequency of 1240 kc with 1000 W of power. WARE-Ware, MA, was not issued until about 1948.

Don Parker, who retired from KFVB, a Group W station, passed along the cartoon accompanying this installment of *Old Timer*. The cartoon was used in Green Bay, WI's WJPG, while he was working there. The engineer facing the rear was supposed to be Don.

This is a little different from the mobile or remote setups we use today.

### What did they say?

In listening to both the AM and FM bands, I sometimes ask myself what happened to the techniques of Fred Waring and Merideth Wilson.

In the early '30s, Waring emphasized the understandability of the spoken word as applied to songs and singing groups. One could understand every word that was spoken or sung by a single performer or a group of singers.

Merideth Wilson further refined the techniques in the late '40s and early '50s with what he called his "Talking People." I just wonder how much better some of today's music and commercials would sound if these techniques were put into play.

### ...I had to wonder whether someone at the Commission failed seventh grade geography.

Alfred Poor, in the article "Turnkey Media from IBM" (*PC Magazine*, 15 May 1990) made some allusions to the quality of AM radio while discussing IBM's new AVC (Audio Visual systems). AVC is a follow-on to the old multi-media presentations that most of us are accustomed to experiencing. Now the assembly and presentation, including graphics and audio, is done on a fair-sized PC.

The interesting thing for me to read was Mr. Poor's comment, "The voice quality, described by IBM as near-AM quality, is the poorest of the lot. But it

(continued on page 37)

## Your Next Four Band Audio Processor is the ...

Audio Signature™

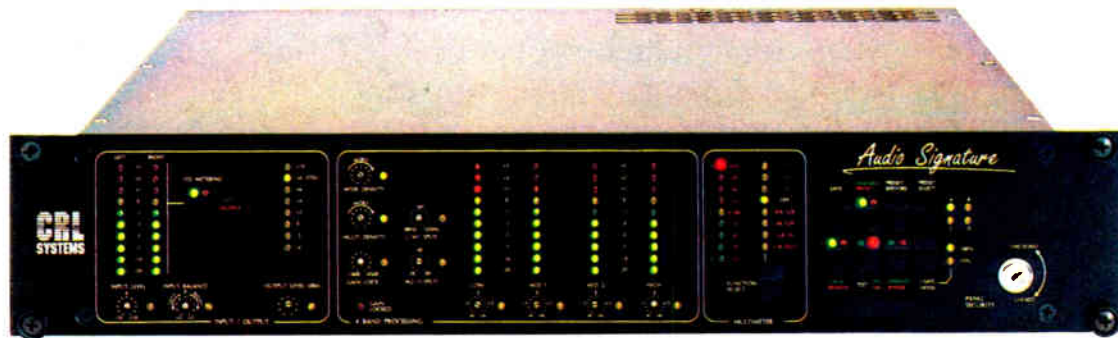

The CRL Audio Signature is a unique way to think of audio processing. Combine a powerful four band stereo compressor to an advanced microprocessor system. The result is a unit that lets you define the processing parameters that you want. Select the band split points—tailor the wide-band and multi-band density for your format. Boost or cut each band as you like. Created the sound that you want? Then store your design in one of four memory positions. Remote control? Dayparting?—You bet! Your PC and modem can control the Audio Signature from anywhere, anytime! The Audio Signature is a perfect replacement for older mono four band processors. Call or write CRL today—discover the power of the Audio Signature.

THE  
PROFESSIONAL'S  
CHOICE



Circuit Research Labs, Inc.  
2522 West Geneva Drive  
Tempe, Arizona 85282-3192 U.S.A.  
(800) 535-7648 (602) 438-0888 FAX (602) 438-8227  
Bulletin Board System (602) 438-0459

Audio Signature is a  
trademark of Circuit  
Research Labs, Inc.



# Built for Business.



The Revox PR99 MKIII Professional Recorder

The **PR99** means business and in today's high-pressure, competitive environment, your station can't settle for anything but the very best. Featuring advanced audio electronics, the PR99 MKIII professional recorder outlasts and outperforms all others. With its superior construction, this recorder was built for long-term dependability, easy maintenance and the highest quality audio. And our reputation for service and technical support remains unsurpassed in the industry.

Take note of these PR99 features: • a solid die-cast aluminum transport chassis and head block • record and playback heads built to the same tolerances as the heads for Studer multitracks

• easily accessible modular electronics for tough, reliable performance • an Autolocator with digital counter in hours, minutes and seconds • rack mounts standard.

With ease and versatility, this no-nonsense machine stands up to the rigors of daily station operations. Whether taping news call-ins, downlinking or uplinking satellite feeds, producing commercial spots or remote recording—whatever your station needs, the PR99 delivers!

For value and performance over the long haul, Play a Pro. The one built for business.

**STUDER REVOX**

Studer Revox America, Inc.  
1425 Elm Hill Pike • Nashville, TN 37210 (615) 254-5651  
New York (212) 255-4462 • Los Angeles (818) 780-4234  
Studer Revox Ltd. • Toronto (416) 423-2831

Call your Studer Revox Professional Products Dealer for more information about the complete line of Studer Revox Professional Products.

Circle 58 On Reader Service Card

World Radio History



# Overview of Amp Characteristics

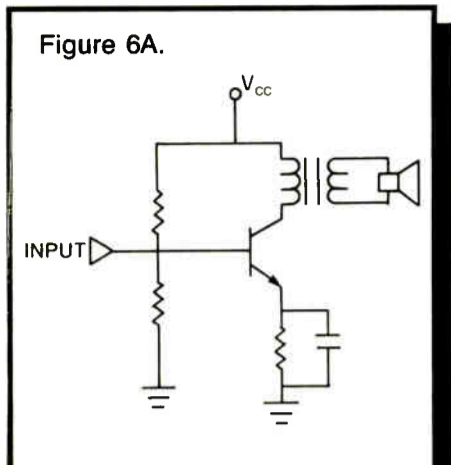

Figure 6A.

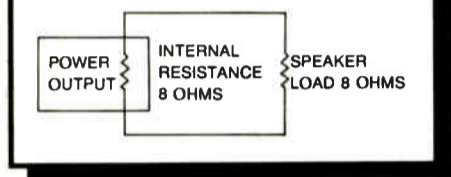

Figure 6B.

(continued from page 31) the next is an important consideration. Figure 6A is an illustration of transformer coupling from an amplifier to a loudspeaker. The impedance of the speaker must equal the output load of the transistor.

### Circuit impedance

Figure 6B is a simplified illustration of what the circuit looks like impedance-wise. The internal impedance built into the design of the amplifier is constant. If

## The Darlington, named after its inventor, offers a high impedance input and low impedance output.

it is not matched in the load, maximum power transfer will not occur. Essentially a series circuit is present with the amplifier connected in series with the load.

Figure 7 illustrates how different load impedances will affect power transfer. Notice how maximum power output in the ■■■■

Ed Montgomery currently is an electronics teacher in the Fairfax County school system. He has taught broadcast engineering at Northern Virginia Community College and worked as broadcast engineer for several radio stations. He can be reached at 703-971-6881.

Figure 7. A=Amperes W=Watts

Amplifier Voltage	Amplifier Impedance	Load Impedance	Total Impedance	Circuit Current	Amp Power	Load Power
12	8	2	10	1.2A	11.52W	2.88W
12	8	4	12	1 A	8 W	4 W
12	8	6	14	.86A	5.88W	4.41W
12	8	8	16	.75A	4.5W	4.5W
12	8	10	18	.67A	3.56W	4.44W
12	8	12	20	.6A	2.88W	4.32W
12	8	14	22	.55A	2.38W	4.17W

load is only achieved when the load impedance equals the impedance of the amplifier.

Load impedances lower than that of the amplifier can cause the transistor to

draw too much current, overheat, create distortion and possibly destroy its junction. Loads higher than the amplifier's impedance can also cause signal distortion and lower than desired power de-

livered from the amplifier.

This analogy is also valid with radio-frequency amplifiers. The antenna impedance must be matched to the output of the transmitters power amplifier.

## Calls Signs and Early Radio Lore

(continued from page 35)

was at least as good as my car radio, not hard on the ear and perfectly suitable for the speaking voice during a tutorial session."

On a long ride north from So Cal to southeastern Washington, I think I listened to every station in two markets for at least a half hour (each station). There was nothing to choose from as far as programming was concerned. They were all playing from the same playlist with the same processing.

No variety. No wonder there were no advertising dollars represented by commercials. No reason for not using the tape player now present in almost all new automobiles to get the music or entertainment of choice.

One note: The station with the best commercial load—not PSAs or sponsored PSAs—was a station with a variety talk format, at least for the mid-day time period.

### That's entertainment

My local public TV station ran a Merv Griffin special on the Big Bands of the '30s and '40s several weeks ago. Rather interesting to see some of the film clips of the famous and hear the same arrangements being performed by young musicians of today. (The producer segued from one group to the other without missing a beat or change in the sound.) Even more interesting to find out that Benny Goodman recorded several of the Beatles' songs and Jim Webb tunes of the late '60s with both his big band and his sextet.

I recently came across an old clipping announcing one of the first large con-

tracts for air personalities. Although it was not dated, the year must have been about 1930, judging by the comments.

Headlined "\$1,000,000 for Amos 'n' Andy," the story ran:

"Chicago, Aug. 29 (UP)-Freeman F. Gosden and Charles J. Correll, everywhere known as Amos 'n' Andy, will be paid more than \$1,000,000 during the next five years for radiocasting the ups and downs of the 'Fresh Air Taxicab Company, Incorporated.'

"The exact terms of the new contract awarded them by the National Broadcasting Company and their other sponsors were not disclosed, but it was

said their scale of wages will slide up between now and 1935.

"Amos 'n' Andy were paid \$100,000 and a bonus for their last year's programmes. It was their first year 'in the big money' and today they hold an all-time record as the highest paid radio stars."

■■■

George Riggins has experience in radio and electronics dating back to the 1930s. He is also a licensed ham operator and has had his own broadcast sales and service company, Riggins Electronic Sales, for over 20 years. He can be reached at 213-598-7007.

# CCA

## Evolution.

CCA has delivered more than 3,000 Broadcast Transmitters over the past 25 years. For 25 years our designs have been refined and improved. The result is the Evolution of the world's most perfected, most tested, most reliable, Radio Transmitter.

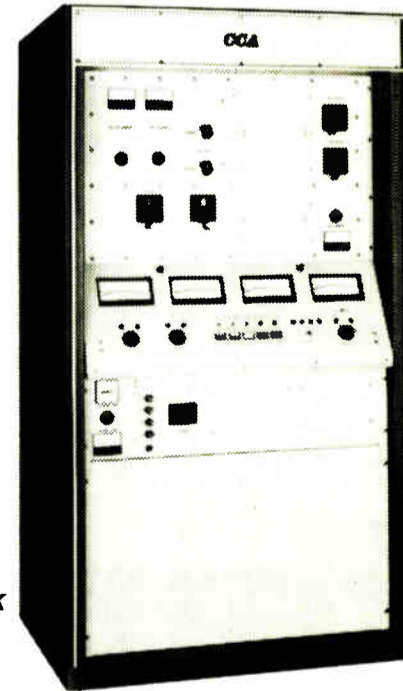

- \* Grounded Grid Triode
- \* Longest Tube Life
- \* Auto Power Control
- \* VSWR Power Foldback
- \* Single Phase Optional

CCA Electronics, Inc.

P.O. Box 426

Fairburn, GA 30213

(404)964-3530 FAX (404)964-2222

**AS-101 Audio Switcher**

- Illuminated and legendable control buttons
- Instant or overlap switching
- Front panel accessible level controls
- Options include: RS-232 interface, remote control, relay-follow-switch outputs
- Network proven quality and reliability!

10 stereo in  
1 stereo out

P.O. Box 1342 Bellingham, WA 98227  
(206) 734-4323 (206) 676-4822 (FAX) **Conex Electro-Systems, Inc**

Circle 43 On Reader Service Card

Circle 54 On Reader Service Card



# Broadcast Equipment Exchange®

"Broadcast Equipment Exchange" accepts no responsibility for the condition of the equipment listed or for the specifics of transactions made between buyers and sellers.

## AMPLIFIERS

### Want to Sell

QSC 1400 stereo pwr amp, 200 W/ch at 8 ohms, 300 W/ch at 4 ohms, 600 W mono, fan cooling, balanced/unbalanced inputs, \$400. R Ross, AP Lab, 88 Sherman 2nd Fl, Brooklyn NY 11218. 718-965-2420.

Nikko Alpha 230 120 W/C, stereo rack mount, pro power amp, black, like new, \$250. C Keith, ALI, 9 Roxbury, Keene NH 03431. 603-352-8560.

AIWA MX-100U, 55 W/chnl, 4 inputs & mic input for mic mixing, LED pwr output meter, vgc, \$175. L Hoover, Logical Audio Solutions, 325 Saude, Essington PA 19029. 215-521-2933.

Edcor HA-400 headphone amp, \$75. C Hall, WZOU, 235 Bear Hill, Waltham MA 01254. 617-290-0009.

Dynakit PAS 2 tube preamp, excel, \$100; Dynakit SCA 35 tube amp, excel, \$150; Langevin mono tube amp, uses 4 GLG's, \$150; Pilot AA 904 tube mono, excel, \$100. Kremer Kraft, 301 SW 16th St, Ft Lauderdale FL 33315. 305-524-5652.

Spotmaster BETMS-200 solid state stereo TT preamp, \$150. A Garza, Foster Comm, 2824 Sherwood Way, San Angelo TX 76901. 915-949-2112.

Harris GTM-88R RF amp, 104.9 MHz, \$100. R Coleman, WGEN, Box 67, Geneseo IL 61254. 309-944-4633.

Spotmaster 5-Input stereo audio DA, \$50; Marti PGM-20 line amp, \$75. P Wells, KJOY, San Diego CA. 619-238-1037.

McIntosh MC-240 in excel cond, \$500. Z Masoomian, WQXR, 141 Park Ave, Arlington MA 02174.

Crown USA Power Line 19" rack mount w/handles, black level control L&R, balance of warranty applies, 120 W (2), will pay UPS, \$300 ea; Nikko Alpha 400 pwr amp, like new cond, balance of warranty applies, wall manuals & packing, \$260. C Keith, ALI, Box 313, Keene NH 03431. 603-352-6460.

Marantz PM500 stereo amp, \$250; Yamaha preamp C4, \$250. J Parsons, Parsons Recd, 10375 Cannas, N Huntingdon PA 15642. 412-863-9590.

Panasonic WA-750 120 W PA amp, 4 inputs, tone controls, master, VU meter, like new, \$100. P Russell, Bowdoin College, Sills Hall, Brunswick ME 04011. 207-725-3066.

Vital AA1A (11) audio DA in main frame, 1 input, 6 output, BO. G Mundkowsky, 12918 Smalley, Grandview MO 64030. 816-966-0731.

### Want to Buy

WE amps in working cond. D deForrest, 7441 Wayne Ste 10-D, Miami Bch FL 33141.

FM RF amp 250-500 W output, 10 W input on 10 W drive w/schematics. F Magloire, POB 370681, Miami FL 33137.

WE, Westrex, Marantz tube amp catalogs, specs, ads relating to above items. D deForrest, 7441 Wayne, Ste 10-D, Miami Beach FL 33141. 305-866-5401.

WE 86, 124, 142 & others; McIntosh & Marantz tube amps, also wrecked amps w/missing parts, any cond. J Kreines, DeMott/Kreines Films, 5330 Kennedy, Millbrook AL 36054. 205-285-6179.

Scully '100' recorders, record/play amplifiers, 8, 16, 24 track heads. Sequoia Electronics, 1131 Virginia Ave, Campbell CA 95008. 408-866-8434.

## ANTENNAS & TOWERS

### Want to Sell

Dielectric 6 bay 1-5/8" FM tuned to 93.5 MHz; 10 kW isocoupler 1-5/8" line; 300' 1-5/8" Helix transmission line. E Neaman, KUMU, 441 N Nimitz Hwy, Honolulu HI 96817. 808-531-4511.

Potomac Instruments AM-10 two tower, gd cond. B Bie, 80 N Tillman St, Memphis TN 38111. 901-458-5818.

Andrew LDF4 50A coaxial 1/2 line, 125', \$200. C Haynes, WJMI, 1850 Lynch, Jackson MS 39203. 601-948-1515.

50 kW AM antenna tuning unit, (2) ITT 25 KV CVFP-2000-255 variable caps, CFED-1000-255 fixed cap, 0-50 amp RF base meter w/TC & switch, BO. T Jordan, Cape Fear Bldg, POB 35297, Fayetteville NC 28303. 919-864-5222.

LDF 5-50 Helix, 250'. J Carroll, 523 Meadow Rd, Towas MI 48764. 517-362-3417.

Scala paraflector, \$100; dbx 142 & 140 NR, \$150 ea; Orban Optimod 8100A/ST studio chassis, \$500; Tripp Lite SB-BC-2000 AC inverter, \$200. C Hall, WZOU, 235 Bear Hill, Waltham MA 01254. 617-290-0009.

Andrew LDF5-50A, 250', 7/8" foam helix, new, still on reel, connectors & hoisting kit, \$4.65/ft plus shpg. B Brown, WMNI, 1458 Dublin, Columbus OH 43215.

Scala CL-FM yagi antenna for translator tuned to 93.5 MHz, new; Kay Industries T-12000A rotary phase converter, 2 hrs of srvc; Andrews LDF-50A coax line, 40' & 30'. E Neaman, KUMU, 441 N Nimitz Hwy, Honolulu HI 96817. 808-531-4511.

ERI 8 bay, Class C FM, 98.5. Regina Dean, KUAR, Univ of Ark at LR, Little Rock AR 72204. 501-569-8485.

Phelps Dodge 3 bay antenna system 103.9 w/deciders. J Carroll, 523 Meadow Rd, Towas MI 48764. 517-362-3417.

Phelps Dodge CFM-LP2 2-bay circular polarization w/radomes tuned 100.9. J Eck, KSAJ, POB 69, Abilene KS 67410. 913-263-1263.

Prodelin 3 1/8" rigid line EIA flanges, 19.5' length, 12 yrs old, gd cond, on ground & avail now, BO. M Doyal, 3625 N Hall St #1300, Dallas TX 75219. 214-522-0979.

## FM ANTENNAS

1 BAY	\$1,500
2 BAY	2,300
3 BAY	3,150
4 BAY	4,000

MORE BAYS AVAILABLE  
All warranted, tuned and tested

ARMSTRONG TRANSMITTER CORP.  
5046 Smoral Road (315) 488-1269  
Syracuse, NY FAX (315) 488-1365

Dielectric A50000-203 3-1/8" motorized coax switch, vgc, BO; MCI 61103 1-5/8" coax switch, solenoid control, gd cond, BO. B Webster, WLIT, 150 N Michigan, Chicago IL 60601. 312-329-9002.

Comark CSW-318 3-1/8" 4 port motorized coaxial switch, never used, \$2700; Electro impulse DPTC-25 KFM forced air cooled dry dummy load, never used, \$3450. D Eresy, WFCO, POB 1308, W Chatham MA 02609. 508-945-4855.

H57-50A 1-5/8" Helix, 250'. J Carroll, 523 Meadow Rd, Towas MI 48764. 517-362-3417.

RCA 4 bay FM antenna BFC-4B w/radomes on 94.5 MHz, \$500. C Hall, WZOU, 235 Bear Hill, Waltham MA 01254. 617-290-0009.

90° 3-1/8" end sections, \$150; UHF harmonic filter & directional coupler on channel 49, BO; 3 bay antenna on 95.1 MHz, \$1000. C Haynes, 1850 Lynch St, Jackson MS 39203. 601-948-1515.

Harmonic filter, 1-5/8", \$250. M Guidotti, KKL, 143 Fifth St, Ste 5, Colusa CA 95932. 916-458-5558.

Scala FMO-Z, excel cond w/cables, tuned to NCE, \$350. T O'Laughlin, O's Own Prod, Rt 1 Box 41, Barneveld WI 53507. 608-924-2001.

Stainless 24" face 380' tower, complete lighting kit. M St Cyr, 3565 29th SE, Grand Rapids MI 49512. 616-949-8760.

Cortana folded unipole for AM upper skirt, \$500. A Garza, Foster Comm, 2824 Sherwood Way, San Angelo TX 76901. 915-949-2112.

Rohn 180' self-supporting tower, standing but not in service, you remove, BO. E Histed, WOH, POB 1104, Honesdale PA 18431. 717-253-1616.

Harris FMA-4 hor 10 kW pwr in, all parts, gd cond, BO, will crate & ship. A Branch, KYAY, 2402 Woodridge, Decatur GA 30033. 404-325-7847.

Andrews 300' 1-5/8" coax, no known defects, on 300' tower, buyer removes, \$1800; also 300' 24" face guyed tower, 21 yrs old. Kept painted, gd cond, heavy material & heavy duty, buyer removes, \$9500. C Sigmon, WBZK, POB 398, York SC 29745. 803-684-4241.

Pirot #24 440' solid tower, 5 yrs old, complete lightning kit. M St Cyr, 3565 29th SE, Grand Rapids MI 49512. 616-949-8760.

## Broadcast Transmission Systems

Sells and Erects  
Tower/Antennas, Too  
In Stock Now:  
260' Utility model 240  
Several H & P light kits with controls  
200' Rohn 45G complete  
(512) 448-0058

Jampro JSCP-5 antenna, 99.3 MHz w/mounting brackets, 1-5/8" EIA flange, on 300' tower, excel cond, buyer removes, \$1500. C Sigmon, WBZK, POB 398, York SC 29745. 803-684-4241.

World Tower 429' w/30"-24" face, 1.5 yrs old, solid leg, to Ohio code, w/lighting package, you remove plus \$15,000. B Carr, WRED, 1201 Fremont Pk, Woodville OH 43469. 419-837-9696.

Andrew 1861 reducer, 3-1/8" to 1-5/8", \$160; 1061A 90° elbow, 1-5/8" A-3-1/2", B-6", \$145; 1062A 90° elbow, 3-1/8", A & B 4-1/2", \$255; 75AN 7/8" to N, female, \$45; 23167 3-1/8" male to male, 9-1/2", \$140. D Agnes, WCLV, 26501 Emery Ind Pkwy, Warrensville OH 44128. 216-464-0900.

ERI 8 bay Class C 98.5, single bay, various RF connectors. T Rusk, KUAR, 2801 S University, Little Rock AR 72204. 501-569-8485.

Shively 6813 2-bay, circularly polarized w/deciders & matching transformer, 5 yrs old, tuned to 90.7, \$2000. J McDermott, KCVO, POB 800, Camdenton MO 65020. 314-346-2783.

Potomac AM 19 (204), 3 tower phase angle/loop current antenna monitor, w/6" phasor cabinet, complete w/tuning coils, freq 1360, \$2500. D Woodrome, KVLL, 100 Spring Valley, Woodville TX 75979. 409-283-3734.

Beacons, rebuilt (glass, gaskets, wiring, hardware), \$650 ea, FOB Verona, WI. Call Jean 608/845-6755.

Phelps-Dodge CFM HP-10 10 bay FM, circularly polarized, tuned to 105.9 MHz, 3-1/8" center led w/3 point tuning, gd cond, you pay freight, \$6000/BO. M Sprysanski, WOCL, 2101 SR 434 Ste 305, Longwood FL 32779. 407-682-2121.

## HE HALL Electronics

**THE BEST DEALS ON QUALITY REBUILT & BRAND NEW BROADCAST EQUIPMENT**

**We BUY & TRADE equipment too!**  
**Please phone or send for our latest flyer.**

**10:00AM-6:00PM EST**  
**804-974-6466**      **1305-F Seminole Trail**  
**FAX 804-974-6450**      **Charlottesville, VA 22901**

Foam transmission line, 1-5/8", 400' section & 200' section, \$5/ft FOB. D Dobrowski, WSSM, 1028 Braemore, Downers Grove IL 60515. 708-963-3795.

Shively 6813 NP 2 bay, 92.7 radomes, 1 yr old. E Santmyre, WWP, 12 N LaVale, LaVale MD 21502. 301-729-8876.

ERI single bay w/radome on 107.1, BO; Multirons 160-220-1 RF contactor, BO. Z Hoffmaster, KTHS, Radio Ave, Berryville AR 72616. 501-521-0104.

Anixter Mark 4' parabolic dish for 950 MHz band, pair w/hardware, \$800. D Schresser, WKFR, 4154 Jennings, Kalamazoo MI 49001. 616-344-0111.

Celwave CFM-LP2 face mount 2 bay on 100.1 w/domes, \$1200 plus shpg. M Heuberger, KTIG, POB 409, Peguot Lakes MN 56472.

Phelps-Dodge CFM-2P 2-bay CP on 107.1 MHz. P Wells, KJOY, San Diego CA. 619-238-1037.

### Want to Buy

One-bay circularly polarized antenna on 93.3 & 6-bay on 100.3. L Fuss, KOQZ, POB 159, Fayetteville GA 30214. 404-460-6159.

UHF TV bdct/translator antennas; Scala paraneels, any channel; Scala SL-8 chnl 19-23, 32-46, 60-64; Bogner B Series chnl 20-30, 31-42, 55-69 or Bogner LPS 1, 2 & 4; Thomas UHF panels any chnl. J Powley, 1536 Logan, Altoona PA 16602. 814-944-8571.

Circularly polarized 2-bay FM, tuned to 91.1 or close. W Wilson, KJTY, 2519 NW Topeka Ave, Topeka KS 66617. 913-357-8888.

UHF TV translator antennas on old chnl 70-63 band; Scala SL-8 or paraneels; Bogner B4, B8, B16 or B24; Emcee DGA-10 corner reflectors. J Powley, 1536 Logan, Altoona PA 16602. 814-944-8571.

Shively 6813 or 6812 NP 2 bay, 104.5 w/radomes. E Santmyre, WWP, 12 N LaVale, LaVale MD 21502. 301-729-8876.

4 Bay tuned to 102.3, must be in excel cond. C Hargrave, KSPK, POB 1052, Walsenburg CO 81089. 719-738-3636.

Bogner B Series, UHF TV bdct/translator antennas, chnl 20-30, 43-54, 55-69, prefer B16U or B24U, can use B4U or B8U antennas, or Bogner LPS 1, 3 & 4, Thomas UHF panels on any UHF TV chnl. J Powley, 1536 Logan, Altoona PA 16602. 814-944-8571.

Laxicon digital delay processor, \$300. C Hall, WZOU, 235 Bear Hill, Waltham MA 01254. 617-290-0009.

Henry Engineering Synchrostart TT/CD recorder synchronizer, new & still in box, \$225/BO. K Conner, KAMO, 4001 W Walnut, Rogers AR 72756. 501-636-4611 (9-3).

MEI Digisound, 2 hard drives, remote keyboard, configured for 10 kHz, 175 minutes mono, 86 minutes stereo, \$8000. D Greer, WDDZ, Genesee Towers, Ste 1830, Flint MI 48502. 313-767-0130.

Everette BD955 digital delay w/15 kHz bandwidth, 6.4 sec delay, \$2500. J Littlejohn, WYSY, POB 2010, Aurora IL 60507. 708-851-4600.

Sequential Prophet 600 MIDI synthesizer w/software upgrade, \$350. P Cibley, Cibley Music, 138 E 38 St, Nyny 10016. 212-986-2219.

Shure M267, excel cond, (2), \$390; Gentner EFT9000, excel cond, \$640; Henry UTC controller, never used, \$350. D Eresy, WFCO, POB 1308, W Chatham MA 02609. 508-945-4855.

Orban 222A stereo spatial enhancer, mint cond, \$400. R Ross, AP Lab, 88 Sherman, 2nd Fl, Brooklyn NY 11218. 718-965-2420.

Conex AS101 10x1 routing switch (2), never used, as new, \$590; Conex AS401 remote control boxes for AS101 routing switch, new, (6), \$99. D Eresy, WFCO, POB 1308, W Chatham MA 02609. 508-945-4855.

## CASSETTES - CARTS - REELS

### J & I AUDIO/VIDEO

A wholesaler in the Radio and Television market.  
Now running SPECIALS on audio and video:  
**BASF CASSETTES - AMPEX R-R'S AUDIOPAK, FIDELIPAC & 3M CARTS**  
For more information call person-to-person collect:  
**Kris Elliot at 818-992-4288**  
or write to: **J&I Audio/Video**  
20899 Kelvin Pl., Woodland Hills, CA 91367

Circle 27 on Reader Service Card

KLH Burwen TNE 7000A & DNF 1201A transient noise eliminator & dynamic noise filter w/manuals, \$600/BO. D Christian, Pacific Lutheran Univ, 121st & Park Ave South, Tacoma WA 98447. 206-535-7265.

Yamaha SPX-90 digital effects unit, like new, \$475. Davis, MCP Studios, POB 521, Newberry SC 29108. 803-276-0639.

Studer Dyaxis digital editing system w/760 MB hard drive, DSP accelerator card & Macintosh II cx w/radius pivot monitor, less than 50 hrs use. T Jones, KNXR, 220 South Bdw, Rochester MN 55904. 507-288-7700.

Boss RPS-10 digital pitch shifter/delay, excel cond, \$100. J Shade, WFAN, 34-12 36th, Astoria NY 11106. 718-706-7690.

Attec 1567A (3), \$125 ea. J Parsons, Parsons Recd, 10375 Cannas, N Huntingdon PA 15642. 412-863-9590.

## AUDIO PRODUCTION

### Want to Sell

PuItec EQH-2 EQ. D Smith, WFCB, Box 94, Chillicothe OH 45601. 614-773-3000.

Henry Engineering Synchrostart TT/CD recorder synchronizer, new & still in box, \$225/BO. K Conner, KAMO, 4001 W Walnut, Rogers AR 72756. 501-636-4611 (9-3).

MEI Digisound, 2 hard drives, remote keyboard, configured for 10 kHz, 175 minutes mono, 86 minutes stereo, \$8000. D Greer, WDDZ, Genesee Towers, Ste 1830, Flint MI 48502. 313-767-0130.

Laxicon digital delay processor, \$300. C Hall, WZOU, 235 Bear Hill, Waltham MA 01254. 617-290-0009.

Everette BD955 digital delay w/15 kHz bandwidth, 6.4 sec delay, \$2500. J Littlejohn, WYSY, POB 2010, Aurora IL 60507. 708-851-4600.

Sequential Prophet 600 MIDI synthesizer w/software upgrade, \$350. P Cibley, Cibley Music, 138 E 38 St, Nyny 10016. 212-986-2219.

## NORTRONICS Replacement Tape Heads

Test Tapes, Degaussers, Gauges  
Cleaners, Swabs, Lapping Films  
Splice Bars/Tabs, Demagnetizers

## SEQUOIA ELECTRONICS

1131 Virginia Ave  
Campbell CA 95008  
(408) 866-8434

dbx 119, \$50; SAE 5000A, \$100; Vector Research VQ-110A EQ 10 band, \$75. V Gray, GCA, 6840 Sterling, Raytown MO 64133. 816-358-8929.

Wegener SCPC satellite rcvr, 6-bay FM antenna tuned to 99.3 MHz, approx 280' of 3.125" air dielectric helix transmission line, Gates stereo Producer audio console, mono Audimax & mono Voliumax. B Herzog, WKPR, 3891 Waukau, Oshkosh WI 54903. 414-236-4242.

## Attention FM CP Holders!

We'll Build Your 3 kw Class A  
For LESS Than \$100,000  
**GUARANTEED**

We Include All This:

- \* Up to 300 ft support tower with necessary Transmission Line and new 4-bay FM antenna
- \* FM transmitter with solid state exciter and stereo generator
- \* All necessary monitors and audio processing equipment
- \* Equipment rack and digital remote control unit
- \* A complete and fully equipped control room as well as a completely equipped 4-track production room

ALL you supply are transmitter building, & remodeled studio site.....We'll do the rest!

Similar savings on construction of B1, C3, C2, and C1 FM facilities, too.

CALL (512) 448-0058 Today For Complete Details

**BROADCAST TRANSMISSION SYSTEMS**  
7008 Lock Lommond Austin, Texas 78749

Circle 33 on Reader Service Card



**AUDIO PRODUCTION . . .**

**Want to Buy**

Tube limiters, compressors & EQ's, especially Fairchild 660 & 670, Teletronix LA2A & LA3A; Pultec EQs or NABECs; Lang EQs, Sontec & SPI EQs, etc; other vintage tube signal processing equip. J Kreines, DeMott/Kreines Films, 5330 Kennedy, Millbrook AL 36054. 205-285-6179.

**WANTED  
DEAD OR ALIVE!  
PULTEC EQ'S**

Fairchild & Teletronix Limiters; Neumann, Telefunken, AKG, RCA, & Schoeps microphones. Tube McIntosh or Marantz amps & pre-amps. Sontec, ITI, & Lang EQs. Neve or API equipment. Boxes of old tubes; Urei, Orban, United Audio, DBX, & other outboard gear. Ampex ATR102s or 104s. Parts for MCI JH110/114 recorders. Altec 604s/crossovers/Tannoy speakers, JBL 2231; Altec 288H drivers; Misc. equipment of all types.

**Please Call:**

Dan Alexander Audio  
2944 San Pablo Ave.  
Berkeley, CA 94702  
1-(415) 644-2363  
FAX: 1-415-644-1848

**AUTOMATION EQUIP**

**Want to Sell**

SMC MSP full feature 2000 event for satellite format, tape service, or live assist, remote control, 4 yrs old, like new cond, \$3200. D Doelitzsch, WDDD, 1 Broadcast Cir, Marion IL 62959. 618-997-8123.

McCurdy Cue System satellite decoder for Fairchild application w/time zone switcher, 2 mos old, \$1500. J Michaels, WJOD, POB 276, Galena IL 61036. 815-777-2555.

SMC MSP automation system w/(4) Otari R-R's, (3) SMC 350 Carousels, SMC 721 dual cart PB's, (3) SMC equip racks, all clean, on air now, avail now, \$16,500. J Wenstrom, Wynne Bdcg, 1338 Oregon, Klamath Falls OR 97601. 503-882-4656.

Complete automation system including CD28M, CD12C, CD28A, CD28P, (5) CD25S, (5) Revox A-77, (3) CD24R, IGM Instacart, Perma Power UPS, Pioneer Centrex monitors (pr), 4-bay rack w/rear doors, cabling, manuals & schematics, spare parts & source cards, \$15,000 (equip in St Cloud MN) G Hoppe, WHMH, 1617 N Poinsettia Pl Ste 205, Hollywood CA 90046. 213-851-0870.

Schafer automation system, older style, working, \$400. E Moody, KJEM, 216 N Main, Bentonville AR 72712. 501-273-9039.

Conex DS25B, dual 25 Hz sensor, never used, \$350. D Eressy, WFCB, POB 1308, W Chatham MA 02609. 508-945-4855.

Robot Jock CD600 60 CD player (4), Toshiba drive, will interface w/IBM. C Keith, ALI, Box 313, Keene NH 03431. 603-352-8460.

Systemation X7 full system w/Nakamichi MR-1 & MR-2 decks, excel cond, BO. L Wheeler, 4350 Johnson Dr, Fairway KS 66205. 816-531-2535.

Harris 9000 automation system w/CRT-70X keyboard, (2) new style & (2) old style Instacarts, (2) 42 slot Go-Carts, (4) ITC 750 R-R's, Sony remote video monitor, (2) Criterion large cart machines, play only, Extel printer w/5 cases of paper, (4) racks, all cables & interfaces & manuals, presently in service, \$37,000. D Greer, WDZZ, Genesee Towers, Ste 1830, Flint MI 48502. 313-767-0130.

Schafer 901-902 automation system w/(6) Teac/Schafer deck R-R's & I/O cards, (6) cart I/O cards, (3) rack cabinets. E Neaman, KUMU, 441 N Nimitz Hwy, Honolulu HI 98817. 808-531-4511.

Shafer 903 w/(3) Carousels, dual cart machine, network card for satellite, plus extras, \$6000. Tom, 509-522-5412.

Live-Assist tape system including (4) ITC 750 series, PB only, stereo, 25 Hz tone detect card, M.W. Persons mini-mixer w/count-up clock, cabling & hardware interfacing, \$3000 (equip in St Cloud MN) G Hoppe, WHMH, 1617 N Poinsettia Pl Ste 205, Hollywood CA 90046. 213-851-0870.

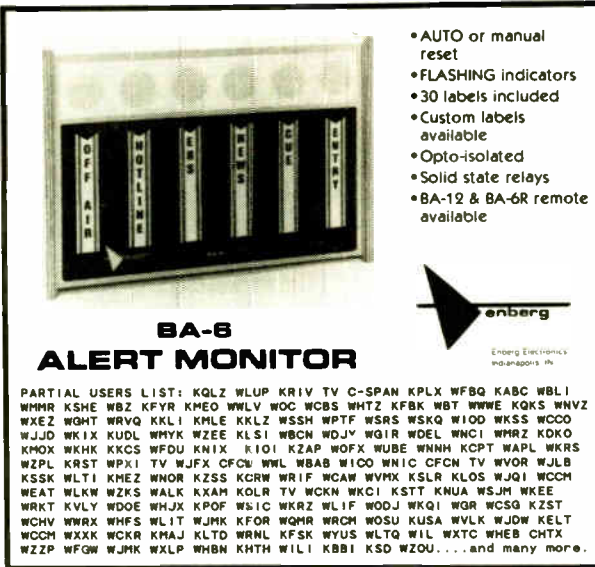

**BA-6  
ALERT MONITOR**

- AUTO or manual reset
- FLASHING indicators
- 30 labels included
- Custom labels available
- Opto-isolated
- Solid state relays
- BA-12 & BA-6R remote available

PARTIAL USERS LIST: KQLZ WLUP KRIV TV C-SPAN KPLX WFBO KABC WBLI WMHR KSHE WBZ KFVR KMEQ WWLV WOC WCB5 WHTZ KFBK WBT WWWE KQKS WNVZ WXEZ WQMT WRVQ KKLJ KMLE KKLZ WSSH WPTF WSR5 WSKQ W100 WKSS WCOO WJDD WKIX KUDL WMYK WZEE KLSI WBCN WOJY WGR1 WDEL WNCI WWRZ KDKO KMOX WKHK KCCS WFDU KNIX R101 KZAP WOFK WUBE WNNH KCPY WAPL WKRS WZPL KRST WPK1 TV WJFX CFM TV WML WBA WCOO WNIC CFM TV WYOR WJLB KSSK WLT1 KHEZ WNOB KZSS KCRW WRIF WCAW WVMX KSLR KLOS WJQI WCOH WEAT WLKN WZKS WALK KXAM KOLR TV WCKN WKCI KSTT KNUA WJSM WKEE WRKT KVLV WDOE WHJX KPOF W51C WKRZ WLIF WOJZ WKQI WGR WCSG KZST WCHV WWRX WHFS WLIT WJMT KFOR WQMR WRCH WOSU KUSA WYLL WJOW KELT WOCM WXXX WCKR KMAJ KLTD WRNL KF5K WYUS WLTO WIL WXTZ WHEB CHTX WZZP WFGW WJMK WJXP WBNB KHTH WILI KBB1 KSD WZOU... and many more.

Automated Broadcast Controls complete automation system w/(5) Otari R-R's, (3) ABC Carousels, will sell all or parts; SMC 581 time announce dual cart machine. D Smith, WFCB, POB 94, Chillicothe OH 45601. 614-773-3000.

Complete IGM EC System Instacart 48-mono, black rack, uninterruptible pwr sup, Is-latron, cables, exc cond, \$7000. D Klahr, 609-692-8888.

ESP-1 automation system including (5) SMC 350 series Carousels; (2) SMC 721 dual play decks, (4) Revox A-77, Extel printer, AL-1 cassette memory loader, PDC-4A superclock, PSB-3 pwr supply, DS-2GA switcher, ESP-1 programmer, RAC-31 remote control, (4) equip racks, (2) TS-25 tone sensor units, was operational when removed from service in 3/90, \$11,000 plus shipping. J Hartmeyer, WCLT, POB 880, Newark OH 43055. 614-345-4004.

Microprobe 100 6 source automation programmer, \$800. R Coleman, WGEN, Box 67, Geneseo IL 61254. 309-944-4633.

MW Persons 25 Hz decoder, \$85; automated bdct Sequencer 16 w/expander, \$200; automated bdct 25 Hz sensors for 2 decks. P Wells, KJQY, San Diego CA. 619-238-1037.

ATC/Gates stereo in gd working cond, \$2000. G Williamson, WASK, Box 7880, Lafayette IN 47903. 317-447-2186.

Schafer 7000, w/(5) Otari ARS1000, (3) Sono-Mag Carousels, (4) ITC cart machines, just out of service in gd cond, BO. W Long, WWMY, 7819 Natl Service Rd, Greensboro NC 27409. 919-668-9450.

Harris System 9000 incl event controller for 12 sources, source cards, all system computer cards, pwr supply, cables for (4) Otari ARS-1000 stereo reel decks plus (4) Carousels, data entry CRT workstation, fully operational when removed, Carousel 24 cartridge units which may need some work, standard system equip racks, buyer pickup, bank cashiers check only, BO. A Kaplan, KWED, 609 E Court, Seguin TX 78155. 512-379-2234.

Satcue 400 switchers for Unistar formats by Colorado Magnetics (2), \$500 ea. H Widsten, KGNB, 1540 Loop 337 North, New Braunfels TX 78130. 512-625-7311.

ABC Network tone decoder, \$200. M Holderfield, WOOB, POB 1427, Dothan AL 36302. 205-792-1149.

MEI Satmaster 1000 event satellite programmer w/(2) Carousels, gd working cond, will sell, lease, rent, or trade for FM xmitr, \$6000. C Crisler, KAFM, Box 41971, Memphis TN 38174. 901-722-7304.

Systemation cassette system w/everything needed to run including (5) cassette decks, BO. R Jensen, KCKR, Box 368, Kanab UT 84741. 801-644-5868.

SMC automation system, complete w/2000 events, currently in use w/Satellite Music, avail 10/90, w/(4) Carousels, (4) reels & controller, works great, \$9500. Tony, FM97, POB 1465, Grand Island NE 68802. 308-381-3697.

Sigma 301R2-24, datacels (7). B Hicks, KBAT, 3306 Andrews Hwy, Midland TX 79703. 915-697-7300.

Robojock CD-600 (4) will interface w/IBM for automation or live assist, like new, complete, \$1200. C Keith, ALI, Box 313, Keene NH 03431. 603-352-8460.

SMC DP-1 intact w/all boards, ideal for spare parts or for backup, w/pwr supply, BO. B Downs, KTSR, Box 3248, Bryan TX 77805. 409-846-1150.

SMC w/DP-1 digital programmer, (6) racks, (6) SMC 350 mono Carousels, (2) SMC 721 dual mono cart decks, SMC 710 PB cart deck, (2) ARS-1000 stereo PB reels, (2) 750 ITC stereo PB reels, network back fill & join, system can accept up to 20 sources for total of 40 stereo inputs, (2) SMC 710 RP decks, one mono, one stereo, stereo deck needs work, automation has desk type brain, many spare cards, manuals, \$8700. G Smith, KORQ, 2449 S Tread Way, Abilene TX 79606. 915-672-5149.

Xtel AF-11R printer, working, \$75; Xtel AF-11R printer for parts, \$25; Otari ARS-1000 w/SMC card, \$800. M Persons, KLTFKFML, 70 N.E. 1st Ave, Little Falls MN 56345. 218-829-1326.

5025 BPC w/(4) Otari's, (4) Carousels, time gate, complete, BO. B Histed, WSIR, 665 Lake Howard Dr SW, Winter Haven FL 33880. 813-425-3411.

Format Sentry FS-12B w/latest updates, remote control panel & wired for satellite of R-R, IBM compatible, computer included, IGM stereo Instacart, 48 trays, all in rack, on air, \$7500/BO. M Wilson, WGRK, POB 248, Greensburg KY 42742. 502-932-7402.

IGM Go-Cart 24 (2), \$2500 ea; SMC 721 dual cart PB, \$500; SMC 710 cart PB, \$250, both SMC's in rack mount drawers. J Wenstrom, Wynne Bdcg. 503-882-4656.

SMC DS20-DP2 Brain, (6) Carousels stereo, (4) Otari ARS 1000 R-R's, in use, excel cond, \$12,500. P Swint, KIXQ, 2620 Dogwood Rd, Joplin MO 64301. 417-624-1310.

Schafer 903E stereo, spare parts, (4) Ampex AG440 stereo tape PB, (3) IGM 42 stereo Go-Carts, Extel printer, (6) equip cabinets, gd cond, \$12,000. Blake, KJAX, POB 201-075, Stockton CA 95201. 209-948-5569.

Audiometrics AMCD5-1000 multi play CD players w/SMC automation controller, live assist CD playing system, gd cond w/all schematics/manuals, BO. J Glass, WZOK, POB 6186, Rockford IL 61125. 815-399-2233.

IGM stereo Instacart 48 trays, Format Sentry interface, gd cond, on air, \$4000/BO. M Wilson, WGRK, POB 248, Greensburg KY 42743. 502-932-7402.

**Want to Buy**

Automation brain for limited duty. C Keith, ALI, Box 313, Keene NH 03431. 603-352-8460.

Complete automation system for use w/Satellite Music Network. D Thibodeaux, WHNK, 215 Centerville, Ste 351, Brentwood TN 37007. 615-737-9143.

Simple function automation Brain, advise via fax, 603-352-8461 as to specs, etc. C Keith, ALI, Box 313, Keene NH 03431.

**CAMERAS (VIDEO)**

**Want to Sell**

Ikegami ITC-240 3 tube studio camera (2), bdct quality, gd cond, \$2000/ea or \$3500/both. L Mintzmyer, KOOD, POB 9, Bunker Hill, KS 67626. 913-483-8990.

Sony BVP-3A w/BVW-1A beta bag, full set ENG equip, mics, batteries, chargers, batt lite, tripod, etc, \$18,000 plus shpg. 305-891-3582.

Ikegami HL-95 w/14 x 9 lens w/2X extender, no recorder, very gd tubes, \$9000. R Yerema, World Video, 10625 Scripps Ranch Blvd, San Diego CA 92131. 619-695-1045.

Ikegami HL-79A in excel cond, Canon 13 x 1 lens, gd plumbicon tubes, \$5000; Ikegami HL-79DA in excel cond, Fujinon 14 x 9 lens, WT 2X extender, gd plumbicon tubes, \$7500. R Yerema, World Video, 10625 Scripps Ranch Blvd, San Diego CA 92131. 619-695-1045.

Ikegami HL-79-E, Fujinon 14 x 9 lens w/2X extender, gd plumbicon tubes, camera in fine shape, \$12,000. R Yerema, World Video, 10625 Scripps Ranch Blvd, San Diego CA 92131. 619-695-1045.

Sony BVW-30, w/Beta camcorder, Fujinon 14 x 9 lens w/2X extender, excel cond, \$10,000. R Yerema, World Video, 10625 Scripps Ranch Blvd, San Diego CA 92131. 619-695-1045.

Sony HVC-2200 3 tube color camera, electronic zoom, excel cond, low hrs, carrying case & manuals, \$150/BO. M Gehring, WKTU, Q-19 Redbank Run Apts, Woodbury NJ 08096. 609-384-1435.

Sony Ero9100 Hi-8 industrial camcorder, 3 mos old, unicates TC on address track internally, Uni-omni mic, extras, \$1500. S Weiss, 1st Generation Film/Video, 429 W Ohio, Chicago IL 60610. 312-661-3456.

Ikegami 730 retubed Canon 15:1, AC/batteries, case, manual, extender card, sharp, \$2800. Gene Sive Productions, 31844 Rancho Amigos, Bonsall CA 92003. 619-749-7662.

Panasonic color CCD WVEX1, \$600. J Parsons, Parsons Recdg, 10375 Cannas, N Huntingdon PA 15642. 412-863-9590.

Sony 1610 single tube, color, aluminum case & access, like new, \$400. R Yerema, World Video, 10625 Scripps Ranch Blvd, San Diego CA 92131. 619-695-1045.

**Want to Buy**

Old RCA, Dumont, GE, etc, tube type TV cameras; Phillips, Bendix, RCA, CBS, etc. early portable camera equipment. A Weiner, 14 Prospect, Yonkers NY 10705. 914-423-6638.

**CART MACHINES**

**Want to Sell**

Harris Criterion 3 deck stereo play, excel cond, w/150 Hz tone, \$900. R Statham, WSTU, 1000 Alice Ave, Stuart FL 34994. 407-829-1000.

Gates Criterion 80 mono R/P, 2 cue tones, new p/roller & lamps, total mech & elect alignment, desktop cabinet, excel cond, \$650/BO. J Stack, WMPO Radio, 614-992-6485.

ITC Premium R/P mono, rack mount, gd cond, \$1150 3 tone; (4) Premium SP, mono rack mount, 3 tone, \$800 ea; Premium 3-D triple deck, mono, 3 tone, rack mount, gd cond, \$1000, all have manuals. D Doelitzsch, WDDD, 1 Broadcast Cir, Marion IL 62959. 618-997-8123.

Gates Criterion 80 mono PB only, desktop cabinet, gd cond, \$450/BO. J Stack, WMPO Radio, 614-992-6485.

**OTARI MTR12-I  
1/2" 4 Track  
Demo, like new**



**One Only  
List  
\$13,525.  
SPEC.  
\$9,999.  
CWO**

**NORTHEAST  
BROADCAST LAB**  
(518)-793-2181/(215)-322-2227  
(603)-483-1002/(214)-612-2053

ITC Premium series record amp, mono, \$300. J Littlejohn, WYSS, POB 2010, Aurora IL 60507. 708-851-4600.

Audicord DL-RS stereo R/P, new, remote control connections, plugs, \$1100. D Stubbs, The Sound Saloon, 1611 E Charleston Ste 1, Las Vegas NV 89104. 702-366-1696.

ITC stereo R-P, mint, mono high speed cue, mono R-P Premium, needs work, BO; BE RP 2000 mono (2), \$750; Gates Criterion, Sparta, Spotmaster, \$150 ea. J Phillips, WZOM, 408 Clinton, Defiance OH 43512.

SMC 721 dual, \$600 & 710 single, \$300, cart PB's; SMC 250 Carousel w/random select electr, \$350; ITC RP 3 tone cart recorder, \$700. J Wenstrom, Wynne Bdcg, 1338 Oregon, Klamath Falls OR 97601. 503-882-4656.



**SENNHEISER  
HD-450  
HEADPHONES**

**FALL SPECIAL  
\$62.95**

**HE HALL  
Electronics  
(803) 974-6466**

Entire inventory of tape cartridge equip including approx 600 Fidelitypac 300 gray carts, 75- ea; Spotmaster 5301-A, \$600; wire cart rack, \$75; ITC triple play cart deck, \$600; (2) BE Series 3000, \$800 and much more, call for more information. E Moody, KJEM, 216 N Main, Bentonville AR 72712. 501-273-9039.

UMC/Beau mono PB (2); UMC/Beau mono R/P (2); ITC SP mono (2). D Smith, WFCB, Box 94, Chillicothe OH 45601. 614-773-3000.

Otari ARS-1000 stereo PB w/25 Hz tone sensor, low hrs in excel cond, \$1000 ea. D Doelitzsch, WDDD, 1 Broadcast Cir, Marion IL 62959. 618-997-8123.

SMC 570 cart PB unit. E Neaman, KUMU, 441 N Nimitz Hwy, Honolulu HI 98817. 808-531-4511.

Tapecaster RP 700, gd cond, \$295. A Ishkanian, Advent Duplication, 9725 Riggs Rd, Adelphi MD 20763. 301-439-7222.

**Sine Systems  
RFC-1/B  
"DIAL UP"  
Remote Control  
Complete systems starting at  
less than \$1,400.00!**

**HE HALL  
Electronics  
804-974-6466**

Pacific Recorders Tomcat PB's (6) w/Max-trax heads, excel cond, \$1000/ea. D Greene, KXEZ, 3500 W Olive Ste 250, Burbank CA 91505. 818-955-7000.

Tapecaster 700RP delay/record, \$100. R Coleman, WGEN, Box 67, Geneseo IL 61254. 309-944-4633.

ITC 99B mono rcd, \$1900; ITC SP mono deck, \$890; (2) ITC RP mono recrs, \$975. P Wells, KJQY, San Diego CA. 619-238-1037.

BE Spotmaster ten spot mdl 610CR (3), rack mountable, unused, \$1695 ea. L Schrecongost Recdg, POB 1032, Indiana PA 15701. 412-349-5706.

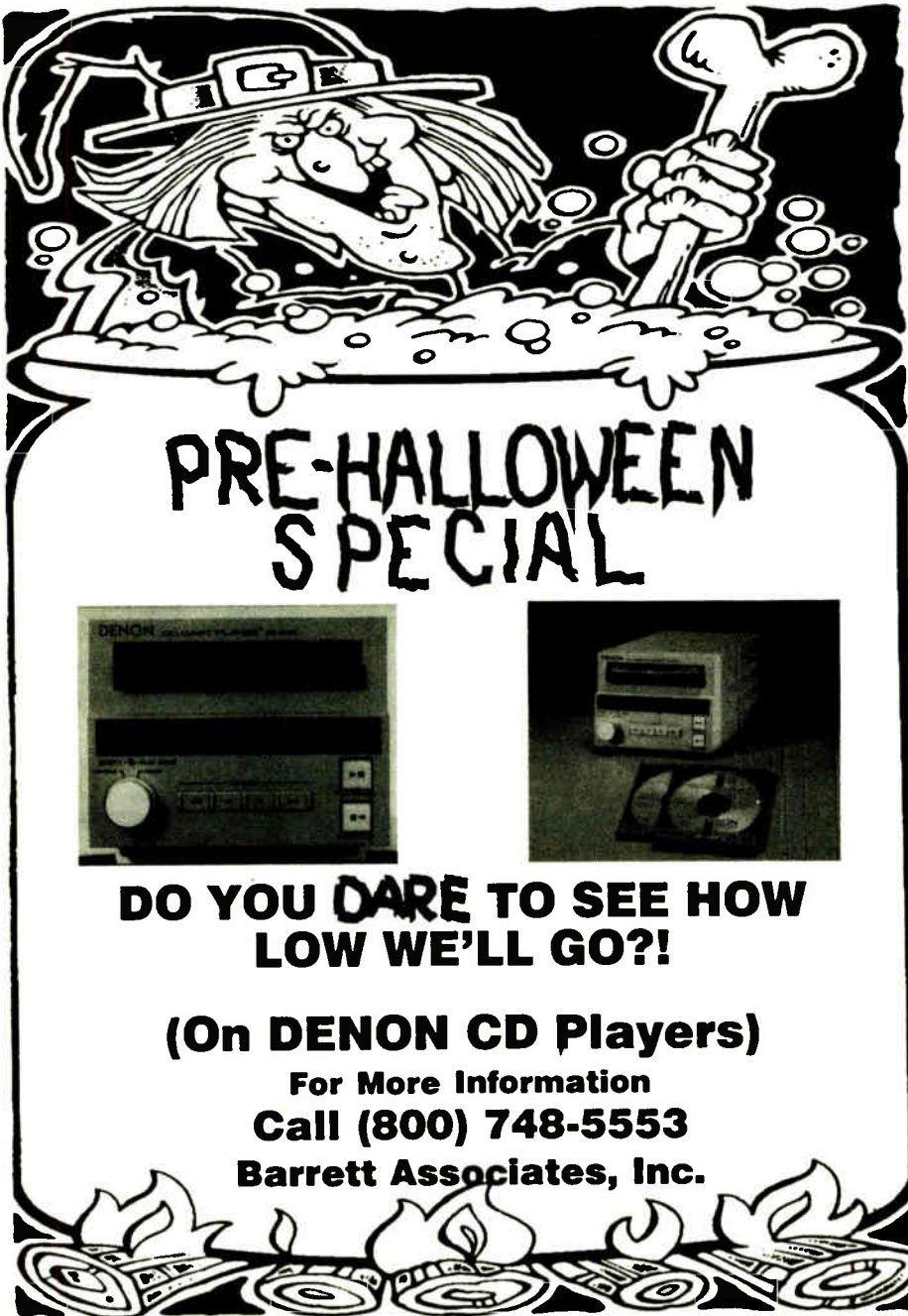

**PRE-HALLOWEEN  
SPECIAL**

**DO YOU DARE TO SEE HOW  
LOW WE'LL GO?!**

**(On DENON CD Players)  
For More Information  
Call (800) 748-5553  
Barrett Associates, Inc.**



**CART MACHINES . . . WTS**

**Ampro 2500 Series**, (2) rec, (3) PB, all 3 tones, FF on rec decks, gd cond, BO. M Black, WEOS, Hobart College, Geneva NY 11436. 315-781-3456.

**Pacific Recorders Tomcat recorder w/Max-trax heads**, excel cond, w/7-1/2 or 15 ips speeds, full featured, \$3000. D Greene, KXEZ, 3500 W Olive Ste 250, Burbank CA 91505. 818-955-7000.

**Telex 36 cart deck**, 4 trk play w/elect trk switching, rack mounting, all new, factory carts, \$200. E Davison, 217-787-0800.

**Sparta MC 104 PB's (4) ea plus spare** in cabinet w/spare pwr supply, 150 Hz & 8 kHz tones, \$700. L Beigel, On-Cue Record, POB 85042, Los Angeles CA 90072. 213-466-3595.

**Audi-Cord 31R**, play, mono, \$500/BO; mdl 36R, play, stereo, \$600/BO; mdl SZ6R R/P, stereo, \$900/BO, all in gd cond. C Ibarra, KTAN, 2300 Busby Dr, Sierra Vista AZ 85235. 602-458-4313.

**SMC 792 dual stereo deck**, mounted in pull-out drawer, works well, \$450. B Downs, KTRS, Box 3248, Bryan TX 77805. 409-846-1150.

**ITC stereo R/P**, \$1200. J Wenstrom, Wynne Bldg, 503-882-4656.

**BE 5301 mono triple deck**, circa 1977, working cond but needs top motor bearing, which is still avail from BE, \$500. B Bicoy, WMFO, POB 65, Medford MA 02153. 617-625-0800.

**Tapecaster 700RPS**, recently rebuilt, new parts, vgc, \$650. M Stephens, WAEC, 1465 Northside Dr, Atlanta GA 30318. 404-355-8600.

**RCA RT-7B (6)**, (4) BA-7 record amps, 4-unit cabinet, gd-poor cond, BO/all or part. R Meyers, Benchmark Comm, 4700 SW 75th, Miami FL 33155. 305-264-5963.

**Want to Buy**

**Erase/splice finder** in gd working cond; cart-winder w/timer in gd working cond. B Golden, WABJ, 121 W Maume, Adrian MI 49221. 517-265-1500.

**PR&E Micromax stereo recorder**. H Landsberg, 818-355-3656.

**Ampro CT5500 Tri-Deck monaural**, 3-tone, must be mechanically sound. J McAulay, KITH, 21810 Hwy 18, Apple Valley CA 92307. 619-247-1111.

**ITC Premium WP Series**, mono, must have all three tones, in gd cond, w/rack ears preferred. D Williams, Lincoln City Bldg, 1103 Utah, Libby MT 59923. 406-293-6234.

**CASSETTE & REEL-TO-REEL RECORDERS**

**Want to Sell**

**MCI JH110-B 1/4" 2-trk**, excel cond, lw hrs; 7-1/2, 15/30 ips in roll around stand, \$2650/BO. T Keenan, 11105 Knott Ave, Cypress CA 90630. 714-892-9469.

**Technics RS-631 w/Dolby timer**, LED peak indicators & mic line mixing, wooden side panels, gd cond, \$150. L Hoover, Logical Audio Solutions, 325 Saude, Essington PA 19029. 215-521-2922.

## HEAD RECONDITIONING

Restore your worn heads to original (new) performance at a fraction of the replacement cost. Our laboratory services include:

- Digital/Optical & Electrical inspection
- Precision recontouring of heads
- Complete digital/optical alignment of assembly
- Exclusive "Audio Magnetic Head Test Report"™ & Data Sheets

We also carry a full line of replacement heads and parts. Our 25 years of experience and reputation are unmatched in the industry.

**AMP MAGNETIC SCIENCES**  
249 Kennedy Road  
P.O. Box 121 • Greendell, NJ 07839  
Tel (201) 579-5773  
Fax (201) 579-6021

**Amplex 440 B mono R/P (4)**; (2) Amplex 440 B stereo R/P; (2) Metrotech 500 PB; (5) Otari PG; Amplex 351 electronics. D Smith, WFCB, POB 94, Chillicothe OH 45601. 614-773-3000.

**Amplex and Scully Spare Parts, Accessories, Motor Remanufacturing.**

**VIF INTERNATIONAL**  
PO Box 1555  
Min View CA  
94042

Direct order line (800) 848-4428  
in area code 408  
dial 739-9740  
Telex 62922869 ESL UD  
FAX: 1-408-739-0809

**Audiometrics AMCD5-1000** multiplay CD players w/SMC automation controller, live assist CD playing system, gd cond w/all schematics & manuals, BO. J Glass, WZOK, POB 6186, Rockford IL 61125. 815-399-2233.

**ITC 750 R/P 2 trk**, fair cond, \$250. A McCarthy, 600 E Main, Valaville CA 95660. 707-446-0200.

**Scully 280 2 trk**, portable cases, vgc, \$900. F Virtue, Virtue Studios, 1618 N Broad, Philadelphia PA 19131.

**Otari ARS-1000 (4) w/25 Hz detectors**, excel cond, \$750 ea. T Jordan, Cape Fear Bldg, POB 35297, Fayetteville NC 28303. 919-864-5222.

**Dokorder 7050 7" auto-reverse**, built in amp & pair of speakers, gd cond, \$150. L Hoover, Logical Audio Solutions, 325 Saude, Essington PA 19029. 215-521-2933.

**Scully 280B-2 recorder/reproducers**, gd cond (2), \$750/both. G Nelson, KSYM, 1300 San Pedro, San Antonio TX 78284. 512-733-2793.

**Nagra 4.2 7" lid**, xtal sync, internal resolver, phantom-T power preamps, A/C supply, extras incl Senn preamp, headsets, PDM leather case, hi impact vinyl carrying case, \$4800. G Lombardo, 61 Stephenville Pkwy, Edison NJ 08820. 201-549-8078.

**Inovonics 375 (4) & 370 w/Amplex R-R electronics**. E Neaman, KUMU, 441 N Nimitz Hwy, Honolulu HI 96817. 608-531-4511.

**Scully 280 14" R-R**, \$250. C Hall, WZOU, 235 Bear Hill, Waltham MA 01254. 617-290-0009.

**Otari ARS1000 w/one defect**, clean & complete, \$900/BO. B Webster, WLIT, 150 N Michigan, Chicago IL 60601. 312-329-9002.

**Amplex 350 R-R transports (3)**; Amplex 354 R-R transport; (2) Teac R720 R-R transports. E Neaman, KUMU, 441 N Nimitz Hwy, Honolulu HI 96817. 808-531-4511.

**ITC 750 (2)**, play only, stereo, \$500 ea. J Littlejohn, WYSY, POB 2010, Aurora IL 60507. 708-851-4800.

**Scully 280B mono R/P**, excel cond, w/manuals, \$500. R Slatham, WSTU, 1000 Alice Ave, Stuart FL 34994. 407-692-1000.

**Amplex 601 (3)**, mono, 7.5, portable case, also 620 speaker amp, \$100 ea. S Cisler, 728 Zorn Ste 10, Louisville KY 40206. 502-895-5596.

**Otari 5050BII R/P decks (2)**, \$1800 ea; (2) Otari 5050B2HD R/P decks, \$1300 ea; (2) Otari remote control units, \$75 ea; (4) Scully 270 PB decks, \$400 ea; (2) Crown 800 R-R's, \$300 ea; ITC 850 mono R/P deck, \$550; M.W. Persons 25 Hz tone detector, \$75. E Moody, KJEM, 216 N Main, Bentonville AR 72712. 501-273-9039.

**Otari MX 5050-8SD 1/2" 8 trk**, low hrs, mint cond, calibration tape & xtrs, \$2700. C Volpe, 540 Stemmens Run Rd, Baltimore MD 21221. 301-391-6927.

**Garner 2056 1 master**, 5 slave, 1/4" stereo 60 ips, 7-1/2 or 10 reels, manual. D Agnes, WCLV, 26501 Emery Ind Pkwy, Warrensville OH 44128. 216-464-0900.

**AKAI M 75E** older type R-R, works fine, one w/7 scale, but does not affect operation, \$100. J Cunningham, KEOR, Rt 2 Box 113B, Stonewall OK 74871. 405-265-4496.

**Telex Series 235 stereo tape duplicator system**, 1 master w/incomplete spare & 4 slaves, in new cond, \$800. J Krepol, RNDL, 6147 Walker St, Philadelphia PA 19135. 215-624-1050.

**Scully 285 repro decks (4)**, \$1000/all; Amplex 354 RF stereo recorder, \$450; Amplex 350 w/Inovonics 370 R/P elect, \$750; 1 pr Inovonics 370 R/P elect, \$350; MCI JH-110B FT stereo for 14" reels, \$2500. P Wells, KJQY, San Diego CA. 619-238-1037.

**Roberts 997 stereo open reel recorder**, tube type, cond unknown, \$35; Amplex 601 open reel recorder, tube type, cond unknown, w/manual, \$50; Amplex 801, no case, \$45. C Sigmon, WBZK, POB 398, York SC 29745. 803-684-4241.

**ITC 750 PB (2)**, \$300 ea; ITC 750 PB for parts only, \$50. R Coleman, WGEN, Box 67, Geneseo IL 61254. 309-944-4633.

**Studer A820 1/4 2 trk**, all hard & software updates, immaculate cond, no head wear, very low hrs w/remote, \$9500 plus shpg. R Cannata, Conrux Recorders, 2119 Fidler, Long Beach CA 90815. 213-498-6492.

**Magnecord 1022 stereo (2)**; (2) Magnecord 1021 mono, transports for parts on both these pairs, electronics OK; (4) Scully 270's for parts only, BO on any items. H Widsten, KGNB, 1540 Loop 337 North, New Braunfels TX 78130. 512-625-7311.

**Stellavox SP-7 portable**, similar to Nagra, 7-1/2, 15, 30 ips, 2-trk stereo, takes 10" reels, pilot tone for film sync, w/pwr supply, reel adaptors, manuals, carrying case, mint cond, \$1000/BO. B Watson, KSAK, Walnut CA. 714-946-6249.

**3M M56 8 chnl 1" tape pro-studio recorder** w/full remote, sel-sync, Dolby A interface cables & new tape stock, \$2900; Audix MXT1000 8 chnl master mix down console, \$1500, or both for \$4000. J Krepol, RNDL, 6147 Walker St, Philadelphia PA 19135. 215-624-1050.

**Amplex 350 1/4" transport w/original 350 elect**, vgc, \$600. L Watson, WCDV, 227 E Forest Ln, Palatine IL 60067. 708-397-2525.

**Crown S/P logger** for parts, \$25. C Sigmon, WBZK, POB 398, York SC 29745. 803-684-4241.

**3M M79 24 trk**, 2" w/selectable one, vgc, w/meter overbridge & roll around console, \$9500. N Cleary, Audio Innovators, 5001 Baum, Pgh PA 15213. 412-621-1950.

**Scully 250 FT, 1/4" w/meter bridge & rolling cart**, gd cond, \$1500/BO. N Cleary, Audio Innovators, 5001 Baum, Pgh PA 15213. 412-621-1950.

**Sony TC-580 1/4 trk stereo**, 3 speeds, bi-directional R/P, new heads, excel cond in walnut cabinet, \$175 plus shpg. A LeFay, APL Prod, POB 371, Walnut CA 91788. 714-920-0175.

**Revox A77 MK III 1/4 trk stereo**, 7.5 & 3.75 ips w/built-in pwr amps & speakers, vgc, just serviced, \$235 plus shpg. A LeFay, APL Prod, POB 371, Walnut CA 91788. 714-920-0175.

**CLEAN PATCH BAYS NO DOWN TIME**



**VERTIGO BURNISHERS AND INJECTORS RESTORE ORIGINAL PERFORMANCE TO YOUR PATCH BAYS**  
\$34.95 Ea. *Please write for additional information and order form today*  
**VERTIGO RECORDING SERVICES**  
12115 Magnolia Blvd. #116 818-907-5161  
North Hollywood, CA 91607 FAX: 818-784-3763

**Teac 450 (2) stereo**, new belts, heads, rebuilt motor, excel cond, \$135 ea or \$260/pr plus shpg. A LeFay, APL Prod, POB 371, Walnut CA 91788. 714-920-0175.

**Scully 280B 4 trk 1/2"**, vgc, \$995/trade. G Liebisch, WPTF, POB 29521, Raleigh NC 27626. 919-876-0674.

**Auditronics AV123-4TS 1/4 trk**; Inonics RR-2 2 trk, all in gd cond, BO/all or part. R Meyers, Benchmark Comm, 4700 SW 75th, Miami FL 33155. 305-264-5963.

**Stellavox SP 7 crystal sync recorder** w/pwr supply, cables, case, (3) manuals & spares, like new, \$1800. Gene Sive Productions, 31844 Rancho Amigos, Bonsall CA 92003. 619-749-7662.

**Magnecord 1024 stereo R/P (2)**, excel cond, \$100 ea; (2) Scully 270 chassis, misc parts, \$150/all. F Fess II, WLRB, POB 250, Macomb IL 61455. 309-833-5561.

**Amplex 350 FT transports w/Inovonics solid state R/P elect & floor cabinets (2)**, \$500 ea. G Liebisch, WPTF, POB 29521, Raleigh NC 27626. 919-876-0674.

**Soundscribe audio logging recorder**, fair cond, BO. R Meyers, Benchmark Comm, 4700 SW 75th, Miami FL 33155. 305-264-5963.

**Reel hubs (2)**, \$20; Amplex mono AG 500 in working order w/record amp, \$525; Emerson MM-314 transistorized w/speeds 15/16, 1-7/8, 3-3/4, 7-1/2 ips, gd working cond, \$45. S Dynes, Dynes Prod, Wheeling WV 26003. 304-233-8858.

**Amplex AG440-C** in Ruslang console, 1/2 trk stereo, 7.5 & 15 ips, (2) Inovonics elects, excel cond, \$1500. R Barwig, Barwig Recdg, 5254 W Agatite, Chicago IL 60630. 312-283-2820.

**RCA RT-21 mono w/cueing knob**, w/manual, \$150. M Cramer, WGBA, 1391 N Road, Green Bay WI 54307. 414-494-2626.

**Tascam 8516 1" 16 trk w/dbx**, stand & wired for synchronizer, \$5500 or possible trade. Funkenstein Recdg Std, 7811 La Cosa, Dallas TX 75248. 214-239-4075.

**Amplex AG-440B 2 trk**, 10.5" rack mount, vgc, \$700 plus shpg; Denon DH-510 prof 2 trk, 10.5" reels, 7.5 & 15 ips, excel cond, \$900. K Peckham, 5824 Danville, Madison WI 53719. 608-271-8763.

**Scully 280 4 trk 1/2"** in Ruslang console, late mdl w/motion sensing, spare cards & capstan motor, low hrs, gd cond, \$1400 plus shpg; Teac 2300X stereo 1/4 trk, 7" reels, excel cond, \$180. K Peckham, 5824 Danville, Madison WI 53719. 608-271-8763.

**Gates ATC recorder**, vgc; (3) Gates ATC tape decks, vgc. L Popp, 814-467-7894.

**Crown 700-SS vgc**, stereo, will pay UPS to you, \$300. C Keith, ALI, Box 313, Keene NH 03431. 603-352-8460.

**Telex 1422 (2) 2 trk**, \$350/both; Tapsonic 70 TRS 2 trk, \$350; Teac A3300 2T 2 trk, \$400; Teac A7030 portable, \$400; Teac tube type 505 stereo, \$300; Crown SS800 4 chnl tube, \$300; Sony TCC30D, \$125; Akai 4000D, \$100; Akai X355, \$225; Wollensak 3M cassette 47CS, \$50; Viking 230 decks (3), \$200/all. J Parsons, Parsons Recdg, 10375 Cannas, N Huntingdon PA 15642. 412-863-9590.

**Tascam 38 8 trk**, 3 yrs old, low hrs, perfect heads, w/remote, like new, \$1500. K Thomas, Rebel Recdg, POB 207, Atlantic Bch FL 32233. 904-388-7711.

**Otari MX-5050QXD 4 trk, 1/4"**, tape heads just lapped, vgc, buyer pays frt, \$850. B Petrucci, Rouse St Prod, 13727 Sylvan Ste 11, Van Nuys CA 91401. 818-780-4572.

**Teac A-3300 SX 2 trk master R/P**, vgc. L Popp, 814-467-7894.

**Amplex AG 440-2**, Altec 21-B mikes, Amplex amps, EV mikes, lots of misc., call for list, must sell. Bob Lindahl, 10680 SW Wedgewood, Portland OR 97225. 503-644-9643.

**Want to Buy**

**Marantz or Sony PMD 201, 221 or Walkman Pro portable** in gd cond. M Markiewicz, 415 Pawnee, Flagstaff AZ 86001. 602-525-1514.

**Scully 250-2 1/4" 1/2 trk erase & record heads**, w/service manual or schematics. M Sokol, 121 E Baltimore St, Hagerstown MD 21740. 301-791-2562.

**Amplex MR-70 2 trk** in gd working cond. D deForrest, 7441 Wayne Ste 10-D, Miami Bch FL 33141. 305-866-5401.

**MCI JH110B or C, 1/4" 1/2 trk stereo**; Casio CFX-200 scientific calculator watch. B Umberger, WNLT, 51 S Main, Ste 957, Clearwater FL 34625. 813-446-0957.

**Amplex MR-70 2 trk** in gd original cond; Amplex NAB test tape, 15 ips; pair of RCA ribbon mics. D deForrest, 7441 Wayne, Ste 10-D, Miami Beach FL 33141. 305-866-5401.

**Metrotech 534A info and/or parts**. A Allegra, Calvary Baptist, 1380 Valley Forge, Lansdale PA 19446. 215-368-4444.

**Amplex MR-70 elect and/or transports** for parts; Otari 4050-OM open reel mastering deck for high speed tape duplication. C Richardson, Richardson Recdg, 1936 Baltimore Annapolis Blvd, Annapolis MD 21401. 301-757-3733.

**Teac/Tascam 3440/80-8 remote controls**, foot or console top operation. J McCallum, McCallum Recdg, 3311 E Bruce Randolph Ave, Denver CO 80205. 303-399-8548.

**Nagra IV-SD**, non-sync stereo recorder, cash or trade. F Beacham, 213-462-2908.

**Amplex ATR100 taperecorders** for parts. Circuit cards, heads, motors, machine parts, or electronic parts. Call 818-907-5161.

**MCI/Sony capstan & reel motors**, any cond., recd heads, most mfgs, machines, new. Relapped then sold. Amp Services, 224 Datura St No 614, W Palm Beach FL 33401. 800-826-0601, in FL 305-659-4805.

**CONSOLES**

**Want to Sell**

**Auditronics 300 series 4 trk**, \$8000; Autogram R-TV 20 chnl stereo, \$7500. C Hall, WZOU, 235 Bear Hill, Waltham MA 02154. 617-290-0009.

**BE 150A 8 chnl dual mono prod & air board**, new in box; Ampro AC-85 8 chnl stereo board, original box & manual, BO; Micro-trak 6444B stereo mixer board, new, \$400; Ram-sa 8 chnl stereo board WR-130. J Phillips, WZOM, 408 Clinton, Defiance OH 43512. 419-792-8591.

**Wheatstone Audio Arts 24 input 8 buss factory patch bay**, mint cond, trades considered, \$10,000. D Kocher, DKL Snd Std, 1901 Hanover, Allentown PA 18103.

**ARCOR**  
2 Channel—Red and Green  
DZ2202  
Zip Stereo™ 2-Channel Shielded  
Pair Audio Cable  
**IN STOCK**  
**\$199.00 /M**  
**NORTHEAST BROADCAST LAB**  
(518)-793-2181/(215)-322-2227  
(603)-483-1002/(214)-612-2053

**Gates II 8 chnl mono solid state (2)**; Collins/Autogram IC-10 10 chnl stereo; Ramko 8 chnl stereo DC-38-BS; Teac 38 chnl 4 out; lg qty modules & parts for RCA BC 7 & 8 consoles; RCA BC 2 console shell. D Smith, WFCB, POB 94, Chillicothe OH 45601. 614-773-3000.

**Sparta A15 5 pot news console**. E Neaman, KUMU, 441 N Nimitz Hwy, Honolulu HI 96817. 808-531-4511.

**BE stereo 8 chnl w/Daven pots**, \$1000; BE mono 8 chnl, \$850; BE mono 4 chnl, \$300; Collins stereo 8 chnl, \$1250; Gates stereo Yard, \$300; McCurdy stereo 8 chnl, \$900. C Haynes, WJMI, 1850 Lynch, Jackson MS 39203. 601-948-1515.

**Sound Workshop 1280 12 chnl board** w/parametric EQ, excel cond, 12 x 8 x 2, complete monitoring section. C Volpe, 540 Stemmens Run Rd, Baltimore MD 21221. 301-391-6927.

**Cotec remote console**, (2) TT's, 5 chnl mixer & cabinets, old Gates remote mixer/TT's/cabinets, \$200; (2) BE 5M250 mono consoles, excel cond, \$900 ea; Shure M67 mixer, \$75; Gates Dualux 12 chnl console, \$250; Gates stereo 80 console w/pwr supply, \$1000. E Moody, KJEM, 216 N Main, Bentonville AR 72712. 501-273-9039.

**Sparta 3310 dual mono audio console**, 10 rotary mixers, program, audition & cue outputs, vgc, \$850. R Beierle, KFYR-TV, POB 1738, Bismarck ND 58502. 701-255-5757.

**Tapco C-12 portable**, stereo, 12 in & 4 out w/manuals, \$1000/BO. D Christian, Pacific Lutheran Univ, 121st & Part Ave South, Tacoma WA 98447. 206-535-7265.

**Tascam 312B 12 x 4 x 2**, less than 20 hrs use, \$3000/BO. B Hansen, WFMB, 3055 S Fourth, Springfield IL 62703. 217-528-3033.

**Peavey MK3-16 portable**, stereo, \$1000/BO; Quantum Audio Labs QM 1010 16/8 w/some documentation, avail in 10/90, \$2000/BO; Quantum Audio Labs QM 8 portable, stereo, w/manuals, \$500/BO. D Christian, Pacific Lutheran Univ, 121st & Park Ave South, Tacoma WA 98447. 206-535-7265.

**BE 8M20**, 8 chnl mono, gd cond, \$450. H Widsten, KGNB, 1540 Loop 337 North,



### CONSOLES . . . WTS

**Micro-Trak Sport III** dial-up remote sports mixer, mixes 2 mics, line level & spotter mic, A/C or battery pwr, VU meter, (3) headphone outputs, compact, briefcase format, nice cond. B Fisher, KPOK, Box 477, Bowman ND 58623. 701-523-3883.

**Wheatstone Audioarts 8X** w/24 input, excel cond. \$9500/BO. D Kocher, DLK Snd Stds, 1901 Hanover, Allentown PA 18103.

**Gates Dualux II** 8 chnl w/manual, gd cond, need only one new stereo pot to put in excel cond. \$800/BO pls shpg. C Ibarra, KTAN, 2300 Busby Dr, Sierra Vista AZ 85235. 602-458-4313.

**Ramsa T820B** 20/40 input, full metering, 18 mos old, like new, full EQ on ea chnl, 8/16 buss out, \$5000. R Thomas, Rebel Recd, 5555 Radio Ln, Jacksonville FL 32205. 904-388-7711.

**McCurdy SS8800** stereo 8 chnl 24 input w/furniture & patch bays, \$3000/BO. B Mitchell, WSYR, 500 Plum, Syracuse NY 13204. 315-472-9797.

**Teac Tascam 3**, like new, 8 x 4 x 2, \$500. E Davison, 217-787-0800.

**LPB Citation C-10S** 10 x 3, stereo, \$2500. P Wells, KJQY, San Diego CA. 619-238-1037.

**Sound Workshop Logex 8** 16 chnl mixing board w/stand & shell, BO. D Coffman, WSOR, 940 Tarpon, Ft Myers FL 33916. 813-334-1393.

**Collins 212-M & 212-S**, one mono, one stereo, lots of spare parts & manuals for both, BO. S Carter, WRKN, POB 145, Brandon MS 39043. 601-825-5045.

**Gates Producer** w/new replacement pots, dual chnl w/q switch not installed, 4 chnl mono, could modify for stereo or mix minus, \$200. L Beigel, On-Cue Record, POB 85042, Los Angeles CA 90072. 213-466-3595.

**LPB 4 chnl mono**, \$475. S Dynes, Dynes Prod, Wheeling WV 26003. 304-233-8856.

**S-S T40**, 2 chnl parts only, trade for Ampex AG 350 transport parts. B Butler, WELE, 432 S Nova, Ormond Bch FL 32174. 904-677-4122.

**SSR 32 x 8** bi-amp recd console, less than 1 yr old, \$9500 or possible trade. Funkenstein Recd Std, 7811 La Cosa, Dallas TX 75248. 214-239-4075.

**Gatesway 10 pot board**, completely rebuilt. L Popp, 814-467-7894.

### Want to Buy

**Stereo console**, 10 or 12 channel in gd cond. KGHT, 7515 Geyer Springs Rd, Little Rock AR 72209. 501-568-5448.

**API & Neve consoles**, also API & Neve EQs, anything considered, especially API 550A & 550B's. J Kreines, DeMott/Kreines Films, 5330 Kennedy, Millbrook AL 36054. 205-285-6179.

**McCurdy SS8500** spare parts needed desperately. R Gates, KTLG, 1602 S Brownlee, Corpus Christie TX 78404. 512-882-4394.

**API & Neve**, also EQs, anything considered, especially need API 550A & 550B's. J Kreines, DeMott/Kreines Films, 5330 Kennedy, Millbrook AL 36054. 205-285-6179.

### DISCO & SOUND EQUIPMENT

#### Want to Sell

**Lexicon 224-4.4** echo unit, excel cond, \$3200. F Virtue, Virtue Studios, 1618 N Broad, Philadelphia PA 19131.

**UREI 529** room EQ's (2), excel cond, \$250. F Virtue, Virtue Studios, 1618 N Broad, Philadelphia PA 19131.

**JBL 4312 L + R** studio mix-down, 3 way monitors, real walnut, like new, balance of 5 yr warranty applies, we pay UPS, \$275 ea. C Keith, ALI, Box 313, Keene NH 03431. 603-352-8460.

**Community Light & Sound RS440** (1 pr) 4-way speakers w/Community VB790 bass bins, in Anvil cases, excel cond, \$1600. J Kreines, 5330 Kennedy Ave, Millbrook AL 36054. 205-285-6179.

**JBL 4350** speakers, electrically perfect, need refinishing, new cones, diaphragms w/cross-over, \$3200/BO; perfect pair Dynaco ST-70s/PAS-Z preamp, \$375; NAD2140 40 W/wh, mint, \$240. R Nelson, Tropical Bdctg, 14093 SW 142, Miami FL 33196.

**JBL 4312 L + R** monitors (6), like new, balance of warranty applies, w/all packing, we pay UPS, \$275 ea. C Keith, ALI, Box 313, Keene NH 03431. 603-352-8460.

**AKG The Tube**, 2 mos old, \$1650; (2) Orban 642B para EQ's, \$650/ea. T Campana, Dan Yessian Music, 33117 Hamilton Ste 175, Farmington Hills MI 48334. 313-553-4044.

**Community Light & Sound RS440** 4-way speakers, pair, w/Community BV790 bass bins in Anvil cases, excel cond, \$1600 plus shpg. J Kreines, DeMott/Kreines Films, 5330 Kennedy, Millbrook AL 36054. 205-285-6179.

**Lexicon 200** reverb, mint cond, \$1800; Lexicon Prime Time II, mint cond, \$900; Sony PCM 701, mind cond, \$950. D Kocher, DLK Snd Stds, 1901 Hanover, Allentown PA 18103.

**Westlake RB5M 6**, (2) woofers, one mid, one tweeter, pr in vgc, \$1000/pr. B Ranes, DIR, 32 E 57th, NNY 10022. 212-371-6850.

**Altec Acoustica** Voice passive filters, individual & rack mount on 1/3 octave centers, \$5-50. J McLane, 115 W Gutierrez, Santa Barbara CA 93101. 805-963-3941.

**Yamaha NS-10** (4) w/remainder of warranty, (2) boxed, (2) open, \$320/pr. C Keith, ALI, Box 313, Keene NH 03431. 603-352-8460.

**Altec co-axial speakers**, 604 series, gd cond w/x-overs, send price & details. D deForrest, 7441 Wayne Ste 10-D, Miami Bch FL 33141.

**Alesis or LXP-1** stereo digital reverb in gd shape for small recording studio. W Dougherty Jr, WLD Recording, Rt 1 Music Valley, Mill Spring MO 63952. After 5:30 PM. 314-998-2377.

### FINANCIAL SERVICES

#### EQUIPMENT FINANCING "LOANS BY PHONE"

- NO FINANCIALS REQUIRED FOR TRANSACTIONS UNDER \$35,000
  - NEW OR USED EQUIPMENT
  - \$2,000 to \$200,000
  - NO DOWN PAYMENT
  - SALE-LEASEBACK EQUIPMENT FOR WORKING CAPITAL
- TO APPLY OR REQUEST ADDITIONAL INFORMATION CONTACT MARK WILSON
- ENF** EXCHANGE NATIONAL FINANCING (800) 342-2093 FAX: (214) 235-5452

### LIMITERS

#### Want to Sell

**Orban Optimod 8000A**, just rebuilt, like new, \$1750. K Krueger, KGTS, 204 S College, College Place WA 99324. 509-527-2991.

**Dorrough DAP 610** (2), set up for AM, may be converted, \$1000 ea/BO. J Littlejohn, WYSY, POB 2010, Aurora IL 60507. 708-851-4600.

**Dorrough DAP 310** AM processor. D Smith, WFCB, Box 94, Chillicothe OH 45601. 614-773-3000.

**CRL Systems FM4G** consisting of SPP-800 Stereo Prep Processor, (2) SEP-400B Spectral Energy Processors, SMP-800 Stereo Modulation Processor & SG-800 Stereo Generator, excel cond, \$4500. B Dickerson, WEAG-FM, 904-964-5001.

**PR&E Multimax processors** (3), \$200 ea; (2) PR&E multimiters, \$200 ea; Hnat-Hindes 104 peak limiter, \$50. C Hall, WZOU, 235 Bear Hill, Waltham MA 02154. 617-290-0009.

**Harris AM limiter**, \$500; Harris ME-1 mod enhancer, \$150; Harris AM tri band AGC, mdl MSP 90, \$1250; Gates Sta Level, \$85. E Moody, KJEM, 216 N Main, Bentonville AR 72712. 501-273-9039.

**UREI LA4**, \$300; Audimax 4440 auto level, \$150; Mari CLA-40H, \$200; Gates Sta-Level, \$75. C Haynes, WJMI, 1850 Lynch, Jackson MS 39203. 601-948-1515.

**Orban Optimod 8000A**, gd cond, just removed from service, \$1600. A McEwing, WGLY, RR 1 Box 1040, Waterbury VT 05676. 802-244-5683.

**CBS audiomax 3** compressor, \$80; CBS audiomax 3S, stereo, \$170; Collins 900-F1 FM SCA mon, \$50; Collins 900-C2 FM stereo mon, \$400; CBS DEP-450 dynamic presence EQ, \$80; Sola Line conditioner, 8.34 amps, mdl 6C128. B Umberger, WNLT, 51 S Main, Ste 957, Clearwater FL 34625. 813-446-0957.

**CRL PMC-300A** peak mod controller, \$500. K Lane, KVRP, Box 1118, Haskell TX 79521. 817-864-8505.

**Gates FM Top-Level**, stereo, \$75. T O'Laughlin, O's Own Prod, Rt 1 Box 41, Barneveld WI 53507. 608-924-2001.

**CRL Systems FM4G** incl SPP-800 stereo preparation processor, (2) SEP-400B's spectral energy processors, SMP-800 stereo mod processor & a SG-800 stereo gen, all in excel cond, 4 yrs old, \$4500. B Dickerson, WEAG, 1421 S Water, Starke FL 32091. 904-964-5001.

**CBS Volumax/CBS Audimax III**, rebuilt, \$250/pr; Gates Solid Statesman limiters (2), \$250/pr. H Widsten, KGNB, 1540 Loop 337 North, New Braunfels TX 78130. 512-625-7311.

**CBS Volumax 410**, \$80. B Umberger, WNLT, 51 S Main Ste 957, Clearwater FL 34625. 813-446-0957.

**Aphex 700** studio Dominator, less than 20 hrs use. T Jones, KNXR, 220 South Bdw, Rochester MN 55904. 507-288-7700.

**Orban/Texar/Kahn**, 222A stereo spacial enhancer, slot 5 card to use w/Prisms, Power Side, complete system, BO. D Doughy, H&D Bdct Group, POB 781, Utica NY 13503. 315-797-1330.

**Radio Design Labs NRSC A**, pre-emphasis & 10 kHz audio filter w/pwr supply & complete manual, \$200. B Fisher, KPOK, Box 477, Bowman ND 58623. 701-523-3883.

**CRL PMC 300A** in excel cond, replacing w/newer unit, must sell. B Fisher, KPOK, Box 477, Bowman ND 58623. 701-523-3883.

**Gentner RCF-1** replacement card #5 for Optimod 8100A when using Prisms, \$300. M Holderfield, WOOF, POB 1427, Dothan AL 36302. 205-792-1149.

**RCA BA-147** FM mono, \$200. G Liebisch, WPTF, POB 29521, Raleigh NC 27626. 919-876-0674.

#### Optimod 8000A \$1495 & UP 414-482-2638

**Radio Design Labs NRSC A** w/pre-emphasis & 10 kHz audio filter w/pwr supply & manual, \$200; CRL PMC 300A, excel cond. B Fisher, KPOK, Box 477, Bowman ND 58623. 701-523-3883.

**Gentner RCF-1** replacement card #5 for Optimod 8100A when using Prisms, \$300. M Holderfield, WOOF, POB 1427, Dothan AL 36302. 205-792-1149.

**UREI BL-40** Modulimiter, gd cond, w/manual, \$100/BO; CBS Volumax 4000A, working when removed, w/manual, \$75/BO. S Carter, WRKN, POB 145, Brandon MS 39043. 601-825-5045.

**UREI 530** 9 band EQ, stereo, looks bad but works, \$50. F Fess II, WLRB, POB 250, Macomb IL 61455. 309-833-5561.

**CRL PMC 300A**, excel cond, \$400. S Manuel, WWJB, 55 W Ft Dade, Brooksville FL 39601. 904-796-7489.

**CRL SMP 900** AM stereo audio processor w/NRSC-1 attachment, \$2500/BO, cash or money order. P Dale Ware, KUTY, Palmdale CA. 805-947-3107.

**CRL SEP-800** audio processing w/book; Orban 674A stereo EQ w/book, all equip in gd cond, BO. L Crumpton, KZZB, POB 20495, Beaumont TX 77720. 409-833-0774.

**Valley People Gain Brain II** (2) limiting amps, \$200 ea/BO/trade. J McLane, 115 W Gutierrez, Santa Barbara CA 93101. 805-963-3941.

**Optimod 8000A** limiter/stereo gen, all lyrics replaced recently & limiter section opsamps upgraded to low noise FET types, works great, \$1500. M Heuberger, KTIG, POB 409, Peguot Lakes MN 56472.

**UREI BL-40** spare circuit board, \$100. J McLane, 115 W Gutierrez, Santa Barbara CA 93101. 805-963-3941.

**Gates FM Top-Level**, excel cond, \$75; Lauderdale Electronics program lock, mono, excel cond, \$75. F Fess II, WLRB, POB 250, Macomb IL 61455. 309-833-5561.

### Want to Buy

**Orban 8100**. D Brooks, WCIC, 3263 Court St, Pekin IL 61554.

**Optimod 8100A** (2). R Roberts, KPUP, 1188 Padre Dr, Salinas CA 93901. 408-758-5400.

**Fairchild 660 or 670**, Teletronix LA2A, LA3, other tube compressors & limiters; & other vintage tube signal processing equip. J Kreines, 5330 Kennedy Ave, Millbrook AL 36054. 205-285-6179.

**Dorrough DAP 310** w/serial nos. 500-1000. B Moennig, 77 Bayberry Ct, Glen Mills PA 19342. 215-558-1670.

**Orban 8000A** Optimod, gd cond. H Voss, WJLY, Rt 2, Ramsey IL 62080. 618-423-2635.

**Tube limiters**, compressors & EQs, especially Fairchild 660 & 670, Teletronix LA2A & LA3A; any Pultec EQs or NAVESCs; Lang, Sontec & API EQs, etc; also other tube signal processing equip. J Kreines, DeMott/Kreines Films, 5330 Kennedy, Millbrook AL 36054. 205-285-6179.

**Orban Optimod 8100A**. M Cooney, Bdct Mgmt, 610 N Kiwanian, Sioux Falls SD 57104. 605-336-2706.

**Audio Prism**, latest pair for stereo operation; Orban 8100A in gd/vgc. D Schaberg, WTHM, POB 21055, Lansing MI 48909. 517-393-1037.

**Fairchild 660 & 670**, Teletronix LA2A & LA3A, other tube compressors & limiters. J Kreines, DeMott/Kreines Films, 5330 Kennedy, Millbrook AL 36054. 205-285-6179.

### MICROPHONES

#### Want to Sell

**Neuman U87** w/shock mount, mint cond, \$1300. D Kocher, DKL Snd Std, 1901 Hanover, Allentown PA 18103.

**RCA 77DX** ribbon mic, gd cond, complete w/shock mount, works, BO. E Duellman, WOMT, POB 1385, Manitowoc WI 54221. 414-682-0351.

**EV RE-16** dynamic mics w/case & stand clip, excel cond, \$125/ea or \$225/pr. C Butler, Butler Bdct Srvc, 1775 Bartlett Ave, Orange Pk FL 32073. 904-264-8169.

**Sennheiser MD-421** dynamic mics w/case & stand mount, mint cond, \$225/ea or \$400/pr. C Butler, Butler Bdct Srvc, 1775 Bartlett Ave, Orange Pk FL 32073. 904-264-8169.

**AKG 451-Eb** condenser mics w/case, wind-screen & stand clip, mint cond, \$250/ea or \$450/pr. C Butler, Butler Bdct Srvc, 1775 Bartlett Ave, Orange Pk FL 32073. 904-264-8169.

**Shure SM-61's** in vgc w/cases & wind-screens, \$160/pr. W Dougherty Jr, WLD Recording, Rt 1 Music Valley, Mill Spring MO 63952. 314-998-2377.

**AKG LBB** super shotgun, perfect, belt pack PS, full case, response certification, fantastic pattern, \$480. L Watson, WCDV, 227 E Forest Ln, Palatine IL 60067. 708-397-2525.

**RCA 44BX**, 74B, 77DX; Brush Sound Cell crystal; Eastern sound ribbon mdl 50, BO individually or for lot. P Weber, Weber Studio, 102 Southgate Blvd, Melbourne FL 32901. 407-724-9590.

**EV RE20**, \$375. B Hansen, WFMB, 3055 S Fourth, Springfield IL 62703. 217-528-3033.

**RCA SV**, works, want to trade for other gear; also F1, SCD2000, trade for Casio DA-2 DAT. T Hill, WBJC, 2901 Lib Hghts Ave, Baltimore MD 21215. 301-396-0404.

**EV 1776** (2), (2) extra batteries, gd cond, \$100/both. R Swan, WROY, POB 400, Carmi IL 62821, 618-382-4161.

**Altec Bird Cage** (2); WE 8 Ball; EV 647 vintage mics, BO. M Massey, WKHX, 360 Interstate N, Atlanta GA 30339. 404-955-0101.

**RCA 44-A** on original desk stand, vgc, \$575/BO; RCA 77DX on orig desk stand, \$500/BO; RCA 74 JRs (2), gd cond, need ribbons, \$150; EV RE 16, \$75; EV RE 55, excel, \$80. Kremer Kraft, 301 SW 16th St, Ft Lauderdale FL 33315. 305-524-5652.

**Syncron AU7A**, mint cond, w/custom pwr supply for 2 mics, w/documents. R Robinson, 203-269-4465.

**Sennheiser ME80/K2U** spot mic w/extra ME80 head, like new, \$275; MKE10-3 tie clip mic module, new, \$75. E Davison, 217-787-0800.

**Schoeps MK-8** bi-directional capsule, new, \$475; (2) Shure SM-18 surface mount mics, new, \$49 ea; Shure SM-89 shotgun mic, new, \$649. C Richardson, Richardson Recd, 1938 Baltimore Annapolis Blvd, Annapolis MD 21401. 301-757-3733.

**Schoeps CMTS-501** coincident stereo mic, switchable multipattern capsules for M-S or X-Y stereo, new, \$1795; (2) Shure 300 bi-directional ribbons, new, \$165 ea; Schoeps MK-3 omni capsule, new, \$285. C Richardson, Richardson Recd, 1938 Baltimore Annapolis Blvd, Annapolis MD 21401. 301-757-3733.

**Norelco D119C5/200**, \$10; GE CB mic, \$10; Altec 570B, \$20; RCA BK-5B, \$200; RCA BK-1A (2), one has base, other has boom mount, \$25 ea; RCA shotgun mic, \$25. S Dynes, Dynes Prod, Wheeling WV 26003. 304-233-8856.

**Altec 639** ribbon & dynamic classic, w/yoke & connectors complete, \$550. L Beigel, On-Cue Record, POB 85042, Los Angeles CA 90072. 800-726-9813.

**RCA ribbon mics** including (1) 44-BX; (1) 77-D; KU3A10,0001; BK-11; BK-5; SK-46; WE639A, will trade for other high quality condenser, dynamic, ribbon mics & audio equip. Tracy Eaves, 615-821-6099 (evenings).

## DENON

*DENON's Successor to the CD CART PLAYER™, the new DN-950FA*



Call for Quote  
In Stock at  
**NORTHEAST BROADCAST LAB**  
(518)-793-2181/(215)-322-2227  
(603)-483-1002/(214)-612-2053

**Microphones** approx 30 from home studio incl AKG 414, \$350 ea, 451, \$200 ea, D-190, \$60, D-224, \$180, Sennheiser 441, \$275, 421, \$175, Shure SM-81, \$225 ea, SM-61, \$85, mdl 300, \$100, many others from EV, Bey-er, Altec, Sony & Ramsa, call for complete list & prices. K Peckham, 5824 Danville Dr, Madison WI 53719. 608-271-8763.

**Shure SM58** (2), new in box, less cable, \$135 ea. G Mundkowsky, 12918 Smallley, Grandview MO 64030. 816-966-0731.

### Want to Buy

**Vintage mic for antique radio display**, all types. D Koehn, KNEN, Box 937, Norfolk NE 68701. 402-379-3300.

**Vintage mics** by Altec, Neumann, Sony, RCA, etc. Kremer Kraft, 301 SW 16th St, Ft Lauderdale FL 33315. 305-524-5652.

**Vintage tube condenser mics**, Neumann, Telefunken, Schoeps, AKG & classic ribbon mics, RCA 77s, 44s; Telefunken ELAM 250s or 251s, any cond; AKG C12s & C24s, any cond; Neumann U47, U48, M249B, KM56, U67, etc, any cond. J Kreines, DeMott/Kreines Films, 5330 Kennedy, Millbrook AL 36054. 205-285-6179.

**RCA, Neuman, Schoeps, AKG**, Telefunken & other makes of vintage mics, any cond or parts, stands & call letter plates, will buy or have mics to trade. R Van Dyke, Caffrey House, 2 Squires Ave, E Quogue NY 11942. 516-728-9835.

**Telefunken ELAM 250 & 251**; AKG C12/C12A, C24, C60; Neumann U47, U48, M49, M50, KM56, U64, U67, SM2, SM69, SM269, etc; also other pro condenser mics incl Neumann U87, U89, TLM170, RSM190, SM69 fet, U47 fet, AKG 412, 414; ribbon mics; also wrecked mics w/missing parts in any cond. J Kreines, DeMott/Kreines Films, 5330 Kennedy, Millbrook AL 36054. 205-285-6179.

**Will buy or trade** for RCA 4 AA condensor mike no major missing parts please. J Webb, 15117



## CONSULTANTS

**EVANS ASSOCIATES**  
Consulting Communications Engineers

FCC Applications, Design & Field Engineering  
Broadcast Engineering Software

216 N. Green Bay Rd.  
Thiensville, WI 53092

**(414) 242-6000**  
Member AFCCCE

**W. LEE SIMMONS & ASSOC., INC.**

BROADCAST TELECOMMUNICATIONS CONSULTANTS

1036 William Hilton Pkwy  
Ste 200F  
Hilton Head Is., SC 29928

**(803) 785-4445**

**SOFTWARE**  
**FM CHANNEL SEARCH**

FM Database pool  
MSDOS  
EGA Graphics-Color  
Broadcast Technical Consulting

**V Doug Vernier**  
Broadcast Consultant  
1600 Picturesque Drive  
Cedar Falls, IA 50613  
**319-266-8402**

**MAGRILL ENGINEERING**  
Radio Engineering Consultants

FCC Applications - Upgrades  
Pre-purchase evaluations  
Station planning & Design  
Turnkey systems - Field service

Experienced, Economical & Fast

**(904) 591-3005**

Barry Magrill P.O. Box 1010  
President Fairfield, FL 32634  
Member IEEE

**RP Communications**  
Robert Cham  
Telecommunications

FCC Application Preparation  
Custom Audio Console Design & Modification  
Digital & Analog Recording & Broadcast Facilities Design  
High Quality Field Recording  
77 1/2 Intervale Ave.  
Burlington, VT 05401

**802-862-7447**

**THIS SPACE AVAILABLE**

Call Simone Mullins  
at 1-800-336-3045

new station construction field service AM directionals

**RON KROB**  
broadcast technical consultant

4910 Four Star Court  
Fort Collins, CO 80524

303 484 2704

**RADIO SYSTEMS ENGINEERING**

FCC Applications • Design • Installation • Field Service

Experienced & Affordable

4289 Roanridge  
Las Vegas, Nevada 89120

24 Hr: (702) 454-2085  
FAX: 702-458-2787

**Moffet, Larson & Johnson, Inc.**  
Consulting Telecommunications Engineers

Two Skyline Place  
5203 Leesburg Pike # 800  
Falls Church VA 22041

703-824-5660  
800-523-3117

Member AFCCCE

**THIS SPACE AVAILABLE**

Call Simone Mullins  
at 1-800-336-3045

**AVIATION CONSULTANTS**

- FAA Obstruction Analysis
- FM EMI Evaluations
- Expert Witness Service
- Tower Marking & Lighting

**WALTER WULFF & Assoc.**

(404) 881-6786  
P.O. Box 77028  
Atlanta, GA 30357

**MEYER GOTTESMAN**  
Broadcast consultant/engineer

FM, TV and LPTV applications. Frequency studies, transmitter field service, etc. We go anywhere! Former CE Boston, Houston, Miami and Ft. Lauderdale. Former HARRIS transmitter field engineer.

3377 Solano Ave., #312  
Napa, CA 94558

Tel: (415) 221-2000 (anytime)  
FAX (415) 387-2425 (days)

Consulting Communications Engineers

- FCC Data Bases
- FCC Applications and Field Engineering
- Frequency Searches and Coordination
- AM-FM-CATV-ITFS-LPTV

**OWL ENGINEERING, INC.**

1306 W. County Road. F,  
St. Paul, MN 55112  
(612)631-1338 "Member AFCCCE"

**Looking for a position in radio or television?**

**Looking for personnel for your station?**

I can help! Reasonable rates. Free information.

Full Service Consulting

Bill Elliott  
48 Imperial Avenue  
Pittsfield, MA 01201  
413-442-1283

**Huntsville Antenna Engineering**

There is hope for AM radio! AM station unipole antennas with circular polarization & beam tilt. Broadband your present AM tower Series R shunt fed.

205-353-9232 205-353-6747

**Kenneth Casey**  
Consulting Radio Engineer

**DISPLAY YOUR CONSULTANT'S CARD HERE AND BE SEEN BY OVER 21,000 READERS**

## SERVICES

**BRENTLINGER BROADCAST ENGINEERING, INC.**

Charles Jayson Brentlinger  
President

COMPUTERIZED REPORTS  
ALLOCATION STUDIES • AM • FM  
AM DIRECTIONALS • AUDIO • STL  
SATELLITE COMMUNICATIONS

4338 East Acoma Drive  
Phoenix, Arizona 85032  
(602)867-0181

**FM TRANSMITTERS**

3, 5, 12, 20, 25KW  
\$24,000 TO \$46,000

FM-AM Transmitter Installation  
Maintenance and Field Service

BROADCAST EQUIPMENT  
REFURBISHED & REPAIRED

BROADCAST TECHNICAL CONSULTANT

**TELO TECHNOLOGY**  
Stanwood, WA. 98292  
**206-387-3558**

FCC's Engineering  
**AM, FM and TV Data Bases for your PC**

Call today to request a free sample.

**Communications Data Services**

6105 E Arlington Blvd  
Falls Church VA 22044  
(703) 534-0034

**Steven L. Delay**  
AM/FM Broadcast Field Service

**International & Domestic**

Ground Systems Field Intensity  
Broadcast Studios Measure  
Turnkey Transmitting  
Construction Facilities  
AM Directionals Purchase  
Microwave Evaluations

RR1-236 Pawnee, IL 62558  
24 HR. 217-498-7339  
FAX 217-498-8197

**CLOUD NINE BBS**

300 to 19200 Baud  
N-8-1  
Multi-Node System

**(713) 855-4382**

FCC Information  
On-Line Call Sign Search  
On-Line Engineering Formulas  
Messages, Conferences, Files, Doors

**BROADCASTING & ELECTRONIC SERVICES LABS**

PO BOX 178  
NEWTON, UT 84327  
801-563-3088

BROADCAST EQUIPMENT  
REFURBISHED & REPAIRED  
AUDIO, VIDEO, RE, DIGITAL

15 YRS EXPERIENCE

**TOWER SERVICES**  
Light Replacement  
Routine Maintenance  
Ground Systems  
Painting  
20 years Experience

**John Nix**

PO Box 13244 Salem, OR 97309  
503-581-4056  
1-800-321-4056

SPECIALIZING IN ERECTION,  
REPAIRING, PAINTING  
AND MAINTENANCE  
RADIO, TWO-WAY, TV, TOWERS  
AND FLAG POLES

**A STEEPLEJACK CO.**  
PAINTING AND STEEPLEJACK  
CONTRACTORS

FULLY INSURED FOR YOUR PROTECTION

DON HIGHLEY 3722 ROMA  
713-462-6105 HOUSTON, TEXAS 77080

**MIRKWOOD ENGINEERING**

Rural & Remote Site  
Field Engineering

50 Park Ave.  
Claremont, NH 03743

**603/542-6784**

**T & W**

**Tower/Antenna**  
Erection • Maintenance

\* 24 Hr. Emergency Service \*

Hurlock, MD  
**301-376-3555**

**TENCO TOWER**

Lic. No. 357096

Installation & Maintenance of  
Broadcast & Communications  
Towers & Antennas

**Donald J. Tenns**

(916) 362-6846  
(916) 638-8833  
9723 Folsom Blvd. Suite A  
Sacramento, CA, U.S.A. 95827  
FAX: (916) 638-8858

**PARAMOUNT**  
COMMUNICATION SYSTEMS

INSTALLATION AND SERVICE OF BROADCAST  
ANTENNA SYSTEMS/TOWER MAINTENANCE & ERECTION

WESTMONT, NJ (609) 869-0222

WIDEST & FINEST CHOICE OF PRODUCTION MUSIC & SFX

**PROMUSIC**

Call For Our Free Demo & Information On  
BROADCAST Plus  
Annual Rates.

**1-800-322-7879**

**RF Components**

Field phasing  
modifications  
and installation

Call Dave Gorman  
**215-249-9662**

POB 401  
Dublin PA 18917

**THIS SPACE AVAILABLE**

Call Simone Mullins  
at 1-800-336-3045

**CONTACT RADIO WORLD NEWSPAPER FOR AVAILABILITIES.**  
P.O. Box 1214 • Falls Church VA • 22041

**1-800-336-3045**



**MISCELLANEOUS . . . WTS**

**Extel AH/PIIR**, like new cond, BO. J Anderson, WKCU, 2192 Hwy 72 East, Corinth MS 38834.

**HP Thinkjet ink jet printer**, \$100. P Cibley, Cibley Music, 138 E 38 St, NYNY 10016. 212-986-2219.

**Henry Engineering logic converter**, \$75; (30) Seimms 66B blocks, \$10 ea; (3) Technics bases for SP-15 or SP-25, \$100; (2) Technics bases for SP-10 Mark II, \$100 ea. C Hall, WZOU, 235 Bear Hill, Waltham MA 01254. 617-290-0009.

**EV RE-20 shock mounts** (3), \$25 ea; Sansui QSE-5B quadrasonic encoder, \$100. C Hall, WZOU, 235 Bear Hill, Waltham MA 01254. 617-290-0009.

**Cinema Engineering/Aerovox 9205** bulk eraser, BO. R Robinson, 203-269-4465.

**Hilomast MK9**, 30' telescoping pneumatic mast w/vehicle bearings. E Duellman, WOMT, POB 1385, Manitowoc WI 54221. 414-682-0351.

**Connecticut readers:** tag sale 9/22-23/90 for a Gates Stereo Steteman, Klipsch Cornwalls, RCA mono cart R/PS, Phase Linear amps & much more, send SASE for complete list & directions. Doc Rock Productions, 3700 Durham Rd, Guilford CT 06437.

**Kato 50 kW 3 phase generator**, Perkins diesel engine w/50 gallon day tank, less than 50 hrs running time, \$20,000/BO or trade for 25 or 35 kW FM xmtr. P Parks, KYKR, 27 Sawyer, Beaumont TX 77703. 409-838-3911.

**Equipment racks** (2). P Wells, KJOY, San Diego CA. 619-238-1037.

**Extel AH11R solid state printers** (2), vg working cond, standard size paper, approx 25 new spool ribbons & all power cords, sold separately or together. A Wasilewski, KMWX, POB 1460, Yakima WA 98907. 509-248-1460.

**Rotron Blowers for Elcom, CCA, CSI, McMartin, rebuilt & new.** Goodrich Enterprises Inc. 11435 Manderson St., Omaha, NE 68164 402 493 1886 FAX 402 331 0638

**Extel AH/PIIR teleprinter**, like new cond w/stand, BO. J Anderson, WKCO, 2192 Hwy 72 East, Corinth MS 38834. 601-286-8451.

**Tandy Mid II computer**, keyboard, 3-drive expansion bay, \$400. C Sigmon, WBZK, POB 398, York SC 29745. 803-684-4241.

**Pelco VS508H 8-position sequential CCTV switcher**, new, original packing, \$600/BO. A Allegra, Calvary Baptist Church, 1360 Valley Forge, Lansdale PA 19446. 215-368-4444.

**1975 Coachmen 22'** camping trailer converted to mobile unit, tandem axle, (2) TT's, console, internal & external sockets, AM/FM monitor, heatpump, range, refrigerator, \$2750. C Sigmon, WBZK, POB 398, York SC 29745. 803-684-4241.

**Switchcraft 1/4"** balanced patch bays, some normalised, \$60 ea; West Penn 291 2 conductor shielded cable, all or part of 1800, new, 8-ft. B Petruzzi, Rouse St Prod, 13727 Sylvan Ste 11, Van Nuys CA 91401. 818-780-4572.

**TIE E300C 13 line TT phone w/schematics**, new, \$50; TIE E100C 5 line key phone 1A2 type, rotary, new w/schematics, \$30. E Davison, 217-787-0800.

**TM Master plan library**; also misc radio & office equip from station that has gone out of business. L Popp, 814-467-7894.

**IGM & Teletype PAL encoding system**, FSK, complete w/Teletype 33 printer/reader & manuals, working cond, recently removed from service. BO. D Gander, KDUZ, Box 10, Hutchinson MN 55350. 612-587-2140.

**UMC 40 H-85 cart motor**, cap 1.5 MFD, 117 V, 60 Hz phase 1, 25 W, 600 rpm, hysteresis synchronous cart motor, \$125; patch bay, \$75; Spotmaster TP1-A cart winder, \$200; ADC patch cord, stereo (2), \$10 ea. S Dynes, Dynes Prod, Wheeling WV 26003. 304-233-8856.

**Executone Equity-1 telephone key system**, 30 phones, KSU's, KTU's, etc, \$1800. A Allegra, Calvary Baptist, 1360 Valley Forge, Lansdale PA 19446. 215-368-4444.

**Ampex motor for an Ampex R-R hyst syn 77**, cont VF-5.0 PH1, 0.4 Amp, 60 Hz, 117 V, \$45; ADC PJ 22 patch cord wire assembly, stereo, \$10; Weston 308 amp meters (2), \$5 ea; table mount goose-neck, \$15; EV 1-666, \$10. S Dynes, Dynes Prod, Wheeling WV 26003. 304-233-8856.

**Audion Proxima 6 rare near-field tower monitor** (2), excel cond, without EQ or subwoofer module, will include EQ schematic, \$395/BO plus UPS. V Gray, GCA, 6840 Sterling, Raytown MO 64133. 816-358-8929.

**CPT 8520 word processor w/monitor**, (2) built-in 8" disk drives, keyboard, program & utility disks, (5) extra disks, user's manual, letter quality printer, (5) extra print wheels, muffler hood w/fan for printer, \$350/BO. R Woolfenden, WFAX, 18322 Cabin Rd, Triangle VA 22172. 703-221-2742.

**WE modern style portable magneto phones** (2), \$100/pr; wall phone, red, single number dialer, new, \$50. E Davison, 217-787-0800.

**WE 111C repeat coils**, \$25 ea; 120H, \$15 ea; 23A 5 kHz EQ, \$25. E Davison, 217-787-0800.

**TIE/GTE 60012G office telephone system**, 4 incoming w/7 stations & KSU, \$2500. J Brown, Joyner Comm, 2000 Regency Pkwy Ste 450, Cary NC 27512. 919-469-8383.

**Want to Buy**

**NBC Hotline decoder unit**. J Haynes, Haynes Bdct Svcs, 81 Knox, Millinocket ME 04462. 207-723-9190.

**Equip necessary for construction of upgrade to 5 kW AM daytime directional on 1380 KHz** including Continental/Harris 5 kW xmtr, 5 kW 2-tower phasing unit in cabinet & antenna tuning units, 180' guyed tower, 16-20" face, (2) tower phase monitor, Delta CPB-1 common point bridge, Delta OIB-1 operating impedance bridge, 5 or 10 kW AM dummy load, (2) Delta TCA-10 & TCA-20 RF ammeters w/current transformers, etc, if you have any of the equip needed for this upgrade call between 8:30AM & 10PM, leave name, number, equip description & asking price. 512-696-5615.

**Early WWII vintage radar equip**, complete systems and/or pieces. A Weiner, 14 Prospect Dr, Yonkers NY 10705. 914-423-6638.

**Blind & paralyzed young man** would like donations of any receiver or word processor, call or write R Les, 5909 W 6th St, Apt 1, Los Angeles CA 90036. 213-938-5347.

**WE, Attec, RCA speakers**; old mics, tube mixers, consoles, limiters, amps, 16" transcriptions, on-air lights, blank recdg discs, bdct/recdg catalogs, magazines, manuals, mic flags. R Van Dyke, Caffrey House, 2 Squires Ave, E Quogue NY 11942. 516-728-9835.

**Jazz record collections**, 10" LP/12" LP bebop, swing, dixie, highest prices paid. B Rose, Program Recdgs, 228 East 10th, NYNY 10003. 212-674-3060.

**MONITORS**

**Want to Sell**

**McMartin TBM 2000A SCA monitor** for 67 kHz, \$400. J Littlejohn, WYSY, POB 2010, Aurora IL 60507. 708-851-4600.

**TFT 760 AM EBS rcvr/decoder/gen**, BO. B Webster, WLIT, 150 N Michigan, Chicago IL 60601. 312-329-9002.

**McMartin tuner mdl TR-55 SCA**, \$50; Marti PGM 20H program line amp, \$65; RCA AM mod mon, \$100; TFT 713 AM freq & mod mon, \$750; TFT EBS rcvr w/FM rcvr, \$325; TFT 704A remote meter, \$50; Pletron FM rcvr 155.49 MHz, \$35. E Moody, KJEM, 216 N Main, Bentonville AR 72712. 501-273-9039.

**Harris FT-80 FM mod mon**, 104.9 MHz, \$450; Harris FS-80 FM stereo mod, 104.9 MHz, \$450. R Coleman, WGEN, Box 67, Geneseo IL 61254. 309-944-4633.

**TFT 730A SCA subcarrier mod mon**, \$900/BO. D Lerner, 115 W 23rd, NYNY 10011. 212-463-0798.

**McMartin TBM-3500 FM**, cond unknown, \$50; Gates GTM-88F freq, cond unknown, \$125. C Sigmon, WBZK, POB 398, York SC 29745. 803-684-4241.

**Modulation Sciences Mod-Minder**, used 2-3 hrs, complete w/software, BO. H Plumlee, WGAP, POB 4939, Maryville TN 37802. 615-983-4310.

**Belar SCM-1 SCA mod mon**, 92 kHz, excel. M Persons, KTLF/KFML, 70 N.E. 1st Ave, Little Falls MN 56345. 218-829-1326.

**QEI 675T200 RF & SWR monitor & PA** voltage & amp monitor, fwd & rev SWR switch, 19" rack mount, 3" high, translator & up to 200 W use, \$125. S Lawson, KAK Prod, 928 Hyland, Santa Rosa CA 95404. 707-528-4055.

**Want to Buy**

**BE/C-QUAM AM10K** prefer 1982 or later. R Payne, 774 Roswell St, Marietta GA 30060. 404-424-9850.

**Any older McMartin mod monitors**. C Goodrich, 11435 Manderson, Omaha NE 68164. 402-493-1886.

**MOVIE PROD EQUIP**

**Want to Sell**

**Nagra III internal xtal, rolloff filter**, Sennheiser 805 w/KAT 15, leather case, ATN pwr supply, excel cond, \$1350; & new Bell & Howell 70 DR w/Anvil case, 1" Comat, instructions, \$325. J Kreines, 5330 Kennedy Ave, Millbrook AL 36054. 205-285-6179.

**Nagra III, internal xtal, roll-off filter**, Sennheiser 805 w/KAT 15, leather case, ATN pwr supply, excel cond, \$1350; New Bell & Howell 70 DR w/Anvil case, 1" Comsat, instructions, \$325. J Kreines, DeMott/Kreines Films, 5330 Kennedy, Millbrook AL 36054. 205-285-6179.

**Want to Buy**

**Mitchell 35 & 16mm cameras & accessories**, other professional 16/35mm cameras, incl Arriflex, Aaton, CP, etc; optical printers, Research Products 1000, 1001, & Acme & Oxberry; cine lab equipment; upright Moviolas, especially 35mm. Westrex 35mm; optical recorders, & RCA & Maurer optical recorders; CP16s any condition; good cine optics (Zeiss, Ultra-T, Angenieux, Cooke, etc); also need Zeiss 9.5mm Distagon, reasonable, need not be mechanically mint. J Kreines, DeMott/Kreines Films, 5330 Kennedy Ave, Millbrook AL 36054. 205-285-6179.

**Mitchell 35 & 16mm cameras & access**, other prof 16/35 mm cameras, incl Arriflex, Aaton, CP, etc; optical printers, esp Research Products 1000, 1001, Acme & Oxberry; Cine lab equip incl ultrasonic cleaner; small to medium size 16 or 16/35mm processing machines; upright Moviolas, especially 35mm; Westrex 35mm optical recorders, RCA & Maurer optical recorders; CP16s any cond; Steenbecks; gd cine optics; Zeiss 9.5mm Distagon, will consider any film equip. J Kreines, DeMott/Kreines Films, 5330 Kennedy, Millbrook AL 36054. 205-285-6179.

**RECEIVERS & TRANSCEIVERS**

**Want to Sell**

**Moseley RPL-2 RPU rcvr** tuned to 161.67 & 161.76; McMartin EBS AM rcvr tuned to 760, tone gen & tone decoder. E Neaman, KUMU, 441 N Nimitz Hwy, Honolulu HI 96817. 808-531-4511.

**AM STEREO RECEIVERS**  
Portable, Home/Studio, Auto  
**RRADCO GROUP**  
708-843-8481

**McMartin EBS system w/AM-R1 AM rcvr**, EBS-2 monitor & TG-2 EBS 2 tone gen, as is, \$200. C Haynes, WJMI, 1850 Lynch, Jackson MS 39203. 601-948-1515.

**Inventory Clearance**  
**ELECTRO VOICE**  
Sentry 100 Studio Monitor



Spec. \$195. CWO  
While they last

**NORTHEAST BROADCAST LAB**  
(518)-793-2181/(215)-322-2227  
(603)-483-1002/(214)-612-2053

**Heathkit HW 100 10-80 M SSB xcvr** 100 W, \$125. A McCartry, 600 E Main, Valaville CA 95660. 707-446-0200.

**Dynakit FM-3 tube tuner**, \$100; Pilot 380 tube stereo tuner, \$90; MacIntosh MR71 stereo tube tuner in Panloc case, near mint cond, \$400; Knight KN 2560 tube CB, excel, \$75; Gonset communicator III orig manual & bill of sale, nice, works, \$65. Kremer Kraft, 301 SW 16th St, Ft Lauderdale FL 33315. 305-524-5652.

**Hammarlund VHF transceiver**, 35 W, cond unknown, \$50. C Sigmon, WBZK, POB 398, York SC 29745. 803-684-4241.

**Two-way radio**, hand-held & mobile UHF radios for shows or remotes, can put on your freq, Icom, Motorola, GE, some fancy, some simple, from \$175. R Nelson, Tropical Bdctg, 14093 SW 142, Miami FL 33192.

**Motorola Micor FM 2-way transceiver** less accessories, mdl T43RKA1900AA, 162-174 MHz, 12 VDC, \$150. B Dickerson, WEAG, 1421 S Water, Starke FL 32091. 904-964-5001.

**GE Phoenix SX & GE MPI hand-held**, hand-held charger stand & belt case, one has mobile mike & one has base mike, dual freq, 460-470 UHF, \$1600/BO. T Trotzer, KGY, POB 1249, Olympia WA 98507. 206-943-1240.

**Swan 240 rcvr** for SSB, covers 75, 40 & 20 meter band power of 200 W, complete w/DC mobile & AC pwr w/Hustler mast, spring & resonators, for 40 & 20 meters, \$175/BO. T Spencer, WODY, Box 545, Bassett VA 24055. 703-629-2509.

**McIntosh MR-65B tube stereo tuner**, mostly new tubes, tuned up, works well, \$150. P Wells, KJOY, 625 B'way, San Diego CA 92101. 619-238-1037.

**Scientific Atlantic decoder 7300** wideband BPSK rcvr, excel cond. L Popp, 814-467-7894.

**Motorola VHF radios**, EBS 15 W Moxly base PL, one 15 W Mocom 35 busy, (3) HT210 5 W hand-helds wchargers, PL, like new, \$100 ea. P Russell, Bowdoin College, Sills Hall, Brunswick ME 04011. 207-725-3066.

# EMPLOYMENT

To place ads in this section, use the ActionGram form. To respond to box numbers, write Radio World, PO Box 1214, Falls Church, VA 22041, Attn: \_\_\_\_\_

**HELP WANTED**

**Field Service Engineer**, creative & challenging work available for those rare individuals who possess the skills & talents necessary to become part of a great team. Must have experience in AM, FM, microwave & TV. We will train the right individual. Salary depends on experience. Send resume & salary history to: Tom Oja, ACM Communications, POB 6926, Napa CA 94581.

**CHIEF ENGINEER- AM-FM** combo in New Jersey is looking for roll-up-the-sleeves type. First Class. SBE Cert. RF & studio design, engineering & maint. exp. EOE. Send resume & salary history to: **Radio World, PO Box 1214, Falls Church, VA 22041. Attn: 90-10-02 RW.**

**Warm water, sand, sun, palm trees**, take charge engineer, 3 powerful FM's in Virgin Islands, re-location assistance, salary, tremendous benefits, commensurate w/exp. Fax 809-775-6063.

**Retired or Semi-retired salesman**, wanting the challenge of getting clients for very small market in Southwest Arizona. B Burdette, Quartzsite AZ. 602-927-5111.

**Metroplex Robinson Communications, Inc.** is seeking a qualified technical director for WUFX/WXBX, Buffalo. Strong studio construction and transmitter maintenance skills a must. Minimum 5 years broadcast technical experience and SBE certification required. Contact Dennis Sloatman at (407) 298-5510, or send resume to: Metroplex Communications, Inc., 2001-N. Mercy Drive, Orlando, FL 32808. Equal Opportunity Employer.

**POSITIONS WANTED**

**Engineer 20 yrs AM, FM, satellite**, automation, bubble gum, baling wire. P Morton, POB 57, Rupert VT 05768. 802-394-2858.

**Operations/Production Mgr** currently employed, seeks challenging new pos, will relocate, extensive travel ok. D Smith, POB 11902, Baltimore MD 21207. 301-591-2128.

**Producer/Engineer w/radio prod/prog exp**, former recording studio owner, seeks program/engineer position. Z Nicall, 6404 Hollywood Blvd 4th flr, Hollywood CA 90028. 213-464-2145.

**27 yr bdctr** looking for mgmt/buy in option. Owner/mgr, sales, announcing, production, contract & consulting firm partner positions. Bosch 3-D DVE, self employed MATV. AJ Anello, 813-933-6009.

**30 yr veteran in radio engineering & equipment sales** seeks agreement w/orgazation to provide field sales &/or engineering support on an expense plus basis. L Darrigo, 803-650-3466.

**27 yr bdctr** looking for mgmt/buy in option. Owner/mgr, sales, announcing, production, CE experience, great turnaround record, prefer NC-SC-VA areas. B Hull, POB 741, Mt Airy NC 27030. 919-786-4675.

**DOE, CE, 29 yrs** exper in station, corporate, contract & consulting firm partner positions. Texas, Louisiana, Oklahoma preferred. Right offer other areas possible. Reply to Radio World, POB 1214, Falls Church VA 22041. Attn: Box 90-08-04RW.

**Chief Engineer/Assistant chief** seeks pos w/major Southeast radio station, FCC general/first class license, SBE certification, amateur EXTRA license, 14 yrs of radio & TV bdct engineering exper, excel ref, quality workmanship, hardworking & hands-on, exper in all aspects of AM/FM radio engineering. H Ginsberg, 12 Beech St, Essex Junction VT 95452. 802-878-8796.

**CE/Asst CE, SBE, FCC, Asst CE** in LA for 2 yrs, seeks position on West Coast but will consider all. T Brooks, 7201 Haven Ave, Ste E-333, Rancho Cucamonga CA 91701. 818-574-7053.

**Ten year satellite TV/C/Ku TVRO technician** seeks FT or consulting position in mid-Atlantic area, experienced Unistar, Comtech & Tridom VSAT installer. M Comer, Box 1285, Colonial Beach VA 22443. 804-224-9711.

**News reporter** in mkt 192 seeks move up, 2 yrs exper in AC/News talk, strong anchor skills, conversational, East Coast but will consider. Matt, 919-452-1133.

**Eleven year pro** seeking work in Midwest'n, solid background in news, sports (P-B-P) & programming. Sam, 218-894-3395.

**Radio Vet w/22 yrs exper**, seeks on-air w/C&W or AC in South Georgia, gd references. B Rachels, 516 Colton, Thomasville GA 31792.

**Dedicated air talent/production specialist** seeks challenging position, 5 yrs exper including ops mgmt, team worker, eager learner, gd communicator. Randy 919-842-7635.

**Looking for PT engineering work** in the greater Mobile AL area. C Strozler, 205-928-9406.

**Sports anchor/PBP w/16 yrs** exper in small mkt seeks position in medium or major mkt in Texas, sports pro. D Blanton, 817-665-0765.

**17 yr vet** has high-tech system for new FM's, save money, make money, dominate market, gain national recognition, reduce overhead, much more. Joe 517-379-4803.

**Bdct eng would like to do repair & new work**, FM only in NW Virginia area, 25 yrs w/FM sta's. V Pat, Box 232, Weyers Cave VA 24486.

**CE/Asst CE, FCC general, ham, ASEE**, non-drinker, nonsmoker, heavy theory, former CE Boston, Houston, Miami, Ft Lauderdale, avail now. M Gottesman, 3377 Solano Ave, Ste 312, Napa CA 94558. 415-221-2000 X11.

**Dedicated announcer**, 7 yrs exper seeks medium/large market challenge, creative, prefer oldies/classic, AC, jazz, also interested in music/promotions/production director position, relocateable. Phil, 6773 Mara Ave 29, Palms CA 92277. 619-367-3731.

**Audio engineer w/4 yrs** exper seeking position in Eastern Ohio or Western PA, serious inquiries only. M Anderson, 412-847-0111.

**Engineer/Newsman/GM w/20 yrs** exper in all areas of radio, seeks Florida position, gd references. Bill, 803-245-4902 (PM) 245-2411 (days).

**Dedicated pro** seeking air/MD position, country & proud of it, will consider all offers. Bryan, 904-478-5321.

**Energetic, reliable PD/AT** seeks position, AM/FM oldies/classic rock in Southern coastal/FL region. Todd, 919-455-2202/6000.

**Entry level position w/community based AM or FM bdctr**, prefer family minded station, willing to learn your way of doing things, some prior exper. Looking for rural area, CO, WY, NC, KY, WV, but open. Steve, 1240 Riverbreeze Blvd, Ormond Bch FL 32176. 904-441-6956.

**Experienced & reliable sportscaster/announcer** seeks sports director position in IA, IL, or WI, football, basketball, baseball PBP, production, will relocate. Robert, 319-652-6640 or 319-242-1252.

**Have a construction permit?** I will get you on the air...construction/hiring/training air & sales staff/programming. Will do programming changes for existing stations. Ritchey Communications, 512-828-9252.

# EMPLOYMENT SECTION

**HELP WANTED:** Any company or station can run "Help Wanted" ads at the flat rate of \$25 per listing per month (25 words max). Payment must accompany insert; **there will be no invoicing.** Blind box numbers will be provided at an extra charge of \$5. Responses will be forwarded to listee, unopened, upon receipt. Call 800-336-3045 for display rates.

**POSITIONS WANTED:** Any individual can run a "Position Wanted" ad, FREE of charge (25 words max), and it will appear in the following 3 issues of Radio World. Contact information will be provided, but if a box number is required, there is a \$5 fee which must be paid with the listing (**there will be no invoicing**). Responses will be forwarded to the listee, unopened.

Mail To: **BROADCAST EQUIPMENT EXCHANGE**  
PO Box 1214, Falls Church, VA 22041



**RECEIVERS . . . WTS**

**Bogen TP200** digital tuner, AM/FM mono/stereo, new, \$200; Bogen TP50 mono AM/FM tuner, new, \$100; 450 MHz mobile RF amp, TPL mdl UD-GAC-7, 15-45 W, \$100. E Davison, 217-787-0800.

**High quality micro-miniature 67 kHz SCA decoder**, about 1" square, prewired & ready to install, \$15. D Jackway, 5742 Fairoak, Springfield MO 65810. 417-881-1846.

**Want to Buy**

**Fairchild Dart 384** satellite receiver w/15 kHz card & down converter. P Reilly, KGRC, POB 1017, Hannibal MO 63401. 314-221-2221.

**REMOTE & MICROWAVE EQUIP**

**Want to Sell**

**Scientific Atlanta 7.5 kHz** dual audio decoder card for CBS, NBC, ABC mainframe rcvr/demod, excel cond, \$500. H Ginsberg, Communications Eng Inc, 12 Beech St, Essex Junction VT 05452. 802-878-8796.

**Macom 23 GHz audio/video link w/Macom MA-2300** xmtr w/dish, Macom MA-2300 rcvr w/dish, dbx digital audio processor system, \$6000 package. C Hall, WZOU, 235 Bear Hill, Waltham MA 01254. 617-290-0009.

**TFT 7601-C & 7601-R** digital remote control for AM, FM & TV xmtrs w/10 chnl of raise/lower or off control & display of telemetry from a remote site w/manual, \$1500/BO. J Strong, WXF, 120 Wildwood Dr, Mt Zion IL 62549. 217-864-4141.

- NEW AND USED -  
Satellite Receive Only  
**ANTENNAS**  
PLUS! Receivers/Demodulators

- Wegener
- Fairchild
- Harris
- Scientific-Atlanta
- Microdyne
- Avcom
- Prodelin

**For ALL Network Affiliations**  
**WE BUY • SELL • TRADE**  
Flexible Lease Financing!  
**TELCOM GROUP INTL**  
PH. (505)883-4737 FAX (505)889-0078  
**OVERNIGHT DELIVERY AVAILABLE**

**Moseley MRC-1600** in excel cond, \$2500. B Williamson, WALL, One Broadcast Pl, Middletown NY 10940. 914-343-7400.

**Marti RMC-2** remote control system, \$950. C Haynes, WJMI, 1650 Lynch, Jackson MS 39203. 601-948-1515.

**Moseley MRC 1600** 4 yrs old, includes cards for both subcarrier or telephone line operation, \$2200. R Watson, WXCO, POB 778, Wausau WI 54401. 715-845-8218.

**Henry Network Commander** currently configured for Drake Chenault, 6 mos old, new cond, \$700. B Downs, KTSR, Box 3248, Bryan TX 77805. 409-846-1150.

**Stationmaster PD-455** 450 MHz fiberglass co-linear, new, in original carton, \$465. D Eressy, WFCC, POB 1308, W Chatham MA 02609. 508-945-4855.

**Moseley TR-55A** telemetry rcvr, \$50. C Hall, WZOU, 235 Bear Hill, Waltham MA 02154. 617-290-0009.

**Wegener 1806-24** stereo rcvr w/tone decoder, 6 mos old, comes w/Henry Eng Net-Commander set for Drake Chenault, avail as package or separate, \$1900. B Downs, KTSR, Box 3248, Bryan TX 77805. 409-846-1150.

**Marti RMC-2AX** dial up type remote control unit, works w/phone line or SCA, complete studio/xmtr units w/manual, \$495. J Moore, KENO, Box 388, Roswell NM 88201. 505-625-2098.

**Rust 108-1C & 108-0C** studio & transmitter remote control units w/manuals, \$500. A Garza, Foster Comm, 2824 Sherwood Way, San Angelo TX 76901. 915-949-2112.

**Wilburt 7-30-357/367 35'** heavy duty telescoping mast w/12 V compressor, braces for rear bumper installation, video showing mounting & operation avail, all in gd cond, \$3000. B Peretic, WYED TV, 919-553-1700.

**Harris 6550** satellite rcvr chassis w/PS & down converter, no demod cards, mint cond, \$400. H Widsten, KGNB, 1540 Loop 337 North, New Braunfels TX 78130. 512-625-7311.

**Burk TC-8** remote control w/dialup & voice (2), wire modem, excel cond, 1 yr old, \$2000/BO. M Black, WEOS, Hobart College, Geneva NY 11436. 315-781-3456.

**Microdyne/Scientific Atlanta 5 meters** satellite receive antenna (3), one w/dual feed, one w/two simulat dual feeds & one S/A Cassegrain dual feed, \$1000/BO. M Comer, Box 1285, Colonial Beach VA 22443. 804-224-9711.

**Silver Lake Audio**

now has available for rental:  
**3-LINE COMREX**  
2-LINE COMREX • PORTABLE DAT  
plus much more at reasonable rates!  
Call Steve for details  
**(516) 623-6114**

**ABC Network decoder**, excel cond, \$200; interface for Revox deck for auto rec w/above, \$100. M Black, WEOS, Hobart College, Geneva NY 11436. 315-781-3456.

**Anderson satellite switchover**, works w/any satellite music network format, like new cond, \$200. B Hearst, WWCH, POB 688, Clarion PA 16214. 814-226-8600.

**Wegener 1806-03** Ku-Band downlink incl dish, excel cond, BO. J Bartels, KANO, 100 E Main, Anoka MN 55303.

**Symetrix TI-101 (2)** telephone interface/hybrids, like new, \$450/both or \$250 ea. M Holderfield, WOOF, POB 1427, Dothan AL 36302. 205-792-1149.

**Marti SGC-10** 92 kHz SCA gen, excel; Marti R30-150 RPU rcvr, \$200. M Persons, KLTF/KFML, 70 N.E. 1st Ave, Little Falls MN 56345. 218-829-1326.

**ABC Network tone decoder**, \$200. M Holderfield, WOOF, POB 1427, Dothan AL 36302. 205-792-1149.

**Wegener gear** for Transtar/Unistar oldies chnl, will work for AM only & Format 41 w/minor changes, \$3500/BO. M Wilson, WGRK, POB 246, Greensburg KY 42742. 502-932-7402.

**Symetrix TI-101** telephone interface, new, BO. H Plumlee, WGAP, POB 4939, Maryville TN 37802. 615-983-4310.

**Wegener 1606** sat rcvr for SMN Star station, 1606-10 down converter, 1606-01 wideband demod, 1645 & 1646 tone decoders, 1605-03 pwr supply, 1601 main frame, \$1500. J Macke, KRBS, POB 5180, Roseburg OR 97470. 503-672-6641.

**Moseley TRC-15** system for studio & xmtr, excel cond; 10 channel master satellite dish, vgc. L Popp, 814-467-7894.

**Comrex LXT, LXR, TCB** single line extender package, \$4500. J Gennaro, WFHR, Box 8022, WI Rapids WI 54495. 715-424-1300.

**Burk Technology TC8** remote control system w/radio modem uplink & telemetry return, perfect cond, \$1800. Mary Clites, WCBC, POB 1290, Cumberland MD 21502. 301-724-5000.

**Tei-E-Mote Mark 60** remote phone, \$35. S Dynes, Dynes Prod, Wheeling WV 26003. 304-233-8856.

**Symetrix TI-101 (2)** telephone interface/hybrids, like new, \$450/both or \$250/ea. M Holderfield, WOOF, POB 1427, Dothan AL 36302. 205-792-1149.

**Want to Buy**

**Any FSR, Gentner, Telos**, telephone hybrid coupler, gd quality, donations acknowledged. A Allegra, Calvary Baptist Church, 1380 Valley Forge, Lansdale PA 19446. 215-368-4444.

**Satellite uplinks**, modulator, HPA, 2° compliant antenna, prefer K-band. U George, U.G. Satellite TV, 314 W 52 St, Nyny 10019. 212-677-2200.

**Rust Series F mdl RI-108** needed for parts, any cond. J Goeman, KJAM, 1015 Eagan, Madison SD 57042. 605-256-4514.

**STATIONS**

**Want to Sell**

**BROKER**

AM AND FM RADIO STATIONS  
HAVE BUYERS AND SELLERS  
FINANCIAL PACKAGE AVAILABLE

**1-813-747-7373**

ALL INFORMATION  
CONFIDENTIAL

**LPTV 1000 W Goleta**, Santa Barbara CA, trade, sell, or take partner, BO. G Erway, 3450 SE Martinique, Stuart FL 34997. 407-283-6871.

**Class IV AM** for sale in SW Oregon. Fast growth area. Joint venture. Active/inactive. \$10K min. M. Gottesman, 3377 Solano Ave., #312; Napa, CA 94558. No calls.

**AM/FM station**, 10,000 W AM, Class A approved for Class C FM, western resort area, gd market, popular program & community reception, priced to sell, terms & information on request. J Gayer, West Engineering, 815 Reed St, Lakewood CO 80215. 303-233-8433.

**AM daytimers (2)**, WFIC, Collinsville-Martinsville VA, 1 kW & WPUV, Pulaski VA, 5 kW, includes real estate, owner financing. L Williams, Rt 1 Box 314, Wirtz VA 24184. 703-647-1530.

**CENTRAL ILLINOIS**  
**\$149,000**  
**414-482-1959**

**Class B FM**, northern California, gd revenue, 3 large county coverage area. R Trumbo, KNLF, POB 117, Quincy CA 95971. 916-283-4144.

**AM / FM / TV BROADCAST OWNERS SELLING? BUYING?**

Let our network of brokers assist you in acquiring or divesting your AM/FM/TV or cable properties.

- Your transaction given professional discreet attention.
- Broadcast Brokers experienced in appraising, negotiation and financing your station.
- We have lenders with loan portfolios up to \$500,000,000.00.

- + FCC Licensed Engineers
- + Brokers Licensed by State R.E. Commissions
- + Graduate Appraisers
- + Certified Public Accountant on Staff
- + Member, Society of Broadcast Engineers

May We Have the Opportunity to Assist You? Call for a Confidential Discussion of your Transaction Needs

**THE JESSE NEAL BROWDER COMPANY INC.**  
BROADCAST BROKERS/APPRISERS  
202 Whittlewood Ct.  
Woodstock, GA 30188  
**404-928-7906**  
SPECIALIZING IN THE SOUTHEAST

**Combo AM/FM & stand alone FM stereo**, Class A, some financing avail to qualified buyer, real estate included, \$925,000. G Shurden, 601-843-4091.

**Upper Midwest FT AM w/FM** possibility, owner financing, gd stable medium market, must be financially qualified before any information is released. 1-404-460-6159.

**BROADCAST APPRAISALS**

- FOR ANY PURPOSES
  - + PRESENT VALUE
  - + LOAN VALUE
  - + TAX VALUE
  - + ESTATE TRANSFERS
- Graduate Appraiser  
FCC License # PG-6-3024  
Georgia Real Estate Broker  
License #134955  
SBE Certified Senior Broadcast Engineer

**THE JESSE NEAL BROWDER COMPANY INC.**  
**404-928-7906**  
SPECIALIZING IN THE SOUTHEAST

Looking to buy w/nothing down, also consider becoming GM for equity & future ownership. L Haber, POB 136, Woburn MA 01801. 617-246-5634.

**FM Class A Oklahoma** single market, nearly new equip, long lease on studio & xmtr tower needs owner-operator & sales exper, less than \$100,000 to qualified w/low down, \$99,500. Joyce Erway, KRMK, Cordell OK 73632. 407-283-6871.

**AM and/or FM** radio stations for sale in central Arkansas or will sell percent to active working partner. Vivian, 501-420-1525 or 501-568-5448.

**Investors for new FM** stations in Midwest & West Coast, must have minimum of \$50,000 cash investment. Dale, 1-715-836-9476.

**Want to Buy**

**LPTV or small market AM**, dark or troubled OK, owner financing w/little or no down. B Turner, 1000 E Third, Del Rio TX 78840.

**CP's, turn arounds & dark stations**. L Fuss, KOOZ, POB 159, Fayetteville GA 30214. 404-460-6159.

**Distressed, failing or dark station**. Low cash price, take over or little cash down. AM or FM anywhere. Must have real estate included. Answers confidential. Private buyer for own operation and ownership.

B. Bridges, 827 Meridian St, Nashville, TN. 37207  
615-226-1122, FAX #615-227-1268

**AM, FM or LPTV** problem stations, turn arounds, daytimers, dark, etc, send complete details w/price & terms. J Powley, 1536 Logan Ave, Altoona PA 16602. 814-944-8571.

**AM, FM or TV**, problem stations, turnarounds, daytimers, dark, etc, OK, bdctr seeking new challenge, send complete details w/price & terms. J Powley, 1536 Logan Ave, Altoona PA 16602. 814-944-8571.

**AM or FM**, little or nothing down, prefer Southeast, consider any, 20 yrs exper. J Dalton, 703 N Webster, Taylorville IL 62568. 217-824-7342.

**Joplin MO super A FM**, \$290,000 firm. D Stubblefield, 417-781-1100.

**FM or AM/FM**, previous ownership & turnaround expert, looking for owner-financed turnaround in MW or South, successful husband/wife team. B Kramer, American Forces Network-Europe, APO New York 09757.

**AM or FM**, Midwest-California-Nevada only, owner financing, small down. D Ganske, 1-715-832-0691.

**STEREO GENERATORS**

**Want to Sell**

**CCA FM 10DS** working when removed from service, \$300/BO. J Stack, WMPO Radio, 614-992-6485.

**Harris MS-15R** digital stereo gen w/overshoot control, \$800; BE FC-30 SCA gen on 67 kHz, \$350. J Littlejohn, WYSY, POB 2010, Aurora IL 60507. 708-851-4600.

**Moseley SCG-9** stereo gen, \$500. R Coleman, WGEN, Box 67, Geneseo IL 61254. 309-944-4633.

**SWITCHERS (VIDEO)**

**Want to Sell**

**Arrakis router switcher**, 16 stereo in, 8 stereo out, rack mount, includes power supply & connectors, 5 yrs old, \$800. D Doelitzsch, WDDD, 1 Broadcast Ctr, Marion IL 62959. 618-997-8123.

**TAPES, CARTS & REELS**

**Want to Sell**

**Sound Ideas Series 1000** sound effects pkg on reels, 71/2" ips, excel cond, \$550/BO. T Keenan, 11105 Knott Ave, Cypress CA 90630. 714-892-9469.

**A&D**  
**Cartridge Rebuilding Service**

We clean, load & pack. Serviced within 10 work days! Work guaranteed!

3380 Makely Ave., Eau Claire, WI 54701  
(715) 835-7347

**Metal reels 10" (60)**, \$60. J King, POB 2308, Roswell NM 88201.

**Easy listening music**, 250 reels, all vgc, no duplicates, \$10/reel or BO. J Wenstrom, Wynne Bdcg, 1338 Oregon, Klamath Falls OR 97601. 503-882-4656.

**Metal reels & boxes**, (28) 14" in perfect cond, \$140. H Widsten, KGNB, 1540 Loop 337 North, New Braunfels TX 78130. 512-625-7311.

**Complete nostalgia/big band format w/2760** stereo cuts on 129 metal reels of Ampex 406, includes 10 reels of big band era Christmas music, comes w/extensive reel sheets, artist, title separation schedules, runs on (3) 10.5 machines, in perfect cond, \$30/reel or trade for equip. S Callahan, WFTI, 1120 Pinellas Bayway, Tierra Verde FL 33715. 813-866-3544.

**Fidelipac carts (580)**, all lengths & conds, extra shells & parts, tape in gd to poor cond, most shells are usable, gray carts, \$500/all. H Widsten, KGNB, 1540 Loop 337 North, New Braunfels TX 78130. 512-625-7311.

**Easy Listening music library**, new, 113 instrumental, 88 vocal, \$1000; Beautiful music library, older, 129 vocal/instrumental, \$200. R Coleman, WGEN, Box 67, Geneseo IL 61254. 309-944-4633.

**MARATHON PRODUCTS COMPANY**

**Audio Cartridge Rebuilding Division**

Rebuilding/reloading, like new, all brands, any length up to & including 2.5 minutes, \$1.50 ea. FOB our plant, 48 hrs delivery.

**New NAB Marathon cartridges prices on request.**

*35 Years professional experience!*

Lifetime member AES R.D.MYERS Sr.

Manufacturers of Audio Devices, Continuous Tape Mag.

**69 Sandersdale Rd.,  
Charlton, MA 01507**

**1-508-248-3157 or 1-508-853-0988**

**ABCO wire cart racks (3)** on floor stands, holds 500 carts ea; (342) Capitol A-2 carts in fair to gd cond; (36) Capitol A-2 carts, new; (1178) Scotchcart II's in gd cond, containing adult poplite jazz library well recorded in stereo; (143) Scotchcart II's, new, all 3.5 or longer; one set of LEL alignment gauges for Ampro cart decks. P Wells, KJQY, San Diego CA. 619-238-1037.

**AC vocal CD library**, great variety of artists, many are Greatest Hits albums; new NAC instrumental CD library, light jazz & new age artists, sold as libraries not individual discs, half price. Nancy Grubbs, KAT-G, 3910 IH 35 South, Ste 300, Austin TX 78704. 512-448-0947 or fax 512-440-0947 for lists.

**Nortronics 9125, 9102, 9103 (2)** complete sets, play, record, erase, mono for Ampex 350-351, new. D Agnes, WCLV, 26501 Emery Ind Pkwy, Warrensville OH 44128. 216-464-0900.

**Fidelipac gray cart shells (170)** w/complete cart except tape & pressure pad, \$1.25 ea or \$200/all. S Dynes, Dynes Prod, Wheeling WV 26003. 304-233-8856.

**Video cassettes**, (100) 3/4", various lengths, \$3 ea/BO. D Staats, WRZZ, POB 1346, Parkersburg WV 26102. 304-863-3319.

**Easy listening music**, 250 reels in vgc, no dupes, \$10 ea; production library w/SFX, mostly unopened, \$250. J Wenstrom, Wynne Bdcg, 503-882-4656.

**Scotchcart Big Band/Nostalgia**, complete, stereo, 1500 units plus software to rotate, \$7500/BO. W Schroeger, WRCH, Radio Park, Farmington CT 06034. 203-678-9100.

**Want to Buy**

**Scotch/Ampex/Agfa 1"** wide audio tape used once & bulk erased, either reels or hubs, boxed or un-boxed. T Houston, Custom Audio Recording, 929 California Ave, Bakersfield CA 93304. 805-324-0736.

**Classical record library** on 78 rpm classical records, pre-recorded R-R tapes, air-checks, etc. D deForrest, 7441 Wayne Ste 10-D, Miami Bch FL 33141.

**Blank, small hole recording discs**, 10" & smaller, used in 1940's & 50's, aluminum, glass or cardboard base OK. T Edwards, KOZY, Box 597, Grand Rapids MN 55744. 218-326-3446.

**Sound effects CD library**, call w/list & price. L Beigel, On-Cue Record, POB 85042, Los Angeles CA 90072. 800-726-9813.

**FINEST REBUILT TRANSMITTERS**

FM TRANSMITTERS			AM TRANSMITTERS		
1 kW	Gates	FM1B	250W	RCA	250GL
1 kW	ITA	1000B	1 kW	Gates	BC1F
1 kW	RCA	BTf1D	1 kW	Gates	BC1T
1 kW	Collins	830D1	1 kW	Gates	BC1J
1 kW	RCA	BTf1E	1 kW	CCA	1000D
1 kW	Harris	FM 1H	1 kW	Collins	20V2
2.5kW	Collins	831D1	1 kW	Collins	820D1
2.5kW	Continental	814R2	1 kW	McMartin	BF-1K
3 kW	RCA	BTf 3E	1 kW	Harris	MW-1A
3 kW	G.E.	3KW	1 kW	Bauer	707
3.5kW	B.E.	3.5A	1 kW	Gates	BC-1G
3.5kW	McMartin	BF 3.5K	5 kW	Gates	BC5E
5 kW	RCA	BTf-5D	5 kW	RCA	BTAS7
5 kW	RCA	BTf-5E	5 kW	Collins	21E
10 kW	RCA	BTf10D	5 kW	RCA	BT-5L
10 kW	Gates	FM10B	5 kW	Harris	BC-5H
1					



## TRANSMITTERS! TRANSMITTERS! TRANSMITTERS!

### AT LAST!

**Quality Rebuilt AM & FM Transmitters Delivered, Matched To Your Antenna, and Placed On The Air. And, For No More Than You'd Pay For a Transmitter In Pieces From The Other Guys.**

When you buy a BTS transmitter, we deliver it on our company truck. We place it in your transmitter building. And, the *very best* transmitter engineer in America places it on the air for you. When we're finished, you know how it will sound because it's On the Air. No other way of buying a used transmitter makes sense. Overseas and Alaskan/Hawaiian services are available, too!

**We'll take your old transmitter and other broadcast gear in trade!**

Complete turnkey station construction available!

*Broadcast Transmission Systems*  
7008 Lock Command Austin, Texas 78749  
(512) 448-0058

Circle 14 on Reader Service Card

### TEST EQUIPMENT

#### Want to Sell

Leader LBO 524, complete w/manuals, probes, needs no calibration, 40 MHz, hardly used, \$600. D Eressy, WFCC, POB 1308, W Chatham MA 02609. 508-945-4855.

HP antenna VSWR test equip incl HP608C signal gen, \$350; HP 415B VSWR meter, like new, \$325; directional couplers, \$100-\$450, slotted line, prices incl packing & UPS with-in continental US. P Onnigan, 1236 40th Ave, Sacramento CA 95622. 916-361-4469.

RCA WO-91B oscilloscope; Hickok 600A tube tester. E Neaman, KUMU, 441 N Nimitz Hwy, Honolulu HI 96817. 808-531-4511.

Potomac Instruments SD-31 RF synthesizer/detector, excel cond, \$1750; Potomac Instruments FIM-21 AM field intensity meter, excel cond, \$1800. H Ginsberg, Communications Eng Inc, 12 Beech St, Essex Junction VT 05452. 802-878-6796.

Potomac Instruments FIM 21 field strength meter, 54-1.6 MHz, gd working cond. G Clarke, Sound Medium Inc. 203-238-7910.

Tektronix 1L30 spectrum analyzer plug-in, 1.0-10.4 GHz, 105 dBm sensitivity at 20 kHz dispersion, for Tektronix 530, 540 & 550 series oscilloscopes, also incl a Narda micro-line coaxial directional coupler mdl 22836 w/20 dB down pickoff, \$800. B Dickerson, WEAG, 1421 S Water, Starke FL 32091. 904-964-5001.

### TEST EQUIPMENT

Why Buy When You Can Rent?  
**POTOMAC, DELTA, BIRD.**  
Other Equipment Available  
Call For Rates and Availability

### RADIO RESOURCES

1-800-54-RADIO  
1-800-547-2346  
301-783-0737

Tektronix 520 vectorscope, strong tube, rackmount, recent recalibration, \$900. G Sive, Video Connection, 3184 Rancho Amigos, Bonsall CA 92003. 619-749-7662.

Cushman CE-5 service monitor, 512 MHz AM/FM w/deviator & wideband preselector plug ins, mint, \$1050; Ballentine 500 MHz freq counter, 0.1-10 sec gate, \$125; Davis 7208, 600 MHz freq counter, \$100; Tek RTM 502, new, \$265. R Nelson, Tropical Bdcg, 14093 SW 142, Miami FL 33192.

Gold Line Loft TS-1 audio test set, osc, counter, dB meter, like new, \$150. E Davison, 135 N Illinois, Springfield IL 62702.

LPB AM-30/TCU-30 30 W carrier on 830 MHz, excel cond, \$700/BO. Neu-Comm, 1240 Riverbreeze, Ormond Bch FL 32176. 904-441-6956.

Collins 830 FM, xmtr, exciter, 4 bay antenna & 165' feedline, all tuned to 95.3 MHz; Gates 250 AM xmtr on 1520 kHz, all working fine when removed, BO. C Veirs, WBHT, POB 198, Brownsville TN 38012. 901-772-3700.

FM 3 kW transformer, never used. D Smith, WFCB, Box 94, Chillicothe OH 45601. 614-773-3000.

**LEASING AVAILABLE ON USED TRANSMITTERS AMERICAN BROADCAST FINANCIAL CORPORATION 414-482-2638**

Collins 1000 W 20V3 in excel cond, on air at 980 kHz, w/manual, \$5100. C Sigmon, WBZK, POB 398, York SC 29745. 803-684-4241.

1 W dual output translators (2) plus 10 element Yagi antennas, gives ERP of 16 W in 2 directions, \$2500 ea. J Landon, WCOO, 501 N Goodlette C-204, Naples FL 33940. 813-434-5557.

Sintronics SI-A-IS 1 kW solid state AM, worked when removed 4 yrs ago, spare parts, boards, manuals, BO. B Bowin, WBCO, POB 789, Bucyrus OH 44820. 419-468-2326.

Jetronic USN-TDD-5 25 W AM set to your freq, gd cond, w/book & cabinet, ready to use, \$450. J Cunningham, KEOR, Rt 2 Box 113B, Stonewall OK 74871. 405-265-4496.

### FOR SALE

- Continental 802A Exciter, Like New
  - Mc Martin B910 Exciter, With Stereo Gen and SCA Gen. Low Low Price
  - Moseley MRC-1600 Remote Control, New W/Full Warranty. Priced at cost!
  - Shively 6810 Eight Bay w/Heaters. Mid-Band
- (816)-635-5959**

Harris/Gates TE1 exciter, great cond, w/SCA gen, \$650. A McEwing, WGLY, RR1 Box 1040, Waterbury VT 05676. 802-244-5683.

RCA BTF-5D 5 kW FM xmtr tuned to 94.9 MHz, less exciter, working when removed as auxiliary xmtr. M St Cyr, 3565 29th SE, Grand Rapids MI 49512. 616-949-8760.

Harris 1976 FM 2.5 H3 2500 W FM w/TE-3 exciter w/stereo gen, spare driver tube, new, (2) finals, \$8000. R Parker, WTAZ, 332 Detroit, Morton IL 61550. 309-263-0102.

### CAPACITORS OVERNIGHT

- Power Supply computer grade: up to 450VDC
- Transmitting - MICA Sangamo, Comel-Dublier
- Oil Filled Non-PCB Oval, Rectangular

Relays - Filters - Transformers  
Any Parts starting with 1N or 2N

1-800-323-0460

FAX 1-802-425-3644  
Kellner Electronics, Inc.  
Charlotte, VT 05445

BE FM 3.5A w/FX-30 exciter, upgrading to C2, will remove 9/90. B Bailey, KJEF, POB 1248, Jennings LA 70546. 318-824-2934.

BE FM3.5A APC for FM 3.5A xmtr, tested but unused, new cond, \$1000/BO. R Ripley, RNI, 41-22 149th Pl, Flushing NY 11355. 718-961-6463.

Johnson Thunderbolt, classic tube 1 kW linear exciter, all tubes, gd cosmetics, \$600/BO. Kremer Kraft, 301 SW 16th St, Ft Lauderdale FL 33315. 305-524-5652.

Harris STX-1B AM stereo exciter, Harris STM-1B AM stereo monitor, both operating true C-QUAM system, excel cond. B Bailey, KJEF, POB 1248, Jennings LA 70546. 318-824-2934.

LPB AM-30/TCU-30 30 W on 830 kHz w/coupler for carrier current, excel cond, \$700/BO. S Neumann, Neu-Comm, 1240 Riverbreeze Blvd, Ormond Beach FL 32176. 904-441-6956.

Elcom Bauer 15 W exciter, 6 mos old, will tune to your freq, \$2500/BO. V Michael, WHTO, 575A Montgomery Pk, S Williamsport PA 17701. 717-323-8200.

McMartin 2.5 kW AM, vgc. L Popp, 814-467-7894.

Gates BC1J, gd looking rig, files light, never used the plates, BO. R Gray, WSUB, 200 Ft Hill Rd, Groton CT 06340. 203-446-1980.

## ARMSTRONG TRANSMITTER

### FINEST REBUILT TRANSMITTERS

We're the leading re-manufacturer of transmitters worldwide.

#### Transmitters are available:

- Tuned & Tested on YOUR Frequency
- Guaranteed and Installed
- Completely Re-manufactured
- Expedited Service Available

Trade-Ins gladly accepted - **WE DELIVER!**  
See your choice in transmitters *WORKING* in our huge new showroom *BEFORE* you take it home!



**NO ONE ELSE OFFERS YOU THIS!  
SEE & TEST IT ALL YOU WANT!**

## ARMSTRONG TRANSMITTER CORP.

5046 Smoral Road Syracuse NY 13031  
Phone 315-488-1269 FAX 315-488-1365

Circle 122 on Reader Service Card

Elcom-Bauer 680 FM exciter, like new cond, w/manual, \$2395/BO. D Phillips, KTCN, POB 372, E Springs AR 72832. 501-253-6101.

Bird Termaline 8745-677 20 kW water cooled dummy load w/3-1/8" EIA flange, \$750. G Liebisch, WPTF, POB 29521, Raleigh NC 27626. 919-876-0674.

Gates BC250-T 250 W tube type w/(6) 8008, (16) 810, (10) 607 tubes, Kintronics RF switcher, manual, all parts replaced w/Harris factory parts, works, tuned to 1190 kHz, BO. M Casey, WKSX, Drawer 1, Johnston SC 29832. 803-275-4444.

Collins 20V2 1 kW AM, exceptionally clean, wired for remote w/remotes equip, \$3500. K Crosthwait, WTNN, 13206 Butermilk, Knoxville TN 37932. 615-531-2297.

Harris TE-3 exciter in excel rebuilt cond, 8-90 w/composite input, \$950 plus shpg, 55 lb. G Garcia, KPEZ, 3001 Lake Austin Blvd Ste 400, Austin TX 78703. 512-478-6900.

Gates FM-250-C tuned to 92.1 MHz, used as back-up, working when removed in 7/90, exciter not included, operates on single 4CX-250B tube, buyer to pick-up or pay for shipping, BO. T Murray, WROI, 100 W 9th St, Ste 306, Rochester IN 46975.



#### High performance at affordable prices.

- New front panel programmable composite STL's.
- New directly programmable FM composite receivers
- New options for synchronous boosters and translators
- New FM exciters, transmitters, amplifiers: 2W to 30kW
- Same old price, quality service and reliability

**Bext, Inc.**  
739 Fifth Avenue.  
San Diego, CA 92101  
619-239-8462

Telex 229882 Fax 619-239-8474

TTC XL1FM2 FM translator, dual 1 W amp, (2) Scala antennas & cables, BO. G Thomas, WMSI, 1375 Beasley Rd, Jackson MS 39206. 601-982-1062.

Bext has some show units at sale price. Full 2 yr warranty, like new. Exciters, amplifiers, STL's. First come first served only. Call for details. Bext, 619-239-8462.

### FM TRANSMITTERS

#### 20 kW

1975 Collins 831-G2B  
1973 RCA BTF-20E1

#### 10 kW

1973 RCA BTF-10E1

#### 2.5 kW

1972 Harris 2.5H

Leasing Available

**414-482-2638**

## TRANSCOM CORP.

Fine Used AM & FM Transmitters and Also New Equipment

For the best deals on Celwave products, Andrew cable, Shively & Comark antennas.

1975	CCA 2500R, 2.5 kW FM	1986	Cont. 314R1, 1 kW AM
1975	Harris FM5H3, 5 kW FM	1974	Harris BC1H1, 1 kW AM
1975	RCA BTF 10ES1 10 kW FM	1981	McMartin BA 2.5 k, 2.5 kW AM
1972	CCA 20000DS, 20 kW FM	1979	Harris MW5A, 5 kW AM
1976	RCA BTF 20E1, 20 kW FM	1966	Cont. 315B, 5 kW AM
1983	Wiik. 25000E, 25 kW FM	1978	Collins 828E1, 5 kW AM
1976	CCA AM-50,000D, 50 kW AM	1981	McMartin BASK, 5 kW AM
		1972	CCA AM5000D, 5 kW AM

201 Old York Rd. • York Plaza Ste 207  
Jenkintown PA 19046  
215-884-0888 • FAX No. 215-884-0738

Circle 109 on Reader Service Card



# PETER DAHL CO.

Save \$\$

Heavy Duty Replacement Transformers, DC Filter chokes and capacitors for AM & FM transmitters manufactured by: AEL, CCA, CSI, COLLINS, CONTEL, CONTINENTAL, BAUER, GATES, GE, HARRIS, ITA, McMARTIN, RAYTHEON, RCA, SINGER, SINTRONIX, WILKINSON. Many other models also available.



FAST Delivery and FREE Technical Support.



5869 WAYCROSS AVENUE EL PASO, TEXAS 79924  
(915) 751-2300 TELEX: 76-3861 PWDCO  
FAX: (915) 751-0768

Circle 25 On Reader Service Card

TRANSMITTERS . . . WTS

**FIRST FOR ALL YOUR FM NEEDS:**

- Exceptional FM Exciter Performance
- Advanced Line of 1kW to 8kW Total Solid State FM Transmitters
- Full Line of FM Transmitters from 150 Watt to 50kW to Meet All Your FM Needs
- Excellent Financing Available

**TTC**  
813-684-7724

Want to Buy

## WANTED

AM and FM Transmitters, all powers. Finders fee for locators. **DON'T** take the chance of not being paid, sell to the oldest broadcast supply house in Latin America.

## GUARANTEE RADIO SUPPLY CO.

1314 Iturbide LAREDO, TX 78040  
(512) 722-3233  
(512) 727-8458 (fax)

Late mdl 1 kW AM wanted, no junk. L. Fuss, KOOZ, POB 159, Fayetteville GA 30214. 404-460-6159.

**USED TV TRANSMITTERS,** antennas, cable, rigid line, etc. one watt to 110 kW. Fair market price paid. Turnkey handling.

**BROADCASTING SYSTEMS**  
602-582-6550  
FAX: 602-582-8229  
Kenneth Casey

AM 250-500 W for auxiliary use, anything but basket cases considered. J McAulay, KITH, 21810 Hwy 18, Apple Valley CA 92307. 619-247-1111.

UHF & VHF TV translators, 10-100 W, will consider old UHF band 70-83 equip; low band 2-6 VHF TV xmtr, 100 W to 11 kW. J Powley, 1536 Logan, Altoona PA 16602. 814-944-8571.

Shortwave, high or low pwr. G McClintock, WWCR, 4647 Old Hydes Ferry Pk, Nashville TN 37218. 615-255-1300.

Single phase, 10K FM, 102.3, must be in excel cond, C Hargrave, KSPK, POB 1052, Wal-senburg CO 81089.

**TOP DOLLAR**  
For Your Old Transmitter, STL or Exciter!  
Call for a quote  
We arrange quick dismantling & removal  
PCB's? No Problem Call Us.

**ARMSTRONG TRANSMITTER CORP.**  
5046 Smoral Rd  
Syracuse, NY  
(315) 488-1269  
FAX (315) 488-1365

Gates BC500G modulation transformer in gd cond, reasonably priced. B Estes, WBHN, POB 1309, Bryson City NC 28213. 704-488-2682.

RCA TTU-2A UHF TV xmtr for parts; GE TT-24-A, 100 W or TT-20-A, 1 kW UHF TV xmtr for parts. J Powley, 1536 Logan, Altoona PA 16602. 814-944-8571.

Solid state 1 kW needed ASAP. K Sleeman, KTOB, 12 E Washington, Petaluma CA 94952. 707-763-1505.

McMartin older B-910 FM exciter. C Goodrich, 11435 Manderson, Omaha NE 68164. 402-493-1886.

McMartin AM/FM xmtr, any model, exciter or stereo modules. Goodrich Ent., 11435 Manderson, Omaha NE 68164. 402-493-1886.

## BROADCASTING EQUIPMENT "AM, FM, TV"

All powers and conditions. We dismantle and pick up.

**TRANSMITTERS STUDIOS STL I.B.S.**

International Broadcast Supply

1771 N. Powerline Road.  
Pompano Beach, FL 33069  
Tel. 305-977-9111  
FAX. 305-977-0488

## TUBES

### Want to Sell

EIMAC 4-400A, (2), approx 1000 hrs, \$125 ea. M Guidotti, KKKL, \*43 Fifth St, Ste 5, Colusa CA 95932. 916-458-5558.

## ECONCO Quality Rebuilt Tubes

Approximately 1/2 the Cost of New

Call for Our Price List  
**800-532-6626**  
**916-662-7553**  
FAX 916-666-7760

3CX3000A7 power tube, just rebuilt, BO. C Springer, KLMR, POB 890, Lamar CO 81052. 719-336-2206.

**For the Best Prices**  
& 24 Hr service on transmitting tubes call 402-493-1886 day or night. FAX 402-331-0638. TELEX 940103 WU PLB TLX BSN

3B28, \$10; 575A, \$30; 813, \$40; 837, \$20, others, all new. R Humphrey, WLJ, 7 Parkway Cir, Pittsburgh PA 15229. 412-921-8254.

Eimac 4-250, new in boxes, \$100 ea. P Deets, WFHR, Box 8022, WI Rapids WI 54495. 715-424-1300

## ELECTRON TUBES

Partial List: 6623, 23791, TH150, 6425F, 5604, 6696, 6697, 5681, 5682, 5671, 7804, 3CX10, 000H3, 3CX20, 000H3, 4CX5000A, 4CX35, 000C

**Vacuum Tube Industries, Inc.**  
1-800-528-5014

3CX1500A7, 4CX5000A, 6146B, 4CX2508, 4CX3000A & more. We carry large inventory all major brands, Eimac, Amperex, RCA, etc. Call Stew 1-800-642-1489.

### Want to Buy

RCA 6181 & 8501 & GE GL-6183 used as final in RCA & GE UHF TV xmtrs. J Powley, 1536 Logan, Altoona PA 16602. 814-944-8571.

### We buy electron tubes.

Contact us if you have any for sale.

**PATH ENTERPRISE**  
507 Superior Ave.  
Newport Beach CA 92663  
714-722-6733 FAX: 714-722-6508

## TUBE REBUILDING FREELAND PRODUCTS

Since 1940  
SAVE ABOUT 50%  
—We buy dud tubes—  
800-624-7626  
504-893-1243  
FAX 504-892-7323

European receiving tubes, EL3N, HM309, EBF-2, EF9, EF43 & others, also buying multiband European auto radios by Telefunken, Becker, Blaupunkt. W Wilkes, Box 103, Brisbin, PA 16820. 814-378-8526.

RCA 6181 & 8501 & GE GL-6183, used as final in RCA & GE UHF TV xmtrs. J Powley, 1536 Logan, Altoona PA 16602. 814-944-8571.

## REBUILT ELECTRON TUBES

Partial List: 6623, 23791, TH150, 6425F, 5604, 6696, 6697, 5681, 5682, 5671, 7804, 3CX10, 000H3, 3CX20, 000H3, 4CX5000A, 4CX35, 000C

**Vacuum Tube Industries, Inc.**  
1-800-528-5014

## TURNTABLES

### Want to Sell

Russco Studio Pro B (2), excel new idler wheels, \$150/ea; Rek-O-Kut G-2 new old sock, \$100; Grey viscous damped 12" arm, \$35. Kremer Kraft, 301 SW 16th St, Ft Lauderdale FL 33315. 305-524-5652.

Harris CB1201 TT's (2) w/arms & cartridges, \$25 ea. R Coleman, WGEN, Box 67, Geneseo IL 61254. 309-944-4633.

Gates CP-77 12" TT w/Gates stereo preamp w/manual, \$75. M Cramer, WGBA, 1291 N Road, Green Bay WI 54307. 414-494-2626.

Presto 6N cutter, \$300; Gray tone arm, \$50. J Parsons, Parsons Recdg, 10375 Cannas, N Huntingdon PA 15642. 412-863-9590.

Harris CB 1201 prof bdct TT's, (2) 3 speeds, in excel working cond, \$50 ea; Audio Technica ATP-N2 replacement stylus tapered cantilever elliptical .4 x .7 mil diamond (2), \$10 ea; Audio Technica ATP-N2 replacement stylus tapered cantilever spherical 0.6 mil diamond, \$10; RCA 8707242 tone arm, \$45. S Dynes, Dynes Prod, Wheeling WV 26003. 304-233-8856.

### Want to Buy

Dual 1218, need a hard shell. A McCartney, 600 E Main, Valaville CA 95660. 707-446-0200.

Presto 80-G & 92-B service info, on lathe & amp, photo copies OK. C Lund, Cycle Sound, 167 Madison St, Waterbury CT 06706. After 5:30 PM. 203-756-7761.

# ACTION-GRAM

## Equipment Listings

Radio World's Broadcast Equipment Exchange provides a FREE listing service for all broadcast and pro-sound end users. Simply send your listings to us, following the example below. Please indicate in which category you would like your listing to appear. Mail your listings to the address below. Thank you.

Please print and include all information:

Contact Name: \_\_\_\_\_  
Title \_\_\_\_\_  
Company/Station \_\_\_\_\_  
Address: \_\_\_\_\_  
City \_\_\_\_\_ State \_\_\_\_\_ Zip \_\_\_\_\_  
Phone Number: \_\_\_\_\_

I would like to receive or continue receiving Radio World FREE each month.  YES  NO

Signature \_\_\_\_\_ Date \_\_\_\_\_  
Please circle only one entry for each category:

### I. Type of Firm

- |                              |                                 |
|------------------------------|---------------------------------|
| D. Combination AM/FM station | F. Recording studio             |
| A. Commercial AM station     | G. TV station/teleprod facility |
| B. Commercial FM station     | H. Consultant/ind engineer      |
| C. Educational FM station    | I. Mfg, distributor or dealer   |
| E. Network/group owner       | J. Other _____                  |

### II. Job Function

- |                       |                           |
|-----------------------|---------------------------|
| A. Ownership          | D. Programming/production |
| B. General management | E. News operations        |
| C. Engineering        | F. Other _____            |

WTS:  WTB:  Category: \_\_\_\_\_

Make: \_\_\_\_\_ Model #: \_\_\_\_\_

Brief Description: \_\_\_\_\_

Price: \_\_\_\_\_

\*Closing for listings is the first Friday of the previous month. All listings are run for 3 months unless otherwise notified.

## Broadcast Equipment Exchange

PO Box 1214 • Falls Church VA • 22041 • 703-998-7600 • FAX: 703-998-2966

# ADVERTISER INDEX

This listing is provided solely for the convenience of our readers. Radio World assumes no liability for inaccuracy.

Page No.	Advertiser	Reader Service No.	Page No.	Advertiser	Reader Service No.	Page No.	Advertiser	Reader Service No.
13	AKG/Orban		19	BSW	120	10	Microwave Filter	61
6	Allied Bdct/Audisk	8, 26	4	Burk Technology	71	12	Northeast Broadcast	116
20	Allied Broadcast	101, 114	37	CCA Electronics	54	26	dbx	91
30	Allied Broadcast	11, 47	31	Comrex	151	33	Pacific Recorders & Engineering	85
32	Allied Broadcast	20, 37	37	Conex	43	17	QEI	40
24-25	Arrakis Systems	31	12	Continental Electronics	66	16	Radio Systems	3
7	ATI	123	22	Cortana	79	28	Radio Systems	118
8	Audio Precision	76	35	CRL	127	34	Radio Systems	73
11	Audiopak	50	22	Dataworld	39	29	RF Specialties	23
22	Belar	48	1	Fidelipac	111	29	Sescom	53
27	Bext	113	32	FM Technology	98	14	Studer Revox	45
3	Bradley Broadcast	81	10	Full Compass	55	36	Studer Revox	58
3	Broadcast Electronics	5	18	Harris	17	32	Summit Audio	7
23	Broadcast Electronics	106	8	Hnat Hindes	35	18	Tannoy	130
9	Broadcast Services	70	17	Inovonics	146	2	Wheatstone	29
			21	ITC	142	47	Wheatstone	13
			7	Jampro	21	48	Wheatstone	105
			20	Logitek	139			

### Advertising Sales Representatives:

East Coast, Art Constantine: 800-336-3045 Fax: 703-998-2966  
Midwest, Art Constantine: 800-336-3045 Fax: 703-998-2966  
West Coast, Pat Macsata: 415-786-2198 Fax: 415-786-2754



# It's Handled!



**Customize your A-500 Console with Wheatstone's powerful accessory modules!** We've handled auto-sequencing, telephone call-ins, and intercom requirements. Our auto-sequencing line input will take the rush out of back-to-back carts. Our multiphone module can handle 3 callers, 3 mics and reel-to-reel machine control all at once. Our new 8-station intercom module will link up all your studios and talent positions...

**AUTO-SEQUENCING:** The SL-500as input module allows the DJ to automatically sequence through a pre-loaded bank of cart or CD machines. All audio and machine control functions are handled by the module's logic circuitry. When the first ON switch is pressed, that module's associated machine automatically starts to play; when it has finished the channel is turned OFF, the next programmed module is turned ON, and its machine starts to play. Dead air and missed spots can be a thing of the past with this sequence function.

**TELEPHONE/TALK SHOW:** The MP-500 multiphone module offers a totally new way of handling telephone talkshow functions. Operation is simple: when the announcer wishes to do a phone segment he simply activates the MP-500 module and all mute, level, combining, and machine control functions are handled automatically. The MP-500 permits conferencing between 3 callers and 3 microphones, and provides separate multitrack tape feeds for various mic/caller signal combinations, permitting simple track punch-ins to replace razor and tape edits. This module eliminates complicated announcer set-ups, miscalls, and feedback problems.

**COMMUNICATIONS:** The ICM-500 module is part of a completely integrated intercom system; a family of modules available for all Wheatstone broadcast and production consoles. It even includes a rackmount version for your equipment room or remote hook-ups. It allows direct communication between 8 locations in your facility. Your intercom needs are handled by simply plugging in this module set.

**TAKE ADVANTAGE** of our expertise and reputation. Call Wheatstone. Let our application engineers handle your toughest requirements.

 **Wheatstone**® Corporation

6720 V.I.P. Parkway, Syracuse, NY. 13211 (tel 315-455-7740/fax 315-454-8104)

Circle 13 On Reader Service Card



# Something Very Good Just Got **BETTER!**



## *A-32EX On-Air Console*

Finally engineers confined to tight budgets can choose a console that won't compromise station reliability or signal integrity. After all, the A-32 is a Wheatstone console. It borrows from the componentry and design of our larger A-500 consoles, currently installed in major markets all over the country, from frontline independents to national networks.

Our new A-32EX is even better, with ample expansion room for additional inputs and a powerful family of accessory modules, including our new MP-32 talkshow module (that neatly interfaces multiple hybrids, tape recorders, announcer mics and studio-to-caller feeds), our ICM-32 six station intercom module (letting you communicate with other console locations and announce studios), and our SC-20 studio module (to provide comprehensive studio monitor, automatic muting, and talkback functions), plus multiple line selector and machine control modules, and a complete family of studio turret components.

The A-32EX console features modular construction, a fully regulated rackmount power supply, logic follow, full machine control and of course, an all-gold contact interface system. It has two mic channels and fourteen stereo line modules, each with A/B source select and Program/Audition bus assign, plus Cue switches on the line modules. Standard features include Program and Audition VU meters, digital timer, and a monitor module for control room and headphone functions. The console is also available in a smaller version (the A-20) with two mic channels and eight stereo line input modules.

The A-32EX is a perfect choice for stations planning an upgrade in signal quality and control room image. It's also a natural choice for the newsroom. So profit from Wheatstone's experience and reputation—call us today for immediate action!

 Wheatstone Corporation

6720 V.I.P. Parkway, Syracuse, NY 13211 (TEL 315-455-7740 / FAX 315-454-8104)

Circle 105 On Reader Service Card  
World Radio History