

Radio Technology for Engineers and Managers

Radio Guide

www.radio-guide.com

July-August 2008 – Vol. 16, No. 4

Preparing Now for The Unpredictable – Yet Probable



Inside

Radio Guide

- 6 - **Cover Story:** Preparing Now for the Unpredictable – Yet Probable
- 24 - **Radio Guide Hall of Achievement:** Recognizing Dave Chenoweth and Ken Branton for their contributions to the broadcast profession.
- 26 - **Station Story:** WNYC Makes the Big Move – After 84 Years
- 34 - **RF Guide:** Nautel – Designing a Next Generation Transmitter
- 36 - **Heavy Metal:** RCA's Transition to Design and Mfg. – the RCA 50E
- 54 - **Field Guide:** Remote Control – Audemat, Davicom, PlusSine

ACCURATE! AM Measurements

This off-air AM Reference Receiver and Mod-Monitor gives accurate AM mod readings, even with IBOC digital transmissions. Includes outdoor antenna.



MODEL
525

For full technical details, visit...

www.inovon.com



Inovonics
1305 Fair Ave. • Santa Cruz, CA 95060
TEL: (831) 458-0552 • FAX: (831) 458-0554
www.inovon.com • e-mail: info@inovon.com

MEAT & POTATOES WITH SOME PRETTY COOL BELLS AND WHISTLES.



Finally, a super compact ultra-portable broadcast mixer that's perfect for any job you want to throw at it. It's loaded with the staples big professional radio consoles have to ensure your shows come off without a hitch. And unlike the big boys, it's got a bell and whistle or two that make it the essential centerpiece part of any ad hoc studio.

Intuitive and easy to use, with large color-coded controls and bright LED meters, it gives you superb audio quality with ten mic and line-level inputs across six mixing channels for real versatility. And you can seamlessly add a guest announcer with their own headphone mix with our optional Multiphones MiniPod (bell).

With its built in DA/AD audio codec via a USB port (whistle), simply connect the SixMix to any USB-compatible computer and you're on the air. Use your favorite software to serve up tunes or any recorded program material through the SixMix. Push your program back to your computer

for recording or streaming. Need to send a separate feed to another PC or server? There's even a dedicated S/PDIF port to handle it.

Factor in its cue speaker and automatic monitor muting, mix-minus output, comprehensive headphone and monitor systems, plus a wealth of output options and it's clear to see that SixMix will transform your laptop or desktop computer into a full-fledged professional broadcast studio.

SixMix. You're on the air.



Henry Engineering • 503 Key Vista Drive, • Sierra Madre, CA 91024 USA • T: 626.355.365 • F: 626.355.0077 • email: Info@henryeng.com
www.henryeng.com

AIR WARRIOR



A modern air warrior needs all of the power and control he can muster to bring to the battle. **When it's you against the other guy, the VORSIS AP-2000 has it ALL.**

NOT AN ACE YET? The AP-2000 comes preloaded with over 70 presets tuned to do battle. Try a test flight with the latest VORSIS 31-band digital processor — and join the broadcast elite!

Wes Davis

Jim Hibbard

Owen Martin

Chip Morgan

Matt Lightner

Jim Loupas

Bruce Roberts

Floyd Turner

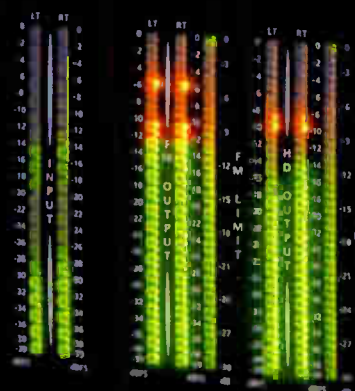

VORSIS AP-2000

VORSIS®

AP-2000

DIGITAL SPECTRAL PROCESSOR

www.vorsis.com

copyright © 2008 by Wheatstone Corporation

World Radio History

Radio Guide

Contents

July-August 2008

Radio Waves
by Barry Mishkind – Editor

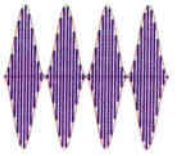

Cover Story: Preparing for the Unpredictable – Yet Probable *Part 2 – The Transmitter Site*

Operations Guide 10
Clear Channel's ERT Responds to Emergencies

Security Guide 14
What Is All the FLAP About?

Studio Guide 18
These "Pops" Orchestrate Nightmares

Hall of Achievement 24
Dave Chenoweth and Ken Branton

Station Story 26
WNYC Makes the Big Move – After 84 Years

Station Story 28
WNYC Archivist Preserves Nine Decades Of History

Tech Tips 28
Transmitter Site Power Monitoring

Field Guide 30
LP Technologies LPT-3000 Spectrum Analyzer

RF Guide 34
Designing a Next Generation Transmitter

Heavy Metal 36
RCA's Transition to Design and Mfg. – Part 2: The 50-E

Radio History 48
WLW's Big Sister: Radio Aspidistra

Larry Cervon – Jan 27, 1922 – Jul 5, 2008 50
Larry Cervon, age 86, passed away on July 5, 2008

Tool Guide 52
Solving Problems for Mobile Computer Users

FIELD GUIDE - Audemat 54
Audemat's Relio Controls Wyoming Public Radio

FIELD GUIDE - Davicom 56
Davicom MiniMAC Remote Control and Monitoring

FIELD GUIDE - Plus Sine 58
Plus Sine Makes a Good Remote Control Better

Service Guide 60
Radio Equipment, Products, and Services

Radio Pipeline 62
New Equipment, Equipment Mods and Updates, Industry Info

Final Stage 63
Radio Date Book, Advertiser Information, Problem Solvers

Cover Photo Credit:

Clear Channel engineers review one of the ERT fleets.
Photo courtesy of Clear Channel Radio.

Radio Guide

Volume 16 – Issue 4

PO Box 20975, Sedona, AZ 86341

Phone: 928-284-3700 Fax: 866-728-5764

Radio Guide: www.radio-guide.com

Radio Links: www.radiolinks.net

Classified Ads: www.radio-classifieds.com

Ray Topp (Publisher)
radio@rconnect.com

Barry Mishkind (Editor)
editor@radio-guide.com

Radio Guide, ISSN 1061-7027, is published bi-monthly, six times a year, by Media Magazines Inc., PO Box 20975, Sedona, AZ 86341. Radio Guide is copyright 2008, Media Magazines Inc., and may not be copied, reproduced, or stored in any format, without the written permission of the publisher.

This month we continue our emphasis on themes which are becoming more and more important: station security and disaster recovery planning.

With budgets being slashed, it may seem like the wrong time for this. But, as Gary Peterson and Charlie Wooten point out (Pages 6-10), only by planning ahead can you avoid lost airtime and income during a local emergency, not to mention the lost confidence and good will of your listeners who had to go elsewhere for information during the emergency.

And for those who think they can "wait until something happens" before investing money on security, please read Kevin Kidd's discussion on Page 14 about the very real danger drug addicts pose to station operations. Kevin reviews ways that major losses can be prevented, but security may need to become a line item on the budget from here on out.

THE CALM VOICE

There is something about a calm, confident voice on the other end of the phone to help an engineer through a crisis. As for many of my age group, it was the team of Dave Chenoweth and Ken Branton who always were there for me when I needed assistance in fixing transmitters.

Anyone who dealt with them cannot help but remember their attitude: They did not view calls from upset engineers as complaints, but as a chance to help. And the goodwill they created for the company was substantial and long lasting. We are pleased to recognize these men in our *Hall of Achievement*. (Page 24)

THE SEMINAR

By the time this reaches you, the current **Radio Guide AM Transmission Seminar** has been held in Austin. We are already receiving requests for seats at the next seminar. If you are interested in the program, drop us a note or call us and let us know, so we can better plan the next one.

Broadcast Software

1-888-274-8721
www.bsiusa.com

Simian - Radio Automation

Fully automated or live assist play out software.



Suitable for radio stations, web casts, music-on-hold & retail outlets.

Complete PC Systems

Ready to run, broadcast ready or retail play out systems.



Optional music, advert & promo scheduling software and remote control hardware.

AudioScience Sound Cards

Multi-output, pro-quality sound-cards and tuners.



On-card processing and memory for glitch free playback & recording.

SkimmerPlus Audio Logging

Advanced radio station or call-center logging with remote web playback.



Satisfies and exceeds the output logging requirements in many countries.

Broadcast Software International
503 E. 11th Avenue
Eugene, OR 97401 USA
Direct: 541-338-8588
Fax: 541-338-8656
www.bsiusa.com sales@bsiusa.com





Impossible Remote? Nah...You've Got ACCESS!

Cape Town's Heart 104.9FM's hot new ACCESS opens new horizons!



Above: Heart 104.9FM DJ **Koketso Sachane** doing his show from the streets of Cape Town.

Top: **Saskia Falken**, Heart 104.9FM Mid Morning Mix host broadcasting from Table Mountain.

With ACCESS, Heart 104.9FM left its competition literally standing still by offering innovative, super-b sounding remote broadcasts that kept listeners (and advertisers) coming back for more. Whether it was from a sailing yacht, from the top of majestic Table Mountain or from the vibrant streets of downtown Cape Town, ACCESS always delivered with its winning combination of pristine audio and ease of use.

ACCESS delivers mono or stereo over DSL, Cable, Wi-Fi, 3G cellular, satellite, POTS (yep, ACCESS is a full featured POTS codec and works seamlessly with Matrix, Vector and Bluebox)—plus some

services you may not have even heard of. Given the challenges of the public Internet, it's no small boast to say that ACCESS will perform in real time over most available IP connections.

Contact Comrex today and find out how ACCESS can help you open up your new horizons— wherever you are!



ACCESS

NEW from COMREX:

BRICts & **AAC-ELD**
TRAVERSAL SERVER Software from Fraunhofer IIS

Two new options to enhance your ACCESS: **BRIC Traversal Server** makes IP connections a snap by automatically syncing with your buddy list.

The **AAC-ELD** option offers exceptionally high quality, low latency audio. Contact Comrex for more info!

Put Comrex On The Line.

COMREX

19 Pine Road, Devens, MA 01434 USA Tel: +1-978-784-1776 • Fax: +1-978-784-1717 • Toll Free: 800-237-1776 • www.comrex.com • e-mail: info@comrex.com

World Radio History



Preparing Now for the Unpredictable – Yet Probable

Part 2: The Transmitter Site

by Gary Peterson

According to Murphy's Law, whatever can go wrong – will. The engineer's job, then, is to anticipate problems as much as possible and minimize or eliminate downtime with a coordinated program of preventive maintenance and backup systems. This time, Gary Peterson takes a look at transmitter site issues.

In a recent phone conversation, Barry Mishkind suggested that I first address the transmitter and its associated power source, shelter, transmission line, tower and antenna. He was absolutely on target because all the personnel and studio equipment in the world are worthless if the programming that results cannot be broadcast to the listening public.

If adversity visits your transmitting site, advance preparations may allow the station to continue serving its listeners and the revenue stream will be uninterrupted. If calamity strikes the station's listening area, adequate preparations may allow the station to serve the public with life-saving information, delivered to the ubiquitous, inexpensive, battery-powered AM and FM radios, in the hands of the public in this country.

MANY OPTIONS

Different licensees have vastly different financial and personnel resources. For that reason, each station will have to choose the most reasonable options that are in line with their practical capabilities.

For example, the very best-equipped stations may have entirely different main and alternate transmitting sites that are geographically separated. Each of these sites would have its own transmitters, generators, buildings, STLs, towers, antennas, remote controls, etc. Of course very few stations, percentage-wise, enjoy this level of redundancy.

At least one group even has portable studio/transmitter sites ready to roll into a disaster area or substitute for a studio or transmitter site that has been destroyed. They even have made plans to provide for generator fuel and shelter for displaced employees. (See Charlie Wooten's article on page 10.)

Having a spare tower, unless it is your STL tower at the studio, can be an expensive proposition. Recently, I have heard of emergency sharing agreements among tower owners. Consider talking to the other broadcasters in your area about the possibility of setting up emergency operations from each other's sites. It is highly unlikely that both of you will lose buildings or towers simultaneously.

Such a mutual-aid agreement would allow – in the event of a building fire or tower collapse, etc. – your station to mount a temporary antenna/transmission line on their tower and place a small amount of backup gear in their building – and vice-versa. If there is insufficient space in the transmitter building, find out if it would be possible to park an old camper or trailer next to the tower. Many stations have vehicles, such as panel trucks used for promotions, which could be pressed into service as an emergency equipment shelter. It would be prudent to make arrangements in advance for electrical power at such alternate sites.

COMPROMISE OR IMPROVISE

Most stations have to compromise. A second site may not be in the cards. Nevertheless, a spare transmission line and antenna, ready for installation on the station's tower – or perhaps back at the studio – could be a real asset.

I worked for a station that suffered a major transmission line/matching section/ten-bay antenna failure. Some

7/8" foam line left over from another project and a piece of copper plumbing pipe was fashioned into a coaxial dipole. With reduced power, it kept the station on the air for two weeks, with surprisingly good coverage, I might add. To the very day that a spare broadband antenna was purchased for emergency backup, the homemade antenna was kept for another similar emergency.

I also have an old translator receive Yagi that has been adjusted for minimum VSWR on transmit, for one of my remote transmitter sites. During repairs to the main antenna, it handled 400 Watts from a solid-state backup transmitter with ease. (Note: any permanent installations of standby antennas should be licensed. Your technical consultant will help you with filing such an application.)

DEALING WITH TOWER FAILURE

It is a bit more challenging when an AM station loses its antenna (tower).

You might consider looking for places where it might be possible to suspend wire over the existing buried ground system. Can you use the STL tower? How about tying off to a phone pole or even a crane?

To "match" to such an emergency antenna, look around your transmitter room. AM stations often have a variety of unused tuning components. Keep items such as inductors, capacitors, insulators and wire for emergencies. In such situations, if the parts are available, one could build a "T" or an "L" network with roller inductor(s) and a selection of mica capacitors.

One of my AM stations was kept on the air during extensive tower work by loading an end-fed wire attached with an insulator to the tower about 100 feet up. The 250-Watt backup transmitter was matched to the wire with a homemade "L" network.

FINDING THE COMPONENTS

I also was fortunate enough to part out a couple of old 50 kW AM transmitters. From these, I was able to build a rather "healthy," fully adjustable "T" network for my AM stations consisting of two roller inductors, a selection of large transmitting mica capacitors, and a large vacuum variable capacitor for fine-adjusting the shunt leg.

We have only used it twice in the last decade, but I am very glad we had it. From time to time, I hear broadcast engineers lamenting that they do not build equipment any more. An AM broadcast-band, homebrew antenna tuner project like this should satisfy some of that longing.

By the way, if you cannot get the station back up to full, normal operations, it is necessary to obtain an emergency STA to allow operation at variance from licensed parameters (transmitter location, antenna type/height, output power, etc). The FCC Communications Center will help you, and may be reached at 202-418-1122; this number is answered 24/7.

SPARE TRANSMITTERS

A backup (or spare) transmitter and a method of transferring it to the radiating system are realistic for many stations.

The backup might have been the previous main or one obtained from the used market. A standby transmitter that will run on single-phase power will be easier to operate under difficult circumstances. If a backup transmitter is not an option, consider, at least, getting a spare exciter (frequency agile, if possible). It is amazing what coverage can be attained with 50 Watts into the licensed antenna system.



A frequency-agile exciter makes a simple emergency exciter or transmitter.

Transfer might be accomplished remotely with a motor driven coax switch. If that option is too expensive, an RF patch panel might be affordable. If *even that* is too expensive, consider buying the necessary RF adapter(s) needed to connect the transmission line to an alternate source of RF, such as your spare exciter. It is possible to homebrew somewhat crude, but effective, adapters on a tight budget.



Not too pretty.

While it will not handle a lot of power, this crude, homemade N-male to 1-5/8" EIA adapter was made from the center of a PL-259, a bolt and a hank of coax with an N-connector. It was not the prettiest connector but, most importantly, it kept a station on the air!



Better to be on the air than pretty.

PROVIDING POWER

A generator and sufficient fuel supply that will keep the main transmitter on-air at full power is the ultimate desirable situation. Yet high-wattage generators, their fuel, and maintenance may not fit the station's pocket-book.

If that is your situation, consider buying or trading-out a smaller, single-phase unit that is designed for home backup service. These 5 or 10 kW units will easily power a smaller backup transmitter or 50-Watt exciter, the STL, audio processing and remote control gear.

These home units are usually available with a transfer panel that will automatically start the generator and transfer the critical loads. After utility power is restored for a pre-set duration, the critical loads will transfer back to the utility mains and the generator will shut down. Many of these generators even will exercise automatically on a weekly basis.

(Continued on Page 8)

Thousands

of people across America use Tieline codecs
for remote broadcasts every day.



“ The broadcast was wonderful
- Tieline’s wireless 3G provided all
the benefits of a remote pickup
unit with bidirectional audio paths,
and a communications circuit. ”

Marcus Xenakis,
Director of Engineering and IT,
Clear Channel Radio in Philadelphia



Watch a live wireless video demo right now
www.tieline.com/videos

Tieline 
www.tieline.com

800-780-4750

Preparing for the Unpredictable Yet Probable

by Gary Peterson

— Continued from Page 6 —



A home-sized generator will provide enough power to get something on the air.

If natural gas is available at the site, the fuel supply is pretty much limitless, unless the disaster affects the gas company's service. A propane tank with enough fuel to run the station for a couple of weeks should be sufficient in all but the most severe disasters. I would avoid gasoline as a fuel. It does not store well and its storage poses all manner of environmental problems. To date, I am unaware of any significant problem with propane theft. If the tank does not leak, propane stores virtually forever.

ENSURING EMERGENCY POWER WORKS

When visiting the transmitter site, log the hours meter on the generator. This will inform you if the unit

is working properly. If it is not showing the expected accumulated time, it is time for a manual test and, possibly, maintenance. I also recommend a means of monitoring utility power via the remote control.

In case of outage, the sooner you can report it, the sooner normal power may be restored and valuable fuel saved. I monitor both the utility mains and the generator output.

I also recommend placing the remote control on a UPS. If the utility power goes out and the generator fails to start and transfer, the telemetry still will indicate the situation. The more information available from a remote site, the less likely you will have to go out in a storm.

THE MINIMALIST APPROACH

At the very least, get a small portable generator. These are commonly used at campsites. They will generate about 1 kW, and are compact and light. One of these easily will run a typical STL receiver, an audio processor, and a 50-Watt exciter.

Furthermore, the portable generator could be used at remote broadcasts where utility power is not readily available.

I am reminded of a radio station that would trade out portable generators and auction them on the air. They never thought to keep one for themselves, in spite of telling listeners how important it was to have one. Over the years the station lost a good deal of airtime due to power outages.

Of course, the downside of smaller generators is having to be at the site to start them and transfer the

load. It also requires refueling every few hours, something only done safely by shutting down for a few minutes. The portable power unit should be run outdoors, so as to not subject you to the carbon monoxide from the exhaust. And a supply of fresh gasoline will have to be safely stored.

GOOD RELATIONSHIPS

Do not be afraid to ask other broadcasters for help. In my 43 years in broadcasting, I have found that when misfortune visits, even fierce competitors are willing to offer help in the form of loaned equipment or labor.

A few years ago, one of our competitors lost their FM exciter. They had no backup transmitter or exciter so I loaned them our frequency-agile spare exciter. Otherwise, I suspect they would have been off the air for a few days. I have little doubt that they would return the favor, if they could.

If you do borrow equipment, return it as promptly as possible in the same condition that it was in when you received it. Treat borrowed equipment as if you owned it. If any borrowed equipment is damaged, make it good by having it repaired or replaced. And, do not lose the lender's equipment manuals.

Finally, if you have surplus equipment such as an old audio processor or some such, keep it in the rack for emergency use. Leaving equipment disconnected makes it a less-likely victim of lightning or power line spikes. Just power it up every few months and verify that it still works. (If the gear is left cold and dark for too long, the electrolytic capacitors tend to short out when powering up.)

We plan to work back from the transmitter site to the studio, analyzing the strengths and weaknesses of the various sites. If you have any suggestions and/or "war stories" to share, that would be much appreciated. Drop me an e-mail.

Gary Peterson is the Chief Engineer for Schurz Communications, Inc. in Rapid City & Sturgis, SD. You can contact Gary with your comments, suggestions, and ideas at engineer@newrusheradio.com

News • Talk • Sports • Music • Audio Logging • Voice Tracking • Traffic & Billing

Summit Traffic & Billing

- 25 years of experience
- Optimized scheduling (yield management)
- Real time avails reports
- Scalable (small to enterprise)
- Fast and accurate billing
- Open Item A/R
- Single-multi-remote user access
- EDI invoicing
- Radio, Television, Cable
- Compatible with all major automation systems

BLACKBOX Audio Logger

- Record up to 16 channels
- Off air & dear air alerts
- Compliance & verification
- Web browser access
- Talent & market monitor
- Podcast recorder
- Available in Spanish
- Extended support for AM/FM/TV tuner boards
- Mic & time skimming

CDS³² Radio Automation

- Live Assist, Satellite, and Music on-Hard Drive
- "Smart Promo" produces professional sounding "Coming up next" style promos
- Watch windows for each commercial break
- Clock synchronization for perfect joins!
- Powerful features allow for complete control
- Interfaces with all major traffic & billing software
- Buffered liners play correctly each time
- Control CDS³² SAT remotely by phone or Internet
- Automate syndicated and local sports
- 24/7 product support available from the company made famous for fast & friendly support



Pristine Systems

25 years of
Broadcast Automation

WWW.PRISTINESYS.COM • WWW.SUMMITTRAFFIC.COM
800.795.7234



RemoteMix 4 Introducing A Field Mixer That's Outstanding In Its...um...Field

Combining a four-channel field mixer with a four-channel headphone amplifier, a phone-line hybrid, a universal PBX handset interface, a wireless phone interface and Bluetooth® Wireless Technology to connect to cell phones and portables, the RemoteMix 4 is ready to work just about anywhere you are.

Use it as a phone-line hybrid, calling into your studio talk show hybrid. Use it as a front end mixer for your POTS, ISDN or IP codec. Or use it as a combination broadcast/IFB mixer. No matter how you use it, you'll find that it's an incredibly versatile mixer.

Plus... IT SOUNDS GREAT! A soft limiter prevents overdriving the phone line interfaces, while the mixer XLR output is pre-limiter (full range), meaning you have a feed for every need. Bass boost adds a bit of low end before sending

the signal down the phone line to provide that "how'd you get it to sound THAT good over POTS lines" nudge. There are convenient 3.5 mm send and receive jacks for recording the show or mixing in your MP3 player.

The RemoteMix 4 can be powered by batteries or the included AC adapter, so you'll never lose a connection – even during a loss in power!

We think we've done our homework with RemoteMix 4. And it'll be in your hands in plenty of time for the fall sports season.



JK Audio

TOOLS FOR SUCCESSFUL RADIO

JK Audio, Inc. Sandwich, IL 60548 USA • Toll Free: 800-552-8346 • Tel: 815-786-2929 • Fax: 815-786-8502 • www.jkaudio.com • info@jkaudio.com

www.jkaudio.com

KINTRONIC LABS ISOCOUPPLERS



AM

FMC-0.2P



FM

FMC-7.5



FMC-1.9G-PCS

www.kintronic.com

IBC STAND # 8.D79



Clear Channel's ERT Responds to Emergencies

When local emergencies occur, there is always a period of time while resources get put into place. In times of disaster, the delays and problems in restoring services can be lengthy and daunting. At least one broadcaster has taken steps to get the local stations back up as rapidly as possible. Charlie Wooten describes the Emergency Response Team (ERT) approach put together by Clear Channel.

Many lessons were learned from the 2005 Hurricane Season. FEMA, State Governments, wireless carriers, Telco, power companies, broadcasters, and even the Red Cross learned hard lessons about what can be done ahead of time to serve the affected population, minimize downtime, and maximize response to situations caused by hurricanes.

Clear Channel Radio has assembled a multi-faceted plan, and hardware to back up the plan, so that their broadcast facilities can effectively serve their listeners under the most trying circumstances.

BUILDING A PLAN

Immediately after the smoke cleared from the 2005 Hurricane Season – which was one for the record books in all aspects – Clear Channel began to build a plan for future emergencies.

The idea was to design hardware and designate personnel who would be ready to respond to any market impacted by a storm or other disaster. Of course, this plan was not limited to hurricanes alone; it also addressed other types of natural and man-made disasters such as earthquakes, floods and tornadoes.

There are many different things that can go wrong during a storm to a broadcast facility. Just to name a few:

- Loss of commercial power at the transmitter and/or studio.
- Loss of connectivity between studio and transmitter.
- Building damage allowing water intrusion into studio and/or transmitting equipment.
- Loss or structural damage to studio and/or transmitting towers and antennas.
- Loss of Telco and/or Internet/Corporate WAN circuits.
- Loss of conventional C band satellite antennas.
- Limited staffing due to severe damage to homes and access to roads.
- Limited fuel for power generation and station vehicles.
- Limited food and drinking water for station personnel.
- Loss of sanitation facilities.
- Need for temporary housing (sleeping, eating, etc) of station personnel at station due to loss of personal property.

While no one could have predicted the widespread problems broadcasters experienced during the 2005 Hurricane season, Clear Channel Radio was able to address most of these needs before the storm – and all of them within a few days after the storm.

Although some solutions were expensive, quiet 2006 and 2007 storm seasons provided time to design and fabricate hardware and fine tune the response plan so that most scenarios can be addressed when (not if) there is another “Katrina, Dennis, Ivan, Rita or Charlie” in the future.

PUTTING THE PLAN INTO ACTION

Steve Davis, Senior Vice President of Engineering and Capital Management put together a team consisting of “first responders” to come up with a list of hardware that would address the issues identified after the 2005 Hurricane season. This group grew out of the Clear Channel “Hurricane Response Team,” which had been around for several years; it included upper management and staff from both Corporate and local levels.

The group met on several conference calls to come up with a list of supplies, equipment, and other resources to have on hand *before* a disaster strikes. These resources would be staged in several regional centers for easy deployment if needed.

Today, Gil Garcia has the task of making all of these technical and personnel resources work as the Clear Channel Disaster Coordinator. Clear Channel has hard assets that are ready to be delivered to a market when the need is identified. These assets are stored in various locations around the U.S. – not just in the Southeast – for rapid deployment where needed.

ASSETS ON THE READY

These assets include:

- Four self-contained “Transmitter Site on Wheels.” These trucks are equipped with a frequency agile 5 kW FM transmitter, self-contained generator, a tower kit for installing a 100 foot tower with base plate and guy wires, and a frequency agile STL system.



The ERT Transmitter Site on Wheels

- There is also a 1 kW AM transmitter that can be put on any AM frequency within 15 minutes, plus the required test equipment to make the frequency move. The AM transmitter is mounted in a separate ruggedized field case with an audio processor so it can be deployed at a separate location.



The ERT package includes a generator, a 100 foot tower (and obstruction light), a four-wheel drive pickup truck, and RV accommodations for staff.

• Three ruggedized 1-ton king cab 4WD pickup trucks specially fitted with the maximum-sized diesel tanks that comply with DOT regulations, pumps for fueling generators, a fully-stocked tool box, and an overhead rack for transporting tower sections, antennas and transmission line. The truck is equipped with a heavy-duty winch that can be mounted on the front or the back of the truck as conditions require.

• An auto-aim data satellite system for WAN/Internet connectivity (this unit was utilized by the writer in Biloxi after Katrina). The system also provides IP phone solutions (this worked great during Katrina – we had phone service immediately after the storm).

In addition to the portable T-1 systems, Clear Channel Radio has installed a new system called “SATL” (satellite STL if you will), that provides both an audio path and an IP path to all Clear Channel Radio studio and selected transmitter sites in areas where a hurricane can damage a market’s STL tower and/or connectivity to the WAN. The audio path utilizes Barix technology which makes it very easy to interface and to maintain.

• Each transmitter site has an IP-controlled audio switcher which can change the audio source from the normal STL path to the satellite path if needed. This can be done at the local, regional, or nation level according to the situation.

Additional bandwidth can and is being used for IP connectivity with transmitter equipment. (In my market, I use the SATL to connect my IP remote control systems and to transport title and artist info to my RDS generators, which are located at the transmitter sites). Each market was required to conduct an actual on-air test of the SATL system to insure the audio and switching systems were working correctly – after all, you do not have time to troubleshoot something like this in the middle of or after a hurricane!



A look inside the “Transmitter Site on Wheels.”

- Three Motor homes/RVs to house relief personnel and station staff.
- A large number of satellite phones for deployment before the storm/event.
- Fuel Tanks and 12-Volt fueling pumps.

While these extensive (and expensive) steps have been taken by Clear Channel, which owns a large number of stations in all areas of the country, hopefully, a smaller group or individual station can use the information in this article to plan for your next emergency. As they say, it is not *if*, it is *when* it happens.

Charlie Wooten is the Market Engineering Manager for Clear Channel Radio, Panama City, FL. You can contact him at charliewooten@clearchannel.com

RADIO GUIDE
www.radio-guide.com

Premier technical information
meets Radio's On-Line Community®
at www.radio-info.com
arriving September 2008

RADIO-INFO.COM
RADIO'S ONLINE COMMUNITY

expect MORE

NX50

AUI

NV40



50kW AM

Advanced User Interface

**44kW FM
Solid State**

**more Engineers
more Innovation
more Award Winning Products**



902.823.2233

www.nautel.com/expectmore

World Radio History

Can a radio console be over-engineered?

(Only if you think "good enough" really is good enough.)

"OCD" redefined

Building great consoles is more than punching holes in sheet metal and stuffing a few switches in them. Building a great console takes time, brain-power and determination. That's why we've hired brilliant engineers who are certified "OCD": **Obsessive Console Designers**, driven to create the most useful, powerful, hardest-working consoles in the world.

How It began

"20-odd years ago," says Axia President Michael "Catfish" Dosch, "I was designing custom consoles for recording studios. Somebody at **PR&E** – it was still called **Pacific Recorders** then – liked what I was doing and invited me to move there. Work with Jack Williams, the guy who practically

invented the modern radio console? I jumped at the chance; BMX consoles were ultra-reliable, sounded great, and nearly indestructible!

"PR&E was a dream job. Jack taught me how to design consoles without compromise — how to **over-engineer** them. It's great to see, 15 or 20 years later, that many of the boards I designed are still on the air.

"By the late 1990s, computers and routing switchers were becoming an essential part of the broadcast studio, and I'd been thinking about how useful it would be to combine console, router, and computer network. I shared some of my ideas with Steve Church, who'd introduced digital phone hybrids and ISDN codecs to radio. He thought the same way I did about computers in radio studios, and we decided to work together."

A new kind of console

In 2003, Axia was launched to make digital consoles, but with a twist: Axia consoles would be integrated with the routing switcher, and **networked** to share resources and capabilities throughout the studio complex. This intelligent network of studio devices lets Axia build consoles that are **more powerful** and easier to use than ever.

Our team of engineers blended the best ideas from

old-school analog consoles with innovative new technology to produce **bullet-proof boards** that can actually make shows run smoother and sound better.

And we invented a way to network studios, consoles and audio equipment using Ethernet. It's called **Livewire™**, and it's now an industry standard.

Livewire carries hundreds of channels of real-time, uncompressed audio plus synchronized control logic and program-associated data on just one skinny CAT-6 cable.

Lots of well-known broadcast software and hardware companies (over two dozen already) now make products that work directly with Livewire. Thanks to this scalable network technology, **integrated router control** is a standard feature of every Element. Any source in any studio can be loaded on any fader with no need for add-on panels.

And Livewire lets you bring computer audio into the air chain without going through multiple A/D/A conversions. Our **IP-Audio Driver** lets you connect computers directly to the network without any intermediate I/O — all that's needed is a CAT-5 cable and your computer's Ethernet port.

Feature packed

Board-ops told us they wanted a console that's **powerful, yet easy to use**. So we designed Element to be user-friendly, yet still have all the power of a full-on production board.

For example, Element Show Profiles can **recall each operator's favorite settings** with the push of a button — audio sources, fader assignments, monitor settings and more. And each jock's Show Profile contains personalized **Mic Processing** and **Voice EQ** settings that load every time they're on the air (so the midday guy will stop badgering you for "just a little more low end"). There's even a "panic button": one key-press returns a Show Profile to its default state instantly. (No more 3 A.M. "Help!" calls.)



Did we say "mic processing"? You bet. Every voice channel gets **studio-grade compression, de-essing and expansion** from the processing experts at Omnia, plus three-band parametric EQ to sweeten the deal. There's even **built-in headphone processing** so you don't

have to waste money building a separate side-chain just for the studio cans.

Jocks have complained for years that making a mix-minus is too hard — so Element **constructs mix-minuses automatically**. Plus, mix-minus settings are saved for each audio source, so that sources, backfeed and machine logic all load at once. And every fader has a "Talkback" key to **communicate with phone callers**, remote talent or other studios using the console mic.

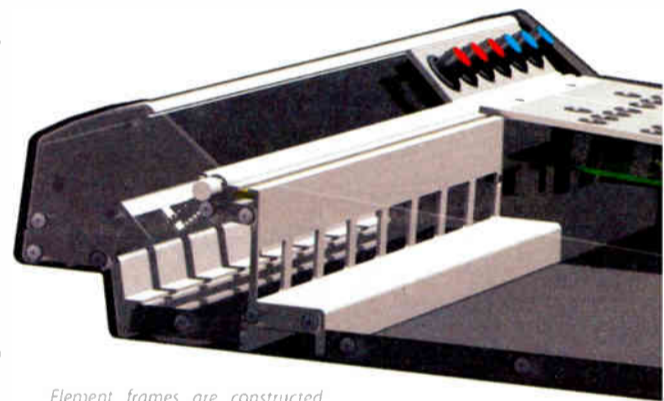

Element frames are constructed from custom aluminum extrusions for maximum rigidity. Module face plates and console side panels are machined from thick plate aluminum. Even the hand rest is a beefy extrusion. With all this heavy metal, even that ham handed overnight jock won't be able to dent it.



Speaking of phones, board-ops have enough distractions without having to reach for an outboard phone control panel. Element has **hybrid controls with dedicated faders** for Telos talkshow systems; there's even a **dial pad** so jocks can dial, pick up, screen and drop calls without ever diverting their attention from the console.

Nearly every air talent has accidentally changed a fader's audio source while it was on-the-air. To prevent that error, **Element "queues" source changes**: the operator must turn the fader off before the next assigned source "takes".

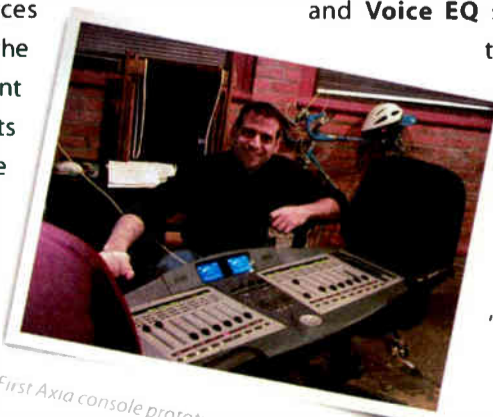

First Axia console prototype. Nice test stand, Catfish.

The radio console, redefined.

Element was designed to fulfill either a **production or on-air** role, with amazingly powerful features waiting just beneath the intuitive surface. For instance, Element can mix in 5.1 Surround as well as stereo. That's standard; **nothing extra to buy** (except more speakers). There are four stereo Aux Sends and two Aux Returns, so production guys can use their favorite outboard FX boxes. Great for **custom IFB feeds**, too.

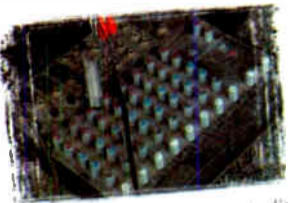

Clear the junk out of your studio. Element has 8 submixers built in.

Got a PA mixer tucked away in a studio corner to mix mics for live performers, talk shows and such? Element has **8 Virtual Mixers** — no outboard gear needed. And the Virtual Mixers emulate ACU-1s, allowing tight integration with automation and satellite systems.

You can **administer Element remotely**, from home, the airport — wherever there's network access. A password-protected web server lets you examine the state of the console, see what's on the air and even fix operator mistakes, without ever leaving the comfort of that new Aeron™ desk chair you (ahem) "requisitioned" from the Sales department.



Small VU meters mounted at desk level are hard to read, so we re-invented the traditional meter bridge. Element's **big meters** are presented on an easy-to-read computer monitor along with large analog and digital clocks, event and countdown timers, and tallies that light when mics are open, delay is active, or during phone calls. You can even customize the display by adding your station's logo.



Beneath the surface

There's more to building a great board than just features. **Consoles have to be rugged**, to perform flawlessly 24/7, 365 days-a-year, for years at a time. So when it came time to choose the components that would go into Element, we literally scoured the globe for the absolute best parts — parts that would take the torture that jocks dish out on a daily basis.

First, Element is fabricated from thick, **machined aluminum extrusions** for rigidity and RF immunity. The result: a board that will stand up to nearly anything.

With so many devices in the studio these days, the last thing anyone needs is gear with a noisy cooling fan. That's why Element's **power-supply is fanless**, for perfectly silent in-studio operation.

Element modules are **hot-swappable**, of course, and quickly removable. They connect to the frame via CAT-5, so pulling one is as simple as removing two screws and unplugging an RJ — no motherboard or edge connectors here.

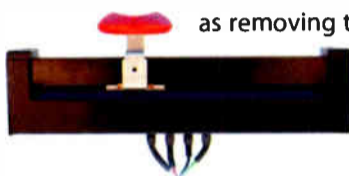

Faders take massive abuse. The ones used in other consoles have a big slot on top that sucks in dirt, crumbs and liquid like the government sucks in taxes. By contrast, our silky-smooth conductive-plastic faders actuate from the side, so **grunge can't get in**. And our rotary controls are high-end optical encoders, rated for more than **five million rotations**. No wipers to clean or wear out — they'll last so long, they'll outlive your mother-in-law (and that's saying something).



Element's **avionics-grade switches** are cut from the same cloth. Our design team was so obsessed with finding the perfect long-life components that they actually built a mechanical "finger" to test switches! Some supposedly "long life" switches failed after just 100,000 activations; when they found the switches used in Element, they shut off the machine after **2 million operations** and declared a winner. (The losers got all-expense-paid vacations to the landfill.)

Individual components are **easy to service**, too. Faders come out after removing just two screws. Switches and rotary volume controls are likewise easy to access. And all lamps are LEDs, so you'll likely never need to replace them.

Engineers have said for years that console finishes don't stand up to day-to-day use. Silk-screened graphics wear off; plastic overlays last longer, but they crack and chip — especially around switches and fader slots, where fingers can easily get cut on the sharp, splintered edges. We

decided that we could do better.

Element uses high-impact Lexan overlays with color and printing on the back, where it **can't rub off**. And instead of just sticking the Lexan to the top of the module like some folks do, our overlays are **inlaid on the milled aluminum module faces** to keep the edges from cracking and peeling — expensive to make, but worth it. For extra protection, there are **custom bezels** around faders, switches and buttons to guard those edges, too. Element modules will **look great for years**.



By the way, those on/off keys, fader knobs and bezels are our own design, custom-molded to give **positive tactile feedback**. The switch is flush with the bezel, so it's easy to find by touch. But if something gets dropped on it, the bezel keeps the switch from being accidentally activated.

More than just products

Catfish learned something else important from his time at PR&E: "Even the best products are nothing without **great support**." So Axia employs an amazing network of people to provide the best support possible: Application Engineers with years of experience mapping out radio studios... the most **knowledgeable, friendly** sales people in the biz... Support Engineers who were formerly broadcast engineers. Plus a genius design team, software authors who dream code... one of the **largest R&D teams** in broadcast.

And now Axia has become radio's **first console company to offer 24/7 support**, 365 days a year. Chances are you'll never need that assistance, but if you do, we'll be ready for you. Our 'round-the-clock help line is +1-216-622-0247.



Proudly Over-Engineered

Are Axia consoles over-engineered? **You bet.** If you're looking for a cheap, disposable console, there are plenty out there — but this ain't it. Not everyone appreciates this kind of attention to detail, but if you're one who seeks out and appreciates excellence wherever you may find it... Axia consoles are built **just for you**.



www.AxiaAudio.com

What Is All the FLAP About?

There is no question that smart broadcasters are scrambling to protect their transmission sites from vandals, especially where intruders can access those sites easily. Whether the concern is cost of copper replacement or loss of airtime, it is more important than ever before to give attention to site security. Kevin Kidd describes a process to reduce such vandalism which he calls FLAP.

As we discussed in a previous article, my acronym for transmitter site protection is FLAP. Fences, Lighting, Alarms and Presence. Please allow me to expand.

AN ATTRACTIVE TARGET

The copper materials used at all of our transmitter sites have become very valuable on the scrap market in recent years – the per-pound scrap price for bare copper has risen above the new material cost of just six years ago.

Such scrap prices of well over \$2 per pound continue to fund the habits of crack heads and tweekers – and you have hundreds or thousands of pounds of copper sitting there, depending upon your frequency and antenna. Some see it as free money, just for the taking.

As a result, the rate of transmitter site thefts and vandalism is growing exponentially. Now we even hear reports of unscrupulous scrap metal buyers suggesting to clients where they can find more copper.



An unwanted withdrawal from your copper bank.

Recently in Tennessee, thieves trying to strip copper grounding wire from a 300-foot tower ended up cutting a guy wire, bringing down the entire tower. Replacing the tower will cost \$250,000 or more; according to the tower owner, the thieves got away with about \$25 worth of copper. Although there have been arrests, chances of any real recovery are slim, essentially from insurance.

Just think, though: if this had happened at your site, how much would you have sustained in lost airtime and spots, not to mention the loss of service to the public?

COPPER AND DRUGS DO NOT MIX WELL

Crack Cocaine and Methamphetamine (Crystal meth, crystal, speed, tina, poor man's cocaine, ice, glass, chalk, krank (crank), tweak, fire, speed, meth, P, go, fast, cat, pure) are highly addictive and common drugs. Both are very commonly the impetus behind copper or other metal thefts.

Here is the math that should make you concerned – if you are not already – about site security: a “normal hit” or bump of crack or meth is between .25 and .50 grams at a common street price of \$100/gram. That means that 12-25 pounds of scrap copper at \$2.00/lb is required for a hit. The high from a hit of meth can last between 2 and 36 hours, depending on the dose, the method of ingestion and the individual. The high from a hit of crack may only last a few minutes to an hour, again depending on the dose and the individual.

To put all this in prospective, a hit of meth or crack costs us (you and I):

Material	Feet per Copper Pound (Approximate)	Feet of material to Net \$25 Scrap @ \$2.00/lb	Approximate Cost of Replacement Material
.032x4 inch Copper Strap	2.00	25	\$129
.020x2 inch Copper Strap	6.45	81	\$126
#10 Copper Wire	32.00	400	\$93
Expanded Copper Mesh	21 lbs per 8x24 foot sheet	0.6 of a sheet	\$500/sheet
1 inch Copper Tubing	1.19	15	\$120
1 5/8 inch Air Dielectric Coax	1.33	17	\$873
3 inch Air Dielectric Coax	0.80	10	\$675
1/2 inch Foam Coax	6.80	85	\$612
7/8 inch Foam Coax	4.80	60	\$567

... and this does not include labor for the repair and replacement.

At times, I have suggested that people tack \$100 bills around their tower fences with a note to “take one but leave the copper alone.” The comment is tongue-in-cheek, of course. But in some ways, you almost have to wonder if that is not a bad idea.

The point is that this is a serious problem. So, let us see what can be done to solve – or at least control – it. Not to sound like a Sue Grafton novel but:

F IS FOR FENCES

Site fencing should generally encompass the entire site – and individually protect high value targets. A high concentration of copper is (or at least *should be*) found in the immediate area of an AM tower base and transmitter building. Base pier and ATU bonding straps are usually in the open and visible. All too often, tower base fencing is only installed because “The Rules” say that you must.

FCC Rule 73.49 states that AM towers must be enclosed within “effective” locked fences. There seems to be many different interpretations of “effective” even among FCC inspectors. A minimally compliant tower fence may satisfy an inspector but do little to deter a crack head.



Fences not only protect the public from RF, they protect your copper from the public.

Perimeter fences and gates should at least make entry tough enough to discourage casual intrusion.

YOU NEED A GOOD FENCE

At a recent job site we witnessed numerous people, ages 8 to 50, climbing over and under a new six-foot chain link perimeter fence. This fence had no barbed wire on top and the trespassers could be over it and

through the site to the other fence in seconds. They thought no more of this small impediment than the small creek that they had to jump to get to the fence.

Although not in a particularly bad area, this large site lies between the local Wal-Mart and “da ‘hood.” One older gentleman that we stopped while about to crawl *under* the new fence said he had noticed the “No Trespassing” signs but did not think that it mattered if he took this shortcut.

The station owner is now working on adding razor wire to the perimeter fence.

DO NOT SKIMP ON THE FENCE

Individual tower and building fences should be substantial enough to resist a determined attack.

At least six feet of commercial quality chain link or *solid* wooden fencing is a minimum. Razor wire or at least multiple strands of barbed wire should encompass the top *and bottom (inside)* of each fence.

Although consulting engineers disagree on the preferred fence construction, either heavy wood or grounded steel fencing is required. Some of the commercial grades of the nylon fencing are quite substantial but I suspect would be inadequate to repel a determined attacker.

Although there is no FCC requirement to have FM and TV transmitting towers fenced, most insurance companies will specifically require “effective” fencing as a condition of the insurance policy. Their definition of “effective” will likely be aimed more at preventing intrusion and theft. Not only are exposed coax and grounding materials in constant danger of being “harvested” from FM and TV sites but thrill seekers regularly climb unprotected tall towers.

MAKE THE GATES STRONG, TOO

Gates should be substantially chained, and the gate hinges welded or otherwise secured. Chains can be added top and bottom on the hinged side.

The flimsy latches supplied with chain link fences provide only seconds of protection. Standard chain link fence hinges can be disengaged easily with a wrench, pliers or hammer. The soft aluminum wire ties that are normally used to secure the fence fabric to the posts and runners can easily be unwrapped by hand. I suggest using steel tie wire at least for the top and bottom ties on each post and along the bottom security wire.

Site driveways should be gated at a location that will not allow vandals cover while they break, cut or otherwise force their way onto the property. Long secluded driveways are an invitation to vandals and other trespassers.

While effective fencing may require serious effort to breach, there are some neighbors that even effective fences cannot stop. For those folks:

L IS FOR LIGHTING

All tower base and transmitter-building approaches should be illuminated with current-monitored dusk-to-dawn lights. If the site has towers that require obstruction lighting, the same area lighting schedule would be appropriate.

Motion detection lighting is handy and generally will save a few bucks on electricity but *will not* provide forewarning of an impending vandalism.

As I have preached for the past five years: of all the site vandalism cases that we have worked on, *every one* of the sites that had area lighting suffered vandalism to the lighting *before* the vandalism to the ground system or coax occurred. Not a few, not some, not many, but *all*.

Some of the lighting damage actually could be traced back several days prior to the copper theft. (At one site the lighting was not operational but the vandals trashed it anyway.) Of course, the sad fact is that many sites have no area lighting in place.

Lighting areas should be on separate breakers so that a problem in one area will not kill the lights in others. We strongly recommend that current sensors be added to

(Continued on Page 16)

The New Sicon-8 Voice Remote Control



The CircuitWerkes Sicon-8 Voice Remote Control

- Use our pre-recorded voice responses or record your own!
- 8 channels of metering, status and control (expandable to 16) and up to 5 alarms per channel.
- No accessories necessary to control your site right out of the box.
- Auto-ranging, auto-calibrating meters make setup a snap.
- Function scheduler, auto-logging & alarm reporting included.

Introducing the Sicon-8, a revolutionary transmitter site controller with custom voice recording technology for perfectly natural sounding dial-up or radio link control. All of the I/O, including 8 channels of relays, are included on the main board so there is no need to buy anything else. All metering, status and control connections are on depluggable screw terminals. An expander chassis, the SX-8, adds eight channels of metering, status & control to an existing Sicon-8 for a maximum of 16 channels. Designed to be controlled from any dial-up telephone, an auto-answer cell phone or from its serial port, the Sicon-8 gives you the control options that you need. A free, Windows program, the Sicontroller, gives you full access to all of the Sicon-8's programming and control functions. Basic logging functions are included. Live Internet interfacing is accomplished with an inexpensive accessory. Visit us online at www.circuitwerkes.com for complete info on the Sicon-8.

Remote Broadcast Solutions



MicTel Mic/Line to Telephone Interface

- Outputs & Inputs for telephone handset, cellular phone or balanced line level at up to +10dBm.
- Operates up to 36+ hours on two 9V alkaline batteries.
- High quality, user-switchable, internal limiter prevents clipping.
- External power input with silent, auto-switching battery backup.
- Individual gain controls for send, receive and headphones levels.



Unattended Dial-Up Broadcasts with the DR-10

- The DR-10 is a Dial-Up remote control with balanced, telephone audio input & output that can control many automation systems or your audio console for unattended remote broadcasts.
- Our Silencer™ option removes control tones from the audio path.
- Use the DPDT relays to insert the phone audio directly into the program path when necessary, especially for emergencies.



TelTap Pocket-Sized Manual Telephone Coupler

- Can be used as a phone tap or a passive manual telephone coupler.
- Send or receive telephone audio.
- Compact size & low cost makes the TelTap a great addition to your remote kit for main or backup capabilities.

Discover more online at www.circuitwerkes.com



CircuitWerkes, Inc. - 2805 NW 6th Street, Gainesville, Florida 32609, USA. 352-335-6555

rfSoftware has the engineering tools you want and money saving features that you'll love!

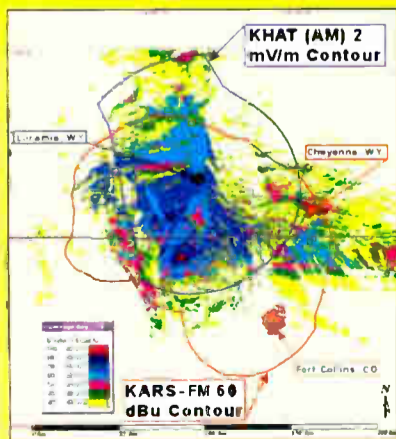

rfInvestigator is a tool for analyzing FCC spacing, FCC contours & much more! Population data, LULC data, terrain data, Longley-Rice models, Topo! maps & drive test data can all be displayed in **rfInvestigator**. It offers a host of advanced features, many of which are not found in similar programs or are offered as expensive additions, like a terrain profile tool and our antenna design tool that can automatically calculate your antenna pattern for you. Add our **DB-Builder** program and **never buy another FCC database!** Ever!

Although **rfInvestigator** offers sophisticated features, the user interface is intuitive & simple to use. **rfInvestigator's** power makes it useful to the experienced engineer while its easy-to-use menus make it friendly for station and group owners.

Need AM Tools? Call Us!

rfSoftware, Inc.
innovative engineering tools

Visit us at www.rfsoftware.com or call us at 352-367-1700 for info on our AM & FM tools!

What Is All the FLAP About?

each area circuit so that each tower or area can be monitored individually. A single outage might not be an immediate concern – but several outages might signal “harvest season.” The current sensors should be incorporated into the secondary alarm system discussed below.



Vandals will attack your lights.

SSAC (as well as others) builds a full line of reasonably priced current sensor/monitor modules that can be added to existing AC circuits with little rewiring.

A IS FOR ALARMS

All situations are different but we suggest that each site have two separate alarm systems. One alarm would be professionally installed and monitored for areas with positive controlled access. Another alarm, possibly based on the station's existing remote control, can be used for uncontrolled access.

Controlled Access can be taken to mean “any area that would not be accessible to persons or animals without keys, codes or specific business inside.” In other words, “If the alarm is activated, someone is there that should not be.”

Examples of this would be the interior of the transmitter building, ATU cabinets/doghouses, generator enclosures, or external power disconnects. Controlled access areas can be protected reliably with door, motion and smoke alarms. Remember the word *reliable*. If an alarm is unreliable or produces excessive false alarms, it is worse than no alarm. Some alarm companies and law enforcement agencies even have begun charging a fee for excessive false alarms.

Uncontrolled Access would be those areas with sensors where external forces (weather, animals, unrestricted human traffic, etc.) could create excessive false alarms. Examples of these sensors would be the area lighting sensors, external motion detectors, external photo/laser beam detection, gate sensors and fence tamper detection.

It has been found that most simple motion detection devices will not work reliably outdoors. This does not mean that they are not useful for small area protection (ie, tower base area), but that they may yield too many false alarms to be used with a professionally monitored system.

AN ALARM EXAMPLE

A typical alarm setup for an AM array might be that the main alarm is installed to monitor the secured transmitter building doors, windows, internal motion, glass breakage, smoke, the covers on an externally mounted generator, and the tuning house doors. If someone kicks or pries a door open, the alarm will activate and the authorities immediately notified by a monitoring service.



An alarm service can notify authorities upon any intrusion.

The secondary alarm might then monitor the area lighting, external motion detectors, bait switches, and an opto/laser line detector running thru the middle of the array. Small animals or weather may occasionally trigger the secondary alarm – but a series of alarms would indicate that someone is attacking the site.

For example, you might notice the laser line detector goes off, followed a few minutes later by a light outage, followed a few minutes later by another different light outage, followed by a motion detection at a tower base, etc., etc. This secondary alarm is probably best monitored by station personnel as monitoring services may not connect the dots fast enough to send help.

Video cameras can augment hardware alarm systems. Good quality network cameras are becoming quite affordable and can be viewed remotely via a web browser. However, I have found that weather and insects limit the reliability of cameras for motion detection alarming.

On the other hand, I was able to use the video from one of my cameras to prosecute a local dooper when he vandalized an outdoor mounted network equipment rack and helped himself to some scrap copper at my warehouse. He left with about \$25 worth of copper but damaged almost \$1,000 of wireless network, UPS and router equipment. Unfortunately, as is often the case, due to his drug dependency and numerous contagious and potentially terminal illnesses, he is still walking around free after being sentenced.

P IS FOR PRESENCE

An uninhabited site or building is a prime target for thieves or vandals.

Someone should visit all transmitter sites at least a couple of times per week. That someone does not have to be a technical type to do a quick look around to check fencing, lights and other security items. Vandalism that is discovered quickly is much easier solved. Quick discovery will also allow more radical steps to be taken to protect the stations property and personnel.

Yet another point to remember: *Not one of the AM vandalism cases that we have been involved in were perpetrated by one person, on one trip, on one date.* All cases have been the result of multiple “visits” at different times.

NO INSPECTION = TROUBLE

One South Carolina external vandalism/theft had been going on for months. Station personnel had not been to the TX site for weeks and had not been to the tower bases for months. Eventually the station dropped off the air.

When someone finally went to the site, it was found that the vandals had cut audio and coax cables *inside* the TX building. They *had already stolen* the ground system infrastructure, HVAC units, HVAC tubing, tower light and control wiring, telephone lines, water cooler and some electrical wiring in the attached but abandoned studio building.

In addition to on-site presence, remote readings of transmitter and directional array should be taken regularly (i.e. several times a day) and investigated immediately if different from normal/licensed. Many vandalism cases could have been discovered early if someone would have noticed that the transmitter or DA perimeters were departing from normal.

Grass or brush overgrowing a site or building approaches will not only suggest that no one is on site but that there probably will not be anyone coming in soon. The overgrowth also provides plenty of cover for vandals as they go about their thievery. Good grounds maintenance will not only help deter would-be thieves but is essential to the proper and stable operation of AM stations.

Most law enforcement agencies will do a regular targeted drive-by if asked. Paid security patrols are another good source of “Presence.”

CASE IN POINT

We rebuilt a site for a station in Ohio in early spring of 2006. Later that year third-party engineers doing due diligence measurements (as required by Sections 22.371, 27.63 and 73.1692) for a nearby cell tower discovered that some of the stations monitor points were magnitudes out of tolerance.

The stations consulting/contract engineer was called for the first time in several months. He discovered damage at two of the station's five towers.

Due to station financial status and other factors, we were asked for a repair estimate in January 2007 but were not contracted to do the repairs until June 2007. Upon our arrival, we discovered further damage on three of the five towers and extensive damage to the grounding around the transmitter building. The second round of damage appeared to have occurred only a few weeks earlier.

It is clear what factors contributed to the damage:

1. The site had no fences or gate. Any vehicle could drive anywhere on the site.
2. The site had some dusk-to-dawn lighting. It was destroyed.
3. The site had no alarm. Nor was anyone observing remote control readings of the transmitter or array.
4. Station or engineering personnel had not visited the site for months.

TO SUMMARIZE

Fences should be capable of repelling all but the most determined attackers. More layers of fencing is better. The harder it is to get to the bounty, the less energy that a common thief will exert in the theft.

Lighting is not just to keep you from tripping over something in the dark. It should be an integrated part of the prevention and alarm system.

Alarms can reliably protect property within a controlled environment. Additional alarms and monitoring devices will give warning of an impending attack. Alarms that are unreliable or produce too many false indications are worse than no alarm.

Presence in the form of regular site visits should be used to give would be thieves a warning and to verify that obvious attempts have not been made to breach or damage any station facility. Regular remote control readings must supplement actual on-site observations.

Will FLAP keep all of your site equipment safe and worry free? Maybe not. But remember: the majority of copper thievery is considered to be “crimes of opportunity” performed by persons given ample time and opportunity at unprotected sites. If we can discourage all but the most determined attackers, damages and downtime will be reduced to a minimum.

Kevin C. Kidd, CSRE, AMD, is the proprietor of AM Ground Systems Company and KK Broadcast Engineering. More information can be obtained by calling 1-877-766-2999 or visiting www.amgroundsystems.com

If you thought that you couldn't afford new Automation,
then think DIGILINK-XTREME !



Xtreme w Bridge

(PC required, Bridge included)

NEW Xtreme-PC

uses the PC's built in sound cards
 (PC required)

NEW Xtreme-ARC

the ARC-10 has a built in sound card w logic
 (PC & ARC-10 console required)

only \$100/month

Xtreme is ideal for Internet Radio, Live On Air, Hard disk automation, Satellite automation and so much more. For less than the monthly cost of a cell phone contract you get everything including support and updates !!!

from the leader in Radio Studio Furniture,
ACCENT line from Arrakis



Contemporary brushed metal and textured panel styling

With ACCENT from Arrakis, the metal structure is artfully integrated into the visual decor of the cabinetry. As a result, ACCENT is a contemporary blend of brushed metals, pleasing colors, and interesting textures. Cabinetry and electronics complement each other in such a way as to create a bold visual environment for talent, guests, and clients alike.

'All NEW' from Arrakis Systems for '2008'

If you thought that you couldn't afford a new console,
the ARC-10U is only \$1,599 !



Available in 3 models, the ARC-10 is perfect for all radio applications from On Air, to Production, to News, to Internet radio. The built in sound card interfaces with Windows & Mac

ARC-10U	unbalanced	\$1,599
ARC-10UP	unbalanced w USB	\$1,999
ARC-10BP	balanced w USB	\$2,495
ARC-10SW	16 in x 3 switcher	\$995

an advanced radio console for the BIG jobs,
the ARC-15 is only \$3,495



The ARC-15 has BALANCED audio inputs and outputs, and with 5 mics is ideal for talk studio applications. The built in telephone channel handles Call in shows

- 15 channels, Pgm & Aud outputs
- Built in telephone channel for Call in shows
- 5 mics. (4 selectable as mic or line)
- PC sound card built in

These "Pops" Orchestrate Nightmares

Last time, I popped off on the pros and cons of windscreens and filters for our studio and remote microphones.

Unfortunately, there may be little convincing either the windscreen or non-windscreen camps to change sides. The best advice is to experiment when possible to see which solution benefits your station while also keeping talent comfortable.

Nevertheless, even in houses where windscreens are regularly used, those of us who have recorded a few announcers or vocalists in our time have found some who will pop even despite the best designed windscreen. Here are a few tips which might help for even the most difficult "poppers."

WHY FILTERS AND SCREENS

Most professional microphones feature built-in pop filters within the microphone's capsule. The pop filter is usually a thin foam which helps to disperse the air pressure we create when our mouths make sounds such as "P." This is the second line of defense against the announcer's onrush of air that can create an unwanted and very unnatural distortion in the audio from the microphone.

In most cases a windscreen is before the pop filter, the first – and usually the best – defense from pops.

LET YOUR FINGERS DO THE LISTENING

If you want an idea of what is hitting the diaphragm of a condenser or dynamic microphone or the thin ribbon of a velocity microphone, just hold your fingers about two inches from your mouth and attempt the old standard "Peter Piper Picked a Peck of Pickled Peppers" line.

The air hitting your hand may not feel like much but microphones, especially those which excel at high frequency response, have *light, thin elements* which can move quickly. The soft plosive you feel on your hand might relatively be "hurricane force" to a wispy thin element.

When the diaphragm or other element moves too far because of the sudden massive gust of the plosive, it may actually contact other stationary parts of the microphone – or at least move much harder and farther than the original design – resulting in the aforementioned distortion; someone blowing into a microphone for a microphone check may be the most obvious extreme example.

Usually this translates to a mostly bass splattering of the sound at the plosive point in the audio. Your ear would never pick this up listening to the original speech sound, but in the audio, it is unmistakable.

ANGLING AWAY

Many announcers enjoy the warm bass proximity effect of working close to the microphone. But if they tend to pop their P's despite the proper use of a

windscreen and pop filter and they have been working directly on-axis (speaking directly into the front of the microphone), a minor adjustment might solve the problem.

For these announcers, simply try a slight repositioning, moving the microphone to a 45-degree angle. This will allow them to work close to the microphone without popping directly into the element.

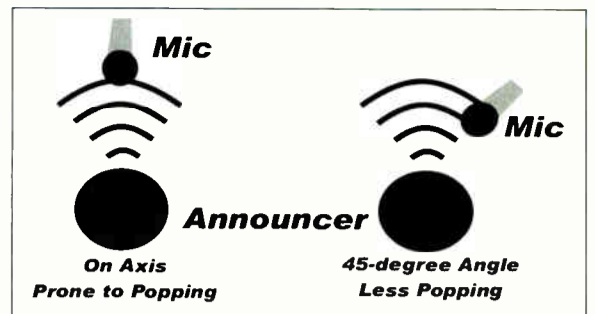

The simple solution for pops may be a slight angle.

If this placement does not work, there are other options. Consider whether the microphone you are using is usually that sensitive. Could there be a problem with the element?

Have the announcer try a second microphone of the same type – easy in many studios – and if they are still popping, move right to step 2, which might be to try a

(Continued on Page 20)

The best use the best.™

9000 stations 100 countries

Welcome to the World's largest broadcast software company



Visit us at www.rcsworks.com or www.prophetsys.com Email us at best@rcsworks.com

© Copyright 2007 RCS, Inc. All Rights Reserved RCS, RCS Sound Software, the featured product names and their logos are registered trademarks, or trademarks, of RCS, Inc.

END2END Solutions From SCMS

GET YOUR RACKROOM SOLUTIONS FROM THE DEALER THAT KNOWS RADIO



Optimod-FM 5300 puts coveted five-band and two-band Optimod processing into a single rack unit package and brings it to you at the most affordable price ever. Quality sound is what 5300 is all about—sound that attracts audiences by providing a polished, professional presentation regardless of format and source material.



Three Processors in One. The Orban 6300 is a high-quality, multipurpose stereo audio processor for digital radio, digital television, netcasts, STL protection, satellite uplink protection, and digital mastering.



Orban's all-digital 9300 Optimod-AM audio processor can help you achieve the highest possible audio quality in monophonic AM shortwave, medium wave and long wave broadcasts. Optimod-AM delivers louder, cleaner, brighter, FM-like audio with an open, fatigue-free quality that attracts listeners and holds them.



STL



RF Site



Studio



Rack Room

Mid-South: 1-877-391-2650 Bob Mayben
 Central: 1-731-695-1714 Bernie O'Brien
 West Coast: 1-866-673-9267 Doug Tharp
 Mid-West: 1-513-899-3036 Mary Schnelle
 South-Atlantic: 1-770-632-1295 Art White
 North-East: 1-315-623-7655 Jim Peck
 South-West: 1-210-775-2725 John Lackness
 North Central: 1-513-376-8600 Pam Leffler
 Pro Audio: 1-877-640-8205 Ric Goldstein
 Latin America: 1-760-650-1427 Lily Massari



www.SCMSinc.com

Contact SCMS
 at any of its offices
 to discuss your needs

1-800-438-6040

Bob, Ernie, Matt, Mike or Andy
HQ in Pineville, NC

Studio Guide

by George Zahn

These "Pops" Orchestrate Nightmares

— Continued From Page 18 —

totally different type of microphone. (Keep in mind that different microphones will yield slightly different colorations of voice.)

It is best to determine if you need to change the microphone before recording an extended piece with the same announcer as opposed to switching microphones in the middle of the recording. Try a plosive test such as having your announcer say a line from "Peter Piper" when checking microphone levels before the official recording and you can avoid some extra work or re-recording later on.

DISTANCE LEARNING

A last resort to prevent popping during the recording or live performance is to simply increase the distance of the announcer from the microphone. This may cost some precious proximity effect warmth from your announcer, but it helps minimize the pops.

Many studios and some stations use external "ring" pop filters, which look like a piece of sheer nylon stretched like a drum head over a circular plastic hoop. The "arm" which holds the external pop filter can attach via gooseneck to the microphone stand and allow the external filter to be moved near or far from the microphone.

For those announcers who need to work close to "something," they can get right on top of the external filter, but then the filter can be moved away from the microphone, creating a safe non-popping distance.

TRUST THE SPEAKERS, LUKE

If you are live and a pop happens, there is not much you can do to fix it, but at least you can try to prevent the next one from happening by subtly moving a microphone. If you are recording, you can usually get a re-take.

But how do you know if that last P actually popped? Headphones as monitors can be deceiving. From personal experience, I have done many recordings where decent headphones were the only available monitor source, and found myself surprised at how many plosive distortions "slipped through." As with most monitoring, trusted audio speakers are generally a much better choice for critical listening. If you only have headphones — and if you are doing critical recording, it is best to ask for a re-take from your announcer if you are at all in doubt.

Of course, no matter how well you plan, place your microphones, and monitor, one or two pops will occasionally get through. Again if you are live, you can only try to prevent the next popped plosive. If we are on disc, tape, or hard drive, what to do? To quote the naïve producer, "we'll fix it in the mix!"

AUDIO MICRO SURGERY

The fix for a plosive distortion is relatively easy with today's digital audio software, such as Adobe Audition or Pro Tools, but even free editors such as Audacity have some basic graphic equalizer either as a standard feature or as a software plug-in.

Since the crux of the plosive problem lies in the bass end of the frequency spectrum, you can start by cutting 12 dB at about 250 Hz and rolling everything below as much as possible. The illustration is the graphic equalizer feature on Adobe Audition 1.5.

This is a good start. You may be able to keep some of the bass by adjusting these settings, because plosive distortions may vary very slightly.

At this point, the novice would say "let's just keep everything from 250 Hz rolled off when we record." To that I would say, "fine, if you want James Earl Jones to sound like Tiny Tim." If applied to more audio than the plosive itself, the EQ will affect the whole mix, includ-

ing the music that is mixed with the voice, thinning everything dramatically.

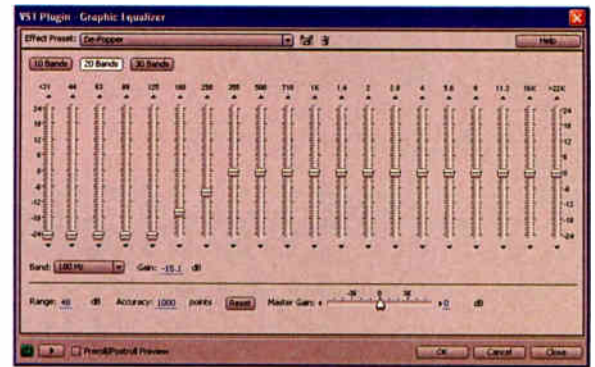

A starting point for pop reduction.

If you want to play around with it, try EQing longer segments, but you will find that is why God made "Undo" buttons. Again the best bet is to avoid the

(Continued on Page 22)

An advertisement for COMET capacitors. The background is a vibrant red with a blue and white grid pattern. In the top right corner, the "COMET" logo is displayed in white on a red oval. The main headline, "Leading the way in Broadcast Capacitors!", is written in large, bold, yellow-outlined black letters. Below this, a collection of various capacitor models is shown, including large cylindrical units and smaller components. The text "COMET is the world leader for high voltage vacuum capacitors and provides a wide range of variable and fixed capacitors..." is written in white. A bulleted list of features follows: "Variety of Solutions for Power Applications", "Large Range of Voltage and Capacitance Values", "Broad Tuning Ranges for Variable Capacitors", "Compact Design Relative to Operation Power", and "Ease of Installation". Below the list, it states "AND COMET provides the most comprehensive industry capacitor replacement and cross-reference guide for your application." The advertisement concludes with the contact information: "Contact us today to help meet all your capacitor needs! 1-877-VAC-CAP1 (877.822.2271) www.comet.ch".

Google Radio Automation

The next giant step forward in automation.

Not only is Google Radio Automation changing the way you work and drive revenues, it's redefining the space itself.

With time-saving new advances in operating convenience, Google Radio Automation helps make your station more efficient and productive than ever before. Features like a fully customizable, widget-based User Interface and a public protocol for easy integration with other systems mean you can achieve unparalleled flexibility and innovation. Finally, a third-generation technology solution to free you from the restraints imposed by current legacy automation systems.

Google Radio Automation. Take a giant step forward. Call today.

Google Radio Automation
1-800-726-8877



google.com/radioautomation

© Copyright 2008. All rights reserved. Google is a registered trademark of Google Inc.

Studio Guide

by George Zahn

These "Pops" Orchestrate Nightmares

– Continued From Page 20 –

plosive distortion altogether by using good pop filters and wind screens, the correct microphone for the job, and the correct placement for the announcer.

THE MICRO PART

If you are editing on digital software, you want to isolate only the audio affected by the plosive. If you highlight and EQ over too large an area, you will obviously "thin" the voice of the speaker dramatically.

This next illustration shows the rather large and erratic peak of a popped P. Notice I highlighted only a small amount (less than .05 seconds). That is the only part I want to EQ to minimize or eliminate the distortion while not disturbing the surrounding audio:

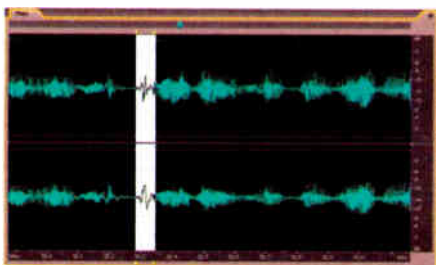

Isolating the part to be equalized for pop reduction.

After equalizing the short piece in question, you will see that the peak of the plosive is gone. With the basic EQ settings described here, you will still get enough of the P sound to easily be discernible while taking out the annoying POP. The new audio wave is shown below:

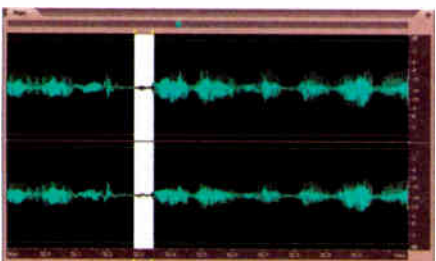

Same audio after equalization. One the pop was affected.

Obviously, you could try the same thing with an outboard EQ in real time playback, but the odds of being able to punch in the EQ on the .05 seconds of the popped P is something that would take timing better than most trapeze artists.

KEEP IT CLEAN

Keep in mind that microphones are the first line of the audio chain for most things we air or record. If we maintain our microphones, and keep them clear of excessive dust and crud, including switches such as -10 dB pads and bass roll-offs, we will have better performing and more dependable tools.

In discussing this with many engineers over the years, the recurring tenets are clean, dry, and protected. Other than specially pro-

tected hydrophones (which *Radio Guide's* contributing writer Jeff Johnson has used on some manatee recording projects), microphones are not designed to be immersed in water or even made slightly wet. Condensers can become somewhat feisty just from high humidity.

Furthermore, it is best to keep all the microphones in your arsenal stored in good protective cases when you do not have them in the studio. Even if you plan for all microphones in a new shipment to stay in place in a studio, it is still a great idea to keep the cases just "in case" you need to pack them up for a remote.

Oh, and for all of us who at one point or another naively created our own plosive by blowing hard into a microphone to do a check, here is a thought: Please keep in mind – especially if you do not know the type of microphone you are using – a swift gust of air blowing into a ribbon microphone can cause incredibly expensive and instantaneous damage. In the business, they call that a CLM, or Career Limiting Move.

Coming up, more on the incredible EV 635 and some of the feedback (whoops!) we received on our article on the "hammer."

George Zahn reports that his parent organization has changed names and email addresses. He still welcomes your email comments and experiences, but now at Maple Knoll Communities: gzahn@mkcommunities.org

RADIO GUIDE

www.radio-guide.com

Premier technical information meets Radio's On-Line Community® at www.radio-info.com arriving September 2008



RADIO-INFO.COM

RADIO'S ONLINE COMMUNITY

Able to leap tall buildings?



No distance or line-of-sight restriction makes **Starlink SL9003T1** the ideal choice for STL/TSL and intercity links.

Starlink T1's bidirectional high capacity significantly reduces communications costs compared to discrete audio, telephone and data circuits.

And **Starlink's** uncompressed digital audio will stand out above your competition.

STL over any distance or terrain... ...Moseley Starlink T1



- HD Radio™ and Multicasting
- Transmitter remote control
- RBDS data
- Telephone extension
- IP-based equipment control
- Internet and e-mail connection

Call the digital STL experts today.

Dave Chancey 805.968.9621

Bill Gould 978.373.6303

www.moseleysb.com

Moseley

WHEN EVERY SECOND COUNTS



Z/IP: THE WORLD'S MOST RELIABLE IP CODEC Just what you'd expect from a Zephyr™.

IP offers clear advantages with regard to cost, ubiquity, and mobility. But also, new challenges. That's why Telos developed ACT™ - Agile Connection Technology. Working in concert with MPEG-ELD, the world's most advanced coding technology, ACT™ continuously monitors the connection, adjusting the buffer and bitrate to compensate dynamically for network conditions. It does so automatically and without audible artifacts to keep delay as low as possible and quality as high as possible.

Telos

AUDIO | NETWORKS

www.Telos-Systems.com

Telos, ACT™, Zephyr and Zephyr/IP are registered trademarks of TLS Corp. ©2008. All Rights Reserved

World Radio History

Hall of Achievement

Recognizing those who have made real contributions to the broadcast profession.

Dave Chenoweth and Ken Branton

Field Service Par Excellence

A whole generation of engineers, including your Editor, learned about maintaining broadcast transmitters from a support team that invariably responded to our panic with knowledge and patience, helping to restore our transmitter operations. Scott Fybush highlights a couple of gentlemen that always treated us as colleagues and friends.

It is 3:00 AM. There is a driving rainstorm outside, and inside your remote transmitter building you are trying to figure out why your transmitter will not come back up. Your pager is buzzing with messages from the General Manager, wondering if you will have the radio back on the air in time for morning drive.

Now, who are you going to turn to for help?

For almost three decades, the answer to that question – at least if the transmitter in question came from Collins or Continental – was a reassuring one: Dave Chenoweth or Ken Branton, the gurus of field service in Dallas, and this month's inductees to **Radio Guide's Hall of Achievement**.



Dave Chenoweth and Ken Branton

MILITARY ELECTRONICS BACKGROUNDS

Despite their many years of service to the broadcast industry, neither Chenoweth nor Branton came from a broadcasting background. Both men first began working with electronics in the military; Chenoweth in the Navy, Branton in the Marines.

After his naval service, Chenoweth spent three years with Philco before joining Collins in 1958; Branton came on board three years later after spending some time working on a radar program for Boeing.

Even after Chenoweth and Branton were both on the Collins payroll, their early careers with the company were in areas away from broadcasting – in Branton's case, really far away from broadcasting.

"Collins was building SSB radios for the U.S. Marine Corps in Japan," Branton recalls, and he soon found himself in Asia working for the company. As the war in Vietnam escalated, Branton ended up living there as part of Collins' military support team, and he was evacuated from the country with his family in 1975 just before the final American exodus from the embassy in Saigon.

"We were just getting to California when that was going on," he says.

A CHANGE OF FOCUS

By that time, Chenoweth had already made the transition from Collins' training department to the Broadcast Field Service office.

"I got tired of the traveling I was doing," he recalls. "Going all over the world at a moment's notice got thin, and I saw those broadcasting guys sitting in their offices

a lot of the time. Most of their travel was within the U.S. – and that appealed to me."

By 1973, Chenoweth was the head of Collins' Broadcast Field Service division. Branton joined him a few years later. According to Branton they "hit it off" as a team.

SERVICING THE FIELD

When Rockwell-Collins sold its broadcast division to Continental Electronics in 1980, both men made the move to the new company.

There, they bolstered a field service operation that had been almost nonexistent. (Continental's Dave Hultsman notes that there was a good reason for that – the big AM transmitters that were Continental's main product line before the Collins acquisition were all going to stations that already had extensive in-house engineering staffs of their own – in contrast to the smaller stations that were buying Collins' lower-powered AM and FM transmitters.)

While Chenoweth became one of the company's public faces, demonstrating operating transmitters on the floors of countless NAB conventions over the years, Branton tended to stay back at the office during the trade shows. At the same time, both men spent plenty of time on the road helping out with installations and troubleshooting.

FIELD TRIP HIGHLIGHTS

Chenoweth says one of his most memorable jobs was the Master FM project in Miami in the early 1980s in which multiple Continental FM transmitters were installed in a new transmitter building.

"I enjoyed all of them," Chenoweth says of his trips. "I enjoyed the work and the people."

For Branton, one particularly memorable install was a massively high-powered FM transmitter site high in the Italian Alps. Two transmitters were combined to produce 50kW of transmitter output power, which was then fed into a custom Kathrein directional panel array that created a tight beam of intense signal aimed at distant Zurich, Switzerland.

"The RF beam was so narrow that it hit Zurich but missed one side of the city, so we went up and adjusted the beam, just like you'd aim a flashlight," Branton says, recalling that Swiss authorities

were none too pleased about a new FM signal coming in to the city from beyond their control, playing American pop and country music.



High in the Italian Alps (10,000 feet), Ken Branton helped install this antenna and two 831G-2C transmitters to pump RF into Zurich.

THE CRYSTAL GAYLE EFFECT

Chenoweth remembers one particular bit of pop music that created some headaches at Collins support.

Not long after the iconic Power Rock transmitter was introduced in the late seventies, Engineers at several stations were calling to report a puzzling problem. Their transmitters would get knocked off the air every time the DJ played Crystal Gayle's "Don't It Make My Brown Eyes Blue."

The problem turned out to be a particular burst of low-frequency energy in the song. Soon Collins had engineered a fix that allowed Gayle's entire hit song to get played over Power Rocks without losing a beat.

ANSWERING THE CALLS

As the legacy Collins and Continental AM rigs gave way to Continental's modern emphasis on high-powered FM transmitters, both Chenoweth and Branton became legendary for their intimate knowledge of the 831 and 816 series of transmitters.

Even after years of late-night phone calls from stressed-out engineers, Chenoweth says he always enjoyed talking with them: "I used to tell my bosses, 'These people aren't complaining, they're asking for help.' And when we could give them the help, they were really appreciative."

Hultsman, who sold many of the transmitters that Chenoweth and Branton serviced, says one of the things that set them apart was the sense of calm they brought to the job, even as the engineers at the other end of the phone line were dealing with some of the more stressful moments in their lives.

CHANGES

Asked about the changes he has seen over the years in the world of broadcast engineering, Branton says he has particularly noticed how local engineers are stretched ever thinner, even as transmitters become ever more computerized.

"With the way it is now, engineers don't have the time to go play with their transmitters even if they wanted to know how they work," he says.

Branton retired from Continental in 1997, but continues to do contract work for clients around the country.

While that work has trailed off in recent years, Branton remains active with another venture in the Dallas area, a small chain of quick-lube oil-change shops that he purchased with a partner.

TAKING IT EASY

Chenoweth says he always enjoyed the opportunity to combine family travel with his working trips during his days at Continental, and he continues to travel since his retirement a few years ago. While he says he misses the engineers he used to work with – "it was so enjoyable, working with the customers," he says – he has resisted the temptation to do any contract work.

When asked what he is doing now, Chenoweth is quick with an answer: "Nothing, which I've learned to do very well."

Radio Guide is proud to focus on the contributions to the industry by men such as Dave Chenoweth and Ken Branton. And, we are pleased to note that many of the best manufacturers in the industry feel the same way.

In addition to the plaques and other gifts we are sending out to our awardees, Tieline, Comrex, Nautel, and Shively, among others, have also recognized them with gifts of appreciation.

Readers are invited to share their comments and suggestions on others who deserve consideration for inclusion in the Hall of Achievement. Please send your thoughts to: Editor@radio-guide.com

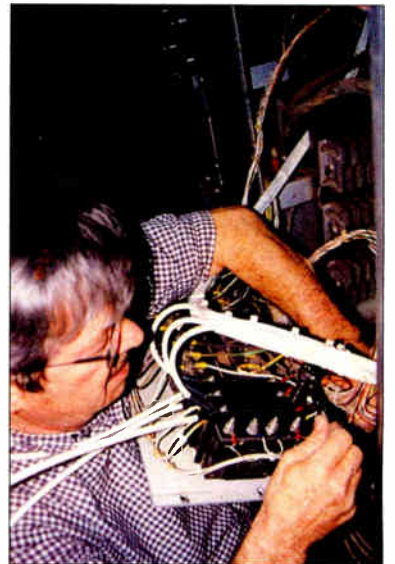

For decades Ken Branton has thrown himself into his work. "Hope I remembered to throw the main switch," he says.

It doesn't take a genius to know that being off the air will cost you...

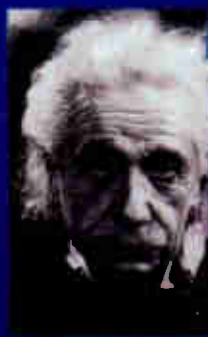

$E=mc^2$
Space + Time = Staco UPS

STACO ENERGY PRODUCTS CO.

Protect Your Revenue Stream with Tailored Power Quality Solutions from Staco Energy Products

For over ten years broadcasters have relied on Staco voltage regulators to keep their digital transmitters up and running. Now that proven reliability is available to protect your in-studio assets too!

Visit our web site—www.stacoenergy.com— to see our line-up of Uninterruptible Power Supplies, Harmonic Filters, and other power quality products and services. Talk to us about your application requirements—and we'll tailor a solution to keep you on the air—without breaking the bank.

UniStar P Series

6, 8, and 10kVA on-line double conversion true sine wave UPS

- Systems are parallelable up to four (4) systems for either redundancy or capacity
- Tower and 19 inch rack configurations

Features:

- Simple hardwire i/o connections (6, 8, & 10 kVA units)
- User friendly control panel
- Precision power conditioning
- Smart battery management
- Remote communications and monitoring
- Optional external battery packs for extended runtime

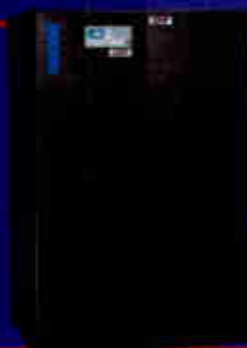

FIRSTLINE

10, 15, and 20kVA on-line double conversion true sine wave UPS

- 208, 220 or 480Vac operation at 60Hz



FIRSTLINE OC

The most comprehensive and flexible power distribution solution available.

- Up to 96 protected branch circuit breakers.
- Three interlocked switches for true wraparound bypass.

StacoSine

Active harmonic Filter

- Available from 208-480Vac (600Vac consult factory)
- Wall mount and free standing models
- 50/60Hz



Features

- Parallelable up to six (5) systems for added capacity or redundancy
- Full-function spectrum analyzer standard on all models
- Digital Signal Processor (DSP) controlled for extremely fast and accurate filtering
- Available in NEMA 3R and NEMA 12 style enclosures (consult factory)

WAVEFORM VIEW

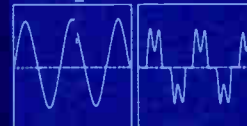

WINDOW 1 - Ia(S)

Waveform after correction

WINDOW 2 - Ia(L)

Waveform before correction

Visit our web site:
www.stacoenergy.com



Staco Energy Products Co.

US Toll Free: 866-261-1191

Phone: 937-253-1191

e-mail: sales@StacoEnergy.com

www.StacoEnergy.com

Power Quality Solutions Tailored To Protect Your Revenue Stream

Station Stories

by Scott Fybus

WNYC Makes the Big Move – After 84 Years

How long does a typical big-market radio station stay in its studios these days? Ten or twenty years is typical; rare indeed is the station that has called the same address home for thirty or forty years.

On the other hand, consider public radio stations WNYC-AM & FM in New York. Eighty-four years after the AM station signed on in 1924, it was still right there on the 25th floor of the Municipal Building, across the street from City Hall in lower Manhattan; but no longer.

NO ROOM AT THE INN

The seeds of WNYC's departure from its longtime home were sown a decade ago, when the City of New York sold the stations to the WNYC Foundation, which then launched a massive fund-raising campaign to pay off the \$20 million purchase price.

While the stations remained in the city-owned Municipal Building, city officials began encouraging WNYC to look for a new home. "Over the past eight years, we've been looking at real estate," says Steve Shultis, WNYC Chief Technology Officer. Finding the right spot for the station's more than 300 employees was no easy task – neither was squeezing them all in at the historic Municipal Building facility in the meantime.

"PARKING TICKETS, THAT WAY"

Entering the Municipal Building today, about the only visible sign of change since city officials spent \$50,000 to put WNYC on the air in 1924 is the metal detector installed after 9/11 to screen visitors. The ornate lobby, the ancient elevators, and the long, tiled hallways upstairs all pay tribute to a different era.

WNYC moved around the upper floors of the building several times over the years, eventually migrating to new studios on the 25th floor after a major renovation in 1985. As it grew, the station expanded haphazardly around the building.

During WNYC's final days in the building, the station was spread across 40,000 square feet of space, from the executive offices on 24, to the air studios and Master Control on 25, and up into the tower that crowns the building – all the way to the 33rd floor, where WNYC archivist Andy Lanset and his staff took care of the station's heritage. (See Page 28) Visitors getting off the elevator were greeted by signs pointing to WNYC's offices in one direction and a maze of unrelated city services in the other.

TIME TO MOVE ON

"That building really [was] prohibitive for camaraderie and working together," says Shultis. It was so short on needed space that many staffers were wedged into places where radio stations were never meant to go.

For example, outside the executive offices on the 24th floor, a door led down a hallway to what looks like a men's room. It was, once, but was then pressed into service to house several news staffers. Inside the office area, a former coat closet became soundproofed and stuffed with a small board, a microphone and a computer, providing a tiny space for voicetracking the classical-music service that started up last year on WNYC-FM's HD2 channel.

"We wanted people who work here to know they're working in radio," Shultis said of the hunt for a new space. After several false starts, that space finally materialized in the form of three floors at 160-170 Varick Street, a few blocks from the Municipal Building in the Lower Manhattan area where WNYC wanted to stay.

In addition to the full seventh, eighth and ninth floors of the onetime printing plant, totaling some 70,000 square feet, WNYC's new home will also include a ground-floor performance space.

All told, the new facility nearly doubles the size of WNYC's current facility. But taking advantage of all that new space required plenty of planning – and even a reorganization of WNYC's engineering department.

NEW STAFF, NEW SPACE, NEW EQUIPMENT

In September 2007, Shultis moved from his former position as Director of Engineering (DE) to the new post of Chief Technology Officer, overseeing all aspects of WNYC's growing multimedia empire. Jim Stagnitto, who had spent 25 years as Chief Engineer of New York commercial station WWPR (105.1) in its many incarnations, joined WNYC as the new DE just in time to oversee the buildout of the new Varick Street facility.

While most of the purchasing decisions for the new facilities had already been made, Stagnitto says he was comfortable assuming his new role during such a critical time. "Everybody here is a consummate professional, and they've made some really good decisions of what equipment to go with," he said.

One of the biggest decisions was to use SAS routers and consoles throughout the new facility. A combination of SAS Rubicon consoles and Rubi-T miniature control surfaces are used in each of WNYC's many new studios.



SAS consoles and routers anchor the studios.

SAS also integrated Rubicon modules into two API Vision consoles that will be used to mix live music and other major productions from WNYC's two performance studios, effectively making those consoles into additional sources on the station-wide network.

AVOIDING THE CLOSET SYNDROME

The design of the new facility went through several evolutions, as Shultis and his team balanced the available budget with the needs of the staff and with other design considerations.

To create an optimum layout for the studios, Shultis built mock schedules of studio usage, laying out several different possible studio configurations. While eight studios could have been placed in the eighth floor core, Shultis said the mock layout showed that the resulting spaces would have been too small.

Instead, the final layout for the eighth floor includes three "on-air control room suites," each with a studio, a control room, and a voiceover booth. A fourth control room handles the station's talk shows and "The Takeaway," John Hockenberry's morning program launched by WNYC in cooperation with Public Radio International. A fifth control room and studio is used for live music production.

Most of the studios float on concrete floors, sandwiched between two other floors that WNYC will occupy, avoiding any concerns about noise transmission from offices on the floors above or below WNYC's space.

THE AMERICAN STANDARD

Master Control ties all the studios together and oversees outbound transmission over WNYC's broadcast signals, uplinks of the network shows WNYC produces, and incoming feeds from National Public Radio and other sources.

"It's done the way radio used to be done," Stagnitto says, rejecting a comparison of WNYC's new layout to a typical European state broadcaster, where program production and transmission are two separate functions. "It's the old American standard. It's what it was before we got into the DJ era."

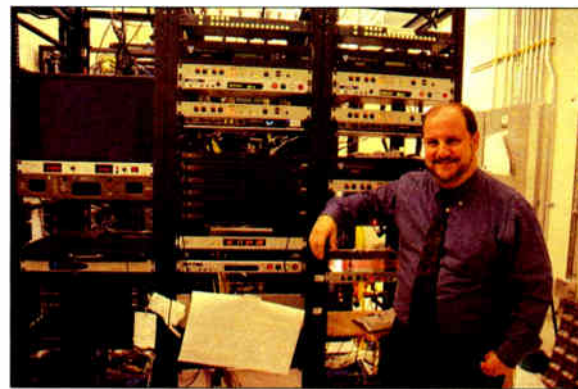

DE Jim Stagnitto oversaw getting all the gear wired correctly in the right places.

To emphasize the point, he asked: "How many radio stations do you know of today that actually have a Master Control Operator on duty?"

NEWS, PRODUCTION, IT

The rest of WNYC's functions are organized by floor. Outside the eighth-floor studio core, the nearest office space belongs to the station's news department, including a "News Hub desk" that routes incoming news feeds into the station's DAVID automation system.

WNYC's production staff mainly works out of space on the ninth floor, where programs such as "Studio 360," "On the Media," and local talk shows have their own office areas surrounding shared production space that includes three production control rooms, five studios, three VO booths, and seven mini-control rooms, all equipped with SAS consoles and Pro Tools editing systems.

"Whether you're using a self-operating VO booth or a 36-frame console surface, everything has to look and feel the same," Shultis said.

The seventh floor houses a spacious IT core for the facility, as well as the station's business offices. Connectivity to the outside world is handled through a combination of spread-spectrum radio, Harris Intraplex and ISDN connections from Varick Street to the FM transmitter at the Empire State Building and the AM transmitter in New Jersey (via the Four Times Square tower.)

A GOOD LOCATION FOR RADIO

Located adjacent to the mouth of the Holland Tunnel, the Varick Street site is served by multiple telco central offices. From the building's roof, WNYC has line-of-sight to all three satellites used by NPR, as well as to both its main FM site at Empire and its auxiliary FM site at Four Times Square.

The entire plant is served by a 500-kilowatt generator and a 225 kVA plant-wide UPS designed to keep the broadcast functions operating no matter what Con Edison does.

As with any big move, delays were inevitable, and the relocation of broadcast operations that were supposed to happen in the spring were pushed back into summer as the new studios were wired up and tested. A temporary T1 link between Varick Street and the Municipal Building linked the new studios with the old, making an orderly, staged move possible.

THE PERFORMANCE CENTER

The last facility completed at Varick Street will be the street-level

Jerome L. Greene Performance Center. The 2,300 square-foot space will include its own control room with an API console integrated into the station's SAS network.

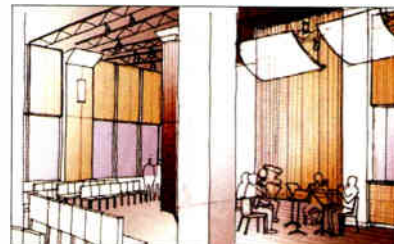

An artist's rendering of the WNYC performance studio.

WNYC is not disclosing the total cost of the move, which is being funded through a \$45 million fund-raising campaign. Despite public radio's reputation for top-notch facilities, Stagnitto said the new studios were built to a tight budget: "We are keeping a very sharp eye on the dollars."

After 84 years, WNYC deserved a beautiful home. From everything I have seen, they got it.

Scott Fybus is a regular contributor to *Radio Guide*. You can contact him at scott@fybus.com

(Continued on Page 28)

RADIO GUIDE
www.radio-guide.com

RADIO-INFO.COM
RADIO'S ONLINE COMMUNITY

Radio Guide and Radio-Info.com form an alliance!

Premiere technical information meets Radio's Online Community at www.radio-info.com -arriving September 2008.

Program your Sine Systems RFC 1/B Using My Sine

Your Sine Systems Remote Control offers classic reliability, now My Sine adds flexible control.



MY Sine

- + Easy-to-use **computer** application.
- + **One click creation** and Quick Set-Up of multiple sites in one place.
- + Built-in ten-key phone pad allows you to **check programming on the fly** inside the program. No need to disconnect cables or restart the program to check your work. Check your progress as you go.
- + **Built-in vocabulary with auto-complete.** Start typing and My Sine will do the rest.

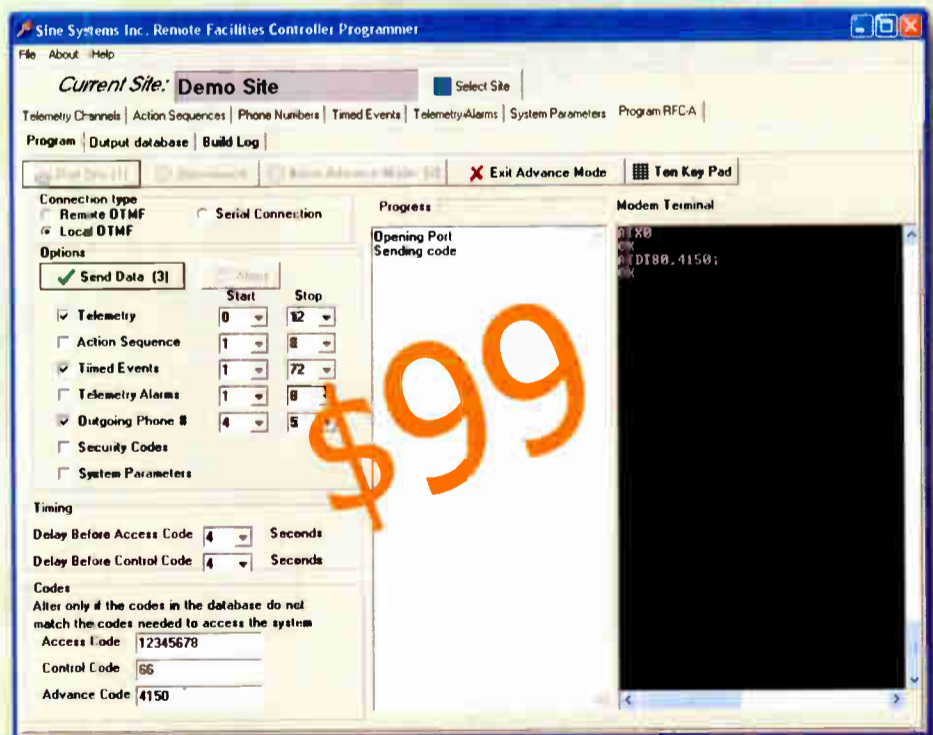

For the affordable price of **\$99**, make your Sine **MY Sine**.

FREE demo at www.PlusSine.com

by **IntrinsicNet**

For your **ultimate** graphical user interface, check out **Plus Sine** for the RFC Series remotes from Sine.

Station Stories

by Scott Fybush

– Continued From Page 26 –

WNYC Archivist Preserves Nine Decades Of History

At too many radio stations, “the archives” amount to little more than a few old photos, newspaper clippings and perhaps a handful of miscellaneous tapes tossed into a box “somewhere in a closet.”

But at New York’s WNYC, they take their history much more seriously. In 2000, the station established the WNYC Archives, overseen by full-time archivist Andy Lanset and two assistants, Cara McCormick and Kabir Carter.

“I think we’re probably the only single public radio station in the country with an archive and an archivist,” Lanset says.

EIGHT DECADES OF AUDIO

WNYC probably has more history to archive than most other stations, too. In its first six decades as the municipal radio voice of New York, the station broadcast – and recorded – speeches and interviews with celebrities and politicians, as well as musical performances and public events of all kinds.

Among the oldest bits of audio in the station’s collection is a 1927 speech by Charles Lindbergh. And Mayor LaGuardia’s famous on-air reading of the newspaper comics during a New York newspaper strike? That was WNYC, too.

Sadly, as the city hit dire budget straits in the 1970s and 1980s, some of that history disappeared. Lanset says “lots of material was lost” during the 1985 renovation of the station’s Municipal Building studios, the first major over-

haul of the facility since “state of the art” studios on the 25th floor were built back in 1937.



From 16 inch ETs to tapes to CDs and DVDs, Andy Lanset presides over a treasure trove of material in the WNYC Archive.

HISTORICAL RESTORATION

With WNYC’s transfer to the not-for-profit WNYC Foundation in 1997, the station began to take an interest in its past again. Lanset began writing an in-house newsletter called “WNYC History Notes” to share nuggets of WNYC history with the staff, a project he hopes to eventually expand into a book about the station.

Lanset and his assistants carry on the work of cataloging and preserving what he estimates to be “50,000 to 60,000 items,” only about half of which are properly cataloged and inventoried. In the old Municipal Building studios, the WNYC archives were stored anywhere Lanset could find room.

Racks of tapes and discs filled the walls of the 33rd floor, with additional storage spaces on the 25th and 27th floors and in the basement. Still more material filled a 5,000 square foot climate-controlled storage space the station rents in New Jersey.

Since the archive launched, Lanset has tried to “repatriate” much of WNYC’s lost history. In addition to working with city historians to find WNYC material that was sent to the city archives, Lanset says he is a regular eBay user, searching for “WNYC ephemera” such as old program guides and publicity material.

In addition to the older archive material, Lanset and his staff are also charged with preserving WNYC’s current output, archiving all of the station’s local and national productions to make sure they remain available to future users.



Navigating and cataloging WNYC’s piles of archive material.

To accomplish that, audio now stored on 78s, transcription discs, reel-to-reel tape, cassettes, DATs, CDs and other media, is transferred to gold Mitsui CD-Rs, with a backup archival copy on reel-to-reel tape. Lanset says he plans to migrate WNYC’s older materials to digital storage, storing audio as 96 kHz/24-bit BWF files, with CD reference copies being maintained for backups.

ENJOYING THE NEW DIGS

With the station’s move to Varick Street, Lanset and his staff enjoy a much more comfortable environment for their work. The archive facility on the eighth floor of the new WNYC studios is fully temperature-and-humidity controlled, eliminating a constant complaint about the aging space in the Municipal Building.

Tapes and discs are stored on compact, moveable shelving, and the archive staff work on audio workstations that are tied in to the rest of the station, making it easy to share archival audio with producers seeking to use it in their programs.

Before he could get to the new facility, though, Lanset had to finish packing up everything at the Municipal Building, a task that began in 2006 and continued even after the last of the WNYC staffers departed the station’s longtime home. “Some of the most fragile stuff, I’d come in with my car on a Sunday morning and move it myself,” Lanset says.

Lanset hopes the move will uncover more material for his archive as WNYC looks to showcase its history as part of the decor at its new building. “We understand the importance of our roots,” he says.

Tech Tips

by Clay Freinwald

Transmitter Site Power Monitoring

In a previous issue of *Radio Guide* (Jan-Feb 2009), we discussed protecting equipment from the loss of a phase in a three-phase system by using a Diversified Electronics module. This time we are going to take a look at the chore of monitoring the power supplied to your transmitter site.

GETTING CRITICAL INFORMATION

Perhaps you have noticed how station remote control system indications have followed a pattern similar to automobiles. Years ago, your vehicle dashboard had gauges indicating oil pressure and coolant temperature, etc. Today, the emphasis is usually on indicator lights that tell the operator “something is wrong” (we commonly call these “idiot lights”).

Similarly, older remote control systems used to have only metering. The next generation of remote controls employed indicator lights – we call them Status Indicators.

The good news is that these status indicators can be configured to show a mode of operation or to inform personnel when something is out of limits or needs attention *without* first having to select a channel.

USING THE STATUS ALARMS

More recently, with unattended operation, most remote control systems have had provisions to call selected parties to inform them when a parameter is out of tolerance and one of those indicators has come on (or has changed state).

In live operations these indicators can be configured to alert the operator via a warning sign, flashing light, etc. If your stations are like those I handle, you have come to

increasingly rely on a call from the system to tell you that your attention is required – and once you are into the system, the ability to dig a bit deeper to determine the cause and what corrective action is required.

In one installation, I monitor the output of the transfer switch and have a relay on the input that enables me to, via the remote control, look at the Public Utility Department or generator output, thereby expanding the role for the monitor. More than a phase monitor, I can see exactly where and what power is available.



Inside Clay’s power monitor box.

The equipment in this example is what we simply call a Power Monitor. I have installed these at our remote transmitter sites and they have proven themselves to be very valuable, if not a true bacon-saver. I typically use an appropriate size Hoffman box and mount them near the related electrical equipment.

STRAIGHT FORWARD LAYOUT

At the top is where power is supplied from the building AC power system. I recommend the sample location *be ahead* of the transfer switch, non-emergency distribution panel.

You may recognize the three items below, they are good old trusty Moseley LVK’s or Line Voltage Kits, without their housings, that provide a DC output that is proportional to their AC input. One of these is connected

to each phase. (Of course for single phase systems, you would scale back appropriately) If you do not have some LVK’s under the bench, you can roll your own. Email me if you need specifics.

Depending on the flavor of three-phase at your plant, you will want to configure these so that when a phase goes down you do not continue to receive telemetry via a sneak-path from your site’s service transformers.

By the way, you may notice that the input to the device is fused. That is because I like to play it safe. You should, too.

TOGGLING THE STATUS

Below that is the Diversified Electronics Phase Monitor. Phase-loss and under-voltage monitors are available from a number of suppliers including Tyco and SSAC.

This is similar to the unit that was used for phase loss detection in that it has dry contacts that will change state when a phase is lost, or is out of sequence. The voltage set-point is adjustable making it usable over a range of voltages.

The phase monitor’s output contacts are connected to the remote control system as a status input and the outputs of the voltage monitors to an analog input. (We do assume your remote control system is connected to a UPS.)

If programmed, any status change will result in a call to you so you can check on the operation of the generator, etc. The analog telemetry from the voltage monitors will allow you to call the power company to report the power outage. If you planned ahead, you can even tell them which phase is down *using their designations*. (This will usually amaze them).

BACK TO NORMAL

When the power is restored, the status from the phase monitor will change state and everyone will then know that power has been restored and you are now in “delay to retransfer mode” waiting for things to get back to normal.

Clay Freinwald has been an RF Systems Engineer in the Seattle area for over 40 years. Currently a member of the SBE Board of Directors, you can contact Clay at k7cr@blarg.net

AM Directional Systems...



without the surprises.



LBA Technology, Inc.

LBA Technology is your proven, worldwide supplier of HD ready AM antenna systems. Our array of RF products includes directional antenna systems, diplexers and triplexers, ATU's, and components for every power level. LBA systems are designed and custom fabricated to your distinct requirements.

We put our 40 years of AM RF experience into helping you reach farther and sound better! See what we can do for you at www.LBAGroup.com or call us at 252-757-0279.

252.757.0279 • www.LBAGroup.com • 3400 Tupper Drive • Greenville, NC 27835

Field Guide

by Dennis Baldrige

LP Technologies LPT-3000 Spectrum Analyzer

Broadcast engineers need good test equipment. From basic hand-held tools to digital multi-meters and oscilloscopes, quality test equipment enables accurate testing, evaluation and calibration within the broadcast facility.

MEETING BROADCAST NEEDS

Observing the RF bands requires a spectrum analyzer. Analyzing FM IBOC signals or digital TV signals necessitates a quality and dependable instrument. For NRSC tests in the AM broadcast band, a resolution bandwidth (RBW) of 300 Hz or less is mandated by the FCC Rules (73.44a).

A spectrum analyzer with this feature usually costs significantly more (on the order of tens of thousands of dollars), than would a typical low-end unit. Often this price tag places access of such a unit beyond the reach of many broadcast engineers. Inopportunistly, the broadcaster is left to borrow, rent the equipment, or hire another engineer to perform the tests. The need for a reasonably priced, fully featured spectrum analyzer is a reality.

LP Technologies, Inc. (www.lptech.com) has produced a low cost spectrum analyzer which has the capability of 300 Hz RBW as well as many of the bells and whistles of units costing significantly more. The LPT-3000 is a fully digital, synthesized spectrum analyzer covering from 9 kHz through 3 GHz.



The LP Technologies LPT-3000

EASY LEARNING CURVE

The LPT-3000 is designed to be user friendly. When the analyzer is turned on it goes through a series of self tests, band alignments and calibrations ending up in a full spectrum view.

Once up and running, the LPT-3000 offers simple user controls which allow the novice or the seasoned expert to use the analyzer right out of the box. One example is the AUTASET feature which automatically locates the strongest signal and centers the analyzer's display on that frequency. With this function, the initial detection of a signal directly connected to the input is a snap.

Screen shots, an immensely practical feature, save displays for later evaluation. Storage is straightforward with either the internal memory or front USB port. Images can simply be saved to a thumb drive and transported to your computer for later use. In addition, there is a LAN option allowing control and use of the LPT-3000 via TCP-IP. The accompanying software makes it easy to control the analyzer and save images directly to your computer.

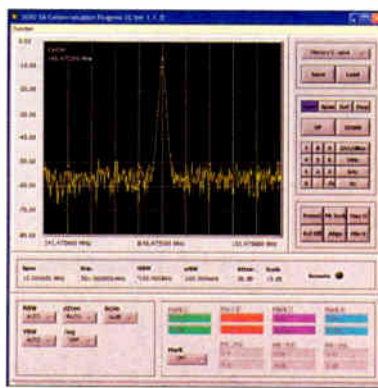

A screen shot.

NRSC AND HD MASKS

Of special interest to the broadcaster are the built in measurement masks. This allows quick verification of the RF signal under test with the FCC's requirements.

The masks are upgradeable, allowing future improvements as requirements change. Included are the AM NRSC mask and HD radio masks for both AM & FM. DTV templates are also included in the system.

The internal analysis software will evaluate the signal to verify it remains within the prescribed mask and give a Pass/Fail response in addition to the image.



The AM IBOC mask.

SPECIFICATIONS

The LPT-3000 is a high-performance digital, synthesized analyzer. The wide frequency range of 9 kHz to 3.0 GHz is accompanied by an equally impressive resolution of 1 Hz and 0.5 ppm high precision reference. The built-in preamp is a feature boasting a wide dynamic range of -130 dBm to +20 dBm.

The unit is compact, portable, and has easy to use key buttons with various interface options such as USB and LAN. The analyzer is not only capable of broadcast analysis, used with or without RF masks, but also does CDMA measurements including ACPR, ACLR, OCWB and Channel Power.



The FM NRSC mask shows pass/fail.

The spectrum analyzer is also available as a rack-mounted unit which boasts four RF inputs to monitor multiple devices. With this arrangement the broadcaster can perform TV, AM/FM HD testing and troubleshooting remotely through the LAN connection with the remote control software.

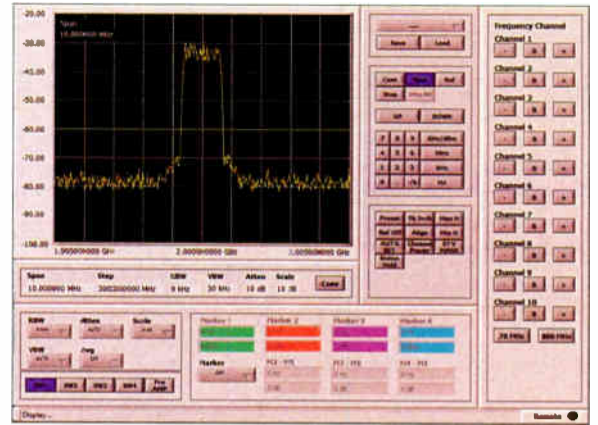

The unit can be remotely controlled with software.

With this feature intermittent conditions would be easier to discover and isolate, making the unit invaluable for diagnosing and analyzing problems remotely.

PRICING BY OPTION

The LPT-3000 is reasonably priced. Options can be added, as needed, to satisfy the needs of the broadcaster. This allows customization to each application. The following table contains the list prices for the spectrum analyzer and several of the most commonly chosen options.

3.0GHz Spectrum Analyzer	LPT-3000	\$4,500
Tracking Generator Option	TKG-3000	\$1,500
Remote Control Option	REM-3000	\$195
Ethernet Option	ETH-3000	\$350
300HZ RBW Option	RBW-300HZ	\$350
Pre-Amplifier	PRE-AMP	\$350
FCC Mask Meas. Option	FCC-3000	\$320
Soft Carrying Case	SCC-3000	\$280

Additional options for the LPT-3000 include the following:

- CDMA (CDMA2000, WCDMA) Signal Generator
- GPIB Interface (IEEE488 Bus)
- Soft Carrying Case
- General Kit Set-CATV Kit Set (cable set)
- Return Loss Bridge Kit Set

The LPT-3000 from LP Technologies, Inc. is a quality, broadcast ready, spectrum analyzer at a modest price, loaded with features and options to meet the most demanding requirements.

A 30 year broadcast veteran, Dennis Baldrige (CPBE, AMD, CBNT), is a Contract Engineer in Wisconsin, as well as an ABIP inspector for WBA. He can be contacted at info@7db.net

Meet our **NEW BABY!**

The Davicom **MicroMAC** Remote Control System

Just as intelligent as other MAC units, but half the size!



davicom
www.davicom.com

t. 1.418.682.3380 | f. 1.418.682.8996
www.davicom.com

Intelligence & Innovation

Supplying an extensive range of audio and broadcast products from top manufacturers at great prices, delivered direct from the US

300w FM Transmitter

Rugged and portable

Ideal for Community Radio,
FM Repeaters and
Transmitter Back-ups



NEW product



The Black Widow Broadcast 300 watt FM transmitter is perfect for community radio use and is ideal for applications that require a rugged transmitter as opposed to a rack mount transmitter. Perfect as a low cost repeater, it has a MPX input that can take a feed from a re-broadcast receiver or from a satellite receiver. The transmitter has an MPX input as well as an N type output for the RF. A standard IEC connector provides a mains connection. The front panel LCD control system controls the frequency and provides readout of the locked status of the transmitter. RF is muted during out of lock conditions.

The transmitter employs the renowned low distortion, low noise BW broadcast PLL PLUS exciter module to drive the power amplifier which is fan cooled & temperature protected making it ideally suited for harsh environmental conditions.

our price \$1390.00

Instreamer 100 / Extreamer 100

The Barix Instreamer and Extreamer 100 are versatile network audio over IP devices offering a variety of applications. They enable users to create flexible, cost-effective distributed audio systems using standard IP technology.

The Extreamer plays MP3 (soon also G.711 & PCM) audio files from PC or web server (http) as well as legacy digital and analog sources (using the Barix Instreamer) and streams from sources like Shoutcast, Icecast (Internet radio) or RTP servers (Instreamer).

Used in pairs, both the Instreamer 100 and Extreamer 100 are needed for a complete solution.



low cost STL
Instreamer \$520.00
Extreamer \$267.00

Zoom H2 Portable Digital Recorder

The H2 is an easy-to-use, ultra-portable portable digital recorder for variety of applications. From electronic news gathering (ENG), interviews and podcasting, to musical performances, songwriting sessions and rehearsals, the H2 provides amazing recording quality. And no matter what kind of recording you want to make, the H2 can effortlessly record it.



Easy to use

our price \$242.00



Worldcast Horizon IP Audio Codec

A fully duplex, two channel stereo codec designed to enable real-time transport of broadcast quality audio over IP networks.



our price from \$2280.00

digital & analogue versions

Plan B Silence Eliminator

Combines a smart silence sensor with an internal replacement audio source and voice notification to provide a complete high quality backup system for digital and analog programme lines.



our price from \$2520.00

no more dead air

Audio Logger Pro

Audio Logger Pro uses your PC and sound card to record audio continuously 24/7. Unlike VHS, DAT, open-reel or other tape-based audio loggers, Audio Logger Pro makes it easy to locate any day, hour, minute and second instantly with its built in playback client. You can store 42 days on a standard hard drive, and up to 365 days by utilizing today's largest hard drives and/or RAID arrays.



download today

our price \$416.00



DSPXtreme FM FM/HD Audio Processor



The DSPXtreme features 2 colour screens, one is touch sensitive, allowing you to navigate, setup and control with a touch of your finger. It's available in 4 versions FM, AM, CD, HD. 6-Bands of audio limiting, distortion controlled clipping and 'look-ahead' limiting allows you to create your own distinct sound. It can be configured and controlled remotely. It's fully upgradeable - you can download enhancements and add features from our website

our price \$9880.00

big sound great price



NetClock (IP Based)

Broadcast and Studio Reference Time clock

Use in Production Suites, Radio & Sound Studios, Schools, Hospitals, Public areas such as Railway and Bus Stations. Financial Industries, banks, stock markets - multi time zone.

- Large easy see numerals in red, white and blue LED's
- Red numeric display for count up to the hour
- Green numeric display for back time to the hour
- Powered locally or by Power Over Ethernet (802.3af)
- Configurable via embedded web server
- DHCP or static addressing
- Custom setups including variable time zone offset via TFTP or Windows utility program
- Strong Aluminum Extruded Case

just plug it into your network and get server or world time accuracy in any room or studio



no special wiring

our price \$630.00

Airmate Production Mixer

The Airmate console was designed to fulfill the need for a low cost radio production mixer. Built around well proven low noise circuitry, this console is a reliable workhorse for the efficient self-op production DJ.

There is an extensive master section focused on radio which include:
Aux send and return
Monitor master with "follow phones"
Phones output with split control and a special Radio on-air / production section which has too many fantastic features to mention...



with stereo aux

our price \$2810.00



EVOLUTION-6

The E-6 is a powerful, compact and cost-efficient networked audio control surface with built-in production tools and a powerful set of PRODUCTION TOOLS for each input channel, allowing a single surface to be reconfigured for different talent, studio and format requirements.



E-6 INPUT CHANNELS can access networked audio sources with the press of a button. All sources are displayed right above the fader. Each fader has its own mix-minus output (in addition to the console's own 4 MXM busses). SET buttons at the top of each channel can access a powerful array of production tools individually tailored for each input strip. These include four bands of parametric EQ, compressor/limiter, expander, pan, mode, HPF, LPF and phase reverse. These EQ /DYNAMIC functions allow powerful per channel mic processing. The console has four output busses (can include 5.1 surround), 4 mix-minus busses and 4 aux mixes (all with TB). Each input channel also has two programmable buttons for customized functions, as well as ON/OFF switches with built-in machine control (logic follows source).

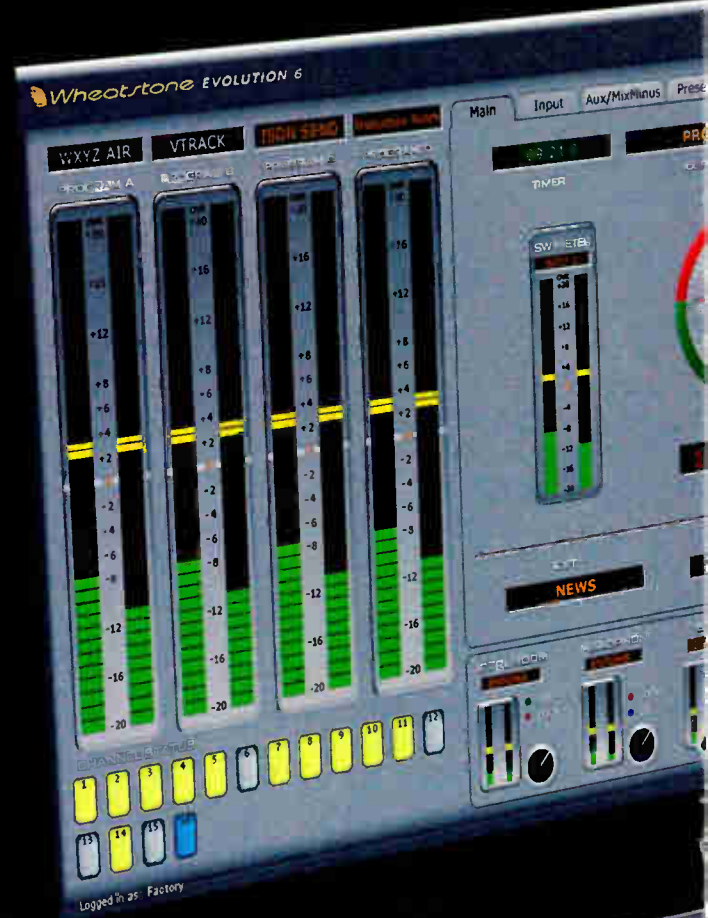

*The Wheatstone
Evolution-6 Digital
Audio Control Surface*

in EVENT RECALL
to be instantly



THE REALTIME HI-RES GRAPHIC DISPLAY keeps operators up to date and completely informed concerning all surface functions. Metering, bus assignment, channel status and sources, event recall, monitors, EQ and dynamics—all appear here via the mouse/trackpad driven GUI. Note the surface drives the VGA monitor with built-in circuitry (no external PC required).

THE MONITOR/SET PANEL (right) has Control Room, Headphone, and two independent Studio outputs. It also allows the operator to program input channels via the SET function: aux mix and mix-minus assign (4 each; all with talkback), input source select, and pan. The panel also has fourteen programmable buttons which can initiate custom functions like remote setups, intercom, machine commands and salvos.



Available in 4, 8, 12, 16, 20,
or 24 channel mainframes



The E-6 audio control surface interfaces directly with Wheatstone's E-Series network switch and associated studio satellite I/O cages. Wiring between components is via single CAT-5 cables, eliminating point-to-point multi-pair runs. Each studio surface operates independently, yet can share all network sources and mixes with others.

 **Wheatstone**

www.wheatstone.com/E6.htm | sales@wheatstone.com | tel 252-638-7000

by Tim Hardy, Nautel Ltd.

Designing a Next Generation Transmitter

Building a transmitter is more than just tossing parts in a box and shaking. Tim Hardy gives us a look over the designer's shoulder, to see how they approach the various part of the project.

Recent developments in the industry and the changing nature of our urban environment have mandated key changes in station and transmitter designs.

DIGITAL AND RFI CONCERNS

The digital transmission modes of HD Radio and Digital Radio Mondiale may be the most visible reasons for creating new transmitters, but other factors have played a role as well.

The increased use of computers, fluorescent lights, dimmers, wireless devices of all kinds, more radio stations on the air, and technologies such as Broadband over Power Lines (BPL) are all driving the noise floor up considerably in reception areas. In order to have the same coverage area, stations may need to consider higher transmitter power levels.

Other concerns include rapidly increasing power costs, the industry's shortage of experienced RF engineers, and upcoming changes to HD Radio including higher injection levels. Manufacturers are also dealing with space constraints in transmitter buildings, when space is at a premium, it may be challenging to use older transmitter designs.

Over the past few years, Nautel has designed several new transmitters designed to help broadcasters overcome most of these challenges. We believe these products clearly represent the next generation in transmitter designs.

It also is very important to have the customer's perspective and direct input.

To illustrate what is involved in designing a next generation product, this article will focus on Nautel's NX Series of AM transmitters. With the NX development we made a special effort to spend time with our customers asking them what problems they were having and how we could help in solving them.

NX BASIC DESIGN CRITERIA

We consider the NX Series "Next Generation" because the design was started with a completely clean slate, meaning we were able to choose new semiconductors and other parts whenever the design benefited in terms of simplicity, performance, or cost. In the end, nothing was kept of the previous XR series in terms of basic circuitry.

However, we consider this an evolutionary design rather than a revolutionary one. With an evolutionary approach, you do not change the fundamental principles of operation but you can significantly update them.

The NX project started with in-depth research around January 2006, initially focusing on the amplifier section. At that point we were still looking at more revolutionary approaches to the fundamental RF power architecture including "outphasing" a.k.a. LINC modulation similar to what was used in the RCA Ampliphase tube transmitters – and is currently used by BE in their high power AM transmitters.

Additionally, we were looking at new semiconductors. Essentially the goals were very broad. We wanted improved

linearity especially with HD Radio and DRM allowing for a reduction in out-of-band spectrum. We also wanted improved power efficiency, a smaller size with similar or reduced cost, and the addition of new features for digital radio that would make the broadcasters' job easier.

Another important goal was that the design be capable of being used for any power level from 1 kW through megawatt super-power systems. This was important both from the engineering standpoint – fewer circuits to design, troubleshoot and maintain – and from the customers' standpoint as the engineers can be focused on "their" product rather than a large slate of different designs. This also means that spare parts, as well as the learning curve, are the same for a broad line of transmitter models.

TRYING DIFFERENT PATHS

After building a Outphasing/LINC experimental system we decided that the risks with that approach were too high and the benefits did not justify those risks. At least one other "revolutionary" technology was discarded because it could not achieve the goal of handling all transmitter power levels.

The relatively conservative approach of going the evolutionary route appealed to us since we did not want to get stuck with a lot of time and money invested in a technology that might have little or no long-term benefit.

For example, using separate devices for modulator and RF amplifier brings some key advantages: the RF transistors operate at a reduced voltage at all times except modulation peaks. On average the voltage is greatly reduced and this makes the amplifier more robust and more efficient.

SEMICONDUCTOR CONCERNS

Next we began looking at what we could do with modern semiconductors and how the existing design could be improved. We made far more extensive use of computer modeling (SPICE) than we had previously.

This modeling brought us an excellent fundamental understanding of high efficiency Class-D operation at high AM frequencies. It is important to note that AM transmitters use transistors designed for switch mode power supplies and these transistors rarely operate at such a high product of both power and frequency. We wanted to make sure that the NX amplifier could sustain 12 kW peak power at 1710 kHz – which is a very demanding requirement.

Modern semiconductors permitted us to use a "hard-switched" transistor gate drive system instead of a "resonant system" that uses a nearly square waveform on the transistor gate instead of a sine wave. The hard-switched waveform eliminates the frequency response issues of the resonant drive circuit which is one source of out-of-band emissions. Additionally the hard-switched waveform allows more precise control of the exact times that the transistors switch, which is necessary to reduce switching related losses.

Another benefit of new technology is that the size of the transistors can be greatly increased because we have such good control of the switching loss. Larger transistors allow operation at higher power and with lower conduction loss (losses related to current flow).

Based on the Joule rating (or thermal capacity) the transistor we now use is more than five times larger than the transistor we used in the XR series. The amplifier power rating was increased by a factor of three from 800 W to 2500 W so that we only require 20 amplifiers in a 50 kW transmitter.

IMPROVING MODULATION

In addition to improvements in the RF amplifier, we also focused on improvements to the modulator. One hurdle: any frequency response errors in the modulator will cause an increase in out-of-band emissions.

Our solution to this problem was to make the modulator filter very small and simple, increasing its bandwidth. To compensate for the change we went to a nine-phase

system as compared to the two-phase system in the previous generation.

The modulation signals are generated using a digital process with a rate of over 300 million samples per second. This means the accuracy of each digital modulation signal is in the range of three nanoseconds, resulting in an extremely low noise floor.

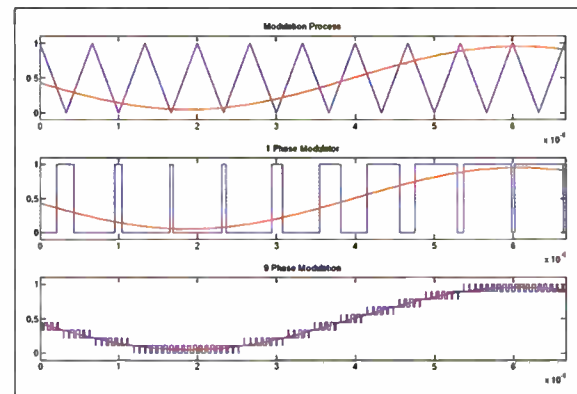

Nine-phase modulation reduces noise and distortion.

Each RF amplifier module in the NX has a three-phase modulator which drives the amplifier directly. One set of three phases from the nine-phase system is delivered to each module such that each phase delivers nearly equal power in the whole transmitter.

The nine modulator phases allow for very high levels of cancellation of the modulator switching harmonics up to the ninth order at a frequency of nearly 1400 kHz. The nine phases of modulation are independently generated in the exciter and separately sample the envelope on both the rising and falling edges of the modulation signal. This means the envelope is sampled over 2.7 million times per second, essentially eliminating the distortion products that can be present in low frequency pulse duration modulation (PDM) systems.

A NEW EXCITER

Once we understood where we were going with the amplifier and modulator, we started on the new exciter development. The new exciter would be just as important as the new amplifier in terms of achieving improved performance.

The exciter design started around November of 2006. It involved designs for the circuit card, a field programmable gate array (FPGA), and the digital signal processing (DSP) code.

This is the first AM transmitter platform at Nautel that is a completely digital system – this means the first analog waveform in the transmitter is the output of the amplifiers themselves. If a user connects a digital audio source via AES, every signal from the exciter to the RF modules and the devices which drive the final transistors are digital with almost no delay, overshoot, or undershoot. Eliminating any such issues in the system improves the ultimate levels of linearity that the transmitter can achieve.

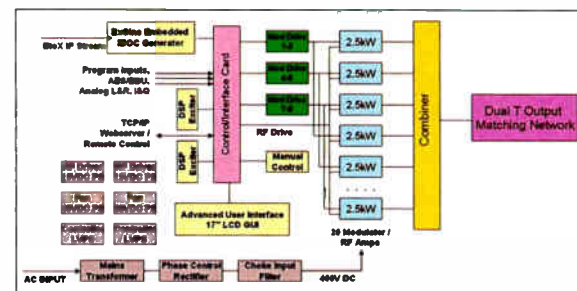

The NX Series is designed to be fully digital right up to the PA output.

The exciter has a signal processing engine composed of a conventional DSP as well as an FPGA used for high speed signal processing. The DSP drives the FPGA with an ideal waveform in I,Q format (complex components of the baseband signal) at a rate of over 300,000 samples per second.

The FPGA interpolates the I,Q signal to higher rates, converts to polar format and contains the pre-correction structures used to compensate for the non-ideal characteristics of the modulator and RF amplifier. In addition the FPGA contains hardware to generate the nine modulator phases and drive the RF digital-to-analog converter (DAC) that synthesizes the RF drive waveform.

(Continued on Page 35)

Designing a Next Generation Transmitter

– Continued from Page 34 –

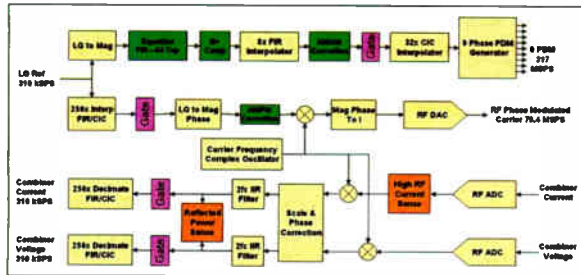

A block diagram of the field programmable gate array exciter.

The exciter also has two analog-to-digital converters (ADC) which sample the output of the RF combiner. These outputs are decimated in the FPGA and transmitted to the DSP. The DSP uses the combiner output to calculate correction curves for the amplifier non-linearities and to protect against fault conditions. The exciter DSP also uses the voltage and current signals coming back from the combiner to make measurements of spectrum and impedance.

WATCHING THE LOAD

We were able to calculate RF impedance vs. frequency in real time using the normal transmitted voltage and current waveforms.

The user can then observe the antenna impedance locus while the transmitter is operating normally, which lets the user make antenna system adjustments and see the effects on both impedance and spectrum at the same time. Thus the user can optimize the antenna network and get the best system performance much more easily than by using conventional test equipment.

We also worked to make the software instruments as accurate as possible. The spectrum analyzer function uses a 64,000-point FFT with 32-bit precision math to achieve high accuracy and is based on a directional sample that eliminates the error typically experienced when a current or voltage probe is used with a spectrum analyzer. Comparing the transmitter-based measurements with a high-end spectrum analyzer in the lab, the measurements are virtually indistinguishable.

PUTTING IT ALL TOGETHER

In 2007 the research phase was beginning to wind down and the development phase started. Several of our engineers began working on the mechanical design, control system, power supplies, wiring and so on.

The mechanical design is done by modeling the whole transmitter in a 3D computer-aided design package; this reduces the design time and improves the results you get when you physically assemble the transmitter the first time. It is really helpful to be able to see the whole thing on a screen before it is put together – it allows you to make sure that the design is easily assembled and serviced, once it is completed.

AN ADVANCED USER INTERFACE

The final part of the project to start up was the software effort. Nautel's new transmitters include an operational and diagnostic package that goes far beyond prior designs – we call it the Advanced User Interface (AUI).

The AUI started with an industrial design which studied how the system would be used. Once we had incorporated the features we wanted and achieved the goals of flexibility and usability, we began developing the actual software. We are very happy with what we achieved and will be using the AUI on other new transmitter platforms including the NV FM family and in new NAVAID products.

The AUI makes use of the extensive information gathering features of the transmitters. Metering can be configured down to the level of each individual amplifier, which aids in troubleshooting.

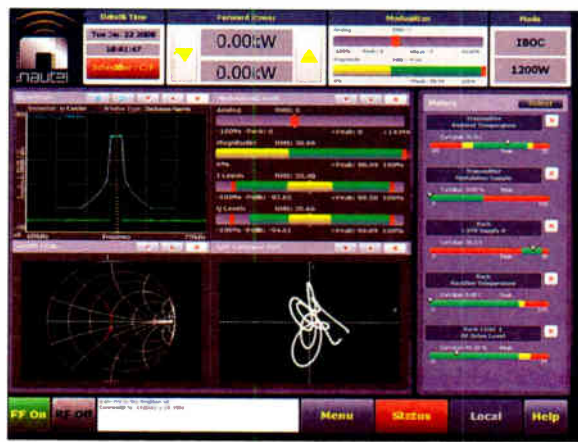

The new Advanced User Interface provides extensive diagnostics to the user.

The AUI also keeps a history of all operating levels so that the user effectively can go back in time to when a fault occurred and determine the cause. However, to make sure that the AUI could not be a detriment to the system performance, we made it a non-critical part of the transmitter so that operation will continue even if it fails, using the backup control interface (a standard feature).

LOAD PRE-CORRECTION

We also attacked the problem of improving the IBOC/DRM performance in two different ways. Wherever possible we eliminated any source of non-linearity from the amplifier and modulator hardware. At the same time we designed the digital exciter to be able to correct for the different sources of non-linearity that we expect.

Three types of pre-correction are currently being used. The AM/AM correction compensates for distortion in the modulator. The distortion is primarily a result of the drain capacitance of the modulator MOSFETs, which causes variability in the time for the modulator to turn off due to the natural changes in modulator current with modulation. This non-linearity manifests itself primarily at very low modulation levels.

The AM/PM correction compensates for undesired changes in the delay from gate to drain of the RF transistors. Similar to AM/AM correction, this is caused by the RF amplifier transistor drain capacitance and the natural variations in current due to modulation.



The AUI monitors the load and pre-correction data.

The final correction system corrects for the linear response of the modulator filter. This response is somewhat dependent on antenna impedance variations. While modulator filter effects are linear in nature, they affect the phase and amplitude of the envelope which in turn causes non-linear emissions when the envelope and RF phase signals are combined in the final amplifier.

Generally the modulator performance into a very broadband antenna needs no correction. However in the case of a narrow-band antenna with higher sideband VSWR, the modulator response can be influenced so the correction feature becomes important.

All three pre-correction systems currently have algorithms where the curves can be adapted to the operating conditions of the transmitter. The adaptation algorithms do not operate continuously but can be used during commissioning to setup the system.

Nevertheless, correction systems in the transmitter cannot correct a badly mistuned antenna system. It is still very important to present the transmitter with hermitian symmetry at the RF amplifier output, where impedance measurements are made.

We have continued to improve our understanding of the sources of non-linearity in the transmitter. The AM transmitter is a much more complex system than FM transmitters because it operates in a fundamentally different non-linear mode and there are more potential sources of non-linearity



The AUI includes a spectrum screen, showing the NRSC mask.

and more complex interactions. The upside of this complexity is that AM transmitters can be far more power efficient as a result, and we can now achieve efficiencies of 90% on certain models.

Currently, we are looking at a new type of correction that addresses our improved understanding of the sources of non-linearity in the transmitter. We have already made significant improvements in the performance of the transmitter when compared to the previous generation of transmitter. However, I hope that there will be further improvements as we continue to refine our existing methods. Fortunately, all the correction systems are totally software-based, so it should be possible to upgrade transmitters in the field.

BEYOND THE COMMON POINT

We also intend to develop facilities for equalization of antenna system response. Especially with complex directional arrays, in many cases the frequency response of the antenna system may not be that good. It is possible to correct for that frequency response in the transmitter.

Of course, this is not a simple matter; antenna frequency response varies on different azimuths, and the correction can only be applied equally for every azimuth. To the best of my knowledge this option is generally not being exploited in the industry, although there could be some advantages in certain situations including improved coverage and shortening the time it takes an IBOC receiver to acquire the station's signal.

To improve the flexibility and reliability of the HD Radio system, we moved to the new exciter architecture developed with iBiquity for FM systems. This includes an embedded OFDM modulator (the Exgine) in the transmitter with an external unit that includes the audio coding software (the Exporter). This allows AM HD Radio broadcasters to move to a more stable IBOC exciter platform.

MULTIPLE FORMAT READY

In general, we consider the transmitter to be ready for any digital format.

All the correction systems are agnostic to the transmitted signal. The transmitter also can use either AES input as a digital I,Q input to describe any signal. We use this input for DRM operation. HD Radio input is over an LVDS interface that can operate at the higher speeds required for the FM system. In theory any digital signal with a reasonable bandwidth limitation can be put on the air by simply connecting it to the transmitter over AES.

Because all corrections are made in the transmitter, it should be a relatively simple matter to work with any new modulation format as it is developed. We can literally generate and play a waveform from a laptop, as if it were an audio file, and see what it will do – and what challenges it poses.

A TEAM EFFORT

The development of the NX Series showed that a new generation of what most people would consider a conventional product – a broadcast transmitter – is not only possible, it can provide dramatic advantages to users. The newer transmitters are more efficient and provide complete redundancy, with the smallest possible footprint at the transmitter site.

Ultimately though, cutting-edge technology is useless if it compromises transmitter reliability. Building transmitters that stay on the air always has to be the number one goal.

All in all, at least 16 different people at Nautel were involved with the NX design, with the majority of them working on the project full time for extended periods. They are committed to achieving the highest performance with the fewest elements or simplest structure. Their passion for design is obvious – and that passion is what makes electronics an art as much as it is a science.

Tim Hardy is the Head of Engineering for Nautel Limited in Hackett's Cove, Nova Scotia. Contact Tim at thardy@nautel.com



Heavy Metal

by Jack S. Sellmeyer

RCA's Transition to Design and Manufacturing

Part 2 – The RCA 50-E

RCA's design for the 50-D included an attempt to get around Western Electric's patents on the Doherty designs. It was noticed for what it was. A new design was called for, and in 1940 RCA brought the 50-E to market. Jack Sellmeyer continues with our discussion of the RCA-designed broadcast transmitters.

After only six of the model 50-D transmitters were delivered, RCA released its first plate-modulated 50 kilowatt AM transmitter, the RCA 50-E, in early 1940. This is believed to be the first production model, high power, plate-modulated transmitter manufactured in the United States.

Unfortunately for RCA, only three or four of the 50-E's were delivered to U.S. stations before World War II intervened and RCA's production capacity was redirected to support the war effort. It has been reported, but not confirmed, that several more were shipped to England for use in supporting the war effort.

THE 50-E GOES INTO SERVICE

The first 50-E was delivered to station KOB in Albuquerque, New Mexico in 1941. It was placed in service on 1180 kilohertz on July 17, 1941.

Others followed to WCAU, Philadelphia, KTRH in Houston, Texas and one reportedly was purchased on the surplus market from the U. S. Army Signal Corps by KGA, Spokane, Washington. The KGA transmitter has been variously reported to be a 50-E or a 100-E by various persons with some knowledge of the station.

Of the four delivered, only the KOB transmitter survives today in the Bolack Electromechanical Museum at Farmington, New Mexico.



KOB's 50-E is preserved in the Bolack Electromechanical Museum.

The RCA 50-E continued the styling first incorporated in the 50-D. Both transmitters were styled by John Vasso – by then a noted industrial stylist who worked principally for RCA.

The 50-E design further increased the overall AC to RF conversion efficiency, principally by incorporating a Class B modulator stage in conjunction with a Class C final amplifier stage. The modulator reached a peak efficiency on the order of seventy percent and the RF power amplifier operated at nearly eighty percent efficiency.

With the overhead for the lower power stages, the cooling system and high power filaments, the overall AC to RF efficiency was raised to nearly 50 percent at 100 percent modulation. Table 1 compares the 50-E efficiency to that of the 50-D, itself a major improvement over the previous models (the 50-B required nearly 300 kilowatts).

MODEL	UNMOD	25% MOD	100% MOD	EFFICIENCY
50-D	140 KW		175 KW	43%
50-E	110 KW	120 KW	156 KW	48%

Table 1

THE RCA "LOOK"

The RCA 50-E transmitter was constructed from functional units contained in free-standing steel frames which were placed behind what RCA called a "unified panel arrangement." The "unified panel" consisted of a series of Art Deco styled painted steel panels which, together, formed the front panel of the transmitter.

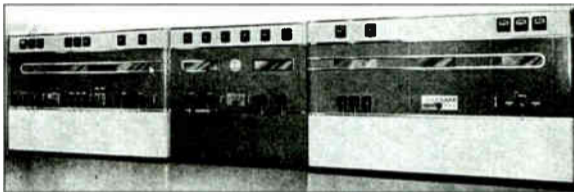

The front panel of the RCA 50-E transmitter.

The individual panels were joined together on a steel rail bolted to the floor of the building and attached to the front of each of the individual assemblies. This arrangement, when combined with an overall "drape wall" atop the transmitter and side walls at the ends of the transmitter presented a very attractive appearance. RCA would retain this approach to transmitter housings for several generations of transmitters, both AM and television.

The 50-E was approximately 37 feet wide by 7 feet tall by 20 feet deep including the high voltage and modulation transformers, their associated reactors and the required safety fences.

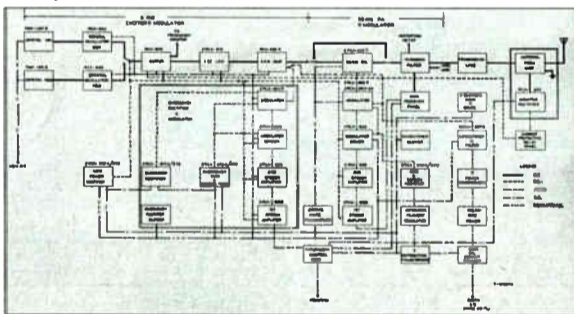

A block diagram of the 50-E.

The 50-E used a total of 39 tubes of ten types in the basic transmitter, ten fewer than the 50-D. Of these, only ten were mercury vapor rectifiers. Four additional tubes of three additional types were used in the hum frequency feedback amplifier and eight additional tubes were used in the emergency modulator, if it was installed.

BUILT-IN BACKUP

The 50-E provided some "built-in backup" in the event of a serious fault in the high power stages and also provided an in-place spare high voltage rectifier tube which could be rapidly inserted into the faulty position in the event of a tube failure. This was a nearly complete carryover from the 50-D. The only difference was the relocation of the high voltage filter capacitors below the frame and a step-start contactor to short out the current limiting resistor in series with them.

Another part of the built-in backup was an "Emergency Modulator" option.

The transmitter used what amounted to a five kilowatt AM transmitter as the driver for the 50 kilowatt RF power amplifier. Unlike the linear amplifiers of earlier days, only the RF portion of the five kilowatt transmitter was

used in regular service; the 50 kilowatt modulator was a complete unit in itself. The "Emergency Modulator" was the modulator stage and associated power supply from the then current 5-E five kilowatt transmitter, repackaged along with the RF section of that transmitter.

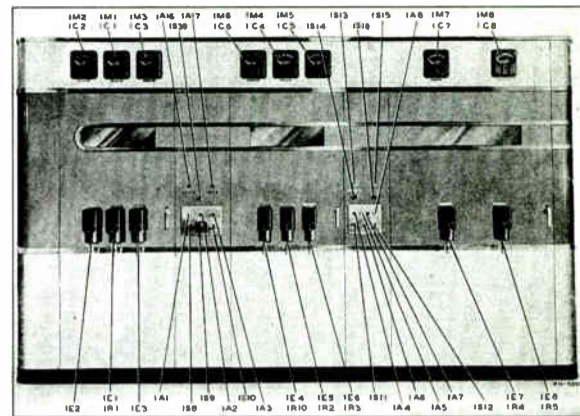

The 50-E left side front panel showing the Emergency Modulator (I), RF Exciter (c), and Main Modulator (r)

The Emergency Modulator was in the first section of the "unified front panel," on the left end. It consisted of an audio driver which was constructed inside the front door of the cabinet, the power supply, and two modulator tubes which were located inside the Emergency Modulator cabinet. The relays visible on the front door are the DC overload relays for the modulator tubes, a pair of 892R's.

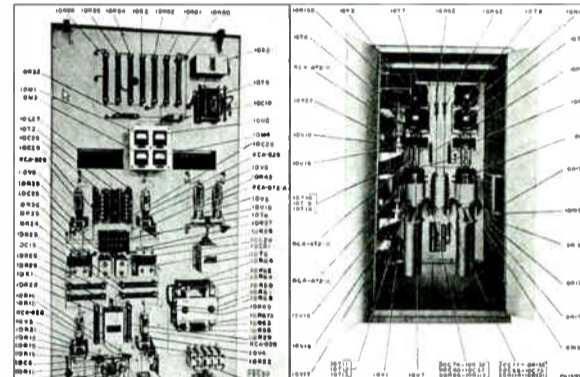

The Emergency Audio Driver and Modulator

The 50-E control system provided for activation of the emergency modulator filaments and RF and high voltage. The control rack and the emergency modulation transformer were installed in the high voltage cage.

This included switching provisions to transfer the high voltage supply for the five kilowatt RF stage to the modulated DC output from the Emergency Modulator cabinet and for transfer of the RF Driver output from the 893R grid circuit to the input of the Tee network "harmonic filter," which fed the output transmission line. Thus the built-in five kilowatt transmitter was available for emergency use.

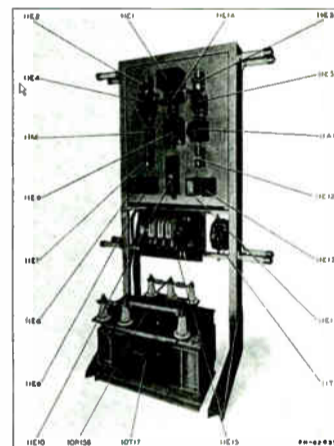

The Emergency Control Panel and modulation transformer.

THE RF EXCITER

The RF Exciter stage was located immediately to the right of the Emergency Modulator. This unit was, effectively, the RF section of the then current 250 Watt AM transmitter.

It consisted of a pair of UV-4292 crystal-controlled oscillators, which were previously used in all of the RCA AM transmitters beginning in early to mid-1930's. A front panel changeover switch was provided for selection of the active oscillator. The crystal ovens were powered from a 110 Volt circuit separate from the 2300 Volt AC mains supply.

The exciter consisted of only four stages to arrive at the five kilowatt level. These were the oscillator stage, an 802, a buffer stage, an 828 followed by parallel 810's operating as the driver stage for the five kilowatt power amplifier stage.

(Continued on Page 38)

the professional broadcaster's choice for IP STLs

WorldCast Eclipse



At last! An IP audio codec that offers a reliable, DSP-based platform and automatic back-up for 24/7 reliability.

APT's WorldCast Eclipse is the ultimate in flexibility and choice offering IP, X.21/V.35 and ISDN interfaces and a selection of popular coding algorithms including Enhanced apt-X, MPEG Layer 2/3, MPEG 4 AAC, G.711 and G.722

All the features you expect from a professional broadcast codec are supplied as standard: analog and AES/EBU I/Os, adjustable silence detection, alarm ports, contact closures, speed dials, embedded auxiliary data and many more...

Configuration and control of the WorldCast Eclipse is straightforward and simple thanks to APT's powerful and intuitive Codec Management System (CMS). Offering extensive real-time management of multiple codec units, the CMS enables alarm monitoring, logging and performance monitoring as well as configurable user and audio profiles.

To see the full functionality of CMS, download a trial version from www.aptx.com.



Also Available:



WorldCast Horizon
Bidirectional stereo audio codec offering Enhanced apt-X over IP



WorldCast Meridian
Multi-algorithm audio codec with both IP & X.21/V.35 interfaces



WorldNet Oslo
Professional, Modular Audio Multiplexing Platform offering up to 14 stereo channels over T1/ E1 or IP links with Enhanced apt-X or linear audio. Built-in redundancy, automatic back-up and hot-swappable cards ensure round the clock reliability for multi-channel STLs.



APT Headquarters
Tel: +44 (0)28 9037 1110
Email: info@aptx.com

APT North America
Toll Free: 800 955 APTX
Boston Tel: 781 810 2260
Email: sales@aptx.com



www.aptx.com

Heavy Metal

by Jack S. Sellmeyer

Continued from Page 36

All of the tubes and components except those associated with the 892R, five kilowatt amplifier were mounted on the front of the RF Exciter unit and were accessible through the second door from the left. The meters above this door were associated with the five kilowatt amplifier stage displaying grid and plate currents and filament voltage for the stage.

THE AUDIO SECTION

The Audio Driver circuit for the 50-E modulator is virtually identical to that of the 5-E modulator which was used for the "emergency modulator" of the 50E, with the exception that the parallel-tuned hum suppression network was not used in the 5-E and the cathode-follower stage used only two 828 tubes. This circuit would be used in several generations of RCA transmitters; The BTA-5F, BTA-10F, BTA-50F, BTA-5G, BTA-10G, BTA-5H and BTA-10H would all use some variation of this circuit.

The cathode-follower stage driven by the 828's operated in push-pull as a Class A amplifier stage. The intermediate amplifier stage was driven by a pair of 6C6 pentodes. Overall feedback taken from the primary of the modulation transformer was applied in series with the split secondaries of the audio input transformer to the 6C6 input stage.

The main modulator consisted of a pair of newly developed 893R forced air-cooled triodes operated in Class B, driven by four 828 beam power tetrodes operated as Class A cathode-followers configured in push-pull parallel. The four 828's were coupled to the 893R's through a novel arrangement using a six-winding, closely coupled, iron-core choke arrangement.

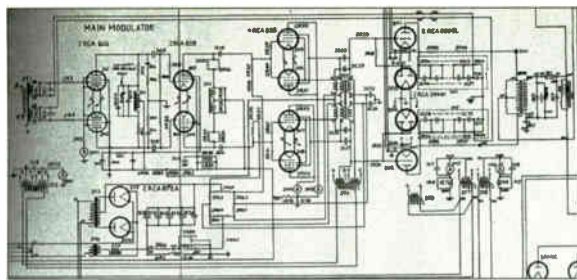

The Modulator schematic for the 50-E.

The modulator stage used a pair of 893R tubes in push-pull, operating in Class B. This improved the efficiency over the Class AB-1 mode used in earlier five and ten kilowatt transmitters by reducing the idling current of the modulators and driving the grids into the positive grid region.

To accomplish this, a very low source impedance was required from the audio driver to deal with the relatively high currents due to the abrupt drop in grid resistance when the grid is driven into the positive grid region. This is readily achieved by the tightly coupled cathode-follower stage. The circuit is easily capable of dealing with the abrupt drop in load impedance due to the Class B operation of the modulator tubes while introducing very little distortion of the waveform.

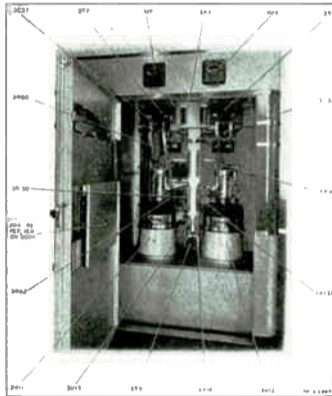

The 50-E Modulator compartment.

HEAVY METAL

The modulation transformer was an oil-filled rectangular tank just over six feet in height and weighing 6,100 pounds, including 190 gallons of 10C mineral oil weighing 1,400 pounds. The modulation reactor was an oil filled round tank about five feet in height using 135 gallons of 10C oil weighing 1,000 pounds.

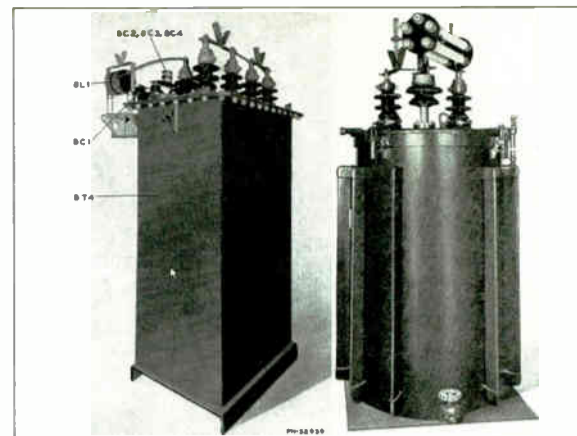

The modulation transformer and reactor.

The three 50 KVA plate transformers were "pole pig" style tanks about four feet in height, with each weighing 1,350 pounds containing 60.5 pounds of 10C oil. All of this gives new meaning to the phrase "Big Iron."

HUM REDUCTION

Hum originating in the high power amplifier filaments was a problem in the early days. This was typically due to the modulation of the electron stream by the AC powered filaments.

Early transmitters used DC motor-generator sets to produce the high current, low voltages required to heat the filaments of the high power RF and Audio stages. With the advent of newer tubes, the filaments were powered by center-tapped filament transformers, sometimes operated from three-phase power and sometimes from single-phase power. Use of the center tap in many cases reduced the hum contribution significantly by balancing out the hum caused by the application of AC power to the filaments.

While this was generally effective it was not sufficient to fully suppress the hum caused by the high power filaments required for the 893R tubes used in the modulator and RF power amplifier. This led to some innovations, including the novel use of negative feedback to aid in further suppression of the predominant hum frequencies.

(Continued on Page 40)

MORE CONTROL LESS PROGRAMMING

NEW SCRIPTEASY™ V2

SIMPLY DRAG AND DROP I/O DATA AND LOGIC FUNCTIONS
TO GENERATE MONITORING AND CONTROL SCRIPTS

RELIO™

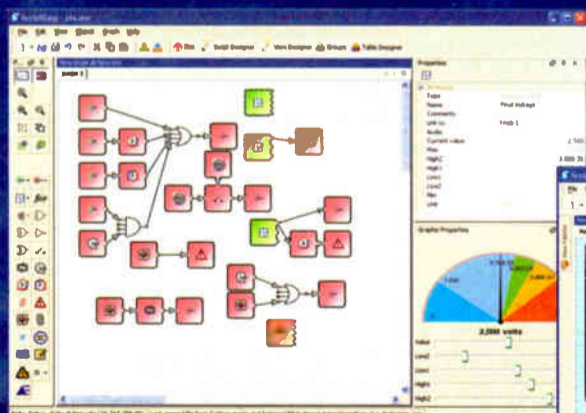

- Integrated IP connectivity
- New WYSIWYG MASTERVIEW™ software
- Voice DTMF interface software
- 9 serial ports (USB, RS232) for API, tunneling
- CF operating system
- Local KVM support
- 64 digital inputs
- 64 control outputs
- 24 analog inputs

Audemat®
Broadcasting Innovation

www.audemat.com

<http://www.relio.us>

Miami, FL USA -
Tel: 305 249 3110

ussales@audemat-aztec.com

SEALEVEL

When You Want More Than Just An Antenna

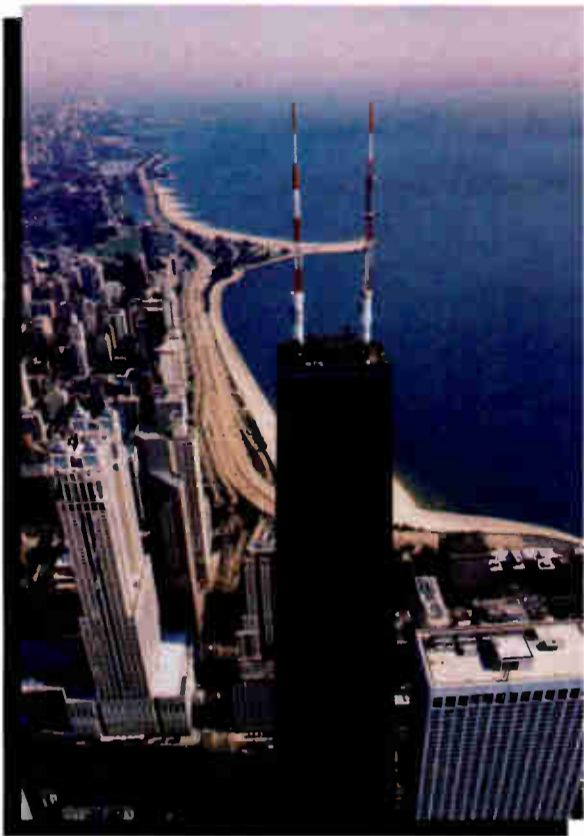

**Full line of
HD Radio Accessories:
Circulators, Mask Filters,
Reject Tuners, and
Rigid Components.**



Made in USA since 1954



**MASTER FM
DUAL INPUT
HD ANTENNA**



**JSHD DUAL INPUT
HD SIDEMOUNT
ANTENNA**



**RCHA 10dB
HIGH LEVEL
HD INJECTOR**

JAMPRO ANTENNAS/RF SYSTEMS, INC. • P.O. Box 292880 • Sacramento, CA 92829 USA • Phone (916) 383-1177 • Fax (916) 383-1182 • www.jampro.com Your Partner for HD Radio Solutions



Scrolling song titles? NO SWEAT!

If your dread of IT nightmares has you too terrified to put dynamic messaging on your station, then fear no more. Our Model 720 is the first in a series of user-friendly Inovonics RDS/RBDS encoders that practically install themselves.

Intuitive, self-guiding software, built-in data diagnostics and safeguards against accidental misuse make installation and operation virtually foolproof. A front-panel USB port enables quick setup, and connection with your playout system is a simple RS-232 link.

The front-panel LCD lets you to scroll through the various flag and message registers to confirm programming without having to connect a computer on-site. You can read incoming data 'on the fly' and also see exactly what is being displayed on listeners' radios.

Compatible with virtually all automation systems, the 720 also features a unique "no headers" mode to accept and automatically parse unformatted, satellite-streamed song title information. Yet the 720 is backward-compatible with earlier models for seamless integration into existing systems.



**For full technical
details, visit...**

www.inovon.com

Inovonics
1305 Fair Ave. • Santa Cruz, CA 95060
TEL: (831) 458-0552 • FAX: (831) 458-0554
www.inovon.com • e-mail: info@inovon.com

RCA's Transition to Design and Manufacturing

In the first audio stage plate circuit a parallel-tuned circuit consisting of inductor 3X-3 and 3C-10 is tuned to the predominant hum frequency of the filaments. The circuit presents a very high impedance load on the 6C6 input stage plate circuit resulting in a sharply tuned peak in the open loop frequency response of this stage.

When the feedback loop is closed, the response is flattened and the hum frequency generated within the modulator system is suppressed by the amount of the applied feedback.

Thus, the overall hum contribution of the modulator is significantly reduced.

MORE HUM REDUCTION

A second hum reduction system was introduced with the 50-E transmitter

This unit was the "Hum Frequency Feedback Amplifier," a rack-mounted assembly connected between the peak limiter output and the audio input to the modulator. The unit took an RF sample of the output line current, demodulated it, and removed most of the predominant hum-frequency components from the signal.

The unit consists of a high gain, two-stage audio amplifier with negative feedback from the plate of the last stage back to the cathode of the first stage. The amplifier also contains a tuned, positive feedback circuit from the plate of the last stage to the grid circuit of the first stage.

Detected audio from an RF sample of the current flowing in the output transmission line to the antenna system was added to the audio output from the peak limiter.

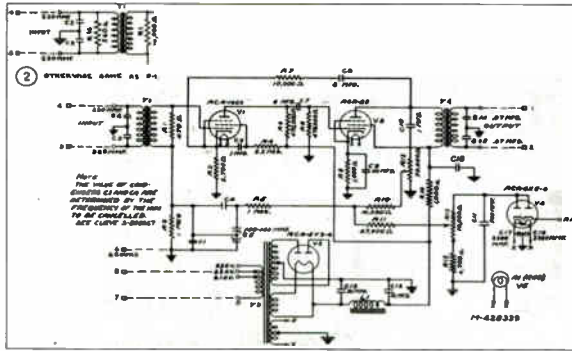

The Hum Frequency Feedback Amplifier Schematic.

The positive feedback loop was carefully tuned to the predominant hum frequency of the RF Power Amplifier stage by use of a phase-shift network inside the loop.

The frequency was adjusted to that of the predominant hum frequency and the envelope feedback was then adjusted to flatten the frequency response of the overall system. The hum frequencies were suppressed by the amplitude of the regenerative peak at the hum frequency. Thus the hum in the entire transmitter was reduced considerably, to the extent that the specification of 55 dB below 100 percent modulation could be achieved.

The Hum Frequency Feedback Amplifier would be carried forward to the BTA-50F model.

50 KW RF POWER AMPLIFIER

The 50 kilowatt RF Power Amplifier, contained in the center cabinet of the transmitter, used four 893R triodes in parallel. Each tube had a separate high-reactance filament transformer to limit the inrush current to the filament.

Due to the high current requirement of the filaments, the transformer was physically mounted above the tube, allowing only sufficient room for the tube to be elevated sufficiently to clear the porcelain insulator in which it rested. The filament connections were made through heavy copper straps from the filament bypass capacitors to the filament connections on top of the envelope.

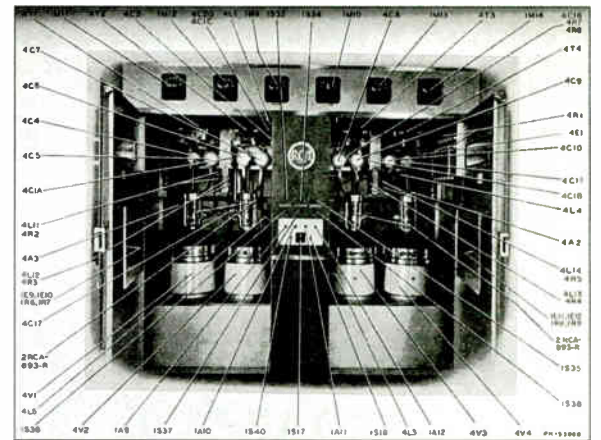

The RF Power Amplifier cabinet.

Meters on the front panel indicated total grid and plate currents and individual cathode currents. Individual parasitic suppressors were installed near the grid connection for each tube, supported by heavy copper straps. The stage was neutralized by parallel resonating the grid to plate capacitance and the associated stray capacitance of the wiring. A very long, fixed inductor was made adjustable by the addition of sufficient taps to the copper wire which formed the winding.

The RF Power Amplifier cabinet would be passed on in its entirety with only minor changes to the BTA-50F series following World War II.

OUTPUT NETWORK

The output network was a conventional Pi network, using air variable capacitors contained in a high pressure tank operated at a pressure of approximately 180 PSI, with dry nitrogen as the dielectric.

(Continued on Page 42)

ALTRONIC RESEARCH INC.

Performance By Design



THE BEST DUMMY LOADS AVAILABLE

OUTDOOR DUMMY LOADS

Convection-Cooled Resistor Loads
Designed for Outdoor Applications

Ideal for HD Applications
No AC Power Required



ALTRONIC RESEARCH INC.

P.O. Box 249 Yellville, Arkansas 72687 870-449-4093 Fax: 870-449-6000
E-mail: altronic@mtnhome.com Web Site: <http://www.altronic.com>

LOOK TO LARCAN FOR TRULY MADE TO MEASURE FM SOLUTIONS

Designed with a difference to ensure the highest quality audio performance - LARCAN offers a superior range of solid-state FM solutions from 25w to 5kW. Customer driven and purpose designed for optimum performance - we bring you the ultimate in FM broadcast technology from 'start to service'.

We hear you. Loud and clear.



25w FM Translator
FMT-25

U.S. Tel: 1-303-665-8000 • Fax: 1-303-673-9900 Canada Tel: 1-905-564-9222 • Fax: 1-905-564-9244

www.larcancan.com

Email: sales@larcancan.com

Custom Fit Features:

- Superior Audio Performance
- Modular Design
- Wideband Operation
- Automatic Tuning (front-end)
- High Selectivity
- Fully Synthesized (Tx and Rx)
- Internal FCC Code Key Module
- Compact 1RU Design

Broadcast Devices, Inc. Essentials for Good Broadcasting Since 1985

The AES-302 Digital Audio Switcher/DA/D-to-A Converter



The *AES-302* switches between two AES3 sources automatically upon loss of feed. Features include a four-output AES3 DA and balanced stereo analog output. The unit triggers on silence, loss of clock or other user determined digital error flags. The *AES-302* is remote control compatible with position status.

The CDS-300 Composite Audio Switcher/DA



The *CDS-300* is a basic two input composite audio switcher distribution system. The unit switches between two composite base band signals. Features include D.C. coupled signal path, low impedance output drivers that can drive long capacitive lines without instability. Another exclusive feature is an RBDS loop through to lock 57 kHz sub carriers to pilot and distribute to all outputs simultaneously. The *CDS-300* also has an accessory port for adding the *CTD-1 Composite to AES output module* providing two AES3 outputs derived from the incoming composite signal. The *CDS-300* is great for upgrading composite STLs and processors to digital output. Feed composite in and get AES3 output in addition to three composite outputs.

The CDS-302 Automatic Composite Audio Switcher/DA



The *CDS-302* is a two input composite audio switcher distribution system with silence sensor for automatic switchover operations. The *CDS-302* has all of the features of the *CDS-300* above including accessory port for adding the *CTD-1 Composite to AES output module*. Provides complete confidence that audio will get to the transmitter in the event of a link failure.

Broadcast Devices Inc.

Tel. 914-737-5032

Fax. 914-736-6916



Visit our web site for more complete product information.

The CMP-300 Composite Audio Mixer/DA



The *CMP-300* provides a means of combining up to three base band signals such as FM stereo, SCA, and RBDS signals. Each input has provision for level control and each of three outputs has a level trim too. Applications include combining signals to feed to excitors with only one base band input or for feeding a common base band signal to up to three locations. The *CMP-300* allows you to manage base band audio signals in one convenient package. Each input features a high quality D.C. coupled instrumentation amplifier and each output features a 50 ohm impedance line driver suitable for driving long capacitive cables without instability.

The CTD-300 Composite to AES Converter



The *CTD-300* converts base band composite FM stereo into two AES3 pairs suitable for application to digital input excitors. Whether you are adding IBOC or upgrading to a digital exciter, like its CDS series cousins the *CTD-300* becomes a cost effective alternative to replacing a composite STL or processor. Or use the *CTD-300* as a high quality stereo decoder for studio applications. Connect to your base band modulation monitor and the *CTD-300* can output AES3 or with a simple jumper selection, balanced left and right stereo suitable for driving an air monitor system.

The ACS-300 Six Channel Audio Control System



Originally designed for the rigors of six channel television sound, the *ACS-300 Audio Control System* provides six channels of balanced I/O where each channel or groups of channels can be remotely turned on, off or dimmed by a pre determined level. Uses include monitor muting for consoles that lack this feature or for paging applications where audio dimming or muting is required. Of course, the *ACS-300* is well suited to six channel audio surround applications too. Each input is differentially balanced and can provide up to 14 dB of gain. All outputs are differentially balanced 600 ohm impedance. Use any time audio needs to be turned on or off and line amplification is desired.

www.Broadcast-Devices.com

RCA's Transition to Design and Manufacturing

The capacitors were rated at 15 kilovolts peak. The tanks were mounted in an inverted position from the top of the cabinet. Each capacitor was driven from a reversible low speed motor. Front panel pushbuttons controlled the motors. A portion of the loading capacitor, **4C17**, is visible on the right side, in the middle.

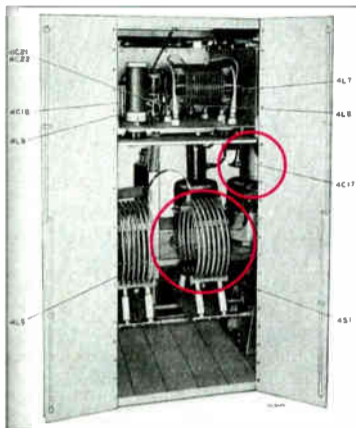

Rear view of the RF PA cabinet showing the output network.

The inductoremployed two large coils mounted on a pair of rails to allow adjustment of the mutual coupling between the pair for a wide range of inductance to accommodate the full band. The coil, **4L5** in the picture, was mounted on the center of the cabinet floor.

A very wide range of power control was provided by the loading control. The balance of the output network was referred to in the literature as the "Harmonic Filter." It took the form of a conventional "Tee" network, and was installed in a copper-plated steel enclosure mounted to the top of the cabinet. It used edge wound ribbon coils with conventional taps along with large mica capacitors as vacuum capacitors were not yet readily available.

Typical transmission line impedances were on the order of 200 to 300 Ohms. Most installations employed a 230 Ohm six-wire transmission line. Coaxial lines capable of handling the high peak power levels were not yet readily available.

KEEPING IT COOL

The cooling system for the 50-E consisted of a pair of blowers coupled through individual dampers to a large cooling duct, approximately four feet on a side, which ran beneath the transmitter for its full length.

The blowers were typically installed in a basement or room located below grade level. One blower was used to cool all of the power tubes using individual pipes attached to the ducts under the floor. They directed the cooling air through the insulators on which the anode coolers rested.

The blowers were large squirrel-cage designs with the motor directly coupled to the impeller. The blowers each delivered 7,000 cubic feet of air at a static pressure of 1.5 inches. Separate contactors were installed in the blower room for each unit. The contactors were controlled by a switch for each blower, so they could be exchanged, if desired, without airflow interruption while the transmitter was in operation.

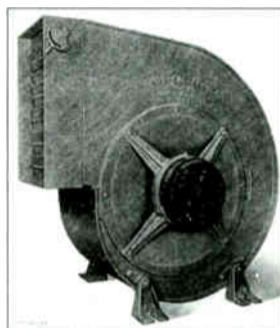

Each of the two blowers could push 7000 cfm.

The air intake was usually a large area, approximately 100 square feet in size and located on an exterior wall of the building. This wall was on the side of a ten foot by ten foot shaft which extended vertically from the top of the screened intake louvers to the sub-floor grade level.

The wall to the blower room was fitted with a group of replaceable air filters charged with a thin layer of oil to capture large particulates carried through the air. Normally a station would have two sets of the filters so they could be rotated and cleaned on a regular basis.

The heated exhaust air from the transmitter cabinets was normally captured by an overhead duct system and either vented outside the building or included in the building heating system for use during the winter.

HIGH POWER TUBES

The modulator and RF power amplifier tubes in the 50-E design were 893R's. Two were used in the Modulator and four in the Power Amplifier. These tubes were an "overgrown" version of the 892R, a forced-air cooled high mu triode used in most five and ten kilowatt transmitters manufactured after approximately 1935.

The tubes used a group of copper fins radiating from the core of the anode. The tube weighed approximately 225 pounds, requiring a hydraulically operated jack and dolly to remove and install the tubes.



The tube jack and dolly supplied with the transmitter by RCA.

The 893R had multiple filament strands connected to a common center point which allowed polyphase operation or single phase operation. The total filament power was 3,660 Watts per tube.

(Continued on Page 44)



Contact us at:
www.devabroadcast.com
sales@devabroadcast.com

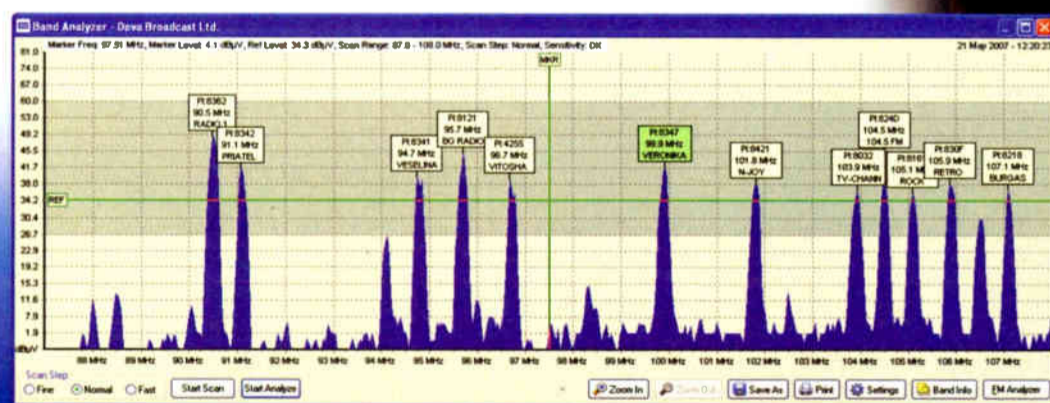

\$795

Band Scanner Pro

The Band Scanner is a tool to evaluate FM broadcast band congestion and to log station identification parameters. The system is powered by the USB port of any Windows PC. Supplied free of charge Windows software sweeps the receiver across the FM band, logging every carrier and generating a spectrum display of carrier level vs. frequency. It then analyzes each carrier and creates a station list. Stations with an RDS presence are further refined to show all the radio data groups being transmitted. Its interface is like a portable radio: It may be tuned manually through the receiver screen or by double-clicking a point on the spectrum plot or an entry on the station list. Spectrum plots may be saved as jpg or bmp files. The RDS data error level is graphed in a separate window on the receiver screen. The program can be monitored with headphones plugged into a standard 1/8" jack.

**Your Next Installation
can be this...**



or this...



**How do you make your installation projects run smoothly?
Use Digital Radio Engineering for the job!**

We have the engineering, project management, order administration, purchasing, and installation talent all in one place, and over 150 years combined experience in Radio. We can help you with researching new products and ideas, ordering new equipment, tracking deliveries, designing and engineering the new facility, manufacturing the new wiring, providing a top-of-the-line install team, and providing thorough and usable documentation for the entire project as well. You make sure your operation continues to run smoothly, and we help you make sure the new facility is a great addition to that operation.

**Call us before you start your next installation project.
You'll be glad you did.**



www.digitalradioengineering.com

(866) 386-4001

solutions@digitalradioengineering.com

Quality *FM & TV* Antenna Systems

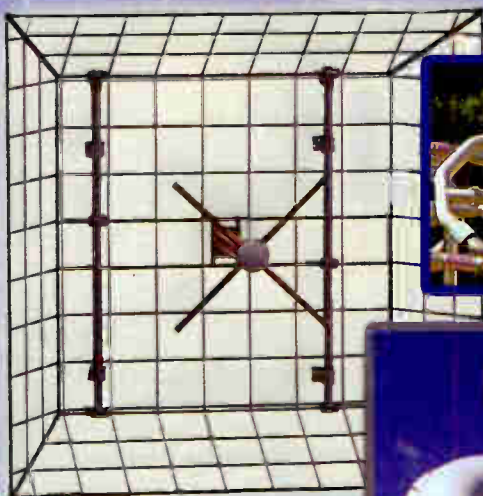

FM PANEL



POWER-TILLER



POWER-TILLER WITH RADOME

SLANT-V DIRECTIONAL

PSI IS DEDICATED TO DESIGNING AND MANUFACTURING THE HIGHEST QUALITY PRODUCT. WORKING DILIGENTLY WITH STATION ENGINEERS, CONSULTANTS AND OUTSIDE VENDORS ENSURES THAT EACH PROJECT IS COMPLETED TO THE CUSTOMER'S SATISFACTION.

WIDE RANGE OF ANTENNA MODELS ARE AVAILABLE AT ALL POWER LEVELS, DIRECTIONAL AND NON-DIRECTIONAL, MULTI-STATION AND MORE....

ADDITIONAL PRODUCTS INCLUDE..

- TRANSMISSION LINE
- COMBINERS
- FILTERS AND
- TURNKEY SYSTEMS



Propagation Systems, Inc.

Phone: (814) 472 - 5540
Email: sales@psibroadcast.com

Fax: (814) 472 - 5676
www.psibroadcast.com

Heavy Metal

Continued from Page 42

RCA's Transition to Design and Manufacturing

IMPROVING THE TUBES

From information available to the author, it is believed that the 893R tube was not a successful tube. It appears to have been used only in the RCA 50-E, and even then was replaced by other types in all four of the known transmitters.

For example, the KTRH transmitter changed to a Westinghouse 895R at some point in its history. The 895R was similar in size to the 893R, with the same radiator dimensions and a shorter glass "neck" dimension reduced from 28 inches to 24 inches in overall height. The filament required slightly less power than the 893R at 2620 watts.

The maximum ratings allowed a pair of 895R's to be used in the RF power amplifier for 50 kilowatt AM operation, this saving the cost of two tubes. This tube was also used by Westinghouse in its type 50-HG, 50 kilowatt AM transmitter which was released in early 1942.

In the late 1940's, RCA developed a replacement tube using thoriated tungsten filaments which resulted in significant reduction in the power required by the filament. The tube also had an exceptionally long lifetime in fifty kilowatt AM applications and would become the industry standard for several years.

This tube, which became the 5671, would become original equipment in later generations of both RCA and Westinghouse fifty kilowatt transmitters. The tube was retrofitted into the KOB and KGA transmitters and probably found its way into the WCAU transmitter as well, due to its proximity to RCA. More information on this tube and its history will appear in Part 3 of this series – the RCA BTA-50F.

POWER SUPPLY

RCA, ever the "creature of habit," retained the high voltage rectifier rack – with the in-place spare tube and associated patching system – used in the 50-D transmitters. The 50-E rack is essentially the same, although some minor differences can be seen in the photo.

The only significant difference is the addition of the six high-voltage filter capacitors, a step-start relay – 5E1 – to short out the current limiting resistor – 5R2 – and the addition of a more modern blower to cool the tube bases. This frame assembly would be carried forward into the later generations of the 50 kilowatt and other high power transmitters manufactured by RCA.

An interesting feature to avoid potential outages first appeared in the 50-E. In the picture, you can see a series of hooks mounted on an insulated horizontal bar. Not shown in the photograph is a series of small gauge nichrome wires which held the spring loaded shorting electrodes across the two terminals of the filter capacitors. In the event of high current fault in one or more of the capacitors, the nichrome wire would heat up rapidly and burn open. This would release the shorting electrode to the defective capacitor without interrupting program-

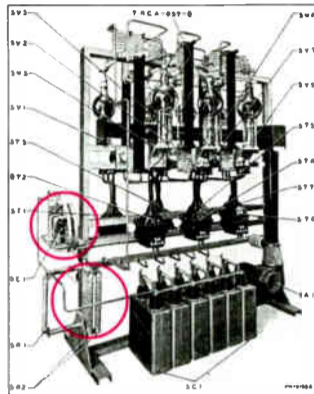

The rectifier rack and capacitor bank.

ming. This feature would be carried forward to other RCA high power transmitters.

ADDITIONAL POWER DATA

Because the 50-E was a Class C final amplifier modulated by a Class B audio stage, the DC Plate Voltage was significantly lower than the linear amplifiers which preceded it, on the order 10,000 to 11,000 Volts.

This voltage was supplied by three 50 KVA plate transformers supplied from a 2,300 Volt distribution line. This was a common local distribution voltage in the 1930's and 1940's and was used by most of the high power transmitters of the day.

The secondaries were connected in the delta configuration and applied to a three-phase, full-wave bridge rectifier arrangement. The primary was arranged so it could be switched into a delta configuration for normal high power operation or a wye configuration a reduced power.

Control of high/low power operation was from the front panel of the transmitter or from the supervisory console sometimes supplied with the transmitter. It appears that KOB and KTRH did not use the RCA supervisory console, opting instead to construct their own.

LOOKING BACK

There appear to be few photographs available for the four known transmitters. A couple of good photographs were obtained from sources in Albuquerque showing the KOB transmitter and the associated RCA 10-C water-cooled transmitter used as a 5 kW driver. The KOB transmitter building is a small Pueblo style building which was common in New Mexico during the era.



The KOB Transmitter Building

(Continued on Page 46)

VoxPro

The Short/cut™ Replacement

Remove Talk-Over
Room to Room
Auto Network
MP3 - WAV - WMA
AGC - Search
Advanced Effects
Multiple Control Panels
And Fast!



audionlabs.com
206 842 5202 x203
Available at all
broadcast distributors.

© 2008 Audion Laboratories Inc. All rights reserved. Audion, VoxPro are registered trademarks of Audion Laboratories Inc. Other company and product names may be trade marks of their respective owners.

Need headphone amps? We've got 'em!

Henry's new Mini Pod headphone amps are perfect for single or multi-user headphone systems.

Use as many as you need, wherever you need them! Mini Pods link together with cat5 cables to make a multi-user system....or use Henry's MultiPhones Master unit to add 3-Zone Talkback. Either way, Mini Pods are compact, efficient, and sound great!

Back view

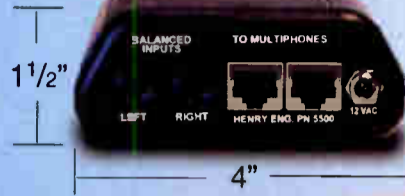

We Build Solutions



626.355.3656

Complete details at
www.henryeng.com/minipod.html



Designed With Your Needs in Mind. It's like having ESP!



ESP Adaptive Correction

Instrument Grade Spectrum Analyzer

Dual RF Outputs

Integrated GPS Receiver

Decoded AES Output

8 Configurable Operating Preferences

Dual Independent AES/EBU Inputs



In addition to ESP Adaptive Correction and "On-the-Fly" mode changing, the new FXi 60/250esp FM/HD Exciter offers a number of unique features that you won't find in any other exciter. We've eliminated the need for several external products that are traditionally a part of your broadcast chain. By incorporating them into our exciter, this translates to lower cost of ownership. Added capabilities make the FXi 60/250esp the most technologically advanced FM/HD exciter on the market.

Eliminating equipment, simplifying your system, and lowering the cost of ownership....we've thought of everything. It's like having ESP!

We know what you're thinking,
so give us a call today!



Tomorrow's Radio Today

Broadcast Electronics, Inc.
(217) 224-9600
bdcast@bdcast.com

RCA's Transition to Design and Manufacturing

Inside you can see the older "C" model, which was used as a driver, in place on the far left.

The houstonradiohistory.blogspot.com contains several good photographs of the KTRH Baytown, Texas transmitter site building, a large Art Deco structure constructed about 1940 specifically for the new 50 kilowatt plant. It appears below.

The KTRH 50-E transmitter used the RCA emergency modulator sections, so it more completely looks like the previous factory drawing in layout than the KOB installation.



Inside the KOB transmitter room.

A SHORT LIFE

As noted, the RCA 50-E production life was drastically shortened by World War II with only four units known to have been produced. There are indications that a few others may have been built during the war and sent to Europe and South America, but the only one known to have returned to this country was the unit that eventually went to KGA, Spokane, Washington.

Regarding KGA: there is some debate as to whether it was a 50 or 100 kilowatt radio. I believe the confusion may be due to the fact that the radio had four tube positions in the RF Power Amplifier but only two active tubes in its later life. As already mentioned, the 50-E was designed to use four type 893R tubes for 50 kilowatt operation. As the KGA transmitter was reportedly converted to use 5671's in the modulator and RF PA, it would have required only two tubes to make 50 kilowatts of power.

This is a plausible explanation for the discrepancy. Unfortunately the radio no longer exists nor are there any known photographs of the installation.



KTRH's 50-E and Phasing Cabinet
Courtesy: Sam Lester



KTRH's transmitter building
Courtesy: Sam Lester

COMING UP

The BTA-50F series replaced the 50-E after the war, inaugurating a new model numbering system for RCA.

Many similarities exist between the 50-E and the BTA-50F series transmitters, and the improvements in the BTA-50F series made it arguably the best of the 50 kilowatt transmitters for many years to come. Join us next time as Heavy Metal continues with this very popular and successful transmitter, with several serving more than one station during their extraordinary lifetimes.

I would like to acknowledge the contributions of several people who provided information about the various 50-E transmitters and their histories. Among them are Mike Langner and Gary Diamond, both of whom had hands on contact with the KOB transmitter in Albuquerque, Tommy Bolack of the Bolack Electromechanical Museum of Farmington, New Mexico, who has lovingly preserved the 50-E and 10-C transmitters from KOB and has them on display for future generations to see.

Also Ralph Green, retired Engineering Manager of CBS Radio and former Chief Engineer of WCAU, Philadelphia for his reminiscences of the WCAU installation; Bob Stroupe, Houston Market Chief Engineer for Clear Channel Radio, the present licensee of KTRH; Ben Dawson, P.E. of Hatfield and Dawson Consulting Engineers for information on the KGA installation, and Walt Jamison, P.E. former transmitter supervisor for Fisher Broadcasting, owner of KOMO Seattle for his comments, knowledge and history of the KGA transmitter.

Jack Sellmeyer has been designing, constructing and maintaining broadcast equipment and stations for over five decades. Jack can be contacted at jack@sellmeyereng.com

RADIO GUIDE

www.radio-guide.com

Premier technical information
meets Radio's On-Line Community®
at www.radio-info.com
arriving September 2008

RADIO-INFO.COM

RADIO'S ONLINE COMMUNITY

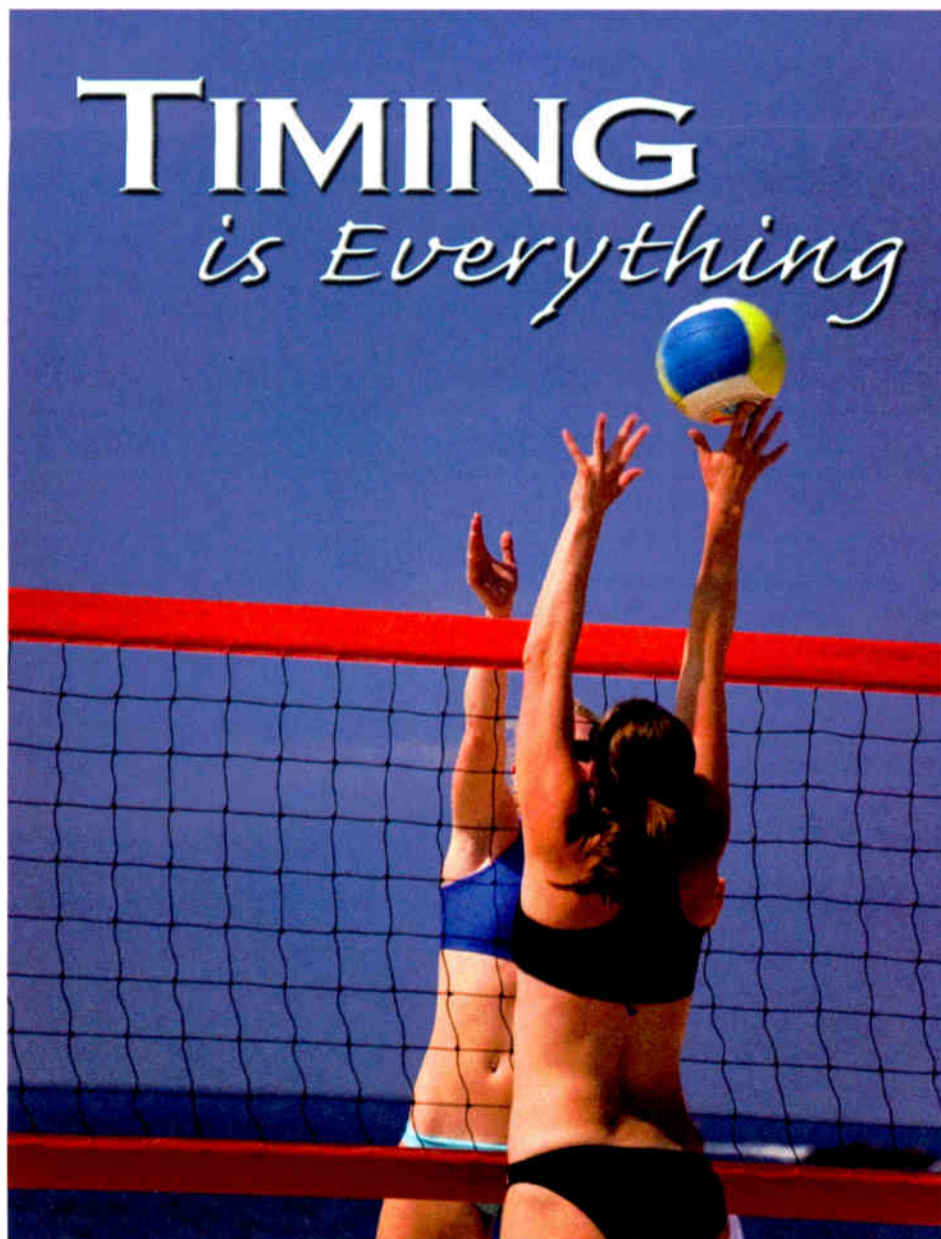

Don't take a chance with your timing needs. Trust the name broadcasters have counted on for precision master clocks and timing-related products for over 35 years—ESE. Our products accurately synchronize broadcast operations using a choice of GPS, WWV, Modem, Crystal or line frequency for affordable, reliable, perfect time.

Visit www.esweb.com to witness world-class timing systems that are designed for easy installation, set-up and operation.

142 Sierra Street
El Segundo, CA 90245 USA
Tel: (310) 322-2136
Fax: (310) 322-8127
www.esweb.com



Elevated Radial System

- Easily inspected.
- Less expensive.
- Performs equal to or better than a buried system.
- Requires less labor and materials to install.
- Fully complies with FCC requirements.
- Can utilize the land below the systems for farming, storage buildings, etc.
- **FREE** systems design with purchase of elevated radial systems from Nott Ltd.

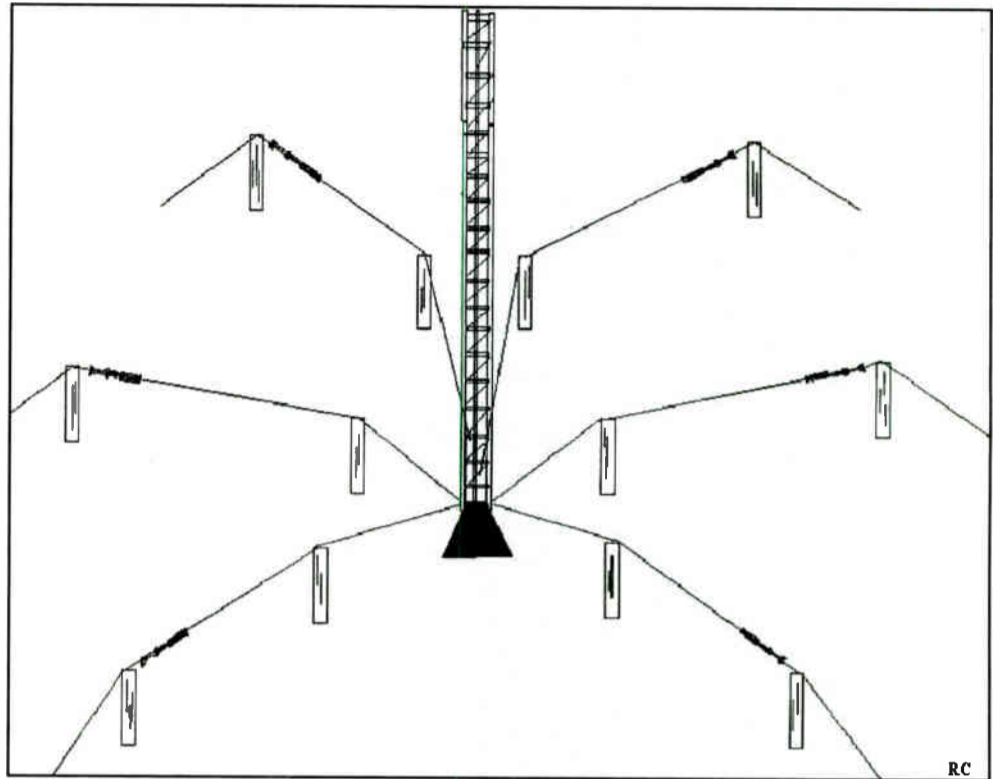

Phone 505-327-5646 • Fax 505-325-1142

3801 La Plata Hwy, Farmington, NM 87401
email: info@nottltd.com

nott ltd

Change the way you think about the clock...

AUDIO TIME MANAGER doesn't just shift time, it shifts the clock paradigm. Imagine inserting an extra traffic report in a network show, with no loss of content. Imagine backtiming into the network perfectly every time, even when breaking local news means you're running long. Imagine eliminating make-goods. Now shift your thinking about time, because your old clock just got a new face.



"The 25-Seven Systems box is an amazing device and leaves all others in its dust. It's truly the **SECRET WEAPON** to make your station sound tighter, time shift segments and never miss a network cue again. We're still finding new and creative ways to use the 25/7 every week."

-Gabe Hobbs

Senior Vice-President of Programming, News/Talk/Sports
Clear Channel Radio



AUDIO TIME MANAGER ...it's about time
25-Seven Systems, Inc. • 888-257-2578 • www.25-Seven.com



copyright © 2008 25-Seven Systems, Inc.

History

WLW's Big Sister: Radio Aspidistra

Many know the story of WLW's 500 kW transmitter (*Radio Guide*, Sept to Nov 2007). But not as many know of WLW's bigger sister, originally planned for use in the USA, but which lived its life in England. Stan Adams explains.

The story has long circulated about a superpower transmitter used during World War II for counter-espionage or what is called "Black Propaganda Broadcasting." Did this really happen? Was there a 600 kW super transmitter made from a surplus "in storage" RCA transmitter?

ASPIDISTRA UNCOVERED

The answer is clearly a yes! Not only have there been mentions of this affair in the popular press of the last thirty or so years but recently there has come to light documentation of the time of modification, shipment and installation this transmitter – code-named Aspidistra – during the early part of WWII.

With pointers from our friend Dr. Alex Magoun, chief curator of the David Sarnoff Research Center, information has turned up at the National Archives' files from the War Department and Army Signal Corps, and the Hagley Library in Wilmington, Delaware, which accessioned the RCA Camden technical library in the early 1990s.

The Hagley has the only extant run of RCA Victor engineering memos and technical reports; some RCA Communications documentation exists for the work at Camden where certain upgrades to the transmitter were to be made.

JUST WHAT THEY NEEDED

As WWII progressed, the British sought a high powered transmitter to broadcast on German frequencies, to foster confusion and demoralize the population. Nothing of that power level was available domestically.

Then Colonel Richard Gambier-Perry (head of Britain's Special Intelligence Service communications) learned that RCA had constructed a "giant" medium wave transmitter for a New Jersey commercial station (WJZ) in 1941. Its use was forbidden by the FCC and it was in storage at the RCA factory in Camden NY.

The transmitter was similar to the 500 kW unit at WLW, except that it had three separate sets of cubicles, each running 200 kW. Essentially, it was an RCAC version with a cover that made it look much like 1939/1940 Westinghouse design.

Gambier-Parry wrote a memorandum describing "a raiding Dreadnought of the ether, firing broadcasts at unpredictable times at unpredictable objectives of the enemy's radio propaganda machine." This language almost guaranteed the necessary funds to secure this transmitter and to ship it to England. The purchase price was over \$500,000 in 1941 funds.

FROM CAMDEN TO ENGLAND

Technician Harold Robin of the Diplomatic Wireless Service was sent to the USA, ostensibly attached to William Stephenson's staff. He spent two months at the RCA factory to become thoroughly familiar with the transmitter and had the power increased from 500 to 600 kW.

The transmitter was built near Crowborough in secret by the Political Warfare Executive (PWE) Committee. Canadian construction battalions were used to rapidly develop a series of underground buildings to house the transmitter and adjacent housing for all support personnel. Nicknamed "Aspidistra," after a popular song of the time, it was readied to send "Black Broadcasts" to Europe during the war.

By this time the BBC had learned of its existence and possible use, and had raised a number of objections,

particularly about its use as a "jammer." Eventually a compromise was reached in May 1942 when it was agreed that Aspidistra could be used by the BBC when it was not required for the still undefined PWE work or by RAF Fighter Command.



The 600 kW Aspidistra transmitter.

ASPIDISTRA IN OPERATION

The modified RCA 500 series had been specially designed for very quick frequency changes (reportedly as little as 1/200th of a second).

To prevent the Germans from getting a "fix" on Aspidistra, it was linked with other transmitters, including one at Dover. Robin would use information gathered by the RAF and quickly bring the transmitter up on the frequencies of local German stations as they switched off during British raids.

The German listeners would barely notice the short "click" as Robin retransmitted real German broadcasts to pave the way for the disinformation. Then misleading information was broadcast in an announcer's voice that would be indistinguishable from the actual announcer who really was off the air at that moment.

Our sources indicate that the BBC obtained its partial use of the transmitter starting in 1942 to transmit the European Service on 804 kHz when not needed by the RAF. After the war, the American-built transmitter was used by the BBC World Service until it was decommissioned in 1982.

Based in Memphis, Tennessee, Stanley Adams comes from a family of broadcasters. Email Stan at: stanleybadams@yahoo.com



Studio Design & Fabrication

RAM Broadcast Systems builds studios for most of North America's major networks, group stations, and news organizations. RAM offers comprehensive studio design, fabrication, systems integration, and components. Put RAM's 35 years of experience to work for you:

- Studio Design & Fabrication
- Broadcast Furniture
- Switchers
- Computers
- Pre-Wired Systems
- On-site Installation
- Racks
- And More!

www.ramsyscom.com
800.779.7575



RAM Broadcast Systems



PROVIDING BROADCAST TOWER
INSTALLATIONS & ENGINEERING SERVICES

30 years

Since 1976 Magnum Towers has been providing the broadcast industry with guyed and self-supporting towers of the highest quality across the United States and around the world.



t: 916.381.5053
www.magnumtowers.com

EXPERIENCE YOU CAN TRUST.

Shively Labs®

Radio is our main line, not just a side-line.

State-of-the-art design

Proven reliability

Cool and blue – no boring black or gray here!

*Visit us at the NAB Radio Show!
Austin, Texas, September 17 - 19
Booth #506*

P. O. Box 389, 188 Harrison Rd., Bridgton, Maine USA 04009
(207) 647-3327 (888) SHIVELY FAX (207) 647-8273
sales@shively.com www.shively.com

- An Employee-Owned Company -
ISO-9001:2000 Certified



Lawrence John Cervon

By Jack Sellmeyer

A major figure for some six decades at RCA, Westinghouse, Gates/Harris, Microwave Associates, and Broadcast Electronics, Larry Cervon passed away on July 5, 2008. He was 86.

Larry Cervon was born in the village of Lazisca on the island of Brac in Yugoslavia. His family immigrated to the United States in 1928 and settled in New York City, New York. Larry graduated from Stuyvesant High School and received a Bachelor of Science degree from the City College of New York. He also attended Fordham Law School.

Larry served in the U.S. Navy during World War II and studied electronics under the "Captain Eddy Electronic Technician" program.

Following the war he began work for RCA International in New York City as a sales trainee in the Broadcast Equipment Section. A year later he joined Westinghouse Electric International Company as a product specialist for Broadcast Equipment Sales Support.

FROM SALES TO MANAGEMENT

At Westinghouse, he met Parker Gates, son of the founder of Gates Radio Company and the President of Gates Radio Company at the time. Larry joined Gates as a sales representative covering New England, New York, Pennsylvania and New Jersey.



Larry Cervon
January 27, 1922 –
July 5, 2008

During the Korean War he secured a contract from the U.S. Army Signal Corps for a complete 5 kilowatt medium wave transmission system packaged in a 40-foot trailer. This began a long term relationship with the Signal Corps leading to many contracts for the supply of radio and television equipment to support the Army's psychological warfare programs.

In 1952, Larry became Sales Manager of Gates Radio Company, moving to Quincy with his wife Louise in 1953 where he remained for the rest of his career with Gates Radio Company.

In 1968 Larry succeeded Parker Gates as head of the Gates Radio Division of Harris Intertype which Harris had acquired several years previously. As Vice President/General Manager of Gates, he moved quickly to bring Gates into the television transmitter market by hiring Hans Bott from RCA to head the television transmitter engineering section. About 1971, Gates purchased the television equipment division of General Electric Company and broadened its product line to include antennas and television studio equipment.

Larry also focused the company on the international broadcast market obtaining a nine million dollar contract with the government of Iran in 1969 for the supply of medium wave transmitters and FM broadcast transmitters for Iranian Radio and Television.

THE ROAD TO BROADCAST ELECTRONICS

In May, 1974 Larry left the Gates Radio Division of Harris Intertype Corporation and joined Microwave Associates as Vice President/General Manager of the Communications Equipment Division.

In 1976 Larry joined Broadcast Electronics (BE), then a subsidiary of Filmways Corporation, located in Silver Spring, Maryland.

He soon determined that the operating costs in Maryland were much higher than in Quincy, Illinois, where a Motorola Consumer Electronics plant recently had been shut down following the sale of the division to

a Japanese company. He decided to relocate BE to Quincy, locating the plant in a building formerly occupied by a discount retailer, leading to the name "Larry's Discount House" being applied to the company by some of his former associates at Gates.

CHANGING BE'S FOCUS

Larry quickly refocused the company from the cartridge tape machine and low-end console business to state-of-the-art FM transmitters, hiring several people from Gates who would become key people at BE – among them, Hans Bott as Manager of Engineering, Geoff Mendenhall, Jim Aurand, and Curt Kring as Sales Manager.

In the following years, BE would introduce the FX-30 FM exciter, which led the industry in performance for several years, a complete line of FM transmitters, and a line of state-of-the-art solid state AM transmitters from 500 Watts through ten kilowatts.

In 1983, Orion Pictures which had acquired Filmways (and BE), disposed of all non-motion picture assets. Larry teamed with Narragansett Capital Corporation to purchase the assets of Broadcast Electronics. He would head the company until his retirement in 1990, when it was sold to Cirrus Corporation.

HONORED BY BROADCASTERS

Larry was honored by the National Association of Broadcasters in 1991 with its "Lifetime Achievement Award." In 2007, Broadcast Electronics honored Larry on the 30th anniversary of its move to Quincy.

Larry was active in the civic affairs of his adopted hometown of Quincy, Illinois, serving on many boards and committees representing business, industrial, medical, and educational aspect of the city.

Lawrence J. Cervon is survived by his wife Louise, son Larry, Jr., daughter Kathryn, and two grandchildren.

He will be missed by his many friends and associates in the industry. – Jack S. Sellmeyer, P.E.

Audio over IP - Radio Messengers from Barix:

"When we finally knocked out the satellites, transmission quality improved and costs went down."

For more about faster, better, lower-cost broadcasting visit www.barix.com



FP-TRO



The Ultimate IBOC Receiver/Translator

Designed to accommodate "full envelope" baseband signals (IBOC and analog), Fanfare's new age receiver/translator, the TRO, is fully self-contained and does not require an IBOC exciter. In fact it arrives in a 2 module configuration ready for deployment under all existing FM modulation forms. The "TRO" offers considerable versatility requiring only connection to the receiving antenna and a linearized PA. If necessary, the receiver and translator modules can be separated by up to 200' of coax, or by STL. The latter would be of value for some repeater applications as well.

At the heart of the TRO design is our patented, Omega NTP-based technology which enables the TRO to establish a noise floor that is often below normal measure. This significant noise reduction manifests itself in significantly increased sensitivity and adjacent noise rejection which is essential to assure reception of low-level IBOC signals.



1-800-268-8637 (U.S. & Canada)

6509 Transit Road, Unit H-1
Bowmansville NY 14026
Email "prinfo@fanfarefm.com"

Voice - 716-683-5451
Fax - 716-683-5421
Website: "www.fanfarefm.com"

Designing receivers that broadcasters can rely on

TRANSCOM CORPORATION

Serving the Broadcast Industry Since 1978

Visit Our Website – www.fmamtv.com

Send your e-mail requests to: transcom@fmamtv.com

Fine Used AM & FM Transmitters & New Equipment

AM	1 kW	1996	Continental 314D
	5 kW	1982	Harris MW5A
	5 kW	1987	Harris MW5B
	5 kW	1988	Harris SX5A Single Phase
	10 kW	1983	Nautel Ampfet
	10 kW	1985	Continental 316F
FM	12 kW	2000	Nautel XL12
	1.0 kW	2007	Crown FM1000A (new)
	1.0 kW	2007	Crown FM 1000E (new)
	1.0 kW	2007	Crown FM2000E (new)
	10 kW	2005	Harris Z16HD IBOC
	10 kW	2005	Harris Z16HDS IBOC
	10 kW	1986	Continental 816R-1A
	10 kW	2001	Henry 10,000D-95
	14+5 kW	2005	BE Fmi1405 Solid State
	25 kW	1989	Continental 816R-3B
	27.5 kW	1988	Continental 816R-4B
	30 kW	1988	BE FM30A
35 kW	1986	BE FM35A	
50 kW	1982	Harris Combiner	

(w/auto exciter-transmitter switcher)

USED MISC. EQUIPMENT:

- Marti STL10 System
- Marti ST15 System
- Bird RF ThruLine Watt Meter, 50S

EXCITERS:

- New – 20W & 30W Synthesized Exciters
- Used Harris Digit Exciter

Please go to our website for updated listings.

Retuning and testing available – call for quote!



OMB STL systems for radio, complete with antenna and cable for under \$5,000!

2655 Philmont Ave, Ste 200, Huntington Valley, PA 19006
800-441-8454 215-938-7304 Fax: 215-938-7361

WHY NOT SWITCH TO MCI? COMPLETE FM/TV PRODUCT LINE



Coax switches from 7/8" through 6-1/8"
Control panels available.

- ANTENNAS
- SPLITTERS
- NOTCH FILTERS
- HARMONIC FILTERS
- POWER COMBINERS
- CHANNEL COMBINERS
- N +1 SWITCHING MATRIX

Free UPS Ground shipping within the continental USA and Canada - SWITCHES ONLY

Micro Communications, Inc.

Toll Free: 800-545-0608
www.mcibroadcast.com



FTA-100P



Some call it
"The Ultimate Translator Receiver"

and it's NOW available WITH AM-STEREO

The Fanfare FTIAP was the original translator receiver that breathed new life into so many 'iffy FM translator sites, providing them a fully airable signal, often when all there was was noise. Add to that, the FT-IAP's established record of reliability, and extraordinarily low maintenance and you have a receiver that will pay for itself many times over with service visits you won't have to make; not to mention a signal that will maintain your listener's attention. In other words, "It leaves you alone to do more important stuff."

Now that AM to FM translation is being considered, Fanfare is pleased to offer the FTA100P, an AM/FM version of the FT-IAP for that purpose. Both models feature our acclaimed, high resolution, analog, front ends. As well, the state-of-art, digital control system maintains tuning accuracy at all times, even after power failure. Included is adjustable Composite Output. Audio (XLR) +10dB outputs are available for AM translation. To further enhance the FT-IAP's FM versatility, optional, level-adjustable, Carrier Sense (to assist in meeting FCC regs); an RS232, Serial I/O port, and a gain-adjustable, stereo headphone outlet are available.



1-800-268-8637 (U.S. & Canada)

6509 Transit Road, Unit H-1
Bowmansville NY 14026
Email "prinfo@fanfarefm.com"

Voice - 716-683-5451
Fax - 716-683-5421
Website: "www.fanfarefm.com"

Designing receivers that broadcasters can rely on

Tool Guide



Test, Tools, Tips and Applications

By Barry Mishkind

Solving Problems for Mobile Computer Users

Notebook computers are wonderful things. They let you take computing power – sometimes as much as your desktop has, or more – to wherever you might need it. Most recent notebooks have built-in WiFi; documentation, email, web searches, etc. are all at your fingertips. What more could you want?

For me, as I wander around, there is the occasional difficulty in sharing files with someone else. And I miss that loveable rodent – a good mouse.

POINTER ISSUES

Often, I find using the pointer device in a notebook computer is not always as convenient as I would like. I dislike joysticks and sometimes the touchpad does not respond to my finger as reliably as I would like.

I also find that being able to point and click, drag and drop, even scroll just is easier with a mouse. And, if you are a Mac user, the lack of a right button (yes, you can reach for the keyboard, but that is not the point) is sometimes slightly annoying.

Most of the solutions I tried were bad compromises for a mobile user. It was just plain annoying to have even more wires to deal with while on the road. And, all too often, the wire had to reach a socket on the wrong side of the notebook. Dongle-based mice were a pain because, even if you did not lose the dongle, it seemed like I was always re-initializing the mouse.

THE RIGHT MOUSE

Then I learned about the Logitech V470 Cordless Laser Mouse for Notebooks with Bluetooth. (www.logitech.com)

After popping in the batteries, it synced up with my Mac in a moment – without any additional software – and just works every time I open the notebook, either in Mac mode or PC mode (using Parallels). There even is an on-off switch to conserve the battery when I will not need it for a while.

With its laser technology, it gives smooth and accurate cursor control almost anywhere. The scroll wheel also does side-to-side scrolling. I can work with it on a table, a pad of paper, my shirt, my leg, anywhere. It just works.

The V470 is not the largest mouse in the attic, but it feels good and easily fits in my carry case. All in all, for around \$50, including the pouch, the V470 does everything I want from a mouse.



The Logitech V470

NO MORE SNEAKERNET

The other major issue I have with notebooks is that, unless you are able to log in on the same network, transferring files to another person is usually a pain. All too often, security concerns make it very hard – or impossible – to accomplish the task.

The old solution was the new sneakernet: the flash drive. Copy to the flash drive and hope there was enough room, then run to the other user and copy.

I found a new solution this year, and it is slick: The Tornado Data Transfer Tool from Data Drive Thru. (www.thetornado.com)

EASY TRANSFER

The Tornado is a self-contained product that allows you to simply pull out the retractable USB cables and connect two PCs together – and transfer files. The software auto-loads and, when disconnected, the cables return to their case and leave nothing behind – except the transferred files. All for under \$50.

When you plug in the Tornado, a file manager appears on the screen of each computer (you do not even need a screen on the second unit). Each computer is identified, and you can drag and drop files from one computer to another in seconds.

From one file to a complete backup, the Tornado transfers via USB 2.0 protocol at speeds of up to 25 Mb/sec. Windows 98SE through Vista are supported (except for NT). The standard cable is four feet, but a USB extender can be used.

I have used the Tornado to transfer files between computers, do a partial and a complete backup, and recover files from a family member's hard drive. I was even able to transfer files to my Mac while using Parallels (a separate product, iTornado, will transfer between PCs and Mac OS's).

It was all quick and easy. And I never needed a flash drive.



The Tornado's retractable cable makes file sharing easy and convenient.

Microwave Filter Company, Inc.

Providing High-Q & STL
Bandpass & Notch Filters for
your AM & FM Applications

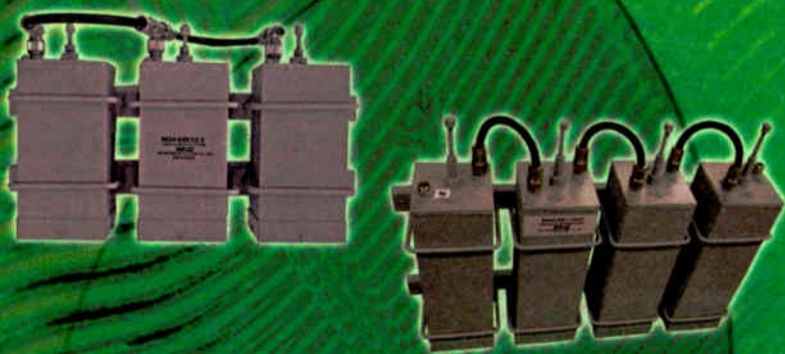

Contact us
for a copy of our
NEW Broadcast
Catalog



Tel: (315) 438-4700
Fax: (315) 463-1467
E-Mail: mfcsales@microwavefilter.com

An ISO 9001:2000 Registered Company • SBE Member

www.microwavefilter.com

FREELAND PRODUCTS, INC.
Quality Tube Rebuilders Since 1940
www.freeland-inc.com
800.624.7626

**NEED A QUALITY REBUILT
TUBE IN A HURRY?**

**Many in stock!
Ready to ship**

Triode
Tetrode
Cermolox
Thomson
Klystrons
Misc
Tube Tips

Mention **Radio Guide** when shipping your
next tube to be rebuilt

Bay Country Broadcast Equipment

Buy • Sell • Trade

Your #1 Source for Quality
Used Radio Broadcast Equipment

View our latest list of equipment on-line at:

www.baycountry.com

Or call and we will fax it to you.

All equipment sold with a 15 day return guarantee.

Turn Your Excess Gear Into Cash

Fax or email your list to us and we will respond with our offer promptly. We only buy good working equipment with traceable serial numbers.

Fax Your List Today – 443-596-0212



<http://www.baycountry.com>

(Website Updated Daily)

E-mail: sales@baycountry.com

877-722-1031 (Toll Free) 443-596-0212 (Fax)

7117 Olivia Rd, Baltimore, MD 21220

The Broadcast Industry's **FIRST** 6-channel UNcompressed Digital STL



Advanced Technology, Only From TFT

- 6 UNcompressed Program Channels, maximum
- PC Configurable from Front Panel for Frequency, I/O, Alarms, LCD
- Supports 48, 44.1, as well as 32 ks/s Sample Rates
- 256 QAM, 64 QAM, 16 QAM Modulation
- AES/EBU or Analog I/O - Built-In Sample Rate Converters
- Major/Minor Alarms on both Transmitter and Receiver
- 3.125 kHz Step Size

TFT
INC

Phone: (+1)408-943-9323

FAX: (+1)408-432-9218

www.TFTInc.com e-mail: info@tftinc.com
1953 Concourse Drive, San Jose, CA 95131



ECONCO Rebuilt Power Tubes



Approximately
One Half the Cost of New

3,000 Hour Unconditional Guarantee

Call for Your Quotation

ECONCO 1318 Commerce Ave., Woodland, CA 95776

Phone: 530-662-7553 Fax: 530-666-7760

Toll Free: 800-532-6626 Website: www.econco.com



• Gibraltar IV Series
• Horizon to Horizon





• Standard AZ-EL
• Heavy Duty Polar

ANTENNAS

ANTENNAS

ANTENNAS

ANTENNAS

ANTENNAS

ANTENNAS

COMMERCIAL QUALITY

(6m, 9m, 1.0m, 1.2m, 1.5m, 1.8m, 2.4m, 2.7m, 3.0m, 3.3m, 3.7m, 3.9m, 4.2m, 4.5m, 5.0m)

Call For Info

800-627-9443 608-326-8406

www.dhsatellite.com

Offering:

- * Feed Horns
- * LNB's
- * Multi-Cable
- * Receivers
- * Controllers
- * Antenna Covers
- * Custom Fabrications

OVER 600,000 Manufactured

- * High Efficiency
- * Custom Fabrications
- * Fast Direct Delivery
- * 5 Year Warranty

Fax: 608-326-4233
Email: dhsat@mhtc.net

Buy Factory Direct & Save!

Audemat's Relio Controls Wyoming Public Radio

by Shane Toven

Audemat manufactures a wide range of RF transmission and monitoring equipment but are perhaps best known in the US for their FMB-80 RBDS generator and the GoldenEagle HD monitoring system. Recently they introduced a remote control product called the "Relio."

The Relio is a joint effort between Audemat and Sealevel; Audemat designed the unit and the software while Sealevel designed the data acquisition hardware.

LINUX-BASED REMOTE CONTROL

Based on an embedded Linux operating system, overall the hardware is solidly built. The one rack-unit box is completely sealed to prevent dust ingress; the chassis itself acts as a heat sink for the components inside.

The front panel of the unit is a bit sparse. It provides only a power and maintenance LED as well as a maintenance switch to disable alarms and remote commands. Local KVM ports are provided, however, for control at the site without a laptop. IP and dialup DTMF modem access are also provided.



The Relio unit sits between the relay panel and the Audemat RDS unit at Wyoming Public Radio.

PLENTIFUL VOCABULARY

The unit is preloaded with a vocabulary of over 700 words; additional words are easily added by uploading WAV files.

The DTMF interface is quite flexible. It allows the user to assign groups of readings or macros to DTMF codes. These groups can contain a single reading or multiple readings. DTMF codes can be mapped to any single input, group of inputs, or macro. Up to 99 user definable status/metering groups and 99 macros are available.

For example, dialing 020 could give the user all readings from the main transmitter while 030 could give all readings from the auxiliary transmitter. Assigning macros to DTMF codes is also supported; the user is not constrained to using specific DTMF codes for specific status or metering inputs on the unit.

PLENTY OF INPUTS AND OUTPUTS

Connectivity on the unit includes 24 analog inputs, 64 digital inputs, and 64 digital outputs. In the future, units will have the ability to be ganged together for additional I/O capacity.

The unit also features two Ethernet ports, four USB ports, and five RS-232 serial ports. The serial ports allow for TCP/IP to serial tunneling. This gives the ability to telnet into a piece of legacy serial equipment.

Direct serial control of transmitters and other equipment via a custom API is also supported. Interfaces using this API are currently in development for Harris Z series and Nautel transmitters. The API is Javascript based which allows users to write their own custom serial control protocols as well.

CONNECTIONS

Analog and digital I/O connections to the unit are made via one rack-unit breakout panels. The panels use

high density locking D connectors (50 pin SCSI-2 or 68 pin Ultra Wide SCSI-3 style) to connect to the Relio. Connections to monitored equipment are made with miniature captive screw terminal strips.

Digital inputs are optically isolated in groups of four. The digital input breakout panel has a bank of dip switches that allow commons from each of these groups to be connected together.

While the digital and analog I/O breakout panels contain no active components, a two rack-unit panel with 32 relays is also available to interface to the unit's open collector outputs. The relay panel requires an external power supply and features LEDs on the front to indicate the status of each relay – a very useful feature in troubleshooting.

PROGRAMMING

The software provided with the unit consists of two components – ScriptEasy and MasterView. ScriptEasy is used in the Relio and other Audemat products to define logic functions within the unit. With the Relio, it is also used to build the operator interface.

MasterView is used as the primary operator interface to the unit and displays the interface built in ScriptEasy. The combination of these two software packages is very powerful. It allows for virtually any combination of complex logic functions while maintaining a simple end user interface.

Those more familiar with other remote control systems may at first find the ScriptEasy software a bit complex. The approach with ScriptEasy is unlike any other current broadcast remote control system but it is infinitely more flexible.



The MasterView main control page for Wyoming Public Radio.

In fact, after sitting down with the software for a while, it becomes quite intuitive. Most functions are done by dragging and dropping elements into the script, then connecting them with various logic blocks (and, or, nor, counters, timers, etc). It is not unlike building a circuit with the exception that all of the components in this case are virtual. Simply drawing the desired circuit into the script can now perform tasks that would have required building an external logic interface in the past.

For those familiar with other remote control systems, however, a "table" method provides a quicker way to build a script for the unit without creating one from scratch.

RELIO SETUP WITH SCRIPTEASY

The first task in ScriptEasy is to configure the site. This defines the name of the site as well as the site identification audio used for the DTMF interface.

Once the site is configured, the next step is to define the equipment connected to the unit.

The ScriptEasy software functions as a database of sorts – defining equipment allows the user to tell the unit what is attached and how many analog and digital I/O ports are required for each piece of equipment at the site.

The labels defined in this section are used throughout the software so, for example, the user can simply remember "Aux transmitter PA voltage" instead of "Input 4." Comment fields are also provided so the user can note things like pin numbers for future reference.

After defining the equipment, the "cabling" section in ScriptEasy allows the I/O defined for each piece of equipment to be mapped to physical I/O ports on the Relio. Again, comment fields are provided for noting things like wire color, etc.

FLEXIBLE MAPPING

The mappings are all reconfigurable. Software functions and physical wiring are not required to be related in any meaningful way. This is helpful, for example, if you later decide to add a meter reading or command from a particular piece of equipment that had not previously been wired. It does not even have to be wired to an adjacent channel in order to show up in sequence with the other readings and commands for that piece of equipment.

The next step is to define calibration curves for the analog inputs on the unit. Curves are currently drawn by hand with the default set to a linear calibration. Unfortunately other preset calibration curves (log, etc) are not available at this time. However, defining and adjusting the calibration curves is fairly straightforward.

Finally, the user has the ability to define any mathematical functions that will be used in the script. This is useful, for example, to calculate power output indirectly although there are a number of other possibilities. Now that these steps are complete, the various I/O elements that have been defined can be dropped into the script along with logic functions.

NEW FEATURES

Several new capabilities were added with the most recent software release.

Perhaps the most exciting addition is the ability to include SNMP SET and GET functions in the script along with the traditional analog and digital I/O. This reduces the amount of discrete I/O wiring required and allows equipment that might not provide discrete digital I/O to be monitored and controlled.

With the addition of SNMP, I was easily able to integrate equipment from our satellite system with the Relio to notify me when the signal level drops below a certain threshold *before* there is an outage.

In addition to SNMP, the new software supports PING to check whether or not a device on the network is still responding. My only request would be adding the ability to display the actual values retrieved via SNMP rather than simply doing a comparison.

LOGGING AND SUPPORT

Another new addition to the software is the ability to log meter readings within the unit itself. Each analog input used in the script can be configured individually to turn logging on or off. The default logging interval is five minutes. The log can be exported as a CSV file from MasterView for further analysis.

The support from Audemat on this product and their other products has been absolutely outstanding. Any issues or questions that have come up have always been addressed promptly.

To sum it all up: the Relio would be an excellent option for a new installation or for upgrading an aging remote control infrastructure anytime you need to monitor and control a wide variety of equipment via either dialup or IP.

For additional specifications, and a rear view, browse to www.audemat.com/radio-products-12-47-2.html

The author is Shane Toven, Engineering Coordinator with Wyoming Public Radio. His email address is stoven@wvpr.com

A Reputation You Can Trust



Since 1943 ERI has served the radio broadcast industry with products of the highest quality and dependability. At the dawn of a new millennium, ERI continues to raise the bar and set the standard for excellence in radio broadcast.

ERI® ELECTRONICS RESEARCH, INC.
(812) 925-6000 | www.eriinc.com

No One Builds FM Better

R.V.R.

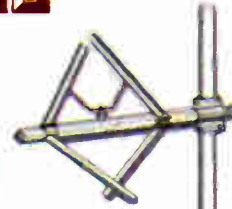

Just One of Our 125+ Popular & Unique Brands

Let our sharp pencils improve your bottom line!

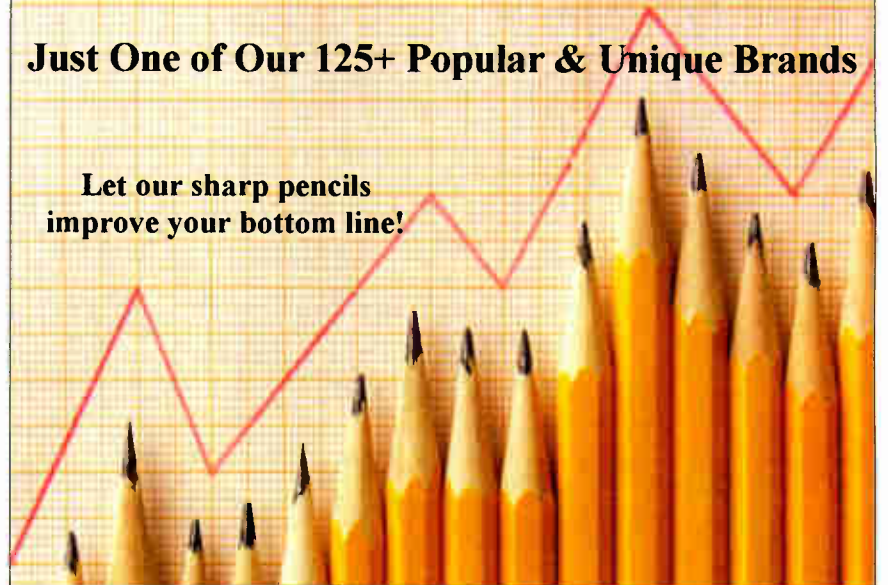

main source
Best Solution. Best Price

☎ : 866-483-4895 [toll-free]
☎ : 765-983-3816
☎ : 765-983-3817
✉ : sales@mainesource.us
* : <http://www.mainesource.us>

Serving the broadcast industry since 1978

FROM THE TALL TO THE SMALL

**FM & TV
Transmitters**
Solid State or Tube
Antennas & Combiners

20 Years of Service
Asistencia en Español
24 Hour Support
2 Years Warranty

www.bext.com

Tel 619 239 8462

Fax 619 239 8474

bext@bext.com



NEW
EXCITERS/TRANSMITTERS
w/stereo generator & audio limiter,
field programmable FSK ID keyer, all built-in!

MAKE WAVES EXPECT MORE FROM YOUR AM TRANSMITTER



MADE IN USA

Presenting the Armstrong Transmitter X-1000B

Bring major market sound to your radio station with the dual, hot-swappable 600 Watt RF modules capable of 150% modulation in Armstrong Transmitter's X-1000B, (1KW HD & DRM ready AM transmitter).

Engineered with the latest technology advances, X-1000B offers high reliability and built-in redundancy. Get ready to save money while improving your sound and reliability. Call us today!



ARMSTRONG
TRANSMITTER CORPORATION

Tel 315-673-1269 ▲ sales@armstrongtx.com ▲ www.armstrongtx.com

Davicom MiniMAC Remote Control and Monitoring by Richard Van Genderen

Idaho Public Television is Idaho's only universally available, interconnected media system – private or public – that stretches across all portions of the state. Idaho PTV consistently is the nation's most watched public TV service per capita.

The system's five primary transmitters and 37 translators reach 97 percent of Idaho's population with its traditional analog signal.

SITE ACCESS AN ISSUE

Naturally, such a system with so many sites includes some difficult to reach locations.

For example, Idaho PTV's Sandpoint TV translator, K16EN, operates in a very harsh and often difficult to access environment. K16EN's site, Sandpoint Baldy, is part of the Selkirk Mountain range that sees very cold temperatures, high winds and deep snow every winter season.



Winter at the Sandpoint, ID, site presents challenges.



Snow and icing of the antennas are obvious issues.

A typical visit to Sandpoint Baldy via helicopter can cost nearly \$1,000.00. When weather is unfavorable for flying, a snowcat trip to the same site will easily run over \$2,000.00. With these expensive options weighing heavily on the budget, it was decided to explore more cost effective solutions for the basic tasks of site monitoring and control.

FINDING THE RIGHT REMOTE CONTROL

At NAB 2007, we looked for remote control units to deploy at this and similar sites where access often was an

issue. We wanted the equipment to be robust, easy to use, reliable and reasonably priced.

At the show we found Davicom and their MAC units. The Davicom-MAC (for Monitoring, Alarm, and Control) products have been around for nearly 15 years and are used extensively in Canada and in the UK. However, it seems they have been somewhat of a well-kept secret here in the U.S.

After seeing the demo at the show, we asked for user references and called engineers who had deployed and used the Davicom units. From the positive comments received, we determined that the MiniMAC would fit the bill well for us.

MODELS TO FIT ALL NEEDS

During the summer of 2007, we installed a MiniMAC at Sandpoint, interfacing it with to our Larcam Translator and other site equipment.

The MiniMAC is a complete, self-contained site monitoring box that includes IP and phone interfaces, eight metering inputs, 16 status inputs, eight relays, three audio inputs and one RS-232 pass-through port.



The Davicom MiniMAC is part of a complete family of remote controllers.

Davicom also makes larger units (the MAC208 and MAC216 series) as well as a smaller unit that they introduced at NAB2008 (the MicroMAC). This whole family of site monitoring devices operates from the same software with the same Graphical User Interface, which makes it easy to use the right sized unit for any given application.

QUICK, EASY INSTALL

The set-up and wiring was easy since Davicom supplies a package that includes all the interconnect cables and accessories. We also connected a webcam to monitor the facility.

The setup process was quite straightforward. By consulting the manual, we were able to configure it and enter our operating parameters without having to consult the factory (which was nice, although we have heard that they have excellent customer support).

The MiniMAC was programmed to remotely measure the various parameters of interest such as power output and system VSWR (which, by the way, it does directly), among others. We also programmed it to send alarms when something goes out of limit at the site, and to take appropriate actions, such as switching the modulators or re-booting the receiver. One note of interest is that the

MAC can be configured so it does not "alarm you to death" by setting its various muting parameters, anti-glitch delays and signal hysteresis functions.

Once installed, the unit was linked back to the NOC by wireless IP through a local commercial Internet service provider.

VIRTUAL LOGIC GATE PROGRAMMING

Programming the MiniMAC for conditional action requires using what Davicom calls Virtual Logic Gates or VLGs.

Each VLG is configured in its own window and can be nested and cascaded with other VLGs to create complex logic functions. This is a bit different from the classical way of programming that involved writing macros, but allows a large number of conditions and actions to be programmed by non-programmers.

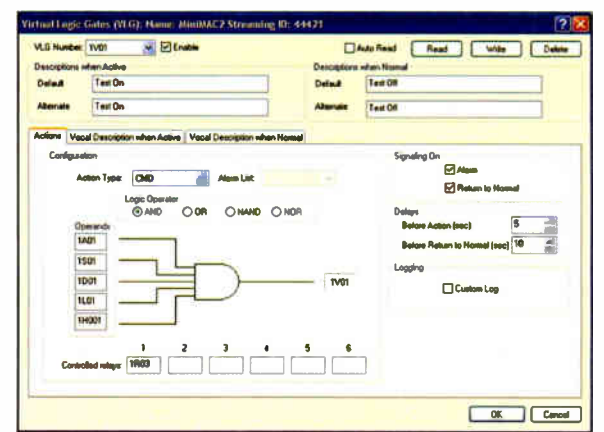

Setting up Virtual Logic Gates is easy with the Davicom configuration utility.

AWARENESS FEATURES

In addition to the VLGs the MAC units have built-in logic flags that automatically monitor such parameters as local sunrise/sunset, presence/absence of dial-tone on the PSTN line, presence/absence of other network devices (IP ping command), unauthorized log-on attempts, and about a dozen others.

To help debug communication problems, the unit has an e-mail test feature that sends an e-mail and steps through the log-on/authentication sequence and reports success/failure for each step. This can help pinpoint ISP or server failures and prevent "passing the buck" by your different service providers.

MACs can also send commands over IP to other, remote MACs, to automatically start up back-up transmitters, for example.

MISSION ACCOMPLISHED

The MiniMAC worked as advertised: following the easy set-up, its high performance and robustness saved us from having to make a single expensive site visit this past winter. In effect, due to its low cost, it essentially paid for itself in one winter of use.

The ability to remotely reset and acknowledge alarms, control key pieces of equipment, and to monitor the health of the translator all proved to be extremely beneficial. The Mini-Mac is robust in operation and fared well in this poor primary power environment. The IP interface performed without fault.

We are very happy with the Davicom MiniMAC. This summer we plan to install a backup phone line so the MiniMAC can automatically call the station (or elsewhere) when problems arise. We also plan to install a second unit at our Cottonwood site during the summer of 2008.

Looking back at our first year with the MiniMAC, we can easily justify recommending it for similar setups elsewhere.

Rich Van Genderen has been the Chief Technical Officer at Idaho Public Television since late 2000. He continues to guide the DTV transition of the statewide network. Contact him at Rich.VanGenderen@idahoptv.org

New Broadcast equipment at exceptional prices.

Quality pre-owned equipment.

Customized automation systems.

Complete turnkey installation

Console pre-wiring packages.

Broadcast equipment repair.

Complete engineering services.

Studio design and project management.

Lightner Electronics Inc.
Your Ultimate Solution.



Toll Free: 866-239-3888

Fax: 814-239-8402

www.LightnerElectronics.com

AM Ground Systems Co.

Ground System Construction,
Evaluation & Repair

1-877-766-2999

www.amgroundsystems.com

- ◇ Has your station lost coverage over time?
- ◇ Is your AM ground system over 30 years old?
- ◇ Do you have a new CP or are moving transmitter sites?
- ◇ Has your ground system been damaged or vandalized?
- ◇ Is your base impedance or directional pattern unstable?
- ◇ Just wondering if you are getting all of the range your station is capable of?

If the answer to any of these questions is YES
Call today for a free construction, repair or evaluation quote.

Reliable On-time Installation
Quality Workmanship
Tower Tune-up
Free Budgetary Estimates &
Quotes

G/R

GORMAN-REDLICH

257 W. Union Street, Athens, OH 45701
Phone: 740-593-3150 – Fax: 740-592-3898

30 Years Experience with
Alerting Equipment



Model CRW-S Weather Receiver

Model CRW-S Weather Receiver

For receiving alerts from the
National Weather Service (NWS).
Redesign of our Model CRW now
with the "SAME" decoder feature.

Easy to Use and Reliable EAS Equipment*

- Pre-programmed for your location.
- Program interrupt relays built in.
- Six audio inputs.
- 2 minutes stored audio.
- All operations via keypad.



EAS1 Encoder-Decoder

EAS1 Encoder-Decoder

EAS1 Decoder

EAS1-CG Encoder Decoder with built-in character generator.

*Optional DTMF interface available.



Model CMR Digital Antenna Monitor

Model CMR Digital Antenna Monitor

- Remote Controllable
- True ratio readings.
- Phase sign automatic, no extra operation.

Contact Jim Gorman at: 740-593-3150
jim@gorman-redlich.com – www.gorman-redlich.com

OMB

MT-MR Platinum STL System



Why the MT-MR Platinum?

- For its excellent quality-price value.
- For its adjustable transmission power output from 0 to 20W for any selected operational frequency.
- For its double conversion receiver that makes it apt for digital codification (Up to 4 audio channels).
- For being digitally synthesized in 20 MHz operational band for frequencies from 150 MHz to 960 MHz.
- For the fact that both the transmitter and receiver can measure the modulation percentage and pilot signal level (19 KHz stereo without disconnecting the audio from the transmitter).

For its remote control.

For its analog telemetry.

For being made for mono or stereo (MPX) signal.

For its capability to work with AC power voltage from 90 to 250 V, 50/60 Hz, and also with external battery if needed.

OMB, the Future of Communication

OMB

OMB AMERICA
phone. (305) 477-0973
(305) 477-0974
fax. (305) 477-0611

3100 NW 72nd. Ave. Unit 112
MIAMI, Florida 33122 USA
http://www.omb.com
usa@omb.com

Plus Sine Makes a Good Remote Control Better

by Glen Musgrove

After 23 years in broadcasting, one thing I have learned about being a Chief Engineer of a small market cluster is that it generally means being the *only* engineer in the cluster.

That means, among other duties in tending to the studio site and transmitter sites spread over four rural counties around Laurel/Hattiesburg, Mississippi, a trip of over 100 miles is required while visiting all of my sites. It does tend to keep a fellow really busy!

IMPROVING THE INTERFACE

Clearly, a reliable remote is a must to insure that the stations receive immediate attention in an off-air situation. I have Sine Systems RFC 1/B's at each of my sites because of their proven dependability. Nevertheless, programming them is usually a dreaded job of entering number after number, only to lose your place when the cell rings with another problem (remember, the *only* engineer in the market gets lots of calls.) It can become quite a challenge.

I did not know that there was any other way until recently, when I met an old friend and engineering comrade, Olen Booth, at WEEZ-AM's site. Olen walked in and said "You know you don't have to do it that way anymore." Booth has developed software that makes programming this unit a small task instead of a painful chore. But wait, there is more! As you will see, Plus Sine is a whole lot more than merely a programming package.

Sine Systems packages Plus Sine as an 8 or 16 channel upgrade to existing remotes, or as a new 8 or 16 channel system, by developing a daughter board called the AD-8 that installs between the existing RP-8 relay panel and its surge protector. The AD-8 has eight differential analog to digital converters that continuously sample analog data and send it to the Plus Sine software.

Nobody had to convince me to try Plus Sine. I worked with The Hawk Remote, the parent product that was developed by Booth over 15 years ago. Booth's drive to develop a solid, reliable remote interface comes from self-interest: Booth and his contract engineering company, IBS, already depend on Plus Sine at over 50 sites throughout Mississippi, Alabama, and Florida.

INSTALLATION

Installing and setting up the Plus Sine for operation is a cinch.

I got an 8 channel upgrade for an existing RFC 1/B, packaged neatly with everything included. Hardware installation was really easy. I removed the surge protector from the RP-8 and installed the AD-8 on five standoff's.

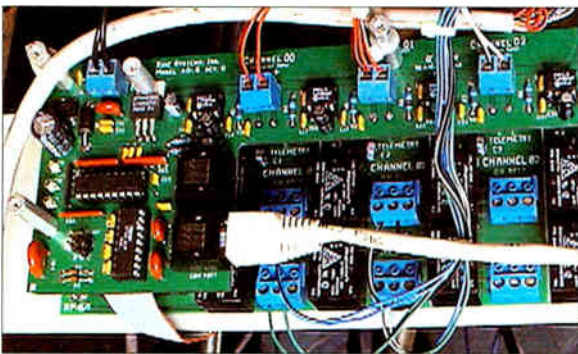

Part of the AD-8 analog to digital converter.

Then I reinstalled the surge protector and connected the supplied RJ-45 cable between the AD-8 and the COM port of the computer at the transmitter site.

The installation of the Sine Systems serial data adaptor was just as easy. Taking the RFC 1/B from the rack, I removed the RFC-1 board from the chassis. The serial data adaptor was then connected to the RFC-1/B and the boards were installed into the supplied chassis. Then I put everything back in the rack and connected the data cable from the serial data adapter to the second COM port of the computer.

SOFTWARE INSTALLATION

Installing the software was even easier. Plus Sine walked me through the process, creating a desktop icon and placing a shortcut in my startup folder to insure that anytime the computer was rebooted, Plus Sine would start running again as well.

I installed the software dongle onto the back of the computer per the instructions in the installation guide, launched the program, and configured the COM ports.

Plus Sine came with a default database already set up. By double-clicking on a meter on the main tab, it took me to the setup screen for that analog meter.

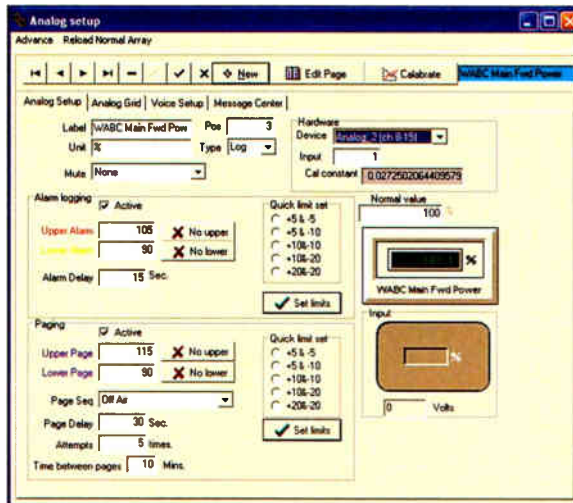

The analog setup page.

For each of the parameters, I simply changed the labels, units, and normal values. I then clicked on the "Quick Limit" button (which does the calculations automatically) and the channel setup was complete.

ALARM OPTIONS

Next, I set up the text messaging and emailing in order to report alarms. This was a little more involved, because Plus Sine let me define a group of people to receive alarms (not just me). Setting up a list of "contacts" was easy – it was a lot like setting up contacts in Microsoft Outlook or other mail delivery programs.

One cool thing I found was that it allowed me to set up two addresses under one contact. Through this, I could set up a "cc" (carbon copy), so that Plus Sine will simultaneously send a text message to my phone and an email to my computer for future reference. While setting up my account, I also set one up for the program director – so that he could be notified of dead air instead of me. Next it was time to set up the "contact groups." Though I could have set up several groups, I only set up two – an "off-the-air" group and a "dead air" group.

Now, look at this: Plus Sine allows you to place a pause between contacts. This causes Plus Sine to wait a predetermined amount of time (the pause) before sending a message when something is in alarm. I set up the "dead air" group, so that Plus Sine pages the program director, waits ten minutes, and then pages him again, *before* ever paging me. This set-up makes the Sine better and very user-friendly.

OPERATING THE PLUS SINE

Plus Sine has an "Overall Page" and multiple metering tabs. The tab that I created had the standard metering: Plate Voltage, Plate Current, Antenna Current, Forward and Reflected Power.

I also wanted to monitor building temperature so Plus Sine created an easy-to-read thermometer with a mercury bulb and a moving mercury level. The graphical representation of everything important on that page is true-to-life and extremely easy to read.

Yellow indicates low, green indicates in range, and red indicates high. There is even a blue bar that indicates "in range" parameters which "mutes" paging and text messages. Status indicators and relay buttons are also

located on this tab. Any channel that is out of limits will have a red flashing box around it. This basically gives me an overall view of the transmitter at just a glance.

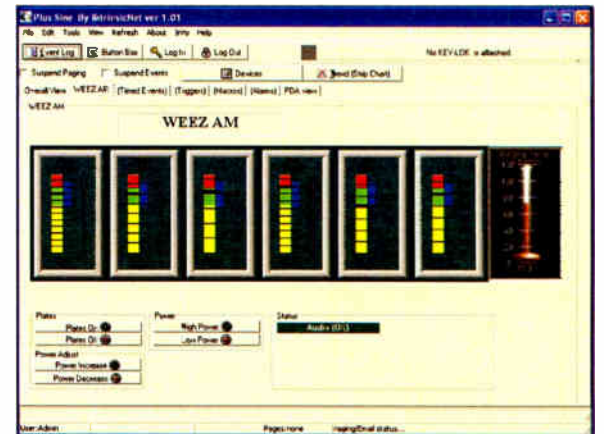

Using color indications for normal operating ranges checking transmitter parameters is quick and easy.

Since Plus Sine collects data in real time, data is ready to review instantaneously. I love the trend chart, because I can see (in real time) the relationship between different parameters that I have defined. I want to see all eight channels at once, paying special attention to the forward and reflected power.

With Plus Sine's "value at cursor" function, I can place the cursor at any point in time on the trend chart and view the values for every channel.



The Plus Sine trend chart.

ON THE AIR AT WEEZ

Clear Channel's station, WEEZ, is a 10 kW daytimer with a small post-sunset power allowed. So I need a remote that can handle this task.

Even though this can be accomplished with the RFC 1/B, it is easier using Plus Sine's pre-sunrise and post-sunset tables. I created one timed event called "post-sunset control." (There is a table defining the dates of Daylight Saving Time, and Plus Sine will off-set the time during these months. Since I can alter this table, the next time the date of Daylight Saving Time changes, it will not be an issue.)

Plus Sine uses its pre-sunrise and post-sunset tables to determine what time to power up and power down my transmitter. I told Plus Sine which relays to use to control power and what the new parameters would be for logging and paging, and it does the rest.

A PROVEN TOOL

In this digital age, there are a lot of software developers. It seems like someone on every corner is developing some sort of software to do most anything.

Plus Sine is not merely a new product. It is something already proven that has been made better. A plus (no pun intended) is that when you need tech support you actually speak with someone inside the good 'ole USA, who not only knows the product but also knows broadcast engineering.

The bottom line: go check it out and see for yourself that Plus Sine is an awesome product.

Demo versions of Plus Sine, as well as tons of other information, are available at www.plussine.com

Glen Musgrove is Clear Channel's Chief Engineer for the Laurel/Hattiesburg, Mississippi. You can contact Glen at glenmusgrove@clearchannel.com

Austincredible!



Radio's Best Information and Innovations = One Incredible Investment

Learn something new this September at The NAB Radio Show® and benefit from:

- Results-oriented insight and ideas to implement the moment you get home
- Strategies to secure your station's success, regardless of market size

This year's event features sessions devoted to new technologies, such as streaming, video and on-demand audio to enhance your station's reach, brand and revenue. Additionally, The NAB Radio Show delivers

expert-led sessions addressing the hottest industry topics, such as: thriving in a multi-platform world; using new technologies to generate new revenue streams; managing in a challenging environment; developing talent; and cultivating the next generation of listeners.

When it comes to return on investment, The NAB Radio Show delivers high-value information, networking opportunities and an exhibit hall packed with new innovations for HD implementation. Register today and you'll soon say, "Austincredible!"

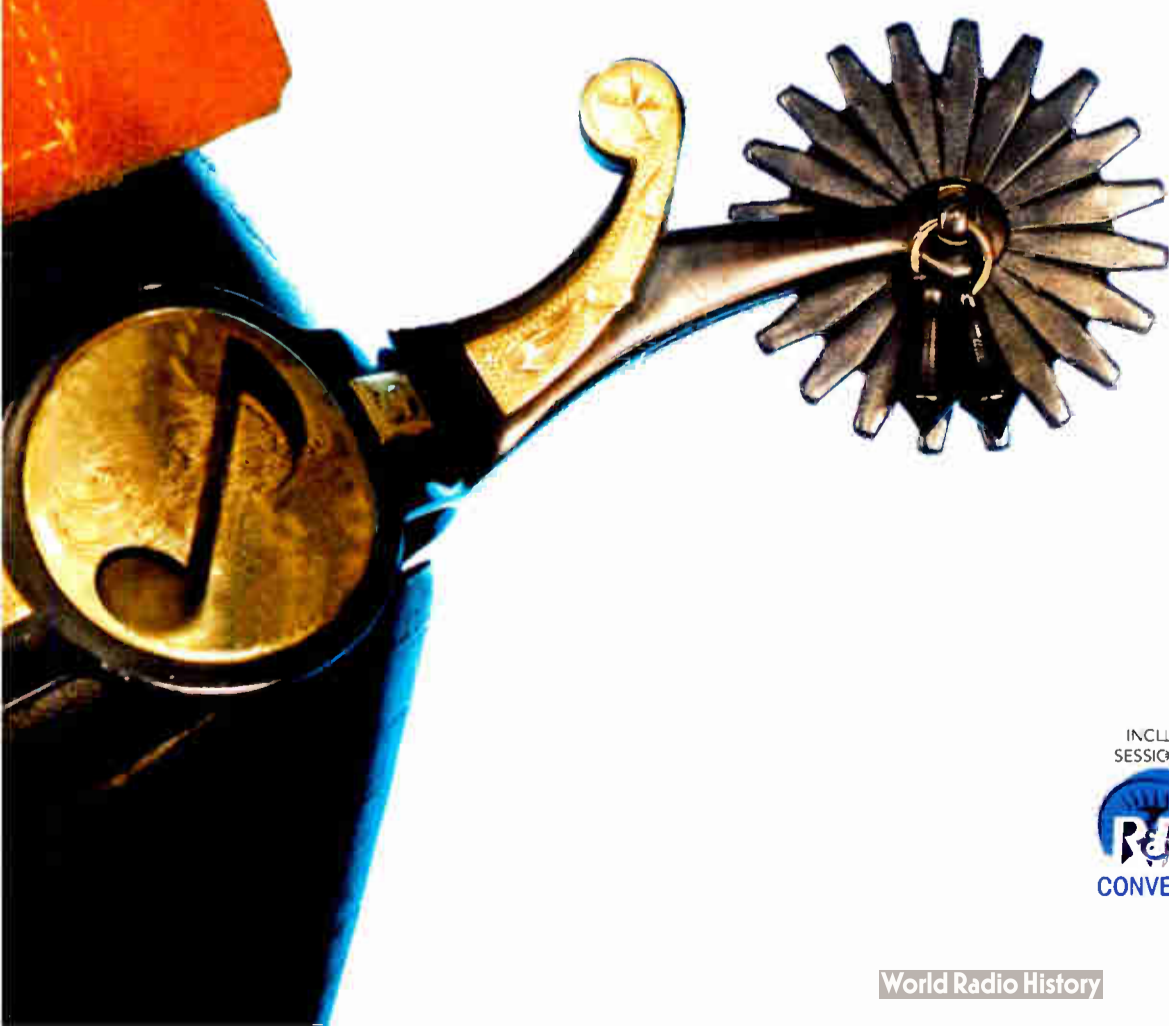

THE NAB RADIO SHOW®

INCLUDES
SESSIONS AT:



September 17-19, 2008
Austin Convention Center
Austin, Texas

www.nabradioshow.com

Service Guide Radio Equipment Products and Services



NEW

New tubes are now manufactured by Econco in expanded facilities in Woodland, California.

ECONCO

NEW

Tel: 800-532-6626 Web: www.econco.com
 Intl: +1-530-662-7553 Fax: +1-530-666-7760



VSoft COMMUNICATIONS
 The Leader in Broadcast Engineering Consulting Software!

- Use Probe 3™ to create stunning "real-world" coverage maps using Longley-Rice and other models.
- Run Terrain-3D™ to plot STL paths and Longley-Rice coverage over 3D terrain.
- Run AM-Pro 2™ to perform AM skywave and groundwave allocation studies, interference analysis, & coverage mapping.
- Use FMCommander™ to study FM allocations using contour-to-contour protections, and minium spacings.

www.v-soft.com • info@v-soft.com • 1-800-743-3684

AM Ground Systems Co.

Ground System Construction, Evaluation & Repair

1-877-766-2999

www.amgroundsystems.com

AM Antenna Solutions

LBA is your trusted supplier of digital engineered AM antenna systems. LBA customized products include Directional Systems, Diplexers, Triplexers, ATU's, Cellular / AM Colocation Systems, RF and Ground Components for all power levels. We offer complete RF project design, and installation services.

NAB Booth #N8733

LBA TECHNOLOGY, INC.

800 522 4464 www.LBAGroup.com SINCE 1963

RF PARTS COMPANY

From Milliwatts to Kilowatts™

Eimac • Amperex • Svetlana • M/A-Com
 Motorola • Toshiba • Philips • Mitsubishi

Se Habla Español • We Export

800-737-2787

760-744-0700 Email: rpf@rfparts.com

www.rfparts.com

BAUER TRANSMITTERS, INC.

www.bauertx.com

BAUER - ELCOM BAUER - SPARTA - CETEC

Re-Manufactured
 Bauer Transmitters Available

AM/FM – 2.5 kW to 25 kW

www.bauertx.com paul@bauertx.com
 915-595-1048 Fax: 915-595-1840

BROADCAST WORKS

Full Service Broadcast Engineering

Project Management - Studio Build Outs
 Transmitter Sites - IBOC Installation
 Automation Systems - STL & RPU Repairs
 Full Service Shop - Emergency Equipment Rental
 24/7/365 Tech Support

We can team up with your engineer to supply extra manpower for big projects – or we can see your project through turn-key.

Serving Broadcasters for over 12 years.

888-509-2470 • www.broadcastworks.com

DA HOOK **DA GAP**

Safety Grounding Hook Lightning Dissipation Gap

Solid Brass Hook & Hardware Available with Horn or Ball Gaps
 Fiberglass Rod Handle Patented (#5,661,262)
 #10 Copper Cable & Alligator Clip Hot Adjust Mechanism

Wilk Science and Technology Inc.
 1112 North Grove Avenue, Oak Park, Illinois 60302
 Telephone & Fax: (708) 524-8588

D&C Electronics Co.

- New Tubes -

We have the alternatives for all your needs, at the lowest prices, direct from our stock!

EIMAC, SVETLANA, PRO-TEK®, EEV, and many others.

352-592-7800 or 800-881-2374

VISA & MASTERCARD Accepted

ChrisScott & Associates

Visit our website
www.scott-inc.com

Ph: (270)781-5301
 Fax: (270)781-1232
 Bowling Green, Kentucky

NRSC Loop Antenna

AM-FM Notch Filters

CCA PARTS & SERVICE

V&J Electronics

Can supply all parts, schematics, and manuals for CCA, CSI, Sintronic, and Visual transmitters. Field service and complete rebuild transmitters available.

Call Van or Jerry Meier: 770-907-2694
 Fax: 770-907-2694 – 24/7 Service
 COD, Visa, Master, Discover, NET-15/30

www.ccaelectronics.net

Alert Monitors

enbergelec.com

TRANSMITTING CAPACITORS

MICA-VACUUM-CERAMIC

SURCOM ASSOCIATES, INC.
 (760) 438-4420
LINK@SURCOM.COM

Silver Plating Powder

Silver Plate On-The-Job with Cool-Amp!!

<p>Cool-Amp Silver plating powder</p> <ul style="list-style-type: none"> *Maintain your RF frequency *Keep your PCBs cool *Increase conductivity *Minimize power loss from corrosion & oxidation 	<p>Conducto-Lube Silver based lubricant</p> <ul style="list-style-type: none"> *Reduce resistance *Prevent power interruptions *Prevent data errors *Prevent power failure
----------------------------------------------------------------------------------------------------------------------------------------------------------------------------------------------------------------------------------------------------------------------------	--------------------------------------------------------------------------------------------------------------------------------------------------------------------------------------------------------------------------------------------------

EEBEL-AMP *Conducto-Lube*

Ph: 503-624-6426 Fax: 503-624-6436
www.cool-amp.com 60 years customer satisfaction! email: sales@cool-amp.com

Service Guide Radio Equipment Products and Services

rf Investigator V 3.0
FM...AM...or Both
You choose!
rfSoftware, Inc.
innovative engineering tools



Are you tired of switching from program to program to complete a project?
 How about displaying your drive test output on top of your Longley-Rice prediction to SEE how your station is operating.
 Save *time, money, and hard drive space*, with software that gives you all the tools in one program to work *smarter not harder*.

Call **352-367-1700** for Details!
 Visit **www.rfsoftware.com Today**

TLM-1 TOWER LIGHT MONITOR
 Avoid Costly FCC Fines for Lighting Violations!



A microprocessor based system designed to monitor the status of FAA type A incandescent tower lights.

- Individual alarms for photocell, flasher, beacon & marker.
- General alarm output for any failure type.
- Status outputs for lights on/off and beacon on/off.
- LED indicators for each alarm and status output.
- Opto-isolated failsafe outputs for each alarm.
- Easy setup – one button calibration.
- Installs inside the transmitter building.

FM Services
www.towermonitor.com • 336-667-7091

MOORETRONIX
 BROADCAST & INDUSTRIAL ELECTRONICS

Our 7th Year

Our client list continues to grow. Thank you for your confidence and equipment purchases.

We Re-Condition
 Pacific Recorders BMX I-II-III, AMX, ABX and RMX, Stereo-Mixer and Mixer News-Mixer products.

We have replacement Wind Screens and Blast Filters for the SM-5B microphone.
 We now have SM-5B hanger hardware as shown in the photo.



See the "News-Update" page at our website.
 Tel: 800-300-0733 Fax: 231-924-7812
WWW.MOORETRONIX.COM

The Band Scanner is a tool to evaluate FM broadcast band congestion and to log station identification parameters. The system is powered by the USB port of any Windows PC. Supplied free of charge Windows software sweeps the receiver across the FM band, logging every carrier and generating a spectrum display of carrier level vs. frequency. It then analyzes each carrier and creates a station list. Stations with an RDS presence are further refined to show all the radio data groups being transmitted. Its interface is like a portable radio: It may be tuned manually through the receiver screen or by double-clicking a point on the spectrum plot or an entry on the station list. Spectrum plots may be saved as jpg or bmp files. The RDS data error level is graphed in a separate window on the receiver screen. The program can be monitored with headphones plugged into a standard 1/8" jack.

Band Scanner
 USB FM-Scanning Receiver and RDS Analyzer



\$495

Contact us at:
 sales@devabroadcast.com
 www.devabroadcast.com

RECEIVERS

OUTSTANDING specifications and pricing on professional quality receivers for **EAS**, station monitoring and translator applications.

The **AFC3** is a three receiver rack mount that is configured for your **EAS** or monitoring specific application.

Our **AF210FM** receivers meet today's Translator application specifications for reliability, linearity and cost.



DAYTON INDUSTRIAL CORPORATION
 2237 Industrial Blvd., Sarasota, FL 34234 Tel: (941) 351 4454
 Quality Receivers Designed and Manufactured in the USA
 Email: sales@daytonindustrial.com Website: www.daytonindustrial.com

Professional Equipment Repair

- ▶ Consoles at Lightner Electronics, Inc.
- ▶ Exciters
- ▶ STLS
- ▶ Automation Systems
- ▶ Audio Processors
- ▶ Transmitters
- ▶ Remote Equipment



Toll Free: 866-239-3888
www.LightnerElectronics.com

BESCO
 INTERNACIONAL
 "Now in Our 34th Year"

World Leader in AM-FM Transmitters

AM & FM Pre-Owned Units in Stock

All Powers and Manufacturers
 Instruction Books - Spares - Complete

Visit our Website: **www.besco-int.com**
 Or Call Rob Malany at: **321-960-4001**

Doug Vernier
 Telecommunications Consultants

- FCC Applications for AM, FM, TV, DTV, LPTV, STL
- Upgrade and Due Diligence Analysis
- Frequency Searches
- Site Relocations
- Propagation Prediction with Custom Mapping
- Demographic Analysis
- Directional Antenna Design

VSoft
 COMMUNICATIONS
 We use V-Soft Software!
www.v-soft.com consulting@v-soft.com 800-743-3684

www.digitalradioengineering.com
 Phone: 845-355-4001

digitalradio/
 /engineering

Professional Broadcast Engineering Services

Consulting • Project Management • Contract Engineering
 FCC Alternative Inspections • Due Diligence Inspections
 Engineering Staff Oversight • Engineering Staff Assistance
 Facility Inventory • Broadcast Equipment Acquisition
 New & Pre-owned Broadcast Equipment Sales

McPherson Radio
 Specializing in pre-owned QEI transmitter products.

QEI – 6 Month Warranty – **QEI**

All equipment tuned and tested on your frequency. MRC has a repair facility to meet your broadcast needs, for repair of QEI exciters and low power transmitters. Other broadcast manufacturer products are welcomed too.

Bob Brown at 856-232-1625 Fax: 856-232-2075
 Email: mcphersonradio@comcast.net

RF Professional Engineering Services

- ★ FCC Applications
- ★ Coverage modeling
- ★ RF exposure limit reports
- ★ STL & microwave path analysis
- ★ Co-location and interference studies
- ★ Expert witness testimony by P.E.s

www.rfengineers.com
RFEngineers, Inc. 352-367-1725

TOWER SIGNS

FCC COMPLIANCE
 STANDARD FCC OR MADE TO ORDER SIGNS
 FCC TOWER REGISTRATION SIGNS
 BEST QUALITY - NO FADING - NO EXTRA COST

RED GUY WIRE MARKER BALLS
 GUY WIRE PROTECTORS
 BIRD MARKERS COAX TAGS

ANTENNA ID PRODUCTS
antennaID@msn.com
antennaID.com
REQUEST FREE CATALOG
610-458-8418

Radio Pipeline

Audemat - Inovonics - Parrot - RVR - Smarts Broadcast - UnattendedWeather.com

New Equipment

Updates and Modifications

Industry Information

PARROT Has New Features

The PARROT is the smallest professional ENG flash recorder with live broadcast capabilities. This professional handheld flash recorder has the right size, the right weight and the right price. Most radio reporters involved in daily sport and news reporting can afford this multi-functional communications device. The reasons for the success of the PARROT are simple: compact, professional, robust, simple and all-in-one. The push buttons are easy to understand and use and there are no hidden functions that are complicated to find. Press record to record, press stop to stop, press GO to connect live to the studio and press GO twice to transfer your audio files directly from the PARROT to the studio. And all of this without a PC. File transfer is via your 3G phone over Bluetooth.



Here are the new features. New telephone models support the file transfer capabilities of Parrot. Battery life has been extended to a minimum of 10 hours, an LED display has been added to indicate takes and clips, even telephone interviews can now also be recorded in stereo and audio files can be sent over 3G networks, achieving 200 kbps file transfer speeds. Recorded commercials may be mixed directly from the Parrot from a remote event.

YouCom

817-371-7033 - parrot@charter.net
www.youcom.nl

New RVR RPU Transmitter Begins Shipping

The new RVR model URPT features include 4 mic/line switchable XLR input channels with individual level controls, pre-monitoring of input audio on each or all channels via push-button switches, dual-mono headphone output, automatic level control (ALC), 27 Hz sub-tone to activate receiver relay, auxiliary mic in/headphone out for headset use, front panel LCD control/display, and much more.



The URPT is fully compatible with current Marti Electronics® RPU receivers. The new RVR RPU companion receivers will begin shipping in late 2008.

For more information and introductory pricing for the RVR URPT, please visit the website.

Mainesource

866-483-4895 - cmaines@mainesource.com
www.mainesource.us

UnattendedWeather.com Airs Severe Weather Warnings

Even when your radio station is unattended, with voice tracked or satellite formats, UnattendedWeather.com can keep your listeners informed about tornadoes, severe thunderstorms, high winds and other dangerous weather. It is software that polls the National Weather Service's Internet feeds every minute for warnings, watches, advisories and local conditions.

Then UnattendedWeather.com's pre-recorded announcements can preempt what is on, or go on the air with the information at the end of the current song. The software also sends text messages, emails, or calls cell phones or pagers advising station personnel and local police of the warning.

In addition, listener versions of the severe weather text messages can have sponsor commercials and urge that listeners tune to your station for details.

Whether weather is severe or not, UnattendedWeather.com gives good sounding timely audio forecasts 24/7. They are especially valuable during unattended shifts. Reports follow station formats as to length, give call letters, dial position and station slogans. The package is affordable and weather is easy to sell for sponsorships.

UnattendedWeather.com is the latest software from Dave Scott, founder and former 14-year CEO of Scott Studios (now Google Broadcast Automation). It provides the weather audio 24/7/365 for XM Satellite Radio's traffic and weather channels 210-230 for the 21 largest markets.



UnattendedWeather.com

888-888-RADIO - info@unattendedweather.com
www.unattendedweather.com

Inovonics Model 720, RDS/RBDS Dynamic RadioData Encoder

The 720 is a third-generation product in the company's line of RDS encoding and decoding products. It incorporates a number of important features to make installation and operation simple, straightforward and safe.



A front-panel LCD screen allows the user to scroll through and confirm all setup and operating parameters without the need for a computer on site. Incoming data from station automation can be seen "on the fly," and scrolling song titles and other messages are displayed exactly as they are seen by listeners.

The 720 automation command set remains compatible with earlier models for seamless integration along existing encoders, and a new "no headers" mode allows use with unformatted, satellite-streamed song title feeds. Intuitive, self-guiding software, built-in data diagnostics and transmission safeguards make installation virtually foolproof.

Inovonics

800-733-0552 - sales@inovon.com
www.inovon.com

Smarts Broadcast Systems Skylla New Generation Digital Audio

Smarts Broadcast Systems has now completed beta testing on the new Skylla digital product. Billed as a new generation of digital audio, the product is designed to handle multiple signals



from a single automation system. This allows broadcasters who run multiple stations, HD radio, digital audio streams, etc. to invest in one digital system and add inexpensive audio heads as the needs arise for more signals.

Skylla is new from the ground up, written entirely in Linux. The Linux operating system allows for use of familiar high resolution user interfaces (similar to Windows) but completely bypasses the Windows operating system. This provides a much higher degree of reliability, protection against viruses, and easy connectivity via Internet to Smarts for support and instructional purposes. Skylla actually notifies the Smarts servers of potential problems with units in the field so technicians can fix the equipment before any problem is manifested on the air.

Smarts Broadcast

800-747-6278 - info@smartsbroadcast.com
www.smartsbroadcast.com.com

Audemat Digiplexer 246 with Audio Backup & FM Transmitter Option

This all-in-one product is an evolution from years of Audemat expertise in this field. Actually, Audemat developed their first all-in-one products several years ago: the Digiplexer FMX series (FMX480 and FMX410). Those units included an RDS and stereo encoder as well as a digital clipper.

Digiplexer 246



Last year Audemat launched a new generation of Digiplexer: the Digiplexer 214. This unit includes now a cutting-edge digital audio processor, 2 or 4 band. This year Audemat is showcasing their new addition to the line, the Digiplexer 246: a 3U unit with front panel touch screen for easy configuration. The Digiplexer 246 includes a world-class digital audio processor (2/4 band), RDS and stereo generators, transmitter remote control capabilities, backup audio over IP capabilities and an optional built-in FM exciter (1, 20 or 100 Watt).

This unit is the first one in its class available on the market. The 4 band version features 2.8 Giga flops of processing power which allows a sampling frequency of 192 kHz for incoming audio and a 1.5 MHz sampling frequency for the final composite/MPX clipper. The Digiplexer series provides an analog feel to the sound with the accuracy you would expect from a digital processor.

Audemat

305-249-3110 - ussales@audemat.com
www.audemat.com

FINAL STAGE



RADIO ROUNDUP

The Radio Guide Event Register

Email your dates and info to: radio@rconnect.com

NAB 2008 Radio Show

September 17-19, 2008
Austin, Texas
www.nabradioshow.com

125th AES Convention

October 2-5, 2008
San Francisco, California
www.aes.org/events/125

SBE 22, Broadcast and Technology Expo

October 7-8, 2008
Verona, New York
www.sbe22expo.org

Broadcasters Clinic

October 14-16, 2008
Madison Marriott West Hotel, Madison, Wisconsin
www.wi-broadcasters.org

IBS Fall 2008 Coast-to-Coast Conference Schedule

October 18, 2008 - Boston, MA
October 25, 2008 - Chicago, IL
December 6, 2008 - Los Angeles, CA
<http://www.ibsradio.org/>

Pittsburgh SBE Chapter 20, 2008 Equipment Expo

October 20-21, 2008
Monroeville, Pennsylvania
www.sbe20.org/expo.html

NAB 2009 Spring Convention

April 17-23, 2009
Las Vegas Convention center, Las Vegas, Nevada
www.nabshow.com

Radio Guide Advertiser Info – Jul/Aug 2008

Advertiser - Page

25-Seven - 47
Altronic - 40
AM Ground Systems - 57
APT - 37
Armstrong Transmitters - 55
Arrakis - 17
Audemat - 38
Audion (VoxPro) - 44
Axia - 12
Bay Country - 53
BEXT - 55
Barix - 50
Broadcast Devices - 41
Broadcast Electronics - 45
Broadcast Software Intl. - 4
Broadcast Warehouse - 31
CircuitWerkes - 15
Comet - 20
Comrex - 5
D&H Antennas - 53
Davicom - 30,
Deva - 42, 56
Digital Radio Eng. - 43
DM Engineering - 63
Econco Tubes - 53, 60
ERI - 55
ESE - 46
Fanfare - 51
Freeland - 52
Google - 21
Gorman Redlich - 57

Website

www.25-seven.com
www.altronic.com
www.amgroundsystems.com
www.aptx.com
www.armstrongtx.com
www.arrakis-systems.com
www.audemat-aztec.com
www.audionlabs.com
www.axiaaudio.com
www.baycountry.com
www.bext.com
www.barix.com
www.broadcast-devices.com
www.bdcast.com
www.bsusa.com
www.broadcastwarehouse.com
www.circuitwerkes.com
www.comet.ch
www.comrex.com
www.dhsatellite.com
www.davicom.com
www.devabroadcast.com
www.didtalradioengineering.com
www.dmengineering.com
www.econco.com
www.eriinc.com
www.es-web.com
www.fanfare.com
www.freeland-inc.com
www.google.com/radioautomation
www.gorman-redlich.com

Advertiser - Page

Henry Engineering - 2, 45
Inovonics - 39
Jampro - 39
JK Audio - 9
Kintronic Labs - 9
Larcan - 41
LBA Technology - 29
Lightner Electronics - 57
Magnum Tower - 49
Mainsource - 55, 63
Micro Communications - 51
Microwave Filter - 52
Moseley - 22
MYSine - 27
Nautel - 11
Nott Ltd. - 47
OMB America - 57
Orban - 64
Pristine - 8
Propagation Systems (PSI) - 43
RAM Broadcast Sys. - 48
RCS - 18
SCMS Inc. - 19
Shively Labs - 49
Staco - 25
SystemsStore - 63
Telos - 23
TFT - 53
Tieline - 7
Transcom - 51
Wheatstone (Vorsis) - 3, 32

Website

www.henryeng.com
www.inovon.com
www.jampro.com
www.jkaudio.com
www.kintronic.com
www.larcan.com
www.lbagroup.com
www.lightnerelectronics.com
www.magnumtowers.com
www.mainsource.us
www.mcibroadcast.com
www.microwavefilter.com
www.moseleysb.com
www.plussine.com
www.nautel.com
www.nottltd.com
www.omb.com
www.orban.com
www.pristinesys.com
www.psibroadcast.com
www.ramsyscom.com
www.rcsworks.com
www.scmsinc.com
www.shively.com
www.stacoenergy.com
www.systemsstore.com
www.telos-systems.com
www.tftinc.com
www.tieline.com
www.fmamtv.com
www.wheatstone.com

Radio Guide – Problem Solvers

GOT ENDEC?
We've Got:

Endec Printer Paper
OEM thermal paper in 9 meter rolls, 10 to the package. That's 30% more than the standard roll and it fits fine. Less paper changes! **\$25.00 for the 10 Pack + shipping**

Replacement Printers
OEM printer modules with step-by-step installation instructions. Takes just minutes to change!
\$57.00 + shipping

Multi-Station Relay Adapters
Control up to 4 stations with one Endec. Rack mount and cabinet models available. **\$529.00 + shipping**

Replacement Power Supplies
Heavy duty high quality switching replacement power supplies. Keep a spare handy.
\$41.95 + shipping

Remote Controls, Automation Interface Modules and more!

For more details on these and other innovative products for the broadcaster, call or visit us on the web at: **www.dmengineering.com**

DM Engineering
2174 Chandler St. Camarillo, CA 93010 805-987-7881 800-249-0487

Need Music?
\$1 per Song

WAVE files for hard drive 1-2 Day Delivery
Mention Radio Guide for Free Christmas music
buy one regular song, get one Christmas song free at time of order

UncompressedMusic.com

The Systems Specialty Hardware Store!

SYSTEMS STORE .com

The Preferred Source For Krone
Punch Blocks, Punch Tools, & Patch Cords **In Stock**

CBT Classic On-Air Lights – Barix - Gepco - Henry Engineering
LEA Surge Protection – Middle Atlantic – Neutrik – OC White Mic Arms
Optelator – Platinum Tools - Switchcraft - Ward Beck

....and Much More

www.SystemsStore.com
Sales@SystemsStore.com Tel: 407-656-3719 Fax: 407-656-5474

AUDIO LEVELS OUT OF CONTROL?

One Word... **audessence**

Another fine brand available from:

main source
Best Solution, Best Price

☎ : 866-483-4895 [toll-free]
☎ : 765-983-3816
☎ : 765-983-3817
✉ : sales@mainsource.us
🌐 : <http://www.mainsource.us>

For more info visit <http://www.mainsource.us/audio.html>



urban erl

THANK YOU

for your loyalty and support.

The demand for our audio processors has never been greater. It's because of customers like you that make the OPTIMOD the industry standard.

OPTIMODs...worth the wait

8500

6300

9400

5300

1100

9300

NOW SHIPPING ALL MODELS WITHIN 30 DAYS!



2008 NORTH AMERICAN MOBILE BROADCAST LABORATORY TOUR

July	17	Roanoke, Virginia	August	6-8	Austin, Texas
August	4-5	Miami, Florida	September	17-19	Austin, Texas

Corporate Headquarters 7970 South Kyrene Road, Tempe, AZ 85284 • (480) 403-8300 • FAX (480) 403-8306 • www.urban.com

PRSR STD
U.S. POSTAGE
PAID
PERMIT NO. 410
BEAVER DAM WI

RADIO GUIDE

www.radio-guide.com

*The New
Radio Guide*

One Website – All Radio

Coming Soon – September 2008

*The New
Radio-Info.com*



RADIO-INFO.COM
RADIO'S ONLINE COMMUNITY