

Radio Guide

Radio's Technology Magazine

Year-End 1992



**Station
Stories**

Page 18

Publisher's Page - Pro
Moving to '93

Tips From the F
ITC Mods & Rec

Transmitter
Electrical P



Radio Press Group
PAID
U.S. Postage
Bulk Rate



Cost-Effective Quality The New Dynamax MX Series Modular Audio Console

- True modular design
- Ultra-reliable motherboard construction
- VCA mixer and monitor control
- Active balanced line inputs, transformer isolated mic inputs
- Active balanced main and monitor outputs
- Full monitoring/cueing facilities with VCA level control and active source selection
- Built-in cue amp with speaker and amplified stereo 8-ohm headphone output
- Remote start logic
- Count-up event timer
- Two input expansion switches standard
- Two inputs per module, mic/line or line/line - line inputs may be mono or stereo, consumer or professional format
- Four assignable outputs - two stereo plus two mono
- Available in 6, 8, 10 or 12 channel models
- Rotary or linear faders
- Separate audio and logic power supplies
- Sturdy, all-steel construction
- Durable Lexan overlay control surfaces
- All inputs/output connection via compact, captive screw barrier strips - no soldering, crimping or spade connectors necessary
- Excellent RF immunity

Call any Fidelipac Dealer for more information about the quality, features and unbelievably low prices of the new modular Dynamax MX Series Console.



Fidelipac Corporation □ P.O. Box 808 □ Moorestown, NJ 08057 U.S.A. □ TEL 609-235-3900 □ FAX 609-235-7779

Inside This Issue

Raymond C. Topp
President/Publisher

Bob Dennis
Vice President/Sales

George Whitaker
Tips From the Field Editor

John Bredesen, P.E.
Transmitter Site Editor

Steve Shrader
BBS Editor & Sysop

Gordon Carter
Studio Site Editor

Mike Patton
Contract Engineer Editor

Business & Production

Raymond Topp - Publisher

511 18th Street SE
Rochester, MN 55904
Phone: 507-280-9668
Fax: 507-280-9143

Technical Editorial

George Whitaker

2306 Oak Lane Suite 100
Grand Prairie, TX 75051
Phone: 817-468-5981

Advertising Sales

Bob Dennis - VP Sales

P.O. Box 654
Green Bay, WI 54305
Phone: 800-972-9841

Radio Guide (ISSN 1061-7027) is published monthly, 12 times a year, by Radio Press Group Inc., 511 18th Street SE, Rochester, MN 55904.

All material contained in Radio Guide is copyright 1992 by Radio Press Group Inc., and may not be reproduced in any form without the written permission of the publisher.

FEATURES

Station Stories - Page 18
Network Radio That is Really Local

Rocky Mountain Radio Applies New Technology to Create a Revolution.

COLUMNS

Transmitter Site	6
Tech Tips From the Field	10
Studio Site	16
Contract Engineer	17

DEPARTMENTS

Publisher's Page	4
Equipment Guide (classified ads)	24
Advertiser Ad Index	26

Next Issue:

More of What You Want ...

**More technology, more tech tips,
more nuts-and-bolts information!**

Radio Guide Bulletin Board ————— **804-468-4957**
Equipment Guide Fax Service ————— **507-280-4045**

Question:

Ever wonder why transmitter manufacturers operate **Altronic** dummy loads at NAB and other trade shows?

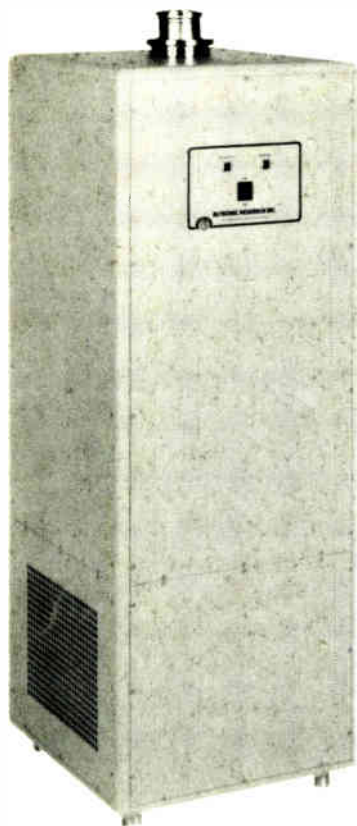

Answer:

The best performance and the most dependable dummy loads built.



**ALTRONIC
RESEARCH
INC.**

Water and Air Cooled
Models From
1000 watts to 1,500,000 watts

1-800-482-LOAD

P.O. Box 249
Yellville, AR 72687
Fax (501) 449-6000

This is The Last Issue of Radio Guide

We gave it our best shot. For the last four years, we've attempted to deliver solid and useful technical editorial to our readers. Judging from your response, I believe that we've accomplished that goal.

However, as a "free" publication, **Radio Guide's** existence is dependant upon manufacturers' tangible support, in the form of paid advertising. We have not done as well in that area. I must add that we don't blame them for this, given the state of the economy. Whentimes are tough, most advertisers will usually go with what's conventional and comfortable. Unfortunately, **Radio Guide** just didn't qualify.

A Few Good Companies

George Yazell (of Noise Free Radio), Systemation, Kahn Communications, Moseley, Holaday Industries, Tom Jones Recording Studios, Accurate Sound, Hallikainen and Friends, Northern Magnetics, Advanced Broadcast Consultants, and Dorrough Electronics. On July, 1988 these companies took the plunge. Their initial commitment to the **Radio Guide** concept helped to launch this publication. Without their support, **Radio Guide** would never have happened.

We also salute those companies who subsequently joined **Radio Guide** in an attempt to bring you sound, effective technical editorial. However, as we tallied up the numbers, the commitment just wasn't there. What some advertisers knew (and the others have yet to learn) is that there are tremendous numbers of conventional and contract engineers out there who have direct responsibility for the selection and purchase of technical equipment.

And until this industry wakes up to the fact that it is the technical personnel who make these decisions (no matter who approves or pays for it), then publications such as **Radio Guide** will never have the advertising support system they need. No sour grapes here -- that's just the way it is.

But there's more to the life of a publication than just ad dollars. I have always believed (and still do) that the primary task of a publisher is to create a loyal readership. Judging from your comments by phone, by letter and during conversations with many of you at radio conventions, we have more than accomplished our mission. You have my gratitude and thanks, for your support, constructive comments, and editorial contributions throughout the last four years.

Even though our future is not clear, **Radio Guide** has been, for the past four years, a useful tool in the pursuit of technical excellence. My only regret would be in not being able to continue to supply this industry with the technical information that I believe it needs. However ...

It's Your Decision Now

Do you want **Radio Guide** to continue or should we close up shop? That decision is, quite literally, up to each of you.

We will continue **Radio Guide** as a subscriber-paid publication. But only if each of you (or your station) is willing to pay for it. Because we will be relying on your paid subscriptions (instead of advertising) to support this publication, we will need to have a response *unheard* of in this industry.

If you believe that **Radio Guide** has value and potential, and would like to support it's continued development, then this is the time to do something about it. This is a one-shot deal. The vast majority of you will have to make a financial commitment. There's just no other way to put it. We are ready to continue to publish **Radio Guide**, but we are now relying on your support. We won't get a second chance at this -- it must be done now!

In our conversations with readers, we've found that hard nuts-and-bolts technical information and tech tips are most often mentioned as an editorial priority. In 1993, that will be our editorial target. If it deals with how to repair, install and maintain equipment, it's in -- if it deals with news, gossip and press releases, it's out! From now on, we won't be talking about equipment -- we'll be talking about how to work with it.

Fill Out The Card

In the center of this issue, you'll find a subscription card. Fill it out and send it back to us. No postage necessary -- we'll take care of that. Just let us know if you wish to sign up. Don't send any money; if there's enough response, we'll invoice you and start your subscription as soon as we receive payment.

Thanks for your continued input and support. It kept us advancing -- and learning. We hope that we have done the same for you. Have a safe and happy holiday season, and next year, we'll be back ... we're relying on you.

Ray Topp -- publisher

SEND YOUR AUDIO ACROSS THE STREET OR AROUND THE WORLD

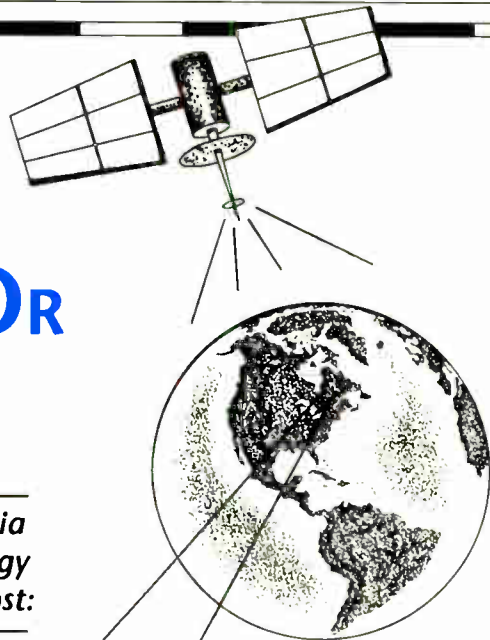

When you think digital audio, think California Digital. We provide satellite/digital technology to make all these options available at low cost:

- Live concerts & performances from any location
- Syndicated program and spot distribution
- Remote broadcasts at a moment's notice
- CD quality news and sports remotes
- Music programming networks
- LMA programming feeds
- Off-site announcer feeds

DIGITAL AUDIO

California Digital offers expertise in:

- Digital satellites
- Fiber Optics
- Training
- System design
- Fiber Optic brokering
- Equipment sales, leasing & financing
- Switch 56 & ISDN program distribution
- Satellite time brokering
(space segment brokering)

Call for details on cost effective solutions:

CALIFORNIA
DIGITAL AUDIO

Phone (805) 523-2310 Fax (805) 523-0480

530 New Los Angeles Avenue, Suite 114-96
Moorpark, CA 93021 USA

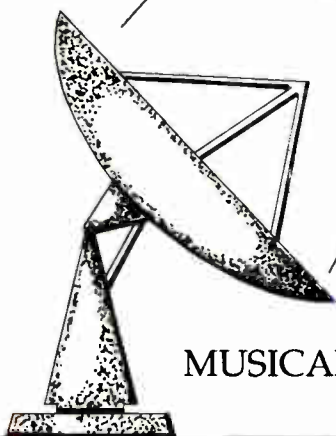

MUSICAM™

**MAKE MONEY BY CREATING A
MUSIC PROGRAMMING NETWORK!**

Electrical Power From the Source

By John Bredesen, P.E.

I want to remind you of the deadline coming up July 1st, 1993 which requires that STL transmitters meet certain technical standards. These were to have gone into effect on July 1, 1990, but broadcasters put up a strong objection. The claim was "we didn't know about it," even though it was adopted as part of the Rules several years before that. And therein lies the rub. The changes were simply forgotten by many stations because it had been in the Rules for some time, and July 1, 1990 seemed so far off. "No need to worry about it today," was the thinking. So the claim was logical in many cases because the new requirements lay there as a sort of time bomb, buried

in the Rules. Many stations simply had forgotten about their existence by the time July 1, 1990 rolled around.

The FCC listened and extended the deadline three years to July 1, 1993. Commonsense says there will not be another extension. Now is not too early to make sure you have acceptable equipment, or else you need to start planning your acquisition. Refer to section 74.550 of the Rules and Regulations as a jumping off place to see what you need to do. You will be able to meet the new requirements by only replacing the STL transmitter. However the existing receiver may not be set up for the correct deviation, which would compromise the integrity of the aural signal. The manufacturer of your STL should be able to tell you if you're OK with your present transmitter, and whether you can continue to use the present receiver if you have to purchase a new transmitter.

Let's get on with our discussion of electrical power which we began in the last issue.

Let's get on with our discussion of electrical power which we began in the last issue.

has installed for your station an electrical service of a certain capacity based upon information supplied before installation. Undoubtedly there will be other customers on the same primary supply lines. The utility will base the size of its transformers and supply lines upon predicted usage of the total connected load. When additional loading occurs because a customer or customers exceed the stated loads, it will ultimately force the utility to install greater capacity if it continues.

The utility doesn't mind if the load is relatively constant and growing over time because the additional kilowatt/hour billing will pay for the necessary rebuilding of facilities when the time comes. However, if a customer (say you) tests the standby transmitter for 15 minutes in a particular month, and then turns it off for six months, the utility must still be able to supply the demand for that period. However it can't derive much revenue because of the short period of time the load was connected. Because this very thing can and does happen, and not just in the broadcast industry, the electrical utility will adjust your demand charge upward if your load exceeds the normal level and exceeds it for a certain time, usually 15 minutes. It's a way of telling whoever is paying the bill that more attention needs to be paid to when and how unscheduled loads are connected.

Your home electric bill is quite simple. There is a basic service or meter charge which doesn't change month to month, plus a variable portion which reflects the number of kilowatt/hours used multiplied by the rate per kilowatt/hour.

Commercial users of electrical energy have an additional item called a demand charge or peak demand charge in addition to the



Econco

REBUILT POWER TUBES



*Approximately
One Half the Cost of New*

3,000 Hour Unconditional Guarantee

Call for Our Price List

Econco 1318 Commerce Ave. Woodland, CA 95695
 Phone: 916-662-7553 Fax 916-666-7760 Telex: 176756
 Toll Free: 800-532-6626 From Canada: 800-848-8841

Peak Demand

Any generation and distribution system runs most efficiently when the load is constant, or at least is predictable. As an end user, the utility

Transmitter Site

... continued

two listed above. The demand charge is essentially a penalty which the electrical utility adds to a bill, and is a charge based on the rate at which power is delivered. The charge is X dollars per kilowatt, not kilowatt/hours. If your main transmitter draws 40 kilowatts at rated TPO, and the demand charge is \$4/kilowatt, your monthly demand charge is \$160. ($\$4/\text{kw} \times 40\text{kw}$) This is in addition to the normal kilowatt/hour charge. Thus your monthly bill will consist of the demand charge, the charge for the number of kilowatt/hours used, plus the meter charge. This will remain reasonably constant month to month if the connected load remains equally constant.

However, let's say you run the standby transmitter one hour into a dummy load for testing. If it draws 25 kilowatts (assuming for purposes of illustration, that electricity costs 6 cents per kilowatt/hour) then you will have used all of \$1.50 worth of electricity. *But*, an additional demand charge of \$100 will be added to the bill. ($25\text{kw} \times \$4/\text{kilowatt}$) An additional danger with some utilities is this: once that additional demand charge has been incurred, a percentage of that charge can remain on the recurring monthly bill for up to a year (depending upon the tariff of your utility), *even if you don't turn the standby transmitter on again in that period*. If we use an arbitrary retention figure of 75%, then you will have an additional charge of \$925 over the period of a year. ($\$100 \times 75\% \times 11$ plus the original \$100) This makes that short test period very expensive over time.

Power Factor

Most broadcast equipment uses a power transformer or other inductive device across the power line. In a transmitter there will be many of these devices such as filament and plate transformers as well as cooling blowers. All of these have an inductive component to them. From basics, you will recall that any

inductive reactance will cause the current in a circuit to lag and be out of phase with the voltage. This indeed occurs in all of these devices mentioned above. The cosine of this difference angle is the power factor, which will always be a number between 0 and 1. If the load were totally resistive, the power factor would be 1. A perfect capacitor or a perfect inductor would yield a power factor of zero.

If the main transmitter has a power factor of 0.91 and requires 40 kw of energy from the line, then dividing 40 kw by 0.91 gives us an apparent load of about 44 kw. The current being drawn from the power line is equivalent to a resistive load of 44 kw. This higher current must be supplied by all the transformers and transmission lines involved in supplying power to your transmitter site, and it causes extra power losses in those components for which the utility isn't paid because the standard kilowatt/hour meter responds only to energy actually supplied to the load which in

this case is 40kw.

The utility will correct poor power factors by installing capacitors on some primary lines because most customers present an inductive load. Just think of your own home and count the number of motors there. However if a commercial customer has a poor power factor, a second meter will usually be installed to measure the reactive load, and the customer will be billed accordingly. Fortunately, the power factor of most broadcast transmitters is such that additional metering usually isn't deemed necessary by the utility company. The utility with which I deal defines a poor power factor as anything less than 0.9. This figure will vary from utility to utility, however.

I'd like to thank the Eugene Water and Electric Board, and especially Chris Webb for her knowledgeable help, in getting some facts straight for both this article and the one last month.

John may be reached at 503-747-4501. Ext. 2478

PROTECT YOUR STUDIO OR TRANSMITTER WITH AFFORDABLE STATE-OF-THE-ART SURGE AND LIGHTNING PROTECTION

it PROTECTOR



The HP Industrial/Broadcast Grade Panel unit will protect up to 1500 amp services. The protector's advanced technology combines both electronic and chemical sciences. A multi-stage solid state suppression network is encapsulated in a solid chemical compound with high energy dissipation properties. The energy is converted to heat and dissipated within the potted compound and not within the electronics.

The HP Series carries a 10-year warranty and FREE replacement if destroyed electrically for any reason ... INCLUDING LIGHTNING!

- Fast Response Time
- Easy Installation Parallel Mount
- Automatically Resets
- Maintenance Free
- Tight Clamping
- Solid-State Construction
- No Clamping Drift
- Electro-Chemical Technology
- No Deterioration
- Ten Year Warranty
- Made in USA
- UL and CSA Listed

Energy Control Systems

P.O. Box 330607, Fort Worth, TX 76163
Phone 817-483-8497 Fax 817-572-2242

INDUSTRIAL/BROADCAST HP SERIES

\$1545 ⁰⁰

The HP-3Y 4-wire 30 120/208 Unit:

Peak Current Surge:

320,000 Amps

Energy Dissipation:

4160 Joules

Response Time:

<1 nanosecond

Common/Normal Protection

& Filtering:

500kHz - 30mHz

Dimensions:

3.75" x 6.25" x 8.25"

NEMA 12 enclosure

Approximate Weight:

12 lbs.

Other Models/Voltages Available

Radio Guide — Technical Info Sheet

Engineering Data Courtesy of Continental Electronics

Frequency Designation of FM Broadcast Channels			
Freq. (MHz)	Channel No.	Freq. (MHz)	Channel No.
88.1	201	90.9	215
88.3	202	91.1	216
88.5	203	91.3	217
88.7	204	91.5	218
88.9	205	91.7	219
89.1	206	91.9	220
89.3	207	92.1	221
89.5	208	92.3	222
89.7	209	92.5	223
89.9	210	92.7	224
90.1	211	92.9	225
90.3	212	93.1	226
90.5	213	93.3	227
90.7	214	93.5	228
93.7	229	97.3	247
93.9	230	97.5	248
94.1	231	97.7	249
94.3	232	97.9	250
94.5	233	98.1	251
94.7	234	98.3	252
94.9	235	98.5	253
95.1	236	98.7	254
95.3	237	98.9	255
95.5	238	99.1	256
95.7	239	99.3	257
95.9	240	99.5	258
96.1	241	99.7	259
96.3	242	99.9	260
96.5	243	100.1	261
96.7	244	100.3	262
96.9	245	100.5	263
97.1	246	1090.7	264
100.9	265	101.1	266
101.3	267	101.3	267
101.5	268	101.5	268
101.7	269	101.7	269
101.9	270	101.9	270
102.1	271	102.1	271
102.3	272	102.3	272
102.5	273	102.5	273
102.7	274	102.7	274
102.9	275	102.9	275
103.1	276	103.1	276
103.3	277	103.3	277
103.5	278	103.5	278
103.7	279	103.7	279
103.9	280	103.9	280
104.1	281	104.1	281
104.3	282	104.3	282
104.5	283	104.5	283
104.7	284	104.7	284
104.9	285	104.9	285
105.1	286	105.1	286
105.3	287	105.3	287
105.5	288	105.5	288
105.7	289	105.7	289
105.9	290	105.9	290
106.1	291	106.1	291
106.3	292	106.3	292
106.5	293	106.5	293
106.7	294	106.7	294
106.9	295	106.9	295
107.1	296	107.1	296
107.3	297	107.3	297
107.5	298	107.5	298
107.7	299	107.7	299
107.9	300	107.9	300

ONLINE/ REMOTE ACCESS

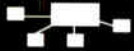

CDS RF Engineering ToolsSM provide broadcast engineers with access to the most current government data files including FCC Broadcast, FAA, US Census and USGS databases. Our online/

remote access programs are invaluable in the preparation of applications, exhibits, coverage predictions and other engineering needs. CDS RF Engineering ToolsSM include:

- Real World PropagationTM Studies
- Online/Remote Access Services
- 3 Arc Second Terrain Data
- 1990 Population Data
- FCC & FAA Databases

Richard P. & Richard L. Biby, Principals



Communications Data Services, Inc.
6105-E Arlington Blvd., Falls Church, VA 22044
(703) 534-0034 • (800) 441-0034



Join the telecommunications revolution! Enter the lucrative paging and personal communications market with **AXCESS 3000/RDS** — the most technologically advanced alphanumeric message transfer system (in any language) available today. Use your existing FM radio station for *effortless* paging, message and information transfer.

- Turn-Key system — at an affordable price
- No major capital investment — you already have the FM subcarrier capability
- Join the network — be part of a nationally franchised paging system
- Vastly greater coverage area — performance your competition can't match
- Ready market — with virtually unlimited growth potential
- Profit potential — with recurring revenue

SEE US AT NAB RADIO SHOW

AXCESS USA



Access USA Communications Corp., P.O. Box 6166, Metairie, LA 70009
(504) 832-7927 Telephone ■ (504) 832-7929 FAX

GOOD COMPANY KEEPS GOOD COMPANY

Continental Electronics and these fine companies

AKG	Innovative Technologies
Altronics Research	Inovonics
Andrew	Jampro
Aphex	Kay Industries
ATI	Kintronics
Atlas/Soundolier	LEA Dynatech
Audioarts	LPB
Audi-Cord	Marantz
Audiolab	Mark Antennas
Audiopak	Marti
Audio Technica	Modulation Sciences
Autogram	Moseley
Belar	Motorola
Bird	MTS
Burk Technology	Myat
Cablewave	Onan
Central Tower	Orban
CRL	Potomac Instruments
Coaxial Dynamics	Q.S.C.
J. W. Davis	Radio Design Labs
Delta Electronics	Register Data Systems
Denon	Ruslang
Dielectric	Scala
DorrOUGH	Shively
Electro Impulse	Shure
Environmental Technology	Sine Systems
ERI	Stanton
Fidelipac	Symetrix
Gentner	TFT
Gorman Redlich	Trimm
Hallikainen	Utility Tower
Henry Engineering	West Penn Wire
Hughey & Phillips	Wheatstone

These companies have joined with Continental Electronics to provide you the **broadcaster** with the best equipment available. We will be pleased to provide you with a quote for all of your broadcast requirements.

Call Continental first.



Continental Electronics Corporation

P.O. BOX 270879 DALLAS, TEXAS 75227-0879 214-381-7161 TELEX: 73-398 FAX: 214-381-4949

Tech Tips From the Field

Practical Solutions to Practical Problems

ITC Mods and Recycled Preamps

By George Whitaker

First off this month, I want to share a "slapper" that I learned from one of the speakers at the S.B.E. convention in San Jose. Unfortunately, I failed to note from which speaker this tip came. Therefore, I am unable to give due credit and offer my apologies for this oversight. I like to give credit where credit is due.

Anyway, he gave me a solution to the problem of the car radio overloading when out at the transmitter. Many, many times I have jumped into the car and driven a mile or so down the road to see what the latest changes had done to the sound.

It turns out that all I really needed to do was take a clip lead and fasten it to the rain gutter, or

other convenient place on the vehicle, and then to the antenna. This, of course, desensitizes the front end and allows normal reproduction even in the heavy field.

Speaking of the convention, I want to say that, in my personal opinion, the papers were the best ever. I learned a lot of things that I have already been able to put into practice. I believe that, if you don't do anything else, you should attend the S.B.E. National Convention.

Dr. Dave (that's Dave Graves) with KHYS in Houston has picked up some information for altering the response on the "cart machine that never dies." I, for one, still have

about 12 of these decks in service and they all have the original boards in them. Therefore, I was glad to learn about:

Modifying Low End Response On The Old ITC

A lot of us still have ITC premium series cart machines around. It seems they were built so "bullet proof" they never seem to die.

However, one of my complaints has been that the low frequency "bump" was about 3 db too low. You can, of course, buy "wonder boards" for these machines. However, Dave Neal at ITC gave me this tip which I would like to share with you all.

(continued on page 11)



**Audio DA's for a
BROAD RANGE
of applications**

- For every requirement and every budget.
- Single rack units to 4 in by 16 out.
- Modular mix and match to 10 in by 60 out.
- Multiple mic and line amplifiers, 4 to 8 channels.
- Transformer and active balanced outputs to +30dBm

ATI
AUDIO TECHNOLOGIES INCORPORATED

CALL OR WRITE NOW FOR FREE DETAILED BROCHURE.
328 Maple Ave. Horsham, PA 19044, USA (215) 443-0330 FAX: (215) 443-0394

Tips From the Field

Continued from page 10

All you have to do is install a 200-250 ohm pot in the second audio driver emitter circuit. This will increase low end response by 4 or 5 dB. There are two play amp boards used in the premium series machines. If you have the 831-0027 board, replace R107 (left) and R126 (right). On the 831-0094 board, replace R107 (left) and R131 (right). Connect the wiper and one end of the pot in place of the resistor. You will now be able to adjust the low end at around 100 Hz. Start with maximum resistance and adjust so that your low end is where you want it.

I have modified several machines in this way, and believe me, it works. The difference in sound is quite remarkable.

One of the few things I find enjoyable about living in the Metroplex is, because so many companies are located here, information and parts are very readily avail-

able. I have, on occasion, dropped by the Continental Electronics field service office just to ask questions and learn things, even if what I was asking about did not directly relate to Continental. The folks there are always very helpful. The other day I called to get some information on something and wound up getting an excellent tech-tip from John Hutson. I don't remember the original purpose of the call, but I found out about:

Using A Scanner To Tune Receivers

If you have ever had the need to change frequency on 2-way or RPU gear, you may have thought you needed a synthesizer or communications monitor to do the job. It is possible to do an acceptable job with nothing but a scanner, a wattmeter, and a VOM.

The first step is to get the receiver local oscillator and its multipliers working. Most high band units multiply a receiver LO crystal by 3 and UHF units multiply by 9 or 12. (Example: A 161.7 receiver which has a 10.7 IF needs a 151.0 injection frequency. $151/3=50.3333$

which is the crystal frequency). Put the scanner on 151.0 and peak the oscillator and multipliers in the receiver for the strongest signal on the scanner. You may also have to adjust the crystal trimmer until the LO signal is on frequency.

Next, we are going to use the local oscillator in the scanner as a signal generator to tune the RF stages in the receiver. My scanner (A Regency R1080) has a 10.7 IF and uses high side injection on low band and low side injection on high band and UHF. So, to get a signal on 161.7, add 10.7 and set the scanner to 172.4 MHz.

Lay a wire over the scanner and stick it in the receiver's antenna connector. Then tune the receiver RF stages for maximum signal, moving the scanner farther away as necessary to reduce the signal, as the receiver is tuned. Some receivers use very sharp cavity resonators in the front ends and will not pass a signal very far off in frequency. I have been successful in this case by removing slugs part way through the filter and putting the wire laying

(continued on page 12)

S.C.M.S, Inc.

Charlotte, N.C

Low Prices — Experienced Staff
New and Re-built R.F. and Audio

This Month's Special

Signet #SK-315
Automatic CD Cleaner

- Wet/Dry Operation
- Cleans and Dries
- DC, or optional AC operation

Only \$59⁰⁰

Toll-Free 800-438-6040
Fax 704-889-4540

Commercial Radio Company

Duttonville School Drive, Cavendish, VT 05142
Phone 802-226-7582 Fax 802-226-7738



Transmitter Parts For:
RCA - Gates - Collins/Continental



Mica Transmitting Capacitors: Sangamo, CD, Sprague, Aerovox, Acushnet types: CM-15, CM-20, CM-25, CM-30, HT, HK, AT, AK, F1, F2, F3, 30B, E, 1996, 291, 292, 293, 294 & G5.

Fixed and Variable Vacuum Capacitors: Jennings, Dolinko & Wilkins. Mounting brackets and flanges. Vacuum relays.

Oil Filled Filter Capacitors: Plastic Capacitor Corp., 600 to 40 kV, 1 mFd to 30 mFd with special mounting brackets. Non-PCB oil capacitor replacements are available for most transmitters.

Ceramic RF Capacitors: Centralab, Jennings, Sprague, High Energy, 5 kV to 40 kV.

Variable Transmitting Capacitors: E.F. Johnson Co., Cardwell Condenser Co., insulated shaft couplings as used in phasors, variable transmitting capacitors.

Weschler-Westinghouse: RF Ammeters, 0-0.5 Amps through 0-50 Amps, internal and external thermocouples, expanded and linear or square-law scales. Sizes are 3 & 4 inch, round and square. Special meters are available.

Radio Corporation of America - A division of Commercial Radio Company: RCA transmitter, phasor and antenna tuning unit parts.

Tips From the Field

Continued from page 11

over the scanner through the hole and tuning the filter a little at a time.

After peaking everything, connect the receiver to the antenna and fine tune everything with an off-air signal. This is necessary because the piece-of-wire antenna we are using does not present a good 50-ohm source.

Transmitters are usually much easier. Just put a dummy load and wattmeter on it and tune everything for maximum. (Just make sure you are *not* turning any harmonic trap slugs!) If you are changing frequency so far that the transmitter will not put out any power at all, try putting an ammeter in the 12 volt B+ lead. Then start with the oscillator and first multiplier, and simply tune everything for peak current. Before long you should see output.

If this doesn't work, set the scanner on the desired transmit frequency and, starting with the transmitter oscillator, tune for maximum the same way you did with the receiver's local oscillator. Even if only the oscillator is working, you should be able to see its harmonic on-frequency.

The last step is often ignored. It consists of tuning the modulator coil (which you have already peaked for RF) for best symmetrical audio. Put a tone through the transmitter and a scope across the scanner speaker, and tune for best looking audio.

A word of caution is in order. *Do not* depend on the local oscillator in the scanner to zero-beat the transmitter's frequency. It isn't accurate enough. A base station on 450 mHz is only allowed a bit more than 1100 Hz frequency error. FCC rules aside, with 12.5 kHz channel spacing, if you are outside limits, you can seriously interfere with your neighbors. Use a known accurate counter or communications monitor for this.

Glenn P. Smith of WEOL-WN WV in Elyria, Ohio has come up with a "slapper" we call:

Recycle Turntable Preamps

Have you ever needed to match a -10 dB output to your console +4 or +8 input? We had several unused Ramko Research model SP-BE turntable preamps on hand that I found would easily do the job. Other similar turntable preamps might also be easily converted.

The SP-BE has a high gain first stage, which also provides the RIAA/NAB equalization for turntable use. If you bypass this stage by connecting the input to the second stage amplifier, you have a flat response audio amplifier.

In the Ramko preamps I did this by removing the jumper from the sensitivity adjustment trim pot and pin 13 (+input) of the second audio stage. Then I connected pin 2 to pin 13, to connect the input to the second stage. Since these units are stereo, I had to convert both left and right channels.

Measured results showed a maximum gain of 30 db with excellent response and distortion figures.

I have already made use of the following Tech-tip from Cliff Glasgow of KROP-KSIQ in Brawley, CA. A variable pad can be a very handy thing to have around. It is also refreshing to find that I am not the only one who has trouble getting pots in correctly. Cliff tells us about a 600 To 600 Ohm Variable Pad.

There are two versions of this variable pad. The first (fig. 1), is the original design that I believe was "stolen" from something that Pacific Recorders built, although I am not entirely sure of its true origin.

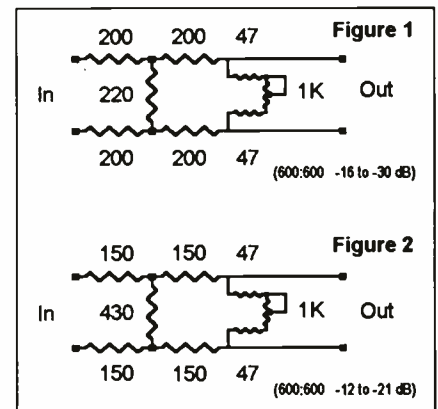

It is very stable, impedance-wise, but has a lot of loss. The second version, (fig. 2) has less loss but is not as linear. However, with audio, it often isn't that critical. I've seen some pretty weird pads with "wrong" values that seem to work

(continued on page 14)

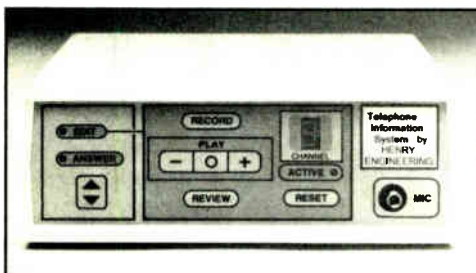

IT'S INSTANT INFORMATION!

"Press 1 for today's weather, press 2 for the Ski Report, press 3 for concert information, press 4 for this week's school lunch menu, press 5 for the listener's club address, press 6 for the request line phone number, press 7 for the surf report..."

NEW! The Telephone Information System...stores up to 10 messages for instant playback via Touch-Tone! Over 8 minutes of digital storage. In stock at an *affordable* price!

HENRY ENGINEERING (818) 355-3656 FAX: 355-0077



The Major Player In Compact Disc Machines.

The Audiometrics CD 10 compact disc cartridge machine: the natural evolution of a great idea. We simply made it better.

The CD 10 is the only broadcast-ready CD player that features cartridge autolock, programmable EOM indicator, instant start with

music, and true broadcast standard construction.

The CD 10 won't let you mess up on the air. The cartridge is secure within the machine until you make a conscious effort to remove it.

Now you can take CDs direct-to-air with confidence.

The CD 10 will make the move with you to DAB. Buy now with no fear of obsolescence. CD quality in a world standard package.

You'll find the CD 10 a friendly, likeable programming tool that will encourage you to take compact discs direct-to-air.

For the best way to air CDs, there's only one place to call: Harris Allied. We've sold more CD cartridge players than all other dealers combined.

8:00 a.m. to 8:00 p.m. EST
1-800-622-0022
Fax 317-966-0623
Canada 1-800-268-6817

 **HARRIS
ALLIED**

Modulation Monitor Repair & Calibration

Reasonable Rates

STL, RPU, & STL Repair and Retuning

All makes and models

Remote Control & Subcarrier Repair

Fast Turnaround

Exciters & Other RF Equipment

(504) 292-4189

Michael Patton & Assoc.
12563 Parkciel Ave.
Baton Rouge, LA 70816

Tips From the Field

Continued from page 12

with no adverse effects. The advantage to these is, of course, that you have considerable range to adjust in the event you need to change output level or equipment.

The trick is remembering which end of the pot to tie the tap to, so that CW yields a higher output and CCW less. I never can remember, so I just tacksolder and check with my meter on the bench, then complete or change as necessary. (I honestly believed that I was the only one who ever had to do that.)

And a tip is a tip no matter what part of the station it refers to. Stu Engle of WZZD in Philadelphia says that, if you take the aluminum hub that comes from a 10-inch reel and lay it on the burner, it will keep the coffee from burning.

Well, that's it for this month and this year. Going into 1993 you will see some changes in Tech-Tips as this column will be expanded in the forthcoming issues. If you enjoy this information, I think you will find the upcoming changes to your liking.

Please note that **Radio Guide** has now opened an office in the Dallas-Ft. Worth Metroplex. The new mailing address for this column is:

Radio Guide Magazine
2306 Oak Lane Suite 100
Grand Prairie, TX 75051

Editor's Note: I have been asked to prepare a paper on "STL Interference -- Horror Stories and Fixes." If you have anything you could contribute to this paper, please send it to me ASAP, as I will readily admit that my experience in this area is limited. This paper is to be presented on SBE day at the April NAB convention in Las Vegas. All contributors will be given credit at the presentation.

MARATHON PRODUCTS CO.

Audio Cartridge Rebuilding Division

Rebuilding/reloading, like new, all brands, any length up to & including 3.5 minutes. \$1.75 ea. FOB our plant, 48 hrs. delivery.

New NAB Marathon Cartridges
Prices Upon Request

35 Years professional experience!
Lifetime member AES, R.D. Myers Sr.
Manufacturers of Audio Devices, Continuous Tape

69 Sandersdale Rd.
Charlton, MA 01507
508-248-3157 or 508-853-0988

Transcom Corporation

Serving the Broadcast Industry Since 1978

FM Transmitters

1 kW	FM	1964	Gates FM1C
1 kW	FM	1978	Collins 831C2
2.5 kW	FM	1978	CCA 2500R
3 kW	FM	1975	CCA 3000D
3 kW	FM	1974	Harris FM3H
3.5 kW	FM	1979	Syntronics SI-F-3
5 kW	FM	1989	Harris HT5
15 kW	FM	1975	AEL 15KG
25 kW	FM	1988	TTC 25,000

AM Transmitters

2.5 kW	AM	1982	CCA 2500D
2.5 kW	AM	1976	McMartin BA2.5K
5 kW	AM	1979	Harris MW5A
5 kW	AM	1968	Harris BC5H
5 kW	AM	1972	CCA AM5000D
5kW	AM	1977	RCA BTA 5L
10 kW	AM	1988	Nautel ND-10
50kW	AM	1977	CCA AM50000D

P.O. Box 26744, Elkins Park, PA 19117

Phone (215) 884-0888 (800) 441-8454

Fax (215) 884-0738



Call-ins don't have to be a shattering experience. After all, your requirements are simple. You want great sounding phones with the ability to monitor callers through open speakers. Sounds easy enough...until you crank up the speakers and get feedback.

Telos comes to the rescue. We are the only manufacturer whose hybrids include digital feedback suppression circuitry. And ours are the only hybrids to offer digital dynamics control for perfect levels, call after call.

Choose from the best selling **Telos ONE**, the dual hybrid **Telos ONE plus ONE**, or our top-of-the-line **Telos 100 Delta**, the only broadcast product with dynamic, digital equalization. Each is a complete digital signal processing package which produces the most natural sounding, full-duplex audio without feedback.

Isn't it time you experienced the pleasure of great phones?



Telos ONE



Telos ONE+ONE



Telos 100 Delta



2101 Superior Avenue
Cleveland, Ohio 44114
216.241.7225 · FAX:216.241.4103

Studio Site

Repair and Maintenance at the Studio

Designing Your Studios

By Gordon Carter

We are finally to the point of designing our studio space. We have assembled our moving team, assessed our needs, and picked the space we will move into. The studio design phase of the project brings together all of the disciplines of the audio engineer. Designing a good studio space requires some knowledge of acoustics, electronics, ergonomics, architecture, structural engineering, air handling systems, and more. Fortunately you don't have to know all of this yourself if you have assembled a good team.

The first thing you have to look at is the space required for each room. To determine the size of each room you will need to know what equipment will be used in the room and how it will be used. This will, to some extent, determine the layout of the equipment in the room. As you look at various ideas, be sure to get feedback from the people who will be using the room. Remember

that not everyone has an easy time relating to room layout drawings, so other techniques may be required to communicate the design. Depending on the resources available to you, you could use perspective drawings, models, full-size mock-ups, computer modelling, and more. As you lay out the equipment room for the people who will be using it, to get around and don't forget to allow adequate room for service access. I have seen many radio stations designed with all of the equipment pushed up against a wall so it requires a strong furniture mover just to plug something in.

While you plan the dimensions of the various rooms, be sure to allow for the necessary wall thickness and ceiling drop to conceal such things as conduits, air ducts, sound proofing, and

structural members. Your studio designer and architect can help you with this.

As your layout takes shape, the necessary size of the room will become apparent. Be careful with the room dimensions if you want the room to sound even the least bit good. If the dimensions of the various sides are close to multiples of one another, standing waves could result that will make the room boomy or have other problems that will be difficult or impossible to tame. Various acousticians have come up with "ideal" room ratios to avoid standing waves in rooms, but reality may dictate a compromise. It is best to have your studio designer check the dimensions for possible

(continued on page 17)

Oh-Oh!

Call CORTANA

STATI-GAT The Affordable Lightning Prevention System

- Charge dissipation with 1/8", type 304, sharpened stainless steel rods
- Won't bend from ice/severe weather
- Provide a continuous low-resistance discharge path for static electricity

Cortana Corporation

Write for a Free Brochure.
P.O. Box 2548, Farmington, N. M. 87499
Call (505) 325-5336

ERITM ELECTRONICS RESEARCH, INC.

108 Market Street • Newburgh, IN 47630
(812) 853-3318 • FAX (812) 858-5706

PRODUCTS
Broadcast Antennas
Directional Antennas
Master Antenna Systems
Filters & Combiners
Towers
LambdaTM System

SERVICES
Antenna & Tower Installation
Field Technicians
Structural Analysis
Antenna Test Range

Super Hi-Power FM Antenna

Multiplexer System with Alarm Monitor

- 49 Years of Experience
- Registered Electrical & Structural Engineers
- Broadcast Consulting Engineering Services

If You Demand Excellence, Make ERI Your Single Source For Antenna & Tower Products.

Studio Site

Continued from page 16

interactions, with a computer program. You may want to move a wall a few inches to improve the sound, and it is easier to do now than later.

There are a myriad of concerns to be addressed with the mechanical design of your studios, relating to isolation and noise control. Your studio designer can discuss these with you in more detail and help work out the combination of techniques that is best for your situation and budget. Some things you may want to consider are floating floors, separate walls for adjoining studios, lead-lined walls, acoustic doors and windows, sound locks, and more. Each of these items has its own set of advantages and disadvantages, so you will want to weigh each one carefully.

If you are even the least bit concerned about noise in your studios, you will want to pay some special

attention to the air handling system. For minimum noise transmission you will want any air handling devices (air conditioners and fans) located as far from your most critical room as possible. They should be mounted on properly designed isolation pads to reduce vibration transmission. An improperly designed isolation pad may actually increase vibration transmission and may fail prematurely.

The routing and design of the ductwork is very important to reduce rumble and air noise. The ductwork should be large enough to allow for adequate air flow to each room (determined by heat loading calculations) with as little velocity as possible. Any turns in the ductwork should be large sweeping turns, not sharp corners. When the duct enters the room it should do so in such a manner that the air is dropping into the room instead of blowing through it. Avoid corners near the air baffles and make sure the baffles are the low turbu-

lence type. Any dampers that are necessary in the ductwork should be as far from the baffle as possible to avoid turbulence. If you have more than one room being served by the same air system, put as much ductwork as possible between rooms. This will help reduce sound leakage between rooms.

As you design your studios, be sure to allow for the necessary electrical systems. Your architect and local building codes will probably require some exit signs and emergency lighting. You will also need lighting for your operations. If your people like to work in low light (like Venus Flytrap on WKRP) that is fine. Just remember to have enough light available when it comes time to sweep the floors or work on the equipment. You really don't want to fight with a work light every time you need to clean some tape heads, do you?

Many designers like to use fluorescent lights for their low cost and

(continued on page 25)

WireReady™

Offering a real choice for today's radio news

Damned if you do, Damned if you don't...

Today, if you still get your wire news service(s) on a printer, you spend hundreds of dollars a year on paper and ribbons and get very little for your money, except a royal headache.

And if you've seen our competition, they charge you as much as \$700/year just to maintain their basic software. And if you want to expand, they begin to double and triple their fees. Want to pull in more than one wire service? More bucks. *Unless you talk to us...our systems cost a lot less.*

Now there's a way to get a world-class PC-based computerized news system for less than you now spend on paper and ribbons...



- Wire News Automation • Split-Screen editing • Archiving • School Closings • Elections • Call-in monitoring •

After four years, WireReady is now used by hundreds of AM and FM stations. Several of the largest state radio networks, and some of the biggest radio newsrooms and names in the business have computerized their newsrooms with WireReady. Toss in a few government agencies and a nuclear-powered aircraft carrier and we think we can handle your needs too. We'll be happy to send you references, information, or a demo, so give us a call today.

31-H Union Avenue, Sudbury MA 01776 USA
(508) 443-8181 (800) 833-4459 FAX (508) 443-5988

WireReady Newswire Systems Inc.

Station Stories

Radio Installation Reports

Network Radio That Is Really Local

By George Whitaker

Rocky Mountain Radio Applies New Technology To Create A Revolution

In my 30 plus years in radio, I have seen very few things come along that were really revolutionary – things that truly changed the way we did the business of radio.

The introduction of the ATC cartridge machine changed the business considerably. The Marti RPU certainly opened the door to economical remotes, and when SMN came along with satellite delivered programming, it made a tremendous impact on the thinking of small market stations.

Now, a couple of gentlemen from Colorado, working with several manufacturers, have developed what I believe to be the next real revolution: a local radio station that

is, in reality, programmed from miles away with a system in which the capital equipment and recurring costs make it extremely economical. It could have been done before, if you had unlimited funds. But the real revolution is the system that makes it economically feasible.

Rocky Mountain Radio consists of seven stations in Colorado. All of these are owned by the network. The central studio is in Avon, and it is from this point that all of the programming, traffic, and billing originates. During a stop-set the spots, local weather information, and/or local news are sent down the network to the down-link stations with each one storing the information in its AUDISK for replay either minutes or hours later. The local listener only hears information tailored for his town. This is

done via the ability of the AUDISK to be playing back a local ad at the same time it is recording one for use at a later time.

Looking at an example of how this works, lets follow a spot from production to playback.

In the production room the announcer, having completed the ad, will call up on a computer screen the files of the Network AUDISK. Then he will store the ad in the file assigned by the

traffic program along with a code that tells on which down-link station this ad is to run. The ad is then held in "ready to send" by the Network AUDISK until the next stop-set. When the announcer pushes the "stop-set start" button in the control room, the Network AUDISK will first send a data burst that will tell the down-link station's AUDISK that the next ad coming next is for that station and where to store it. Then the actual ad is sent and stored in the local station's AUDISK.

The program log information is also sent to the individual stations each hour, in the form of data packets, so that each down-link station's AUDISK knows which announcement to play at what time.

At KZYR, the originating station, the programming is actually from the satellite feed in order to keep it operating exactly like the other down-link stations. The announcer has two computer screens in the control room. One of them is the network AUDISK and the other is the KZYR AUDISK. By observing the screens, the announcers can keep up with what is going on at the network level, and they can hear the station in which they are located operating just like the other down-link stations.

Cliff Gardiner, a long-time radio man and investment banker, took the idea of programming stations from a central location using satellite delivery as his starting point. This concept was, of course, in place all across the nation.

He then added the following criteria: local ads would be run at each station, as well as local weather, news, and time. But all of these would originate at the central studio. All traffic and billing would be handled at the central studio location.

"Serving the World With Quality"



"Large Electron Power Tube
Rebuilders Since 1940"

Freeland Products, Inc.

75412 Highway 25
Covington, LA 70433

800-624-7626 or 504-893-1243
Fax 504-892-7323

Station Stories

Continued from page 18

If these items could be accomplished, it would allow for operation of the down-link stations with nothing more than a person to maintain the office during business hours and a sales staff.

As Cliff tells it, "I determined that I wanted to have a way to run local radio stations from one location and not give up *anything* that makes them local.

Our first priority was to make the radio stations sound local. This means that you have to have local weather, local news, and the ability, every hour, to easily interject local comments and local talk. But yet we had to find a way to save all that operating cost."

At first, the economics would just not work. Then Cliff met up with Marty Hijmans, an area engineer working with National Supervisory Network and others. Through his experience with NSN,

Marty was familiar with VSAT (very small aperture terminals), and also with the MUSICAM compression system, which would allow them to put stereo audio and a data channel in a bandwidth small enough to become economically attractive.

Marty came to work with Cliff at Rocky Mountain Radio, which is located just about a half a mile from National Supervisory Network in Avon, Colorado. The two of them then set about to assemble a system that would meet the criteria that Cliff had established.

As Cliff tells it, "When I first started looking at doing this, which has been about two and a half years ago now, the only way that I could find to deliver this kind of programming to radio stations was to use an audio subcarrier on a video transponder. An uplink to do that would have cost us about \$120,000 and the satellite time was going to be \$22,000 a month. Then I discovered that we could lease an SCPC. Even then, the uplink would have been about \$60,000 and the satellite time about



Marty Higman, in Rocky Mountain Radio Technical Operations

\$7,000. And, of course, these would have been analog instead of digital.

As Marty got into it he discovered that we could use the VSAT technology with the MUSICAM

(continued on page 20)

A Point-To-Point Audio Transmission Problem Solved

WGUC FM is the University of Cincinnati's prestigious classical music NPR station. It is located adjacent to Music Hall which hosts the Cincinnati Pops and Symphony Orchestras. Its audio quality is scrutinized by listeners who have come to expect a tradition of excellence. When WGUC chose two of T-TECH's Pro-Audio Fiberoptic STL's, one from studio to transmitter, and the other from transmitter to studio, its expectations of sonic transparency and freedom from code compression delays were fully met. WGUC's chief engineer, Brent Reider, describes his experience with the system:



"I was impressed with the ease of installation -- these are well constructed units. T-TECH has thoughtfully designed the system from the ground up. With four DC to 67 kHz circuits to and from our transmitter site, our remote and monitoring capabilities have multiplied. The link sounds great and is free of the encode/decode delays which our announcing staff had noticed with another digital audio link. I have utmost confidence in the link's performance and reliability. Most importantly, I am assured of full support from T-TECH."

For the best sound quality and reliability in an audio link, it simply has to be fiberoptic, and the best fiberoptic audio link is made by T-TECH Corp. Circle the reader service number below or contact:

T-TECH

P.O. Box 151, Hudson, MA 01749
Phone (508) 562-5820 Fax (508) 568-1219

Station Stories

Continued from page 19

compression system. Now our up-link cost us \$22,000 and our air time for a stereo channel, plus data, is \$2400 per month. That's an amazing progression in 2-1/2 years."

The AUDISK was selected as the medium for storage, the MUSICAM based ComStream VSAT system was selected for up

and downlinking and the BURK ARC-16 was selected for transmitter control.

Marty continues the story from his point of view, "Before I came to work with Cliff, I was working with Bill and Muffy at National Supervisory Network. That's where I was introduced to a lot of this equipment because NSN did a lot of pioneering on how to deliver digital audio on VSAT. NSN was very crucial in making this work.

As far as we know, we're the first to use the new ComStream equipment with MUSICAM encoding. They previously had an APT product that had been in use for several years. The new developments in ComStream equipment, however, gave us a lot more than just audio and a data channel. Built into the ComStream system was the ability to cause contact closures and to make the receivers agile by remote control so that we could switch to different carriers, if necessary. That was a quantum leap in features for a lot less money.

We knew then how we could get the signal from the network origination point to the affiliates. That was the first step.

Next was some kind of automation. In surveying all the automation manufacturers' products that were available at the time, it was clear that AUDISK was way ahead of everybody else out there. They actually had experience in other countries networking their product and doing *some* of what we needed to do. So, they had a giant head start. And, I believe they still do."

Since they were starting out to do something with computer based systems that had never been done before, the big hurdle was software. At this point Tim Valley, with Gentner Electronic's AUDISK, became an integral part of the team and, working with Marty, wrote and rewrote the software as the hardware and software were being field tested at Rocky Mountain Radio.

The results of their efforts are now being marketed jointly by the three companies primarily involved with the development. The programming package by ROCKY MOUNTAIN RADIO, (303) 949-0140, the AUDISK and software package by GENTNER, (801) 975-7200, and the up-link, down-link and transmitter control package by NATIONAL SUPERVISORY NETWORK. (800) 345-VSAT, They have

(continued on page 21)

The ENCO DAD486x

DIGITAL AUDIO DISTRIBUTION SYSTEM

*Special
Introductory
Price
\$4500

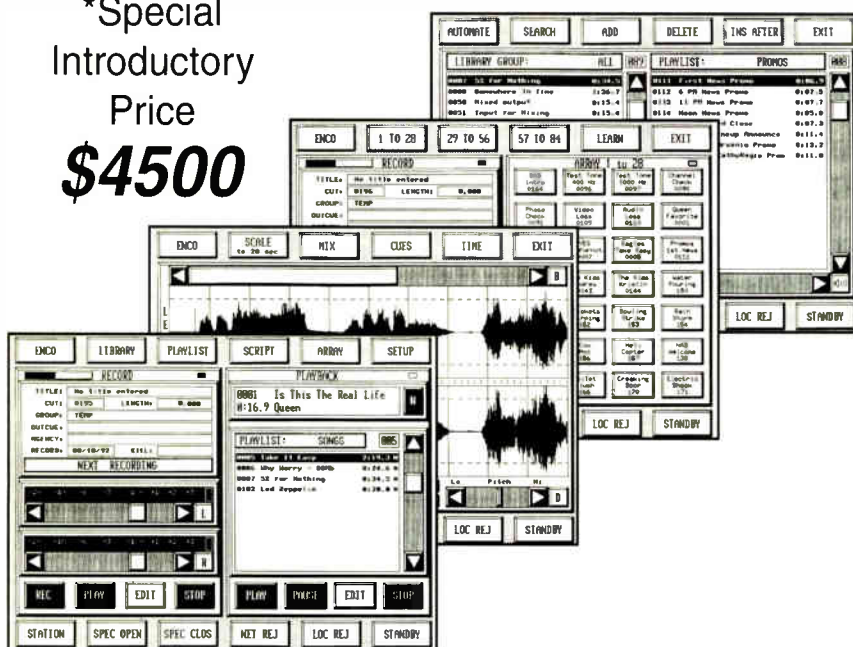

Professional Software for Digital Audio Broadcasting

- Full Bandwidth Stereo Audio Record/Playback
- Intuitive Graphic Audio Editing
- Instant Play "Array" & "Hot" Buttons
- Multiple Playlist Creation & Editing
- Data Compression Options

Operates on Any Common PC/AT 486 System

- Choose Your Own Hardware Source & Options
- Network Multiple Workstations with LAN

ENCO Systems, Inc.

1866 Craighsire Drive • St. Louis, Missouri 63146-4006 USA
Telephone: 800-ENCO-SYS (USA) • 314-453-0060 • Fax: 314-453-0061

Booth #653 NAB New Orleans • Booth #133 SBE San Jose

*Includes S/W and D.S.P. PC adapter

CALL OR FAX FOR SPECS and TURNKEY OPTIONS

Station Stories

Continued from page 20



Cliff Gardner, with up-link showing compact size dish requirements

a very cooperative effort going and any one of the three can help you with tailoring a system to meet your specific needs.

During my visit, I could feel the excitement as the concept continues developing. The first affiliate station not owned by the parent company is due to go on line in January. A dedicated channel for feeding the local information will be in operation by the time this article goes to press. And, negotiations are in progress with several stations in Colorado and California to become affiliates or network O & O's.

A lot has been said and written about Rocky Mountain Radio as the development process has been going on. However, having visited Avon and seen the operation, (or more importantly, *heard* the operation), I think that it is safe to paraphrase Colonel Pickering and say, "By George, I think they've got it!"

**Remember — fill out the
Radio Reply Card for
a chance to win:
A New VCR**

Get Ready For The 1993

Radio Guide

More of What You Want ...
More of What You Need ...
And All Technology!

Tired Of Replacing Expensive Headphones?

Designed to provide vivid sound reproduction when used with today's digital sources, these stereophones feature high-performance 40 mm drivers. The maximized power handling capability ensures full, accurate reproduction of the wide dynamic range found in digital program material.

The soft leatherette earpads and adjustable headband provide for hours of comfortable listening while the closed-back design of the earpieces allows for privacy and prevents unwanted outside sounds from interfering with your listening enjoyment. The 3.0 m (9.8 ft.) cable is terminated in a 3.5 mm mini plug, ideal for portable systems, and a 1/4" plug adapter is included for home use.



Only \$29⁹⁵

Designed to provide vivid sound reproduction when used with today's digital sources, these stereophones feature high-performance 40 mm drivers. The maximized power handling capability ensures full, accurate reproduction of the wide dynamic range found in digital program material.

The soft leatherette earpads and adjustable headband provide for hours of comfortable listening while the open-back design of the earpieces allows extended, accurate low-frequency response. The 3.5 m (11.5 ft.) cable is terminated in a 3.5 mm mini plug, ideal for portable systems, and a 1/4" plug adapter is included for home use.



Only \$24⁹⁵



**AUDIO
BROADCAST
GROUP**

2342 S Division Avenue
Grand Rapids, Michigan 49507

1-800-999-9281

200 Fareway Drive - Suite 2
Smithfield, North Carolina 27577

1-800-369-7623

Contract Engineer

The Business of Radio Contracting

The Second Effort

By Mike Patton

We've talked in this column before, about what I feel is important to check when I go to a seldom-visited radio station; that is, "engineering triage," the life-and-death problems a station is likely to have and how to stop the worst "bleeding." But what about the station that you see regularly?

At stations that choose to spend enough money on engineering to allow you to make a second effort, you need to be on the ball to stand out from the next contract engineer. In this month's column we will look at making that second effort.

You can and should always give your clients an extra effort, but you have to keep your priorities straight. It doesn't make sense to worry about how clean the top of the transmitter is when the transmitter itself is a

smoking ruin. But you might be surprised at how some simple things can make your job easier and make your client's station work and look better. Here are some examples:

Manuals:

Make a list of all the equipment the station owns. Don't forget items like remote broadcast and sports equipment, plus the equipment at the transmitter site. Note the serial numbers and give a copy of this list to the G.M. as an equipment inventory, while keeping a copy in the engineering files.

Check your list off against the manuals at the station. Order any manuals that are missing, or make a copy of one from another station (I'm not actually advocating that

you violate the copyright laws, you understand). Many times equipment comes in pairs or sets (STLs, phono preamps, audio processing, etc.), including a manual for each unit. You can take the extra copy to another site or station where it is needed (with the owner's permission, of course). Make sure that the manuals are really at the site where they are needed, e.g., the exciter's book does you absolutely no good at the studio.

Equipment like remote controls and STLs that have a studio end and a transmitter end often come with only one manual that covers both units. Theoretically this equipment should come with two books, but over the years one is likely to have been misplaced or lost. To be useful, you must have a copy of this book at each site. (I think that you can safely copy for your own use a book that you already own without running afoul of the copyright laws.) If you work at it, you can even locate manuals for consumer gear the station might own, like cassette machines and CD players. A side benefit of making sure that you have all the books is that they end up in one place and in some semblance of order.

Fuses:

While you're going through the manuals, make a list of all the fuses that should be in all the equipment. Add up the totals, but keep a list of which equipment takes which fuses. Go and get the right fuses (at least a box of five for each value needed). Then, go around the station and check the equipment for proper fuse types. I have been amazed at how many times I have found a 20 Amp "No-Blo" in place of a 1/2 Amp fuse. You may find a piece of equipment that has been working but blows the correct value fuse because of a hidden problem. Presto! You have found a problem before it was a problem, hopefully a very impressive feat.

Unless you've laid the proper ground work with management, you may catch hell for "breaking" the equipment. So don't pick a bad time to play musical fuses (e.g., don't "fix" the RPU transmitter the

(continued on page 23)



24" X 18" white background with black lettering and yellow triangle

Warning Signs

Available in metal or "peel & stick" vinyl:

Radiation sign (metal).....	\$25
Radiation sign (vinyl).....	14
High voltage (metal).....	20
High voltage (vinyl).....	10

9" X 12.5" white background with red letters

DANGER HIGH VOLTAGE RADIO EQUIPMENT

¡Disponible también en Español!



Microphone Flags

\$100 for initial FOUR,
Call for detailed pricing!

Crouse-Kimzey

COMPANY

(800) 433-2105 Main office
(800) 955-6800 Annapolis office

Contract Engineer

Continued from page 23

Friday before the state football championship game). As with manuals, make sure that the right fuses are at the right site.

Parts:

Take a day and dig up all the spare parts scattered around the station and gather them in one place. Go to Wal-Mart and buy a cabinet of drawers or other organizational device and put your parts in order (as opposed to on order). Get what spare parts are needed.

Many manufacturers have recommended spare parts kits for their equipment. If you know from experience that a particular part is prone to fail, stock several. If you're not familiar with a piece of equipment, talk to an engineer who is, or ask for opinions at the next local SBE meeting, or talk to a field service person at the factory (if they are willing to admit that their equipment fails).

Make sure that there is a good stock of common parts like light bulbs, pinch rollers, capacitors, and air filters. Be sure that alcohol and q-tips are on hand in each studio. As with any engineering expense, before you spend any money (particularly your own), make sure that management knows, approves, and has agreed with you on how you will be reimbursed.

Transmitter Site Supplies:

The three topics discussed above obviously apply also to transmitter sites. There are some special considerations for these sites, which are usually remote and not visited very often — and not very hospitable, either. A list of things I have found indispensable at transmitters includes: toilet paper, paper towels, rags, solvents and hand cleaner; spare overhead light bulbs, flash-light (and spare batteries); wasp spray, first aid/snakebite kit; emergency hand tools and test gear (an old Simpson 260, maybe); a garbage can and extra bags, shelves for the parts and supplies, chairs (at least

2), and a workbench/table (even a card table beats troubleshooting something sitting on the floor); station license and posting statement copies, pen and paper, a blackboard for making notes, phone books for the city of license, the community where the transmitter is located, where the studios are located (if they are different), and the nearest big city. Also include a phone number list which should have key station employees' home, car and pager numbers, studio hot line numbers, your (the contract engineer) numbers and those of your employees (in case a station employee has you walk him through some simple repair to save you a trip), parts house numbers, police and fire department numbers, and the nearest pizza delivery service (very important). I am always adding to this list, so I'm sure that it is still very incomplete.

Next month we will examine the care and feeding of that most unusual species, the general manager.

OPTIMIZE — don't compromise:

If you demand optimum performance from your tape recording equipment . . .

JRF maintains a complete lab facility insuring precision relapping and optical alignment of all magnetic recording heads and assemblies. Worn unserviceable heads can be restored to original performance specifications.

24-hour and special weekend service available.

- Broadcasting
- Mastering
- Recording Studios
- Tape Duplicating

New and reconditioned replacement heads from mono to 24-track . . . Many in stock.

For repair or replacement, we're at your service!



249 Kennedy Road
P.O. Box 121
Greendell, NJ 07839

Tel.: (201) 579-5773
Fax: (201) 579-6021



MICRO SOUND Digital Audio Workstations

Delivering Your Expectations

You expect the ultimate quality, precise editing and faster production that digital audio promises... Meet MicroSound.

Now produce any audio project with true sonic transparency and noiseless performance in a fraction of the time! Make undetectable edits instantly, no matter how long your files; or undo-redo them any time, since your masters are untouched. Sync audio cues instantly to sample-precision, moving thousands unbounded on unique Floating-Tracks™. Disk-Layering™ allows up to 38 cues at any location, to be mixed and output to stereo or 4-tracks!

Assembled/tested AT-486 Workstations start under \$7,800; or add to your 386/486 computer for under \$3,700.

Contact MTU today for your free 24 page brochure to find out how fast MicroSound can meet your expectations.

Quality digital audio since 1977



(919) 870-0344

Fax: (919) 870-7163



Micro Technology Unlimited

156 Wind Chime Court
Raleigh, NC, USA 27615

Equipment Guide



Call: (507) 280-4045
From Your Fax-Phone

Radio's Most Effective Classified Ad Listings

Classified Ads: On-Line — On Your Fax

Here's How to Get the Latest Equipment Listings:

1. Call the Equipment Guide at (507) 280-4045, from your Fax Phone.
2. Follow the operator's voice instructions, and you will be asked to press one or more of the following buttons on the phone:

- #1 — Used Equipment for Sale
- #2 — Equipment Wanted
- #3 — Employment Classifieds



3. Remember, just follow the voice instructions, and you'll get a complete fax printout of all the information you want — right on your fax machine.

Send Your Equipment Listing to Us — We'll Place it on the Equipment-Guide

1. Copy this ad form.
2. Use one form for each category.
3. Fill it out & fax or mail it to us at:

Equipment Guide

Box 7001, Rochester, MN 55903
Fax # (507) 280-9143

Name: _____ Station: _____

Address: _____

City: _____ State: _____ Zip: _____

Phone: _____ Fax: _____

Ad Copy Below: (Use a New Form for Each Category)

Equipment Categories:

For Sale Wanted

- AM Transmitters
- Antennas, Towers, Coax
- Automation Equipment
- Computer Equipment
- Consoles and Mixers
- Exciters: AM, FM, SCA & Stereo
- FM Transmitters
- Misc. Audio & Telephone Equipment
- Misc. Equipment & Parts
- Misc. RF Equipment
- Processing & Equalization
- Satellite Equipment
- Schematics, Tech-manuals & Books
- Speakers, Headphones & PA Equip.
- Source Equip: TTs, CDs, Mikes
- STL, RPU, TSL & Remote Control
- Tape Equip: Reel, Cart, DAT, Cassette
- Test, Monitor & EBS Equipment
- Tubes, Sockets & Misc. Parts
- TV & Video

STUDIO TRANSMITTER LINKS

Who builds the best?
Who warranties the best?

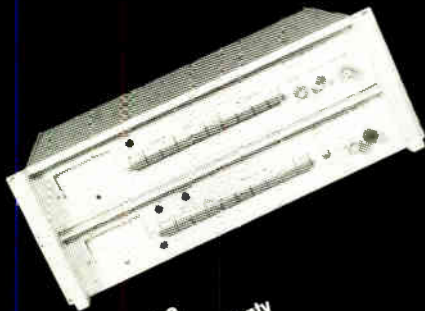

\$5,995.00
Five (5) year warranty

REMOTE CONTROL SYSTEMS

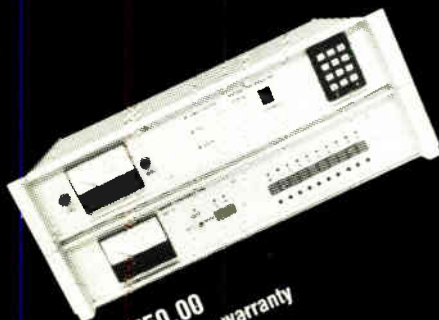

\$2,750.00
Five (5) Year warranty
Analog or Digital

21 YEARS OF
PERFORMANCE DURABILITY

Call or write today
for more information

MICRO CONTROLS

P.O. Box 728
Burleson, Texas 76028
(817) 295-0965

Studio Site

Continued from page 17

high efficiency. If you choose to have fluorescent lights in your studios, have the ballasts for the lights located outside the studio itself. Ballasts hum, especially as they get older, and this can be a real annoyance to your people and your listeners. Another popular item is dimmers on incandescent lights. If you use dimmers, be sure to get the "zero-crossing" type which greatly reduce the electrical noise generated by the dimmer. I have seen complete control rooms rendered useless by one improper dimmer at the other end of the building.

While on the subject of power, be sure to put all of your technical equipment on the same phase of the AC power. If possible, have a special transformer installed that steps down to a true single phase. If this is not available, make sure the phases are balanced to prevent line-induced problems. Also, take whatever precautions are necessary to insure that your power is clean. Dirty power can create noise and operating problems with some equipment and may even shorten its life. ■

QEI QEI QEI QEI QEI

W H Y Q E I ?

Free.



Our FREE spares kits include every solid state component of the transmitter, exciter and remote control.

Call us toll free at 800-334-9154 for all the facts on QEI "New Reliables" FM transmitters from 1kw to 30 kw.

QEI CORPORATION
ONE AIRPORT DRIVE • P.O. BOX D
WILLIAMSTOWN, N.J. 08094

TEL (609) 728-2020 • FAX (609) 629-1751

QUALITY • ENGINEERING • INNOVATION

Protect Your
Transmitter &
Antenna System
- with -
Coaxial Dynamics



WATTCHMAN MODEL 81070 adds protection to your transmitter and loss of air time. The WATTCHMAN installation consists of a 19" dual meter panel for monitoring both FWD and RFL power, a dual socket line section (7/8", 1 5/8", 3 1/8", 4 1/16", and 6 1/8") and two elements.

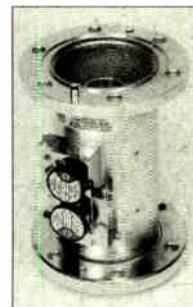

The reflected meter incorporates a front panel adjustable set point which controls the trip point on the meter alarm. Abnormal load conditions

quickly cause transmitter shut-down within less than 15 milliseconds (including control relay). An audible single tone alarm will indicate system / transmitter malfunction. Relay contacts are provided for remote alarm and reset switching.

Contact Us Regarding The Entire Family Of Wattchman Transmitter Protection Systems



Coaxial Dynamics
15210 Industrial Parkway
Cleveland, OH 44135 USA
Phone: 216-267-2233
FAX: 216-267-3142

Service and Dependability . . .
A Part of Every Product

Advertiser Listing — Year-End 1992

Advertiser	Page#	Advertiser	Page#
Altronic Research	4	Freeland Products	18
ATI	10	Harris Allied	13
Audio Broadcast Group	21	Henry Engineering	12
Axcess	8	JRF Magnetics	23
California Digital	5	M-Street	26
Coaxial Dynamics	25	Marathon Products	14
Commercial Radio	11	Michael Patton	14
Communication Data	8	Micro Controls	25
Computer Concepts	28	Micro Technology	23
Continental	9	Professional Audio	26
Cortana	16	QEI	25
Crouse Kimzey	22	QEI	26
Econco	6	SCMS	11
ECS International	7	T-Tech	19
Enco Systems	20	Telos	15
ERI	16	Transcom	14
Fidelipac	2	Wheatstone	27
		Wireready	17

How to Submit Articles

Radio Guide welcomes your comments, letters, articles and Tech-Tips. We prefer electronic submissions:

1. **Modem:** Call 507-280-9668 and request an XMODEM transfer.
2. **Mail** a 3.5" or 5-1/4" double or high density floppy disk (Wordperfect 5.x or ASCII) to: Ray Topp, at **Radio Guide**, 511 18th St. SE, Rochester, MN 55904.

We also accept clean, typewritten or printed manuscripts mailed to the above address. Photos and clean, camera-ready art with articles and Tech-Tips appreciated.

Articles should be 750-1000 words in length and Tech-Tips should be 200-500 words. **Radio Guide** pays for all articles accepted for publication and Tech Tipsters will receive a **Radio Guide** pocket calculator.

PROFESSIONAL AUDIO SERVICES

.....
Acoustic design
.....

.....
Electronic systems design
.....

BROADCAST STUDIOS CONTROL ROOMS

.....
Project supervision
.....

.....
*Ask about our
"Share the Risk"
program*
.....

.....
Training
.....

.....
Maintenance
.....

.....
*Over 25 years hands-on
experience in the broadcast industry*
.....

(708) 482-4142

The New 1992-93 M Street Directory IS HERE!

- Over 25,000 updates
- Complete, accurate listings of all radio stations
- Unique dial card station listing for all markets
- Formats, addresses, ownership, groups, facilities, CP's

\$32.95 +\$3.00 shipping

Send check or money order to:

M Street Corporation

304 Park Ave. S, 7th Floor,
New York, NY 10010

American Express orders call (800) 248-4242

A Little Bit of MAGIC...



Revealed!

THE R-10 IS BASED ON A SIMPLE PREMISE: Low cost does not have to be synonymous with low quality (as is so often experienced). When you've got Audioarts' experience and expertise, value engineering becomes a task of carefully defining the features required and manufacturing in an efficient manner, utilizing the best of computer and machine technology.

THE RESULTS ARE SELF-EVIDENT: the R-10 is a fully modular console, with the componentry you'd expect to see in a much larger design. *No other console in its price range can even come close!*

The R-10 has gold audio switches, gold edgcard connectors, conductive plastic faders, conductive plastic monitor pots, fully burned-in socket-mounted ICs, industry standard machine control switches and, of course, documentation and instructions that make installation really simple.

With the R-10 you can take advantage of Audioarts' reputation and experience, and be assured that quality and performance will be yours.



AUDIOARTS ENGINEERING

6720 V.I.P. Parkway, Syracuse, NY. (tel 315-455-7740/fax 315-454-8104)

SEE SPOTS RUN.

On-screen traffic log display

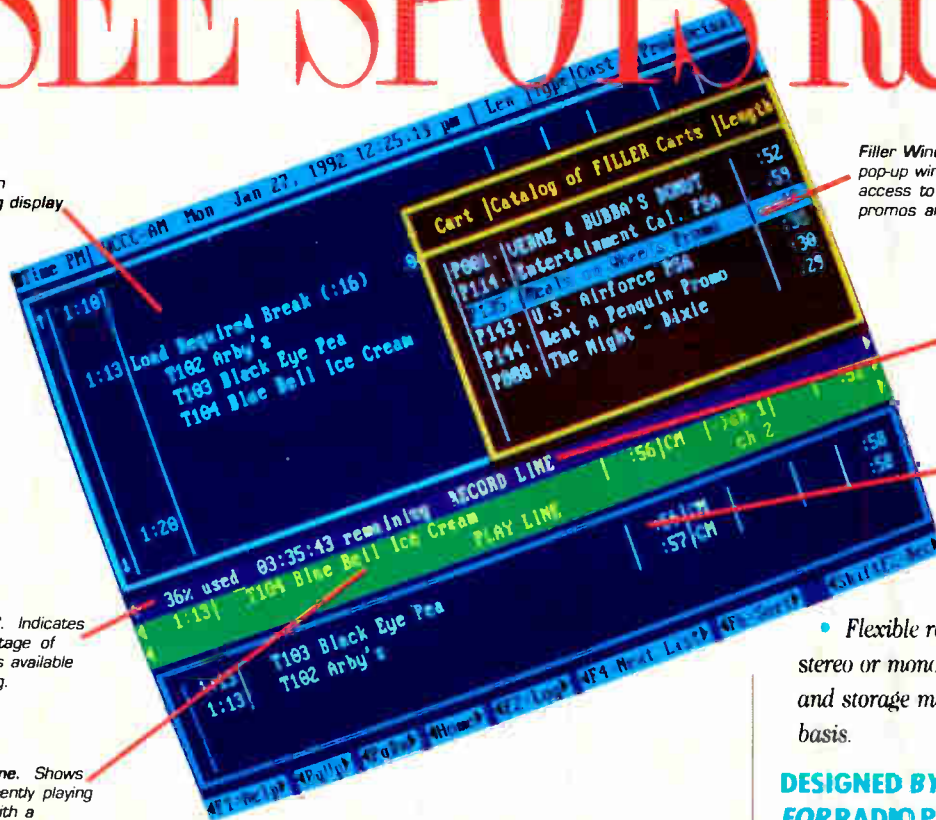

Filler Window. This special pop-up window gives you quick access to PSAs, jingles, promos and other fillers.

Record Line. Shows what DCS is currently recording.

Queue Window. Just click on a listing, to place recordings in the queue for playing.

"Gas Gauge". Indicates what percentage of the system is available for recording.

The Play Line. Shows what's currently playing on-the-air, with a count-down timer.

Replace the chaos of carts with the speed and precision of the Digital Commercial System (DCS) from Computer Concepts.

By combining a standard industrial-grade PC with an advanced stereo audio board, DCS lets you program a day, a weekend, even entire weeks!

AUTOMATE EVERYTHING, FROM PRODUCTION TO BILLING.

Production Studio. DCS simplifies board work and replaces the muddy sound of analog tape with crisp CD sound quality.

Control Room. No more manual logs! DCS handles all your paperwork automatically, posting a commercial's actual airtime next to that listing. And DCS interfaces with traffic!



ADVANCED FEATURES ENGINEERS DEMAND...

- **Digital Audio Editing.** The quickest and most flexible real-time editing function available makes editing news stories and commercial cuts simple.

- **Satellite /Live-Assist Operation.** Total support, including automatic back-fill of breaks.

- **Support of multi-cut "carts"**

- **Complete audit of all DCS activity -- airplay of audio, relays, etc.**

...PLUS FEATURES OTHERS DON'T OFFER!

- **Simultaneous Play/Record features.** Handle three stereo sources simultaneously -- overlap two spots for a tight segue, and record from another source at the same time.

- **High quality data reduction, without distortion**

- **No pre-allocation of disk space required.**

- **Flexible recording options -- choose stereo or mono, varying sample rates and storage methods on a cut-by-cut basis.**

DESIGNED BY RADIO PEOPLE FOR RADIO PEOPLE.

Computer Concepts is one company you can count on---we've provided automated business systems to the radio industry for over seventeen years. We know how radio stations work and how to make them work more efficiently. That's why the DCS interface is so easy to learn, so simple to use.

ASK ABOUT OUR AFFORDABLE ENTRY-LEVEL SYSTEM.

To find out more about our entry-level system, or to receive a free DCS demo disk, call or FAX us today. You'll soon see one thing very clearly. You just can't manage as well without us.

FREE UPDATED DEMO DISK!
(800) 255-6350, EXT. 25
OR FAX (913) 541-0169
(ATTN: MARKETING)

Computer Concepts CORPORATION

8375 MELROSE DR. LENEXA, KS 66214