

# Radio Guide

Radio's Technology Magazine

September 1990

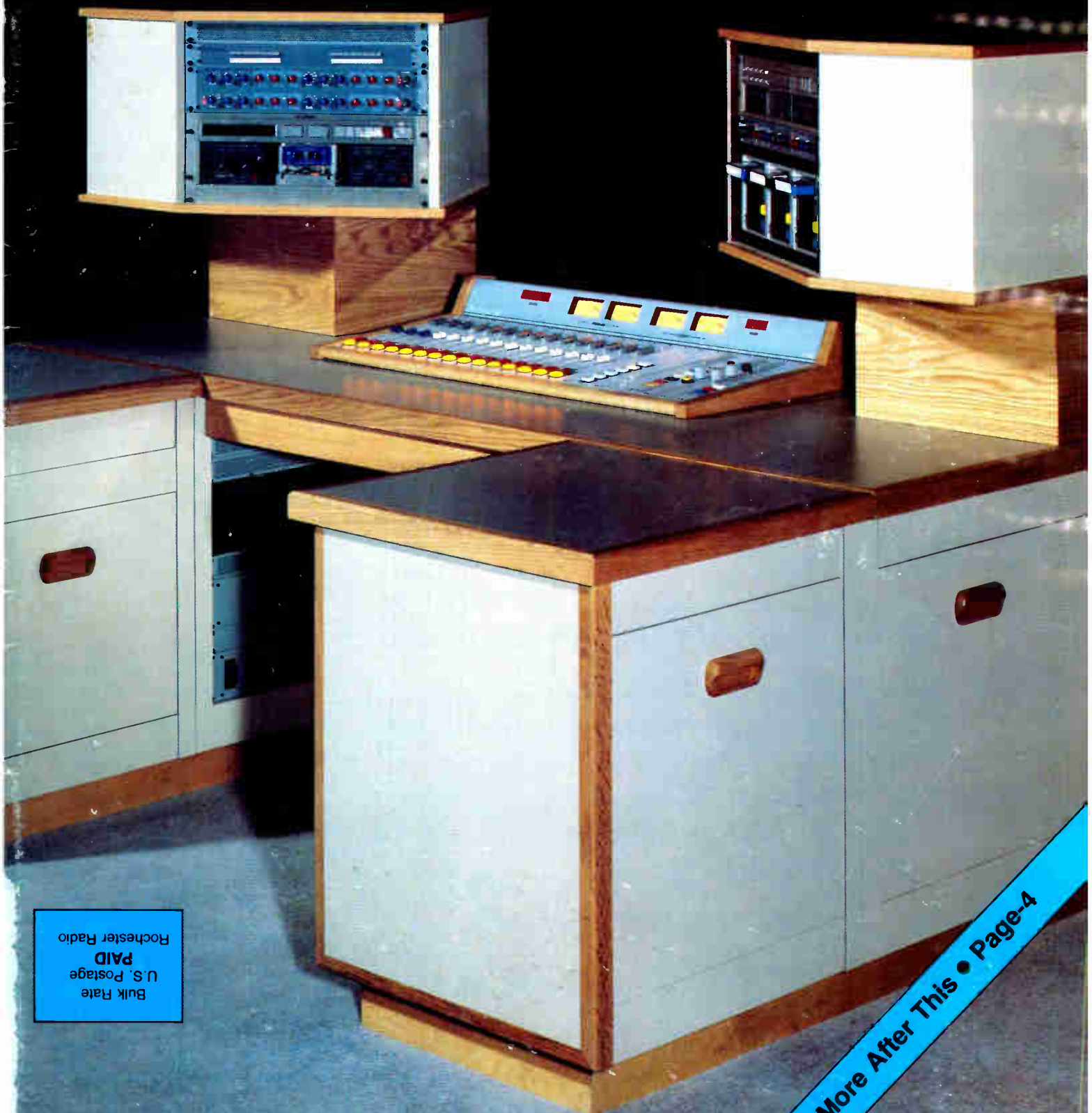

Bulk Rate  
U.S. Postage  
**PAID**  
Rochester Radio

More After This • Page-4

# "GORILLA WARFARE" ...

## ... BRING THEM OUT OF THE JUNGLE!



**The all NEW SERIES 6000 from THE EXPRESS GROUP is made to handle the "Monkey Business."**

- Non-splitting, Non-marring, high impact corner guards.
- Unique edging system at base of cabinets to prevent chipping.
- High impact, high grade, laminates
- Solid void-free birch plywood construction

**TAME YOUR SAVAGE BEAST with ... THE BEST OF THE BEST.**

*Call or write The Express Group today for our new free color brochure, that includes all 6 of our Fine Furniture lines.*



**The Express Group**

3518 3RD AVE., SAN DIEGO, CA 92103 • (619) 298-2834 • FAX (619) 298-4143

## Radio Guide

- Contents -

September - 1990  
Volume 3 Issue 9

- 4 More After This  
*Editorial Comments*
- 6 Radio Guide Forum  
*Letters From Readers*
- 8 Radio Engineer  
*The Heros Among Us*
- 9 Tips From The Field  
*Tech Tips From Readers*
- 10 SBE National News
- 13 Test & Measurement  
*Differential Temperature Test*
- 14 Station Automation  
*Automation Basics*
- 16 DA Systems  
*Proof Measurements Tally*
- 22 Transmitters  
*PA Cavities, Drive, Neutralization*
- 24 Soldering Tips  
*Build An AGC Amplifier*
- 30 NFR Up-Date  
*WQYK NFR Tests*
- 32 Looking Back  
*Past FCC Rules*
- 34 Contract Guide  
*Contract Engineers List*
- 35 Product Guide  
*MCI RF Switcher*
- 36 Equipment Guide  
*Classified Ads*
- 46 Business Guide  
*Industry Services & Products*
- 48 Broadcast BBS  
*Logging Onto A BBS*
- 50 Computer Connection  
*Schematic Drafting Program*

## Digital Quality Transmission

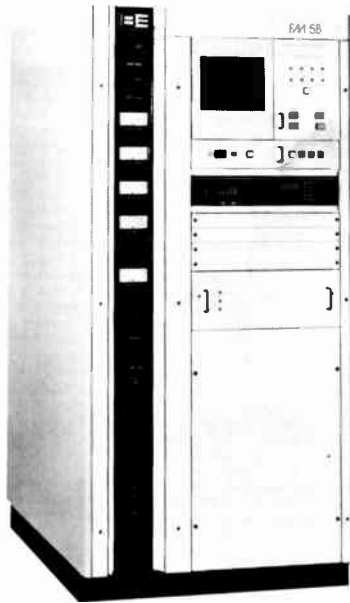

### The Model FM 5B 5500 Watt FM Transmitter

- New world standard FX 50 Exciter.
- **Guaranteed** 85 dB S/N.
- **Built-in** synchronous AM noise test facility.
- **Patented** folded half-wave coaxial cavity eliminates plate blocking capacitor and sliding contacts.
- **Self Contained** solid state broadband IPA in slide out drawer.
- **Emergency** 250 watt RF patching.
- **Automatic** power control with proportional VSWR foldback protection.
- **Single** or three phase version available.
- **Optional** microprocessor video display system (MVDS) with diagnostics.
- **Optional** PC Remote Control from MVDS.

With typical performance specifications of 0.02% IMD and 0.01% THD and guaranteed 85 dB FM S/N your listeners will hear the difference from a new FM 5B.

**BE**® **BROADCAST  
ELECTRONICS INC.**

4100 N. 24th ST. PO. BOX 3606. QUINCY, IL 62305. (217) 224-9600. TELEX 250142. FAX (217) 224-9607

# CCA



*"Simplicity is the highest form of science."  
-Albert Einstein*

### CCA Transmitters

P.O. Box 426  
Fairburn, GA 30213  
(404)964-3530 FAX (404)964-2222



# Puts your signal in it's place!

If you need a quality antenna, you need:  
**JAMPRO ANTENNAS, INC.**  
The really experienced one for over 30 years.

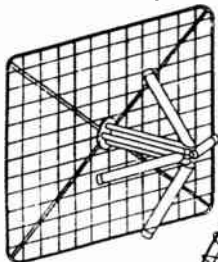

JAHD CP  
Arrowhead  
Screen Dipole

JSDP CP Spiral  
Broadband Antenna

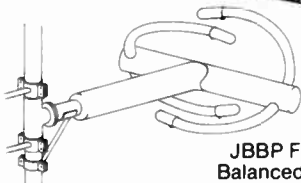
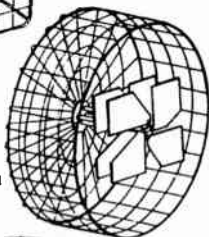

JBBP FM Antenna  
Balanced Excitation

**JAMPRO** is the world leader in custom-designed, directional, CP antennas.

- With over 1600 of our penetrators delivered, more stations have penetrated their market.
- Our custom-made directional antennas are operating world wide.
- Full-scale antenna measurements on **JAMPRO's** all-year, all-weather test range.
- We custom-make tower structures to duplicate your's, for optimum results.
- Ask about **JAMPRO's** low-power educational packages.

Give us your requirements and see how fast we produce.

## **JAMPRO Antennas, Inc.**

6939 Power Inn Road  
Sacramento, CA 95828  
(916) 383-1177 • Telex: 377321  
FAX (916) 383-1182

# More After This!

Editorial  
Comments

## Moving Right Along

### Radio Guide

You've said you like Radio Guide's new magazine format, but still want more technical editorial copy. Radio Guide is Radio's technology magazine, so we're going to add more technical columns to the pages of Radio Guide. The new format, that you've seen in the last two issues, will be continued. We've established about 20 categories/columns to cover all of Radio's technical topics.

Some of these columns will be authored by the same person each month, while others are being reserved for you. All you have to do is send in your technical articles, and you'll find yourself in print. If you have any questions about the style, content or format of your articles, please give me a call at (507) 280-9668. I'll be looking forward to hearing from you.

### Equipment Guide

Occasionally someone will call or write with a complaint. More often than not, it concerns the classified ad section -- Equipment Guide.

We've been painfully aware that the readers have found it rather difficult to find certain categories of used equipment. If you've been looking for a console, for example, you have had to spend too much time wading through the classified ads. "Categorize the ads," you've said. And so we will!

In fact, we're going a step further and removing them from the Radio Guide altogether. We will be printing a separate publication called -- Equipment Guide (of course). The Equipment Guide will be a convenient size, classified-only publication. It will be mailed out, along with Radio Guide, in your monthly information packet.

The Equipment Guide classified ads will be categorized by equipment function. Consoles listed under CONSOLES, and transmitters under TRANSMITTERS . . . ect. It will be easier to find the gear you need, and the Equipment Guide may be kept on

file as a handy resource guide for pricing your used equipment should you decide to sell it.

### Product Guide

In the past few issues of Radio Guide, you've seen the Product Guide pages. We've published manufacturer's new product releases to let you know what's new in the industry.

We're going to take this new product information and combine it with manufacturer's product information sheets, and place them all in a new publication called Product Guide. The Product Guide will be mailed along with the Radio Guide and Equipment Guide in your monthly packet of information.

The Product Guide will make it easier for you to keep yourself updated on product information. It will also provide product information in an easy to file reference format.

Look for next month's issue in a plastic bag -- your information packet!. You'll like what you see . . . editor

## Radio Guide

Volume 3 Issue 9 Sept. 1990  
Publisher: Ray Topp

### Sales Offices

Dale Tucker - sales manager  
865 Hawthorne Dr.  
Walnut Creek, CA 94596  
(415) 935-1470

### Editorial/Publishing Offices

Ray Topp - publisher  
511 18th St. SE  
Rochester, MN 55904  
(507) 280-9668  
Fax (507) 280-9143

Radio Guide is published monthly by Rochester Radio Publishing. Copyright 1990, all rights reserved.

Free subscriptions are available to all people involved in radio broadcasting and allied fields. Send name and address or any changes to Radio Guide at the above address.

All letters and copy submitted to Radio Guide are assumed to be for publication, unless notified otherwise.

# RADIOMIXER.<sup>®</sup> For everyone who thought a PR&E console was out of reach.

**Y**ou've tried, but your console budget just can't accommodate a Pacific Recorders BMX— not this time. So you're probably thinking about settling for a copy, even though it won't have the standard-setting features, performance and long-term reliability that have made our BMX consoles so successful.

Fortunately, you don't have to settle. Radiomixer is genuine PR&E. All the way from its high quality components to its efficient BMX-style layout, comprehensive telephone mix system and unique Off Line Mix Matrix. Yet its manufacturer-direct price is no higher than the "clones."

How did the PR&E engineering team build a less expensive console without lowering our standards? Let's start with what we didn't do:

We didn't compromise on quality. Radiomixer uses the highest caliber components throughout, including our standard professional-spec meters, faders, and switches. Plus the best-sounding VCA technology in the industry. To keep Radiomixer's cost down, we've limited the number of different module types and mainframe sizes, and simplified the construction of the card frame, mainframe and modules.

The final result? In less than a year, Radiomixer has quietly become one of our most popular consoles. In fact, it's now one of the best-selling boards in broadcasting. Our color brochure will tell you more of the reasons why, and help you configure a Radiomixer for your particular application. To get your copy, call PR&E direct at 619-438-3911.



**PACIFIC RECORDERS & ENGINEERING CORPORATION**  
2070 Las Palmas Drive • Carlsbad, CA 92009 • Tel 619-438-3911 • Fax 619-438-9277



## Letters to the Editor

### Controlling The Spigot

Editor:

In response to your editorial comments in the August 1990 Radio guide, let me offer this word of advice. When creating your own "spigot," be sure you operate the control valves and not the GM to whom you sold the idea. Company-run contract engineering firms are fine if you and the GM both agree on the pros and cons of its operation.

Let me relate the results of showing this new spigot idea to a bottom-line GM. After selling him on the idea and developing a 30K per year income to the station, the GM arbitrarily raised the contract rates by 50% across the board. "This will get rid of the slow payers and make your job a lot easier," he said. "The station will get the same income out the of consulting business and you and your assistant will have more time to spend around here."

"By the way," he asked. "After the thunderstorm in East Texas, why weren't you and your assistant in the shop?"

After explaining that the thunderstorm knocked two of the contract stations off the air, and that those stations certainly expected (after a 50% increase in rates) a timely appearance by their contract engineers, it was time to sit down with the GM and discuss the contract business again.

"The idea is great," he states, "but how do I get the same level of income and at least 40 hours of work a week from you and your assistant?" "I do still pay you for that, and this is what I expect."

Two months later, after a concentrated effort to be more available around the radio station, the GM calls you into his office. "I don't think things are working well," he goes on, "none of the contract stations have paid their bills since we raised the rates and I'm not happy with the time I'm getting from you and your assistant. Your replacement is on his way to town, I expect you to tell your assistant he is no longer needed, and you need to stay on long enough to train the new guy. Buy the way, the last time I talked to the GM's at the other stations, they had all found contract engineers for the original rates we had charged them."

This is not a far fetched story. It did occur here in NW Louisiana. The great income producing spigot put two good engineers out of work.

John F. Rutten

KWKH - Shreveport, Louisiana

John:

*You're right. The engineer should have control of the "spigot" -- sometimes not an easy task ... editor*

### Audio Alarm Correction

Editor:

In the June issue of Radio Guide, there is a correction that needs to be made. On page-19, on the drawing of the Loss of Audio Alarm schematic I submitted, the polarity on pins 2 and 3 of U1 was reversed. Pin-2 should be negative or low (-) and pin-3 should be positive of high (+).

Several people called me and said that they couldn't get the alarm to work properly. This correction should solve the problem.

David. P. Woodcock  
WNWC - Madison, Wisconsin

David:

*Sorry, our mistake ... editor*

**Get it off your chest.  
Get it in the  
Radio Guide Forum!**

### Editor's Notes:

#### **October Information Packet**

The October issue of Radio Guide will be a milestone. Thanks to all who have made this possible. Our goal is to provide the Radio engineering community with a complete package of technical information each month.

Thanks for your response to Radio Guide as well as to our supporting advertisers. We won't stop here. With your help, we will continue to supply you with the nuts-and-bolts, no-nonsense publications you deserve.

Look over the October technical information packet. Give us your comments and suggestions.

#### **Timely Classifieds**

We are developing the Equipment Guide (see page-4) into a separate publication. Fax your ads to us right away to insure that they will appear in the October issue of Equipment Guide.

#### **Short Tech Tips**

We need short (500 words or less) tech tips. These will be placed in the new Equipment Guide classified ads. \$15 bucks apiece, if we use them (and we always will). Those of you who have already sent in tech tips -- we're getting to them. It's first come, first served; so you should see yours in a month or two.

Ray Topp  
editor/publisher

### **Are You a Writer?**

**Radio Guide  
is looking for  
monthly columnists  
in these areas.**

**FM Antennas  
AM Antennas  
AM Transmitters  
FM Transmitters**

**Do You Know Someone  
Who Can Use  
Radio Guide?**

**Send Us Their Name  
We'll Get Them on The List**

## Jobs Available

### Technical Dir. - Buffalo

Metroplex Robinson Communications Inc. is seeking a qualified technical director for WUFX/WXBX, Buffalo. Strong studio construction and transmitter maintenance skills a must. Minimum 5 years broadcast technical experience and SBE Certification

Contact: Dennis Sloatman at (407) 298-5510, or send resume to: Metroplex Communications Inc., 2001-N Mercy Drive, Orlando, Florida 32808. EOE

### Assistant Chief - Pittsburgh

WPTT-TV, Pittsburgh's 22, has an immediate opening for an assistant chief engineer. Applicants must have FCC general or SBE Certification, 2 plus years in television broadcasting, strong knowledge of high-power UHF-TV transmitters and baseband video. This is a 24-hour on-call position with a major market station. Those qualified may send their resumes to: Neal Ardman, Chief Engineer, WPTT-TV, P.O. Box 2809, Pittsburgh, PA 15230. WPTT-TV is an equal opportunity employer and a non-smoking facility.

### Radio Chief - Baltimore

B-104 is looking for a qualified engineering professional to assume responsibilities for the technical performance of our station. Interested applicants should contact: James Fox, General Manager, WBSB (B-104), 3701 Malden Ave., Baltimore, MD 21211. Call (301) 466-9272.

### Field Service Engineer Napa, California

Creative and challenging work available for those rare individuals who possess the skills and talents necessary to become part of a great team. Must have experience in AM, FM, microwave and TV. We will train the right individual. Salary depends on experience. Send resume and salary history to: Tom Oja, ACM Communications, P.O. Box 6926, Napa, CA 94581.

### Chief Engineer Quincy, California

Chief Engineer for class-C FM and directional AM in Northern California's Sierra Nevada. FCC/SBE Certification preferred. Must be eager to be team player. Good equipment support. Low cost of living in beautiful community. Send resume to: Ralph Wittick, KPCO, P.O. 11370, Quincy, CA 95971. (916) 283-1370.

### Chief Engineer Lewisburg, Pennsylvania

Chief maintenance technician. Rebuilt AM. New FM. Latest studio equipment and automation. Satellite, RPU's, two-way's. University town, prosperous area. Call: Lou Maierhofer, WTGC/WUNS-FM, 101 Armory Blvd., P.O. Box 592, Lewisburg, PA 17837. (717) 523-3271.

## Equipment Wanted

### Wanted: Digital Receiver

Fairchild Dart 384 digital satellite receiver in good condition. 15kHz card preferred, possibly 7.5mHz and cue card as well. Call: Scott Crater, GM, WPRB, Pimpton, NJ (609) 258-3655. Leave Message.

### Wanted: AM transmitter

Gates BC-250GY 250 watt AM transmitter. Also need two 1kW AM transmitters (1970's vintage) in good condition. Call: Don Moore, KOKB, 608 W. Ferguson, Blackwell, OK 74631. (405) 363-4469.

### Wanted: Tall tower

800-1000 foot tower standing or on the ground. Also need 400 feet of 3-1/8" Helix. Call: Ken Austin, KFXI, P.O. Box 433, Lawton, OK 73055. (405) 658-9292.

### Wanted: Harris System 90 Brain

Harris System 90 "brain." It doesn't need to work -- we just need the parts! If I'm not in, leave your name and number and I'll call you back. Call: Don Dixon, KPCH-FM, P.O. Box 977, Ruston, LA 71270. (318) 251-3697.

### Wanted: Remote Control

Rust "series F" remote control system. Model RI-108. Call: John H. Goeman, KJAM AM/FM, 101 S. Egan, Madison, SD 57042. (605) 256-4514.

### Wanted: Rewind Units - etc.

Need six BE-AR-1 auto rewind units. 120-150 feet HJ-50A, 1-5/8" air Helix. 1-5/8" 90-degree elbow. 100 or 250 watt UHF-TV transmitter. Also need Centrimax 208-230 volt Rotron blower model #CXH29A52B as used in Harris 2.5K transmitter. Call: Joseph Bahr, WVIS-FM, 154 Guajataca St., Crown Hills, Rio Piedras, Puerto Rico 00926. (809) 751-8947, Fax (809) 756-5941.

### Wanted: Hallicrafters Rx

Want a small Hallicrafters or Heathkit receiver. Must be in working condition at a reasonable price. Call: Herb Gardner, WHHV/Magnum Communications, P.O. Box 648, 343 Virginia St., Hillsville, VA 24343. (703) 728-9114.

### Wanted: BE Processor Tech Manual

Need a technical manual for a BE "Spotmaster" CLE/FM Stereo Sound Brightener. Will pay any copy charges. Call: Paul Mueller, 522 E. Curlew Place, Tarpon Springs, FL 34689. Call collect (813) 934-3466.

### Wanted: Disc Gear

Need blank recording discs, disc cutting gear, accessories, books, etc. Any sizes or manufacturers. Especially Wilcox-Gay recording gear. I also collect recorded acetate discs from the 40's and 50's. Please call or drop me a line if you have any disc gear along these lines. Call: Tim Edwards KOZY/KMFY, P.O. Box 597, 507 11th St. SE, Grand Rapids, MN 55744. (218) 326-3446.

### Wanted: Cart Deck

Need a Pacific Recorders Micromax stereo cart recorder. Call: Hank Landsberg, Henry Engineering, 503 Key Vista Drive, Sierra Madre, CA 91024. (818) 355-3656 or Fax (818) 355-0077.

### Wanted: Monitor - etc.

Need a stereo monitor, a UREI stereo limiter, and a UREI mono limiter. Call: H. Haley, KETX, P.O. Box 1236, Livingston, TX 77351. (409) 327-8916.

### Wanted: AM transmitter

Late model 1kW AM transmitter needed - no junk. Also need one, single bay CP FM antenna on 93.3 mHz and one 6-bay on 100.3 mHz. Looking for CP's, turnarounds and dark stations as well. Call: Larry Fuss, KOOZ, P.O. Box 159, Fayetteville, GA. (404) 460-6159, Fax (404) 460-6129.

### Wanted: 10kW FM transmitter

Need a 10kW FM transmitter. Harris or Collins preferred. Also need Moseley STL equipment, Orgban 8100 Optimod. Call: Dennis Orcutt, KZBS-FM, 3545 NW 58th, Suite 800, Oklahoma City, OK 73112. (405) 942-3399.

Radio Guide September -1990 Page-7

## Radio Engineers: The Heroes Among Us

For the most part, society looks to the wrong people for its heroes and heroines. Politicians and professional athletes fail too frequently to achieve the high ethical standards expected of them. Meanwhile, the baby boom generation and others turn to musicians and artists for their pedestal assignments. As radio engineers, it is appropriate that we look more within our own ranks for heroes. Fortunately, the choices are plentiful.

### "Hero" Inspiration

Recently, three hero-related themes have led me to think about this topic. Earlier in the year I attended a retirement celebration for a former supervisor of mine -- an Indian school superintendent of some 20 years on the Turtle Mtn. Chippewa Indian Reservation in Belcourt, North Dakota. Since I have long viewed as an inspiration his ability to successfully motivate people, I was so pleased to hear a speech sufficiently eloquent to the occasion.

A local Indian woman wanted him to be considered an Indian hero now. And, she argued that the other Indian leaders be likewise identified -- educators with doctorates, business people, administrators, teachers, and civic leaders. This truly indigenous suggestion is to reverse living heroes now.

Another source of hero inspiration is a Mary Chapin Carpenter folk song. When noting a scarcity of "Heroes and Heroines," she brings together images of pioneers worthy of eulogy. "Heaven bless the ones who keep their bearings strong and certain. And lord help the fool who said you'd better quit while you're ahead. A dreamer born is a hero bred."

And for inspiration from the lighter side comes a 1988 public TV documentary about comedian W.C. Fields. Apparently "Bill" decided early in life that he would not walk any fences -- he

would become a certain person and be that person. For him, this decision meant performing comedy precisely in his own style, not according to the rules handed down by movie company executives. On just enough occasions W.C. won these battles. Had he decided to cave in to Hollywood's finicky ways, we probably would not even know his name today. The W.C. Fields we remember was his own creation. So, since most of us aren't Indian leaders, songwriters, or comedians, what about engineers?

### Radio Engineer Heroes

It is difficult to clearly define heroes, particularly when they are our own colleagues. A rough parallel is the way some jazz enthusiasts are unable to define what jazz is; rather, the best they can offer is a description of what jazz is not! For example, heroes are probably not those who make careers out of trivializing the legitimate efforts of colleagues.

A positive identification of the heroes among us requires that we take note of the people who make a difference in our profession. Many radio engineers have had significant impact: designers, managers, manufacturers, consultants, journalists, announcers, producers, publishers, workshop organizers and speakers, the leaders of our organizations, contract engineers, and even chief engineers!

Another way to identify heroes is to recall our proteges: the ones who saw something inside us and persevered until we "blossomed." It is entirely realistic that our personal heroes are recognized by nobody else. When thinking about their levels of achievement, it is easy to feel as if any attempts at following in their footsteps have generally failed. But, let's hope this is not always the case.

### Hero Recognition

It is correct to recognize today's leaders in radio engineering as heroes and heroines. We can talk up their accomplishments and offer our encouragement. We can persuade conference organizers and trade publishers to seek their comments and insights. The next time you read an NAB or SBE conference paper, consider how much of the author's life went into the document. If you believe the contribution to be significant, let the author know. Which engineers have faced imminent risk when forcing egotistical managers to hear the truth?

Emerging with your integrity intact is an heroic act, even if nobody else knows. Anything less and you would not be the calibre of person you are today. So, the heroes are among us. We know their names and their contributions. Hopefully, all of us will someday achieve such an honor in our own way. The human qualities inherent in heroes and heroines are critical to keeping broadcast engineers true professionals. Let's recognize our heroes now.

QEI QEI QEI QEI QEI

W H Y Q E I ?

Free.



Our FREE spare kits include every solid state component of the transmitter, exciter and remote control.

Call us toll free at 800-334-9154 for all

the facts on QEI "New Reliables" FM transmitters from 1kw to 30 kw.

QEI CORPORATION  
ONE AIRPORT DRIVE • P.O. BOX D  
WILLIAMSTOWN, N.J. 08094

TEL (609) 728-2020 • FAX (609) 629-1751

QUALITY • ENGINEERING • INNOVATION



## CD Player Cleaning Tips Revisited

By Ed Sackley - WRKR

Portage, Michigan - (616) 327-2000

The experiences recounted by T. Alan Dickerson in the October/November-90 issue of Radio Guide regarding Technics consumer CD players were very familiar. We, too, felt plagued by dependability problems relating to contamination of the optical mechanism. After several months of anxiety, frustration, anger and trial-and-error, we feel we've licked our problems completely. In the process, we haven't been forced to give up the economic and technical advantages we see in the Technics SL-P520 unit.

WRKR-FM 107.7 signed on-the-air October 13, 1988 with an "all CD" Classic Rock/AOR format. Our original turnkey air studio, superbly designed and installed by Audio Broadcast Group in nearby Grand Rapids, featured two Tascam CD-501 players. During our preparatory "dry run" with the airstaff, it was determined that the Tascam units were wholly unacceptable in a live AOR environment due to imprecise cueing and onboard logic that was very prone to lockup errors. We scrambled at the last minute and installed two Technics SL-P520 players within 90 minutes of initial sign-on.

Our production room already contained an SL-P520, which features manual flywheel cueing, full-feature digital time, indexing (not available in the original Denon 950) and a price tag of around \$350. Everything went flawlessly for a few weeks, but we began to experience a series of frustrating problems with the Technics units. One at a time, they would refuse to cue certain disks. We were usually able to rearrange play orders and use the other air studio machine or swap a player with the production room. This clearly wasn't a long-term solution.

Our initial approach to our problems was to remove the cover, dust and vacuum the insides and clean the optics lens gently with alcohol. That would usually take care of the problem, but only for a short period of time. Some units were getting cleaned every two or three days. There had to be a better way. At the suggestion of Steve, at Audio Broadcast Group, we began to be much more liberal with the alcohol and less gentle with the cotton swab. We immediately got better, longer-lasting results, but still had some problems. Then we happened across the secret ingredient -- grease!

As we cleaned our units from day one, we sometimes stripped the light grease on the rails, along which the optics traveled, when they looked contaminated and re-greased them with the excess left in nooks and crannies during the manufacturing process. Eventually, we ran out of leftover grease.

I checked with our local radio/TV audio repair shop and ordered a supply of Sony rail grease. This "lifetime" supply runs about \$35. The alcohol/grease combination did the trick! We'd been focusing on keeping the lens clean, but equally important is a clean, smooth track mechanism. The optics assembly no longer binds on the rails and the vigorous cleaning by cotton swab has not damaged the unit. Our Technics SL-P520s have been used 24 hours a day for nearly 18 months. We have not found it necessary to perform any alignment. All it takes is the right touch and a regular diet of grease and alcohol. It's a shame Technics no longer manufactures this player, which was the last to feature a "manual" cueing wheel. Later models, such as the SL-P555 and SL-P999, feature a 2-speed "search dial" that differs in operation from the original manual cueing wheel. Disc jockeys seem to prefer the manual system which "feels" more precise.

### Radio Engineering For The Non-Engineer

*If you are a manager with  
limited technical knowledge, you need  
**Radio Engineering For The Non-Engineer.***

Complete book and cassette home study course.

Send \$150 check to:  
**Metroplex Wireless**  
3505 Daniel Drive  
Arlington, TX 76014

## Water-Cooled Dummy Load Using No City Water Supply

By John Bredesen, PE - KLCC  
Eugene, Oregon (503) 726-2224

KLCC recently had the luxury of building a new transmitter site. New tower, new antenna, new transmission line, and a new building -- a new building with no water! I know your first thoughts are, "The poor guy will have to use a porta-potty or go into the woods." All of that's true. However, strange as it may seem, that's not the real problem.

We also have the luxury of a standby transmitter, a 4-port coax transfer switch, and a water cooled dummy load. At the old site, it was a matter of hooking up the hoses to the city water supply and turning on the spare transmitter. Obviously, that was impossible at the new location, as was replacement of the dummy with one of the neat packaged, self-contained units -- finances eliminated that.

We came up with a solution which, I'm sure, doesn't break any new ground, but rather is a common sense approach to the problem. We built a self-contained cooling system from scratch.

The system consists of four basic components:

1. The dummy load needs a flow of six gallons per minute at rated power (20 kW). We purchased a good quality used shallow well pump with a rating of 1/3 HP.

2. W.W. Grainger supplied an epoxy coated water storage tank of perhaps 40-50 gallon capacity, originally designed as a pressure storage vessel. Don't get one with the pressurized bladder; it isn't needed. Water in this system isn't stored under pressure.

3. Perhaps the most difficult component(s) to obtain will be the radiators or heat exchangers to dissi-

pate the generated heat. We located a pair of heaters that had been used in a warehouse, and which used hot water as a heat source -- perfect for our needs.

They are complete with fans to force air over the fins. The sizing is a bit more of a problem. We wrote to the manufacturer and obtained specifications for the units on hand, and calculated whether they would shed the generated heat with an acceptable water temperature rise during hot weather.

4. The final major component, of course, the dummy load itself. The rating will depend on your transmitter's output power.

The system was plumbed with 3/4" copper water pipe, but I would assume that CPVC plastic could be used satis-

factorily. The pump was installed with union joints to allow removal at a future time, if needed. A gate valve, before the first union, eliminated the need to drain the tank, if pump removal were to become necessary.

Water is drawn out of the bottom of the tank, through the pump, and to the dummy load. A pressure gauge was installed BEFORE the dummy and a flow switch (in the interlock circuit of the appropriate transmitter) AFTER the dummy, to keep tabs on on the operation.

Heated water from the dummy then passed to the heat exchanger(s) (plumbed in parallel rather than series) and was allowed to return to the tank through a 3" hole cut in the top. We control the fans with a thermostat to avoid the potential problem of freezing the water, if the pump should be left on when the outside temperature is below freezing and the transmitter is not on.

In most installations, the heat exchangers will be installed outdoors where freezing presumably will be a problem. One way around this is to use an appropriate mixture of water and ethylene glycol. Don't use automotive anti-freeze because I understand that some of the additives can attack the dummy load element. Also be aware that glycol will necessitate a slightly greater flow for the same cooling because of the change in the specific heat of the coolant mixture. I feel an even better way to handle the freezing problem is to slope the lines so that all water drains back into the storage tank when the pump isn't running.

Our system has been in use for several months, and it has worked well. The cost was reasonable, and it certainly solved the problem.

QEI QEI QEI QEI QEI

W H Y Q E I ?

### Power Up.



With our FMQ  
3.5/5/10 kW or 20/30 kW  
FM transmitters, you  
can upgrade power in  
the field.

Call us toll free at  
800-334-9154 for all  
the facts on QEI "New Reliables"  
FM transmitters from 1kw to 30 kw.

QEI CORPORATION  
ONE AIRPORT DRIVE - P.O. BOX D  
WILLIAMSTOWN, N.J. 08094  
TEL (609) 728-2020 • FAX (609) 629-1751

QUALITY • ENGINEERING • INNOVATION

# WHY YOU SHOULD PAY MORE FOR LESS.

**New Name-  
Same Great Cart!**  
The ITC Cart II Cartridge, formerly ScotchCart® II

*Less phase jitter caused by poorly tracking tape, because the naturally lubricated concave guides gently position the tape and allow the cartridge machine to perform critical guidance.*

*Less tape noise and signal loss with our 100% laser-inspected, high output, low noise tape which delivers better frequency response and keeps signal-to-noise ratio high, harmonic distortion low.*

*Less wow and flutter or stop cue overshoot, because there's no rotating hub to wear out, warp or rattle.*

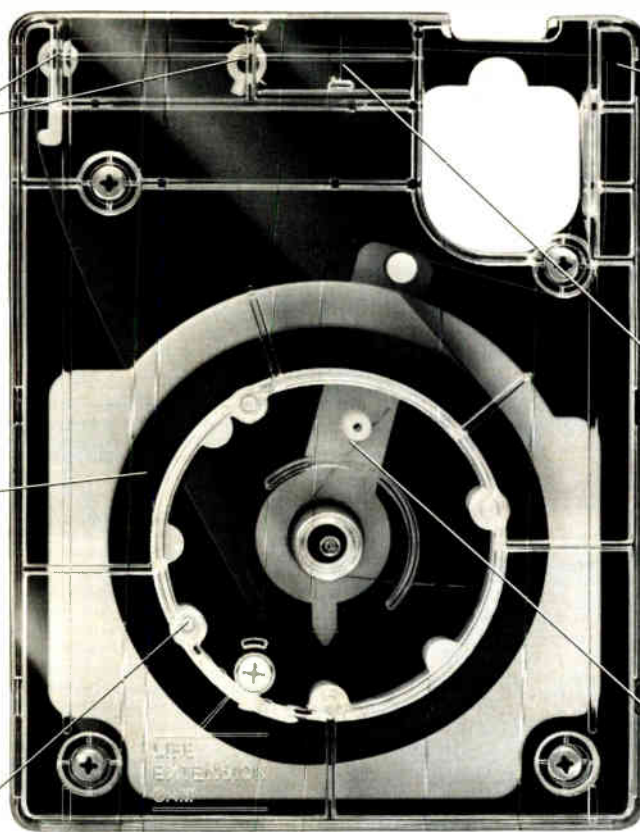

The ITC Cart II Cartridge, formerly ScotchCart® II

*Less chance of the cartridge cracking or breaking, because the tough polycarbonate cover withstands repeated use and abuse.*

*Less head wear, tape steering and modulation noise, because there aren't any pressure pads to add friction.*

*Less chance of tape destruction, because our patented dynamic tension control system ensures proper tape-to-head contact, and provides constant tension to control looping and prevent twisting.*

With broadcast cartridges, like everything else, you get what you pay for. With ITC Cart II cartridges, you get a revolutionary design that delivers trouble-free operation, superb sound quality and a life expectancy that's second to none.

We have renamed the cartridge due to trademark considerations, but only the name has changed, the cartridge and tape are the

same. New name, same great cartridge and performance.

For a complete listing of ITC Cart II dealers, call ITC toll-free at 800-447-0414 (in Illinois, call collect 309-828-1381.) Or write to ITC at P.O. Box 241, Bloomington, IL 61702-0241.

Because a cheaper cartridge may be more trouble than you can afford.

# CHAIRMEN of the BOARDS

*"It's amazing that you can offer a console of that quality for the low price tag that was on it."*

*"I would recommend the XL SERIES audio consoles to anyone with a small budget who is looking for 'big quality'."*

*"Congratulations! We believe you've built the most perfect audio console available to broadcast stations."*

*"We have found that noise and distortion are lower --much lower, in fact-- than audio consoles selling at three to four times the price of the RAMKO XL Series!"*

## JUST PART OF THE STORY:

- STEREO, SINGLE & DUAL CHANNEL
- HUGE, INDIVIDUAL, MULTI-COLOR "VU" METERS
- LONG LIFE SWITCHES. Silent, illuminated, 5 million operation input/output switches
- DISTORTIONLESS, SOLID STATE SWITCHING & VCA audio control.
- EASE OF INSTALLATION. 2 screw drivers & a wire stripper. All other functions switch & jumper programmable.
- TOTAL RF PROOFING. Of the hundreds installed absolutely no RF reported.
- FREE 2 WEEK TRIAL & 2 year parts & labor warranty.
- SUPER 20TH ANNIVERSARY BONUS! For a limited time, take 10% off all published prices.
- ROTARY & OPTIONAL NOISELESS, LONG LIFE LINEAR FADERS (exclusive, non-moving contact design!).
- EXTRAORDINARILY LOW PRICES. Check the competition!
- 4, 6, 8, & 12 MIXER, 15 to 31 inputs.
- 9 INPUT MIX/MINUS BUSS & programmable start/stop controls
- AND A WHOLE LOT MORE.

EXAMPLE WITH ANNIVERSARY DISCOUNT:  
 8 mixer, single channel.....\$2,606 !!!  
 12 mixer, dual channel.....\$3,735 !!!



**Q92**  
 Klap-FM

P.O. BOX 70  
 MADISON, MINNESOTA 56256

January 5, 1990

Dear Sirs:

Just a note to let you know how much we like the Ramko xl625 stereo console we installed in our FM broadcast operation a few months ago.

The audio quality is excellent and our announcers like the ease of operation. It's amazing that you can offer a console of that quality for the low price tag that was on it.

I had one occasion to call your service department for an answer to a question I had on a minor problem and I received some friendly and accurate advice. Incidentally, the minor problem resulted from a severe lightning strike at our studios, the Ramko board survived it nicely!

I would recommend the XL SERIES audio consoles to anyone with a small budget who is looking for "big" quality.

Very Truly Yours,

*Maynard R. Meyer*  
 Maynard R. Meyer  
 General Mgr./Chief Engineer

**WBZM**  
 94.3 FM  
 Peoria

Central Illinois Pure Gold Station

April 24, 1990

RAMKO Research  
 3501 #4 Sunrise Blvd.  
 Rancho Cordova, CA 95670

Gentlemen:

Congratulations! We believe you've built the most perfect audio console available to broadcast stations.

We've been using an XL Series stereo console for four months with outstanding results. Indeed, your specifications for this console are quite conservative. We have found that noise and distortion are lower-- much lower, in fact-- than audio consoles selling at three to four times the price of the RAMKO XL Series!

Dollar-for-dollar and feature-for-feature, RAMKO consoles are the finest available in broadcast applications.

What sets RAMKO apart, however, is not simply the quality of the product. When problems develop (and with today's complex circuits, it's inevitable), your technicians have provided invaluable assistance over the telephone which has enabled us to make fast repairs.

It appears to us that your competitors spend a lot of money on slick four-color ads, while RAMKO puts its resources to good use quietly developing rugged, dependable consoles. So good, in fact, that our technicians refer to the RAMKO console as the "noise-free" board.

Yours truly,

*Bill Bro*  
 Bill Bro  
 President

FOR THE REST OF THE STORY CALL:

TOLL FREE (800) 678-1357 or FAX: (916) 635-0907

3501-4 SUNRISE BLVD.  
 RANCHO CORDOVA, CA 95742

**RAMKO RESEARCH**

## Monitoring Differential Transmitter Temperature

We all use several different methods to determine just how well our transmitters are operating. Here's one more to add to your bag of tricks.

Let's consider what differential temperature (or Heat Rise) is.

It's the heat generated by the transmitter in the process of doing its job. To measure it, just subtract the temperature at the transmitter's air intake from that leaving its exhaust chimney. It should be apparent that this heat is a waste. The better the efficiency, the less waste there will be.

When output power and efficiency are held constant, the differential temperature will also be constant.

You should first determine the normal temperature rise of the transmitter. Be sure that output power and efficiency are correct. Armed with this data, it's a simple matter of making differential temperature measurements a part of your normal routine. Remember that the transmitter will need to be operated at the same power level each time. There should be little change in differential temperature reading while the transmitter is operating normally.

If you notice the temperature rising, then the efficiency has dropped. This may indicate a need for tuning, a change in load impedance, reduced filament emission or any number of things.

If the temperature drops, the transmitter is probably not operating at the same power level used to establish the normal differential temperature value. This might mean a power meter is no longer accurate.

Because we are subtracting the inlet temp from the outlet temp, ambient room temperature changes should have little effect. Also, once you have collected sufficient data, it's easy to track any normal changes.

An often suggested method of measuring these temperatures is to use one thermometer at the air inlet and a meat thermometer (as purchased at the grocery store) inserted into the exhaust chimney above the transmitter and away from any RF circuitry. Refrigeration thermometers will provide better accuracy. However, if the same thermometers are used each time, the exact temperature is not necessary (as long as differential temperature is accurate).

Another method is to use LM34cz. This small temperature sensor chip is produced by National Semiconductor. Typical room temperature accuracy is within one half a degree.

The LM34 comes in a TO-92 case style which resembles a small transistor. It may be operated from a single polarity 5 volt to 30 volt supply. No external components are usually necessary.

Figure 1 shows just how easy this chip is to use. The DC supply is connected to pin 1. Pin 3 is the common ground. The output voltage at pin 2 is +10 mv for every degree Fahrenheit. If the temperature is 70 degrees, then your voltmeter would read 700 mv.

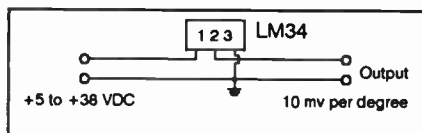

Almost any site can take advantage of this inexpensive device. Those with a Moseley MRC-1600 are ideally suited and can remotely check their transmitter's health.

The MRC-1600's telemetry calibration mode allows any analog input channel to be set to "MVOLT" (millivolts). This is perfect for our application. Now the temperatures may be read directly at the transmitter site or the studio. Best of all, no routine calibration is ever required!

All you will need is a supply voltage and some shielded cable to connect the chip. Use low capacitance cable and keep the runs short.

I placed each chip in small metal tubing (obtained from an old telescopic antenna) and soldered the cable's shield to the tubing for RF shielding. One tube was placed near the transmitter air filter, and the other was inserted into the side of the exhaust chimney. Although the tubing takes a little extra time to respond to temperature changes, this is not a factor.

We've used this method for three years with absolutely no problems. You will not find greater piece of mind for such a small price. I have avoided many unnecessary trips to the transmitter site by reading the differential temperature remotely. It's one of the best ways available to verify proper transmitter operation.

Those of you without a MRC-1600 can use the LM34 and a voltmeter to take temperature measurements if you like. It should not be too difficult to interface the chip to other remote controls, especially if an input can be set to measure millivolts.

Whether you use the method described here or not, make it a point to check your transmitter's differential temperature and log it along with all transmitter meter reading regularly don't you?

The LM34cz chip is available from DigiKey Corporation (1-800-344-4539) for \$6.00.

More information about this and similar chips can be found in National Semiconductor's Linear Databook #2, also available from DigiKey for \$10.00.

## Automation Basics and A Remote Terminal

It was about three in the morning when Randy was awakened at home by his overnight FM board-op. "That sorry excuse for an automation system you've got on the AM is all screwed up again!" was the cry. "There's tape all over the floor, and something is going 'clickity-clickity-click' real fast..."

Sound familiar? Well, there are automation systems all over the country in worse shape than Randy's. Each month in this column, I'll do my best to help you make sure your automation system doesn't get you up at 3 AM.

We'll talk about ways to maintain and repair common automation gear, how to make do with tiny budgets, and how to prevent equipment failures. We'll discuss methods for making your automation sound better and we'll take a look at new technology as it applies to automation. This month, let's just talk about automation in general.

For the benefit of any automation amateurs that may be reading, we'll start out with pretty basic material. Many engineers are afraid of automation, because they think it involves

mystical secrets or black magic which they know nothing about. That's only true of certain automation systems, not of the whole industry. The fact is, automation is not that difficult to understand. There are a few points that must be understood in order to have a firm grasp of the automation concept.

1. Automation involves a sequence of events. 2. Each event has a beginning and an ending. 3. The automation system knows about the beginning of each event but it must be told about the end.

Over-simplification? Maybe. But if you don't understand these ideas, you won't understand automation. So let's go over them one at a time.

Even in time-based automation controllers, each time something happens, such as a cart deck or reel-to-reel playing, it happens because it was next in the sequence of programmed events. In time-based controllers, where you can program things to happen at a certain time instead of just in sequential order, the time command simply changes the sequence of events. The system then continues along its merry way, playing one event after another.

The beginning of a programmed event is the start pulse, be it a TTL signal or a relay contact closure, from the automation system. The end of the event is the EOM (End Of Message) signal from the cart deck or other audio source.

The automation system knows about the beginning of each event but it must be told about the end.

The automation system creates the start pulse for each event based on the program you supply. This program may be little pegs stuck into little holes, as in some of the earliest automation systems, or it may be a disk file stored on a floppy disk. It could be a piece of paper punch tape, or a stack of IBM cards, or it could be stored on your station's mainframe computer mass

## Audible Improvement!

FM

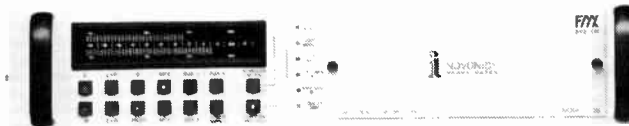

Our 706 FM Stereo Generator maintains 16kHz response and 75dB separation through *digital synthesis* of pilot and subcarrier. This assures **full modulation** with an *inherent* low residual above 54kHz, though an adjustable pre-pilot composite clipper is included.

The 706 also features internal combining and metering of up to 3 SCA/RDS channels, and has two independent composite outputs. It is 100% -compatible with *your choice* of audio processing, and the FMX™ System is a plug-in option.

AM



Inovonics' 222 is the simple, effective and affordable path to NRSC compliance. Its built-in peak control, adaptive preemphasis and no-overshoot 10kHz filter make you *sound better* too!

### Inovonics Inc.

1305 Fair Ave., Santa Cruz, CA 95060

CALL: 1-800-733-0552 - FAX: (408) 458-0554



(continued on page-15)

# Station Automation

## ... (continued)

storage device. Wherever it is, by looking at this program, the controller always knows what event to start next.

What it doesn't know is when the event currently on-air will be over. The on air device must tell it by means of an EOM signal. For cart machines, this means a 150 Hz tone recorded on the cue track of the cart. For reel-to-reels, it is usually a 25 Hz tone encoded on the left audio channel (don't worry, it gets filtered out later). For radio program syndicator CD's, it's a special index encoded near the end of the program or song. And for satellite-delivered formats, it's a variety of special tones sent by the format syndicator, usually on a separate channel from the audio.

When the automation controller sees the EOM from the current source, it knows to start the next source immediately. Most systems will hold the audio from the current source on the air until the EOM goes away, thus avoiding chopping the end off a song or spot.

### Cetec 7000 terminals:

If you have a Cetec 7000 (level 2) Automation System, with a sick or dying terminal, you may be wondering what to do about a replacement. Or maybe you just want to add a second terminal for your control room or PD's office. If you can't afford a new terminal from the factory or a good used terminal, you can take an old PC, an RS-232 cable, and a good communications software program like Procomm Plus and roll your own.

PC	Cetec 7000
2	3
3	2
5	20
7	7
6	
20	
25 pin female D	25 pin male D

RS-232 Cable: PC to Cetec 7000

When choosing a communications (or terminal) program, make sure it has terminal emulation capabilities. The one that seems to work best is the TVI 950 with IBM 3270 key-mapping. Your terminal program should have a menu with this emulation as one of the choices. If it doesn't, try all the emulations available. You'll probably find something that works.

Any PC with an unused RS-232 port will work, as long as it has enough memory to run the software you've chosen. Buy or build an RS-232 cable (see accompanying figure) and set your terminal program up for 9600 baud, even parity, 7 data bits and 1 stop bit. Be sure you choose the correct com port (COM1: or COM2:).

Plug the female end of the cable into your PC and the male end into your Cetec 7000 SIO board. There are two 25 pin D connectors on this board; use the upper one.

Remove any other terminal cables that are connected to the SIO board.

Fire up your communications program, go to terminal mode, and choose the correct emulation as discussed above. You'll also have to hit the CAPS LOCK key, just like on your old terminal. Now you should be able to talk to your 7000 with your PC.

If you just want to add a PC as a second terminal, swap pins 2 and 3 at one end of the above RS-232 cable and connect the PC to the EXT connector on the back of your existing terminal.

The primary disadvantage of using a PC for your Cetec 7000 is that you lose the convenience of a color-coded keyboard with all the available functions engraved on corresponding keys. But a cleverly made template would look nice hanging on the wall next to your computer, and fingernail polish comes in all colors these days.



Improved Tapecaster® X-100 cart loader with single lever control enables error-free loading to one-second tolerance. Long-life, heavy-duty synchronous motors and rugged all-steel chassis and top deck make X-100 the only loader you'll ever need. Among its features are:

- Adjustable tape tension
- Precision electronic timer with automatic reset
- Editall splicing block

For complete information call or write.

## TAPECASTER®

a division of

**Auditronics, Inc.**

3750 Old Getwell Road • Memphis, TN 38118  
Phone: 901-362-1350 • FAX: 901-365-8629

## Documenting An AM Directional Proof of Performance

With all the field work out of the way, you can put away your field strength meters and get ready for preparing the documentation. You can look forward to creating scores of graphs, maps, and tabulations. Sometimes this can actually take longer than the measurements themselves did, depending on how well equipped you are for the creation of graphics.

The proof document should consist of the following items:

1. An engineering statement describing the methods used in adjusting the array and making the proof measurements.
2. FCC Form 302, Section II-A.
3. A typed tabulation of all the field strength measurements on all radials.
4. A log-log graph of the measurements on each radial for each mode of operation (ND, DA-D, DA-N, etc.).
5. A polar graph of the measured pattern for each mode of operation (ND, DA-D, DA-N, etc.).
6. A tabulation of the non-directional IDF, average ratio, resulting DA IDF for each pattern, and the standard pattern IDF for each radial.
7. A map showing the location of all the selected monitor points.
8. A complete description, directions to, and a photograph of each monitor point.
9. Topographical maps showing the location of all the measurement locations.

It would probably be a good idea to get a good copy of another station's directional proof of performance to use as a template for preparing your own. It should be a recent proof (less than ten years old) and the units should be metric. You can obtain this from your communications attorney, or from the Downtown Copy Center in Washington, DC, although you will have to be very specific about what you want when ordering from DCC.

Radio Guide September -1990 Page-16

### Engineering Statement

The engineering statement should be a capsulized description of the actions taken to adjust the array and make the proof of performance measurements. Enough detail should be given for clarity, but not so much as to make the document tedious reading. This part of the proof document is not required by the FCC;

However, it provides an official forum in which you can record important facts pertaining to the DA construction, adjustment, and proof.

Included should be an introduction that gives the purpose of the application, licensee's name, the call sign of the station, and the FCC file number of the construction permit. The date on which construction began, as well as the date(s) on which testing began and ended.

Following the engineering statement should be a synopsis of the steps taken to bring the array into proper adjustment.

The statement should include the names and qualifications of all persons making readings, as well as the model number, serial number, and date of last calibration of all field strength meters used in the proof. If more than one meter was used in the proof, a statement that all the meters were checked against one another and found to be in agreement should be included.

It is also a good idea to document in the statement the make, model, and serial number of all the other pieces of test equipment used. Such might include an operating impedance bridge or other impedance bridge, bridge oscillator or synthesizer, any detectors used, RF ammeters, and the like.

Any other pertinent facts relating to the construction, adjustment, or proof can also be included. Remember, though, to keep it direct and to the point.

### FCC Form 302 Section II-A

This is the AM engineering section of the FCC license application. It is relatively self explanatory, but it must be filled out properly or the application will be returned.

The first item requested is the applicant's name. This must be exactly the same as the applicant's name on the construction permit! Have the CP in front of you as you fill out the Form 302.

Following is the purpose of the application. Check "Station License".

The next items can be copied right off the CP. These include call sign, FCC CP file number, frequency, hours of operation, and day and night power. Station location (city of license), transmitter location, main studio location, and remote control point follow.

The next few items relate to the data accumulated in the proof. They are: RF common point current, common point resistance and reactance, and antenna monitor indications (with the array properly adjusted). The manufacturer and type of antenna monitor is also requested.

Next are items related to the antenna towers. Type of radiator (guyed, free standing, etc.), height, top loading, and excitation (series or shunt) are requested. Make sure that all heights agree with the numbers in the construction permit!

Geographic coordinates are requested next, and again, take these off the CP. The numbers must agree or the application might be bounced.

The next section deals with other antennas that are mounted on the towers (such as STL/TSL antennas) and their isolation circuits. If you have such antennas mounted on any of the towers in the array, a sketch of the installation of these antennas, including dimensions and the location and



## DA Systems . . . (continued)

type of isolation circuits must be included and referenced by number here.

The ensuing section asks in what respect does the construction of the station differ from that specified in the construction permit. There should be no difference, but if the address of the transmitter site or some other very minor item does differ, note it here. On one proof I filed, the transmitter site on the CP was described as being east of a highway when in fact, it was west of the road, although the geographic coordinates were correct in the CP. This was where I corrected the discrepancy.

The last question on the form does not apply to most DA proofs, unless the proof was submitted along with a change in the common point resistance.

### Measurement Tabulations

A complete tabulation of the field strength measurements on all radials, including close-ins, in both non-directional and all directional modes of operation is next on the list.

The tabulations must include DA/ND ratios for all points on which directional measurements were made. The average of the ratios should be noted at the end of the column.

Be neat with the tabulations, presenting the information in as concise a manner as possible. From left to right, the columns should be: point number (must agree with maps), distance from station, ND field, date and time of the ND measurement, DA field, date and time of the DA measurement, and DA/ND ratio.

If more than one pattern is included in the proof, continue with more columns for the other pattern DA measurements. Be sure to differentiate between the DA columns with headers such as DA-D Field, DA-N Field, etc.

Measurement points that you have selected as monitor points should be so marked in the left margin. Use the notation [MP] or some other appropriate abbreviation.

Be sure to specify units. In the header for the distance column, specify "km" as the unit of measure. In all field column headers, specify "mV/m".

### Ground Wave Field Strength Graphs

There will be at least two graphs for each radial and possibly more. One graph will be the non-directional graph, the other(s) will be for directional modes of operation.

You can use the log-log graph paper published by the NAB or you can make your own; the bottom line is that the paper must overlay properly with the FCC ground wave graphs contained in the Rules. Since the NAB also published the FCC graphs, if you use NAB paper, a match is assured. Personally, I do not care much for the NAB paper for a number of reasons, and I always make my own paper using a CAD (computer aided design) program and a plotter.

Starting with the non-directional measurements on a radial, plot the field strength versus distance on the graph paper. Use the typed tabulations as the source of information for plotting your points; this will insure that all the data submitted in the proof document agrees.

The close-in measurements (inside about 0.5 km) will have to be plotted on a folding scale. In the upper right-hand corner of the paper, the 50 km

vertical line will become 0.5 km, and the 1000 mV/m horizontal line will become 10,000 mV/m. Plot the close-ins in this corner of the paper using the folded scale until the next point is below 1,000 mV/m. Starting with that measurement, plot on the regular scale.

With all the points plotted, draw the inverse distance line for the non-directional inverse distance field on that radial on both the regular and folded scales.

Next, overlay your graph of the ND measurements over the FCC graph on a light table, aligning the inverse distance lines and vertical scales. Figure out which of the conductivity lines is the best match to the measured points on the radial and trace that conductivity line onto your graph. Begin as far to the left as the FCC graph's conductivity line goes and trace as far as the last measured point on the radial.

Label the graph for radial, mode of operation, and figure number. Label the inverse distance lines on both regular and folded scales with the value in mV/m. Place this number in about the middle of each line and a few millimeters above it. At the end (right side) of the inverse distance lines, label the lines "ID". At the end of the conductivity line, label it with its value.

(Continued on page-18)

**ANDREW 1-5/8" AIR CABLE**

**In Stock  
Ships Next Day**



**CARTWRIGHT**  
COMMUNICATIONS COMPANY

7812 Red Sky Drive  
Cincinnati, Ohio 45249

**800-543-8614**

## DA Systems . . . (continued)

Mark the scale in the upper right corner of the page with the folded scale values. Then check the graph for neatness, correctness, and readability.

Repeat for all directional modes on that radial on a separate sheet of paper. Draw on the inverse distance line corresponding to the measured directional IDF on that radial. Next, place the non-directional graph under the directional mode graph on a light table, aligning the inverse distance lines (regular scale) and vertical scales. Trace the conductivity line off your ND graph onto the directional mode graph.

While the DA and ND graphs are overlaid is a good chance to look for plotting errors. Check to be sure that for every far-field point at a given distance on the ND graph, there is a corresponding point on the DA graph. They will be in different locations vertically, but all points should be horizontally aligned. Correct any omissions or mistakes.

Repeat this process for any other directional modes on that radial. Then, repeat the entire process on the next radial, continuing until all modes of operation on all radials have been graphed.

Making the graphs is a very time consuming process. Engineers have probably gone blind doing this. Take your time and take frequent breaks.

As an alternative to graphing by hand, I use a CAD program both to make the paper and to plot the points. I wrote several routines within the CAD that calculate the point placement, inverse distance line location, and other functions that are mathematically derived. The end result is a very accurately plotted graph with all points, lines, and labels printed at the same time as the paper is created.

I will be happy to provide a copy of the blank paper drawing and the routines for plotting points and ID lines to anyone who wants them. However, you get to buy your own CAD program.

### Tabulation Of Measured Fields

The next tabulation is the one that really shows the results of the proof. It includes, for each radial, the ND measured field (non-directional IDF), the average DA/ND ratio, the resulting measured DA field, and the Standard Pattern IDF.

The whole project comes together on this one piece of paper. Some things to be careful of are as follows:

Be sure to use the IDF maximum values from the CP as the Standard Pattern IDF on the CP radials. Use all the decimal places the FCC specified and do not round. Round all the measured ND and DA measured field values the same number of significant digits.

Lastly, be sure everything agrees. Make sure the ratio averages agree with the tabulations, that the ND measured fields agree with the ID lines on the graphs, etc.

### Measured Pattern Polar Graphs

There will be one polar graph for each mode of operation, ND and DA. Using a sheet of polar graph paper with clockwise angular notation, establish the proper scale for your non-directional measurement. A scale of 1,000 mV/m is probably best for this graph. Plot the measured field on each radial. Then, connect the points, interpolating smoothly between them in a circular fashion.

(continued on page-19)

# Marti Red Tag Sale!

Move up to Marti  
at a fraction of  
the new cost.

We have dozens of pre-owned  
STL and RPU systems that  
were taken in trade for new  
Marti Equipment. These units  
are completely rebuilt and  
carry a full 1 year warranty.

Call Marti now!  
(817) 645-9163

## DA Systems . . . (continued)

Label the scale divisions as necessary, and mark the measured radials with a large dot. Note the station coordinates somewhere on the page outside the graph area. Then, label the graph for mode of operation, figure number, call, date, etc. Make a legend showing measured radials and measured ND pattern.

Measure the area inside the ND measured pattern line with a polar planimeter. Divide the result in inches by  $\pi$  and take the square root. Multiply this by the scale (number of mV/m to the inch) to get the RMS of the non-directional pattern. Do this several times and average the results to improve the accuracy. Note the RMS of the ND pattern on the page somewhere outside the graph area.

Repeat this procedure on a new sheet for each directional mode of operation, but start by drawing the Standard Pattern on the graph using a dashed line.

Be careful to use scale(s) that are permitted by the FCC. The allowable scale multipliers are spelled out in the FCC Rules. Generally, if you use the same scales that were used in the CP application (provided that they were metric), you will be okay.

Measure the DA pattern RMS and note it on the page. Also, note the theoretical pattern parameters (ratios, phases, spacing, and orientation) on the page.

Make a legend showing measured radials, Standard Pattern, and measured pattern. Double check to be sure that the measured pattern does not exceed the Standard Pattern anywhere. Repeat all of this for any other directional modes of operation.

Once again, I use a CAD program to both generate the graph paper and plot the points/patterns. This is doubly useful in that the CAD will tell me the area inside any given entity, so I can be quite accurate with the measured pattern RMS.

(continued on page-20)

# Let the CIA listen to your competition and playback only the commercials!

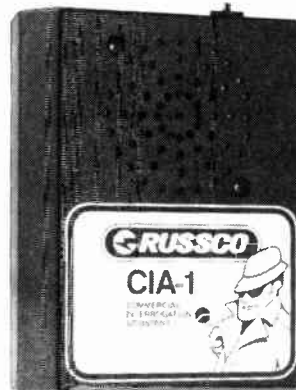

Spying was never so Easy! When you hook up the RUSSCO CIA-1 to a radio & a cassette player, it records only the speech, filters out the music! Makes the sales manager's job a lot easier. This little spy practically pays for itself!

**New! Only \$299.**

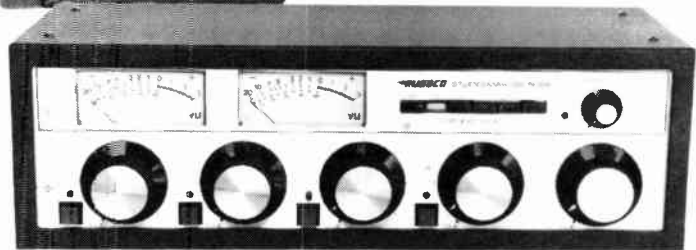

## The RUSSCO Newsroom stereo mixer works right & easy!

The compact 505S gives you 5 channels of easy mixing. 4 channels with preamps, 1 channel accepts 5 balanced, hi-level inputs. Cues on any channel with fast Mod-Pots. 2 VU meters. Great specs, terrific performance and an economical price of only \$2239.

## Match up a CD player Cheap!

You'll save money with the CD100 impedance matching amplifier that interfaces inexpensive CD & cassette players to your professional console. The Least expensive on the market.

**Only \$79.**



Call for our catalog at (209) 291-5591.



ELECTRONICS INCORPORATED

5690 E. Shields Ave., Fresno, Calif. 93727

TURNTABLES, TONEARMS, DIST. AMPS, PREAMPS, MIXERS & MORE.

# DA Systems . . . (continued)

## Monitor Point Map Descriptions, and Photos

Next, make a map of the routes from the station to all the monitor points. Use a street map, if possible, and trace the important roads. Label everything. Be as accurate as possible.

For each MP, the directions to the point from the station, the point description, and a photo of the point

including a person standing at the point holding a field strength meter oriented toward the station must be given. Do this all on a single sheet for each MP.

Look at your MP map when writing the directions to each point. Don't reference anything that is not on the MP map. Be accurate enough in your point description so that anyone can get to within a few feet of the selected spot following your directions.

Note the DA field strength at the point as measured in the proof, the

point number, and the distance to the station on the radial.

If you desire, you can calculate the MP limit and submit that as well, as long as you also submit the method used to arrive at the limit. The limit at the point is determined as follows:

$$LMP = \frac{FMP \times FMAX}{FDA}$$

where:

LMP = Monitor Point Limit (mV/m)

FMP = Field Strength at the MP (mV/m)

FMAX = CP Maximum IDF on the radial (mV/m)

FDA = Measured DA IDF on the radial (mV/m)

To make a professional and easy to read MP description, I type the description at the top of the page and paste a color photo at the bottom of the page. Then, I duplicate the sheet on a color copier. These seem to have popped up at print shops and reprographics/drafting supply houses everywhere. The going rate for a single color copy is about \$2.50/page for up to 10, with discounts for quantity over that point.

## Topographic Maps

The last items in your proof document are the maps. Use the field maps with the numbered points and radials on them with a light table with a clean map and redraw the radials and points.

Mark the maps first with pencil, then ink the lines with a Rapidograph .050 drafting pen. Each point should be noted with a small circle at its exact location (the circle should interrupt the radial line), and the point number noted alongside inside another circle.

Close-in, include only the points that are more than 0.1 km from the site and then those points that are close to multiples of 0.1 km out to 3 km or so. Otherwise, there are too many points that are too close together and the map is difficult to read.

Mark each radial on the center map as it leaves the page. On other maps,

**(continued on page-21)**



## CRL SPOTLIGHT

**Have a  
news/talk/sports  
format?**

**Want to improve  
coverage of your station?**



**MBL-100 AM NEWS/TALK  
PROCESSOR**

The MBL-100 news/talk AM audio processor was designed for you. The MBL-100 provides very high levels of average modulation density or loudness. The added density it provides helps to overcome noise and interference problems. The MBL-100 is useful for filling in null areas and reducing the effects of powerline reradiation. And if your antenna bandwidth or symmetry is not that great, the 7.5 kHz bandwidth of the MBL-100 will make life easier for your transmitter. The MBL-100 is designed to give your station better coverage area. To learn more about the MBL-100 call or write now for details. The MBL-100 is available on our two week trial program.



**Circuit Research Labs, Inc.**  
2522 West Geneva Drive  
Tempe, Arizona 85282-3192 U.S.A.  
(800) 535-7648 (602) 438-0888 FAX (602) 438-8227  
Bulletin Board System (602) 438-0459

## DA Systems . . . (continued)

mark the radial as it enters and leaves the page. On the last map for a radial, mark where it enters the page and the end of the radial. Give each map a figure number as appropriate.

Submit full scale copies of the central map (the one with the transmitter site and the close-in measurements on it). Other maps can be reduced to letter size, but be sure that the reductions are of sufficient quality so that all the radial bearings, point numbers, and figure numbers are readable.

### Putting it All Together

Finish the document with a cover sheet and table of contents. The cover sheet should include the document title, call sign, city of license, licensee name, and date. The table of contents should show each item, figure number, and a brief description of each item.

With all this done, proofread the document! Take a few days to be sure that everything in the document is in agreement. Statements made in the Engineering Statement should not contradict data in the CP or proof. The Form 302 should agree with the construction permit and the data in the proof.

Make sure the tabulations are correct, including point numbers and distances (must agree with the maps). Double check the ratios, and ratio averages. Look for typos and numeric transpositions.

Triple check the graphs. Be sure there are the correct number of points, and check the distances and field strengths against the tabulations. Use a light table to be sure all the graphs for a given radial agree with each other for number of points and distances.

Check everything on the proof tabulation, making sure the average ratios agree with the individual radial tabulations. Check the Standard Pattern values against the CP on CP radials.

Closely examine the polar graphs, looking for irregularities in the measured patterns. Does the ND polar graph resemble a circle for the most part? Does the measured directional pattern follow the Standard Pattern for shape? Is the DA measured RMS

greater than 85% of the Standard Pattern RMS as stated on the CP? Does the measured pattern exceed the limits of the Standard Pattern at any point?

Check the MP map and MP descriptions for agreement and accuracy. Be sure there are no references to roads or landmarks not on the MP map in the MP directions. Double check any numbers given in the MP descriptions against the rest of the proof.

Finally, look the maps over. Check for numbering, radial markings, point locations/distances, etc. Check the reductions for readability.

The whole document should have a professional look to it, nothing "cheesy" or done halfway. Remember that people will be looking at your work for years to come. Is the finished product something you can be proud of? Make it that way.

Before you go to press with the master document, have a consultant or other experienced engineer proofread the document for you. He will look for the same things as noted above, but with a practiced eye that is likely to spot irregularities.

Use the services of a good, professional architectural/engineering reprographics firm. Avoid the quick-copy places. Make nine or ten copies - an original and three copies for the FCC, one for your communications attorney, one for the station licensee, one for the public file, one for your file, and one to keep at the transmitter site.

Submit the original (including Section I of the Form 302 signed by the licensee, the fee form, and the appropriate filing fee) to the FCC. Distribute the other copies as necessary.

Within ten days, you will receive Program Test Authority from the FCC, and you can begin operation with the new facility. A condition of the Program Test Authority will be that you measure all monitor points, base currents, and antenna monitor parameters once each 7 days for 30 days. You will be required to submit this data in a "Stability Showing" to the FCC within a specified period of time.

Once through the stability measurements, you will be in the maintenance mode and can get back to business as usual.

## Upgrade Your MRC 1600 Remote Control for the Nineties

If you own a Moseley MRC 1600 Remote Control and want to interface it with a PC, you can easily upgrade the system with **MRC 1600 to MRC 1620 conversion kits**.

Use the TaskMaster20 PC Program to take advantage of these powerful features:

- Dial-up access for both the Remote and Control end
- Smart control algorithm
- Automatic logging
- Multiple site capability

Conversion kits consist of the following:

- Remote Terminal kit includes CPU module and Intel modem.
- Control Terminal kit includes CPU module and RS-232 port.
- Taskmaster20 Software program for your PC.

You'll be surprised how easy these kits are to install (*no re-wiring your transmitter*) and how easily they will fit your budget. Upgrade today to ensure your remote control won't be left behind the times.

**Contact Moseley for a free TaskMaster20 demo disk.**

**Moseley**

Moseley  
Associates  
Inc.

111 Castilian Drive  
Santa Barbara, CA  
93117 USA

Phone 805-968-9621  
Telex 658448  
Fax 805-685-9638

## PA Cavities, Drive, and Neutralization

RF is a very interesting part of radio, and although there were a lot more Engineers around when I first got started, not many seemed interested in the RF aspect of the plant. No glitter. No custom furniture. Just noisy blowers, late nights, and that familiar "RF dust" (the gritty kind that seems to get in your eyes, and nose, and throat, and eats, and etc.).

Well the situation is no different today, except now there seems to be even fewer engineers interested in RF. Hopefully we can cover some topics that you find interesting, and that may help you better understand RF. And if there are any Owner or Program Directors reading this, hopefully this series of articles may help you keep alive when you decide you have to fix the transmitter. To start, let's look at some basic theory.

In modern high power FM transmitters, there are generally two basic approaches to cavity design, the 1/4

wave cavity and the folded 1/2 wave cavity. The two most popular amplifiers are either a grid-driven tetrode or a grounded grid triode. This month we will investigate the differences in philosophy in cavity design.

The 1/4 wave cavity has been popular since the 1970's, even though the basic concept has been around longer. One reason it was designed, was to offer less space consumption than the original 1/2 wave cavity.

The original 1/2 wave cavity was large, as can be seen in the Gates "G", "H", and "K" series FM transmitters of the 60's and 70's. Not only were they large, but they had sliding contacts for output tuning and loading at the high RF current points (like the RCA transmitters did), and they needed a plate blocking capacitor.

Continental has used the 1/4 wave PA cavity the longest. The current 10kW, 20kW, and 25kW transmitters are essentially the same Collins design

from long ago. The 27.5kW transmitter is a souped up version of the original 20 and 25, basically by increasing the plate transformer size.

They use a shorting plane in the coarse tuning of the PA cavity. This shorting plane is a "deck", which is mechanically adjusted depending on frequency. This deck uses finger stock for RF connection to the cavity walls, and you should ensure a tight fit periodically so as to avoid the possibility of cavity wall burning.

As all good engineers know, some simple preventative maintenance (and the opportunity to do it!) can save a lot of money, downtime, and headaches.

Curved metal plates in the Continental PA cavity, that are in vicinity of the anode, act as capacitors for output tuning and loading. These capacitors are motor driven, resonating the cavity and coupling the energy out of the tank.

The Harris FM-25K, 25kW FM transmitter was the first high-performance single tube FM transmitter with a 1/4 wave cavity and a solid-state IPA stage, released in 1978. It did not use sliding contacts for tuning and loading, instead Harris utilized a "paddle" type coupling arrangement for inductive pick-up (loading). Tuning was accomplished by using a variable capacitor. It also used a shorting plane (or deck), and depending on the frequency, changing the final tube could get pretty creative.

The Broadcast Electronics FM-30 was the first high performance single tube 30kW FM transmitter with folded half wave PA cavity and a solid-state IPA stage, released in 1980.

The folded half wave cavity was a novel approach as no plate blocking capacitor was needed because they attached the incoming B+ to the RF voltage null point. Also, tuning is accomplished by physically adjusting the mechanical size of the cavity by means of an electrically shorted tuning section. This re-entrant approach makes

### LPTV Sideband Suppression Notch Filters & Video Aural Combiners

Reduce sideband radiated power & meet FCC transmitter standards.

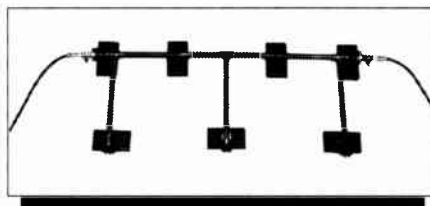

Full Details In Bulletin #15  
Ask For Our FREE Catalogs!

Request BTV/87 which describes TV/FM/MMDS Broadcast Filters and Combiners for service radio bands

Catalog BTV/87

Need A Special Filter? Call Us Today!

**"We Make Filters In A Hurry For Customers In Trouble!"**

Microwave Filter Co., Inc. • 6743 Kinne St. • E. Syracuse, NY 13057

Toll Free (US/Can.): 1-800-448-1666 • Collect (NY/AK/HD): 315-437-3953

FAX: 315-463-1467 • Telex: 249-613

up the second quarter wave of the folded half wave cavity. Output loading is accomplished by a loop that adjusts through the magnetic flux lines of the RF current, and operates at DC ground.

The final amplifiers in these transmitters all basically use the same approach -- grid-driven design. They are all obviously class "C" amplification, with the grid driven into saturation. Always make sure you are not "starving" out your final tube by not running it into full saturation. On the other hand, excessive drive to the grid will simply cause overheating of the grid, and you are throwing electricity away in the form of dissipated heat.

To ensure adequate drive to the final, raise or lower the output power from the IPA, watching the grid current on the final tube (your screen current will change slightly too). There will be a point where the transmitter output power drops off with the lowering of the drive to the final grid. Conversely, there will also be a point where the increased drive to the final will cause no appreciable rise in output power. The point you want is the point where you can achieve full rated transmitter power with just enough drive for stable operation. Simply put, lower the drive to the final until the output power starts to drop off, then increase the drive back up to stabilize the amplifier. Adequate drive also helps maintain bandwidth of the amplifier.

Something to watch for in a grid-driven tetrode final amplifier: If the screen current starts to bounce with modulation, the bandwidth of the load is restricted. This could mean the transmission line is degraded, but it usually means the antenna has gotten out of tune. Now I know there are those of you who may think this doesn't make theoretical sense, but believe me, I have seen it happen many times, and it either means the antenna is iced up, or the tuning slug has slipped, or something of that nature. When you remove modulation, the screen current doesn't bounce any more. Keep in mind, antennas can get reactive.

Neutralization is required on a typical grid-driven tetrode, unless the screen grid of the tube is grounded (eg. Continental). Neutralization is simply stabilizing the amplifier by tuning out any reactions between the grid and the anode by way of the screen grid. FM transmitters are generally neutralized to -40 to -45dB. A grid-driven tetrode will operate with as little as -28dB worth of neutralization, but tuning is very erratic.

When the final amplifier is not neutralized sufficiently, what you will see is the grid circuit tuning will go out of tune when you tune up the final, and/or the final will become detuned as you tune up the grid circuit. This interaction indicates there is insufficient isolation between the two stages.

To verify the amplifier is neutralized without using a spectrum analyzer, do the following. Drive the input of the final directly from the exciter at about 10-20 watts, with no voltages applied to the final amplifier (the final amplifier is "cold" or passive). Take a relative output sample with a relative field strength meter like the Coaxial Dynamics model 7600. Vary the neutralization adjustments slightly and carefully, and recheck. If you can minimize the feed-through RF power to the absolute minimum, you know the amplifier is neutralized. Also, always make sure the neutralization adjustments will be sharing an equal amount of the current by ensuring they are adjusted symmetrically around the tube.

## How do you interface a thingumajig to a whatchamacallit ?

We don't know, but the *UNI-200* Universal Interface card from Broadcast Devices could help! The *UNI-200* gives you a neat and reliable way to interface remotely controlled devices ranging from antenna switches at the transmitter site to CD players in your production studio. The *UNI-200* is a compact (2.5 x 3.5) circuit card with four opto-isolated inputs. It provides on and off control of a relay (momentary or latching) and two open collector status outputs with lamp flashing capability. The various modes of the card are dip switch programmable and have adjustable flash and

momentary hold rates.

Try one — you may even come up with a way to interface that old whatchamacallit!

Contact Broadcast Devices or your local broadcast distributor today for more details.

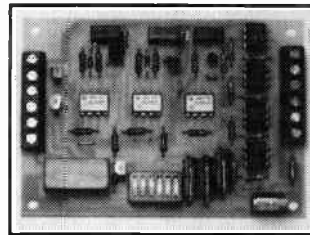

The *UNI-200* Universal Interface Card



Broadcast Devices, Inc.

5 CrestView Avenue  
Peekskill, NY 10566  
(914) 737-5032

## POWER-side™

### PROBLEMS

Adjacent Channel Interference
Antenna Null Distortion
Co-Channel Interference
Power-line Re-Radiation
Building Re-Radiation
Receiver Tuning
Low Fidelity Home Radios
Co-Channel Beat
Selective Fading

### SOLUTION!

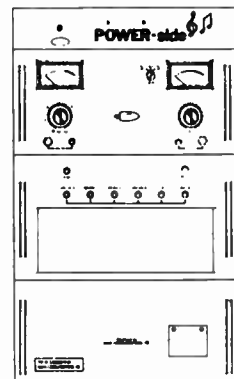

### POWER-side™

The solution to many of AM radio's most serious technical problems



From the developers of the AM STEREO system that isn't afraid of the dark and will let you drive right past FM Stereo

222 Westbury Avenue, Carle Place, NY 11514

## AGC Amp. With Adjustable Attack/Release

The automatic gain control (AGC) amplifier shown in figure 1, features time domain adjustable AGC attack, and release. This design employs the SSM2122 VCA IC, SSM2110 precision rectifier IC, bipolar low noise Op-Amps, and a BiFET Op-Amp.

The design includes an inverting or non-inverting input buffer amplifier, a voltage controlled amplifier (VCA) with adjustable attack and recovery characteristics, feedback driven by a true RMS level detector. Additionally, there is selectable gain reduction compression, along with adjustable AGC output level, and maximum gain limit controls. The signal-to-noise ratio is better than 100dB and the wideband true RMS level detector allows the AGC amplifier to operate transparently throughout the audio spectrum.

The gain recovery is linear and adjustable, and has maximum gain limiting (gating) to preclude source input noise (floor) rise.

The circuit includes line level input (-10dBu to 0dBu nominal) amplifier, with inverting or non-inverting inputs with 10K ohm input impedance. The buffer also isolates the input source from the compressor gain reduction ratio selector, and limits input source step function slewing voltages from causing signal distortion.

The six position gain reduction selector provides adjustable signal compression to smooth the AGC action and prevent hole punching. GAIN REDUCTION slope ratios of 2 to 22 can be selected and will avert the irritating hole producing and pumping character of most AGC circuits. The

VCA control voltage conditioning circuits. Constructed around U5 (TL072), a BiFET amplifier, it forms a level detector integrator while the other amplifier is a control voltage buffer that prevents loading of the integrator capacitor by the low impedance VCA control port. The AGC output level is set by the rectified signal voltage as compared to the reference voltage from the OUTPUT LEVEL control.

The AGC attack and compression response is altered by adjusting the integrator charging time constant or integrator's current wave shape. The three position ATTACK switch selects fast, mid, and slow compression and AGC response times. When the slow position is selected, a small amount of compression will take place, while fast and mid combine compression with the AGC action. The AGC release rate is controlled by a constant current discharge of the integrator capacitor. The recovery time is linear and adjusted by changing the integrator capacitor discharge current (supplied by Q1) regulated by the AGC Release rate control.

The NE/SE5534, VCA current summing amplifier, has been selected for low noise and its high performance characteristics. The high performance of this design, along with the simplicity and cost effectiveness, makes it suitable for incorporating in a mixing console or telephone coupler or in stand-alone project.

*Richard Majestic is an engineering division chief at the USIA Voice of America in Washington, since 1985, and is an active audio consultant. Richard has designed numerous broadcast and production audio consoles of all sizes, along with designing many professional audio products for well regarded manufacturers. An expert in audio systems design and analog audio circuit design, he holds numerous patents for instrumentation and analog circuit designs, and has written many design papers and magazine articles. He received a B.S. degree in physics and mathematics from Hofstra University, Oakdale, NY, in 1973, and is a senior member of AES, IEEE, and SMPTE. In his spare time he enjoys boating, photography, and music . . . editor*



SMARTS Broadcast Systems announce an affordable way to interface with satellite music services. The SMARTCASTER replaces all your carts, carousels, instacarts and other commercial sources with one low cost unit.

SMARTCASTER from **barrett associates, inc.**

BROADCAST EQUIPMENT

WE'VE JUST MADE ALL OTHER AUTOMATION SYSTEMS OBSOLETE.

For Information Call 1-800-748-5553

SSM2122 voltage controlled element is a high performance unit, with dynamic range greater than 94dB over the frequency range 20 to 20kHz., and typically has less than 0.01% THD (plus noise), and less than 0.03% IMD.

The SSM2110 precision rectifier IC is configured for true RMS operation and the AGC regulating circuit is configured as a feedback class control. Resulting in a consistent and precise AGC action that retains some of signal dynamics while leveling the input signal.

Following the true RMS rectifier is



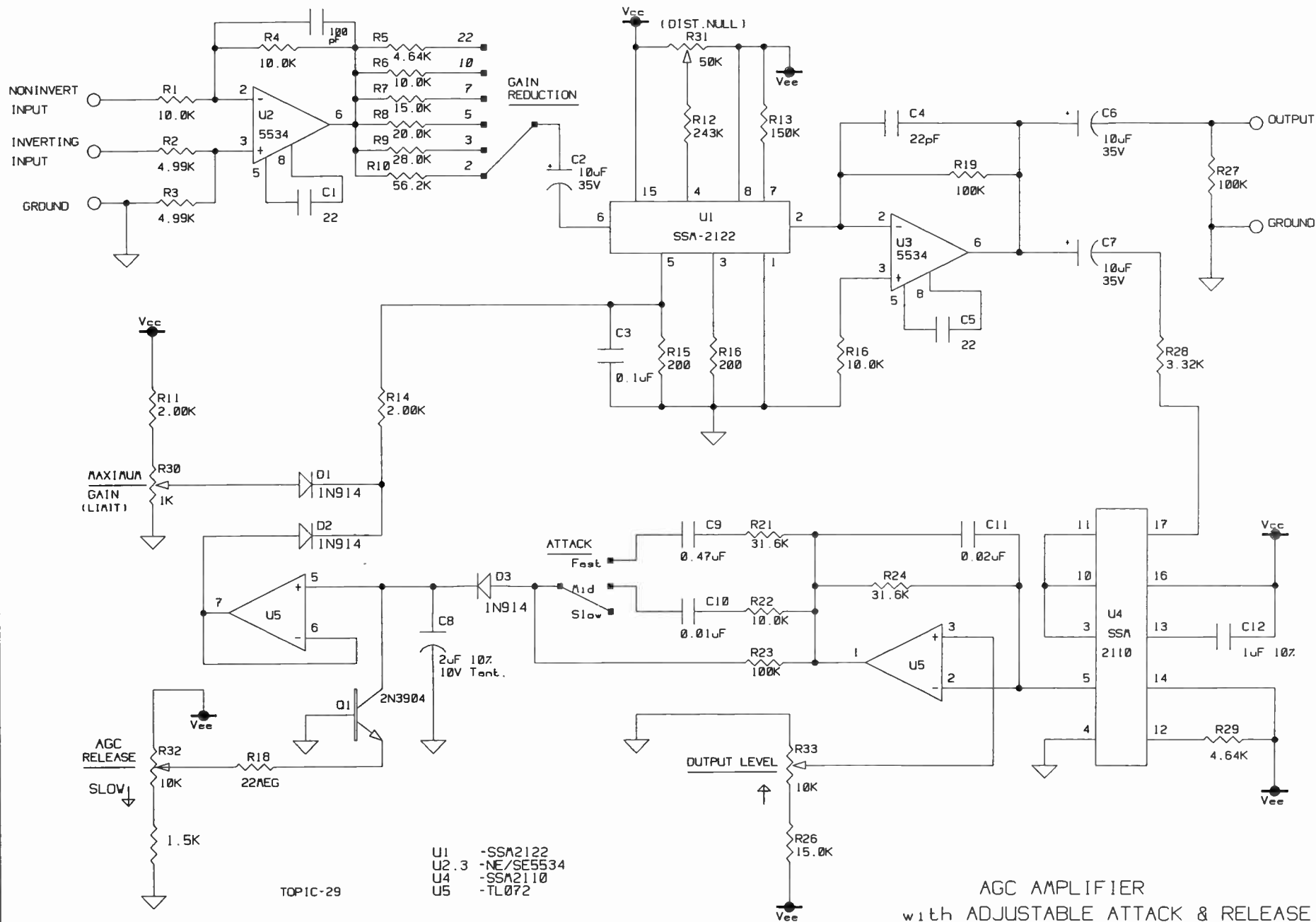

FIGURE -1- AGC Amplifier

## A Chronology of On-Air Tests at WQYK

Narrow Band Frequency Modulation on the AM band is the brainchild of George Yazell, a retired PE living in Lakeland, Florida. Several years ago, George started experimenting with the transmission of medium wave FM across his workshop. His first research used a simple Function Generator as a transmitter and he "slope detected" his transmissions on a standard AM radio. Convinced that this system was superior to standard amplitude modulation, he began experimenting to see if he could combine frequency modulation with amplitude modulation and constructed a system to receive his FM component while ignoring the amplitude modulation that was on the same carrier. The results of his tests were encouraging so he invited me to help continue his experiments, design and construct new types of transmitting and receiving equipment and conduct "over the air" tests of his NFR (Noise-Free Radio) system on WQYK-AM.

### Getting Licensed

In January of this year, with the blessing of Infinity Broadcasting, I applied for a Temporary Experimental Authorization to transmit a Narrow Band FM component on the carrier of WQYK-AM for a period of six months. The Commission requested further supporting evidence that NFR would not disrupt our standard AM transmissions or cause harmful interference to adjacent stations. Taking the better part of two months to fully research frequency modulation, George and I provided the FCC with written documentation, block diagrams and professional opinions.

WQYK-AM was granted a six month Temporary Experimental Authorization on March 22nd. The TEA permits testing through WQYK's normal transmission facilities at full operating power twenty-four hours a day. The following is a re-print of portions of my monthly reports to the Federal Communications Commission.

### March 27

Conducted low power listening tests using a commercial FM exciter operating at 106.0 mHz.

Fed the exciter output to a digital 100/1 prescaler for a final output frequency of 1060 kHz.

This RF signal was used to drive a simple amplitude modulated one watt transmitter operating into a dummy antenna.

Adjusted the FM exciter for + and - 100 kHz peak deviation so that the resulting transmitter output at 1060 kHz showed a peak deviation of + and - 1 kHz.

Fed high quality modulation from a compact disc player to both the AM and FM inputs on the transmitter.

The receiver consisted of a Drake communications receiver. The 455 kHz IF frequency was picked off and multiplied 75 times to a frequency of 34.125 mHz. This signal was hetero-

dyned with 23.425 mHz and the resulting difference frequency of 10.7 mHz was injected into the FM IF strip of a Scott consumer receiver and processed as a wideband FM signal.

While no measurements were made, listening tests were very impressive. The standard AM signal sounded dull but the FM signal sounded just like normal wideband FM.

The amplitude modulation was turned off while the frequency modulation was permitted to continue. Using the AM tuner within the Scott receiver, sidebands were monitored at 1050 and 1070 kHz. There was but the slightest hint of audio, down perhaps 40 dB below the peak audio level at 1060 kHz.

When frequency modulation was turned off and amplitude modulation turned back on, the same sidebands were monitored. This time, as one would expect, our sidebands were much more severe.

(continued on page-27)

QEI QEI QEI QEI QEI

WHY QEI?

24 Hours.



Our 24 hour service hotline number is 609-728-2020.

Call us toll free at 800-334-9154 for all the facts on QEI "New Reliables" FM transmitters from 1kw to 30 kw.

QEI CORPORATION  
ONE AIRPORT DRIVE • P.O. BOX D  
WILLIAMSTOWN, N.J. 08094

TEL (609) 728-2020 • FAX (609) 629-1751

QUALITY • ENGINEERING • INNOVATION

QEI QEI QEI QEI QEI

WHY QEI?

Less is More.

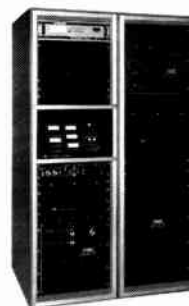

All of QEI's FM transmitters have no plate blockers or sliding contacts.

Call us toll free at 800-334-9154 for all the facts on QEI "New Reliables" FM transmitters from 1kw to 30 kw.

QEI CORPORATION  
ONE AIRPORT DRIVE • P.O. BOX D  
WILLIAMSTOWN, N.J. 08094

TEL (609) 728-2020 • FAX (609) 629-1751

QUALITY • ENGINEERING • INNOVATION

## NFR Up-Date . . . (continued)

The addition of frequency modulation to this amplitude modulated carrier did not increase the sidebands by any amount that was noticeable in these listening tests.

### April 18, 1990

Spectrum Analysis of the WQYK carrier with 90% amplitude modulation and 100% frequency modulation (1 kHz peak deviation with 75 microsecond pre-emphasis) showed that the transmission was well within the NRSC-2 RF mask. The Spectrum Analyzer was adjusted to sample and store for a period of 10 minutes. Sideband energy at 10.2 kHz below the carrier was attenuated 43.9 dB. Sideband energy at 10.2 kHz above the carrier was attenuated 46.9 dB. At +20 kHz, sidebands were attenuated 68.1 dB and at -20 kHz, sidebands were attenuated 64.4 dB. At all frequencies removed from the carrier by more than 40 kHz, the sideband energy was more than 70 dB attenuated, well into the noise.

All sidebands were well within the NRSC-2 RF mask even with pre-emphasized 15 kHz FM audio.

A failure in the Tektronix model 2710 Spectrum Analyzer forced a termination of measurements. Further analysis will resume as soon as a replacement for the 2710 can be obtained. Preliminary FM to AM crosstalk measurements indicate an attenuation figure of -57dB with the transmitter 100% frequency modulated by a 1 kHz sine tone.

No AM to FM crosstalk measurements have been made at this time. Further receiver design refinements should be complete in the near future. These refinements will include wideband RF and IF systems which should permit accurate audio measurements from the output of the receiver.

It is interesting to note that while the Continental 317-C transmitter uses a dougherty RF power amplifier with 90 degree networks around the peak and carrier tubes, the frequency modulation did not cause

these frequency sensitive networks to amplitude modulate the RF output as one would expect. The "Q" of these networks must be very low.

Not a single sign of transmitter instability was indicated by the transmitter meters, the internal transmitter phascope or the common point meter. During the period of time when I was frequency modulating the transmitter with no amplitude modulation, the transmitter was rock solid with absolutely no signs of any modulation of any kind.

### April 26, 1990

Performed spectrum analysis of Continental 317-C transmitter under all possible modulation conditions:

1. AM only
2. FM only
3. AM and FM with FM audio in phase
4. AM and FM with FM audio 180 degrees out of phase
5. 10 kHz AM audio and 10 kHz FM audio
6. 10 kHz AM audio and 15 kHz FM audio

(continued on page-28)

## FM Harmonic Low Pass Filters 500 - 50,000 Watts

Delivery: 30 Days (Faster For Your Emergencies)

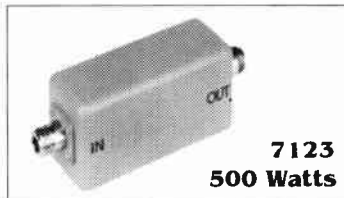

7123  
500 Watts

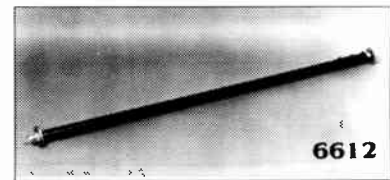

6612

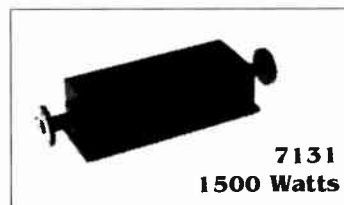

7131  
1500 Watts

Model #	Watts
6612	6,000
6516	15,000
7772	30,000
7455	50,000

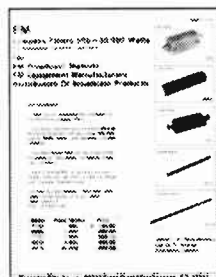

Bulletin #14

### Full Details In Bulletin #14!

Also, request BTV/87 which describes TV/FM/MMDS Broadcast Filters & Combiners for service radio bands.

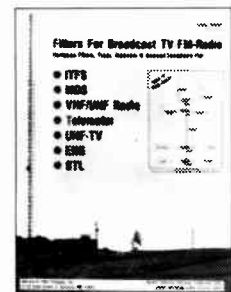

Catalog BTV/87

**Need A Special Filter? Call Us Today!**

**"We make Filters In A Hurry For Customers In Trouble!"**

**Microwave Filter Company, Inc.**

**6743 Kinne St. • E. Syracuse, NY 13057**

Toll Free(US/Can.): 1-800-448-1666 • Collect(NY/AK/HI): 315-437-3953  
FAX: 315-463-1467 • Telex: 249-613

## NFR Up-Date . . . (continued)

### 7. 75 microsecond FM audio pre-emphasis

When the transmitter was fully modulated with NRSC 10 kHz AM program audio only, the transmission system exhibited very well controlled sidebands beyond +/- 10.2 kHz. The system passed the NRSC-2 RF mask tests with plenty of room to spare.

When amplitude modulation was removed and 15 kHz frequency modulated program audio was applied (+/- 1kHz deviation), the signal was again analyzed. The signal still remained

within the NRSC-2 RF mask with sideband energy below that which was produced by 10 kHz amplitude modulation alone.

An interesting observation was made at this point. Sidebands which were removed from the carrier by more than 15 kHz were far lower in level with frequency modulation than when the transmitter was amplitude modulated with NRSC 10 kHz program audio. This is due, I believe, to the harmonic and intermodulation distortion products produced in the process of transmitting an amplitude modulated signal through a tuned RF system where the sidebands are slightly advanced or delayed in phase with respect to the carrier. Such phase distortion is less

pronounced in the FM process.

When the transmitter was frequency modulated with NRSC 10 kHz program audio, the sidebands looked very much like an ideal signal, easily passing the NRSC-2 RF mask tests. Sideband energy beyond +/- 10.2 kHz was attenuated to such a degree that it was difficult to detect. Clearly, narrow band frequency modulation is far more spectrum efficient than is standard amplitude modulation.

With 10 kHz NRSC program audio amplitude modulating the carrier and 15 kHz program audio frequency modulating the carrier, the analyzer showed that the transmitted signal passed the NRSC-2 tests.

### May 6, 1990

Completed the construction of a receiver which is designed to strip off the AM component with great precision, process the clipped carrier and, using a PLL (Phase Locked Loop), re-generate the carrier frequency without any amplitude modulation or AM induced frequency or phase jitter.

At a transmitted peak amplitude modulation of 85% the receiver was able to remove all traces of frequency/phase jitter so as to permit the detection of the FM component. Positive modulation in excess of 100% does not affect the ability of the receiver to detect the FM signal.

It was at this point that I calculated the effective maximum transmitter power output for the detection of frequency modulation at various amplitude modulation percentages as broadcast through a 50kW transmitter:

Modulation	Effective RF Pwr
90% AM	500 watts
86% AM	998 watts
80% AM	1914 watts
69% AM	4915 watts
50% AM	12500 watts

It is clear that the narrow band frequency modulation of a transmitter on the AM medium wave band is possible and offers some very definite advantages over

# 125 REASONS TO CALL RADIO RESOURCES

...plus one we can't mention.\*

At Radio Resources, we're home to over 125 manufacturers of high quality equipment, supplies, accessories, and rental items. ■ For over 20 years, we've earned the business of thousands of broadcasters like yourself by providing exceptional service and competitive prices – all delivered with a friendly touch.

**\* And that other little reason...** it's our ever-changing monthly special. Too outrageous to advertise – you'll have to call each month for details. ■ So pick up the phone – it's on our nickel!

**WE'LL EARN YOUR BUSINESS**

**RADIO  
RESOURCES**

7483 Candlewood Road  
Hanover, Maryland 21076

1-800-54-RADIO  
in Maryland: (301) 859-1500  
24-Hour Fax: (301) 859-3042

## NFR Up-Date . . . (continued)

amplitude modulation. It is also clear that frequency modulation which is superimposed on a standard AM carrier will meet the NRSC-2 RF mask. The problem, however, is the interference to the FM signal from the AM signal.

### May 13, 1990

Completed construction and adjustment of a new CMOS & PLL circuit which is designed to strip the RF carrier of all traces of amplitude modulation and AM induced phase jitter. Preliminary tests show that the circuit can accurately remove the AM component and process (re-generate) the frequency modulated signal with amplitude modulation levels up to about 98% in the negative direction.

At amplitude modulation levels exceeding 98%, some "spitting" was heard on the output of the FM receiver even though an oscilloscope on the RF output of the processor board showed absolutely no amplitude modulation.

### June 18, 1990

Conducted numerous field tests and monitored both AM and FM com-

ponents of the signal. At all times during these tests, the signal contained amplitude modulation and frequency modulation. The FM receiver consisted of a wide band RF amplifier tuned to 1010 kHz driving a precision clipper and a Phase Locked Loop for regenerating the FM signal. The AM component was detected at the output of the tuned RF amplifier.

No frequency response or S/N measurements were made due to the problems observed in receiving a frequency modulated signal in the presence of amplitude modulation. These were merely "listening" tests.

1. The AM component did not suffer from the addition of FM.

2. Reception of the FM component was not affected by the amplitude variation of the carrier under very strong signal conditions but did suffer under weak signal conditions or when the AM sidebands were not equal (as when the signal was monitored in a pattern null). Reason unknown.

3. Meaningful skywave measurements were not possible due to the inability to receive a clean FM signal under weak signal conditions. Design changes will be made on the receiver.

4. The FM component, as received on our equipment, was more likely to be bothered by static (lightning crashes) than was the AM component. This was very likely due to the effective reduction in transmitted RF power caused by the AM component. Eliminating or greatly reducing the amplitude modulation will, more than likely, improve the received FM S/N.

### Conclusion

1. The frequency modulation of an amplitude modulated carrier is technically feasible and does not produce significant additional sidebands.

2. It is possible to transmit a full 15 kHz audio bandwidth within the confines of a 10 kHz AM channel without exceeding the NRSC-2 RF mask.

3. Narrow band frequency modulation offers the advantage of producing less sideband energy than does standard amplitude modulation.

4. Narrow band frequency modulation is compatible with standard amplitude modulation only if the amplitude modulation is reduced to some value which will leave a significant

amount of carrier for detection by the FM receiver.

5. Alternate FM receiver designs which can accurately strip the AM component from the FM component should be evaluated.

### July 17, 1990

No tests were conducted this month due to an unusually heavy work load. Measurements will continue next month with the investigation of sky-wave and pattern null performance, frequency response and distortion, AM to FM and FM to AM crosstalk.

### Aug 18, 1990

Field measurements were made to test the performance of Narrow Band FM under conditions of skywave intrusion from distant stations, AM and FM frequency response and harmonic distortion, FM performance in directional pattern nulls and crosstalk measurements under various signal conditions.

These tests complete my measurements of the performance of MW Narrow Band Frequency Modulation on an Amplitude Modulated Standard Broadcast carrier.

QEI QEI QEI QEI QEI

W H Y Q E I ?

### Single Phase 30 kW.



Our new FMQ 30000B is the only 30 kW transmitter available with a single phase power supply.

Call us toll free at 800-334-9154 for all the facts on QEI "New Reliables" FM transmitters from 1kw to 30 kw.

QEI CORPORATION  
ONE AIRPORT DRIVE • P.O. BOX D  
WILLIAMSTOWN, N.J. 08094

TEL (609) 728-2020 • FAX (609) 629-1751

QUALITY • ENGINEERING • INNOVATION

**MICRO-TRAK**

**THE SPORT 5**



FOR SPORTS...  
FOR CHURCHES...  
TALK SHOWS

LIGHTWEIGHT-TOUGH  
DIAL — DTMF OR TONE  
FOUR MIX CHANNELS  
MIC/HIGH LEVELSON 3 & 4  
FREQUENCY EXTENDER OPT

**413 594-1940**

**MICRO-TRAK CORP**  
CHICOPEE, MASSACHUSETTS



## Buying AM RF Components

More often than not, the engineer is called upon to replace a failed or worn out RF component in a phasor or ATU. What you buy to replace the worn or failed component will be a factor in how long the replacement will last. This month we will tell you what to look for when buying replacement inductors.

A phasor or ATU is essentially made up of inductors (both fixed and variable), capacitors (mica and/or vacuum -- fixed and variable), jacks, meters, clamps, interconnect tubing, etc., and other things that might be peculiar to your equipment. The various manufacturers of components each has their own way of doing things -- some because of economics and some because "that's the way they always did it." How each manufacturer builds its components does not make one right or wrong, but you, as the customer, should know there are differences. By knowing these differences, you can decide what is best for you and your station.

Inductors are made in fixed and variable types. The fixed types are wound with either edgewise copper ribbon or copper tubing. The area of copper employed determines the current handling ability of the inductor. The manufacturer usually has a catalog listing showing what size ribbon or tubing will carry what amount of current. Here is a table you can use:

Material Type	Current (RMS)
1/4" ribbon	10A
3/8" ribbon	15A
1/2" ribbon	20A
3/8" tubing	30A
1/2" tubing	40A
5/8" tubing	50A
3/4" tubing	60A
1-1/8" tubing	90A
1-5/8" tubing	130A
2" tubing	160A

It is important to remember the manufacturer's ratings are probably at 1 mHz. Therefore, if you plan to use the inductor at another frequency (F), you must change the rating (I) according to the following formula:

$$I (FmHz) \approx I (1mHz) \sqrt[4]{\frac{1}{FmHz}}$$

You should make sure the original equipment was properly designed, in that a sufficient allowance was made for modulated currents. Sometimes a manufacturer, in an effort to keep his bid price low, will skimp on current ratings. A good rule of thumb is to allow at least 1.5 times (preferably 2 times) the calculated current rating when searching for a replacement inductor.

Many times people will call us for an inductor, not knowing the manufacturer's part number (ours or others). Before you call, if you do not have a

(continued on page-31)

**QE1 QE1 QE1 QE1 QE1**

**WHY QE1?**

**The Longest.**



Our PA tube warranty is the longest in the business — 15,000 hours.

Call us toll free at 800-334-9154 for all the facts on QE1 "New Reliables" FM transmitters from 3.5 kw to 30 kw.

QE1 CORPORATION  
ONE AIRPORT DRIVE • P.O. BOX D  
WILLIAMSTOWN, N.J. 08094

TEL (609) 728-2020 • FAX (609) 629-1751

**QUALITY • ENGINEERING • INNOVATION**

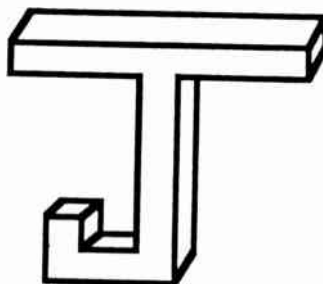

**SQUARED** TECHNICAL SERVICE

543 West 100 North  
West Bountiful, Utah 84010

801-298-8515

**Equipment Repair and Calibration**

**We service most AM/FM broadcast monitors, remote control systems, exciters, STL's, TSL's RPU's, Etc.**

**Give Us A Call**

**Check Our Rates**

**STL Loaner Program**

## RF Transmission . . (continued)

part number, determine what the inductor is wound from, count the number of turns, the pitch (that's the distance between the winding centers) and the diameter of the coil. The manufacturer can determine from that, what size coil you are replacing.

The inductor itself is supported by means of support bars (3 or 4) held in place by means of metal end brackets. It is important that the support bars be made of heavy duty insulator - an epoxy glass laminate such as GP0-3 is excellent - and be treated with a moisture resistant coating. All types of insulator bars used by the various manufacturers do absorb some moisture. Therefore, it is important that the bars be moisture treated.

Since most manufacturers use metal end brackets to secure the support bars, some means must be made to prevent closed loops in the inductance field created by the inductor itself. The hardware used to secure the

end brackets must have the proper insulation to prevent a closed loop. In the small inductors, an insulated bushing is usually sufficient but, as you go up on inductor size, the insulated bushing just will not be satisfactory. The proper way is to use a ceramic type insulator on each set of brackets to break up the loop. Just how the inductor is insulated can usually be determined before you buy, just by looking at the pictures in the manufacturers literature.

Variable inductors have a different set of problems. Unlike a fixed inductor that has a tap connection to vary the inductance, the variable inductor has a roller assembly that rides on the inside of the coil, for the most part. Where the roller sits, in relationship to the length of the inductor, is how much of the total inductance is available.

At Vector Technology we have two ways of making the roller assembly. Which one is used depends upon the type of inductor. The ribbon type variable uses a pair of spring loaded contact discs that ride on both sides of the ribbon and is driven by a fixed shaft

riding the center of the inductor. This type is relatively easy to manufacture by almost anyone. The problem arises when you try to make a roller assembly for high current inductors. At higher current, the inductors are tubing type coils. At Vector, on tubing type inductors, we use a system that has a large contact area and is spring loaded for equal tension along the inside of the coil winding. Some manufacturers use other systems but we know from years of experience with high powered systems, the spring loaded roller disc and roller contact works best. So much so, that we are able to use it with variables up to 80 amperes.

Last, but not least, when buying inductors (both fixed and variable), is the need to have "cap" nuts on hardware to prevent corona buildup and arcing from the high voltage gradients typically found on inductors carrying high currents. Before ordering that replacement inductor, make sure that the component comes this way as well as asking about the other items mentioned here.

## Don't Retire that Old Executive ... Retrofit!

With Broadcast Devices' field proven 10-minute retrofits you can make your old sturdy Harris Executive console perform like today's top of the line. These affordable retrofit electronics are modern plug-in replacements for the old technology mic preamps and line amps. They eliminate the cost and time it takes for a complete studio redesign and still give you 1990's specs! The reliability of our retrofits eliminate the maintenance headaches that cause embarrassing downtime.

Contact Broadcast Devices or your local broadcast distributor today for more details.

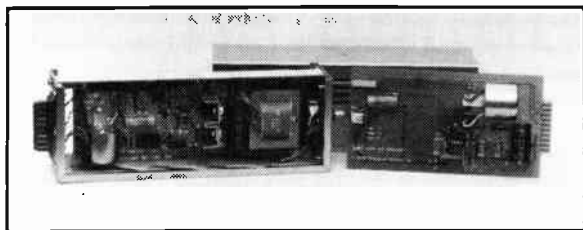

BDI HLR-100 Line Amp and HPR-100 Retrofit Preamp

These modules will also retrofit other Harris consoles including the Diplomat, President and Ambassador series.



**Broadcast Devices, Inc.**

5 Crestview Avenue  
Peekskill, NY 10566  
(914) 737-5032

## Rebuilt Power Tubes **Econco**

Approximately  
**One Half the Cost of New**  
3,000 Hour Unconditional Guarantee  
Some of the Tubes We Rebuild

3CX2500F3	3CX3000A1
3CX3000F7	4CX5000A
4CX10000D	4CX15000A

5762 / 7C24

Call for Our Price List



### **Econco**

1318 Commerce Avenue  
Woodland, CA 95695 USA

Telephone: 916-662-7553

Fax: 916-666-7760

Telex: 176756

Toll Free: 800-532-6626

From Canada: 800-848-8841

## The Good Old Days: !!! or ???

The "good old days", before de-regulation, can either rate an exclamation point or a question mark depending on one's recollection.

For those of us with little hair and lots of memories, and for some who may not go back that far, I thought we might take a look at some of the FCC rules that were in effect in 1957. This just happens to be the year that I wandered into radio and, along the way, I kept a complete set of the rules updated to June of 1957.

Interestingly enough, we have come almost full cycle on the license required for operators. Sec. 13.61 and 13.62, (the numbering system was different then), provided that the holder of a restricted radiotelephone operators license, known to us as a "boxtop", could operate, "A standard broadcast station with authorized operating

power of 10KW or less and employing a non-directional antenna....." They could also operate FM stations up to 10 KW. All other stations required that a holder of a first class radiotelephone operator's license be on duty.

This, of course led to the development of license mills to turn out operators who could pass the test, but might not really know anything. Later it was required that all operators hold, at least, a third class license requiring some knowledge of radio operations. This, of course, was dropped and now any station of any size may be operated by anyone who can sign their name and coughs up the required fee.

Some of the other operator related things that have been dropped along the way include the statement under Sec. 13.64 that "All licensed radio operators shall obey and carry out the

lawful orders of the master or person lawfully in charge...." There also is shown a proposed amendment that says, "No person shall hold any grade of commercial radio operator license or permit who is a member of: (1) The Communist Party, or .....(2) any communist-front organization .....or (3) any organization which advocates or teaches the overthrow of the United States Government.....by force or violence.

Sec. 13.91 provided that, "A station licensee.....shall endorse the service record appearing on said operator license showing the call letters,....the nature and period of employment, and quality of performance of duty. This, of course, was indicative of the fact that many of the rules applicable to broadcast stations were simply carryover from the ship-to-shore era. The FCC

**Davilys**  
CORP.

**4CX250B/7203 EIMAC**  
**\$175.00/PAIR**



NEW—  
ORIGINAL BOX  
EIMAC—

MIC & VISA  
ACCEPTED

13406 SATICOY STREET  
N. HOLLYWOOD, CA 91605-3475  
TEL: (818) 787-3334 FAX (818) 787-4732  
(Inside U.S.A.) 800-235-6222

YOUR NEXT RADIO STATION  
CAN LOOK LIKE THIS!  
SMARTCASTER AND YOUR  
SATELLITE NETWORK  
DOES IT ALL!



**Smarts Broadcast Systems**  
Box 293  
Emmetsburg, IA 50536  
(800) 747-6278



had not yet recognized the broadcast services as a different animal and many of the questions on the operator license test dealt with ship-to-shore operations.

One rule that was a carryover from the days when each station had a live studio band and almost nothing was recorded was sec. 3.188. This rule required that, if any program was recorded, an announcement would be made at the beginning and at the end to the effect that "The preceding program was transcribed". This was officially known as a Mechanical Reproduction Announcement.

By 1957 every station with which I was familiar was broadcasting all, or almost all, of their music off of records. This required a slightly different announcement. When doing a disc jockey show, we were required each 15 minutes to say "The music is recorded.", or something like that in order to explain to the listener that Frank Sinatra, Patti Page, and Ray Coniff's orchestra were not really at 250 watt KCON that day. Actually we didn't have room for even a five piece band much less a full orchestra.

Another interesting situation that developed as a result of the coming of records was the operation of some stations. I remember that, at one station in Little Rock, they had three people at the studio to do a disc jockey type program. The records were handled by a member of the musicians union up to the point of placing the record on the turntable. Then a member of the engineers union would cue the record and play it on the air when called for by the announcer, who was a member of the talent's union. Then, the musician would remove the record from the turntable and file it after placing the next record on the turntable, starting the cycle over again. Counting the engineer required at the transmitter, it took four people just to play records.

Speaking of the engineer at the transmitter, almost all stations had to have one since a directional, or any station of 10kw or more, could not be operated by remote control. Sec. 3.111 provided that the operator on duty make "An entry of the following each 30 minutes: ...operating constants of last radio stage (total plate

current and plate current and plate voltage) . . . . Antenna current...Frequency monitor reading...Temperature of crystal control chamber if thermometer is used.

Due to these requirements, most transmitter buildings included basic living quarters. There would be an office, kitchen, workshop, full bath facilities, and many times an actual apartment for someone to live there. Some transmitters, such as the Raytheon, even had a fold-down writing desk built into the transmitter to do your logging on.

Another rule that some of us lament the passing of is Sec. 3.40 (e) which required, "A spare tube of every type employed in the transmitter and frequency and modulation monitors shall be kept on hand." Those of us who do contract engineering on the side are very familiar with the stations who don't have a spare anything.

I hope you've enjoyed this brief look at some of the old regulations. If you would like to see some more on the ancient rules, let me know. Or let Radio Guide know.

## SINE SYSTEMS

*Innovative Solutions*

### DIAL UP REMOTE CONTROL



- \* Up to 64 channels of status, control, and metering.
- \* User programmable dial out tolerance and status alarms on six channels.
- \* FCC legal.
- \* One year warranty.
- \* User friendly.

**Complete 8 channel system starts at less than \$ 1,400!**

Call your HE sales engineer today.

**HE HALL**  
**Electronics**  
(804) 974-6466

1305-F seminole Trail  
Charlottesville, VA  
22901

## IT'S METAL!

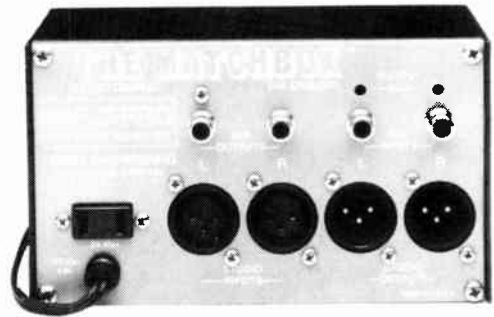

### THE MATCHBOX IS IMPROVED!

The industry's most used level and impedance converter has been updated, with an all-metal chassis, gold-plated RCA connectors, and new XLR's. The metal box keeps out hum, noise, and RF. The new connectors keep the audio clean. The only thing we didn't "improve" was the price!

**HENRY ENGINEERING**

**(818) 355-3656**

**We Build Solutions**

# Contract Guide

Contract Engineering Services  
For The Broadcast Industry

**Harnack Engineering**  
Girk Harnack & Robert Benjamin  
385 Lamar Suite 5  
Memphis, TN 38104  
(901) 278-1306 or (800) 366-7618  
Studio Design & Construction, Maintenance  
RTL Engineering, RF Plant Design & Const.

**Electro-Labs**  
James Chase  
PO Box 124  
Bloomington, IN 46703  
(317) 339-6427  
Contract Engineering Service, Field intensity  
measurements for AM, FM, TV (UHF & VHF).

**Lloyd Broadcast Technical Services**  
1818 SW Columbia Circle  
Seaside, OR 97062  
(503) 692-6074

**South Jersey Broadcast** - Dan Garafolo  
Box 63 North Main St.  
Williamstown, NJ 08094  
(609) 875-9728

**Phoenix Broadcast Engineering** - David Dickson  
51-A East Coshise Dr.  
Phoenix, AZ 85020  
(602) 371-0991  
2 yrs. experience in recording studio  
and broadcast engineering

**Central Broadcast Engineering Group**  
(707) 847-8244  
Construction/Monthly contracts/Emergencies  
Ask for: Ken Ruhland

**Contract Engineers  
Call Radio Guide  
To Be Listed Here  
(507) 280-9668**

**Blank Cassettes...  
Perfect for Demo Spots**

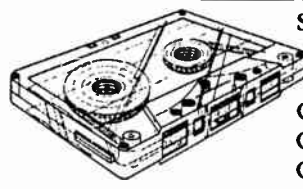

BASF Pure Chrome  
Shape Precision see-thru shell  
in quantities of:

	50	100
C-5's	\$.63 ea.	\$.55 ea.
C-10's	\$.69 ea.	\$.60 ea.
C-15's	\$.74 ea.	\$.65 ea.

Custom lengths are also available

BASF LHD Normal Bias  
Michelex German made shells  
in quantities of:

	50	100
C-5's	\$.49 ea.	\$.42 ea.
C-10's	\$.53 ea.	\$.46 ea.
C-15's	\$.58 ea.	\$.50 ea.



**PHONE: (507) 288-7711**  
**FAX: (507) 288-4531**  
Tom Jones Recording Studios  
220 South Broadway  
Rochester, Minnesota 55904

**Send Your  
Tech-tips  
to Radio Guide**

**The Folded  
Unipole:**

**The Ultimate Antenna  
for AM Broadcast!**

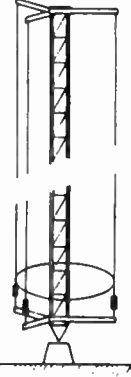

- Broad bandwidth
- Grounded antenna
- Eliminates isocouplers
- AM-FM site consolidation
- Effective as detuning skirt
- Custom kit; easy assembly

**nott ltd.**  
*atmospherics • electromagnetics*  
Box 761, Farmington NM 87499 • (505) 327-5646

## MCI Coax Switch Family From Micro Communications Inc.

MCI's unique coplanar **Coax Switch** saves the broadcaster money because it requires fewer costly elbows.

The **MCI Coax Switch** is driven by a high torque AC motor with a built-in manual override. Interlock and logic circuits are included as a standard item on each switch. DC voltage control is optional.

Available in three sizes; 1-5/8", 3-3/8" and 6-1/8", **MCI's Coax Switch** prices are \$2,200, \$3,100 and \$5,000 respectively. Delivery is 1 to 2 weeks. Frequency range is DC to 900 mHz. The 1-5/8" model is operable up to 2000 mHz.

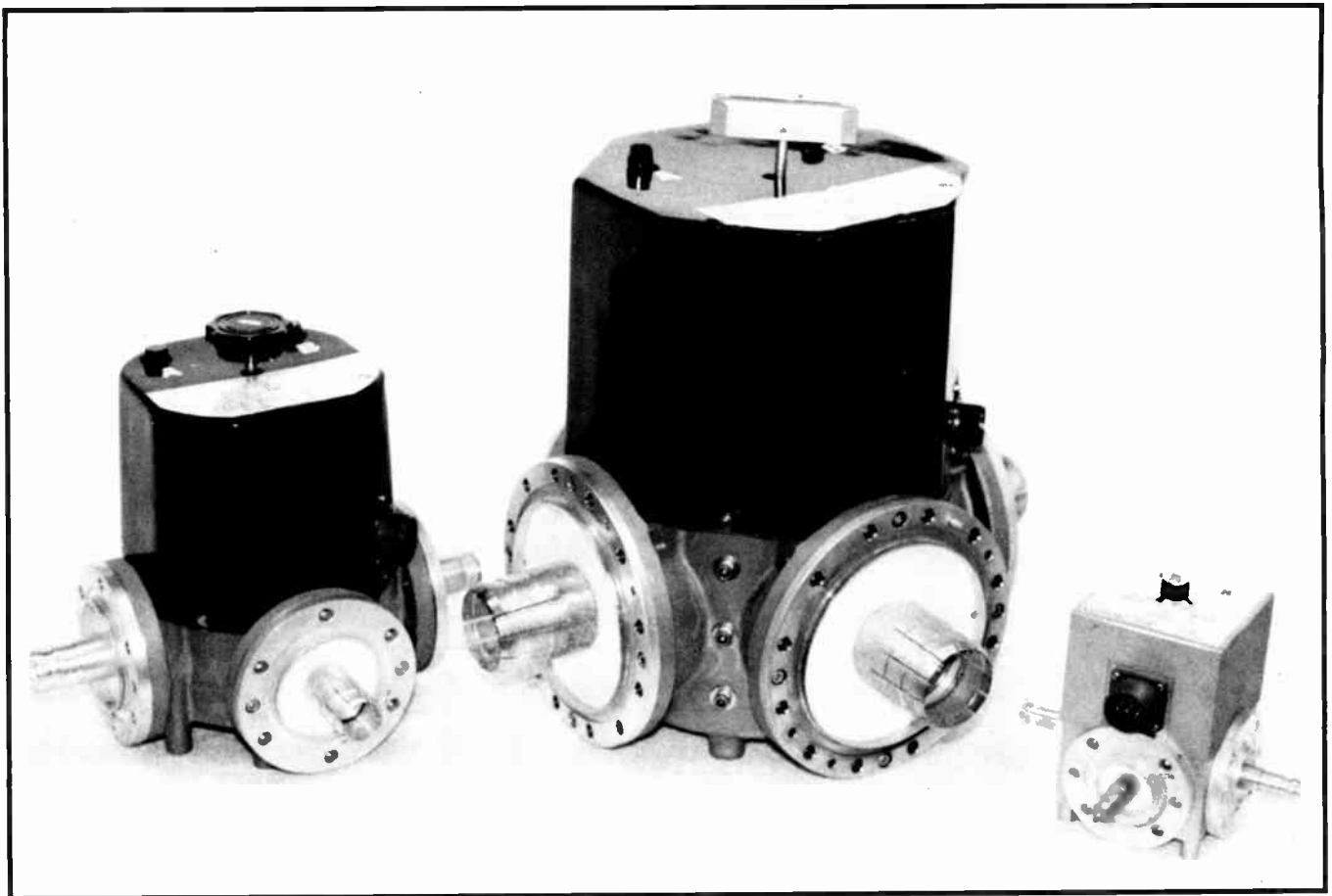

**Micro Communications  
Grenier Field  
P.O. Box 4365  
Manchester, New Hampshire 03108  
(603) 624-4351 Fax (603) 624-4822**



# Equipment For Sale

**Andrew RF switch.** 6" motorized, 4-port. Also have 3-1/8 switches.

**McMartin B-910 FM exciter.** 15 watt, mono or stereo, tuned to your frequency. \$1000

**McMartin monitors.** FM mono, stereo, SCA. tuned and calibrated to your frequency.

**Electro-Impulse 20 kW air cooled dummy load** with 3-1/8" Bird Wattmeter. Also 75 kW Electro AM dummy load.

**Moseley PCL-606 STL composite receiver** only. Also PCL-505.

**Goodrich Enterprises Inc.**

11435 Manderson St.

Omaha, NE 68164

402-493-1886

---

**Bext has some used and show units** available at sale prices. Full 2-year warranty. In some cases, like new. 2, 10, and 20 watt exciters. 100 watt and 500 watt amplifiers. Call for details.

**Michelle De Fazio**

**Bext Inc.**

739 5th Ave.

Suite 7A

San Diego, CA 92101

619-239-8462

---

**Stellavox SP-7 portable stereo reel-to-reel recorder.** Similar to Nagra. 7-1/2, 15, 30 IPS, 2-track with pilot for film/video sync. Mint condition. \$1000 or best offer.

**Hank Landsberg**

**Henry Engineering**

503 Key Vistas Drive

Sierra Madre, CA 91024

818-355-3656

Fax 818-355-0077

---

**Complete Sonomag Automation:**

1) DAS-12 audio switcher

5) SMC mono carousels

4) SMC (Otari) reels

1) Mutual Tone decoder (age 2 years).

1) 25Hz tone generator.

Complete in rack with monitor.

**LPB model s-13C Console.** 8-pot stereo, 24-input, like new with little use.

2) **Ampex reel transports.**

2) **Inovonics model 370 record/play amps.**

3) **Harris mono playback carts.**

1) **Gates (ATC) mono playback cart decks.**

**Rob Brennan**

**WQLK/WHON**

P.O. Box 1647

Tingler Road

Richmond, IN 47374

312-962-1595

---

**Kahn "Power-Side" complete.**

**Orban 222A Spacial Enhancer.**

**Texar "slot-5" card.**

**Shafer 700 brain and programmer.**

**Audiofile cart machine.**

**Dave Doughty**

**H&D Broadcast Group**

P.O. Box 781

Utica, NY 13503

315-797-1330

---

**Harris TE-3 FM exciter.** \$1,200

**TFT-7610 wireless emote control.** Needs work.

**Harris FM exciter MS-15 modulated oscillator** and MS-15 auto-frequency control cards.

**Moseley 303 composite stereo STL** on 950 mHz. \$2,000 or best offer.

**Collins A810W FM exciter.** \$600

**Wilkinson S-61E stereo generator.** \$700

**Energy-Only model MK25 25kW FM transmitter.** Will produce 30 kW output. Only 2 years old, ideal for class C FM station. Includes new final tube.

---

**Joseph Bahr**

**WVIS-FM**

154 Guajataca St.

Crown Hills, Rio Padres, Puerto Rico 00926

809-751-8947

Fax 809-756-5914

**Sintronics S1-A-1S 1kW AM transmitter** on 1540 kHz. Solid state, many spare parts, boards, etc. In storage for 4 years, was working when removed. Make offer.

**Bill Bowrn**

**WBCO/WQEL**

403 E. Renssecaer St.

Bucyrus, OH 44820

419-562-2222

---

**Sparta 3310 dual mono audio console.** 10 rotary mixers. Program, audition & cue outputs. Very good condition. \$850

---

**Contact: Rich Beierle**

**KFYR-TV**

P.O. Box 1738

Bismarck, ND 58502

701-255-5757

---

**Shure M267 mixer.** \$390

**Gentner EFT9000 telephone interface.** \$640

**Henry controller.** \$350

**Leader LBO-524U scope.** With manuals, needs no calibration. \$600

**Conex DS25B dual 25Hz sensor.** \$350

**Comark CSW 3518 1-3/8", 4-port motorized coaxial switch.** Never used. \$2,700

**Electro-Impulse DPT25KFM forced air cooled dry dummy load.** Never used. \$3,450

---

**Dick Eressy**

**WFCC**

1457 Main Street

West Chatham, MA 02699

508-945-4855

---

2) **Telex 1422 2-track plus 4-track playback.** Both for \$350

**Tapesonic 70TRS 2-track.** \$350

**Teac A3300 2-track.** \$400

**Teac A7030 portable.** \$400

**Teac "Tube Buff's" 7" reel stereo deck.** \$300

**(continued on page-38)**

Crown SS800 4-track 4-channel tube deck. \$300

Sony TC630D. \$125

Akai 4000D. \$100

Panasonic WVEX1 camera. New, in box. \$600

3) Altec 1567A. \$125 each.

Gray 108 tone arm. \$50

Marantz PM500 stereo amp. \$250

Yamaha C4 pre-amp. \$250

3) Viking 230 tape decks. New heads. \$200 for all three.

Presto GN record cutter. \$300

Wollensak/3M 4765 cassette deck. \$50

All above in good or mint condition. Many Teacs for sale.

Call: John Parsons

10375 Cannas St.

North Huntingdon, PA 15642

412-863-9590

---

Rane ME-1S 2/3 octave stereo equalizer. Excellent condition. \$250

Mark Osborne

WKSQ

P.O. Box 9494

Buttermilk Rd.

Ellsworth, ME 04605

207-667-7574

---

Gatesway-80 solid state 8-channel mono console. Good condition, for sale or trade.

Larry Fuss

KOOZ

P.O. Box 159

Fayetteville, GA 30214

404-460-6159

Fax 404-460-6129

---

Digimax D-1200 9-digit frequency counter. Brand new, never used, with manual. Paid \$299.95, asking \$250 plus shipping.

Precision/PACO E-200-C RF signal marking generator. Good condition with manual. \$75 plus UPS.

Broadcast Electronics AM-400 compressor limiter. Working when removed, with manual. \$225 plus UPS.

United Transformer power supply chokes: (1) CG-104, 10 Henrys, 350mA; (2) CG-44, 30 Henry, 100mA. \$150 for all plus UPS.

Ohmite, Memcor, IRC, High Voltage. Resistors, vitreous enameled slide adjustment, 6-3/4" long, all 100 watt, various current ratings and resistances. 300 total units. \$100 for all plus shipping.

CCA remote control studio and transmitter units with auxiliary relay panel. \$100 plus shipping.

Tektronix model 503 scope with manual. \$100 plus shipping.

General Radio signal generator. 50-250 MHz with power supply. \$200 plus shipping.

TOA public address amplifier model TA-958. 100 watts. \$200 plus shipping.

Ampex 6-Input mike mixer. \$150 plus UPS collect.

Shure model SR101 series 2 audio console. 8-input, as is. \$150 plus UPS collect.

Lloyd Spivey

WLLS AM/FM

Highway 231 South

Spinks Shopping Center

Hartford, KY 42347

502-298-3268

---

Andrews Connectors:

#1861 reducer. 50-ohm, 3-1/8" to 1-5/8". \$160

#1061A 90 degree 1-5/8" elbow. \$145

#1062A 90 degree 3-1/8" elbow. \$255

#75AN 7/8" to N (female). \$45

#23187 3-1/8" male to male. \$140

FT heads for 350/351. 2 complete sets (never used). Nortronics 9125-9102-9103. \$400

High speed duplicator. Garner model 2056 stereo. 60 IPS, 7-1/2" or 10" reels, 1 master, 5 slaves. Needs tuneup. \$750

Dick Agnes

WCLV

26501 Emery Industrial Pkwy.

Warrensville, OH 44128

216-464-0900

---

2) Russco studio-pro turntables with micro-trak tone arms. \$150 each.

ITC RP mono with 2 tones. \$950

2) Audimax model 4450A. \$450 each.

Bill Kulper Jr.

WFUR

399 Garfield SW

Grand Rapids, MI 49504

616-451-9387

---

Complete Collins 21-A 5kW transmitter. Completely disassembled. All parts including transformers in good condition. Includes several 891R and 892R good and dud tubes. Will sell all or part.

H. Haley

KETX

P.O. Box 1236

Livingston, TX 77351

409-327-8916

---

ROH 192B-16T stereo bridging line switcher. 16-input, new. \$1,995

ROH 202B 10-slot powered enclosure with internal 205B power supply. 9-slot capacity, new. \$560

ROH 211B distribution cards (1x6). 9 cards total, new. \$195 each.

ROH 210C 10-watt power amp modules. 3 cards total, new. \$200 each.

Elcom Bauer 690 FM exciter. Used 1 month, manuals included. \$2,395

Shure M67 mike mixer, M675 production mixer, A67B battery pack. Excellent condition. \$435

Eddor MX20 mike/line mixer. 8-input, great shape. \$235

Ramko SMA1000E 100-watt stereo amp. Like new. \$160

Technics SB-X30 linear phase speaker. New \$92.50

2) ESE 174 12/24 hour console mount clocks. New. \$128 each.

Bob Stewart

P.O. Box 1208

Roswell, GA 30077

404-992-2230

---

4) Scully 285 reproduce decks.

Ampex 354 FT stereo recorder.

Ampex 350 with Inovonics 370 R/P electronics.

MCI JH-110B FT stereo for 14" reels.

ITC 99B mono cart recorder.

(continued on page-39)

- ITC SP mono cart deck.
- 2) ITC RP mono cart recorders.
- UMC PB mono cart deck.
- Sony CDP-620es CD player.
- Spotmaster 5-input stereo audio DA.
- Martí PGM-20 line amp.
- Apt Holman phono pre-amp/control center.
- M.W. Persons 25Hz decoder.
- Automated Broadcast "Sequencer-16" with expander.
- 2) Equipment racks.
- 3) ABCO wire cart racks on floor stands. Hold 500 carts each.
- 342) Capitol A2 carts in fair to good shape.
- 36) Capitol A2 carts. New.
- 1178) Scotchcart II's in good shape containing an adult pop/lite jazz library, well recorded in stereo.
- 143) Scotchcart II's, new, all 3-1/2 minute or longer.
- 1 set) LEL alignment gauges for Ampro cart decks.

Call: Phil Wells  
 KJQY - San Diego  
 619-238-1037  
 Fax 619-238-6157

- 
- Collins 1000 watt 20V3 transmitter in excellent condition. Currently on air at 980 kHz. New in 1966, with manual. \$5,100
  - Tandy Model-2 computer. Keyboard, 3-drive expansion bay. \$400
  - Jampro JSCP-5 antenna tuned to 99.3 mHz. Taken off air April. Included mounting brackets, 1-5/8" flange. On 300' tower. Excellent condition, buyer removes. \$1,500
  - Approx. 300' 1-5/8" Andrew coax. No known defects, removed from air April. On 300' tower, buyer removes.
  - 300-foot, 24-inch face, guyed tower. 21 years old, painted and in good condition. Heavy material and heavy duty. Buyer removes. \$9,500
  - 1975 Coachman 22', tandem axle, camping trailer converted to mobile unit. Two turntables, console, internal and external sockets, AM/FM monitor, heatpump, range, refrigerator. \$2,750
  - Roberts model 997 stereo reel to reel recorder. Tube type, condition unknown. \$35
  - Ampex model 601 reel recorder. Tube type, condition unknown, with manual. \$50
  - Ampex 601 with no case. \$45
  - Crown logger, for parts. \$25

# PETER DAHL CO.

Save \$\$

Heavy Duty Replacement Transformers, DC Filter chokes and capacitors for AM & FM transmitters manufactured by: AEL, CCA, CSI, COLLINS, CONTEL, CONTINENTAL, BAUER, GATES, HARRIS, SINGER, McMARTIN, GE, RAYTHEON, RCA, SINTRONIX, ITA, WILKINSON. Many other models also available.

*FAST Delivery and FREE Technical Support*

5869 WAYCROSS AVENUE  
 EL PASO, TEXAS 79924  
 (915) 751-2300  
 TELEX: 76-3861 PWDCO  
 FAX: (915) 751-0768



- McMartin TBM-3500 FM monitor. \$50
  - Gates GTM-88F frequency monitor. \$125
  - Hammarlund VHF transceiver. 35 watts. \$50
- Contact Jeff or Curtis  
 WBZK  
 P.O. Box 398  
 York, SC 29745  
 803-684-4241

- 
- Harris Stereo-80 audio console. \$500
  - Gates turntable with tonearm. \$100
  - 2) Russco turntables with tonearms. \$150 each.
  - 3) Turntable preamps. \$125 each.
  - Lot of gates Criterion 80 mono cart machines. 4 working when removed and others for parts. \$1,200
  - 2) Gates Criterion record amplifiers (mono). \$100 each.
  - 2) Ampex 440 mono reel decks. \$400 each.
  - 2) Ampex 440 stereo reel decks. \$450 each.
  - 2) Floor consoles for Ampex 440's. \$75 each.

- Dorrrough DAP310 processor. \$50
- CBS stereo Audimax \$100
- CBS mono Audimax. \$50
- Sparta 5-mixer mono console. \$50
- Belar AM Mod monitor. \$250
- 7-foot equipment rack. \$30
- Harris MW1A AM transmitter. \$5,000

H. Carr Stalnaker  
 P.O. Box 100  
 Little Rock, AR 72203  
 501-372-7740  
 Fax 501-372-7787

---

TTC XL1FM2 FM translator with 2 Scala antennas. Contains (2) one watt amplifiers. Best offer.

George Thomas  
 WMSI  
 1375 Beasley Rd.  
 Jackson, MS 39206  
 601-982-1062

**Complete Automation System:**

SMC DP1 programmer, AS-20 audio switcher, SMC 721 dual-play decks, (6) SMC 350RSB Carousels, (3) SMC 250 Carousels, racks, cables, and much more. \$6,995

**Ed Dulaney**  
 KYKK/KZOR  
 619 N. Turner  
 Hobbs, NM 88240  
 505-397-4969

---

**Marti RPT-15** transmitter with Morse code identifier and Marti CR-10 receiver for TSL. 10F3 emission on 450.980 mHz. Only 1-1/2 years old, like new, with racks mounts. \$1,500

**Al Baxa**  
 WAVV  
 11800 Tamiami Trail E.  
 Naples, FL 33962  
 813-775-9288

---

**Technics RS-1500** reel to reel tape deck. 1/2-track stereo, 7-1/2 & 15 IPS. Good condition. \$350

**David Janzer**  
 Associated Technical Services  
 10010 West Schlinger Ave.  
 Milwaukee, WI 53214  
 414-476-4200

---

**Collins 212-M** mono console. Needs work.

**Collins 212-S** stereo console. Could make one good board out of both.

**UREI BL-40** Modulimiter. Good condition.

**CBS Volumax 4000A.** Fair condition. All equipment includes manuals, make offer on any or all.

**Stan Carter**  
 WRKN/WRJH  
 P.O. Box 145  
 Brandon, MS 39043  
 601-825-5045

---

**Harris System 9000 Automation:**

1) Event controller (brain) for 12 sources, including source cards, all system computer cards, power supply, and cables for (4) Otari ARS-1000 stereo reel decks plus Carousels. With data entry CRT workstation. Controller fully operational when removed from service on 7-10-90.

4) **Carousel-24** cartridge units. May need some work, not used in 5 years since live announcers.

2) **Standard system** equipment racks containing all above equipment.

No reasonable offer refused, buyer responsible for pickup and delivery to destination. Bank cashiers check only.

**Al Kaplan or Ken Eilert**  
 KWED  
 609 E. Court St.  
 Sequin, TX 78155  
 512-379-2234

---

**Tektronix RM545B** scope with Type B plug-in.

**Hewlett Packard 5245L** electronic counter.

**Wayne Nestor**  
 KDUH  
 1523 First Ave.  
 Scottsbluff, NE 69334  
 308-632-3071

---

**Gentner SPH-4** telephone hybrid. \$450

**Orban 111B** reverb. \$350

**Gentner 10x2** program switcher. \$500

**Dennis Orcutt**  
 KZBS-FM  
 3545 NW 58th  
 Suite 800  
 Oklahoma City, OK 73112  
 405-942-3399

4) **Eimac 4-250** tubes. New in original boxes. \$100 each.

**Pete Deets**  
 WFHR/WWRW  
 P.O. Box 8022  
 Wisconsin Rapids, WI 54495  
 715-424-1300  
 Fax 715-424-1347

---

**Comrex single line frequency extender system:**

1) LXT encoder  
 11) LXR decoders  
 3) TCB telephone couplers  
 \$4,500 for whole package.

**Jack Gennaro**  
 WFHR/WWRW  
 P.O. Box 8022  
 Wisconsin Rapids, WI 54495  
 715-424-1300  
 Fax 715-424-1347

---

**189-feet of Cablewave HCC-158-50J**, 1-5/8" air cable. \$6.50 per foot, on the spool, ready for shipment.

4) **1-5/8" EIA connectors** for 1-5/8" line. \$125 each. Will package 2 connectors with coax if desired.

6) **10-foot sections** of Rohn 45G tower. Excellent condition.

**1 section of Rohn SSV tower.** The section is an 8N with cross sections. No hardware. \$800

2) **6-foot Anixter Mark** grid dishes. \$150 each.

**4-foot Anixter** grid dish. \$75

No elements for any of the dishes.

**Adam Wantuck**  
 WAXY-FM  
 1975 E. Sunrise Blvd.  
 Fort Lauderdale, FL 33304  
 305-463-9299

---

**CRL model SPF-300** standard pre-emphasis filter to bring your AM up to NRSC. \$500

**Inovonics "MAPII" model 231** broadcast audio processor. \$500

**Pat Cahill**  
 WOBR  
 Highway 345  
 P.O. Box 400  
 Wanchese, NC 27981  
 919-473-3434

---

**One Wegner SCPC** satellite receiver for use with SMN's "The Heat" format.

**6-bay FM antenna** tuned to 99.3 mHz.

**(continued on page-41)**



Approx. 280 feet of 3-1/8" air Helix line.  
Gates Stereo Producer audio console.  
Mono Audimax.  
Mono Volumax.

Jime Coursole or Bruce Herzog  
WKPR-FM  
3891 Waukau Ave.  
P.O. Box 3450  
Oshkosh, WI 54903  
414-236-4242

---

SMN satellite receiver ready for "Country Coast to Coast" format. Wegner LNB system includes all instruction and installation manuals. Brand new, still in box! \$2,500

Daniel Smith  
WIXK AM/FM  
125 East 3rd St.  
New Richmond, WI 54017  
715-246-2254

---

2) Scully 270 mono 2-track auto reverse reproducers. 1985 vintage. \$1,000 each.  
50) Johnson ST-4A SCA receivers. \$50 each.  
All equipment working when taken off-line.

Robert L. Evans Sr.  
Cable Music Network Inc.  
156 Prospect St.  
Wilkes-Barre, PA 18702  
717-823-1166

---

Schafer 903 automation system. Includes printer, recently used in fully automated station. \$8,000

Ms. Deanie W. Galloway  
KIOU  
606 Sophia Lane  
Shreveport, LA 71115  
318-797-7946

---

2) Magnecord 1024 stereo record/playback decks. Excellent condition. \$100 each.

2) Scully 270 chassis. Lots of misc. parts. \$150 for all.

# FM BROADCASTERS!!

## We can meet all your FM transmitter needs!!



### SOLID STATE - LOW POWER

Amplifiers and transmitters are available at the popular levels of 30W, 100W, 300W, 500W, and 1KW. All units are solid state, broadband, and designed for both local and remote operation.



### ONE AND TWO TUBE HIGH POWER

Medium transmitters with broadband solid state drivers and one zero bias grounded grid triode in their PA are available at 1.5KW, 3.5KW, 5.5KW, 7.5KW, and 12KW. Higher power transmitter utilizing two grounded grid triodes (one as a driver) are available at standard outputs of 15KW, 22KW, 25KW, 30KW, 40KW, and 50KW.



## Energy-Onix

752 Warren Street Hudson, New York 12534  
(518) 828-1690 FAX (518) 828-8476

*A Wise Enterprise*

UREI model 530 9-band stereo equalizer. Looks bad but works. \$50

Gates FM Top-Level. Excellent condition. \$75

Lauderdale Electronics Program Lock (mono). Excellent condition. \$75

Hewlett Packard model 400D VTVM. Like new. \$100

---

Frederick E. Fess II  
WLRB/WKAI  
P.O. Box 250 119 West Carol  
Macomb, IL 61455  
309-833-5561

---

Marti SCG-10 92kHz SCA generator. Excellent condition.

Belar SCM-1 SCA mod monitor with 92kHz. Excellent condition.

Xtel AF-11R printer. Working. \$75

Xtel AF-11R printer for parts. \$25

Marti R30/150 RPU receiver. \$200

Otari ARS-1000 with SMC card. \$800

Optimod 8000A. Excellent condition. \$1,500

---

Mark Persons  
218-829-1326  
Fax 218-829-2026

---

McCurdy SS800 stereo audio console. 8-channel, 24-input, excellent condition. With furniture and patch bays. \$3,000 or best offer. Call for more info.

---

Bob Mitchell - WSYR/Y94FM  
500 Plum St.  
Bridgewater Place  
Syracuse, NY 12204  
315-472-9797

---

*Radio Guide September -1990 Page-41*

**Cornell Dubilier model CDB-5** decade capacitor. 0.01 to 1.1 uF (+/- 5%).

**Nestronics model B105** decade resistor. 10 ohms to 1.99999 meg (+/- 0.1%). 2-watt, pushbutton style.

\$150 each or \$225 for both.

**Wayne Nestor**

KDUH

418 1st Ave.

P.O. Box 4

Baynard, NE 69334

308-632-3071

---

2) **Symetrix TI-101** hybrids. Like new. \$250 each or \$450 for both.

**ABC tone decoder.** \$200

**Gentner RCF-1** card (Optimod #5) for use with Prisms. \$250

**Michael Holderfield**

WOOF AM/FM

P.O. Box 1427

Dothan, AL 36302

205-792-1149

---

**CRL PMC-300A.** Excellent condition. \$400

**Steve Manuel**

WWJB

55 West fort Dade Ave.

Brooksville, FL 34601

904-796-7469

---

**Gates BC1-T** transmitter and related parts. \$1,100

**Collins 831-G1** (1975) upgraded to an 831-G2B. \$17,500

Both transmitters still hooked up, good condition, as is, where is. We remove the capacitors, you replace them.

**Guy Patteson**

KBTM

P.O. Box 9375

Jonesboro, AR 72403

501-935-5597

---

**Orban 9000A.** Upgraded to 9100A and NRSC. Includes manuals. \$1,500

*Radio Guide September -1990 Page-42*

**Robert Smith**

R.M. Smith Associates

8 Deer Run Rd.

Windham, NH 03087

603-894-6968

---

**10-bay FM antenna.** Phelps Dodge CFM HP-10 circularly polarized, tuned to 105.9 MHz. 3-1/8" center fed with 3-point tuning, in good condition. You pay freight. \$6,000 or offer.

**Mike Sprysenski**

WOCL-FM

2101 S.R. 434

Suite 305

Longwood, FL 32779

407-682-2121

---

**TIE E300C** key telephone. 13 lines, TT, with schematics, new. \$50

**TIE E100C** key telephone. 5-line, 1A2 type, rotary, new. \$30

**Various telephones** (TT and rotary). Trim-line, Princess, wall and desk key phones. Most are WE, many telephones relays, coils, power plants, etc. Call for details.

2) **Portable magneto phones.** \$100 for pair.

**Wanless/Brute power supply.** Either 25 or 50 volts @ 50 or 25 amps, regulated. Variable and filtered, a beauty. \$200

**Wall phone.** Red with single number dialer. New. \$50

**Conference call switcher** for key phones. 5 lines, new. \$25

**Repeat coils:** WE-111C, \$25 each; WE120H, \$15; WE 23A (5kHz EQ), \$25.

**Telex 36 cart deck.** 4-track play with electronic track switching and rack mount. Brand new in factory sealed carton. \$200

**Shure wireless mike:** W15HT/58 hand held and W20R receiver. On 183.3 and 177.8 MHz. New. \$525 each.

**Bogen TP200** digital mono/stereo AM/FM tuner. Brand new in carton. \$100

**Bogen TP50** mono AM/FM tuner. Brand new in carton. \$100

**450 mHz mobile RF amp.** TPL model UD-6AC-7 (15-45 watts). \$100

**Bogen MO-100A** power amps. 100 watts, tube. \$50 each or 3 for \$1254

**TEAC/TASCAM model 3** mixer. 8x4x2, like new. \$500

**Sennheiser ME80/K2U** spot mike with extra ME80 head. All like new. \$275

**Sennheiser MKE10-3** tie-clip mike. New, requires power module. \$75

10 day return for full credit!

**Ed Davison**

135 N. Illinois

Springfield, IL 62702

217-787-0800

---

**Optimod 8000.** Used as a loaner when needed. \$1,500

**Broadcast Technical Services**

**James J. Free**

5290 Wellestey Dr.

Las Vegas, NV 89122

702-379-2446

---

**Gates BC-250T** AM transmitter with manuals. All factory parts, (6) 8008's, (10) 810's, (10) 807's. Includes Kintronics RF switcher (new). Taken out of service and used as an auxiliary. Worked perfectly when removed from service. Will sell any or all Best deal as a package.

**Mike Casey**

WKSX-FM/WJES-AM

Drawer 1

Johnston, SC 29832

803-275-4444

---

**Scientific Atlanta 2.8 meter** dish antenna with LNA. DAT not included. Make offer.

**Jeff Bretner**

WDFX-FM

306 S. Washington Suite 500

Royal Oak, MI 48067

313-398-1100

---

**McMartin TBM-3500** FM modulation monitor.

**McMartin TBM-2500A** RF amplifier.

Both set for 94.3 MHz, make offer, both work and have manuals.

**Jed Duvall**

WJNZ Radio

RR 6 Dunvbar Hill Rd.

P.O. Box 494

Greencastle, IN 46135

317-653-9717

**Gates FM-250C** FM transmitter. Tuned to 92.1 mHz, exciter not included. Used as auxiliary transmitter, worked when taken off line on June-90. Uses single 4CX-250B tube. Best offer. Buyer to pick up or pay shipping.

**Tom Murray**  
**WROI**  
100 W. 9th St.  
Suite 306  
Rochester, IN 46975  
219-223-6059

---

2) **IGM Go-Cart 24's**. \$2,500 each.  
**SMC 721** dual cart playback deck. \$500  
**SMC 710** playback cart deck. \$250  
**ITC stereo R/P**. \$1,200  
**B&K model 820** digital capacitance meter. \$125  
**Easy listening music**. 250 reels, very good condition with no dupes. \$10 each.  
**Production library** with sound effects. Mostly unopened. \$250

**Jim Wenstrom**  
**Wynne Broadcasting**  
503-882-4656

---

**Modulation Sciences Mod-Minder**. Used 2-3 hours. Best offer.  
**Symetrix TI-101** telephone interface. New, never used. Best offer.

**Harry N. Plumlee**  
**WGAP-FM**  
316 Court St.  
P.O. Box 4939  
Maryville, TN 37802  
615-983-4310

---

**Wegner satellite receiver** for SMN Star Station. 1606-10 downconverter; 1606-01 wideband demod; 1683-08 translator; 1621 dual demod; 1645 & 1646 tone decoders; 1605-03 power supply; 1601 mainframe. \$1,500

**Jim Macke**  
**KRSB**  
P.O. Box 5180  
Roseburg, OR 97470  
503-672-6641

# TRANSCOM CORP.

**Fine used AM & FM Transmitters  
and also New Equipment**

**For the best deals on Celwave products  
Andrew cable,  
Shively & Comark antennas.**

1978	CCA 2500R, 2.5 kW FM
1975	Harris FM5H3, 5 kW FM
1975	RCA BTF-10ES1, 10 kW FM
1972	CCA 20000DS, 20 kW FM
1976	RCA BTF-20E1, 20 kW FM
1983	Wilkinson 25000E, 25 kW FM
1986	Continental 314R1, 1 kW AM
1974	Harris BC1H, 1 kW AM
1981	McMartin BA-2.5K, 2.5 kW AM
1979	Harris MW5A, 5 kW AM
1966	Continental 315B, 5 kW AM
1984	CSI T5F, 5 kW FM
1981	McMartin BA-5K, 5 kW AM
1972	CCA AM5000D, 5 kW AM
1976	CCA AM5000D, 50 kW AM

**201 Old York Rd.  
York Plaza Suite 207  
Jenkintown, PA 19046**

**215-884-0888 or 800-441-8454**

**Fax No. 215-884-0738**

**AKG D58E** dynamic cardioid microphone. \$76.67

**Alliance U-110** antenna rotor, new. \$48

**Avanti goose-neck** light fixtures. \$20

**BES C-60D** flat panel 360 degree speakers. \$75

**Celestion HF-50** tweeters (JBL clone) new. \$50

**Cerwin-Vega DB-10** subsonic filter. \$67.50

**Custom 8"** two-way enclosures. \$75

**Electro-Voice RE-10** microphone. \$125

**Electro-Voice RE-635A** microphone. \$75

**Harmon Kardon Citation 11** pre-amp/switcher/EQ. \$150

**Harmon Kardon Citation 14** FM tuner with Dolby. \$125

**Howard Sams 21857** Sound System Engineering book. New. \$15

**JBL 2404H** bi-radial tweeter. \$92.50

**JBL 3102** passive 7kHz crossover. \$60

**JBL 2118H** extended range 8-ohm, 8" woofer. \$60

**JBL 2110H** extended range, 8-ohm, 8" woofer. \$50

**JBL 2202H** 12" woofer. \$110

**JBL 2225H** re-coned 15" woofer. \$117.50

**JBL 2308** slant plate/2391/2392, 10" lens. \$15

**JBL 4301** 8", two-way, studio monitor. \$137.50

**JBL 8216** fore-ground industrial, 8", two-way speaker. \$47

**JBL MA-15** woofer mounting bracket kit. \$6

**Pamotor 4600XP** fan motor. 4" mount with grills and connector. \$13.80

**Radio Shack Optimus-50**, 12", 3-way speaker system. \$75

**Radio Shack Lab-15**, linear tracking turntable. \$75

**Rane SM-26** mixer/splitter with 6 channels. \$210.80

**(continued on page-44)**

Rane MA-6 150 watt, 6 channel power amp. \$814.30

Rane SC-1.7 security cover \$13.18

Shure SM-58 microphone. \$67.50

Shure M64A phono pre-amp. \$49.95

Revox A-77 reel tape deck. \$500

TEAC SL-1800 turntable. \$125

Technics SL-1200 dustcovers & SL-1800 covers. \$10

TOA A-912A mixer/power amp. 120 watts, 6 ports. \$369

UREI 501 subsonic filter. \$67.50

Lonnie Domnitz

750 LaPlaya #1100

San Francisco, CA 94121

415-750-0931

---

3.0 meter and 3.7 meter T-bar SMATV earth station antennas. Best offer.

Reverend Joe Jagodensky

3501 S. Lake Dr.

Milwaukee, WI 53207

414-769-3453

---

Regency hi/lo 8-channel scanner. As is. \$10

Datapoint computers. \$100

Sparta Century cart machine (bad motor). \$25

Dourrough stereo generator. \$100

Dourrough loudness meter. \$25

Audimetrics stereo line/mike amp. \$25

2) Scully 270 stereo decks. \$200 plus shipping.

ATC (Gates) "55" cart machine. U-ship. \$150

Fairchild 658 stereo reverb system.

TI-810 printer. \$300

Atlantic Data Products II amber monitor. \$25

Extel AF-11 RO teleprinter. \$50

Gates Criterion cart machine. \$50

Shure M-64 stereo phono preamp. \$25

SMC TA C-1 time announce control. \$75

SMC 721 dual mono cart playback. \$200

Sparta Century dual playback. \$150

Gates Criterion-80 R/P with delay. \$150

Many Gates SP-10 switcher accessories and interfaces. Make offer.

All items -- if you don't like the price, make an offer!

Radio Guide September-1990 Page-44

Donald R. Russel

WDAN/WDNL

1501 N. Washington

Danville, IL 61832

217-442-1700

---

Grass Valley 1600-3F video switcher (s/n 3106057). 15 input, 2 ME bank, DSK, (2) pattern generators, (2) shadow chroma keyers, (1) encoded chroma keyer, and quad split. Completely realigned by GVG field service in March-90. Good production board, all manuals and original docs. \$7,500 plus shipping or you pick up.

Grass Valley model 1600-1V video switcher (s/n 1462-076). 10 inputs, 1 ME bank, USK, (1) pattern generator, (1) shadow chroma keyer. Completely realigned by GVG field service in March-90. Good production board. All manual and original docs. \$4,000 plus shipping or you pick up.

Yamaha model M-916 audio mixer. 16 fader with 2 inputs per fader (mic or line). Has cue and equalization for each channel plus effects rcv/send. Good board for post production or remotes. Very good condition. Selling due to getting larger board. \$850 plus shipping or you pick up.

2) Sections of Dielectric/RECA 6-1/8" copper transmission line with bolt flange ends. On ground, needs to be cleaned, not physically damaged or dented or arced. Some new bullets are available. Each section is 20 feet long. \$225 per section. You transport.

2) Harris model 6522 C-band satellite receivers. (s/n 0938 & 0942). Composite baseband, regular video, and two sub-carrier outputs on 6.20 and 6.80 MHz. \$1,000 each or \$1,750 for both, plus shipping.

2) Ikegami model 730A ENG cameras with Fujinon 1/10 lens. Including CCU's (camera cables not available but can be locked via standard video cable). 9" hooded monitor with tally lights. used in studio. \$2,500 for each camera/CCU combo or \$4,750 for both, plus shipping.

2) RCA model TK-44 studio camera with Schneider lens. Plumtype camera, some CCU components available. Good physical condition, but operational condition is unknown as they were removed from service in 1984. Make a "reasonable" offer for each or both. if both are purchased, will include camera truck and camera head at N/C. Must pick up.

Several racks are available at \$50 each. Sorry, no description here; too many different racks in many different styles.

Inspection by appointment:

Fred Vobbe - WLIO TV

1424 Rice Ave.

Lima, OH 45805

419-228-8835 (9am - 11am EDST)

Fidonet Netmail to 1:234/16.0

---

Full track Wollensak A/V tape recorder. Like new and hard to find. Only 110 hours of use. It's a real workhorse. All tape heads like new. Includes complete service manual. \$550

Hector R. Sanchez

WNOZ

79 Sevilla St.

URB. Vista Alegre

Aguadilla, PR 00603

809-891-3011 (4pm to 7pm)

809-891-1340 (9am to 1pm)

---

Kintronics 3-tower 1 kW phasor. 10 years old in mint condition. Also one ATU made by Kintronics.

Ron Simpson

WQKR-AM

817 N. Broadway

Portland, TN 37148

615-325-3250

---

HP330B distortion analyzer. \$100

HP206A audio generator. \$100

Some new tubes in each units. Good to about 1% distortion. Would like to sell as a set.

Bill Keaton

608-362-0086

608-365-8865

---

Harris 9000 Automation: (6) Scully reel decks; CRT keyboard; logging printer.

Wegener Panda receiver for Transtar country format. With all manuals.

Cash offers or trade for R/P's (reels or carts).

Brent Harmon

WPLA

7201 E. Hillsboro

Tampa, FL 3361

813-689-9191

**Continental 802A** FM exciter. Like new and set to your frequency. \$3,900

**McMartin B-910** FM exciter with stereo generator and SCA generator. Good condition. \$995

**Shivley 6810** 8-bay FM antenna with heaters. On 101.1 mHz.

**Chirs Kreger**

22406 NE 159th St.

Kearney, MO 64060

816-635-5959 or Fax 816-635-4508

---

2) **Gates Solid Statesman** AGC's. \$250 for the pair.

2) **Satcue 400** switchers for Unistar formats, by Colorado Magnetics. \$500 each.

2) **Magnecord 1022** stereo machines. Electronics OK, transports good for parts.

2) **Magnecord 1021** mono machines. Electronics OK, transports for parts.

4) **Scully 270's**. Good for parts only. Make offer on any or all tape machines.

600) **Fidelipac carts** in all lengths. Extra shells and parts. These are the gray carts. \$500 takes them all.

28) **14" metal reels** and boxes in perfect condition. \$140

**Hal Widsten - KGNB/KNBT**

1540 Loop 337 North

New Braunfels, TX 78130

512-625-7311

---

**TFT EBS system** including 760-04 2-tone generator, 760-01 Ma synthesized receiver, 760-03 tone decoder. Serial #6876. Unit was purchased new and used for a short wave broadcast station. Unit is in excellent condition. \$750

**Tim Coucke - KNLS - Short Wave**

P.O. Box 473

Anchor Point, AK 99556

907-235-8262

---

**SMC DP-2 Automation:** DS-20 switcher; (3) Carousels; (4) Otari tape decks. Make an offer.

**Doyle Barron or Clynn Daves**

KWJM

113 N. Main

Farmerville, LA 71241

318-368-3094

**ERI Type G5CPS-2AE.** 2-bay rototiller, 32kW, complete with shorting stub, input transformer, face mounts for Rohn 55-G tower. On 98.3 mHz. New in late 1984 and in excellent condition. Now in storage. Best offer.

**Terry Baun - WFMR**

W172 N7348 Shady Lane

Menomonee Falls, WI 53251

414-255-3100

414-449-5300

---

**Wang traffic and billing system** for 2 stations. Complete system with two remote RS-232 terminals. In working condition, just removed from service. \$990

**Jeff L. Watts - WFMX**

1117 Radio Rd.

Statesville, NC 28677

704-872-6348

---

**830F 10kW Collins** FM transmitter with 310Z-1 solid state exciter. \$16,000

**8100A/1 FM Optimod/stereo** generator. \$4,500

**TFT-724** FM monitor, 730 stereo monitor, 734 SCA monitor. \$2,200

**Lee Clardy**

KADN

1500 Eraste Landry Rd.

Lafayette, LA 70506

318-237-1500

Fax 318-237-2237

2) **Telex MC series** cart players.

**Moseley TCS-2** remote control.

**ITC triple stack** RP series.

**ITC mono cart** recorder.

**QRK Futura-6S** console.

**CCA FM 10-DS** exciter.

All equipment on air and working when replaced. Make offer.

**Dave Hill**

KWBR-FM

3195 McMillan Rd.

Suite G

San Luis Obispo, CA 93401

805-541-8878

Fax 805-543-3642

**Kintronics** power reduction unit. New condition.

**Gates 6-channel** yard console. Use for parts.

2) **Gates (MO2639)** modulation monitors. Use for parts.

**Gates frequency** monitor (MO 2890).

**Collins 26J3** audio level amp.

**Collins 26U3** audio limiting amp.

**Phillip Beal**

WRGS

Burem Rd.

Rogerville, TN 37857

615-272-3900

---

**Jampro JSCP-8** on 98.3 mHz. Will tune easily. 8 years old, excellent condition. On air recently, make offer.

**Kato 50kW** 3-phase AC generator. 151 amps @ 208/240 volts. Supercharged diesel engine with less than 150 hours. 8 years old with spare voltage regulator and water heater. \$12,000.

**Patrick Parks**

KYKR

27 Sawyer

Beumont, TX 77702

409-838-3911

Fax 409-838-3233

---

**Jampro JSCP-10** on 93.3 mHz. Broadband, will tune. On air recently with Andrew 4" Helix. 55kW rating, with connectors. 480' coax is one year old. Both in excellent condition. Will sell separately. Make offer.

**Patrick Parks**

KYKR

27 Sawyer St.

Beaumont, TX 77702

409-838-3911

Fax 409-838-3233

**Watch For The "New"  
Classified Ads.  
A Better Way to  
Sell Your Gear**

# Business Guide

Products and Services  
for the Broadcast Industry

## Test Equipment

*Why Buy When You Can Rent?*

**POTOMAC - DELTA - BIRD**

Other Equipment Available

*Call for Rates and Availability*

### Radio Resources

1-800-54-RADIO (1-800-547-2346)

(301) 859-1500

## **BRENTLINGER BROADCAST ENGINEERING, INC.**

*Charles Jayson Brentlinger  
President*

COMPUTERIZED REPORTS / ALLOCATION STUDIES  
AM • FM • AM DIRECTIONALS • AUDIO • STL • SATELLITE COMMUNICATIONS  
4338 East Acoma Drive • Phoenix, Arizona 85032 • (602) 867-0181



(802) 226-7582  
FAX: 802-226-7738

## COMMERCIAL RADIO COMPANY

Transmitter Parts for: RCA, Gates, Collins  
Non-PCB Filter and Mica Transmitting Capacitors

DUTTONSVILLE SCHOOL DRIVE  
CAVENDISH, VT. 05142  
DANIEL W. CHURCHILL

## Tube Rebuilding Freeland Products

- We Buy Duds -

*Since 1940  
Save About 50%*



800-624-7626  
504-893-1243  
Fax 504-892-7323

Including for TV  
RCA Cermolox and UHF Klystrons

## LIGHTNING PREVENTION SYSTEMS

LIGHTNING PROTECTION AND PREVENTION SYSTEMS  
FOR COMMUNICATIONS TOWER SITES.

204B Cross Keys Road, Berlin, NJ 08009  
FAX 609-767-7547 • (609) 767-7209

*Don't Wait Until It's Too Late!*

## **HALL** Electronics

**THE BEST DEALS ON QUALITY  
REBUILT & BRAND NEW  
BROADCAST EQUIPMENT**

We BUY & TRADE equipment too!  
Please phone or send for our latest flyer.

10:00AM-6:00PM EST

804-974-6466

FAX 804-974-6450

1305-F Seminole Trail  
Charlottesville, VA 22901

# Business Guide

Products and Services  
for the Broadcast Industry

FCC's Engineering  
**AM, FM and TV Data Bases**  
On floppy (or) 9-track tape

*Call today to request a free sample*

**Communication Data Inc.**

6105 E. Arlington Blvd.  
Falls Church, VA 22044  
703-534-0034

## SBE

**STANLEY BROADCAST  
ENGINEERING**

**James S. Stanley**

P.O. Box 24601  
Tempe, AZ 85282

(602) 264-8752

East  
**BOB STEWART**  
404-992-2230

West  
**TOM BUTLER**  
501-253-8127

Fax 501-253-6151

### **ROSCOM GENERAL**

BROADCAST EQUIPMENT SPECIALISTS  
RF AND STUDIO EQUIPMENT

**GET IT ALL WITH ONE CALL  
FROM TOWERS TO TONEARMS**

**Complete Service for Lightning Protection,  
Grounding and Power Conditioning**

**We Guarantee NO Strikes**

Call Lightning Eliminators & Consultants, Inc.



6687 Arapahoe Road  
Boulder, Colorado 80303  
(303) 447-2828  
FAX (303) 447-8122

**Consulting Communications  
Engineers**

- FCC Data Bases
- FCC Applications and Field Engineering
- Frequency Searches and Coordination
- AM-FM-CATV-ITFS-LPTV

**OWL ENGINEERING, INC.**

1306 W. County Road. F,  
St. Paul, MN 55112  
(612)631-1338 "Member AFCCE"

**GOODRICH** enterprises, Inc.

Parts and technical service for all  
**McMartin - Transmitters, Consoles, Exciters**  
*Modulation Monitors Calibrated*  
*Transmitter Tubes - New and Re-Built*

11435 Manderson St.  
Omaha, NE 68164  
Phone (402) 493-1886  
Fax (402) 331-0638  
Telex 940103 WU PUB TLX BSN

## **NORTHERN MAGNETICS**

CERTIFIED TAPE HEAD SERVICES

Northern Magnetics is an industry leader in the supply and service of tape heads and tape head products.

P.O. Box 16409  
Minneapolis, MN 55416

Phone: (612) 333-3071  
Telex: 1561238 MPS UT  
FAA Repair Station # C14-57

## Logging Onto A BBS

A number of interesting things have happened in the broadcast-oriented computer bulletin board system community!

Perhaps one of the most notable events was the fact that The Idiot Box BBS in California is now available via a national toll-free number, 1-800-766-1720.

"Radio Guide On-Line", Radio Guide's toll-free BBS is not quite ready to accept calls. In order to be absolutely certain that "Radio Guide On-Line" users have a wide variety of information available from individuals and equipment manufacturers, certain areas of the system are still "under construction." We are all looking forward to a very unique on-line source of information and conversation when the system becomes available!

### The Log-On Process

Last month's introductory "Broadcast BBS" column introduced you to the concept of "BBSing." In this month's column, we'll talk about the process of "logging on," or signing on, to a computer bulletin board system (BBS).

If you're calling one of the systems that are listed on the following page for the first time, *relax!* Many system operators, or "SysOps," are used to helping new users through their first time on the system. If you're lucky enough to be calling while the SysOp is right next to the computer you're connected to, he or she may actually drop into "chat mode," and take you on an on-line tour of the BBS you just called! "Chat mode" enables you to have a keyboard-to-keyboard conversation with the SysOp! It's almost like having your computer talk back to you, except that there's a person on the other end.

Most of the time, when a new user logs on to a BBS, the SysOp is not  
*Radio Guide September-1990 Page-48*

available. The BBS displays a new user questionnaire with your first call, and the answers to several personal questions about you are stored for the system operator to peruse. This helps the SysOp determine your security level, or level of access to that system, that is available with your user account on that system.

User accounts are similar to bank accounts. Each user that regularly accesses a computer bulletin board system has their own account, which is password protected against unauthorized use. Fortunately, most BBS's allow you to select your own password. Please try to use a password that's unique to each system you call -- there have been situations in the past when unscrupulous SysOps have tried using their user's password on other systems to gain access to a particular BBS under someone else's user account. Don't worry though; most SysOps are

very respectable people, and most new user applications remain confidential.

Your application to use a particular BBS is actually an application for a user account. BBS's maintain a user database, and your user account is in that database. Information stored in the user account of a particular BBS usually includes the number of "uploads" (file transfers from your computer to the BBS); the number of "downloads" (file transfers from the BBS to your computer); the number of times you've called the BBS; and the last message you read so that you can read the new messages posted by other users since your last call, and other administrative information.

Once you've filled out the new user application, your user account is updated to reflect the security level that the SysOp has allowed to all new users. The SysOp may or may not call you on the phone to "validate" you, or to be sure that the information provided in your user account application is valid. Some people attempt to gain more access time on BBS's by logging on as two different people. That defrauds the SysOp, and steals time from other users. Many SysOps will personally validate their users to maintain the integrity of their BBS. After the validation process, you should have full access to almost all of the features of a BBS.

Now that you *can* access a BBS, what's to do there? Call one and see! Explore some of the menu options. Don't worry about entering a wrong choice -- most BBS's are fairly "crash proof." That means that you can't damage them when accessing them with your user account.

In next month's column, we'll discuss features available from BBS's. We'll also publish a list of BBS-related terminology that will help you to understand "BBS lingo." Stay tuned to Radio Guide for more BBS news.

QEI QEI QEI QEI QEI

WHY QEI?

24 Hours.



Our 24 hour  
service hotline  
number is  
609-728-2020.

Call us toll free at  
800-334-9154 for all

the facts on QEI "New Reliables"  
FM transmitters from 1kw to 30 kw.

QEI CORPORATION  
ONE AIRPORT DRIVE • P.O. BOX D  
WILLIAMSTOWN, N.J. 08094

TEL (609) 728-2020 • FAX (609) 629-1751

QUALITY • ENGINEERING • INNOVATION



# Broadcast BBS

## Broadcast Oriented BBS Listing

<u>Phone</u>	<u>BBS Name</u>	<u>Program</u>	<u>Baud Rates</u>	<u>Sysop</u>
201-769-1779	Visions Infoline II	Wildcat	300-1200-2400	Jeff Morgan
201-857-8880	Rockboard	Hermes (Mac)	300-1200-2400	Adam Curry
205-859-3030	Traveler	Phoenix	300-2400	Mike Bennet
206-443-6170	W. Washington Freq. Coord.	OPUS	300-1200-2400	Walt Jamison
206-566-1155	Amocat	Wildcat	300-9600 HST	Rich Langsford
212-415-3500	Hypercube Systems	PCBoard	300-1200-2400	Mike Oswald
212-645-8673	Communication Specialties	Searchlight	1200-9600 HST	Rich Brooks
214-647-0670	DFW Freq. Coord. Council	OPUS	300-9600 HST	Darryl Doss
215-364-3324	Satalink	PCBoard	1200-2400-9600	Ron Brandt
216-529-0121	Signal BBS	PCBoard	300-1200-2400	Lynn Laymon
219-256-2255	Radio Daze	Gap	300-1200-2400	Mike Shannon
301-725-1072	FCC Public Access	Custom	300-1200	Bob Weber
303-949-3253	Master Control	----	300-9600	Lynn Osburn
315-474-5070	SBE Chapter 22	RBBS	300-1200-2400	Steve Hines
317-935-0531	Allied Radio World	Michtron	300-1200-2400	Bob Groome
402-289-2515	KFMQ 102 Connection	WWIV	1200-2400	Dan
404-320-6202	AV-Sync Atlanta	PCBoard	1200-9600 HST	Bill Tullis
404-982-0960	Rock & Roll Atlanta	PCBoard	1200-2400	Bob Helbush
407-239-2607	Producer's Circle	GT Power	300-1200-2400	Skeeter Durham
407-649-9834	Electronic Arts Info	QuickBBS	300-1200-2400	Jeff Alwin
408-985-8675	KOME Silent Side	Michtron	300-1200	Greg Argendell
412-981-3151	Mabel's Mansion	OPUS	1200-9600 HST	Charles Ring
414-771-3032	Second Opinion	Wildcat	1200-9600 HST	Mark Timpany
415-391-2657	NCFCC	RBBS	300-2400	Tim Pozar
415-571-6160	Production World	Red Ryder	300-1200-2400	Wes Dorman
415-641-4373	Information Radio	Wildcat	300-2400	Dave Evans
419-228-7236	Black Hole BBS	QuickBBS	300-1200-2400	Fred Vobbe
501-753-6536	N.L.R. 80	Spitfire	1200-2400	James Padgett
518-283-4067	Northeast Networks	PCBoard	1200-2400	John Nelson
601-373-0160	Net-Works	Galacticomm	1200-2400	Herb Jolly
602-438-0459	CRL	RBBS	1200-2400	Hank Langlinals
602-482-1001	Catalyst	TBBS	300-1200-2400	David Kidder
602-872-9148	Broadcaster's BBS	RemoteAccess	300-1200-2400	Mark Shander
608-274-7776	Communications Exchange	GT Power	1200-9600 HST	David Willow
614-766-2162	RadioLink!	QuickBBS	2400	Steve Craver
616-530-0821	Trillion	Wildcat	300-1200-2400	Dick Castanie
619-298-4027	Southern CA Medialine	PCBoard	1200-2400-9600 HST	Steve Tom
703-455-1873	VideoPro	PCBoard	300-1200-2400	Tom Hackett
703-538-6540	East Coast Pub Net	PCBoard	300-2400	Charlen Kyle
707-553-8452	KDA Message System	PICS	300-2400	Keith Davidson
713-782-5454	Ed Hopper's	PCBoard	300-1200-2400	Ed Hopper
713-855-4382	Cloud Nine	PCBoard	300-9600 HST	David Armstrong
713-974-3912	SBE Chapter 105	PCBoard	300-1200-2400	John Harvey
717-731-8966	Cat's Castle	Wildcat	200-1200-2400	Dale Fedorchik
719-634-5661	Colorado Springs Bdcst.	TBBS	300-1200-2400	John Anderson
801-967-9716	Planet Vulcan	Wildcat	300-14.2K HST	Chuck Condron
804-393-6390	Tidewater Medialink	PCBoard	1200-2400	George Randell
804-550-3338	Flamethrower	OPUS	300-1200-2400	Jeff Loughridge
804-973-8235	Broadcaster's BBS	PCBoard 12	300-1200-2400	Pat Wilson
806-352-2482	Radio On-line	PCBoard	1200-9600 HST	Ron Chase
813-527-5666	St. Pete Pgm Exchange	PCBoard	1200-9600 HST	Bill Bomgren
818-248-3088	Hot Tips	Wildcat	1200-2400	Mike Callaghan
818-363-3192	Call Sheet	TBBS	300-1200	Wayne Parsons
818-567-6564	Hotline	PCBoard	1200-19.2K HST	Jon Badeaux
916-338-5227	KBBS	QBBS	300-1200-2400	Mark Stennett
916-646-3600	FM102	QuickBBS	300-1200	Les Tracy
916-646-9358	Scratching Post	QuickBBS	300-1200-2400	Stacy Rothwell
916-728-5700	Entertain-Net	TBBS Multiline	300-1200-2400	Les Tracy
918-437-9004	The Radio BBS	QuickBBS	2400	Clark Dixon
919-481-2947	Recording Studio	WWIV	300-1200-2400	Greg Nowak

## "ORCAD" for Drawing Schematics

I have looked everywhere in the past for a program to draw schematics. I have tried improvising with word processors with the line draw capabilities, and even tried simple computer drawing programs. Nothing really seemed to work. I even spent days constructing a library of schematic symbols for KD-Draw-PC, a shareware CAD program, only to abandon it later. I did get to where I could construct a schematic in pretty short order using KD-Draw, and it didn't look all that bad, but it just didn't have the resolution I wanted. Nor did it have the ease of use that I felt should be available in a schematic drawing program.

I have spent quite some time with Auto-Cad as well. I have had a little more success with that program, but you really need to have a library of schematic symbols already made up unless you want to spend half your life. Schematic symbols are already available through various sources including shareware. The resolution is definitely acceptable in AutoCad. However, to the average Joe like you and me, AutoCad isn't all that available. If you don't have AutoCad, or have a friend who already has it up and running on their computer, it still leaves you out in the cold. It is usually inconvenient to run over to use your friend's computer just to draw a schematic diagram.

Surely, somewhere out there with all the computer geniuses, there must be a program on which someone like me can sit down and, with very little effort, draw a nice looking circuit diagram, then print it to the printer. I have seen several of them advertised in trade magazines but could not justify the price tag.

Quite by accident, I ran into a friend who uses Orcad. I believe I have seen this program advertised in various publications in the past. He was gracious enough to let me sit down at his computer and play with it. I fell in love instantly. Although his version is an older one, with a copyright of 1985

*Radio Guide* September -1990 Page-50

and 1986, it was everything I had dreamed of in a circuit drawing program. It is a program so easy to learn, you really don't need the manuals.

Orcad can be operated with either the keyboard or a mouse. I prefer the mouse, but the keyboard is very handy, and actually just as easy, if a mouse is not available. Some programs like AutoCad are not actually meant to be use without a mouse, but Orcad can go either way.

The version I was using was equipped with several different drivers, depending on which computer and video monitor you are using. There was even a driver for the AT&T 6300's 640 x 400 screen resolution, and I must say, it looks very impressive. More so than the 2 color CGA or 4 color CGA drivers that were also included with the program. There were also drivers for EGA monitors, but conspicuous by their absence were the drivers for VGA monitors. The age of the program, circa 1985-86, was a dead give away.

Several printer drivers came with the program. The computer I used was configured for use with the Epson printer driver, but the printer used was an IBM narrow carriage Proprinter, which worked just fine. Not being able to leave anything well enough alone, I tried some experiments. Using just the Epson printer driver with the Proprinter, and *without* loading DOS's graphics.com, the circuit diagram would still print out, but spaces were left in the vertical plane. Loading GRAPHICS.COM back in made the print out normal. I then hooked up a Star Gemini 10-X printer. I found it necessary to use the Epson MX driver to get it to print at all and, even then, there were spaces in the vertical plane with the Star printer. The moral of this story is to be sure the printer drivers match your printer.

One thing that impressed me with Orcad is that you don't need a \$3000 plotter to print out diagrams. During an experimental session with AutoCad

2.52, I could not print the drawing to an IBM Proprinter because that particular dot matrix printer was not supported by that version. There is a shareware program that allows you to use an Epson or Okidata dot matrix printer with AutoCad, and it works very well. However, with Orcad, printing to the Proprinter was available within the program itself.

When you enter the program, you are faced with the upper left hand corner of the drawing board and an arrow which moves via the mouse, or the keyboard if you are not using a mouse. Each push of the cursor key moves the arrow one increment, which is actually more accurate than using the mouse. If you don't have a steady hand, you may be better off using the cursor keys.

A press of the ENTER key brings up the MAIN MENU which gives you a choice of 17 commands. Everything you do in Orcad is done from this menu along with its menu submenu's. You can get to the submenu's by either pressing the first letter of each command name or by moving the highlight bar with the mouse or the cursor keys. The index finger button on the mouse activates the command as does pressing the ENTER key.

To start drawing a diagram, you choose the GET choice from the MAIN MENU. This takes you to a submenu of different types of symbols and chips. You have a choice of several different libraries. One for TTL, CMOS, DEVICE, ASSEMBLY, ROCKWELL and several others. The chip libraries have the fully drawn schematic for hundreds of different chips. The DEVICE library contains your standard electronic schematic symbols such as transistors, caps, resistors etc. Just about anything you need to draw a circuit diagram can be found in one of the libraries.

Going into detail would require several pages. But, if you are looking for an excellent program with which to draw from simple to sophisticated circuit diagrams and pictorials, you would do well to investigate Orcad.

# It's Handled!

**Customize your A-500 Console with Wheatstone's powerful accessory modules!** We've handled auto-sequencing, telephone call-ins, and intercom requirements. Our auto-sequencing line input will take the rush out of back-to-back carts. Our multiphone module can handle 3 callers, 3 mics and reel-to-reel machine control all at once. Our new 8-station intercom module will link up all your studios and talent positions...

**AUTO-SEQUENCING:** The SL-500as input module allows the DJ to automatically sequence through a pre-loaded bank of cart or CD machines. All audio and machine control functions are handled by the module's logic circuitry. When the first ON switch is pressed, that module's associated machine automatically starts to play; when it has finished the channel is turned OFF, the next programmed module is turned ON, and its machine starts to play. Dead air and missed spots can be a thing of the past with this sequence function.

**TELEPHONE/TALK SHOW:** The MP-500 multiphone module offers a totally new way of handling telephone talkshow functions. Operation is simple: when the announcer wishes to do a phone segment he simply activates the MP-500 module and all mute, level, combining, and machine control functions are handled automatically. The MP-500 permits conferencing between 3 callers and 3 microphones, and provides separate multitrack tape feeds for various mic/caller signal combinations, permitting simple track punch-ins to replace razor and tape edits. This module eliminates complicated announcer set-ups, miscalls, and feedback problems.

**COMMUNICATIONS:** The ICM-500 module is part of a completely integrated intercom system; a family of modules available for all Wheatstone broadcast and production consoles. It even includes a rackmount version for your equipment room or remote hook-ups. It allows direct communication between 8 locations in your facility. Your intercom needs are handled by simply plugging in this module set.

**TAKE ADVANTAGE** of our expertise and reputation. Call Wheatstone. Let our application engineers handle your toughest requirements.

 Wheatstone® Corporation

6720 V.I.P. Parkway, Syracuse, NY 13211 (tel 315-455-7740/fax 315-454-8104)

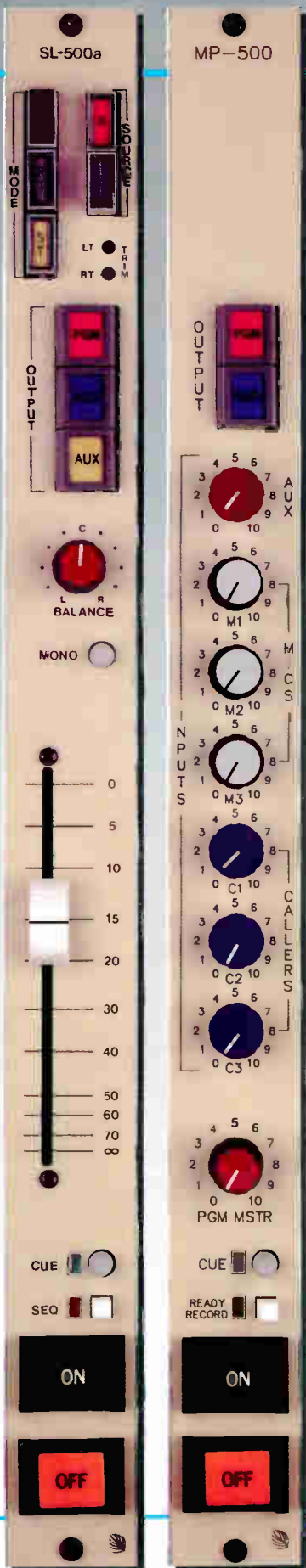

# WHAT BEATS A CRL, OPTIMOD® OR TEXAR PROCESSOR?

simple... The *Audio Signature*™



Audio Signature™ four-band audio processor

The Audio Signature is the most advanced combination stereo AGC and multi-band compressor ever combined into one unit. Full micro-processor control lets you define the processing parameters that you want. The Audio Signature gives you unmatched flexibility in getting just the sound you want. It's almost like designing your own custom audio processing.

## Does your current audio processing have:

- separate AGC and 4 band compression stages in one unit?
- adjustable release times and compression slopes?
- adjustable multi-band crossover frequencies?
- complete control capability via an IBM PC?
- 4 position program memory storage?
- the ability to make dayparting easy?
- the power and sound quality that you have wanted?

## Well, it looks like you need the Audio Signature!

It's perfect to use in front of a CRL or Optimod,® processor. Best of all—you can get this digitally controlled new technology now! Why keep waiting for an all digital box that never happens? Call or write us today and discover what the CRL Audio Signature can do for you.

Audio Signature™ is a trademark of Circuit Research Labs, Inc.  
OPTIMOD® is a registered trademark of Orban — a division of AKG Acoustics, Inc.

THE  
PROFESSIONAL'S  
CHOICE



Circuit Research Labs, Inc.  
2522 West Geneva Drive  
Tempe, Arizona 85282-3192 U.S.A.  
(800) 535-7648 (602) 438-0888 FAX (602) 438-8227  
Bulletin Board System (602) 438-0459