

ABOVE GROUND LEVEL

# agl Magazine

DONALD J. TRUMP

## U.S. 5G LEADERSHIP

WOMEN OF WIRELESS

Emily Kosmalski

LIGHTNING PROTECTION

Surge Suppression  
Small Cell Protection

AGL Media Group LLC, 44715 Pentecost Drive #2080 Ashburn VA 20146-2090  
 078318 SUBSCRIBER #: 078318  
 BARRY MISHKIND  
 OWNER  
 2033 S AUGUSTA PL  
 TUCSON AZ 85710-7905  
 PRSRT STD  
 US Postage P0  
 Permit 45  
 Liberty MO  
 536 • 19873

June 2019



# 5G Infrastructure: The Experience Matters

Ask about  
*InvisiWave*<sup>™</sup> 5G mmWave Proven  
Concealment Solution

**Raycap** |  **STEALTH**

[www.stealthconcealment.com/invisiwave](http://www.stealthconcealment.com/invisiwave)



## FEATURES

## COVER STORY

- 6 **U.S. to Commit More Spectrum, Speed Antenna Site Deployment for 5G Leadership**  
*By Donald J. Trump*
- 8 **FCC on 5G: Promote National Competitiveness, Improve Lives With Digital Revolution**  
*By Ajit Pai*
- 10 **A Deep Dive Into Surge Protection**  
*By Dan Rebek*
- 18 **Lightning Protection for New-generational Small Cell Infrastructure**  
*By A.J. "Tony" Surtees, Ph.D.*
- 22 **AGL Tower of the Month – Lone Pine, California**
- 24 **Smart Cities and the Technologies That Will Transform Our Urban Environments**  
*By Tom Caruso*
- WOMEN OF WIRELESS**
- 28 **Building the Environment for Successful Leadership**  
*By Don Bishop*
- 32 **Untangling Polarization Technology**  
*By Justin G. Pollock, Ph.D.*



Page 10

## DEPARTMENTS

## EDITORIAL COMMENT

- 4 **New Investors Must Avoid the Jam**  
*By Don Bishop*

## COMPANY SHOWCASE

- 37 **Compliance Testing and Monitoring Companies**

## PRODUCT SHOWCASE

- 39 **Lightning Protection, Surge Suppression and Grounding Products**
- 42 **Advertiser Index**
- 42 **Professional Directory**

**Advertise**

Interested in advertising with AGL Media Group's magazines, website, AGL eDigest email newsletter, or sponsoring AGL Local Summits? Visit [www.aglmediagroup.com/advertise](http://www.aglmediagroup.com/advertise) for information.

AGL Magazine (Above Ground Level) is published 12 times a year by AGL Media Group LLC, and is mailed free to qualified individuals in the United States of America.

POSTMASTER: Send address change to AGL Media Group Circulation Department, 44715 Prentice Drive #2090, Ashburn, VA 20146-2090.

# New Investors Must Avoid the Jam



All the drama may not affect the largest tower companies much. Some of the smaller ones, maybe. Factors that bubbled out during the Connectivity Expo last month involve disruptive infrastructure investors who are acquiring towers and building new towers. In this context, disruptive means something that creates a new market and value network and significantly affects the way a market or industry functions.

What it means for the tower business is that some new infrastructure investors are — in the view of seasoned tower operators — paying too much for towers they buy and not charging enough rent for towers they build. Some of these investors have had hot hands when they invested in other markets. Having a hot hand means that success in one endeavor tends to be repeated in the next endeavor. Believing in hot hands is human nature and a fallacy and maybe some business babble — sorry about that.

“An infrastructure investor is primarily focused upon preserving value and providing moderate returns,” according to Joel Moser, CEO of Acquamarine Investment Partners, who writes about infrastructure investing for *Forbes*.

When an investor pays too much for a tower, the return may be slim to none, and that puts an investor in a jam.

According to Ron Bizick, CEO of Tarpon Towers — let’s call him one of the seasoned investors — “The only thing that gets you out of a jam is

lease-up, right? So if you can last long enough and capture some lease-up, you should be fine.” That’s what he had to say about it at Connectivity Expo.

But maybe not if you don’t charge enough rent.

## The Cover

It is unique to have a reason to highlight the president on the cover of *AGL Magazine* ... because ... in 35 years as a telecommunications magazine editor, I never previously heard a president say something about wireless communications newsworthy enough for a cover story.

What a remarkable thing it was, to have tower workers wearing their personal protective equipment attend a press conference in the White House to hear Donald Trump speak about U.S. leadership in 5G wireless communications. I see the hand of the amazing National Association of Tower Erectors in this. Congratulations to the association for achieving such recognition and national publicity for tower workers.

Thank you to the tower workers who helped to bring attention to the tower construction and maintenance business and its role in building 5G wireless communications facilities: Jordyn Ladner, Kenneth Massengale, John Dougherty, Carlos Church, Jack Ray and Jeff Tinio.

The cover story begins on Page 6.

**Don Bishop, Executive Editor**  
dbishop@aglmediagroup.com

**Executive Editor/Associate Publisher**  
Don Bishop  
913.322.4569  
dbishop@aglmediagroup.com

**Copy Editors**  
Christina Huth  
Brye Steeves

**Contributing Editors**  
Ted Abrams, P.E.  
206.661.8429  
tabrams@aglmediagroup.com

J. Sharpe Smith  
515.279.2282  
ssmith@aglmediagroup.com

**Art Director**  
Brian Behm  
Riverworks Marketing Group  
423.710.3866

**AGL Media Group, LLC**  
Richard P. Biby P.E., CEO/Publisher  
540.338.4363  
rbiby@aglmediagroup.com

Rick Heilbrunn, President/COO  
703.759.0743  
rheilbrunn@aglmediagroup.com

**Eastern Region Sales Representative/  
Advertising Coordinator**  
Karen Clark  
303.979.0621  
kclark@aglmediagroup.com

**Western Region Sales Representative**  
Deborah Plank  
832.484.8465  
dplank@aglmediagroup.com

**Circulation Manager**  
circulation@aglmediagroup.com

**Corporate Office**  
AGL Media Group, LLC  
44715 Prentice Drive #2090  
Ashburn, VA 20146-2090  
703.594.8500

**Press Releases and Advertising Materials**  
press@aglmediagroup.com

**Subscription Information**  
To subscribe online, go to:  
www.aglmediagroup.com/signup

Copyright ©2019. AGL Media Group, LLC.  
All rights reserved.

# Antennas Engineered To Exceed



## NEW PROLINE SECTOR & PARABOLIC ANTENNAS

**Available for Same-Day Shipping!**

KP Performance Antennas helps wireless internet service providers maximize ROI with products engineered to exceed industry expectations. Choose KP for superior throughput, greater service coverage, dependable performance and reduced maintenance costs—innovative, reliable antenna solutions backed

by the KP team's decades of in-field expertise as former WISP operators and Ph.D. antenna engineers. With same-day shipping for everything we sell, expert technical support, and a 100% performance guarantee, KP has you covered. Call or visit us today at [Kppformance.com](http://Kppformance.com).

1-855-276-KPPA (5772)  
[Kppformance.com](http://Kppformance.com)

**KP** PERFORMANCE  
ANTENNAS  
an INFINITE® brand

## U.S. to Commit More Spectrum, Speed Antenna Site Deployment for 5G Leadership

By the end of this year, the United States will have 92 5G deployments in markets nationwide. American companies must lead the world in cellular technology, and 5G networks must be secure.

By Donald J. Trump

A critical issue for our country's future is winning the race to be the world's leading provider of 5G cellular communications networks. Secure 5G networks will absolutely be a vital link to America's prosperity and national security in the 21st century.

5G will be as much as 100 times faster than the current 4G cellular networks. It will transform the way our citizens work, learn, communicate and travel. It will make American farms more productive, American manufacturing more competitive and American health care better and more accessible.

Just as 4G networks paved the

way for smartphones, 5G networks will create astonishing and thrilling new opportunities. We cannot allow any other country to out-compete the United States in this powerful industry of the future. We are leading by so much in so many different industries of that type, and we just can't let that happen. The race to 5G is a race America must win, and it's a race that our great companies are now involved in. We've given them the incentive they need.

In the United States, our approach is private-sector driven and private-sector led. The government doesn't have to spend lots of money. According

to some estimates, the wireless industry plans to invest \$275 billion in 5G networks, creating 3 million American jobs and adding \$500 billion to our economy.

We had another alternative for doing it: that would be through government investment and leading through the government. We don't want to do that because it won't be nearly as good or nearly as fast.

To accelerate and incentivize these investments, my administration is focused on freeing up as much wireless spectrum as needed — we're going to free it up so they'll be able to get out there and get it done — and removing regulatory barriers to the buildout of networks.

The FCC is taking bold action to make wireless spectrum available. By next year, the United States is on pace to have more 5G spectrum than any other country in the world. That's a big statement because some people got ahead of us. We should have been doing this a long time ago, as advanced as it may be.

Last October, I directed the U.S. Department of Commerce to develop a national spectrum strategy to free up even more spectrum for economic activity, including 5G.

The FCC has also taken action to



President Donald J. Trump speaks about U.S. 5G deployment as tower technicians John Dougherty of Millennia Contracting, New Castle, Delaware (left) and Carlos Church of MillerCo, Gulfport, Mississippi, look on. Source: White House video



streamline the permitting process for 5G infrastructure with state and local governments. That's a big deal. It takes too long to get permits. We're going to free that situation up, and we're going to put limits and the local areas are going to listen to us very, very strongly. They have a big incentive to do that.

They must now approve new physical infrastructure within 90 days, instead of many years. It can sometimes take three, four and five years. We're going to put a limit of 90 days. And there is now a cap on the unreasonable fees local governments often charge. They get greedy. They think, "Hey, we can really take advantage." And it ends up that everybody gets hurt. So we're putting a cap on those

fees. These changes will contribute greatly to building high-speed networks across America.

By the end of this year, the United States will have 92 5G deployments in markets nationwide. The next nearest country, South Korea, will have 48. So we have 92, compared to 48. And we're going to accelerate that pace greatly.

But we must not rest; the race is far from over. American companies must lead the world in cellular technology. 5G networks must be secure. They must be strong. They have to be guarded from the enemy — we do have enemies out there — and they will be. They must cover every community, and they must be deployed as soon as possible.

As we are making great progress with 5G, we're also focused on rural communities that do not have access to broadband at all — the farmers and others. They just haven't been treated properly. And now, we're making it a priority. That's the areas we want to go to first, so they're covered. We're working closely with federal agencies to get networks built in rural America faster and at much, much lower cost than it is even today. ■

*Donald J. Trump is president of the United States. Edited for length and style, this article was excerpted from a speech given in the Roosevelt Room at the White House on April 12. For the unabridged text, visit [www.whitehouse.gov](http://www.whitehouse.gov).*

## Wireless News and Expert Content straight to your phone.

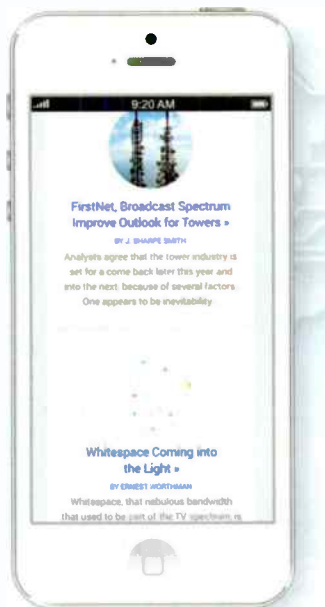

ABOVE GROUND LEVEL

**agl** eDigest™

SUBSCRIBE TO THIS AND MORE:  
[AGLMEDIAGROUP.COM/SUBSCRIBE/](http://AGLMEDIAGROUP.COM/SUBSCRIBE/)

[aglmediagroup.com](http://aglmediagroup.com) | 703.594.8500 | 44715 Prentice Drive #2090, Ashburn, VA 20146

## FCC on 5G: Promote National Competitiveness, Improve Lives With Digital Revolution

The FCC is taking two steps to build on 5G deployment momentum: conducting a third 5G spectrum auction on Dec. 10, and creating a \$20.4 billion Rural Digital Opportunity Fund to extend high-speed broadband in rural America.

By Ajit Pai

America must win the race to 5G — the next generation of wireless connectivity. And this matters for two key reasons:

The first is national competitiveness. We want the good-paying jobs that develop and deploy 5G technologies — jobs that support some of the folks in this room — to be created here, in America. We want these technologies to give our economy a leg up as we compete against the rest of the world.

The second reason U.S. leadership matters is that 5G will improve Americans' lives in so many ways, from precision agriculture, to smart transportation networks, to telemedicine

and more. We want Americans to be the first to benefit from this new digital revolution while protecting our innovators and our citizens. We don't want rural Americans to be left behind.

I'm pleased to report that America is now well positioned to win the race to fast, secure and reliable 5G. And don't just take my word for it. In February, ABI Research stated, "It is the United States who will win the 5G race in the short term." That same month, Cisco projected that, in three years, 5G would be more than twice as prevalent in North America as in Asia.

In early April, CTIA reported that America leads the world with the

most commercial 5G deployments of any nation.

And April 10, it was reported that 5G-related job listings here in the United States increased 12 percent in the previous three weeks, according to data from an online job search service.

Today, 5G is a success story — an American success story. Well, how are we getting the job done? As the lead agency on 5G, the FCC is pursuing a three-part strategy called the 5G FAST Plan. First, we're freeing up spectrum, the invisible airwaves that carry wireless traffic. We finished our first 5G spectrum auction in January, and we're holding a second, right now,



President Donald J. Trump delivers remarks on U.S. 5G deployment technology on April 12 in the Roosevelt Room at the White House. FCC Chairman Ajit Pai spoke next. *Official White House photo by Tia Dufour*





President Donald J. Trump shakes hands with FCC Chairman Ajit Pai in the Roosevelt Room in the White House during the U.S. 5G deployment technology press conference on April 12. Looking on, from left: Jordyn Ladner of MillerCo, Gulfport, Mississippi; Kenneth Massengale of Teltronic Towers, Capital Heights, Maryland; Jimmy Miller, chairman of the National Association of Tower Erectors; John Dougherty of Millennia Contracting, New Castle, Delaware; Larry Kudlow, director of the National Economic Council; and Carlos Church of MillerCo, Gulfport, Mississippi. *Official White House photo by Tia Dufour*

that has already generated almost \$2 billion in bids.

Second, we're making it easier to install wireless infrastructure. 5G will rely heavily on a web of small antennas. But when I came into office, regulations designed for tall towers threatened to strangle our 5G future in red tape. We have eliminated these rules, because infrastructure the size of a pizza box shouldn't have to jump through the same regulatory hoops as a 200-foot cell tower.

And third, we've taken action to encourage the deployment of optical fiber. That is because 5G isn't just about wireless. We'll also need strong fiber networks to carry 5G traffic once it goes from the air to the ground. And we've done a lot to make

that happen, including ending heavy-handed regulations imposed by the prior administration.

And here, too, we are getting results. Last year, fiber was deployed to more new locations in the United States than in any year before. But in the race to 5G, our early success is still early. We still need to do more, and we will.

I'm announcing two new steps the FCC will take to build on our momentum. First, the FCC intends to start its third 5G spectrum auction on Dec. 10. This will be the largest spectrum auction in American history. We will be selling 3,400 megahertz in three different bands. That is a lot of spectrum.

Second, to help build the infrastructure of the future, the FCC

aims to create a \$20.4 billion Rural Digital Opportunity Fund headed by the agency. This money will extend high-speed broadband to up to 4 million homes and small businesses in rural America. These next-generation networks will bring greater economic opportunity to America's heartland, including some of the great jobs building infrastructure, and they will help support future 5G technologies. ■

*Ajit Pai is chairman of the FCC. Edited for length and style, this article was excerpted from the chairman's remarks made during the U.S. 5G deployment technology press conference in the Roosevelt Room at the White House on April 12. For the unabridged text, visit [www.whitehouse.gov](http://www.whitehouse.gov).*

A graphic of a lightning rod on a tower with a white protective arc above it, set against a dark sky with lightning bolts and a sunburst effect behind the tower.

# LIGHTNING PROTECTION

## A DEEP DIVE INTO SURGE PROTECTION

Protection against transient voltages and surge currents safeguards lives and property. Selecting the right protective devices can be tricky. Here are some suggestions and explanations.

By **Dan Rebeck**

**N**early every application that uses sensitive electronic circuitry will require surge protection in stages to buffer damaging power surges from lightning or other random happenstance, such as a severe power surge with the local electrical company. The same lines used to transmit signals form an ideal conduit for lightning strikes, and although lightning strikes may rarely occur, they can cause a catastrophic failure. Camera systems in video surveillance applications, radio equipment in wireless applications and power over Ethernet (PoE) equipment require some sort of surge protection at the systems and subsystems levels. The following information takes a deeper dive into the inner workings of surge protection equipment for wireless networks, IT infrastructure, industrial automation and video surveillance applications.

**Multiple Stages of Protection**

Varying levels of power surges happen frequently in a facility. Even the minor, frequent surges can corrupt data files. Larger, more infrequent surges will eventually damage equipment. An estimated 60 to 80 percent of power surges are smaller and are caused by anomalies that arise within the facility housing the electrical equipment (See “Protecting Commercial Facilities from Power Surges” at [disastersafety.org/ibhs/commercial-power-surges](http://disastersafety.org/ibhs/commercial-power-surges).)

Surge currents from these events can be sent down the signal chain through power cords, telephone lines, data lines and coaxial lines. The most frequently cited high-power surges caused by lightning strikes or electromagnetic pulses (EMPs) can rapidly cause irreparable failures all the way down to internal

**Table 1. Causes for Power Surges in a Commercial, Residential, Military or Industrial Facility**

Surge Type	Causes	Description
Small/Medium Surges	External electric company power system issues	Faulty wiring by utility, equipment breakdown, downed power line, grid shifting, capacitor switching, sharing power line with a large power-consuming facility
	Internal facility issues	High-powered motors, elevators, HVAC equipment, refrigerators, pumps, compressors, electric arcs in welding, tripping of fuses and circuit breakers
TVS Diode MOV	Natural electric phenomena	Direct lightning strike, indirect lightning strike
	Induced events	EMP, over-volts by severe power faults in power company

**Table 2. Standards for Surge/Lightning Protective Equipment**

Standard	Category Name
UL 467	Ground and bonding equipment
UL 497B	Standard for protectors from data communications and fire-alarm circuits
UL 96/96A	Lightning protection systems installations
UL 1449	Surge protective devices (SPDs)
IEEE C62.1/C62.11	Surge arresters over 1,000 volts

equipment. Additionally, indirect lightning strikes can generate strong electromagnetic fields that induce power surges within a building. This is especially true for RF equipment that operates at much lower voltages than typical data lines and power lines. Coaxial cabling will be susceptible to strong electromagnetic (EM) fields and may carry excess voltage or added noise to sensitive equipment.

The cost of the smaller surges is difficult to gauge because they often go unnoticed. Nevertheless, they end up costing facilities millions of dollars in downtime. Causes of small surges can vary from external power issues with the local electrical grid to internal transient voltages caused by malfunctioning high-powered equipment, such as motors in the facility’s heating ventilation and cooling (HVAC) system. Table 1 lists the various power surges and some

of their common causes. Nearly all businesses are subject to various levels of power surges and should therefore take measures to protect their internal equipment from these risks.

Although it would be difficult to entirely protect a system from a massive electrical event such as a direct lightning strike, steps can be taken to ensure that the equipment in a facility is not entirely damaged. The same steps also provide protection from smaller transients. This level of protection requires several stages.

Often, the first line of defense is placed at the facility’s service entrance where power can enter a building. The second line of defense is placed at the distribution panel, buffering any excess surges that the first stage did not adequately absorb or redirecting surge current to prevent the excess power from being redistributed. However,



**Table 3. Various Protective Devices**

Device	Description	Parameters	Response Time	Voltage Capability	Capacitance
Gas Discharge Tube	Dissipate voltage through a contained inert gas, acts as an open circuit until triggered becoming a short to ground.	DC sparkover voltage, impulse sparkover voltage, discharge current capacity, insulation resistance, low capacitance.	Long	High	Low/Medium
TVS Diode	Rapidly shunts excess current when the induced voltage exceeds the diode's breakdown voltage. Will clamp a signal to a different DC level.	Reverse stand-off voltage, breakdown voltage, clamping voltage, capacitance.	Short	Small	Low
MOV	High resistance at low voltages, but when voltage increases, the resistance will drop and MOV will shunt the excess current.	Continuous voltage, peak current, varistor voltage, maximum energy.	Medium	Medium	Medium

these steps only protect a facility from external events. Remember, smaller transients from internal equipment in the facility generate the most surges. This means that sensitive, critical equipment will need protection.

Standards listed by the Underwriters Laboratory (UL) include the parameters and testing for lightning and surge protective equipment. Table 2 shows some of these standards. What follows will focus more on UL 1449-certified surge protective devices that are often used to protect sensitive internal equipment.

Deciding what to protect is often a customized, application-specific design process because any and all potential damage must be mitigated. Regardless, there are some protective devices that are often used. Here are some protective devices, relevant parameters and design considerations:

**Gas discharge tube:** The various surge protection devices (SPDs) can use a number of components, often in stages, to suppress or redirect any transient overvoltages. A gas discharge tube (GDT) is frequently used because it handles voltages from 70 volts to 6,000 volts. This is accomplished through the use of an inert gas that acts as an open

circuit until triggered. Once triggered, the GDT shorts to ground, redirecting any high voltage pulses. To trigger a GDT, the device must be presented with a high voltage for a significant amount of time, a characteristic that potentially allows damaging surge currents to pass through them. Moreover, a GDT can handle only a few large transients in its operational lifetime.

Additionally, the gas within the GDT tends to remain ionized after the surge event concludes, because of the current supply from the power line. The sustained ionization only occurs when the GDT breakdown voltage is smaller than that of the power line. At this point, the tube enters what is known as a “discharge mode” in which it continues to decrease in voltage while increasing in current. This leads to an inevitable demise of the device, so typically various resistor or nonlinear devices are placed to interrupt the follow-on current. The follow-on current, combined with the relatively slow response time, accounts for why a GDT is often paired with some type of clamping device (e.g., a Zener diode, a metal-oxide varistor [MOV] or a transient voltage suppression [TVS] diode).

There are a few notable clamping devices, including the TVS diodes and MOVs. They are known as clamping devices because, when the voltage exceeds a certain limit, the device clamps the signal to a voltage level and often steers surge current into the ground rail. An MOV exhibits a high resistance at low voltages, but when voltages increase, its resistance drops in order to shunt excess current.

One major difference between the varistor and the TVS diode is the bidirectional nature of the varistor. (Varistor is short for variable resistor.) Some TVS diodes have bidirectional characteristics. The TVS diode has the shortest response time of all the transient overvoltage protection devices listed, on the order of picoseconds.

Another consideration when choosing between clamping devices is capacitance because capacitive loading degrades frequency response. The MOV has a higher capacitance than the TVS. An individual TVS diode will have a higher capacitance unless it is used in an array with other diodes. One significant consideration with TVS diodes is that although they can handle relatively high voltages, they cannot handle as high currents as an MOV. Table 3 offers a simple overview of these devices, some of their considerations and an idea of their respective response times, voltage capability and capacitance.

### Various Topologies of SPDs

When these major protective devices are combined with supplementary devices such as current-limiting resistors or suppression coils, the SPD can have cascaded protection that addresses some of the weak points of these individual devices. For instance,



# ***FASTEST*** TIME TO TOWER

- Rapid Deployment
- Rugged Durability
- High Performance

## **Rapid Deployment**

RadioWaves antennas are fully pre-assembled from the factory, designed to minimize part count and ensure “set and forget” installation.

## **Rugged Durability**

RadioWaves rigid diecast mounts use 6-point connection ensuring precise, durable antenna alignment, eliminating costly site revisits.

## **High Performance**

RadioWaves antennas offer ETSI class 3 radiation patterns, excellent front/back ratio, higher gain, and best in class wind ratings of 130/160 mph.

### ***If it's rugged, it must be RadioWaves!***

Our Application Engineers are available now to provide immediate support. Contact us at +1 978 459 8800 or go to [RadioWaves.com](http://RadioWaves.com) to learn more.



**radiowaves**  
an INFINIT@ brand

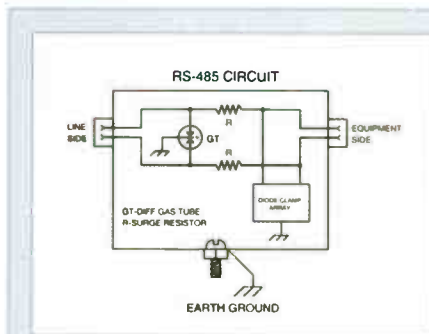

Figure 1. A sample protective circuit for a RS-485 control line.

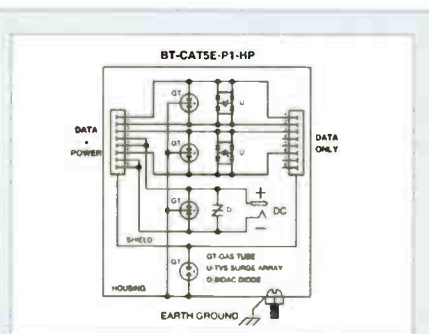

Figure 2. A sample set up of midspan PSE.

the GDT has a remarkably high over-voltage protection for its size compared with other protective devices, so it is often the first device to be placed in parallel with the line that needs surge protection. These devices can be used in tandem with clamping devices, such as a diode array or an MOV, because they have a higher response time.

Figure 1 shows a sample protective circuit for an RS-485 control line. Equipment failure caused by the GDT's slow response time can be mitigated with the use of the fast-responding diode clamp array. In the case of a sustained pulse, the current limiting resistors limit the power dissipation of the diode array, thereby allowing the GDT to flash over, that is, to make an electric circuit by sparking across a gap. Other iterations can involve suppression coils to limit the current through the clamping device, allowing time for the GDT to respond.

### Video Surveillance

Equipment used for video surveillance that is subject to lightning strikes can be compromised without proper protection. This is especially true for high-security facilities, such as nuclear power plants, military bases, and oil and gas refineries. Across industries, video surveillance uses various

technologies from analog video to high-definition (HD) over coax, and even power over Ethernet HD cameras. More often than not, these installations use a 75-ohm coaxial interface to allow the video surveillance system to be incrementally improved without the need for a complete overhaul.

Commonly used pan, tilt and zoom (PTZ) cameras can use three main lines: an analog video line, a RS-485 control line and a power line. Each of these lines requires different levels of buffering. Various device topologies are used to protect the different lines of a PTZ camera. For analog video lines, the BNC connector shield can be directly tied to ground or can be isolated for installations prone to ground loops.

### PoE Injectors

The Ethernet backbone has infiltrated many applications including industrial automation with PoE inspection cameras and IT infrastructure. The IEEE 802.3 standard states that power can be delivered to a powered device (PD) in one of three ways:

- Endpoint power sourcing equipment (PSE): sends power and data directly to a PD from a PoE-based switch
- Midspan PSE (PoE Injector): sends power and data from a non-PoE switch

- Extender PSE: increases the range of PoE endpoint

The nature of powered devices can vary from security cameras and touch-screen devices to access points and call stations. For this reason, there is a broad range of applications for PoE. A midspan PSE would most likely be used to add PoE capability to a network that previously had none. An endpoint PSE would be for newer networks that already have PoE capabilities. Figure 2 shows a sample connection between an Ethernet hub and DC injector to a PoE device. Many companies use injectors because it is often more costly to change an existing non-PoE switch.

A PoE PSE can also take the form of one of two power topologies:

- Mode A: power pins 1/2 and 3/6
- Mode B: power pins 4/5 and 7/8

Most endpoint PSEs are Mode A; midspan PSEs are compatible with Mode B. Some SPDs have both Mode A and B compatibility. Although there is no explicit IEEE requirement for protection, the PSE controllers often come with pins to connect to equipment for surge protection because it is increasingly necessary. A PD can be damaged by power surges from an electrostatic discharge (ESD) carried by the Ethernet cable or the device's input power connection. In the IEEE 802.3af standard, a field-effect transistor (FET) switch is recommended for letting the power go through to the PD. The FET is particularly susceptible to transient electrical surges. Moreover, facilities that use long unshielded twisted-pair (UTP) cable runs to outdoor PDs create a large antenna that attracts large transients. For this reason, more and more installations use fiber-optic cabling for its inherent lightning resistance.



# ACE THE TEST WITH KAEELUS!

[ANALYZER CALIBRATION EXTENDER]

- ✓ SELF-CALIBRATE KAEELUS PIM ANALYZERS IN THE FIELD
- ✓ SUCCESSFUL CALIBRATION IN LESS THAN ONE HOUR
- ✓ CALIBRATE MULTIPLE IPA, ITA, IQA, IBA AND SI E-SERIES INSTRUMENTS WITH ONE ACE UNIT



The **Kaelus ACE-1000A** is the industry's first calibration extender that allows customers to self-calibrate their PIM analyzers onsite. Reducing downtime to less than one hour, the ACE-1000A verifies successful calibration then extends your analyzer's validation date by 12 months, eliminating costly shipping and service center charges.

***Same-day shipping now available!***



Kaelus ACE-1000A

For more information contact us:  
US: +1 303 768 8080, Australia: +61 (0) 7 3907 1200,  
China: +86 512 6296 0028, Europe: +44 784 244 7532  
[www.Kaelus.com](http://www.Kaelus.com).

**kAELUS**  
an INFINIT® brand

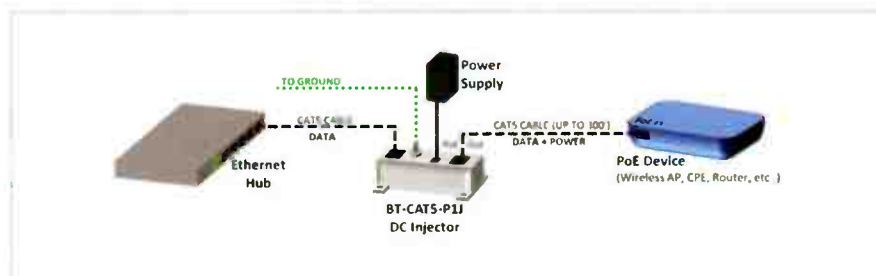

Figure 3. A PoE midspan/injector SPD sample circuit.

Figure 3 shows a sample Mode B injector SPD circuit. Despite the benefits of using PoE SPDs, these devices add capacitance that can cause an unavoidable slight signal degradation. The use of the low-capacitance three-pole differential gas tubes, diode array and silicon diode for alternating current (SIDAC) allows for a low-line-to-line (L-L) and line-to-ground (L-G) capacitance that, in turn, minimizes distortion of any high-speed signals.

It is ultimately more costly and risky not to implement any kind of protective device for PoE systems as Ethernet speeds become faster and components become much more sensitive to surge currents. As speeds increase, integration also tends to increase where the Ethernet interface is now integrated into the main printed circuit board (PCB) assembly. If any caused by a surge current occurs, the entire motherboard or even the entire piece of equipment will require replacement. This result not



Photo 1. A quarter-wave stub coaxial surge protector.

only has the obvious cost of equipment repair or replacement, but also the less apparent cost of downtime caused by the troubleshooting and repairing.

### Coaxial Surge Protection

Telecommunications systems and various wireless applications can be particularly sensitive to transients because of their inherent low-voltage operations. Fortunately, most transients have a low frequency. The average lightning strike has a frequency between DC to 1 MHz. Therefore, a signal filter often is adequate for shunting lightning surge current to ground and maintaining the desired transverse electromagnetic (TEM) mode of propagation along the coax. This can be accomplished in a number of ways. One example is the use of quarter-wave stubs because they effectively block low-frequency surges to ground (see Photo 1).

The coaxial quarter-wave stub SPD appears as a tee that is perpendicular to the signal path. During normal operation, a quarter-wave stub will take a portion of the signal through the stub portion and it will be scattered down the length of the stub. The signal will be reflected off the short-circuit in the stub and travel back down in phase with the desired signal, because the length of the stub is one-quarter of the center-frequency wavelength. A low frequency, however, has a much longer wavelength

than the normal operating frequencies and will therefore scatter into the stub and short-circuit to ground, thereby diverting a transient to ground. The benefit of this is that it operates with a low VSWR so that it minimally impedes signal flow during normal operation. GDTs can also be used to shunt extremely high voltages to ground. The downside is that replacing this technology when necessary can be costly.

### Conclusion

SPDs are essential to protect sensitive electronic equipment from small to large transients. As technology advances, this equipment requires extra precautions against damage because of the increased use of smaller trace widths, extensive use of low-voltage circuitry and increased integration. Although all of these factors allow for remarkably fast data speeds within small packages, this increases the cost of any damage occurring with these components. Because this trend can be seen across countless applications, it is critical that lightning protection be a heavy consideration in any cable installation. Long runs of copper cabling tend to act as a fantastic antenna that attracts transients, so they must be adequately connected to ground via a grounding lug that provides a tie point for earth ground. There is a fairly vast repertory of protective devices from which to choose. All of these devices come with their own set of considerations when implementing them in an SPD. A designer most likely will have to assess all these factors when implementing SPDs in specific application. ■

*Dan Rebeck is product line manager at L-com.*



CONNECT (X)

# JOIN US IN MIAMI

MAY 18-21

2020



MIAMI BEACH CONVENTION CENTER

WHERE INFRASTRUCTURE MEETS EVERYTHING

CONNECTIVITYEXPC.COM

SPONSORED BY





# LIGHTNING PROTECTION FOR NEW-GENERATIONAL SMALL CELL INFRASTRUCTURE

Paying attention to the specific measures required to protect equipment mounted on and contained within light poles used as small cell supports and enclosures saves airtime lost to outages and repair costs.

By A. J. "Tony" Surtees, Ph.D.

**T**he next generation of millimeter-wave (mmW) 5G wireless communications technology deployment, will spur the use of short-range, small cell structures, mostly in the form of integrated street poles, in urban areas and cities.

These structures, often referred to as "smart" or "small cell" poles, usually comprise pole assemblies densely populated with electronic systems. The small cell sites can be built on existing or new metallic street lighting poles, either partially concealed or fully concealed, and on existing wooden utility poles. These electronic systems typically include:

- AC-powered mmW 5G radios and their associated multiple-input multiple-output (MIMO) beam-forming antenna systems
- AC- or DC-powered 4G radios
- AC/DC rectifiers or remote power-ing units
- Alarm systems and intrusion sensors
- Forced-cooled ventilation systems
- AC and DC power distribution panels with utility smart energy metering

In more sophisticated instances, these smart poles will also integrate smart city hubs containing sensors, such as high-resolution concealed cameras, gunshot detection microphones and atmospheric sensors for calculating the ultraviolet (UV) index and measuring solar brightness and solar radiation. In addition, the poles may accommodate additional structural subassemblies, such as support arms for LED street lighting, conventional sidewalk luminaries and receptacles for electric vehicle charging.

A centralized equipotential bonding system is usually provided within the pole via strategically positioned grounding bars, to which the different radio systems are connected. Typically, the neutral conductor of the incoming utility power supply also is bonded to ground at the energy meter's socket, which in turn is bonded back to the main grounding bar. The pole's external system ground is then bonded to this main grounding bar.

The simple light pole seen along sidewalks and city pavements is changing and will soon become a pivotal

component of the new 5G wireless infrastructure. These systems will have paramount importance because they support the new technological layer of cellular networks for high-speed services. No longer will such pole structures simply accommodate incandescent light fixtures. Instead, they will become the core of a highly sophisticated technology. With this advance in integration, capability and reliance comes inevitable risk. Even with their relatively low heights compared to macro cell sites, such sophisticated electronic subsystems are set to become exponentially more susceptible to damage from overvoltage surges and transients.

## Overvoltage Damage

The importance of these small cells in the 5G infrastructure cannot be underestimated. Far from just being used to fill gaps in radio coverage and increase capacity, in 5G networks small cells will become the radio access network's primary nodes, providing high-speed services in real time. These technologically advanced systems may well



Photo 1. A typical AC power and equipment compartment in an integrated 5G small cell pole.

provide critical gigabit service links to customers where outages cannot be tolerated. This necessitates the use of highly reliable surge protection devices (SPDs) to maintain the availability of these sites.

The source of such overvoltage risks can broadly be categorized into two forms: those caused by radiated atmospheric disturbances and those caused by conducted electrical disturbances.

**Let us consider each in turn:**

**1.** Radiated disturbances are largely created by airborne events, such as nearby lightning discharges that create rapid changes in both electromagnetic and electrostatic fields around

the structure. These rapidly varying electric and magnetic fields can couple with the electrical and electronic systems within the pole to produce damaging current and voltage surges. Indeed, the Faraday shielding created by the contiguous metallic structure of the pole will help reduce such effects; however, it cannot fully mitigate the problem. The sensitive antenna systems of these small cells are largely tuned to the frequencies at which much of the energy in the lightning discharge is centralized (5G will operate in frequency bands up to 39 GHz). Thus, they can act as conduits to allow this energy to enter the structure, causing

possible damage to not only the radio front ends, but also to other interconnected electronic systems within the pole.

**2.** Conducted disturbances are largely those that find their way into the pole via conductive cables. These include utility power conductors and signal lines, which can couple the internal electronic systems contained within the pole to the external environment. Because it is envisaged that the deployment of small cells will largely use the existing infrastructure of municipal street lighting or replace it with customized smart poles, small cells will rely on existing distribution



Photo 2. An example of an AC power distribution enclosure with integrated overvoltage protection.

wiring. Often, in the United States, such utility wiring is aerial and not buried. It is particularly susceptible to overvoltages, and a primary conduit for surge energy to enter the pole and damage the internal electronics.

### Overvoltage protection (OVP)

Standards such as IEC 61643 describe the use of surge protective devices to mitigate the effects of such overvoltages. SPDs are classified by test class for the electrical environment within which they are intended to operate. For example, a Class I SPD is one that has been tested to withstand — using IEC terminology — “a direct or partial direct lightning discharge.” This means that the SPD has been tested

to withstand the energy and waveform associated with the discharge most likely to enter a structure in an exposed location.

As we consider the deployment of small cell infrastructure, it is clear that the structures will be exposed. Many such poles are expected to appear along residential curbsides and pavements of metropolitan cities. It is also expected that such poles will proliferate in communal gathering places, such as indoor and outdoor sports stadiums, shopping centers and concert venues. Thus, it is important that the SPDs selected to protect the primary service entrance utility feed are suitably rated for this electrical environment and meet Class I testing, i.e.,

that they can withstand the energy associated with direct, or partially direct, lightning discharges. It is also recommended that the SPD selected have an impulse withstand level ( $I_{imp}$ ) of 12.5 kA in order to safely withstand the threat level of such locations.

Selection of an SPD capable of withstanding the associated threat level is not in itself enough to ensure the equipment is afforded adequate protection. The SPD must also limit the incident conducted surge to a voltage protection level ( $U_p$ ) lower than the withstand level ( $U_w$ ) of the electronic equipment within the pole. IEC recommends that  $U_p < 0.8 U_w$ .

Raycap’s patented Strikesorb SPD technology is purposefully designed to provide the required  $I_{imp}$  and  $U_p$  ratings to protect sensitive mission critical electronic equipment found in small cell infrastructures. Strikesorb technology is considered to be maintenance-free and can withstand thousands of repetitive surge events without failure or degradation. It provides a highly safe and reliable solution that eliminates the use of materials that could burn, smoke or explode. Based on years of field performance, Strikesorb’s expected lifetime is more than 20 years, and all modules are supplied with a 10-year limited lifetime warranty.

The products are tested according to international safety standards (UL and IEC) and offer unparalleled performance against lightning and power surges. Furthermore, Strikesorb protection is integrated into a compact AC distribution enclosure suitable to being installed within the small cell poles. This provides over-current protection to the incoming AC service and outgoing distribution



ABOVE GROUND LEVEL  
**agl** TOWER  
OF THE  
MONTH

**JUNE 2019**

**Site Name:** Sierra Nevada View

**Owner:** Crown Castle International

**Year Constructed:** 1995

**User:** AT&T Mobility

**Height:** 190 feet

**Location:** Lone Pine, California

*Photography by Don Bishop*



## Smart Cities and the Technologies That Will Transform Our Urban Environments

Sensory devices supported by the internet of things (IoT) promise to improve functions provided by cities, large and small.

By Tom Caruso

According to the United Nations' World Urbanization Prospects report, nearly 55 percent of the Earth's population now lives in metropolitan areas, and that figure is expected to increase to 70 percent by 2050. People are drawn to cities for a number of reasons — in fact, 1.4 million people migrate to urban areas every week — whether seeking employment and educational opportunities, exposure to the arts and cultural institutions, or a more cosmopolitan lifestyle enjoyed in a diverse community.

However, despite its attractions, the experience of urban living is fraught with challenges — from overtaxed energy and transit systems, to persistent issues surrounding crime and public safety, to concerns about the quality of the water we drink and the air that we breathe. Many of these urban hazards are rooted in outdated infrastructure. Hence, as the number of people living in cities continues to surge, modernizing the urban environment becomes a matter of social responsibility that sweeps across both public and private domains.

Enter the smart city and its promise to transform how we live, work and play — not as a matter of hype or fantasy, but of making use of existing and emerging technologies to create safer, healthier and more sustainable urban communities.

According to a survey by the National League of Cities, 66 percent of U.S. cities report that they are investing in smart city technology, and 25 percent without any smart city systems are exploring future implementations. The most common smart city applications are smart meters for utilities, intelligent traffic signals, Wi-Fi kiosks, radio-frequency identification (RFID) sensors in pavement for monitoring road damage and traffic flow, and e-governance applications.

### Internet of Things

The core technology behind all smart city initiatives is the internet of things (IoT), the network of physical, connected devices that generates, collects, exchanges and acts upon data. According to research by the business intelligence firm IoT Analytics, the number of active IoT devices in 2018 was 7 billion. The number is expected to grow to 10 billion next year and reach 22 billion by 2025.

Smart cities and IoT-enabled devices create enormous amounts of data, and turning this into actionable information requires a layered ecosystem. Cloud computing provides a strong enabling platform for smart cities because it provides the necessary scale, storage and processing power, along with the ability

to integrate all the disparate data sources to effectively derive insights from this information. However, as smart cities grow in complexity, placing increasingly high demands on centralized cloud data centers, edge computing will be needed to overcome limitations in latency and the demand for more local processing.

Gartner defines edge computing as solutions that facilitate data processing at or near the source of data generation. In the context of the IoT, the sources of data generation are the things with sensors or embedded devices. Critical for such applications as autonomous vehicles, edge computing allows smart applications and devices to respond to data almost instantaneously, as it is being created, thus eliminating lag time. For the driverless car entering a busy intersection at rush hour or confronted with a jaywalking pedestrian transfixed by his smartphone, latency is not an inconvenience but a human safety issue.

Many industry experts also believe that collocation facilities will become essential to smart city development, particularly data centers in or near major metro areas. In turning to collocation, smart city planners and service providers will need to prioritize scalable storage for the exponential increase in data and the computing

circuits, thereby providing a convenient point at which the utility service from the electric meter can enter and distribute within the pole. These AC distribution enclosures are designed to meet the requirements of the National Electrical Code (NFPA 70) in order to be classified "suitable for use as service equipment" (SUSE) and are listed under UL 67.

### Summary

With the advent of 5G technology wireless, capacity-hungry communication systems are poised for an era of connectivity like never before, with better spectral efficiency, ultra-low latency and many times the number of connections per site when compared with present Long Term Evolution

(LTE) modulation technology. The use of MIMO antenna technology operating in the millimeter-wave bands will require a dense infrastructure comprising many thousands more small cells than our present-day macro infrastructure.

Not only will this infrastructure become more widespread, it will become increasingly relied upon and critical to everyday activity. New technologies, such as autonomously driven vehicles, ultra-high-definition video and virtual reality-based systems are expected to become only a small part of possible applications relying on the connectivity that this new 5G infrastructure will bring.

With such reliance and criticality comes risk. Where only five years ago,

such risk may have meant little more than the inconvenience of not having mobile communications when a macro cell was damaged, in the future it may well mean loss of a critical system that is relied upon for a lifesaving service, such as remote surgery. The growing awareness of such risks and the increasing susceptibility of our electronics systems to damage from overvoltages are behind the need to reliably protect our infrastructure with purposefully designed SPDs. ■

*A.J. "Tony" Surtees, Ph.D., is vice president of engineering at Raycap. He is a former chairman of the IEEE Power & Energy Society's Surge Protection Devices Committee. His email address is [surtees@ieee.org](mailto:surtees@ieee.org).*



## NEX10 - small, robust, low PIM

The new miniature RF coax connector system with outstanding features for Small cells, DAS, and In-Building applications.

› [wireless-infrastructure.com](http://wireless-infrastructure.com)

HUBER+SUHNER INC. Charlotte NC 28273/USA

**HUBER+SUHNER**  
Excellence in Connectivity Solutions



power needed for advanced analytics. Many edge devices and smart systems do not have adequate computing power to accomplish this on their own. And, once again, moving data back and forth to the cloud presents challenges of latency and bandwidth as well as security.

### 5G, Small Cells

Along with the cloud, edge computing and collocation, next-generation 5G wireless networks will be integral to meeting the needs of smart cities.

According to the National League of Cities, wireless data consumption in 2018 reached approximately 1.8 exabytes per month in North America alone. That number is projected

to increase six-fold over the next three years. In contrast to current 4G LTE networks, 5G wireless is expected to provide gigabit speeds, sub-1-millisecond latency and the capacity to connect 2.5 million devices per square mile.

5G, in turn, will require both macrocell and small cell technologies, which, although they serve different purposes, complement each other. Traditional macrocell towers have a coverage area that spans several miles in each direction; however, their signal degrades toward the edge of their coverage areas. With the increasing use of wireless devices and data, small cell facilities can be used to increase the mobile broadband network capacity in smart cities.

Unlike traditional macrocell towers, small cell installations generally cover much smaller geographic areas, measured in hundreds of feet. The antennas are much smaller than those deployed at macrocell sites and are often attached to buildings, rooftops and structures in public rights of way, including utility and light poles, on street furniture or on other public or private property. These installations help to extend macrocell coverage and add capacity in high-demand urban areas. Small cell infrastructure is typically deployed to alleviate capacity constraints in public spaces, high-traffic pedestrian areas, parks, office buildings, campuses, and stadiums and arenas.

## WANHO Manufacturing's Universal Grounding Solutions Portfolio is designed & engineered to protect your investment for all of your equipment applications

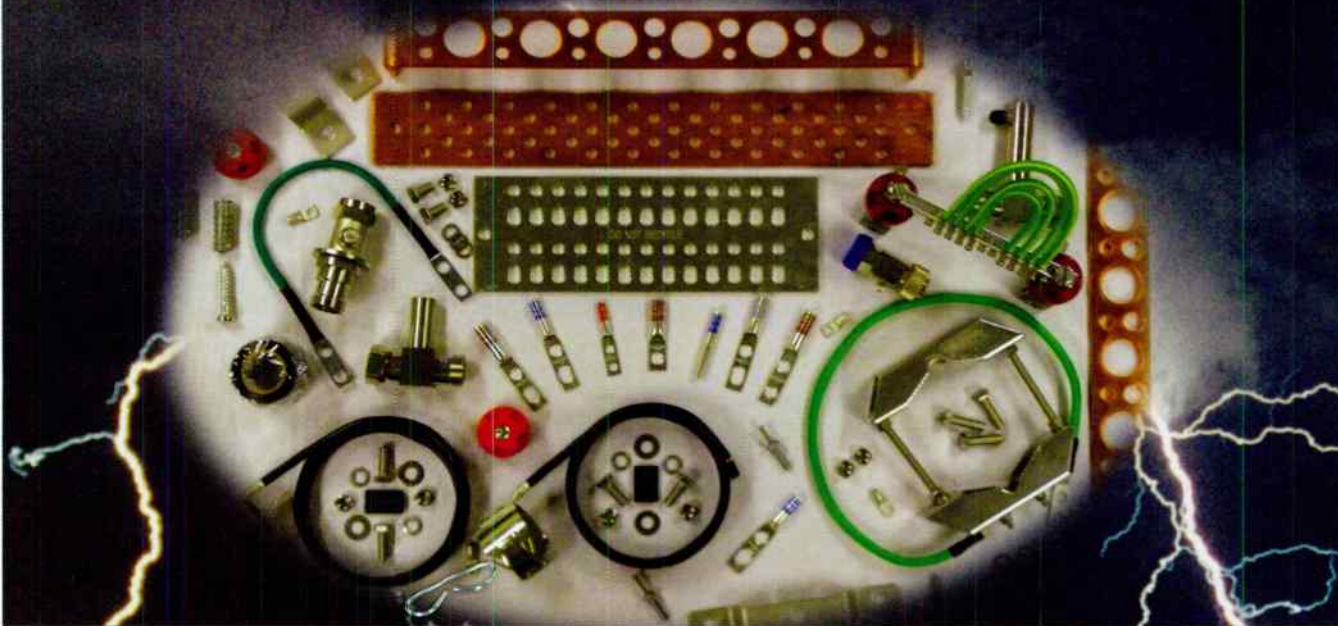

Contact us for all of your grounding needs  
sales@wanho.com www.wanho.com  
856-926-4686



ISO9001: 2015 Registered  
ISO14001: 2015 Registered



For 5G to deliver on its promise of smart city enablement, both macrocell and small cell technologies require connections to high-capacity wired networks, and these connections will ideally be made with fiber. Copper will not work for 5G because of its limited bandwidth. And although some industry prognosticators point to microwave in areas where laying fiber is not practical for geographic reasons or where access is not permitted, microwave is not a scalable solution. There's no question that fiber is the optimal choice for serving the increasing number of wireless endpoints that 5G small cells will create, and at the necessary transport bandwidth these new technologies will demand.

Smart city planning must include

massive fiber-optic backbones to support small cells and traditional cell sites, private communications networks for city services, and public and private Wi-Fi and private networks for internet connections to businesses. Whether in service of smart buildings, smart utilities or mobile health (mHealth) applications that will transform ambulances into mobile emergency rooms, all of these smart city applications and systems will depend on high-speed, low-latency, ultra-reliable communications networks running on fiber.

The Fiber Broadband Association estimates that nearly 1.4 million miles of fiber-optic cable will be required to provide comprehensive 5G service to just 25 metropolitan

areas in the United States. The most demanding 5G applications will require fiber to be extended to each small cell, but the exact fiber cable requirements for each deployment will differ based on local geography and expected demand.

**Top Smart Cities – Some Surprises**

The Eden Strategy Institute, a sustainability consulting firm based in Singapore, recently announced its rankings of the top 50 smart cities worldwide. It's interesting to note that 12 of the smart cities recognized were in the United States — including Chicago, Los Angeles, New York and San Francisco — but it's even more interesting that so-called Tier II and III cities such as Columbus, Ohio, and

**WE UNDERSTAND EVERY TOWER OWNER FACES UNIQUE RISKS**



**McGriff Insurance Services** is a large, independent insurance agency and an expert in protecting tower owners from unexpected risks. We offer complete, competitively-priced programs endorsed by WIA and tailored to suit your specific exposures, including self-supporting, guyed or monopole towers; support equipment; shelters and fencing; plus general liability, business auto, workers' compensation, umbrella and more.

Find out why we protect more tower owners than any other agency. Call 410-480-4413 or 410-480-4423, or email David Saul at dsaul@mcgriffinsurance.com or Kimberly Calhoun at kimberly.calhoun@mcgriffinsurance.com



The Hanover Insurance Group® WIA Wireless Infrastructure Association



**For Families. For Safety. For Advocacy.**

*Dedicated to Supporting the Families of the Fallen*

Help us help the families of fallen telecommunications tower technicians. Hubble Foundation provides several forms of assistance to families, and active technicians including, but not limited to:

- › Scholarships to the Children and Spouses of the Fallen
- › Bridge Funds to Aid the Family after a Fatality
- › Yearly Christmas Assistance
- › Burial / Funeral Expenses
- › A Safe Place to Obtain Safety and Reporting Information
- › Comprehensive Help to Locate Services Local to the Families
- › Injured Climber Assistance

**ONLINE**  
hubblefoundation.org  
option to send monetary donations or shop from our store.

**BY MAIL**  
Dr. Bridgette Hester  
Hubble Foundation  
3204 Upton Gray Pl.  
Foley, AL 36535

**Donate Today**

Isaiah 117

Kansas City, Missouri, were also on the list. In fact, a recent survey by the U.S. Conference of Mayors found that of 335 smart city projects in 54 metro areas across the country, 98 have been deployed in small cities, compared to 69 in large metropolitan areas.

That would include Ketchum, Idaho, with a population of about 5,400 people. In Ketchum, a smart irrigation project has replaced existing irrigation systems with weather- and soil-activated sensors that can be managed and monitored remotely. The IoT-enabled irrigation systems are expected to reduce water usage by 20 to 60 percent, saving more than 1 million gallons annually.

You may not yet live in a smart city, and for that matter, life in a briskly paced metropolis might not ever be for you. But considering the example of Ketchum, a town better known for hiking, fishing and skiing than technology, it's likely that smart city infrastructure will be coming to your community soon, too. ■

*Tom Caruso is vice president of operations at Hellman Electric.*



**SAFETY LMS**



**NORTHEAST MARITIME INSTITUTE**  
COLLEGE OF MARITIME SCIENCE

**Warriors4Wireless in collaboration with Northeast Maritime Institute and Safety LMS is proud to offer the Tower Technician Level One Program!**

Warriors4Wireless (W4W) provides military veterans with training, advanced certification, and transitional support, leading to lucrative new careers in the telecommunication industry. W4W works pro-actively with wireless companies to pinpoint applicable positions and promote the hiring of veterans.

**Warriors4Wireless...  
Serving those who have faithfully served!**

**Register Today!**

Call (508) 992-4025 or Email [registration@northeastmaritime.com](mailto:registration@northeastmaritime.com)

**NORTHEAST MARITIME INSTITUTE | 32 WASHINGTON STREET FAIRHAVEN MA 02719**

## Peppertree Capital Management, Inc.

>\$1B under management  
and >75 communication  
infrastructure investments  
in 10 countries since 2004.

towers  
fiber  
DAS  
spectrum  
data centers  
small cells  
real property



**PeppertreeCapital.com**

## Building the Environment for Successful Leadership

Providing opportunities and welcoming outside involvement makes one's own life easier and enriches the careers of others. There is no better way to create a trustworthy team and achieve work-life balance.

By Don Bishop

Emily Kosmalski oversees a team of project managers at Terracon, where she manages the company's national telecommunications program and several of the company's largest national accounts. She is a senior associate, environmental/NEPA group manager and national account manager. NEPA is short for National Environmental Policy Act, the 1970 law that requires federal agencies to assess the environmental effects of their proposed actions. The procedure is referred to as "the NEPA process" or "the environmental impact assessment process." FCC licensing is the federal hook that requires the telecommunications industry to comply with NEPA. An environmental, materials testing and geotechnical firm, Terracon has 4,500 employees in more than 140 U.S. offices. The company

has performed work on thousands of cell sites.

The daughter of a police officer and a mother who worked several part-time jobs to make ends meet, Kosmalski grew up in Cleveland. In high school and college, she worked multiple jobs to provide for herself. She earned a bachelor's degree after having studied in the geography program at Ohio University, and stayed for a master's degree focused on environmental planning and impact assessment, working as a teaching assistant and as a research assistant. She graduated magna cum laude in 2006.

"Shortly after graduating, I began my career at Terracon as an entry-level environmental scientist, performing due diligence assessments on proposed cell tower sites," Kosmalski said. "During my first several years, I

said 'yes' to virtually every opportunity that came my way. I did not turn down any chance to learn a new skill set or work on a new project."

When Terracon's NEPA manager left in 2012, Kosmalski's work ethic, wide range of project experience and education earned her the position.

"I became the contact for the majority of our telecommunications clients and began overseeing a staff of project managers," Kosmalski said. "I also became responsible for one of Terracon's largest national accounts. With just six years of experience, I was one of the youngest staff members to be given such responsibility."

When she became pregnant with her first child last year, Kosmalski said, many people told her that she would never be truly happy unless she left her job — that achieving work-life balance as a new mother in a high-performance consulting job would be impossible. "I was told to just forget it — I might as well quit for a few years and come back later," she said. "This feedback only fueled my desire to prove everyone wrong."

### How She Did It

In the months leading up to maternity leave, Kosmalski detailed every aspect of her job and chose a team to take over



“ “When you are receptive to others, you'll find that every person in your work journey can be a mentor in one form or another.” ”

—Emily Kosmalski, senior associate, environmental/NEPA group manager and national account manager, Terracon



## Q-and-A with Terracon Senior Associate Emily Kosmalski

**Q: How do you encourage creative thinking within your organization?**

A: I try to give employees freedom and latitude to make their own decisions. The idea is to give people a larger framework of rules in which they must operate, but give them great freedom within that frame. This enables a more creative thought process.

**Q: What are characteristics that every leader should possess?**

A: Leadership and failure are fundamentally connected. Learning to embrace failure as a positive step toward growth is a defining characteristic of leadership. An iconic quote from Michael Jordan really hits it home: "I've missed more than 9,000 shots in my career. I've lost almost 300 games. Twenty-six times I've been trusted to take the game-winning shot and missed. I've failed over and over and over again in my life. And that is why I succeed."

**Q: What is a behavior or trait that you have seen derail more leaders' careers?**

A: Ego and anger.

**Q: What are you doing to ensure you continue to grow and develop as a leader?**

A: The continuous setting and achieving of new goals is key for growth as a leader. A current career goal for me is to obtain my American Institute of Certified Planners designation. To that end, I am reading books, studying materials and immersing myself in the current trends of environmental planning.

**Q: What do you like to ask other leaders when you get the chance?**

A: I am interested in how other leaders start their day. So when I can, I ask "What is your "morning routine?" Morning routine is a simple defining characteristic of leaders. It has been found through numerous studies that great leaders all have a consistent ritual that helps them start their day on the right foot. The routine itself differs, but having one seems to make all the difference."

her various roles based on their talent and work ethic and her positive experiences working with the team members.

"When the day of my departure came, I was fully confident that all aspects of my job would be covered," Kosmalski said. "Not only did my team deliver, they far exceeded expectations. Having a successful replacement team on the job meant I could ease my way back into work when I returned and take my old responsibilities back as my capacity allowed. Without this team in place, my departure from and transition back into work would have been painful at best and disastrous at worst."

Kosmalski's university, personal and working lives intertwine with her husband's. The two joined forces and dominated every class together almost immediately after meeting during their freshman year of college, she said. They took the same undergraduate and

graduate classes and worked several jobs together. At Terracon, they are co-group managers, with offices just doors from one another.

"My husband played a vital role in the past two years while I was pregnant and during the first year of raising our child," Kosmalski said. "I cannot imagine the struggle of a single mother trying to raise a child and put food on the table. Having a partner who could help take care of things at home was invaluable. It was one of the reasons I was able to successfully return to work. I am fortunate to have such a partner in both business and life."

The single most significant barrier to female leadership is the lack of affordable day care, in Kosmalski's view. She said that the more children a woman has, the less chance there is that she will return to work. "Even a single child can result in a woman

staying home if her earnings don't outweigh the cost of day care," she said.

### Kudos to Mentors

Numerous well-known women inspire Kosmalski, she said, but with *AGL Magazine* as a telecommunications publication in mind, she named Robin Haeffner, a now-retired NEPA compliance leader with Verizon Wireless, as a source of inspiration throughout her career.

"Robin was a strong leader," Kosmalski said. "She knew the regulations backward and forward, worked hard and stood with the best of industry's regulators and stakeholders. When Robin led a meeting, there was no question who was in charge. But most important, she commanded respect for all the right reasons. When she opened her mouth, you knew she was the smartest person in the room, and it made people

sit down and listen. That is what I aspire to be in my career. When I speak, I want people to view me as a knowledgeable resource who can provide trustworthy guidance.”

Throughout her working career, Kosmalski said, she has witnessed many powerful female role models in the telecommunications industry who gave her a snapshot of exactly the woman she wanted to be. She cited the guidance and mentorship of those who came before her as absolutely invaluable. “I am fortunate to work in an industry with so many inspiring leaders,” she said.

“When you are receptive to others, you’ll find that every person in your work journey can be a mentor in one form or another,” Kosmalski said. “I

have learned as much from a college student fresh out of school as I have from a 30-year industry professional. My employees and teammates are often my greatest sources of inspiration. It’s important to seek out knowledge and perspective anywhere it is offered and not discount someone based on age or experience.”

Kosmalski said that she has found that many people often are afraid to open themselves and their careers to outside help. She said it appears that they feel a need to be the one who is needed and not let anyone else help. In the case of women, this can sometimes be attributed to an element of fear that there is only so much room at a table of men, and thus, women have to fight for their place, she said. As a

result, she said, instead of building up others around them, some spend time only building up themselves.

“What I have found is that a far richer career is based on lifting up those around you,” Kosmalski said. “When you provide opportunities and welcome outside involvement, you are not just making your own life easier, you are enriching the careers of others. You are providing opportunities and allowing people the chance to achieve their own success.

“This is how a trustworthy team is created. Work-life balance as a working mother in a fast-paced industry like telecom can truly be achieved when you have a fully functioning, dependable and successful team in place,” she said. ■



Consulting Engineers

**JOIN AFCCE**

[AFCCE.org/Become-A-Member](http://AFCCE.org/Become-A-Member)

Regulatory Compliance  
FCC Rules and Regulations  
Wireless • Broadcast • RF Exposure

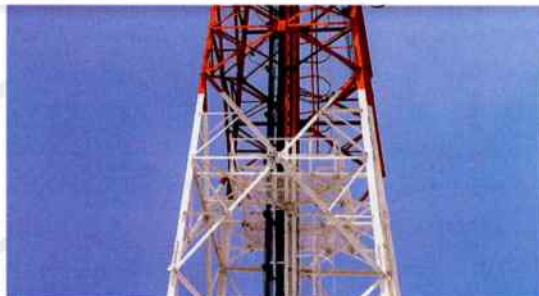



# NATE UNITE 2020

February 17-20 | Raleigh, NC

**MAKE YOUR  
PLANS TODAY!**

**10%**  
*Discount*

for Space Secured  
by July 1, 2019



[www.natehome.com](http://www.natehome.com)



# Untangling Polarization Technology

Multiple-input multiple-output (MIMO) wireless communications requires polarization diversity [the use of antennas with different polarizations], one of which is  $\pm 45$ -degree slant polarization.

By Justin G. Pollock, Ph.D.

Optimizing signal propagation over wireless transmission paths has never been easy, hindered as it is by obstructions, fading, multipath propagation and various other impediments between the transmitted signal and its intended recipient. Fortunately, there are ways to mitigate some of these factors, ranging from antenna designs and polarization schemes, as well as multiple-input multiple-output (MIMO) communications technology. To understand how these schemes deliver their benefits, it's first important to cover the basics.

## Linear Polarization

There are three general types of antenna polarization: linear, circular

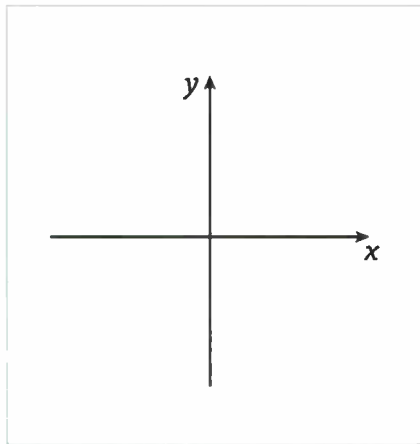

Figure 1. The basic orientation of electromagnetic waves, whose polarization is either horizontal or vertical in relation to the Earth's surface.

and elliptical. An antenna is linearly polarized when it radiates RF energy on a single plane, either horizontal or vertical in relation to the Earth's surface (see Figure 1) or some angle in between. Radiation from horizontally polarized antennas parallels the Earth's surface; vertically polarized antennas radiate energy on a plane perpendicular to it.

Ideally, the transmitting and receiving antennas should have identical polarization because signal strength decreases in direct proportion to how far they stray from that relationship. This is termed polarization mismatch, and the loss in signal strength is calculated in dB as  $20 \log_{10} \cos(\theta)$ , where, in an ideal scenario,  $\theta$  is the angle between the receive and transmit antennas.

## Circular Polarization

Circular polarization is mathematically defined as a linear combination of equal magnitude horizontally and vertically polarized waves that are 90 degrees out of phase. This equates to a wave rotating in time at a steady rate that is either left-hand or right-hand polarized (i.e., spinning in opposite directions) and includes the horizontal and vertical planes and all planes in between.

Compared with two linearly polarized antennas of the same orientation

and forward gain, having one circularly polarized antenna and one linearly polarized antenna will reduce the link's range because the circularly polarized antenna splits its power equally across two planes, reducing the system gain by 3 dB. Although this scenario does reduce the link budget, circularly polarized antennas are beneficial when the opposite antenna's linear polarization is not known, or fixed.

## Elliptical Polarization

The third common type of polarization is the generalization of circular polarization, known as elliptical polarization. It occurs when the electric field's two linear perpendicular components are 90 degrees out of phase and have unequal magnitude. Like circular polarization, an elliptically polarized antenna can be either right- or left-hand polarized. Circular and elliptical polarizations are shown in Figures 2 and 3.

All this being said, once an antenna launches a radio wave, the wave's characteristics continuously change. So, once the wave reaches the receiving antenna, the result is typically the initial polarization modified by fading, reflections, multipath interference, changes in phase and many other factors specific to the operating environment (urban or rural, for example) that

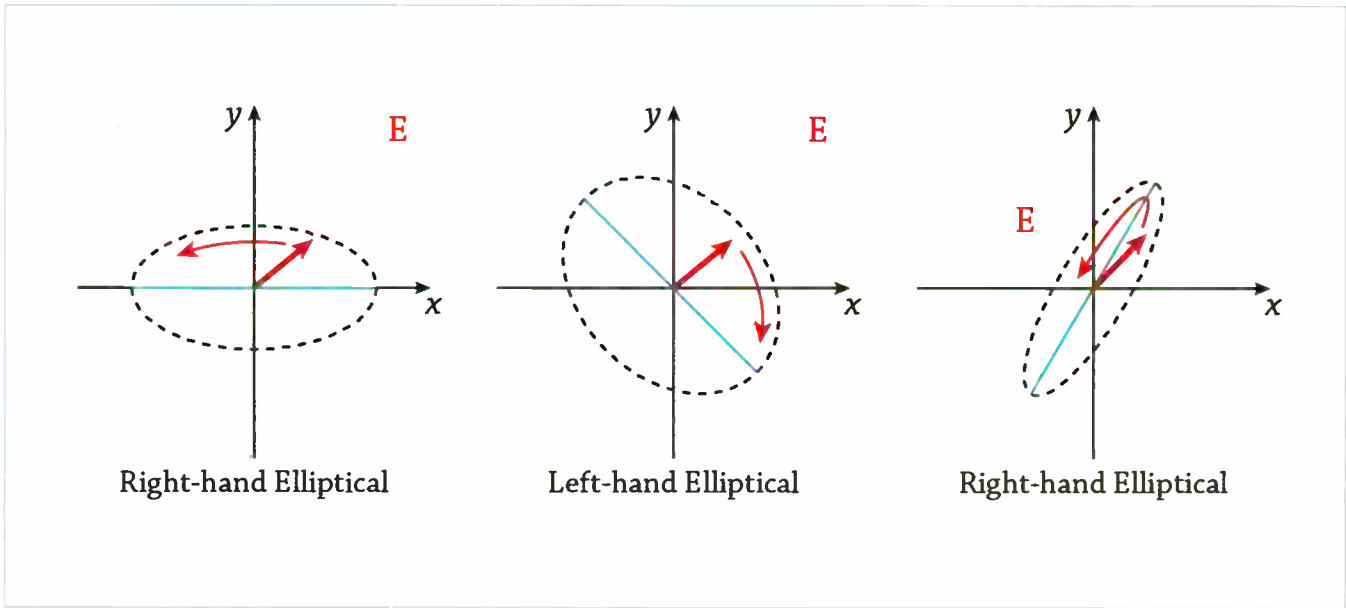

Figure 2. Diagram of circular polarization and variations of elliptical polarization.

affect the received signal strength. These factors can significantly degrade the signal in both strength and quality, and this is where the challenges begin for any type of system.

The following information will concentrate on the regions in which cellular and other services operate, currently from about 600 MHz to 3700 MHz. Propagation at these frequencies is best accomplished over an unobstructed visual line-of-sight (LOS) path between transmitter and receiver, as attenuation and changes in signal characteristics are minimal. LOS is an ideal condition for a wireless transmission because the propagation challenge comes only from weather or atmospheric parameters and the characteristics of its operating frequency. Consequently, the transmission path can be longer and signal strength higher, resulting in greater throughput.

The non-line-of-sight (NLOS) scenario is far more common and presents challenges for all types of wireless

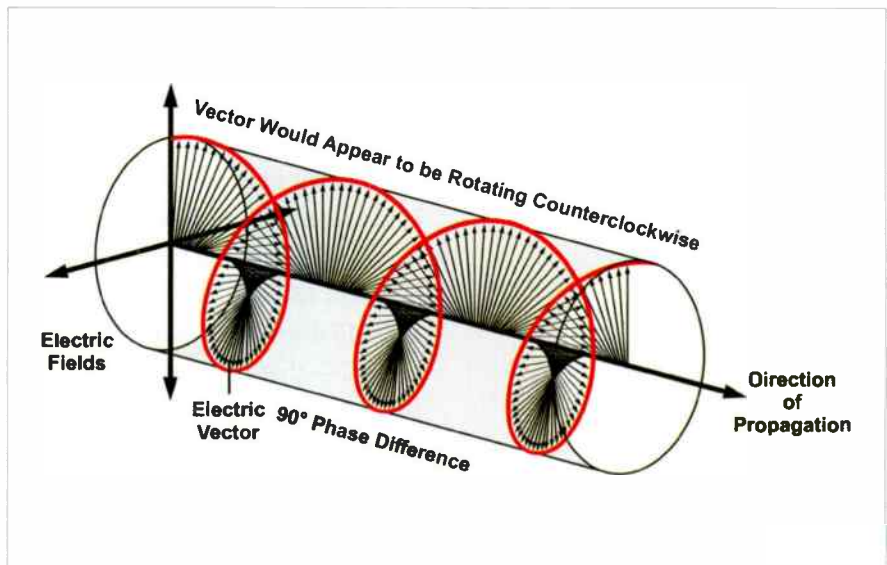

Figure 3. 3D model of circular polarization and variations of elliptical polarization.

systems, especially those in which one end of the link is mobile. When there is no clear line of sight, degradation will result from reflections, refraction, diffraction, scattering and atmospheric absorption. The multiple signals created by these factors will then arrive at the receiving antenna at different times, from different paths and with different strengths. The result

will be a reduced link margin and decreased throughput, and in a worst-case scenario, make communications impossible.

Antennas can mitigate some of these problems using various techniques, the most common being polarization diversity. It is used in all types of wireless applications including cellular and the fixed wireless access

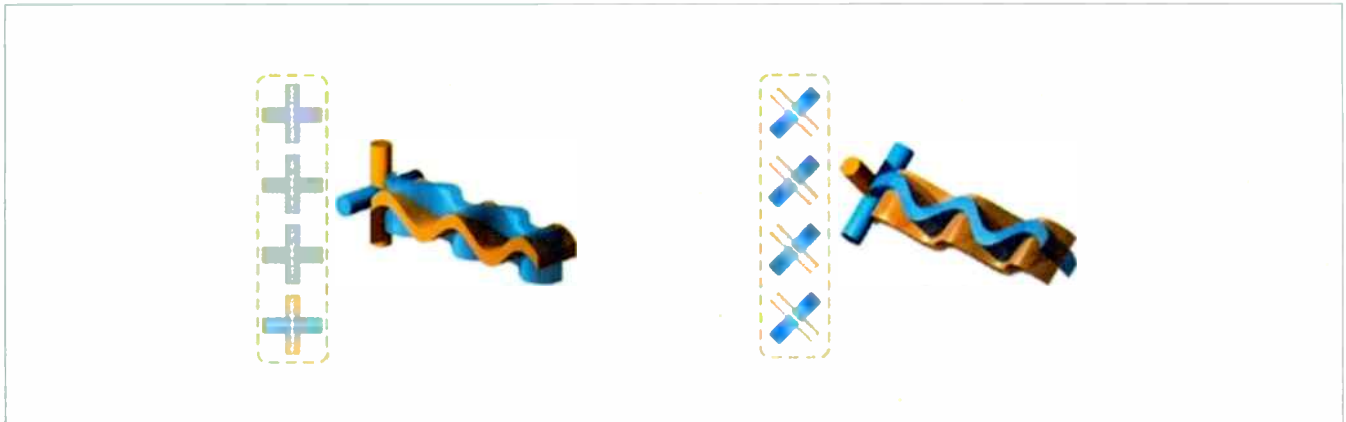

Figure 4. At left is horizontal/vertical polarization with respect to the horizon, and at right, the depiction is polarized  $\pm 45$  degrees. The electric and magnetic fields are shown in blue and brown.



Figure 5. This is a depiction of model KP-900-DPOMA-45, an omnidirectional  $\pm 45$ -degree slant-polarized antenna covering 824 MHz to 928MHz.

(FWA) systems used in rural areas to deliver residential broadband service. Polarization diversity is basically the use of antenna systems that radiate signals in more than one polarization, such as horizontal and vertical.

Horizontal and vertical dual polarization was used for many years in wireless systems but has mostly been replaced by slant polarization (see Figure 4) in which two linearly polarized antennas radiate at 45-degree angles (+45 degrees and -45 degrees) from horizontal and vertical — that is, midway between the two fundamental polarization angles. Polarization slants don't have to be 45 degrees, and in some applications including satellite communications systems they're not, for reasons specific to their operating environments. Of course, the wireless industry could have chosen a variant other than 45 degrees, but having chosen 45 degrees, manufacturers increasingly supported it, ensuring its longevity.

### Slant Configuration Benefits

Various studies have determined that this  $\pm 45$ -degree slant configuration can provide benefits that H and V configurations do not. Dual-slant

polarization is midway between horizontal and vertical and signals from the two antennas combine into a linearly polarized transmitted wave, therefore reception can be improved over pure H or V. Slant polarization has also proven its ability to provide signal improvement through foliage as well as in NLOS conditions.

In addition, slant polarization can minimize some of the effects of signal variability, reduce interference between antennas and increase the signal-to-noise ratio (SNR). These benefits apply to any operating scenario and especially to urban and other environments where signals are scattered, reducing their strength in a given location.

In antenna design, the horizontal and vertical polarizations often have unequal patterns and gain due to the physical asymmetries of the antenna's construction and the antenna's modal electric field pattern in the E and H planes. This can be readily observed in each polarization's patterns, in which the beam width of the vertical polarization is narrower than the horizontal beam width. As a result, the gain of the vertical signal is weaker



near the sector edges, which causes a chain imbalance. In a  $\pm 45$ -degree slant configuration, there are no physical asymmetries in the antenna and each polarization has nearly identical patterns that equalize the signal strength of both polarizations.

### Withstanding Fading

Slant polarization appears to be able to withstand the effects of fading caused by reflections better than horizontal/vertical polarization, and some sources cite its ability to reduce interference where there are many simultaneous emitters. Finally, received signals typically appear at the receiving end more vertically than horizontally polarized, creating an unequal relationship, as vertical polarization often delivers

a stronger signal than its horizontal counterpart at the receive location. Slant polarization can minimize this issue by equalizing the signal levels from both orientations.

Although slant polarization paired with linear polarization should theoretically cause a 3-dB (half-power) reduction in link budget caused by polarization mismatch, multipath propagation has the effect of restoring it because polarization is no longer purely horizontal/vertical and at a  $\pm 45$ -degree slant. The result is typically only about a 1-dB reduction in link budget.

### Dual Polarization Benefits

Dual polarization offers other benefits not related to signal propagation

but nevertheless potentially beneficial when attempting to receive local approval for antenna installations. It effectively results in having two single-polarization antennas together in a single housing, eliminating more than one enclosure. In addition to reduced visual effect, this approach also has little effect on wind loading and adds minimal additional weight.

The model KP-900-DPOMA-45 (see Figure 5) is an example of an omnidirectional  $\pm 45$ -degree slant-polarized antenna for operation between 824 MHz and 928 MHz. It provides 360-degree coverage with minimal azimuth ripple and 10 dBi signal gain. The antenna supports any 900-MHz radio, including the popular Cambium model PMP450i. KP Performance Antennas

## Set It and Forget It

Take the worry out of tower light maintenance with our new Vanguard® Inclusive Program (VIP).

- Capital expense model — no operating expenses
- Predictable budgeting — one-time flat rate fee
- For new and existing Vanguard lighting systems
- 5-year parts and labor warranty on new systems
- Flash automatically dispatches and repairs

Non-Vanguard or competitor lighting system?  
Ask about our TLC program.

flashsales@spx.com | 888.313.5274

flashtechnology.com/vip

**FLASH TECHNOLOGY** 



also makes omnidirectional antennas for other bands, including the recently released dual-band, four-port model KP-25DOMNI-HV that covers the 2300 MHz to 2700 MHz and the band from 5150 MHz to 5850 MHz with a gain of 12 dBi and supports 2x2 MIMO on both bands.

Another technique for reducing the losses associated with polarization mismatch is MIMO communications, whose best-known benefit is dramatically increasing link performance and capacity by simultaneously sending and receiving multiple data streams. It also exploits the normally detrimental effects of multipath propagation. Even a minimal 2x2 MIMO approach can effectively double the maximum data rate of a communications channel.

MIMO communications requires polarization diversity (the use of antennas with different polarizations), one of which is  $\pm 45$ -degree slant polarization or spatial diversity (the use of spatially separated antennas). One approach, employed by Mimoso, combines spatial multiplexing and polarization diversity to allow two data streams to maintain their separation in a way that allows them to arrive with high isolation between them.

**Summary**

Overcoming propagation problems has become more and more important as wireless services employ new modulation techniques, operate at higher frequencies and deploy large numbers

of small cells to provide extremely high data rates and low latency. Polarization diversity employing slant polarization along with the innovative use of MIMO-enabled radios are playing a central role in making these possible — and further advances are sure to come. ■

*Justin G. Pollock, Ph.D., is a senior antenna engineer at KP Performance Antennas and RadioWaves, which are subsidiaries of Infinite Electronics. He is the technical lead on the product development of industry-leading antenna technologies. He has co-authored refereed journal, conference and white papers for leading publications in the field of RF and microwave engineering, antennas, physics and optics.*



# CONNECT AND PROTECT

**The new word in telecommunications is densification.** The densification of the network unfortunately also means that in the modern telecommunications network, telecommunications facilities will be closer to the public domain and often in densely populated area.

Earth potential rise that can occur at or near a telecommunication facility that is close to power utility assets and near to other consumers requires new considerations for grounding methods.



Learn more about these considerations by downloading our whitepaper, **Earth Potential Rise in Public Spaces near Telecommunications Facilities**, online at:

[nVent.com/AGLJune19](http://nVent.com/AGLJune19)

CADDY ERICO HOFFMAN RAYCHEM SCHROFF TRACER





Sponsored Content

# AGL Company Showcase

FEATURING: *Compliance Testing and Monitoring Companies*



## LBA Group, Inc.

3400 Tupper Dr.  
Greenville, NC 27834 USA  
Bryan Dixon  
Safety Director  
bryan.dixon@lbagroup.com  
252.757.0279  
www.lbagroup.com

**OVERVIEW:** LBA is your one stop source for all things RF Safety—backed by 50 years of RF experience! Our RF Safety One Stop, offers RF safety training, NIER studies, FCC/ OSHA compliance audits, RF test instruments, personal RF monitor PPE, and RF shielding.



## NB+C

6095 Marsalee Dr., Suite 300  
Elkridge, MD 21075 USA  
Keesha Fausto  
Marketing, Communication  
and Events Specialist  
kfausto@nbcllc.com  
410-721-7092  
networkbuilding.com

**OVERVIEW:** NB+C is a wireless site development firm with three divisions: Site Development, Engineering Services and Construction and Technical Services. We employ over 400 professionals who are totally committed to client service and project results.



## Southern California Edison

2 Innovation Way  
Pomona, CA 91768 USA  
Brian Ryan  
Principal Manager—Account Management  
carriers@sce.com  
909-274-1949  
edisoncarriersolutions.com

**OVERVIEW:** Southern California Edison offers an extensive portfolio of towers, land, and streetlights available for cell site development backhauled over our wholly owned 5,700+ route miles of diverse fiber-optic network.

## *Advertise Your Company in the Company Showcase!*

AGL Magazine makes opportunities available to companies to advertise themselves in this Company Showcase section. If your company is interested in boosting awareness or growing your sales, please get in touch with AGL Magazine about advertising here.

**Eastern Region: Contact Karen Clark** by phone at 303.979.0621 or via email at [kclark@aglmediagroup.com](mailto:kclark@aglmediagroup.com).

**Western Region: Contact Deb Plank** by phone at 832.484.8465 or via email at [dplank@aglmediagroup.com](mailto:dplank@aglmediagroup.com).



Tower  Xchange

9-10 July, Boca Raton Resort and Club, Boca Raton

# Meetup Americas 2019

A unique networking opportunity with 250 leaders of the CALA telecom tower industry

Top towercos, MNOs, investors, advisors and solution providers active across Central and Latin America will gather in Boca Raton, 9-10 July 2019, for the 6th edition of the TowerXchange Meetup Americas.

#### What to expect:

- 250+ key experts under one roof to discuss and learn more about the strategic, operational and financial challenges of doing business in CALA
- Formal panel discussions mixed with TowerXchange's unique networking roundtables & working groups
- Countless hours of business interaction in the prestigious cornice of the Boca Raton Resort & Club
- Enhanced focus on technical and operational know-how, in line with the critical changes occurring across the CALA telecom infrastructure industry

Participating companies include SBA Communications, Entel Chile, American Tower, Phoenix Tower International, Inter-American Development Bank, Mexico Tower Partners, Telefónica, Torrecom, Tower One Wireless, Digital Bridge and more...

Find out all the details at [www.towerxchange.com/meetup/meetup-americas/](http://www.towerxchange.com/meetup/meetup-americas/)  
Quote TXAM19AGL

#### Diamond sponsor:



#### Silver Sponsors:

accruent



#### Bronze sponsors:



Vinson&Elkins RLLP

World Radio History

Sponsored Content

# AGL Product Showcase

FEATURING: *Lightning Protection, Surge Suppression and Grounding Products*



## XIT Ground Rod

Ahead of its time, the UL-listed, self-moisturizing and maintenance-free XIT Grounding System provides low resistance in diverse climates around the world, without harmful effects on the environment. Lyncole provides total site and facility lightning protection by designing site-specific lightning protection, grounding solutions, surge suppression, and lightning warning systems. These systems provide solutions to protect your operations and infrastructures while offering peace of mind. [www.lyncol.com](http://www.lyncol.com)



## ESE OPR Lightning Protection System

For today's modern industrial facilities, conventional approaches to Lightning Protection

are often impractical or even impossible. At VFC Lightning Protection, we have teamed up with the international leader in Lightning Protection technology, ABB®, to provide these facilities with Total Site and Facility Protection. The ABB® OPR Lightning Protection system is the world leading ESE technology. [www.vfclp.com](http://www.vfclp.com)

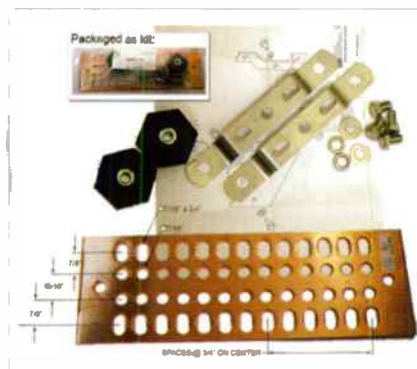

## Lightning Protection Components

ALT manufactures a full line of UL listed lightning protection components, including Air Terminals typically used in tower applications; image shown: ALT p/n 548B-3WH. This comprehensive line also includes conductors, bases, connectors, special application air terminals. To compliment this line, ALT offers surge suppression. ALT specializes in custom ground bars; any configuration, material, and size you need. We manufacture UL Listed grounding materials (#E169796), including ground bars, Advanced Grounding Electrodes (AGE), and lugs. ALT's grounding line also includes exothermic welding, standard and custom ground mats, ground plates, ground wire, rebar bonding assemblies, and an array of test well solutions [www.ALTFAB.COM](http://www.ALTFAB.COM)



## Superior Data Line Surge Protection

Transtector's ALPU (Advanced Lightning Protection Unit) Series offers state-of-the-art protection for small cell networks, GSM, CDMA, LTE, WiMAX, 3G and 4G applications providing Mobile Operators with reliable surge protection solutions. This series of data line surge protectors are designed with installation in mind to protect GbE, PoE, PoE+ and PoE++ communication networks. Using hybrid, Silicon (SASD), and gas tube technology (GDT) the ALPU series of dataline protectors provides superior technology for indoor and outdoor GbE data applications. Available for Same-Day Shipping. [www.transtector.com](http://www.transtector.com)





### Small Cell Cabinets

Transtector Systems engineers a full line of reliable, safe and configurable compact cabinet solutions engineered specifically for Small Cell deployments. These cabinets integrate dependable surge suppression, are compact to reduce public visibility, provide several current configurations, and are UL listed to meet industry safety standards. Transtector Small Cell Cabinets are in stock and available for same-day shipping. Contact us at 1 208 635 6400 or visit our website at [www.transtector.com](http://www.transtector.com)



### Lightning Prevention and Protection Solutions

Towers and cellular operators know only too well the grief that lightning can bring to unprotected towers, antennas, and associated equipment. Outages and equipment failure mean expensive tower climbs. Adding radio heads, MIMO, and beam steering antennas amplify the problem. Since 1963, LBA Technology has offered lightning prevention and protection solutions to government, tower and cellular industries. LBA systems have even been adopted by the US military as the sole deployment protection for the F-35 fighter fleet! LBA offers lightning dissipation arrays

and terminals for towers, antennas, and satellite dishes, including portable mast systems for ground mobile assets.

[www.lbagroup.com/products/lightning-protection](http://www.lbagroup.com/products/lightning-protection)



### IS-B50 Series—Superior Coaxial RF Surge Protection

The IS-B50 Series of DC block surge arrestors from PolyPhaser are designed to protect against lightning events and are ideal for HF, UHF and VHF radios. The IS-B50 family of RF protectors can be used for general radio use with frequency ranges between 1.5 MHz to 1000 MHz. PolyPhaser products are in stock and available for same-day shipping. Contact PolyPhaser at 1 208 635 6400 or visit our website at [www.polyphaer.com](http://www.polyphaer.com).

[www.polyphaer.com](http://www.polyphaer.com)



### High Capacity Surge Protection

Phoenix Contact's VAL-US surge protection is Listed to UL 1449 and is available with up to 80 kA surge capacity. The VAL-US provides a UL Listed alternative to traditional hardwired SPDs, allowing for fewer installation steps and easy integration into virtually any system. The

VAL-US series offers remote status indication, which allows the user to easily monitor SPD status. The high-capacity plugs of the VAL-US series offer a high degree of protection. The VAL-US series has products specifically configured for single phase, split phase, and three phase applications. DC configurations are also available. Learn more on our website.

[www.phoenixcontact.com/us](http://www.phoenixcontact.com/us)



### Lightning Protection Solutions

Raycap provides lightning protection solutions for macro and small cell sites, such as this AC Disconnect product designed for small cell concealed poles, and featuring the Strikesorb 30 CHV surge protective device. Raycap's cell tower lightning protection solutions have been developed specifically to protect Remote Radio Heads (RRHs) and Base Band Units (BBUs)—both parts of a distributed base station architecture—providing cell-site surge protection from electrical overvoltage damage caused by lightning strikes. Our lightning protection solutions are thoroughly tested to international standards and suitable for use in both AC and DC power environments.

[www.raycap.com/surge-protection](http://www.raycap.com/surge-protection)





### Telecom Protection Products

nVent ERICO is the global leader in precision-engineered electrical products for protecting structures, equipment and people. With an extensive range of telecom-specific products and expertise, we offer protection solutions that can be customized for any application need. Whether you need a lightning protection system, want to prevent equipment or data losses with surge protection solutions or need to improve grounding system resistance, nVent ERICO has you covered from the ground up. Contact us today!

[www.nVent.com/ERICO](http://www.nVent.com/ERICO)



### Ground Lugs and Terminals

WANHO Manufacturing, LLC is excited to announce the availability of a full line of UL & CSA listed ground lugs and terminals that are Top 4 Carrier approved as part of our "Options, Choices and Solutions" portfolio. These lugs include specific CEQ assigned numbers for AT&T and are readily available for shipments. One call to Wanho and you can consider it done! Call 866-926-4686; email [sales@wanho.com](mailto:sales@wanho.com)

[www.wanho.com](http://www.wanho.com)



### Surge Arrestor Series

The Times Protect® LP-BTR high performance surge arrestor series from Times Microwave

addresses applications in the 20MHz-1000MHz spectrum. Our unique DC blocking technology employed in this design provides optimum isolation of the antenna port from the protected equipment port for maximum surge protection. LP-BTR surge protectors have exceptional RF performance and are constructed from the highest quality materials for unsurpassed durability and longevity. These units meet and surpass all applicable industry standards.

[www.timesmicrowave.com](http://www.timesmicrowave.com)



### Bonding Component System

The BONDWASHER from BONDWASHER BRAND can be used as a stand-alone bonding component or as a component of BONDWASHER'S BONDINGWARE® System. The BONDWASHER, used along with a BONDWASHER component, completes the BONDINGWARE System (see graphic). The BONDWASHER is designed to serve one (1 of 2) part of a two-part BONDINGWARE System, the other part (2 of 2) being a BONDWASHER of any matching model or size, fitted accordingly to perform the desired bonding of separate assemblies. The BONDWASHER reduces Hand-tool count by 50%, improves Time Management by 50%, greatly reduces assembly torque loss due to environment, and matches all current BONDWASHER Part Numbers/Sizes and meets DFARS Regulation.

[www.bondwasher.com](http://www.bondwasher.com)

## Advertise Your Product in the Product Showcase!

AGL Magazine makes opportunities available to companies to advertise specific products in various categories of Product Showcases. If your company offers a product or service listed in the editorial calendar on the AGL Media Group website, please get in touch with AGL Magazine about advertising here.

**Eastern Region: Contact Karen Clark** by phone at 303.979.0621 or via email at [kclark@aglmediagroup.com](mailto:kclark@aglmediagroup.com).

**Western Region: Contact Deb Plank** by phone at 832.484.8465 or via email at [dplank@aglmediagroup.com](mailto:dplank@aglmediagroup.com).

# ADVERTISER INDEX

AFCCE .....	30	KP Performance Antennas .....	5	Slatercom-WCD .....	42
AGL Summits .....	43	McGriff Insurance Services .....	26	Southern California Edison .....	42
AGL eDigest .....	7	National Association of Tower Erectors .....	31	Times Microwave Systems .....	44
Allstate Tower .....	42	Noash Construction .....	42	TowerXchange .....	38
Flash Technology .....	35	nVent Erico .....	36	Two Hops Wireless .....	42
Hubble Foundation .....	26	Peppertree Capital Management .....	27	Wanho Manufacturing .....	25
Huber + Suhner .....	21	RadioWaves .....	13	Warriors4Wireless .....	27
Kaelus .....	15	Raycap .....	2	WIA/ConnectX .....	17

# PROFESSIONAL DIRECTORY

**SOUTHERN CALIFORNIA EDISON** Carrier Solutions

- 530,000 Streetlights
- 14,000 towers & Steel Poles
- 1.5 Million Distribution Poles
- 890+ Substations
- 5,700+ Route Miles of Fiber

edisoncarriersolutions.com

**ALLSTATE TOWER**  
PITTSBURGH TOWER GROUP

Manufacturer of Guyed & Self-Support Towers  
Complete line of Tower Accessories  
Full Range of Maintenance & Installation Services

**Kevin Roth**  
VP of Sales

270-830-8512 Ext. 3601      P.O. Box 25 Henderson, KY 42419  
Fax: 270-830-8475      kroth@pttg.com  
Mobile: 270-831-3632      www.PTTG.com

— CONSTRUCTING —  
**CONNECTIVITY**

**Noash Construction, Inc.**

- Communication Tower Service
- Microwave
- Wireless Internet
- AMR/AMI Installation
- Antenna/Coax Installation
- Tower Inspections
- Tower Lighting Service

www.noashconstruction.com  
Phone (270) 835-9100 • P.O. Box 249, 11079 St. Rt. 132 East, Sebree, Kentucky 42455  
info@noashconstruction.com      Facebook / Linked In

**Two Hops Wireless, LLC**

RF Engineering & Design  
FCC & FAA Compliance  
Rural WISP and Cellular Networks  
Aerial Photography & Inspections  
Network Operations

540 987 0500  
rbiby@two-hops.com  
www.two-hops.com

**TWO HOPS**  
WIRELESS, LLC

**Slatercom-WCD** **Dialight**

- DUAL RED-WHITE (E1/E2) LED SYSTEMS AVAILABLE FROM STOCK
- GENUINE DIALIGHT PRODUCTS & WARRANTY
- RAPID DELIVERY ON "KITTED" SYSTEMS
- UNBEATABLE PRICING

D1RW  
MASTER DISTRIBUTOR

SALEM, OR. (503) 581-5550      www.slatercom.com

Put the power of AGL Magazine to work for you with a display ad.

**agl**

Contact your sales rep  
Karen Clark, Eastern Region  
303.979.0621  
Deb Plank, Western Region  
832.484.8465





# Local Landings



## LANDING IN A CITY NEAR YOU IN 2019

[aglmediagroup.com/localsummits](http://aglmediagroup.com/localsummits)

World Radio History

# When Everything is Important... the NEW *Clarity*™ Series is the Clear Choice

## Applications:

Research & Development Labs  
VNA Test Port Extension Cables  
High Volume Production Test  
Bench or Portable Test equipment  
RF Module Testing

## Clarity™ Series 40 GHz Test Cables



*Industry leading performance, unparalleled value,  
and stock to 4-week lead times.*



Abrasion  
resistant PTFE  
outer weave

Stainless steel  
spring armor  
(optional)

Micro porous  
PTFE

Phase stability  $<3.5^\circ$

Guaranteed up to 50,000 flexes

Super-sharp Sure-Grip™ knurl

Ergonomically designed Sure-Grip™ molding

 **TIMES** MICROWAVE SYSTEMS  
An Amphenol Company

World Headquarters: 358 Hall Avenue, Wallingford, CT 06492 • Tel: 203-949-8400, 1-800-867-2629 Fax: 203-949-8423

International Sales: 1+ 203 949 8503 • 1+ 800 867 2629

China Sales: TMC Building 4, No. 318 Yuanshan Road, Xinzhuang Industrial Park, Shanghai, China 201108 Tel: 86-21-5176-1209 Fax: 86-21-64424098

[www.timesmicrowave.com](http://www.timesmicrowave.com)