

FOR THE PRO & SEMI PRO

RECORDING INDUSTRY DIRECTORY

VOL. 3 NO. 4

JULY 1979

the Mix

STUDIO LISTINGS

Northern California

Oregon, Washington

RECORD PRESSING

a Plant Tour

DRUM MIKING

with Fred Catero

MALCOLM CECIL

by Ken Kubernik

FREE

Versatile...

is the word for Everything Audio. We have a wide range of clientele because we satisfy a wide range of needs. From the most elaborate studio design and installation to the smallest equipment need, we are ready to serve you. Pictured at left is one of our



installations, **Spectrum Recording Studios** in Venice, California. Our involvement in this project was limited to that of design—to maximize their available funds, the owners had their own builders handle construction. Pictured at right is **Compact Video Systems** in Burbank, California, an advanced

audio/video facility utilizing computer assistance in the post production audio room. It is one of our newest and most elaborate installations. We designed this facility in an existing structure, supplied the audio equipment, and assisted their crew during construction, clarifying and modifying the plans as the work progressed. The combined effort of the Compact Video crew and the Everything Audio staff resulted in an installation that is innovative in its technology as well as its finish and materials.



Another of our recently completed studios is the **Record Star** in Hamburg, West Germany. (We have representation in Great Britain, Germany, Australia, and Mexico.) We



supplied the plans in metric measurements and, through local representation, kept involved in the project until its completion. In all of our projects—anywhere in the world—the home office keeps abreast of everything with on-site inspections. If you are contemplating upgrading or building a new facility, we'd like to show you what we can do for you. Or if you're just looking for a new piece of equipment—let us help. From total design and installation, to supplying the smallest equipment need—we do it all.



16055 VENTURA BLVD., SUITE 1001 • ENCINO, CALIFORNIA 91436 • (213) 995-4175

Versatility: Let it work for you.

Why settle for a copy . . .



when Tangent gives you the original?

Why settle for an imperfect copy of your sound, when Tangent will give you the original?

Tangent's crystal-clear transparency allows your original sound to flow cleanly to the tape, with only the coloration that **you** add.

And beyond this foundation of solid quality, Tangent invites comparison on these features:

Automation

Automation from Tangent uses the innovative and widely-respected Allison 65K programmer and Fadex designs. Tangent chose the Allison system because it is **the** proven-in-the-field system.

VCA Grouping

For those not needing full automation, Voltage Controlled Amplifier (VCA) Grouping utilizes up to **nine** VCA groups, while other manufacturers normally use fewer.

Sub-Group Solo

Programmable Sub-Group Solo allows the engineer to solo an entire sub-group in place by pushing only one button. This convenience is not found in all competing VCA grouping or Automation systems

Semi-Parametric EQ

Three-band sweepable frequency equalization on each channel is a standard Tangent feature. Not an expensive option as with some competing systems.

Transformerless Balancing

Transformerless Balancing keeps your original sound pure with incredible transient response. Noise is within 3 dB of the theoretical limit.

Transformerless Balancing is suddenly a big deal among the other console manufacturers. It should be. Tangent's been doing it for years.

16 Submasters

Tangent's 16 submaster busses plus "Direct" allow tremendous flexibility for 16 or 24-track work.

FET Switching

Electronic FET switching silently rearranges the signal flows for maximum convenience and minimum repatching.

Lots of Extras

Penny & Giles faders, multiple Echo and Cue send, Phase Reverse, Tape Return Gain, and many other features on each channel give full professional control and reliability.

Compare Tangent's features to consoles costing twice as much and you'll see what a value Tangent is.

As for comparing Tangent's quality, well, you just can't get better than the original.

Tangent Model 3216 AVAILABLE AT THESE DEALERS:

Bananas at Large
802-804 4th Street
San Rafael, CA
(415) 457-7600

Audio Concepts, Inc
Dave Kelsey Sound
7138 Santa Monica
Hollywood, CA
(213) 851-7172

The Express Sound Co.
1833 Newport Blvd.
Costa Mesa, CA
(714) 645-8501

tangent
MUSICAL ENGINEERING
2810 South 24th Street/(602) 267-0653
Phoenix, Arizona 85034

Rhodes reveals the inside story:

This is one instrument worth looking into. Because the Rhodes' overwhelming acceptance on stage and in studio is the result of an engineering concept combining the unique qualities of an

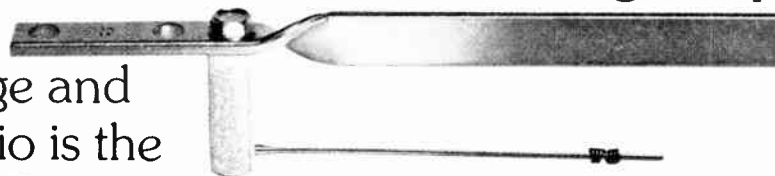

Modified tuning fork produces that unmistakable Rhodes sound. Tuning spring on tine sets pitch accurately in seconds.

electric instrument with the unsurpassed advantages of the traditional piano. A patented, modified tuning fork and adjustable pick-up for each note produce the Rhodes' distinctive tone and allow a variety of timbre settings. Yet mechanical keys, hammers and dampers offer you true touch dynamics for complete sensitivity and control. And you can tune a Rhodes® yourself. In minutes. Without special tools. Get the whole story from your authorized Rhodes dealer today. You know the sound. Now see the difference.

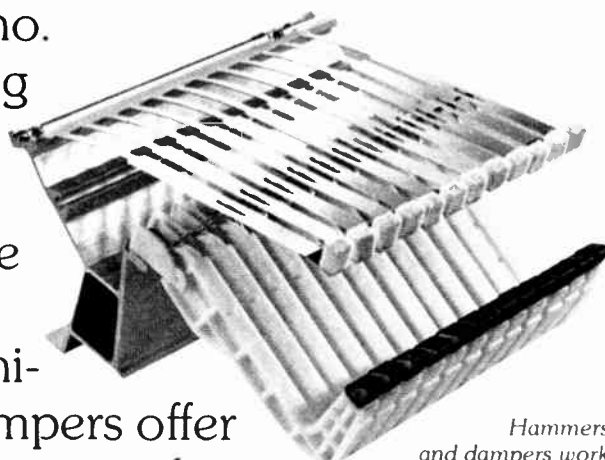

Hammers and dampers work mechanically for true touch dynamics. The harder a key is struck, the greater the volume.

Harp assembly raises easily for tuning.

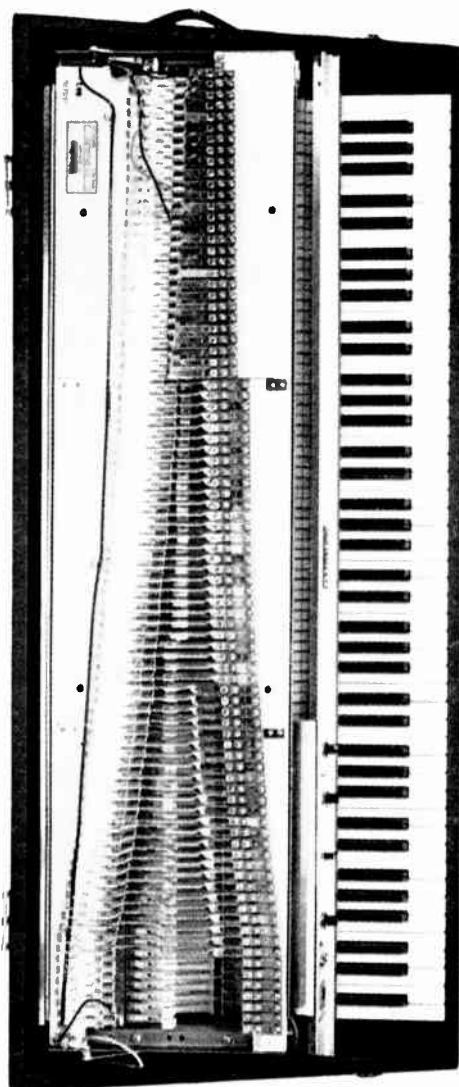

Pitch, volume and timbre are all easily adjusted in the harp assembly. Tuning fork, tone bars, tuning springs and pickups are all adjustable.

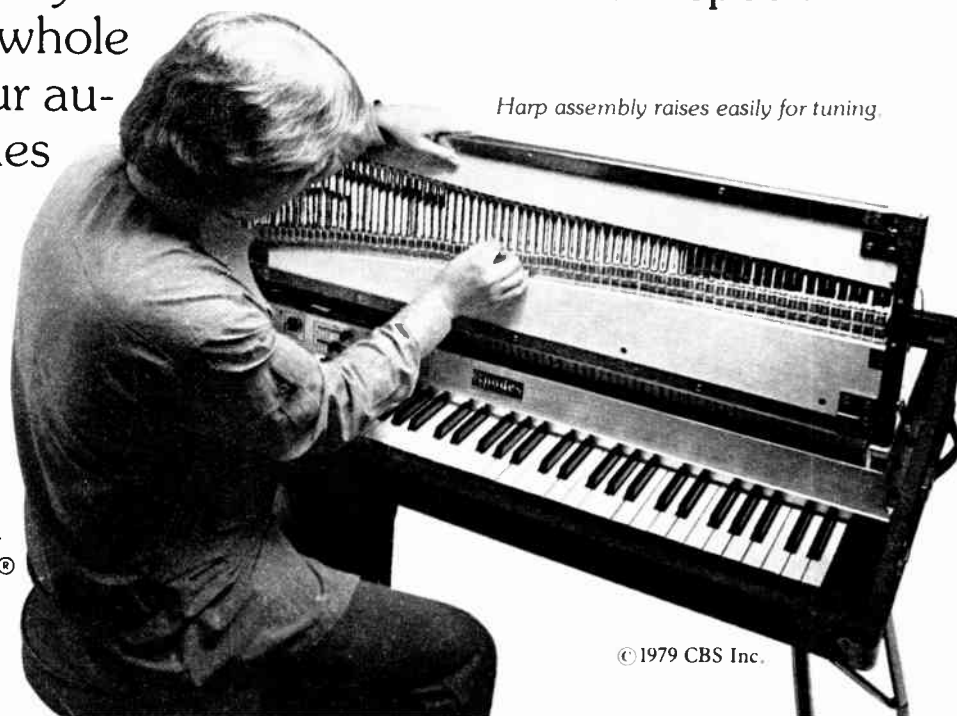

Nothing sounds like a Rhodes.

Rhodes®
Keyboard Instruments U.S.A.

© 1979 CBS Inc.

the Mix

Recording Industry Publications

JULY 1979



Cover: Photography by Dennis Bayer.

A special thanks to the staff of Sound Genesis 2001 Bryant St., San Francisco for the use of the equipment.

VOLUME 3, ISSUE 4

FEATURES

- 6** INSIDE TRACKS
- 8** RECORD PRESSING
by Penny Jacob
- 14** PROGRESSIONS
by Larry Blakely
- 16** MALCOLM CECIL
by Ken Kubernik
- 22** SOUND ADVICE
by Dr. Richie Moore
- 24** EQUALIZERS
by Tom White
- 28** SBA LOANS
by Jo'Ann Semones
- 30** DRUM MIKING, PT. II
with Fred Catero
by David Schwartz
- 34** CLEANING UP THE SIGNAL PATH
by Lane Poor

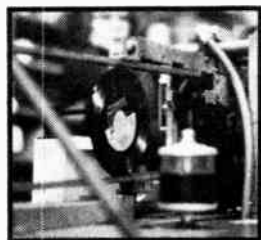

- 88** SOUND OFF
The Recording Academy
by Beverly Sommerfield
- 92** FEEDBACK
- LISTINGS**
- 36** STUDIO LOCATION INDEX
- 38** 4 TRACK
- 50** 8 TRACK
- 66** 16 TRACK
- 78** 24 TRACK
- 90** INDEPENDENT ENGINEERS AND PRODUCERS OF NORTHERN CALIFORNIA AND THE NORTHWEST
- 92** ADVERTISERS' INDEX

David M. Schwartz PUBLISHER / EDITOR Penny Riker Jacob
 • William I. Laski •

ART DIRECTOR Skeeter	OPERATIONS MANAGER Mary Lowman	CONTRIBUTING EDITORS Ken Kubernik Larry Blakely Dr. Richie Moore
ART DEPARTMENT Henry Harrison McUmbert Leslie Wozniak Christian Locherbach	RESEARCH DEPARTMENT Kirk Austin Susan George	PHOTOGRAPHERS Dennis Bayer Penelope Paul McKenna
TYPESETTING Sandy Cann	DISTRIBUTION MANAGERS Frank Grygus Zena Shack	

The Mix is published at 956 San Pablo Ave., Albany, CA 94706 and is © 1979 by Mix Publications. This is Volume 3, Number 4 July 15, 1979.

Please address all correspondence & changes of address to The Mix, P.O. Box 6395, Albany Station, Berkeley, CA 94706, (415) 526-6102.

The Mix is published monthly. Subscriptions are available for \$15.00 per year, single issue price is \$2.00. Subscriptions outside U.S.A. are \$20.00.

Controlled circulation paid at Berkeley, California. Mix (USPS 445-070). Controlled circulation paid at San Francisco, Calif. Mix (USPS 473-870).

The Mix is distributed in recording studios, pro-audio stores, music stores and other related businesses. If you have a recording or music related business and would like to distribute the Mix, please give us a call. (See coupon on page 82.)

Display advertising rates and specs are furnished upon request. Ad closing for next issue: August 1, 1979.

M.I.—Musicians' Industry Magazine © 1979 by Mix Publications.

This publication may not be reproduced or quoted in whole or in part by mimeograph or any other printed means, or for presentation on radio or television without written permission of the publishers.

Subscription

SINGLE ISSUE PRICE \$2.00
 12 ISSUES/1 YEAR \$15.00
 OUTSIDE U.S.A. \$20.00
 Send Check or Money Order to:
 The Mix
 P.O. Box 6395
 Albany Branch
 Berkeley, CA 94706

name		
company name		
address		
city	state	zip

T

wo professional organizations, designed to assist the constructive development of the audio recording industry, have recently been created.

On June 15th of this year, the Soci-

ety of Professional Audio Recording Studios emerged from a gathering of the owners of sixteen of this country's leading studios. According to its organizers, the Society "will be dedicated to achieve excellence in the craft, suggest professional standards, and to provide a forum for statements on technical matters affecting the industry." Board members include Joe Tarsia, Sigma Sound Studios, Philadelphia; Bob Leftin, Regent Sound Studios, New York City; Chris Stone, Record Plant, Los Angeles; Mac Emmerman, Criteria Recording Company, Miami; and Glenn Snoddy, Woodland Sound Studios, Nashville. Membership is open to studios throughout the country and applications should be directed to Kerit Duncan of Kendun Recorders in Burbank, (213) 843-8115, or Dave Teig at Atlantic Studios in New York, (212) 484-8490.

An organization of manufacturers of audio products, CAMEO (Creative Audio and Music Electronics Organization) has the goal to provide education to retailers and users of audio equipment and to generate feedback from the users to the manufacturers as the technology expands. Ken Sacks, former national sales manager of TEAC/Tascam, serves as executive director. Much of CAMEO's activities to date have centered around seminars offered at recent NAMM (National Association of Music Merchants) and CES (Consumer Electronics Show) conventions, where industry personalities discussed such topics as "Converting to a Pro Sound Dealer," "Cashing in on Multi-track Recorders" and "New Developments in Sound Modification" with musical instrument dealers making the transition to the pro and semi-pro audio markets. Plans for CAMEO's near future include the publishing of an audio dictionary, designed with simple and easily understood definitions. More information on CAMEO is available from Ken at CAMEO's headquarters at 5430 Los Angeles Ave., Simi Valley, California, 93063.

We at the Mix applaud the goals of these new organizations. It is our hope that the Society of Professional Audio Recording Studios will use their talents and influence to bring about improved quality in recorded sound, high standards of performance in the professional industry, a means to achieve compatibility in the developing technologies and wise use of economics and resources by the sharing of research and experience. Our desire for CAMEO is to see them play an important role in the enlargement of the audio market by stimulating and enlightening dealers and potential dealers of audio equipment, and by strengthening the communication and trust between dealers and manufacturers. Best of luck!

Listings

We are pleased to include, for the first time, listings of studios in the Oregon and Washington

areas with our friends in Northern California. This fast growing scene in the Great Northwest is beginning to make its mark and promises to be a major force in the near future.

...and Features

Malcolm Cecil is known to many as the producer of Stevie Wonder's most well-known albums. In this month's feature interview, Ken Kubernik uncovers some astounding tales behind the platinum and the Grammys.

For those of you curious as to the manufacturing procedure of today's records, we present a plant tour of a major pressing plant. Our hosts are the folks at Monarch Records in Sun Valley, California.

Part two in our series on drum miking continues with Fred Catero, chief engineer at San Francisco's Automatt, discussing the techniques and tricks that captured the sound on some of today's finest music.

Tom White, executive vice president of White Instruments, has put together a primer for us on equalization, as it applies to the studio and recording engineer.

Of special interest to the small business people among us, Jo Ann Semones from the Small Business Administration has written to tell us how we might approach the SBA as a source of financing.

And, if those little snap, crackle, and popping demons haunt you in the studio, be sure to catch Lane Poor's piece on Cleaning Up The Signal Path.

Also, your old friends Larry Blakely and Dr. Richie Moore are back with words of wisdom and, in this month's Sound Off, we hear from San Francisco's Recording Academy.

On the Horizon...

Beginning in September the Mix goes monthly with some great new features and surprises. Soon to follow will be listings of studios in the New York City area and the Nashville/Memphis area. Also coming to the Mix will be a classified section where you can shop for equipment, jobs, services, etc. More information on that will be in the September issue.

But that's not all. September will also bring the second issue of M.I. Magazine. M.I. (for Musicians' Industry) is the new, free, bi-monthly (every other month) for the active musician, brought to you by the same folks who bring you the Mix. Be sure not to miss this special issue which will include profiles of industry personalities, tips and techniques from the professionals and communications from the concert trail, as well as listings of the California access points for audio equipment, musical instruments, repair and rentals. ♪

COMING

UNDERSTANDING TAPE TALK

A primer

THE NEUMANN STORY

by Steven Temmer

PHIL RAMONE

An Interview

STUDIO MUSICIANS

Tips and Techniques

ATTRACTIONS

"The Grouper"

Model OAS-24 Grouping System

Cancels clutter—It's like having more hands and fewer knobs to control with them.

Complete Subgrouping provides maximum flexibility for any mixing console.

Instant muting of any subgroup.

Special "Sequence" muting logic function.

Noiseless attenuation and no clicks, pops or thumps.

Fully portable—perfect for SR and multi-studio recording applications.



B & B
audio

Call or write for free brochure

"The Grouper" by B&B audio is available exclusively from

APHEX SYSTEMS LTD.

7801 Melrose Avenue • Los Angeles, California 90046
(213) 655-1411 • TWX: 910-321-5762

RECORD PRESSING

A TOUR OF THE MONARCH PLANT

by Penny Jacob

You've just finished the last mixing session... all twelve cuts have been played, EQ'd, delayed, processed, picked apart, and put back together into the perfect two-track mix. You kiss your precious master tape goodbye at the record company and hop the first plane to Manchu Picchu. But what happens to your creation once you've relinquished possession to your label? How does the last six months of your genius and sweat wind up as a finished product in the record store rack?

To find out about a major part of the process of turning a master tape into a packaged record, we took a tour of the Monarch Records pressing plant in Sun Valley, California. The Monarch plant, a new, \$6 million, 130,000 square foot facility which has been in full operation since November 1978, is one division of the Electro-sound Group, Inc. which manufactures phonograph records, sleeves and tape duplicating equipment in six cities around the country. Monarch is a full-service facility which deals with such clients as ABC, A&M, Atlantic, Capitol, CBS, EMI, MCA, the Polygram Group, TK, Warner Brothers, and many others.

Our tour guide was Bob Barone, Vice President and General Manager of the Monarch plant.

The process of pressing a record begins when the plant receives notification from the production department of a record company that a lacquer is ready and on the way. At the same time, the plant's printing department receives information about the copy to be used on the labels. The copy is usually typeset and printed at the plant on the large selection of "backdrops" (pre-printed labels with record company logos, etc.) which Monarch keeps in stock. The labels are then ready to be applied to each record during the pressing process.

When the lacquers arrive (usually 2 "A" sides and 2 "B" sides) they are taken to an environmentally controlled area of the plant where they are rigidly inspected and stored in the cleanest possible conditions. Lacquers are made of acetate and are therefore very delicate and highly susceptible to dust, dirt, and changes in temperature. They must be handled carefully and processed as rapidly as possible to prevent deterioration in the sound quality. Each lacquer carries identifying marks from the record company. Additional markings are made at the plant for filing

and identification purposes. These markings can be seen on every record on the smooth part of the vinyl near the center.

Larry Schmidt, Plant Manager, and Don Kawasaki, Matrix Department Head, guided us through the processes in the department where the lacquers are turned into metal parts used to press the records.

At Monarch, the optimum number of metal parts which can be made from one lacquer include: one Master from the lacquer, eight Mothers from a Master, and up to twenty Stampers from each Mother. Each Stamper can be used to press about 1,000 records. This means that approximately 160,000 records may result from this matrix process. The average pressing however, runs about half that number.

The lacquer is first washed thoroughly in order to remove even the most minute particles of dust or dirt which may affect its quality. It is then dipped in a mild solution of stannous chloride (tin) and water which puts about a 100,000th-of-an-inch coating of metal on the acetate. Since only metal can attract metal, this layer of tin will be used to attract a layer of silver during the following spraying process.



Record company label "backdrop", which will be applied during pressing.

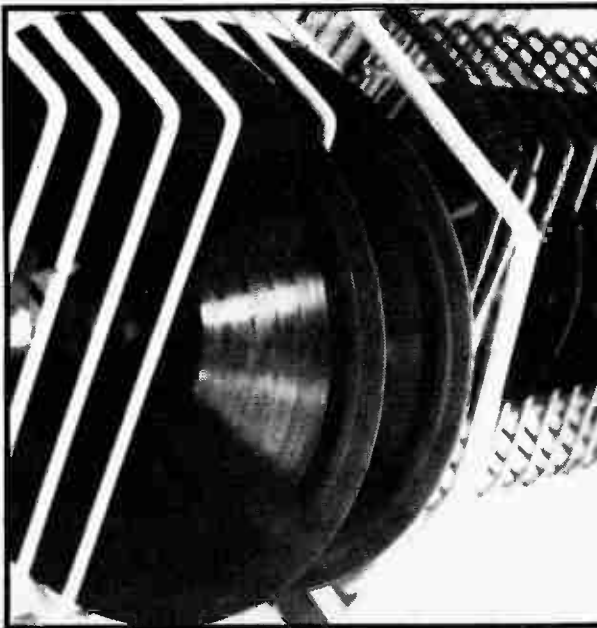

Lacquers ready to begin the matrix process.



lacquer being sprayed with silver prior to electro-plating process.

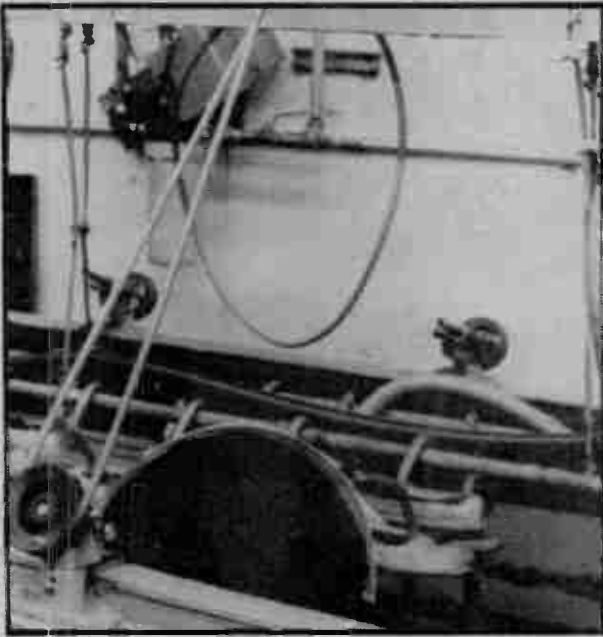

Pre-plating tank where lacquer is covered with a fine layer of nickel.



Left: Pre plated lacquer, Right: Silvered lacquer.

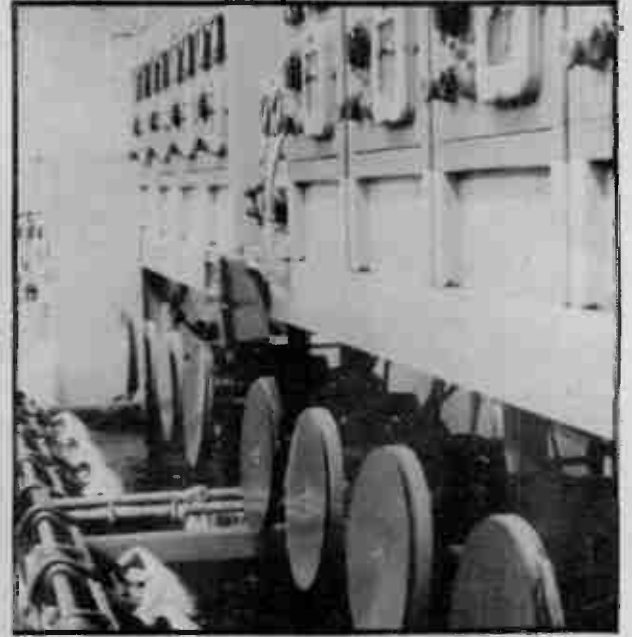

Hi-speed electro-plating tank where stampers are processed.

The lacquer is placed in a large revolving drum and sprayed with a coating solution made up of ammonium hydroxide, silver nitrate, and sodium hydroxide mixed with a reducer which prevents the silver from coagulating and keeps the coating even. This silver solution coats the lacquer completely about one mil thick (a thousand of an inch) and is used to form a base to attract, still another, yet harder, metal—nickel, during the subsequent electro-plating operation.

The silvered lacquer is attached to a rotating disc and immersed in a pre-plating tank containing a nickel solution. A low amperage direct current is run from a bar in the center of the tank over the silvered lacquer. In about 15 minutes, a time-controlled layer of nickel is built up to form the metal base which will be finished in a low-speed plating tank. The lacquer is transferred to a larger tank, again rotated constantly under a higher charge of electric current to finish building up the layers of nickel to create a metal plate. When this

process is finished, in about 6 hours, the lacquer is separated from this exact **negative** metal image of itself which is called the Master. The Master is then thoroughly cleaned and put through the same electro as the lacquer to create a **positive** metal image known as a Mother. When separated from the Master, the Mother is put through the same plating process to create a series of Stampers which are a positive image of the Mother. These Stampers in the pressing machines stamp their negative image on to the vinyl which will become a positive that you can play—a record.

After the Stampers are made, they are inspected and cleaned. The backs are sanded by machine and by hand to assure a smooth pressing surface. The Stampers are then centered by a process using a calibrated microscope. The outside diameter is trimmed of any excess metal, and a center cup and outer ring are formed to create a perfect fit for the pressing

machine.

The entire matrix process at Monarch is constantly monitored and controlled to assure the very highest quality sound reproduction from the metal pieces. Prior to the Stampers being made, the Mother is taken to a special room where it is played on highly sophisticated machines and carefully inspected under a microscope for any defects or sound problems which might affect the entire pressing. Should any problems which cannot be corrected, at this point, occur, the Mother is scrapped and the process is done over.

The matrix operation which converts lacquers to metal takes about twenty-four hours. This process can be speeded up significantly should a record company demand faster production. A Stamper can be made in as little as 2½ hours by utilizing only hi-speed electro-plating tanks and, occasionally, creating Stampers directly from the lacquer, bypassing the Mother and Master stages.

Cont'd on page 10

LACQUER → MASTER → MOTHER → STAMPER → RECORD

+

-

+

-

+



Stamper being separated from Mother.

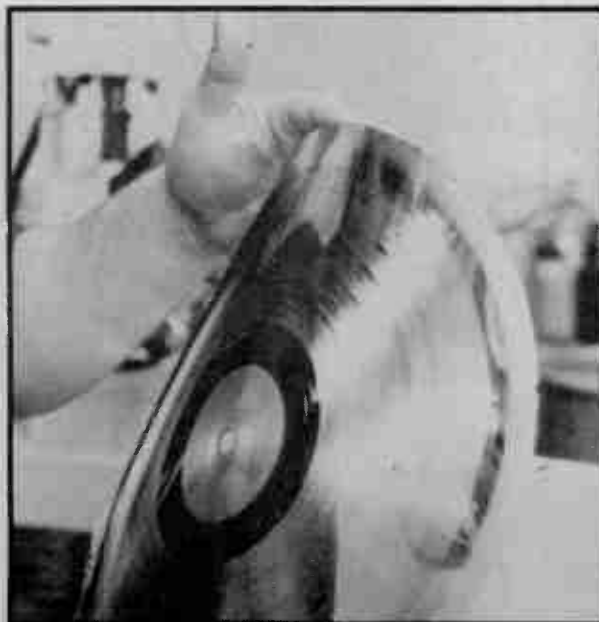

Nickel Stamper, after matrix operation, will be finished and used in press.



Stampers waiting for centering and processing for press.

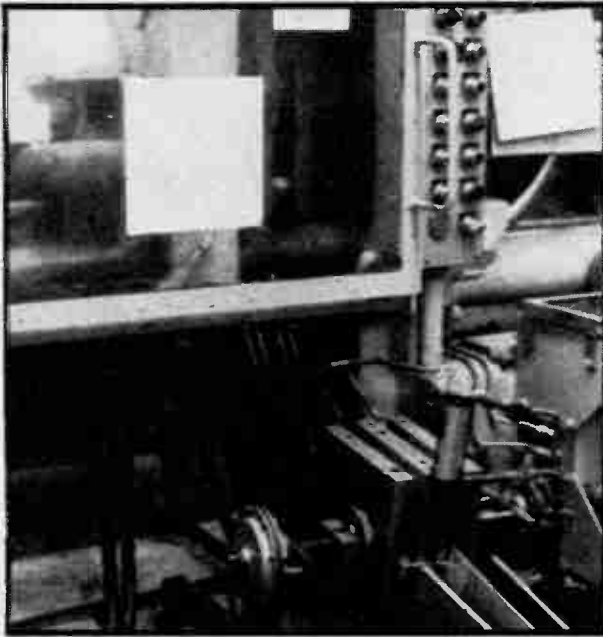

Injection molding press used to make 7-inch singles of styrene.



Finishing station for 7-inch singles where labels are applied and records boxed.



Row of compression molding presses for albums.

LACQUER → MASTER → MOTHER → STAMPER → RECORD

Continued from page 9

At this point, we move from the matrix department on to the actual pressing operation. Monarch has the capacity to produce an incredible volume of records; 90,000 singles and 150,000 albums per day. Single and albums are produced by different methods. Singles are injection molded of styrene, a plastic, and albums are compression molded in vinyl.

We looked first at the production of singles. The injection molding of singles is a two-step process carried out in any of 12, 2-cavity molding presses.

The metal Stampers created by the matrix department are placed inside the machine to form a cavity. A precisely measured amount of styrene is then injected into the cavity, the cavity closes and the Stampers are pressed together to form the record. There is no trimming involved in this method of molding since there is no excess styrene. The pressed discs are moved out of the machine and on to the second

step, labeling. Labels backed with heat sensitive glue are placed on both sides of the disc and heated on a transfer block to the proper temperatures to make them adhere. The labeled discs are then passed on to another machine which centers and punches a hole in each one. They then move on to be jacketed and packaged for shipping. This injection process turns out about one record every second.

The compression molding process used to produce albums is a bit more complex and is done in a different part of the factory in order to make sure that the materials used in the different processes are kept separate.

Monarch has 50 SMT presses which use cannon-type extruders from Extruder Products of New Jersey, designed by Bob Philips.

In the compression method, a biscuit of vinyl is

extruded on to a cup in the machine. Two labels are lifted by mechanical arms on to either side of the vinyl biscuit. The biscuit is raised into a cavity which closes around it to heat the vinyl. Once the vinyl is heated the cavity opens and a squeezing device closes around the cup to make sure that the labels adhere to the vinyl. The biscuit drops on to one of the metal Stampers affixed to the machine. The other Stamper is brought down on top of the biscuit and the two Stampers are compressed to form a dye in which the vinyl is again heated in a steam-press process at just under 275 degrees. At this point, the mechanical information in the negative image metal Stamper is pressed into the vinyl and a record is formed in about six seconds. Then 70 degree water is pumped into the dye formed by the Stampers and the steam is driven out. This water process takes about 14 seconds and cools the vinyl so that it hardens.

The dye is then opened and the vinyl disc with

Continued on page 12

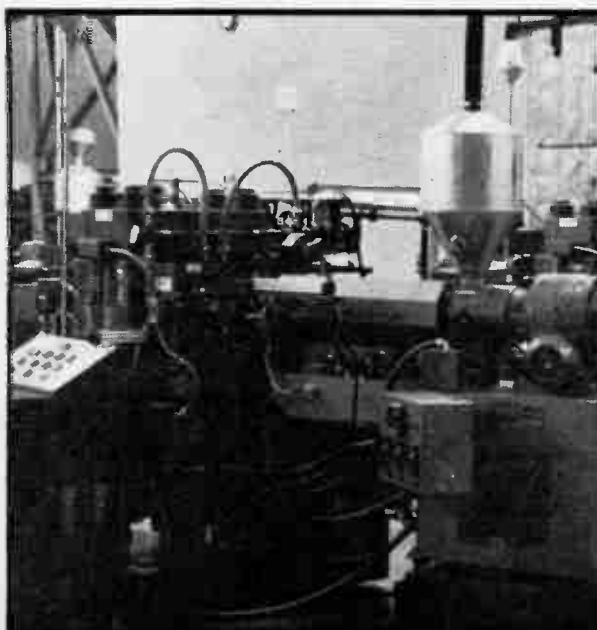

SMT compression molding press.

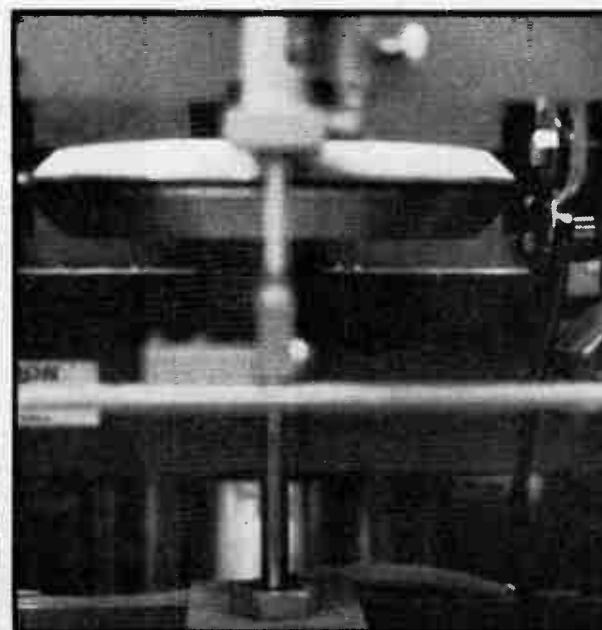

Dye formed by Stampers in compression molding press.

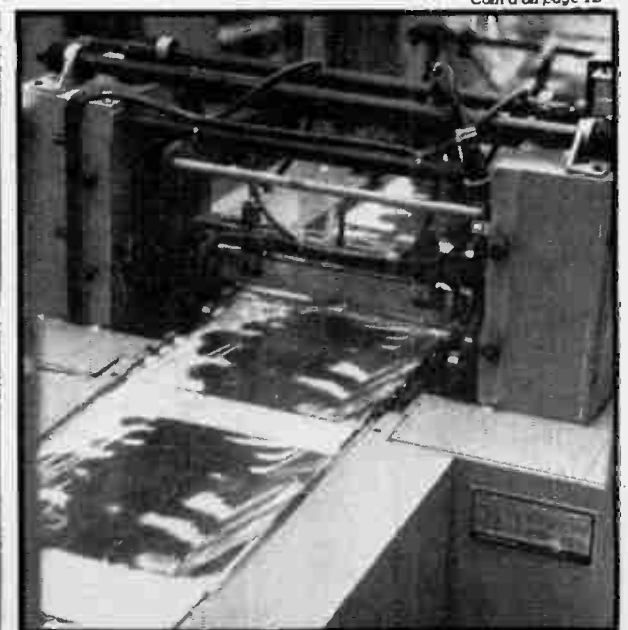

Heat-shrink machine forming plastic covering on finished albums.



Professionals Swear by Them, Competitors, at Them.

They're the new BGW pro amps you'll go for—From top to bottom, The Model 10 Electronic Crossover, The Model 100B Power Amp, and the 250E Power Amp. Each one an extension of our basic philosophy at BGW; The Best.

Whether its a simple resistor or a complex semiconductor, BGW is dedicated to the principle that a pro knows the difference between "good enough" and "outstanding." Because we know that quality in a pro product is indeed something you can see, touch and hear, everything that goes into a BGW product, everything we do in its manufacture, is designed to back up the man who depends on our gear to make his living. And, like all BGW products, the new 250E with our exclusive arc-scale power indicators joins with the new 100B and Model 10 in answer to your demands. They're worthy additions to the solid-gold reputation that's been earned in recording studios, discos and concert stages throughout the world.

If you're not already a BGW Pro we invite you to compare any of our products with anybody else's. Anybody's. You'll then see why so many of your pro friends swear by us. And our competitors, at us.

Go For The Best



BGW Systems, Inc.
 13130 South Yukon Avenue.
 Hawthorne, California 90250
 In Canada: Omnimedia Corp.,
 9653 Cote de Liesse
 Dorval, Quebec H9P 1A3

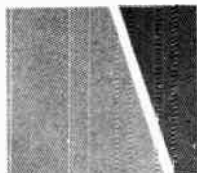

fact: the Pro Master™ sound system is not an evolution... it's a full-blown REVOLUTION!



The PRO MASTER modular sound system ushers in a new generation of sound system versatility, reliability, and quality for today's entertainers, musicians, and speakers — for use in settings as diverse as intimate clubs, lounges, large auditoriums, churches, and schools. Its multitude of performance-proven features is the result of sophisticated computer design techniques, advanced materials, and countless hours of personal consultation with performers and sound technicians.

Revolutionary New Console

Finally! The best of *both* worlds. A console so easy to use that it won't overwhelm the beginning group, yet with the advanced features and capabilities required by experienced professional performers — such as pre-fader monitor mixing, effects and/or built-in reverb, with their own tone controls, LED clipping indicators with attenuators on each input, and full patching facilities for every system component. Super power: *twin 200-watt solid-state power amplifiers!* Doubles as a stereo recording console for groups that want to "lay down a few tracks" without paying for studio time, or can be used as an ultra-sophisticated keyboard mixer with power. Unitized ARMO-DUR™ structural foam combination case and chassis makes it more durable than steel. Ultra-light — only 47 pounds.

Revolutionary New Loudspeaker

Every extra ounce — every unnecessary cubic inch — has been computer designed OUT of the PRO MASTER loudspeaker. Modern materials and molding techniques accommodate a high-performance 15-inch woofer and a high-frequency horn and compression driver in a startlingly small, efficient enclosure. Less than 28 inches high, 23 inches wide, 16 inches deep. Weighs an easy-to-handle 58 pounds. Yet, the power handling capacity is a remarkable 150 watts, and the frequency response is 50 to 15 kHz.

Revolutionary: Variable Dispersion Sound System

Advanced new variable dispersion high-frequency horn system projects your sound — everywhere in the house, giving you a choice of 60° long-throw, or 120° wide-angle dispersion with the twist of a knob. Tailors the sound to the room — even L-shaped rooms.

Replaces All This Equipment... And Does More!

The impressive array at left includes a mixing console, two graphic equalizers, a pair of 200-watt power amps, a monitor mixer and an octave analyzer. The PRO MASTER gives you all these capabilities — plus features that you can't find in any other console, at any price. Unique FEEDBACK FINDER™ circuit, exclusive PATCH BLOCK™ patch panel, wide-range LED peak output and input clipping indicators. Plus pre-fader monitor send controls, LED power amp overload, temperature warning and shutdown indicators. 0 to 30 dB input attenuators, full stereo features, simultaneous effects and reverb on each channel. What's more, you have Hi-Z and Lo-Z balanced transformer-coupled mic inputs on all six mic channels, (can handle 12 mics simultaneously), plus two additional auxiliary input channels for adding synthesizers, tape players, tuners, sub mixers or any other high level output components. And each Lo-Z input features built-in simplex powering for condenser microphones.



The full line of Shure Products are available at:

LEO'S MUSIC
Oakland

GUITAR CENTER
San Jose & San Francisco

Hear the Revolutionary New Sound!



PRO MASTER™ sound system

Shure Brothers Inc., 222 Hartrey Ave., Evanston, IL 60204 In Canada: A.C. Simmonds & Sons Limited
Manufacturers of high fidelity components, microphones, sound systems and related circuitry.

Ask for
Brochure
AL581A

Progressions



SOFT KNEE

COMPRESSION

by Larry Blakely

In last issue's Sound Advice column, Dr. Richie Moore discussed many of the types and uses of compressors and limiters. This time we will look at a new form of compressor that has an old fashioned effect. Let's begin with a quick review.

Over the years compressor/limiters have found their way into many applications for audio and have become one of the most popular signal processing devices. Providing a method whereby the dynamic range of an audio signal can be decreased electronically, compressor/limiters are commonly used during the tape recording process to prevent loud signals from exceeding a certain level or to achieve a certain effect desired by the engineer/mixer.

Compressor/limiters are commonly used when transferring master tapes to disc, usually to prevent wide groove excursions, thereby allowing more time to be cut on the disc. Radio stations also use compressor/limiters to decrease the dynamic range of the broadcast signal in an effort to maintain near maximum modulation of the transmitted radio signal. Maintaining maximum modulation will allow a broadcaster to cover more square miles with the radio signal. As a matter of fact, we listen to very little recorded music that has not been processed at some point by a compressor or limiter.

A compressor is an electronic device that will decrease the gain of an audio signal above a given level (commonly referred to as a threshold.) The exact amount of gain reduction that is achieved is determined by the compression ratio. If a compressor has a compression ratio of 2:1 all signal levels that exceed the threshold will be decreased in level by one-half. If a compressor has a compression ratio of 4:1 all signals that exceed the threshold will be decreased to one-fourth of their original level, 10:1 would be one-tenth of the original level, etc.

So, what is the difference between a compressor and a limiter? A compressor and a limiter are both compressors. The term compressor is usually used with a compression ratio of less than 10:1. A compressor with a compression ratio that exceeds 10:1 is usually called a limiter. A compressor will, thus, provide a smaller amount of compression to a signal than will a limiter.

Now that we have established some understanding of compressors and limiters, let us look at the most common complaint about those devices. Many a recording engineer, disc mastering engineer or broadcast engineer has expressed, "I like and need what they do but I can hear them work." Engineers want to alter the original signal (sometimes drastically) to achieve a certain result but don't want to hear any side effects from the process. Although there have been many significant improvements in compressors and limiters over the years, many astute engineers still claim that they can hear even the best of them work.

In yet another effort to reduce or eliminate the audibility of compression and limiting a new concept has recently come to the forefront: Soft Knee Compression. Let us look at a very basic behavior of a conventional compressor or limiter.

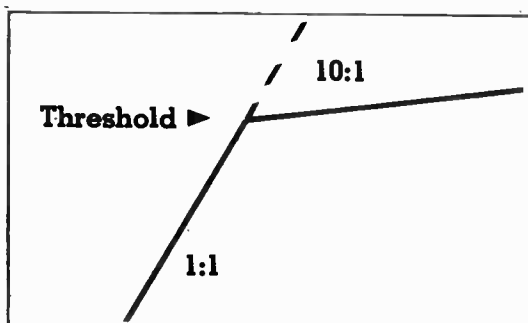

It can be seen, in the above drawing, that when the signal level exceeds the threshold it is sharply and abruptly reduced in level by the compression ratio of 10:1. It has been determined by some engineers that this abrupt change in signal level has played a large part in the audible side effects of compressors and limiters.

When the signal level is below the threshold there is no level change made to the signal. When the signal level exceeds the threshold, that portion of the signal that goes over threshold will be reduced in level.

It can be seen that the signal is not abruptly changed to a compression of 10:1 as it exceeds the threshold. The transition is done on a gradual

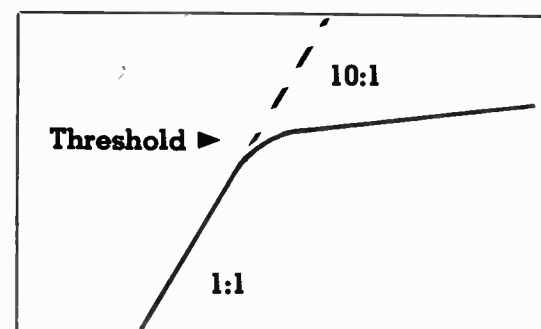

By similar reasoning, if a compressor or limiter could reach its compression ratio gradually as it crossed the threshold, that compressor/limiter would be less audible in the action. A process like this would look like this graph.

basis and compression ratio increases from 1:1 (no compression) to 2:1, 3:1, and on to 10:1 as it exceeds the threshold. This unique compression approach will work virtually at compression ratio up to infinity to one ($\infty:1$). Soft Knee Compression, as the illustration implies, is the name given to this concept.

It is my purpose in this installment of Progressions to inform you of this new approach to compressors and limiters. There are several new models utilizing this design, either currently on the market or soon to be introduced. I have used some of these units and confirm the feelings of many others that there is a definite audible improvement

One interesting side note is that Teletronix manufactured a compressor called the LA-2A that provided soft knee compression due to the nature of a photo resistor utilized in the circuit design. (Editor's note: Although regular production on the LA-2A was halted over ten years ago, overwhelming demand for the units has influenced UREI to remanufacture the LA-2A in limited production runs, according to vice president Ray Combs.) Few, if any, compressor/limiters since have utilized the soft knee compression until very recently. Newer and more advanced VCA technology will allow a better execution of this concept as, once again, audio technology takes one giant step forward by taking a giant step backward. 



professional quality delay plus special effects



Lexicon's new Model 93 "Prime Time" digital delay processor gives recording studios and entertainers an easy-to-use professional quality time delay with special effects and convenient mixing all at a price you can afford. It combines a degree of flexibility and versatility never before offered in equipment of full professional quality.

- Two delay outputs independently adjustable from 0 to 256 ms
- Complete mixing for delay and reverb processing, freeing up main console channels and tape tracks
- Integral VCO for special effects like vibrato, doppler pitch shift, flanging and automatic double and triple tracking
- Long delay special effects — up to 2 seconds
- All dynamic functions can be footswitch controlled
- 90 dB dynamic range, total distortion below 0.08% at all delay settings

lexicon

Lexicon, Inc., 60 Turner Street
Waltham, MA 02154 (617) 891-6790

Export: Gotham Export Corporation, New York, New York

Regional Sales Office: 1010 Trestle Glen Road, Oakland, CA, 94610; Phone 415/832-1621

MALCOLM CECIL



Producing in the Key of Life

by Ken Kubernik

Producer/engineer Malcolm Cecil is a generous, gentle, unaffected soul, cast adrift in the tumultuous seas of the recording industry. His diminutive, lean physique supports a zen-like presence; his large, lucid eyes betray a calm spiritual wholeness that comes through a lifetime of successes, failures and resurrections.

He lives an austere existence. Numerous career disappointments have tested his buoyancy and, at present, he is composed, and not bitter. He conducts business in an innocuous, faded yellow one-story building just a few feet from the Santa Monica beach. Housed inside is the wondrous T.O.N.T.O. — The Original New Timbral Orchestra — a magnificent synthesizer showcase of Oberheims, Moogs, ARPs, digital delays, and tape machines, all hooked together in a space-age fuselage. Malcolm, smiling and spinning from within his extra-terrestrial calliope, conjurs up musical landscapes reminiscent of the land of Oz.

Malcolm has installed a 24-track studio into the building, and is capable of producing state-of-the-art records. The recording area is cramped and often the musicians perform alongside Malcolm at the console. He encourages the closeness. "The proximity," he explains, "opens the communicative channels to their fullest; while a player is performing we can have eye contact and make adjustments on the spot. It takes some getting used to but the coziness breeds successful results." It also characterizes the familial sincerity and caring that goes into every one of his projects.

Next door to the studio is Malcolm's workshop outfitted with all manner of tools and devices where he tinkers and fidgets with gadgets and creates new appendages for TONTO. Out in the alley is his home, an Air Stream trailer. Malcolm has had to make tracks often and the practicality of a mobile home reinforces his searching, inquiring demeanor.

Inside, Malcolm brewed tea, fussed about in a crochety manner and talked about his work, about music and electronics, about Stevie Wonder and curiously, about eggs.

"What does an egg producer do," he begins; "An egg producer does not lay eggs, a chicken lays eggs. The producer is not the chicken, he is something else. He is responsible for getting the eggs to market. First, he has to get his chickens to lay the eggs. Second, he has to grade them, this egg is a big egg and this one is a small egg, this one is brown and that one is white. He can get more for large brown eggs than for large white eggs and he can get more for large white eggs than for small brown eggs and more for small brown eggs than for small white eggs. He has developed discrimination, some demarcation between product. He is now choosing. That is his job as a producer—to recognize what is the most valuable production, whether it be large brown eggs or hot guitar solos.

"He can produce his chickens one of two ways: he can mass produce some eggs using a regulated conveyor belt approach; he will end up with a lot of eggs but the quality won't be that good. The other way is free-range. Say, 'chickens, you are great. You're free to go anywhere you like.' Now he's got to walk around and check out where they're laying the eggs. He's also got to be on such good terms with

the chicken that it doesn't mind if he comes in and takes its egg. Not only that, but what to a chicken is a good egg might be to the producer a lousy egg. To a chicken what makes a good egg is one that makes a chick. It may be misshapen, may be the wrong size, etc., but the chicken might love it so the producer gives it to her and says, 'You have it, it's your egg. Give me this one which is the one you know is valuable, that's the one the public wants.

"So if he free-ranges his chickens and collects only large brown eggs, eventually he will have a dozen. Now his job is to put them in a box. Print the outside of the box in an attractive way and give it to somebody who can sell it to the general public, a distributor.

"Replace the word 'egg' in everything I just said with 'record' and you have the same philosophy for record production. This is what I retain from my days as a production trainee at the B.B.C. The most important thing in the studio is to have the artist produce the best possible performance at that time. And whatever it takes you have to be able to do.

"I like to have my chickens free-range. I'll chase the eggs. And even though they may think the eggs are great, I know they are unmarketable. I'll take the ones that I know are marketable, put a dozen of them in a package and call it an album. The most important thing it takes is a rapport with the artist and a minimum number of people getting in the way. And that's why I engineer myself because I am capable of doing it and I've been a chicken myself a few times, still am, and that's why I can say to some artist that his eggs are spotted or they are too small. It is no good to grab a chicken by the throat and say, 'lay mother-fucker, lay!' It is much easier to say, 'Take your time, I don't care if you never lay another egg and I won't chop you up for Christmas.' Offer her anything that makes her happy and that is my production philosophy in a nutshell, or should I say eggshell!

"That is why many of the artists I work with think that they are the producer—because I give them all that they could possibly want and impress upon them that I am not the source. I try to make them believe that they are the source but sometimes that backfires. For the sake of the product it is worth it, although I get screwed many times by this philosophy. My biggest problem is my different, humble approach. How can I walk into some label president and demand my five points or whatever. It destroys the whole concept of what I'm trying to do. I am putting myself on the line every time and I've been burnt but I've also been part of some of the finest music ever produced, I think. Consequently, I don't care if people don't know if I did it. I know what I did, that it would have never happened without me being there. I know that my free-range chicken would have been on somebody's Christmas table if it hadn't been for me. I am sorry to refer to artists as chickens but most of them have, when it comes to this concept, as much insight as a chicken has."

Malcolm Cecil's musical odyssey began some forty odd years ago in London. His mother was the "Queen of the Accordion," and his christening was covered by all the tabloids.

Right away it was discovered that he held an aptitude for music and electronics. During the day he laboured over the

piano and at night he devised flashlights and radio sets from discarded wire and tubes. As an adolescent he was enrolled at London Polytechnic, ostensibly preparing for a career in engineering and electronics. Yet the dreaded curse of the "killer hormone" reared its ominous head and Malcolm, enslaved like the rest, discovered girls.

One time I went to a gathering," he recalls, flashing a sheepish grin, "and there was this boy sitting behind the piano and he was surrounded by girls. I thought, wait a minute, I used to play the piano, I can get girls. My style developed by watching the fingers of the pianist. My mother attempted to get me to study formally again but I just wanted to do it on my own, just to be popular with the girls. But my technique was so far behind my desires that I decided to become proficient with another instrument and study it formally and develop the proper attitude and technique. My predilection toward deep-toned instruments led me to the upright bass. Within six months time, I was playing professionally with jazz bands. At 19, I was winning polls and appearing on TV, all the while studying electronics at school, never seeing a connection between the two as far as a livelihood was concerned. The players called me the professor and I grew a beard real quick."

Hassles eventually developed when he began spending more time playing music than going to class. "There was one professor who fixed me though," Malcolm reflects. "He took a dislike to my musical ambitions and had me thrown out of college for breaking some obscure rule about attendance having to be at sixty percent to maintain a full student status. Next thing I knew I was signed into the RAF (Royal Air Force) just one year short of my degree."

During his time in the service he had established quite a reputation as a bass player and was somewhat of a celebrity. After the service he went ahead with a music career, abandoning his considerable technological talents. His first tour found him in the support band to an English tour by jazz giant Miles Davis. "What I remember most was on one night in particular when we were all on the coach (a bus) and I was sitting on my own. The first one on the bus from Miles' band was Sonny Stitt and he was really copping an attitude. Jimmy Cobb, the drummer, and the pianist, Wyn Kelly, sat down together and then Paul Chambers came on. He came right over and sat down next to me and said, 'Hey man, I saw you at the club last night and you play great bass.' It broke the ice immediately. It blew me away because, here we were, expecting these guys to be heavy duty, the finest in the world, all legends, and he comes over and lays a compliment on this poor, sickly English cat. He said, 'C'mon, let's get together sometime and we immediately got into it. Sonny Stitt came right over to him and pulled him away and said, 'Hey man, what are you talking to these honkeys for?' And Paul said, 'Hey man, this is my buddy.'

"Around the same time I began to dabble again in electronics, developing PA systems and the like for bands. I became quite accomplished at that and garnered a bit of notoriety from it to the point that bands were calling me all the time to work on their electronics. I also began rewiring and redesigning guitar amps and the like.

Cont'd on page 18

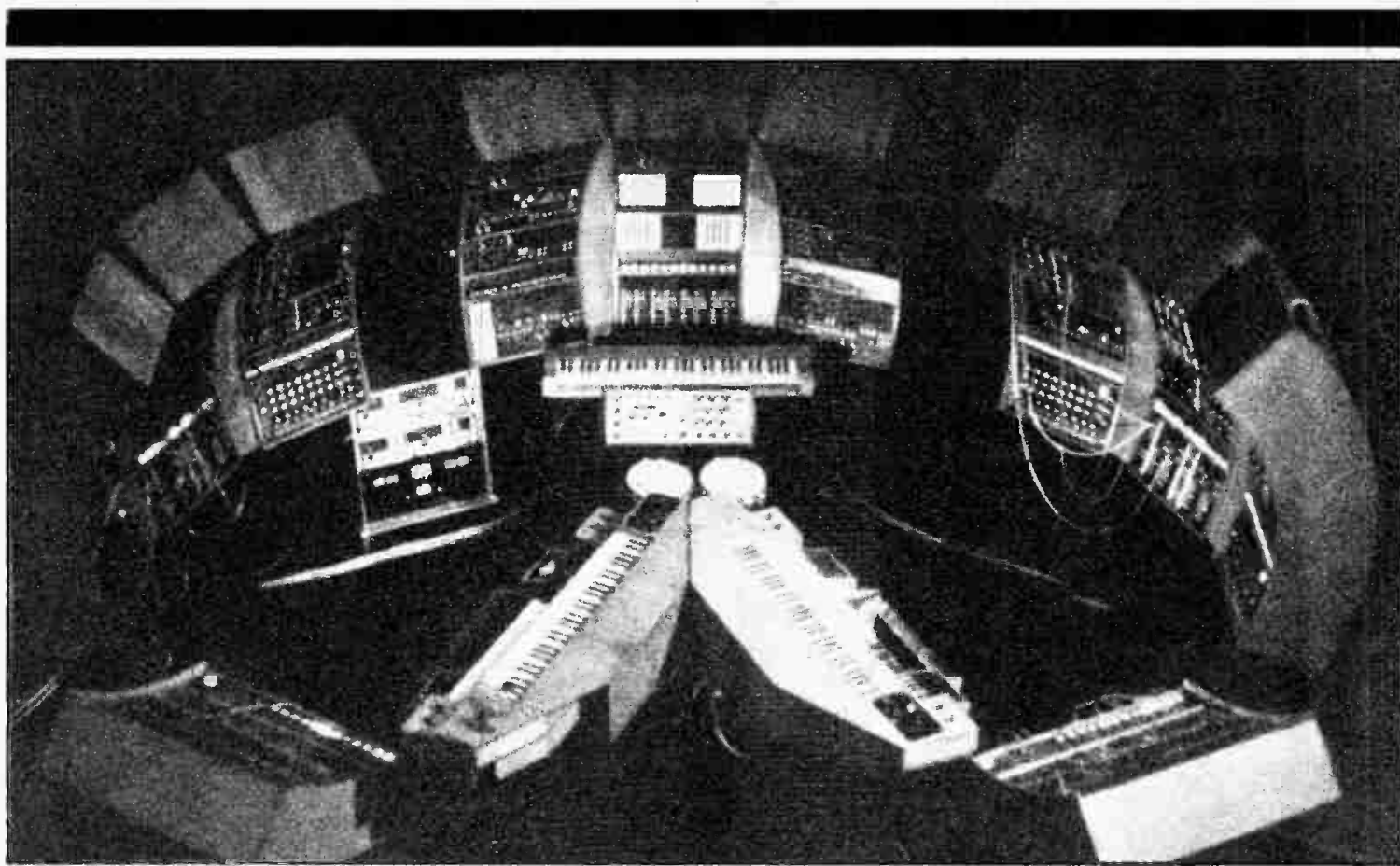

Cont'd from page 17

The jazz label had prevented me from acquiring other types of work, studio sessions and whatnot so I came to the conclusion that I would have to change my focus. So I applied for the bass position on the BBC Orchestra. At the same time I was developing my electronics consulting business and was commissioned by the Marquee Studios to make renovations in their studio, to bring it up to four-track capacity like the American studios. I was also finally becoming an in-demand studio musician."

Malcom paid dearly for his accomplishments; a collapsed lung landed him in a hospital bed for three months and under doctor's orders was advised to leave the country for a warmer, healthier climate or risk losing his life in a short time. His first choice was South Africa but the murky political atmosphere created an intense, unyielding air of artistic stagnation. After a year he packed his bass and headed for the Golden Gates of California. "It became inevitable that I come to the States and with my wife's encouragement I proceeded on a boat to California where I proceeded to have my mind blown! The first day there I was walking around the Golden Gate Park when, for the first time in my life, a stranger came up to me, smiled, and said, 'Hi.' Completely blew my mind and I thought 'This is the place!' This being 1968 I went to Haight-Asbury and checked the whole place out. I eventually hooked up with some players and made my way to Los Angeles."

While in pursuit of the elusive green card, Cecil befriended Tom Hidley, a leading studio industry figure, who arranged for Malcolm to become the maintenance engineer at the Record Plant East.

TONTO (The Original New Timbral orchestra)

Shortly thereafter, he relocated at Media Sound as their chief engineer. "It was there that I met Bob Margouleff. When I got to Media Sound, one of the things that enticed me to stay there was the Moog, which belonged to Margouleff. The studio got me an apartment right next door so I could be on 24 hour call. I usually worked all night and Margouleff would come in around midnight. He was the studio's Moog effects man and I would open up the studio for him and sit in while he fooled around on the synth. He struck up a bargain with me wherein I would provide access to the studio when he needed it and he would teach me everything he knew about the Moog. He started to play me some tapes he made and was very apprehensive about them saying, 'Well, I don't know if this is music or not but here goes.' I got totally into it.

"During this time I built Media a 16-track studio and tried to convince them that as an ad studio, it was losing out on all the musicians who looked to record on off hours, and that they should turn it into a record producing studio at night. It was finally agreed to and we got people like Richie Havens and Herbie Mann, who heard the tapes I made with Bob on the synthesizer, and put it out on Bob's Embryo Label which became the first TONTO album.

At first I was totally mystified by the synthesizer in that I had to revise my theories on music and on sound. Back in England I had been doing synthesis with tape manipulation, but the Moog was an extremely unique thing, quite apart from my previous sound experimentations. We acquired a second Moog 3 which was in desperate

need of repair. And, as I learned the circuitry and met the people who made it, like Bob Moog and Ray Updike, I leapfrogged over Margouleff in my knowledge of the instrument.

TONTO started off with the one instrument and then we added this other one. It was becoming physically enormous in space and very unmanageable to work with so we decided to reshape it into a semi-circle and build all the enclosures which house it. As TONTO was growing we first encountered Stevie Wonder, who heard of us from our album. A mutual musician friend of ours played it for him and Stevie asked to meet WITH US.

"All these activities coalesced to the point that it became obvious that I would not be able to maintain my position at Media as their chief engineer. I was upsetting the engineers, I was upsetting the owners by walking off with the top clients. Well, I decided to burn my bridges and take a stand behind the synthesizer and work exclusively with Stevie Wonder.

Bob and I knew from the beginning that we were onto something special. At first it was purely a business client relationship—Stevie to utilize TONTO and us to serve as technical and production assistants. But it grew very quickly. We took away all the problems, took care of every detail, of every facet of the recording process and we even dealt with his lawyers. The first album we did was *Music Of My Mind* and I came up with that title. With the next LP, *Talking Book*, we came to Motown and said here is the single,

Cont'd on page 20

THE 'OVER EASY' COMPRESSOR/LIMITER. YOU'LL SWEAR IT ISN'T THERE.

Until now the recording engineer had to settle for a compressor/limiter that was somehow... limiting. Most compressor/limiters utilize a threshold above which compression kicks in, suddenly and audibly. The engineer has to use this device quite sparingly to preserve the "naturalness" of the music he's recording.

The dbx Model 165 is a compressor/limiter that is nothing short of revolutionary. "Over Easy"[™] compression allows the signal level to pass through the threshold and gradually adds the desired amount of gain change over the range of several dB. The result is compression that doesn't sound "compressed." Engineers who have used it have checked to make sure it was really connected.

The 165 incorporates other exclusive dbx design features such as true RMS level detection and feed forward gain control. A separate input is provided to the level detector. Because attack can be completed before the signal arrives at the gain control stage, this input allows the creation of special effects.

The 165 is the most flexible compressor/limiter in the dbx line. It is strappable for true stereo operation. (A master/slave switch is located conveniently on the front panel). It has manual attack and release rate controls that can be switched on for special effects. Despite all its features, it occupies only 3½" of rack space.

In the hands of a good engineer, dbx's new 165 is more than the most natural-sounding compressor/limiter you can buy; it is an integral part of the creative recording process. dbx, Incorporated, 71 Chapel Street, Newton, MA 02195, 617-964-3210.

dbx

UNLOCK YOUR EARS

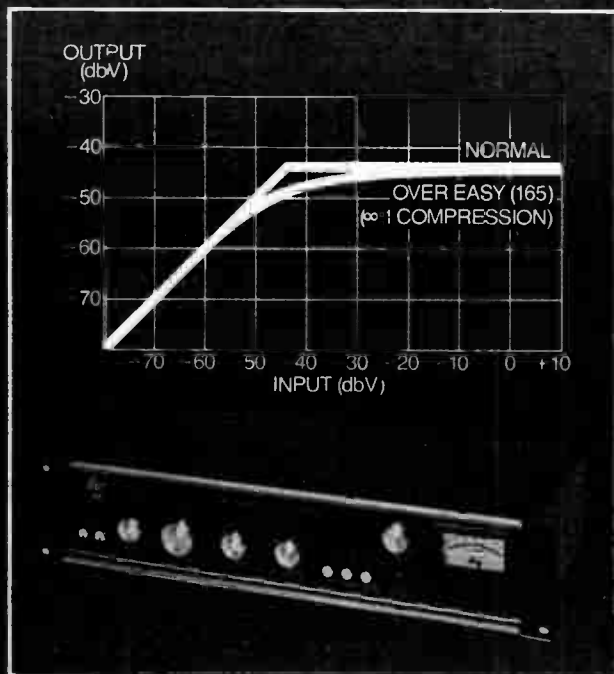

Cont'd from page 18

'*Superstition*.' They couldn't relate to it at all but Stevie pressed them on it and it was a smash as was the follow-up, '*You're The Sunshine Of My Life*,' another tune Motown was dead set against. We were on top of the world and the album went straight to the top.

In the studio it was just the three of us. We spent enormous amounts of time getting sounds for instruments, particularly the drum sounds. Bob and I encouraged Stevie to play drums on his own tracks. He'd put basics down on piano and vocal and bass and he said, 'look, I don't play drums.' But he ended up playing drums on all those tracks, all those classics. Only he could figure out when to play and where the accents were. He tried to teach me the bass parts so I could play upright bass on the tunes but I had a different idea. I said, 'Stevie, come on over here for a minute' and I sat him in front of the synthesizer and asked Bob to program us a bass sound, which was easily arranged. Then I turned on the machine and Stevie played the bass lines on the synthesizer. It blew him away that he could do that.

'Each track had its own sound and I would never repeat for example, the same drum sound on any two tracks. Another example of our approach was on '*All In Love Is Fair*.' There was piano, voice and bass Moog and nothing else. I divided up the piano into four tracks on the left side, four on the right side and the voice on the other eight. And when we overdubbed the bass, we put it on two of the voice tracks. Two tracks, not one; reason being that you've got two inches of tape, why only use a fraction of it. You get better signal-to-noise ratio if you use more tape and you also get much better dynamics.

'On '*Livin' For The City*' Bob and I put the narrative section together based on an idea of Stevie's. It was his brother who did the rap of the young black arriving in the city. The dialogue was basically improvised, the key was finding the right people for the right things. The bus driver who, in the beginning, shouts, 'All aboard,' was a truck driver who happened to be by the studio having coffee. We asked him to yell out of the cab as he drove away, 'all aboard!' and we would tape it. Gave him ten bucks for it too. Bob went and got some real cops on tape for the confrontation scene. He explained to them the idea and they improvised something akin to their normal procedure. It was Stevie who insisted that the word nigger be included during the jailing dialogue. The judge at the end of the rap is actually Stevie's real life lawyer.

'The synthesizer voicings were a combination of his ideas and ours. On '*Boogie On Reggae Woman*,' I set up a sample-and-hold on an ARP for a click track in lieu of drums. And, as I was adjusting the sound, Stevie heard a sound that set him off and a barage of things would follow. That's what was so magical about that period, the spontaneity and the results. You can preplan to some extent on some things but you can't preplan everything and much of our studio technique was as improvised as Stevie's songwriting. Very often the composition process was like this, particularly the good things: We would be setting up the drums for an overdub on one song while Stevie, bored out of his mind, sits down at the piano and starts to play. And while he was screwing around, something would fall together and he would start yelling, 'Put on the seven!, put on the seven!' I told him to shut up and play!

'There was always a tape running. He knew that and he was free to do whatever he wanted to do. That was the big service we provided him, the free-range.

'We began at Media Sound and moved to Electric Ladyland until one day when Bob and I came out of the studio and looked up at a putrid yellow sky. I turned to him and said, 'Let's get to California.' Bob was worried about Stevie coming and I told him that he would follow us to the ends of the earth. Even when Stevie worked on other projects like Syreeta's album and The Jacksons, he never went anywhere without us.

'We were helping him realize his dream. When he came to us, he hadn't done anything yet and he was looking for validation. He was still 'Little Stevie Wonder.'

'Stevie kept us busy the entire time, for four years and four albums, all mindblowers. We had all sorts of problems with our credits. Never once was TONTO listed on any of his LPs. We were supposed to get one-third of the production points which was one point each but we never did. We never saw a penny. We got a flat hourly wage for services as engineers and production assistants.

'At one point he listened to everything we said; he was very much an Anglophile and took a personal liking to me. But as time progressed and he became more successful, he became increasingly difficult to deal with, to communicate with. The biggest problem in working with me and in egg production in some sense, is the presence of yes men which was running rampant with Stevie. I can't turn to him and say it's wonderful if it wasn't, whether he likes it or not. I would fight with him if it was necessary. What Bob and I used to do was that we would wink at each other as a cue to engage Stevie in some criticism. Bob would assume one extreme position and I the other. Stevie was then forced to take sides with one of us and that is how much of the production was handled. Stevie never even knew it happened. We made him decide.

'A lot of the time Stevie wouldn't bother to learn the lyrics to his own songs and what I would do was have a mike that went straight into his headphones and I would have the words and I would read to him a line ahead of what he would sing. If you listen to some of the records, you can hear my voice buried in the back. Most of the time we ducked it out when we could.

'Originally it was the three of us in the studio but towards the end there seemed to be hundreds of people milling about, a party every night, and our authority was quickly undermined by Stevie's new allegiances. It wasn't sour grapes on our part but it was inevitable. Stevie had the car accident and was never the same. That closeness to death really affected him. I was changed after my bouts with hospitals and I know it put him through some changes.

I talked to him the night before the accident in North Carolina. I was at the New York Record Plant doing the mastering on '*In-nervisions*.' It was too long and I wanted to cut '*Mister Know-It-All*' and '*Golden Lady*,' the last tracks on each side. I told him we would put them on the next album. I was adamant about this point, the sound loss to my ears was sub-

stantial. I said, 'Let's get this one out, let's do it. This is a very important album, we're going to get a Grammy with this one.' He said, 'No way, you get those mother-fuckers on there. Don't you take one note off.' He won the Grammy, of course, and also for production and engineering. Both Bob's and my name were never mentioned publicly.

I worked with Stevie for over a year after the accident but it was never the same as before. My next project, after severing ties with Bob, was Mandrill and then the Isley Brothers, with whom I was again spared production credits and points. Their attitude was that since Stevie didn't give you points then we're not going to give you points. Ronnie Isley promised me that after '*Harvest The World*' sold more than 100,000 units I would then be taken care of. I never heard from him again and the album went platinum who knows how many times. Joe Zawinul from Weather Report employed my services for their '*Tale Spinning*' album and I was suitably credited but, overall, I was depressed over the way I was treated. Maybe I did nothing more than turn on the tape machine, who really knows? Considering all the success I had with Stevie I expected the production offers to flood in but they never did. Maybe people thought I was worth a fortune now and couldn't be bothered. That couldn't be farther from the truth but I take it as a compliment nonetheless.

'My next project was with an English guitarist, who contacted me because of what he heard on the TONTO albums and not because of Stevie. From a producer's point of view, that was the album I made the most money from and it never sold anything in this country. Which just goes to show me how much money I could have made. There's one born every minute.'

There is no despair, no self-pity. Malcolm reiterates his optimism, about working with such gifted players, and that his life has been a rich, uniquely rewarding one, with new music and new encounters on the horizon. Presently he is serving as co-producer on Gil Scott-Heron's newest release and with occasional time purchased to employ TONTO's venerable skills [Francisco & The Cosmic Beam Experience are recording special musical effects with TONTO for the forthcoming Star Trek feature film.] he is content and occupied. Also, he is teaching synthesizer at the Cazadarc Music Camp later this summer and is excited at the prospect of engaging a number of people into the rarified air of electronic music.

Our conversation ends as Malcolm prepares for his Tai Chi class later that evening. The Eastern discipline has steadied his mind, made him reflective but always engaging. He manages a toothy, crooked grin that seems to be characteristic of so many English musicians and muses aloud, 'I am too sincere and too devoted to the business of making music as opposed to the music business. I've had the opportunity to be associated with some of the finest people in the world and I hope that my reputation is impeccable.

'I am full of hope personally, full of optimism. I am proceeding along a certain route in life which seems to be to complete the work I am doing here and that I have to be humbled. Overcoming the adversity is building up my self-confidence and I am perfectly prepared for whatever comes.' ☺

Is your P.A. gain stuck in a whistle thistle?

UREI
QUALITY
OF COURSE

The UREI model 562 Feedback Suppressor allows increased gain before howlback in sound reinforcement systems, a common dilemma in stage monitor systems, auditoriums, concert halls, meeting rooms, schools, and churches. By tuning the 562's five active notch filters to the most prominent resonant frequencies, gain can be increased 12dB or more and intelligibility improved without undesirable changes in fidelity. Tunable high and low end cut filters allow bandwidth restriction for added control. The 562 provides feedback suppression without defeating room equalization. A bypass switch allows A-B comparisons and a setup switch protects speakers during tuning. XLR/QG connectors and barrier strips are provided for both input and output.

Don't suppress your urge to get one. See it at your UREI dealer today!

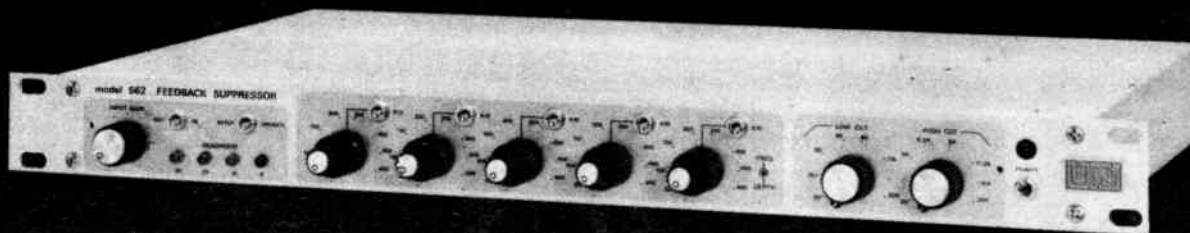

UREI

8460 San Fernando Road, Sun Valley, California 91352 (213) 767-1000

Worldwide: Gotham Export Corporation, New York; Canada: E. S. Gould Marketing, Montreal

470
250
220

On the Care and Feeding of the Analogue Tape Machine

Dear Dr. Moore;

With the knowledge that the digital age is upon us, many of us professionals and semi-professionals have no where the means to go digital in our boards and tape machines, until we strike platinum. Although we constantly upgrade when we can afford to, what do you recommend that we do to keep our sound competitive while we wait for the cost of digital equipment to come down?

Very truly yours,
Robert Denson
Laguna Hills, CA

Dear Mr. Denson;

Although the digital age is now upon us, I don't think that we should consider the current consoles and tape machines the audio dinosaurs of the near future. Few of us at this time can go out and buy an automated console or lease a digital tape machine. So, while we are faced with making the most of what we have, let's talk about a subject critical to our sound quality—the care and feeding of the analogue tape machine.

Before we go into the machines themselves, let us dwell for a second on tape. The last ten years or so have seen great strides in the development of tape oxides and backing. Thus we have been able to produce a better quality of sound by being able to hit the tape harder with level, giving higher output with lower noise and distortion. Both Ampex "Grandmaster" series and Scotch 250 Studio Mastering Tapes claim about the same electromagnetic performance: higher output, lower noise, greater saturation capability, and improved backcoating for better mechanical handling during all modes of operation and for elimination of electrostatic pickup of contaminating particles. These tapes do indeed reach the manufacturer's specifications under ideal test conditions, something akin to the testing of loudspeakers in an anechoic chamber.

Here we have the first bugaboo in the feeding of the tape machine. Having had access to large batches of both Scotch and Ampex tapes, I have noticed an inherent instability due to mass production. Some tapes are slit improperly, bias levels are slightly different, as are frequency response and third harmonic distortion. Mind you that the difference may only differ a dB or two from reel to reel of the same production run, but to the real professional this is enough to make a big difference.

So as far as feeding your tape machine, never take for granted that any two reels will be identical. Since time is money in the studio, allow time for you the engineer, or your maintenance person, to optimize every reel of tape that you use. A conscientious engineer will point out to the producer that it is in his and the artist's best interest to optimize every reel of tape.

We now move on to the care of the machine, that wonderful and astounding device that can capture the sounds of magic for generations to come. Yet, for the tape recorder to give its best, it must be given the closest attention, and a thorough program of regular maintenance. We'll clean out some of the cobwebs here with a basic review.

First, we turn off the power to the machine. Then we use a head degausser to remove any of the residual magnetism from any of the metal parts in the tape path. It should be noted at this point that stainless steel is not that impervious to residual magnetism, so we demagnetize all the metallic parts in the tape path. When the degaussing procedure is finished, turn the power on to the machine.

If it is at all possible, your solid state machines should be left on at all times. The reason for this being that it takes anywhere from a half hour to an hour for the electronics to stabilize after the machine has been off for any length of time. If alignment procedures for the electronics are started during this period they may drift by the time the session begins. I also recommend that if the machines are in daily use, an alignment verification be run at least once a week to ensure peak performance at all times.

After cleaning the heads and all the other surfaces that the tape might contact (and I suggest that you only use wood grain alcohol to prevent any damage to rubber or metallic parts, and it dries quickly and leaves no residue,) load your reel of tape onto the machine. Watch the tape path over the heads, to see whether or not it rides up and down. If it does one or the other, check with another roll of tape to make sure that the tape is slit properly.

Remember, the basic principle of tape path alignment is that all parts of the surfaces which the tape contacts must be in line or parallel. Putting on the test tape, you continue to adjust the head wrap, azimuth and zenith. Using a dual trace scope or a combined meter reading you can check the reproduce head for peak parameters. Then by putting the machine into the sync mode you can check that the record head is adjusted,

using the measuring equipment, to be in phase with the reproduce head. Complete the reproduce frequency alignment using the test tones.

Now we make sure that the height and zenith adjustments are proper. Shuttle the tape in both directions. Watch the tape buildup in each reel. The tape should not rub against either the top or bottom of either reel and should be centered and even on both the supply and takeup reel. There should be no up and down movement of the tape across the heads. Always look for "crinkling" of the tape edges at the machines fixed guides. If this is out of adjustment refer to the machine's service manual as to the proper adjustment procedure. On most machines there is an adjustment for the head height. Adjust this to make sure that the visible part of the tape's top track shield is the same width as the bottom half of the head shield.

From here there are erase adjustments, bias adjustments, bias trap adjustments, record adjustments, cue trap adjustments, and low frequency adjustments. These are all done in the record mode. Record linearity adjustments will assure that the intermodulation distortion characteristics will be optimum. This varies from tape to tape, depending on the manufacturer. Using a frequency counter you can easily detect any speed problems with the machine as well as proper tension.

If you want the best sound from your tape machine, take the responsibility that for every roll of tape that you use, the reproduce and record alignment is totally optimized. If you do not have the equipment to perform total machine care, contract with an outside firm to check your machine on a monthly basis. The following is the basic check list to assure your tape machine is giving its best to you:

1. Make sure that the tape that you are using is in good shape. If at all possible, bulk erase it before using it, even if it is virgin tape.
2. Run the tape through at the highest normal running speed (preferably 30ips) to unpack and properly pack the tape for best tape to head contact.
3. Make sure that your reference test tapes are in good condition. They do wear with age, especially in the higher frequency range.
4. Make sure that the tape path alignment is proper and that the tape has good contact with all the heads.
5. Schedule a periodic check-up of all the variable systems in the tape machine other than those done in routine alignment.
6. Read the tape manufacturer's tape specifications so that the machine is properly biased and level set for your usage.
7. Check reel tension and capstan puck pressure and wear.
8. Clean and demagnetize the machine as often as possible, or at least every eight (8) hours of usage.
9. If you are not sure about how to correct a problem, don't wing it. Get someone who knows what they are doing with the proper tools. Keep an accurate log on the machine and its repair.
10. Whatever you do, be nice to your machine, and it will do the same for you. ☺

The P50 Professional Power Amp by SAE. It's 1 $\frac{3}{4}$ " high and does absolutely everything except take up a lot of space.

In the conventional two-channel mode, it puts out at least 70-watts per channel. (But don't be surprised if you get over 100.)

In full bridged mode, it'll go 350-watts into four ohms, driving one full-range system or just the woofers in a bi, tri, or quad system.

Its 30 amp output devices and built-in fan allow it to run all the way down to *two ohms!* And we don't know another 1 $\frac{3}{4}$ " amp that can say that.

Just plug into the mono input jack and the P50 automatically bridges to produce a powerful 350 watts. No switches. No jumpers. No headaches.

There's more. The P50 has switchable independent high

and low frequency filters that guard against RF and allow for use with the latest cinema noise reduction systems.

If you're into a stereo tri-amp system, terrific. So are we. Bridge two P50s for 350 watts per side for woofers, take one in stereo mode for 70-watts per side for midrange, one in stereo mode for tweeters, and it's done. Four amps. Or just 7" of rack space!

As if that's not enough, there are separate frequency and load independent channel overload indicator lights, *fully* complementary circuitry, easy serviceability, plus SAE's renowned sonic accuracy.

So the next time you've got a lot to do, without a lot of rack to do it in, ask for the little amp that does it all. The P50. By SAE. \$500* each.

*Actual retail prices determined by individual SAE dealers. For information write: Dept. 22, P.O. Box 60271, Terminal Annex, Los Angeles, CA. 90047.

Introducing 1 $\frac{3}{4}$ " of performance, flexibility and power.

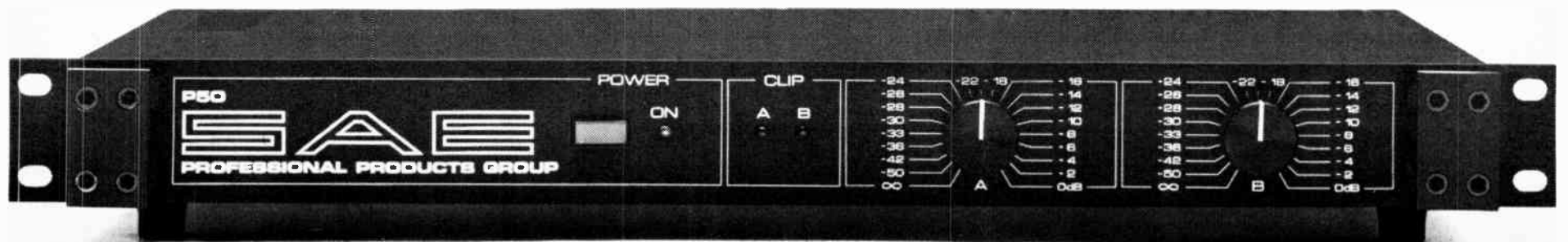



EQUALIZERS AND THE SOUND ENGINEER

by Thomas H. White

The Past

The equalizer has become nearly as ubiquitous as the mixer and the power amplifier. Virtually every sound system—large or small, public address, concert sound, large system reinforcement, recording studio monitor—employs some form of equalizer.

What is an equalizer? Prior to a few years ago, the equalizer as most of us know it today did not exist. Sound system equalization consisted of not much more than the casual adjustment of tone controls on the amplifiers or, in more sophisticated systems, the balancing of high and low frequency acoustic energy by means of taps on high level crossover networks.

In the late 1950s, as instrumentation became readily

available to match the increased desire for better sound, a need developed for more exacting control over the frequency response of the sound system in its environment. Filter specialists were called upon to design sets of filters which provided needed control of the electrical response of the sound system to conform to the increased accuracy of acoustic measurements made by acousticians. The evolution of the equalizer has directly followed the development and availability of acoustic instrumentation.

It should also be noted that the development of instrumentation and the concomitant development of equalizers responded directly to the willingness of financiers of sound systems to invest more and more capital in search of bigger and better sound.

Early instrumentation was structured around sine wave analysis of sound systems. The system was swept with an oscillator, and the response of the

system was measured with a sound level meter. This produced an often confusing array of data, which was very difficult to interpret and even more difficult to control. In the late 1950's, acousticians began experimenting with random wide band noise as a source for exciting the system during measurements. At first, white noise was used, but as measurement methods evolved, pink noise became the standard. Pink noise has the property that it has equal energy for a given percentage bandwidth over the entire spectrum. Thus, an octave in the bass region has as much pink noise energy in it as an octave in the treble. This is a much more convenient method of measuring a sound system, as the filters commonly used to divide the spectrum for either measurement or control are much more economical if they are designed around constant percentage bandwidths.

By the pink noise method, sound system analysis was at first done by stepping a contiguous

series of filters across the spectrum and measuring the energy in each band. The set of filters was either in front of the sound level meter to band limit the meter while the system was energized with pink noise, or the set of filters was placed between the pink noise generator and the system to band limit the signal applied to the system. In either case, the results were the same. But as it was a point-by-point step procedure, it was very tedious. It was not uncommon for the tuning of a system to take all night!

In the 1960's, the state of the art in electronics allowed for the development of "real time analyzers". Instead of stepping the filters through the spectrum, making a measurement at each point with the sound level meter, the system was energized continuously with pink noise while all of the filters (via a microphone and a preamplifier) saw the acoustic output simultaneously. The output of the filters was then scanned electronically, and the energy metered and presented as a graphic display on an oscilloscope. The set of filters was scanned approximately every .03 seconds, fast enough to avoid flicker when presented to the eye and fast enough to seem as though it were really "real time" even though it was only being updated every 30 milliseconds. With refinements, this is the basis of what we consider to be the real time analyzers we know today. Refinements may consist of LED raster displays to replace clumsy and delicate CRT displays and the addition of ancillary functions such as RT60 measurements within the same instrument.

With the development of analysis systems came the pressure to develop equalizer systems to correspond to the data available. If it was possible to conveniently and economically measure a sound system response by octaves (only ten are required to cover the spectrum), then one would like to be able to control the electrical signal by octaves. As it developed, segments of one-third of an octave became the accepted standard, though octave bands are still used for some applications. One-third octave steps require 25 to 30 filters to cover the spectrum. While this has represented the current state of the art for the last decade, we are beginning to see pressures developing for even more exacting measurement and control as the desire and economic factors dictate better and more realistic sound.

The Present

The sound system engineer is today confronted with a confusing array of equalizers to choose from. They can be divided into several general classes, however, and according to the application, the choices can be limited. With the application of each device, the sound system engineer must consider the electrical specifications and limitations of the particular equalizer he or she is using. Nominal operating conditions (to maintain a good signal-to-noise ratio, adequate headroom, and to assure the proper interfacing with other equipment) must be considered. Every system engineer or specifier must review the specifications of the other components in the system and compare them with the equalizer under consideration in order to assure proper overall system operation.

Most equalizers manufactured today are either octave band or one-third octave band. Though there are some half-octave band equalizers available, they are not commonly used for sound system equalization as there are no corresponding analysis systems available by which the audio engineer can adjust them. Almost all of the octave and one-third octave equalizers have band centers based on the same internationally accepted set of band centers as is incorporated in all the analyzers being manufactured. While this is not to say that a half-octave equalizer or some other combination should not be used, one should consider the analysis system to be employed before choosing. If the ear is the system to be used for analysis, then as a general rule, the broader the bands of an equalizer, the easier it will be to adjust. Very few of even the most experienced engineers will claim to be able to adjust a one-third octave equalizer by ear! Though in stage monitor applications, where they are used to limit the stage monitor's response to suit a particular instrument and to provide maximum output before the system goes into feedback, it is frequently done by the ear of a very experienced operator. But for providing a good response for the house system or the recording studio monitor, adjustment is always carried out with the aid of an analyzer with bands corresponding to those of the equalizer.

1. Active Equalizers

Active equalizers may be divided into two broad band classes: boost/cut and cut-only. In application, these two classes differ very little in a practical sense. Most boost/cut equalizers provide at least 10dB of range in each direction. The user should be aware that 10 dB is a power increase (or decrease) of 10 times! Just imagine what asking your speakers or your power amp to handle at ten times the power at a given frequency might do. Generally speaking, most equalization is done by only cutting the response in a particular band. Boosting of the response must be done very judiciously. Deep holes in the response of a sound system are generally caused by serious acoustic resonances in the room or by crossover deficiencies in the loudspeakers. One should not attempt to cure these problems by cranking in 10 dB of boost. They can be detected by the system operators observing the real time analyzer while adjusting the equalizer. If when the equalizer is adjusted upwards in a band by five dB and little change is noted on the analyzer in that band, then it is obvious that the lack of response is a problem of room resonance or crossover phasing and cannot be cured by simply jacking up the power response in that band. On the other hand, response peaks may be brought down in a line with the rest of the response with little danger. It is amazing the clarity a system can suddenly assume when a bass or midrange peak is removed, thus allowing the rest of the system's response to be heard. All of this is not to say that the boost/cut active equalizer should be second choice to the cut-only equalizer. It does allow for flexibility in smoothing a system response. For stage monitor applications where the need is to deliver maximum sound pressure level to the performer's ears in the range that his or her instrument is producing, it is unsurpassed.

The cut-only active equalizer generally provides about 15 dB of attenuation only in each of its bands. This acknowledges the fact that one should not attempt to fill in a hole in the system response but rather should only attempt to bring response peaks into line with the rest of the curve. These equalizers are generally used in fixed systems (as opposed to portable or show systems). In these systems, the flexibility of a boost/cut equalizer is not needed, as there is time to correct resonances and crossover deficiencies and frequently the sound system engineer or consultant wants to avoid the hazards of having inexperienced personnel cranking up a band and thus requiring more power in that band that the system can deliver.

Most professional active equalizers are constructed around various types of feedback circuitry involving operational amplifiers and inductor-capacitor resonant circuits. This type of circuitry is "state of the art" (in spite of some claims made) and provides the cleanest sound with least distortion. Gyrotors are a class of circuits in which the inductor is replaced by solid state devices to simulate its function. These require the signal to be processed by more active devices and thus are generally degraded more than the simpler inductor circuitry. Gyrotors do have the advantage of providing some flexibility in terms of frequency adjustment, but by the present state of the art, they do so at the expense of clear, distortion and noise free sound.

2. Passive Equalizers

Truly passive equalizers utilize only inductor-capacitor resonant circuits and no active devices to provide the desired response control. These equalizers have some very excellent advantages over their active counterparts, and some disadvantages which must be considered.

On the advantage side, they will control the response of a sound system in octave bands, one-third octave bands, or whatever they are designed for without adding any noise to the system and very little distortion. Most people involved with sound system design very long have come across the acronyms "TIM" and "SID". These describe a kind of distortion created by active devices (amplifiers) and if present only to a slight degree, impart an undesirable harshness to the reproduced sound. Passive devices do not produce this kind of distortion. Their distortion is referred to as "odd harmonic" distortion and if present to only a slight degree is not considered too objectionable. Further, passive equalizers do not "hard limit" as active devices in active equalizers do. This means that, as the signal peaks increase beyond some nominal operating point, they are not suddenly clipped but rather, in the passive device, they are gradually more distorted. Maximum signal levels for passive equalizers are considerably higher than most active ones. One can expect the operating headroom in a passive equalizer to be at least 10 to 20 dB greater than their active counterparts. Further, the signal to noise ratio ceases to be a problem as the passive device adds no noise.

Cont'd on page 26

Cont'd from page 25

Another real advantage not to be overlooked with the passive equalizer is that of reliability. Having no active devices and thus no power supply, failure is much less likely to occur than it would be with an active device. Let's face it, in spite of all of the testing and care a manufacturer might take in the process of constructing an active equalizer, there are still random failures that will occur. Passive equalizers are all iron and copper and capacitors. Failure is practically unknown in this class of components.

What then, are the disadvantages? There are three which from the user's standpoint, are to be considered. The first is that this type of circuitry can be cut-only. I have already discussed the relative advantages of cut-only versus boost/cut equalizers, and they apply in this case.

The second consideration is that of proper interfacing to the other equipment in the system. With the active equalizer, this consideration is largely one of assuring proper signal levels so as not to overload its circuitry or degrade the signal-to-noise ratio of the entire system. Very little consideration has to be given to source impedance of the preceding device or the load impedance of the following device, as today's designs are mostly low impedance out and high impedance in, which allows for their interfacing with little or no consideration whatsoever. A passive device is different in that it MUST see the source and load impedances it was designed for if it is to have the response it was designed to have. This means that the system engineer must take care to see that the device preceding the passive equalizer presents the source impedance the equalizer manufacturer has designed it for, and it must also have the proper load impedance for the same reason. Some of these equalizers are designed to see 600 ohms both as a source and a load. This interfacing restriction must be adhered to if the equalizer's filters are to have their designed response. For large fixed reinforcement systems, this kind of interfacing is commonly found and is even required by other system considerations. The first equalizers ever developed were passive ones of the 600 ohm in and out variety and are still specified for many large sound reinforcement systems today.

Recently, a class of passive equalizers have become available which are designed to be interfaced with the low impedance out and high impedance in equipment, which is in most common use today. These equalizers are designed to see a low source impedance (say, a few hundred ohms or less), which is common for the output of most solid state devices in use, and to see a high load impedance. It is generally specified to be an exact amount, such as 10,000 ohms, and must be provided if the equalizer is to perform correctly. Most following devices are designed with an input of 10,000 ohms or more so the engineer need only shunt that device with the resistance necessary to bring its impedance down to 10,000 ohms. As the preceding device "sees" this impedance through the passive equalizer, it will be loaded by 10,000 with a load of this size. Thus passive equalizers designed for high impedances can be interfaced with little trouble, but the terminating

impedances must be adjusted to meet the manufacturer's specifications.

The third consideration is that of response. Because of electrical considerations and restraints, the actual bandwidths of the filters in a passive equalizer are about 50% wider than those in the corresponding active devices. This may seem like a considerable hindrance at first, but in actual operation it is not. The broader response and gentler phase slopes of the passive devices are considered by many, if not most, acousticians to give a more pleasing sound than the steeper one frequently encountered in active devices. While this may cause more interaction between bands, they do not require that much more time to adjust. The pleasing sound and lack of noise and distortion more than make up for the additional trouble.

One further point that may be considered with the passive devices is cost. They generally cost a little less than their active counterparts. Though this is not really a consideration in large systems where only "the best will do", it certainly might be for the smaller system on a strict budget, where the system engineer is trying to get the best sound for his money.

3. Parametric Equalizers

By their very nature, parametric equalizers are active devices in which the frequency, bandwidth and gain/attenuation can be varied. Generally, these equalizers have about four or more sections or filters in which these variables may be adjusted. All of the consideration involving active equalizers previously discussed apply here.

These equalizers are not usually used for sound system equalization. Rather, they are generally used in the recording studio for adding sizzle to an instrument or voice. By varying the bandwidth from very wide to very narrow and by adjusting the frequency up or down, varying degrees of gain or attenuation may be applied over desired frequency ranges to change the quality of the sound. They may also be used to eliminate a few feedback modes in a sound system by adjusting them to a very narrow bandwidth and attenuating the system at a point it is trying to feed back.

In order to provide all of this adjustability, the circuitry employs many active devices. These devices add noise and distortion to the system. Thus, if many filter sections are stacked up in an effort to provide equalization over the entire spectrum, the distortion and noise figures will become unacceptable. Their limited application does make them a valuable tool, however, and no recording studio should be without them.

The Future

As the state of the art and our ever increasing expectations evolve, we should expect to see filter systems of increasing resolution and a higher degree of control. Real time analyzers with increased resolution are already in the market place, and soon

the audio industry will find them economically feasible on an everyday basis. With the availability of these analyzers will come the demand for equalizers with more resolution and control. We at White Instruments have recently introduced one-sixth octave analyzers and equalizers for the adjustment and control of sound systems and have had them accepted by the leaders in the industry. As the level of awareness of audiences increases, and as the demands by the audio engineer to fulfill this need dictate, the economics of sound reproduction will allow for the more precise control provided by narrower filtering. In not too many years, we can expect to see the analyzer and equalizer systems we know today evolve to all digital systems which will provide nearly unlimited analysis and control over the audio spectrum. It is the acoustician and the sound engineer who must keep abreast of these developments and stand ready to provide them to their clients as they become available and economically feasible. ☺

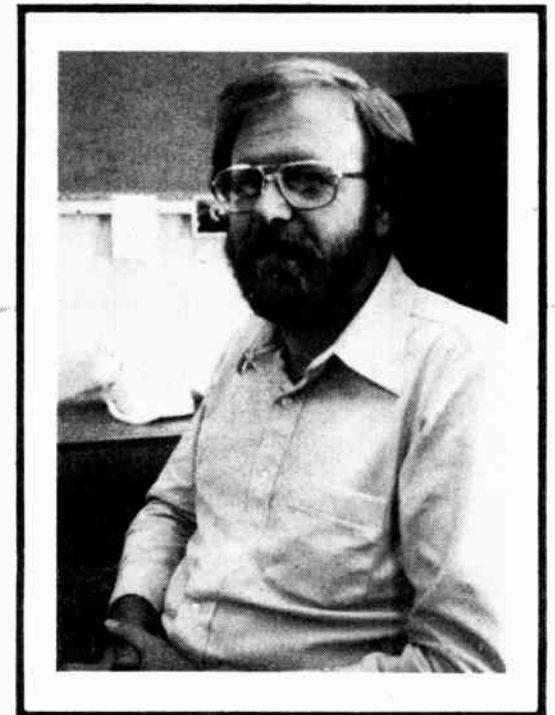

Thomas H. White was born on March 23, 1942 in New York. He has lived in Austin, Texas since 1953. He attended the University of Texas from 1959 to 1963 and has been associated with the family owned business of White Instruments, Inc. since 1964. He is married and has two teenage children. His hobbies are sailing, backpacking, and jogging.

White Instruments, Inc. pioneered the development of equalizers and analyzers for the audio industry. Founded in 1953 by G.E. White, White Instruments designs and manufactures filters and networks for the scientific, aerospace, and audio industries.

When it comes to De-Essers, less is more.

The Orban 526A single-channel Dynamic Sibilance Controller is a simple, economical dedicated de-esser — without the complexity and compromises of multi-function processors. It sets up fast to produce sibilance levels that sound natural and right. Features include mic/line input, fully-balanced input and output, LED level meter, GAIN control, compact size, and more. Special level-tracking circuitry assures consistent control with varying input levels. And our control technique doesn't emphasize residual IM when de-essing occurs.

De-essing doesn't have to be complex, expensive, and time-consuming. At \$399* the 526A does it fast and right in recording studios, cinema, broadcast, and cassette duplication.

The 526A De-esser is available at your Orban pro-audio dealer.

*suggested list

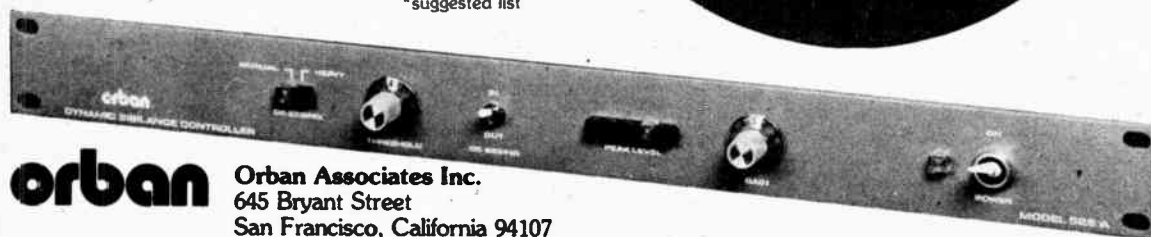

orban Orban Associates Inc.
645 Bryant Street
San Francisco, California 94107
(415) 957-1067

orban

See it at your ORBAN DEALER:

NO. CALIFORNIA

Accurate Sound Co.
Redwood City
(415) 365-2843

Alco-Paramount Corp.
San Jose
(408) 297-7111

FM Productions
San Francisco
(415) 647-5600

Pro Media
San Francisco
(415) 957-1383

Protronics
San Mateo
(415) 574-8511

Sound Genesis
San Francisco
(415) 285-8900

Taber Manufacturing and Engineering Co.
San Leandro
(415) 635-3832

WAH Sound
Sacramento
(916) 444-5491

WASHINGTON

Bennett Engineering Associates
Mercier Island
(206) 232-3550

Broadcast Supply West
Tacoma
(206) 565-2301

Pro Audio Seattle
Seattle
(206) 622-6984

The ADR Compex-Limiter... ... one of my favourite things

says Lee De Carlo*

"I've been using ADR's Compex-Limiter for well over a year — always with the same gratifying results.

It's capacity for effects seems endless while its reliability in its performance as a Compressor; Peak Limiter and Expander/Gate is only surpassed by its flexibility in these same modes.

I use it constantly — it is one of my Favourite Things.

P.S. If there is a fire in the studio and a Compex-Limiter is destroyed, it is probably better to buy a new one."



F 760X-RS COMPEX-LIMITER features:-

- * Separate Peak Level Limiting with
- * Multi-Ratio Variable Threshold Compressor and
- * Noise-Reducing Expander with Gate option
- * 19" Rack Mount with integral Power Supply
- * EXCELLENT TECHNICAL SPECIFICATION

audio & design recording inc.

Nigel Branwell, PO Box 902, Marina, Calif. 93933 Tel: (408) 372 9036



Lee De Carlo is Chief Engineer for Record Plant Studios, Los Angeles working with such artists as Aerosmith, Aretha Franklin, The Rolling Stones, Angel, Frankie Miller and Chicago.



SMALL BUSINESS ADMINISTRATION

A Financing Alternative

by Jo Ann Semones

Most people are aware that the U.S. Small Business Administration is a place to borrow money. The question is, how?

One important restriction applies to all SBA loans. By law, the agency may not make a loan if a business can obtain funds from a bank or other private source. You, therefore, must first seek private financing before applying to SBA. This means that you must apply to your local bank or other lending institution for a loan. If you live in a large city—one with more than 200,000 people—you must apply to two banks before applying for a direct SBA loan.

If you are an established business, you will need to do the following:

1. Prepare a current financial statement (balance sheet) listing all assets and all liabilities of the business—do not include personal items.
2. Have an earnings (profit and loss) statement for the previous full year and for the current period to the date of the balance sheet.
3. Prepare a current personal financial statement of the owner, or each partner or stockholder owning 20 percent or more of the corporate stock in the business.
4. List collateral to be offered as security for the loan, with your estimate of the present market value of each item.
5. State amount of loan requested and explain exact purposes for which it will be used.
6. Take this material with you and see your banker. Ask for a direct bank loan and if declined, ask the bank to make the loan under SBA's Loan Guaranty Plan or the participate with SBA in a loan. If the bank is interested in an SBA guaranty or participation loan, ask the banker to contact SBA for discussion of your application. In most cases of guaranty or participation loans, SBA will deal directly with the bank.
7. If a guaranty or a participation loan is not available, write or visit the nearest SBA office. SBA has 100 field offices and, in addition sends loan officers to visit many smaller cities on a regularly scheduled

basis or as the need is indicated. To speed matters, make your financial information available when you first write or visit SBA.

If you are a new business, you will need to do the following:

1. Describe in detail the type of business to be established.
2. Describe experience and management capabilities.
3. Prepare an estimate of how much you or others have to invest in the business and how much you will need to borrow.
4. Prepare a current financial statement (balance sheet) listing all personal assets and all liabilities.
5. Prepare a detailed projection of the earnings for the first year the business will operate.
6. List collateral to be offered as security for the loan, indicating your estimate of the present market value of each item.
7. Take this material with you and see your banker. Ask for a direct bank loan and, if declined, ask the bank to make the loan under SBA's Loan Guaranty Plan or to participate with SBA in a loan. If the bank is interested in an SBA guaranty or participation loan, ask the banker to contact SBA for discussion of your application. In most cases of guaranty or participation loans, SBA will deal directly with the bank with the bank.
8. If a guaranty of participation loan is not available, write or visit the nearest SBA office. SBA has 100 field offices and, in addition, sends loan officers to visit many smaller cities on a regularly scheduled basis or as the need is indicated. To speed matters, make your financial information available when you first write or visit SBA.

Generally, a loan applicant must:

- Be of good character.
- Show ability to operate a business successfully.
- Have enough capital in an existing firm so that, with an SBA loan, one can operate on a sound financial basis.
- Show the proposed loan is of sound value.
- Show that the past earnings record and future

prospects of the firm indicate ability to repay the loan and other fixed debt, if any, out of profits.

Be able to provide from your own resources sufficient funds to have a reasonable amount at stake to withstand possible losses, particularly during the early stages, if the venture is a new business.

Providing financial assistance, is not all that SBA has to offer.

Each year, the Federal Government contracts for billions of dollars with private companies. SBA helps small businesses obtain a share of this government business by providing several forms of assistance to small firms that want to obtain government prime contracts and related subcontracts.

Specialists in SBA field offices counsel small businesses on prime contracting and subcontracting. They direct them to government agencies that buy the products or services they supply; help to get their names placed on bidders' lists; assist in obtaining drawings and specifications for proposed purchases and offer many other related services, which include supplying leads on research and development projects.

Most businesses fail for lack of good management. For this reason, SBA also offers a diversified program of management and technical assistance to strengthen small firms and to improve their operations. Much of this assistance is free, whether you are an SBA client or not.

Under SBA's program of management assistance, conference problem clinics and individual counseling are offered so that the management ability of increasing numbers of small business owner-managers can be improved. Special seminars are available for those already in and interested in going into business for themselves.

Jo Ann Semones serves as Assistant Regional Director for Public Affairs and Communications for the U.S. Small Business Administration. ☺



THE NEW CS-800

Leaving the
competition
another step
behind.



Since its introduction in 1975, the CS-800 has had a lot of competition among other commercially available stereo power amplifiers. But, nobody has been able to match the quality, versatility, performance and incredible dollar value offered by the CS-800. Due to the CS-800's enormous success, some of our competitors have quietly returned to the drawing board to improve their product and, we'll be the first to admit that they have. Unfortunately for them, so have we.

Our new CS-800 has been refined to offer new features such as DDT compression, more advanced circuitry, and expanded patching facilities, at only a very slight increase in price,* making it an even greater value than before.

Take, for example, Peavey's unique Distortion Detection Technique® (DDT) compression circuitry. DDT® electronically senses the onset of amplifier clipping and engages a specially designed circuit that virtually eliminates power amp

clipping, thus greatly decreasing the possibility of square waves reaching the speakers. Not only does this feature offer maximum protection for your speakers, DDT® enables the total system to enjoy freedom from most of the commonly encountered headroom problems with power amplifiers. This compression feature may be easily defeated from the front panel by built-in switches on each channel.

The CS-800 features an improved patching system with provision for electronic crossovers and transformer balanced inputs for each channel. The convenience of the rear patch panel combined with the optional, low cost plug-in accessories give the CS-800 versatility that is unmatched by other professional quality power amps.

Our competitors will be advertising and displaying their new units soon. While you're looking at theirs, we'd like to invite you to compare specs and features with ours. You'll see why the Peavey CS-800 is still one step ahead.

Performance Specs:

Frequency Response:
+0, -1 dB 5 Hz to 60 kHz (1W, 8 Ohms)

Power @ Clipping:
400 W RMS per channel into 4 Ohms
800 W RMS bridge mode into 8 Ohms

IM Distortion:
Less than 0.1%, typically below .04%

Total Harmonic Distortion:
Less than .05%, typically below .02%

Damping Factor:
Greater than 200

Input Sensitivity:
1.3 V for 400 W into 4 Ohms

Load Protection:
Short, mismatch, open circuit proof
voltage/current limiting instantaneous with
no thumps or cutout.

Speaker Protection:
Instantaneous crowbar circuit c amps the
output upon advent of amplifier failure.

Cooling System:
2 speed forced air cooling over massive
aluminum heatsinks

Output Transistors:
20, 4 drivers (TO-3)



PEAVEY ELECTRONICS CORP.
711 A Street/Meridian, MS. 39301

© 1979

Drum

MIKING PART 2

with Fred Catero

by David Schwartz

An engineer and mixer for nearly thirty years, Fred Catero has achieved a unique kind of respect throughout the industry for his ability and perception behind the mixing board. Fred's drum sounds have helped to pave the way for sophisticated rock and roll recording techniques and much of his work with such artists as Santana, Blood Sweat and Tears, Chicago, Simon and Garfunkle, and Herbie Hancock stand today as landmarks in the creative art of the recording studio.

In the mid-sixties, Fred, a top mixer with Columbia Records in New York, began working with the freshman staff producer at CBS, David Rubinson. Five years and many gold records later, Fred and David moved to California and formed the Fillmore Corporation with Bill Graham. Since that time Fred has recorded many fine albums, served as president of the San Francisco chapter of the National Academy of Recording Arts and Sciences (NARAS) and co-founded the internationally acclaimed Automatt Recording Studios, in San Francisco, where he is chief recording engineer.

We spoke with Fred recently to pass along some of his feelings and observations concerning the complex problems of drum miking.

Tell us something about your drum miking techniques, when and how you first started concentrating on it.

Let me start by saying that there is no secret set-up for drums. Up until just a few years ago, we weren't spending much time on getting a drum sound because the drums weren't really a featured instrument. As long as we could hear the two and four, it was usually okay. But when rock and roll came along and we were working with guitar, drums, bass and a piano, the drums became a very important part of the sound of the music and more and more time began being devoted to getting a drum sound.

I remember the first time I had a chance to go for an all out drum sound. It was with Blood, Sweat, and Tears Bobby Columby, the drummer, and I literally spent a day and a half trying all kinds of microphones, different positions, different drums, different locations in the studio, anything at all that we could change in order to get a killer drum sound.

And we got it. I was luckier than most engineers in that the budget was large enough and the studio was not so expensive and we had the time to fool around and get the best sound.

The funny part was that after getting this great sound I made sure to write down exactly what I did—all the mikes, positioning and EQ settings. A month later I was doing another rock group and I thought I'd blow them away with the drum sound so I set up everything exactly the same way. As you can probably guess, it sounded terrible. It did show me, though, how sensitive drums were—to the player, the environment, the temperature, and the other instruments in the room.

Do you get the drummer involved in the control room when you're going for the drum sound?

I find it's best to keep the drummer on his kit in the studio until I get something on tape. Here's what can happen if I don't do it that way. I'll be working to get a drum sound with the drummer out in the studio playing and, for instance, the bass player will be in the booth with me. When I finally get it just right the bass player will call in and say to the drummer, "Hey, come in and listen to this. I want you to hear how your drums sound, I'll go out and play your drums." So the drummer will come in and the bass player will go out and sit at the drum set and play the drums and they'll sound absolutely different, I mean night and day different. The drummer will look at me and say, "You like that, you think this is a good sound?" Of course I explain the difference between the sound of different players, but it leads me to avoid that situation.

Back in those early days, how were you miking the drums?

The classic style of miking a drum was one over-

head, one on the snare, and one on the kick. The overhead was meant to pick up everything, including the kick. It was far enough away so that it got an overall picture of the drums. The snare mike was there to touch-up or to add extra control when he went to brushes or rim shots, or whatever. The mike on the bass drum (which we now call the kick) was there to be sure that we got the low end fullness in the bass drum because that was the only drum that was not facing up to the overhead microphone. It was facing out and all the energy was going at right angles to the overhead.

That was the classic way of miking. Then we went to two overheads when we wanted a little bit of stereo effect on the drums and one on the right side, one on the kick and one on the snare. But then came the problem where everybody wanted absolute control of all the facets of the drums and we started putting microphones on everything.

When you went 8-track at CBS, how many channels did you use for the drums?



Three maximum, two preferable. The eight track stuff we did in New York: Blood, Sweat, and Tears, Chicago, Simon and Garfunkel—all those—they were all eight track dates and generally we just couldn't piss away tracks so we did the drums on two tracks in stereo. The kick was common to both, the snare was either a little to the right or in the center and we had left and right overheads, but they were all on two tracks. On typical sessions we had two tracks of drums, one track of bass, one track of guitar, one track of vocal, one track of keyboards or maybe horns. Generally the idea was to get it in as good a balance as possible on as few tracks as possible. On the eight track formal dates, all strings were on a track, all horns were on a track, guitars were on a track, bass and drums were on a track, lead vocal was on a track, all the background singers were on another track, all the keyboards were on another track; and we recorded it in sections.

You've had the good fortune to have nearly any microphone at your disposal. What are some of your favorites?

There are a lot of engineers who will walk into a studio and unless they can get the microphone of their choice, they automatically feel that they can't get a drum sound. I really feel that if you can't get a decent drum sound with the compliment of mikes available in most studios, you shouldn't be engineering. I can understand favoring certain mikes but to think that one microphone is the only one to use is childish—it's like a guitar player who will only plug into one particular type of amp, or a keyboard man who will only play a Steinway.

I'll generally use dynamic mikes on the toms, snare and kick. On the high frequency stuff—cymbals, etc., I'll use condensers but I'll keep them far enough away so that they won't get hit by the drummer. Condenser microphones are very delicate devices and I hate to go into a studio and see Neumann 87's and Sony condensers and other expensive mikes all beat to shit—the cases dented and the screens fractured. I wouldn't take a chance putting a \$600 microphone an inch away from where the guy's hitting. It's wonderful to impress somebody or say, "Hey, I'm going to get the best pickup in the world," and put a \$700 microphone on the kick drums—but if it's going to wreck the microphone, then you're not a very good engineer.

I use a lot of Shure SM-56's on the drums because they are very rugged, cheap and reliable. They also pivot easily for positioning and are small enough to stay out of the drummer's way. I like the Sony C-22 on the high hat for some of the same reasons. It's a condenser, but it's small and I can sneak it in without getting in the way of things. Usually I'll use Neumann U-87's for overheads and I'll make sure I keep them out of the drummer's way.

How do you deal with some of the problems encountered in multi-miking?

Today's technology requires usually a handful of microphones on the drums; a snare mike, overhead mike, a mike on the toms, mike on the kick, mike on the cymbals. What we must always remember is that any time we have more than one mike picking up any given thing, we're going to have phase problems. This is going to cancel some frequencies and reinforce others, and the more we recognize these properties of physics, the more constructively we can use them. We need to be aware of acoustical and electrical phase properties.

Before I even start to get my balances, I go through a complete phase check. I may start with my left overhead microphones and, as the drummer plays the tom tom, I switch the phase on the right overhead mike, noticing that the depth of the tom will disappear if the mikes are out of phase. One by one I check each mike this way and sometimes I'll purposely use some of the mikes out of phase if I want a thinner sound or if the overall drum sound is too tubby. Now, some mixing boards don't have phase reversal switches so with those I'll use phase reversing patch cords.

What about leakage and acoustical phasing?

Sometimes I'll have a situation where my tom mike is picking up and canceling too much of the kick and I'll go out and move the mike around. I may not get as close a pickup but it may help the overall sound of the drum kit. Another thing to remember is that if too much of the toms are leaking into the overhead mikes, which are intended for the cymbals, you can roll off the low end to cut down the leakage without losing any of the cymbals.

Cont'd on page 32

Cont'd from page 31

There's another interesting phenomenon, too. When the drummer hits a floor tom which has an open bottom, the sound wave radiates off the head in two directions. One wave comes up to the mike and another goes down, bounces off the floor, and back up to the mike. Now, depending on where the mike is placed, you can alter the richness of the tom. This is one reason that the drummer can raise and lower the height of his tom—to tune the return wave to the pitch of the drum.

Speaking of toms, here's another little trick. Let's say the drummer has five toms and each one is miked. Since each tom is tuned differently, you can improve the leakage factor by boosting that frequency and dropping the overall level on a particular mike, without significantly changing the sound of the drum. An easy way to do this is with a perimetric equalizer. You have the drummer hit at a steady pace and boost a narrow band all the way, sweeping it to find the highest intensity area of the signal. Then back-off the

EQ a little and you'll find that you can take off about 5 or 6 dB of level from microphone without losing the sound of the drum.

This brings to mind a strong feeling that I have; that it makes sense to understand the frequency response of the instrument you are dealing with. For instance, if you are recording a guitar that has a frequency range of 60 to 8000 Hz, it doesn't hurt to roll-off at 10 or 15K and below 40 Hz, because there may be certain frequencies in the room from other instruments bleeding into that microphone that you could decrease very easily using your cutoffs.

Another factor in tonality deals with what part of the head you are using. When you are miking directly over a drum, you will get the full fundamental, however, when you move the mike off to the side you pick up proportionally more of the harmonics and the sound thins out. Drummers and conga players use this technique when they want to vary their timbre on a drum—they'll move to the edge for that high sound and back to the center for the deep full sound.

Do you isolate the drums?

I don't like putting somebody in an enclosed padded house. Sometimes it's necessary, though, when the studio is acoustically such a rotten thing that, unless you do that, the drums get into everything else. In general, I like to put screens around the lower edge of the drums to keep the bass drum, which is a very powerful thing, from causing problems in the other instruments. The same with the tom toms, so that the sound that generates down towards the floor does not spread out into the room but is trapped by the low bass traps.

Time was, studios had a sound of their own and people would record in a studio because the room enhanced their instruments and it had a great sound and you wanted to record in that room because it made everything sound good. You didn't get isolation that way because the room became part of the sound.

When people started demanding isolation we had to figure out ways of keeping a sound from getting away.

That's why we ended up with drum booths and anechoic chambers and bass traps and all kinds of devices to allow the producer or the engineer another shot at it. Another reason we have drum booths is not necessarily to keep the drums from getting into everything else, but to keep everything else from getting into the drums.

What about setting levels?

One definite rule that I have with drum mikes is that before I open up any of the faders, I make sure that the pads are on, at the mike and at the input of the board. I've seen engineers wreck VU meters, blow speakers, and destroy pre-amps because they go from nothing to full on. What I do is start with full padding on all my mikes and bring them down to the point where it's practical on the board, keeping in mind that the padding should be a little greater for drums than for most other instruments, because of the transients.



When it comes to putting the sound on tape I find that a little bit of distortion generally makes the drums sound fuller. I'll usually set my levels to peak at 0 and +1VU and although the sound may not come back as clean as if I had set it for -10, the sound will be more exciting, more intense. It's really a constructive form of distortion that goes along with the sound source. When you hit the head of a drum, it distorts—it's a jagged configuration of harmonics because the skin is literally flapping and distorting. Of course sometimes I may want the drums to have a crystal clean sound and so I'll go lighter on my levels. But don't be afraid to put on level—let your ears be the judge. After all, the ultimate product is going to be a record that you listen to, not that you take home and put on a scope.

Do you find yourself trying to capture the sound of the drums or creating the sound?

I'm basically a purist when it comes to the drum sound and I don't like to muffle the drum by putting screens all over and stuffing blankets everywhere. I think that kills the sound of the drum. It's just as big a mistake as throwing lots of blankets over a piano—it just takes its life away.

One thing that I will do, though, and it's against my better nature as a purist, is to put a mike underneath as well as on top of the snare when I am close miking. This is because when the mike is so close to the head of the snare and the drum is eight or ten inches deep,

I find very often that I don't get enough of the actual rasp of the snares and have to add some presence of the lower head to keep the snare from sounding like a tom tom.

Now if we're at the mixing stage and it turns up that we don't have enough of the rasp of the snares, I discovered a great trick. I take the snare track and put it through a Kepex and close it down so that only the impulse of the snare drum hit comes through. Then I put it through a limiter, to keep the pulse at an even intensity, and then feed that signal into a speaker in the studio—like an Auratone or even a JBL monitor lying on its back. Just above the speaker I put the snare drum and mike it so that everytime the snare pulse comes through the speaker, it rattles the snares on the drum exactly in time with the original snare. I then mix the new snare with the old track and, presto, the snares are back! You can use a similar technique to recover the bottom of the kick drum, for instance, except you would use the pulse created by the inadequate kick drum track taken through a Kepex to trigger a signal generator. The generator would be set at 50 Hz and mix that resulting 50 Hz pulse back in with the original kick drum track and you've got it. The signal generator is a handy tool and you can use this same technique to retune a tom tom when there is no Harmonizer available. The frequency that you add will mask enough of the old drum sound to put it back in tune and you haven't lost any of the tone quality or decay.

Did you get involved in those exotic drum effects that became popular in the late Beatles era—like the backwards drum?

Now that wasn't backwards drums, that was bad limiters. What a lot of engineers don't realize when they idolize some of these great effects, is that these effects weren't usually planned. The equipment was so rotten that they generated their own sounds and sometimes it was such a hip, unusual thing that they kept it. The old tube type limiters, which are not available too often, have the "ability" to get some of those hip sounds. You can use one on the kick and, because the limiter is so slow in its action, you can have a lot of compression and not lose the attack of the kick. The attack is of such high frequency and short duration that the old tube limiters can't compress it quickly enough so it gets through, then they grab it and it breathes. So you get a whoosh as it recovers.

You've put a real bag of tricks together over the years. Any words of wisdom for up and coming engineers?

Well, there's all kinds of things you can do and it's the freedom of thought that makes you an inventive engineer. If you are not so regimented to keep doing things the same way over and over again, you can be free to be original and creative. They say that the greatest inventors are the ones who don't know it can't be done. The same is true with musicians. Some of our best musicians were never educated to know that this chord could not be followed by that chord and so, in their "ignorance" they often came up with very unique and inspired progressions.

Realize that if you can screen something in, you can screen something out. If you can record something forward, you can record it backward. And we must resist the temptation to be lazy. There are many devices out now to create effects and to save time, but these are all designed to be used as tools and not crutches. ☺

Edcor  *Cabrec*
CM 1000, 2000, 2100
Capacitor
Microphone
System

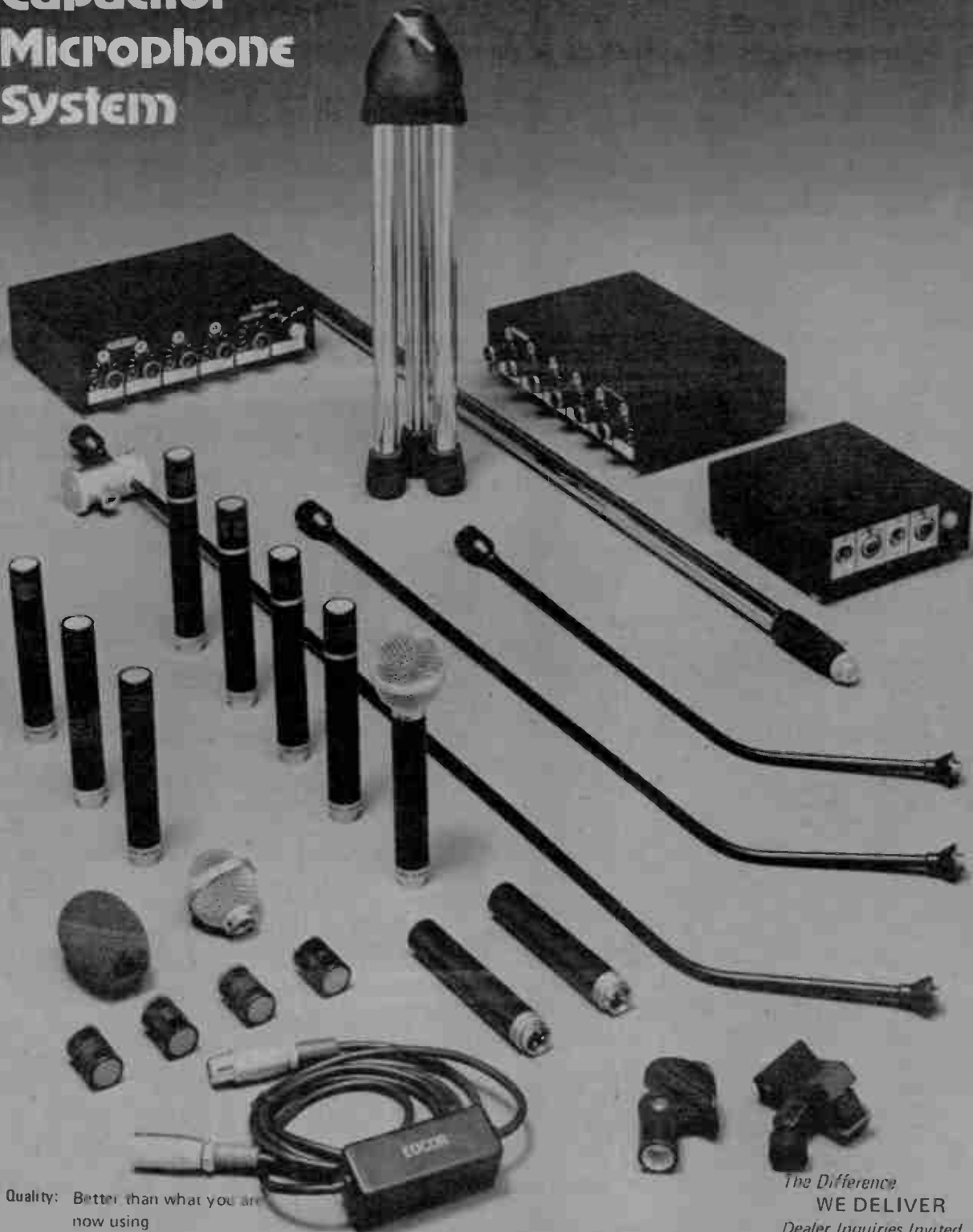

Quality: Better than what you are now using

Pricing: A shade less

Service: Quicker than what you are use to

Specs: Please compare

Delivery: How quick do you want them?

The Difference
WE DELIVER
Dealer Inquiries Invited

Edcor

16787 Hale Avenue • Irvine, CA 92714 • (714) 556-2740

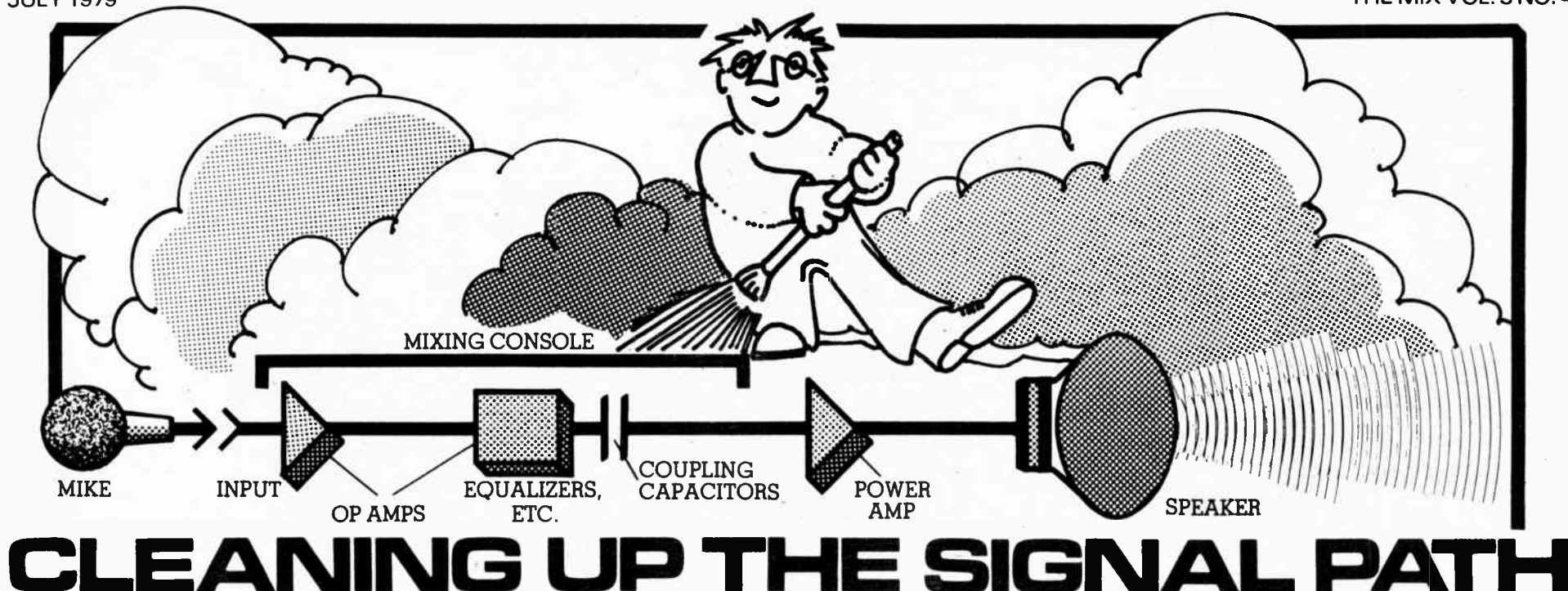

CLEANING UP THE SIGNAL PATH

by Lane Poor

Sound. From the moment we plug a microphone into its cord, sounds can change. Every element in the ensuing signal path has something to say about the fidelity of the original sound and we are more aware than ever before of the need to provide a clean path for our plucky little electrons.

We are learning. Tests are being changed, old measures challenged and it is sounding "better" all the time. Clean it up, that's the process. We've come from the cylinder to the tape, with signal to noise ratios getting so good the first note can hit hard without a whisper to let us know it's coming.

By way of analogy, we are striving for a straight wire. Any time we can pull a device out of the circuit and replace it with a piece of wire so that all chances of change are gone, we can listen, evaluate, and learn. Is it transparent? And as it gets to an A/B test, one speaker against another, we have to rely on memory and our faculties of listening. Aural memory is hard to retain but we must realize that in the title bout of live against reproduced, our ear is referee, judge, and audience.

Let's take a walk through the signal path and see what demons are lurking behind the trees.

Microphones and Input Termination

The two most common types of microphones are the condenser and the dynamic. A condenser microphone is basically a lightweight diaphragm with a charge relative to a stationary plate. Move the diaphragm with sound and the plate will have a greater or lesser voltage on it. Dynamics are like little speakers that work backwards, complete with voice coils, diaphragm, and a magnet. Both types need to work against a load, a little resistance to keep the circuit from overshooting or ringing.

Most mic specs state 150 ohms out, and yet the resistance offered by most input stages are in the order of one to two thousand ohms. Some boards offer no resistance at all, creating a very crisp, often brilliant sound. What's right? First of all, most microphones are designed to work into a load. (Hi-Z mics obviously need high loads, in the order of fifty to one hundred K.) Generally one to two K sounds best, for the low impedance type.

To check a specific input impedance you need to start with pin two and three of the mic input. Some simple termination can be done directly between these two pins. If there is a transformer the secondary must be terminated in its respective impedance in order to load the primary. (For a good description of termination see "Audio Cyclopaedia" by Howard Tremaine.) If your board is equipped with a phantom power supply use care in taking the two hot pins to ground. You can load the supply down. In any case if you think it's not "right" try putting in termination with a switch, cutting it in and out, using your ears as the final judge. Solidity and depth can often magically appear with a microphone that sounds a bit thin.

Op Amps

Most boards, equalizers, and effects today use the operational amplifier. (Op amps come from their ability to perform the arithmetic operations of addition, subtraction and so on.) The industry is still trying to determine how to measure performance, and although TIM tests are here, the slew rate argument persists, faster is clearly better to a point. (My personal opinion is that 10 volts per microsecond is really nice.) But back to our ears, a Signetics 5533 or 5534 clearly sounds better than an old 741. Replacement can be tricky. In general a 4558 can be replaced with a 5533 and the result will be obvious. Replacing a single is more difficult. Compensation pins still aren't standardized, so you may have to change the circuit around. Careful use of the spec sheets and clear understanding of the op amp, however, can result in a much clearer signal. (You can also write to the manufacturer asking them how to make the change.) As of this writing I feel that the 5534 and 5533 by Signetics offer a better sound than the competition.

Power Supply Bypassing

As the speed of boards increases, it is critical that proper bypassing of the power supply at the op amp be provided. A 0.1 ceramic disc from both the positive and negative pin can often be added under the board. This will cut down on radio frequency problems and keep transients from wandering around. (Walter Jung has an excellent review of bypassing and other problems in chapter one of his "Audio IC Op-amp Applications", Sams #21558.)

Crosstalk

A related problem to speed, and bypassing is crosstalk from one channel to another. While an op amp's ability to exclude changes in power supply variations is good at low frequencies, at higher frequencies transients can get through to the audio path. A simple brute force test is to put a pulse through one channel and listen to another. A one shot square wave, a continuous high frequency square wave (five to ten thousand cycles) will often show up on an adjacent channel. While this can be poor board layout, stray capacitances, etc., often it can be traced to the common power supply lines. A 1 uf tantalum can help along with the 0.1 ceramic. Don't be afraid to pour it on. If the adjacent channel is down eighty dB or better, great, if not, look at the power supply lines and see if you can find the transients there and slow them up with good bypassing.

Output Capacitors

Op amps have made the designers life pretty easy. They are cheap and plentiful. Board design is getting better, but one area that is still weak is at the output. As op amps are good down to D.C. levels, there is often a little voltage at the output. While this can be trimmed out, often designers will use a capacitor to block the voltage from getting down the line. A quick check of the board will reveal what kind of capacitor is there. Ceramic discs look like little discs, generally brown or green and in general sound terrible. Electrolytics often are used because we can get a lot of capacitance into a very small container. If you take an ohm meter and read the "resistance" in both directions you can see that charging in one direction takes a different amount of time than the other. And electrolytics do exhibit a funny sound that is close to crossover distortion. One way around this is to put another capacitor of the same type and value in parallel but with the plus terminal of one with the minus terminal of the other.

Another solution is to add an op amp after the output capacitor and trim it up so that it feeds the outside world directly. This will give you a much better transient response, especially if there is a long cord from the output to the next piece of equipment down the line. (Once again see W. Jung's "Audio I.C. Apps".)

CLEANING UP THE SIGNAL PATH

CLEANING UP

Power Amplifiers

With TIM (transient intermodulation) tests we are beginning to find some correlation between the world of numbers and our ears. The transistor versus tube distortion mechanisms are being broken down, the specs reflecting that which our ears have told us all along. The exclusive consumer audio market is moving toward tubes again. Radio frequency feedback is a necessity, with some testing being done at gigahertz regions. Very high slew rate amplifiers have been introduced and, as we learn more, manufacturers will be forced to follow the transparent trail. Double zero I.M. seems to be important, .005, etc. TIM is still new, standards are still being proposed, but it is clear that the human ear is very sensitive to transient distortion. Sansui's B-1 and the British TVA tube amps have an astonishing clarity... and they're fast. Once again, listening can tell us more than specs.

The Loudspeaker

If there is a single source of coloration that dominates all others it is the loudspeaker. The cleanest front end, best power amps, and finest cords can end up as mush coming off the wall. Coherent waveforms are important. A single kick of a bass drum can excite many octaves of response. It is an impulse of sound containing lows and highs. And if it's going to sound coherent, all the leading waveform edges from the different speakers and drivers must arrive at our ears at the same time. Ed Long of Ed Long Associates in Oakland has clearly shown, both with his own speakers and the UREI 813, that Time-Aligned™ is important. The theory is simple. An impulse containing multiple harmonics can only be reproduced by a speaker system with all the drivers aligned so the waveform starts from all the drivers at the same time. Although a complete and thorough aligning requires a lot of equipment, simple alignment is not difficult. And it can be done with a simple pulse and alert listening. (A jingling set of keys in front of a good microphone also works, although it's a little harder to perceive.) The task is to move the treble driver, back and forward in relation to the woofer until the sharpest click is heard. (Pink noise, too, can be used—moving the treble driver will Doppler beat against the woofer and, as the critical point is reached, the Doppler becomes faster and occurs at higher frequencies until there is a clear null point.) The change is obvious, the sound really does get clearer. [Editor's note: Speaker placement, covered in the January, 1979 Mix, by Ed Long, is a must for understanding why poor placement is just like notch filtering.]

Final Notes

Sometimes things just change. Everything may appear to be the same as yesterday—all the settings identical and all the patches the same—and yet the sound is different. Move along through the chain, listen to each step, compare whenever possible the straight wire to the device, in and out, back and forth. And don't let a meter upstage your ear when it comes to decisions of fidelity.

Lane Poor built his first Heathkit at age twelve and became enamoured with quad after a demonstration at Julliard in 1955. More recently, Lane has been practicing electronics research with Alembic, Inc., Stars Guitars in San Francisco, and the Stanford Artificial Intelligence Lab as well as design consulting.

BACK ISSUES

• VOL. 2 #3

- Engineers' Forum
- Chris Stone
- Ambrosia
- Studio Building
- Audio/Video at IAM



• VOL. 3 #1

- Near Field Monitoring
- Studio Economics
- Van Morrison
- Aphex and EXR
- Jean Luc Ponty



• VOL. 2 #4

- TDS, PZM, TA and LEDE
- Signal Flow
- Digital Delay
- Future of Magnetic Tape



• VOL. 3 #2

- Audio for Television
- SMPTE Time Code
- Armin Steiner
- Ron Nevison

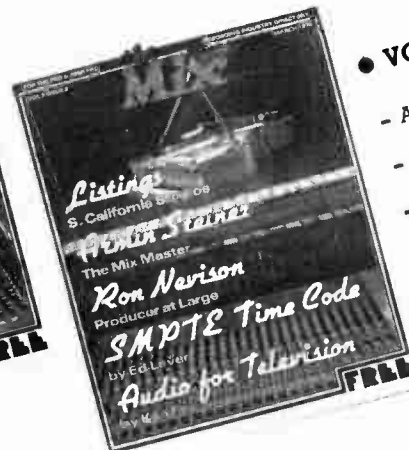

• VOL. 2 #5

- Dylan in the Studio
- Kent Duncan
- VCA's
- Book Reviews

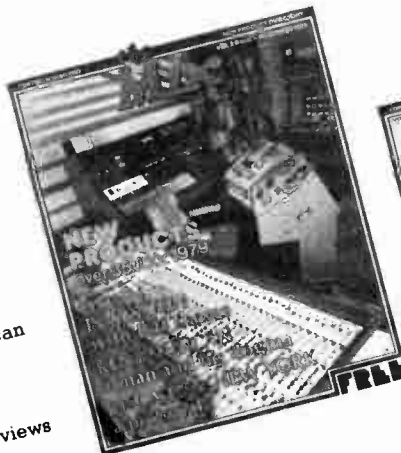

• VOL. 3 #3

- Architectural Acoustics
- Fiber Optics
- Drum Miking Part 1
- Doug Sax



Send \$2 per back issue to The Mix, P.O. Box 6395, Albany, California 94706

Check desired issues:

- Vol. 2 #3 Vol. 3 #1
- Vol. 2 #4 Vol. 3 #2
- Vol. 2 #5 Vol. 3 #3

Name _____

Address _____

City _____

State _____ Zip _____

N. California

Page	SANTA CRUZ	No. of tracks	Page	STOCKTON	No. of tracks
67	Fane Productions.....	16	52	Custom Recording/Studio C.....	8
56	Magic Sound.....	8			
	SANTA ROSA		44	TAHOE CITY	
54	Foxfur Studios and Services.....	8		Soundcapsule Studios.....	4
82	Punk Studio.....	24	60	VISALIA	
	SAUSALITO			Sierra Recording Studio.....	8
39	Command Productions.....	4		WALNUT CREEK	
82	The Record Plant.....	24	38	Bedroom Studios.....	4
64	White Rabbit.....	8	44	S.B. Productions.....	4
	SEBASTOPOL			WATSONVILLE	
51	Beggar's Banquet.....	8	62	Twilight Studio.....	8
	SUNNYVALE			WINTON	
74	Studios.....	16	56	Mix-Master Recording.....	8

Oregon

Page	EUGENE	No. of tracks	Page	PORTLAND	No. of tracks
82	Producers' Studio.....	24	52	Desitrek Recording & Sound.....	8
42	"Real to Reel Recording Studios".....	4	54	Grass Roots Sound Studio.....	8
86	Tri-Ad Recording Studio, Ltd.....	24	84	Recording Associates.....	24
	GREENLEAF		58	Recording Techniques.....	8
80	Rockin "A" Ranch Studio.....	8	72	Rex Recording Co.....	16
	LINCOLN CITY		62	Sound Smith Studios.....	8
40	Little Bird Productions.....	4	72	Spectrum Studios.....	16
			46	TALENT	
				Suncrest Sound Studios.....	4

Washington

Page	BELLEVUE	No. of tracks	Page	No. of tracks	
70	Pacific West Recorders.....	16	80	Kaye-Smith Studios.....	24
	BOTHELL		40	Lew's Recording Place.....	4
39	Crinkle Studio.....	4	82	Music Farm.....	24
74	Thunder Oak Audio.....	16	58	Puget Sound.....	8
	ENUMCLAW		72	Rolling "R" Mobile Recordings.....	16
74	Warthog Studios.....	16	84	Sea West Studios.....	24
	OLYMPIA		46	WNA Audio Video Inc.....	4
52	Capitol City Studios.....	8		SPOKANE	
	PORT ORCHARD		72	Sound Recording Co.....	16
54	Horizon Audio Recording Co.....	8		TACOMA	
	SEATTLE		66	All World Productions.....	16
50	AAA/Triangle Recording Studio.....	8	40	Hart Commercial Recording.....	4
38	Applewood Recording Studios.....	4		VANCOUVER	
50	Audio Recording Inc.....	8	52	Cozy Dog Recording Studio.....	8
39	The Dayspring Recording Studio.....	4	72	Ripcord Recording Studio.....	16
68	Holden, Hamilton and Roberts.....	16		WOODENVILLE	
			78	Bear Creek.....	24

All studio information listed has been supplied to the Mix by studios responding to questionnaires mailed in June, 1979. People, equipment and locations change, so please verify critical information with the studios directly. The Mix does not take responsibility for the accuracy of the information supplied to us by the studios.

Did we miss you?

Don't be left out.

Mix studio listings will be coming soon to major recording areas of the U.S.

To be sure your studio is included, get in touch.

Send to:
 Mix Publications,
 P.O. Box 6395,
 Albany, CA 94706

- 4 TRACK 16 TRACK
- 8 TRACK 24+ TRACK

Studio _____

Owner _____

Manager _____

Address _____

Phone _____

Comments or suggestions:

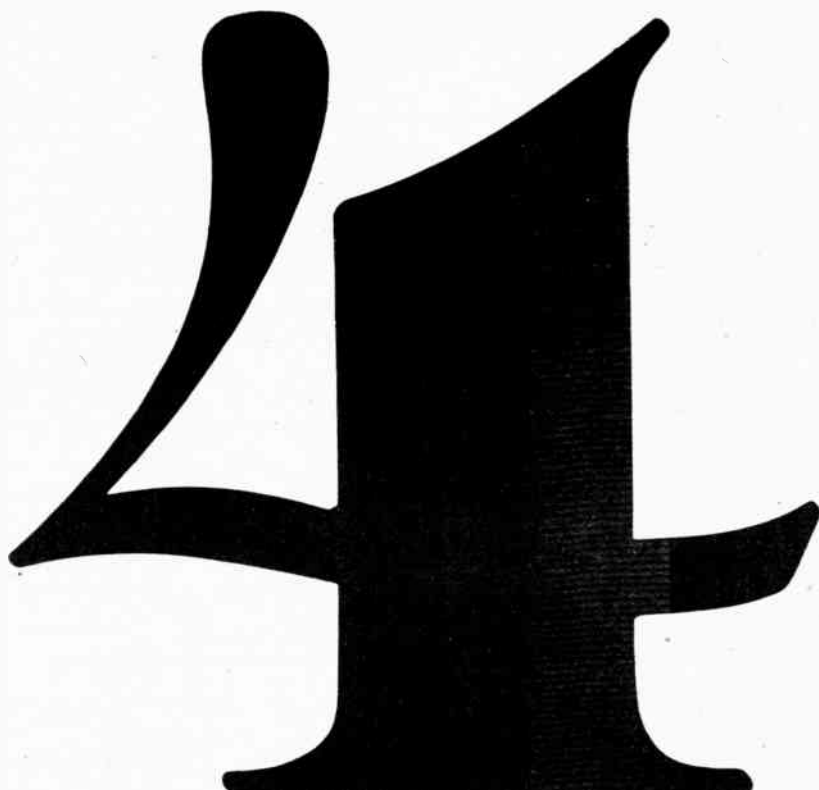

Direction: We offer work to beginning bands and musicians looking for help and direction. We are reasonably cheap.



BRAINSTORM PRODUCTIONS, Palo Alto, CA
Debbie Hopping

• BRAINSTORM PRODUCTIONS
Palo Alto, CA 94306
(415) 493-4026

Owner: Jack Levy.
Studio Manager: Doug Hopping.
Engineers: Doug Hopping.
Dimensions of Studios: 22' x 10'.
Dimensions of Control Rooms: 8' x 10'.
Tape Recorders: Dokorder 1140 4 track; TEAC 3300 2T 2 track; Sansui SC 3110 2 track; Technics 677 2 track; Sony TC 152 2 track; Sony TC 131 2 track; Pioneer CTF2121 2 track.
Mixing Consoles: Tascam 5A, 8 in x 4 out; Tapco 6200A, 6 in x 2 out; Numark DM1500W, 6 in x 2 out.
Monitor Amplifiers: Sansui AU717, Sansui AU317.
Monitor Speakers: JBL 100A, custom design.
Echo, Reverb, and Delay Systems: Orban/Parasound 111B reverb, Ibanez AD230, Clone Theory.
Other Outboard Equipment: UREI compressor/limiter; MXR 15-band EQ; Sansui TU717 tuner; dbx 155; Phase Linear 1000.
Microphones: Sennheiser 421's; Sony ECM33p's; AKG D1000E; Beyer M260; Shure SM-57's; Audio-Technica AT 812's.
Instruments Available: Upright piano, Wurliizer electric piano, Hohner Bass Ovation 6-string, Yamaha 6 & 12-string, Fender Stratocaster, Pig Nose, Leslie, Ampeg V2, Fender Princeton.
Extras: Warm relaxed atmosphere.
Rates: \$10/hr.
Direction: Brainstorm is moving into a larger building at the end of the year. Our direction is toward high quality recording at a price songwriters can afford. We are also set up for radio production projects.

• CHELSEA RECORDING, LTD.
REMOTE RECORD only
P.O. Box 497, Milpitas, CA 95035
(408) 262-7101

Owner: Morning Star Productions.
Studio Manager: The Grand Sorcerer.
Engineers: The Grand Sorcerer, K.C., Richard W. Brooke.
Dimensions of Studios: All recording done on location.
Tape Recorders: TEAC 3440 4 track; Dokorder 7140 2 track; Marantz CRS-4000 cassette; 3M 8075 8-track cartridge w/ Dolby.
Mixing Consoles: Tascam Model 5, 8 in x 4 out.
Monitor Amplifiers: Marantz.
Monitor Speakers: Infinity Columns, Pioneer TS-X9.
Echo, Reverb, and Delay Systems: Loft Series 440 delay line/flanger.
Other Outboard Equipment: dbx 155 noise reduction.
Microphones: AKG, Electro-Voice, Shure, Sescam direct box, DiMarzio acoustic guitar pickup.
Instruments Available: QSC recording amp, Korg electronic tuner, MXR flanger, MXR Phase Shifter, electronic bow, frequency analyzer.
Extras: We bring the studio to you in the comfort of your own home. Also: promotional services, tape copying service, lead sheet service.
Rates: \$15.00 for 1st hour; \$12.50 per hour for up to 10 hours; \$10.00 per hour for 10 hours or more booked in advance.
Direction: We can help you to get the most out of your sessions with us by offering our experience as: musicians, engineers, songwriters, and arrangers. By making musicians feel at ease when they first come to us to record, we generate a lot of repeat clientele. We are really into music and recording, and we will keep on expanding our studio all the way up to 24 tracks—and beyond! Hi mom!

• A & J's REELS ON WHEELS
REMOTE RECORDING
1549-B Marina Ct., San Mateo, CA 94403
(415) 341-3116

Owner/Studio Manager: Jesse Feliciano.
Engineers: Jesse Feliciano, Mike Fermer.
Dimensions of Studios: Sky's the limit.
Tape Recorders: TEAC A3340S 4 track; Sankyo STD 1750 2 track stereo cassette; E.R.C. 8 track stereo.
Mixing Consoles: Malatchi Electronic Systems "Performer", 12 in x 6 out.
Monitor Amplifiers: Kenwood KA 3500.
Monitor Speakers: Fisher and Infinity 1000's.
Echo, Reverb, and Delay Systems: Intersound R100 reverb.
Other Outboard Equipment: ADA flanger, Mutron III, Small Stone phase shifter, MXR distortion, Cry Baby wah-wah, dbx 155 noise reduction.
Microphones: AKG D1000E's, Shure SM-58's, SM-57's, Electro-Voice PL76.
Instruments Available: Les Paul Deluxe guitar, Fender Jazz Bass, Fender Super Reverb amp, Gallien-Kruger bass amp, and speaker cabinet.
Rates: Please call for rates (415) 341-3116. Block discounts available.
Direction: Our equipment consoles are completely portable and ready to turn your house, rehearsal space, or whatever, into a quality recording studio. That means you pick the best location and the best atmosphere to suit your band's needs.

• A V ASSOCIATES
725 Second St., San Francisco, CA 94107
(415) 957-1131

Owner: Al Vedro.
Engineers: Rick Berkvam.
Dimensions of Studios: Control room 13' x 13'; booth 9' x 13'.
Dimensions of Control Rooms: 15' x 22' screening room.
Tape Recorders: Ampex 354 2 track; Ampex 350 2 track; Ampex 350 1 track.
Mixing Consoles: Tascam Model 3, 8 in x 4 out.
Monitor Amplifiers: Altec 1568A.
Monitor Speakers: Auratone.
Outboard Equipment: Soundcraftsmen graphic equalizer, Kepex Model 500 Keyable Program Expander, dbx 160 compressor/limiter, pulsing units, Technics SL-20 turntable.
Microphones: Sennheiser MC421 and MB301.
Extras: AV production facilities, video camera and recorders, screening rooms, light tables.
Rates: \$40/hr for everything.
Direction: We are a custom audio/visual production studio specializing in sound tracks for sound/slide presentations, sound filmstrips, and radio commercials.

• ANZA STUDIOS
P.O. Box 64, Davis, CA 95616

• APPLEWOOD RECORDING STUDIOS
4542 49th S.W., Seattle, WA 98116
(206) 932-8348

Owner/Studio Manager: Harlan Michael.
Engineers: Harlan Michael, James Devine.
Dimensions of Studios: 17' x 24' main; (2) 7' x 8' isolation booths.
Dimensions of Control Rooms: 12' x 18'.
Tape Recorders: Scully 280-4 4 track; Scully 280-2 2 track.
Mixing Consoles: Custom built, 8 in x 4 out; multi-band graphic, all channels.
Monitor Amplifiers: McIntosh 240 main speakers.
Monitor Speakers: Altec 604E with Mastering Lab crossovers.
Echo, Reverb, and Delay Systems: Delta Lab DL-1 digital; EMT stereo plate.
Other Outboard Equipment: (2) UREI 1176LN limiters, flanger, high/lo pass filters.
Microphones: Neumann U-87; Electro-Voice RE-15, RE-55; Shure SM-57.
Instruments Available: Ludwig drums, Baldwin piano.
Extras: Relaxed environment tailored to creativity.
Rates: \$30/hr.
Direction: Various albums, 45's, radio & TV commercials, songwriter, and artist demo tapes.

• BEDROOM STUDIOS
2055 Olympic Blvd., Walnut Creek, CA 94596
(415) 932-8328

Owner: Thomas Evoniuk.
Studio Manager: Thomas Evon.
Engineers: Thomas Evon and Kent Peters.
Dimensions of Studios: 10' x 12'.
Dimensions of Control Rooms: 10' x 12'.
Tape Recorders: TEAC 2340 SX 4 track; Sankyo cassette.
Mixing Consoles: TEAC Model 2A, 6 in x 4 out.
Monitor Amplifiers: Allied, Sankyo headphone.
Echo, Reverb, and Delay Systems: Fender Reverb.
Microphones: Shure SM-57's, SM-58's.
Instruments Available: Traynor amp for acoustic pickups.
Rates: \$8/hr; plus cost of tape.
Direction: Have worked recording acoustic people for 5 years.

• BLUE NOTE STUDIO / BLUE DOG STUDIO
Mt. View, CA 94040
(415) 964-5689

Owner: Snuffy Smith & Brady Austin.
Engineers: Geoff Giese, Brady Austin.
Dimensions of Studios: Large bedroom.
Tape Recorders: TEAC A-3340-S 4 track; TEAC 4300 2 track; Marantz 5120 stereo cassette deck, Dolby System.
Mixing Consoles: Sony MX-16, 8-channel, 8 in x 4 out.
Monitor Speakers: Kenwood.
Microphones: Cardioids condensers EC-3S; Super Scope; Maestro DM 100s; AKG 200 ohms; Shure Professionals.
Extras: Amps, electric piano, guitars, harmonicas, musicians, percussions and access to other studios, Pioneer, Monarch, Ashidavox headsets.
Rates: Call for information.

• CHINA BLUE STUDIOS

also REMOTE RECORDING
860 2nd St., San Francisco, CA 94107
(Corner of 2nd and Berry)
(415) 777-9568/956-3442

Owner: William "Doc" Palumbo, Michael J. Kriche.

Studio Manager: "Doc" Palumbo.

Engineers: Michael Kriche — Chief Engineer, Robin Minnerly — 2nd Engineer.

Dimensions of Studios: Studio A: 16' x 20'; Studio B: 12' x 18'; Studio C: 20' x 32'.

Dimensions of Control Rooms: 8' x 10'.

Tape Recorders: TEAC A-3340S 4 track; TEAC 3300's 2 track; Revox A-77 high speed w/sync 2 track; Akai GX-570 vari-speed cassette 2 track; Akai GX-760D 2 track cassette; plus others available.

Mixing Consoles: Tascam Model 3, 8 in x 4 out; TEAC Model 2A w/meter bridge, 6 in x 4 out; Yamaha EM-200, 8 in x 2 out; Sony MX-8 submixer, and others.

Monitor Amplifiers: Phase Linear 400's, Soundcraftsmen MA 5002, Sony 3200F, Harman Kardon 12, Lexon AP-1, Dynaco stereo 120, 70's, and others.

Monitor Speakers: Yamaha NS-690, Braun 2000, Klipsch Heresays, Sonosphere SP-1, EPI 100's, 60's and others.

Echo, Reverb, and Delay Systems: Sansui AX-7 reverb, tape echo loops, etc.

Other Outboard Equipment: Countryman direct boxes, Sansui 4-channel direct boxes, dbx compressor/limiters, Burwen noise reduction units, Dolby noise reduction, ADC 12-band graphic EQ's, Acoustic bass amp w/EQ, and others.

Microphones: MB 301 studio ribbons, MB 541 studio condensers, Sony 64P studio condenser, MB dynamic, Shure SM-58's, TEAC M-80 condenser, RCA dynamic, Sennheiser dynamics, Teledyne condensers, and others.

Extras: Rehearsal space, loading dock, plenty of parking (even though we're located in downtown S.F.), lounge, refrigerator, 24-hour donut/coffee shop one block away, helicopter to airport across the street, access to studio musicians, video specialists, production work and showcasing.

Rates: Rehearsal \$4.50-\$7.00/hr. Please call for recording. Special demo and mastering for record pressing always available.

Direction: Our basic direction is to furnish artists with an extremely relaxed and comfortable environment in which to work and create their craft. Artists can rehearse and record in similar atmospheres that we create to help ease their studio blues. No other studio we know of works in this unique way and still we work at affordable rates. We have very unusual assortment of high quality equipment not normally found in 4 track studios, and 11 years experience in all phases of the industry.

• CHONK MOONHUNTER

ASIAN AMERICAN MEDIA CENTER, INC.
All hours by appointment
(415) 221-9488

Owner: Curtis Choy.

Engineers: C. Choy, C. Chow, M. Chan, E. Omori, T. Sasaki.

Dimensions of Studios: 12' x 14'.

Dimensions of Control Rooms: 9' x 12'.

Tape Recorders: Sony 854 4 track; Sony 770 2 track; Nagra 4.2L mono; Magnasync 602 mono and 16mm; various cassettes.

Mixing Consoles: TEAC Model 2, 6 in x 4 out; Ampex AM-10.

Monitor Amplifiers: Dynaco 120.

Monitor Speakers: JBL-100, Altec A-7, Auratone 5C, B&H 179.

Echo, Reverb, and Delay Systems: Fisher reverb, VSC pitch control.

Other Outboard Equipment: 35mm slide, 16mm film projection, cine-slate interlock, dbx noise reduction, Phase Linear auto-correlator, Soundcraftsmen and Delta Graph EQ.

Microphones: Electro-Voice 635A, 666, RE-15, RE-20, RE-55; Neumann U-87; Schoeps CMT 441; Shure SM-53; Sony ECM-50, ECM-54P, C-22, C-37, C-77.

Extras: 16mm cutting facilities.

Rates: \$20/hr, variable, all hours by appointment.

Direction: Completion of Manongs/International Hotel Documentary film, opening our Yellow Image Archive (a picture and sound bank). Our previous work includes remote music recording, filmstrips, slide-sync, narration, theatrical special effects, production for radio broadcast, small-format video. In film — location audio, transfer, syncing, editing, sound cutting, interlock, mixing.

• COMMAND PRODUCTIONS

Industrial Center Building, Suite 107, Harbor Dr.,
Sausalito, CA 94965
(415) 332-3161

Owner: Warren Weagant.

Studio Manager: Michael Baird.

Engineers: Michael Baird.

Dimensions of Studios: 6' x 9'.

Dimensions of Control Rooms: 9' x 16'.

Tape Recorders: Ampex 440 4 track; Ampex 440 2 track; Ampex 500 2 track; Ampex PR-10 2 track; TEAC 3340S 4 track.

Mixing Consoles: Allen & Heath, customized by Taber, 16 in x 4 out; TEAC Model 2 8 in x 4 out.

four track

Monitor Amplifiers: McIntosh MC-30, Dynaco 120.

Monitor Speakers: JBL-L100's.

Echo, Reverb, and Delay Systems: Orban/Parasound reverb.

Outboard Equipment: (2) Universal Audio limiters, UREI S727A graphic equalizer, Altec Model 9073A equalizer.

Microphones: Neumann U-47, Electro-Voice 668.

Extras: Coffee, beer, and coke.

Rates: \$25.00/hr.

Direction: Command Productions has been producing radio commercials, complicated mixes for TV and A/V sound tracks, commercial films, syndicated radio shows and speciality albums for nine years in the Bay Area. For musicians promoting their own music, we can arrange for small quantity record pressings and supply mailing labels for every radio station music director in the USA (over 8,000 radio stations). We can provide high speed cassette and reel copies while-you-wait in small quantities - larger quantities overnight.

• CRINKLE STUDIO

15700 Bothell Way S.E. #12, Bothell, WA 98011
(206) 743-2391, 622-2960 (days).

Owner: Fred C. Taylor.

Tape Recorders: TEAC 3340S 4 track; Tandberg TD 20A 2 track; Tandberg TCD 320 cassette.

Mixing Consoles: Tascam Model 3.

Microphones: Shure.

Instruments Available: Fender Rhodes piano, Rogers drums.

Direction: Expected expansion to 8-track in 1981. Possible production of jazz/creative groups and Christian music. Crinkle Music started out as a production company for my own jazz groups, but I have decided to open the studio to a limited group of special musicians (and simple free-lancing, such as tape copying, etc.) We will soon be releasing a number of recordings made here. Excellent quality at unbeatable rates. Unlimited access to Seattle's best musicians, singers, and arrangers. Give us a call, y'all.

• CUSTOM RECORDING

also REMOTE RECORDING
305 Melville, Palo Alto, CA 94301
(415) 321-5776

Owner: John DiLoreto.

Dimensions of Studios: 18' x 12' x 10'.

Tape Recorders: Otari MX5050 4 track.

Mixing Consoles: Tascam console, 8 in x 4 out.

Monitor Amplifiers: Yamaha.

Monitor Speakers: Bose, Yamaha, Auratone.

Echo, Reverb, and Delay Systems: Roland Echo.

Other Outboard Equipment: UREI comp/limiters, MXR graphic EQ, dbx.

Microphones: Sennheiser, Shure, AKG.

Instruments Available: Steinway, Fender Rhodes, Wasp synthesizer.

Extras: Clean and comfortable location for mastering, mixdown, cassette duplication, live remote recording.

Rates: Call for rates.

• THE DAYSPRING RECORDING STUDIO

P.O. Box 30012, 1222 North 49th, Seattle, WA 98103
(206) 634-2580

Owner: Jan Lind.

Studio Manager: Jan Lind.

Engineers: Jan Lind, Wayne Dyrness.

Dimensions of Studios: Main studio: 23' x 11' with alcove 8' x 11'; vocal and drum isolation booth (doubles as duplication room): 10' x 10'.

Dimensions of Control Rooms: 9' x 11'.

Tape Recorders: TEAC 3340S 4 track; Dokorder 1120 stereo and 2 track; Kenwood cassette deck KX1030; Sony, Hitachi, Superscope.

Mixing Consoles: TEAC Model 2, 6 in x 4 out; Tapco 6201, 6 in x 2 out (main), 1 out (monitor).

Monitor Amplifiers: Pioneer 4 channel, Phase Linear 400.

Monitor Speakers: Main: SonRise Trinity; small: Auratone.

Echo, Reverb, and Delay Systems: (2) Tapco 4400 reverbs.

Other Outboard Equipment: SAE 1/2-octave EQ, dbx 155.

Microphones: Electro-Voice RE-16, Sennheiser, TEAC, Shure, Sony.

Instruments Available: Upright acoustic piano, guitars.

Extras: Full cassette duplication facilities; franchised Pentagon dealer, use Pentagon high speed copiers; 8-track duplication; convention and seminar recording; distributor for Nortronic tape care products; Agfa tape; Irish tape; equipment sales — stereo and sound reinforcement; Record-a-Call; conduct recording classes.

Rates: Recording studio \$15/hr; duplication rates and convention recording vary, call for more information.

Direction: Goal is to build up a highly competitive duplication facility, increase tape sales and eventually expand to an eight track format. Studio philosophy has always been to give the customer the best job and service we can at the best price.

• EXTRANEOUS STATIC REFINEMENT SYSTEMS Oakland, CA

Note — Please phone for appointment.

(415) 655-1283

Owner: Paul Kalbach.

Engineers: Paul Kalbach.

Dimensions of Studios: 10' x 30', 20' x 20'.

Dimensions of Control Rooms: 10' x 10'.

Tape Recorders: TEAC 3340S 4 track; Sony RC-277-4 4 track; TEAC A-7030 2 track; Concertone 505 2 track; Uher 4000-L mono; Pioneer H-R99 8 track cart.

Mixing Consoles: TEAC 2/MB-20, 6 in x 4 out, stacked into the TEAC is a custom Buchla (keyboard voltage controlled) mixer, 10 in x 3 out; Sony MX-6, 6 in x 2 out; assorted mixers in the synthesizer system.

Monitor Amplifiers: Dyna 120.

Monitor Speakers: Bose.

Outboard Equipment: Large custom modified Buchla studio synthesizer; 4 channels of reverb (Buchla-Accutronics); Quad panning system (voltage controlled); 100-band octave graphic EQ by Advent; 9-band octave graphic EQ by Southwest Tech; Dolby B9 Concord DBA-10; 4-channel TEAC AN-50-4; 12-channel Dukane tape system for mixing, loops, and multiple time delay.

Microphones: AKG D200E; Superscope EC-35; FRAP studio pickup (high and low outputs).

Instruments Available: Buchla synthesizer, Fisher upright piano, Hohner electric piano, parlor pump organ, Magnus organ, accordian, Gretsch drums, acoustic 6 and 12 string and electric guitars, violin, trombone, bugle, sitar, ukelin, assorted percussion and unusual instruments.

Extras: Electronic music instruction, photo and graphic services (album covers, etc.), kitchen, fireplace, tub, garden, room to move, funky relaxed environment.

Rates: \$10/hr and up, or negotiable.

Direction: I'm a synthesizer specialist. I've put this studio together primarily for my own purposes as a composer and visual artist. (I was featured on KRE's "Sounds By The Bay" in Jan. 78, have received much exposure on KPFA since 1973, and have exhibited widely in Bay Area museums) and am now offering my services on a limited basis. I'm presently building a 16mm optical printer and film editing facility, giant horizontal animation carriage, and expanding and improving sound facilities.

• FILM GENESIS

MOTION PICTURE SOUND STUDIO
445 Bryant St., San Francisco, CA 94107
(415) 957-9333

Owner: Bruce G. Hatch.

Engineers: Andy Wiskes, Morgan, Bruce Hatch.

Dimensions of Studios: Studio/Mix/Screening Room: 16' x 20'.

Dimensions of Control Rooms: 9' x 12'.

Tape Recorders: Nagra 1 and 2 track; Otari's 2 and 4 track; Magnasync 3000 16mm recorder, 6 tracks of Magnasync playback and dubbers; Ampex.

Mixing Consoles: Tascam.

Monitor Amplifiers: McIntosh Model 2505.

Monitor Speakers: JBL 4311.

Outboard Equipment: Little Dipper notch filter; UREI graphic equalizers, Phase Linear auto-correlator (to remove hiss), Kepex and Gain Brain.

Microphones: Neumann and Sennheiser.

Extras: 16mm editing rooms for rent, fully equipped. Rates: 1/4" work: \$35/hr mono, \$40/hr stereo; 16 mm mixes \$80/hr (3 channel or less) and \$10.00 each additional channel; 16mm editing rooms for rent at \$600 and \$700 per month, \$175 and \$200 per week, \$35 and \$50 per day, \$15/hr; 1/4" editing at \$35/hr.

Direction: We are a 16mm post production sound studio. We edit, transfer, and mix 16mm sound for television spots and shows, documentary and independent films, 16mm theatrical and industrial use. We mixed 'American Shoeshine', an Academy Award nominee, and numerous Liberty House and Zenith radio TV spots.

• GOLD RUSH RECORDING STUDIO
P.O. Box 541, Camino, CA 95709. Studio located on Alder Drive, Camino, CA. (916) 644-3767

Owner/Studio Manager: Lee Ingram.
Engineers: Steve Bishop, Lee Ingram, and other nice people.
Dimensions of Studios: 780 sq. ft.
Dimensions of Control Rooms: 200 sq. ft.
Tape Recorders: TEAC 3440 4 track; TEAC MK 6100 2 track; DK 4180 4 track; plus 8-track and cassette.
Mixing Consoles: TEAC/Tascam 2A, 6 in x 4 out; Custom made, 8 in x 4 out.
Monitor Amplifiers: Pioneer, Peavey, Fisher.
Monitor Speakers: Custom made with ESS components.
Echo, Reverb, and Delay Systems: Echo and reverb available.
Other Outboard Equipment: dbx 155 tape noise reduction system.
Microphones: Shure, E-V, and AKG.
Instruments Available: Gibson TD 335, banjo (5-string), hand made Rich Herring-Bone rosewood guitar, Music Man 130, Mitchell box with K-120 JBL's, Roth fiddle, and a Fender-Pro amp.
Extras: Musicians upon request. Clean air and tall pines.
Rates: \$20/hr, musicians extra, block rates available, call for more info.
Direction: Our goal, here at Gold Rush, is to give the serious musician a chance to record in a professional atmosphere without having to mortgage your house to do so.

• HARBOR CENTER GUITARS
555 Francisco Blvd., San Rafael, CA 94901
(415) 459-0280

Owner: Bo Bryant.
Engineers: Bo Bryant.
Dimensions of Studios: 10' x 14'.
Dimensions of Control Rooms: Control from store area.
Tape Recorders: TEAC 2340 4 track, JVC 1636 2 track.
Mixing Consoles: TEAC Model 2.
Monitor Amplifiers: Onkyo power amp.
Monitor Speakers: DWD Sound System.
Microphones: Shure, Sony, Electro-Voice, Sennheiser.
Instruments Available: Guitars, string bass, piano, banjos.
Extras: A very comfortable, no pressure store, to get some of your stuff down on tape.
Rates: Approx. \$20.00 per session. Please call or come in to schedule time.
Direction: We are a perfect place for one, two, three or four acoustic musicians to see how they are doing. Vocals and small vocal group welcome. Electric guitar and bass low volume only. We will send you out with a reel or cassette of exactly what you sound like. Nothing fancy...just good!

• HART COMMERCIAL RECORDING
5722 Swan Creek Dr. E., Tacoma, WA 98404
(206) 472-2740

Owner: Dean K. Hart.
Studio Manager: Dean K. Hart.
Engineers: Dean K. Hart.

• HAYMARKET PRODUCTIONS—RAVE
(Reliable Audio Video Enterprises)
90 Glenn Way #4, Belmont, CA (415) 595-3750
Business office only: (415) 981-4396

Owners and Engineers: Phyllis Axt, Bill Blaha, Tim Houlihan, George Hubbard, Craig Richins, Rhode Roberts, Ron Schaeffer, Gay Richie Yoeman.
Dimensions of Studios: Audio 21' x 21'; Video: 21' x 18'.
Dimensions of Control Rooms: 11' x 14'.
Tape Recorders: Scully AG-300 4 track; Scully 280 electric 4 track; Ampex AX-300 2 track.
Mixing Consoles: Tascam Model 10, 12 in x 4 out.
Monitor Amplifiers: Crown D-150A, McIntosh 2505.
Monitor Speakers: JBL 4311, Altec 602-C.
Outboard Equipment: dbx 160 (2); Urban/Parasound 111B reverb (2); Ampex MX-10; super high band 1 in video, standard 3/4" video and editors.
Microphones: Sennheiser MD-412-U; Electro-Voice RE-15, 635A, 676; Shure SM-58.
Extras: Lots of coffee.
Rates: Audio: \$15/hr 4 track; \$10/hr 2 track. Video: \$20/hr. Engineer/producer daily rates available.
Direction: H.P. is part of RAVE, an Audio/video production and engineering collective. The RAVE group offers quality audio/video for broadcast and/or industrial applications. We also specialize in live remote recordings, audio and/or video for musical events; and, provide complete 1" or 3/4" U-type post production facilities.

• NEIL JANKLOW STUDIO PRODUCTIONS
Palo Alto, CA 94303
(415) 858-0132

Owner: Neil Janklow.
Engineers: Neil Janklow.
Dimensions of Studios: 14' x 17'.
Dimensions of Control Rooms: 10' x 12'.

four track

Tape Recorders: TEAC A3340-S 4 track; TEAC 3300-2T 2 track; Sankyo RD-4250 cassette.
Mixing Consoles: Tascam Model 3, 8 in x 4 out; Tapco 6201, 6 in x 2 out; Shure, 6 in x 2 out.
Monitor Amplifiers: Dynaco 400, Kenwood KA6000.
Monitor Speakers: Custom JBL/E-V 3 ways, KLH 38's, E-V FM-12's.
Outboard Equipment: dbx 154, Tapco 4400 reverb, Tapco 2200 EQ, various signal processors - Autopan, for example; MXR Phase Shifter, envelope follower, tape loop.
Microphones: Shure SM58's; E-V condenser.
Instruments Available: (New) Baldwin 5'8" studio upright, stereo custom Rhodes, Oberheim two voice with sequencer, Yamaha organ YC45-D, Ampeg V-4.
Extras: Private instruction concentrating on creative and technical skills involved in multitrack studio production. (See direction).
Rates: Radio production, commercials and jingles negotiable, private instruction \$50 monthly and tape.
Direction: Neil Janklow Studio Productions offers high quality, fully produced radio productions and commercials at very low cost. Demo presentation is available on call. Also offered: A unique opportunity for the aspiring songwriter/producer to get "inside production experience" from individualized weekly instruction.

• JESUS NAME RADIO MINISTRY
2nd & "R" St., Merced, CA 95340

Owner: Rob Hudgins — First Apostolic Church.
Studio Manager: Rob Hudgins.
Engineers: Gary Spears, Ron Love, Bert Espanzoa.
Dimensions of Studios: 30' x 60'.
Dimensions of Control Rooms: 12' x 12'.
Tape Recorders: TEAC A3340 4 track; TEAC 3300 2 track (half-track); TEAC A400 2 track.
Mixing Consoles: TEAC/Tascam Model 3, 8 in x 4 out.
Monitor Amplifiers: BGW 250, 3 Pioneer amps for PA.
Monitor Speakers: JBL 4311 for control room, Alamo for auditorium.
Echo, Reverb, and Delay Systems: Tapco 4400 reverb.
Other Outboard Equipment: Bi-Amp graphic EQ, TEAC 64 patch bay, Telex, Mark IV, cassette duplicator, Sescam direct boxes, Dwarf Amp, Sennheiser headphones.
Microphones: Sennheiser 441, Shure SM-58's, Sennheiser 402's, Shure lavalier.
Instruments Available: 73 key Rhodes, baby grand, Wurlitzer organ, Gibson ES 175 guitar, Kramer bass, Ibanez mandolin, violin, trumpets, trombone, xylophone.
Rates: \$25/hr.
Direction: Affiliated with the Baptism in Jesus Name & The Revelation that Jesus is the Name of the Father, Son & Holy Ghost.

• LEW'S RECORDING PLACE
1219 Westlake Ave. N., Seattle, WA 98109
(206) 285-7550

Owner/Studio Manager: Lew J. Lathrop
Engineers: Lew J. Lathrop, Cary Wakeley.
Dimensions of Studios: 18' x 24'.
Dimensions of Control Rooms: 18' x 15'.
Tape Recorders: Ampex 440's — 4 track, 2 track, and mono; Ampex 3200 hi-speed dup. 5 slaves.
Mixing Consoles: Speck Electronics SP 800 C, 16 in x 16 out.
Monitor Amplifiers: Crown D150 A, BGW 100.
Monitor Speakers: Advent.
Echo, Reverb, and Delay Systems: MICMIX.
Other Outboard Equipment: Universal Audio Dual 350 graphic EQ; (2) Ashly limiter/compressor; Symetrix HA-10 headphone amp.
Microphones: AKG C414EB's; Telefunken U-47's.
Direction: This is a voice-over studio only.

• LITTLE BIRD PRODUCTIONS
also REMOTE RECORDING
4416 S.E. Hwy 101, Lincoln City, OR
(503) 996-2575

Owner: Beryl Duenweg, Forrest Caulkins, Paul Carlsen.
Studio Manager: Paul Carlsen.
Engineers: Paul Carlsen, Forrest Caulkins, Gary Hayes.

Dimensions of Studios: 15' x 10', drum booth: 13' x 7' x 7'.
Dimensions of Control Rooms: 13' x 7' x 7', LEDE Design.
Tape Recorders: TEAC 3340 4 track; TEAC 3440 4 track; Akai GXC 310 2 track cassette; Technics RS686DS 2 track; Sony TC126 2 track.
Mixing Consoles: Bi-Amp 1282, 12 in x 2 out; Bi-Amp 882, 8 in x 2 out; cascaded 20 in x 4 out.
Monitor Amplifiers: Bi-Amp TC 225 (studio); Bi-Amp TC 120 (control room); Dynaco 120 'phones.
Monitor Speakers: Community Light & Sound PBL's. Ed Long MDM-4 Near Field Monitors.
Echo, Reverb, and Delay Systems: Electro-Harmonix echo, flanger, chorus doubling, phase and reverb; Bi-Amp/Hammond reverb (4 channels).
Other Outboard Equipment: 8 channels dbx 155.
Microphones: Sony ECM 21 condensers; ECM-22 condensers; AKG D1000; Shure SM-53's, SM-57's, SM-56's.
Instruments Available: Rhodes 88, Rhodes Suitcase 73, ARP Odyssey, Moonstone Custom studio guitar, Slingerland drums.
Extras: A beautiful Oregon coastal bay view, sundeck, 4-min walk to beach; an in-house studio band, on location recording, synthesizer programming, arranging, and career guidance.
Rates: \$15/hr, \$10 block rate.
Direction: Eclipse Productions is a complete audio production facility. Our production staff has a combined experience totalling over 30 years at writing, performing, arranging, promoting, and producing music professionally. We do albums, demos, singles, jingles and career consultation. We also have an in-house ad-agency, Little Bird Advertising. We love our work, let us work with you.

• McCUNE STUDIOS
951 Howard St., San Francisco, CA 94103
(415) 777-2700

Owner: Harry McCune.
Studio Manager: Mort Feld.
Engineers: Don Geis, Dennis Minnick, Judy Belter, Ken Jacobs, Mike Brady.
Dimensions of Studios: 16' x 17' x 25'.
Dimensions of Control Rooms: 16' x 15'.
Tape Recorders: Scully 280 4 track; Ampex 440 2 track; Ampex/Inovonics 351 2 track; (2) Ampex 351 2 track; Ampex AG350 mono; Ampex 351 mono; Crown 4 x 1/4 track.
Mixing Consoles: Altec 250, 8 in x 3 out.
Monitor Amplifiers: Bi-Amp Labs 150 watt.
Monitor Speakers: Altec 604 8G.
Echo, Reverb, and Delay Systems: AKG's.
Other Outboard Equipment: UREI 1176, LA3A, LA4A, 537's, 560's, Urban parametrics, cart machines.
Microphones: Neumann U-87, AKG 451, RCA 77DX, Shure SM-53, E-V 618.
Extras: Free coffee.
Rates: \$38/hr days; \$48/hr nites & weekends.

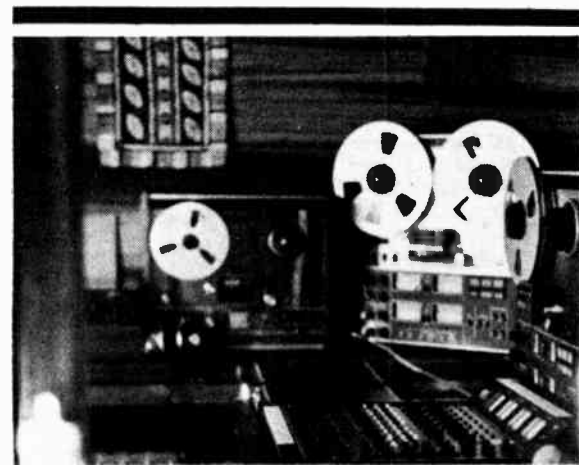

MELON STUDIO
San Francisco, CA

• MELON STUDIO
P.O. Box 2168, San Francisco, CA 94126
(415) 584-7397

Owner/Studio Manager: Robin Woodland.
Engineers: Robin Woodland, Tim Ruedell, Teresa Sharp. Equipment maintenance and deluxe tweaking by Harry Sitam - Artist's Engineering.
Dimensions of Studios: 20' x 20' x 8'.
Dimensions of Control Rooms: 8' x 16'.
Tape Recorders: TEAC Model A-3340S 4 track; TEAC Model 1230 1/4 track stereo; Pioneer CT-F500 stereo cassette deck; Revox A-77 (w/custom 15ips speed) 2 track.
Mixing Consoles: TEAC/Tascam Model 3 8 in x 4 out.
Monitor Amplifiers: Dynaco Stereo 400; Dynaco SCA-80Q integrated amp; Fisher X-101-B integrated amp (headphones).
Monitor Speakers: Dynaco A-25 XL's.
Echo, Reverb, and Delay Systems: Smith/Hammond custom stereo reverb; tape delay.

Ready to record?

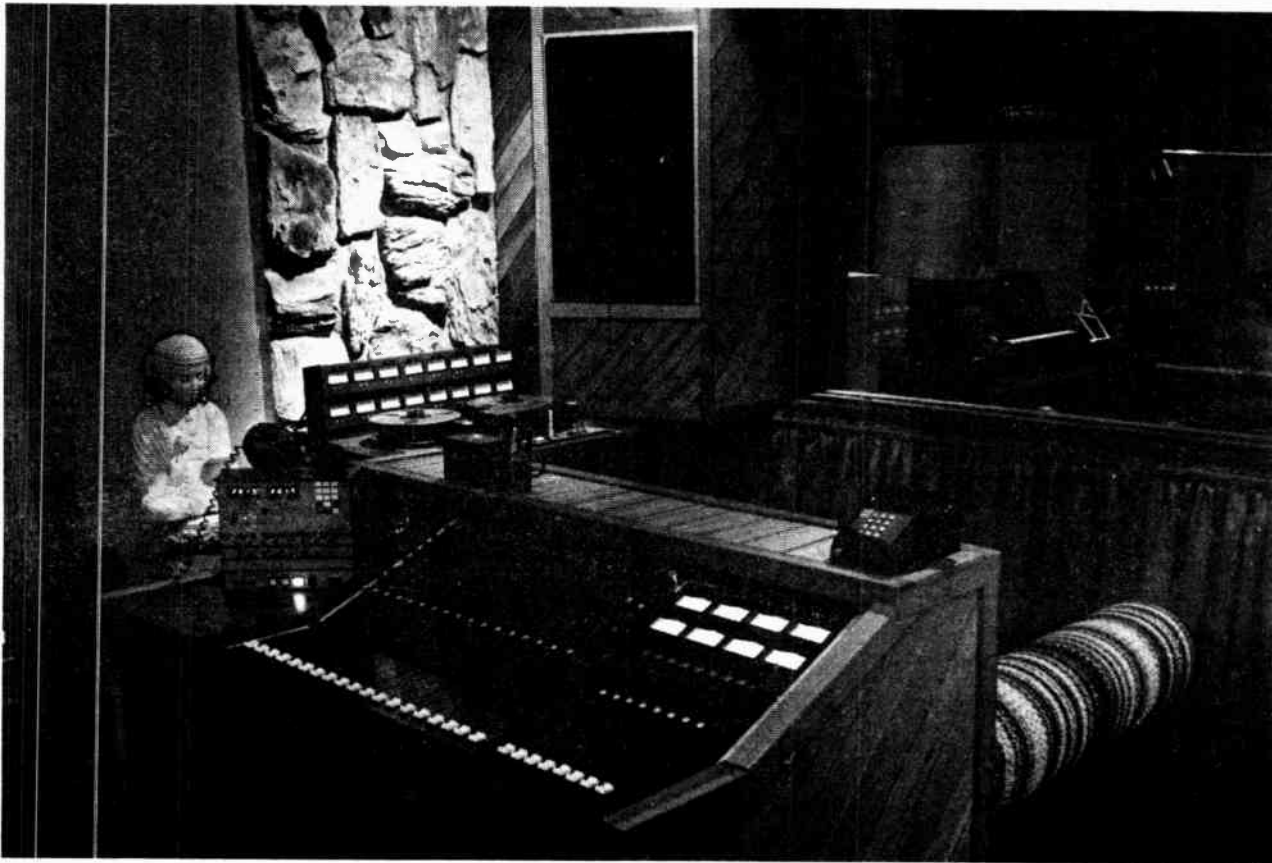

When Larry Shamus of Dusk Recording Studios, in Santa Clara was ready, he came to Alco Pro-Sound.

We helped him put together a half-inch eight track studio, selecting components from the many lines of pro-audio gear available at Alco.

As Dusk expanded, we continued to assist in the constant upgrading of their equipment.

Last month, with the addition of a new MCI 2-inch machine (with the Auto Locator III), Dusk went 16 track.

DUSK RECORDING STUDIOS, 2217-A The Alameda, Santa Clara 95050/Telephone (408) 248-3875

Dusk Recording Studios is just one of the success stories we helped write. We'd like to help you write yours.

Call Ron Timmons at 297-7111, ext. 271. He can arrange financing and leasing.

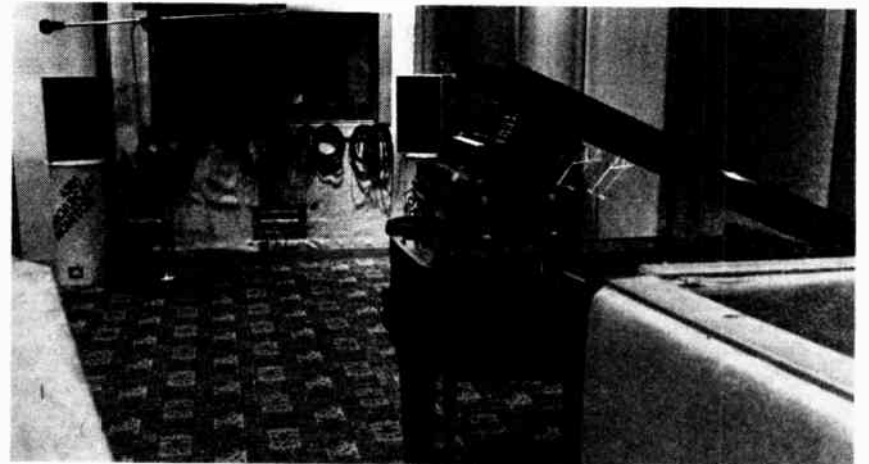

ALCO
PRO-SOUND

When you talk, we listen.

79 South 3rd Street, Downtown San Jose • Hours: Monday-Saturday 9:30-5:30

Outboard Equipment: dbx 124 and 122 noise reduction; 6 channels of synergistic sound systems 12-band graphic EQ; 2 channels of dbx 163 compressor/limiters; Pioneer PL-12D-II turntable; Pioneer SE-405 headphones.

Microphones: Sennheiser 421's; Shure SM58's, SM57's; AKG SE5E's; Active direct box.

Instruments Available: Traynor "Twin" amp; Rhythm Ace rhythm machine; Korg tuner; Small Stone phase shifter.

Extras: Free production consultation, including: session planning and budgeting; arranging; record manufacturing and distribution info.

Rates: Recording, editing, mixdown, and copying: \$10/hr. Extra fee for Revox 2 track mastering deck.

Direction: We're recording albums and singles in a \$10 per hour studio, but you won't believe it until you come see and hear for yourself! Melon Studio, founded in 1971 and one of the first "cheapie" studios in San Francisco, is designed to provide musicians and theater people with access to quality tape production at the lowest possible cost.

• **MOMS (MY OWN MUSIC STUDIO)**
1622 Yosemite Ave., San Francisco, CA 94124
(415) 822-2809
Owner: Jerry Southern

• **MYSTIC ISLE RECORDING STUDIO**
5621 Dewey Blvd., Sacramento, CA 95824
Mail address: P.O. Box 160281, Sacramento, CA 95816
(916) 393-2488

Owner: Mystic Isle, Ltd., a California Corp.
Studio Manager: Bob Williams and John Doyle.
Engineers: Bob Williams, Denny Sacco, Kerry Shearer.
Dimensions of Studios: 16' x 12' main studio, 8' x 12' sound booth.

Dimensions of Control Rooms: 8' x 12'.
Tape Recorders: Accurate Sound: MCI electronics 1200 4 track; Accurate Sound: MCI electronics 1200 2 track; Accurate Sound: MCI electronics 1200 1 track.

Mixing Consoles: Tascam Model 5 8 in x 4 out.
Monitor Amplifiers: Crown D60's.
Monitor Speakers: Marantz HD 550.

Echo, Reverb, and Delay Systems: Tapco 4400 reverb.
Outboard Equipment: Audio Design Recording "Vocal Stresser" F769X-R, UREI LA-4 compressor, UREI 530 graphic EQ, dbx 157 all channels, Audio-Design Recording F760X Compressor, voice gate, and expander, Audio Design E900 parametric equalizer.

Microphones: (4) Sennheiser 421's, (8) Shure SM-58's.
Extras: Coffee room, conference room, complete graphic services, as well as audio/visual services at the same location.
Rates: Special package for demo work available for \$150. Hourly rate \$35/hr.

Direction: Mystic Isle is a high quality working production studio. Most of work done in the past has been filmstrip sound track production. However, a number of musicians have started to use the studio because they seem to like the down-to-earth approach. Most of the music recorded has been C&W and we intend to focus in that area.

• **OUTBACK STUDIOS**
489 1/2 Cavour St., Oakland, CA 94618
(415) 655-2110

Owner: Wilson Dyer, Steve Berryman.
Studio Manager: Wilson Dyer.

Engineers: Wilson Dyer, Steve Berryman.
Dimensions of Studios: 20' x 20' x 10'.
Dimensions of Control Rooms: 10' x 20' x 10'.

Tape Recorders: TEAC 3340S (modified) 4 track; Pioneer RT-701 2 track; Revox A-77 2 track; Sony TC-129, TC-160 st. cassette; Technics RS 646 stereo cassette; Sankyo stereo cassette.

Mixing Consoles: Uni-Sync Trouper stereo, 8 in x 4 out; TEAC Model 2, 6 in x 4 out; Shure M67, 4 in x 1 out.
Monitor Amplifiers: BGW 250C, Dyna MK III, MK IV.
Monitor Speakers: JBL 4311, 4301, Auratones, AR 4X, Dynaco Minis.

Echo, Reverb, and Delay Systems: Fisher reverb.
Other Outboard Equipment: Sunn 10-band EQ, BSR stereo 5-band EQ, dbx 160 compressor, dbx 155 noise reduction, Dolby B stereo noise reduction.

Microphones: AKG, Sennheiser, Shure, Neumann, Sony.
Instruments Available: Gibson ES 335, Marauder, Fender Jazz and P-Bass, Wurliizer acoustic piano, Prophet 5 synthesizer, MESA/Boogie 100/60 W, JBL K130 15" speaker, (2) Fender Showman tops, misc. cabs.

Extras: One block from freeway (Rt. 24), Leo's Music, and Soul Brothers Kitchen. We have a good stable of studio musicians available, (yes, they read music!).

Rates: \$12.50/hr plus materials, block time available.
Direction: We are primarily a 4-track workshop for producers, groups, songwriters, anyone seeking high quality, low-cost services. We do cassette duplication, lead-sheets, arranging... in other words a full production service, including helping your project find a 16/24-track facility if necessary through our connections in the industry. We are also doing radio commercial production with two in-house announcers.

four track

• **PLAY IT AGAIN, SAM**
950 Battery St., San Francisco, CA 94111
(415) 981-0154

Owner/Studio Manager: Samuel Hall.
Engineers: Samuel Hall, Shelley Brown.
Dimensions of Studios: 6' x 8' voice booth.
Dimensions of Control Rooms: 10' x 15'.

Tape Recorders: Ampex AG440B 4 track; Ampex ATR700 2 track; Nagra IV-L 1 track; Magnasync 16mm 1 track.

Mixing Consoles: Altec 1592A customized 5 in x 1 out.
Monitor Amplifiers: BGW 100.
Monitor Speakers: JBL 4301, Auratone.

Outboard Equipment: Furman parametric equalizer, ARP 2600 synthesizer.
Microphones: Electro-Voice, AKG.

Instruments Available: Roland electric piano, ARP 2600 antique cornet.
Extras: Tsing Tao beer on hand when available.

Direction: Narration recording and post production sound for films, TV, radio and A/V shows. Emphasis on music scoring — library or original.

• **RAINBOW STUDIO**
3131 Stone Valley Rd., Danville, CA 94526
(415) 820-2900 Ext 253

Owner: Monte Vista High School.
Engineers: Advanced recording students. On special request graduate students. All work supervised by the instructor, Chester Farrow.

Dimensions of Studios: 26' x 17'.
Dimensions of Control Rooms: 13' x 8'.
Tape Recorders: TEAC 3340S 4 track; Akai 250 2 track; TEAC A-100 cassette.

Mixing Consoles: Tascam Model 5, 8 in x 4 out; Altec 342-B, 4 in x 1 out; Shure Vocal Master, 6 in x 1 out.

Monitor Amplifiers: McIntosh 2100; (2) Dyna Stereo 70's.
Monitor Speakers: (2) JBL 4311's; (2) Auratones.

Outboard Equipment: dbx 161 compressor/limiter; Shure spring reverb.
Microphones: Sennheiser 421-U's; Shure SM-56's; Sony 280 condensers; AKG D-1000's, Shure 545's.

Instruments Available: Acoustic upright piano, Fender Rhodes electric piano.

Extras: Lounge, Coke machine, digital slot machine, video tape machine with plenty of tape.

Rates: FREE - Recording for the past 4 years. On Tuesdays only from 2-10pm, (8 hours). Available September to June.

Direction: Producing demo tapes. We have recorded such personalities as Greg Douglass, John Coinman, Billy Roberts, Nimbus & Companion. We have a full 2 camera, black & white studio for those musicians whose prospective producers/managers would like a quality 3/4" video-tape of a band's performance. These are broadcast quality tapes.

• **REAL TO REEL PRODUCTIONS**
777 N. First St., San Jose, CA 95112
(408) 287-5775

Owner: Alta Broadcasting Company/KEZR-FM Radio
Studio Manager: Steve Johnson

Engineers: Steve Johnson, (Chief Recording Engineer); Chris Holt, (Chief Engineer).

Dimensions of Studios: 157 square feet.
Dimensions of Control Rooms: Control #1 - 117 square feet; Control #2 - 95 square feet.

Tape Recorders: MCI JH 110A-2 2 track; MCI JH 110A-4 4 track; Technics RS 1520 2 track; Scully 280 2 track; Technics RS-M85 cassette; Technics RS-1500 2 track.

Mixing Consoles: Quantum QM-168 16 in x 8 out; McMartin B 802 8 in x 2 out; Tascam 2 A 12 in x 4 out.
Monitor Amplifiers: Technics SE 9060.
Monitor Speakers: TSS 4312.

Echo, Reverb, and Delay Systems: Orban 111-B reverb.
Outboard Equipment: UREI LA-4 limiters, Orban 622B parametric equalizer.

Microphones: Sennheiser MD 441, MD 421; Electro-Voice RE-20.



REAL TO REEL PRODUCTIONS
San Jose, CA

Extras: Technics SP10 MK II turntables, ITC Series 99 cart machine, complete sound effect libraries from CBS, Sound of Broadcast. Also Sound of Broadcast production music library, cassette, reel dubbing. Nice restaurant/bar down the hall.

Rates: 2 track: \$20/hr. Add \$5 1/4 hr. 1/2 hour minimum. 4 track: \$30/hr. Add \$7.50 1/4 hr. 1/2 hour minimum.

Direction: Real to Reel Productions was designed exclusively for voice production - radio commercials, television audio back-up, employee training tapes, etc. We offer a unique service, uncommon to most radio stations, yet more affordable than most "music oriented" studios.

• **REAL TO REEL RECORDING STUDIOS**
1170 Pearl St., Eugene, OR 97401
(503) 485-5977

Owner: Cliff Nagler.
Studio Manager: Cliff Nagler.
Engineers: Cliff Nagler, Chris Murray.

Dimensions of Studios: 15' x 13' x 8'.
Dimensions of Control Rooms: 15' x 12' x 8'.
Tape Recorders: Ampex 350 with (2) 354 electronics 4 track; Ampex ATR-100 2 track; Ampex ATR-700 2 track; Nakamichi Model 550 2 track.

Mixing Consoles: TEAC Model 5A, 8 in x 4 out.
Monitor Amplifiers: BGW 250D, Crown D-60.
Monitor Speakers: JBL 4311's, Advents.

Echo, Reverb, and Delay Systems: Orban stereo reverb.
Other Outboard Equipment: Eventide Clockworks Harmonizer H-910; dbx noise reduction (4-tracks); Bi-Amp graphic equalizer; Orban/parametric EQ; UREI compressor/limiters (2).

Microphones: Neumann U-87; AKG D-1000E, D200E, D-140, D-190, D-2000E; Shure SM-57's.

Instruments Available: Guitars and piano.
Extras: Refreshments and hi-speed cassette duplication.

Rates: Call for information.
Direction: Basically Real to Reel was developed as a commercial voice-over studio with an abundance of creative flexibility for radio commercials and TV audios. That has been expanded on and now we are up for just about any type of recording including music demos, multi-media presentations, jungles, radio drama, and programming syndication.

• **RED DRAGON RECORDING**
618 Shrader St., San Francisco, CA 94117
(415) 752-5750

Owner: Haight-Ashbury Community Radio (a non-profit org.)
Engineers: Richard Hanson, Conrad Corrao, Richard Chandler, Rob Waters, Larry Leight.

Dimensions of Studios: 12' x 18' x 8'.
Dimensions of Control Rooms: 12' x 7' x 8'.
Tape Recorders: TEAC A3340S 4 track; Crown 822 2 track; Pioneer RT-1050 2 track; TEAC AG-100 2 track; Akai CS-7020 cassette; Studor-Revox G-36 MKIII 2 track.

Mixing Consoles: Kustom 12, 12 in x 4 out; Shure MG-88, 6 in x 2 out.

Monitor Amplifiers: Sansui AU-717, Scott 299-D.
Monitor Speakers: JBL-4011, BIC Venturi Model "G".

Echo, Reverb, and Delay Systems: Spring reverb in Kustom SRM, echo possible through Crown 800 record amp.

Other Outboard Equipment: Dolby Model 101 NR unit, MXR compressor, Sony PS-T1 turntable, 52-point patchbay.
Microphones: Altec 655; AKG D-200E, D-190E, C-451EB; Shure 545, 565S, 555; E-V 636; Sony ECM 270.

Extras: Access to radio play for local artists and audio training for interested people.

Rates: \$10/hr commercial; \$5/hr community group.
Direction: Organized in 1973 as an alternative media access facility, Haight Ashbury Community Radio produces news and features for Bay Area radio stations including KPFA, KPOO, KRE, and KSAN. We now have a 4-track recording facility in which we strive to provide professional equipment and personnel to the community in a non-sexist, non-racist environment.

"LET IT BE KNOWN"

LEO'S MUSIC

HAS:

AKG
AMPEX
AURATONE
BEYER
BGW
CREST AUDIO
dbx
DELTA-LABS

EVENTIDE
FURMAN
HARBINGER
IVIE
JBL
KLARK-TEKNIK
LEXICON
MICMIX
MXR
NEARFIELD MONITORS

NEUMANN
SENNHEISER
SHURE
SONY
SOUND WORKSHOP
TASCAM/TEAC
UNI-SYNC
UREI
WHITE
YAMAHA

AND A COMPLETE
**\$ 50,000 PROFESSIONAL
8TRK RECORDING STUDIO**

IN-STOCK & ON DISPLAY AT

LEO'S music



5447 TELEGRAPH AVE. OAKLAND, CA 94609
653-1000

M/C VISA FINANCING AVAILABLE

• RUBBER CHICKEN RECORDING
32nd Ave., San Francisco, CA 94116
(415) MOIST-11 (664-7811)

Owner: Gary Mankin.
Engineers: Gary Mankin.
Dimensions of Studios: 11' x 18'.
Dimensions of Control Rooms: 12' x 12'.
Tape Recorders: TEAC A-3340S 4 track; TEAC A-3300SX 2T half-track stereo; Sony 353D quarter-track stereo; Sanyo RD-5030 cassette stereo.
Mixing Consoles: Tapco 6200B, 6 in x 2 out; Sony MX-14, 6 in x 2 out.
Monitor Amplifiers: Pioneer SA-9100, Pioneer SA-500 (head-phones).
Monitor Speakers: JBL L36, Auratone 5C.
Echo, Reverb, and Delay Systems: Sennheiser/RCL CV-571 stereo reverb, Pioneer SR-101 mono reverb (modified), tape delay.
Other Outboard Equipment: Soundcraftsmen Model 20-12 graphic EQ, Custom compressors, Advent Model 100 Dolby.
Microphones: Sony ECM-22P, ECM-21 condensers; Sennheiser MD-421; Shure SM-58, SM-53, SM-11, 565SD; E-V 665, DS-35; AKG D200E, D401 guitar pickup; Uni-Sync DB-1104 direct box.
Instruments Available: Steinway upright grand piano, Fender Contempo organ, Gibson SG, Dwarf amp.
Extras: Ocean view from control room, good humor.
Rates: \$8/hr for recording, mix, editing and copying. Up to one hour free set-up from scheduled arrival time.
Direction: The best advertising Rubber Chicken gets is from our clients. They walk out happy and spread the word. If no one's told you about us yet, make an appointment to stop by and check out the Chicken. We're easygoing without being terminally mellow, lighthearted without being cute. Most important, recordings made here sound good. We've added several new mics and a new stereo reverb in the last few months, and hope to move to more spacious quarters soon. Bigger won't mean less personal though. Our primary concern remains to provide quality recordings at a reasonable price.

• S.B. PRODUCTIONS
Walnut Creek, CA
(415) 937-1544

Owner/Studio Manager: Scott C. Boorey.
Engineers: Scott C. Boorey.
Dimensions of Studios: 10' x 20' x 9'. Larger studio in construction.
Dimensions of Control Rooms: 10' x 12' x 8'.
Tape Recorders: Tascam Series 40-4 w/dbx noise reduction 4 track; TEAC A-2300SX 2 track; B.I.C. cassette T-1 2 track.
Mixing Consoles: Tascam Series Model 3 8 in x 4/8 out.
Monitor Amplifiers: Uni-Sync Model 50.
Monitor Speakers: Mitsubishi MS-10.
Echo, Reverb, and Delay Systems: EP-4 Echoplex.
Outboard Equipment: (2) dbx 163 compressor/limiters, (4) track dbx noise reduction, Uni-Sync PMS-1.
Microphones: Shure SM-56's, SM-57's; Electro-Voice 1777 condensers.
Instruments Available: Marshall 100 watt, Vega Bass Bear.
Extras: Free coffee and spirits.
Rates: \$15/hr; block rates available.
Direction: With hopes of 8 tracks soon, we can give you the best possible 4 track sound today. Give me a call.

• SOUNDCAPSULE STUDIOS
P.O. Box 6363, Tahoe City, CA 95730
(916) 583-1836

Owner/Studio Manager: Michael Loomis.
Engineers: Michael Loomis.
Dimensions of Studios: 13' x 15'.
Tape Recorders: TEAC 3340S 4 track; Sony 640B 2 track.
Mixing Consoles: Tascam Model 5, 8 in x 4 out; Tapco 6200B, 6 in x 2 out.
Monitor Amplifiers: BGW Model 100.
Monitor Speakers: JBL and Altec.
Echo, Reverb, and Delay Systems: Delta Lab DL-2 "Acoustic-computer" digital delay/reverb synthesizer (2 channels).
Other Outboard Equipment: Patch bay, Pioneer PL-516 turntable, access to outboard signal processors.
Microphones: Sennheiser MD-421, Shure SM-58.
Instruments Available: Gibson SG, Gibson ES-295, MESA/Boogie guitar amp, assorted percussion instruments.
Extras: Session musicians available, recreational facilities of Lake Tahoe nearby.
Rates: Negotiable (cheap!).
Direction: This studio is in my home and grew out of my personal recording needs, as I am a musician myself (15 years professional experience). I can accommodate small acoustic groups and/or low volume electric instruments. Although mainly involved in demo and audition tape production, SoundCapsule Studios is interested in any audio project you might have. With an eye on the future, I'm always in search of more and better equipment to expand and update the studio's capabilities.

• SOUND CONSCIOUSNESS STUDIO
340 Monroe Dr., Palo Alto, CA 94306
(415) 948-0507

four track

Owner: Phillip Greek.
Engineers: Phillip Greek, Jeff Hook.
Tape Recorders: TEAC 2340SX 4 track; Sony TC-570 1/4 track stereo; Pioneer cassette CT4141E; Nakamichi cassette.
Mixing Consoles: Custom board.
Outboard Equipment: Yamaha analog delay Model E1010, dbx compatible noise reduction, Roland SH-5 studio synthesizer, RUS and spring reverb.
Microphones: AKG D1000E, Shure 545SD, Shure PE56D.
Monitor Amplifiers: Marantz 2220B.
Monitor Speakers: Modified Ultra Linears, with AKG K-141 and Sennheiser HD414 head phones.
Instruments Available: Story and Clark upright grand (exc. tone), Rhodes piano, Roland synthesizer, RVS keyboard amp, Rogers drum set, a vast array of African and Brazilian percussion (Berimbau, Quica, Tombeke, slit drums, congas, etc), tubular bells, steel drum, tabla, glass harmonica (crystal glasses of 2 octave range).
Extras: Large outdoor patio and orchard, with ping pong and kitchen facilities.
Direction: A professional approach to super-clean solo or small group demo production. Specialization in expanded electronic music concepts, nature recording, and innovative recording techniques. Also experience in film making and film sound tracks.
Rates: Negotiable according to project. Tapes supplied.

• THE SOUND SERVICE
860 Second St., San Francisco, CA 94107
(415) 433-3674

Owner: David Dobkin, Steven Pinsky.
Engineers: David Dobkin, Steven Pinsky.
Dimensions of Studios: Studio A: 10' x 12'.
Dimensions of Control Rooms: Studio A: 12' x 20'; Studio B: (transfer room): 9' x 14'.
Tape Recorders: (3) Ampex 440B's — (1) 4 track, (2) 2 track; Ampex 350 mono; Nagra 4S 2 track; Nagra 4.2 mono; Magna-Tech 436 mono film.
Mixing Consoles: Quantum 8P, 12 in x 4 out; Quantum 8A, 8 in x 4 out.
Monitor Amplifiers: McIntosh 30, SAE 32.
Monitor Speakers: JBL 4311.
Echo, Reverb, and Delay Systems: Orban.
Other Outboard Equipment: UREI filters, graphic EQs, phone patch.
Microphones: Schoeps collettes with various capsules, assorted Sennheiser, AKG, and E-V dynamics, Swintek wireless.
Instruments Available: Slide whistle.
Extras: Great coffee and easy parking.
Rates: Film transfers \$30-\$35/hr; Mono-2-track \$30/hr; 4-track \$35/hr.
Direction: We are a service facility for motion picture television and audio/visual producers. Our original music library and extensive sound effects library make us a resource for other studios as well as agencies and producers. We also do extensive location recording for film and video producers. We are in the design stages of a video mixing and sweetening system. We specialize in the recording of voice tracks for film narration, radio/TV commercials and audio visual presentations.

• SOUND TECHNIQUES
also REMOTE RECORDING
5156 Adair Way, San Jose, CA 95124
(408) 356-3333 (after 6pm) or 985-8020 (ask for Marty).

Owner: Martin McGuire.
Engineers: Martin McGuire.
Dimensions of Studios: 22' x 47', 14' x 16'.
Dimensions of Control Rooms: 24' x 38'.
Tape Recorders: TEAC A-3340S 4 track; Dokorder 7140 (modified for 15ips) 4 track; Sony TC-558 2 track; TEAC R-310 (1/2 track - 15ips) 2 track; TEAC A-450 cassette 2 track.
Mixing Consoles: Altec 1220AC (modified), 11 in x 3 out; (2) Gately Model SM-6 (modified), 12 in x 4 out; (2) Grommes Model G-5, 10 in x 2 out; Grommes Model G-7, 6 in x 2 out.
Monitor Amplifiers: (3) Dynaco 416's; Harman-Kardon Cit 12; Crown D60, (2) Dynaco Stereo 70's; (2) Dynaco MKIII's; Dynaco Stereo 120.
Monitor Speakers: Altec 604E's; Altec A7-500's (tri-amped with Electro-Voice T-350 Supertweeters); Altec 816A cab's; Altec 815 cab's; Altec 1221 cab.

Outboard Equipment: UREI 529 1/3 octave graphic EQ; Altec 8050A real time analyzer with calibrated mic and pink noise generator; (2) Crown VFX-2 dual channel filter/crossovers; (2) dbx 118 NR units; dbx 155 four channel NR unit; Advent Dolby NR unit; (2) TEAC AN-60 Dolby NR units.
Microphones: Shure SM-58's; Unidyne IV's, III's; Electro-Voice RE-15's; Sony ECM 65P's, ECM 33P's, AKG D200's.
Instruments Available: Ludwig 10 piece maple drums; Takamine F-3605 acoustic guitar.
Rates: Flexible, usually \$10.00 to \$25.00/hr or bulktime discounts. Remote recording is a specialty — \$100.00 minimum.
Direction: Sound Techniques is primarily a sound reinforcement company but has always provided a remote recording service. Sound Techniques also specializes in tape recorder, amplifier, studio and sound equipment repair and calibration. Room frequency response, EQ charts for studios or concert halls prepared. Special acoustic problems examined and solved.

• SPEED OF LIGHT
2430 Jones St., San Francisco, CA 94133
(415) 441-7806

Owner/Studio Manager: Joseph Van Witsen.
Engineers: Joseph Van Witsen, Lou Casabianca, Jack Joy.
Dimensions of Control Rooms: 15' x 15'.
Tape Recorders: TEAC 3340S 4 track; Akai 2 track; Panasonic 9500 3/4" color video editor, 2 audio, 1 sync; Panasonic 9200 3/4" color VTR, 2 audio, 1 sync; (2) Panasonic 9100 3/4" color edit feed decks, 2 audio, 1 sync; Sony Betamax cassette recorder.
Mixing Consoles: Tascam Model 3, 8 in x 4 out.
Monitor Amplifiers: Sansui.
Monitor Speakers: Dynaco.
Echo, Reverb, and Delay Systems: Nikko EQ-1 graphic EQ.
Other Outboard Equipment: 3M P-100 color video process amp, 3M pulse driver, 3M sync generator, 3M subcarrier regenerator, 3M Comtec 3100 video mix board 3 bus, 11 input with title keying, soft wipe, pattern modulator, color correction; Panasonic NV-950 editing computer w/rehearse edit.
Extras: Production company to create video promo tapes from concert through distribution. Located in the heart of San Francisco.
Rates: Negotiable.
Direction: Speed of Light is an automated video post production facility. We offer Round-The-Clock video editing services with quality and imagination. Most of our work is post production for record label promo tapes. Astral Projections is our in-house production company which produces promotional tapes and films for the performing arts. We are the most easy cruisin' off-line edit house in town. Try our low night coach rates!

• STAR MAKER STUDIO
3244 San Pablo Ave., Oakland, CA 94609
(415) 652-2322
Owner: Frank Corbin.

• STAR MOUNTAIN STUDIO
also REMOTE RECORDING
P.O. Box 114, Bodega Bay, CA 94923
(707) 875-9925
Owner: Moses Moon.
Studio Manager: Elm Bordner.
Engineers: Elm, One-Heart, Dan, and Paul.
Dimensions of Studios: A: 20' x 30'. B: 12' x 16'.
Dimensions of Control Rooms: 12' x 10'.
Tape Recorders: TEAC 3340S 4 track; Otari 5050SX 2 track; Ampex PR-10 2 track; Stellavox single track with film sync; Advent cassette.
Mixing Consoles: TEAC Model 5, 8 in x 4 out; Tapco 6600, 6 in x 2 out; Ampex PR-10, 4 in x 2 out.
Monitor Amplifiers: BGW-100, McIntosh stereo, Heath 4-channel.
Monitor Speakers: JBL 4311, Altec-Lansing A-7.
Echo, Reverb, and Delay Systems: Echoplex, Orban/Parasound, TEAC, Sound-On-Sound.
Other Outboard Equipment: dbx, Dolby A, both 4-channel; Orban parametric EQ, 621B 2-channel.
Microphones: E-V RE-20's, Sony ECM-21, AKG C-60's, Shure 540's, Sennheiser 402's, Sescor direct boxes.
Instruments Available: Acoustic piano, bass, and guitar, electric bass, Ludwig traps.
Extras: Complete facilities for theatrical sound, PA, and disco. Remote recording and film sound a specialty. Video available on special request. Hot tub, kitchen, overnight available.
Rates: Full studio: \$15/hr, other rates are variable but cheap.
Direction: We've been serving the needs of north coast musicians since 1972. Our setting amid the tall trees is rustic but comfortable, and our schedule is wide open. Our philosophy is service to the musician, and lack of money doesn't mean you're not welcome at Star Mountain. Give us a call, and let's get started!

• STUDIO IV RECORDINGS
28468 Ruus Rd., Hayward, CA 94544
(415) 782-2177
Owner: Dwain Vigil.
Studio Manager: Wendy Sawyer.
Engineers: Dwain Vigil.
Dimensions of Studios: 22' x 12'.
Dimensions of Control Rooms: 15' x 8'.

YOU DESERVE THE BEST



AKG
ALPHA
AMPEX
AUDIO ARTS
AUDIO FILE
AUDIO TECHNICA
AUDIO TECHNOLOGY
AURATONE
BIAMP
BOZAK
BURWEN
BEYER
COILCRAFT
COUNTRYMEN ASSOC.
CROWN
DBX
DISCWASHER

EDITALL
ELECTROVOICE
EVENTIDE
HAMMOND IND.
JBL PRO
KEITH MONKS
KLARK-TEKNIK
LEXICON
MIC MIX
MICRO SEIKI
MRL
NEPTUNE
NORTRONICS
OTARI
RAMKO
SCOTCH-3M
SENNHEISER

SHURE
SPECTRO ACOUSTICS
SONAR RADIO
SONY MICS
SOUND CONCEPTS
SOUND WORKSHOP
STANTRON
STL
SWITCHCRAFT
TABER MFG
TAPCO
TASCAM
TDK
TEAC
UNI-SYNC
URSA MAJOR
SPACE STATION

We specialize in 2, 4, 8 and 16 track recording systems for audio installations and multi-media Production, which includes application for Professional, college and home use.

(714) 985-0701 P. O. Box 734
1620 W. Foothill Blvd. UPLAND, CA

Tape Recorders: TEAC Model 3340S 4 track; TEAC 3300S 2 track; TEAC cassette A-400 2 track.

Mixing Consoles: TEAC Model 2 6 in x 4 out; MB 20 meter bridge.

Monitor Amplifiers: Kenwood KA-9100.

Monitor Speakers: Auratone sound cubes, custom monitors.

Outboard Equipment: MXR equalizer, Dolby noise reduction.

Microphones: Shure.

Instruments Available: Univox Stringman, Fibes drum set, acoustic guitars, electric bass, piano, Rhodes electric piano and percussion accessories.

Extras: Musicians available, photography producing available and publishing.

Rates: \$10/hr

Direction: In the near future we will be expanding to 8 track while continuing 4 track service. We offer projects from demo work through record pressing and publishing.

• SUNCREST SOUND STUDIOS

695 Suncrest Road, Talent, ORE 97520
(503) 535-2603

Owner: Gregory Hayes

Studio Manager: Robert L. Levreault

Engineers: Chief Engineer: Michael Bennett, Asst. Engineer: John Wilson.

Dimensions of Studios: 16' x 24' (384 sq. ft.)

Dimensions of Control Rooms: 12' x 8' (96 sq. ft.)

Tape Recorders: TEAC 3340s 4 track; TEAC 3300s 2 track.

Mixing Consoles: TEAC/Tascam Model 5, 8 in x 4 out; TEAC/Tascam Model 2; Shure M688.

Monitor Amplifiers: Crown, Kenwood KA-4006.

Monitor Speakers: JBL-100, RTR, Auratones.

Echo, Reverb, and Delay Systems: Tapco 4400 reverb.

Outboard Equipment: dbx model 154 NR, TEAC AN-300 Dolby NR, TEAC AN 60 Dolby NR, BSR-FEW 111 12-band equalizer, Yamaha UP-701.

Microphones: Sennheiser MD-441, MD421, AKG 451-E, Maestro CM-2000, SE-5 w/CE-2 omni-capsule

Instruments Available: Yamaha C7 grand piano, Fender Rhodes electric piano, ARP String Ensemble, Rogers concert drum set, percussion cabassa, tambourine, finger cymbals, marracas, shaker, triangle, woodblock, guiro, claves, bongos, Mini-Moog Micro-Moog.

Rates: Studio recording - \$30/hr, mixing - \$15/hr, editing - \$15/hr, rehearsal - \$10/hr, set-up - \$10/hr.

Direction: Suncrest Sound Studios is an association of individuals engaged in humanitan activity. It is our purpose to perform a service in the continuing involvement of the philosophic and spiritual condition of mankind, within the environments of the motion picture and musical mediums. This is but one of many foundations only recently forming, in this country and the world, all dedicated to similar ideals. It is the sincere intent of this association to assist any individual or organization who share sympathetic concerns.

• SUNSHINE WIZARD TRAVELLING SHOW REMOTE RECORDING ONLY

7935 Fremont Ave., Ben Lomond, CA 95005
(408) 336-2494

Owner: Errol G. Specter.

Engineers: Errol G. Specter.

Tape Recorders: Akai GX-400 SS 4 track; TEAC A-106 cassette.

Mixing Consoles: Roland KM 6A.

Outboard Equipment: Roland Analog Echo DC 10.

Microphones: Shure SM-57's.

Instruments Available: Micro Moog, ARP Odyssey, Korg MS 20 synthesizer, ARP 2600 synthesizer, Oberheim digital sequencer.

Extras: A lot of Sunshine Wizardry, electronic musician, The Sunshine Wizard himself.

Rates: \$10/hr recording time, instruments rental rates vary.

• 3-B PRODUCTIONS

701 16B Kings Row, San Jose, CA 95112
(408) 289-1383

Owner: Kevin Boone

Engineers: Kevin Boone

Dimensions of Studios: 24' x 18'

Dimensions of Control Rooms: 12' x 18'

Tape Recorders: TEAC 3340S 4 tracks, TEAC 3300S 2 tracks, TEAC 160 cassette 2 tracks, Sony cassette 2 tracks, Crown 1/2 track 2 tracks.

Mixing Consoles: West Series II, 12 in x 12 or 4 out, Yamaha PM 1000-16, 16 in x 4 out, TAPCO 6100 RB, EB, 14 in x 2 out.

Monitor Amplifiers: Crown D150, Marantz 140.

Monitor Speakers: Altec, Electro-Voice.

Outboard Equipment: Tapco 4400 reverb, Tapco 2200 stereo graphic equalizers, MXR, limiter, auto flanger, auto phaser, Echoplex, Hohner echo, Roland Space Echo.

four track

Microphones: Shure SM58, SM57, SM56, PE50SP, PE56; AKG D1000E; Electro-Voice 635A, over 40 to choose from.

Instruments Available: Rhodes piano, Lesage studio piano, 4 Voice Oberheim, Mellotron, Cat Synthesizer, Moog Taurus bass pedals, Ludwig double tom drum kit, Ampeg SVT bass amp, Fender Twin amp.

Extras: Kitchen, stove, shower.

Rates: \$15.00/hr, with block time discount.

Direction: Having just finished the songwriters contest held at Fargo's, I have become more aware of the many songwriters, and their need to express themselves. We are here to get the sound they are looking for. We are available 24 hours a day. We have a direct placement with an international publisher in New Zealand, and Hollywood for T.V. shows. We also do live on stage recording.

• TRANSMEDIA, INC.

also REMOTE RECORDING

380 Embarcadero West, Jack London Square, Oakland, California 94607.

(415) 465-8172

Owner/Studio Manager: David B. Adams.

Engineers: David B. Adams, Kathy Braun, Barney Lerten.

Dimensions of Studios: 15' x 8'.

Dimensions of Control Rooms: 15' x 23'.

Tape Recorders: Revox (2) A-77 2 track; Tascam 40-4 4 track; Akai (dubbing) X-355-D 2 track.

Mixing Consoles: RCA 76-B2 (custom), 6 in x 2 out.

Monitor Amplifiers: Fisher Model 400 (tube).

Monitor Speakers: Electro-Voice EV 16-A (studio & listening room), Fisher Studio Standard ST-750 (control room).

Echo, Reverb, and Delay Systems: Spring reverb, loop echo.

Other Outboard Equipment: Four "Sparta" full-track cartridge machines, Soundcraftsmen 1/3-octave EQ on each channel, Ampex cassette deck, Pioneer PL-112D turntable (2).

Microphones: Electro-Voice 668, Sennheiser MD-421, Calrad 10-2's, 11-30.

Instruments Available: Synthesizer with sequencer circuit.

Extras: Free door-to-door "Limousine" service for ad-agency clientele, complete on-location recording services, extensive SFX and music library, home of the "Sessions" voice-over classes endorsed by leading San Francisco talent agencies. Coffee, beer, wine and complete wet bar.

Rates: \$25/hr or per project quote on broadcast jingles and syndication.

Direction: Directed exclusively at the advertising industry and its related fields. We are "producers" not simply a recording facility. Some of our regular clients include: The Record Factory, Taco-Bell, Long's Drugs, Phillipine Airlines, Glorietta Foods, and the Mutual Radio Network. Heavily into broadcast syndication, we have created and successfully marketed shows ranging from 5-minute daily comedy shows to full length 3-hour specialty format programs.

• DICK VANCE SOUND

3249 Grand Avenue, Oakland, CA 94610
(415) 444-8746

Owner: Dick Vance.

Engineers: Dick Vance.

Dimensions of Studios: 15' x 30'.

Dimensions of Control Rooms: 10' x 10'.

Tape Recorders: Ampex 354 4 track; Ampex 601 2 track.

Mixing Consoles: Sony, 8 in x 4 out.

Monitor Amplifiers: Custom.

Monitor Speakers: Ampex custom.

Outboard Equipment: Disc cutter, tape reverb, and other equipment.

Microphones: Shure, RCA.

Instruments Available: Piano.

Rates: \$45/hour.

Direction: We do mainly sound tracks for slide films. We've recently added high speed tape duplication.

• WALKERSOUND

1874 Carlotta Drive, Concord, CA 94519

(415) 686-4347

Owner/Studio Manager: David L. Hootwalker

Engineers: David L. Hootwalker.

Dimensions of Studios: 14' x 16'.

Dimensions of Control Rooms: 4' x 8'.

Tape Recorders: TEAC/Tascam A3340S 4 track; TEAC/Tascam A3300SX 2T 2 track; TEAC/Tascam A450 cassette 2 track.

Mixing Consoles: Tascam Model 10, 12 in x 4 out, Quad panning.

Monitor Amplifiers: Crown DC 300A, Dyna ST70 (2), Marantz 2270.

Monitor Speakers: Altec Lansing Coax 15" in Botec cab's w/Herald Piezo tweeters, Auratone 5C Super Sound Cubes, JBL D130 w/Altec/H-811B horns.

Echo, Reverb, and Delay Systems: Tapco 4400, Fender.

Other Outboard Equipment: dbx 154, Dyna Pas ZX preamps.

Microphones: AKG D1000E, Shure 545's, various Shure and Electro-Voice.

Instruments Available: Fender bass and guitar amps, spinet piano, Hammond C3 w/Leslie, Micro Moog.

Extras: Friendly support, creative ideas, lead sheets and arrangements, musicians.

Rates: \$15/hr, block time available.

Direction: I like to work with artists and groups wanting good quality demos for all applications. I'm moving more into commercials and jingles but I specialize in producing demos of material for song contests, publishing contests, etc.

• WELLESOUND

REMOTE RECORDING ONLY

2935 Judah, San Francisco, CA 94122

(415) 681-9181

Owner/Studio Manager: Rob Welles.

Engineers: Rob Welles, Allen Lam, Greg Parker.

Dimensions of Control Rooms: 10' x 12'.

Tape Recorders: TEAC A-3340S 4 track; TEAC A-3300SX 2 track.

Mixing Consoles: Tascam Model 3, 8 in x 4 out, (soon expanding to 12 inputs!)

Monitor Amplifiers: Dynaco Stereo 400, Yamaha P2050, Pioneer SA-8500.

Monitor Speakers: AR-14's, Klipsch La Scala Industrials.

Echo, Reverb, and Delay Systems: Sound Workshop 242C.

Other Outboard Equipment: dbx 157, MXR stereo 10-band EQ, MXR dual fifteen EQ.

Microphones: Shure SM-58; Sennheiser K-2-U; AKG 190.

Instruments Available: ARP 2600, programmer available.

Extras: Human concern and great coffee.

Rates: Remote: service charge \$20, 4 track \$15/hr, 1/2-track \$8/hr, Mixdown: \$8/hr; sound reinforcement: \$45/gig min.; Bulk rates available on larger projects.

Direction: In our first year of business, we have expanded operations beyond the scope of theatre and dance productions. We now specialize in producing high quality stereo audition tapes, and are also moving into sound reinforcement. Our equipment can currently handle areas for up to 400 people, but we are constantly changing and expanding our setup.

• WNA AUDIO VIDEO INC.

1200 Stewart St., Seattle, WA 98101
(206) 623-5934

Owner: Wally Nelskog.

Studio Manager: Peter B. Lewis.

Engineers: Peter B. Lewis, Gary B. "Zac" Zacuto.

Dimensions of Studios: 40' x 60' x 20' ceiling.

Dimensions of Control Rooms: 20' x 30' x 9' ceiling.

Tape Recorders: Ampex 351 2 track; Ampex 351 full-track; Scully 280-B 2 track; MCI 2 track; Ampex 351 4 track.

Mixing Consoles: Speck 800C, 16 in x 8 out.

Monitor Amplifiers: BGW/McIntosh.

Monitor Speakers: Altec 9844-A.

Echo, Reverb, and Delay Systems: Stereo EMT, Clover (spring type).

Other Outboard Equipment: Ashly limiter (2); Orban parametric EQ, Wollensak cassette, Sony 3/4" video cassette, JVC 1/2" video cassette, Orban D'Esser.

Microphones: AKG 414A's, E-V RE-16, RE-20's.

Extras: Full audio service including: pre-production consultation, cassette, and reel-to-reel duplication, location recording, talent search, sound mixing for video, music scoring, sound effects.

Rates: Audio Rec/edit/mix: \$45/hr; Audio dubbing: \$40/hr; Audio w/video playback: \$70/hr.

Direction: WNA Audio Video offers complete post production video featuring CMX computerized editing, film transfers, duplicating, and the audio services mentioned above. We are installing a micro-processor based SMPTE interlock audio/video system for film and video tape sound mixing.

MORE SOUND PRESSURE. FEWER SPEAKERS.

CLEAN SOUND. Gauss sound. And for what you paid for your present system, you could probably have had Gauss. The professional loudspeaker system. Speaker for speaker, Gauss costs a little more than those other speakers. But you buy fewer speakers to get the same sound pressure. And when you consider Gauss' double-spider construction that stands up to all the db's you want to pump through it, you could be way ahead of the game. Because what you're aiming for is a concert...instead of a blowout.

gauss
by **Cetec audio**

CETEC AUDIO
13035 Satcoy Street
North Hollywood, CA. 91605
(213) 875-1900 TWX: 910-499-2669

CETEC INTERNATIONAL LTD.
Sapphire House
16 Uxbridge Rd.
Ealing, London W5 2BP, England
01-579-9145
Telex: 935847

Divisions of Cetec Audio

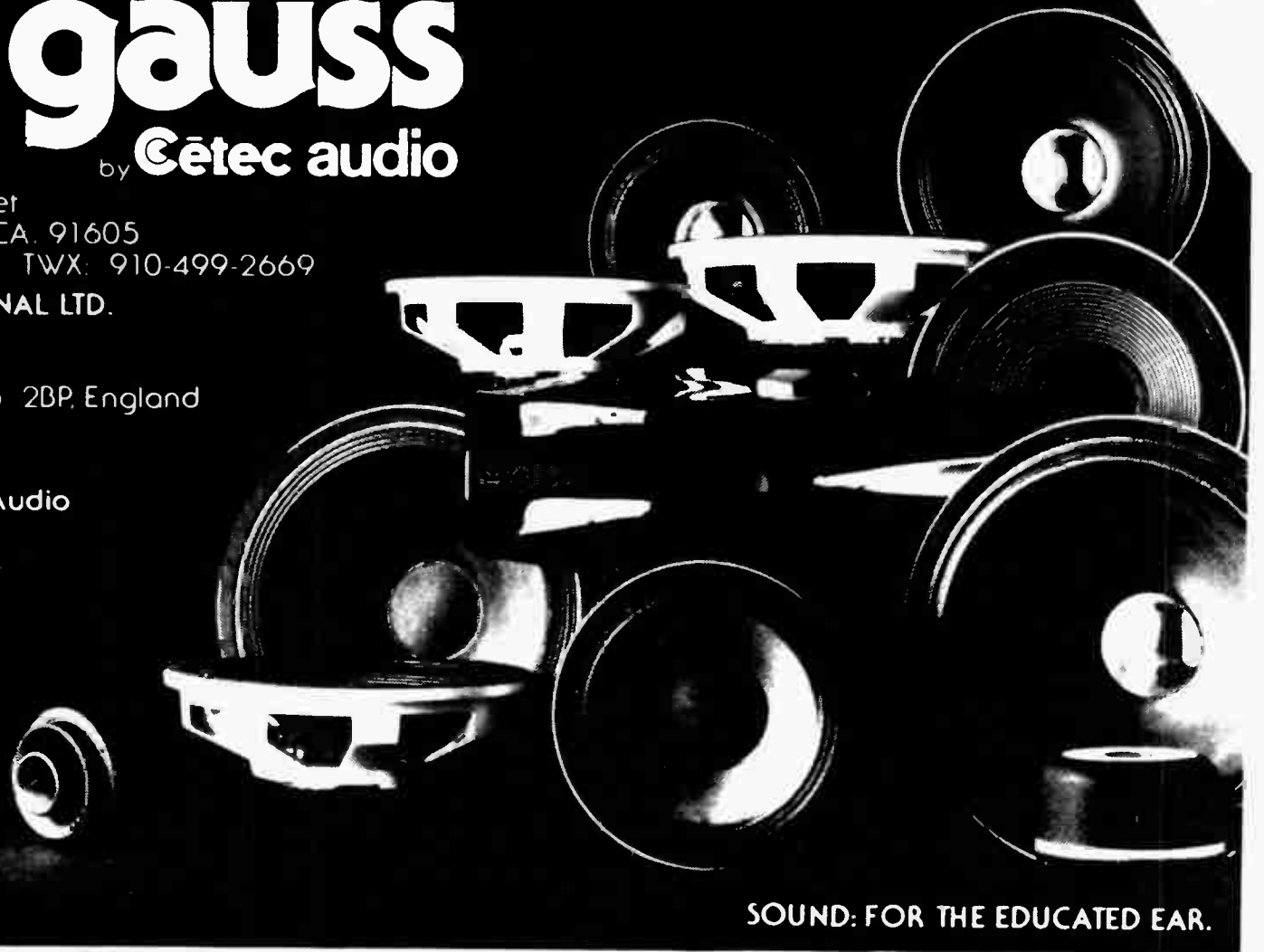

SOUND: FOR THE EDUCATED EAR.

The complete line available through:

**HUN
SOUND**

The Alternative

professional
audio sales:service:rental
rehearsal studios:

647 IRWIN STREET*SAN RAFAEL, CA
(415) 454-2911 (office/studio)
(415) 924-2600 (24 Hr. Ans. Service)
Telex: 340-229

H.U.N. Sound is:Humans Understanding Needs

THE MACHINE THAT HOLDS THE WORLD TRACK RECORD.



The Tascam Series 80-8 has become the most popular 8-track multichannel recorder in the world. Its reliability has been proven in basements, garages, and recording studios everywhere.

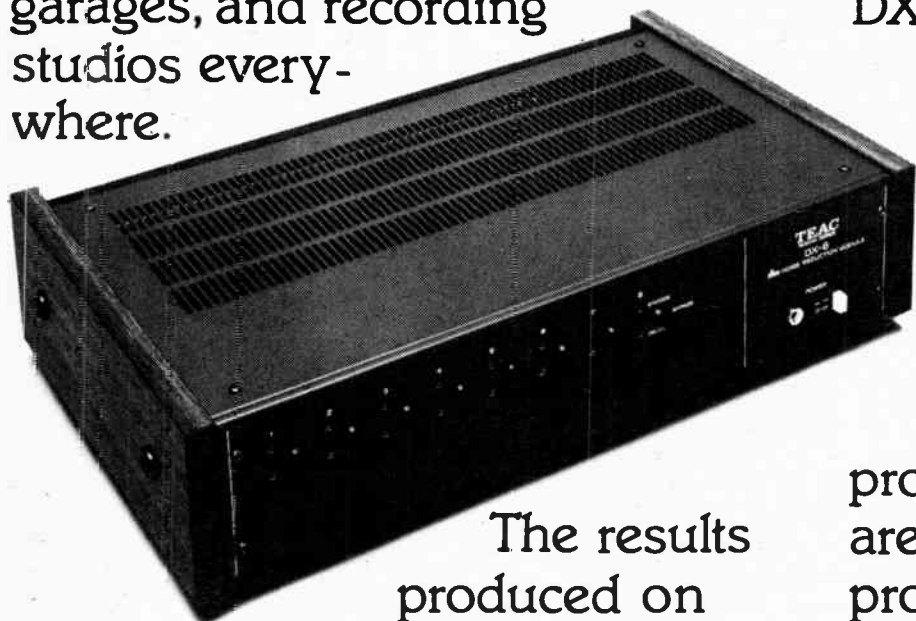

The results produced on the 80-8 are a matter of record. Sometimes gold.

The 80-8 proved a new standard was needed. Eight tracks on half-inch tape. 15 ips only. This new format allowed us to create a combined record/reproduce head, with full frequency response in the sync mode.

The 80-8 proved multichannel recorders could be relatively easy to operate. Our Function Select buttons determine the record, monitoring and dbx* status. One button for each track.

The 80-8 proved that performance and versatility could be affordable. Signal-to-noise is better than 95 dB (weighted) with our integral dbx unit (Model DX-8). Once installed, it's totally automatic. And our new Variable Speed Control** lets you adjust 15 ips $\pm 20\%$ to solve tough cueing and timing problems or add creative effects.

The 80-8 is proving that in professional recording, results are all that count. Because to us, pro means results. On demand. For payment.

If you agree, see your Tascam Series dealer for the machine



that can prove it. Because it makes sense to do business with the people who have the track record.

*Registered trade mark of dbx, Inc.

**Installation required; a new DC servo-controlled motor is included.

TASCAM SERIES
TEAC Professional Products



•• AAA / TRIANGLE RECORDING STUDIO

4230 Leary Way N.W., Seattle, WA 98103
(206) 783-3869

Owner/Studio Manager: Jack Weaver.

Engineers: Eric Betten, Jack Weaver.

Dimensions of Studios: 5 sided, 16' x 24' x 28' x 14' x 18' with 12' ceilings.

Dimensions of Control Rooms: 16' x 10' x 12' x 14', 12' ceiling.

Tape Recorders: Scully 284-8 8 track; Revox A-77 2 track; Ampex 601 mono; Nakamichi 550 cassette.

Mixing Consoles: Catalina C-12, 12 in x 12 out.

Monitor Amplifiers: Crown D-60's, D-110's, D-300's.

Monitor Speakers: UREI 813 Time Aligns (control room), Dahlquist DQ-10 Phased Array (studio side).

Echo, Reverb, and Delay Systems: Audiopulse, Roland Chorus Echo, Eventide Harmonizer Digital Delay.

Other Outboard Equipment: Eventide Harmonizer, Eventide Instant Flanger, Eventide Omnipressor, UREI 1/3-octave graphic, (4) UREI parametric EQ's, UREI stereo graphic EQ's, (3) UREI LA3A limiters, Altec tube compressor, Langevin graphic EQ, (3) Symetrix parametrics EQ's, (2) Symetrix signal gates.

Microphones: AKG 414EB's, Beyer 160's, 260's, 500's, M69's; Sennheiser 421's; E-V RE-20; Uni-Sync direct boxes.

Instruments Available: Yamaha grand piano, Oberheim 4-voice synthesizer, various instrument amplifiers.

Extras: Close to downtown Seattle, next door to tavern and all night restaurant where the slickest pool players in town hang out.

Rates: \$30/hr for 8 track; \$25/hr for 2 track.

Direction: Our control room was designed by Matthew Sutton of Audissey Sound, using principles of the LEDE technique. Put that together with the UREI 813's and you'll be hearing accurately what's on tape. Also our five-sided studio room sounds great and is considered one of the best around. We offer classes in multi-track recording in conjunction with Matthew Sutton. Classes are limited to five students for better individual attention and more "hands-on" time. For more information call 783-3869.

•• ARMY STREET STUDIOS / B.S.U. PRODUCTIONS

P.O. Box 31425, San Francisco, CA 94131
(415) 285-0952

Owner: Jim Keylor.

Studio Manager: Lester Gass.

Engineers: Jim Keylor, Jack May, Jim Alcivar.

Dimensions of Studios: 20' x 25'.

Dimensions of Control Rooms: 10' x 12'.

Tape Recorders: Otari MX5050 8 track; Otari MX5050 2 track.

Mixing Consoles: Soundcraft Electronics Series 2, 16 in x 8 out.

Monitor Amplifiers: Crown DC 300.

Monitor Speakers: JBL 4311; Auratones.

Echo, Reverb, and Delay Systems: Orban/Parasound reverb, Delta Lab DL-2.

Other Outboard Equipment: dbx noise reduction; dbx comp/limiter, U.A. limiters; UREI graphic EQ.

Microphones: Sennheiser 441's, 421's, 409's; AKG 414; Neumann KM-84; Shure SM-58's.

Instruments Available: Fender Jazz Bass, Fender Strat.; Gibson Melody Maker; Yamaha electric grand; various guitar amps; B-3/Leslie.

Extras: Full production available, studio musicians.

Rates: \$25/hr, \$20/hr bulk.

Direction: Blue Cheer, OFFS, Dead Kennedys, VIPS, Symptoms,

Bandaloons, Tuxedo Moon, Pink Section, Mutants, V.S. Metro Police, Permanent Wave, Peddicord & Co., Urban Action, Philo. — Make Platinum Records.

•• ASTRAL SOUNDS RECORDING

Suite 482, Reynolds Circle, San Jose, CA 95112
(408) 294-5153

Owner/Studio Manager: Jeff Tracy.

Engineers: Jeff Tracy, Brian Ware, Jon Wright.

Dimensions of Studios: 28' x 18' x 12'.

Dimensions of Control Rooms: 12' x 18' x 12'.

Tape Recorders: Tascam 80-8 8 track; TEAC 3340 4 track; TEAC 350 cassette.

Mixing Consoles: Tascam Model 5A, 8 in x 4 out; Tascam Model 1, 8 in x 2 out.

Monitor Amplifiers: ESS 500 watt, Toshiba.

Monitor Speakers: ESS AMT 1's.

Echo, Reverb, and Delay Systems: Tapco 4400 stereo reverb, MXR Digital Delay.

Other Outboard Equipment: Moog parametric, MXR/Haeco limiters, 9-band stereo EQ, Sennheiser and Koss headphones.

Microphones: Altec, Beyer, Electro-Voice, Shure, Sony, Sennheiser.

Instruments Available: Acoustic piano, drums, bass, assorted percussion, guitar amp.

Extras: Echoplex, MXR Flanger, Cry Baby, Boss Tone, coffee and tea, mood lighting, lead sheets available, musicians available.

Rates: \$20/hr; block rates available.

Direction: Many players comment on the size of the studio — larger than other 8 track studios in the area to help create a comfortable working atmosphere. We are flexible. We don't rush our clients or charge them from the moment they walk through the door. Free set-up and break-down. Before you make a rushed decision visit Astral Sounds.

•• AUDIO RECORDING INC.

also REMOTE RECORDING
2227 5th Ave., Seattle, WA 98121
(206) 623-2030

Owner/Studio Manager: Kearney W. Barton.

Engineers: Kearney W. Barton, Maggie Murphy.

Dimensions of Studios: 40' x 45' x 18'; 12' x 19' x 18'.

Dimensions of Control Rooms: 17 1/2' x 13 1/2' x 16'.

Tape Recorders: Scully 284 8 track; Ampex MR70 4 track; Ampex (3) 351-2 2 track; Ampex 300-2 2 track; Sony 770-4 (1/4) 2 track.

Mixing Consoles: Langevin custom 24 in x 8 out; in-house custom portable for location, 28 in x 4 out.

Monitor Amplifiers: Dynaco stereo 70's.

Monitor Speakers: Altec A7-500's, Altec 604E's.

Echo, Reverb, and Delay Systems: Live chambers (3).

Other Outboard Equipment: Noise reduction.

Microphones: Neumann U-47's, M-49's, M-269's, U-67's; Sony C-37A; Electro-Voice 655, 666; Altec M-11.

Instruments Available: Grotrian-Steinweg 7'3" concert grand piano, Rinkytink piano, Hammond C-3 organ, ARP synthesizer.

Rates: 8 track: \$50/hr, add \$10 Sundays and Holidays. 4 track: \$40/hr, 2 track: \$32/hr. Location add \$10 each.

Direction: Several Gold Records in Top 40, Country and Jazz; recorded 15 symphonies and major classical works, 32 operas in NW region. Numerous award-winning commercials. We believe in a relaxed studio atmosphere, and a casual approach so creativity can function without ego hang-ups or nervousness.

•• A.V.E. STUDIOS (AUDIO VISUAL ENTERPRISES)

2 S. Amphlett Blvd., San Mateo, CA 94402
(415) 343-6376

Owner: Robert Boak, Wayne Carlson.

Studio Manager: Bob and Wayne.

Engineers: Bob, Wayne, George Rivas, Dave Frediani, and Johnny 'V' Vernazza—in-house producer, plus independents.

Dimensions of Studios: 21' x 30' (A) recording and rehearsal, 14' x 16' (B) rehearsal.

Dimensions of Control Rooms: 14' x 21'.

Tape Recorders: Otari MX 5050-8 8 track; Ampex ATR 700 2 track; Sony (1/4 track) 2 track.

Mixing Consoles: Quantum AQ 3000, 8 in x 8 out; Tangent (PA) 1202A, 8 in x 8 out; Sunn (PA) Magna 2200 8 in x 8 out.

Monitor Amplifiers: Studio control room: ESS Professional, Phase Linear 400; Rehearsal studio: Shure SR105, Unisync 400.

Monitor Speakers: Control Room: JBL 4333A's, custom made small speakers; Rehearsal: Altec A-7's, JBL.

Echo, Reverb, and Delay Systems: Orban 111B, custom Echoplex, tape delay system, Roland Space Echo.

Other Outboard Equipment: Eventide Clockworks Flanger, UREI 1176N comp/lim. (5), Tapco 2200 EQ, Moog.

Microphones: Neumann U-47, U-87, KM 85's, Sony, Shure, AKG, E-V.

Instruments Available: Custom built Les Paul, Gibson bass, other equipment available on request.

Extras: Refrigerator, hot plate, etc., equipment storage, separate lounge and pressing room combination, TV, radio.

Rates: Block rates available as low as \$17/hr, or hourly rate of \$35/hr, exceptionally reasonable rehearsal \$10/hr—also with block rates available.

Direction: We're movin' up! We plan to be an automated 24-trk studio in a matter of months at a new location. Our present location will try to fill the urgent need of rehearsal space with three updated rooms to offer at low rates. Look for us and check it out! Let the music play!!!

•• AUDIOS AMIGOS

1411 6th Ave., San Francisco, CA 94122
(415) 665-7390

Owner/Studio Manager: Jim Renney, Doyle Williams.

Dimensions of Studios: 23' x 20'.

Dimensions of Control Rooms: 12' x 8'.

Tape Recorders: Tascam 80-8 w/dbx 8 track; Tascam 70H2 w/dbx 2 track; TEAC 3340 w/dbx 4 track; TEAC 6100 w/dbx 2 track; Sony 651 2 track; Sony 152SD cassette.

Mixing Consoles: Soundcraft Series II, 16 in x 8 out, with sweep EQ on all inputs.

Monitor Amplifiers: Altec biamped.

Monitor Speakers: Studio: JBL 4332 biamped; Control Room: JBL L-65; Auratones.

Echo, Reverb, and Delay Systems: (2) analog delay lines, vocal doublers, variable tape delay echo, spring reverb system.

Other Outboard Equipment: Symetrix noise gates, dbx 160 limiter/compressors, UREI LA3A's, (8) 10-band graphic EQ's, turntables, stereo cue and echo systems, patch programmable synthesizer.

Microphones: Over 50 to choose from: Neumann U-47's, U-87's, KM-83, 84, 85, 88's, KM-56's, SM-2; AKG C-60's, C-12, 451's, 414; RCA 77-DX; Shure SM-56's, SM-53's; Sony ECM 22's, ECM 56's; E-V; MB; Telefunken; and direct boxes.

Instruments Available: Yamaha C-3 conservatory grand piano, Fender Rhodes elect. piano, Fender Super Reverb amp.

Extras: Sun deck, grocery store next door.

Rates: 8 track: \$25/hr, 2 and 4 track: \$20/hr, editing: \$20/hr.

Direction: Master quality work at a price musicians can afford. You can book days with us for what you would pay for hours at other studios. Why take a chance? We have the facility and staff to get the job done right. The studio has a relaxed studio-in-the-home atmosphere and the engineer is experienced, competent and easy going. Find out why so many of the Bay Area's best are taking their projects to Audios Amigos.

•• BAY RECORDS

1518 Oak St., Suite 320, Alameda, CA 94501
(415) 865-2040

Owner: Michael Cogan.

Engineers: Michael Cogan.

Dimensions of Studios: 30' x 40'.

Dimensions of Control Rooms: 18' x 12'.

Tape Recorders: Ampex MM1000-8 8 track; Ampex AG350-2 2 track; Sony 854-4S 4 track.

Mixing Consoles: Tascam Model 10, 8 in x 4 out; (plus 8 out — highly modified).

Monitor Amplifiers: McIntosh MC-60.

Monitor Speakers: JBL 4311.
Echo, Reverb, and Delay Systems: Spring reverb.
Other Outboard Equipment: dbx 160 compressor, SAE graphic, Metrotech graphic.
Microphones: Neumann U-87's; AKG D224E, CA51E; Beyer M26C; E-V RE-15, etc.
Instruments Available: Grand piano.
Extras: 2 isolation booths.
Rates: \$25/hr plus tape, 1,000 LP's from your tape and artwork for \$2400 including color covers, everything.
Direction: Since we are a record label (we have produced 17 LP's to date on our own label), we specialize in doing complete album packages. We are also an excellent demo studio. Our rooms were originally built as a radio station in 1947 and our main studio remains one of the best rooms acoustically in the Bay Area.



BAY SOUND REPRODUCTION, Oakland, CA
 L: Glenn Oey, R: Gene Mick

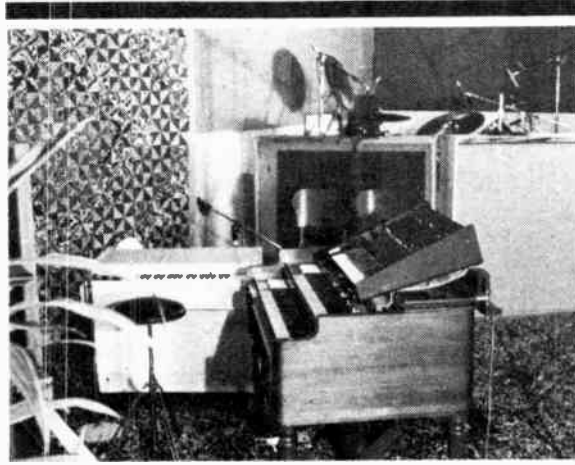

BAY SOUND REPRODUCTION
 Oakland, CA

•• BAY SOUND REPRODUCTION
 5 Yorkshire Drive, Oakland, CA 94618
 (415) 655-4885

Owner: Glenn Oey and Gene Mick.
Engineers: Glenn Oey and Gene Mick.
Dimensions of Studios: 30' x 19'.
Dimensions of Control Rooms: 16' x 14'.
Tape Recorders: Otari MX 5050-8SD 8 track; Otari MX 5050-2SD 2 track (1/2-track); Otari MX 5050 QXD 4 track; Nakamichi 700II and 550 2 track cassettes.
Mixing Consoles: Soundcraft Series 11, 16 in x 8 out; (all inputs have 4-band equalizers with sweepable frequencies).
Monitor Amplifiers: Nakamichi 620 (100 watts); Dynakit (70 watts); Marantz 4070 (35 watts — headphone cue amp).
Monitor Speakers: JBL 4311, Auratone, ADS 710.
Outboard Equipment: UREI LA-4 comp/limiter; MXR Digital Delay; Orban/Parasound 111B dual reverb; dbx noise reduction, Phase Linear 1000 autocorrelator; Nakamichi 610 pre-amp; SAE 2700 graphic EQ, SAE 1800 parametric EQ.
Microphones: Beyer 260, 500 (ribbons); Sennheiser 409, 421's; Shure SM-57, 58's; AKG 501, 505; Nakamichi CM 300's; Neumann KM-84's; direct boxes; Sescam SM-1A; guitar pick-up; FRAP F-100, E-V RE-15.
Instruments Available: Martin 000-18 and Epiphone Zephyr guitars, Indonesian Angklung, MESA/Boogie amp, Les Paul.
Extras: Waiting lounge with video games, refreshments and quiet garden outside.
Rates: 8 track: \$20/hr, 2 and 4 track: \$15/hr, all rates include everything but cost of tape. Also possible to rent tapes. Special rates are available for block booking.
Direction: Bay Sound Reproduction offers excellent 8 track recording facilities situated in the North Oakland Hills. It is

eight track

important that we work in harmony with the recording artist to create a relaxed and productive environment for recording. Give us a call if you are interested in seeing the studio and listen to some of our recordings. If you are unfamiliar with the multi-track recording procedure, we will be glad to explain it in detail.

•• BEGGERS BANQUET RECORDING CO.
 also REMOTE RECORDING

7736 Elphick Rd., Sebastopol, CA 95472
 (707) 823-7185

Owner/Studio Manager: Warren Dennis.
Engineers: Warren Dennis.
Dimensions of Studios: 650 sq. ft.
Dimensions of Control Rooms: 180 sq. ft.
Tape Recorders: Tascam 80-8 w/dbx noise reduction 8 track; Tascam 40-4 w/dbx noise reduction 4 track; Tascam 25-2 w/dbx noise reduction half-track; Sony reel to reel 4 track stereo; Aiwa cassette w/Dolby; Kenwood KX1030 3-head cassette w/Dolby; Advent 201 Dolby cassette; Pioneer Contrex portable cassette.
Mixing Consoles: Sound Workshop 1280-8 EQ, 12 in x 8 out; Tapco 6100-RB, 6 in x 2 out.
Monitor Amplifiers: Nikko Alpha 1, 220 watts/channel; Marantz 240, 120 watts/channel; Symetrix HA-10 headphone amp; Harman-Kardon Citation II pre-amp.
Monitor Speakers: JBL 4311 (pair) control room monitors, JBL L100 (pair) in studio for playback, Phillips mini-type speakers in control room, AKG headphones (6 pair), Sennheiser earphones (4 pair).
Echo, Reverb, and Delay Systems: Tapco 4400 stereo reverb w/EQ, Loft Series 440 analog delay and flanger unit.
Other Outboard Equipment: UREI LA compressor/limiter, (2) Bi-Amp graphic EQ's (stereo), MXR Phase 100 phaser, (3) Sescam direct boxes, Sony PST3 direct drive turntable w/Stanton 681EEE cartridge.
Microphones: Sennheiser 441, 421; AKG D-224E's w/double diaphragms, D-202's w/double diaphragms, D-200E's; Shure SM-57's, 54S; Advent MDC-1.
Instruments Available: Yamaha acoustic piano (beautiful!), full set of Slingerland drums w/Zildjian cymbals, Fender Rhodes electric piano, Fender Bass guitar, Fender Princeton Reverb amp, assorted percussion instruments.
Extras: Complete production assistance as well as career counseling. Tape copying facilities available. Country view and country air free!
Rates: \$16/hr studio. (Mobile rates negotiable). Bulk rates available for block projects depending on duration.
Direction: We've enlarged our facilities to accommodate the rapidly increasing recording industry in the Sacramento area. But we still have the same relaxed atmosphere with the same affordable prices (some things never change!) All engineers are experienced musicians. The Location Studio Van is equipped with full 8-track facilities. The equipment will interface with any sound reinforcement system to insure the best possible quality. And more good things to come.

•• ROBERT BERKE SOUND PRODUCTION & RECORDING
 (415) 661-6316

Owner: Robert Berke.
Studio Manager: Joe Hunter.
Engineers: Joe Hunter, Robert Berke, Mark Escott.
Dimensions of Studios: 10' x 16'.
Dimensions of Control Rooms: 12' x 15'.
Tape Recorders: Otari 7800-1" w/full function remote 8 track; Scully 280B w/varisync 2 track; (2) Scully 280B servo 2 track; Sony 854-4S 4 track; (2) Akai 760D 2 track cassette recorders; Aawai 6900 2 track cassette recorders.
Mixing Consoles: Audiotronics 110-8, 12 in x 8 out.
Monitor Amplifiers: BGW 750, Crown D-60 (3), Sansui Au-717.
Monitor Speakers: Altec 604/UREI crossover & horn, JBL 4311, Auratone.
Echo, Reverb, and Delay Systems: Master-Room, Orban, Eventide Harmonizer.
Other Outboard Equipment: UREI 530 EQs (2), UREI 539 EQs (2), UREI 527-A EQ, SAE 2700 EQ, UREI 565T filter set, UREI 964 digital metronome, UREI 1176LN limiters (2),

UREI LA-4 compressors (4), Eventide Harmonizer, Inovonics noise suppressor, Orban 516EC sibilance limiter, dbx noise reduction, ESE timer, Technics SL-1400 MK II turntables.

Microphones: Neumann U-87's, Neumann KM-84's; Shure SM-7, Electro-Voice RE-20; Beyer M500; Sony ECM-54P; Sennheiser 421MD.

Rates: 2, 4, 8-track recording & mixing: \$30/hr. Edit, transfer, and demo voice recording: \$25/hr.

Direction: We are a fully equipped audio production facility specializing in media and commercial sound production. The studio is located in a relaxed and informal environment and features a full sound effects and music library, along with professional equipment. The studio services a wide variety of media production companies and advertising agencies with a reputation for quality work and fast turnover at a reasonable rate.

•• "BIG PINK WEST"
 507 Browning St., Mill Valley, CA 94941
 (415) 388-2987

Owner: Dick Darling D.D.S.
Studio Manager: Bob Emma.
Engineers: Bob Emma.
Dimensions of Studios: 27' x 20' with 8' x 8' drum booth, 13' x 11' piano and vocal booth.
Dimensions of Control Rooms: 10' x 8'.
Tape Recorders: TEAC 80-8 (1/2") 8 track; JVC KD75 stereo cassette deck; TEAC 3300S stereo 1/4-track tape deck.
Mixing Consoles: Speck SP 800C, 16 in x 16 out
Monitor Amplifiers: Yamaha PZ100, Crown D150A, Crown D60
Monitor Speakers: JBL L-100's.
Echo, Reverb, and Delay Systems: AKG BX10 reverb
Other Outboard Equipment: dbx noise reduction — DX-8 Tascam; Eventide Harmonizer; UREI LA-4 limiters; UREI 1176 peak limiter; (2) Shure M688 stereo mic mixers.
Microphones: Neumann U-87, KM-84's; Electro-Voice RE-11, RE-15's, RE-20, 1751; Beyer M-101N, X1N, M-500N; Sony ECM 33P, ECM 280; Shure SM-57's.
Instruments Available: Fender Stratocaster; ARP Odyssey, Baldwin-Hamilton piano; Rogers, Ludwig drums; various percussion instruments at no additional charge.
Extras: Fully furnished 2-bedroom home with living room, kitchen, etc., Fender Twin Reverb amp w/15" JBL K130 speaker, MXR 90 Phaser and MXR "Blue Box"; FRAP F200 pre-amp; Countryman FET 85 active direct box; (2) passive direct boxes.
Rates: \$25/hr, \$15/hr mixdown; 1 hour free set-up; the rates are flexible depending on the project. Block time available at tremendous savings.
Direction: Since the opening of Big Pink West in November of '78, we have hosted artists such as Van Morrison, SVT, Spell Bound, and the newly formed Greg Douglass Band. We offer our clients a comfortable, fully furnished home, a well equipped studio, and we work to create a no pressure atmosphere. With the addition of an extensive patch bay system we can now patch in any equipment you may need for your project. We are conveniently located in Marin County. Situated in a rural setting, yet only 15 minutes away from San Francisco.

•• BRANDT'S RECORDING STUDIOS
 1030 48th St., Sacramento, CA 95819
 (916) 451-3400, 451-7794

Owner: Charles M. Brandt, Edna A. Brandt.
Engineers: C.M. Brandt (Chief Eng.), E. Brandt (Assistant Eng.)
Dimensions of Studios: Studio A: 40' x 42' x 15'. Studio B: 12' x 26' x 9'. Mixing & dubbing studio.
Dimensions of Control Rooms: Control Room A: 10' x 16' x 8 1/2'. Control Room B: 6' x 10' x 8'.
Tape Recorders: TEAC 701 Electronics Series 70 (1/2") 8 track; and 4 track; Ampex, with Inovonics 2-channel Electronics, 354 2 track; Ampex with new electronics, 351 mono; TEAC A-170-S cassette; Magnacord 1/2-track (1/4") 2 track; Ampex reel to reel master and 3 slave units, Model 10, 1/4 and 1/2 track stereo.
Mixing Consoles: Tascam (Studio A) Model 10-B, 16 in x 8 out; Altec (Studio B) 1567-A, 10 in x 2 out.
Monitor Amplifiers: Crown D-150-A's, DC-150's, and DC-300's.
Monitor Speakers: Electro-Voice Sentry II control room monitors, Utah Electronics MP-3000 (4-way) Studio A play-back monitors.
Outboard Equipment: Orban/Parasound 111-B reverb units (2), Orban/Parasound 106CX reverb units, Shure Audio-Master M-63 EQ, UREI 530 dual channel graphic EQ, dbx 187 noise reduction (4-channel).
Microphones: Electro-Voice 666, 654-A, 635-A, RE-15, RE-16, RE-50; Telefunken Elam-251; RCA 77B, 44, BP-90, 88-A; Shure SM-58, SM-60; and Commando 425.
Instruments Available: 7 1/2' A.B. Chase grand piano, Gulbransen electronic organ, RCA Story-Tone electric piano, for special sound effects.
Extras: We are also a music publisher, Gentle Wind Publishing Company, affiliated with BMI.
Rates: \$35/hr for the 1st hour, thereafter is based on \$25/hr. Studio block-time is at the rate of \$20/hr, 6 hr minimum. Master tape mixdown is \$20/hr plus tape.
Direction: We have been in the recording business since 1942 here in Sacramento. We own our studio and building. Charles

M. Brandt has been in the radio broadcasting business since 1932, Asst. Engineer for radio station KGDM Stockton, (Peffer Music Station) for 6 years. Our record labels are Camelia and Pel-Mel.

•• CAPITOL CITY STUDIOS
911 East Fourth Avenue, Olympia, WA 98506
(206) 352-9097

Owner: Allen P. Giles.
Studio Manager: Allen P. Giles.
Engineers: Allen P. Giles, John Burch, Dan Lundberg.
Dimensions of Studios: 40' x 86' x 32' high.
Dimensions of Control Rooms: 12' x 23'.
Tape Recorders: Ampex 440B 4 track; Ampex 351-2 2 track; Stellevox SP8 2 track; Ampex MM 1000 8 track.
Mixing Consoles: Langevin A 301, 8 in x 2 out; Speck Electronics 820C, 28 in x 16 out; Gately EM6, 18 in x 4 out.
Monitor Amplifiers: SAE, McIntosh, Ampex.
Monitor Speakers: SAE, Altec, KLH.
Echo, Reverb, and Delay Systems: SAE, Tapco, Fisher.
Other Outboard Equipment: SAE graphic EQ, dbx, 8 in x 8 out noise reduction, dbx limiting.
Instruments Available: 7' 6" Yamaha conservatory grand, Hammond B-3 organ, Micro Moog synthesizer.
Rates: \$50/hr, 2 hour minimum.
Direction: Concentration on Gospel, large orchestra, vocal, symphonic band, and jazz recording.

•• CENTER FOR CONTEMPORARY MUSIC
Mills College, Oakland, CA 94613
(415) 632-2700, ext. 337; 635-7620

Owner: Mills College.
Engineers: Maggi Payne and Bob Sheff.
Dimensions of Studios: 16' x 16'.
Dimensions of Control Rooms: 11' x 11'.
Tape Recorders: Scully 280 12 track; Scully 280B 2 track.
Mixing Consoles: Opamp Labs custom board, 12 in x 12 out.
Monitor Amplifiers: McIntosh 2505.
Monitor Speakers: Altec 601.
Echo, Reverb, and Delay Systems: AKG BX-10 2 channel reverb.
Other Outboard Equipment: Phase Linear 1000 auto-correlator, SAE graphic EQ.
Microphones: AKG C451E's, C414EB's; Sennheiser MD-421's; Electro-Voice RE-15, 635A's, 666; Sony C-22's.
Instruments Available: Baby grand piano, Hammond organ.
Rates: \$15/hr.
Direction: The Center for Contemporary Music is a non-profit public access audio facility at very nominal rates. Aside from the 8-track recording studio, we also have a dubbing studio, Moog & Aries synthesizer studios, a 16mm and 8mm film studio, 16mm mag transfer to film sound mixing, and a tape library. The center began in 1969 with a grant from the Rockefeller Foundation. Located at Mills College, we also have a free weekly concert workshop series of new music. We close for the summer months and reopen in September.

•• CORASOUND RECORDING
122E Paul Drive, San Rafael, CA 94903
(415) 472-3745

Owner: Stephen A. Hart, J.D. Sharp, John Rewind.
Studio Manager: Stephen Hart.
Engineers: Stephen Hart, Michael Raskovsky, J.D. Sharp.
Dimensions of Studios: 24' x 32' x 12'.
Dimensions of Control Rooms: 9' x 12'.
Tape Recorders: Otari MX 5050 8 track; Otari MX 5050B 2 track; Nagra IVS 2 track; TEAC A3340S 4 track; TEAC, Sony, Dokorder cassette decks.
Mixing Consoles: Sound Workshop 1280B, 12 in x 8 out.
Monitor Amplifiers: McIntosh MC2505, Crown.
Monitor Speakers: JBL 4311, Auratones.
Echo, Reverb, and Delay Systems: Ibanez AD 230 delay, Roland Space Echo 201, Tapco reverb with limiters.
Other Outboard Equipment: Ashly parametric EQ, Furman parametric EQ, Bi-Amp graphic EQ, dbx noise reduction, dbx comp/limiters, Ibanez AD-230 flanger, Orban/Parasound stereo synthesizers, Clic-Trac, Countryman and Sescor direct boxes, MXR Phaser and noise gate.
Microphones: AKG 414EB, 451's, D-1000, D-200's; E-V RE-20, RE-15, RE-10's, CS15; Neumann KM-84; Sennheiser 421's; Beyers 160, M-500, M-201; Shure SM-57's.
Instruments Available: Hammond B-3, Korg Poly S (string synthesizer), Oberheim 2-voice synthesizer, upright grand piano, Poly-fusion synthesizer, 360 Systems guitar synthesizer, drum sets, electric bass, congas, GMT and Acoustic amps, Gibson ES-175.
Extras: Production service, pro. studio musicians available.
Rates: \$25/hr; block time (6 hrs or more) \$22/hr.
Direction: Specializing in budget LP's and singles, radio and television commercials, and film sound tracks. We also offer a complete production service for your music or commercial. Since

eight track

the last issue of The Mix, Corasound has recorded a number of records, and commercials for west coast and national broadcast. For a reasonable price, Corasound will give you a high quality master tape.

•• COZY DOG RECORDING STUDIO
603 Morrison Rd., Vancouver, WA 98664
(206) 694-1845

Owner/Studio Manager: Tad Suckling.
Engineers: Tad Suckling.
Dimensions of Studios: (Temporary) 16' x 15'.
Dimensions of Control Rooms: (Temporary) 12' x 7'.
Tape Recorders: TEAC/Tascam 80-8 8 track; TEAC/Tascam A3300 SX 2T 2 track.
Mixing Consoles: (2) TEAC Model 5A's, 16 in x 8 out, 250 pt. patch bay Switchcraft component.
Monitor Amplifiers: Crown 150, Crown 60.
Monitor Speakers: JBL L-36, Micro Sonics Mini Monitors.
Echo, Reverb, and Delay Systems: Orban/Parasound 111B spring reverb, Intersound RV 100.
Other Outboard Equipment: SAE 1800, parametric EQ.
Microphones: Sennheiser 421 MD's, AKG 451's, Shure SM-57's.
Instruments Available: Mason Hamlin upright grand, Guild D-50 acoustic guitar, Les Paul (Gold Top Deluxe), Fender Pro Reverb with JBL.
Extras: Phantom power built into patch bay.
Rates: \$15 - \$20/hr.
Direction: Demo work; personal and outside childrens' production, advertisement spots, personal production advice and arrangement help. I like to see good music with any style on tape. Very soon I will be constructing a new building nestled among lovely maple trees, with a definitely cozy cuisine.

•• CREATIVE SOUND STUDIO
802 Cree Dr., San Jose, CA 95123
(408) 224-1777

Owner: Richard and Ramah Dias.
Studio Manager: Richard Dias.
Engineers: Richard Dias.
Dimensions of Studios: 16' x 20'.
Dimensions of Control Rooms: 9' x 12'.
Tape Recorders: TEAC 80-8 8 track; TEAC 3340 4 track; Ampex 300 2 track.
Mixing Consoles: Tascam Model 10, 12 in x 8 out.
Monitor Amplifiers: GAS, Dyna 120, Crown.
Monitor Speakers: MDM-4, ALX, JBL.
Echo, Reverb, and Delay Systems: Sound Workshop, MICMIX.
Other Outboard Equipment: dbx comp/limiters, dbx noise reduction, flanging, Pioneer CT-F 9191 cassette.
Microphones: AKG, Sony, RCA, E-V, Shure, Sennheiser.
Instruments Available: Grand piano, Hammond B-3, assorted guitars, bass and amp.
Extras: Coffee, cold drinks, and a warm friendly atmosphere.
Rates: \$20/hr for 4 or 8 track plus 1/2-hour free set-up time.
Direction: We want to enlarge our studio and install 16 or 24 track equipment. A new addition to the studio has been our grand piano as well as other new outboard equipment. Credits would include one of the Bay Area's Top-40 performers called "Flipside". Also several albums by area's Gospel artists.

•• CUSTOM RECORDING / STUDIO C
2220 Broadridge Way, Stockton, CA 95209
(209) 477-5130

Owner: Thomas T. Chen, M.D.
Engineers: Drew Palmer, Greg Jones, Doug Rinkor, Thomas T. Chen.
Dimensions of Studios: 30' x 30'.
Dimensions of Control Rooms: 8' x 12'.
Tape Recorders: 3M M-56 8 track, Ampex AG-351 2 track; Otari MX 5050 4 track; Tandberg cassette.
Mixing Consoles: Langevin Am-4, 12 in x 4 out; Interface Series 100, 8 in x 4 out; Altec, 6 in x 2 out.

Monitor Amplifiers: Crown DC-300, Crown D-60.
Monitor Speakers: Bozak concert grand; Bozak Monitor C, Electro-Voice Interface A; MDM-4, Auratone, control room EQ via White 1/3-octave equalizers.
Outboard Equipment: Orban stereo matrix, Inovonics limiter, AKG BX-20 reverb, Altec Hi-Lo filter, UREI graphic EQ, Eventide Flanger, Eventide Harmonizer, Countryman phaser, ITI parametric EQ, Kepex, Gain Brain, Lexicon stereo digital delay, dbx noise reduction.

Microphones: Neumann U-47 fet, U-67, KM-84; Electro-Voice RE-15, RE-16; Shure SM-53, SM-58, SM-60; Sennheiser MD-421, MKH-451; AKG C-451 system, D-200; MB 215, 301; Warrenbrock P2M; FRAP; Countryman direct boxes; custom MSD boxes.

Instruments Available: Steinway grand piano, Hammond B-3 w/Leslie, Oberheim eight-voice w/sequencer, Traynor bass amp, Fender Vibroverb amp, Oberheim guitar amp, ARP String Ensemble, Gibson Les Paul recording guitar, Fender Precision Bass (noiseless), Alembic graphite neck bass, Guild D-50 acoustic guitar, Yari Alvarez classical guitar, recording drum set (2), assorted percussion instruments.

Extras: Otari high-speed cassette duplicator.
Rates: \$35/hr. 1-hour set-up time allowance per 3-hr session for basic tracks.

Direction: We have spent the last 2 years in developing instruments for recording. We have completely eliminated the noise, inductive hum pick-up and interference in a Fender Precision Bass. We have developed a new concept with the Oberheim synthesizer unig delayed slave voicing. We have developed a recording drum set with unique drum mounted mics. We have developed a noiseless Les Paul recording guitar. Our country location enables you to relax and perform to the best of your ability.



CUSTOM RECORDING/STUDIO C
 Stockton, CA

•• DESITREX RECORDING & SOUND
3003A S.E. Division, Portland, ORE 97202
(502) 232-8806

Owner: Joe Perez, David Harrison, Douglas Durbrow, Michael Demmers.
Studio Manager: Douglas Durbrow.
Engineers: Douglas Durbrow, Michael Demmers.
Dimensions of Studios: 19' x 20', drum cage: 8' x 8'.
Dimensions of Control Rooms: 9' x 19'.
Tape Recorders: Tascam 80-8 w/dbx (1/2") 8 track; Tascam Series 70 (1/2") 4 track; TEAC A-3340S (1/4") 4 track; TEAC A-6100 (1/4") 2 track; Sony TC-766-2 (1/4") 2 track; TEAC A-1200U (1/4") 2 (1/4 track); and assorted cassette and cartridge decks.
Mixing Consoles: Soundcraft Series II 16/8 with sweep EQ, 16 in x 8 out.
Monitor Amplifiers: Crown, Pioneer.
Monitor Speakers: Altec, Sony, Pioneer car stereo speakers, Sennheiser and Pioneer headphones.
Echo, Reverb, and Delay Systems: Orban/Parasound 111B stereo reverb, D.E.L. analog and digital delays, assorted tape delays.
Outboard Equipment: dbx noise reduction, dbx limiters, D.E.L. graphic and parametric EQ's.
Microphones: AKG, Electro-Voice, Shure, Sony, (assorted models).
Instruments Available: Acoustic piano, mini-moog, assorted percussion.
Extras: Friendly, relaxed atmosphere; free coffee and tea to customers; production assistance available; top quality pressings and dubs; promotional packages also available.
Rates: \$20.00/hr (full production), \$15.00/hr (limited production). Discounts on block time and project rates (deposit required).
Direction: Our goal is to continue to offer the best deals in recording, as we've been doing for years, even though we will be expanding. Our high quality/low price combination is the natural choice for novice or pro musicians.

THANKS HOLLYWOOD

(Nashville, New York and San Francisco)
 For Hanging in There Until SEATTLE Was Ready to Happen

**PRO
AUDIO
SEATTLE**
 Professional Audio
 Equipment & Services



EXCLUSIVE MCI REPRESENTATIVES IN THE PACIFIC NORTHWEST

A lot of people in the recording business are looking at the Pacific Northwest as the next place to happen.
 In the past 3 years Pro Audio Seattle has seen more and more national recording artists, producers and engineers become LA expatriates and head north.

To help build the new studios and upgrade the existing studios that will serve this influx of talent, PRO AUDIO SEATTLE is proud to announce that we are the newest franchised MCI dealer in America.
 Thanks for helping us make it happen.

Craig G. Ingle

Craig G. Ingle
 President

2320 Sixth Avenue

Seattle, Washington 98121

(206) 622-6984



**PRO
AUDIO
SEATTLE**
 Professional Audio
 Equipment & Services

Exclusive MCI Representatives in the Pacific Northwest
 2320 Sixth Ave. • Seattle, Washington 98121 • (206) 622-6984

•• ELECTRONIC MUSIC ASSOCIATES

3400 Wyman St. Oakland, CA 94619
(415) 532-5034

Owner: Howard Moscovitz.
Engineers: Howard Moscovitz.
Dimensions of Studios: 8' x 16'.
Dimensions of Control Rooms: 8' x 16'.
Tape Recorders: Tascam Series 70 8 track; TEAC 3300 2 track; Sony 370-4 4 track.
Mixing Consoles: EMA, 20 in x 20 out.
Monitor Amplifiers: McIntosh.
Monitor Speakers: Rectilinear III.
Outboard Equipment: EMA plate reverb, EMA phase shifter, EMA ring modulator, equalization equipment.
Microphones: Sony ECM-22.
Instruments Available: Large studio Moog synthesizers (921 Series) with sequencers; ring modulators, phase shifter and plate reverb, Lunetta digital synthesizer, Farfisa organ, electric violin, electric viola, electric cello.
Extras: Composition services available and contacts with many creative musicians. Many film score credits.
Rates: \$20/hr; composition fees negotiable.
Direction: EMA is particularly well suited for production of electronic music for film scores, commercials, etc. We have experience in electronic music logos, soundtrack "sweetening" and sound effects.

•• FEATHERSTONE RECORDING STUDIOS

8996 Fruitridge Road, Sacramento, CA 95828
(916) 383-4385

General Manager: Vladimir Sirota.
Engineers: Chief Eng. Tom Conrad; 2nd Eng. Gene Peneau.
Dimensions of Studios: 23' x 28' (13' slope ceiling 4 non-parallel walls).
Dimensions of Control Rooms: 14' x 12'.
Tape Recorders: Tascam 80-8 8 track, Dokorder 7140 4 track, TEAC 6100 2 track.
Mixing Consoles: Tascam Model 5, 8 in x 4 out, Tascam w/expander Model 5, 8 in x 4 out.
Monitor Amplifiers: Peavey CS 400.
Monitor Speakers: JBL 4311.
Outboard Equipment: dbx compressor/limiters, Tapco graphic equalizers, Tapco reverb, MXR digital delay, dbx noise reduction, Tascam Model 1 line mixers (headphone cue system).
Microphones: Neumann U-87's; Sennheiser 441's, 421's; Beyer 260's, 160's, 500's; Electro-Voice RE-15's; Shure SM-57's, SM-53's; Altec 624's.
Instruments Available: Grand piano, organ w/Leslie.
Extras: Dubs available in session packages at NO extra cost. High-speed cassettes & reel dubs made from your master tape at super low cost.
Rates: Call for rates.
Direction: We'll do all we possibly can to obtain what our client wishes for in quality. No short-cuts to a professional sound, just good engineering is what we offer, and the best engineering staff.

•• FOXFUR STUDIO

4709 Guerneville Rd., Santa Rosa, CA 95401
(707) 823-9511

Owner: Stuart Quan.
Engineers: Randy Quan, Jeff Brown.
Dimensions of Studios: 12' x 20' x 8'.
Dimensions of Control Rooms: 12' x 8' x 8'.
Tape Recorders: Scully 280-B 8 track; TEAC 25-2 w/dbx 2 track.
Mixing Consoles: Tascam Model 10, 12 in x 6 out; Tapco 6200B, 6 in x 2 out.
Monitor Amplifiers: Dynaco ST-120.
Monitor Speakers: JBL 4311, Auratone.
Echo, Reverb, and Delay Systems: Orban 111B dual reverb.
Other Outboard Equipment: Allison Gain Brain (2), Allison Kepex (2), SAE 2800 2-channel parametric, Altec tube compressor amps (2), Bi-Amp EQ 210.
Microphones: Beyer M500's, M160; Shure SM-56's, SM-57's; Sennheiser 421, 441; Sony (4 misc. condensers); AKG D190E's, D-1000E's.
Instruments Available: Yamaha electric grand, Milton upright, Fender Rhodes 88, RMI electric, Hammond M-3 w/Leslie, Micro Moog, Elka String Choir keyboards, Gibson Les Paul Std., Fender Stratocaster, Rickenbacker bass, guitars.
Rates: Please call for rates.
Direction: Our work consists mainly of our own in-house music productions, although outside projects are welcome if an artist or producer desires more than just a budget demo.

•• GOPHER GOLD

also REMOTE RECORDING
495 Primevera, Boulder Creek, CA 95006
(408) 425-7784

Owner/Studio Manager: Gopher.
Engineers: Gopher, Robert Beede.

eight track

Dimensions of Studios: 11' x 33'.
Dimensions of Control Rooms: 9' x 15'.
Tape Recorders: Otari MX 5050 8SD 8 track; Otari MX 5050 1/2 track.
Mixing Consoles: Sound Workshop 1280, 8 EQ, 24 in x 8 out.
Monitor Speakers: Speck 2.
Monitor Amplifiers: JBL Auratones.
Echo, Reverb, and Delay Systems: Orban, tape echo.
Other Outboard Equipment: dbx 160 compressors, dbx noise reduction, programmable effects.
Microphones: Sennheiser, Shure, E-V, AKG.
Instruments Available: Buchla Series 200/300 computer controlled electronic music system.
Extras: Espresso, excellent vocalist for back-ups, and arranging.
Rates: \$20/hr for 8 track.
Direction: We are leaning more toward remote recordings. Credits so far for remotes: James Brown, "Live In Monterey", Starbaby, Airtight, and Streamliner. Our engineers are excellent and can give the sound you want. We are located on the peaceful San Lorenzo River and can make you comfortable and relaxed so you can do your best work.

•• GRASS ROOTS SOUND STUDIO

2737 NE 25th, Portland, OR 97212
(503) 284-9274

Owner: Michael O'Rourke.
Studio Manager: Matt Blender.
Engineers: Andy Simon, Lee Lusted.
Dimensions of Studios: 13' x 26'.
Dimensions of Control Rooms: 13' x 26'.
Tape Recorders: Otari 5050 8SHD 8 track; TEAC 3340 4 track; Otari 5050 2SHD 2 track.
Mixing Consoles: TEAC Model 3, 8 in x 8 out; Sony MX20, 8 in x 4 out.
Monitor Amplifiers: Pioneer SA 7500.
Monitor Speakers: JBL 4311.
Echo, Reverb, and Delay Systems: Tapco.
Other Outboard Equipment: TEAC Dolby NR (4-channels), Tapco graphic EQ.
Microphones: Sony C-37P, AKG 451E, Primo, AKG D200.
Extras: Free beer, coffee during session. Comfortable surroundings.
Rates: 8 channel: \$25/hr, 4 channel: \$15/hr, set-up \$12/hr.
Direction: Grass Roots Sound Studio is used primarily as a production facility for Grass Roots Records. Grass Roots Records is an independent record label producing traditional and contemporary music from the Northwest. Most of the releases on Grass Roots Records have been recorded in our studio. The studio is available for hire and produces very good results for projects requiring up to 8 tracks. Our major experience has been record and demo tape production.

•• HOLY MOSES PRODUCTIONS

P.O. Box 12357, San Francisco, CA 94112
(415) 333-8833

Dimensions of Studios: 16' x 20', high ceiling; vocal booth 6' x 16'.
Dimensions of Control Rooms: 14' x 16'.
Tape Recorders: Otari 7308, 1 inch, 8 track; TEAC 3340S 4 track; TEAC 3300SX 2 track; TEAC A650 cassette.
Mixing Consoles: Quantum 168 with 16 track monitoring 16 directs.
Monitor Amplifiers: Crown DC 300.
Monitor Speakers: JBL 4333A, JBL 166, Auratones.
Outboard Equipment: 3 UREI 1176 LN limiters, reverb, equalizers.
Microphones: Neumann U-87's; E-V RE 20's; AKG; Sennheiser; Sony condenser; Shure.
Instruments Available: Yamaha upright grand, studio bass.
Rates: \$35.00 per hour.
Direction: We have created a virtual 'oasis' in San Francisco for our musicians. Here you can live-in while creating quality recordings at reasonable rates, with a fully equipped kitchen and hot tub. Our sound system speaks for itself.

•• HORIZON AUDIO RECORDING CO. (H.A.R.C.)

10297 Bethel Burley Rd., S.E. Port Orchard, WA 98386
(206) 876-4972

Owner/Studio Manager: Kerry L. Pilling.
Engineers: Kerry L. Pilling, Bert Schneider.
Dimensions of Studios: 15' x 24'.
Dimensions of Control Rooms: 9' x 10'.
Tape Recorders: TEAC 80-8 8 track; Pioneer RT-707 4 track; TEAC A-420 4 track cassette dub's.
Mixing Consoles: TEAC Model 5A, 8 in x 8x4x2 out.
Monitor Amplifiers: Kenwood.
Monitor Speakers: Infinity 1001A's.
Echo, Reverb, and Delay Systems: Roland Space Echo RE-201.
Other Outboard Equipment: Bi-Amp 210 graphic EQ, PB-64 patch bay, 1/4" phone jack, double row 19" rack mount patch bay, MB-20 4-ch meter bridge, B.I.C. turntable, test-tone oscillator, db meter portable, AKG and Koss headphones.
Microphones: Shure SM-57, SM-53, 5565; Sony ECM-51; AKG 1000E's, and assorted mic stands.
Instruments Available: Ovation 6-string Classic, spinet piano, Ludwig 6-piece drum set w/24" ride Zildjian, 20" ride Zildjian, 16" hi-hat Zildjian; 135-watt twin twelve custom made guitar amp; various Latin percussion inst's available: cabasa, gourds, bells, wood blocks, tamborines, etc.; Sunn bass amp and cabinet, Fender Precision Bass.
Extras: Gibson Fuzz Tone, Maestro guitar pick-up, Promo pic's available upon request.
Rates: \$25/hr recording plus cost of master tape; \$15/hr mixdown rate plus cost of tape. Block booking rates available. 8-track master tapes can be rented for 1/2 the cost of purchase of same. Mixdown tapes can be purchased at our cost — satisfaction or no charge.
Direction: We're relatively new and are the 1st 8-track in Kitsap County. Currently doing demo's for groups. This studio was founded on the premise that musicians deserve a break and we'll tackle anything, commercials, demo's, record masters, etc. Aspirations: To grow to a full service studio, i.e.: publishing, copy-righting, record pressing, photo layouts, promo pics, etc.

•• HUMBOLDT SOUND SERVICES

P.O. Box 3063, 411 D Street, Eureka, CA 95501
(707) 445-3760

Owner/Studio Manager: Edward Lapple
Engineers: Edward Lapple, Mary Gant.
Dimensions of Studios: Main studio: 24' x 14', vocal booth: 8' x 5'.
Dimensions of Control Rooms: 17' x 14'.
Tape Recorders: Tascam Series 70-8 8 track; Tascam Series 70-2 2 track; Studer A62 2 track.
Monitor Amplifiers: Crown DC-150 & Crown D-60.
Monitor Speakers: ESS 1 AMT control room monitors & Davids for radio and TV jingles.
Echo, Reverb, and Delay Systems: Marshall Time Modulator 5002, Multi-Track stereo reverb.
Outboard Equipment: dbx noise reduction, dbx compressor/limiters, Kepex, MXR Studio Phase, SAE 2800 parametric EQ, Tapco 2200 graphic EQ, two turntables, cart machine, cassette duplications.
Microphones: Electro-Voice RE-20, 666's; Sony ECM 22P's, C37; AKG C451E's, DM700, D202E's; Shure SM-57's, 545.
Instruments Available: Rich Bass, Goya acoustic, Fender Rhodes 88 key, upright grand, octave Cat SRM synthesizer.
Extras: A wet bar and game room to relax and create or organize in and a complete electronic repair service to put your mind at ease. Custom record production and video cassette duplication facilities in house.
Rates: 1/2" 8 track: \$20.00, 1/4" 2 track: \$17.50 per hour.
Direction: Humboldt Sound Services has been serving the North coast of California for five years with professional quality at reasonable rates in a most comfortable environment for anyone to create in. We are BMI music publishers and specialize in all phases of audio and video production.

•• ISOLATION

24 Geriola Ct., Pleasant Hill, CA 94523
(415) 937-8552

Owner: David Denny.
Engineer: David Denny.
Dimensions of Studios: 12' x 15'.
Dimensions of Control Rooms: 9' x 10'.
Tape Recorders: Tascam 80-8 w/dbx 8 track; TEAC A3300SX 2 track with dbx 155; TEAC A 2340 SX 4 track; Sony TC K2A cassette.
Mixing Consoles: Sound Workshop 1280 B, 12 in x 8 out, with Super EQ; Tascam Model 1, 8 in x 2 out; Technical Audio 6201B, 6 in x 2 out.
Monitor Amplifiers: Kenwood KA 8100, QSC 150, Fisher 500C.
Monitor Speakers: JBL 4311's, Auratones.
Outboard Equipment: dbx 4-channel 155, SAE 1800 parametric EQ, Ashly SC-50 peak limiter-compressor, Shure Level-Loc, ADR Phase, Roland RE-301 Chorus Echo/reverb, Echoplex, 150 point patch bay, Korg tuner, Sony headphones.
Microphones: Sennheiser, AKG, Shure, Sony, E-V, Sescorm directs.

WE SUPPLY THE REVOLUTION.

Northern California has become a major center in the business of recording. Five years ago, it wasn't. If revolutions can happen, one has happened in the Bay Area. We know. We've been supplying the tools.

If you don't know about Sound Genesis, you should. Among Northern California's professional audio dealers, Sound Genesis stands out as the most complete in terms of equipment offered and service delivered.

You be the judge. We carry over 100 lines of the best in pro-audio. Recorders, amps, signal processing, automated boards, mics, PA, anything you could need. But it's not just the hardware, it's what you get with it that counts.

At Sound Genesis, you'll get the competent advice you need to keep your studio cost effective while upgrading for new technology. And you'll get the service it takes to keep your equipment working at optimum performance.

Our Tweaking is among the industry's best. Some manufacturers even rely on it to help test and perfect their equipment designs.

Above all, Sound Genesis is not too big to get small with you. No matter what level you're on, professional engineer or musician, our people will help you get what you need, within your budget.

Sound Genesis, 2001 Bryant St., corner of 18th, San Francisco, CA. (415) 285-8900, TWX 910-372-7393.

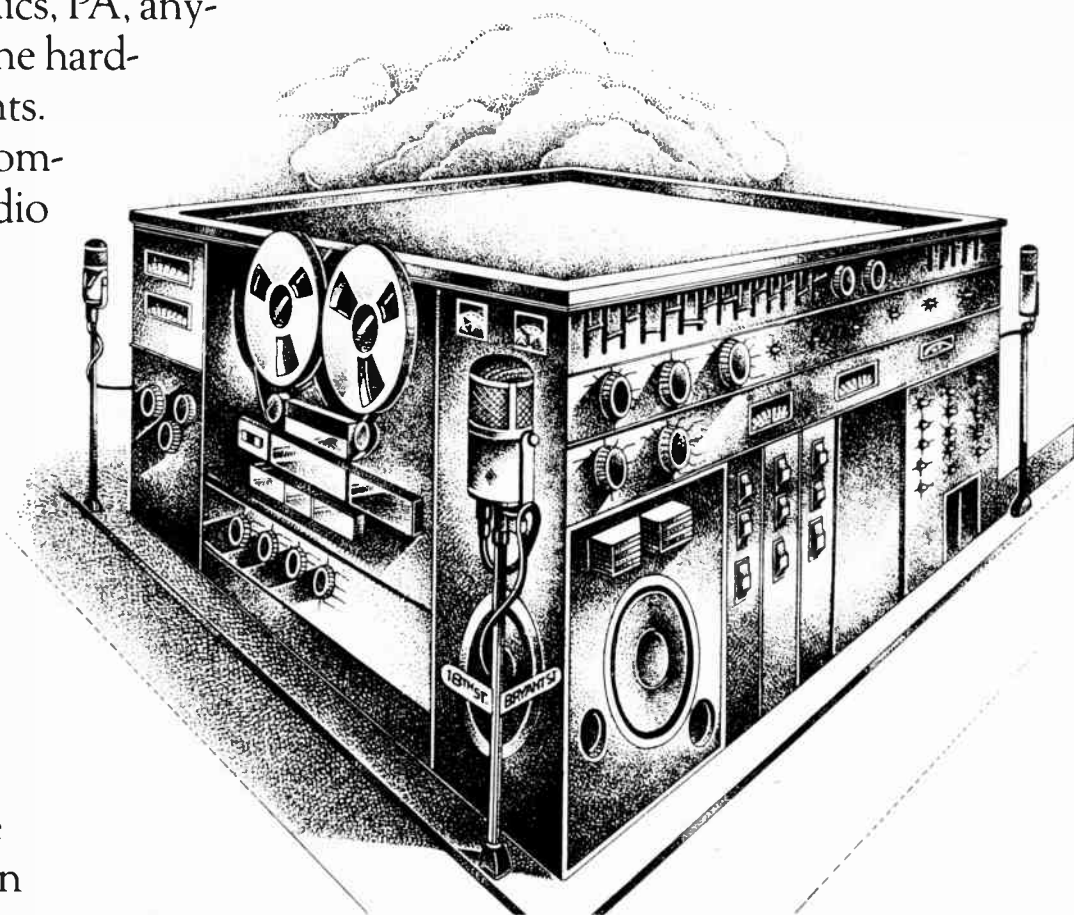

Before you make a sound, listen to us.

sound genesis
SAN FRANCISCO

Instruments Available: Roland synthesizer, Mitchell, Traynor, Kustom, Fender amps; 330 Gibson, Fender Delux Telecaster, Ovation 12-string, Ibanez Artist guitars; percussion instruments and Valja congas, Roland sustain/phase, MXR distortion.

Extras: Professional seasoned studio musicians available (all have played in name bands). Lots of top equipment at their disposal from string machines to top synthesizers — Prophet 5, etc. \$45 per man per 4-hours. Excellent studio drummer available. Redwood deck to relax with BBQ and refrigerator.

Rates: \$20/hr, bulk rates negotiable.

Direction: David Denny — a musician, writer, engineer, producer/arranger has been involved with the music business for close to 20 years, and has logged hundreds of hours in the studio while a member of the Steve Miller Band. The studio is capable of jingles, film tracks, Gospel sessions, or any kind of demos for record companies.

•• JOYFUL SOUND;
P.O. Box 7351, Sacramento, CA 95826
(916) 487-1212

Owner: Robbie and Rosina Robertson.

Engineers: Robbie.

Dimensions of Studios: 14' x 20'

Dimensions of Control Rooms: 10' x 11'

Tape Recorders: TEAC/Tascam 80-8 8 track; Tandberg; Revox.

Mixing Consoles: TEAC/Tascam Model 5 console, 2 Shure Model 5 mic mixers.

Monitor Amplifiers: SAE Model 2200 (100 Watts per channel).

Monitor Speakers: JBL 4311 control monitors.

Outboard Equipment: 8-channels of dbx noise reduction.

Microphones: Sennheiser MD 421-U dynamics, MKE 402 electret condensers; assorted Shure mics: SM-53, 54 & 58's.

Instruments Available: Grand piano.

Rates: \$25/hr studio time; \$15/hr mixdown.

Direction: We offer to the Sacramento area a well equipped 8 Track semipro studio for demo tapes for professionals and a very adequate facility for semipro musicians. We offer multi-track sessions with 2 Track mixed-down masters for demos or record manufacture of vocal and instrumental musicians from church, school and community organizations. Gospel and sacred sessions are our specialty.

•• LION TRACKS/CREATIVE ENTERPRISES

also REMOTE RECORDING

Box 846, Cotati, CA 94928

(707) 762-3482

Owner/Studio Manager: Mario Lewin.

Engineers: Mario Lewin, Pattie Lewin — Assistant Engineer.

Dimensions of Studios: 25' x 25'

Dimensions of Control Rooms: 25' x 15'

Tape Recorders: TEAC/Tascam 80-8 8 track; Sony TC-355 2 track; TEAC A-150 2 track.

Mixing Consoles: TEAC/Tascam Model 5, 8 in x 4 or 8 out; Peavey MC-12, 12 in x 2 out.

Monitor Amplifiers: Sherwood, Peavey.

Monitor Speakers: Peavey, JBL's, Transaudio.

Outboard Equipment: Peavey EQ, reverb, dbx.

Microphones: Shure SM-57, 58's; AKG D-190E, D-160E, D-2000E.

Extras: Mobile recording at excellent rates, refrigerator, country setting w/laid back atmosphere, session musicians available on advance request, production and creative assistance on request, no extra charge, creative atmosphere.

Rates: \$12/hr even though we have the best rates going, we will negotiate for blocks of time. No charge for tape on short term projects. (Groups or artists may always supply their own.) Rates subject to change without notice. We reserve the right, etc.

Direction: We put out a good product at exceptionally affordable prices and we will endeavor to continue this policy.

•• MAGIC SOUND

also REMOTE RECORDING

1780 Chanticleer Ave., Santa Cruz, CA 95062

(408) 475-7505

Owner: Alan Goldwater.

Engineers: Alan Goldwater, Gary Culton.

Dimensions of Studios: 18' x 20'; 12' x 14' drum room; 5' x 6' x 7' vocal booth.

Dimensions of Control Rooms: 12' x 14' x 16'

Tape Recorders: Ampex/Inovonics 300/375 8 track; Ampex 440B 2 track; Sony 355 2 track; Sony TC 152 cassette; Kenwood 1030 cassette.

Mixing Consoles: (2) Magic Devices, 16 in x 8 out; Tapco 6000 (rehearsal PA mix).

Monitor Amplifiers: Dynaco 150 & 400.

Monitor Speakers: Altec 604E (control room); JBL LE 14 (studio PB); Sennheiser (4) and Koss (4) phones.

Outboard Equipment: Eventide Flanger, MXR Flanger, Multi-Track stereo reverb, Roland Space Echo, misc. black boxes.

Microphones: Shure SM-57's, 58's, 53, 56's; Beyer XLN's, M260; AKG C414EB's, D160, D190; Sony ECM 22, ECM 280, ECM 16.

eight track

Instruments Available: Upright piano, Guild and Gibson guitars, Fender Deluxe and Princeton amps. Hammond B-3 w/Leslie, Rhodes, Hohner clavinet available with prior notice.

Extras: Kitchen access, hot tub, concert sound system for live remotes, studio musicians, arranger, and copyist on call.

Rates: \$25/hr with engineer, \$20/hr block, free set-up (1 hour max.), \$6/hr rehearsal prior to session.

Direction: Thanks to many friends and clients whose support has made the studio a continuing success. Our motto: Loud and Clear.

•• PETER MILLER RECORDING STUDIO
Union Street (at Fillmore), San Francisco
P.O. Box 11013, San Francisco, CA 94101
(415) 567-7040

Owner/Studio Manager: Peter Miller.

Engineers: Peter Miller.

Dimensions of Studios: 28' x 23'

Dimensions of Control Rooms: 12' x 12'

Tape Recorders: 3M Series 410 8 track; Sony 854-4 4 track; Revox A-77 2 track.

Mixing Consoles: Response (English) BM 104, 10 in x 4 out.

Monitor Amplifiers: Quad 33/303; McIntosh MC 30.

Monitor Speakers: Altec 604-8G in nine cubic foot cabinets, Auratone Sound Cubes.

Echo, Reverb, and Delay Systems: AKG BX 10 Reverb (stereo); Orban/Parasound Reverb (stereo); Binson delay echo; Sansui reverb; various tape delay machines.

Outboard Equipment: Apollo compressor/limiter; SAE 2700B forty band graphic equalizer; Kepex noise gates; Goobly Box; four isolation booths.

Microphones: Neumann U-87, KM-84; AKG C28, D1000E, D19C; Shure SM-54, SM-58; Sony electret condensers.

Instruments Available: Kimball piano; Ludwig drums; Fender, Peavey, Kustom amplifiers; Gretsch electric guitar; Levin acoustic guitar.

Extras: Kitchen, garden.

Rates: \$25/hr and tape; block time available.

Direction: Hit records. Peter Miller has worked in studios since 1959, as artist, engineer, producer and session musician. He has been associated with the release of over 20 records in England and in the U.S.A. with hits in England and Germany. He has had in excess of 200 songs published and toured extensively with the Beatles and Stones during the 60's. The studio has recently begun doing video demos also.

•• MIX-MASTER RECORDING

6881 Oakdale Rd., Winton, CA 95388

(209) 358-5744, if no ans. 358-3822

Owner/Studio Manager: Jim Schriber.

Engineers: Jim Schriber, Bill Schriber, Lynn Shultz, Greg Prince.

Dimensions of Studios: 21' x 18', drum booth 8' x 7', instrument booths 4' x 5', 4' x 5½', and 4' x 6'.

Dimensions of Control Rooms: 6' x 18'

Tape Recorders: Tascam 80-8 8 track; TEAC 3300S2-T 2 track; Sony TC-630 2 track; Technics 858 4 track; Roberts, Pioneer, and Craig 2 track cassettes; Technics, Sound Design 8-track cart.

Mixing Consoles: Tascam Model 5, 8 in x 8 direct and 4 sub; Peavey modified PA600, 6 in x 2 out; Kasino, 5 in x 1 out.

Monitor Amplifiers: Crown, Sony, Sunn, Peavey.

Monitor Speakers: Altec A7's, JBL, Sony.

Echo, Reverb, and Delay Systems: Tape echo, custom spring reverb, Echoplex.

Other Outboard Equipment: Distortion analyzer, phase shifter.

Microphones: Shure, AKG, Electro-Voice, Sony.

Instruments Available: Gibson acoustic, Gibson ES-345, Gibson EB-2, Ludwig and Rogers drums, Twin Reverb, Sunn 1200's, bongos, tamborine, or misc. percussion at no extra cost. Rentals include Elka String Machine, Rhodes piano, and Hammond B-3.

Extras: Studio musicians at amazingly reasonable rates, lead sheets, arranging, cassette and 8-track duplication on a 1:1 basis.

Rates: \$25/hr on down, 8 hour block \$100, 6 hour block \$85, 4 hour block \$65, 2 hours \$40, "Special!" 40 hour block \$300. With the 40 hour block, musicians may bring sleeping bags and

sleep at the studio if they wish. The 40 hour block is perfect for bands cutting low cost albums to sell at the gig.

Direction: To serve the music industry as best we can, and produce high quality tapes at a good price. We are also a "jingles" facility with excellent writers, arrangers, singers, and musicians. We believe we can cut a better commercial for the money you are putting out, and are willing to guarantee it, money back! We are located in the exact middle of California, within hours of anyone in the state.

•• MONTEREY SOUND
121-A Ocean View, Pacific Grove, CA 93950
(408) 373-5408

Owner: Corporation.

Studio Manager: Woody Barr.

•• MUSIC ARTS RECORDING STUDIOS M.A.R.S.

also REMOTE RECORDING

5944 Freedom Blvd., Aptos, CA 95003

(408) 688-8435 (for appointment or info.)

Owner/Studio Manager: Ken Capitanich.

Engineers: Ken Capitanich, and others available.

Dimensions of Studios: 14' x 18'

Dimensions of Control Rooms: 14' x 7'

Tape Recorders: Tascam w/dbx 80-8 8 track; Tascam w/dbx 25-2 2 track; TEAC 3340-S 4 track; Sony ½ track TC756-2 2 track; Sony TC158-SD 2 track cassette.

Mixing Consoles: Tangent 3216, 12 in x 12 out; (2) Tascam Model 5, 16 in x 8 out.

Monitor Amplifiers: Marantz 250; Pioneer.

Monitor Speakers: ESS AMT 3; JBL 4301; Auratones.

Echo, Reverb, and Delay Systems: Sound Workshop 242 reverb, S24 Time Shape Module, ADT flanger.

Other Outboard Equipment: 12-channels dbx noise reduction; MXR Limiters; MXR Phaser; Burwen dynamic noise filter; Soundcraftsmen 10-band EQ; ADR expander gates; ADR compressor/limiter; ADR parametric EQ.

Microphones: Electro-Voice RE-20, RE-16, DS-35; Shure SM-57's, SM-54, 545SD; Sony ECM 33's, ECM 22; AKG 451's, 414's; Sennheiser 421-U's, 441-U; Beyer M 500N's, direct boxes.

Instruments Available: Piano, organ, amps, Rhythm Box.

Extras: Sundeck with view, kitchen, located in the tranquil Aptos Hills, free from freeway and residential madness.

Rates: \$25/hr, block rates available.

Direction: M.A.R.S. has been growing with the Santa Cruz musical community for the past five years. A comfortable and relaxed environment exists here without high pressure or high prices. We specialize in demo tapes, low budget production, jingles for radio and TV, and some location recordings.

•• NOVA SOUND CO.
3048 Rollison Rd., Redwood City, CA 94063
(415) 384-7489 or 387-0782
Owner: Mark S. Cooper



OASIS RECORDING STUDIO
San Francisco, CA

•• OASIS RECORDING STUDIO
395 Sussex St., San Francisco, CA 94131
(415) 587-3564

Owner: Greg Goodwin

Engineers: Greg Goodwin, Wayne Lewis, Brian Gendron.

Dimensions of Studios: 15' x 30'.

Dimensions of Control Rooms: 10' x 16'.

Tape Recorders: Tascam 80-8 8 track; TEAC 3340 4 track; Revox A77 ½ track; SAE C3D cassette.

Mixing Consoles: (2) Tascam Model 5's 16 in x 8 out.

Monitor Amplifiers: BGW, McIntosh, Symetrix.

Add a Touch of Gold

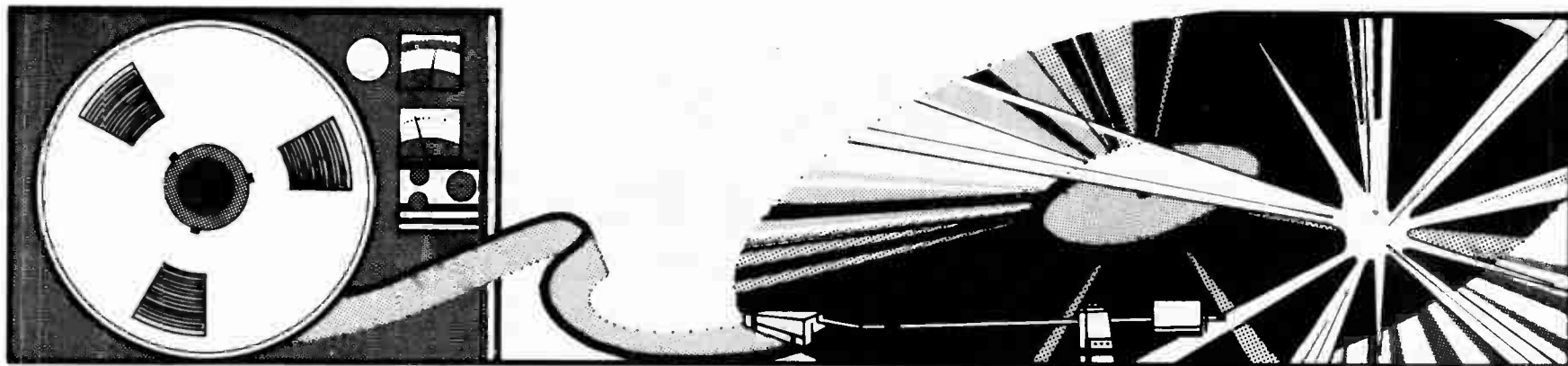

to your next Demo

For a limited time only, Tres Virgos Studio is offering the Ultimate Demo Package.

Engineering by Dr. Richie Moore

- 15 Gold albums, 5 Platinum albums, 1 Emmy
- Credits include: Beatles, Led Zeppelin, Little Feat, Pablo Cruise and many more

State-of-the-art 8 track recording studio

Located on three acres in the beautiful foothills of Mt. Tam

15 minutes from San Francisco

\$30 per hour

Tres Virgos Studio
Mill Valley

Phone 388-7799 for details

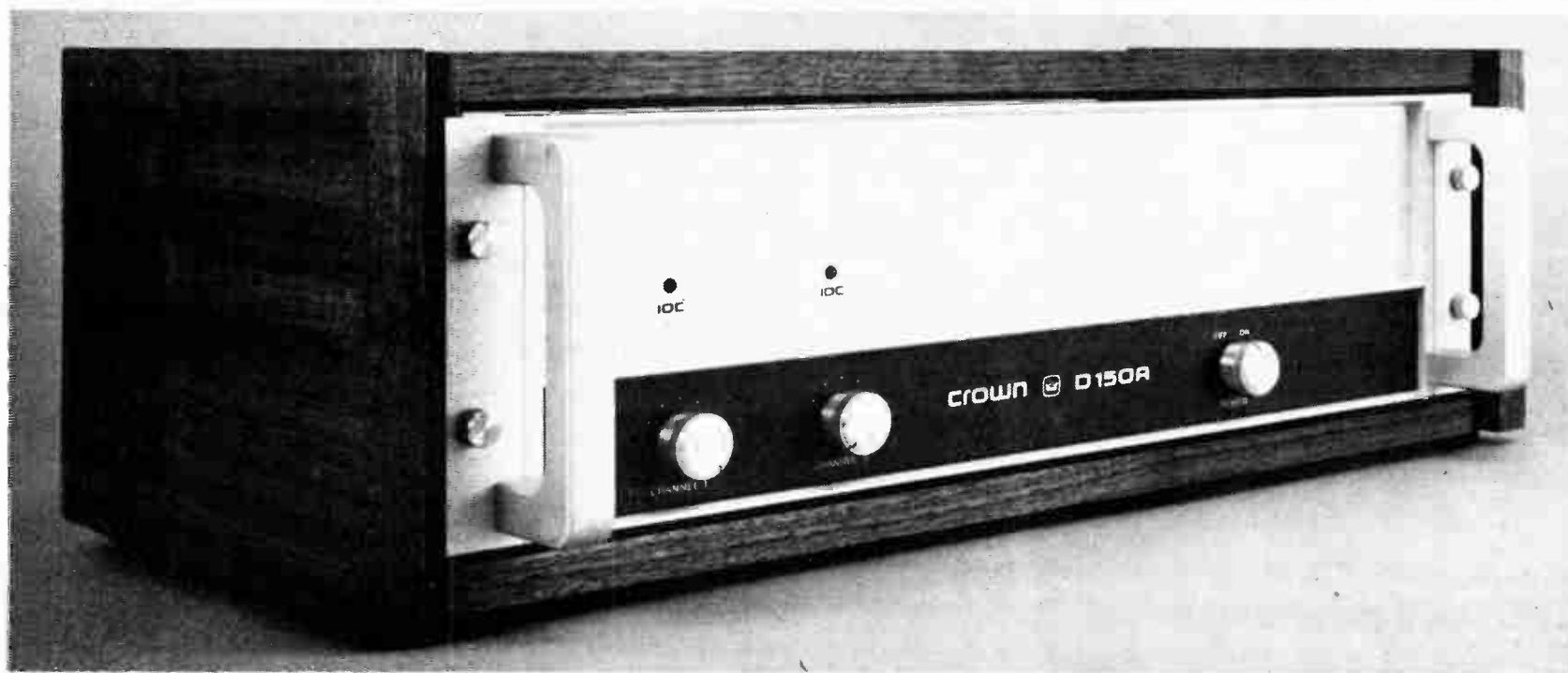

(714) 985-0701 P. O. Box 734
1620 W. Foothill Blvd. UPLAND, CA

Monitor Speakers: JBL 4311's, Klipsch, Altec, Auratones.
Echo, Reverb, and Delay Systems: Orban 111B reverb, Loft 440 delay/flanger, Roland Chorus.

Outboard Equipment: dbx noise reduction (8 track), UREI compressor/limiters, Orban parametric EQ, Bi-Amp graphic EQ, (2) Tascam Model 1's for stereo headphone mixes.

Microphones: Neumann U-87, KM84; Sennheiser 421, 402; AKG 414; Beyer M500, M260; Electro-Voice RE-20, 1776; Shure SM81, 57.

Instruments Available: Studio upright piano (excellent tone); Fender pre-CBS Superamp; Peavey Mace.

Extras: Production assistance available; also studio musicians; conveniently located in San Francisco but away from the downtown madness. Call for advice on how to make the most of your studio time.

Rates: \$20/hr 8 track; \$15/hr 2 and 4 track. Prices may vary; block rates available.

Direction: Our specialty is producing high quality demos, but we have handled material extending from mastering for record cutting to soundtracks for film advertising seen on national television. Oasis strives to provide a comfortable, low-key atmosphere while producing as professional a recording possible.

•• PEEKABOO MOUNTAIN STUDIOS

117 Palmyra St., Auburn, CA 95603
 (916) 885-1708

Owner: Jeff and Charles Hester.

Engineers: Charles Hester.

Dimensions of Studios: 14' x 28'

Dimensions of Control Rooms: 14' x 10'

Tape Recorders: TEAC 80-8 8 track; (2) TEAC 3340-S 4 track; TEAC 2 track cassette.

Mixing Consoles: TEAC Model 5, 8 in x 8 out.

Monitor Amplifiers: Kenwood KA-7100, Marantz 2200B.

Monitor Speakers: ESS Studio Monitors (control room), Altec monitors for the studio.

Echo, Reverb, and Delay Systems: Tapco 4400 stereo reverb.

Other Outboard Equipment: Tapco 2200 10-band stereo EQ, dbx 160 compressor/limiter, DX-8 noise reduction for the 80-8 8 track.

Microphones: AKG C414EB; Sennheiser MD 421; Beyer M260's, M500's; Shure SM-57, PE515.

Instruments Available: Baldwin piano, Music Man amp, Fender Deluxe with JBL.

Extras: Studio musicians available for custom radio commercials with male or female announcers.

Rates: No set rate for commercials, base price \$60 for 30 second commercial, \$100 for 60 second commercial.

Direction: We will open to the public when we have the equipment and environment available to satisfy the musicians and our needs. We give credit to Doc Siegal for his patience.

•• POLITE PRODUCTIONS

El Cerrito, CA
 (415) 525-6289

Owner: Randy Rood.

Engineers: Randy Rood.

Dimensions of Studios: 15' x 17'

Dimensions of Control Rooms: 17' x 15'

Tape Recorders: Tascam 70-8 8 track; Revox A77 2 track; assorted cassette machines.

Mixing Consoles: TEAC Model 3, 8 in x 4 out.

Monitor Amplifiers: Marantz, Dynaco tube amps.

Monitor Speakers: Altec 604's, Auratones.

Echo, Reverb, and Delay Systems: Ibanez analog delay, flanger, Orban/Parasound, Fender and Tapco reverb units.

Other Outboard Equipment: dbx compressors, dbx noise reduction, Furman parametric EQ, noise gates, phase shifters, etc.

Microphones: Neumann, AKG, Sennheiser, RCA, Electro-Voice, Shure, Beyer.

Instruments Available: Old Fender amps, old piano, old Farfisa organ, new harmonica, some percussion.

Extras: Secluded and homey environment.

Rates: \$15/hr, block rates and set-up time available.

Direction: All types of music.

•• THE PRODUCTION RESOURCE

1 Holland Court, San Francisco, CA 94103
 (415) 543-7522

Owner: P.R. is a Corporation

Studio Manager: Matthew Elsen.

Engineers: Douglas McVickar (President), Matthew Elsen.

Dimensions of Studios: 23' x 16'

Dimensions of Control Rooms: 15' x 18'

Tape Recorders: Tascam 80-8 8 track; Ampex 441B 4 track; Ampex AG350 2 track; Ampex AG350 mono; Otari MX 5050 2 track; Sony and Dual cassette machines.

Mixing Consoles: Speck 800C, 16 in x 8 out; TEAC Model 10, 12 in x 4 out.

Monitor Amplifiers: SAE Mark XXX 1B, Crown D60.

Monitor Speakers: DWD's, Auratone Sound Cubes.

eight track

Echo, Reverb, and Delay Systems: Multi-Track stereo reverb.

Outboard Equipment: dbx compressor, dbx noise reduction system, Multi-Track parametric EQ, Russco Pro Model B turntables.

Microphones: Sennheiser 441's, Shure, Electro-Voice, MB.

Instruments Available: MSA pedal steel guitar, amplifiers, guitars and synthesizer with sequencer.

Extras: Our facility is pleasant, roomy and comfortable, Franklin Stove, skylights and refreshments, also ping-pong table and electronic games.

Rates: \$30/hr, (\$40/hr eves and weekends). Substantial reduction for music/block booking. Rates include all services and equipment except dubs and creative fees.

Direction: Commercial production house/recording studio; the Tascam 80-8 should be in by the time this issue is distributed. Speciality — production of radio and TV commercials, presentations, jingles, music soundtracks, and radio program production. Projects from concept to finish. Our success is our top quality sound, service and attitude. We produce!

•• PUGET SOUND

(206) 523-1087

Owner/Studio Manager: Pat Hewitt.

Engineers: Pat Hewitt.

Dimensions of Studios: 13' x 15', 13' x 12'

Dimensions of Control Rooms: 13' x 10'

Tape Recorders: TEAC 80-8 8 track; Sony 854-4 4 track; Sony 854-2 2 track.

Mixing Consoles: Antares Model 16, 16 in x 4 out; E-V/Tapco.

Monitor Amplifiers: Tube McIntosh 75's and 30's, Dynaco 120 head phones.

Monitor Speakers: A7B's and Auratones.

Echo, Reverb, and Delay Systems: Tapco spring.

Other Outboard Equipment: Symetrix compressor/limiters, and phase, dbx.

Microphones: Neumann U-87's, Sennheiser 421's; Beyer M500N's, Shure SM-54, 53's, 57's.

Instruments Available: Gibson & Fender guitars, Hammond C-3 elect. piano, Fender amps.

Direction: Funky-clean.

•• RAL-TBK RECORDING

also REMOTE RECORDING

3130 W. Bailey (mail); 2851 Oleander (studio),

Merced, CA 95340

(209) 722-3220

Owner/Studio Manager: Robert Laughton.

Engineers: Robert Laughton, Terry Kelley.

Dimensions of Studios: 20' x 20' down stairs.

Dimensions of Control Rooms: 20' x 15' up stairs with close C, TV monitoring.

Tape Recorders: Tascam T80-8 15ips 8 track; Dokorder 7140 15ips 4 track; Sony TC-377 2 track; Sharp 2 track cassette.

Mixing Consoles: TEAC/RAL, 24 in x 8 out; (3) TEAC Model 1 submixers, 8 in x 2 out or headphones.

Monitor Amplifiers: Dynaco ST400 (bass), Dynaco QSA 300 (mid), TBK Class A for (hi).

Monitor Speakers: RAL 210 (bass) & (mid), ESS (hi), JBL.

Echo, Reverb, and Delay Systems: Hammond spring reverb, Audio Pulse Model 1 digital time delay system.

Other Outboard Equipment: Dolby noise reduction, compressor/expanders, 8-9-band graphic EQ, and complete patch bay facilities.

Microphones: Teledyne EC 100 ELE condensers, Shure SM-58 and SM-57.

Instruments Available: Elka Strings, Roland jazz chorus 60 amp, other instruments available upon request.

Extras: Kitchen, bathroom, coffee. We also manufacture ATA road cases, bass and guitar and PA speakers manufacturing also.

Rates: \$15/hr for 2 & 4-track. \$20/hr for 8-track. Add \$10/hr to above rates for remote recording. 2 & 4-track mixdown \$7/hr. 8-track mixdown \$15/hr plus tape cost.

Direction: We are in this business for you. We like to have fun recording and hope it will be just as enjoyable for you and your group. We are also constantly upgrading our equipment and hope to go 16-track in the near future. We would also

like to help you in any way we can from album cover design to pressing. So feel free to give us a call. PA rental also available.

•• RAM RECORDING

727 Caliente Ave., Livermore, CA 94550

(415) 443-2205

Owners: Don Nelson, Richard Marsh.

Engineers: Don Nelson, Richard Marsh.

Dimensions of Studios: Combination studio/control room: 20' x 10'.

Tape Recorders: Otari 5055 8 track.

Mixing Consoles: Tapco 6200-B 4-er, 24 in x 8 out.

Monitor Amplifiers: Dunlap Clark 500.

Monitor Speakers: Electro Research 340's.

Echo, Reverb, and Delay Systems: Analog custom built delay.

Outboard Equipment: Sony TC-850 mix-down deck.

Microphones: Shure, Sennheiser, Sony, E-V.

Rates: Depends on what musicians can afford.

Direction: Ram started out specializing in strictly on-location live recording, but after 3 years of experience in this area we would like to just concentrate on producing 2 or 3 good music groups per year.

•• BILL RASE PRODUCTIONS, INC.

also REMOTE RECORDING

955 Venture Ct., Sacramento, CA 95825

(916) 929-9181

Owner: Bill Rase.

Engineers: Ray Nakamoto, Ester Marcroft, Stu Boyer, Wayne Johnson.

Dimensions of Studios: Studio Two: 33' x 24'; Studio One: 10' x 24'.

Dimensions of Control Rooms: Control room Two: 24' x 14'; Control room One: 24' x 13'.

Tape Recorders: Ampex M440-C 8 track; Ampex MR-70 4 track; Ampex 351-1, 1 track, Otari 7000 2 track Otari MX-5050 2 track, Ampex 602, 2 track. Plus ten audiophile reel, cassette, eight track, etc, recorders, Movieola-Magnasync edge track 16 mm sound recorder, two Nagra recorders.

Mixing Consoles: Tascam Model 10, 12 in x 4 out, Tascam Model 10, 8 in x 4 out, Shure remote mixer package Model Shure, 12 in.

Monitor Amplifiers: Two Dynakit Stereo.

Monitor Speakers: Altec 604E's and others (7 in all).

Outboard Equipment: Various — including Soundcraftsmen equalizers, Altec compressors, etc.

Microphones: Altec Condensers, Sony Condensers, Shure Dynamics, RCA D-77 ribbons, Altec Dynamics, etc.

Instruments Available: Baby grand piano, Hammond A-100 organ with separate Leslie, Fender Rhodes electric piano, extra Fender amp and speaker, etc.

Rates: \$35.00/hr. first hour for (1 thru 4 track) and \$25.00/hr. thereafter.

Direction: We specialize in producing radio, television and audio-cassette, packaging and shipping). Complete motion picture, cassette and reel duplicating facility (including labeling, printing on cassette, packaging and shipping). Complete motion picture, slide, and film strip production. Both 16mm and 35mm filming available. Full editing facility for rent. Large studio available for live filming. Complete in-studio or remote professional facility.

•• RECORDING TECHNIQUES

also REMOTE RECORDING

4724 S.W. Vacuna St., Portland, OR 97219

(503) 246-6476

Owner: Alan S. Marston, Mark L. Kaltman.

Studio Manager: Mark Kaltman.

Engineers: Mark Kaltman, Stephen Phillips.

Dimensions of Studios: 20' x 18'. Isolation booth A: 10' x 6'; Isolation booth B: 8' x 6'.

Dimensions of Control Rooms: 10' x 8'.

Tape Recorders: TEAC 80-8 8 track; TEAC A6100 ½ track, 2 track; TEAC A-4300SX ¼ track, 2 track; Pioneer 9191 2 track.

Mixing Consoles: Soundcraft Series II, 16 in x 16 out (all inputs have 4-band EQ).

Monitor Amplifiers: Crown D-60, Pioneer SA700.

Monitor Speakers: JBL 4311.

Echo, Reverb, and Delay Systems: Roland RE301 Chorus Echo, Loft 440 delay line/flanger.

Other Outboard Equipment: (4) dbx 161 compressor/limiters, (2) Bi-Amp EQ 210, ORK turntable.

Microphones: AKG 414EB, Sennheiser 421; E-V RE-10, RE-20; Shure SM-57, 58; AKG D707, D-1000, etc.; direct boxes.

Instruments Available: Kimball baby grand piano.

Extras: Free set-up time, location recording, studio musicians, arrangers, singers, and lead sheets. Record pressing at our cost as a service to you. Relaxed air conditioned environment, kitchen, and refrigerator. Private recording engineering classes, and discount blank tape sales.

Coming Soon to the Sound Workshop Series 1600...

New Options.

High Resolution Metering

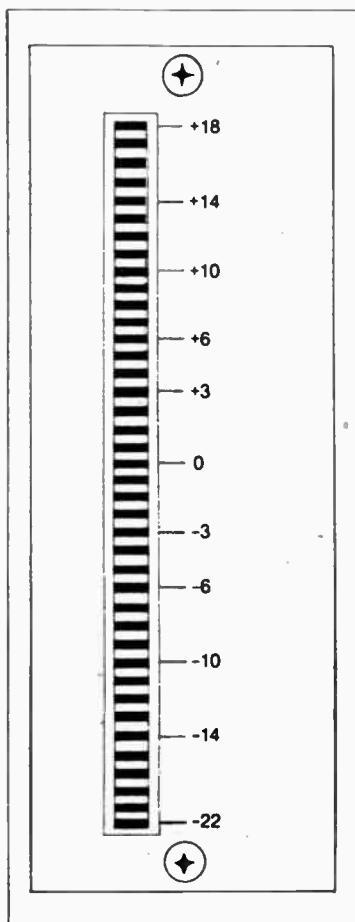

The Sound Workshop Series 1600 is now offered with a High Resolution Meter/Output Module. The 40 segment light bar meter features a 40dB dynamic range, built in spectrum analyzer, and peak, average, and peak/hold modes. (The standard LED column meter is now available with peak reading capability and the Series 1600 can also be fitted with standard mechanical VU meters.)

New Sweepable EQ

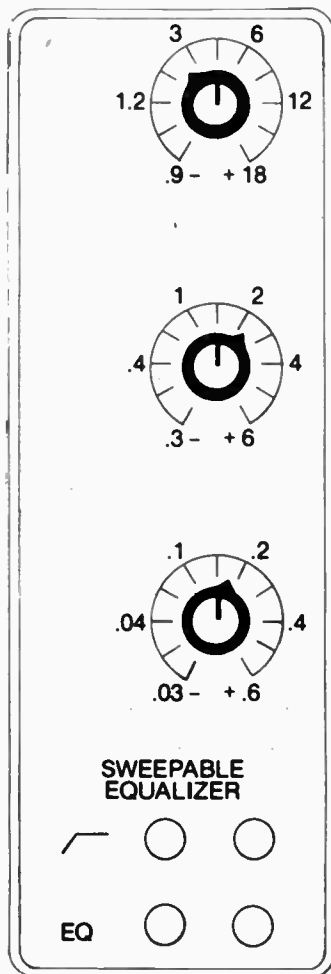

In addition to the standard 15 frequency equalizer and the full parametric EQ, a new sweepable equalizer is available for the 1600. Functionally it is identical to the parametric EQ without variable "Q." Three bands are offered, each with a 20:1 frequency range, and a boost/cut capability of 14dB. As with all Sound Workshop equalizers, the new sweepable EQ is fully stable in all parameters and is totally musical in its action.

Super Group

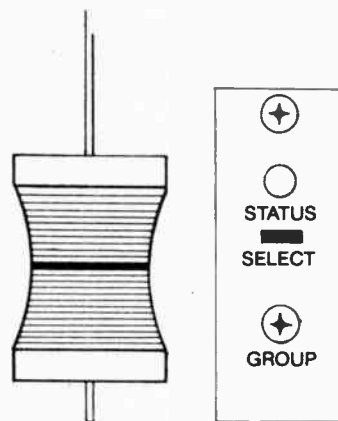

Planned as an option for ARMS Automation is Super-Group; a unique, user oriented grouping system, which provides input subgrouping, limited only by the number of inputs in the console. Super-Group allows instant visual indication of group assignment and status and can be retro-fitted into existing ARMS Automation systems.

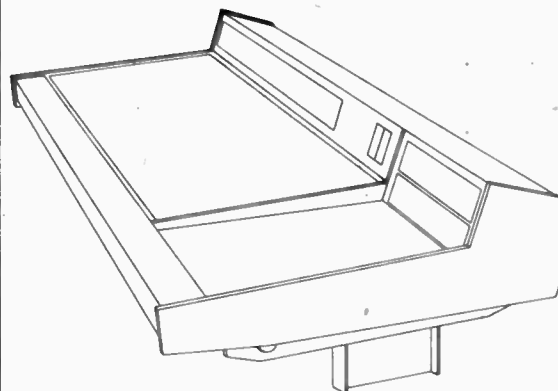

**The Series 1600
Recording Console.**

BRINGING THE TECHNOLOGY WITHIN EVERYONE'S REACH.
Sound Workshop

Sound Workshop Professional Audio Products, Inc.
1324 Motor Parkway, Hauppauge, New York 11787 (516) 582-6210

Rates: \$30/hr on down — 8 track. \$25/hr on down 4 track. \$15/hr 2 track. Package prices. Special prices on album projects.
Direction: Many thanks to the Northwest musicians who, over the past four years, helped to develop Recording Techniques into one of the most popular 8 track studios around.

•• REDWOOD RECORDING

P.O. Box 58, Cotati, CA 94928
 (707) 795-7786 or 823-2007

Owner/Studio Manager: Tom Hallstein.

Engineers: Tom Hallstein, Zeb Stine.

Dimensions of Studios: 20' x 30' x 10'.

Dimensions of Control Rooms: 9' x 12' x 10'.

Tape Recorders: Tascam 80-8 w/dbx 8 track; Otari MX 5050B 2 track; Pioneer 1020H 1/4 track stereo.

Mixing Consoles: Sound Workshop 1280B-8EQ, 12 in x 8 out.

Monitor Amplifiers: SAE 2400L (control room), Kenwood 8006 (cue system).

Monitor Speakers: E-V Sentry V, Auratone 5C.

Echo, Reverb, and Delay Systems: Tapco 4400 reverb, Roland and Maestro tape echo machines.

Other Outboard Equipment: dbx compressor, various phasers and flangers, Ashly parametric EQ.

Microphones: AKG C-414EB, C-451E, C-501; E-V RE-15; Sennheiser MD 421U, 413; Shure SM-57.

Instruments Available: ARP Strings, Roland Sh-3 synthesizer; Aries System 300 synthesizer, Fender Rhodes.

Extras: Musicians, lead sheets, production, information and guidance.

Rates: \$20/hr for recording, mixing, dubbing. Block time discounts available. Keyboards: \$10 per keyboard per session. Synthesizer programming at no extra charge. Nearly any piece of equipment is available for a small extra fee.

Direction: Redwood Recording is in the process of relocating and upgrading our equipment, and hope to be in a new location by September. Synthesizers and signal processing are our strong points. As always, the goal is dynamic and efficient service at affordable rates, as we've been doing since 1976.

•• ROCKIN' A RANCH STUDIO

91770 Nelson Mtn. Rd., Greenleaf, OR
 (503) 984-3225

Owner/Studio Manager: Michael Ayling.

Engineers: Michael Ayling.

Dimensions of Studios: 12' x 28' x 8' ceiling; 8' x 8' drum booth; all in cedar and sound board; full heating and air conditioning.

Dimensions of Control Rooms: 12' x 12'.

Tape Recorders: TEAC 80-8 8 track; TEAC SX3300 2 track; Sansui SC-1110 2 track cassette.

Mixing Consoles: Sound Workshop 1280B Super EQ, 12 in x 8 out.

Monitor Amplifiers: Kenwood KA 7100.

Monitor Speakers: RSL 3300 studio monitors, Auratones, Sonics.

Echo, Reverb, and Delay Systems: Tapco 4400 reverb, MXR Phaser.

Other Outboard Equipment: dbx 160 limiters, full dbx on 8-track machine.

Microphones: Sennheiser 421's; E-V RE-16's, 76's; Sony 22, 23, 33; AKG E-1000; Shure SM-56.

Instruments Available: Mason-Hamlin 5'4" grand, Gibson 335, Martin 000-28, Fender Bass, Ludwig drums.

Extras: Accommodations available in the country on 8 1/2 acres within our home located above the studio which is in the basement in hillside foundation. Home built with studio in mind from the ground up. 40 miles west of Eugene, Oregon.

Rates: \$15/hr plus tape and accommodations.

Direction: Built by a musician dedicated strictly to music productions at low cost with good atmosphere.

•• RANDALL SCHILLER PRODUCTIONS

also REMOTE RECORDING
 1207 Fifth Avenue, San Francisco, CA 94122
 (415) 681-7553

Owner/Studio Manager: Randall Schiller.

Engineers: Randall Schiller.

Dimensions of Studios: 12 1/2' x 15', Drum Room: 9' x 9'.

Dimensions of Control Rooms: 12 1/2' x 15'.

Tape Recorders: TEAC/Tascam 80-8 8 track; Sony TC-854-AS 4 track; Sony TC-850-2T 2 track; Pioneer RT-707 2 track; Sony TC-152 SD 2 track.

Mixing Consoles: TEAC/Tascam Model 5 8 in x 4 out. TEAC/Tascam Model 3 8 in x 4 out; TEAC/Tascam Model 1 8 in x 2 out.

Monitor Amplifiers: Harman-Kardon Citation 12, SAE 2200, SAE 2400L, BGW Model 100-01.

Monitor Speakers: Altec A7-500 (bi-amplified), Bose 800, Pioneer Model 88.

Echo, Reverb, and Delay Systems: Delta Labs DL-2 Acoustic-computer stereo digital delay and Sound Workshop 242 stereo reverb.

eight track

Outboard Equipment: MXR dual fifteen band graphic equalizers, dbx 154 declinear noise reduction system, dbx 161 compressor/limiter, Crown VFX-2A electronic crossover/filters, Advent Model 100A Dolby noise reduction, SAE 5000 impulse noise reduction, and assorted patch bays, switching systems and necessary support equipment.

Microphones: Electro-Voice RE-15's, 635A's; Shure SM-57's, SM-58's; Sony ECM-16, ECM-33p's, ECM-19B's and Sennheiser MC 431.

Instruments Available: Story & Clark console piano.

Extras: Kitchen available.

Rates: Studio recording: 8-track \$20/hr; 4-track \$15/hr; 2 track \$15/hr. Location recording: prices available upon request.

Direction: Randall Schiller Productions is a multi-faceted company providing facilities, services and products in the areas of audio, film and theater. We are dedicated to providing the highest quality in a relaxed but professional environment. Immediate expansion plans call for the addition of more outboard equipment and various microphones. In addition to recording studio services, we provide sound reinforcement services, portable disco sound systems, audio design and installation, film production and lighting services. Our recent album was recorded live at the Geary Theatre: "Ruth Hasings Plays the Geary", on Topaz Records.

•• 1750 ARCH STUDIOS

also REMOTE RECORDING
 1750 Arch St., Berkeley, CA 94709
 (415) 841-0216 or 841-0232

Owner: 1750 Arch Inc.

Engineers: Bob Shumaker.

Dimensions of Studios: Dead studio 23' x 13' x 8'; live recording room 36' x 17' x 11'; many other interesting small rooms.

Dimensions of Control Rooms: 17' x 12' x 8'.

Tape Recorders: 3M Model M23 8 track; Ampex Model AG-440-B 4 & 2 track; Studer Model B-67 2 track; Revox Model A-77 2 track; Sony Model 366-4 4 & 2 track; Nakamichi Model 600 cassette; Wollensak cassette.

Mixing Consoles: MCI Model 416, 16 in x 16 & Quad out; Tapco Model 6701, 6 in x 2 out.

Monitor Amplifiers: Phase Linear 400, Marantz 250, Dyna 70 JBL SE 400.

Monitor Speakers: JBL 4310, 4315, 4320.

Outboard Equipment: Automatic Dolby A301's for 8 track, 4 track and 2 track. UREI 1176LN limiters; dbx 160 limiter; Furman PEQ-3 parametric EQ; Countryman 150X direct box; portable equipment for high quality stereo location recording.

Microphones: Neumann SM-69, KM-84, KM-86, KM-74, U-87; Sony C500, MB-C520; E-V Re-16, 666, 1776; Sennheiser 421; Shure SM-57; Countryman condenser; Sennheiser 405; E-V 635.

Instruments Available: Steinway 'B' grand, Baldwin grand, Knabe baby grand.

Extras: Tennis court, kitchen, lounge, view of Golden Gate, windows in all rooms, large maintained garden, back issues of Mandolin World News.

Rates: \$45/hr for 8 track; \$40/hr for 4 track; \$30/hr for 2 track; \$25/hr editing; \$20/hr copying. Stereo remote recording at the same rate, door to door. 8 track & 4 track remote rates by request. Block rates by request.

Direction: We make clean recordings of any type of music. Classical, avant garde, jazz and bluegrass are specialties. There is a concert hall in the building that has a musical series 9 months of the year. Friday night concerts are broadcast live on KPFA. We are affiliated with 1750 Arch Records, producers of early music, classical, avant garde and contemporary jazz.

•• SHOWCASE SOUND

3090 S. Bascom Ave., San Jose, CA 95124
 (408) 377-5864

Owners: Jim Bruno, Jack Van Breen.

Engineers: Jack Van Breen, Dave Petrucci, Randy Widen.

Dimensions of Studios: 19' x 19' x 10'.

Dimensions of Control Rooms: 12' x 9' x 8'.

Tape Recorders: TEAC/Tascam 80-8 w/dbx noise reduction, 8 track; TEAC 3300SX 2 track; TEAC 3605 cassette.

Mixing Consoles: TEAC/Tascam Model 15, 16 in x 8 out.

Monitor Amplifiers: G/K 1000S, Dynaco 100.

Monitor Speakers: JBL 4311, Auratone 5W.

Outboard Equipment: Tapco 2200 EQ, Bi-Amp 210 EQ, Tapco 4400 reverb, dbx 161 compressors, Tascam DX8 noise reduction for free. For a slight additional charge flangers, delay lines, doublers, cue available.

Microphones: E-V RE-20, D535, RE-10; Beyer M201; Shure SM-62, SM-56; MB 215; Sony ECM-23F; Sescom SMIA direct box.

Instruments Available: For free: acoustic piano, drum set, Gallien Kruger guitar and bass amps. For a slight extra charge, Yamaha CP70, synthesizers, Moogs, ARP's are available.

Extras: Good session men all styles, drums, keyboards, bass, guitar, vibes, stick, synthesizers, mellow atmosphere.

Rates: Since everyone's tastes and needs are different, we feel that a firm rate would be unfair to the easy projects. Please call for an estimate. We are very reasonable!

Direction: To continue to offer the very best possible sound and service for the least possible charge. We shall continue to upgrade our equipment and environment as we grow!

•• SHYNE SOUND

40 Woodland, San Rafael, CA
 (415) 459-2833

Owner/Studio Manager: Leroy Shyne.

Engineers: Leroy Shyne.

Dimensions of Studios: 30' x 15'.

Dimensions of Control Rooms: 15' x 15'.

Tape Recorders: TEAC 80-8 8 track; Pioneer RT 2044 4 track; Scully 280 2 track; Pioneer cassette CT-P8282 2 track.

Mixing Consoles: Allen & Heath SD 12-2 (8 directive), 12 in x 2 out; Allen & Heath Mini Mix 6-2, 6 in x 2 out.

Monitor Amplifiers: (2) McIntosh C-30's, Dyna-70 headphones.

Monitor Speakers: Shyne, JBL.

Echo, Reverb, and Delay Systems: Orban/Parasound stereo reverb.

Other Outboard Equipment: Pioneer stereo graphic.

Microphones: Shure 57's, 59, Omni's; E-V RE-15; AKG 1000E; Sescom direct boxes, FRAP pickup.

Instruments Available: Bass, guitar, piano, drums, percussion.

Extras: Kitchen area, rehearsal space rental, custom speaker enclosure and/or PA design and manufacture, complete concert sounds system service, artist management consultation, musician referral, music theory instruction.

Rates: \$10 - \$20/hr.

Direction: I've been a working musician for nearly 20 years, and have been designing and building speaker enclosures for nearly 10-years. I have been designing and operating concert sound systems for 5 years, and have been recording people on tape since childhood, and have recently become a 'Syn-Aud-Con' graduate.

•• SIERRA RECORDING STUDIO/THE SONG SHOP

also REMOTE RECORDING
 518 N. Court St., Visalia, CA 93277
 (209) 733-5538, 734-0994

Owner: Manny Alvarez.

Studio Manager: Manny Alvarez/Katie Huston.

Engineers: Clark De Coux, Steve Bryant, Manny Alvarez.

Dimensions of Studios: Main room: 14' x 22', drum room: 7' x 14', vocal room: 6' x 9'.

Dimensions of Control Rooms: 12' x 16'.

Tape Recorders: Ampex AG440B 8 track; Ampex 350 2 track; Sony 756 2 track; Sony 660 2 track; Concertone 20-20 2 mono; Superscope cassette; Lafayette 8 track cartridge.

Mixing Consoles: Custom C-D 100B 12 in x 8 out.

Monitor Amplifiers: Crown D150A, Crown D40 headphones.

Monitor Speakers: Custom speakers - Auratone 5C mixing cubes.

Echo, Reverb, and Delay Systems: Custom Fidelity (2 sends) tape delay machine.

Outboard Equipment: Altec 348A compressor amps, Universal Audio Model 550A filters Dolby "B".

Microphones: Altec M21, 654A; Electro-Voice RE-50, RE-11; AKG D100, D202E, DM700; Shure 585 SD, SM57; Sony ECM21.

Instruments Available: Vox Jaguar electric organ, Acoustic 360 bass amp, Fender Precision Bass, upright grand piano.

Extras: Coke machine - "groupie" room.

Rates: \$20/hr 2 track stereo, \$17.50/hr 2 track mono; \$40/hr 8 track; \$22.50/hr mixing & editing; \$10/hr duplicating; on location remote recording: 2 track stereo \$30 plus mileage - 8 track rates upon request.

Direction: Founded in 1974, our studio is owned and operated by musicians. We can go out and record a band "live" at a nite club, or a choir at their church. In the past we've done a lot of gospel recordings, and our Chicano product has been released on Luna Records, Anavach, Pega Records, Fogata Intl., and Fama Records. We've also opened a new branch (The Song Shop) which is designed to help new talent get exposure.



CROWN



PERFORMANCE FOR PROFESSIONALS

* CROWN AMPLIFIERS ARE USED NEARLY 2 TO 1 BY PRO STUDIOS AS REVEALED IN A RECENT INTERNATIONAL STUDIO DIRECTORY.

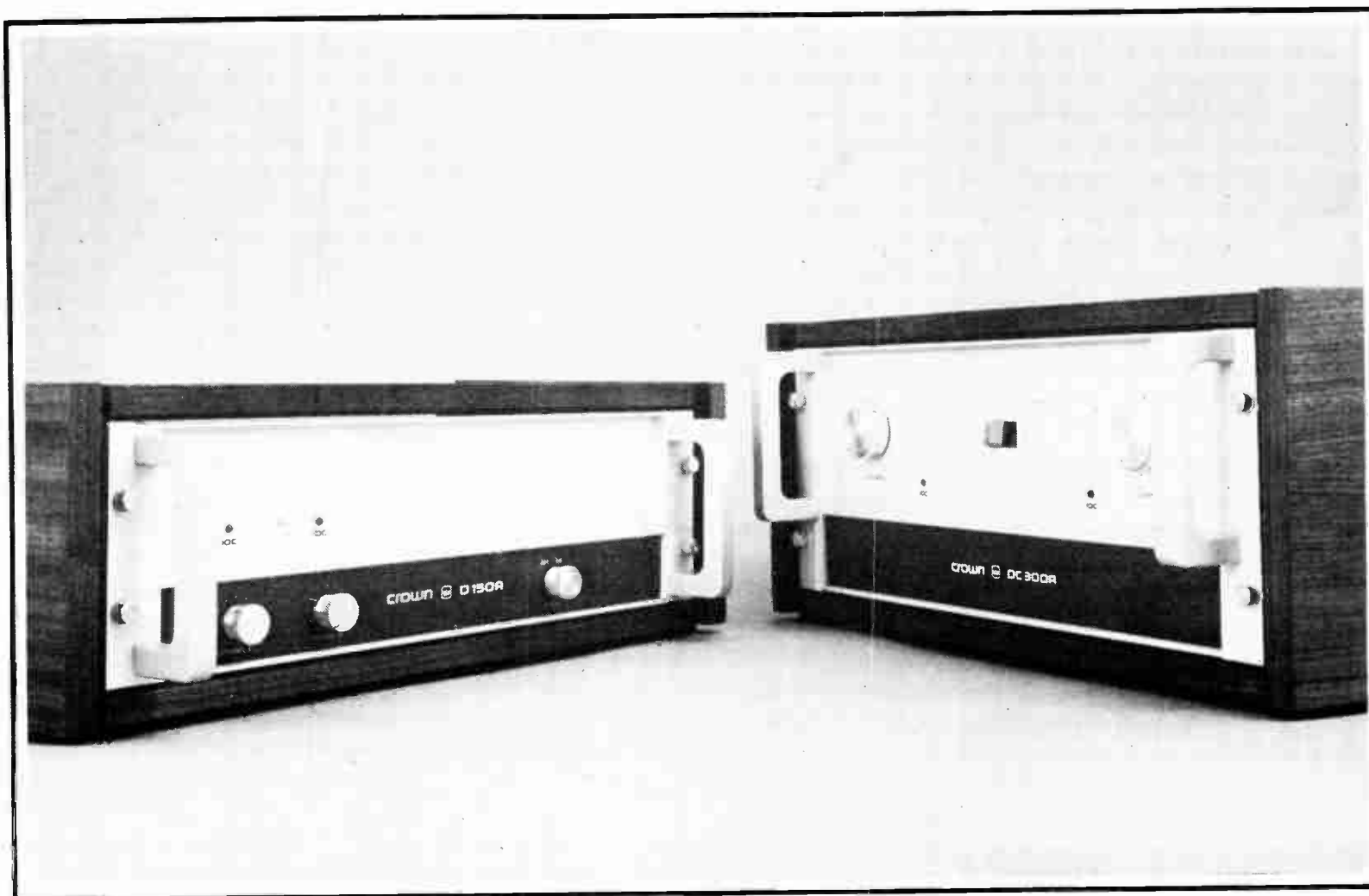

AMERICAN INNOVATION SINCE 1951

* COPIES AVAILABLE AT THESE DEALERS

**HUN
SOUND**
The Alternative

Professional, Rehearsal Studios, Audio Sales, Service, Rental
647 IRWIN STREET SAN RAFAEL CA 94901 (415) 454-2911 (office/studio)
(415) 924-2600 (24 Hr. Ans. Service) Telex. 340-229
H.U.N. Sound is: Humans Understanding Needs

•• SOUND SMITH RECORDING

Pacific Grove, CA

(408) 649-8922

Owner: David Kempton, Sylvanah Hertzberg.

Studio Manager: Sylvanah Hertzberg.

Engineers: David Kempton.

Dimensions of Studios: 14' x 9' x 10'.

Dimensions of Control Rooms: 10' x 9 1/2'.

Tape Recorders: 3M M23 8 track; TEAC 3340 4 track; Ampex 350-2 2 track; Revox 77 2 track; Nakamichi 600 II 2 track cassette.

Mixing Consoles: Proper Sound custom, 14 in x 8 x 2 out.

Monitor Amplifiers: Crown DC 150, Dyna ST 70, Symetrix HA-10.

Monitor Speakers: JBL 4311, Quadraphlex, Auratones.

Echo, Reverb, and Delay Systems: Fisher Space Expander, Roland analog, tape delay to rub. send.

Other Outboard Equipment: Symetrix noise gate, Ling cycling oscillator, HIP low f_q. function generator, full patch bay.

Microphones: Sony C22, Sennheiser 421's, E-V cons., American ribbon-dynamic combination, American dynamic omni, (1947-era unique mics, very fine quality), A46's, Shure's, etc.

Instruments Available: Rhodes 88, ARP 2600, Emu expander, programmable percussion generator, sarad, small steel drum, tambura, Tibetan bell bowl, Angklung, phasers, MXR graphic EQ, Roland Jazz Chorus amp, Joystick, octave doubler, zither, Esquinteles.

Extras: Good coffee, 16mm sound projector, TLC, no-pressure atmosphere, session musicians available, synthesizer programming, food and/or drinks arrangeable in advance. Tell us your needs and inner desires! Electronic music instruction, studio techniques instruction available.

Rates: \$20/hr, block and project rates on request. Production or production assistance rates are reasonable.

Direction: We are a small but growth oriented pro studio specializing in commercials, small group demos, voice-overs, and songwriters demos. Extensive electronic music and jazz and fusion experience, but we like all kinds and qualities of music. Much professional experience and effort has gone into the design of our in-house facilities, so the room is voiced to sound good on acoustic instruments and voices.

•• SOUND SMITH STUDIOS

426 N.W. 6th Ave., Portland, OR 97209

(503) 224-7680

Owner: David Tower, Greg Smith, Tom Gandy, Gary McRobert.

Studio Manager: David Tower.

Engineers: Greg Smith, Tom Gandy, Gary McRobert.

Dimensions of Studios: 5' x 10' booth; 12' x 15', 10' x 15' room; 20' x 20' room; all rooms are acoustically tuned and are fitted with active bass trap ceilings.

Dimensions of Control Rooms: State of the art Live End Dead End reversal room 20' x 12', 20' x 10'.

Tape Recorders: Otari MX 5050 8 track; Otari MX 5050 2 track; Akai GX 400DS 4 track; Sony TC 730 2 track.

Mixing Consoles: Quantum QM-8A, 8 in x 4 out; Sound Smith Labs 140A, 16 in x 2 out; Sound Smith Labs 14BE effects mixer, 16 in x 2 out.

Monitor Amplifiers: Custom built 75 watt per channel.

Monitor Speakers: Klipsch Studio Monitors.

Echo, Reverb, and Delay Systems: Tapco 4400, 5400 cubic ft. natural chamber, tape loop.

Other Outboard Equipment: 4 dbx 161 compressor/limiters, 4-channel Bi-Amp graphic EQ, dbx noise reduction, other outboard equipment available on rental.

Microphones: Warena Brock pressure zone mics, Shure, Primo, AKG, Sony.

Instruments Available: Pearl drums, Piano, Conn trumpet, all other instruments available on rental.

Extras: Real time spectrum analyzer, Tectronics R 5031 dual beam oscilloscope, lounge with color TV, pin ball, pressing and distribution available, licensee TDS (Time Delay Spectroscopy).

Rates: \$35/hr. Project discount available.

Direction: We started in a house in 1976; our new 2,500 sq. ft. studios opened May 1st this year and our 24-track control room will open this Fall. Sound Smith has a reputation for promoting local talent. We are presently producing "Northwest Exposure" a syndicated radio show spotlighting the diverse musical talent in our area.

•• SPECTRUM

P.O. Box 757, San Carlos, CA 94070

(415) 593-9554

Owner/Studio Manager: Paul Weaver.

Engineers: Jim Conklin, Jay Beardslee, Wes Weaver.

Direction: All studio sizes and equipment are the same as Music Annex, Menlo Park, CA. We work in conjunction with them but operate as a separate recording studio. Spectrum is primarily a production co.; for the purpose of developing our stage musicals, concerts, and the development of new talent. A brochure explaining spectrum's many activities will be sent on request.

eight track

•• STUDIO "C" AT THE ANNEX

970 O'Brien Drive, Menlo Park, CA 94025

(415) 321-7774

Owner: Amusex Corp., Dennis Reed/Recording Etc. Productions

Studio Manager: Dennis Reed.

Engineers: Dennis Reed, Jimmy Goings, Roger Wiersema.

Dimensions of Studios: 20' x 30' x 16'.

Dimensions of Control Rooms: 10' x 12' x 16'.

Tape Recorders: Tascam 80-8 with dbx 8 track; Ampex 351/440 with dbx 2 track; Otari 5050 SH 2 track; Pioneer 701 2 track; TEAC A-103 2 track cassette.

Mixing Consoles: Sound Workshop 1280-B with meter bridge, 12 in x 8 out; Ampex MX 10, 4 in x 2 out; TEAC Model 1, 8 in x 2 out.

Monitor Amplifiers: Yamaha Model P 2200, Crown D-150A, Crown D-60.

Monitor Speakers: JBL 4311, JBL 4301, Auratones.

Echo, Reverb, and Delay Systems: AKG BX10E, Delta Lab Acousti-computer, MXR DDL, (EMT 240 Gold Foil & 140 plate echo available on time share basis at extra charge), Roland Space Echo.

Other Outboard Equipment: UREI LA4A limiter, dbx 160 limiters, UREI & Bi-Amp graphic EQ's, noise gates, Countryman direct boxes.

Microphones: Neumann U-87's; AKG 414, 451; Electro-Voice RE-20's; Sony 377-P, ECM 22-P, ECM 33-P, 280; Sennheiser 441, 421; Shure SM-57's.

Instruments Available: Yamaha C-5 (6 1/2') grand piano, ARP String Ensemble, Peavey Vintage, Rogers drums, Ovation classical, Fender Jazz Bass, Gibson Les Paul, beaucoup percussion, (ask about availabilities).

Extras: Mini kitchen, lounge, refrigerator, coffee, storage, stage, lights, PA rehearsal, video, air conditioning, high quality cassette and reel duplicating done in "real time" available, ask for Dennis Reed.

Rates: Call for quote, block rates available, (we are competitive!).

Direction: State-of-the-art, acoustically engineered facility, constructed from the ground up. Housed in the Music Annex, calling on the resources of this "world class" 24-track facility while maintaining an independent staff of the finest engineers and techs available. Albums, singles, demos, rehearsals, and all types of media work. Professional people, a wealth of equipment and the right environment.

•• TRAC RECORD COMPANY

170 North Maple, Fresno, CA 93702

(209) 255-1717

Owner: Stan Anderson.

Engineers: Stan Anderson.

Dimensions of Studios: 20' x 40'.

Dimensions of Control Rooms: 12' x 12'.

Tape Recorders: Ampex AG-440-C 8 track.

Mixing Consoles: Gately, 16 in x 8 out.

Monitor Amplifiers: Stereophonic Crown.

Monitor Speakers: Altec.

Outboard Equipment: Altec EQ, limiters, EMT reverb.

Microphones: Neumann, Altec, RCA, Sennheiser.

Instruments Available: Yamaha grand piano, Elka string synthesizer.

Rates: \$40.00/hr - minimum of 1-hour plus tape. Deposit of 20% of time block.

Direction: We have been in business for 20 years and do record production and movie backgrounds.

•• TRES VIRGOS STUDIO

1219 West California Ave., Mill Valley, CA 94941

(415) 388-7799

Owner: Allen Rice, Mike Stevens, Rob Yeager.

Studio Manager: Rob Yeager.

Engineers: Rob Yeager, Richie Moore, Ph.D., Mike Richards.

Dimensions of Studios: 17' x 25'.

Dimensions of Control Rooms: 13' x 17'.

Tape Recorders: Otari 7308-1" 8 track; Ampex ATR-100 2 track; Pioneer 2022 2 track; TEAC 3340 4 track; Pioneer CT-F9191 cassette.

Mixing Consoles: Soundcraft Series II, 16 in x 8 out.

Monitor Amplifiers: BGW 750A, SAE, Crown D-60.

Monitor Speakers: UREI Time Aligned 813's, Auratones.

Echo, Reverb, and Delay Systems: Lexicon Prime Time, Marshall Time Modulator, Tapco 4400 reverb.

Other Outboard Equipment: UREI LA-4 compressor/limiter, UREI graphic EQ, dbx, White 1/3-octave tuned room.

Microphones: All AKG mics including top line 452's, C-414 condensers; Sennheiser 441's, 421; Beyer M-260's, M-500's; Electro-Voice RE-10, RE-20, 635A; Shure 545's, 565's.

Instruments Available: Fully tuned drum kit, Yamaha CP-70 electric grand piano, Polymoog synthesizer, a dozen different premium guitars from 6-string classical to electric 12-string and everything in-between including 8 custom guitars commissioned for the studio, including bass, Fender Twin - 100 watts, Roland Chorus amp 160, acoustic bass amp, Countryman direct boxes, assorted percussion and special effects boxes, and the rare Chamberlin Mellotron! You've got to hear this baby to believe it! Live strings and horns and woodwinds — incredible machine!

Extras: 3-acres gorgeous Mill Valley countryside in foothills of Mt. Tam; free coffee, beer, We're building a deck with a hot tub also. Our biggest extra: Dr. Richie Moore — our new engineer is available upon request. He has 275 album credits, including 15 gold albums and 5 platinum.

Rates: \$25/hr, block available for regular staff, \$30/hr for Richie Moore.

Direction: Tres Virgos is a musicians' studio, owned, operated, and built from the ground up by people who love music and love recording. The studio was built for comfort and creativity and we are always more than willing to share our talents and experience with clients. Aside from the studio, we have an in-house production company that writes, performs, records and produces commercial radio jingles.



TRES VIRGOS STUDIO, Mill Valley, CA
Robin Yeager, Studio Manager

•• TRULLION STUDIO

P.O. Box 23051, Sacramento, CA 95823

(916) 391-9691

Owner: Kurt and Nancy Bischoff.

Studio Manager: Kurt Bischoff.

Engineers: Kurt Bischoff, Bob Browning, Mike Hannickel.

Dimensions of Studios: 19' x 22'.

Dimensions of Control Rooms: 8' x 12'.

Tape Recorders: Tascam 80-8 8 track; TEAC 3340 4 track; Telectro (modified) RD-146 2 track; Pioneer CTF500 cassette.

Mixing Consoles: Tascam Model 5 & Model 3, 16 in x 8 out.

Monitor Amplifiers: Kenwood, Sony, Harman Kardon.

Monitor Speakers: JBL 4311's, Triac Audio, Auratones.

Echo, Reverb, and Delay Systems: Trac Audio MX-8 reverb, Quad echo, Dokorder 4-track tape delay.

Other Outboard Equipment: Tapco 2200 graphic EQ's, Lunnetta Sound Box, Cromatron.

Microphones: Sennheiser 421's; Shure 545's, SM-57's; Electro-Voice PL-76's; Beyer M69's; AKG D-1000E's.

Instruments Available: Ivers and Pond upright grand piano, Farfisa VIP255 organ, Leedy vibraphone, Deagan xylophone, Traynor bass amp, large double-bass drumset with Zildjian cymbals.

Extras: Versatile studio musicians on call, kitchen, color TV, and pong.

Rates: \$20/hr. Block time rates available.

Direction: We are a progressive and innovative studio utilizing a relaxed and creative atmosphere to help recording artists achieve their goals. Our engineers genuinely care about the finished product and strive to make the recording experience both enjoyable and artistically rewarding for our clients. Our advertising arm, Trullion Productions, specializes in commercial ad jingles — from concept, composition and arrangement to final recording.

•• TWILIGHT STUDIO

642 Palm Avenue, Watsonville, CA 95076

(408) 722-7819 or 724-7140

Owner: Steve Loveless.



TASCAM Model 15



8 x 8^{*}

12 x 8^{*}

^{*} Exclusively by Suntronics

16 to 24 x 8

SUNTRONICS now has available the Teac Tascam Model 15 Recording Mixing Console, available with 8 to 24 input module configurations, which are determined by your particular requirements. This allows you to maintain eight outputs and add extra input modules for effects and microphone inputs, as needed.

PRICES

8 x 8 [*]	\$5,500
12 x 8 [*]	\$6,500
16 x 8	\$7,500
20 x 8	\$8,500
24 x 8	\$9,500

Additional modules are available for \$250 each (exchange) with blank filler Panel.

These Prices include Teac cables for hookup to the recorder and auxiliary equipment (cables up to 10 feet).

Quantity to be determined at point of sale.

(714) 985-0701

P. O. Box 734
1620 W. Foothill Blvd.

UPLAND, CA

lost in the mix?



If you have a commercially available 4/8/16/24 track recording studio in California, Washington, Oregon, New York, or the Nashville/Memphis area, and would like to be listed, free, in our directory, fill in the coupon below and return it to:

The Mix
P.O. Box 6395
Albany Branch
Berkeley, CA 94706

PLEASE PUNCH ME INTO THE MIX

- 4 TRACK 16 TRACK
- 8 TRACK 24 plus TRACK

Name _____

Studio Name _____

Address _____

City _____ State _____ Zip _____

Phone _____

Comments: _____

eight track

Dimensions of Studios: 22' x 20' including 8 specially made room baffles.
Dimensions of Control Rooms: 13' x 12'.
Tape Recorders: Tascam 80-8 8 track w/dbx; Sony TC 755 2 track; Revox B-77 2 track; Sony TC-1185D cassette deck.
Mixing Consoles: Tascam Model 5, 8 in x 8 out; Tascam Model 2, 6 in x 4 out.
Monitor Amplifiers: Kenwood KA-3500.
Monitor Speakers: Altec.
Outboard Equipment: dbx 162 compressor/limiter, MXR phase shifter, Tapco 4400 echo unit, Roland-Echoplex.
Microphones: Sennheiser; Shure; Electro-Voice; Sony; AKG.
Instruments Available: Baldwin piano, Elka Rhapsody, ARP Odyssey synthesizer, Ludwig 7 piece drums; we can provide session musicians for any kind of studio work, Jenko vibes.
Extras: Lounge room, echo room.
Rates: \$20.00 for 1st 5 hours; \$15.00 following.
Direction: We are trying to do the best possible job without costing you an arm and a leg. That is one reason we do not charge for set-up time. The best equipment in the world is useless if you can't afford it, or work with the people who own it. We have people that are concerned about your work because all our engineers have been on the other side of the glass.

•• WESTMONT RECORDING COMPANY
 1279 Antwerp Lane, San Jose, CA 95118
 (408) 264-2916
Owner: Richard E. Quick
Engineers: Richard E. Quick
Dimensions of Studios: 21' x 22' x 15'.
Dimensions of Control Rooms: 22' x 14' x 10'.
Tape Recorders: Scully 284-B-8 8 track; Scully 282-4 4 track; Scully 282-2 2 track; Magriacord 1028 2 track; Tandberg Model 64 2 track Sony.
Mixing Consoles: Quantum Audio Labs, Inc. Model QM 128, 12 in x 8 out.
Monitor Amplifiers: Dynaco Mark III 60 watts.
Monitor Speakers: Altec 604E's, Altec A-7's, Acoustic Research AR 3A's.
Outboard Equipment: Altec EQ and limiters.
Microphones: Neumann U-67's, U-87's, U-47's; Altec M-20's, M-11's; Electro-Voice 666R's; RCA 77DX ribbon mics and direct instrument hookups.
Instruments Available: Mason-Hamlin grand piano.
Rates: \$25/hr for 2,4,8 track recordings and mixdown plus tape charge. \$12/hr for editing and tape copy plus tape charge. No set up charge.
Direction: Westmont is a congenial two man recording studio with a relaxing working atmosphere and special concern to excellent sound and accurate engineering. Our clients have our assurance of satisfaction and continued confidence and good will.



WHITE RABBIT
Sausalito, CA

•• WHITE RABBIT
 301 Harbour Dr., Sausalito, CA 94965
 (415) 332-4852

Owner: J. Mitchell, Dick Grove.
Studio Manager: Seth Dworken.
Engineers: Seth Dworken.
Tape Recorders: Otari 1" & 1/4" 8 track.
Mixing Consoles: Quantum 12 in x 8 out.
Monitor Amplifiers: 605-8G monitors.
Microphones: AKG, Shure, Sennheiser.
Instruments Available: Heipinstill PG-21 grand piano, etc.
Rates: Call or come by for rates or further information.
Direction: White Rabbit has the best acoustic design and audio equipment available, a recording environment that is beautiful and comfortable, the bay, mountains and sunny weather, and a knowledgeable staff prepared to make you feel at home.



XANDOR RECORDING STUDIOS, Orinda, CA
 Jim Weyeneth, Owner

•• XANDOR RECORDING STUDIOS
 also REMOTE RECORDING
 Orinda, California
 (415) 254-5730
Owner: James Weyeneth, Bill Mitchell, Lee Payne.
Engineers: James Weyeneth and Independents.
Dimensions of Studios: 19' x 18' x 10' ceiling — dead studio; live chamber: 19' x 26' x 10' ceiling.
Dimensions of Control Rooms: 15' x 16' x 10' ceiling. Both studio and control room acoustically tuned with the room as opposed to the use of electronic equalizers.
Tape Recorders: Tascam Series 70 8 track; TEAC 7030 GSL 2 (half track); Sony 854-4 4 track; Sony 158 SD 2 track cassette; Pioneer CT-F1000 2 track cassette. Extra 1/4-track or cassette machines for copying at request of client.
Mixing Consoles: Tascam 24 in x 24 out with 8 submix busses, (this board is extensively modified: rewired electronics, new power supply, new faders, phantom powering to mics etc.); plus custom Xandor 12 input stereo (2) output board.
Monitor Amplifiers: McIntosh 2505 solid state, or for that tube "warmth" McIntosh 30's, in control room. In the studio: Dyna 120 solid state or Dyna 60's, (dual tube amps); Dyna stereo 70 for echo chamber speaker systems.
Monitor Speakers: Altec 604G in nine cubic foot cabinets; JBL 4310's Auratones; Sennheiser headphones (10-pairs).
Outboard Equipment: (2) UREI 1176LN limiting amplifiers; Spectra Sonics 610 Complimiter; (2) 3-band Furman parametric EQ's; TEAC AN-180 noise reduction units; variable speed tape machines and delay machines; two channels of Orban/Parasound reverb units; Conn Strobotuner automatic tuning machine; acoustic echo chamber; complete electronic repair workshop (voltmeter, oscilloscope, frequency counter, signal generator, etc.); MXR noise gates; Barcus Berry; direct boxes.
Microphones: Sennheiser 421, 441, MD 21; AKG D224E, 451E, DM-500; Electro-Voice 644, 664, 635A, RE-15, 1711; Sony ECM 33P; RCA ribbon KU-3A; Shure SM-57, SM-56, SM-58; Electro-Voice 623.
Instruments Available: 20 year old Ludwig drum set with sturdy Sonar hardware, misc. percussion, Fender Twin with Altec 12's, Fender Rhodes.
Extras: Coffee, hot plate, Coke machine, shower, non-fluoridated ice water, ice cold refrigerator, TV in lounge, closed circuit TV monitoring. All tape supplies available through us. Plenty of parking with no stairs to studio access. "Dial an atmosphere" lighting control, basketball. The desire to please. Both studio and control room negative ion injected to reduce fatigue.
Rates: Still only \$20/hr for recording, playback, copying, editing. This rate includes generous 60 minute free set-up, mic placement time. Rates for 2 track, 4 track, studio time and 8 track remote time on request.
Direction: We enjoy the musical bands but do jingles, announcements, lectures, voice-overs and remote Gospel recording as well. We encourage local musicians to send tapes for inclusion in our Talent Library for clients looking for announcers, musicians, actors, etc. (no tapes returned). Xandor is located in a secluded mansion in the peaceful Orinda Hills behind Berkeley.

HUN SOUND

H.U.N. Sound is Humans Understanding Needs
Professional Recording & Rehearsal Studios
Pro Audio Sales, Service and Rentals
647 Irwin Street — San Rafael, Ca. 94901
Phone (415) 454-2911 — Telex #340-229

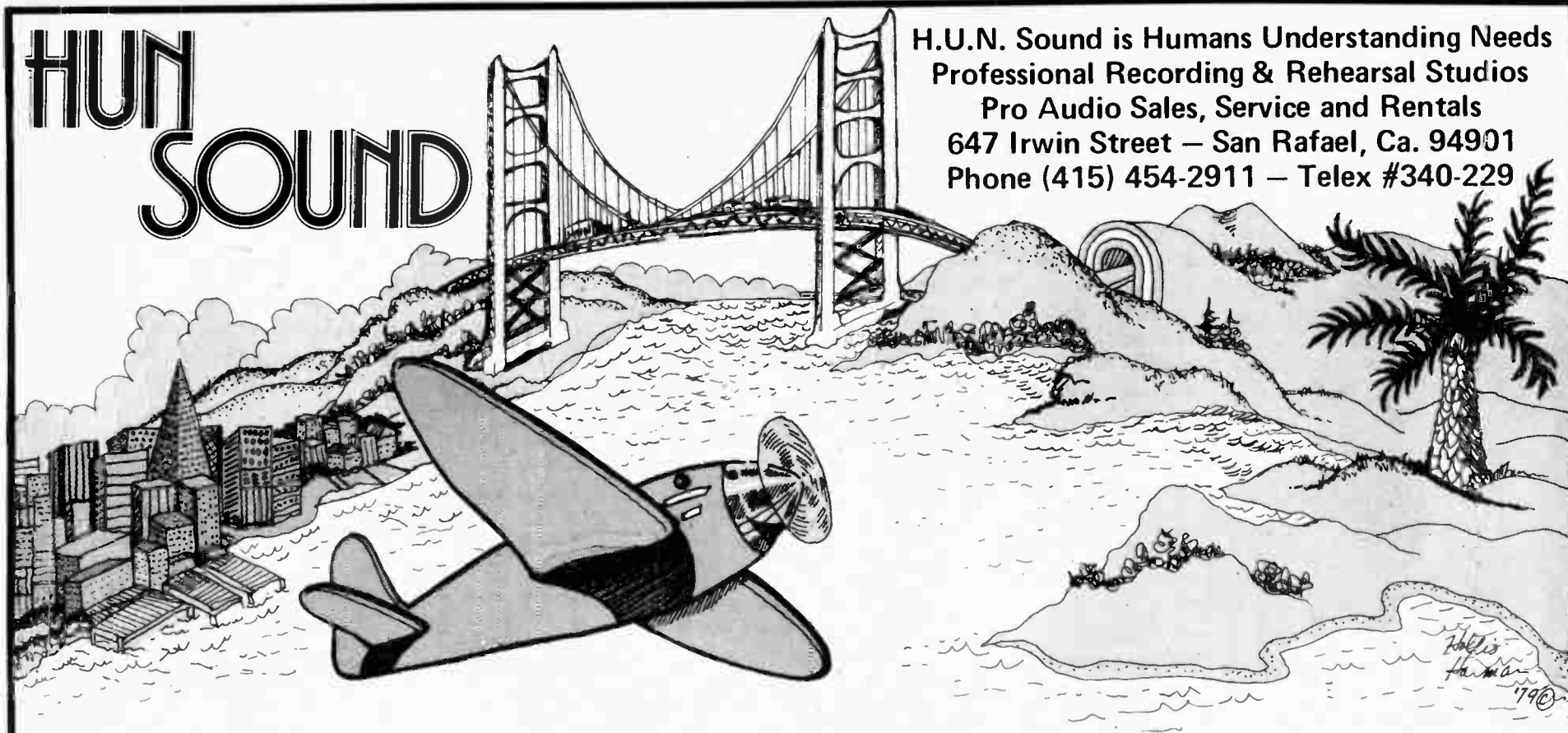

Take a look at what is
available for your
professional needs

DBX
Klark-Teknik
Frap
Delta Labs
Whirlwind
Countryman Assoc.
Sony
Sennheiser
Gauss Speakers
Furman Sound
Shure
Crown
Electro Voice
Linear Audio Systems

PML Mics
Road Runner Cases
Anvil Cases
Marantz
White Instruments
Speck Electronics
Superscope
Hard Truckers
Sweet "C" Amplifier's
Allen and Heath
H & H Amplifier's
Harbinger
Eventide
EXR

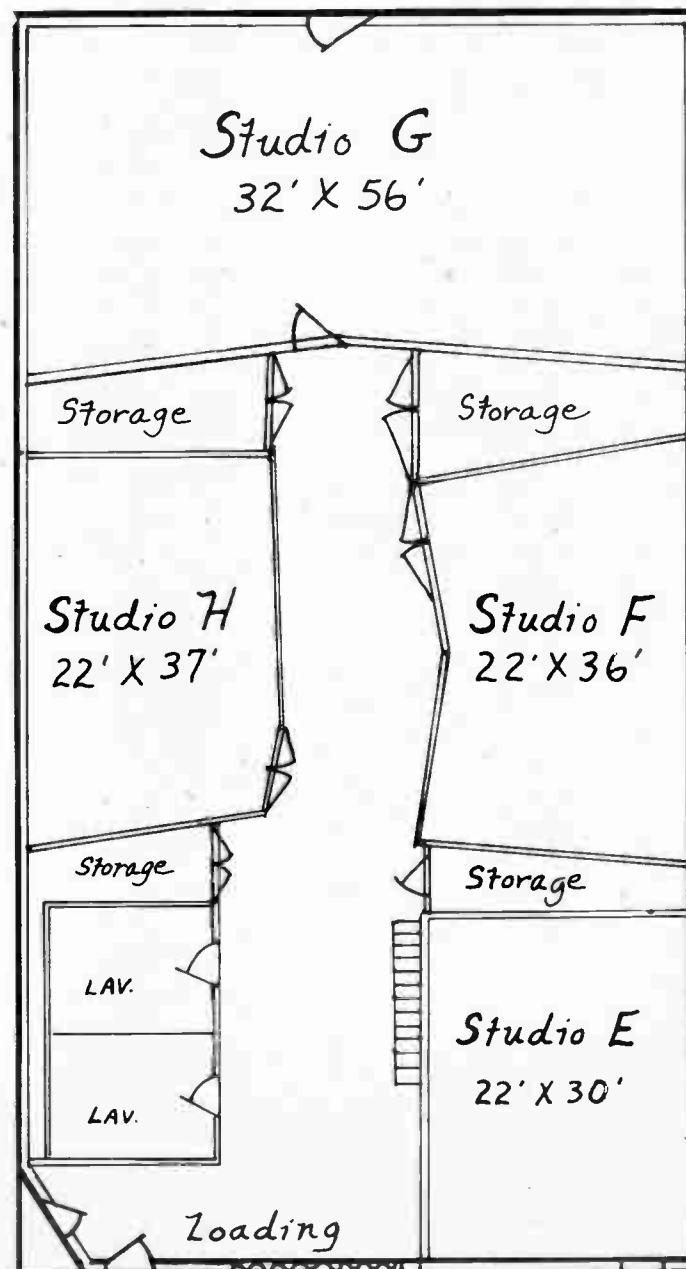
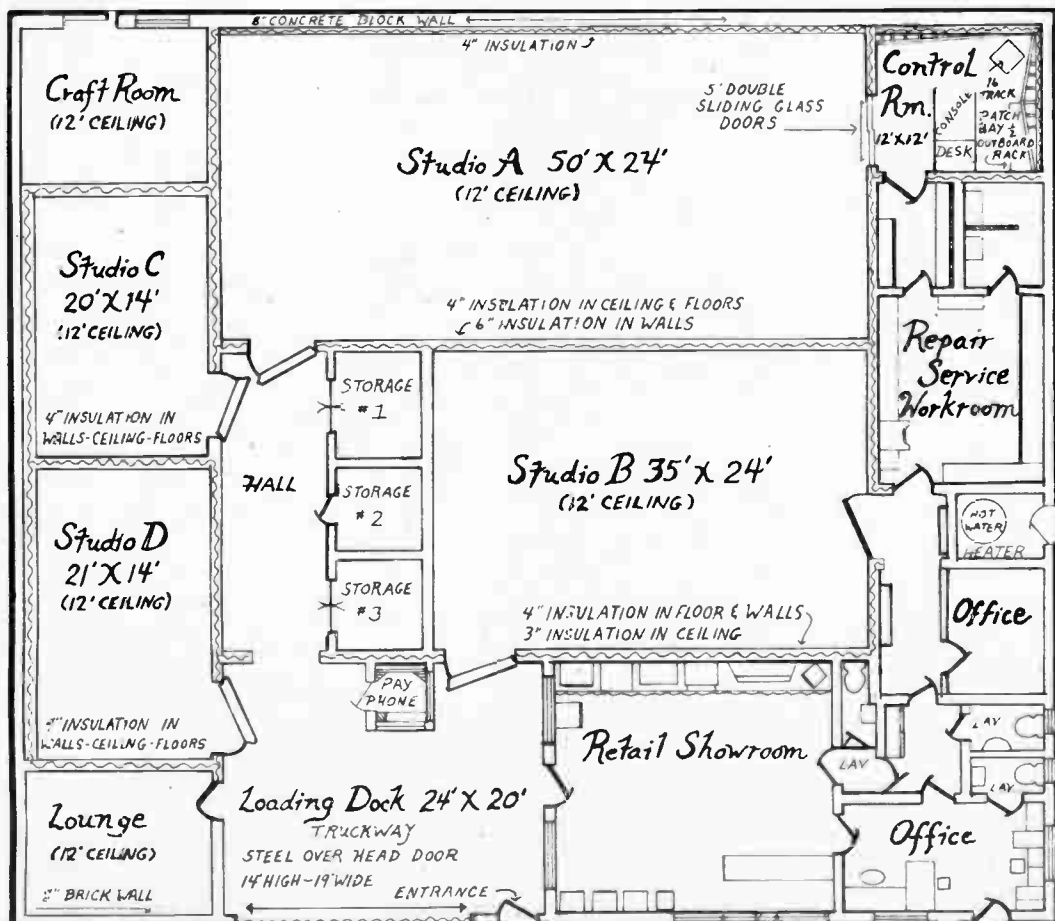

166

••• ALL WORLD PRODUCTIONS INC.
4805 North Pearl St., Tacoma, WA 98407
(206) 759-4480

Owner: Maurice & Lois Killenbeck.
Studio Manager: Maurice Killenbeck.
Engineers: Maurice Killenbeck.
Dimensions of Studios: 26' x 32'.
Dimensions of Control Rooms: 12' x 20'.
Tape Recorders: TEAC/Tascam 90-16 16 track; Ampex MM1000 2 track.
Mixing Consoles: Tangent 3216, 16 in x 16 out.
Monitor Amplifiers: Sansui AU 999.
Monitor Speakers: JBL 4311.
Echo, Reverb, and Delay Systems: Clover R500.
Other Outboard Equipment: dbx 161 compressor/limiter, dbx 154 noise reduction units, Symetrix signal gate, Tapco 2200 EQ.
Microphones: Sony ECM 280, ECM 99's; Sennheiser 421; University 5020; Ampex 3001; Audio-Technica AT 812; Shure 565, 5455, 330, SM-59; and others.
Instruments Available: Piano.
Extras: Thompson Voice Eliminator Model D2, Rythmer.
Rates: \$35/hr for recording & mixing.
Direction: To offer those a chance of success who might otherwise never have the opportunity.



JOHN ALTMANN RECORDING, San Francisco, CA
John Altmann, Owner/Engineer

••• JOHN ALTMANN RECORDING
1310 20th Ave., San Francisco, CA 94122
(415) 564-4910

Owner: John Altmann.
Studio Manager: Colette Salaun.
Engineers: John Altmann, Steve O'Hara, Phil Crescenzo, Woody Simmons.
Dimensions of Studios: 23' x 15' x 11½' high, including vocal booth, piano booth, and drum booth.
Dimensions of Control Rooms: 15' x 15' x 11½'.

Tape Recorders: Ampex MM1000, 16 & 8 track; Otari MX5050 2 track; Revox A77 2 track; custom modified TEAC 4 track.
Mixing Consoles: Sound Workshop Series 1600, 20 in x 16 out.
Monitor Amplifiers: BGW 250.
Monitor Speakers: 2 pair MDM 4's, 1 pair JBL L100's; Auratones.
Outboard Equipment: SAE, Soundcraftsmen and Bi-Amp equalizers; Marshall Time Modulator; UREI LA4 compressors; Parasound stereo reverb; Quad/Eight noise gates; Conn Strobotuner; Alembic Varispeed; UREI 1176 limiters; ADR vocal stressor; Aiwa 6900 cassette decks; ½-octave room equalization; Symetrix noise gates.
Microphones: Neumann U-87's; E-V RE-20's, RE-15's; Shure SM-58's, SM-56's, 566's; AKG D50's, C451's, D202; Sony 33P's; Beyer 101.
Instruments Available: Steinway upright grand 1905 (a great instrument, very well liked).
Extras: Kitchen.
Rates: \$40/hr for 16 track; \$25/hr for 4 and 8 track. Discounts available and vary with job.
Direction: We are perfectionists in our art, honest, and we love our work. We sincerely care about your work as well. Our continued success depends on it. We've put together a completely professional yet relaxed and comfortable studio. We've tried to create an environment where musical creativity is encouraged, not stifled. We invite you to give us a call to discuss your recording needs, or stop by to check us out. We specialize in working with groups on a continuing basis throughout their development, i.e. demos to albums. We offer full production service and assistance as well.

••• AYRE STUDIOS
458-A Reynolds Circle, San Jose, CA 95112
(408) 279-AYRE: 279-2973

Owner/Studio Manager: Richard Nebel.
Engineers: Richard Nebel and independent engineers.
Dimensions of Studios: 26' x 23'.
Dimensions of Control Rooms: 16' x 15'.
Tape Recorders: Ampex MM1000 (all mods) 16 track; Ampex AG-440B-servo 2 track; Nakamichi 700 II cassette; Dokorder 8140 4 track.
Mixing Consoles: Tangent 3216, 24 in x 16 out; Tascam modified line level, 8 in x 2 out.
Monitor Amplifiers: McIntosh MC2205; Crown DC 300A, D60, D40.
Monitor Speakers: Altec 604E "Big Reds" with Mastering Lab crossovers; JBL; Auratones.
Echo, Reverb, and Delay Systems: EMT stereo plate; AKG stereo echo; Eventide Harmonizer (2 delay outputs); Lexicon-Delta T DDL (2 delay outputs); MXR DDL (full memory); tape echo; Orban/Parasound stereo reverb.
Other Outboard Equipment: Eventide Flanger; Eventide Omnipressor; Eventide Harmonizer; Inovonics compressor/limiters; UREI LA-3A; Altec compressor; EMS voltage controlled signal processing synthesizer w/remote. Additional equipment available on request. New—EXR Psycho-acoustic Exciter.
Microphones: Neumann U-87's, KM-84's; AKG C-414 EB's, 452's; Electro-Voice RE-20's; Sennheiser 441's, 421's; Shure SM-57's; Beyer 201's and more.
Instruments Available: Chickering concert grand piano; ARP 2600 synthesizer; 360 Systems "Spectre" guitar synthesizer; EMS

"Hi-Fi" synthesizer; Gibson, Fender and Rickenbacker guitars and basses; Boogie Amp; other instruments and devices on request.

Extras: Production and arrangements; studio musicians; free coffee, etc; refrigerator; lounge area; pressing available.

Rates: \$45/hr, please phone for quote.

Direction: Our studio and control rooms were professionally designed and constructed for acoustical excellence with all of the "creature comforts" that make a highly creative environment possible. We specialize in contemporary music and signal processing while providing modern facilities and personal service perfect for musical and commercial requirements. We are available 24 hours and offer very low rates. Future plans include 24 tracks, a second studio, and digital reverberation.



AYRE STUDIOS
San Jose, CA

••• COAST RECORDERS, INC.
1340 Mission St., San Francisco, CA 94103
(415) 864-5200

Owner: United Recording Corp.
Engineers: Steve Atkin, Sol Weiss, Bob Lindner, Gary Dominguez.
Dimensions of Studios: 30' x 40' x 18'; 15' x 20' x 12'; 12' x 15' x 12'.
Tape Recorders: Ampex, 3M 16 track, Ampex, 3M 8 track; Ampex, MCI 1 track.
Mixing Consoles: Bushnell, 20 in x 12 out; Quantum, 20 in x 4 out.
Monitor Amplifiers: UREI, Crown.
Monitor Speakers: UREI 813, JBL, Auratone Cubes.
Outboard Equipment: UREI LA-3A, 1176 LN, 527, 530, 537, 545, 565T, Orban D'Esser, Allison, Kepex, Eventide UREI DDL, UREI Digital Metronome.
Microphones: Neumann U-87, U-67, U-47; EV RE-20, RE-15; Shure SM 56, 57; Sennheiser 405; AKG 451.
Instruments Available: Steinway, A.B. Chase grand pianos, Hammond C-3, Leslie, Celeste.
Extras: Large music library, sound effects, production studio, Hi-speed reel to reel, cassette duplication, complete labeling, mailing service.
Rates: \$35.00 to \$85.00/hour.
Direction: The leader in audio services for the advertising industry. Offering the whole spectrum of audio services except film and location recording.

••• COPPERWOOD RECORDING STUDIOS,
LOCATION STUDIOS
also REMOTE RECORDING

2616 Garfield Ave., Sacramento, CA 95608
(916) 485-7999, 483-1170, 488-7864

Owner/Studio Manager: Jim Hibbard, Scott Welch.
Engineers: Jim Hibbard — Chief Engineer, Scott Welch, Mark Ishikawa, Kathy Coffey.
Dimensions of Studios: Main room: 17' x 21'; drum room 8' x 15'; piano room 9' x 11'; vocal room 6' x 11'.
Dimensions of Control Rooms: 13½' x 18½'.
Tape Recorders: MCI JH-16 with auto locator 16 track; Otari MX5050 8 track; Tascam 25-2 2 track; Dokorder 1140 4 track; Hitachi 3500D 2 track cassette; Akai CR81D 2 track cart.
Mixing Consoles: Tangent 3216, 18 in x 16 out; Yamaha EM180, 6 in x 2 out; Neptune 1180, 16 in x 2 out; Ampex 4 in x 2 out.
Monitor Amplifiers: Yamaha, Crown, Acoustic (for cue).
Monitor Speakers: JBL 4311, Auratones.
Echo, Reverb, and Delay Systems: Orban stereo spring reverb 1-11B, Ibanez analog delay/flanger AD230, Tascam Model 1/effects submix-modified.
Other Outboard Equipment: dbx limiting, dbx noise reduction, Bi-Amp stereo EQ, Pioneer 250 turntable, 16-channel 2-way splitter, 8 x 8 keyboard subsnake.

Microphones: AKG 414, C451E; E-V RE-20, 1776, 635A, 1751, 627-C; Sennheiser 441, MD 421U; Shure SM-58, SM-56, SM-53, SB-585.

Instruments Available: Star upright piano, ARP and Moog synthesizers, Yamaha electric grand, Prophet Synthesizers, Rhodes piano, Hammond organ w/Leslie (by appointment).

Extras: Kitchen, lots of trees, cozy atmosphere.

Rates: In Studio 16 track: \$40/hr. Block rates available. 8 track: \$25/hr. Location rates upon request.

Direction: We have enlarged our studio to accommodate the experienced studio musicians as well as the novice. In the past year we have added a separate drum room and enlarged the control room. With the addition of the 16 track we can handle any type of session, but are able to keep our rates affordable. The Location Van is equipped for 16 track, and will interface with any sound reinforcement system to insure the best possible quality.

... db RECORDING

3486 21st St., San Francisco, CA 94110
(415) 282-9080

Owner: Furman Films.

Studio Manager: Jack Bailey.

Engineers: Jack Bailey, Will Furman.

Dimensions of Studios: 14' x 26'.

Dimensions of Control Rooms: 13' x 19'.

Tape Recorders: Ampex MM-1200 with search/cue & VSO 16 track; Ampex AG 440-B 4 track; Ampex AG 440-B 2 track; Ampex 440-C 1 track; Nagra IV-L 1 track; TEAC A-2300S ¼ track; Sony TC-152SD cassette.

Mixing Consoles: Spectra Sonics custom, 16 in x 8 out.

Monitor Amplifiers: Spectra Sonics.

Monitor Speakers: JBL 4310, Auratone Minispeakers.

Echo, Reverb, and Delay Systems: Master-Room-II echo.

Outboard Equipment: dbx 187 noise reduction; Spectra Sonics Complitter; UREI 530 graphic EQ; Furman parametric EQ; Kepex program expander; real time digital counters; direct phone patch; Aphex Aural Exciter available.

Microphones: Neumann U-87's; E-V RE-20's; RE-15's; RCA 77-dx's, 44; Shure SM56's; Sennheiser MKH 415, 805; Sony ECM 50.

Instruments Available: Spinnet piano.

Extras: Complete music and sound effects library; transfer and resolving to 16mm mag film; looping with 16mm projection; 16mm interlock and projection with digital footage counter; ¾" videotape playback.

Rates: \$35 to \$50/hr.

Direction: db Recording (formerly Recording/Furman) remains affiliated with its parent company, Furman Films, but it is now managed as an entirely self-sufficient business, specializing in commercial audio production. The comfortable rooms were built with great care, expense and acoustical know-how, and their superb sound has delighted producers of simple voice-overs and extensive 16-track music sessions alike. Brass, strings and vocals are present and bright. The engineers offer professional experience balanced equally between advertising and music production, and we think you'll find them, and the entire facility, ready to give you the best commercial product available.

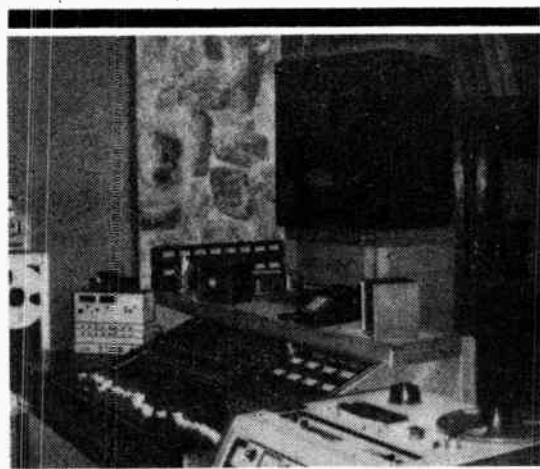

DUSK RECORDING STUDIOS
Santa Clara, CA

... DUSK RECORDING STUDIOS

2217A The Alameda, Santa Clara, CA 95050
(408) 248-3875, (408) 727-2840 - Dusksongs/BMI

Owner: Larry Shamus, Bob Langlie, Mike Shamus, Don Tirado.

Studio Manager: Larry Shamus

Engineer Staff: Bob Langlie, Larry Shamus, plus independents; music publishing, Paul Blote.

Dimensions of Studios: 16' x 28' x 16'.

Dimensions of Control Rooms: 16' x 14' x 12'; 16' x 8' x 12' copy room.

Tape Recorders: MCI Model JH114-16 w/auto locate III 16 track; TEAC Model 80-8 w/dbx 8 track; MCI Model JH110 w/dbx 2

six- teen track

track; TEAC Model 25-2 w/dbx 2 track; Sony Model TC-640 ¼ track; JVC Model KD-65 cassette.

Mixing Consoles: Soundcraft Series II w/sweep EQ 16 in x 16 out.

Monitor Amplifiers: SAE 2400L, BGW 100.

Monitor Speakers: UREI 813 Time Align, JBL 4315, JBL 4311 Auratones.

Echo, Reverb, and Delay Systems: Lexicon Prime Time DDL, Audio and Design Complex limiter(F760X-RS), Systech flanger/delay, UREI 1176 LN, UREI LA-3A, dbx 161 compressor/limiters, Orban/Parasound parametric equalizer, Orban/Parasound 516-EC D'Esser, AKG BX10 reverb, tape delay UREI ½ octave room EQ.

Microphones: AKG 414, 451, D1000E; E-V RE 20's; Sennheiser MD 421's; Shure SM-57's 58's; Direct Boxes.

Instruments Available: Aeolian grand piano, Yamaha drum set, almost any instruments available with 24 hours notice.

Extras: Kitchen area, refrigerator, coffee, recreation room, record pressing and cassette duplication, copy room.

Rates: 8 track: \$30.00/hr, 16 track: \$50.00/hr. Block rates available.

Direction: Dusk Recording provides a quality studio to meet the exacting needs of the artists in the Bay Area. We would like to extend an invitation to the independent producers, engineers, and musicians of the Bay to stop by and check us out. We think you will like what you hear. From all of us at Dusk, thank you for your continued support. "We're ready when you are," Dusksongs/BMI.

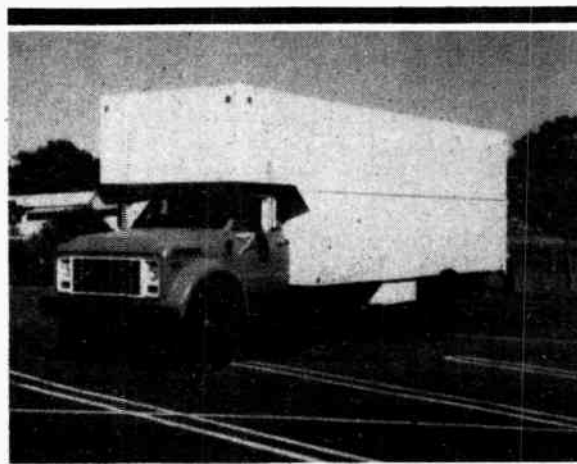

PHIL EDWARDS RECORDING
San Francisco, CA

... PHIL EDWARDS RECORDING

also REMOTE RECORDING
1338 Mission Street, San Francisco, CA 94103
(415) 861-4439

Owner/Studio Manager: Phil Edwards.

Engineers: Phil Edwards, Jim Hilson, Ron Davis.

Dimensions of Studios: Mixdown A: 13' x 14' x 7'; Mixdown B: 12' x 10' x 7'; Remote Truck: 21' x 8' x 7'.

Tape Recorders: (2) 3M 79 16 track; 3M 79 8 track; Studer A80, 2 track; Ampex 440-C 2 track (2) Ampex-Inovonics 300/355 2 track; Ampex-Inovonics 300/375 mono.

Mixing Consoles: DeMedio 2416, 24 in x 16 out; API 1604, 16 in x 4 out; Langevin custom, 10 in x 4 out.

Monitor Amplifiers: Mixdown A: Crown DC 300A; Mixdown B: McIntosh MC 240; Remote Truck: McIntosh MC 2100.

Monitor Speakers: Mixdown A: Altec 9845A, Auratone 5C; Mixdown B: JBL 4315, KLH CL4; Remote Truck: Altec 604-8G.

Outboard Equipment: UREI 1176 LN limiters, UREI LA3A limiters, Orban 621B parametric EQ, Orban 516EC D'Esser, Dolby 361 noise reduction (16 tracks), SMPTE interlock audio-audio and audio-video, ITC cart machine three deck, assorted ¼ track, cassette and elcassette machines.

Microphones: Shure SM-56, SM-58, SM-53; Neumann U-87, U-47fet, KM-84; AKG 414, 451, 405; Sennheiser 421; Electro-Voice RE 15; RCA 77DX.

Rates: 16-track mix: \$75/hr; 8-track mix: \$55/hr; all other work (4tk, 2tk, etc): \$35/hr; remote base price: \$1500/day and up.

... FANE PRODUCTIONS

115-B Harvey West Blvd., Santa Cruz, CA 95060
(408) 425-0152

Owner: Fane Productions

Studio Manager: Corie Anastasion.

Engineers: Fane Opperman; Seth Dworken; David Martone, gopher; assistant engineer: David Luke.

Dimensions of Studios: 30' x 16'.

Dimensions of Control Rooms: 29' x 12'.

Tape Recorders: Ampex MM 1000 16 track; Tascam 80-8 8 track; Ampex AG-440 2 track; Tascam 25-2 2 track; Sony ¼ track; TEAC A-800 cassette.

Mixing Consoles: Allen & Heath 16 channel.

Monitor Amplifiers: Crown DC-300A, Yamaha P2100, Symetrix HD-10.

Monitor Speakers: UREI 813 Time Aligned, JBL 4311, Altec A7's, Auratones.

Echo, Reverb, and Delay Systems: Ursa Major Space Station Digital Reverb System, Orban/Parasound 111B dual reverb, Bi-Amp reverb, Eventide Harmonizer and Digital Delay Line, Ibanez AD-230 analog delay and multi-flanger.

Outboard Equipment: 26 channels of dbx noise reduction, dbx Model 160 compressor/limiters, Bi-Amp graphic EQ, Mutron Phasor, direct boxes.

Microphones: Neumann U-87; AKG 414, 452 EB's, D224, D1000E; Beyer M500; E-V RE-20's, RE-11's; Shure SM-57's, SM-58's.

Instruments Available: Hammond B-3 with Leslie, acoustic piano, Polymoog synthesizer, Micro-Moog, Wuritzer electric piano, Guild Jumbo 12-string, Fender Stratocaster, Fender Jazz Bass, Fender Twin Reverb amp, Ludwig 6pc drum set with timbales, Syndrum drum synthesizer. Many Latin percussion instruments. All instruments available at no extra charge.

Extras: Studio musicians, arrangers and jingle writers are available. A restaurant/bar with pool tables and pinball is next door. The studio has a redwood geodesic dome lounge. Free coffee and tea. We also offer record pressing service.

Rates: 16 track: \$35.00/hr. 8 track: \$25.00/hr. 2 track: \$20.00/hr. Block rates are available. Free use of all studio instruments. Free one hour set-up time.

Direction: Since moving to our new studio on January 2, 1979, Fane Productions has been one of the busiest studios in Northern California. We offer excellent 16 track and 8 track equipment and an extraordinary assortment of studio instruments in a comfortable, professional environment at very low rates. Our engineers and producers are creative, efficient and easy to work with. We offer song writers complete service including arrangements, production and excellent studio musicians. Our clients include: Leslie West, Steve Marriott, Chris Spelling, Michael Toste, The Ravers, Vic Phillips, Jesse Pessoa and Los Gringos.

... FREEWAY RECORDING STUDIO, INC.

2248 E. 14th St., Oakland, CA 94606
(415) 532-3700

Owner: Corporation, Bernie Rivera, President; General Manager: Tom Matthews.

Studio Manager: David Blossom.

Engineers: David Blossom, Steve O'Hara; Jan Waling, Associate Engineer; Assistant Engineers: James Gillerman, Garth Leerer, Gayle O'Hara.

Dimensions of Studios: Studio A with isolation chamber, drum booth and sound traps: 46' x 37' x 12'; Studio B: 15' x 17' x 12'.

Dimensions of Control Rooms: Control Room A: 24' x 15' x 10' with sound traps; Control Room B: 15' x 17' x 12'.

Tape Recorders: 3M M-56 16 track; (2) 3M Series 410 2 track; TEAC 3340 4 track; Revox A-77 III ¼ track; (2) Pioneer CTF 900 cassette.

Mixing Consoles: RCA Custom (Studio A) 8900, 24 in x 16 out; Yamaha (Studio B) PM 700, 12 in x 4 out.

Monitor Amplifiers: McIntosh 2300, 2100's, 60's, Crown DC 300A, DC 150A, D 40's.

Monitor Speakers: Control Room A — Altec "Big Reds" custom design, Close-field ESS 210, Cubes, and Auratones. Studio A: JBL 2315's, Quad Electrostatic; Studio B: Altec A-7's. Listening Lobby: Modified McIntosh C-1/Leaks, three types of headphones.

Echo, Reverb, and Delay Systems: Live echo chamber, Orban reverb, digital and analog delay as needed.

Other Outboard Equipment: 16-channel dbx noise reduction, Audio Design Recording F769-R Vocal Stressor, Spectra Sonics Complitters, digital UREI metronome, UREI 550 filter, Multi-Sync MDA 1B motor drive amplifier.

Microphones: Neumann U-47, U-87; Sennheiser 409N, 413, 441; MBC 250; Shure SM-33, 53, 56, 57, 60; Electro-Voice RE-11, RE-15, RE-20, 1751, 635A; AKG D1000E, D202E1; Sony ECM-22F, ECM-51, ECM-280, C-37A.

Instruments Available: ARP 2600 synthesizer, ARP String Ensemble, Baldwin grand piano, Hammond B-3 organ, Ludwig drums, Zylidj cymbals, Hohner clavinet D-6, Celeste keyboard and assorted Latin percussion instruments.

Extras: 2 large rehearsal rooms with storage. PA available. 2-way, 3-way Community Light and Sound reinforcement system, McIntosh & Crown amplifiers with custom built tri-amp electronic crossover. UREI 527-A 3rd octave EQ. Yamaha PM Series mixing console. Refreshment center.

Rates: \$40 - \$105/hr 16 track. Special rates available for block bookings or project.

Direction: As well trained ears, we hear you and we are looking for the new, the not-yet-heard as well as "traditional" styles. We welcome creative artists who want to enhance their professional careers, who want their best performances packaged and properly presented. Located just off BART and one mile from the Oakland Coliseum, our facility provides generous size, pre-recording rehearsal studios, decompression areas and a large central studio. Please note: We also do sound reinforcement from clubs to concerts.



FREEWAY RECORDING STUDIO
Oakland, CA

... FUNKY FEATURES RECORDING
142 Central, San Francisco, CA 94117
(415) 621-2646

Owner: Jack Leahy.
Engineers: Richard Green, Neil Schwartz, Eric Buck, Jack Leahy.
Dimensions of Studios: 20' x 20'.
Dimensions of Control Rooms: 18' x 15'.
Tape Recorders: 3M 16 track and 8 track; Series 560 Ampex 440B 4 track and 2 track.
Mixing Consoles: Board is a charming antique combination of Ampex and Shure mixers.
Monitor Amplifiers: McIntosh amps.
Monitor Speakers: JBL.
Outboard Equipment: Electrodyne, Shure and Metrotek EQ, UREI 1176 compressor/limiters, phaser, filters, noise gate.
Microphones: Neumann U-87's; Electro-Voice RE-10's, 16's, 20's; Shure SM-56's, SM-53's; RCA 77DX's, Sony C-37A's C-22's, C55's; Nakamichi etc.
Instruments Available: Hammond organ and Leslie, Steinway grand, Everett upright tack piano, synthesizers.
Rates: \$40/hr M-F 9am-6pm; \$50/hr after 6pm and on weekends.
Direction: Funky Features has long been a combination workshop-studio for countless Bay Area musicians and producers. We provide a first rate sound, a comfortable atmosphere and fast professional approach to our work. In business since 1969, SF's 1st small multi-track studio; demos and masters, complete production coordination. Albums by Steve Miller, Hoodoo Rhythm Devils, Country Joe MacDonald, Link Wray, Cold Blood, Terry Garthwaite, Wah Wah Watson, Herbie Hancock, Steamin' Freeman, Miroslav Vitous, Norton Buffalo, Mel Martin & Listen.



FUNKY FEATURES, San Francisco, CA
Neil Schwartz, Engineer

... HEAVENLY RECORDING STUDIOS
1020 35th Ave., Sacramento, CA 95822
(916) 428-5888

Owner: President Steven G. Somers; Vice President Martin Ashley.

six-teen track

Engineers: Chief Engineer: Martin Ashley, Larry Lauzon, Mark Ishikawa.
Dimensions of Studios: Studio A: 30' x 40'; Vocal Booth 10' x 8'; Drum Cage: 9' x 9'.
Dimensions of Control Rooms: Control Room A: 30' x 15'; Control/Studio B (production): 10' x 20'.
Tape Recorders: MCI JH-16 16 track; MCI JH-16 8 track; Ampex AG-440B 4 track; Scully 280-B 2 track; Ampex 351 2 track; Ampex 351 mono.
Mixing Consoles: Quad-Eight Pacifica, 24 in x 16 out; Collins 212-G (broadcast console) 10 in.
Monitor Amplifiers: McIntosh 2100; McIntosh MC 275.
Monitor Speakers: JBL 4333; JBL 4311; JBL 4301; Altec 604E; Auratone 5C.
Echo, Reverb, and Delay Systems: AKG BX 20E reverb; Eventide H-910 Harmonizer/Digital Delay; Marshall Time Modulator.
Other Outboard Equipment: dbx; Dolby A; Pultec EQ; UREI 1176 LN comp/limiters; Quad-Eight comp/limiter/expander/D'Essers CL-22; Ampex VSO; voice gates; electronic metronome; Pultec filter; Sonovox; demo-cutter; broadcast cart.
Microphones: Neumann U-67, U-87, KM-84; AKG C-451E; RCA77-DX; Sennheiser MD 421U; Altec M-30; Sony ECM 280; Shure SM-7, SM-53, SM-58, 545, 300; Electro-Voice RE-16, RE-20, 654A, 666, 1751; Trouper directs.
Instruments Available: Yamaha Conservatory grand piano, Synthesizers (by appointment).
Extras: Heavenly is located 1000 ft. east of the Sacramento River with boating and docking facilities; also near shopping center. Coffee, tea, munchie box, refrigerator, and frisbee on premises.
Rates: 16-track: \$40-\$75/hr; 8-track: \$40-\$60/hr; 2 & 4-track: \$30-\$45/hr.
Direction: We have just finished extensive re-design and construction of vocal booth and drum cage. We are continuing to grow both technically and creatively. 24-track in 1980.

... HOLDEN, HAMILTON, AND ROBERTS
also REMOTE RECORDING
2227 North 56th St., Seattle, WA 98103
(206) 832-8300

Owner: Holden, Hamilton, and Roberts, Inc.
Studio Manager: Herb R. Hamilton, Jr., Miriam Hamilton.
Engineers: Herb R. Hamilton, Jr., Greg Branson, Bob Holden, Curt Blood.
Dimensions of Studios: 29'6" x 16'7" x 8'9".
Dimensions of Control Rooms: 17' x 12'5" x 8'2".
Tape Recorders: Scully 288 16 track; Scully 280-4 4 track; Scully 280-2 2 track.
Mixing Consoles: Audiotronics 501, 16 in x 16 out (expandable to 24).
Monitor Amplifiers: Spectra Sonics.
Monitor Speakers: JBL 4311, Auratones, Electro-Voice EVS 16B (studio monitors).
Echo, Reverb, and Delay Systems: EMT mono and stereo plates, Fairchild dynamic reverberation system.
Other Outboard Equipment: dbx noise reduction, Dolby (2 ch) noise reduction, dbx comp/limiter, Universal Audio comp/limiter, SAE parametric, Spectro Acoustics graphic EQ, Symetrix audio gates, Pultec and Langevin passive filters and EQ's, Multi-Track parametric, Fairchild comp/limiter.
Microphones: Neumann U87, U67, U47, KM83, KM56; PML; Sennheiser MKH 405, C452, MD 421; E-V RE-11, 666; Norelco C60, C61; Shure SM-57, 56, 330; Sony C37; RCA DX77; Microphone Baur MB 301, MB 527; Beyer dynamic BD 160, BD 500.
Instruments Available: Baldwin 9' concert grand SD10; Hammond B-3 organ with Leslies and Polyphonic synthesizer; Mini Moog; Fender Dual Showman guitar amps; Gibson guitar amp; Rogers drum kit; Ovation 12 string, vibes; Fender Bass; tack piano, various percussion instruments, Wurlitzer Model 200EP.
Extras: Assorted cassette decks, 1/4" R/R decks and Technics turntables, etc.; King automatic cassette loaders, Accurate Sound hi-speed cassette duplicator with loop bin; Pentagon and Ampex R/R and cassette duplicators (hi-speed); Audico manual loaders.
Rates: 16 track: \$70/hr. 8 track: \$50/hr. 4 track: \$40/hr. 2 track: \$35/hr. Remote semi-pro: \$50/hr. two track pro remote: \$65/hr. Remote, 4 track pro: \$75/hr.

Direction: Recording everything from Bach to Rock. Winner of twenty world-wide awards, including many Cleo's and IBA's. Northwest's largest duplicator of reel to reel and cassette tapes. Northwest's exclusive franchise for Recording Institute of America (N.Y.). Aspire to develop Northwest talent and provide professional quality and service to the Pacific Northwest in record production, hi-speed tape duplication, recording classes, and radio and TV commercials. Expecting to go 24 track in the near future. In business for over nine years.

... HUN SOUND
647 Irwin St., San Rafael, CA
(415) 454-2911

Owner: Tom Harney and Don Podesto.
Studio Manager: Barret Bassick.
Engineers: Barret Bassick and David Brown.
Dimensions of Studios: Recording Room 24' x 50'; Rehearsal Rooms 24' x 34', 21' x 14', 20' x 14', 22' x 30', 22' x 36', 32' x 56', 37' x 25'.
Dimensions of Control Rooms: 12' x 12'.
Tape Recorders: MCI JH-10 16 track; Sony TC-788-4 4 track; Sony TC-880-2 2 track; Revox A77 2 track.
Mixing Consoles: Speck SP-800-C, 16 in x 8 out; Allen & Heath SR-20, 20 in x 8 out; Allen & Heath SD-12-2, 12 in x 3 1/2 out; Troupier I, stereo, 20 in x 3 out; H&H Stereo 12, 12 in x 3 1/2 out.
Monitor Amplifiers: Crown PSA-2, Crown DC300A, Crown D-150A, Crown D75.
Monitor Speakers: JBL 4311, Audio Technique Big Red and Little Red, Hard Trucker HT-01 (cubes).
Echo, Reverb, and Delay Systems: Furman RV-1, Delta Labs DL-1 and DL-2, Klark-Teknik DN34, Fisher Space Expander, Eventide Harmonizer and Flanger.
Other Outboard Equipment: White 1/6-octave EQ, Ashly parametrics, Furman parametrics, Crown EQ-2, dbx noise reduction—all recorders, Ashly and dbx comp-limiters, Eventide Omnipressor, White 140 spectrum analyzer, White 142 spectrum monitor, EXR Exciter.
Microphones: Sennheiser 421, 441, 409; Shure SM-56, SM-57, SM-58, SM-59; Electro-Voice DS-35, RE-15, RE-16.; PML F69, DC-63; Sony ECM 53P, C-38B, ECM 280, ECM 50P, ECM 33F, ECM 23F and more.
Instruments Available: Yamaha 5' baby grand, Hammond B-3.
Extras: Loading dock, lounge, air conditioning, refrigerators, service facility.
Rates: \$40/hr.
Direction: HUN means Humans Understanding Needs. We offer professional audio equipment in our retail showroom, a full service arrangement with Audio Works on the premises, and our professional technical staff is available to help you with any problems you may encounter on stage, on the road, or in the studio. We have many private, secure rehearsal studios available to help you get your thing together as well as a 16-track studio to get it on tape. Quality, service, privacy is our motto.

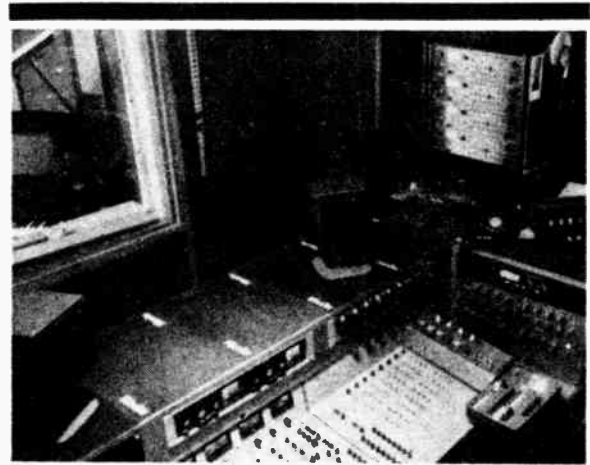

MOBIUS MUSIC RECORDING
San Francisco, CA

... MOBIUS MUSIC RECORDING
1583 Sanchez St., San Francisco, CA 94131
(415) 285-7888

Owner/Studio Manager: Oliver DiCicco.
Engineers: Oliver DiCicco, Phil Crescenzo, Ken Kessie.
Dimensions of Studios: 25' x 15'.
Dimensions of Control Rooms: 16' x 12'.
Tape Recorders: 3M 56 16 track; Ampex MR70 4 track; Ampex 351 2 track; Revox A77HS 2 track; Nakamichi 600 2 track.
Mixing Consoles: Quantum 168 16 in x 16 out.
Monitor Amplifiers: Crown D150, D60.
Monitor Speakers: Altec 604-BG with UREI time-aligned cross-overs, Auratone 5C, EPI 100, Sennheiser HD414.
Echo, Reverb, and Delay Systems: Master-Room reverberation, Lexicon 92 DDL.
Outboard Equipment: Orban 622B parametric EQ, UREI 530

THERE IS A PLACE

Where you can be yourself
Where you can think
Where you can work
Where you can expand your
talents to the limit
Where you can be a musician



WHERE YOU CAN FIND PROFESSIONAL
SIXTEEN TRACK RECORDING AND
REMIX FACILITIES.

We offer a fine selection of
exceptional instruments, unusual
equipment, and studio musicians,
in addition to pressing,
production and arranging services.

If you're thinking about putting
your sound down on tape,
but your pocket book
is holding you back,
call the professionals
at Ayre Studios—
you may be surprised.

JUST ARRIVED:
EXR PSYCHOACOUSTIC EXCITER!

SEE OUR LISTING ON PAGE 66.

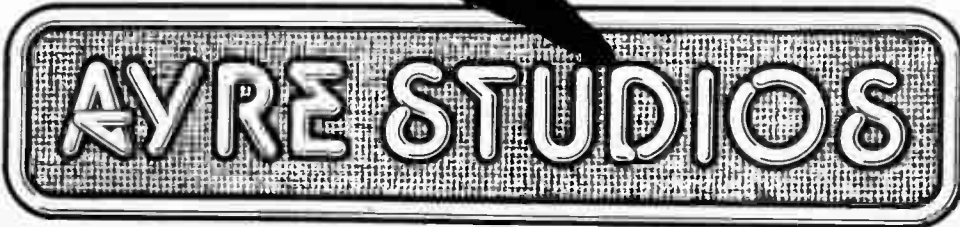

(408) 279-AYRE or 279-2973
458-A Reynolds Circle, San Jose, CA 95112

graphic equalizer, UREI LA 4 limiters, dbx 160 limiters, dbx noise reduction, AR turntable, Moog model 12 synthesizer. **Microphones:** Neumann U-87, Km-84, Km-85; Sennheiser 421, 402; Beyers M-500; Electro-Voice Re-15, Re-11, 635; Shure Sm-57; AKG D-200 E, D-160; Socom direct boxes. **Instruments Available:** Yamaha C-3 grand piano, Yamaha 4 voice synthesizer, Slingerland Radio King drums, Guild electric guitar, custom bass, King tenor sax, Fender amp, various percussion and esoteric instruments. **Extras:** Free coffee, kitchen, easy parking, photographic services including darkroom available at extra cost. **Rates:** 16 track: \$40/hr; 2 and 4 track: \$20/hr. Block booking discount available. **Direction:** Since the last issue of The MIX we've upgraded the studio with the addition of a Yamaha grand piano, Master-Room reverb and UREI time aligned crossovers. Plans for the near future include expanding the studio and control room and the addition of a 24 track recorder and console. Our many thanks to the friends and musicians who are making it happen.

... PACIFIC WEST RECORDERS

3415 W. Lake Sammamish Rd. S.E., Bellevue, WA 98008 (206) 748-0734

Owner/Studio Manager: John Frechette.

Engineers: Dave Perry.

Dimensions of Studios: 22' x 34'.

Dimensions of Control Rooms: 12' x 18'.

Tape Recorders: MCI JH-100 16 track; MCI JH-110 2 track.

Mixing Consoles: MCI JH-428B 18 in x 18 out.

Monitor Amplifiers: BGW, Bozak, McIntosh.

Monitor Speakers: JBL 4343's, JBL 4311's, Auratone.

Echo, Reverb, and Delay Systems: Master-Room Super 'C' reverb, Lexicon Model 92 digital delay, and MXR digital delay.

Outboard Equipment: Orban parametric EQ, UREI 1176N peak limiter, dbx Model 161 compressors, Roger Mayer noise gates, Aphex, dbx noise reduction on 1/2 track recorder.

Microphones: Neumann U-87, U-47, KM-84; AKG 451, 441EB; Sennheiser 421, 441; Beyers M-160N(C); Electro-Voice RE-20; Shure SM-57; RCA 77-DX.

Instruments Available: 7 Chickering grand piano, Hammond B-3 w/147 Leslie, Fender Rhodes electric piano, Rodgers drums, Zildjian Paiste cymbals, LP congas, bongos, and effects.

Extras: Lab Series guitar amps, MXR Effect Boxer and free coffee.

Rates: \$50.00/hr record and mix; \$40.00/hr when booked in blocks of 8 hours or more.

Direction: Pacific West Recorders is in a continual state of studio upgrade. It changes week to week, month to month.



PACIFIC WEST RECORDERS
Bellevue, WA

... PARVIN STUDIOS

P.O. Box 16191, San Francisco, CA 94116 (415) 359-1853

Owner: M.B. Eads Co.

Engineers: Lee Parvin, Henry Parvin.

Dimensions of Studios: 22' x 16'.

Dimensions of Control Rooms: 12' x 13'.

Tape Recorders: MCI JH-110 16 track with auto locate; Ampex 440-B 8 track; Ampex 440B 4/2 track; Ampex AG500 1/2-track; Akai 950-B stereo 1/4-track; Akai 950-B stereo cassette.

Mixing Consoles: Audiotronics 501-26, 16 in x 16 out.

Monitor Amplifiers: Marantz 15, Crown DC300.

Monitor Speakers: Altec 604-8G, Auratones 5C.

Echo, Reverb, and Delay Systems: Master-Room Stereo 'C' Series reverb, Orban/Parasound reverb.

Other Outboard Equipment: UREI model 1176 LN limiters, UREI model LA 4 compressor limiters, Orban/Parasound parametrics, UREI 530 equalizer, dbx noise reduction.

Microphones: Neumann U87, U47, KM86, KMS85; Sennheiser 421, 441; AKG 1000, D-200; Shure SM58, MB 301 Ribbon, Shure 549, SM81.

six-teen track

Instruments Available: Emerson baby grand piano, Hammond B-3 organ and Leslie.

Rates: Call for rates.

Direction: We record artists for demos, records, film scores, video sound tracks and commercials. This is our fifth year of operation.

... planet Mars RECORDING STUDIO

1445 Koll Circle (near Le Baron Hotel), San Jose, CA (408) 294-6176, 279-9893

Owner/Studio Manager: James R. Oldham.

Engineers: Garry Miller, James R. Oldham, Matt Howe, Jerry McReynolds.

Dimensions of Studios: 20' x 20'.

Dimensions of Control Rooms: 7' x 15'.

Tape Recorders: Ampex 16 track; TEAC/Tascam 80-8 8 track; TEAC 3340S 4 track; TEAC 2330SX 4 track; Ampex ATR 700 1/2 track 2 track; TEAC 2 track cassette.

Mixing Consoles: Sound Workshop 1280B-EXP, 12 in x 8 out; TEAC/Tascam Model 5 Neptune Special, 16 in x 16 out.

Monitor Amplifiers: Kenwood, Peavey, Accoustic.

Monitor Speakers: E-V, Vega, Yamaha, Peavey, Visonik David.

Echo, Reverb, and Delay Systems: Tape and electronic echos, Reticon Chorus echo — digital delay, assorted graphics, phasers, etc.

Other Outboard Equipment: String Ensemble, synthesizer, B-3 Leslie, piano.

Microphones: AKG, Audio Technica, Shure, etc.

Instruments Available: Everything!

Extras: Rehearsal space, production, photograph, mgt.

Rates: 16 track: \$20/hr. 8-track: \$16/hr. 4-track: \$10/hr. Block rates available on request. Mixdown \$20/hr.

Direction: Revolution in the recording industry pricewise! Our Motto! In our first six months we've recorded such Bay Area musicians as Mark Ford, "Dreamer", "Sunstone", "Ryde", "Promise", "Egypt", Religious groups, and even the S.J.C. Symphonic Orchestra. High quality demos made well and inexpensively. We will soon start work on Studio "B" with 24 tracks. We look forward to meeting you and discussing your audio projects and needs.

... PRARIE SUN STUDIOS

925 E. Cotati Ave., Cotati, CA (707) 795-7011

Owner: Mooka.

Studio Manager: Jay Klein.

Engineer: Chet Connick, Mooka.

Dimensions of Studios: 30' x 25'.

Dimensions of Control Rooms: 15' x 13'.

Tape Recorders: Scully 100 16 track; Ampex 350/440 2 track; Sony TC 158 cassette.

Mixing Consoles: Clover custom, 30 in x 24 out.

Monitor Amplifiers: Yamaha 2100, Dynaco 70 stereo.

Monitor Speakers: Altec 604's, Ed Long MDM 45, Auratones.

Echo, Reverb, and Delay Systems: Furman reverb, Roland Space Echo, Intersound reverb.

Other Outboard Equipment: Gain Brain, band pass filters, Morely phase, ADA flanger, Alembic F2 B pre-amp.

Microphones: Neumann U-64; AKG 414 condenser; Sony ECM 22P; Beyers 500, M160; E-V RE-20, RE-15, 666's, 664, 635; Shure Sm-57, 545's.

Instruments Available: Yamaha electric grand, handmade Frankfuller custom acoustic, and Ibanez bass. Access to any other rental is available.

Extras: Refreshments, smiles, nice people, and funky sleeping quarters.

Rates: \$17.50/hr with second engineer. Additional \$5.00/hr engineering costs if you don't have a first engineer and we'll supply one of ours.

Direction: We are a demo studio, but also involved in long term creative projects. We recently had the privilege to acquire a Clover custom board previously used by LA studios (Helen Reddy, Beach Boys). We go for the feel and spontaneity, as well as technological concepts. Our clients seem to appreciate the excitement that our staff is into cultivating in sessions. Our rates reflect our willingness to offer a highly saleable product for people who need the technology, not the sterility.

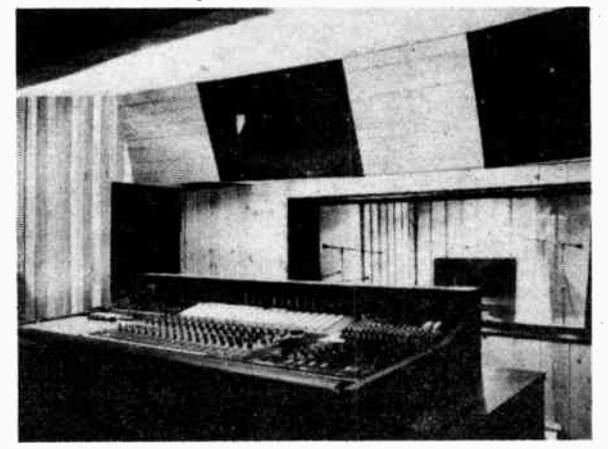

PYRAMID RECORDING
San Jose, CA

... PYRAMID RECORDING

617 Stendhal Lane, San Jose, CA 95129 (408) 255-6379 (appointment only, please)

Engineers: Jess Meek.

Dimensions of Studios: 24' x 22' x 9'.

Dimensions of Control Rooms: 14' x 17' x 10'.

Tape Recorders: Ampex MM1100 16 track; Ampex 351-2 2 track; Ampex 440-2 2 track.

Mixing Consoles: KJM Productions A2008, 20 in x 8 out.

Monitor Amplifiers: Phase Linear 700.

Monitor Speakers: Altec 604E mounted into an acoustically tuned control room.

Echo, Reverb, and Delay Systems: (2) Quad Accutronics springs, acoustical chamber, 4-channels of digital delay are available.

Outboard Equipment: Spectra Sonics compressors (4), octave graphic EQ (4).

Microphones: Neumann U-67, U-47; Shure SM57, SM56, Electro-Voice RE10, RE16, RE20; Sony C37, C22; AKG C451, D202.

Instruments Available: Piano.

Extras: Production and promotional services, for both music and artists.

Rates: 16 track demo time: \$25 - \$35 depending on time scheduling. 16 track mastering: \$35 - \$50. Set-up time is not charged.

Direction: Our desire is to supply the Bay Area music industry with high quality sound at a reasonable price and to expose and promote Bay Area musicians, writers, and their product. We do not limit our services to recording, but extend it to all the music oriented needs of our clients.

... KELLY QUAN RECORDING

Business Office: 55 White St., San Francisco, CA 94109

Studio: 1249 1/2 Green St., San Francisco, CA 94109

(415) 771-6716

Owner: Mr. Kelly Quan.

Engineers: Joe Tarantino, Bruce Cooley.

Dimensions of Studios: 320 sq. ft. with a 7' x 8' isolation booth.

Dimensions of Control Rooms: 13' x 11'.

Tape Recorders: Ampex 16 track, Ampex 2 track machines, Ampex 1/4 track, cassette, etc.

Mixing Consoles: Electrodyne, custom 24 in x 16 out.

Monitor Amplifiers: Crown, Opamp Labs, Dynaco.

Monitor Speakers: JBL 4320's, JBL studio monitors, Auratones, and external speakers.

Echo, Reverb, and Delay Systems: EMT 140 ST stereo plate reverb, equalized Multi-Track stereo, Fisher K-10.

Other Outboard Equipment: UREI 1176 limiters, Eventide Harmonizer, MXR Digital Delay, MXR Flanger, Furman parametric EQ's, UREI 550A recording filter, MXR Phase Shifter, Allison Kepex, Teletronix LA2A limiters.

Microphones: Neumann, Electro-Voice, Sennheiser, Shure, MB, AKG, Sony, etc.

Instruments Available: Hammond B-3, Yamaha grand piano, Fender guitar amps.

Extras: Air conditioning, provision for external speakers, vending machines.

Rates: \$48/hr 16-track recording and mixing. \$25/hr 2-track studio time. Rates double after midnight. Block rates available for albums, etc. Telephone for more information and/or appointment to see the studio.

Direction: The complete 16 track studio facilities available for record albums, film sound, and TV and radio advertising production. Numerous film, album, 45's, and spot credits to date. More equipment and larger facilities are all in the near future of Kelly Quan Recording.

... RANCHO RIVERA RECORDING

1124 Rivera St., San Francisco, CA 94116 (415) 681-6977

Owner: Tom Sharples, Michael Ward.

**Where
to find the
musical
instruments,
P.A. equipment,
repair and
rentals
in California?**



JOHN ALTMANN RECORDING 1310 20th Ave San Francisco, Ca 94122



**2, 4, 8 & 16 Track Recording
Hi Quality, Low Rates, Friendly People (415) 564-4910**

It's time the Professionals were given a few things they've never had before.

McCAULEY Commercial Series

McCaughey Sound Co
13608 94th Ave. E.
Puyallup, WA 98371
(206) 848-C363



**Check the listings
in September's
M.I. Magazine.**

**Available FREE
at an M.I. dealer
near you.**

**A Mix Publication
...for the active musician**

SOUND·USE

407 Garfield So., Parkland, WA 98444
206-537-6900

K&K SOUND ENGINEERING

1904 W. San Carlos, San Jose, CA 95128
408-249-5760

six- teen track

Engineers: Yves Gautsche, Emil Flock, independents.
Dimensions of Studios: Approx. 16' x 20', irregular acoustically correct design.
Dimensions of Control Rooms: Approx. 8' x 10'.
Tape Recorders: Ampex MM1000 16/8 track; Ampex 300 and 350, 1 and 2 track; Nakamichi D-600 2 track.
Mixing Consoles: Cetec/Electrodyne Model 1604, 16 in x 4/16 out.
Monitor Amplifiers: Dynaco, Crown, McIntosh.
Monitor Speakers: JBL 4310, Visonik David 50's, Altec 604E's.
Outboard Equipment: UREI LA3A, RCA BA-6, Multi-Track parametrics, MCI JH-2 EQ's, MXR DDL, MXR Flanger, SAE Impulse noise reduction.
Microphones: Neumann U-47, U-67, U-64; Beyer M-500's, M66; Sennheiser MKH 405, MD 421; Sony ECM 377, ECM-22, ECM-51; AKG C-451E's, D-202, E-V CS-15, 666's; RCA 77DX; Shure SM-57, 58, 545.
Instruments Available: Grand piano, Hammond B-3, Fender Vibrolux, Fender Bassman.
Extras: Redwood bathroom, lounge with kitchen, hardwood floors and trimwork, beautiful surroundings.
Rates: 16 track rec'd and mix: \$30/hr; 8 track: \$25/hr; R-R editing and assembly: \$20/hr; real time cassette copies: \$3.50 each for 22 mins or less. Open accounts to well-rated firms or individuals.
Direction: We cater to independent engineers and producers who want to work in a small but beautifully appointed studio with complete recording and post production capacity. We plan to install a small disc-cutting system and to expand to 24 track mix capability.

••• REX RECORDING CO.

1931 S.E. Morrison, Portland, OR 97214
 (503) 238-4525

Owner: Russell E. Gorsline
Engineers: Russ Gorsline, Cal Scott, Steve Heugli
Dimensions of Studios: 21' x 23'
Dimensions of Control Rooms: 14' x 18'
Tape Recorders: 3M 79 16/8 track; 3M 23 4 track; Scully 280B 2 track.
Mixing Consoles: Electro-Dyne modified 1204 16 in.
Monitor Amplifiers: Klein & Hummel mon. amp/speaker internally biamped, Marantz 2440.
Monitor Speakers: Klein & Hummel, JBL.
Echo, Reverb, and Delay Systems: EMT 140, custom analog delay.
Outboard Equipment: dbx noise reduction, dbx limiter, UREI limiter.
Microphones: Neumann U-67; Sony C500, C37P, ECM 377, C22P; E-V RE15; Shure SM57, 546.
Instruments Available: Chickering 7.5 ft. grand piano, Hammond B-2 w/Leslie.
Rates: 16 track - \$55; 7 hour block evenings: \$50/hr - \$350.

••• RIPCORD RECORDING STUDIO

(Gene Breeden Productions)
 4009 E. 18th St., P.O. Box 2089, Vancouver, WA 98661
 (206) 695-2112, 694-8818

Owner: Gene Breeden.
Studio Manager: Blaine Allen.
Engineers: Gene Breeden, Blaine Allen, Ellis Miller, Dave Dixon, Dan Breeden, Ron Stephens.
Dimensions of Studios: 900 sq. ft. in the studio room itself, excluding control room.
Dimensions of Control Rooms: 225 sq. ft.
Tape Recorders: Ampex MM-1000 16 track; Ampex AG-440-8 8 track; Ampex AG-440-2 2 track; Ampex 351-1, mono; TEAC A-3300SX 2 track; Optonica RT-6505 cassette.
Mixing Consoles: El-Tech 1616-25, 16 in x 16 out.
Monitor Amplifiers: McIntosh, Crown.
Monitor Speakers: Control Room: JBL 4320, Studio: Altec 604.
Echo, Reverb, and Delay Systems: EMT stereo reverb, Eventide Harmonizer and Digital Delay, Ibanez electronic echo, flanger and analog delay.
Other Outboard Equipment: UREI, Teletronics, dbx limiters, Orban/Parasound sibilance control; MXR Flanging.
Microphones: Full microphone complement: Electro-Voice RE-20, Telefunken U-47, AKG C-12, various models, Sennheiser, Shure, Altec, Sony, Electro-Voice, AKG, RCA.
Instruments Available: 9' concert grand piano, Poly Moog, Pearl drums, Syndrums, Thomas 3 manual organ, Roto-toms, various amplifiers: Fender, Ampeg, Standel.
Extras: Complete studio band on staff.
Rates: \$65/hr 16 track; \$50/hr 8 track; we also specialize in package deals and time blocks, and allow considerable discounts in these areas.

••• ROLLING 'R' MOBILE RECORDING

REMOTE RECORDING
 2514 Dexter Avenue North, Seattle, WA 98109
 (206) 941-4569
Owner: Rupert & Associates.

Engineers: Chief Engineer: Wayne Pommer; Robert Holden, Roland Anderson, D.B. Fader.

Dimensions: 27 foot Winnebago.
Tape Recorders: 3M Model 56 16 track; Ampex 440C 2 track; Crown mono; TEAC 3340 4 track; Studer Revox A77 HS 2 track; Tandberg MX II 500 and Techniques cassettes.
Mixing Consoles: Audiotronics Model 501, 26 in x 16 out.
Monitor Amplifiers: Crown 150 A, (2) Crown D60's.
Monitor Speakers: MDM 4's, JBL 4311's, JBL 100's, Auratones.
Outboard Equipment: EXR Aural Exciter, MICMIX Master-Room reverb, (5) Ashly SC-50 compressor/limiters, Orban stereo synthesizer, Orban stereo compressor/limiter, El Tech take finder, (4) Bi-Amp 27-band graphic equalizers.

Microphones: 30 microphones including: Neumann U-87's, KM-84's; MicrofonBau MB 301; AKG C-451's, D-202E; Shure SM-56's, SM-57's, 545; Electro-Voice RE-10, RE-15; Sennheiser MD 421; Beyer M160, M500; Sony ECM 22P.

Instruments Available: Rogers drum set, String Ensemble, ARP Axxe, Roland synthesizer, Hammond B-3, upright piano, Fender Stratocaster, Martin D-35, Epiphone 12-string, Epiphone 6-string, and complete percussion kit. Fender Bassman and Twin Reverb amps.

Rates: \$1500/day, \$7500/week, includes 1st and 2nd engineer. 50¢ per mile outside Seattle metropolitan area.

Extras: Video monitor system, complete kitchen and shower/bathroom facilities, air conditioning, and free cue-tips.

Direction: Rupert & Associates/Rolling 'R' Mobile Recording is a multi-faceted company providing full production assistance in all areas of record producing including: arranging, producing, copying, and studio musician referral service. We are looking to the future to advance our technical excellence and track capability to provide the Northwest with the finest quality possible, and with 1st rate service at reasonable rates.

••• SIERRA SOUND LABS

1741 Alcatraz Ave., Berkeley, CA 94703
 (415) 655-7636

Owner: Robert C. De Sousa.
Engineers: Robert C. De Sousa, James Nielsen, Lucy Sherak.
Dimensions of Studios: Main studio: 30' x 40'; isolation studio 9' x 13'.
Dimensions of Control Rooms: 15' x 20'.
Tape Recorders: Scully 100 16 track; Scully 280-2 2 track; Scully 280-4 4 track; Kenwood cassette recorder KX-620 2 track.
Mixing Consoles: Custom built with 15 band graphic EQ on each input, 24 in x 16 out.

Monitor Amplifiers: JBL SE-408S.

Monitor Speakers: JBL studio monitors; Auratones.

Outboard Equipment: Universal Audio, 1176, dbx 160 compressor/limiter, Gates Sta-Level; Orban/Parasound program controlled amplifier (compressor/limiter); Orban/Parasound reverb, live chamber (stereo); Peterson strobe tuner, VSO on any machine.

Microphones: Neumann U-87's, KM-84's; Sony C500's, ECM-22P; Electro-Voice RE-15, RE-20; MB; RCA 77, 44; Shure SM56's.

Instruments Available: Grand piano, tack piano.
Extras: Free coffee.

Rates: 16 track rates: generally figures on a block time basis, 5 hour: \$205.00, 10 hours: \$380.00, 20 hours: \$700.00, 30 hours: \$1020.00 Basic hourly rate \$50/hr. 2-track time sold by the hour only, \$34/hr.

Direction: Our basic concept is to provide a reasonably priced, professional recording facility for a wide variety of projects. We are experienced in complex musical productions and will gladly provide assistance on any level. Our facilities have evolved from a simple 2-track beginning in 1960 to our present large and comfortable 16-track studios. Future plans include 24 track and computer controlled mixing.

••• SONIC ARTS / GOLDEN STATE RECORDERS

665 Harrison St., San Francisco, CA 94107
 (415) 781-6307
Owner: GSR, Inc.
Studio Manager: Leo de Gar Kulka.

Engineers: Leo de Gar Kulka, James Economides, Jr., David Tonelli, Bud Osterberg.

Dimensions of Studios: A: 40' x 50' with 20' ceiling; B: 10' x 10' x 9'; Mastering Room: 20' x 35' x 9'.

Dimensions of Control Rooms: A: 30' x 20' x 10'; B: 10' x 10' x 9'; Mastering Room: 20' x 35' x 9'.

Tape Recorders: Ampex: 200, 300, 300/8, 350/2, AG350/2 (2), AG440/2; 3M stereo 2 track 15, 30 ips; Inovonics stereo 2 track 7 1/2, 15, 30 ips; Stephens 16/8 track; Sony PCM 1 digital stereo.

Mixing Consoles: Custom, 15 in x 16 out, Quad/Eight, 24 in x 24 out; custom mastering console, 4 in x 2 out for disc mastering; custom, 15 in x 2 out.

Monitor Amplifiers: Mac 70 and Altec 70 W all vacuum tube, Crown 300.

Monitor Speakers: Throughout Altec A-7 in studios (4); Altec 604E in A and Mastering Room, also JBL Signature.

Echo, Reverb, and Delay Systems: AKG, Fisher, Delmo, Sennheiser, and three others.

Other Outboard Equipment: UREI, Spectra Inovonic limiter/compressors, graphics, Pultecs, noise reductions, dbx and Dolby; D'Essers, high-frequency limiters — Neumann; frequency analyzers, peak VU meters, LED peak indicators, volume memory circuits, video Betamax, PCM digital converter, variable pitch and depth control, phase correction.

Microphones: 30 microphones, among them: AKG C-24, Neumann 47, 49 a.o., Sennheiser, AKG, Norelco, Altec condensers; Sennheiser 421D and 441's; Audio Technica condenser, Electretts, RCA 44 and 77BX.

Instruments Available: Grand piano, baby grand, Hammond B-3 with Rhythm Box and bass, Hammond and Leslie speakers, Yamaha synthesizer, Old German pump organ in excellent condition, Fender Rhodes, ARP synthesizer.

Extras: Disc mastering facility, late Neumann lathe with variable pitch and depth control controlled with digital computer, VG66 cutting amp, half-speed capability from 30 ips master tape and 15 ips master tape, 45 rpm 12" cutting. Pressing, art, and packaging service. Direct to disc recording and direct to digital and digital to disc trl.

Rates: From \$35/hr for simple stereo to \$90/hr for 16 track. Special rate for digital recording. Special rates for direct to disc recordings. Ask for quotation.

Direction: Acoustic oriented, large groups to fit in large room, contracting for top pro musicians, classic, choir. Studio philosophy: Fidelity in recording and reproduction that only personal integrity and total dedication, coupled with state-of-the-art equipment can achieve. The artist's friend and accomplice, rather than "engineering". When love and dedication work together with skill, expect a masterpiece.

••• SOUND RECORDING CO.

503 W. Indiana, Spokane, WA 99205
 (509) 326-0222

Owner/Studio Manager: Irene Carter.
Dimensions of Studios: 30' x 50'.
Dimensions of Control Rooms: 16' x 20'.
Tape Recorders: Scully 16 track; Ampex 440's 4 track.
Mixing Consoles: Custom.
Monitor Speakers: Altec A7 speakers.
Echo, Reverb, and Delay Systems: Reverb.
Microphones: Neumann, Electro-Voice.
Instruments Available: Steinway grand.
Rates: \$35.00 and \$50.00/hr.

••• SPECTRUM STUDIOS, INC.

905 S.W. Alder St., Portland, OR
 (503) 248-0248

Owner: Michael Carter, Lindsey McGill.
Studio Manager: Michael Carter.
Engineers: Michael Carter, Lindsey McGill, Chris Pouthitt, Bob Carlson, Mark Gottwig.
Dimensions of Studios: 20' x 33', 14' x 19'.
Dimensions of Control Rooms: 20' x 18', 20' x 16'.
Tape Recorders: Ampex MM-1100 16 track; Scully 280B-4 4 track; Scully 280B-2 2 track; Scully 280B-1 mono.
Mixing Consoles: Optronics 3030, 16 in x 10 out; Optronics 3030, 12 in x 6 out; Yamaha PM1000, 16 in x 4 out.
Monitor Amplifiers: Crown, Spectro Acoustics.
Monitor Speakers: E-V Sentry II (voiced with UREI S27A EQ's).
Echo, Reverb, and Delay Systems: AKG BX-20E, 2 Eventide DDL's.

Other Outboard Equipment: dbx noise reduction, dbx 162 comp/limiters, Eventide Harmonizer, Instant Flanger, UREI S27A graphics (2), UREI notch filter, Orban D'Esser, Kepex noise gates.
Microphones: Neumann U-87 fets, U-47 fets; AKG D1000E, D200, D190; E-V RE-16, 50; Shure SM-54 ribbon, Countryman fet direct boxes, E-V CS-15.

Instruments Available: Yamaha G3 6' grand, percussion FXS, ARP synth's, guitars, Rhodes.
Extras: Dual & single headphones (24) system, Varispeed 16tk, 2tk, hard/soft studio floor, (5) 8' x 8' gobos, Auratone 5C Little speakers.

Rates: 16 track: \$70/hr day, \$80/hr nite; 8 track: \$60/hr day, \$70/hr nite; 4 track: \$50/hr day, \$60/hr nite; 2 track: \$45/hr day,

Tewksbury

IS NOT JUST ANOTHER
WELL EQUIPPED
RECORDING
STUDIO

WE'RE HERE TO TAKE OVER!
HOURLY RATES:

24 track.....	\$60.00
16 track.....	\$40.00
8 track.....	\$30.00

Tewksbury Sound Recorders

Richmond, Ca. (415) 232-7933

\$55/hr nite.

Direction: A good, clean 16 track studio to record and mix. Performers and engineers like the environment.

**••• STUDIO RECORDERS
REMOTE RECORDING**

(415) 739-2684 or (415) 941-4873

Owner: Brian G. Job.

Engineers: Brian G. Job, Dave Nodiff, independents.

Direction: Originally a remote recording service, we are nearing completion of our new room, adding a variety of synthesizer and outboard gear. We aim to provide a complete creative musical environment. Please call for information and rates.

**••• SUTTON SOUND STUDIO
8390 Curbaril, Atascadero, CA 93422**

Owner: Rick Sutton

**••• THUNDER OAK AUDIO
23717 Bothell Way S.E., Bothell, WA 98011
(206) 487-2177**

Owner: Mark Alexander, Vic Coupez, Tim Nordgren.

Studio Manager: Vic Coupez, Mark Alexander.

Engineers: Vic Coupez, Larry Netzger.

Dimensions of Studios: 600 sq. ft.

Dimensions of Control Rooms: 180 sq. ft.

Tape Recorders: Ampex MM 1000 16 track; Otari MX 5050 8 track; Revox A-77 MK IV 2 track; Revox A-77 MK III 2 track; Ampex AG 440-C 2 track.

Mixing Consoles: Custom built, 16 in x 16 out.

Monitor Amplifiers: Crown D 150A, (2) Crown D60's.

Monitor Speakers: JBL 4310's, Auratones, 3 styles of headphones.

Echo, Reverb, and Delay Systems: Master-Room C Series stereo reverb, MXR Digital.

Other Outboard Equipment: dbx 160 and 162 compressors, Eventide Instant Flanger, Techniques parametric EQ, Delta Graph 10-band graphic, dbx noise reduction.

Microphones: Neumann U-87, KM-84; E-V RE-20, CS-15, RE-10; AKG C-451; Shure SM-57, SM-58; Sennheiser 421; Beyer M500, M260, etc.

Instruments Available: Yamaha 7' concert grand piano, Hammond B-3 with JBL Leslie, Conn Strobotuner, all other instruments available on a rental basis.

Extras: Full production services available including exposure to major labels. Deck under construction overlooking cosmic meadow complete with RIAA cows and horses. Free caffeine, liquid or tablet form, and a refrigerator.

Rates: Yes, we have rates. \$25/hr to \$55/hr. Discounts for block bookings.

Direction: We celebrated our first year in business by going from 8 to 16 track, with enthusiastic response from an ever-growing list of clients. With the proposed acquisition of an MCI JH-16 and JH-110A 16 & 2 track recorders, Kepex noise gates, EMT plate reverb, plus other signal processors and instruments (target date Aug. 1) and the completion (Feb. 1980) of our new 32 in 32 out mixing console, we feel that Thunder Oak will be second to none of our competitors for overall quality and cost of recording.



THUNDER OAK AUDIO
Bothell, WA

**••• WARTHOG STUDIOS
43125 SE 264th, Enumclaw, WA 98022
(800) 852-7777, ext M-485**

Owners: Sam Longonia & Barbara Vetter

six- teen track

Direction: We have 16 tracks of tape sync-interlocked with 6 tracks of 35mm magnetic film. We are geared mostly for 35mm motion picture production, and various commercials. All tracks dbx-encoded.

**••• XANDU RECORDING COMPANY
1050 Geneva Ave., San Francisco, CA 94112
(415) 239-1612**

Owner: Jose Ragadio.

Engineers: John Barsotti, Richie Moore, Karl Derfler.

Dimensions of Studios: 20' x 30'.

Dimensions of Control Rooms: 15' x 12'.

Tape Recorders: MCI JH 100-16 16 track; MCI JH 110-2LP 2 track; MCI Auto Locator Model MK11; Otari MX 5050 2SH 2 track; Technics RS 9900US cassette deck.

Mixing Consoles: MCI JH 428-24VU, with full equalization and monitoring, 24 in x 24 out.

Monitor Amplifiers: Crown DC-300A, D-150, D-60.

Monitor Speakers: Tannoy SPL 4437A, with 3118 infrasonic subwoofer and SPL-ESS 2242 electronic crossover; in control room. JBL 4311 WX studio speakers, Auratones & JBL 4301.

Outboard Equipment: Marshall Time Modulator; ADR F760XRS compressor/limiter; UREI 1176 LN limiters, UREI 920-16 Time Cube, FL201 flanger, UREI 565T Little Dipper; UREI 530 equalizers; MR111 Master-Room reverb, NK48A Neumann Phantom mic supply, AIC direct boxes and JVC LX-3000E System.

Microphones: Neumann U-87's; Sennheiser 441's, 421's; AKG 414's; Shure SM-56's; Beyer M500; E-V RE-20, RE-16.

Instruments Available: Steinway grand.

Extras: Kitchen facilities, coffee, color TV, client lounge and sun deck.

Rates: \$50/hr on the three hour minimum; 10 hour block rates at \$40/hr.

Direction: We cut high quality masters and master quality demos! Our engineers have gold albums and 45's and have taught many of the new engineers now employed in various studios in San Francisco and Los Angeles.

NEW LISTINGS COMING TO THE MIX:

September:
Southern California
Studios

October:
New York Studios

November:
New Product
Listings

December:
Nashville/Memphis
Studios

TAPCO

Products are available at these dealers:

CALIFORNIA

Bananas At Large
San Rafael, CA
(415) 457-7600

Bizarre Guitar
Sun Valley, NV
(702) 673-1000

Downey Music Center
Downey, CA
(213) 861-5813

Guitar Center
San Diego, CA
(714) 234-8731

Guitar Showcase
San Jose, CA
(408) 377-5864

Leo's Music Inc.
Oakland, CA
(415) 653-1000

The Music Factory
San Luis Obispo, CA
(805) 544-8944

Nadines Music
Hollywood, CA
(213) 464-7550

Professional Music
& Drum Center
Las Vegas, NV
(702) 382-9147

R.P.S. Electronics
Los Angeles, CA
(213) 748-1271

Otto Stein Music
Phoenix, AZ
(602) 248-9114

Stonebridge Music
Garden Grove, CA
(714) 636-2423

NASHVILLE/MEMPHIS

Atlanta Sound Works
Doraville, GA
(404) 393-0698

Gorby's Music Inc.
S. Charleston, W. VA
(304) 744-9452

Metro Music Center
Atlanta, GA
(404) 261-3611

Music Mart
Smyrna, GA
(404) 433-1112

The Pied Piper
Huntington, W. VA
(304) 529-3355

Robbins Music
Huntsville, AL
(205) 539-2474

The Sound Shop
Hartselle, AL
(205) 773-0708

Strings and Things in Memphis
Memphis, TENN
(901) 278-0500

Tipton's
Hazelwood, MO
(314) 731-6161

NEW YORK AREA

Sam Ash Music
Hempstead, NY
(516) 485-2151

Sam Ash Music
White Plains, NY
(914) 949-8448

Cintoli Music Center
Philadelphia, PA
(215) 533-2050

NEW YORK AREA

Danbury Electronics Music
Danbury, CT
(203) 792-2794

Drome Sound
Schenectady, NY
(518) 346-6800

K&L Sound
Watertown, MA
(617) 926-6100

Lasalle Music Shop
W. Hartford, CT
(203) 233-3021

Lebow Labs
Boston, MA
(617) 782-0600

Martin Audio/Video Corp.
New York, NY
(212) 541-5900

Medley Music Corp.
Bryn Mawr, PA
(215) 527-3090

The Music Center
Ephrata, PA
(717) 733-0396

Music Museum
Wilmington, DE
(609) 589-4318

Music Workshop
Salem, NH
(603) 893-1544

Professional Sound Labs
Hempstead, NY
(516) 486-5813

Professional Audio Video
Paterson, NJ
(210) 523-3333

Quantam
New York City, NY
(212) 260-2300

The Sound Lab
York, PA
(717) 845-9186

T.D. Audio
Montclair, NJ
(201) 746-1233

Unistage Inc.
Buffalo, NY
(716) 853-6500

Whirlwind Audio
Rochester, NY
(716) 663-8820

Zapfs Music Center
Philadelphia, PA
(215) 924-8736

WASHINGTON/OREGON

American Musical Retailers
Seattle, WA
(206) 633-1774

Bandstand of Bellevue
Bellevue, WA
(206) 455-0495

HiS Sound
Gresham, Or
(503) 667-1162

Horseshoe Music
Portland, Or
(503) 235-7095

Puget Sound Audio
Tacoma, WA
(206) 759-4701

Red & Black Music Shack
Boise, ID
(208) 375-8878

Showcase Music & Sound
Portland, OR
(503) 231-7027

12X4X2X1-

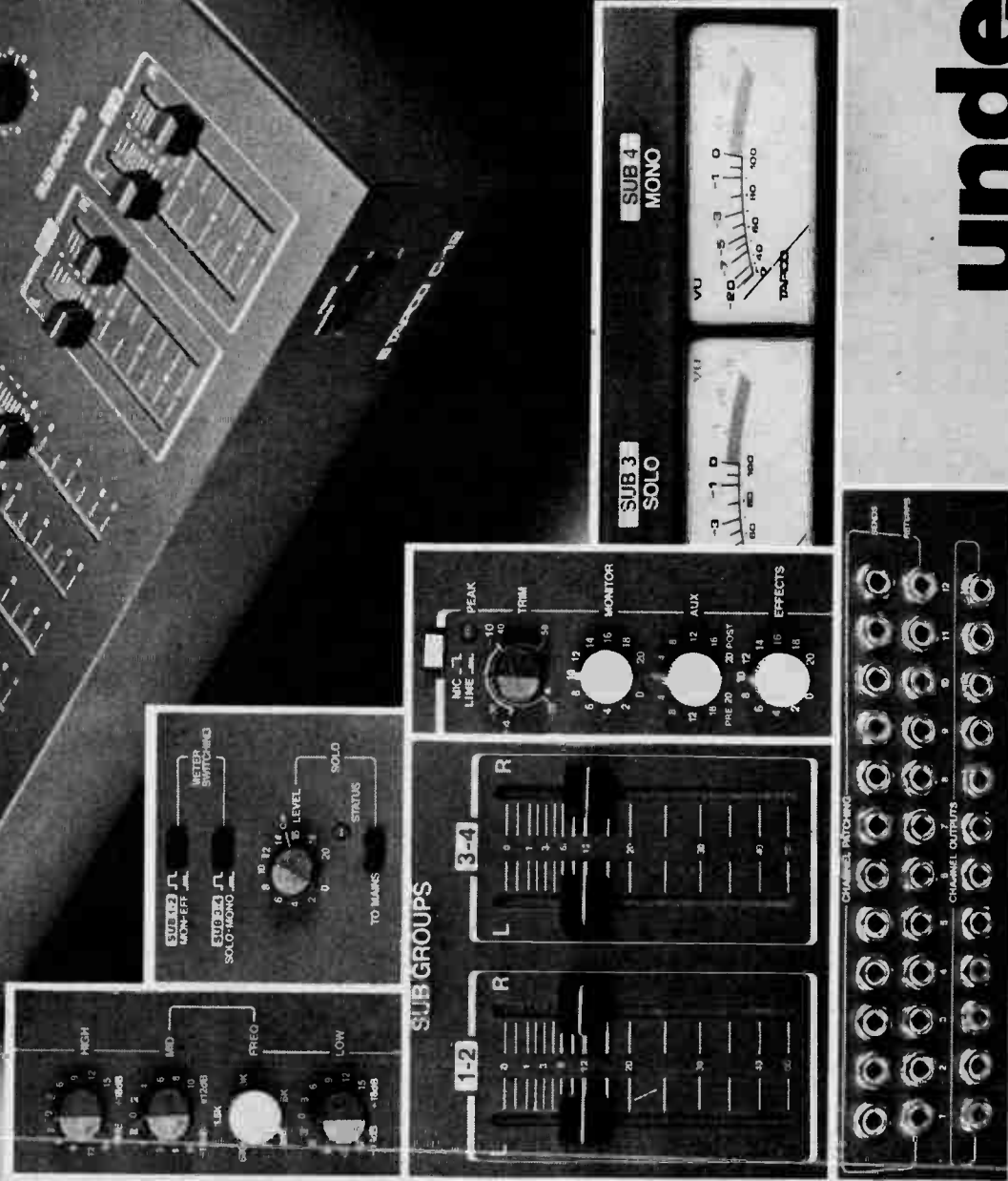
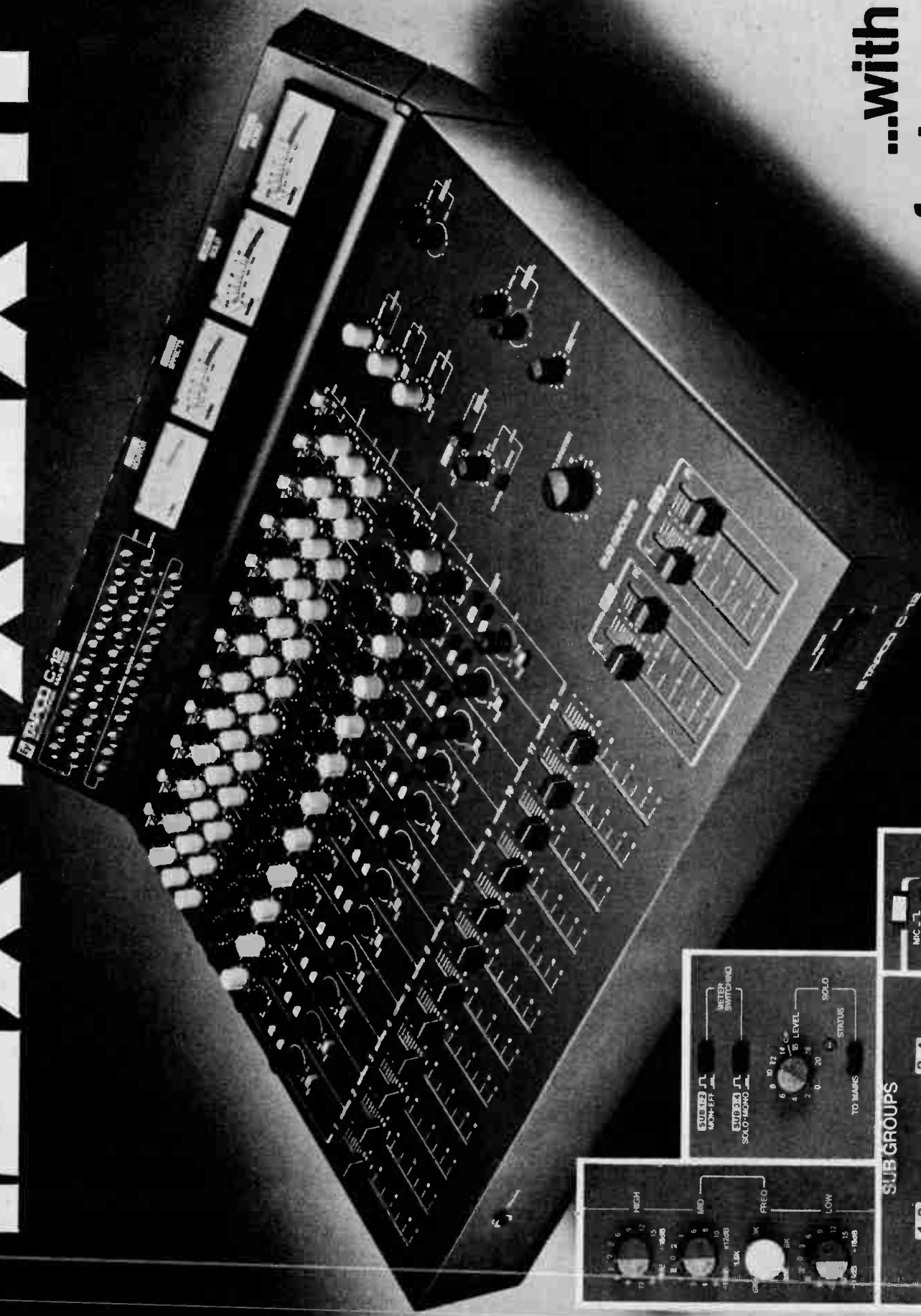

...with
 features
 you need
 and the
 performance
 you demand...

under \$2000.

See your TAPCO dealer and get acquainted with the CATALINA — a logically-designed, ruggedly-built multi-purpose mixing console.

Purchase before Aug. 31 to receive a limited edition condenser vocal mic free. *Hurry!* Mic supply limited.

the **C-12** from **Ev TAPCO**

3810 148th Ave. NE
 Redmond, WA 98052

THE BEST VALUE IN A PROFESSIONAL TAPE RECORDER

When you evaluate a tape recorder, here are the most important areas to consider for value, quality, and sound.

PERFORMANCE:

Overall Signal-to-Noise: 66 dB unweighted at 520 nWb/m (30 Hz to 18 kHz audio filter).

Playback Signal-to-Noise (electronics): 72 dB unweighted (with audio filter).

Headroom: +24 dB. Maximum Output: +28 dBm.

Overall Frequency Response (15 ips): 30 Hz to 22 kHz ± 2 dB.

Playback Frequency Response (MRL test tape): 31.5 Hz to 20 kHz ± 2 dB.

RELIABILITY: An unmatched four-year track record of on the job performance for the original compact professional recorder. Day in, night out. Just ask someone you trust.

ALIGNABILITY: Any tape recorder must be aligned to achieve maximum performance. With the MX-5050-B, all primary alignments are on the front panel. So is a 1-kHz test oscillator. Secondary alignments are inside the bottom panel. You or your maintenance people can align it fast and easy. This saves you time, money, and enhances your reputation.

INTERFACEABILITY: With a flick of the output switch you can plug-in to any system: +4 dBm 600 ohm or -10 dB high impedance. No line amps or pads to mess with. A perfect match everytime.

ADDITIONAL BENEFITS: Three speeds, dc servo $\pm 7\%$, $\frac{1}{4}$ track reproduce, full edit capability, over-dubbing, noise free inserts, XLR connectors, NAB/CCIR switching, unique three-position alignment level switch.

PRICE: Suggested retail price \$1,945 (USA).

**MX-5050-B:
THE CHOICE
IS OBVIOUS**

OTARI[®]

Call Ruth Pruett on 415/593-1648 for the name of your nearest Otari professional dealer.

Otari Corporation, 981 Industrial Road,
San Carlos, CA 94070 TWX 910-376-4890

In Canada: BSR (Canada, Ltd.),
P.O. 7003 Station B, Rexdale, Ontario M9V 4B3
416/675-2425







BEAR WEST STUDIOS
San Francisco, CA

•••• **AMERICAN ZOETROPE RECORDING INC.**
916 Kearny St., San Francisco, CA 94133
(415) 789-8345
Studio Manager: Richard Beggs, Chief Engineer/Manager.
Direction: In addition to standard 24 track recording capacity, American Zoetrope Recording can provide an extensive array of outboard signal-processing hardware, a Kawai piano, and a large collection of state-of-the-art synthesizer equipment, including Moog, Arp, Oberheim, Emu, and Yamaha. Please call for rates.



THE AUTOMATT
San Francisco, CA

•••• **THE AUTOMATT**
829 Fulsom St., San Francisco, CA 94107
(415) 777-4111
Owner: David Rubinson.
Studio Manager: Gail Baker, Studio Administrator: Cheryl Ward.
Engineers: Chief Engineer: Michael Larner; Chief Mixing Eng.: Fred Catero; Engineering: Michael Fusaro; Ass't. Eng's.: Leslie Ann Jones, Chris Minto, Ken Kessie, Bill Steele; Equipment/set-up: Wayne Lewis; Mastering Engineer: Paul Stubblebine.
Dimensions of Studios: A: 1500 sq. ft.; B: 500 sq. ft.; C: 750 sq. ft.; D: 1200 sq. ft.
Dimensions of Control Rooms: A: 320 sq. ft.; B: 320 sq. ft.; C: 500 sq. ft.; D: 200 sq. ft.
Tape Recorders: MCI 24 2 track; Ampex 24 track; Ampex 440 4/2 track; Scully Model 8 2 track; TEAC 4 track; Nakamichi and Sony cassettes; also a new addition of a portable MCI 24-track that can be set up in any of the studios to provide 48-track capability.
Mixing Consoles: Harrison 4032 w/Allison 65K automation interfaced with the Z-80 computer system (patent pending by The Automatt), Auto punch; custom by CBS w/API, each 38 in x 24 out; custom, 24 in x 8 out; Tascam Model 1. Studio B (recently up-graded and automated) now has a Harrison 3624 with Allison 65K automation.
Monitor Amplifiers: McIntosh and Pioneer.

Monitor Speakers: UREI 813's, Big Reds (with Mastering Lab crossovers), JBL 4311's, Auratones, Sonex (time aligned).
Echo, Reverb, and Delay Systems: (6) EMT echo chambers, remote controlled; Prime Time digital delay, Lexicon digital reverb.
Other Outboard Equipment: Sennheiser Comm. System; Marshall Time Modulator; ADR Compex-limiter; Inovonics 201 limiter; Eventide Omnipressor & Harmonizer; UREI digital metronome; Orban parametric EQ; EMT compressor; MXR Phaser & Flanger; Kepex (2); auto-correlator; Orban D'Esser; Countryman Phaser.
Microphones: AKG 414, 452, C-12; Beyer M-160; Electro-Voice RE-15, RE-20; Shure SM-56; Sony C-37, 377.; Sennheiser 421, 441, 805; Neumann U-67, U-87, KM-84, M-49, KM-88; Telefunken U-47.
Instruments Available: CP-70; Yamaha drums; Quad bass; acoustic guitar and bass, clavinet, ARP Odyssey, Rhodes electric piano, Wurlitzer organ, Cry Baby wah-wah, Vocoder, Phophet 5 Voice synthesizer; Princeton amp, Music Man amp, Wehr bass amp, Super Reverb amp, Echoplex I & II, Maestro synthesizer system, filter, sample and hold, fuzz, sustainer, full range booster, percussion kit, Compu-rhythm drums; Rhythm King, Maestro, Mutron II, Jet Phase phase shifters.
Extras: Several lounges, game room, pinball, "Shoot the Bear" game. Also, plenty of free coffee and popcorn.
Rates: Studio A: \$125/hr for 24-track. Studio B: \$135/hr for 24-track. Studio C: \$135/hr for 24-track. Add \$25/hr for automation in both Studio B and Studio C.
Direction: The Automatt's recent expansion and technical advancements make it not only the largest and most advanced recording facility in Northern California, but one of the best in the world. This recording complex included four studios that can fulfill any variety of recording needs. Late breaking news: Studio A is now being completely automated with a Trident TSM 40 x 24 board. More news to follow.

•••• **BEAR CREEK**
6313 Maltby Road, Woodinville, WA 98072
(206) 487-2533
Owner/Studio Manager: Joe and Manny Hadlock.
Engineers: Tim Killeen; Joe Hadlock, producer/eng; Mark Sterling.
Dimensions of Studios: 30' x 40'.
Dimensions of Control Rooms: 16' x 19'.
Tape Recorders: MCI JH114 16, 24 track.
Mixing Consoles: Quad Eight modified 28 x 16 x 24.
Monitor Amplifiers: Phase Linear, BGW, Crown.
Monitor Speakers: JBL, Altec, Auratone.
Echo, Reverb, and Delay Systems: Lexicon, MICMIX.
Outboard Equipment: UREI 1176's, LA3A, LA4, Trident; UREI and Orban parametrics.
Microphones: Neumann, AKG, Shure, E-V, Sennheiser.
Instruments Available: Steinway B, Rhodes, clav., ARP 2600, drums, misc.
Extras: Production services, live room, windows in control room, studio, kitchen, guest room, lodging available on advance notice.
Direction: "Private" studio located on farm in country 20 minutes from Seattle. Peaceful, beautiful grounds. Booked mostly by the week or month.

•••• **BEAR WEST STUDIOS**
915 Howard St., San Francisco, CA
(415) 543-2125
Owner: Chuck Vincent & Ross Winetsky.
Studio Manager: Christine Lark.
Engineers: Chief Engineer: Mark Needham; Engineers: Doyle Williams, Vance Frost, Steve Andreatta, 2nd Engineers: La'Ertes Muldrow, Susan Gottlieb.
Dimensions of Studios: Studio A: 50' x 30' x 25' ceilings, 3 isolation booths. Studio B: 30' x 20' x 15' ceiling, 1 isolation booth.
Dimensions of Control Rooms: Studio A: 25' x 20'. Studio B: 15' x 15'.
Tape Recorders: Ampex modified MM1100 24 track; Tascam Model 70 with dbx 8 track; Ampex AG350 2 track; Ampex 350/354 2 track.
Mixing Consoles: DiMedio custom, 32 in x 24 out; TEAC (2) Model 5's, 16 in x 8 out.
Monitor Amplifiers: McIntosh, BGW — Studio A. McIntosh — Studio B.
Monitor Speakers: JBL 4332, biamped; JBL 4311, Auratone.
Echo, Reverb, and Delay Systems: Live chamber, Multi-Track reverb, MXR DDL.
Other Outboard Equipment: 32-channels of dbx noise reduction, UREI 1176 comp.; (2) dbx comp.; 24-channels API EQ's, Furman parametrics, Gain Brain comp., Symetrix noise gate, Ashly audio parametric, Soundcraftsmen graphic.
Microphones: Neumann 87's, 84; E-V; Shure; Sennheiser; AKG.
Instruments Available: Specially built Yamaha C-3.
Extras: Free coffee and lounge area.
Rates: Studio A(24-track): \$80/hr, \$15/hr extra for dbx noise reduction. Studio B (8-track): \$25/hr w/dbx.
Direction: Clients each year turn out successful products at Bear West. This is due to the consistent level of engineering and the care that we take to communicate well with our clients, whether they are experienced producers and musicians, or just starting their recording career. We also have a staff of producers and arrangers that can help with budget planning, pre-production work, track sweetening promotion, consultations, and other special needs. We are experienced in recording all kinds of music, advertising, demos, records, and movie and TV sound tracks in a professional yet relaxed creative atmosphere.

•••• **DIFFERENT FUR**
3470 Nineteenth Street, San Francisco, CA 94110
(415) 864-1967, 864-1968
Owner: Patrick and Patty Gleeson.
Studio Manager: Patty Gleeson, assisted by Nanette Grimm and Amy Britton.
Engineers: Steve Mantoani, Chief Engineer. Stacy Baird, Bill Koepnick, Don Mack, Tom Paddock, Maintenance Chief.
Dimensions of Studios: 25' x 35'.
Dimensions of Control Rooms: 17' x 15'.
Tape Recorders: MCI JH 16/24 24/16 track; MCI JH110A 2/4 track; MCI JH110A 2 track; Scully (assembly) 2 track.
Mixing Consoles: Harrison 4032, 34 in x 32 out.
Monitor Amplifiers: BGW, Spectra Sonics.
Monitor Speakers: Westlake double 15's, White EQ, Quad 4313's, stereo 4310's, Auratones.
Outboard Equipment: Allison 65 K automation, 28 channels dbx, 26 channels Dolby A, Kepex's, Gain Brains, 1176's, LA4A's, Eventide Harmonizer, Delay, Time-Aligns, Lexicon Prime Times (2), EMT 240, Lexicon 224 digital echo (4 programs), digital metronome, etc. or we will have whatever you need in the studio when you arrive.
Microphones: Neumann, AKG, Beyer, Sony, Sennheiser, E-V, Shure, all current models in quantity, and some very rare oldies.
Instruments Available: Yamaha C-7B, Yamaha 6-C, synthesizers, amp, Vocoder, etc.
Extras: Acclaimed coffee, lounge, full bath, TV, frig., games, parking, and "Family Style" staff.

TO ALL WHO
HAVE SHARED
IN MAKING
A 10 YEAR
BIRTHDAY
POSSIBLE,

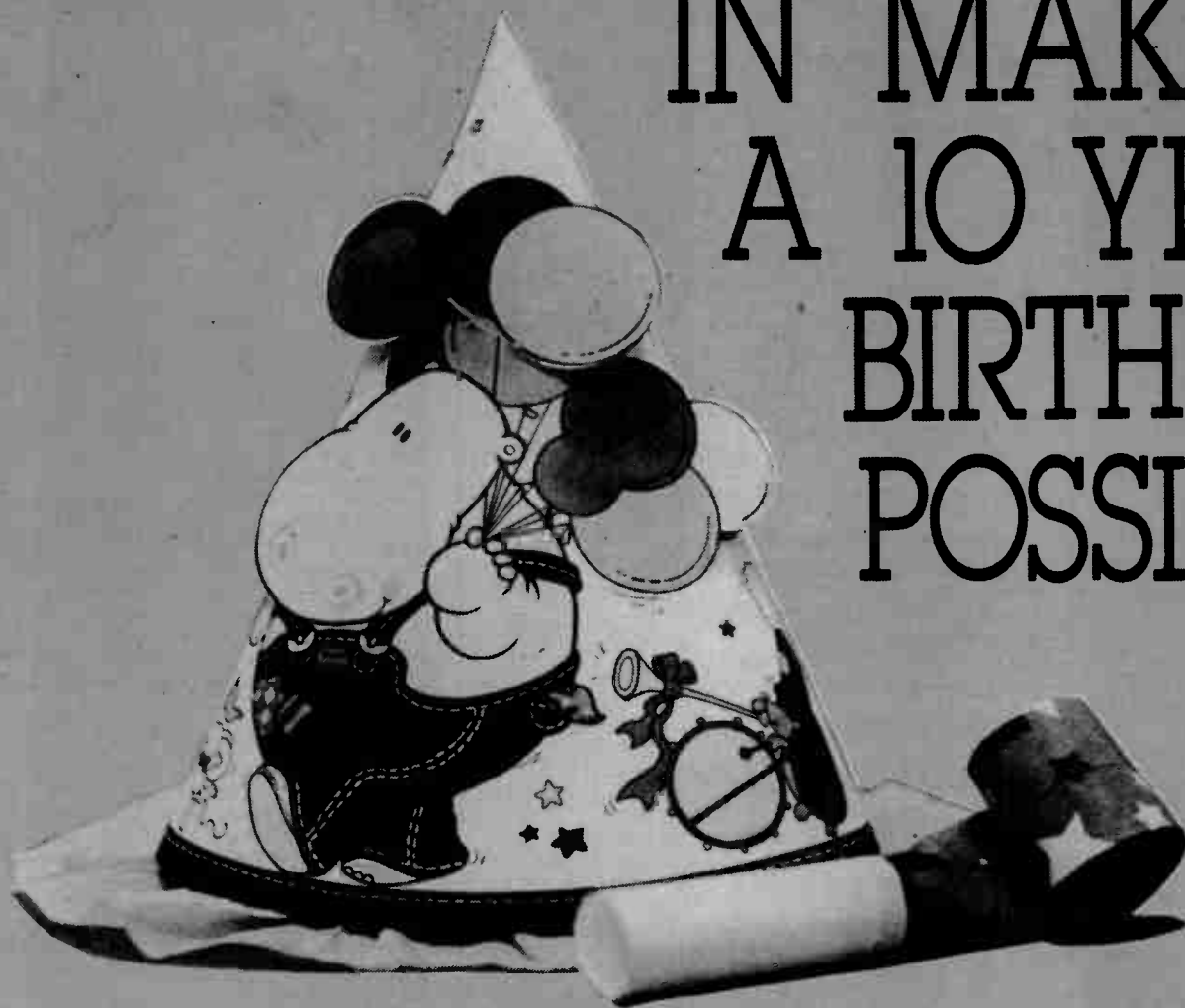

THANK YOU!



FILMWAY/HEIDER
RECORDING

245 HYDE STREET, SAN FRANCISCO, CA. 94102 • (415) 771-5780

Rates: \$60 to \$150 per hour. Call for rates re: engineers, automation, block booking.

Direction: We have added a parking lot to our facilities, as well as a complete lounge (full kitchen and bath) and anticipate an acoustically state-of-the-art re-do of our control room by Sugarloaf View within three months. Ours will be the first LEDE Room in the Bay Area. Our satisfied clients include: Patti LaBelle, Pablo Cruise, DEVO, Sylvester, Sammy Hagar, Harvey Fuqua, Skip Scarborough, Lenny White, Herbie Hancock, Huey Lewis, SVT, Avengers, Crime, Walter Hawkins Singers, Brian Auger, The Waters Family, and scores of dear friend-clients who have helped to make our studio a success and doing business a pleasure. Thank you all.



*DIFFERENT FUR, San Francisco, CA
L to R: Steve Mantoani, Pat Gleason, Mark Devo*

.... FANTASY STUDIOS
10th and Parker St., Berkeley, CA 94710
(415) 549-2500

Owner: Fantasy Records & Films.
Studio Manager: Jim Stern — Vice President Engineering & Studio Operations.
Engineers: Six engineers, three technicians, one tape copyist, one mastering engineer.
Dimensions of Studios: A: 50' x 30'; B (mix only): 25' x 25'; C: 40' x 30'; D: 60' x 40', plus tune demo studio 16-track; disc mastering 26' x 26' Hidley.
Dimensions of Control Rooms: D: 26' x 26'; C: 25' x 20'; B (mix only): 25' x 25'; A: 20' x 30'.
Tape Recorders: Studer A800, A80 24 and 2 track; Ampex MM-1200, ATR100 24 and 2 track; Scully 280-A 8, 4, 3, and 2 track; 3M 5C 2 track; Telefunken M5 2 track play only; Ampex MM-1000 16 track.
Mixing Consoles: Custom
Monitor Amplifiers: McIntosh, Crown.
Monitor Speakers: UREI 813, Hidley, JBL, Auratone.
Echo, Reverb, and Delay Systems: Eight acoustic chambers, EMT plates, EMT 250, Eventide, Lexicon, Roland, UREI.
Other Outboard Equipment: Scamp, ADR, UREI, PDM, Orban, RCA, Countryman, AD/A, Quad/Eight.
Microphones: AKG, Neumann, (new and old), Telefunken, Shure, E-V, Sennheiser, PZM, PML, Sony, RCA.
Instruments Available: Hammond organs, Yamaha 9 ft. grand, Steinway B, Yamaha electric grand, Rhodes (customized), clavinet, ARP Odyssey & Pro Soloist, Wurlitzer piano.
Extras: Vast assortment of phasers, flangers, tape recorders, pedals and gizmos. Disc mastering; Neumann & Fantasy custom.
Direction: Fantasy Studios are at present only an in-house facility; however, plans are to open to the public sometime in early 1980.

.... FILMWAYS/HEIDER RECORDING
245 Hyde Street, San Francisco, CA 94102
(415) 771-5780

Owner: Filmways, Inc.
Studio Manager: Ginger Mews, Vice President.
Engineers: Susie Foot, Jeff Melby, Jeffrey Norman, Allen Sudduth, Steve Malcolm, Jesse Osborne, David Kahne.
Dimensions of Studios: Studio A: 20' x 35' x 12'; Studio C: 20' x 34' x 12'; Studio D: 15' x 30' x 13'; Studio E: 18' x 10' x 10'.
Dimensions of Control Rooms: Studio A: 16' x 20'; Studio C: 14' x 15'; Studio D: 18' x 18'; Studio E: 18' x 14'.
Tape Recorders: Ampex MM-1200 24 track; (2) 3M M79 24 track; (3) 3M M56 16 track; Several 3M and Ampex 8, 4, 2 and mono tape recorders; Ampex ATR-100 2 track.
Mixing Consoles: Neve (Studio A) 8068 (24 busses) 32 in x 32 out; MCI (Studio C) JH 428 (24 busses) 28 in x 28 out; Neve (Studio D) 8058 (24 busses) 28 in x 28 out.
Monitor Amplifiers: McIntosh 275's and 2100's, Yamaha P-2200's.
Monitor Speakers: Altec 604 E's with 1/2 octave equalization and UREI time aligned.

twenty four track

Echo, Reverb, and Delay Systems: 4 live echo chambers, 3 EMT's (also see Outboard Equipment), Cooper Time Cube, AKG-BX20.

Other Outboard Equipment: Kepex, Gain Brain, digital delays, phaser, flanger, VSO's, Lang, Pultec, Eventide Digital Delay with pitch change, Dolbys, graphic EQ, LA-2A's, LA-3A's, LA-4, limiters, stereo parametrics.

Microphones: Shure, Neumann, AKG, Beyer, RCA, Sony.
Instruments Available: (2) 7 ft. Steinway grand pianos and (1) 6 ft. Steinway grand piano, Mini-Moog.

Extras: Game room. Studio E is a 16-track Media Studio set up especially for radio, TV and film. Copy room facilities for full track mono, 2 track, 1/4 track and cassette duplication on Em, Ampex Revox, Sony, Pioneer and Kenwood recorders.

Rates: Variation — call for quote.

Direction: Filmways/Heider Recording will continue to expand its remote and studio facilities so as to best be able to serve the audio industry in its music and spoken word needs. What this will entail will depend on the demands of our clients with service always being emphasized. Recently redesigned Studio D and installed new Neve 8058 console.

.... KAYE-SMITH STUDIOS
2212 Fourth Avenue, Seattle, WA 98121
(206) 624-8651

Owner: Lester M. Smith, Danny Kaye.
Studio Manager: Winslow Kutz.
Engineers: Reed Ruddy, Rob Perkins, Rick Fisher.
Dimensions of Studios: Studio 'A': 25' x 32' x 12'; Studio 'B': 20' x 25' x 12'.
Dimensions of Control Rooms: 'A': 16' x 19' x 10'; 'B': 16' x 19' x 10'.
Tape Recorders: 3-M 79 16 & 24 track; Ampex 1200 16 & 24 track; Ampex ATR-104 1 & 2 track; Ampex 440 1, 2, 4 track; 3-M 238 track.
Mixing Consoles: API custom, 32 in x 24 out.
Monitor Amplifiers: Dynaco & Crown (tube & transistor).
Monitor Speakers: 'A': Altec 604-E monitors with Mastering Lab cross-overs; 'B': Westlake.
Echo, Reverb, and Delay Systems: AKG, EMT, Live MXR Digital, Pandora, Eventide, Eventide Harmonizer.
Outboard Equipment: BTX synchronizer, UREI, ITI, Trident parametric equalizers; Eventide Harmonizer; Allison Gain-Brains, Mayer noise gates, Kepex's, LA3A, 1176 limiters, API compressor/limiters.
Microphones: 90 microphones - all major manufacturers.
Instruments Available: Studio 'A': Steinway 7', Studio 'B': Yamaha 7', Fender-Rhodes 73 electric pianos, Hammond B-3 organ w/Leslie, Ludwig drum kits (2), Musser Vibes, percussion kit, bass amps, guitar amps, Auratone Sound Cubes, Advents, B.&O., JBL 4333 & L-100.
Rates: \$125/hr.

.... MIX-NUT RECORDING STUDIO
3810 Twin Oaks Way, Oakland, CA 94605
(415) 568-7398

Owner/Studio Manager: Kenneth A. Cole.
Engineers: Kenny Cole alias "The Mix-Nut"; Dr. Richie Moore.
Dimensions of Studios: 750 sq. ft. Separate vocal booth, 35 sq. ft. Fireplace in wall is floor to ceiling, 11 feet across. Opposite wall is windowed for secluded creek and oak tree view.
Dimensions of Control Rooms: 255 sq. ft. Overhangs down slope of five acre canyon as canyon slopes to creek. On its own foundation with no structures connecting to studio. Custom acoustic by Paoletti/Lewitz Associates (40 Gold St., San Francisco), and Dr. Richie Moore.
Tape Recorders: MCI JH 114 24 track; MCI JH 110A-2-14 V.P. 2 track.
Mixing Consoles: MCI JH636-32 VU, 32 in x 24 out, fully automated, tweaked and installed by Dr. Richie Moore.
Monitor Amplifiers: Yamaha P2201, P2100, P2050.
Monitor Speakers: E-V PI 15-3 studio playback mon., JBL 4301 WX mon., Auratone 5-C mini-monitors.
Echo, Reverb, and Delay Systems: Marshall Time Modulators, Loft 440 delay devices, Audio Design Recording Complex stereo.

Other Outboard Equipment: UREI 1176-LN limiter, UREI LA-4 compressors, Tapco C-201 graphic EQ's, shared access memory-system main frame with four delay modules, 1 in x 2 out, 400ms; Harrison.

Microphones: Neumann KM-84, KM-88, KM-86, U-87Z, U-47 FET with EA 47 shock mount; AKG C-414EB, C-452EB combo, D-224 dynamic two-way, D-190-E, D-12; Beyer M201, M169, M500; Sennheiser MD 421-U, MD-441-U.

Instruments Available: Baby grand piano, Yamaha polyphonic synthesizer CS-80.

Extras: Mix-Nut Studio is located in a mansion, nestled on the down-slope of oak tree/pine tree creek-split canyon. Virtually all the comforts of living the good life, lodging by special arrangements.

Rates: Please call for rates.

Direction: State-of-the-art electronics, enthusiastic creative atmosphere, plus the personal touch one can only achieve by one living one's business, is the ingredience mix we applied in creating Mix-Nut. Archetectonic and acoustical design: Paoletti & Lewitz Asso. — Consultants in Acoustic. Dr. Richie Moore: Audio Electronic scientist. Kenneth A. Cole The mix-nut engineer & owner.



*MUSIC ANNEX
Menlo Park, CA*

.... MUSIC ANNEX
970 O'Brien Drive, Menlo Park, CA 94025
(415) 328-8338

Owner: Porter-Soper Enterprises.
Studio Manager: David H. Porter.
Engineers: Dave Porter, Harn Soper, Roger Wiersema, Russ Bond, Alison Ballard, Dennis Reed.
Dimensions of Studios: Studio A: 34' x 28', isolation: 10' x 8', Studio B: 16' x 21', Studio C: 30' x 20', Studio D: control room only.
Dimensions of Control Rooms: A: 28' x 25', B: 22' x 18', C: 14' x 12', D: 14' x 12'. Studio A designed by Everything Audio; Studio B designed by George Augspurger.
Tape Recorders: (2) MCI JH-114 24/16 track, Ampex MM1000 8 track; MCI JH-110A 2 track; (3) Ampex 351/440 2 track; (2) Otari 5050 2 track; Tascam 80-8 (1/2") 8 track; Sony PCM-1600 digital 2 track.
Mixing Consoles: (2) Amek 2824, 28 in x 24 out; Tascam modified Model 10, 12 in x 8 out; Sound Workshop 1280, 12 in x 8 out.
Monitor Amplifiers: Studios A and B: BGW 750/250.; White 1/3-octave EQ in B, no EQ needed in A; C: Yamaha fet 2200; D: Crown D-150.
Monitor Speakers: A: JBL 4333A, B: custom designed by George Augspurger Gauss 5831, JBL 2121, Tad Drivers, C: 4311, D: 4311. Auratones in every room.
Echo, Reverb, and Delay Systems: EMT 240, EMT 140ST, AKG BX-10, Harmonizer, Scamp delay, (2) MXR Digital Delays, Prime Time.
Other Outboard Equipment: (4) UREI 1176 LN, (4) Inovonics (201) limiters, (2) dbx 161, (2) Altec compressors, ADR Vocal Stressor, ADR compressor, Scampracks with parametrics, sweep EQ's, digital metronome, tube type pre-amps, dbx and Dolby, (4) Roger Meyer noise gates.
Microphones: Neumann U-87, KM-84; AKG 451, C-60 (tube), 224, D-1000; Sony 377, 22P, 33P; Sennheiser 421, 441; Shure 57, 58, 53; E-V RE-20, RE-16, 664; Beyer 500 ribbon; Altec 651.
Instruments Available: Yamaha C-3 and C-5 conservatory grands, drums, misc. percussion, String Ensemble, Ampeg bass amp, special equipment by request.
Extras: Lounge area, Coke machine, coffee, rehearsal space, equipment lockers, drive-in loading, parking for 40 cars.
Rates: 24 track: \$85 - \$105/hr, \$850/day. 16 track: \$65 - \$85/hr, \$750/day. 8 track: \$30 - \$45/hr. 2 track: \$25 - \$45/hr depending on studio. Block rates available on multi-track time.
Direction: We have 4 studios in a 12,000 ft. facility in Menlo Park. Each of the studios was designed to meet individual requirements and budgets. Studio A for tracking & mixing 16/24, Studio B for over-dubbing and mixing 16/24 and narration, Studio C for demos, and Studio D for media production. We are also the first Bay Area studio to offer digital recording.

The Orban 672A:

A Dream Equalizer at a Practical Price



The 672A is a single-channel equalizer offering astonishing control and versatility. There are eight non-interacting parametric bands with reciprocal curves and the convenience of graphic-style controls. Highpass and lowpass filters with 12dB/octave slopes that tune continuously over a 100:1 frequency range. And, separate outputs that let you use the 672A as an eight-band parametric cascaded with an electronic crossover in reinforcement and monitor tuning applications.

The dream equalizer is usable practically everywhere in professional and semi-pro-

fessional sound: recording studios, cinema, theater, reinforcement, broadcasting, disco — you name it! Yet its price is down-to-earth: \$499*. And, it's built to full professional standards.

orban

Orban Associates Inc.
645 Bryant St.
San Francisco, CA 94107
(415) 957-1067

*suggested list

orban

See it at your ORBAN DEALER:

NO. CALIFORNIA

Accurate Sound Co.
Redwood City
(415) 365-2843

Alco-Paramount Corp.
San Jose
(408) 297-7111

FM Productions
San Francisco
(415) 647-5600

Pro Media
San Francisco
(415) 957-1383

Protronics
San Mateo
(415) 574-8511

Sound Genesis
San Francisco
(415) 285-8900

Taber Manufacturing and Engineering Co.
San Leandro
(415) 635-3832

WAH Sound
Sacramento
(916) 444-5491

WASHINGTON

Bennett Engineering Associates
Mercier Island
(206) 232-3550

Broadcast Supply West
Tacoma
(206) 565-2301

Pro Audio Seattle
Seattle
(206) 622-6984

Dolby Noise Reduction is in use everyday, everywhere.

Wherever you or your tapes go — for recording, mixdown or disc cutting — it is almost certain Dolby noise reduction will be there to do its job — ensuring reduced hiss, crosstalk and print-through in your recordings.

You can rely on the Dolby system.

DD Dolby

Dolby Laboratories Inc

Dolby and the double D symbol are trademarks of Dolby Laboratories.

731 Sansome Street
San Francisco CA 94111
Telephone 415 392-0300
Telex 34409

346 Clapham Road
London SW9
Telephone 01-720 1111
Telex 919109

DISTRIBUTE

If you have a recording or music related business and would like to be a distribution point for The Mix, please fill out and mail the coupon below and we will give you a call.

_____ name
 _____ address
 _____ city
 _____ state, zip
 _____ phone number

Outside of California, Oregon, Washington, New York and Tennessee, there is a charge for postage and handling.

Check one:

20 copies 40 copies 60 copies
 \$10.00 \$18.00 \$25.00

For uninterrupted delivery of each issue printed for one year:

20 copies 40 copies 60 copies
 \$120.00 \$216.00 \$300.00

Add \$5 per bundle outside U.S.A.

Send to The Mix, P.O. Box 6395, Albany, California 94706

•••• MUSIC FARM
 615 East Pike, Seattle, WA 98122
 (206) 323-6847

Owner: Jim Wolfe.
Studio Manager: Dave Raynor.
Engineers: Dave Raynor, Cal Wood.
Dimensions of Studio: 30' x 30'.
Dimensions of Control Rooms: 10' x 15'.
Tape Recorders: Ampex 24 track.
Mixing Consoles: Custom 32 in x 24 out.
Monitor Amplifiers: Phase Linear, McIntosh.
Monitor Speakers: JBL, Auratone, Speakerlab.
Echo, Reverb, and Delay Systems: Live chamber, AKG BX-10.
Outboard Equipment: Harmonizer, Dolby, dbx.
Microphones: Neumann, Altec, E.-V., RCA, Shure, AKG, Sennheiser.
Instruments Available: Steinway grand piano, Rhodes, drums, guitars, and amplifiers.
Rates: 24-track: \$50/hr; 2-track: \$40/hr.
Direction: To have a mellow, affordable studio that gets great sounds and is a fun place to record.

•••• PRODUCERS STUDIO
 975 Oak St., Suite 730, Eugene, OR 97401
 (503) 683-1400

Owner: Michael S. Dilley
Studio Manager: Steve Diamond
Engineers: Steve Diamond, Bob Trano - asst. eng.
Dimensions of Studio: 35' x 27 1/2' - 11,550 cu. ft.
Dimensions of Control Rooms: 15' x 17' - (256 sq. ft.)
Tape Recorders: Ampex 1200 w/20 point search & cue, 24 track; Ampex 440-4 4 track; Ampex 440 2 track; Ampex 700 2 track.
Mixing Consoles: Spectra Sonics 1026 26 in x 26 out.
Monitor Amplifiers: Spectra Sonics.
Monitor Speakers: JBL 4333 bi-amped, JBL 4311.
Echo, Reverb, and Delay Systems: AKG reverb, (2) Lexicon Prime Times w/extended memory, and currently planning 2 acoustic chambers.
Outboard Equipment: Kepex, Gain Brains, Spectra Sonics complimiters.
Microphones: Neumann U87, KM84; AKG D900 shotgun, D1000E, C452; Sony C37A, ECM50 lapel; Shure 57, 565; Electro-Voice RE85 lavalier.
Instruments Available: Yamaha grand piano, studio drum set, wide range of percussion instruments, plus we can rent instruments of any type with notice (chargeable to client), music stores within walking distance.
Extras: Kitchen and great Oregon outdoors for relaxation. Beach and mountains within an hour in either direction. We can arrange lodging for out-of-towners. CLEAN AIR!
Rates: \$100/hr, (bulk rates available).
Direction: Everyone at Producers Studio is enthusiastic about bringing state-of-the-art recording to Eugene. We opened our new facility in April 1979, and have been getting excellent feedback on the great acoustics in our room. The flexible design allows for a live yet controllable environment, in which musicians can hear each other clearly, be comfortable, and create. We have worked with several notable musicians who have come to appreciate our studio as much as we appreciate their performance.

•••• PUNK STUDIO
 Santa Rosa, CA
 (707) 545-9820
 Rates: 16 & 24 track work: \$35 - \$65/hr.

•••• RECORD PLANT
 also REMOTE RECORDING
 2200 Bridgeway, Sausalito, CA 94965
 (415) 332-6100
Owner: Christopher Stone.
Studio Manager: Nina Urban.
Engineers: Tom Flye.
Dimensions of Studio: 20' x 40' (Studios A & B).
Dimensions of Control Rooms: 15' x 20' (Studios A & B).
Tape Recorders: 3M Model 79 2, 4, 16, 24 track; Ampex 2 and 4 track.
Mixing Consoles: API w/Allison automation, 32 in x 24 out.
Monitor Amplifiers: Crown.
Monitor Speakers: Westlake, JBL.
Other Outboard Equipment: Limiters, phasers, Dolby, dbx, Harmonizer, digital delay, Kepex, flangers, Cooper Time Cube.
Microphones: AKG, Neumann, Shure, Sennheiser, Sony, Electro-Voice, RCA.
Instruments Available: Yamaha grand pianos, Hammond B-3 organ.
Extras: New pre-production room, kitchen, game room, conference room, patio, Jacuzzi w/shower, barbeque, basketball, lounge, 2 houses for out-of-town clients.
Rates: Please call for quote.

Sonoma Recording Studios

24 and 16 TRACK
 707 528-0304 COTATI
 open 24 hours
 NEVE • MCI

We provide complete recording services, from professional studio musicians and exceptional instruments to copyrights, lead sheets and pressing.

RECORDPLANT / *Sausalito*



PRE-PRODUCTION ROOM AVAILABLE FOR REHEARSAL

RATES:
HOURLY \$25
DAILY \$200
WEEKLY \$1000
ASSISTANT ENGINEER \$10/HR
2 TR. TAPE MACHINE \$100/DAY

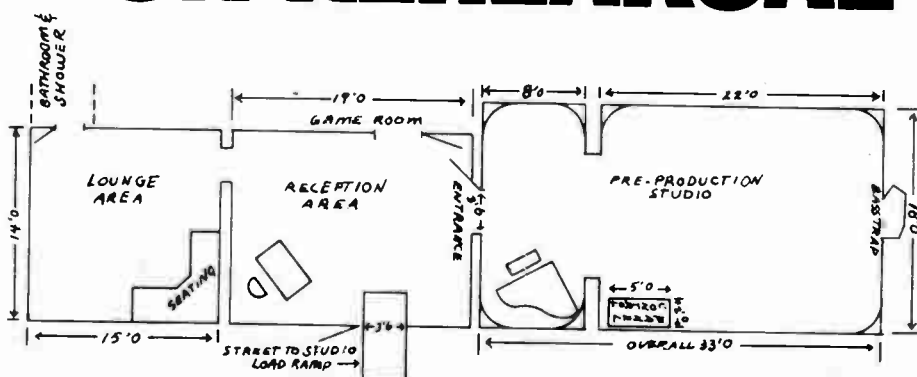

**RATE INCLUDES
 P.A. SYSTEM
 AND 1/4 TRACK
 OR CASSETTE
 MACHINE.**

PLEASE CALL NINA AT 332-6100 FOR BOOKING INFORMATION.

lost in the mix?



If you have a commercially available 4/8/16/24 track recording studio in California, Washington, Oregon, New York, or the Nashville/Memphis area, and would like to be listed, free, in our directory, fill in the coupon below and return it to:

The Mix
P.O. Box 6395
Albany Branch
Berkeley, CA 94706

PLEASE PUNCH ME INTO THE MIX

- 4 TRACK 16 TRACK
 8 TRACK 24plus TRACK

Name _____

Studio Name _____

Address _____

City _____ State _____ Zip _____

Phone _____

Comments: _____

twenty four track

Direction: In addition to our two studios here and our four at our LA facility, we have three remote recording trucks and a pre-production room, which is available for rehearsal by the hour or on a long term basis. With our hillside homes for our out-of-town clients, and studios with all their extras, we can offer the artist a complete recording environment that has become the standard of excellence in the Bay Area.

•••• RECORDING ASSOCIATES
5821 S.E. Powell Blvd., Portland, OR 97206
(503) 777-4621

Owner: Jay Webster, Bob Stoutenburg.
Studio Manager: Jay Webster, Bob Stoutenburg.
Engineers: Bob Stoutenburg, Mike Moore, Jim Newell, Brian Willis, Mike Bauske, Dennis Franklin.
Dimensions of Studios: Studio A: 30' x 30'; Studio B: 15' x 20'.
Dimensions of Control Rooms: Studio A: 23' x 27'; Studio B: 17' x 15'.
Tape Recorders: Ampex (Studio A) MM1100 with VSO 24/16 track; MCI (Studio B) JH-10 16 track; Ampex with Dolby-A ATR 100 2 track; TEAC (2) 3340 4 track.
Mixing Consoles: MCI (Studio A) JH-416, 24 in x 24 out; custom, 16 in x 8 out.
Monitor Amplifiers: Crown, McIntosh.
Monitor Speakers: Studio A: JBL 4350's, JBL 4311's, Auratone, Studio B: JBL L-100's.
Echo, Reverb, and Delay Systems: MICMIX CS-23 spring reverb, LSI plate, Eventide Harmonizer.
Other Outboard Equipment: Eventide Harmonizer, SAE parametrics (3), Delta-graph 10-band graphics (2), UREI 1/3-octave EQ, dbx compressors, LSI limiters, Orban/Parasound D'Esser, Teletronix limiter.
Microphones: Neumann U-87, KM-86; Sennheiser 441's, MKH-405, 421's; Shure SM-7's, SM-57's; E-V 668, RE-20's; Beyer M500's, M69N; Sony C-22's; AKG 451's, D224E.
Instruments Available: Conover 6 1/2' grand (Studio A); Aldrich upright (Studio B).
Extras: Dolby A on ATR-100, VSO on 24 track Ampex, Strobotuner, AKG K240 and Sennheiser MD414 headphones, stereo headphones, LSI vocal stressor, studio musicians, tape duplication, record pressing and packaging, recording seminars.
Rates: Studio A: 24 track: \$75/hr, Mix: \$65/hr, 16 track: \$60/hr, Mix: \$50/hr. Studio B: 16 track: \$30/hr, 4 track: \$20/hr.
Direction: Recording Associates has served the local and regional music and advertising communities for the past six years. We continuously upgrade our equipment and building to bring the finest equipment and recording to our clients at the lowest possible price.

•••• SEA-WEST STUDIOS
also REMOTE RECORDING
319 North 85th St., Seattle, WA 98103
(206) 783-2524

Owner: Richard Keefer, President.
Studio Manager: Donna-Alexa Keefer.
Engineers: Rick Keefer and various independent engineers.
Dimensions of Studios: 22' x 40'/ceiling 12' x 14'.
Tape Recorders: (2) Ampex MM-1100-16 with full BTX/SMPTE, Time code generator & synchronizer for 32 track recording format, 32 track; Ampex ATR-100/Stereo Master recorder 2 track.
Mixing Consoles: Harbour/Jensen 32 Channel Master mixing console, 32 in x 32 out, using Jensen input transformers and Jensen 918 mic pre-amps.
Monitor Amplifiers: Crown, JBL Dyna.
Monitor Speakers: Choice of: Altec 604E, Super Reds, JBL 4325, Auratones.
Echo, Reverb, and Delay Systems: (2) EMT plates, MICMIX Master-Room, Delta Labs DDLs, Prime Time DDL, MXR DDLs.
Other Outboard Equipment: UREI 1176 LN limiters, UREI parametric EQ, UREI Little Dipper filters, Gain Brain compressor, dbx 162 compressor, SAE 20-band graphic EQ, Roger Mayer noise gates (12), Pultec EQ.
Microphones: Neumann U-87, U-47, KM-84; Beyer M500, M201, M69; AKG C-414, C-451E; Sennheiser MD 421; Shure SM-57, SM-58, SM-61.

Instruments Available: Wurlitzer electric piano, Hohner clavinet, ARP 2600 synthesizer, studio drum kit, Syndrums, Honky-tonk piano, Fender bass, acoustic guitars, and various amps.
Extras: Lounge area with refrigerator, microwave, TV, etc. The Explorer Location Recording Truck is the remote recording vehicle for Sea-West Studios, with over 100 'on Location' live recordings for national acts.
Rates: \$100/hr recording and mixing.
Direction: Sea-West Studios has recorded the last two Platinum LPs for Heart; "Magazine" and Dog & Butterfly"; and the million selling 45 "Livin' It Up (Friday Night)" for Bell & James.



SONOMA RECORDING, Cotati, CA
Paul Stubblebine

•••• SONOMA RECORDING
Cotati, CA (707) 528-0304

Engineers: Paul Stubblebine, Nancy Evans.
Tape Recorders: MCI JH 110A 2 track; MCI JH 110 24 track; various 1/4-track and cassettes.
Mixing Consoles: Neve 24 x 24.
Monitor Amplifiers: McIntosh, Crowns.
Monitor Speakers: JBL 4315's, Ed Longs, Auratones, Altecs.
Outboard Equipment: Stereo EMT, Scamp gates, Scamp parametrics, Scamp analog delay and flanger, White 1/3 and 1/6 octave EQ's, Neve limiters, UREI limiter, Orban reverb, Orban equalizer.
Microphones: Neumann U87's, KM86, U47 (tube); Sennheiser 421's, MKH 404; E-V 20's, 15's, 16's; AKG; Sony C-377, ECM 22, ECM 50; Shure 56's, 57's; Countryman directs.
Instruments Available: Hammond B-3 with Leslie, Apollo grand piano, Fender Precision Bass.
Extras: Musicians lounge, TV, electronic games.
Rates: 16 track record rates: \$50/hr, demo rates: \$35/hr. 24 track \$65/hr. Block book rates available upon request. Prices quoted are for current location.
Direction: We have been working hard developing a reputation for high quality engineering. The studio has a comfortable and productive atmosphere. We can take care of your complete recording needs, from providing lead sheets and copyright forms to the final finished album. Many thanks to the Bay Area musicians who have worked with and have supported us.

•••• SUPER SOUND, INC.
600 E. Franklin, Suite E, Monterey, CA 93940
(408) 649-4100

Owner: Dorothy and Stephen Walton.
Engineers: Jim Behrendt (eng.); Paul Smith (tech.); Chuck Leary (eng./consultant).
Dimensions of Studios: 22' x 22'.
Dimensions of Control Rooms: 14' x 22'.
Tape Recorders: 3M M-79 24 & 16 track; Ampex A6-440 2 & 4 track; Otari MX 50-50 2 track; Sony TC-850 2 track; Sony TC-788-4 4 track; (2) Optonica cassette.
Mixing Consoles: MCI (Allison automation) JH-424, 24 in x 24 out.
Monitor Amplifiers: Altec 9440; Crown DC 300-A; McIntosh 275; Crown D-60.
Monitor Speakers: Altec 604 8G (White room EQ), JBL 4311, Auratones.
Echo, Reverb, and Delay Systems: EMT echo, Eventide Digital Delay.
Other Outboard Equipment: ADR vocal stressor, UREI limiters, UREI graphic EQ, dbx noise reduction, Dolby noise reduction, AKG and Sennheiser headphones, Technics turntable, Multi Sync motor drive, Kepex, Allison 65-K programmer, Eventide Flanger.
Microphones: Neumann U-87's; Electro-Voice RE-20's; AKG 451's; D-58E; Shure SM-54, SM-56's; Sennheiser MKH-405's, MK404's; MD-421's; MD-441.
Instruments Available: ARP strings; ARP Omni; 1928 Steinway 6' grand piano; Camco drums; Zildjian cymbals; Hammond C-3 organ; Leslie speaker; Yamaha bass amp; Fender Twin Reverb.

NOT JUST ANOTHER FLANGER ...

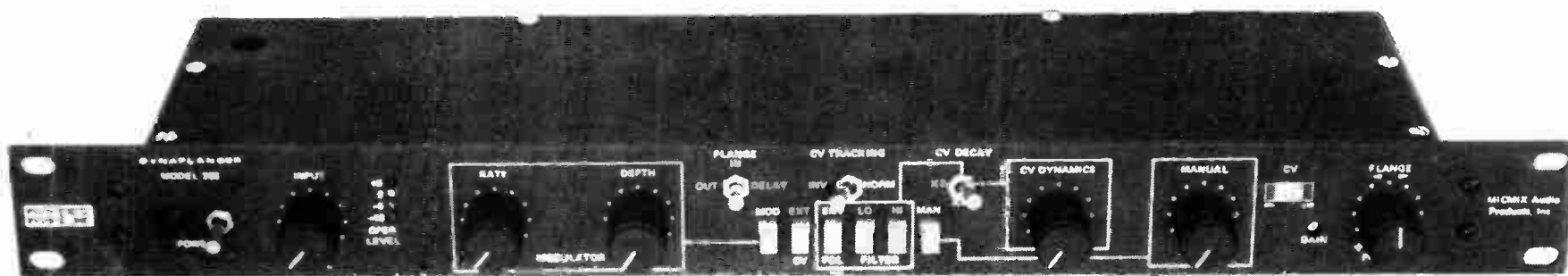

DYNAFLANGER™

Dynamically Controls Flanging Effects Automatically In Response To Frequency or Amplitude Variations Of The Program Material.

True Automated Flanging from the people who bring you MASTER-ROOM. "No 1 Rated American Reverb" — Billboard Magazine

MIX MICMIX Audio Products, Inc.

(214) 352-3811

2995 Ladybird
Dallas, Tx 75220

St. Regis  *Leuenberger*

727 Market St. ■ San Francisco, CA 94103
[415] 543-1888

THE KEYBOARD PLACE!

Yamaha-CS
Series modified to your special needs!
Come in and hear our own modified pre-sets.

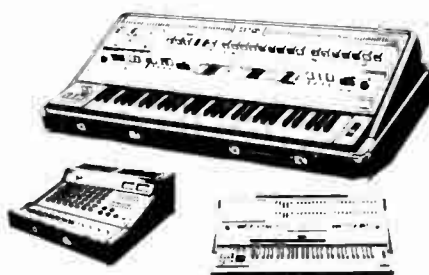

Instructions
We will teach you to develop the full potential of any instrument we sell!

WE'RE DIFFERENT!!
All Brands Set Up for Comparison

Roland **YAMAHA** **HOHNER**  **WASP** **SEQUENTIAL CIRCUITS INC** **STEINER** **KORG**

Yamaha Sound Reinforcement Custom Designed for Keyboard or Other Application!

Amps•Speakers•Mixers•Echo•Reverb•Combo Organs•Acoustic&Electric Pianos•Anvil Cases•Stands•Monitors•Rhythm Units

We Service What We Sell on the Premises!

Specialists in all keyboard products.

Don't get a salespitch, get an education at . . .

St. Regis  *Leuenberger*

Extras: Jacuzzi sunken hot tub, patio, kitchenette, shower and electric amusements.
Rates: Call or write for information.
Direction: Super Sound is situated in the uniquely creative environs of Monterey, a scant 1/2 hour north of Big Sur. Over five years of operation, the studio has sought to evolve to meet the needs and expectations of the most discerning of artists. To include; Mark Almond Band, Alun Davies, Cat Stevens, Paul Anka, Harpers Bizarre, The Beach Boys, and many others. Having recently refurbished the control room and studio, along with the installation of such creature comforts as a jacuzzi/hot tub, Super Sound will continue to seek to provide a state-of-the-art recording facility enabling artists, producers, and independents to make the music they enjoy.



TEWKSBURY SOUND RECORDERS
 Richmond, CA

••• TEWKSBURY SOUND RECORDERS

6026 Bernhard, Richmond, CA 94805

(415) 232-7933

Owner: Dan Alexander.

Studio Manager: Christa Corvo.

Engineers: Richard Van Dorn, Dan Alexander; Assistant Engineers: Christa Corvo, Stef Simonides, Mark Wallner.

Dimensions of Studio: 32' x 23', isolation booth 12' x 14'.

Dimensions of Control Rooms: 20' x 15'.

Tape Recorders: Ampex MM1000 16/24 track; (2) Ampex AG 440B-2 2 track; Otari 7800 8 track; (3) Revox A77 (1/4 & 1/2 tracks) 2 track; Nakamichi and Sony cassettes.

Mixing Consoles: Helios of England Model 2808, 28/8/28.

Monitor Amplifiers: Crown, McIntosh, G.A.S., Texas Scientific.

Monitor Speakers: JBL 4350 (four-way, biamped), Auratones.

Echo, Reverb, and Delay Systems: EMT 140 plate reverb, MICMIX Super C reverb, Sennheiser spring reverb, Lexicon Delta T, dual stereo, digital delay line, MXR Digital Delay, Pandora delay line.

Other Outboard Equipment: (2) Audio and Design stereo limiters, UREI 1176LN limiter, (2) Teletonix LA2A limiters, Eventide Omnipressor, Allison Gain Brain, (2) Orban stereo parametric EQ's, UREI parametric EQ, (2) API parametric EQ's, Pultec HLF3 and EQH2 EQ's, Lang PEQ2 EQ, (3) Tempo 33 frequency EQ's, Orban stereo synthesizer, (4) Roger Mayer keyable noise gates, 2-channels Dolby A noise reduction.

Microphones: Including, but not limited to: Neumann U-67, U-87's, U-64's, U-48, KM-84's, SM-69 stereo, KM-53; AKG C414EB, D-30, D-15, C-24 stereo tube; Schoeps CMT36, CMH32; Electro-Voice RE-20's, 666; PML DC-96, F69; Shure SM-56, 545's; RCA: various ribbon mics; Sony C500, C55, C56; Beyer M88's, M69.

Instruments Available: 1910 9' Mason-Hamlin concert grand (tuning fee), Hammond CV organ, Vox continental organ, Martin D18, Fender and Ampeg amps, Chamberlin (similar to Mellotron).

Extras: Coffee from Mr. Peets, mono cassette duplication.

Rates: 8 track: \$30/hr; 16 track: \$40/hr; 24 track: \$60/hr.

Direction: With the acquisition of our Helios console from Olympic Studios in London, and the other additions we have made recently, Tewks is bringing a new level of quality equipment to the Bay Area. The Helios has made albums such as "Beggars Banquet" and "Led Zeppelin II". We predict in the immediate future a 3M or MCI 24 track recorder and Studer 2-track machines, more gadgets and instruments, and, of course, the best coffee. Disc mastering, cigarette machines, and a gourmet catering service.... Whose ta say??!

•••• TIKI SOUND STUDIO INC.

792 East Julian St., San Jose, CA 95112

(408) 286-9840

Owner: Inc.

Studio Manager: Gradie J. O'Neal.

Engineers: Gradie J. O'Neal, Bob Berry, Tom Tomasello.

Dimensions of Studio: 1600 sq. ft.

Dimensions of Control Rooms: 20' x 18'.

twenty four track

Tape Recorders: Ampex 1100 24 track; Ampex 1100 16 track; Ampex 1100 8 track; Ampex 440 4 track; Ampex 440 2 track.

Mixing Consoles: Sphere, 24 in x 24 out.

Monitor Amplifiers: Crown DC 300.

Monitor Speakers: Altec 604.

Echo, Reverb, and Delay Systems: EMT, Eventide, Scamp.

Outboard Equipment: Scamp-gates, flangers, MXR.

Microphones: E.-V., RCA, Sony, AKG, Altec, Sennheiser, Neumann.

Instruments Available: Acc. piano, organ, clavichord electric piano, ARP.

Rates: 8-track: \$35/hr. 16-track: \$45/hr. 24-track: \$60/hr.

Direction: We record nice people.



TRI-AD RECORDING STUDIOS, LTD.
 Eugene, OR

•••• TRI-AD RECORDING STUDIOS, LTD.

1825 Oak St., Eugene, OR 97401

(503) 687-9032

Owner: Gene P. Moritz & Peter Lorincz.

Studio Manager: Gene P. Moritz.

Engineers: Peter Lorincz, Don Ross.

Dimensions of Studio: 22' x 24'.

Dimensions of Control Rooms: 14' x 16'.

Tape Recorders: Ampex 1200 24 track; Studer B67 2 track; Otari 5050 4 track; Revox A-77 2 track; Nakamichi 700 cassette.

Mixing Consoles: Tangent 3216, 24 in x 24 out, 8 returns.

Monitor Amplifiers: Spectro Acoustics P-202, Crown D-60, Spectra Sonics.

Monitor Speakers: (4) JBL 4311's, (2) Auratones.

Echo, Reverb, and Delay Systems: Master-Room Super C reverb, Klark-Teknik DN-36, Delta Lab DL 1, Lexicon Prime Time.

Other Outboard Equipment: (2) dbx 160 compressor/limiters; dbx 119 expander; digital delay; Exciter; (2) Roger Mayer RM68 noise gates, VSO, Alarm Time Processor.

Microphones: AKG 414's, 1000; Shure 57's, 58's, 53's; Sony P22's; Neumann KM-87's; AKG 501's.

Instruments Available: Yamaha grand, synthesizers, String Ensemble, Fender Rhodes, pre CBS Fender Super Reverb, current and older amps available upon request.

Extras: Coffee, refrigerator, 24-hour market one block away, high speed cassette duplicator, video slide film audio recorder, sync pulse.

Rates: 24 track: \$80/hr; 16 track: \$60/hr; 8 track: \$40/hr; 2 track live: \$40/hr. Block rates available.

Direction: Tri-Ad began as a 4-track studio in 1974 and with the continued support of satisfied musicians, producers and ad agencies has expanded to a 24-track full service studio. Current plans include automation, expanding our studio complex, designing and building equipment to facilitate ease of operation and musical creativity.



VILLA RECORDERS
 Modesto, CA

•••• VILLA RECORDERS

3013 Shoemaker Ave., Modesto, CA 95351

(209) 521-1494

Owner: Fred Eichel, Scott Snider.

Engineers: Chief Engineer: Ken (Hop) Hopkins; Chuck Leary, Steve Malcom, Ken Pedan, Greg Fleegar.

Dimensions of Studio: Main studio: 30' x 32', isolation booths: 12' x 12' and 13' x 12'.

Dimensions of Control Rooms: 25' x 25'.

Tape Recorders: Ampex MM-1200 16 and 24 track; (2) Ampex ATR 102 2 track; Scully 280 2 track; TEAC 3340 4 track.

Mixing Consoles: Trident, 28 in x 24 out.

Monitor Amplifiers: Spectra Sonics, Yamaha, Crown.

Monitor Speakers: Gauss 4-way System, Altec 604 Big Reds, JBL 4311, Auratones.

Echo, Reverb, and Delay Systems: AKG BX20, live chamber, Lexicon DDL.

Other Outboard Equipment: UREI LA3A, UREI 1176 LN, Kepex Gain Brain, dbx 160 limiters, Marshall Time Modulator, Eventide Harmonizer with keyboard, Trident parametric EQ, Orban parametric EQ, White 1/3-octave EQ.

Microphones: Neumann U-87, KM-84; Sennheiser 421, 441; Electro-Voice RE-20; AKG C-414 EB, C-452, D-200E; Beyer M-500; Sony C-22; Shure SM-56, SM-57; Countryman direct boxes.

Instruments Available: Baldwin 9' concert grand piano, Fender Rhodes electric piano, Fender Twin Reverb amp, MESA/Boogie amp, Oberheim 2-voice synthesizer, ARP Odyssey, Slingerland drums with Paiste & Zildjian cymbals, Fender Bass guitar.

Extras: Complete lodging facilities with 40' x 27' swimming pool, jacuzzi, sauna, rehearsal room with PA.

Rates: 24 track: \$50/hr. 16 track: \$35/hr. 4 and 2 track: \$30/hr.

Direction: Villa Recorders is a sophisticated 24 track studio on 80-acres of almonds in a very relaxed country atmosphere. Open for only 10-weeks, since March 1, the studio has already attracted the attention of such notable artists as Bill Champlin (Sons of Champlin), Steve Marriot (Humble Pie), Edgar Winter, Bobby Kimball (Toto), Uncle Rainbow, and others. Located only one and a half hours from the San Francisco, Bay Area, this facility offers the serious alternative to over-priced, over-hyped, and congested recording situations to be found elsewhere.

CLASSIFIEDS
 Coming Soon to
 The Mix
 Watch for details
 in the
 September Issue

Time-Based Effects . . . Without the Side-Effects.
Introducing the 440 Delay Line/Flanger from Loft Modular Devices.



There is a new solution for time-based effects. Filling the gap between expensive digital lines and low cost 'black boxes', the Series 440 Delay Line/Flanger delivers the amazing depth and dramatic realism rightly associated with analog delay effects. Yet it avoids so many unwanted side effects you expect from analog and even some digital systems.

Now, you don't have to sacrifice the dimensional impact of your music to severely limited bandwidths, nor lose that bright crisp edge to compromised electronics. Gone too, are the 'rumps', 'whistles', background oscillations, quantizing noise, 'grainy' digital audio, and other strange distortion you may have noticed before. Even headroom, a real problem with so many units, is no problem with the Series 440 Delay Line/Flanger.

All you get is great sounding delay combined with the creative flexibility of VCO time based processing. Mixed to any degree with straight delays from .5msec all the way out to 160msec., VCO processing permits such effects as resonant flanging, Leslie-type sounds with different 'rotation' speeds, vibrato, double tracking with realistic pitch and timing errors, or a wide range of more subtle effects to control the spatial perspective of your music. In addition to the built-in VCO feature, control voltage jacks allow further modification of the system's special effects capability. Impressive? We think so, but there is more. Why not check out the details at a representative dealer near you.

The Series 440 Analog Delay Line/Flanger is in stock and ready for immediate delivery.

LOFT MODULAR DEVICES, INC. 91 Elm St. Manchester, CT 06040 (203) 646-7806

btx 30-track audio

The superb BTX 4500 SMPTE interlocking system allows the operation of any two multi-track recorders in tandem for 14, 22, 30 or 46-track capability. Any two recorders may be precisely locked regardless of make, format, speed or number of tracks.

The BTX Corporation | 438 Boston Post Road, Weston, Massachusetts 02193 • (617) 891-1239
6255 Sunset Boulevard, Hollywood, California 90028 • (213) 462-1506



The Recording Academy



Sound off

by Beverly Sommerfeld

The Recording Academy, also known as the National Academy of Recording Arts and Sciences (NARAS), is a non-profit organization formed in Los Angeles in 1956 by record industry personnel to award excellence for artistic, creative and technical craftsmanship in the recording industry, that award being the prestigious Grammy Award. Seven chapters now make up the Recording Academy: Atlanta, Chicago, Los Angeles, Memphis, Nashville, New York and San Francisco; and the total membership is well over 5,000. The national office is still in Los Angeles, and the Recording Academy Hall of Fame, which will house memorabilia depicting the history of the recording industry along with outstanding recordings made prior to the inception of the Academy, is currently being built there.

The San Francisco Chapter, the youngest of the seven chapters, was organized and chartered in 1974 and covers the north-western United States—Northern California, Oregon, Nevada, Utah, Washington, Idaho, Colorado, Wyoming, Montana—and Canada. The 250 members come from every facet of the recording industry—vocalists, musicians, engineers, producers, conductors, arrangers, cover designers, and liner note writers—and from every type of music—jazz, classical, rock, R&B, country, and some that have no categories.

An obvious benefit of membership, besides awarding their peers for their contributions to the industry, is that members can buy currently-released albums at drastically-reduced prices. But there is more to it than that. The local chapters offer educational programs and social activities, wherein the members have the opportunity to stay current on the technical developments of the recording industry and to meet and talk with others in their field.

The San Francisco Chapter is entering an exciting and innovative stage of development. An unprecedented number of special programs and activities are being planned for the coming six months, which include:



San Francisco Style

- July - Demonstration of current recording techniques, analog and digital
- Aug - Dave Brubeck concert at the Concord Pavilion with artist reception and preferred seating
- Sep - Private screening and production planning of Grammy Awards telecast
- Oct - Concert and dance in wine country—(Grape Stomp)
- Nov - Graphic design lecture and album art display
- Dec - Studio miking techniques with Fred Catero

And we haven't stopped there. Currently on the drawing board for the '79/80 season are a Sunday at the Bach Dancing & Dynamite Co., a promotion and publicity discussion, a tour of a new studio facility, motion picture highlights at the Dolby Labs screening room, a record pressing quality panel, and a demonstration of voices as instruments. More details on these events will be published later.

Also in the works is another intensive 4-day music-industry seminar covering such topics as management, record production, studio engineering and management, music contracts and agreements, concert and club promotion, and

radio airplay and record promotion.

Not only does the Academy create activities which unite the local music industry, it also offers the opportunity to bring increased recording activity into the area. Much like how winning an Oscar contributes to the sales of a movie, so does winning a Grammy increase the sales of a record. The moment an album becomes a Grammy nominee or winner, sales for the album and artist are renewed, thereby leading to more record production and a chance for yet another Grammy. Thus, the Grammy becomes a fantastic merchandising tool. With increased membership comes greater voting powers; and perhaps as the local membership grows, more Grammys will be won by local artists, producing an increase of recording activity in the area.

Qualifications for voting membership are as follows: Vocalists/Singers; Leaders/Conductors; Producers; Engineers; Instrumentalists/Musicians; Arrangers; Spoken Word: Must have recorded and commercially released at least 6 sides of a 45 or one half of an album. Songwriters/Composers: Must have written 6 songs which have been recorded and commercially released or 1 song which has been recorded and commercially released by 6 different artists. Art Directors/Photographers/Artists/Designers: Must have 6 commercially-released album covers. Annotators/Literary Editors: Must have written liner notes for 6 commercially-released album jackets.

Associate memberships are also available for persons who don't yet qualify as voting members but who are actively identified with the recording industry.

For more information or membership applications, contact:

Beverly Sommerfeld, Executive Director,
The Recording Academy,
829 Folsom Street,
San Francisco, CA 94107, or call
(415) 543-7029 between 11am and 6pm.

Music Annex announces the opening of studios B and C.

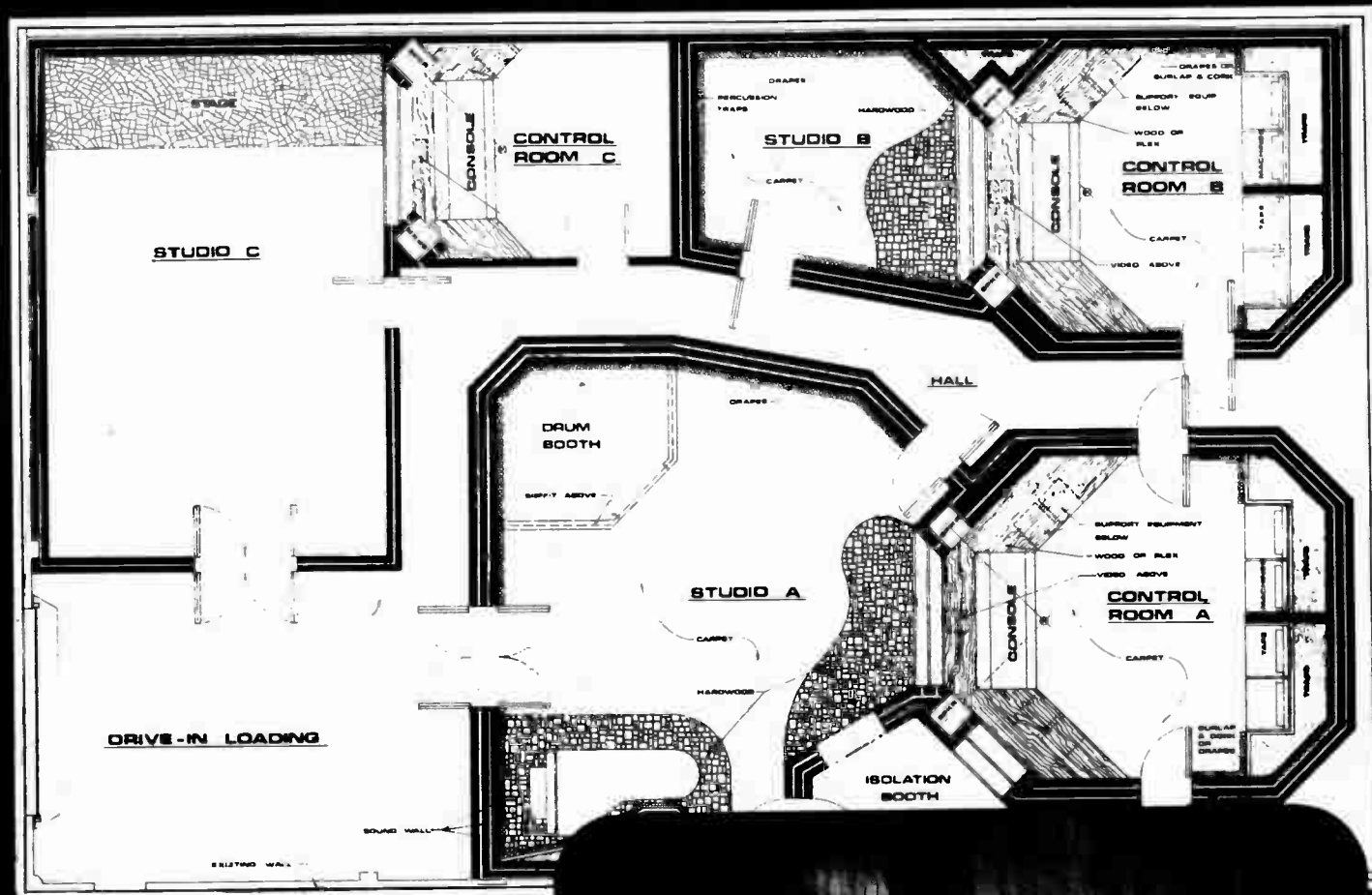

Music Annex now has four great rooms in the Bay Area: Studios A, B, and C located near Highways 84 and 101 in Menlo Park, and our Cowper Street studio in Palo Alto. Call (415) 328-8338 for rates.



MCI 16/24 track • Amek 28/24 consoles
Studios designed by Everything Audio



Music Annex Recording Studios

INDEPENDENT ENGINEERS & PRODUCERS OF NORTHERN CALIFORNIA & THE PACIFIC NORTHWEST

TO ALL INDEPENDENT ENGINEERS & PRODUCERS

The Mix will have free listings in all future Recording Studio Directories for independent engineers and producers. If you would like to be included in the next issue, please fill in and return the coupon below to:

the Mix
P.O. Box 6395
Albany, CA 94706
Please type or print legibly

name _____
address _____
city _____
state _____ zip _____
phone _____ 101

Engineer Producer

Experience _____

Direction _____

BRADY AUSTIN — ENGINEER/PRODUCER
Villa St., Mt. View, CA 94040
964-5689

Experience: 7 years roadie and sound tech. Much studio experience and presently working for API—Associated Promoters, Inc., Castro Valley; and Blue Dog Studio.

Direction: I love it and live it as you can tell. So whatever it takes to keep in operation I will do until I die. Blues with a feelin'.

BAKER BIGSBY — ENGINEER
703 Pleasant St., Santa Paula, CA 93060
(805) 525-1721

Experience: A dozen Gold and Platinum records, Oscar and Grammy Awards. 10 years in business.

Direction: Prefer rich crazy musicians.

BLECMAN & HEDGES — ENGINEER/PRODUCERS
442 Holladay, San Francisco, CA 94110
(415) 641-1962

Experience: Disco specialist. Produced and mixed "Fever" on Fantasy Records. Disco Mixes: "Lord Of The Rings", Blue Notes, Idris Muhammad, Billboard's D.J.'s of the Year 76 & 78. 6 years experience—K101 Wed. Nights' Disco.

Direction: Disco production, A&R, mixing, producing, promotions. To further Blecman & Hedges Productions, Blecman & Hedges Publishing. Need a mix, a producer, a record deal, or promotion? See us.

DAVID BLOSSOM — ENGINEER
P.O. Box 5953, San Francisco, CA 94103
(415) 864-9357

ALLEN CRAFT — ENGINEER/PRODUCER
6724 Superior Dr., Sacramento, CA 95660
(916) 331-8112

Experience: 9 years as a musician, 5 years studio. Have built own private studio, assisted in construction of several others, concert-tour sound. Credits on request. Video too!

Direction: Onward and Upward! Always seeking new information, material, people, etc. I have been exploring the uses of video and it's growing interaction with the audio scene. I am interested in all types of music, experimental to legitimate. In a word Quality with Personality!

PHIL CRESCENZO — ENGINEER/PRODUCER
124 5th Ave., #5, San Francisco, CA 94118

Experience: Engineered at many studios in New England and New York, including S.B.S., Scoull Productions, Conn. Sound, Sun Sound. Mixing engineer for Miroslav Vitous' 1978 tour. I have a good technical background that includes one year at Record Plant (L.A. and Sausalito.) I have just finished an album for Theresa Records' Babatunde and have worked with Steve Stills, Miroslav Vitous, Clive Stevens, Eddie Henderson, Mel Martin, and Santur.

Direction: I am a musician and composer, these qualities along with my engineering abilities enable me to communicate well with musicians in the studio. I love what I do and am open to any and all types of music and I work hard to keep the quality of my production high on any budget.

HEWLETT CRIST/RED DIRT PRODUCTION PRODUCER
5885 Bridle Way, San Jose, CA 95123
(408) 429-9414

Experience: 11 years studio musician—Mercury, Columbia. Recorded with Dr. Hook, Shel Silverstein, Doug Sahm, Chuck Berry, Roy Head, Boz Scaggs, Dr. John, Screamin' Jay Hawkins, produced Queen Ida, others.

Direction: Complete production services, A&R, arranging. Production package consultant. Also available for playing sessions—guitar, harmonica, vocal arranging.

STEPHEN GAUDET — ENGINEER/PRODUCER
20383 Yeandle Ave., Castro Valley, CA 94546
(415) 537-9151, (415) 471-2819

Direction: On-going productions. Looking for musicians for session work only.

STEPHEN JARVIS — ENGINEER/PRODUCER
3622-C Mt. Diablo Blvd., Lafayette, CA 94549
(415) 284-7721

Experience: Journey, Montrose, Sammy Hagar, Companion, ORE, Commander Cody, John Sebastian, Holly Penfield, Tommy Tutone. Engineer/mixer on staff Wally Heider's (S.F.) 4 1/2 years. Independent 5 years. Studio/traffic manager, Rudy Records/S.F., 1978. Owner of Akashic Records (label formed Dec. 1978.) Business and recording consultation service since Sept. 1977 (by appt.), remote recording experience.

Direction: To produce and promote unsigned talented artists of the Bay Area. To assist signed artists in the exploration of the new dimensions of digital recording as it relates to their art.

BILL KOUMARELOS — PRODUCER
P.O. Box 983, Pleasanton, CA 94566

Experience: Have produced demo sessions at Freeway, Mantra, and Tewksbury.

Direction: Currently working on sessions of my own material as well as that of the musicians I work with. In late '79 or early '80, I expect to serve the Amador Valley area as producer. Musically, I am geared towards vocal harmonies, synthesizers, and combinations thereof.

DR. RICHIE MOORE — ENGINEER/PRODUCER/AUDIO CONSULTANT

10 Lakewood Drive, Daly City, CA 94015
(415) 755-8771 or (213) 374-4134

Experience: Ph.D Communications Science. Engineer/mixer staff at Wally Heiders (L.A.), EMI Studios (Abbey Road), Village Recorder, and The Burbank Studios. Recorded over 175 albums; 200 singles; and have earned 11 gold albums and four platinum. Have scored many films and TV programs. Have worked on the design, construction, and trouble-shooting of many devices in the audio/video industry. Extensive road tours with major groups. Graduate of MCI Technical School, 1978. Co-Founder of the University of Sound Arts.

Direction: To continue the very best audio technician service available anywhere. I want to be able to impart my 15 years of experience in the industry to all those who seek it. I am available for production, mixing, and audio consultation, no matter how big or small the project. I own my own extensive analog/digital test equipment, and acoustic measuring devices. I have done this to guarantee quality assurance on all projects I am involved with.

TOBY MOUNTAIN — PRODUCER
291 Broderick St., #5, San Francisco, CA 94117
(415) 626-2138

Experience: Extensive practical and academic musical training: B.A. Princeton University, M.A. University of California, Berkeley. Produced own album of original songs, "Journeys"; studio experience.

Direction: Acoustic arrangements, soft rock, folk rock, classical, pop, or anything which is inherently musical.

DAWAN ABDUL MUHAMMAD — PRODUCER

1074 Broadway Ave., San Jose, CA 95125
(408) 293-3227

Experience: 5 years audio and video production experience for Evidence Music International.

Direction: Artistic integrity and business acumen.

THE MUNDANE COMPANY — PRODUCER

P.O. Box 901, Pacifica, CA 94044
(415) 355-2262

Experience: A dozen years in radio, T.V., A.V., commercials, jingles, and studios, and recently a part of San Francisco's comedy community, with strong writing background.

Direction: Quality commercial work, with emphasis on humor and entertainment, not phone numbers and addresses. "If you hear it every day, you know it's Mundane." We've got bills to pay, we've got to do a better job.

STEVE O'NEILL — ENGINEER/PRODUCER

P.O. Box 11472, San Francisco, CA 94101
(415) 673-1640

Experience: 10 years of radio and music production for the Canadian Broadcasting Corporation in Toronto. Operated my own 8 track studio at the same time.

Direction: Production for individuals or groups working toward social change and alternatives. Information and radio dramas being my favorite!

KELLY ROADS WALNUT WEST SOUNDS & VISUALS — ENGINEER/PRODUCER

1527 Grant Ave., San Francisco, CA 94133

Experience: In and out of studios since 1971. Worked at Far-out Recording in Bridgeville, CA, for 2 years. Mixed first demo for Joint Sessions—A jazz-rock combo. Just finished "In Memory Of Berry Oakley" with Jim Davis, on album with music from jazz-rock to country, to blues to rock and back.

SNUFFY SMITH — ENGINEER/PRODUCER

1620 Villa St., Mt. View, CA 94040

Experience: Sound and Engineer 7 years as roadie. Presently working for Blue Dog and Blue Note Studios, Sunnyvale and Mt. View; mixing, video, and sound production.

Direction: My parents do it and I've been doing it most of my life. Hope to play the rest.

JERRY SOUTHERN — PRODUCER
1622 Yosemite Ave., San Francisco, CA 94124
(415) 822-2809

Experience: 9 years studio sessionman. 3 years co-producer and producer. I play keyboards on the sessions and back-up singing. I've recorded people known and unknown in the business.

Direction: I'm interested in what the people want to hear. I'm showing my music from a positive side, but if the world is going negative then I'm going to show just that. My job is to keep my finger on the pulse of what the world is saying and doing, I feel if you are going to be a loud-speaker then you should voice what you see before your eyes. Through my music I'm trying to tune everyone in on the same wave-length. If I do that mission then I will have accomplished a lot. If you would like to discuss a project contact me at the above number or write to me.

ROBIN SYLVESTER — ENGINEER

296 Bonview, San Francisco, CA 94110
(415) 821-7244

Experience: Independent engineer in London 69 - 74; worked at most major London studios: Trident, Marquee, Abbey Rd., et. al. Many rock and British jazz albums, inc. Rory Gallagher, Caravan, John Surman (Melody Maker jazz album of the year, 1970), Mike Westbrook. Since moving to U.S. have combined pro bass playing with freelance engineering, most recently at the Automatt in S.F.

Direction: Recently moved to S.F. and working hard as bass player/arranger; would love to find engineering projects with some musical involvement, particularly jazz or rock.

CARSON C. TAYLOR — ENGINEER/PRODUCER

48 Mariposa Ct., Danville, CA 94526
(415) 820-5297, (415) 781-2603

Experience: 39 years in recording. Over 20 at Capitol Records. Sr. mixer/chief engineer for Angel Classical division. Recorded in many foreign countries for Capitol/Angel/EMI. Classical specialist. 4 Grammy nomination awards.

Direction: Assist wherever my expertise is needed. To teach others to use coincident mic techniques for which I am well known. Consultant/engineer/producer.

FRED C. TAYLOR D/B/A CRINKLE MUSIC COMPANY — ENGINEER/PRODUCER

Terminal Box 24767, Seattle, WA 98134
(206) 622-2860, 743-2391

Experience: 12 years professional performance and recording on drums and keyboards, arranger, photographer. 3 years as recording engineer. Have produced several demo recordings of my own and other groups—all recordings highly successful—no published recordings so far.

Direction: As leader/producer of jazz group—"Sanctuary" will produce albums by the above and possibly other jazz/creative music ensembles. Also am recording Seattle area Christian musicians—am making plans for a Christian album featuring some of these. Primarily a jazz/improvisational musician, with major experience in all popular styles as well.

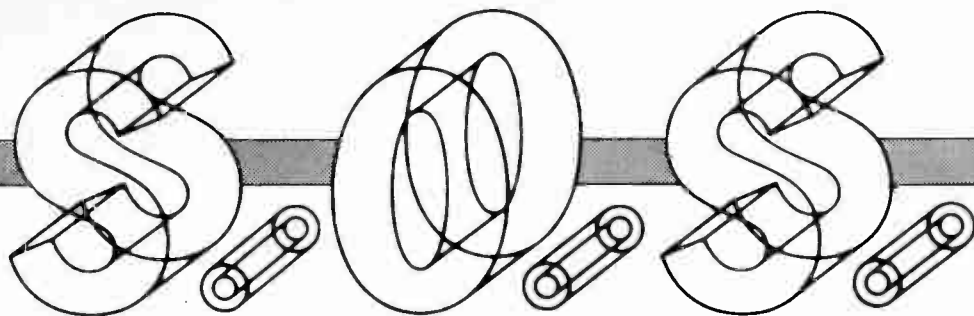

STUDIO OPERATIONS SERVICES

The Complete Studio Operations Consulting Service for Pro and Semi-Pro Audio and Video Systems

Counseling for:

- Equipment Purchases
- On-Site Analysis
- Acoustical Design
- Audio/Video Interface
- Studio Management
- Personnel Training
- Studio Finances

Studio Services:

- Engineering and Mixing
- Trouble Shooting
- Systems Alignment
- Routine Maintenance
- Spectrum Analysis

24 Hour Emergency Service in the Bay Area

For information and rates call

S.O.S. 415/566-8600

A DIVISION OF KEA, INC.

we'll show you ours, if you'll show us yours!

The Mix is interested in finding out who our readers are. We'd appreciate it if you would fill out the form below and return it to us so we can learn more about you and what you like. To show our appreciation, we will send you a free copy of our next issue. Thanks for your time.

1. What is your age?
 - 15-25
 - 25-34
 - 35-40
 - over 50.
2. Are you male or female?
3. What is your occupation?
 - A. RECORDING STUDIO
 - Owner
 - Engineer
 - Staff
 - Independent
 - Maintenance
 - Producer
 - Independent
 - Staff
 - Studio Employee
 - B. MUSICIAN
 - Full Time
 - Part Time
 - On contract to record label
 - C. PROFESSIONAL AUDIO
 - Manufacturer
 - Dealer
 - Store Owner
 - Employee
 - Manufacturers Rep.
 - Designer
 - Consultant
 - D. MISCELLANEOUS
 - Radio/TV
 - Student
 - Other (please specify)
4. How long have you been involved in recording? _____
5. How much time do you spend in recording studios in one month? _____
6. What other recording related publications do you read? _____
7. Do you have recording equipment in your home?
 - professional
 - reel to reel
 - cassette
8. Where did you get your copy of The Mix? _____
9. What other listings, features or articles would you like to see in future editions of The Mix? _____
10. Comments or suggestions? _____

Please return this form to:
 The Mix Publications
 P.O. Box 6395
 Albany Branch
 Berkeley, CA 94706

name _____
 address _____
 city _____
 state _____ zip _____

Thank you. Watch for your free copy of our next issue to be delivered soon.

TDK introduces high fidelity for the eyes.



When TDK's engineers set out to make a video cassette for home use, they started with the tape they developed for professional broadcast use and *improved* it, so it could stand up to the rigors of four-hour home recording. In *any* deck, TDK Super Avilyn VHS and Beta cassettes offer performance so

superior, that they are ushering in a new era in home video: the age of "high fidelity for the eyes." TDK Electronics Corp., Garden City, NY 11530.



feedback

Dear Mix,

How about looking into the situation of improving the over-all quality of the average record being pressed today.

Take a poll in your magazine, find out what your readers think about the final finished product and how it relates to all the fine work done in the studios and live.

I can't believe that people continue to lower their standards when it comes to music reproduction. The solution is awareness of what people really want to see and hear.

Dan Nelson
RAM Recording
Livermore, CA

Dear Dan,

We couldn't agree with you more about record quality; and from what Doug Sax says in the May issue (Vol. 3 No. 3) the industry awareness is rising rapidly.

Beginning in September the Mix will be running reader polls on controversial topics and supplying the results to manufacturers, record companies, and others in the industry who are in a position to improve the situation.

Dear Mix,

I would like to see more space in the Mix devoted to amp and speaker set-ups for stage applications.

Mark Johnson
Easton, PA

Dear Mark,

We who put out the Mix have started a new magazine, called M.I. (Musicians' Industry), which deals with the concerns of the active musician. It will contain regular features on PA and stage sound. M.I. will be available from the same place you received the Mix. If you can't find it, you can subscribe using the coupon in this issue.

Dear Mix,

It sure would be nice if you had some type of classified ad section. I would like to be connected to a candidate for studio manager and can't think of a better place to advertise for it.

Jess Meek
Pyramid Recording
San Jose, CA

Dear Jess,

Hang tight. Classifieds are coming soon to the Mix. Watch the September issue for complete details.

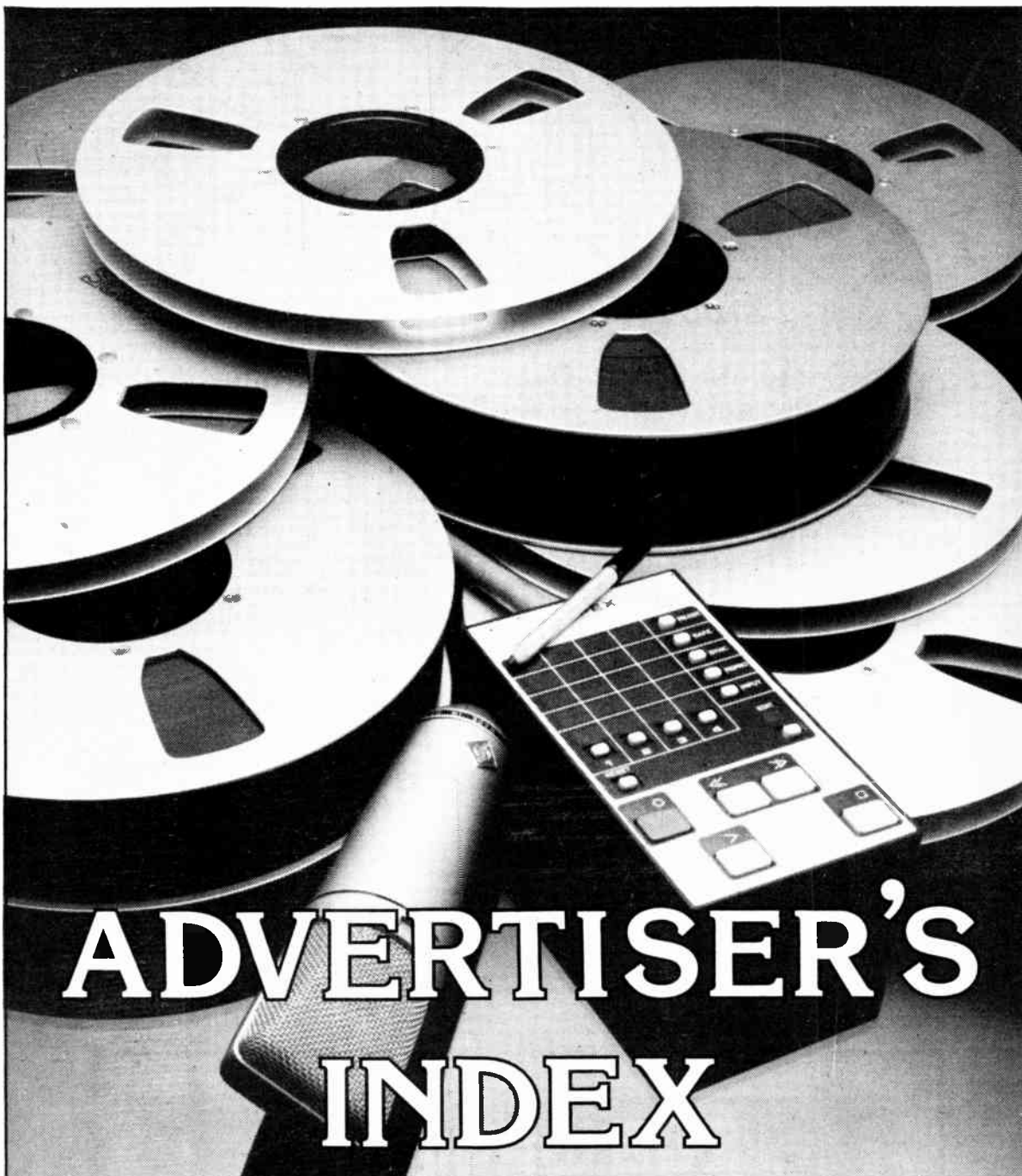

ADVERTISER'S INDEX

Alco.....	41	Orban Associates.....	27,81
Altmann Recording.....	71	Otari Corporation.....	76,77
Aphex Systems.....	7	Peavey.....	29
Audio & Design Recording.....	27	Pro Sound Seattle.....	53
Ayre Studio.....	69	Quad/Eight.....	back cover
BGW.....	11	Record Plant.....	83
BTX.....	87	Rhodes Keyboards.....	4
Crown.....	57,61	SAE.....	23
dbx, Inc.....	19	Shure Brothers.....	13
Dolby Laboratories.....	81	Sonoma Sound.....	82
Eddor.....	33	SOS.....	91
Everything Audio.....	2	Sound Genesis.....	55
Filmways/Heider Recording.....	79	Sound Workshop.....	59
Gauss.....	47	St. Regis & Leuenberger.....	85
HUN Sound.....	65	Suntronics.....	45,94
Leo's Music.....	43	Tangent Systems.....	3
Lexicon.....	15	Tapco.....	75
Loft.....	87	Tascam.....	63
McCauley Sound.....	71	TDK.....	91
M.I. Magazine.....	93	TEAC/Tascam.....	48,49
MICMIX Audio.....	85	Tewksbury.....	73
Music Annex.....	89	Tres Virgos' Studio.....	57
MXR Innovations.....	95	U.R.E.I.....	21

FOR THE ACTIVE MUSICIAN

M.I. MAGAZINE

**Charlie
Daniels Band**

inside
Peavey

**Keith
Knudsen**
doobie brothers

Available for free at most recording studios
and music stores
Or subscribe at \$10 per year

name _____
address _____
city _____ state _____ zip _____

Send to:
M.I. Magazine
P.O. Box 6395
Berkeley
CA 94706

The deck that separates the pros from the amateurs.

There is a difference between so-called consumer decks and professional decks. Several, in fact.

That's why TASCAM SERIES created its Model 40-4 Recorder/Reproducer. While consumer decks are designed for play, our Model 40-4 is meant for work. Hard work.

It's a tough, heavy-duty deck with the professional specs, features and functions it takes to qualify for professional, in-studio use. But our Model 40-4 costs a lot less than its in-studio peers.

Our Tascam 40-4 has a suggested retail price of \$1600*. That's more than most consumer decks, but it's designed to do a lot more.

The 40-4 transport is the same as our 80-8 half-inch eight-

track deck. Designed to move heavier half-inch tape, the 40-4 handles lighter quarter-inch tape smoothly without strain.

It's rugged enough to take the constant wind and rewinding to build your tracks to where you want them. The 40-4's tape transport system is a good example of the mechanical overkill that separates our 40-4 from lesser decks.

Okay. If you're just beginning, you can buy any consumer deck; TEAC makes the best around.

But if your commitment is serious enough to require a four-track recorder/reproducer you can rely on for a long time and produce studio-quality results, it's our Tascam 40-4.

Check out the details below, then check in at your authorized TASCAM SERIES Dealer.

The impedance roller is strictly professional caliber. Along with the heavy dynamically-balanced flywheel, it guarantees better tape-head interface. Therefore, reducing the possibility of dropouts during a critical recording session.

Our exclusive Function Select initiates TAPE/SOURCE, PLAY-BACK/RECORD and dbx ENCODE/DECODE modes with just one button. Additionally, FET circuits (not mechanical relays) enable you to punch in and punch out without pops.

Heavy-duty motors, bearings and brakes assure you of smooth tape handling throughout the long hours of the multitrack recording process.

Individual, removable PC cards carry the electronics for record, reproduce and bias amps. So calibration or replacement comes quick and easy. Just swing down the meter panel for quick access.

The optional dbx module (DX-4) gives you a dynamic range of over 90dB. Because it's integrated, its electronics are perfectly calibrated to match the recording/reproduce circuits of the 40-4.

Full IC logic and motion-sensing circuit lets you enter play mode quickly without risking tape spill or stretch.

The heavy-duty power supply features a pro-quality toroidal transformer. This assures that each deck function will receive its correct voltages without any fluctuations. Even if your 40-4 runs constantly for 24 hours a day.

Thanks to our single record/playback head, you'll hear existing tracks in sync with full frequency response while over-dubbing at 15 ips.

*Price subject to dealer preparation charges where applicable.

TASCAM SERIES BY TEAC®

A new generation of recording instruments for a new generation of recording artists.

TEAC Corporation of America • 7743 Telegraph Road • Monroeville, California 90640 • In Canada TEAC is distributed by White Electronic Development Corporation (1966) Ltd.

Available at:



1620 W. Foothill Blvd., P. O. Box 734 Upland, CA 91786 (714) 985-0701

Imagination fuses two powerful illusions.

**Experimentation leads to the
discovery of new realities.**



Introducing the MXR Flanger/Doubler.
For more information see your MXR dealer or write us.
MXR Innovations, Inc., 247 N. Goodman Street,
Rochester, New York 14607, (716) 442-5320

MXR Professional
Products Group

