

# MIX

PROFESSIONAL AUDIO AND MUSIC PRODUCTION

## SURROUND SOUND

- Consoles for 5.1
- Multiformat Mixing

## SCORING WITH...

- Danny Elfman
- Armin Steiner
- Robert Rodriguez
- Cliff Martinez
- Gohl/McLaughlin

## SHOW REPORTS

NSCA • MusikMesse • Replitech

## On the Road With

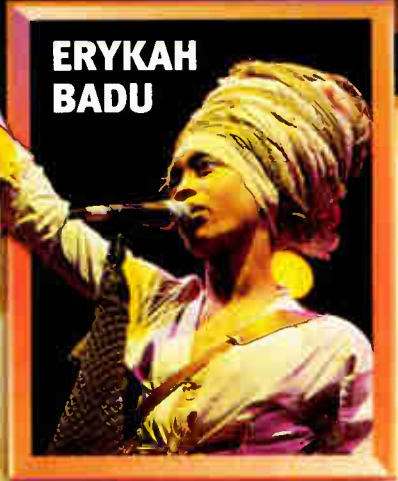

**ERYKAH  
BADU**

#BXNMDTC \*\*\*\*\*AUTO\*\* 3-DIGIT 913  
MIXM 116



MARK GANDER  
JBL  
8500 BALBOA AVENUE  
NORTHRIDGE CA 91329-0002

F9  
S0032

An INTER



0 09128 43974 7

# METADATA FOR MAXIMUM CONTROL

## CHAPTER TWO: DYNAMIC RANGE

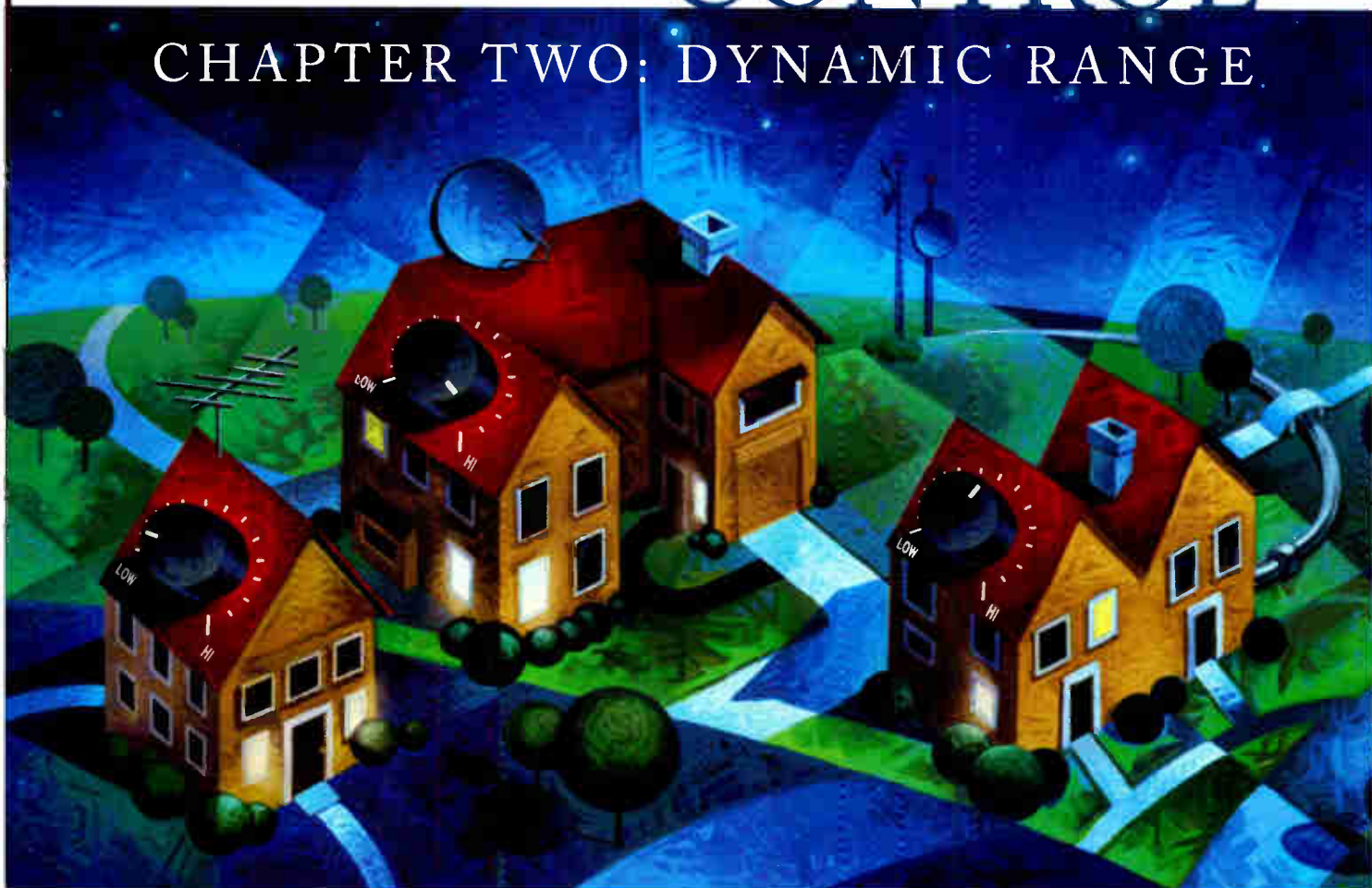

Dolby Digital uses metadata to change the entire television listening experience. Whether viewers have mono, stereo, or 5.1 systems, Dolby Digital provides the best audio television offers.

Dynamic range control (DRC) parameters set during program production ensure optimal DTV audio presentation in home environments, and also offer choice. Dolby Digital preserves the full dynamic range, however, consumers can apply DRC to limit dynamics for late-night viewing, turn off DRC to maintain full dynamics for home theaters, or choose a setting in between.

With the new DP570 Multichannel Audio Tool, program producers and broadcasters can easily select DRC profiles and hear their effects in real time. For more information, please visit our website.

[www.dolby.com/metadata](http://www.dolby.com/metadata)

 **Dolby**

BREAKING SOUND BARRIERS

Dolby Laboratories, Inc. • 100 Potrero Avenue • San Francisco, CA 94103-4813 • Telephone 415-558-0200 • Fax 415-863-1373  
Wotton Bassett • Wiltshire SN4 8QJ, England • Telephone (44) 1793-842100 • Fax (44) 1793-842101 • [www.dolby.com](http://www.dolby.com)

Dolby and the double-D symbol are trademarks of Dolby Laboratories. © 2001 Dolby Laboratories, Inc. 801/13579

**CIRCLE #001 ON PRODUCT INFO CARD**  
World Radio History

‘Mixing is like painting a picture. I don’t want to use the same colors all the time. That’s what’s really cool about the MT; it gives me a larger palette to experiment with. But, if I need to, I can quickly get back to where I was.’

#### DIGITAL MIXING TIP

The ability to copy settings quickly is great. If I need a compressor gate setting, or I think the EQs and processing work in the same way for several vocal tracks... copy, copy, copy and it’s done. The MT’s speed is a tremendous advantage.

‘When I work on the MT I can trust the most important tool in the recording process - my ears. I don’t have to sit down to mix with predetermined ideas. One of the best things about working on this board is that I never feel confined or restricted.’

‘MT GIVES ME MORE CHOICES...  
AND I LOVE CHOICES’



Photographed at Skip Saylor Recording, Los Angeles



#### TAAVI MÕTE

Top recording engineer and mixer Taavi Mõte has been involved in the creation of albums for a number of successful recording artists over the last two decades, and his golden touch continues into the 21st century.

The recordings on which Mõte has left his mark combine to a staggering figure of over 40 million units sold, with 15 Platinum and Multi-Platinum, and 25 Gold albums to date.

#### CREDITS INCLUDE

MADONNA  
U2  
NATALIE COLE  
ANITA BAKER  
TUPAC SHAKUR  
CHANTE MOORE  
DJ QUIK



## Solid State Logic

INTERNATIONAL HEADQUARTERS

Begbroke Oxford OX5 1RU England Tel: +44 (0)1865 842300 Fax: +44 (0)1865 842118  
Email: sales@solid-state-logic.com www.solid-state-logic.com

NEW YORK

LOS ANGELES

TOKYO

PARIS

MILAN

TORONTO

SINGAPORE

+1 (212) 315 1111

+1 (1)323 463 4444

+81 (0)3 5474 1144

+33 (0)1 3460 4666

+39 039 2328 094

+1 (1)905 655 7792

+65 (0)438 2272

# POWERHOUSE

"The System 6000 not only changes the way I work but speeds the process up!"



Chuck Stone

## NEW VERSION 1.3

- *Always Faster* - supports 16 digital I/O - 4 Analog I/O
- *More Control* - more software tools
- *More Integration* - ProTools, Sadie, Avid and more...

## SYSTEM 6000

Ultimate Multichannel Processing Platform



Only the System 6000 platform offers a full range of essential tools for your Multi-channel and Stereo applications. From stunningly real Room Simulations with multiple sources and expressively dense Reverbs to Pitch Shifting, the System 6000 delivers unparalleled power, control and integration to your studio.

Only the System 6000 and its touch screen remote offer specialized software options. These include true benchmark standards like Multi-channel MD5.1™, Stereo MD-3™ Multi-band Compression and Brickwall Limiting. Backdrop™ Psycho-acoustic Noise Reduction, Engage™ Binaural Processing, Stereo to 5.1 Conversion, the 5.1 Monitor Matrix with Bass Management, Multi-channel EQ and much more...

Only the System 6000 is fully networkable via Ethernet. Talk about expansion... a single TC ICON remote can control up to 256 channels of digital audio, all using industry standard Ethernet cabling and routing hardware supported by continuous free software updates on the Internet.



"I've been using the System 6000 as a four engine device connected to my console at BackStage studio in Nashville. Configuring the unit for each application could not be easier allowing me to use it for stereo as well as 5.1 mixes. I must say, at this point, I do not think I could get along without it!"

Chuck Stone

FILM

POST

MUSIC

MASTERING

BROADCAST

MULTIMEDIA



[www.SYSTEM6000.com](http://www.SYSTEM6000.com)

**t.c. electronic**  
ULTIMATE SOUND MACHINES

CIRCLE #002 ON PRODUCT INFO CARD

TC ELECTRONIC A/S • DENMARK • ☎ +45 8742 7000  
TC ELECTRONIC INC. USA • ☎ (800) 288 5838 • [FAX] (805) 379 2648

INFO@TCELECTRONIC.COM • [WWW.TCELECTRONIC.COM](http://WWW.TCELECTRONIC.COM)

# One fish two fish red fish blue fish

In an ocean full of nearfield monitors, it is almost impossible to know whether or not you will make a good catch. That is, until now. Clearly, there are two distinctively different monitors on the scene.

Tannoy Reveal and Reveal Active. Sure, they feature the latest in transducer technology, cabinet integrity and styling, but clearly what sets them apart is performance.

Dual high speed mosfet amplifiers are driven by beefy toroidal transformers. The amplifiers are divided by precision active filter networks that combine to help you clearly navigate the murky depths of your next mix, no matter how many fathoms deep it is. But let's face it, they're all just fish stories until you listen for yourself. Go ahead, stick your toes in the water at your nearest dealer and find out why the New Tannoy Active Reveal is catching on!

  
**TANNOY**  
FOR THOSE WHO KNOW  
**REVEAL**  
ACTIVE

Tannoy/TGI North America Inc.  
335 Gage Ave., Suite 1  
Kitchener, Ontario, Canada N2M 5E1  
Phone: (519) 745-1158 • Fax: (519) 745-2364  
Dealer order hotline: (Fax) 1-800-525-7081

Literature hotline: [litplease@tgina.com](mailto:litplease@tgina.com)

e-mail: [inquiries@tgina.com](mailto:inquiries@tgina.com)

Web site: [www.tannoy.com](http://www.tannoy.com)

World Radio History CIRCLE #003 ON PRODUCT INFO CARD



# MIX

PROFESSIONAL AUDIO AND MUSIC PRODUCTION  
MAY 2001, VOLUME 25, NUMBER 5

## FEATURES

### 26 Formats: So Many Choices, So Little Time

DASH, ADAT, DA-88 and analog tape. SCSI drives, FireWire, CD-R or DVD-R, and any number of digital tape cartridges, including Exabyte, DDS, Data DAT and AIT. Throw in DVD-V, DVD-A and SACD, and what's a mixing or mastering engineer to do? *Mix* New York editor Paul Verna asks top engineers how they survive in the multiformat world.



### 35 Surround Sound Consoles

Dozens of mixing consoles, large and small, are now vying for surround sound bragging rights, and each has its appeal. *Mix* contributing editor Michael Cooper breaks down the options, distinguishing those desks with purpose-built surround functionality from the wannabes.



### 40 Trade Show Times Three

It was a busy month for equipment manufacturers and their customers. *Mix* editors George Petersen, Sarah Jones, Mark Frink and Dan Daley lead a tour of the hottest products shown at NSCA, MusikMesse and REPLItch.

### 46 Ani DiFranco: Stretching Beyond the Periphery

Ani DiFranco is a busy woman. She's just put out her thirteenth record, has been signing hands to her record label and is about to embark on yet another leg of her endless tour. *Mix* editor Sarah Benzuly chatted with DiFranco about the new release and what *really* goes on in the studio.



### 184 L.A. Studios Resurgent

The doldrums of Year 2000 have given way to renewed enthusiasm for the world's largest recording market, and, not surprisingly, technology is playing a major role. *Mix* contributor Robyn Flans surveys the scene, asking studio owners, equipment rental houses and retailers what to make of 2001.



**On the Cover:** O'Henry Sound Studios, Burbank, has become a favorite among both film and record engineers, and many come for the custom 88-input API console in Studio A. For more, see page 14. **Photo:** Ed Colver. **Inset photo:** Steve Jennings.

**Check Out Mix Online!** <http://www.mixonline.com>

Mix magazine is published at 6400 Hallis St., Suite 12, Emeryville, CA 94608 and is ©2001 by PRIMEDIA Intertec Publishing Corp. Mix (ISSN 0164-9957) is published monthly. One year (12 issues) subscription is \$46. POSTMASTER: Send address changes to Mix magazine, P.O. Box 1939, Marion, OH 43306. Periodical class postage paid at Oakland, CA, and additional mailing offices. This publication may not be reproduced or quoted in whole or in part by printed or electronic means without written permission of the publishers. Printed in the USA. Canadian GST #129597951; Canada Post International Publications Mail Product (Canadian Distribution) Sales Agreement #0478733.

## SECTIONS

### SOUND FOR PICTURE

- 66 **Robert Rodriguez on Music for "Spy Kids"**  
*by Tom Kenny*
- 67 **Danny Elfman: Self-Taught, Self-Styled**  
*by Rick Clark*
- 68 **Sound for Film: For Once, A Warm and Fuzzy Column**  
*by Larry Blake*
- 70 **Gohl/McLaughlin Productions**  
*by David John Farinella*



### LIVE MIX

- 150 **Tour Profile: Eric Clapton**  
*by Mike Mann*
- 156 **Jeff Beck Live**
- 158 **All Access: Erykah Badu**  
*by Steve Jennings*
- 177 **New Sound Reinforcement Products**
- 178 **Handheld Vocal Microphones: Top-of-the-Line Dynamic and Condenser Models for Live Performance**  
*by Randy Alberts*

### RECORDING NOTES

- 196 **Neil Young on the Rocks**  
*by Bob Buontempo*
- 197 **Buckcherry: Loud and Proud**  
*by Elianne Halbersberg*
- 197 **In "The Room" With Harold Budd**  
*by Blair Jackson*
- 198 **Classic Tracks: Neil Young's "Heart of Gold"**  
*by Elliot Mazer*
- 200 **Cool Spins: The Mix Editors Pick Some Favorite CDs**
- 202 **Mick Guzauski's Latest Project Is a "Thriller"**  
*by Paul Verna*

### COAST TO COAST

- 218 **L.A. Grapevine**  
*by Maureen Droney*
- 218 **New York Metro**  
*by Paul Verna*
- 219 **Nashville Skyline**  
*by Dan Daley*
- 219 **Sessions & Studio News**  
*by Robert Hanson*

## TECHNOLOGY

- 110 **New Hardware/Software for Audio Production**
- 120 **Preview/Hot Off the Shelf**
- 124 **Field Test: Mark of the Unicorn 1296 Multichannel Digital I/O**  
*by Rob Sbrock*
- 130 **Field Test: Shure PSM400 Personal Monitor System**  
*by Mark Frink*
- 134 **Field Test: Aardvark DirectPro 24/96 Windows-based Audio Interface**  
*by David Ogilvy*



PAGE 142

- 140 **Field Test: CEDAR DNS1000 Dynamic Noise Suppressor**  
*by George Petersen*
- 142 **Field Test: iZ RADAR 24 DAW**  
*by Pete Leoni*
- 256 **Power Tools: Sonic Foundry Sound Forge Tips for Audio Restoration**  
*by Bob Buontempo*

### Remote Recording's Finest

A special advertising supplement featuring some of the industry's best remote recording facilities begins on page 161.

## COLUMNS



PAGE 16

- 16 **The Fast Lane: How Do I Write Them?**  
*by Stephen St. Croix*
- 18 **Insider Audio: NAMM Bits**  
*by Paul D. Lehrman*
- 54 **Producer's Desk: Elliot Mazer—Renaissance Man in a Digital World**  
*by Chris Michie*
- 92 **Mix Masters: Armin Steiner—Tips and Tales From an L.A. Studio Pioneer and Scoring Engineer**  
*by Maureen Droney*
- 106 **Bitstream: Son of Tosh—More Trade Show Mac News**  
*by Oliver Masciarotte*
- 112 **The Tech's Files: My Piece de Resistance**  
*by Eddie Ciletti*
- 194 **The Project Studio: Composer Cliff Martinez**  
*by Robyn Flans*

## DEPARTMENTS

- 8 **From the Editor**
- 10 **Feedback: Letters to Mix**
- 12 **Current/Industry News**
- 14 **On the Cover: O'Henry Sound Studios, Burbank**  
*by Maureen Droney*
- 224 **Ad Index/Product Info Card**
- 225 **Demo Room**
- 234 **Studio Showcase**
- 235 **Mix Marketplace**
- 241 **Classifieds**

# Get the MX-2424 Advantage!

You probably  
machines in  
is the  
What you  
advantages  
multitracks,  
transition  
just getting  
understand

“ The ‘Golden Ears’ all found the TASCAM performed extremely well, nearly beating out a unit priced four times higher. The listening tests confirmed what I already knew: the MX-2424 is a solid performer at a great price. ”

- Glen O'Hara,  
*Pro Audio Review Magazine*

“ ...the MX-2424 puts high-resolution sound quality and professional recording features at your fingertips. ”

- *Electronic Musician Magazine*,  
2001 Editor's Choice Award

“ ...the TASCAM MX-2424 is a rock-solid, excellent studio recorder that performs well, sounds great and is priced right. ”

- George Petersen,  
*Mix Magazine*

“ The machine alone is impressive enough to warrant close attention, but the implications inherent in the control and networking capabilities make it potentially astounding. ”

- Rob James,  
*Studio Sound Magazine*



\* based on an average 3 1/2 minute song of 24 tracks at 24-bit/48kHz. Your mileage may vary.

† Offline CD-R backup is possible with an Ethernet-equipped computer. The \$749 (USD) reference is based on TASCAM's CDR-Pro Bundle.

**MX-2424 24-TRACK 24-BIT HARD DISK RECORDER/EDITOR**

World Radio History

All copyrights are the property of their respective holders



know that with thousands and thousands of use around the world, the **TASCAM MX-2424** most popular 24-track recorder ever made. You might not know is that the MX-2424 offers huge advantages that aren't available on other standalone hard disk recorders regardless of price. Whether you're making the transition from analog and tape-based digital recorders or you're already into digital recording, here's some info to help you truly appreciate the MX-2424 advantage.

### Ph.D. in Nuclear Physics Not Required

If you've ever recorded before, you'll find the MX-2424 as easy to use as any multitrack recorder. Flip the Power switch, arm a track and hit the Record and Play buttons. Voila...you're tracking to its internal hard disk. Since TASCAM has been the world leader in multitrack recording for over 25 years, we know how to create gear that's powerful and sophisticated without making the learning curve too steep.

### Edit How You Like: MX-View™ Waveform Graphic Interface and Extensive Front Panel Editing

One of the main reasons to get into hard disk recording is the incredible editing power versus tape. Running in native Mac and PC versions and connected via a fast 100Mb Ethernet interface to your computer, the upcoming MX-View is a powerful graphic editing interface that offers sophisticated, sample-level editing on par with full-featured digital audio workstations. You can drag and drop on the fly, get onscreen metering for up to six MX-2424s, set up custom configurable keyboard shortcuts, manage virtual tracks and much more. If you want to use the MX-2424 in the field, its



extensive built-in front panel editing tools let you edit without lugging around a keyboard, monitor and mouse.

### True Recording Power: Take the Punch-In Challenge

24-track, 24-bit digital audio requires a powerful hard disk recording engine. The MX-2424 is so strong that it allows for seamless, gapless punches across 24 tracks, with up to 72 tracks of throughput to accomplish this considerable task. If you're brave, try arming 24 tracks on any other standalone 24-track hard disk recorder and quickly punching in and out. It's just one example of the MX-2424's awesome dual-processor recording power and extremely fast SCSI bus. You can choose between TapeMode and Non Destructive recording, and access up to 999 virtual tracks per project with 100 locate points, 100 levels of Undo and much more.

### Sound Designer II, Broadcast Wave Files and SCSI Drives for Ultra Flexible Compatibility

TASCAM understands the reality that you may need to interface your audio with other pieces of equipment. Since the MX-2424 writes Sound Designer II™ audio files to Mac-formatted disks and

Broadcast Wave audio files to PC disks, it's easy to move sound back and forth between your computer and the MX-2424. With these standard time-stamped file types and professional SCSI drives, you're ensured sample-accurate compatibility with Pro Tools™, Nuendo™, Digital Performer™ and more. With compatibility being so important to MX-2424 owners, it's no surprise that its 24-channel interfaces are ready to connect to just about any console, digital or analog. Or that its analog, TDIF and AES/EBU interface modules are 96kHz ready.

### Back Up Your Tracks: As Low As A Buck Per Song

Media	Cost of Drive	Media/10 Projects	Total Cost
90 Minute IDE Drive	\$299	10 Drives	\$2990
Orb Drive	\$299	1 Drive + 86 Disks	\$2879
TASCAM DVD-RAM	\$599	1 Drive + 20 Disks	\$1739
Offline CD-R Backup*	\$749	1 Drive + 19C Disks	\$959

*If you're forced to use cheap disk drives to backup, you'll pay in the long run. DVD-RAM drives may be connected to the MX-2424's front panel or rear SCSI port, and offline CD-R backup via Ethernet transfer to your computer is the most cost-effective backup method available on any HD recorder by far.*

Hard disks are great for recording...but not so great for archiving and transferring audio. That's why the MX-2424 gives you choices like 9.4GB DVD-RAM discs for your backup solution. Or simply transfer your audio to your computer and backup to CD-ROM for as low as one dollar for an average pop tune\*.

### Get the Advantage of the Most Powerful and Most Affordable 24-Track Hard Disk Recorder Available Today

There's much more to the MX-2424 than what fits on this page, like its award-winning sound quality, professional built-in synchronization tools and TASCAM's amazing online support forums. So if you're getting into the hard disk revolution, you might as well take advantage of the recorder with all the advantages. Just go to [www.mx2424.com](http://www.mx2424.com) for the complete MX-2424 story, or check out the MX-2424 for yourself at any TASCAM dealer.

Available soon, the new MX-View graphic editing software offers DAW-style waveform editing power, drag-and-drop editing on the fly, control of up to six MX-2424s with metering and much more.

**TASCAM**  
a whole world of recording

[www.mx2424.com](http://www.mx2424.com)

CIRCLE #004 ON PRODUCT INFO CARD



# FROM THE EDITOR

## SURROUND: THE NEXT STEP

5.1: It's here. It's now. And with an increasing number of consumers climbing aboard the home theater bandwagon, there's actually a (potential) audience for audio-only DVD releases. There are some hurdles to overcome, but overall, the industry is making significant progress.

One problem is the limited number of DVD-A capable players in the market. Right now, they're expensive, although this situation has been improving. Given the small percentage of DVD-A players, savvy producers have been including DTS and/or Dolby Digital mixes on most discs, so the consumer can buy product now and enjoy the surround experience—even if they aren't listening to DVD-A. Of course, a couple years down the road, when most DVD decks are DVD-A-compliant, this will become a moot point.

Unfortunately, creating several mixes of each product complicates the production process, but here again, there are some good signs. Both Dolby and DTS have been selling encoder/decoder hardware for some time, and more recently, companies such as Kind of Loud and Minnetonka have offered software for DTS and Dolby Digital encoding. Checking reference surround mixes outside the confines of a control room's optimized listening space is little more complicated than burning some DTS or Dolby Digital tracks on a 50-cent CD-R and tossing it into the DVD player in a home system. One caveat here is the unfortunate fact that some home DVD players don't recognize CD-Rs, so a pre-purchase checkout with a home-brew disc is important when selecting a DVD player for home reference use.

One production snag is the plethora of mixdown formats used for storing surround mixes. At least with stereo, the choices were relatively few (i.e., DAT, ½-inch analog, ¼-inch analog, etc.), but with 5.1 mixes, just about anything goes, such as Genex, ADAT or DA-88 (with or without bit-splitting) and just about any imaginable variation of data storage media; the list is seemingly endless. In this issue, Paul Verna talks to top engineers, producers and mastering pros about how they're handling the situation.

On the studio hardware side of surround production, things are definitely on the upswing. Michael Cooper takes a look at 28 consoles designed specifically for surround mixing, focusing on models that include full multi-channel panning, busing and monitoring functions. Not everybody is ready to take the plunge into a full-on multiformat mixer, so there is also a healthy market of third-party accessories—such as surround monitor controllers, panners and routers—that expand the functionality of existing consoles and may buy a couple more years of life for that board you currently have.

We've had a few changes at *Mix* this month. Our art director, Tim Gleason, who was a major force behind the look of *Mix* for more than 20 years, is no longer with our company, and we wish him all the best in his future endeavors.

Also, you might notice a new icon on some of our new-product pages this month. We are debuting Demo Rooms, offering streaming video information about products and technologies. Check them out at [www.mixonline.com](http://www.mixonline.com). And the AES convention returns to Amsterdam—everybody's favorite city—May 12-15. If you're in town, stop by the *Mix* booth and say hello.

See you there!



George Petersen

EDITORIAL DIRECTOR George Petersen  
 EDITOR Tom Kenny  
 SENIOR EDITOR Blair Jackson  
 ASSOCIATE EDITOR Barbara Schultz  
 TECHNICAL EDITORS Sarah Jones Chris Michie  
 COPY EDITOR Sarah Benzuly  
 EDITORIAL ASSISTANT Robert Hanson  
 SOUND REINFORCEMENT EDITOR Mark Frink  
 NEW TECHNOLOGIES EDITOR Philip De Lancie  
 LOS ANGELES EDITOR Maureen Dronay  
 EAST COAST EDITOR Dan Daley  
 NEW YORK EDITOR Paul Verna  
 TECHNICAL PROVOCATEUR Stephen St. Croix  
 CONSULTING EDITOR Paul Lehrman  
 FILM SOUND EDITOR Larry Blake  
 CONTRIBUTING EDITORS  
 Rick Clark Michael Cooper Bob McCarthy  
 Eddie Ciletti Oliver Masciarotte Gary Eskow

SENIOR ART DIRECTOR Dmitry Panich  
 ASSISTANT ART DIRECTOR Kay Marshall  
 GRAPHIC DESIGNER Mae Larobis  
 GRAPHIC DESIGNER Lizbeth Heavren  
 PHOTOGRAPHY Steve Jennings  
 MARKETING DIRECTOR Christen Pocock  
 SALES PROMOTIONS MANAGER Angela Rehm  
 SALES PROMOTIONS COORDINATOR Starla Estrada  
 SALES PROMOTIONS/EVENT COORDINATOR Alison Eigel  
 SALES PROMOTIONS ART DIRECTOR Wendy Shiraki

PUBLISHER John Pledger

ASSOCIATE PUBLISHER Carrie Anderson  
 510/985-3228

### EASTERN REGION

EASTERN ADVERTISING DIRECTOR Michele Kanatous  
 718/832-0707

MIDWEST/EASTERN ADVERTISING MANAGER

Greg Sutton 847/968-2390

342 N. THIRD ST., LIBERTYVILLE, IL 60048

### WESTERN REGION

NORTHWEST ADVERTISING DIRECTOR

Dan Hernandez 510/985-3266

SOUTHWEST ADVERTISING MANAGER Albert Margolis

949/582-2753

26134 SAN REMO PLACE, MISSION VIEJO, CA 92692

### MIX MAGAZINE

6400 HOLLIS ST., SUITE 12, EMERYVILLE, CA 94608  
 510/653-3307

SALES ASSISTANT Joe Madison

CLASSIFIEDS/MARKETPLACE ADVERTISING DIRECTOR

Robin Boyce-Trubitt

CLASSIFIEDS SALES ASSOCIATE Kevin Blackford

CLASSIFIEDS ASSISTANTS Monica Cromarty

Diane Williamson-Suber

FACILITIES EASTERN SALES MANAGER Shawn Langwell

DIRECTOR, SPECIAL PROJECTS Hillel Resner

DIRECTOR OF OPERATIONS AND MANUFACTURING

Anne Letsch

PRODUCTION MANAGER Valerie Whitesell

ADVERTISING PRODUCTION COORDINATORS

Douglas Ausejo Michael Mott

COMPUTER SUPPORT TECHNICIAN Erik Shank

GROUP CIRCULATION DIRECTOR Phil Semler

CIRCULATION MARKETING MANAGER Austin Malcomb

CIRCULATION FULFILLMENT COORDINATOR Jef Linson

CIRCULATION ASSISTANT Jeremy Schmidt

HUMAN RESOURCES MANAGER Julie Nave-Taylor

HR/OFFICE COORDINATOR Janette Rosbroy

FACILITIES COORDINATOR Norm Shea

### An INTERTEC®/PRIMEDIA Publication

CEO Tim Andrews

PRESIDENT Ron Wall

VICE PRESIDENT, ENTERTAINMENT DIVISION John Torrey

DIVISION DIRECTOR OF MARKETING Stephanie Hanaway

### PRIMEDIA Business-to-Business Group

PRESIDENT AND CEO David G. Ferm

### PRIMEDIA Inc.

CHAIRMAN AND CEO Tom Rogers

PRESIDENT Charles McCurdy

VICE CHAIRMAN Beverly C. Chell

### Subscriptions and Customer Service:

POSTMASTER: For subscription inquiries and changes of address contact: *Mix* magazine, P.O. Box 1939, Marion, OH 43306 or call 800/532-8190. Outside the U.S., call 740/382-3322. Send back issue requests to *Mix* magazine, 6151 Powers Ferry Road N.W., Atlanta, GA 30339-2941 or call toll-free 877/296-3125. Outside the U.S., call 770/618-0219.

NATIONAL EDITORIAL, ADVERTISING AND BUSINESS OFFICES, 6400 Hollis St., Suite 12, Emeryville, CA 94608. 510/653-3307, fax: 510/653-5742. Web site: [www.mixonline.com](http://www.mixonline.com). PHOTOCOPY RIGHTS: Authorization to photocopy items for internal or personal use of specific clients is granted by PRIMEDIA Intertec Publishing, provided that the base fee of U.S. \$2.25 per copy, plus U.S. \$00.00 per page is paid directly to Copyright Clearance Center, 222 Rosewood Drive, Danvers, MA 01923. The fee code for users of this Transactional Reporting Service is ISSN 0164-9657/2000 \$2.25 + \$00.00. For those organizations that have been granted a photocopying license by CCC, a separate system of payment has been arranged. Before photocopying items for educational classroom use, please contact CCC at 978/750-8400. Organizations or individuals with large quantity photocopy or reprint requirements should contact Reprint Management Services at 717/399-1900. Microfilm copies of *Mix* are available by calling Bell & Howell Information and Learning, 800/521-0600.

Founded in 1977 by David Schwartz and Penny Riker Jacob

MIX magazine is affiliated with



### Subscriber Privacy Notification:

*Mix* makes our subscriber list available to carefully screened companies that offer products and services that may interest you. Any subscriber who does not want to receive mailings from third-party companies should contact the subscriber service department at 800/532-8190 (U.S.), 740/389-6720 (outside U.S.), and we will be pleased to respect your wishes.

SONY

"What a great machine!"

- ROGER NICHOLS, Grammy Award Winning Engineer/Producer, [www.eqmag.com](http://www.eqmag.com)

"The R100 packs more creative power per sample than most full size digital consoles." - BRUCE BOTNICK

# HOW DO YOU EVALUATE A DIGITAL MIXER? LISTEN.

"Sony clearly broke the mold with the DMX-R100. A dramatic improvement over other small digital consoles."

- JOHN NEWTON, Grammy-nominated engineer and owner of Soundmirror, Inc.

"We loved it... sonically beautiful and clean...the best small-format console ever... outstanding performance, execution and design."

- ROBERT MARGOULEFF and BRANT S. BILES, Proprietors of Mi Casa Multimedia Inc.

"This is the first digital console of this size that sounds this good.  
What goes in comes out. The R100 is right on the money."

- TOM LAZARUS, Engineer and owner of Classic Sound, NYC

"...pretty fantastic...rave reviews...incredible sonic integrity...and  
incredibly easy to learn and operate...a new generation of digital console."

- DENNY PURCELL, Award-winning mastering engineer, President - Georgetown Masters

"Sounds great, reliable and easy-to-use." - ALLEN SMITH, Chief Engineer, Soundtrack Boston



The DMX-R100 is changing even the experts' opinion of what to expect from a compact, affordable digital console. A full input module with a knob for every key function; selectable high sample rate operation; 5.1 surround mixing and

monitoring; and a high resolution touch screen that becomes an extension of your hands. The next thing to do is go out and hear one for yourself. In the meantime call today and we'll send you a brochure and tutorial CD-ROM.

## DMX-R100



1-800-472-SONY ext. DMX

[www.sony.com/proaudio](http://www.sony.com/proaudio)

# FEEDBACK

## THE BEST THINGS IN LIFE COST MONEY

March letters by Jim Stagnitto and Roger Hughes typify what I believe are false assumptions by those championing the brave new world of "free" digital music.

First is the assumption that the quality of new music will be unaffected by the minor detail that composers will be unable to earn a living. All creating in this not-for-profit realm will be done as a hobby in whatever spare time one has after work—the work that pays the bills. I ask you to imagine the quality of, say, the NBA, if all players participated in their spare time and for no pay. There is, in nearly all endeavors, a profound difference between the amateur and the professional.

Second, Mr. Hughes writes that, "Future artists will not be the 'creators' of 'original' tunes and other works of 'art,' but the assemblers and disassemblers of the signs and symbols of the times... We will all be 'repro' people." Well, we already have a pretty good preview of this future in much of modern art, where paying dues is considered anachronistic. So-called artists cut and paste what genuine artists have created into hodge-podges of unedifying junk. If this is followed to its logical conclusion, each generation of music "collagists" will be re-assembling and re-dissembling the works that its predecessor assembled and dissembled. And the ever-diminishing gold they will be mining will be the real music that was originally created by real composers. The other possible future will be one much like today's Broadway theater, where the public, having lost interest in new musicals, is served up endless recycled versions of *Annie Get Your Gun*, etc.

The "music" we can look forward to, if intellectual property cannot be protected, "the digital flotsam of interesting sounds and symbols," is going to make the term "Golden oldies" ring more and more true.

*Hugh Prestwood  
Greenport, N.Y.*

## STOP AND SMELL THE MUSIC

When I was just a teenager, I remember trying to save all the money I could to buy some record of, let's say, Dire

Straits, and my limited budget made me choose from among other records. This fact, which perhaps looks negative, was possibly great for me because of the added value it gave a record: It was an "object of desire."

Nowadays, you can almost instantly have any record, with no effort to get it. There is no wait, no cover booklet, even no smell. Do you remember the smell of a new vinyl record?

I know all of this sounds a bit stupid, but I don't like free things. How will people understand the value of something that costs nothing? How will they guess the hours of working—sometimes a whole life—when an MP3 file is so easy to get in seconds and for no money? And, finally, even with a watermarking system to ensure (legal) downloading, I will always prefer my old vinyl and CDs, as much as I'll like the feel of a real book and hate its screen alias. Yes, I know times change, and I will always try to adapt to them, but I'll miss the smell of records.

*Pablo Vega  
Ruido Studios, Spain*

## MIDI BOOSTER

I enjoyed Paul Lehrman's article about FireWire and MIDI and your disappointment with Gibson's CEO ("Insider Audio," February 2001). To address the lack of reliable information about Vision 4.5.1, I put together a Website documenting its quirks and hardware setup strategies, as well as general FAQs and other info based on posts to the Topica Opcode User's Group.

We're just keeping the torch alive for an awesome MIDI/audio production environment: [www.fm-music.com](http://www.fm-music.com).

*Fred Meggs  
Via e-mail*

## THE REAL PROJECT STUDIO

Can you please give me the definition of a "project studio"? In your February "The Project Studio" column, you state that Peter Moshay has a barn to work with, with a control room the size of a large raquetball court and two more rooms for live tracking! Not to mention Hall & Oates' money. I hardly think that this fits the definition of a project studio.

I agree that many people now have the advantage of setting up a studio in their house or in a connected space for a reasonable price, but this isn't one of those. I have worked since last summer on a small space in my garage (8x17 feet). My budget has been close to nothing, and I have done all the work myself, except for a helping hand from a friend in putting up drywall.

Within this "project studio" are my hopes and dreams and everything else that I have stuffed into this small space. There, I will record, mix and master. I have no other rooms to go to, no control booth or isolation booth. I have yet to make a dime, yet I hope to. That, to me, is what defines a project studio. I have nothing against the studio that you mentioned. It is obviously well-established and making decent money. But, I think you should highlight the struggling project studio owners. Get the guy who's running MOTU gear out of his closet, or the girl who has her setup in the dining room next to the kitchen. These people are truly running a studio with a tight belt and are trying to make a musical difference and a living.

*Brook Dillon  
Via e-mail*

## EDITOR'S REPLY

You are correct. The definition of a project studio is pretty loose, and *Mix* does not define it by space available or budget. Most often, we rely on the fact that it is noncommercial: Hall & Oates do not rent their studio out for money. The overriding definition we use is that a project studio is primarily run by an owner/operator who works on his or her projects and is not looking for commercial time. That said, however, we have in the past featured commercial project studios, and we've often struggled with the distinction between project studios and home studios. The lines are murky. Thank you for your insights.

*Tom Kenny  
Editor, Mix*

*Send Feedback to Mix  
[mixeditorial@intertec.com](mailto:mixeditorial@intertec.com).*

Make your sound as vibrant as your vision.



Los Angeles Film School, Hollywood, CA

Finland –  
where all  
Genelec's  
are made

Did you realize that Genelec offers more monitoring solutions for your multi-channel surround needs than any other professional loudspeaker company in the world? It's good to have a lot of choices: four different main soffit-mounted systems, three tri-amp systems, four bi-amps, and three subwoofers. All fourteen feature line level crossovers, room response controls, direct-coupled amplifiers and protection circuitry. All come with more than 20 years of active monitoring expertise and the intrinsic quality that will make you feel confident about your work again. Perhaps even passionate.

When L.A.'s busy *Los Angeles School of Film* recently renovated their main dubbing stage, they

selected Genelec monitors to satisfy the diverse needs of a teaching institution's audio post-production instructors and students. For main L-C-R monitoring, they chose an array of our **1038AC's** – industry renowned for their high-output, dynamic headroom, sonic accuracy, and precise, stable imaging. For additional surround monitors, **Model 1031A's** were selected. Each active system is a superlative audio solution designed and manufactured by a professional monitor company with more real-world, multi-channel surround expertise than anyone else.

Audition a Genelec 5.1 system. Listen to your ears – and your peers. Because if you're making sound decisions for your facility, it's as good a time as any to make your sound as brilliant as your vision.

**GENELEC**<sup>®</sup>  
ACTIVE MONITORING

The Whole Truth and Nothing But The Truth™

Genelec Inc., 7 Tech Circle, Natick, MA 01760 508/652-0900 Fax: 508/652-0909 www.genelec.com  
Genelec OY, Olvitie 5 FIN-74100 Iisalmi, Finland +358 17-83881 Fax: +358 17-812267

CIRCLE #005 ON PRODUCT INFO CARD

### DOLBY OPENS NEW L.A. OFFICE



Dolby Laboratories celebrated the opening of its brand-new Burbank office building with a huge party on March 21, demonstrating the company's service commitment to the Hollywood entertain-

ment community. David W. Gray, VP of the Hollywood film division, says, "Our new location in the heart of the entertainment industry's working center means that we will be more accessible than ever to our enormous Los Angeles client base."

Located at 3601 West Alameda at Hollywood Way, and adjacent to many film and TV production centers,

the 21,000-square-foot facility is three times as big as the previous office and houses the 49-seat Larry Umlang Presentation Theatre II, equipped with the latest technology for projecting all

formats of film and video with 5.1 surround sound playback. The beautiful and sonically insulated theater, named after Dolby's original Hollywood theatrical engineer who died in 1988, "floats" on neoprene blocks built into the building's foundation. In addition to offices for Dolby's L.A. staff, there are project and home demonstration theaters for DVD and HDTV, rooms equipped for audio testing and experimentation, in-house production suites, conference rooms and event spaces.

In attendance at this royally catered affair were hundreds from the L.A./Hollywood film/TV/music industries, as well as executives from corporate headquarters in San Francisco, Dolby founder and chairman Ray Dolby, and president Bill Jasper.

—Barry Rudolph

### NOTES FROM THE NET

#### NEW LIFE FOR SCOUR

##### BETA TESTING: PHASE ONE

CenterSpan Communications Corporation has begun Beta testing for the new Scour Exchange system, powered by agreements with EMusic, Moonshine Music, Crush Media and Management, FILMSPEED and Tvparty.com. Volunteer registered users, numbering more than 200,000, will be able to download and share over 100,000 music and video files during the testing period, previewing a new Scour Website that will include the addition of a paid service. The new service is expected to be up and running by third quarter 2001.

According to Howard Weitzman, president of CenterSpan's

Digital Media and Entertainment Group, "The labels and studios want a legal and commercial platform that meets their needs, as well as those of consumers, and that's exactly what we are bringing to market."

Artists in the CenterSpan library range from modern performers, such as Green Day and Arrested Development, to classic artists like Creedence Clearwater Revival and Bob Marley. Users will also be able to access the video library, which includes full-length films, film shorts, trailers and classic TV clips.

Scour was sued for copyright infringement last October and ultimately filed for Chapter 11. CenterSpan bought the failing company for \$9 million last December.

#### MUSIC LICENSING MADE EASIER

##### MP3.COM OPENS ONLINE SERVICE

Instead of searching through stacks and stacks of CDs to find that one "perfect" song for a movie or TV show, music supervisors and producers can now find it online—and license it, too.

MP3.com announced the creation of its Music Licensing Program that provides multimedia creators with a comprehensive online resource to search for, listen to and license digitized music. MP3.com is joined by its exclusive music licensing partner, enableyourmusic Inc. (EYM), which offers representation services for the majority of artists on MP3.com, including song price, contract negotiation, collection of licensing fees and royalty income. Currently, the program hosts over 850,000 songs that can be accessed for an annual fee of \$25.

Searching for content is offered through three steps: The Licensing Search Tool allows users to locate music by

its exact attributes, such as tempo, mood and lyrical keywords (clicking on the License button next to the chosen song initiates the licensing transaction); users can post a request on the Licensing Opportunities on either the MP3.com or EYM sites; or users can contact EYM directly and will be e-mailed a personalized compilation of music with info on why each song is relevant to the request.

According to Michael Bayer, director of music licensing at MP3.com, "We have created a resource to easily find great music for every commercial licensing application."

Visit [www.mp3.com/music-supervisor](http://www.mp3.com/music-supervisor) or [www.enableyourmusic.com](http://www.enableyourmusic.com) for more information.



MP3.COM'S MICHAEL BAYER

# Industry News

Producer, engineer and recording artist Alan Parsons joined Artistpro.com's (Vallejo, CA) adviser forums staff...AMS Neve (Burnley, England) announced a restructuring in its board of directors; co-founder of AMS, Stuart Nevison, joins the board as marketing adviser; John Lawrence is the new chairman; and Douglas Graham brings his business experience to the board...Former VP of Apogee (Santa Monica, CA) David Kimm returned to the company as its new president...RealNetworks (Seattle) looked to the former president of Fox Network and Ticketmaster, Larry Jacobson, to fill the positions of president and COO. In other company news, Gary Drucker was hired as the new VP of the consumer division and Scott Ehrlich as the new VP of programming...Neutrik (Liechtenstein, Germany) announced the retirement of its founder, Bernhard Weingartner, as chairman of the board...Dolby Laboratories (San Francisco) has restructured its consumer division: Richard Hockenbrock was promoted to VP of licensing operations and heads the operations group; Steve Vernon joins the consumer division as VP of licensing technology and also heads the technology group; and senior VP and general manager Ed Schummer continues to oversee the intellectual property group...Line 6 (Thousand Oaks, CA) had many new appointments to its executive team: Watt Webb, VP of marketing; Teresa Covington, VP of finance and CFO; Ken Bauer, VP of human resources; Keith Carnall, managing director of Line 6 Europe; Dan Garrett, director of international sales for the Pacific Rim and Central and South Americas; Paul Wright, director of European sales; and Dan Cohen, presentation material designer...Technology and entertainment industry vet Scott Smith joins Sonicbox (Mountain View, CA) as the new CEO, while Jon Holtzman is the new CMO, and co-founder Niko Bolas assumes the role of chairman of the board...Klipsch (Indianapolis) promotions: David P. Kelly, senior VP of worldwide sales, and Cris Pyle, director of marketing, Klipsch also welcomed Dave Rutz to the company as the new senior VP of marketing and product development...Get out those address books! TC Electronic (Westlake Village, CA) opened a new office in China, at Apt. 702 bld. 8, Julong Garden, No. 68 Xinzhongjie, Dong Cheng District, 100 027 Beijing, China; 86/106/552-3490; fax 86/106/553-2634. Bitheadz (East Greenwich, RI) also opened a new office at 2850 South County Trail, East Greenwich, RI 02818; 401/886-7045; fax 401/886-7049. Gallery Software UK (London) has moved to Gallery 8 Somerset Gardens, Highgate, London N6 5EQ; 44/208/340-5677; fax 44/870/130-5336...The new general manager over as Mass Audio Visual (Burlington, MA) is Jeff Robinson. ■

## ON THE MOVE

Who: Ted Keffalo

What: President, COO Event Electronics

Main Responsibilities: Oversee day-to-day operations: sales, marketing and financials

Previous Lives:

- VP sales and marketing, Event Electronics
- Director of marketing, Alesis
- Sales manager, Alesis
- Manager, Hogan's Music, Torrance, Calif.
- Owner/engineer, WE Studios, Redondo Beach, Calif.

•House mixer, Concerts by the Sea

What do you have in your CD changer right now? "I have a demo of 'I Love This Time in My Life,' a country song I wrote for Jennifer Starr & Silver Spur. I'm a huge guitar fan, so I've got Robben Ford, Stevie Ray Vaughan and Eric Johnson. I also always have to have at least one Beatles album close by."

What book is on your bedside table? "You



never know who you'll meet on a plane. I once sat next to animator Howie Hoffman and gave him a copy of a Beatles bootleg CD; he returned the favor by sending me *Lennon in America*. It's a fascinating book." Favorite films and why? "I can watch *Indiana Jones* or *Star Wars* anytime, anywhere. They're total escapism and still have an effect on me. *Almost Famous* is another favorite—it takes me back to my rock 'n' roll days."

When I'm not at work, I'm usually off doing... "I write songs in my studio, mostly for therapy. I have way too many guitars, but I have a 1970 Martin D35 I bought in 1971 that has all the songs in it. It's magic."

## SIXTH ANNUAL MIX L.A. OPEN

The Mix L.A. Open charity golf tournament, presented by the Mix Foundation for Excellence in Audio, will take place Monday, June 11, 2001, at the Malibu Country Club.

This popular industry event is a "best ball" tournament. Registration and a continental breakfast start at 8 a.m., with the shotgun start signaling the opening of the tournament at 10 a.m. An awards ceremony, silent auction and dinner are scheduled for 3:30 p.m. For more information about sponsorship opportunities and entry fees for individuals or companies, check the Website at [www.tecawards.org](http://www.tecawards.org); for an order form, contact Karen Dunn at 925 939-6149 or [KarenTEC@aol.com](mailto:KarenTEC@aol.com).

## POST-PRODUCTION CONSOLIDATION TELEVISION CORPORATION ACQUIRES PACIFICA MEDIA AFFILIATES



Pacifica Media Affiliates, an entertainment post-production sound company, announced that it has been acquired by Television Corporation plc, a London-based TV facilities and production company.

Under the agreement, Television Corporation's equity share in PMA raises to 75% from 50%. PMA's former president, Galen Walker, is now CEO; PMA's former executive VP, Ricky DeLena, becomes executive director; and PMA's former controller, Chuck Valdez, is now CFO. Additionally, Dana Arnold, former CEO of PMA, and former chairman Hal Katensky have resigned.

Terry Bate steps up as chairman of the board at PMA and will work alongside directors Walker, DeLena and Chris Rowlands. A final director will be named at a later date.

For more information, visit: [www.pacificamedia.com](http://www.pacificamedia.com).

## CORRECTIONS

The Universal shockmount profiled in December's "Preview" is offered by Gary Young, not Gary Plant. Visit [www.shockmount.com](http://www.shockmount.com) to learn more.

The "Mega-Synths" article (February 2001) inadvertently named Arboretum Systems as the company responsible for Metasynth. The product is sold directly through its creator company, U&I Software.

Also in the February issue, Sniffy Walden's album came out in March, not "early next year."

The "Field Test" on Empirical Labs FATS0 (April) ran the incorrect phone number. The correct number is 973/728-2425.

Mix regrets these errors.



# O'Henry Sound Studios

BURBANK

by Maureen Droncy

Even in a mixed market like Los Angeles, only a handful of recording studios successfully combine work for pop music with jingles and scoring for film and television. Burbank's O'Henry Sound Studios is one of those. The 14,000-square-foot, two-room facility opened in 1993, after engineer Hank Sanicola and his wife, Jackie, decided to close their home studio and build a from-the-ground-up commercial complex. In the ensuing eight years, O'Henry has become a favorite orchestral recording place for such top scoring mixers as Shawn Murphy, Armin Steiner and John Richards. Film credits include *Austin Powers*, *Chicken Run* and *Dinosaur*. The studio has also played host to album projects for artists from REM and k.d. lang to Mariah Carey, Ray Charles and Sugar Ray. Commercial soundtracks have included work for Southwest Airlines, McDonalds and National Geographic, among many others.

"People told me you couldn't build rooms that you'd be able to rent to both record and film people," recalls Hank Sanicola. "But with the help of people like Shawn, Armin and John, we have. From the beginning, they liked our location and our staff, and they helped us learn how to provide what the scoring business needs.

"We spent a lot of time at it. For the first string date we did, I ran out to Costco and bought, I think, 40 chairs. It was a 30-piece date, and, all of a sudden, we needed headphones, music stands, chairs...Then we did a 40-piece and then a 50-piece. It just took off. We didn't really go after the business, we just got some sessions and learned how to make them happy."

The O'Henry complex, originally designed with the help of architect Jack Edwards and studio consultant Rick Ruggieri, has always had a stylish and comfortable vibe, featuring a garden patio, a large common lounge and kitchen, and private lounge/offices for each studio.

In 1998, Studio B was renovated with a new design by studio baurton and the



PHOTO: ED COVER

O'Henry's Studio A

installation of an 80-input SSL 9000 J Series console fitted with an SL 956 J multiformat monitoring system. In 2000, it was time to upgrade Studio A, which had housed a custom API console since the facility opened. The Sanicolos and chief engineer Harold Kilianski decided to stick with the custom direction, embarking upon building one of the largest fully discrete consoles in the world. Studio A's desk now features 88 inputs fitted with enhanced API modules, Flying Faders, and 5.1 mixing and monitoring capability.

"Our objective was to have the capacity to satisfy the demand of high-profile record projects and/or scoring and mixing in a 5.1 mode on something that sounded really good and was easy to use," Hank Sanicola explains. "Also, we knew that our clients liked Flying Faders. I had specific applications that I needed to address, and I wanted something simple. There was nothing out there that quite fit the bill."

"The whole mission of this project was to keep the original sound and to improve what we could," adds Kilianski. "We wanted more buses; we wanted to balance everything to minimize connection issues, we needed more inputs and a 5.1 center section. But, in obtaining those things, our emphasis was on a short signal path. We wanted to go through as few electronics as possible in order to maintain the sonic character."

Sixty-four of the original modules were reconditioned, and Andrew Isett newly built 24 more, an endeavor requiring painstaking detail (making metal plates, painting and silk screening). All of the modules are now housed in a frame specially constructed by Dale Manquen, because the original API frame wouldn't carry the weight and size of the new 16 $\frac{1}{2}$ -foot console.

The modules house traditional API-style 2520 amps. The center section, also all discrete, was designed by Kilianski with board design by Steve Firlotte of Inward Connections, using SPA 690 amp blocks designed by John Hall. The Flying Faders automation system now supplies 95 automated faders.

To complete the project, Studio A was shut down for two months. In addition to the console rebuild, the control room was stripped down to cement and redone, complete with new floor and wall treatments designed by studio baurton. Since reopening, projects in Studio A have included Dianne Reeves, Placido Domingo, *Star Trek Voyager* and mixing for the soundtrack of Stephen Spielberg's upcoming film *AI*.

"The only way to do this well is to really stay on top of it," Sanicola concludes. "It's about taking care of all the little things, consistently. The main thing is, you try to make people feel welcome when they walk in the door." ■



# firewire audio is here!



## introducing the **MOTU 828**

The MOTU 828 audio interface connects directly to a FireWire port — no PCI or PC card required

- 8 channels of 24-bit TRS analog in/out with over 40dB of front panel trim • includes 2 mic/guitar-preamps with 48V phantom power
- 8-channels of 24-bit ADAT optical in/out (switchable to optical S/PDIF) • RCA S/PDIF in/out • ADAT sync input for sample-accurate transfers and timecode synchronization • CueMix Plus™ no-latency monitoring of live inputs • separate front-panel volume control for main outs and monitor levels
- Includes AudioDesk™ workstation software for MacOS and ASIO drivers for all major MacOS and Windows 2000/NT audio software • \$795

**CIRCLE #006 ON PRODUCT INFO CARD**

MOTU, Inc. • 1280 Massachusetts Avenue • Cambridge MA 02138 • 617-576-2760 • 617-576-3609 fax • [www.motu.com](http://www.motu.com)  
All trademarks are the property of their respective owners.



# HOW DO I WRITE THEE?

WHEN I CAN'T EXPLAIN MY WAYS



ILLUSTRATION: JAMES YANG

**M**usic. Painting. Internal combustion engine design. All the same. As far back as I can remember, the act of creation has been the same for me, no matter what I am creating.

A blank sheet of paper, an endless yet constricting expanse of clean white—an invitation to create; an opportunity to fail.

Maybe that paper has a light blue grid on it, and you are supposed to create the next-generation, 1,700-horsepower, titanium V8 for a top fuel dragster, or maybe it has groups of horizontal lines to help you create the next “Stairway To Heaven.” Or maybe it’s just...blank. Or canvas or a giant computer display on the wall—bristling with 24-bit digital potential, while you stand there bristling with 24 thousand bucks worth of cool 3-D. radio-

linked paint brushes in your hand...

You take a deep breath, chant your tried and true cosmic mantra—“It don’t matter, it’s all good!”—and hit the sheet with the tool. And so it begins.

Sometimes, there’s no schedule at all; you can take three years for one piece. Other times, you are commissioned and have only three weeks. And then there are those reality benders when you are just late—way, way late and you only have three lawyers, but they have *nine*. No difference. Remember—it don’t matter, it’s all good.

As far back as I can remember, there have only been three ways to create, three *types* or conditions of the creative process. Please allow me to introduce myself and my three

conditions to you—Flash, Crunch and Stall. I will detail these in reverse order, just so you will wonder why the hell I listed them in that order as if I was planning all along to discuss them in the opposite order.

1. Stall. A creator’s biggest fear—drawing a blank.

The pen, the brush, the guitar—the instrument of choice is in your hand, but your brain is on strike. No matter what you do, absolutely *nothing* happens, you are *blocked*. In fact, the more you try, the further away any faint glimmer of a concept that you may have vaguely sensed retreats.

Solution? There is only one. I have spent decades pretending to ignore this simple fact, but once I gave in and accepted it for the truth that it is, my total annual down-

BY STEPHEN ST. CROIX

—CONTINUED ON PAGE 231



**Ed Cherney** has engineered for some of the biggest music artists of the last two decades – and is still going at it. Cherney's engineering credits are literally a Who's Who of the music industry: Jackson Browne, Eric Clapton, Bob Dylan, The Judds, Bette Midler, Iggy Pop, Bonnie Raitt and The Rolling Stones – to name only a few.

World-renowned producer **Don Was** has worked with Ed on numerous projects over their long and prolific partnership. Was has produced an impressive number of major recording artists including The B-52's, Barenaked Ladies, Bob Dylan, Elton John, B.B. King, Willie Nelson, Randy Newman, Bonnie Raitt and The Rolling Stones.

When it comes to choosing the right mic for their Grammy winning work, the Audio-Technica 40 Series tops the list. "My **AT 4060's** have great body and warmth and still give me the clarity and presence I want," says Ed. "I put up a 4060 and everyone is happy – the artist, me, everyone."

Take an "insider's" tip from one of the music industry's most successful A-teams, and try a 40 Series mic on your next session. Who knows? You might just be making musical history – like they have.

Special thanks to The Record Plant, Hollywood, CA



## 40 Series

 **audio-technica**

# NAMM BITS

## COOL ALTERNATIVES FROM ANAHEIM



ILLUSTRATION JACK DESROCHER

This past January, the Winter NAMM show returned to Anaheim, Calif., the home of Mickey Mouse, Knott's Berry Farm and countless other institutions dedicated to the proposition that, dammit, you *are* going to have fun! And I returned, too. The last three years, this gigantic music industry trade show, second only in enormity to Frankfurt's MusikMesse (which I've never been to and have no great desire to go to) has been held in downtown Los Angeles. During that time, the Anaheim Convention Center was undergoing a giant facelift, and, although it was still open for business, the NAMM powers-that-be decided that it would be—believe it or not—*safer* to hold the show in downtown L.A., a place

where even the taxi drivers won't wander at night without a bodyguard. So I have stayed away. But this year, I came back. And, yes, I did have fun.

A lot of other people came back, too, apparently. The number of registrants at the show, which celebrated the 100th anniversary of the organization (whose full name is the International Music Products Association), was 65,372, which represents a 10% increase from last year.

Anaheim hasn't changed much in the interim, and the "new" convention center isn't much different from the old one, except there's now an impressive, but not particularly useful, three-story glass lobby occupy-

ing the space that used to be outside, between the convention center and the adjacent Hilton Hotel. The remaining sliver of open space, although they've tried to soften it with plants, is something of a claustrophobic concrete wind tunnel.

Inside, the center is much the same as it's always been—a cavernous bunker—only they've removed most of the walls separating the various "halls" so that it feels even larger. And it definitely seemed noisier: Even in the acoustic guitar and saxophone sections of the building, the ambient SPL was well up into the New York-subway-at-rush-hour range.

Anaheim, itself, was unusually cold, even for January. When I left Boston in the morning, it was 37°,

BY PAUL D. LEHRMAN



*Where will  
you buy?*

**Discover**  
*the Sweetwater Difference!*

- Best **Prices**
- Amazing **Service**
- Unparalleled **Support**

**CALL NOW TO EXPERIENCE THE SWEETWATER DIFFERENCE FOR YOURSELF!**

**(800) 222-4700**  
**sweetwater.com**

**Sweetwater**<sup>®</sup>

World Radio History  
CIRCLE #007 ON PRODUCT INFO CARD

and when I arrived that night at my hotel, it was 38°. Southern Californians, who don't understand winter, think that the way to warm up a room is to blow electrically heated air into it. So the relative humidity inside the hotels and convention center, already low to begin with (remember, if it wasn't for all that water coming from north of Sacramento, Orange County would still be a desert), felt like it had dropped to zero. Bottles of water were selling briskly from machines on the show floor at \$2.25 a pop. It's no wonder it took me just one day to come down with a nasty case of "convention throat," or "NAMMyngitis."

During the week of the NAMM show, there always seems to be some disaster going on in the outside world. One year, the show began two days after the Northridge earthquake. Another year, we went to war with Iraq, and every monitor in the place was tuned to CNN, watching the bombers as if they were a video game. This year, there was the installation of George II in Washington, but everyone ignored that. The threat of rolling electrical blackouts throughout California, however, was harder to ignore, but, thankfully, Orange County was spared that week. I was a little sorry about this—it would have been interesting to see how conventioners (not to mention Disneyland) would have coped without electricity.

There are two reasons I go to NAMM: I get to see old friends and new technology. I wasn't disappointed on either count this time. I won't bore you with the details of my social calendar, but it was great to see fellow *Mix* columnist Stephen St.Croix, who, although we are separated by but a few sheets of paper every month, I actually get to see in meatspace infrequently. Stephen was sporting his cool new 21st-century short 'do, and, for a change, you could actually see his face, which is really quite pleasant.

As for new technology, there were, of course, lots. This year, I happened to be on a particular mission to find "alternative" electronic musical controllers for a course I hope to teach in the fall, and the show gave me a terrific opportunity to scope out what folks all over the world, in companies large and small, have been doing in their workshops and laboratories. My sympathies at any trade show tend to be with the smallest and most struggling companies, and there were plenty of those in attendance. Some of them were showing some pretty cool stuff.

Alternative music controllers have a habit of appearing and disappearing quickly. It's tough to get people to agree to learn a new instrument, and making a successful product that requires players to learn a new technique and, God forbid, *practice*, takes time. That's something that cash-strapped startups don't often have, and so sales of new controllers by small companies, no matter how well-received they might be by the press, rarely reach the critical mass necessary to make their manufacturers viable. For me, every NAMM show brings back fond memories of glorious oddities like Palmtree's Air-Drums (also known as the "MIDI maracas"); the SynthAxxe, which looked like a guitar that had been run over by a truck; and the MIDI "tap shoes," "dog collar"

**Even in the acoustic guitar and saxophone sections of the building, the ambient SPL was well up into the New York-subway-at-rush-hour range.**

and stringless harp from companies whose names I can't remember.

Larger companies, too, have felt the pressures of the market when it comes to making innovative and unusual instruments, and many of them have pulled out of that side of the business. But a few have hung in.

Yamaha ([www.yamaha.com](http://www.yamaha.com)) has been flying the flag of MIDI wind controllers for many years, and the company's latest is the WX5, which, like its predecessors, uses fingerings similar to a flute or saxophone, with additional knobs and keys to change octaves and operate pitch bend and other continuous parameters. The WX5 incorporates most of the features of earlier WX Series controllers, but the price is considerably lower: \$699. Of course, to get the most out of it, Yamaha recommends a pairing with its physical-modeling synth module, the VL70M, which is \$799.

Roland ([www.rolandus.com](http://www.rolandus.com)) has always pursued MIDI drums and guitars, and many of its products have straddled the pro and consumer music worlds successfully. The latest result is the HPD-15 Hand Percussion Pad—let's call

it a "MIDI Conga"—and, in fact, they were showing a few of them attached to conga drum shells, but they're hardly required. The HPD-15 is a rubber pad with 15 different sections, each of which can be programmed to play a different sound. All of the pads have pressure sensing, and the larger pads also have positional sensing, so you can change a sound by pushing on the pad or by moving around on it. It also has two ribbon controllers and a "D-Beam" infrared distance sensor, so you can wave your hands in the air and do weird things to the sound. It comes with 600 (!) percussion sounds in ROM and a built-in sequencer, all for \$1,300.

Speaking of waving your hands around, Alesis ([www.alesis.com](http://www.alesis.com)) has come up with two nifty little devices, the airSynth and the airFX. Both units look a little like trackballs for an iMac, but the glass ball in the middle doesn't move. Instead, it houses an infrared sensor that detects hand positions in 3-D, using technology that the company has applied for a patent for. They have no other controls except a program-select dial. The airSynth contains 50 sounds, while the airFX has 50 filters, time-based effects, reverbs and a few synth sounds. At \$249 each, these are slated for the DJ market. Both devices have RCA outputs and pass-through inputs, so you can put them in the same signal path as, say, a CD player without tying up mixer inputs or aux sends. There are no MIDI jacks, so there's no way to interface the units with anything else, but a company representative told me that Alesis is considering using the technology in MIDI devices in the future. I hope they do—it's way cool, and it would be great to open it up to other types of performers.

Any discussion of musical hand waving would be incomplete without mention of Bob Moog's Theremins. Before there were any Moog synthesizers, there were Moog-built Theremins. Moog has gone back to his roots, and his company, Big Briar ([www.bighbriar.com](http://www.bighbriar.com)), was showing two of the beasts. The Etherwave Theremin is a classic two-antennae job, housed in a small box with a vertical pole for pitch and a horizontal loop for volume. It goes for \$369, but there's also a "Bob Moog Signature" Version for an extra \$30, or you can save \$70 and buy it as a kit, which comes with an assembled and pre-tested circuit board, in case your soldering chops aren't what they used to be. At the high end is the Ethervox MIDI Theremin (\$3,500), which is in a large wood case that's modeled after Leon

# 3-Way Active Accuracy!

The first affordable 15" 3-way active system: Mackie's SR1530 with electronic processing and FR Series™ internal tri-amplification.

Meet our active SRM450's big, over-achieving brother... the new SR1530. This 3-way triamplified active system delivers flat response at high output with low distortion and extremely wide dispersion in a surprisingly compact, portable enclosure that takes up less than two-and-a-half square feet of stage or floor space.

The new SR1530 features...

- Electronic equalization, time correction/phase alignment plus complete electronic and component protection circuitry
- Active circuitry makes the FR Series™ high-current tri-amplification more efficient than passive speakers because passive speakers have inefficient cross-overs which cause significant power loss. Because of this, the on-board SR1530 amplifiers, with 500 total watts, can drive the speaker system to 126dB peak SPL.
- RCF Precision components...
- Wide-dispersion, high-output HF/mid-horn design with phase plug
- High-output, low-distortion 6-inch horn-loaded midrange transducer
- High-precision 1-inch exit, high-frequency driver
- 15-inch, high-efficiency, cast-frame woofer with heat dispersing Inside/

Outside voice-coil technology

- Correctly weight-balanced with two comfortable side handles for easy carrying and set-up plus top and bottom handles for easier positioning on stage
- Weather-resistant steel grille

Sound quality that's only possible with a true active system.

Though just 44 inches tall, SR1530s generate the sound output of much bigger systems... and are far more accurate to boot. Our active design achieves near-perfect interaction between transducers and internal amplifiers. Together, you get transparent and precise, high-resolution audio performance... only at PA output levels, which is the beauty of properly engineered, high-end 3-way systems



SR1530 rear panel with amp, heat exchanger, female XLR input and male XLR full-range through.

Optimized Wavefront™ system "marries" high frequency and midrange.

In typical 3-way designs, mid- and high-frequency horns have symmetrical cross sections which physically force their output to different parallel locations in front of the box, causing uneven frequency response across the audience.

The SR1530's Optimized Wavefront™ horns have asymmetrical shapes with the high-frequency horn firing down into the six-inch midrange's dispersion pattern. Combined with built-in electronic time and phase correction, this creates a unified, wavefront with excellent phase and power response characteristics: Everybody in your audience hears the same thing.



Optimized Wavefront™ horn system



You gotta hear it to believe it.

Yes, you can log onto our web site for more info or call toll-free for an excruciatingly complete brochure.

But the real amazement won't kick in until you hear a pair of SR1530s at a Mackie dealer.

If you're looking for the smooth frequency response and articulated midrange inherent in a 3-way system, there's only one Active way to go. The new SR1530 from Mackie. ■



CIRCLE #008 ON PRODUCT INFO CARD

World Radio History

MACKIE

www.mackie.com • 800.258.6883

Made in Reggio Emilia, Italy  
by Meckolds. Who don't aim  
to be the best, but only the best.

Theremin's original instrument. It's a very clever design: As you move toward or away from the pitch antenna, it sends MIDI data in the form of either individual note commands or pitch bend commands or some combination of the two that you can program. It also receives MIDI, so you can record (and edit) your swoopings and play them back.

Besides Moog, one of the pre-eminent names in the early days of synthesis was Don Buchla, builder of wonderful nonkeyboard-oriented (which is one reason why it never caught on like Moog's) modular systems, named after their cre-

ator. I learned all about voltage control and sequencing on one of those beasts in college. Although the old machines are now collector's items, Buchla, himself, is still very active and has designed some really interesting electronic musical interfaces with names like "Thunder" and "Lightning." His latest creation, the Marimba Lumina, is being marketed by a company called Nearfield Systems ([www.multimedia.nearfield.com](http://www.multimedia.nearfield.com)), which primarily makes radio antenna measurement products but has formed a new multimedia division just to sell this instrument. Much more than a MIDI xylophone, the Marimba Lumina (and its new \$1,000-cheaper little brother, the

two-and-a-half-octave ML2500) has a ribbon controller, 10 control pads, storage for 50 setups, a built-in Yamaha XG synthesizer, and inputs for seven trigger or controller pedals. It has all kinds of expression and duration control, arpeggiation, alternative scales and much more. The instrument comes with four color-coded, foam-covered mallets, each of which can be programmed separately; so, for example, hitting a note with the red mallet will play one kind of sound, while hitting the same note with the green mallet will play a different sound. You don't have to be a killer xylophone player to get the most out of this baby, but if the guy demoing it was any indication, it does help.

And speaking of built-in synths, I've been writing about software synthesis for a number of years, but so far I've yet to see anything that I can put on my computer that I would consider to be a reasonable replacement for a good general-purpose hardware synth module. But the latest version of Native Instruments' ([www.native-instruments.de](http://www.native-instruments.de)) Reaktor is getting awfully close. The \$500 software, which works on Mac and Windows platforms, puts a completely configurable polyphonic/polytimbral synth, a sampler, a drum machine and a groove generator onto your computer in one fell swoop. Version 3.0, due out this quarter, has a more intuitive user interface with modules that make the architecture of the system much clearer. To get more than a handful of voices out of it, you need at least a 400MHz computer, but we all know those aren't hard to find anymore. The German company has also released a "Junior" Version of the software, called Dynamo, at \$200.

A new company from Victoria, B.C., Tactex Controls, is making "digital skin": fabrics that can detect position and pressure when they are touched. The technology grew out of the Canadian Space Agency (you didn't even know there was one, did you?) and is now being applied to touch pads, game controllers, cell phones, "wearable" computers and—you guessed it—musical instruments. The company's first music-oriented product, the MTC Express, is a hand-sized touch pad that hooks up to a computer through the serial port (or a serial-to-USB converter). At NAMM, Tactex was demonstrating it on a Mac using custom objects created in the musical programming language, Max, to do interesting things with sound and spatialization. By itself, the MTC Express sells for \$495, but the technology was also

—CONTINUED ON PAGE 252



## Professional Microphones



### SOUND DIFFERENCE

MXL pioneered the revolution in low priced Condenser Microphones. We brought technology, previously out of the reach of most recording enthusiasts, into the mainstream of music recording. Today, there are a number of companies importing Condenser Microphones. Critics claim that they are all the same. Not the case. We at MXL design, assemble and test our microphones to a standard that equals our European counterparts. All this, and at a fraction of their price. We invite you to audition MXL Microphones and enjoy classic performance at truly extraordinary prices. Experience the difference, the MXL difference. Call us for the name of your local MXL retailer.

Now with 3 year warranty

www.MXLmics.com      1-800-800-6608



# CONTROL YOURSELF



With world-class feel and response, and expandability to a full 48 ultra-smooth DigiFaders,<sup>™</sup> ProControl<sup>™</sup> is the ultimate control surface for Pro Tools.<sup>™</sup> Add Edit Pack<sup>™</sup> and speed through editing and surround mixing tasks like never before.

## ProControl

## Control|24

Control|24<sup>™</sup> combines Focusrite<sup>®</sup> analog technology with an ergonomically designed control surface, creating a sophisticated front end for Pro Tools — perfect for project and music studios.

Bring the power of Pro Tools out of the computer and place it under your fingertips. More than just boosting your workflow, a dedicated control surface becomes the center of your studio.

## Motor Mix

Order a *FREE DVD* today and learn why a control surface is more than just a digital mixer.

[www.digidesign.com/controldvd](http://www.digidesign.com/controldvd)

1.800.333.2137 code **729**

With its motorized faders, the affordable and scalable CM Labs<sup>™</sup> Motor Mix<sup>™</sup> provides the ease of tactile mixing in a compact size.

CIRCLE #010 ON PRODUCT INFO CARD

© 4/01. Control|24, Digidesign, DigiFaders, Edit Pack, Pro Tools, ProControl, and Pro Tools are trademarks or registered trademarks of Avid Technology, Inc. or its subsidiaries or divisions. All trademarks are the property of their respective holders. All features and specifications subject to change without notice.

**digidesign<sup>®</sup>**

A division of **Avid**



Unit is 19" wide and will not fit in a mixing console.

dbx® the Standard in Professional Signal Processing

World Radio History



# It's Time to Change the Channel...

In the digital world, you're only as good as your weakest link or channel. So, why settle for any less than the warmth and integrity offered by the new **dbx 376 Tube Preamp Channel Strip with 96k Digital Outs?** For more than 25 years dbx has been setting the standard, and the 376 is the culmination of those years of innovative success.

With a feature list that includes a vacuum tube preamp section, three-band parametric EQ, compressor and the *real* kickers: built-in De-Essing and AES/EBU and S/PDIF digital outputs, make the 376 an all inclusive Channel Strip toolbox that's just as much at home in a conventional analog mixer application as it is in a state-of-the art digital workstation. With the 376 you can bypass the mixer all together, while producing warm and rich tube mic preamp tones in the digital domain by using dbx's proprietary Type IV™ A/D conversion system. Stop by your local authorized dbx dealer and tune into all that is available on the next channel.

- Tube microphone pre-amp
- De-Esser
- 3-Band Equalizer
- dbx® Compressor
- Type IV™ conversion system
- AES/EBU and S/PDIF digital outputs
- Front panel instrument input
- +48 Volt phantom power
- Selectable dither and noise-shaping algorithm
- Selectable sampling rates (96, 88.2, 48, 44.1kHz)
- 24, 20 and 16 bit wordlengths
- Word clock sync input and output
- Selectable mic/line switch
- 20 dB pad

## Tube Preamp Channel Strip w/ Digital Out

# 376

**dbx**®

PROFESSIONAL PRODUCTS

**H** A Harman International Company

CIRCLE #011 ON PRODUCT INFO CARD

For information call: 1-800-777-1363 • Harman Music Group • 8760 South Sandy Parkway • Sandy, Utah 84070 • [www.dbxpro.com](http://www.dbxpro.com)

# So Many Choices, So Little Time

ONCE UPON A TIME, AN ALBUM WAS AN ALBUM, a single was a single, and the number of formats available to recording professionals and consumers could be counted on one hand.

How times have changed. Today, in order to create recordings and release them commercially, mixing and mastering engineers have to contend with a dizzying array of formats. For stereo projects, the choices go beyond analog and digital. Nowadays, any engineer worth his or her salt must be able to handle DASH, ADAT, DA-88 and analog tape, which exists in various track configurations, record-

## MIXING AND MASTERING ENGINEERS FACE THE FORMAT QUAGMIRE

ing speeds and noise-reduction types. In addition to those tape-based formats, mix engineers can expect to receive multitrack masters in any number of hard disk systems, especially Pro Tools, which has no standard storage medium. That means that a Pro Tools session might come in on a SCSI drive, a FireWire drive, a CD-R or DVD-R or any number of digital tape cartridges, including Exabyte, DDS, Data DAT and AIT.

**BY PAUL VERNA**





Once the mixer has possession of the master (or sets of masters) and has procured all of the necessary hardware to handle the formats in question, a new set of choices opens up with regard to the mixdown medium. Here, the options include DAT (either in the new 24-bit version or the more common 16-bit variety), CD-R, DVD-R, magneto-optical disc, ADAT or DA-88 (sometimes using bit-splitting techniques, which are not standardized), Alesis MasterLink (which uses optical discs), and any of the aforementioned hard drive systems and their associated backup devices. Then, of course, there's analog tape, which most mastering engineers say they still prefer. Not to be outdone by digital, analog 2-track tape exists in various guises, including half-inch, 1-inch and 2-inch reels; speeds of 30, 15 and 7.5 ips; and noise-reduction systems, like Dolby SR.

In the multichannel domain, the spectrum is even more complex, with mixdown options ranging from hard disk recorders, like Pro Tools and Genex, to tape-based MDMs, such as DA-88 and ADAT. Beyond the decision



Tom Jung, owner of DMP Records

of which format to use for the multichannel master, engineers must figure out—to the best of their abilities—what the final release medium for the project will be. For instance, will it appear on DVD-Audio, DVD-Video, Super Audio CD, Dolby AC3 or DTS, each of which

offers varying degrees of choice with regard to bit budgets, compression algorithms, disc types and allocation of non-music items, like videos, liner notes, bios and Web access.

At the consumer level, the bombardment of format options is no less intense than it is for the people who create the music. Even a “simple” stereo release may encompass such disparate mediums as CD, cassette, vinyl, DVD-Video, DVD-Audio, MiniDisc and any number of download formats like MP3. In the multichannel world, DVD-Audio, DVD-Video, Super Audio CD and DTS are vying for consumers' attention and threatening to confuse them with format overload.

Posing a rhetorical question that many engineers are asking themselves these days, Skywalker Sound director of music recording and scoring Leslie Ann Jones says, “How many formats does it take? Too many, as far as I'm concerned.”

Jones should know. Not only does she serve in a managerial capacity at one of the largest and busiest commercial facilities in the world—where part of her job is to make equipment purchases—but she is also an award-winning engineer who faces format dilemmas every time she starts a project. “In my experience, the format decision affects the creative process right from the beginning,” she says. “I'm about to record a live album with Michael Feinstein in Israel, and the first thing I had to think about was what format I was going to use, and then I had to fit my format and mic selection into a [pre-existing] budget.”

Mixers and mastering engineers who own their own facilities—like Bob Clearmountain, Mick Guzauski and Bob Ludwig—face the same combination of creative choices and financial burdens that Jones describes. They complain that the pressure to invest in multiple systems—ranging from DASH recorders to tape-storage systems for digital audio workstations—is so intense, it sometimes gets in the way of creativity.

Commenting on the data storage demands of a large-scale multichannel project like the live DVD *Bruce Springsteen and the E Street Band: Live in New York City*, which he recently mixed in stereo and surround, Clearmountain says, “The data shuffling



**The data shuffling gets to be mind-boggling. Even the manufacturers don't realize it.**

**—Bob Clearmountain**

gets to be mind-boggling. Even the manufacturers don't realize it. You go to AES, and they all talk about 5-channel this, 7-channel that, and I wonder how many of them have ever had to deal with an entire project in 5.1? It's insane, the amount of data involved, especially for a home studio like mine.”

One of the factors that complicates the format quagmire is the sheer number of people involved in a typical recording project, particularly pop, hip hop and R&B albums that use multiple producers, engineers and studios. Mastering engineer Tony Dawsey, who has been working at New York powerhouse Masterdisk since 1980, says, “There was a time when you would get a ¼-inch or ½-inch master from one studio, one engineer and one producer, and it was all put together on a reel. Now it's a lot more complex, because there are a lot more people involved. I often get into situations where an album gets held up, because one producer didn't turn in his track. Sometimes we're waiting for days with everything in place except for the one track, and it ends up getting down to a crunch when the track comes in. When you have different producers, different engineers and different studios, everything becomes an emergency.”

The rapid proliferation of formats may have complicated the lives of engi-

# Never say Never again...

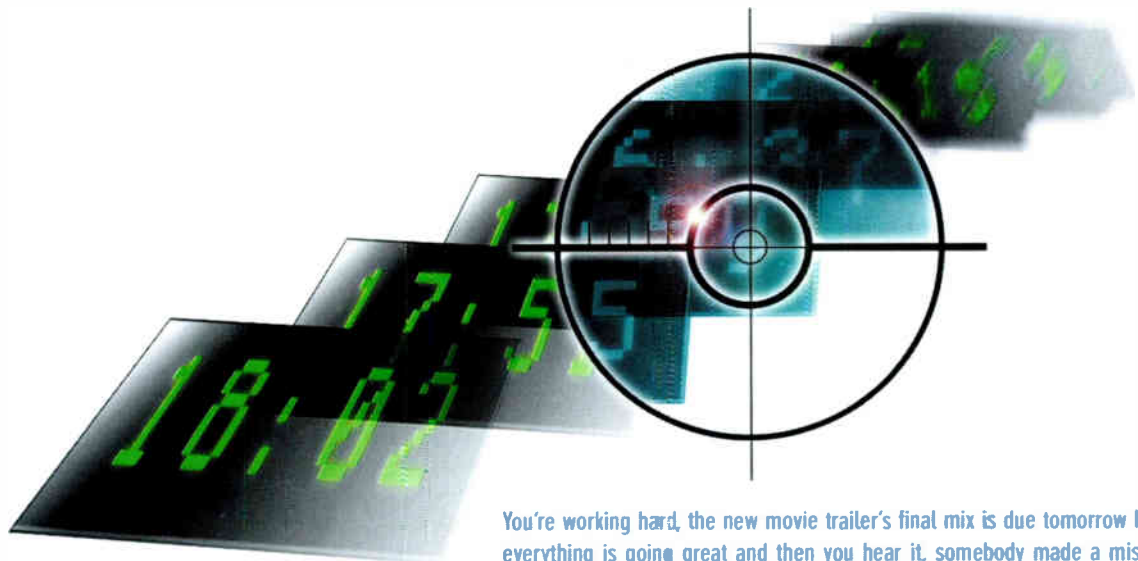

You're working hard, the new movie trailer's final mix is due tomorrow by 10 am, everything is going great and then you hear it, somebody made a mistake, you think it might be about twenty edits back, but you don't have a backup!

The bad news...

In this ever changing fast paced world of studio project deadlines one mistake like this can quickly add up to hours, or even days of extra work, costing you both time and money.

The good news...

With Nuendo, mistakes are a thing of the past.

Thanks to Nuendo's powerful unlimited Undo and Redo, it's no problem if a mistake is twenty edits back or a hundred. The Edit History window displays all changes made the past hour, three hours, or until you Close the project, making it easy to target that potentially costly mistake. And rest easy as the original audio files remain untouched unless you choose otherwise.

But Nuendo goes even further. You can process any audio segment with a wide variety of powerful edit operations and plug-in effects with the integrated Sample Editor, or even from directly within the Project or Browser windows. And as each segment has its own individual off-line history which is stored with the Project, the edits you make today can be selectively removed, or even re-applied with new parameters within seconds tomorrow, giving you total freedom of choice.

With Nuendo you'll never say never again...

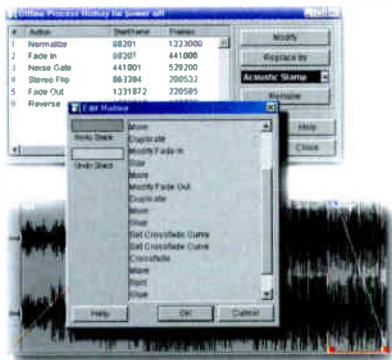

\*The top grayed section of the Edit History window indicates events you can Undo or Redo, while the Offline History window behind it shows the various processes that can be modified, replaced, or removed for each audio segment.\*

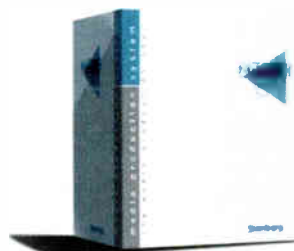

New Times.  
New Thinking.

**Steinberg**

www.nuendo.com

## So Many Choices, So Little Time



neers and studio owners, but it has also generated more business for them, which they appreciate. "These days, it can take twice as long to EQ an album as it used to," says Dawsey. "If it took four hours before, it takes eight hours now, with all the different formats we're dealing with, and because people are putting 15 or 20 tracks on an album instead of eight or 10 tracks.

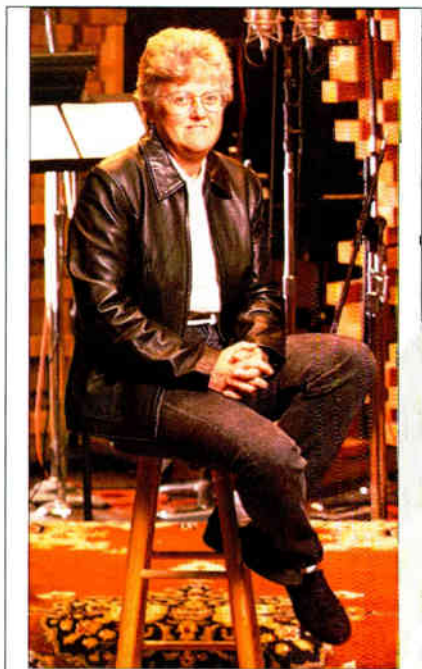

**The format decision affects the creative process right from the beginning.**

**—Leslie Ann Jones**

Studio time has gotten longer per project than what it used to be. All told, it takes me about a day to do a 'normal' project, that being one version of an album. But any time there's more than one version, like clean, 'street' and instrumental versions, it's another day."

Ludwig, who mastered the Spring-

steen DVD and CD at his Gateway Mastering studio in Portland, Maine, adds, "If this had just been a CD, Bruce might have booked only one day here. But because of all this complexity, it was two days with Bruce and lots of post-production afterward."

On the mixing side, engineers like Clearmountain, Guzauski and Chuck Ainlay are seeing a steady stream of work mixing albums in 5.1, and the material ranges from current titles such as Mark Knopfler's *Sailing To Philadelphia*, Springsteen's *Live in New York City* and Eric Clapton's *Reptile* to classics like Peter Dinklage's *Live at the Blue Note* and Michael Jackson's *Thriller*. In these early days of surround sound production, there are as many opinions on how to execute 5.1 channel mixes as there are engineers doing them, but there is virtual unanimity among mixing and mastering engineers that creating separate stereo and surround mixes is preferable to using the automatic "fold-down" features built into such multichannel compression systems as Dolby AC3 and Meridian Lossless Packing (MLP).

Clearmountain says, "If you pan something in five channels and then fold it back to stereo, very often it's not going to work. You might have something spread between the left front and left rear, and when that folds down to mono, it's just going to be on the left channel. That might be fine, but maybe you want it to be a stereo sound. If you're going to commit to doing that for an entire project, it's like working with your hand tied behind your back."

For projects with budgets that do not allow for separate mixes, engineers are willing to accept a fold-down, albeit reluctantly. Ainlay notes, "As far as making a DVD-Audio disc compatible with a portable DVD system, using the fold-down gives you the option for somebody to take that DVD-Audio disc and play it on the beach. Say somebody, for economic reasons, didn't do separate mixes, the fold-down is applicable there. But I still think there should be a separate mix."

In most cases, engineers working in the 5.1 domain are not concerned with the final release format of their mixes. After all, whether a title will appear on DVD-Audio, DVD-Video, Super Audio CD or DTS does not affect the creative decisions that go into a mix. However, some engineers, like DMP Records owner Tom Jung, have honed in on favorite formats and are tailoring their work accordingly. In Jung's case, all of his projects—which consist mainly of



**The biggest thing with 5.1 remixes is finding all the elements: the masters, the technical notes, the bits of gear used in the mix initially, etc.**

**—Chuck Ainlay**

acoustic recordings done live to six channels—are now being done in Direct Stream Digital and released on Super Audio CD.

"I love the way DSD sounds," says Jung. "It's a simpler system than PCM. Even at high [PCM] bit rates, you have decimation and interpolation, and those are things that don't exist in the 1-bit DSD world. At 24/96, the damage is minimal, but it's still there. To me, DSD is a much purer interpretation of the analog signal."

For Jung, the purity of the audio signal takes precedence over all other aspects of his projects. Pop engineers, on the other hand, must add a battery of logistical considerations to their concerns over sound quality.

"The biggest thing with 5.1 remixes," says Ainlay, "is finding all the elements: the masters, the technical notes, the bits of gear used in the mix initially, etc. There may be loops that weren't recorded back to the multitrack, and other material that's hard to find."

In an effort to simplify and standardize the multitrack archiving process, some facilities are consolidating entire



# works of art

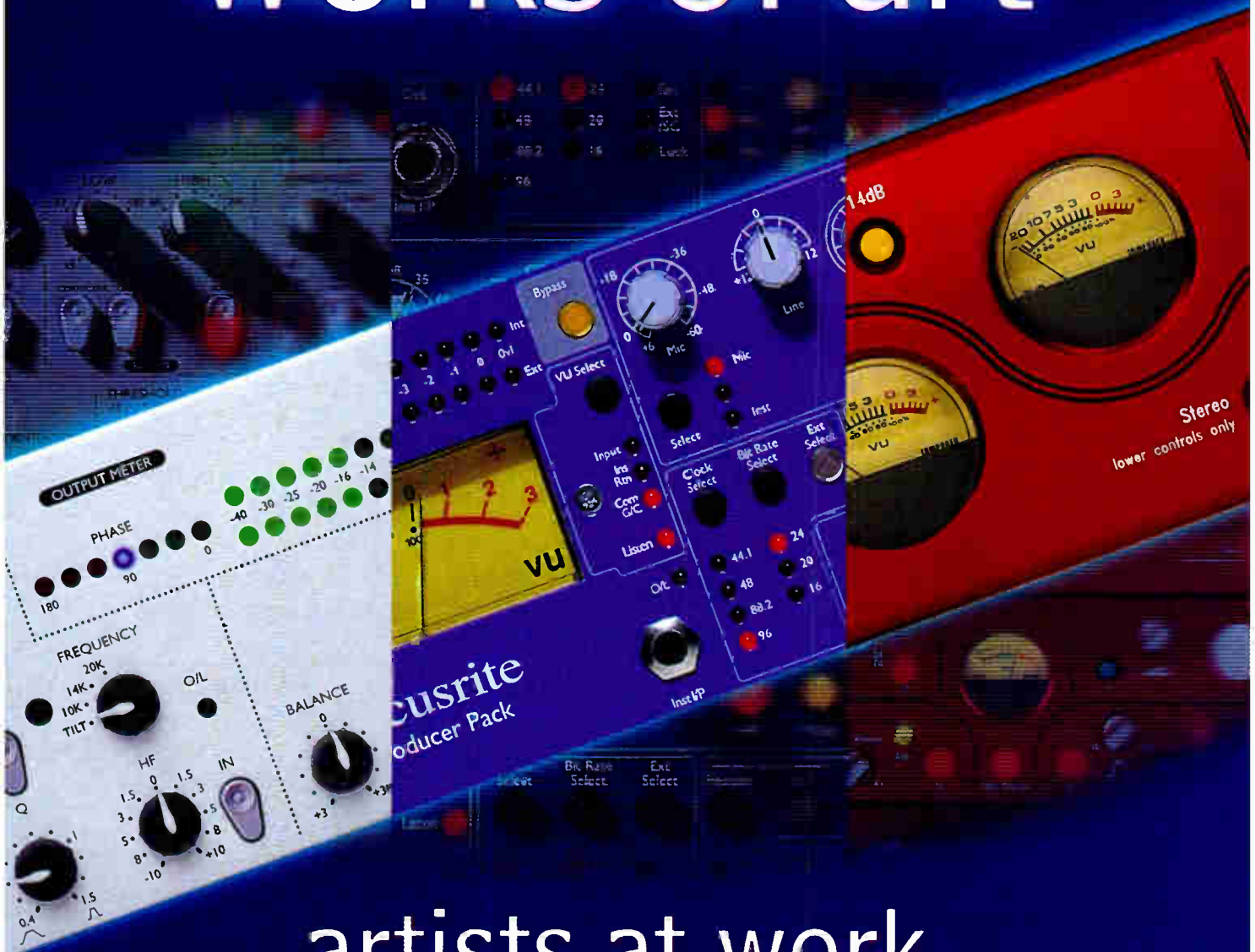

# artists at work



Walter Afanasieff

Mark "Spike" Stent

MJ Cole

Sir George Martin

Robbie Williams & Guy Chambers

Jay Kay

Acknowledgement Focusrite would like to thank these artist and our countless other customers in the world of music recording.

PRODUCED IN THE UK BY

  
**Focusrite**<sup>®</sup>

[www.focusrite.usa.com](http://www.focusrite.usa.com)

DISTRIBUTED IN NORTH AMERICA BY

CIRCLE #013 ON PRODUCT INFO CARD

[www.digidesign.com](http://www.digidesign.com)

**digidesign**

1.800.333.2137, code 727



projects on FireWire drives—which have become increasingly affordable—and keeping them there for posterity. Skywalker's Jones says, "We're trying to get to the point here where we treat hard drives like analog tape reels. It used to be you shipped the masters to the record company when you were done with your project. Now, you're usually shipping Exabyte tapes, which can be very cumbersome. By transferring all our digital data now to FireWire drives, where the entire project exists on one drive, if you end up remixing something, it's easy to access. You don't have to take the Exabyte and restore an entire project to remix one tune."

While the FireWire system may work for Skywalker, the industry at large has no standard—or even a prevailing pattern—when it comes to archiving its

recordings. Observers say that such past nightmares as sticky tape syndrome and lost masters will pale in comparison to what future generations of engineers can expect to encounter when they try to remix projects that are being archived under present-day conditions.

"With recordings, nowadays, on people's Pro Tools systems, a lot of times all the stuff doesn't get turned into the record companies," says Ainlay, adding, "It's going to get *really* strange."

If the archiving choices themselves seem overwhelming, then the questions regarding the stability and longevity of current data formats are downright frightening. Despite certain manufacturers' claims, no one really knows how long a CD-R, Exabyte, DAT or hard drive may last. And, while they anxiously back up their data to their format of choice and hope that the medium holds up in the long term, engineers are grappling with an entirely new set of format and sound quality issues with regard to audio on the Web.

"The whole MP3 thing is interesting," observes Ludwig. "It's very difficult to figure out in advance how the MP3 encoder is going to react to the material you send into it. I've done classical

projects with extremely wide dynamic range with high MP3 encoding rates, and you can't hear the difference in the noise floor. On the other hand, we were encoding this Paula Cole track, and the encoder was really affecting her vocal in a nasty way. That's not the kind of thing you can EQ for."

Clearmountain says he avoids sending MP3 files of his mixes because of quality concerns. Instead, he encourages his clients to find an ISDN-equipped studio in their area or directs them to his FTP site, where he posts uncompressed Sound Designer II files of mixes in progress.

As Internet audio matures, it will probably further complicate the lives of recording professionals by presenting them with new technological challenges. In the meantime, mixing and mastering engineers are working furiously to keep pace with a rapidly evolving format landscape. "It keeps life exciting," says Dawsey, letting out a hearty laugh. "I'm a very blessed and lucky man to be as busy as I am, but it adds to the stress level. After all, I'm just one individual!" ■

*Paul Verna is Mix's New York editor.*

# Did you know this...

about

## mitsui

### CD & DVD

#### recordable media



**Gold on Gold®** Professional applications require a life expectancy rating of 100 years or better. Mitsui **Gold on Gold®** is your only choice for a write-once technology that provides safe, longterm archival storage. 

**Patented Organic Dye** Our **highly compatible** DVD-R's are certified to 2X recording speed, CD-R's to 24X! Mitsui's **innovative DVD-R dye technology** is leading the next generation of optical media for consumer formats.

**Custom Printing** Mitsui offers the only **"Full Surface Printable"** media, available in gold or white, for thermal transfer printing and **superior customer service** values in quick, cost-effective **custom silk-screen printing** for all CD & DVD products.

**Superior Audio Recording** Mitsui 74 & 80 minute Audio CD-R's are a favorite of the **professional audio industry** for their fullness and warmth in sound reproduction, as well as their **resistance to heat and damage** from UV light.



**mitsui advanced media, inc.**  
The Difference is Innovation.  
[www.mitsuidr.com](http://www.mitsuidr.com)  
10045 Federal Drive, Colorado Springs, CO 80908  
Phone **800/682-2377** • Fax 914/253-8623  
email [info@mam-a.com](mailto:info@mam-a.com)

# Champagne Tastes...

## On A Beer Budget?

*Ready for an FX Server,  
but gotta watch the  
bottom line?*

Introducing SoundQuery from mSoft, makers of ServerSound, the "Champagne" of FX server systems! SoundQuery is totally "plug and play" – next to no set-up is required, and adding pre-loaded FX package is as easy as plugging in a drive! Don't spend countless hours of CD ripping and database corrections with a "do-it-yourself" (so-called) solution – get the power without the price with SoundQuery!

# SoundQuery

## FX Server

Toll Free: 800-489-9314 | Phone: 818-716-7061 | [www.maftinc.com](http://www.maftinc.com)



"I thought I owned the best preamp...  
...until I heard the Aphex 1100."



**S**tephen Krause, award winning recording engineer and producer with over 60 films, 10 TV series and 20 records to his credit, is always in search of better tools. He compared just about every preamp that came on the market to his favorite. Nothing impressed him—until he tried the Model 1100 tube preamp from Aphex Thermionics.

"I always had to choose either an intimate, detailed sound or a large image. The 1100 gave me *both* at the same time. It was so dramatically better than any other preamp I had to get the composer and other engineers to hear it for themselves. Everyone was blown away."

The Model 1100 is a 2 channel discrete Class A tube microphone preamplifier with 24-bit/96kHz A to D converters. Proprietary designs and highest quality components achieve the performance that has set a new standard for "the best preamp." Doesn't your music deserve the Model 1100?

**Aphex** Thermionics  
a division of  
**APHEX**  
SYSTEMS

*Improving the way the world sounds*<sup>SM</sup>

11068 Randall Street, Sun Valley, CA 91352 U.S.A. 818-767-2929 • Fax: 818-767-2641 • [www.aphex.com](http://www.aphex.com)

CIRCLE #016 ON PRODUCT INFO CARD



# Surround Sound Consoles

## Examining the Options for Multichannel Studio Production and Film Post Mixing

BY MICHAEL COOPER

With this issue's focus on mixing, we thought we'd look into some recent products and time-proven consoles designed for surround sound production in both music and sound for picture applications.

With dozens of mixing consoles claiming surround sound bragging rights, we thought it would be helpful to distinguish those desks with purpose-built surround functionality from the wannabes. To be sure, many of the new breeds of 8-bus digital consoles can be adapted for surround operation, but not without serious handicaps or adding third-party add-ons. For 5.1 monitoring during mix-down, for instance, six of the eight buses in these boards are typically delegated to serving the 5.1 monitor feeds, leaving only two buses with which to mix! Also, a MIDI joystick or some other third-party add-on is often required to effect continuous surround panning. And, usually, the only way you can raise or lower all six monitor levels simultaneously is by first subgrouping the buses.

Although it's great that cost-effective consoles designed for stereo operation can be adapted—sometimes rather marginally—for surround sound work, engineers who must work efficiently to meet unforgiving deadlines require a console that was expressly built for the job at hand. Accordingly, all of the consoles featured in this article can continuously pan tracks in real time in surround format using a single pan control (e.g., mouse, touchscreen or joystick). These boards also allow you to listen back to a surround mix and still retain at least eight buses for mixing. And they all provide a dedicated master monitor level control, so you can raise or lower the output of all of your speakers with the twist of one knob or by moving one fader. We note where a company provides an in-house, surround-specific option in order for its console to achieve this level of functionality. But consoles requiring third-party add-ons are not included in this roundup. Also, surround



Soundtracs DS3

consoles that are tied to workstations and/or integrated recording systems (e.g., the Digidesign Pro Control) are also not covered here.

Inevitably, whatever criteria we choose to weed with, the patch will leave out some eminent products. One such example is the Amek Media 51 audio recording and production console. The Media 51 supports 5.1, 7.1, LCRS and stereo formats and can be ordered with up to 64 inputs. The console features SMPTE-based Supertrue™ automation, Virtual Dynamics™ on every channel, Cue List event triggering, two groups of six buses (configurable as two multi-format stems), an optional joystick, and mic preamp and EQ sections designed by Mr. Rupert Neve. See the accompanying chart for contact info for Amek.

Of course, the chart on the following pages should only be used as a starting point in your research. Most of the consoles listed are highly configurable, making it difficult to quantify some features (such as number of inputs and channels) in absolute terms. That said, we've narrowed the surround consoles field down to a manageable list of standout candidates. Sit down with your hands up—we've got you surrounded! ■

*Michael Cooper is a Mix contributing editor and owner of Michael Cooper Recording in beautiful Sisters, Ore.*

# Surround Sound Consoles

Studer D950



Sony DMX-R100



Model	Telephone	Website	Analog/Digital	Max Mic/Line ins	Max Total Inputs	Max Input Faders/Channels	Assignable Fader Banks	Output Buses	Automation	Metering	Individually Calibrated Monitor Outs
Amek 9098i	888/286-9358	www.amek.com	Analog	128 (120 mono + 4 stereo)	248	24/248	N/A	32	Recall w/manual reset; faders; dynamic switch on/off Complete	VU/PPM/LED (configurable)	Yes
Amek DMS	888/286-9358	www.amek.com	24-bit/48 kHz digital	64	64	64/64	16	32	Recall w/manual reset; faders; dynamic switch on/off Complete	Any type (configurable)	Yes
Amek Galileo Post	888/286-9358	www.amek.com	Analog	56	112	112/112	N/A	24	Recall w/manual reset; faders; dynamic switch on/off Complete	LEDs, RTW 5.1, VU	Yes
AMS-Neve Capricorn	212/965-1400	www.ams-neve.com	24-bit/48 kHz digital	192, in any combination	256	64/256	12	64	Complete	Peak Full-Scale (FS) LCD	Yes
AMS-Neve Libra	212/965-1400	www.ams-neve.com	24-bit/48 kHz digital	96, in any combination	256	48/256	4	64	Complete	Peak FS LED	Yes
AMS-Neve Libra Post	212/965-1400	www.ams-neve.com	24-bit/48 kHz digital	192, in any combination	256	48/256	4	64	Complete	Peak FS LED	Yes
AMS-Neve Logic DFC	212/965-1400	www.ams-neve.com	24-bit/48 kHz digital	512, in any combination	512	120/512	4	86	Complete	LCD wrth selectable ballistics	Yes
AMS-Neve Logic 3SC	212/965-1400	www.ams-neve.com	24-bit/48 kHz digital	64, in any combination	96	16/96	N/A	32	Complete	Peak FS LED	Yes
Euphonix CS3000	650/855-0400	www.euphonix.com	Digitally controlled analog	104 mic, 208 line	312	104/52	2	up to 48	Complete	VU/PPM (configurable)	Optional
Euphonix System 5	650/855-0400	www.euphonix.com	24-bit/96 kHz digital	Modular blocks of 24 mic, 28 line	672	24/200	2	up to 128	Complete	PPM, average (configurable)	Yes
Harrison MPC2	615/641-7200	www.harrisonconsoles.com	24-bit/48 kHz digital	2,240	2,240	144/288	4	120	Complete	VU/Peak FS	Yes
Harrison Series Twelve	615/641-7200	www.harrisonconsoles.com	24-bit/48 kHz digital	2,240	2,240	144/288	4	120	Complete	VU/Peak FS	Yes
Harrison MPC	615/641-7200	www.harrisonconsoles.com	Analog	832	832	144/288	2	120	Complete	VU/PPM	Yes
Ttari Elite+	800/877-0577	www.ttari.com	Digitally controlled analog	48 mic + 48 line	144	96/48	N/A	46	Fader; mute; routing; EQ in/out; snapshots	PPM	Optional
Publison Digital Film Console (France)	33/143/608-464	perso.wanadoo.fr/.publison	24-bit digital	128	128	128	yes	112	Faders and rotary controls	TFT PPM	Yes
Roland VM-7000 Series	323/890-3700	www.rolandus.com	24-bit/48 kHz digital	40 (84 with optional A/D/D/A)	94	24/94	48	32	Complete	LED bridge option	Yes
Sony DMX-R100	800/686-SONY	www.sony.com/proaudio	24-bit/96 kHz digital	24 mic/line	56	56/56	3	8	Complete	LED	No
Sony DXF-R3	800/686-SONY	www.sony.com/proaudio	24-bit/48 kHz digital	120 mic/line	120	65/120	5	48	Complete	LED bar graph	Yes
Soundtracs DPC-II	800/4-FAIRLIGHT	www.soundtracs.co.uk	24-bit/48 kHz digital (96k option)	224 (modular)	224	96/160	N/A	40	Complete	LED (VU master option)	Yes
Soundtracs DS3	800/4-FAIRLIGHT	www.soundtracs.co.uk	24-bit/48 kHz digital (96k option)	112	112	24/96	6	32	Complete	LED vr/VU ballistics	Yes
SSL SL 9000 J Series	212/315-1111	www.solid-state-logic.com	Analog	120	500+	240/240	0	>60	Faders and switches with Total Recall	VU/PPM	Yes
SSL SL 9000 Scoring System	212/315-1111	www.solid-state-logic.com	Analog	120	500+	240/240	0	>60	Faders and switches with Total Recall	VU/PPM	Yes
SSL Avant	212/315-1111	www.solid-state-logic.com	24-bit/48 kHz digital	2,000*	2,000*	96/384	up to 3	>120	Complete	VU/PPM	Yes
SSL Axiom-MT	212/315-1111	www.solid-state-logic.com	24-bit/48 kHz digital	2,000*	2,000*	48/96	1	>60	Complete	VU/PPM	Yes
SSL SL 4000/8000 G+ Series	212/315-1111	www.solid-state-logic.com	Analog	112	>300	224/224	0	>40	Faders and mutes	VU/PPM with Total Recall	Yes
Stagetec Cantus	818/701-6201	www.stagetec.com	24-bit/52-bit (28-bit digital A/Ds)	128	128	96/120+	10	64	Complete	LED (PPM or VU ballistics)	Yes
Stagetec Cinetra	818/701-6201	www.stagetec.com	24-bit/52-bit digital	128	128	96/120+	10	64	Complete	LED (PPM or VU ballistics)	Yes
Studer D950 M2	416/510-1347	www.studer.ca	24-bit/48 kHz digital	250+	500+	96/96	10	112	Complete	VU/PPM	Yes

Notes: 1. Bus bit depth and maximum sampling frequency noted for digital consoles; 48 kHz also implies 44.1 kHz operation; 96 kHz may or may not indicate 88 kHz operation. 2. Complete denotes scene recall, mute, fader, EQ, pan and dynamics automation. 3. All types denotes compressor, limiter, gate, and expander. 4. All consoles offer moving faders. \* Via digital routing matrix.



I/O Types	Channel Input EQ (# of bands and type)	Pan Control Type	Aux Sends	Dynamics Processors	Other Features
Balanced analog	2 parametric bands 2 bell-curve/shelf, 2 HPF/LPF	2 joysticks plus dual pots	16	All types	Rupert Neve-designed audio path, 6-channel monitoring, two automated sends per channel, 24 automated switches per channel; Supertrue™ 4.0 automation
Balanced analog, AES/EBU, S/PDIF	Parametric, bell, shelving, HPF and LPF (6 bands total)	Multiple joysticks, touchscreen	12	64 of any type	Analog and digital inserts; 8-channel monitoring; sample rate conversion (SRC) available for all channels; one hardware control for each function
Balanced analog	4-band parametric, HPF, LPF	2 joysticks plus dual pots	16	All types	Rupert Neve-designed mic pre's; 8-channel monitoring; two automated inserts per channel; eight automated switches per channel; Supertrue™ 4.0 automation
Analog; up to hundreds of AES/EBU, TDIF, MADI, SDIF	4-band parametric/shelving + HPF and LPF	Up to 6 joysticks plus 4 rotary controls	16	All types	CSX monitoring panel provides confidence monitoring in multiformats up to 7.1; touch-sensitive rotary panning; 3-operator layout maintains sweet spot
Balanced analog; up to hundreds of AES/EBU, TDIF, MADI, SDIF	8-band parametric, shelf, HPF, LPF	Up to 2 joysticks plus 4 rotary controls	16	All types	Multiformat mixing/monitoring up to 7.1; single-operator layout; centralized channel strip maintains sweet spot; touch-sensitive rotary pan controls
Balanced analog; up to hundreds of AES/EBU, TDIF, MADI, SDIF	8-band parametric, shelf, HPF, LPF	Up to 2 joysticks plus 4 rotary controls	16	All types	Multiformat mixing/monitoring up to 7.1; single-operator layout; centralized channel strip maintains sweet spot; touch-sensitive rotary pan controls
Balanced analog; up to hundreds of AES/EBU, TDIF, MADI, SDIF	8-band parametric, shelf, HPF, LPF	Up to 6 joysticks plus 4 rotary controls	36 (12 per operator)	All types	Multiformat mixing/monitoring up to 7.1; 3-operator layout; touch-sensitive rotary panning; pre-dub input groups several inputs on one fader; explodes parts throughout desk
Balanced analog; up to hundreds of AES/EBU, TDIF, MADI, SDIF	4-band parametric/shelving + HPF and LPF	Up to 2 joysticks plus 4 rotary controls	8	All types	New for NAB 2001; up to 64 channels within a very compact working area; single-operator, multiformat console brings film-style features to TV post work and budgets
Balanced analog	4-band parametric plus 2 dedicated	Trackball	6 (48 with optional system)	All types	8-channel monitoring; snapshot recall; assignable metering; 8-character fader display; three insert sends per channel; stereo faders; GPI relays option
Balanced analog; AES/EBU, SDIF-2, TDIF, Pro Tools, MADI, ADAT	4-band parametric/shelves plus 2 dedicated HPF/LPF	Trackball/motorized joystick	up to 24	All types	Up to 16 7.1 bus stems; snapshot recall; multiformat faders; full machine control; simultaneous multiformat mix/monitoring; redundant DSP
Balanced analog	4-band parametric w/HPF	Knobs, motorized joystick, touchscreen	16	Gate & compressor	64x8 matrix; 56 assignable PEC/DIR; multi-operator automation; Toys effects plug-in control panel; sweet spot control; 48 grouping faders; sectional aux buses
Balanced analog	4-band parametric w/HPF and LPF, touchscreen	Knobs, motorized joystick, touchscreen	16	Gate & compressor	64x8 matrix; 56 assignable PEC/DIR; multi-operator automation; Toys effects plug-in control panel; sweet spot control; 48 grouping faders; sectional aux buses
Balanced analog	4-band parametric w/ HPF and LPF shelving; graphic EQ optional	Knobs, motorized joystick touchscreen	16	Gate & compressor	32x8 matrix; 32 assignable PEC/DIR, multi-operator automation; sweet spot control; 48 grouping faders; sectional aux buses/solo, sectional PEC/DIR solo
Balanced analog	(2) 4-band parametric EQs, HPF, LPF	2 assignable, automated joysticks	10	96 gates & compressors	8-channel multiformat monitoring; Direct Assign/five-way Pan Option provides two sets of LCR/LRs pan buses and can hard assign inputs to buses
Balanced analog, AES/EBU, MADI	10-band parametric	4 motorized joysticks	16	All types	Supports all major surround formats up to 7.1; each channel can use three dynamics processors and equalizers simultaneously
Balanced analog; up to 48 channels of AES/EBU, S/PDIF, ADAT, TDIF	5-band parametric, bell, HPF, LPF	Joystick or fader/knob shelf, combination	24 (12 per I/O processor)	All types	16 stereo effects onboard, including COSM Speaker, mic and guitar modeling and 3-D processing; storage/recall of input trim settings; remote I/O processors; RTA
Balanced analog; up to 38 channels of AES/EBU, S/PDIF, ADAT, TDIF	4-band parametric, bell, shelf + dedicated HPF and LPF	Touchscreen, mouse	8	All types	Up to 5.1 monitoring; work surface features one knob per function; high-resolution color touchscreen; 10-bit fader resolution, touch-sensitive faders; machine control
Balanced analog; AES/EBU, TDIF, ADAT optical, MADI	5-band parametric, bell, shelf + HPF and LPF	2 motorized joysticks plus rotary pots	24	All types	Up to 7.1 surround monitoring; five different equalizer types; up to 1.2 seconds of channel delay; four different compressor types including GML, machine control
Balanced analog, AES/EBU, TDIF, ADAT optical, MADI	4-band parametric, bell, shelf, filter + dedicated HPF and LPF	Joystick and/or rotary pots	up to 20	Gate & compressor	Offline automation editor; simultaneous stereo, LCRS, 5.1 and 7.1 monitoring; interactive color touchscreens; 40x8 monitor matrix; virtual stems
Balanced analog; AES/EBU, TDIF, ADAT optical, MADI	4-band parametric, bell, shelf, filter + dedicated HPF and LPF	Joystick and/or rotary pots	up to 20	Gate & compressor	Offline automation editor; simultaneous stereo, LCRS and 5.1 monitoring; interactive color touchscreens; 32x6 monitor matrix; machine control
Balanced analog + HPF and LPF	4-band parametric/shelving automated fader	Rotary control and 2 stereo	6 mono, 2 stereo	All types	Selectable monitoring modes and inserts for downmix and matrix decode selection
Balanced analog + HPF and LPF	4-band parametric/shelving	Rotary control and automated fader	6 mono, 2 stereo	All types	Full Scoring Surround Monitor section with integral bus/tape switching; programmable monitor matrix with 96x8 crosspoints
Balanced analog; SDIF-2, MADI, AES/EBU	4-band parametric/shelving + HPF and LPF	Rotary control, joystick, panpoint	8, plus 2 on pre-cub channels	All types	Selectable monitoring modes and inserts for downmix and matrix decode selection; multiple operator options for larger film applications
Balanced analog; SDIF-2, MADI, AES/EBU	4-band parametric/shelving + HPF and LPF	Rotary control, panpoint	12	All types	Selectable monitoring modes and inserts for downmix and matrix decode selection
Balanced analog	4-band parametric/shelving + HPF and LPF	Rotary control, joystick option	4 mono, 2 stereo	All types	Programmable monitor matrix (SL 8000) allows easy selection of different monitoring modes
Balanced analog; AES/EBU, S/PDIF, SDIF, ADAT, Y2, MADI, ATM	8-band parametric, shelf, HPF, LPF	2 motorized, touch-sensitive joysticks	up to 32	All types	Eight configurable knobs per strip; shared NEXUS router allows facility-wide I/O; up to four slave consoles possible; 10 Project Recall buttons restore favorite setups
Balanced analog; AES/EBU, S/PDIF, SDIF, ADAT, Y2, MADI, ATM	8-band parametric, shelf, HPF, LPF	2 motorized, touch-sensitive joysticks	up to 32	All types	Eight configurable knobs per strip; shared NEXUS router allows facility-wide I/O; up to four slave consoles possible; 10 Project Recall buttons restore favorite setups
AES/EBU, MADI, ADAT, TDIF	4-band parametric, bell, shelving	Rotary knob, joystick	32 mono	All types	Multiformat monitoring up to 7.1; Virtual Surround Panning provides proprietary room + 16 stereo modeling per channel; multiple reverbs; central assign section with history buffer

# THE SIMPLE TRUTH IS RADAR® 24 SOUNDS BETTER, IS EASIER TO USE AND IS MORE RELIABLE THAN ANY OTHER DIGITAL HARD DISK RECORDER. JUST ASK THE EXPERTS.

## RADAR® 24 FEATURES

- Export files to Pro Tools® and other DAW's
- "ADRENALINE™" Board 192kHz recording engine with "TRINITY™" Chip
- "NYQUIST™" 24-Bit world class high resolution converters
- Toll-free, 24 hr, 7 day a week, person-to-person tech support
- Fully compatible with RADAR® I and RADAR® II
- Optional professional remote with aluminium jog wheel
- No external computer required - Just plug in any SVGA monitor
- Dedicated function keys - No endless scrolling through menus
- 24-channel digital I/O (you choose AES, TDIF or Lightpipe)
- All drives factory installed - Fully tested
- Real-time waveform rendering in record!
- Real-time, ultra reliable BeOS® operating system
- 2X DVD-RAM and high speed/capacity tape back-up options
- Integrated S/PDIF and AES 2 ch digital I/O
- Integrated 100-BaseT Ethernet for networking
- Control RADAR® 24 from your MAC® or PC via MMC
- Integrated SONY® 9-pin machine control
- Full timecode sync (SMPTE/EBU and MTC)
- RADAR® 24 is Soundmaster™ ION compatible
- Outputs 24 analog and digital signals simultaneously.
- Assign any track input to be digital or analog.
- Accesses up to 36,000 Gigabytes of Hard Disk Storage
- Link up to eight RADAR® 24's with RADARLINK™
- Many more features listed at [www.recordingtheworld.com](http://www.recordingtheworld.com)



"Hey, if it was good enough for U2 to record "Beautiful Day," it is good enough for me."

- PRO AUDIO REVIEW

"The iZ Technology Radar 24 sounded absolutely incredible at 96 KHz!"

- AUDIO MEDIA MAGAZINE

"RADAR is the most analogue sounding digital recorder. It is stable as a rock and brilliantly designed by an expert team that know their audio"

- JOHN ORAM "FATHER OF BRITISH EQ"

"The sonics are superior to everything else I've ever used."

- TONY SHEPPERD (BOYZ II MEN, BARBARA STREISAND, BACKSTREET BOYS . . .)

"If you want to catch a glimpse as to where our industry is headed look no further than the iZ Technology RADAR 24 . . . they also offer a service hotline staffed by devoted users. Hopefully other manufacturers will follow their lead."

- SURROUND PROFESSIONAL MAGAZINE

"RADAR 24 sounds excellent . . . Bottom line, RADAR 24 does what it has always set out to do; bring the high quality sound and simplicity of a tape recorder to the world of digital recording."

- RECORDING "MAGAZINE FOR THE RECORDING MUSICIAN"





# RADAR

T W E N T Y F O U R

EXPERIENCE THE ART OF RECORDING

ANALOG LOVERS BUNDLE

LIMITED TIME OFFER AT [WWW.RECORDINGTHEWORLD.COM](http://WWW.RECORDINGTHEWORLD.COM)

1-800 776-1356

**iz**  
technology  
[izcorp.com](http://izcorp.com)

WE HAVE THE EXPERIENCE

CIRCLE #017 ON PRODUCT INFO CARD  
World Radio History

# MusikMesse

R E P O R T

By Sarah Jones

# 2001



Meanwhile, Emagic ([www.emagic.de](http://www.emagic.de)) debuted Logic Audio 5. The redesigned automation is now tied to individual tracks, with 32-bit fader values, and automation data can be copied or moved with objects. Logic plug-ins keep on coming: Logic Platinum 5 now has more than 50! In addition, 24 Audio Instruments are supported in Platinum 5, and hardware-independent scrubbing and high-end dithering have been implemented.

**iZ Technology** released Version 3.1 software for RADAR, which makes it compatible with other DAWs, with a new Export to Broadcast Wave and .WAV2 function; exported projects can be loaded onto computers equipped with a DVD-RAM or standard DVD-ROM drive, and then dragged and dropped directly into workstation applications for mastering or mixing. The 3.1 release adds the ability to transfer files between multiple RADAR 24 machines via Ethernet, and iZ also announced Version 2.50 upgrade to RADAR II, free to all Otari RADAR users. Version 2.50 features enhanced graphics, accommodation of multiple SCSI backup devices and Macro import and export, and many improvements made during RADAR 24 development. Either upgrade is available at iZ's Website, [www.recordingtheworld.com](http://www.recordingtheworld.com).

## PRODUCT HITS FROM FRANKFURT

March brought dueling trade shows: While the NSCA Convention went on in sunny Orlando (see report on page 40), those wishing to maintain studio tans checked out the hottest new software, hardware, instruments and audio gear at Frankfurt MusikMesse 2001, the granddaddy of music trade shows, from March 7 to 11. With more than 2,100 international exhibitors in nine exhibit halls, there was something for everyone. Here are some of our favorites...

One of the biggest introductions at the show had to be **Mackie's** ([www.mackie.com](http://www.mackie.com)) hardware controller for **Emagic's** Logic Audio. The first product of the strategic partnership between Emagic and Mackie, Logic Control has eight 100mm motorized, touch-sensitive P&G faders, Mackie's rotary V-Pots, and transport and jog/shuttle wheel controls. The controller provides for hands-on adjustment of hundreds of MIDI and audio functions, with simultaneous control over multiple parameters of software instruments and plug-ins. Up to 128 channels can be addressed via bank-switching, and two Logic Control XT extender fader packs can be added for 24 simultaneous motorized fader controls. The Logic Control base unit lists for \$799, and is expected to ship next quarter.



Mackie Logic Control



Emagic Logic Audio 5

Shipping this quarter, **Steinberg's** ([www.steinberg.de](http://www.steinberg.de)) Nuendo 1.5 offers editing enhancements developed for both music and post-production. These include Open TL import/export for Tascam MMR-8 dubbers, Premiere EDI import, and support for additional audio file formats like MP3 and video options such as DirectShow. Full VST 2.0 support is also provided, and V.1.5 is fully compatible with Steinberg's new HALion software sampler. The Nuendo Surround Edition is a set of six plug-in tools designed exclusively for Nuendo, offering multichannel compression, EQ, reverb and more. Finally, the new Nuendo 8 I/O 96k offers sampling frequencies up to 96 kHz, dithering and storage of all settings.

**Celemony** ([www.celemony.com](http://www.celemony.com)) says its Melodyne software will extract notes from mono audio tracks and let you then edit melody, pitch, duration, formant and transitions. Melodies can be recorded directly into Melodyne or imported. Once in the Melody Editor, notes can be grabbed and moved to any pitch or time position. Phrasing is preserved, but vibrato and transitions can be edited (getting that Cher sound, for example). Up to 20 tracks can be processed in real time. Melodies can be saved as MIDI files, or pitch and amplitude information can be exported. Melodyne supports ASIO2 and hosts VST1 plug-ins.

The **Behringer** ([www.behringer.com](http://www.behringer.com)) V-Amp marks its entry into the funky-looking-amp-modeler market. This guitar body-shaped box has 16 amp models emulating classic guitar amps, with settings like Brit Class A and Tweed Combo, with 15 cabinet simulations and stereo effects including delay, chorus, flange, tremolo, compression, rotary speaker emulation and more. Retailing at \$269, the V-Amp comes with dual footswitch and gig bag. Now all it needs is a fretboard.

Pulsar XTC is **CreamWare's** ([www.creamware.de](http://www.creamware.de)) new VST-compatible DSP hardware/software system. The PCI card adds six 32-bit SHARC processors and four I/O options, each providing up to 28 I/Os and 24-bit/96kHz resolution. (The processing power is scalable with additional DSP cards.) Software includes more than 30 effects plug-ins from the SCOPE/SP system and an assortment of virtual instruments, including Vectron Player, based on vector synthesis. Pulsar XTC includes CreamWare's new Volkzämpler, which allows sampling at up to 96 kHz



**Behringer V-Amp**

with 32-bit resolution, an extensive graphical editor and compatibility with a variety of standard formats. List is \$999.

**Audient** ([www.audient.co.uk](http://www.audient.co.uk)) showed the ASP 510 console surround controller. The remote unit offers comprehensive control of monitoring and record functions for surround formats, including 5.1, LCRS, Dolby Surround, DVD-Video, DVD-Audio, SACD and DTS. The ASP 510 integrates with any console and supports three 6-channel and three 2-channel

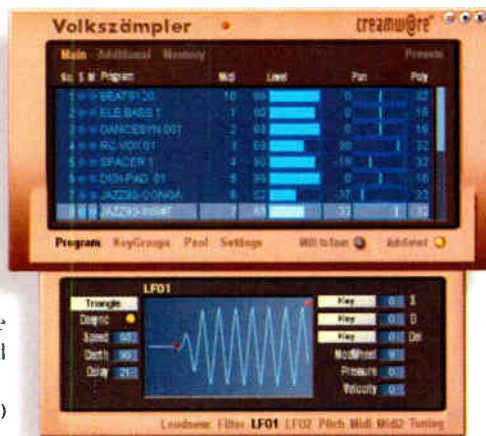

**Creamware Volkzämpler**

sources, a 6-channel speaker output, and 2-channel and 6-channel recorder outs.

**Waves** ([www.waves.com](http://www.waves.com)) demoed its new Renaissance Bass plug-in for TDM and Mac native (Windows on the way) platforms. The Renaissance Bass technology is the second-generation MaxxBass algorithm for psychoacoustic bass enhance-



**Native Instruments FM7**

ment, with a simplified user interface.

**Berkley Integrated Audio Software** ([www.bias-inc.com](http://www.bias-inc.com)) introduced Version 3.0 of its Deck multitrack audio workstation. This upgrade enhances Deck's real-time effects capabilities and updates the user interface. Following the recent release of Deck 2.7, which added ASIO support, Deck 3.0 offers support for VST and a completely redesigned graphical interface. Deck 3.0 will be available this quarter, for a suggested retail price of \$399.

## VIRTUAL SYNTHS KEEP COMING!

Of course, no visit to MusikMesse would be complete without checking out some cool software synths: **Native Instruments** ([www.native-instruments.de](http://www.native-instruments.de)) showed the FM7, which re-creates good old FM synthesis and adds distortion, filter operators, modulation, effects and more. The FM7 can read and reproduce sound libraries from the original DX7, DX7-II, DX11, TX81Z, DX21, DX27, DX100 and TX802. It runs either as a stand-alone or as a plug-in, supporting VST 2.0, Dxi, DirectConnect, MAS and ASIO. Absynth, another new software synth from NI, offers graphical breakpoint envelopes, multiple synthesis techniques, MIDI and modulation. Our coolest-swap-of-the-show award goes to Native Instruments for handing out free absinthe (the green liquid kind) at the booth.

**Emagic** announced lots of new software products, but our favorite was the ES2 synth, with up to 16-note polyphony, three oscillators per voice (oscillators 2 and 3 can sync to oscillator 1), and analog and digital source waveforms, including FM, Ring Mod, Noise and more. A time-based effects processor offers chorus, flanging and phasing. Emagic also introduced the EVO20 multiband vocoder/formant filter for Logic Audio and EVP88, a vintage electric piano synth. **Steinberg** announced **Waldorf Attack**, a VST percussion synth (featured on page 110).

The **VirSyn** software synth combines analog and digital synthesis with physical models, with a user interface that navigates through an 8-dimensional sound space. Up to 12 modular synthesizers can be used simultaneously; effects are included. Check out [www.virsyn.com](http://www.virsyn.com) for more information.

Look for more cool stuff from MusikMesse in our regular product columns in future issues. Next month: hits from NAB! ■

# REPLitech 2001

## Audio, Video and the Next New Format?

By Dan Daley

**REPLitech**, the media manufacturing show, celebrated its 10th anniversary at the Los Angeles Convention Center in February. Ironically, the Grammys were presented right next door, at the Staples Center, on the second day of the show, so the people who make the music were a stone's throw away from the people who make their CDs, DVDs and MDs, audio cassettes and videos. And soon, their DVD-As and SACDs.

This stew of three-letter acronyms rubbing shoulders with the glitterati of the music business is more than coincidental. For the past few years, REPLitech has given the recording industry a peek under the hood of format developments.

This year's North American show (REPLitech also has a European and an Asian edition) had one panel dedicated to audio: The topic was mastering and authoring for high-resolution audio formats, specifically the still-nebulous DVD-A and the Sony/Philips-backed Super Audio CD. Panelists included mastering veterans Bernie Grundman and Steve Hall, VP and chief engineer of Future Disc Mastering, respectively, and Paul West, senior VP of studio operations at Universal Music in Los Angeles.

Grundman, Hall and West all bemoaned the shortage of authoring tools for DVD-Audio and were particularly critical of Sonic Solutions' software packages, which Hall described as "bare-bones and very inadequate." He also described the DVD-A authoring and mastering process as laborious, noting that several projects he has done have taken as long as three weeks of studio time. "You're literally writing code as you go along, because the tools aren't there yet," he says.

Perhaps it's just as well that there are few DVD-A titles and a virtually nonexistent market. West, whose operations are part of the Universal Music Group holdings, declined to address that label's plans for DVD-A titles, but was in agreement with other panelists that DVD-A is a victim of corporate politics and intramural confusion as much as anything else.

Grundman, who opened a satellite mastering facility in Tokyo four years ago, pointed out that in Japan, a trend seems to be emerging to use the basic DVD-V format as a music product. "In Japan, where the prices of CDs are still high, they seem to like discs with three or four songs and some video on them," he explained. "The regular DVD format is fine for that. Also, there's no market [in the U.S.] for CD singles anymore. But in Japan, it's a big product." Likewise, Sony's MiniDisc format never really caught on here, but it's a resounding success in Japan and certain other parts of Asia. The Video CD (VCD), a

highly compressed video format on a Red Book-type disc, is virtually unknown in the States but is the format of choice for the 1 billion-plus Chinese market and has been for over a decade.

If there was an overarching mood at this REPLitech show, then it was concern about the dramatic slowdown in the media manufacturing industry over the last year. Despite record numbers of replicated discs, of all types, the unit price has plummeted, with packaged CDs now routinely selling for under 20 cents on large-volume orders—often not enough to even cover the patent royalties on discs.

DVD disc prices have also dropped sharply, and the entry late last year of two major Taiwanese DVD replicators into the U.S. market (Ritek and Infodisc, the latter being the world's largest DVD maker) has increased pressure on U.S. disc makers. Another depressing factor is the recent lackluster sales figures for music and film titles. The ripple effect of these events has been felt throughout REPLitech's constituency, including heavy equipment manufacturers who make CD production lines—the prices of which have dropped significantly—and the used equipment market, which has seen a flood of CD-R and, to a lesser extent, CD manufacturing equipment. "You want CD-R equipment? I can have 20 lines on your doorstep tomorrow," cracked Larry McGowan, sales manager for Canadian equipment reseller Targray.

And the tide of new formats continues. One of the more interesting ones is DataPlay, a micro-optical disc and drive combination about the size of a matchbox. DataPlay's storage is impressive, at up to 500 MB per disc, which translates to about five hours of "CD-quality" music or 11 hours of MP3 data. The format allows for both pre-recorded and recordable portions on the disc and includes Internet links for downloading. The company intends to position the DataPlay disc and its drive in a number of markets, including cell phones, e-books and video games, but the company clearly signaled that music is the first frontier it must conquer.

Remember the drive for a single universal and reliable format for everything? Maybe next year. ■

**WE DID THE ROCKET SCIENCE.**

**SO YOU WOULDN'T HAVE TO.**

**MEET THE NEW DACSYS 2000 DIGITAL SIGNAL PROCESSOR:  
EASY-TO-USE INTERFACE. PLUG-IN I/O MODULES.  
BULLETPROOF RELIABILITY... AND KILLER SOUND.**



Plug-in modules allow you to add up to four inputs, four outputs, or two of each to the basic two-in/six-out DP-0206 model.

THAT "TOA SOUND" comes from an innovative new dual processor technology we call *CLEAR Conversion*™. We make it easy to get this sound, too. The TOA interface—already considered the industry's most straightforward—has been totally redesigned for the DACSYS 2000, making set-up easier than ever. You also get full matrixing, modular I/O expandability, and TOA's legendary reliability—all at a price that's surprisingly affordable. For details and ordering information, visit us at [www.toaelectronics.com](http://www.toaelectronics.com).



# NSCA Expo 2001

## New Ideas, New Directions, New Products

By Mark Frink

Appropriately located between the "Travel & Leather" and the "Electronic House" trade shows in the cavernous Orlando Convention Center, the 21st Annual National Systems Contractors Association show had a few surprises and the fruits of several emerging trends in live sound. From March 8 to 10, 2001, a record-breaking crowd of nearly 11,000 people attended the show, which also marked the first year that NSCA allowed larger booths, giving the show a more polished, professional appearance. For those who didn't attend, here are a few highlights...

Turbosound co-founder Tony Andrews' decades of designing speakers have culminated in the new company Funktion-One ([www.funktion-one.com](http://www.funktion-one.com)) and its Resolution line. Though the first impression is the familiar heritage of previous products, these speakers are infused with a subtle color and a host of refinements: light-weight, high-efficiency, startlingly clear vocal reproduction and simple, yet elegant flying hardware characterize the Resolution speakers. Distributed in America by Carl Taylor's Zag Inc. (so named as a humorous allusion to the direction the rest of the industry has taken).

Successful Compact Driver and the dispersion of a line source: a stunning combination. The use of Neodymium magnets and Kaladex™ diaphragms offer a line source rated at 750 watts with a maximum SPL of 118 dB. Though it reproduces frequencies down to 100 Hz and was demonstrated with full-range jazz playback, its polar characteristics and the mechanics of cylindrical wavefront propagation suggest crossovers above 500 Hz in combination with LF cone line arrays. Three shorter models are 50, 40 and 28 inches tall.

L-Acoustics ([www.l-acoustics.com](http://www.l-acoustics.com)) unveiled the dV-SUB, a 27-inch cube with triple 15s in a dual-vented, 2.7-ohm bandpass configuration weighing 200 pounds. Designed with the same width as the company's compact dV-DOSC, they can fly above in a separate column or provide a convenient base for ground-stacked applications. Equal in height to three dV-DOSCs, a 3:1 ratio is recommended.

Peak Audio ([www.peakaudio.com](http://www.peakaudio.com)) released CobraCAD software and saw several new products join its growing family of CobraNet digital audio products that use low-cost 100BASE-T



JBL MPro Series

Crown ([www.crownaudio.com](http://www.crownaudio.com)) introduced the IQ-PIP-USP2/CN module, which, when installed in Crown's Com-Tech 10 Series and Macro-Tech 02 Series amps, creates the industry's first CobraNet-compatible amplifier. Onboard processing includes alignment delay and eight filters per channel. It also connects the amp to an IQ System for control and monitoring.

Whirlwind ([www.whirlwindusa.com](http://www.whirlwindusa.com)) debuted its DCS88 (Digital Contracting Series), a small, brick-shaped digital audio transceiver with eight mic or line analog inputs and eight analog line outputs on Phoenix connectors. A small power supply injects low voltage from up to 100 meters away on the same CAT-5 network cable. Whirlwind plans a larger DTS Cobra Snake later this year.

SIA Software's Smart Live Version 4.5 adds cool new features. Available as a downloadable upgrade from [www.siasoft.com](http://www.siasoft.com) or a fully operational, 30-day demo CD-ROM, it now includes magnitude thresholding, coherence blanking, vector averaging and phase smoothing. Recently added remote-control devices include the Symetrix 9022, Biamp's MSP Advantage and

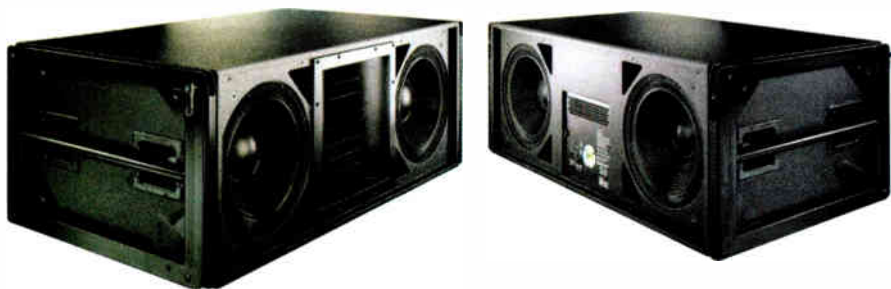

Front and rear views of Meyer's M3D line array show the front- and rear-firing woofers.

Radia Pro Systems' ([www.radiapro.com](http://www.radiapro.com)) new Z-190 is a six-foot-tall, 5-inch wide ribbon driver with a fidelity similar to Stage Accompany's suc-

Ethernet components for system integration. Up to 64 channels of 48kHz, 20-bit audio can be sent in each direction over a CAT-5 or fiber link.

Mackie's DX8 mixer, with the Sony SRP-F300, BSS MiniDrive and dbx DriveRack coming soon. AcousticTools V.4 now features a new interface and interconnectivity with SmartLive.

Sabine's ([www.sabine.com](http://www.sabine.com)) new True Mobility 2.4GHz spread spectrum wireless systems operate in a trouble-free RF band that is internationally accepted, and up to 50 systems can operate at once. Onboard SHARC-based processing offers mic capsule SuperModeling, automatic de-essing, compression, 10 FBX feedback filters, 10 user presets and an optional network interface with AES digital output. Available with single- and dual-channel receivers, and a companion-active, antenna-distribution amp supports 12 channels.

This was perhaps the last good chance to get into the line array business, and four exhibitors made it under the wire, with products just in time for this year's touring season. Meyer ([www.meyersound.com](http://www.meyersound.com)) unveiled its M3D two-way line array with a performance by Delbert McClinton. The 400-pound, self-powered enclosure has a pair of 15s on the front, a CQ horn in the center and another pair of rear-firing 15s. EAW ([www.eaw.com](http://www.eaw.com)) demonstrated its three-way, 200-pound KF 760 line array enclosures with a concert by the fabulous Monhegan Sun All Stars. At each end, an LF 12 is housed in a tuned, vented enclosure with a tall, wide aperture, and between these are a pair of horn-loaded 10s and a pair of 2-inch compression drivers. McCauley ([www.mccauley.com](http://www.mccauley.com)) announced a three-way line array system with a few details, and E-V's X-Line has been re-engineered since its outing last year with Diana Ross.

JBL ([www.jblpro.com](http://www.jblpro.com)) launched its MPro lines of two-way speakers with optional passive and active subwoofers—the latter has internal amps and signal processing built by Crown Audio. The full-range models feature molded front baffles

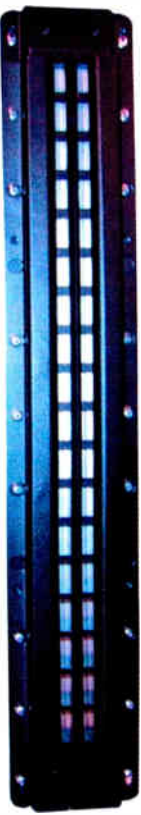

Radia Pro Systems Z-190 6-foot ribbon driver

## Hits You Might Have Missed

With 500 booths to see over three days, NSCA had plenty to check out. Here are some items you may have overlooked.



Rockustics' OmniPlanter

mics and thrus to the monitor board.

- Rapco's Sweet-T tube DI employs a 12AX7 tube for a warm sound. Features include 16- and 40dB pads and sweepable cut-only notch filters for lows and highs.

- Technomad's ([www.technomad.com](http://www.technomad.com)) Vernal compact 9x6x6-inch, weatherproof speaker comes in 12 colors and is loaded with a 5-inch woofer, a horn-loaded HF driver and an optional 70V transformer.

- i-TEK's ([www.fps-inc.co.jp/itd](http://www.fps-inc.co.jp/itd)) Pipeline speaker uses a vertical array of flat-panel transducers within a 3-inch diameter tube. The speakers can be used alone for unobtrusive installs or paired with an optional sub that doubles as a base and extends response to 34 Hz.

—George Petersen

i-TEK's Pipeline speaker

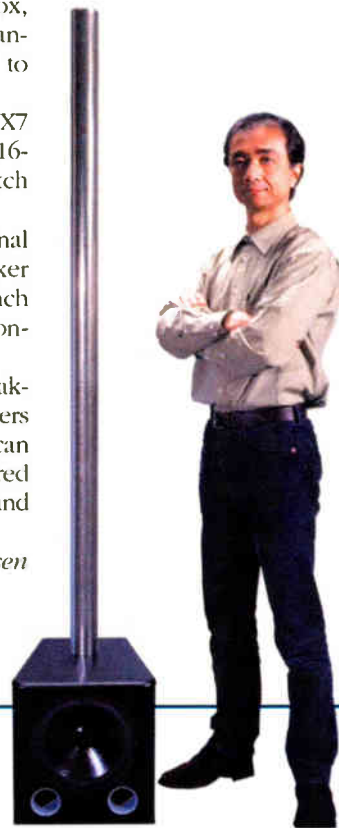

that integrate horn, ports and woofer mounting. The MPro Series 200 includes the MP215 (with 70°x70° horn, 1-inch HF driver and 15-inch woofer) and the MPro MP255S dual-15 sub in an innovative handpass box. The first MPro Series 400 models are the MPro MP410 10-inch, two-system, and the MPro MP418, a powered, single-18, bass-reflex sub—all with a Duralex finish.

In other speaker news, Klipsch ([www.klipsch.com](http://www.klipsch.com)) announced an alliance with the Hard Rock Cafe to place Klipsch systems in HRC hotels, venues and restaurants worldwide. The agreement may include future co-branded retail products bearing the names of both companies.

Checkpoint ([www.checkpoint3d.com](http://www.checkpoint3d.com)) showed its Sound Alignment Systems

- Rockustics' ([www.rockusticsinc.com](http://www.rockusticsinc.com)) Omni-Planter is a 2-foot high by 2-foot diameter, floor-standing imitation terra-cotta planter housing a down-firing 8-inch co-ax that provides 360° sound.

- Marshall Electronics' mic division ([www.mxl.com](http://www.mxl.com)) showed a built-in, 5-inch LCD video display panel, Mic Mute switch and an optional gooseneck mic.

- Radial Engineering's ([www.radialeng.com](http://www.radialeng.com)) Spider is a 48-channel house snake with a central stage box, with eight 12-channel sub-snakes to

line of precision laser tools. The LG-120 laser line generator has a calibrated quartz beam-spreader that adjusts from 15° to 120°, aiding in coverage prediction. A magnetic base allows it to stick it right onto a speaker grille. Another model that speaker manufacturers should inquire about is permanently installed inside a speaker cabinet and activated with a contact closure.

Next year's NSCA Expo comes to Denver April 25 to 27, 2002. More information will be available at [www.nscexpo.org](http://www.nscexpo.org) later this spring. ■

Mark Frink is Mix's sound reinforcement editor.

# ANI DIFRANCO

Stretching Beyond the Periphery



PHOTO: RHEA ANNA

*I'm no heroine  
Least not last time I checked  
I'm too easy to roll over  
I'm too easy to wreck  
I just write about what I  
Should have done  
I sing what I wish I could say  
And I hope somewhere  
Some woman hears my music  
And it helps her through her day.*  
—"I'm No Heroine"

by Sarah Benzuly

While the rest of the world was listening to the likes of Janet Jackson's "Escapade," New Kids On the Block's "Step by Step" and Wilson Phillips' "Hold On," indulging themselves in everything pop in 1990, a folksinger was making her way around small clubs and coffee houses, constantly touring and exposing a new generation of music fans to a different side of the tracks—her vision of reality. Preaching her own gospel, Ani DiFranco's first albums brimmed with an awareness of the sociopolitical/economic situations in her hometown of Buffalo, N.Y., and across the nation. Crowds flocked to see this energetic, charismatic singer/songwriter expose a social consciousness that seeped through poetic melodies and the seemingly casual strumming of an acoustic guitar.



DiFranco is a woman determined to be heard. Since 1990, she has released 13 self-produced albums, including two collaborations with storyteller Utah Phillips. With each release, she delivers compelling rhythms and harmonies that extend into the areas of rock, punk and spoken word, but always find a home in the folksinger way of life—keeping it simple and honest and doing it all on her own. Despite her tremendous accomplishments, many critics have found DiFranco's lyrical style too aggressive, too far removed from the mainstream. And they've found their ammo within her lyrics—in their sometimes stark realism.

Certainly, much of DiFranco's success has come from the appeal of those lyrics. "I don't know how people take [the lyrics], it's a bit of a mystery to me," DiFranco says. "I suppose each person hears things differently. In terms of being a poster child [for feminism], there are probably ideas about self-empowerment or about becoming one's self that are attractive or exhilarating to young women who maybe are just becoming acquainted with those feelings for the first time. Like, 'Maybe I don't have to put up with this,' or 'Maybe I don't agree with this,' or 'Maybe I want to wear this.' So I guess there is room for a pretty visceral emotional response there. Themes of self-empowerment or even just self-questioning or exploration come up a lot in my songs."

Recording since she was 20, this prolific singer/songwriter/musician/producer infiltrated the music scene from the fringe. She never signed with a major label, opting instead to create



her own record company, Righteous Babe Records, which allows DiFranco to have full control over her artistic ventures. Now, too, the label also



Ani DiFranco and sound engineer/tour guru Andrew Gilchrist

**She just blows my mind. How fluid, so natural, it just comes out of her, and my job is just to keep up, speed-wise. And the hours we spent in the studios—there were times when I would say, "Hmm, it's light again. I think we should stop."**

**—Andrew Gilchrist**

hosts other artists DiFranco believes in, including the DiFranco-produced Drums 'n' Tuba. The label has grown to become a touring company, a management company, a music publishing company and the Righteous Babe Foundation, a nonprofit organization that seeks grassroots solutions to real-world problems.

Working against the mainstream, DiFranco has nonetheless managed to make her presence known in the music industry. Besides touring successfully year after year, her last four albums have made *Billboard's* Top 200, and her double live album, *Living in Clip*, went Gold. She has received six Grammy nominations and was included in VH-1's "100 Greatest Women of Rock," which called her "one of the most influential musicians of the 1990s."

Her latest effort, *Revelling/Reckoning*, another double-disc CD, finds DiFranco expanding in yet another direction. The addition of a full band creates a problematic hurdle for critics wishing to simplify her and keep her on the fringe. And, at the same time, the release creates yet another reason why fans love her—DiFranco stead-

fastly fails to compromise her artistic vision.

"I've got a new, improved and expanded band. I've got a horn section now, so that's pretty new for me," DiFranco says. "I've always had a huge hard-on for brass, and two summers ago, I did a tour with Maceo Parker [who has worked with DiFranco on the past couple of CDs, including the new release], and after a month of hanging with him, playing, sharing music together to the point of no return, it was like, 'Oh, now I have to have my own horn section.' So this is the first record with all six of us; my band."

The new and improved band on the record consists of multi-instrumentalist DiFranco on her usual acoustic and electric guitars, as well as some drums, bass, tamboritzita, tongue drum, shakers and keys; Shane Endsley on trumpet and vocals; Daren Hahn on drums and vocals; Jason Mercer on bass, kazoo and vocals; Hans Teuber on reeds (flute, saxophone, clarinet) and vocals; and Julie Wolf, a longtime fixture in DiFrancoland, on keyboards and vocals.

But even with the addition of new instruments and talents, DiFranco

## ANI DIFRANCO

Stretching Beyond the Periphery

sticks to what she knows best: maintaining her edgy folk sensibilities on *Revelling* and clinging to her acoustic guitar on the mostly solo acoustic second CD, *Reckoning*. And, as on previous releases, DiFranco continues to take control of her musical destiny by placing herself behind the console.

"Initially, and certainly for the first 10 years, [I produced my records] out of necessity," DiFranco recalls. "I was making recordings without a record company and with no big record company to hire a big producer man. It's not like I had some guy around saying, 'Oh, I know how to do this.' So, I was like a lot of young, independent musicians making their own recordings—I just made it up. And certainly, for the first five or eight albums, I had absolutely no facility with machines at all. I walked into a recording studio and I was your typical artist—I sing and play guitar. Tell me where to sit.' And then, even as I started to become familiar with, 'Okay, what's a preamp and what's a compressor and how does this work?' it took me many years to develop an aesthetic. Like, how do I want my guitar to sound? So the first seven records, all the sounds and the sensibilities of the recording had to do with the engineer who was there. He would choose the mic. So, basically, my involvement in mixing at that time was level setting. Over the years, I started to find my way around patchbays, and I started to understand being able to use gear and also develop a sense of involvement in the recordings.

"At this point, I'm just beginning to have a facility of my own in the studio, and it's a journey. That's another outlet of creativity—the recording studio—and for learning. Now it's not so much out of necessity, but it's because it's another thing that I can do," she says with a laugh. "And enjoy doing."

Since the mid-'90s, Andrew Gilchrist has been DiFranco's primary technical foil, working as an engineer for her both on the road and in the studio. That studio work, he explains, is usually ongoing rather than tied to a specific project. "When people ask me how the album started...it never really did," he says. "There is no pre-production. It's continuing. There are things that I've recorded [during this album] that will be on the next record, and I

don't even know it yet."

Whatever time frame (or lack thereof), recording the album took place at DiFranco's home studio, the Dust Bowl in Buffalo, N.Y., and, to a lesser degree, at an Austin, Texas, studio called the Congress House, where she'd worked on her previous album, *To the Teeth*. "This new record is the first one where most of it was record-



PHOTO: BREA ANNA

**That's another outlet  
of creativity—the  
recording studio—  
and for learning.  
Now it's not so  
much out of  
necessity, but it's  
because it's another  
thing that I can do,  
and enjoy doing.**

**—Ani DiFranco**

ed at home," DiFranco says. "Certainly, the second record, which is almost all just me—that was a 'middle of the night at home, wake up, turn on a tape machine' kind of situation. It's such a luxury to be able to work any time. The Congress House is a studio that I've been going to for so many years now; it's been at least five. And it's just

a really small, unassuming, little studio in a tiny little house. It's just really comfortable."

While the record was still a work in progress, coming together throughout the last tour, DiFranco was rarin' to go when she walked into the studios. "As soon as I write songs, I start teaching them to the band because we are always touring," DiFranco says. "By the time we hit the studio, the songs are fully formed in their arrangements. Some songs start with a guitar riff, and even some on the new record started with a rhythm—a drumbeat or kind of a bass line—and then some of them start with words. It's different all the time. It really depends on where the song lives, what its focus is. Certainly the second album, *Reckoning*, which is a very folk album—it's very quiet, acoustic, mostly solo songs, so, of course, those really focus around the meaning and the words a lot more."

The CD was recorded over the course of a year and, again, working within that "keeping it real" sensibility, DiFranco opted to record direct live to tape, except for most of the second disc, "which, of course, is just a lot of overdubbing, because it's just me," she says. But the band disc was cut live in the studio: "That's my great luxury of having my band and all these musicians: We have the ability to go live to tape and capture performances, rather than this business of overdubbing.

"I think that when I first started making records," DiFranco continues, "there was a lot of overdubbing involved, 'cause that's how I was told to make records. It took me a bunch of years to figure out a lot of stuff for myself, like, 'That's dumb' and 'That doesn't make for good recordings.' I have a problem with the perfectionism side of the studio. I have all of these albums [I've done] and dubious versions of otherwise decent songs. My solution the past few albums has been to record direct live to tape, because I can only play a song a few takes before I'm bored."

Like all of her previous albums, *Revelling/Reckoning* comes complete with in-studio banter, casual moments where DiFranco is caught on tape not knowing if tape was rolling, screwing up lyrics and just having a ball in the studio.

According to Gilchrist, "Traditionally, we make recordings really quickly—just put the stuff down and do it. We'll do the songs a bunch of times. We'll start in Buffalo [at the Dust Bowl], record the

# Audio Nirvana



## 9098i

*"My choice for the AMEK 9098i was inspired by opportunity and the desire to run ahead of the pack. I was absolutely stunned by the sound of the desk. The power and fullness reminded me of the older Neve modules I've collected over the years. Beyond the sound, in one afternoon, I was able to mix like I was used to mixing and more! The automation package is as engineer-friendly as it is comprehensive, plus I've got dynamic options on every fader!!! It was a dream come true, finally a console with the sonics akin to my old Neve modules, combined with the automation power of an SSL!! Audio nirvana is here! I was receiving calls to book the console before it was even installed!!"*

Jim Zumpano, Owner  
Stonehenge Recording at ZAC  
Atlanta, GA

Like his earlier classic consoles, the Amek 9098i designed by Mr. Rupert Neve, reflects the audio subtleties, nuances and attention to detail that have made his designs so highly desirable for decades. Featuring extended frequency response, the sweetest of EQ curves and an unsurpassed ergonomic design, the 9098i is equally at home in broadcast, film, post and music production.

- The only new console with the right to bear the words 'designed by Mr. Rupert Neve'.
- The 9098i combines the ultimate in analog sound with the world's leading console automation system, **Supertrue V4™**
- Designed from the ground up for 5.1 and other multiformat work



**US Headquarters**

1449 Donelson Pike  
Nashville, TN 37217  
Tel: (615) 360-0488  
Fax: (615) 360-0273

Email: [amekusa@harman.com](mailto:amekusa@harman.com)  
Web: [www.amek.com](http://www.amek.com)

**H** A Harman International Company  
CIRCLE #018 ON PRODUCT INFO CARD



**UK Headquarters**  
44 (0) 161 868 2400



**Los Angeles**  
1 (800) 585-6875



**Nashville**  
1 (888) 286-9358



**Montreal**  
1 (800) 449-5919

World Radio History



**Tokyo**  
81 5606 3101

songs, have a band session, track the tunes, tour, book studio time in Texas [at the Congress House], do the same songs as if we never did them before." In the end, many of these songs on the new album were tracked three different times in different studios, and then DiFranco chose the version of each that she liked best. There were, not surprisingly, some variations in equipment and even recording format from studio to studio. For instance, some of the songs were recorded to 2-inch analog, but most of the album was tracked to ADAT and edited in Pro Tools.

"As soon as Ani is playing, I'm recording," Gilchrist says. "Even imperfections, personality or weird takes. We'll create dozens upon dozens of tapes just in one week. We're not gonna tweak until it's 'perfect,' and I guess that goes back to folk music—the feeling of real people making music. We try to come out of the studio as unbutchered as possible. She smokes me in the studio, which is my world, which gives credit to her hands-on experience in the studio.

"I just got into Pro Tools editing," he continues, "but I want to stay fairly basic. The idea of tracking to Pro Tools...I just don't want to go there—I'm scared enough of tracking on ADATs. We didn't do a lot of editing; just a few pieces. You know, the old-school style editing of just chopping sections if a song is too long. But we didn't do a lot of tweaking. With Pro Tools, the possibilities are scary. It's frightening how fast I can do it!"

The songs were recorded direct live to tape through either the Amek desk at the Congress House or the Soundcraft console at the Dust Bowl. Monitor pairs included Genelec 1031, Westlake BBSM 6, Yamaha NS-10M and Auratones. The equipment list also included an impressive array of outboard gear, including Avalon mic pre's, a Joe Meek compressor and much more. "A Tube-Tech [CL1B] compressor pretty much sat on the vocals," DiFranco says. "There are a couple of tube compressors always at work somewhere. TC Electronic has a new multi-effects [processor] called FireWorX that has come in real handy the past year of my life. We just got one, and it has so many different sounds;

we've utilized it in all kinds of different ways. The Eventide H3000 SE is also a fave, which I use for all kinds of things—reverbs and delays and also the little Sampling function. Because I don't really have any sampling gear, if I want to make a loop, [I'll use] the H3000 or Jamu Man."



Ani DiFranco working her magic on the acoustic guitar

Gilchrist and DiFranco strive to keep the sound as natural as possible, but the engineer also notes, "We like to experiment a lot, try to get something that sounds like the studio that we're in. I like to use a lot of mics and exper-

**We try to come out of the studio as unbutchered as possible. She smokes me in the studio, which is my world, which gives credit to her hands-on experience in the studio.**

**—Andrew Gilchrist**

iment with different ones. I'm a self-proclaimed gear freak, but I like to set up with mics I already know. I like to use the Sony C800 tube mic, because it sounds like she sounds. I also use a Manley Gold Reference mic and an Audix 111 large-diaphragm condenser mic, because it sounds right for her voice. We'll use anything, depending on the song."

"My vocal mic has been shifting depending on where we're recording,"

DiFranco adds. "Actually, all the mics are shifting. I'm constantly experimenting with guitar mics and overheads. There weren't really any same ones for the whole record. It changes based on the guitar and the song. But I've kind of fallen into this new thing this last year or two of two mics on the guitar to get a stereo picture of the guitar in the room. Generally, one of them is sort of underneath my chin and pointing down, and the other one I have kind of underneath the bridge pointing up. Not pointing at the guitar [with either]—I find all kinds of problems when I actually face a microphone at a guitar anywhere. It sounds boxy or boomy or dull. But I so love the sound of my guitar just as my head floats above it. Then I also take a DI, usually for a punchy bass. On a fourth channel, I usually send my guitar to an amp.

Acoustic guitar through an electric guitar amp has kind of been my thing for a bunch of years. You can kind of shift it between a more amp-y and a more acoustic sound in the mix."

Gilchrist used a combination of room mics and close mics to record the new brass section. He found a Coles ribbon mic to be particularly good on brass. Other mics used throughout the recording sessions included Neumann TLM170 and -103, Royer R121 ribbon mics, and a plethora of AKG, Sennheiser and Beyers models. Gilchrist also tried working in different room settings to get more variation out of DiFranco's amps and vocal mics, including recording in the bathroom "for a great room sound."

DiFranco's friend Maceo Parker joined up with the clan at the Congress House, adding some vocals and saxophone to the new release. (Parker also appeared on *To the Teeth*.) "I've been a huge fan of his for years," DiFranco recounts, "and a couple of summers ago, I was going on an outdoor/shed tour, and we were looking for someone to open the show. And I was like, 'Well, why don't you try calling my musical hero?' We just called him up to see if he wanted to do some shows. He's been kind of family since then."

And, according to Gilchrist, recording Parker's sax couldn't have been any easier. "Just put a mic near him and you get his sound. We used condenser mics—I think a Neumann TLM170 and U87s. He always sounds



AKG C 4000 B

FOR THOSE WHO COLOR NOWHERE NEAR THE LINES.

**H** A Harman International Company

www.akgusa.com • 615-360-0499  
1449 Donelson Pike • Nashville, TN 37217

Circle #012 on Product's Info Card

World Radio History



RAISE THE LEVEL



Pure Class A  
Vacuum Tube  
Preamp, Compressor  
& Equalizer

Email: [avalon@avalondesign.com](mailto:avalon@avalondesign.com)

[www.avalondesign.com](http://www.avalondesign.com)

Fax: 949-492-4284

Tel: 949-492-2000

© Copyright 2001 Avalon Industries, Inc.

CIRCLE #020 ON PRODUCT INFO CARD

## ANI DIFRANCO

Stretching Beyond the Periphery

great; he's that good. I put up the track, let him listen to it in the control room, he goes into the room and just *does* it. He only does three takes and he's done. He tells me he's done and I'm like, 'Okay, that sounded great!'

With all the recording finished, Gilchrist and DiFranco set out to pull the CD together and master the tracks, a process that turned out to be a revelation of its own.

"Mastering was scary," Gilchrist admits. "There were so many DATs. I had so many spreadsheets open that I had a hard time trying to keep track of things. [Ani] would add songs when we were listening to things in playback, because she felt that something was missing. So, she would just do it and I would run tape. I would walk

reveals, "if you listen way under the tremolo and electric guitar, you can hear a TV. We were locking ADATs up to rough cuts of this movie, and we didn't realize that we were going to get interference. But it sank its way into the recording. We left it, but I can hear it now and say, 'Oh well.' But when we were dubbing for a sample CD for radio, I thought, 'Wow, this sounds really good.' Because in the past few months, I'm just hearing all those things that made me cringe.

"But this is a beautiful record," he continues. "She just blows my mind. How fluid, so natural, it just comes out of her, and my job is just to keep up, speed-wise. And the hours we spent in the studios—there were times when I would say, 'Hmm, it's light again. I think we should stop.' I'm just glad that the record is done. It was getting to be so long.

"We'll just keep going, though. She's



Andrew Gilchrist and Ani DiFranco at DiFranco's home studio, the Dust Bowl, in Buffalo, N.Y.

into the studio each day and not have any idea of what we were doing that day—if it's an idea she has, screwing around or actually recording."

"Initially, I thought I was just making one record," DiFranco explains, "and then there were certain songs that didn't really want to be put into one box with other songs. And then I started to conceive of it as two records. At first, it was just gonna be *Reckoning*, and then the idea for the second record came to me. And the flipside of 'reckoning' was the idea of 'revelling.' I guess, basically, the songs ended up kind of divided thematically along those lines. The *Revelling* record has a lot more complexly produced stuff and a lot more band material. And then the *Reckoning* record is much quieter and simpler."

As with many projects, final playback exposed a few hidden surprises that, for the benefit of a natural sound, were kept in. "On one of the recordings," Gilchrist

like no one I've ever worked with or ever encountered. Her level of concentration and speed of activity are unreal. I mean, the quality is really good and her writing is incredible. Also, her guitar work is strangely overlooked."

As for Ms. DiFranco, she'll just keep doing what she loves and what her fans love her for: her powerful lyrics and melodies, the nearly hypnotic rhythms that seem to emanate from her without much effort. "I guess I'm most interested in writing what reflects someone's reality, because I think that there are so many stories all around us that don't necessarily find their way onto the TV," she comments. "I think the act of telling one's own story and broadening the palette of colors in a culture is a good place to start. I'm just doing what I do—touring and making records and otherwise living for music." ■

Sarah Benzuly is Mix's copy editor.



# TC • POWERCORE

THE DSP TURBO FOR NATIVE RECORDING SYSTEMS



## WELCOME TO ULTIMATE DSP POWER!

**TC POWERCORE** will provide your native system with the power to do it all – and more.

This PCI-card transforms any VST or MAS-compatible software into a professional high performance audio workstation, delivering the equivalent power to 2.8 GHz. This power is being added to your existing production environment – **TC POWERCORE** integrates seamlessly with all sound systems and any software that supports VST or MAS Plug-Ins!

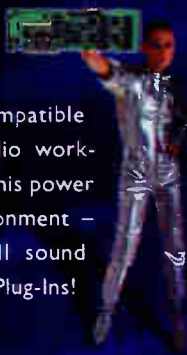

This is the “Turbo” you have been waiting for: Run 8 studio-quality Plug-Ins simultaneously without reducing your track count or even worse, stealing all of the CPU’s available horsepower.

**TC POWERCORE** Plug-Ins run in addition to any of your standard VST Plug-Ins – seamlessly integrated into your native environment with no limitations as to the routing or signal path. Mix and match in any way you desire!

## TC POWERCORE, ANOTHER INNOVATION BY TC WORKS

### INCLUDES TC TOOLS/96

At last, the renowned TC TOOLS studio-quality FX package with TC MegaReverb, TC Chorus/Delay and TC EQSat Plug-Ins is accessible from within any VST or MAS application. In fact, you can run all 3 TC TOOLS Plug-Ins on a single TC POWERCORE DSP, something previously impossible even on the fastest available CPUs!



### SUPPORTS VST & MAS



### SUPPORTS ALL I/O CARDS



### 3RD PARTY SUPPORT

TC POWERCORE is an open processing platform – 3rd party announcements to follow shortly.



System requirements: G3 PCI PowerMac, MacOS 9, VST or MAS recording software, any I/O card.

**TC WORKS**  
ULTIMATE SOFTWARE MACHINES

CIRCLE #080 ON PRODUCT INFO CARD

# ELLIOT MAZER

## RENAISSANCE MAN IN A DIGITAL WORLD

Elliot Mazer has had a long, varied and distinguished career as a record producer, studio owner/engineer, entertainment technology company executive and audio consultant. Primarily known for his 30-year association with Neil Young, Mazer has also produced hit albums by Linda Ronstadt and Janis Joplin, worked on The Band's *The Last Waltz* film and album, and developed the AirCheck monitoring system, which automates the recovery of publishers' royalties from radio stations.

Most recently, Mazer has been working with Neil Young on a DVD-Audio reissue of *Harvest*, Young's chart-topping album from 1971. For Mazer's description of the recording of "Heart of Gold," the Number One single from *Harvest*, see Classic Tracks on page 198.

*I understand that you are mixing the Harvest DVD-A at Neil Young's Redwood Digital studio. Can you describe the technical setup?*

I thought that it would be important for Neil to have a dedicated 5.1 monitoring system in his control



room that is reflective of what a consumer would have at home. He has a 5.1 soffit-mounted TAD system that works well for tracking and film mixing, but that's not really representative of current consumer 5.1 systems. Craig Street, a wonderful producer and longtime friend, talked to me about the stereo moni-



Elliot Mazer in Neil Young's Redwood Digital studio while mixing the DVD-A for *Harvest*.

toring system that he carries between studios. He came over to my house and played a few of his projects on my new Parasound/Energy system. Craig concluded that my system properly reflected the subtle decisions he had made on his bigger system. Neil purchased a six-speaker system with Studio 100 speakers and associated power amps. This worked well, and the mixes we made sound good on other systems.

DVD-A has amazing potential. It enables the public to enjoy high-resolution recordings on relatively inexpensive consumer products. I am convinced that we will be able to buy complete DVD-A systems—with six speakers—for under \$500 by Christmas 2001. Right now, the price point is around \$650 for the complete system I use, which is a Technics A-10 and a Creative Labs Desk Top Theater 5.1 speaker system that cost me \$139.95. I used it in my hotel room to review new mixes every night. It was very helpful.

Setting up Neil's studio for a 5.1 mix was interesting. We set up both digital and analog recording systems, using Genex MOD recorders for digital storage and an analog

Studer 827 2-inch 8-track. We transferred the original masters to digital through PMI HDCCD Model 2 boxes at 192kHz, 24-bit; the sound of 192/24 is amazing and very different from 96/24.

*How is Neil's attitude toward digital these days? He made an impassioned speech on fidelity and "bad" digital at the TEC Awards event a few years ago.*

John Nowland, Neil's studio manager—and a wonderful Bay Area engineer who did projects at His Master Wheels [Mazer's San Francisco studio] and ran Merle Haggard's studio—did a 192kHz, 24-bit transfer of the *Harvest* stereo master through PMI converters. I played a DVD-A of that for Neil in his control room, and he, like all of us, was amazed at how real it sounded. It sounded like analog. Neil has spent a considerable amount of time and money on digital gear. He wants it to work, and I think he is happy now. Neil is transferring his analog library of music through the PMI Model 2 HDCCD boxes at either 176.4/24 or 192/24. He is spending his own money on this project, and that is a serious level of commitment to digital. I believe Neil makes his new recordings on 16-track 2-inch 30 ips. He uses SMPTE to lock

BY CHRIS MICHIE



together the necessary machines.

For the DVD-A remix, we had to overcome some technical and practical issues. Recording six channels of 96/24 uses lots of disk space. Neil has been using Genex MOD recorders at his studio, Redwood Digital, for years. The current Model 8500 is in Beta release, so far as I know, and has its share of problems. We were getting a huge number of errors during takes while writing to the MOD disks. Denny Purcell of Georgetown Masters gave us a bunch of workarounds for these problems. One was to never put more than 13 minutes of music on a disk per side, and the other was to only use certified disks. We tried both and still had problems. We came up with a system that worked, but we incurred unnecessary costs and spent a lot of extra time.

Here's how it worked: During the DVD-A mix sessions, we only wrote to the internal hard disk, and when we had 13 minutes on the hard disk, we made a SCSI backup to a MOD. After



we listened to the SCSI backup, we made a second MOD SCSI backup. The SCSI backups have to be done in real time, as does the listening. So 13 minutes of security cost us 3x 13 minutes for listening and 2x 13 minutes for SCSI copying, so 13 minutes of music took us 75 minutes to check. We did get perfect copies, but we wasted 20 percent of the disks and a lot of time. I know that you can argue that we would have to make the copies anyway and listen to them, but you cannot selectively backup files from the Genex hard disk to MOD. I needed the hard disk for my next mix, and I wanted both MODs to be made from the original hard disk master. This made it necessary to do this during the mixing sessions, which was disruptive and costly.

A second problem we came across is that to get these bits into a DAW, you have to make a real-time AES transfer.

Some of the DAWs don't sound great at high bit rates, and one has to be careful about degradation. It would be much better if Genex, Sonic Solutions, Pro Tools and other manufacturers all complied with AES 31 and enabled us to move files around.

*How practical was it to use Young's Neve 8078 for mixing for 5.1?*

The audio quality of the 8078 is amazing and therefore worth the effort to make it work for DVD-A. It's obviously a vintage console, but Neil has spent a lot of money getting it in shape, getting it back to original specifications, and it is so versatile that it is not much of a chore to make it work for 5.1. The monitoring section was obviously not 5.1-ready, so Neil had some third-party gear installed to handle 5.1 switching, level matching, etc., but this gear deteriorates the audio quality in the monitoring chain. I hope that a manufacturer comes along with a high-fidelity 5.1 monitoring system that can be used on consoles built for stereo or quad.

Our signal chain was simple. The front two channels and surround channels we sent through two pairs of buses, and used Rev Send 3 for the center channel and Rev Send 4 for the subwoofer (LFE) send. Deciding what goes to the subwoofer is one of the trickiest aspects of mixing 5.1. If you rely on the subwoofer for most of your low-frequency information, your final mix will be bass-light on systems that do not have subwoofers, so I turn the subwoofer off when I am doing my basic mix. When this mix starts to sound like music, I turn on the subwoofer and blend in an appropriate amount from various instruments.

The buses fed three Model Two HDCD converters and the 2-inch 8-track Studer. On some songs, I preprocessed the mix through the Studer before it reached the HDCD box, so some of the songs on the *Harvest* DVD-A have been run through the Studer Record/Play chain, and some were sent right into the HDCD boxes. Plus, Neil has an analog backup of all the 5.1 mixes on the 2-inch 8-track. The audio quality of the analog backup is amazing.

*You mentioned that you had a portable 5.1 system, but surely you used some-*



Elliot Mazer in session at Quadrafonic Sound, early 1970s.

*thing a bit more sophisticated for checking your mixes at home?*

I have a bunch of playback systems at home. The main system consists of two Ed Long speaker systems, each one larger than me! They are fed by a pair of McIntosh tube amps and a Parasound P/LD 1100 preamp designed by Bay Area audio legend John Curl. The CD player is a Rotel RCID 971 HDCD player. I also have a wonderful turntable and assorted DAT machines.

When we started to talk about the *Harvest* DVD-A project, I decided that I needed a 5.1 system. I went to Parasound and found an HCA 2205 5-channel power amp designed by Curl and a multichannel preamp/processor that did Dolby Digital, DTS, TMX and high-resolution analog (AVC 2500). The Energy xl1613 speakers are a little bigger than NS-10s, and I have an 8-inch powered subwoofer. The DVD-A machine is the Technics A-10, which has analog outputs for 5.1. I set up the speakers at home and at Neil's studio using a formula designed by Georgetown Masters, the mastering studio we are using for *Harvest*. This was tricky, but in the end I could hear well from most places within the speakers. I can't presume that most people will set up six speakers perfectly and always sit in the middle—most people cannot set up two speakers correctly. Engineers, headphone users and people that listen on their PCs are among the only people that sit in the "correct" place to listen. If the music

changes substantially when you move around or when the six speakers are not set up properly, there is something wrong with the mix.

*You grew up in New York City and suburban New Jersey and went to college there. How did you get into the industry?*

I loved music as a kid. Jazz and folk were my passions growing up until Elvis landed. I loved looking at and listening to records and got a job in the Sam Goody record store while I was going to college. One of my jobs was singles buyer for the store, and one day the Decca salesman came in and played me "My Generation" by The Who. I loved it and ordered five copies for the store, even though it was not on radio and nobody had heard of them in 1965. I played the record in the store, and people bought it. That really got me excited. Eventually, I got to know Bob Weinstein, the founder of Prestige Records. He asked me what I wanted to do, and I told him that I wanted to make records. He hired me, and I went to work for him doing all kinds of stuff like delivering DJ copies to stations, sorting the tape library, listening to new releases, checking label copy. He let me visit the studio and watch the recording process.

Esmond Edwards was the A&R guy, and they used Rudy Van Gelder's studio in Englewood Cliffs, N.J. Esmond was making records with Red Garland, Oliver Nelson, and the studio was, and still is, fantastic. Rudy had a tube board with rotary pots, similar to what Columbia had at their studios, and he had mono and stereo Ampex 300s and perhaps a 3-track ½-inch 300. Rudy got the sounds, the A&R guys worked with the musicians and the stuff sounded great. The room is beautiful and very lively. Rudy recorded big bands as well as small groups. This *was* live recording—you put down exactly what the consumer would hear. My first production was a bossa nova album with Dave Pike. Clark Terry played trumpet, and I produced two of Clark's albums a few years later for Cameo.

*Skipping ahead to the '70s, you produced albums for American artists such as Neil Young, Janis Joplin and Linda Ronstadt, but you also went to England to record Frankie Miller, Rab Noakes, Mike D'Abo and Andy Fairweather-Lowe. How was life as a continent-bopping freelance producer back then, and how have things changed?*

The '60s and '70s were wonderful times

for recording. You could really hear where a recording was made. Memphis sounded like Memphis, L.A. like L.A. and London sounded like nothing we had ever heard. The British studios, musicians and producers had a completely different rulebook and completely different kinds of equipment and tastes in music. American engineers, for the most part, used rooms and miking technique in an attempt to translate a literal copy of an instrument onto tape. British engineers used EQ and whatever gear they could find to create a sound, which did not necessarily have to be a literal copy. U.S.-made consoles had EQ with  $\pm 12$  dB, while British desks had  $\pm 20$  dB. A

**It is now possible to make complex-sounding records anyplace, and for a fraction of the cost of years ago.**

**But the essential thing about a great record is the quality of the song and what emotion is transferred to the listener.**

British studio setup would have a zillion U67s, while an American setup would have a bunch of different mics. The British producers, engineers and musicians loved the music coming out of Memphis and Florence, Alabama and Detroit. Americans wanted to sound like The Beatles, who really started out wanting to sound like the Everly Brothers or Chuck Berry, etc.

Early UK studios, pre-Neve and pre-Trident, had very simple equipment. Most desks had little or no EQ, and most control rooms had one or two compressors, if any. Reverb came from live chambers. Glyn Johns told a story recently about the desk at Olympic, which had one EQ knob and only two settings—pop or classical. Glyn, like most engineers and producers who started in the '60s, learned to get his sounds from the musicians. People ask him which compressor he used on the bass drum

on "Honky Tonk Women." I get asked which one I used on "Heart of Gold." The answer to both those questions is none. We worked with great drummers who knew how to make their kits sound great, and we know how to capture those sounds and put them in perspective. Those were literal sounds. George Martin used whatever voodoo was appropriate to get sounds on Beatles records. They were not necessarily literal sounds.

During the '70s, things started to even out between the U.S. and England. Neve desks were coming to the U.S., and many of us were working on both continents. Brits made records here, we made records there, and, by the end of the '70s, records started to sound the same—too bad. Then MTV came along and really clinched it. Everybody could see and hear everybody else's music. The labels wanted the artists and producers to make hits that sounded like the current hits, and individuality started to overtake creativity. It was no longer the case that a record made in a specific city sounded like that city.

Today, Pro Tools and other technologies level this playing field even more. It is now possible to make complex-sounding records anyplace, and for a fraction of the cost of years ago. But the essential thing about a great record is the quality of the song and what emotion is transferred to the listener.

*The two records you made with Area Code 615 were recently re-released on CD by Koch. They were very influential at the time, and I was surprised that it took so long for them to be re-released.*

We had to go through a huge amount of red tape to get the CD out. The reissue happened in 2000, 30 years after we cut the records, and Universal could not find the contracts. It turned out that Mac Gayden had them, and we sent a copy to Andy McKaie at UMG. He got us back into the system, and Koch made a deal with them. UMG had the original ½-inch master for the first album, but Polygram had lost the master for the second LP—we had to use a Dolby A tape dupe master and a Dolby A 8-track copy.

The Area Code 615 records were cut at Cinderella Sound, which is a two-car garage behind Wayne Moss' house in Madison, Tenn. Wayne, a top session player in Nashville, had converted his garage by building a control room and adding acoustical treatment to isolate and shape the sounds. It had a drum booth built by Wayne and Kenny Buttrely, legendary drummer for the Everly Brothers, Neil Young, Bob Dylan, Elvis,

# APOGEE DIGITAL SOLUTIONS.

# TRAK2

mic preamp & digital converter.

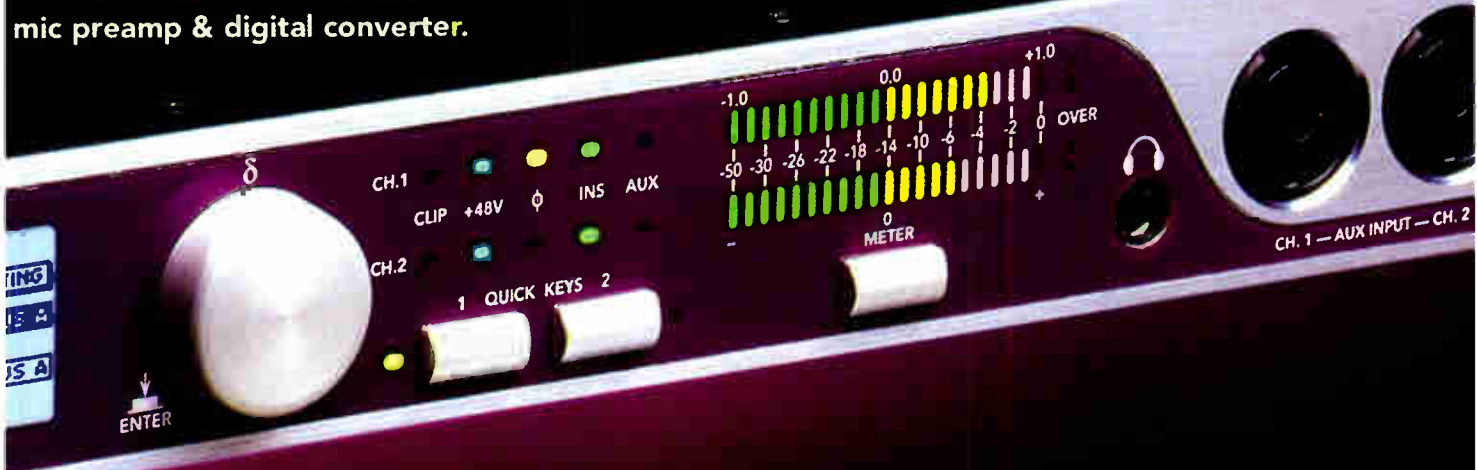

## ...THE ULTIMATE MIC PRE.



The Trak2's comprehensive LCD display allows direct access to all mic preamp settings...



...and there are additional configuration options for the ultimate in rapid, precise control...

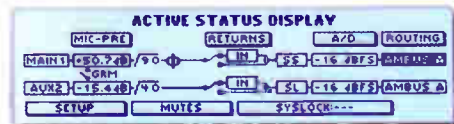

...while the Active Status Display gives an overview of the entire Trak2 topology.

**A**POGEE'S TRAK2 digital audio conversion system is a box full of solutions – a superb mic pre is just one of them.

The front end of the Trak2 offers mic and instrument-level inputs, with direct access from the front panel's universal connectors as well as rear-panel mic and line inputs.

The mic pre itself offers an astonishing range of features. Here's just a selection:

- ±90 dB gain/attenuation
- Phantom power that's automatically disengaged if you change mics.
- Clip LEDs that monitor the mic pre stage independently of the main metering.
- -109 dB THD+N.
- Polarity reversal.
- +24dBu maximum input level.
- 40 and 90 Hz high-pass filtering.
- ...and there's much more!

Different gain-control elements are introduced at different gain levels to insure that the noise floor, distortion and headroom characteristics are always optimized. You can gang the two channels together for rapid stereo level-setting.



A software controller runs on Macintosh and Windows machines to allow remote access to the Trak2 via MIDI.

There's even a Gain Ride Mode that enables you use the main knob to track the level, just as you would ride a fader. In fact, this mic pre sounds so good, you'll want to use it on its own – so we've provided an analog output/insert point in the path.

And of course the mic pre is followed by the very latest Apogee 2-channel 24/96 converter, including

our exclusive processes: Soft Limit for up to 6 dB more level without overs; Soft Saturate to simulate tubes and tape compression; and UV22HR for flawless 16- or 20-bit output – plus a comprehensive 8-channel routing, interfacing and format conversion section featuring two AMBus card slots supporting most major industry standard interfaces, from ADAT, TDIF and Pro Tools to SSL, SDIF-2 and Firewire. There's even a slot for a 2- or 8-channel D/A card.

**Apogee's Trak2. It's everything you need, from mic in to digital out. Hear it today – at your authorized Apogee dealer.**

**Apogee**  
SOUND AMAZING

# Left Brain

24 tracks

24-bit/96kHz

Motorized faders

384 Virtual Tracks

8 XLR, 16 1/4" TRS inputs

Mouse and PC keyboard inputs

VGA "Information Display" output

8 stereo/16 mono effects processors\*

"Drag-and-drop" editing on LCD using mouse

64-channel mixer w/individual dynamics

2 R-BUS ports for 16 ch. digital I/O

Phrase pad playback w/sequencing

Audio CD-burning capability\*\*

SMPTE and Word Clock input

\*With optional VS8F-2 Effects Expansion Boards

\*\*With optional VS-CDR11/CD-Rack CD Recording Systems



Burn audio CDs and archive data using the optional VS-CDR11 or CD-Rack.



A VGA output confirms playlist, mixer settings, routing and more using an optional computer monitor.



VS-2480 back panel

The AKG C3000B: the perfect input source for the VS-2480's COSM Mic Modeling effect.



# Right Brain

## Wow.



What were we thinking when we created the new VS-2480? It's pretty obvious. Only the best of the best workstations ever. With 24 tracks to give you all the room you need to take your music anywhere it wants to go, without having to build a studio to get it. And drag-and-drop mouse editing on the LCD to make operation easy and intuitive. Check it out for yourself. Because once you get your hands on it, you'll only have one thing on your mind.

**VS-2480 24-track Digital Studio Workstation** 



Call (800) 336-7575 for the VS-2480 demo video (\$5.00) Roland Corporation U.S., (323) 890-3700 [www.rolandus.com](http://www.rolandus.com)

FaxBack Information: (323) 890-3780 (Doc.#10522). Specifications and appearance are subject to change without notice.

CIRCLE #023 ON PRODUCT INFO CARD

World Radio History

## PRODUCER'S DESK

George Harrison, Simon & Garfunkel, etc.. Wayne, Kenny, guitarist/songwriter Mac Gayden (who wrote "Everlasting Love" and played with J.J. Cale and Bob Dylan) and harmonica virtuoso Charlie McCoy (George Jones, Bob Dylan, Simon & Garfunkel) had a band called Charlie McCoy & The Escorts. They were mostly an R&B band, and the 615 project was conceived to have R&B rhythms under country sounds.

*You also worked with The Band on The Last Waltz.*

From the start of *TZW*, it was obvious that none of us would settle for anything except perfection. We would have one show, one night to document the music of The Band and their friends. We spent months preparing for this gig. Robbie Robertson, Marty Scorsese, The Band, Bill Graham and his people met many times to plan this massive event. Marty wrote a shooting script that was from The Band's lyrics. The seven cameras and my truck got their cues from these pages. We rented Wally Heider's truck, which had a large API console, two 3M 24-tracks and racks of Dolby A units. We recorded at 15 ips, Dolby A, with sync

on track 24. I used my Neve Melbourne 12x2 desk for additional inputs. The truck split many of the P.A. mics, and we added extra mics for piano and

song was rehearsed, and most of the guest artists did onstage rehearsals. Muddy Waters and Bob Dylan did private rehearsals at the Miyako Hotel. Ray Thompson, one of the great remote recording engineers, came up to help me mike the show during the rehearsals. Ray knew how to make live sound live—*Frampton Comes Alive* and *Aretha Franklin Live at the Fillmore West* are part of his repertoire. Ray worked mostly on the house mics and the piano.

The gig was amazing. There was one place in the show where all of us had a problem. When Paul Butterfield came onstage, Robbie broke a string, Paul went to the wrong vocal mic, a lighting panel went down and half the cameras ran out of film during the delay. It took all of us a few minutes to recover, and then everything was fine throughout the show. There was a problem with the AC power feed to the truck, and some hum got on tape as a result.

The post-production for the film and record were done at The Band's studio in Malibu, Shangri-La. I was not involved in this process, as I was too busy in the studio. I like the way the movie sounds and hope I get to hear a great-sounding DVD-A out of the music.

**The computer  
allows us to do things  
that we could not do  
in the analog world.**

**The song and the  
performance are the  
essence of a record.**

**What is recorded  
is much more important  
than how it is recorded.**

drums. I did not use any compression, and I had to hand-ride everything. I had to anticipate every move onstage.

We rehearsed for two days. Every

# "All The Sound You've Never Heard"™



# BBE®

**INTERACTIVE  
DEMO  
ON LINE NOW!!**

*"The BBE can be a real life saver when dealing with poor quality source material, whether it be in film/video or broadcast production, mastering or tape duplication chains."*

George Petersen  
MIX MAGAZINE



Tel: 714. 897. 6766 Fax: 714. 896. 0736 Web: [www.bbesound.com](http://www.bbesound.com)  
In Canada Please Contact Kief Music LTD (604) 590-3344

CIRCLE #024 ON PRODUCT INFO CARD

World Radio History

(( DON'T BELIEVE EVERYTHING YOU HEAR. ))



COMING SOON: fully digital bi-amped front end

(( UNLESS, OF COURSE, YOU'VE HEARD IT FROM A KRK STUDIO MONITOR. ))

Top engineers and producers know that KRK studio monitors still give you the truest, most natural mix around. And with our V series, the fact is KRK has never sounded better.



But as we said - don't believe everything you hear. See your local KRK retailer and listen to the true sound of your mix from one of our new advanced studio reference monitors today.

**THE V SERIES  
OF SELF-POWERED BI-AMPED MONITORS**



**V 6**

Big Sound in a small package, plus built-in crossover and video shielding



**THE NEW V 8 8**

More low frequencies, and more SPL thanks to twin 8" woofers



**V 8**

Excellent translation for the most critical listening requirements

KRK Systems, LLC • 954.929.8999 • [www.krksys.com](http://www.krksys.com)

KRK is a registered trademark of KRK Systems, LLC

CIRCLE #025 ON PRODUCT INFO CARD

World Radio History



*Tell us more about the Jack Nitzsche album.*

That project was recorded in St. Giles Cripplegate, a first-century Church of England gothic church in the Barbican area of East London. The timpani were literally placed over the grave of poet John Milton. Bob Auger set up his Neve rig in the rectory office, which is next to the pulpit. The pews were removed, and the London Symphony Orchestra was set up in the traditional way. (David Meacham, the conductor, had previously conducted the LSO on the two songs they recorded with Neil Young on *Har-*

*rest*.) Bob Auger knew the hall and the orchestra.

We recorded to 8- and 4-track machines at 30 ips. The speakers were Tannoys. Jack sat mostly on the lounge chair between the speakers listening. David Meacham would ring the intercom and ask me if in measures 134 to 140 the first violins were to play F, F-sharp, G, G-sharp, etc. I would look at the score and see if that was what Jack had written and then ask Jack if this was okay. It was correct, and, for the most part, we just had them make one or two takes. The sessions took two days, and all went exceedingly well. I did the stereo mix at Quadrafonic. I wound up

using just the monitor section of the console, since the mix was really a re-balance and no processing of any type was needed. We hope to do a DVD-A version of this album soon.

*How did you get involved with the Jazz Masterpiece reissue program for Columbia Records?*

A friend at Columbia Records (Jack Rovner, now president of RCA) asked me about my association with Windham Hill—I had produced a few projects for them, including a Michael Hedges album—because Columbia felt that they did not know how to market to the “new age” consumer. I told them that I thought that this market would love many of the albums that Columbia had in their catalog. They asked me to make up a list of potential releases, and I did. This was the start of their Jazz Masterpiece Series. I suggested that Erroll Garner’s *Concert By the Sea* was the prototype new age album, as were many Dave Brubeck, Billie Holiday and Miles Davis records. They were jazz records that spoke to a mass audience. Along with *Concert By the Sea*, I targeted albums such as *Kind Of Blue* and *Take Five*. Larry Keyes, a Columbia engineer who I had worked with on Janis Joplin projects, did the transfers.

*Can you explain your association with CCRMA and “the world’s first all-digital recording studio”?*

One of the engineers at His Master’s Wheels kept telling me about the musicians at Stanford who were using computers to create and modify music. Eventually I visited CCRMA [Center for Computer Research in Music and Acoustics] and was truly amazed. They were in the DC Power Lab at Stanford, which they shared with the Artificial Intelligence group. They were using PDP II computers to do synthesis and digital processing. The machines were the size of large New York apartments, and they had 64 MB of RAM and huge external hard disk packs that stored something like 300 MB. This was in 1977. Andy Moorer, the inventor of Sonic Solutions, John Grey, a musician with a Ph.D. in psychoacoustics, and Loren Rush, a well-known composer, were the core of CCRMA under the leadership of John Chowning, the inventor of FM synthesis. They had primitive AD/DA boxes.

CCRMA amazed me. I saw music being composed, arranged, processed, morphed, created and stored in boxes. I heard the box do things to analog sounds that could never be done in the analog world. Check out our CD on Elektra, *The Digital Domain*. This project

**LOS ANGELES  
RECORDING  
WORKSHOP**



**Introducing our  
900-hour  
Recording Engineer Program**



**Hands-on Training on:  
Sony Oxford Digital Console  
Five Sony Dmx-R100 Digital Consoles  
Neve-VR Console  
Solid State Logic 4000 Console  
Four Pro Tools-24's  
Six-Console MixLab**

**Dorm Housing  
Federal Financial Aid if Qualified  
Outstanding Job Placement Assistance**

**818-763-7400**

5278 Lankershim Bl., North Hollywood, CA 91601  
www.recordingcareer.com



# GIGASTUDIO™

Innovate. Never Imitate.

"Unless you explore it, emotionally you cannot understand how revolutionary GigaStudio is. I never have to worry about having enough space for my samples, and the low pass filters and crossfades are done right — natural and transparent — they really work. Nemesys has built a classic."



**Hans Zimmer**  
Academy Award Winning Composer

### Sample Outside the Box.

Patented Hard Disk Based Sampling Technology, 160 Voice Polyphony (all disk based), Multimode Resonant Filters with External Q and Fc, DSP Station™ 32 Bit Zero Latency Effects, 32 Channel 32 Bus Digital Mixing with Automation, QuickSound™ Database, Dimension Articulation Switching/Crossfading



MEDIA VENTURES

"Academy Award" is a registered trademark and service mark of the Academy of Motion Picture Arts and Sciences

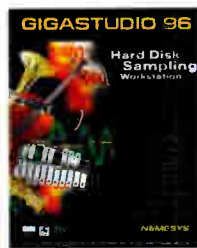

CIRCLE #027 ON PRODUCT INFO CARD

www.nemesysmusic.com • 1.877.NEMESYS

**NEMESYS™**

was created mostly in the box. It consists of analog sounds, fully digital sounds, synthesized sounds, and it was recorded in the early 1980s. Andy Moor-er created a piece called "The Lions Are Growing"—the first time I had heard morphing. A human voice becomes various instruments.

I was their analog person, and I showed them how we made records in the analog world. I got to play with their stuff and very much enjoyed being around some really smart people. Julius Smith, another CCRMA guy and a fine musician with a band, later did the

audio stuff for nEXt. I think Julius is still at the lab. Mickey Hart and John Meyer spent time there. We showed CCRMA stuff to Ampex, the leader of the analog world, Wally Heider, Glen Glenn, Neil Young and many others. Those that saw the system were amazed, although it took a few years for the software and hardware to become universal and accessible to the masses. CCRMA bred the Yamaha DX7 synth, Sonic Solutions, nEXt and Apple audio, Liquid Audio and many other companies and many recordings.

*As an early proponent/developer of digital recording technology, are you surprised or disappointed by the cur-*

*rent state of the recording industry? Has Pro Tools been a positive force in the industry?*

I think that Pro Tools and MIDI and samplers are wonderful enabling tools. These tools have created a new way of making music. The song and the performance are the essence of a record. What is recorded is much more important than how it is recorded. It is music. I am sure we will see great products such as Pro Tools, SampleCell and Vision working at 192 kHz/24-bit. When this happens, these tools will let us create recordings that sound analog, and, to me, that is a good thing.

*What is the AirCheck monitoring system and how did that evolve?*

AirCheck is passive broadcast monitoring technology that I started in San Francisco in the early '80s. This system listens to the radio, the Internet and watches TV. It identifies what it hears—it is very intelligent software. The idea for this technology came from meetings I had with a friend who was a marketing guru at Columbia Records, Jon Birge, who told me that nobody really knew what was on the radio. I spoke to my friends at CCRMA, and we started to come up with an idea of how a computer could do this.

Neil and I were working on *Everybody's Rockin'*. We heard a story about a DJ who suddenly made a lot of money at the tables in Lake Tahoe. This guy had convinced a label that he was playing their record. The joke was, he wasn't and he was getting paid anyway—listen to "Payola Blues" on *Everybody's Rockin'*. Cut to a few years later, and we find that the labels know what is on the radio, because AirCheck and BDS tell them. I sold my company to Radio Computing Services in 1989. AirCheck is being used to monitor radio in the U.S., France, Holland and Brazil, and monitors TV in Germany and Brazil. RCS is the leading supplier of technology to the radio industry, and I am happy to be a part of it.

*Is it too early to say whether the launch of DVD-A is a success or a failure? What might have been done differently?*

The DVD-A machines that I have played with sound great and are fun to use. The system has great potential. It is too soon to know much about all this, but I am very optimistic. Warners have put a huge amount of effort into this project, and I am happy about that. Wait 'til people hear 192/24 on a consumer player that they can buy for \$500! ■

*Chris Michie is a Mix technical editor.*

## MEET THE NEW FAMILY



BOLD-BEAUTIFUL-POWERFUL  
AND SELF PROTECTING



The ultimate live-performance machines  
have finally been created.

-The XLT500 Series-

**Community**  
PROFESSIONAL LOUDSPEAKERS

333 East 5th Street, Chester, PA USA 19013-4511  
Tel: 800-523-4934 610-876-3400 Fax: 610-874-0190  
[www.loudspeakers.net](http://www.loudspeakers.net)

# "THE NEW POWERLIGHT 2A IS ABSOLUTELY ASTOUNDING."

Schubert Systems Group (SSG) uses PowerLights on the road with major acts such as Glenn Frey, Sugar Ray, Incubus, and Brian Setzer. Recently, J.D. Brill, FOH engineer and co-owner of SSG, added new PowerLight 2As to their inventory.

"The PowerLight 2A's built-in processing allows you to custom configure your amplifier. Internal EQ and time alignment corrections can be made to make virtually any speaker system sound great. It also improves your system's reliability by taking out the crossover, cabling, and the rack between the processor and the amplifier. You're getting a more reliable, customized solution."

Call 1-800-854-4079 for more information or visit our website at [www.qscaudio.com/pl2/mix.htm](http://www.qscaudio.com/pl2/mix.htm)



PowerLight 4.0

PowerLight 236A



Schubert Systems Group uses PowerLight 236As, 2.0<sup>th</sup>s and 4.0s throughout their sound systems.

### PowerLight 2A built-in signal processing:

- Selectable input sensitivity (+4 dBu, 32 dB, or 26 dB)
- Adjustable 4th-order two-way crossover with driver time-alignment
- Adjustable high-frequency attenuation
- Independent power limiters with adjustable attack, release, and threshold
- CD horn equalization

PL 2	8Ω	4Ω	2Ω*
PL 218	310	525	900
PL 224	440	740	1200
PL 230	575	900	1500
PL 236	725	1100	1850

FTC rating: 20 Hz-20 kHz, 0.03% THD  
 \*1 kHz, 1% THD  
 Represents PL2A and PL2 Base Models

# QSC™

AUDIO

CIRCLE #D29 ON PRODUCT INFO CARD



PHOTO: STEVE JENNINGS

The orchestral setup at the Skywalker Scoring Stage

# ONE FOR THE CHILDREN

## Robert Rodriguez on Music for "Spy Kids"

BY TOM KENNY

When we first checked in with director Robert Rodriguez, it was 1993, and young fellow Austinite Eric Guthrie was putting together a synth score for the breakthrough, low-budget film *El Mariachi*. The score was recorded wild to DAT; Rodriguez, Guthrie said, did not know what timecode was. In 1996, we found Rodriguez at the SSL Axiom, mixing the music on his film *From Dusk Till Dawn*. Last month, we tracked him down at Skywalker Sound's Mix G, where he was mixing music along-

side Michael Semanick, this time on a Neve DFC for *Spy Kids*.

Rodriguez writes, directs and serves as camera operator, edits, cuts sound effects, produces and supervises visual effects on his films. For *Spy Kids*, he also wrote a few music cues, did some orchestration and supervised the music. He's hands-on, to say the least. When he needs a break from editing on the Avid in his garage, he either swivels to his SGI computer to look at visual effects coming in from Canada, or to his fully blown Pro Tools/Digital

Performer/Kurzweil rig to play with music. He now, needless to say, knows about timecode.

Counting Rodriguez, there are no fewer than six composers on *Spy Kids*, with roughly 70 minutes of music in the 84-minute film. Originally, Harry Gregson Williams of Media Ventures was hired to score the film, but he took sick in the fall (he's better now) and couldn't finish. Then facing a tight Christmas release deadline, Rodriguez turned immediately to Los Lobos, who had written songs for

*Desperado*.

"I had this idea of Latin orchestral cues that had action, instead of the European orchestra that we're so used to hearing," Rodriguez says. "I wanted sort of a Latin James Bond sound, Latin music that sounds spy-like, because it's all in minor keys. A lot of my favorite music is A minor, B minor, D minor. I immediately thought of Los Lobos, which has that off-rhythm. What's great about them is that they're very parts-oriented. Steve Berlin will play a sax part, and you think, 'I'll just take that sax part and make it horns.' It's almost orchestral already, and that's what inspired me. Their normal playing is so much more orchestrated and arranged than straight rock."

Los Lobos ended up providing the driving rhythm for two climactic cues: the wedding scene, which Rodriguez wanted to be as dynamic as John Williams' "Duel of the

Fates," and the final conflict. Rodriguez then wrote the orchestral parts in his home studio, which were later recorded by a 90-piece orchestra. "I wasn't really sure what a Latin orchestra would sound like," Rodriguez laughs. "Then I found this composer from the 1930s, Reivueltas, doing this amazing off-tempo stuff, like in 7-time, where you never knew when the 1 was coming in. I thought,

—CONTINUED ON PAGE 72



PHOTO: MEXICO FEATURES

# DANNY ELFMAN

Self-Taught,  
Self-Styled

BY RICK CLARK

When Danny Elfman's name first appeared on major film scoring credits, those who recognized him most likely thought of him as the frontman for the new wave band Oingo Boingo, who scored modern rock hits in the '80s with "Only a Lad," "Dead Man's Party" and "Weird Science," among others. However, Oingo Boingo was not your run-of-the-mill pop band, and their eclectic arrangements and irreverent songs earned them a devoted following over the course of almost 15 years and 10 albums. Today, anyone aware of Elfman's history realizes that his step from pop music to a successful film-scoring career was a perfectly natural move.

Before Oingo Boingo, Elfman spent a number of years working as a "music director" for his brother Richard's theatrical troupe, The Mystic Knights of the Oingo Boingo. It was during that period that Elfman immersed himself in the music of Harry Partch and Terry Riley, as well as pioneering jazz artists like Cab Calloway and Duke Ellington. He also taught himself to transcribe music and create arrangements. This musical development, coupled with Elfman's love of old monster movies, '50s and '60s sci-fi and fantastical films (like Ray Harryhausen's *Jason and the Argonauts*) helped pave the way to his recording work, and then to projects with Burton, Sam Raimi and Gus Van Zandt, among others.

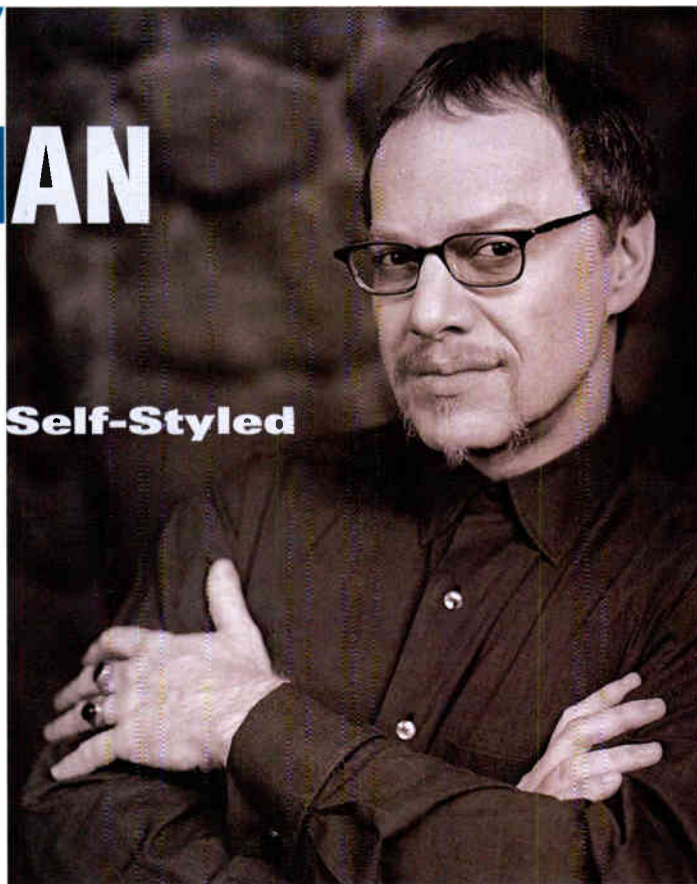

PHOTO: LIVIA COKORVA

Elfman's first foray into film scoring was in 1980 for his brother's film *Forbidden Zone*. His first major studio film, however, was Tim Burton's *Pee Wee's Big Adventure*. That marked the beginning of a long, productive relationship; Elfman has worked on every one of Burton's films since, with the exception of *Ed Wood*.

In all, Elfman has scored music for 45 films, including *Men In Black*, *A Simple Plan*, *Good Will Hunting*, *The Family Man*, *Proof of Life*, *Beetlejuice*, *Edward Scissorhands*, *Batman*, *Batman Returns*, *The Nightmare Before Christmas*, *Midnight Run*, *Scrooged*, *A Civil Action* and *The Legend of Sleepy Hollow*. It would be tough to label Elfman's style—words like quirky, playful and whimsical come to mind, but they don't do him justice. Quirky or not, Elfman is not afraid to experiment, and he creates empathetic nuances and surprises that are unique to each score.

*I understand that you are getting ready to work on Tim Burton's version of Planet of the Apes.*

I haven't started yet, but I took my daughter today to the set and had her pose with a few of the apes. [Laughs.] My daughter had a great time. She is 16 and has known Tim Burton her whole life. She was born the same year I did *Pee Wee's Big Adventure*. She tortures him still by constantly calling him Uncle Tim. He goes [makes an exasperated sound]. She does that because she knows it annoys him. [Laughs.] The only anecdote I have so far is seeing the trailer in a packed theater full of rowdy half- and fully clothed apes all hollering and clapping. They screened it for the cast. It was a moment.

*Let's talk about scoring music for film.*

Why talk to me, for God's sake? [Laughs.] I'm thinking about getting into it some day.

—CONTINUED ON PAGE 74

SONS  
DZ  
FOR  
P  
C  
T  
E  
R  
E  
F

# For Once, A Warm and Fuzzy Column

**BY LARRY BLAKE**

A funny thing happened as I was riding in a van last year with fellow crew members coming back from location. I had been working my cell phone, arranging a weekend get-together with some film sound buddies and buddies, and a department head (let's call him "William") figured out what was going on.

"This would never happen in my field," he said. I didn't understand him: "You mean, you don't get together with colleagues/competitors to break bread and share war stories?" "No way," he said. Too many top people in his profession regarded themselves as *artistes*, and with that comes a lot of sniping and bitching. As a result, they just don't hang together. This was shocking to me.

He asked me the nature of my relationship with these folks. It had not really occurred to me, but I had never

worked with most of them—we just knew each other by reputation and visits to each other's facilities. But we keep in touch and are friends, despite the fact that the business side of our relationships are mostly competitive.

All of this got me thinking not only about the nature of our respective jobs, but also of work in the film industry. And pretty much all of the answers I came up with were overwhelmingly positive. Thus, the title of this column.

The merest mention of sample rates or timecode is *verboten* this month, as I'm putting myself in my sitting-around-the-campfire-at-high-school-retreat mode: Kumbaya, "I love you man," etc., ad nauseum. There are many relationships in this equation: with others in post sound, as noted above, with production mixer friends, with the other departments during production and with the industry as a whole. The latter is perhaps a good place to start, be-

cause most of *Mix's* readers are more Grammy than Oscar, more Nashville than Nicasio (home of Skywalker Sound), more ADAT than DTRS. (Okay, okay, nothing technical!)

We all grow up with certain stereotypical images of Hollywood: directors with megaphones and bull whips, temperamental movie stars who won't come out of their trailers, fawning sycophants, etc. While I've yet to see a director so equipped, indeed all of the above and more can be found in the movie industry. But I think these examples are much more the exception than the rule.

In fact, I think that in many ways, the tone of a film set is a much more democratic environment than many workplaces. A good "non-pro" (*Variety*-speak for people with jobs outside the entertainment industry) friend of mine works at a top hotel in New Orleans, and I hear

—CONTINUED ON PAGE 86

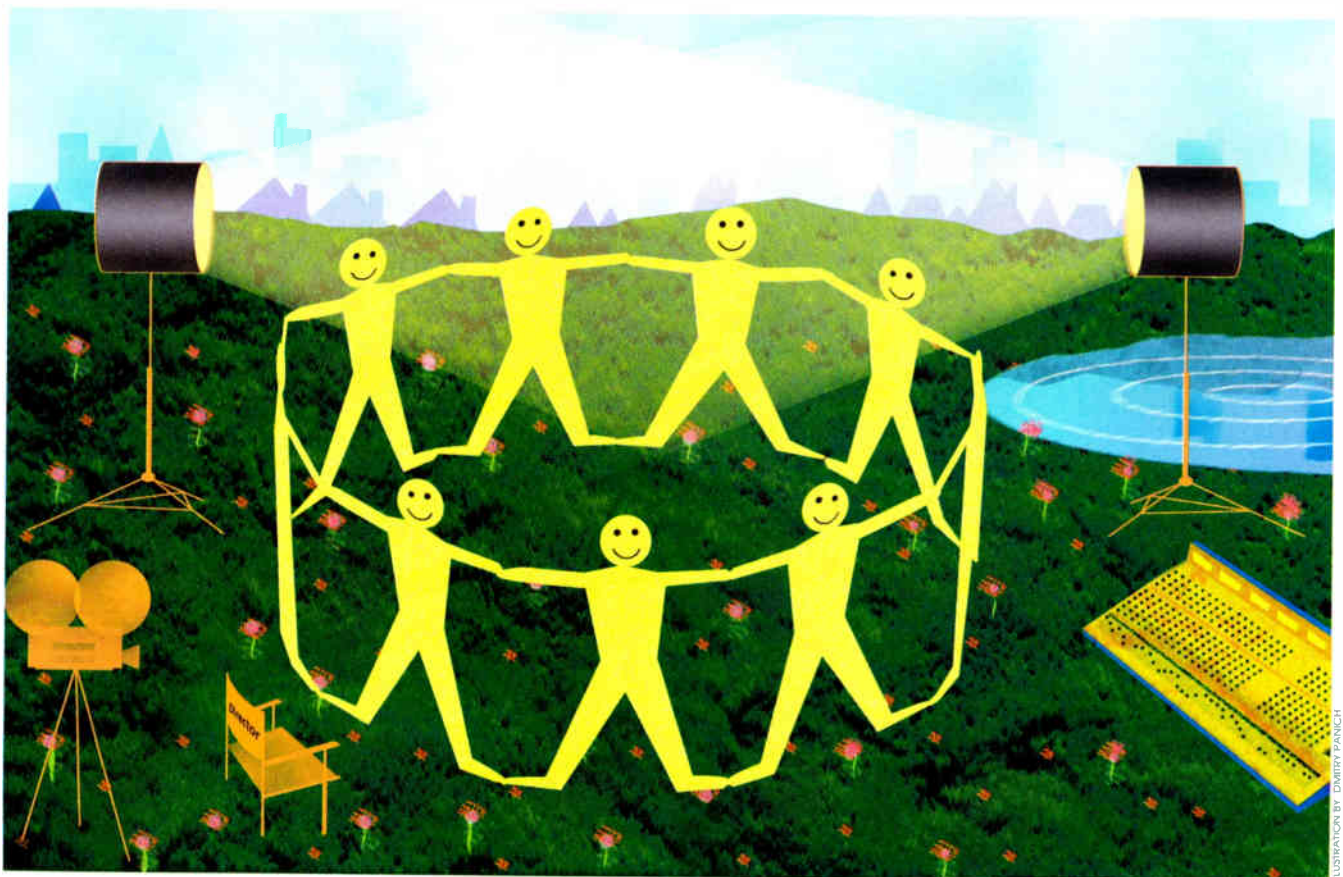

# IF YOU'RE THINKING ABOUT NEW SPEAKERS, ASK ROGER. HE THINKS ABOUT THEM ALL THE TIME.

Roger Qusted's got a bit of a thing  
about speakers.

He lives, eats and breathes them.  
He even dreams about them. But then  
if you'd put your name to a range  
of professional monitors as  
advanced as Qusted's,  
you'd be a little  
preoccupied too.

In fact, you'll find  
the whole team at  
Qusted equally  
single minded.

Which is worth  
thinking about the  
next time you're  
looking for  
serious advice.

*Shown is the VS2109  
full range monitor with  
the VS1115 Sub-Woofer/  
Surround sound manager,  
featuring 4 inputs - LCA  
plus a separate effects  
input with independent  
filtering. Just one of the  
many options from Qusted's  
broad range of professional  
products for surround sound monitoring.*



CIRCLE #065 ON PRODUCT INFO CARD



Qusted Monitoring Systems Ltd., Unit 2A, West Ealing Business Centre, Alexandria Road, London, W13 0NJ.

Tel: + 44 (0) 20 8566 2488. Fax: + 44 (0) 20 8566 2484. e-mail: [qmssales@compuserve.com](mailto:qmssales@compuserve.com) [www.quested.com](http://www.quested.com)

QUSA 5816 Highway K, Waunakee, Wisconsin 53597. Tel: 608 850 3600. Fax: 608 850 3602. e-mail: [brian@quested.com](mailto:brian@quested.com)

World Radio History

# Gohl/McLaughlin Productions

BY DAVID JOHN FARINELLA

Whether they're creating simple pop songs or grand, sweeping orchestral scores, musicians across the globe are looking to express emotion and evoke emotion in their listeners. Composing music for a film, though, is a bit different than straight songwriting. Rather than pour out their own emotions, film composers are called on to heighten the emotions being evoked by the images. It's a challenge for many musicians, and that's why the film music production team of Teese Gohl and Steve McLaughlin, collectively known as Gohl/McLaughlin Productions, gets the call from a handful of A-list film directors and producers.

To date, Gohl/McLaughlin has worked on such films as *The Red Violin*, which earned them an Oscar for Best Score, *Titus*, *The Iron Giant*, *Cookie's Fortune* and *Flawless*. Most recently, McLaughlin produced Michael Kamen's score for *X-Men*, Guy Pratt's score for *County Kilburn* and was working on *The Count of Monte Cristo* with Ed Shearmur. Gohl produced Michael Small's score for *South Pacific*, and Elliot Goldenthal's tracks for *Final Fantasy* and the upcoming Julie Taymor film *Frida Kahlo*. Gohl is a keyboard player/producer, and McLaughlin is a Grammy Award-winning engineer. What makes their pairing a bit odd is the fact that Gohl works in New York and New Hampshire and McLaughlin in London. "We'd like to be in the same place," says Gohl. "We always hook up at some point, but it's not always possible to spend a month or two months locked away in some studio, and it's also not necessary any-



Steve McLaughlin, in London.

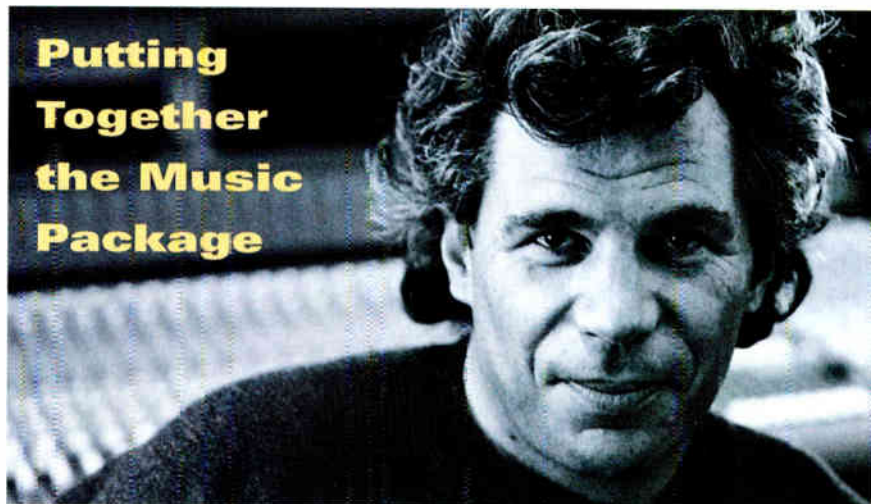

Teese Gohl, the New York connection

more. We both have studios in our homes that can facilitate everything from rough demos to final mixes."

Though they have worked with well-known composers like Michael Kamen and Elliot Goldenthal, Gohl and McLaughlin have recently started to work with such musicians as Dave Stewart of Eurhythmics, Rich Robinson from the Black Crowes and songwriter Bruce Roberts. The goal, so far, has been to combine the twin desires of pop artists getting songs onto film soundtracks and directors getting functional music for their film.

"Pick any rock icon or pop artist who basically has no experience doing film scores but would love to do it and has talent for it," Gohl explains. "We provide the vehicle to make sure that the music gets done on time and on budget. The film producers are usually very afraid of hiring someone who is used to being in the studio for a month to a year doing an album. Most commonly, you'll have a few weeks to a couple months to complete a score, and the money is much tighter than in record projects. What we do, through our experience, is provide facilities where that can happen."

Gohl points to the recent *Trip* soundtrack, which he produced with Rich Robinson of the Black Crowes, as an example of his studio's flexibility. "We did a lot of great stuff in my loft in New York," he says. "In fact, we had trouble when we moved to a studio, because we tried to get some of the vibe."

Of Gohl's two studios, the New

Hampshire joint is the most ambitious. Not only does it boast the typical Pro Tools and Digital Performer setup, it's stocked with some impressive studio gear, including an old analog Topaz console. "I could record a small chamber orchestra or a rock 'n' roll band up there," he says. "Instead of a small control room and a larger live room, I made it a big open room, put all the hard drives and the noisy gear behind glass, sealed-off doors, and have one sizable iso booth. A lot of the work I do by myself, and I don't want to be cooped up looking out into this beautiful space." His New York facility is simply a Macintosh G4, a Roland VM-7200 mixer and a couple of Tascam DA-88s.

Though McLaughlin's London studio includes some random bits of vintage gear such as Korg Chaos pads, Electro-Harmonix pedals and Decca Tree mic setups, he also relies on the relatively simple Macintosh/Pro Tools/Performer system.

Throughout their production careers, Gohl reports, technology has provided opportunities to experiment as well as save precious time. He points to the score he recorded with Robinson as an example: "Where something was loud and raucous, like a full-distortion guitar, it becomes a much smaller sound sweetened by a string arrangement that I might have done. That can be done fairly quickly outside of the recording schedule while the film is being dubbed."

If he gets a call during the mix that

—CONTINUED ON PAGE 80



# It's "Australian" for faster post production.

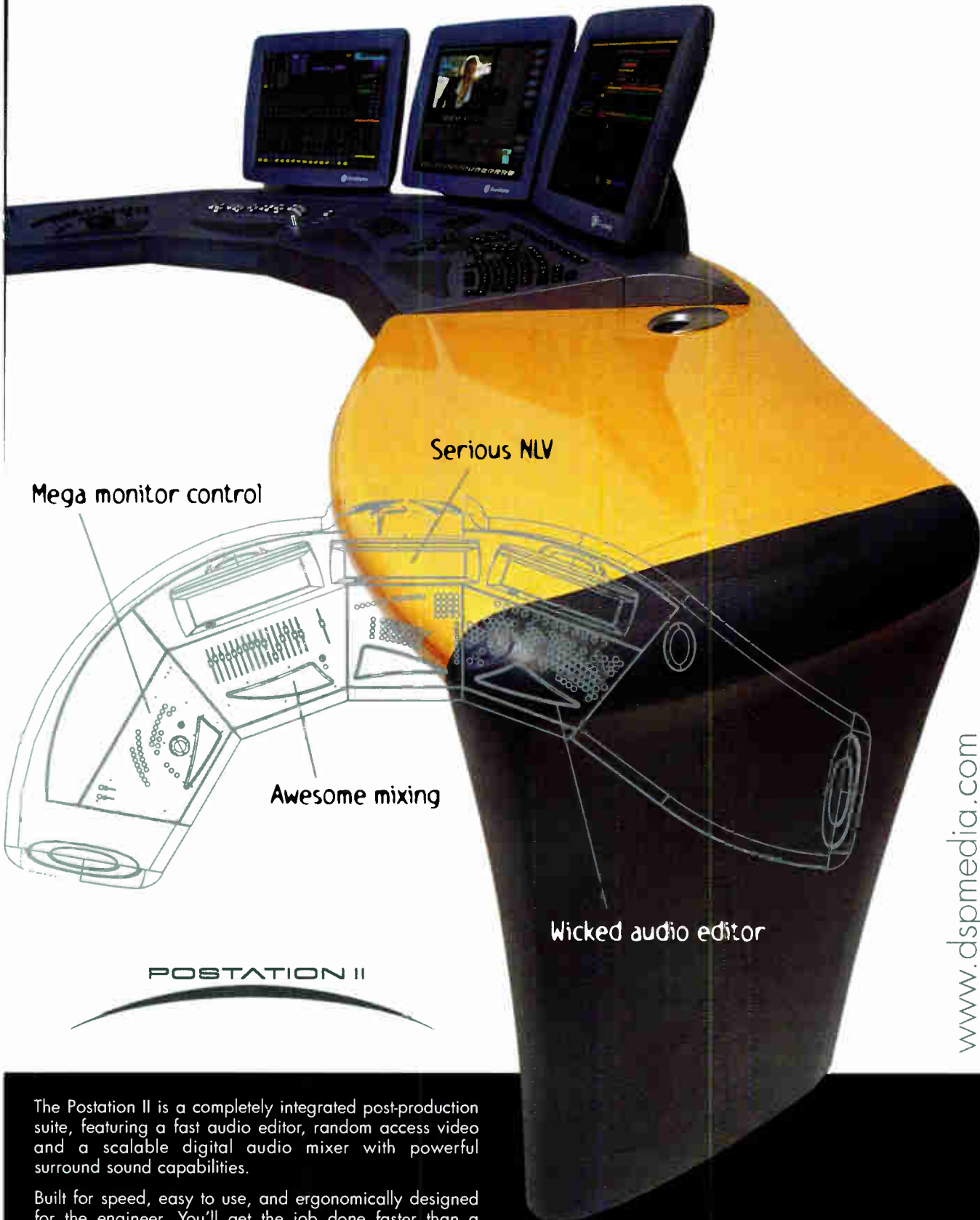

Mega monitor control

Serious NLV

Awesome mixing

Wicked audio editor

POSTATION II

www.dspmedia.com

The Postation II is a completely integrated post-production suite, featuring a fast audio editor, random access video and a scalable digital audio mixer with powerful surround sound capabilities.

Built for speed, easy to use, and ergonomically designed for the engineer. You'll get the job done faster than a boomerang in the Outback mate!

Sydney +61 (2) 9557 2292 (R&D)  
Los Angeles +1 (818) 487 5656 (Headquarters)  
London +44 (0) 207 664 5688



World Radio History

CIRCLE #031 ON PRODUCT INFO CARD



—FROM PAGE 66: "SPY KIDS"

'This is what a Latin orchestra sounds like,' where the rhythm is a little different, a little off-kilter." [Editor's note: You

written the main spy theme, but he was unavailable to write any more. When the film got pushed back to a late March release, he contributed more

for Gregson Williams. The orchestra was recorded at the Skywalker Scoring Stage, then mixed down by Alan Meyerson at Media Ventures.

Rodriguez came up with the idea for *Spy Kids* in 1994, before he had the first of his three boys. He began writing it in 1997. For a director associated with the likes of *Desperado* and *The Faculty*, this was to be his homage to the innocence of *Willy Wonka* and *Chitty Chitty Bang Bang*.

"The concept that I wanted from the beginning was to feel like a child wrote, directed, edited and composed this," Rodriguez says. "The themes would be almost childlike in their simplicity. Melodies you could hang on to after the movie was over. A simplicity to the notes. There are so many composers, and they all had their own flavor, and it's seamless. I think they all got excited, because it's a whimsical movie. It's fun, it has spies and it's about kids. There are some very cool cues that you're just not used to hearing in a kids' movie. It's very musical, and I think kids are going to love the soundtrack."

Tom Kenny is the editor of Mix.



Robert Rodriguez behind the camera, with his son Rocket

can hear Rodriguez playing power chords on guitar during some of the changes. And there's a playful take on Santana's "Oye Como Va," which Rodriguez calls "Oye Como Spy."]

At the same time, Danny Elfman had

cues based on the same theme. "Danny showed me how one theme played differently throughout the movie can come out kind of neat," Rodriguez says. Meanwhile, Heitor Pereira and Gavin Greenaway of Media Ventures filled in

# another beautiful day...

apogee digidesign motu otari sony studer tascam  
t.c. roland manley neumann neve korg emu avalon ams akai

and everything that goes between

nyc london nashville 24/7

212.691.5544/0208.451.5544/615.321.5544

# Dreamhire

## professional audio rental

www.dreamhire.com ....whatever

# THE WHOLE PICTURE

## DIGITAL PRECISION



- ARTEMiS
- 24•96
- RADiA
- SADiE 4 Software System
- SADiEnet networking

Some people would have you believe that only they can provide the right choice of workstation for your application.

Other people are wedded to a specific operating system when deciding upon a workstation.

There are even those who underestimate the importance of effective customer support in keeping their business running.

Fortunately there are those who are able to see beyond the hype and recognise the power of SADiE for the widest range of applications backed by unparalleled customer support.

Isn't it about time *you* considered the whole picture?

Visit our website or contact us directly for further information.

[www.sadie.com](http://www.sadie.com)



### THE WORLD'S FINEST AUDIO WORKSTATIONS

USA  
Tel: +1 615 327 1140  
Fax: +1 615 327 1699

Europe  
Tel: +49 (0)711 3969 380  
Fax: +49 (0)711 3969 385

United Kingdom  
Tel: +44 (0)1353 648 888  
Fax: +44 (0)1353 648 867

**SADiE**  
DIGITAL PRECISION

CIRCLE #033 ON PRODUCT INFO CARD

—FROM PAGE 67, DANNY ELEMAN

*You ought to give it a try.*

I should give it a try. It seems like these days, just about anyone can do it, so why not? Huh?

*Just get your sampler and some Pro Tools and slam it together.*

Yeah. Slam it together.

*To your credit, your music doesn't sound that way in the films you've scored. You do a great job of blending rich-sounding symphonic and choral elements with more interesting percussive and synthesized components. Give me an idea of how your process evolves.*

Oh, boy. Organized chaos. I'm not a naturally methodical person, but I have to force myself to create a bit of a methodical way of thinking at the beginning of the process, and then it becomes chaos. It's really both. There is a methodical approach that I take at first. I can't start writing the score until I have all of my themes completely laid out. I have to know what they are and how they are going work and how they interrelate. I always think about it like doing a painting, and I can't start the painting until all of my colors are completely worked out.

A painter friend of mine in New York once brought me to his studio, and he was setting up all of these jars of pigments and colors. I asked him what he was doing, and he said, "I've been doing this for about a month, and I'm about to start some paintings, and I don't start until I've settled on exactly what tones and pigment and colors are compared and laid out in a certain fashion. When it is completely done, I'll start my first picture." I thought to myself, "That is exactly what I'm doing when I start a film." I'm laying out all the melodic pieces, knowing in my head how it is all going to work together.

Once I have all of those elements together, there is no method anymore. I just dive into the first cue. I go as close to chronologically as I possibly can. I don't plan or think about where the music is going to go. It really is extremely unmethodical. I tend to let the music carry itself, and I become very often surprised by it. I never question it. The beauty of working with Tim is neither does he.

For example, on *Sleepy Hollow*, I wrote this dark theme for the Horseman and I wrote a kind of a child's theme for Ichabod Crane, which in fact would play when he was a child, on flashbacks. For reasons that I don't understand and never questioned, that



PHOTO: LIVIA CORONA

theme kept coming in the middle of the Horseman's theme. This bit of innocence would just happen, and I remember thinking, "What is this doing here?" What I've learned over the years is to never ask that question. You just enjoy it, use it and move on. Everything musically...if it appears in a cue in a certain way, it is there for a reason. The less I try to analyze it, the better I am. So, that innocent theme juxtaposed against that monster just worked for me.

See, a lot of directors wouldn't let you do that. They would think very methodically and intellectually about music and say, "Oh my God! How can

you play this theme over that character?" Well, what Bernard Hermann taught me is that basically it was all bullshit. You can do any goddamn thing you want. [Laughs.] The only rule is that there are no rules. Whatever works! Period!

*So you basically trust the mystical process of the art.*

Absolutely. My trick is really simple. I prepare as much as possible in the beginning, and then I let it take over. If I don't do the preparation in the beginning, it is likely to not be cohesive in the end, and that isn't acceptable. Ultimately, it has to fit together like a puzzle. It is like, "Do the homework in the beginning and then don't ever think about it again."

I love the fact that Tim never questions that stuff and goes, "What in the hell are you doing playing Ichabod's theme over the Horseman?" He reacts to it the same way I do. He'll chuckle. He thinks only about the music on a totally visceral level. He doesn't intellectualize it, and that is how I write it. *Speaking of visceral, I really enjoyed the classic horror movie vibe of Sleepy Hollow.*

It was fun. There is this one scene in that movie that I thought was so great for Tim, and it was the first thing that he showed me. It was the scene where the family is putting the little boy to bed and the Horseman breaks in. First, the Horseman decapitates the father, and then the mother gets it. The little boy is hiding under the floor when his mother gets it, and he sees his mother's head rolling on the floor and [the Horseman] ends up looking down through the cracks at the boy. Up to that point, Tim never had gotten like that. His violence has never been that intense. The level of violence in Tim's movies is like that of a Western; he is so not into graphic violence. But this was such a visceral scene, and the Horseman does, in fact, catch the kid and get him, too.

We grew up on a lot of the same kinds of fantasy and monster movies, and that is why I think we share similar sensibilities. *Sleepy Hollow* was very much like a good version of those kinds of films. I grew up a block from a movie theater, and that was like the center of my existence. I went there every weekend, with the exception of weekends when they would have what I would've called "kids' movies," which I hated as a kid. When I say that, I mean films with no monsters or mutants or fantasy.

# STUDER



Picture was prepared by Bachmann and Suter

## Studer Creates Surround Solutions

### Sound with the power of picture

As digital television becomes a reality, post-production in surround sound becomes an essential. With over 10,000 analog and digital consoles installed worldwide, Studer has the experience to offer the finest surround sound solutions to television program-makers and broadcasters. Optimized for operational simplicity and easy to integrate into existing environments, Studer systems deliver the creativity and flexibility that the audio engineer has been waiting for. So he can deliver sound that is as powerful as picture.

Over the last 50 years, Studer's name has become synonymous with excellence in professional audio. Thousands of television and film producers all over the world put their trust and their professional reputations in our hands. Because our technology will not let them down. Because it is by Studer.

### Studer North America

Main Office:  
 Toronto, Ontario M3B 2M3  
 Phone +1 416 510-1347  
 Fax +1 416 510-1294  
 eMail [studer@mail.studer.ch](mailto:studer@mail.studer.ch)

[www.studer.ch](http://www.studer.ch)



The new Studer 0950 M2 Digital Mixing System

ALPHASORB FABRIC-WRAPPED WALL PANELS

- ▲ Sound Absorbers
- ▲ Sound Barriers
- ▲ Sound Diffusors

# BASIC ACOUSTICS

from



FREE Catalog & Sample  
(800) 782-5742

www.acousticalsolutions.com

CIRCLE #035 ON PRODUCT INFO CARD

*I lived a block from a movie theater, but they ran The Sound of Music for five years.*

Oh my God! That would've been the death of me! As a kid, I wouldn't see musicals if you paid me. I hated musicals, and I hated comedies, for the most part. I feel so fortunate to have lived so near a theater that catered to the tastes of kids at that time, which were monster movies and science fiction.

I loved the Ray Harryhausen stuff, which had Bernard Herrmann's music—movies like *Jason and the Argonauts* and *The Seven Voyages of Sinbad* and *Mysterious Island*. I also loved Roger Corman's Edgar Allan Poe stuff, like *The Raven* and *Tales of Terror* and *House of Usher*. These were my ideas of a comedy. It wasn't *Flubber* or *Chitty Chitty Bang Bang* or that kind of stuff, which I really detested. My idols were Peter Lorre, Boris Karloff and Vincent Price.

One of my very favorite movies growing up was a movie called *The Haunting*, which would definitely stay up there on my permanent Top 10 list. It was so great. I didn't realize at the time that this was the same Robert Weiss that did *The Day the Earth Stood Still* and *West Side Story*. [Laughs.] Talk about a bit of versatility?

*The Day the Earth Stood Still* is my favorite of those fantasy films. It is also where I discovered Bernard Herrmann's name, and it suddenly had meaning to me. I was so taken and moved by that film. It was the first time it dawned on me that the music was composed by an individual. As a kid, you just assume that everything is just "there." That was the first time I realized that it wasn't just "there," and it isn't all the same. This was great music, and it was moving me.

*When did you start getting into music?* Most of my high school friends were musicians, and I wasn't. I figured it was way too late for me, because everyone I knew had been playing since they were seven. At the time, it seemed like, "Forget it. It's never going to happen." I mean, I had a guitar and doodled on organ and piano. I tried to take some lessons, and I was really bad at lessons. I would memorize my lessons really quickly, but I couldn't play stuff back to the teacher. I'm really bad at one-on-one. I'm much better in front of a thousand people, instead of one person.

Anyway, I never went to college, and I never even quite finished high school, actually. I went off to France

## More from SCHOEPS:

### VMS 5 U

Stereo Microphone Preamp  
20 Hz to 80 kHz



professional tools

- 48 V phantom power
- inputs both for XLRs and for Schoeps active Y cable
- switchable M/S matrix
- pre-/post-matrix headphone output (switchable)
- operable with internal/external batteries, rechargeables or mains adaptor
- carefully designed power management with protection against deep draining of batteries
- high-quality, long-life switches and sockets (gold-plated contacts)
- robust aluminium housing (169x60x163 mm)

Distributed in the United States by:

Redding Audio, Inc. Tel.: (203) 270 1808 E-mail: [reddingaudio@aol.com](mailto:reddingaudio@aol.com)  
 97 South Main Street Unit 10 Fax: (203) 270 2934 Web site: [www.schoeps.de](http://www.schoeps.de)  
 Newtown, CT 06470

CIRCLE #036 ON PRODUCT INFO CARD

# DISCOVER PURE GENIUS!

INTRODUCING THE ALL-NEW FAIRLIGHT PRODIGY2 FULLY INTEGRATED DIGITAL AUDIO PRODUCTION SYSTEM. THE WORLD'S FASTEST INTEGRATED DIGITAL RECORDING, EDITING AND MIXING SYSTEM NOW GIVES YOU MORE... MORE TRACKS... MORE BUSSES... MORE LIVE FEEDS... IN FACT, A WHOLE LOT MORE!

PRODIGY2 FEATURES FAIRLIGHT'S QDC TECHNOLOGY ENGINE BOASTING THROUGH NOISE LESS THAN -110DB AND THD IN OF LESS THAN 0.0008% FOR SPARKLING AUDIO PERFORMANCE. WITH A DISTRIBUTED PROCESSOR ARCHITECTURE EMPLOYING ANALOG DEVICES SHARC CHIPS, PRODIGY2 DELIVERS 40 BIT FLOATING POINT PROCESSING FOR EFFORTLESS REAL TIME DSP CAPABILITY. NO MATTER HOW COMPLEX, PRODIGY2 WILL PERFORM SEAMLESS, GAPLESS, PUNCH-IN AND PUNCH-OUT ACROSS ALL 48 TRACKS WITH 24-BIT RESOLUTION TO A SINGLE HARD DISK, AND, OF COURSE, IS 96KHZ READY.

PRODIGY2 GIVES YOU EXPANDED FUNCTIONALITY WITH 32 BUSSES, 48 TRACKS, 24 LIVE FEEDS AND UP TO 64 INDEPENDENT CHANNELS OF 10 - 32 ANALOG AND 32 DIGITAL. PLUS YOU GET FULLY AUTOMATED MIXING WITH MOTORIZED FADERS, 24-BIT A/D AND D/A CONVERTERS, AN ALL-DIGITAL SIGNAL PATH WITH INTERNAL ROUTING AND PATCHING, STEREO AND 5.1 SURROUND MONITORING WITH AUTOMATED JOYSTICK PANNERS, AND THE OPTION TO ADD FAIRLIGHT'S MEDIALINK NETWORKING AND FILE EXCHANGE WITH MOST POPULAR WORKSTATIONS - ALL IN A FULLY INTEGRATED DESKTOP SOLUTION.

PRODIGY2, FROM FAIRLIGHT - IT WILL BRING OUT THE GENIUS IN YOU.

**(800) 4-FAIRLIGHT**  
**WWW.PRODIGY2-1.FAIRLIGHTESP.COM**  
IN CANADA CALL (416) 867-9000

# Prodigy 2

QDC  
TECHNOLOGY

FAIRLIGHT

World Radio History

CIRCLE #101 FOR PRODUCT INFO CARD

# In the Studio?

**FREE Guide Saves You Time and Money!**

Nothing is more frustrating than making CDs or cassettes and finding out that there's something wrong with your master. **DISC MAKERS' Making A Great Master** provides insider information, as well as common sense tips, on preparing an error-free master on the first try. *No matter where you record your product, you need this 36-page booklet before leaving the studio.*

**Call Today For Your FREE Guide:**  
**1-800-468-9353**

[www.discmakers.com/mix](http://www.discmakers.com/mix) · [info@discmakers.com](mailto:info@discmakers.com)

**DISC MAKERS**  
CD, CASSETTE, AND VINYL MANUFACTURING MADE EASY

CIRCLE #038 ON PRODUCT INFO CARD

## THE SAC-2K

The one computer control surface for now and the future! MOTU Digital Performer, Steinberg VST and Nuendo, Emagic Logic and Sound Diver, Digidesign Pro Tools from Mix Plus .001 to Pro Tools Free, Creamware, SEKD and many more. For all synthesizer programmers, you can program any virtual or hardware MIDI instrument with total parameter names and amounts laid out the way you always wanted it!



Look for the new SAC-8x expansion and our new surround matrix for the total professional environment!

Radikal Technologies  
1119 North Wilson Avenue  
Teaneck, New Jersey 07666  
201-836-5116 phone  
201-836-0661 fax  
[radtek@jdt.net](mailto:radtek@jdt.net)  
[www.radikaltechnologies.com](http://www.radikaltechnologies.com)



**RADIKAL TECHNOLOGIES**

CIRCLE #039 ON PRODUCT INFO CARD

World Radio History

before my last year in high school in 1971. My brother was in a crazy music theatrical troupe there called Le Grande Magic Circus. I was just 18, and I joined him in France. I had just picked up the violin that year and was planning on traveling around the world. I wanted a small instrument to try to learn while I was traveling. Guitar was just too big. I ended up getting hired and touring with them, and I spent close to a year traveling throughout Africa, primarily through West Africa. I remember I spent my 19th birthday in Africa, because the Nigerian border guards sang me "Happy Birthday." I lived for a brief while in the Canary Islands.

My brother returned to Los Angeles and started a theater troupe inspired by Le Grande Magic Circus called the Mystic Knights of the Oingo Boingo. He recruited me to become the "music director" of the Mystic Knights the day after I arrived home with hepatitis. It was like, "You don't have to work hard. Just soak it in and watch while you are getting your health back." [Laughs.]

There were eight years of really intensive work with the Mystic Knights. In that period, it went from being like a ragtag street group to being a really full-blown theatrical troupe, where everyone had to play three instruments. I picked up trombone. I taught myself to write and transcribe. I started really getting into percussion.

A lot of the driving force of the Mystic Knights were these two percussion ensembles and early jazz. I refused to listen to contemporary music for almost 10 years. I wouldn't listen to anything after 1935.

Leon Schneiderman, who was the saxophone player and a high school friend, went with me to Africa, and we brought back these balafons, but they were too delicate, so we built our own. We built bass balafons. Then we started building a pot-and-pan orchestra, with big racks of tuned mining pans and beer cans and measuring cups.

There was a large portion of my life where I really wanted to become a modern-age Harry Partch, who was kind of my idol. Harry Partch was a very eccentric American composer from the '40s and '50s who built his own instruments. He developed some scales and used microtonal tuning and devised ways to write for these microtonal marimbas and instruments that he built. I loved that and was fascinated by

—CONTINUED ON PAGE 82



great sound

# JUST GOT EASIER



## The ORIGIN STT-1



**AT THE TOUCH OF A BUTTON**

Vacuum Tube  
OR

Discrete Transistor  
Selectable at Every Function



*with Twin Topology...  
combines a single channel  
of every Millennia solid state  
and vacuum tube audio  
function ...over 130  
product combinations  
in one toolbox.*



Transformer  
or  
Transformerless  
Input



Vacuum Tube Mic Preamp  
Solid State Mic Preamp  
Vacuum Tube DI Instrument Input

Eight  
Input &  
Output  
Choices



4-Band Vacuum Tube  
Parametric EQ  
4-Band Solid State  
Parametric EQ



Vacuum Tube Opto-Compressor & De-esser  
Solid State Opto-Compressor & De-esser

**Uncompromised Millennia sonic performance. Priced under \$3,000**

Millennia Media, Inc.  
Pleasant Valley, CA

530-647-0750  
Fax 530-647-9921

[www.mil-media.com](http://www.mil-media.com)  
World Radio History  
CIRCLE #040 ON PRODUCT INFO CARD

**Millennia**  
Music & Media Systems

—FROM PAGE 70, GOHL/MCLAUGHLIN

a cue doesn't quite work, then Gohl will spend an hour working something up, often from the tracks they've recorded and not used, and then send it over via bike messenger. "Or, chances are, we'll have a music editor on the dubbing stage, and I'll just work with him in Pro Tools until we get something that works. You use your resources. You might have recorded anywhere from a half-hour to an hour-and-a-half worth of music; there's a lot of stuff there. If a cue doesn't work, that doesn't mean you have to go back and rewrite it overnight and get another orchestra.

When Gohl gets a chance to write scores of his own, he often begins on an acoustic piano. Once he's ready to get the music down to demo form, he turns to a number of samples housed within a Kurzweil 2500, or he sits at a Roland JV-1080 or the vintage Korg M1, Moog and Prophet DX. As far as modules, he goes back to the Proteus Orchestra for woodwind sounds and analog modules by Oberheim. There are even the rare times when he'll use a Yamaha VL-1 to perform some physical modeling. "It is a difficult instrument to master, but it is a fantastic instrument for monophonic sounds," he says of the VL-1. "It was too compli-

cated and too expensive to catch on with the mass market."

Much like a pop music producer, Gohl is charged with helping the composer down the path while spotting a film. "Depending on how much a composer knows what to do, he'll just come up with something, or we further coax him along, maybe playing some ideas until we have some themes that we can apply to various scenes. Then we build it up from there," he says. "During something like *The Red Violin*, you're talking about a very experienced, polished composer in his own right. So, during that project, I did not write a single note. My job was to produce everything from the recording sessions to the technical aspects of music editing, how it's cut in and how it appears in the final dub of the film."

The team's main responsibility, it seems, is to make sure that all involved are happy with the final score, including directors, producers and composers. Gohl points to the recent work his partner performed on *The X-Men* soundtrack, written by Michael Kamen. "The director wanted that type of John Williams soaring orchestral score, the producers wanted more of a drum-oriented, Hans Zimmer rock 'n' roll thing," he recalls. "What happened in the end was a combination of the two, all of which landed on Steve's shoulders, because the composer had no interest in doing something that's not him. So, he started to generate some of those loops, some of those rhythms, and integrating with the music that Michael had written. In the end, you have a working compromise. It's always a compromise; it's not always satisfying, but you have something that everybody's happy with."

Obviously, that's not always possible, and that fine line of making everyone happy is a challenge. Gohl takes the long view to survive the internal battles. "You walk [the line] by knowing that this is just another movie," he says. "Even if it's the biggest hit of all time, you know what the best music was for the film and why it's there." And having a sense of humor helps, he adds. "When Steve and I work together, we have a lot of fun. You've got to have fun. The sense of humor and the lightness, especially in the tough parts, is really important."

*David John Farinella is a freelance writer based in the San Francisco Bay Area.*

## Turn Your Laptop into a Powerful Production Tool

### THE VXPOCKET PORTABLE LAPTOP SOUND CARD



+mic/line level: +10dBu (+8dBV)  
(-10dBV nominal with 18 dB overhead)  
+24 bit analog to digital converters  
(64x oversampling delta-sigma)  
+microphone level adjustable from -41dBu to -20 dBu

- PC-Card II Format • 2 Balanced Analog Audio I/O
- Digital 24bit SPDIF Stereo I/O • SMPTE-LTC Time Code

Whether you're performing live with dual balanced Mic inputs, synchronizing audio in the studio, or experimenting on the road with 24-bit stereo effects via the SPDIF I/O, the VXpocket is the perfect laptop solution for achieving excellence in audio quality. Add the convenience of portability and you'll enjoy a whole new aspect of creative freedom. Check out the VXpocket Sound Card today at your Foxtex Dealer.



**Digigram**

compatible with:



Mac OS



Windows

Distributed By: **FOSTEX** [www.foxtex.com](http://www.foxtex.com)

CIRCLE #076 ON PRODUCT INFO CARD

World Radio History

**M3D™**

Keeping the third dimension in line

## Control the vertical Control the horizontal ...right to the outer limits of sound reproduction.

### Reinventing the Line Array – Top to Bottom, Side to Side, Inside and Out.

After more than two years of intensive research and development, Meyer Sound proudly introduces the new Meyer 3D (M3D) Line Array Loudspeaker System – the first totally integrated, self-powered directionally controlled line array.

**BroadbandQ™ Directivity Control** marries a remarkable new high-frequency REM™ (Ribbon Emulation Manifold) and constant-Q horn with our award-winning low-frequency directional control technology. The result is consistent 90-degree horizontal coverage from 40 Hz to 18 kHz, for optimized performance that's markedly superior to conventional line array systems. If you need more low-end power, add M3D-Subs to extend directional control down to 30 Hz.

- Self-powered, quick to set up
- Arrayable vertically and horizontally in multiple columns
- Captive QuickFly™ rigging with custom CamLink system
- Remote Monitoring System (RMS™) ready
- Immensely powerful

**Greater Configuration Flexibility** – Unlike other line array systems, the M3D doesn't require a minimum number of cabinets. You can use it singly, or fly up to eighteen units per array for incredible power and throw. The M3D is arrayable horizontally in multiple columns – and because it's compatible with most of our Concert Series products, you can mix and match down fills and short-throw arrays to optimize near-field coverage.

**Self-Powered Integration** – Meyer's proven 4,960-watt four-channel amplifier with proprietary, phase-corrected processing powers the M3D. RMS™ (Remote Monitoring System) interface is an available option.

**Designed to Move** – Road-tough, weatherproofed cabinets incorporate captive QuickFly™ rigging with no separate components to lose. Easily removable caster rails and truck-smart dimensions make for efficient load-in/load-out.

Interested? Then we'd really like to talk to you. Call us for a brochure and the name of your local representative. And check out [www.meyersound.com/m3d](http://www.meyersound.com/m3d). There's lots more information there...

**The M3D with BroadbandQ technology.**  
Taking the line array to the outer limits of sound reproduction.

Meyer Sound Laboratories, Inc.  
2832 San Pablo Avenue  
Berkeley, CA 94702  
Phone 510-486-1165  
Fax: 510-436-8356



**Meyer  
Sound**

[www.meyersound.com/m3d](http://www.meyersound.com/m3d)

Copyright © 2003 Meyer Sound. All Rights Reserved. Patents pending: M3D, BroadbandQ, Ribbon Emulation Manifold, REM, Intelligent AC, TopPower, RMS, and QuickFly are trademarks of Meyer Sound.

PUT YOUR HEAD WHERE  
YOUR HEART IS...



Come to  
New York City

the center of the  
recording industry.  
Learn recording  
engineering at the

## INSTITUTE OF AUDIO RESEARCH

Our 6 month  
Recording Engineering  
and Production Program  
includes:

Multitrack Recording,  
Mixdown Techniques,  
MIDI, Digital Audio  
& more. + a diploma  
from a world  
renowned school.

Call 800-544-2501

212-777-8550  
(NY, CT & NJ)

Your focus is music,  
our focus is you.

[www.audioschool.com](http://www.audioschool.com)



INSTITUTE OF AUDIO  
RESEARCH

64 University Place  
New York, NY 10003

CIRCLE #041 ON PRODUCT INFO CARD

—FROM PAGE 78, DANNY ELEMAN

the music of Terry Riley. I really loved percussion.

The Mystic Knights was this odd theatrical union of crazy percussion ensembles and the music that I loved most during the '70s, which was a lot of vintage Cab Calloway, Duke Ellington and Django Reinhardt. It was through that early jazz that I taught myself to write and notate, because I used to have to transcribe the solos and the arrangements.

*So you are utterly self-taught?*

Yes. I owe a great debt to Duke Ellington, really. Those were the first transcriptions I did. His arrangements were not that simple, and the harmonies were really interesting. I learned that, if I took the time, I could get it exactly right. That is where I learned my confidence in my ear.

Cab Calloway's arrangements were also really a big deal to me. Some of those arrangements had some really dense, crazy shit, and they were not that easy to write. They could be very fast and complicated. I would listen to videocassettes of Betty Boop cartoons and old records, but I learned that if I listened hard, I could freeze it in my head and hold it there and write it down. It ended up being critical training for me, even though I didn't know it at the time.

This was also where I began to compose. The last big and most ambitious composition for the Knights ended up being what really gave me the confidence many years later when I was asked to compose for film. It was the "Oingo Boingo Piano Concerto 1 and a Half."

*What caused you to move from the Mystic Knights into starting up a band?*

It was really hearing the ska that came out of England around 1978. That is what turned me around. I loved listening to the High Life music of West Africa. It was a little more Latin than ska, but really up-tempo. It was the same exact-size band as Oingo Boingo became—an eight-piece band with a horn section. It was hearing The Specials, Selecter and Madness and then XTC, who really clicked for me. I wasn't a fan of '70s rock at all, but when I heard all this energetic stuff coming out of England, that is what totally did it for me. Bang!

*So it wasn't until the very end of the '70s that you heard any popular music that you could relate to?*

Yeah. Somewhere, early on in that

decade, a trumpet player friend of mine turned me onto Miles Davis' *Bitches Brew* and Stravinsky's *Rites of Spring*, and it was probably six short months after that that I threw away almost my entire record collection. [Laughs.] I've always been prone to extremes. I don't know what exactly clicked me into old jazz, but I felt that I was displaced in the '70s. I felt I really belonged in the '20s. I felt like I was a character out of late-1920s Paris that somehow got stuck in 1970s Los Angeles.

*Was your family musical?*

No. My parents listened to folk music like Pete Seeger. I know my Dad listened to Beethoven, I seem to recall. Classics. They were schoolteachers.

*So how did they feel about you leaving high school?*

They weren't happy. I did get a diploma sent to me. I just didn't want to stick around to get it. I managed to squeak enough credits and take off. It

**When I go into  
the studio,**

**I send an entire  
duplication  
of my setup  
in a mobile rig.**

wasn't like I wasn't interested in college. I just wanted to get the f\*\*\* out of high school as fast as I could. I really disliked people my age, for the most part. I just had as much as I could take of teenage boys in general. It was that weird out-of-place thing. Being surrounded by teenage boys was, for me, like being in some kind of zoo full of orangutans. For the most part, they were so f\*\*\*ing stupid and proud of it that it was mind-boggling. [Laughs.] It probably hasn't changed that much. I just wanted to be around girls. I couldn't stand boys. I had some friends who were boys, but they were misfits like myself. They were eccentrics.

*I was very much in a similar situation in junior high and high school. I was the tall skinny guy who was given a hard time by all the jocks.*

And I was the little weird-looking albino kid that couldn't see anything in the sun. When they did team sports, I was blind as a mole in the light. Of course, in those days, you couldn't wear sunglasses to school. I didn't un-

*Valve mics?  
The choice is yours...*



**NTK**

**The point at which sound becomes music, is where your art, your dreams and your emotions have become a reality. NTK - when professional performance counts.**

**RØDE**<sup>®</sup>  
MICROPHONES



**CIRCLE #042 ON PRODUCT INFO CARD**

USA: 1 866 8411 457 INTERNATIONAL: PO BOX 3101, 5 AVERILL STREET RHODES NSW 2138 AUSTRALIA PH: 61 2 8765 9333 FAX: 61 2 8765 9444  
info@rodemicrophones.com www.rodemicrophones.com/NTK

World Radio History



This is a microphone  
that will make you  
question what  
"natural sound" is.

Recording Magazine  
June 2000

...The Royer's sound  
was unbelievable;  
warm, clear, and  
incredibly lush.

Pro Audio Review  
July 2000

(818) 760-8472  
Burbank, CA.

CIRCLE #043 ON PRODUCT INFO CARD

derstand that I simply wasn't designed to be out in daylight under any circumstances, much less catch a ball under a sunlit sky. I was a pretty bitter kid, a nerd, at that age.

*Is there anything that I haven't touched upon that you would like to address?*

You didn't ask me about a lot of equipment, which I really appreciate. I'm always grateful when it is not a super-technical talk of "what's my gear."

I will say that I'm constantly changing my rig, but the most common, long-lasting staples from the beginning that I have been using are the Emu samplers, which I've been using since their very first E-I, the Macintosh, which I've used since the Jurassic version, and Mark of the Unicorn Performer, which I've used since its earliest incarnation. My extensive personal sample library of percussion is all laid out for the Emulators, but recently I began converting some of that library to use on the Gigastudio as well.

Concerning Mark of the Unicorn, that is one of those things that, once you are really good at a certain software, it would take a really compelling reason to change. The speakers I listen to are Questeds. I love listening to those. I have a pair of the small Genelecs, which are nice. If I have to set up in another space, I'll use the Genelecs.

I have a bunch of stuff spread out in different places, but I never use more than two in one place. Actually, I have two G4s, eight Emulators and two Pro Tools systems, because everything is duplicated. When I go into the studio, I send an entire duplication of my setup in a mobile rig. That is because it was getting more ridiculous having to drag all of my shit down into the studio.

See, a lot of the samples and things that I use stay in the score. A lot, like the orchestra sounds, get replaced by the real thing. But very often, there are anywhere from a dozen to 48 tracks or more of my own stuff. My engineers are always moaning and groaning about this, because I lay down stuff that isn't orchestral. It is stuff I'm playing, and I want to bring it in. Almost all of the percussion and synthesizers in my scores are mine. So, finally, I realized that the only way I could do this was to have a rig that I could roll in and plug in and set up and be up and running in a couple of hours—instead of dragging half of my studio down and taking an entire day setting it up and then dragging it

back. It just didn't make sense.

That said, the whole art is non-technical. It has become technical, in terms of laying it out. I have to say that working out stuff with a director, in one's home studio, before you get in front of an orchestra, is usually a very positive thing. Because whatever differences you have, you try to get through as many of them as possible without a big orchestra there, so you can duke it out on your own time, so to speak. I think that is good. It is good to know that the technical stuff doesn't make the score. It helps with the presentation, and directors really want that nowadays, but I started out with just a piano and a couple of little sequencers and then grew into other things. It still hasn't changed the fact that the art is still the art, and it is still about capturing the tone.

*Your scoring for the film Edward Scissorhands was truly magical at capturing a tone. It is probably the most mimicked film piece that you have done to date.*

That is clearly true. Closer to Christmas time each year, the Edward stuff just starts popping out all over the place. It is really funny. The phone really starts ringing as it gets close to that season. People will call up and say, "Did you hear so and so? You've got to check it out?" It also rings at some odd times, for different commercials.

*It certainly is one of my favorite Tim Burton movies, and even though there was plenty of humor, I found it to be a wonderfully touching movie.*

So did I, but then anything that is emotional in movies is because you "buy" it. I know a lot of people who thought *Titanic* was extremely emotional and that it moved them to tears. This was from people who had relatively good taste. [Laughs.] For me, I didn't feel a single stir inside of me. Why we find anything moving or not is a pretty subjective thing.

*It has been said that Burton's movies always have this compassionate thread for the misfit underdog. Obviously, you relate to that, the kid who needed sunglasses and had a hell of a time trying to catch a football in school. It makes perfect sense that the two of you would enjoy such a positive collaboration.*

That is definitely true. [Laughs.] Tim and I both were probably the underdogs in our past. Weird kids who struggled hard to find the niche.

*Rick Clark is a Mix contributing editor.*

“ Clean, rich and soaring reverbs with superclean tails...one of the most classy reverbs I have encountered and I would seriously consider giving it rack space for the reverb programs alone. ”

—Rob James, Studio Sound



**Orville™ Voted Top Outboard Reverb by readers of Studio Sound Magazine**

## SEE A TREND DEVELOPING HERE?

**Orville™  
World's  
Best Pitch  
Shifter**



“ The UltraShifter™ algorithm is everything you'd expect from the folks who developed the Harmonizer® units: smooth, accurate...more natural and open sounding than any of my other effects boxes. ”

—Dave Martin, Recording Magazine.

### Most Versatile Multi-channel Effects Processor Family



Mix and match any number of channels in standalone, Eve/Net™ remote controlled, or economical blank front panel Orville/R configurations. The Orville + Eve/Net system changes and grows with your requirements.

**Eventide®**  
the next step®

www.eventide.com • 201-641-1200

The Best of  
Everything  
**Orville™**  
Harmonizer® Brand Effects Processor

CIRCLE #044 ON PRODUCT INFO CARD

—FROM PAGE 68, A WARM AND FUZZY COLUMN stories of how the executives have name tags with their last name ("Mr. Blake"), while the blue-collar workers are identified by their first names. At the same time, these staffers would *never* address the hotel manager by *their* first name. This idiocy makes perfect sense to me, as ritzy hotels have always left a weird taste in my mouth due to the frequency in which the staff simultaneously fawn obsequiously while looking down at you.

A film set, on the other hand, is a notably democratic place to work. More often than not, the leading lady will be addressed by her first name. Sure, she will be staying in a suite and will have her own driver, but everyone is brought together by the camaraderie of long hours in sometimes difficult and dangerous locations. Even though my solitary nature has me spending most of my time either alone or with a few other people in dark rooms, I cherish the time that I have spent the past nine years on sets, most of them on Steven Soderbergh's films. His production team is nothing short of aces in every depart-

ment and is almost completely void of stereotypical movie-set histrionics.

In general, I have been lucky enough to work primarily on films whose production track is the foundation for the overall mix, and I relish the opportunity to collaborate closely with the first part of the film sound chain. I have had a chance to work with some of the best in the business, who are also, not co-

incidentally, some of the nicest. This has been further proven to me because when I have had run-ins, it was with some mixers whose work is not at the top of the game.

There has been plenty of fur flying back and forth between production and post-production sound over the years, in the form of finger pointing and accusations. Much of this can be found on

## GLOSSARY

**OSCAR:** The name of the awards handed out by the Beverly Hills-based Academy of Motion Picture Arts and Sciences. Oscar statuettes for Best Achievement in Sound are given to the production mixer and up to three re-recording mixers, while the Best Achievement in Sound Editing is the domain of the supervising sound editor and/or sound designer, for a total of no more than two.

**VARIETY:** The daily and weekly entertainment industry trade paper that is famous for its distinctive industry "slanguage": films are "pix," writers are "scribes," you don't quit or get fired from a job, you "ankle" it. Thus, one of the most famous *Variety* headlines: "Sticks Nix Hick Pix."

# ProSoundweb.com

[www.prosoundweb.com](http://www.prosoundweb.com)



Log on for valuable interaction, contacts and resources

**The Power of Connection for The Pro Audio Community**

Universal Concept, Inc.  
99 Church Street  
Whitinsville, MA 01588

email [info@prosoundweb.com](mailto:info@prosoundweb.com)  
phone 508-234-8832  
fax 508-234-8870



emagic

logic audio

Music Production Software

BT grabs a quick shower before starting his day with Logic Audio.

Definitely First.

BT sets his alarm early because he loves to work with Logic Audio first thing every morning. He particularly appreciates the in-demand features that Logic Audio provided first. Much copied, but never bettered. For example, unlimited tracks, high MIDI resolution, 32 Bit internal signal processing, and realtime, non-destructive editing. Not to mention Logic Audio's freely-configurable user interface, with 90 Screensets and extensive Key Command list. These trend-setting features, plus the unique Environment and DTP-quality scoring, help BT work faster and more creatively. All first class reasons to get up early. Logic Audio – definitely the right choice.

Technology with Soul.

CIRCLE #046 ON PRODUCT INFO CARD

www.emagic.de

Internet news groups, where flaming is all too often the rule. Sometimes I want to compare the relationships between the two camps to the war of the sexes: "You just don't understand me!"

No, I don't understand completely the issues that production crews face, but it has been an immense help, both to me and I suspect to them, my witnessing first-hand the problems that they face. Because, ultimately, they all become *my* problem, and any time one can put forth a unified front in the heat of battle in production, the better chance the production track has of shining in the final mix.

The other internecine battle in film sound sometimes occurs between sound editors and re-recording mixers. The complaints here are less related to the work performed by the other side as it is to how the line is drawn between them. This skirmish also doesn't cross my radar, because I feel very comfortable in both worlds, and am indeed friends with a good percentage of the dozen or so people in the industry who also go "both ways." This collegial feeling perhaps peaks every year at the

sound effects bake off, where 800 members and fans of good sound editing gather at the Academy.

While there has been criticism of this night from various folks, I—being the nerd that I am—think that it's nothing less than wonderful to have good work celebrated in such a manner. When I was having the discussion at the beginning of this column, it gave me pause to think if there were any other departments that have this level of closeness. I gather that the world of visual effects would be a good candidate, because not only is that field so large, but it's commonplace for them to work on the same films together.

My hands-across-the-water experiences in my career in film sound has also literally been just that, as I have been fortunate enough to meet colleagues from around the world. Sometimes this has been through visits to Europe for foreign language mixes, and sometimes this has been through my writings and seminars. I find it very humbling to go to other countries and find out that we indeed have more in common than we don't. (Please pardon the cliché, but I

warned you of the tone of this column.)

What's the dark side of working in film sound? Certainly it takes its toll in your private life because of the demands that it makes on your time. Yes, you get paid good money—stupidly good sometimes—but you have to give up any hope of living a 9-to-5 existence. There is very little glamour and celebrity to be found in making a line of ADR integrate seamlessly into a film, other than the knowledge that you were able to keep audiences focused on the film.

But I, for one, cannot even consider what I would be doing if I weren't able to work in film sound. Maybe I'd be a camera man...

Send your warm, fuzzy comments to PO Box 24609, New Orleans, LA 70184, or via the Internet: [swelltone@aol.com](mailto:swelltone@aol.com).

*Larry Blake is a sound editor/re-recording mixer who lives in New Orleans for reasons too numerous to mention, although one of them would have to be that the film community there is so small that not only do you know everyone, you probably went to school with their spouses.*

# SELLING EQUIPMENT?

## GET IT SOLD!

**It's Fast and Easy on Digidid!**

**digidid.com**<sup>®</sup>

the professional equipment marketplace

[www.digidid.com](http://www.digidid.com)

# Digital Audio Essentials

from the digital audio interface experts

---

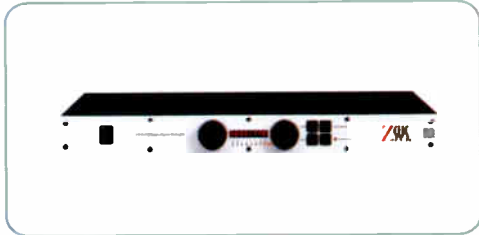

## **NEW! ADAT ↔ S/PDIF conversion**

z-8.8a Lightpipe Detangler is a Lightpipe patch bay and also converts bidirectionally between ADAT Lightpipe format and S/PDIF (AES/EBU optional). S/PDIF inputs also feature defeatable sample rate conversion, allowing four asynchronous stereo digital sources to feed an eight-channel Lightpipe destination.

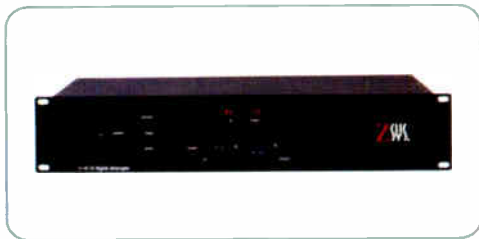

## **Digital Detangler automated digital audio patchbay**

Available with 8x8 or 16x16 inputs and outputs. Supports AES/EBU, S/PDIF optical & coaxial, ADAT Lightpipe optical (no format conversion to and from ADAT format). Mix and match port configurations to build the perfect solution for your studio (standard configurations also available).



## **Rack-mount sample rate converters**

With a full range of input and output formats, input and output wordwidths up to 24 bits at sample rates up to 96 kHz. Available in two-channel (z-3src) and eight-channel (z-8src) packages.



## **Digital Detangler Pro automated digital audio patchbay**

Available in 8x8, 16x16, 32x32, and 64x64 configurations. Can be controlled from dedicated remote controller, Mac, or PC software (network versions available).



## **NEW! 24/96 miniature sample rate converters**

z-link96 and z-link96+ support up to 24 bits at 96 kHz with user-selectable 16- or 24-bit output

Lightpipe and ADAT are trademarks of Alesis Corporation

---



## **Z-Systems Audio Engineering**

Tel: 352.371.0990 ▷ Fax: 352.371.0093  
z-sys@z-sys.com ▷ www.z-sys.com

CIRCLE #063 ON PRODUCT INFO CARD

World Radio History



# RECORD! EDIT! CREATE!

**P**lug in the HDR24/96 Recorder/Editor and start recording. No computer to boot up. No hardware and software configuration nightmares. No compromises like settling for 20-bit audio or just eight tracks at a time.

## Recording's easy with the HDR24/96.

Simultaneously record twenty-four tracks of 24-bit digital audio... without waiting for lock-up, tape shuttle or CPU lag. Drop up to 192 alternate takes into "virtual tracks." Record onto affordable, removable media that you can swap in and out for each project.

And do it all with your hands on a familiar, analog-style machine (or choose from two sizes of wired remotes) instead of resorting to myriad mouse clicks. All basic functions are right on the HDR24/96 front panel including transport buttons and a Record Enable button for each track.

## Editing is easy with the HDR24/96.

Plug in an SVGA monitor, keyboard and mouse, choose from 2x, 4x, 8x, 12x or 24-track views and then watch them scroll smoothly past a centerline. Mark hundreds of cue points and four locate points for looping and auto-punch-in modes.

Use the mouse to "scrub" individual tracks, Cue, Punch and Loop points with continuously variable velocity.

You can mark a segment (or multiple non-adjacent segments) as a *region* and then cut, copy and paste it anywhere — onto a blank track or right in the middle of an existing track

without erasing anything (the part of the track after the insert just "slides down").

You can audition regions or modify their start/end points instantly, capture them as "sound elements" for later use or quantize them to user-defined time grids.

Create fade-ins, fade-outs and cross-fades just by dragging and dropping them ... and then set their length by dragging the mouse.

Add volume envelopes for simple level automation of regions or whole tracks.

Then use Render Track to combine all or selected regions of a track just as you hear it complete with cross-fades, volume envelopes, mutes, etc.

## Play with the HDR24/96.

Play back twenty-four tracks of pristine digital audio — instantly without any pause or lag time. It will be synced rock-solidly to everything in your studio — from MIDI-based sequencers to VTRs (via SMPTE or video sync).

Then let your partners, clients and friends "play" with your tracks anywhere in the world, thanks to the HDR24/96's Ethernet port and FTP server capability.

## The non-linear HDR24/96 vs. linear hard disk recorders.

Ever since the invention of magnetic tape, recording over something means it's

**"...the HDR24/96 is a stunning development with excellent sonic quality, an extensive feature set and versatile file management... it's easy to use and priced right. This one rocks!"**

**George Petersen  
Mix Magazine March 2001**

*If only life had 999 levels of undo. HDR24/96's History list lets you take loads of creative chances.*



\* The real-time view of 192 tracks @ 48kHz/24-bit is a liberal estimate of extra regions and virtual takes. Does not apply to extended format remotes. ©2001 Motic Design, Inc. All Rights Reserved. Motic and the Running Man logos are registered trademarks of Motic Design, Inc. Motic Design is a trademark of Motic Design, Inc. HDR is a trademark of Bartwood Systems.



# SAVE YOUR COMPUTER FOR E-MAIL.



**Need to back up just one song? Plug a MackieMedia Project drive into the HDR24/96 external bay and transfer over 2GB to an ORB™ disk.**

gone... which makes doing "punch-ins" a dicey gamble. This is called *linear* (destructive) recording. Even some current hard disk recorders use this old-fashioned technology!

The HDR24/96 employs true, non-destructive, *non-linear* recording and editing. That means you can record as many versions of a track or track segment as you want without destroying the original. During playback, the recorder recombines the non-linear segments into a seamless *stream*.

And unlike *linear-style* recorders that treat disk space like digital tape, the HDR24/96 doesn't automatically eat up 24 tracks of disk space when you're just recording one or two tracks. Because it uses only the space needed for actual audio, you get far more recording time per gigabyte of hard disk space.

## Professional performance and affordable creativity with the HDR24/96.

Non-linear hard disk recording is possible to do with a computer-based system. But to achieve what the HDR24/96 delivers – simultaneous, lag-free 24-track/24-bit recording and playback and waveform accurate

editing – requires major investment in a *very* expensive digital audio workstation system. Cheap "recorders-on-a-computer card" just don't have the horsepower for multi-track, twenty-four-bit 48kHz recording, much less *twelve-channel 96kHz capability* like the HDR24/96.

## Listen to somebody else instead of us.

Here's what *Mix* magazine had to say about the HDR24/96: "... *The HDR24/96 is a stunning development with excellent sonic quality... The unit offers an ease of use that should make disk-recording novices comfortable while including an impressive feature set that will appeal to seasoned pros.*"

*"The recorder's faceplate holds few mysteries and most users can be up and recording just minutes after unpacking the HDR24/96."*

**Professional remote for a very professional hard disk recorder. Our new Remote 48 lets you run two HDR24/96s – 48 tracks of total control including a weighted jog/shuttle wheel and full display!**



*Audio Media, "As a recorder (the HDR24/96) is transparent. As a tool, it's powerful. As a creative helper it's perfect. With focus on functional,*

*inexpensive, simple-to-use 24-track recording, Mackie has hit the mark."*

## Get a demo at a Mackie dealer.

There are a bewildering array of digital recording options on the market right now. You've heard our two cents worth.

We honestly believe that we've created the best of two worlds: the best standalone non-linear digital recorder, and an extremely robust editing system with ultra-functional graphic user interface. And we've done it without making you enter the *really* cruel world of computer interface compatibility problems.

Call toll-free or visit our web site (using that computer you won't need to tie up) for more info.

Then get your hands on an HDR24/96 and track some hits.



**T**wenty-four track masters for under ten bucks each!! Divide the cost of a MackieMedia M90 into the 20+ pop tunes you can record on it and you're looking at under a ten-spot for each 24-track master\*. Remember, non-linear hard drives store audio data only, not silence. Tape (and linear hard disk recorders) just roll merrily along...eating oxide and costing money.



[www.mackie.com](http://www.mackie.com) • 800.258.6883

CIRCLE #049 ON PRODUCT INFO CARD

Made in Massachusetts • Made in the U.S.A.

# ARMIN STEINER

## TIPS AND TALES FROM AN L.A. STUDIO PIONEER AND SCORING ENGINEER

Armin Steiner is a self-described survivor, having achieved the kind of career longevity that, in the music business, eludes all but a select few. A gracious man with a polite, almost courtly style, he's also highly opinionated, offering an educated and well-articulated point of view that stems from both his past experiences in the recording industry and his current commercial recording work.

Steiner's pop engineering credits include more than 100 Gold and Platinum albums with major artists starting in the mid-'60s and including hits for Glen Campbell, Neil Diamond, the Fifth Dimension, Bread, Heart, Dolly Parton, Johnny Rivers, Hall & Oates, Helen Reddy, Barbra Streisand and many more. In recent years, he's returned to his youthful roots as a classical violinist and has become an in-demand scoring engineer, recording orchestral soundtracks for



PHOTO: MAUREN DRONEY

coming episodes of *King of the Hill*. Afterward, we adjourned to the Fox dining room, where, seated beneath historic wall murals harkening back to the 1930s, we settled in for lunch and a long chat.

*You're one of the very few engineers who started out to be a classical violinist.*

Yes, Phil Ramone is the only other one I know of. And I hear he was pretty good! It's true that I went quite far with my music, to the point where I played with symphony orchestras and was a Columbia artist, all while I was very young.

Then I got serious about this end of the business. I decided I wanted more of a normal life, that I didn't want to live out of a suitcase as I thought I'd have to do if I stayed in the classical scene as a soloist or a concertmaster.

*Somehow, with all those hours you'd spent practicing your instrument, you still found time to develop some technical skills.*

I always had this technical thing going. I was 11 when my father bought me a tape recorder. He was an international chess master, and

he traveled all over the world. But his hobby was disc recording. We're Hungarian, and my father used to record gypsy music directly to disc in our living room.

I used to record myself and my mother, who was a concert pianist and who played accompaniment for me. And it used to drive me crazy that I couldn't record my violin properly, because that old recorder had so much wow and flutter—there was always wavering in the background.

*What formal training did you have to be an engineer?*

My first job was at Electrovox Recording Studios, when I was 15 or 16 years old. I was actually told after two weeks that I didn't have any talent for the business and should really give up.

After that, I went to City College here in L.A. for two years studying music, and also engineering and physics and chemistry. There I became friendly with the man who was head of the intercampus radio station. He took me under his wing, and pretty soon I was recording big bands and opera—all of that at 17 years old.

I went from there to UCLA, where I was in the music depart-

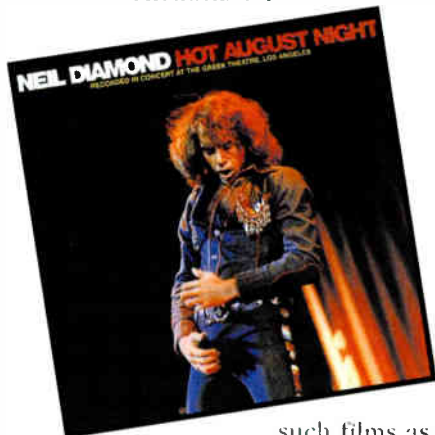

such films as *Silverado*, *Home Alone*, *Born on the Fourth of July*, *JFK*, *A League of Their Own*, *Witches of Eastwick* and *Cocoon*, and for television shows from *Dynasty* and *Star Trek: The Next Generation* to *Beauty and the Beast* and *King of the Hill*.

We met for this interview at the Newman Stage on the Fox Studios lot, where Steiner was recording a series of orchestral cues for up-

BY MAUREN DRONEY



# A Pre-Owned SSL Console

**Hundreds Of Hits Already Produced.  
Thousands More Still To Come.**



As the great studios of the world refit with new SL 9000 SuperAnalogue™ and Axiom-MT digital consoles, it's never been easier to buy a classic, pre-owned SL 4000.

Professional Audio Design is North America's exclusive factory-authorized supplier of pre-owned SSL consoles, each sold with a full warranty and on-site commissioning by our SSL-trained technicians.

Every console is prepared for sale in strict accordance with factory procedures and we can also undertake custom upgrades, expansions and reconfigurations to customers' requirements.

Professional Audio Design always has a wide choice of pre-owned SSL consoles in stock and favourable financing is available. Call today or visit our web site for a full list.

**[www.usedssl.com](http://www.usedssl.com)**

Professional Audio Design, 357 Liberty Street, Rockland, MA 02370 Tel: 781-982-2600 Fax: 781-982-2610 [info@proaudiofdesign.com](mailto:info@proaudiofdesign.com)

ment. I played a lot, and I also took engineering classes. And I did the same thing there but for a different reason. Even back then, UCLA was an impossible place to park. So in order to get a parking pass, I offered to do recording for them—at Royce Hall, all over campus. I had a big heavy Magnacord machine, and I was carrying this stuff everywhere, but I had my parking pass! Meanwhile, I had also gotten a job at Radio Recorders, which was one of the first independent studios.

***It wasn't long before you opened your own studio. Actually, you were way ahead of your time, because your first commercial studio, which you built in about 1960, was in your house.***

Yes. A bedroom over the garage, which was 10 by 14, became the control room. The studio, in the garage, was 25 by 15, with 14-foot ceilings. I soundproofed and air-conditioned it with a flow-through system. I took the air from the basement, which was cold, and built it so it went through the pipes at a very low velocity and therefore was quiet. My uncle helped me, and although my mother thought I was nuts, she supported me in every way.

I also put an iso booth in. Studios didn't really have iso rooms then, just portable ones that they moved around. But I actually made a little room that was very bright. It was lined with masonite, which was very shiny and reflective—an acoustical equalizer. It was wonderful for all the R&B vocals that we did in there. I also built the recording console.

***From scratch?***

Yes, of course. You couldn't go out and buy a lot of things back then; you had to build them. The console was stereo and had six faders, three on each side. Later, I added three more faders on each side without preamps to use with high-output microphones like the U47. Especially with close-miking, there was sufficient gain structure with those mics so that it worked pretty well, and I got cleaner sound that way. We also added a center-channel mixer, made up of Langevin modules that had three mic inputs, one line input and reverb sends. It was designed by Sherwood "Bet" Sax, the brother of Doug Sax of The Mastering Lab. He's a brilliant engineer who designed most of the electronics and put it all together.

One thing that was really significant to that studio, and part of the reason our sound was so good, was that we

developed a phase-correcting network that we used on every channel of our tape machines.

Using tape, as opposed to recording direct to disc, made phase shift properties more apparent. When the fundamental and its overtones don't arrive at the same place at the same time, and the sound is a little bit spread, you don't hear it coming back exactly like you do in the room. What Bert did was design a device we called a "scrambler." So if we had a 3-track recorder, we would have a scrambling device for each of the three channels, and they would be

**I used to have  
The Supremes up there,  
Marvin Gaye—  
my mother used to  
cook for them.  
Stevie Wonder  
was in when  
he was 9 years old.  
People think  
I'm making this stuff up,  
but it's true.**

tuned to the characteristic of the tape track. We'd come out of the bus, into the scrambler, out of the scrambler, into the tape machine. And it would decode itself better. It was a compromise between shifting the high end and the low end at the same time, and it created better transients. We were the only ones who had that.

***What other equipment did you have?***

When 3-track came out, I had two 3-track machines, Ampex 350-3s, two Ampex 350 2-track machines and one that was mono, an Ampex 200—a great big machine. It was a well-equipped place. I even had reverb. One was a combination of three spring devices that I'd made and hung on the wall, and one was a wonderful-sounding live chamber that I'd built underneath the house.

***Your mother let you build an echo chamber in the basement? And run cables through the walls?***

Yes. She even let me use her Thunder-

bird to haul the trailer full of tile that I needed for it. My mother was quite amazing. She also let me use her piano, on which we ended up cutting several hit records.

***You had no background in pop music before you built the studio. How did you learn about it?***

Two people who were very influential in the commercial rock 'n' roll business helped me and actually went into business with me: Lincoln Mayorga, who is a great pianist and the arranger for the Four Preps, among many artists, and Eddie Cobb, who was the bass voice in the Four Preps. They were producing records for other people, and they taught me. I had never really paid attention to commercial music before, only classical.

***How did you get clients to come to you?***

After the studio was all built, I did a couple of demo sessions, and we thought it sounded pretty good. Then one afternoon I got a call from the Wilder Brothers, two very nice and crazy men who had heard I had a studio. They came over with a little group called Dick and Dee Dee. We cut a demo, and three or four weeks later it was a Number One record called "The Mountain's High."

From that moment on, word started traveling. Motown got interested, and I was busy all the time. I had Glen Campbell, Billy Strange, Tommy Tedesco, Dennis Budimir, all these guitar players sitting there at my house. There was Ray Pohlman, one of the truly great Fender bass players and the first man to actually build a distortion device. Hal Blaine, Earl Palmer, Joe Osborne, Larry Knechtal, Bill Pittman, Mike Deasy and, of course, Carol Kaye. I'd get a call at three in the morning from Herb Alpert saying, "I've got to overdub a tambourine on this piece." I'd be in my pajamas and I'd walk up there and we'd do it—that was that. I used to have The Supremes up there, Marvin Gaye—my mother used to cook for them. Stevie Wonder was in when he was 9 years old. People think I'm making this stuff up, but it's true. As a matter of fact, I did a film session with Stevie awhile back, and he remembered both me and my studio.

It was a different time, a different place. You couldn't do that kind of thing now, the city wouldn't allow it. I mean, it was all illegal. And there was a lot of activity.

***Why did you finally move your studio out of the house?***

Really, I would have to blame it on the



# MUSIC TO OUR EARS...



*"StorCase carriers have become the de facto standard removable for transporting and mounting hard drives. They allow seamless integration between digital workstations and enable us to work fast with proven reliability. That's why we choose StorCase."*

**Sony Picture Studios**



*"The Kingston/StorCase products are the choice of the professional in the film, audio and post production industry."*

**TASCAM**  
a whole world of recording

**Jim Lucas  
TASCAM**



TASCAM MX-2424 shown with StorCase DE100 removable



*"The StorCase Data Express system is such an integral fixture in motion picture sound post production that it is impossible to imagine any aspect of our work where it is not used."*

**Liberty Livewire Audio,  
Todd Hollywood Division**

**LIBERTY LIVEWIRE  
CORPORATION**

... ARE THE HIGH-NOTES THAT KINGSTON/STORCASE HAVE received from prestigious customers like Sony, TASCAM, FPC/Kodak and Liberty Livewire Audio. Editing commonly requires the use of multiple removable drives that are often swapped between workstations or transported from location to location. Whether mounted into a TASCAM unit or into our Data Silo® DS320 2-bay or DS351 4-bay rack mount chassis, Data Express® is the removable drive unit of choice in the entertainment industry and has been for years because it continues to work flawlessly.

Call a Kingston/StorCase representative today at (800) 435-0068 to order your 60-day evaluation unit and experience reliable, worry-free removable storage for yourself.

[www.storcase.com/jump/av/](http://www.storcase.com/jump/av/)

 **StorCase**<sup>®</sup>  
TECHNOLOGY  
A Kingston Technology Company



©2001 StorCase Technology, Inc. A Kingston Technology Company. 17600 Newhope Street, Fountain Valley, CA 92708, USA (714) 438-1850, Fax (714) 438-1847. All trademarks and registered trademarks are the property of their respective owners.

World Radio History  
CIRCLE #051 ON PRODUCT INFO CARD

## MIX MASTERS

100,000  
samples &  
sound FX.  
Searchable  
in seconds.

Hmm, now what to do  
with all those CDs?



Instant Access  
to the Sounds  
You Need™

Finding the right sound has  
never been easier. Go to  
[www.sonomic.com](http://www.sonomic.com).  
Discover the planet's largest  
online library of samples and  
sound FX.



some of our partners:



©2001 Sonomic. All rights reserved. 1-877-SONOMIC

CIRCLE #052 ON PRODUCT INFO CARD

Watts riots—that very tragic happening in Los Angeles that made many people really paranoid. I was recording a lot of black acts there—mostly for Motown. And we would have lots of cars and people outside the house. Most of my neighbors didn't mind, but one who lived across the street called the city.

I was off working at Radio Recorders one day, and my brother called to say that a city inspector was there, telling him that I had to have the business out within 24 hours. So I did. I'd operated it for a good seven years, and probably had 10 or 11 Top 10 records, but I disassembled the whole thing, took all the equipment over to Radio Recorders and never looked back.

*You built two more studios after that.*

Yes, I had Sound Recorders from '65 to '71, then I moved across the street where I built Sound Labs, which I operated until 1980. Then I was at Evergreen in Burbank for a year-and-a-half, then Lionel Newman hired me here at Fox.

*You've said that out of all the pop music that you've recorded, the Richard Harris epic, "MacArthur Park," is probably your favorite.*

That's a subject all in itself. It was 7 minutes and 20 seconds long, and we recorded the music at my studio, Sound Recorders. I think that [songwriter] Jimmy Webb was inspired to do an epic by The Beatles' "Hey Jude." The way Jimmy conceives a song is that he sees the whole thing, then goes back and

does it. He's one of the few people who can see the whole picture at one time. And that was an extraordinary piece of music, because it had chord progressions and melodies that were far more reaching than your average pop record, to say nothing of a great lyric.

So it was conceived as a whole and he wanted to record it as a whole, with absolutely no edits and no stopping, not even within the movement structure. If you remember, it was a three-movement piece. He wanted to do the whole thing as a complete piece of music, because he wanted to capture the whole inspiration.

*What was the session like?*

It was our usual rhythm setup. Hal Blaine on drums, Joe Osborne on bass, Mike Deasy on guitar, Larry Knechtal and Jimmy himself on piano and harpsichord—I can't remember which one did what, they were playing in unison.

We started rehearsing at 10 in the morning. We rehearsed and rehearsed, changed and rehearsed, because it was very complicated, especially the rhythms. The slow section had to be a certain mood...it was like a mini movie.

They rehearsed the same piece for six hours, then put the music down and played the entire piece of music from memory in one take. And that was the magic. Anybody else would have taken it and edited—chopped it up in little sections—and it wouldn't have worked.

*What did you record to?*

Eight-track. Sound Recorders was one of the first commercial studios to have

## SELECTED CREDITS

E: Engineering; M: Mixing; R: Remixing

Bread: *Best of Bread* (1972, E)

Glen Campbell: *Southern Nights* (1977, E)

Judy Collins: *Hard Times for Lovers* (1979, E/R)

Neil Diamond: *Hot August Night* (1972, E)

Danny Elfman: *Music for a Darkened Theatre, Vol. 1: Film & Television Music* (1990, E)

Hall & Oates: *Daryl Hall & John Oates* (1976, E)

Heart: *Dog & Butterfly* (1978, E)

The Nitty Gritty Band: *Nitty Gritty Dirt Band [Liberty]* (1967, E)

Helen Reddy: *I am Woman* (1972, E)

The Simpsons: *Songs in the Key of Springfield* (1997, E)

The Turtles: *Happy Together* (1967, E)

*Empire of the Sun* original soundtrack (1987, R)

*Die Hard 2: Die Harder* original soundtrack (1990, E/M)

*A League of Their Own* original soundtrack (1992, E)

*Robin Hood: Men in Tights* original soundtrack (1994, M)

*Cocoon* original soundtrack (1997, E)

*Way of the Gun* original soundtrack (2000, M)

# New Tool.

Get two boxes in one.

Our most-acclaimed L2 peak limiter is not all you get in this box. The L2's converter sections are "better than \$2000 standalones ... a bargain at twice the price"

— Bob Katz, Digital Domain

It's the perfect front end to any DAW system or mixing job, ideal for channel insert, guitar racks, broadcasting, remix, sound design, and of course, mastering.

Use the A/D converters to boost your quality and the limiters to never clip your track. Spank a voice or snare beyond any imaginable point. Scare yourself a little.

There's simply nothing else in the class of the L2 Ultramaximizer. We pushed our limit, so you can push yours. Try one today! Just call your dealer.



▶ Astonishing transparent brickwall limiter

▶ Get 4 bits better. 16 sounds like 20 with Waves dither

▶ 96, 88.2, 48, 44.1kHz stereo or dual mono

▶ True 48-bit processing



Get your own demo unit!

see [www.waves.com](http://www.waves.com)

# New Tool.

Simply no comparison.

Waves has newly built the L2 Ultramaximizer as a software plug-in, and as in the L2 hardware, completely outstrips your expectations, with 3 major differences over the original L1 that dramatically improve the level, resolution, and performance:

Waves ARC auto-release (so good you'll never turn it off), the IDR dithering system now with 9th-order noise shaping, and our most-acclaimed limiter algorithm.

Download the L2 software and stun yourself a bit or two. There's a 24-hour demo available right now, but it won't take you 24 hours to realize you gotta have the L2.

▶ Now in software too

▶ 4 more bits with

▶ Algorithm is same as hardware

▶ The New Essential



CIRCLE #053 ON PRODUCT INFO CARD

**gotta  
get Waves**

(North & South America)  
306 W. Depot St., Suite 100 Knoxville, Tennessee 39717  
phone: 1.865.546.6115, fax: 1.865.546.8445

(Headquarters) Azrieli Center 1, Tel-Aviv, 67011 Israel  
phone: 972.3.6081648, fax: 972.3.6081656



[www.waves.com](http://www.waves.com)

World Radio History

## Where do You Need to Record Today?



### With Sound Devices USBPre, the World is Your Recording Studio

You've imagined that someday, someone would build a small, simple box that does everything needed for hard disk recording. That day is here.

Introducing USBPre. Very big performance in a very small package. It is unquestionably the easiest and most direct digital audio interface for your computer. Plug the USBPre into your Mac or PC's USB port with

one cable and you're ready. Start recording. Start streaming. Start ripping!

Features include: 24-bit A/D converters, two channels of studio quality mic preamps, 48-volt phantom, high-impedance low-noise instrument DI, line inputs, headphone monitoring, all powered by your computer.



For detailed product information visit us at our web site, [www.sounddevices.com](http://www.sounddevices.com) or call (608) 524-0625.

[www.sounddevices.com](http://www.sounddevices.com)

CIRCLE #054 ON PRODUCT INFO CARD

an 8-track. Columbia had done it, as I recall, by running two 4-track machines together, not even with a synchronizer—it was kind of all makeshift. But we actually built one. We took an Ampex 200 deck, that huge thing with big motors, built as a monaural machine, and, as I recall, we used Ampex PR10 electronics. The PR10 was two channels in one box, so we didn't have to have so many amplifiers hanging around. So, we added together four packages of Ampex 2-track electronics.

Then we needed heads. We had the idea to take the specs from a 4-track head and use the same geometry to

**A lot of composers will discuss with me beforehand the kind of texture they're looking for. To me, that's absolutely the most valuable information.**

make one that was 8-track. We found a company called IEM, in Chicago, whose chief engineer, John Pretto, was building 7-channel data heads for telemetry for satellites, and we had them build it for us.

We didn't even have automatic tape lifters on this thing, so we had to pull the head gate back by hand when we did the rewind, which was difficult to do with 1-inch tape. There was a lot of resistance there, but we made it work.

Of course [laughs], after the rhythm section was done, they took the tape to London to record Richard Harris, and they had to go through a similar process. At Landsdowne Studios, they built an 8-track machine out of Scully parts in order to put his voice on.

*Do you recall how you miked the band?*

I'm a creature of tremendous habit, so I know that, probably, I used two Sony C-37 microphones over the drums. There may not have been a snare mic, but if there was, it was a Sony C-500.

## WE WILL BEAT ANY DEAL!

ON EVERY MAJOR BRAND OF...

GUITARS • AMPS • DRUMS • KEYBOARDS • SYNTHESIZERS  
SAMPLERS • SOUND SYSTEMS • RECORDING EQUIPMENT • COMPUTERS  
MUSIC SOFTWARE • DJ EQUIPMENT • LIGHTING • ACCESSORIES

### Where The Pros Shop:



West L.A. Music's Don Griffin with legendary keyboardist, George Duke



Journey singer, Steve Perry, with West L.A. Music staff member



R&B singer, D'Angelo, with fan, Holly Kraft hanging backstage at the Montreux Jazz Festival



Duran Duran singer, Simon LeBon, with West L.A. Music staff member



West L.A. Music's Glenn Noyes with TV and film composer, Danny Elfman



West L.A. Music's Noel Gould with "The Tonight Show" keyboardist, Bob Hurst

### Phone, Fax or Email us today!

Tel: (310) 477-1945 • Fax: (310) 477-2476

Email: [sales@westlamusic.com](mailto:sales@westlamusic.com) • Web: [www.westlamusic.com](http://www.westlamusic.com)



# West L.A. Music

CIRCLE #055 ON PRODUCT INFO CARD

World Radio History

"Full Sail gave me the confidence and know-how to make it in the entertainment industry."

**-Carlton Lynn**

**Credits include:**

TLC  
Monica  
Sammie  
Stevie Nicks  
Brandy  
Collective Soul  
Joi

"Full Sail gave us the chance to have our hands on the latest studio equipment. . . .

Now, we've got our hands on some GRAMMYS®. We got the education we needed to succeed tremendously and in a relatively short period of time."

**-Leslie Brathwaite**

**Credits include:**

TLC  
OUTKAST  
Micheal Jackson  
Monica  
Toni Braxton  
Aretha Franklin  
Boyz II Men



**FULL SAIL**  
Real World Education

**School of:**

**Audio • Show Production & Touring  
Film/Video • Computer Animation  
Digital Media • Game Design**

**800.226.7625**

Full Sail grads and winners  
of five GRAMMY® awards  
**Carlton Lynn and  
Leslie Brathwaite.**

Tune into **webstationzero** SM at **www.fullsail.com**

CIRCLE #056 ON PRODUCT INFO CARD

3300 University Boulevard • Winter Park, FL 32792 • Financial aid available to those who qualify • Job placement assistance • Accredited by ACCSCT

© 2000 Full Sail Recorders, Inc. All rights reserved. The terms "Full Sail", "Full Sail Real World Education", and the Full Sail and WebStationZero logos are either registered service marks or service marks of Full Sail Recorders, Inc. Other product and company names mentioned herein may be the trademarks of their respective owners. The appearance of these marks does not necessarily indicate a formalized sponsorship or affiliation with other such companies.

On the bass drum, probably an Electro-Voice 666—you could hammer nails with it. Piano: always a single mic, a U47. The harpsichord would have been an AKG 451E, taped to the stick of the harpsichord. We always took the bass direct. On the guitar, just a single mic—an AKG 451E—I had a series of those, and I liked them because I could put a pad in them to take down the level so that we wouldn't have any distortion.

And, always, of course, I'd set it up to have everyone sitting close together. That's very important. If the rhythm section can hear well and feel well together and have eye contact, it's going to be much better for the ensemble and for whatever magic you're going to get from that ensemble.

*Would you have compressed the bass?*

No, I very seldom use compressors, except for the bass on rhythm and blues records. I rarely even use them on vocals. I always feel like I can ride the level myself better. Once I hear the melody, I've memorized it, and I'd rather deal with it that way.

The only limiters that I ever used were LA-2As, LA-3As, 1176s and, later,

the Inovonics. I still like the Inovonics if I have to use one—I think it's the most "unlimiter" limiter that I know. And, of course, in the early days we had the old Fairchild tube job, that brute-force, heat-producing monster that adds so much distortion along with its limiting that it creates a "sound."

*Mastering a 45 rpm record of that length, which you also did at Sound Recorders, must have been another story unto itself.*

We had to get 7:20 on a 45 rpm record. The only other record that had been done that way was "Hey Jude." Cal Frisk, who worked for me and was a super-great engineer, did the mastering. It was done manually; we didn't use variable pitch—we opened and closed the grooves manually.

I knew the music so well, you see, that we could maximize cutting it by doing it by hand. When the music gets very quiet, you can close the grooves, because it doesn't take up much space.

When you have louder sound and deeper bass, you need more land between the grooves in order to reproduce it. Knowing the music, you pretty much know your limits.

In those days, don't forget, it was a

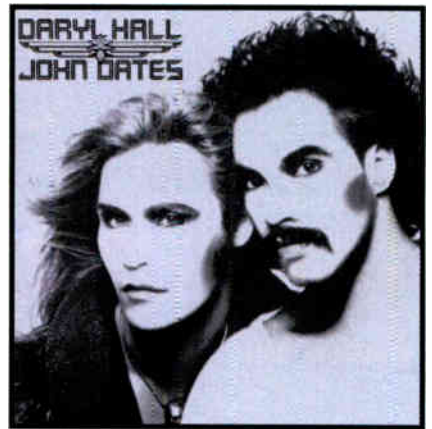

real battle of levels with 45 rpm records. It was always about trying to make the loudest disc and defeat all the stuff in the transmitters and the radio stations so that you could produce the loudest single over the air.

There were two factors to consider: the amount of space that is technically allowed—up to so many centimeters from the center—and the distortion factor. As you get toward the inside of the record, you have greater distortion. It was art and science at the same time; that was the romance of the business in those days. And, since the masters were all cut by hand, maybe there was a

## MODEL 101

microphone preamplifier



- \* fully balanced, transformerless design
- \* fast, musical transimpedance architecture
- \* 10-60dB gain with 10dB trim control
- \* extended gain ribbon mic input available
- \* high Z instrument input
- \* 75Hz high pass filter
- \* 48V phantom power
- \* MSRP \$699.00

Presenting the model 101, a single serving of the critically acclaimed Grace Design microphone preamplifier circuit. This compact, affordable module is designed to transform plain project studio tracks into stellar, high-fidelity recordings.

We proudly used the same amplifier architecture of the venerable model 801, preserving its untouchable technical specs and purebred sonic performance. Then we packaged it to be priced within reach of any recording engineer or studio.

Regardless of budget, the Model 101 is an invaluable tool for any recording setup. With an integrated high impedance 1/4 inch input, the model 101 is the ultimate DAW input tool.

Whether using it on your favorite large diaphragm condenser mic or plugging in an acoustic guitar, the model 101 will help you achieve results previously available only to big budget studios and Grammy winning engineers.

high fidelity by

# GRACE DESIGN

po box 204 boulder CO 80306 tel 303.443.7454 [www.gracedesign.com](http://www.gracedesign.com)

Unparalleled Audio and Technical Dominance...

**Again**

PC2



**PC2**  
— Digital Multi-Effects  
— 22-Bit Digital Output  
— Balanced Line Outputs  
— KB3 Tone Wheel Organ Model  
— Expandable to 128-Note Polyphony  
— Expandable to 48MB of Sound ROM  
*Performance Controller*

Kurzweil takes great pride in offering an instrument designed to meet and exceed the expectations of the world's most demanding sound professionals. The PC2 Performance Controller represents a continuing quest to achieve the highest musical and technical quality possible. Stunning new sounds, fantastic effects, precise control, and superior audio quality, are only a few of the features that make the PC2 the finest instrument of its kind.

**KURZWEIL®**  
*Music Systems*

Kurzweil Music Systems  
9501 Lakewood Drive, S.W.  
Suite D  
Lakewood, Washington 98499  
253-589-3200  
Fax: 253-588-6809  
[www.kurzweilmusicsystems.com](http://www.kurzweilmusicsystems.com)

Canadian Division  
3650 Victoria Park Avenue  
Suite 105  
Toronto, Ontario M2H 3P7  
416-492-9899  
Fax: 416-492-9299

CIRCLE #107 ON PRODUCT INFO CARD

slight difference between each of them. Maybe I made a better one the second time!

*These days, the bulk of your work is orchestral recording. How do you prepare for a large scoring date?*

The most important thing is to know what it's going to sound like beforehand. You must get a mental picture of that by knowing your composers and their style.

I also try very hard to go over the details before we ever get into the studio. A lot of composers will discuss with me beforehand the kind of texture they're looking for. To me, that's absolutely the most valuable information.

Normally, our actual setups are going to be pretty much the same, unless you want something special. Like on the *Witches of Eastwick* score, John Williams wanted me to put the tubas next to the French horns, because they all played together. Now that isn't something that you would normally do, but it worked marvelously well. He was 100 percent right, as usual. Those are the kinds of things that create a sound. When I did *Silverado* with Bruce

Broughton, another magnificent composer, there were times when it was so loud in the room that it was impossible. We had a very small string section, so I decided to put the strings over to one side of the room and then let the brass and the winds have all the space. Then we put up three microphones for them and came in a little closer with the microphones on the strings. And it worked. Really, it's about letting the music be your guide.

*On the Newman Stage, where you often work, the console is an SSL 9000. You also like working on the large API console at O'Henry Studios. (See this month's "On the Cover" on page 14.)*

Yes. O'Henry's is an all-custom board, with API equalizers, a marvelous-sounding console that was a great product of love and very precise engineering. I do like the SSL 9000, and I work also on the Neve V Series.

*You're not a fan of tube mics for scoring dates.*

It depends on the maintenance of the microphone. You don't want a breakdown, because it will always come at the wrong time. It will always happen when you're ready to make a take, or you're in the middle of something that is begin-

ning to come together in a most unique manner, and there you fall on your face. Plus, the fact that none of these [tube] mics are even. They don't sound similar, and if you're going to use them across the front of an orchestra, with peculiarities and artifacts different for each microphone, you've got problems.

*What mics do you prefer then?*

There are great mics by Sennheiser, which I think are the best modern microphones made, and that's the MKH Series. Their characteristics are extraordinarily musical, and that's what's important to me—how musical they sound, how real they sound. The reason they sound so good is because their off-axis response is totally linear. In a Neumann microphone, for example an M50, the off-axis response is very jagged, very nonlinear. Remember, any leakage you get in the room must combine. That's why it's very important many times to use the same type of microphone, so that the characteristics of the leakage will be the same. It's just logical. Practical physics.

I rarely do any close-miking. For TV, we do go in a little closer, but for scoring motion pictures, you want the sound of an orchestra, and you cannot

# GRAPHI-Q: 5 PRODUCTS. 1 UNIT. 2 BUTTONS?

It's your choice: 91 sliders, knobs & buttons for the ultimate in hands-on control – or the 2 buttons on your computer mouse using our New Version 3.3 software!

"Other imitators are poor substitutes – don't waste your money."

—Mark Frink, A1X  
Field Test, January 2001

## FBX Feedback Exterminator

Up to 12 filters of the industry standard in automatic feedback control. Works in setup and during the program. Super-accurate algorithm places filters only on feedback, not on music.

## Compressor/Limiter

Now with additional features: graphic transfer function display, and stereo mode\*

## Digital Delay

Up to 1 second delay, adjustable in 20 microsecond increments.



ALL DIGITAL!



GRQ-3102 Front Panel Control (two in/two out)

## Graphic EQ

31-band, with +6 or 12 dB range and High & Low Cut Filters.

## Parametric EQ

Up to 12 fully programmable filters.

## New! Firmware/Software Version 3.3

Free upgrades available online!



\*Controllable via GRQ Remote Software only

**SABINE**  
ADAPTIVE AUDIO

PATENTED • MADE IN USA  
[www.Sabine.com](http://www.Sabine.com)  
Tel: (386) 418-2000 • Fax: (386) 418-2001

\*FBX and FBX Feedback Exterminator are registered trademarks of Sabine, Inc. and are the brand names of its line of automatic feedback controllers. Covered by U.S. Patent No. 5,245,665, Australian Patent No. 653,736, German Patent No. 01114481.0, U.K. Patent No. 01866791, and Canadian Patent No. 2,091,624-2. Other patents pending.



**PERFECT FOR  
PRO TOOLS!**

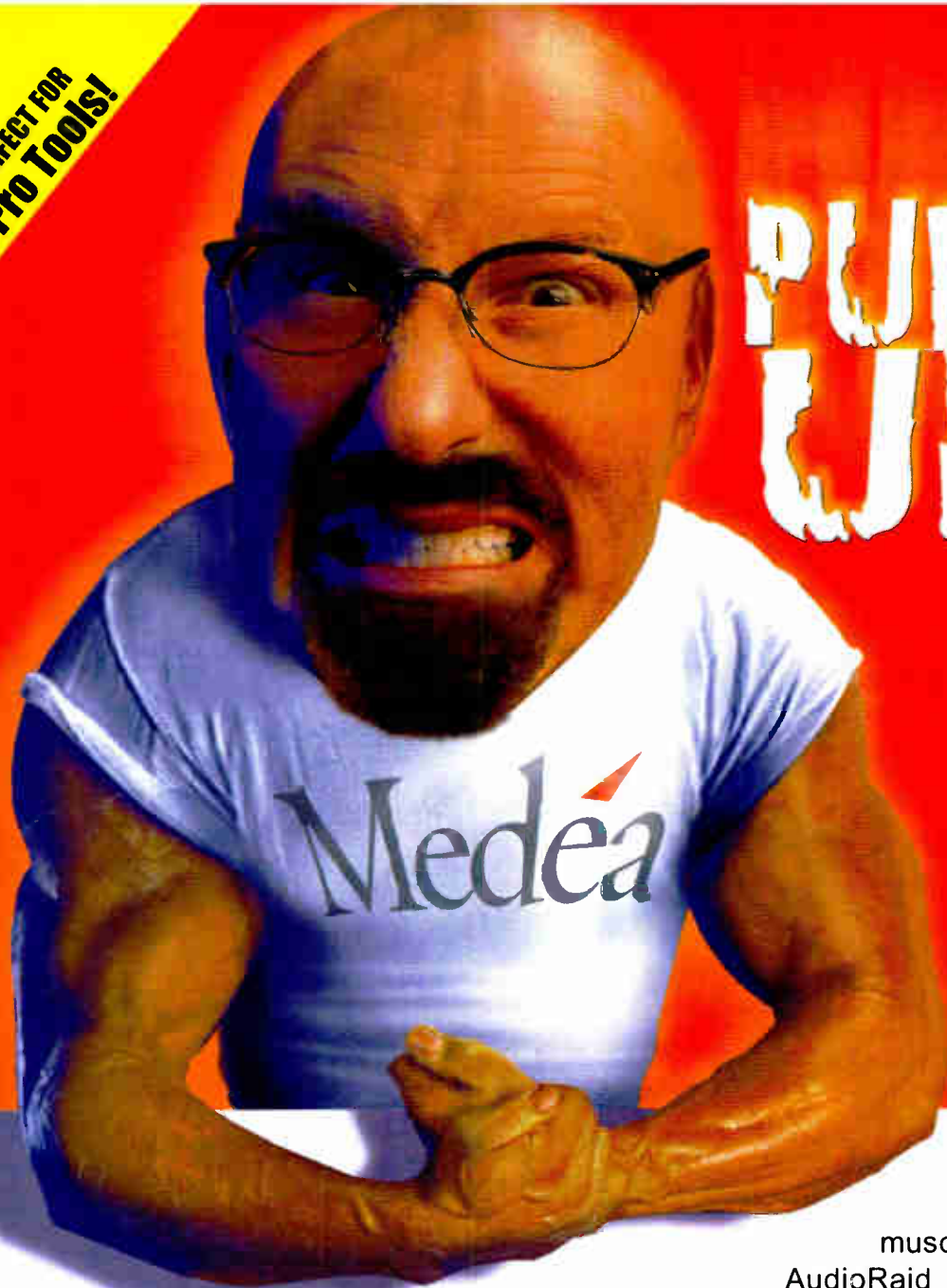

**PUMPED  
UP FOR  
THE  
BIG  
GIG!**

Flex your audio editing muscle with Medea's new AudioRaid SCSI disk arrays. The line-up includes 2 and 4-drive desktop models and dual-channel rackmounts all optimized for digital audio workstations (DAWs). AudioRaid supports mixing of up to 128-tracks of 24-bit/96 kHz audio and offers storage capacities to 240 gigs! Full compatibility with the leading DAWs plus a 5-year warranty makes AudioRaid a real heavyweight. And since AudioRaid appears to your DAW as a single SCSI disk drive, configuration is no sweat. Best of all, at the industry's lowest price per gig, AudioRaid is all gain and no pain.

Performance. Reliability. Value.

**Medea**

**888-BY-MEDEA**  
**www.medeacorp.com**

From outside the U.S. (818) 597-7645



Desktop and rackmount models available

World Radio History  
CIRCLE #060 ON PRODUCT INFO CARD

get it by sticking a microphone in front of somebody's face. It will just sound small.

Therefore, almost everything is coming from the overheads, which would be MKH 80s or 800s. I use five across the front. I also use either MKH 20s or the solid-state M50s for the two surrounds, which are placed overhead back from the orchestra. Then, I'll maybe put a couple of MKH 40s over the woodwinds, just in case I need to accentuate a solo or change the balances. For the most part, for a brass section I'll stick up a couple of TLM170s at

a great distance, and I might open them up just a bit and use just five percent of those mics.

*What about the percussion?*

Perhaps a TLM170 over the timpani for some accentuation, and perhaps some high over the overall percussion. I would always rather pick things up in a natural balance. I want to get what you would really hear if you were in a fine concert hall.

*You use very little processing when you record.*

The only thing I use is a little reverb.

*You monitor with reverb.*

No, I record with it. Absolutely. I have a favorite that I've used for the last 12 years

or better, the Roland R-880. I have a very special program that we developed the algorithm for, on a card that I burned at the factory about 10 years ago.

*What new equipment have you been impressed with lately?*

Nothing, really. At the risk of sounding dated, I'll state that nothing much has really changed in 40 or so years. You still have to get from microphone to line-level, and what we've done in the intervening years is merely to put a lot of garbage in between them, which serves to degrade the sound.

*Okay, then, is there any old equipment that you can't live without?*

No, I use what I have. I don't want to make a big deal out of it. I just need to get the signal properly, and then the proper balance, the sonority. I like to preserve dynamics. If something is quiet, it should be extremely quiet. If something is loud, it should be earthshaking. If the music is exciting, it should come off as excitement, not as something the engineer tries to interpret.

We are not interpreters. We are servants of the music, and all we're doing is taking what the composer did and, hopefully, putting it down in the perspective that they heard.

*What advice do you have for someone who wants to become a scoring engineer?*

I think he or she should come and listen. Listen to what the orchestra is doing, and after they have that in their heads, they should go in and listen with somebody who has some years of experience.

That's how I learned. When I was 14 or 15 years old, I sat with Thom Nogar at Radio Recorders, who would be doing an Elvis Presley session in the morning and then Henry Mancini in the evening. I saw what he did and learned why he did it. I learned from all of the wonderful staff engineers at Radio Recorders. You can learn so much from observation, if you have a keen ear.

Your job is to try to create the excitement that the artist intended to have in the music. When it gets exciting, your fundamental obligation is to be able to capture that dynamic. It's not only loud or soft, it's all that intensity that happens. It doesn't matter if it's rock 'n' roll, big band, operatic or symphonic, the most important thing is to let the music be your guide. No matter what you're recording, if you let the music be your guide, you will never go wrong. ■

*Maureen Droney is Mix's L.A. editor.*

# EUROPADISK, LLC

## CD REPLICATION

Retail-Ready Packages or Bulk

**Work direct with the factory and save. All products made in our plant, the U.S.' most complete facility!**

- **CD Replication - Fast and Competitive**
- **Vinyl Records - Direct Metal Mastering**
- **Mastering Studio - BB Charted Records Every Week**
- **Cassette Duplication - Lyrec w/ HX-Pro**
- **On-Demand Printing - Stunning Color**
- **Graphics Studio - Custom Design & Film Output**
- **CD-R Silk Screening - Up to 6 colors - Fast Turns**

**NEW! - Digital Business Cards & Shaped Disks**

**Best Service...Best Price...Period.**

Free catalog or quote: **(800) 455-8555**  
(718) 407-7300

Major credit cards accepted

# EUROPADISK, LLC

Check out our cool website at: **www.europadisk.com**

# CD-R/DVD-R

The Complete Spectrum of CD-R & DVD-R Products

## The Total Package



### The DSR 1203

The DSR 1200 Series is a low cost, high performance CD Recordable Duplication system that utilizes superior technology.

### The Saturn IIP

- 150 disc standalone CD publishing
- Simultaneous print and record
- Unattended batch job processing
- Intuitive user interface

### The Orbit II

- 50 disc standalone CD duplication
- Low cost, entry level
- Sleek desktop aesthetics
- Easy operation, friendly user interface

### The Apollo II

- 150 disc standalone CD duplication
- Unique FIFO Disc Up Stacker
- Unattended batch job processing
- Intelligent "Menu Mentor" navigation

### The CopyWriter 121

- One to One CD Duplication
- Support for 12X recording speed
- Compact footprint, contemporary design
- One button user operation
- Ruggedized acrylic enclosure

### StartREC Editor/Duplicator

is a 4 recorder CD-R duplicating and editing system for on the fly recording.

MicroBoards Technology offers the highest quality **CD Recordable Media** from Taiyo Yuden, Inc. the inventor of CD-R technology.

Corporate Headquarters: (952) 556-1600  
Toll Free: (800) 646-8881 • Fax: (952) 556-1620  
Latin America (Miami): (305) 932-2600 • Fax: (305) 932-2603  
Europe: 44-1789-415-898 • Fax: 44-1789-415-575  
Japan: 81-3-3561-2266 • Fax: 81-3-3561-2267  
India: 91-40-6504213 • Fax: 91-40-3326566

[www.microboardsproaudio.com](http://www.microboardsproaudio.com)

 **MICROBOARDS**  
Technology

CIRCLE #062 ON PRODUCT INFO CARD

# SON OF TOSH

## MORE TRADE SHOW MAC NEWS



If you use a Mac at home or work, then by now you've probably already seen the ads, purchased the cocktail napkins and generally gotten caught up in the spin of Apple's PR machine. But hang in there, Genteel Reader (who am I kidding), as here lurks a few choice morsels for you... This month, I'm veering away from CES (which I covered last month) to discuss a follow-on show at San Francisco's Moscone Center: Macworld. It was annoyingly busy, making it difficult for me to get my work done. I shouldn't complain, though, as recent metrics indicate that 17% of new Macintosh purchases are by users switching from a Windows world. The new operating system, along with Gigabit Ethernet-equipped, five-slot CPUs and the new TiBook, fueled the big buzz and will pull in yet more converts and lapsed pilgrims. Though Apple hasn't sent out my Solutions Provider copy of X, I can safely say that it will beat the pants off Win ME as a desktop OS.

If you didn't make it to my Pueblo by the Bay for the show, then you missed more network-

ing, storage, productivity and rich media tools than you can shake a CD-R at. Let's start with the obvious stuff.

FireWire has come into its own, and Macworld's home court advantage allowed storage vendors to show their hard drives, bridges, repeaters, way fast networking, DVD and CD-RW drives. More, cheaper, better. Now that Plector does ATAPI, its mechanisms showed up at several booths, disguised as external FireWire drives. Ecrix debuted its long-awaited, 1394-attached VXA tape drive, which is all I'll say about that for now, as a future column will get into backup options and the new tape formats. Other storage stalwarts like Atto and Adaptec proclaimed their support for OS X, and 3ware showed its new midrange 1000BaseT SAN product, a first for the Mac OS space. Think SCSI over IP (block-level transfers rather than file), and you'll begin to see why this trendy product category is heating up. More on that in the months ahead.

BY OLIVER MASCIAROTTE

In other storage news, Arco Computer was one of several vendors testing the Mac waters with a simple IDE RAID controller line—great for you tinkerers too cheap to buy a ready-made. Archos Technology was demo'ing its USB combo 6GB storage/MP3 player gadget, a fun item for you other tinkerers with disposable income. Those of you with a music or effects library in a jukebox will appreciate studioZee's ZephIP, a widget that easily lets you control your consumer TV, CD or DVD transport via infrared commands from your Mac.

There were no fewer than four pure-play Digital Asset Management vendors. This is another product/service class showing signs of long-term growth.

On to the big excitement for me: Unix on PPC. Linux is the current darling of the server set and is making significant inroads into the enterprise as well. But, despite the work of Eazel and others, I don't see Linux making a huge impact on the desktop. Enter another processor-independent, open-source project: Darwin, the basis for Apple's

# Born to be... Weird.



## **Weird Al Yankovic**

Accordion player, disguise artist, writer/director and the musical King of Parody - heading for the studio to skewer our idols and icons.

# Think Quantegy

At Quantegy we set the standard with products like GP9 Grand Master™ Platinum. So it's no wonder that more music around the world goes gold and platinum on Quantegy media than on all the other brands combined. While opinion may vary on what it takes to make a hit, there's no argument on what it takes to master one.



**QUANTEGY**

The Hit Maker's Media

Tel: 800-752-0732

Fax: 800-628-0535

[www.quantegy.com](http://www.quantegy.com)

CIRCLE #048 ON PRODUCT INFO CARD

World Radio History

OS X. During development, Apple's goals were a simple and elegant UI, a modern, reliable kernel, killer graphics, the best Internet experience of any desktop OS, and, finally, gentle migration from the current, classic Mac environment. Sounds like a plan.

OS X is scheduled for general availability before this issue hits the street, so I won't bore you with stale stuff. But I did find the double hit of new hardware and the new OS generally buoyed my spirits. The four usable slot towers would make admirable studio processors and the new svelte portables are great for on-the-go production. But what really got me going was the small signs that Apple is now a Unix platform, with the accompanying up and downside. The upside: unprecedented speed and stability, rapid migration of existing hardware and software from other Unix flavors and a wee peerage in the court of

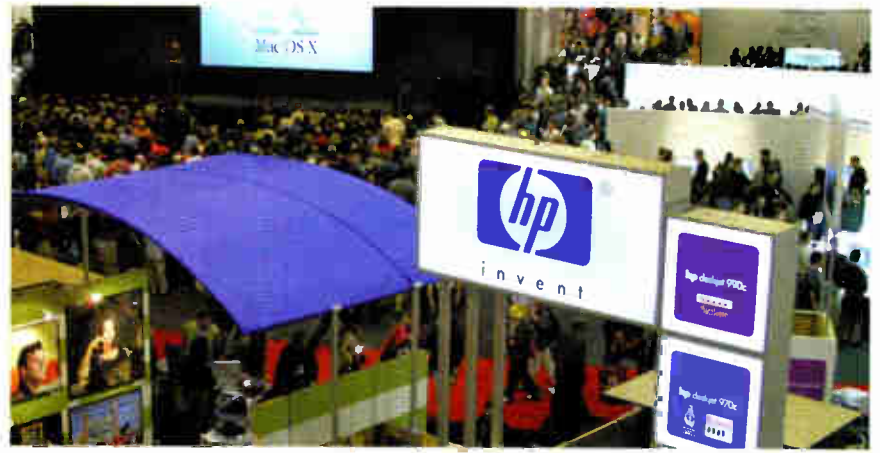

Enterprise Computing. The downside: weaker security without significant bolstering.

So, what about audio at the show? Oh yeah, audio. Other than to say that Tascam had a small booth showing their nifty control surface, I'll defer the discussion until OS X ships. Fear not, we'll keep you informed as the plot thickens. Meanwhile, happy mousing!

*OMas works on content creation infrastructure issues and lives just up the hill from the site of the first Yerba Buena rancho. This column was created while under the influence of Radiohead's Kid A and Grant Hart's Good News For Modern Man. Links and occasional commentary for "Bitstream" at <http://seneschal.net>.*

## CONDENSED CREAM OF OS X

Mac OS X, a layer cake of software modules, is not really new. Its lineage extends back to over 30 years ago, to a time when Big Iron dominated computing and AT&T needed software to run their public switched network, the phone system. Since that time, Unix has grown into the dominant enterprise operating system. It also became the brains that made, and continues to make, the Internet possible.

The foundation of OS X is Unix or, more precisely, Darwin. Darwin is somewhat akin to the current Mac's System suitcase, the fundamental bit on which everything else is built. Because it's based on a Mach 3 microkernel developed at Carnegie-Mellon and UC Berkeley's Standard Distribution Unix 4.4, Darwin provides all of the stuff one would expect from today's Unix: full pre-emptive multitasking, advanced virtual memory and complete memory protection with modern networking services. Because Darwin is open-source, improvements and fixes are rapidly accomplished by a collective of international zealots, not anesthetized worker bees. That work is examined by Apple, and the juicy bits are incorporated back into the next version of their commercial product. Also, savvy end-users can tweeze the code to their liking, something you can't do with proprietary operating systems.

Sitting on Darwin are three presentation engines: Quartz, OpenGL and QuickTime, handling 2-D, 3-D and motion/rich media, respectively. Quartz, the 2-D graphics engine, is based on Adobe's PDF, the Portable Document Format. It provides anti-aliased, on-the-fly rendering with transparency and masking. This means that the OS itself can read, generate and write PDFs. Three-dimensional

chores are dealt with by OpenGL, the industry standard developed by Silicon Graphics.

The third presentation service is QuickTime, playing on its superior quality and rich media support for audio, video, sprites and text tracks. QuickTime holds the number two spot in end-user adoption, with Real ahead and Windows Media Framework behind. After many, many months of requests, Apple still hasn't gotten back to me about OS X developments for MIDI, synchronization and multichannel I/O, so I'll have to defer discussion until Apple PR opens the corporate kimono a bit. But QuickTime 5, now in beta, adds support for Flash 4, DLS-2, SHOUTcast and the Sorenson Video 3 codec.

The next-to-the-top layer in the OS X torte provides three APIs (Application Programming Interfaces) for high-level development, Classic, Carbon and Cocoa. Classic allows old-school MacOS applications to stretch their legs. Carbon is a collection of modernized OS 9 APIs, the mechanism by which propeller heads create applications. Carbon-compliant apps will run under OS 9 or X. Cocoa is the most advanced and powerful development environment. In Apple's words, Cocoa is a "next-generation, object-oriented application framework, accessible from Objective-C or Java." That translates into developer productivity, consistency and maintainability, all important if you're building the next generation of audio applications. Also tucked in there somewhere are the networking hits and welcome additions like Java 2.

The icing on the cake is Aqua, a user interface hybrid drawn from many influences and a thing of beauty. Because most desktop users are unlikely to open a shell or command line interface and interact with the kernel directly, Aqua is where most of us will spend our time.

—*Oliver Masciarotte*

They say, "If it ain't broke, don't fix it."  
But we just couldn't help ourselves.

## Introducing **Auto-Tune 3**

A major upgrade of the worldwide standard in professional pitch correction

Hailed as a "holy grail of recording" by *Recording Magazine*, Auto-Tune is used daily by thousands of audio professionals around the world. Whether to save studio and editing time, ease the frustration of endless retakes, save that otherwise once-in-a-lifetime performance, or even to create unique special effects, Auto-Tune has become the professional pitch correction tool of choice.

Now, never content to leave a good thing alone, Antares introduces Auto-Tune 3. Preserving the great sound quality, transparent processing, and ease of use of Auto-Tune, Auto-Tune 3 adds significant new features as well as a snazzy new user interface.

Don't fix it.  
It ain't broke.

I can't help  
myself.



**AUTO-TUNE 3'S AUTOMATIC MODE** corrects the pitch of a vocal or solo instrument in real time, without distortion or artifacts, while preserving all the expressive nuance of the original performance.

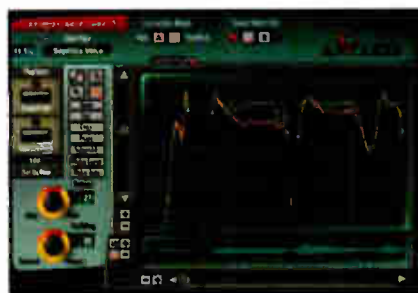

**FOR METICULOUS TWEAKING**, the Graphical Mode displays the performance's detected pitch envelope and allows you to draw in the desired pitch using a variety of graphics tools.

### KEY NEW FEATURES OF AUTO-TUNE 3 INCLUDE:

- "Source Specific" processing algorithms that provide even faster and more accurate pitch detection and correction.
- Phase-coherent pitch correction of stereo tracks.
- High sample rate (96kHz) compatibility
- A Bass Mode that optimizes pitch correction of low bass range instruments.
- The ability to set target pitches in real-time via MIDI from a keyboard or sequencer track.
- A new Make Scale From MIDI function that lets you play a melody from a MIDI keyboard or sequencer and have Auto-Tune 3 construct a custom scale containing only those notes that appear in the melody.
- An AudioSuite version and enhanced MIX chip efficiency for more instantiations per MIX chip (TDM only)

### GOTTA HAVE IT

If you already use Auto-Tune, you're going to want Auto-Tune 3. It's as simple as that. (Check out our website for upgrade details.)

If you're one of the few who are still not convinced, we encourage you to scamper over to our web site and download a fully functioning 10 day trial version. Try it out on a variety of your own projects. We're confident that once you experience what it can do, you'll have to have it.

### Auto-Tune 3

**We made it better because we just couldn't help ourselves.**

*Auto-Tune 3 will be available in TDM, MAS, RTAS, Mac VST, and DirectX versions. Upgrades are available for registered Auto-Tune owners. Check our website for details.*

**ANTARES**

WHERE THE FUTURE'S  
STILL WHAT IT USED TO BE

ANTARES AUDIO TECHNOLOGIES 231 Technology Circle, Scotts Valley, CA 95066 USA  
voice: 831 461 7800 | info@antarestech.com | [www.antarestech.com](http://www.antarestech.com)

# NEW SOFTWARE/HARDWARE FOR AUDIO PRODUCTION



## WALDORF ATTACK

Steinberg ([www.steinberg.de](http://www.steinberg.de)) announced Attack, a VST percussion synth by Waldorf. Attack generates sounds in real time, with direct control over all parameters. Each percussion set allows 24 sounds, spread across two octaves. Two oscillators, each with nine waveforms, represent the sources. Other features include ring modulation, frequency modulation and a Crack module that reproduces analog handclaps. The filter section features six filter types, resonance of up to self-oscillation and an overdrive of up to +52 dB. Attack is integrated into the VST 2.0 interface, so all parameters can be addressed via MIDI controller. Retail: \$149.

Circle 339 on Product Info Card

## AUDIOCUBE 5

Spectral (distributed by Sascom Marketing, [www.sascom.com](http://www.sascom.com)) introduces Version 5 of its AudioCube multichannel mastering and audio restoration solution. The base system includes a 24-channel audio card and eight channels of AES/EBU I/O, expandable to 16 or

24 channels with optional rackmount I/O modules. AudioCube 5 provides Native, Pentium-optimized software, running on dual 1GHz Pentium III processors, with 256 MB of RAM. The system, based on Windows 2000, includes Wavelab and Nuendo, both of which are fully integrated into the AudioCube 5 architecture. The system also features 29 24-bit/96kHz, 64/32-bit floating-point mastering, restoration and analytical tools. Surround software, such as Dolby AC3, can be added for DVD-A or other multichannel work.

Circle 340 on Product Info Card

## KORG D1600 DIGITAL RECORDING STUDIO

Building on its previous 24-bit, 16-track workstations,

the D1600 from Korg ([www.korg.com](http://www.korg.com)) adds numerous updates for a portable, pro recording package. Features include 128 tracks (16 tracks with eight virtual tracks for each), a removeable media using standard IDE hard drives, a 20GB internal

drive (31 hours at 24-bit/44.1 kHz), control of standard Copy/Paste/Erase edit functions via a TouchView waveform display, optional CD-R drive, 24-bit S/PDIF optical I/O, audio scrubbing, and built-in autochromatic tuner and PCM drum machine. Its 24-channel/8-bus mixer includes XLR balanced preamps (with phantom power), 3-band EQ with sweep mids, 192 onboard DSP effects and 100 scene memories for storing fader/panning and effects settings.

Circle 341 on Product Info Card



## KOL SMARTCODE PRO ENCODERS

Kind of Loud ([www.kindofloud.com](http://www.kindofloud.com)) is now shipping its SmartCode Pro Dolby and DTS encoders. Both versions of SmartCode Pro are AudioSuite plug-ins that allow Pro Tools users to preview their 5.1 sur-



round mixes in real-time 5.1, then encode and decode the mix to create a 6-channel surround master. DTS-CD (\$495) allows you to encode and burn a Red Book CD (using most desktop CD drives) for playback on most DTS-equipped home theater systems. The full version of SmartCode Pro DTS-DVD (\$1,495) is intended for DVD authoring, which requires additional bit rates and includes SmartCode Pro/DTS-CD. SmartCode Pro Dolby is \$795.

Circle 342 on Product Info Card

## T-RACKS 24 VERSION 2.0

IK Multimedia announces





Version 2.0 of T-RackS 24 (www.t-racks.com), a stand-alone software mastering suite for Mac and Windows that is physically modeled after analog gear. With Version 2.0, T-RackS is now 24-bit, reading and writing 24-bit .AIFF, .WAV and SD2 files. An enhanced

multiband peak limiter algorithm and an output stage with soft-clipping shaper with pre and post levels allows for more loudness without using compression or limiting. The saturation shape is continuously variable from hard digital clipping to

ultra-smooth, tape-like saturation. A new compressor ratio control makes the unit more flexible and musical, and T-RackS 24 now lets you adjust such "internal" settings such as the multiband limiter's single-band levels, thresholds or attack times; compressor sidechain low-frequency cutoff; and global internal patch routing and more. T-RackS 24 users will also be able to share these settings online through a new T-RackS pro-mastering Web forum. Other new features include eight new "vintage" skins, more than 50 presets and dongle-free operation. List \$299; regis-

tered users can upgrade for free.

Circle 343 on Product Info Card

**DIGIDESIGN CONTROL | 24**

Now shipping, Control | 24 from Digidesign (www.digidesign.com) is an analog front-end and control surface for controlling Pro Tools. The system features 24 touch-sensitive moving faders, 16 Class-A Focusrite mic preamps, full 5.1 control room monitoring control and dedicated transport/editing and DSP

functions. Retail: \$7,995.

Circle 344 on Product Info Card



**UPGRADES AND UPDATES**

SADiE announced the immediate release of the AES31 standard for network and file transfer of digital audio. AES31 defines the source material alongside edited audio (including crossfades) that is text-based in the manner of a traditional EDL. The format is sample-accurate and supports multichannel files in excess of 99 channels, as well as interchange between PAL and NTSC formats. The format is also open and non-proprietary. Visit www.sadie.com... Access Music (www.access-music.de) released a new version of its Virus A soft-

ware, supporting owners of this discontinued product. The release has bug fixes and new features such as analog boost, an enhanced arpeggiator, random pitch generator and Sound Categories, which scan Virus' memory for like sounds...Midiman is the new U.S. and UK distributor for Propellerheads. For more information, visit www.midiman.com...Spin-Audio introduces 3D Panner Studio, a plug-in for VST and DirectX that allows you to place your audio tracks in a 3-D space around your head and arrange them in a single window. Go to www.spin-audio.com for details... Emagic has licensed the POW-R algorithm for digital wordlength reduction.



POW-R, short for Psychoacoustically Optimized Wordlength Reduction, converts longer wordlengths (up to 32 bits) to 16-bit format, while maintaining perceived dynamic efficiency and low noise...CD Cyclone Duplication (www.cdyclone.com) announced its newest CD-RW product, the CDRevo FireWire drive with 16x burn capability. Retail price: \$399...Cakewalk is now the distributor of Image-Line's FruityLoops 3.0. New features include a photo-realistic interface,

support for DX1 soft synths, DirectX audio effects and support for Windows 2000...Digigram (www.digigram.com) signed an agreement with AT&T to license AT&T's implementation of MPEG-2 AAC, for use in its multichannel audio codecs...PSP (www.psp-audioware.com) introduced the MixTreble, the fourth plug-in in the PSP MixPack: MixTreble offers four processing algorithms for removing hiss, processing transients, enhancing stereo and harmonics and switchable soft clipping. ■

# MY PIECE DE RESISTANCE!

## UNDERSTANDING AC/DC, SERIES/PARALLEL, RESISTANCE AND IMPEDANCE

We interface equipment every day, assuming and hoping that the relationship between source and destination will be a happy one. In any electrical circuit, impedance is a major part of that relationship, a rather deep subject that had me pouring through old textbooks and wishing I could still do the math. Here is my "Piece de Resistance," an overview of basic electronic information that will prepare you for next month's further adventures.

### AC/DC: THE JUICE

Electricity can be described as an Electromotive Force (EMF). You know AC—alternating current—as sound and power (the giant hum that comes from wall outlets). Batteries deliver direct current (DC). Both are expressed in volts. AC can be transformed, rectified and filtered into DC—power supplies do this most of the time.

AC implies time by way of repetition. The frequency of AC is stated in Hertz—Hz—formerly known as "Cycles Per Second," or CPS. It is easiest to imagine one complete cycle of a sine wave starting at zero volts—going positive, then crossing zero, going negative and returning to zero. Before vacuum tubes, transistors or IC op amps can amplify AC, they must first be "turned on," biased with DC using resistors!

### STORAGE

AC cannot be contained like DC, which can be "stored" in an electrochemical form as a battery or in an electrostatic form as a capacitor. Imagine filling a bathtub with water or parking a car at the top of a very steep hill. With gravity as "the force," throwing the switch is equivalent to pulling the drain plug or releasing the brake.

Unlike the popular water analogy, DC does not leak from the bat-

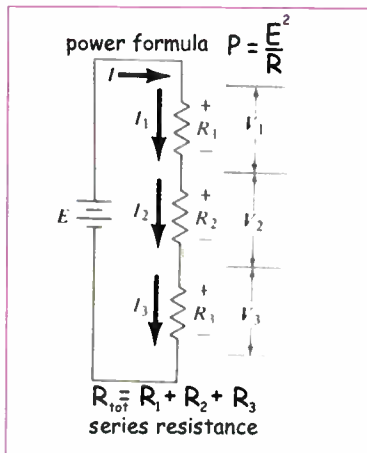

Figure 1a: Series circuit configuration and formula plus the power formula

tery terminals, although, sometimes, the chemicals do. When AC and DC are put to work, however, magnetic energy is radiated into the air from the cabling, the principle behind inductors and transformers. Radiated AC, in the form of hum and buzz, finds its way into vulnerable "appliances" such as electric guitar and bass—another topic!

DC might imply a constant polarity and voltage, but time cannot be frozen. Even a battery—disposable or rechargeable—holds a charge over a defined period of time that is primarily determined by use. Within time as we know it, a rechargeable battery has a charge and recharge "cycle," still technically DC, yet one could argue it being of sub-sonic frequency.

### SERIES AND PARALLEL

Two circuit configurations are shown in Fig. 1a and Fig. 1b using resistors for each example, along with the respective formulae for calculating total resistance. Figure 1a shows resistors in series configuration, and Fig. 1b demonstrates parallel. In series, resistor values

are simply added together. The total resistance decreases in the parallel configuration; the formula as shown matches the example but can be continued ad infinitum. Add more resistors, and the end result will eventually approach zero ohms; in essence, a piece of wire.

Note: Both "E" and "V" may be used to denote voltage.

Test No. 1: It is common knowledge that two 8-ohm speakers connected in parallel becomes 4 ohms. What if the two speakers were 8 ohms and 4 ohms? (Answer No. 1: 2.6 ohms.)

Tip: Most Windows PCs have a calculator with both Standard and Scientific modes.

Test No. 2a: Ohm's Law and the power formula are included in Fig. 1. These essential electronic tools are used to determine current flow and power consumption. Most cars have a 12-volt bat-

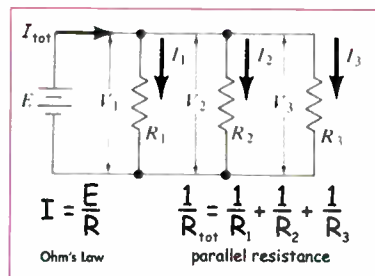

Figure 1b: Parallel circuit configuration and formula plus Ohm's Law.

tery. Assuming that the sound system's amplifier can swing 10 volts peak-to-peak, what is the peak power output of one channel into an 8-ohm load? (Answer No. 2a: 12.5-watts peak power.)

Test No. 2b: (Bonus Question) What is the RMS power for the same sound system? Hint: See the February issue of this column. (Answer No. 2b: 1.56-watts RMS.)

### LYNN EAR

Like the water analogy, a variable

BY EDDIE CILETTI

# create DVD-Audio disks

with the MASS 5.1 System  
from Microboards and Minnetonka



## Mix it

### Mx51.

Mixing is incredibly easy and fun with Mx51. Take your multitrack recording and place each track anywhere in the surround sound field.

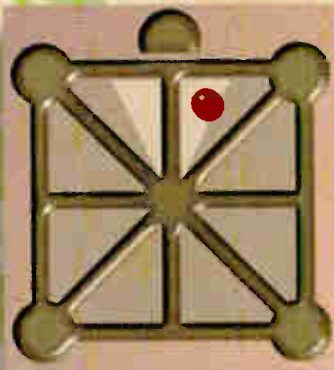

Mx51 uses Minnetonka's unique "Build-Your-Own-Mixer" architecture, letting you build a custom mixer in minutes. Includes an interface for a motorized joystick, letting you **FEEL Surround Sound as you HEAR it.**

## Compile it

Assemble a playlist of songs in any order. MASS 5.1 makes it EASY to assemble your DVD-A. Just drag-and-drop the soundfiles from your master recordings into the bottom window. MASS 5.1 accepts the masters as 6 soundfiles or as an MLP-encoded file. Just line up the recordings in order, and hit the Record button!

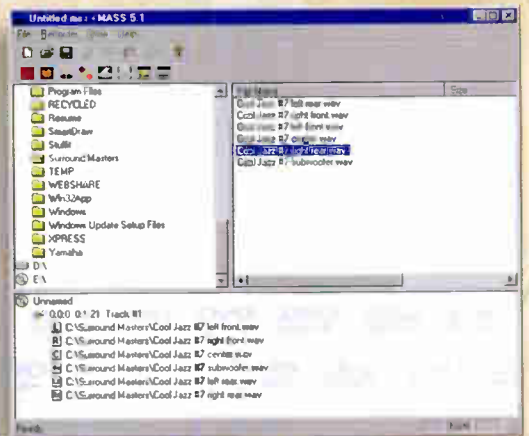

## Burn it

Included in the package is a **Pioneer S201** DVD-R recorder.

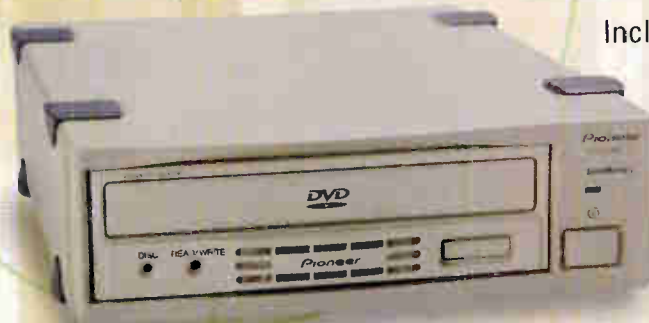

Corporate Headquarters: (952) 556-1600  
Toll Free: (800) 646-8881 • Fax: (952) 556-1620  
Europe: 44-1789-415-898 • Fax: 44-1789-415-575  
Japan: 81-3-3561-2266 • Fax: 81-3-3561-2267

[www.microboardsproaudio.com](http://www.microboardsproaudio.com)

 **Minnetonka**  
AUDIO SOFTWARE INC.

 **MICROBOARDS**  
Technology

CIRCLE #096 ON PRODUCT INFO CARD

resistor can be viewed as a valve, although vacuum tubes and transistors are much more efficient when "heavy lifting" is required. In a recording console, for example, the effect and aux sends are examples of variable resistors in the form of rotary potentiometers (pots).

Most pots are three-terminal devices. Typical connections to a linear fader are detailed in Fig. 2. The input is at the top, output via the middle terminal (called the "wiper") and the bottom terminal is the signal common, typically connected to ground. The wiper divides the resistor into two parts: The ratio of the bottom resistor to the total resistance determines the amount of input signal that is output. The very first example in the table on p.116 is the easiest to visualize.

The table defines 16-bits of dynamic range in 6dB increments as represented by the change in voltage and the equivalent resistance for a 10-kilohm fader.

A mechanically linear fader may also be electronically linear when a DC control voltage is used for VCA-type automation. The table on p. 116 shows how an audio taper pot differs. Starting with 10 volts at the top of a 10-kilohm fader, each 6dB drop represents a 50% voltage reduction from the previous value. While the first drop from 10 volts to 5 volts is half the electrical value, you know that the wiper knob will not be halfway down.

Test No. 3: Imagine a fader that is both mechanically and electrically linear. Put in 10 volts at the top, set it halfway and get 5 volts out. The fader comes in three resistance options—1,200 ohms, 4,800 ohms and 10 kilohms. The equivalent circuit is a series resistor pair consisting of...(Answer No. 3: 600, 2,400 and 5 kilohms, respectively.)

Test No. 4: The resistive element in an audio taper pot is "logarithmic," matching the ear's nonlinear sensitivity to level changes. It's hard to avoid the math, but I encourage those with access to a scientific calculator to engage the dB formula at the lower right corner of Fig. 2. Divide any two voltages from

the table, take the log and multiply by 20. Compare your answers with those in the table. It feels good, doesn't it? I used to do this on a slide rule!

**MIX MASTER**

In a mixer, an IC op amp may have to feed several effect sends as well as the primary fader. If four pots will be connected to an op amp, then it is important, for the sake of efficiency, to choose an optimal resistance value that, when combined in parallel, isn't so low as to overload the op amp or so high as to be vulnerable to stray capacitance (next month's topic).

For ease of head calculation, I chose four 2,400-ohm resistors. Combine the first two pairs into a single pair of 1,200-ohm resistors and then combine those into one 600-ohm load. This, too, is a magic number, vintage gear having input and output impedances of 600 ohms and being referenced to 0 dBm. The Power formula (in Fig. 1a) states that P equals E-squared divided by R. In this case, E is 0.775 volts.

Test No. 5: Apply .775 volts to

the load and determine the power. (Answer No. 5: 1 milliwatt.)

Note: One mW is the reference for 0 dBm, 4 dB below "nominal" level for professional equipment.

Many op amps can comfortably drive a 600-ohm load. But within a mixer module, only the output amps need to be prepared to work this hard and only when driving vintage-style equipment. Typical pot values are between 5k and 10 kilohms. Four 10-kilohm pots represent a 2,500-ohm load to the op amp.

Test No. 6: Can you calculate the power if 0.775 volts appear across a 2,500-ohm load? (Answer No. 6: 0.24 milliwatts.)

**THE SCIENTIFIC METHOD**

In all of the sciences, it is common to minimize the variables to facilitate understanding and simplify calculation, if only for the moment. With that in mind, consider impedance as the full-color version of resistance. The series parallel circuit examples in this article consisted mostly of a battery

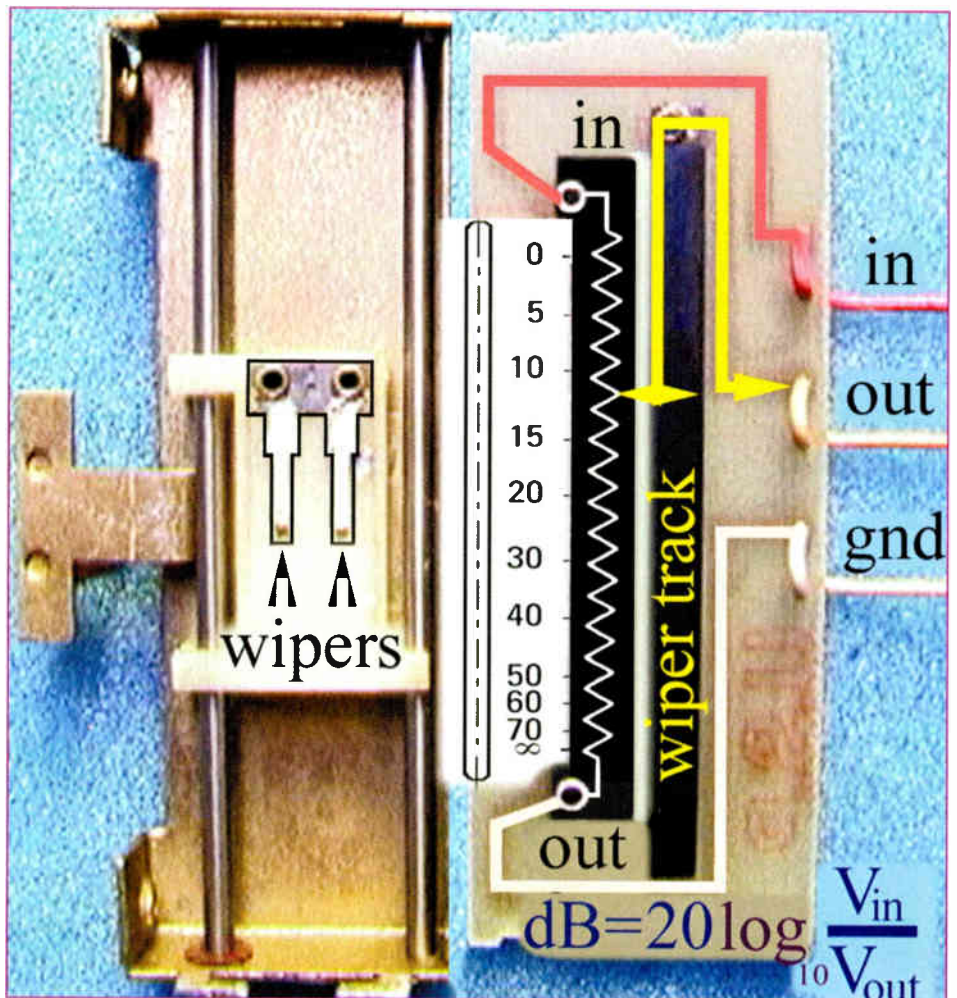

Figure 2: A photo-schematic of an open linear fader. The formula for calculating dB from two voltages is shown in the lower right corner.

# SHURE®

Beta52 • Beta56 • Beta57A • Beta58A • Beta87A • Beta87C • Beta91 • Beta98D/S • SM58LC • SM57LC • SM81LC • VP64 • VP88 • KSM32SL • KSM44  
SM7A • PSM • E-1 • E-5 • T-Series Wireless • UT-Series Wireless • LX-Series Wireless • VP-Series Wireless • UC-Series Wireless • UHF-Series Wireless

# Absolutely In Stock!

\*models listed above (4-15-01 thru 06-30-01)



**800-356-5844**  
**www.fullcompass.com**



**...buy now and get a free hat**

**\*while supplies last**

CIRCLE #066 ON PRODUCT INFO CARD

world radio history

and resistors—certainly not the real world, so black and white that there wasn't even a power switch! AC voltages were treated like DC, except when calculating peak and RMS power.

Oversimplified, impedance is to AC as resistance is to DC. While both quantities are expressed in "ohms," the former requires higher math (trigonometry and calculus); the latter can pretty much be ciphered in your head. With the exception of the "dB" formula, the math presented in this article is quite basic. You calculated current using Ohm's Law—10 volts divided by 10 ohms is 1 ampere—but

if a capacitor or inductor were in the circuit, the voltage and current would change over time, requiring several calculations. Even the switch would play a key role!

Next month's math takes time into consideration, but don't get nervous about it. A demo version of "Micro-Cap 6" is available at [www.spectrumsoft.com](http://www.spectrumsoft.com) as a free download. Just draw a schematic and it does the ciphering. Meanwhile, let's look at the basic concepts comparing resistance to impedance.

**SPECIFIC HEIGHTS**

Resistance is a scalar quantity measured in ohms, just as the term "height" is

defined by its magnitude (inches, feet, centimeters, meters) and no more. By contrast, temperature is defined by its magnitude—degrees—which alone does not tell the whole story. Wind can make a 20° day feel like 10° (wind chill), while humidity can make 70° feel like 80° (the yuck factor). Like the temperature example, impedance is a vector quantity defined by its magnitude in ohms, but instead of wind chill, there is a phase angle, a manipulation of time.

**I-C-E IS N-I-C-E**

Remember that DC can be stored over long periods of time in batteries and to a lesser extent in capacitors. Add a

Fader Top	Volts	Resistance (10-kilohms total) Top-to-Wiper / Wiper-to-Bottom
0 dB	10	0 / 10k
-6	5	5k / 5k
-12	2.5	7.5k / 2.5k
-18	1.25	8.75k / 1.25k
-24	0.625	9,375k / 625
-30	0.3125	9,687.5 / 312.5
-36	0.15625	9,843.75 / 156.25
-42	0.078125	9,921.875 / 78.125
-48	0.0390625	9,960.9375 / 39.0625
-54	0.01953125	9,980.46875 / 19.53125
dB	millivolts	
-60	9.765625	9,990.234375 / 9.765625
-66	4.8828125	9,995.1171875 / 4.8828125
-72	2.44140625	9,997.55859375 / 2.44140625
-78	1.220703125	9,998.779296875 / 1.220703125
-84	0.6103515625	9,999.3896484375 / .6103515625
-90	0.30517578125	9,999.69482421875 / .30517578125
-96	0.152587890625	9,999.84741209375 / .152587890625
Fader Bottom	millivolts	All resistor pairs add up to 10 kilohms

Table: Based on a typical 10-kilohm console fader, the table shows the relationship between fader position (in dB), output voltage and resistance.

More possibilities. More professional.  
More better.



*Introducing the*  
**USB AUDIOSPORT Quattro™**

- 4 balanced ins and outs • 24-bit/96kHz
- Zero latency direct monitoring • MIDI i/o • Mac and PC

*USB Audio the way it should be.*



**M POWERED.**

800-969-6434 • [WWW.M-AUDIO.COM](http://WWW.M-AUDIO.COM) • EMAIL: [INFO@M-AUDIO.COM](mailto:INFO@M-AUDIO.COM)  
CIRCLE #067 ON PRODUCT INFO CARD

**Compatible with the OMNI i/O**



- Additional 8 inputs to the mixer section
- Insert compressors on your mics
- Buss to outboard FX or submixers
- Mix to DAT/CD burner and cassette
- Monitor your MIDI gear in playback and record
- Track with 2 headphones and/or monitors

**Mt. San Jacinto College Audio Technology Department...**

**Breaking the "Sound" Barrier!**

**Audio  
Instruction  
Certificate &  
Degree Programs**

**Small class sizes**

**"Hands On" instruction**

**Call (909) 487-6752  
ext. 1576 for a FREE  
brochure, or Email us  
music@msjc.cc.ca.us**

**Mt. San Jacinto College's  
Audio Technology  
Program is proud to be  
in an educational  
partnership with OTARI**



**3 control rooms**

**Pro-Tools 24**



**Audio for video**

**Otari Radar**

CIRCLE #068 ON PRODUCT INFO CARD

switch to the series or parallel resistor examples. At the moment, the voltage  $E$  is applied to the resistance  $R$  no matter whether the source is AC or DC, the current will be instantaneous.

Reactive components—capacitors and inductors—manipulate the time relationship between voltage and current. A fully discharged capacitor appears as a dead short at the moment it is connected to a DC voltage source, the current leading the voltage by  $90^\circ$ . In engineering school, simple expressions such as "E-L-I the I-C-E man" helped students remember that voltage-leads-current by  $90^\circ$  in an inductor  $L$  (a coil of wire).

### SPARK!

Have you ever plugged or unplugged a device when its switch was in the On position? At the exact moment the plug and socket made or broke the connection, a sizeable spark most likely occurred. Connecting AC power to a reactive device such as a transformer is one of the reasons lights dim but don't stay dim when a device is turned on.

### ABSOLUTE ZERO

Getting back to the temperature analogy for a moment, the materials used for making or plating wire—copper, silver, gold or aluminum—all have a defined resistance at room temperature. Absolute zero on the Kelvin scale (0 K) is the lowest temperature theoretically possible—at approximately  $-273.16^\circ\text{C}$  ( $-459.69^\circ\text{F}$ ). Wire that cold becomes a more perfect conductor. That's why audiophiles love winter here in Minnesota!

In reality, the slight amount of resistance per foot becomes cumulative with extremes of distance or of thinness. For example, speaker cable consists of a pair of conductors separated by insulation, a capacitor by definition that becomes a contributing factor as the series resistance increases. At high frequencies, the wire also has some inductance. Hold that thought...

Next month, the circuit examples will include capacitors and inductors in real-world examples of signal corruption and failing components. In the meantime, drop by [www.tangible-technology.com](http://www.tangible-technology.com) for a visit. ■

*This past winter, Eddie shoveled 65 inches of snow. By the time you read this, he'll be planting a vegetable garden. Got any seeds?*

# Cherokee Studios

**If you haven't HEARD of us, you've HEARD us.**

David Bowie - Anthrax - The Cars  
Madonna - Rod Stewart - The Pixies  
The Rolling Stones - Tantric - Puya  
Suicidal Tendencies - Led Zepplin  
Rollins - Lenny Kravitz - KISS  
Bliss - Motley Crue - Goldfinger  
Quincy Jones - Showoff - Elton John  
Ozzy Osbourne - Christina Aguilera  
Alice Cooper - Boys I Men - Seal - Guns N' Roses

Movies: Any Given Sunday - Aliens 3 - Blue Velvet  
Coyote Ugly - Ghosts of Mars - The Doors

Cherokee Studios is a world renowned recording facility. Comprised of five studios ranging in technology from the highest quality vintage analog to the cutting edge of D.S.P., Cherokee has produced hundreds of gold and platinum records during its 25 years of operation.

**For rates and availability please call Natalie Jacobson: (323) 653-3412**

CIRCLE #069 ON PRODUCT INFO CARD



# ESSENTIAL READING



HHB CDR850/850PLUS CD Recorders



HHB CDR830 BurniT CD Recorder



PORTADISC Professional MD Portable



HHB Circle Active/Passive Monitors



HHB Advanced Media Products



Genex GX8500 Multi Format Recorder



TLA VTC Vacuum Tube Console



HHB Radius Tube Processors



HHB Classic Tube Processors



Genex 24-bit/192kHz + DSD Converters



Quantec Yardstick Reverb



Rosendahl Nanosyncs Clock Generator

**Download information • Locate a dealer • [www.hhbusa.com](http://www.hhbusa.com)**

HHB Communications USA LLC · 1410 Centinela Avenue, Los Angeles, CA 90025-2501, USA  
Phone: 310 319 1111 · Fax: 310 319 1311 · E-Mail: [sales@hhbusa.com](mailto:sales@hhbusa.com)

HHB Communications Canada Ltd · 260 King Street East, Toronto, Ontario M5A 4L5, Canada  
Phone: 416 867 9000 · Fax: 416 867 1080 · E-Mail: [sales@hhbcanada.com](mailto:sales@hhbcanada.com)

HHB Communications Ltd · 73-75 Scrubs Lane, London NW10 6QU, UK  
Phone: +44 20 8962 5000 · Fax: +44 20 8962 5050 · E-Mail: [sales@hhb.co.uk](mailto:sales@hhb.co.uk)

Pro Audio Digital SA de CV · Rousseu No. 26 Col. Nueva Anzures, México D.F. 11590  
Phone: 525.531.5859 · Fax: 525.203.0018 · E-mail: [irbach@audiosistemas.com.mx](mailto:irbach@audiosistemas.com.mx)

SK Audio Professional Products · R. Barão de Jaguará 148f, cj 142, Centro Campinas, Sao Paulo, CEP 13015-910 Brasil  
Phone/Fax: (5519) 3236-0450 · E-mail: [skaudio@uol.com.br](mailto:skaudio@uol.com.br)



# PREVIEW



## SCHOEPS POLARFLEX MIC SYSTEM

Schoeps (now distributed by Redding Audio, 203/270-1808) is shipping its Polarflex Microphone System, which combines a DSP processor paired with two omni and two figure-8 (or four cardioid) capsules to emulate the sound of nearly any microphone. Polarflex can be used conventionally—like any stereo mic—or the signals from the four capsules can be recorded separately and combined after the recording, with processing handled in the analog or digital domain, giving the user full control over reverberant ambience, directional characteristics and tonal shaping.



Circle 327 on Product Info Card

## APOGEE ELECTRONICS INTELLIDAC 9616

The IntelliDAC 9616 from Apogee Electronics ([www.apogeedigital.com](http://www.apogeedigital.com)) is a 16-channel, 24-bit, D/A converter capable of operating

at sample rates of up to 96 kHz. The converters can source their digital input from AES/EBU, ADAT optical or TDIF signals, and the unit can sync to wordclock or a specified input. ADAT and TDIF inputs are organized into two groups of eight, and channels 1-8 and 9-16 can accept different sources. Individual channel gain is digitally adjustable, and balanced analog outputs are supplied in groups of eight on 25 pin D connectors. (Pinout is the same as for other Apogee D/A converters and the Tascam standard.) An "intelligent" two-stage reclocking system de-jitters both incoming clock and data, and the system is capable of correcting phase errors between synchronous digital sources of up to 150°.

Circle 328 on Product Info Card

## BEHRINGER TRUTH B2031

The Truth B2031 bi-amplified studio reference monitor from Behringer ([www.behringer.com](http://www.behringer.com)) are sold in hand-matched pairs for \$799/pair. Featuring a 150-watt, 8.75-inch, long-throw woofer with a polycarbonate diaphragm and a

rugged cast-aluminum chassis, plus a 75-watt, 1-inch, Ferrofluid-cooled tweeter, the Truth B2031 offers a frequency response from 50-20k Hz and is fully shielded. Features include adjustable low-frequency roll-off, room compensation adjustment, peak limiter protection circuitry, Mute functions and automatic stand-by switching. Inputs are servo-balanced, 1/2-inch TRS and XLR connectors.

Circle 329 on Product Info Card

## ALESIS POWER AMPS

Alesis ([www.alesis.com](http://www.alesis.com)) adds three amps to its RA range: the RA150 (\$259), the RA300 (\$359) and the RA500 (\$459). Housed in a heavy-duty steel chassis, each model features detented front panel level controls, overload/protect indicators, bridged mono operation and relay-controlled turn on/off. The DC-coupled, fully complementary discrete amp topology features dual-differential input

## AUDIX SCX-25 CONDENSER

The SCX-25 from Audix ([www.audixusa.com](http://www.audixusa.com)) is a studio condenser mic with a new suspension-mounting system that effectively iso-



lates the capsule from the housing and electronics. This both minimizes reflective surfaces and maximizes phase coherence, while eliminating the need for an external shock-mount. Featuring a 25mm, gold-sputtered diaphragm, 135dB SPL handling, a 20-20k Hz response and a low-noise preamp design, the SCX-25 provides a wide cardioid pattern and an "open"



stages and uses noiseless convection cooling. Inputs are balanced 1/2-inch and RCA-type; outputs are dual-binding posts. RA300 and RA500 models offer XLR-input connectors and bar graph metering.

Circle 330 on Product Info Card

sound usually only found in much larger (and more expensive) classic microphones. The mic requires standard 48-52V phantom power, measures 5.5 inches in length and weighs 8 ounces. Price: \$799.

Circle 331 on Product Info Card

## PREVIEW

**TL AUDIO TUBE PROCESSOR**

The VP-1 Tube Processor from TL Audio (distributed by HHB, [www.lhlbusa.com](http://www.lhlbusa.com)) combines a pentode preamp, 4-band parametric EQ, compressor, expander/gate, de-esser and peak limiter. The VP-1 features a Siemens EF86/6267 pentode in the front end of the preamp, followed by six Sovtek ECC83/12AX7A stages in the secondary stage of the preamp, compressor and four in the EQ section. The preamp stage accepts mic, instrument and line inputs and has a 30dB pad, phase reverse and a variable high-pass filter. The transformer-balanced mic input offers a choice of tube or Class-A signal paths. The compressor offers both hard and soft knee characteristics and a choice of tube or optical compression stages. Additional features include stereo link facility, optional wordclock input and AES/EBU and S/PDIF digital outs. Price: \$2,699.

Circle 332 on Product Info Card

**DPA MICROPHONES STEREO KIT**

DPA Microphones ([www.dpamicrophones.com](http://www.dpamicrophones.com)) offers its large-diaphragm condenser mics as a stereo kit, including a stereo boom, stereo mic preamp,

all necessary cables and accessories—packaged in a Samsonite briefcase. The complete A-B Stereo Kit has two matched omni Type 4041 mics with 130V preamps and self-noise matched to within 1 dB. Frequency response is 10-20k Hz with a 4-6dB soft boost around 8 kHz; peak SPL handling is 144 dB. The modular mics can be used with either the 3532-S solid-state preamp or the 3532-T, with a pentode vacuum tube preamp driven as a cathode follower in a unity gain, Class-A design. Both systems offer low noise: 7 dBA for the 4041-S and 10 dBA for the 4041-T.

Circle 333 on Product Info Card

**CAD TUBE MIC**

CAD Professional Microphones ([www.cadmics.com](http://www.cadmics.com)) offers the M9 large-diaphragm tube condenser model. This

cardioid studio mic features a 1.1-inch (inside diameter), gold-sputtered capsule and a wide dynamic range, low-noise head amp circuit based on a 12AX7 tube. The output stage is a high-speed dual op amp in a balanced differential configuration.

Frequency response is 10-20k Hz, with a slight rising response characteristic at 15 kHz. Switches on the mic body engage a highpass filter and a -20dB pad. The M9 is supplied with a swivel mount, dedicated power supply (no phantom power needed), a 30-foot, 7-conductor mic cable and rugged carrying case. Price: \$499.

Circle 334 on Product Info Card

**TRIDENT-MTA SERIES 80 EQ**

The new Series 80 dual-classic channel module from Trident-MTA, distributed by Fletcher Electroacoustics ([www.joemeek.com](http://www.joemeek.com)), is based on the famed Trident Series 80 console, introduced over 20 years ago. Designed by Trident founder Malcolm Toft, the new Series 80 is a dual-channel, fully discrete mic/line preamp and two bands of EQ per channel with sweepable center frequencies, plus 2-position

high- and low-shelving filters and a 50Hz highpass filter. Additional features include 48V phantom power, polarity reverse, an EQ in/out switch and independent output level controls. Price: \$2,499.

Circle 335 on Product Info Card

**KS STUDIO MONITORS**

A supplier of high-quality speakers in Europe for more than 20 years, KS products are now available in the USA (distributed by CAP Audio, [www.cap-audio.com](http://www.cap-audio.com)). Its line of powered monitors range from the 6.5-inch/two-way ADM 4 near-fields to the massive, tri-amped ADM 1, which are capable of 125dB SPLs and feature analog and AES/EBU digital inputs. The ADM 2s shown here offer analog and digital interfacing, 300 watts of internal bi-amplification and a frequency response of 38-20k Hz.

Circle 336 on Product Info Card



# PREVIEW

## MBHO CONDENSER CAPSULE EXTENSION

The MBC-603A from MBHO (distributed by MTC-MBHO U.S. at 718/963-2777) is similar to its MBP-603 miniature condenser mic, but includes a 9-foot extension cable, useful in recording and broadcast applications where traditional mic placement techniques are unsuitable. The MBC-603A features transformerless circuitry and smooth on-/off-axis frequency response. Price of the preamp and extension cable is \$382. Small-diaphragm capsules—sold

separately—list between \$237 and \$281.

Circle 337 on Product Info Card

## Z-SYSTEMS 96kHz SRC

Z-Systems Audio Engineering ([www.z-sys.com](http://www.z-sys.com)) announces the z-link96 and z-link96+ miniature sample rate converters. Both units support up to 24-bit digital audio at sample rates up to 96 kHz, and both allow output word

length to be set at 16- or 24-bits. Dynamic range is greater than 120 dB, and THD+N is better than -115 dB. Both the z-link96 and z-link96+ feature internal clock references that allow

the units to generate 44.1/48/88.2/96kHz output sample rates internally, and the z-link96+ can be synchronized to an external AES11 reference.

Circle 338 on Product Info Card



## HOT OFF THE SHELF

Lexicon has announced a major software upgrade for the 960L Digital Effects System. Available free to 960L system owners, Version 2 (V.2) software adds support for a second reverb card, doubling the system's DSP horsepower, support for 16 channels of I/O and several new Lexicon presets. Additional features of V.2 software include both global mix control and global I/O control (allowing users to override individual mix settings), enhanced input metering, dual-LARC2 support and several new cascaded configurations, including mono in/stereo out configurations for 96kHz operation. Call 781/280-0300 or surf to [www.lexicon.com](http://www.lexicon.com)...Zero International's 44-page 2001 catalog of door and window sealing solutions provides specification guidance and

full-size schematics for hundreds of components and integrated systems for blocking flames, smoke, air, light and sound. Call 800/635-5335 or click on [www.zerointernational.com](http://www.zerointernational.com)...Independent Audio has announced the FREQue II effects processor, featuring fully floating, balanced inputs and outputs, adjustable input gain and output wet/dry mixing. The unit offers an output frequency range from 1-55k Hz. For more information, call 207/773-2424 or visit [www.independentaudio.com](http://www.independentaudio.com)...GEPCO's 5596GFC Series 100-ohm AES/EBU digital multipair cables feature a 12.3MHz bandwidth, ultra-low attenuation and jitter, mechanical stability and precision 110-ohm impedance. Available in 4/8/12-pair configurations, the 5596GFC is optimized for 96kHz bandwidth requirements but is suitable for long runs in 44.1/48kHz

applications. Cables feature color-coded and alphanumerically printed pair jackets, bonded foil shield and a flexible outer jacket. Visit [www.gepco.com](http://www.gepco.com)...KK Audio studio furniture is designed to house workstations, compact mixers and rack equipment. The MAX D 8 (\$1,195) is designed for the Mackie D8B, but can house other compact consoles, such as the Yamaha 02R and Ramsa DA7. The unit includes a monitor bridge, adjustable keyboard shelf and 10-space rack. The MAX D 7 (\$1,145) is designed specifically for the Panasonic DA7. KK also offers video monitor and speaker stands. Call 818/765-2921...Neutrik PatchLink SPL 1/2-inch patch panels require no soldering and feature individually replaceable PC cards. The modular 19-inch rackmount patch panel is fully PCB-wired without nut fastening and features 48-balanced

channels in one rackspace. The front and rear panels have two rows of 24 sockets for mating with stereo phone plugs. Configurations can be half-normaled or isolated. Accessories include individual send/return split print modules and a Patch-Box with eight send/return modules, a solution for console insert jacks that eliminates the need for specially wired Y-cables. Drop by [www.neutrikusa.com](http://www.neutrikusa.com)...Yamaha has discontinued its NS10M studio monitor, in part because the wood pulp used in the woofer cone is no longer available. Long used as a reference standard in recording facilities worldwide, the NS10M was introduced in 1978. Yamaha says replacement drivers will be available for the foreseeable future, and remaining NS10M production for 2001 will be allocated according to dealer purchase levels of last year. Visit [www.yamaha.com/proaudio.com](http://www.yamaha.com/proaudio.com). ■





# Year of the Dragonfly.

Fast, maneuverable and beautifully engineered, the BLUE Dragonfly employs an innovative design that offers fine tuning and precise placement to please the most discerning recordist, combined with an ease of use that is without equal among contemporary microphones—and at a price that's considerably less than anything in its class. The Dragonfly is a unique pressure-gradient cardioid condenser microphone, employing the BLUE hand-built single-membrane large diaphragm capsule coated with a 6-micron mylar film of pure gold and aluminum. Enclosed within a rotating spherical grille, the capsule can be positioned and adjusted in the smallest spaces. Complete with an integrated elastic shockmount, the microphone's electronics are based on a class A discrete circuit, with a transformerless output. Its neutral sonic character gives flight to everything from vocal to percussion, electric guitar and bass, as well as more "difficult" sources such as saxophones and stringed instruments. Oh, and did we mention that among its rave reviews, the Dragonfly is one of *Electronic Musician's* 2001 Editor's Choice award-winners?

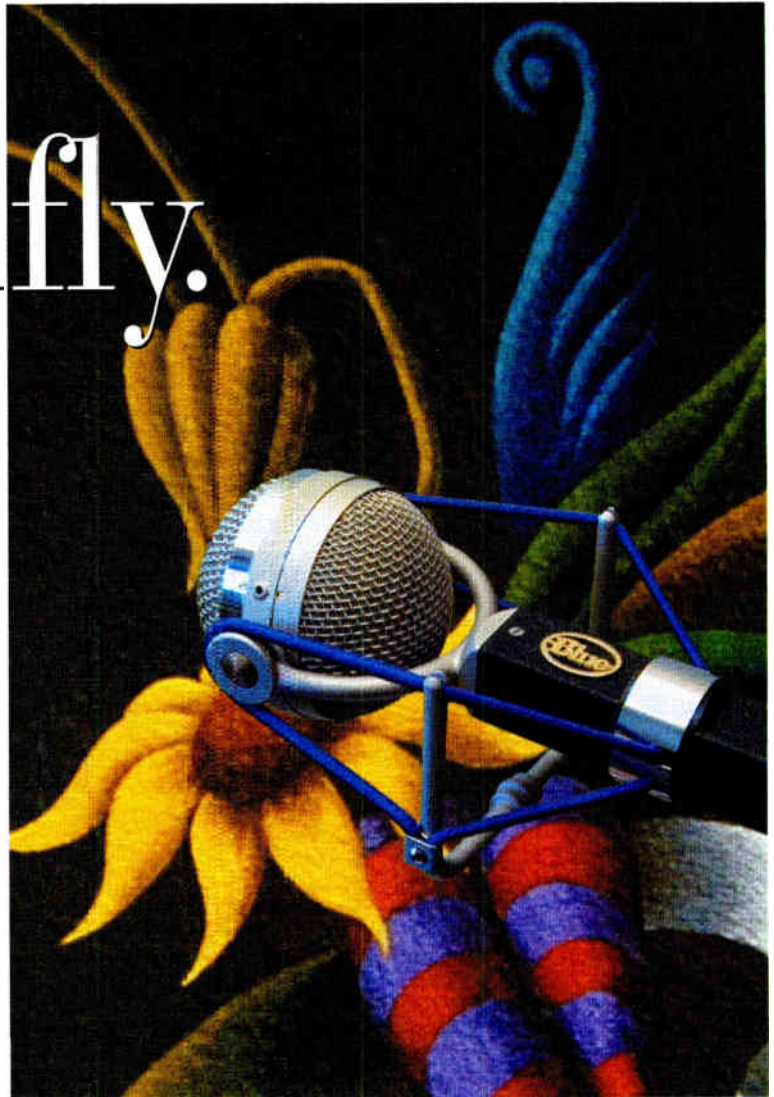

*Matched sets of Dragonflies can be purchased exclusively from BLUE. This limited edition set is uniquely colored in deep green lacquer with gold accent trim and housed in handmade cherrywood boxes. Contact BLUE for more information.*

**Winner of *Electronic Musician's* 2001 Editor's Choice Award**



Microphones



Dragonfly



Blueberry



Mouse



Kiwi



Cactus



Bottle

# MARK OF THE UNICORN 1296

## MULTICHANNEL 96KHZ AUDIO I/O

I've worked with Mark of the Unicorn devices for quite a while now. Back in 1999, I reviewed MOTU's original and wildly successful 2408 audio interface for *Mix's* sister magazine, *Electronic Musician*. Working extensively with MOTU's subsequent audio interfaces, I've recorded and mixed everything from commercial CD tracks to live theater music to soundtracks for film and TV, and I've found that the quality of MOTU's interfaces have always served me and my associates well.

However, I've been in some critical recording situations where either an interface with multiple balanced XLRs were required or we wanted to record at sampling rates higher than 48 kHz. Until recently, other hardware solutions were the only choice. MOTU's 1296 now provides these features, plus a lot more.

The 1296 provides 12 analog channels of inputs and outputs via XLR connectors operating at +4 dBu. AD/DA converters are 24-bit, "enhanced multibit," 128-times oversampling, a third-generation step up from the converters used in previous MOTU interfaces. Two channels of AES/EBU are also available. Both wordclock I/O and an extra "AES Word In" allow the AES/EBU output to resolve independently to an external wordclock source (more on this later). Inputs and outputs for all 12 channels have 19-segment LED metering on the front panel for easy viewing.

The 1296 connects to the host computer via the PCI-324 card, which is included in the 1296 core system (\$2,095). The 1296 interface is compatible with MOTU's other PCI-324 interfaces—including the 2408, 2408mkII, 1224, 308 and 24i—and can be purchased separately as an expansion I/O (\$1,795) for those who already own a MOTU core system. Up to three interfaces in any combina-



tion can be connected to a single PCI card via Audio Wire connectors, which are a high-bandwidth, low-latency, 72-channel, bidirectional digital format developed by MOTU that employs the same socket components and cables as the 1394 (FireWire) protocol. Each PCI-324 card also provides an ADAT Sync In and an RS422 din-8 "Control Track" connector for interfacing with MOTU's Digital Timepiece for sample-accurate synchronization between ADATs, DA-88s and other digital devices. Multiple MOTU interfaces automatically resolve with each other via the PCI-324 card. Three 1296 interfaces provide 36 simultaneous channels of 24-bit, 96kHz audio I/O on a single PCI card.

The PCI-324 Console software controls routing of signal flow, sample rate, synchronization, buffering and monitor settings. In addition to being a perfect hardware fit for MOTU's Digital Performer, the 1296 ships with standard ASIO and Wave drivers for compatibility with third-party Mac and Windows audio software. Subject to the capability of the host software, the 1296 supports both 16- and 24-bit depths and can operate at 44.1, 48, 88.2 and 96kHz sampling rates.

The 1296 core system also ships with AudioDesk, a full-featured au-

dio workstation for Mac OS. AudioDesk is basically Digital Performer without the MIDI features, and it is fully capable of professional recording and mixing.

### SETUP

As with the original 2408, the initial setup of the 1296 could not be easier. The trickiest part of the whole process is installing the PCI-324 card. If you know how to install a PCI card in your computer, you're home free. A setup wizard on the installation CD helps you figure out the best way to set up connections by asking specific questions about your gear and making recommendations based on your answers. For those who already have a PCI-324 core system, it is still necessary to install the latest version of the software to allow proper configuration of the 1296.

The manual is well-written and provides both Mac and Windows versions in the same binding. The manual also provides explicit instructions for interfacing the 1296 with Digital Performer, AudioDesk, Cubase VST and Sound Manager.

Once the software is properly installed, you'll notice that you now have the options of 88.2- and 96kHz sampling rates in your host software. Choosing one of these higher sampling rates in the PCI-324 Console will automatically dis-

BY ROB SHROCK

# Q: MUFFLED SOUND DRIVING YOU MAD?



24bit/96kHz digital output card  
with 120dB of dynamic range!

**A: PRESONUS VXP [INSTANT VOCAL KARMA]**



*"...a Swiss army knife among preamps." Rip Rowan, ProRec.com*

- Award Winning Class A/Transformer-Coupled Mic Preamp
- Smart Compressor
- Downward Expander
- De-esser with Tunable Frequency Range
- 4 Band Semi-Parametric Equalizer
- Brickwall Limiter
- Balanced Send/Return for patching in outboard processing

**PreSonus**  
AUDIO ELECTRONICS

CIRCLE #072 ON PRODUCT INFO CARD

World Radio History

Go to [www.presonus.com](http://www.presonus.com) or call 1.800.750.0323 for more info.

able any other MOTU interfaces connected to the PCI-324 that operate only at 44.1 and 48 kHz, so be sure to also reassign the main monitor outputs to one of the 1296 pairs if you want to hear the stereo bus output of any previous sessions.

The Audio Wire cable provided is 15 feet long, which is the maximum length recommended by MOTU. This will likely be long enough for most users, but if you keep your CPUs in a remote location from your working position, you may have to assess your setup to ensure that you still have good visual contact with the front panel meters of the 1296.

I found the meters to be excellent and easily viewable from across an average-sized control room, so it's not necessary to have the 1296 located right next to you for normal operation. The meter scale ranges from -42 to -1 dB, with LEDs below -6 dB showing 3dB increments, while those above -6 show 1dB increments from -4 to -1 dB, allowing for fairly precise metering. There are two indicators for "overs": The first LED lights up only momentarily, whereas if even a single sample reaches full scale, the second-level LED remains illuminated until cleared in the software. I would have liked a Front Panel button for manually clearing the "over" LEDs.

Both the clip timeout and peak/hold timeout of the meters can be set by the user to any duration from a few seconds to a few minutes to infinity. A separate display to the left of the meters indicates system clock rates, AES/EBU clock rates and whether any sample rate conversion is taking place.

### FIRST USE

Both AudioDesk and Digital Performer automatically sense when the 1296 is active on the PCI card, allowing recording at the higher sampling rates. Because I have already been recording 24-bit at 48 kHz into Digital Performer via my 1224 interface for a while now, I was immediately interested in creating some new 24-bit recordings at 96 kHz.

For a lot of electronic-based recording (synths and samples), I can get by just fine with a single audio interface, needing only a few inputs and one or two pairs of outputs for monitoring; a single 1296 will work fine for many users who want to make the jump to recording and mixing at higher sampling rates. I have a tracking rack that

contains a pair of Neve 1272 preamps and a few other goodies, which I usually run everything through on the way to the computer, so I connected the rack's XLR outputs to the 1296's first pair of inputs and wired four buses of my mixer to inputs 3 through 6 and monitored playback of Digital Performer through outputs 1 and 2.

A quick comparison between the 1296 and 1224 interfaces of recordings made at 48 kHz revealed no significant differences in quality, even though the 24-bit converters in each are a generation apart. However, I have always thought both the AD/DA converters in MOTU's audio interfaces have sounded great, including even the 20-bit converters in the original 2408.

After recording a basic track at both 48 kHz and 96 kHz with the 1296, comparisons between the two versions did reveal a qualitative difference. The

would allow for some incredibly affordable 36-track audiophile recording.

### A HANDSHAKE CAN REVEAL A LOT

As I mentioned earlier, the 1296 contains some versatile synchronization and interfacing right out of the box. It can operate internally at double the wordclock input rate, while the AES/EBU output can be synched to an independent word rate. This allows the 1296 to sync to incoming wordclock at 48 kHz (such as from a digital mixer) while operating internally at 96 kHz, and at the same time providing an AES/EBU output synchronized to a DAT player at 44.1 kHz.

The 1296 also has built-in, real-time sample rate conversion, allowing the sample rate of an incoming AES/EBU signal to be converted to the sample rate at which the 1296 is currently

## MOTU 1296 SPECIFICATIONS

### CONVERTERS (AD/DA)

ANALOG I/O

DIGITAL I/O

BIT DEPTHS

SAMPLE RATES

SYNCHRONIZATION

### METERS

DYNAMIC RANGE

WEIGHT

DIMENSIONS

PCI-324

AUDIO WIRE

CONTROL TRACK

ADAT

### 24-BIT, 128-TIMES OVERSAMPLING

12 INPUTS, 12 OUTPUTS; XLR +4 BALANCED

AES/EBU

16-BITS, 24-BITS

44.1, 48, 88.2, 96 KHZ

WORDCLOCK I/O; AES WORD IN

(INDEPENDENT OF 1296 SYSTEM)

19-SEGMENT (ALL I/O)

117DB INPUT; 116DB OUTPUT

8 POUNDS, 14 OZ.

19X8X3.5 INCHES

INCLUDED WITH THE CORE SYSTEM

(3) 1394 (PROPRIETARY) I/O CONNECTORS

RS422 DIN-8 CONNECTOR

9-PIN ADAT SYNC IN CONNECTOR

96kHz recording sounded a little more open overall—I wouldn't say that I heard more top end (which it actually contains), but I would say that I could "feel" a difference between the two, with the 96 kHz sounding a shade more "realistic." The effect is cumulative, and the more tracks you add at 96 kHz, the more you notice the difference.

Of course, your hard disk management becomes much more of an issue. Upping the bit depth from 16- to 24-bits adds 50% more to each sound file's size; doubling sampling rates from 48 to 96 kHz adds even more bulk. A three-minute song containing 18 front-to-back, 24-bit, 96kHz tracks takes roughly 1 GB of data to store. But the higher resolution sounds great, and three 1296 interfaces and a screamin' computer

running at. This means an incoming 44.1kHz signal can be converted to 96 kHz on-the-fly. How does the sample rate conversion sound? In a phrase—really, really good. As much as we all hate sample rate conversion, sometimes we have to do it; at least the 1296 does it well. Consider it a bonus.

The AES/EBU output can be set to mirror any pair of analog outputs, which remain simultaneously available. The AES/EBU output can also directly mirror any pair of 1296 inputs (and at a different sample rate, don't forget). Very cool features.

### BIG BAND AUDITION

I was recently involved in arranging and recording two days of big band sessions in Los Angeles with some of



# Increase Your Dynamic Range

Everything audio pros  
need from equipment  
and software reviews  
to project profiles  
and expert tutorials  
delivered FREE to your  
email box.

Sign up for **FREE** weekly news!  
[www.loudnewsletter.com](http://www.loudnewsletter.com)

**LOUD!**

The Voice of the Pro Audio Community

Digital Media **NET** <sup>D</sup><sub>M N</sub>  
Where the Creative Community Meets  
[www.digitalmedianet.com](http://www.digitalmedianet.com)



Capture  
the  
Moment!



QFC1mp  
4Hz to 40kHz  $\pm 1$ dB

1024

1024

2 Hz to  
100 kHz  
 $\pm 0.01$  dB

Distortion  
under 1 ppm  
(0.0001%)

Zero  
Distortion  
Technology

A whole new concept  
in sonic realism

Earthworks

real: +1 603-654-6427 (fax -6107)

virtual: [www.earthwks.com](http://www.earthwks.com)

postal: Box 517 Wilton NH 03086 USA

## FIELD TEST

the best players in town. The client requested that we deliver Pro Tools stem mixes, which we created as 16-bit Pro Tools sessions at 44.1 kHz. Although the stem mixes came out fine, the original masters had been recorded on a Studer 24-track machine at 15 ips with Dolby SR and had really sounded great. Something had definitely been lost in the translation between the original analog masters and the Pro Tools stems—mostly the “air” surrounding the band and the detail at soft volume levels. Because I was also going to create 2-track mixes of the sessions, I thought this would be a good opportunity to really put the 1296 to the test.

A few weeks later, I went into Luminous Sound in Dallas with the original 24-track masters, a computer setup running Digital Performer and the 1296. Setting up a desktop computer rig in the studio has never been my idea of fun, but within a few minutes we had the computer up and the 1296 patched: direct outputs split from the 24-track into the 1296 and the 1296 outputs straight into the console. Because I had only one 1296 for evaluation, each song transfer would take two passes, which wasn't a problem, as both the 24-track and the computer were resolved to house sync. A little tone matching between the 24-track and the computer, and we were in business.

I had previously created Digital Performer files for each tune at 24-bit, 88.2 kHz, which would potentially make for an easier sample rate conversion down to CD later. Rob Weschler, the chief engineer at Luminous, and I began our listening tests by comparing the direct outputs of the first 12 tracks of the analog master (rhythm section and trumpets) to the output of the 1296's converters as a simple patch-through: No difference in sound, whatsoever. Next, we recorded a pass into Digital Performer and compared it to the master: Again, no difference in sound, whatsoever.

All of the “air” surrounding the band that had been missing in the 16-bit stems was now just as present as on the original master. In fact, we could not tell the difference between the analog master and the 1296 output. After a second pass, all of the remaining tracks were now in the computer. After reducing the master fader in Digital Performer to prevent output clipping of the stereo bus (all of the faders in Digital Performer were still

set to 0 dB), we verified that all of the tracks had made it across and happily moved on to the next song and repeated the process.

This was a recording of a live band (four-piece rhythm section, three trumpets, two trombones, four saxes and a *bunch* of mics), so the dynamic range was very wide on some songs and little to no compression had been used while recording the master. Some piano and horn intros and entrances were at a whisper level, and some big band swing sections really ripped. Never once did the 1296 clip or distort on input, while all of the really dynamic, low-level material retained its full detail and clarity. Those of you who have already made the jump from 16-bit to 20- or 24-bit digital recording already know the virtues of higher bit depths with dynamic material. In my case, I found that the pleasing detail and analog coloration from the 24-track master were perfectly preserved in the transfer process through the 1296. The result did not sound better or worse than the master—it sounded exactly the same.

## CONCLUSIONS

The 1296 provides audiophile recording on host-based systems, bridging the gap that had previously existed between MOTU's other audio interfaces and the professional demanding sample rates higher than 48 kHz. The converters sound excellent, and the synchronization features solve several of the problems that occur when trying to resolve to different digital devices at the same time.

No, the 1296 does not record at 192 kHz; but I'm still not convinced that sampling rates above 96 kHz are worth the accompanying overhead, as long as the bit rates are high and the converters are good. In my tests, the 1296 output exactly what was put into it as far as I—or anyone else—could tell. MOTU has another winner. I'll buy this one and take a second, please.

Mark of the Unicorn Inc., 1280 Massachusetts Ave., Cambridge, MA 02138; 617/576-2760; fax 617/576-3609; [www.motu.com](http://www.motu.com). ■

*Rob Shrock served as one of the music directors for the 72nd Academy Awards. He has recorded and/or performed with Burt Bacharach, Garth Brooks, Elvis Costello, Sheryl Crow, Faith Hill, Whitney Houston, Chrissie Hynde, Mikaila, 'N Sync, LeAnn Rimes, Dionne Warwick, Stevie Wonder, Wynonna and a host of others.*

CIRCLE #073 ON PRODUCT INFO CARD

World Radio History

# I CAN DO IT ALL BY MYSELF.



The Yamaha AW4416 is all the studio you need to single-handedly record, mix and master a multi-platinum CD. This digital audio powerhouse comes fully equipped with every feature, specification and extra you could possibly want, including many crucial items our competition inexplicably left out. And it's all integrated with the signature style, performance and innovation that's put Yamaha digital gear in a class by itself. Once again, Yamaha gives you more for less.

**NO DATA COMPRESSION** – THE AW4416 delivers full-fidelity 24-bit or 16-bit audio all the time on all 16 tracks

**.WAV FILE FORMAT** – Files are stored in standard .wav format for ultimate compatibility and import/export ease

**SONIC FOUNDRY® SOFTWARE SUITE** – Acid®, Sound Forge® and Siren Xpress® are included for comprehensive editing

**02R LEVEL DIGITAL MIXER** – Motorized fader automation accompanies an internal digital patchbay, providing infinite routing options

**STUDIO-GRADE EFFECTS** – Yamaha loaded the AW4416 with dedicated 4-band parametric EQ and dynamics on all channels, plus two patchable multi-effects processors

**INSERT I/O** – Patch your analog gear onto any track to augment the AW4416's capabilities

**EXPANDABILITY** – Dual card slots let you add analog and digital I/O options, Apogee® converters or the new WAVES® multi-effects processor card

**YAMAHA CD BURNER ON-BOARD** – CD mastering and backup are always available and easily accessible

**DEDICATED METER BRIDGE** – It's not a pricey option, it's included

**MAXIMUM PORTABILITY** – The AW4416 is small and light enough to carry or location in our new hardshell case\*

**AFFORDABILITY** – Get all this power for only \$3,299\*\*



## YAMAHA

CIRCLE #074 ON PRODUCT INFO CARD

WWW.AW4416.COM

For literature, call (800) 937-7171 ext. 627. Visit [www.yamaha.com/aw4416](http://www.yamaha.com/aw4416) and [www.yamaha.com/proaudio](http://www.yamaha.com/proaudio). \*Case is optional. \*\*Estimated street price. All trademarks are the property of their respective companies. © 2001 Yamaha Corporation of America, Pro Audio Products, P.O. Box 6600, Buena Park, CA 90622. All rights reserved. Yamaha is a registered trademark of Yamaha Corporation.

World Radio History

# SHURE PSM400

## PERSONAL MONITOR SYSTEM

After the first week of rehearsal for last year's k.d. lang tour, the background singers decided that they would be better off with in-ear monitors (IEMs). The tour budget had already been set, but the money saved by sending the wedge monitors back to the rental company more than paid for the entire IEM rack. In order to provide dedicated stereo mixes for three background singers, plus a spare that doubled as my cue mix, I used four Shure PSM400 systems, supplemented with John Hardy mic preamps and three of TC Electronic's affordable M1 reverbs. Compared to Shure's more expensive PSM systems, the frequency response of the 400 drops off a third of an octave earlier, roughly at 12 kHz instead of 15 kHz. I missed it, but it didn't bother my singers much. The companding characteristic (common to all PSM systems), while noticeable under controlled listening conditions, is acceptable in rock 'n' roll applications.

The front panel of the Shure P4T transmitter (\$470 list) offers a volume control for local monitoring (via a stereo mini jack), four-segment stereo metering, a single-digit RF channel indicator, and a permanently attached, quarter-wave antenna. The half-rack format allows two P4Ts to be mounted in a single rackspace and, unlike the previous Shure PSM600 and -700 systems, the P4T uses an external power supply, so its depth is shortened by three inches. The 5½-inch-deep chassis has extruded aluminum sides similar to the Lexicon LXP-1, with a single slide-in PC board. The transformer has two screw holes to mount it; it employs an AC plug on a cord rather than the common "wall wart" design, and its chassis connector has a locking ring.

Though there are no XLR con-



nectors, the ¼-inch inputs are balanced. The transmitter has no Mono/Stereo switch; instead, the unit automatically switches to mono when only one of the ¼-inch inputs is plugged in. The unit operates at a nominal 0dB input level, and the absence of an input volume control and a +4/-10 switch effectively prevents these controls from being set incorrectly.

The gain structure of wireless in-ear systems dictates that, for best signal-to-noise figures, they should be driven close to their clipping points. With no input volume control, keep an eye on the meters, which aren't much more than idiot lights similar to those on power amps. The 400 transmitter does not clip gracefully, so it's especially important not to run into the red.

The P4R receiver (\$490) is almost half the weight of the ½-pound, metal-bodied PSM600 and -700 receivers (often referred to as "hand grenades" by performers familiar with them tugging on their wardrobe). Although I'd guess the plastic case is not as durable, I've seen them take drops and abuse without failing. Battery life is a healthy eight hours when running on the recommended Duracell 9-volt, alkaline batteries, and a three-segment "fuel indicator" icon in the LCD screen shows the battery life status. Though battery life depends

on many variables, I found that changing batteries every other day was sufficient enough to get through two soundchecks and two two-hour shows. When the battery is about to die, the entire LCD screen is illuminated with a red backlight that is easily noticed by the user.

The P4R receiver's controls are two momentary pushbuttons on the side—labeled Select and Scroll—and an LCD screen on the top, a layout similar to that found on Shure's professional UHF wireless mics. A lock-out feature can be used to prevent performers from unintentionally changing the settings.

As with the other PSM models, a "MixMode" allows the user to listen to and balance a mono blend of the transmitter's two inputs, allowing for a "me vs. them" or "vocals vs. instruments" self-mixing strategy. The PSM400 also includes the familiar 6dB boost at 10 kHz and a defeatable limiter.

PSM400 (and -700) systems operate on one of 16 channels (0 through F), spread across UHF channels 56 to 59. Channels 0 to 4 are in TV 56; 5 to 7 are TV 57; 8, 9 and A are TV 58, and B to F are TV 59. In cities where one (or more) of these channels are being used by broadcasters, you'll want to avoid using the corresponding PSM400 channels. As for their other wireless products, a table on Shure's Website ([www.shure.com/products/frequency/frequency.asp](http://www.shure.com/products/frequency/frequency.asp)) helps with frequency coordination

BY MARK FRINK

World Radio History

# ALTER YOUR EGO.



Our WaMI Rack 24 is a machine of many faces. Interfaces, that is. Where else can you find a box that acts as a professional audio interface, a MIDI interface, a SMPTE interface, and a Word Clock Sync? Not to mention the fact that it has preamps on all four balanced inputs - all at a cost that won't break your bank account? So go ahead. Alter your ego. Then alter your creativity.

• **WaMI Rack 24** - 120dB Dynamic Range, 24-bit converters, 1 MV Floating Out (Balanced), 48V Phantom (Mid Point), 240V Isolated Word Driver Support (AES, MPE, DVC, etc.)

#### • The E-WDM driver.

Now available on the WaMI Rack 24 is the solid state version, the E-WDM (Enhanced WDM). EGO SYS has developed a fully factory tested but untested (unimpaired) program available Windows 2000/XP/XP (32bit) (32bit) mode with the following:

Can be used with Windows, 98SE, ME, 2000, XP  
Can run on 2000 (Windows XP)  
Supports digital audio drivers such as ASIO, DirectX, and WDM.  
Windows XP  
Multi-tasking.

#### • The GIGASTATION.

Turn your PC into an 8 channel multi-sample using Gigastation, designed to provide specifically for Windows products, providing a professional cost-effective system, allowing you to the best of a full-time supplier.

24 BIT 24 Converter  
4 Channel Output - 4 Stereo Analog Outputs  
2 SMPTE & Clock (Digital Outputs)  
Supports DSP  
Digital (Analog) CD Media

**E-WDM**

[www.egosys.net](http://www.egosys.net)  
[webmaster@egosys.net](mailto:webmaster@egosys.net)

Compatible with:

Windows 2000 / ME / 98SE

EGOSYS SYS  
10000 Dufferin Ave. # 200  
New York, NY 10019-4000



Tracer Technologies, Inc.

**EGO-SYS**

World Radio History  
CIRCLE #075 ON PRODUCT INFO CARD

# Keep Your Ears Tuned to the Music



... Give Them  
a Sound Check

The House Ear Institute  
Invites You to Join  
Sound Partners™



SOUND PARTNERS

Listen Longer...  
Practice Safe Sound

For Hearing Conservation  
Information Call  
(213) 483-4431  
[www.hei.org](http://www.hei.org)

## FIELD TEST

in the 30 largest U.S. cities.

One of the useful features of Shure's PSM700 receiver is a Frequency Locator Mode feature that turns off the tone squelch, allowing the operator to listen for interference from outside sources and verify clear frequencies. Many bands often can't afford to carry a frequency analyzer or scanner with them, so this is a very helpful field tool. A similar feature on the P4R allows it to be used to scan its 16 channels. To engage this feature, press both the Select and Scroll buttons while turning the P4R on; the RF icon on the LCD will scroll, indicating that the tone squelch is off. The resulting white noise is quite loud, so be careful with the volume setting. If any sounds can be heard mixed in with the normal white noise of an open frequency, then there are other transmissions on that channel. These sounds may be anything from whistles, tones or rumbles, to the intermodulation product of an FM broadcast with another PSM transmitter or even the audio portion of a TV signal.

The P4R receiver is somewhat compatible with the PSM700 transmitter, as its 16 frequencies are the same as the 700's Group 1. Though the 400 offers 16 frequencies, Shure recommends running no more than eight simultaneously. This is because the P4R has less "front end" filtering, resulting in lower RF selectivity. When employing multiple units, it's best to skip channels so that transmitters are not susceptible to intermodulation. Aside from interference from outside sources, I had the best luck with channels 2, 4, 6, B and D when using four or five units together. What with trying to space out channels to avoid intermods and having to negotiate around TV broadcasts or other environmental RF, I wouldn't recommend trying to coordinate more than five PSM400 systems in a touring situation.

Despite some shortcomings for touring professionals, many features of the PSM400 make it simple to use. Changing the frequency on the transmitter is a simple matter of pressing a recessed button beside the single-digit display to increment the channel (easily done with the tip of an 1/8-inch plug) and then holding it in for a moment to set the new frequency. The receiver's channel is changed (when unlocked) when the user presses Select and then scrolls. On the 700, both operations require a tiny screwdriver, enough

light and, if you're getting on in years, a pair of reading glasses.

A rugged antenna is permanently attached to the receiver so it can't get lost. The transmitter's antenna is also fixed, which doesn't allow users to run multiple units with a combiner and a single-directional antenna. Because the 400 is designed to be used with a companion half-rack P4M mixer onstage, this limitation is understandable. Without the benefit of a combiner or log antenna, I had occasional problems with dropouts, though my singers were typically only 30 feet away.

The P4HW hard-wired beltpack (\$360 list) suffers from none of the frequency response or companding problems associated with wireless. I carried three as backups for the one day on the tour when I couldn't use the wireless (BBC: 'nuf said), but my singers didn't like having to worry about tripping on the cables while they danced, so we only used them that one time. For stationary players like drummers or keyboardists, this hard-wired beltpack option has both a sonic and a cost advantage. Also, Shure's recently unveiled AuxPander, which takes eight inputs from channel inserts and group outputs on an FOH console to create four stereo mixes, offers a way to create custom in-ear mixes without a dedicated monitor console.

All PSM400 products can be bought separately, and, in my opinion, those shopping for their first in-ear monitor system on a tight budget won't find a better value. Professional users with 700 transmitters may also want to use 400 receivers as spares or even primaries, because their Group 1 is the same frequency set and they're less than half the price. The money saved on the economical PSM400 system can easily pay for Shure's better two-way E5 ear piece [reviewed in February 2000 *Mix*] instead of the less-expensive E1. The E5 is more rugged and provides greater sensitivity, extended frequency response and a more enjoyable listening experience. I got nothing but compliments from my singers every night, and I found that I needed to do little for them except find clear frequencies, change batteries and smile.

Shure Inc., 222 Hartrey Ave., Evanston, IL 60202-3696; 847/866-2200; fax 847/866-2279; [www.shure.com](http://www.shure.com). ■

*Mark Frink (mix@markfrink.com) would like to thank Kate Markowitz, Windy Wagner and Amy Keys, three of the most talented and professional singers he's worked with.*

# THE BEST KEPT SECRET IN THE PRO AUDIO UNIVERSE

The only Microphones Endorsed by Aliens!

"... I was reminded of a U-67".  
Rob Shrock, EM Review

"A studio musician who brought in his gorgeous Martin guitar  
Instantly fell in love and wouldn't try any other mics ..."  
Mike Sokol, EQ Review

"...new mics that have similar sonic characteristics  
to these classic mics, but are priced so cheaply that  
someone with a modest home studio can afford a pair."  
Steven Stone, Vintage Guitar Magazine Review

**DON'T MISS**  
TONY MARTIN'S NEW CD,  
"ENGLAND-CARVED IN TIME"  
EXCLUSIVELY WITH ADK MICS.

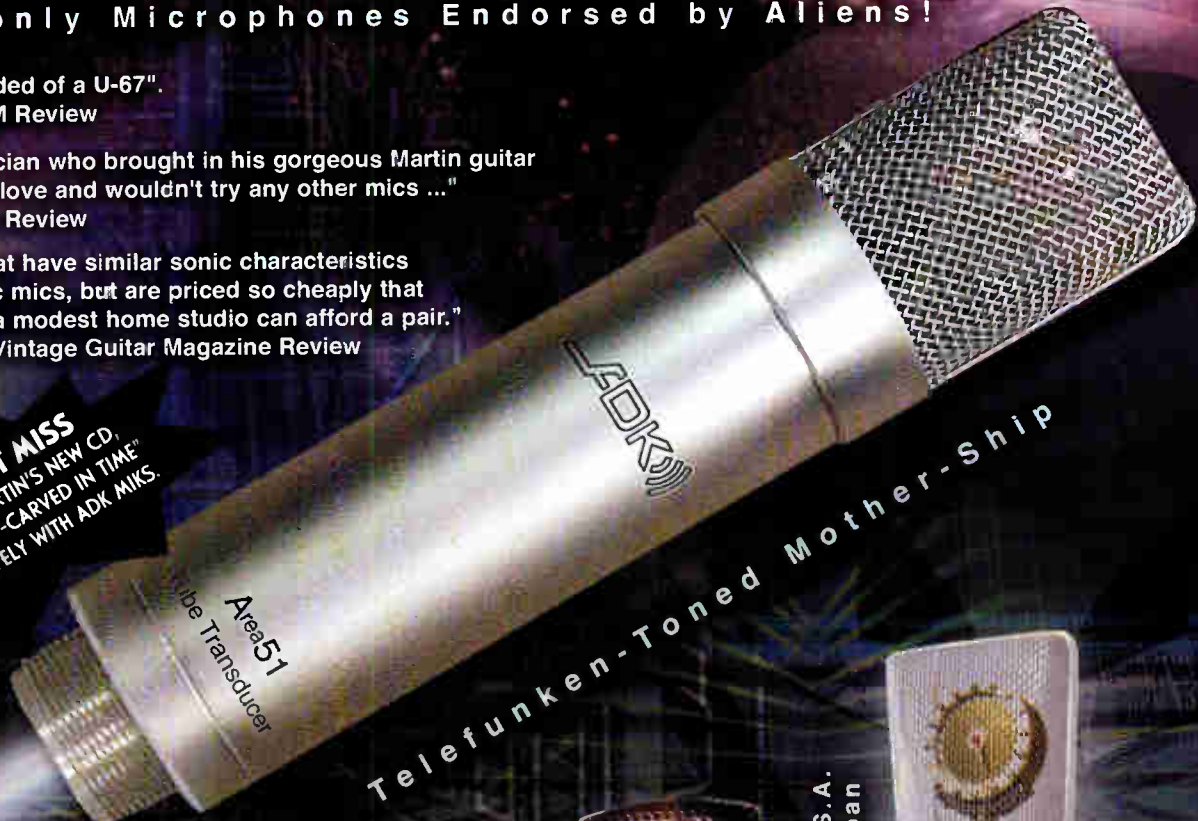

Telefunken-Toned Mother-Ship



Twin Brothers from Different Galaxies  
Combine to create Cosmic Overtones



Thomas and Betts Switches from U.S.A.  
Toshiba Low Noise FET from Japan



# AARDVARK DIRECTPRO 24/96

## WINDOWS-BASED AUDIO INTERFACE

Well-known for making the reliable Aardsync II master clock, Aardvark touts its DirectPro 24/96 as the "all-in-one personal studio system." With four discrete mic preamps, 48V phantom power, 24-bit 96kHz converters, a headphone amp, digital I/O, six analog output channels and a virtual mixer, the DirectPro comes surprisingly close to a complete studio. Bring your own transducers—headphones, speakers and microphones—and you're almost there.

The actual recording and editing takes place in the software of your choice. The Aardvark package includes Cakewalk Pro Audio 9, but it should be understood that the DirectPro does not actually record. It is an extremely efficient input/output for a wide variety of available programs. The 10-channel virtual mixer features EQ, compression (on input only) and reverb, all with zero latency, so you can hear your adjustments in real time, without waiting for the computer to calculate the changes. Typical latency in similar devices is around half a second.

Out of the box, the system appears simple: two software disks, a manual, a PCI card, a breakout box and a sturdy shielded 25-pin cable. The breakout box has four combo 1/4-inch/XLR inputs, a phantom power switch with LED and a headphone jack on the front panel; the rear panel has four 1/4-inch outputs, two RCA outputs, and MIDI in and out. S/PDIF in and out can be found on the card at the back of the computer. All 1/4-inch jacks allow both balanced and unbalanced connections at +4 dBu and -10 dBu, respectively.

Optional accessories include rack adapters for one or two breakout boxes (each occupy two rackspaces) and AES/EBU-to-S/PDIF adapters (manufactured by Aardvark to change voltage and impedance).

The manual is brief but effective, with separate instructions for installation on both Windows 95 and Windows 98 platforms. After consulting the recommendations for the placement of the PCI card into my computer, onscreen messages prompted me through the rest of the install. Thereafter, I only consulted the 35-page pamphlet for quick-start guides that explain integration of the DirectPro with Samplitude, Cubase VST, Cakewalk Pro Audio, Sound Forge and Wavelab.

### THE INSTALL

For DirectPro, Aardvark recommends a Pentium PC or compatible, running at 200 MHz or higher, with Windows 95 or Windows 98, a minimum of 64MB RAM and one available PCI slot. For this review, I used a modestly equipped 300MHz Pentium II 300A PC with CD-ROM/DVD drive, 128MB RAM and 4 GB of available disk space.

Hardware installation was simple. However, the DirectPro software didn't load properly the first time I tried, but tech support at Aardvark is excellent (there was always more than one able-minded technician available when I called during East Coast business hours), and they e-mailed me the file I needed for a smooth install.

### ONSCREEN

The virtual console—or "Control Panel" screen—is laid out well, with four channel strips on the left for the four inputs. Each of these includes gain, compression, EQ, reverb send, pan and a "fader," while the playback (or output of the recording program) appears on the right as three permanently linked stereo pairs with reverb



sends. Each channel has a Mute and a Solo switch, but the playback pairs will not mute or solo one side of the stereo pair—this has to be done within the recording/editing program you've selected.

All 10 channels are summed to the stereo-linked master fader ("Monitor Out"). There are 12 replicas of LED-style meters, one next to each fader. Each meter uses over 40 segments in green, yellow and red, and peak hold is an option. There is also a large replica of a 2-channel VU meter, redundant with the Monitor Out "LEDs." The VU meter "needles" are understandably slow to react, as Aardvark has justifiably assigned their movement a low priority in terms of DSP operations.

Below the VU section is the Master Reverb panel, with controls for Decay, Diffusion, Brightness and Room Size ("Room," "Hall" or "Church"). A Preset button opens a window of reverb presets (initially blank until favorite settings are stored here), and the master reverb return is either on or off (no level control) according to the Bypass button.

Under the reverb section, there are buttons for Source Select, Presets (snapshots of the entire console available for instant recall), Advanced and Patch Bay. The Source Select button determines whether the sampling rate is internally clocked at 32/44.1/48/96 kHz or externally for incoming S/PDIF signals. (SCMS is thankfully deactivated.) The Advanced button opens a window that monitors the status of the I/O driver pairs (active or inactive), shows the serial number

BY DAVID OGILVY



**Open House**  
May 6<sup>th</sup> • 2-6 pm  
SAE New York

professional training in

**sound engineering  
multimedia  
digital film**

since 1976

INSTITUTES

**NEW YORK**

269 W 40th Street, New York NY 10018

Tel. **(212) 944 9121**

**NASHVILLE**

7 Music Circle North, Nashville TN 37203

Tel. **(615) 244 5848**

**Other main locations**

LONDON (0207) 609 2653 PARIS (1) 4811 9005  
AMSTERDAM (020) 622 8790 SYDNEY (02) 9211 3711  
MILANO (002) 8912 0540 ATHENS (01) 321 7661  
BERLIN (030) 4986 0054 MUNICH (089) 6 55 167  
ZURICH (01) 445 2040 SINGAPORE (65) 741 1257  
AUCKLAND (09) 373 4712 STOCKHOLM (08) 730 6100  
VIENNA (01) 961 0303 FRANKFURT (069) 543 262  
KUALA LUMPUR (03) 724 0935 MADRAS (044) 821 4227  
MELBOURNE (03) 9521 4055 FRANKFURT (069) 543 262  
GENEVA (022) 800 3000 COLOGNE (0221) 954 1220

\* ALL OUR STUDENTS RECEIVE  
INDIVIDUAL STUDIO TIME!

25 YEARS

**SAE**  
INSTITUTE

[www.sae.edu](http://www.sae.edu)

CIRCLE #078 ON PRODUCT INFO CARD

World Radio History

## FIELD TEST

and registration key number, adjusts the ASIO buffer and sample size and gives the option for the program to issue warnings on sample rate errors. New in the Advanced window (Version 2.2) is output level selection for playback channels 1 through 4; all four can either output +4 dBu or -10 dBu—no mixed choices. Incidentally, output channels 5 and 6 are -10dBu RCA plugs.

The Patch Bay window allows most conceivable routings; for example, playback channels 1 and 2 can be assigned to output jacks 5 and 6. However, one cannot connect playback channels 1 through 6 correspondingly to outputs 1 through 6 while still monitoring all six through the DirectPro headphone jack. This limitation is surmountable with the use of external monitoring equipment, such as a small mixer. While "Analog 1, 2 Out" has its own patch point, "Analog 3, 4 Out" and "Analog 5, 6 Out" share their patch points with "S/PDIF L/R Out" and "Headphone L, R Out," respectively. This can create limitations as with the previously cited example. The Patch Bay also includes a test tone, which can route to all three output points at once.

## PRACTICE

Using the DirectPro as a mic pre-amp and a digital mixer, I combined live tracks with a stereo DAT and recorded to the hard drive with a variety of multitrack editing programs. The S/PDIF input shows up on input channels 3 and 4 and allows a large degree of gain in the digital domain. A square at the top of the channels illuminates when digital interfacing is correct, even when tape is not rolling—a handy feature. Unfortunately, only one digital signal may be input at once, even when multiple DirectPro units are ganged together.

The gain for analog inputs is well-thought out, with three separate gain stages, all optimized for their range: one for large amounts of mic preamplification, one for nominal amounts and one for line-level inputs. Although the line amp only allows up to 9 dB of gain, the mic pre's provide up to 75 dB. Input gain is done in the analog stage to maximize audio level before the A/D conversion. The discrete, eight transistor-per-channel preamps sound very good—the specs boast a frequency response of 1.6 to 200k Hz (at -3 dB).

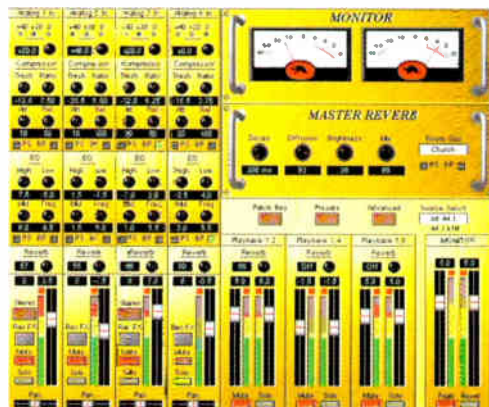

The DirectPro Control Panel screen

Acoustic guitar, banjo, snare and vocals were captured extremely well, retaining their brightness without sounding brittle. While playing along to the DAT, DirectPro followed the clock of the DAT machine, which was playing at 48 kHz.

Next, I tried recording the same instruments at 96 kHz. Reproduction quality was predictably better—increased definition was accentuated by the quietness of the card. The combination of discrete mic pre's with 24-bit resolution makes this setup a real bargain.

One disadvantage of selecting a 96kHz sampling rate is that the EQ, compression and reverb are disabled,

The advertisement features a central image of the Element 78 hardware unit, a black rack-mountable device with various knobs and buttons. The top of the ad has the 'element 78' logo in a stylized font. Below the logo, the text reads 'ELEMENT-78.COM · FROM SUMMIT AUDIO.COM' and 'DESIGNED WITH MR. RUPERT NEVE'. A large gold ribbon graphic on the left contains the text 'TEC WINNER 2000' and 'TECHNICAL EXCELLENCE & CREATIVITY'. On the right, a list of features is provided: '2 CHANNELS, MIC-PRE AND E.Q.', 'FULL DIGITAL CONTROL OF ALL PARAMETERS', '25 USER PRESETS', 'MIDI OR PRO TOOLS CONTROLLABLE', 'CLASS A DISCRETE, ANALOG SIGNAL PATH', 'WINNER 2000 TEC AWARD', 'PHENOMENAL PERFORMANCE', and 'CONTROL FOR UP TO 32 CHANNELS'. At the bottom, the Summit Audio logo and contact information are listed: 'P.O. BOX 223306, CARMEL, CA 93923 · USA · 831-728-1302'.

**element 78**  
ELEMENT-78.COM · FROM SUMMIT AUDIO.COM  
DESIGNED WITH MR. RUPERT NEVE

**TEC**  
TECHNICAL EXCELLENCE & CREATIVITY  
WINNER 2000

Summit Audio®

- 2 CHANNELS, MIC-PRE AND E.Q.
- FULL DIGITAL CONTROL OF ALL PARAMETERS
- 25 USER PRESETS
- MIDI OR PRO TOOLS CONTROLLABLE
- CLASS A DISCRETE, ANALOG SIGNAL PATH
- WINNER 2000 TEC AWARD
- PHENOMENAL PERFORMANCE
- CONTROL FOR UP TO 32 CHANNELS

P.O. BOX 223306, CARMEL, CA 93923 · USA · 831-728-1302

# Now Open...



**Featuring online product demonstrations of the  
hottest new gear on the market today!**

**Turn to:**

# MIX

**and [www.mixonline.com](http://www.mixonline.com)**

[www.intertec.com](http://www.intertec.com)

**DigitalMediaClick™**

Stay on Top

World Radio History

## FIELD TEST

but I really didn't use them that often. Although the reverb is handy for monitoring while overdubbing, the EQ and compression are not very effective. For example, the low-frequency knob is fixed at 220 Hz—almost useless as a bass roll-off. The high frequency is set at 8 kHz, where 12 kHz or higher might have been a better choice. The mid frequency is adjustable but with no bandwidth selection, and it is stepped at frequencies that are too far apart, especially below 1 kHz and above 5 kHz. Additionally, the compressor cannot be used solely as a lim-

iter, nor does it provide a gain-reduction meter. The lack of visual confirmation of its action was unnerving.

While not in 96kHz mode, the RecFX button on each input channel allows EQ and compression to be recorded along with real-time volume changes. Otherwise, the input gain stage is sent directly to the recording software, with the bulk of the console acting as a monitoring path. Reverb can also be recorded, but only after selecting inputs 5 and 6 in the Patch Bay window.

Auxiliary sends on each channel would have been useful, but I managed to fashion an effects loop by

assigning one of the playback pairs to analog outputs on the breakout box. By panning individual instruments hard left or hard right, they can be sent to external processors and returned to one of the four input channels. Of course, software plug-ins can also be utilized. In both cases, one must make auxiliary output assignments within the chosen editing software (such as the mixer in CoolEditPro).

The DirectPro Control Panel is best used as an input stage and monitoring console—especially for overdubbing—rather than as a mixing device. Automation of Control Panel settings through MIDI is not possible—the MIDI I/O is only for conveying MIDI data to the host software. I had many digital and analog tapes in need of editing, and their sound was never compromised through the Aardvark. I also tried a variety of microphones—AKG 414s; Countryman Iso Omnis; Shure SM57s and other dynamic models—on various voices and instruments, always with great results.

On my wish list, I would have liked a knob on the breakout box for headphone volume (as opposed to adjusting the Monitor Out fader)—the knob is included on Aardvark's Direct Pro LX6, which does not feature XLR inputs. The DirectPro's EQ and compression leave a bit to be desired, but the wide variety of plug-ins available can take care of most situations.

Certainly, the unit's zero latency performance is a major plus, although DirectPro's real strength lies in the sound quality of the preamps and conversion process. The gain stages sound very good, certainly better than the ubiquitous preamps we find in many budget consoles, and, in general, the audio is extremely quiet. Credit is due to Aardvark for shielding the PCI card so well.

With the addition of 24-bit, 96kHz converters and the inclusion of Cakewalk Pro Audio 9, this package is hard to beat, especially at a U.S. list price of \$699. It should also be noted that Aardvark expects to release Windows 2000 and Macintosh in the near future. Overall, DirectPro is an excellent interface for computer audio work. I've decided to keep this one!

Aardvark, 202 E. Washington, Suite 306, Ann Arbor, MI 48104; 734/665-8899; fax 734/665-0694; [www.aardvark-pro.com](http://www.aardvark-pro.com). ■

*David Ogilvy is a Northern California recording and broadcast engineer and producer.*

**Still compromising  
with a 'standard' Cardioid?**

**DPA**  
MICROPHONES

**TYPE 4011 CARDIOID MICROPHONE**

- ◆ Award winning technical performance
- ◆ Highest SPL handling
- ◆ Widest frequency range

**and much, much more...**

**Never compromise on quality.**  
Visit [dpamicrophones.com](http://dpamicrophones.com)

DPA Microphones / TGI North America Inc.  
335 Gage Ave., Suite #1 Kitchener, ON Canada N2M 5E1  
Tel: (519)745-1158 Fax: (519)745-2364  
Toll Free Dealer Faxline: (800)525-7081  
e-mail: [inquiries@tgina.com](mailto:inquiries@tgina.com) Literature requests: [litplease@tgina.com](mailto:litplease@tgina.com)

CIRCLE #116 ON PRODUCT INFO CARD

World Radio History

# Fall in Love Again



## Introducing the Universal Audio 2-610™ Vacuum Tube Microphone Preamplifier

Wouldn't you like to fall in love with making music again? The UA 2-610 is our new dual channel tube mic-pre — a preamp that will breathe new life into any microphone collection, bring out the emotion in vocals and reveal the true nature of your instruments. The 2-610 captures those elusive attributes that will make you fall in love with your gear — and with making music — all over again.

Unlike other "vintage style" mic preamps, the UA 2-610 — modeled on the Putnam-designed 610 console — is true to its heritage. From Sarah Vaughan to Frank Sinatra, *Pet Sounds* to *LA Woman*, the 610 preamp left its imprint on countless classic recordings.

### UA Classic Compressors

Whether you're tracking pure analog or running a digital studio, you'll find the UA 2-610 the perfect companion to our classic compressors, the 1176LN Limiting Amplifier and the Teletronix LA-2A Leveling Amplifier.



#### 1176LN™ Limiting Amplifier

Hand-built to exacting standards, no studio is complete without this classic compressor.



#### Teletronix LA-2A™ Leveling Amplifier

Obsessively precise, right down to the point-to-point hand wired components.

We've retained the best of the original while adding functions designed to meet the rigors of the modern recording studio, including phantom power, impedance control and expanded EQ settings. Custom transformers feature specially selected double-sized alloy cores and sophisticated winding techniques; every tube is scrutinized before qualification. Our expert analog design team has produced a classic tube mic-pre with uncommon character and uncompromising quality.

### UA 2-610 Features

- > Two variable gain channels
- > Mic, Direct and Hi-Z inputs
- > Phantom power
- > Polarity reverse
- > Variable Mic/Hi-Z impedance
- > HF/LF shelf stepped EQ controls
- > Selectable frequency EQ
- > Custom-wound transformers
- > 12AX7 and 6072 tubes/channel

Sure it's a lot to attribute to a pre-amp, but wouldn't you like to fall in love with music all over again?

Universal Audio Classics from the Analog Ears and Digital Minds of Universal Audio.

Visit [www.uaudio.com](http://www.uaudio.com) today to learn more and to register to win your own LA-2A!



UNIVERSAL AUDIO

ANALOG EARS | DIGITAL MINDS

# CEDAR DNS1000

## DYNAMIC NOISE SUPPRESSOR

CEDAR is no stranger to audio restoration tools. The company is known for its cutting-edge, PC-based systems and plug-ins for studio workstations, as well as specialized rackmount units that offer near-real-time processing—declicking, decracking, azimuth correction, etc.—of problematic source material. Now, CEDAR offers the DNS1000, a dynamic noise suppression device for cleaning vocal and dialog tracks.

Like other recent CEDAR hardware, the stereo DNS1000 has no analog I/O, which keeps costs down and lets users choose their preferred converters—or simply stay within the digital domain. Between the rear panel's XLR AES/EBU and coaxial S/PDIF digital I/Os are four LEDs that indicate input sample rate (32, 44.1, 48 kHz) and whether the XLR or coax input is active. Although these LEDs offer useful indications of status and the presence of a stable signal, the rear panel location is inconvenient.

The DNS1000 has a deceptively simple interface—it's about the size of a console-top reverb controller—but there's a lot happening under the hood. The digital I/Os are 24 bits wide, and the unit is driven by dual 40-bit, floating-point DSPs. The DNS1000 works by dividing the input signal into multiple bands. There are six faders on the control panel, but many more analysis and processing filters within the unit. A noise "Level Control" acts as a global threshold slider to determine at what point the noise suppression action kicks in—or stays out—and the processing depends on the interaction of the level control, the signal content and the algorithm itself.

Just punch a button or two to select a filter frequency range: Low (20 to 400 Hz); Mid (200 to 6,000 Hz); High (4k to 18k Hz); Low plus Mid (20 to 6k Hz); Mid plus High

(200 to 18k Hz) and Fullrange (10 Hz to 18k Hz). Six "Band Gain" faders (+6/-24 dB) determine the maximum amount of processing in each band, and their center points vary, depending on the selected filter range. For example, the filters are narrow if the High range only is set and much broader when Fullrange is selected.

The remaining controls (Left/Right/Stereo, for applying the processing to each of those choices, and Bypass) are much simpler to grok, and all operations become clear within a few minutes.

I began testing the DNS1000 by feeding it an assortment of dialog tracks with varying degrees of continuous noise problems. The key word here is *continuous*; the unit is not designed to remove transient noise sources, such as clicks, pops or burps, but steady-state noise problems, such as camera motors, rumble, rain, hiss, air conditioning, distant aircraft or traffic.

On a selection with excessive camera noise, a touch of midband processing attenuated the offensive sound almost completely, turning an unusable take into a clean track. Similar results were achieved on a vocal track with what sounded like hurricane-level amounts of wind noise. Here, the DNS1000 did the trick, offering deep noise attenuation without destroying the source material. Of course, it's possible to overdo the DNS1000 processing, resulting in a flat, lifeless recording, but the real-time controls make determining the right amount of filter action quick and simple.

One track that surprised me was some indoor dialog on which the mic placement seemed like it was 10 feet away. The take was



boomy and reverberant, with poor intelligibility and way too much room tone. But, by selecting the Low and Mid filters, setting all the faders to -24 dB and adjusting the level control, I was able to use the DNS1000 to process the reverb tails on the end of each word, resulting in a clean track. I've never encountered a product that could do this—I'm impressed!

The DNS1000's ultrafast processing has a latency stated as less than 10 samples—about a quarter of a millisecond! So, for processing sync information (dialog tracks, etc.), latency isn't a factor; there's no need to slip tracks against timecode.

Priced at \$5,895, the CEDAR DNS1000 is a fast, effective tool for dealing with noise problems in dialog tracks. And with today's skyrocketing production and talent costs, a product that minimizes the need for pricey ADR sessions is very valuable indeed.

CEDAR Audio USA, 43 Deerfield Road, Portland, ME 04101; 207/828-0024; fax 207/773-2422; www.cedaraudio.com. ■

BY GEORGE PETERSEN



## Networking.

### Fibre Channel Hard Drive Systems Optimized for Pro Tools®

- you will get 64 tracks - 24bit audio on one hard drive
- you will no longer have DAE errors (6042-9073) etc.
- you can access any drive from any control room  
(1.8 TB per 3 rack space chassis)
- you will have password protection
- you will see a definite increase in Pro Tools performance  
(call for client refs)
- you can back up data while using drives at the same time
- you will have SANscan® file management software
- you can afford this system
- call us now toll free 877.537.2094



Pro Tools® is the  
property of Digidesign®

Visit our website or call for more info on  
this amazing new technology from SNS...  
[studionetworksolutions.com](http://studionetworksolutions.com)

877.537.2094

**A/V SAN**®

World Radio History

CIRCLE #082 ON PRODUCT INFO CARD

# iZ RADAR 24

## 24-TRACK DISK-BASED RECORDER/EDITOR

Like it or not, we are fast approaching the time when linear tape-based machines will be a thing of the past. In 1992, RADAR (distributed by Otari) was the first stand-alone system to offer disk-based, 24-track recording. Now distributed by iZ Technology Corporation—the original creators of the RADAR system—RADAR 24 bridges the gap between the traditional linear tape decks and the more elaborate DSP-based editing systems. Offering a simple, stable and solid product is the philosophy that has always reigned at iZ, and RADAR 24 continues that approach, while offering new systems at a fraction of the cost of its predecessors.

### THE BASICS

The unit I tested consisted of the RADAR 24 (a four-rackspace unit), the optional Session Controller, a 48-channel meter bridge and the Nyquist 24/96 I/O board set. All the units are attractive and well-made, and convey a feeling of quality. The front panel has an On/Off switch,

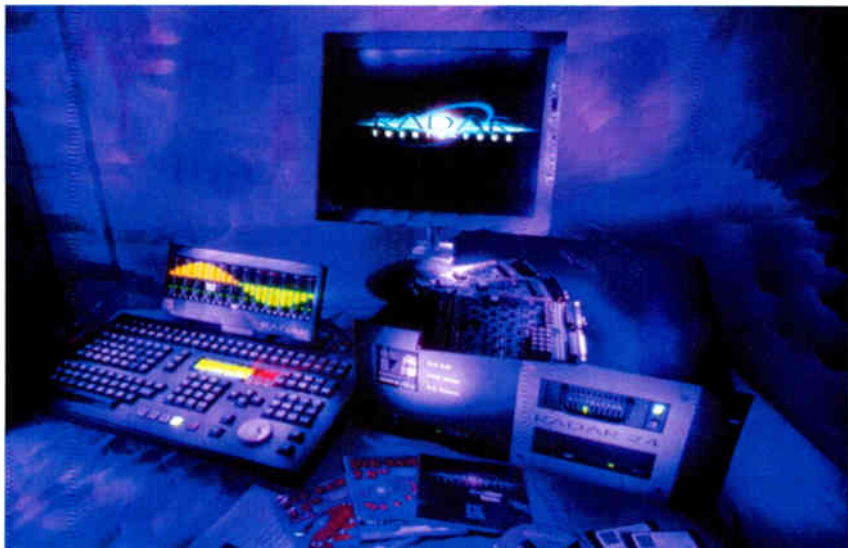

IDE drive, while digital audio is written to the removable high-speed SCSI drive. Besides the DVD-RAM drive, factory installed backup options are numerous, including Exabyte Eliant, Mammoth, Mammoth Lite, AIT and Orb.

The unit's chromed rear panel features six sets of DB-25 connectors for 24 tracks of audio I/O, as well as three sets of DB-25 TDIF connectors (with an additional three sets of DB-25 connectors for optional ADAT and multichannel AES for a total of 48 digital I/Os, which can be used simultaneously with the analog I/O). Stereo AES/EBU and S/PDIF connectors round out the selection.

Sync connections are via two pairs of BNC connectors for wordclock and video (house) sync, and there are also standard MIDI In/Out/

Thru and Sony 9-pin machine control connectors. These provide access to RADAR's SMPTE timecode chase lock/generator, MIDI timecode chase/generator, video sync,

wordclock sync and machine control. Additional interfaces include an UltraWide SCSI connection for external drives, standard parallel port connectors, keyboard and mouse sockets, and the proprietary RADARLINK connector, which allows for simultaneous operation of up to eight RADAR 24 (or RADAR II) units.

In addition to audio levels, LEDs on the meter bridge indicate the status of the track, including solo and edit states. All of this eye candy makes it entirely possible to operate the RADAR 24 and Session Controller without a monitor, though a monitor will be necessary if you intend to operate RADAR with the (included) standard PC keyboard alone. Projects can be named, and all menu options can be accessed using the front panel controls and the LCD window.

### IN SESSION WITH RADAR 24

Anyone familiar with autolocator remotes will have no trouble getting around on the Session Controller. The familiar standard transport buttons, jog wheel, QWERTY keypad, numeric keypad and dedicated hot keys make all operations fast and efficient. Most of the



RADAR main screen shows meters, status and waveforms.

floppy drive, 18-gigabyte SCSI drive in a removable Kingston Fast-Wide Ultra SCSI hard disk carrier, and a 9.2-gig 2x DVD-RAM drive for backing up the system and archiving projects. Operating system chores are handled via an internal

BY PETE LEONI



# THE MUSICIAN'S CHOICE FOR GREAT GEAR AT GREAT PRICES!



## MUSICIAN'S Friend



**TDK**  
74-Minute 12X CD-R  
with Jewel Case  
950156Y  
List \$1.78  
**ONLY 69¢ each**

### Four Easy Ways To Order!

- Call: 800-776-5173
- Click:  
[www.musiciansfriend.com](http://www.musiciansfriend.com)
- Write: P.O. Box 4520  
Medford, OR 97501
- Fax: 541-776-1370

### Rapid Delivery!

- Most orders shipped same day!\*

### 45-Day Double Guarantee!

- Money-Back Satisfaction Guarantee
- Best Price Guarantee

### NEW LEASE PROGRAM!

- Call: 800-359-4790 for details

**FREE CATALOG!**  
One-year subscription!



### YAMAHA

01V Digital Mixer  
630045Y List \$2,199.00  
**\$1799<sup>99</sup>**

### midiman

USB Midisport  
2x2 MIDI Interface  
701226Y List \$129.95  
**\$89<sup>99</sup>**



**NADY**  
SYSTEMS INC.  
CL-5000  
Compressor/Limiter/Gate  
183700Y List \$255.95  
**\$99<sup>99</sup>**



**RED**  
eleVAta  
16-Voice Modeling Synth  
709003Y List \$995.00  
**\$749<sup>99</sup>**



**ELECTRIX**  
Repeater Loop/Phrase Sampler  
700910Y List \$749.99  
**\$599<sup>99</sup>**



## musiciansfriend.com

**WEEKLY WEB GIVEAWAY! WIN UP TO \$1000 IN FREE GEAR!**

**CALL 800-776-5173**  
or visit us online at  
**www.musiciansfriend.com**

**Order today and use code: MIMA0502**

Limited to stock on hand; prices subject to change; standard catalog shipping rates apply.

\*On orders received by 5PM ET Mon. - Fri. World Radio History  
CIRCLE #003 ON PRODUCT INFO CARD

To get your **FREE** Catalog subscription, fill out this handy coupon and mail to: Musicians Friend, Dept. 170, P.O. Box 4520, Medford, OR 97501

Name \_\_\_\_\_  
Address \_\_\_\_\_  
City \_\_\_\_\_ State \_\_\_\_\_ Zip Code \_\_\_\_\_  
E-mail address \_\_\_\_\_  
Area(s) of interest:  Guitar  Bass  Keyboard  Drums  
 Studio (recording)  Stage (PA, lights, etc.)  DJ

Refer to this code: 170-0105

## FIELD TEST

buttons on the Session Controller contain an embedded LED that indicates status. The current operation is displayed both on the LCD screen on the Session controller itself and on a similar virtual window in the RADARVIEW screen (more on this later).

All connectors and cables are clearly labeled, and I found the setup to be about as simple as it gets. However, when I plugged a generic 19-inch computer monitor in the standard SVGA connector and flipped the Power switch, I found that RADAR generates a bit more fan noise than is necessary. I have been building PC-based audio systems for years and have found that a lot can be done to lower the noise level, simply by carefully choosing the case fans, power supply and CPU fans. In an ideal situation, the RADAR units should be located in an isolation box or in a separate room away from control room or recording areas. Perhaps this is not as big an issue as it first appears. I spoke to the people at iZ and was informed that RADAR is now shipping with a much quieter power supply and fan.

I repositioned the unit outside of the control room and rebooted. As RADAR is based on the PC platform

running the stable and reliable BEoS 5 operating system, the familiar PC "post" screen appeared and was quickly followed by the BEoS logo. This was briskly replaced by the RADARVIEW track screen and after that, the PC and BEoS operating system became completely invisible to the user. RADARVIEW—the one and only screen you

have to deal with—is an overall graphic view of all 24 tracks, similar to the track view screens seen on almost all editing software. Similarly, individual tracks can be zoomed into and out of for detailed waveform editing. Overall, I found RADARVIEW to be simple, good-looking and intuitive.

The sound of a digital recorder is primarily the sound of its converters, so I first checked out the AD/DA section to see what all of the fuss was about. A bluegrass session with acoustic instruments gave me a real chance to hear the detail the converters were capable of, and I was not disappointed. A Martin D-28 box guitar came though with a sheen I had not previously heard, and the transient punch of the banjo was remarkable. Such clarity is not inexpensive—the Nyquist 24/96 card is a \$2,995 option.

Next I decided to try a real-time digital transfer from a friend's Tascam DA-88 via the TDIF connectors.

viding full-range, 24-track LED metering without having to use the onscreen meters. The Meter Bridge 48 (\$795) offers 48-track metering for dual-RADARLINKed RADAR 24 or RADAR II systems.

**Digital I/O:** Twenty-four channels of 96kHz-capable pathways in AES/EBU format on three DB-25 connectors, \$995.

**Classic Analog I/O:** Essentially the same 24-channel, 48kHz AD/DA converters used in RADAR II, \$1,695.

**Nyquist Analog I/O:** Twenty-four channels of 48/96 kHz AD/DA conversion, \$2,995. The \$3,995 S-Nyquist Analog I/O option is similar but offers improved conversion.

**Drives:** The standard 18GB Barracuda drive that comes with RADAR 24 can be upgraded with a variety of



Because the DA-88 offers SMPTE, MIDI and Sony 9-pin sync, and also included the SY88 synchronizer, I had a chance to test almost all available sync options. I didn't expect to find any issues with RADAR's sync capabilities, and I didn't. Later, using both SMPTE and MMC where appropriate, I was able to achieve rock-solid sync with my studio PC running Logic Audio, Cakewalk Sonar and Cubase 5.0. This brings me to my second and final gripe with RADAR. At the time of writing, RADAR 24 was not able to import projects from other editing systems, nor is it able to import audio files via the DVD-RAM drive; in fact, only small .WAV files can be imported via the floppy drive. [Editor's Note: Several of these concerns have been addressed with the upcoming release of Version 3.10 software. See the "RADAR 24 Software Update" sidebar for details.] However, iZ promises that RADAR 24 will soon have the ability to import Pro

## RADAR 24 Pricing

The base RADAR 24 system is \$4,995, with an 18GB drive; 24-channel TDIF I/O; 2 channels of AES/EBU and S/PDIF I/O; SMPTE/MTC/AES/video/word/9-pin sync; standard KC-24 keyboard; port for SVGA monitor; and all necessary software. By selecting from a wide range of options, RADAR 24 can provide a customized system to fit a variety of user needs.

### Options include:

**Session Controller:** \$1,195, with 33-foot cable. This full-function autolocator/controller features an LCD screen, dedicated transport controls, jog wheel, macro keys, dedicated editing keys and menu shortcut keys. An optional 66-foot extension cable is \$150.

**Meter Bridges:** The \$495 Meter Bridge 24 is designed for console-top or Session Controller mounting, pro-

optional hard disks ranging up to 36 GB, for nearly three hours of 24-track recording at 48 kHz.

**Backup:** An assortment of auxiliary drives are offered for archiving or backup, including: double-sided 9.4GB 2x DVD-RAM, \$695; 7- to 14GB Eliant 820S 8mm tape drive, \$1,795; 14- to 28GB Mammoth LT drive, \$2,995; 20- to 40GB Mammoth drive, \$2,995; and the 60- to 150GB Mammoth 2, \$4,995.

**Cabling:** To access the TDIF digital or analog I/O, you'll need D-25 sub-to-XLR (or -TRS) breakout snakes. These are available from numerous vendors, ranging from the ordinary to the exotic—depending on your budget needs and tastes, but they must be figured into your RADAR budget.



# Brittle is for **nuts**, not **audio**

Does your audio sound brittle and hard? Now Empirical Labs has TWO great toys to make tracks jump with excitement, and help take that “plastic” edge off of your digital multitracks and masters.

Since its debut in 1995, the Distressor has become a workhorse, both in the studio and on the road. With its easy to use classic knee compression and exclusive harmonic generation capabilities, it has found its way onto thousands of major records, from artists as diverse as Pavorotti to Nine Inch Nails.

Now Empirical Labs Introduces the Fatso (Full Analog Tape Simulator & Optimizer – get it?) With a soft clip harmonic generator, a high frequency saturator to soften the treble, a transformer for tape head emulation ... plus some basic kick-butt compression... the Fatso is an arsenal of tools designed to bring back the sweet high end and low frequency warmth you loved on your classic old punchy analog tape recordings.

So save the brittle hard stuff for your sweet tooth, and count on Empirical Labs to sweeten your day – and your music – with its “Swiss Army knife”, session-saver processors: the Distressor and the new Fatso.



## **Distressor Model EL-8 and EL-8X**

*Classic Knee Sound • Programmable Analog Distortion/Warmth • Eight Unique Curves including 10:1 Opto Ratio & the famous “Nuke” mode • new British Mode & Stereo Image Link*



## **Fatso Jr Model EL-7**

### **Full Analog Tape Simulator and Optimizer**

*Harmonic Generator & Soft Clipper • Transformer & Tape Head Emulation  
High Frequency Saturation (warmth!) • Classic Knee Compression • 5.1 Surround Linking*

To find out who's Distressed and who's Fat, check out [www.empiricallabs.com](http://www.empiricallabs.com) or call to arrange a demo.



1170 Greenwood Lake Turnpike, Ringwood, NJ 07456  
tel (973) 728-2425 • fax (973) 728-2931 • email [eli@wavedistribution.com](mailto:eli@wavedistribution.com)

CIRCLE #084 ON PRODUCT INFO CARD

## FIELD TEST

Tools projects, and other file-import capabilities are planned.

Once the tracks were in RADAR, it was time to explore the editing possibilities. Those accustomed to editing on more elaborate, computer-based DAWs may find the editing functions of RADAR 24 rather limited. However, as RADAR is intended as a direct replacement for linear tape machines, the developers at iZ decided to stick to the editing basics: Anyone who is familiar with other digital editing platforms will not have a problem getting around on RADAR 24 and will appreciate its plusses, such as real-time waveform rendering, the ability to perform multiple in/out paste marks on-the-fly, and its dedicated controls on the hardware controller for fast, one-touch setting of in/out/sync points and 10 Locate buttons.

After defining the in and out point of the area to be edited, the user can then place it in a virtual clipboard from which it can be cut, copied, pasted, moved, erased, slid, looped and reverse-pasted. It is a simple matter to position the clip, either by using the jog wheel or by using the autolocator, to find a pre-defined point. All edits

can be auditioned, and there are up to 99 levels of undo. All of this is so simple that it is quite possible to edit on-the-fly during a session, something you may be afraid to try on a more complex system. Another nice feature is the Mark Sync button, which allows sound effects and audio cues to be easily and precisely positioned during

video post-production.

In keeping with the tradition of simplicity, archiving and retrieving RADAR projects via the DVD-RAM drive could not be easier. From the LCD window, you can choose either the Backup or Restore menu, pick the project you want to archive or load and hit Enter. RADAR does the rest, and the 9.4-gig

### GOT RADAR II? Download V2.50 Software for Free

In keeping with its commitment to support the sizeable user base of owners of earlier RADAR systems, iZ now offers free downloads of Version 2.50 software for the award-winning RADAR II. Many improvements made during the development of RADAR 24 were ported to this new RADAR II software build, which adds features while addressing several operational and reliability issues present in RADAR II Version 2.20. Additionally, the V2.50 software is required to RADAR Link a RADAR II unit with a RADAR 24 system run-

ning Version 3.05 or higher.

RADAR II's upgraded Version 2.50 software features numerous improvements and updates, including enhanced graphics, accommodation of multiple SCSI backup devices and Macro import/export. RADAR Link protocol has also been improved, resulting in enhanced performance and stability. V2.50 software is available in the support/downloads area of iZ's Website: [www.recordingtheworld.com](http://www.recordingtheworld.com). Software downloading instructions for the Mac are also available.

—George Petersen

## Why does this software perform like hardware?

Along with the STS-5000 sampler, which we covered in the last issue, the brand new SCOPE /SP Studio Package includes a whole library of great sounding synthesizers. Many more highly desirable synths are available from CreamWare (such as the Vectron and the SB-404) and from third-party developers like Orbitone (with their Syn-Chrome), Zarg Music (with their Red Dwarf and Orion) and Sequential Circuits (with their Pro One software survival kit). While each of these synths has a very distinct character, all of them have a few things in common. They sound absolutely great. They respond to MIDI like hardware instruments, without latency. They produce a guaranteed number of voices. They feel like hardware and they rock like hardware. But - how can you believe all this when all those synths are a software implementation?

The answer is simple. There's no magic involved. We merely use the world's most advanced and powerful DSP hardware technology to run our software. Think of our DSP boards as time machines. They enable us to provide you with the software of the future, right now.

Can you afford the hassles and limitations of native software? If so - then go native.

Got professional requirements? Go SCOPE /SP.

Call (604) 435-0540 and order your set of SCOPE /SP literature today. SCOPE /SP comes with a 30-day money-back guarantee - we know you'll love it. SCOPE /SP runs on both PC and Mac platforms. SCOPE /SP is available only at authorized /SP dealers.

**The time machine.** 15 ultra-fast floating point DSPs provide 2.7 GFLOPs of real audio power - roughly comparable to a 3-4 GHz PC/Mac host processor of the future. Want even more? Add another time machine.

CreamWare Audio Solutions  
6879 Russell Ave.  
Burnaby, B.C.  
V5J 4R8, Canada

Phone: (604) 435-0540  
Fax: (604) 435-9937

[www.creamware.com](http://www.creamware.com)

[info@creamware.com](mailto:info@creamware.com)



PC & Mac compatible

creamw@re®

fidelity at work.

# GET 6 TIMES THE POWER



...with the new **ULTRA-DYNE® PRO** from **BEHRINGER®**.  
The ultimate **6-band** 24-bit mastering processor.

#### A new dimension of power mastering

The new BEHRINGER® ULTRA-DYNE® PRO is our ultimate 6-band mastering machine with unheard-of power. Two high-performance DSP's, combined with ultra high-resolution 24-bit A/D and D/A converters, give you perfect multiband mastering with incredible loudness, transparency and sound optimization.

#### 6 bands for 6 times the power

Simply stated: the more frequency bands you have, the more loudness you get without side-effects like pumping etc. While the competition offers a mere 3 or 4 bands, the ULTRA-DYNE® PRO delivers ultimate power from 6 bands.

#### VIRTUOSO®: mastering magic

You won't believe your ears! Your sound can now stand up to top-rate CD productions. Extreme punch with no dynamic loss. The magic word is VIRTUOSO®, a synonym for intelligent and fully automated parameter settings based on your program material. Quick, easy and always perfect. The incomparable wizard VIRTUOSO®: available only from BEHRINGER®.

#### ULTRA-DYNE® PRO DSP9024: experience the ultimate revolution in multiband mastering

ULTRA-DYNE® PRO stands for total power mastering. Next to an explosive multiband Exciter for complete transparency and powerful low end, and a multiband Denoiser®, the DSP9024 features authentic tube simulation for that extra bit of heat in your sound. Hear and experience the ULTRA-DYNE® PRO—and feel free to compare it with any other unit, including broadcast equipment in the \$25,000 range.

**But remember to buckle up: the ULTRA-DYNE® PRO is pure power.**



2-band power mastering with Exciter, Denoiser® and Surround Processor:  
The new ULTRAMIZER® PRO DSP1400P. At your dealer's now!

©2001 BEHRINGER  
Spezielle Studiotechnik GmbH

Technical specifications and appearance subject to change without notice.

a	Canada	Tel.: +1 902 860 2677	Fax: +1 902 860 2078	Email: support.ca@behringer.de
	International	Tel.: +49 2154 920 666	Fax: +49 2154 920 665	Email: support@behringer.de
	Japan	Tel.: +81 3 528 228 95	Fax: +81 3 528 228 96	Email: support.jp@behringer.de
	Singapore	Tel.: +65 542 9313	Fax: +65 214 0275	Email: support@behringer.com.sg
	USA	Tel.: +1 425 672 0816	Fax: +1 425 673 7647	Email: support@behringer.com

#### The ULTRA-DYNE® PRO's powerful features:

- Digital stereo mainframe with two 24-bit high-power signal processors
- State-of-the-art 24-bit A/D and D/A converters from Crystal for phenomenal audio quality
- Up to 600 msec. of delay for "look-ahead" compression, limiting and noise gating
- 6-band compressor with separate peak limiter section
- ULTRAMIZER® function for extreme loudness and signal density
- 6-band noise gate for "inaudible" noise reduction
- Multiband Exciter with adjustable ratio of odd and even harmonics for punchy bass and dazzling highs
- Tube simulation with selection of popular tube types
- Extensive MIDI implementation
- 24-bit AES/EBU digital interface (optional)
- Large high-resolution graphic LCD display
- Servo-balanced XLR and 1/4" TRS inputs and outputs
- Relay-controlled hard bypass with auto-bypass function for power failures (safety relay)

Free downloadable  
Windows® editor  
software for  
ULTRAMIZER® PRO  
DSP1400P.



<http://www.behringer.de/eng/support/software/dsp1400p.htm>

More information at:

[www.behringer.com](http://www.behringer.com)

CIRCLE #086 ON PRODUCT INFO CARD



**JUST LISTEN.**

\* Windows is a registered trademark of Microsoft Corporation

## FIELD TEST

capacity of the DVD drive eliminates the hassle of backups from slow tape loads, as in earlier versions of RADAR, or multiple CD-Rs.

Readers familiar with the previous RADAR and RADAR II are already acquainted with the superb sound quality, 24-hour tech support and bulletproof stability of RADAR 24. The list of artists and producers who have recorded using RADAR reads like a "Who's Who" of the recording industry. So, what does the latest incarnation of RADAR bring to the table? RADAR 24 features an improved



user interface and supports sample rates of up to 192 kHz. Add to that the robust BEoS 5 operating system, SOUNDMASTER compatibility and 9.4-gigabyte 2x

DVD-RAM backup, and you have a package that's fairly hard to beat. Did I mention price? The RADAR 24 system I tested priced out at \$10,870 retail, while a similarly configured RADAR II system would have sold for over \$20,000. Quite a reduction!

iZ Technology Corporation, 8988 Fraserton Court #214, Burnaby, B.C. V5J 5H8, Canada; 604/430-5818; fax 604/430-5828; www.izcorp.com. ■

*Pete Leoni is the technical director at QPerformance, a division of East Coast Music Mall. He can be reached at demotech@qperformance.com.*

## RADAR 24 Software Update

As we went to press, iZ Technology was shipping its new RADAR 24 software Version 3.06, and the company had just announced Version 3.10, which should be available soon.

RADAR 24 Version 3.06 offers support for multiple backup devices, selectable via SCSI ID; increases the amount of addressable storage available for recording to 36,000 GB; macro import/export via floppy disk; and improves the RADAR Link protocol for sample-accurate linking of multiple RADAR 24 units.

Major features coming in RADAR 24 Version 3.10 include an "Export to Broadcast Wave and .WAV2" functionality, which allows RADAR 24 users to output projects and files to UDF-formatted, DVD-RAM media in the time-stamped Broadcast Wave format or the non-time-stamped .WAV format. Exported projects can be loaded onto Macs or PCs equipped with either a DVD-RAM drive or a standard DVD-ROM drive, offering the ability to drag-and-drop files and projects directly into other DAW applications for mastering/mixing. The 3.1 release also allows files to be moved between multiple RADAR 24 machines via Ethernet. Unique IP addresses assigned to each unit will allow transfers between machines, while avoiding backup and restore cycles or unnecessary drive swapping.

—George Petersen



So go to our page:

[www.rolls.com](http://www.rolls.com)

There you'll find detailed info on all Rolls products including pictures, specification data sheets, even owners manuals.



**CORPORATION**  
5968 South 350 West  
Salt Lake City, UT 84107  
(801) 263-9053 • FAX (801) 263-9068  
email: rollsrfx@rolls.com

# Denon. Heard around the world in perfect clarity.

## Advanced CD and Mini-Disc technology for broadcast.

In 1995, Denon introduced the world's first family of professional MiniDisc products. Since then, the industry has looked to Denon to take this medium even farther. The DN-M1050R does just that. With recording and editing features that are faster and easier than before and options that include a PC compatible keyboard, SMPTE, FS Converter and Hot Start, this MD recorder is a must have. And when paired with the DN-C680, Denon's best CD player

technology for studio and broadcast production applications, you have a reliable and uniform operating environment ready to deliver superior sound quality using innovative, easy-to-use controls. The DN-C680 features dedicated buttons instead of dual purpose scroll menus, a wide range of connectivity options, easy-adjust output levels, and options like SMPTE — and that's just the beginning. Hear Denon for yourself. After all, the rest of the world has.



**DENON**  
The first name in digital audio



CIRCLE #109 ON PRODUCT INFO CARD

[www.del.denon.com](http://www.del.denon.com) • Denon Electronics, 19 Chapin Rd., Pine Brook, NJ 07058  
(973) 396-0810 • Denon Canada, Inc., 17 Denison St., Markham, Ontario, Canada L3R 1B5  
(905) 475-4285 • Laborador, S.A. de C.V., Zamora No. 154, 06140 Mexico, D.F., (52) 5-286-5509

TOUR  
PROFILE

## ERIC CLAPTON

## 19TH CENTURY ACOUSTICS MEET 21ST CENTURY TECHNOLOGY



ALL PHOTOS BY MIKE MANN

Eric Clapton and the band onstage at the Royal Albert Hall, London



The old Reptile himself

From 1989 until 1994, Eric Clapton's annual two-week residency at London's Royal Albert Hall became something of a tradition. Though the lineup of guest musicians varied over the years, the quality of the show's sound production steadily improved, and, despite the room's difficult acoustics (the RAH was designed in the late 19th century and was intended only for classical music concerts, for which many would claim it is poorly suited), Clapton's audio team consistently managed to produce finely tuned sound balances. (See *Mix*'s January 1992 issue for a related article on the recording of Clapton's *24 Nights* album.)

Clapton's FOH engineer for many of the annual RAH shows and concurrent tours was Robert Collins,

BY MIKE MANN



an independent engineer whose client list also includes The Who. When it came time to design the sound system for Clapton's 2001 tour, which kicked off with six nights at the RAH on February 3, Collins opted to move away from the traditional tools and methods that had made the "Clapton at the RAH" shows such a success. Instead, he placed his reputation on the line by using EAW's new (and previously untried) KF900 Series P.A. Not only was the Clapton tour the first in Europe to be equipped with the recently introduced KF900 "Phased PointSource Technology" system (supplied by UK-based Concert Sound), Collins compounded his bravery by choosing to take Yamaha's long-awaited PM-1D digital mixing console on its debut European tour.

Known for his dislike of unnecessary technical frills, Collins was keen to introduce some changes into his mixing environment, but not if it meant having to discard a lifetime's touring experience. "I looked long and hard at the various new boards that were around," he recalls. "When it came to the Yamaha, I thought, 'Maybe an old bastard like me could use this.' The jury's still out, but I haven't had any problems getting my head 'round the basics. Of course, it can do so much—it just depends on how far you want to go. At the moment, I'm trying to make it work the way I like to, in very much the same way as a traditional analog console." Though this may not be the way that the PM-1D's designers intended it to be used, Collins notes it is he who has to face the audience—and the band—every night, not the console designers.

#### MODULAR DESIGN AIDS MIXER CONFIGURATION

The PM-1D is based on a modular concept, providing for an almost limitless variety of console configurations, though all share the same 48-channel control surface. Inputs and outputs may be analog or digital, and digital formats include both the AES/EBU professional standard and S/PDIF/TDIF semi-pro options. A range of 3U and 4U input/output racks are available, each of which

can handle up to 32 separate feeds. Auxiliary mixes, matrix sends and insert send/returns only appear as real connectors if required, saving rackspace and money by eliminating unnecessary hardware. Every adjustable parameter, including the analog gain control for the input A/D converters, is automated as a series of snapshots. While dynamic (i.e., continuous) automation is not yet available, it should be pointed out that the Concert Sound PM-1D started the Clapton tour equipped with Version 1.0 software.

The console's audio connections and converters, which are located onstage, are configured to the tour's exact requirements—48 analog inputs from the stage, plus a couple of stereo line inputs for pre-show playback. To enable the PM-1D to cope with the enormous dynamic range encountered in a live environment, the console's A/D converters are 28-bit—configured by cascading two 24-bit devices—so that even when a signal is at a low level, resolution is high. Headroom, according to Yamaha, is exceptional.



*The EAW KF900 system hung as a center cluster. Front section of the audience is covered with ground stacked EAW KF750s.*



Inputs—whether analog or digital—are linked digitally to the console's "engine," a powerful DSP rack that performs all of the mixing, equalization, dynamics and delay functions for the system. For this tour, this is positioned in the FOH enclosure, but would normally be onstage to cut down on the cabling from the input racks.

The control surface and engine are connected by a 32-pair digital audio cable (used for passing the FOH engineer's local monitoring signals and other local audio feeds) and a pair of coaxial control cables. Other connections include a 48-track Mackie hard disk recorder, which is fed from each channel's direct output as a pre-fade digital signal. Collins requested the Mackie unit as part of the team's rehearsal rider, and it has stayed for the tour. "I wanted a multitrack for rehearsals to let me hear what I was doing," he explains. "I would record tracks without any EQ or processing, so that I could replay them later and go over the mix."

Despite the fact that the PM-1D offers a sophisticated onboard package of dynamic processors and effects devices, Collins was keen to use some of his tried-and-trusted outboard gear. These include a number of dbx 160S compressor/limiters, which he has inserted into key channels via AD/DA cards in the PM-1D racks. Effects, which include

an Eventide DSP7000, TC Electronic M5000 and D-TWO, plus a clutch of Lexicon reverbs, were originally fed from auxiliaries and returned to inputs in the analog domain. But, at Yamaha's suggestion, these were rewired to preserve the all-digital signal path. "I was impressed with the clarity and cleanness of the effects when we connected them digitally," noted Collins. "In fact, when we ran instruments through the board for the first time, they were so clean it frightened me!"

#### FLIPPING FADER BANKS

Collins, like most engineers, is accustomed to having his mixing console

laid out in a certain manner and had to think carefully about how to condense a large number of inputs onto the PM-1D's comparatively small control area. The control surface includes four "banks" of 12 channels each, with a second layer of inputs hidden below the first, for a total possible input count of 96. Collins assigned his most important inputs (bass, acoustic bass, five guitar channels and vocals) to channels 13 through 24, immediately to the left of the console's output section. To the right, occupying channels 37 to 48, he assigned the percussion instruments; being wildly dynamic, these needed more attention. Above these



The Yamaha PM-1D (left) at the FOH position

# Sounds Great. Less Schilling.



## Minidrive™. It's BSS for less.

You already know that Omnidrive™ Loudspeaker Management Systems are insisted upon by many of the world's biggest tours and most prestigious venues. But on smaller gigs, the budget can often be even more demanding than the acoustics. That's why BSS made the new, affordable Minidrive™. In a front of house rack, the 2 input/6 output FDS-336 is ideal for controlling a stereo 3-way system, while the 2 input/4 output FDS-334 is perfect for monitors. And unlike other low-cost processors, Minidrive™ is much more than just a digital crossover, delivering all the core functions of the larger BSS Omnidrive™ system: crossover, assignable PEQ, mid-band limiters and input/output delay.

### MINIDRIVE™

So if you thought you couldn't afford a BSS loudspeaker management system, talk to us today about Minidrive™.

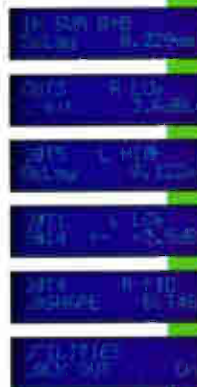

### BSS Audio USA

1449 Donelson Pike, Nashville, TN 37217

Tel: 615.360.0277 Fax: 615.360.0480 E-mail: BSSAudioUSA@harman.com

www.bss.co.uk

A Harman International Company



CIRCLE #089 ON PRODUCT INFO CARD

World Radio History

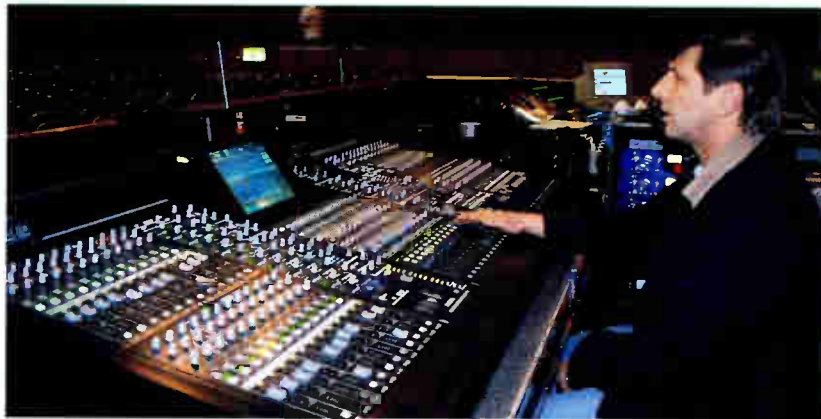

Eric Clapton's FOH engineer Robert Collins at the Yamaha PM-1D

key channels, Collins arranged the remaining 24 inputs, with the drum kit (kick, snare top and bottom, splash, hi-hat and ride cymbals, two overheads and four toms) as one bank of 12. Miscellaneous feeds and effects returns were assigned to the last bank. "After having had this board for a couple of weeks—mainly in rehearsal for this tour—flipping between banks of faders becomes second nature," says Collins, and watching him flip instantly between banks, bringing troublesome channels to his fingertips in an instant, dispelled any doubts about the console's intuitive design. "This is the beauty of this board—having 48 real faders," Collins adds. "If Yamaha had given me something with six faders and forced me to page through everything, I wouldn't even have put it in my bedroom!"

As is common with large and complicated P.A. rigs, the console is used to produce multiple mixes, and at the RAH, the PM-1D generated a main stereo feed and three auxiliary sends. One aux mix was used to drive a number of diminutive EAW JF80 frontfill speakers, essential for that section of the audience sitting on-axis with the backline of guitar amps. A second aux mix fed left and right ground stacked EAW KF750s, which were used to cover the audience located under the main array, while a third aux mix fed the "choir stalls" at the Royal Albert Hall, additional seating to the side and behind the thrust stage. "Up at the back, the audience is hearing a lot of the monitor sound, so we put a lot of vocals and the acoustic guitars into the rear mix," notes Collins. "One of the great things about

the Yamaha board is that you'll never run out of outputs!"

The main stereo feed would normally be fed to a left-right pair of flown loudspeaker arrays, but Collins and Concert Sound chose to use a single central cluster to deal with the circular RAH. Rusty King, formerly of Spectrum Sound in Nashville, takes care of the mighty rig. "We've zoned the center cluster to provide a stereo mix for the front and mono round at the sides, where stereo wouldn't make any sense," he explains. "Rather than dealing with the system as a number of loudspeaker cabinets, it's actually divided into 'cells.' Each of these is a single horn or pair of horns, and by changing the level and delay of the signal that we give to each of them, we can actually change the pattern of the coverage that the whole system gives."

At the RAH, three different cabinet types were combined to form the array; the KF930 long-throw, low-fre-

quency enclosure (which has two independent 15-inch loaded horns), the KF920 long-throw midrange cabinet (fitted with a trio of 10-inch drivers, again horn-loaded) and a number of KF913 medium-throw/downfill HF boxes. These latter feature three 2-inch compression drivers mounted on EAW's SimplePhase horns, each of which is angled differently to produce a spreading coverage pattern. By flying one row of KF913s upside down, the team was able to cover the tall auditorium (which has no less than seven levels of seating) from a single vertically hung array.

#### DSP OPTIMIZES SYSTEM

The EAW system is heavily dependent on DSP to create the required system coverage, and no less than 10 BSS Soundweb digital matrix processors fed 33 separate audio channels to the system's LAB Gruppen power amps. As well as providing the required delay and level correction, the Soundwebs are also used for equalization, band-pass filtering for each driver type and dynamic control to ensure that the system is working optimally. Collins, faced with mastering an unfamiliar console, was happy to hand the system over to King. "It's quite amazing how much control you have over this system—whatever happened to the simple crossover with four knobs?" comments Collins. "The only thing you have to be careful about is that you don't change anything while you're doing something else—when I'm listening to the band, it's 'hands off!'"

Concert Sound's Tim Boyle has been working in the European live



System tech Rusty King at the Soundweb screen

# ABSOLUTE POWER

## 4000 WATTS RMS



- **4 channels**
- **1000 watts per channel**
- **Dual 2000 watt bridged-outputs**

**DCM4000 - 4000w** List \$2395 **\$1199.99**

This is not just another power amp! Think of it as two 2000 watt amps in a 3 space chassis. 'Cause that's what it is! In the 4 channel mode, you can use a single DCM4000 to run both monitors and mains. For concert applications, the bridged mode gives you dual 2000 watts into 4 ohms or dual 1400w into 8 ohms! You're guaranteed transparent, crystal clear power from these continuous duty RMS amps.



**DCM2000 - 2000w** List \$1195 **\$599.99**

**DCM1500 - 1500w** List \$895 **\$499.99**

**DCM1000 - 1000w** List \$795 **\$399.99**

**DCM600 - 600w** List \$695 **\$349.99**

**DCM150 - 150w** List \$395 **\$229.99**



**DCM4000 REAR**

### DCM4000 FEATURES

- 4000 Watts RMS from 3 rack spaces
- Configure as four independent 1000W or two 2000w amps
- OUTPUT x 4: 8Ω 425w, 4Ω 700w, 2Ω 1000w
- BRIDGED x 2: 8Ω 1400w, 4Ω 2000w
- Freq. Resp. 20 - 20k Hz. THD less than .1%
- Continuous RMS - not pulse or peak
- 2Ω stable for multiple speaker loads
- Two independent toroid power supplies - one for each 2000w amp
- XLR hot inputs & parallel through connectors
- Speaker Twist-Loks & banana/binding posts

- Speaker Twist-Lok bridge connectors
- Indicators for bridged mode, signal & clipping
- Limiters for clipping and speaker protection
- Sub-sonic filters and ground lifts
- Thermal, short-circuit, over-current, voltage spikes & DC output protection
- Soft-start power-up, "Wind-tunnel" cooling
- Includes rear support bracket (13" to 19" deep)
- Performance guaranteed or your money back
- Wt. 70 lbs. Size: 19" W x 5 1/4" H x 16" D
- Made in USA! 3 Year Warranty

**BUY FACTORY DIRECT AND SAVE**

*"These amps are so tough, you could arc weld with them" - Beyond the Limit Productions*

*"We use Carvin power amps exclusively for our installations. We have found that these amps are the only choice for the power and reliability we require" - The Guitammer Company*

DCM amp users:

- Steve Vai • Steve Morse • Allan Holdsworth
- Craig Chaquico • Reeves Gabrels (David Bowie)
- Pete Anderson (Dwight Yoakam) • Chris Squire
- Philip Bynoe (Steve Vai) • Larry Carlton • Will Lee
- Don Weiss (Beach Boys Engineer)...

For specs and to order, visit [carvin.com/power-amps](http://carvin.com/power-amps)

**carvin.com 800.854.2235**

Factory Direct Sales • Guitars • Amps • Pro Sound

sound industry since its early days. "We've always had a close relationship with EAW and with Spectrum, who have been using the KF900 system for a while," says Boyle. "Twenty-five years ago, it was the normal thing to do to stack horns in columns—we knew how to couple more than one speaker to 'throw' a long way. Somewhere along the line, someone had the bright idea of putting all the elements into one cabinet, but for some applications, it doesn't work as well. What EAW has done is in some ways a big step forward, but in others it's like looking back in time. The advantage now is that with the technology we have at our fingertips, the result is much more coherent and completely controllable."

For Eric Clapton's other European

dates, which included bigger arena shows in the UK, a more conventional pair of arrays was used. In the case of Manchester's 15,000-capacity MENA venue, the KF900 rig was used without delay speakers, a rare opportunity to save time and money on a tour of this scale. Interestingly, even at these larger venues, the Concert Sound crew did not need to call upon EAW's ultra-long-throw design, the KF910. (This HF cabinet contains a total of five 2-inch drivers on long horns, arrayed in a straight line and using line array principles to increase the system high-frequency coverage to over 700 feet.)

A dozen EAW SB1000s provided sub-bass (always an issue on tour, especially with acoustic instruments playing a major part in the music). The dual 18-inch SB1000 has become

extremely popular in Europe where its tight low-end control and general musicality are greatly appreciated. For the larger arena shows, the SB1000 contingent was doubled to 24.

### TRADITIONAL MONITOR SYSTEM

Faced with so much new technology, it almost comes as a relief to find that Clapton's monitor system is very traditional and has not varied much in the last few years. A Midas XL1, supplemented by a 24-channel XL3, handles the mixing, while Concert Sound's wedge monitors provide the band with their every musical wish.

Taking a new piece of equipment on the road is never an easy decision—and it is made many times harder when the equipment in question is critical to the show. Add the fact that Robert Collins has spent a long time developing a relationship of trust with Clapton and his band, and the temptation to play it safe must be very strong indeed. However, given the right level of manufacturer backup (and, at times, there were more technical people from EAW and Yamaha on the tour than actual sound crew), little problems should never get the chance to develop into major ones. The live sound industry has long been criticised for using technology that lags behind the lighting, set design, video and sometimes even catering departments—but according to Robert Collins, it's the engineers themselves who are to blame. "The bottom line is that, if it all goes wrong, give me a basic desk and a normal P.A. and we'll have a good gig tomorrow. They say you can't teach an old dog new tricks, but learning to work with this level of technology is only a minor problem for us old guys. I might go back to an old Midas after this tour—or I might become a convert. If you don't try, you'll never know, will you?"

Eric Clapton's 2001 tour takes him to 25 European cities before a rare performance in Moscow. Following a short break, the tour then heads for North America and will wind up in the Pacific Rim toward the end of the year. ■

*Mike Mann is a freelance writer living in England.*

## JEFF BECK ON TOUR "EARTHQUAKE" HITS SAN FRANCISCO



On a world tour to promote his latest album, *You Had It Coming*, Jeff Beck began the U.S. leg on the West Coast in February, reached New York in March and is scheduled to tour Europe with Sting for six weeks beginning in June. Accompanying Beck are veterans Jennifer Batten (guitar, MIDI guitar, vocals)

and Randy Hope Taylor (bass), with newcomer Andy Gangadeen on drums and loops.

Independent engineer Andy May (left), on his first tour with Beck, is at the Yamaha PM4000 at FOH (using No. 23 from Clair Bros. extensive stock of 4ks), while Showco staffer Jerrel Evans (right) is using a Harrison SM-5 for monitors. Showco system tech Stephen Cross takes care of the Showco Prism® System.



PHOTOS BY STEVE JENNINGS

In Concert Productions • J.D.M. Records • Jonas Productions • Keleysys • La Boite a Sons • Lars Brogaard • LD Sys  
 Lisbon Culturgest • Logic Systems • LT Sound • Martins Music • Maryland Sound Int'l • Masque Sound & Recording  
 ne Audio Visual • Melpomen • Mercury Sound • Mid America Sound Corp • Mikam Sound • Minnesota Production  
 MS Srl • Modul • Motorola Rentalservice • MPM Sound • Musical Box • Nelson Sound • Norwest Productions • Oce  
 io Melbourne • Oceanita Audio Victoria • ON / OFF • Orbital Sound • PADCO Konzertakustik GmbH • Paragon Produc  
 c • Powa Audio • Prague Culture Palace • Pro Sound Inc • Production Technology LLC • Promix Inc • Purple Sound  
 City Music Hall NY • Rainbow • Rampa • Rat Sound • Richard Knowle Sound Services • Rock City NY • Rock City S  
 c • Rocksound Network GmbH • Rocky Mountain Sound • Schallwand GmbH • Scorpio Sound Systems Inc • Seattl  
 venue Theatre • SES Sound Electronics Service Sdn Bhd • Shaped Music • Showco • Siramv • Skan PA Hire • Slad  
 o Tech • Sound Art Calgary • Sound Art Toronto • Sound Art Winnipeg • Sound Associates Inc • Sound Attitude • Sc  
 e • Sound Image Inc • Sound Productions • Soundcraft Inc • South West Audio • Southeast Audio • Specialized Au  
 al • Spectrum Sound Inc • SSE Hire Ltd • Stage & Sports Audio • Stage Line • Stage Point • Staras • Starlight • TE  
 bh • Thunder Audio Inc • TourTech East • Trio Electrico • Try Audio Inc • TSE AG • Unusual Productions Pte Ltd • V  
 chnology • West Evenement • Westfalen Sound • Wigwam Acoustics • Acoustic Co • Alfason • Allstar Audio • Amj  
 ent • Apogee Telecommunications • Arcadia Srl • Arpege • Art System • Artesicilia • ASR Pro Events • Audio Lite •  
 echniques • Aufersom • Autograph Hire • AVAD-CAC • Babel & Haeger GbR • Balance Audio-Media • Bartons • BI  
 Black Box Music • Blackhawk Audio Inc • Blue Man Group • Boston North Shore Music Theatre • Briere Sound • Bri  
 Row • Canal Plus • Cane Green • Capital Sound • Capitol Design Group Inc • CAV • Cirque du Soleil • Clair Bros Aud  
 oc • Concert Sound • Concert Systems • Crewco • Crystal Sound GmbH • Dallas Backup Inc • Db Sound • Dee Soun  
 ight • Delicate Productions • Delta Sound Inc • Dispatch • Dobson Sound Productions Ltd • Dodd Technologies • E  
 tage Productions • ECS Technologies Inc • EFX Audio • Eighth Day Sound Systems Inc • ELTEK • EML • Entec Sound  
 ht • Esosound Srl • Espoo Culture Centre • Firehouse Productions • Flashlight/APR • Focus Showequipment • For l  
 erleih • FX Music • Gabisom • Gand Music & Sound • Gearforce • George Helles Sound • Giambattista Zerpelloni •  
 e • Grand Theatre de Quebec • Hi-Tech Audio Systems Inc • Hokkaido Butaihisaku • Horne Audio • Hudson Theat  
 In Concert Productions • J.D.M. Records • Jonas Productions • Keleysys • La Boite a Sons • Lars Brogaard • LD Sys  
 Lisbon Culturgest • Logic Systems • LT Sound • Martins Music • Maryland Sound Int'l • Masque Sound & Recording  
 ne Audio Visual • Melpomen • Mercury Sound • Mid America Sound Corp • Mikam Sound • Minnesota Production  
 MS Srl • Modul • Motorola Rentalservice • MPM Sound • Musical Box • Nelson Sound • Norwest Productions • Oce  
 io Melbourne • Oceanita Audio Victoria • ON / OFF • Orbital Sound • PADCO Konzertakustik GmbH • Paragon Produc  
 c • Powa Audio • Prague Culture Palace • Pro Sound Inc • Production Technology LLC • Promix Inc • Purple Sound  
 City Music Hall NY • Rainbow • Rampa • Rat Sound • Richard Knowle Sound Services • Rock City NY • Rock City S  
 c • Rocksound Network GmbH • Rocky Mountain Sound • Schallwand GmbH • Scorpio Sound Systems Inc • Seattl  
 venue Theatre • SES Sound Electronics Service Sdn Bhd • Shaped Music • Showco • Siramv • Skan PA Hire • Slad  
 o Tech • Sound Art Calgary • Sound Art Toronto • Sound Art Winnipeg • Sound Associates Inc • Sound Attitude • Sc  
 e • Sound Image Inc • Sound Productions • Soundcraft Inc • South West Audio • Southeast Audio • Specialized Au  
 al • Spectrum Sound Inc • SSE Hire Ltd • Stage & Sports Audio • Stage Line • Stage Point • Staras • Starlight • TE  
 bh • Thunder Audio Inc • TourTech East • Trio Electrico • Try Audio Inc • TSE AG • Unusual Productions Pte Ltd • V  
 chnology • West Evenement • Westfalen Sound • Wigwam Acoustics • Acoustic Co • Alfason • Allstar Audio • Amj  
 ent • Apogee Telecommunications • Arcadia Srl • Arpege • Art System • Artesicilia • ASR Pro Events • Audio Lite •  
 echniques • Aufersom • Autograph Hire • AVAD-CAC • Babel & Haeger GbR • Balance Audio-Media • Bartons • BI  
 Black Box Music • Blackhawk Audio Inc • Blue Man Group • Boston North Shore Music Theatre • Briere Sound • Bri  
 Row • Canal Plus • Cane Green • Capital Sound • Capitol Design Group Inc • CAV • Cirque du Soleil • Clair Bros Aud  
 oc • Concert Sound • Concert Systems • Crewco • Crystal Sound GmbH • Dallas Backup Inc • Db Sound • Dee Soun  
 ight • Delicate Productions • Delta Sound Inc • Dispatch • Dobson Sound Productions Ltd • Dodd Technologies • E  
 tage Productions • ECS Technologies Inc • EFX Audio • Eighth Day Sound Systems Inc • ELTEK • EML • Entec Sound  
 ht • Esosound Srl • Espoo Culture Centre • Firehouse Productions • Flashlight/APR • Focus Showequipment • For l  
 erleih • FX Music • Gabisom • Gand Music & Sound • Gearforce • George Helles Sound • Giambattista Zerpelloni •  
 e • Grand Theatre de Quebec • Hi-Tech Audio Systems Inc • Hokkaido Butaihisaku • Horne Audio • Hudson Theat

# SOUND



For Making The

**MIDAS**



**"The Industry Standard"**

CIRCLE #091 ON PRODUCT INFO CARD

[www.midasconsoles.com](http://www.midasconsoles.com)

# ERYKAH

**E**rykah Badu has released *Mama's Gun*, the long-anticipated follow-up to her 1997 multi-Platinum debut, *Baduizm*. Out on a seven-week tour to promote her second studio album and its hit single, "Bag Lady," Badu crossed the country from Cleveland to Las Vegas; *Mix* caught one of two sold-out shows at the famed Paramount Theater in Oakland, Calif.

Monitor engineer Kenny Nash (above) has toured with Brian McKnight, Maxwell and D'Angelo, and notes that on the past four tours, he's been mixing for in-ear monitor (IEM) systems, with or without additional wedge mixes. For the Bodu tour, Nash is using a combination of Shure PSM700 and PSM600 Series wireless IEM systems.

"The stage level is pretty controlled," notes Nash. "[Badu] doesn't like when it gets really loud, but she still wants it loud enough so that she can feel it—she comes from a hip hop background, and she wants to hear percussion and bass. I have sidefills and floor wedges, and depending on the size of the room, I may have to add a little kick drum or boss in the sidefill just so it keeps it tight onstage and she can still feel she's with the band."

Badu's IEMs are fed a full band mix, says Nash. "If there's anything that she may want in her mix, she'll actually sing it [as an ad-lib] during the show, so you really have to pay attention."

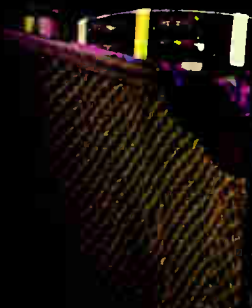



# BADU

Combining the roles of FOH engineer, production manager and assistant tour manager is Gordon Mack III (below). Mack is mixing on a Midas Heritage 3000, using about 45 inputs and four stereo returns, and records the show every night to DAT and video. "Erykah checks them out and critiques them," says Mack, whose company, Siahson Entertainment, is providing production for the tour.

Mack uses relatively few effects. "We have one reverb, one delay and one multi-effects that I use two effects on," he says. "There's a flange that was on the album and a chorus. That's it. Everything else I try to run as dry as possible."

Erykah Badu sings into a slightly modified Shure SM58. "We tried different vocal mics," says FOH engineer Gordon Mack III.

"Erykah's happy with the regular Shure 58, but she didn't like the wind screen, so we took that off and put a Beto 57 wind screen on it, and it works just fine."

Erykah Badu Mama's

Erykah Badu Mama's

What's your jam

583

583

583

583

2001

Erykah Badu Mama's

All Acces

THE PHOTODUPLICATIONS OF THIS PAGE ARE THE PROPERTY OF THE PUBLISHER AND SHOULD NOT BE REPRODUCED WITHOUT THE WRITTEN PERMISSION OF THE PUBLISHER.



Phattie Drums

The Erykah Badu crew, pictured left to right: Perry Winston (stage manager/backline tech), Jamie Adams (FOH tech), Phil Milferi (lighting tech), Kenn Dugan (monitor tech), Pamela J. Harris (production asst.), Drew Scott (rigger/etc.) and Martin Thomas (lighting director)

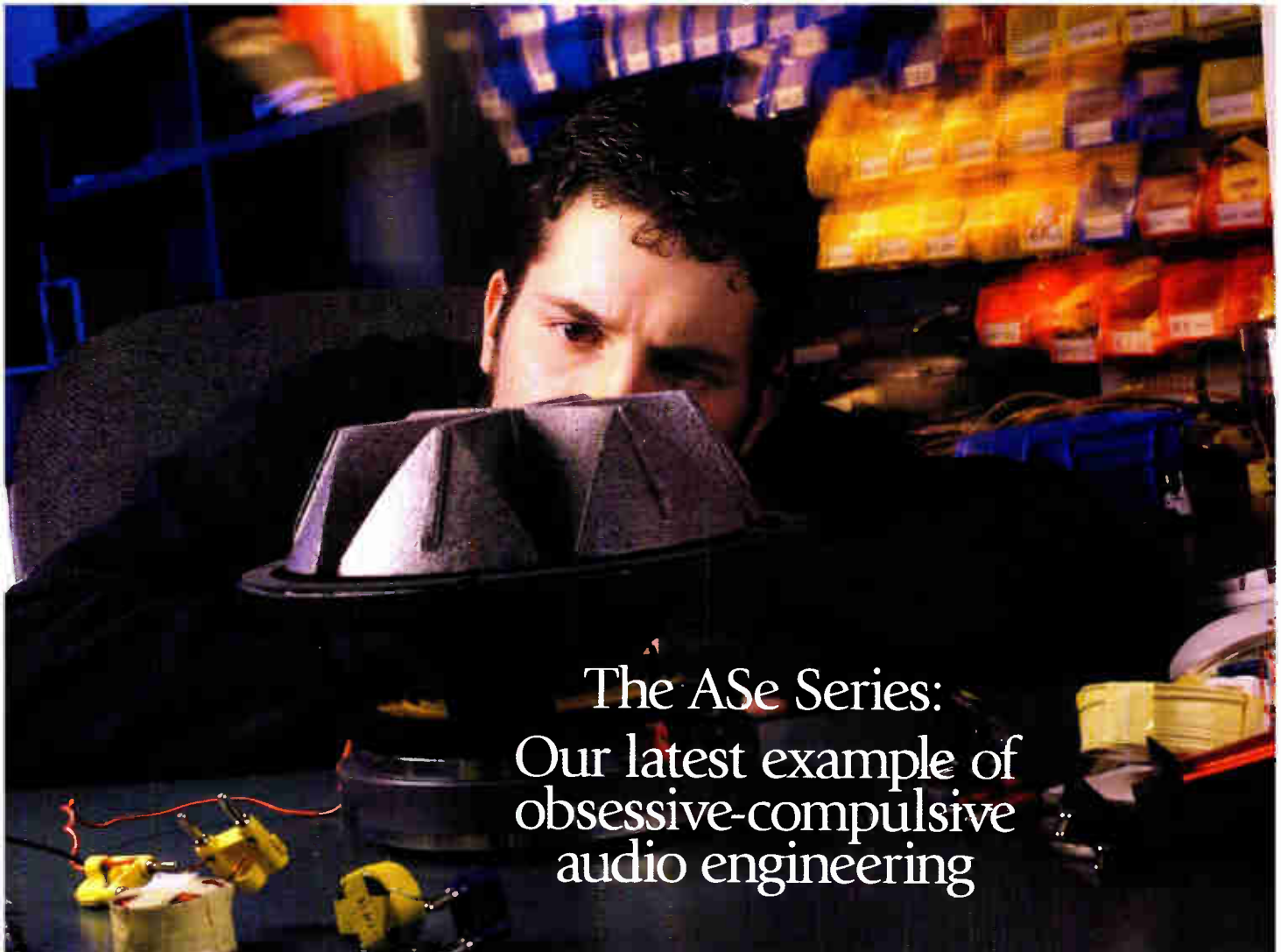

The ASe Series:  
Our latest example of  
obsessive-compulsive  
audio engineering



Our loudspeaker engineers love their jobs. As a matter of fact, they're rather obsessive about it.

Take our popular AS Series. Its long-standing reputation for quality sound reinforcement has made it one of the most successful loudspeaker series for permanent installations currently available. Yet, such credibility only motivated our engineering team to nit-pick the series for ways to make it even better. This led to the implementation of our patented Radial Phase Plug™ for superior intelligibility, a new 2.5-in voice coil neodymium compression driver for higher SPL and improved power handling, new powering configurations for greater flexibility and additional suspension points (18 total) for easier installation.

With so many new features and benefits, who can argue with neurotic perfectionism?

**ASe Series:** The latest result from EAW's obsessive-compulsive engineers.

For more information about the revamped ASe Series, visit us at [www.eaw.com](http://www.eaw.com). In addition to detailed product descriptions about this already successful family of loudspeakers, you will also find downloadable datasheets. Or call 508-234-6158 and request an ASe lit pack.



One Main Street, Whitinsville, MA 01588  
800 992 5013 / 508 234 6158  
[www.eaw.com](http://www.eaw.com)

CIRCLE #092 ON PRODUCT INFO CARD

Mix presents

# REMOTE RECORDING'S

Mix Magazine May 2001

*Finest*



VU LEVEL INDICATOR



*These Legendary Professionals have  
Discovered the Sound of FBT ...*



**PRO  
AUDIO  
REVIEW**  
2000  
**Pick**  
reviewer's

**FBT MaxX 4A**  
Self-Powered Polypropylene  
Speaker Cabinet

*Now it's Your Turn*



Robin DiMaggio  
Drummer  
Paul McCartney  
Steve Vai, Mariah Carey



Vince Garcia  
Audio Engineer  
Universal Studios



Alan Parsons  
Engineer - Beatles and Pink Floyd  
Performer - Alan Parsons Project



Mike Porcaro  
Bassist - Toto



Les Camacho  
Multi-Platinum Studio  
Engineer, Co-Owner  
Cornerstone Studios  
Chatsworth, CA

FBT offers affordable professional quality mixers,  
powered mixers, power amps, speakers and one of the  
World's largest selections of powered speakers and subwoofers for  
Live, Installed and Studio Sound.

So, discover what hundreds of thousands of European Musicians  
and Audio Professionals have since 1961....

The Quality, Sound and Innovation of FBT.

Now available in North America.

**FBT**

FBT USA - North America, PO Box 8144, Berlin, CT 06037-8144 Phone: 800-333-9383 email: [fbt@worldradiohistory.com](mailto:fbt@worldradiohistory.com) www.fbt.com

CIRCLE #093 ON PRODUCT INFO CARD  
World Radio History

by Dan Daley

## Where the Media

# Meets the Road

**T**hey are the last of the professional audio cowboys. Whether in an independently owned rig or a corporate tractor-trailer, remote recording specialists have maintained a mystique that has survived the transformation of audio into a multinational mega-business. They've managed to do that with a unique combination of technical resourcefulness (not many people can wire harnesses for patchbays and spark plugs), recording and mixing acumen, and the ability to apply their talents and skills across a wide range of situations—from recording a large-venue music concert to a network awards broadcast to a critical club gig. And often in the same week.

Remote recording is one of the few threads that run the length of the professional audio industry. Starting with field recordists like Art Satherly in the 1920s and Alan Lomax in the 1930s—who exposed the world to music from outside the traditional recording centers—the notion of “taking it on the road” blossomed as rock became the primary driver of the music business in the 1960s and '70s. Live concert albums often became the career-makers for recording artists, most notably for Peter Frampton with the 1976 blockbuster *Frampton Comes Alive!*

With more music on television and a dramatic increase in live concerts broadcast in prime time, remote recording has become a critical link between the two entertainment domains. Audio, it seems, has been inching toward a parity with picture in the broadcast industry, laying the groundwork for the success of new broadcast audio innovations such as Dolby Surround and now Dolby E. With the explosive growth of cable and satellite television in the 1990s, remote recording trucks proved crucial in helping the entertainment industry develop new content to fill scores of new channels. There are now, as *Daily Variety* has noted, more awards shows on television than ever before, and each of them has at least one audio rig parked outside the venue, making sure they all sound great. And as programming ranges further and further afield to capture content (can you say “reality TV?”), the trucks will roll with them.

The fact that remote recording vehicles are self-contained studios has compelled the leaders in that market to stay as cutting-edge as possible, artfully devising ways to integrate new systems and platforms into limited spaces. On the other hand, the owner/operators must retain the best of the classic gear to assure that the music tracks are on par with any top-flight, land-based recording facility. That's a balancing act that deserves its own awards show.

The need for high-quality remote recording and mixing services will continue to expand for all of the reasons noted above, and because one of the Internet's most significant effects on show business has been decentralization, making almost anywhere a potential Media Mecca. New business has also broadened the base of mobile facilities, as have new and cost-effective digital technologies. Add a computer room, and you have a Webcast remote. There are now more remote companies that can service more strata of the music and media business. And it will only keep growing.

Still, there will only be a few that occupy the high end. And those are commemorated in this edition of “Mix's Finest.” When you only have one chance to get it right, you'd better be relying on the best. ■

## Contents

- RF2 Artisan Recorders—Mobile
- RF3 Aura Sonic Ltd.
- RF4 CSP Mobile Productions
- RF5 Design FX Remote Recording
- RF6 Eurosound
- RF7 Native Country
- RF8 Record Plant Remote
- RF9 Remote Recording Services
- RF10 Sheffield Remote Recording
- RF11 Skyelabs Mobile Recording & Broadcast
- RF12 Studio on Wheels



PHOTOS: MARK DIAMOND OF PANORAMIC SERVICES

## Artisan Recorders—Mobile

**F**ounded in 1977 by president and chief engineer Peter Yianilos, Artisan Recorders Inc. is the oldest continuously operated remote recording company in the Southeast.

Yianilos' philosophy is reflected in the name of the company—Artisan—and he has focused the company on one market: music. "I love to make music and make it well," says Yianilos. As a result, Artisan has become the truck of choice for a lengthy list of leading recording artists, engineers and producers. These include the Rolling Stones (*Steel Wheels* live album), Luciano Pavarotti, Whitney Houston, Trisha Yearwood with the London Symphony Orchestra, the Dave Matthews Band, Smashing Pumpkins, and many more. And for two years, Artisan has been the mobile control room throughout the country for Tom Joyner's acclaimed live music syndicated radio program.

Artisan's first incarnation was as a clever conversion of a GMC motorcoach, which Yianilos remembers fondly as more of an expression of youthful exuberance than the result of careful analysis of studio design. But that willingness to keep the music at the center of every decision, business or technical, has been at the core of Artisan's success over the last 24 years.

The current Artisan truck came online in 1993, and in 2001, underwent a comprehensive upgrade, with new acoustical, technical and aesthetic additions that further enhanced Artisan's already renowned reputation for music recording and mixing. The extensive remodeling of the control room by John Arthur of Miami-based John Arthur Design Group included en-

hanced isolation, thanks to over 2-tons' worth of mineral-loaded vinyl (no lead content) and MDF board suspended on springs. "The ability to get this level of isolation in a remote truck is critical for music," says Yianilos. "In concert situations, we can get this control room as close to the venue as needed and not have the recording affected by high SPL." And this Artisan truck is designed with a very human touch—Yianilos purposely had the 38-foot-long trailer positioned at just 24 inches off the ground. "It might seem like a small thing, but what that serves to do is to make the truck much more inviting from the first moment you encounter it," he says. "Standard-height trucks can be intimidating. This one actually beckons you aboard."

An Amek Hendrix console fitted with Super True automation offers analog warmth and high flexibility; combined with onboard analog and digital sidecar mixers, Artisan offers up to 120 inputs. Vintage analog outboard gear, such as UREI 1176 and LA-4 units, and a microphone array including Neumann, AKG and Sennheiser, truly bring a classic music studio right to any doorstep. Artisan director of operations Natalie Eckart says that building a truck and a business around music has proven to be a successful plan. "Peter is a musician, and there's always at least one other musician on the crew," she says. "The technical excellence has always been there—Peter wouldn't have it any other way. But there is also always the fact that we can communicate with musicians in a very unique manner. We speak the same language. We always have, always will." ■

### SPEC SHEET

**Company Name:** Artisan Recorders Inc. **Contact:** Natalie Eckart, Director of Operations. **Services Offered:** Remote audio recording, editing and mixing; audio production and mastering; audio remote broadcasting; customized equipment flight pack also available. **Main Technology Platforms:** Amek Hendrix (40 mono, 4 stereo, 4 stereo returns; 24 group, 12 aux sends, full Super True automation); Hill Multimix 16x4 submixer (2); Yamana 02R V.2 (2); Yamaha 01V; Sony PCM-800/Tascam DA-78 HR digital 8-track with timecode and remote (10); MCI JH114 24-track (14-inch reel capacity) with Dolby SR/A noise reduction (2); Ampex ATR102 1/2-inch stereo mastering recorder; Dolby 363 SR/A stereo noise reduction; Pro Tools 5.1, 24Mix system, 838/24 I/O, software from Waves, TC Works and Bias; Hafler TRM 8 active monitors; custom 50-channel active splitter systems, three-way line-level output, plus direct out/channel 800-foot cable (2). **Truck Information:** 36x8.5-foot custom-designed trailer, 370-h.p. Cummins-powered Volvo tractor. **Partial Credit List:** Barenaked Ladies, Disney/ABC, Gloria Estefan, MTV Networks, Prince, Sony, Universal, Univision.



### Artisan Recorders—Mobile

PO Box 70247  
 Ft. Lauderdale, FL 33307  
 Tel.: 954/566-1800  
 Fax: 954/566-3090  
 Website: [www.artisanmobile.com](http://www.artisanmobile.com)  
 E-mail: [mobile\\_red@aol.com](mailto:mobile_red@aol.com)

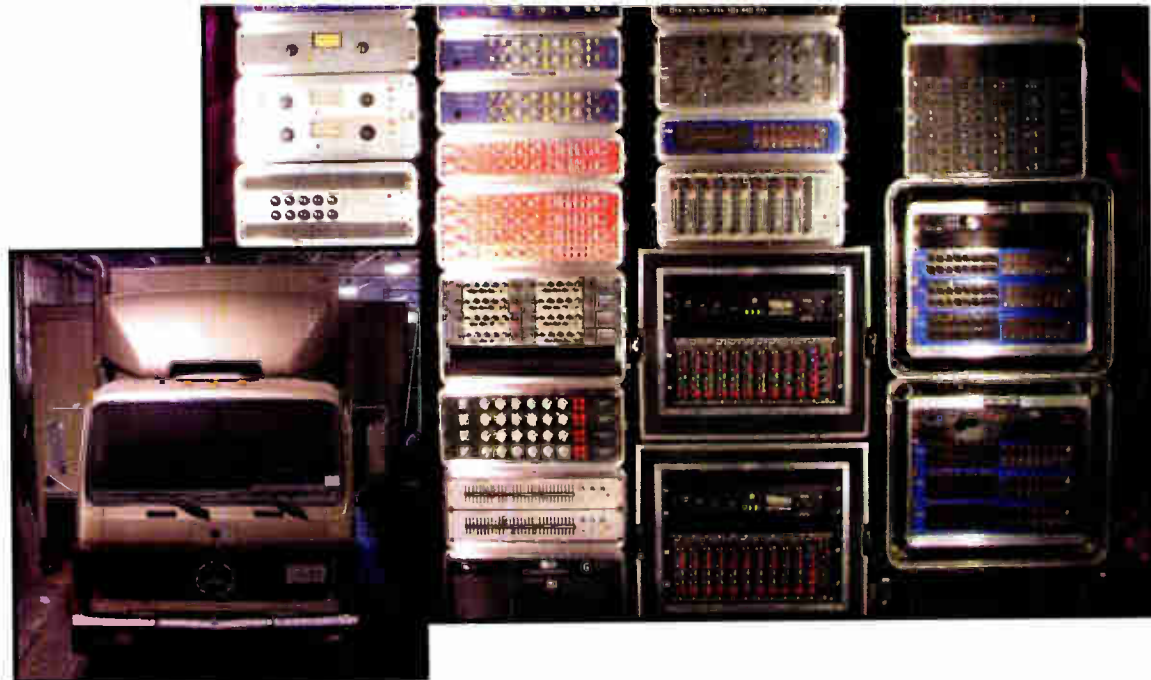

PHOTO: STEVE REMOTE

## Aura Sonic Ltd.

**A**ura Sonic Ltd. (ASL) was established in the late 1970s by Steve Remote to provide a variety of location recording and broadcast production facilities. Remote has arranged his resources in a flexible manner to allow for a number of custom configurations, ranging from ASL's two fully equipped remote trucks to portable "break-away" audio recording and mixing packages, customized for each project. ASL custom systems can be set up at any facility, venue or location for local or global remote recording and live mix coverage.

ASL's two well-outfitted trucks are just as flexible. Analog and digital audio components can be configured to meet the client's request in an "a la carte" style. The new "multifunction" mobile unit with hydraulically expanding control cabin (available summer 2001) can handle 2- to 144-track audio recording, with over 264 inputs available. The second mobile unit can handle 2- to 96-track audio recording with over 172 inputs available. The ASL trucks are customized for each and every project from a full complement of analog and digital gear.

Both ASL mobile control cabins have been ergonomically designed for maximum efficiency. Complete control and overview of the console, signal processing and video monitors are possible from the mix position, and the main patchbay system is centrally located. Additional ASL and/or guest equipment, including mic pre's, mixers, processing, multitrack machines, etc., can be interfaced to the ASL system via various audio/video panels. Separate air conditioners provide consist-

tent, reliable cooling, and Ultra isolation and power conditioning keep the AC power clean.

Though its beginnings were in live music recording, ASL,

today, is a multifaceted mobile and location facility, with credits in recording, film, video, radio and the television broadcasting industries. ASL clients include ABC, BBC, CBS, ESPN, FM Osaka, FM Tokyo, FOX, HBO, Matsushita/Panasonic Visuals Inc., MTV, Netherlands Programme Service, NHK, NPR, PBS, Paramount, Showtime, Tokyo Broadcasting, Turner Broadcasting, USA Networks, VH-1, Warner Bros. Pictures, WBCN-FM, WBGO-FM, Westwood One, WNYC-FM, WQCD-FM, plus many record labels.

Capturing the sound the client wants is, of course, key to the success of Steve Remote and ASL. Remote also attributes his longevity to ASL's unique position in the business. "The niche I fell into was having the truck that is between the large and small trucks that are around," Remote explains. "Today, our mobiles and portable packs can complement any production venture, big or small, from a super-small box to a multifunction expanding truck.

"ASL takes a fresh look at each and every audio recording and live mix project it gets involved in," continues Remote. "The company is designed to provide an efficient and economical way to integrate quality audio components with the finest on-location audio production techniques. We've always been dedicated to satisfying the needs of our colleagues and clients, and we've succeeded consistently with this approach."

### SPEC SHEET

**Company Name:** Aura Sonic Ltd. **Contact:** Steve Remote, President/Chief Engineer; Victoria Bonadonna, Director of Client Relations. **Services Offered:** Truck-based and portable audio recording, editing and mixing; audio engineering and consulting services for broadcast, music recording, film sound, teleproduction audio, streaming media and live sound reinforcement. **Main Technology Platforms:** Otari Status 18R 48-channel, 96-fader dual-path console; Millennia Media Mix Suite (3); API 3124 48-channel mic pre's; True Systems Precision 8 48-channel mic pre's; 48 channels of Focusrite ISA215. Audio Toys Pro6, Midas XL42, Daking 52270; Yamaha 01V (3); Otari MTR90 MkII 2-inch analog multitrack (2); Tascam MX-2424 (2); Tascam DA-88 (14); Tascam DA-45 HR (2); Alesis ML9600 Masterlink (2); M&K 2510P (5); M&K 5:1 OSUB (2); Genelec 1031A (4); K&H 92 (2); Mackie HR824 (4); Over 240 microphones by AKG, Audio Technica, B&K/DPA, Beyer, Caler, Crown, E-V, Milab, Neumann, Royer, Sennheiser, Shure. **Partial Credit List:** Rod Stewart; Netherlands Metropole Orchestra; The Corrs; 'N Sync Bon Jovi, Staind; POD; Sinead O'Connor; Stone Temple Pilots; Everclear; Carlos Santana; Christina Aguilera; Tori Amos; Chick Corea & Origin; Marc Anthony; Joe Jackson; Red Hot Chili Peppers; Live; Silverchair; Faith Hill, Fuel; Wynonna.

## Aura Sonic Ltd

THE HOME OF ASL'S MOBILE & LOCATION PRODUCTION

### Aura Sonic Ltd.

(ASL Mobile & Location Production)  
PO Box 520791  
Flushing, NY 11352-0791  
Tel.: 718/886-6500  
Website: www.aurasonicltd.com  
E-mail: aurasonic@aol.com



PHOTOS: GEORGE BENNINGTON

## CSP Mobile Productions

The latest addition to CSP Mobile Productions' remote recording fleet is Unit Six, a cutting-edge, dedicated audio truck. This state-of-the-art studio on wheels is

crafted around Yamaha's new PM1-D digital console, already widely acclaimed for a design that performs excellently in both live and studio settings. The 96-input Yamaha console is supported by 48 tracks of Tascam DA-78 MDMs, 48 tracks of hard disk recording/editing capability and a Macintosh G4 editing front end with MOTU interface. Also integrated into the original design is 5.1 surround monitoring and mixing capability, with monitoring provided by Genelec self-powered units.

The truck also offers a full complement of analog processing gear and a wide array of microphone choices. CSP VP/operations manager Len Chase designed the tight and remarkably accurate acoustical environment, which features diffusion in the control room's ceiling and bass traps in the corners. Two 43-inch plasma display monitors are easily visible, both from the engineering position and from the client lounge, features that make Unit Six one of the most comfortable remote units on the road.

CSP's two remote video trucks were also designed by Chase and his engineering team and constructed at CSP's Maine headquarters by New England craftsmen. That design combination of comfort and cutting-edge technology is part of a strategic plan to position Unit Six as a leader in remote music production and mixing.

"With our emphasis on 5.1 surround, Unit Six was designed to be as close to a recording studio as feasible in a remote facility," explains CSP Mobile Productions president Nat

Thompson. "Our aim is to make recording artists, producers and visiting engineers as comfortable as possible." Adds Lance Vardis, the mixing engineer who helped significantly in the design of Unit Six, "It's as close as you can get to being in the club or the arena for a performance. But going one step further, what we're doing here is basically bringing the surround capability out of the studio and right to the venue. What we hope is that when broadcasters and concert promoters hear how much surround adds to a music broadcast, it'll encourage them to pursue more and more music broadcasts in surround." Thompson also says that DVD is rapidly becoming the format of choice for in-concert music videos—such as the one that Unit Six recorded for the Foo Fighters recently—and that DVD-A will create further demand for surround capability in remote recording operations.

CSP Mobile Productions is a division of Maine Radio and Television Company, an icon of American broadcasting since 1925, and still owned and operated by members of the founding family.

CSP offers an entire package of audio and video-remote capability, along with a technical and creative team that underscores the company's long heritage. "And we offer one more thing," adds Thompson, "and that's a vision of the future of remote music recording." ■

### S P E C S H E E T

**Company Name:** CSP Mobile Productions. **Services Offered:** Full-service remote audio and video recording, mixing and editing; discrete 5.1 surround audio monitoring and mixing; production services, including scripting, directing and post-production in conjunction with Tupelo Honey Productions. **Main Technology Platforms:** 96-input Yamaha PM1-D digital console; Tascam DA-78 and hard disk multitrack recording; Genelec monitoring; processing includes Lexicon, Drawmer, Eventide, TC Electronic; 42-inch plasma displays (2); control room: 8'6x13; lounge: 8'6x9; engineering area: 8'6x6. **Truck Information:** 1996 Chevy W7, 6-cylinder/270-h.p. w/a 2,000 28-foot Morgan box. **Partial Client List:** Foo Fighters, Allman Brothers, Barenaked Ladies, Tibetan Freedom Concert, Woodstock.com, Aerosmith, Stone Temple Pilots, Third Eye Blind, Wynton Marsalis. (Many of these performances were distributed by Spring Communications.) CSP also provided facilities for a long list of major league sports, corporate and network broadcast productions.

# CSP

Mobile Productions, LLC

### CSP Mobile Productions

One Delta Drive  
Westbrook, ME 04092-4745  
Tel.: 207/375-6052  
Fax: 207/856-2861  
Website: [www.cspmobile.com](http://www.cspmobile.com)  
E-mail: [go@cspmobile.com](mailto:go@cspmobile.com)

World Radio History



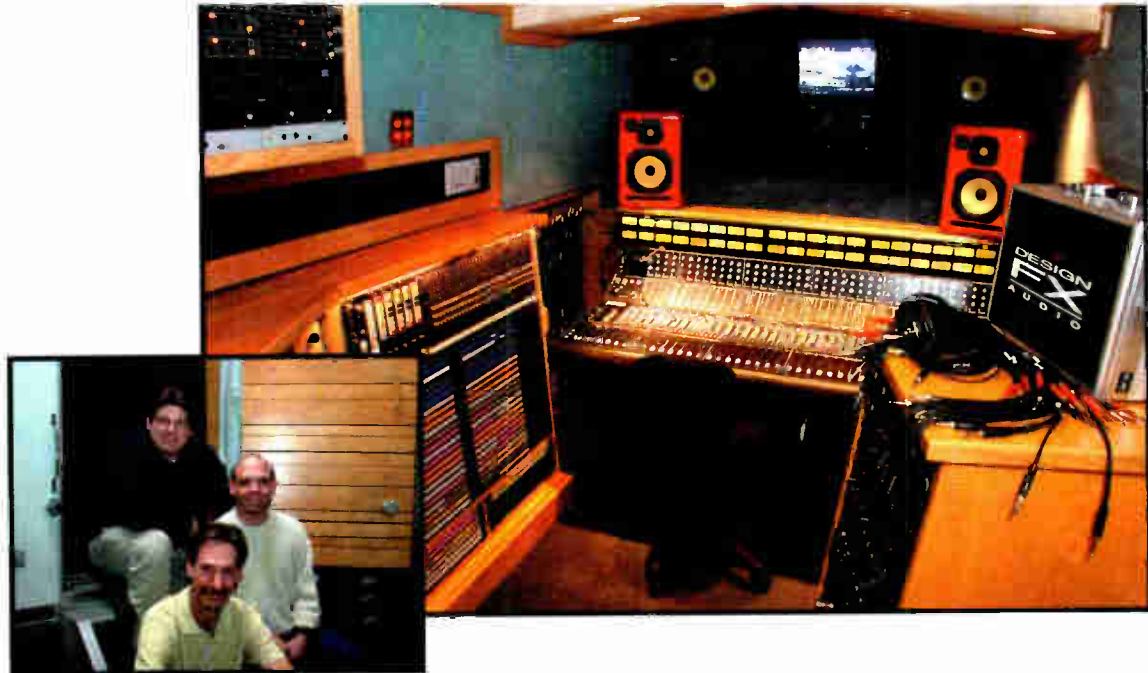

PHOTOS: DAVID GOGGIN

## Design FX Remote Recording

**D**esign FX Remote Recording came into being in 1991 when Design FX Audio, one of the professional audio industry's leading equipment rental companies, purchased one of the original Record Plant remote recording trucks and proceeded to completely remodel and upgrade it. Jack Crymes, the original designer of both the Record Plant trucks and the early Wally Heider trucks, came on-board to oversee and direct all of the technical engineering, along with Design FX tech Allen Baca and master carpenter Dave Mailand. The result is a superb combination of technology, creativity and mobility.

The remodeled truck, equipped with a vintage 44-input API console, made its debut at the 1991 MTV Music Awards, which were broadcast live from L.A.'s Universal Amphitheater. The mobile studio was later moved onto a more powerful International cab, and since then, the Design FX Remote unit has been from Vancouver to Mexico City and many points in between.

In 1994, Design FX decided to further upgrade the truck's classic API console. Jack Crymes, a pioneer in remote recording for the past 25 years, joined forces with API specialists John Dressel, Jeff Bork and Design FX Audio president Gary Ladinsky to design a new custom API input module, one adapted especially to live music recording. Retaining the classic API components, such as the 2520 op amps and the legendary 550A EQs, the design team added an entirely new level of flexibility for live recording applications with modifications such as additional aux sends, dual-mix buses, direct outs, P&G faders, fader flips and a versatile solo system. Design FX Remote Recording has an un-

usual advantage: As a division of a leading equipment rental company, the remote truck operation can call upon an extensive menu of both stock and exotic audio devices, from mixers to micro-

phones, outboard gear to hard disk recording systems. And, as Ladinsky points out, access to such a wide array of equipment has given the staff of Design FX Remote Recording a tremendous depth of knowledge and operational experience. "We're in the unique position of being able to not only supply any hardware you could want, but also the expertise to operate it to its maximum potential," says Ladinsky. "Our clients get a crew that has probably done it all on anything you can think of under any circumstances and at every type of venue. We've done live recordings directly to Pro Tools, and we can do that with the same level of confidence that you would get with an open-reel multitrack machine. The range of hands-on experience we can bring to a project is very, very intense."

That kind of performance is what's behind a long and acclaimed list of Design FX Remote Recording clients. In addition to an Emmy Award for Best Sound for a Special Presentation (Natalie Cole's "Unforgettable-With Love"), the truck and its crew were responsible for this year's Grammy for Best Jazz Album (Dianne Reeves' *In the Moment*), plus five Emmy nominations, various TEC Award nominations and Golden Reel awards.

"It's a great remote truck," says Ladinsky. "But behind the door, there's more than a control room—there's a huge wealth of human and technological resources at your service."

### SPEC SHEET

**Company Name:** Design FX Remote Recording.  
**Contact:** Scott Pests, Remote Recording Manager.  
**Services Offered:** Remote audio recording, remote broadcast, mixing transfers, field packages available.  
**Main Technology Platforms:** 44-input API analog console with 55A EQ and expanded input modules; every type of recording media, from tape (analog and digital) to MDM to hard disk is available through Design FX Audio Rental Divisions.  
**Vehicle Information:** International cab, 37-foot box. **Layout:** Control room area: 14x6'6" (from console edge).  
**Partial Client List:** Elton John, Vanessa Williams, Babyface, Faith Hill, Seal, David Foster, Clint Black, Eagles' Hell Freezes Over tour, Sheryl Crow, Tony Bennett, Aerosmith, Neil Young, Barbra Streisand, Guns N' Roses, American Music Awards, Tom Petty, Santana, Sting.



#### Design FX Remote Recording

PO Box 491087  
 Los Angeles, CA 90049-9087  
 Tel.: 818/843-6555  
 Fax: 818/562-6978  
 Website: [www.dfxaudio.com](http://www.dfxaudio.com)  
 E-mail: [remote@dfxaudio.com](mailto:remote@dfxaudio.com)



## Eurosound Mobiles

**E**urosound Mobiles has truly broadened the definition of the term "mobile recording." Since its founding by veteran live sound engineer Jan de Groot in the

Netherlands in 1971, Eurosound's trucks and systems have ranged around the world, from Moscow to Athens to Nicaragua to Curacao. Celebrating its 30th anniversary this year, Eurosound now operates from bases in the Netherlands and Germany, where the company established a presence in 1989. Chief Engineer Peter Brandt heads the group.

Six mobile trucks are now in operation, along with Eurosound's globe-trotting Airpack System, a compact and flexible flight case-based recording system for both analog and digital, which can be configured for up to 96 channels and can play back and mix in 5.1 surround.

Each of Eurosound's mobile units has unique characteristics, but they all share the common attributes of being highly flexible and configurable, having advanced technology and high-maintenance standards with accurate acoustics. More specifically, to enable them to cover a wide range of applications, each Eurosound mobile unit is equipped with triple-standard (PAL, SECAM and NTSC) video monitors and cameras, one- and two-pair wired communications, wireless communications adaptable to any local frequency standards, full timecode and sync capability, active and passive splitter systems and a massive microphone selection. Each mobile unit also has a broad selection of

outboard gear, including models from Lexicon, UREI. Eventide, Drawmer, Dolby, GML and Summit, as well as a variety of 36, 48 and 96-input Raindirk consoles and other consoles, including Crest Vx and Yamaha submixers available.

Options for each mobile unit include vintage Neumann tube microphones, a 6-channel headphone system with up to 100 headsets, surround recording and monitoring, and 64-channel Pro Tools systems, with a variety of A/D converters available.

Eurosound Mobiles' trucks and systems have been used by a broad range of artists, engineers and producers, in an equally wide variety of applications and venues. Rock artists such as Bon Jovi and The Scorpions, producer/engineers including Ed Cherney and Elliot Scheiner, and the Berlin Philharmonic Orchestra have all used Eurosound's resources. Little wonder that Chris Stone, founder of the World Studio Group, called Eurosound Mobiles "the finest remote recording company in Europe."

They certainly are the most multicultural. Says Peter Brandt, "Europe is a huge market to service. While the EU has made getting around it easier, we still have to be fluent in several languages, and we have to have the technical and aesthetic ability to go from recording rock to Bach. Much of Eurosound's success is based on our technical abilities and our cost-effectiveness. But it's also because we know how to treat both Luciano Pavarotti and the Rolling Stones."

### SPEC SHEET

**Company Name:** Eurosound Mobiles. **Contact:** Peter Brandt. **Services Offered:** Live recording; broadcast audio; recording and production for DVD, television, video and film; stereo and 5.1 surround recording and mixing. **Main Technology Platforms:** Raindirk Symphony consoles (4), Crest Vx console; Sony 3348 HR, Studer and Otari analog multitrack and Tascam DA-88 (16-bit) and DA-98/78 (24-bit) tape formats; Pro Tools: Genex 8-track hard disk recorder, Euphonix 48-track hard disk recorder. **Vehicle Information:** Mercedes 809, 914, 1117, Daf 1900 Ns, VW Lt. **Layout (in meters):** Mobile 1—7, 15x2.2x3.45; Mobile 2—8, 3x2.4x3.45; Mobile 3—9, 4x2.45x3.6; Mobile 4—11, 3x2.5x3.82; Mobile 5—(under renovation); Mobile 6, 6x2.3x2.5. **Partial Client List:** The Rolling Stones, The Eagles, Sting, Elton John, Bruce Springsteen, Bon Jovi, The Scorpions, Luciano Pavarotti, Genesis, Toto, Dire Straits, Peter Gabriel, Madonna, Bryan Adams.

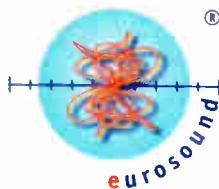

#### Eurosound Mobiles

GERMANY: PO Box 180220

42627 Solingen, Germany

Tel.: 49/212/254-1225 • Fax: 49/212/254-1227

GSM: 49/171/212-3171

Website: [www.eurosound-mobiles.com](http://www.eurosound-mobiles.com)

E-mail: [info@eurosound.de](mailto:info@eurosound.de)

NETHERLANDS: Dijkstraat 5

6674 AG Herveld, The Netherlands

Tel: 31/488/451048 • Fax: 31/488/451042

Website: [www.eurosound-mobiles.com](http://www.eurosound-mobiles.com)

E-mail: [info@eurosound.nl](mailto:info@eurosound.nl)



March 1, 2001 Universal Studios, Florida  
Ikegami DNS-201 digital disk camera in action.  
Dave Faires, producer and Athena Barton, actress  
in production of the feature film *The Calendar*.

PHOTO: STAFF



March 1, 2001 Universal Studios, Florida

## Native Country Studios

**M**obile Disk sets a new benchmark for the future of integrated, disk-based multimedia remote production and post-production. The truck, which was nearly two years in development, design and construction, combines complete digital audio, video and graphics capabilities into a single, highly sophisticated mobile unit with applications that range from film and television production and post-production to Internet and satellite data transmission. Owned by Native Country Studios, the truck is ready for the advent of HDTV, even as it covers all of the bases in contemporary broadcast and film production.

While Native Country Studios was intended to be a highly comprehensive mobile multimedia suite, the vehicle's design put a considerable emphasis on audio. All signals in the truck, including audio, are routed through a central digital PESA routing system, and AES/EBU and analog I/Os are included. Two Avid 9000 Media Composer stations and one of the two Mac G4-based graphics stations have a dedicated Yamaha 03D digital mixer. An 8-channel Digidesign Pro Tools system with Mac G4 front end is the truck's main audio recorder/editor, but any other format, digital or analog, can be specified. As Wayne Wolfe, Mobile Disk chief engineer, observes, "Someone once told me that picture without great audio is just surveillance. We really put a lot of thought into this truck's audio capabilities."

Furthermore, the truck offers many of the technical and comfort amenities of the most sophisticated post facilities, in-

cluding an iso booth designed for ADR and voice-over applications. "Having the ability to do ADR onsite is a tremendous asset to any type of production," says Wolfe. "Audio fixes can be accomplished immediately while the talent is still at the production site. That has significant artistic and economic implications." The truck also features a very comfortable VIP lounge, which can seat up to seven people.

Mobile Disk's audio design also includes dedicated 5.1 surround capability, using Tannoy Active Reveal main monitors in the front and rear arrays, with a Bose center channel. Acoustically, says Wolfe, the truck's audio areas approach anechoic accuracy, thanks to the use of advanced absorption materials and a control room design that virtually eliminates reflections.

State-of-the-art video capability includes Ikegami DNS-201 disk-based digital cameras and Sony 42-inch plasma display, easily viewable from both the workstation and VIP areas. Audio and video are fully synchronized within the routing system, and all of the truck's technology platforms—from hard disk recorders to interior lighting—can be self-sufficient, thanks to a Litepower 120kW/933-amp onboard generator.

Lewis Barton, president of Native Country Studios, notes that, "This is what remote recording is moving toward: an integrated, multimedia, nonlinear digital environment that can go anywhere and work in virtually any application. This truck is ready for the future. Fortunately, it's here now."

### SPEC SHEET

**Company Name:** Native Country Studios. **Contact:** David Ferris, manager of remote productions; Wayne Wolfe, chief of engineering. **Services Offered:** Remote recording, mixing, 5.1 surround encoding/decoding, DVD authoring, ISDN, ADR, real-time satellite transmission, digital hard disk video recording, editing and graphics. **Main Technology Platforms:** Yamaha 03D digital mixers (3); Dolby 5.1 Surround codec, Pro Tools w/Mac G4 front end, Avid Media Composer (2); all analog and digital audio formats available upon request, Pesa AES router, Tannoy main monitors w/Bose center channel, Ikegami DNS-201 disk video cameras. **Vehicle Information:** Peterbilt tractor with 120kW/933-amp onboard generator, 50-foot Gerstenlager trailer. **Partial Client List:** Universal Pictures, ESPN, Native Country Studios of Nevada, Channel 4 Orlando.



#### Native Country Studios

9000 Las Vegas Boulevard  
North Las Vegas, NV 89115  
Tel: 702/644-4000 (Las Vegas, NV);  
407/932-3000 (Orlando, FL)  
Fax: 702/644-7000

Website: [www.nativecountrystudios.net](http://www.nativecountrystudios.net)  
E-mail: [info@nativecountrystudios.net](mailto:info@nativecountrystudios.net)



## Record Plant Remote

**R**ecord Plant Remote has been a leading presence on the highways and at music venues for over two decades. Originally the mobile arm of the legendary Record Plant Studios in New York City, Record Plant Remote has retained not only the studio's heritage but its human heart as well, in the person of Kooster McAllister, who first came to Record Plant in 1978 and became chief engineer for the studio's remote operations in 1983. In 1989, McAllister acquired the remote operations and has continued to add to its legacy and reputation. Both man and truck have accumulated a slew of industry accolades, including four TEC Awards for Remote Recording Facility, and the past two TEC Awards for McAllister himself as Remote Recording Engineer.

McAllister has always been Record Plant Remote's guiding force, but in the dozen years that he has been its owner, McAllister has deftly managed to balance the classic elements of the mobile studio—which was originally designed by Tom Hidley—with an evolutionary thread that has kept the truck at the cutting edge of audio, technologically and acoustically. Over the years, the outboard signal processing has grown to encompass the best digital systems available, yet vintage items such as UREI 1176 compressors still lend warmth to the sound. The venerable 54-input, all-discrete API console has been constantly upgraded and meticulously maintained and still retains the classic sound that has made Record Plant Remote the first choice for leading producers and engineers, including Kevin Shirley, Elliot

Scheiner, OB O'Brien and David Thoener, to name just a few.

"It's amazing how many people come back, year after year, saying that the sound of this truck rivals any studio they've ever worked in," McAllister says. "And I believe that's due in large part to the fact that Record Plant Remote has always been cultivated as a recording studio control room first, with the fact that it's mobile an added attraction."

Record Plant Remote has supported dozens of live network, cable and satellite music broadcasts—for instance, the studio does the vast majority of the live music acts appearing on ABC-TV's *Good Morning America*—and has developed significant expertise in multichannel audio, from Dolby Pro Logic matrixed surround to 5.1. In fact, Record Plant Remote is in the process of carving out a significant niche in the new high-resolution DVD-Audio format, having done the recording for two groundbreaking multichannel best-sellers (Peter Dinklage and Janet Jackson). Furthermore, Jackson's DVD was also edited and mixed to picture aboard Record Plant Remote, underscoring how the truck has evolved into a mobile music post-production environment.

Last year, Record Plant Remote underwent another round of upgrades, with many cosmetic changes to enhance the truck's interior and the addition of a dedicated producer's desk area. What will never change, McAllister stresses, is his and Record Plant Remote's dedication to making the music the primary mission. As he puts it: "The music has always—and will always—come first in this truck. Our reputation speaks for itself." ■

### SPEC SHEET

**Company Name:** Record Plant Remote. **Contact:** Kooster McAllister. **Services Offered:** Audio remote recording, editing and mixing; broadcast; audio post-production. **Main Technology Platforms:** 54-input/48-bus API console w/Touch Reset and API 560 EQ and GML Moving Fader automation; Sony 3348, Pro Tools, Ampex MM1200 24-track (2); Tascam DA-98 (12 units/96 tracks); monitors include Meyer HM-1 and HD-1, Genelec 1031, Yamaha NS-10 and Tannoy 6.5; large selection of vintage and digital outboard gear; Panasonic and NEC color monitors (3); 56-input splitter box w/Jensen transformers, Apogee PSX-100 converters. **Vehicle Information:** 1990 Volvo FE7-15, 36x8-foot. **Partial Client List:** Bruce Springsteen, Korn, Billy Joel, Aerosmith, Sarah Brightman, Pearl Jam, Black Crowes w/Jimmy Page, Itzhak Perlman, Tom Petty, Mariah Carey, Godsmack, Dave Matthews Band, Collective Soul, Sevendust, Faith Hill, Vince Gill, Bela Fleck, Alan Jackson, Macy Gray, Metallica, Stone Temple Pilots, Limp Bizkit, Ozzy Osbourne.



#### Record Plant Remote

1170 Greenwood Lake Turnpike  
Ringwood, NJ 07456  
Tel.: 973/728-8114  
Fax: 973/728-8761

Website: [www.recordplantremote.com](http://www.recordplantremote.com)  
E-mail: [kooster@warwick.net](mailto:kooster@warwick.net)



## Remote Recording Services

**F**ounded in 1979, Remote Recording Services is one of the longest-running, top-tier, independently owned remote operations in North America, and owner David Hewitt is widely considered one of the deans of the remote recording industry. It's also still a family business, with Hewitt's sons Ryan and Nathaniel often sharing engineering responsibilities with their father. As a result, Remote Recording Services offers a unique combination of cutting-edge technologies and highly personalized service.

Hewitt—who has won seven TEC Awards and numerous Grammy and Emmy Awards—presides over one of the most efficient and effective crews in the business, including director of operations Phil Gitoimer and engineer Sean McClintock.

Designed by Hewitt, Remote Recording Services' Silver Studio features custom-built double walls and ceiling for optimal sound isolation. Construction is of MDF sandwich over sprayed foam insulation, finished in cherry hardwoods, fabric panels and carpeting. The floor is 1.75-inch ship lap oak over 3-inch steel I-beams with foam insulation.

The main technology components of the Silver Studio are a 48-input Neve VR M console (with Studer Series 900 submixers), flanked by dead front wall-mounted cabinets holding an assortment of outboard gear, patchbays and machine remotes. There is banquet seating to the rear for the producer and other VIPs, and numerous tielines allow this area to function as a second mix position or other production, communications or video tasks. There is complete wiring for up to five 48-

track decks, with sync, timecode and house video reference control. Monitoring is via custom-built soffited main monitors with KRK components, and the Silver Studio can accommodate

multichannel monitoring with additional self-powered KRK speakers. The control room's media array features two Studer D827 digital 48-track decks, a pair of Studer A820 analog 24-track machines and Sony PCM-800 MDMs. Hewitt has configured the truck for any type of interface with the rest of the technological universe, from video trucks to venues.

In fact, it's that very adaptability that characterizes Remote Recording Services. "If you ask me what our specialties are, I'd have to say it's whatever the clients' specialties are because of our flexibility, and that's been our biggest asset over the years," observes Hewitt.

That flexibility has led to a broad array of clients over the company's 22 years of operation, including the Academy Awards, the Grammys and the Emmys. The Silver Studio has also pulled up for Live Aid and, more recently, A&E's "Live by Request" with k.d. lang, the Dixie Chicks' CBS-TV special, Neil Young's *Red Rocks Live* DVD and PBS's acclaimed "Live From the Met" series. Hewitt's long career in music recording—he directed remote operations for Record Plant Studios in New York City in the 1970s—has attracted myriad top artists and producers who choose Hewitt and his truck. "I'm a music guy at heart," Hewitt says, "but I've learned to speak all of the languages you need to interface with television, broadcasting and the rest of the world."

### SPEC SHEET

**Company Name:** Remote Recording Services Inc.  
**Contact:** David Hewitt **Services Offered:** Remote audio and broadcast recording, editing and mixing; flexible equipment package configurations, many equipment rental options available; full interface capability with film and video. **Main Technology Platforms:** 48-channel Neve VR M console w/Total Recall and Flying Faders 3.0; Studer 900 Series submixers; Millennia and API outboard mic pre's; KRK and other monitoring; Studer D827 (2), Studer A820 (2) w/Dolby A, SR or Telcom noise reduction; Sony PCM-800 (48 tracks); Video: Sony XBR 27-inch color monitor w/switcher; NEC 12-inch monitors (2). **Truck Information:** 1997 Peterbilt tractor with 400-h. Cummins turbo-diesel engine, 44-foot Dorsey Air Ride trailer; 6'8" square engineering area; 7x7'6" VIP seating area; 12'8"x7'6" machine area; 6'4"x7'4" acoustically treated multi-use area. **Partial Client List:** (Artists) Aerosmith, Miles Davis, Pearl Jam, Don Henley, Rolling Stones, Billy Joel, Elton John, Berlin Philharmonic, Backstreet Boys, Madonna, Bruce Springsteen, Eric Clapton, Barbra Streisand, U2, Aretha Franklin, Nine Inch Nails. (Producers/engineers) Phil Ramone, Ed Cherney, Bob Clearmountain, Tom Dowd, Mutt Lange, Elliot Scheiner, Arif Mardin.

#### Remote Recording Services

PO Box 319  
 Lahaska, PA 18931  
 Tel.: 215/794-5005  
 Fax: 215/794-3263

Website: [www.remote-recording.com](http://www.remote-recording.com)  
 E-mail: [david@remote-recording.com](mailto:david@remote-recording.com)

MAIN PHOTO: DAVE KING



INSET PHOTO: DUKE GORE



## Sheffield Remote Recording

**T**he name Sheffield has been synonymous with high-end professional audio for over 30 years, and as part of the larger Sheffield Audio Video Productions, Sheffield Remote

Recording has been in existence for over 20 years. Sheffield's remote truck has evolved in that time, starting with a 30-foot Mack truck loaded with a Neve 8068 console, and is considered by many to be one of the best-sounding remote recording trucks in the world.

Designed by Sheffield Audio Video Productions CEO John Ariosa, Sheffield Remote's new 48-foot truck came online five years ago. This spaciously configured air-ride trailer houses the only Solid State Logic Axiom MT digital console on wheels in North America, confirming Sheffield's position at the forefront of recording technology. With the Axiom MT, Sheffield Remote can offer up to 96 digital inputs; the signal chain includes a fiber-optic connection to remote A/D converters/mic pre's, which can be placed on the stage. "The integrity of the signal is simply amazing," observes Vance, president of Sheffield Remote Recording.

The need to keep clients on the cutting edge of new digital audio technologies stems from Sheffield's roots in both music and audio and video post-production. The company maintains state-of-the-art facilities in Maryland, where there are digital editing suites and a full soundstage, as well as a fully equipped 48-foot video remote truck. However, adds Vance, "As much as we keep the technology up to date, we always make sure that it's proven, tested and reliable technology. The very core notion of remote record-

ing is that you're going out there, and you are going to have one chance and one chance only to get it right. So the equipment has to be the best, the people running it have to be the best, but the technology has to be totally reliable."

Flexibility has been another key feature of Sheffield's operations. For instance, the Axiom MT has Instant Reset of all parameters on the console, allowing instantaneous transitions between events onstage or in the studio. Also, the truck's patchbays and external interfaces allow it to shuttle between diverse situations with ease. "In less than a month, we had worked with NFL Films on the Super Bowl doing voice-overs, set up next to Mariah Carey's house for music recording and we just got back from Ellis Island, where we recorded the Three Irish Tenors for a PBS show," Vance notes.

Sheffield Remote is also equipped with the latest in monitoring—a full 5.1 surround playback system includes Genelec 1031 self-powered speakers and a sub, soft-fitted in the control room area. In addition, a TC Electronic 6000 multichannel processor has been added to outboard racks that are already laden with a wide array of state-of-the-art processors.

"This is a high-end, cutting-edge truck, this is a digital truck, and digital high-technology is the language of the future of music, television, film and Internet audio," says Vance. "But the beauty of this truck is that it strikes a perfect balance between what clients in all those areas need now and what they'll need in the future. It's a tight line for us to walk: it takes constant vigilance. But it's worth that effort to stay on top."

### SPEC SHEET

**Company Name:** Sheffield Remote Recording. **Contact:** Vance, President. **Services Offered:** Audio location recording, editing, mixing, voice over and overdub capabilities. **Main Technology Platforms:** 96-input SSL Axiom MT; 48-track Studer D827; Otari MTR-90 MkII; DA-78 (48 tracks). **Truck Information:** 48-foot air-ride trailer with White Freightliner with super sleeper cab. **Layout:** 10-foot ceilings, throughout, 8x8 raised client area; 40x8 control room. **Partial Client List:** Mariah Carey, Luis Miquel, Sting, New Orleans Jazz Festival, Boston Pops, NFL/Super Bowl.

*Sheffield*  
AUDIO VIDEO  
PRODUCTIONS

#### Sheffield Remote Recording

13816 Sunnybrook Road

Phoenix, MD 21131

Tel.: 410/628-7260

Fax: 410/628-1977

Website: [www.sheffielddav.com](http://www.sheffielddav.com)

E-mail: [vance@sheffielddav.com](mailto:vance@sheffielddav.com)



MAIN PHOTO: ED ALONIA

INSET PHOTO: CHRISTOPHER BUTTNER

## Skyelabs Mobile Recording & Broadcast

**S**kyelabs Mobile Recording was conceived from the beginning as a balance of high technology and human comfort. "Rover," as Skyelabs' highly customized GMC motor coach mobile recording unit is affectionately known, offers the finest in mobile acoustic environments and equipment for live concert recording, remote broadcast, audio for picture and in-house recording. Rover is flexibly configured and can efficiently and accurately handle any type of project with the appropriate technology—from live to 2-track to multiple 33-48s, from complex live broadcasts to straight-ahead multitrack recordings. In any configuration, Skyelabs delivers clean, accurate recordings and broadcasts.

Rover's acoustical design is equally advanced and flexible, featuring both stereo and full 5.1 surround sound mixing capabilities, utilizing Genelec powered monitors. In fact, says Skyelabs president and chief engineer Bob Skye, "This was a case in which acoustics came first, well before the technology platforms were chosen. Job one was to create an environment in which ears came first." And that was definitely achieved with the significant help of noted audio expert Neil Muncy. The result was the first mobile recording studio to offer a certified Live End, Dead End™ acoustical control room design. The accuracy of Rover's control room remains an industry standard to this day.

Rover first rolled out in 1982, when it and Skye were based out of Dover, Del., a central location that enabled the remote unit to cover the major Eastern cities and venues. Since 1986, it has been based in

the San Francisco Bay Area, where Skye also owned The Plant Recording Studios in Sausalito from 1986 to 1993. Rover's technology complement has changed over the years, keeping the

rig at the forefront of changes in pro audio, yet deeply invested in the best that analog has to offer. However, in the course of the most recent upgrade last year, Skye chose to install dual Mackie D8B digital consoles, augmented by Mackie 1604 VLZ analog submixers. "I admit, I'm an analog-oriented engineer," says Skye. "But in recent years, the sessions that clients have been bringing in have become increasingly challenging. There's more broadcast interaction, more input demands, more recall issues all taking place in shorter periods of time. I'm a bottom-line-type of thinker, so, I've chosen technologies that not only sound great, but are also fast to operate, cost-effective and easy to maintain. It's not about brand names anymore—it's about getting the job done right and within budget."

Still, Skye made sure that Rover's creature comforts were on par with its technology. A spacious lounge that overlooks the mixing area has comfortable amenities within easy reach. The coach has been fitted with central air and heat for complete comfort in all weather. Power cables, audio snakes, mic stands and associated hardware are located in the coach's cargo bays, along with the electrical isolation transformers and A/C line regulation. It is, says Skye, a unique overall design that combines ergonomics, aesthetics and efficiency into a single, very well-maintained, self-contained environment on wheels. ■

### SPEC SHEET

**Company Name:** Skyelabs Mobile Recording & Broadcast. **Contact:** Bob Skye. **Services Offered:** Remote recording, mixing, broadcast. **Main Technology Platforms:** Mackie D8B Digital Consoles 48x48 with API mic preamps (2); Mackie 1604 VLZ Pro 16x4 (2); Genelec 1031/1029 monitors; Otari MTR-90 MkII 24-track analog decks (2); Sony PCM-800 digital recorders (3); Panasonic 3700 DAT recorders (2); RTS/Telex audio communications with wired and wireless systems, CCTV color video monitoring and camera, full video truck interface. **Truck Information:** "Rover" is a 1962 GMC PD4106 35-foot diesel coach completely redesigned for mobile studio work. **Layout:** 8x18-foot control room with two work tables and producer's desk; 8x10-foot lounge wired for overdubs and other production uses. **Partial Client List:** AC/DC, the San Francisco Opera, U2, Herbie Hancock, Van Morrison, Chick Corea, Dave Matthews, Bruce Hornsby, Keb' Mo', Brian Setzer, Ozzy Osbourne, Arrested Development, MTV, Santana, Direct TV, ABC in Concert, National Public Television and Radio.



#### Skyelabs Mobile Recording & Broadcast

520 Penngrove Avenue  
 Penngrove, CA 94951  
 Tel.: 707/792-2000  
 Website: [www.skyelabs.com](http://www.skyelabs.com)  
 E-mail: [info@skyelabs.com](mailto:info@skyelabs.com)



## Studio on Wheels

**S**tudio on Wheels' CEO John Falzarano started in remote recording while still in his teens, literally learning the trade from the ground up. A young hi-fi enthusiast, he would modify mixing boards and record his own drum kit onto a 2-track machine. When a local jazz group began rehearsing in his garage, Falzarano experimented with 4-track, eventually becoming the group's live sound engineer. Later, Falzarano would pack his multitrack, mixer and microphones into a 1961 Ford Econoline van and head out to other musicians' homes to record. "One day, instead of taking the gear out of the van and into the house, I left the gear in the van and ran the cables inside," he recalls. "From that moment on, I was in the live remote recording business."

Since then, Studio on Wheels has grown to a top-tier, three-truck company, with two vehicles based in Southern California and the other in Nashville. All of the trucks have become known for their ample assortment of vintage analog equipment and significant history—each was acquired from major remote operators, including the Record Plant. Outfitted with classic analog Auditronics, API and Amek consoles, as well as a combination of analog and digital recording gear, each of the Studio on Wheels vehicles has garnered a reputation as true musicians' trucks.

"We have a vintage analog orientation with our trucks and equipment choices," Falzarano explains. "A lot of the live radio broadcasts prefer the digital tape formats, of which we have plenty. But so many individual artists come to us specifically for

our analog consoles, tape decks and vintage outboard gear. For instance, D'Angelo and Rage Against the Machine both used Mobile Unit 3, originally designed by the Record Plant, which has the API console and Ampex 1200 tape machines to

capture their live shows for album releases. Like any good recording studio, each truck has its own distinctive sound. Studio on Wheels regularly uses the trucks to mix a world-wide syndicated radio program called 'The Road,' as well as other projects. We are equipped to handle any remote situation."

That ability to make musicians feel at home is the reason that Studio on Wheels has garnered favor with such a diverse range of artists from virtually every major genre, from rock to pop, country to gospel, blues to jazz.

In addition to technology, Studio on Wheels brings three decades' worth of experience to projects. Falzarano notes that a predilection for perfection and a large microphone selection—over 100 on hand—have enabled him to capture live performances in more detail. For instance, he says, "When doing large gospel choirs, a lot of engineers would choose to use a few microphones placed around the choir. We use a lot of microphones and therefore attain a very high degree of isolation throughout the choir, which makes a big difference in terms of options when it comes time to mix."

Studio on Wheels offers an experienced staff, including Falzarano and engineer Kathleen Yore. "It's about the equipment, the technique and the people," Falzarano says. "But in the end, it has to be about the music." ■

### SPEC SHEET

**Company Name:** Studio on Wheels. **Contact:** John Falzarano. **Services Offered:** Remote live recording, mixing. **Main Technology Platforms:** (Mobile 1) Auditronics console, Otari MTR-90 MkII 24-track, 48 tracks of DA-88, 48 tracks of ADAT; (Mobile 2) Amek console, 3M M-79 24-track, 48 tracks of ADAT; (Mobile 3) API console w/550A EQ, Ampex 1200 (2), 48 tracks of DA-88; large selection of contemporary and vintage outboard gear. **Vehicle Information:** MU1: 20-foot; MU2: 25-foot; MU3: 30-foot. **Partial Client List:** D'Angelo, Dwight Yoakam, Moby, Rage Against the Machine, Beck, Dixie Chicks, Trisha Yearwood, Johnny Cash, LeAnn Rimes, Red Hot Chili Peppers, Soundgarden, Van Morrison, Mötley Crüe, Joni Mitchell, Andre Crouch, Edwin Hawkins, Trenora Parker, Herbie Hancock, Billy Taylor, Westwood One and United Stations Radio Network.



#### Studio On Wheels

6745 Washington Avenue, Ste. 331  
Whittier, CA 90601  
Tel.: 562/789-9937  
Fax: 562/698-3513  
Website: [www.studioonwheels.net](http://www.studioonwheels.net)  
E-mail: [studioonwls@aol.com](mailto:studioonwls@aol.com)



PROFESSIONAL RECORDING EQUIPMENT

MANLEY

Langevin



**COMPANY PROFILE:** Manley Laboratories, Inc. in recent years has expanded and thrived under EveAnna Manley's leadership. Our 11,000 sq. ft. building houses our own machine-shop, printed circuit board manufacture, audio transformer winding, engraving, and silk-screening facilities. All custom design, R&D, assembly, testing, and quality control processes are performed with precision and pride at the Manley factory, located just 35 miles east of Los Angeles.

**NEO-CLASSIC:  
MANLEY ALL-TUBE GEAR**

We take a purist approach to everything we build; refining, executing, and expanding upon Manley's legacy of vacuum tube design philosophies proven over years of real-world experience, using high quality modern components, many of which are fabricated in-house. This attention to detail delivers the rich, present, and natural sound our vacuum tube designs are renowned for. Never small, sterile, or boring.

Beyond this, Manley means reliability, real technical support, and a company attitude that professionals depend on.

**BIG BANG FOR THE BUCK: LANGEVIN**

LANGEVIN is a legendary marque of premium electronics whose lineage goes back to World War II. MANLEY acquired the LANGEVIN brand name several years ago. With these products we offer you the different sonic flavor that ALL-DISCRETE CLASS A CIRCUITRY brings using fresh, original designs built alongside and to the same exacting standards as the Manley equipment.

We believe that good music and those who create it deserve the finest gear.

The choice is yours.

CIRCLE #088 ON PRODUCT INFO CARD

**MANLEY LABORATORIES, INC.**  
13880 MAGNOLIA AVE.  
CHINO, CA. 91710 USA  
TEL: (909) 627-4256  
FAX: (909) 628-2482  
email: [emanley@manleylabs.com](mailto:emanley@manleylabs.com)  
<http://www.manleylabs.com>



# VLZ<sup>®</sup> PRO Series

## with XDR<sup>™</sup> mic preamplifiers. Precise creative tools for serious artists.

If you're serious about your creative product, your equipment list should start with a really good mixer like our VLZ<sup>®</sup> PRO Series. The industry standard for compact mic/line mixers, they're used day-in and day-out by more professionals to create more albums, demos, movie and broadcast sound tracks, commercials and web casts than any other brand.

### XDR. The finest microphone preamp design ever built into a compact mixer.

Because the preamps in mixers have long been considered a poor second to \$1000 to \$2000-per-channel outboard preamps, Greg and our Analog Engineering Department spent two years of meticulous experimentation creating a sonically comparable mic preamp circuit.

According to numerous cynical recording engineers, magazine reviewers and a lot of satisfied owners, we succeeded.

One reason is the advanced 2068 op-amp that is a foundation of the XDR design. It blows away our competitors' op-amps in terms of noise and distortion. Consider these real, measurable XDR<sup>™</sup> (Extended Dynamic Range) microphone preamp specs:

- 0.0007% CCIF Total Harmonic Distortion
- 0.0008% CCIF Intermodulation Distortion
- 130dB total dynamic range to handle hot digital sources
- 3Hz to 192kHz bandwidth
- Ultra-low mic E.I.N. at practical gain levels

### The VLZ PRO Compact Mixer Series:

- Premium XDR mic preamps and VLZ circuitry for ultra-low noise
- New high-performance 2068 op-amps
- Musical, sweet-sounding equalization at useful, logical frequencies
- Sharp 18dB/octave Low Cut filters
- Stereo In-Place Solo
- Easy channel level setting via Solo
- Constant Loudness pan pots
- Inserts on all mono mic/line channels
- 60mm long-wearing, logarithmic-taper faders (except 1202-VLZ PRO)
- Sealed rotary controls
- Thick MIL-spec fiberglass circuit boards
- Built-in high-current power supplies
- Steel chassis
- Easy-to-understand manuals
- Best Technical Support in the industry

Call your nearest Mackie office for a 72-page brochure/ hook-up guide that explains the VLZ PRO line in excruciating detail. Or log on to our web site. Then visit a Mackie dealer to decide which VLZ PRO model best meets your creative needs.



MADE BY  
MACKIE'S IN  
WOODINVILLE  
WA, USA

# MACKIE<sup>®</sup>

800.258.6883 • [www.mackie.com](http://www.mackie.com)

CIRCLE #037 ON PRODUCT INFO CARD

World Radio History

©2007 Mackie Design, Inc. All Rights Reserved. Mackie, the "Mackie" logo, and VLZ are registered trademarks of Mackie Design, Inc. XDR is a trademark of Mackie Design, Inc.



# NEW SOUND REINFORCEMENT PRODUCTS

## CREST CPX AMPS

Crest Audio ([www.crestaudio.com](http://www.crestaudio.com)) debuts its CPX Series power amplifiers in three power ratings. The CPX900 produces 450 W/channel at 2 ohms (900 W at 4 ohms, bridged mono), the CPX1500 delivers 750 W/side at 2 ohms (1,500 W at 4 ohms, bridged mono), and the CPX2600 produces 1,300 W/channel at 2 ohms (2,600 W at 4 ohms, bridged mono). Frequency response is 20-20k Hz; THD is less than 0.1% at rated power for all models. CPX Series amplifiers provide a built-in crossover (150 Hz, 24 dB/octave tuned for subwoofers) with individual in/out switches for channels A and B. Features include thermal/DC protection, on/off output muting, barrier strip and combo XLR $\frac{1}{4}$ -inch TRS inputs and Speakon outs. A two-speed fan combined with a unique heat sink configuration enhances cooling. All CPX Series amps are 2U tall, offer switched-stereo or bridged-mono operation and have a three-year warranty.

Circle 314 on Product Info Card

## EAW KF760 LINE ARRAY

Eastern Acoustic Works ([www.eaw.com](http://www.eaw.com)) announces the KF760 Series Line Array, consisting of two horn-loaded, three-way loudspeaker models used in multiples to create a curved line source. Using a technique called "divergence shading," the KF760 Line Array is designed for minimal signal processing with all loudspeakers set for equal output levels. Used together, model KF760 (medium- to long-throw coverage) and model KF761 (short-throw coverage) can provide uniform SPL and frequency response to the entire audience, from the front row to the farthest seat. Both models offer a usable 45-16k Hz range and are constructed of Baltic birch plywood with polyurethane structural foam, integral flying, and rigging hardware with captive, retractable hinges. The KF760 is about 190 pounds, and the KF761 is about 160 pounds, while their overall dimensions are the same: 14.5x45x31 inches (HxWxD).

Circle 315 on Product Info Card



## E-V QRX SPEAKERS

Electro-Voice ([www.electrovoice.com](http://www.electrovoice.com)) introduces the QRx line with three full-range, two-way cabinets offering a rotatable 75x50° constant directivity horn and three direct radiator subwoofers. All QRx two-way systems are designed for pole mounting, and two (the QRx112/75, featuring a 12-inch woofer, and the QRx115/75, loaded with a 15-inch woofer) have five-sided cabinets for use as floor wedges or as wall-/ceiling-mount speakers. All three Q-Rx Series full range units are bi-ampable (a secure external switch selects Passive or Bi-amp modes) and include high-frequency driver protection circuitry. Safe-Grip handles, standard pole mount and L-track fittings are standard. The QRx215S dual 15-inch sub and the QRx218S dual 18-inch sub are also available in Flying versions. A QRx212/75 (dual 12-inch) and QRx118S (single 18-inch) sub are available.

Circle 316 on Product Info Card

## 10 CO. ROAD CASES

The TP 5025 truck pack road case from 10 Co. Industries ([www.10co.com](http://www.10co.com)) is a light and sturdy container, suitable for equipment, cables and instruments. Made of lightweight, high-impact polyethylene, the steel-reinforced road cases are designed for stacking and have tightly locking lids. The TP 5025 (shown) is available with internal dividers for  $\frac{1}{2}$ -ton and 1-ton chain hoist motors. 10 Co. also offers a range of wheeled utility trucks in several colors. Options include security lids, handles, shelves, dividers, garment hanging bars, drains and caster upgrades.

Circle 317 on Product Info Card

## STUDIOMASTER FOUR-BUS MIXER

The Trilogy T 406 4-bus console from Studiomaster ([www.studiomaster.com](http://www.studiomaster.com)) provides 32 inputs (28 balanced mono mic channels and four stereo line inputs) and is designed for use as an FOH board, stage monitor mixer or recording desk. Mono channels feature inserts and direct outputs, 3-band EQ, 100Hz highpass filter, six pre/post selectable aux sends, channel mute and signal present LED indicators, PFL and solo-in-place and 60mm faders. The four subgroups may be assigned to the main left/right, and direct outputs are also available. Four stereo returns offer individual level control, PFL/AFL switches and may be assigned to groups and/or the main stereo bus. Other features include: 48V global phantom power, stereo control room outs, 2-track tape outs, headphone monitor bus and rackmount PSU. The T 406 can be expanded to 42 channels (62 total inputs) or 52 channels (76 total inputs) with Studiomaster's T 140ex 10-channel expander. Price is \$1,895.

Circle 318 on Product Info Card



# Handheld Vocal Microphones

*Top-of-the-Line Dynamic and Condenser  
Models for Live Performance*

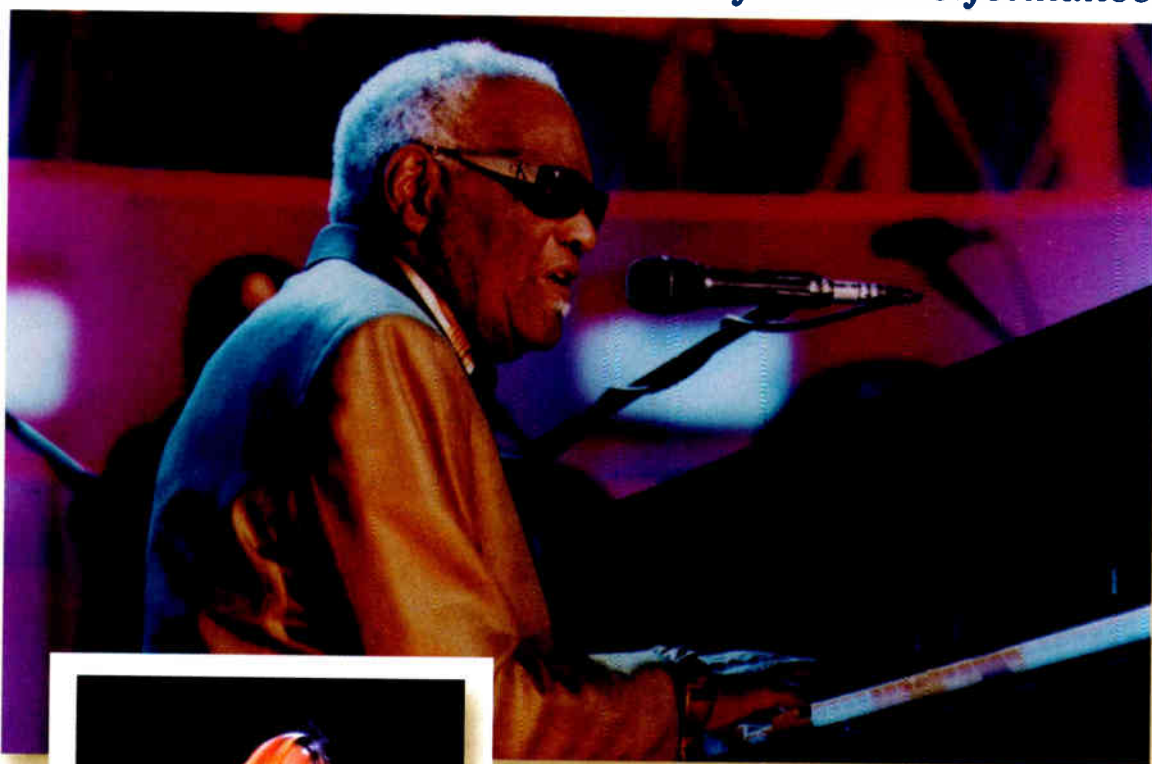

by **Randy Alberts**

Studio users spend years searching for the ultimate *vintage* mic, but the situation is reversed with live sound. Mics for onstage performance keep getting better, and the market for old handheld models from the '40s, '50s and '60s is virtually nonexistent. Most performers and sound reinforcement engineers are constantly checking out recent models, looking for the ultimate new mic.

Technically speaking, most high-quality microphones could be handheld, but those specifically designed for vocal use in live performance offer advantages such as internal shock-mounted capsules, nonreflective finishes and a high degree of feedback rejection to improve performance.

There's no shortage of good-sounding condenser and dynamic mics at every price, but for the purposes of this article, we decided to focus on top-of-the-line, hard-wired models from various manufacturers, and we limited each mic builder to one condenser and one dynamic mic each. All prices quoted here are manufacturer's suggested retail (street price may vary considerably), and besides vocals, many of the models listed are also suitable for instrumental miking, both onstage and in the studio.

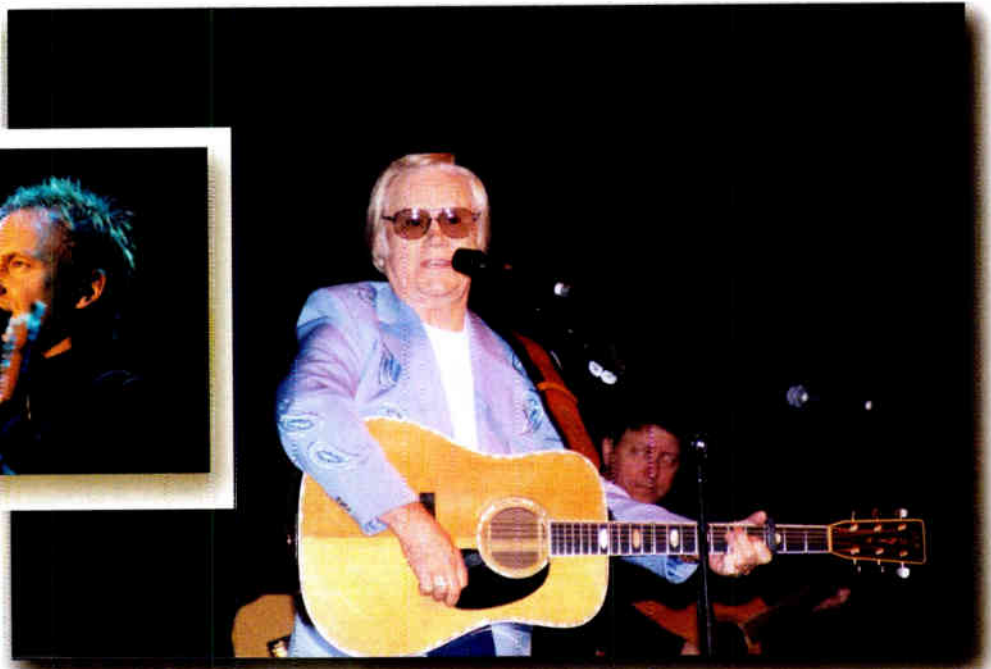

Some vocal mics in action: Sheryl Crow with a Shure Beta 58; Ray Charles with an Audio-Technica AT4055; Sting with a Sennheiser ED 865 and George Jones with a Neumann KMS105.



**AKG**

The condenser Model C-5900 features a no-roll triangular body, along with AKG's InterSpider internal suspension system and a recessed access panel with -12dB low-frequency cut and -6dB/octave roll-off switches. The hypercardioid C-5900 lists for \$378. AKG's Model D-3800 Tri-Power uses a patented moving magnet system to reject handling noise, is equipped with separate high- and low-frequency contouring switches and can take up to 147dB SPL without distorting. The D-3800, like the AKG C-5900, is a hyper-

cardioid mic, and it features the same triangular body shape. Retail is \$300.

**AUDIO-TECHNICA**

Audio-Technica's 40 Series handheld condenser mics, including the AT4055 (\$499), are essentially handheld versions of the company's well-used AT4050 studio mic. The AT4055's large-diaphragm element brings out an extended low end and handles high SPLs and features internal shock-mounting. A-T's top-end vocal dynamic, the \$270 ATM-61HE, has a high-output neodymium with a patented floating diaphragm that reduces handling noise. This hypercardioid mic has a frequency response of 50 to 18k Hz and is available in the ATM61HE/S model with integral On/Off switch and nonremovable grille. Retail is \$270.

**AUDIX**

The Audix OM-7 (\$359) was designed as a tough hypercardioid dynamic mic that can take up to 144 dB before cracking up. The mic comes in a satin black finish and uses a controlled output stage to net higher gain before feedback onstage. The company's \$599 VX-10 is a new handheld vocal condenser that wears the same black

finish and has a 16mm gold vapor diaphragm and a 40 to 20k Hz frequency response.

**BEHRINGER**

The XM8500 from Behringer is a dynamic model with a mid frequency presence boost to increase vocal projection and an overall response of 50 to 15k Hz. The mic features a cardioid polar pattern and a gold-plated XLR connector. Retail is \$49.

**BENSON AUDIO LABS**

BAL's ND80 is a hypercardioid dynamic mic with a hot-output neodymium magnet, steel wind-screen, and an easy-to-hold, ergonomic "Soft Touch" finish.



# Handheld Vocal Microphones



and vocal miking, with a frequency response of 40 to 15k Hz and a slight presence rise. The mic has a list price of \$199 but is sold direct through Carvin for only \$89, including a 20-foot XLR cable.

## CROWN

Featuring Crown's patented Differoid technology, the CM-310A is a cardioid electret condenser mic with a 60 to 17k Hz response. Retail is \$309, and the



## ELECTRO-VOICE

The Electro-Voice N/D767a is a dynamic design featuring a N/DYM magnet structure for high output. This supercardioid mic features a 25 to 22k Hz response, multistage capsule shock-mounting for low-handling noise, a comfortable Warm-Grip handle and VOB (Vocal Optimized Bass) tailoring that's intended to provide a smooth proximity effect without muddiness. Retail is \$252.

## NEUMANN

Neumann's TEC Award-winning KMS105 (\$595) is a supercardioid condenser mic with a triple-layered acoustic filter windscreen that dramatically reduces popping and wind noise. The KMS105 also includes special mechanical and electrical filters to virtually eliminate handling noise, as well.

## PEAVEY

Part of Peavey's Diamond Series, the PVM 22 dynamic cardioid mic has a neodymium magnet with more than twice the sensitivity of conventional designs. The mic also features a diamond-coated diaphragm and a new shock-mounting system using high-tech polymers for reduced handling and cable noise. Retail is \$149.99.

## ROLAND

The Roland DR-20 is a hypercardioid

Retail is \$350. Also priced at \$350, Benson's RC22 is a cardioid condenser mic that incorporates a low-mass mylar diaphragm and is intended for general vocal and instrument applications.

## BEYERDYNAMIC

Beyerdynamic's TG-X 80 (\$469) is a sharp-looking handheld dynamic mic with a fire-engine-red shock absorption ring that helps with structure-borne noise attenuation. Part of the company's TourGroup Series, the TG-X uses a hypercardioid polar pattern and has a 30 to 18k Hz frequency range. The MCE 90 is a condenser model with cardioid polar pattern and an 139 dB SPL to fit a wide range of singers. Retail is \$649.

## CAD

CAD's CAD90 dynamic microphone features an internal multistage pop filter to minimize breath noise. This cardioid model is priced at \$239. The CAD95, the company's top-end vocal condenser, which is also priced at \$239, is a transformerless cardioid electret mic. The CAD95 also features an internal multistage pop filter, CAD's exclusive INR (Impact Noise Rejection) shock-mount system and a rugged Flex-For grille screen.

## CARVIN

Carvin's CM67 cardioid pattern microphone is designed for both instrument



CM-310ASW model with a built-in magnetic reed On/Off switch is also available.

## EARTHWORKS

Earthworks offers handheld vocal mics in cardioid (SR69) or hypercardioid (SR68) versions. Both are phantom-powered condenser designs with frequency response extending beyond 20 kHz and 145dB SPL handling capability. The mics are available in black, silver and crimson finishes, and each includes a removable windscreen for use in instrumental live or studio applications. Retail for the SR68 is \$450; the SR69 is \$400.



A PERFECT MIX OF FORM AND FUNCTION



## RECORD || PLAY

AN ANALOG MIXER WITH AN S/PDIF DIGITAL OUTPUT. THE SPIRIT M SERIES IS A NEW BREED OF COMPACT-CONSOLE, DESIGNED AND BUILT FOR THE WAY YOU RECORD. AND WITH A STURDY RACK-MOUNTING SYSTEM CLEVERLY CONCEALED BEHIND BRUSHED METAL SIDE PANELS\*, YOU'LL FIND THE M SERIES EQUALLY WELL EQUIPPED WHEN THE TIME COMES TO TAKE YOUR MUSIC ON THE ROAD. A CHOICE OF THREE FRAME SIZES, EACH WITH 4 STEREO CHANNELS AND 4 RETURNS, A NEWLY DESIGNED FOCUSED EQ AND MIC PREAMPS TAKEN FROM THE AWARD-WINNING GHOST CONSOLE MAKE THIS A MIXER YOU NEED TO FIND OUT MORE ABOUT. BUT MORE THAN ANYTHING, THE M SERIES IS A MIXER YOU NEED TO HEAR.

THE NEW SPIRIT M SERIES BY SOUNDRAFT.  
A PERFECT MIX OF FORM AND FUNCTION.

1-888-251-8352 WWW.SOUNDRAFT.COM

M8 AND M12 ONLY



Soundcraft

H A Harman International Company

# Handheld Vocal Microphones

dynamic mic with a 60 to 15k Hz frequency response and a built-in On/Off switch. Retail is \$150, including cable.

## SAMSON

Samson's Q1 (\$400) is a cardioid condenser mic slated for live and project studio recording use. Like every condenser, the Q1 requires phantom power. A built-in windscreen and gold-plated XLR connector are standard.

## SENNHEISER

Sennheiser's handheld line includes the MD-431 II (\$495) and ED 865 (\$399). The dynamic MD 431 II is an improved version of its predecessor, featuring a steel-mesh grille, shock-suspended capsule, a humbucking coil, recessed On/Off switch and internal electronics for refining proximity effect. The ED 865 is the first condenser handheld mic in the company's new Evolution Series that's great for live performance or recording vocals in the studio. This supercardioid mic sports a metal housing and steel-inlet basket.

## SHURE

The Shure Beta 87A is an electret condenser mic with a new, slightly thicker handle design and break-resistant swivel adapter. This supercardioid model features a three-stage pop filter and high isolation with minimal off-axis coloration. The Beta 87A retails at \$445. Shure's top-end dynamic mic is the Beta 58A, a model with a high-output Neodymium element. The supercardioid mic features a shaped frequency response for close-up vocals, a pneumatic internal shock-mount system, a hardened steel-mesh grille and a 50 to 16k Hz bandwidth. Retail is \$289.

## SONY

Sony's F-780/9X (\$375) handheld dynamic mic is an improved version of the company's F-780, its previous top-of-the-line dynamic vocal mic. An improved capsule design, tightened unidirectional polar pattern and a new urethane coating for lower handling noise further enhance this mic's performance.



## STEDMAN

The Stedman Transonic TR1 is a supercardioid dynamic microphone offering two distinct response curves for stage and studio applications. With its recessed switch in the "stage" position, the TR1 offers a subtle bass boost and presence peak to cut through on live performances. The "studio" position provides a smooth response, ideal for recording vocals, instruments and cabinets. Response is 33 to 19k Hz; retail is \$159. ■

*Randy Alberts is a musician, engineer and writer exploring music and recording technology in his Pacifica, Calif.-based studio.*

## HANDHELD VOCAL MIC MANUFACTURERS

AKG	<a href="http://www.akg-acoustics.com">www.akg-acoustics.com</a>
Audio-Technica	<a href="http://www.audiotechnica.com">www.audiotechnica.com</a>
Audix	<a href="http://www.audixusa.com">www.audixusa.com</a>
Behringer	<a href="http://www.behringer.com">www.behringer.com</a>
Benson Audio	<a href="http://www.bensonaudiolabs.com">www.bensonaudiolabs.com</a>
Beyerdynamic	<a href="http://www.beyerdynamic.com">www.beyerdynamic.com</a>
CAD	<a href="http://www.cadmics.com">www.cadmics.com</a>
Carvin	<a href="http://www.carvin.com">www.carvin.com</a>
Crown	<a href="http://www.crownaudio.com">www.crownaudio.com</a>
Earthworks	<a href="http://www.earthwks.com">www.earthwks.com</a>
Electro-Voice	<a href="http://www.electrovoice.com">www.electrovoice.com</a>
Neumann	<a href="http://www.neumann.com">www.neumann.com</a>
Peavey	<a href="http://www.peavey.com">www.peavey.com</a>
Roland	<a href="http://www.rolandus.com">www.rolandus.com</a>
Samson	<a href="http://www.samsontech.com">www.samsontech.com</a>
Sennheiser	<a href="http://www.sennhsiser.com">www.sennhsiser.com</a>
Shure	<a href="http://www.shure.com">www.shure.com</a>
Sony	<a href="http://www.sonyproaudio.com">www.sonyproaudio.com</a>
Stedman	<a href="http://www.stedmancorp.com">www.stedmancorp.com</a>





*Don't just record.  
Capture.*

Carefully interwoven technologies.

Like no other microphone you've ever used.

The KSM44 multi-pattern studio condenser captures the essence of sound.

Three polar patterns and an externally biased dual-diaphragm design let you record any situation with incredibly low self-noise (7 dB). Once you listen with the KSM44, you'll discover a uniqueness that makes recordings stick. To join the growing number of KSM44 enthusiasts, call 1-800-25-SHURE or visit [www.shure.com](http://www.shure.com).

**SHURE**<sup>®</sup>  
IT'S YOUR SOUND™

# L.A. Studios

## Resurgent in 2001

Many Los Angeles studios experienced a severe business downturn during 2000, leading to speculation that, perhaps, finally, the long-anticipated fear that home studios would render commercial studios obsolete had become reality. However, not long into 2001, facilities both large and small were reporting that they were on their way to a banner year

### Technology Has Changed

of bookings, with musicians, producers and engineers apparently deciding that both home and commercial recording environments have their pros and cons, and their time and place. Both options, for the moment at least, are enjoying a seemingly healthy co-existence, a situation that makes for thriving studios

### the Landscape, But Not

of every kind, as well as for a flourishing market in both equipment rentals and sales.

### the Rules for Success

The continuous advance of technology, though, constantly changes the variables, and there seems to be an overwhelming awareness in the industry that what is true today may not be so tomorrow. A sense of foreboding shadowed some of the responses of those questioned for this article, along with the pervasive knowledge that tomorrow's invention could affect the industry either positively or negatively. Still, industry vets know that the damage caused by yesterday's concerns—the advent of synthesizers, drum machines and digital workstations, for example—has not been realized to the extent that the original fears warranted. And they seem bent on enjoying these good times despite ambivalence toward the future.

**BY ROBYN FLANS**

ILLUSTRATION BY KITTY MEEK



RECORDING  
STUDIOS

BOOKING

World Radio History



David Angress, executive VP of Guitar Center, notes that L.A. is a unique recording market, packed with individual musician/composers creating at home, as well as high-, middle- and low-end commercial venues and a huge film and post industry. Retail outlets cater to all of these, and according to Angress, 2001 is looking like a stellar year for sales. While Guitar Center has long been selling Portastudios, ADATs and the like, the last few years have, of course, seen a huge upswing in computer-based recording. Now, technology permits much more affordable gear, and customers are better able to get more value for their money.

"Specifically in the last year, higher-resolution audio has gotten less expensive," Angress says, "so we have more vendors, and, in turn, more customers buying products who are recording 24/96. A lot more of the recording equipment we're selling has moved out of the hardware rack and into the computer. We're Digidesign's largest Pro Tools dealer, and we've also been very successful with their Pro Control and their upgrades over the last year. At the same time, the lower end of the market has been expanding. The lower-end recording system that Digidesign introduced last year is doing very well, as is Steinberg's. Customers are getting a better value, and we're selling a lot more systems—so many more systems that even with lower price points, our business is up in dollars and in systems and units."

There's no doubt that while Guitar Center's clients run the gamut, their primary customer is the individual musician and project studio. "If I had to focus on one thing, I'd have to say that there's a remarkable amount of Pro Tools product being purchased in the L.A. market," Angress continues. "But we also sell a lot of microphones. Many of the studios being put together now are designed for electronic music, so miking of acoustic instruments is less and less important. But, at the same time, those studios are putting in the one or two good mics that they'll need when they're recording an

acoustic instrument or a vocal. So there tends to be more attention paid to getting those one or two mics to be really good ones. We sell a lot of the Neumann high-end and also B.L.U.E., and we do particularly well with a line we import from Russia called Oktava—a studio microphone patterned after the Neumanns. The physical construction isn't as pretty, but they're amazing-sounding microphones and very inexpensive. Of course, we sell lots of Shure, Audio-Technica and AKG.

"High-end mic preamps are very popular for the very same reason—you've got to get a good signal into these hard disk recorders somehow. Some of the popular ones are Avalon and Focusrite, both in terms of their hardware products and their software plug-ins. We also sell a lot of the integrated multitrack recording, mixing and effects systems: Roland, Akai and Korg are very strong in that area, as is Tascam's new offering, the 788. Alesis



David Angress, executive VP of Guitar Center

continues to be a strong performer, and the Mackie D8B digital mixer has been a huge hit for the past couple of years. Five years ago, you would have had to spend \$100,000 to get equipment that does what it does for about \$8,000, so it's become the heart of many of today's project studios. The other area doing tremendously well is the high-end keyboard workstations. These kinds of products tend to blur the line between keyboards and recording products. Trinity and Triton from Korg, in particular, have really revolutionized the way composers operate. They have also just started shipping a product they introduced at

the January NAMM show called Karma, and we're already finding that we can't keep them in the store."

Even with all the equipment currently available to outfit the project studio, Dusty Wakeman, owner of the three-room Mad Dogg Studios in Burbank, confirms the positive climate in L.A.'s commercial studios, stating that the last quarter of 2000 was Mad Dogg's best period ever. This was also the year that the facility invested in a major makeover, replacing the "mid-era" Neve previously housed in Studio A with what Wakeman calls the "queen mother vintage Neve console"—an 8088 fitted with Flying Faders.

"One of the things that people really need to go to a commercial studio for is tracking," he comments. "This Neve is the ultimate tracking console, so that's increased our business in that room. Then, we've set up Studio B as an all-digital room for surround mixing, which is starting to take off. It's fitted with a Sony DMX-R100 console, DA-88s and DA-78s. We also have a couple of regular producer clients, like Sylvia Massy and David Bianco, who like working in the open-studio environment of our third room, The Stage, which is a studio without walls. That seems to be a trend right now. It's hand-friendly—the ultimate garage studio. So we're very diversified. Having something for everybody is working for us."

At Mad Dogg, where recent clients have included such artists as Heather Miles, Keb' Mo', From Zero, Insolence, The Virgos and The Damned, three Pro Tools systems are available for client rental. Wakeman notes that, while equipment options have made home studios a viable working environment for many projects, some composers feel overwhelmed by the multitude of rapidly changing choices offered on the market.

"I think people have learned that just having a Pro Tools rig doesn't mean you have a studio," he says. "If you want to record a band, you need a lot of infrastructure—stands, cables, a headphone system and a good acoustic environment. Plus, Pro Tools rigs are computers and they crash, so you need people around who can get you back online. I think the realization of these things has actually brought a lot of work back to the studios."

Larrabee Studios owner Kevin Mills echoes Wakeman's sentiments. "Just because you have a kitchen at home doesn't mean you're never going to go out for dinner," he remarks. Larrabee

Once you know what can be done,  
you have the power to make art out of technology.

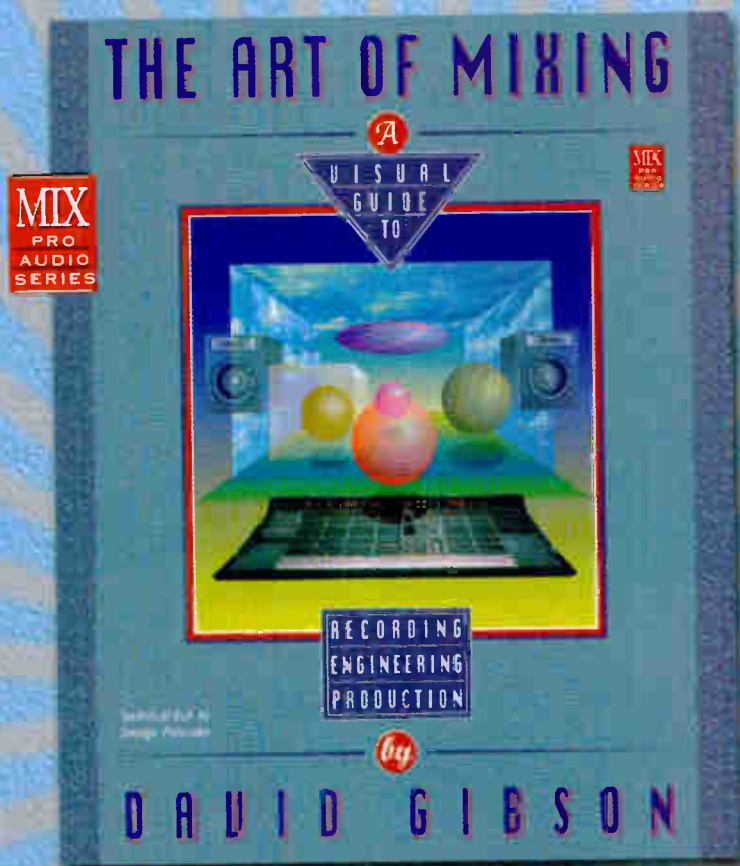

## THE ART OF MIXING

David Gibson

This expansive book uses visual representations of imaging (sounds between the speakers) to explain and show how to mix every style of music in the world, from big band to hip-hop. Gibson has mapped out everything that can be done to create various effects in a mix. It's an in-depth exploration into the aesthetics of what makes a great mix illustrated in a simple, visual manner.

Technical Edit by George Petersen

Item #330318 \$49.95 list price (plus Se<sup>3</sup>H and applicable sales tax)

Call: (707) 554-1935—Fax: (707) 554-9751  
Order Online at the Artistpro Shop – <http://www.artistpro.com>

CIRCLE #130 ON PRODUCT INFO CARD



artistpro.com  
236 Georgia Street, Ste. 100  
Vallejo, CA 94950



MixBooks is an imprint of artistpro.com, LLC



Also available through your local book or music retailer exclusively through: Hal Leonard Corp.

Aardvark  
 API  
 Apogee Electronics  
 Audix  
 B&B Systems  
 Brauner  
 Bryston  
 Calrec  
 Drawmer  
 Gefen Systems  
 Genelec  
 Great River  
 Lexicon  
 Lucid Technology  
 MediaFORM  
 Mytek  
 PMC  
 Prism Sound  
 Quartz Electronics  
 Rorke Data  
 Sonic Solutions  
 SoundField  
 Westlake  
 White Instruments  
 Z-Systems

# 30 years!

now in our 30th year of helping our customers choose the very best

## studio consultants, inc.

321 West 44th Street, New York, NY 10036  
 (212) 586-7376

Equipment, support, and design services for professional audio facilities and broadcasters in the New York area—since 1971.

CIRCLE #099 ON PRODUCT INFO CARD



## L.A. Studios

Studios, which now encompasses seven high-end rooms in three facilities, also has its own pro audio equipment arm, dubbed Gear Works, which services Larrabee's rooms, as well as outside commercial and home studios.

"The way it is now," Mills explains, "one day a project can be on analog, the next day it can be 3348 HR, the next it can be DA-88 and the day after it can be Pro Tools. We've found that with seven rooms, the best way to be able to effectively handle the changeovers that are going on during any given day is with Gear Works. It has five dedicated employees who just handle the gear. We have five Pro Tools



Learn Audio Recording Like No Where Else.

## The Conservatory of Recording Arts & Sciences 1.800.562.6383

All students train, hands-on, in cutting edge 48-track Analog/ Digital Recording Studios that feature:

-SSL -Studer -Otari -Neumann  
 -Neve -Neotek -Lexicon -Hatler

Plus...

-Mac G3/TASCAM Digital Lab  
 -Studio Master Mix Down Lab  
 -Individual Pro Tools Work Stations  
 -And Much, Much More!

No more than 12 students per class - taught by award winning professionals.

Every student completes an internship in the industry for graduation.

Only recording school authorized by Avid/Digidesign, T.C. Electronics, WAVES, and SIA to certify students in the use of their products.

t.c. electronic



CIRCLE #100 ON PRODUCT INFO CARD

I don't think the taste for analog is going to go away completely. I don't think people hear in bits and bytes; I think they hear analog.

—Ellis Sorkin

systems, HR machines and, because I've been collecting it for years, what is probably L.A.'s largest inventory of out-board gear."

Like many observers, Mills sees that trends are moving away from tape "toward things like RADAR, Pro Tools, the R-1 from Euphonix or DA-88s—a bigger variety of storage media that come from home studios."

All around the city, plenty of equip-



# ARGOSY

## Studio Furnishings Guide

Console Enclosures  
Rack Enclosures

Digital Workstations  
Video Control Stations

The new ARGOSY 2001 Studio Furnishings Guide is a collection of the latest innovative designs and enhancements in specialized furniture for recording, television, film and video.

To receive your free copy by mail, please call toll free: 1.800.315.0878 or email: [info@argosyconsole.com](mailto:info@argosyconsole.com)

- online catalog -  
[www.argosyconsole.com](http://www.argosyconsole.com)

The ARGOSY 90 Series console enclosures are designed to exactly fit today's most popular mixers.



90 Series for  
Control 24

Patented, Innovative Designs  
One to One customer service  
"What could be more perfect?"  
- Patrice Rushen

CIRCLE #102 ON PRODUCT INFO CARD



An  
independent  
professional  
music store.

**grandma's**  
music & sound

800-444-5252  
[grandmas.com](http://grandmas.com)

albuquerque, new mexico

CIRCLE #103 ON PRODUCT INFO CARD



ment is still being rented, as is studio time. Ellis Sorkin of Studio Referral Service concurs that business is up in 2001, and conjectures that the end of last year was a slow period for the studios due to a number of factors, including the Napster situation, the class-action lawsuit on price fixing that was brought against major labels and, of course, the large number of Pro Tools systems purchased. "I think people bought them and thought, 'I'm going to be doing everything at home now,'" he muses. "But once they got into them, they realized it wasn't that simple."

Sorkin says that while Pro Tools is practically ubiquitous at this point, he believes there are still plenty of people working who love the sound of tape. "I don't think the taste for analog is going to go away completely. I don't think people hear in bits and bytes; I think they hear analog."

As far as the preferences that he sees among his clients, Sorkin states that the SSL 9000 is the top choice for mixing consoles. "There are still those who want to be on vintage equipment and will go to the large-frame vintage Neve consoles, but it seems that more are pushing the 9000 edge. As far as the SSL vs. Neve situation, the people who are in each camp tend to stay where they're at.

"On the lower end of things, there are certainly a lot of people going into that Sony DMX-R100, which is a digital 5.1-capable, very multifunctional console that is not terribly expensive."

Sorkin, who has a daily pulse on the finger of the recording community by virtue of booking studios for producers and artists, notes, "A successful studio is a mixture of knowing what to do and when, knowing how to present what you're doing and giving the proper service."

Larrabee's Kevin Mills agrees that presentation is the name of the game that sets the commercial studio apart from home digs. And to prove his point, Larrabee, which has recently completed a number of client comfort-oriented renovations, has been booked almost solid

this year, so far. Over a quarter of a million dollars was spent developing an additional 4,000 square feet of lounge space at the three-room Larrabee North. "Studios aren't just equipment anymore," he states. "They're a space where clients can come and know they will be provided with services: runners to get their food, a variety of lounges and places to hang out, as well as assistants to help with their equipment needs, full-time, around-the-clock technical maintenance, desk people to handle the phones, gated security and clean bathrooms. This is stuff that can't fully be gotten at home. I think home studios will continue to proliferate, but there will always be room for the high-end commercial facility.

"But unlike 10 or 20 years ago, it is definitely becoming about value-added. When you take a look at one of our rooms and realize that it costs perhaps \$400,000 just to build the room acoustically, including floating, isolating and wiring it, adding dedicated



Ellis Sorkin of Studio Referral Service

electrical and AC and then installing the big double-woofer monitors, you just can't do that at home."

Whether it's the trickle-down effect, or because it offers its own particular niche of amenities, even Sonora Recorders, a much smaller (two rooms—one large and one small), funkier environment (Los Lobos' Steve Berlin described it as his favorite "non-designed" room) is enjoying a steady stream of clients. Not long ago, Sonora even managed to nab the Backstreet Boys for some sessions. Conjecturing on the state of the business, Sonora co-owner (with engineer/producer Jeff Peters) Richard Barron remarks, "With



# EVERYTHING FOR THE RECORDING PROFESSIONAL

## NEW GEAR



*We stock thousands of pro audio products from hundreds of manufacturers. From a single microphone to a turnkey studio system, you'll find it all at [www.proaudiodesign.com](http://www.proaudiodesign.com). Or if you need advice, our staff of experienced audio professionals are ready to take your call.*

## USED & VINTAGE



*We always carry a large inventory of desirable used and vintage gear and are experts at locating hard-to-find equipment. And because we refurbish everything in our own workshops, all items are sold with a warranty.*

## SYSTEMS INTEGRATION



*We have successfully designed and installed many studios, large and small, providing a full service including room design, equipment supply, custom monitoring and wiring. Call Professional Audio Design to discuss your project.*

## PRE-OWNED CONSOLES



*With exclusive factory authorization from SSL, our workshops are world renowned for preparing pre-owned large format consoles for resale. Sales include optional installation by our own technicians. Call today for a current list of SSL, Neve, Trident, etc.*

**Find it all at Professional Audio Design**

Visit our new website: [www.proaudiodesign.com](http://www.proaudiodesign.com)

Professional Audio Design, 357 Liberty Street, Rockland, MA 02370  
Phone: (781) 982 2600 Fax: (781) 982 2610 Email: [info@proaudiodesign.com](mailto:info@proaudiodesign.com)

**Professional  
Audio  
Design  
Inc.**



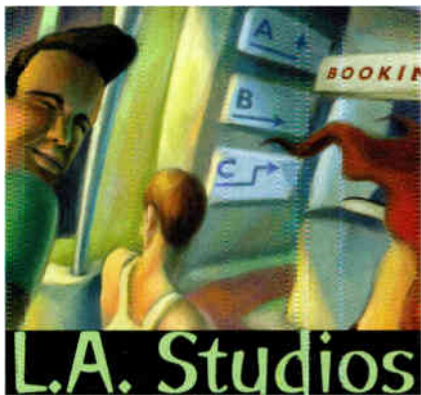

## L.A. Studios

all the home studios, I'm not sure why commercial studios are doing well right now. But maybe it's because people might try to do a whole band in their living room and bathroom one time, but the second time, the wife is going to say, "No way!"

Barron adds that the Backstreet Boys ended up at his facility after trying to record at the home studio belonging to their engineer, Tony Shepperd. "But there were so many people involved and so many security guards that it was just too much."

About his studio's draw, Barron notes that, as well as being a great-sounding facility with a main recording space that is particularly popular with drummers, Sonora is known for its vin-

tage equipment, including an API console that once belonged to Laura Nyro and a Stephens analog 24-track recorder. The convenient location is also a plus, as is the fact that Sonora is a "free-standing building and there aren't other bands around." As for amenities, Sonora boasts a somewhat notorious snack table stocked with Twinkies, Ding-Dongs and other classic trash foods that musicians love to eat. "I try to go with vintage junk food, just like the rest of the vibe in the studio," Barron laughs.

Vintage lovers, though they may be, Sonora's owners have also heavily invested in Pro Tools so that their clients may go back and forth between their home setups and the studios. "A lot of times, people will track their drums and bass on the 2-inch machine, then we'll do a transfer for them to Pro Tools so they can take it away to do vocals, guitars, synths—whatever they can at home. Then they'll come back here to mix. And a lot of times when they mix, we move it back to the 2-inch, because it really does sound better. Pro Tools allows us to talk to all the home studios really accurately."

As a successful small studio owner,

Barron comments, "I look at some of these places that own SSL J boards and I think there's no way I could make the arithmetic work. That board is a half a million dollars. My board is gorgeous and draws people in, but it only costs a fraction of that. Yes, those studios maybe get twice or three times what I get in a day, but still, the arithmetic doesn't make sense to me."

As Barron notes, the investment is major for a studio that wishes to compete for commercial business. It can take years to get a payback on the amount of financial output necessary to buy all of the latest toys to lure the customer. Hence, the attraction of the personal home studio. In that realm, however, the composer must not only be the creative force, but the engineer and producer. Delegating the responsibility to others can become something worth buying.

As Guitar Center's Angress says, "The studio that adds value, that has a tremendous acoustic space, really creative engineers and a nice environment, is always going to prosper." ■

*Robyn Flans is a freelance writer in the Los Angeles area.*

# The Dawning of a New Sound

## SRS Pro 220 Sound Retrieval System

SRS (Sound Retrieval System) is an award-winning patented technology that retrieves the spatial information from any stereo recording and restores the original three-dimensional sound field. Use the SRS Pro 220 to convert mono to 3D stereo, expand the sound stage, restore natural spatial cues and control the center channel.

### SRS PRO 220 APPLICATIONS

- Recording
- Broadcast
- Live Performance
- Audio post production
- DJ Systems



**Everything Else is Only Stereo**

*"SRS creates width and depth in my recordings that were next to impossible to create before"*  
Chris Gibson, Micworks



**SRS**  
www.srslabs.com

Available at a store near you,  
or call 1-800-2HEAR3D  
[1-800-243-2733]

**SRS**  
by SRS

©2001 SRS Lab, Inc. All rights reserved. SRS and the SRS symbol are trademarks of SRS Labs, Inc.

Internet Audio is Mix's new quarterly magazine focusing on Web-based audio production and delivery. Internet Audio is designed to educate the audio production community in making sense of emerging technologies while offering insight and perspective to this expanding market.

Editorial content of Internet Audio includes step-by-step guides to putting audio files online, examination of the shifting face of music distribution, exploration of Webcasting and profiles of Internet innovators who are creating great sounds online.

Subscribe FREE at  
[www.mixonline.com](http://www.mixonline.com)

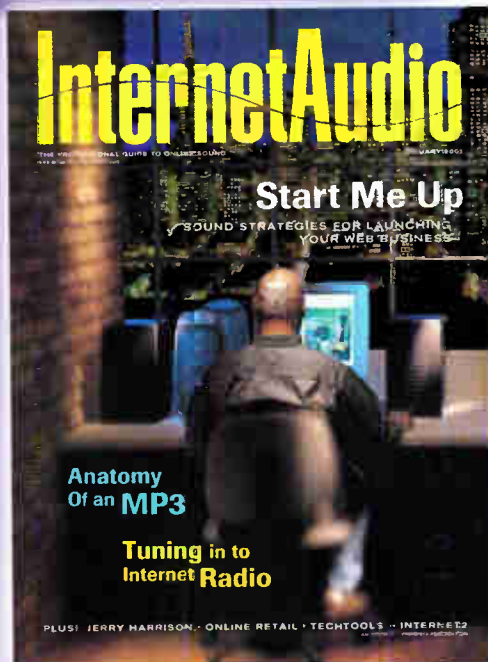

# InternetAudio™

# CLIFF MARTINEZ

## SOUND GENERATION AT HOME

When you listen to the suspenseful rhythms at the core of the score for the hit movie *Traffic*, it comes as no surprise that the composer once made his living as a drummer. After performing and recording with The Weirdos, Lydia Lunch, Captain Beefheart, The Dickies and the Red Hot Chili Peppers in 1989, Cliff Martinez decided to trade in his sticks for recording gear. Actually, not just his sticks.

"I decided I didn't really want to be wearing a sock on my weiner for the rest of my life," he says with a laugh. "Plus, my taste in music changed, and after being on the road with the Chili Peppers on and off for three years, bouncing around in a smoke-filled van all day and living on deli plates kind of wore thin."

So, naturally, he gravitated toward the film world, working with an SP12 sampling drum machine and a Prophet 2000 sampling keyboard in his West Hollywood apartment. "I had drums used for planters and table tops and literally slept under the keyboard," he recalls. "I began sampling household items, sound effects recordings and rude body noises and with them, created a series of semi-musical sound collages. At the time, I thought I was being brilliant and highly original, but was frustrated that I couldn't come up with an outlet for it. Then I was channel surfing one day [in 1987] and stumbled on Pee Wee Herman."

After scoring an episode of *Pee Wee's Playhouse*, he was invited to work with sound designer Mark Mangini for the film *Alien Nation*. He hit it off with Mangini's good friend, Steven Soderbergh, who then asked Martinez to score his first film, *sex, lies, and videotape*.

In 1993, Martinez bought a house in Topanga Canyon and built a project studio in the 20x15-foot family room. "I put up a couple of

double-glass doors and double-glass windows so I could keep the music in and the external noise out," he explains. "I have a line out for all the mics so I can record elsewhere in the house. There's one large space downstairs—the kitchen, dining room and living room—which has a high ceiling and makes a great area for live recording.

"I haven't recorded a lot of human beings in the house," he continues. "So far, I've recorded mainly percussion and guitars. The most ambitious home recording so far has been a choir. We [with engineer Leanne Ungar] overdubbed four singers who swapped parts and mic positions to create the illusion of size."

For *Traffic*, Soderbergh showed Martinez a rough cut of the film with a temp score. "Steven wanted a score similar in style to *sex, lies, and videotape*, which was slow, ambient and had a conspicuous absence of melody, harmony and rhythm. It was an unusual approach to take back in 1989, and I was a little surprised that Steven wanted to go down that road again with a \$50 million dollar picture."

Martinez estimates that about 60% of the music for *Traffic* was "recorded" via samplers in his studio. Pianist Herbie Hancock and guitarists David Torn and Michael Brook were recorded in their respective home studios, while Flea and percussionists Alex Acuna and Paulinho Da Costa were recorded at Media Ventures in Santa Monica. Because it was primarily an ambient score, Martinez and scoring mixer Alan Meyerson decided to add space and size to the sound by



PHOTO: MAUREEN DRONEY

pumping the elements into a live space and recording the ambience. This enabled them to create a full, warm surround mix without using much in the way of electronic processing. They chose the famous Capitol Studios for the task with excellent results. The score was mixed by Meyerson at Media Ventures.

While Martinez has an elaborate home theater with a surround system (Snell speakers, Aragon amps and Lexicon CP3) and a 53-inch projection set, the heart of his home studio is the sound-generating capability. His main controller is a Fatar SL-88 keyboard, and he makes frequent use of the Roland SP-700 sampler, three Akai S1000 samplers, a Studio Electronics SE1 synthesizer, an Access Virus synthesizer, an E-mu Proteus/2 module, a Kurzweil PX-1000 module and a DrumKat MIDI percussion controller. He is dual-platform, running MOTU PCI and Logic Audio off of a 500MHz Apple G4 and GigaSampler off his PC. Digital video is through a MiroMotion DC30 software. Rough mixes are done on a pair of Mackie 1604s, and he monitors on Genelec 1031As.

"It's hard to imagine how composers ever did film soundtracks before MIDI and SMPTE," he laughs. "If it weren't for computers, I'd probably still be playing drums, or maybe I'd be an accountant." ■

BY ROBYN FLANS

# surround sound?



## 5.1 reasons why you need the ASP510

- 1 The ASP510 integrates seamlessly with any console.
- 2 Comprehensive control of monitoring and record functions for multiple surround sound formats.
- 3 Six preset monitor formats.
- 4 Supports three 5.1 Surround, three stereo sources and encoder/decoder insertion.
- 5 Eight inputs from console/ 8 outputs to recorders.
- 5.1 5.1, 5.1 Film, LCRS, Dolby Surround, DVD-Video, DVD Audio, DTS, and SACD formats supported.



Manage your Surround Sound system direct from the ASP510's simple to use remote control

**ASP 510**

SURROUND SOUND CONTROLLER

*audient*

ANALOGUE SIGNAL PROCESSING TECHNOLOGY

[www.audient.co.uk](http://www.audient.co.uk)

U.S. distribution:  
AUDIO INDEPENDENCE, LTD. 2140 West Greenview #7 Middleton WI 53562 USA  
tel.: (608) 831 8700 fax: (608) 831 7100 e-mail: sales@audioind.com  
CIRCLE #106 ON PRODUCT INFO CARD



RECORDING • NOTES



PHOTO: DANNY CLINCH/COURTESY R. TWEEDS & CO. (GARY BURDEN)

NEIL YOUNG  
ON THE ROCKS

A LIVE CD AND DVD  
SHOW THE ROAD  
WARRIOR AT HIS BEST

by Bob Buontempo

Neil Young has encompassed many different musical styles over the course of a nearly 40-year career, from delicate folk-based acoustic music to hardcore country to rockabilly to electronically processed rock, to feedback-saturated proto-grunge. He's touched on punk and reggae and horn-driven, big band-influenced music



and much more, yet, through it all, he always sounds like Neil. It's in the voice, the songwriting, the distinctive harmonica style, the guitar solos dripping

with feeling. He may be a musical chameleon, but he is always unmistakably himself.

Technically, he has covered just about all of the bases, as well. Young has employed all sorts of different methods of recording, from traditional analog multitracking to his experimental "digi-tube" technique. That term was coined for a process Young explored to record tracks well over a decade ago. During those sessions, he virtually pioneered the use of a digital storage media, softened by an all-tube, analog front end. To this day, that methodology continues to be a common practice, used by many engineers and producers when making digital recordings.

Young was also one of the first private owners of a Sony 3324 digital multitrack, at a time when only major recording facilities would have expected to see any financial returns from offering their clients the use of that extremely expensive machine. Then again, Young is not above using a crude recording of himself singing by a crackling fire at home on an album. That's Neil Young, too.

While we all patiently await the long-promised and longer-delayed first installment of the Neil Young box set series (volume one is reportedly eight CDs and only goes through 1972!), Young has been characteristically busy, and last Christmas he released both a fine live CD, *Road Rock Vol. 1*, and a con-



PHOTO: PEGGY YOUNG

cert DVD, *Live at Red Rocks*. Handling the recording for both projects was David Hewitt's Remote Recordings Services, based in Lahaska, Pa. "I called David because he's the best," says John Hanlon of Young's production crew. They were looking to book Hewitt's mobile Silver Studio for three days in late September 2000, for Young's performances at Red Rocks, a breathtakingly gorgeous amphitheater situated in Morri-

—CONTINUED ON PAGE 202

# BUCKCHERRY

LOUD AND PROUD

by Elianne Halbersberg

"Rock and roll all night and party every day" is the *modus operandi* of any band worth their weight in piercings, or so we're led to believe. But spend time with Buckcherry—brash, loud, covered in body art—and the stereotypes quickly disappear. No one knows this better than John Travis, who produced the band's new album, *Time Bomb*.

Travis met with vocalist Joshua Todd, guitarists Keith Nelson and Yogi, bassist Jonathan Brightman and drummer Devon Glenn at their request. He'd received a 35-song work tape from the band and was familiar with their self-titled debut. "I took



L to R: Yogi, Jonathan Brightman, Joshua Todd, Devon Glenn, Keith Nelson

the meeting because they were interested in me as a producer," he says. "I thought they were an interesting, cool band who could make a great record. When I met them, I realized how focused and driven they are, how intelligent and committed. That's why it was important to me to do the record—because they

were so passionate about it."

Buckcherry introduced themselves to radio two years ago with the single "Lit Up," a three-minute assault of cocky, aggressive vocals and driving guitars. While so many of their colleagues relied on DJs, samples, computers and assorted technology, Buckcherry's back-to-basics approach



owed much to early Aerosmith and the Rolling Stones and nothing to the Korn-field of new bands. *Time Bomb* remains true to those roots, its only change being that the

—CONTINUED ON PAGE 208

# IN "THE ROOM" WITH HAROLD BUDD

by Blair Jackson

The music of Harold Budd is steeped in mystery. It bubbles up from deep silences and softly reverberant spaces, insinuating itself like some sort of pleasant, mind-altering soma. His music has been variously dubbed ambient, minimalist, avant-garde, neo-classical, even new age (gasp!), but none of those quite captures it. His piano and keyboard melodies float in the ether like beautiful hallucinations, at once calming and yet strangely compelling. Though a native of L.A.



PHOTO: CHAPMAN BAERLER

(where he still lives), Budd has long enjoyed a greater following in Europe than America, in part because he first came to prominence at the wing of Brian Eno—the



harold budd

the room

two made the landmark late-'70s ambient album *The Plateau of Mirrors* together and later cut the superb record *The Pearl*. Budd has also worked with such intriguing, forward-thinking European musicians as the Cocteau Twins, XTC's Andy Partridge and Hector Zazou.

Intriguing as these collaborations are, it is Budd's solo works that are most inviting to me. Album after album since his EG Records debut in 1978, *The Pavilion of Dreams*, Budd has carefully painted sonic landscapes of often breathtaking beauty, allure and aural poetry. Eno summed it up best when he noted, "Harold works with simplicity, clarity and sensuality. He's a great abstract painter trapped in the body of a musician." His tools are relatively simple—usually

—CONTINUED ON PAGE 212

# NEIL YOUNG'S "HEART OF GOLD"

by Elliot Mazer

Introduction by Blair Jackson

By the time Neil Young rolled into Nashville to begin recording his *Harvest* album, 30 years ago this past winter, he had already enjoyed several different careers as a musician. And, as we learned subsequently, he was only warming up for what has been one of the most fascinating odysseys of any rock musician.

After playing folk and rock in his native Canada during his teens, Young and his friend/bandmate, bassist Bruce Palmer, moved to Los Angeles in 1965 and, the following spring, formed the groundbreaking country-influenced rock band Buffalo Springfield with guitarists Stephen Stills and Richie Furay and drummer Dewey Martin. Over the next two years, Buffalo Springfield would go

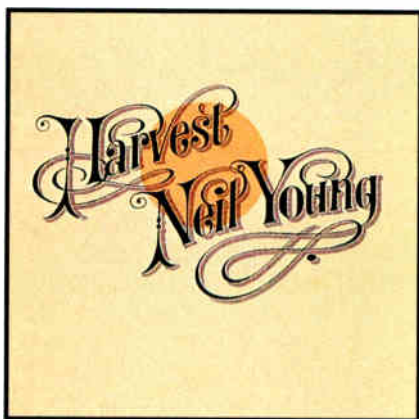

through various personnel changes (including the departure of Palmer and the addition of Jim Messina) and record two well-received albums for Atco. It was a band filled with strong singers and songwriters, and Young quickly established himself as an utterly distinctive presence, as songs such as "Mr. Soul," "Broken Arrow" and "Expecting to Fly" showed. However, by May of '68, the battles between Young and Stills had led to the dissolution of this promising group. At that point, Young became a solo artist, releasing his eponymous first album, produced by the eccentric genius Jack Nitzsche, in January 1969. In the course of making that album, Young encountered a group called The Rockets (guitarist Danny Whitten, bassist Bill Talbot



Neil Young (left) and Elliot Mazer listening to playback at Young's Redwood Digital studio during January 2001 remix sessions for the *Harvest* DVD-A.

and drummer Ralph Molina), and he hooked up with them and changed their name to Crazy Horse. Together, they cut the classic, hard-rocking *Everybody Knows This Is Nowhere* album, which contained such defining Young numbers as "Cinnamon Girl," "Cowgirl in the Sand" and the epic "Down By the River." Then, just as that album was taking off, Young joined Crosby, Stills & Nash for a tempestuous year or so that included the making of the multi-Platinum *Déjà Vu* album. A third solo album, *After the Goldrush* (featuring Crazy Horse, Stills and an up-and-coming young axe-slinger named Nils Lofgren) came out in September of '70, and continued

Young's incredible rise. At this point, Young took a turn in a somewhat different direction, heading to Nashville to record *Harvest*.

Elliot Mazer, producer of that album (and subject of this issue's Producer's Desk on page 54) tells the story of the recording of this issue's "Classic Track," the Number One single "Heart of Gold."

...

"Heart of Gold" was recorded during the first set of the *Harvest* sessions at Quadrafonic Sound Studios in Nashville in early 1971. This project was full of coincidences and surprises. Neil, Linda Ronstadt, James Taylor and Tony Joe

20 TRACK IDENTIFICATION CHART									
QUADRAFONIC SOUND COMPANY									
ARTIST	TITLE	TRACK	INSTRUMENT	PERFORMER	REMARKS	REMARKS	REMARKS	REMARKS	REMARKS
NEIL YOUNG	ALABAMA	REP							
SW 1	ALABAMA								
I	FOOT	SNARE	H H	NEIL	SAFETY	NEIL	NEIL	NEIL	NEIL
		RIDE	CORN	GTR	STEEL	SAFETY	SAFETY	SAFETY	SAFETY
	NEIL	H I	LO	STEEL	GRAPES	GRAPES	GRAPES	GRAPES	GRAPES
	SAFETY	STEER	GUITAR						
II	FOOT	SNARE	H H	CHORUS	NEIL	NEIL	NEIL	NEIL	NEIL
				1	SAFETY	SAFETY	SAFETY	SAFETY	SAFETY
	CHORUS	NEIL		STEEL	FEEDY				
	2	GIT							
III	FOOT	SNARE	H H	AWAY A	PIANO	PIANO	NEIL	NEIL	NEIL
				PIANO	R	R	SAFETY	SAFETY	SAFETY
	NEIL	NEIL	CHORUS	STEEL	JAMES	CHORUS	CHORUS	CHORUS	CHORUS
	SAFETY	GIT	2ND TIME		GUITAR	BOTH TIMES	1ST TIME		

Track sheet for "Heart of Gold." The "Neil safety dry" vocal recorded on track 8 is identical to that on track 6, but recorded at -4 dB. (The version of "Alabama," shown here, is not the one used on *Harvest*.)



**REMIX** *is cool*  
UNDERGROUND MUSIC PRODUCTION • DJ PERFORMANCE

It's where DJs and remixers go for product info and reviews, applications and techniques, dance music business resources, and marketing/promotional ideas—and now they're going for it monthly.



**MORE  
CORE**

from the publishers of  
Electronic Musician &  
Onstage Magazines

Read about current trends in electronic music, turntablist tips, the latest recording gear, and profiles of the top artists in today's club scene. Get out of the dark and into the light with *Remix*. 800.275.1989

**The magazine for underground  
music production and DJ performance**

World Radio History

Get it monthly, subscribe now: [remixmag.com](http://remixmag.com)

White were in town to shoot the final *Johnny Cash Show* for ABC-TV. I was living in Nashville, working mostly at Quad, which I co-owned with David Briggs—the Nashville musician, not the David Briggs who had produced other Neil Young records—and Norbert Putnam. I decided that the studio would host a dinner for some of the [Cash show] guests and some of our studio friends. I called Elliot Roberts, Neil's manager then and now. Elliot and I had

known each other in New York; I produced some demos with a group he called Roberts Rules of Order. He took Neil to the party. I had produced Linda's *Silk Purse* LP. So, I called Peter Asher, Linda's manager, and he brought Linda and James Taylor. We had around 50 people for dinner. During dinner, Elliot introduced me to Neil, and we started talking about studios and musicians. Neil had heard of our band, Area Code 615, and asked if I could get the drum-

mer, a bass player and a steel player into my studio the next day. Kenny Buttrey was available and keen to play [drums] with Neil. Norbert had gone home to Muscle Shoals for the weekend, and Weldon Myrick, the steel player in Area Code 615, could not make it, because he had to do his regular gig on the *Grand Ole Opry*. So we found Ben Keith—he's still working with Neil after 30 years [see story in "Recording Notes"].

Neil and I met for breakfast Saturday morning at the old Ramada Inn, and we decided to meet up at the studio that afternoon. Neil showed up and asked us to move things around so that he could be next to the drums. We got Troy Seals, an amazing songwriter, to play bass, and Teddy Irwin, a session player-friend, played guitar. A few hours later, Tim Drummond showed up with his bass. Marshall Falwell, the photographer, had seen Tim walking on the street and told him to go to Quad with his bass.

"Heart of Gold" was the second song we cut. Teddy, Ben, Tim and Kenny played on it. I used a [Neumann] U87 on Neil's voice; a [Neumann] KM86 on his guitar; drum overheads were KM86s, snare most likely a [Shure] SM56, hi-hat a 224E; bass was direct; we had a KM86 on Teddy's guitar and an 87 on steel. We were recording to 2-inch 16-track Scotch 206, 30 ips, no noise reduction. The console was a Quad Eight 20x8x16. No compressors were used. I hand-rote his voice, which meant I had to learn the song and anticipate his moves. The vocal effect on Neil's voice is 15 ips tape slap-back, and it is on the multitrack.

A vivid recollection of the session that produced "Heart of Gold" was hearing Neil play and sing the song for us the first time. The song and arrangement came alive. Kenny Buttrey and I made eye contact while listening, and we both raised a finger that said we knew it was going to be a Number One hit. It took a few minutes for the band to learn the song and figure out how to capture the magical feel that Neil was laying down. Neil was very specific to Kenny about what *not* to play. Tim Drummond and Kenny played together so much that they just connected to each other. Teddy Irwin found some harmonics and rhythm chops, and Ben Keith just sailed through the song. We did one or two takes. Neil and the band played live, same as every song on *Harvest*. After we got the master take, we got Linda and James to add their harmonies in the control room while sitting on the couch. They were facing the control monitors and the vocal

—CONTINUED ON PAGE 202

## Cool Spins

The Mix Staff Members Pick Their Current Favorites

### The Spanic Boys: *Torture* (Checkered Past Records)

The Spanic Boys are father and son, and their concoction of interwoven Fenders and provocative vocals isn't easy to pigeonhole, but here's an attempt: It's sort of like George Harrison playing with Chuck Berry, with David Lowery and the Everlys on vocals—retro and rocking with lots of roots influence, but totally irreverent and original. All original songs, too. It's said that family members have a special ability to harmonize, and in their vocal duets, the Boys sound exactly like what they are: made for each other. They've also got a superb rhythm section in drummer Brad Elvis (formerly an Elvis Brother) and



Melanie X of Big Hello. Generations of rock 'n' roll somehow come together beautifully in the Spanic Boys to form something really new.

Producer: Ian Spanic. Recording engineers: Ian Spanic, Trevor Sadler, Shane Olivo. Mixer: Ian Spanic. Studio: Lone Scout (Milwaukee, Wis.) Mastering: Trevor Sadler/Mastermind Productions.

—Barbara Schultz

### Tortoise: *Standards* (Thrill Jockey)

A veritable who's who of the Chicago un-

derground music scene, Tortoise's collective membership—Dan Bitney, John Herndon, Doug McCombs, John McEntire and Jeff Parker—have come back together after a three-year hiatus to create a tem-

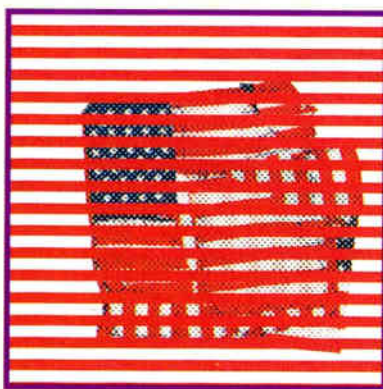

plate from which many an indie rock band will be formed. Instead of continuing to create and perfect the studio-manipulated sounds of 1996's *Millions Now Living Will Never Die* and 1998's *TNT*, Tortoise returns to a more organic approach that is quite direct, while still maintaining the exploratory aspects that have been the heart of their post-rock style. The first track, "Seneca," rumbles through one-and-a-half minutes of processed and manipulated synths and guitars before exploding into a heavy break beat that is tempered with vibes, manmbas and guitar. The absence of the ever-intrusive studio can be best heard in "Blackjack," where the musicianship of Tortoise truly shines through with soaring melodies that are reinforced by percussion sounds reminiscent of Can and Kraftwerk. Recorded mostly on Pro Tools by Tortoise's own John McEntire at his own Chicago studio, Soma Electronic Studios, *Standards* was spawned by a nonlinear approach where segments of groove and melody are layered on top of one another, leaving very little room for traditional verse-chorus-verse arrangements.

Producer/Engineer: John McEntire.

—CONTINUED ON PAGE 216

**onstage** *is hot*

It's where performing musicians who live to play live get the latest word in equipment reviews, music business techniques, and vital survival tips—and now they get it every month.

20 Tips for Better Harmonies • Stars PSM 400 and 3 more reviews

FEBRUARY 2001 Vol. 2, No. 2

# onstage

**MORE  
CORE**

*from the publishers  
of Electronic Musician  
& Tonic Magazine*

**CLINT BLACK**  
At Home  
on the  
Road

**Vertical Horizon**  
Nice Guys  
Finish First

*Onstage* is filled with features of high-profile artists, technology spotlights, performance tools and columns by industry pros. Get out of the audience and into the act with *Onstage*. 800.275.1989

Get it 12x this year, subscribe now: [onstagemag.com](http://onstagemag.com)

**The magazine for bands & musicians**

World Radio History

# MICK GUZAUSKI

HIS LATEST PROJECT IS A "THRILLER"

by Paul Verna

If a great mix truly contributes to the commercial fortunes of a record, then Mick Guzauski has got to be the King Midas of pop music. By a recent count, he had mixed 27 Number One singles by such artists as LeAnn Rimes, Eric Clapton, Mariah Carey, Earth, Wind & Fire and Boyz II Men. And that's just the tip of the iceberg. Factor in the artists Guzauski has worked with who *didn't* happen to peak at Number One, and you've got names like Kiss, Aaliyah, Kirk Franklin, Whitney Houston, Jennifer Lopez, Quincy Jones, Britney Spears, Joan Jett, Talking Heads, Barbra Streisand and many more.

Given Guzauski's impressive track record, it's no surprise that the self-proclaimed King of Pop himself—Michael Jackson—called on the veteran engineer to mix the 5.1 channel version of his 1982 masterpiece *Thriller*, still the best-selling album of all time.



Without a firm deadline or a specific release plan for the new version of that classic LP, Guzauski has been able to approach it at a leisurely clip, starting with two mixes ("Wanna Be Startin' Somethin'" and "Billie Jean"), then moving on to other projects and eventually returning to *Thriller*. We caught up with Guzauski at his Barking Doctor studio

in Mt. Kisco, N.Y., just after he had completed those two mixes. He seemed to take great pleasure in playing them for visitors, while also talking about some of the other work he has been doing recently.

For *Thriller*, Guzauski had transferred the original analog masters—which were on two synchronized reels of Scotch 2-inch tape—to 24-bit DASH reels, using the converters on his Sony Oxford digital console to feed his Sony 3348HR multitrack. Once in the digital domain, the tracks were mixed through the Oxford, using a minimum amount of outboard processing, and recorded to six channels of Pro Tools via the AES/EBU outputs of the Oxford, which fed the Digidesign 888|24 Pro Tools interface.

Guzauski also transferred the original version of *Thriller* onto the same Pro Tools session that contained the multichannel information. This allowed him to refer quickly to the 2-track master as a template for how to do the surround mix. "I really wanted to respect what Michael did," he says. In addition, the stereo version gave Guzauski a

—CONTINUED ON PAGE 216

—FROM PAGE 200, "HEART OF GOLD"

mic; an 87 on cardioid was facing them. They listened to the studio monitors and sang along listening to each other. Two passes, and it was finished. I guess it took less than two hours to record everything on "Heart of Gold." I can't remember where we mixed it—either at Quad or in Neil's house. We did a mono and a stereo mix—15 ips, no noise reduction.

A side note: It was very easy to get good sounds in the studio in Nashville. The rooms were set up properly, the musicians knew how to tune and make their instruments sound good, and the engineers were expected to get sounds quickly and to give the musicians good earphone mixes. At Quad, we had a 3-channel cue system that sounded great. In my studio in San Francisco, His Master's Wheels, we had a 4-channel system. Each musician got a box with controls for level. We only spent a few minutes getting sounds for Neil. I had listened to *After the Gold Rush*, and we all seemed to respond to the intimacy of Neil's music. I don't recall why we started to use slapback on Neil's voice, but that worked wonderfully. Neil really got excited when he heard the first playback. Later on, after he had gone home

to California, he told me that this was the first time a tape sounded better at home than in the studio.

In the '70s, Bob Dylan said that when he first heard "Heart of Gold" on the radio, he got mad, because it should have been him; it sounded like him! The song peaked at Number One in *Billboard*, as did the album.

Where's everyone now? Neil, obviously, is still writing, making records and touring. Ben Keith is still playing; he also produced Jewel's first album. Teddy Irwin is living in Nashville, playing and composing music for TV shows. Teddy has toured with Roy Buchanan, Petula Clark and Doc Sevrenson, among others. Tim Drummond worked with Neil and CSNY and Bob Dylan and many more in what has been a long and brilliant career. Kenny Buttrey made many, many great records over the years; he is retired now. And these days, I'm living in New York, working in the technology world and making the occasional record. Quadrafonic Sound Studios is now associated with Quad Studios of New York, which is owned by Lou Gonzalez, who was an engineer I worked with on a Gordon Lightfoot record back in the '60s! ■

—FROM PAGE 196, NEIL YOUNG ON THE ROCKS

son, Colo. Besides the planned CD and DVD releases, Young also wanted to do a live Webcast of one of the concerts.

Normally, this sort of gig wouldn't cause Hewitt—a six-time TEC Award winner for Outstanding Remote Engineer—much consternation. However, due to the location of the venue, combined with the lack of cooperation from the weather, Young's project ended up presenting quite a challenge.

"Red Rocks, a beautiful amphitheater, formed by nature from stone, is located at the peak of a sharp incline in the Rocky Mountains," Hewitt explains. "Access to the location is via a very steep, rather narrow, cliff-edged road. So, they've built a loading station at the base of the site, allowing the semi trucks hauling the P.A. and band equipment to unload the gear onto smaller Bobcat straight trucks, in order to more easily proceed the rest of the way up to the performance area. However, since my Remote Recordings studio is permanently installed in a tractor-trailer and not designed to be dismantled, that situation didn't work for me. We considered running cabling from the loading station up to the

Get out of the dark and into the light with Remix, where DJs and turntablists go for product info and reviews, applications and techniques, dance music resources, and marketing/promotional ideas.



# onstage

# REMIX

UNDERGROUND MUSIC PRODUCTION • DJ PERFORMANCE



It's where performing musicians get out of the audience and into the act with the latest word in equipment reviews, music business techniques, and vital survival tips.

## WE COVER IT ALL—

Now, every month, from the publishers of Electronic Musician, remixers read about current trends in electronic music, turntablist tips, the latest recording gear, and profiles of the top artists in today's club scene in Remix—and those who live to play live turn to Onstage for features of high-profile artists, technology spotlights, performance tools and columns by industry pros. Get into them!

[www.remixmag.com](http://www.remixmag.com)

[www.onstagemag.com](http://www.onstagemag.com)

800.275.1989

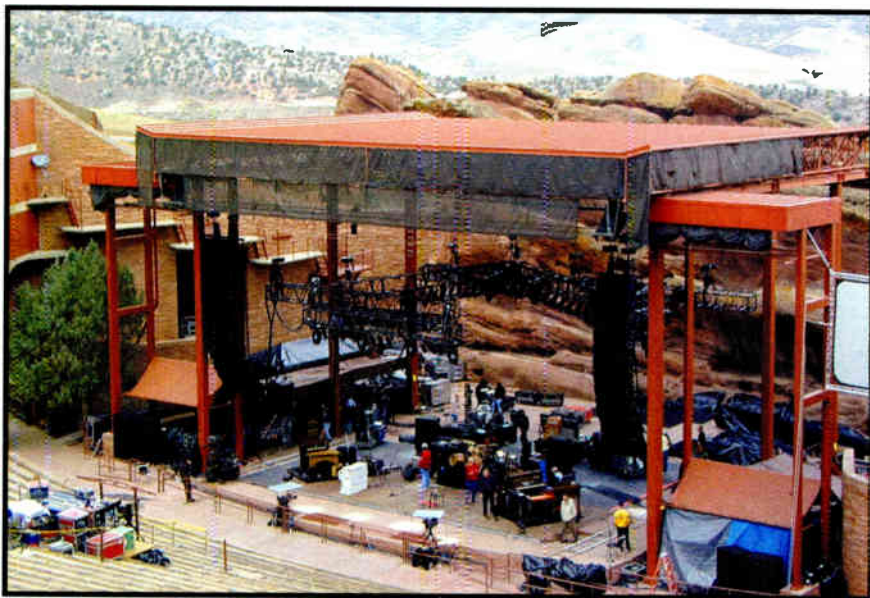

PHOTO JOHN DRANE

The load-in and setup at Red Rocks

stage, but that was quite a long distance, so we dropped the idea rather quickly."

So, Hewitt and his son, Ryan, who was the assistant engineer for the sessions, attempted to drive the truck to the top of the grade. "We tried to make it up several times, but it was virtually impossible, and we started to burn up the clutch in the cab," Hewitt recalls. "So, ultimately, we called a local heavy-duty tow truck service. They ended up *carefully* maneuvering around us and got up to the summit, right where we wanted to park our trailer. Luckily, the tow cables on their truck were quite long, and they lowered the extended towlines down the pavement to us. We attached them to our vehicle, and when we started to drive up the road again, they started reeling the cables back onto their wrecker. That caused us to get pulled up a bit by the now recoiling cables and helped us make it to the top of the site. Working together, we were finally able to get the studio to the stage."

Hewitt was hired as the "remote engineer" rather than the principal recordist for the shows, because Young tends to use the same personnel he has for the last 20 to 30 years for all of his projects. In fact, the tour that these projects document was named "Friends and Relatives"; the Friends being the musicians and crew that Young works with, and the Relatives being his wife, Pegi, and his sister, Astrid, who are the background vocalists in the band. Young's all-star band for the tour included Jim Keltner on drums, Donald "Duck" Dunn on bass, Spooner Oldham on keyboards (he also co-produced the CD) and Ben Keith on various guitars, from dobro to

pedal steel and other instruments.

Young's son Zeke is also involved behind the scenes; he records every show to 48 tracks on six Tascam DA-78s. He assigns one of the machine's eight tracks in this manner: First, he grabs the FOH mix, taking it pre-fader, post-EQ and post-effects. That stereo mix is printed on the first two of the tracks. The remaining six tracks are used as three additional stereo pairs, which are dedicated to the audience and stage ambience mics. The other five DA-78s consist of 40 tracks taken from the FOH board.

"Neil uses digital media to archive all his shows," says John Hanlon, who was the principal engineer on the project. "First, there are Zeke's DA-78 tapes of every concert. Neil also takes a DAT of the FOH mix home with him after the gig, so he can listen to, and study, the performance of that show. The performance is *everything* to Neil, so he is constantly evaluating each one."

Still, Hanlon notes, "Neil insists on 2-inch analog tape for all his commercial releases," which is one reason why Hewitt's truck was chosen. The mobile control room has a pair of Studer A820 analog 24-track recorders, as well as a Neve VR M48 console and plenty of outboard gear, which Hanlon supplemented with some of his own.

Hanlon explains the approach to recording these shows: "We split the mic signals from the stage three ways: one split was for the recording truck, one for the FOH mix and one for the monitors. Each feed was transformer-isolated, by a Whirlwind box, which was custom-built for Neil. I took my 60 inputs and subgrouped them so I could fit everything on

one 24-track machine. I needed one track for timecode, which was provided as house sync by the video crew, and I used a guard band track, as well. So, I really only had 23 tracks to work with. We ran the two Studers with about a five-minute start time stagger and fed them both, simultaneously, with identical signals, which consisted of a mult from the console's outputs. That way, we could have two first-generation, 2-inch analog master tapes at the end of the night: one for mixing the CD and the other to be used for the DVD. Since we had to make some tight deadlines in order to have product out for Christmas, the CD and DVD were mixed concurrently, at two different locations."

Hanlon adds, "All the tape machine reel changes were timed out to happen during cues and were done live and 'hot' during the show by the tape op, Phil Gitomer."

Hanlon had to be very active during the performances. He also did a lot of pre-production homework. "I submixed the drums to four tracks," he explains, "kick, snare and a stereo pair of the rest of the kit. Then I also had a pair of tracks for each of the keyboards. I made sure that I had a mic for each instrument feeding one of the two tracks of the pair and a direct box output of that same keyboard feeding the other track. When you consider all the different guitars Neil uses, plus the variety of keyboards onstage, there's quite a few instruments that are played during each show. And that's before you include any miscellaneous items, like the squeezebox, pump organ, lap steel or harp. Between Neil and the other four musicians, they play a total of about 21 different instruments during a concert. Then, if you add to that the bandmembers' background vocals, the two female background vocals, plus Neil's lead vocal, you have a lot of things going down to 21 or 22 tracks. I was constantly muting and moving faders to get the appropriate instrument up at the right time for each song."

"With the redundancy of the direct and mic feeds assigned to opposite channels of the pair, if I missed a cue for a channel mute or a fader move on one track, I had that instrument covered by its other feed to the second track."

During band rehearsals in both Hawaii and at Young's ranch in Northern California, Hanlon studied the songs that were going to be performed during the show in order to learn his cues. "I needed to know where each instrument and vocal came in on every tune and when they finished their parts, as well,"

platinum sponsor



gold sponsors



media sponsors



millimeter



AV Avenue



MIX



Where DVD Means Business

DVD pro CONFERENCE

4th annual Discus Awards



NEW! Live@Monterey



July 30-31, 2001

Monterey Conference Center

DoubleTree Hotel Monterey, CA

DVD PRO is where top minds in the industry meet to share knowledge...

and help you turn your next project into a high-resolution success! Come learn how the interactive and Web-connected features of this maturing technology make a powerful case for your business and entertainment applications.

www.dvdpro.net

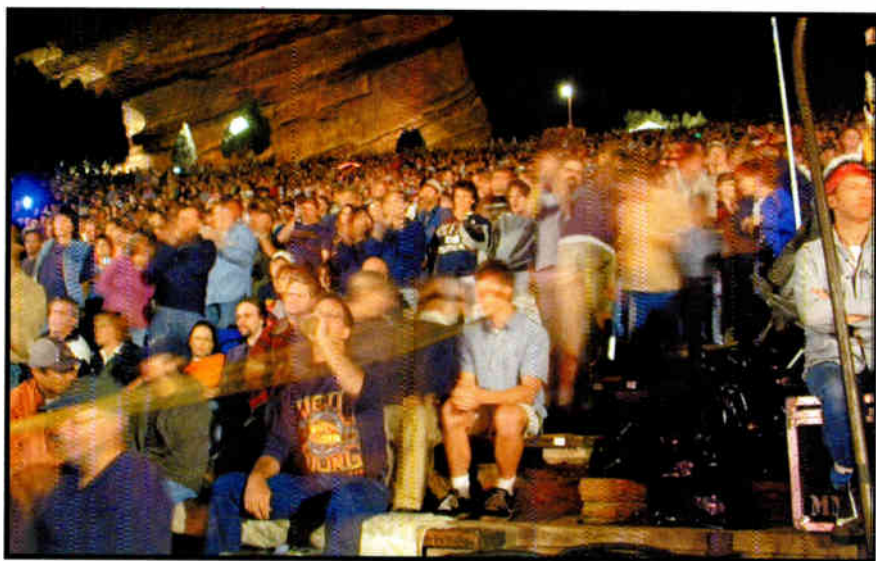

PHOTO: JOHN DRANE

**The crowd goes wild during Young's performance.**

he notes. "Plus, I had to know which of the many instruments onstage were going to be used on each song and who would play it. A couple different musicians play several of the instruments, and each guy has his own touch, style...and level. There's a lot of swapping that goes on during shows.

"I made color-coded charts for each song," Hanlon continues. "Because of the limited number of available tracks, I had a few instruments share tracks. I found out which ones weren't used together in a song and bused them to the same tracks. So, I wanted to be sure only the correct mic or DI was open on each track at the right time. That way, I could cut down on the noise, leakage and mud that the unused open mics would have added to the track. This pre-production would come in very handy later on during the shows."

"The mic preamps were all remote, staying on the side of the stage," explains Hewitt. "They were mostly Millennias, with a few APIs used as well. We ran everything into the truck at line-level. Sean McClintock, the stage manager, would trim the levels to John's specifications."

Hanlon set the levels once before the show rather than adjusting for the different players. "I just set them for the hottest level they would get and left them alone all night," he says. "For instance, although the acoustic piano is played by a few musicians during the show, I know that Neil bangs it the hardest. He only plays piano for one song, 'Tonight's the Night.' So I'd just have the preamps for the piano adjusted so they didn't clip on that tune, and then it was good for all the others. That just comes from knowing and working

with these guys for so many years."

The microphone list for the dates was extensive, as might be expected. Neumann KMS150s were used for all the vocals. The drum set had a Sennheiser 421 on the kick, a Neumann KM184 on the hi-hat, a Shure SM56 on the snare, E-V 408s clipped onto the rims of all the toms and a pair of Neumann KM84s for overheads. AKG 460s were used on the acoustic piano, along with a Heppinstill pickup for the direct feed. That and the rest of the direct signals ran through Demeter DI boxes. Other mics included an SM56 and AKG 414 on the Leslie for the Hammond B-3, a Shure SM98 and Audio-Technica Pro-35R on the pump organ, ECM-33Ps on the vibes, Sennheiser 409s on the guitar amps and KMS150s for the dobro and squeezebox. Young's acoustics had FRAP contact mics with FRAP preamps on them, and the harmonica went through a Nady system.

A pair of AKG C-460s, augmented by an MKH 60 shotgun mic, were used for the stage ambience mics. Three additional shotguns onstage and a couple of pairs of Shure SM81s, fitted with omni capsules, were set up in the house for audience pickup.

"I had them set up in stereo pairs," notes Hanlon. "Tracks 1 and 2 were 'stage ambience,' with the shotgun mic placed center stage, facing the band. Tracks 3 and 4 were 'close audience,' with three shotguns onstage, facing the crowd but pointing a bit toward the sky. Tracks 5 and 6 were 'mid-audience' at the FOH position, and 7 and 8 were the 'far audience' tracks. The audience/ambience mics were printed to an additional DA-78, synched to the Studer 820s. I got the levels for those during the opening act, The Pretenders. A

Studer 962 console on Hewitt's truck was used for the audience/stage ambience microphones.

"All the inputs going to the multi-tracks were EQ'd, and any additional signal processing was added prior to them being assigned to buses or on the bus inserts," continues Hanlon. "I used an API EQ and half of a modified Quad Eight compressor on Neil's vocals. The other half of the Quad Eight went on Spooner's vocals. There was a Pultec EQP-A inserted on the kick, and the rest of the drums were EQ'd by the Neve console in David's truck. The bass had a Neve 1084 EQ, a Neve 2254 compressor and a Pultec EQ-1A3 in series on its mic insert, and the same processing but with an EQ-1A on its direct signal.

"Neil's two guitar tracks each had a Neve 1084 and a Neve 33609 on them. The pedal steel amp had a Summit compressor, and the harmonica, a Tube-Tech compressor. Both the acoustic piano tracks and the other pair of additional keyboard tracks had Empirical Labs Distressors on each of them. The background vocals for Ben Keith, Astrid and Pegi all had UREI 1176s on their inserts.

"I monitored through KRK E8s and Yamaha NS-10s, powered by an H&H Mosfet V-800 amp. Occasionally, I threw the mix up on the mains in the truck [custom KRK 15A3s] for bottom-end reference."

Young's regular crew handled the sound reinforcement end of the show: John Drane was the system engineer and crew chief, Tim Mulligan did the FOH mix and Mark Humphries handled the monitors, assisted by Tommy Sterling. Randy Aspillaga also assisted onstage.

Upstream Multi-Media of Sherman Oaks, Calif., supplied video for the DVD shoot and the Webcast. Larry Johnson, who has known Neil since working on the original *Woodstock* movie, was the producer/director. "Larry is like a dancer, coordinating all his shots and switching them himself," comments Marcy Gensic, the assistant producer for the project. "We had no video truck, so we constructed a little video tent on the side of the stage. The six digital betacams were switched live through an SDI digital switcher for the feed to the digital beta deck that would be used for the DVD, as well as the Webcast, and the two large projection screens for the audience. All the cameras were also taken as ISO signals, in case we needed to add or change anything in post." The video was shot in a 16x9 widescreen format.

The audio and video teams had their



# Find Great Deals ...Online or On Your Desk.

Mics, Amps,  
Mixers,  
Speakers,  
Keyboards,  
DJ Gear,  
Video, Software  
and More!



Call for the best catalog  
in the business!

**800-356-5844**



**AUDIO • VIDEO • AV • LIGHTS**

608-831-7330 • Fax: 608-831-6330

8001 Terrace Ave. • Middleton, WI 53562



The Xpress order division of Full Compass.  
Call 800-476-9886 from 8 a.m. to 10 p.m. CST weekdays  
and 10 a.m. to 6 p.m. CST weekends!



Check  
[www.fullcompass.com](http://www.fullcompass.com)  
for the latest sales  
and closeouts!

systems in place and were working smoothly together, but what they hadn't foreseen was the impact the weather would have on the project. "It started out being 80 degrees and sunny that first day," Gensic says, "but things started going downhill from there."

"The weather was atrocious for all three shows, with heavy rain, snow and high winds," adds Hanlon. "Now I had to be *extra* vigilant and mute any open mics constantly, because the wind noise made them unusable when no signal was present. The mics in the audience also started to crap out. We tried to cover them, but the noise of the rain hitting the plastic covering was way too loud to do that. The 'roof' on the stage was 60 to 100 feet above the stage floor, and since the wind was blowing the rain horizontally, it was no real help. Fortunately, no mics or equipment on-stage went down, except for the change of a soaked drum kit."

"We needed to build a shelter over the FOH console," notes crew chief Drane. "We only had a little slit to look out to the stage. Otherwise, we were ensconced in that tarp."

"But, the worse the conditions, the more determined Neil was to do a good show," adds Hewitt. "Looking at him on the stage, with his hair blown back and a look of defiance on his face, standing in the rain, with lightning in the background was something else. He looked like some sort of Norse god."

"The audio got a little messed up from some of the audience mics failing," says John Nowland, who mixed the DVD at Redwood Digital, Young's studio in Northern California. "But we were able to work around it, by and large, by manipulating the different audience tracks. We also were able to take the occasional track from Zeke's 48-track tapes to get around a few problems."

Nowland, who has been with Young since 1983, mixed the DVD-Audio on Young's Neve 8078, assisted by John Hausmann. The studio has custom monitors with TAD drivers. Mixes were stored to Studer 827 2-inch, as well as a Genex 8500 optical hard disc recorder fed through a Pacific Microsonics Model 2 converter using 24-bit/48kHz sampling rates. The audio was also HDCD encoded.

"We usually mix to both formats and pick the one that sounds best for the project," Nowland says. "The added bonus is also to have the analog for future archival purposes, as sampling rates and bit depth increase down the road."

DVD-Video post was handled by

Complete Post in L.A. The video had a few minor problems, as well. "We got video noise from the weather and the cables running through puddles," says Gensic, "but we were able to replace those shots from the ISO cams where needed."

That *should* be the end of the story. However, there are two little plot twists that remain.

After Young listened to all the FOH DATs from the tour, he decided that his best performances were *not* from the Red Rock concerts. Although all those performances were used for the DVD and live Webcast, the *Road Rock* CD was compiled from the 2-track FOH mixes, printed on the DA-78 from *other* shows during the tour, augmented by some of the stage ambience/audience tracks. These included one song each from Cleveland and Santa Barbara and three each from San Diego and Vancouver. A DVD-A using the same performances as the CD was compiled in a Sonic Solutions system, upsampling to 96 kHz from the DA-78 tapes, sequenced and configured for 5.1 by Tim Mulligan. Mulligan then took his hard drive to Bob Ludwig at Gateway Mastering for some final touches.

It was a marathon of hard work on every front. But the deadline was met, and Neil Young fans were rewarded with a bounty of Christmas treats. ■

---

—FROM PAGE 197, BUCKCHERRY

band now has two guitarists, completing Keith Nelson's mission.

"Things started changing while touring with Yogi," he says, "because, for the first time, I started hearing the music as big as it was on the record. It changed the songwriting process, showed us where we could take things sonically. It was a big adjustment, but it was always the goal. The recording process [for *Time Bomb*] was a lot of fun, trading licks. For example, 'Whiskey in the Morning' was done live with the two of us facing each other, blowing solos at each other, adding textures and bouncing ideas.

"When Yogi joined the band, some of the pressure was taken off of me to cover all the bases. I could focus more on songwriting and honing in on what I do instead of just being the guy who carries the record and everything outside of the vocals and rhythm. Yogi's an educated guy who'll say, 'You should go to the fourth,' and I'll say, 'Is that the one with the dot on it?' That's not far from

the truth. It's an interesting combination. I think we both have a lot of respect for what the other guy does, so the key to it working is that we know when it's on and when it isn't."

Buckcherry was again thoroughly prepared before entering the studio. "The first thing I was involved with was song selection," says Travis, "myself, the band, Michael Goldstone [A&R, DreamWorks Records] and [manager] Scott McGhee. Then it was six to eight weeks of me driving to their rehearsal room every day, sitting with them, making suggestions on arrangements, bridges, chords, then leaving them alone and letting them work on it. There are very talented songwriters in this band; they're all talented musicians, and it was better to let them take it in their direction. Then I'd come back and say, 'I like it' or 'Try something else.' Some of the songs were written several times until everyone was happy. I think every song stands on its own as being great. Some songs that didn't make the record were still great."

Because of this groundwork, songs were recorded in just one or two takes. "We were always going for the great overall track to add to the album, not to spend nine months in an overdubbing process," Nelson says. "This band operates best when we don't have to create at \$2,000 a day. It's so expensive and hard to survive in this business, so to try to make the *White Album* is ridiculous. You hear about people holed up in the studio and locked in for five months—don't they know what they want? We've either got it or we don't. When something doesn't feel right, we move on."

A musician himself, Travis was perfectly suited to complement Buckcherry. "I was a guitar and bass player in various bands in England and Germany," he says. "Every time we recorded, the recordings never came out like I wanted them to. The guitars weren't big enough; the drums weren't big enough. One day I said, 'Let's pay for one more day and let me remix.' Then other bands asked me to remix them. I interned in a studio, became assistant engineer, then engineer." Travis worked in Berlin, England and then New York, where he spent several years producing rap records. "After a while, I thought I should be working with rock, because that's the music I played and was into, and it seemed a waste to be a player who wasn't playing. I spent two years engineering with Michael Beinhorn, who did Social Distortion's *White Light White Heat White Trash* [Travis recorded the CD and



# Take Control of Your Room!

## London-14 Studio

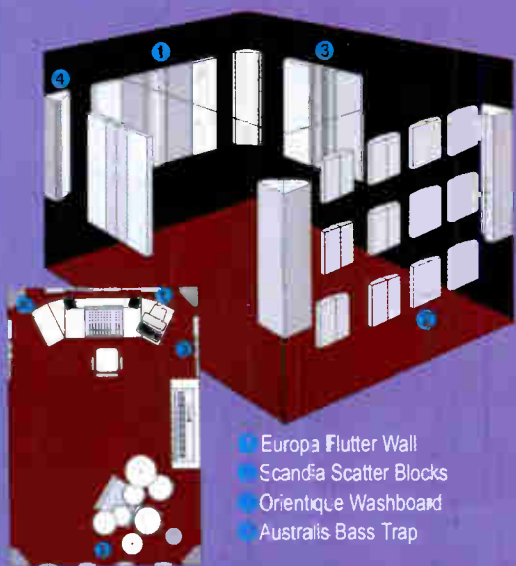

- 1 Europa Flutter Wall
- 2 Scandia Scatter Blocks
- 3 Orientique Washboard
- 4 Australis Bass Trap

Face it. Most project studios and post-production rooms are built in typical rectangular rooms. You spend thousands of dollars on gear only to battle standing waves, flutter echo, and all the hash that makes it difficult to get a good mix. Battle no more.

Introducing Primacoustic. A new concept in broadband acoustical treatment that is easy to install, affordable, and has the look and performance of an architecturally designed studio.

Primacoustic is based on a modular concept whereby precision-cut acoustical absorbers are combined to resolve the four main problems common to all square rooms: The Europa Flutter Wall controls front to back flutter and works with the Scandia Scatter Blocks to reduce standing waves. The Orientique Washboards reduce side wash and powerful primary reflections. The Australis Bass Trap is a corner wedge that tightens up bass and brings balance back into your room.

## London Calling for Under \$600\*

The London-14 is one of the more than dozen studio packages available. London combines all four acoustical systems into one affordable package (London Studios start at \$450\*). Other packages include the New York Voice Over Booths, Rio Video Suites and Montreal Studios. With complete rooms starting at \$200\* - no other acoustical treatment is as affordable or so effective! We even include the glue.

For more information call Primacoustic and ask for a brochure, visit our web site, or go to your local pro audio shop.

Tell 'em you want to Take Control!

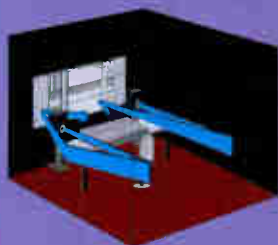

**Europa Flutter Wall**  
Reduces front to back echo, standing waves and monitor fold back. Over 28 creative patterns to choose from. Prices start at \$150\*.

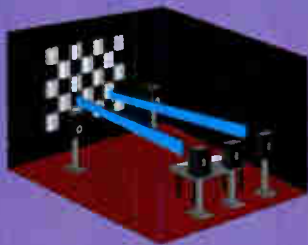

**Scandia Scatter Blocks**  
Affordable alternative to diffusion. Keeps room live and reduces standing waves. Over 12 creative patterns to choose from. Prices start at \$100\*.

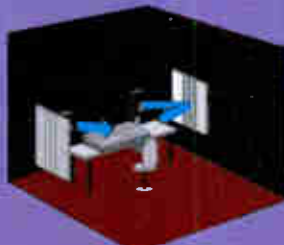

**Orientique Washboard**  
Absorbs primary reflections and side-to-side flutter. Six creative patterns to choose from. Prices start at \$80\*.



**Australis Bass Trap**  
Effective down to 45Hz, tightens up bass and reduces smear. Can be used in corners or on walls. Priced at \$100\* each.

\*Suggested US retail price.

mixed it with Social Distortion frontman Mike Ness] and David Kahne, who did two Sugar Ray records and a bunch of other things." Travis' diverse production credits include Dope, Wilco, Kid Rock, Chris Isaak, Monster Magnet and No Doubt.

Buckcherry's tour ended on January 2, 2000. The band worked on songs until May, then tracked for six weeks at Sunset Sound with Travis, engineer Jason Corsaro (Soundgarden, Madonna, Robert Palmer) and assistant engineer Geoff Walcha. James Barton spent two weeks mixing at Encore Studio. While the band did not co-produce, Nelson says they were involved from start to finish. "We're very hands-on," he says. "At the same time, we're open to taking directions. We're dealing with professionals, and that's the reason they're there in the first place—because we have a lot of respect for what they do. The real challenge is knowing when to stick up for something you really want to hear and when to shut your mouth. Some songs we definitely had ideas for. I had a vision I needed to see through for a few, whether it worked or not. Others, it was, 'We have the songs, you're the producer, where do you want to take it?' There

was a lot of interaction in the pre-production process of writing, moving songs in and out, working on parts with

**I have no hard and fast rules on how to make a record. It's always different, and you have to set up in a way to make the band as much at ease as you can, because the studio is a strange environment.**

**—John Travis**

John. From what I hear from other bands, there's not a lot of that kind of producing going on. They say, 'I create

the vibe for you.' We know how to light incense; we don't need that. We need someone to help make our songs as good as they can be."

For Travis, that simply meant "getting the performances and making sure the band was comfortable enough in the studio to shine and do what they do best," Travis says. "I have no hard and fast rules on how to make a record. It's always different, and you have to set up in a way to make the band as much at ease as you can, because the studio is a strange environment. The whole band was set up all playing at the same time, and everything was miked up so they played like what they are: a live band. It was just a matter of getting takes, and they got them in one or two. They played live, and we got it on tape. It wasn't really tough at all. Everyone is a great musician.

"The whole record was done analog," he continues. "The drums were recorded at 15 ips, 16-track, 2-inch. Everything else—guitar, vocals, keyboards—was at 30 ips on 16-track, 2-inch. The record was cut through Sunset Sound Studio 3's custom Demidio console. So many mics were used; we used an insane amount of equipment. There's nothing in particular

# MERCENARY FOR HIRE

KILLER SOUND, KILLER PRICE, KILLER BOX!

Active Tube Instrument DI

Twin Hi-Rez Mic Preamps

Twin JFET Stereo Buss Compressors

Variable Tube Output

**The Drawmer 1969 Mercenary Edition \$2,949 MSRP**

**TRANSAMERICA AUDIO GROUP DRAWMER**  
Call Us at: (702)365-5155

**Coming in Mix July 2001**

**NASHVILLE**

**APPLICATIONS & TECHNIQUES**

**ACOUSTIC RECORDING**

**EQUIPMENT SPOTLIGHT**

**STUDIO MICS**

**LIVE MIX**

**TOUR SURVIVAL GUIDE**

**Ad Close: May 11**  
**Materials Due: May 18**

[www.mixonline.com](http://www.mixonline.com)



# America's Finest



## INSTRUMENT MICS DON'T GET ANY BETTER THAN THIS.

When it comes to making microphones, it's no secret that Audix is the professional's choice. By choosing the D-Series mics, you can be sure that your audience hears exactly what is being played on stage.

D-series mics deliver extremely accurate sound, incredible SPL handling, lightning fast transients, and exceptional isolation.

- › Built in America
- › Built Tough
- › Built to last a lifetime

Don't buy an instrument mic before you check out the Audix D-Series. Call 800-966-8261 for a dealer near you.

**AUDIX**  
PERFORMANCE IS EVERYTHING

CIRCLE #131 ON PRODUCT INFO CARD

CALL: 503-682-6933 FAX: 503-682-7114

[www.audixusa.com](http://www.audixusa.com)

I have to have. I can use whatever's around. I bring in lots of guitars, amps, basses and compressors, a truckload of gear, and some gets used. We used a '65 Vox AC 30 Soldano rack; a Mellotron on a couple of songs. We didn't record in Pro Tools, but a couple of sounds were manipulated in Pro Tools with a plug-in.

"My favorite part of making the record was, at one point, on 'Whiskey in the Morning,' Keith and Yogi were both playing through several amps with the sound blaring and solos live together and guitars sparring with each other. It goes on pretty much through the song—they answer the vocals with little licks, and there's a part where they both play lead. That was a great moment. A lot of cool things happened in making this record."

"One of the reasons we love John," says Nelson, "is because he could have a conversation with us about T-Rex and Bowie and *Exile on Main Street* and *Give 'Em Enough Rope* by The Clash, and he can transcend that to make modern records like [Kid Rock's] *Devil Without a Cause*. I love what he did with Social Distortion. He understands the past, the present, he has amazing ears and a sense of song and is a true producer in every sense of the word.

He can get the sounds. He understands the dynamics of how bandmembers interact. He understands songwriting and how important this record is to us. He pushed us, inspired us to overachieve, and I think through that process we ended up a better band, better songwriters and better musicians.

"I think there's something going on here that's not present in music today," he continues. "It's the swagger and the energy of punk, a little sex appeal in the music and the vocals, combined with an amazing frontman with definitely his own take on lyrics and life. Joshua's favorite artists are Michael Jackson, Prince, The Ramones and the Sex Pistols, and so as a band we have that whole spectrum...and he's got to be able to dance to it, too.

"We're not any more real than what's going on, but hearing rich white kids from the suburbs talking about their bitches doesn't seem real. In this day and age, to make it happen, the quick fix would be to get a DJ or a rapper on our record and have someone remix it, but that's not a concern for us. It's not a sprint; we're in it for the long term. Who wouldn't want to sell a million records? But earning our fans one show at a time, taking the slow road, is more ful-

filling, because we're doing so on our own terms. Being like our peers is not a concern of ours, because we get to make the music we want the way we want. This is the best job in the world; how can you complain about it?" ■

—FROM PAGE 197, HAROLD BUDD

just a few keyboards and processors. And there's nothing flashy about his playing; he's the first to admit he's not a virtuoso pianist. But he is a great conceptualist. He works in mysterious ways, as they say, and he has become quite adept at using the recording studio to his advantage.

Budd's latest album, *The Room* (on Atlantic Records), offers a fascinating glimpse into the working methods of this singular artist. As is often the case with Budd's work, the CD's 13 pieces (one hesitates to call them "songs") began as titles—though the inspiration actually goes back much further, first to a painting Budd saw in the late '80s called "The Room," and then to a more recent visit to the Museo Marino Marini, which is situated in a medieval church in Florence: "The architects had left a lot of things," Budd explains, "like stairs that just end, going nowhere. Pillars that don't hold anything up. It was completely renovated and modernized, but they kept the spirit of the old alive. I thought it was quite remarkable. I loved the interior—it was haunting, striking, dark, brooding, and just out and out weird. I thought, 'If I take "The Room" as a base and begin exploring the aspects of what rooms can be, then I have an almost inexhaustible source to begin working from.'" For this series of pieces, titles of finished pieces include "The Room of Ancillary Dreams," "The Room of Stairs," "The Room of Corners," "The Room Alight," "The Room of Forgotten Children," "The Room of Accidental Geometry" and "The Flowered Room."

From there, Budd's process involved writing copious notes about the qualities and characteristics of these rooms. Some were musical ideas, some specific sonic notions, but there were also impressionistic literary conceptualization and free association. "I'm sitting at my desk with titles and concepts and ideas and writing them down in longhand," he explains. "Sometimes I write them down in musical notation as a trigger to remind me about certain directions to go. Or I can be specific about a sound I'm looking for. I remember that for 'The Room Upstairs,' I wrote down to myself, 'Remem-

## THE WORKSTATION COMPANY

### EXPERIENCE

*The Industry's Widest Selection*

### WHY

*waste time and money canvassing the country when one call to **EAR** will do it all?*

### If

*you need complete digital workstation systems or computers and peripherals,*

### Call EAR for

- Most Extensive Selection in the U.S.
- Leasing, Buy/Sell/Trade
- New and Used, Buy/Sell/Trade

# EAR™

PROFESSIONAL AUDIO/VIDEO

2641 E. McDowell, Phoenix, Arizona 85008  
602.267.0600 • Fax: 602.275.3277  
email: info@ear.net • www.ear.net

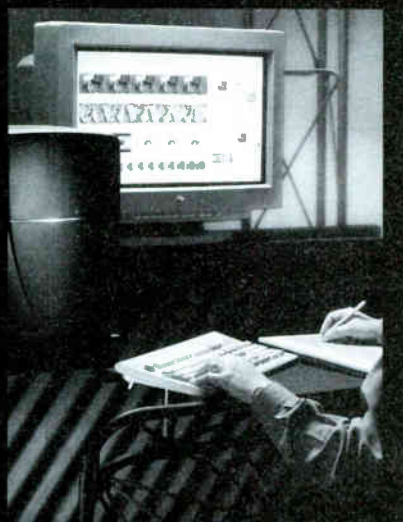

Merging Post Production  
and Music Technology  
since 1977.

DIGIDESIGN

AVID

STEINBERG

YAMAHA

TASCAM

ROLAND

MACKIE

GLYPH

APPLE

ber, there is a treated windbell track on one of my earlier CDs that's on tape at the studio where I'm going to be. Be sure to drop that on and see if it works." To Budd, this stage of the process is every bit as important as the piece that eventually flowers in the studio. The art is in the act of creation as well as the result.

It's noteworthy that, from start to finish, the album took three years to make, but only a small part of it was actual recording time. When it came time to make the CD, Budd returned to a studio that's been his recording refuge for the past several years, Orangewood Recording in Mesa, Ariz. The L.A.-based Budd discovered the studio on a trip to Arizona to visit his musician friend Daniel Lenz. The pair decided they wanted to make a CD of music and poetry, a project that became *Walk Into My Voice: American Beat Poetry*. It was recorded at Orangewood with owner/engineer Michael Coleman handling the technical end, and Budd says, "I just loved the atmosphere there, and I loved working with Mike." Orangewood is equipped with a Trident Series 65 console and, important for this project, a Yamaha concert grand piano. "The room is like the rest of Mesa, Arizona—dead," Budd says with a laugh. "But that's fine, because I like to have control of the ambience. So, all of the echo-type effects were digitally produced, not spatially produced." The CD was recorded to ADAT, with most cuts requiring fewer than a dozen tracks. Piano was captured with two AKG 461 mics. The Hammond M-3 was recorded in stereo, as well, while electronic keyboards—such as his "primitive analog piece of crap Casio 202 that I adore," an "ancient" Ensoniq digital and a couple of Rolands—were cut direct. Chas Smith contributed a pedal steel guitar line to one piece, and Budd's son Terrence played acoustic guitar on another.

Budd's working method in the studio usually combines some careful planning with bursts of improvisational playing and, always, an openness to serendipity. For example, on the complex track "Room of Mirrors," which features piano, synth, M-3 and various effects, "The piano bit that starts out after a minute-and-a-half or so was planned, but where it went after that was totally improvised," Budd explains. "I had originally planned and composed out in standard notation two pages of so-called mirror canons for celeste, and my idea was to play them all, upside-down and backward, so I would have this glittering curtain in the background that would be all mirror canons. No one would know what they were ex-

cept for me. That was my idea. But when I got into the studio, I realized this curtain made it impossible for anything to happen in front of it, irrespective of how far back I put it in the mix. It just sucked up all the oxygen in the piece. So I reluctantly scrapped the idea and replaced it with little pieces [of the sound curtain instead]."

Comments engineer Coleman, "He loves to experiment. I think he comes in with some ideas in his head, but he's certainly open to change. Usually, we'll start a track and I'll say, 'You want a click on this?' and he'll say, 'Yes,' so I'll set up a click; maybe he'll ask for it to be a little bit slower or a little bit faster,

and then he'll start playing, and it will have absolutely *nothing* to do with the click! At the end he'll say, 'Maybe we won't use the click.'" Adds Budd, "I always go into the studio with a very solid conceptual idea of what direction I believe I'm going to take. But I also know that in the working environment things are going to change, sometimes radically, and I take that as a given.

"Michael's got me pegged to a T," Budd continues. "He knows what I want, and he knows how to get to it fast. He knows that I like to play with effects, and by this point he knows what my taste is there. We like to improvise with effects, too; we get into some very, very

## Studio Condenser Microphones

**New**

**M 930**



**M 940**



- Extreme dynamic range
- Noise floor 7 dB-A
- Universal applications
- New large membrane capsule
- Advanced circuit design
- Transformerless output
- Internal elastic suspension
- Compact design
- Priced right

SEIT 1928

KONDENSATORMIKROFONE  
FÜR STU- UND MESSTECHNIK

**MICROTECH GEFELL**



MICROTECH GEFELL GMBH MÜNCHEN BERG 18 D-07926 GEFELL TEL. 036649/882-0 FAX 036649/882 11

INTERNET <http://www.microtechgefell.com//> E-mail [microtechgefell@t-online.de](mailto:microtechgefell@t-online.de)

USA, G-Ptime Ltd. 790 Broadway 4th Floor New York NY 10019  
Int. <http://www.g-ptime.com/mtg> Phone ++1 212 765 3415 Fax ++1 212 581 8938



## LEARN the ART of RECORDING®

You can get the practical, real-world skills needed to successfully start your career as a recording engineer or producer. For 27 years, thousands of students from the US and around the world have started their career at the Recording Workshop.

- The Original since 1971
- Hands-On Training
- On-Campus Housing
- 8 Studio Facility / Latest Gear
- 3 - 6 Students per Class
- Job / Internship Assistance
- Affordable Tuition
- 2 Month, 300+ hrs Training
- Financial Assistance



## RECORDING WORKSHOP®

Contact us for a Free Brochure:

**800-848-9900 or 740-663-2544**

**www.recordingworkshop.com**

email: [info@recordingworkshop.com](mailto:info@recordingworkshop.com) fax: 740-663-2427

455-X Massieville Road, Chillicothe OH 45601

Ohio State Board of Proprietary School Registration #80-07-0696T

CIRCLE #114 ON PRODUCT INFO CARD

elaborate effects, where we harmonize [sic] it, put it through another chorus, re-chorus that in another way, with no real plan. We're just throwing it in there and seeing what we get, and then trying to fine-tune it. Like on 'The Candied Room,' we have some very elaborate improvised feedback and the live piano. It sounds like a zither or something, but it's just a piano, and we messed with the sound until I got something magical on it." Among the reverbs and delays Coleman and Budd used on the CD are Lexicon PCM 60, PCM 70, PCM 42, Yamaha SPX 90 and REV7.

"When a piece is done, I mix it before going on to any other piece," Budd notes, "so there isn't really ever a mixing session per se. I like to work that way to retain the freshness of the inspiration and improvisation." Because of the degree of experimentation with effects, there is usually just one master take of each composition. Occasionally, Budd will take notes about how certain finished effects were achieved, but for the most part, these sonic events are undocumented and, perhaps, cannot be reproduced without considerable effort.

Budd performs infrequently and rarely in the U.S. He lived in England from 1986 to 1991 and says, with a touch of wistfulness in his voice, "I had a wonderful life there. I had a British version of a green card, and I traveled all over the continent and concertized a lot and had quite a professional life there. I had to get out of America to get a professional life going where I could actually make a living. I'm not complaining, mind you," adds this warm self-effacing gentleman. "It's just something you have to do." These days, his concerts usually consist of him improvising on piano against a CD containing some of the electronic backdrops he has conjured in the studio.

He rarely plays when he isn't working on a specific project; in fact, he no longer even has a piano in his L.A. digs. "I'm not really a pianist," he says with typical humility. "I'm somebody who plays the piano...sometimes." But when he does sit down at the keyboard, he makes the most of it, as his impressive discography from the past 25 years attests. And there's always something interesting on the horizon. When we spoke, it was a prospective group collaboration with British guitarist/composer Bill Nelson, bassist Jah Wobble, singer/accordionist Anna Domino and several others that had the wheels spinning. He knows, more than most, that his next inspiration might be just around the corner...or in the next room.

# STUDIO SUITE®

STUDIO MANAGEMENT SOFTWARE

**New!**  
**5.0**

Office	Studio	Tech
Contacts	Projects	Sessions & Events
Calendar	Invoices	Library & Labels
Messages	Services	Titles & Tracks
Petty Cash	Media Inventory	Recall
Purchase Orders	Bar Codes	Samples & Clips
		Rooms
		Equipment
		Maintenance Log
		Patchbay Labels
		Parts

Mac/Win, networkable across platforms

Setup Open All Open Preferred About Set Menu Log Out

THE #1 CHOICE OF TOP STUDIOS WORLDWIDE

**1.800.450.5740**

1.770.303.0970 International

ORDER NOW!

by **altermedia®**  
**www.studiosuite.com**

CIRCLE #115 ON PRODUCT INFO CARD



Thinking of buying musical equipment?

**'THINK SAM.'**



Since 1924, when Sam opened his first music store in Brooklyn, New York, musicians have come to rely on the Sam Ash family for the biggest selection, best service and guaranteed lowest prices.

*...It's 2001 and we're still rockin'!*



**WIN ON THE WEB!!!**  
Today's Hottest Music Gear!  
Get Your **FREE** samash.com Catalog!

**samash.com**

The on-line musical instrument megastore!

Check out our new website!

**1-800-4-SAMASH • www.samash.com**

Samash.com is part of the Sam Ash family of companies, including 30 musical instrument megastores nationwide.

—FROM PAGE 202, MICK GUZAUSKI

roadmap for the edits that were done on the original master so that he could duplicate them in the Pro Tools domain.

With a dedicated surround mix matrix and panning joysticks, the Oxford is made to order for multichannel mixing, according to Guzauski. "It's set up pretty much so that you can go into the multichannel mix mode, in which case every channel feeds the multitrack buses, and you can pan to 5.1 or 7.1 channels," he explains. "Panning is easy. There's a divergence control and a sublevel control on every channel. The console is made for 5.1, so you don't have to resort to a makeshift method. You can concentrate on the mix rather than, 'How do I bus *this* to make it do *this*?'"

Rather than start with a stereo mix and then pan elements to the rear channels, Guzauski tried to conceive of his *Thriller* mix as a multichannel experience from the ground up. "I thought to myself, 'Now that I have the space to put things in, where do I put them?'" he recalls. "I didn't do any live panning or movement right away, but I basically tried to set up a nice sound field, starting with the center and building out." The center channel in Guzauski's *Thriller* mixes consists of kick drum, snare, bass and lead vocal, with different degrees of divergence into the front side speakers for each of those elements. "In the case of music with a lot of punch, like *Thriller*, it's nice to have three [front] speakers to do that with," he says.

The subwoofer channel predominantly contains kick and bass, sometimes with a small amount of added subharmonic synthesis from a dbx 120X Subharmonic Synthesizer, according to Guzauski. Among the outboard effects he used for the mixes are two Sony 777 sampling reverbs, an Eventide SP2016, a TC Electronic 3000S effects processor, a Sony V-77 and an EMT 140 plate. He also used Distressor dynamics processors and Drawmer analog gates on some signals.

Ironically, Guzauski had not done much multichannel mixing when he got the call to do *Thriller*. His surround experience was limited to a couple of quad albums in the late '70s and a few experimental 5.1 mixes in his studio. Undeterred by his lack of experience and not intimidated by the prospect of working with Jackson (after all, Guzauski has worked with virtually every pop star *other* than Jackson), the award-winning engineer took on the project with the same level of gusto he applies to all his endeavors. "I just thought it would



be fun," he says. "I was planning to get into doing 5.1 mixes, so I had collected three pairs of Tannoy SRM-10Bs, which I love. I hadn't set them up yet when I got the call to do *Thriller*, so we set them up and listened. [Sony Music Studios VP of engineering] David Smith came down with a real-time analyzer and the room measured very well, so we kept it that way."

Asked if his quad experience was relevant to *Thriller*, Guzauski says, "Not at all. The quad mixes I did [for jazz artist Chuck Mangione] were designed to try to create a natural front-to-rear ambience of an orchestra in a room, rather than using it for effects. On the other hand, *Thriller* lends itself to being creative. There's a lot of movement in the music. You can really choreograph the sound."

Although *Thriller* was not recorded with surround mixing in mind, the disposition of the original multitracks worked well in a circular medium, Guzauski says. "All the elements are there to spread out," he says, adding that producer Quincy Jones and engineer Bruce Swedien "did a great job recording [the album]. The parts that work well in the rear aren't married to the elements that are in the front. It's not so much that each sound has multichannel ambience on it, because it doesn't. It's more about movement and choreography than a live performance in the hall."

As he proceeds with the surround mixes for *Thriller*, Guzauski has a few other 5.1 channel projects to add to his schedule: the Eric Clapton/B.B. King album *Riding With the King* and Clapton's latest solo project, *Reptile*, both of which Guzauski mixed in stereo. Now that he has enough perspective on surround mixing to compare it to stereo, Guzauski offers the following comparison between the two arts: "I find 5.1 easier. You don't have as much competition for available space. If you're doing a

stereo mix and it's complex, you have to carve around stuff frequency-wise, reverb-wise and level-wise. In 5.1, you have that much more space for placement. You can move stuff out of the way for something else."

If anyone should know about frequencies, levels, reverbs and placement, it's Guzauski. He's got the hits to prove it. ■

—FROM PAGE 200, COOL SPINS

Studio: Soma Electronic Studio (Chicago). Mastering: Roger Seibel/SAE Mastering (Arizona). —Mike Mott

#### Robert Cray: *Shoulda Been Home* (Ryko)

I'm happy to report that the Cray band's dynamite, Memphis-soul influenced last album *Take Your Shoes Off* was not just a one-off. The group's latest, which comes out May 15, is cut from the same cloth and stands as a nice companion to that 1999 Ryko effort. As with that CD, *Shoulda Been Home* is loaded with songs—most written by Cray; a few by other

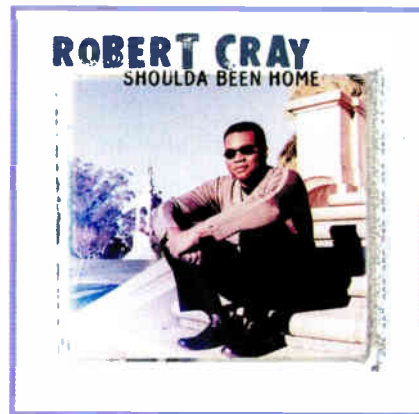

bandmembers—that sound like they could have been penned with Sam & Dave or Al Green or Otis Redding in mind. Most of this CD shoots for a classic late '60s, early '70s soul sound, but with a healthy dollop of Cray's blues sensibility thrown in for good measure. The smooth-voiced Cray is up to every vocal challenge the material presents, and his crack band—keyboardist Jimmy Pugh, bassist Karl Sevareid and drummer Kevin Hayes—provides sterling backup worthy of the MGs or BarKays. Cray only cuts loose on guitar on a few tracks here, but, as always, his playing shows impeccable taste throughout—a Steve Cropper trademark. Strong tunes, solid tracks, great vocals. These guys are onto something!

Producer: Steve Jordan. Recording Engineer: Don Smith. Recording Studio: Woodland Studios (Nashville). Mixing Engineer: Don Smith. Mixing Studio: Bay 7 Studios (Valley Village, Calif.). Mastering: Greg Calbi/Sterling Sound (New York City). —Blair Jackson

**Endo: *Evolve* (Columbia)**

You can feel it in your stomach: the punchy bass, searing guitar power chords, the schizophrenic tonality of the vocals and the hell-bent drive of the drums. Endo's debut release, *Evolve*, sounds more like a sophomore release than a first-time outing for this Miami group. It is a well-produced, well-oiled product: The tracks are clean, the transitions are seamless and it has enough fire to perk up the ears of even the most forlorn metal fan. Endo melds the likes of Ministry, PJ Harvey and even some Pantera to create the most diversified production the metal scene has heard this past year. With all of these influences, it is no wonder that each track has a distinctively different sound, from the Rage Against the Machine-like "G.A.D." to the Korn-inspired "Suffer" and "Burn," and they even blend in a bit of Filter, just for good measure. But there is always the heavy metal attitude piercing through songs such as



"Mindset" and "Malice." The group's ultra-modern, post-industrial attitude never lets up throughout the entire release, exposing a knife-edged assault on the listener each step of the way.

Produced and mixed by Paul Trust. Mastering: Tom Baker at Precision Mastering (North Hollywood, CA). Studios: Criteria Studios and Audiovision Studios (both in North Miami, FL).  
—Sarah Benzuly

**Sharon Shannon & Friends: *The Diamond Mountain Sessions* (Grapevine/Compass)**

Irish accordion virtuoso Sharon Shannon continues to distinguish herself from other traditional players by spicing her arrangements with all sorts of influences. *Mix* last covered her in 1996 when she had recorded a reggae-influenced album with producer Denis Bovell. Her latest album stems from a session she did in Dublin with Steve Earle that moved her to record with a variety of special guests. She and her band, The Woodchoppers, set up a studio in Letterfrack, County Galway, and invited some favorite singers to join them. The Earle track, "Galway Girl," is a standout; his earthy, sardonic voice



makes a perfect foil for the traditional music. Other highlights include recordings with John

Prine and Mary Staunton and the Hothouse Flowers. There are a couple of tunes that come off a little too jazz fusion-y for me, but on the whole, this is another delightful, inventive album by an inspired Irish player.

Producers: Sharon Shannon, John Dunford, Donal Lunny. Location recording: Totally Wired Mobile/Tom Skerritt and Ciaran Byrne ("The Galway Girl"). Digital editing: Keith McDonnell. Mixers: Tom Skerritt, John Dunford, Keith McDonnell, Sharon Shannon, Donal Lunny. Studios: The Old Monastery (Letterfrack, County Galway), Totally Wired Studios (Dublin), Westside Studios (London) and Sharon's House (Galway). Mastering: Aidan Foley/Windmill Lane Master Labs (Dublin).  
—Barbara Schultz ■

**GET RIGHT TO THE POINT...**

*At first glance all powered monitors may look similar- they have woofers and tweeters and amplifiers, all mounted in a box. But that's where the similarity ends.*

- Patented trans-nova/trans-ana amplifier circuitry for more open, dynamic sound
- MOSFET power amplifiers for transient dynamic power and reliability
- Hafler manufactured speakers and electronics
- Magnetically shielded for CRT and monitor protection
- Custom high frequency waveguide for better dispersion
- Precision crafted double thickness stepped enclosures
- No tweeter compression - eliminates listening fatigue
- Made in the USA

**USE HAFLER. GET IT RIGHT.**



**Hafler**  
the standard

Conservatory of Recording Arts & Sciences, Tempe, AZ  
Studio D-5.1 room with TRM8s & TRM12s

[www.hafler.com](http://www.hafler.com) • 888-hafler1

CIRCLE #127 ON PRODUCT INFO CARD

# COAST TO

## L.A. GRAPEVINE

by Maureen Droney

It was an easy run from the Valley through a spring-green Topanga Canyon to 4th Street Recording in Santa Monica, where I found

jects. While he does much of his work at the cozy 4th Street, as a producer he tends to tailor studio choices to fit both the budget and style of his clients.

"Our room here is really good for drums," he comments, "but for this project, we wanted more of an am-



Studio owner Jim Wirt (far right) and the members of Hoobastank at 4th Street Recording, Santa Monica, Calif.

producer/engineer/studio owner Jim Wirt cranking out overdubs with (Valleyites themselves) Hoobastank for their debut release on Island/Def Jam.

Although Pro Tools was running in a corner, 4th Street's Studer 827 was getting a rapid-fire workout as Wirt kept the session jumping, laying down bass and guitars on tracks that had been recorded at The Village's Studio A.

Wirt, a bass player in his own right and a definite band maven, purchased 4th Street in 1989. Since then, he's become known for his production and engineering work with Incubus, Sprung Monkey, Fiona Apple and 24-7 Spyz, among other pro-

ducent sound, so we went to The Village and worked on their old Neve. We did four takes of each song, with a little punching, then some comping in the computer. I think it's really important to have good solid takes before you send them over to the computer. In my opinion, the whole mentality of Pro Tools is really lazing up the business. You can't expect the computer to do everything for you. If you do, you end up losing fills, looping the same thing over and over. Eventually, it just sounds like a big drum machine, and then you're asking a lot of your guitars to make it work. I think you've got to make the music hap-

—CONTINUED ON PAGE 220

## NY METRO REPORT

by Paul Verna

Let's face it. These aren't the easiest of times for owners of recording studios. With costs escalating, label budgets shrinking, and more and more work being lost to home and project studios, proprietors of top-flight commercial facilities are having to work harder than ever to keep their rooms booked and draw ancillary revenues from studio-related activities like management and sound design.

In New York, the rigors of the recording studio business are exacerbated by skyrocketing overhead. However, in true New York style, studios here are toughing it out, determined not to let a little thing like an economic slowdown or an inhospitable business climate break their stride.

At Sound on Sound Recording—a four-room, midtown Manhattan facility that

has weathered numerous financial storms since opening in 1987, starting with that year's stock market crash—staying afloat means simply doing what the studio has always done: giving clients their money's worth, plus a little more.

Sound on Sound founder/owner Dave Amlen says, "It has become more and more of a creative gambit of, 'How do you pay for the million-dollar room—which is more than a million, by the way—charge a rate that people think is fair, pay your staff, pay your vendors and still make money at the end of the year?' The answer is, you've gotta be really careful. You've gotta watch what you're doing and treat your clients well so that you don't have too much down time."

Giving customers what they want involves providing them with the equipment they need. In the not-so-distant past, that meant a large, state-of-the-art console, 48-track digital recorders, 24-track analog recorders, an

—CONTINUED ON PAGE 222



Producer/engineer Greg Ladanyi inside his home project studio, Los Angeles

# COAST

## NASHVILLE SKYLINE

by Dan Daley

Spring has sprung again in Nashville, bringing with it a few new studio developments. Here, you can see the ongoing trends in the industry: New studio start-ups are increasingly predicated on computer-/software-based technology platforms—as opposed to the heavy machinery of analog consoles and machines—and on the pursuit of niche business.

Soundstation Studios and Franklin Mastering are part of a complex of independently owned facilities linked to a new contemporary Christian record label created as a joint venture with Zomba. (At press time, the label name was still being formulated.) Although the recording studio and the mastering facility are independently owned, each owner realized the potential benefit of huddling the facilities together in the same building with the label. “Projects are getting channeled from the record labels—there’s another one close by called Inpop—to the studio and the mastering studio,” says Franklin Mastering owner and chief engineer Jeff Baggett. “They’re not the only sources of business for the studios, but it’s nice to have them as kind of anchors for the businesses.”

Both Soundstation and Franklin Mastering are built around the upper end of the mass-market digital technology revolution. Soundstation, owned by Paul Wright, features a 64-channel Pro

Tools 24|MIXplus with a 32-fader Pro Control, RADAR II, ADATs and DA-78s. Franklin Mastering is based on a SADiE system, with other gear such as Z-Systems z-Q2 digital mastering EQ, Waves L2 limiting, Apogee PSX-100 with UV22 dithering and Z-systems routing.

“This is a whole new way to do things for this area,” says Baggett. “We’re not targeting the country artists as intently as the studios on the Row do. There’s a huge group of people here who make music that’s not country, and they don’t have the budgets that studios on the Row need.”

With mastering services going for about \$125 per hour, and the studio for \$750 to \$1,000 a day, the technical infrastructure available is sophisticated, considering the budgets those artists have to work within.

“The Nashville studio infrastructure, as it is, can’t address all the [economic] needs of the growing base of different types of music that are out here that major labels don’t sign,” Baggett says. “They need more budget options than the traditional studio setup can give them.”

Another somewhat higher-toned niche is also being addressed in what will become Georgetown Masters’ new 5.1 surround mastering suite. In February, owner and chief mastering engineer Denny Purcell began gutting the mini-movie theater he had in the studio’s basement, and, with input from consultant Rick Loomis, he expects to have a dedicated 5.1 mas-

—CONTINUED ON PAGE 223

## SESSIONS & STUDIO NEWS

### SOUTHERN CALIFORNIA

In an attempt to prove just how much cooler they are than the rest of us, singer/songwriter Marianne Faithfull and ex-Smashing Pumpkins frontman Billy Corgan were recently in at The Village (West Los Angeles) conjuring dead spirits, sipping absinthe and co-writing songs for Faithfull’s follow-up to the 1999 release *Vagabond Ways*. The

album for Interscope Records at Music Grinder Studios (Los Angeles); Ken Allardyce was there to engineer with Peter DiRado assisting...Graham Nash cruised into Conway Studios (Hollywood) to work on a solo project with the father-and-son production team of Russ and Nathaniel Kunkel. Mariah Carey was also hanging out at Conway with engineer Dana Chappell; the two were working on the soundtrack to Carey’s new movie *All That Glitters*... Ocean Way Recording (Hollywood) hosted Buena Vista Social Club alumni Eliades Ochoa. Ochoa was in work-



Billy Corgan, of Smashing Pumpkins fame, gives Marianne Faithfull a squeeze while tracking at The Village (West Los Angeles).

Village also recently hosted a session with Harry Connick Jr., who was in working on the soundtrack for the film *Life Without Dick*...Producer engineer Don Gilmore (Eve 6, Linkin Park, Sugar Ray) was at NRG Studios (Los Angeles) cutting tracks for new Dreamworks act the Apex Theory...Weezer was busy putting the final touches on a long-awaited new

ing on a new album with his group Record One. John Wooler was given the nod to produce the effort with engineer Sally Browder... Out at Bernie Grundman Mastering (Hollywood), mix engineer Alan Meyerson and mastering engineer Pat Sullivan added the final tweaks to *Gladiator II*, the second CD from the Hans

—CONTINUED ON PAGE 228

pen first; then that stuff can get it even better."

The four members of Hoobustank, who cite Faith No More, Mr. Bungle and Fishbone as their influences, have been together for six years. They hooked up with Wirt about five years ago. "They were friends with Incubus," recalls Wirt. "And they used to come and hang out at the studio."

"We've known Jim so long that when it came time to get a producer for the album, there was really no contest," remarks drummer Hesse. "He helped us learn how to write. We used to come to him with all sorts of crazy parts, and he helped us figure out how to put them together. And he's always been a lot of fun."

"[Guitarist] Dan [Estrin] and I originally started out about nine years ago in a Chili Peppers-type band, doing crazy funk, total silliness," explains bassist Markku. "And [singer] Doug [Robb] was in another rival band playing bass. We got together, then we got Chris from an ad we placed in the *Recycler*."

"We went through a lot of changes in the kind of music we played," says Hesse. "Like we used to have saxophones and kind of a ska direction. We had a lot of industry interest a few years ago before the [PolyGram/Universal] merger. When that happened, a lot of people were losing their jobs, and it all kind of fell apart. It was a funny time, and we just kind of threw up our hands, got rid of the horns, fired our manager and started writing rock songs—heavier stuff like we all like to listen to. The first three songs we wrote, we recorded with Jim, and right away people got interested. It clicked."

"Paul Pontius from Island/Def Jam, who used to work at Immortal and who signed Korn, made an offer," he continues. "We liked him a lot. We didn't have a manager at the time, but with the help of our lawyer, Jeffrey Light, we did the deal."

Asked to describe the band's music, Wirt says: "The combination of melody and heaviness is what makes it unique. I wouldn't say it's pop, but it's got great melodies and really strong choruses."

As a studio owner, engineer and producer, Wirt often burns the candle at several ends. In between Hoobustank sessions, he was shuttling to Larrabee West, where he was mixing Maverick artists One Side Zero. The right studio for the right job, even though it must be difficult to leave 4th Street's idyllic four-blocks-from-the-beach-best-weather-in-

L.A. location.

"I do like the way it sounds here [at 4th Street]," he admits. "It's a good, punchy tracking room and great for overdubbing guitars. It does look a bit like the Winchester Mansion—very quirky—there are a lot of surfaces, both soft and hard, most of them are at different angles. But the guy who built it did a pretty good job. It's extremely solid."

4th Street's MCI JH-428 console is also a holdover from the previous owner. "It's the only thing that fits in here," laughs Wirt. "It used to belong to the Beach Boys' studio that was over on 5th Street."

Along with analog tracking, 4th Street also offers a Pro Tools 24 system with 888 24 I/O and Audio Logic Platinum software. Monitors include Genelec 1031As, Yamaha NS-10s and T.O.C. mains. Among the outboard selection are Neve 1066, Focusrite and Telefunken V-72 mic pre's, UREI 1176, LA-3A and dbx limiters, and Klark Teknik DN22 and DN360 graphic EQs. The recording space features a Yamaha C7 grand piano, a Hammond C-3 with Leslie, Fender, Vox, and new and vintage Marshall amplifiers.

In addition to Wirt's projects, 4th Street counts among its clients No Doubt, George Clinton, Brian Setzer, David Hidalgo, Michel Penn, the Beach Boys and Spinal Tap.

Dropped in at producer/engineer Greg Ladanyi's spiffy home studio for a listen to singer/songwriter Jo Davidson's upcoming release, *Kiss Me There*. Co-produced by Davidson and Ladanyi, the CD is scheduled for a May release on a joint venture between edel America Records and Ladanyi's own Tidal Wave Entertainment Group Inc., with the single of the same name already creating a buzz on radio.

Ladanyi, of course, is well-known for his production and engineering for artists such as Jackson Browne, Don Henley, David Lindley, Jaguares, Fleetwood Mac and Toto. (He won a Grammy for Best Engineered Album for *Toto IV*.) Although he's spent much of his career in high-end studios working on top-of-the-line technical setups, these days, he's found that the digital home studio is a pretty good place to be making records.

"It was an experiment; I was just kind of messing around," he explains. "I moved in, and because of all the digital equipment I was using, I had the idea to put a studio here. I love the analog world, but unfortunately it's become much more expensive to record

that way. A setup of this kind allows you to work with an artist in a way where you have more time to be creative and flexible and maintain the sonic quality."

Although just a vocal and mixing space, the studio has expanded to fill two rooms.

"It just grew," he muses. "First, it was for vocals and some rough mixing. Then, on one project I did a mix here and also on an SSL 9000. The mix from here felt better. I imagine most of that had to do with the fact that I could leave it up for two or three days and work on it when I wanted to, whether it was six in the morning or 11 at night. When we A/B'd the mixes, there wasn't a decisive sonic difference. That was an eye-opener."

The nuclei of Tidal Wave's setup is a pair of 32-channel Panasonic Digital DA-7 consoles. Ladanyi is a recent convert to Steinberg's Nuendo recording software, but for Davidson's album, he recorded onto Alesis M20 ADATs and mixed to an Alesis MasterLink 9600, using almost exclusively TC Electronic signal processing. Monitoring is on both Westlake Audio BBSM-4 and -5 speakers and Yamaha NS-10s.

The Ladanyi/Davidson collaboration seeds were planted when Ladanyi first heard Davidson's music some six years ago. The two kept in touch, and when she began working on songs for what became *Kiss Me There*, he offered to help out. "I'd always related to Jo's music," he says. "She's very independent and very focused, with a lot of great songs and ideas. But she didn't have a deal at the time and no real money to pay people. So it became a labor of love."

The project started on 16-bit ADAT at a Sherman Oaks guest house where Davidson's piano was set up. When Ladanyi came onboard, he enlisted the help of friends to enlarge upon the equipment options with Panasonic consoles, ADATs and TC Electronic outboard.

"Jo had started recording a lot of the songs herself; I came in and helped her organize and clean it up," he explains. "I brought over the Panasonic boards, which I think sound really great, and the tracks ended up on ADAT M20s as we progressed and transferred stuff around. We got a lot of help from a lot of people like Ed Simeone at TC Electronic, Peter Chaikin at Alesis and Fred Jones at Panasonic, who were really supportive of the project. Doing a project like this reminds you that people do

# 110<sup>th</sup> AES CONVENTION AMSTERDAM

12 - 15 MAY 2001

RAI CONGRESS CENTER

The world of sound is moving fast...  
Catch it at the largest Pro-audio event in Europe!



**AUDIO ENGINEERING SOCIETY**

For information, AES 110<sup>th</sup> Convention Office :

ZEVENBUNDERSLAAN 144 / 1- BE - 1190 BRUSSELS (Belgium)

Phone : +32-2-345.7971 - Fax : +32-2-345.3419

Internet : [www.aes.org](http://www.aes.org) - Email : [110th\\_info@aes.org](mailto:110th_info@aes.org)

care—a lot of people were touched by Jo's music and wanted to help out."

Although some cuts used as many as 54 tracks, the bulk were 48-track with the ADAT tracks being mixed from a chain that ran through the Panasonics, a TC Electronic Finalizer and into MasterLink.

"We used the Finalizer for overall compression," Ladanyi comments. "It's also got some really good presets in it for stereo enhancing and for dance mixing.

"Actually, I think we used everything that TC makes," he continues with a laugh. "We have the FireWorx for special effects; we used that a lot on Jo's piano and vocals. We have two 3000s, one for long reverb and one for short chorus reverb. The 2000 we use either for chorus or flanging, or specific lead vocal delay and reverbs. The M-1, which is a more hard-sounding reverb, I use specifically on drums. The D-2 is a really cool delay box where you can do different kinds of delays, ping-pong or tap in your own delays to make it follow a certain rhythm. It's also got reverse chorus, flangers and all kinds of greatness.

"The Helicon, the vocal effects box, is fantastic, great for doubling lead vocals. It also creates harmonies. In a mix, it's a good tool; they're not real vocals, but they cover the notes and they sound really cool."

The studio does have a couple of boxes that aren't TC—a Tube-Tech MEC LA, which was used on Davidson's vocals, electric guitar and bass, along with another favorite Ladanyi weapon: GT's Vipre tube mic preamp. "It's got five tubes in there, and you can control the impedance," he enthuses. "You can raise the highs and bring the mic closer to you, or smooth it out and make it rounder. There's a rise time control that will push the mic away or bring it closer. If somebody has hard 'esses,' you can slow it down, and they become softer without having to go into using a de-esser. It's a classic."

Additional "secret weapons" at Tidal Wave include a pair of Mastering Lab mic pre's and the Panasonic 8-channel A/D converter mic pre.

Microphones include a Soundelux U95S and an Audio-Technica AT40, both of which were used for Davidson's vocals. An AT404 was used for pianos. Groove Tubes, both FET and tube, were also put to use on piano, guitars and drums.

"When I did Jackson Browne's *Run-ning on Empty* at a very young age, it

broke a lot of rules," Ladanyi notes. "You recorded anywhere, and you did whatever you had to do to get the music on tape. I learned that there is no one right way to do everything.

"I love tracking and going to the big studio—it's a lot of fun. But when you get into overdubs, vocals and mixing—all the things that paint the picture—it takes time, and it's nice not to have financial pressure over it."

---

*Got L.A. news? E-mail MsMDK@aol.com.*

---

—FROM PAGE 218, NY METRO REPORT

ample supply of outboard gear, top-notch microphones and preamps and a crack maintenance team that could keep the gear running fault-free.

Today, ensuring client satisfaction involves all of the above, plus Pro Tools. Lots of Pro Tools.

"One of the things we noticed about Pro Tools is how it became integrated into the professional environment," says Amlen. "When we picked up on that, we decided to make a serious investment in the technology. We now have three systems for four rooms. One is a Pro Tools edit room that you could mix in, with a Pro Control and up to 48 channels of I/O. Then we have one in our AMS Neve Capricorn digital room, and another system that goes back and forth between our two analog rooms, which have Neve VR and Solid State Logic 9000 J consoles."

Sound on Sound COO Christopher Bubacz notes that Pro Tools has infiltrated areas that used to be dominated by analog recording, such as jazz—traditionally one of Sound on Sound's fortes.

"There are more and more jazz sessions being done in Pro Tools," says Bubacz. "Even some of the diehard analog fans are, if not recording to Pro Tools, at least editing and sequencing in the format before they go to mastering."

Even though Sound on Sound is committed to Pro Tools, it has by no means de-emphasized the many other formats it offers.

"For most home studios, Pro Tools is their console, their multitrack, their outboard—everything other than, maybe, what they burn their CDs on," observes Amlen. "On the other hand, we have Sony 3348s, Studer A827s and A820s, racks of DA-88s and Sony PCM-9000s. There really isn't anything you could walk in with that we wouldn't be prepared to handle."

The Sound on Sound staff's approach toward Pro Tools mirrors their attitude toward the MDM movement of the early '90s. Rather than fight the trend, as some professional studios did (and continue to do), Sound on Sound embraced the new technology without abandoning core products.

"Years ago, when ADATs and DA-88s were such the rage, we were sitting here with our A827s and 3348s, trying to figure out what to do," recalls Amlen. "We decided to buy DA-88s and make them available to our clients. We told them, 'Here they are. The rate's the same whether you use an A827 or a rack of three DA-88s or ADATs.' We thought to ourselves, so many people are using this technology, and they're not going to pay extra to rent it from outside or inside. But we, being a state-of-the-art studio, can afford to embrace a technology that a home studio is totally based upon and can't build upon. To us, it's an add-on—a value-added item that our clients can use and integrate into the larger picture, as opposed to it just being the beginning and end unto itself."

The technology mix at Sound on Sound includes a healthy assortment of outboard gear—and a punctilious approach toward how that gear is positioned in each control room. Amlen explains: "My former employee [engineer] John Siket used to call this the Noah's Ark of studios, because we have two of everything," says Amlen, laughing. "He always teased me about it, because we even reached the point where the gear is in the same position in the respective racks."

Bubacz adds, "It allows our clients to move from room to room and not have to think, 'This room doesn't have a Lexicon 480L, but the other one does.'"

On a recent visit to Sound on Sound, Amlen and Bubacz were gathered in Amlen's office while the studios hummed with activity. Contemporary jazz guitar icon Mike Stern was doing overdubs in the Capricorn suite, while rock act the Verve Pipe had the two analog rooms locked out. The band was mixing with Chris Shaw on the Neve VR in Studio A and with John Holbrooke on the SSL 9000 J in Studio B. Producers Brian Malouf and Adam Schlesinger (of Fountains of Wayne and Ivy fame) were overseeing the project.

Among the topics on Amlen's and Bubacz's agenda were the ancillary businesses that Sound on Sound is exploring in an effort to supplement the revenue from its rooms. Like many fa-



cilities with experienced, well-connected owners and dedicated staffs, Sound on Sound has ventured into management, with clients including mixing engineers Matt Hathaway, Mark Partis, Jason Standard, Joe Pirrera and musician/producer Ted Cruz.

"We're trying to diversify from the main core of just being a recording studio," says Bubacz, who joined Sound on Sound after managing Bear Tracks Studios in Suffern, N.Y., for nearly a decade. "We're trying to put together a situation where the main members of the company are actively involved in these new revenue streams."

Besides the management wing—which goes under the name SOS Management—the company has launched a mastering division aimed at servicing indie clients who are looking for a more affordable alternative than New York's world-class mastering studios.

"We're not trying to compete with Sterling or Masterdisk," says Bubacz. "It's an entry-level mastering operation for regional and local acts."

In addition, Sound on Sound has entered into an alliance with sound designer/composer Fred Samalin, who runs New York-based Eagle Peak Music. Operating mostly out of the Capricorn room—which is equipped for 5.1 channel mixing—Samalin brings to the table a long trackrecord of writing original music for film and TV hits (including *The Sopranos* and *Dharma & Greg*), as well as extensive production music and sound effects libraries.

"The goal," says Amlen, "is to not be at the bottom of the food chain where you get told what you're going to be able to charge, but to be more high up and have more discretion as to how things are going to be done."

Send your New York news to [pverna@vernacularmusic.com](mailto:pverna@vernacularmusic.com).

—FROM PAGE 219, NASHVILLE SKYLINE

tering studio up and running by the beginning of summer.

The design could be called minimalist: There will be no specific console, just whichever small analog or digital mixer Purcell feels is right for each job. Monitoring will be via Nova speakers and custom subs powered by Nelson Pass amplifiers.

Purcell won't discuss the costs associated with the new studio, but he did say that a slew of surround titles from Warner Records are already com-

## We Carry A Complete Line of SONY Recording Media



**Shipped from Stock, Great Prices, Immediate Delivery**  
**Easy Ordering: Phone, Online, Mail, Fax, E-Mail**

764 5th Avenue,  
Brooklyn, New York 11232  
In New York: (718) 369-8273  
24 Hour Fax: (718) 369-8275



**NRS**  
National Recording Supplies Inc.  
<http://www.tapes.com> - e-mail: [sales@tapes.com](mailto:sales@tapes.com)

CONTACT US FOR A FREE FULL LINE RECORDING SUPPLIES CATALOG

**CALL TOLL FREE 1-800-538-2336 - Outside NY Only**

CIRCLE #117 ON PRODUCT INFO CARD

**Alternative Lifestyle**

Tired of over-priced scene. Looking for deserving musician or DJ for LTR. I'm colorful, accurate, sturdy and got my mojo workin'. Will improve your life. No heavy tweekers. Pics available at [www.rane.com/mojohome.htm](http://www.rane.com/mojohome.htm)

**Let's Mix It Up**

Seeking outgoing and smooth to be seen at parties and and gentle

like my le chain. a not like abilitas at  
I boost or cut ju... it. Complex curves are my spec... See what lengths I'll go to at  
[www.rane.com/eqs.htm](http://www.rane.com/eqs.htm)  
Can handle even 5-way ar  
Explore my connectors  
[www.rane.com](http://www.rane.com)  
like em all with me. I ears can phones, bu want me t pairs at o back. My my outpt separate jack

# RANE MÓJO

SERIES™

## Rane – Personal Preference

Mukilteo, Washington USA tel 425-355-6000

CIRCLE #118 ON PRODUCT INFO CARD

# Ad Index & Advertiser

PAGE	PRODUCT INFO NUMBER	ADVERTISER	PAGE	PRODUCT INFO NUMBER	ADVERTISER	PAGE	PRODUCT INFO NUMBER	ADVERTISER
76	035	Acoustical Solutions	BC	126	JBL Professional	73	033	Studio Audio Digital Equipment (SADiE)
133	077	ADK	61	025	KRK Systems	188	099	Studio Consultants
51	019	AKG	101	107	Kurzweil Music Systems	141	082	Studio Network Solutions
49	018	Amek	62	*	Los Angeles Recording Workshop	214	115	Studio Suite
109	064	Antares	21	008	Mackie (SR1530)	136	079	Summit Audio
34	016	Aphex Systems	90-91	049	Mackie (HDR24/96)	19	007	Sweetwater Sound #1
57	022	Apogee Electronics	RF-BC	037	Mackie (VLZ Pro Series)	229	120	Sweetwater Sound #2
190	102	Argosy Console	IBC	125	Mackie (D8B)	253	123	Sweetwater Sound #3
187	130	artistpro.com #1	233	*	Macworld	254-55	124	Sweetwater Sound #4
232	122	artistpro.com #2	RF-IBC	088	Manley Laboratories	3	003	Tannoy
195	106	Audient	15	006	Mark of the Unicorn	6-7	004	Tascam
221	*	Audio Engineering Society	117	067	M Audio	2	002	TC Electronic
17	*	Audio-Technica	103	060	Medea	53	080	TC Works
52	020	Avalon Design	81	*	Meyer Sound	43	*	TOA Electronics
226-27	119	B & H Photo-Video	105	062	Microboards Technology	210	129	Transamerica Audio Group
60	024	BBE Sound	213	113	Microtech Gefell	139	081	Universal Audio
147	086	Behringer	157	091	Midas	145	084	Wave Distribution/Empirical Labs
123	071	B.L.U.E. Microphones	79	040	Millenria	97	053	Waves
153	089	BSS Audio	113	098	Minnotorka Software	98	055	West L.A. Music
155	090	Carvin	32	014	Mtsui	129	074	Yamaha
118	069	Cherokee Studios	118	068	Mount San Jacinto College	89	063	Z Systems
64	028	Community	33	015	mSoft			
188	100	Conservatory of Recording Arts & Sciences	143	083	Musician's Friend			
146	085	Creamware	22	009	MXL Professional Microphones			
24-25	011	dbx Professional Products	223	117	National Recording Supplies			
149	109	Denon Electronics	63	027	Nemesys			
88	047	digibid.com	231	121	Neumann/USA			
23	010	Digidesign	201	*	Ornstage			
80	076	Digigram/Fostex	125	072	PreSonus			
127	*	Digital Media Online (DMO)	209	111	Primacoustic			
78	038	Disc Makers	93	050	Professional Audio Design #1			
IFC	001	Dolby	191	104	Professional Audio Design #2			
138	116	DPA Microphones	86	045	ProSoundweb.com			
72	032	Dreamhire	65	029	QSC Audio Products			
71	031	dsp Media	107	048	Quantegy			
205	*	DVD Pro Conference	69	065	Qusted			
212	112	EAR Professional Audio/Video	78	039	Radikal Technologies			
128	073	Earthworks	223	118	Rane			
160	092	Eastern Acoustic Works (EAW)	214	114	The Recording Workshop			
131	075	EGO*Systems	199	*	Remix			
87	046	Emagic	83	042	RØDE Microphones			
104	061	Europadisk	58-59	023	Roland			
85	044	Eventide	148	087	Rolls			
77	101	Fairlight	84	043	Royer Labs			
RF-IFC	093	FBT	102	059	Sabine			
31	013	Focusrite	135	078	SAE Institute of Technology			
115	066	Full Compass #1	215	*	Sam Ash			
207	110	Full Compass #2	76	036	Schoeps			
99	056	Full Sail	183	097	Shure			
11	005	Genelec	1	*	Solid State Logic (SSL)			
100	057	Grace Design	96	052	Sonomic			
190	103	Grandma's Music & Sound	9	*	Sony Broadcast & Professional Company			
217	127	Hafler	98	054	Sound Devices			
119	070	HHB Communications	181	096	Soudercraft			
132	*	House Ear Institute	192	128	SRS Labs			
82	041	Institute of Audio Research	29	012	Steinberg			
193	*	Internet Audio	95	051	StorCase Technology			
38-39	017	iZ Technology	75	034	Studer			

## MARKETPLACE

235	252	ATR Service Company
238	269	American Duplication Supply
236	257	Boutique Audio & Design
239	272	C & C Music
235	251	ClearSonic
236	260	Crystal Clear Sound
238	271	D.W. Fearn
236	255	Demeter Amplification
237	262	DigiDoc Productions
239	275	Digital Domain
238	267	Earth Disc
240	281	Gefen Inc.
240	278	Lonely Records
236	256	Markertek
239	274	Marquette Audio Labs
238	270	McGraw Publishing
236	259	Media Services
240	279	Multimedia Recording Systems
239	276	Neato, LLC
237	264	Pendulum Audio
237	265	Primal Gear
235	254	Princeton Disc
235	253	Progressive Music
240	280	Rainbo Records and Cassettes
238	266	Requisite Audio
237	261	Shreve Audio
240	277	Sonic Circus
238	268	Sound Anchors
235	250	Sound Ideas
240	282	Sound Technology
236	258	TerraSonde
237	263	Universal Recording Supplies
239	273	Vintage King



# STREAMING VIDEO

any time...  
anywhere!

See online product  
demonstrations  
for the hottest  
new gear.

## www.mixonline.com

A digitalmediaclick site



### Sony DRE-S777

See an exciting video on how Sony captured the sound of some of the most perfect acoustic spaces in the world for the DRE-S777 Digital Sampling reverb.

### Attention Manufacturers!

Now you can show professional engineers and producers your hottest products—available 24 hours a day, 7 days a week. Every advertisement and new product announcement featuring the Demo Room logo has a streamed demonstration online. Users can also view Archived Demos of previous Demo Room Stars from our entire Entertainment Division. Don't miss out on this exciting opportunity to connect directly with the industry through [www.mixonline.com](http://www.mixonline.com). Please contact your Mix sales representative for details!

### Contact Information:

#### Associate Publisher

Carrie Anderson, (510) 985-3228,  
[carrie\\_anderson@intertec.com](mailto:carrie_anderson@intertec.com)

#### Eastern & Special Projects Advertising Director

Michele Kanatous, (718) 832-0707,  
[mkanatous@intertec.com](mailto:mkanatous@intertec.com)

#### Midwestern Advertising Manager

Greg Sutton, (847) 968-2390,  
[gsutton@intertec.com](mailto:gsutton@intertec.com)

#### Northwestern Advertising Director

Dan Hernandez, (510) 985-3266,  
[dhernandez@intertec.com](mailto:dhernandez@intertec.com)

#### Southwestern Advertising Manager

Albert Margolis, (949) 582-2753,  
[amargolis@intertec.com](mailto:amargolis@intertec.com)

#### Facilities/Eastern Advertising Manager

Shawn Langwell, (510) 985-3275,  
[slangwell@intertec.com](mailto:slangwell@intertec.com)

# B&H

PHOTO - VIDEO - PRO AUDIO

- ▶ The Latest Gear At The Best Prices
- ▶ Expert Advice From Working Professionals
- ▶ Worldwide Shipping Usually Within 24 Hours



Complete Hardware & Software Solutions For Computer-Based Audio Production



Panasonic DA-7 & Mackie D8B Stations

Interactive Mic Shootout

World Radio History

Detail



Character



Confidence



Resolution



Control



Maximum Potential

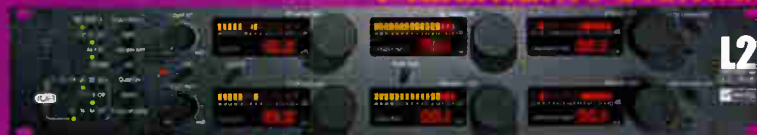

Deliverance



Visit The B&H Superstore  
 Featuring Our State-Of-The-Art  
 Interactive Pro Audio Showrooms  
**420 Ninth Ave**  
**New York City**  
 (Between 33rd & 34th Sts)

Call Toll Free:  
**800.947.5508**  
 In NYC:  
**212.444.6698**  
 On The Web:  
[www.bhphotovideo.com](http://www.bhphotovideo.com)

The Professional's Source For All Of Your Pro Audio Equipment Needs

CIRCLE #119 ON PRODUCT INFO CARD



ProTools|24 Mix Plus Station

Interactive Studio Monitor Shootout

World Radio History

ing to his door, perhaps a sign that the major labels are beginning to turn their attention toward new releases and away from legal battles with online music companies and the huge mergers they've been going through.

"I hope so," says Purcell, "because I think that DVD-Audio is the last chance for the professional audio business to present the consumer with quality, with an idea of how good music can sound. This [format] is the closest they're ever going to get to being in the same room with the artist while they're performing. It's that good. So it's worth the risk."

School of Audio Engineering's Nashville location now has a new 5.1 surround classroom. The studio, equipped with Mackie-powered monitors and a Mackie 8-bus console, was built by Nashville-based Michael Cronin Acoustical Construction. The studio has one unique wrinkle: Cronin added a second pair of rear surrounds behind the first rank to widen the surround field for a class of 20-some students.

Cronin will also be building the classroom studios at SAE's next location, which is in North Miami, not far from the Hit Factory Criteria complex. The 30,000-square-foot building will be a departure from SAE president Tom Misner's otherwise boilerplate designs for the company's other 30-plus studio/schools. In Miami, three control rooms, equipped with an SSL G-plus, a Digidesign Pro Control and a console to be named later, will face on a large central recording area. It will also, Misner explained, be an aesthetic departure. "This is going to be much more of

an up-market type of facility in terms of design," he says. "It will be closer to Studio 301 [Misner's opulent flagship facility in Sydney, Australia]." The reason? "Miami is critical for developing our school in the South American market," the always-candid Misner replied. "Down here, we want the glitz."

Contact Dan Daley at [danwriter@aol.com](mailto:danwriter@aol.com).

—FROM PAGE 219, SESSIONS AND STUDIO NEWS

Zimmer film score...Future Disc Systems (West Hollywood) put the final coat of gloss on Kina's (Dreamworks) current remix single "Me"; the cut was remixed by Barry Harris and Chris Cox. In on the mastering session were Future Disc engineers Kris Solem and vinyl specialist Kevin Gray. Solem also mastered the new album by artist Rome entitled *To the Highest*, set for release on JJJ Empire Records.

#### NORTHEAST

Out promoting his latest album, *Eat at Whitey's*, Everlast treated a lucky few at Indre Studios (Philadelphia) to an acoustic set hosted by local radio station Y100; studio owner Michael Comstock recorded the session...Sound on Sound Recording (NYC) saw a number of high-profile artists pass through in recent weeks: Jennifer Lopez got the remix treatment from producers Puff Daddy and Mario Winans; Jim Janick and assistant Bojan Dugich were in to engineer. Arista's Faith Evans cut

some vocals with producer Mario Williams, engineer Janick and assistant Alison Lauth. 112 also camped out at Sound on Sound with producer Saint, engineer Wayne Allison and assistant Stennett Cyril working on some vocal takes...It's been a busy spring at Shelter Sound (NYC): Bob Power produced the new Citizen Cope CD for Dreamworks. Joe Ferla mixed the new Chris Cheek album for Fresh Sound records. Producer Gary Katz and engineer Dave Dill worked with artist Sarah Buras on an upcoming release for Dreamworks. Steve Addabbo produced a new effort with Love Seed Mama Jump for Plump/Artemis; Matt Kane was in to engineer.

#### NORTHWEST

A moody '80s synth pop classic gets a facelift at Toast! (San Francisco). Studio owner/producer Philip Steir recently remixed New Order's "True Faith"; Steir created entirely new music for the song, keeping only the original vocal tracks. Also at Toast!, Butterfly Jones, which includes Michael Gurley (formerly of Dada), were in Studio B with Steir working on their debut effort for Vanguard Records. And, as always, SF locals Third Eye Blind spent some of their label's money working on a new song for an upcoming film...Studio 880 (Oakland, CA) hosted the shooting of VH-1's *Behind the Music* for Green Day. Members of the band returned to Studio 880, where they tracked their Platinum record *Warning*, to talk about their musical career. Also, Castro Sinatra, the new project of the rhythm section of Faith No More, tracked drums for 12 songs. Tone engineered the session, and Reto Peter assisted. Artist Shane Kelly also cruised out to Studio 880 with producer Jeffrey Chin and engineer Mark Needham to work on her new record; Tone was in to assist...Full Spectrum Jazz recently stepped into Annex Digital (Menlo Park, CA), formerly Music Annex, to work on their second album. The effort was tracked and mixed by senior engineer Tom Carr...Rainstorm Studio (Bellevue, WA) hosted hardcore industrialists Contingence. They were tracking a new album with staff engineers Paul Speer and Steve Carter. Additionally at Rainstorm, punk rock outfit Bound by Fate were in working with Carter on their debut single, and Speer finished mixes for Room XIII's latest EP...Chris Bingham stopped in at Audio Logic Inc. (Seattle) to begin work on his fourth CD. Jay Kenney got the nod to engineer the effort, and Chris Bingham and Sue Tin-



L to R: engineer Tim Nitz, producer Battlegat and Soundcastle owner Buddy King behind the new SSL SL 4000 G Plus inside Studio 2.



Mastering engineer Pat Sullivan (left) and recording engineer Alan Meyerson in working on *Gladiator II* at Bernie Grundman Mastering, Hollywood

ney shared production duties. Jim Evans put three more songs in the can for his upcoming release *Boundless*; Kenney was again in to engineer, and the production was handled by Jim Evans and Bingham. A cappella sensation m-pact tracked vocals for their contribution to an all-vocal tribute to The Beatles. Britt Quentin's arrangement of "8 Days a Week" was engineered by Kenney and Guy Staley and produced by Quentin.

**SOUTHEAST**

New England's Staind finished up their new album at Southern Tracks Recording (Atlanta). Nu metal-god Josh Abraham was in to produce the effort with Brendan O'Brien mixing. Ryan

Williams was the second mix engineer, and Karl Egsieker was tapped to assist. Ruby Red Productions (Atlanta) recently hosted Island/Def Jam recording artists Injected. Butch Walker of the *Marvelous 3* switched gears to produce and co-engineer the forthcoming project. Union Station stepped into the Neve room at Seventeen Grand (Nashville) with producer Alison Krauss, engineer Gary Paczosa and assistant Chris Scherbak to work on a new project for Rounder Records. Artist Chris Thile was also hanging around mixing and making some final tweaks to a new self-produced release; the sessions were engineered by Paczosa and assistant Bobby Morse.



Gold Sound president Bryan Gold seated at the facility's new AMS Neve Logic 3 console.

# BUY GEAR ONLINE

**Sweetwater** Year #1 Music Equipment Retailer On the Internet

Welcome to Sweetwater

For over 20 years Sweetwater has provided musicians and audio professionals with the best value in music equipment retail. Sweetwater offers a huge that goes beyond great prices. We are leading customers in all aspects of music technology. We are authorized dealers and service providers for the industry's top manufacturers. We have the most talented customer service staff. If you're looking to buy from a company that truly cares about its customers, Sweetwater offers the ultimate. We are proud to provide the best service in music technology equipment.

**Hook up with a Monster and register for free STU MONSTER CLUB**

Every time you buy a Monster cable from Sweetwater, we'll automatically add the retail price of any new Monster cable to your account. You'll be able to use it to buy more cables, or to get a free Monster cable. To learn more, visit [www.sweetwater.com/monster](http://www.sweetwater.com/monster) for free stuff. There's no sign up fee, it's that easy.

**Incredible Soundware Offer!**

For a limited time, whenever you purchase any of our Soundware software titles from Sweetwater, we'll give you a \$50 credit towards your next purchase. Spend \$100 and get \$50 off. Spend \$200 and get \$100 off. The store credit can be applied to any purchase of ANYTHING in Sweetwater's huge music technology store. It's the best music technology deal you'll ever see. It's a \$50 credit towards your next purchase. Spend \$100 and get \$50 off. Spend \$200 and get \$100 off. The store credit can be applied to any purchase of ANYTHING in Sweetwater's huge music technology store. It's the best music technology deal you'll ever see. It's a \$50 credit towards your next purchase. Spend \$100 and get \$50 off. Spend \$200 and get \$100 off.

**New In Stock**

The new... (text partially obscured)

**Sweetwater**  
music technology direct

[www.sweetwater.com](http://www.sweetwater.com)  
**(800) 222-4700**

# Visit

[www.mixonline.com](http://www.mixonline.com)

## RESOURCES FOR AUDIO PROFESSIONALS!

- Access *Mix* anywhere, anytime: Check out highlights of our current issue or browse through back issue archives to find the information you need, with news, interviews, application articles, field tests, equipment reports and more—all online!
- Don't get ripped off! Peruse *Mix*'s "Stolen Equipment Registry," and help take a bite out of crime.
- Click on hot links to important sites such as the TEC Awards, *MixBooks* and "20 Years of *Mix*," a complete database listing the contents of issues since 1982.
- Log on and renew or subscribe to *Mix*, or send in change of address info conveniently, online.
- Advertisers: Get up-to-date info about upcoming *Mix* issues, rates and guidelines for submitting ads.

## EXCLUSIVE BENEFITS!

Register for your *free* membership to [mixonline.com](http://mixonline.com) and check out lively, interactive forums where audio pros can access information, ask advice, or simply share experiences and opinions with other engineers and producers.



## DEMO ROOM!

Enter the Demo Room and view streaming video tutorials of specific products, with spotlights on special features and applications. Available exclusively at [mixonline.com](http://mixonline.com)!

## VALUABLE INFORMATION, JUST A CLICK AWAY!

Visit [www.digitalmediaclick.com](http://www.digitalmediaclick.com)—a portal hosted by [www.industryclick.com](http://www.industryclick.com) that links the Websites of a variety of magazines and service providers within the digital media production community. Besides *Mix*, [digitalmediaclick.com](http://digitalmediaclick.com) offers access to essential sites by leading magazines such as *Broadcast Engineering*, *Electronic Musician*, *Entertainment Design*, *Lighting Dimensions*, *Millimeter*, *Netmedia*, *Onstage*, *Remix*, *Sound & Video Contractor*, *Special Events*, *Video Systems* and more.

[www.mixonline.com](http://www.mixonline.com)



PHOTO: GEORGE PETERSEN

Farmer Beach Boy Al Jardine was at Shark Bite Studios in Oakland, Calif., mixing his recent concert CD, which was recorded live at the MGM Grand in Las Vegas. L to R: studio owner/engineer Mark Keaton, Jardine and producer Stevie Heger.

## MIDWEST

Sunsinger Recording artist Edwin Ray recently completed tracking at Pogo Studios (Champaign, IL) with producer Mark Rubel. The upcoming release features Starcastle guitarist Matt Stewart. Also recording at Pogo was Tibanna, of Portland, Ore, with Paul Malinowsky engineering...Grammy-nominated artist Billy Branch recently finished his latest blues album *Super Harps* at Paragon Studios (Chicago) with engineer Jack LeTourneau.

## STUDIO NEWS

Allen Sides of Ocean Way and Akira Taguchi of JVC have teamed up to open the new Ocean Way/JVC Mastering Studio (Hollywood). The new room

boasts a dizzying array of both digital and analog mastering solutions... Soundcastle (Los Angeles) recently installed a Solid State Logic SL 4000 G Plus console. The 80-input board will reside in Soundcastle's Studio 2...Soundtrack Boston, a seven-room recording and post facility, upgraded its Studio E with the installation of a Sony DMX-R100 digital console...Gold Sound (Southfield, MI) an audio post facility, recently installed a 16-fader Logic 3 mixing console and AudioFile audio editing system in its new room, Audio Post 3. ■

Send your sessions and studio news to [rbanson@intertec.com](mailto:rbanson@intertec.com) or fax 510/653-5142.



PHOTO: DAVID GOGGIN

Alan Yashida (left) and Allen Sides hanging out at the recently opened Ocean Way/JVC Mastering Studio, Hollywood



## THE FAST LANE

—FROM PAGE 16, HOW DO I WRITE THEM

time, time wasted stalled, has been cut by 90%! And here is the wisdom of the ages, embarrassing simple, said daily but never heard—walk away. Take the Harley out for a sandwich somewhere in the next state. Go home and take your family out for a nice long dinner and do *not* discuss or think about the stall. Maybe you could watch Lexx backward (it almost makes sense that

**Of course, if the dot  
is there, you had better  
jump on that sucka  
real fast, because its  
zeitgeist assures  
that it has also  
appeared to a hundred  
other people  
around the world  
at the same time.**

way) or crack open that bottle of Patron. Or, better yet, do both at the same time. (Then *everything* makes sense.)

When it comes to games for breaking a block, there is an old saying: "It don't matter, it's all good." Anything goes, as long as it has absolutely nothing to do with the dreaded stall.

### 2. Crunch.

About one half of everything I create is done this way—the hard way. I sit down and with an even-paced, methodical follow-through, I literally *build* the project. Piece by piece, hour by hour, I construct the thing, review and destroy parts only to redo and re-evaluate them, as well. Slowly, but steadily (and this is important), the piece emerges. It always gets done, and it is always done just about when I tell people it will be. More or less, kinda sorta.

But the thing about working this way is that I never really feel it is my best work. As in a vocal that took 18 takes, there is a certain structured coolness. I sense magic lost forever.

Let me give you an example. About one half of my *Mix* columns are crunched, methodically built on the ker-

nels of concepts. I work hard to slip in the hidden meanings, the inside references, the double and triple entendres, and even the horrible puns and pointless alliteration. I move and splice paragraphs over and over until I feel the flow is right. They take me four to eight days each, and I can spot these crunched columns easily when I read one later, even if it's 15 years old.

### 3. But the other half are flashed.

I either wake up with them already in my head, or I sit down on the last day of deadline and they instantly appear, all done, ready to transcribe. These are my best columns, the ones that get the most response, the ones

that generate a feeling of bidirectional communication with you. These take me one-and-a-half hours, and I never even re-read them for spelling errors. They are the real thing.

Let's take music. The single challenge when flashing a song is getting it down before that crystal clear, 100% complete, tracked, mixed and four-color packaged vision fades. It's just a race to see if you can get it captured before you lose it. And, for me, it is complicated by the fact that the act of capturing it is apparently destructive. That is, once I start the process, the fade begins with a vengeance. So I get one shot, and it must be in one sitting. Maybe some of

vintage  
2001

The M150 Tube represents more than seventy years of experience building the world's finest microphones. It's not a reissue, but a stunning new tube mic that is the culmination of all that has gone before. It is the ultimate Neumann microphone — for now.

Available only in the US with this vintage-style power supply.

Give us a call or visit our web site to learn more about the M150 Tube

**Neumann|USA** the M150 Tube

Tel: 860.434.5220 • FAX: 860.434.3148 [www.neumannusa.com/M150/mix](http://www.neumannusa.com/M150/mix)

## THE FAST LANE

you are more lucky (read disciplined) than that.

### SO WHAT'S ALL THIS REALLY ABOUT?

It's all about the kernel—that tiny dot floating in the cosmos. Every column, every painting, every song is built around a *dot*. An idea, a concept, a vision that is almost infinitely small, yet can be opened, with skill, to encompass and display a complete and satisfying story or feeling.

But if the dot isn't there, the piece can't flash, and you must then resort to constructing it, to synthesizing it, using what you have learned from flashing.

Of course, if the dot *is* there, you had better jump on that sucka real fast, because its zeitgeist assures that it has also appeared to a hundred other people around the world at the same time.

But there are even cosmic rules that help you here as well. (The world actually *wants* you to succeed.) So 100 people got the same exact vision dropped into their heads at the same time—the perfect three-minute tune. Thirty-one of them are farmers and really don't even remember

it the next day; 17 hate their jobs so much that they never even heard it; 19 are too young to know that they can do anything with it; five are in high school bands; one is a tone deaf welder; one a rodeo clown; and two are lounge lizards who will screw up *any* song they hear, be it from the radio *or* the cosmos.

Of those 76, trombones are the instrument of choice for three, so they are not a threat, but the other 24 are racing to get the thing jotted down as fast as possible. It will sound way weird to most Chinese musicians, so 13 more walk away wondering why that stupid, decadent, western pop tune appeared in their heads at all. This leaves 11 after your tune, including two in Nashville! You had better get on these flashes as soon as they appear.

### SO WHO REALLY CARES ABOUT WHAT THIS IS ALL REALLY ABOUT?

Ahh. This finally brings me to the important difference between flash and crunch. I see in others what I feel in myself—the flash is real, but the crunch is just we being technicians. Skilled techs, for sure, but still only techs, copying the true artistic creativity that we know well from actually having done it

before. When we crunch, we are in a way forging work. We are copying our best flashed work, or at least constructing a piece using all of the components and techniques that we believe made us successful with our flash work.

Granted, there is nobody better qualified to rip us off than ourselves, but the fact remains that a copy is never as good as the original. The range of expression, integration, flow, detail, the seemingly effortless brush strokes, guitar licks, or even the unfolding of a story or idea in prose is always less and even a bit stilted to the most discerning.

But since Mickey the Angel and the Sistine Chapel, artists have been struggling to keep a healthy balance between pure creation and working to pay the rent. And you know that we all—you all—do both. I guess the trick is to get so good at the crunch that almost nobody can tell it from the flash. You want the day to come when they know you flashed *and* crunched your way through life, but they say: "It don't matter, it's all good." ■

*You get born. You die. In between you can watch I Love Lucy or you can kick ass. You decide.*

## Sound for Picture, 2nd Ed.

Tom Kenny

The updated version of this popular MixBooks title—which, because of the advent of DVD, is as timely as the day the movies first appeared—features the details of assembling audio tracks for some of the highest-profile motion pictures of the 1990s, including: *Titanic*, *The Thin Red Line*, *Austin Powers 2: The Spy Who Shagged Me*, *Yellow Submarine* and *The Green Mile*. Also included is an exclusive interview with the dean of film mixers, Walter Murch, Larry Blake's comprehensive glossary of film sound terminology, a complete appendix of Oscar for Best Sound and Best Sound Effects Editing, and much more!

©2000 softcover • Item #330470 • List Price \$24.95 (plus S&H and applicable sales tax)

Available online at the Artistpro Shop – [www.artistpro.com](http://www.artistpro.com)



artistpro.com  
236 Georgia Street, Suite 100  
Vallejo, CA 94590  
(707) 554-1935



MixBooks is an imprint of artistpro.com, LLC

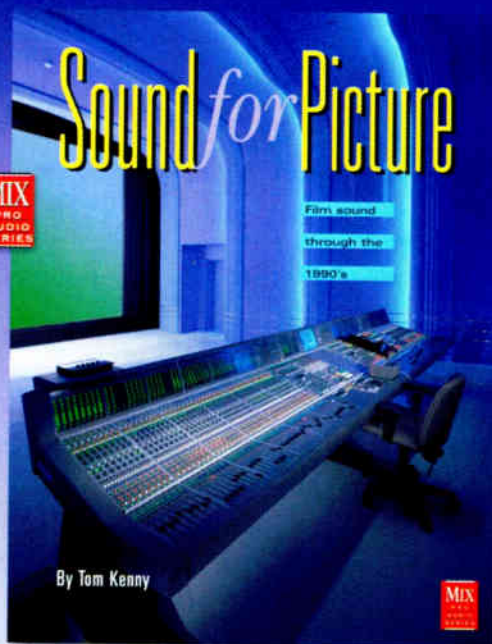

POWERED BY  
**HAL LEONARD**  
CORPORATION  
3777 W. BLANCKHORN DR., P.O. BOX 14012 SACRAMENTO, CA 95814

Also available through your local book or music retailer exclusively through: Hal Leonard Corp.

Technology for Life

Register Online by June 18, 2001  
for special savings!

Refer to Priority Code: **A-MX**

# Macworld Conference & Expo™

Conference Programs & Workshops  
**July 17-20, 2001**

Exposition  
**July 18-20, 2001**

Jacob K. Javits Convention Center  
**New York City**

*In its seventeenth year, **Macworld Conference & Expo** remains the ultimate venue for all levels of Mac users, professionals, enthusiasts and the Mac-curious to gather and experience the excellence of Mac technology!*

Macworld Conference & Expo showcases the hardware, software and peripherals you are looking for, as well as the technologies, applications, techniques and solutions you may not be aware of.

*Excel in life with the knowledge and solutions found at Macworld Conference & Expo.*

- Visit over 400 exhibiting companies
- Discover thousands of new products and services
- Test-drive the latest Mac OS X applications
- View live demonstrations
- Participate in competitions, drawings and giveaways
- Expand your digital lifestyle
- Evaluate the latest technology innovations

*Macworld Conference & Expo's world-renowned conference programs offer educational and in-depth training sessions for all experience levels.*

**MacBeginnings** are high-energy, informative sessions that acquaint you with the Mac community.

**Macworld/Users** continues to be one of the best educational values anywhere for the general practitioners.

**Macworld/Pro** offers the most sophisticated training available on Macintosh for the advanced users and skilled professionals.

*Visit [www.macworldexpo.com](http://www.macworldexpo.com) for continuous event updates!*

Owned and Managed by



© 2001 IDG World Expo. All rights reserved.  
All other trademarks contained herein are the property of the respective owners.

Flagship Sponsors

**Macworld** Macworld.com

**MacWEEK.com** MacCentral.com

Call Toll Free 1-800-645-EXPO or Register Online Today

[www.macworldexpo.com](http://www.macworldexpo.com)

# STUDIO SHOWCASE

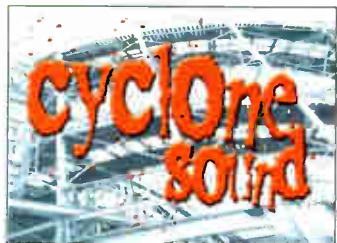

## Cyclone Sound

1220 Surf Avenue  
Brooklyn, NY 11224  
ph/fx: 718 266 7755  
email: cyclonesound@danfury.com

On Coney Island Beach. In New York City. A big, beautiful loft with an awesome drum room. 13 foot ceilings. Tons of light. Sea breeze. Surrounded by roller coasters, go-karts, bumper cars, and the freak show. Private roof overlooking the ocean. Cool, hard, and funky. 25 minutes from lower Manhattan.

Owned and managed by Don Fury.



## Artisan Recorders Mobile

P.O. Box 70247  
Ft. Lauderdale, FL 33307  
(954) 566-1800; Fax (954) 566-3090  
e-mail: mobile\_red@aol.com  
www.artisanmobile.com

For over 20 years, Artisan Recorders has been providing excellence in remote recording and broadcast. Along with an extensive array of equipment in a comfortable aesthetic environment, our "Mobile Red" studio boasts an expert staff of technicians with a love of music and a desire for perfection. Currently touring with ABC's *Tom Joyner Morning Show*. When you rock, we roll.



## NPR

635 Massachusetts Ave., N.W.  
Washington, D.C. 20001-3753  
(202) 414-2482; Fax (202) 414-3033  
e-mail: rgi@npr.org  
www.npr.org/studios

Located in downtown Washington, D.C., Studio 4A offers a spectacular recording environment well-suited to all music genres. Studio 4A, at 2,600 sq. feet, is one of the largest recording facilities on the East Coast. We offer digital and analog multi-track recording, an extensive mic collection, digital editing suites and CD mastering. NPR also offers satellite uplinking, fiber-optic and ISDN capabilities worldwide.

## STUDIO A

- Have VR-60 with Madlabs CP-4 and Flying Faders
- Studer A-800 48 Track
- Protools 24 Digital Recording and Editing
- S-1 Surrounded by George Auggsinger
- Excellent Selection of Vintage and State-of-the-Art Outboard Gear
- 12x12 Iso Booth



## STUDIO B

Coming June 2001, SSL 9080J

SL 9000  
J-SERIES

1140 N. WESTERN AVENUE, HOLLYWOOD, CA 90029 • PHONE 323.462.7761 • FAX 323.462.3393  
www.studio-atlantis.com

# MARKETPLACE

What's New  at Sound Ideas?

**THE DARK SIDE OF SOUND**  
**SCI-FI WARP 2**  
**8000**

**XV SERIES**

**The Art of FOLEY**  
**EMERGENCY**  
**IMPACT EFFECTS**

905-886-5000 Fax 905-886-6800 US: 1-800-387-3030 www.sound-ideas.com

CIRCLE AD NUMBER 250 ON PRODUCT INFO CARD



**CLEARSONIC PANEL & SORBER**  
Absorption Baffles

Effective  
Free-Standing  
Portable  
Factory Assembled  
Durable Full-length Hinge

**BUY FACTORY-DIRECT AT NEW LOWER PRICES!**

clearsonic.com  
1.800.888.6360

**CLEARSONIC**

On Stage or in the Studio...

CIRCLE AD NUMBER 251 ON PRODUCT INFO CARD

**GET IT FAST**

Don't trust your audiophile duplication needs to anyone else!

**Progressive Music**

www.progressivecds.com

Avail: VISA & Master Card

2116 Southview Ave.  
Tampa, FL 33606  
(813) 251-8093  
FAX: (813) 251-6050  
Toll Free: (800) 421-TAPE

**ALL COMPLETE:**  
Full color Pkgs. with Inserts, from your CD & Film

500 CD'S	\$980.00
500 CASS	\$690.00
1000 CD'S	\$1275.00
1000 CASS	\$905.00

\*\*\*also\*\*\*  
**NEW! 100 CD. RETAIL READY PACKAGE IN 5 DAYS!!! \$589.00**  
( just give us a photo & mockup!!!)

"Fastest Turn-Around in the Known Universe!"

CIRCLE AD NUMBER 253 ON PRODUCT INFO CARD

"The sound of my 1-inch ATR is incredible."

**Ainlay Mixes 1-Inch**

Over two years ago, Chuck Ainlay bought this 1-inch machine from ATR Service Company. It's been his exclusive stereo mixdown deck ever since. Listen to the results on recent CDs by Mark Knopfler, Travis Tritt, and Trisha Yearwood, among others. Then call ATR Service, the originator of 1-inch stereo on the legendary ATR-102. Now, more than ever, the ultimate music mastering machine.

717.852.7700 / www.atrservice.com

**ATR SERVICE COMPANY**  
AMPEX SPECIALISTS

I won't mix to stereo without it."

CIRCLE AD NUMBER 252 ON PRODUCT INFO CARD

**The complete solution for all your recording needs.**

**CDXpress Plus CD Copier/Recorder/MP3 Player**

- Record from virtually any sound source.
- Copy software or audio.
- Internal hard drive for track extraction & editing.
- Record analog or digital sound.

Princeton Dis

Call today!  
**800.426.0247**  
www.princetondisc.com

Ask about our full line of duplication services & blank CDR media!

CIRCLE AD NUMBER 254 ON PRODUCT INFO CARD

**Real Spring Reverb for the digital age**  
*"The best sounding spring reverb" Ry Cooder*



channel 2 long delay  
 phase mixer overload  
 input max output  
 reverse hi pass

**Real Reverb**  
 analog spring reverb  
 by James Demeter  
 Demeter Amplification

**Demeter Amplification**  
 818-994-7658 demeteramps.com • demeter@gte.net

CIRCLE AD NUMBER 255 ON PRODUCT INFO CARD

**SALE! PLUS FREE ADHESIVE!**

**GIANT 54" x 54" MARKERFOAM™ ACOUSTIC FOAM**

**IMMEDIATE SHIPPING** 2" Reg. \$29.95 Now \$19.99  
 3" Reg. \$39.95 Now \$29.99

**KILL NOISE QUICK!** High performance, full-size sheets of super high density Markerfoam. EZ mount. Blue or charcoal gray. Super-effective sound absorption for studios. Markerfoam offers the best value, looks professional & is proven in studios worldwide. Request Catalog, specs & free samples today

**MARKERTEK JUMBO SOUND ABSORB BLANKETS**

Heavy-duty 76" x 68" padded blankets absorb sound wherever they're hung or draped. Fabulous for stage, studio or field use. Top professional quality at a super saver price! Weight: 6 lbs. \$19.99



**MARKERTEK 16" x 16" BLADE TILES™**  
 HIGH PERFORMANCE - LOW, LOW COST!!!  
 America's best acoustic tile value only from Markertek!  
 2" Thick - \$3.49 per tile, charcoal or blue; 3" Thick - \$4.49 per tile, charcoal or blue; 4" Thick - \$5.49 per tile, charcoal.



**MARKERSTIK™ FOAM ADHESIVE**  
 FREE with any foam purchase in this ad! Limited offer. A \$4.00 per tube value.

**SONEX**  
 All the Colors, Styles and Sizes Plus Great Prices!



**FREE!** America's most unique catalog featuring 328 pages of over 16,000 exclusive and hard-to-find supplies for Pro Audio, Broadcast Video, Audio Visual & Multimedia production.

**MARKERTEK VIDEO SUPPLY**

4 High St., Box 397, Saugerties, NY (USA) 12477  
 Toll Free: 800-522-2025 • 914-246-3036 • Fax: 914-246-1757  
 Order On-Line Today: www.markertek.com • E-Mail: sales@markertek.com •

CIRCLE AD NUMBER 256 ON PRODUCT INFO CARD

**The Audio Toolbox™**  
 The amazing DSP-powered acoustical analysis, audio test, calibration and troubleshooting tool.

**Functions**  
 SPL - 1/12 octave RTA - RT60 - Energy Time Graph  
 Distortion Meter - Speaker Polarity - Signal Generator  
 Frequency Counter - Stereo dB Meter - MIDI Analyzer  
 Audio Scope w/phase - Impedance Meter - Cable Tester  
 Time Code Generator / Reader / Re-gen / Analyzer  
 Headphone Monitor Amp - Phantom Power Tester  
 PC/Mac Interface - 40 memories - more...



Tel: 303 545 5848  
 Fax: 303 545 6066  
 Toll-free: 888 433 2821  
 www.terrasonde.com

Available in Rack-mount, Plus, and Standard models (shown).

TerraSonde

CIRCLE AD NUMBER 258 ON PRODUCT INFO CARD

**MEDIA services** CALL with any questions or inquiries  
**1.888.891.9091**  
 www.mediaomaha.com

**LOW PRICE GUARANTEE!**

**NEW 10 FREE CDR's**

\*MEDIA SERVICES WILL BEAT ANY QUOTE BY 5% OR RECEIVE 10 FREE CDR'S\*  
 PROVIDE A COPY OF A COMPETITORS WRITTEN QUOTE ON THEIR LETTERHEAD (1000 piece minimum order)

**4 Panel Retail Ready CD's**

**Includes:**  
 Glass Mastering, CD Replication (with 3 color printing)  
 CD films, 4 panel (4/1 Book), Tray (4/0), Print Films,  
 FREE Barcode, Jewel Case, Assembly & Wrap

**\$1350**

**CD's .. Tapes .. CDR's .. Graphic Design .. Designer CD's .. Posters .. Postcards .. Printing .. DVD's .. CD-Rom's**

CIRCLE AD NUMBER 259 ON PRODUCT INFO CARD

CDs • CD-ROM • CD-R • SHAPED CDs • AUDIO CASSETTES

**NEED CDs?**  
 the choice is  
**CRYSTALCLEAR**  
 DISC & TAPE

Trusted experience for over 30 years.

**1-800-880-0073**  
 visit us at www.crystalclearcds.com

DIGITAL MASTERING • ART DESIGN • PRINTING • PACKAGING

CIRCLE AD NUMBER 260 ON PRODUCT INFO CARD

**Boutique Audio & Design**  
 Presents

A safe harbor for your valuable vintage modules at a great price.  
**\$895.00 (Any Rack)**  
 \*Modules not included

Neve 1272  
 Neve 1073, 1084, 1089  
 Telefunken V72, V72a, V72b, V78

- Enclosed 3RU Chassis
- Internal shielded power supply
- Conductive plastic output pots
- All steel chassis
- Rear chassis mount XLR's
- Front panel 1/4" line/inst inputs

Also available: Neve 8 channel racks and custom racks

PHONE: 818-708-7716 FAX: 818-708-7105 Web: www.boutiqueaudio.com

CIRCLE AD NUMBER 257 ON PRODUCT INFO CARD

WWW. *Click Here for Great Deals!*

# SHREVE AUDIO

1-800-214-9222 We Buy Used Gear! [com](http://www.shreveaudio.com)

Marshall Mics ON SALE! Price TOO LOW to advertise! Ask about FREE gift included!

**HR824** active reference monitor

**MACKIE Digital Systems** Digital 8 Bus

**NEW!** The most powerful digital console made today!

Prices reflect a 2% cash discount and are subject to change without notice. Returns are subject to a 15% restocking fee. Not responsible for typographical errors.

**SHURE**

AKAI DPS 12 v2

Starting at \$699

Now with 2 GB FREE HD

CALL! Limited Time Only!

**BOSS** Shreve Audio is the Boss when it comes to low prices!

1200 Marshall St Shreveport, LA 71101

# Roland

We have Roland keyboards, recorders, guitar synthesizers...anything you need!

VS 1880 MC-303

**audio-technica** BLOWOUT on atm41a's!

**BEHRINGER** JUST LISTEN!

**TASCAM** Adat's at \$699 US-428-Interface Controller- ON SALE!

CIRCLE AD NUMBER 261 ON PRODUCT INFO CARD

# IT'S YOUR BABY AND WE DELIVER.

FULL COLOR CD PACKAGES From supplied CDR & print ready film

500 \$423.00 1000 \$1,193.00 2000 \$2,999.00

Other Services Include: Mastering Design Film

ONE YEAR FREE MEMBERSHIP WITH V.M.G. WORLDWIDE INTERNET MARKETING AND DISTRIBUTION COMPANY

**VISION** MUSIC GROUP

**800-DIGIDOC** www.digidocpro.com

CIRCLE AD NUMBER 262 ON PRODUCT INFO CARD

## Class A Vacuum Tube Signal Processors



**MDP-1 Mic/DI Preamp**  
The ultimate front end for high resolution recording

**OCL-2 Optical Compressor**  
Smooth dynamics processing without coloration

**ES-8 Variable-Mu Limiter**  
Classic feedback compression with a modern twist

At Pendulum, our modern tube designs provide superior audio performance and a level of clarity, intimacy and detail that is unattainable with vintage tube products.

**Pendulum Audio**  
P.O. Box 339, Gillette, NJ 07933 (908) 665-9333

Hand-built in the USA - [www.pendulumaudio.com](http://www.pendulumaudio.com)

CIRCLE AD NUMBER 264 ON PRODUCT INFO CARD

# Unbeatable Prices! Unsurpassed Service!

on all your **Recording Supplies** and related services

- Blank audio, video and data media
- Studio mastering supplies
- Labels, albums, sleeves, jewel cases
- Cassette duplication
- CD replication
- Graphic design services

**877-778-7987**  
[www.universaltapes.com](http://www.universaltapes.com)  
(732) 367-TAPE • Fax: (732) 886-TAPE  
61 Whispering Pines Lane • Lakewood, NJ • 08701

CIRCLE AD NUMBER 263 ON PRODUCT INFO CARD

# NEW AND PREHISTORIC RECORDING EQUIPMENT AT HISTORIC PRICES.

We carry the finest new, used and vintage recording equipment available. And if we don't have it in stock, we can get it fast. That's why studios, engineers and producers around the world call us first.

**PRIMAL GEAR**

Tel: 615-269-0704 Fax: 615-269-0905  
1622 16th Avenue South, Nashville, TN 37212  
[www.primalgear.com](http://www.primalgear.com)

CIRCLE AD NUMBER 265 ON PRODUCT INFO CARD

"After 27 years of Mastering, I can use anything I want and I use Requisite limiters, everyday."

Denny Purcell - Georgetown Masters - Nashville



ALL-TUBE, ALL-TRANSFORMER, POINT-TO-POINT

requisiteAudio.com

818-247-2047

CIRCLE AD NUMBER 266 ON PRODUCT INFO CARD

www.earthdisc.com

**500 Free CDS !!!**  
WHEN YOU PURCHASE A CD PACKAGE AT EARTH DISC YOU'LL BE ENTERED IN OUR FLAVOR OF THE MONTH CONTEST! ONE WINNER WILL BE PICKED EACH MONTH. GO TO OUR WEBSITE FOR CONTEST RULES. RESTRICTIONS MAY APPLY.

**\$986.00**

500 CDS package includes:  
full color 2 page/4 panel insert  
3 color on cd printing  
glass master,  
jewel box, shrink wrap

**\$1299.00**

500 CDS we do it all!  
package includes:  
graphic design/film  
full color 2 page/4 panel insert  
3 color on cd printing  
glass master,  
jewel box, shrink wrap

**\$1385.00**

1000 CDS package includes:  
film separations  
full color 2 page/4 panel insert  
3 color on cd printing  
glass master,  
jewel box, shrink wrap

cd • cd rom • dvd • cassette • mastering • graphic design • printing



Free Barcode Fast, reliable and friendly service

**1.800.876.5950**

CIRCLE AD NUMBER 267 ON PRODUCT INFO CARD

**ANCHOR Your Speakers**  
With  
**Sound Anchor Stands**

SOUND ANCHORS is your first choice when it comes to speaker stands for your studio. We have a complete range of designs to fill any speaker stand requirements.

The Adjustable Stand in this picture is designed to support small to mid sized monitors behind the console.

STABLE.....RIGID.....DAMPED

**Sound Anchors Inc.**

Phone/Fax (321) 724-1237

http://www.soundanchors.com



CIRCLE AD NUMBER 268 ON PRODUCT INFO CARD

**MAKE MONEY MAKING CDS**

Start your own duplication shop!

Duplication suite #9

InfoPro 10 Bay 12x Tower • Ink-Jet CD Printer • Shrinkwrapping System  
Lease as low as \$199.00 per month

TOWERS  
starting from  
**\$99.00**  
per month

WWW.SUPERDUPS.COM

500+ CDS  
PER DAY  
POSSIBLE!



QUALITY  
CD-R's  
as low as  
**29¢**

VISIT OUR WEBSITE FOR EXPERT ADVICE - LOWEST PRICES GUARANTEED

TRADE IN YOUR 4x OR 8x DUPERS FOR 12x & 16x!

**800-617-3877**

American Duplication Supply

CIRCLE AD NUMBER 269 ON PRODUCT INFO CARD



Herman  
Miller

**800-883-9697**

www.sittingmachine.com

AERON

CHAIR



CIRCLE AD NUMBER 270 ON PRODUCT INFO CARD

**VT-2 Dual-Channel Vacuum Tube Microphone Preamplifier**  
Anyone who has heard it knows . . .



**D.W. FEARN**

www.dwfearn.com

**610-793-2526**

610-793-1479 fax

PO Box 57 • Pocopson, PA • 19366 • U.S.A.

CIRCLE AD NUMBER 271 ON PRODUCT INFO CARD



**CDs & CASSETTES**



**Compact Disc Replication  
Cassette Duplication  
Complete Packages  
Digital Mastering  
Graphics and Printing**

*deal direct  
and SAVE*

**FREE CATALOG or CUSTOM QUOTE  
800-289-9155**

OUTSIDE THE U.S. CALL: 516-244-0800

**You'll Hear and Feel the Difference**  
[www.CandCmusic.com](http://www.CandCmusic.com)



CIRCLE AD NUMBER 272 ON PRODUCT INFO CARD



[www.vintageking.com](http://www.vintageking.com)

**New or Used  
Package Deals  
Buy, Sell, Trade**

*Over 250 Vintage EQ/Pres &  
More Than 75 Tube Mics in Stock*

- 12a/C24/C28/C60-61/D12/D30/D45/461/452/414bulbs /460b pr
- DR COMPLEX ALAN SMART CL1+2; AMS RMX16/1580s
- AK 16/26/24 consoles/racks/525/550a-1/550a; ALTEC 1567/4365
- AKU BX 35102/35101 classic eq/pre racked; BBC classic tube mic pre
- B-K 4003 w/preamp; COLES/STC 4038 new/used
- CALREC 1061/1161 racked/DL1656 comp-lm-gate
- DBX 160/161VU/162/165pr/902 deesser rack
- DECCA eq-pre/Mastering comp pair rack; DOLBY SR racks
- DRAWMER DS201; EAB 6x2 tube console; EMT 2561 comp
- EVEN TIDE Instant Flanger; FAIRCHILD 670/681 comps
- FLICKENGER 3-band eq/rack; FOCUSRITE ISA115/215
- HELIOS Island/Olympic eq/pre Helios 20 input console KLARK TECH DN780;
- KORBY Empytan mics/new; GM3; LANGE PEQ4/PEQ2;
- LEXICON LXP1-S; MRC/PCM41/480L/300; MASSENBURG 8200
- NEVE consoles: BCM10/Melbourne 12x2-12x4/24x8x14-1081x24x8-1073x/805B/80
- series 24x8 frame-fits 1073/8036 frame-24x8x16-holds 1081VR Legend
- NEVE 1073 MIC PRE ONLY-racked in pairs, output level, 48v, DI in;
- 1C68/1073/1081/1089/1091/1095/2052/2074/33314/
- 83065/2254a/3415/1272/1279/1290/racks
- NEUMANN U47a/U47M49/M249/M50/M250/UM57/UM70/U77/KM253/53 cons./
- 254/54/64/84/85/86/U67/U87/582/CMV563/SM23/
- LEIPZIG 7151-TLM 170/shock mounts/M49 screens-shells; NTP 179 comps;
- OPTIFILE 3d 56 chan. automation
- PANSCAN; PULTEC EOP1A/EOP1A3 cons. Pr/EOP1/EQ2; PYE comps
- QSC 1200; QUANTEC QRS; RCA 44 jr/77
- Rhodes and Swartz measurement mic; ROLAND Dim D/SBF 325 Flanger
- SCHEORP 221; SONTEC 250C; SONY C37p; SPENDOR SA300/
- SSL 4048,4056; 4080 factory G+; STUDDER 827- 700 hrs-6000 hr/A80C/MKW
- TELEFUNKEN V72/76/V76s/7778/V677/V676/V695eq
- TRIDENT 80C/classic stereo comp-lm;
- UREI 1178L black-silver/1178LA2/LA3/LA4/565 filter;
- VALLEY dynamite/Keyplex II

**NEW ITEMS: Fairman, Universal Audio, ATC Speakers,  
Rcyer, Chandler and Boutique Audio**

*Please inquire about items not listed.*

*info@vintageking.com \* Ph: (313) 965-0645 \* Fax: (313) 964-3338*

CREDIT CARDS ACCEPTED FINANCING AVAILABLE

CIRCLE AD NUMBER 273 ON PRODUCT INFO CARD

Master at **DIGITAL DOMAIN™** where music still sounds like music. Where punch, vitality, space, imaging, clarity, warmth and quality are not just buzz words. We enhance musical values with specialized techniques invented here.

Unsurpassed mastering quality by **Bob Katz**. Custom-built hardware and software. **Stereolization, Microdynamic Enhancement**. Unique Processes. Sonic Solutions Editing. Tube and Solid-State Analog Recorders.

*CD Mastering is an art. Levels, dynamics, fades, spacing... everything is important to you and to us.*

**Recorded & Mastered 1997 Latin Jazz Grammy**

**CD Replication... Booklet Printing... Graphic Design...**

How to make a superior pressed CD:

- 1) 1X speed Glass Mastering
- 2) Quality control
- 3) Attention to detail
- 4) Personalized Service
- 5) Good, clean packaging and packing
- 6) Dependable, on-time delivery

**Digital Domain**

(800) 344-4361 in Orlando, FL

**The Definitive, Award-Winning  
Internet CD Mastering Website**  
<http://www.digido.com>

CIRCLE AD NUMBER 275 ON PRODUCT INFO CARD

**CD LABELING & PACKAGING FROM YOUR DESKTOP!**

**DESIGN • PRINT  
APPLY • PACKAGE**

**40 FREE  
HIGH-GLOSS  
CD LABELS**

**NEATO2000 Kit**

**ONLY  
\$29.95**



**KIT INCLUDES**

- NEATO 2000 CD Label Applicator
- Assortment of Labels and Jewel Case Inserts
- MediaFACE-II
  - Design Software (PC), Templates (Mac)
  - Digital Background Art for Labels and Inserts
  - Label and Insert Templates for Popular Graphics Programs (PC/Mac)

**800-984-9800**

Also available...  
Other Media Labeling Products Including -  
Video Sleeves/Wraps/Labels,  
Business Card CD Labels/Sleeves

**NEATO**  
Media Labeling Products

250 Dodge Ave. • East Haven, CT 06512 • 800-984-9800 • 203-466-5170 • Fax 203-466-5178

[www.neato.com](http://www.neato.com)

CIRCLE AD NUMBER 276 ON PRODUCT INFO CARD

**MARQUETTE AUDIO LABS**



**New, Used & Vintage  
Recording Equipment**

*Specializing in  
Custom Racking*

- Neve • Telefunken
- Siemens • Calrec
- Langevin and more

**Phone 510-581-3817 • Fax 510-581-3917**  
[www.marquetteaudiolabs.com](http://www.marquetteaudiolabs.com)

CIRCLE AD NUMBER 274 ON PRODUCT INFO CARD



**Mercury Recording Equipment Co.**

*"There's nothing better than the best!"*

- "All Tube and All Transformer," fully-balanced, variable-bias limiting amplifier, (comp./lmtr.)
- Hand built in the USA, No PC board or ICs (chips).
- Mono (linkable)



For more info and closest dealer please go to our website.

**Phone 510/581-3817 • Fax 510/581-3917**  
[www.mercury-rec.com](http://www.mercury-rec.com)

# MARKETPLACE

## SONIC CIRCUS



6 1 7 . 6 9 6 . 9 3 6 0

CIRCLE AD NUMBER 277 ON PRODUCT INFO CARD

**Lonely Records.com**

- graphic design
- web service
- mastering
- cassettes
- print
- dvd
- cd

**100 Retail CDs**  
as low as **\$1.99** per cd

**1000 Retail CDs**  
as low as **\$0.99** per cd

**100 Bulk CDs**  
only **\$1.50** per cd

**1000 CDs**  
as low as **\$0.56** per cd

Mastering as low as \$45  
Blank CD-R as low as 49¢  
For A P...

**1 800-409-8513**

• FREE national distribution  
Amazon.com, Yahoo.com  
LonelyRecords.com.  
Sell your music today!

CIRCLE AD NUMBER 278 ON PRODUCT INFO CARD

**D.J. VINYL PROMO**

**100 12" VINYL \$775.00**  
(in WHITE JACKET w/ HOLE) \$1.30 each for additional LPs

**1000 7" VINYL 45's (WITH WHITE SLEEVE) \$849.00** REORDER - \$479.00

**500 7" VINYL 45's (WITH WHITE SLEEVE) \$675.00** REORDER - \$299.00

**1000 12" VINYL (in WHITE JACKET w/ HOLE) \$1,779.00** REORDER - \$1199.00

**500 12" VINYL (in WHITE JACKET w/ HOLE) \$1,249.00** REORDER \$699.00

ALL PACKAGES INCLUDE: MASTERING / FULL PROCESSING / TESTS / 2-COLOR LABELS / SHRINKWRAP (12" only) / QUICK TURN AROUND

IN-HOUSE CD, VINYL & CASSETTE REPLICATING & PACKAGING • OVER 60 YEARS OF EXPERIENCE  
ASK FOR OUR FREE BROCHURE! PRICES SUBJECT TO CHANGE WITHOUT NOTICE

**Rainbo Records and Cassettes**  
1738 Berkeley St. • Santa Monica, CA 90404 • (310) 829-3476 •  
Fax: (310) 828-8765 • www.rainbo records.com • info@rainbo records.com

CIRCLE AD NUMBER 280 ON PRODUCT INFO CARD

**CD & DVD Duplication**

- Duplicators **Low price!**
- Printers **Next-day delivery!**  
Rimage • Signature III • Inscripta
- Blank Media **All major brands!**  
We will beat any advertised price.
- Supplies **In Stock - ready to ship!**  
MediaFORM • Rimage • Cedar • Primera • More...
- Duplication Services **24 hour turnaround!**  
Duplicated • labeled • sleeved

Check out our **HOT deals** online at [www.goMRS.com](http://www.goMRS.com)

**GO MRS**  
MULTIMEDIA RECORDING SYSTEMS  
[WWW.GOMRS.COM](http://WWW.GOMRS.COM)  
**1-800-769-2715**

CIRCLE AD NUMBER 279 ON PRODUCT INFO CARD

ex-tend-it  
**CAT5-3000**

**Show your noisy computer the door.**

- Extends Two Monitors, USB, Audio & RS232
- Ideal for Protocols & Avid Users

**extend-it CAT5 3000S**

800-545-6900 [www.gefen.com](http://www.gefen.com) [gsinfo@gefen.com](mailto:gsinfo@gefen.com)

CIRCLE AD NUMBER 281 ON PRODUCT INFO CARD

**SOUND TECHNOLOGY**  
Instrumentation and Automation

**SPECTRA SERIES**

Transform Your PC Into A Powerful Spectral Analysis System

Call To Order 1 800-401 3472  
Fax: 408-378-6847  
[info@soundtechnology.com](mailto:info@soundtechnology.com)  
<http://www.soundtechnology.com>  
**FREE Software Demo**

The Best In Test offers a totally new dimension in Audio Testing...  
CIRCLE AD NUMBER 282 ON PRODUCT INFO CARD

# CLASSIFIEDS

**MIX Classified Ads** are the easiest and most economical means to reach a buyer for your product or service. The classified pages of Mix supply our readers with a valuable shopping marketplace. We suggest you buy wisely; mail-order consumers have rights, and sellers must comply with the Federal Trade Commission, as well as various state laws. Mix shall not be liable for the contents of advertisements. For complete information on prices and deadlines, call (800) 544-5530.

## Acoustic Products

### Hear Today. Gone Tomorrow.



#### INTRODUCING THE MAX-Wall from Auralex.

It's the super-affordable, world-class, stand-mounted recording & mixing environment that can go ANYWHERE!

Our patent-pending, interlocking MAX-Wall system can grow & grow as your needs change and allows you to do critical stereo or 5.1 work in ANY room at ANY time.

The MAX-Wall offers linear acoustic control in an attractive, portable package that's the perfect solution when wall-mounted & ceiling-mounted acoustical treatments are out of the

question. Amazingly, its absorption only varies .04 over the entire test frequency spectrum! That's accuracy & performance you can't get anywhere else.

Add Sunburst-360s™ or some of our new stand-mounted 4' tall LENRD™ Bass Traps and you've got an incredible amount of AFFORDABLE and TOTALLY MOBILE acoustical control. Visit [www.auralex.com](http://www.auralex.com) for more info & put a MAX-Wall to work...today!

ON DISPLAY & IN-STOCK AT MAJOR DEALERS EVERYWHERE! • 800-95-WEDGE

### ARCHITECTURAL ACOUSTICS FROM Professional Audio Design, Inc.

- DESIGN AND CONSULTATION FOR EVERY PROJECT
  - NO MATTER THE SIZE OR BUDGET
- EXCLUSIVE U.S. REPRESENTATIVES FOR MUNRO ASSOCIATES DESIGN, LONDON
- ROOM ANALYSIS AND MONITOR SYSTEM TUNING
- CUSTOM DYNAUDIO/MUNRO MAIN MONITOR SYSTEMS
- CUSTOM WIRING SYSTEMS DESIGNED AND INSTALLED
- EXCLUSIVE U.S. RESELLER FOR PRE-OWNED SSL CONSOLES

V (781) 982-2600 F (781) 982-2610  
[www.proaudiodesign.com](http://www.proaudiodesign.com)

THE SYSTEMS COMPANY  
 RECORDING STUDIOS • MASTERING  
 FILM • POST • BROADCAST



### Acoustics by db

...all the others are just brokers.

New products from Queded-Daking  
 Neotek • Martech • Sontec • MFL  
 Trident • Shep/Neve • United Audio  
 Prizm • Eventide • Alan Smart

- Total studio concepts created by experienced producers & engineers.
  - Control rooms, studios, full facilities and turnkey packages.
  - Wiring system design, custom cabling and full installations.
  - Consultation and advice on equipment or system choices.
  - Room tuning, noise problems, existing plans and custom traps.
  - Packages of used & vintage consoles, 24 tr. mics & processing available.

Building Studios & Keeping 'em alive for 86 31 years!

Neve Classic 80 Flange • Neve VI-VR Flange  
 SSL 4000 • 5000 • 6000 • E/G/G+ • 9000J  
 Flying Faders • API 3224 • Trident 80C/80B  
 Neumann U47 VF14 • U67 • U47 • KM84  
 Studer A827 • A820 • A800 MKIII • A80 MKIV  
 Otari MTR90 • MX80 • Radar • Sony JH24ALIII  
 Sony PCM3346 • Studer D827 • Dolby XP/SR  
 EMT 250/251/140 • Lex 480/224 • Sony DRE  
 AKG C24 • C452EB • C12 clone • C28 • C60  
 AKG C414EB Silver • Neve 1066/1073 • Shep  
 Fairchild 670/660 • Quantec • AMS RMX/DMX

Building a project studio?  
 Designs from existing plans  
 start at \$1,000 per room.

**SMALL AFFORDABLE SPECIALS**  
 Trident 24 • Studer 169 • Alesis • Eventide  
 Neotek • Amek Big • Tascam MSP24 • MS16  
 Neumann U87ai • UREI 813C • 809 • Manley  
 Urei 1176LN • 1178 • LA3A • LA2A • LA3A  
 Neumann TLM103 • KM184 • U87 • KMS106  
 AKG C414EB • C451E • C60 • C12VR  
 Digidesign • Otari • Ampex • API

1194 Walnut St, Suite 205 Newton, MA 02461 • 617 969-0585 • fax 617 964-1590  
 Now on the web @ [www.db-engineering.com](http://www.db-engineering.com) • email [ob1db@earthlink.net](mailto:ob1db@earthlink.net)

**AcousticsFirst™**  
 Toll Free: 888-765-2900  
 Full product line for sound control and noise elimination.  
 Web: <http://www.acousticsfirst.com>

[kgvg.com](http://kgvg.com)  
 Design & Integration  
 800.822.3443

### NEED TECH HELP?

- Studio Design!
- Custom Wiring!
- Equipment Installation!

Small or Large Projects -  
**CALL US NOW**

301.607.6607

**AUDIO DESIGN SOLUTIONS**

**Business  
 Opts. &  
 Consulting**

### Starting a studio?

Get advice, ideas and guidance from an experienced studio owner and educator

[www.CriticalPathCoach.com](http://www.CriticalPathCoach.com)  
 301-596-5018

**VIBRANT TECHNOLOGIES**  
**SOUND CONTROL  
 DIFFUSER PANELS**  
 800-449-0845  
[www.vibranttech.com](http://www.vibranttech.com)

\$68,500 buys you So. Florida's most charming high-end project studio. Incredible location, just 1 mile from the ocean. Long lease & low overhead. Steady client base; strong name recognition. Serious inquiries to:  
[yourownstudio@aol.com](mailto:yourownstudio@aol.com)

**SILENT**  
 59 Northuzki St., Northampton, MA 01082  
 INFO (413) 584-7944 • FAX (413) 584-2377  
**ORDER (800) 583-7174**  
[info@silentsource.com](http://info@silentsource.com) • [www.silentsource.com](http://www.silentsource.com)  
 AcoustiCore Fabric Panels • Sound Barrier Isolation Hangers • A.S.C. Tube Traps  
 Silence Wallcovering • Whisper Wedge  
 Metaflex • S.D.G. Systems • Technifoam  
 R.P.G. Diffusers • Sonex • Sound Quilt

**WhisperRoom INC.**  
 SOUND ISOLATION ENCLOSURES  
  
 "Celebrating 10 years of reducing sound to a Whisper!"  
 Practice / Vocal Booths, Etc.  
 Immediate Shipping!  
 3 Year Warranty  
 Various Sizes & Configurations  
[www.whisperroom.com](http://www.whisperroom.com)  
 PH: 423-585-5827 FX: 423-585-5831

**VocalBooth.com**  
 Multi Purpose Recording & Practice Rooms  
  
 Starting at \$1499  
 Affordable Portable  
 4x4, 6x6 & larger  
 (541)330-6045

**Check Out Mix Online**  
[www.mixonline.com](http://www.mixonline.com)

## Employment Offered

### WANTED:

#### CRUISE SHIP TECHNICIANS.

We are accepting resumes for experienced technicians to work aboard luxury cruise ships. Positions include: AUDIO ENGINEER, MASTER ELECTRICIAN, WARDROBE, BACKSTAGE TECH, VIDEO TECH & STAGE MANAGERS. We recruit for most major cruise lines w/ exotic destinations all over the world. Travel & get paid for it! For more info, please visit our Website @ [www.c-deck.com](http://www.c-deck.com). Interested applicants should send a current resume w/ references to:

**C-deck Inc., PO Box 230548,  
Las Vegas, NV 89123  
or e-mail:  
reception@c-deck.com**

Whenever you have a job vacancy, reach 50,000+ job candidates through a classified in Mix.

**Call us at  
(800) 544-5530**

**Faculty Position—Malaysia** in Music Production and Technology. Must have minimum 5 years teaching experience at college level. Some knowledge of theory and practical in recording and multimedia. E-mail inquiries.

ops@icom.edu.my  
www.icom.edu.my

## House of Blues® All Venues

HOB Entertainment, Inc., the Los Angeles-based global entertainment company, continues to delight a wide variety of guests with its famous venues that provide a truly unique blend of live music, food, retail and art through its affiliated companies. House of Blues operates 500–40,000 capacity venues located in the US and Canada.

If you are interested in an extraordinary career in a DIVERSE and exciting environment, consider joining our innovative and highly creative team in the following positions:

**Production Manager  
Production Coordinator  
Lighting Designer / Operator  
Lighting Technician / Operator  
Audio Engineer / Operator  
Stage Manager  
Stage Hand / Loader**

In these amazing roles, you will work side by side with the venue production staff, operating staff, special event clients and the artists/bands to produce high quality and memorable live performances. The Production Manager's responsibilities include everything from advancing all show details for artist and special events; management of sound, lighting and video crews, which include salaried & hourly staff. Operate and maintain state of the art equipment. Manage, track and control department P&L. Participate in the day-to-day operations of the venues. Ensure high level of customer service and quality towards staff and artists.

We are looking for a minimum of 2 years experience touring with a music production, in either a Production Manager, Stage Manager, FOH/Monitor Engineer or Lighting Director role. Working knowledge of pro audio, lighting, video and band gear is required. Basic computer skills and hands-on experience in production is a must.

For immediate consideration, FAX/e-mail resume indicating Job Code PM/MIX3 to: (323) 769-4940 or recruiter@postman.hob.com EOE.



## The job you want.

Sales • Service • Technical Support • Contracting/Install Recording Studio • Creative Marketing • And More

Call and ask for Kristine Haas or the Career Center today!



## Sweetwater

music technology direct

**800-222-4700**

[www.sweetwater.com](http://www.sweetwater.com)  
careers@sweetwater.com  
5335 Bass Road, Fort Wayne, IN 46808  
(219) 432-8176 • FAX (219) 432-1758

## Equipment Financing

got gear?



Insure it now!



Insuring Professional Audio, Video, Editing, Film, P.A. and Band Gear for over 25 years in Southern California and Nationwide.

Insurance services provided by  
**United Agencies, Inc.**  
**(800) 800-5880**  
CA Lic. #0252636

## EQUIPMENT FINANCING

- FAST, EASY APPROVALS
- We Specialize in Audio-Visual Equipment
- No Financials Necessary
- True Lease or Finance Lease Option
- New or Used Equipment

LOANS BY PHONE

Call Jeff Wenter

**(800)699-FLEX**

24hr. Fax (972) 599-0650



**FLEXLEASE, Inc.**  
COMMERCIAL EQUIPMENT FINANCING

Contact Us at Our Web Address:  
[www.flexlease.com](http://www.flexlease.com)

## A/V EQUIPMENT FINANCING

Specializing in Audio-Video Equipment

Visit Our Web Site For Applications & Qualifications

- No Financials Required
- New & Used Equipment
- Upgrade Existing Leases

**LFCI** [www.lfci.net](http://www.lfci.net)

We Are Direct Lenders

Call: 800 626 LFCI

TAKE A BITE OUT OF STUDIO CRIME

WITH THE MIX ONLINE STOLEN EQUIPMENT REGISTRY

[WWW.MIXONLINE.COM/SER](http://WWW.MIXONLINE.COM/SER)

## Equipment For Sale

VT-2 Vacuum Tube Mic Preamp  
www.dwfearn.com



**D.W. FEARN**

Switch between  
any combination  
of two computers.  
(PC and Mac)

800-545-6900  
www.gefen.com

ex-tend-it  
mini PC/Mac



GEFEN, INC.

SEE OUR AD IN MARKETPLACE pg. 238

SEE OUR AD IN MARKETPLACE pg. 240

## AVALON DESIGN

PURE CLASS A MUSIC RECORDING SYSTEMS

www.avalondesign.com

tel: 949-492-2000 fax: 949-492-4284

email: avalon@avalondesign.com

## HARBOR SOUND

HUGE SELECTION OF  
USED, VINTAGE & NEW GEAR

Consoles, Mics, Recorders,  
Buy & Sell vintage NEVE & API  
modules, Pultecs, tube mics.  
New equipment in stock. Credit  
cards accepted.

Ph: (781) 231-0095

Fax: (781) 231-0295

www.harborsound.com

## SOUTHERN CALIFORNIA PRO AUDIO

NEW, USED AND VINTAGE  
THE LAST CALL YOU'LL HAVE  
TO MAKE!

Phone: (818) 222-4522

Fax: (818) 222-2248

www.socalproaudio.com

**"YOUR SOUND CONNECTION  
SINCE 1973"**

MIXERS • AMPS • SPEAKERS  
EFFECTS • CASES • CABLE • WE FINANCE!  
NEW • USED • DEMOS • B-STOCK

**VISA** The Best Selection of Pro Audio Anywhere! **AMERICAN EXPRESS**

**800-203-5611**

**www.soundpro.com • buy@soundpro.com**

**MasterCard** **DISC 100**

## CLASSIC MICS FROM RUSSIA

### VINTAGE TUBE & FET

Telefunken, NEUMANN  
AKG, LOMO, OKTAVA, etc.  
TEL/FAX: 011-7-095-377-1394  
E-mail: aeg210268@mtu-net.ru

Since 1984 we have had the largest equipment Data Base in the world.

**Ocean  
Audio  
Inc.**

Call (303) 449-8322 Fax (303) 449-8558  
Email: hadlers@mi.net  
http://oceanaudioinc.com

**POPFISS**  
VOCAL EFFECTS

**UPGRADE  
YOUR  
VOCALS**

voice/fax: (800) 252-1503  
or (914) 253-3367  
www.popfisser.com  
e-mail: info@popfisser.com

**Now in Stock!**  
Mixpander, R Ext, Mixtreme  
& Plug-ins  
at Neirk Audio, Inc.

www.neirk-audio.com  
toll-free (800) NEIRK

**Coles 4038  
RCA 44s & 77s**

**(800) 798-9127**

Call Wes Dooley

**THE MIC SHOP**  
TUBE MICROPHONES  
BOUGHT/SOLD/SERVICED  
Mic Power Supplies & Cables  
Bill Bradley: (615) 595-1717  
Fax: (615) 595-1718  
www.micshop.com

**MISTY HILL AUDIO**

**VINTAGE**  
NEUMANN • NEVE • AKG • STUDER  
API • TRIDENT • AMEK • UREI • RCA • SSL • TELEFUNKEN

Buy/Sell - We pay top dollar - FAX us your list  
Worldwide Shipping • Visit our website

**512.338.6777 • http://audio.home.texas.net**

**Professional Audio Design**  
THE SYSTEMS COMPANY

- Exclusive factory authorized U.S. agent for pre-owned Solid State Logic consoles..
- US representatives for Munro Associates studio design and custom monitors.

**QUALITY  
EXPERTISE  
VALUE**

- In-house service, custom wiring design and fabrication and installation services.
- New, used and vintage equipment sales.

Please call us to discuss your facility's requirements.

**Professional Audio Design Inc.** Voice (781) 982-2600 Fax (781) 982-2610

REPRESENTING OVER 100 MANUFACTURERS PLUS HARD TO FIND VINTAGE GEAR  
API, AKG, AVALON, DYNAUDIO, FOCUSRITE, GML, LEXICON, MANLEY LABS, MUNRO CUSTOM MONITORS, NEVE, OTARI, SONY, SSL, T.C. ELECTRONIC, & MORE

www.proaudiodesign.com

SSL-NEUMANN K.G.B. STUDER-NEVE

www.killergearbroker.com

VISA Professional Audio Specialist MC  
phone (818) 904-9400; fax (818) 904-9444; pgr (818) 999-8970  
SPECIALS-jpg photos available

U47 Vintage, VF14 Tube.....	\$7,000
U67 Vintage Tube, original.....	\$3,500
SSL 4064 G/G-Plus, loaded-56/Bik, TR, VU, Ultimition.....	\$190k
Neve VR 60 FF, loaded-60 w/5.1 Surround & Dynamic meters..	\$150k
MCI JH-16 w/24- & 16-Track heads.....	\$5,000
Teletronix LA-2A vintage, original.....	\$3,500
Neumann M149, M147, U87ai (New) .....	lowest prices - Call

AMS Avalon Fostex JBL TAD Telefunken United Audio

## Equipment For Sale

**Sweetwater**  
music technology direct

1-800-222-4700  
www.sweetwater.com



PERFECT FOR PRO TOOLS OR ANY DAW

SRM80

- Mix down or dub between any 4 stereo devices
- Monitor the output of any 4 stereo devices
- Switch between 3 speaker sets
- High powered headphone amp

**FURMAN**

visit us on the web @ <http://www.doucets.com>

### NEW AND USED GEAR

- Manley
- Summit
- ADL
- Langevin
- John Hardy
- Daking
- Presonus
- Vintech Audio
- Sytek
- Purple Audio
- R.D.A.M. Monitors
- Acoustics First

**DOUCET'S**  
*Studios*  
and...  
**AUDIO SALES**

toll free 1-888-923-0123

### MARQUETTE AUDIO LABS

New, Used & Vintage Gear - Specializing in Custom Racking



Phone: 510-681-2017 • Fax: 510-681-2017

[www.marquetteaudiolabs.com](http://www.marquetteaudiolabs.com)

SEE OUR AD IN MARKETPLACE pg. 239

### ES-8 Variable Mu Tube Limiter



A Modern Approach to Classic Tube Compression  
Same Compression Profile as the Fairchild Limiter  
Class A Sonically Accurate Signal Path

*Pendulum Audio* (908) 665-9333  
[www.pendulumaudio.com](http://www.pendulumaudio.com)

SEE OUR AD IN MARKETPLACE pg. 237

MCI JH-600 32-ch., 24-bus console w/patchbays & cables; **LEXICON 480L 3.0** w/sampling memory expansion and road case; **TASCAM DA-88**, **TASCAM SY-88** sync card. Call for pricing & details:  
(303) 296-1885  
**Audio Consultant Services, Inc.**

### SoundBroker.com

Bringing buyers & sellers together.

CONSOLES/SPEAKERS/AMPLIFIERS

(310) 333-1960

[sales@SoundBroker.com](mailto:sales@SoundBroker.com)  
[www.SoundBroker.com](http://www.SoundBroker.com)

Open for business  
24 hours

<http://www.mercenary.com>



"this is not a problem"

TEL: (508) 543-0069  
FAX: (508) 543-9670

### GARRISON PRO AUDIO

FOR SALE: NEVE CAPRICORN, MCI JH-24, TASCAM ATR-80, STUDER A827, A820.

Much More!!!

**We Buy & Sell Gear**

(310) 814-7607 [gpa\\_us@yahoo.com](mailto:gpa_us@yahoo.com)  
Visa/MC Accepted

### AtlasProAudio.com

B.L.U.E. Microphones  
Universal Audio  
Teletronix

813.662.5028 **Atlas**

### LOOKING FOR BETTER SOUND?

Component-level upgrades for mixing consoles, tape machines, mics & all outboard gear. Also, high-speed, high-quality mic preamps.

AUDIO UPGRADES

6410 Matilija Ave.  
Van Nuys, CA 91401  
(818) 780-1222  
Fax: (818) 886-4012  
[www.audioupgrades.com](http://www.audioupgrades.com)

ITC Cart Recorders  
Parts & Service  
Now At

### SEQUOIA ELECTRONICS

TEL: (800) 848-4428  
FAX: (408) 363-0957

## The gear you need.

**We've got it.**

Recording • Guitars  
Amplifiers • Pro Audio  
Keyboards • & More

We have everything you need  
for studio and stage!



**Sweetwater**  
music technology direct

800-222-4700

[www.sweetwater.com](http://www.sweetwater.com)  
[sales@sweetwater.com](mailto:sales@sweetwater.com)  
5335 Bass Road, Fort Wayne, IN 46808  
(219) 432-8176 • FAX (219) 432-1758

**BEST PRICES & SELECTION OF  
WORKSTATIONS, DIGITAL  
MIXERS, RECORDERS,  
OUTBOARD GEAR,  
MICROPHONES AND MONITORS.**

Pro Tools MIX/MIX Plus, ToolBox, Plug-ins, Mackie Digital, Manley, TC Electronic, dbx Quantum, Panasonic Digital, Amek, Tube-Tech, Apogee, Dolby, Neumann, MOTU 2408 and 1224, API, Summit, Genelec, Hafler, Lexicon, AKG, Otari, Yamaha Digital, Soundcraft, Tannoy, Roland Digital, Alesis Digital.

- Very Aggressive Pricing
- Experienced & Knowledgeable Sales Staff
- Serving the Recording Industry For Over 20 Years
- Ask About Our Used & Demo Selections

**EAR PROFESSIONAL AUDIO**  
(602) 267-0600

Visit our Website for more  
Product Information  
and Incredible Blowouts at

## ODYSSEY

New, Used & Vintage Pro Recording Equipment  
**AEA-API-BLUE-BRAUNER-DAKING-FEARN  
MANLEY-MARTECH-PRESONUS-QUESTED**  
and more....

800-249-1821

[www.odysseyprosound.com](http://www.odysseyprosound.com)

### VINTECH AUDIO CLASS A MIC PREAMPS MADE WITH



**NEVE™ 1272 COMPONENTS**  
[www.vintech-audio.com](http://www.vintech-audio.com)  
call toll free: 1-877-4-mic-pre

**SINGERS! REMOVE VOCALS**  
**Unlimited Backgrounds™**  
From Standard Tapes, Records, & CDs  
with the Thompson Vocal Eliminator™  
Call for Free Demo Tape.  
Internet <http://itsound.com>  
LT Sound, Dept. WX-1  
7988 LT Parkway  
Lithonia, GA 30058  
24 Hour Demo/Info  
Line (770) 482-2465 • Ext. 8  
Best Vocal Eliminator™, Key Changer, Voice Enhancer!

Every major brand of everything.  
Millions of dollars of musical gear  
in stock. ALTO MUSIC guitars,  
recording, keyboards, amplifiers,  
drums, pro sound, new & used.  
One of the largest selections in  
the country. We ship everywhere!  
(845) 692-6922 • 680 Rt. 211 E.  
Middletown, NY 10940  
[www.Altomusic.com](http://www.Altomusic.com)  
[altomusic@altomusic.com](mailto:altomusic@altomusic.com)

[www.vintageking.com](http://www.vintageking.com)



Buy, Sell, Trade...New and Used...Package Deals  
Ph: (313) 965-0645 Fax: (313) 964-3338

SEE OUR AD IN MARKETPLACE pg. 239

## GREAT EQUIPMENT



212-502-1880  
234 WEST 30TH ST. NYC 10001  
[geraudio@aol.com](mailto:geraudio@aol.com)

**NO FUNNY AFTERTASTE**

# SELLING EQUIPMENT? GET IT SOLD!

It's fast and easy on Digibid!



the professional equipment marketplace

www.digibid.com

## ALAN SMART COMPRESSORS



### C-1, C-2 & Multichannel version

available in the U.S. & exclusively distributed by:  
**Sunset Sound, Hollywood (323) 469-1186**  
www.sunsetsound.com

### Industry-known sound company liquidating gear.

EAW, Crest, racks and stacks with outboard gear, pre-wired & show ready. Serious inquiries only, please. Will fax inventory list upon request.  
**(818) 957-4859**

- Trident English console \$15k, 28-in/24-out, 8 aux sends, full metering, 180 point patchbay.
- Otari Radar Digital 24-Trk hard disk recorder \$9k incl. Exabyte & Travan back-up system
- Ramsa WR-T820 20-in/16-out, \$2,500, full metering. (716) 621-6270.

Information & photos:  
www.dynrec.com/forsales.

## The Marketplace

usedproaudio.com

### Used Pro Audio

AKG 414-EB \$650, 452-EB \$325; Neumann U47-FET \$2k, KM84 \$650; Sennheiser 421 \$150; Sony C-37P \$650; Lexicon 480L; Sony PCM-7030 DAT w/TC; SSL 4000 E 32-ch w/TR \$39,900; Quad Eight Film Console 68-in; Mitsubishi Filmstar w/GML -National Tech-Traders, T-free (888) 256-3650 or (902) 477-6860  
E-mail: linus@techtraders.com  
www.techtraders.com

## VINTAGE NEVE™ 1272 PREAMPS with D.I.



**\$1089 Single w/p.s. \$1859 Two channel**

VINTAGE NEVE™ 3415 PREAMPS with D.I. (PRE FROM NEVE 1081 EQ)  
**\$849 Single w/p.s. \$1349 Two channel w/p.s.**

CLASSIC MIC PREAMPS MADE FROM VINTAGE API™ COMPONENTS  
**\$1449 Two channel w/p.s. \$549 Plug-in module**

POWERED RACKS FOR VINTAGE API™ PREAMPS AND EQ'S  
**\$569 6-Module portable \$569 6-Module rack mt \$899 11-Module rack mt**

**Brent Averill**  
ENTERPRISES

14300 Hortense Street • Sherman Oaks, CA 91423  
818 784•2046 FAX 818 784•0750  
www.brentaverill.com

## API, Jensen, etc....

2520™ / 990™

Finally, pure Class-A, all discrete direct replacement J-FET op-amps of exceptional musical realism.  
From Millennia Media, Inc.

T 530-647-0750 www.mil-media.com  
info@mil-media.com

EXCLUSIVE FACTORY AUTHORIZED RESELLER

www.UsedSSL.com

PROFESSIONAL AUDIO DESIGN, INC.  
(781) 982-2600

Radial "Winner" Mix Magazine  
www.radialeng.com  
Direct Box  
(604) 942-1001

## masterpieceav.com

blank media  
cd-r recorders  
microphones  
studio gear  
digital audio workstations  
**impeccable customer service**

call aaron & jamey toll free  
(888) 776-2835

## NEUT. TT CABL: \$10.99

New - 24" w/3-yr warranty!  
**SWTCH TT BAY new: \$269**  
**HHB CDR \$30: \$695**  
Includes 50 FREE TaiyoYud.CDR!  
**GREEN DOT (615) 366-5964**  
www.greendotaudio.com

CONSOLES FOR SALE  
SSL 9080 J, 80 Series Neves  
60- & 72-channel Neve VRs  
Flying Faders or GML  
Contact Gary Belz  
House of Blues Studios  
(818) 990-1296

Digital Recording  
Factory Direct Discount Dealer  
\* Alesis \* Yamaha \* Sony \* Tascam \*  
\* Roland \* Akai \* Event Electronics \*  
\* Digital Audio \* Fostex \* Korg \*  
Pro Audio Plus (800) 336-0199  
Division of Rolls Music Center  
www.rollsmusic.com

STUDIO SALE  
NEVE 5116, 36-ch console, dynamics on each module, mint \$35K; Tascam MSR-16 1/2", \$2k; Tons of outboard, Lexicon, Eventide, KT.  
(414) 272-6699.

**Primal Gear**  
www.primalgear.com  
New and Used Vintage Gear  
(615) 248-0007  
Fax: (615) 248-0781

SEE OUR AD IN MARKETPLACE pg. 237

THE CASE SPECIALISTS  
FREE CATALOGUE  
**(800) 346-4638**  
(631) 563-8326, NY  
(631) 563-1390, Fax  
Custom or stock sizes.  
Our prizes can't be beat!  
Discount Distributors

## PATCHBAYS VINTAGE GEAR

we buy-sell-trade, see our list at  
www.audiovillage.org  
**(760) 320-0728**

Boutique Audio & Design  
Neve 1073  
See our ad in Marketplace

SEE OUR AD IN MARKETPLACE pg. 238

## Equipment Rentals

## Pro Tools Rental!

Pro Tools Training!  
Call us now!  
**(301) 607-6607**  
AUDIO DESIGN SOLUTIONS

Add **COLOR** to  
your Classified Ad  
& get Noticed!  
Mix Color Classifieds  
**(800) 544-5530**

## WORLD LINK DIGITAL

RENTALS . Pro Tools . Storage . Dubbers . Vintage



Non Linear Editing Systems  
Digital Storage  
Pro Tools, Audiovision  
Vintage Gear

< 818 > 842-2828

www.WorldLinkDigital.com

## Equipment Wanted

Sales@SoundBroker.com

(310) 333-1960

**SoundBroker.com**

Linking Buyers & Sellers Together

We Buy & Sell For You

**New & Used**

Consoles - Speakers - Amps

Meyer, Crown, Crest, QSC

Satisfaction Guaranteed

Subscription Questions?



Call (800) 532-8190

We want your used **recording**, audio and keyboard equipment. We will airmail you **cash \$\$\$** or take your gear in trade. Over 350 brands of new and used gear in stock. **Absolutely the best prices anywhere!** Come in or do it all through the mail. Over 70 years in business.

Call (800) 264-6614 or e-mail sales@carusomusic.com today for a free appraisal. Fax: (860) 442-0463.

**Caruso Music,**

94 State St., New London, CT 06320 www.carusomusic.com

## Furniture

**ARGOSY**



NEW 90 series console enclosure for SONY DMX-R100

Specialized Studio Furnishings  
www.argosyconsole.com  
catalog: 800-315-0878

**OMNIRAX**  
STUDIO FURNITURE



CODA DB with Sidecars

OMNIRAX 800.332.3393 415.332.3392  
FAX 415.332.2607

www.omnirax.com

**SOUND ANCHOR**  
SPECIALTY AUDIO STANDS  
(321) 724-1237

DESIGNED FOR ULTIMATE PERFORMANCE BEHIND CONSOLE AND FREE SPACE APPLICATIONS.

Standard & Custom Models

SEE OUR AD IN MARKETPLACE



SEE OUR AD IN MARKETPLACE pg. 238

www.rackittm.com

Modular, stackable media furniture holds all formats and equipment  
Free brochure (please mention Mix)

*Per Media Design*  
(800) 821-4883

**Studio Chair**



8" Subwoofer

5 1/4" 3 Way Speakers

The Only Way To Mix Music

www.BattleChair.com  
805-650-9956

## Instruction

**Recording Engineer**  
**Broadcasting**

Multimedia/Digital/Video/Film  
Radio/TV/Sports/News/DJ/Talk Show

No experience required!

**On-the-job-training**

in local major Recording Studios & Radio/TV Stations

Part-time, nights, weekends - Call recorded info line for FREE video

1-800/295-4433 www.radioconnection.com



## Learn the Art of Recording

- Recording Technology
- Recording for TV/Film
- Music Business
- Music Theory
- Small Classes
- Placement Assistance

6305 Ft. O'Connor Blvd, Suite 119  
Irving, Texas 75039

1-972-869-1122  
www.dallassoundlab.com

- Solid State Logic
- Neve
- Yamaha O2R
- Protocols
- Synclavier
- Otari
- Tascam DA88

**MUSIC RECORDING INDUSTRY CERTIFICATE PROGRAM**  
San Francisco State University  
College of Extended Learning.  
Classes taught by Bay Area pros. Expand skills and earn certificate. Engineering, management, song-writing & more! www.cel.sfsu.edu.  
Call (415) 405-7700

**BE A RECORDING ENGINEER**  
★ **TRAIN AT HOME**  
Easy Home-Study practical training in Multi-track Recording. Join our successful working graduates or build your own studio. Career guidance... Diploma... Licensed.  
**FREE INFORMATION:**  
Audio Institute of America  
814 46th Ave, Suite F, San Francisco, CA 94121  
Or visit us at www.audioinstitute.com



**Audio Recording Technology Institute**

- Extensive Hands-On Training •
- Analog and Digital Workstations •
- Music, SFX Design, Audio Post •
- Low Student/Teacher Ratio •
- Placement Assistance •
- Financing to Qualified Applicants •
- Accredited by ACCSCT •
- Located in Beautiful Orlando, Florida •

888-543-ARTI • audiocareer.com

## Mix Marketplace Mix Classifieds

For Rates and Deadlines  
Call Kevin Blackford

(800) 544-5530

FAX (510) 653-8171

e-mail:

mixclass@intertec.com

## Maintenance Services & Repairs

**AMPEX ATR PARTS**

All common replacements in stock!  
Key parts made by ATR Service  
Flux Magnetics heads • 1/2-inch conversions • Precision motor rebuilding

(717) 852-7700

**ATR SERVICE COMPANY**  
AMPEX SPECIALISTS  
www.ATRservice.com

SEE OUR AD IN MARKETPLACE pg. 235

**PRO DIGITAL INC.**  
www.PRODIGITALINC.COM  
DAT/ MULTITRACK DIGITAL REPAIRS  
OVER 13,000 DATs SERVICED  
ALL BRANDS AND MODELS  
FAST SERVICE  
(610) 353-2400

**ANALOG HEADS**



- Head Relapping
- Replacement Heads
- Precision Alignments
- 1/2" 2-Track Conversions
- Custom Heads and Assemblies

Unsurpassed service for over 19 years!

**JRF**  
MAGNETIC SCIENCES

973-579-5773 fax 973-579-6021

e-mail jrf@jrfmagnetics.com  
www.jrfmagnetics.com

Midwest Digital Services Inc.  
DAT and DA-88 Repair  
(Chicagoland Area)  
Professional DAT Service since 1985.  
Authorized by Sony,  
Panasonic, Tascam & Fostex  
(888) 809-3309  
Ph: (708) 448-7539  
www.midwestdigitalservices.com

**DATs FIXED FAST!**

Expert solutions for all DAT recorder problems

- All makes and models
- Experienced, factory-trained techs
- Fast turnaround
- Repairs, overhauls, parts
- "The DAT doctor is in!"

**NXT GENERATION**

973-579-4849 FAX 973-579-7571



## Maintenance Services & Repairs

HEAD RELAP/REPLACEMENT  
multitrack analog specialists

**iem**

Palatine, IL  
(800) 227-4323  
www.iemmag.com

SPEAKER RECONING  
REPLACEMENT DIAPHRAGMS

ACCUTRACK RECORDING  
AND SOUND INC.  
WWW.ACCUTRACKRECORDING.COM  
(847) 465-8862

## Recording Services

**THE GATE** **THE GATE MEDIA GROUP**

CD, CD-ROM, DVD and Vinyl replication  
Audio & DVD Mastering & Authoring  
Graphic Design proofing on the Internet  
Retail-Ready & Specialty Packaging  
Posters, Stickers & Promotional Material  
Promotion and Internet development

CHECK OUT OUR SPECIAL'S ON-LINE AT:  
**WWW.GATEMUSIC.COM**  
OR CALL US TOLL FREE AT: 800-655-1623

GRAPHIC DESIGN SERVICES & FILM INCLUDED IN ALL RETAIL PACKAGES!

1000 CD'S RETAIL-READY \$1495.00	500 CD'S RETAIL-READY \$1295.00	COMBO GATE \$2295.00
500 130 GRAM VINYL \$1495.00	1000 FULL COLOR POSTERS \$425.00 w/cd package	2000 POST CARDS \$225.00

WE WILL BEAT ANY PRICE!

Better CD/Tape Duplication!  
Premium CDs: As low as \$5.54 ea.

Creative Sound



(800) 323-PACK  
www.csoundcorp.com

**The Digital Sunspot Inc**  
Affordable Professional  
**CD MASTERING**  
1-888-985-3333  
www.digitalsunspot.com

### CD - R DUPLICATION

50+	2.49	300+	1.89
100+	1.99	500+	1.75
200+	1.94	1000+	1.69

Price Includes: CD - R, Duplication, Thermal  
Imprinting, Jewel Box,  
& Shrinkwrapped



(936) 756-6861

small ad...big savings  
cd...cassettes...graphics  
(800) 801-SONG

www accuratemediaservices.com

## Records Tapes CD Services

AMERICA'S BEST CD PACKAGE **HANDS DOWN**

**1000 CDs Only \$1399 Includes:**

- full color inserts • design • film • reference CD • glass master
- 2 color on disk • shrink wrapped • priority proofs
- manufactured at a Major Manufacturing plant for the  
*Very Best Quality • Fast Turnaround • Free Overruns!!*

100 cassettes  
With Inserts  
**\$199**

**ELECTRIC**  
*Disc*

100 CDs Only \$379

includes full color inserts,  
full color on disc, design, shrink wrapped  
Retail Ready!

800-367-1084

www.electricdisc.com



Best Price... Best Service... Period.

## CD REPLICATION

Retail-Ready Packages or Bulk

- Graphics Studio - complete custom design & film output!
- On-Demand Printing - stunning color, fast delivery!
- Audio Mastering Studio - BB charted records every week!
- Vinyl Records - Direct Metal Mastering - simply the best!
- Cassette Duplication - Lyrec w/ HX-Pro!
- Digital Business Cards & Shaped Disks - now available!

Work directly with the factory and save - U.S. MOST COMPLETE FACILITY

(800) 455-8555  
(718) 407-7300

www.europadisk.com  
Major Credit Cards Accepted

**EUROPADISK, LLC**

www.gvrjr.com

Good Vibrations-RJR Digital  
800-828-6537

"Simply the best prices and  
service for CD Replication,  
Duplication and Design!"

SINCE 1976

**1000 Bulk  
CDs \$620!**

**III MEDIA**

1.888.891.9091

SEE OUR AD IN MARKETPLACE pg. 238

Check Out Mix Online  
www.mixonline.com

### 46 PRODUCTIONS

25 CD-Rs - \$80.00  
50 CD-Rs - \$140.00  
100 CD-Rs - \$200.00  
200 CD-Rs - \$340.00

### FREE CD-Rs WITH EVERY ORDER

From CD or CD-R master. Includes CD-R in jewel box  
with text printing on CD label. Add \$19 for other digi-  
tal master, \$33 for analog master. Orders must be  
pre-paid. Shipping not included.

42 W. 557 Hawk Circle  
St. Charles, IL 60175  
Phone: (800) 850-5423  
E-mail: info@46p.com

Visit our Web page at http://www.46p.com

## EARTH DISC

YOUR NEXT  
REPLICATION OF  
500 CDS COULD BE  
**FREE**  
800-876-5950  
www.earthdisc.com

SEE OUR AD IN MARKETPLACE pg. 238

## THE WAREHOUSE

Studio Sales & Services  
• CD & Cassette Albums  
CDRs • DATs • ADATs • Rt&R  
• Blank Cassettes  
Call, Fax or Email for

FREE

Catalog

• Overnight CDRs & Graphics

800-483-8273

www.warehouse-studio.com

Email: info@warehouse-studio.com  
2071-20 Emerson St., Jacksonville, FL 32207  
904-399-0424 fax: 904-398-9683

## RECORDING & DUPLICATING SUPPLIES



ARCAL® TDK BASF SONY  
QUANTEGY MAXELL

Cassettes • Reel-to-Reel Tapes  
C-O's • Cassette Albums • Labels  
R-Dat's • CDR's • Video Tapes  
Data Storage Media

### ARCAL CORP.

2732 Bay Rd., Redwood City, CA 94063  
TOLL FREE 1-800-272-2591  
FAX (650) 369-7446

Visit our web site: http://www.arcal.com

## Records Tapes CD Services

**1000 CD's** only **\$599**  
BULK • MIX Magazine Special

**100 CD's** **FULL COLOR**  
**Retail-Ready**

COMPLETE PACKAGE INCLUDES:  
FULL COLOR insert & traycard,  
direct-on-disc printing,  
jewelcase & shrinkwrap

**\$369**

**1-800-365-8273**

59¢ CD'S?!  
THEM BOYS  
IS CRAZY!!



- Let us "ENHANCE" your CD by adding VIDEO!
- Audio/Video Tape Duplication
- Mastering/Digital Editing
- Design, Printing, & Packaging

FREE COLOR CATALOG!

Serving the World since 1985  
**EASTCO PRO MEDIA**  
CORPORATION

SPECTRUM'S

# FastTrack

Full Color CDs...  
From your CD or DAT master

AUDIO CDs  
CD ROMS  
AUDIO TAPES

100 CD's  
Full Color  
only \$595  
complete

Mix Special GET 25 FREE  
CD'S W/EVERY  
100 ORDERED

INCLUDES:

- Full color one side front insert card
- Matching color tray card with color photo
- Fast Track layout and design
- One color black print on disc
- Jewel case and wrap



**Spectrum**  
**1.800.334.9328**

Fast Track  
Digital Chrome Cassettes  
**100 \$445** GET 25 FREE  
W/EVERY 100  
ORDERED

# CDs on time or FREE!

call for details



**MUSIC  
MANUFACTURING  
SERVICES**

We stake our reputation on it.

**1-800-MMS-4CDS**  
**mmsdirect.com**

We're the MMS in **MMSdirect**.  
Since 1988

"A huge part of our success is due to our classified ads in Mix and EM Marketplace and Classifieds! We've been advertising for years and it just keeps getting better! Mix and EM are vital to consistently promoting our competitive services!"

Jim Cocke  
Crystal Clear Disc & Tape  
Dallas, TX

## Musicians-Bands-Studios

### HIGH BIAS BULK/BLANK AUDIO CASSETTES

**BASF maxell** **TDK**

C-10..... 18 / ea. PERFECT  
C-20..... 22 / ea. DEMO  
C-30..... 28 / ea. LENGTHS

CHROME Cr02 C-94..... .50 / ea.

Clear Noreico Box/Round Edge .12 / ea.

All Lengths Available From 1 to 126 minutes

**DAT** Quantegy, Maxell  
DIGITAL AUDIO TAPE **BASF or Sony**

124 94 64 48 34 15  
\$5.40 \$4.75 \$4.20 \$4.00 \$3.60 \$3.10

All Formats and Brands Available.

Please Contact our Sales Department For the Lowest Prices!!!

COMPACT  
Recordable

### CDR'S

**TDK OR MITSUI** BLANK FACE WITH JEWEL BOX

10-99..... .95 100-499..... .90 500+..... .85

**BULK / SPINDLES**

Princo..... .55 / ea. Mitsui..... .80 / ea.  
Generic..... .50 / ea. TDK..... .80 / ea.  
Taiyo Yuden..... .70 / ea.

**Volume Discounts**

CD Jewel Boxes With Trays .15 / ea.



### 2" ANALOG

QUANTEGY 499..... \$138  
QUANTEGY GP9..... \$142  
BASF SM-900..... \$140

WE WILL MATCH ANY ADVERTISED  
OR CATALOG PRICE!

**adat** QUANTEGY \$8.50  
BASF \$8.50  
SONY \$8.50  
HHB \$7.00

Master  
Distributors  
of:



QUANTEGY  
**maxell**  
PROFESSIONAL



**BASF**  
**SONY**  
Taiyo Yuden



MICHELEX  
MILLEX



**SKC**



**PRINCO**

**TELEX**

MAJOR LABEL QUALITY!  
**2,000 CD'S**  
**\$1100!**

WE SPECIALIZE IN RUSH ORDERS!

**1-888-691-3150**

**NOVA MUSIC**

THE MUSIC INDUSTRY RESOURCE CENTER  
**www.novamusic.com**

Mix Classifieds (800) 544-5530  
**mixclass@intertec.com**

**Recording Supplies**

**UNIVERSAL**  
Unbeatable  
Prices!

**877-778-7987**  
**www.universaltapes.com**

SEE OUR AD IN MARKETPLACE pg. 207

764 5th Avenue,  
Brooklyn, New York 11232  
In NY: (718) 369-8273  
24 Hour Fax: (718) 369-8275

**NRS**  
National Recording Supplies Inc

CONTACT US FOR A FREE  
FULL LINE RECORDING  
SUPPLIES CATALOG

http://www.TAPES.com · e-mail: sales@NRSTAPES.com

**TOLL FREE 1-800-538-2336** (Outside NY Only)

## State of the Art CDs and Cassettes in 2 – 3 Weeks!

1,000 Packaged CDs - \$975.00 / 1,000 Packaged Cassettes - \$699.00

Take advantage of our superior product & customer services!

• Awesome Graphic Design • Full Color Proofs & Printing • No Hidden Fees  
• Digital Mastering • Film / Color Separations • FedEx Correspondence

OUR QUALITY AND PRICES CAN'T BE BEAT!

TOLL FREE 1-877-456-9385



Serving you since 1987

CD CD ROM DIGITAL CASSETTE  
**888.655.2272**  
digital duplication solutions

www.tapeanddisc.com sziegler@tapeanddisc.com

## Lyric CD Studios Small Run Duplication

- 10 CD's \$49
- 25 CD's \$99
- 50 CD's \$150
- 100 CD's \$250

-over 100 call for pricing  
INCLUDES CD's from CD/CDR  
Master, Text Design, Text Printed  
on white or silver CD.

### NO UGLY LABELS

Jewel Case and Insertion.  
Add \$35 for transfer from  
DAT/analog masters or cassette.  
Dep. Req'd./Shipping not incl.

Full Color/B&W Graphic CD's Avail.  
FULL DESIGN SERVICES

MENTION MIX GET FREE SET-UP  
\$25+ SAVINGS

1-800-77-LYRIC  
www.lyricstudios.com

## Check Out MIX Online

http://www.mixonline.com

## Got Fat Sound?

AnalogMastering.com  
(800) 884-2576

**Do you offer  
duplication services?**

**Do you offer  
mastering services?**

Then let Mix readers  
know by placing a  
classified ad!  
Face it.  
Your ad should be here.

Mix Classifieds  
(800) 544-5530

# SINGLE-SPEED GLASS CUTTING NOW AVAILABLE FOR OASIS® CD CLIENTS

CAN YOUR REPLICATION COMPANY  
CUT YOUR GLASS MASTER AT SINGLE SPEED?

Yet another unique offering from Oasis CD Duplication,  
the most unusual replication company in the world.

We also offer our clients:

- Complete CD packages
- Patent-pending eco-packaging alternatives  
including the Oasis Jewel-Free™ Box.
- Free radio promotion
- Free national distribution via CDnow,  
amazon.com, & more



**!OASIS!**  
CD & CASSETTE  
DUPLICATION

Call now for free information and samples of our products.  
888/296-2747 • info@oasisCD.com • www.oasisCD.com

Our CD & Cass's are  
**BETTER & CHEAPER!**  
(800) 421-8273  
Progressive Music

SEE OUR AD IN MARKETPLACE pg. 235

## FREE DESIGN

RETAIL READY CDs  
IN-HOUSE GRAPHIC DESIGN  
using your files / images / photos  
MAJOR LABEL QUALITY

ONE PRICE ALL INCLUDED  
1000 @ \$1250 ~ 500 @ \$925  
DESIGN & DUPLICATION SINCE 1983  
dbsduplication.com  
OEAL DIRECT • 888-565-8882

## IT'S YOUR BABY AND WE DELIVER

CD & Cassette Packages  
(See ad in Marketplace)

**800-DIGIDOC**  
www.digidocpro.com

SEE OUR AD IN MARKETPLACE pg. 237

Next time you call a classified advertiser,  
let them know you saw their ad in Mix!

EST 1967 "IF IT'S RECORDABLE WE HAVE IT" EST 1967

**ANDOL**  
1-800-221-6578

SONY BASF TDK QUANTEQ

maxell MediaFORM  
FOR EASY SECURE ORDERING  
CHECK US OUT ON THE  
WEB www.andol.com

**12X SILVER CDR'S**  
100-----@ .64  
500-----@ .58  
1000-----@ .53

CUSTOM LENGTHS AVAILABLE  
FROM 1 MIN TO 126 MIN

LENGTH	TDK SA PRO	MAXELL XLI
C-10	.22	.21
C-20	.28	.26
C-30	.33	.31
C-60	.47	.45
C-74	.53	.50
C-90	.61	.58

Vinyl Pressing Special Radio & Promo Packages

- \*12" Vinyl Pressing
- \*Dub Plates
- \*Compact Discs
- \*Cassettes

**A+R** Est. 1969  
Record & Tape Manufacturing  
Call Today 1-800-527-3472 (Outside TX)  
(214) 741-2027  
www.arrecordsmfg.com  
902 N. Industrial Blvd Dallas, TX 75207

experience  
the difference

500

CDs for every budget!

Retail Ready CD Package \$999  
with color insert

Includes "film separations"

Need 1000 CDs? Just add \$499

1.800.835.1362

www.healeydisc.com

**Healey**  
disc manufacturing

## Records Tapes CD Services

**Click Productions** can finance your next CD duplication project for as little as \$59.00 a month! Call 1.888.738.2573 for your info now!

**1000 CD duplications - \$1199.00**  
includes one color on disc, 4/1 insert, 4/0 tray, jewel case, poly wrap, FREE barcode!  
You supply artwork on Click's Templates  
www.eclickpro.com

**500 Bulk CD Duplications - \$625.00**  
includes one color on disc, jewel case

**www.eclickpro.com**

## Lovingly Handcrafted CDs at Factory Direct Prices.

We own the factory. (And the Elves aren't unionized.)

**CD SOURCE.NET**

www.cdsource.net

toll free 1-877-CD PRESS

**CD duplication**  
Guaranteed | Reliable | Highest Quality!

**.59** each! Bulk CDs  
**1000 for \$590**

**100 CD**  
Retail Ready  
Promo Package **\$379**

Call Toll Free 888-673-2615  
877 591.6000  
www.newenglandcd.com

New England  
Compact Disc  
A Division of New England Digital Media, Inc.

**In the Studio?**

**FREE Guide**  
Saves You Time & Money!

Contact Us Today!  
**1-800-468-9353**  
www.discmakers.com/mix  
info@discmakers.com

**DISC MAKERS**

**CD PACKAGES**

300 - 585.00  
500 - 625.00  
1000 - 999.00

CALL RIGHT NOW FOR A BOTTOM LINE QUOTATION!

**BASE Multimedia Inc.**

USA **800-579-7010** CANADA

CDs • CD ROM • CO-R • SHAPED CDs • AUDIO CASSETTES

**CRYSTALCLEAR**  
DISC & TAPE

**1-800-880-0073** www.crystalclearcds.com

DIGITAL MASTERING • ART DESIGN • PRINTING • PACKAGING

**HARVEST**  
Music Productions

Expert mastering & Graphics  
Short runs & Custom orders  
Great prices on cardboard sleeves & packaging

1,000 CDs  
\$1395.00  
Includes 4-panel book, CD label & packaging

**1-888-626-2250**  
All major credit cards accepted

**500 CDs and Jewel Boxes for \$650<sup>00</sup>**

**800-859-8401**

Great prices on complete packages w/ printing, graphic design & mastering  
www.go-QCA.com

**MWORKS**

617 577-0089

**MASTERING STUDIOS**

sonic solutions • restoration  
sony PCM 1630 • HDCD  
CD replication and one offs

Cambridge, MA

**Lowest Price Period!**

- CD CD Rom DVD cassette & video manufacturing
- Graphic design & print production
- Customized packaging solutions
- Low run capability

**1-888-256-DISC** ballmedia.com

- Compact Discs
- Mastering
- Graphic design
- Free over runs
- 24 hr online tracking

**1000 CD's \$599**

**SOLID!**

www.xtcdisc.com  
Call Toll Free **1-866 XTC DISC**

**TMM Disc Manufacturing**

Highest Quality!  
Best Price!  
Best Service!

**Better! Period! CALL TODAY!**

www.tmdiscman.com **1-800-324-8568**

Mix Classifieds (800) 544-5530

## Stand out in a crowd.



**Advertise in Mix Marketplace**

For rates and deadlines call Kevin Blackford, Sales Associate (800) 544-5530  
email:mixclass@intertec.com

## Records Tapes CD Services

### CD, CASSETTE, CDR and CD-ROM Complete Packages!



**DDAI**  
DIGITAL DYNAMICS AUDIO INC.  
800-444-DDAI  
www.444ddai.com

- CD/CASS MASTERING
- CD/CASS REPLICATION
- CEDAR RESTORATION
- GRAPHIC DESIGN
- FILMS AND PRINTING
- CD-ROM AUTHORING

888-DISC-MFG

**1000 CDs \$0.62<sup>ea.</sup>**

compact discs  
cassettes  
posters  
postcards  
cd-r media

**TGS** www.tgsdisc.com  
Get an online quote or a free catalog!

TO SUBSCRIBE TO MIX CALL:  
**(800) 532-8190**

CHECK OUT  
**MIXONLINE.COM**

## Studios

**Recording Studio For Sale**  
Miami, fully equipped. One of the three best tracking rooms in Miami, large recording room 43x25-foot, control room. Offered @ \$365k; price incl. bldg., land & all recording equip. Call Miami Beach Real Estate Co. (305) 535-1122

**RECORDING STUDIO W/COUNTRY HOME FOR SALE**  
Eugene, Oregon. Rock-solid, acoustically excellent, artistic, creative, turnkey 24-track studio & separate four bedroom home in picturesque setting. Price & photos at www.brightway.org. brightway@earthlink.net (541) 686-3114

SEND YOUR CLASSIFIED AD BY E-MAIL:  
**MIXCLASS@INTERTEC.COM**

## Miscellaneous

**DI-GI-ROM** Full Services For Electronic Media

**CD-ROM • DVD • AUDIO CD**

**MASTERING REPLICATION PRINTING**

- CD-ROM One-Offs: Same Day - On Site • 2000 CD-R Duplication: Next Day - On Site
- Video Compression: BetaSP & VHS to AVI, Quicktime, MPEG1 & MPEG2 - On-Site
- Audio & DVD Mastering Suites: On-Site • DVD-R Disc Duplication: On Site

Audio Archival Restoration with **CEDAR** • **Personalized Service: Outta Sight!**

**800-815-3444**

In New York City: 212-730-2111 On the web: www.digirom.com

## MIX CLASSIFIEDS WORK FOR YOU

**Text rate:** \$120 (minimum) per inch; eight (8) lines per inch (approx. 27-32 lower case character spaces per line).

**Enhancements:** \$50 per inch for 4-color; \$25 for 1-color screen (CMYK only); \$10 per bold line; \$10 for a black border; \$25 for reverse type (white on black background).

**Display rate:** \$156 per inch; 1-inch minimum / half-page maximum. Classifieds display must be camera-ready, sized to MIX column widths and art specs. Frequency discount rates available.

**Deadlines:** Fifteenth of each month, six weeks prior to the cover date (e.g.: April issue closes February 15). Ads received after closing will be held for the next month unless otherwise stated. Cancellations will not be accepted after the closing date. Please submit copy changes and cancellations in writing.

**Other requirements:** Payment must be included with copy: check, Visa, MasterCard or American Express accepted. Sorry, no billing or credit available. Full street address (PO boxes aren't sufficient) and phone numbers must accompany all requests. All words to be bold should be underlined. Copy must be typed or printed legibly in standard upper/lower case. Publishers are not responsible for errors due to poor copy. Arrangement of characters may be altered in typesetting process due to space. The publishers are not liable for the contents of advertisements. The small print: No stated or implied discounts allowed on new equipment sales. Publishers reserve the right to refuse or discontinue any ad deemed inappropriate.

Direct all correspondence to: **MIX CLASSIFIEDS 6400 Hollis Street, Suite 12, Emeryville, CA 94608**  
Tel. (800) 544-5530 or (510) 653-3307; fax (510) 653-8171 E-mail: mixclass@intertec.com

### CATEGORIES AVAILABLE (check one):

- |  |   |
|--|---|
| <input type="checkbox"/> Acoustic Products               | <input type="checkbox"/> Maintenance Services & Repairs |
| <input type="checkbox"/> Business Opps. & Consulting     | <input type="checkbox"/> Music/Software                 |
| <input type="checkbox"/> Computer Products               | <input type="checkbox"/> Music Production               |
| <input type="checkbox"/> Employment                      | <input type="checkbox"/> Publications/Books             |
| <input type="checkbox"/> Equipment Financing & Insurance | <input type="checkbox"/> Recording Services             |
| <input type="checkbox"/> Equipment for Sale              | <input type="checkbox"/> Records, Tapes & CD Services   |
| <input type="checkbox"/> Equipment Rentals               | <input type="checkbox"/> Studios                        |
| <input type="checkbox"/> Equipment Wanted                | <input type="checkbox"/> Video Equipment                |
| <input type="checkbox"/> Furniture                       | <input type="checkbox"/> Miscellaneous                  |
| <input type="checkbox"/> Instruction                     |   |

Attach Your Classified Ad Copy on a Separate Sheet, Typed Double-Spaced or Printed Clearly in Capital and Lower-Case Letters.

Company Name \_\_\_\_\_  
Name \_\_\_\_\_  
Address (no PO Boxes) \_\_\_\_\_  
City \_\_\_\_\_  
State \_\_\_\_\_ Zip \_\_\_\_\_  
Phone ( ) \_\_\_\_\_  
Signature \_\_\_\_\_

Display (\$156 per inch) \$ \_\_\_\_\_  
Text (\$120 per inch, one-inch minimum) \$ \_\_\_\_\_  
Bold @ \$10 per line \$ \_\_\_\_\_  
Border @ \$10 \$ \_\_\_\_\_  
Reverse @ \$25 \$ \_\_\_\_\_  
Screen @ \$25 \$ \_\_\_\_\_  
Blind PO box @ \$25 \$ \_\_\_\_\_

TOTAL PAYMENT INCLUDED \$ \_\_\_\_\_

Visa  MC  AMEX  Discover

Check/Money Order # \_\_\_\_\_  
Card # \_\_\_\_\_  
Exp. \_\_\_\_\_

**COMING IN MIX  
JUNE 2001**

**"CLASS OF 2001"  
STUDIO PHOTO  
SPECTACULAR**

**APPLICATIONS  
& TECHNIQUES**

**Networking Your Facility**

**LIVE MIX**

**Room Tuning**

**EQUIPMENT  
SPOTLIGHT**

**Acoustic Materials**

**TOUR PROFILES**

**U2**

**Matchbox Twenty**

**PLUS!**

**The Dave Matthews Band,  
Summer Blockbusters,  
The Mix Interview  
with Chris Pelonis**

**ATTENTION  
ADVERTISERS:**

**CALL (510) 653-3307 FOR  
A 2001 MIX EDITORIAL  
CALENDAR, SPACE  
RESERVATIONS AND  
COMPLETE ADVERTISING  
INFORMATION.**

**MIX**

Visit Mix Online at  
[www.mixonline.com](http://www.mixonline.com)  
a DigitalMediaClick Community

## INSIDER AUDIO

—FROM PAGE 22, NAMM BITS

being shown in a prototype of a configurable music and/or mixing controller, called Surface 1 at the MIDIMan booth around the corner. Tactex also says that its fabric will show up as a left-hand controller on a new analog synthesizer that will soon be introduced by Moog. Max, which was formerly marketed by Opcode, was thankfully spun off before that company's demise to Cycling '74, which is owned by David Zicarelli, one of the authors of the software; his booth was right across the aisle.

Besides weird musical instruments, there were a number of other somewhat obscure but very exciting technological developments unveiled at NAMM that bear reporting. The smallest booth with the biggest crowd belonged to Celemony Software ([www.celemony.com](http://www.celemony.com)), a tiny three-month-old German company that was demoing an early-in-development voice-processing program called "Melodyne." It looks very simple: You record a vocal (or solo instrumental) line into it and it shows up graphically on the screen, with vertical position as pitch, vertical width as volume and horizontal length as duration. So far, no big deal. But then the bearded gentleman doing the demo would grab a note and move it to another pitch, grab another note and change its duration and reverse the order of two other notes, and you'd swear the soprano re-recorded her solo with different sheet music—the algorithm they're using, whatever it is, is that good. For four days, the duo manning the booth played the same demo over and over, but the reaction they got was always, undoubtedly gratifying, the same: jaws dropped. It will be interesting to see how this evolves and what it will look like when it comes to market—not to mention how well it works on other program material.

On the other hand, the biggest company with the smallest booth was Apple Computer. They were in a little room with no chairs upstairs from the show floor, which you had to be told how to find ("turn right at the Pepsi machine") or else you'd never make it. There, industry veteran Kord Taylor, now the company's music and audio market manager, was demonstrating a G4 hooked up to one of Yamaha's new mLAN8P audio/MIDI interfaces for IEEE-1394, also known as FireWire. The two companies have agreed to cooperate in implementing Yamaha's mLAN "media layer" extension to the

Apple-invented 1394 standard, which could be a significant development for our industry: Hopefully, it means a much smoother path for implementation of FireWire—which has already had a tremendous impact on the video world—in music, audio and post-production tools.

Finally, one company was highly conspicuous in its absence from NAMM. Sonic Foundry, maker of products like Sound Forge, Acid and Vegas Pro, which have become standards for audio and video types who use Windows, and who, by any reasonable measure, should be considered highly successful, was supposed to be occupying a 600-square-foot booth in an extremely desirable location right by the entrance doors. Instead, there were just a few potted plants and empty chairs.

Three weeks before the show (i.e., the week before Christmas), the company announced it was cutting spending by \$20 million, first by laying off 40% of its staff, and second by canceling its NAMM presence. In fact, according to the company's corporate communications manager, they will not be at *any* trade shows this year and, instead, will be "concentrating on developing new products." No doubt the downturn in high-tech stocks last year had a lot to do with their problems, but still, for a company as well established as Sonic Foundry to have its stock lose 91% of its value in the past year was pretty astonishing. Some observers were saying that the company's costly acquisitions—of a streaming media company and a company that "repurposes content for international development"—were too far away from its core strengths, as well as too much for it financially. Let's hope the company survives this bout with economic distress: We've seen too many innovative music software companies bite the dust thanks to greed, recklessness, over-reaching or just plain stupidity.

Speaking of companies that didn't deserve to die, I've received quite a bit of mail regarding my little diatribe against Gibson's treatment of Opcode, all of it from folks, like me, who are trying to continue to use Opcode's software despite the lack of upgrades and support. Two excellent resources are the Vision Info Site, at [www.fmmusic.com/v/](http://www.fmmusic.com/v/), and a discussion and support group at [www.topica.com/lists/opcode-users](http://www.topica.com/lists/opcode-users). ■

*Paul Lebrman is glad to be back home. Visit his home at [www.paul-lebrman.com](http://www.paul-lebrman.com).*

# MOTU Dream Studio 1

- MOTU 828™** — MOTU's new 18-channel FireWire audio interface connects instantly to any FireWire-equipped laptop or desktop computer with no PCI card required!
- Digital Performer™ 3.0** — MOTU's award-winning audio sequencer has been re-engineered from the ground up, with a completely new look and hundreds of new features, including full surround production up to 10.2.
- MotorMix™** — 8-fader automated control surface for Digital Performer.
- Auto-Tune™ 3.0** — the worldwide standard for real-time pitch correction.

"The perfect portable studio for your laptop!"

## HANDS-ON AUTOMATED WORKSURFACE

With its new, custom software written specially for Digital Performer, MotorMix becomes a seamless, tactile extension of your MOTU recording environment. Put your hands on eight 100mm motorized faders and rotary encoders to tweak your mixes in record time. Gain instant easy

access to all MIDI and audio tracks with control banks. You'll never even think about

mixing with a mouse again. Imagine having tactile control over most of Digital Performer's features with MotorMix's intuitive layout and easy operation. MotorMix gives you all the advantages of a professional mixing board, at an incredibly affordable price. Bring motorized mixing to your MOTU desktop today. For more info, visit [cmlabs.net](http://cmlabs.net) or contact your Sweetwater sales engineer today to enter the future of mixing.



## MotorMix™



## THE 'HOLY GRAIL' OF PERFECT INTONATION

Hailed as a "Holy Grail of recording" by Recording Magazine, Auto-Tune is used daily by thousands of audio professionals around the world. Whether to save studio and editing time, ease the frustration of endless retakes, or save that once-in-a-lifetime performance, Auto-Tune has become the professional pitch correction tool of choice. Now Antares has introduced Auto-Tune 3. Preserving the great sound quality and ease of use of Auto-Tune, Version 3 adds significant new features and a snazzy new look. As a result of Antares research into the unique characteristics of various types of audio signals, Auto-Tune 3 offers a selection of optimized, "Source Specific" processing algorithms for the most common types of pitch-



corrected audio material, resulting in even faster and more accurate pitch detection and correction. Choices include Soprano Voice, Alto/Tenor Voice, Low Male Voice, Instrument, and Bass Instrument. Other key new features include phase-coherent pitch correction of stereo tracks, and Bass Mode, which lets you easily apply pitch correction to fretless bass lines and other low bass range instruments. Auto-Tune 3 also lets you set target pitches in real-time via MIDI from a keyboard or sequencer track. For harmonically complex material, the "Make Scale From MIDI" lets you simply play the line from a MIDI keyboard or sequencer and then Auto-Tune 3 constructs a custom scale containing only those notes! Auto-Tune 3 also now supports high sample rates like 88.2kHz and 96kHz. Get Auto-Tune 3 today!

## Auto-Tune™ 3.0



**ORDER YOURS TODAY 800-222-4700**

**Sweetwater®**  
music technology direct™

**www.sweetwater.com**  
Voice: (219) 422-8176 • Fax: (219) 422-1758 • Email: [sales@sweetwater.com](mailto:sales@sweetwater.com)  
5335 Bass Road • Fort Wayne, IN 46808

CIRCLE #123 ON PRODUCT INFO CARD

©2007 Sweetwater, Inc.

# MOTU Dream Studio 2



- **MOTU 2408mkII™** — 24-channel expandable PCI audio interface
- **Digital Performer™ 3.0** — award-winning workstation software with MIDI sequencing
- **SAC-2K™** — expandable, touch-sensitive, 8-fader automated control surface for Digital Performer
- **DigiMax™** — 8-channel mic pre-amplifier with 24-bit optical connection to the 2408mkII/computer
- **Bias Peak 2.5 VST™** — award-winning waveform editing software

## PRECISION TOUCH-SENSITIVE CONTROL

## SAC-2K™

The Radical Technologies SAC-2K sets a new standard for hands-on control of Digital Performer. The SAC-2K's custom plug-in for Digital Performer gives you easy, one-touch access to every element of the recording process in Digital Performer with responsive, touch-sensitive automated controls. Within minutes, you'll achieve a whole new level of interaction and creativity that you never thought possible. Fader

groups, mix automation, plug-in automation for up to 12 parameters at a time, window sets, transport control with jog/shuttle, I/O routing and assignments, solos, mutes, track-arming... it's all just one touch away. The SAC-2K is your all-access ticket to the world of Digital Performer-based recording, editing, mixing, processing and mastering.



## PRISTINE MIC PRE-AMPLIFICATION

## DigiMax™

Why is the PreSonus DigiMax perfect for your MOTU rig? Because it's the purest path to digital. DigiMax combines 8 channels of

award winning 24-bit mic pre-amplification with our unique simultaneous RMS/peak detection limiting and EQ enhancement, giving you maximum gain before clipping while maintaining the musical

transparency of a compressor. The result? Fast, natural and versatile limiting on every channel. And DigiMax connects all 8 channels optically to your MOTU system in pristine, 24-bit digital glory.



## ADVANCED WAVEFORM EDITING AND MASTERING

## Peak 2.5 VST™

BIAS Peak 2.5 VST is the ultimate editing and mastering companion for Digital Performer! Peak gives you lightning fast, nondestructive waveform editing with support for audio files up to 32 bits and 10 MHz, including 24-bit/96kHz files. Unlimited Undo/Redo with independent edit histories for each audio document gives you the freedom to work creatively. Select an audio region in Digital Performer, choose the "Use External Waveform Editor" command, and instantly

switch into Peak! Peak's sophisticated options for on-the-fly marker, region and loop creation are simply unparalleled. Advanced looping tools include Loop Tuner™, Loop Surfer™, Loop It™ and Guess Tempo™. Process thousands of files—or just a few—using Peak's batch processor. Peak directly supports the 2408mkII and all other MOTU audio interfaces and includes Toast™ CD burning software for making your own redbook audio CDs directly from Peak's powerful playlists. Or create web or multimedia content using Peak's support for Shockwave, RealAudio, MP3 and more.

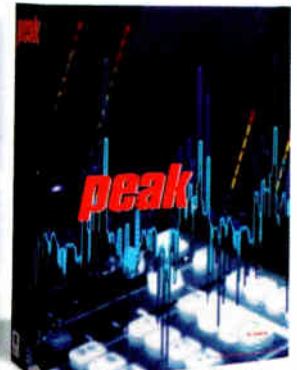

**order yours today**

**Sweetwater**

music technology direct™

World Radio History



"If timing is everything, MOTU is definitely on top.  
This is one tough program to beat."  
—Electronic Musician, January 2001

# MOTU Dream Studio 3



Digital Performer



- **MOTU 1296™** — 12-channel expandable 24-bit / 96kHz PCI audio interface
- **Digital Performer™ 3.0** — award-winning workstation software with MIDI sequencing
- **HUI™** — automated, touch-sensitive control surface for Digital Performer
- **PowerCore™** — DSP accelerator for TC Works MAS plug-ins (and other advanced 3rd-party MAS plug-ins)
- **MAS STOR™** — reliable, high-performance SCSI storage and backup for MOTU Audio System based studios

## FULLY AUTOMATED WORK SURFACE

HUI™

The Human User Interface (HUI) from Mackie is so tightly integrated with Digital Performer, it's like placing your hands on Digital Performer itself. Sculpt your mix with HUI's silky smooth motorized faders. Tweak effects parameters with firm, yet responsive V-Pot rotary encoders. Instantly locate to any position and track in your mix. You can even

call up plug-ins on-screen directly from HUI. Keypad and transport controls let you locate Digital Performer's main counter instantly, just like the familiar keypad on your computer keyboard. HUI is an advanced hardware workstation console, complete with built-in monitoring and the user-friendly ergonomics that Mackie mixers are known for. Boost your productivity through direct hands-on control.

**MACKIE.**



## DSP TURBO™ FOR MAS•POWERCORE PLUG-INS

TC•PowerCore™

TC•PowerCore is a major breakthrough for Digital Performer's real-time MAS plug-in environment because it provides DSP-turbocharged plug-in processing. At last, the renowned TC TOOLS/96 studio-quality FX package (included), with TC MEGAVERB, TC Chorus/DELAY and TC EQ<sup>sat</sup>, can be at your fingertips in Digital Performer, plus other TC I Works plug-ins such as TC MasterX (sold separately). These powerful TC plug-ins

appear in DP's mixing board, just like regular native plug-ins, but they run on four powerful 56K DSP chips on the TC•PowerCore PCI card. It's like adding four G4 processors (equal to 2.8 gigahertz of extra processing power!) to your computer. Run 12 studio-quality TC plug-ins with no hit on your CPU power, and run other native plug-ins at the same time! TC•PowerCore is an open platform, so it will also run plug-ins from other respected 3rd party developers, too (details TBA).

**TC | WORKS**

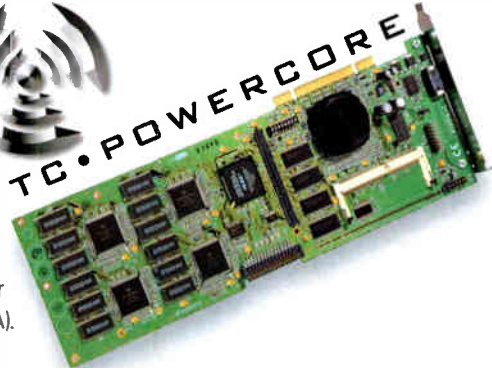

## HIGH PERFORMANCE DRIVES AND BACKUP

MAS STOR™

Glyph Technologies is the undisputed leader in storage solutions for audio. Now Glyph partners with MOTU to bring you the absolute latest in high-performance storage technology: MAS STOR is a two-rack high, two-bay, removable-drive storage solution that provides enough massive throughput to support even the most demanding multitrack recording environments. MAS STOR the ONLY

drive you'll want to use for multitrack 96kHz projects recorded with the MOTU 1296 audio interface. Configure a system that's perfect for you with the following removable drive components: 15,000 RPM 18GB Ultra3 SCSI drive, VXA 33GB backup tape drive and/or a Plextor 12x redbook compliant CD burner, all backed by Glyph's legendary service and support.



[www.sweetwater.com](http://www.sweetwater.com)

Voice: (219) 432-8176 • Fax: (219) 432-1758 • Email: [sales@sweetwater.com](mailto:sales@sweetwater.com)

5335 Bass Road • Fort Wayne, IN 46808

**800-222-4700**

World Radio History

CIRCLE #124 ON PRODUCT INFO CARD

# SONIC FOUNDRY SOUND FORGE

## TIPS FOR AUDIO RESTORATION

Beyond cleaning up old vinyl recordings and forensic audio chores, Sonic Foundry's Sound Forge 2-track editing system (with its DirectX Noise Reduction plug-in) can be used for mastering as well as for day-to-day enhancement of audio files. Here are some techniques I used on the CD re-releases of vinyl recordings, such as Martin Luther King's "I Have a Dream" speech and Freddie Fender's *Live at Gilley's* (where it looked as if someone took a knife to the grooves). I used Sound Forge Version 4.5g and Noise Reduction Version 1.0b, which have since been upgraded to Versions 5.0 and 2.0a, respectively, but these tips will work on any version of the programs.

### TURN THE CLICK AROUND

The Noise Reduction plug-in can remove clicks and pops from old recordings as well as in brand-new ones, such as occasional clicks/pops in digital files. Usually, the Click and Pop (V.1.0b) or Click and Crackle (V.2.0a) removal plug-in handles the problem nicely. But, every once in a while, a click is so stubborn that the preset won't do it successfully. You can adjust the parameters of the software to try and remove that pesky pop or try the Vinyl Restoration algorithm. However, this may cause audible side effects if you use extreme settings.

A Pencil tool is available in Sound Forge, but I shy away from redrawing audio waveforms. Here's another way to handle the click problem: First, define the close region around a click or pop and double-click to highlight it. Go to Sound Forge's Process menu, and use the Reverse function on that region. Apply the Click and Pop/Crackle Removal algorithm. In Version 1.0b, use the Interpolate rather than Replace function. Then, re-reverse the highlighted region. In 99% of the cases, the click is gone, without audible side effects.

### PRINT ME SOME HISS, PLEASE!

The Noise Reduction feature does a good job of getting rid of hiss, but capture a "noise print" of the hiss in a mix before the track starts for an accurate, song-specific sample of the noise you want to remove. When mixing, print some hiss before the song's count off, with all of the effects units on, faders up, etc.—*sans* any automation, mutes and gates.

Capture that noise print where the hiss is steady-state, as described in the manual. Apply a few dB of the Noise Reduction twice, rather than a lot in one shot. The noise reduction will be virtually transparent if used in this manner, with no audible side effects.

Check the Keep Residual Output box during your real-time preview to hear what the program is removing. If it sounds like swirly, dithery zipper noise, then it's probably okay. If you hear any of the program material, then you're overdoing the NR, so back it off. Find what works without side effects and remove that amount of noise. Then try re-applying it a second time, at the same or less amount. On difficult passages, you might try a little bit a third time, if you're daring. When you get it right, you will truly believe that digital audio can perform miracles.

You might want to keep these noise prints on file (in the presets location), so if you get a tape without any hiss before the song starts, you'll have a library of prints to try out, and see if these work better than a default.

### NEED SOME AIR?

The Noise Reduction program has a



Sound Forge offers 2-track editing and mastering features.

nice high-shelving EQ that defaults to +3 dB at 7k Hz. Designed to compensate for overusing the Noise Reduction, it's designed to sound like an air band-type EQ. The corner frequency is adjustable from 500 to 15k Hz, with a  $\pm 20$ dB gain range. Sometimes, a 1 to 2dB boost works nicely, even without any noise reduction, giving you a bonus signal processor you didn't even think you had.

### MP3 ME!

If you're working on material to be used online—data compressed, downloaded or streamed—you can encode the sound file and find out what gets ruined when you convert it. If a tune needs some bottom, a little compression and a bit of top to fix it, then try doing that same processing to the file *before* you convert it. After some experimentation when it's converted this time, it should sound the same as the "fixed" file you tried to restore the first time. Also, try taking a noise print of some hiss from a bit of pre-roll on the converted file and add that to the preconversion processing to remove some of the hiss you're sure to get after it's converted. ■

*Bob Buontempo is a freelance engineer, producer and writer based in the New York City area.*

BY BOB BUONTEMPO

# "REASONS NOT TO BUY A MACKIE D8B...ZERO."

—Roger Nichols, EQ Magazine

PLUS 3 MORE REASONS TO GO FOR IT.

## OS Version 3.0 NOW SHIPPING!

Download direct from [www.mackie.com](http://www.mackie.com)



### 1 FREE UPGRADE! NEW OS 3.0 ADDS OVER 30 NEW FEATURES!

Our Programming Department has been chugging the double lattes to create Mackie Realtime OS™ Version 3.0, packed with more new features and enhancements than you can shake a mouse at. Here's just part of what 3.0 adds to the already amazing D8B.

- **New key (sidechain) inputs** for all 48 onboard dynamic processors featuring soft knee architecture and single band 20-20k parametric EQ for frequency dependent processing such as de-essing
- **3rd-party plug-ins** via our new UFX card. Up to 16 simultaneous plug-ins on the first 48 channels, pre or post DSP, pre-fader via up to 4 UFX cards. Each plug-in is available twice — once when tracking, and again at mixdown!
- **Multiple Undo List** — 999 levels!
- New **Snapshot libraries**.
- Externally or internally accessible **inserts across Mains and Buses** plus **channel inserts pre and post DSP**.
- **Updated GUI** including 48-channel fader bank view screen.
- **Time Offset** (delay) adds a delay of up to 255 samples to the signal at the pre-DSP (dynamics / EQ) point in the signal path.
- **New surround capabilities** including depth-of-center control (LCR mixing with divergence), multiple surround panner window, individual LFE channel level control.
- **Multiple direct outs** per channel.
- **Optional level to tape** fader control.
- **Assignable, bidirectional MIDI control** of all parameters.
- **Cross patching** allows substitution of channels between various banks.

### ANTARES

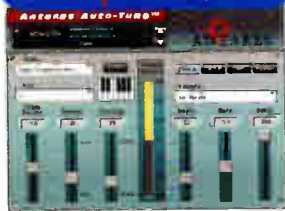

### 2 DSP PLUG-INS!

**Antares' Auto-Tune** for the D8B uses advanced DSP algorithms to detect the incoming pitch of a voice or solo instrument as it's being tracked and instantly pitch-correct it without introducing distortion or artifacts. Fully automatable.

### Massenburg DesignWorks



**Massenburg Parametric EQ.** MDW 2x2 High-Resolution Parametric Equalizer plug-in from Grammy-winning engineer/producer George Massenburg. Mono/stereo EQ at 96kHz sample rate for unprecedented clarity and high frequency smoothness.

### DRAWMER



**Drawmer ADX100** includes their industry standard frequency conscious gating, plus compression, expansion and limiting.

### IVL VocalStudio Technologies



**IVL Technologies' VocalStudio** provides real time vocal doubling, multi-part harmonies and pitch correction in an easy-to-use interface. A free demo is built-into the Digital 8 • Bus. Just add a second MFX card to own this innovative plug-in from a world leader in vocal processing.

### t.c. electronic



### 3 1999 TEC AWARD WINNER!



**TC Electronic Reverb** (bundled with the D8B UFX card) provides Reverb 1 and Reverb 2 algorithms from the renowned TC Electronic M2000 Studio Effects Processor.

The list of top engineers and producers who use the award-winning Mackie Digital 8 • Bus is growing daily. For info on the D8B, new UFX and Optical • 8 cards, 3rd-party plug-ins and how D8B owners can get their free OS upgrade, visit [www.mackie.com](http://www.mackie.com) or call your local D8B dealer.



**MACKIE**  
Digital Systems

DIGITAL MACKIES  
AT OUR FACTORY IN  
WEDDINGVILLE, WA, USA

[www.mackie.com](http://www.mackie.com) • 800/258-6883

Normally we don't name competitors in our ads. But in this case, Mix Magazine published the other nominees for the 1999 TEC Award for Outstanding Technical Achievement in Small Format Consoles: Allen & Heath's GS-3000, Digidesign's ProControl, Panasonic's WR-DA7, Spirit's Digital 328 and Yamaha's O1V. Thanks to all who helped us win this prestigious award.

CIRCLE #125 ON PRODUCT INFO CARD  
World Radio History



A Harman International Company

## The Line Between High Performance And Precision Coverage Just Became A Bit More Indistinguishable.



It comes as no surprise that loudspeaker system requirements for concert audio, AV rentals, televised events and corporate presentations are now merging. Audience expectations... *and yours...* continue to rise.

What may surprise you is a new speaker system that expertly addresses these varied applications.

A system combining precision coverage and maximum output with outstanding audio performance. A system that seamlessly blends light weight, premium sound, setup flexibility and safer rigging in an affordable package.

You've *heard* about other line arrays. Now, *hear* the best. VERTEC™ Series from JBL Professional.



Move to the head of the line

World Radio History

CIRCLE #126 ON PRODUCT INFO CARD

Visit us at [www.jblpro.com](http://www.jblpro.com).