

# EDISON Phonograph Monthly

EXACT REPRODUCTION

By  
Wendell Moore

First Edition  
February 1979

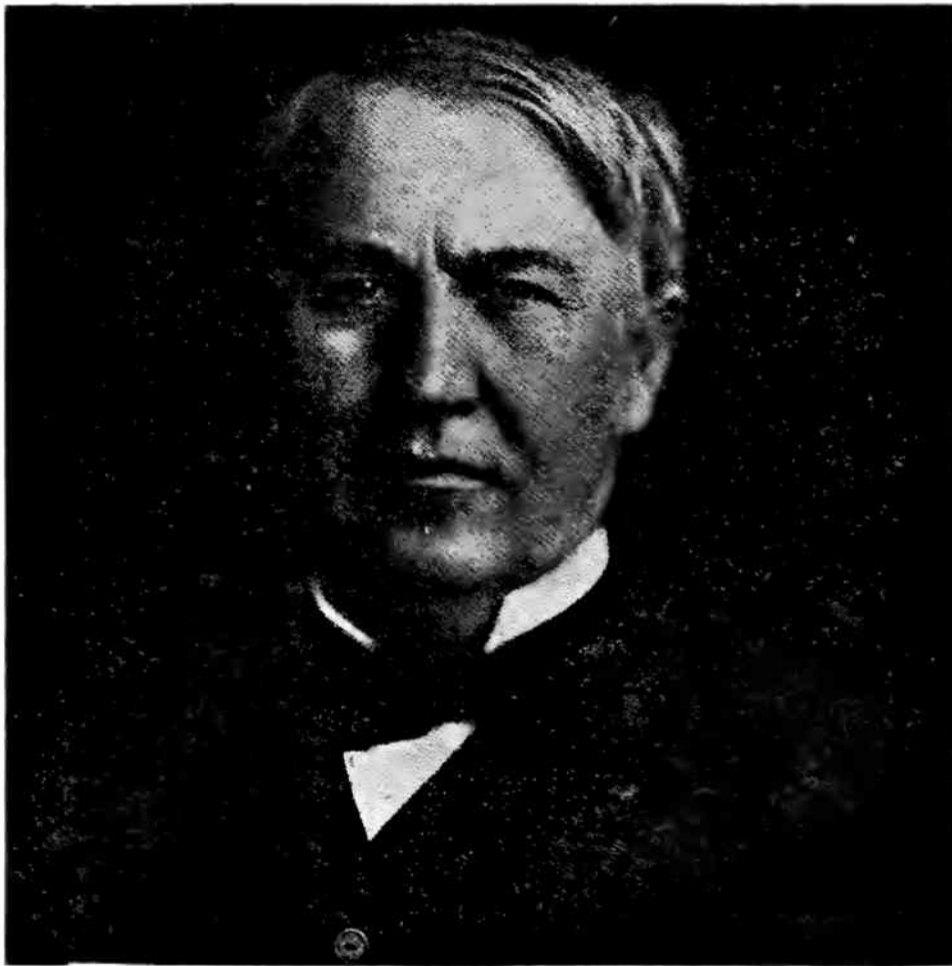

*Thomas A. Edison.*

*Reprinted By  
Pennant Litho, Inc.  
Louisville, Kentucky*

1908 – VOLUME VI, NUMBER 1

BOOK NUMBER 500

*Wendell Moore*

ML155

.59

.E3

Vol. 6, 1908-1909

RSS

*This book is dedicated to M. R. McMillion and the thousands of phonograph collectors who are active in preserving the true Edison phonograph story — historically and mechanically.*

*My thanks also to William R. Rawson and Edward Orbann, of Thomas A. Edison Industries, for their favorable comment in their letter of October 15th, 1965.*

*Wendell Moore*

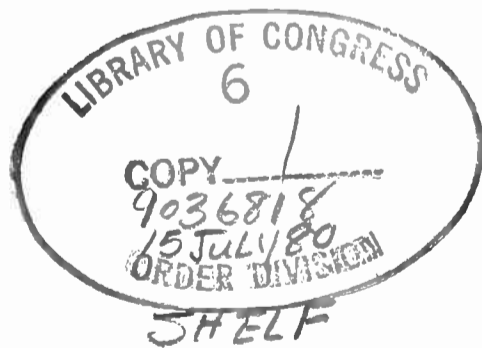

# EDISON PHONO- GRAPH MONTHLY

Vol. VI

January, 1908

No. 1

## CONTENTS

	PAGE		PAGE
Business as We See It.....	1	Last Call for Unsigned Dealers.....	10
Advance List Edison Gold Moulded Records for March, 1908.....	2	Suspended Lists.....	10
About Credits for Returned Records.....	5	Electrotypes Cut from Catalogue.....	11
New Foreign Records.....	5	Our Advertising "Extra".....	11
Copies of E. P. M. Wanted.....	5	New Horn a Decided Selling Advantage....	11
Keep Up Your Stocks.....	6	Printed Matter .....	12
Use of Mr. Edison's Picture and Signature..	6	No Change in Phonogram and Supplement Date .....	12
Special Notice About Mailing Phonograms and Supplements .....	6	Name of Ideal Changed to "Idelia".....	12
Advance List of Seven Selections by Harry Lauder .....	7	Another Injunction Against a Price Cutter..	12
Advance List Grand Opera Records for March, 1908 .....	8	Phonogram Information .....	13
Records by Harry Lauder.....	9	More Phonograph Jingles.....	14
No Let Up of Any Kind.....	10	An Hour of Classical Music.....	15
		Ready Made Ads. ....	16
		Suspended List January 1, 1908.....	18
		Jobbers of Edison Phonographs.....	Cover pp. 2-3

*Published for Trade use only by  
The National Phonograph Co., Orange, N.J.*

# Jobbers of Edison Phonographs and Records

## ALABAMA.

Birmingham—Talking Machine Co., 2007 Second ave.  
Mobile—W. H. Reynolds, 167 Dauphin st.  
Montgomery—R. L. Penick, 119 Dexter ave.

## CALIFORNIA.

Los Angeles—Southern California Music Co., 332 South Broadway.  
Oakland—Kohler & Chase, Inc., 917-921 Wood street.  
Sacramento—A. J. Pommer Co., 9th and J sts.  
San Francisco—P. Bacigalupi & Sons, 1021 Golden Gate ave.

## COLORADO.

Denver—Denver Dry Goods Co., 619 16th st.  
Hext Music Co., 15th and California sts.

## CONNECTICUT.

New Haven—Pardee-Ellenberger Co., Inc., 96 State st.

## DISTRICT OF COLUMBIA.

Washington—E. F. Droop & Sons Co., 925 Pennsylvania ave., N. W.

## GEORGIA.

Atlanta—Atlanta Phonograph Co., 50 Peachtree st.  
Phillips & Crew Co., 37-39 Peachtree st.  
Savannah—Youmans & Leete, 116 Barnard st.  
Waycross—George R. Youmans.

## IDAHO.

Boise—Eiler's Piano House.

## ILLINOIS.

Chicago—Babson Bros., 1419 19th st.  
Lyon & Healy, Wabash ave. & Adams st.  
James I. Lyons, 192 Van Buren st.  
The Vim Co., 68 E. Lake st.  
Montgomery Ward & Co., 111 Michigan avenue.  
Rudolph Wurlitzer Co., 266 Wabash ave.  
Peoria—Peoria Phonograph Co., 416 S. Adams street.  
Quincy—Quincy Phonograph Co., 411 Hampshire st.

## INDIANA.

Indianapolis—Indiana Phono. Co., 45 Virginia avenue.  
Kipp-Link Phonograph Co., 217 N. Illinois street.  
A. B. Wahl & Co., 119 S. Illinois st.

## IOWA.

Des Moines—Hopkins Bros. Co., 620 Locust st.  
The Vim Co., 204 Seventh st.  
Dubuque—Harger & Blish, 904 Main st.  
Fort Dodge—Early Music House, 822 Central avenue.  
Sioux City—Early Music House, 315 Court st.

## KENTUCKY.

Louisville—Montenegro-Riehm Music Co., 527-531 Third ave.

## LOUISIANA.

New Orleans—William Bailey, 600 Frenchmen street.  
National Automatic Fire Alarm Co., 614 Gravier st.

## MAINE.

Bangor—S. L. Crosby Co., 186 Exchange st.  
Portland—W. H. Ross & Son, 43 Exchange st.

## MARYLAND.

Baltimore—E. F. Droop & Sons Co., 231 North Howard st.

## MASSACHUSETTS.

Boston—Boston Cycle & Sundry Co., 43 Hanover st.  
Eastern Talking Mach. Co., 177 Tremont street.  
Iver Johnson Sptg. Goods Co., 163 Washington st.  
Fitchburg—Iver Johnson Sptg. Goods Co., 247 Main st.  
Lowell—Thomas Wardell, 111 Central st.  
New Bedford—Household Furnishing Co., 170 Purchase st.  
Springfield—Flint & Brickett Co., 489 Main st.  
Worcester—Iver Johnson Sptg. Goods Co., 304 Main st.

## MICHIGAN.

Detroit—American Phono. Co., 106 Woodward avenue.  
Grinnell Bros., 219 Woodward ave.

## MINNESOTA.

Minneapolis—Thomas C. Hough, 714 Hennepin avenue.  
Minnesota Phono. Co., 505 Washington av., So.  
St. Paul—W. J. Dyer & Bro., 21-23 West 5th st.  
Thomas C. Hough, 392 Wabasha st.  
Koehler & Hinrichs, 255 E. 3d st.  
Minnesota Phonograph Co., 37 E. 7th st.

## MISSOURI.

Kansas City—J. W. Jenkins' Sons Music Co., 1013-1015 Walnut st.  
J. F. Schmelzer & Sons Arms Co., 710 Main st.  
St. Louis—Conroy Piano Co., 11th and Olive streets.  
Koerber-Brenner Music Co., 1006 Olive street.  
Silverstone Talk. Mach. Co., 1010 Olive st.

## MONTANA.

Helena—Frank Buser, 509 N. Main st.

## NEBRASKA.

Lincoln—Ross P. Curtice Co., 1125 O st.  
H. E. Sidles Phono. Co., 13th and P sts.  
Omaha—Nebraska Cycle Co., 15th and Harney streets.  
Shultz Bros., 16th and Chicago sts.

## NEW HAMPSHIRE.

Manchester—John B. Varick Co., Varick Bldg.

## NEW JERSEY.

Hoboken—Eclipse Phono. Co., 203 Washington st.  
Newark—Douglas Phonograph Co., 20 New st.  
A. O. Petit, 57 Halsey st.  
Rapke Phono. Store, 287 Bank st.  
Paterson—James K. O'Dea, 117 Ellison st.  
Trenton—Stoll Blank Book and Stationery Co., 30 E. State st.  
John Sykes, 105 N. Broad st.

Continued on page 3 of cover

# Edison Phonograph Monthly

VOL. VI.

January, 1908

No. 1

## Business as We See It

The manufacturer of goods sold all over the country is in a position to know just what effect a stringency in the money market or any other adverse circumstance may have upon his business as a whole. Such is our position with reference to the manufacture of Edison Phonographs and Records. It would be idle to say that our business has not been effected by the conditions of affairs during the past two months, and yet we can honestly express our surprise that it has not been greater, considering the noise that has been made about the money market and business matters in general. The volume of our business was less in November and December than it would have been had money been plentiful, but we only regard the falling off as temporary, fully believing that the loss will be more than made up before March 1st.

Our sales and shipments of Phonographs and Records during November and December were much larger than in 1906, but only about seventy-five per cent. of what they should have been. The usual number of Jobbers discounted their statements due November 1st and December 1st. The business that we did in November and December would have been considered as enormous eighteen months ago. Of course, we can only discuss that part of the general business world pertaining to Edison Phonographs and Records, but, speaking for such a portion, we confess to a feeling of surprise that so much fuss was made about trade conditions in November and December. Judging from newspaper reports, one would expect to find the entire business world at a standstill. And yet, here is a manufacturing and selling organization doing a great business, that has been doing within twenty-five per cent. of its normal volume, and that regards the twenty-five per cent. as suspended business and by no means lost.

It is true that we cut down our factory force and decreased the production of Phonographs and Records, but neither of these would have been possible had we not accumulated a surplus stock

during the summer that, because of the new equipment, had not yet moved.

Since December 1st orders for Phonographs and Records have shown a steady and decided increase in number and size, and orders to cancel or defer shipment have ceased. These facts show that the trade has been doing business with goods on hand and letting their stocks run down to the lowest ebb. Even now they are only ordering what is needed to carry them through the month, although such orders are large in the aggregate.

We have been putting on hands right through December, and a large number of those laid off a month before are now working as if nothing had happened. Our stock of surplus machines is practically used up, so that we shall be compelled early in January to resume the full schedule of production in order to keep pace with the demands of the trade. In fact, we would not be surprised if the demand made it necessary to produce even more goods than provided by our former schedule.

Business conditions really look good to us. The scare is over. Money is rapidly being released by individuals and banks. Business houses have found that there is not so much to be alarmed about and are planning for the future quite the same as ever. Manufacturing firms are putting back their laid-off employes and are again manufacturing for future sales, with growing confidence that there will be no trouble to sell when the time comes. Banks are making loans. It is easier to get currency and more of it. Many thousands of individuals, who deferred making purchases of articles of comfort or luxury, are finding themselves as well off as ever and quite as likely to remain so, and are again buying. Confidence is everywhere returning almost as fast as it was lost in November. When affairs have finally regained lost ground the entire business world will be better and wiser for our experience.

I like the business of selling Phonographs fine in connection with my other musical instruments. I shall live up to my agreements to the letter, to the best of my ability, and wish you every success for making such a fine music maker.—*David H. Francis, Boyne City, Mich.*

## The New Edison Gold Moulded Records Advance List for March, 1908

**R**ECORDS listed below will be shipped from Orange in time to reach all Jobbers in the United States and Canada before February 25th, 1908, all things being favorable, and they may be reshipped to Dealers at 2 P. M. on February 24th. They must not, however, be exhibited, demonstrated or placed on sale by Jobbers or Dealers until 8 A. M. on February 25th. Supplements, Phonograms and Bulletins will be shipped with Records. These may be distributed to Dealers after February 20th, but must not be circulated among the public before February 25th. Jobbers are required to place orders for March Records on or before January 10th. Dealers should place March orders with Jobbers before January 10th to insure prompt shipment when Jobbers' stock is received.

**9770 Cavalry Charge**

**Edison Military Band**

An exceptionally stirring military "charge" by the composer of the "Prince of Pilsen" music, which proved so popular when this opera held the attention of theatre-goers throughout the country some time ago. This fact in itself is sufficient evidence of the high character of the selection. Bugles and drums, with an imitation of a cavalry charge, are heard at intervals throughout the Record. Composer, G. Lüders; publishers, The John Church Co., New York.

**9771 When the Springtime Brings the Roses, Jessie Dear**

**Manuel Romain**

This latest sentimental ballad will do much to sustain Mr. Romain's reputation as "America's foremost minstrel tenor." The tuneful introduction to the verse, the melody throughout, and Mr. Romain's peculiar style of delivery, all will recall the many similar successes which have been offered in minstrel productions from time to time. The story is the familiar one of a lover's fear that his sweetheart's affection may not last until "the springtime brings the roses." Orchestra accompaniment. Words, Robert F. Roder; music, J. Fred Helf; publishers, Helf & Hager Co., New York.

**9772 Sahara**

**Collins and Harlan**

As may be inferred from its title, this song is a love tale of the desert, with Cowboy Texas Dan as the lover and Sahara Jane as the fair maid. Dan swears eternal constancy. The maid declares that he must ride a camel, to which he replies that such riding is better than the Erie, and he'd ride on the latter for her. The long training that Collins & Harlan have had together in singing duets for the Phonograph enable them to give "Sahara" an attractive rendition. Orchestra accompaniment. Music by Egbert Van Alstyne; words, Harry Williams; publishers, Jerome H. Remick & Co., New York. Van Alstyne & Williams wrote "San Antonio" and many other hits.

**9773 Her Bright Smile Haunts Me Still**

**Edison Venetian Trio**

The Records we have previously listed by our instrumental trio, violin, flute and harp, are hardly to be compared with this delicate and finished arrangement of one of the old songs, which are ever dear to those whose tastes are for music of a decidedly artistic nature. Each of the artists in our trio is a prominent soloist in New York musical organizations, and their work is always of the highest order. As usual, the harp is featured with an incidental solo. Composer, W. T. Wrighton. Original arrangement and not published.

**9774 Golden Sails**

**Florence Hinkle**

It is some time since we have listed a Record by Miss Hinkle, and this one will serve to renew the popularity she attained in her charming selection, "The Lover and the Bird," issued some months back. The words of "Golden Sails" tell a pretty story of "childhood's happy hour" and of the dreams, in story books, of a fairy prince whose ship "would come some day, it seemed, with beautiful golden sails." Miss Hinkle's ability to accentuate the composer's idea, as expressed in a somewhat unusual way in the words, will surely be appreciated by those who hear this Record. Orchestra accompaniment. Words, Wallace Irwin; music, Alfred G. Robyn; publishers, M. Witmark & Sons, New York.

**9775 Upper Ten and Lower Five**

**Favor and Meeker**

A true to life rendition of Lawlor & Thornton's famous character duet. It is a dialogue in speech and song between a swell (Edward M. Favor) and a tramp (Edward Meeker), following a "touch" by the tramp for a coin. The Record is unlike anything in our present catalogue. Its unique character and the excellent manner in which it is made by this new duet combination will make it one of the most popular in the March list. Orchestra accompaniment. Words and music, James Thornton. Cannot be had in published form.

**9776 "Moolbarri"**

**James Brockman**

One could hardly imagine from the foregoing title what the song is about. It's merely the Italian dialect for "Mulberry," and refers to the street of that name in New York. An Italian is asked which neighborhood he prefers, and while he admits that Fifth Avenue, the Bowery, and Broadway all have their attractions, his favorite is "Moolbarri Street-a," for it was there that he first met his "Josephina." The air is quite in keeping with the words, and Mr. Brockman, as the composer of many similar songs, does the selection proper justice. Orchestra accompaniment. The words and music are by Junie McCree, whose character songs and acting have made him widely famous. Publishers, Helf & Hager Co., New York.

**9777 The Teddy Bears' Picnic**

**Edison Symphony Orchestra**

A characteristic novelty by a favorite composer of instrumental numbers. The music is at times "spooky" in character and suggests a gathering or march of "Teddy Bears." The various instruments are used to advantage in suggesting large bears, small bears, and bears of all kinds. The bassoon is heard prominently at intervals in the rendition. Composer, John W. Bratton; publishers, M. Witmark & Sons, New York.

**9778 When You Love Her and She Loves You**

**Byron G. Harlan**

A waltz song, of the kind that rapidly attains popularity, telling of a "nice young lady," who says to her "nice young man," "there's one thing I can't see, you go with no other girl but me." The reason is apparently quite clear to the young man, who explains:

When you know that you love her and she loves you,  
When you look into her eyes and she looks too,

You cannot help forget,  
Any other girl you've met,  
When you know you love her and she loves you.

The song is given by Mr. Harlan in his usual pleasing manner. Orchestra accompaniment. Words and music, Kerry Mills; publisher, F. A. Mills, New York.

**9779 Sheriff's Sale of a Stranded Circus**

**Spencer and Girard**

Getit Bros. Circus comes to grief in a country town and the animals are put up at auction by the sheriff. They are bid in by Cyrus Pippin, whose voice sounds very much like that of Byron G. Harlan's when taking part in rube sketches. Cyrus bids the animals in at "a dollar and a quarter" each, with the exception of the elephant, which he gets at "a dollar and a half." He then presents them to the town for a "Zoo-a-ma-logical park," amid the plaudits of his assembled townsmen. The sketch is full of local color and witty dialogue. Mr. Girard's imitations of the different animals are lifelike. The circus band is also a feature. Not published.

**9780 I'm Afraid to Come Home in the Dark**

**Billy Murray**

Jonesy had but recently married, in fact his honeymoon was hardly over before he began to stay out until the break of day. His wife asks the reason why, and Jones explains rather confidentially:

Baby dear, listen here,  
I'm afraid to come home in the dark,  
Ev'ry day the papers say "a robbery in the park."

So I sat alone in the Y.M.C.A.,  
Singing just like a lark, "there's no place like home",  
But I couldn't come home in the dark.

His wife turns the tables on him the next day by coming home in an intoxicated condition and offering the same excuse. Very amusing and cleverly rendered. Orchestra accompaniment. Words, Harry Williams; music, Egbert Van Alstyne; publishers, Jerome H. Remick & Co., New York.

**9781 The Marriage of Figaro Overture**

**Edison Concert Band**

Mozart wrote "The Marriage of Figaro" in 1784 (he was then twenty-eight years old), and his greatest success began with the presentation of this opera, a success that continued till his death in 1791. This overture is one of the best known parts of the opera. It is much loved by all musicians. Our Record of it will be regarded by many as the best in the list. It is in music of this high class character that our Concert Band appears to best advantage, for its members are more familiar with it than in the music of the present day.

**9782 The Heart You Lost in Maryland You'll Find in Tennessee**

**Frederic Rose**

Two lovers quarrelled in Maryland and separated. One day there came to him a letter, reading:

The heart you lost in Maryland, you'll find in Tennessee,  
For there the birds sing all the day, how dear you are to me.

Although we've been a-part so long, our love the same will be,  
For the heart you lost in Maryland, you'll find in Tennessee.

This is Mr. Rose's second contribution to the Edison catalogue and that it will be as cordially received as the first there is not a doubt. He has a pleasing voice, well fitted to sentimental songs of this kind. Orchestra accompaniment. Music, Alfred Solman; words, Arthur J. Lamb; publishers, Joseph W. Stern & Co., New York.

**9783 To the Work**

**Edison Mixed Quartette**

This widely known gospel hymn never had a more delightful reproduction than is here given. It is a splendid addition to our now extensive catalogue of sacred selections. The work of our mixed quartette is full of expression and artistic feeling. Unaccompanied. Music, W. H. Doane; words, Fanny J. Crosby; published in hymn books.

**9784 Nothin' Ever Worries Me**

**Arthur Collins**

The song of a philosophic coon who takes things as they come. Not even the report of the doctor that his mother-in-law would not die caused him any worry, for he declared she might have a relapse. The following chorus sums up his philosophy, and many other people might follow his doctrine to their own benefit:

Nothing ever worries me, nothing ever hurries me,  
Slow but sure's a safer gait,  
All things come to them who wait.

So let the foolish people weep and sigh,  
I let troubles amble by;  
What is to be is bound to be  
So nothing ever worries me.

The air is along lines different from many coon songs. Mr. Collins, as usual, makes the most of the song. Orchestra accompaniment. Music, Lou Hirsch; words, John B. Lowitz; publishers, Helf & Hager Co., New York.

**9785 "Smile, Smile, Smile," and "Kiss, Kiss, Kiss"**

**Albert Benzler**

Two very popular selections recorded as a bells solo. The first from "The Rogers Brothers in Panama," and the other from "The Parisian Model." Both are declared to be the biggest hits in their respective operas. Mr. Benzler's work with the bells is quite as wonderful as his performances on the xylophone. Between the two he has gained a most enviable position among Phonograph Artists. Original arrangement and not published.

**9786 Bygone Days**

**Harry Anthony**

A most beautiful sentimental selection by the composers of many ballads of the better sort. The words of the song are reminiscent in character, looking back to bygone days. A decidedly pleasing feature is the violin obligato by Eugene Jaudas. By way of a further change, Mr. Anthony is accompanied on the piano by Mr. Benzler. Mr. Anthony always sings with much feeling, and particularly in this selection his work will be greatly admired. Words, David Reed; music, Ernest R. Ball; publishers, W. Witmark & Sons, New York.

**9787 Muggsy's Dream**

**Ada Jones and Len Spencer**

Muggsy (Mr. Spencer) is selling his papers on a cold night. He finds a warm corner in which to take a quiet sleep. At this point in the Record, effects to imitate a runaway horse, a dog's bark and a girl's scream are introduced. The girl is crying for some one to save her dog. Muggsy is right "on the job," and after restoring the "mut" to its owner is invited to ride with her to her home. After experiencing pleasures almost unheard of, he is rudely awakened by a policeman, and feels rather forlorn when he finds out that it was but a dream. During the sketch Miss Jones sings "Won't You Be My Baby Boy." Original arrangement and not published.

**9788 I Marched Around Again**

**Edward Meeker**

A comic song of many laughable situations. Four verses and choruses are given on the Record. The first tells of the singer's experiences in his attempt to marry a second time. His first wife walked in just as the ceremony was about to begin, so he "marched around again." Another tells of a bunco-steerer who offered to sell the Flatiron Building to a rube. He was not successful, however, for as the rube explained: "I bought that building once before." Mr. Meeker's clear articulation makes it possible to hear plainly every word on the Record. Orchestra accompaniment. Words and music, Rose & Snyder; publishers, Rose & Snyder Co., New York.

**9789 The Merry Widow Selection**

**Edison Symphony Orchestra**

The popularity of "The Merry Widow" music increases as the operetta becomes better known throughout the country. We listed "The Merry Widow" waltz in December (No. 9701), and the soprano and tenor duet, "I Love You So," in February (No. 9748). We now present in this orchestra selection five singing numbers from this great Viennese operetta, namely, "The Girls at Maxim's", "The Cavalier", "Vilia", "Maxim's" and "Women." It is seldom that five such tuneful and charming airs are found on one Record. "The Merry Widow" music was composed by Franz Léhar and is published by Chappell & Co., New York, but our arrangement is by Leader Ecke, of our Concert Band, and cannot be had in published form.

**9790 Flanagan's St. Patrick's Day**

**Steve Porter**

It is fitting indeed that Mr. Porter should select St. Patrick's Day as his theme for the March



offering. As Flanagan he relates his experiences in a restaurant, where an Englishman at a nearby table orders rare roast beef, tomatoes and several other articles red in color. Flanagan, not to be outdone, orders green turtle soup, green peas, and most anything else green in color. The waiter asks him whether he wanted anything else, to which Flanagan replies: "I just want that guy over there to say something to me." He then goes on to tell of his further experiences during the day, and makes humorous references to the "A. P. A." and Clancy's fight with three "Orangemen." The sketch concludes with a funny verse by Mr. Porter to the tune of "a little green music."

**9791 The Sword of Bunker Hill****Edison Male Quartette**

A most impressive quartette Record of a familiar old song. The listing of it will undoubtedly recall to many the days at school where it was a prime favorite, being sung almost invariably on patriotic occasions. The story of the veteran's dying gift to his son is too well known to require description. Special arrangement and unaccompanied. Words by Wallace; music by Covert.

**9792 She Forgot to Bring Him Back****Ada Jones**

A most amusing story of a wife who had a "lovely lady friend" living next door, who frequently borrowed dishes to entertain a friend at tea. Can you blame the poor wife for being broken-hearted when she discovered that her husband was the only company her neighbor ever had? The neighbor borrowed her husband to help search for a burglar alleged to be in her house, and forgot to bring him back. Miss Jones sings the selection in a most entertaining manner, and brings out the amusing situations in her usual clever way. Orchestra accompaniment. Words, William J. McKenna; music, May Irwin; publisher, Rose & Snyder Co., New York.

**9793 Down the Field March****Edison Military Band**

The fact that the students of Yale College have made this march one of the airs sung and played at all college functions will be sufficient to give it wide vogue. It also stamps it as possessing more than ordinary merit, for out of the hundreds of compositions written for college use, few survive the first trials. "Down the Field" deserves its success. In our Record the bells are featured in one of the principal strains. Composer, Stanleigh P. Friedman; publisher, Charles H. Loomis, New Haven.

## About Credits for Returned Records

Dealers who are getting impatient at not receiving their credit for Records returned under the exchange proposition, should bear in mind that Records were returned to us by several thousand other Dealers, and that to unpack, sort and check them over and make out the necessary credit papers is a task of no small magnitude. We are using every effort to complete the work, but it must necessarily be another two or three weeks before we can complete it. We therefore ask the indulgence of the trade for a short time longer. If the credit does not reach you during January, write us about it.

sung by them, they are as attractive as domestic Records are to an American. Foreigners are now to be found everywhere in this country, and as they are good patrons of instruments like the Phonograph they would buy rapidly if they know that they can get Records in their own languages. Look over your field, Mr. Dealer, and see how many you can locate. Then go after them.

## Copies of E. P. M. Wanted

We want to get a few copies of the EDISON PHONOGRAPH MONTHLY for each of the following dates: November, 1903; July, 1904; August, 1906, and September, 1906. We will pay ten cents each for a limited number of each issue if sent at once.

## New Foreign Records

The 9 new Bohemian Records, the 8 new German Records, and the 13 new Mexican Records, all listed in November, will be shipped to the trade early in January. Supplements of these selections have just been mailed to the entire trade. There is scarcely a Dealer anywhere, especially in the cities, who cannot find sales for some of these Records if he tries. To those who understand the languages spoken or

## Do Your Part

Did you see that handsome full page advertisement in colors that we had in *Collier's Weekly* for December 14th? Does not advertising of this expensive kind show that we have the greatest confidence in the continued success of the Edison Phonograph? If you will make the same effort to sell as we will to advertise there will be no question about the success of your business in Edison goods.

## Keep Up Stocks

We do not want to imitate the hosts of advice givers and tell the Phonograph trade that the way to help restore business confidence is to buy more goods than ever, for we cannot overlook the cruel fact that they will have to be paid for, something that many moralists don't seem to take into consideration. At the same time, there is always a danger in times like these that Jobbers and Dealers will let their stocks run down too low and get caught "without the goods," when the demand returns. We are not going to buy a lot of raw material that we don't need just because some one tell us it's the thing to do. Nor do we expect Jobbers to load up just because we want to sell goods. For the same reason Dealers will not buy to relieve Jobbers of their stock. In all cases the bills must be met and if the money is not at hand there will be trouble.

We would be foolish, however, if we did not buy and have on hand enough raw material to enable us to increase our output at short notice. Jobbers would lack business acumen if they did not keep their stocks in shape to meet any ordinary increased demand from Dealers, and the latter, in turn, will lose money if they do not carry such a stock of Phonographs and Records as will permit them to fill any order that comes their way.

That business in Edison goods is going to be as good as ever after January 1st we feel assured, and we are going to manufacture to meet it. We want Jobbers to place such orders as will bring their stock of Phonographs and Records up to a proper standard and we want every Dealer to make sure that his stock is sufficient for ordinary requirements.

If your stocks are low and you don't want to inventory a new lot on January 1st, send orders for shipment after the first of the year. There is no question that you will need more Phonographs and more Records early in January, and by placing orders ahead you will have gained just so much time.

---

## Send Us Papers

Dealers who have had electros from us for advertising purposes must send us copies of the papers in which they were used, before we will fill any requests for other electros. We are glad to furnish electros to Dealers, but we do so for the purpose of having them used for advertising. It should be a small matter to send us evidence that the electros had been used in this way.

## The Use of Mr. Edison's Picture and Signature

During the past four months there has been a tendency among some of our Jobbers and Dealers to use pictures of Mr. Edison for advertising purposes in a manner objectionable to Mr. Edison and ourselves, and so as to make it appear as if Mr. Edison was doing the advertising personally. Consequently we have decided not to permit the use of Mr. Edison's photograph by the trade in any way whatever different from the use to which we put it ourselves. That is, the use of the standard bust picture. As to the trade-mark signature, we will permit its use only in a way to call attention of the public to the fact that genuine Edison Phonographs and Records bear this trade-mark signature. We will not permit the use of this signature in advertising in a way to make it appear that the trade-mark is a signature to some statement purporting to come from Mr. Edison or this company. The use heretofore made of the full-size or three-quarter photograph of Mr. Edison does not meet with either the approval of Mr. Edison or this company; and, in order to prevent repetitions of the uses heretofore made, we are obliged to draw the line and prohibit the use of such photographs in any form.

---

## Special Notice About Mailing Phonographs and Supplements

Beginning with the February Records, Dealers may place Phonographs and supplements in the post office or letter boxes after 5 p. m. on the *day before* the new Records go on sale, so as to reach retail customers in the first delivery on the Record selling day. They must not be mailed so as to reach customers on the day before. The object in establishing a uniform time for distributing Phonographs and supplements at retail is to prevent a species of competition that can only cause confusion and trouble.

---

## Volume 6, No. 1

This issue of the EDISON PHONOGRAPH MONTHLY is designated on the cover page and on page 1 as Volume 6, No. 1. Volume 6 would not begin till March 1st if we continued the old plan of numbering. We think it better, however, to have the volume begin with the January issue each year and have, therefore, made the change that begins with this number.

---

---

## Advance List of Seven Selections by Harry Lauder The Great Scotch Comedian

The Records named below will be ready for shipment from Orange between February 1st and 10th. Samples of them will be shipped January 1st to all Jobbers whether ordered or not. Jobbers' stock orders received by January 20th will be shipped as fast as possible after February 1st. Care will be taken to make shipment at one time to all Jobbers in the same city. Supplements will be shipped with Records to all Jobbers who request a supply. State quantity required.

**19173 Rob Roy Mackintosh.**

Descriptive of Rob Roy's first visit to London and Paris, and the havoc he caused among the fair sex in his Highland costume. He sings "They adore ma with ma troosers on, but they love ma in ma kilts." The song has a rollicking air, which Mr. Lauder handles in his best manner.

**19174 She's My Daisy.**

Sandy is a soldier man and the admiration of all the "Slaveys." Daisy, his bonny Daisy, is his choice of the lot, and he sings of her charms and of his willingness to lose his spurs before he will lose her. Sandy also tells of an interview he had with his General about keeping the colors and the canteen. He says that he and the General are very thick; in fact, he is the thickest of the two. A clever Record.

**19175 Tobermory.**

This song was suggested to Mr. Lauder while standing on Gourock pier, Scotland, watching an excursion steamer starting for the west coast. Two Glasgow men, partially drunk, were among the passengers, and from the deck of the boat they were waving bottles of whiskey in farewell to friends on shore. Just as the steamer sailed one of the men yelled out, "We'll fairly knock them up at Tobermory."

**19176 We Parted on the Shore.**

According to Lauder, many cycles of years had passed since he parted with his sweetheart on the shore. She wept more tears than he had ever seen before. She asked if he would think of her and he replied that perhaps he would. But he had often broken promises before. The singer points out the dangers of being hundreds and thousands of miles out at sea, but adds that it is a long ways from anyone to whom you owe money. The manner in which the singer rolls his r's is an effective part of the Record.

**19177 The Safest o' the Family.**

The "safest" is a younger number who goes to school, but doesn't always get there. Some of the reasons that he assigns for his absences furnish the basis for the song. These reasons must be heard to be appreciated. They are laugh-provoking.

**19178 I Love a Lassie.**

A letter from his wife was handed Mr. Lauder in Scotland one night as he was finishing a turn, the attendant remarking "I suppose you love the lassies." Mr. Lauder replied, "I'm fond o' a', but I only love yin (one)." This incident gave rise to the song. While not without its humor, it is really a charming bit of sentiment, revealing the actor's love for his wife. The air of this song, while simple, has a catchy lilt that will become popular here with the sale of the Record.

**19179 Stop Yer Ticklin', Jock.**

This was the exclamation of the farmer's daughter when "Jock," in the ordinary process of courting, attempted to kiss her. It was also a frequent remark on the day that she and "Jock" spent at the seashore. Mr. Lauder's imitation of the girl's laughter, when "Jock" was offending, is a feature of the Record. One of Mr. Lauder's best-known songs.

---

---

## Advance List Edison Grand Opera Records Supplement No. 9, March, 1908

**R**ECORDS listed below will be shipped from Orange in time to reach all Jobbers in the United States and Canada before February 25th, 1908, all things being favorable, and they may be reshipped to Dealers at 2 P. M. on February 24th. They must not, however, be exhibited, demonstrated or placed on sale by Jobbers or Dealers until 8 A. M. on February 25th. Supplements will be shipped with Records when ordered. These may be distributed to Dealers after February 20th, but must not be circulated among the public before February 25th. Jobbers are required to place orders for these Grand Opera Records on or before January 10th. Dealers should place Grand Opera Orders with Jobbers before January 10th to insure prompt shipment when Jobber's stock is received.

**B. 60 Figli miei, ("Let Us Pause, O My Brothers"), Sansone e Dalila" Saint-Saens**

By ARTURO FRANCESCHINI, TENOR Sung in Italian, Orchestra Accompaniment  
"Samson and Delilah," a biblical opera, suffered neglect when first it left the composer's hands. It was written in 1872. Two years later it was heard in private, at a performance participated in by the famous Madame Viadot. Not until 1877 was "Samson and Delilah" performed on a public stage—and then Germany was the country to give it welcome, for its first production occurred at Weimar. Three years later France awoke to the beauty and importance of this, one of its finest musical products. Finally, in 1892, the Paris Grand Opera House put the opera on its boards. The present excerpt occurs in the first act, the opening scene of which is laid in the city of Gaza, in Palestine. There is an opening chorus, an appeal to God of Israel, and then Samson enters upon the scene and sings the present aria, which is an entreaty to the people to take faith and hope. Musically, it is a very beautiful bit of writing, full of sincerity.

**B. 61 Nonconosci il bel suol, ("Dost Thou Know That Sweet Land"), "Mignon" Thomas**

By SIGNORINA GIUSEPPINA GIACONIA, SOPRANO Sung in Italian, Orchestra Accompaniment  
Ambroise Thomas' most tuneful opera, "Mignon," is founded, in its librette, on Goethe's familiar "Wilhelm Meister." In the opera, Mignon, daughter of noble parents, is stolen by gypsies; and she suffers her miserable lot until she is rescued by Guglielmo, a young student, who takes compassion on her and buys her from the gypsy chieftain. Guglielmo asks Mignon about her childhood and parents, and she tells him that she can remember little more than the wretched day on which she was stolen from her home. Guglielmo presses her to recall something more definite about her native land, and then Mignon sings this exquisite aria. This song is not alone the most beautiful bit of sentiment in the entire opera of "Mignon," but it is also among the most popular airs created by Ambroise Thomas.

**B. 62 Rondo vom Goldenen Kalb, ("Song of the Golden Calf"), "Faust" Gounod**

By ROBERT BLAÏS, BASS Sung in German, Orchestra Accompaniment  
In the first act of Gounod's opera "Faust," the aged and life-weary Doctor Faust signs a compact with Mephistopheles by which he is to deliver up his soul if the devil will grant him youth and show him life. This compact is signed and sealed, and the youthful Faust is led forth to find the charm of love and living. The second scene of the opera shows the animated square of a town celebrating its fair. Students, soldiers and maidens are making merry when Faust and Mephistopheles mount the scene. The latter comes upon a group, one of which attempts to amuse his comrades by singing the song of a rat that once sat in the Abbot's cellar. Mephistopheles rudely interrupts the singer and asks permission to join the party and to sing his song. He is pressed to do so, and immediately begins this famous round. The music of this number is stirring in its fine swing and in its rhythm. The melody is rousing in the extreme, and the whole number appeals tremendously to the enthusiasm of the listener.

**B. 63 Una furtiva lagrima, ("In Her Dark Eye There Stood the Furtive Tear"),  
"L'Eliser d'Amore" Donizetti**

By FLORENCIO CONSTANTINO, TENOR Sung in Italian, Orchestra Accompaniment  
Donizetti's comic opera, "The Elixir of Love," has, of recent years, again come to occupy a position of vogue with the opera-going public. For some time the work was little more than

a name to most opera-goers, but with its revival came the quick recognition that this work contained some beautiful music, and among the several attractive numbers embraced by this opera none is more charming than this tenor aria. It is sung by Nemorino, toward the close of the opera, just before he learns that Adina is really devoted to him. Its measures are laden with pleading melodious beauty.

**B. 64 Canzone del Torrero, ("Song of the Toreador"), "Carmen"**

**Bizet**

By GIUSEPPE CAMPANARI, BARITONE      Sung in Italian, Orchestra Accompaniment  
The curtain of the second act of Bizet's immortal masterpiece, "Carmen," rises upon a scene in the tavern of Lillas Pasta. Gypsies, smugglers and officers are scattered about, and the gypsy girls dance to the accompaniment of tambourine and castanet. Carmen and her comrades, Frasquita and Mercedes, participate in this lively scene. Just as it is about to conclude there passes a torchlight procession which proves to be the escort of the bull-fighter, Escamillo, who had done valorous deeds in the arena at Granada. He is welcomed by the party. He describes the scene and the sensations witnessed and experienced in the arena. The music is of unbounded enthusiasm and it is fiery in its surge. The tender portions refer to the Toreador's love, the inevitable lady who casts smiles upon him and is charmed by his gory deeds. In this particular case it is Carmen under whose glances Escamillo languishes. The excerpt is the most popular one in "Carmen"—and that is exalted praise indeed.

## Records by Harry Lauder

The seven Edison Records by Harry Lauder, the famous Scotch comedian, listed on another page, should receive more than ordinary attention at the hands of Edison Jobbers and Dealers, for they only need to be placed before the public in the proper manner to create large sales. The Records are unique and unlike anything else in our catalogues. They are the kind that "grow on you" with each playing—your appreciation grows each time you hear them. When you have mastered their dialect (and it is not hard to do so) and have pictured in your mind that they are being sung by one of the funniest artists on the stage, you cannot fail to regard them as about as entertaining Records as you have ever heard. Their merit entitles them to the same sale as the monthly list of Edison Records. Every Dealer who buys the latter should buy the Lauder series.



HARRY LAUDER.

These Records will be ready for shipment after February 1st, and as the probable demand is

difficult to determine, we hope that Jobbers and Dealers will place orders promptly. Special supplements for retail distribution will be printed and shipped with Records when ordered by Jobbers.

As an imitator of Scotch characters Harry Lauder probably has no equal. His renditions of Scotch songs may be compared to the coster songs of England. His characters are from similar walks of life, but they speak in Scotch dialect instead of English. Fifteen years ago Harry Lauder was a miner in the coal pits of West Scotland, amusing his comrades with his songs and imitations and glad to earn an occasional shilling or two at a village entertainment. Today he is the best-known comedian in the British Isles, is one of the most popular and is the highest salaried man in his class. Last November he was induced, by the offer of an unusual salary even for high-class artists, to play a limited engagement at the New York Theatre. He there duplicated his home success. He drew crowded houses at every performance. He became the lion of the hour, dividing the honors with the most famous singers and actors then appearing in New York. Much of Mr. Lauder's great success depends upon his ludicrous make ups, his mannerisms and his inimitable impersonations. These features are lacking in his Records, and yet the latter are brimful of jovial laugh-impelling humor.

Edison Phonographs appeal to the multitude, to your present customers and to those whose money you cannot get in any other way. When you put an Edison Phonograph in a home that home becomes a steady source of revenue because it is the new Edison Records that make the Phonograph a continuous pleasure.

---

---

# Edison Phonograph Monthly

Published for the Man Who Sells Edison Phonographs and Records by The National Phonograph Co., Orange, N. J.

All communications to *The Phonograph Monthly* should be addressed to the Advertising Department, Orange, N. J.

---

NEW YORK : 10 FIFTH AVENUE.

NATIONAL PHONOGRAPH CO., LTD., 25 CLERKENWELL ROAD, LONDON.

NATIONAL PHONOGRAPH CO. OF AUSTRALIA, LTD., 340 KENT STREET, SYDNEY, N. S. W.

MEXICAN NATIONAL PHONOGRAPH CO., AVENIDA ORIENTE No. 117, MEXICO CITY.

COMPANIA EDISON HISPANO-AMERICANA, VIAMONTE 515, BUENOS AIRES.

EDISON GESELLSCHAFT, M. B. H., SUD-UFER 24 25, BERLIN.

COMPAGNIE FRANCAISE DU PHONOGRAPHE EDISON, 42 RUE DE PARADIS, PARIS.

---

VOL. VI.

January, 1908

No. 1

---

## No Let Up of Any Kind

In spite of the present depression in business generally, the outlook for Edison Phonographs and Edison Records in 1908 never was brighter. Business may be a little slow during January and possibly part of February, but by March 1st we feel sure that the volume of sale will be as great as at any time in the history of the Phonograph. The remainder of the year, we predict, will show as great a gain as ever. As an evidence of our belief that such will be the case, we have made no reduction in the amount we are spending for advertising and have decided to make no change in any of our advertising plans for the coming year. We shall do just as much newspaper advertising, use just as much, or even more, space in magazines and similar periodicals and there will be no less billboard advertising, no fewer railroad bulletins, more electric and other painted signs and larger editions of all kinds of catalogues, supplements, folders, cards and other forms. We are not going to lose any of the impetus that the Edison business has gained, and if we can get the cooperation of Jobbers and Dealers we will not only hold our own but we will all make great gains.

---

## Our January Advertising

The illustration shown in the reproduction of our January magazine advertisement on page 20 is made from a sketch drawn especially for us by James Montgomery Flagg, one of the best known American artists of the present day. The character of the sketch is equal to any of the work that Mr. Flagg is contributing to the best magazines.

## Last Call for Unsigned Dealers

This is the last copy of the EDISON PHONOGRAPH MONTHLY that will be mailed to Dealers who have not signed the new Agreement. Just as soon after January 1st as we can check up the Agreements received prior to that time, we shall remove from our files the names of all unsigned Dealers and will deny such firms the privilege of buying Edison goods at Dealers' discounts. We don't want to drop a single name. We want to see every firm now selling Edison Phonographs continue in the business and make it a greater success than ever. We have the utmost faith in the future of the business and believe the ability of a Dealer to make money out of it depends entirely upon himself. We are going to render greater assistance than ever in aiding Dealers to sell our goods during 1908 and no enterprising firm should drop the line now, or permit his interest to decrease. Even though a Dealer's Agreement does not reach us until after January 1st, it will still be in time for reinstatement. Because business may be a little quiet just now, don't give up the line. Business is coming back very rapidly and it is going to be bigger than ever next year. Stick to it.

---

## Suspended Lists

Separate copies of the list of suspended Dealers will no longer be mailed to Dealers. The list will appear in each issue of the PHONOGRAPH MONTHLY, and Dealers are expected to give it the same attention that they would give to a separate list. Jobbers will continue to get separate copies of the entire list, and also special notices of suspensions in their territory.

## Electrotypes Cut From Catalogue

The trade is advised that the following electros shown in our Catalogue, Form 832, are now obsolete and we are not in a position to fill further orders for them.

Nos. 525, 526, 527 and 528, on page 8.

Nos. 531, 532, 533 and 534, on page 9.

Nos. 535 and 536, on page 10.

Nos. 545, 546, 547 and 548, on page 13.

No. 549, on page 14.

Nos. 552, 553, 554 and 555, on page 15.

Nos. 580, 581 and 582, on page 19.

Nos. 615, 616 and 617, on page 24.

No. 637, on page 30.

No. 639, on page 32.

We have also decided not to list smaller electros than a single column size of our various machines, and will not, therefore, be able to fill orders for cuts similar to Nos. 501, 521, 541 and 561.

Our reason for discontinuing the furnishing of electros with flower horns is that they are practically the same as the horn now being furnished with all our machines, and since we are now filling orders for electros illustrating the new equipment, it seems unnecessary for us to carry a stock of such numbers as 525, 526, etc.

Dealers will save us considerable correspondence if they will make note of the above corrections in the Electrotypes Catalogues in their possession. We are correcting all of our originals so as to show the new equipment, and expect in the near future to issue an up-to-date Electrotypes Catalogue.

## Our Advertising "Extra"

What did you think of our newspaper "Extra" mailed out during December? Wasn't it novel? It is seldom that we care to indulge ourselves in so much conceit or egotism, which ever it may be, but we couldn't resist the temptation of laying before the trade some statements about our advertising plans, especially when everybody is talking as if business was going to the demnition bow-wows, and we wanted to do it in a way that was out of the ordinary. You'll admit that it was unusual, won't you? It did sound like a lot of brag, we'll admit, and yet we said nothing that was not well within the limits of the truth. The amount that we are spending to bring trade to your doors was understated, if anything. Did not the "extra," as a whole, make you feel as if you were tied up to a good business proposition, and didn't you declare to yourself that you would do your share in making 1908 the greatest year ever? If it didn't, then we are afraid that you lack that essential part called enthusiasm.

## New Horn a Decided Selling Advantage

When you sell an Edison Phonograph you sell a complete machine, ready for use. The horn and supporting crane go with it, as a part of it and are included in the price. The new Edison horn makes a quick appeal. It looks the part—large, prettily shaped and designed in every way to set the Phonograph off to fine advantage.

You need carry no horn stock for the benefit of Edison Phonograph customers. The Edison horn which they get with the Phonograph is exactly what they want—made exclusively for the Edison instrument in a shape and size best calculated to enhance its sweet, clear tones.

The price protection which Edison Dealers have always enjoyed is now as true of horns as of Phonographs. The same prices for complete Edisons prevails everywhere and every Dealer is assured of a good horn profit as well as a good Phonograph profit. Taking it all in all, the new equipment of the Edison Phonograph is the most important happening in the talking machine world.

## Australian Comments

B. G. Holton, manager of the New Century Talking Machine Company, Auckland, N. Z., writes the following:

Just a few lines in praise of the Edison goods. The following unsolicited testimonials have reached us lately, and no doubt may prove useful to you for insertion in your valuable trade medium:

A mail-order client sent for two Records that were out of stock in the Edison's, so we forwarded two others of same title in different make, which drew forth this reply: "The *song* is passable, but the *band* is *simply diabolical*, and if that is a good band selection, I shudder to think what the bad ones are like. At any rate, I have decided to purchase none but Edison Records in future." He also wished to subscribe to the new *Phonogram*.

Another client sent his Edison reproducer in from the country for repairs and wants it returned first possible chance, as he says he will be quite lost without his "Phonograph."

A dealer says: "The last lot Edison Records received were very satisfactory, and what I like about the Edison Records is the scarcity of dead stock. The orchestra accompaniments put all other kinds of Records completely out of business."

Another Dealer says: "I do not think one person has asked to hear the 'disc machine' since the Edison goods have been in the store. We tell them: 'Hens cackle when they lay an egg.' Mr. Dealer, *Edison goods* are *golden eggs*, and when you have them 'cackle' and let the public know (advertise).

Printed Matter

We regret that the semi-annual edition of the Numerical and Alphabetical Catalogue for the trade, due January 1st, will not be ready for use till February. Orders from Jobbers will not be filled till after it is mailed to the trade, and even then the orders must be limited. This catalogue is for *trade use only*, and as we will mail one copy to every Dealer there is no occasion for Jobbers wanting large quantities.

Supplements of the new Bohemian, German and Mexican Records, forms Nos. 1249, 1251 and 1252, respectively, have just been mailed to the trade. Jobbers will supply these supplements to Dealers stocking the Records.

Quantities of a new colored hanger, Form No. 1160, have been shipped to all Jobbers. It will not be mailed. Dealers may obtain copies from their Jobbers. The hanger shows a charming girl of the Colonial period, and a feature is a bar of music from the old ballad "Love's Old Sweet Song." The hanger is a companion to the Dixie girl hanger issued a short time ago.

Copies of another hanger are being mailed to the entire trade with this issue. It is Form No. 1189. This is of a more striking character, because of its brilliant coloring. It shows a group of cowboys gathered around an Edison Phonograph and being entertained with songs reminding them of their Eastern homes. It is called "Voices from Home."

No Change in Phonogram and Supplement Date

No change has been made in the date when Jobbers may supply Phonograms and supplements to Dealers, because none seems to be necessary. The advanced date for selling new Records at retail still leaves Dealers four days in which to get them ready for mailing, and this time ought to be sufficient for the purpose. Jobbers will please continue to supply them on or after the 20th, as heretofore.

Any talking machine will bring a crowd to your door, but an Edison Phonograph will bring customers. It is one thing to draw a crowd and another thing to sell goods. To listen to an Edison Phonograph is to be impressed by its superiority, its wide range, its perfect reproduction of sounds. Those that come to hear, stay to buy. It isn't alone the advertising that makes the Edison easy to sell. It is also the Phonograph itself which, once heard, is its own best advertisement.

Name of "Ideal" Changed to "Idelia"

Because of the difficulties in some countries of registering dictionary words as names of Phonographs, the name of the new Ideal Phonograph has been changed to "Idelia." This is a coined word. This change will be made effective as fast as catalogues are reprinted and new transfers will be placed on the Idelia horns as soon as possible. The similarity in the old and new names will prevent confusion being caused by the change.

Another Injunction Against a Price Cutter

We print in full below copies of an order and writ of injunction obtained by the National Phonograph Co. against John G. Adams, doing business under the name of the Philadelphia Record Exchange, Philadelphia. The injunction in this case is of more than ordinary interest, because of the fact that not only was it obtained against a party selling Edison Records at a cut price, but Adams was not an authorized Edison Dealer and never had signed our Dealers' agreement. The decision again makes it clear that Edison Records cannot be sold at cut prices, even though an individual has not signed our agreement. The papers:

UNITED STATES CIRCUIT COURT.  
Eastern District of Pennsylvania.

NEW JERSEY PATENT Co., and NATIONAL PHONOGRAPH COMPANY, Complainants,	} IN EQUITY. October Session, No. 13. 1907.
vs. JOHN G. ADAMS, doing business under the name of the PHILADELPHIA RECORD EXCHANGE, Defendant.	

Present—McPherson, J.

Complainants having exhibited their bill of complaint in this cause, charging the defendant with infringement of letters patent of the United States, No. 782,375, to J. W. Aylesworth, for Composition for Making Duplicate Phonograph Records, issued February 14th, 1905, to the complainant, New Jersey Patent Company; and the defendant having admitted that said New Jersey Patent Company is the exclusive owner of said letters patent, and that said National Phonograph Company is the exclusive licensee under said letters patent, that said letters patent are good and valid in law, that said defendant, John G. Adams, has infringed each and all of the claims of said letters patent, and that said complainants are entitled to a perpetual injunction, accounting and costs; and said defendant having agreed that a decree and injunction should issue directing and perpetually restraining him from any further manufacture, use or sale of said patented articles, it is by the Court

ORDERED, ADJUDGED AND DECREED as follows, to-wit:

That said letters patent No. 782,375, to J. W. Aylesworth, for Composition for Making Duplicate Phonograph Records, issued the 14th day of February, 1905, to New Jersey Patent Company, are good and valid in law, and that said New Jersey Patent Company is the exclusive owner of, and said National Phonograph Company is the exclusive licensee under said letters patent as alleged in their bill of complaint, and that said defendant, John G. Adams, has infringed upon each and all of the claims of said letters patent and upon the exclusive rights of the complainants under the same by the use and sale in the United States of articles therein described and claimed;



That the complainants, New Jersey Patent Company and National Phonograph Company, are entitled to recover from the defendant, John G. Adams, the profits derived by said defendant and the damages sustained by said complainants by reason of the aforesaid infringement of said claims by said defendant, and it is hereby referred to \_\_\_\_\_ as Master, to take and state the amount of said profits and damages and to report thereon to the Court;

That the defendant, John G. Adams, his clerks, attorneys, agents, servants and workmen be perpetually enjoined and restrained from any further manufacture, use or sale of articles embodying the invention of said letters patent No. 782,375; and

That the said complainants do recover from said defendant, John G. Adams, the costs of this suit to be taxed.

BY THE COURT.

Attest:

GEORGE BRODBECK, JR.,  
Deputy Clerk.

I agree to the entry of the above decree.

CORNELIUS HAGGERTY, JR.,  
Atty. pro John G. Adams.

UNITED STATES CIRCUIT COURT.

Eastern District of Pennsylvania.

NEW JERSEY PATENT CO. and NATIONAL PHONOGRAPH CO., Complainants,	} IN EQUITY. No. 13. October Session, 1907.
vs. JOHN G. ADAMS, doing business under the name of THE PHILADELPHIA RECORD EXCHANGE, Defendant.	

WRIT OF INJUNCTION.

UNITED STATES OF AMERICA, }  
EASTERN DISTRICT OF PENNSYLVANIA. } ss.

The President of the United States, to John G. Adams,  
Greeting:

Whereas, New Jersey Patent Company and National Phonograph Company lately exhibited their bill of complaint, in the Circuit Court of the United States, for the Eastern District of Pennsylvania, in the Third Circuit, against you, the said defendant, praying to be relieved touching the matters therein complained of, and especially that you, John G. Adams, and all acting under you may be restrained from further infringing the patent and the rights of the said complainants in the premises, in the said bill mentioned, in any way or manner, contrary to law or equity: We, therefore, in consideration thereof and also of the particular matters in the said bill set forth, do strictly command and enjoin you, the said John G. Adams, your servants, workmen and agents, and all others acting under or with you, that henceforth you do absolutely and entirely desist and refrain from constructing, or using, or selling, in any way or manner, directly or indirectly, articles made according to the invention described and claimed in the claims, or either of them, of said patent No. 782,375, set out in said bill of complaint.

WITNESS the Honorable Melville W. Fuller, Chief Justice of the Supreme Court of the United States, at Philadelphia, this 20th day of November, A. D. 1907, and in the one hundred and thirty-second year of the Independence of the United States.

GEORGE BRODBECK, JR.,  
Deputy Clerk.

Photographs of Edison Artists

Dealers who are asked by Phonograph customers where photographs of Edison artists may be had are probably not aware that the Channell Studio of Photography, 20 Harrison street, East Orange, N. J., making a specialty of supplying cabinet photographs of all artists at thirty-five cents each, with special discounts to the trade, or the same photographs in framed effects may be had for fifty cents each. A supply of these photographs may also be had through Edison Jobbers.

Phonogram Information

The *Phonogram* continues to be a popular piece of literature with the trade, and the fact that its monthly issue remains unchanged at nearly 600,000 copies shows that Jobbers and Dealers regard it as a useful means for disseminating information about new Records, and as a good medium for increasing Record sales. It is practically the only piece of advertising matter for which the National Phonograph Company makes a charge. The price placed upon it, however, does not cover the cost of production.

The forms of the *Phonogram* close ten weeks before date of issue and printing is completed two months in advance of date. Dealers desiring to get a supply to mail to their customers must order them of Jobbers two months in advance, and we cannot agree to fill Jobbers' orders unless placed with us a similar period in advance. Following is a schedule of prices at which *Phonograms* may be obtained by the trade:

DELIVERED WITH GOODS.

Blank, per 1,000 copies.....\$2.50  
Smaller quantities pro rata.

Imprinted with Dealer's name and address, 25 cents additional, without regard to quantity. No orders filled for less than 500 copies requiring imprint, and all imprinting orders must be for multiples of 500.

Jobbers will be glad to supply Dealers on the above basis.

BY MAIL.

Single copies, per year.....\$ .20  
Five copies to one address, per year..... .40  
Twenty-five copies to one address, per year..... 1.80  
Fifty copies to one address, per year..... 3.60

Unless they have open accounts on our books, Dealers ordering *Phonograms* sent by mail are requested to send cash or stamps with their orders. The amounts are too small to handle in any other way.

Courtesy Pays

Some time ago we referred a retail inquirer to a Philadelphia Dealer, and he bought a Phonograph and a good supply of Records. The inquirer later wrote as follows:

"I must say a few words, also, for the young man you recommended me to, for his willingness in every way to instruct me in the management of it—for he displayed much patience in order to get me to understand all that was necessary to give satisfaction."

Because of his courtesy and kindness this Dealer has made a friend of his customer that no competition can effect. It probably took a little more time than usual to be courteous, but that it will pay handsomely in future sales we have no doubt.

## Kohler & Chase Temple of Music Building

Kohler & Chase are now fully established in their Temple of Music Building on Second avenue, between Union and University streets, Seattle, Wash., and have one of the most up-to-date, convenient and original music emporiums in the entire West. The firm occupies the entire five-story and basement brick building, with the exception of a few offices on the top floor. The building is elegantly furnished throughout, many of the individual piano display parlors above the first floor being carpeted with velvet, an innovation in music room floors in this part of the country. The fixtures are of the latest pattern, and the electrical effects extremely artistic. The first floor is taken up almost entirely with small instruments and sheet music. On the mezzanine floor is the firm's offices and the talking machine department. On the second floor is the piano display stock, where more than 200 pianos of many makes can be seen. On the third floor are the autopianos, the piano players and parlor organs. More pianos and organs are on display on the fourth floor, and the main stock is in the basement.

The top floor is set apart entirely for art and music, where some of the best-known artists in the city are housed. The firm of Kohler & Chase is one of the most widely known music concerns in the country, the main headquarters being at San Francisco. The local business is under the direct management of Horace Chesbrough. The president of the firm is Quincy A. Chase, who established the business fifty-seven years ago. His son, George Q. Chase, is vice-president, and Thomas P. Winter is secretary. The entrance to the new building is especially attractive, and the firm considers that it has one of the most advantageous locations in the city.

## More Phonograph Jingles

Below are given some additional jingles submitted in the Washington Evening Star contest:

A Phonograph for Christmas, we would suggest—  
No better gift in which you could invest.  
The Edison will entertain with song or jest,  
And it's always ready to play upon request.

Edison, the wizard, the wonderful magician,  
Has given to the world an automatic musician.  
To the Phonograph we owe a great deal of pleasure.  
They give us all the new operas in correct time and measure.

You should buy a Phonograph for Christmas Day.  
It will furnish music, either sad or gay;  
Will sing a song, or band selection play.  
It's the very thing to drive dull care away.

On winter evenings 'tis my delight,  
To listen to music that is catchy and bright,  
From an Edison Phonograph whose tones are so sweet,  
It entrances its listeners. Oh, what a treat!

If you want to get a present for your wife at Christmas time,  
Buy an Edison Phonograph and you'll find the music fine.  
It will be a joy and pleasure to your friends both old and new,  
And your family will bless you and vote you popular, too.

Don't worry over how to entertain your friends—  
The Phonograph, a welcome to your guests extends.  
It plays, it sings, it talks and drives dull care away.  
An Edison's the thing to make an evening gay.

The Edison Phonograph in the home is a prize,  
It entertains the old and young, the foolish and the wise.  
If you do not possess one, your lonely home to cheer,  
Purchase one for Christmas, to start the glad New Year.

"I cannot sing the old songs,"  
Which fondly I recall,  
For—if the truth I must confess—  
I cannot sing at all.  
An Edison Phonograph I'll buy,  
With songs both new and old;  
For this fine invention, one can't deny,  
Is worth its weight in gold.

The Edison Phonograph gives pleasure untold,  
To all ages and sizes—the young and the old.  
No home without it is ever complete,  
So at Christmas be sure to give some one a treat.

A wonderful invention is the Edison Phonograph.  
In a voice distinctly human it can cry or laugh,  
Can sing, recite or play; every note is clear and true.  
It in every way surpasses all that the others do.  
If you want a Phonograph, and don't know which to buy,  
Make no mistake, get Edison's; it's above the rest "sky high."

Here's to the Edison Phonograph,  
The best the world has ever known.  
It makes both old and young folks laugh  
To listen to its musical tone.

E is in Edison; in Phonograph it's not,  
But put the two together and an E-see thing you've got  
To play a tune or sing a song,  
Morn or eve, or all day long.

Easy it is to be merry,  
Drinking the music so cheery,  
In Edison's Phonograph.  
Sweetly it sings to the weary:  
"O, tired heart, be not dreary,  
Now is the time to laugh."

To keep your boys and girls at home at night,  
So they won't always be beyond your sight,  
Get an Edison Phonograph and hear them shout,  
"We'd rather stay home, we don't want to go out."

There are some who like a tenor voice, and some a high soprano;  
Some folks prefer the violin, and others the piano;  
Some like the music of a band, melodious, loud and strong;  
Some like the ancient ballad, and some the rag-time song.  
For all these folks of different tastes a Phonograph's the thing  
To drink their favorite music from as from a magic spring.

For young and old, girl or boy,  
The Edison Phonograph beats any toy.  
Its music to the home brings cheer;  
So buy one for your family dear.

If you're feeling sad and weary from the troubles of the day,  
And long for some amusement to drive dull care away,  
No matter what your fancy craves—music, song, or laugh—  
Your every wish is gratified with an Edison Phonograph.

The Edison Phonograph, there's nothing it cannot do.  
It can sing, talk, and give good music, too.  
Songs that make the tears flow, and stories that make you laugh,  
Can all be produced on this wonderful Phonograph.

In selecting gifts to present to your friends,  
It behooves us again to call your attention  
To a beautiful thing that serves many ends—  
The Edison Phonograph—that marvellous invention.  
It will beat almost anything else you can choose;  
It will brighten the home—it's a cure for the "blues."

## Classical Music With the Phonograph

The B. E. Nelson Drug Co., Edison Dealers at Granite Falls, Minn., sends the following copy of an announcement made in the *Granite Falls Journal*, of a concert of classical music given by an Edison Phonograph at their store on November 16th. We print the programme as well as the announcement, because it is one of unusual excellence and will serve as a model for other Dealers who may not be so familiar with classical music. Such a programme would not be possible with any other type of musical instrument.

### AN HOUR OF CLASSICAL MUSIC

Recognizing the importance of cultivating a taste for classic music, especially in the young, the B. E. Nelson Drug Co., have arranged for a programme to be presented at their store, free of charge, by artists of world-wide reputation, including the wonderful Mme. Jacoby, contralto, and the inimitable baritone, Sig. Scotti, which will meet with the approval of the most finished musicians. This concert will be presented next Saturday evening from 8 to 9 o'clock, and you are invited to be present with your family. Do not miss this opportunity to hear virtuosos whom you may never have the good fortune to hear again. They will also give a concert of miscellaneous music in the afternoon from 3 to 4 o'clock to accommodate those who cannot be present at the evening performance. The management have arranged the following:

#### PROGRAMME.

November 16, 1907.

#### PART I.

1. Overture to "William Tell".....*Rossini*  
CONCERT BAND
2. "Danube Waves" Waltz.....*Ivanovici*  
SYMPHONY ORCHESTRA
3. Soprano Solo—"The Last Rose of Summer,"  
from "Martha".....*Flotow*  
EDITH HELENA
4. Flute Solo—"La Traviata".....*Verdi-Popp*  
EUGENE C. ROSE
5. Violin Solo—"El Miserere," from "Il Trovatore".....*Verdi*  
CHARLES D'ALMAINE
6. Selection from "Bohemian Girl".....*Balfe*  
CONCERT BAND
7. Baritone Solo—"Quand' Ero Paggio," from  
"Falstaff".....*Selected*  
SIG. SCOTTI
8. Cornet Solo—"Oh Promise Me".....*DeKoven*  
BOHUMIR KRYL
9. Clarinet Solo—"L'Estudiantina" Waltz.....*Waldteufel*  
WILLIAM TUSON
10. Violin Solo—"Spring Song".....*Mendelssohn*  
CHARLES D'ALMAINE
11. Cornet Solo—"Le Secret" Polka.....*Hazel*  
JOHN HAZEL
12. Clarinet Solo—"The Heart Bowed Down,"  
from "Bohemian Girl".....*Balfe*  
WILLIAM TUSON
13. "Hearts and Flowers".....*Tobani*  
PEERLESS ORCHESTRA

#### INTERMISSION.

#### PART II.

1. Overture to "Fra Diavolo".....*Auber*  
CONCERT BAND
2. Intermezzo from "Cavalleria Rusticana".... *Mascagni*  
SYMPHONY ORCHESTRA

4. Cornet Solo—"Inflamatus, from Stabat Mater".....*Rossini*  
BOHUMIR KRYL
4. Baritone Solo—"The Heart Bowed Down,"  
from "Bohemian Girl".....*Balfe*  
JAMES F. HARRISON.
5. Harp Solo—"Angels' Serenade"....*Bragga-Hasselman*  
CHARLES SCHUETZE
6. Violin Solo—"Then You'll Remember Me,"  
from "Bohemian Girl".....*Balfe*  
CHARLES D'ALMAINE
7. Contralto Solo—"L'Air Des Fleur's," from  
"Faust".....*Gounod*  
MME. JACOBY
8. "El Miserere," from "Il Trovatore".....*Verdi*  
CONCERT BAND
9. Cornet and Clarinet Duet—"Hear Me, Norma"..*Bellini*  
JOHN HAZEL AND WILLIAM TUSON
10. Baritone Solo—"Oh Promise Me".....*DeKoven*  
IRVING GILLETTE
11. Violin Solo—DeBeriot's 6th Air.....*DeBeriot*  
CHARLES D'ALMAINE
12. Violoncello Solo—"Ave Maria".....*Gounod*  
HANS KRONOLD
13. "Heavens Are Telling," from "The Creation"..*Haydn*  
CONCERT BAND

## Sell Records and Blanks

The constantly increasing sale of Edison Records and Blanks shows that more and more Dealers are recognizing the business to be gained by interesting Phonograph owners in making Records at home. Our business in both Records and Blanks has grown to large proportions. It will pay every Dealer to give the subject more attention and get some of this extra business. Below we print a letter sent out to Phonograph owners by Charles R. Zacharias, an Edison Dealer at Asbury Park, N. J.

DEAR SIR:—Increase the value of your Phonograph by purchasing a Recorder, and make your own Records.

Anyone can make them; it doesn't require any knowledge of music. Your friends all have some little stunt they do extra well. One tells a funny story, another plays the mouth organ; sings comic songs, or other things that would make a fine Record.

You have photographs of their faces, why not have one of their voices?

An Edison Recorder is a wonderful device. It adjusts itself automatically to every sound, and costs you \$3.00.

The Edison Shaved Blanks are twenty cents each, and can be used over and over for new impressions.

Half the fun of owning a Phonograph is in making one's Records.

When your friends gather in for a social evening, then is the time you will appreciate its real worth, as the bright sayings of everyone present can be made permanent and a reminder in after years of happy times past.

We are enclosing you a booklet of the "Art of Record Making," and trust it will prove of interest to you.

## French Records

Again I wish to congratulate you on the nice French Records you have just issued. Like the first lot, these forty-two new Records are beautifully registered and give a perfect life-like reproduction. If I may give you a hint for a future choice of French songs, I will say that there is a larger sale of Mercadier's Records than of any other singer's, and that any quantity of that singer's Records will be sold by scores.—*Joseph Beaudry, Quebec, Can.*



**EDISON  
PHONOGRAPHS**

**Auld Lang  
Syne**

And other old songs are rendered just as well by the Edison Phonograph as the modern popular airs. "All music for all people"—that is the motto. You are losing much every day by not becoming the owner of this wonderful entertainer.

**GEORGE WHEELER**  
218-220 Chestnut St.,  
Dalton, Tenn.

Electro in above ad is: Single column wide, No. 661. Double column wide, No. 662.

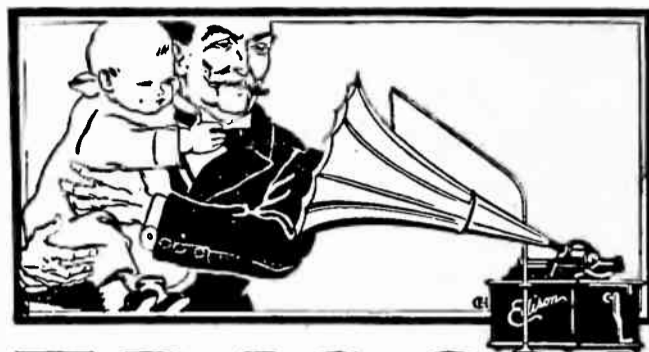

**EDISON  
PHONOGRAPHS**

**E**DISON invented the Phonograph. He made it an entertainer for all. It is manufactured at a price which everyone can afford, and we sell it on the easy-payment plan so that no one need be without it.

Have you heard and seen the new model?

**JOHN HARPER**

PHONOGRAPHS

88-90 Ormand Street  
Chicago, Ill.

Electro in above ad is: Single column wide, No. 663. Double column wide, No. 664.

## Ready-Made Ads

Another set of three ready-made ads for trade use are presented on this and the next page. They tell their own story. They are designed to assist Dealers in doing newspaper advertising in their own cities and towns, and thereby divert to their stores some of the benefits of the advertising we are doing in a general way. The "copy" is only suggestive. If you can write some that you think is better, or that fits your conditions better, write it by all means. No one has a monopoly of writing "pulling" ads; you may be able to do it better than an expert. It is important, first, to do the advertising, and second, to make an interesting appeal to the public.

Local Dealers have many advantages over out-of-town competition in being able to deliver machines right into a purchaser's home at the same price as paid at a distance. He can also offer his assistance in giving patrons such attention as they may need from time to time.

We are again willing to send any three of the above cuts on the same conditions as last month, namely, application to be made on the blank opposite, or the same form copied in a letter, and copies of newspaper in which they are used to be sent to our Advertising Department at Orange, N. J. Dealers who have had electros in the past must show that they have used them (unless they have already done so) before we will send any of the new series.



# EDISON PHONOGRAPHS

A business man's best relaxation comes in the form of music available with the least

effort. You want, in two words, the Edison Phonograph. It gives not only the new popular airs, but also all kinds of music. It can be adjusted perfectly to your taste in entertainment just as it can be adjusted to your pocket-book in purchasing.

JOHN WESBROOK  
23 Ogden Street  
Denver, Col.

Electro in above ad is: Single column wide, No. 665. Double column wide, No. 666.

## REQUEST FOR ELECTROS

NATIONAL PHONOGRAPH Co.

ADVERTISING DEPARTMENT, ORANGE, N. J.

DATE.....190.....

Mail Electros No.....

We agree to use them in newspaper advertising and to send you copies of papers containing them before asking you for other electros. We intend running a..... inch advertisement.

Name.....

Street.....

City and State.....

We buy through.....

Edison Dealers who have not signed the Agreement are urged to do so before January 1st, if they intend continuing in the business. Shortly after January 1st we shall remove from our files and mailing list the names of all old dealers who have not re-signed.

**SIGN NOW AND SAVE TROUBLE FOR YOURSELF,  
YOUR JOBBER AND US.**

---

---

**SUSPENDED LIST, JANUARY 1, 1908**

SUPERSEDING ALL PREVIOUS LISTS.

**CALIFORNIA.**

**Petaluma**—Thomas McGuire, 875 Main st.

**CANADA.**

**Ottawa, Ont.**—Ketchum & Co., Sparks and Bank sts.

**COLORADO.**

**Boulder**—Bentley & Craig.

**GEORGIA.**

**Valdosta**—H. K. McLendon, 109 West Central ave.

**ILLINOIS.**

**Champaign**—Eggleston Bros., or Eggleston Music House, J. P. Eggleston, Prop.; also Danville, Ill.

**Chicago**—A. Gloss & Son, 727 W. North av.

**Cooksville**—Geo. Swinehart & Son.

**Danville**—Eggleston Bros., or Eggleston Music House, J. P. Eggleston, Prop.; also Champaign, Ill.

**Kempton**—C. E. Bute.

**Ottawa**—Edward Hayne.

**Peoria**—H. Meyer, 1307 S. Adams st.

**Quincy**—Giles Bros., 107 North 4th st.

**Wheaton**—E. Irving.

**INDIANA.**

**South Bend**—Eugene Marsh, 126 Vistula ave. South Bend Book Bindery, Robert Lebolt, Prop., 203 North Michigan st.

**IOWA.**

**Burlington**—John P. Weiss, 711 Jefferson st.

**Cushing**—Bullock & Lyman.

**Independence**—E. O. Parker, 110 E. Main st.

**McClelland**—J. W. Rounds & Co.

*IOWA—Continued.*

**Mederville**—John J. Carpenter.

**Sioux City**—Hattenbach Bros. Co.

A. V. Larimore, 518 Fifth st.

**State Center**—Ora Sargeant.

\***Whiting**—The Cassady & Whiting Co.

**KANSAS.**

**Clay Centre**—E. M. Gowenlock.

**Lawrence**—Bell Bros.

**Topeka**—R. H. Morehouse, 510 E. 4th st.

**Wichita**—Frank R. Powell, 132 N. Main st.

**KENTUCKY.**

**Louisville**—Irvine Simons, 942 W. Market st. (formerly 543 W. Market st.).

**MAINE.**

**Biddeford**—W. H. Field.

**Gardner**—C. H. Cobb, 293 Water st.

**Lewiston**—J. W. Skene.

**Monmouth**—G. H. Stetson.

**Oldtown**—H. M. Burnham.

**Waterville**—Frank Blanchard, 150 Main st.

**MASSACHUSETTS.**

**Boston**—Henry H. Savage, 166 Hanover st.

T. Singer, 60 Leverett st.

**Florence**—William Oates, 87 Main st.

**Franklin**—E. P. Blackmar.

**Great Barrington**—Frank W. Wheeler, Main st.

**Lawrence**—Lord & Co., 314 Essex st.

E. O. Mosher, 420 Essex st.

**Malden**—A. T. Fuller.

**Nantucket**—Arthur M. Taylor.

**New Bedford**—H. B. DeWolff.

**Somerville**—E. J. Winchester, 32 Summit ave.

**Woburn**—Osborn Gillette, or The Boston

Jewelry Co., L. F. Maloney, Manager.

**Worcester**—Joseph Tukman, 44 Front st.

Guy Furniture Co., 521 Main st.

## SUSPENDED LIST CONTINUED.

### MICHIGAN.

**Ann Arbor**—Ann Arbor Music Co., F. J. Schwankovsky, Prop.  
**Blissfield**—Rothfuss Piano Co., (William Rothfuss, Geo. M. Rothfuss and Frank B. Jones.)  
**Detroit**—F. J. Schwankovsky.  
**Saginaw**—Geo. W. Emendorfer.  
 James V. Calahan, 217 Genessee st.  
 Tierney Bros., 217 Genessee st.

### MINNESOTA.

**Willmar**—Willmar Furniture Co., Ruble Block.  
**St. Cloud**—Fritz Guy.

### MISSOURI.

**Ewing**—Hal R. Ewalt.  
**Fairfax**—Hinde Hardware Co.  
**Kansas City**—The Wittmann Co.  
**St. Louis**—Knight Cycle Co., 1215 Olive st.

### NEBRASKA.

**David City**—John Albright.  
**Lincoln**—The Wittmann Co.  
**Omaha**—The Wittmann Co.  
 Piano Player Co.  
**Red Cloud**—Albright Bros. or L. P. Albright.  
**Sterling**—Sterling Drug Co., W. G. Morrill, Prop., and W. G. Morrill, M. D.

### NEW HAMPSHIRE.

**Dover**—H. C. Ingalls & Co., 444 Central ave.  
**Hillsboro Bridge**—E. M. Barnes.  
**Manchester**—A. E. Dumas.  
**Nashua**—F. A. McMaster & Co.

### NEW JERSEY.

**Atlantic City**—Sam'l D. Wolf, 32-34 Arkansas ave.  
**Bayonne**—J. Wigdor, 450 Avenue D.  
**Jersey City**—W. L. Hoffman, 151 Montgomery street.  
**Long Branch**—A. N. Alexander, 103 Broadway.  
 A. Nastasio, 103 Broadway.  
**Newark**—R. L. Corwin; also New York City.  
 R. Rosenthal, Prop. Springfield Hdw. and Sptg. Goods Store, 71 Springfield ave.  
 D. Reinhorn, 91 Springfield ave.  
**Passaic**—I. Hurwitz.  
**Paterson**—Chas. H. Kelly, 25 N. Main st.  
**Plainfield**—S. W. Frucht, or R. Frucht; also New York City.  
 Elston M. Leonard.  
**West Hoboken**—Emil Hollander, or The West Hoboken Bicycle & Phono. Co., 169 Spring st.

### NEW YORK.

**Albany**—G. Linde, 353 S. Pearl st.  
 G. A. Birdsall, 114 S. Pearl st.  
**Amsterdam**—D. C. Kirchner, 26 Market st.  
**Bedford Park**—Geo. H. Tyrrell.  
**Brooklyn**—Nathan Abrahams, 602 Broadway.  
 Wm. Albrecht, 294 Knickerbocker ave.  
 H. Hindermann, Bushwick Phonograph Exchange, 1421 Myrtle ave.  
 Emil Smith, 634 Eleventh st., and 230 Summer ave.  
**Hobart**—F. H. Marshall.  
**New York City**—A. T. Armstrong, or American Phono Co., 106 Wall st.  
 Automatic Zither Co., M. Cohen, Prop., 58 Second ave.  
 Bern Bearwald, 373 W. 11th st.  
 Edward Bielfeld, 481 Willis ave.  
 I. & S. Birnsweig, Birnsweig's Music Store, and Birn's Music Store, 510 E. 138th st.  
 Bronx Phono. Co., or David Switky, 506 Willis ave.  
 R. L. Corwin; also Newark, N. J.  
 Eagle Phono. Co., or C. Lowenthal, 83 Nassau st.  
 Empire Phono. Co., 2 W. 14th st.  
 S. W. Frucht, or R. Frucht, 7 Barclay st., or 68 Cortlandt st., also Plainfield, N. J.  
 O. Hacker, 2 Murray st.

### NEW YORK—Continued.

Hawthorne & Sheble, 297 Broadway; also Philadelphia, Pa.  
 Holober Bros., 350, 421 and 491 West st.  
 N. Horn, 148 E. 58th st.  
 W. L. Isaacs, 114 Fulton st.  
 Italo-American Phono. Co. (R. Gerard & Co.)  
 S. Lemburg & Co., 194 Broadway.  
 J. McEllyne, 202 Broadway.  
 Parker & Cooley, 2087 Amsterdam ave.  
 Richmond Pease, 44 W. 132d st.  
 F. M. Prescott, 44 Broad st.  
 Winthrop Cycle Co., 2212 Seventh av.  
**Oneonta**—G. B. Shearer Co., 259-261 Main St.  
**Rome**—Charles Tuttle.  
**Saratoga**—W. J. Totten.  
**Saratoga Springs**—Marvin A. Cote.  
**Watertown**—H. S. Wardwell & Co., 39 Public Square.  
**Wayland**—John Gross, Pursel Block.

### NORTH CAROLINA.

**Kinston**—S. A. Quinerly.

### NORTH DAKOTA.

**Fargo**—Ben Hart.

### OKLAHOMA.

**Oklahoma City**—Armstrong, Byrd & Co. (also Shawnee).  
**Shawnee**—Armstrong, Byrd & Co. (also Oklahoma City).

### OHIO.

**Ashtabula Harbor**—Chas. W. Askew (Gregory, Askew & Co.).  
**Bellevue**—H. E. Rouser.  
**Brookville**—H. K. Merritt.  
**Cincinnati**—J. L. Andem.  
**Coshocton**—Burns & Gosser.  
**Dayton**—W. E. Sapp, 1042 W. Third st.  
**Springfield**—D. & M. Vanderpool.  
**Uhrichsville**—F. A. Mazurie.

### PENNSYLVANIA.

\***Athens**—J. T. Stalford, 405 Main st.  
**Bradford**—C. C. Griffen, 29 N. Washington st.  
**Johnstown**—J. M. Bunnell; also Phillipsburg, Pa.  
**Lancaster**—J. H. Tragresser, 249 N. Queen st.  
**Mt. Pleasant**—Benjamin Posner.  
**New Castle**—Will Hartland, 70 E. Long st.  
**Philadelphia**—A. R. Cassidy, 2783 Emerald st.  
 Thomas Gunson, 1003 Carpenter st.  
 Hawthorne & Sheble, 604 Chestnut st., or Oxford and Mascher sts.; also New York City.  
 A. Krouse, 832 Arch st.  
 Penn Novelty Co., 15 South 9th st.  
**Phillipsburg**—J. M. Bunnell; also Johnstown, Pa.  
**Pittsburg**—A. Lippard, 615 Wylie ave.  
**Royersford**—Granville B. Tyson, 215 Main st.  
**Titusville**—E. H. Fortney, Prop. Exchange Cigar Store, 21 W. Central ave.

### RHODE ISLAND.

**Providence**—F. P. Moore.  
**Rockville Center**—O. A. Clark.

### TENNESSEE.

**Alexandria**—Clarence J. Baird Music Concern.

### TEXAS.

**Whitney**—H. E. Randle & Co.

### UTAH.

**Salt Lake City**—Daynes Romney Music Co., 25 East South 1st st.

### VERMONT.

\***Barre**—Averill Music Co. (H. L. Averill & Co.), 28 N. Main st.

### VIRGINIA.

**Norfolk**—W. Reichenstein, 296 Church st.

### WISCONSIN.

**Ashland**—J. F. Pool Co.  
**Milwaukee**—J. C. Blatzek.  
**Walworth**—G. H. Stewart.

\*Added since December 1st, 1907.

Jobbers and Dealers are asked not to supply any of the above named firms with our apparatus, either at addresses given or any other address.

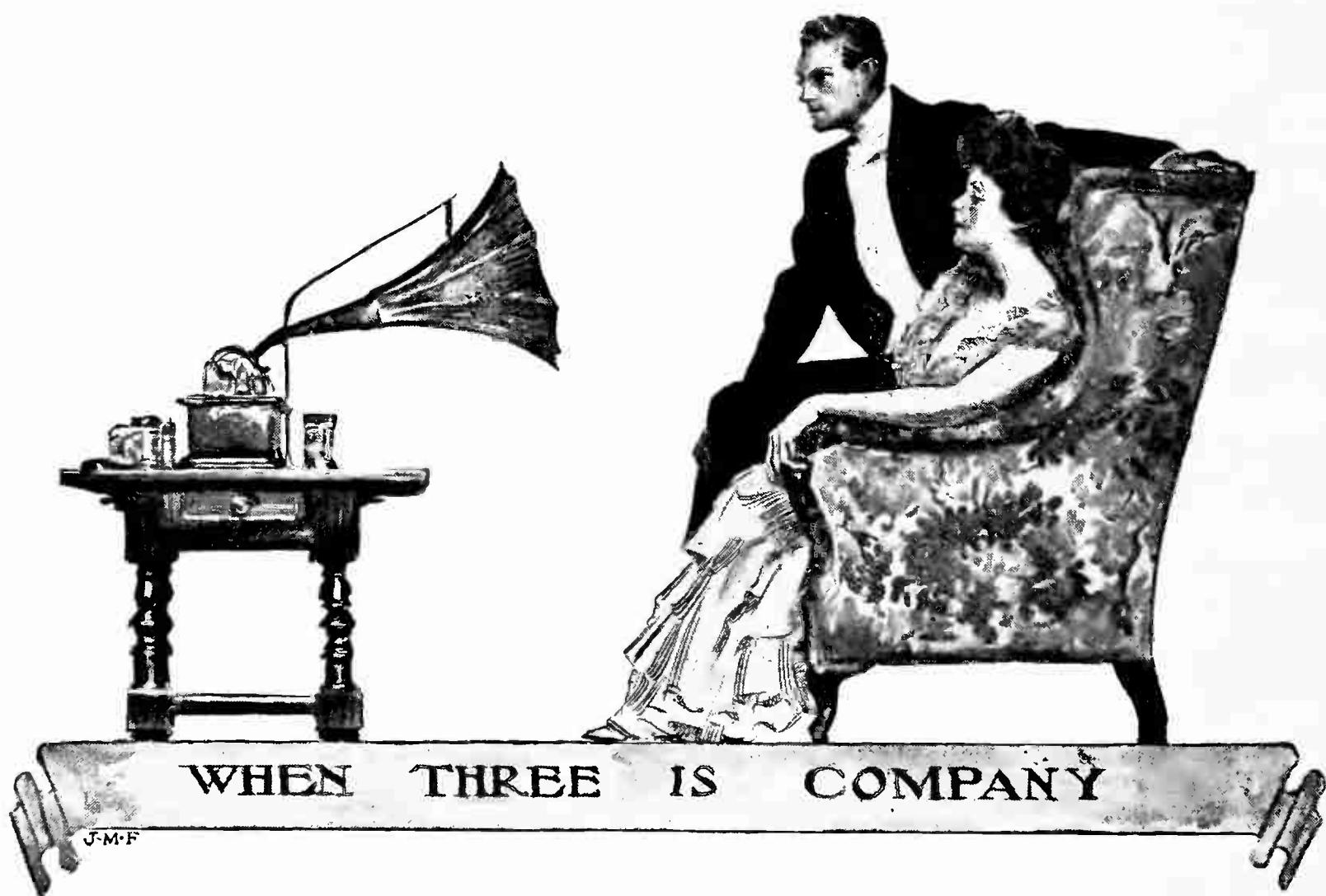

**N**OTHING can equal the satisfaction of offering your guests delightful entertainment that takes care of itself, which does not interfere with other forms of amusement, but rather helps them. Such an entertainer is

## The Edison Phonograph

It can amuse the guests by rendering music, popular or classic, or aid them with dance music, marches and other things played by the best orchestras and brass bands. It costs less than the hiring of even a small orchestra for a single evening's entertainment.

Hear the new model with the big horn at the nearest Edison store, or write for a booklet describing it. At the same time

## Hear the January Records

(out December 24th)—hear the song hits that everybody is talking about—hear the best orchestral and band music splendidly performed—hear the fine instrumental solos by well-known virtuosos—hear the talking records of really funny comedians—and then buy generously of the January records, for in no other way can you obtain for so little money so much delightful entertainment for your family and friends.

Ask your dealer or write us for these three books: THE PHONOGRAM, describing each Record in detail; the SUPPLEMENTAL CATALOGUE, listing the new January Records and the COMPLETE CATALOGUE, listing all Edison Records now in existence



Thomas A. Edison

NATIONAL PHONOGRAPH COMPANY, Lakeside Avenue, Orange, N. J.



# Jobbers of Edison Phonographs and Records

Continued from page 2 of Cover

## NEW YORK.

Albany—Finch & Hahn, 402 Broadway.  
Astoria—John Rose, 99 Flushing ave.  
Brooklyn—A. D. Matthews' Sons, 394 Fulton street.  
Buffalo—W. D. Andrews, Seneca and Wells sts.  
Neal, Clark & Neal Co., 647 Main st.  
Elmira—Elmira Arms Co., 117 Main st.  
Gloversville—American Phono. Co., 99 W. Fulton st.  
Kingston—Forsyth & Davis, 307 Wall st.  
New York City—Blackman Talking Machine Co., 97 Chambers st.  
J. F. Blackman & Son, 2787 3d ave.  
I. Davega, Jr., Inc., 125 W. 125th st.  
S. B. Davega, 32 E. 14th st.  
Douglas Phono. Co., Inc., 89 Chambers st.  
Jacot Music Box Co., 39 Union square.  
Victor H. Rapke, 1659 Second ave.  
Regina Co., 41 Union square.  
Siegel-Cooper Co.  
John Wanamaker.  
Alfred Weiss, 1622 First ave.  
Oswego—Frank E. Bolway, 32 W. Bridge st.  
Rochester—A. J. Deninger, 345 North st.  
Mackie Piano, O. & M. Co., 100 State st.  
Talking Machine Co., 97 Main st., E.  
Schenectady—Finch & Hahn, 504 State st.  
Jay A. Rickard & Co., 253 State st.  
Syracuse—W. D. Andrews, 216 E. Railroad st.  
Troy—Finch & Hahn, 3 Third st.  
Utica—Clark-Horrocks Co., 54 Genesee st.  
Arthur F. Ferriss, 89 Washington st.  
William Harrison, 50 Columbia st.  
Utica Cycle Co., 16 Columbia st.

## OHIO.

Canton—Klein & Heffelman Co., 220 E. Tuscarawas st.  
Cincinnati—Ball-Fintze Co., 108 West 3d st.  
Ilsen & Co., 615 Vine st.  
Lawrence McGreal, 29 East 5th st.  
Rudolph Wurlitzer Co., 121 East 4th st.  
Cleveland—Eclipse Musical Co., 1870 East Ninth st.  
Columbus—Perry B. Whitsit Co., 213 S. High street.  
Dayton—Niehaus & Dohse, 35 E. 5th st.  
Newark—Ball-Fintze Co.  
Toledo—Hayes Music Co., 422 Superior st.

## OREGON.

Portland—Graves & Co., Inc., 65 No. Park st.

## OKLAHOMA.

Oklahoma City—Smith's Phono. Co., 818 West Main st.

## PENNSYLVANIA.

Allentown—G. C. Aschbach, 539 Hamilton st.  
Easton—William Werner, 422 Northampton st.  
Harrisburg—S. K. Hamburger, 12-14 N. Market square.  
Philadelphia—Louis Buehn & Bro., 45 N. 9th street.  
C. J. Heppe & Son, 1117 Chestnut st.  
Lit Bros., Market and 8th sts.  
Musical Echo Co., 1217 Chestnut st.  
Penn Phonograph Co., 17 S. 9th st.  
John Wanamaker, 13th and Market sts.  
Western Talking Mach. Co., 41 and 43 N. 9th st.  
H. A. Weymann & Son, 1010 Chestnut st.

## Pennsylvania—Continued.

Pittsburg—Pittsburg Phono. Co., 937 Liberty st.  
Powers & Henry Co., 101 Sixth st.  
Standard Talk. Mach. Co., 435 Wood st.  
Reading—S. K. Hamburger, 723 Chestnut st.  
Reading Phonograph Co., 48 N. 8th st.  
Scranton—Ackerman & Co., 217 Wyoming av.  
Technical Supply Co.  
Sharon—W. C. DeForeest & Son.  
Williamsport—W. A. Myers, 145 W. 3d st.

## RHODE ISLAND.

Providence—J. M. Dean Co., 785-795 Westminister st.  
J. A. Foster Co., Weybosset and Dorrance sts.  
J. Samuels & Bro., 154 Weybosset st.

## TENNESSEE.

Chattanooga—J. H. Templeman Co., 253 Montgomery ave.  
Knoxville—Knoxville Typewriter and Phonograph Co., 421 Gay st.  
Memphis—F. M. Atwood, 160 N. Main st.  
O. K. Houck Piano Co., 103 S. Main st.  
Nashville—Magruder & Co., 27 Arcade.  
Nashville Talking Mach. Co., 723 Church st.

## TEXAS.

Dallas—Southern Talking Machine Co., 347 Main st.  
El Paso—W. G. Walz Co., 101 El Paso st.  
Fort Worth—Cummings, Shepherd & Co., 700 Houston st.  
Houston—Texas Piano & Phono. Co., Capitol and Fannin sts.  
San Antonio—H. C. Rees Optical Co., 242 West Commerce st.

## UTAH.

Ogden—Proudfit Sporting Goods Co., 351 24th street.  
Salt Lake City—Clayton Music Co., 109 S. Main st.

## VERMONT.

Burlington—American Phono. Co., 34 Church street.

## VIRGINIA.

Richmond—C. B. Haynes & Co., 603 E. Main street.

## WASHINGTON.

Seattle—D. S. Johnston Co., 903 Second ave.  
Kohler & Chase, 719 Pike st.  
Spokane—Spokane Phonograph Co., 7 Post st.

## WISCONSIN.

Milwaukee—Lawrence McGreal, 176 3d st.

## CANADA.

Montreal—Peter Kelly, 232 St. Lawrence st.  
Quebec—C. Robitaille, 320 Rue St. Joseph.  
St. John—W. H. Thorne & Co., Ltd., 42-46 Prince William st.  
Toronto—R. S. Williams & Sons Co., Limited, 143 Yonge st.  
Vancouver—M. W. Waitt & Co., 553 Granville street.  
Winnipeg—R. S. Williams & Sons Co., Ltd., 121 Princess st.

# In the Words of Others

## "Sell I.C.S. Language Outfits"

The best proof that it will pay you to sell I. C. S. Language Outfits comes from the statement of dealers that have tried them. We have published several of these letters before; here is another one from the Denver

Dry Goods Co. This is piling up evidence that you are losing profits of from 10 to 30 per cent. on your business if you are not handling these Outfits. The phonograph system is fast becoming recognized as the most perfect way in the world to teach foreign languages. As a commercial enterprise, the I.C.S. System has always paid dealers well in the past, and it is growing very rapidly. Wouldn't it be a good idea for you

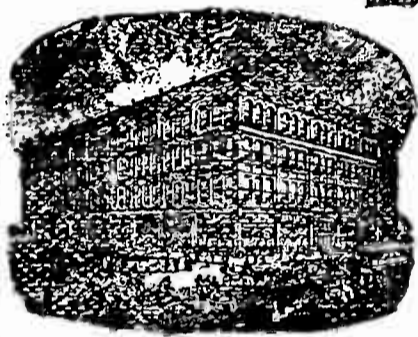

**THE DENVER DRY GOODS CO.**

325 BROADWAY, DENVER, COLO.

RECEIVED

DENVER, COLO. 11/21/06.

International Correspondence Schools  
Scranton Pa.

Gentlemen:

In reply to your letter of the 17th inst., will say we considered the demonstration of Mr. Mistraud very successful and while he was here we sold several Language Outfits. We have also sold some since he left us. We expect to advertise these Language Outfits during December as gifts as you may rest assured we will communicate with the parties to whom demonstration was given and who have not as yet made a purchase. We think the plan of advertising or demonstrating these Outfits is successful and leads to sales which could not be obtained otherwise.

We have placed several orders with you since the demonstration and would like to know if we could make arrangements to purchase whatever we need in this line through your Denver office as we have had to do several times recently; same can be billed to us by you. This would be quite an accommodation to us.

We will keep you advised from time to time of the results of sales on I. C. S. Language Outfits.

Yours very truly,

THE DENVER DRY GOODS CO.,

per *A. Shultz*

to write us today for full particulars of what we can do for you? Let us put our advertising to work for you. It will not only bring you customers for language work, but will increase your regular business. Send us a postal card NOW.

**International Correspondence Schools**  
SCRANTON, PA.

# EDISON PHONO- GRAPH MONTHLY

Vol. VI

February, 1908

No. 2

## CONTENTS

	PAGE		PAGE
Plan for a Bigger Year Than Ever.....	1	Forty-six Edison Records Made Over.....	11
Lauder Records Going Big.....	1	Foreign Selections Cut Out.....	11
Advance List Edison Gold Moulded Records for April .....	2	Playing Fair.....	12
Eight Selections Made Over.....	5	Must Sign an Agreement with Each Jobber..	12
Important Cut-Out Notice.....	5	Pushing Foreign Records.....	13
Don't Let Stocks Run Low.....	5	Printed Matter .....	14
Throw Away Printed Matter with Old Prices	5	Record Exchange Proposition.....	14
Our Selling Contracts Sustained by England's Highest Court.....	6	Remove Marks from Cases.....	16
Meetings of the Selling Force.....	7	Holiday Window Display by Flint & Brickett.	17
New Prices on Horns and Cranes.....	8	A Gem Victory.....	18
Advance List of French and Holland-Dutch Selections .....	9	Going After Record Business.....	18
A Defiant Infringer Quickly Disposed of....	10	Suggested Copy for Dealer's Ads.....	19
New Horn Meets Long Felt Want.....	10	Ready Made Ads.....	20
		February Advertising .....	20
		Suspended List February 1, 1908.....	22
		Jobbers of Edison Phonographs, Cover pp. 2 & 3	

*Published for Trade use only by  
The National Phonograph Co., Orange, N.J.*

# Jobbers of Edison Phonographs and Records

## ALABAMA.

Birmingham—Talking Machine Co., 2007 Second ave.  
Mobile—W. H. Reynolds, 167 Dauphin st.  
Montgomery—R. L. Penick, 119 Dexter ave.

## CALIFORNIA.

Los Angeles—Southern California Music Co., 332 South Broadway.  
Oakland—Kohler & Chase, Inc., 917-921 Wood street.  
Sacramento—A. J. Pommer Co., 9th and J sts.  
San Francisco—P. Bacigalupi & Sons, 1021 Golden Gate ave.

## COLORADO.

Denver—Denver Dry Goods Co., 619 16th st.  
Hext Music Co., 15th and California sts.

## CONNECTICUT.

New Haven—Pardee-Ellenberger Co., Inc., 96 State st.

## DISTRICT OF COLUMBIA.

Washington—E. F. Droop & Sons Co., 925 Pennsylvania ave., N. W.

## GEORGIA.

Atlanta—Atlanta Phonograph Co., 50 Peachtree st.  
Phillips & Crew Co., 37-39 Peachtree st.  
Savannah—Youmans & Leete, 116 Barnard st.  
Waycross—George R. Youmans.

## IDAHO.

Boise—Eiler's Piano House.

## ILLINOIS.

Chicago—Babson Bros., 1419 19th st.  
Lyon & Healy, Wabash ave. & Adams st.  
James I. Lyons, 192 Van Buren st.  
The Vim Co., 68 E. Lake st.  
Montgomery Ward & Co., 111 Michigan avenue.  
Rudolph Wurlitzer Co., 266 Wabash ave.  
Peoria—Peoria Phonograph Co., 416 S. Adams street.  
Quincy—Quincy Phonograph Co., 411 Hampshire st.

## INDIANA.

Indianapolis—Indiana Phono. Co., 45 Virginia avenue.  
Kipp-Link Phonograph Co., 10-12 E. Washington st.  
A. B. Wahl & Co., 119 S. Illinois st.

## IOWA.

Des Moines—Hopkins Bros. Co., 620 Locust st.  
The Vim Co., 204 Seventh st.  
Dubuque—Harger & Blish, 904 Main st.  
Fort Dodge—Early Music House, 322 Central avenue.  
Sioux City—Early Music House, 315 Court st.

## KENTUCKY.

Louisville—Montenegro-Riehm Music Co., 527-531 Third ave.

## LOUISIANA.

New Orleans—William Bailey, 600 Frenchmen street.  
National Automatic Fire Alarm Co., 614 Gravier st.

## MAINE.

Bangor—S. L. Crosby Co., 186 Exchange st.  
Portland—W. H. Ross & Son, 43 Exchange st.

## MARYLAND.

Baltimore—E. F. Droop & Sons Co., 231 North Howard st.

## MASSACHUSETTS.

Boston—Boston Cycle & Sundry Co., 48 Hanover st.  
Eastern Talking Mach. Co., 177 Tremont street.  
Iver Johnson Sptg. Goods Co., 163 Washington st.  
Fitchburg—Iver Johnson Sptg. Goods Co., 247 Main st.  
Lowell—Thomas Wardell, 111 Central st.  
New Bedford—Household Furnishing Co., 170 Purchase st.  
Springfield—Flint & Brickett Co., 489 Main st.  
Worcester—Iver Johnson Sptg. Goods Co., 304 Main st.

## MICHIGAN.

Detroit—American Phono. Co., 106 Woodward avenue.  
Grinnell Bros., 219 Woodward ave.

## MINNESOTA.

Minneapolis—Thomas C. Hough, 714 Hennepin avenue.  
Minnesota Phono. Co., 505 Washington av., So.  
St. Paul—W. J. Dyer & Bro., 21-23 West 5th st.  
Thomas C. Hough, 392 Wabasha st.  
Koehler & Hinrichs, 255 E. 3d st.  
Minnesota Phonograph Co., 37 E. 7th st.

## MISSOURI.

Kansas City—J. W. Jenkins' Sons Music Co., 1018-1015 Walnut st.  
J. F. Schmelzer & Sons Arms Co., 710 Main st.  
St. Louis—Conroy Piano Co., 11th and Olive streets.  
Koerber-Brenner Music Co., 1006 Olive street.  
Silverstone Talk. Mach. Co., 1010 Olive st.

## MONTANA.

Helena—Frank Buser, 509 N. Main st.

## NEBRASKA.

Lincoln—Ross P. Curtice Co., 1125 O st.  
H. E. Sidles Phono. Co., 13th and P sts.  
Omaha—Nebraska Cycle Co., 15th and Harney streets.  
Shultz Bros., 16th and Chicago sts.

## NEW HAMPSHIRE.

Manchester—John B. Varick Co., Varick Bldg.

## NEW JERSEY.

Hoboken—Eclipse Phono. Co., 203 Washington st.  
Newark—Douglas Phonograph Co., 20 New st.  
A. O. Petit, 57 Halsey st.  
Rapke Phono. Store, 287 Bank st.  
Paterson—James K. O'Dea, 117 Ellison st.  
Trenton—Stoll Blank Book and Stationery Co., 30 E. State st.  
John Sykes, 105 N. Broad st.

Continued on page 3 of cover

# Edison Phonograph Monthly

VOL. VI.

February, 1908

No. 2

## Plan for a Bigger Year than Ever

January is the rounding-up month. It is the month when inventories are taken, books are balanced, and profits are determined. It is the month when the good business man looks back over the happenings of the past year, and, taking cognizance of the good and bad things of the year, prepares to apply their lesson to his business of the new year. It is the time when plans are formed for the coming months—when decisions are reached to carry larger or smaller stocks, to extend one department or decrease another.

All of this applies quite as well to Edison Dealers as to any other class of business men. We believe that with few exceptions, 1907 demonstrated more strongly than ever that Edison Phonographs and Records comprise a remarkably fine line, either as a complete business in itself or as a department where other goods are sold. The hundreds of glowing reports that we get by mail, personally and through our salesmen, leave no doubt as to the success of the Edison line with Dealers as a whole, and more especially with those who push the business and give it the attention it deserves. Each Dealer, however, knows better than we how successful he was in 1907. He also knows, if he was properly observant, why he did not do even more business in Edison goods, and he should be prepared to benefit by his experience.

If he has lost sales because he did not carry sufficient stock, he should arrange to increase it this year. If the lack of a little additional capital has been a handicap, especially in making instalment sales, efforts should be made to get more capital in 1908. If his business has suffered from lack of advertising, circularizing or other means of getting publicity, then a determination should be made to give it more attention this year. It is surprising what a volume of new business can be secured by the expenditure of a little money for advertising.

If stocks have not been kept in good shape, with machines nicely displayed and Records kept in a convenient place and using a proper system, then attention cannot too soon be given to plans that will remedy such shortcomings. Keep machines clean and looking new, and carry Records in trays, so that they will make a good display on your shelves and so you can put your hand on any desired Record at a moment's notice. To know your stock is to sell it. Haven't you often admired the man who had his work at his fingers' ends and could tell you about everything in his line that you wanted to know. Be such a Dealer. Be able to say that, considering the size of your business and the limitations of your field, no one carries his stock of Edison goods in better shape. The pride you will feel in being able to make this statement will have a marked effect upon the public, and it will prove a valuable asset. If you have been indifferent about your window displays, compel yourself to do differently. This is a kind of advertising that yields handsomely and costs you only the time it takes to keep the window attractive. If you haven't discounted your bills, resolve to do so this year. With a little planning you will find that discounts are "easy money."

You can do your share in making 1908 what we feel sure it will be, the greatest in the history of the Phonograph, and with proper attention you can make it the biggest Edison year for yourself.

## Lauder Records Going Big

The Lauder Records, to be shipped to Jobbers early in February, are a tremendous success. The advance orders from Jobbers are especially heavy, and we believe that the after orders will be even larger. Jobbers who have not given them the consideration they merit should lose no time in sending in orders, for not to have a stock of Lauder Records will mean a loss of desirable business. Dealers, also, will need them in stock.

## The New Edison Gold Moulded Records Advance List for April, 1908

**R**ECORDS listed below will be shipped from Orange in time to reach all Jobbers in the United States and Canada before March 25th, 1908, all things being favorable, and they may be reshipped to Dealers at 2 P. M. on March 24th. They must not, however, be exhibited, demonstrated or placed on sale by Jobbers or Dealers until 8 A. M. on March 25th. Supplements, Phonograms and Bulletins will be shipped with Records. These may be distributed to Dealers after March 20th, but must not be circulated among the public before March 25th. Jobbers and Dealers may, however, deposit Supplements and Phonograms in Mail Boxes or Post Offices after 5 P. M. on March 24th, for delivery on the following day. Jobbers are required to place orders for April Records on or before February 10th. Dealers should place April orders with Jobbers before February 10th to insure prompt shipment when Jobbers' stock is received.

### 9794 Marche Turque—Patrol

Edison Concert Band

Another ambitious effort on the part of our Recording Department is this Record of a composition by one who has a national fame as a composer of instrumental music. The feature of this selection from a recording standpoint is the heavy cymbal effect that has been secured without any of the discordant sounds usually heard. The composition partakes of a Turkish character and is one of more than ordinary attractiveness. It has been officially adopted by a branch of the Masonic order. Composer, R. Eilenberg; publisher, Carl Fischer, New York.

### 9795 There Never Was a Girl Like You

Byron G. Harlan

A rustic sentimental ballad with simple words and an air that improves with each hearing. Its publishers confidently assert that it will be one of the most popular songs of this spring and summer. It will be widely exploited and the fame of the writers of the words and music will do much to add to its popularity. Mr. Harlan gives the song an excellent rendition for our Record. Orchestra accompaniment. Music, Egbert Van Alstyne; words, Harry Williams; publishers, Jerome H. Remick & Co., New York.

### 9796 Under Any Old Flag at All

Billy Murray

This is a song hit from George M. Cohan's "The Talk of New York," in which it is sung by Victor Moore. It is based upon the fact that "with a good supply of money, everything is milk and honey, under any old flag at all," and the chorus dwells upon the assertion that "when you're rich you're the smoke; when you're broke it's a joke." The air is as novel as the words and Mr. Murray sings it as if he knew all about both ends of the game. Orchestra accompaniment. Music and words, George M. Cohan; publisher, F. A. Mills, New York.

### 9797 Hornpipe Medley

Charles D'Almaine

Medley records by the violin are among the most popular of instrumental selections. Their initial sale is always heavy and they are in such demand afterwards as to always remain in our catalogue. This Record includes the following well known hornpipes: "Jenny Linn," "Lockers," "Acrobat," "Champion," and "Autograph." Orchestra accompaniment. The arrangement is original and not published.

### 9798 Rambling Rose

Harry Anthony

Rose is a flower, but not of the woodlands. She loved to ramble and she loved to tease. Thus runs this charming new sentimental ballad, the chorus being as follows:

My Rambling Rose  
Sweetest flow'r that grows,  
When you are near me, dear, my heart a-throbbing goes;

And though you ramble so,  
That your heart is true, I know,  
To me, just me, my Rambling Rose.

Orchestra accompaniment. Music, John Heinzman; words, James J. Walker; publishers, Joseph W. Stern & Co., New York.

**9799 When You Steal a Kiss—or Two****Ada Jones and Billy Murray**

One of the good things from "The Girl Behind the Counter," at Lew Fields' Herald Square Theatre. Our Record will be quite as much of a success as was "Smile, Smile, Smile," made for the January list by the same popular artists. The chorus:

Words are not the only thing  
When you are making love,  
Your eyes are always whispering  
"Come, be my turtle dove."

Ev'ry time you take her hand  
She knows your love is true  
And lips are only needed  
When you steal a kiss or two.

Orchestra accompaniment. Music and words, Kenneth S. Clark; publishers, M. Witmark & Sons, New York.

**9800 When the World Don't Treat You Right, Come Home****Bob Roberts**

"But don't come around near me." Jones has decided to go West, and in parting his lady-love gives him some advice, and closes with the above injunction. Mr. Roberts has not in some time had a song so well adapted to his style of singing coon songs. May Irwin wrote the words and music, and has many times delighted large audiences with her renditions of the song. Orchestra accompaniment. Publishers, Rose & Snyder Co., New York.

**9801 Spangles—Intermezzo****Edison Symphony Orchestra**

An intermezzo by the composer of "The Teddy Bears' Picnic" (No. 9777). It affords the same opportunity for instrumental coloring and should be widely popular. Composer, John W. Bratton; publishers, M. Witmark & Sons, New York.

**9802 When We Listened to the Chiming of the Old Church Bell****Manuel Romain**

Few singers for the Edison Phonograph have achieved such a popularity in so short a time as Mr. Romain. And deservedly, too, for he is one of the most entertaining artists on the Edison staff. His success as a singer for the Phonograph is no less pronounced than his success as the leading tenor in Dockstader's Minstrels. This Record is reminiscent of the wedding day in May long, long ago, when the youthful couple listened to the chiming of the old church bell. Mr. Romain's voice never appeared to better advantage. Orchestra accompaniment. Music, J. Fred Helf; words, Robert F. Roden; publishers, Helf & Hager Co., New York.

**9803 Way Back****Collins and Harlan**

A lively rube duet, having for its subject the visit of Uncle Josh to New York, the greeting accorded him, his general dissatisfaction with city ways, and his desire to get quickly back to old Oshkosh, where "he wouldn't swap an acre for the hull durned city, by gosh." The song has one of those airs that catch on quickly, and which, together with the singing by Collins and Harlan, will cause this Record to be "in the money" for April. Orchestra accompaniment. Music, Lester Keith; words, John Kemble; publishers, Jerome H. Remick & Co., New York.

**9804 The Romany Lass****Frank C. Stanley**

Mr. Stanley's many admirers will be delighted with the listing of this Record, because of the opportunity it will afford them of hearing his splendid baritone voice once more. It is some time since he has made a solo Record of this kind. The song is a gypsy love tale—one of those songs perfectly fitted to Mr. Stanley's capabilities. Orchestra accompaniment. Music, Stephen Adams; words, F. E. Weatherly; publishers, Boosy & Co., New York.

**9805 Call of the Wild March****Edison Military Band**

The arrangement of this spirited march is such as to show to advantage the different sections of our military band. The execution is unusually good. Composer, F. H. Losey; publisher, Carl Fischer, New York.

**9806 I'm Looking for the Man That Wrote "The Merry Widow Waltz"****Edward M. Favor**

Charlie took his Lizzie to see "The Merry Widow." The "waltz" was so entrancing that it set her dancing, and she waltzed the shoes off her feet. The various members of the family and sundry other occupants of the flat also caught the fever. Charlie was finally driven to longing for an opportunity to wreak vengeance upon the author of the now famous waltz. Part of the song is set to strains from the "Merry Widow Waltz." Mr. Favor's rendition is very amusing and entertaining. The Record will be close to the top of the April list. Orchestra accompaniment. Music, Seymour Furth; words, Edgar Selden; publisher, Shapiro, New York.

**9807 The Vagabonds****Spencer and Girard**

A capital rendition of the old poem by Trowbridge, sometimes called "Roger and I." The vagabonds are a wandering fiddler and his dog Roger, who live from day to day by the violin playing of the master and the tricks of the dog. Mr. Girard's imitation of the intelligent canine is especially realistic. Original arrangement and not published.

**9808 See-Saw****Ada Jones**

Everybody is familiar with the popularity attained by "School Days." In "See-Saw" the same composer has written its natural sequel and companion piece, and is entitled to feel certain of its equal success. The composition has all of the elements that make songs known from ocean to ocean. Those who buy this Record will find themselves familiar with the song when its popularity arrives. This was the case with "School Days." Orchestra accompaniment. Music, Gus Edwards; words, Ed. Gardenier; publishers, Gus Edwards Music Co., New York.

**9809 Sweetheart March****Albert Benzler**

Mr. Benzler's bi-monthly xylophone selection is one of Arthur Pryor's earliest compositions. Had it been written expressly for the xylophone it could not have been better suited to that instrument. Mr. Benzler has given it an excellent rendition. Orchestra accompaniment. Publisher, J. W. Pepper, Philadelphia.

**9810 Flanagan's Mother-in-Law****Steve Porter**

Flanagan has had the laugh on other members of his family, to say nothing of various other individuals, and it was not to be expected that his mother-in-law would escape. She "gets hers" in this Record. Her shape is first made the subject of several funny remarks. Flanagan states that his wife's name is Pearl. He hadn't been married a week before he found there was a flaw in the mother-o'-pearl. When the doctor told Flanagan that his mother-in-law was a very sick woman, Flanagan heartlessly replied: "Now, Doc, quit your jokin'. Don't make me laugh, me lips are chapped." The incidental singing has an orchestra accompaniment. Original and not published.

**9811 Lord, I'm Coming Home****Anthony and Harrison**

No new list of Edison Records would be complete without a sacred selection by either Messrs. Anthony and Harrison or the Edison Mixed Quartette. Both combinations are very popular. The initial sales of this selection are large and there is always a heavy and steady after-sale. "Lord, I'm Coming Home" is one of the better grade of sacred songs. Our Record will add much to its popularity as a hymn. Orchestra accompaniment. Music and words, William J. Kirkpatrick. Published in hymn books.

**9812 I Got to See de Minstrel Show****Arthur Collins**

Parson La Gran, a New Canaan preacher, married the daughter of a minstrel man and declared that he would convert her. He warned her that she would have to stay away from shows and learn to pray. Everything went smoothly till the minstrels came to town. Mrs. Le Gran then threw off restraint and announced that she had to see the show. The tuning up of the minstrel brass band and the music incidental to the street parade are given in the Record and add to its realism. Mr. Collins is quite as clever as ever with his coon dialect and by-play. Orchestra accompaniment. Music, Harry Von Tilzer; words, Vincent Bryan; publishers, Harry Von Tilzer Co., New York.

**9813 Christ Arose!****Edison Concert Band**

This is an Easter selection and it has been arranged by Leader Ecke in a manner similar to our Christmas number, "Ring Out the Bells for Christmas." It introduces a quartette of mixed voices, together with bells and chimes. It is fully as attractive as the Christmas selections and its sale should be quite as large. Special arrangement and not published.

**9814 The Message of the Eyes****Allen Waterous**

A sentimental song by the composer of "Love Me and the World Is Mine," introducing a new baritone soloist to our catalogue, although Mr. Waterous has sung in duets with Mrs. Waterous. He possesses a fine voice and will be a welcome addition to the corps of Edison artists. The song itself will appeal to admirers of the better class of ballads. Orchestra accompaniment. Music, Ernest R. Ball; words, Michael Resnick; publishers, M. Witmark & Sons, New York.

**9815 Si and Sis, the Musical Spoons****Ada Jones and Len Spencer**

Si and Sis are typical down East lovers. They engage in a series of "swops," or exchange of compliments, and Si convinces Sis that he is a musical prodigy. He plays on two clarinets at one time, giving an imitation of bagpipes; on a violin with one string, and on two ocarinas at one time. The musical features are played by Mozart, the playing of two clarinets at one time and of two ocarinas in unison being an unusual "stunt." This vaudeville sketch is original and is not published.

**9816 Nancy Lee****Edison Male Quartette**

The revival of this old and popular song of the sea, especially in male quartette form, is a Phonograph event. Its re-appearance will be heartily welcomed. Our Male Quartette gets better all the time. The arrangement is special. Unaccompanied. Music, Stephen Adams; words, F. E. Weatherly.



9817 Rain-in-the-Face Medley

Edison Military Band

A merry medley, consisting of the two comic hits, "Rain-in-the-Face" (Record No. 9755), and "I'm Afraid to Come Home in the Dark" (Record No. 9780), and the clever coon song, "Much Obligated to You" (Record No. 9768). Original arrangement and not published.

## 8 Selections Made Over

In accordance with the notice printed on page we list below eight selections that have been made over by the same or new talent. The April printed matter prepared for retail use will contain these selections. Dealers should replace their stock of the original Records of these numbers with the new ones.

8774 Algonquin March

Edison Military Band

8409 In the Valley Where the Blue Birds Sing

Byron G. Harlan

7824 Le Carnaval de Venise (Violin)

Charles D'Almaine

8799 Maple Leaf Forever

Reinald Werrenrath

Formerly by W. H. Thompson

8136 Nearer My God to Thee

Edison Concert Band

8717 Noisy Bill

Edison Military Band

8256 O That We Two Were Maying

Mr. and Mrs. Waterous

Formerly by Miss Morgan and Mr. Stanley

7659 Waltz from Faust (Violin)

Charles D'Almaine

### Important Cut Out Notice

The moulds of the selections named below are in such poor condition that it has been deemed advisable to cut them from the domestic catalogue. Ordinarily they would be made over but they have been listed for several years and the present demand does not warrant making new masters.

7438 Mary Was a House Maid

Dudley

7787 Intermezzo from Naila

Edison Military Band

7945 Little Darling Dream of Me

Edison Male Quartette

When our present stock of these selections is exhausted no further orders will be filled. Jobbers and Dealers are especially asked to note these cut out selections, for they cannot be omitted from the domestic catalogue until the April edition appears.

### Don't Let Stocks Run Low

The most important duty that Jobbers and Dealers can perform at the present time is to watch their stocks of Edison Phonographs and Records and make sure that they are sufficiently complete to meet even an unusual demand upon them. Stock-taking is now past, books have been balanced for the past year and plans for the future are now in order. The latter will be incomplete without a careful inspection of the stock of goods on hand and placing orders for such new goods as will bring the stock up to date, both in quality and quantity. Don't let any business get away because of your neglect to put in a few more machines or to fill in the vacant places of your Record stock. Also, don't forget, Mr. Jobber, that in many cases you are

some distance away from the Orange factory, and that consequently it takes some time for goods to reach you by freight. Unless you want to pay express charges on rush shipments, order well in advance. Place an order for a quantity of machines to be shipped at regular intervals, the time to be named by you. You found that standing orders of this kind worked well in the past; it will be equally satisfactory now. Keep Records ordered well ahead, too.

### Throw Away Printed Matter With Old Prices

Jobbers and Dealers are asked to look over their stocks of our printed matter and throw away or destroy all catalogues and other forms showing the old prices of Edison Phonographs. To distribute such printed matter can only cause trouble and confusion, and it is better to destroy it, even though it seems like a considerable loss to do so.

### 1097 Out of 1219 Were Edison Records

Our Australian office recently received a letter from an owner of an Edison Home Phonograph in Brisbane, Queensland, giving the percentage of Edison Records in his collection as compared to all others. Out of 1219 titles, 1097 were Edison Records. The remainder was divided among five other makes. Since the competition in cylinder records is much greater abroad than it is here, this preponderance of Edison Records is most gratifying.

## Our Selling Contracts Sustained by England's Highest Court

On December 18, 1907, the Lord Chief Justice of England, Lord Justice Buckley and Lord Justice Kennedy, sitting in the Supreme Court of Judicature, rendered a decision in the case of National Phonograph Company (Limited) vs. Edison-Bell Consolidated Phonograph Company (Limited) which is a sweeping victory for our selling contracts. Each of the justices wrote a separate opinion, but they all agreed in holding that one who causes a factor (Factors in England are what we call Jobbers in the United States) to break his contract with the National Phonograph Company may be enjoined from continuing such practices, and may be made to account in damages.

The contract between the English Factors and the National Phonograph Company contains a clause as follows:

"Factors must not sell or supply, or place on commission either directly or indirectly, Edison Phonographs or parts thereof, records, or blanks, to any Dealer who has not signed the agreement required by the National Phonograph Company (Limited), governing and controlling the sale of same, nor to Dealers who are on our suspended list."

The Edison-Bell Company was on the suspended list, and was, therefore, unable to purchase Phonographs and supplies from the Factors, and being desirous of obtaining Edison Phonographs, which are greatly superior to the Edison-Bell machines, for sale to its customers, evolved a scheme to obtain Edison Phonographs by deceit, and, in pursuance of this scheme, sent two men, Hughes and Leach by name, to the Factors of the National Company to buy Edison Phonographs for the Edison-Bell Company. Hughes and Leach represented to the Factors that they were Dealers of the National Phonograph Company, and signed the regular Dealer's contracts with these Factors under fictitious names, which were not on the suspended list. By this means the Edison-Bell Company was able to obtain a number of Phonographs from Factors at trade discounts, and the National Company, on finding out what had been done, brought suit against the Edison-Bell Company for an injunction against its causing and procuring the Factors to break their contracts and praying for an accounting and damages. When the case came up for trial in the Court of the King's Bench, Mr. Justice Joyce, after finding the facts as

above stated, decided the suit in favor of the Edison-Bell Company, holding that the National Company was not entitled to the relief asked.

The National Company thereupon took this appeal, resulting in a reversal of the decision of the lower Court, by the Court of final resort; and in the complete final vindication of the selling contracts of the National Phonograph Company.

The views of the Justices are suggested by the following extracts from their opinions. The Lord Chief Justice says, after citing the clause of the contract above quoted:

"It was suggested in argument that this restriction imposed by the plaintiff upon Factors was open to some objection. I am unable to appreciate upon what ground any such objection can be founded."

Lord Justice Buckley says:

"The act which the defendant did was, I think, a violation of a legal right of the plaintiffs, because it interfered with the contractual relations subsisting between the plaintiffs and the Factors, and there was no sufficient justification for such interference."

Lord Justice Kennedy says:

"That Hughes and Leach and the defendant Company which employed them, did what is morally wrong, is patent. They induced the Factors to sell these goods to them by an untrue representation; not indeed in order to defraud either the Factors or plaintiffs in any pecuniary respect, for they paid the price which the plaintiffs had authorized the Factors to accept; but it must be assumed that, if the Factors had known they were selling to persons who were agents of a firm and on plaintiff's suspended list, they would not have sold Hughes or Leach any of the machines which had been obtained from the plaintiff."

The Edison-Bell Company's counsel argued that since the Factors were deceived into breaking a contract with plaintiff, that plaintiff had no right of action against the Factors, and that, therefore, it had no right of action against the Edison-Bell company, but Justice Kennedy, in disposing of this contention, said:

"I think that this is too narrow a view. I am certainly disposed to hold that if A, who knows that B, the user of an article, has stipulated in selling it to C, the Factors, that he should not re-sell it to A, should procure by an intentional misrepresentation to C a sale to himself, he has committed and done B an actionable wrong (provided that B can prove that he has been thereby damaged), although, in the particular circumstances, B may have no cause of action against C in respect of the transaction."

This decision will effectually prevent any further interference by outside parties with the contracts between the Factors and the English

National Phonograph Company (Limited). A case involving the same question was before the United States Courts in Edison Phonograph Company and National Phonograph Company vs. Pike, 116 Fed. Rep. 863, in which, as in the case in England against the Edison-Bell Company, an injunction was granted against interference with the carrying out of our selling contracts. It is not strange that this question should be decided the same way in the two countries, for these decisions are not based on statute law, which varies in different countries, but on broad, equitable principles, which are as established and controlling in America as in England.

## Meetings of the Selling Force

F. K. Dolbeer, General Manager of Sales, and E. H. Philips, Manager of Salesmen of this company, held two interesting and profitable conferences with the members of the selling force during the past month. The first was held at 304 Wabash Avenue, Chicago, on December 28th, and the second at the Orange factory on January 7th. The Chicago meeting was for the purpose of meeting the Western salesmen. Besides Messrs. Dolbeer and Philips, there were present at the Western meeting the following salesmen: George A. Renner, Will. P. Hope, M. G. Kreuzsch, Frank L. Fritchey, F. M. Kitchen, W. H. Hug, E. A. Neff, A. H. Kloehr, A. V. Chandler, and W. A. Turner. Those comprise all the Edison men covering territory west of Ohio, with the exception of C. S. Gardner, who has the Coast, and John H. Gill, both of whom were unable to be present.

After the conference an informal dinner was given by Mr. Dolbeer at the "Tom Jones" cafe on Jackson boulevard. Among the guests, besides those already mentioned above, were John Hardin, W. C. Patrick and E. C. Barnes, representing various branches of the Edison interests in Chicago, and Daniel Hopkins, of Hopkins Bros., the Edison Jobbers at Des Moines, Ia., who happened to be in Chicago at the time. After the dinner the party attended a performance at the Majestic Theatre.

The conference at Orange was attended by Messrs. Dolbeer and Philips, Assistant General Manager C. H. Wilson, and the following salesmen: L. J. Kocher, J. W. Scott, J. F. Stanton, H. D. Clark, G. A. Hedden, C. D. Warren, F. W. Ewan, B. R. Barklow, W. P. Coughlin and John H. Gill. One or two other department heads were interested listeners. Mr. Gill attended the conference because unable to attend

the one in Chicago. R. H. Veale, who covers Florida and Georgia, could not attend. The salesmen present represent the States east of Ohio. Messrs. Ewan and Kocher represent Canada. The entire afternoon was taken up with brief addresses by Mr. Dolbeer and Mr. Philips, hearing reports from the salesmen bearing upon the condition of business and the outlook in their respective districts, and in a general discussion of selling plans for the new year. All of the reports were very satisfactory as to the past and extremely optimistic for the future. J. W. Scott, who has the New England section, was presented by Mr. Dolbeer with the Sales Department prize of \$100 in gold for having established the greatest number of new Dealers in 1907. Mr. Scott's "spiel" (this is Mr. Scott's own word) of acceptance was a feature of the occasion. This is the second year in succession that Mr. Scott has won this prize.

Following the conference, the party sat down to a dinner at the Orange Club. In addition to the above named there were present Superintendent Peter Weber, Cashier Harry F. Miller, Assistant Manager of Sales A. C. Ireton, Manager of Foreign Department Walter Stevens, and Advertising Manager L. C. McChesney. The affair was entirely informal. No efforts at speechmaking were attempted.

Both the Eastern and Western salesmen started out on the road after the conferences and the reports they have since sent in show that the holiday vacation and the conferences have given them a new enthusiasm. The salesmen now on the force and the territory covered by each are the following:

- B. R. Barklow—New York City and Brooklyn.
- A. V. Chandler—Chicago and suburbs.
- H. D. Clark—New Jersey.
- W. P. Coughlin—Pennsylvania.
- F. W. Ewan—Ontario, Can.
- F. L. Fritchey—Indiana, Michigan.
- C. S. Gardner—Arizona, California, Idaho, Oregon, Utah, Washington.
- J. H. Gill—Minnesota, North Dakota, South Dakota.
- G. A. Hedden—New York State.
- W. P. Hope—Wisconsin and Upper Peninsula.
- W. H. Hug—Kentucky, Ohio, Tennessee.
- F. M. Kitchen—Iowa.
- A. H. Kloehr—Kansas, Missouri.
- L. J. Kocher—Canada, east of Ontario.
- M. G. Kreuzsch—Illinois.
- E. A. Neff—Arkansas, Indian Territory, Oklahoma.
- G. A. Renner—Colorado, Montana, Nebraska, Wyoming.
- J. W. Scott—Connecticut, Maine, Massachusetts, New Hampshire, Rhode Island, Vermont.
- J. F. Stanton—Delaware, District of Columbia, Maryland, Virginia, West Virginia.
- W. A. Turner—Texas.
- R. H. Veale—Florida, Georgia.
- C. D. Warren—North Carolina, South Carolina.

New Prices on Horns and Cranes

TO ALL DEALERS:

ORANGE, N. J., Jan. 27, 1908.

On and after February 1st, we will discontinue listing or supplying the standard finish new style Edison horns and horn cranes in sets, as heretofore, and will thereafter list and supply them separately, at the following prices:

HORNS.	Dealer.		CRANES.	Dealer.	
	net.	List.		net.	List.
Gem Horn.....	\$1.15	\$1.60	Gem Crane.....	\$ .18	\$ .25
Standard Horn.....	1.65	2.25	Standard, Home, Triumph, Bal-		
Home Horn.....	1.80	2.50	moral, Conqueror and Alva		
Triumph Horn.....	2.00	2.75	Cranes .....	.90	1.25
Idelia (Mahogany finish)....	5.00	6.50	Idelia (Oxydized finish).....	1.80	2.50

MAHOGANY FINISH HORNS.

We will also list and supply mahogany finish horns for different types of machines at the following prices:

	Dealer.	
	net.	List.
Gem Horn.....	\$2.00	\$2.60
Standard Horn.....	4.60	6.00
Home Horn.....	4.80	6.25
Triumph Horn.....	5.00	6.50

These horns, except when furnished with machines equipped with mahogany cabinets, will have to be ordered as extras; that is, they are a specially finished horn designed for such machines with mahogany cabinets as are now in the hands of users, equipped with some other style or finish horn.

SPECIAL NOTE.

These changes in prices of horns and horn cranes do not in any way affect the Jobbers, Dealers or List prices of machines with outfits complete. Such prices remain the same as established October 1, 1907.

The list prices on horns and cranes sold separately are restricted and must be maintained.

*We will not supply Edison Phonographs of any type except with equipment complete as per catalogue.*

NATIONAL PHONOGRAPH CO.,

F. K. DOLBEER,  
General Manager of Sales.

The foregoing is a copy of a letter that is being mailed to Dealers with this issue of the PHONOGRAPH MONTHLY. When the new equipments were decided upon the retail prices were increased to cover not only the additional cost of the equipment, but also part of the increased manufacturing cost of Phonographs, which was considerably greater than when the old prices were fixed. To uniformly maintain the new prices it was necessary to put higher prices on the new horns and cranes than was warranted by their manufacturing cost and to compel the trade to pay these prices for such new equipments as they required to bring their machines up-to-date. We have believed that the new Edison Horn had unusual tonal qualities, and knowing that it would be wanted by those who bought Phonographs before the change, it has always been our intention to sooner or later reduce the prices of the new horns and cranes to favorably compare

with the prices of horns and cranes of other manufacture. Now that there are but few of the former machines in the hands of the trade, it was decided that the time had come for the new prices. With the new prices a Dealer may sell a Standard Horn and Crane at retail at \$3.50 and net a profit of 95 cents or he can sell a Standard Horn alone to those having adjustable stands or cranes at \$2.25 and net a profit of 60 cents. It ought to be possible for the trade to get considerable new business for Edison Horns and Cranes at the above prices from those who own machines equipped with the former small horn. The margin on Edison Horns and Cranes may not be as large as that sometimes made on horns of other make, but it must be borne in mind that our prices are protected and the profit is guaranteed. Edison Horns and Cranes are subject to the same restrictions as are other Edison goods and must not be sold at cut prices.

## Advance List of French and Holland-Dutch Selections

The Records named below will be ready for shipment from Orange between April 1st and 10th. Samples of any or all of them will be shipped March 1st to such Jobbers as place orders for them. None will be shipped without orders. Jobbers' stock orders received by March 20th will be shipped as fast as possible after April 1st. Care will be taken to make shipment at one time to all Jobbers in the same city. Separate supplements of each list will be shipped with Records to all Jobbers who request a supply. State quantity required of each kind.

### 15 French Records

17157	La Marseillaise	M. Baer
17827	La Muette de Portici, <i>Auber</i> (Duo)	M. Gluck et M. Ragneau
17830	Plaisir d'Amour, <i>Martini</i>	M. Gilibert
17832	Louise (Air du Père), <i>Charpentier</i>	M. Albers
17839	Le Retour au Pays, <i>Seipieri</i>	M. Bérard
17840	Les Mémoires de l'Institutrice	Mme. Gaudet
17841	La Fée Verte	M. Bérard
17842	Lakmé (Stances), <i>Leo Delibes</i>	M. Gilibert
17846	Carmen (Duo de Micaëlla et de Don José), <i>Bizet</i>	Mme. Ida Vaudere et M. Gluck
17847	La Perichole (Lettre), <i>Offenbach</i>	Mme. Ida Vaudere
17852	Monsieur Beautemps (Tyrolienne), <i>Chaillier</i>	Mme. Rollini
17853	Don Juan (Sérénade), <i>Mozart</i>	M. Gilibert
17855	Les adieux de Suzon	M. Mercadier
17857	Xavière (Duo de la Grive), <i>Th. Dubois</i>	Mme. Ida Vaudere et M. Ragneau
17859	Le Petite Mariée (Couplet du Podestat), <i>Lecocq</i>	M. Ragneau
17860	Musique d'antichambre (Duo), <i>Bruet et Guyon</i>	Mme. Rollini et M. Maréchal

### 15 Holland-Dutch Records

18438	De Beurs, <i>Kokadoris</i>	Prof. Kokadoris
18442	Naar den Dam, <i>Phil. Loots</i>	Gerard Zalsman
18443	De gefopte Vogelaar, <i>Cath. van Rennes</i>	Alida Lutkeman
18444	De ontslagen Boef, <i>Speenhof</i>	J. H. Speenhof
18445	Wat is Liefde, <i>R. Ganz</i>	Walter van Son
18447	Leve de Militairen, <i>Paulus</i>	Duo Paulus
18448	Loterij, <i>Paulus</i>	Duo Paulus
18464	Wilhelmina van Nassauwe, <i>Phil. Loots</i>	Gerard Zalsman
18465	Het Liedje can den Smid, <i>A. Loman</i>	Alida Lutkeman
18467	Mijne Moedertaal, <i>Brandts Buys</i>	Walter van Son
18468	Dansen op het Huwelijksfeest, <i>Paulus</i>	Duo Paulus
18469	Fietsvermaak, <i>Paulus</i>	Duo Paulus
18470	Vlaggeried	H. Gros
18471	Wien Neerlandsch Bloed	H. Gros
18472	Wilhelmus van Nassouwe	H. Gros

## Biography of Mr. Edison

An official biography of Thomas A. Edison is being written by Frank L. Dyer, his personal counsel, collaborating with Thomas C. Martin, editor of the *Electrical World*. It will appear in Harper's Magazine during part of 1908 and will later be published in book form. Mr. Edison has so often been misrepresented and misquoted

in print, especially in the daily newspapers, that an official life or a personally endorsed transcript of what he has accomplished of scientific and commercial value, from his earliest days as a newsboy to his present-day eminence, was deemed necessary in justice to his well-earned fame and position in history. The biography will be treated chronologically and profusely illustrated, with a number of important chapters devoted to the Phonograph and its perfection.

## A Defiant Infringer Quickly Disposed of

Judge Reed, of the United States Circuit Court, sitting at Dubuque, Ia., on January 14th, granted a restraining order enjoining Edward H. Martin, of Webster City, Ia., from interfering with the selling system of the National Phonograph Co. and from inciting Edison Jobbers and Dealers to sell him Edison goods in violation of their contracts. This case was one of the most flagrant that has yet been prosecuted by our legal department.

The facts of the case are as follows:

Martin bought several lots of goods during the year 1906 and the early part of 1907 from Jobbers and direct from the National Phonograph Company, and each time he, of course, signed the Dealers' agreement. In April, 1907, the National Phonograph Company was informed that he was not keeping on hand a sufficient number of Phonographs and wrote him a letter inquiring about the matter. Martin replied that he did not keep a line on hand, but got the goods from Fort Dodge (twenty miles away) as needed. To a further letter requiring him to put in the goods or have his name dropped from the list of Dealers, he made no reply, and thereafter on June 12, 1907, his name was dropped from the list of authorized Dealers, and he was notified that this had been done and that he was no longer entitled to Dealers' discounts.

Martin then cast about until he was able to locate some unscrupulous Jobbers and Dealers, whom he procured to sell him goods at Dealers' discounts, in violation of their contracts, which obligated them to sell to no one but authorized Dealers, and he then placed the goods so obtained on sale at cut prices and extensively advertised such sales.

When this condition of affairs was brought to the attention of the National Phonograph Company, a man was immediately sent to Webster City to obtain evidence against Martin. He arrived there on December 4th, and as soon as he had obtained the necessary evidence, the National Phonograph Company filed a bill in equity in the United States Circuit Court against Martin.

This bill and the evidence obtained in the form of affidavits were presented to Judge Reed of that Court, and when he thus learned of the flagrant character of Martin's conduct, he forthwith, on December 23d, granted a restraining order enjoining Martin and his employees from interfering with the selling system of the National Phonograph Company, and from inciting its Jobbers

and Dealers to sell goods to him, an unauthorized dealer, in violation of their contracts, and from selling or dealing in any of its patented goods.

At the same time, Judge Reed gave Martin until January 2nd to file answering affidavits and set the case down for preliminary hearing on January 14th. Martin did not file any affidavits, nor did he appear at the time fixed for the hearing.

On January 14th, Frank L. Dyer, General Counsel of the National Phonograph Company, went to Dubuque, Iowa, where the United States Circuit Court was sitting, and argued the case in behalf of the National Phonograph Company. At the conclusion of the argument Judge Reed rendered an oral opinion, continuing the restraining order already granted.

The purchases made by Martin since he was placed on the Suspended List are now being investigated, and this investigation will probably result, within a short time, in the suspension of those from whom he obtained the goods. Of course, should Martin make any further effort to sell these goods, even at the full list price, or should he in any way interfere with our business system, he will in our opinion be in contempt of the injunction, and will be promptly proceeded against for so doing.

---

## New Horn Meets Long Felt Want

The new horn is big, shapely and handsome. It sets the instrument off and gives to the reproduced sounds a clearness and sweetness not possible with other horns. The appeal it makes to the consumer is instantaneous. It looks the money and it gives the results. The horn is sold with the Phonograph as a part of it—one price for both. One set of motions and the whole transaction is completed.

The horn brings the Dealer a good profit. The price is fixed, just as the price of the Phonograph is fixed. No competitor can influence a sale by cutting the price on the horn and as the Edison horn is made for the purpose of assuring the best results from the Phonograph, no stock of horns is necessary.

The new equipment of the Edison puts the Phonograph selling proposition on the right basis. It means easier and quicker sales, full profits every time, no unfair competition and no accessory stock.

---

**Have you ordered a stock of Lauder Records?**

## 46 Edison Records Made Over

Below is printed a list of 46 Edison Records that have been made over by the same or new artists since the list of 158 made-over selections (Form 1166) was issued several months ago. It embraces such selections as have been made over to and including November 15th, 1907.

As the trade already knows, whenever circumstances render it necessary to make new moulds of selections, the work gets the advanced experience of our Recording Department and such new Records benefit in all the other improvements of the art. Such Records are in all respects equal to those of the monthly list. We believe that if the public knew of their existence they would sell quite as readily as the new Records.

It is our intention beginning with April to add certain of these made over selections to the monthly Advance Lists, Order Blanks, Supplements, etc. In the April printed matter we will insert such selections as have been made over in December and thereafter will work three months behind, believing that in this time Dealers, in the regular course of business, will have disposed of their stock of the older selections and be carrying only the new.

Folders including these made-over selections will later be issued for retail distribution.

*Unless otherwise indicated they have been made over by the same artists or combinations.*

### EDISON MILITARY BAND.

- 8424 American Patrol  
*Formerly by Edison Concert Band*
- 16 Columbian Exposition March
- 8261 Don't Be Cross Waltz  
*Formerly by Edison Concert Band*
- 32 Hapsburg March  
*Formerly by Edison Concert Band*
- 8213 In the Good Old Summer Time
- 8043 Morning in Noah's Ark  
*Formerly by Edison Concert Band*
- 8587 New Colonial March
- 8562 Peaceful Henry  
*Formerly by Edison Concert Band*
- 8337 Second Reg't Conn. N. G. March  
*Formerly by Edison Concert Band*

### EDISON CONCERT BAND.

- 8516 Ballet Music from Faust, Part 2
- 8333 Boston Commandery March
- 8221 Columbia, the Gem of the Ocean
- 8584 Dixie Girl
- 8168 God Save the King
- 8432 Polacca from Mignon
- 8391 Selection from Maritana

### EDISON HUNGARIAN ORCHESTRA.

- 8502 Hungarian Dance No. 1

### INSTRUMENTAL SOLOS.

- 8490 Ballet Music from Mathias Sandorph  
(Clarinet) *Tuson*
- 2613 Happy Days in Dixie (Banjo) *Ossman*  
*Formerly by Ruby Brooks*
- 8487 Minstrel Boy (Bagpipe) *McAuliffe*
- 8965 Schubert's Serenade ('Cello) *Kronold*
- 7386 Sounds from Tyrol (Zither) *Wormser*
- 7195 Spring Song (Violin) *D'Almaine*
- 7458 Then You'll Remember Me (Violin) *D'Almaine*

### INSTRUMENTAL DUETS.

- 8906 Dreamy Moments (Violin and Flute)  
*Jaudas and Rose*  
*Formerly by Jaudas and Atz*
- 8404 Spring of Love (Violin and Flute) *Jaudas and Rose*  
*Formerly by Jaudas and Atz*
- 8598 Two of Us (Cornet duet) *Hazel and Bartow*  
*Formerly by Hazel and Seltzer*

### VOCAL SOLOS.

- 7317 All Coons Look Alike to Me *Collins*
- 8550 Bedelia *Murray*
- 1027 Girl Wanted *Murray*  
*Formerly by S. H. Dudley*
- 8418 Hottentot Love Song *Jones*
- 8267 I'll Be With You When the Roses Bloom  
Again *Potter*  
*Formerly by Harry MacDonough*
- 8267 I'm Wearing My Heart Away For You *Miller*  
*Formerly by James F. Reed*
- 6504 Lost Chord *Miller*  
*Formerly by Harry MacDonough*
- 5016 Ninety and Nine *Stanley*
- 7840 Rocked in the Cradle of the Deep *Stanley*
- 7242 Sing Me a Song of the South *Miller*  
*Formerly by Harry MacDonough*
- 8380 Somebody's Waiting For Me *Harlan*
- 8084 Violets *Werrenrath*  
*Formerly by W. H. Thompson*
- 7670 When the Harvest Days Are Over *Harlan*
- 8747 Where the Mocking Birds Were Singing *Werrenrath*  
*Formerly by James F. Harrison*

### VOCAL DUETS.

- 8553 I'm Going to Leave *Collins and Harlan*
- 8662 Robin and the Wren *Harlan and Belmont*

### TALKING RECORDS.

- 8089 Auction Sale of Household Goods *Spencer*  
*Formerly by Spencer and Girard*
- 8941 Hans Krausmeyer and His Dog Schneider  
*Spencer and Meeker*  
*Formerly by Spencer and Holt*
- 8441 Reuben Haskins of Skowhegan, Me. *Spencer*

## Foreign Selections Cut Out

The trade is hereby advised that we have no more moulds or masters of the following selections and we will discontinue furnishing them as soon as our stock is exhausted:

- No. 12374 Lose munt're Lieder (German) *Porten*
- No. 12403 Im tiefen Keller (German) *Biberti*

H. M. Holleman, President of the Texas Piano & Phonograph Co., [Edison Jobbers at Houston, Texas] recently entertained the employes of the company at his residence in Hyde Park, in order to fittingly mark the close of the most prosperous year in the history of the house. A fine musical program was arranged.—*Music Trade Review.*

---

# Edison Phonograph Monthly

Published for the Man Who Sells Edison Phonographs and Records by The National Phonograph Co., Orange, N. J.

All communications to *The Phonograph Monthly* should be addressed to the Advertising Department, Orange, N. J.

---

NEW YORK: 10 FIFTH AVENUE.

NATIONAL PHONOGRAPH CO., LTD., 25 CLERKENWELL ROAD, LONDON

NATIONAL PHONOGRAPH CO. OF AUSTRALIA, LTD., 340 KENT STREET, SYDNEY, N. S. W.

MEXICAN NATIONAL PHONOGRAPH CO., AVENIDA ORIENTE No. 117, MEXICO CITY.

COMPANIA EDISON HISPANO-AMERICANA, VIAMONTE 515, BUENOS AIRES.

EDISON GESELLSCHAFT, M. B. H., SUD-UFER 24 25, BERLIN.

COMPAGNIE FRANCAISE DU PHONOGRAPHE EDISON, 42 RUE DE PARADIS, PARIS.

---

VOL. VI.

February, 1908

No. 2

---

## Playing Fair

The changes made last fall in the selling date for new Records and in permitting Jobbers to ship to Dealers on the day before, has worked admirably and appears to be greatly appreciated by the trade everywhere. Advancing the date to the 25th has met with the approval of all Jobbers and Dealers. It has enabled everyone to largely realize on the sales of Records in the same months as bought, the longer months especially affording a liberal time in which to promptly turn over purchases.

Permitting shipments to Dealers after 2 P. M. on the 24th has served to lessen the troubles of Jobbers, has put Dealers on a more even selling basis with Jobbers, and it has almost entirely eliminated the unequal competition between Jobbers and their own Dealers—a competition that has frequently existed between firms in the same city or town.

The most gratifying feature of the new shipping arrangement is the splendid manner in which the entire trade is complying with its requirements. It was with no little apprehension that we made this change. We felt very dubious about the advisability of permitting Dealers to have new Records in their possession for so long a time before the selling hour. All sorts of things were predicted by those not in sympathy with the plan. It was not possible, they said, to put several thousand Dealers on their honor and not be imposed upon.

But the unexpected has happened, or rather the expected has not happened. The plan has been in operation for three months and the violations have been few. Most of these have been due to a misunderstanding. Each complaint has been promptly investigated and treated accord-

ing to its merits. As a whole, Edison Dealers have shown that they are loyal and are quite as willing to work for the good of the business as we are to have them. Their compliance is an eloquent expression of their feeling toward this company, for we believe that nothing but a desire to "play fair" with us could secure such an unanimous co-operation from them.

Lest some might forget, we are sending Jobbers a supply of notices like the February notice printed below, these to be enclosed with shipments of new Records or mailed with invoices for them:

### NOTICE TO EDISON DEALERS.

In accordance with our notice to the trade, dated October 25, 1907, these February Edison Records may be sold at retail at 8 A. M. on January 24th. They must not, however, under any circumstances, be sold, exhibited or leave your possession before that day and hour, even though they reach you on the day before. This restriction is of the utmost importance and must not be violated.

NATIONAL PHONOGRAPH CO., ORANGE, N. J.

---

## Must Sign an Agreement with Each Jobber

Dealers who have already signed the new Edison Agreement through one Jobber should send their copy of the Agreement to any other Jobber from whom they may desire to buy Edison goods. This will show that they are entitled to Dealers' discounts. They must, however, sign another copy of the Agreement through the new Jobber before the latter can fill orders. The necessity for the above procedure has not been generally understood by Dealers. If any Dealers have failed to execute a copy of the Agreement for their own use they should sign one and have it accepted by their Jobber. The latter will furnish copies or they will be mailed by our Sales Department upon request.



## Pushing Foreign Records

The following letter was sent to all Jobbers under date of December 27th, for the purpose of arousing among Jobbers a greater interest in Foreign Records than has been manifested in the past. It is reprinted here because it is of interest to Dealers as well as Jobbers. It was accompanied by a copy of the new Foreign Record catalogue and a blank calling for certain information.

DEAR SIR: The enclosed advance copy of our new catalogue of Foreign Records is sent to you for two reasons: First, to enable you to re-arrange your stock, so as to bring it up to date. Second, to solicit your co-operation in increasing the sale of Foreign Records.

This new catalogue contains the following selections:

37 Bohemian	88	Italian	
88 British	14	Japanese	
46 Chinese	38	Mexican	
60 Cuban	8	Norwegian	
18 Danish	65	Polish	
86 French	6	S. A. and C. A. National	
23 French-Canadian	61	Spanish	[Hymns]
199 German	25	Swedish	
50 Hebrew			
12 Hungarian	924		

Your attention is directed to the "Foreword" on page 3.

While the sale of these Records is by no means small, it is not what it would be if given more attention by the entire trade. We are handicapped in advertising to foreign speaking people, because they complain that Dealers do not carry the Records, and many Dealers state that their Jobbers do not carry an adequate stock of Foreign selections, and they lose sales because they cannot get orders filled in time.

\* \* \* \* \*

One of the most frequently used arguments of a Jobber in endeavoring to get a Dealer to increase his business is this: "It pays to carry the full list of Edison Records," meaning of course, the domestic list.

May we not use a similar argument on you and say, "It will pay you to carry the entire list of Edison Foreign selections?" If it pays the Dealer to carry the domestic list so as not to lose sales, will it not pay you many times more to say and to advertise that you carry every Edison Record, domestic and foreign? Do you know of any better way to give your Dealers perfect service? With price protected goods like ours, service counts more than any other feature.

\* \* \* \* \*

With the issuance of the new catalogue, we have reduced the total of our Foreign selections about 30 per cent., making it easier to carry the full list, and we intend adding in the future only such selections as seem to be demanded by the trade. We will also continue in the Foreign Catalogue the plan of cutting out slow-selling selections and keeping the total within reasonable bounds.

Will you not give this matter the attention that we believe it deserves?

F. K. DOLBEER,  
General Manager of Sales.

Two Jobbers have expressed the opinion that the lack of sequence in the numbers of the Foreign Records has a tendency to keep Jobbers from stocking the entire list. They point out that it is not possible to tell from time to time which series of numbers will be added to, and that therefore it is difficult to arrange shelves or bins in a systematic manner. They have asked that the numbers be changed to run in invoiced order as issued. It is not possible to change the present system of numbering our

Records. They are being made in this country, London, Berlin, and Paris, and each place has been assigned certain numbers to be used for any masters they make. For instance, we are using here numbers in 19000 and 20000. London is using numbers in 13000; Berlin in 15000, and Paris in 17000.

In our opinion the following plan will be the best for Jobbers and Dealers to follow, especially where the entire list is carried in stock: Arrange shelves or bins in the numerical order shown in Trade Catalogue No. 1240, leaving no room between any of them for additional selections. After the highest number at the end leave space, say, for 200 new titles. As new titles are issued, place them at the end in as near numerical order as possible. Then place an indicator (a colored cord or something similar) at the point in the regular stock, where the new numbers would go in if in the proper order. For instance, if new British selections should be issued to follow 13084 an indicator after this number would show that the later titles were placed at the end of the racks. By using trays for carrying Records in, it would be an easy matter once a year or once in eighteen months to re-arrange the trays to a close numerical order. This plan would not answer for domestic Records, but for the less active Foreign list it should answer every purpose.

## A Doubtful "Endorsement"

A department in the *Success Magazine* for January, edited by Edwin Markham, contained a paragraph making what the casual reader would consider as a sweeping commendation of one style of talking machine. It was apparently a comparison between the Phonograph and a disc machine, the former being condemned and the latter approved. It was evident that Mr. Markham did not know one from the other, so we took the matter up with the editors of *Success*. The resulting correspondence elicited the admissions from *Success* that Mr. Markham did not know the difference, but had somewhere heard a high grade disc record and was simply commenting upon the general improvement made in talking machines in the past few years. The *Success* people also stated that Mr. Markham, instead of being especially friendly to disc machines, had just bought an Edison Phonograph for his personal use and was delighted with it.

Mr. Dealer:- If you haven't signed the new Agreement do it at once.

## Printed Matter.

A copy of the new Numerical and Alphabetical Catalogue of Records, Form 1240, has just been mailed to all Dealers who signed the new Agreement. This catalogue contains all domestic and foreign selections listed to and including January, 1908, and will be current until July 1st. Jobbers will be supplied with a limited number of additional copies for their own use and also to furnish extra copies to Dealers who need more than the one mailed to them. Both Jobbers and Dealers should understand that this catalogue is for trade distribution only and should not be distributed to the public. The edition printed will make it impossible to supply more than a limited number of extra copies to Jobbers and it will be useless to send in orders for large quantities.

We have just mailed to the trade, a copy of an artistic colored hanger printed in eight colors. The original design for this hanger was made especially for us by Guernsey Moore, whose sketches have won for him a national fame. He has drawn many covers and done much other illustrating for the better magazines and other publications. This sketch was made for us before the change in our outfit and will explain why a flower horn was used. Mr. Moore had a machine equipped with one of these horns before him when he did the work.

The copy of the Foreign Record Catalogue, Form 1250, that has just been mailed to the entire trade, includes all selections in foreign languages listed in the United States to and including January, 1908. The "Foreword" enclosed in this catalogue gives some interesting information about these Foreign Records as follows:

"During the last six months our catalogue of Edison Records in foreign languages or made abroad has undergone a complete revision. A large number of Records, for which the demand has been limited or for which the moulds have become defective or damaged, have been dropped entirely. New selections in Bohemian, Cuban, Danish, French, German, Hebrew, Italian, Mexican, Norwegian, Polish and Swedish have been added, and others have been made over by new artists or under new conditions. The entire catalogue is now thoroughly representative of the high standard of the Edison name and we commend it to all interested in foreign Records."

The letter to Jobbers about foreign Records reprinted on another page, gives the number of different selections in each language contained in this catalogue. Dealers should carefully inspect the copy being sent to them and arrange

to push the sale of such Records as are in demand in their territory.

Beginning with the April issue the Record show card, printed in two colors, will be printed on both card and paper, and Jobbers' standing orders will be filled with part of each kind. A number of Jobbers complained that part of their trade ordered only one or two of each new Record monthly and the packages or cases in which shipments were made were not large enough to take in the show cards and as the latter could not be folded they were inconvenient to get to Dealers. With part of the edition printed on paper it will be easy to supply the smaller Dealers.

Jobbers have been supplied with quantities of a new four-page folder in two colors, entitled, "When Three's Not a Crowd," Form 1185, a sample copy of which has just been mailed to the entire trade. We regard this folder as a useful medium for increasing business and hope that the trade will get a quantity for distribution in their territories.

## Record Artists as Minstrels

Orange Lodge, No. 135, B. P. O. Elks, gave two minstrel performances at Orange on the nights of January 13th and 14th that were of considerable interest to the Phonograph trade, because among the prominent amusement makers were Arthur Collins, Byron G. Harlan, Steve Porter and Edward Meeker. Albert Benzler, also of the Edison recording staff, led the orchestra.

## Record Exchange Proposition.

The matter of handling the Record exchange proposition is practically completed. There still remain a few cases where Dealers neglected to comply with the stipulations sent out, in failing to put their names on or inside of the cases, or omitting some feature necessary to the identification of the cases. There are, too, the usual number of disputed cases still to be adjusted. Wherever orders have been sent us equal to double the number of Records returned, credit has been given on our books. Some of these credits have not yet been entered because a sufficient quantity of Records have not yet been ordered. This exchange proposition has given the trade an opportunity to clean up its Record stocks and Dealers have themselves to blame if they do not start the new year with an up-to-date stock of Edison Records.

## Got Square on the Opera

He is a genial, convivial soul—and how he does love music! Why, he loves his wife almost as well as he loves music. But he doesn't love the grand opera magnates—and that's why he got square with them.

"It's this way," explained an intimate friend. "Jim is a season subscriber for two seats at the opera. His wife generally goes, but Jim never. Oh, yes, he used to go. But you see, he's devoted to music and he's so emotional that at a performance he never could restrain himself from whistling and humming in time with the orchestra.

"Of course, you know, this wasn't what the people all around him paid for; and as repeated protests by them and by the management didn't work a cure, Jim was politely requested to keep away.

"He has got square, all right. How? Why, he bought a Phonograph and loaded her up with grand opera selections. Now on every opera night he lights a cigar, puts his feet up on the other chair, turns the crank, and has a musical evening just the same. Neat scheme—and he whistles by the hour."—*New York Globe*.

## Cannot Use Names "Edison" or "Edisonia"

A suit which may be of interest to our readers, recently brought in the United States Circuit Court at Philadelphia, has just been decided in Mr. Edison's favor. The defendant, one McCusker, carried on an amusement parlor under the name of "Edisonia," without Mr. Edison's consent or approval. An application for injunction was made, which was granted, as appears from the documents printed below. Other instances of similar practice have been brought to our attention in connection with which it is proposed to take corresponding measures to protect Mr. Edison's name.

IN THE  
CIRCUIT COURT OF THE UNITED STATES  
FOR THE EASTERN DISTRICT OF PENNSYLVANIA.  
THOMAS A. EDISON,  
Plaintiff,  
v.  
JAMES MCCUSKER,  
Defendant.

IN EQUITY.  
No. 16. Oct. Sess., 1907.

DECREE.

HOLLAND, J.

Plaintiff, Thomas A. Edison, having exhibited his bill of complaint in this cause, charging the defendant, James McCusker, with the unauthorized and unlicensed use of the words "EDISON" and "EDISONIA," in violation and infringement of said plaintiff's rights therein; and said defendant having admitted plaintiff's rights therein and that said defendant has no right or license to use said names, or either of them, or any name resembling the word "EDISON" for the designation of his place or business or otherwise, and that said plaintiff is entitled to a perpetual injunction and costs as prayed in his bill of complaint; and said defendant having agreed that a decree should be entered and an injunction should issue directing and perpetually restraining him from any further use of the names "EDISON" and "EDISONIA"

or their equivalents, for the designation of his place or business or otherwise as complained of in the bill of complaint:

It is by the Court ORDERED, ADJUDGED AND DECREED that said defendant, James McCusker, his attorneys, servants and agents, be and are hereby perpetually enjoined and restrained from using the names "EDISON" and "EDISONIA" or any equivalent thereof for the designation of his place or business or otherwise, as complained of in the bill of complaint, or any further infringement of the rights of said plaintiff in the premises, and that said plaintiff recover from said defendant the costs of this suit to be taxed.

I agree to the entry of the above decree.

(Signed) JAMES MCCUSKER,

Defendant.

BY THE COURT.

Paid to Chas. N. Butler

Attest:

\$27.64 in full settlement.

GEORGE BRODBECK, JR.,  
Deputy Clerk.

IN THE  
CIRCUIT COURT OF THE UNITED STATES  
FOR THE EASTERN DISTRICT OF PENNSYLVANIA.

THOMAS A. EDISON,  
Plaintiff,

v.

JAMES MCCUSKER,  
Defendant.

IN EQUITY.

No. 16. Oct. Sess., 1907.

WRIT OF INJUNCTION.

UNITED STATES OF AMERICA,

EASTERN DISTRICT OF PENNSYLVANIA.

ss.

The President of the United States,

To James McCusker, Greeting:—

Whereas, Thomas A. Edison lately exhibited his bill of complaint, in the Circuit Court of the United States for the Eastern District of Pennsylvania, in the Third Circuit, against you, the said defendant, praying to be relieved touching the matter therein complained of, and especially that you, James McCusker, and all acting under you may be restrained from any further infringement of the rights of said plaintiff in the premises in the bill mentioned, in any way or manner contrary to law or equity.

We, therefore, in consideration thereof and also of the particular matters in said bill set forth, do strictly command and enjoin you, said James McCusker, your attorneys, servants, and agents, and all others acting under and with you, that henceforth you do absolutely and entirely desist and refrain from using the name "EDISON" or the name "EDISONIA" or any equivalent thereof for the designation of your place or business or otherwise as set out in said bill of complaint.

WITNESS, the Honorable Melville W. Fuller, Chief Justice of the Supreme Court of the United States, at Philadelphia, Pennsylvania, this seventh day of January, A. D. 1908, and in the One Hundred and Thirty-second year of the Independence of the United States.

GEORGE BRODBECK, JR.,  
Deputy Clerk.

## Advertising Brings Customers

We have done two things. We have made a Phonograph so perfect that a hearing means a sale. We have advertised this Phonograph until it is known to everybody who can read.

You must do the rest. You must carry it in stock, believe in it, show it, talk it and exhibit its powers. Do not let a Phonograph customer get to your store before the Edison does. If you do, our advertising, so far as you store is concerned, is wasted.

## Remove Marks from Cases

On every case that we ship from the factory the words "From National Phonograph Company, Orange, N. J.," appear in one corner. If Dealers and Jobbers use these cases for re-shipping, these words should be removed before the cases are delivered to the transportation company. Our Traffic Department is constantly in receipt of requests from the Agents of Transportation Companies throughout the country asking for disposition of shipments apparently made by us but which we find after long investigation originated from the store of one of our Jobbers or Dealers. The Agents naturally write us direct since our name appears in the corner as being the shippers of the cases. The trade will save us considerable trouble and correspondence by making a note of the above request and complying with it.

---

## \$13,500 Edison Business in a Town of 5000

A Western Edison Jobber a few days ago sent us a copy of a letter received by him from one of his Dealers. Omitting names, it read as follows:

"A hasty examination of our books shows we bought of you in 1907 \$10,159 in Phonograph goods also \$3,400 from the [naming another Jobber], making a total of \$13,500 for the year. Will work to do better next year."

Our Jobber corrected the letter by stating that the exact amount of the purchase through him was \$10,406.85. This Dealer is located in a town of less than 5,000 population.

## Lost Money by Waiting

Here's an interesting letter about Edison goods. It was written to one of our salesmen by a salesman from one of our Jobbers, and, as it was not intended for publication, we are compelled to omit names of individuals and places.

You will excuse me for not answering sooner, when I tell you that we were nearly wild with business. Our Edison business is growing so fast that we can hardly keep pace with it. The Saturday before Christmas our boys (7) picked orders until 3 o'clock Sunday morning. In two weeks I got eight initial Edison orders out on the road. I signed up the \_\_\_\_\_, \_\_\_\_\_, and \_\_\_\_\_, of \_\_\_\_\_, and have two more prospects in \_\_\_\_\_. Why, it's the biggest kind of a proposition. Mr. \_\_\_\_\_ said last week he was confident that it had cost us thousands of dollars because we waited that year before we put in the Edison line.

Mr. \_\_\_\_\_ says I've got to stay out all the time, and we have another regular man West, and before the year is out will probably put on two more. He is tickled with it, and you can imagine he is when I tell you he already figures on giving the Talking Machine Department another floor in the building so we can handle it.

My last trip before Christmas was a sixteen-day trip, and I sold a trifle over \$2,100 in that time, not counting mail order repeat orders. To-day I sold almost \$400 worth right here in \_\_\_\_\_. Monday I expect to place an Initial Order in \_\_\_\_\_ for about 1,000 titles to start with. I've got some dandy prospects all along the line. We are just beginning to realize what we have been missing; in fact, "Our eyes were open, but we were sound asleep" until we put in the Edison.

Well, I don't want to bore you with any more, but I will say I never was as enthusiastic in my life over the prospects of business in sight as I am now.

---

## Practical Gratitude

I wish to thank you for liberal exchange allowance, and I shall make my thanks practical and mutually profitable by using all, and more than the amount credited, in advertising Edison Phonographs and Records.—*W. D. Wilmot, Fall River, Mass.*

To show that he is doing as he said, Mr. Wilmot enclosed copies of some excellent newspaper advertising that is appearing in the papers of Fall River.

---

---

## ONE MORE OPPORTUNITY

It was found to be impossible to check up the re-signed Dealers' Agreements in time to remove from our files and mailing lists the names of firms who have not re-signed. Consequently they will be continued a month longer. We wish that Jobbers would make one more effort to round up any of their Dealers who may not have signed and get their Agreements to us early in February. Dealers who want to continue handling Edison goods are urged to sign the new Agreement at once.

## Catching the Crowd

We are going to tell you how we have a machine going out doors and attend to everything inside. We have a Triumph repeater mounted on a cabinet, a two-inch hole bored through one door, a crane held in a grooved block screwed to store front, big flower horn suspended by it and an 18-inch piece of flexible rubber hose connecting with machine inside. Our doors are double, so hole is bored in the one remaining stationery.

During the holidays we attracted considerable attention. It is quite amusing to watch people passing the store when a march is being played, as nine out of ten are keeping perfect step and "tumble" before they get by, when they look up and grin to see if anyone is noticing it.

We do not keep it going all the time as we are up the street a ways and this is only a 15,000

town; hardly enough people going by to keep it going all hours. One afternoon there was a fire a few doors farther up on our street, so we hustled the machine into position and caught the crowd on the way back.

We can remember the time when we carried only about 50 Edison Records and one machine. Never thought of ordering a Triumph for stock. Now we frequently order two for stock. The beauty of the Triumph is when you sell one you make something. We can look back to people who bought a Standard, and we know now that we could have just as well sold a Triumph if we had one in stock. We now carry the complete catalogue of Domestic selections and have two rooms partitioned off in the rear of our store. In comparing our holiday trade with last year the Phonograph department is all that kept up to last year's volume. Pianos and musical merchandise showed a falling off of over a third.—*Alden, Bidinger & Co., Waukegan, Ill.*

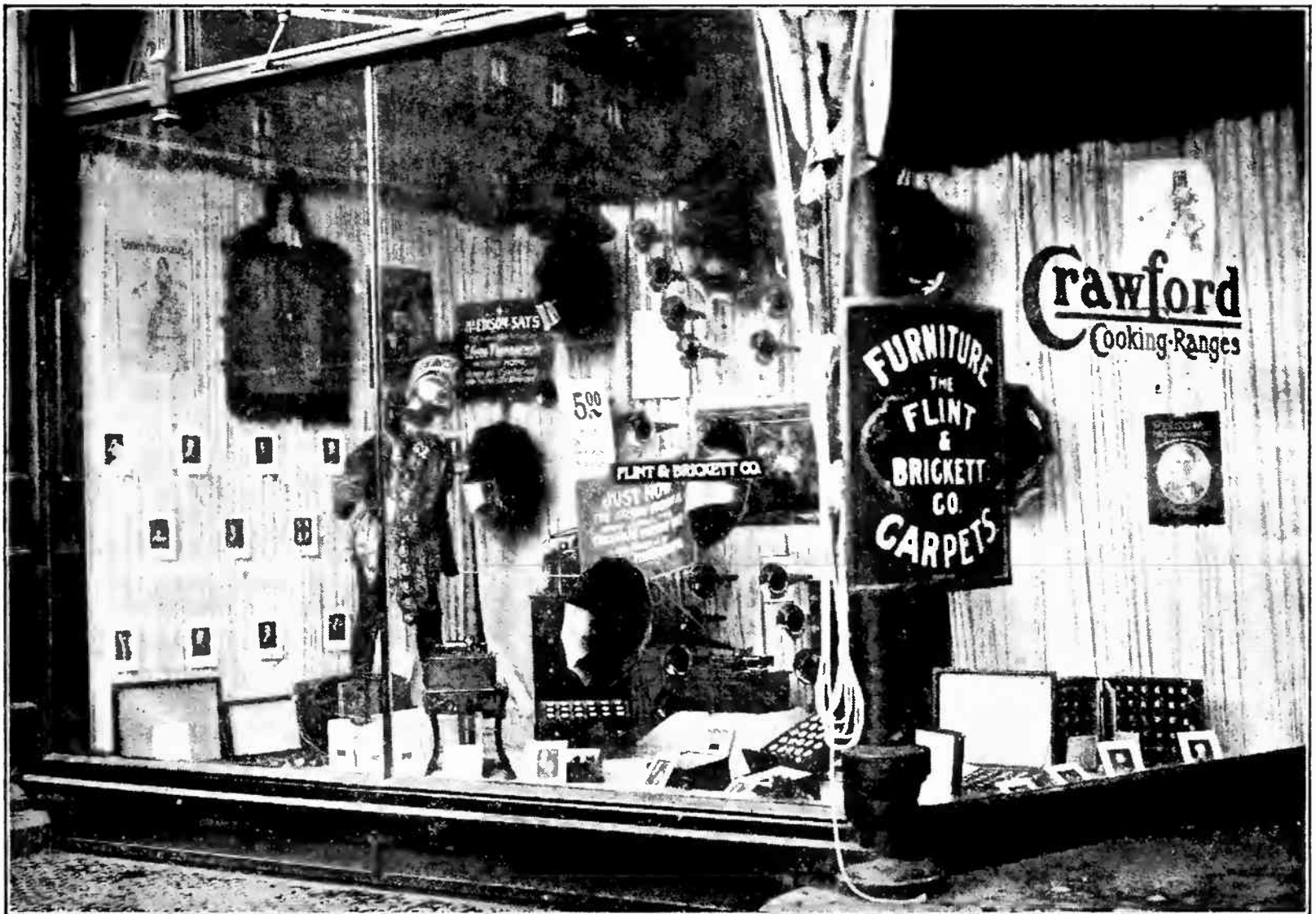

NOVEL HOLIDAY WINDOW DISPLAY BY FLINT & BRICKETT, SPRINGFIELD, MASS.

The above photograph shows a window display made during the holidays by Flint & Brickett, Edison Jobbers at Springfield, Mass. It shows a "Roman Knight" in full armor, standing in the center of a group of Edison Phonographs and pointing from time to time to a sign reading: "\$5.00 puts one of these in your home." The "Knight" was about six feet three inches high and in his armor presented a striking figure. "We had the sidewalk packed for

three days and evenings to the extent that the police asked us to desist as we were blocking traffic," wrote Flint & Brickett. "People came way over from the other side of the street through the snow, and teamsters got off of their teams. Every one in the cars was talking about the man in Flint & Brickett's Phonograph window. What was he doing? There was no doubt that 50,000 people were held up, and they all know we sell Edison Phonographs. It was the talk of the town. Every one concedes it was the best piece of advertising ever done here."

## A "Gem" Victory

We ask the indulgence of the Edison trade for the reference to competing goods in the letter printed herewith, but the letter would lose its point if the comparison was omitted. We get many letters of this kind, but seldom print any of them. This one is reproduced because it is above the ordinary. The name and address of the writer is purposely omitted.

DEAR SIR: Eighteen months ago I wrote to you for information about your Phonographs, and you sent me abundant literature, and referred \_\_\_\_\_, of this city, to me. I wasn't worried into buying a machine either by that firm or yourselves, much to my satisfaction.

In November of last year I read an advertisement of the "Gem," a *New Model*, and as a devotee of talking machines it naturally interested me; we already had a \_\_\_\_\_, which as you must know are very (and deservedly) popular. Still, my ideal was by no means reached by it. As you know, scratch and false volume is the chief drawback of the disc method of sound-reproduction. Anyway, that's my opinion in the matter.

So I got a Gem. My brother has a \$56 disc machine—and it is undoubtedly very nice and also very loud—and when I told him of my purchase he said that I would be disappointed in a short time. Since then I have made a small collection of Records, three dozen, and of the following numbers:

Band—8160, 8105, 8139, 9410, 8104, 9721, 9026, 68, 79, 9698. Orchestra—9269, 9681, 9717, 9029. Instrumental—9677, bells; 8024, clarinet; 9270, flute; 9437, piano; 7633, violin; 9549, 9659, Venetian Trio; 9637, 8940, 9413, 'cello; 8335, xylophone. Vocal—8499, 9675, 9718; duets, 9255; vaudeville, 9495, 9704, 9687, 9715. French—Ave Maria, Gluck; Toreador's Song, Carmen. Grand Opera—L'air du Bijoux, Bessie Abbott.

I have a few more of other makes (which were given to me) each demonstrating the superior tone of your Records by comparison.

Now this collection is small, but you will agree with me that each Record is well chosen, and thoroughly representative of your Records. Now for the object of this letter.

On Christmas I took machine and Records to the brother's house I mentioned. Naturally it was in direct competition with the disc machine.

*The Edison was voted best for home use, because of its sweetness, purity of tone and distinctness.*

Mark you, for home use—what else is it intended for? Surely not to disturb neighbors—if they were I wouldn't have one. No, volume isn't so much needed as the three qualifications above mentioned, and the Edison has the first two absolutely, and the last to a large extent—more so than any disc ever heard.

---

## Louis J. Gerson Succeeds H. E. Marschalk

Henry E. Marschalk has withdrawn his interest and relinquished his management of the Musical Echo Company, Edison Jobbers of Philadelphia. Louis Jay Gerson, formerly assistant manager, has assumed the management, taking charge of the business January 1st. Mr. Gerson is very well known, having been identified with the talking machine industry for years. The President of the Musical Echo Company is F. W. Woolworth, of New York.

## Going After Record Business

The letter given below is reprinted for the purpose of pointing out to the trade an excellent means of getting Edison business. It was sent out in the latter part of December by the Austin Music Co., of Dayton, O. As the letter indicates it was accompanied by a copy of the *Phonogram*. It was mailed to a special list of Phonograph owners.

DEAR CUSTOMER: In handing you the new Phonogram for January, I most sincerely wish you a Happy New Year, and a prosperous one at that. I also wish to thank you for your kind patronage during the past year, and hope I will be able to serve you and your wants during the coming year. You will always find at my store a welcome for you.

I run this store to supply you in your wants for your Phonograph. This is a Phonograph store. I make this my business and study its detail, also keep in touch with all the latest and new Records, machines, and supplies that come out. Here is a little motto of my own. If I want to buy clothes I go to a clothing store. If I wish to buy groceries I go to a grocery store. And if I want to buy shoes I go to a shoe store. The same can be applied to pianos and sporting goods. But if I want to buy Records I go to a Phonograph store. For this reason, that these different lines are a distinct business to themselves, and you cannot do two things equally as well as one. In one line the dealer can buy more of his particular line than he could if he bought three or four lines, therefore giving the customer better prices, as he buys cheaper than the dealer who buys small.

However, we all know Edison Records sell for 35c all over the United States. And so I try to win your confidence by having the most complete stock of Records you will find in the city and will extend to you courteous treatment at all times. If at any time my clerks do not or cannot wait on you, kindly inform me. This I will consider a favor and I will graciously attend to your wants. Remove pleasure from business and nothing remains. My private Edison room permits you to hear Records without being disturbed or annoyed.

Do you get the Phonogram each month? We send this valuable booklet each month to you free of cost at an expense to ourselves. Do you get it? If not, kindly let us know. Read it carefully, as you will find it very interesting. It has lots of hints and suggestions how to get the full enjoyment out of your Phonograph, which you should get. It is very valuable. The first thing I do is to read this when it comes in. That is why I can answer all your questions, etc., about your machine. Also the other printed matter we enclose is helpful to you.

In reference to the new January Records, just out, I wish to call your attention to a few that are very good, and you should have one of them at least:

9722 In a Clock Store.

9726 Dreaming. This beautiful ballad is exceptionally good.

9732 Every Ship Will Find a Harbor. Sung by Harlan.

Try and make it a rule to buy at least one Record a month. Put this down as one of the New Year's pledges. That's only 35c, and the enjoyment derived will come back ten-fold.

The new Records are on sale the 25th of each month. On that evening we have a concert and play over these Records. So if the Phonogram doesn't happen to reach you on that day it's the fault of the postoffice. But you know we have the Record lists here, so come in.

Hoping this will be a prosperous and happy year for you, allow me to remain.

---

In sending us a copy of a quarter-page advertisement that they have been running in their local papers for several months, The Century Co., Edison Dealers of Bridgeport, Conn., report that their business has increased over forty per cent. during this time.

## Suggested "Copy" for Dealers' Advertisements

The following matter is printed for the purpose of furnishing Dealers with suitable "copy" for changing their advertisements in local newspapers or to encourage them in beginning such advertising.

### PHONOGRAPH "COPY"

#### HEAR THE EDISON PHONOGRAPH

Have you a Phonograph? How long has it been since you have critically listened to one? Do you know how good the Edison Phonograph is to-day, how pure the tone, how satisfying the reproduction? If you have one, you know. If you have not one, you ought to know—It's easy to know. Come here and hear. Learn how inexpensive it is for a complete outfit, including records—and how favorable the terms. Then think of the pleasure you can give yourself, your family and your friends with the world's best music, it's most catchy songs and the monologues and dialogues of it's funniest comedians. And after doing all this you'll buy one—you simply can't help it.

---

#### THE EDISON PHONOGRAPH

The voice of the Phonograph is more versatile than even the human voice. It not only reproduces singing, but all music, no matter how rendered. It can reproduce the forty combined instruments of a band as well as it reproduces the singing voice. That is why the Edison Phonograph brings entertainment into every home where it goes. It is the most popular invention of the many which Mr. Edison has made, and is the best form of talking machine because it is the personal work of the inventor, and not an adaptation of his idea. Come in at once to our store and it will not be long before you have one in your home.

The strongest proof of the real superiority of the Edison Phonograph over other talking machines has been in the large number of sales.

Every American citizen knows Edison and his work and therefore feels convinced that the Phonograph, which is his pet invention, must be better than other forms of talking machines and sound producers—because Edison made it.

The Phonograph may be a plaything and amuser, but it is nevertheless a scientific article and must be made with great care in a particular laboratory which knows just how to make every part just right.

The great success of the Edison Phonograph is due to the fact that it reproduces perfectly all sounds. Thus it has become the greatest amusement maker ever produced.

---

#### DANCE TO THE EDISON PHONOGRAPH

The dance music of the Edison Phonograph is irresistible. Its selections are clear, distinct, tuneful and in perfect time. It offers the most fascinating waltzes and spirited two-steps of the world's greatest composers as well as the popular dance music of the hour. It is a military band or a symphony orchestra at will, affording a delightful and widely varied program without expense or attention. The Phonograph represents the personal work of Mr. Edison, the inventor of the talking machine idea. Hear it at our store; you must compare it with others to fully appreciate its entertaining powers.

### RECORD "COPY"

#### A NEW PLEASURE IN EACH NEW EDISON RECORD

It is the Record that is new—not the Phonograph. Each March Record is as entertaining as any you ever heard when you heard it for the first time. The way to keep up your pleasure in the Edison Phonograph and get from it all the enjoyment you should, is to hear the new Records and pick out those you like. Let us help you make a selection.

---

#### NEW EDISON RECORDS

The delight with which you heard the first Record on your Edison Phonograph returns with every new Edison Record that you buy. Every month twenty-four new Records are added to those which are available for your enjoyment. They are on sale at our store on the 25th of the month. The new records for March are especially good. Come to our store and hear them. You will not leave the store without at least half a dozen to try on your Phonograph at home.

---

#### GET THESE NEW MARCH EDISON RECORDS FOR YOUR PHONOGRAPH

Keep in touch with the new songs and music. Enjoy the old successes. Laugh at the country's best fun-makers. The best talent in the land is represented in this list of new Edison Records for March, on sale February 25th. Humorous selections predominate, but they are of a high order; just the sort of breezy entertainment the season suggests. Then there are songs, waltzes and marches enough to well round out the list. Go over these at our store and take home the ones you like. Then you will hear your Phonograph at its best.

---

#### THE BEST TALENT IN THE LAND MADE THESE MARCH EDISON RECORDS

Never forget that any musical instrument will grow stale unless it has new music. You may have an Edison Phonograph, and you may have forgotten how delightful it was when the Records were new. The way to renew that delight is to buy the new Records. You would get tired of a piano, a violin, an orchestra or a vocal quartette, unless it gave you new music from time to time. The Edison Phonograph is like other musical instruments: It will entertain you if you do not forget to keep in touch with the new music—the new records. Ask us for the March list, or hear them played at our store.

---

#### MARCH RECORDS

Keep your Phonograph always fresh by supplying it with the newest Records—it is what you hear in the Phonograph that makes it interesting, not the Phonograph itself. Hear the March Records as our store, and then order them.

## Ready-Made Ads

A large number of Dealers have taken advantage of our offer to furnish electros of the illustrations in these ready-made ads. We are sorry to say that all of them have not complied with our request to send us copies of papers or printed matter in which the electros were used. Dealers who have failed to do this will not receive any more of these electros. If Dealers will not comply with so simple a matter as sending the evidence that they have used electros already sent them, they cannot complain if we do not honor any further orders. These electros are sent out for the purpose of getting additional advertising, and we are entitled to the same evidence of their use that we would ask if we were doing the advertising ourselves. To new Dealers or to those Dealers who have had electros and have complied with the requirements for their use, we will be glad to send either or both of the electros in the ready-made ads shown in this issue. The order on the next page should be used or similar matter written in a letter.

## February Advertising

The copy of our February Magazine advertisement, reprinted on page 20 of this issue, has been illustrated with a specially drawn sketch by Guernsey Moore, a well-known illustrator for magazines and other publications. This advertisement appeared in the Saturday Evening Post, Collier's, Associated Sunday Magazines, and about twenty of the magazines of largest circulation in the country. Our newspaper advertising has also gone on as originally planned. One of the large Phonograph ads appeared in nearly 145 newspapers published in the largest cities of the country on January 7th and 8th, being used in evening papers on the first date and in morning papers on the 8th. Another of the Record advertisements appeared on January 24th and 25th in the same list of papers. Another of the series of Phonograph ads will appear on February 11th and 12th, and another Record advertisement on February 24th and 25th. We believe that this advertising, together with all the advertising of other kinds that we are doing, has had much to do with maintaining the present volume of Edison business. Advertising is one of the features of our business in which there was no retrenchment nor will any attempt be made to cut it down in any particular. On the contrary, we are planning to increase its scope during the present year, giving the trade more and more assistance as these plans are worked out.

If there is any one class of young men who can appreciate an entertainer like the

# EDISON



# PHONOGRAPH

It is the college class. Think what it would mean to hear all the new popular songs in your own rooms, whenever you pleased, simply by turning them on.

## Thos. Smith & Sons

SCHENECTADY, N. Y.

Electro in above ad is: Single Column, No. 667.  
Double Column No. 668.



# EDISON



There are many old songs, almost forgotten now

## PHONOGRAPHS

had in Record form, and come into our store and

except by older people, which can be restored by the Edison Phonograph.

hear some of them on the Edison Phonograph. You will never rest until you own one.

Look over the catalogue and see how many of your favorites are to be

**GEORGE MASON,**  
12 State St., Boston, Mass.

Electro in above ad is: Single column wide, No. 665. Double column wide; No. 666.

## REQUEST FOR ELECTROS

NATIONAL PHONOGRAPH Co.

ADVERTISING DEPARTMENT, ORANGE, N. J.

DATE.....190.....

Mail Electros No.....

We agree to use them in newspaper advertising and to send you copies of papers containing them before asking you for other electros. We intend running a..... inch advertisement.

Name.....

Street.....

City and State.....

We buy through.....

## Busier Than Ever

Graves & Co. are busier than ever. They have recently received several carloads of goods. A carload of Edison Gold Moulded Records weighing 20,000 pounds, and a carload of 440 machines have recently arrived. They do an immense Edison trade. It was only a few years ago that F. W. Graves established this concern on a modest scale. The possibilities of the venture soon became apparent to him.

Several changes of location followed the quick demand for more room for the retail trade and increased stock. The last and most important move was to the present retail location opposite the Imperial Hotel in Washington street. Beautiful parlors were opened in this establishment and about this time the wholesale branch was added. This grew by leaps and bounds

until the company found it necessary to erect their own building for the jobbing business in the northern part of the city near the customs house.

"It seems but yesterday that I started in a little store handling Edison machines," said Mr. Graves. "Although in reality it has been several years since I made the venture, yet I can scarcely realize that a business of such magnitude as we now control should grow in so short a time. The past season has been a brilliant and busy one with our house. We felt the recent stringency to a slight degree, but the holiday trade is magnificent. The Northwest has money and the people feel confident of the future, so do not hoard their dollars so closely as would be the case otherwise. Future prospects are of the best."—*Seattle, Wash., Correspondence to the Music Trades.*

## SUSPENDED LIST, FEBRUARY 1, 1908

SUPERSEDING ALL PREVIOUS LISTS.

### CALIFORNIA.

Petaluma—Thomas McGuire, 875 Main st.

### CANADA.

Ottawa, Ont.—Ketchum & Co., Sparks and Bank sts.

### COLORADO.

Boulder—Bentley & Craig.

### GEORGIA.

Valdosta—H. K. McLendon, 109 West Central ave.

### ILLINOIS.

Champaign—Eggleston Bros., or Eggleston Music House, J. P. Eggleston, Prop.; also Danville, Ill.

Chicago—A. Gloss & Son, 727 W. North av.

Cooksville—Geo. Swinehart & Son.

Danville—Eggleston Bros., or Eggleston Music House, J. P. Eggleston, Prop.; also Champaign, Ill.

\*Elgin—James W. Mill, 18 Spring st. and 166 Chicago st.

Kempton—C. E. Bute.

Ottawa—Edward Hayne.

Peoria—H. Meyer, 1307 S. Adams st.

Quincy—Giles Bros., 107 North 4th st. J. F. Whittaker 618 Hampshire st.

\*Robinson—A. D. Foreman, or A. D. Foreman & Son.

Wheaton—E. Irving.

### INDIANA.

South Bend—Eugene Marsh, 126 Vistula ave. South Bend Book Bindery, Robert Lebolt, Prop., 203 North Michigan st.

### IOWA.

Burlington—John P. Weiss, 711 Jefferson st.

Cushing—Bullock & Lyman.

Independence—E. O. Parker, 110 E. Main st.

McClelland—J. W. Rounds & Co.

Mederville—John J. Carpenter.

Sioux City—Hattenbach Bros. Co.

A. V. Larimore, 518 Fifth st.

State Center—Ora Sargeant.

Whiting—The Cassady & Whiting Co.

### KANSAS.

Clay Centre—E. M. Gowenlock.

Lawrence—Bell Bros.

Topeka—R. H. Morehouse, 510 E. 4th st.

Wichita—Frank R. Powell, 132 N. Main st.

### KENTUCKY.

Louisville—Irvine Simons, 942 W. Market st. (formerly 543 W. Market st.).

### MAINE.

Biddeford—W. H. Field.

Gardner—C. H. Cobb, 293 Water st.

Lewiston—J. W. Skene.

Monmouth—G. H. Stetson.

Oldtown—H. M. Burnham.

Waterville—Frank Blanchard, 150 Main st.

### MASSACHUSETTS.

Boston—Henry H. Savage, 166 Hanover st. T. Singer, 60 Leverett st.

\*Fitchburg—M. Stienert & Sons Co.; also Pittsfield, Mass.

Florence—William Oates, 87 Main st.

Franklin—E. P. Blackmar.

Great Barrington—Frank W. Wheeler, Main st.

Lawrence—Lord & Co., 314 Essex st. E. O. Mosher, 420 Essex st.

Malden—A. T. Fuller.

Nantucket—Arthur M. Taylor.

New Bedford—H. B. DeWolff.

\*Pittsfield—M. Steinert & Sons Co., 254 North st.; also Fitchburg, Mass.

Somerville—E. J. Winchester, 32 Summit ave.

Woburn—Osborn Gillette, or The Boston Jewelry Co., L. F. Maloney, Manager.

Worcester—Joseph Tukman, 44 Front st. Guy Furniture Co., 521 Main st.

### MICHIGAN.

Ann Arbor—Ann Arbor Music Co., F. J. Schwankovsky, Prop.

Blissfield—Rothfuss Piano Co., (William Rothfuss, Geo. M. Rothfuss and Frank B. Jones.)

Detroit—F. J. Schwankovsky.

\*Manistee—Gus Ilse, and A. H. Ilse Co., 311 River st.

Saginaw—Geo. W. Emendorfer.

James V. Calahan, 217 Genessee st.

Tierney Bros., 217 Genessee st.

## SUSPENDED LIST CONTINUED.

### MINNESOTA.

**Willmar**—Willmar Furniture Co., Ruble Block.

### MISSOURI.

**Ewing**—Hal R. Ewalt.  
**Fairfax**—Hinde Hardware Co.  
**Kansas City**—The Wittmann Co.  
**\*Osceola**—C. H. Green.  
**St. Louis**—Knight Cycle Co., 1215 Olive st.

### NEBRASKA.

**David City**—John Albright.  
**Lincoln**—The Wittmann Co.  
**Omaha**—The Wittmann Co.  
 Piano Player Co.  
**Red Cloud**—Albright Bros. or L. P. Albright.  
**Sterling**—Sterling Drug Co., W. G. Morrill, Prop., and W. G. Morrill, M. D.

### NEW HAMPSHIRE.

**Dover**—H. C. Ingalls & Co., 444 Central ave.  
**Hillsboro Bridge**—E. M. Barnes.  
**Manchester**—A. E. Dumas.  
**Nashua**—F. A. McMaster & Co.

### NEW JERSEY.

**Atlantic City**—Sam'l D. Wolf, 32-34 Arkansas ave.  
**Bayonne**—J. Wigdor, 450 Avenue D.  
**Jersey City**—W. L. Hoffman, 151 Montgomery street.  
**Long Branch**—A. N. Alexander, 103 Broadway.  
 A. Nastasio, 103 Broadway.  
**Newark**—R. L. Corwin; also New York City.  
 R. Rosenthal, Prop. Springfield Hdw. and Sptg. Goods Store, 71 Springfield ave.  
 D. Reinhorn, 91 Springfield ave.  
**Passaic**—I. Hurwitz.  
**Paterson**—Chas. H. Kelly, 25 N. Main st.  
**Plainfield**—S. W. Frucht, or R. Frucht; also New York City.  
 Elston M. Leonard.  
**West Hoboken**—Emil Hollander, or The West Hoboken Bicycle & Phono. Co., 169 Spring st.

### NEW YORK.

**Albany**—G. Linde, 353 S. Pearl st.  
 G. A. Birdsall, 114 S. Pearl st.  
**Amsterdam**—D. C. Kirchner, 26 Market st.  
**Bedford Park**—Geo. H. Tyrrell.  
**Brooklyn**—Nathan Abrahams, 602 Broadway.  
 Wm. Albrecht, 294 Knickerbocker ave.  
 H. Hindermann, Bushwick Phonograph Exchange, 1421 Myrtle ave.  
 Emil Smith, 634 Eleventh st., and 230 Summer ave.  
 \*Totten Furniture & Carpet Co., 216 Grand st.  
**Hobart**—E. H. Marshall.  
**New York City**—A. T. Armstrong, or American Phono Co., 106 Wall st.  
 Automatic Zither Co., M. Cohen, Prop., 58 Second ave.  
 Bern Bearwald, 373 W. 11th st.  
 Edward Bielfeld, 481 Willis ave.  
 I. & S. Birnsweig, Birnsweig's Music Store, and Birn's Music Store, 510 E. 138th st.  
**Bronx Phono. Co.**, or David Switky, 506 Willis ave.  
 R. L. Corwin; also Newark, N. J.  
**Eagle Phono. Co.**, or C. Lowenthal, 83 Nassau st.  
**Empire Phono. Co.**, 2 W. 14th st.  
 S. W. Frucht, or R. Frucht, 7 Barclay st., or 68 Cortlandt st., also Plainfield, N. J.  
 O. Hacker, 2 Murray st.  
**Hawthorne & Sheble** 297 Broadway; also Philadelphia, Pa.  
**Holober Bros.**, 350, 421 and 491 West st.  
 N. Horn, 148 E. 58th st.

\*Added since January 1st, 1908.

### NEW YORK—Continued.

W. L. Isaacs, 114 Fulton st.  
 Italo-American Phono. Co. (R. Gerard & Co.)  
 S. Lemberg & Co., 194 Broadway.  
 J. McEllyne, 202 Broadway.  
 Parker & Cooley, 2087 Amsterdam ave.  
 Richmond Pease, 44 W. 132d st.  
 F. M. Prescott, 44 Broad st.  
 Winthrop Cycle Co., 2212 Seventh av.  
**Oneonta**—G. B. Shearer Co., 259-261 Main St.  
**Rome**—Charles Tuttle.  
**Saratoga**—W. J. Totten.  
**Saratoga Springs**—Marvin A. Cote.  
**Watertown**—H. S. Wardwell & Co., 39 Public Square.  
**Wayland**—John Gross, Pursel Block.

### NORTH CAROLINA.

**Kinston**—S. A. Quinerly.

### NORTH DAKOTA.

**Fargo**—Ben Hart.

### OKLAHOMA.

**Oklahoma City**—Armstrong, Byrd & Co.; also Shawnee.  
**Shawnee**—Armstrong, Byrd & Co.; also Oklahoma City.

### OHIO.

**Ashtabula Harbor**—Chas. W. Askew (Gregory, Askew & Co.).  
**Bellevue**—H. E. Rouser.  
**Brookville**—H. K. Merritt.  
**Cincinnati**—J. L. Andem.  
**Coshocton**—Burns & Gosser.  
**Dayton**—W. E. Sapp, 1042 W. Third st.  
**\*Hicksville**—W. R. Holden Co.  
**Springfield**—D. & M. Vanderpool.  
**Uhrichsville**—F. A. Mazurie.

### PENNSYLVANIA.

**Athens**—J. T. Stalford, 405 Main st.  
**Bradford**—C. C. Griffen, 29 N. Washington st.  
**Lancaster**—J. H. Tragresser, 249 N. Queen st.  
**Mt. Pleasant**—Benjamin Posner.  
**New Castle**—Will Hartland, 70 E. Long st.  
**Philadelphia**—A. R. Cassidy, 2783 Emerald st.  
 Thomas Gunson, 1003 Carpenter st.  
 Hawthorne & Sheble, 604 Chestnut st., or Oxford and Mascher sts.; also New York City.  
 A. Krouse, 832 Arch st.  
 Penn Novelty Co., 15 South 9th st.  
**Pittsburg**—A. Lippard, 615 Wylie ave.  
**Royersford**—Granville B. Tyson, 215 Main st.  
**Titusville**—E. H. Fortney, Prop. Exchange Cigar Store, 21 W. Central ave.

### RHODE ISLAND.

**Providence**—\*E. H. Gainsbury, 59 Plainfield st.  
 F. P. Moore.  
**Rockville Center**—O. A. Clark.

### TENNESSEE.

**Alexandria**—Clarence D. Baird Music Concern.

### TEXAS.

**Whitney**—H. E. Randle & Co.

### UTAH.

**Salt Lake City**—Daynes Romney Music Co., 25 East South 1st st.

### VERMONT.

**Barre**—Averill Music Co. (H. L. Averill & Co.), 28 N. Main st.

### VIRGINIA.

**Norfolk**—W. Reichenstein, 296 Church st.

### WISCONSIN.

**Ashland**—J. F. Pool Co.  
**Milwaukee**—J. C. Blatzek.  
**Walworth**—G. H. Stewart.

**Jobbers and Dealers** are asked not to supply any of the above named firms with our apparatus, either at addresses given or any other address.



## The EDISON PHONOGRAPH

Makes home the most entertaining spot on earth. You can give a dance with an Edison Phonograph, supply music at a reception, accompany a singer, entertain the children, break the ice at a party, while away pleasantly a few hours when you are alone.

Put it to the test. Go to the nearest Edison store and hear the new model with the big horn. Let the dealer play for you some of the **NEW FEBRUARY RECORDS**. (Out January 25th.)

If you already own an Edison remember that to get the fullest enjoyment out of it you must keep up with the new records.

Ask your dealer or write to us for the new catalogue of Edison Phonographs, **THE PHONOGRAM**, describing each Record in detail; the **SUPPLEMENTAL CATALOGUE**, listing the new February Records, and the **COMPLETE CATALOGUE**, listing all Edison Records now in existence. Records in all foreign languages.



TRADE MARK

**NATIONAL PHONOGRAPH COMPANY,** Lakeside Av., Orange, N. J. *Thomas A Edison*

Advertisement in February Magazines

# Jobbers of Edison Phonographs and Records

Continued from page 2 of cover

## NEW YORK.

Albany—Finch & Hahn, 402 Broadway  
Astoria—John Rose, 99 Flushing ave.  
Brooklyn—A. D. Matthews' Sons, 394 Fulton street.  
Buffalo—W. D. Andrews, Seneca and Wells sts.  
Neal, Clark & Neal Co., 645 Main st.  
Elmira—Elmira Arms Co., 117 Main st.  
Gloversville—American Phono. Co., 99 W. Fulton st.  
Kingston—Forsyth & Davis, 307 Wall st.  
New York City—Blackman Talking Machine Co., 97 Chambers st.  
J. F. Blackman & Son, 2737 3d ave.  
I. Davega, Jr., Inc., 125 W. 125th st.  
S. B. Davega, 32 E. 14th st.  
Douglas Phono. Co., Inc., 89 Chambers st.  
Jacot Music Box Co., 39 Union square.  
Victor H. Rapke, 1659 Second ave.  
Regina Co., 41 Union square.  
Siegel-Cooper Co., 6th ave. and 18th st.  
John Wanamaker, Broadway, 8th and 9th sts.  
Alfred Weiss, 1622 First ave.  
Oswego—Frank E. Bolway, 32 W. Bridge st.  
Rochester—A. J. Deninger, 845 North st.  
Mackie Piano, O. & M. Co., 100 State st.  
Talking Machine Co., 97 Main st., E.  
Schenectady—Finch & Hahn, 504 State st.  
Jay A. Rickard & Co., 253 State st.  
Syracuse—W. D. Andrews, 216 E. Railroad st.  
Troy—Finch & Hahn, 3 Third st.  
Utica—Clark-Horrocks Co., 54 Genesee st.  
Arthur F. Ferriss, 89 Washington st.  
William Harrison, 50 Columbia st.  
Utica Cycle Co., 16 Columbia st.

## OHIO.

Canton—Klein & Heffelman Co., 220 E. Tuscarawas st.  
Cincinnati—Ball-Fintze Co., 108 West 3d st.  
Ilse & Co., 615 Vine st.  
Lawrence McGreal, 29 East 5th st.  
Rudolph Wurlitzer Co., 121 East 4th st.  
Cleveland—Eclipse Musical Co., 1870 East Ninth st.  
Columbus—Perry B. Whitsit Co., 218 S. High street.  
Dayton—Niehaus & Dohse, 35 E. 5th st.  
Newark—Ball-Fintze Co.  
Toledo—Hayes Music Co., 422 Superior st.

## OREGON.

Portland—Graves & Co., Inc., 65 No. Park st.

## OKLAHOMA.

Oklahoma City—Smith's Phono. Co., 818 West West Main st.

## PENNSYLVANIA.

Allentown—G. C. Aschbach, 539 Hamilton st.  
Easton—William Werner, 432 Northampton st.  
Harrisburg—S. K. Hamburger, 12-14 N. Market square.  
Philadelphia—Louis Buehn & Bro., 45 N. 9th street.  
C. J. Heppe & Son, 1117 Chestnut st.  
Lit Bros., Market and 8th sts.  
Musical Echo Co., 1217 Chestnut st.  
Penn Phonograph Co., 17 S. 9th st.  
John Wanamaker, 18th and Market sts.  
Western Talking Mach. Co., 41 and 43 N. 9th st.  
H. A. Weymann & Son, 1010 Chestnut st.

## Pennsylvania—Continued.

Pittsburg—Pittsburg Phono. Co., 937 Liberty ave.  
Powers & Henry Co., 101 Sixth st.  
Standard Talk. Mach. Co., 435 Wood st.  
Reading—Reading Phonograph Co., 48 N. 8th st.  
Scranton—Ackerman & Co., 217 Wyoming av.  
Technical Supply Co.  
Sharon—W. C. DeForeest & Son.  
Williamsport—W. A. Myers, 145 W. 3d st.

## RHODE ISLAND.

Providence—J. M. Dean Co., 785-795 Westminster st.  
J. A. Foster Co., Weybosset and Dorrance streets.  
J. Samuels & Bro., 154 Weybosset st.

## TENNESSEE.

Chattanooga—J. H. Templeman Co., 253 Montgomery ave.  
Knoxville—Knoxville Typewriter and Phonograph Co., 421 Gay st.  
Memphis—F. M. Atwood, 160 N. Main st.  
O. K. Houck Piano Co., 103 S. Main st.  
Nashville—Magruder & Co., 27 Arcade.  
Nashville Talking Mach. Co., 723 Church st.

## TEXAS.

Dallas—Southern Talking Machine Co., 347 Main st.  
El Paso—W. G. Walz Co., 101 El Paso st.  
Fort Worth—Cummings, Shepherd & Co., 700 Houston st.  
Houston—Texas Piano & Phono. Co., 1019 Capitol ave.  
San Antonio—H. C. Rees Optical Co., 242 West Commerce st.

## UTAH.

Ogden—Proudfit Sporting Goods Co., 351 24th street.  
Salt Lake City—Clayton Music Co., 109 S. Main st.

## VERMONT.

Burlington—American Phono. Co., 34 Church street.

## VIRGINIA.

Richmond—C. B. Haynes & Co., 603 E. Main street.

## WASHINGTON.

Seattle—D. S. Johnston Co., 903 Second ave.  
Kohler & Chase, 710 Pike st.  
Spokane—Spokane Phonograph Co., 7 Post st.

## WISCONSIN.

Milwaukee—Lawrence McGreal, 176 3d st.

## CANADA.

Quebec—C. Robitaille, 320 Rue St. Joseph.  
St. John—W. H. Thorne & Co., Ltd., 42-46 Prince William st.  
Toronto—R. S. Williams & Sons Co., Limited, 143 Yonge st.  
Vancouver—M. W. Waitt & Co., 553 Granville street.  
Winnipeg—R. S. Williams & Sons Co., Ltd., 121 Princess st.

# In the Words of Others

## "Sell I.C.S. Language Outfits"

The best proof that it will pay you to sell I. C. S. Language Outfits comes from the statement of dealers that have tried them. We have published several of these letters before; here is another one from the Denver

Dry Goods Co.

This is piling up evidence that you are losing profits of from 10 to 30 per cent. on your business if you are not handling these Outfits. The phonograph system is fast becoming recognized as the most perfect way in the world to teach foreign languages. As a commercial enterprise, the I.C.S. System has always paid dealers well in the past, and it is growing very rapidly. Wouldn't it be a good idea for you

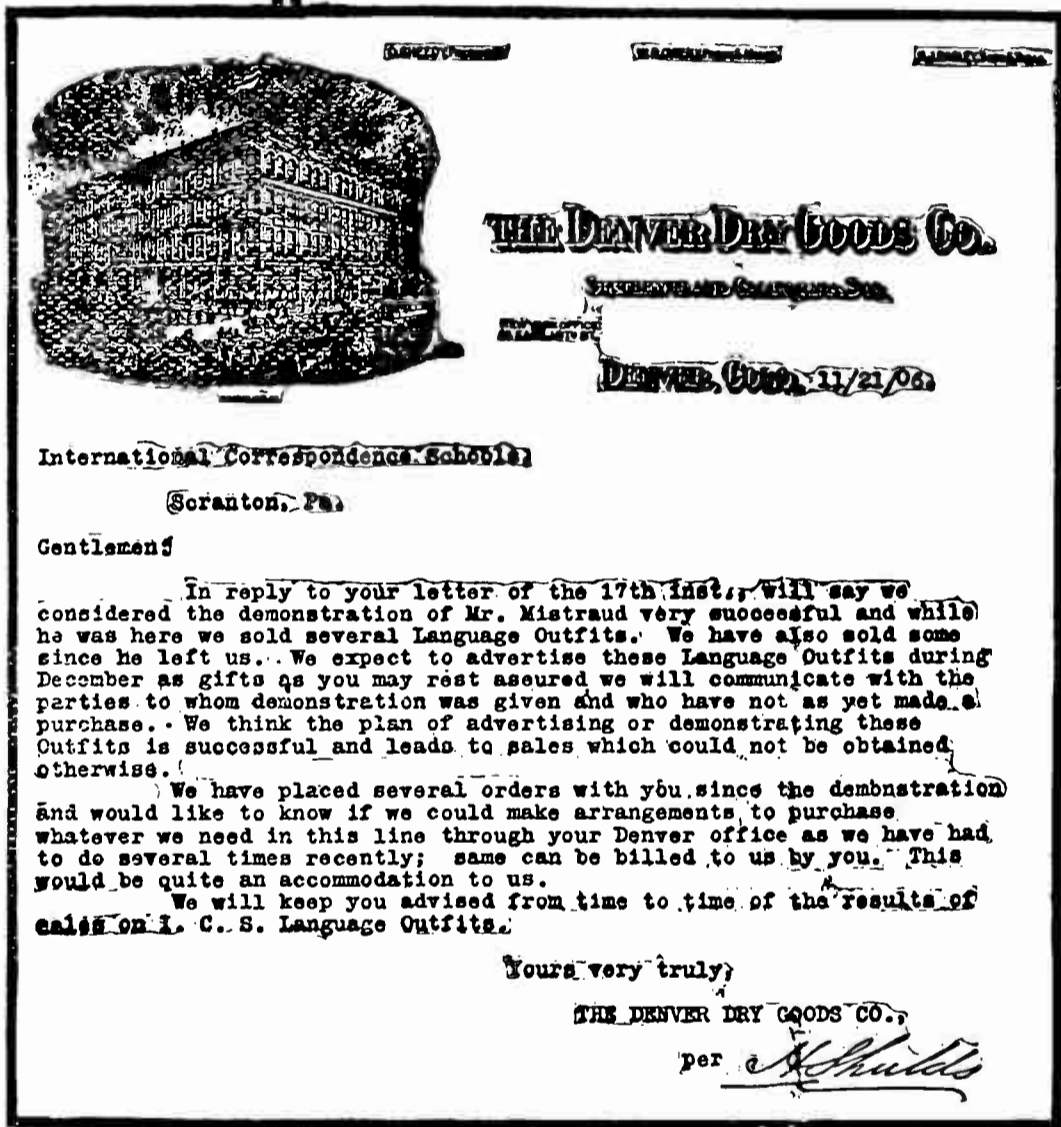

to write us today for full particulars of what we can do for you? Let us put our advertising to work for you. It will not only bring you customers for language work, but will increase your regular business. Send us a postal card NOW.

**International Correspondence Schools**  
 SCRANTON, PA.

# EDISON PHONO- GRAPH MONTHLY

Vol. VI

March, 1908

No. 3

## CONTENTS

	PAGE.		PAGE.
Keeping At It.....	1	Miss Jones is in Good Health.....	11
Advance List Edison Gold Moulded Records for May .....	3	Mailing Supplements and Phonograms.....	11
Remove Packing Under Spring Barrel.....	5	Personal .....	11
Lauder Records .....	5	Record No. 12470 Cut Out.....	11
Dinner to Mr. Edison.....	7	Stick to Standard Goods.....	12
New Freight Rate on Horns.....	7	Mr. Randolph's Successors.....	13
Australia Reduces Duty on Phonographs....	7	A New South Wales Opinion.....	13
The New York Case.....	8	Gives Music With His Stamps.....	14
Pushing the Game.....	8	Easier to Keep Than to Break.....	15
John F. Randolph.....	9	Dealers, This is Worth Reading.....	16
Most Old Dealers Have Re-signed.....	9	What Dealers Say and Do.....	17
Foreign Records.....	10	The Phonograph and Art.....	18
No Flower Horn Contemplated.....	10	About Edison Jobbers.....	20
Edison Idelia Phonograph.....	10	Ready-made Ads .....	20
Printed Matter.....	10	Suspended List .....	22
Change in Equipment.....	11	Jobbers of Edison Phonographs and Records, Cover pages .....	2 and 3

*Published for Trade use only by  
The National Phonograph Co., Orange, N.J.*

# Jobbers of Edison Phonographs and Records

## ALABAMA.

Birmingham—Talking Machine Co., 2007 Second ave.  
Mobile—W. H. Reynolds, 167 Dauphin st.  
Montgomery—R. L. Penick, 119 Dexter ave.

## CALIFORNIA.

Los Angeles—Southern California Music Co., 333 South Broadway.  
Oakland—Kohler & Chase, Inc., 917-921 Wood street.  
Sacramento—A. J. Pommer Co., 9th and J sts.  
San Francisco—P. Bacigalupi & Sons, 1021 Golden Gate ave.

## COLORADO.

Denver—Denver Dry Goods Co., 619 16th st.  
Hext Music Co., 15th and California sts.

## CONNECTICUT.

New Haven—Pardee-Ellenberger Co., Inc., 96 State st.

## DISTRICT OF COLUMBIA.

Washington—E. F. Droop & Sons Co., 325 Pennsylvania ave., N. W.

## GEORGIA.

Atlanta—Atlanta Phonograph Co., 10 Walton st.  
Phillips & Crew Co., 37-39 Peachtree st.  
Savannah—Youmans & Leete, 116 Barnard st.  
Waycross—George R. Youmans.

## IDAHO.

Boise—Eiler's Piano House.

## ILLINOIS.

Chicago—Babson Bros., 1419 19th st.  
Lyon & Healy, Wabash ave. & Adams st.  
James I. Lyons, 192 Van Buren st.  
The Vim Co., 68 E. Lake st.  
Montgomery Ward & Co., 111 Michigan avenue.  
Rudolph Wurlitzer Co., 266 Wabash ave.  
\*Peoria—Chas. C. Adams & Co., 324 South Adams st.  
Peoria Phonograph Co., 416 S. Adams st.  
Quincy—Quincy Phonograph Co., 411 Hampshire st.

## INDIANA.

Indianapolis—Indiana Phono. Co., 45 Virginia avenue.  
Kipp-Link Phonograph Co., 10-12 E. Washington st.  
A. B. Wahl & Co., 119 S. Illinois st.

## IOWA.

Des Moines—Hopkins Bros. Co., 620 Locust st.  
The Vim Co., 204 Seventh st.  
Dubuque—Harger & Blish, 904 Main st.  
Fort Dodge—Early Music House, 322 Central avenue.  
Sioux City—Early Music House, 315 Court st.

## KENTUCKY.

Louisville—Montenegro-Riehm Music Co., 527-531 Third ave.

## LOUISIANA.

New Orleans—William Bailey, 600 Frenchmen street.  
National Automatic Fire Alarm Co., 614 Gravier st.

## MAINE.

Bangor—S. L. Crosby Co., 186 Exchange st.  
Portland—W. H. Ross & Son, 43 Exchange st.

## MARYLAND.

Baltimore—E. F. Droop & Sons Co., 231 North Howard st.

## MASSACHUSETTS.

Boston—Boston Cycle & Sundry Co., 48 Hanover st.  
Eastern Talking Mach. Co., 177 Tremont street.  
Iver Johnson Sptg. Goods Co., 163 Washington st.  
Fitchburg—Iver Johnson Sptg. Goods Co., 347 Main st.  
Lowell—Thomas Wardell, 111 Central st.  
New Bedford—Household Furnishing Co., 170 Purchase st.  
Springfield—Flint & Brickett Co., 489 Main st.  
Worcester—Iver Johnson Sptg. Goods Co., 204 Main st.

## MICHIGAN.

Detroit—American Phono. Co., 106 Woodward avenue.  
Grinnell Bros., 219 Woodward ave.

## MINNESOTA.

Minneapolis—Thomas C. Hough, 714 Hennepin avenue.  
Minnesota Phono. Co., 505 Washington av., So.  
St. Paul—W. J. Dyer & Bro., 21-23 West 5th st.  
Thomas C. Hough, 392 Wabasha st.  
Koehler & Hinrichs, 255 E. 3d st.  
Minnesota Phonograph Co., 37 E. 7th st.

## MISSOURI.

Kansas City—J. W. Jenkins' Sons Music Co., 1013-1015 Walnut st.  
Schmelzer Arms Co., 710 Main st.  
St. Louis—Conroy Piano Co., 11th and Olive streets.  
Koerber-Brenner Music Co., 1006 Olive street.  
Silverstone Talk. Mach. Co., 1010 Olive st.

## MONTANA.

Helena—Frank Buser, 509 N. Main st.

## NEBRASKA.

Lincoln—Ross P. Curtice Co., 1125 O st.  
H. E. Sidles Phono. Co., 13th and P sts.  
Omaha—Nebraska Cycle Co., 15th and Harney streets.  
Shultz Bros., 16th and Chicago sts.

## NEW HAMPSHIRE.

Manchester—John B. Varick Co., Varick Bldg.

## NEW JERSEY.

Hoboken—Eclipse Phono. Co., 203 Washington st.  
Newark—Douglas Phonograph Co., 20 New st.  
A. O. Petit, 57 Halsey st.  
Rapke Phono. Store, 287 Bank st.  
Paterson—James K. O'Dea, 117 Ellison st.  
Trenton—Stoll Blank Book and Stationery Co., 30 E. State st.  
John Sykes, 105 N. Broad st.

Continued on page 3 of cover



# Edison Phonograph Monthly

VOL. VI.

March, 1908

No. 3

## Keeping At It

The man who attempts to say that business today is as good as it was six months ago fools no one but himself. The volume of every business has, in the past few months, undergone a shrinkage that in the aggregate is large, and that has varied considerably, according to the character of business. No one of sense will deny these facts and no good will be had by concealing them. The facts are like the proverbial spilled milk, they cannot be recalled. What caused the trouble is now of little moment, except to point out reefs to be avoided in the future. The chief concern of every business man should now be: What can I do to aid in building up the financial and industrial interests of our great country? Every man, with his eyes to the future, should resolve that he will strive to do his full share in restoring prosperity.

Such will be the effort of the National Phonograph Company and it solicits the co-operation of every Jobber and Dealer to the same end. In common with all other manufacturers we have not relished the reduced volume of business, but this reduction has not been anything like what some other lines have suffered. An offsetting gain has been the elimination of many items of expense that had crept in from time to time, and the re-organization of departments to a greater efficiency at less cost. From an organization and expense standpoint the depression has been advantageous, although we frankly admit that we would rather not have been compelled to reorganize and reduce. The same conditions have prevailed throughout the talking machine trade. All Jobbers and Dealers have eliminated every unnecessary expense and are now doing business on a solid and substantial foundation. They are in splendid shape for the future.

That the turning point was reached some time ago and that financial and industrial affairs are now showing a marked improvement are admitted everywhere. Our own business is showing a steady increase week after week, and the

character of the orders sent in by Jobbers evidences a similar condition with the latter. The latter's orders, of course, are but a reflection of the state of business with Dealers. Considering that Phonographs and Records are classed as luxuries, (although many thousands seem to regard them as necessities), the talking machine trade is in splendid shape.

The trade can co-operate in making it better by not only putting forth the same efforts as they formerly did, but by increased effort. After all, ninety per cent of the people are as well off as they ever were. They have suffered no loss of positions or wages, and they are just as able as ever to buy Phonographs and Records. Dealers' advertising, circularizing, window displays, salesmanship and personal work will make sales almost as readily now as at any time in the past. The fact that we are doing no less advertising, are getting out just as much printed matter, and are keeping our salesmen on the road, show that we believe in keeping at the game the same as before, and our own work will accomplish the greatest results when the trade pushes business locally. Dealers should not relax in their efforts because of the feeling that it won't pay; they believed in pushing things a few months ago, and what has happened since has not been sufficient to make a material change. Don't seize upon a pretext to lay down. Keep on your feet and with head in air, eyes front and chest out, show the people of your cities and towns that you believe in your goods and are losing no opportunity to tell them so.

## Keep Up Stocks

Conservatism in ordering Phonographs and Records is a trait to be commended in all Dealers, but to be conservative does not mean to let stocks run so low as to cause the loss of sales. Not to have a stock on hand sufficient to fill the demands of every customer is a lack of business judgment. Don't be that kind of a Dealer.

## The New Edison Gold Moulded Records Jobbers' Advance List for May, 1908

**R**ECORDS listed below will be shipped from Orange in time to reach all Jobbers in the United States and Canada before April 25th, 1908, all things being favorable, and they may be reshipped to Dealers at 2 P. M. on April 24th. They must not, however, be exhibited, demonstrated or placed on sale by Jobbers or Dealers until 8 A. M. on April 25th. Supplements, Phonograms and Bulletins will be shipped with Records. These may be distributed to Dealers after April 20th, but must not be circulated among the public before April 25th. Jobbers and Dealers may, however, deposit Supplements and Phonograms in Mail Boxes or Post Offices after 5 P. M. on April 24th, for delivery on the following day. Jobbers are required to place orders for May Records on or before March 10th. Dealers should place May orders with Jobbers before March 10th to insure prompt shipment when Jobbers stock is received.

### 9818 Down in a Coal Mine

Edison Concert Band

A Record descriptive of daily life in a coal mine. To music of an appropriate character, the miners assemble, greet each other, enter the cage and are conveyed into the mine; they are heard working with pick and shovel; they stand back for a blast, and as they return to work they sing "Down in a Coal Mine," a song very popular some thirty or more years ago. Composer, Otto Langey; publisher, Carl Fischer, New York.

### 9819 If Those Lips Could Only Speak

Allen Waterous

Living in a beautiful mansion, with unlimited wealth and surrounded by luxury, the singer gazes upon the framed portrait of his dead wife and laments her departure in the following words:

If those lips could only speak,  
If those eyes could only see,  
If those beautiful golden tresses  
Were there in reality;

Could I only take your hand,  
As I did when you took my name!  
But it's only a beautiful picture  
In a beautiful golden frame.

Allen Waterous, who, by the way, is a brother of the Mr. Waterous who has sung duets with his wife, and not the duet singer, as stated last month, makes a splendid Record of this composition. Orchestra accompaniment. Words and music by Charles Ridgwell and Will Goodwin.

### 9820 Chimmie and Maggie at "The Merry Widow"

Ada Jones and Len Spencer

Chimmie and Maggie have yielded to the New York craze and have been to see Lehár's operetta "The Merry Widow." The Record begins as they are leaving the theatre. The calls for carriages are heard and the boys are selling the sheet music in the lobby. Maggie is inclined to be sarcastic about the members of her sex whom they have just seen on the "stoige." She especially comments on the "Widow" thusly:

Little puffs of powder,  
Little dabs of paint,

Makes the merry widow  
Look like wot she aint.

Jimmie's replies make Maggie somewhat jealous. He, in turn, is put out when she wants to find the man who wrote the famous waltz. The sketch is original and is not published.

### 9821 Love's Roundelay

Anthony and Miller

"The Merry Widow" has a rival in the Viennese operetta "A Waltz Dream." It was given its first presentation at the Broadway Theatre, New York, in January and has since steadily grown in popularity. Its music is very attractive. A number of its airs are of the kind that are widely sung and whistled. Chief among these is "Love's Roundelay," which is most charmingly sung for our Record by Messrs. Anthony and Miller, two of the best singers in the Edison galaxy. Orchestra accompaniment. Music, Oscar Straus; words, Joseph Herbert; publishers, Joseph W. Stern & Co., New York.

**9822 Somebody That I Know and You Know Too****Manuel Romain**

Fully equal to Mr. Romain's previous fine Records is this short love tale with its somewhat unusual title. As might be surmised, the individual known to both is the object of the singer's admiration. Mr. Romain is a delightful singer of ballads of this kind. Orchestra accompaniment. Music, J. Fred Helf; words, Ed. Gardenier; publishers, Helf & Hager Co., New York.

**9823 My Gal Irene****Collins and Harlan**

Irene is a village belle and this song dwells upon her charms and her talent as a performer on the accordian. What the playwright would call the "plot" is given in the chorus as follows:

My Irene is the village dream,  
She's the queen of the village green,  
And when she plays on the a-cor-deen,  
A slicker gal why you never seen,

Jones's Sal and the Simpkins gal,  
They never could touch Irene.  
Everybody on the street gets a ticklin' in t'ee feet.  
When she plays on the a-cor-deen.

The air fitted to the song is of the easy-to-learn kind—the kind that holds the attention of those fond of popular airs. Collins and Harlan's rendition of the song will make it a big seller in the May list. Orchestra accompaniment. Music and words, J. Hapgood Burt; publishers, Jerome H. Remick & Co., New York.

**9824 Tipperary****Stella Tobin**

A sentimental son of Erin's fair isle sings of his love for a "typical Tipperary miss." Every line is full of "blarney," just the language that a lovelorn Irishman would use in singing of his charmer. Perhaps the most attractive feature of the song is the clever way in which the well-known Tipperary air is worked into it. This is Miss Tobin's second selection for the Edison catalogue, and in our opinion is even better than her first one, No. 9753, in the February list. Orchestra accompaniment. Music and words, Leo Curley, James M. Fulton and J. Fred Helf; publishers, Helf & Hager Co., New York.

**9825 La Papillote****Edison Symphony Orchestra**

From a musical standpoint, this is one of the best things of the month. The melody of the composition is delightful and its interpretation by our Symphony Orchestra is of a most artistic character. Altogether the Record is a gem. Composer, R. Gruenwald; publishers, Oliver Ditson Co., Boston.

**9826 When Sweet Marie Was Sweet Sixteen****Frederic Rose**

One of the ever popular sentimental ballads, in which a tale of love is set to enticing musical strains. Its composer will be remembered as the writer of "Sweet Marie." The chorus:

When sweet Marie was sweet sixteen,  
In fairyland of woodland green,

And I was king and she my queen,  
When sweet Marie was sweet sixteen.

Although Mr. Rose has been singing for the Edison public but a short time, he has acquired a wide popularity and his ballads are regarded by many as equal to any ever put out by this company. Orchestra accompaniment. Music, Ernest R. Ball; words, Raymon Moore; publishers, M. Witmark & Son, New York.

**9827 My Mother's Prayer****Edison Mixed Quartette**

A sacred selection with solo by James F. Harrison, accompanied by the organ and chorus by the quartette of mixed voices. It is a Record fully up to the high standard of the department of sacred music in our catalogue. The hymn is a well-known favorite. The rendition is fine. Music, W. S. Weeden; words, J. W. Van de Venter; published in hymn books.

**9828 Just One Word of Consolation****Irving Gillette**

Mr. Gillette has not, in some time, sung for us a more attractive ballad than this. The song is well known and its range fits Mr. Gillette's voice to a nicety. The refrain:

Just one word of consolation,  
Just a sigh of sigh of sympathy,  
Often helps the situation.  
When distress o'er shadows thee.

E'en in silent meditation,  
When the soul from earth would part,  
Just one word of consolation  
Sometimes soothes a breaking heart.

Orchestra accompaniment. Music, Tom Lemoinier; words, Frank B. Williams; publisher, Charles Harris, New York.

**9829 Under Freedom's Flag March****Edison Military Band**

A stirring march of a semi-patriotic character, rendered with precision by our Military Band. One of those march selections that win a lasting popularity. Composer, F. Nowowieski; publishers, Joseph W. Stern & Co., New York.

**9830 Hannibal Hope****Arthur Collins**

Hannibal is a moke who left his Nashville home to go with a circus show. The circus is billed for Nashville one day and the song tells how his girl Mandy Green is enthusiastically waiting for his advent. Hannibal plays the steam calliope, which according to Mandy's notion of music has the angels' golden harps played to a standstill. Introduced into the Record are the effects of Mandy and a crowd of spectators waiting for the circus parade. Mandy can hardly contain

---

# 4 Edison Phonograph Monthly, March, 1908

---

herself. Her remarks about Hannibal get the spectators keyed up to great expectancy. Now comes the band. Then the horses are heard. The animals cry, laugh and roar. Mandy suddenly shouts "That's My Hannibal!" and the fearful music of the calliope fills the air. The effect is made all the more ludicrous by an exaggerated burlesque of the calliope. Orchestra accompaniment. Music, Lou Hirsch; words, John B. Lowitz; publishers, F. B. Haviland Publishing Co., New York.

## 9831 The Girl Who Threw Me Down

Edward M. Favor and Chorus

An already very popular ditty, sung by an artist whose experience on the comic opera stage has made him a master of the art of producing a loud and clearly enunciated Record. The song concerns the lover who couldn't stay away from "that old Long Island town," notwithstanding the "twenty-three's" and other similar things that his girl handed him. An additional feature of the Record is the quartette chorus. An "in-the-money" Record. Orchestra accompaniment. Music, Albert Gumble; words, Benj. Hapgood Burt; publishers, Jerome H. Remick & Co., New York.

## 9832 One! Two! Three! All Over

Billy Murray

A bit of fun that cannot fail to make a hit with the public. It comprises two verses with choruses appropriate to each. Verse one relates the story of the would-be pugilist who, in the first round, was struck by something hard. As he fell he heard, intermingled with the count of the referee, the singing of birds, the ringing of bells and the rustling of angels' wings. Verse two tells of the similar visions of the youth who went skyward after his cigar came in contact with a gasolene tank of his automobile. Orchestra accompaniment. Music, Safford Waters; words, Paul West; publishers, Helf & Hager Co., New York.

## 9833 Jigs and Reels

Charles D'Almaine

Another brisk violin solo of the following well-known jigs and reels: "Bannocks o' Barley Meal," "Haste to the Wedding," "Prince Charles," "Cosmopolite" and "Rory O'Moore."

## 9834 Hoo-oo, Aint You Coming Out To-Night?

Byron G. Harlan

This song will carry most men back to the days of their boyhood, when their playmates gathered at dusk in front of their homes and shrilly cried out the above title. Johnny wants to go out to play, but mother, as mothers ever did, thinks that it is too near bedtime and refuses permission. Then, to Johnny's further discomfiture, comes the cry "Hoo-oo, Aint You Coming Out To-night?" Sad, indeed, are these tragedies of childhood. The "kid" call is by Miss Stella Tobin. This song will be one of the hits of the coming season. Orchestra accompaniment. Music and words, Herbert Ingraham; publisher, Shapiro, New York.

## 9835 Summertime

Allen Waterous and Chorus

The warm weather character of this song is aptly shown in the words of the chorus, as follows:

Summertime, summertime,  
We will be together, in sunny weather,  
Down the lane, once again,  
All the world in rhyme;

Summertime, summertime,  
Wedding bells will chime,  
All will be sunny, peaches, cream and honey,  
In the summertime.

Its publishers declare with confidence that this will be one of the leading songs in the coming summer, and their past predictions have demonstrated that they know what they are talking about. Orchestra accompaniment. Music, Harry Von Tilzer; words, Jack Mahoney; publishers, Harry Von Tilzer Music Publishing Co., New York.

## 9836 Stuttering Dick

Edward Meeker

A funny song about the love-making of Dick Alexander Simpson, who stutters badly, with a damsel similarly afflicted. His efforts to propose and her struggles to accept are very ludicrous. The stammering chorus is funny. Mr. Meeker scored a great success with this song while acting as an end man at the minstrel performance of Orange Lodge of Elks, some weeks ago. Orchestra accompaniment. Words and music, Clifford J. Werner; publishers, Orange Music Store, Orange, N. J.

## 9837 When You Steal a Kiss or Two

Albert Benzler

This song was listed in April as a vocal selection, but its air was too attractive to pass without further consideration and it is here given as a bells solo. It is a good one, too. Composer, Kenneth S. Clark; publishers, M. Witmark & Sons, New York.

## 9838 Pass It Along to Father

Ada Jones

Another of the "father" songs in which poor old dad gets the worst of everything. Whatever the rest of the family don't want is passed "along to father." He has reached that stage in married life when "he takes what he gets and he's not much bother." For instance, while the rest of the family have duck at dinner he is given the wish-bone and the suggestion is offered that he can "wish for a change of luck." One of the best songs of its kind since "Everybody Works but Father." Orchestra accompaniment. Music, Harry Von Tilzer; words, Vincent Bryan; publishers, Harry Von Tilzer Music Publishing Co., New York.

## 9839 The Country Constable

Edison Vaudeville Co.

Scene, a country roadside. The constable (Mr. Porter) is discovered "detectivin'." He is so disguised with false whiskers that Zeb (Mr. Harlan) does not recognize him until he takes them off. They lay in wait for speeding automobilists. The first one pays no attention to the constable's call. The second one stops, but a ten dollar bill changes the speed from ninety to eight miles an hour. A singing party comes along, asks some questions, get pert replies and "hand out" some remarks of their own in return. Zeb backs his wagon across the road to stop another speeding red auto, but, with a crash and a squeeze of the siren horn, the machine goes its way, leaving Zeb to wonder what has become of his wagon. A funny number.

## 9840 Sidewalk Conversation

Steve Porter

In this Record Mr. Porter gives a clever imitation of the vaudeville artist whose partner has gone back on him and he is left to talk the parts of both Mac and Reilly. Mac has a high voice and Reilly a low one. They indulge in one of those exchanges of pleasantries at each other's expense so familiar on the vaudeville stage, and which much be followed every second to catch all the funny things said. The Record closes with singing by Edward Meeker. As good as anything Mr. Porter has made.

## 9841 A Wee Bit o' Scotch

Edison Military Band

Distinctively Scotch is this band selection, for woven into the melody are strains of "Annie Laurie," "Coming Through the Rye," "Charlie is My Darling," "The Campbells are Coming" and "Blue Bells of Scotland." The composition as a whole is striking and our Record does it full justice. Composer, J. Fred Helf; publishers, Helf & Hager Co., New York.

## 2 Selections Made Over

In accordance with the notice already sent to Jobbers, we list below two selections that have been made over by the same talent. The May printed matter prepared for retail use will contain these selections. Jobbers should replace their stock of the original Records of these numbers with the new ones.

### 8765 Alexander

Billy Murray

Made Over by Same Artist

### 8379 Pretty Peggy (Bells)

Albert Benzler

Made Over by Same Artist

---

---

## Remove Packing Under Spring Barrel

Folowing is a copy of a notice sent to all Jobbers under date of February 3d:

TO ALL JOBBERS.

Please instruct your clerks, your salesmen and your Edison Dealers to always remove the piece of corrugated paper from underneath the spring-barrel of each Edison Phonograph, but the Gem, when unpacking it for use. Unless this is done the machine will not operate properly.

We are once more calling your attention to this matter because we find that frequently this packing is not removed as directed by the tag on each machine, which causes complaints that machines do not play the proper number of records.

NATIONAL PHONOGRAPH CO.

This notice should also have the attention of Dealers. In packing all Edison machines but the Gem we find it necessary to put a piece of corrugated paper in the bottom of the cabinet to support the main barrel and prevent the jars of travel from breaking the bolts which hold the mechanism in the cabinet. If this paper packing is not removed, as directed on the tag fastened to each machine, the spring barrel will not turn

freely and the Phonograph will not operate properly. An investigation of a number of complaints that machines were not working right, resulted in finding that the paper packing had not been taken out and we believe that many similar cases still exist, without owners knowing the cause. Dealers who get complaints from customers that their machines are not working smoothly should ask if this packing has been removed and they should make it a duty to see that it is removed from every machine now in stock or hereafter received.

---

## Lauder Records

The total of the advance orders for Lauder Records so far exceeded our expectations that we have been considerably delayed in making shipments to Jobbers. Dealers who do not get their orders filled as early as they expected will understand that Jobbers were not to blame. The advance orders, although unusually heavy, do not in our opinion represent the ultimate success of these Records. We are certain the later orders will be much greater as soon as the public have heard them. They are clever Records and deserve their success.

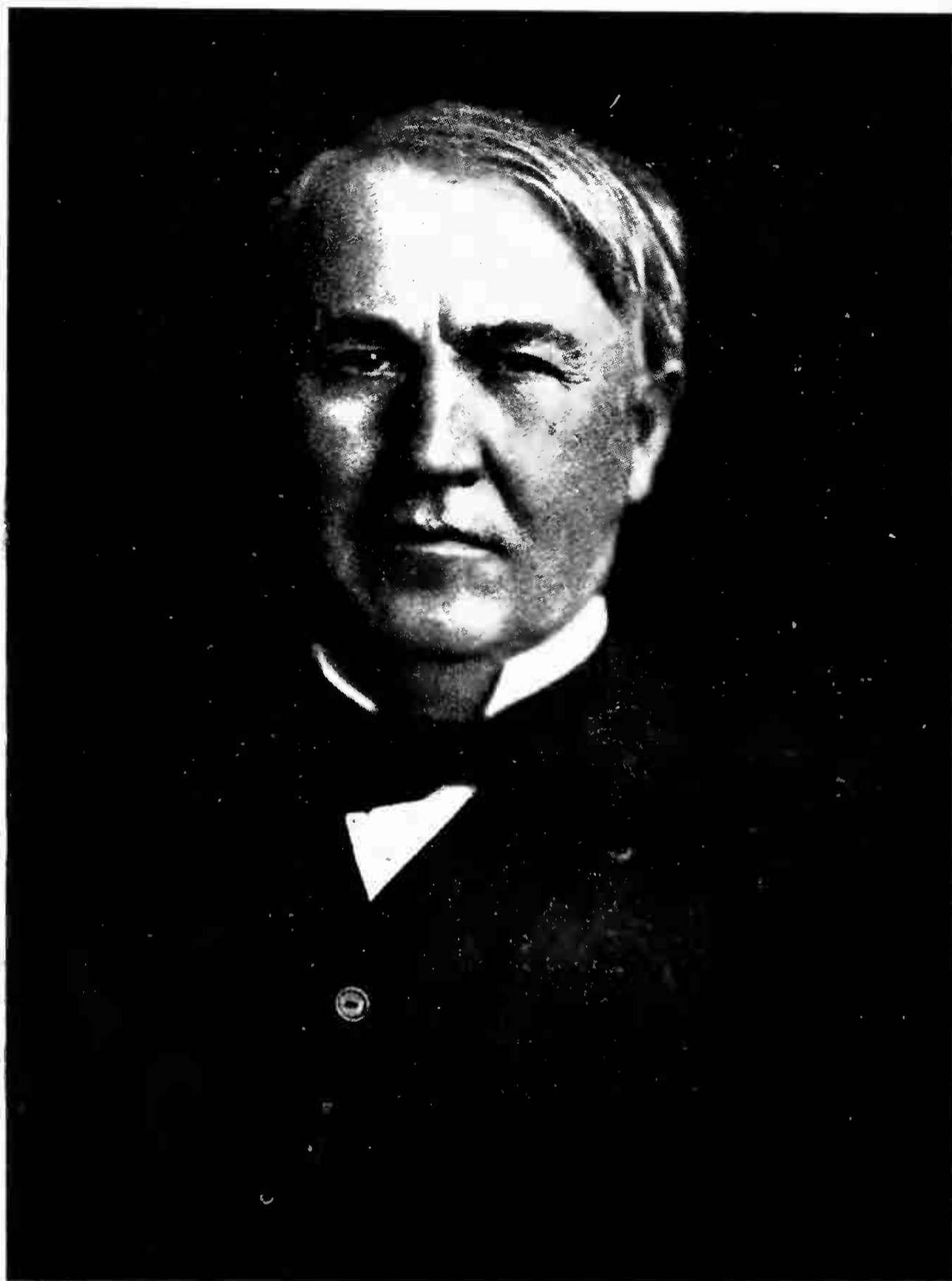

*Thomas A. Edison.*

## Dinner to Mr. Edison

Thomas A. Edison passed his sixty-first birthday on Tuesday, February 11, and in the evening of that day he was the guest of honor at an informal dinner given in celebration of the event at the Krueger Auditorium, Newark, N. J. His hosts were various officials and department heads of the National Phonograph Co., Edison Phonograph Works, Edison Manufacturing Co., Bates Manufacturing Co., Edison Portland Cement Co., and the Edison Storage Battery Co., men whom are brought in contact with him more or less frequently in their daily tasks. They were: R. A. Bachman, W. G. Bee, F. A. Burnham, Jr., W. H. A. Cronkhite, D. A. Dodd, F. K. Dolbeer, N. C. Durand, W. E. Gilmore, J. E. Helm, A. M. Hird, A. C. Ireton, W. S. Mallory, L. C. McChesney, H. F. Miller, John V. Miller, W. H. Miller, J. H. Moran, A. T. Moore, H. I. Moyer, C. S. Osborne, Fred Ott, William Pelzer, E. H. Philips, Edward S. Porter, O. A. Rogers, Walter Stevens, A. P. Waterman, Peter Weber, Alphonse Westee, C. H. Wilson, Albert Wurth and Charles Würth. Messrs. Weber, Moore and Durand had charge of the arrangements. The dinner was of the most informal character and the entertainment that followed was marked by the same lack of formality. A number of songs were rendered by Harry Anthony and Edward Meeker. Two of the latter's selections were parodies on "Harrigan" and "I'm Afraid to Come Home in the Dark," in which Mr. Edison was made the subject of some comments that greatly amused all present because of their familiarity with them. No speeches were made. A number of late motion pictures were shown. Among them was a specially posed reproduction, in colors, of the "Old Couple" picture so familiar to the trade. The "old couple" were shown bringing in a Phonograph and setting it on a table. After a bit of by-play by the man and a display of eager expectancy by the woman, the machine was set in operation and the couple dropped into the pose shown in the regular picture. The reproduction made a great hit. The half-tone of Mr. Edison shown on the opposite page is made from one of his most recent photographs.

---

## Edison Record Talent

This may be of interest to people who like to have the pictures of the Edison artists while the machine is playing. I have cut the photos out of all the *Phonograms* I had, and have pasted them on a board, and they are always handy to see the singers.—*Adolph Blumenthal, Standish, Mich.*

## New Freight Rate on Horns

H. T. Leeming, Traffic Manager of the National Phonograph Co., appeared before the Western Classification Committee at the Homestead Hotel, Hot Springs, Va., on January 15th in behalf of our petition for a reduction on the classification of talking machine horns. He was the only representative present interested in this proposition. Our petition was favorably acted upon, and, effective about April 1st, the following change in the classification will be made:

Tin or sheet iron amplifying horns, first class nested; and one and one-half times first class, not nested. In car loads a third class rate will be charged, minimum weight of 16,000 pounds. The classification on brass and nickel plated horns will remain the same as heretofore.

The advantage of the above change to the trade is that Jobbers and Dealers in making shipments to Dealers or customers will have to pay one and one-half time first class rate on shipments of a single horn as against double first class heretofore; and first class on shipments of two or more nested horns as against one and one-half times first class charged formerly.

It will be especially beneficial to Jobbers located west of the Mississippi River, as it will now enable them to compete favorably with Jobbers located east of the Mississippi.

---

## Australia Reduces Duty on Phonographs

Australia has abolished the duty on Phonographs and Records. For several years, and until August 9, 1907, this duty was twenty per cent ad valorem. On and after that date this duty was increased to thirty-five per cent. This increase in duty brought forth a storm of protest from the users, dealers and jobbers, and also from the press, and efforts were immediately made to have the duty restored to the old rate, which resulted in a petition being presented to Parliament, praying for a reduction of the duty. The matter came up for discussion on Friday, December 6th, and on that date the duty on Phonographs and Records and accessories was entirely removed, these articles being put on the free list. This news proved very acceptable to all concerned, and, notwithstanding the fact that there was an enormous sale of Edison Phonographs in Australia, the removal of the duty (which naturally means a substantial reduction in the price of Phonographs and Records) will still further increase the sale of our goods in that territory.

## The New York Case

The latest development in the litigation which for the past seven years has been pending against this Company, involving its right to do business in the State of New York, comes in the form of an opinion by Judge Hazel, of the United States Circuit Court. The immediate action in question was a motion to punish the Company for contempt of an injunction granted in March, 1906. At the time of the injunction we were advised by counsel that there were two patents involved in our products to which the New York Phonograph Company had territorial rights, giving to their contracts the interpretation placed upon them by the court, and which we, of course, accepted without question. The features of those two patents were therefore eliminated—and we warrant the assertion that but few of our friends ever noticed their disappearance—and on the advice of our attorneys we continued our business as before.

Last fall, more than a year after the injunction was granted, the New York Phonograph Company brought on their motion for contempt, and argued, as they had often done before, that they were the owners of exclusive agency contracts in Edison Phonographs and supplies for the State of New York, running probably in perpetuity, but at any rate for many years to come; and that no one could sell or use an Edison Phonograph or Record in that State without paying tribute to them. Our attorneys, on the other hand, argued that whatever rights the New York Company had were based absolutely on certain Edison patents, taken out in the early days of the North American Phonograph Company, and that since those patents had expired the rights under them had lapsed.

Judge Hazel holds that as to a few patents on the Phonograph, which have expired in this country by reason of the fact that corresponding earlier foreign patents have expired, the rights of the New York Company still exist; or in other words, that while such patents are public property as to everyone besides ourselves, we cannot use them.

The effect of the decision is to require us to omit a number of minor features, which we are now taking care of. The elimination of these features will not in any way affect the high character of our machines, but on the contrary will actually improve them, as we are now in position to make certain changes in design which we have had in contemplation for a long time. When the new models are examined, it will be found that our views on this point are fully confirmed.

On the whole, considering the persistent and untiring efforts of our adversaries to do us harm, and the proverbial uncertainty of litigation, we feel that the present situation is one for sincere congratulation, as it would seem to effectively put a quietus on the avowed determination of the New York Phonograph Company to control the business in the State of New York.

---

## Pushing the Game

The March advertising for Edison Phonographs shows that we are not abating one jot in our determination to create business for Edison Jobbers and Dealers. On the last page of this issue we reproduce an advertisement that appeared, or will appear in a score of the magazines of greatest circulation in the United States. We also have a back cover in colors in the Saturday Evening Post for February 22, and a full page in colors in Colliers for February 29. The large advertisements in the newspaper series appeared in 145 leading newspapers on February 7 or 8 and February 24 or 25. Similar advertisements will appear in the same papers on March 12 or 13 and 24 or 25. If the trade would continue their local advertising and not let up in their other selling efforts, to the same extent as we are pushing the game, there would be the same increased demand for Edison goods as ever before. Go at the proposition, Mr. Dealer, just as if it was new, and put into it the same energy and thought that you did when you put in the line. More people know about and are interested in Edison Phonographs than ever before and many in your territory need only a little urging to buy. Try it and you will be surprised to find how much more business you can get out of your locality than you ever before thought possible.

---

## Mexican Records

Some regret has been expressed because we cut out of our Foreign Record Catalogue certain Mexican selections that had become quite popular. This referred more especially to some of the band and orchestra Records. While most of the Mexican list was cut out of our regular catalogue, we can still furnish any of them to such Jobbers and Dealers as may have a demand for them. They are all being sold by our Foreign department and we can as readily fill domestic orders as before. We have no printed matter referring to them that we can supply in quantities, but will be glad to mail a complete list to any Dealer on request.



## John F. Randolph

It is with the deepest regret that we announce the death, at his home in West Orange, N. J., on February 17, of John F. Randolph, Treasurer of the National Phonograph Co., and private secretary to Thomas A. Edison. His death was caused by a wound from a shot-gun, self-inflicted while temporarily insane. The sad affair shocked and grieved his employers and his business associates.

Mr. Randolph was born at Metuchen, New Jersey, October 22, 1863. His boyhood was spent at his native place, where he received the limited education afforded by the public schools. At the age of sixteen he entered the employ of Thomas A. Edison as an office boy. Mr. Edison then had his laboratory at Menlo Park, but a few miles from Mr. Randolph's birthplace. He continued in the service of Mr. Edison till the day of his death. He rose from one position to another, till he became the personal representative of Mr. Edison in most of his great enterprises. At his death his relations with Mr. Edison were the closest and of the most confidential character. No other man enjoyed Mr. Edison's confidence to the same extent, and the trust reposed in him was never broken in the slightest degree. He was at all times faithful and watchful of his chief's interests. The death of no other man in his service could have caused Mr. Edison as much grief as did that of Mr. Randolph. No other man was more highly esteemed.

Mr. Randolph was the private secretary of both Mr. and Mrs. Edison, even their household expenses being paid by him. He was Treasurer of the National Phonograph Company, Edison Phonograph Works, Edison Manufacturing Company, Bates Manufacturing Company, Edison Portland Cement Company, Edison Storage Battery Company and of several other lesser companies. He personally signed every check drawn by all of these companies and he performed an amount of work that would have been impossible for one who had not grown up with the several companies.

Mr. Randolph had witnessed the evolution of nearly all of Mr. Edison's most important inventions, including the Phonograph, dynamo, electric light, telephone, kinoscope, storage battery, improvements to telegraphy, and many others not so prominent or not so successful commercially.

In 1887, when Mr. Edison built his present laboratory at West Orange and moved from Menlo Park to Llewellyn Park, Mr. Randolph followed him and lived there till his death. On June 29, 1893, he married Miss Anna E.

Pierson, who survives him with two daughters, aged twelve years and ten years.

Mr. Randolph was unassuming and retiring to a fault. He could not be induced to join his fellow officers and employees in the various functions that occur in all large corporations. He was a member of practically no societies or organizations. He seemed to have no other ambition than to perform the duties devolving upon him by day, and be with his family by night. The respect in which he was held by all with whom he came in contact was no less complete than the high regard for him felt by Mr. Edison.

The funeral of Mr. Randolph was held at his late home, Valley Way, West Orange, February 19. It was attended by Mr. and Mrs. Edison and a large number of his former associates and employees of the companies with which he was connected. The pall bearers were R. A. Bachman, W. G. Bee, H. F. Miller, J. H. Moran, Fred Ott, Peter Weber, Alphonse Westee and C. H. Wilson, all business associates of the deceased. The services were conducted by the Rev. Robert S. Steen, pastor of the Hillside Presbyterian Church, Orange. The singing was by the Edison Male Quartette.

The interment was in Rosedale Cemetery, Orange. The entire Edison plant and also the Edison Laboratory were shut down at noon and kept closed the remainder of the day.

---

## Most Old Dealers Have Re-signed

On February 1 we removed from our files and mailing lists the names of those Dealers who did not sign the new Agreement dated October 1, 1907. This operation showed that 80 per cent of our old Dealers had re-signed, a fact that speaks volumes for the stability of the Edison trade. This percentage was larger than had re-signed any previous Agreement. It is plain that as the years pass, there are fewer people taking on Edison goods in an experimental manner, and more of them making a success of it and continuing in the business. We believe that many have not re-signed because of negligence or oversight, and that when the work is finally checked up the unsigned number will not exceed 10 per cent. A special letter was sent to each unsigned Dealer on February 8, and a large number of replies have already been received. Another healthy sign about business is the fact that just so many new firms are becoming Edison Dealers as ever before. There seems to be no lack of confidence in Edison Phonographs and Records as a profitable business proposition.

## Foreign Records

Our repeated references to foreign Records may weary some Dealers, but we would not talk or write about them so much if we did not believe that many Dealers fail to appreciate the money-making opportunity afforded by an intelligent handling of some of these Records. The foreign born population of this country is large. The average foreigner has a greater appreciation of music than Americans, and he is more delighted when he can hear it in his own language. With the possible exception of some parts of New England and the South, every Dealer is located in the center of some foreign born people. They may be German, French, Italian, Hungarian, Swedish, Danish, etc., but whatever language they speak, Dealers should find out what it is, put in a stock of the best Records in their tongues and then get some of them to call and hear them played. The sale of a machine or two in an Italian settlement, for instance, would soon be followed by others, and in a short time a substantial trade in Italian Records would be created. Jobbers who do not carry foreign selections would do so if there was a demand from Dealers, and they would help the latter to a selection of the best sellers. Many Dealers are now doing a nice business in foreign selections and many more would do equally well if they gave the subject the proper attention.

---

## No Flower Horn Contemplated

The use of a flower horn in certain of our February advertisements and on a colored hanger of the same subject sent to the trade at the same time, has caused some Dealers to ask if it was our intention to get out a horn of this kind as an alternative to the present black horns. Nothing of the kind is contemplated. The horn shown in the illustration was used with no other thought than to work in some colors that would accord with the other colors in the sketch. We now appreciate that it would have been better not to have used the sketch in this form. In fact, in some later uses of the same sketch the horn was changed to accord with the present equipment.

---

## Made-Over Records

Two more made-over Records are listed on page 5 of this issue. They are fully equal to any in the regular May list and Dealers can well afford to put in a stock and call the attention of their customers to them.

## Edison Idelia Phonograph

A reproduction of the new Edison Idelia Phonograph, printed in four colors, was mailed to the entire trade on February 15. The print clearly brings out all the colors of the cabinet, the oxidized finish of the machine and the mahogany finish of the horn. Dealers are asked to put it up in their stores and call the attention of their patrons to the merits of the machine. In every community, however small, there are people who will buy a high-grade Phonograph when they would not consider one of ordinary cost. The Idelia is fully described in current catalogues.

---

## Printed Matter

In printing the new order sheets with numbers of the foreign selections (from 12000 up) blank spaces were left at the end of each series of numbers for such numbers as might be listed later, the idea being that the trade would fill them in by hand when using the sheets for ordering. Since but few of the sheets are being used in this way, it would look as if the matter was not so understood. We prefer that Jobbers, any way, will use these sheets in ordering Records from us, and wish that they would fill in by hand such numbers as are not printed on the sheets.

A new edition of the new Foreign Record Catalogue, Form 1290, has just been issued. It contains all foreign selections listed for sale in the United States to and including March, 1908, except the Mexican and Cuban Records which we advised the trade some time ago would be eliminated from our catalogues, but carried in stock for such Jobbers as could find a demand for them. With the exception of a new cover and the omission of a few cut-out Records, this catalogue is practically the same as Form 1250, dated January, 1908.

The attention of the trade is directed to an error which appears in the new Alphabetical and Numerical Catalogue, Form 1240, on page 61. The German selection "Grusse an die Heimat," by Rost'sches Solo-Quartet, is listed under No. 15070. Its correct number is 15079. Dealers and Jobbers are asked to make note of this correction in the catalogues in their possession.

---

We are Edison Phonograph enthusiasts and handle them only. We believe in their superiority over any other machine on the market to-day. It is not difficult to make sales in competition with other machines, and let us say here that we are indebted to the National Phonographs Co. for their systematic advertising, which does so much for the dealer.—*Jones, Lloyd & Co., Richfield, Utah, per J. Lloyd.*

## To the Trade. Change in Equipment

As soon after February 1st as circumstances will permit, we shall discontinue furnishing a chip brush as part of the regular Phonograph equipment and will substitute for it an oil can and a sample bottle of "3 in One" Oil.

This change will be effective when our present stock of each type of Phonograph is exhausted and the time may vary with each different type. No effort will be made to have shipments uniform in this respect—part may be equipped each way. Nor will any attempt be made to change the equipments of machines now in the hands of the trade.

### NATIONAL PHONOGRAPH COMPANY.

The principal reason for the above change is to bring about the use of a standard brand of oil for use on Edison Phonographs—a brand that can be had everywhere. We have found that the use of various kinds of oil, without proper regard for quality, has caused many machines to gum up and work badly. Many Phonograph owners have gone on the plan that anything would do so long as it was oil. Any oil will not do. On the contrary, there are few kinds that are suitable. "3 in One" Oil is not the only good kind, but its present universal distribution makes it the best for our purpose. The sample we shall send out will be accompanied

by a circular giving cost and stating that it can be had from all dealers. Heretofore if a dealer did not carry our regular Phonograph oil, his customer used any kind that came handy. "3 in One" Oil is especially well adapted to Phonograph work and we believe that its general use by the trade will be beneficial to all. It is sold in two sizes, retailing at ten cents and twenty-five cents a bottle. Its price to the trade will be: 10c. size (sold only in two dozen packages) per dozen, 80 cents; per gross, \$9.00; 25c. size (sold only in one dozen packages) per dozen, \$1.50; per gross, \$17.50. It will probably be carried by all Jobbers.

---

---

## Miss Jones is in Good Health

A report has apparently gained considerable circulation in the Middle West to the effect that Miss Ada Jones died recently. There is absolutely no foundation for the report. Miss Jones is in good health and is making Records for us each month. We have received a large number of letters from the admirers of her Records, asking for news on the subject and expressing the deepest regret should the report be true. The esteem in which Miss Jones is held cannot fail to please her, however much she may not relish the report about her health. Dealers are asked to deny the report when repeated in their hearing.

---

## Mailing Supplements and Phonograms

As stated in the heading over the Advance List on page 2, Dealers are now permitted to deposit Supplements and *Phonograms* in mail boxes or local postoffices *after* 5 P. M. on the day preceding the selling date, for delivery on the selling day. This change was made at the request of Dealers who wanted to put mail matter into the hands of their patrons early on the morning of the selling date, something difficult to do under the old plan.

## Personal

Mr. and Mrs. Thomas A. Edison and son Theodore, with Fred Ott, one of Mr. Edison's oldest employes, left on February 25 to spend two months at Mr. Edison's plantation at Fort Myers, Florida.

Edward L. Aiken, Assistant Superintendent of the factory of the National Phonograph Co., and Thomas J. Tighe, foreman of the moulding plant, sailed on the *Lusitania* on February 8 for London, where they will spend several weeks at the Record moulding plant connected with our London branch. They will introduce some new features of this department that have been successful at Orange.

F. K. Dolbeer, General Manager of Sales of the National Phonograph Co., and Mrs. Dolbeer will sail on March 7 to spend three weeks on the Bermuda Islands.

---

## Record No. 12470 Cut-Out

The trade is advised that we have no more moulds or masters of No. 12470 "Sulla tomba che rinserra" (*Italian*), Mielino. As soon as our present stock of this selection is exhausted, we will place it on our cut-out list.

---

---

# Edison Phonograph Monthly

Published for the Man Who Sells Edison Phonographs and Records by The National Phonograph Co., Orange, N. J.

All communications to *The Phonograph Monthly* should be addressed to the Advertising Department, Orange, N. J.

---

NEW YORK: 10 FIFTH AVENUE.

NATIONAL PHONOGRAPH CO., LTD., 25 CLERKENWELL ROAD, LONDON.

NATIONAL PHONOGRAPH CO. OF AUSTRALIA, LTD., 340 KENT STREET, SYDNEY, N. S. W.

MEXICAN NATIONAL PHONOGRAPH CO., AVENIDA ORIENTE No. 117, MEXICO CITY.

COMPANIA EDISON HISPANO-AMERICANA, VIAMONTE 515, BUENOS AIRES.

EDISON GESELLSCHAFT, M. B. H., SUD-UFER 24 25, BERLIN.

COMPAGNIE FRANCAISE DU PHONOGRAPHE EDISON, 42 RUE DE PARADIS, PARIS.

---

VOL. VI.

March, 1908

No. 3

---

---

## Stick to Standard Goods

When is it advisable for a Dealer already carrying the standard lines of talking machines and records, to take up a new make of either? This is a question that Edison Dealers should give most careful consideration. The writer visited the store of one of our Western Dealers some weeks ago and was shown about the place. In addition to a complete stock of Edison goods and a line of standard disc goods, the Dealer had in stock a few machines and a few records of about every make that had been put on the market in the past ten years. Some of them were so old that their names are almost forgotten. Other had names that many people remember only too well and wish they never had known. They represented the greatest lot of talking machine junk imaginable. They represented a considerable money investment that never can be regained. And yet each brand in its turn had back of it claims that were designed to put the older companies out of business. They had been put on the market by companies with "ample" capital; they had been widely advertised; they had been pushed by a selling force and many dealers had been induced to put them in stock. Then the "ample" capital had run out, the advertising was cut down or discontinued, the salesmen were recalled and the trade "stuck" with the stocks on hand. In other cases, they were put out of business because they were infringing patents, but the result to the dealer was just the same. Hundreds of Edison Dealers will appreciate the truthfulness of these statements.

As a company, we do nothing to prevent our Dealers from selling as many different makes of talking machines and records as they may desire. We do not fear the competition of these

companies of brief life. They deprive us of a small amount of business for the time being, but we become stronger than ever after they have gone their way. Our loss is nothing compared to the loss to Dealers who have put in their goods and cannot get rid of them. The subject is one, therefore, that we can discuss in good taste. The long established talking machine companies are spending enormous sums of money to create a demand for their goods and to uphold the trade. They do this not for a day, but year after year, the sums increasing with the years. They make their goods as stable as possible. Dealers who put them in stock know in advance that there will be a constantly increasing demand for them. The effort of these companies enable Dealers to build up a profitable business, without which the manufacturers of new machines would find no one to sell to. In fact, the latter trade upon the credulity of the Dealer in this respect. They count upon the efforts of the older companies bringing customers to Dealers' stores and hope to induce the latter to substitute their goods for those advertised. Fortunately for the established companies, even the arguments of Dealers do not in many cases swerve a prospective customer from getting the machine he wants.

The moral of all this is that every Dealer should carry the goods that are widely and steadily advertised, and back up the companies manufacturing them by refusing to consider other lines, no matter how alluring they may be offered. There will be no junk stock if this is done.

---

There was once an old merchant in Wales  
Who complained of the slowness in sales.

Said a neighbor: "Be wise,  
And your stock advertise."

Then his orders congested the mails.

—*Fame.*

## Mr. Randolph's Successors

The positions in the various Edison companies left vacant by the death of John F. Randolph have been filled as follows: Alphonse Westee has been made Treasurer of the Edison Phonograph Works, National Phonograph Co., Edison Manufacturing Co. and the Bates Manufacturing Co. and some of the smaller companies, in addition to his former duties as Secretary of the same companies; Harry F. Miller has been appointed private secretary to Mr. Edison and Assistant Treasurer of the above companies.

Mr. Westee has been identified with the Edison interests from boyhood. For the past ten years he has successively filled many important positions in the various companies. Mr. Miller entered the employ of Mr. Edison when he built the laboratory at Orange in 1888, and in point of service is now one of the oldest in Mr. Edison's employ. For several years past he has been cashier of the Edison Phonograph Works, National Phonograph Co., Edison Manufacturing Co. and the Bates Manufacturing Co. The exigencies of business made it necessary for both Mr. Westee and Mr. Miller to enter upon their duties the day following Mr. Randolph's death. Walter Eckert, formerly Assistant Auditor, has been appointed Cashier vice Mr. Miller.

---

## Thomas Alva Edison

Thomas Alva Edison was sixty-one years old yesterday. But if we were to measure his life by what he has accomplished, we would find him with two or three centuries to his credit. Take out of the world the things Edison has given to it and you take away things that have come to be necessities. There are, for instance, the numerous improvements in the telegraph apparatus, such as the quadruplex and sextuplex devices; the phonograph, based on a principle upon which all talking machines are constructed; the incandescent lighting system, the kinoscope and even the simple megaphone. The world owes a vast debt to this wonderful man. He has had more patents issued to him than any other man, living or dead. He has now taken out nearly a thousand patents. He has done more than any other American for the advancement, comfort, ease and amusement of the human race.—*Utica (N. Y.) Observer, February 12, 1908.*

---

The Edison Phonograph has demonstrated to dealers that it pays, because it has demonstrated to users that it pleases. There is no limit to the business you can do with Edison Phonographs, because it is the most perfect talking machine, has the most accurate and distinct Records, and is the machine that comes nearest to expressing Edison's idea of what a Phonograph should be.

## A New South Wales Opinion

P. W. Blake, an Edison Dealer at Albury, New South Wales, recently issued a circular to the prospective patrons in his vicinity, expressing his views about the Edison Phonograph in the following terms:

All who are acquainted with Edison's Phonograph, and the present day Gold Moulded Records, are of one opinion, that they are without doubt the best means for home entertainment procurable and the price is now so reasonable that they are within reach of all classes of the community.

The established prices of the machines are as follows \* \* \*

There are a number of other Talking Machines on the market, such as the \* \* \* I am familiar with most of them and have handled them in business and they have all, with the exception of the true Edison Phonograph proven to some degree unsatisfactory. The Edison Phonograph, which I have in my home, is one that delights my family and friends and I have always pleasure in introducing it to my visitors. It is an endless source of delight and merriment, reproducing perfectly the singing of the best artists of the world, the recitations of the best reciters, the concerted music of the best bands, the laughable jokes and funiosities that fertile brains the world over can produce. All this and more right at our own fireside.

Since I had the responsibility of a home I can think of no purchase that has given me more genuine satisfaction and so much pleasure as my Phonograph.

The earlier results on the Phonograph had the effect of prejudicing me against them, and I know of many who feel the same way, to those and to all others I extend a cordial invitation to favour me with a visit at my Phonograph Department, attached to my business at the Book Bazaar and give me the pleasure of contributing to your enjoyment and proving the bona fides of all I say. You are always welcome, the department is removed from the bustle of the Bazaar and you will not feel in the way, nor in any way interfere with the general conduct of business.

---

## The Difference

I had been in the Talking Machine business some fourteen years and am an Edison man from A to Z, and have always earned my daily bread, not by the sweat of my brow, but by the Edison Phonograph. I had an experience some few days ago, which struck me as being the limit.

A gentleman came into our place of business, not to buy a talking machine, neither does he own one, but to make inquiries about a man who used to work in the store. While talking to the proprietor, one of the clerks put on a disc Record, "Traumerei," a 'cello solo, afterwards putting on the same piece by the same man on the Edison Phonograph. As soon as the Edison had finished, he told the clerk, "For God's sake never bring out the disc machine and try to sell it again."—*Letter from a Western Jobbing firm.*

## Harry Lauder

When Harry Lauder, the famous singer of Scotch songs, first appeared in New York the *New York Journal* spoke of his singing and comicalities as follows:

Harry Lauder, the Scotch comedian who is advancing vaudeville at the New York Theatre, threatens to become as popular as the Scotch highball. He is the longest and at the same time one of the shortest headliners that we have helped across in many a tide. He is as long as an hour about his high-salaried job, and he is almost as short as the lowest waiter in Lew Field's employ. To say that he is beautiful would be to break our golden rule to tell the truth no matter whom it hurts. And so as near as we can get to a description of Mr. Lauder without being too flattering, is to say that he has Arthur Dunn's face and Francis Wilson's legs.

You may judge by this that he is not strangely beautiful. He is a comic picture in kilts. His bare legs are always turning a corner, but his shamelessly bare face keeps ever to the front, even if it has to do so by looking backward.

And now for the songs: Two riotously funny affairs, judging by Lauder's convulsive laughter, interfered with his really funny monologue when he broke into the bill yesterday afternoon. Usually when a comedian laughs at himself, you're quite content to leave it all to him. Your shy smile fades away and hides itself under—well, whatever you happen to be wearing. But it's different with Lauder—or rather, it's different with you. Before you know it, you are laughing with him. You have taken your laugh out of cold storage and told it to spread itself through the house. You may have heard "Stop Your Tickling, Jock" before and thought it very silly, but now you know it is silly and rejoice in the discovery that you are equally silly.

Lauder's next song, "I'm the Safest of the Family," was horribly funny, just as a half-witted lad is sometimes horribly funny. This Lauder lad was almost an imbecile. The bleary-eyed, twisted, mumbling boy, pulling his toy treasures from a deep pocket and telling the little story that went with each, was a job for the alienist, not for the critic. This bit was often unpleasant and its homely humor was sometimes very "strong," but it showed Lauder to be a character actor of uncommon cleverness and raised him far above the level of the ordinary comic singer. Here and there were real boyish touches, as, for instance, the reply of the lad when the angry old man whose "windy" he had broken caught him by the collar and asked why he was running away: "Wasn't I runnin' home for money to pay for it?"

"My Scotch Bluebell," as Lauder sang and danced it, with a pretty, light-haired girl, was pure, light-hearted gayety. He pranced about with joy and pride in his fair possession, and the audience danced with him to the pretty music of the song.

Lauder then tried to get away, but after arguing the matter with the balcony and gallery, he finally rigged up in sailor clothes and "obliged"

with "We Parted on the Shore." Here again his talk was better than the song. The song was really a running sea of conversation. "I've seen the sea so bad," he remarked, "that the captain couldn't stand on the bridge." And then lighting his pipe he added: "An' I've seen the captain so bad he couldn't stand on his feet."

Our list of Lauder Records includes all of these songs, and they are as funny as they are described.

---

## Gives Music With His Stamps

(From the *Chicago Daily News*.)

Some of the most even-tempered postal patrons in Chicago belong to Winnemac station of the Chicago postoffice. Bowmanville is the other name of the place.

The reason that the people of this station in the far northwestern section of the city are so good natured is that they have been soothed and charmed by the music that goes with every two-cent stamp and postal card that is sold in the place. A man buys a money order to the tune of some patriotic air, and is impelled to keep time with his feet while he is registering a letter.

Milton M. Potter is the genius and the superintendent of Winnemac. Inside the carriers' railing of the station is a Phonograph. Attached to the instrument is a horn in which one could hide a bag of mail. Near by is a specially contrived rack that holds 200 Records. There is a medley in that rack that eclipses anything that ever came from a brass band or a full orchestra. From the newest productions in ragtime to the dearest old songs of the long ago, they are all stacked up in the case and any one of them may be found in the dark. From behind the wicket of the money-order department the superintendent scans a face as the owner fills out an application. From a nice discriminating sense that has been developed in the office, Uncle Sam's servant knows exactly what kind of music will best please the patron. While the writer is still scratching away on the bit of blank on the desk, the superintendent sticks his first two fingers in a record and extracts it from the rack. The next instant it is on the Phonograph, and about the time that the patron is separating himself from his money for the little blue strip that the postmaster makes out, he is hearing his favorite song or instrumental selection.

Postoffice inspectors have made scores of reports to the effect that Winnemac is one of the best-managed stations in Chicago.

The foregoing clipping from the *Chicago Daily News* was sent us by Mr. Potter with the following comment:

It attracted a good deal of attention and for several days and weeks after, I had compliments and congratulations showered upon me in profusion. Friends I had not seen for years, read it and called to see me and to hear the wonderful music and see the wonderful instrument that could produce it.

The following day after its appearance, a large delegation of representative citizens called to congratulate me and asked me to "make good." I did it to their entire satisfaction and after I had played a score or more favorite airs voted, unanimously, to endorse all the writer had said. The Phonograph I have is an Edison Home.

---

## Easier to Keep Than to Break

Under date of January 15, F. K. Dolbeer, General Manager of Sales, sent a letter to all Dealers in Cleveland, Ohio, reading as follows:

We have been advised that some of our Dealers in your city are still selling Edison Phonographs with the old equipment, notwithstanding the fact that you have been notified that such action upon your part would be considered a violation of our Terms and Conditions of Sale as outlined in our Contract, copy of which you have signed.

We cannot believe that you would place yourself in a position to be suspended for a violation of this nature, and we would respectfully request, if you have been disposing of Edison Phonographs with anything other than the equipment supplied by our factory, that you discontinue this practice at once, or we will take such action as the case may warrant.

Hoping to have your assurance that you understand this matter very fully, we remain,

The replies as a whole were satisfactory, but two of them were especially interesting from our standpoint. They were:

I beg to assure you that I am not one of those Cleveland Dealers who have been selling Edison Phonographs with old equipment.

I bought new equipments for all Edison machines I had in stock as soon as I could procure them, and have never sold a machine without the new home equipment since the new contract went into effect.

I have been very particular to conform in every way to the strict letter of the contract in all respects.

It is my opinion that a Dealer who has no more principle than to violate any conditions of the Dealers' contract should be cut without delay.

For my part I am glad to have the protection and equity which the contract affords to every Dealer. With best wishes for "Edison" supremacy and continued prosperity.

H. G. MERTON.

---

I have been selling the Edison line for six years and have not found it necessary to violate terms and conditions of agreement signed by me. It is easier to live up to the agreement than it is to break it.

We have not sold nor have had in stock since October 1, 1907, any horn other than Edison.

HUGH GULLEY,  
*Prop. Talking Machine Co.*

---

It is as foolish to waste money in advertising a poor article as it is to lose money in not advertising a good one.

## Machine Troubles

Having had a peculiar experience with a Home machine I herewith write you the way I corrected the trouble. This machine always had a peculiar tremble or tremlo tone which I looked long to find the cause of. It was in the governor disc, which had become untrue in the flat, and each revolution the felt pads on the friction device would cause a momentary stop or rather retarding which gave the tremlo effect. To correct this I removed the disc and sleeve and put in a jeweler's universal or bezel chuck and turned a new face with a slide rest and tool, after which I stoned the face with a slate pencil to make it smooth. When replaced and in use the tone of the machine is as perfect as it could be. I had looked the reproducer over many times for some defect, which afterwards I found in the governor disc. For the benefit of others who may have some such trouble will say to use a pointed piece of wood in testing for the trueness of the face.  
—F. R. Pancoast, Hastings, Mich.

---

## A Monster Newspaper Advertisement

The Knoxville Typewriter & Phonograph Co., of Knoxville, Tenn., broke all advertising records, (so far as we have any knowledge) on January 22d, when they used four full pages of the Knoxville *Sentinel* at one time, the entire space being devoted to exploiting talking machines. A unique feature was the printing of about 3,000 names of those who have purchased talking machines from the firm in the past four years, these being part of a total of over 5,000.

---

## Form for Recital Invitation

The form given below is a reproduction of an invitation used by J. S. Sweet, an Edison Dealer at Galt, Ont., Canada, in announcing his monthly Phonograph recital. The necessary details as to time, etc., are filled in the blank spaces.

Galt,.....

Dear.....

You are cordially invited to be present at our  
Edison Phonograph Recital  
to be held at

.....  
on.....at 8 p. m., when you will have  
an opportunity of hearing the.....issue  
of Edison Gold Moulded Records.

Yours respectfully,

J. S. SWEET.

Present this card at door for admission.

The back of the card is printed with blank spaces so that listeners may put down the numbers or names of such Records as they want.

## Dealers, This is Worth Reading

The January issue of the *Hardware Dealers Magazine* contained an article written by B. P. Stone that was of unusual interest, and all that was said in it is quite as interesting to talking machine dealers as to those selling hardware or any other merchandise in competition with mail order or catalogue houses. The article in scathing terms first tells in detail how the catalogue houses succeed in getting a big business, a large part of it coming from under the very noses of local dealers. All of the reasons for their success are known to dealers themselves and need not be repeated here, even if we could spare the space for the purpose. The article then tells in equally plain words how dealers can fight the competition. Part of this refers quite as well to talking machines as to any other line and we reprint it, with the request that all Edison Dealers read it carefully:

### THE WAY TO BEAT THE GAME.

You have viewed the situation with a great deal of dissatisfaction for a long time. You have talked it over with others many a time. Perhaps it has at times alarmed you and you have wondered where the thing was going to stop. It is not going to stop at all. If you want it stopped you will have to get out and put a stop to it yourself. It is all very well to talk the thing over in your conventions, and so on. It is all very well to say that the standard goods must be kept out of the hands of these people. But all this does not hit the situation where it affects you. Do you know how much money is going out of your own town to these same concerns? I will warrant that you will be both surprised and disgusted when you find out. This money belongs at home. It belongs in your town, where every dollar of it will pay a \$100 worth of debts or make a hundred dollars' worth of purchases, if it is kept in circulation. The point is how? The answer is: Educate your trade. All the talking you merchants do among yourselves is so much time wasted. It never reaches the correct place. It is not criticism but education which will do the business. Do the thing the way the C. H. does it. Get after them and keep after them. Keep up the fight. It can not be done in a day, or a week, but must be a continuous process, for as soon as you let up a little the C. H. will be after them again. In fact they will keep after them, too, just as they are doing now. Do not try to reform the whole country at once, nor to put the C. H. out of business. Let other sections of the country fight their own battles. You will have enough to do, you and your fellow-merchants, to get the people of your own locality in line. Now for a definite plan.

### EDUCATE YOUR PEOPLE.

The plan is strictly educational. It will do less than no good at all to call the C. H. a pirate and a menace. Nobody cares about the menace

part of it. You must educate your people until they can see that there is an actual money saving in buying at home. Then you must add all the other arguments one by one. Keep at this and you can get back your trade and keep it. This cannot be done by you alone. You must have the support and assistance of every business and professional man in your community so far as you can get them together. Remember that this is not a campaign for the good of your business alone. It is to keep the money at home and all should join. In the first place you want the assistance of the local paper or papers. Just here let us ask a question. Have you in the past and are you now giving the right sort of support to the local paper? If not this is the time to commence. Get the paper into the game and give it the right sort of support, both in the way of advertising patronage and otherwise.

### DO SOME GENEROUS ADVERTISING.

What you want to do now is to present to the village, town and farming population all the arguments you can muster in favor of home trade. Use, for this purpose, advertising in the local paper, advertising by circulars and personal appeal. Form a local association or club. This will make concerted action possible and will allow of a much greater spread of your activities as all can contribute toward the cost. Put a standing advertisement in the paper, bearing on this subject, and let it be issued in the name of the club. In addition to this let each one interested insert individual advertisements, but let all of them tend to the same point. Let this be helped out by editorial comment, not once in a while, but in every issue of the paper. The publisher of your local paper will fall in with your plans readily enough, for he depends for success on the general prosperity of the community just as much as you do, and it is a pretty safe bet that he realizes that fact fully as well as you do and possibly a little better. There will be no difficulty about him you may be assured. Every man who owns a foot of real estate in your town should be with you, and will be if the case is properly put. The value of his holding depends on the prosperity of the town. Let one store or factory move out of town and it lessens the value of that holding appreciably. If the business of the community is not going to stay at home, some one will move out. If enough business goes abroad, all of you will move out. Where will the values of the real estate go then?

The same is true of the professional men. A town which is no good for business is no good for them. The same is the case with the clerk and the laborer. And if prices and service are equal the farmer would rather trade at home than go abroad, so it is simply a case of showing him that prices and service are a little better at home than abroad.

### EXTEND YOUR DELIVERY SERVICE.

There is another point. It is easy for the farmer on a rural mail route to write a check and send away for what he wants. Make it just as easy for him to get the same stuff from you. Extend your delivery service. Anything which the C. H. can send by mail, you can send by mail just as well. Lay stress on that. Make it



easy to buy from you and the trade will come your way. The comments of the local paper on the situation will have weight with all who read the paper. See that every one does read it. If there is a family in the district which is not a reader of one of the local papers, see to it that frequent sample copies are sent. An arrangement to this effect can easily be made. This gets your arguments into the hands of the people you want to reach. Follow this up with other matter, both that issued by the association and that issued by yourself. You will see by this time that advertising is the only way to do the thing you want done and so you must become an advertiser.

Now about the advertising. Don't have it written and prepared by the office boy or the porter. Get some one to do the job who makes a business of it. Remember that you are competing with those who understand the advertising game thoroughly, and get the best there is to be had. See what the catalogue house has done with their advertising and do not be afraid to follow suit. The other fellow offers bait and there is no reason why you should not do the same. An occasional big bargain will do the cause no harm and will bring in trade. Use all legitimate methods of getting your customers into town and into your store. And when you get them there do not waste time in reproaches or statements that there is a wrong done when goods are bought outside, but be diplomatic and simply show them that the goods are cheaper and better at home than abroad.

It is either fight or lie down. Which shall it be in your town? If the trade is worth having it is worth going after. Go after it if you want it. You are not called upon to fight the battles of the trade at large. All you are interested in is the trade which is legitimately yours. You can get it all if you will pull together with the other retailers and get all those vitally interested to help. It is up to you. Don't whine, but hustle.

---

## An Edison Phonograph Now a Complete Instrument

Heretofore the sale of a Phonograph and the sale of horns have been two distinct transactions. This was because no Phonograph had a satisfactory horn. Now the Edison Phonograph has its own horn and swinging support. The horn is large, handsomely shaped and exactly adjusted to the instrument's needs. It sets the Phonograph off, attracts interest, and best of all, it pleases purchasers every time. The horn business has always been a drawback to the trade. It led to price-cutting which affected profits, necessitated carrying a large stock of horns and complicated selling methods generally. Now the customer gets the best and most suitable horn to be had, as a part of the Phonograph, pays the price for both in one transaction, and the Dealer makes a good profit on both.

## What Dealers Say and Do

I have been doing a successful piano business for about eight years, always having instruments in stock. Recently I added your Phonographs and have not at *any time* been without Triumph, Home and Standard machines, Edison Records and record cabinets in stock; have demonstrated your Phonographs in public, in families and given many entertainments at my home, disposed of several thousand cards and catalogues, and feel that I did a fair amount of business during the brisk season. I have given this business considerable thought and have planned to increase my sales for the next season. I am personally acquainted with men who started your goods in this small way and are now extensive Dealers.—  
*W. C. Doyle, Pittsburg, Pa.*

---

Last August, six months ago, I stocked the minimum quantity of Edison Records and Phonographs. Immediately I received a good patronage, notwithstanding that there was an old established Phonograph store in a better location than mine. Gradually my business has increased, (not even affected by another new store being opened in the same business) until I am compelled to move into a better location and nicer and larger store. This is due to the success of Edison goods which are always popular here. Will open my new Phonograph store February 12. Wishing you success in the continued sale of Edison goods.—  
*Louis R. Murray, Ogdensburg, N. Y.*

---

Charles W. Card, an Edison Dealer of Port Ewen, N. Y., sends an odd form of advertising. It is a tin cup with his advertisement of Edison goods on the inside of the bottom, so that the drinker from it cannot fail to read it. The advertisement is glazed over so that water does not effect it. Mr. Card places them at school houses, springs and wells along the highways, in railroad stations and other places where they will benefit him.

---

C. H. Breon & Co., Edison Dealers at Millheim, Pa., sent us a series of six post cards, each showing a pair of interesting youngsters in a different photographic pose in connection with an Edison Phonograph. The series is called "Our Three Friends."

---

The following is extracted from letter received from B. T. Parson, salesman in the employ of C. T. Hussey, Edison Dealer, Caribou, Me.:

"Since I was at the factory your salesman has been here and persuaded us to put in the complete list of domestic Records. It is the best business proposition in the Phonograph line that a man ever took hold of, for I know it has more than trebled our sales."

---

## Sketch by Sheridan

The illustration in our March magazine advertising, reproduced on the last page, was drawn by John E. Sheridan, of New York, an artist who has made a more than ordinary success with his sketches showing types of college boys.

## The Phonograph and Art

[From the Fort Worth (Texas) Telegram, February 6, 1908.]

In New York recently a number of prominent musicians, mostly composers, formed an organization to combat the spread of Phonograph music. Not that they objected to hearing it, but because they argued that the dissemination of phonographic Records deprives composers and singers of the true artistic appreciation and, what gets nearer the heart of the matter, money the composers might get for sales of sheet music and money the singers might get for tickets to theatres and concert halls where they sing.

It is a selfish and narrow view. Perhaps it applies to New York. Certainly it does not apply to the considerably large portion of the United States outside the borders of Manhattan.

A composer writes a song. Before it becomes popular and there is any demand for its sale it must be sung by a singer of repute before a good many audiences. If it is not a song, and is a piano composition, or one for an orchestra, it must be played, and often, before people take enough interest in it to create a market demand. Then, if the song or the composition is a hit, people want copies of it. Vesta Victoria sings "Waiting at the Church." It is not an artistic masterpiece, but the men like it and applaud. Straightway young women who can play the piano want copies of it to play on Sunday evening when their best young men call. The composer reaps a harvest from the sale of sheet copies and gradually, as other vaudeville singers present the song at different places in the remainder of the country, the demand for it spreads.

A Phonograph company hires the fascinating Vesta to sing her song into a brass horn and the records of it are put on sale almost immediately at every city of size in the country. Does the young man who calls on Sunday evening like to hear his best girl play it badly on the piano so much as he does the phonographic reproduction of the original? Whether he does or not is foreign to the real essence of the discussion. The best girl might play the tune on the piano every Sunday night for six months and it would not create the same demand to hear Vesta sing it as a single reproduction of her song on the Phonograph. No matter if the Phonograph plays the tune a hundred times the hearer wants to hear the original when she comes to town. The Phonograph makes a market for originals and originals pay composers royalties every time they appear. Is it much different whether the composers get the royalties from the singers or from the sheet music?

Supposing Vesta's song made a hit in New York, but the rest of the country heard nothing about it? And Vesta should suddenly jump from New York to Fort Worth for a single night. How many would go to hear her? A market for

songs and all music has to be built up and the Phonograph is the best builder.

Jan Kubelik played in Fort Worth the other night to a house that downstairs was hardly half full. Had Kubelik's playing been made familiar by a year of phonographic records in the homes of Fort Worth, the opera house would not have held the people who would have wanted to hear him.

The Phonograph's manufacture of a market goes even further. It goes into the little towns and villages and hamlets, where the artists themselves never venture. And when the artists themselves come within reaching distance people travel from the towns, villages and hamlets to hear them.

Aside from the work the Phonograph does in familiarizing the masses with music they could never otherwise get, as a cold business proposition, it is a money-maker for the artists themselves.

Moving picture shows at a nickel might be imagined to have an effect on theatre receipts, but they do not. People pay a nickel to see a clever pantomime reproduced on a film and then, when they pay a dollar and a half to go to the theatre, they appreciate all the pantomime arts of the actors which they had never been taught to enjoy before. Shrewd actors recognize this and that is why we are seeing more pantomime on the stage every year, and less dependence on the effects attained by shouting lines and repeating jokes so that the audience may catch them.

To spite their chins the New York and Eastern musicians would bite off their noses. If they succeed in keeping their music from the Phonographs they will only succeed in getting themselves forgotten or ignored by the masses. And, of course, if they want that, they are welcome to it.

## Two Letters and a Moral

The letters printed below are given in full because they show how a Phonograph in perfect condition can be made to work badly by a cause quite apart from the instrument itself. The moral it teaches is that a too careful examination cannot be made of everything connected with the machine when it operates badly. The letter was written by a man of more than usual intelligence and business capacity, and one not likely to overlook ordinary causes of Phonograph troubles.

### THE COMPLAINT.

Minneapolis, February 10, 1908.

I bought a Standard in December, 1900, then a Home, and finally a Triumph No. 58766, and Records every month since. I had the reputation of having one of the best machines in the city, but the last three weeks it has "gone back" on me. I have had it twice to Mr. Hough's, but he says it is a puzzle to him. He thought at first that the mandrel had too much play, but that does not meet the difficulty. The machine runs finely, but all the Records, no matter, songs, bands, or solo instrumental, are harsh, flat, not up

to key—make discords. For instance, B-21, at the high notes, about three-fourths from the commencement, and about one-fourth from the ending, it blasts so it is like a shriek, and would drive one from house and home; same with B-4, about one-fourth from the commencement, there is a fearful blast or rather shriek. It is not in the Records, for at Mr. Hough's they sound all right and as they should. It is not in the reproducers, for I have three, two of Model C, one Model B, for wax, and have borrowed two of C from Mr. Hough, and the discords are same when used on my machine, and O. K. when on Mr. Hough's.

I have regulated the feed nuts, and the gait from so would not run, to would give plenty of play, and to with no play, and feed nuts right, still the same discords, blasts and shrieks. Mr. Hough also has regulated, but still the same.

Instead of the Phonograph being a comfort and pleasure, it is harrowing to hear it, would drive one from home if played. It's a puzzle to Mr.

Hough—says he never ran up against such a proposition.

Can you inform me what and where the trouble is? It is some minor defect that suppose can easily be remedied.

It went wrong all at once, and without my doing anything to it, for all I have done is to keep it well oiled. Tried it to see if any nuts loose, but all O. K. Please let me hear from you soon.

#### THE EXPLANATION.

Minneapolis, February 11, 1908.

Found out last night what was the trouble with my Triumph. Borrowed a Standard from Mr. Hough and found the same discords, etc. Then examined the horn and found there had some way got into it a piece of rubber hose, formerly used to connect reproducer and horn. When I forced it out, the Triumph was the same good machine it was before. Regret that I did not find out before writing you yesterday. Please pardon any trouble I may have caused you.

---

---

## Stores of Four Edison Dealers

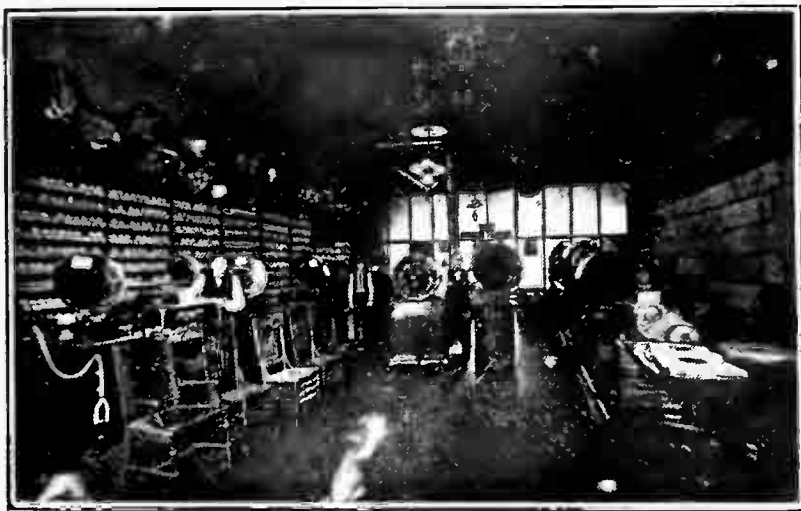

E. B. SILBERMAN 1641 Milwaukee Avenue, Chicago



THOMAS A. PURSEGLOVE, Northampton, Mass.



CLARION MUSIC HOUSE, Clarion, Pa.

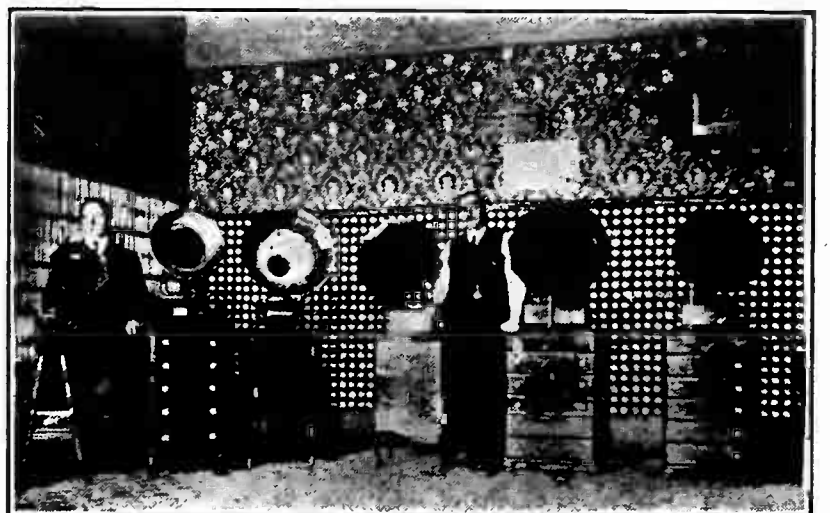

BARNHART & DE FOREST, Warren, Pa.

## Ready Made Ads

Judging by the demand for electros and the number of papers that we receive containing them, these ready-made ads have struck a popular chord among Dealers. Either or both of the electros shown in the ads on pages 20 and 21, either single or double column, will be mailed to any Dealer who will comply with the simple provision that copies of papers containing them shall be sent to us. This must also be done by those who have already had electros, but have not yet sent us papers containing them. These electros can be had in no other way than direct from our Advertising Department. They will not be supplied to Jobbers for redistribution.

## About Edison Jobbers

Charles C. Adams & Co., of Peoria, Ill., one of the largest music and piano houses in the State outside of Chicago, have become Jobbers of Edison Phonographs and Records. The *Peoria Journal* on February 7th contained the following reference to the fact:

### BREAKS ALL RECORDS.

The biggest shipment of musical instruments ever received in Peoria reached here yesterday afternoon, consigned to the Charles C. Adams Company on South Adams street. There were 150 Edison Phonographs and 15,000 Records, all of which made a carload. The shipment was from the National Phonograph Company to the local firm, which is the western distributors of the Edison instruments.

A fire in the establishment of I. Davega, Jr., 125 West 12th street, New York, January 18, inflicted damage to stock to the amount of \$5,000. It was fully insured, and since then the loss has been satisfactorily adjusted. The place has been redecorated and rearranged throughout, the wholesale talking machine department now being transferred to the basement, 20 x 85 feet, which is entirely occupied for this purpose. The retail department is on the second floor, with the sporting goods stock in the store off the street. Mr. Davega occupies the entire building, and reports business greatly improved.

The Standard Talking Machine Co., of Pittsburg, who secured the business of the Theo. F. Bentel Co., last March, have recently purchased and taken over the entire talker business of H. Kleber & Bro., piano dealers, who have been handling talking machines for the past fourteen years. They have also bought out the Keystone Musical & Specialty Co., 444 Sixth avenue, Pittsburg, and have greatly increased their record capacity.

The pleasure of the Edison Phonograph as an entertainer in the home cannot be guessed. You must try it to know.

# EDISON



# PHONOGRAPHS

You can hear an Edison Phonograph at our store with very little trouble, and you can buy one with very little outlay.

Ask to see the new model, hear some of the new Records, and find out what our easy-payment plan is.

**John Palmer & Co.**  
Elizabeth, N. J.

Electro in above ad is: Single column wide, No. 671;  
Double column wide, No. 672.



## For the Whole Family

**EDISON** **T**HE EDISON Phonograph is the greatest wonder work of the Wizard of Llewellyn Park. It is the genius of Edison that has made possible the interpretation of sound into Records, and then of Records into sound. All music with perfect clearness can be had with the Edison.

**A. B. PIERSON**

44 Wood Street, Sacramento, California

Electro in above ad is: Single column size, No. 673; Double column size, No. 674.

## REQUEST FOR ELECTROS

NATIONAL PHONOGRAPH Co.

ADVERTISING DEPARTMENT, ORANGE, N. J.

DATE.....190.....

Mail Electros No.....

We agree to use them in newspaper advertising and to send you copies of papers containing them before asking you for other electros. We intend running a..... inch advertisement.

Name.....

Street.....

City and State.....

We buy through.....

## SUSPENDED LIST, MARCH 1, 1908

SUPERSEDING ALL PREVIOUS LISTS.

### CALIFORNIA.

Petaluma—Thomas McGuire, 875 Main st.

### CANADA.

Ottawa, Ont.—Ketchum & Co., Sparks and Bank sts.

### COLORADO.

Boulder—Bentley & Craig.

\*Denver—Wagman & Bloomfield (The Phonograph Circulating Library), 1631 Champa st.

### GEORGIA.

Valdosta—H. K. McLendon, 109 West Central ave.

### ILLINOIS.

Champaign—Eggleston Bros., or Eggleston Music House, J. P. Eggleston, Prop.; also Danville, Ill.

Chicago—A. Gloss & Son, 727 W. North av.

Cooksville—Geo. Swinehart & Son.

Danville—Eggleston Bros., or Eggleston Music House, J. P. Eggleston, Prop.; also Champaign, Ill.

Elgin—James W. Mill, 18 Spring st and 166 Chicago st.

Kempton—C. E. Bute.

Ottawa—Edward Hayne.

Peoria—H. Meyer, 1307 S. Adams st.

Quincy—Giles Bros., 107 North 4th st.

\*J. F. Brenner, 627 Main st.

J. F. Whittaker 618 Hampshire st.

Robinson—A. D. Foreman, or A. D. Foreman & Son.

Wheaton—E. Irving.

### INDIANA.

South Bend—Eugene Marsh, 126 Vistula ave. South Bend Book Bindery, Robert Lebolt, Prop., 203 North Michigan st.

### IOWA.

Burlington—John P. Weiss, 711 Jefferson st.

Cushing—Bullock & Lyman.

Independence—E. O. Parker, 110 E. Main st.

McClelland—J. W. Rounds & Co.

Mederville—John J. Carpenter.

Sioux City—Hattenbach Bros. Co.

A. V. Larimore, 518 Fifth st.

State Center—Ora Sargeant.

\*Webster—E. H. Martin and Fred N. Martin.

Whiting—The Cassady & Whiting Co.

### KANSAS.

Clay Centre—E. M. Gowenlock.

Lawrence—Bell Bros.

Topeka—R. H. Morehouse, 510 E. 4th st.

Wichita—Frank R. Powell, 132 N. Main st.

### KENTUCKY.

Louisville—Irvine Simons, 942 W. Market st. (formerly 543 W. Market st.).

### MAINE.

Biddeford—W. H. Field.

Gardner—C. H. Cobb, 293 Water st.

Lewiston—J. W. Skene.

Monmouth—G. H. Stetson.

Oldtown—H. M. Burnham.

Waterville—Frank Blanchard, 150 Main st

\*M. Steinert & Sons Co., at all points.

### MASSACHUSETTS.

Boston—Henry H. Savage, 166 Hanover st.

T. Singer, 60 Leverett st.

Fitchburg—M. Steinert & Sons Co.; also Pittsfield, Mass., and at all points.

Florence—William Oates, 87 Main st.

Franklin—E. P. Blackmar.

Great Barrington—Frank W. Wheeler, Main st.

Lawrence—Lord & Co., 314 Essex st.

E. O. Mosher, 420 Essex st.

Malden—A. T. Fuller.

Nantucket—Arthur M. Taylor.

New Bedford—H. B. DeWolff.

Pittsfield—M. Steinert & Sons Co.; 254 North st.; also Fitchburg, Mass., and at all points.

Somerville—E. J. Winchester, 32 Summit ave.

Woburn—Osborn Gillette, or The Boston Jewelry Co., L. F. Maloney, Manager.

Worcester—Joseph Tukman, 44 Front st.

Guy Furniture Co., 521 Main st.

### MICHIGAN.

Ann Arbor—Ann Arbor Music Co., F. J. Schwankosky, Prop.

\*Bay City—J. M. Kopec, 1006 S. Madison st.

Detroit—F. J. Schwankovsky.

Manistee—Gus Ilse, and A. H. Ilse Co., 311 River st.

Saginaw—Geo. W. Emendorfer.

James V. Calahan, 217 Genessee st.

Tierney Bros., 217 Genessee st.

### MINNESOTA.

Willmar—Willmar Furniture Co., Ruble Block.

### MISSOURI.

Ewing—Hal R. Ewalt.

Fairfax—Hinde Hardware Co.

Kansas City—The Wittmann Co.

Osceola—C. H. Green.

St. Louis—Knight Cycle Co., 1215 Olive st.

\*F. Ringwood and J. Ringwood, or Central Phono. Co., or Franklin Phono. Co.

### NEBRASKA.

David City—John Albright.

Lincoln—The Wittmann Co.

Omaha—The Wittmann Co. Piano Player Co.

Red Cloud—Albright Bros. or L. P. Albright.

Sterling—Sterling Drug Co., W. G. Morrill, Prop., and W. G. Morrill, M. D.

### NEW HAMPSHIRE.

Dover—H. C. Ingalls & Co., 444 Central ave.

Hillsboro Bridge—E. M. Barnes.

Manchester—A. E. Dumas.

Nashua—F. A. McMaster & Co.

## SUSPENDED LIST CONTINUED.

### NEW JERSEY.

- Atlantic City**—Sam'l D. Wolf, 32-34 Arkansas ave.  
**Bayonne**—J. Wigdor, 450 Avenue D.  
**Jersey City**—W. L. Hoffman, 151 Montgomery street.  
**Long Branch**—A. N. Alexander, 103 Broadway.  
 A. Nastasio, 103 Broadway.  
**Newark**—R. L. Corwin; also New York City.  
 R. Rosenthal, Prop. Springfield Hdw. and Sptg. Goods Store, 71 Springfield ave.  
 D. Reinhorn, 91 Springfield ave.  
**Passaic**—I. Hurwitz.  
**Paterson**—Chas. H. Kelly, 25 N. Main st.  
**Plainfield**—S. W. Frucht, or R. Frucht; also New York City.  
 Elston M. Leonard.  
**West Hoboken**—Emil Hollander, or The West Hoboken Bicycle & Phono. Co., 169 Spring st.

### NEW YORK.

- Albany**—G. Linde, 353 S. Pearl st.  
 G. A. Birdsall, 114 S. Pearl st.  
**Amsterdam**—D. C. Kirchner, 26 Market st.  
**Bedford Park**—Geo. H. Tyrrell.  
**Brooklyn**—Nathan Abrahams, 602 Broadway.  
 Wm. Albrecht, 294 Knickerbocker ave.  
 H. Hindermann, Bushwick Phonograph Exchange, 1421 Myrtle ave.  
 Emil Smith, 634 Eleventh st., and 230 Summer ave.  
 Totten Furniture & Carpet Co., 216 Grand st.  
**\*Haverstraw**—F. E. Newman, Broadway.  
**Hobart**—F. H. Marshall.  
**New York City**—A. T. Armstrong, or American Phono Co., 106 Wall st.  
 Automatic Zither Co., M. Cohen, Prop., 58 Second ave.  
 Bern Bearwald, 373 W. 11th st.  
 Edward Bielfeld, 481 Willis ave.  
 I. & S. Birnsweig, Birnsweig's Music Store, and Birn's Music Store, 510 E. 138th st.  
 Bronx Phono. Co., or David Switky, 506 Willis ave.  
 R. L. Corwin; also Newark, N. J.  
 Eagle Phono. Co., or C. Lowenthal, 83 Nassau st.  
 Empire Phono. Co., 2 W. 14th st.  
 S. W. Frucht, or R. Frucht, 7 Barclay st., or 68 Cortlandt st., also Plainfield, N. J.  
 O. Hacker, 2 Murray st.  
 Hawthorne & Sheble, 297 Broadway; also Philadelphia, Pa.  
 Holoher Bros., 350, 421 and 491 West st.  
 N. Horn, 148 E. 58th st.  
 W. L. Isaacs, 114 Fulton st.  
 Italo-American Phono. Co. (R. Gerard & Co.)  
 S. Lemburg & Co., 194 Broadway.  
 J. McEllyne, 202 Broadway.  
 Parker & Cooley, 2087 Amsterdam ave.  
 Richmond Pease, 44 W. 132d st.  
 F. M. Prescott, 44 Broad st.  
 Winthrop Cycle Co., 2212 Seventh av.  
**Oneonta**—G. B. Shearer Co., 259-261 Main St.  
**Rome**—Charles Tuttle.  
**Saratoga**—W. J. Totten.  
**Saratoga Springs**—Marvin A. Cote.  
**Watertown**—H. S. Wardwell & Co., 39 Public Square.  
**Wayland**—John Gross, Pursel Block.

### NORTH CAROLINA.

- Kinston**—S. A. Quinerly.

### NORTH DAKOTA.

- Fargo**—Ben Hart.

### OHIO.

- Ashtabula Harbor**—Chas. W. Askew (Gregory, Askew & Co.).  
**Bellevue**—H. E. Rouser.  
**Brookville**—H. K. Merritt.  
**Cincinnati**—J. L. Andem.  
**Coshocton**—Burns & Gosser.  
**Dayton**—W. E. Sapp, 1042 W. Third st.  
**Hicksville**—W. R. Holden Co.  
**Springfield**—D. & M. Vanderpool.  
**Uhrichsville**—F. A. Mazurie.

### PENNSYLVANIA.

- Athens**—J. T. Stalford, 405 Main st.  
**Bradford**—C. C. Griffen, 29 N. Washington st.  
**Lancaster**—J. H. Tragresser, 249 N. Queen st.  
**Mt. Pleasant**—Benjamin Posner.  
**New Castle**—Will Hartland, 70 E. Long st.  
**Philadelphia**—A. R. Cassidy, 2783 Emerald st.  
 \*Wm. Dyer, 321 Queen st.  
 Thomas Gunson, 1003 Carpenter st.  
 Hawthorne & Sheble, 604 Chestnut st., or Oxford and Mascher sts.; also New York City.  
 A. Krouse, 832 Arch st.  
 \*Geo. W. Lowden, or Geo. W. Lowden, Prop. Pioneer Studio of Music, 2616 Frankford ave.  
 Penn Novelty Co., 15 South 9th st.  
**Pittsburg**—A. Lippard, 615 Wylie ave.  
**Royersford**—Granville B. Tyson, 215 Main st.  
**Titusville**—E. H. Fortney, Prop. Exchange Cigar Store, 21 W. Central ave.

### RHODE ISLAND.

- Providence**—E. H. Gainsbury, 59 Plainfield st.  
 F. P. Moore.  
 \*M. Steinert & Sons Co., Westminster st.; also Fitchburg, Pittsfield, Mass., and at all points.  
**Rockville Center**—O. A. Clark.

### TENNESSEE.

- Alexandria**—Clarence D. Baird Music Concern.

### TEXAS.

- Whitney**—H. E. Randle & Co.

### UTAH.

- Salt Lake City**—Daynes Romney Music Co., 25 East South 1st st.

### VERMONT.

- Barre**—Averill Music Co. (H. L. Averill & Co.), 28 N. Main st.

### VIRGINIA.

- Norfolk**—W. Reichenstein, 296 Church st.

### WISCONSIN.

- Ashland**—J. F. Pool Co.  
**Milwaukee**—J. C. Blatzek.  
 \*Reedsburg—Fish & Greenwood.  
**Walworth**—G. H. Stewart.

\*Added since February 1st, 1908.

Jobbers and Dealers are asked not to supply any of the above named firms with our apparatus, either at addresses given or any other address.

# The EDISON PHONOGRAPH



*"For it's always fair weather when good fellows get together"*

—particularly if that prince of good fellows, the Edison Phonograph, happens to be one of the crowd. Never was there a jollier companion or a more versatile entertainer. It's a whole show in itself. It sings all the new songs, has a wonderful repertoire of all sorts of good music and can tell a funny story with the best of them. You need never be lonely or blue, or lack for amusement if you have an Edison Phonograph for company.

Ask your dealer to show you the new Edison model with the big horn, or send for booklet describing it.

## A Remarkable List of March Records

On sale at all Edison stores February 25th.

### Seven New Records by Harry Lauder, the Famous Scotch Comedian

A New York manager paid Harry Lauder a fabulous salary to come over from England and sing for a few weeks at his theatre, because nobody else can sing comic songs in the Scotch dialect as Harry Lauder does. Harry Lauder has enriched the March list by making Records of seven of his best songs.

### Five New Grand Opera Records

have been added to our already large list. Well-known selections from standard operas, sung by famous operatic stars.

### The Regular List of Twenty-four New Records

contains the newest songs, the best recent instrumental music and the best of the old music that you never get tired of.

Go to the nearest Edison store today and spend a delightful half-hour in hearing the new March Records.

Ask your dealer or write to us for THE PHONOGRAM, describing each Record in detail; THE SUPPLEMENTAL CATALOGUE, listing the new March Records; THE COMPLETE CATALOGUE, listing all Edison Records now in existence.

Records in all foreign languages.



TRADE MARK  
Thomas A. Edison



# Jobbers of Edison Phonographs and Records

Continued from page 2 of cover

## NEW YORK.

Albany—Finch & Hahn, 402 Broadway.  
Astoria—John Rose, 99 Flushing ave.  
Brooklyn—A. D. Matthews' Sons, 394 Fulton street.  
Buffalo—W. D. Andrews, Seneca and Wells sts.  
Neal, Clark & Neal Co., 645 Main st.  
Elmira—Elmira Arms Co., 117 Main st.  
Gloversville—American Phono. Co., 99 W. Ful-ton st.  
Kingston—Forsyth & Davis, 307 Wall st.  
New York City—Blackman Talking Machine Co., 97 Chambers st.  
J. F. Blackman & Son, 2737 3d ave.  
I. Davega, Jr., Inc., 125 W. 125th st.  
S. B. Davega & Co., 32 E. 14th st.  
Douglas Phono. Co., Inc., 89 Chambers st.  
Jacot Music Box Co., 89 Union square.  
Victor H. Rapke, 1659 Second ave.  
Regina Co., 41 Union square.  
Siegel-Cooper Co., 6th ave. and 18th st.  
John Wanamaker, Broadway, 8th and 9th sts.  
Alfred Weiss, 1622 First ave.  
Oswego—Frank E. Bolway, 32 W. Bridge st.  
Rochester—A. J. Deninger, 345 North st.  
Mackie Piano, O. & M. Co., 100 State st.  
Talking Machine Co., 97 Main st., E.  
Schenectady—Finch & Hahn, 504 State st.  
Jay A. Rickard & Co., 253 State st.  
Syracuse—W. D. Andrews, 216 E. Railroad st.  
Troy—Finch & Hahn, 3 Third st.  
Utica—Clark-Horrocks Co., 54 Genesee st.  
Arthur F. Ferriss, 89 Washington st.  
William Harrison, 50 Columbia st.  
Utica Cycle Co., 16 Columbia st.

## OHIO.

Canton—Klein & Heffelman Co., 220 E. Tus-carawas st.  
Cincinnati—Ball-Fintze Co., 103 West 3d st.  
Ilsen & Co., 615 Vine st.  
Lawrence McGreal, 29 East 5th st.  
Rudolph Wurlitzer Co., 121 East 4th st.  
Cleveland—Eclipse Musical Co., 1370 East Ninth st.  
Columbus—Perry B. Whitsett Co., 213 S. High street.  
Dayton—Niehaus & Dohse, 35 E. 5th st.  
Newark—Ball-Fintze Co.  
Toledo—Hayes Music Co., 422 Superior st.

## OREGON.

Portland—Graves & Co., Inc., 65 No. Park st.

## OKLAHOMA.

Oklahoma City—Smith's Phono. Co., 318 West West Main st.

## PENNSYLVANIA.

Allentown—G. C. Aschbach, 539 Hamilton st.  
Easton—William Werner, 432 Northampton st.  
Harrisburg—S. K. Hamburger, 12-14 N. Mar-ket square.  
Philadelphia—Louis Buehn & Bro., 45 N. 9th street.  
C. J. Heppe & Son, 1117 Chestnut st.  
Lit Bros., Market and 8th sts.  
Musical Echo Co., 1217 Chestnut st.  
Penn Phonograph Co., 17 S. 9th st.  
John Wanamaker, 13th and Market sts.  
Western Talking Mach. Co., 41 and 43 N. 9th st.  
H. A. Weymann & Son, 1010 Chestnut st.

## Pennsylvania—Continued.

Pittsburg—Pittsburg Phono. Co., 937 Liberty ave.  
Powers & Henry Co., 101 Sixth st.  
Standard Talk. Mach. Co., 435 Wood st.  
Reading—Reading Phonograph Co., 48 N. 8th st.  
Scranton—Ackerman & Co., 217 Wyoming av.  
Technical Supply Co.  
Sharon—W. C. DeForest & Son.  
Williamsport—W. A. Myers, 145 W. 3d st.

## RHODE ISLAND.

Providence—J. M. Dean Co., 735-736 Westmin-ster st.  
J. A. Foster Co., Weybosset and Dorrance streets.  
J. Samuels & Bro., 154 Weybosset st.

## TENNESSEE.

Chattanooga—J. H. Templeman Co., 253 Mont-gomery ave.  
Knoxville—Knoxville Typewriter and Phono-graph Co., 421 Gay st.  
Memphis—F. M. Atwood, 160 N. Main st.  
O. K. Houck Piano Co., 103 S. Main st.  
Nashville—Magruder & Co., 27 Arcade.  
Nashville Talking Mach. Co., 722 Church st.

## TEXAS.

Dallas—Southern Talking Machine Co., 347 Main st.  
El Paso—W. G. Walz Co., 101 El Paso st.  
Fort Worth—Cummings, Shepherd & Co., 700 Houston st.  
Houston—Texas Piano & Phono. Co., 1019 Capitol ave.  
San Antonio—H. C. Rees Optical Co., 242 West Commerce st.

## UTAH.

Ogden—Proudfit Sporting Goods Co., 351 24th street.  
Salt Lake City—Clayton Music Co., 109 S. Main st.

## VERMONT.

Burlington—American Phono. Co., 34 Church street.

## VIRGINIA.

Richmond—C. B. Haynes & Co., 603 E. Main street.

## WASHINGTON.

Seattle—D. S. Johnston Co., Third ave. and University st.  
Kohler & Chase, 710 Pike st.  
Spokane—Spokane Phonograph Co., 7 Post st.

## WISCONSIN.

Milwaukee—Lawrence McGreal, 176 3d st.

## CANADA.

Quebec—C. Robitaille, 320 Rue St. Joseph.  
St. John—W. H. Thorne & Co., Ltd., 42-46 Prince William st.  
Toronto—R. S. Williams & Sons Co., Limited, 143 Yonge st.  
Vancouver—M. W. Waitt & Co., 553 Granville street.  
Winnipeg—R. S. Williams & Sons Co., Ltd., 131 Princess st.

# In the Words of Others

## "Sell I.C.S. Language Outfits"

The best proof that it will pay you to sell I. C. S. Language Outfits comes from the statement of dealers that have tried them. We have published several of these letters before; here is another one from the Denver

Dry Goods Co. This is piling up evidence that you are losing profits of from 10 to 30 per cent. on your business if you are not handling these Outfits. The phonograph system is fast becoming recognized as the most perfect way in the world to teach foreign languages. As a commercial enterprise, the I.C.S. System has always paid dealers well in the past, and it is growing very rapidly. Wouldn't it be a good idea for you



**THE DENVER DRY GOODS CO.**

1234 Broadway

DENVER

DENVER, Colo., 11/21/08

International Correspondence Schools  
Scranton, Pa.

Gentlemen:

In reply to your letter of the 17th inst., will say we considered the demonstration of Mr. Mistraud very successful and while he was here we sold several Language Outfits. We have also sold some since he left us. We expect to advertise these Language Outfits during December as gifts as you may rest assured we will communicate with the parties to whom demonstration was given and who have not as yet made a purchase. We think the plan of advertising or demonstrating these Outfits is successful and leads to sales which could not be obtained otherwise.

We have placed several orders with you since the demonstration and would like to know if we could make arrangements to purchase whatever we need in this line through your Denver office as we have had to do several times recently; same can be billed to us by you. This would be quite an accommodation to us.

We will keep you advised from time to time of the results of sales of I. C. S. Language Outfits.

Yours very truly,

THE DENVER DRY GOODS CO.,

per *A. Shultz*

to write us today for full particulars of what we can do for you? Let us put our advertising to work for you. It will not only bring you customers for language work, but will increase your regular business. Send us a postal card NOW.

**International Correspondence Schools**  
**SCRANTON, PA.**

# EDISON PHONO- GRAPH MONTHLY

Vol. VI

April, 1908

No. 4

## CONTENTS

	PAGE		PAGE.
Business Outlook Bright.....	1	Off to Mexico.....	10
More New Dealers Than Ever.....	1	Lauder Records Grow More Popular Daily..	11
Advance List Edison Records for June.....	2	Interesting but Visionary.....	11
Scotch Record Recital.....	5	Edison Phonograph as a Public Instructor...	11
New Plan for Supplying Trade Information	5	Window Dressing .....	12
Another Decision Against Price-Cutting—		A Compact Record Stock.....	13
This Time in Philadelphia.....	6	Phonograph on the Wellman Expedition...	14
Mr. Edison in Florida.....	7	Hanger for Dealers' Stores.....	15
Foreign Record Changes.....	7	Ready Made Ads.....	16
Trade Information for Dealers.....	8	Suspended List for April, 1908.....	18
April Advertising Spells Optimism.....	10	Jobbers of Edison Phonographs and Records	
		Cover pp. 2 & 3	

*Published for Trade use only by  
The National Phonograph Co., Orange, N.J.*

# Jobbers of Edison Phonographs and Records

## ALABAMA.

**Birmingham**—Talking Machine Co., 2007 Second ave.  
**Mobile**—W. H. Reynolds, 167 Dauphin st.  
**Montgomery**—R. L. Penick, 119 Dexter ave.

## CALIFORNIA.

**Los Angeles**—Southern California Music Co., 332 South Broadway.  
**Oakland**—Kohler & Chase, Inc., 917-921 Wood st.  
**Sacramento**—A. J. Pommer Co., 9th and J sts.  
**San Francisco**—P. Bacigalupi & Sons, 1021 Golden Gate Ave.

## COLORADO.

**Denver**—Denver Dry Goods Co., 619 16th st.  
Hext Music Co., 15th and California sts.

## CONNECTICUT.

**New Haven**—Pardee-Ellenberger Co., Inc., 96 State st.

## DISTRICT OF COLUMBIA.

**Washington**—E. F. Droop & Sons Co., 925 Pennsylvania ave., N. W.

## GEORGIA.

**Atlanta**—Atlanta Phonograph Co., 10 Walton st.  
Phillips & Crew Co., 37-39 Peachtree st.  
**Waycross**—George R. Youmans.

## IDAHO.

**Boise**—Eiler's Piano House.

## ILLINOIS.

**Chicago**—Babson Bros., 1419 19th st.  
Lyon & Healy, Wabash ave. & Adams st.  
James I. Lyons, 192 Van Buren st.  
The Vim Co., 68 E. Lake st.  
Montgomery Ward & Co., 111 Michigan ave.  
Rudolph Wurlitzer Co., 266 Wabash ave.  
**Peoria**—Chas. C. Adams & Co., 324 South Adams st.  
Peoria Phonograph Co., 416 S. Adams st.  
**Quincy**—Quincy Phonograph Co., 411 Hampshire st.

## INDIANA.

**Indianapolis**—Indiana Phono. Co., 45 Virginia ave.  
Kipp-Link Phonograph Co., 10-12 E. Washington st.  
A. B. Wahl & Co., 119 S. Illinois st.

## IOWA.

**Des Moines**—Hopkins Bros. Co., 620 Locust st.  
The Vim Co., 204 Seventh st.  
**Dubuque**—Harger & Blish, 904 Main st.  
**Fort Dodge**—Early Music House, 822 Central ave.  
**Sioux City**—Early Music House, 315 Court st.

## KENTUCKY.

**Louisville**—Montenegro-Riehm Music Co., 630 4th ave.

## LOUISIANA.

**New Orleans**—William Bailey, 600 Frenchman st.  
National Automatic Fire Alarm Co., 614 Gravier st.

## MAINE.

**Bangor**—S. L. Crosby Co., 186 Exchange st.  
**Portland**—W. H. Ross & Son, 43 Exchange st.

## MARYLAND.

**Baltimore**—E. F. Droop & Sons Co., 231 North Howard st.

## MASSACHUSETTS.

**Boston**—Boston Cycle & Sundry Co., 48 Hanover st.  
Eastern Talking Mach. Co., 177 Tremont st.  
Iver Johnson Sptg. Goods Co., 163 Washington st.  
**Fitchburg**—Iver Johnson Sptg. Goods Co., 247 Main st.  
**Lowell**—Thomas Wardell, 111 Central st.  
**New Bedford**—Household Furnishing Co., 170 Purchase st.  
**Springfield**—Flint & Brickett Co., 439 Main st.  
**Worcester**—Iver Johnson Sptg. Goods Co., 304 Main st.

## MICHIGAN.

**Detroit**—American Phono. Co., 106 Woodward ave.  
Grinnell Bros., 219 Woodward ave.

## MINNESOTA.

**Minneapolis**—Thomas C. Hough, 714 Hennepin ave.  
Minnesota Phono. Co., 505 Washington ave., So.  
**St. Paul**—W. J. Dyer & Bro., 21-23 West 5th st.  
Thomas C. Hough, 392 Wabasha st.  
Koehler & Hinrichs, 255 E. 3d st.  
Minnesota Phonograph Co., 37 E. 7th st.

## MISSOURI.

**Kansas City**—J. W. Jenkins' Sons Music Co., 1013-1015 Walnut st.  
Schmelzer Arms Co., 710 Main st.  
**St. Louis**—Conroy Piano Co., 11th and Olive sts.  
Koerber-Brenner Music Co., 1006 Olive st.  
Silverstone Talk. Mach. Co., 1010 Olive st.

## MONTANA.

**Helena**—Frank Buser, 509 N. Main st.

## NEBRASKA.

**Lincoln**—Ross P. Curtice Co., 1125 O st.  
H. E. Sidles Phono. Co., 13th and P sts.  
**Omaha**—Nebraska Cycle Co., 15th and Harney sts.  
Shultz Bros., 16th and Chicago sts.

## NEW HAMPSHIRE.

**Manchester**—John B. Varick Co., Varick Bldg.

## NEW JERSEY.

**Hoboken**—Eclipse Phono. Co., 203 Washington st.  
**Newark**—Douglas Phonograph Co., 20 New st.  
A. O. Petit, 57 Halsey st.  
Rapke Phono. Store, 287 Bank st.  
**Paterson**—James K. O'Dea, 117 Ellison st.  
**Trenton**—Stoll Blank Book and Stationery Co., 30 E. State st.  
John Sykes, 105 N. Broad st.

Continued on page 3 of cover

# Edison Phonograph Monthly

VOL. VI.

April, 1908

No. 4

## Business Outlook Bright

Business is coming back in a healthy manner; steadily, surely, and bearing with it the undoubted marks of general confidence. It is healthy because conservatism is still the strongest factor in the make-up of every order. There is no disposition anywhere to plunge; no desire to take unusual chances by putting in needlessly large stocks of goods. March orders were smaller than they were a year ago, but there were more of them. Instead of placing one order a month for a large quantity of machines and Records, some Jobbers will place three orders in the same time and the aggregate will be nearly the same. This practice, while not as desirable from the manufacturers' standpoint as the old one, is the best indication of a healthy business condition. That it will give way to the former order of things in a short time there is no doubt. The change will come with the strengthening of confidence.

With us orders have more than held their own during March. A satisfactory increase has been made over February and the outlook for April is still brighter. Orders for machines are still slow, but the demand for Records has been surprisingly large. The orders both for current stock and the advance list show but a slight difference over the same months of 1907.

Now that the trouble is largely over and business everywhere is on the mend, we cannot refrain from expressing our satisfaction at the splendid way in which Edison Jobbers and Dealers passed through the depression. Beyond a slowing up in orders and a smaller volume of business none have suffered greatly. The failures have been so small in number as to be hardly worth noticing, and most of the few Dealers who did stop business would have stopped sooner or later, no matter what the condition of trade might be.

The outlook for the future gets better every day. No one is overstocked, useless expenditures have been cut out and it needs but a little further improvement to get business back into its former state of activity.

## More New Dealers Than Ever

One of the most gratifying features of the Edison business at the present time is the unusually large number of firms who are becoming Dealers in Edison Phonographs and Records. At no time in the history of the Phonograph have so many agreements been received from new Dealers. For several weeks the weekly average has been greater than at any time last year. The greater part of these come through Jobbers, but our salesmen are also having unusual success in interesting new firms, especially in towns where we heretofore have not been represented. During January, February and March the number of new Dealers created by the salesmen was decidedly in excess of the same months in 1907. Existing business conditions seem to have had the effect upon many firms of causing them to drop some of the lines they have been selling and take on others that offer better profits and have the additional advantage of novelty. It cannot be gainsaid that the introduction of the Phonograph into a Dealer's store awakens a new interest among his customers and not only gets business for the new line, but also aids in selling all others in the store. Much credit for the increase in Dealers must be given to our present extensive and widespread advertising. It is reaching everywhere and creating a demand that literally compels firms to see the advantages of putting in Edison goods.

An amusing incident happened a few days ago. Party had heard a prominent talking machine play a duet that he liked the swing of, and had figured out the title to be "Harry Warner." He wanted to hear the song on an Edison machine. I told him there was no such Record listed, but by further questioning, decided it must be "Arrah Wanna." We played it for him and struck it the first time. We sold him an Edison outfit and a small collection of Records. He said that if he wanted good music and be able to get all the words right, he must have an Edison—*Wadena Phono Co., Wadena, Minn.*

## Advance List of New Edison Records for June, 1908

**R**ECORDS listed below will be shipped from Orange in time to reach all Jobbers in the United States and Canada before May 25th, 1908, all things being favorable, and they may be reshipped to Dealers at 2 P. M. on May 23d. They must not, however, be exhibited, demonstrated or placed on sale by Jobbers or Dealers until 8 A. M. on May 25th. Supplements, Phonograms and Bulletins will be shipped with Records. These may be distributed to Dealers after May 20th, but must not be circulated among the public before May 25th. Jobbers and Dealers may, however, deposit Supplements and Phonograms in Mail Boxes or Post Offices after 5 P. M. on May 23d, for delivery on the following Monday. Jobbers are required to place orders for June Records on or before April 10th. Dealers should place June orders with Jobbers before April 10th to insure prompt shipment when Jobbers stock is received.

**9842 Thousand and One Nights Waltz**

**Edison Concert Band**

One of the earliest and best known compositions of the famous "Waltz King." It may truly be styled a dance classic. It was originally from the operetta "Arabian Nights." Everyone who has ever danced will recognize the air as an old friend, even though they may not know its name or history. The work of the band is fine. Composer, Johann Strauss; publisher, Carl Fischer, New York.

**9843 Good-Bye, Sweetheart, Good-Bye**

**Alan Turner**

Ever since No. 9291, "In Happy Moments," by Alan Turner, was listed in July, 1906, we have had numerous letters from Phonograph owners, expressing admiration for his voice and asking when another Record by him might be expected. Mr. Turner has made over masters of selections previously catalogued, but this is the first opportunity we have had to include another of his Records in the monthly list. The ballad selected is one that displays his fine voice to perfection, and the Record will surely increase his popularity. Orchestra accompaniment. Music, Albert Von Tilzer; words, Arthur Lamb; publishers, The York Music Co., New York.

**9844 When the Song of Love is Heard**

**Ada Jones and Billy Murray**

Miss Jones and Mr. Murray have each acquired an added vogue with these duet selections, for each new Record of their making is more in demand than the previous one. The above is a comic song from "A Waltz Dream," the Viennese operetta that is becoming as well known as "The Merry Widow." The song portrays the feline love-making of the back-yard denizens. The chorus is more general in its meaning, a feature being the long kiss, neatly imitated by the violin. The air is catchy. The singers also intersperse a funny dialogue. Orchestra accompaniment. Music, Arthur Weld; words, Joseph Herbert; publishers, T. B. Harms Co., New York.

**9845 Rag-time Don't Go With Me No More**

**Arthur Collins**

A comic coon song, wherein Hannah expresses her deep aversion to rag-time songs and music and declares that hereafter she wants nothing but Wagner, Strauss or Verdi, Lohengrin or Trovatore. It has a rag-time accompaniment, with a phrase of "Pinafore" in the chorus. It is one of those songs of which Mr. Collins is the recognized leading exponent among Phonograph artists, and it is quite up to his reputation. Orchestra accompaniment. Music, John B. Lowitz; words, Matt. Woodward; publishers, Helf & Hager Co., New York.

**9846 Lollypops**

**Albert Benzler**

A splendid xylophone solo, with a lively attractive air and played exceptionally well by the versatile Mr. Benzler. Its composer styles it a "musical confection." Orchestra accompaniment. Composer, J. B. Mullin; publishers, J. B. Mullin Music Co., New York.

**9847 Just Some One**

**Manuel Romain**

Words of more than usual merit, an air of singular piquancy and sweetness, and the singing of as delightful an artist as ever made an Edison Record, combine to make this selection

one of our most attractive ballad Records. Few people ever tire of songs like these, and to be able to sing them over again, as often and where one will, is one of the Phonograph's greatest charms. Orchestra accompaniment, with a violin obligato as an extra feature. Music and words, Will R. Anderson; publishers, M. Witmark & Sons, New York.

**9848 Shall We Gather at the River?**

**Edison Mixed Quartette**

Beyond a word of praise for the excellent manner in which our Mixed Quartette renders this widely known and universally admired sacred song, it is unnecessary to say anything. Few sacred selections have been sung more times since its music and words were written by the Rev. Robert Lowry. Unaccompanied. Published in hymn books.

**9849 Somebody Loves You, Dear**

**Harry Anthony**

Somebody loves you, dear,  
Somebody loves you, dear,  
And tho' the world divide us,  
Love's pow'r shall draw us near.

Somebody loves you, dear,  
Call me and I shall hear,  
Altho' the world divide us, remember  
Somebody loves you, dear.

So runs the chorus of this delightful sentimental ballad. Mr. Anthony's singing is quite as charming as the words. Orchestra accompaniment. Music and words, Annie Andros Hanley; publishers, M. Witmark & Sons, New York.

**9850 When It's Moonlight on the Prairie**

**Byron G. Harlan and Chorus**

This Record will gratify the oft-expressed wish of Mr. Harlan's legion of admirers that he sing something different from his usual repertoire. The song tells a pretty love story of the prairie. A quartette joins in singing the chorus, a feature that enhances the attractiveness of the Record. Orchestra accompaniment. Music, S. R. Henry; words, Robert F. Roden; publishers, Joseph W. Stern & Co., New York.

**9851 Humoresque on "The Merry Widow Waltz"**

**Edison Concert Band**

"What, more 'Merry Widow?' " we can hear the Phonograph public exclaim, upon reading the title of this selection, but when that public once hears this Record played it will agree with us that the series would not be complete without it. It gives the famous waltz in four funny instrumental imitations, as follows: 1. As the little German street band plays it. 2. As played on the banjo, (a la Rag). 3. A street piano imitation. 4. Imitation of the amateur trombone artist. In the language of the street, "it's a scream." Every one will want it. Music, Léhar-Bellstedt; publishers, Helf & Hager Co., New York.

**9852 Daddy's Little Tom Boy Girl**

**Stella Tobin**

The motherless little girl pathetically complains to her father that the other girls call her "tom boy" and will not play with her. He replies in the chorus:

You will always be Daddy's best girlie,  
You will always be Dad's best chum,  
We were pals in the days of old, dear,  
We'll be pals in the years to come.

For you've had no mother to guide you  
To put your dear hair in a curl,  
And there ain't another girlie in the world like you,  
Daddy's little Tom Boy Girl.

The verse is written in common time and the chorus in march tempo. Orchestra accompaniment. Music, J. Fred Hager; words, Robert F. Roden; publishers, Helf & Hager Co., New York.

**9853 Krausmeyer's Birthday Party**

**Spencer and Mozarto**

Although humorous in itself this vaudeville sketch is more noteworthy for the clever instrumental selections by Mozarto, a well known vaudeville artist. These include a one-string violin playing an Hungarian Rhapsody, a one-string violin and an ocarina playing a selection from "Faust," and a clarinet duet. Mozarto actually plays all the instrumental features. In the violin and ocarina duet the ocarina is played by means of a rubber tube leading from his mouth to the ocarina, which is fastened to the violin. He plays the two clarinets at the same time, one in each side of his mouth. These facts will give added interest to the Record.

**9854 I Said "Hello" She Said the Same, Then We Both Said "Good-bye"**

**Bob Robert**

A comic number of which three verses are given on our Record. The singer is placed in most perplexing predicaments throughout the song, but gracefully extricates himself on each occasion by carrying out the title of the selection. Mr. Roberts' rendition is fully up to his high standard. Orchestra accompaniment. Words, Edward Rose; music, Max Silver; publisher; F. A. Mills, New York.

**9855 Cecilia, With a Capital C**

**Edward M. Favor**

"Not Bedelia, nor Cordelia, nor Ophelia, nor Amelia, but Cecilia, with a Capital C" is the way the Irish lover sings of his fair charmer. To save his voice he sang several songs to the Phonograph and sent them to Cecilia. They told of his love for her Irish ways and they created quite a sensation when she played them the following Sunday night before a gathering of friends. Mr. Favor is a pastmaster of the art of singing Irish songs. Orchestra accompaniment. Music, Seymour Furth; words, E. P. Moran; publisher, Shapiro, New York.

## 9856 Nigger in the Barnyard

Edison Military Band

A selection that is brimful of darkey melody and dance music—quite typical of this light-hearted and music-loving race. Interpolated in the band music is the chorus:

When the sun rise in de mornin,  
Down by the yellow corn,

Dat's de time de dark's take warnin',  
When Dinah blows de horn.

It is one of those Records combining band music and singing, so popular in the past and of which we have not made one in some time. Composer, Charles Lovenberg; publisher, Carl Fischer, New York.

## 9857 Over the Mountain of Sorrow

James F. Harrison

It is some time since Mr. Harrison has made a solo Record for us. His rich baritone voice is heard to excellent advantage in this sacred selection, with its sweet melody and beautiful words of comfort and hope. Orchestra accompaniment. Music, George Lowell Tracy; words, Dexter Smith; publishers, Louis H. Ross & Co., Boston.

## 9858 Honey, Won't You Please Come Down?

Collins and Harlan

A colored Romeo is serenading his dusky Juliette, with the same shining moon, blinking bobalinks, glimmering stars and rippling stream, characteristic of the Shakespeare version. It is a rag time appeal to Liza Brown to descend and hear the love-tale of the darkey swain. A typical Collins & Harlan coon duet. Everyone who has a Phonograph will know what this means. Orchestra accompaniment. Music and words, Dave Reed; publishers, M. Witmark & Sons, New York.

## 9859 All She Gets from the Iceman is Ice

Ada Jones

Another song that Vesta Victoria is singing with great success. Jane's divinity and affinity is the iceman. There is something about his business that effects his temperature, for he is as frigid as his ways. Between the first and second singing of the chorus, there is a funny bit of by-play. The iceman is heard driving up the street and stopping in front of the house. Jane cordially invites him in, but he is as cold as his reputation and his business, and replies: "Naw, I can't; dis is me busy day." Mr. Meeker impersonates the iceman. Orchestra accompaniment. Music, Alfred Solman; words, Arthur J. Lamb; publishers, Joseph W. Stern & Co., New York.

## 9860 The Lanky Yankee Boys in Blue

Edward Meeker

A march song that shows by its martial air and patriotic words that the spirit of '76 still lives. At the call of their country the Yankee boys leave their work and homes, and without regard for rank or wealth, go forth to meet the common foe. The music is of a lively marching character, with enthusiastic cheering, drums and bugle calls between the verses. Mr. Meeker improves with each new Record that he makes. Orchestra accompaniment. Music, Theodore Morse; words, Edward Madden; publishers, F. B. Haviland Publishing Co., New York.

## 9861 Yankee Girl Caprice

Edison Symphony Orchestra

To a composition written in caprice tempo, add an attractive arrangement of notes and a practically perfect orchestration and the resultant product is a Record of marked beauty. Composer, Theodore Moses-Tobani; publisher, Carl Fischer, New York.

## 9862 Big Chief Smoke

Billy Murray

The tale of an Indian whose chief occupation is smoking. His fondness for the weed is objected to by his squaw and brings on a family row. The squaw hits the chief's pipe a swipe. "No more he smokes the pipe of peace, he smokes a piece of pipe." The melody and orchestral effects are Indian like. The peculiar guttural grunt of the Indian is well featured. Sung in the musical comedy play "Lonesome Town." Orchestra accompaniment. Music, J. A. Raynes; words, C. William Kolb; publishers, M. Witmark & Sons, New York.

## 9863 Santiago Flynn

Ada Jones and Len Spencer

Santiago serenades Norah McCarty in true Spanish style. In broken Spanish he sings his love-story to the accompaniment of a mandolin. Norah has nothing for him but sneers and quips, till he tells her that, although born in Mexico, his father's name was Flynn. Then nothing in the house is too good for Santiago, and the priest in due time made them possible subjects for the divorce court. Toward the close of the Record, Miss Jones sings a verse from "Santiago Flynn," of which the music is by Theodore Morse, the words by Edward Madden and the publishers are F. B. Haviland Publishing Co., New York.

## 9864 The Laughing Spectator

Steve Porter

Did you ever go to a vaudeville performance when the jokes of the "sidewalk conversationalists" were greeted by one of those billy goat laughs from a spectator that in five minutes had the remainder of the house in an uproar? This Record is a life-like duplication of such a scene. Mr. Porter again talks the dual part of Mac and Reilly, Mr. Meeker does the laughing spectator and various members of our Recording Department staff add to the realism. In the incidental singing Mr. Porter is accompanied by the orchestra.



## 9865 Harry Lauder Medley

Edison Military Band

The tremendous popularity achieved by the Harry Lauder vocal Records will gain for this medley a wide and heavy sale. It introduces: "Tobermory" (Record No. 19175); "We Parted on the Shore" (Record No. 19176); "Stop Yer Ticklin' Jock," (Record No. 19179); "I Love a Lassie," (Record No. 19178); "The Safest o' the Family" (Record No. 19177); "She's My Daisy," (Record No. 19174).

## 5 Selections Made Over

We list below five selections that have been made over by the same talent. The June printed matter prepared for retail use will contain these selections. Dealers should replace their stock of the original Records of these numbers with the new ones.

<b>14</b> Bridal March from Lohengrin	<b>Edison Concert Band</b>
<b>1559</b> Where is My Wandering Boy To-night? <span style="padding-left: 150px;">Formerly by Harry MacDonough</span>	<b>Reed Miller</b>
<b>7323</b> Dare Devil March	<b>Edison Military Band</b>
<b>7722</b> Dancing With Ma Baby	<b>Edison Military Band</b>
<b>7885</b> American Eagle March <span style="padding-left: 150px;">Formerly by Edison Concert Band</span>	<b>Edison Military Band</b>

## New Plan for Supplying Trade Information

With a view to simplifying the matter of issuing trade information to Jobbers and Dealers, we have put into effect a plan of doing so by means of special bulletins, these to take the place of form letters and the present advices in the PHONOGRAPH MONTHLY. The plan provides for mailing specially printed bulletins direct to Jobbers in every case, and for using the pages of the PHONOGRAPH MONTHLY to furnish the same information to Dealers, following in the latter case the same bulletin form of notification. These bulletins may be issued from any one of several departments, but in each case it will be made clear which department they emanate from. Each department will have its own set of numbers, so that they may be filed separately, or those of one department may be kept and another thrown away if desired. To illustrate the plan: Suppose the sales department wants to advise the entire trade of a change in prices. It will issue "Sales Department Bulletin No. 1," print it especially for Jobbers and mail copies direct to the latter. The same matter will be printed in the PHONOGRAPH MONTHLY, bearing a sales department number. This number may differ from that of the Jobbers' bulletin, because more bulletins are sent to Jobbers than to Dealers. Jobbers are urged to keep separate files for the bulletins of each department. Dealers should carefully watch the pages of the PHONOGRAPH MONTHLY and keep a complete file for future reference.

Where, because of tariff conditions, etc., the same bulletin will not apply to Canadian Dealers, a special bulletin will be mailed direct to the latter. Where they do not receive a special

bulletin, Canadian Dealers will understand that those printed in the PHONOGRAPH MONTHLY are also addressed to them.

## Scotch Record Recital

In order to introduce to its retail trade the seven Lauder Records, the R. S. Williams & Sons' Co., of Toronto, gave a Scotch recital on February 29th. They made up the following programme of Scotch music and songs, which our readers will admit was an interesting idea:

12876—Blue Bells of Scotland.....	Band
48th Highlanders Band	
9325—Bonnie Banks o' Loch Lomond.....	Soprano
Miss Marie Narrelle	
8470—Coming Thro' the Rye.....	Piccolo
Frank S. Mazziotta	
19173—Rob Roy Mackintosh.....	Comic
Harry Lauder	
19174—She's My Daisy.....	Comic
Harry Lauder	
9454—Bonnie Jean.....	Tenor
Byron G. Harlan	
9626—Coming Thro' the Rye.....	Humoresque
Edison Concert Band	
19175—Tobermory .....	Comic
Harry Lauder	
19176—We Parted on the Shore.....	Comic
Harry Lauder	
9549—Love's Serenade.....	
Edison Venetian Trio	
9773—Her Bright Smile Haunts Me Still.....	
Edison Venetian Trio	
9689—Sweet Spirit Hear My Prayer.....	
Edison Venetian Trio	
19178—I Love a Lassie.....	Comic
Harry Lauder	
19179—Stop Your Ticklin', Jock.....	Comic
Harry Lauder	
9254—Coming Thro' the Rye.....	Soprano
Miss Marie Narrelle	
12877—Cock of the North.....	Band
48th Highlanders Band	
19177—The Safest o' the Family.....	Comic
Harry Lauder	
5021—God Save the King.....	Baritone
Frank C. Stanley	

**Keep up your stock. Advertise. Circularize.  
Call on your customers personally. Don't let  
any business get away.**

## Another Decision Against Price-Cutting—This Time in Philadelphia

By hard experience persons who set out to cut prices on Edison Records have learned that they can only carry on their illegal operations until they have been discovered, and that when application is made to the courts, these illegal practices will be speedily stopped. Occasionally, however, someone imagines that he can sell Edison Records at cut prices, and that the courts will protect him in so doing, and, therefore, at intervals a price-cutting suit is fought through the courts until final hearing. This has happened only four or five times since our present selling system was inaugurated, and in every such case the decision has been in favor of our selling contracts, and the illegal sale of Records at cut prices has uniformly been enjoined.

Just recently a new case has been added to this list of contested cases, and this decision is precisely in line with former decisions of the Federal courts upon the subject. This is the decision of the New Jersey Patent Company and National Phonograph Company vs. Fred G. Schaefer, in the U. S. Circuit Court for the Eastern District of Pennsylvania. The decision in this case was rendered in February, 1908. Schaefer kept a small store in Philadelphia, and each month he succeeded in obtaining a number of Edison Records, which he sold at cut prices. He was not himself a Dealer, but he got a man by the name of Dyer to sign a Dealer's contract and buy a hundred or two Records each month at Dealer's prices, with money which he advanced to Dyer.

These practices were brought to the attention of the National Phonograph Company and suit was immediately brought against Schaefer, and a preliminary injunction was granted, enjoining him from selling Records at cut prices during the pendency of the suit. Schaefer, thinking he had a right to sell Edison Records at whatever price suited him, decided to contest the suit, and evidence was taken on each side, and the case was brought to final hearing and argued by Frank L. Dyer, General Counsel, with the result above mentioned. Now, Schaefer is not only prevented from the sale of Edison goods, but he is out his expenses in the suit, together with the costs of both parties. The effect of this decision will be to effectually prevent further price-cutting on Edison goods, and it will probably be the last case of this sort which will be contested for some time, as a contest of this kind costs quite a tidy

little sum and its outcome can be clearly predicted from the start. Our selling contracts have been carefully drawn up in view of the decisions of the Federal courts, and have been uniformly sustained thereby, and any contest against their provisions will be highly unprofitable to the contestant. The opinion in the Schaefer case is as follows:

IN THE CIRCUIT COURT OF THE UNITED STATES FOR THE EASTERN DISTRICT OF PENNSYLVANIA.

NEW JERSEY PATENT COMPANY and NATIONAL PHONOGRAPH COMPANY, <i>Complainants,</i>	} April Sessions, 1906, No. 7 In Equity.
<i>vs.</i> FRED G. SCHAEFER, <i>Defendant.</i>	

FINAL HEARING.

FRANK L. DYER and CHAS. N. BUTLER for Complainants.

JOHN H. FOW for Defendant.  
HOLLAND, J.

This is a suit to restrain the infringement of Letters Patent No. 782,375, and for an accounting. The Complainants are the New Jersey Patent Company, a corporation of New Jersey, to which the patent was granted as the assignee of the inventor and which holds the legal title to the patent, and the National Phonograph Company, another New Jersey corporation, which holds the exclusive right to manufacture, use and sell throughout the United States phonograph records embodying the invention of the patent. The patent covers a composition comprising a metallic soap and a hard wax added thereto adopted for the manufacture of phonographic records. These records are manufactured and sold to jobbers and retail dealers under the trade name of "Edison Records," "Edison Standard Records," or "Edison Gold Moulded Records," by the National Phonograph Company through a selling agreement which they have adopted and incorporated in a license which all jobbers and retailers are required to secure from the company. These licenses and agreements are the same for all, requiring every jobber to agree to sell these records at certain prices fixed in the agreement and only to licensed retail dealers, and the agreement which the company has with the retailer restricts his right to sell at retail for less than thirty-five cents apiece. The licensee is required to observe other conditions, and both the jobber and retail dealer stipulate, amongst other things, that

"All Edison Phonographs, Records and Blanks are covered by United States patents and are sold under the condition that the license to use and vend them, implied from such sale, is dependent on the observance by the vendee of all the foregoing conditions; upon the breach of any of said conditions the license to use or vend said Phonographs, Records and Blanks immediately ceases and any vendor or user thereafter becomes an infringer of said patents, and may be proceeded against by suit for injunction or damages, or both."

Each record is encased in a box or carton, upon which is printed in prominent type, a notice that

"This record is sold by the National Phonograph Company upon the condition that it shall not be sold to an unauthorized dealer or used for duplication, or that it shall not be sold or offered for sale by the original, or any subsequent purchaser (except by an authorized jobber to an authorized retail dealer) for less than thirty-five cents apiece.

"Upon any breach of said condition, the license to use and vend the record, implied from such sale, immediately terminates."

In his answer he swore that "the records sold by him and offered for sale, about which the complaint is made, were purchased from owners of phonographs, who, after having used the same, sold them to him, or exchanged them for others, that he was practically a dealer in second-hand records," \* \* \* \* \* and further, that "he never aided or assisted any other person in the violation of any contract made with the complainants."

These statements are untrue, and his testimony at the first examination was directed to the support of these allegations. It subsequently developed that he had induced Dyer to procure a retail license, for the purpose of enabling him to secure new records at a price less

than he could purchase them from jobbers or from the company, and that he did sell new records, obtained in this manner, at less than licensed retailers were permitted by the company to dispose of them to the public. The evidence shows that he purchased second-hand records from the owners of phonographs and disposed of them at such figures as he was able to secure. With this, however, we have no concern. The bill charges the defendant with an infringement of the patent, in that the defendant has sold these records in violation of the restrictions contained in their form of license and the notice upon the box or carton in which the records are encased, and the evidence in the cause fully establishes the truth of these allegations. True, he acted through his representative, Dyer, in whose name the license was secured, but he is the responsible party. He disposed of the records of the complainant company to the public in direct violation of the restrictions contained in their retail license. It is true he did not hold a license from the complainants, but his representative did. Dyer was a retail licensee who, in direct violation of the agreement, sold to defendant records at a price which made him an infringer, and the defendant secured his records from Dyer by inducing him to avoid his license and infringe the patent. In so doing, the defendant became the infringer himself. Where an infringement of a patent is brought about by concert of action between a defendant and complainants' licensee, all engaged directly and intentionally become joint infringers. *Heaton, & Co., Button & Co. v. Eureka Specialty Co.*, 77 Fed. Rep. 288; *Wells & Co., v. Abraham*, 146 Fed. Rep. 190 and 149 Fed. Rep. 408. If they are empowered, under the patent law, to place such restrictions upon the sale of the invention, the complainants are entitled to an order restraining the defendant and requiring him to account.

These contracts restraining the right of licensees to sell upon certain conditions have been before the courts in a number of instances, and the last to which my attention has been called was upon a jobbers' agreement to sell only at a certain price. The defendant sold the patented article at a price less than those agreed upon and to retail dealers who had not signed the agreement prescribed for retailers. The Circuit Court dismissed the bill on the ground that such agreements could not be upheld even though the article of merchandise was covered by patents. The Circuit Court of Appeals for the Eighth Circuit, in the case of *National Phonograph Company v. Schlegel*, 128 Fed. Rep. 733, reversed the Circuit Court and held that the restrictions placed upon the jobbers in the sale of their invention was valid and would be upheld by the courts.

The patentee has an exclusive monopoly of the right to manufacture, use and sell the patented article. These substantive rights to manufacture, use and sell may be granted together or separately and subject to such restrictions in each case as the patentee may see fit to impose. He may limit the minimum price at which his licensee may sell at retail to the public, and a violation of the license by the latter is an infringement. *Victor Talking Machine Company v. The Fair*, 123 Fed. Rep. 424; *National Phonograph Co. v. Schlegel*, supra; *Rubber Tire Wheel Co. v. Milwaukee Rubber Works Co.*, 154 Fed. Rep. 358.

This record shows that the defendant has been engaged in selling the complainants' records in violation of the restrictions which it placed upon retail dealers, and a perpetual injunction will be awarded restraining him from infringing the complainants' right in this particular.

Let a decree be entered accordingly.

---

I heartily approve of the Dealers' agreement. I do not think the Phonograph has had its day. My outlook is better every day for Edison goods. The future never was so bright for Edison Phonographs and Records. Mark me down as an Edison worker, who will not deviate one penny from agreement.—*Ziler Grove, Milford, Ind.*

---

Are you trying as hard now to get business as you did six months ago? No? Then go back to the old way. It's a mistake to let up at any time.

## Mr. Edison in Florida

Mr. and Mrs. Edison and son did not go to Florida on February 25th, as stated in the March issue of the PHONOGRAPH MONTHLY. All arrangements had been made to start on that date, but on February 23rd Mr. Edison went to New York to consult Dr. Arthur B. Duel, specialist in aural diseases, about some trouble in his ear that had affected his hearing more than usual. Dr. Duel advised an operation for mastoiditis, similar to one performed by him on Mr. Edison about two years ago. Mr. Edison went to the Manhattan Eye, Ear and Throat Hospital and the operation was performed the same day. It was entirely successful. Except for one day, when his temperature was somewhat alarming, Mr. Edison made a steady recovery. He returned to his home in Llewellyn Park, Orange, on March 10th, and left for his plantation at Fort Myers, Florida, on March 14th, accompanied by Mrs. Edison, Master Theodore Edison, Miss Margaret Gregory, of Montclair, and Mr. Edison's private physician, Dr. Page, of New York. They left Newark at 9.58 a. m. in a private Pullman car, "Pilgrim," which was attached to the Florida and West India Limited and which arrived at Jacksonville, Fla., 2.20 p. m. Sunday, continuing on to Lakeland, Fla., arriving at 9.40 Sunday night. On account of there being no through train service to Fort Myers, the car was placed in a quiet spot until Monday morning, when it was attached to train leaving Lakeland at 7.55 a. m., arriving on time at Fort Myers, Fla., 1.05 p. m. Mr. Edison stated just prior to his boarding the car that he felt first rate and he was in excellent spirits. The party was accompanied as far as Philadelphia by Mr. Edison's daughter, Madeline, Miss Lucy Bogue and J. V. Miller. The party will return in May.

---

## Foreign Record Changes

The Trade is hereby advised that we have no more Records or masters of Record No. 18609, "Himno Nacional Mexicano" (Mexican), by Banda de Zapadores. Our entire stock of the above has been discarded. This selection has, however, been made over by the Banda de Policia, and is now listed under No. 20083 in our catalogue.

The Trade should also take note of the following cut-out: No. 15318, "Eine Szene auf der Alm" (German) by Renoth und Huber. This Record is defective, and since we cannot obtain additional masters or moulds, it will be dropped from our catalogues.

## Trade Information for Dealers

### Sales Dept. Bulletin No. 1—March 13th, 1908

FOR UNITED STATES DEALERS ONLY

Correspondence concerning this Bulletin should mention its number and be addressed to National Phonograph Co., Sales Department, Orange, N. J.

We append herewith price list for Edison Horn Crane parts:

	DEALERS.	LIST.
Gem chain rod and chain.....	\$ .11 net	\$ .15
Gem upright rod.....	.11 "	.15
Standard, Home and Triumph chain rod and chain.....	.18 "	.25
Standard, Home and Triumph upright rod and thumb Screw.....	.36 "	.50
Standard, Home and Triumph base.....	.36 "	.50
Standard, Home and Triumph brace.....	.07 "	.10
Standard, Home and Triumph base holder and s.....	.11 "	.15

These prices are based on the Triumph style of horn crane, which has now been adopted for the Standard and Home also. Such prices will, however, apply to parts of the cranes heretofore used in the Standard and Home.

Prices for parts of the Idelia Horn Crane will be just double those of the Standard, Home and Triumph.

The above are all net prices, from which no discounts whatever are to be allowed.

### Sales Dept. Bulletin No. 2—March 13th, 1908

FOR UNITED STATES DEALERS ONLY

Correspondence concerning this Bulletin should mention its number and be addressed to National Phonograph Co., Sales Department, Orange, N. J.

Beginning at once all Phonographs ordered with mahogany cabinets will be equipped with mahogany finish horns, instead of the regular black horns, as heretofore. This will change the prices of the complete outfit, and instead of quoting an extra price for the mahogany cabinet and horn (as heretofore), we will quote prices on the outfits complete, which will be as follows:

Gem Phonograph with mahogany cabinet and mahogany finish horn.....	\$ 16.50 List
Standard " " " " " " " ".....	36.50
Home " " " " " " " ".....	47.50
Triumph " " " " " " " ".....	75.00
Balmoral " " " " " " " ".....	85.00
Conqueror " " " " " " " ".....	100.00
Alva " " " " " " " ".....	105.00

These prices are subject to the regular machine discounts. Should you have any machines mounted in mahogany cabinets in stock, they should be equipped with the mahogany finish horns, which can be purchased from us as extras, and then sold at the above list prices. This will leave in your possession to be sold as extras the black horns with which such machines were originally

### Sales Dept. Bulletin No. 3—March 13th, 1908

FOR UNITED STATES AND CANADA DEALERS

Correspondence concerning this Bulletin should mention its number and be addressed to National Phonograph Co., Sales Department, Orange, N. J.

### Made Over Selections

We list below five selections which have recently been made over by the same or new talent. Continuing the plan begun last month, we will print them as part of the June printed matter prepared for retail distribution.

14	Bridal March from Lohengrin	Edison Concert Band
1559	Where is My Wandering Boy To-night? Formerly by Harry MacDonough	Reed Miller
7323	Dare Devil March	Edison Military Band
7722	Dancing With Ma Baby	Edison Military Band
7885	American Eagle March Formerly by Edison Concert Band	Edison Military Band

If you are not ordering these Records regularly and do not exploit them among your patrons, you are overlooking an excellent opportunity to increase your Record business. These made-over selections are equal in every way to the new Records listed by us each month, and in reality should be considered as an addition to the twenty-four.

## German Selections Re-listed

The trade is hereby advised that we have obtained new moulds for German Records No. 15102, "Die Kappelle," by the Meistersanger Quartette, and No. 15391, "O Susanna," by H. Grossman, and are now in a position to fill orders for both selections.

Orders cancelled in December last, because of our inability to fill them, due to defective moulds, should now be renewed, and Jobbers who have not ordered at any time should put in at least a small stock of each selection.

---

---

## Sales Dept. Bulletin No. 4—March 17th, 1908

FOR UNITED STATES AND CANADA DEALERS

Correspondence concerning this Bulletin should mention its number and be addressed to National Phonograph Co., Sales Department, Orange, N. J.

It has been brought to our attention that, in anticipation of a continuation of the Record Exchange Propositions which have taken place during the past two years, certain Jobbers are already taking back Records from their Dealers and storing them, with the expectation of returning them to us whenever the next Exchange Proposition takes place.

If this policy is being pursued now, it, no doubt, has been in the past. Such methods are not only a direct violation of agreement, but are, and always were, directly and absolutely contrary to the interest and purpose for which our Record Exchange Propositions were adopted.

It may be that such conditions do not now, or never did, exist, but to prevent any controversy or misunderstanding arising later on, we consider it advisable to now notify you that there will be no further *Record Exchange Propositions* along the same lines, or of the same nature as those which have heretofore taken place.

---

---

## Production Dept. Bulletin No. 1—March 20th, 1908

FOR UNITED STATES AND CANADA DEALERS

Correspondence concerning this bulletin should mention its number and be addressed to National Phonograph Co., Production Department, Orange, N. J.

We are now furnishing the same horn crane for all types of machines, with the exception of the Gem, it being understood that the Idelia crane has the oxidized finish.

The packages containing cranes are marked for the reason that the braces for the three different types vary. The brace for the Standard crane is a little longer than the brace for the Home, and the brace for the Triumph machine is longer than the brace for either the Home or Standard, this being necessary in order that they properly line up with the crane bases. The cabinet base of the Standard machine being wider than the base of the Home, the relative position of the crane base is not the same as on the Home, and the base moulding of the Triumph cabinet being wider, brings the horn crane base further away from the machine, thereby changing its relative position.

To take care of the different lengths of horns, the chain rod is to be adjusted in the usual way. When the crane is in proper adjustment, the suspension chain is in a perpendicular position. In future all envelopes containing the small parts of horn cranes will be illustrated, showing the proper position of horn and crane.

---

---

It is pleasant indeed to record the return to health of that notable inventor, Thomas A. Edison, of whom all Americans are proud. At the close of last month, after submitting to a delicate operation, the life of this grand old man, according to medical experts, was for a short time trembling in the balance, but thanks to splendid medical skill and excellent vitality Mr. Edison rallied from the shock successfully and has been steadily improving ever since. He is now out of all danger and has been removed from the hospital, a statement which will gladden the hearts of thousands of World readers in every land on earth who have grown to admire

and love this splendid man and inventor, who has shed so much luster upon American inventive ability. May the span of life be long extended to Edison.—*Talking Machine World*.

---

## The Alva a Wonder

At last we have *the* Phonograph, "*The Alva*," it's great, and to say that it's the wonder of the twentieth century is expressing it very mildly. One and all of us join me in wishing a speedy return to good health of our dear friend, Mr. Edison, and to you all, continued success.—*Sol. Heller, 235 W. 102nd St., New York*.

---

---

# Edison Phonograph Monthly

Published for the Man Who Sells Edison Phonographs and Records by The National Phonograph Co., Orange, N. J.

All communications to *The Phonograph Monthly* should be addressed to the Advertising Department, Orange, N. J.

---

NEW YORK: 10 FIFTH AVENUE.

NATIONAL PHONOGRAPH CO., LTD., 25 CLERKENWELL ROAD, LONDON.

NATIONAL PHONOGRAPH CO. OF AUSTRALIA, LTD., 340 KENT STREET, SYDNEY, N. S. W.

MEXICAN NATIONAL PHONOGRAPH CO., AVENIDA ORIENTE No. 117, MEXICO CITY.

COMPANIA EDISON HISPANO-AMERICANA, VIAMONTE 515, BUENOS AIRES.

EDISON GESELLSCHAFT, M. B. H., SUD-UFER 24-25, BERLIN.

COMPAGNIE FRANCAISE DU PHONOGRAPHE EDISON, 42 RUE DE PARADIS, PARIS.

---

VOL. VI.

April, 1908

No. 4

---

## April Advertising Spells Optimism

Here is the list of weekly and monthly publications in which the advertisements of Edison Phonographs and Edison Records appeared, either in the latter part of March or in the April issues: Collier's Weekly, Saturday Evening Post, Associated Sunday Magazines, Youth's Companion, Puck, American Magazine, Cosmopolitan, Everybody's, McClure's, Munsey's, Review of Reviews, Ladies' Home Journal, Woman's Home Companion, Ladies' World, Argosy, Red Book, Metropolitan, Pacific Magazine, Sunset Magazine, World To-Day, National Magazine, and Ainslee's.

The two large advertisements in the regular newspapers appeared in 145 daily papers on March 12th or 13th and March 24th or 25th. Similar advertisements will appear in the same papers on April 14th or 15th and April 24th or 25th.

We shall have a full page advertisement in colors on the fourth cover of the Easter number of Collier's Weekly on April 11th. It has been designed by Will Bradley, one of the foremost men in his line in this country. Mr. Bradley has charge of the designing and typographical work of Collier's Weekly and is probably the highest salaried man occupying a position of this kind. He has designed our advertisement to harmonize with the front cover, which will also be done by him. Both pages will be printed in four colors. Dealers should get a copy of this issue and let the Edison advertisement occupy a prominent place in their stores or show windows.

Don't all of this advertising, costing many thousands of dollars every month, show that we have even greater faith than ever in the future

of Edison Phonographs and Records? Do you suppose that we would keep on advertising like this if we didn't feel certain that it will pay big dividends in the near future? We know that just now it is not making as many retail sales as it would if there were less men out of work and more money available for luxuries. We feel assured, however, that it is as active as ever in creating in thousands of homes a desire to own an Edison Phonograph and that the desire will be gratified as soon as the means are at hand. In other words, it is making just as many sales as ever and only the formality is lacking of making the payments and carrying home the goods.

In continuing our advertising plans as made last fall, we will have no lost ground to regain, no vain regrets for lack of faith. We will be in the position of the victorious general who won because he did not let up at any point of his campaign, even though at times it seemed easier to do so.

We wouldn't want to give the trade the impression that our advertising is not making present sales, for it is not only making sales, but it is a strong factor in the present status of our business, which we believe is in much better shape than nineteen out of twenty other lines throughout the country. It is in such shape that it needs but little to make its volume equal to anything in its history.

---

## Off to Mexico

Walter Stevens, manager of the Foreign Department of the National Phonograph Co., left on March 16th for a visit to the Mexican office of his department at Avenida Oriente No. 117, Mexico City. He will be absent about six

weeks. He was accompanied by his wife and daughter. Rafael Cabanas, formerly in charge of the Mexico City office, but who has been in New York for some months past, returned to Mexico at the same time. Mr. Cabanas will shortly sever his connection with the company and become a Jobber in Edison Phonographs and Records in Mexico City. George J. Werner and Frederick Burt, of the New York City Recording Department, sailed from New York on March 19th on the steamer Monterey, of the Ward line. They went by boat to Vera Cruz and from there by rail to Mexico City. With the assistance of Mr. Stevens and Mr. Cabanas, they will make another series of Mexican selections to supplement those already in the Edison catalogues.

---

## Lauder Records Grow More Popular Daily

No series of Records, other than the monthly list, ever put out by the National Phonograph Co., has achieved such a success as the seven Lauder Records issued in the latter part of February. Jobbers generally recognized their attractiveness and placed orders that in the aggregate far exceeded our expectations. The judgment of the Jobbers, however, fell short of meeting the demand. The Records did not get fairly before the public until March 1st, and since then the original orders of Jobbers have been entirely sold out and many of them have sent in rush orders for quantities larger than their first orders. Even this cannot be said to represent their ultimate sale, for they will get more popular as time passes and their fame gets into the smaller and more distant places. It will pay every Jobber and Dealer to carefully watch his stock of these selections and keep ordered ahead. At present we are working the moulds to the limit and expect to do so for some time. Consequently it will be a case of first orders in, first filled.

---

## Advertising and Sales

It is not half so hard to get trade as it is to retain it.

What an advertisement sets forth the advertiser should bring forth.

Don't jar the "funny bone" too much. Business is a serious matter.

Every advertising man who lives up to his profession is an advance agent of optimism.

A customer dissatisfied, either in his purchase or by the service rendered, can be marked non-returnable.—*Printers' Ink.*

## Interesting But Visionary

Everyone is familiar with the legend "with photographs," which appears on the title pages of books. Some day the legend may be expanded to read: "With photographs and phonograms," or, perchance, one may come upon the phrase "with phonograms" alone. In other words, there seems to be very little to hinder an enterprising author or publisher from issuing, along with a book, a set of phonographic records, which, by means of sound, may serve to illustrate far more forcibly than photographs ever can, sometimes, the subject matter of the book. When "phonograph" supplements become tolerably common, your booklover will have, as a necessary adjunct to his library, a Phonograph, by means of which he may use the phonographic records of a book while he reads the volume. Coming to page 13, for instance, he may find a star in some important paragraph, and against the star at the bottom of the page he may come upon a note, "See" or hear "phonographic record No. 1." It will be a matter of a minute or so to adjust "record No. 1" upon the machine and turn on the power.

Of course, if "phonograms" with books ever become popular some genius, possibly Edison himself, will find a cheaper means of making the records lasting, and gradually, like the growth of the bicycle, and apparently that of the automobile, they will become cheaper and cheaper, so that an author or publisher who does not furnish "phonograms" with his books will be hopelessly out of the book market.—*Newark, (N. J.) Sunday Call.*

---

## Edison Phonograph as a Public Instructor

Recently a lecture was given in one of our public school halls on "The Makers of Wisconsin History." Among other important personages mentioned were the authors of song—"Silver Threads Among the Gold"—Record No. 9162 and—"Sweet Bye-and-Bye"—Record No. 2021, both men being natives of our State. To better illustrate the subject, the speaker, who happens to be a friend of mine, kindly requested the loan of my Edison Phonograph and at the proper moment while he was referring to the above authors and their work I turned on the Record and caused the words of the song to be thrown on the screen so that the audience could easily follow the lines as they were being played. It instantly took the "house" by storm, coming as it did a complete surprise and something that was not on the programme. So prolonged and insistent was the applause that I was obliged to repeat the Records again and again. The Edison Phonograph certainly did cover itself with glory that evening. I understand that these two Records have since become a part of the regular equipment of the lecture course and are being played wherever practicable.—*W. P. W., Milwaukee, Wis.*

## Window Dressing

Are you one of the Edison Dealers who takes advantage of the splendid opportunity to advertise your business by constantly keeping an attractive display in your show window and changing it from time to time?

If you are, then we want to congratulate you upon your enterprise and progressiveness. You doubtless have your own ideas about attractive window displays and do not need assistance from us, although you may get some additional ideas from this department.

graph of an attractive window display, with some comments on it that will aid Dealers in duplicating it so far as the size of their window and stock of goods will permit. The displays will be simple in character, care being taken to use only such stock and material as can be had in almost any Dealer's store. Nor will any displays be made that will require unusual or difficult carpentry.

Before dressing a window, the Dealer should see that the glass is clean and bright and that dirt and dust are removed from the space



WINDOW DRESSING EXHIBIT No. 1.

If you have given window display but little attention, then we want to enroll you as a student of our window dressing department and urge you to give it serious consideration. As a means for increasing your business it is as good as any other form of advertising that you can use. In fact, if you do not dress your show window invitingly, all other means you may employ to advertise will suffer. Many a sale has been lost because the prospective purchaser was repelled by the unattractive appearance of the entrance and show window of a Dealer's store.

Every month, for a time at least, we are going to print in the PHONOGRAPH MONTHLY a photo-

back of the glass. No window display can ever be attractive unless cleanliness prevails. Every article placed in the window must be dusted, and care taken to keep out dust after the window has been dressed.

The display illustrated this month was made in a window ten feet wide and six feet deep. The opening is six feet high. Other than the Phonographs, Records, etc., there are used in the display five boxes 1 x 1 x 3 feet in size, open at the top (see Fig. A), about twenty-five yards of white cheesecloth and about half that quantity of green cheesecloth. The boxes and cheesecloths are the only articles involving expense, and they may be used over each month.



Having carefully cleaned the glass and display space, tack up green cheesecloth lengthwise and with an occasional fold, so as to give a draped effect (see illustration). Do not tack it smoothly like wall paper. Next tack up a festoon of white cheesecloth at the top of the green cloth, to get the effect shown in the picture. The rosettes are made by gathering up the cloth at regular intervals and fastening it with pins. Lay white cloth on the floor, getting the same loose effect as shown on the sides. Tuck in the ends neatly

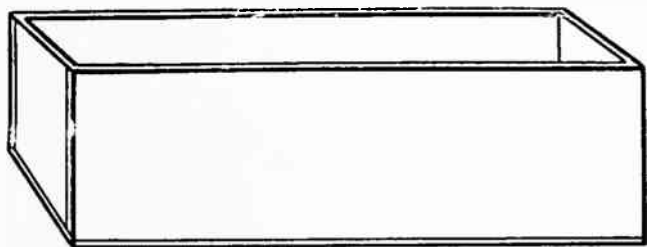

FIG. A.

where they meet the sides. Use one of the back folds as an entrance and dress the window so that the features near this entrance can be arranged last and while standing on the store floor. Be careful not to walk on the white cloth with dirty shoes.

Five of the boxes referred to above are used in this display. Two stand on end, one in each corner at the rear of the window. Two are placed across the back, one on top of the other, so as to make the height two feet. The fifth is placed at right angles with the front and close to the two in the rear. All are covered with white cloth. The display is now a matter of arrangement, according to the picture. The machines should be placed in position first, except the one nearest to the entrance, which should be left till the last. Begin the placing of Records, catalogues, signs, etc., at the farthest point and work back toward the entrance. Look at the work once in a while from the front to be sure that the balance is right.

Dealers who want to duplicate these displays but do not have all of the material are asked to do the best they can with what material they have and make application to us for the missing articles, stating what they do not now have and giving the name of the Jobber through whom shipment may be made. Or shipment will be made by express at the expense of the Dealer when so requested. It may not always be possible to supply everything shown in the displays, but we will send all that we have. Some of the matter can be supplied by Jobbers without writing to us. All correspondence referring to window dressing must be addressed to Advertising Department, Orange, N. J.

We will be glad to have the names of Dealers who follow this display, with photographs of such displays where convenient.

## A Compact Record Stock

I send a photograph of my Record Stock, the feature of which is the small floor space and the unusual capacity for the space occupied. The floor space is 5 feet 4 inches by 10 feet 4 inches and the Record capacity 1,829; height of Record shelves, 6 feet 5 inches. Cost of counter and shelving in cash, \$4.50. I did my own work. Your paste-board fillers, or what you pack Rec-



ords in to ship by freight, are used in my shelving in full size sections with wire inserted to hold them in place. It works fine. However, the convenience, compact feature, extreme cheapness, etc., etc., would make a hit with many merchants where space cuts a figure. Shelving so cheap would be a great inducement for carrying a full stock of Records where Dealers have only been carrying part of them and have been bothered by not having them in an economical arrangement. The wholesale house could furnish these paste-board fillers made special for this work.—Chas. Bawden, Lake City, Ia.

H. L. D'Entremont, an Edison Dealer at Peabody, Mass., in advising us of the removal of his business to 18½ Lowell Street, writes:

I have placed a horn over the top of the window and pointing directly toward the square, and we can always attract attention by playing a few Records on the Phonograph inside, and it is a profitable advertisement, as I sold three Phonographs in two days last week. Edison's inventions are well represented here, as directly across from my store is Thomas Renzi, also selling Phonographs, and the Olympic Theatre with moving pictures is also across the street. This section of the street is being called "Amusement Row" now.

## Phonograph on the Wellman Expedition

A year ago, just before the Wellman Expedition left on its trip in search of the North Pole, President Gilmore, of the National Phonograph Co., presented Major H. B. Hersey, the well-known meteorological expert and balloonist, with an Edison Home Phonograph and a supply of Edison Records. In the latter part of July, Major

seem never to tire of it. Two or three times a week we take the outfit over to "Pike House," where our Norwegian workmen sleep, and give them a serenade. They enjoy this keenly. The other evening we took a photograph of their quarters with the Phonograph working. The expression on their faces is so good that I am going to send you a copy of it.

In closing I will add that the Phonograph and Records have given splendid satisfaction in every way.

H. B. HERSEY,  
*Executive Officer.*



THE PHONOGRAPH IN THE ARCTIC CIRCLE

Hersey wrote to Mr. Gilmore concerning the pleasure that the Phonograph afforded to the members of the expedition and enclosed a photograph showing a party of the explorers enjoying a concert by the Phonograph. Through some mistake the letter and photograph failed to reach Orange. We have just succeeded in getting another copy of the letter and a duplicate of the photograph. The letter is as follows:

CAMP WELLMAN,  
DANE'S ISLAND, SPITZBERGEN,

July 25, 1907.

I want to tell you how the Phonograph works up here in the Arctic close to 80° north latitude. We unpacked it soon after arriving here and found it to be in perfect condition. The Records came through the rough trip without injury. Dr. Fowler, our surgeon, was appointed "master of ceremonies," and soon had the Records rolling out the sweet song that carried us back in spirit to the homes and friends we left far away.

And you have no idea what a treat it is up here in this land of eternal ice and snow to listen to this music. Nearly every night, if we may say night when the sun shines 24 hours in the day, we have the instrument at work, and we

## The System Suits Him

P. H. Idol, Edison Dealer at Beaver, Utah, in writing about signing our new Dealer's Agreement, said in part:

Regarding that part of your letter concerning continuing selling the Edison machine, will say I do not see any reason why I should not, provided our business relations continue as pleasant in the future as they have been in the past and you keep me posted with the latest literature published by you and at the earliest possible moment. Since I came into this territory a little more than one year ago the other agents have gone to parts unknown to me. The country hereabouts is thickly settled, but of course you are aware that I have sold more than 200 Edison machines and a large quantity of Edison Records and very few of any other makes of machines. I might state for your information that the reason why the business all went to you was because you kept me posted with your latest publications; and you maintain a uniform price with us all. These two things suit me and are worthy of the consideration of every Dealer who has the ability to sell goods at all. Of course, a good salesman can sell any machine made, but your business methods are a great help to any salesman.

## Hanger for Dealers' Stores

Almost every Edison Dealer has, at one time or another, been asked by customers to do something contrary to the provisions of the Dealers' agreement and been compelled to enter into a long explanation as to the reasons why they could not comply. To save Dealers the trouble of making explanations and show that they are

not to blame for the restrictions, we have printed a supply of hangers like the above and shipped a small quantity to each Jobber, who in turn will furnish one to each Dealer on request. It is Form 1292. It is 22 x 28 inches in size and printed in blue ink on white paper. Dealers having trouble with customers are urged to get one of these hangers and put it up in their stores.

### As a Protection to the Public and the Trade, Edison Dealers are Positively Forbidden:

1. To sell Edison Phonographs and Records at less than the prices given in our catalogues.
2. To sell Edison Phonographs without horn or in any other way than shown in our regular catalogues.
3. To offer Edison Phonographs and Records as prizes of any kind.
4. To allow rebates or commission of any kind on sales of Edison goods.
5. To accept other goods in part payment for Edison goods.
6. To make advertising contracts in exchange for Edison Phonographs or Records.
7. To offer for sale as second-hand articles, Edison goods that have been used, or shopworn or damaged.
8. To sell, play or exhibit Edison Records on advance lists before 8 a. m. on the selling date fixed by this Company.
9. To exchange Edison Records on ANY basis.
10. To sell any other than genuine Edison repair and supply parts for use on Edison Phonographs.

---

Violation of any of these provisions renders a Dealer liable to suspension and loss of his right to sell Edison Phonographs and Records.

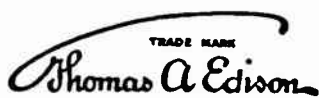
 TRADE MARK  
Thomas A Edison

NATIONAL PHONOGRAPH CO.

ORANGE, NEW JERSEY

---

I am glad to say that we are doing much more business in selling the Edison Phonograph now than before, on account of its new equipments. Last Saturday two brothers (attorneys) came into my store, asking me to show them some styles of Edison Phonographs. They at once fell in love with the Edison Gem, telling me that they liked the Gem on account of its horn and stand.

After trying some of the March Records for them, they each bought an Edison Gem Phonograph and one dozen Records. Therefore I think this new equipment is a very good idea, as I have no trouble whatsoever in selling an Edison Phonograph.—*A. Abelowitz, 132 St. Mark's Place, N. Y.*

## “Follow-up” Letters

C. W. Graves, Edison Dealer at Logansport, Ind., uses with much success, in “following-up” prospective customers, the two letters printed below, the second following the first after a short interval:

### FIRST LETTER.

DEAR SIR: I am enclosing you printed matter relative to the most wonderful invention and the most charming home entertainer of the present day.

The Edison Phonograph is the original and the only perfect talking machine—invented, perfected and manufactured by Thomas A. Edison, the most wonderful inventor the world has ever known. You may have been disgusted with some imitation phonograph—you surely will be delighted with the genuine Edison Phonograph and the Edison Gold Moulded Records.

There are no disagreeable noises in the Edison Records. You can understand them. Their volume and brilliant quality of tone is especially adapted to parlor use. This is a feature that Mr. Edison caters to. Neither the musical detail or the natural life-like tones of the voice are drowned out by a mechanical surface noise. You cannot afford to be without an Edison Phonograph in your home. Most valuable as an educator and indispensable as a versatile entertainer. The most reasonable priced machine and the only pure life-like toned Records on the market today.

With the “Edison” you can make perfect records of your friend’s voice—of grandpa’s—or the baby’s. Why not have photographs of their voices as well as of their faces to remember them by when they are gone?

Let us demonstrate to you how badly you need “Edison Music” in your parlor.

It will be a real pleasure to us, and to you, if you will call and hear the wonderful Edison Phonograph of today.

Do yourself, your family, your friends, and us a favor and let us hear from you soon regarding the Edison Phonograph.

Edison Standard Phonograph, Horn and Stand and your choice of 12 Records for \$29.50. Payments made easy.

### SECOND LETTER.

DEAR SIR: We trust you have not abandoned the idea of putting a Phonograph in your home. As we have already written you, no printed matter can adequately tell what this instrument is or what it will do.

We want to show you. We want you to call, select the music you like and hear it played or sung. We want you to operate the instrument—to put on the Records, wind the motor—in short, get acquainted with it.

Until you do you cannot decide whether you want it or not with fairness to yourself or to the Phonograph. This is a home proposition; it delights every member of the family; it plays and sings what you want.

The Phonograph affords a life-time enjoyment. It never becomes a bore any more than the theatre does, because the bill continuously changes. New Records, including all of the songs, band and orchestra selections are always obtainable, and every new Record makes the Phonograph new.

We do not believe you fully appreciate the possibilities of this instrument, and it is to prove that it is more than the most enthusiastic descriptions of it would indicate that we are asking you to call.

Very truly yours,

---

## Another Dealer’s Invitation

Louisburg, N. C., March 2nd, 1908.

You and your family are most cordially invited to call at our store on the 11, 12, 13 and 14th of March and each evening from seven-thirty to eleven to participate in a free concert given by us to our friends and patrons

on

Edison Phonograph

With the largest horn made and several hundred of the very best selections of music turned out. Come and have a good time, bring your friends.

J. W. HOLLINGSWORTH.

## Ready Made Ads

Whether or not Dealers use the ready made ads that we are running in these columns is of little moment, so long as they do *some kind* of advertising. It does not follow that these specimens represent the best advertising that can be done. Many Dealers can write advertisements that will get better results in their own localities than any of these, and no one who can do so should hesitate to write and print his own copy. Next to doing some kind of advertising it is important to change the matter with each insertion. If you cannot write an advertisement of your own, these ready made ads will help you.

Dealers may have an electro of either or both of the illustrations in these ads on request. They must, however, agree to send our Advertising Department copies of the papers containing them. If they have had electros of previous ads they must send us papers showing them or no attention will be paid to new requests. Dealers who prefer to use an electro of the Phonograph, or a combination of the Edison portrait and signature, or any other electro carried in regular stock by us, may have it mailed by stating type of machine or otherwise designating electro wanted. Requests for electros must be addressed to Advertising Department, Orange, N. J.

---

## The Customer is the One You are Trying to Please

He wasn’t pleased with the old Edison Phonograph Horn. He isn’t pleased with the horns of other machines. Neither is he pleased with the idea of buying a horn in addition to the machine, or pleased with the results after he gets one.

This is why we brought out a new Edison Horn with crane to support it and have included this equipment in the price of the Phonograph.

The customer gets a better horn than he could buy from a horn stock, gets better results with it, because it is made especially for the Phonograph, and is pleased over his purchase.

You benefit from his satisfaction and you benefit in other ways. You sell a Phonograph and a horn with one set of motions, you make a liberal profit on both and you are relieved of the expense of carrying a stock of horns.

The Edison Phonograph, with its new equipment is the best talking machine proposition on the market.

# EDISON



## PHONOGRAPHS

No single thing furnishes so much entertainment to a family, especially where there are children and young folks, as an Edison Phonograph. It supplies all kinds of amusement at little expense; it keeps you up to date with every kind of music; it gives you a means of entertaining your friends.

**W. E. WILSON**  
 No. 44 Canada Street  
 Richmond, Va.

 Electro in above ad is: Single column wide No. 675. Double column wide, 676.

# EDISON



## PHONOGRAPHS

At less per week than the price of a cheap theatre ticket you can put the Edison Phonograph into your home. And it's a lot more comfortable and a lot more enjoyable to hear good music in the easy chair at your own fireside than it is to hear it in a hard, uncomfortable seat at the theatre.

**F. K. SMITH & CO.**  
 No. 57 Henry Street  
 Columbus, Ohio

 Electro in above ad is: Single column wide No. 677. Double column wide. No. 678.

## REQUEST FOR ELECTROS

NATIONAL PHONOGRAPH Co.

ADVERTISING DEPARTMENT, ORANGE, N. J.

DATE.....190.....

Mail Electros No.....

We agree to use them in newspaper advertising and to send you copies of papers containing them before asking you for other electros. We intend running a..... inch advertisement.

Name.....

Street.....

City and State.....

We buy through.....

SUSPENDED LIST, APRIL 1, 1908

SUPERSEDING ALL PREVIOUS LISTS.

CALIFORNIA.

\*Chico—J. L. Crick, 234 Broadway.  
 Petaluma—Thomas McGuire, 875 Main st.

CANADA.

Ottawa, Ont.—Ketchum & Co., Sparks and Bank sts.

COLORADO.

Boulder—Bentley & Craig.  
 Denver—Wagman & Bloomfield (The Phonograph Circulating Library), 1631 Champa st.

GEORGIA.

Valdosta—H. K. McLendon, 109 West Central ave.

ILLINOIS.

Champaign—Eggleston Bros., or Eggleston Music House, J. P. Eggleston, Prop.; also Danville, Ill.  
 Chicago—A. Gloss & Son, 727 W. North av.  
 Cookville—Geo. Swinehart & Son.  
 Danville—Eggleston Bros., or Eggleston Music House, J. P. Eggleston, Prop.; also Champaign, Ill.  
 \*Miss Ruth Grey.  
 Elgin—James W. Mill, 18 Spring st and 166 Chicago st.  
 Kempton—C. E. Bute.  
 Ottawa—Edward Hayne.  
 Peoria—H. Meyer, 1307 S. Adams st.  
 Quincy—Giles Bros., 107 North 4th st.  
 J. F. Brenner, 627 Main st.  
 J. F. Whittaker 618 Hampshire st.  
 Robinson—A. D. Foreman, or A. D. Foreman & Son.  
 Wheaton—E. Irving.

INDIANA.

South Bend—Eugene Marsh, 126 Vistula ave.  
 South Bend Book Bindery, Robert Lebolt, Prop., 203 North Michigan st.

IOWA.

Burlington—John P. Weiss, 711 Jefferson st.  
 Cushing—Bullock & Lyman.  
 Independence—E. O. Parker, 110 E. Main st.  
 \*Indianola—L. C. Barnett.  
 McClelland—J. W. Rounds & Co.  
 Mederville—John J. Carpenter.  
 Sioux City—Hattenbach Bros. Co.  
 A. V. Larimore, 518 Fifth st.  
 State Center—Ora Sargeant.  
 Webster—E. H. Martin and Fred N. Martin.  
 Whiting—The Cassady- & Whiting Co.

KANSAS.

Clay Centre—E. M. Gowenlock.  
 Lawrence—Bell Bros.  
 Topeka—R. H. Morehouse, 510 E. 4th st.  
 Wichita—Frank R. Powell, 132 N. Main st.

KENTUCKY.

Louisville—Irvine Simons, 942 W. Market st.  
 (formerly 543 W. Market st.).

MAINE.

Biddeford—W. H. Field.  
 Gardner—C. H. Cobb, 293 Water st.  
 Lewiston—J. W. Skene.  
 Monmouth—G. H. Stetson.  
 Oldtown—H. M. Burnham.  
 Waterville—Frank Blanchard, 150 Main st.  
 M. Steinert & Sons Co., at all points.

MASSACHUSETTS.

Boston—Henry H. Savage, 166 Hanover st.  
 T. Singer, 60 Leverett st.  
 Fitchburg—M. Steinert & Sons Co.; also Pittsfield, Mass., and at all points.  
 Florence—William Oates, 87 Main st.  
 Franklin—E. P. Blackmar.  
 Great Barrington—Frank W. Wheeler, Main st.  
 Lawrence—Lord & Co., 314 Essex st.  
 E. O. Mosher, 420 Essex st.  
 Malden—A. T. Fuller.  
 Nantucket—Arthur M. Taylor.  
 New Bedford—H. B. DeWolff.  
 Pittsfield—M. Steinert & Sons Co.; 254 North st.; also Fitchburg, Mass., and at all points.  
 Somerville—E. J. Winchester, 32 Summit ave.  
 Woburn—Osborn Gillette, or The Boston Jewelry Co., L. F. Maloney, Manager.  
 Worcester—Joseph Tukman, 44 Front st.  
 Guy Furniture Co., 521 Main st.

MICHIGAN.

Ann Arbor—Ann Arbor Music Co., F. J. Schwankosky, Prop.  
 Bay City—J. M. Kopec, 1006 S. Madison st.  
 Detroit—F. J. Schwankovsky.  
 Manistee—Gus Ilse, and A. H. Ilse Co., 311 River st.  
 Saginaw—Geo. W. Emendorfer.  
 James V. Calahan, 217 Genessee st.  
 Tierney Bros., 217 Genessee st.

MINNESOTA.

\*Morristown—Wm. Zimmerman.  
 Willmar—Willmar Furniture Co., Ruble Block.

MISSOURI.

Ewing—Hal R. Ewalt.  
 Fairfax—Hinde Hardware Co.  
 Kansas City—The Wittmann Co.  
 Osceola—C. H. Green.  
 St. Louis—Knight Cycle Co., 1215 Olive st.  
 F. Ringwood and J. Ringwood, or Central Phono. Co., or Franklin Phono. Co.

NEBRASKA.

David City—John Albright.  
 Lincoln—The Wittmann Co.  
 Omaha—The Wittmann Co.  
 Piano Player Co.  
 Red Cloud—Albright Bros. or L. P. Albright.  
 Sterling—Sterling Drug Co., W. G. Morrill, Prop., and W. G. Morrill, M. D.

NEW HAMPSHIRE.

Dover—H. C. Ingalls & Co., 444 Central ave.  
 Hillsboro Bridge—E. M. Barnes.  
 Manchester—A. E. Dumas.  
 Nashua—F. A. McMaster & Co.

## SUSPENDED LIST CONTINUED.

### NEW JERSEY.

**Atlantic City**—Sam'l D. Wolf, 32-34 Arkansas ave.  
**Bayonne**—J. Wigdor, 450 Avenue D.  
**Jersey City**—W. L. Hoffman, 151 Montgomery street.  
**Long Branch**—A. N. Alexander, 103 Broadway.  
 A. Nastasio, 103 Broadway.  
**Newark**—R. L. Corwin; also New York City.  
 R. Rosenthal, Prop. Springfield Hdw. and Sptg. Goods Store, 71 Springfield ave.  
 D. Reinhorn, 91 Springfield ave.  
**Passaic**—I. Hurwitz.  
**Paterson**—Chas. H. Kelly, 25 N. Main st.  
**Plainfield**—S. W. Frucht, or R. Frucht; also New York City.  
 Elston M. Leonard.  
**West Hoboken**—Emil Hollander, or The West Hoboken Bicycle & Phono. Co., 169 Spring st.

### NEW YORK.

**Albany**—G. Linde, 353 S. Pearl st.  
 G. A. Birdsall, 114 S. Pearl st.  
**Amsterdam**—D. C. Kirchner, 26 Market st.  
**Bedford Park**—Geo. H. Tyrrell.  
**Brooklyn**—Nathan Abrahams, 602 Broadway.  
 Wm. Albrecht, 294 Knickerbocker ave.  
 H. Hindermann, Bushwick Phonograph Exchange, 1421 Myrtle ave.  
 Emil Smith, 634 Eleventh st., and 230 Summer ave.  
 Totten Furniture & Carpet Co., 216 Grand st.  
**Haverstraw**—F. E. Newman, Broadway.  
**Hobart**—F. H. Marshall.  
**New York City**—A. T. Armstrong, or American Phono Co., 106 Wall st.  
 Automatic Zither Co., M. Cohen, Prop., 58 Second ave.  
 Bern Bearwald, 373 W. 11th st.  
 Edward Bielfeld, 481 Willis ave.  
 I. & S. Birnswieg, Birnswieg's Music Store, and Birn's Music Store, 510 E. 138th st.  
 Bronx Phono. Co., or David Switky, 506 Willis ave.  
 R. L. Corwin; also Newark, N. J.  
 Eagle Phono. Co., or C. Lowenthal, 83 Nassau st.  
 Empire Phono. Co., 2 W. 14th st.  
 S. W. Frucht, or R. Frucht, 7 Barclay st., or 68 Cortlandt st., also Plainfield, N. J.  
 O. Hacker, 2 Murray st.  
 Hawthorne & Sheble, 297 Broadway; also Philadelphia, Pa.  
 Holober Bros., 350, 421 and 491 West st.  
 N. Horn, 148 E. 58th st.  
 W. L. Isaacs, 114 Fulton st.  
 Italo-American Phono. Co. (R. Gerard & Co.)  
 S. Lemburg & Co., 194 Broadway.  
 J. McEllyne, 202 Broadway.  
 Parker & Cooley, 2087 Amsterdam ave.  
 Richmond Pease, 44 W. 132d st.  
 F. M. Prescott, 44 Broad st.  
 Winthrop Cycle Co., 2212 Seventh av.  
**Oneonta**—G. B. Shearer Co., 259-261 Main St.  
**Rome**—Charles Tuttle.  
**Saratoga Springs**—Marvin A. Cote.  
**Watertown**—H. S. Wardwell & Co., 39 Public Square.  
**Wayland**—John Gross, Pursel Block.

### NORTH CAROLINA.

**Kinston**—S. A. Quinerly.

### NORTH DAKOTA.

**Fargo**—Ben Hart.

### OHIO.

**Ashtabula Harbor**—Chas. W. Askew (Gregory, Askew & Co.).  
**Bellevue**—H. E. Rouser.  
**Brookville**—H. K. Merritt.  
**Cincinnati**—J. L. Andem.  
**Coshocton**—Burns & Gosser.  
**Dayton**—W. E. Sapp, 1042 W. Third st.  
**Hicksville**—W. R. Holden Co.  
**Springfield**—D. & M. Vanderpool.  
**Uhrichsville**—F. A. Mazurie.

### PENNSYLVANIA.

**Athens**—J. T. Stalford, 405 Main st.  
**Bradford**—C. C. Griffen, 29 N. Washington st.  
**Lancaster**—J. H. Tragger, 249 N. Queen st.  
**\*Lock Haven**—Floyd Gallery, H. W. Swope, Prop., 131 Main st.  
**Mt. Pleasant**—Benjamin Posner.  
**New Castle**—Will Hartland, 70 E. Long st.  
**Philadelphia**—A. R. Cassidy, 2783 Emerald st.  
 Wm. Dyer, 321 Queen st.  
 Thomas Gunson, 1003 Carpenter st.  
 Hawthorne & Sheble, 604 Chestnut st., or Oxford and Mascher sts.; also New York City.  
 A. Krouse, 832 Arch st.  
 Geo. W. Lowden, or Geo. W. Lowden, Prop. Pioneer Studio of Music, 2616 Frankford ave.  
 Penn Novelty Co., 15 South 9th st.  
**Pittsburg**—A. Lippard, 615 Wylie ave.  
**Royersford**—Granville B. Tyson, 215 Main st.  
**Titusville**—E. H. Fortney, Prop. Exchange Cigar Store, 21 W. Central ave.

### RHODE ISLAND.

**Providence**—E. H. Gainsbury, 59 Plainfield st.  
 F. P. Moore.  
 M. Steinert & Sons Co., Westminster st.  
 also Fitchburg, Pittsfield, Mass., and at all points.  
**Rockville Center**—O. A. Clark.

### TENNESSEE.

**Alexandria**—Clarence D. Baird Music Concern.

### TEXAS.

**Whitney**—H. E. Randle & Co.

### UTAH.

**Salt Lake City**—Daynes Romney Music Co., 25 East South 1st st.

### VERMONT.

**Barre**—Averill Music Co. (H. L. Averill & Co.), 28 N. Main st.

### VIRGINIA.

**Norfolk**—W. Reichenstein, 296 Church st.

### WISCONSIN.

**Ashland**—J. F. Pool Co.  
**Milwaukee**—J. C. Blatzek.  
**Reedsburg**—Fish & Greenwood.  
**Walworth**—G. H. Stewart.

\*Added since March 1st, 1908.

Jobbers and Dealers are asked not to supply any of the above named firms with our apparatus, either at addresses given or any other address.

# The EDISON PHONOGRAPH

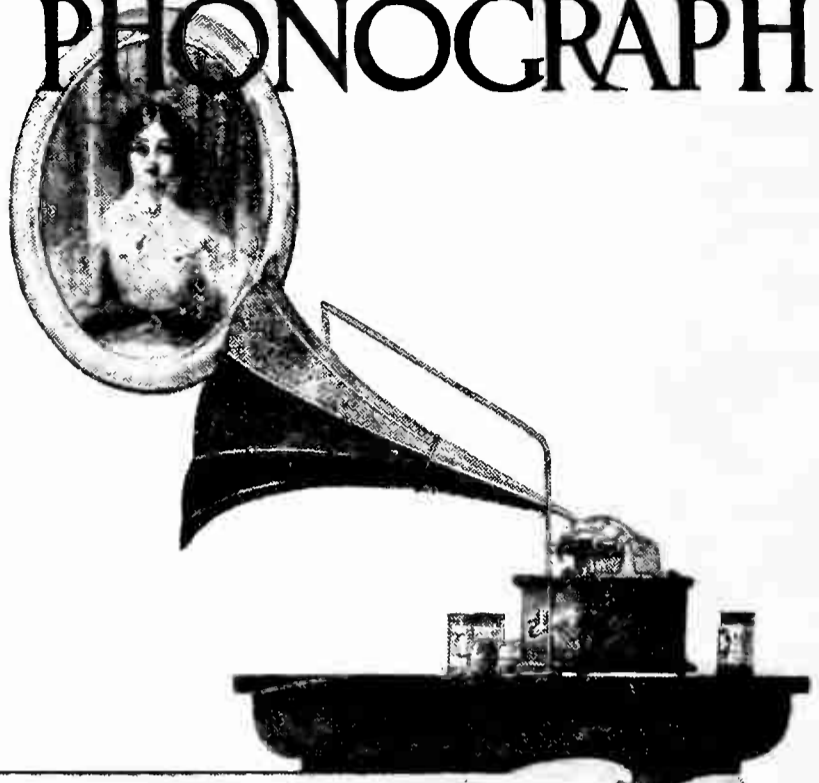

1858 THEIR WEDDING MARCH 1908

**S**OME music never grows old, particularly if it recalls pleasant memories. The Edison Phonograph can reproduce for you the marches, ballads and airs that stirred you in the old days, just as well as it can sing the song that is the current hit in the metropolis, doing it with a clearness, a fidelity and a beauty and volume of sound that is not to be found in any similar instrument.

The Edison Phonograph is all things to all men at all times. Simply by changing a Record it may be a brass band at one moment and a violin virtuoso the next, a singer of ragtime or of grand opera, a funny vaudeville team or a quartette singing a sentimental ballad.

If you haven't heard the Phonograph lately, you'll be surprised at the wonderful improvement in the new model Edison with the big horn. Ask your dealer to show it to you or send to us for booklet describing it.

## On March 25th go to the nearest Edison Store and hear the April Records

The April list of twenty-four new Records is made up of the choicest bits of vocal and instrumental music recently produced together with a sprinkling of things not new but good. These Records have been made by the best procurable talent with a skill and artistic finish that



TRADE MARK

Thomas A. Edison

assure you rare pleasure in listening to them. And if you hear the April Records you'll buy—there's no doubt of that.

Ask your dealer or write to us for THE PHONOGRAM, describing each Record in detail; THE SUPPLEMENTAL CATALOGUE, listing the new April Records; THE COMPLETE CATALOGUE, listing all Edison Records in existence. Records in all foreign languages.

NATIONAL PHONOGRAPH COMPANY, 24 Lakeside Ave., Orange, N. J.

APRIL MAGAZINE ADVERTISEMENT



# Jobbers of Edison Phonographs and Records

Continued from page 2 of Cover

## NEW YORK.

**Albany**—Finch & Hahn, 402 Broadway.  
**Astoria**—John Rose, 99 Flushing ave.  
**Brooklyn**—A. D. Matthews' Sons, 894 Fulton st.  
**Buffalo**—W. D. Andrews, Seneca and Wells sts.  
Neal, Clark & Neal Co., 645 Main st.  
**Elmira**—Elmira Arms Co., 117 Main st.  
**Gloversville**—American Phono. Co., 99 W. Fulton st.  
**Kingston**—Forsyth & Davis, 307 Wall st.  
**New York City**—Blackman Talking Machine Co., 97 Chambers st.  
J. F. Blackman & Son, 2737 3d ave.  
I. Davega, Jr., Inc., 125 W. 125th st.  
S. B. Davega & Co., 32 E. 14th st.  
Douglas Phono. Co., Inc., 89 Chambers st.  
Jacot Music Box Co., 39 Union square.  
Victor H. Rapke, 1659 Second ave.  
Regina Co., 41 Union square.  
Siegel-Cooper Co., 6th ave. and 18th st.  
John Wanamaker, Broadway, 8th and 9th sts.  
Alfred Weiss, 1622 First ave.  
**Oswego**—Frank E. Bolway, 32 W. Bridge st.  
**Rochester**—A. J. Deninger, 345 North st.  
Mackie Piano, O. & M. Co., 100 State st.  
Talking Machine Co., 97 Main st., E.  
**Schenectady**—Finch & Hahn, 504 State st.  
Jay A. Rickard & Co., 253 State st.  
**Syracuse**—W. D. Andrews, 216 E. Railroad st.  
**Troy**—Finch & Hahn, 3 Third st.  
**Utica**—Clark-Horrocks Co., 54 Genesee st.  
Arthur F. Ferriss, 89 Washington st.  
William Harrison, 50 Columbia st.  
Utica Cycle Co., 16 Columbia st.

## OHIO.

**Canton**—Klein & Heffelman Co., 220 E. Tuscarawas st.  
**Cincinnati**—Ball-Fintze Co., 108 West 3d st.  
Ilsen & Co., 615 Vine st.  
Lawrence McGreal, 29 East 5th st.  
Rudolph Wurlitzer Co., 121 East 4th st.  
**Cleveland**—Eclipse Musical Co., 1870 East Ninth st.  
**Columbus**—Perry B. Whitsit Co., 213 S. High st.  
**Dayton**—Niehaus & Dohse, 35 E. 5th st.  
**Newark**—Ball-Fintze Co.  
**Toledo**—Hayes Music Co., 422 Superior st.

## OREGON.

**Portland**—Graves & Co., Inc., 65 No. Park st.

## OKLAHOMA.

**Oklahoma City**—Smith's Phono. Co., 818 West Main st.

## PENNSYLVANIA.

**Allentown**—G. C. Aschbach, 539 Hamilton st.  
**Easton**—William Werner, 432 Northampton st.  
**Harrisburg**—S. K. Hamburger, 12-14 N. Market square.  
**Philadelphia**—Louis Buehn & Bro., 45 N. 9th st.  
C. J. Heppe & Son, 1117 Chestnut st.  
Lit Bros., Market and 8th sts.  
Musical Echo Co., 1217 Chestnut st.  
Penn Phonograph Co., 17 S. 9th st.  
John Wanamaker, 13th and Market sts.  
Western Talking Mach. Co., 41 and 43 N. 9th st.  
H. A. Weymann & Son, 1010 Chestnut st.

## Pennsylvania—Continued.

**Pittsburg**—Pittsburg Phono. Co., 937 Liberty ave.  
Powers & Henry Co., 339 Second ave.  
Standard Talk. Mach. Co., 435 Wood st.  
**Reading**—Reading Phonograph Co., 48 N. 8th st.  
**Scranton**—Ackerman & Co., 217 Wyoming av.  
Technical Supply Co.  
**Sharon**—W. C. DeForest & Son.  
**Williamsport**—W. A. Myers, 127-129 W. 3d st.

## RHODE ISLAND.

**Providence**—J. M. Dean Co., 785-795 Westminister st.  
J. A. Foster Co., Weybosset and Dorrance sts.  
J. Samuels & Bro., 154 Weybosset st.

## TENNESSEE.

**Chattanooga**—J. H. Templeman Co., 253 Montgomery ave.  
**Knoxville**—Knoxville Typewriter and Phonograph Co., 421 Gay st.  
**Memphis**—F. M. Atwood, 160 N. Main st.  
O. K. Houck Piano Co., 103 S. Main st.  
**Nashville**—Magruder & Co., 27 Arcade.  
Nashville Talking Mach. Co., 723 Church st.

## TEXAS.

**Dallas**—Southern Talking Machine Co., 347 Main st.  
**El Paso**—W. G. Walz Co., 101 El Paso st.  
**Fort Worth**—Cummings, Shepherd & Co., 700 Houston st.  
**Houston**—Texas Piano & Phono. Co., 1019 Capitol ave.  
**San Antonio**—H. C. Rees Optical Co., 242 West Commerce st.

## UTAH.

**Ogden**—Proudfit Sporting Goods Co., 351 24th st.  
**Salt Lake City**—Clayton Music Co., 109 S. Main st.

## VERMONT.

**Burlington**—American Phono. Co., 34 Church st.

## VIRGINIA.

**Richmond**—C. B. Haynes & Co., 603 E. Main st.

## WASHINGTON.

**Seattle**—D. S. Johnston Co., Third ave. and University st.  
Kohler & Chase, 710 Pike st.  
**Spokane**—Spokane Phonograph Co., 7 Post st.

## WISCONSIN.

**Milwaukee**—Lawrence McGreal, 176 3d st.

## CANADA.

**Quebec**—C. Robitaille, 320 Rue St. Joseph.  
**St. John**—W. H. Thorne & Co., Ltd., 42-46 Prince William st.  
**Toronto**—R. S. Williams & Sons Co., Limited, 143 Yonge st.  
**Vancouver**—M. W. Waitt & Co., 558 Granville st.  
**Winnipeg**—R. S. Williams & Sons Co., Ltd., 121 Princess st.

# In the Words of Others

## "Sell I.C.S. Language Outfits"

The best proof that it will pay you to sell I. C. S. Language Outfits comes from the statement of dealers that have tried them. We have published several of these letters before; here is another one from the Denver

Dry Goods Co. This is piling up evidence that you are losing profits of from 10 to 30 per cent. on your business if you are not handling these Outfits. The phonograph system is fast becoming recognized as the most perfect way in the world to teach foreign languages. As a commercial enterprise, the I.C.S. System has always paid dealers well in the past, and it is growing very rapidly. Wouldn't it be a good idea for you



**THE DENVER DRY GOODS CO.**

Denver, Colo. 11/23/25

International Correspondence Schools,  
Scranton, Pa.

Gentlemen:

In reply to your letter of the 17th inst., will say we considered the demonstration of Mr. Mistraud very successful and while he was here we sold several Language Outfits. We have also sold some since he left us. We expect to advertise these Language Outfits during December as gifts as you may rest assured we will communicate with the parties to whom demonstration was given and who have not as yet made a purchase. We think the plan of advertising or demonstrating these Outfits is successful and leads to sales which could not be obtained otherwise.

We have placed several orders with you since the demonstration and would like to know if we could make arrangements to purchase whatever we need in this line through your Denver office as we have had to do several times recently; same can be billed to us by you. This would be quite an accommodation to us.

We will keep you advised from time to time of the results of sales on I. C. S. Language Outfits.

Yours very truly,

THE DENVER DRY GOODS CO.,

per *A. Schull*

to write us today for full particulars of what we can do for you? Let us put our advertising to work for you. It will not only bring you customers for language work, but will increase your regular business. Send us a postal card NOW.

**International Correspondence Schools**

SCRANTON, PA.

# EDISON PHONO- GRAPH MONTHLY

Vol. VI

May, 1908

No. 5

## CONTENTS

	PAGE.		PAGE.
Loosen Up.....	1	Personal .....	9
An Absurd Claim.....	1	Binder for Phonograph Monthly.....	9
Advance List of New Edison Records for July .....	2	Tray System and Larger Record Stocks....	10
Advance List of Edison Grand Opera Rec- ords, Supplement No. 10.....	5	Printed Matter.....	11
Trade Information for Dealers.....	6	May Advertising.....	11
Advance List of New German, Polish and Swedish Selections.....	7	Copyright Legislation.....	12
Stock Up and Advertise.....	8	The New Phonogram.....	12
Among the Jobbers.....	8	Will Tell Story by Phonograph.....	13
London Office Removal.....	9	Our Buenos Aires Branch.....	14
Idelia Reproducers and Recorders.....	9	Window Dressing.....	15
		Ready Made Ads.....	16
		Suspended List for May, 1908.....	18
		Jobbers of Edison Phonographs and Records, Cover pp. 2 & 3	

*Published for Trade use only by  
The National Phonograph Co., Orange, N.J.*

# Jobbers of Edison Phonographs and Records

## ALABAMA.

**Birmingham**—Talking Machine Co., 2007 Second ave.  
**Mobile**—W. H. Reynolds, 167 Dauphin st.  
**Montgomery**—R. L. Penick, 119 Dexter ave.

## ARKANSAS.

\***Fort Worth**—R. C. Bollinger, 704 Garrison Ave.

## CALIFORNIA.

**Los Angeles**—Southern California Music Co., 332 South Broadway.  
**Oakland**—Kohler & Chase, Inc., 917-921 Wood st.  
**Sacramento**—A. J. Pommer Co., 9th and J sts.  
**San Francisco**—P. Bacigalupi & Sons, 1021 Golden Gate Ave.

## COLORADO.

**Denver**—Denver Dry Goods Co., 619 16th st.  
Hext Music Co., 15th and California sts.

## CONNECTICUT.

**New Haven**—Pardee-Ellenberger Co., Inc., 96 State st.

## DISTRICT OF COLUMBIA.

**Washington**—E. F. Droop & Sons Co., 925 Pennsylvania ave., N. W.

## GEORGIA.

**Atlanta**—Atlanta Phonograph Co., 10 Walton st.  
Phillips & Crew Co., 37-39 Peachtree st.  
**Waycross**—George R. Youmans.

## IDAHO.

**Boise**—Eller's Piano House.

## ILLINOIS.

**Chicago**—Babson Bros., 1419 19th st.  
Lyon & Healy, Wabash ave. & Adams st.  
James I. Lyons, 192 Van Buren st.  
The Vim Co., 68 E. Lake st.  
Montgomery Ward & Co., 111 Michigan ave.  
Rudolph Wurlitzer Co., 266 Wabash ave.  
**Peoria**—Chas. C. Adams & Co., 324 South Adams st.  
Peoria Phonograph Co., 416 S. Adams st.  
**Quincy**—Quincy Phonograph Co., 411 Hampshire st.

## INDIANA.

**Indianapolis**—Indiana Phono. Co., 45 Virginia ave.  
Kipp-Link Phonograph Co., 10-12 E. Washington st.  
A. B. Wahl & Co., 119 S. Illinois st.

## IOWA.

**Des Moines**—Hopkins Bros. Co., 620 Locust st.  
The Vim Co., 204 Seventh st.  
**Dubuque**—Harger & Blish, 904 Main st.  
**Fert Dodge**—Early Music House, 822 Central ave.  
**Sioux City**—Early Music House, 315 Court st.

## KENTUCKY.

**Louisville**—Montenegro-Riehm Music Co., 630 4th ave.

## LOUISIANA.

**New Orleans**—William Bailey, 600 Frenchman st.  
National Automatic Fire Alarm Co., 614 Gravier st.

## MAINE.

**Bangor**—S. L. Crosby Co., 186 Exchange st.  
**Portland**—W. H. Ross & Son, 43 Exchange st.

## MARYLAND.

**Baltimore**—E. F. Droop & Sons Co., 231 North Howard st.

## MASSACHUSETTS.

**Boston**—Boston Cycle & Sundry Co., 48 Hanover st.  
Eastern Talking Mach. Co., 177 Tremont st.  
Iver Johnson Sptg. Goods Co., 163 Washington st.  
**Fitchburg**—Iver Johnson Sptg. Goods Co., 247 Main st.  
**Lowell**—Thomas Wardell, 111 Central st.  
**New Bedford**—Household Furnishing Co., 170 Purchase st.  
**Springfield**—Flint & Brickett Co., 439 Main st.  
**Worcester**—Iver Johnson Sptg. Goods Co., 304 Main st.

## MICHIGAN.

**Detroit**—American Phono. Co., 106 Woodward ave.  
Grinnell Bros., 219 Woodward ave.

## MINNESOTA.

**Minneapolis**—Thomas C. Hough, 714 Hennepin ave.  
Minnesota Phono. Co., 505 Washington ave., So.  
**St. Paul**—W. J. Dyer & Bro., 21-23 West 5th st.  
Thomas C. Hough, 392 Wabasha st.  
Koehler & Hinrichs, 255 E. 2d st.  
Minnesota Phonograph Co., 37 E. 7th st.

## MISSOURI.

**Kansas City**—J. W. Jenkins' Sons Music Co., 1013-1015 Walnut st.  
Schmeizer Arms Co., 710 Main st.  
**St. Louis**—Conroy Piano Co., 11th and Olive sts.  
Koerber-Brenner Music Co., 1006 Olive st.  
Silverstone Talk. Mach. Co., 1010 Olive st.

## MONTANA.

**Helena**—Frank Buser, 509 N. Main st.

## NEBRASKA.

**Lincoln**—Ross P. Curtice Co., 1125 O st.  
H. E. Sidles Phono. Co., 13th and P sts.  
**Omaha**—Nebraska Cycle Co., 15th and Harney sts.  
Shultz Bros., 16th and Chicago sts.

## NEW HAMPSHIRE.

**Manchester**—John B. Varick Co., Varick Bldg.

## NEW JERSEY.

**Hoboken**—Eclipse Phono. Co., 203 Washington st.  
**Newark**—Douglas Phonograph Co., 20 New st.  
A. O. Petit, 57 Halsey st.  
Rapke Phono. Store, 287 Bank st.  
**Paterson**—James K. O'Dea, 117 Ellison st.  
**Trenton**—Stoll Blank Book and Stationery Co., 30 E. State st.  
John Sykes, 105 N. Broad st.

Continued on page 3 of cover

# Edison Phonograph Monthly

VOL. VI.

May, 1908

No. 5

## Loosen Up

If we should ask every Edison Jobber and Dealer to raise his right hand to the question: "Are you to-day making the same effort to get business that you did six months ago?" we doubt if one in a hundred would put up his hand. Fully nine-tenths would frankly admit that they were not doing so and would defend their position with the claim that business did not warrant their making the effort or spending the money. This is one of the great drawbacks of quiet times. When everything is booming and everybody is doing a big business, every firm of any life advertises, circularizes and adopts every known method for getting business. The more they have the more they want. Their efforts add to the work of printers, salesmen, solicitors and scores of people in other lines. Those in other lines then come back and buy Phonographs and Records. It's a case of "tickle me and I'll tickle you."

But let something happen to business generally and everybody instinctively lets up in his efforts. Advertising of all kinds is cut down, salesmen are withdrawn and retrenchment becomes the cry. Many times this is done before a firm's business shows any signs of being affected and apparently only in obedience to a cry of "wolf." Clerks get the germ and use it as an excuse for relaxed efforts. The natural result of such a state of affairs is to make business poorer and times harder. The tickling game once stopped, the volume of everyone's business suffers. Those who have ready money hold on to it like grim death, fearful that it will not return if once spent.

Business to-day needs nothing but a loosening up on all sides. Edison Jobbers and Dealers can do their part by patronizing the printer, the newspaper publisher, by putting men on the road and doing all the things they did six months ago. It may seem unprofitable for a short time, but the printer will put more men at work, the newspaper publisher will extend his

efforts, the families of salesmen will have more money to spend and before long the wheels of business will hum as merrily as ever. Put your shoulder to the great business wheel and do your part in making it go round. Don't lie down, crying: "It's no use." That is not the part of the up-to-date American business man.

## An Absurd Claim

Our attention has been called to the fact that the traveling salesmen from a competing company are making the statement that the reason for the difference in price between their Records and ours, is due to the fact that we are compelled to pay them a heavy royalty.

This statement is so absurd on the face of it, that we have never paid any attention to the matter, but in order that the trade may be fully posted on the situation, we need only say that the report is absolutely false and without any foundation, and that the difference in price between the Edison Records and those supplied by our competitors, is due to the care with which our Records are made, the special quality of materials used, and the high character of labor employed, all of which make it necessary for us to obtain a higher price for our goods.

## Orders for No. 8591 Held Up

We have no more moulds or masters at present of Record No. 8591, "Come Ye Disconsolate," mandolin solo, by Samuel Siegel. It is expected that we will be able to secure Mr. Siegel some time during the month to make over this selection, and that we will again be in a position to fill orders about the middle of June. In the meantime we ask the indulgence of Jobbers who have orders on file for this selection.

Now is the time to sell Phonographs to people going to the country for the summer. They cannot take their piano and as they want music even in summer, what better substitute can they get than an Edison Phonograph.

## Advance List of New Edison Records for July, 1908

**R**ECORDS listed below will be shipped from Orange in time to reach all Jobbers in the United States and Canada before June 25th, 1908, all things being favorable, and they may be reshipped to Dealers at 2 P. M. on June 24th. They must not, however, be exhibited, demonstrated or placed on sale by Jobbers or Dealers until 8 A. M. on June 25th. Supplements, Phonograms and Bulletins will be shipped with Records. These may be distributed to Dealers after June 20th, but must not be circulated among the public before June 25th. Jobbers and Dealers may, however, deposit Supplements and Phonograms in Mail Boxes or Post Offices after 5 P. M. on June 24th, for delivery on the following day. Jobbers are required to place orders for July Records on or before May 10th. Dealers should place July orders with Jobbers before May 10th to insure prompt shipment when Jobber's stock is received.

**9866 Polish Dance, No. 1** **Edison Concert Band**

A famous composition by a famous composer and known the world over. Our Record gives a true interpretation of the grace, gay abandon and fire of this national dance of Poland. It is played in mazurka tempo. Composer, X. Scharwenka; publisher, Carl Fischer, New York.

**9867 Needles and Pins** **Edward M. Favor**

In three verses and three choruses the old saying, "Needles and pins, when a man marries his troubles begins," is made the subject of a funny travesty on married life, beginning with the little hen-pecked man who wrote "No Wedding Bells for Me," and ending with Yankee fathers who sell their daughters to the highest bidder among the dukes and counts and earls. Each chorus includes a phrase from the "Bridal Chorus." Orchestra accompaniment. Music, J. Fred Helf; words, Edward Moran; publishers, Helf & Hager Co., New York.

**9868 Tell Me the Old, Old Story** **Anthony and Harrison**

Few gospel hymns are better known or more popular than this selection by W. H. Doane. Many hymns have been written by Mr. Doane, but it is doubtful if any of them have more admirers than "Tell Me the Old, Old Story." The words were written by Miss. Kate Hankey. The singers are accompanied by the orchestra.

**9869 Cupid's Wedding March** **Albert Benzler**

A bells solo of one of the songs featured in "Playing the Ponies." It is a charming, simple melody, particularly well adapted for a bells solo. The arrangement includes a phrase from the Bridal March from "Loheñgrin," effectively played on the chimes. Composer, Theodore Morse; publisher, F. B. Haviland, New York.

**9870 O'Brien Has No Place to Go** **Edward Meeker**

O'Brien is the father of three pretty daughters of marriageable age. Each has a "steady," and not infrequently they all call at the same time. Then Nellie goes to Dad with this plea:

Don't go into the front room, Dad,  
Nancy's in there with a caller.  
Daddy, dear, won't you stay out here,  
Rose has her friend in the parlor.

Don't go into the kitchen, dad.  
I'll be out there with my beau.  
Since each of his girls has a steady young man,  
Sure, O'Brien has no place to go.

But one night O'Brien came home tight and did the turning act of the proverbial worm. When things had quieted down the three young men were on the street, much the worse for "Daddy's" persuasive methods and O'Brien had changed the title of the song. Orchestra accompaniment. Music, George Evans; words, Stanley Murphy; publisher, Jerome H. Remick & Co., New York.

**9871 Whistling and Singing Farmer Boys** **Harlan and Belmont**

An amusing combination of whistling and singing, together with a lively and realistic rural scene between the farmer and his "boys." The chorus is the well-known song about the farmer who had a dog named "Bingo." The Record is one of unusual attractiveness and certain to be popular. Mr. Belmont's whistling is clever, as usual. Orchestra accompaniment. Words, Joe Fulton; arrangement is special and not published.

**9872 Smarty**

Ada Jones

What grown-up cannot look back to his or her childhood days and recall the chorus of this song as follows:

Smarty, Smarty, Smarty, thought you had a party,  
Don't forget what the teacher taught,  
You'll be sorry if you get caught,  
I'm goin' to tell your mother,

Just see if you don't care,  
You're nothing but a smarty cat,  
So there, there, there.

Miss Jones cleverly adds to the realism of the song by singing it in the childish accents of a five-year-old. Orchestra accompaniment. Music, Albert Von Tilzer; words, Jack Norworth; publishers, York Music Co., New York.

**9873 Fawn Eyes**

Edison Symphony Orchestra

A new selection by the composer of "Iola," (our Record No. 9417). It is graceful in theme and has all of those characteristics familiar to admirers of recent popular Indian songs. Composer, Charles L. Johnson; publishers, Charles L. Johnson & Co., Kansas City, Mo.

**\*9874 Parson Jones' Three Reasons**

Arthur Collins

Parson Jones is about to leave his congregation. In consequence of a notice given out the week before, the church is crowded to hear his three reasons for leaving. They are given in the chorus:

Firstly, there ain't no love in this congregation.  
I haven't tied a knot since I've been here;  
Secondly, you all don't love your pastor,  
Ain't had a cent of sal'ry in a year,

And thirdly, I done accepted a call  
As chaplain of the pen'tentiary,  
And I go to prepare a place for you all.

The parson also makes an address between the first and second verses. Orchestra accompaniment. Music and words, Arthur Longbrake, (writer of "Brother Noah Gave Out Checks for Rain," our Record No. 9642); publisher, Joe Morris, Philadelphia.

**9875 When We Are M-A-Double-R-I-E-D**

Ada Jones and Billy Murray

This unique spelling duet is one of the successful songs in "The Talk of New York," in which it is sung by Nella Bergen and Jack Gardenier. The love passages between the happy pair as sung in the chorus are particularly original. A witty dialogue follows the first chorus. Music and words, George M. Cohan; publisher, F. A. Mills, New York.

**9876 Queen of the Earth**

Alan Turner

An old standard song very much admired by vocalists who cater to audiences that enjoy music of the higher grade. Mr. Turner's rendition is that of the true artist. Orchestra accompaniment; music, Ciro Pinsuti; writer of words unknown; publishers, Oliver Ditson Co., Boston.

**9877 Whistling—Intermezzo**

Edison Military Band

An intermezzo full of bright and catchy melody, introducing a chorus of whistlers, who assist in emphasizing the principal theme. The whistling feature is a decided novelty in band Records. It will make the selection a pleasing and popular number. Composer, Leon Copeland; publisher, L. J. Scovelle, Milwaukee, Wis.

**9878 You Have Changed the Winter in My Heart to Glad Spring-Time**

Manuel Romain

The title of this song leaves little to tell concerning its character or its sentiment, just as the fact that it is sung by Mr. Romain leaves nothing to say about its attractiveness as a ballad Record. After listening to the Edison Records made by Mr. Romain it is not hard to see why he was so popular as a member of Dockstader's Minstrels. Orchestra accompaniment. Music and words, Jean Havez; publishers, Helf & Hager Co., New York.

**9879 When the Roll is Called Up Yonder**

Edison Mixed Quartette

Another well known sacred hymn reverently and splendidly rendered by our Mixed Quartette. Messrs. Anthony and Harrison sing the verses as a duet and the quartette join in the refrain. This makes a new combination of duet and mixed quartette. Orchestra accompaniment. Music and words, J. M. Black; published in hymn books.

**9880 I Was a Hero, Too**

Billy Murray

Sam Bernard's big success in the musical comedy "Nearly a Hero." It defines in witty verse and chorus just when a man is really a hero. One of the occasions was when he was compelled to eat a mince pie made by his wife. The song tells of several other times, all combining to make the Record desirable from the comedy standpoint. You get every word, too, when Mr. Murray sings. Orchestra accompaniment. Music, Egbert Van Alstyne; words, Harry Williams; publishers, Jerome H. Remick & Co., New York.

**9881 Medley of Irish Jigs**

John Kimble

An accordion solo of a number of well known Irish jig airs. The large and steady sale of Mr. Kimble's Records shows how popular the accordion is throughout the country. This selection is made with a piano accompaniment as usual, bands and orchestra accompaniments serving to confuse the peculiar melody of the accordion. Original and not published.

**9882 Topeka**

Frederick H. Potter and Chorus

A spirited song descriptive of Indian life on the plains and telling of the love of an Indian brave for his little maid Topeka. The chorus:

\*This selection will be illustrated on cover of the July *Phonogram*.

My own Topeka, I've come to seek her,  
Who'll be forever, my hope and pride,  
You'll be that one dear.

If you'll become, dear,  
My own Topeka, my sunflower bride.

Indian yells, tom-toms, bells and the quartette chorus are other features of this selection. Orchestra accompaniment. Music, Henry W. Jones; words, James O'Dea; publishers, Jerome H. Remick & Co., New York.

### 9883 Nothing Hardly Ever Bothers Me

Collins and Harlan

A jolly coon duet, full of mirth and laughter. This happy dusky couple never borrowed trouble and considered life "one big jubilee." Their motto was "Be cheerful while you may." When they died they expected to be dead quite a while, so while they lived they were going to laugh and smile. The music is of a typical rag-time character. Orchestra accompaniment. Music, Albert Von Tilzer; words, Jack Norworth; publishers, York Music Co., New York.

### 9884 If I Had a Thousand Lives to Live

Allen Waterous

A new song of high merit, full of deep sentiment and splendid melody. Rendered with true feeling and artistic finish. It will appeal to lovers of the better class of songs. The chorus:

If I had a thousand lives to live,  
I'd live each one for you!  
If I had a thousand hearts to give,  
I'd give each one to you!

A thousand sorrows I would bear,  
For one so fair, so true,  
If I had a thousand lives to live,  
I'd live each one for you!

Orchestra accompaniment. Music, Alfred Solman; words, Sylvester Maguire; publishers, Joseph W. Stern & Co., New York.

### 9885 The Rose of Mexico Waltz

Edison Symphony Orchestra

A typical Spanish waltz, fascinating in its dreamy rhythm. The principal theme is each time played by the mandolin, its dulcet tones adding to the charm of the Record. Composer, John J. Dunn; publishers, T. B. Harms & Co., New York.

### 9886 Common Sense

Bob Roberts

Another song hit by the writers of "He's a Cousin of Mine," (our Record No. 9412). Jim Green was a Tennessee coon, who was credited with being the bravest man in town. One day the circus came to town and Jim was offered one hundred dollars to lead the lion around. Jim declined, declaring that one hundred dollars wouldn't be of much use to him after his death. His chief reason for declining was because he had too much common sense. Jim thought it would be fine to go to war and fight. But one day on the battle field Jim could not be found. He sent the captain a note, however, stating that a soldier's life was too much like flirting with the undertaker to suit him, so his common sense compelled him to refuse to become a target for the enemy. Orchestra accompaniment. Music and words, Chris. Smith and John Larkins; publishers, Thompson Music Co., New York.

### 9887 The Frisky Farmer and the Modest Manicure

Ada Jones and Len Spencer

A vaudeville sketch which opens with a scene in a barber shop. The fun begins there: After the Irishman (who is slightly under the influence) has been tonsorially and electrically treated, the frisky farmer enters. He is at once taken in charge by the modest mercenary manicure, who proceeds to trim his nails and likewise his purse. The dialogue between the farmer and the manicure is extremely witty and the sketch concludes with Miss Jones singing "The Modest Manicure," a song from "The Hurdy Gurdy Girl." Orchestra accompaniment.

### 9888 "He" and "She" in Vaudeville

Steve Porter

"He" and "She" are two Irish characters in vaudeville. They are married and their stunt is to stand before the audience and abuse each other. Mr. Porter enacts both parts. "He" begins with a song to the effect that he is the bravest man in town. "She" butts in and asks

"What brave thing did you ever do?"  
"I prevented you from dying an old maid, didn't I?"

Then follows an exchange of complimentary remarks of which these are samples:

She: Say, you promised to give me a quarter of your salary every week.

He: Well, what did I give you?

She: Twenty-five cents.

He: Well, that's a quarter ain't it?

She: Everyone knows that you married me for money.

He: Well, it was the only way I could get it.

She: Is that so?

He: Niver moind, darlin', I know a man that would give tin thousand dollars to see you.

She: Who is he?

He: A bloind man.

She: Mebbe I'm not good lookin', but I dress out o' sight.

He: Well, that's the proper place to dress. Say, I'm goin' to celebrate me golden weddin' tomorrow.

She: We've only been married a year; not fifty.

He: Well, it seems that long.

The sketch is original for our Record and not published.

### 9889 Cubs on Parade March

Edison Military Band

A new and spirited march, full of stirring strains and military dash. It is dedicated to the Chicago National League Baseball team. Like these champions, it is a sure winner. Composer, H. R. Hempel; publisher, Tomaz F. Deuther, Chicago.



## Advance List of Edison Grand Opera Records Supplement Number 10, July, 1908

**R**ECORDS listed below will be shipped from Orange in time to reach all Jobbers in the United States and Canada before June 25th, 1908, all things being favorable, and they may be reshipped to Dealers at 2 P. M. on June 24th. They must not, however, be exhibited, demonstrated or placed on sale by Jobbers or Dealers until 8 A. M. on June 25th. Supplements will be shipped with Records *when ordered*. These may be distributed to Dealers after June 20th, but must not be circulated among the public before June 25th. Jobbers are required to place orders for these Grand Opera Records on or before May 10th. Dealers should place Grand Opera orders with Jobbers before May 10th, to insure prompt shipment when Jobber's stock is received.

**B. 65 Eri tu, ("And would'st thou") "Un Ballo in Maschera" Verdi**

By ANTONIO SCOTTI, Baritone. Sung in Italian, Orchestra Accompaniment

Verdi's opera "Un Ballo in Maschera"—"The Masked Ball" scored one of the big successes of this composer's artistic career. Its first performance occurred in Rome, in 1859. It deals with the love of *Riccardo*, Earl of Warwick and Governor of Boston, for *Amelia*, wife of his secretary *Renato*. Conspirators plot to take the life of *Riccardo*, and when *Renato* discovers that the Governor is in love with *Amelia*, he—*Renato*—joins them and is chosen as the one to assassinate *Riccardo*. The final scene is a masked ball. The love between *Riccardo* and *Amelia* being an innocent one, the two had chosen to meet at this ball and bid each other eternal farewell; but the jealous husband *Rebato* penetrates the disguise of *Riccardo* and stabs him to death. The present aria is sung by *Renato*, near the beginning of the third act. He has accused his wife *Amelia* of infidelity and then, alone, he ruminates upon the perfidy of his friend *Riccardo*, and he pours forth his woe in this aria, the text of which begins: "And would'st thou thus have sullied a soul so pure, in whose chasteness my spirit delighted!" It is an appealing, dramatic moment of the opera.

**B. 66 Stride la vampa, ("Fierce flames were raging") "Il Trovatore" Verdi**

By MME. JACOBY, Contralto. Sung in Italian, Orchestra Accompaniment

The story and music of "Il Trovatore" are too familiar to need any particular introduction, so there remains but to be pointed out the dramatic circumstances attending this canzone. It occurs as the second number of the second act, coming immediately after the familiar "Anvil Chorus". The scene is that of a gypsy camp in the mountains of Biscaya. *Azucena* sings this song to the gypsies obviously in order to paint the gloom of the gypsy's life, but in reality it is a word picture of the death of her mother who was burned at the stake. The words begin: "Fierce flames are raging, loud clamor fills the air, mad crowds rush forward, eager for horrors." The melody of this canzone is one of the best beloved in the entire score, its frank tunefulness not having lost its charm with years.

**B. 67 Sono un poeta, ("I am a poet") "La Boheme" Puccini**

By FLORENCIO CONSTANTINO, Tenor. Sung in Italian, Orchestra Accompaniment

*Rodolfo*, a poor poet, lives in an attic in the Latin Quarter. With him, as with his three friends, *Schaunard*, *Marcello* and *Colline*, life is gay and care free so long as there is a coin in the purse; and when there is none, then the task of living becomes wearisome and cruel. Into his attic there comes to *Rodolfo*, the youthful *Mimi*, a fellow lodger, and she begs for a light for her candle. She is faint and swoons, dropping her candlestick and key. *Rodolfo* revives her and she goes on her way, with her candle lighted; but she returns in an instant to look for her key, and then a draught from the open door blows out both her own candle and *Rodolfo's*. In darkness the two grope about the floor for the missing key, and then their hands meet. She gives forth a little cry of surprise, and he finds that her hand is frozen, and holds it to restore it to warmth. It is then that *Rodolfo* confides to *Mimi* that he is a poet, living by means of his fancy's thoughts. The composer Puccini has taken this opportunity of writing one of the finest lyric bits to be found in the entire opera.

**B. 68 Ihr heisset mich willkommen, ("Ye bid me welcome")**

**"Der Trompeter von Sackingen" Nessler**

By OTTO GORITZ, Baritone. Sung in German, Orchestra Accompaniment

Victor Nessler's opera "Der Trompeter von Sackingen" is a work that has enjoyed an enormous success in Germany. It is still frequently produced there; and in other countries the work is known by its favorite songs. The present song is one of these numbers. The English

text begins: "And so ye bid me welcome! A stranger here am I! Restless, inconstant, ever from North to South I fly." And then it proceeds: "What vainly I have sought for, tho' every place I've scanned, at last my sight encounters in this enchanting land." The music is frankly melodious, rising at its close to a moment of climax which voices the mood of the wanderer who has found his goal.

**B. 112 Il fior che avevi a me to dato, ("The flower you gave to me") "Carmen" *Bizet***  
By ANGILO PINTUCCI, Tenor. Sung in Italian, Orchestra Accompaniment

When first the fickle *Carmen* spies the soldier *Don Jose*, she begins to coquet with him and finally plucks a flower from her hair and throws it in his face, while she scampers away. *Don Jose* picks up the flower and tucks it away in the bosom of his military coat. It follows afterward that *Carmen* cajoles him to aid in her escape, while on his way to prison; then the two meet again in an inn, and here she dances for him, and makes him a slave to her charms. He is recalled to the sense of duty by the trumpet signal of his regiment, and he prepares to leave. In rage, that he can have thoughts other than of her, *Carmen* bids him go, and jeers at his declaration of love. He protests, and taking the faded flower from its hiding place in his uniform, he sings is romance, which is one of Bizet's most lyric inspirations.

## Trade Information for Dealers

### Sales Dept. Bulletin No. 5—April 13th, 1908

FOR UNITED STATES AND CANADA DEALERS

Correspondence concerning this Bulletin should mention its number and be addressed to National Phonograph Co., Sales Department, Orange, N. J.

We list below one selection which has recently been made over. Continuing the plan already begun, we will print this selection as part of the July printed matter prepared for retail distribution.

8800 Ballet Music from Coppelia

Edison Concert Band

Did you follow our advice last month and order a stock of these made-over selections? If not, don't you think they are worth some consideration, at least?

### Sales Dept. Bulletin No. 6—April 22, 1908

FOR UNITED STATES AND CANADA DEALERS

Correspondence concerning this Bulletin should mention its number and be addressed to National Phonograph Co., Sales Department, Orange, N. J.

Dealers are hereby advised that inasmuch as we have no more moulds or masters of them, the following selections will be considered as cut-outs after our present stock is exhausted.

12093 El Cafe de Puerto Rico (Spanish)

Vargas

12155 Yo quiero un besito (Spanish)

Vargas

12184 Yas Cigarreras, De Madrid a Paris (Spanish)

Vargas

12407 Martha, nimm zum frohen Bunde (German)

Walter and Hofmann

## Texas Sentiment

"When its moonlight, Mary darling, 'neath the old grape-arbor shade."

I've just been playing this on my Edison Phonograph, and the words and the music keep ringing in my ears.

When all the world seems dark and dreary and all affairs seem sad and weary, and my mind's all topsy-turvy, I find there is nothing—nothing mechanical at least—that brings sweet solace to my tired and weary soul like a few

choice selections on the Edison Phonograph; something catchy by Bob Roberts or Billy Murray or something snappy or otherwise by Ada Jones, or a sentimental song by Manuel Romain.

I want to re-echo what Thomas A. Edison, its inventor, said: "I want to see a Phonograph in every home." It's a great machine and I am glad he invented it; why life without it would be as desolate as a home without happiness—or its home newspaper.—From the "Midnight Musings" of the editor of the *Belton, Texas, Evening News*.

## Advance List of New German, Polish and Swedish Selections

The Records named below will be ready for shipment from Orange between June 1st and 10th. Samples of any or all of them will be shipped May 1st to such Jobbers as place orders for them. None will be shipped without orders. Jobbers' stock orders received by May 20th will be shipped as fast as possible after June 1st. Care will be taken to make shipment at one time to all Jobbers in the same city. Separate supplement of each list will be shipped with Records to all Jobbers who request a supply. State quantity required of each kind.

### 10 German Records

15189	Edelweiss, <i>Peuschel</i>		Robert Leonhardt
		Mit Orchesterbegleitung	
15664	Ich bete an die Macht der Liebe, <i>Bortnianski</i>		Nebe-Quartett
		Mit Orchesterbegleitung	
15669	Lotte, du süsse Maus, <i>Morse</i>		Max Steidl
		Couplet mit Orchesterbegleitung	
15670	Goldfishlied, aus "Geisha," <i>Sidney-Jones</i>		Hofopernsängerin Gertrud Runge
		Mit Orchesterbegleitung	
15675	Mädel gib acht! Walzerlied, <i>Böhme</i>		Opernsänger Paul Biegler
		Mit Orchesterbegleitung	
15676	Wenn ich ein Kannibale wär! <i>Meinhold</i>		Gustav Schönwald
		Couplet mit Orchesterbegleitung	
15693	Piccolo-Duett aus "Walzertraum," <i>O. Strauss</i>		Adelheid Rubens und Max Steidl
		Mit Orchesterbegleitung	
15695	Aennchen von Tharau, <i>Silcher</i>		Opernsänger Carl Nebe
		Mit begleitung der Billau'schen Klavier-Organ	
15698	Zieh hinaus beim Morgengrau'n, Quartett, <i>Dregert</i>		Nebe-Quartett
15699	Lehmanns Hochzeitsfeier, Humoreske, <i>Original</i>		Martin und Paul Bendix

### 6 Polish Records

15679	Arja z opery "Janek," <i>Zelenskiego</i>		Henryk Drzewiecki
15681	Rozmowa pijaka z księzcym,		Anton Fertner
15682	Arja z opery "Rajskie Jańuszko," <i>Offenbach</i>		Wincenty Rapacki
15684	"Ja czekam cie," <i>Szteinberg</i>		Wiktorya Kawecka
15685	Pozegnanie Wotana, <i>Wagner</i>		Dr. v. Zawilowski
15686	Jaskowa dola, <i>Niewiadomski</i>		Ignacy Dygas

### 16 Swedish Selections

20500	Ett vittnesmål,		Herr Nergårds-Lasse
20501	En Helsingehistoria,		Fru Dr. Blumenthal
20502	Pojkar ha'vi smått om Bond-tur, Comisk Sång,		Herr Bondesson
20503	De ä synd om männisikorny, Comisk Sång,		Herr Noree
20504	Lelle Karl Johann, Comisk Sång,		Herr Noree
20505	Aldrig en Fris, Quartett,		Bellmann Chor
20506	Gubben och Sancte Per, Drag Spel och Sång		Herr C. Barcklind
20507	I. skogen,		Fru Mally Högberg
20508	Grytprofvet,		Frk. Leijmann
20509	Soldatgossen,		Herr Gentzel
20510	Ljungby horn,		Herr O. Edberg
20511	Visa i folkton,		Frk. Larsén
20512	Romans ur Mignon,		Fru Hellström-Oseár
20513	Nattmarschen,	Herr O. Edberg och G. Wennmann	
20514	Serenade,		Herr Källström
20515	Canios sång,		Herr Nyblom

## Stock Up and Advertise

Our advertising campaigns are designed not only to cover the whole field of magazine readers but by special advertising in local newspapers to stir up a wide universal interest in all parts of the country. This great publicity will result in a greater demand than ever before for Edison Phonographs and Records. Every Edison Dealer must get the advantage of this, but the man who reaps the greatest profit from it will be the man who carries a good stock. The "I want what I want when I want it," spirit is always in evidence among buyers of Edison Phonographs. If another Dealer has the machine desired, the purchaser will seldom wait until the first has stocked up. The small Dealer can never be expected to carry a full stock of Records or a large number of Phonographs; but if he studies his customers' tastes he will seldom go wrong in ordering from the monthly list.

No Dealer should imagine that because we spend an enormous amount of money in advertising and advertising literature, he is relieved from doing any for himself. He should supplement what we do with advertisements in his home papers, fitted to local conditions. If he is in a district given up to agriculture, he should make special efforts to make sales to farmers. He should remember that farmers cannot always come to town as readily as other people, and consequently may not hear and buy new Records as often as they would if they were close to the Dealer's store, and able to hear them played over. One of our Dealers makes a monthly list of visitors to his store, and when he finds Phonograph owners who have not been in, he takes the Records to their homes, and rarely fails to make sales.

It's a peculiarity about the Phonograph, and a peculiarity that is a money making one, that people who do not buy new Records and use their machines often, are inclined to regard it as an unprofitable investment. It is like having a horse in the stable eating his head off in idleness. Most people object to this state of things and Phonograph owners seldom like their machines long idle. There is a deal of sentiment talked about the old songs and, although this may be genuine, it is the new ones that are in demand, and it is not often that anyone is content with a few Records. Human vanity plays some part in the matter of Record collecting. One Phonograph owner does not like to feel that his collection is numerically far inferior to that of a friend, and the tactful Dealer by recommending Records that he knows to be good

will often make large sales, where the man who is not enterprising and does not study his customer will sell very little. It pays Dealers to know all they can about the Records they sell, and to know, makes the selling a hundred per cent. easier.

## Among the Jobbers

The Pittsburg Phonograph Co., of 937 and 939 Liberty avenue, Pittsburg, was completely burned out on the night of April 9th, causing a loss of from \$20,000 to \$25,000, covered by insurance. The company occupied the two lower floors of the building and had a storage room on the fourth floor. The blaze started on the third floor, which was occupied by the Hamburg Furniture Company. The loss on the building is fixed at \$15,000. The Pittsburg Phonograph Company have secured temporary quarters, have put in a stock of goods and are already filling the orders of their Dealers.

The Utica Cycle Co., Jobbers of Edison Phonographs and Records in Utica, N. Y., have purchased the property at 11 and 13 Columbia street, and will erect a modern four-story building 55x112 feet. The site will be completely cleared and the work of erecting the new block will be started about May 1, with the expectation that it will be finished about October 1. The front and side walls of the building will be of Indiana limestone, which will give it a most attractive appearance. On the ground floor there will be two stores having a frontage of about 26 feet, with an entrance to the upper floors in the center. The Cycle Co. will use the store No. 13 as an office and salesrooms, the second and third floors as stock rooms and the fourth floor as a shop and repair department. The Utica Cycle Co. began business in 1895. The firm consists of M. J. and W. F. Carroll.

Grinnell Bros., Edison Jobbers at Detroit, Mich., have removed to their new store on Woodward avenue. The occasion was celebrated informally and it is expected that the formal opening will take place later in the spring. The removal marks an epoch in the business history of Grinnell Bros., who started in 1882 in a small way. In a little over twenty-five years the firm has grown to be one of the largest in the middle west. The new building contains seven floors. Fourteen rooms have been set aside on the basement floor for showing Phonographs and talking machines. The floor also has a capacity for 200,000 Records. For some time to come

Grinnell Bros. will have two stores on Woodward avenue, and besides their establishments in Detroit, the firm have seventeen branch stores in the largest cities of Michigan and one branch at Madison, Wis.

The corporate name of the Clayton Music Co., Edison Jobbers at Salt Lake City, has been changed to the Clayton-Daynes Music Co. In all other respects the business is unchanged.

R. C. Bollinger, Music House of Fort Smith, Arkansas, are new Edison Jobbers. A large part of their initial order for approximately \$11,000 worth of Phonographs and Records has already gone forward. The firm is one of the largest and oldest established in their section of the country, having been actively engaged in the sale of high grade musical goods since 1878. For some years they have had remarkable success as Edison dealers and Mr. Bollinger has been of the opinion that they could repeat their success in the jobbing field. W. H. Petrie, late of Lyon & Healy, Chicago, is to have full charge of the talking machine department, and altogether it looks as if the Bollinger Music House are to be very important factors in the distribution of Edison goods.

---

## New Equipment an Achievement

When you sell the new Edison Phonograph, you sell a complete instrument. The new horn and swinging crane have eliminated the necessity of additional purchases on the part of buyers. You are relieved of the expense and trouble of carrying horns and pleasing a buyer with what you have in stock.

The customer gets a better horn, a handsomer horn, and a horn more suited to the Phonograph, for less money than he or she would otherwise spend. You are assured a profit on the horn as well as on the Phonograph, as one cannot be sold without the other, and the price of both cannot be cut by anybody. The Edison Phonograph was never so attractive a proposition as it is now.

---

## Idelia Reproducers and Recorders

The following prices have been fixed for the Edison Reproducers and Recorders, when made with oxidized bronze finish, as used on the Idelia Phonograph: Reproducer, \$6.00; Recorder, \$4.00. Both prices are subject to regular machine discounts.

## London Office Removed

Most of the departments of the National Phonograph Company, Limited, London, have been moved from the Clerkenwell Road address to the Edison Works at Willesden. Work on the offices has been pushed with all possible speed, and much has been accomplished. Considerable work, however, still remains before the various departments can settle down into the regular routine. The offices, when the further improvements are completed, will be everything that can be desired. The Recording Department will remain for the present at 103-105 St. John street, the old address, until suitable premises can be secured in the West End, where a city office will also be maintained in place of the Clerkenwell Road address. By centralizing practically the whole of the work at Willesden, the company will save time in many ways, much to the advantage of its trade. Present trade conditions in Great Britain are satisfactory, all things considered, and the future holds out good prospects of a considerable all-round trade increase in both machines and Records.

---

## Personal

F. K. Dolbeer, General Manager of Sales and Credit Manager, spent three weeks during April on a trip through the South. He visited nearly all of the Jobbers in the Gulf States.

W. E. Gilmore, President of the National Phonograph Company, with his family, went to Virginia Hot Springs, on April 13th for a two weeks' stay.

Mr. and Mrs. Thomas A. Edison and party have returned from their vacation at Mr. Edison's plantation, Fort Myers, Florida. Mr. Edison has almost entirely recovered from the effects of his recent operation.

---

## Binder for Phonograph Monthly

Do you file all numbers of the EDISON PHONOGRAPH MONTHLY as issued? If so, do you have any trouble in finding them readily when wanted? Inasmuch as we have practically discontinued the mailing of separate form letters covering changes in prices, etc., to Dealers, and further since we will in future print all notifications of this kind in the PHONOGRAPH MONTHLY, it is important that you keep all issues in some convenient manner for easy reference. Although Dealers in general are not aware of the fact, we are furnishing a neat binder, which will contain twelve issues, at 50c. If your Jobber does not carry them in stock, we will fill your order direct, post paid, upon receipt of the above amount.

---

---

# Edison Phonograph Monthly

Published for the Man Who Sells Edison Phonographs and Records by The National Phonograph Co., Orange, N. J.

All communications to *The Phonograph Monthly* should be addressed to the Advertising Department, Orange, N. J.

---

NEW YORK: 10 FIFTH AVENUE.

NATIONAL PHONOGRAPH CO., LTD., VICTORIA ROAD, WILLESDEN, LONDON.

NATIONAL PHONOGRAPH CO. OF AUSTRALIA, LTD., 340 KENT STREET, SYDNEY, N. S. W.

MEXICAN NATIONAL PHONOGRAPH CO., AVENIDA ORIENTE No. 117, MEXICO CITY.

COMPANIA EDISON HISPANO-AMERICANA, VIAMONTE 515, BUENOS AIRES.

EDISON GESELLSCHAFT, M. B. H., SUD-UFER 24-25, BERLIN.

COMPAGNIE FRANCAISE DU PHONOGRAPHE EDISON, 42 RUE DE PARADIS, PARIS.

---

VOL. VI.

May, 1908

No. 5

---

## Tray System and Larger Record Stocks

There are two features connected with the business of selling Edison Records about which few Dealers disagree, namely: Keeping Records according to some approved system and carrying the full list of American selections. In some of the smaller places it may not be profitable to carry every selection in the Edison catalogue, but no matter how small a Dealer's stock of Records may be, there is no question about the wisdom of keeping the stock in a systematic manner—in such a way as to know just what titles are in stock, and be able to find any one of them at a moment's notice. Making proper allowance for the merits of all other systems of carrying Records, none seem to possess as many advantages as the one known generally as the tray system, originally devised by Victor H. Rapke and now used in probably four-fifths of the large stores carrying Edison Records. This system keeps Records clean and compact. It makes an attractive display and with it Records are always found quickly. No matter how small or how large a Dealer's stock may be, it is easy to find any Record wanted. We have no interest in the sale of anything that enters into the tray system. Our interest lies in selling more Records, and we know that Dealers who carry Record stocks in a systematic manner sell more goods than those who do not, and the better the system the larger the sale. Therefore we favor the tray system.

Hundreds of Dealers are to-day pointing with much pride to the fact that they carry every Edison Record in the domestic catalogue. They make it a feature of their advertising, they announce it in their circulars and they glow

with satisfaction when they say to customers: "Name any Edison Record you want and we can produce it in an instant." But they don't carry the full line for the pleasure it gives them. They carry it solely because of the greater profit. It is nothing but good business. We can point to scores of Dealers who were persuaded somewhat against their judgment to put in the full line, but who to-day frankly admit that it was the best move they ever made. Hundreds of Dealers still labor under the mistaken idea that their towns are too small to make the full list profitable. Dealers in towns of but 500 population have made it a success. Even where the full list is not possible, it is an unquestioned fact that the greater the number of titles carried the larger the profit earned. The Dealer who carries 200 different titles would do better with a total of 400; and one with 400 could double the number with a proportionate increase in profit. The subject is one worthy the thoughtful attention of all Dealers who are carrying a limited Record stock without a proper system.

---

## French Records Popular

The National Phonograph Company's list of French Records has proven to be in great demand among the French Canadians employed in the mills in Maine and other border States.—*American Exporter.*

---

## An Original Business

"Canned Music Our Specialty," is the original designation given their business by the Musical Echo, James L. Andrews, Manager, Edison Dealers at Bradford, Pa.

## Printed Matter

Copies of the April edition of the Record Catalogue (American selections) Form No. 1300 have just been mailed to all Dealers. Shipments were made to Jobbers as early as March 1st and all Jobbers now have a supply on hand. The only difference between this and the previous edition is the addition of the Records for January, February, March and April—a difference not sufficient to affect the usefulness of such copies of the December edition as Dealers may have on hand. They should be used up before getting a supply of the later edition.

A limited edition has been printed of a four-page folder advertising the Edison Idelia Phonograph. The new machine is shown on the inside pages, printed in four colors. A description is given on page four. In cities or towns where there are a number of wealthy people, Dealers should get a few of these circulars and mail them to such individuals, accompanied by a specially written letter on the subject. Many people can be induced to buy a Phonograph of this kind who otherwise would not consider doing so. The Idelia is a handsome machine and well worth the attention of the trade.

We have in stock a small quantity of three-color prints of our oil painting, "The Phonograph," and will take pleasure in filling Jobbers' orders for a limited supply while they last. The size of the print itself is 6x9 inches, on paper 9x12 inches in size. Dealers will undoubtedly find use for two or three in connection with any window display they might make.

In announcing last month, the appearance of a new hanger, Form 1292, "As a Protection to the Public," etc., we should have stated that the posters in question would be packed with the May monthly printed matter sent to Jobbers, which would in most cases reach them before the 15th of April. If your Jobber delayed filling your order for a copy, it was probably due to the late arrival of his supply. At any rate, he has a quantity of them now. If you have not done so, secure a copy at once and display it in a conspicuous position in your store, as proof to your customers that certain restrictions are placed by us on the sale of Edison goods.

Copies of a new edition of the Accessories Catalogue has just been mailed to the entire trade. It is Form No. 1319. It contains the list prices on a number of articles not found in

the machine catalogues. Dealers should keep the copy mailed them, so as to have it handy for easy reference.

## May Advertising

The full page magazine advertisement shown on the last inside page of this issue appeared in the latter part of April in the following periodicals, comprising the best and most widely circulated publications of their kind in this country: Ainslee's, Associated Sunday Magazine, Collier's Weekly, Cosmopolitan, Delineator, Everybody's, Ladies' Home Journal, Ladies' World, McClure's, Munsey's, Outlook, Pearson's, Puck, Saturday Evening Post, Success, Sunset, Woman's Home Companion, World's Work and Youth's Companion.

The back cover in the Easter number of Collier's Weekly, dated April 11th, referred to last month, was a beauty. We looked for something very attractive, but the printed page far exceeded our expectations. Our advertisement was designed by Will Bradley, of Collier's, to harmonize with the front cover and we are inclined to think that we had the more attractive page of the two.

The newspaper advertising went on as usual, the two large advertisements appearing on April 8th and 25th, in the same list of prominent daily papers as before.

The illustration in the May magazine advertisement is from a sketch by J. J. Gould, of Philadelphia. It is the first of a new series, each one of which has been drawn to illustrate an idea in connection with the Edison Phonograph. Each will be an interesting picture aside from its use for advertising purposes.

## One Year After

Just one year ago this month we made our bow as Jobbers of Phonographs and talking machines. Our only regret is that we did not start in this great business long before.

Our success has seemed wonderful to us, and we know that our service and treatment has been satisfactory to the trade, or we could not have built up a business in one short year, which is now the largest of its kind in this section of the country.

We know that your efforts have helped us to do this, and we want to thank you most sincerely for contributing so generously to our success, and trust that during the coming year we may receive even a larger share of your business.—*Letter to Trade from Ross P. Curtice Co., Lincoln, Neb.*

### Copyright Legislation

When asked recently for an opinion concerning the proposed compromise copyright bill before Congress, Frank L. Dyer, general counsel for the National Phonograph Co., who has followed all the copyright developments with great interest, and who spoke at the hearings, said:

"The National Phonograph Co. have signed no agreement providing for a two-cent royalty. The agreement to which you refer does not appear to include any talking-machine manufacturer.

"It was suggested by Senator Smoot at the close of the copyright hearings in Washington, on March 28, that the conflicting interests, if possible, should agree on some mutual agreement, and it was the understanding that the conferences for this purpose should be held in New York.

"Admitting that copyright protection can constitutionally extend to talking-machine records, and that the public interests require new legislation on this point, my client, the National Phonograph Co., is willing to agree to any fair and reasonable arrangement. I am convinced, however, that the scheme is neither constitutional nor expedient. Matters of this sort, involving enormous commercial interests, cannot be disposed of hurriedly, but should have serious consideration in order that the rights of all parties may be protected.

"I am willing at any time to meet the responsible interests which favor the new legislation, and to discuss the question fully with them with a view of reaching some mutual understanding, but I certainly cannot permit my company to be prejudiced in any way by any so-called 'compromise' to which it is not a party, and which appears to have been made by persons having no

### Shelving from Record Boxes

F. M. Atwood, Edison Jobber at Memphis, Tenn., recently wrote to the *Talking Machine World* as follows: "I have lately increased the capacity of my Edison Record bins from 12,000 to 22,700. The new part I consider to be both novel and original. It is what I call sectional shelving and can be run to any height or any length and is made entirely of lumber taken from the Edison 300 Record packing cases. They are first knocked entirely apart except the ends which are cut into pieces to form the height or distance between each shelf, leaving the cleats on to give strength. The shelf is then nailed on the top of two of the ends also piece on the back. They hold six records deep and ten wide. Of course, the width may be divided to suit the Jobber or Dealer. I use no partitions in them, but use gum labels over each number. They could also be used in connection with tray system. These shelves are set one on top of the other and the lower sections are held in place by quarter-inch iron rod run through a hole at each end. The base should be made about 6 inches wider to project in front and is 12 inches high. This projection of the base is very convenient to step on in getting Records from the top shelves. I have stained

the front of this a dark green and it makes a very nice appearance. In conclusion, will say that my wholesale business so far this month is more than double what it was the entire month of March last year.

### The New Phonogram

In accordance with our practice in the past we reprint below the terms upon which PHONOGRAMS may be had by the trade, this information being chiefly of value to firms who have become Dealers in the past six months:

DELIVERED WITH GOODS.

Blank, per 1,000 copies.....	\$2.50
Smaller quantities pro rata.	
Imprinted, 500 copies .....	1.50
Imprinted, 1,000 copies.....	2.75
No orders filled for less than 500 copies requiring imprint, and all imprinting orders must be for multiples of 500.	

Jobbers will be glad to supply Dealers on the above basis.

BY MAIL.

Single copies, per year.....	\$ .20
Five copies to one address, per year.....	.40
Twenty-five copies to one address, per year.....	1.80
Fifty copies to one address, per year.....	3.60

Unless they have open accounts on our books, Dealers ordering PHONOGRAMS sent by mail are requested to send cash or stamps with their orders. The amounts are too small to handle in any other way.

PHONOGRAMS must be sold by the Jobber to his Dealers at the prices quoted above; any reduction of these prices will be considered as a violation of contract. The Jobber who gives PHONOGRAMS away is offering a special inducement to Dealers to trade with him, and may obtain thereby an unfair advantage over the Jobber who charges, in the same way as he would if he cut prices.

### An Imposter

Franklin E. Bomberger went to York City, Pa., a short time ago and, representing himself as an agent of the National Phonograph Co., secured a lease of a prominent store for the purpose of handling a line of Phonographs and Records. His actions, however, aroused suspicion, and the officers of the National Phonograph Co., at Orange, were communicated with. They informed those interested that Mr. Bomberger was an imposter and asked that he be arrested. Bomberger, however, fled the city. A few days ago, however, he was captured in Lancaster and is now in the county jail in York awaiting a hearing. He is charged with improperly securing a signature to a lease for a room and with falsely representing himself as an agent for the National Phonograph Co. in making a lease for a Bell telephone.



## Will Tell Story by Phonograph

If what I tell you here below is of interest to you, the PHONOGRAPH MONTHLY can have it for what it is worth. In 1857 a band of Sioux Indians massacred all the settlers at Spirit Lake, Iowa, 42 in all, and carried into captivity three white women and one little girl, 13 years old. In memory of this event the State of Iowa erected a monument on the grounds of the massacre and Spirit Lake has become one of the great summer resorts of the Northwest. The little girl that was taken captive fifty-one years ago is now the only survivor of the Spirit Lake massacre and during the outing season she returns to her father's log cabin on the banks of the lake in which her father, mother and little brothers and sisters were murdered by the Indians. Every one of the thousands of tourists who come to the lake go to the log cabin and ask the woman, now Mrs. Abbie Gardner Sharp, to tell them the story of the massacre. This she has told so many times that her nervous system has been wrecked by the continual strain. I went to see the old lady last week and induced her to repeat the story to my Edison Phonograph, which she did very distinctly. She immediately ordered a Phonograph and will use it in the old log cabin to tell of this harrowing event of her girlhood. Here in Spencer, where the Records were made, a constant stream of people have poured into my residence all day long to hear the Phonograph story of the Indian massacre.—*H. S. Jones, Edison Dealer at Spencer, Iowa.*

## The Same But Different

"In offering an Edison Phonograph to the public on instalments," said an Edison Jobber recently. "We never quote the total price, as for instance, 'This Edison Phonograph and six Records, \$40.00,' but placard the machine or quote as follows: 'This Edison Phonograph and six Records, \$3.00 down and \$1.50 weekly, for 12 weeks.' It never seems so high to a customer when the price is given in this way. Then, too, it enables us to get a better price for instalment sales than for cash."

This is something worth imitating by other Jobbers and Dealers.

## You Get the Benefit

It isn't enough that we make the best Phonograph that can be constructed. It isn't enough that you know that the Edison is the best. It is necessary that the user, the Phonograph buyer, should know. That is why we advertise. This trade will go by your store if you do not encourage it to come in.

## The Edison Won

A little incident occurred here recently which we thought you might like to hear as it is rather complimentary to your Phonograph. One of the moving picture halls in this city is using a ——— to sing the illustrated songs, and also for music during the performance. We went to him at the request of many of our friends and Edison enthusiasts, and asked him if we might furnish the music for him for a time on an Edison machine. He said that the Edison would not fill the room, but if we wanted to say he would allow us to do so, and would play both machines, and let the people decide which was the best. The majority decided for the Edison. The good point, however, is that it created a great deal of talk, and was the best advertisement we have had since we have been in business. As a result we have had an exceptionally good sale on Phonographs. We sold every Phonograph we had in stock, and were compelled to bring down a Phonograph from home to play Records. We have placed an order for more Phonographs, and will probably receive them to-day. Among the Phonographs sold in the last week, was one to another picture parlor in this city. We wish to say that The National Phonograph Co. is the most satisfactory firm we have ever dealt with. We are putting out a great many Phonographs in this vicinity.—*Shaw Bros., Aledo, Ill.*

## Pertinent Points for Dealers

Quit thinking about what this or that competitor of yours can seemingly do so much better than you.

Stop fearing the retail mail order houses, and this or that store so much "bigger" than yours.

Work your own field. Use all your own tools. No matter how little you are you can win.

Determine what territory you can reasonably hope to draw trade from. Set out to make everyone in that territory know you and your store.

Admit that you cannot advertise on the scale of the big fellow. Don't try to do so. Do less, but make that distinctive.—*Talking Machine World.*

A great deal of favorable comment is heard regarding the extensive advertising in the local dailies by the National Phonograph Co. Not only is large space being used, but the text is forceful and convincing and presents in simple but strong manner the advantages of owning a phonograph. A systematic campaign such as the Edison people are making along these lines cannot but enable Edison dealers to make sales to many people whom they have not hitherto found it possible to interest.—*Chicago Correspondence of the Talking Machine World.*

## Our Buenos Aires Branch

Printed below are reproductions of photographs showing the exterior of the building occupied by the Compañia Edison Hispano-Americana, Via-monte 515, Buenos Aires, branch of the National Phonograph Co., in this city; also of a part of the retail department. The branch is in charge of T. J. Kennedy, who is shown standing in the right hand door, under the company sign. This

company is making excellent headway in extending the sale of Edison Phonographs and Records, and in fact all Edison products, in South American countries. Jobbers and Dealers are rapidly being established and a large volume of business has been created. South America is regarded as being a great future field for Edison Phonographs and Records, the name of Edison being held in the highest esteem in those countries.



EXTERIOR OF BUENOS AIRES BRANCH



INTERIOR VIEW RETAIL DEPARTMENT

## Window Dressing

The second photograph in the window dressing series is given below. The display was arranged in the same 6x10 window as that of last month and the same materials are used. The 1x1x3 boxes have again been used as platforms upon which to place the Phonographs, and the Records, catalogues, signs, etc., are such as may be found in the store of the average Dealer. At a glance one forms the impression that there is too much in the window and yet it is this feature that gives it additional advertising value. It is striking enough to get the attention of the passer-by and cause him to stop and look it over

in detail. When he does this, the mission of a window display has been accomplished.

The sides of this window are again draped with white cheesecloth and the same material is loosely placed on the floor. The boxes are also covered with cheesecloth. They are placed diagonally in the window, the horns of the machines pointing to the right hand corner. The Records festooned in the left corner in back are threaded on pieces of stout cord.

We shall be glad to have good photographs of displays made by Dealers. They must not, however, show glass reflections, for such photographs do not make good half tones.

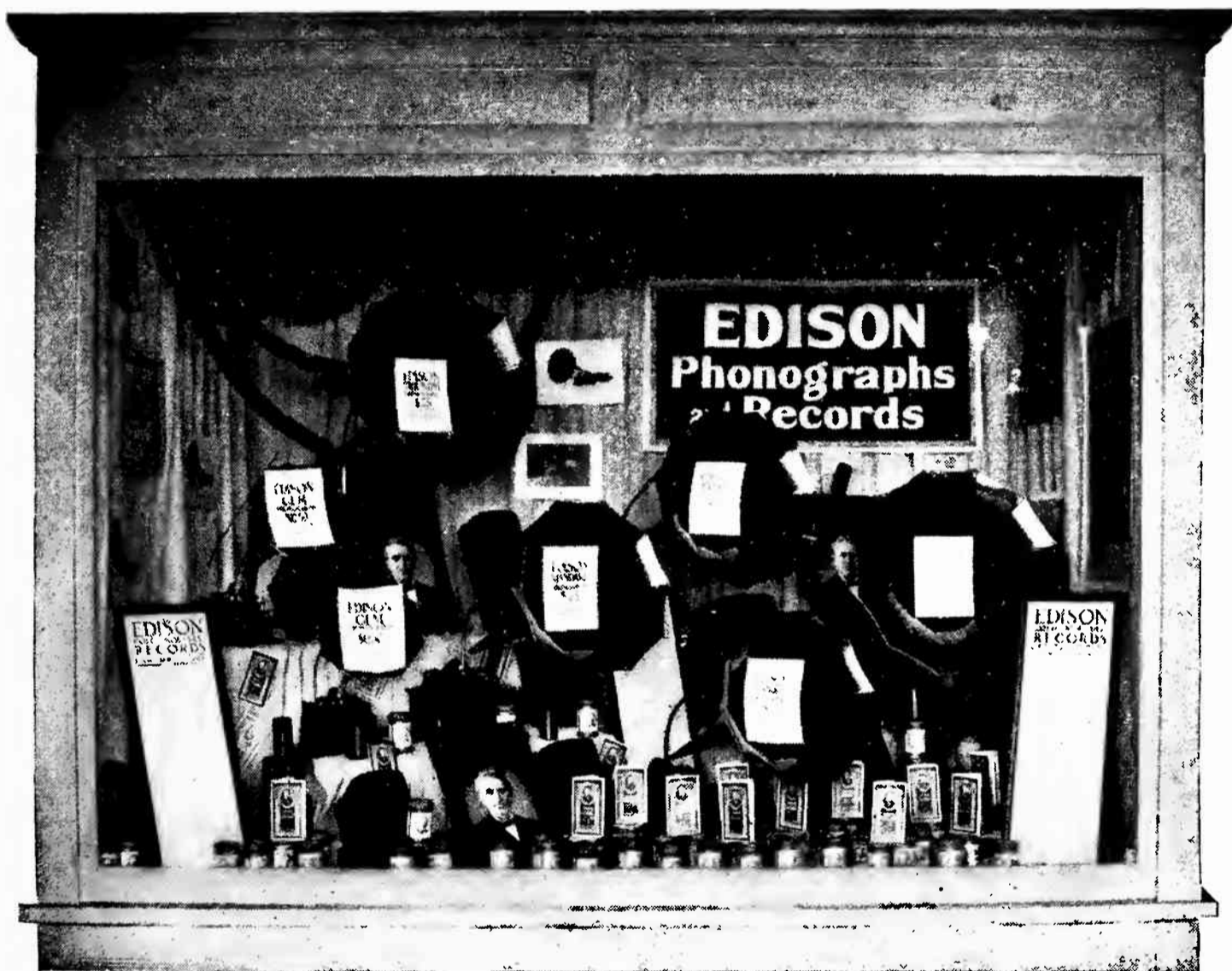

WINDOW DRESSING EXHIBIT No. 2

## A Good Reading Notice

E. O. Little, Edison Dealer at Auburn, Ind., sends the following reading notice advertisement, which he says has been widely commented on and has brought him much business:

THE NEW CITY HALL.

A committee of Councilmen will leave in a few days on a tour of inspection of city halls in cities the size of Auburn. They will make quite an extensive trip and expect to find a hall suited to the needs of Auburn. Incidentally while looking up city halls they will see if they can find a better or more complete line of Phonographs, jewelry, etc., than that carried by E. O. Little, the Little Jeweler.

Have you a Phonograph? How long has it been since you have critically listened to one? Do you know how good the Edison Phonograph is to-day, how pure the tone, how satisfying the reproduction? If you have one, you know. If you have not one, you ought to know—its easy to know. Come here and hear. Learn how inexpensive it is for a complete outfit, including records—and how favorable the terms. Then think of the pleasure you can give yourself, your family and your friends with the world's best music, its most catchy songs and the monologues and dialogues of its funniest comedians. And after doing all this you'll buy one—you simply can't help it.

Ed sells Phonographs on easy payments and it will pay you to investigate his. One dollar per week proposition.

It is offered as a pattern for other Dealers.

## A Good Store and Complete Stock

Under another cover I am sending you a picture of my Phonograph department, which perhaps will be of interest. The fixtures are black mission finish, and the drapery is red silk. The tops of tables, etc., are of red. We use jet black wrapping paper with the red

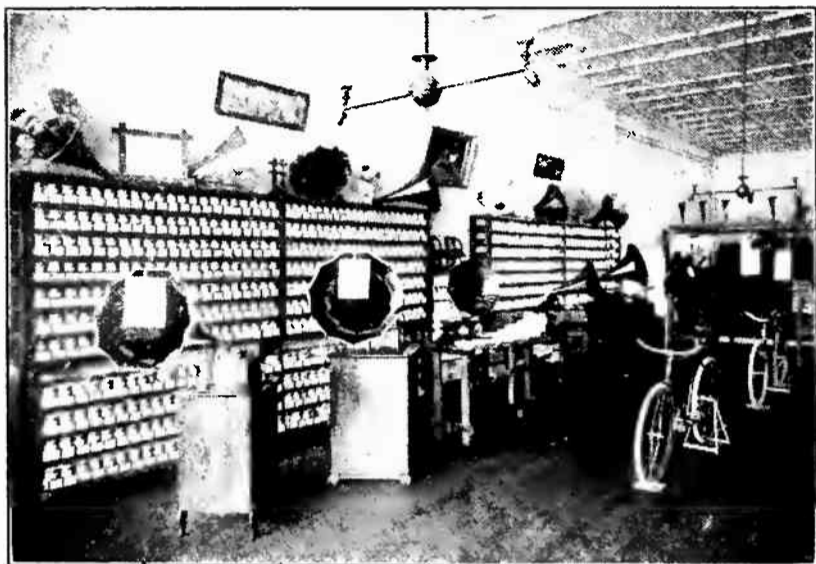

twine and the sticker to match. We keep the full list of Edison Records in the box trays, all labeled with numbers. I have found the den which the picture shows a great Record seller, and since the picture was taken it has been much improved with cushions, pictures, draperies, etc.—*E. G. Bassett, Bristol, Conn.*

## Ready-Made Ads

Until we began printing ready-made ads in these columns and instituted our present system of compelling Dealers to send us papers showing that they had used the electros sent them, we did not realize the extent to which Dealers were advertising Edison goods. It is evident that Dealers are more and more alive to the advantages of doing local advertising and otherwise benefit from the national advertising being done by us. Hundreds of Dealers have taken advantage of our offer to send electros of the illustrations in these ready-made ads and have used with excellent results. These electros are furnished with the simple stipulation that Dealers getting them shall send copies of papers in which they are used. Some Dealers have refused to do this and have waxed sarcastic at our expense, but we regard the request as fair and shall continue the system. Furnishing these electros costs us a large sum of money in the aggregate and the least that Dealers can do is to show that they have used them. We will furnish electros of the illustration in the two ads on the next page, either single or double column, upon request. Order by number.



WHOLESALE PHONOGRAPH DEPARTMENT OF THE DENVER DRY GOODS COMPANY



# EDISON PHONOGRAPHS

**D**ON'T let the young folks get into the habit of seeking amusement outside of their own homes. It's so easy to give them the best sort of amusement—clean, hearty, wholesome fun—in their own homes by means of an Edison Phonograph. It sings the songs they like to hear, gives them the monologues of clever comedians, plays the music they are fond of and renders waltzes and two-steps that set their feet a-tripping.

**YOUMANS & CO.**  
409 Pearl Street  
Duluth, Minn.

Electro in above ad is: Single column wide No. 679.  
Double column wide. 680.



# EDISON PHONOGRAPHS

**Y**OU needn't be barred from the fun of having an Edison Phonograph in your home simply because you can't afford to pay for it all at once. We'll be glad to fix it so that by paying a small amount down you can have the Phonograph delivered and begin to enjoy it at once, paying the rest in instalments that will be less than it costs you for an evening's entertainment at the theatre.

**M. J. MONTAGUE**  
49 Alden Street  
Toledo, O.

Electro in above ad is: Single column wide No. 681.  
Double column wide. No. 682.

## REQUEST FOR ELECTROS

NATIONAL PHONOGRAPH Co.

ADVERTISING DEPARTMENT, ORANGE, N. J.

DATE.....190.....

Mail Electros No.....

We agree to use them in newspaper advertising and to send you copies of papers containing them before asking you for other electros. We intend running a..... inch advertisement.

Name.....

Street.....

City and State.....

We buy through.....

SUSPENDED LIST, MAY 1, 1908

SUPERSEDING ALL PREVIOUS LISTS.

CALIFORNIA.

Chico—J. L. Crick, 234 Broadway.  
 Petaluma—Thomas McGuire, 875 Main st.  
 \*San Luis Obispo—J. Dormer.

CANADA.

Ottawa, Ont.—Ketchum & Co., Sparks and Bank sts.

COLORADO.

Boulder—Bentley & Craig.  
 Denver—Wagman & Bloomfield (The Phonograph Circulating Library), 1631 Champa st.

CONNECTICUT.

\*Chapinville—Geo. S. House.

GEORGIA.

Acworth—Webb & Awtrey.  
 \*Eastman—Red Cross Pharmacy.  
 Valdosta—H. K. McLendon, 109 West Central ave.

ILLINOIS.

Champaign—Eggleston Bros., or Eggleston Music House, J. P. Eggleston, Prop.; also Danville, Ill.  
 Chicago—A. Gloss & Son, 727 W. North av.  
 Cooksville—Geo. Swinehart & Son.  
 Danville—Eggleston Bros., or Eggleston Music House, J. P. Eggleston, Prop.; also Champaign, Ill.  
 Elgin—James W. Mill, 18 Spring st and 166 Chicago st.  
 \*Galesburg—O. T. Johnson Co.  
 Kempton—C. E. Bute.  
 Ottawa—Edward Hayne.  
 Peoria—H. Meyer, 1307 S. Adams st.  
 Quincy—Giles Bros., 107 North 4th st. J. F. Brenner, 627 Main st. J. F. Whittaker 618 Hampshire st.  
 Robinson—A. D. Foreman, or A. D. Foreman & Son.  
 Wheaton—E. Irving.

INDIANA.

South Bend—Eugene Marsh, 126 Vistula ave. South Bend Book Bindery, Robert Lebolt, Prop., 203 North Michigan st.

IOWA.

Burlington—John P. Weiss, 711 Jefferson st.  
 Clinton—Totten Music House.  
 Cushing—Bullock & Lyman.  
 Danbury—J. W. O'Day.  
 Independence—E. O. Parker, 110 E. Main st.  
 \*Keokuk—W. H. Davis, Surgical Supply Co., 17 4th st.  
 Indianola—L. C. Barnett.  
 \*McClelland—J. W. Rounds & Co.  
 Mederville—John J. Carpenter.  
 \*Radcliffe—W. F. Drackley.  
 Sioux City—Hattenbach Bros. Co. A. V. Larimore, 518 Fifth st.  
 State Center—Ora Sargeant.  
 Webster—E. H. Martin and Fred N. Martin.  
 Whiting—The Cassady & Whiting Co.

KANSAS.

Clay Centre—E. M. Gowenlock.  
 Lawrence—Bell Bros.  
 Topeka—R. H. Morehouse, 510 E. 4th st.  
 Wichita—Frank R. Powell, 132 N. Main st.

KENTUCKY.

Louisville—Irvine Simons, 942 W. Market st. (formerly 543 W. Market st.).

MAINE.

Biddeford—W. H. Field.  
 Gardner—C. H. Cobb, 293 Water st.  
 Lewiston—J. W. Skene.  
 Monmouth—G. H. Stetson.  
 Oldtown—H. M. Burnham.  
 Waterville—Frank Blanchard, 150 Main st. M. Steinert & Sons Co., at all points.

MASSACHUSETTS.

Boston—Henry H. Savage, 166 Hanover st. T. Singer, 60 Leverett st.  
 Fitchburg—M. Steinert & Sons Co.; also Pittsfield, Mass., and at all points.  
 Florence—William Oates, 87 Main st.  
 Franklin—E. P. Blackmar.  
 Great Barrington—Frank W. Wheeler, Main st.  
 Lawrence—Lord & Co., 314 Essex st. E. O. Mosher, 420 Essex st.  
 Malden—A. T. Fuller.  
 Nantucket—Arthur M. Taylor.  
 New Bedford—H. B. DeWolf.  
 Pittsfield—M. Steinert & Sons Co.; 254 North st.; also Fitchburg, Mass., and at all points.  
 Somerville—E. J. Winchester, 32 Summit ave.  
 Woburn—Osborn Gillette, or The Boston Jewelry Co., L. F. Maloney, Manager.  
 Worcester—Joseph Tukman, 44 Front st. Guy Furniture Co., 521 Main st.

MICHIGAN.

Ann Arbor—Ann Arbor Music Co., F. J. Schwankosky, Prop.  
 Bay City—J. M. Kopec, 1006 S. Madison st.  
 Detroit—F. J. Schwankovsky.  
 Manistee—Gus Ilse, and A. H. Ilse Co., 311 River st.  
 Saginaw—Geo. W. Emendorfer. James V. Calahan, 217 Genessee st. Tierney Bros., 217 Genessee st.  
 \*Union City—Jay Hartman.

MINNESOTA.

\*Minneapolis—T. M. Roberts Co-op. Supply Co., 717 Nicollet ave.  
 Morristown—Wm. Zimmerman.  
 Willmar—Willmar Furniture Co., Ruble Block.

MISSOURI.

Ewing—Hal R. Ewalt.  
 Fairfax—Hinde Hardware Co.  
 Kansas City—The Wittmann Co.  
 Osceola—C. H. Green.  
 St. Louis—Knight Cycle Co., 1215 Olive st. \*Edward L. Reeve, and the Red Bud Floral Co., 910 Franklin st. F. Ringwood and J. Ringwood, or Central Phono. Co., or Franklin Phono. Co.

NEBRASKA.

David City—John Albright.  
 \*Elwood—W. M. Warner.  
 Lincoln—The Wittmann Co.  
 Omaha—The Wittmann Co. Piano Player Co.  
 Red Cloud—Albright Bros. or L. P. Albright.  
 Sterling—Sterling Drug Co., W. G. Morrill, Prop., and W. G. Morrill, M. D.

NEW HAMPSHIRE.

Dover—H. C. Ingalls & Co., 444 Central ave.  
 Hillsboro Bridge—E. M. Barnes.  
 Manchester—A. E. Dumas.  
 Nashua—F. A. McMaster & Co.

## SUSPENDED LIST CONTINUED.

### NEW JERSEY.

**Atlantic City**—Sam'l D. Wolf, 32-34 Arkansas ave.  
**Bayonne**—J. Wigdor, 450 Avenue D.  
**Jersey City**—W. L. Hoffman, 151 Montgomery street.  
**Long Branch**—A. N. Alexander, 103 Broadway.  
 A. Nastasio, 103 Broadway.  
**Newark**—R. L. Corwin; also New York City.  
 R. Rosenthal, Prop. Springfield Hdw. and Sptg. Goods Store, 71 Springfield ave.  
 D. Reinhorn, 91 Springfield ave.  
**Passaic**—I. Hurwitz.  
**Paterson**—Chas. H. Kelly, 25 N. Main st.  
**Plainfield**—S. W. Frucht, or R. Frucht; also New York City.  
 Elston M. Leonard.  
**West Hoboken**—Emil Hollander, or The West Hoboken Bicycle & Phono. Co., 169 Spring st.

### NEW YORK.

**Albany**—G. Linde, 353 S. Pearl st.  
 G. A. Birdsall, 114 S. Pearl st.  
**Amsterdam**—D. C. Kirchner, 26 Market st.  
**Bedford Park**—Geo. H. Tyrrell.  
**Brooklyn**—Nathan Abrahams, 602 Broadway.  
 Wm. Albrecht, 294 Knickerbocker ave.  
 H. Hindermann, Bushwick Phonograph Exchange, 1421 Myrtle ave.  
 Emil Smith, 634 Eleventh st., and 230 Summer ave.  
 Totten Furniture & Carpet Co., 216 Grand st.  
**\*Buffalo**—Buffalo Phono. Co., 16 Seneca st.  
 Simon Farber, 672 William st.  
 Herman A. Reinhardt, 1214 Lovejoy st.  
**\*Dolgeville**—Clarence Richmond.  
**Haverstraw**—F. E. Newman, Broadway.  
**Hobart**—F. H. Marshall.  
**New York City**—A. T. Armstrong, or American Phono Co., 106 Wall st.  
 Automatic Zither Co., M. Cohen, Prop., 58 Second ave.  
 Bern Bearwald, 373 W. 11th st.  
 Edward Bielfeld, 481 Willis ave.  
 Bronx Phono. Co., or David Switky, 506 Willis ave.  
 R. L. Corwin; also Newark, N. J.  
 Eagle Phono. Co., or C. Lowenthal, 83 Nassau st.  
 Empire Phono. Co., 2 W. 14th st.  
**\*Equity Furniture Co.**, Edward V. Kraus, Prop., 705 3d ave.  
 S. W. Frucht, or R. Frucht, 7 Barclay st., or 68 Cortlandt st., also Plainfield, N. J.  
 O. Hacker, 2 Murray st.  
 Hawthorne & Sheble, 297 Broadway; also Philadelphia, Pa.  
 Holober Bros., 350, 421 and 491 West st.  
 N. Horn, 148 E. 58th st.  
 W. L. Isaacs, 114 Fulton st.  
 Italo-American Phono. Co. (R. Gerard & Co.)  
**\*Edward V. Kraus**, 607-611 Ninth ave.  
 S. Lemburg & Co., 194 Broadway.  
 J. McEllyne, 202 Broadway.  
 Parker & Cooley, 2087 Amsterdam ave.  
 Richmond Pease, 44 W. 132d st.  
 F. M. Prescott, 44 Broad st.  
 Winthrop Cycle Co., 2212 Seventh av.  
**Oneonta**—G. B. Shearer Co., 259-261 Main St.  
**\*Putnam Valley**—Edgar F. Mallory.  
**\*Rochester**—George Lintz, 286 Bernard st.  
**Rome**—Charles Tuttle.  
**\*A. S. Noonan**, 105 E. Dominick st.  
**Saratoga Springs**—Marvin A. Cote.  
**Watertown**—H. S. Wardwell & Co., 39 Public Square.  
**Wayland**—John Gross, Pursel Block.

### NORTH CAROLINA.

**Kinston**—S. A. Quinerly.

### NORTH DAKOTA.

**Fargo**—Ben Hart.

### OHIO.

**Ashtabula Harbor**—Chas. W. Askew (Gregory, Askew & Co.).  
**Bellevue**—H. E. Rouser.  
**Brookville**—H. K. Merritt.  
**Cincinnati**—J. L. Andem.  
**Coshocton**—Burns & Gosser.  
**Dayton**—W. E. Sapp, 1042 W. Third st.  
**\*Greenville**—Omer E. Westerfield, 5th and Broadway.  
**Hicksville**—W. R. Holden Co.  
**Springfield**—D. & M. Vanderpool.  
**Uhrichsville**—F. A. Mazurie.  
**\*Wilmington**—Raymond Hale, or American Woolen Mills Co.

### PENNSYLVANIA.

**Athens**—J. T. Stalford, 405 Main st.  
**Bradford**—C. C. Griffen, 29 N. Washington st.  
**Lancaster**—J. H. Tragresser, 249 N. Queen st.  
**Lock Haven**—Floyd Gallery, H. W. Swope, Prop., 131 Main st.  
**\*Mauch Chunk**—Kuehner Bros., Prop. Kuehner's Phono. Parlors, 78 Susquehanna st.  
**Mt. Pleasant**—Benjamin Posner.  
**New Castle**—Will Hartland, 70 E. Long st.  
**Philadelphia**—A. R. Cassidy, 2783 Emerald st.  
 Wm. Dyer, 321 Queen st.  
 Thomas Gunson, 1003 Carpenter st.  
 Hawthorne & Sheble, 604 Chestnut st., or Oxford and Mascher sts.; also New York City.  
 A. Krouse, 832 Arch st.  
 Geo. W. Lowden, or Geo. W. Lowden, Prop. Pioneer Studio of Music, 2616 Frankford ave.  
 Penn Novelty Co., 15 South 9th st.  
**Pittsburg**—A. Lippard, 615 Wylie ave.  
**Royersford**—Granville B. Tyson, 215 Main st.  
**Titusville**—E. H. Fortney, Prop. Exchange Cigar Store, 21 W. Central ave.

### RHODE ISLAND.

**Providence**—E. H. Gainsbury, 59 Plainfield st.  
 F. P. Moore.  
 M. Steinert & Sons Co., Westminster st.  
 also Fitchburg, Pittsfield, Mass., and at all points.  
**Rockville Center**—O. A. Clark.

### TENNESSEE.

**Alexandria**—Clarence D. Baird Music Concern.

### TEXAS.

**Whitney**—H. E. Randle & Co.

### UTAH.

**Salt Lake City**—Daynes Romney Music Co., 25 East South 1st st.

### VERMONT.

**Barre**—Averill Music Co. (H. L. Averill & Co.), 28 N. Main st.

### VIRGINIA.

**\*Covington**—Covington Furniture Co., 213 Maple ave.  
**Norfolk**—W. Reichenstein, 296 Church st.

### WASHINGTON.

**Seattle**—Cline's Piano Co., 1205 2nd ave.

### WISCONSIN.

**Ashland**—J. F. Pool Co.  
**Milwaukee**—J. C. Blatzek.  
**Reedsburg**—Fish & Greenwood.  
**Walworth**—G. H. Stewart.

\*Added since April 1st, 1908.

Jobbers and Dealers are asked not to supply any of the above named firms with our apparatus, either at addresses given or any other address.



*"One touch of harmony makes the whole world kin."*

**T**HE Phonograph would never have become the great popular entertainer it is but for Edison. He made it desirable by making it good; he made it popular by making it inexpensive.

## *The* EDISON PHONOGRAPH

has brought within reach of all, entertainment which formerly only people of means could afford. It has even displaced more expensive amusements in homes where expense is not considered.

### THE NEW RECORDS FOR MAY

are the work of artists of reputation. Each is perfect of its kind and many of your kind are included. You can hear them at any Edison store April 25th. Get of your dealer, or of us, THE SUPPLEMENTAL CATALOGUE, listing all the new May Records, THE PHONOGRAM, describing each Record in detail, and the COMPLETE CATALOGUE, which lists all Records now obtainable for the Phonograph.

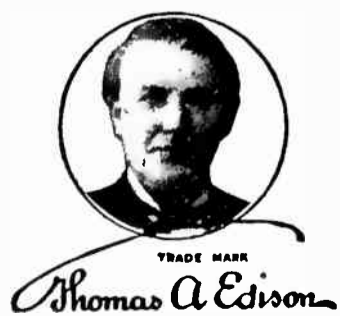

NATIONAL PHONOGRAPH CO., Lakeside Avenue, Orange, N. J.  
MAY MAGAZINE ADVERTISEMENT



# Jobbers of Edison Phonographs and Records

Continued from page 2 of cover

## NEW YORK.

**Albany**—Finch & Hahn, 402 Broadway.  
**Astoria**—John Rose, 99 Flushing ave.  
**Brooklyn**—A. D. Matthews' Sons, 894 Fulton st.  
**Buffalo**—W. D. Andrews, Seneca and Wells sts. Neal, Clark & Neal Co., 645 Main st.  
**Elmira**—Elmira Arms Co., 117 Main st.  
**Gloversville**—American Phono. Co., 99 W. Fulton st.  
**Kingston**—Forsyth & Davis, 307 Wall st.  
**New York City**—Blackman Talking Machine Co., 97 Chambers st.  
J. F. Blackman & Son, 2737 3d ave.  
I. Davega, Jr., Inc., 125 W. 125th st.  
S. B. Davega & Co., 32 E. 14th st.  
Douglas Phono. Co., Inc., 89 Chambers st.  
Jacot Music Box Co., 39 Union square.  
Victor H. Rapke, 1659 Second ave.  
Regina Co., 41 Union square.  
Siegel-Cooper Co., 6th ave. and 18th st.  
John Wanamaker, Broadway, 8th and 9th sts.  
Alfred Weiss, 1622 First ave.  
**Oswego**—Frank E. Bolway, 32 W. Bridge st.  
**Rochester**—A. J. Deninger, 345 North st.  
Mackie Piano, O. & M. Co., 100 State st.  
Talking Machine Co., 97 Main st., E.  
**Schenectady**—Finch & Hahn, 504 State st.  
Jay A. Rickard & Co., 253 State st.  
**Syracuse**—W. D. Andrews, 216 E. Railroad st.  
**Troy**—Finch & Hahn, 3 Third st.  
**Utica**—Clark-Horrocks Co., 54 Genesee st.  
Arthur F. Ferriss, 89 Washington st.  
William Harrison, 50 Columbia st.  
Utica Cycle Co., 16 Columbia st.

## OHIO.

**Canton**—Klein & Heffelman Co., 220 E. Tuscarawas st.  
**Cincinnati**—Ball-Fintze Co., 108 West 3d st.  
Ilsen & Co., 615 Vine st.  
Lawrence McGreal, 29 East 5th st.  
Rudolph Wurlitzer Co., 121 East 4th st.  
**Cleveland**—Eclipse Musical Co., 1870 East Ninth st.  
**Columbus**—Perry B. Whitsit Co., 213 S. High st.  
**Dayton**—Niehaus & Dohse, 35 E. 5th st.  
**Newark**—Ball-Fintze Co.  
**Toledo**—Hayes Music Co., 422 Superior st.

## OREGON.

**Portland**—Graves & Co., Inc., 65 No. Park st.

## OKLAHOMA.

**Oklahoma City**—Smith's Phono. Co., 818 West Main st.

## PENNSYLVANIA.

**Allentown**—G. C. Aschbach, 539 Hamilton st.  
**Easton**—William Werner, 432 Northampton st.  
**Harrisburg**—S. K. Hamburger, 12-14 N. Market square.  
**Philadelphia**—Louis Buehn & Bro., 45 N. 9th st.  
C. J. Heppe & Son, 1117 Chestnut st.  
Lit Bros., Market and 8th sts.  
Musical Echo Co., 1217 Chestnut st.  
Penn Phonograph Co., 17 S. 9th st.  
John Wanamaker, 13th and Market sts.  
Western Talking Mach. Co., 41 and 43 N. 9th st.  
H. A. Weymann & Son, 1010 Chestnut st.

\*Added since April 1, 1908.

## Pennsylvania—Continued.

**Pittsburg**—Pittsburg Phono. Co., 937 Liberty ave.  
Powers & Henry Co., 339 Second ave.  
Standard Talk. Mach. Co., 435 Wood st.  
**Reading**—Reading Phonograph Co., 48 N. 8th st.  
**Seranton**—Ackerman & Co., 217 Wyoming av. Technical Supply Co.  
**Sharon**—W. C. DeForeest & Son.  
**Williamsport**—W. A. Myers, 127-129 W. 3d st.

## RHODE ISLAND.

**Providence**—J. M. Dean Co., 785-795 Westminister st.  
J. A. Foster Co., Weybosset and Dorrance sts.  
J. Samuels & Bro., 154 Weybosset st.

## TENNESSEE.

**Chattanooga**—J. H. Templeman Co., 253 Montgomery ave.  
**Knoxville**—Knoxville Typewriter and Phonograph Co., 421 Gay st.  
**Memphis**—F. M. Atwood, 160 N. Main st.  
O. K. Houck Piano Co., 103 S. Main st.  
**Nashville**—Magruder & Co., 27 Arcade.  
Nashville Talking Mach. Co., 723 Church st.

## TEXAS.

**Dallas**—Southern Talking Machine Co., 347 Main st.  
**El Paso**—W. G. Walz Co., 101 El Paso st.  
**Fort Worth**—Cummings, Shepherd & Co., 700 Houston st.  
**Houston**—Texas Piano & Phono. Co., 1019 Capitol ave.  
**San Antonio**—H. C. Rees Optical Co., 242 West Commerce st.

## UTAH.

**Ogden**—Proudfit Sporting Goods Co., 351 24th st.  
**Salt Lake City**—Clayton-Daynes Music Co., 109 S. Main st.

## VERMONT.

**Burlington**—American Phono. Co., 34 Church st.

## VIRGINIA.

**Richmond**—C. B. Haynes & Co., 603 E. Main st.

## WASHINGTON.

**Seattle**—D. S. Johnston Co., Third ave. and University st.  
Kohler & Chase, 710 Pike st.  
**Spokane**—Spokane Phonograph Co., 7 Post st.

## WISCONSIN.

**Milwaukee**—Lawrence McGreal, 176 3d st.

## CANADA.

**Quebec**—C. Robitaille, 320 Rue St. Joseph.  
**St. John**—W. H. Thorne & Co., Ltd., 42-46 Prince William st.  
**Toronto**—R. S. Williams & Sons Co., Limited, 143 Yonge st.  
**Vancouver**—M. W. Waitt & Co., 558 Granville st.  
**Winnipeg**—R. S. Williams & Sons Co., Ltd., 121 Princess st.

# In the Words of Others

## "Sell I.C.S. Language Outfits"

The best proof that it will pay you to sell I. C. S. Language Outfits comes from the statement of dealers that have tried them. We have published several of these letters before; here is another one from the Denver

Dry Goods Co. This is piling up evidence that you are losing profits of from 10 to 30 per cent. on your business if you are not handling these Outfits. The phonograph system is fast becoming recognized as the most perfect way in the world to teach foreign languages. As a commercial enterprise, the I.C.S. System has always paid dealers well in the past, and it is growing very rapidly. Wouldn't it be a good idea for you



**THE DENVER DRY GOODS CO.**

Denver, Colo. 11/21/06

International Correspondence Schools  
Scranton, Pa.

Gentlemen:

In reply to your letter of the 17th inst., will say we considered the demonstration of Mr. Mistraud very successful and while he was here we sold several Language Outfits. We have also sold some since he left us. We expect to advertise these Language Outfits during December as gifts as you may rest assured we will communicate with the parties to whom demonstration was given and who have not as yet made a purchase. We think the plan of advertising or demonstrating these Outfits is successful and leads to sales which could not be obtained otherwise.

We have placed several orders with you since the demonstration and would like to know if we could make arrangements to purchase whatever we need in this line through your Denver office as we have had to do several times recently; same can be billed to us by you. This would be quite an accommodation to us.

We will keep you advised from time to time of the results of sales on I. C. S. Language Outfits.

Yours very truly,

THE DENVER DRY GOODS CO.,

per *A. Shultz*

to write us today for full particulars of what we can do for you? Let us put our advertising to work for you. It will not only bring you customers for language work, but will increase your regular business. Send us a postal card NOW.

**International Correspondence Schools**  
SCRANTON, PA.

# EDISON PHONO- GRAPH MONTHLY

Vol. VI

June, 1908

No. 6

## CONTENTS

	PAGE.		PAGE.
Summer Business .....	1	Attractive Stores .....	14
Advance List of New Edison Records for August .....	2	Ready for Your Scissors.....	15
Grand Opera in Summer.....	5	R. C. Bollinger's First Shipment.....	16
Ten Records by William Jennings Bryan...	6	Advertising Banner Free to Dealers.....	16
Newsy Notes .....	8	Jobbers' Convention.....	17
Tolstoy Uses the Phonograph.....	9	Window Dressing .....	18
Trade Information for Dealers.....	10	Effects of Trade Depression.....	19
Real Wolf Howls.....	11	Ready-Made Ads.....	21
What's the Use.....	12	June Advertising.....	22
Our New Power Plant.....	13	Suspended List for June, 1908.....	23
Personal .....	13	Jobbers of Edison Phonographs and Records, Cover pages.....	2 and 3

*Published for Trade use only by  
The National Phonograph Co., Orange, N.J.*

# Jobbers of Edison Phonographs and Records

## ALABAMA.

**Birmingham**—Talking Machine Co., 2007 Second ave.  
**Mobile**—W. H. Reynolds, 167 Dauphin st.  
**Montgomery**—R. L. Penick, 119 Dexter ave.

## ARKANSAS.

**Fort Smith**—R. C. Bollinger, 704 Garrison Ave.

## CALIFORNIA.

**Los Angeles**—Southern California Music Co., 332 South Broadway.  
**Oakland**—Kohler & Chase, Inc., 917-921 Wood st.  
**Sacramento**—A. J. Pommer Co., 9th and J sts.  
**San Francisco**—P. Bacigalupi & Sons, 1021 Golden Gate Ave.

## COLORADO.

**Denver**—Denver Dry Goods Co., 619 16th st.  
Hext Music Co., 15th and California sts.

## CONNECTICUT.

**New Haven**—Pardee-Ellenberger Co., Inc., 96 State st.

## DISTRICT OF COLUMBIA.

**Washington**—E. F. Droop & Sons Co., 925 Pennsylvania ave., N. W.

## GEORGIA.

**Atlanta**—Atlanta Phonograph Co., 10 Walton st.  
Phillips & Crew Co., 37-39 Peachtree st.  
**Waycross**—George R. Youmans.

## IDAHO.

**Boise**—Eller's Piano House.

## ILLINOIS.

**Chicago**—Babson Bros., 1419 19th st.  
Lyon & Healy, Wabash ave. & Adams st.  
James I. Lyons, 192 Van Buren st.  
The Vim Co., 68 E. Lake st.  
Montgomery Ward & Co., 111 Michigan ave.  
Rudolph Wurlitzer Co., 266 Wabash ave.  
**Peoria**—Chas. C. Adams & Co., 324 South Adams st.  
Peoria Phonograph Co., 416 S. Adams st.  
**Quincy**—Quincy Phonograph Co., 411 Hampshire st.

## INDIANA.

**Indianapolis**—Indiana Phono. Co., 45 Virginia ave.  
Kipp-Link Phonograph Co., 10-12 E. Washington st.  
A. B. Wahl & Co., 119 S. Illinois st.

## IOWA.

**Des Moines**—Hopkins Bros. Co., 620 Locust st.  
The Vim Co., 204 Seventh st.  
**Dubuque**—Harger & Blish, 904 Main st.  
**Fort Dodge**—Early Music House, 822 Central ave.  
**Sioux City**—Early Music House, 315 Court st.

## KENTUCKY.

**Louisville**—Montenegro-Riehm Music Co., 630 4th ave.

## LOUISIANA.

**New Orleans**—William Bailey, 600 Frenchman st.  
National-Automatic Fire Alarm Co., 514 Gravier st.

## MAINE.

**Bangor**—S. L. Crosby Co., 186 Exchange st.  
**Portland**—W. H. Ross & Son, 43 Exchange st.

## MARYLAND.

**Baltimore**—E. F. Droop & Sons Co., 231 North Howard st.

## MASSACHUSETTS.

**Boston**—Boston Cycle & Sundry Co., 48 Hanover st.  
Eastern Talking Mach. Co., 177 Tremont st.  
Iver Johnson Sptg. Goods Co., 163 Washington st.  
**Fitchburg**—Iver Johnson Sptg. Goods Co., 247 Main st.  
**Lowell**—Thomas Wardell, 111 Central st.  
**New Bedford**—Household Furnishing Co., 170 Purchase st.  
**Springfield**—Flint & Brickett Co., 439 Main st.  
**Worcester**—Iver Johnson Sptg. Goods Co., 304 Main st.

## MICHIGAN.

**Detroit**—American Phono. Co., 106 Woodward ave.  
Grinnell Bros., 219 Woodward ave.

## MINNESOTA.

**Minneapolis**—Thomas C. Hough, 913 Nicollet ave.  
Minnesota Phono. Co., 505 Washington ave., So.  
**St. Paul**—W. J. Dyer & Bro., 21-23 West 5th st.  
Koehler & Hinrichs, 255 E. 2d st.  
Minnesota Phonograph Co., 37 E. 7th st.

## MISSOURI.

**Kansas City**—J. W. Jenkins' Sons Music Co., 1013-1015 Walnut st.  
Schmelzer Arms Co., 710 Main st.  
**St. Louis**—Conroy Piano Co., 11th and Olive sts.  
Koerber-Brenner Music Co., 1006 Olive st.  
Silverstone Talk. Mach. Co., 1010 Olive st.

## MONTANA.

**Helena**—Frank Buser, 509 N. Main st.

## NEBRASKA.

**Lincoln**—Ross P. Curtice Co., 1125 O st.  
H. E. Sidles Phono. Co., 13th and P sts.  
**Omaha**—Nebraska Cycle Co., 15th and Harney sts.  
Shultz Bros., 16th and Chicago sts.

## NEW HAMPSHIRE.

**Manchester**—John B. Varick Co., Varick Bldg.

## NEW JERSEY.

**Hoboken**—Eclipse Phono. Co., 203 Washington st.  
**Newark**—Douglas Phonograph Co., 20 New st.  
A. O. Petit, 57 Halsey st.  
Rapke Phono. Store, 287 Bank st.  
**Paterson**—James K. O'Dea, 117 Ellison st.  
**Trenton**—Stoll Blank Book and Stationery Co., 30 E. State st.  
John Sykes, 105 N. Broad st.

Continued on page 3 of cover

# Edison Phonograph Monthly

VOL. VI.

June, 1908

No. 6

## Summer Business

The Edison Dealer must begin now to talk up the Edison as the world's leading summer-time entertainer. No form of summer amusement is better than sitting on the porch or lawn and listening to the bright, snappy song hits from the new musical plays, or to charming band pieces played with real military dash and swing by the Edison Military Band. Did you ever hear an Edison on a summer's night across the lawn or over a stretch of water? Great! Here is an opportunity to paint a word-picture that will make your customers hungry for an Edison Phonograph, and don't forget the possibilities of the Edison for furnishing the finest two-steps and waltzes for summer dances.

How about the people who are going away for the summer? They will be in a position to take life much easier perhaps than at home, so must have more music to fill idle hours. They will not take their pianos along. Why not an Edison? It is so easy to carry one from place to place, and they can have the new Records mailed to them if they wish. Look through your city directory and pick out the names of persons who will likely go away for the summer. Suggest by letter or personal call that they take a Phonograph with them. Tell them all about how easy it will be to have the new Records mailed to them. This will land you a few sales.

How about your vacationists—business men and women who go away for visits of ten days or more? Some of them will take Edison Phonographs if you only bring it to their attention. Get up a list of business people who go away on vacations and go after them the same as you do after families who go for the summer. One letter could be gotten up that would do to send both classes—something like the following:

Dear Mr. Smith:

Going away this summer?

You will certainly want to take an Edison Phonograph with you.

It's as easy to carry as a hand-satchel. And there'll be no dull moments on your vacation.

You can pick out a selected assortment of good Records, and should you want others, we will gladly mail them to you.

When you get back you will have the Edison as a permanent feature of your home. You can look to it for no end of the cleanest and best entertainment in the world. Ask any Edison owner.

Have you heard the new type of Phonograph, which embodies Thomas A. Edison's latest ideas, including the big horn that gives a perfectly natural and musical reproduction?

Did you know that the new-process Edison Records will wear for years and be as good as the day you got them?

And, best of all, did you know we will sell a complete, up-to-date Edison "Gem" Phonograph for \$12.50 or a "Standard" for \$25.00 on terms as low as \$1.00 a week?

Come in and hear a few of the new Records. It's a pleasure to play them whether you think of buying a Phonograph or not.

Yours very truly,

T. A. WILLIAMS & CO.

No doubt you can improve greatly on the above letter. However, it gives a good idea of what should be used. Put vacation talk into your newspaper advertisements. Remember, the quieter the places they go on vacations the more enjoyable an Edison will be. Whatever you do, don't let any present owners of machines slip away without taking their Phonographs and a lot of new Records along. When you mail out your next Supplements put in a type-written circular on this subject.

Here is another thought: why not interest the summer hotels and boarding houses in Edisons? Could anybody use one to any better advantage? Furthermore, think of what fine Record customers they would make. Their guests would enjoy the concerts, and dances could be arranged for any evening without the expense of a regular orchestra to furnish the music.

Are there any moving picture shows in your section? Any new ones starting up this season? They need Edison Phonographs for attracting people at the front and for the illustrated songs that are a feature of the programs of most of the shows of this class. Did you ever try giving free Phonograph concerts at lawn party fetes and other church entertainments during the summer? There are many such, and you can get some fine advertising by taking advantage of such occasions.

## Advance List of New Edison Records for August, 1908

**R**ECORDS listed below will be shipped from Orange in time to reach all Jobbers in the United States and Canada before July 25th, 1908, all things being favorable, and they may be reshipped to Dealers at 2 P. M. on July 24th. They must not, however, be exhibited, demonstrated or placed on sale by Jobbers or Dealers until 8 A. M. on July 25th. Supplements, Phonograms and Bulletins will be shipped with Records. These may be distributed to Dealers after July 20th, but must not be circulated among the public before July 25th. Jobbers and Dealers may, however, deposit Supplements and Phonograms in Mail Boxes or Post Offices after 5 P. M. on July 24th, for delivery on the following day. Jobbers are required to place orders for August Records on or before June 10th. Dealers should place August orders with Jobbers before June 10th to insure prompt shipment when Jobber's stock is received.

### 9890 Sweet Sixteen March

Edison Military Band

Kerry Mills' latest march and one of his best. To many this is the only recommendation needed. "Sweet Sixteen" has an infectious military air running through it and has inspired the Edison Military Band to give one of their most spirited performances. A fine out-of-doors Record for summer nights. Music, Kerry Mills; publisher, F. A. Mills, New York.

### 9891 Only an Old Fashioned Cottage

Manuel Romain

A sentimental home ballad of very decided heart-interest. Mr. Romain has endeared himself to Phonograph owners everywhere by his charming rendition of songs of this type. The national reputation he first won as a minstrel tenor has been fully equalled by the great following he has built up as an Edison artist. The sub-title of the song is, "But it's all the World to Me." The words and air are so fascinating that they will hold one's interest from beginning to end. Orchestra accompaniment; music, Alfred Solman; words, J. Hayden-Clarendon; publishers, Jos. W. Stern & Co., New York.

### 9892 It Always Comes With the Summer

Dorothy Kingsley

A new Edison singer makes her debut in this dainty summer song and makes good too. While it is different in style from both, still there is much in this song to recall two other famous successes by the same composer, "The Bird on Nellie's Hat" (our Record 9450) and "When the Snowbirds Cross the Valley" (our Record 9459). Orchestra accompaniment; music, Alfred Solman; words, Arthur J. Lamb; publishers, J. W. Stern & Co., New York.

### 9893 Lady Binnie and the Shores of Lake Erie

William Craig

A new Edison artist, William Craig, the violinist, of Glenburnie, Scotland, is presented with this Record. Mr. Craig was especially engaged to give us a series of the celebrated Scotch dances, Strathspey and Reel. His first selection offers an opportunity for some dexterous bowing and shows him to be a violinist of very unusual ability. Piano accompaniment. Original and not published.

### 9894 I Want to be Loved Like a Leading Lady

Ada Jones

The comic song success that Marie Dresser has used to delight thousands in "The Girl Behind the Counter." Mandy Lee's beau hugged too much like a bear to suit her high ideals. What she most wanted was to be wooed and won in the tender passionate way of her favorite stage heroes. Ada Jones is entirely at home in this selection. Orchestra accompaniment; music, Herman Avery Wade; words, Paul West; publishers, J. W. Stern & Co., New York.

### 9895 Yankee Doodle Comes to Town

Billy Murray

General U. S. Grant used to say he only knew two tunes; one was Yankee Doodle and the other wasn't. Here is a "Yankee Doodle" song that is a sure enough "dandy." It is being featured in the latest Geo. Cohan show, "The Yankee Prince." We think this George Cohan-Billy Murray number is due to repeat the success of "Yankee Doodle Boy" (our Record 8900) and "You're a Grand Old Flag" (our Record 9256). Orchestra accompaniment; music and words, Geo. M. Cohan; publishers, Cohan & Harris Pub. Co., New York.

**9896 By the Old Oaken Bucket, Louise****Frederic Rose**

One of those songs, distinctly popular in flavor, that the public seem never to tire of. It recites "Love's old, sweet story" in a setting that is very familiar to most:

Let us wander over yonder, where in childhood,  
I first told love's story old, my dear Louise,  
Down the hillside past the millside, through the wildwood,  
To the little rustic bench beneath the trees.  
Can't you see the moonlight gleaming on the well, dear,  
And the oaken bucket hanging by the chain?  
And in fancy's golden land, tonight let's dwell, dear,  
Those happy days let's live them o'er again.

By the old oaken bucket, Louise,  
While the moon shed its light thro' the trees,  
There I drank from your eyes, 'neath the soft summer skies,  
That sweet story old, your lips never told.  
In the deep mossy dell, dear Louise,  
By the old fashioned well, on my knees,  
And I vowed I'd be true, just to you, only you,  
By the old oaken bucket, Louise.

Mr. Rose sings the entire selection in capital voice and the effect of an exceedingly pretty refrain is augmented by an accompaniment of bells and violin. Orchestra accompaniment; music, Harry I. Davis; words, Earle C. Jones; publishers, J. W. Stern & Co., New York.

**9897 Forest Whispers****Edison Symphony Orchestra**

This is the kind of selection in which the Edison Symphony Orchestra most delights. The music can best be described as softly sweet with a perfect blending of remarkably lifelike bird whistling and some clever bells solo work. We do not know of an instance in which music and title have fitted one another better, for the effect of this piece, as played by the Symphony Orchestra, is about as soothing as a trip through a picturesque stretch of woods in mid-summer. Music, F. H. Losey; publisher, Carl Fischer, New York.

**9898 Mother Hasn't Spoke to Father Since****Arthur Collins**

It seems Father had a letter in his pocket from some other lady whom Mother at once took to be an Affinity. She also found a hair upon his coat. That would seem to be about the limit. But no, Dad did not stop at simply causing her jealousy. He left the window up one stormy night with the thermometer 22 below. The bed filled with snow and when Father awoke to find his feet icy cold his first thought was to raise their temperature by a hot application of Mother's back. Mother made it warm for him all right when she came to and "Mother Hasn't Spoke to Father Since." Two verses and three choruses. Orchestra accompaniment; music, Jean Schwartz; words, Wm. Jerome; publishers, Shapiro, New York.

**9899 The Home Over There****Edison Mixed Quartette**

No lover of sacred music will willingly miss the chance to add this beloved hymn to his collection. As it is sung by the Edison Mixed Quartette, unaccompanied, the full effect of its noble words and music, which have been an inspiration and an incentive to countless thousands, is obtained. Music, Tullius C. O'Kane; words, Rev. D. W. C. Huntington.

**9900 Let Me Hear the Songs My Mother Used to Sing****Byron G. Harlan**

This attractive ballad contains a very pretty bit of sentiment, the scene portrayed being that of boyhood's happy home graced by the songs and gentle care of a sainted mother. The words:

I can see the shady woodland by a bright and sparkling stream,  
Where a boy I used to wander all the day,  
And I see the fragrant blossoms as they used to brightly gleam  
In the dear old days that long have pass'd away.  
When the shadows fell at evening to our happy little home,  
I would hasten with a heart that knew no care.

For I always found her waiting when at eventide I'd come—  
Mother's face and mother's songs were always there.  
REFRAIN:  
Let me hear the songs I heard in days of childhood,  
Let me feel again the joys they used to bring;  
Far away tonight I'm lonely for their music,  
Let me hear the songs my mother used to sing.

Harlan sings it with a world of feeling. Indeed his manner strongly recalls that great seller by himself, "Always in the Way," (our Record 8501.) Orchestra accompaniment; music, Edward Gabriel; words, Janet Gordon; publishers, McKinley Music Company, New York.

**9901 Blue Violets****Edison Concert Band**

A really excellent concert number—one of the earlier and best known compositions of Rich. Eilenberg, the celebrated European composer. Its leading features are a showy introduction, a brilliant clarinet cadenza and a mazurka movement of unusual grace and beauty. Music, Rich. Eilenberg; publisher, Carl Fischer, New York.

**9902 When the Autumn Moon is Creeping Thro' the Woodlands****Will Oakland**

This Record introduces a new Edison artist, Will Oakland. He has a counter-tenor voice of bell-like sweetness, which is heard to excellent advantage in this pretty, romantic ballad:

I can see in fancy far away, the mossy meadow brook,  
And the cottage with the ivy 'round the door;  
Once again with you I linger, dear, in a bright and sunny nook,  
On our way to school my sweetheart, my Lenore.  
We were children then together and my first true love was yours.  
Would you have me now forget those happy days?  
They will linger in my mem'ry, dear, as long as life endures,  
And cheer me in a thousand different ways.

CHORUS:  
When the Autumn moon is creeping thro' the woodlands,  
When its golden lustre floods the meadows o'er,  
By your side I seem to be,  
Waiting by the old oak tree,  
When the Autumn moon is creeping thro' the woodlands,  
sweet Lenore.

Many of our Edison friends have expressed a desire to hear a good counter-tenor or falsetto singer, and Mr. Oakland can rest assured of a flattering reception. Orchestra accompaniment; music, Alfred Solman; words, Monroe H. Rosenfeld; publishers, J. W. Stern & Co., New York.

**9903 A, B, C's of the U. S. A.****Ada Jones and Billy Murray**

Alphabet songs are the "latest." It remained for George M. Cohan to top all such successes with this unique Alphabetic Duet. It is easily one of the brightest things in "The Yankee

Prince," the newest Cohan show. The breezy musical dialogue as given by Ada Jones and Billy Murray will be pronounced O. K. from A to Z. Orchestra accompaniment; music, and words by Geo. M. Cohan; publishers, Cohan & Harris, New York.

**9904 I'm Savin' Up My Money for a Rainy Day**

**Edward Meeker**

A genuine comic rag-time song that recalls the well known "All In, Down and Out" (our Record 9492). Like his selfish predecessor this coon believed firmly in holding on to a dollar every time he got his hands on one, only his stinginess carried him to much greater extremes, which are told about in the song. The chorus has a musical swing. Orchestra accompaniment; music, Percy Wenrich; words, C. P. McDonald; publishers, McKinley Music Company, New York.

**9905 "Dialogue"—Flute and Clarinet**

**Edison Symphony Orchestra**

Something decidedly new: an animated musical conversation between a flute and a clarinet with the orchestra "butting in" between times. A clever idea, which was originated by a well known European composer. The questions and answers are clearly defined and easily understood. A highly interesting and amusing Record. Music, J. V. Hamm; publisher, Carl Fischer, New York.

**9906 All For Love of You**

**Harry Anthony**

A love song by the composer of the most popular ballad of the day, "Love Me and the World is Mine" (our Record 9371). Few songs have been waited for more eagerly than "All for Love of You," but we feel that it will fully measure up to expectations, as it's the same style of sentimental ballad as its famous predecessor and gives Mr. Anthony equally as good a chance to display his sweet high-tenor notes. First verse and refrain:

The world to me seems born anew,  
Since fate, love, guided you my way;  
My life is but a golden dream of you.  
Ah! would that dream might last for aye.  
My path was as the darkest night,  
What lay beyond I never knew  
Till lo! your beauteous vision brought the light  
And now I live, dear, all for love of you.

All for love of you, dear heart,  
All for love of you,  
I'd gladly brave e'en death's dark lair  
If I but thought I could serve you there.  
Dismal waste though the earth might be,  
Shorn of all beauty, too,  
Your eyes would make it as heav'n to me,  
And I'd live all for love of you,  
All for love of you.

Orchestra accompaniment; music, Ernest R. Ball; words, Dave Reed; publishers, M. Witmark & Sons, New York.

**9907 A High Old Time in Dixie**

**Collins and Harlan**

We feel perfectly safe in guaranteeing a great demand for this dandy negro duet by those two past-masters, Collins and Harlan. It's in the same class as "Nigger Loves His Possum" (our Record 9160) and "Bake Dat Chicken Pie" (our Record 9499). Rastus and his Mandy have been north and are "Gwine Back to Dixie." A farewell committee of friends wait on them at the train and there are great doings. As the train pulls out the clang of the engine bell and the toot of the whistle are mingled with cheering and affectionate good-byes. Orchestra accompaniment; music, George Schleiffarth; words, Ben Lowen; publishers, Albright Music Co., New York.

**9908 For the Red, White and Blue**

**James F. Harrison**

An inspiring song of our new navy, dedicated to "Fighting Bob" Evans. Patriotic devotion to Old Glory is reflected in every line and there is a swing to the music that makes you mark time. Mr. Harrison sings it with an enthusiasm that amounts almost to a patriotic hurrah in the chorus. Orchestra accompaniment; music and words, Monroe H. Rosenfeld; publisher, The Powers Clearing House, New York.

**9909 The Kerry Mills Barn Dance**

**Edison Symphony Orchestra**

The barn dance is on the top wave of popularity this summer. Kerry Mills, of "Georgia Camp Meeting" fame, has given us a typical barn dance number that is sure to be accepted at once as the standard for this class of music. The music is perfectly timed for the steps of the dance and the orchestration is above criticism. Music, Kerry Mills; publisher, F. A. Mills, New York.

**9910 I'm the Man**

**Bob Roberts**

Everybody knows what a great success "That's Gratitude" (our Record 9864) has been. The words and music of this song are by the same composers. Of course, Bob Roberts had to sing this as well as their earlier effort. Notice particularly the self-conceited and self-sympathetic way in which he says, "I'm the Man." That alone is worth the price of the Record. The words of the two verses and choruses are so clever we give one of each below:

Who held the Nation's honor high at old Manila Bay?  
I'm the man.  
And in the scrap at San Juan Hill, who was it saved the day?  
I'm the man.  
Who faced the hell of shot and shell that came with each attack,  
Who saw his comrades all around him falling in their tracks,  
Who bears the battle scars to-day, three bullets in his back?  
I'm the man.

I'm the man, the very self-same man,  
That wore a soldier's uniform, and marched behind the band.  
We've got good fighters left us yet,  
And some fast runners, don't forget,  
But who can beat them on a bet?  
I'm the man.

Orchestra accompaniment; music, Sheppard Camp; words, George A. Norton; publishers, F. B. Haviland Co., New York.



**9911 Fun at the Music Counter**

Jones and Spencer

A laugh-making burlesque on familiar scenes at a sheet-music counter. The fun results from the saleslady taking the literal meaning of the titles of songs asked for by customers. An Irishman calls for "Won't You Come Out To-night, Mary Ann" and she considers he is asking for a date. Somebody asks for "The Songs My Mother Used to Sing." "What songs did she sing? I'm no mind reader," is the answer he gets. The saleslady, cash boy, floor-walker, also a German, Irishman, Rube, Tough and several other customers get in on the fun, which is fast and furious, and concludes with "Much Obligated to You" sung by the saleslady. Original vaudeville sketch not published.

**\*9912 Finnegan's Flat**

Steve Porter

A laughable descriptive sketch which tells of how Mike and Mary Ann did their best to observe the Day of Rest in their flat. Their plans were opposed by their musical neighbors. There was a crying infant, an amateur cornetist, a couple of pianos in the hands of the O'Brien and Guggenheimer kids, a near-professional trombonist, taking a fall out of the "Merry Widow Waltz," and a German Saengerbund—the grand finale being a united effort to break the Finnegan door down. Mike, in despair, goes bravely out to mix it with his tormentors. There are vivid sounds of a free-for-all fight and Mike returns to Mary Ann with a black, black eye. She asks who did it, is told the "Dutchman," and begins to call him fearful names, but Mike cautions her, "Don't spake that way o' the dead." The sketch is original and is not published.

**9913 "Smarty" Medley**

Edison Military Band

A highly effective medley arrangement of three recent song hits; "Smarty," the dainty child-song in which Ada Jones scored last month (our Record 9872), "Summertime," the tuneful Von Tilzer number (our Record 9835), and "I Was a Hero, Too," another of the July successes, sung by Billy Murray (our Record 9880). Nothing in the way of a band piece meets with wider popular favor than a good medley, played with characteristic dash by the Edison Military Band. A Record of this description, that combines several up-to-date hits, represents extra value for the cost. Arrangement is special for our Record and not published.

---

## 2 Selections Made Over.

We list below two selections that have been made over by the same talent. The August printed matter prepared for detail use will contain these selections. Jobbers should replace their stock of the original Records of these numbers with the new ones.

**7597 Over the Waves Waltz**

Joe Belmont

**8838 Jovial Joe**

Edison Military Band

Formerly by Edison Concert Band

\* This selection will be illustrated on the cover of the August *Phonogram*.

---

### Grand Opera in Summer

Had it occurred to you that Edison owners can listen to Grand Opera all summer when their friends in the great opera centers have to make out on the memory of last seasons' performances? There's a thought well worth acting on. Patrons of the Metropolitan and Manhattan Opera Houses in New York City must wait until next fall before the great Scotti, Constantino, Abott, Campanari, Rappold, and the many other Edison opera stars can be heard again. The great singers are now away enjoying well-earned vacations, but the Edison Grand Opera Records mean opera all summer—on the porch—beneath the trees—in vacation haunts. Edison owners can hear at their pleasure all the music that New Yorkers raved over and spent hundreds of thousands of dollars to hear the past season. Put this thought before the more musical of your customers.

### One Dealer's Success

There is one point about the Edison Phonograph that sticks out with the distinctness of a sore thumb, and that is, there is nothing to compare with it as a profitable side-line. We receive hundreds of letters like the one printed below. Many of them state that while the Dealer took the Edison on as a side-line at first, it soon became his leader.

A. H. Curry, Corpus Christi, Texas.

Kodaks & Supplies, Phonographs & Records.

"At the time of placing my initial order for Edison Phonographs and Records, two years ago, the net worth of my business was less than \$700. To-day it is worth \$3,800, and is on a secure foundation. I have made \$6,000 in a little over two years, which is not bad, considering the size of my town and the limited amount of capital on which I started. I now carry in stock all of the American and Mexican Records, and can at all times give my customers just what they want."

The ten Bryan Records are going to help you do a fine summer business. See pages 6 and 7.

## Ten Edison Records by William Jennings Bryan

**W**E take great pleasure in announcing ten Edison Records by William Jennings Bryan. They were made by the "Great Commoner" in the library of his home in Lincoln, Nebraska, one of our recording experts going there for the purpose. They are among the plainest and most natural Records we have ever turned out. No one who has ever heard Mr. Bryan speak will fail to recognize all of the wonderful charm of voice and manner for which he is famous.

Mr. Bryan needs no introduction. His prominence as the two-time and prospective third-time Democratic candidate for President, together with his remarkable gifts as an orator, have made him known everywhere, while his upright, Christian character and fearless exposition of his political beliefs stamp him as one of the foremost Americans of history.

The Records are composed of telling passages chosen by Mr. Bryan from his favorite orations. Hearing one of these tabloid addresses produces the same effect as a long speech from almost anyone else, so carefully has Mr. Bryan chosen his remarks.

In soliciting trade on these Records, Jobbers and Dealers should not fail to make it plain that the Records are made by Mr. Bryan himself and that they will appeal very strongly to women as well as men, as women always flock in large numbers to hear Mr. Bryan whenever he makes a public speech.

The Bryan Record should go a long way towards offsetting the present trade dullness. We shall not be surprised if they outsell any set of Records we have ever issued, owing to Mr. Bryan's prominence in the current Presidential campaign.

---

***T**HE Bryan Records will be shipped from Orange to all Jobbers in the United States and Canada as soon after June 1st as possible, and they will be reshipped to Dealers as soon as received. They may be placed on sale at once. Dealers will ship Supplements to such Dealers as place orders for these Records. State number required. Dealers should at once place orders with Jobbers to insure prompt shipment when Jobber's stock is received.*

---

### TEN RECORDS BY WILLIAM JENNINGS BRYAN

#### 9914 Swollen Fortunes

This is a subject of national interest that is likely to figure prominently in the coming Presidential campaign. Mr. Bryan favors active enforcement of the "Equal rights to all, special privileges to none" clause of the Bill of Rights, in order to secure a more equal distribution of the country's wealth. The reasons he advances for his views form a veritable gem of political logic. They are sure to cause wide discussion when Mr. Bryan takes the "stump" actively later on.

#### 9915 The Labor Question

In a thoroughly characteristic way Mr. Bryan upholds the fairness of the eight-hour day and arbitration of labor disputes. With equal vehemence he attacks government by injunction, which, he states, amounts to a practical denial of the laboring man's right to trial by jury. These are all live topics of the day and the Record will appeal particularly to the laboring classes. Every paragraph is a carefully rounded period freighted with vivid meaning.

**9916 The Railroad Question**

"Where does Bryan stand on the Railroad Question?" is being asked on all sides. He has been so widely, and in most cases, erroneously, quoted since his recent Madison Square Garden speech that the whole country has been waiting for an authoritative answer to their question. This Record comes as his personal word on this important subject. It is certain to be greatly in demand.

**9917 The Trust Question**

A brilliant exposition of the Bryan idea of trusts and trust evils, delivered with all of that rare enthusiasm with which the speaker is gifted. You may or may not share his political views, but must admit that none has ever shown a better mastery of the greatest problems of the day. He says: "Private monopolies can not be regulated by the government. We have tried that and the result was the monopolies regulated the government instead of being regulated by the government." He advocates extermination as the only practical remedy and brings the full measure of his persuasive eloquence into play to drive the point home.

**9918 The Tariff Question**

"During the civil war," says Mr. Bryan, "the tariff was raised to carry on the war. It was continued after the war to allow our infant industries to stand on their feet. But it was not long until the 'infant industries' were standing not only on their own feet, but all over the feet of other people." A telling shot on the tariff. It is one of many delivered in his most vigorous style, for the tariff has always been a favorite subject with Mr. Bryan.

**9919 Popular Election of Senators**

Never is the commanding power of Bryan's eloquent logic shown off so favorably as when he strikes at some great legislative evil. He describes the popular election of Senators as "The most popular reform of the day." What follows is of the deepest interest, for it gives us a splendid example of his wonderful grasp of public questions and his untiring zeal in getting at the bottom of existing evils. This Record will appeal to all alike for, as Mr. Bryan points out, it is not a party question.

**9920 Imperialism**

This is a subject on which Mr. Bryan never fails to delight his hearers. Territorial expansion will never want for a "fiery foe" so long as he is in the lists. "Our experiment in Colonialism has brought us not profit but loss," he says, and piles argument upon argument to show that he is in the right. He believes the retention of the Philippine Islands to be contrary to all American precedent and to the republican form of our government, which derives its power from the consent of the governed. The climax of his address comes with an impassioned demand that the Filipinos be given their independence and allowed to work out their own destiny.

**9921 Guaranty of Bank Deposits**

Here is a subject that is brimming with interest because it outlines the much-discussed Bryan remedy for the banking troubles through which the country has just passed. "The Government demands protection on its own deposits," says he. "Why should not private individuals have equal protection?" This Record also treats of a live political issue and the Record will undoubtedly be very popular.

**9922 An Ideal Republic**

Perhaps no American of to-day can equal Mr. Bryan in the difficult dual art of conceiving ideal conditions and finding suitable language for describing them. This Record gives him the same kind of opportunity as his speech on "Immortality," and seldom has he drawn on the wonderful store-house of his imagination with such fine effect. "Behold a Republic," he exclaims, "where every citizen is a sovereign, but none cares to wear a crown; whose flag is love while others' is only fear." His peroration is very fine and concludes with these words, "A Republic, whose history, like the path of the just, is as the shining light that shineth more and more unto the perfect day."

**9923 Immortality**

This Record consists of selections from Mr. Bryan's best known lyceum lecture, "The Prince of Peace." Mrs. Bryan likes it best of all his addresses. We do not recall having heard a more affecting description of supreme faith in a "life beyond." Mr. Bryan is evidently as profound a thinker upon such questions as upon those affecting the country's political welfare. There are passages in "Immortality" that have rarely been excelled for beauty of thought and expression. It shows the speaker at the height of his oratorical powers, and, as an example of fervent American oratory, can only be classed with Ingersoll's "At the Tomb of Napoleon."

## Newsy Notes

Ross P. Curtice Co., Edison Jobbers of Lincoln, Neb., are getting out a house organ, which they call "The Curtice Phonometer." The first issue is highly creditable and contains much interesting news matter. The Phonometer will be mailed free to Dealers in Phonographs, pianos, small instruments, and sheet-music in the section tributary to Lincoln.

Lawrence McGreal, Edison Jobber of Milwaukee, Wis., has moved to his handsome new quarters at 172-176 Third street. Saturday, April 25th, was formal opening day and 10,000 visitors including Mayor Rose and the city officials, called to inspect the beautiful store. Each visitor received rose and carnation souvenirs of the occasion. Mr. McGreal was also the recipient of a large number of floral offerings from Milwaukee's leading business men. A feature of the new establishment is eight sound-proof Record Parlors. These are octagonal in shape and are finished in mahogany and French bevel plate glass. The equipment of the entire store is of correspondingly high grade. Every improved feature for the conduct of the wholesale and retail Phonograph business on a large scale is to be found on the four floors of the building, which makes one of the handsomest talking-machine establishments in the country. Mr. McGreal has been in business in Milwaukee since 1902 and has quickly become recognized as one of the foremost business men of the city.

Charles E. Robertson, formerly a successful Edison Dealer at 4223 Lancaster Avenue, Philadelphia, has discontinued business at his old stand in order to take charge of the retail department of Louis Buehn & Brother, 45 North 9th Street, Philadelphia.

The Milner Music Company, 25-27 West 6th Street, Cincinnati, Ohio, have bought out the Edison Jobbing Agency of L. E. McGreal of that city, and will succeed that firm as wholesale representatives of the Edison goods. The Milner Music Company are widely known as successful dealers in pianos, Edison Phonographs and musical merchandise. Joseph Milner, President, and Raymond Strief, Secretary and Treasurer, are excellent types of hustling, modern music tradesmen and there is no doubt that they will make a fine record as Edison Jobbers.

Louis Buehn & Brother, Edison Jobbers at Philadelphia, suffered about \$1,200 water damage from a fire on the fourth floor of their building May 2nd. There was no interruption of regular business.

It is seldom that a lot of new Foreign Records sell as rapidly as have the 10 German, 16 Swedish and 6 Polish Records announced in last month's PHONOGRAPH MONTHLY. They are being ordered out in unusually large numbers by Jobbers who look for a wide demand. They are better than any previous Records in those languages. Jobbers' shipments will go forward between June 1st and 10th.

Jobbers should see to it that their Dealers get the benefit of the reduced freight rate on horns. Nested horns in shipments of two or more now take first-class rate, as against 1½ times first-class previous to May 1st. Single horn shipments take 1½ times first-class, instead of the old double first-class.

The five new Grand Opera Records for July will probably prove to be the most popular we have ever issued. Jobbers' orders are even heavier than expected. Dealers who have not already ordered, should do so at once, or Jobbers may not be in a position to supply them in time for opening day, which is June 25th.

The fifteen French and fifteen Holland-Dutch Edison Records that went on sale April 1st are having a very gratifying sale. Are there any French or Holland-Dutch people on your list of Phonograph owners? They will be greatly pleased with these excellent Records. Are there not a number of families of these nationalities in your city who would be glad to invest in an Edison if they knew they could get their native music by the best native singers?

A few of the three-color prints of our famous oil painting, "The Phonograph," are left. Jobbers who speak quickly can get them for their Dealers' use. No charge.

We shall be very glad to hear from Dealers who have made a success by putting in the complete line of Domestic Records, also from those who are building up a good trade on the Foreign Records. Address the Advertising Department.

## Truth in Advertising

The more truth you put into your advertising the stronger it will be. A promise made must be kept, because no business can now be sustained by dishonest methods. The confidence of people may not be abused without a reaction. Once lost it is never regained. Some misstatement is made and it will take a generation to kill that lie.—*Talking Machine World*.

## Tolstoy Uses the Phonograph

The millions that admire and love Tolstoy will learn with interest that that wonderful old gentleman, now eighty years of age, has just begun using an Edison Phonograph as a labor saving device.

Tolstoy learned from Stephen Bonsal that many newspaper reporters used Phonographs. Bonsal told the story to Tolstoy, while visiting the grand old Russian, and the latter was deeply interested.

Subsequently Arthur Brisbane, of the *New York Evening Journal*, who had bought seven of the Edison Phonographs at different times for his own use, sent to the Edison Business Phonograph Company an order to ship a Phonograph with full equipment of cylinders, etc., to Mr. Tolstoy in Russia, as a present from the Hearst newspapers.

The order reached the hands of Thomas A. Edison, who insisted that he himself would send the Phonograph to Tolstoy.

Tolstoy got the Phonograph, and is using it, as may be seen from the letter received by Mr. Brisbane some time since from Vladimir Tchertkoff, Mr. Tolstoy's literary agent and intimate friend.

Dear Sir:—My friend, Leo Tolstoy, has requested me to inform you that he has at last received the Phonograph so kindly sent him. He thanks you most cordially for your kind attention and begs you to transmit to Mr. Edison his sincerest thanks for his generous present.

He does not usually care about new inventions of a complicated mechanical kind, seeing that their practical application is as yet mostly confined to the needs and fancies of the wealthy and used for purposes of more successful oppression and exploitation. But in this particular case he is *exceedingly* glad of the possibility granted to him of dictating into this wonderful instrument answers to the numerous letters he receives and has to deal with after his day's literary work, when he naturally feels tired from writing and desires quiet and solitude.

I may add that incidentally this instrument will be the means of conserving his voice for those who are not able to converse personally with him, and for future generations, which will undoubtedly afford great pleasure to many and many.

I have just come from Tasnaya Poliana, where, together with another friend, I have fixed up the apparatus sufficiently well to take and reproduce his dictation and reading. But in order to put everything in perfect order and give his daughter, who is his amanuensis, the necessary instructions for keeping the machine in good working order, I have engaged a mechanic in Moscow who will in a few days run down to Tasnaya for this purpose.

I will in a short time send you and Mr. Edison a copy of all my publications of Tolstoy's and

kindred writings in English, issued under the forms of "The Free Age Press," and beg you and Mr. Edison to accept them as a very slight token of my deep feeling of gratitude to you for your kind consideration towards one whose life work we esteem in common.

Yours very sincerely,

VLADIMIR TCHERTKOFF,

Editor of "The Free Age Press."

The *New York Journal*, commenting on the incident in its editorial columns, says:

"The use of the Phonograph is perfectly simple, but it is intensely interesting to know that Mr. Tolstoy, in his old age, is still young enough to utilize this modern invention to simplify the task of communicating thought to the rest of the world.

How beautifully and simply mankind's problems are solved when human beings co-operate to help one another, instead of combining to fight one another!

Here you have the mechanical genius of an Edison serving marvelously the literary genius and the high conscience of a Tolstoy. The fine combination of two kinds of human genius benefits the entire world. Thomas A. Edison represents America and its kind of brains just about as Tolstoy represents Russia and its mental strivings."

Subsequently to the receipt of the above-mentioned letter by Mr. Brisbane, Mr. Edison received the following from Tolstoy himself:

Tasnaya Poliana, Toula, Russia.

Dear Mr. Edison:—

My friend Tchertkoff has already, at my request, written to thank you for the Phonograph you have so kindly given me. But owing to a misunderstanding the letter was posted to you without having previously been handed to me to be signed as I had intended to do.

Not wishing to appear discourteous, I am now sending you these lines in order to repeat how grateful I feel to you for your amiable attention. I am using your Phonograph for answering letters and as I gradually get more accustomed to its manipulation, I find it more and more helpful.

Hoping you have recovered from the illness you have, I hear, been suffering from, I am

Yours very sincerely,

LEO TOLSTOY.

March 1st, 1908.

The new binders that we are getting out to hold twelve copies of the PHONOGRAPH MONTHLY are proving just what a great many Dealers wanted to preserve their copies of the MONTHLY. Order through Jobbers, or if yours does not have them, we will send one direct, postpaid, for fifty cents.

## Trade Information for Dealers

### Sales Dept. Bulletin No. 7—April 27, 1908

FOR UNITED STATES AND CANADIAN DEALERS

Correspondence concerning this Bulletin should mention its number and be addressed to the National Phonograph Co., *Sales Department*, Orange, N. J.

Beginning at once, all orders for reproducing points only will be filled with reproducing points assembled in the arms, and no orders whatever will be filled for reproducing points separate from the arms.

The list price for reproducing points assembled to arms will be the same as heretofore charged for reproducing points only, and Dealers' discounts will remain the same as heretofore.

This change is made because in a great many instances where we ship the reproducing points and arms separately, they are not properly assembled by outside parties.

---

### Sales Dept. Bulletin No. 8—April 30, 1908

FOR UNITED STATES AND CANADIAN DEALERS

Correspondence concerning this Bulletin should mention its number and be addressed to the National Phonograph Co., *Sales Department*, Orange, N. J.

Dealers are hereby advised that inasmuch as we have no more moulds or masters of them, the following selections will be considered as "cut-outs" after our present stock is exhausted.

12087 Sal á tu Ventana (Spanish)  
12204 Guarda esta flor (Spanish)

Vargas  
Vargas

---

### Sales Dept. Bulletin No. 9—May 2, 1908

FOR UNITED STATES AND CANADIAN DEALERS.

Correspondence concerning this Bulletin should mention its number and be addressed to the National Phonograph Co., *Sales Department*, Orange, N. J.

This Bulletin is issued to clear up a misunderstanding that exists with part of the trade concerning the allowance of 25 cents each on horns, whether ordered with machines or as extras. This matter was covered by our letter to Dealers dated February 25, 1908.

The allowance can only be made on lots of 5 of any one kind or even multiples of 5, that is 10, 15, 20, etc.

It cannot be allowed where we are put to an extra expense for re-crating. If an order calls for 12 horns of one kind, the allowance will be made on 10 only.

Nor can it be allowed when 5 or its multiples is made up of two or more kinds. For instance, no allowance can be made on an order for 2 Gems, 2 Standards and 1 Home.

An order for 7 Gems, 9 Standards, 6 Homes and 3 Triumphs would get the allowance on 5 Gems, 5 Standards, 5 Homes and no Triumphs, a total of 15 out of 25 machines ordered.

We are able to make the allowance on even lots of 5 of one kind because the horns are shipped to us in crates of 5 or multiples thereof and we are not compelled to re-pack them.

If you are still in doubt on any feature of this allowance, please write the Sales Department at once.

---

### Sales Dept. Bulletin No. 10—May 6, 1908

FOR UNITED STATES AND CANADIAN DEALERS.

Correspondence concerning this Bulletin should mention its number and be addressed to the National Phonograph Co., *Sales Department*, Orange, N. J.

Hereafter all orders for feed nuts will be filled with the feed nut riveted to the feed nut spring, and no orders whatever will be filled for either feed nuts or feed nut springs separately.

The list prices for the Standard and Gem feed nut combined will be 25 cents, and for the Home

35 cents, these prices being the same as heretofore charged for feed nuts only. The list price of the Triumph feed nut and spring combined will be 50 cents, this being 20 cents less than heretofore charged for the 2 nuts only. Discounts to Dealers will remain the same as heretofore.

This change is made because in a great many instances, feed nuts and feed nut springs are not properly assembled when shipped separately.

---

---

## Sales Dept. Bulletin No. 11—May 8, 1908

FOR UNITED STATES AND CANADIAN DEALERS.

Correspondence concerning this Bulletin should mention its number and be addressed to the National Phonograph Co., *Sales Department*, Orange, N. J.

We list below two selections which have recently been made over. Continuing the plan already begun, we will print these selections as part of the August printed matter prepared for retail distribution.

7597 Over the Waves Waltz  
8838 Jovial Joe

Joe Belmont  
Edison Military Band

(Formerly by the Edison Concert Band.)

The quality of these Records is equal in every way to our new monthly lists and the selections themselves have always been consistent sellers. It's "up to you" to order a quantity of them for shipment with August Records.

---

## Legal and Agreement Depts. Bulletin No. 1—May 20, 1908

TRADE INFORMATION FOR UNITED STATES AND CANADIAN DEALERS.

Correspondence concerning this bulletin should mention its number and be addressed to the National Phonograph Company, *Legal Department*, 10 Fifth Avenue, New York, N. Y.

We desire to caution all Dealers against disposing of Edison Phonographs or Records in bulk, to any individual or concern at prices or under conditions contrary to those governing the sales of Edison goods by Dealers. Sales by Dealers in bulk to unauthorized Dealers are strictly prohibited.

We will take immediate action against any Dealer disregarding this notice.

---

---

## Real Wolf Howls

"Have you heard the wolves howl at the Lyric Theatre?" That is the way they are advertising "The Wolf," a play of the Canadian woods, in New York City. In the climax of the third act, when the hero and villain fight in the dark, a pack of wolves send forth their shrill cries. The effect is so realistic that the audience are said to hold their breath, expecting the animals to rush upon the stage. And it's all done by a Phonograph behind the scenes. When the play was first put on a gang of stage hands did the wolf-howling act, but the author decided it lacked the proper realism. He determined to get the real thing. So an expedition was made to the Bronx Zoo and the cries of seven hungry, full-grown wolves were recorded just before feeding time. Their appetites were specially whetted for the occasion, and in order to increase one mother wolf's howls her baby was taken from her and placed outside the cage. This explain the question that one mets on

every hand in New York, "Have you heard the wolves howl at the Lyric?"

---

## A Dealer's Circular

A very clever advertising circular has been received from the Klar & Kress Jewelry Company, Hillsboro, Ill. There are four pages, 12 x 18, printed in red and black, with a good-sized cut of the four Edison leaders—Gem, Standard, Home and Triumph. A full description accompanies each and a special installment offer. Klar & Kress Company are another instance of a jewelry store that have found the Edison Phonographs and Records very profitable in themselves and a means of drawing a desirable class of jewelry customers to their store. We will venture the guess that this firm are having no trouble whatever because of competition by mail order houses, and would commend their methods to other firms who are out for their share of the local trade.

---

---

# Edison Phonograph Monthly

Published for the Man Who Sells Edison Phonographs and Records by The National Phonograph Co., Orange, N. J.

All communications to *The Phonograph Monthly* should be addressed to the Advertising Department, Orange, N. J.

---

NEW YORK: 10 FIFTH AVENUE.

NATIONAL PHONOGRAPH CO., LTD., VICTORIA ROAD, WILLESDEN, LONDON.

NATIONAL PHONOGRAPH CO. OF AUSTRALIA, LTD., 340 KENT STREET, SYDNEY, N. S. W.

MEXICAN NATIONAL PHONOGRAPH CO., AVENIDA ORIENTE No 117, MEXICO CITY.

COMPANIA EDISON HISPANO-AMERICANA, VIAMONTE 515, BUENOS AIRES.

EDISON GESELLSCHAFT, M. B. H., SUD-UFER 24-25, BERLIN.

COMPAGNIE FRANCAISE DU PHONOGRAPHE EDISON, 42 RUE DE PARADIS, PARIS.

---

VOL. VI.

June, 1908

No. 6

---

## What's the Use?

We have seen a clever drawing of a forlorn-looking little boy wiping tears from his eyes. It's a dandy sketch and would stand on its own merits. But its value is doubled by this title, printed in four lines:

What's the use of livin'?  
All the dogs bark at me—  
All the cats spit at me—  
And I've just been chased by a turtle.

Foolish childhood! Period of imaginary ills and misfortunes. Yes, but how about you with your grown-up wisdom? Have YOU any more nerve in facing your grown-up problems than the youngster has in facing his little ones?

What are you doing to get more business nowadays? Are you going after it with newspaper advertising, and window displays, and Edison demonstrations every day? Are you mailing out your monthly Supplements of the new Edison Records? Are you talking to your customers as strongly as ever about the advantages of owning an Edison Phonograph? Or if they already own one are you telling them about those fine new Records? Are you offering them Edisons on time payments to make it easier for them to buy? In a word—are you hustling as hard for sales as ever you did in your life, or are you being chased by the hard times "turtle"?

Of one thing you can rest assured—the goods are going to move out of your store no faster than the turtle moves—and the dollars are coming into your cash drawer no faster than the turtle moves if you sit back and say, "What's the use?"

There's all the use in the world. Ralph Emerson, who has said so many of the most

practical and sensible things ever said by anybody, tells us that the true American hustles most when things seem to be breaking worst for him. Not that business is worse now than ever, for it isn't. Things are a little dull, but we want to point out that the Dealer in Edison Phonographs and Records can do an absolutely normal business—can even improve on the ordinary business of fairly busy times by a little aggressive hustling.

How shall he go about it? First of all, by advertising in the local newspaper. Newspaper advertising at this time will pay far better than when business is humming and everybody is advertising. If you have your ad in the paper along with those of two or three other Dealers you divide the attention of the reader between you. If your ad has only one other to compete with you get a larger share of the reader's notice. If yours is the only one you get it all. That's a pleasant thought!

Now, let us suppose a condition that actually does exist everywhere all the time. Suppose a dozen people in your town are going to buy Phonographs within the next few days. In the ordinary course of things we will say you would land three of the sales. What effect will a little advertising have? In all probability three or four more of the buyers seeing your announcement of a complete new stock of Machines and Records will be led to make their purchases of you instead of from some one of your competitors. It doesn't matter at all to the average buyer which particular store his outfit comes from and seeing your announcement at the right moment decides him in your favor. So you sell a machine and Records to each and add some new Record customers to your list.



Dealers will find this rule works out every time and every satisfied customer gotten in this way means sales to that customer's friends.

You have no idea how many people there are who are ready to buy Edison Phonographs, but hold back simply because they are not asked by some home Dealer to buy. In order to appreciate the impression that is being made by our advertising, which reaches 25,000,000 people regularly month after month, you must do a little advertising yourself, reminding your part of the public that the latest type of Edison Phonograph and all the new Records are right at their doors.

While others are saying to themselves "What's the use?" and letting the cobwebs grow on their stock and in their doors, is the time for you to make a noise like "the biggest Edison Dealer in your section." You will find the ready-made ads that we supply free of all charge a very great help in doing this.

---

## Personal

W. E. Gilmore, President of the National Phonograph Company, has returned from a three weeks' vacation spent with his family at Virginia Hot Springs.

Walter Stevens, Foreign Manager, is back at his desk after a seven weeks' business trip to Mexico. George J. Werner and Frederick Burt, experts from the Recording Department, accompanied him for the purpose of making 300 new Mexican Records. All the latest mechanical accessories in use at the main laboratory were carried along and as the foremost Mexican singers and instrumentalists have been engaged to make the Records, the trade can look for something extra when they come out.

F. K. Dolbeer, General Manager of Sales and Credits, is away on a trip to the Pacific Coast. He hopes to visit Edison Jobbers throughout the West and Northwest. Returning he will reach Denver, Colo., in time for the annual convention of the National Association of Credit Men, at that city, June 23rd to 26th.

H. T. Leeming, Traffic Manager, addressed the Trans-Continental Traffic Bureau, at Chicago, on May 18th, on several matters of interest to the trade, one of the principal ones being the restoration of the commodity rate of \$2.50 a hundred on Phonographs and Records to the North Pacific coast. It was owing to his representation that the rate was secured some time ago, but it was cancelled May 9th.

## How Many Records?

There are 2,710 Records listed in the three Edison Record Catalogs up to and including the Records for June, 1908. There are 1,649 Domestic, 996 Foreign, and 65 Grand Opera. The Domestic list is about equally divided between vocal and instrumental selections. There are 596 Vocal Solos, 161 Vocal Duets and 93 Vocal Quartets, 327 Band and 83 Orchestra Records. In the Foreign Catalog 19 languages are represented, viz.: Bohemian, British, Chinese, Cuban, Danish, French, French-Canadian, German, Hebrew, Holland-Dutch, Hungarian, Italian, Japanese, Mexican, Polish, S. A. Bands, Spanish and Swedish. The Grand Opera Records are sung in five different languages and are divided: French 4, German 21, Latin 2, Italian 36, Spanish 2.

---

## Our New Power Plant

The work of erecting new concrete buildings for the National Phonograph Company and the entire Edison interest at Orange, N. J., has been going on steadily for some time past. It is now about finished and the long line of white walls spread out over more than eighteen acres of ground presents an appearance not unlike that of some great fortress. One of the last buildings to be completed was the new boiler house. This is 35x69 feet and is a model in design and equipment. Three Climax tubular boilers have recently been put in—two of 750 H. P. and one of 500 H. P. This makes seven boilers altogether, with a total capacity of 3,400 H. P. In the engine house, which adjoins the boiler house, a new 1500 H. P. Allis-Chambers vertical cross compound Corliss engine has just been installed. A special feature of this remarkable piece of machinery is a three-wire generator, which produces 4,000 amperes of 250 volts in one side and 125 in the other. The entire engine which weighs in the neighborhood of 100 tons, rests upon a foundation of solid concrete. Added to the previous equipment of one Allis, one French and one Arrington and Sims engine, this brings the capacity of the power plant up to 2,860 H. P. and places it in the front rank of the world's great manufactories. Power is here generated for the entire Edison interests, which take up fourteen acres of floor space and include the Edison Phonograph Works, the National Phonograph Record Works, Edison Laboratory, Edison Kinetoscope and Film Works, Edison Storage Battery Plant, Bates Numbering Machine Works and the office buildings, electric light, elevator and pumping systems.

## Attractive Stores

"I send a flashlight photo of an end of my store, showing part of my Edison stock. The plate did not take it all in, but enough is shown to give a good idea of arrangement, etc. I believe the long horn, shown standing, is the



largest in use in this State. It is seven and a half feet long and has been used often for giving concerts from the balcony at the front of my place. It may interest you to know I am overhauling for a customer Home Machine No. 703, which is pretty old, as you can judge from the number."—George Smith, West Newcastle, N. S. W., Australia.

We have previously published correspondence from Martin & Company, of Young, N. S. W., Australia, telling of their fine success in handling the Edison goods. Below is a view of an exhibit made by them at a local fair. It is reproduced as a striking sample of how they do things in the Antipodes. Was anybody under the impression that they are behind the times on the other side of the world?



The illustration of the warerooms of the Macon Phonograph Company, of Macon, Georgia, which is printed below, shows a very neat arrangement of Phonographs and Records without too much crowding. Their Record stock looks especially good. They are great believers in "a place for every Record and every Record in its place."



## Rough on Rats

"Such a peculiar remark was passed in my store to-day that I could not resist the temptation to pass it on," writes the Garland City Music Store, Ashland, Wis.

"Some three months ago I sold an Edison Standard Phonograph on the easy payment plan to a man here. He came in night before last and said he was unable to pay any more on the machine. I told him in that case the Phonograph would have to be returned, according to the terms of his contract, as he had not paid for it. He replied: 'All right. My wife doesn't like it anyway, as it scares the baby.'

"His wife accompanied him when he brought the machine in to-day. I asked her what the trouble was. She said it scared the baby; that every time a Record was put on the baby would cry. I asked her if she did not think that in time the baby would learn to love the music.

The baby is a girl and is only five months old, and I thought if given a fair chance, we might make good with her. But the mother said: 'I don't think so, as baby cries every time she hears it, but I will say this for the Phonograph, it certainly did scare all the rats away from the house, and the house was over-run with them before we got it.'

"We read many different testimonials about the good qualities of the Edison from enthusiastic owners, but this brings out a point that I do not think anyone has touched on before."

"P. S. Forgot to mention that after his wife said the above, the gentleman turned to one of my clerks and said that as soon as he could get a divorce he would be the owner of a new Phonograph."

**There are a whole lot of people in your town who wont put off owning an Edison Phonograph another day if you tell them about the Bryan Records. Do it now.**

Ready for Your Scissors

Below are a set of three advertisements and three readers for newspaper use. They may be of help to the Dealer who is too busy to write his own ads. The ads will be made more effective by the use of an illustration, such as those we furnish free in the Ready-Made Ad Department.

GOING ON A VACATION?

Take an Edison Phonograph with you.

It's the most wonderful entertainer in all the world, because it's all the world's best entertainers in *one*.

It's a Band if you like, an Orchestra, a Grand Opera Singer, a Vaudeville Team, a Singer of the latest popular songs, a Violin, Banjo, Cornet, Xylophone—in a word, everybody and everything you care to listen to on any occasion.

So light and easy to take along with, too.

It will be the jolliest summer trip you ever took with the jolliest companion, if you take an Edison.

Edisons at \$12.50 and \$25.00, on easy payments of \$1.00 a week.

Come hear the new Records just received.

[Firm name and address here.]

IS EVERYBODY HAPPY?

The Edison Phonograph equals a \$1,000-a-week Grand Opera or Vaudeville Artist, and yet *One Dollar a Week* soon makes it yours.

You can listen in your own home to the real voices of Scotti, Abott, Constantino, and many more of the highest-priced Grand Opera stars.

You can hear the magnificent Edison Symphony Orchestra play "The Merry Widow Waltz."

You can laugh till your sides ache at the funny cracks in the "Georgia Minstrels" by the Edison Minstrel Company.

You can listen to the catchy air of the latest Broadway song-hit sung by one of the celebrated Edison artists.

All this and much more for only \$1.00 a week.

Come in and let us play a few of the latest Records and explain the easy payments.

[Firm name and address here.]

A MAN 72 YEARS OLD SAYS:

"A few tunes on the Edison Phonograph every morning are all the medicine I ever take."

Maybe *you* would need less medicine if you took good cheer in large doses from this wonderful Home Entertainer, which is all the musical instruments of the world rolled into one.

A dandy Edison Phonograph, all complete, sells at \$12.50, and others at \$25.00 and \$35.00.

Easy \$1.00 a week payments.

Records that wear forever only 35 cents each.

Come in and hear the newest Edison with the big horn.

FOR READING NOTICES

The following are intended to be run in the newspapers as straight news matter. Give your paper an order for some regular display advertising and ask them to run the following as free notices. You will thus get double value for your money, for a notice like these is very effective in arousing interest and gives the impression that a store is the leader in its line.

THE HAPPIEST HOME.

Opinions differ as to just what is needed to constitute the ideal happy home, but everybody agrees that music is one of the most important things. Can you think of a single happy home where they do not have music in some form? Music promotes happiness because it improves the tempers and dispositions of the worst of us. Especially in summer, when it is possible to sit on the porch or lawn and listen to the charming music of an up-to-date Edison Phonograph. The Edison is by turns a band, an orchestra, a soloist, a comic talker, or anything you can call for in the realm of music or entertainment. A great many are being sent to local homes by ....., the popular Phonograph Dealers.

VACATION DAYS HERE.

Now is the time when the vacationist and summer boarder is studying advertisements in the papers and railroad time-tables, deciding where to go for a breathing spell. We want a place where there's boating and bowling and fishing and driving, dancing and tennis, hammocks and croquet, and by all means one where there is good music. The way to be sure of getting the music you want when you want it is to take along some handy music-maker like the Edison Phonograph. .... are Edison headquarters and they have any quantity of Records that are just the thing for vacation purposes.

SICK PEOPLE TAKE MUSIC.

A great many doctors prescribe music for sick people. It is claimed that music soothes the nerves and puts the patient in a calm and peaceful frame of mind that is most favorable in promoting recovery. Here is a great chance for ..... of ..... St. to sell Edison Phonographs. Doctors may disagree about the kind of music a patient needs, but an Edison will fit any doctor's prescription, as it's all the musical instruments of the world combined in one.

## R. C. Bollinger's Large First Shipment

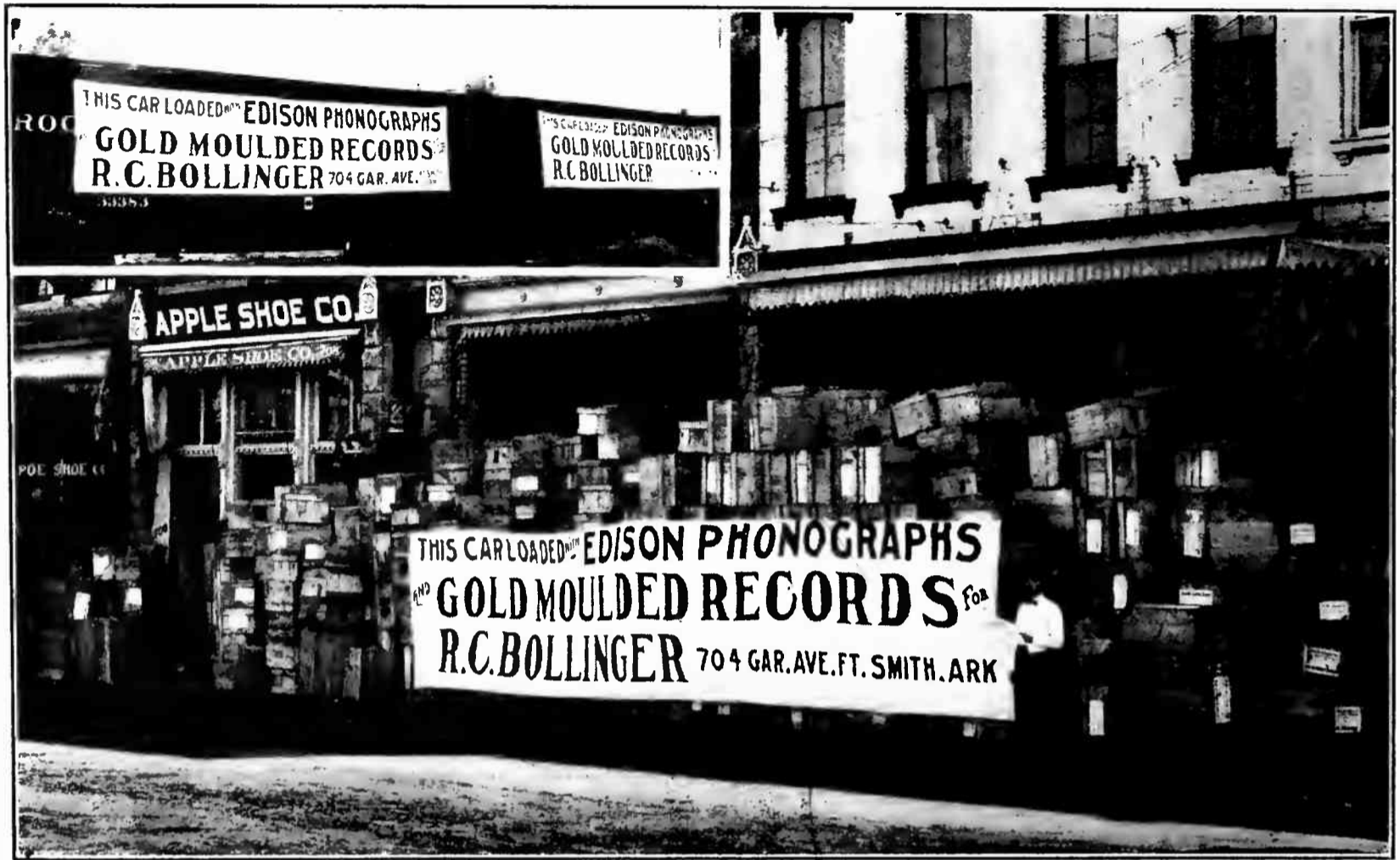

R. C. Bollinger, the new Edison Jobber of Fort Smith, Arkansas, has received his first Jobbers' shipment of Edison Phonographs and Records. The goods filled two large size cars and when placed on the sidewalk in front of the Bollinger

store, extended about thirty yards up and down the street. There was room for just two people to pass between the boxes and building. The gentleman standing guard over the boxes is W. H. Petrie, manager of the Talking Machine Department.

## This Advertising Banner Free to Dealers



An advertising banner, like the above reduced fac-simile, is to be sent to Edison Dealers through their Jobbers about July 1st. Size, 10 feet long by 3 feet deep; printed in four rich colors on white muslin; edges turned and stitched; fixed ready for hanging at the store front or in the window. If you failed to order one of these handsome banners on the order blank which was

sent out in last month's PHONOGRAPH MONTHLY, and want one to use as suggested, fill the blank out now and send it in. If the blank has been misplaced, write at once to National Phonograph Company, Advertising Department, Orange, N. J. There is no charge whatever for the banners.

## Jobbers' Convention

The annual convention of the National Association of Talking Machine Jobbers will take place at the Hotel Chalfonte, Atlantic City, N. J., July 6th and 7th.

The committee of arrangements in charge of the details of the convention are J. Newcomb Blackman, proprietor of the Blackman Talking Machine Co., New York City; C. V. Henkel, president Douglas Phonograph Co., New York City, and Louis Buehn, of Louis Buehn & Bro., Philadelphia, Pa.

A large room at the hotel has been placed at the disposal of the members as a meeting room, as well as another room for the accommodation of committees. A material reduction in the hotel rates has also been given.

It is suggested that in order to get the benefit of reduced rates, members of the association or representatives of manufacturers will mention that they are to attend the convention as delegates and ask accommodations based on special rates offered the association.

A better opportunity could hardly be offered to Jobbers and members of the trade in general to take a pleasant vacation and at the same time attend an important convention. In selecting the days—July 6 and 7—it was with the idea that most everybody would arrive on the 3d or early on the morning of the 4th, thus getting the benefit of Saturday, the 4th, and Sunday, the 5th, without taking two days from business.

It is quite likely that most every jobber will take some vacation himself and provide one for the family, and with this idea in view, the committee urge Atlantic City as first choice. Jobbers will find plenty of opportunity to make use of their trip for business visits while the family are enjoying the pleasure of the seashore. It is very likely that the leading manufacturers of talking machines and supplies will be well represented, and it will be a very good opportunity to bring jobber and manufacturer together on anything, such as new goods, improvements and plans for the fall business.

Dealers who would like to make this trip should take advantage of the reduced hotel rates and railroad fare, which the committee will be very glad to offer them. The second day's session being to a very large extent an open one, it may be that some of the live dealers would like an opportunity to bring up subjects from the dealers' standpoint. A letter addressed to any member of the committee will receive prompt attention, for it is proposed to make this convention a record breaker in attendance. Members of the association should come prepared to give their ideas on any subject they would like considered.

While the Traffic Association have not yet committed themselves regarding the application for reduced railroad rates, it is likely that they will grant the same and take action at their next meeting, which will be held in the near future. A circular letter will be addressed to members of the association and the jobbing trade in gen-

eral, giving such details as are considered necessary, and in any cases where the jobber receives this letter and is not a member, it should be a notice for him to immediately send in his application for membership.

It may be that some of the jobbers do not understand the benefits of membership, and it is therefore well to explain that one of the most important features is the system of credit reports, which are very valuable to jobbers who have outstanding accounts. For example, one case may be mentioned where an account, amounting to over \$100, had been charged by a jobber to profit and loss about two years, and through the system of credit information he learned that another member had succeeded in finding the debtor and obtaining a settlement. This resulted in the second jobber getting busy, with the result that he made a settlement of \$50, which therefore went to the credit of profit and loss. This is only one of many cases, and this feature of membership alone is worth several times the annual dues, which are but \$15.

It is very much easier for manufacturers and jobbers to get together on any subject if the former can feel that the National Association includes practically every jobber. Various single ideas are brought into one perfected thought, and improvements result. Many changes and desirable improvements that have been made by the leading manufacturers were the result of suggestions made through the association. It will therefore be understood that every new member adds to the strength and improvement of the organization. The dealer is also benefited, for if he has any subject that he would like taken up he can ask his jobber to do so through the association, or probably a letter on the subject addressed to the secretary would receive attention.

Everyone interested in the advancement and improvement of the talking machine industry should support the National Association of Talking Machine Jobbers, for they are working in a good cause. There should be fully 40 or 50 new members before the convention. Applications should be sent to the secretary, Perry B. Whitsit, 213 South High street, Columbus, O.

## A Live Question

Do you make it a point to keep in close touch with the people to whom you sell Edisons? When a month or two elapses without selling them any Records do you find out why? There may be some trifling reason that can be at once adjusted. Sometimes through carelessness or accident something will happen to put a Phonograph out of commission. One of your employees could put it in running order in a few minutes and make the customer a regular buyer again.

The temptation to sidetrack a Phonograph if it slips a cog is just as strong in your customer as is your temptation to forget him if he doesn't call for a month or two. It's like throwing good money away to neglect owners of Phonographs.

## Window Dressing

Our model window this month is simple and very easy to reproduce. The walls are hung in the white cheese cloth used last month. It is gathered at frequent intervals all the way around to give a slight wave effect. Floor and boxes are covered with the same material, which is tufted on the floor. Three of the 1 x 1 x 3 ft. boxes stand on end at the back with boards across their tops to support Phonographs and Records. Three more of the boxes are laid flat, the middle upright box standing on the centre one. The four leading types of machines—Gem, Standard, Home and Triumph—are shown set up complete with price cards in their horns. The Gem rests on four Record boxes. The machines on the floor without horns are a Standard and a Home. Cards advertising the

Idelia are placed between them. Most Dealers have in stock all the material needed to duplicate this window trim. Price cards like those shown can be secured of Jobbers, also the steel signs containing the picture of Mr. Edison, and the Idelia window cards. The lists of new Records are the ones sent Dealers regularly, and it's a very simple matter to get suitable frames for them. The cheese cloth is very inexpensive and can be made to last some time if care is used to keep it clean. Always have the window perfectly clean before you start to dress it and the glass clear so that everything may be plainly seen. Remember the customer judges your store by the window, and if it is not attractive he may never feel any curiosity to know what the interior looks like. Your window can be made one of the best possible advertisements of your business, and it is an advertisement that costs you practically nothing at all.



## Wu Ting Fang Visits Mr. Edison

Wu Ting Fang, Chinese Minister to the United States, spent the morning of May 21st with Mr. Edison in his laboratory at Orange, N. J. The distinguished foreigner is greatly interested in the Edison Phonograph and other matters on which Mr. Edison is engaged and enjoyed his visit immensely. He started back to New York in an automobile, which conformed to the Far-Eastern opinion of "Devil Wagons" by breaking down in Newark. Newspaper reporters at once besieged him, and between seeing to the repairs of the

machine and standing the reporters off he spent a very busy half-hour. One reporter succeeded in breaking through the Oriental reserve and secured the following for his paper:

"I was very interested in what I saw to-day. The Edison works are indeed wonderful, and Mr. Edison, he is wonderful, too. No wonder you Americans call him the—the—the——"

Wu became confused over the deficiency of his memory, and had his skin not been a dull yellow a blush might have been seen.

"The electrical wizard," interpolated the reporter.

"Yes, yes," went on the executive representative of the Chinese Empire. "He has done a great deal for his country and for the world."

## Effects of Trade Depression

In these times of business depression it is encouraging to find that many regard the present outlook most hopefully. A striking example of hopefulness in the Talking Machine Trade is the following article by J. Newcomb Blackman in the May *Talking Machine World*:

"It is generally conceded that all business has been affected by the general depression, which started with the financial panic last October, and has been felt throughout the country since that time. The country before this period was considered at the height of prosperity, from what appeared on the surface. During the present depression the "light" has been "turned on," and it will be well for manufacturers, jobbers and dealers of talking machines and supplies to carefully note what it reveals.

You will have no trouble in finding people in our line who condemn the talking machine business at the present time, but their opinion is probably based entirely on the fact that sales are not as large as they were a year ago. Most things are judged by comparison and the present condition of the talking machine industry is no exception to this rule. Let us, therefore, compare the effect of the business depression on the talking machine industry with other lines of, not only luxury, but business in general.

In what line of business will you find the statement that sales are larger than they were a year ago? It is not likely that you can name one case. In this respect we will say that the comparison is about the same, although you will find that as compared to other articles of luxury the talking machine business has not shown as large a decrease in sales and has certainly more than held its own. Don't overlook the fact, however, that the word sale does not always mean profit. How many sales at the present time made in other lines of luxury, or even what might be termed staple lines, are bringing the same profit?

Is it not true that most articles sold throughout the country in general business are regulated very largely by the law of supply and demand, and that prices fluctuate accordingly? Will you not therefore find that in most lines of business the manufacturer, jobber and dealer is not only selling less goods, but selling them at lower prices than he anticipated or expected would be necessary when they were purchased? It will be very easy for you to figure the damage this does, not only through the dwindling of profit, but by the depreciation of the value of stock on hand. We will compare this condition with what we find in the talking machine industry based 'of course' on goods sold under price restrictions. We find that sales are less, but we do not find that values have depreciated. The dealer still gets full price for machines and records, so that although he must suffer a little temporarily by the loss in sales he makes the same percentage of profit, and stock on hand has not depreciated in value on account of the business depression.

This condition illustrates the value of restricted prices and every jobber and dealer at the

present time, to be fair, should first compare the talking machine business with other lines in general before attempting to criticise the former. If he does this, and will make a fair comparison, I think he will agree that the talking machine business has more than held its own in sales and stands in a class by itself in regard to values being maintained. It is not a bad thing to be in the talking machine business during a business depression, if you handle lines that are sold under restricted prices, and the present test should be recognized as a valuable guide to the future policy of manufacturers, jobbers and dealers.

You will note by my remarks that I am a strong advocate of the policy of the leading talking machine companies in insisting upon a maintenance of prices from the time the goods leave the factory until they are paid for by the retail purchasers at the full list price. This naturally requires a firm stand on the part of the manufacturer in order to enforce conditions that will insure the jobber and dealer maintaining prices and preventing unfair competition. Suppose most of us jobbers and dealers were not surrounded by this cloak of protection at the present time and during the last few months.

Have you considered what might have resulted and what good cause you would have had for complaint, not only on sales, but with the methods employed in this business? Certain dealers who have been unable to meet their accounts as promptly as jobbers would expect, would have been forced to dispose of their stock at prices that would ruin the trade in that vicinity. A dishonest dealer could have auctioned his stock off and disappeared thus, not only hurting values in that territory, but causing the jobber a certain loss. This class of dealer is now held in check, for it is generally known by auctioneers that they have not the same liberty in selling talking machines under the hammer that they find in other lines.

This may have kept many a dealer in the straight path and the jobber's pocketbook in a better condition than had the situation been otherwise. The dealer who has, to a certain extent, been attacked with what might be termed "cold feet," I claim, is benefited because he is unable to quit so easily at cut prices, and at the same time injure others in the trade, for he will probably "stick to the ship" and "weather the storm." There are cases where dealers will not be able to do this, but these are handled in such a diplomatic way by the manufacturer that failures, so far, have not resulted in injuring the maintenance of prices. With jobbers the situation is practically the same. Many who handle talking machines as a side line and are not sufficiently interested financially would not hesitate to turn their stock into money in ways injurious to the business in general. The manufacturers themselves are forced to maintain the policy which they have inaugurated, although I have no doubt that they would have plenty of opportunity to keep busy now if they were to accept ruinous propositions from cut price merchants, who would like an opportunity at the

present time to advertise, at cut prices, goods known throughout the world as standard in price.

This depression of business must be only temporary for the foundation of prosperity is still here. I believe it will have a wholesome effect on the country and on every individual, employer and employe. If he makes use of the lesson it has taught he will realize (if an employer) that certain methods which he may have used in competing are not safe, risks that must not be taken again, and that in time of prosperity his methods must not be such that they cannot stand the inroads of adversity. The employe will realize that when it comes to the question of the supply being more than the demand, it is the employe who has worked for something more than his salary that will hold his position, and

will be considered a part of the organization who has contributed to the building, and will therefore remain a part of the structure.

During the summer the manufacturer will make use of the present slackening of business and prepare to stimulate the business with improvements that will make the talking machine industry as desirable as ever. The jobber who maintains a suitable stock of goods will hold what trade he has and probably draw trade from others, who have not had the required amount of optimism to keep them alive. The dealer who maintains a suitable stock and puts in all his spare time in getting in touch with everyone in his territory, will be known and remembered in the fall when, I believe, everything will again have assumed a good momentum."

**THE EDISON  
BUSINESS  
PHONOGRAPH**

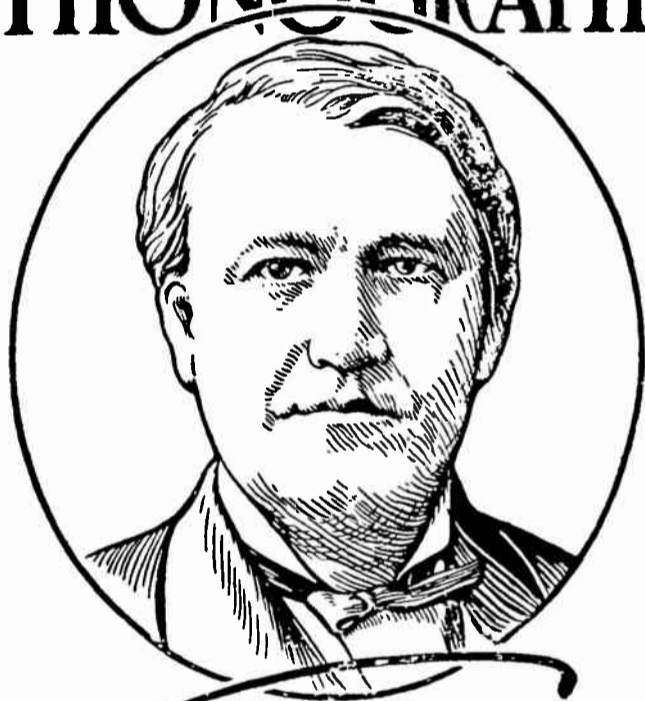

TRADE MARK

*Thomas A Edison*

**Dealers Wanted**

After three years perfecting the Business Phonograph and securing electric motors for all electric currents, we are prepared to appoint dealers in every locality to sell the appliances at a liberal discount. Write for circulars and terms of agreement TO-DAY.

**EDISON BUSINESS PHONOGRAPH CO.**  
250 Lakeside Avenue  
ORANGE, NEW JERSEY

**REQUEST FOR ELECTROS**

NATIONAL PHONOGRAPH Co.  
ADVERTISING DEPARTMENT, ORANGE, N. J.

DATE.....190.....

Mail Electros No.....

We agree to use them in newspaper advertising and to send you copies of papers containing them before asking you for other electros. We intend running a..... inch advertisement.

Name.....

Street.....

City and State.....

We buy through.....



**New Ready-Made Ads**

Here are two more Ready-Made Ads that we furnish free for Edison Dealers' use in newspaper advertising. Hundreds of live Dealers all over the country are asking for these electros and using them regularly in their local papers with fine results. The thing that pleases us most, next to seeing them advertise, is that they often write up some copy of their own to go with the cuts we send in preference to using the talk we print in the Ready-Made Ads. This shows that they are going in to win. They are thinking the matter out for themselves, and the result is they know just about what to say in their ads to attract customers. The electro cut that we furnish include the illustration and the word "Edison" or "Edison Phonograph," as the case may be. Dealers then add reading matter to take up whatever space they wish. The original drawings from which our electros are made are the work of the best New York artists and are quite costly, but we figure that they are not any too good for the goods they advertise and as long as they help Edison Dealers to get results in their advertising as they have been doing, that part is all right.

We will send you either or both of the electro illustrations shown on this page in single or double column width, prepaying postage, so that they will cost you nothing. All you need do to get them is to agree to use them in your paper and send us copies of the newspapers containing your ads for our files.



**EDISON  
PHONOGRAPHS**

Don't make the mistake of thinking that every talking machine is a Phonograph.

The Edison Phonograph is the only one invented by Thomas A. Edison. It gives clearer and better renditions of music than any other form of sound-reproducing machine. Hear the new model at our store.

**R. W. FOSTER**  
197 North 18th Street  
New York City

Electro in above ad is: Single column wide No. 683. Double column wide. No. 684.

Electro in ad below is: Single column wide No. 685. Double column wide. 686.



**EDISON  
PHONOGRAPHS**

hear the Edison Phonograph and have one sent home. A very small preliminary payment will make it yours.

**L. W. MACK**  
14 Cosmopole Street, Scranton, Pa.

AT home, in the evening, with an Edison Phonograph to make things lively—what better combination can be imagined? Stop and think of his, father of a family, on your way home, and then stop in and



"Marching Through Georgia"

**The EDISON PHONOGRAPH** represents not only the original sound-reproducing idea invented by Mr. Edison, but it also represents every improvement Mr. Edison has been able to make in his original invention.

It is an improvement that the Edison Phonograph uses a reproducing point of such hardness that it lasts for years and does away with the annoyance of continually having to change needles.

It is an improvement that the horn is constructed in such a way as to give the greatest clearness and volume of sound, without sacrificing the quality of the sound.

It is an improvement that the Edison Phonograph and Edison Records can be bought so cheaply that they make good music possible to all.

Edison's records are made by the National Phonograph Company, 75 Lakeside Avenue, Orange, N. J.

**THE TWENTY-FOUR NEW RECORDS FOR JUNE** are made up of some of the cleverest song records and some of the best instrumental records that the well-known artists on the Edison staff have ever made for us. Hear them at any Edison store on May 27th. You'll be sure to want some of them for your Phonograph.



Thomas A. Edison

See a complete list of the new records in the June issue of the Edison Phonograph Monthly. Write for a copy to the National Phonograph Company, 75 Lakeside Avenue, Orange, N. J.

**NEWSPAPER ADVERTISING.**

The advertisement of which this is a reduction occupied 36 inches, on May 11th, in a list of 146 leading daily papers throughout the United States. Their combined circulation is 8,107,143, so that it would be safe to say that the advertisement was read in a large majority of homes that can afford Phonographs. In addition to this we also ran a double-page advertisement in the twenty-fifth anniversary edition of the *New York World*, Sunday, May 10th. This was a 200-page paper and had a wide distribution, covering a very large part of the country. It was a costly bit of publicity, in fact, the costliest single talking machine advertisement ever inserted in a newspaper. Dealers everywhere are bound to profit by our extensive advertising, but the ones that profit most are those who go in for local newspaper advertising themselves.

Have you gotten one of the new hangers, "As a Protection to the Public," from your Jobber? If you have not, by all means do so at once and hang it in a conspicuous place where your customers can read it as an answer to their requests that you make this, that and the other, special concession on Edison Phonographs and Records. It will save explanations and useless argument.

Have you been wishing something would happen to help business? Something has happened—the ten Bryan Records, with a big percentage of the country's population is the best argument you can offer for an Edison Phonograph.

**MAGAZINE ADVERTISING.**

This is a fac-simile reproduction of our full-page advertisement in the following list of twenty national monthly and weekly periodicals: American Magazine, Argosy, Everybody's, McClure's, Metropolitan, Munsey, National, Pacific Monthly, Red Book, Review of Reviews, Outlook, World Today, Saturday Evening Post (back cover). It also occupied a half page in Collier's Weekly and quarter-pages in Ladies' Home Journal, Ladies' World, Woman's Home Companion, Youth's Companion, Associated Sunday Magazines, and Puck. The combined circulation of this list of national magazines is eight-and-a-half millions. Allowing for only three readers to a magazine, that means over twenty-five million people reached by the June announcement. Is it any wonder that more Edison Phonographs are sold than all other talking machines combined when this advertising is kept up month after month throughout the year? The Dealer that does not follow our lead in going after business in a sincere, aggressive manner, cannot complain if competitors get the lion's share of sales. Read this copy of the PHONOGRAPH MONTHLY through for advertising suggestions.



**The EDISON PHONOGRAPH**

**M**R. EDISON would like to see an Edison Phonograph in every American home because he knows that there is in this, his favorite invention, more

**sound, healthy amusement**

than can be had in any other way for so little money. After all, what is it that we want in the way of entertainment? We go to the theatre to hear songs and dialogues; to the dance hall for music and motion; to the concert hall or grand opera to hear good singing, when we can get them all, at far less expense and trouble, in our own homes with the Edison Phonograph.

See and hear the new Edison model with the big horn at the nearest Edison store, or send for a complete catalogue describing it.



BUSINESS MEN who use the Edison Business Phonograph say that it's like having a competent stenographer continually at their elbow. Write us for information.

WE DESIRE GOOD, LIVE DEALERS to sell Edison Phonographs in every town where we are not now well represented. Dealers having established stores should write at once to

**National Phonograph Co., 75 Lakeside Avenue, Orange, N. J.**

## SUSPENDED LIST, JUNE 1, 1908

SUPERSEDING ALL PREVIOUS LISTS.

## CALIFORNIA.

Chico—J. L. Crick, 234 Broadway.  
 \*Crescent City—Peter Duffy.  
 Petaluma—Thomas McGuire, 875 Main st.  
 San Luis Obispo—J. Dormer.

## CANADA.

Ottawa, Ont.—Ketchum & Co., Sparks and Bank sts.

## COLORADO.

Boulder—Bentley & Craig.  
 Denver—Wagman & Bloomfield (The Phonograph Circulating Library), 1631 Champa st.

## CONNECTICUT.

Chapinville—Geo. S. House.

## GEORGIA.

Acworth—Webb & Awtrey.  
 Eastman—Red Cross Pharmacy.  
 Valdosta—H. K. McLendon, 109 West Central ave.

## ILLINOIS.

Champaign—Eggleston Bros., or Eggleston Music House, J. P. Eggleston, Prop.; also Danville, Ill.  
 Chicago—A. Gloss & Son, 727 W. North av.  
 Cookville—Geo. Swinehart & Son.  
 Danville—Eggleston Bros., or Eggleston Music House, J. P. Eggleston, Prop.; also Champaign, Ill.  
 Elgin—James W. Mill, 18 Spring st. and 166 Chicago st.  
 Galesburg—O. T. Johnson Co.  
 Kempton—C. E. Bute.  
 Ottawa—Edward Hayne.  
 Peoria—H. Meyer, 1307 S. Adams st.  
 Quincy—Giles Bros., 107 North 4th st.  
 J. F. Brenner, 627 Main st.  
 J. F. Whittaker, 618 Hampshire st.  
 Robinson—A. D. Foreman, or A. D. Foreman & Son.  
 \*Rock Island—Totten Music House.  
 Wheaton—E. Irving.

## INDIANA.

South Bend—Eugene Marsh, 126 Vistula ave.  
 South Bend Book Bindery, Robert Lebolt, Prop., 203 North Michigan st.

## IOWA.

Burlington—John P. Weiss, 711 Jefferson st.  
 Clinton—Totten Music House.  
 Cushing—Bullock & Lyman.  
 Danbury—J. W. O'Day.  
 Independence—E. O. Parker, 110 E. Main st.  
 Indianola—L. C. Barnett.  
 Keokuk—W. H. Davis Surgical Supply Co., 17 4th st.  
 McClelland—J. W. Rounds & Co.  
 Mederville—John J. Carpenter.  
 Radcliffe—W. F. Drackley.  
 Sioux City—Hattenbach Bros. Co.  
 A. V. Larimore, 518 Fifth st.  
 State Center—Ora Sargeant.  
 Webster City—E. H. Martin and Fred N. Martin.  
 Whiting—The Cassady & Whiting Co.

## KANSAS.

Clay Centre—E. M. Gowenlock.  
 Lawrence—Bell Bros.  
 Topeka—R. H. Morehouse, 510 E. 4th st.  
 Wichita—Frank R. Powell, 132 N. Main st.

## KENTUCKY.

Louisville—Irvine Simons, 942 W. Market st. (formerly 543 W. Market st.).

## MAINE.

Biddeford—W. H. Field.  
 Gardner—C. H. Cobb, 293 Water st.  
 Lewiston—J. W. Skene.  
 Monmouth—G. H. Stetson.  
 Oldtown—H. M. Burnham.  
 Waterville—Frank Blanchard, 150 Main st.  
 M. Steinert & Sons Co., at all points.

## MASSACHUSETTS.

Boston—Henry H. Savage, 166 Hanover st.  
 T. Singer, 60 Leverett st.  
 Fitchburg—M. Steinert & Sons Co.; also Pittsfield, Mass., and at all points.  
 Florence—William Oates, 87 Main st.  
 Franklin—E. P. Blackmar.  
 Great Barrington—Frank W. Wheeler, Main st.  
 Lawrence—Lord & Co., 314 Essex st.  
 E. O. Mosher, 420 Essex st.  
 Malden—A. T. Fuller.  
 Nantucket—Arthur M. Taylor.  
 New Bedford—H. B. DeWolff.  
 Pittsfield—M. Steinert & Sons Co.; 254 North st.; also Fitchburg, Mass., and at all points.  
 Somerville—E. J. Winchester, 32 Summit ave.  
 Woburn—Osborn Gillette, or The Boston Jewelry Co., L. F. Maloney, Manager.  
 Worcester—Joseph Tukman, 44 Front st.  
 Guy Furniture Co., 521 Main st.

## MICHIGAN.

Ann Arbor—Ann Arbor Music Co., F. J. Schwankovsky, Prop.  
 Bay City—J. M. Kopec, 1006 S. Madison st.  
 Detroit—F. J. Schwankovsky.  
 Manistee—Gus Ilse, and A. H. Ilse Co., 311 River st.  
 Saginaw—Geo. W. Emendorfer.  
 James V. Calahan, 217 Genessee st.  
 Tierney Bros., 217 Genessee st.  
 Union City—Jay Hartman.

## MINNESOTA.

Minneapolis—T. M. Roberts Co-op. Supply Co., 717 Nicollet ave.  
 Morristown—Wm. Zimmerman.  
 Willmar—Willmar Furniture Co., Ruble Block.

## MISSOURI.

Ewing—Hal R. Ewalt.  
 Fairfax—Hinde Hardware Co.  
 Kansas City—The Wittmann Co.  
 Osceola—C. H. Green.  
 St. Louis—Knight Cycle Co., 1215 Olive st.  
 Edward L. Reeve, and the Red Bud Floral Co., 910 Franklin st.  
 F. Ringwood and J. Ringwood, or Central Phono. Co., or Franklin Phono. Co.

## NEBRASKA.

David City—John Albright.  
 Elwood—W. M. Warner.  
 Lincoln—The Wittmann Co.  
 Omaha—The Wittmann Co.  
 Piano Player Co.  
 Red Cloud—Albright Bros. or L. P. Albright.  
 Sterling—Sterling Drug Co., W. G. Morrill, Prop., and W. G. Morrill, M. D.

## NEW HAMPSHIRE.

Dover—H. C. Ingalls & Co., 444 Central ave.  
 \*Exeter—Daniel Kelleher, 63 Lincoln st.  
 Hillsboro Bridge—E. M. Barnes.  
 Manchester—A. E. Dumas.  
 Nashua—F. A. McMaster & Co.

## SUSPENDED LIST—CONTINUED.

## NEW JERSEY.

Atlantic City—Sam'l D. Wolf, 32-34 Arkansas ave.  
 Bayonne—J. Wigdor, 450 Avenue D.  
 Jersey City—W. L. Hoffman, 151 Montgomery street.  
 Long Branch—A. N. Alexander, 103 Broadway.  
 A. Nastasio, 103 Broadway.  
 Newark—R. L. Corwin; also New York City.  
 R. Rosenthal, Prop. Springfield Hdw. and Sptg. Goods Store, 71 Springfield ave.  
 D. Reinhorn, 91 Springfield ave.  
 \*Newton—A. Berkowitz, 99 Spring st.  
 Passaic—I. Hurwitz.  
 Paterson—Chas. H. Kelly, 25 N. Main st.  
 Plainfield—S. W. Frucht, or R. Frucht; also New York City.  
 Elston M. Leonard.  
 \*Westfield—Harry Berkowitz, 165 Broad st.  
 West Hoboken—Emil Hollander, or The West Hoboken Bicycle & Phono. Co., 169 Spring st.

## NEW YORK.

Albany—G. Linde, 353 S. Pearl st.  
 G. A. Birdsall, 114 S. Pearl st.  
 Amsterdam—D. C. Kirchner, 26 Market st.  
 Bedford Park—Geo. H. Tyrrell.  
 Brooklyn—Nathan Abrahams, 602 Broadway.  
 Wm. Albrecht, 294 Knickerbocker ave.  
 H. Hindermann and George Hindermann, Bushwick Phonograph Exchange, 1421 Myrtle ave.  
 Emil Smith, 634 Eleventh st., and 230 Summer ave.  
 Totten Furniture & Carpet Co., 216 Grand st.  
 Buffalo—Buffalo Phono. Co., 16 Seneca st.  
 Simon Farber, 672 William st.  
 Herman A. Reinhardt, 1214 Lovejoy st.  
 \*Cohoes—John H. Smith, 188 Remsen st.  
 Dolgeville—Clarence Richmond.  
 Haverstraw—F. E. Newman, Broadway.  
 Hobart—F. H. Marshall.  
 New York City—A. T. Armstrong, or American Phono Co., 106 Wall st.  
 Automatic Zither Co., M. Cohen, Prop., 58 Second ave.  
 Bern Bearwald, 373 W. 11th st.  
 Edward Bielfeld, 481 Willis ave.  
 Bronx Phono. Co., or David Switky, 506 Willis ave.  
 R. L. Corwin; also Newark, N. J.  
 Eagle Phono. Co., or C. Lowenthal, 83 Nassau st.  
 Empire Phono. Co., 2 W. 14th st.  
 Equity Furniture Co., Edward V. Kraus, Prop., 705 3d ave.  
 S. W. Frucht, or R. Frucht, 7 Barclay st., or 68 Cortlandt st., also Plainfield, N. J.  
 O. Hacker, 2 Murray st.  
 Hawthorne & Sheble, 297 Broadway; also Philadelphia, Pa.  
 Holober Bros., 350, 421 and 491 West st  
 N. Horn, 148 E. 58th st.  
 W. L. Isaacs, 114 Fulton st.  
 Italo-American Phono. Co. (R. Gerard & Co.)  
 Edward V. Kraus, 607-611 Ninth ave.  
 S. Lemberg & Co., 194 Broadway.  
 J. McEllynn, 202 Broadway.  
 Parker & Cooley, 2087 Amsterdam ave.  
 Richmond Pease, 44 W. 132d st.  
 F. M. Prescott, 44 Broad st.  
 \*P. A. Rosenthal, 391 8th ave.  
 Winthrop Cycle Co., 2212 Seventh av.  
 Ononta—G. B. Shearer Co., 259-261 Main St.  
 Putnam Valley—Edgar F. Mallory.  
 \*Ripley—Henry Barton, 615 Main st.  
 Rochester—George Lintz, 286 Bernard st.  
 Rome—A. S. Noonan, 105 E. Dominick st.  
 Charles Tuttle.  
 Saratoga Springs—Marvin A. Cote.  
 Watertown—H. S. Wardwell & Co., 39 Public Square.  
 Wayland—John Gross, Pursel Block.

## NORTH CAROLINA.

Kinston—S. A. Quinerly.

## NORTH DAKOTA.

Fargo—Ben Hart.

## OHIO.

Ashtabula Harbor—Chas. W. Askew (Gregory, Askew & Co.).  
 Bellevue—H. E. Rouser.  
 Brookville—H. K. Merritt.  
 Cincinnati—J. L. Andern.  
 Coshocton—Burns & Gosser.  
 Dayton—W. E. Sapp, 1042 W. Third st  
 Greenville—Omer E. Westerfield, 5th and Broadway.  
 Hicksville—W. R. Holden Co.  
 Springfield—D. & M. Vanderpool.  
 Uhrichsville—F. A. Mazurie.  
 Wilmington—Raymond Hale, or American Woolen Mills Co.

## PENNSYLVANIA.

Athens—J. T. Stalford, 405 Main st.  
 Bradford—C. C. Griffen, 29 N. Washington st  
 Lancaster—J. H. Tragresser, 249 N. Queen st  
 Lock Haven—Floyd Gallery, H. W. Swope, Prop., 131 Main st.  
 Mt. Pleasant—Benjamin Posner.  
 New Castle—Will Hartland, 70 E. Long st.  
 Philadelphia—A. R. Cassidy, 2783 Emerald st  
 Wm. Dyer, 321 Queen st.  
 Thomas Gunson, 1003 Carpenter st.  
 Hawthorne & Sheble, 604 Chestnut st., or Oxford and Mascher sts.; also New York City.  
 A. Krouse, 832 Arch st.  
 Geo. W. Lowden, or Geo. W. Lowden, Prop. Pioneer Studio of Music, 2616 Frankford ave.  
 Penn Novelty Co., 15 South 9th st.  
 Pittsburg—A. Lippard, 615 Wylie ave.  
 Royersford—Granville B. Tyson, 215 Main st  
 Titusville—E. H. Fortney, Prop. Exchange Cigar Store, 21 W. Central ave.

## RHODE ISLAND.

Providence—E. H. Gainsbury, 59 Plainfield st.  
 F. P. Moore.  
 M. Steinert & Sons Co., 327 Westminster st.; also Fitchburg and Pittsfield, Mass., and at all points.  
 Rockville Center—O. A. Clark.

## TENNESSEE.

Alexandria—Clarence D. Baird Music Concern.  
 \*Chattanooga—Ed. Marler, 11 E. 7th st.

## TEXAS.

Whitney—H. E. Randle & Co.

## UTAH.

Salt Lake City—Daynes Romney Music Co  
 25 East South 1st st.

## VERMONT.

Barre—Averill Music Co. (H. L. Averill & Co.), 28 N. Main st.

## VIRGINIA.

Covington—Covington Furniture Co., 213 Maple ave.  
 Norfolk—W. Reichenstein, 296 Church st.

## WASHINGTON.

Seattle—Cline's Piano Co., 1205 2nd ave.

## WISCONSIN.

Ashland—J. F. Pool Co.  
 Milwaukee—J. C. Blatzek.  
 Reedsburg—Fish & Greenwood.  
 Walworth—G. H. Stewart.

\*Added since May 1st, 1908.

Jobbers and Dealers are asked not to supply any of the above named firms with our apparatus, either at addresses given or any other address.

# Jobbers of Edison Phonographs and Records

Continued from page 2 of cover

## NEW YORK.

**Albany**—Finch & Hahn, 402 Broadway.  
**Astoria**—John Rose, 99 Flushing ave.  
**Brooklyn**—A. D. Matthews' Sons, 894 Fulton st.  
**Buffalo**—W. D. Andrews, Seneca and Wells sts.  
Neal, Clark & Neal Co., 645 Main st.  
**Elmira**—Elmira Arms Co., 117 Main st.  
**Gloversville**—American Phono. Co., 99 W. Fulton st.  
**Kingston**—Forsyth & Davis, 307 Wall st.  
**New York City**—Blackman Talking Machine Co., 97 Chambers st.  
J. F. Blackman & Son, 2737 3d ave.  
I. Davega, Jr., Inc., 125 W. 125th st.  
S. B. Davega Co., 32 E. 14th st.  
Douglas Phono. Co., Inc., 89 Chambers st.  
Jacot Music Box Co., 39 Union square.  
Victor H. Rapke, 1659 Second ave.  
Regina Co., 41 Union square.  
Siegel-Cooper Co., 6th ave. and 18th st.  
John Wanamaker, Broadway, 8th and 9th sts.  
Alfred Weiss, 1622 First ave.  
**Oswego**—Frank E. Bolway, 32 W. Bridge st.  
**Rochester**—A. J. Deninger, 345 North st.  
Mackie Piano, O. & M. Co., 100 State st.  
Talking Machine Co., 97 Main st., E.  
**Schenectady**—Finch & Hahn, 504 State st.  
Jay A. Rickard & Co., 253 State st.  
**Syracuse**—W. D. Andrews, 216 E. Railroad st.  
**Troy**—Finch & Hahn, 3 Third st.  
**Utica**—Clark-Horrocks Co., 54 Genesee st.  
Arthur F. Ferriss, 89 Washington st.  
William Harrison, 50 Columbia st.  
Utica Cycle Co., 16 Columbia st.

## OHIO.

**Canton**—Klein & Heffelman Co., 220 E. Tuscarawas st.  
**Cincinnati**—Ball-Fintze Co., 108 West 3d st.  
Ilsen & Co., 615 Vine st.  
\*Milner Musical Co., 25-27 W. 6th st.  
Rudolph Wurlitzer Co., 121 East 4th st.  
**Cleveland**—Eclipse Musical Co., 1870 East Ninth st.  
**Columbus**—Perry B. Whitsit Co., 213 S. High st.  
**Dayton**—Niehaus & Dohse, 35 E. 5th st.  
**Newark**—Ball-Fintze Co.  
**Toledo**—Hayes Music Co., 422 Superior st.

## OREGON.

**Portland**—Graves & Co., Inc., 65 No. Park st.

## OKLAHOMA.

**Oklahoma City**—Smith's Phono. Co., 818 West Main st.

## PENNSYLVANIA.

**Allentown**—G. C. Aschbach, 539 Hamilton st.  
**Easton**—William Werner, 432 Northampton st.  
**Harrisburg**—S. K. Hamburger, 12-14 N. Market square.  
**Philadelphia**—Louis Buehn & Bro., 45 N. 9th st.  
C. J. Heppe & Son, 1117 Chestnut st.  
Lit Bros., Market and 8th sts.  
Musical Echo Co., 1217 Chestnut st.  
Penn Phonograph Co., 17 S. 9th st.  
John Wanamaker, 13th and Market sts.  
Western Talking Mach. Co., 41 and 43 N. 9th st.  
H. A. Weymann & Son, 1010 Chestnut st.

\*Added since May 1st, 1908.

## Pennsylvania—Continued.

**Pittsburg**—Pittsburg Phono. Co., 937 Liberty ave.  
Powers & Henry Co., 339 Second ave.  
Standard Talk. Mach. Co., 435 Wood st.  
**Reading**—Reading Phonograph Co., 48 N. 8th st.  
**Scranton**—Ackerman & Co., 217 Wyoming av.  
Technical Supply Co.  
**Sharon**—W. C. DeForeest & Son.  
**Williamsport**—W. A. Myers, 127-129 W. 3d st.

## RHODE ISLAND.

**Providence**—J. M. Dean Co., 785-795 Westminster st.  
J. A. Foster Co., Weybosset and Dorrance sts.  
J. Samuels & Bro., 154 Weybosset st.

## TENNESSEE.

**Chattanooga**—J. H. Templeman Co., 253 Montgomery ave.  
**Knoxville**—Knoxville Typewriter and Phonograph Co., 421 Gay st.  
**Memphis**—F. M. Atwood, 160 N. Main st.  
O. K. Houck Piano Co., 103 S. Main st.  
**Nashville**—Magruder & Co., 27 Arcade.  
Nashville Talking Mach. Co., 723 Church st.

## TEXAS.

**Dallas**—Southern Talking Machine Co., 347 Main st.  
**El Paso**—W. G. Walz Co., 101 El Paso st.  
**Fort Worth**—Cummings, Shepherd & Co., 700 Houston st.  
**Houston**—Texas Piano & Phono. Co., 1019 Capitol ave.  
**San Antonio**—H. C. Rees Optical Co., 242 West Commerce st.

## UTAH.

**Ogden**—Proudfit Sporting Goods Co., 351 24th st.  
**Salt Lake City**—Clayton-Daynes Music Co., 109 S. Main st.

## VERMONT.

**Burlington**—American Phono. Co., 34 Church st.

## VIRGINIA.

**Richmond**—C. B. Haynes & Co., 603 E. Main st.

## WASHINGTON.

**Seattle**—D. S. Johnston Co., Third ave. and University st.  
Kohler & Chase, 710 Pike st.  
**Spokane**—Spokane Phonograph Co., 102 2nd ave.

## WISCONSIN.

**Milwaukee**—Lawrence McGreal, 176 3d st.

## CANADA.

**Quebec**—C. Robitaille, 320 Rue St. Joseph.  
**St. John**—W. H. Thorne & Co., Ltd., 42-46 Prince William st.  
**Toronto**—R. S. Williams & Sons Co., Limited, 143 Yonge st.  
**Vancouver**—M. W. Waitt & Co., 558 Granville st.  
**Winnipeg**—R. S. Williams & Sons Co., Ltd., 121 Princess st.

# Broaden Your Field

—and increase your sales. A dealer makes a serious mistake by selling records and instruments for amusement purposes alone. There is besides the amusement field the vast field of education from which can be reaped an abundant business. Here the dealer can increase the sale of records to those who already own phonographs, and can sell both instruments and records to a very large number of cash customers who would never think of buying a phonograph except for educational purposes. All this is made possible through

## I.C.S. LANGUAGE SYSTEM

WITH  
*Thomas A. Edison*  
PHONOGRAPH

There is a great opportunity for **you** to sell I. C. S. Language Outfits to people who are going abroad or who desire to learn a language for the sake of the knowledge of it alone; to those who desire to qualify for positions as translators and foreign correspondents; and to foreigners who wish to learn to speak English. No sledge hammer is needed to get it clearly into your head that this presents a sure way of broadening your field of work and increasing your sales. For the sake of good business sense, boom the I. C. S. Language feature of the business.

**International  
Correspondence Schools  
SCRANTON, PA.**

# EDISON PHONO- GRAPH MONTHLY

Vol. VI

July, 1908

No. 7

## CONTENTS

	PAGE		PAGE
Our Aim .....	1	Praise for Bryan Records.....	11
Don't Play Records too Fast.....	1	Over the Counter.....	11
Foreign's Pay Him.....	1	Foreign Records Sell.....	12
Advance List of New Edison Records for September .....	2	Ready for Your Scissors.....	13
Appellate Division of New York Supreme Court Decides Davega Case in Favor of the National Phonograph Co.....	6	Questions and Answers.....	14
Jobbers' Convention.....	7	Two Window Displays.....	15
How to Unpack and Set Up Edison Phono- graphs .....	8	Making the Bryan Records.....	16
Push the Bryan Records.....	9	New Edison Gas Plant.....	17
William E. Gilmore to Go Abroad.....	11	Grand Opera Records.....	17
Selling Record Blanks.....	11	Our July Advertising.....	18
		Suspended List .....	19
		Ready-Made Ads. ....	20
		Jobbers of Edison Phonographs and Records Cover pp. 2 & 3	

*Published for Trade use only by  
The National Phonograph Co., Orange, N.J.*

# Jobbers of Edison Phonographs and Records

## ALABAMA.

Birmingham—Talking Machine Co., 2007 Second ave.  
Mobile—W. H. Reynolds, 167 Dauphin st.  
Montgomery—R. L. Penick, 119 Dexter ave.

## ARKANSAS.

Fort Smith—R. C. Bollinger, 704 Garrison Ave.

## CALIFORNIA.

Los Angeles—Southern California Music Co., 332 South Broadway.  
Oakland—Kohler & Chase, Inc., 917-921 Wood st.  
Sacramento—A. J. Pommer Co., 9th and J sts.  
San Francisco—P. Bacigalupi & Sons, 1021 Golden Gate Ave.

## COLORADO.

Denver—Denver Dry Goods Co., 619 16th st.  
Hext Music Co., 15th and California sts.

## CONNECTICUT.

New Haven—Pardee-Ellenberger Co., Inc., 96 State st.

## DISTRICT OF COLUMBIA.

Washington—E. F. Droop & Sons Co., 925 Pennsylvania ave., N. W.

## GEORGIA.

Atlanta—Atlanta Phonograph Co., 10 Walton st.  
Phillips & Crew Co., 37-39 Peachtree st.  
Waycross—George R. Youmans.

## IDAHO.

Boise—Eller's Piano House.

## ILLINOIS.

Chicago—Babson Bros., 1419 19th st.  
Lyon & Healy, Wabash ave. & Adams st.  
James I. Lyons, 265 Fifth ave.  
The Vim Co., 68 E. Lake st.  
Montgomery Ward & Co., 111 Michigan ave.  
Rudolph Wurlitzer Co., 266 Wabash ave.  
Peoria—Chas. C. Adams & Co., 324 South Adams st.  
Peoria Phonograph Co., 416 S. Adams st.  
Quincy—Quincy Phonograph Co., 411 Hampshire st.

## INDIANA.

Indianapolis—Indiana Phono. Co., 45 Virginia ave.  
Kipp-Link Phonograph Co., 10-12 E. Washington st.  
A. B. Wahl & Co., 119 S. Illinois st.

## IOWA.

Des Moines—Hopkins Bros. Co., 620 Locust st.  
The Vim Co., 204 Seventh st.  
Dubuque—Harger & Blish, Security Bldg.  
Fort Dodge—Early Music House, 822 Central ave.  
Sioux City—Early Music House, 315 Court st.

## KENTUCKY.

Louisville—Montenegro-Riehm Music Co., 630 4th ave.

## LOUISIANA.

New Orleans—William Bailey, 600 Frenchman st.  
National Automatic Fire Alarm Co., 614 Gravier st.

## MAINE.

Bangor—S. L. Crosby Co., 186 Exchange st.  
Portland—W. H. Ross & Son, 43 Exchange st.

## MARYLAND.

Baltimore—E. F. Droop & Sons Co., 231 North Howard st.

## MASSACHUSETTS.

Boston—Boston Cycle & Sundry Co., 48 Hanover st.  
Eastern Talking Mach. Co., 177 Tremont st.  
Iver Johnson Sptg. Goods Co., 163 Washington st.  
Fitchburg—Iver Johnson Sptg. Goods Co., 247 Main st.  
Lowell—Thomas Wardell, 111 Central st.  
New Bedford—Household Furnishing Co., 170 Purchase st.  
Springfield—Flint & Brickett Co., 439 Main st.  
Worcester—Iver Johnson Sptg. Goods Co., 304 Main st.

## MICHIGAN.

Detroit—American Phono. Co., 106 Woodward ave.  
Grinnell Bros., 219 Woodward ave.

## MINNESOTA.

Minneapolis—Thomas C. Hough, 913 Nicollet ave.  
Minnesota Phono. Co., 505 Washington ave., So.  
St. Paul—W. J. Dyer & Bro., 21-23 West 5th st.  
Koehler & Hinrichs, 255 E. 3d st.  
Minnesota Phonograph Co., 37 E. 7th st.

## MISSOURI.

Kansas City—J. W. Jenkins' Sons Music Co., 1013-1015 Walnut st.  
Schmelzer Arms Co., 710 Main st.  
St. Louis—Conroy Piano Co., 11th and Olive sts.  
Koerber-Brenner Music Co., 1006 Olive st.  
Silverstone Talk. Mach. Co., 1010 Olive st.

## MONTANA.

Helena—Frank Buser, 509 N. Main st.

## NEBRASKA.

Lincoln—Ross P. Curtice Co., 1125 O st.  
H. E. Sidles Phono. Co., 13th and P sts.  
Omaha—Nebraska Cycle Co., 15th and Harney sts.  
Shultz Bros., 16th and Chicago sts.

## NEW HAMPSHIRE.

Manchester—John B. Varick Co., Varick Bldg.

## NEW JERSEY.

Hoboken—Eclipse Phono. Co., 203 Washington st.  
Newark—Douglas Phonograph Co., 20 New st.  
A. O. Petit, 57 Halsey st.  
Rapke Phono. Store, 287 Bank st.  
Paterson—James K. O'Dea, 117 Ellison st.  
Trenton—Stoll Blank Book and Stationery Co., 30 E. State st.  
John Sykes, 105 N. Broad st.

Continued on page 3 of cover



# Edison Phonograph Monthly

VOL. VI.

July, 1908

No. 7

## Our Aim

The EDISON PHONOGRAPH MONTHLY is not a smart or "slick" publication. At least not in the sense in which those terms are generally used.

We are doing our best to get out a serious, practical, matter-of-fact trade journal that will *help Edison Dealers sell goods.*

It shall be our ambition to make the PHONOGRAPH MONTHLY more readable—more helpful each succeeding month.

The most we ask of you is that you make use of all the practical suggestions you find for improving your business. The least we expect of you is that you read your copy through each month.

Isn't that a fair deal?

## Don't Play Records too Fast

We cannot make this caution strong enough. It is absolutely necessary to run an Edison Phonograph at a speed of exactly 160 revolutions per minute to get perfect results. All master Records, from which Edison Records are made, are recorded at this speed. They must be reproduced at this speed—no more, no less.

Every Phonograph is adjusted to run at 160 revolutions a minute when it leaves the factory. If by accident or carelessness, the governor should become displaced on the pinion shaft or the speed-adjusting screw underneath the top plate turned so as to change the speed, it can be easily adjusted. Raise the top on the Standard or Home and turn the speed-adjusting screw to the right to make the cylinder run more slowly or to the left to make it run faster. The way to judge the speed is to have the Phonograph fully wound up and running at full speed with Reproducer arm down as for reproducing. The Reproducer arm should travel from one of the circular rings on the back rod to the other in exactly one minute. The circular rings are 1 6-10 inches apart. When the Reproducer arm travels this distance it indicates 160 revolutions.

## Foreigners Pay Him

We want every Edison Dealer to read the following letter. The good thing about it is there is some German or French or other foreign customer of yours waiting to be "shown" just as Mr. Haupt's friend was. You ought to go after this trade the same as he is doing:

"A friend of mine whom I had not seen for some time paid me an unexpected visit. He had just returned from Germany where he had heard a number of German Records which he supposed were never made in this country. He especially mentioned one Record, 'O Susanna.' I did not answer him but took the Record and put it on the machine. He was so delighted with it that he immediately gave me an order for an Edison Triumph Phonograph, a cabinet, and a great many Records, most of which were German. His purchase amounted to \$107.50. He never before had any thought of buying a machine until he heard 'O Susanna.' Now he is so interested in the machine that he regrets that he had passed so many years without an Edison Phonograph." —*Star Phonograph Co., B. Haupt, Prop., 1034 Broadway, Brooklyn, N. Y.*

## A Question

Are you one of the Edison Dealers who invite Phonograph owners to come to their stores one night each month to hear the new Edison Records played?

"INITIATIVE," WRITES ELBERT HUBBARD, "MEANS DOING A THING WITHOUT BEING TOLD. THE NEXT BEST THING IS DOING IT WHEN YOU ARE TOLD ONCE." THE DEALER WHO DOES HALF THE THINGS HE IS TOLD IN *THE PHONOGRAPH MONTHLY* TO DO IS GOING TO WIN, BUT THE DEALER WHO DOES THREE-FOURTHS IS GOING TO BEAT HIM TO IT.

## Advance List of New Edison Records for September, 1908

**R**ECORDS listed below will be shipped from Orange in time to reach all Jobbers in the United States and Canada before August 25th, 1908, all things being favorable, and they may be reshipped to Dealers at 2 P. M. on August 24th. They must not, however, be exhibited, demonstrated or placed on sale by Jobbers or Dealers until 8 A. M. on August 25th. Supplements, Phonograms and Bulletins will be shipped with Records. These may be distributed to Dealers after August 20th, but must not be circulated among the public before August 25th. Jobbers and Dealers may, however, deposit Supplements and Phonograms in Mail Boxes or Post Offices after 5 P. M. on August 24th, for delivery on the following day. Jobbers are required to place orders for September Records on or before July 10th. Dealers should place September orders with Jobbers before July 10th to insure prompt shipment when Jobber's stock is received.

### 9924 Mexican Kisses

Edison Concert Band

Here is a most delightful concert number that has much in common with the ravishingly sweet "Habanera," the Spanish national dance. It is built upon a melody that is as dreamy and rhythmic as any olive-tinted danseuse of old Spain could wish for. As usual with Spanish and Mexican dance music, castenets are introduced with fine effect to emphasize the dance tempo. Composer, Charles J. Roberts; publisher, Carl Fischer, New York.

### 9925 Let Me Crown You Queen of May with Orange Blossoms

Manuel Romain

A picturesque love ballad that vividly recalls Record 9728, "When It's Moonlight, Mary Darling, 'Neath the Old Grape Arbor Shade." The music is by the same composer and serves equally well to bring out all the latent sweetness of Romain's fine tenor voice. To hear this Record is to wish to own it. Orchestra accompaniment; music, J. Fred Helf; words, Bartley Costello; publishers, Helf & Hager Co., New York.

### \*9926 Take Me Out to the Ball Game

Edward Meeker

The base-ball hit of the season—a home run at least. Katie Casey is a true-blue, dyed-in-the-wool base-ball "fan," and can give her big brothers pointers on "rooting" for the home team. She'd rather munch peanuts on the bleacheries than caramels at a matinee—which is saying a good deal for a girl. Meeker must have taken Katie to a game or two, judging from the interest he takes in singing about her. The tune is a jolly, infectious one and you get every word. Orchestra accompaniment; music, Albert Von Tilzer; words, Jack Norworth; publishers, York Music Co., New York.

### 9927 Dancing in the Barn

Edison Military Band

A new interpretation of an old-time favorite greatly in demand for the reigning barn dance, which seems to have come to stay. The Band has succeeded in making a remarkably good Record, loud and clear in tone with the rhythm perfectly marked. Publishers, Thompson & Odell, Boston, Mass.

### 9928 Hugo

Ada Jones

Here is more proof that Ada Jones' versatility has no limit. This charming entertainer can sing an Irish song "to beat the Dutch," and then turn right around and sing Dutch to beat the Irish. That may seem like a very difficult feat, but there will be no room for doubt after hearing "Hugo," which is her latest Dutch dialect song. A winning combination of genuine comedy with a pleasing waltz tune that suggests the most musical of Vesta Victoria's English comedy songs. Orchestra accompaniment; music, Ted Snyder; words, Edgar T. Farran; publishers, Ted Snyder Co., New York.

### 9929 Sim and Sam, the Musical Coons

Len Spencer and Mozarto

A racy vaudeville sketch. Sam and Sim are a pair of vivacious coons who get back at one another with a lot of witty ragtime repartee leading up to some clever musical stunts. The latter are done by Mozarto, the European vaudeville performer, who was tempted to visit America by the large salaries paid here to artists in his line. He plays about every type of

\* This selection will be illustrated on cover of September Phonogram.

instrument, his strong point being taking them two-at-a-time. We are treated to a saxophone duet, "Sycamore Tree"; to "Suwanee River" on a one-string violin and ocarina, and to a clarinet duet, "Jamaica Two-Step," Mozarto being the sole performer in all three duets. As good as it's novel. Not published.

**9930 Childhood****Byron G. Harlan**

Byron Harlan's child-songs are classics in their way. Many owners of Edison Phonographs give them a place ahead of all other Records. And no wonder, for who could turn a deaf ear to such rare gems of song as "Why Don't They Play with Me?" "Daddy's Little Girl," "Will I Find My Mamma There?" "Little Boy in Blue," "Hello, Central, Give Me Heaven" and "School Days." In "Childhood" Kerry Mills gives us his idea of a song written in the popular waltz time. The fascinating refrain is accompanied with bells. Simply charming and charmingly simple. Words and music, Kerry Mills; publisher, F. A. Mills, New York.

**9931 Dance of the Clowns****Edison Symphony Orchestra**

A realistic descriptive number that portrays the frolicsome glee of a whole company of clowns belonging to "the greatest show on earth." Apparently they have been given a free rein to do as they like and have the centre ring of the circus all to themselves. The entire selection is played in a lively quick-step to keep time with the make-believe quips and pranks of the sportive merrymakers, the oboe and bassoon having solo parts that are decidedly bright and tuneful. Composer, Geo. J. Trinkhaus; publishers, Theo. Bendix Music Co., New York.

**9932 Mother's Lullaby****Matt Keefe and George Stricklett**

A plaintive slumber song with yodle—the first in a long while. The song is by Stricklett and the yodle by Matt Keefe, a new Edison artist. Mr. Keefe is also the composer and has worked in many of those peculiar and strikingly pretty yodling effects that have made his fame in vaudeville. Orchestra accompaniment; music and words, Matt Keefe; not published.

**9933 I've Taken Quite a Fancy to You****Ada Jones and Billy Murray**

Nothing that these clever duetists have done together rivals their spicy love-duets. "Kiss, Kiss, Kiss" (Record 9683) was the starting point of their success in this field. Later we were treated to "Smile, Smile, Smile" (Record 9724) and later still, to "When the Song of Love is Heard" (Record 9844). Their latest is a distinctly amorous flirting-song, which offers both singers a number of spirited solo parts and a swinging chorus, in which their voices blend delightfully. Orchestra accompaniment; music, Theodore Morse; words, Edward Madden; publishers, F. B. Haviland Publishing Co., New York.

**9934 Cohan's Rag Babe****Arthur Collins**

Still another of the bright musical things from "The Yankee Prince." A jolly, rollicking number that's as typically raggy as the "raggedy man." It tells a story of a new two-step that's coming to town (and of course George Cohan would be expected to know about a new two-step ahead of anybody else). If you want a lightning-fast Cohan ragtime number, served up in style by Arthur Collins, don't omit this Record from your list. Orchestra accompaniment; words and music, George M. Cohan; publishers, Cohan & Harris Publishing Co., New York.

**9935 Society Swing Two-Step****Edison Military Band**

A catchy two-step played in dance tempo that will at once take a conspicuous place in the repertoire of the leading dance orchestras. The composer was also responsible for the fashionable "College Life Two-step." The Edison Military Band gives a finished, even performance with ample volume for dancing. Music, Henry Frantzen; publishers, F. B. Haviland Publishing Co., New York.

**9936 Somebody Lied****Bob Roberts**

Bob Roberts has a great opportunity here in one of the best comic coon songs heard in months. Both words and melody are away above the average. The story the coon tells on himself is that somebody (presumably a phrenologist) felt his head in his pickaninny days and said he'd be a President at least—and of course "somebody lied." Later in life he was at work in a livery stable and somebody ordered him to curry a mule, saying, "Don't be afraid of her hind legs, she's gentle as can be." Once again "somebody lied," this time with disastrous effects. Orchestra accompaniment; music and words, Jeff T. Branen and Evans Lloyd; publisher, Will Rossiter, Chicago.

**9937 Throw Out the Life Line****Edison Mixed Quartette**

No hymn in the entire Gospel Hymn Book is more universally beloved than this one. It is probably more used than any other in church revival work. The Edison Mixed Quartette has given it an original interpretation that will reveal new beauties not yet thought of by its tens of thousands of admirers, the soprano and tenor singing the verse and the quartette the refrain. This affords a most unusual example of contrast in forte and pianissimo singing that many church choirs will undoubtedly copy. Music and words, Rev. E. S. Ufford.

**9938 Starlight Maid****Billy Murray and Chorus**

The brilliant feature-song of "The Auto Race," this season's spectacular production at the

New York Hippodrome. This song has probably won more encores at the world's largest theatre than any ever offered there. Billy Murray sings the solo part and a male quartette assists in the captivating chorus, accompanied by a bells obligato. Orchestra accompaniment; music and words, Manuel Klein; publishers, M. Witmark & Son, New York.

**9939 Beau Brummell****Albert Benzler**

An Edison owner asks, "Can we have too many of the Benzler bells solos?" The answer is a decided "no," especially if we could always have a favorite selection like the ever-charming "Beau Brummell"; but unfortunately there are not many such. The arrangement, in gavotte tempo, lends itself nicely to bells work, and chimes are introduced with just sufficient prominence to bring out the full harmonic contents. Music, Theo. Bendix; publishers, Oliver Ditson Co., Boston, Mass.

**9940 Oh, Glory!****Murry K. Hill**

Murry K. Hill's cleverest comic song-success that has been heard and O.K.'d all around the big vaudeville circuits. The singer has a droll method which is all his own, although he has been widely imitated. He has only made one other Record, "In the Good Old Steamboat Days" (9619). The thousands of Phonograph owners, who have this, will hardly wait to read the announcement of a new and even better one by this ever-popular vaudeville artist before determining to own it. The words picture several highly amusing situations and Hill works in a couple of his odd introductions on two of the verses that if anything are more comic than the lines of the song. Orchestra accompaniment; words and music, Murry K. Hill.

**9941 Down in Jungle Town****Collins and Harlan**

We were all ready and waiting for another Collins and Harlan Jungle Song ever since they gave us "In Monkey Land" (Record 9700). It certainly had a "more" taste, and it might be added, its popularity shows no signs of waning. "In Jungle Town" is by the same composers and they call it the legitimate successor to their earlier effort. We wish to stamp our cordial O. K. on their opinion, but think Collins and Harlan deserve a world of credit for the splendid manner in which they have brought out all its good points. The tune is fetching and the chorus goes with a double-swing, helped considerably by a xylophone accompaniment. Orchestra accompaniment; music, Theodore Morse; words, Edward Madden; publishers, F. B. Haviland Publishing Co., New York.

**9942 Flanagan's Shopping Tour****Steve Porter**

This is probably the most comical experience our friend Flanagan ever had. It seems Mrs. F. was sick and Flanagan, like the good fellow that he is, offers to do her shopping. She sends him out to tackle the bargain counters at the department stores. He has a long shopping list and isn't very clear in his own mind as to what is wanted. The sales-girls (mean things) take advantage of him at every turn. For instance, he asks innocently if they have the thinnest thing in shirt waists. The answer is, "We have, but she's out to dinner." This is kept up through eight different departments, each situation being funnier than its predecessor. The act concludes with a rousing comic song. The sketch is original and is not published.

**9943 Schottische Medley****John Kimble**

Have you heard a Kimble accordion solo? No? Then don't fail to ask your Dealer to put this Record on for you. The accordion used by Kimble has no relation to the ordinary concertina type of instrument. You will be astonished at its sweet tone and variety of musical expression, while the volume is sufficient to fill a large-size concert hall. This selection is a potpourri of popular melodies played in schottische tempo. It is well suited to the barn dance. Piano accompaniment; not published.

**9944 Your Picture Says, "Remember" tho' Your Letter Says, "Forget"****Frederic Rose**

This month's sentimental ballad represents the united efforts of A. J. Lamb, who wrote the words of "The Heart You Lost in Maryland You'll Find in Tennessee" (Record 9782), and S. R. Henry, who composed the music of "Down in the Old Cherry Orchard" (Record 9723). The first will be recalled as Rose's great success on our March list, while the latter was the song selected by him for his first Edison Record. This touchingly pretty ballad may therefore be fairly said to have been made to order for the singer and to fit him "like a glove." Orchestra accompaniment; music, S. R. Henry; words, A. J. Lamb; publishers, J. W. Stern & Co., New York.

**9945 Tony and Rosetta****Ada Jones and Len Spencer**

Ada Jones and Len Spencer in their element. As Tony and Rosetta they run a "dago" fruit stand and make a fair start to riches. The competition for laughs is very keen between their fast and witty repartee and that of their customers. These include an Irish cop, a Jew, a bootblack, and Danny, Rosetta's second-best friend. The mandolin, harmonica, popping corks, fizzing soda and steaming peanut roaster provide incidental music, and Rosetta (Ada Jones) tops it all off with a great dialect song, "He's My Brud." The sketch is original and is not published.

**9946 Every Mother's Son There Sang "The Wearing of the Green"****Edward M. Favor**

Truly Irish and truly comic. The events of McVeigh's birthday celebration are graphically

pictured in lines that abound in real Irish wit. All the neighbors had assembled on the parlor floor of the McVeigh tenement and proceeded to make an Irish night of it, by partaking of the cup that cheers and singing "The Wearing of the Green." Then followed a genuine Irish scrap, resulting from Dan McCann trying to dance the "Merry Widow Waltz" with the wife of Murphy's bosom. A copper "blew in" on the scene in time to pinch the whole "shebang," so the rest of the evening was spent in jail. Three verses and three choruses. Orchestra accompaniment; music, Joe Hollander; words, Ed. Rogers; publisher, Shapiro, New York.

**9947 The Top Notch March**

**Edison Military Band**

All that the name implies—a new march and a sure enough live one. One hears so many so-called marches that are simply a jumble of old worn-out tunes "oft heard before" that a snappy, original number such as this one is as refreshing as a cool shower after a hot day. Note particularly the haunting melody in the trio, and the stirring military flavor which gives the Edison Military Band an opening for some of their wonderful ensemble work. Music, Charles Arthur; publisher, Carl Fischer, New York.

## 2 Selections Made Over

We list below two selections that have been made over by the same talent. The September printed matter prepared for retail use will contain these selections. Jobbers should replace their stock of the original Records of these numbers with the new ones.

**2216 The Old Oaken Bucket**

**Edison Male Quartette**

**8270 Santa Claus Song**

**Geo. P. Watson**

### Home Made Records

Get the owners of Edison Phonographs started on making their own Records at home. It's easy to do and will pay you big. Voice photography is more novel—more fascinating than ordinary photography and far less trouble. Baby prattle recorded now will prove the most delightful music in the world in later years. And the recorded words of relatives and friends will be a priceless possession when they are far away. Such talking points make an irresistible argument with Edison owners.

Be the first to push home-made Records in your town. It will pay you big because you sell the Record Blanks at a good profit and charge for shaving them off. You also sell the recording horns and (to owners of Gem and Standard machines) the Recorders. Don't lose a sale because a customer objects to buying the recording horn. Sell it if you can, but failing in this, show them how to make one of card board.

The minute you announce that you can supply the equipment for making Records at home and are prepared to shave the blanks, it is bound to add greatly to your prestige. It will attract Edison owners to your store who have been going elsewhere for their regular Records. It will also influence the prospective buyer of a machine to get an Edison, as it is the only type on which Records can be made at home.

We are going to give liberal space in the

*Phonogram* to home record-making from now on. That will help you.

Write at once to the National Phonograph Company for a catalogue of accessories and any further information.

### An Idea

One Edison Dealer makes it a rule to print the full lists of new Edison Records in his newspaper advertisements. He features this double line in bold face type:

*Call and hear the new Records*

*Whether you own a Phonograph or not.*

A very clever scheme, for it not only reminds Phonograph owners that the new Records are out, but invites the public in to hear them. Use the idea in your advertisements.

### They Are "With Us"

We have looked over the Edison bill-boards and find them well located and nicely put up.

They are certainly fine and an expensive piece of work. But without a doubt, like all GOOD advertising, they will pay well.

We are spending considerable this year for advertising Edison Phonographs in local newspapers, sign boards and mailing advertising matter direct. Last, but not least, we endeavor to sell every customer a quiet running, carefully adjusted machine, and a good selection of Records, which secures a satisfied customer—the best advertisement procurable—free of cost. We are with you to strengthen the Edison business.—*Olinger & Warvel, No. Manchester, Ind.*

## Appellate Division of New York Supreme Court Decides Davega Case in Favor of the National Phonograph Co.

The decision of Judge Keogh, in the Davega suit in favor of the New York Phonograph Company, was reversed on June 5th, by a unanimous decision of the Appellate Division of the Supreme Court of New York. As several hundred suits brought against New York jobbers and dealers of the National Phonograph Company by the New York Phonograph Company are substantially terminated by this decision in the Davega suit, which was selected practically as a test case, it is of exceptional interest to New York Jobbers and Dealers. The decision is a document of very considerable length and while its importance would merit its reproduction here in full, lack of space restricts this article to a brief statement of the material points decided and a few extracts from the more important portions of the decision.

Judge Miller, in writing the opinion, concurred in by all the Judges of the Appellate Division, treats the case in two branches; first, deciding that on the merits of the controversy the decision in the court below should have been against the New York Phonograph Company, and secondly, directing a dismissal of the bill of complaint on the ground that the suit was really a patent case, which should have been tried in the Federal Courts and of which the State Courts have no jurisdiction.

On the question of the merits, the decision is in substance as follows: On June 28th, 1888, the North American Phonograph Company, under an agreement with Mr. Edison, acquired the exclusive right to exploit and introduce the Phonograph commercially throughout the United States and Canada. This was a license agreement under certain inventions patented prior to that time, which patents would expire, by the termination of the seventeen-year period for which they were granted, not later than 1905. By a subsequent agreement of August 1, 1888, Mr. Edison undertook to assign to the North American Company, his Phonograph inventions made within a period of fifteen years thereafter, on condition that the North American Company should pay his expenses for experimental work, and for obtaining the patents.

The North American Company granted an exclusive license to the New York Phonograph Company, the plaintiff, and its predecessors, to sell Phonographs and appliances within the State of New York, up to March 26th, 1903, and so long thereafter as it should have exclusive rights

to grant, under its contract with Mr. Edison. This contract was one between the North American Company and the New York Phonograph Company, and its predecessors. Mr. Edison was not a party to it.

In the year 1894, the North American Phonograph Company became insolvent and a receiver was appointed, and in February, 1896, its assets were sold to Mr. Edison, who was the sole bidder and the largest creditor. The North American Company, after its insolvency, paid no part of the expenses incurred by Mr. Edison in making his subsequent experiments and in securing his patents, and therefore, under the terms of its agreement with him, acquired no right to such inventions. The decision of the trial Court, which granted an injunction restraining the defendant, Davega, from selling Phonographs and phonographic appliances, within the State of New York, up to August, 1921, was based upon the theory that the rights of the New York Phonograph Company continued during the life of a patent of Mr. Edison, granted in August, 1904, and applied for on August 1, 1903, the last day of the fifteen years during which Mr. Edison was to make inventions for the North American Phonograph Company, assuming that the above conditions were complied with. No one pretends that the patent in question was used by the National Phonograph Company, or by any one else, but the patent was practically selected as a *measure of time*, during which the original rights of the New York Company were supposed to be in force, and not, as is ordinarily the case with patents, to define the scope or extent of a right. But as the North American Company, subsequent to its insolvency in 1896, paid none of the expenses relating to the making of inventions and the taking out of patents, the Court held that it was not entitled to an assignment of that invention and hence its rights could not possibly be dependent thereon; and for this reason, the decision of the Court below was reversed.

On the question of jurisdiction, the contention of the New York Phonograph Company was that this was not a patent suit, because the validity of patents or the violation of patent rights was not presented for decision, but the Court found that an infringement suit does not necessarily involve the validity of a patent, that the rights which the New York Phonograph Company asserted arose, if at all, under the patent laws of the United States and that the construction of the patent laws, as well as the construction of the patents themselves were involved and announced its determination upon the subject of jurisdiction as follows:

"The conclusion seems inevitable that whatever rights the plaintiff has as against the defendant (Davega, the jobber) or his vendor (the National Phonograph Company) are patent, not contract rights. If so, any suit to enforce those rights arises under the Patent Laws of the United States, and the Courts of this State cannot take jurisdiction of it."

The decision furthermore disposes summarily of the principal contention of the New York Phonograph Company that the rights secured from the North American Company were derived from a general selling contract and not from a license under patents, in the following language:

"I do not discuss the point argued by the plaintiff that the term of said contract was not limited by the life of the patents owned or controlled by the licensor, or which it might become entitled to under its contract with Mr. Edison, as that position is obviously unsound. The parties understood when said contract was made that all of the patents then in force would expire before or during the year 1905 and the continuance of the contract beyond that time depended on the making of subsequent inventions by said Edison, which said licensor should become entitled to as aforesaid."

Another contention which lies at the foundation of the claims made by the New York Phonograph Company was that the National Phonograph Company, which acquired a part of the assets of the North American Phonograph Company is the successor of that company and as such is bound to perform all its agreements for the future. On this subject the Court says:

"The respondent's position is that the National Phonograph Company is the successor of the North American Phonograph Company; but that position is untenable (N. Y. Bank Note Co. v. Hamilton B. N. Co., 180 N. Y., 280.) The National Company purchased through Mr. Edison the assets of the North American Company at receiver's sale pursuant to a judicial decree. There was nothing in that decree which required the purchaser to assume the obligations of the insolvent company, and the purchaser at a judicial sale of the assets of an insolvent corporation does not assume the latter's obligations."

\* \* \* \* \*

"If it be the law that the purchaser at a receiver's sale of the assets of an insolvent corporation assumes its obligations even under executory contracts, no responsible person could safely bid at such a sale; but as already shown that is not the law."

Throughout this litigation numerous unfounded accusations have been made against Mr. Edison in relation to his conduct toward the North American Company. As a matter of fact it was through Mr. Edison's efforts that the North American Company remained in business as long as it did; and instead of endeavoring to wreck it, as he has been accused of doing, he made many personal sacrifices to sustain it. We are pleased to note the following passages in this decision which indicate how unfounded were the charges made against Mr. Edison:

"There is a finding 'that such acts' (referring to acts set forth in previous findings) 'were done pursuant to a scheme or plan and as an expedient and device to unlawfully invade the said exclusive territory of this plaintiff.' But so far as that may refer to the appointment of a receiver of the North American Phonograph Company, the sale of its assets and the purchase thereof by the National Phonograph Company, there is no evidence to support it. It is unquestioned that the North American Phonograph Company was insolvent, a receivership was necessary, and Mr. Edison or a company organized by him had as much right to purchase the assets as anybody had. In fact, his purchase was probably fortunate for the creditors."

\* \* \* \* \*

"I am not saying that Mr. Edison could wreck the North American Phonograph Company for the purpose of acquiring its assets and destroying the value of the plaintiff's contract without being answerable in some form of action, for I believe the law is adequate to deal with every wrong, but while much is said by the learned counsel for the respondent on that subject, there is no proof whatever in the record to warrant it."

We regard the decision in the Appellate Division as of great importance, and believe that it must substantially end the campaign which for

years has been directed against our Jobbers and Dealers by the New York Phonograph Company.

## Jobbers' Convention

Everything is in readiness for the annual convention of the National Association of Talking Machine Jobbers at Atlantic City, N. J., July 6 and 7. The committee of arrangements reports that there will be a fine attendance and many Dealers will also make the trip, as it offers an unusual opportunity for combining business and pleasure. Atlantic City is the nation's playground about the time set for the convention, and hotel accommodations should be engaged in advance. The Hotel Chalfonte will be headquarters. The committee also recommends the Raleigh Hotel, which is near at hand, and suggests that everyone attending the convention ask for the special hotel rates that they have arranged for.

## Prices for Gold Plating the Idelia

The Sales Department, in response to a request from the trade, recently quoted a list price of \$135.00 for the Idelia Phonograph *gold plated* instead of oxidized, subject to the regular Jobbers' and Dealers' discounts. This makes the additional price of gold plating \$10.00 list. If a gold-plated Idelia is ordered with repeating attachment, no extra charge will be made for gold plating. Only the regular charge for the repeating attachment, \$12.50, will be made.

### Sales Department Bulletin No. 12. June 20th, 1908.

FOR UNITED STATES AND CANADA  
DEALERS.

Correspondence concerning this Bulletin should mention its number and be addressed to the National Phonograph Company, Sales Department, Orange, N. J.

Dealers are hereby advised that inasmuch as we have no more moulds or masters of them, the following selections will be considered as "cut-outs" after our present stock is exhausted:

- 12174 La Marcha de Cadiz (Spanish) Vargas
- 12876 Blue Bells of Scotland (French-Canadian) 48th Highlanders' Band

WHY NOT BECOME A DEALER IN EDISON BUSINESS PHONOGRAPHS? OTHER DEALERS ARE FINDING IT HIGHLY PROFITABLE. FOR FULL INFORMATION WRITE TO EDISON BUSINESS PHONOGRAPH CO., ORANGE, N. J.

## How to Unpack and Set Up Edison Phonographs

There is a right way to unpack Edison Phonographs and Records that is so far ahead of the multifarious wrong ways that we are going to explain it fully for the benefit of Edison Dealers who do not have it in use.

Edison Phonographs reach the Dealer in the same shape as when they leave the Edison Phonograph Works at Orange, N. J., as the Jobber re-ships them just as they are received. This means they are in perfect condition, and all that's needed is a little care to get them out whole.

The box should be placed on a bench, or on another box, top-side up. If you are a six-footer, the store counter may not be too high for the purpose. Now draw the nails out with a NAIL-PULLER. We write this with capitals because it's by far the most important part of the operation. If you do not have a nail-puller, by all means get one. Ninety-nine per cent of all damaged goods found in our shipping boxes comes from indiscriminate, strong-arm use of hatchet or hammer and chisel in opening them up.

The latter is just about as effective a way of opening up Phonograph goods as an axe is on a can of tomatoes. Your little ten-cent can opener does the trick in thirty seconds and saves the can, saves the contents, saves your good humor for the day. And you know how the axe scheme works. Well, the Phonograph is not far below the top of its box, and it won't take much of a stab from hatchet or chisel to open up a gaping hole in its cover. Get the nail-puller and save all of those good boxes that will come in fine to sell or to set things on in your window trims.

When the box top comes off a good thick layer of excelsior padding is found. Take this out and a couple of stout strips will be seen extending across, to help hold the Phonograph firmly and prevent slipping around. The way to get these



out is to turn the box over on its side and get busy with your nail-puller, as shown above.

After the strips are out look out for a parcel containing the horn crane in four parts. The Phonograph is found tightly wrapped in tough, heavy wrapping paper. Remove this and at each end is a catch lever. Pull these out and the cover can be lifted off. The Reproducer will be found tied securely. Lift the lid on which the mechanism rests until the supporting link at the left end catches to hold it in position. Now remove the straw-board blocking that is underneath the spring barrel. [See illustration below.]



It is put there to hold the mechanism firmly in position and prevent its being jostled in shipping. It is surprising how many Dealers send the Phonographs out without removing the padding or telling their customers about it. The result is the machine refuses to go.

A package will be found inside the case containing winding crank, horn connection, oil can and sample bottle of oil, and set of instructions. With machines higher-priced than the Standard a Recorder is also included. Follow the directions to the letter when you are ready to set the Phonograph up and start it playing.

An envelope will be found in with the horn crane parts containing diagrams and instructions on adjusting the horn. There is one thing in which great care must be exercised—and that is the position of the horn. Connect the horn with the Reproducer and set the Reproducer at the centre of the Record cylinder. Now make the chain rod of such length that when the horn is swung from the end the chain will hang perfectly straight, or perpendicular as seen from the end of the machine. If the chain slants toward the Phonograph it pushes against the Reproducer so as to cause friction and slow up the movement of the carriage. If it slants the opposite way, it pulls the Reproducer away from the Record and weakens the tone.

Use the same care in opening up your Records, only more of it, for the Records are much more fragile and apt to break. Use the nail-puller and use it carefully. In handling a



Record, insert two fingers in taking it out of carton and putting it back, also in removing it from the Phonograph cylinder after it is played. Put it into the carton straight. Don't put it in on a slant, knocking against the edge of the box.

Some Dealers, who know as much as we do about opening up their goods, may suggest that all this sounds like A. B. C.'s to them. The answer is, "Can any Dealer know too much about the A. B. C.'s of the business?"

## Push the Bryan Records

What are you doing on the William J. Bryan Records?

The question is suggested by the fact that the Bryan Records will help you to do a much larger summer business if you push them properly. Many Edison Dealers began advertising the Bryan Records in their newspapers when they were first announced. They had public interest worked up to a high pitch when they received the Records and put them on sale.

There are very few Dealers who are not making especially strong efforts to sell the Bryan Records to Phonograph owners. That's right. It's the easiest thing you know, getting almost anybody to pay 35 cents to own one of Bryan's speeches delivered by Bryan himself. Be sure all of your Edison owners know about them and you can depend upon them to do the rest.

You ought by all means, to advertise in local newspapers. Make use of the advertisements that were printed on the circular we mailed you. And see that your paper runs some reading notices for you free of charge. We gave you a few good ones with the advertisements. Ask the editor to write an editorial. Many of them have done so. Editors of democratic papers would like nothing better.

Fix up your window like the sample window shown in this issue of the PHONOGRAPH MONTHLY. You will see that we have made the most of Bryan's prominence in the Presidential campaign in introducing the platform idea. This makes the window a capital eye-catcher and above all it is perfectly simple for you to copy.

The window display ought to be made at the same time your newspaper advertising is running so that the two will pull together.

Have you mailed out to your Phonograph owners your special Bryan supplements that came with the Records? That should be done by all means. You should also put the supplements in the hands of non-owners who may thus be interested in purchasing Phonographs. You ought to be ashamed to look your Phonograph

business in the face if you fail to sell a lot of machines on the strength of the Bryan Records.

Another thing—don't make the mistake to think that men are your only possibilities. Far from it. Women flock to hear Bryan whenever he speaks. It takes a large "men only" sign to keep them away, and even then they do not stay away through choice. The few women who are not interested in politics in the heat of a Presidential election will still be delighted with his orations on Immortality and An Ideal Republic—no indeed, you cannot afford to overlook the ladies.

It wouldn't be a bad idea to have some hand bills printed up, to be left at front doors and posted in conspicuous places. The same reading matter given for the advertisements would answer nicely.

A typewritten letter to be mailed, sealed, to a list of men would give you good results. Something like the following:

DEAR MR. JONES:

If William Jennings Bryan offered to deliver his favorite orations in your home, you would consider you had a very great privilege, would you not?

Well, we make you an offer that practically amounts to the same thing.

Bryan has just made Records of his ten best speeches for the Edison Phonograph, and hearing them is like hearing the man.

The Records are composed of telling passages chosen by Bryan from his favorite orations. He discusses leading issues of the Presidential campaign, and you can hear first-hand just what his views are, if you own a genuine Edison Phonograph.

Will you not call at our store and hear a few of the Bryan Records?

It will not obligate you in any way. We want you to hear the Records whether you have any idea of securing a Phonograph or not.

Should you want a genuine Edison we will sell you one for \$12.50 or \$25.00, on terms as low as \$1.00 a week. The Records are only 35 cents each.

Do not fail to call.

Yours very truly,  
SMITH & CO.

All of the above mentioned forms of advertising will pay you. Adopt as many as you can.

## The Phonograph Sells Sheet Music

A music dealer writes that the Edison Phonograph helps him immensely in the sale of sheet music. A great many others have made the same report. Here is a hint to sheet music dealers. Why not have an Edison Phonograph in the sheet music section for demonstrating your music?

There is an Edison Record of most of your music, and it would help the sale of both vocal and instrumental pieces. Then, too, many of your sheet music customers may be interested in an Edison Phonograph by hearing how well it plays and sings their favorites. Try it.

---

---

# Edison Phonograph Monthly

Published for the Man Who Sells Edison Phonographs and Records by The National Phonograph Co., Orange, N. J.

All communications to *The Phonograph Monthly* should be addressed to the Advertising Department, Orange, N. J.

---

NEW YORK: 10 FIFTH AVENUE.

NATIONAL PHONOGRAPH CO., LTD., VICTORIA ROAD, WILLESDEN, LONDON.

NATIONAL PHONOGRAPH CO. OF AUSTRALIA, LTD., 340 KENT STREET, SYDNEY, N. S. W.

MEXICAN NATIONAL PHONOGRAPH CO., AVENIDA ORIENTE No. 117, MEXICO CITY.

COMPANIA EDISON HISPANO-AMERICANA, VIAMONTE 515, BUENOS AIRES.

EDISON GESELLSCHAFT, M. B. H., SUD-UFER 24 25, BERLIN.

COMPAGNIE FRANÇAISE DU PHONOGRAPHE EDISON, 42 RUE DE PARADIS, PARIS.

---

VOL. VI.

July, 1908

No. 7

---

## House-to-House Work

There is a large and constantly growing number of Edison Dealers who make a specialty of selling Edison Phonographs the way sewing machines are sold. That is, they have a light wagon that will accommodate one of each of the three leading types of Phonographs and about 50 Records. They get up their lists of prospects and make regular rounds so as to let the people hear the Edison in their homes.

This is certainly a very effective way of going after business, especially in small towns where a Dealer has trade scattered through the country district. Combine this policy with an offer of the Edison on the weekly payment plan and it will certainly land many sales that could not be made in any other way.

A rig similar to the one shown below would be just right. This is owned by M. J. Learn, of Cuba, N. Y.

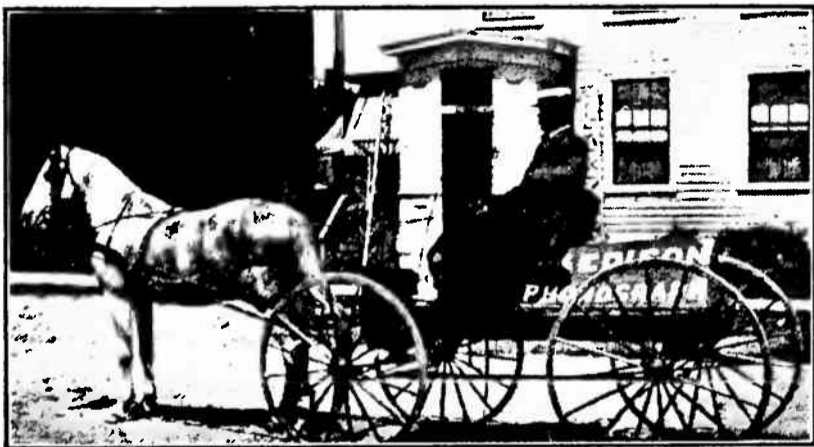

## So Can You

The *Talking Machine World* says: "The Milner Musical Co., of Cincinnati, will entertain the big Democratic club of that city. in a few days, by giving a concert, using an Edison Phonograph and ten Bryan Records."

## Edison Jobber Honored

C. A. Grinnell, head of the firm of Grinnell Bros., Detroit, Mich., has been elected president of the National Association of Piano Dealers for the year 1908-09.

---

## This Really Happened

A Dealer's salesman was playing an Edison Phonograph for the benefit (?) of a customer. The Phonograph was going at a fierce clip that ought to have gotten him arrested for exceeding the speed limit if he had been driving an automobile instead. The customer quickly left (without buying of course) and the salesman's attention was called to the mistake. Imagine the surprise that resulted when he replied, "Oh, that was all right. I was hittin' her up to get through in a hurry."

Are YOU studying your customers' likes and playing the Records you think will please them most so as to make them feel they simply must own an Edison Phonograph? Are you going about it as if you really enjoyed it as much as anybody? Or are you "Hittin' her up to get through in a hurry?"

ANOTHER WAY INSTALLMENT SALES FIGURE AHEAD: THE PROFIT ON RECORDS SOLD TO INSTALLMENT BUYERS OF PHONOGRAPHS WHEN THEY CALL TO MAKE PAYMENTS, TAKES CARE A HUNDRED FOLD OF THE INTEREST ON THE MONEY OUTSTANDING.

## William E. Gilmore to go Abroad

William E. Gilmore, President and General Manager of the National Phonograph Company and the several other Edison interests, will leave July 7th for Europe on a year's vacation. His family will accompany him. During his absence the executive management of the Edison Manufacturing Co., National Phonograph Co., Bates Manufacturing Co., and Edison Business Phonograph Co. will be vested in an Executive Committee composed of Frank L. Dyer, Chairman; P. Weber, C. H. Wilson, A. Westee, F. K. Dolbeer and L. C. McChesney. The committee will meet regularly once a week or oftener if necessary. The report that Mr. Gilmore had resigned from the management of the Edison interests is without foundation. Both Mr. Edison and Mr. Gilmore authorize the statement that Mr. Gilmore has not resigned and has no intention of doing so.

## Selling Record Blanks

Below is a letter from an Edison Dealer that shows how easy it is to interest Phonograph owners in making their own Records at home.

"I will give you a little experience we had. A number of friends met at our home a few nights ago, and as several were leaving us, I requested all present to talk, sing or whistle into the Phonograph, and to pronounce their names. There were fourteen in the party and all did as requested when we found we had about a third of the blank left. One of the ladies completed it by singing a verse of a song. It was quite a success, and makes a nice souvenir.

"On the strength of the Record, we sold a number of blanks."—*C. F. Winnek, Prineville, Ore.*

## Praise for Bryan Records

(Taken from Letters.)

Have just received word of your latest achievement and feel that congratulations are in order. The Bryan Records will be beyond doubt the greatest sellers your list can show.—*S. M. Field & Bros., Little Rock, Ark.*

We are more than pleased to state that we are receiving telegraph orders for Bryan Records. We feel there will be a larger demand for these than for any other set.—*Schmelzer Arms Co., Kansas City, Mo.*

We are glad to hear you are getting out Records by our distinguished citizen and certainly believe they will be a tonic to the present trade dullness. We believe repeat orders will be much larger even than initial orders.—*H. E. Sidles Phonograph Co., Lincoln, Neb.*

## Over the Counter

(The Dealer in EDISON PHONOGRAPHS, who reads these Counter Conversations regularly every month is going to get a mighty good line on the kind of talk that sells EDISON PHONOGRAPHS and RECORDS.)

CUSTOMER: "What kind of talking machines do you sell?"

SALESMAN: "We sell the genuine EDISON PHONOGRAPH. But I hate to hear it called a talking machine. It's considerably more than a talking machine. It's the greatest musical instrument in the world.

The EDISON PHONOGRAPH is the one that was invented by Thomas A. Edison and bears his trade-mark signature. Edison has been working on it ever since and has gotten it so good that it will repeat the music of a band or orchestra or the human voice so truly to life that there is no difference from the original.

Mr. Edison called his invention the PHONOGRAPH from the two Greek words, "Phonos" and "Grapho" which mean a sound-writer. You can see that the Phonograph is the standard talking machine of the world from the fact that the word Phonograph has become a part of the English language. You will find it in all of the modern dictionaries.

Dealers call ordinary talking machines Phonographs but Edison's is the only one that can use the word PHONOGRAPH on the instrument.

Broadly speaking the EDISON PHONOGRAPH is the best Phonograph because it is the original and genuine. It's Mr. Edison's favorite of all his great inventions. And it is made by his own companies working under his supervision. He is at the factories every day to see that everything is carried out according to his own ideals. Of course it is no miracle that Mr. Edison and his own companies can turn out a better instrument than any of the imitations.

There are a great many imitations, and many of the companies making them only stay in business a year or two before they fail and go out of business. The Edison has gained in sales every year since it was first put on the market. More Edisons are sold to-day than all others combined. Could you ask for any better argument than that?

It is the ambition of Mr. Edison's life to see an Edison Phonograph in every American home and they are already in more than a million. Yes sir, a million and there are only about eighteen million homes in this country. Think of that."

(To be continued next month.)

## Foreign Records Sell

The Foreign Record business of a prominent Edison Jobber has doubled twice within the past sixty days! This is of great interest to Edison Dealers because it means that the Foreign Record business of a number of Edison Dealers has gained in the same proportion.

How did it happen?

In just the way that the PHONOGRAPH MONTHLY has repeatedly pointed out as a sure winner. The Jobber stocked the full line of Foreign Records, urged his Dealers to go after their foreign trade, and many were wise enough to take the hint.

On February 10th the Jobber put in a stock of 1,700 Foreigns. Previously he had been handling his orders for Foreign Records as specials, and by this method sales had averaged about 150 Records a month. From the date of putting in the full line to April 22nd—a little over sixty days—the jobbing firm had re-ordered 1,800 Foreign Records and found it necessary to increase their regular Foreign stock from 1,700 to 2,000.

The point is right here: there is nothing in the success of this Jobbing concern's Dealers that any Edison Dealer cannot duplicate. There is a ready-made demand for the Foreign Records in every community. The way to make the most of it is to first stock the Records and then make it known that you have done so.

The public is not going to run after any dealer on any article, for the public has many uses for its hard-earned dollar and isn't over anxious to spend it on anything. A dealer couldn't sell clothing—he couldn't sell groceries, shoes, pianos, jewelry or anything else if he did not first get the goods on his floors and then make it known. No; your customers are never going to force you to put the Foreign Records in—not in a thousand years. Foreign customers would be the last to think of such a thing. You do the thinking for them. They are not the recipients of many such special propositions as you have to offer in the songs and instrumental music of their native land. When they get your suggestion that they can hear in their own homes their favorite national songs, dances and concert numbers by leading native artists, it will strike them as a very happy thought.

The proper way to start in is to look around you to find what nationalities of foreigners are best represented and order your Records accordingly. Any Jobber who carries a full stock of Foreign Records can help you on selection,

and it would be a good idea to take this part up with some of your foreign-speaking acquaintances. When the Records arrive, have some of the people you are seeking to reach, come in and hear them. Just make a sale or two and you will find orders for machines and Records will come in thick and fast. Foreigners are clannish, live within a small circle as a rule and keep in close touch with one another. When they get a good thing they pass it along.

About 1,000 Foreign Records are available in the new complete Edison Foreign Selections Catalog. They comprise vocal and instrumental numbers in German, French, French-Canadian, Italian, British, Bohemian, Swedish, Polish, Hungarian, Hebrew, Spanish, Holland-Dutch, Danish, Norwegian, Cuban, Mexican, Chinese, Japanese and a list of South and Central America National Hymns. The vocal Records were made by the foremost native talent, not by foreign-speaking Americans. They are faultlessly recorded and are perfect in accent and enunciation.

Write to your Jobber to-day for the Foreign Record Catalog and get a line on your Foreign prospects while the catalog is on the way.

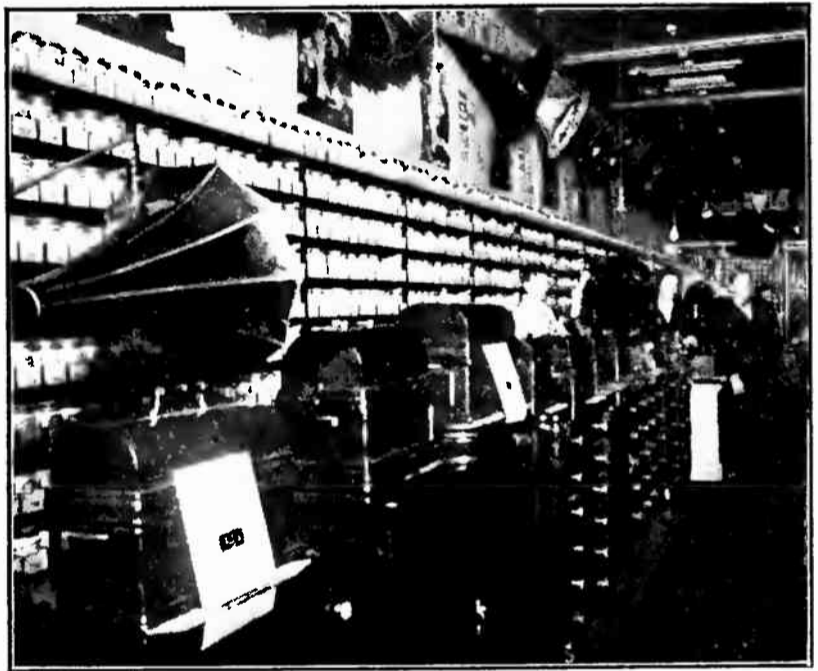

A SECTION OF THE STORE OF ALONZO WILKES, AMSTERDAM, N. Y.

Mr. Wilkes uses the Tray System for keeping his Records and his racks have a capacity of 10,000 Records.

## Jobbers' Advertising

We have received samples of attractive circular matter gotten out on the Bryan Records by the following Edison Jobbers: Schmelzer Arms Co., Kansas City, Mo.; The Ball-Fintze Co., Cincinnati, O.; Harger & Blish, Dubuque, Iowa; R. C. Bollinger, Fort Smith, Ark.; W. J. Dyer & Bro., St. Paul, Minn.

## Ready for Your Scissors

Here are three timely advertisements and three reading notices to run in your local newspaper. Order the display ads. and see that your paper runs the readers free as news matter.

### (Advertisements)

#### HAVE A TIME ON THE FOURTH

Get the family together. Call in a few friends. Start up your genuine *Edison Phonograph* with "Yankee Doodle," "Dixie," "Stars and Stripes Forever," and "Star Spangled Banner"—all played with true military dash by the famous Edison Military Band.

Next give them "Lincoln's Speech at Gettysburg," and the patriotic poem, "Our National Airs" with incidental band and orchestra music.

Then the inspiring vocal duet, "The Battle Cry of Freedom."

What a program!

Genuine Edison Phonographs, \$12.50 and \$25.00—\$1-a-week payments. Edison Records, 35 cents each.

At such a price and terms can your home afford to longer do without the world's greatest entertainer?

(Dealer's name and address.)

#### BRYAN SPEAKS TO-DAY.

William J. Bryan delivers choice passages from his best orations at our store to-day.

The Great Commoner has made Edison Records of his ten best speeches. When you hear these Records on a

#### *Genuine Edison Phonograph*

you hear his actual voice. Bryan decided the perfected Edison would do his oratorical gifts full justice.

You are cordially requested to come in and hear Bryan speak on

The Trusts	Imperialism
The Railroads	The Bank Laws
The Labor Question	Election of Senators
The Tariff	Swollen Fortunes

A Genuine Edison Phonograph, \$12.50, or \$25.00 at \$1.00 a week. Records, 35 cents each.

(Dealer's name and address.)

#### GOING TO GO?

Don't go on your vacation without an Edison Phonograph.

It costs so little, is so light and easy to carry around, and it will give you a whole world of the jolliest pleasure.

There won't be a dull moment on your trip with your Edison singing all the popular song hits, playing the band pieces heard in the park concerts—delivering William J. Bryan's great speeches (by Bryan himself).

The Genuine Edison at \$12.50 and \$25.00 on \$1.00-a-week payments.

Come and hear the new Records.

(Dealer's name and address.)

### (Reading Notices)

#### WM. J. BRYAN IN TOWN

William Jennings Bryan, the "Peerless One," is in our midst in the person of Thomas A. Edison's Phonograph. Bryan decided that Mr. Edison's perfected machine would do full justice to his oratorical powers in reproduction, so he delivered extracts from ten speeches into the horn of an Edison. The wax Records did their duty, catching every word just as he spoke it.

Now the Edison Company are unable to cope with the demand all over the country for the duplicate Bryan Records. Bryan himself is being heard in thousands of homes upon all the burning political questions.

\_\_\_\_\_ of \_\_\_\_\_ street, are giving free demonstrations of the Bryan Records at their store daily and are entertaining large and enthusiastic audiences.

(The following reader calls for the window trim shown on page 15.)

#### A SIGHT WORTH SEEING

Have you seen the Fourth of July show window of \_\_\_\_\_ at \_\_\_\_\_ street? Don't miss it. It's a sight worth seeing. They certainly hit on the most original idea for a patriotic window that has been seen.

Thomas A. Edison's Phonograph is made the centre of the picture which we would take pleasure in describing fully if it were not certain that seeing will be much more enjoyable than hearing of it.

#### HAPPY VACATIONISTS

The woods are full of 'em, as the saying goes. If you wish to be an up-to-date vacationist you must make your plans so that there'll be no dull moments on the trip. A great many of our citizens have been won over by the suggestion of \_\_\_\_\_ at \_\_\_\_\_ street that they take an Edison Phonograph along. Probably there never was a summer when so many Phonographs were to be heard in the country at summer homes and in camp. Fishing parties find them just right for an evening's entertainment before turning in, and house parties depend upon the Edison to furnish dance music for the nightly soirees. Then there are the speeches by Wm. J. Bryan that everybody is talking about. If Mr. Business man wants to set the political pot boiling for a few minutes he settles himself comfortably in a hammock and summons up the Great Commoner to repeat his views on the political issues of the presidential campaign—nothing like it.

## Questions and Answers

We have opened this department in order to print, each month, questions asked us in letters from Dealers and Phonograph owners about the regulation of their machines, together with our answers. This information will serve to clear up many important points on which you should be posted so as to keep your own Phonographs in perfect running order, and also give your customers valuable advice.

A. C. B., Bridgeport, Okla.—My Edison Standard Phonograph gave perfect satisfaction until recently. It trembles and at times plays so low it can scarcely be heard. We have cleaned it carefully, but this only helps for a few seconds. The Reproducer weight seems to get caught and won't let go, and then quivers until hardly intelligible.

[This is probably due to the Reproducer weights not being in proper balance. Take the Speaker from the Speaker Arm and hold it in front of you, with the weight hanging toward you. If one side of the weight hangs lower than the other, or if it does not balance perfectly, the hinge screw on which the weight hangs has probably become bent. You should take the weight in your hand and give it a slight twist to straighten the hinge and cause the weight to hang in proper balance.

When the Speaker and a Record are placed on the machine the weight should hang parallel to the surface of the Record; and when reproducing, the little pin in the weight should rest in the centre of the wire loop. You should also apply a tiny drop of oil to the speaker weight hinge screw and clean out the other joints of the Reproducer with a soft cloth.

The tremble might also be due to the fact that the Feed Nut does not fully engage with the threads of the Feed Screw. The tension of the Feed Nut spring should be such that when the Speaker Arm is let down on the straight edge, you can tap it with your finger and it will not bound upward. On the other hand, the tension should be strong enough to make sure that the threads of the Feed Nut engage fully with the threads of the Feed Screw, so they will not slip out at any time when the machine is running.

The reason the Speaker does not give satisfactory results is that the point is either dragging behind or dropping ahead of the groove in the Record. The object of our suggestions is to enable you to adjust your Speaker so as to overcome the tendency of the sapphire point to leave the groove in the Record.]

As the Phonograph Monthly goes to press, it is plain that the W. J. Bryan Records are causing a great sensation all over the country. Jobbers' orders are far in excess of our strongest expectations. Many Jobbers have three and four separate orders in. Do not wait until you are sold out before reordering. Your Jobber may not be able to fill your order if you do.

## Fourth of July Window

The best thing about the Fourth of July window on the opposite page is that it is timely and so simple that it can be duplicated by any Dealer. The flag is pinned to the white drapery so as to give it a waving effect. The Edison Standard Phonograph stands on the box in which it is shipped. White cheese cloth is thrown loosely over this and over the floor. Small blocks are placed under it at intervals to give a tufted appearance. The large signs are home-made, and anyone who is at all handy with a brush can equal them.

The wording on the two cards at the sides is as follows: No. 1—Have a Time on the 4th. The Edison Phonograph Will Give You "America," "Stars and Stripes Forever," "Yankee Doodle," "Dixie," "Star Spangled Banner," etc., etc. All played by the Famous Edison Military Band. Come in and Hear an Edison. Sign No. 2—Hurrah for the 4th. The Edison Will Deliver "Lincoln's Speech at Gettysburg." It will recite the poem, "Our National Airs." It will sing the Inspiring "Battle Cry of Freedom." Own a Genuine Edison Phonograph. Be Patriotic Independence Day and Every Day.

Price cards like the one in the horn can be secured from Jobbers for "Gem," "Standard" and "Home" machines. Be sure to get your window looking just like this a day or two ahead of the Fourth. It is good enough to cause town talk.

## Bryan Window

Here is another rattling good idea window that will talk almost as strongly as Mr. Bryan himself. The thought it plainly expresses is that Bryan now speaks in everyone's home on the leading political issues through the Edison Phonograph. Simplicity is again the keynote. The platform is nothing but a couple of boxes with light 30 x 4½ inch boards on top. Each board is lettered on the end to correspond with a Bryan Record and a plank in the Democratic platform. The sign at the back is the two-color hanger that went out with the Bryan Records. The Bulletins of the new July Records you should have also, and the illustrated card on the same subject. The other two signs are home-made. After you get your boards made you can trim this window in fifteen minutes. You should do so as soon as your 4th of July window is taken out. If it does not sell Edison Phonographs and Records we are mighty poor guessers.

### A Fourth of July Window

[See page 14 for description]



### A Wm. J. Bryan Window

[See page 14 for description]

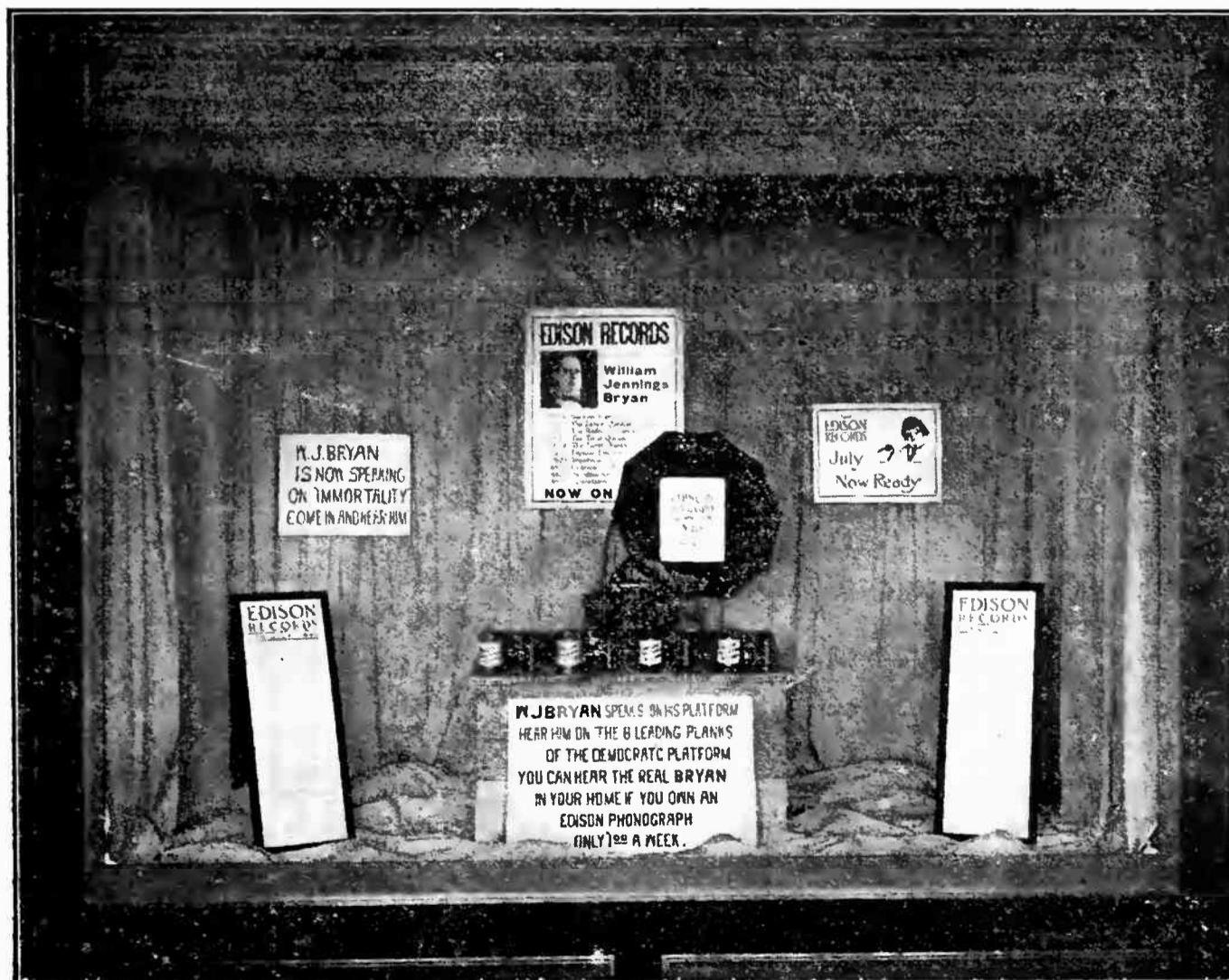

## Making the Bryan Records

"When I was detailed to go to the home of William Jennings Bryan and direct the making of a series of Edison Records by Mr. Bryan, I felt a little 'shaky,'" said Harold Voorhis, of the Recording Department of the National Phonograph Co.

"If it had been a coon song, or a band piece, or a grand opera selection or all together I

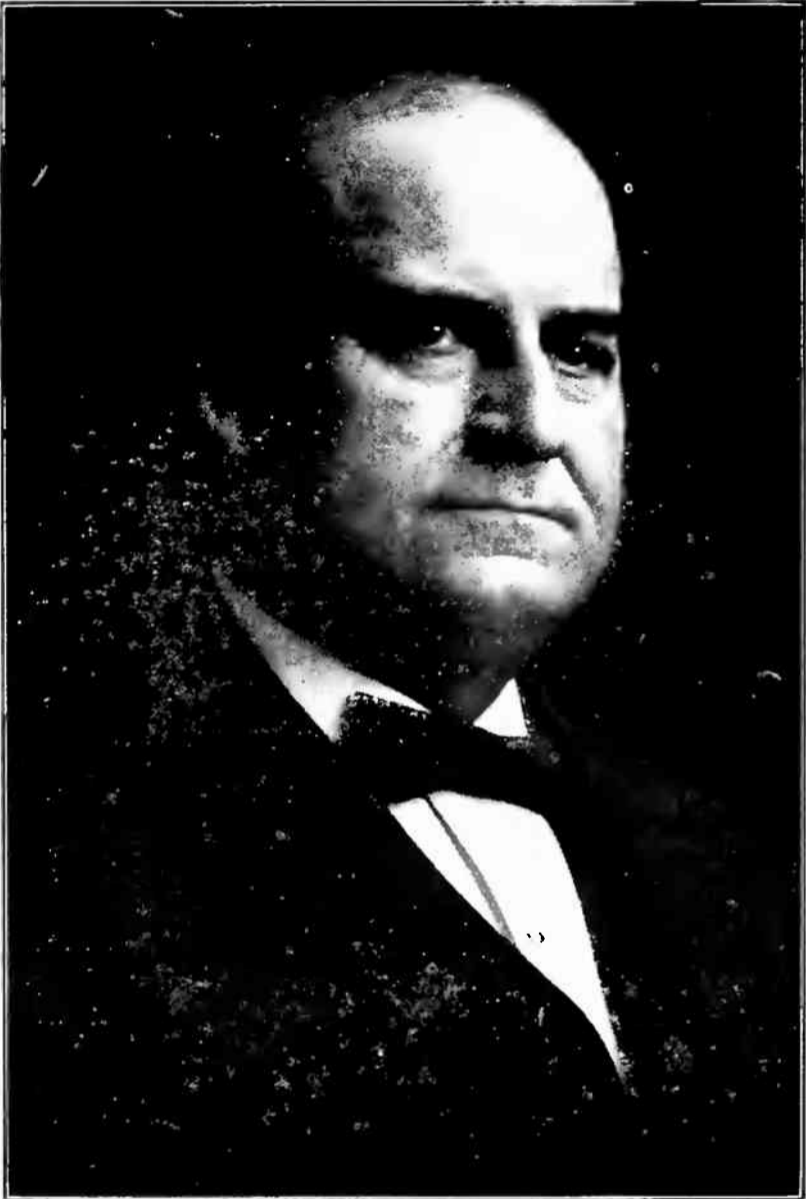

wouldn't have worried, for those are every-day affairs. But a trip half-way across the continent to the home of the Great Commoner was different. I don't think any one can appreciate how different without trying it themselves.

"I knew the Records were to be important ones, especially with Mr. Bryan so prominent in the Presidential campaign, and I was more than anxious to secure good results.

"I reached Lincoln, Nebraska, on a Friday morning, with my recording apparatus and a plentiful supply of wax masters. Everything had been arranged and when I got to the Bryan home I found Mr. Bryan ready for work.

"We lost no time in putting the library in shape and were soon ready to make a start. Mr. Bryan had his speeches in typewritten form, and had timed himself several times in getting them

the right length. Nevertheless we found on trying the first that it was too long to get on the Record so it had to be cut down and another trial made. Mr. Bryan seemed a little nervous when he first started, much more so he said than he ever felt in facing an audience of ten thousand people.

"Considering that his words were to be reproduced all over the world in perhaps a million homes, and that it might mean a great deal to him how his speech was received, I thought he showed remarkable composure. All Record artists are very nervous on their first attempts and it usually takes a good many trials to get a good Record. Mr. Bryan had practiced a little, however, and was quickly at his ease. We kept at it pretty steadily all of Friday and Saturday mornings, and a few Records were thrown out, though not nearly so many as I expected.

"Mr. Bryan rested occasionally and several times went to his private office to dictate an important letter or two. Once his son came in for a few minutes, and on another occasion Mrs. Bryan entered. She is a charming lady and intellectually she appeared to be a fit "running mate" for the Great Commoner. I understand she is a full graduate in law. Mrs. Bryan said she liked Mr. Bryan's address on 'Immortality' best of all. It is taken from his lecture on 'The Prince of Peace.' The latter was rather long for a title, so Mr. Bryan decided to call the Record 'Immortality.'

"Some workmen who were engaged in repairing a porch annoyed us with their hammering and Mr. Bryan went out to tell them to let up for a while. He did not want to arouse their curiosity so told them he was talking into the 'phone. For all that we heard a few stray knocks later on and one or two of these were caught by the Phonograph in his speech on The Tariff Question.

"When our work was at last finished on Saturday, the library floor looked as if it had been visited by a snow storm, so thickly was it strewn with the wax shavings. I made apologies to Mrs. Bryan, which she assured me were entirely unnecessary, and as quickly as I could get my things together I was on the way back to Orange, N. J., with the Records. If I had been the bearer of the crown jewels I wouldn't have guarded them more carefully."

**The Ready Made Ads on page 20 will do nicely for vacation advertising. You can get either or both electros, in single or double column width, free, by filling out the coupon and mailing it in.**



## New Edison Gas Plant

The last of the Edison concrete buildings to be completed was the gas house. This is 30x80 feet and is located across the street apart from the main group of buildings. Three late model Wiles gas generators, each with a capacity of 20,000 cubic feet, produce the gas. The process from start to finish is much simpler than would be supposed and is a highly interesting subject for study.



The starting point is the pea and buckwheat coal, small mountains of which are kept near at hand for supplying the generators. A small quantity (100 pounds) is used for starting the fire in the hopper on top of the generator. By lifting a lever this is moved down into the generator and an automatic supply system is constantly delivering one hundred pound lots inside as needed. The coal inside is all afire and burning continuously, thus converting it into carbonic acid gas. A pipe at the bottom supplies a constant draft to keep the fire going. A pound of coal will produce 95 cubic feet of gas on an average, and each of the three generators will deliver 17,000 cubic feet an hour.

As fast as the crude gas is extracted from the hard coal it is sent through a blower pipe into what is known as the wet scrubber. This is an 18.5-foot tank which is filled to within a short distance of the bottom with coke and water. This serves to clean the gas which enters at the bottom and passes up through the coke. A pipe next takes it to a large 9x20-foot holder tank. Here we meet with an ingenious tank-within-a-tank arrangement. The larger one contains water and the smaller is inverted and placed inside of it. The large delivery pipe runs up above the water line within the inverted tank and the gas is thus stored within the vacuum above the water, which seals it and effectually prevents leakage. Two other pipes enter the holder tank. One returns all surplus gas to be cleaned over again and the other carries the regular supply on to the dry scrubber, a 3x10.5-foot tank resting on the floor and filled with excelsior and sawdust. At this point the gas is ready for distribution and at once enters the 16-inch main gas line, which

is 250 feet long and is laid four feet under the ground. The size tapers to 12 inches at the farther end.

The outsider can form no idea of the prominent part that gas takes in the manufacturing end of the Edison business. Two 10-inch pipes supply it in enormous quantities to the National Phonograph Record Works, where it is used in the gas furnaces that melt all of the Record material. Another 6-inch line distributes it throughout the Edison Phonograph Works where it is used for japanning all black metal parts used on the outside of the Phonograph cabinets and also for soldering. Thus it will be seen gas is one of the most vital auxiliaries of our business, and were the gas plant to go on a sudden strike, it would be necessary to partly shut up shop. Moreover, it is by far the best and most economical form of heat for our special requirements.

Before the completion of the new gas plant illuminating gas was used from an outside concern. Four times as much of the present gas is used, but even at that the company finds it far cheaper to do their own manufacturing.

Together with the new boiler house and the electrical power house the gas plant completes a power, heating and lighting system that is considered one of the wonders of the manufacturing world.

## Grand Opera Records

Five new Grand Opera Records went on sale June 25th. Did you order a supply? We have never presented a more attractive selection of classic songs than this list. There is not one among the more musical of your customers who would not be delighted to secure several of these exquisite Records. And do not overlook your extra profit. Here is the list. Look it over and do not put off ordering a few of each number, if you have not already done so:

- By ANTONIO SCOTTI, Baritone  
*Sung in Italian. Orchestra Accompaniment*
- B. 65. Eri tu (And would'st thou), "Un Ballo in Maschera".....Verdi  
By MME. JACOBY, Contralto  
*Sung in Italian. Orchestra Accompaniment*
- B. 66. Stride la vampa (Fierce flames were raging), "Il Trovatore"..Verdi  
By FLORENCIO CONSTANTINO, Tenor  
*Sung in Italian. Orchestra Accompaniment*
- B. 67. Sono un poeta (I am a poet), "La Boheme" .....Puccini  
By OTTO GORITZ, Baritone  
*Sung in German. Orchestra Accompaniment*
- B. 68. Ihr heisset mich willkommen (Ye bid me welcome), "Der Trompeter von Sackingen".....Nessler  
By ANGILO PINTUCCI, Tenor  
*Sung in Italian. Orchestra Accompaniment*
- B. 112. Il fior che avevi a me tu dato (The flower you gave to me), "Carmen" .....Bizet



## The EDISON PHONOGRAPH

is the only sound-reproducing instrument with Edison's latest improvements. It has the clearest, strongest Records, the most durable reproducing point and the correctly shaped horn.

THE Edison Phonograph also offers a form of amusement which cannot be obtained in any other similar instrument, and that is the fun of making your own records. For a small additional expense you can obtain from your dealer a recorder and blank records, by which you can make your own records, and listen to the sound of your own voice and that of your friends. Many an evening's novel entertainment may be had in this way.



### Ten Edison Records made by Mr. William Jennings Bryan

We have pleasure in announcing ten Edison Records made by Mr. Bryan at his home in Lincoln, Nebraska, consisting of the best passages from his favorite speeches. Ready at all Edison stores this month. Ask your dealer. Besides the twenty-four Records in the regular list, the July Records contain five new Grand Opera selections by famous operatic stars. Hear them at the nearest Edison store on June 23th.

Ask your dealer or write to us for the new catalogue of Edison Phonographs, THE PHONOGRAM, describing each July Record in detail; and the Catalogue of Records, listing all Edison Records now in existence.

NATIONAL PHONOGRAPH COMPANY, 600 Lakeside Avenue, Orange, New Jersey

# BRYAN

## Speaks to Millions through the Edison Phonograph

YOU can now hear William Jennings Bryan speak at your convenience and in your own home. He has recorded the most telling passages from ten of his favorite speeches on Edison Records. These Records are remarkably successful, faithfully reproducing not only Mr. Bryan's voice but every mannerism and inflection.

Recognizing the wonderful achievement of the Edison Phonograph, Mr. Bryan consented to make these Records, presenting his views on leading questions, and at the same time availing himself of the splendid opportunity to give his views the widest currency.

This is the first opportunity the American people have had to hear Phonograph Records made by a statesman of national importance.

The ten Bryan Records are as follows:

- |                       |                              |
|-----------------------|------------------------------|
| Swollen Fortunes      | The Labor Question           |
| The Railroad Question | The Trust Question           |
| The Tariff Question   | Popular Election of Senators |
| Imperialism           | Guaranty of Bank Deposits    |
| An Ideal Republic     | Immortality                  |

These Records may be heard at all Edison dealers. 35 cents each.

NATIONAL PHONOGRAPH CO., 75 Lakeside Ave., Orange, N. J.

## Magazine Advertising

Fourteen of the highest class and most widely circulated monthly and weekly periodicals will carry our advertising for July. The advertisement, of which a reduction is shown here, will occupy full pages in Ainslie's, Cosmopolitan, Delineator (200 lines), Everybody's, Munsey's, Review of Reviews, Success, Sunset and World's Work. It will also occupy half-pages in Collier's Weekly and Saturday Evening Post and quarter-pages in Associated Sunday Magazines, Puck and Youth's Companion.

This means that some twenty-five million people will read another very interesting story of what an Edison Phonograph will do for their homes in the way of music and entertainment.

The illustration is from a drawing by Hitchcock, one of the cleverest artists in the country. It has the true vacation atmosphere and it is not at all likely that any magazine reader could pass it by even if he were so inclined. Notice also, the reference to the Bryan Records.

It is a very good plan for Dealers to do an extra amount of local newspaper advertising at the time the magazines containing our advertising are circulated. The first come out about the middle of the month. From then until the first

of the next month is a good time to go doubly strong on your newspaper advertising and window displays.

Our national magazine publicity creates a desire for the Edison Phonograph and Records, but the dealer should supplement this with reminders to the readers in his town that his store is the place to secure the goods.

## Newspaper Advertising

The advertisement above is a reduced duplicate of one devoted to the William J. Bryan Records that we ran in a list of 146 daily newspapers throughout the country. The announcement occupied a space of six inches, double column—12 inches altogether.

The combined circulation of the newspapers is over eight millions. There are supposed to be about 18,000,000 homes in the entire country, so it is safe to say that our advertisement was read in a large majority of the homes that can afford to pay for a Phonograph.

This same advertisement could be used by Dealers with the last few lines changed to give the Dealers' name and address, and an invitation to come in and hear the Bryan Records.

Don't miss the golden opportunity offered by these Records to double your summer business.

### A New Zealand Episode

Whilst a party of Auckland yachtsmen were cruising along unfrequented parts of the New Zealand coast, it so happened that they dropped anchor for the night in a bay where there was a small Maori settlement, and as an Edison Phonograph is always kept aboard, they proceeded to while away the time after the evening meal by listening to "Ada Jones and Len Spencer," singing in their own inimitable style. Suddenly and without any warning out of the darkness appeared a canoe with a solitary Maori, slowly paddling towards the yacht, hailing them with the usual "Tenakoe" (how are you). He rested on his paddles and seemed disinclined to come nearer, the Phonograph being the reason of his "aloftness;" asked how he liked the "sing," he replied: "That fella the best singer I ever hear. The 'Daihive' (Lady) your wife?" (meaning Miss Jones) he inquired, and when assured that no one on board had the honor of claiming Miss Jones as their better half, he didn't seem to grasp the situation. It was explained to him that it was the "Phonograph" that had been producing such sweet music, so he listened attentively to many Records and then exclaimed "Kaipar" (good), "the good fellow he sing all the time, he never get tired, I buy him next time I go to Auckland."

He was invited on board and after having the yachtsman's usual lotion prescribed for him, he was introduced to the Edison Phonograph and its many marvels.

As he slipped away in his little "dug-out" he was heard muttering—"Him the fella, he never get tired, I buy him."—*B. G. Holton, Auckland, N. Z.*

### Advertises Bryan Records

We are sending you under another cover a copy of the *Aledo Democrat*. As you will notice we are using space on the back page of the paper. This week, however, we got a nice free advertisement on the front page, first column. As you will notice it is in regard to the Bryan Records. We are giving them as much popularity as possible before they arrive, and we anticipate a big sale on them, and probably will sell some Phonographs through these Records. As you will notice by reading the article I mention we have accepted an invitation to play the Records at the first meeting of the Bryan Club in this city after they have arrived. The National Phonograph Co. have certainly shown themselves up-to-date in securing Mr. Bryan to make these Records.—*Shaw Bros., Aledo, Ill.*

### An Appreciative Dealer

Please find enclosed order for banners, as I'm willing to do advertising when anyone furnishes the goods. I have felt the good effect of your splendid ads. in the magazines and large newspapers. I sold out twice lately and had to telephone my orders for more machines to Denver, Colo.

I read the PHONOGRAPH MONTHLY. It is a great help to all Dealers.—*P. A. Bowers, Center, Colo.*

## SUSPENDED LIST, JUNE 20, 1908

### SUPERSEDING ALL PREVIOUS LISTS.

This list is supplemental to the Suspended List printed in the Edison Phonograph Monthly for June, 1908, which, with the following exceptions, is still in force and must be given the same consideration by the trade as if reprinted in full herewith.

Totten Music House, Rock Island, Ill., & Clinton, Ia., reinstated as authorized dealers.  
 H. A. Reinhardt, 1214 Lovejoy st., Buffalo, N. Y., reinstated as an authorized Dealer.  
 H. B. De Wolff, New Bedford, Mass., deceased.  
 F. A. McMaster & Co., Nashua, N. H., deceased.

### SUSPENDED.

#### CALIFORNIA.

**Chico**—Moriss Kyrous (or Kryicus), Broadway and First st.  
 The Postoffice News Stand, Broadway and First st.

#### COLORADO.

**Ouray**—C. C. Stratton.

#### IOWA.

**Sidney**—I. L. Morgan.

#### KANSAS.

**Cuba**—Mrs. Frank Barnett.

#### MASSACHUSETTS.

**Newburyport**—Pertucket Phono. Store, M. H. McKinney, Prop., 4 Market square.

#### NEW YORK.

**Brooklyn**—A. Becker, 585 Fifth ave.  
**Watertown**—L. A. Maxson, 51 Court st.  
 Byer & Susskind, 108 Court st.

#### PENNSYLVANIA.

**Philadelphia**—Eastern Phono. Co., M. Futernik, Prop., 143 North Eighth st.

#### TEXAS.

**New Braunfels**—Ed. Gruene.

Copies of the complete Suspended List will be mailed on request. Jobbers and Dealers are asked not to supply any of the above named firms with our apparatus, either at addresses given or any other address.

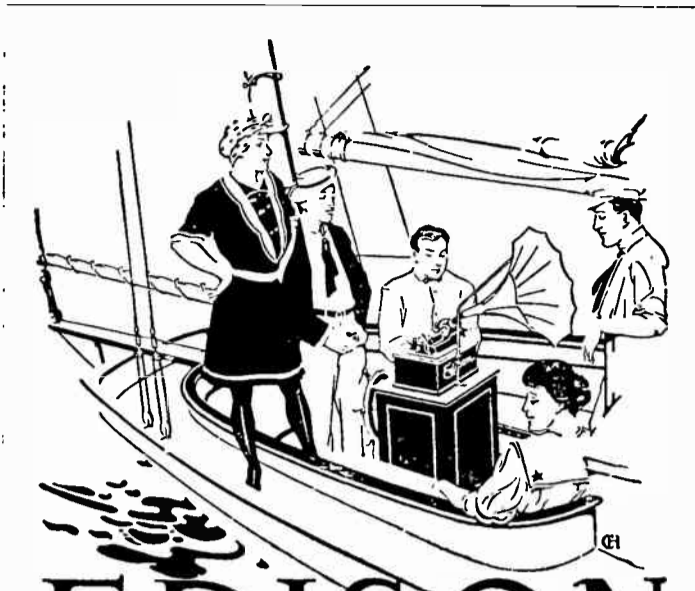

# EDISON PHONOGRAPHS

Real Entertainment  
Anywhere and All the Time

**H**AVEN'T you ever noticed that no matter where you start an Edison Phonograph it immediately becomes the center of interest? As an entertainer it has no competitor. With each new record, whether a song from the latest musical comedy, a waltz or two-step by band or orchestra, a selection from grand opera or a ballad of long ago, the Phonograph becomes a new pleasure. An Edison Phonograph in your home means enjoyment for each member of the family and for all occasions. Come here to-day and let us play some of the latest Records for you.

**FRANK COBB**  
Victor, N. Y.

Electro in ad above is: Single column wide No. 687.  
Double column wide, 688.



# EDISON PHONOGRAPHS

The Edison Phonograph is a case where three is company and not a crowd.

Two people and an Edison Phonograph can pass a very pleasant evening. This does not prevent it from being the best entertainer for any kind of a gathering, from an informal evening up to a large reception.

If you do not know the possibilities of the Edison Phonograph, come into our store and hear what it can do.

**J. M. BUDEN**  
Santa Barbara, Cal.

Electro in above ad is: Single column wide No. 689.  
Double column wide. No. 690.

## REQUEST FOR ELECTROS

**NATIONAL PHONOGRAPH Co.**  
ADVERTISING DEPARTMENT, ORANGE, N. J.

DATE.....190.....

Mail Electros No.....

We agree to use them in newspaper advertising and to send you copies of papers containing them before asking you for other electros. We intend running a..... inch advertisement.

Name.....

Street.....

City and State.....

We buy through.....

# Jobbers of Edison Phonographs and Records

Continued from page 2 of Cover

## NEW YORK.

**Albany**—Finch & Hahn, 402 Broadway.  
**Astoria**—John Rose, 99 Flushing ave.  
**Brooklyn**—A. D. Matthews' Sons, 894 Fulton st.  
**Buffalo**—W. D. Andrews, Seneca and Wells sts.  
Neal, Clark & Neal Co., 645 Main st.  
**Elmira**—Elmira Arms Co., 117 Main st.  
**Gloversville**—American Phono. Co., 99 W. Fulton st.  
**Kingston**—Forsyth & Davis, 307 Wall st.  
**New York City**—Blackman Talking Machine Co., 97 Chambers st.  
J. F. Blackman & Son, 2737 3d ave.  
I. Davega, Jr., Inc., 125 W. 125th st.  
S. B. Davega Co., 32 E. 14th st.  
Douglas Phono. Co., Inc., 89 Chambers st.  
Jacot Music Box Co., 39 Union square.  
Victor H. Rapke, 1659 Second ave.  
Regina Co., 41 Union square.  
Siegel-Cooper Co., 6th ave. and 18th st.  
John Wanamaker, Broadway, 8th and 9th sts.  
Alfred Weiss, 1622 First ave.  
**Oswego**—Frank E. Bolway, 32 W. Bridge st.  
**Rochester**—A. J. Deninger, 345 North st.  
Mackie Piano, O. & M. Co., 100 State st.  
Talking Machine Co., 97 Main st., E.  
**Schenectady**—Finch & Hahn, 504 State st.  
Jay A. Rickard & Co., 253 State st.  
**Syracuse**—W. D. Andrews, 216 E. Railroad st.  
**Troy**—Finch & Hahn, 3 Third st.  
**Utica**—Clark-Horrocks Co., 54 Genesee st.  
Arthur F. Ferriss, 89 Washington st.  
William Harrison, 50 Columbia st.  
Utica Cycle Co., 16 Columbia st.

## OHIO.

**Canton**—Klein & Heffelman Co., 220 E. Tuscarawas st.  
**Cincinnati**—Ball-Flintze Co., 108 West 3d st.  
Ilsen & Co., 615 Vine st.  
Milner Musical Co., 25-27 W. 6th st.  
Rudolph Wurlitzer Co., 121 East 4th st.  
**Cleveland**—Eclipse Musical Co., 1870 East Ninth st.  
**Columbus**—Perry B. Whitsit Co., 213 S. High st.  
**Dayton**—Niehaus & Dohse, 35 E. 5th st.  
**Newark**—Ball-Flintze Co.  
**Toledo**—Hayes Music Co., 422 Superior st.

## OREGON.

**Portland**—Graves & Co., Inc., 111 4th st.

## OKLAHOMA.

**Oklahoma City**—Smith's Phono. Co., 818 West Main st.

## PENNSYLVANIA.

**Allentown**—G. C. Aschbach, 539 Hamilton st.  
**Easton**—William Werner, 432 Northampton st.  
**Harrisburg**—S. K. Hamburger, 12-14 N. Market square.  
**Philadelphia**—Louis Buehn & Bro., 45 N. 9th st.  
C. J. Heppe & Son, 1117 Chestnut st.  
Lit Bros., Market and 8th sts.  
Musical Echo Co., 1217 Chestnut st.  
Penn Phonograph Co., 17 S. 9th st.  
John Wanamaker, 13th and Market sts.  
Western Talking Mach. Co., 41 and 43 N. 9th st.  
H. A. Weymann & Son, 1010 Chestnut st.

## Pennsylvania—Continued.

**Pittsburg**—Pittsburg Phono. Co., 937 Liberty ave.  
Powers & Henry Co., 339 Second ave.  
Standard Talk. Mach. Co., 435 Wood st.  
**Reading**—Reading Phonograph Co., 48 N. 8th st.  
**Seranton**—Ackerman & Co., 217 Wyoming av.  
Technical Supply Co.  
**Sharon**—W. C. DeForeest & Son.  
**Williamsport**—W. A. Myers, 127-129 W. 3d st.

## RHODE ISLAND.

**Providence**—J. M. Dean Co., 785-795 Westminster st.  
J. A. Foster Co., Weybosset and Dorrance sts.  
J. Samuels & Bro., 154 Weybosset st.

## TENNESSEE.

**Chattanooga**—J. H. Templeman Co., 253 Montgomery ave.  
**Knoxville**—Knoxville Typewriter and Phonograph Co., 421 Gay st.  
**Memphis**—F. M. Atwood, 123 Monroe ave.  
O. K. Houck Piano Co., 103 S. Main st.  
**Nashville**—Magruder & Co., 27 Arcade.  
Nashville Talking Mach. Co., 723 Church st.

## TEXAS.

**Dallas**—Southern Talking Machine Co., 347 Main st.  
**El Paso**—W. G. Walz Co., 101 El Paso st.  
**Fort Worth**—Cummings, Shepherd & Co., 700 Houston st.  
**Houston**—Texas Piano & Phone. Co., 1019 Capitol ave.  
**San Antonio**—H. C. Rees Optical Co., 242 West Commerce st.

## UTAH.

**Ogden**—Proudfit Sporting Goods Co., 351 24th st.  
**Salt Lake City**—Clayton-Daynes Music Co., 109 S. Main st.

## VERMONT.

**Burlington**—American Phono. Co., 34 Church st.

## VIRGINIA.

**Richmond**—C. B. Haynes & Co., 603 E. Main st.

## WASHINGTON.

**Seattle**—D. S. Johnston Co., Third ave. and University st.  
Kohler & Chase, 710 Pike st.  
**Spokane**—Spokane Phonograph Co., 102 2nd ave.

## WISCONSIN.

**Milwaukee**—Lawrence McGreal, 176 3d st.

## CANADA.

**Quebec**—C. Robitaille, 320 Rue St. Joseph.  
**St. John**—W. H. Thorne & Co., Ltd., 42-46 Prince William st.  
**Toronto**—R. S. Williams & Sons Co., Limited, 143 Yonge st.  
**Vancouver**—M. W. Waitt & Co., 558 Granville st.  
**Winnipeg**—R. S. Williams & Sons Co., Ltd., 121 Princess st.

# Broaden Your Field

—and increase your sales. A dealer makes a serious mistake by selling records and instruments for amusement purposes alone. There is besides the amusement field the vast field of education from which can be reaped an abundant business. Here the dealer can increase the sale of records to those who already own phonographs, and can sell both instruments and records to a very large number of cash customers who would never think of buying a phonograph except for educational purposes. All this is made possible through

## I.C.S. LANGUAGE SYSTEM

WITH  
*Thomas A. Edison*  
PHONOGRAPH

There is a great opportunity for **you** to sell I. C. S. Language Outfits to people who are going abroad or who desire to learn a language for the sake of the knowledge of it alone; to those who desire to qualify for positions as translators and foreign correspondents; and to foreigners who wish to learn to speak English. No sledge hammer is needed to get it clearly into your head that this presents a sure way of broadening your field of work and increasing your sales. For the sake of good business sense, boom the I. C. S. Language feature of the business.

**International  
Correspondence Schools  
SCRANTON, PA.**

# The EDISON PHONOGRAPH MONTHLY

Vol. VI

August, 1908

No. 8



*“A Man’s Voice, Anyhow.”*

---

This is the dollar coupon  
issue - - - see page 13

# *The* EDISON PHONOGRAPH MONTHLY

Published by the National Phonograph Co., Orange, N. J.

All communications to *The Phonograph Monthly* should be addressed to the Advertising Department, Orange, N. J.

## *Contents for August, 1908*

Foreword . . . . .	1
For the New Dealer, the New Clerk and the New Owner . . . . .	2
Store Management . . . . .	3
Selling the Goods . . . . .	5
Questions and Answers . . . . .	6
The Jobbers' Convention . . . . .	7
Repeating Profits on Repeating Attachments . . . . .	7
A Clever Bryan Record Cartoon for Your Window . . . . .	8
The Dealer Who Forgot . . . . .	8
To Help the Window Sell the Goods . . . . .	9
A Special Invitation From You . . . . .	10
Run This Ad in Your Local Newspaper . . . . .	11
Lessons for Dealers . . . . .	12
This Big Trade Bringing Banner is Free to Edison Dealers . . . . .	13
Advance List New Edison Records for October, 1908 . . . . .	14
Advance List New Hebrew and Norwegian Selections . . . . .	18
Trade Bulletins . . . . .	19
Suspended List . . . . .	19
September Magazine Advertisement . . . . .	20
Jobbers of Edison Phonographs and Records . . . . .	3rd Cover Page

NEW YORK: 10 FIFTH AVENUE.

NATIONAL PHONOGRAPH CO., LTD., VICTORIA ROAD, WILLESDEN, LONDON.  
NATIONAL PHONOGRAPH CO. OF AUSTRALIA, LTD., 340 KENT STREET, SYDNEY, N. S. W.  
MEXICAN NATIONAL PHONOGRAPH CO., AVENIDA ORIENTE No. 117, MEXICO CITY.  
COMPANIA EDISON HISPANO-AMERICANA, VIAMONTE 515, BUENOS AIRES.  
EDISON GESELLSCHAFT, M. B. H., SUD-UFER 24-25, BERLIN.  
COMPAGNIE FRANCAISE DU PHONOGRAPHE EDISON, 42 RUE DE PARADIS, PARIS.



If the new, big, flat envelope which carries this issue of the Phonograph Monthly has induced you to look inside, and the attractive cover of the publication has induced you to investigate farther, then we would like your attention for a minute to say—that

beginning with this number we shall endeavor to make this little publication more informing and more helpful to you than ever before.

We want you to read every issue for your good and for ours. If you have been in the habit of laying it aside for future perusal and then forgetting about it, or if you have decided that it contains nothing that will make you any money, then break the habit or reverse your decision as the case may be, for you are wrong on both counts.

It is impossible to get out a publication every word of which will be vital to every dealer. But we are positive that somewhere in each issue every dealer will find some bit of advice, some helpful suggestion, some item of news that will be worth the effort of sifting it out.

This publication is our best method of keeping in touch with you. We want to help you all we can and we want you to help us. We are the producing end of the business; you are the selling end. We have experience that you need; you have experience that we need. Let us swap this valuable information.

Let us consider the Phonograph Monthly a Clearing House for ideas. Send us yours and we will print them along with our own.

Ask us questions and we will answer them. Call for our views on any subject and we will give them. Thus we will have a live publication that will help all of us to make more money.

---

## 2 Edison Phonograph Monthly, August, 1908

---

### For the New Dealer, the New Clerk and the New Owner

After our advertising has created an interest—after your advertising has brought an interested prospect to your store—then it is up to the Phonograph.

The demonstration is the important thing. It either clinches or kills the sale.

Most Edison Dealers are experts in the handling of the Phonograph. These suggestions on how to play a Record are for Dealers who have just taken on the line, for the new clerk of an old Dealer and possibly, for all Dealers to reprint and give to purchasers so that they may get the same results at home as the demonstration at the store afforded.

Wind the motor by inserting the winding crank in its hole at the right end and turning it to the right with an even, steady motion. Be very careful not to over-wind. Stop winding when the spring seems to "give."

Open the swing arm at the right end of the Record cylinder. Put the Record on the cylinder, having the title end next to the swing arm. Push it as far as it will go with a slight pressure. Close the swing arm.

Make sure that the horn is swinging just right by sliding the reproducer to the center of the Record cylinder and regulating the length of the chain rod so that the chain hangs perfectly straight looked at from the end of the machine.

Start the Phonograph running by pushing the starting lever to the left. (On the Gem, turn the starting knob to the right to the first stop.)

Slide the reproducer arm to the point where the threads of the Record begin. Let the reproducer down by pulling out the button on the Gem and Standard or by pushing down the lift-lever on the Home and Triumph. This brings the sapphire point of the reproducer in contact with the surface of the Record, when it will track in the minute grooves, following exactly all of the numerous indentations.

When the Record is played, lift the reproducer by the opposite method from that used to lower it, and stop the machine's playing by pushing the starting lever to the right. (On the Gem the starting knob is turned to the left.)

Slide the reproducer to the left about half-way and loosen the Record from the cylinder by pushing gently on the left end with the thumb and forefinger of the left hand. Open the

swing arm and remove the Record with the right hand by inserting two fingers in the end and spreading them apart.

---

### A "Bryan" Window

A very clever and original window display on the Bryan Records was that gotten up by the Silverstone Talking Machine Co., St. Louis. A Ferris Wheel nine feet in diameter was made of wire. Edison Record cartons were fastened around the inside of the rim and seventeen 14-inch horns were placed around a smaller circle half way between the center and the outside rim. "Gem" machines were suspended from the cross beams to represent the cars of the Ferris Wheel and on each was a price ticket.

In front of the hub Bryan's picture and the words, "Records by Wm. J. Bryan For Sale Here" were shown on a pasteboard card. On the spokes of the wheel were pasted strips with the titles and numbers of the different Bryan Records. All of the lettering was taken from one of the Bryan hangers sent out with the Records.

The wheel carried twelve red, white and blue electric lights and revolved slowly so that all of the wording could be read. Across the bottom of the window at the front there were nine Standard machines bearing price cards.

---

### A Fourth of July Float

The Winnek Co., Prineville, Ore., have been responsible for some clever Edison advertising. Their latest "stunt" was a Fourth of July float which made a decided hit.

The float consisted of a rough copy of a large Edison Phonograph and Record mounted on a flat-top wagon. The machine cabinet was a 6x3½ feet box, with the word "Edison," on all four sides. The Record was on top of this and was 4 feet long by 3 feet in diameter. The words, "Edison Phonographs and Records" were pasted on the black Record in large white letters and the Record was made to revolve slowly by a rope belt running from a drive wheel at its end to a drive wheel on the hub of a wagon wheel.

The horn was 8 feet long and 4 feet across the bell end. It was made of ½ by ¾ inch strips covered with red cloth, which was striped with gilt. A large cloth sign hung on each side of the wagon below the machine and bore the name of the firm.

The Winnek Co. write, "Advertising pays. July 1st we thought we had enough goods to last through the season. When we closed the store the evening of July 4th, we had only one Standard machine left. All 'Homes' had been sold, also two that were on the way."

# Store Management

A monthly comment on things Edison dealers have done with a few suggestions on what they should do to increase sales.

If you want a bargain—a genuine bargain—take advice.

Considering its cost—which is usually only a minute or two, just long enough to listen or to read—advice is the greatest bargain on the market to-day.

Take advice. Listen to it. Read it.

But don't act on it unless your better judgment tells you it is *good*.

The man who "knows it all" puts cotton in his ears, blindfolds his eyes, and starts down hill.

The man who succeeds is the man whose eyes and ears are open, who profits by the experience of others, and who has the wit to let other men's wits work for him, as well as use his own.

It is with this purpose in view that we plan to run a department in the PHONOGRAPH MONTHLY called "Store Management. A monthly comment on things Edison Dealers have done with a few suggestions on what they should do to increase sales."

You, as an Edison Dealer, must realize that we have all the same interests in common. We do not sell a single Phonograph or Record except to a Jobber, who in turn sells to you. When you sell a Phonograph we sell a Phonograph. When you lose a customer we lose a sale, too. We are vitally interested in your personal, individual success, because our success depends on yours.

Naturally, then, we are anxious to help you sell all the Phonographs and Records you can.

One of our ways to help is to give you the best advice and suggestions that we can secure. We shall give you the ideas of men who have been successful in solving those problems which every Dealer must meet. And from the suggestions published each month we are confident that you will get at least one idea which you can adapt to your particular business needs and use with profit.

In return we are going to ask that you help us

with your experience. Write us. Tell us of successful selling plans, of practical economies in store managing, and of special schemes that have worked out well.

It costs just as much to operate your store whether you sell one Phonograph a week or ten. You cannot cut down your fixed expenses and you must push up your profits. One way to increase your sales is to make your store work more.

You work—your clerks work—your stock works—but how about your store? Does it work? Does it make people want to buy Phonographs? And when you have sold Phonographs, does it make people want to buy Records?

When the Bryan Records were put on the market they sold like hot cakes. They are selling yet. When Bryan was nominated, how many of you made a special push on Bryan Records? How many put his picture in the window? The nomination of Bryan was the most important news in the papers Wednesday, July 8th. A very little effort on your part would have made it your advertising.

But that's all over now. Let's take up to-day. The new Records are new only one day in the month, but you can sell old Records all the time. An old Record is just as good as a new one if a man hasn't heard it. Some Dealers begin to look forward to new Records as early as the middle of the month. Next month's Records are no newer to most of your customers than those you have right on your shelves, and the profit is just as good. Don't let the dust gather on old Records while you try to sell new ones.

Make the outside of your store work as well as the inside. Use the wall space to advertise your goods, something you sell—Edison Phonographs. We have a big banner for any Dealer who will put it up outside—where it can be seen—where it will work for you.

---

---

## 4 Edison Phonograph Monthly, August, 1908

---

A Dealer who appreciates that a lively store sells most goods will make the Edison Phonograph sell itself. Keep it playing. Nothing you can say about a Phonograph will have as much effect in making a man want to own one as what the Phonograph says for itself. Nothing you can tell them about the Records will sound as well as the Records. Have a regular concert once a week and an impromptu concert whenever there are several people in the store.

---

A certain number of people are going to buy Phonographs and Records every week; not all of them are going to buy Edison Phonographs, and not all of them are going to buy at your store, but you can count on a certain, steady trade somewhere in your town—it is up to you to get it.

It is up to you to make the people in your town believe that your store is the best store to buy Phonographs and that the Edison Phonograph is the best Phonograph to buy.

If you do this you will get your share of the trade. The trade is there. It is just as certain and just as steady as the trade in any other line of goods.

Our national advertising takes care of that. We are reaching practically every family in the United States every month with advertisements of the entertaining qualities of the Edison Phonograph.

---

Making the windows work is simply keeping in them Records and Phonographs which will interest the passing public.

Elsewhere in this number will be found attractive show cards which can be easily lettered in your own store.

These call attention to the new Records, to old Records or to the Phonograph itself; to some special phase of enjoyment to be had with the Phonograph.

Very little skill in window dressing will make your windows good advertising for your store.

---

Never forget that the primary object of the Edison Phonograph is to amuse—a number of people are willing to pay for amusement. The best of theatres are crowded with spectators with high prices for good seats—all catering to amusement.

The Edison Phonograph supplies the same sort of amusement that people go to the theatre to get. In no other form can so much of this sort of amusement be had for so little money as in the form of the Edison Phonograph.

If you have a successful window display take a photograph of it and write to us about it; tell us how you did it and what the results were. It will do you good to describe your own window and how it worked and it will help other Dealers in other towns.

We are so interested in getting Edison Dealers to make the most of their windows that we propose shortly to offer a series of prizes for the best windows.

If you have a bright, young clerk in your employ with a knack for such things, set him to work dressing windows using only the material in the store, that is, the Phonograph, the Records, the various cards, posters and other things that we supply. We furnished enough material to produce a series of excellent windows if intelligently handled.

All this matter is free to the dealers who will use it; the whole thing is to get you to use it—to make the most of your opportunity. The entire advertising system of the National Phonograph Company is intended to help you sell more Phonographs and more Records—but you must take advantage of it.

---

Have the Records people ask for and they will ask oftener.

---

An old Record is new to all who have not heard it. Let the people hear those on your shelves as well as those which have just arrived for August.

---

Sell for cash if you can; on the payment plan if you must.

---

August is an out-of-doors month. The Phonograph is an out-of-doors entertainer.

---

A Phonograph lasts a life time; the new monthly Records mean a perpetual revenue.

---

Make the welkin ring with the Bryan speeches—now's the time.

---

One-price puts it squarely up to the Dealer. Your Competitor who orders by the carload has no advantage over you. Whether you make a success depends upon your service and your advertising. Study to make both perfect.

# Selling the Goods

ADVERTISING:—One of the most important and often one of the most neglected branches of a dealer's business.

## *Team Work*

Team work is a great thing.

When you pour forth music into the street from the big horn of a talking machine you draw an interested but curious crowd—interested in the music; curious to know what instrument it is that affords such real entertainment.

When you announce by means of a window card that the instrument is an Edison Phonograph and that the selection is the big scream of a new Broadway success, then you make a general proposition a specific one.

That's team work.

On page 20 of this issue we show our September magazine advertisement. On or about August 20th this advertisement will reach the eyes of millions of people. It has a pleasing picture and presents arguments calculated to interest readers in the Edison Phonograph and Edison Records.

On page 11 of this issue you will find a newspaper advertisement similar to our magazine advertisement in picture but differing somewhat in type matter.

Enclosed herewith is this same advertisement in larger size. The small ad is for your local newspaper; the larger one is for your window.

Here is a chance for some profitable team work.

When we say in our advertising to the people in your city: "You ought to have a Phonograph," your part is to say: "We sell them."

Then the people have been reminded of a need by us and told where that need can be satisfied by you.

Put the enclosed hanger in your window just about the time the August magazines are on sale in your city. Run the small ad, with your name and address, in your newspaper at the same time.

We furnish an electrotype of the picture free on request; the reading matter the newspaper will set for you. Send for the cut to-day so that it will reach you in time.

Remember our part is creating the demand. Results go to the dealer who announces that he is in shape to meet it.

## *If It's an Edison Phonograph, Say So*

The crowd around the big horn in front of your store knows that some sort of a sound-reproducing instrument is entertaining it.

It would be a better advertisement if the crowd knew what instrument it was.

It would be a still better advertisement if the name of the selection or song was announced.

Songs or music coming out of a horn advertise talking machines to those who pass by.

Of the hundreds that stop and listen but few come in and say, "I like the sound of that instrument; what is it?"

The rest pass on carrying away no definite thought with them.

If, however, a card is displayed saying, "The Edison Phonograph is now playing Ada Jones' new song hit, 'Smarty,'" and another card announces what the next selection will be, then a distinct impression is made on all who stop and listen.

Halting the passing crowd is one thing. Recruiting Phonograph and Record purchasers from it is another.

It is the part of the Phonograph to draw an audience. It is your part to see that the audience has all the information it should have.

Try window cards.

Do not despise the one-Record-a-month customer. He has his friends and you need his endorsement.

Hold concerts. Many who stop to listen, stay to buy.

Treat strangers as you would customers and they'll become customers.

## Questions and Answers

We have opened this department in order to print, each month, questions asked us in letters from Dealers and Phonograph owners about the regulation of their machines, together with our answers. This information will serve to clear up many important points on which you should be posted so as to keep your own Phonographs in perfect running order, and also give your customers valuable advice.

F. K., Sparta, Wis.—In winding up my "Triumph" Phonograph, that I use for exhibition work, there is a rumbling noise and the handle feels as if the spring were relaxing or the ratchet were about to give way.

[It is evident the springs have become dry or rusty, causing them to stick so that the sudden release of the spring produces the jarring noise. Stand the Phonograph on end, with the mechanism exposed to view and apply powdered graphite to the springs, followed by oil. There is also an oil hole in the top of the spring barrel through which oil should be applied.]

E. A. H., Nevada City, Calif.—I have an Edison Standard Phonograph and some of my Records have developed a kind of whistling sound. The noise seems like a sharp grind not unlike the squeak of machinery that needs oil.

[The trouble probably lies in your Reproducer not being properly adjusted or needing new parts, such as rubber gaskets, which act as cushions for the diaphragm. Secure a new copper diaphragm with rubber and paper washers. First place one of the rubber gaskets into the cup, then the cupped paper washer into the cupped edge of which should be inserted the rim of the copper diaphragm. On top of this should be placed the plain paper washer, followed by another rubber gasket; then the metal washer, and finally the clamping ring. The clamping ring should be screwed up just tightly enough to hold the diaphragm and washers firmly in the cup. If you find the tone too sharp or shrill, loosen the clamping ring slightly. If there is a tendency to blast, screw the ring up slightly.]

Canadian Dealer.—Why not advertise the *retail prices* of Gem, Standard, and Home outfits in your ads and literature, as you did when the prices were \$10.00, \$20.00 and \$30.00? It would save us Dealers a lot of explanation regarding change in prices. I think it only fair and business-like to do so.

[To advertise retail prices of our machines, as suggested, would, in our opinion, be detrimental to the sales of Edison Phonographs. To advertise the new prices would have the effect of keep-

ing people away from Dealers' stores and give the latter no opportunity to explain why the prices had been raised. We realize that this causes the Dealer some trouble in having to explain the situation, but isn't it better to go to this trouble than to keep people away entirely? Then, too, if we attempted to put prices in our advertisements, we would have one set of prices in American publications, many of which go into Canada, and another set of prices in Canadian publications. This would cause a complication that would have a tendency to keep the people away from Dealers' stores.]

F. N. S., Chicago.—My Edison Standard Phonograph plays half a tone flat in music, talking records being all right. The Motor, Reproducer and Horn are all right. My Reproducer works satisfactorily on other machines, but other Reproducers used on mine disclose the same fault.

[We think the trouble is due to poor regulation of the machine. Any one of several things may cause this. We suggest that you first try the adjustment of the cylinder shaft between centres by moving it endwise by hand. If there is too much or too little play you can adjust it by means of the centre pivot adjusting screw in the swing arm. There should be just enough play of the shaft between centres to make sure it does not bind when the machine runs. Next see that the Idler Pulley works freely. Apply a little oil to its hub, but be careful to get none on the belt. The tension of the pulley should not be so strong as to obstruct the free running of the machine.

If these suggestions fail, notice whether any of the Governor springs have become bent or there is another irregularity. You might turn the Governor to a different position on the shaft by unscrewing the collar and screwing down again when it is in a new position. Be sure the Governor bearings do not become worn through lack of oil. You should apply a little graphite to the pinions and oil to the bearings at frequent intervals.]

---

## Sees Good Times Ahead

Sales Manager F. K. Dolbeer, of the National Phonograph Co., has returned from a seven weeks' trip through the west, northwest and to the Pacific coast. He traveled 16,000 miles and visited Edison Jobbers in 28 cities.

Returning, Mr. Dolbeer attended the convention of the National Association of Credit Men at Denver, as a delegate from the New York branch. As a result of his own observations and reports by the credit men, Mr. Dolbeer is confident that the fall trade in Edison Phonographs will show a decided improvement in every section of the country.

Meet Mr. Good Times half way—Write for the free advertising banner (p. 13); the free newspaper electro (p. 11); the free post card electro (p. 10)—these will help some.

## The Jobbers' Convention

The 1908 convention of the Talking Machine Jobbers' National Association, at Atlantic City, N. J., on July 6 and 7, was in every way the most successful gathering of talking machine men ever held.

The two days were taken up with listening to reports by the association's officers, to able papers prepared by leading members on the different features of the business, and to open discussion of means of fostering the growth of the talking machine business.

The former officers were re-elected, as follows: President, James F. Bowers, Chicago; Vice-President, W. D. Andrews, Buffalo; Secretary, Perry B. Whitsit, Columbus; Treasurer, Louis Buehn, Philadelphia; Executive Committee, Lawrence McGreal, Milwaukee; W. E. Henry, Pittsburgh; Edward H. Uhl, Chicago; E. Percy Ashton, Detroit; J. Newcomb Blackman, New York.

Important matters discussed included "cut outs" and defective Records, the convention favoring a plan whereby such Records would be exchanged on an even basis. Another subject was that Dealers be required to invest more capital in stock and that the number of Dealers be limited in different localities. Disapproval of manufacturers' supplying the retail trade direct and conducting retail establishments was also expressed.

The Executive Committee was instructed to take up with manufacturers the question of sending out all Records in sealed packages. The association also favored a plan requiring members of the association to refer applications from new Dealers to the manufacturer for the latter to pass on their eligibility. There was talk of establishing a Record clearing house, the idea being for each of the Jobbers to file a list of over-stock in Records with the secretary of the association so as to make exchanges among themselves on an even basis.

Assistant General Manager C. H. Wilson, of the National Phonograph Company, gave the Jobbers an optimistic talk on the trade outlook for fall and said there would be some important business announcements in the near future that would interest Edison Jobbers.

Frank L. Dyer, chairman of the executive committee of the National Phonograph Company, assured those present that President Gilmore's policies would be carried out during his absence abroad. At the banquet of the association which was held at the Royal Palace Hotel, Mr. Dyer read a letter from Mr. Edison regretting that he could not take advantage of the invitation to attend the convention.

C. H. Wilson also spoke at the banquet and announced amid loud applause that the National Phonograph Company would hereafter take back all "cut outs" and defective Records.

## Repeating Profits on Repeating Attachments

Do you remember when you were a small boy and went to the circus? The twenty-five cents you parted with for a ticket to the main tent merely admitted you to a whole assortment of temptations, all costing more money.



Model D Reproducing Attachment

The purchase of a Phonograph is something like this. The original purchase leads on to others, and all of these others mean added profits to you.

Among the temptations which the purchaser of a Home or Triumph machine meets with is a Repeating Attachment which enables the Phonograph owner to hear a favorite Record over and over without going near the Phonograph.

Also for dance music, when everybody wants to dance and nobody wants to operate the Phonograph, this device keeps the waltz or two-step going indefinitely.

Model D Reproducing Attachments for both the Home and Triumph instruments retail at \$7.50 and afford the same profit as Phonographs and Records.

Carry a few of these Attachments in stock and see that every Home or Triumph purchaser is made acquainted with them.

---

## W. E. Gilmore Sails for Europe

W. E. Gilmore, President of the National Phonograph Co., sailed for Europe July 7th, on the Kronprinzessin Cecile of the North German line. He was accompanied by Mrs. Gilmore and their son and daughter. As Mr. Gilmore was embarking he was handed a special delivery letter conveying the good wishes of the National Association of Talking Machine Jobbers, who were holding their annual convention at Atlantic City, N. J. The signatures of all of the senders were attached to the letter.

## A Clever Bryan Record Cartoon For Your Window



Courtesy of Philadelphia Record

*"Why didn't you think of that for me, Teddy?"*

Of the hundreds of cartoons on the Bryan Records, which have appeared in the newspapers throughout the country, none has made a bigger hit than the one shown here, which appeared in the *Philadelphia Record*. Being non-partisan in its nature, it brings a laugh from both sides of the fence.

Believing that all of our Dealers will see the advertising value of such a cartoon, we have secured the original from the *Record*, and have struck off several thousand for Dealers who want it.

The cartoon is about 16 inches square and is sure to draw a crowd and thus spread the good news that Bryan's Records are on sale.

The cartoon is free. Write for it.

## 375 Attend a Recital

Three hundred and seventy-five people attended an Edison Recital, given on the night of July 2nd, by the Alhambra Furniture and Undertaking Company, of Alhambra, California.

This is a very fine attendance for a town of only 1,500 population. It goes to show how much interest there is in Edison Concerts when they are properly gotten up and advertised:

This firm went about it in the right way and succeeded in arousing great enthusiasm over Edison Phonographs and Records. They expect

to land a number of sales as a result of their enterprise.

A neat invitation card was mailed out a few days in advance to a list of Phonograph owners, prospects and other names selected from the town directory. The card was  $3\frac{1}{4}$  by  $5\frac{1}{4}$  inches in size and was printed in script lettering. The wording was as follows:

*You are cordially invited to attend an  
Edison Recital at the  
HIGH SCHOOL AUDITORIUM,  
Thursday evening, July 2nd, at 8 p. m.  
The new July Records will be used.  
This is the first of a series of Recitals  
which we expect to give.  
Please present this invitation at the door.  
ALHAMBRA F. & U. CO.  
Admit two.*

## The Dealer Who Forgot

There was once a dealer who forgot that August was a dull month. Instead of letting all of his clerks go, putting a five-per-week boy in charge and going away fishing, he kept right on doing business just as if it were the month before Christmas.

His advertisements appeared in the newspapers getting the prominence of half-page spreads because all the other fellows had quit.

When the August Records arrived he arranged an evening concert and invited the public in to hear them.

As all the other places of amusement had closed down for August, the public came in droves.

He fixed up some attractive window displays, sent out the Phonogram to his list of customers, kept the air in his vicinity filled with music and, in fact, smashed all trade traditions.

Likewise, he smashed all records for sales since January first.

And the moral is: It is profitable to profit by the unprofitable actions of others.

With many the Edison Phonograph as a side line has become the main line.

That big free banner offered on page 13 will bring your store out beyond the building line.

In August two Records are possible, one for sales, the other for lack of sales. It's up to you.



## To Help the Window Sell the Goods

If there is any free advertising medium it is your window.

It should be more than an exhibit of goods—it should be a mine of information.

The goods in a window are the pictures. The story should be told on cards.

If the illustration is right and the argument is right, then you have an advertisement as large as your window that is reaching thousands.

Window cards need not be pretty. The most effective window cards ever written were done with a blue pencil on wrapping paper.

What they need do is say something of interest about the goods shown, and say it briefly.

Just an eye-full—just what can be gathered at a glance is enough.

They may be written, lettered or printed. The thing is to have something to say and say it in the most legible way at your command.

We show here some good sentences. Use them in connection with your window displays. They will help the window sell the goods.

**MUSIC MAKES THE  
EVENINGS GO.  
An Edison Phonograph  
makes the music.**

**AN  
EDISON  
PHONOGRAPH  
PARTY**

**THE NEW RECORDS  
AND A FEW FRIENDS**

*Everybody is  
whistling it—  
"I'm savin' up my  
money for a rainy  
day" a new rag-time  
Edison Record*

**BETTER THAN A  
ROOF-GARDEN  
Your front porch AN  
EDISON Phonograph  
and the NEW AUGUST RECORDS**

*A Recipe for  
Warm Nights  
The Edison Phonograph  
and the front porch*

**AN EDISON  
PHONOGRAPH—  
It keeps the  
children happy  
and keeps the  
father home.**

Hear the New  
Edison Phonograph

Post Card



*A. N. Owen*  
*Yourtown*

**HUSTLE & PUSH**  
44 MAIN STREET  
YOURTOWN

### A Special Invitation from You

Our September advertisement which will appear in the magazines about August 20th, requests readers to go to an Edison Dealer on August 25th and hear the new September Records.

Why not back up this request with a special invitation from your store?

For the purpose we would suggest a souvenir post card. On the front have printed the picture which appears on the September Supplement. On the back say:

Hear the new Edison Phonograph  
Records at Our Store and Make  
Your Selections.

Follow this with the names of the new Records and your name and address.

The cost of getting out such a card is small. The cost of sending it out to Phonograph owners and prospective Phonograph buyers is small.

And results will be large.

It is another case of team work—hitching your advertisement to ours—focusing our advertising to your store.

If you will agree to get out the post cards, we will send you an electrotype of the illustration free.

Run This Ad In Your Local Newspaper

See Article on "Team Work"



*Broadway Vaudeville at Perkins Corners.*

## Broadway Vaudeville Anywhere

On your front porch, for instance, when you are tired with your day's work and lack the energy necessary to entertain yourself. Then

## The Edison Phonograph

will stir you with its marches, amuse you with its rag-time songs and dances or soothe you with its melodies. It sings as sweetly as the most cultivated singer and renders perfectly the tones of the various instruments of orchestras and bands.

Possibly you have heard "talking machines." Have you heard a genuine Edison Phonograph? There's a difference. Some machines merely reproduce sounds and noises. The sweetness and the perfect expression for which you prize music are qualities which distinguish the Edison from its imitators.

*Phonographs \$12.50 and up. Records 35 cents.*

**WILLIAM SMITH'S SONS COMPANY**

BALTIMORE, MD.

An electrotype (No. 691) of the above illustration will be sent free to any Edison dealer who will insert the advertisement in his local newspaper and send us a copy of the paper in which it appears.

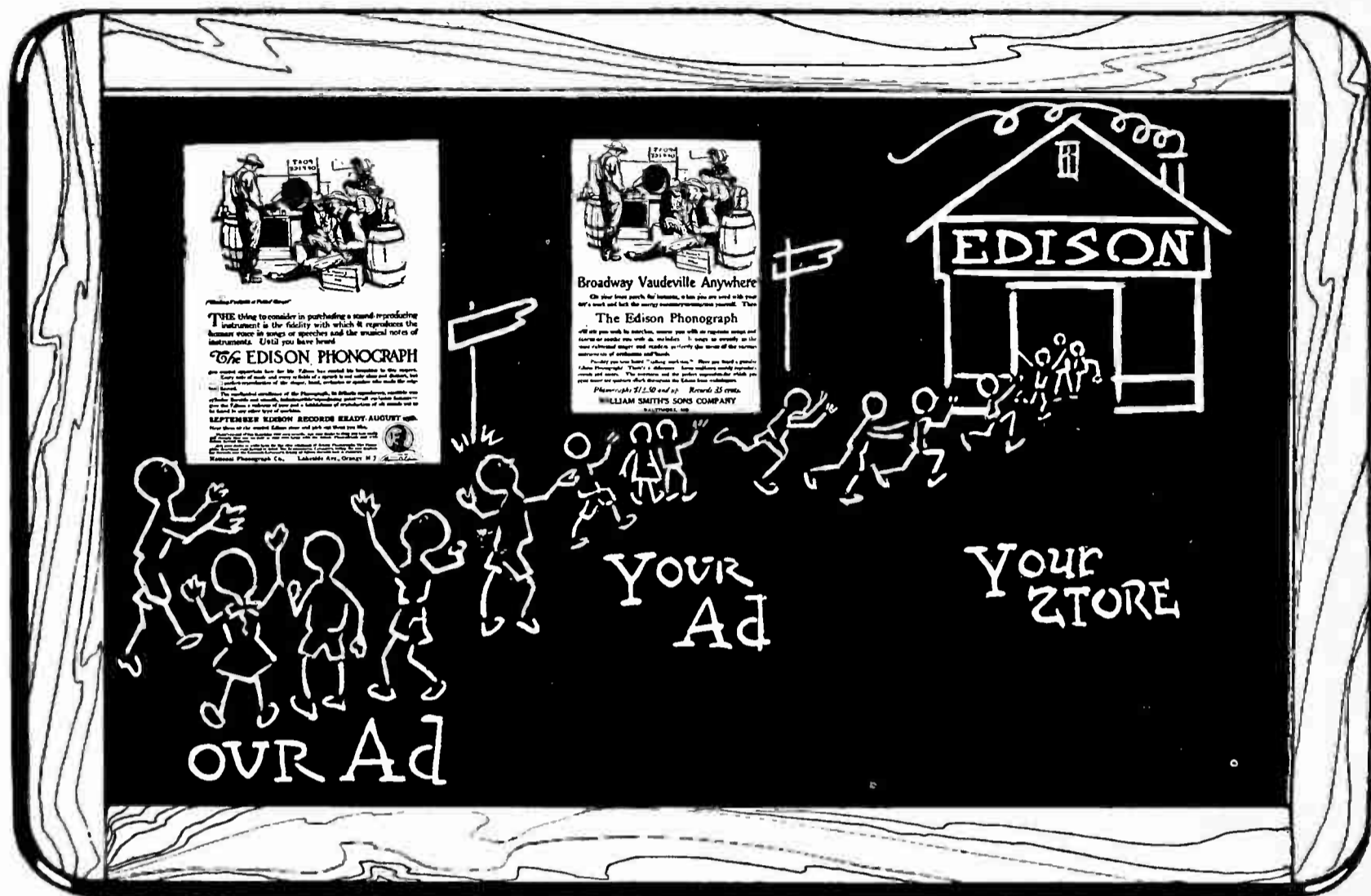

# Lessons for Dealers

## Lesson I.

Our ad-ver-tis-ing sends Pho-no-graph buy-ers to some Edison store.

Your ad-ver-tis-ing should bring Edison buy-ers to your Edison store.

All we can do is make cus-to-mers. But cus-to-mers do not put mon-ey in your till un-til they are your cus-to-mers.

There-fore, you must hitch\* your ad-ver-tis-ing to our ad-ver-tis-ing to sell the goods.

\* Hitch: This is, of course, a figure of speech referring to "team-work."

This Big, Trade-Bringing Banner is  
Free to Edison Dealers

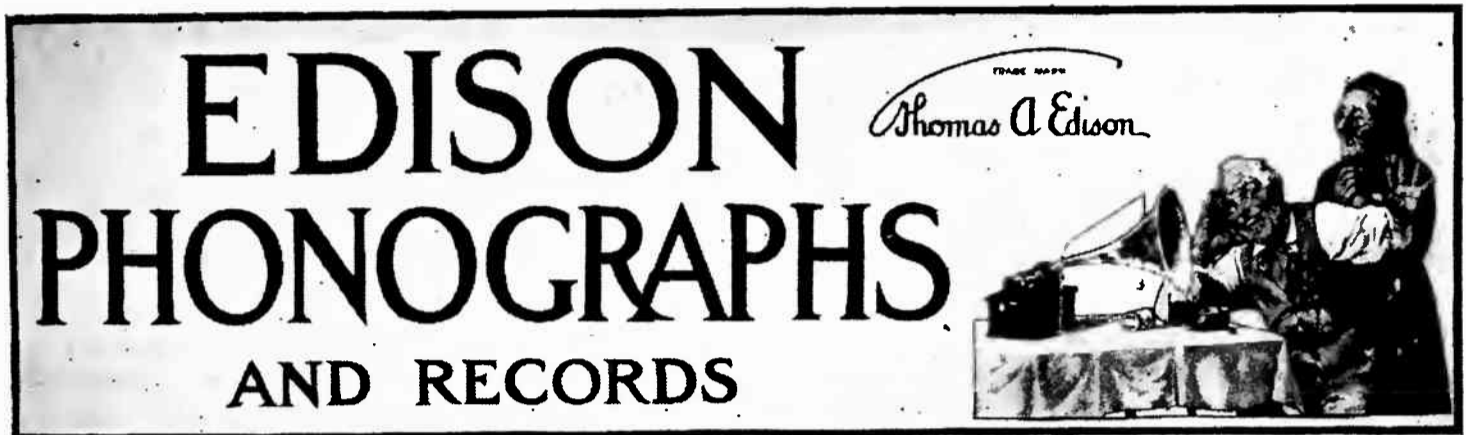

If the sign over your door were white with black letters and you were to change it some morning to red with gold letters, more people would see the new sign than ever saw the old. That is because we soon fail to notice the things we see unchanged for a long time.

Variety is the ginger of business.

Every new way of attracting attention to your store is a paying investment whether it is a sign, a newly trimmed window, a hanger, a Phonograph in operation or an advertisement in the newspaper.

The cheapest advertising space you have is the front of your store—cheap because the rent is

the same whether you use it for advertising purposes or not.

The banner illustrated above will make your store front work for you. It is made of heavy muslin, painted in four colors, and will cover a space ten feet long and three feet deep.

Put it across the front of your store and it will reach the eyes of everybody on both sides of the street from one end of the block to the other.

If you have not already ordered one, fill out and send us the coupon below and you will get a banner free. It would cost you several dollars to duplicate it.

Send for it, put it up and make your store the most conspicuous one in the block.

---

NATIONAL PHONOGRAPH COMPANY,  
Orange, N. J.

Please send me through my Jobber.....

.....  
one muslin banner as per your offer in the PHONOGRAPH MONTHLY. In consideration of its being sent me free of all cost, I agree to prominently display it on the front of my store.

Name.....

Street.....

City..... State.....

# Advance List

## New Edison Records for October, 1908

**R**ECORDS listed below will be shipped from Orange in time to reach all Jobbers in the United States and Canada before September 25th, 1908, all things being favorable, and they may be reshipped to Dealers at 2 P. M. on September 24th. They must not, however, be exhibited, demonstrated or placed on sale by Jobbers or Dealers until 8 A. M. on September 25th. Supplements, Phonograms and Bulletins will be shipped with Records. These may be distributed to Dealers after September 20th, but must not be circulated among the public before September 25th. Jobbers and Dealers may, however, deposit Supplements and Phonograms in Mail Boxes or Post Offices after 5 P. M. on September 24th, for delivery on the following day. Jobbers are required to place orders for October Records on or before August 10th. Dealers should place October orders with Jobbers before August 10th to insure prompt shipment when Jobber's stock is received.

**9948 Old Daddy Peg Leg Two-step**

**New York Military Band**

A catchy two-step played in accented tempo by the New York Military Band (formerly the Edison Military Band). It is from the pen of the gifted composer of "Mosquitos' Parade," (Record 7503), and "Mouse and the Clock," (Record 9434). A strikingly original effect is worked into the trio in the marking of time by "old daddy's peg leg." This has been voted one of the best of the new two-steps and is to be used extensively for dancing this fall and winter. Composer, Howard Whitney; publishers, M. Witmark & Sons, New York.

**9949 Don't Take Me Home**

**Ed Morton**

A new Edison artist in one of the comic song hits of the season. Ed Morton is a warm favorite at the New York roof gardens and no vocalist is more in demand in vaudeville. He is a wonderfully expressive singer and you are able to catch his every word in the Record. This one recites the fortunes (or misfortunes) of a poor married man who had been out "on the town." Everybody he meets insists on taking him home. He has visions of what is waiting for him there and tearfully protests. Orchestra accompaniment. Music, Harry Von Tilzer; words, Vincent Bryan; publishers, Harry Von Tilzer Music Publishing Co., New York.

**9950 Cuddle Up a Little Closer, Lovey Mine**

**Ada Jones and Billy Murray**

The charming seashore flirting duet from the musical play, "Three Twins." Ada Jones and Billy Murray sing the lines of the verse by turns and both join in the chorus. The duet is the equal of anything these premier duetists have done together. It is sure to win as many encores from Edison Phonograph owners as the original piece did during the successful run of "Three Twins" in New York last season. At that time it broke all records for curtain calls. Orchestra accompaniment. Music; Karl L. Hoschna; words, O. A. Hauerbach; publishers, M. Witmark & Sons, New York.

**9951 Summer Recollections**

**Albert Benzler**

Easily the best piano solo since "Violets" (Record 8394), and a rare example of successful piano recording. The selection begins with Gustav Lange's enticingly sweet "Flower Song," and concludes with the dainty "La Fontain" by Karl Bohm. Mr. Benzler's performance displays faultless technique and does full justice to the masterpieces of these two well known European composers. All the elusive nuances of light and shade in the piano tone are perfectly reproduced. Composers, Lange-Bohm.

**9952 Miserere from "Il Trovatore"**

**Miss Hinkle and Mr. Anthony**

The wonderful duet "Miserere," from Verdi's greatest opera. One of the finest gems of dramatic song in any language. The duet is sung by Leonora and her lover, the Troubadour, who is in prison. The music begins with the maiden's lament, which is sung in a series of beautiful, plaintive notes. These are heard in the prison by her lover, who takes up the song with the famous "Ah! I have sighed to rest me." Miss Hinkle and Mr. Anthony give a highly artistic interpretation of the Verdi masterpiece. The Record is in English and will prove a never-ending delight to all who have a love for music. Orchestra accompaniment. Composer, Verdi.

**\* 9953 Jubilee Minstrels**

**Edison Minstrels**

The curtain rises on "College Life," sung in real "rah! rah!" style by the entire company. Then follows a volley of new and breezy jokes (no sign of a chestnut among them) by the Edison Company's famous coterie of minstrel men. If there's anything in the saying, "It makes you smile to see others smile," this Record is due to score a huge success. It's one endless succession of riotous fun with those king-pins of minstrelsy, Collins, Harlan, Murray and Porter, "whooping 'em up" to the last strains of the closing chorus, "I'm Happy When the Band Plays Dixie." Arrangement original and not published.

**9954 I Lost My Heart When I Saw Your Eyes**

**Manuel Romain**

Admirers of the great minstrel tenor (and their name is legion) will enthuse over this exquisite tone-poem. It breathes a sentiment as sweet as "the breath of new mown hay." Indeed, it is just such a tenor solo as a Lew Dockstader or Al G. Fields would select as the vocal center-piece of an old time minstrel performance. The title tells much of the story, but it must be mentioned that the refrain, which is the prettiest part, is in the ever-pleasing waltz time. Orchestra accompaniment. Music, J. Fred Helf; words, Arthur Lamb; publishers, Helf & Hager Co., New York.

**9955 House Cleaning Time**

**Ada Jones and Len Spencer**

A thrilling domestic episode that everyone knows about from sad experience. Ada Jones as the "lady behind the broom" is as peevish as the occasion demands, even if she does say she is "A woman of few words." Len Spencer, as John, only succeeds in getting in her way—(Poor John!) He is given a good dusting until he feels he is the most unnecessary piece of furniture in the house. Mary's mood changes suddenly though, when they run across a packet of their old love letters. Household cares fly out of the window with the remembrance of happy bygone days. Mary: "You remember how hard I used to try to make the biscuits?" John: "Yes, and how hard you used to make them." (Both laugh.) A tender bit of pathos is added as Mary sings: "In After Years When I Am Old." Original vaudeville sketch, not published.

**9956 The Old Time Rag**

**Arthur Collins**

The "real thing" in a rag time ditty and just Arthur Collins' style. He sings of the "Wiggly, giggly two-step time" that the coon does with his dusky affinity, and throws off many a genuine negro giggle, expressive of the aforesaid coon's ticklish feelings. The melody is Theodore Morse's best brand and shows plenty of action throughout. Two verses and two choruses. Orchestra accompaniment. Music, Theodore Morse; words, Ed Madden; publishers, F. B. Haviland Publishing Co., New York.

**9957 Waltz from "La Bohème"**

**Edison Concert Band**

"Bohème" is probably the most talked-about opera of the day. It is also one of the most recent and has won Puccini a place among the music masters of operatic history. In the entire score there is nothing more admirable than his exquisite waltz. Its soft, tripping rhythm may fairly be likened to the murmur of the waterfall—especially those passages in which bells are featured. The Edison Concert Band give it a grand presentation. Composer, Puccini; publisher, Carl Fischer, New York.

**9958 Sunbonnet Sue**

**Byron G. Harlan**

Gus Edwards' cleverest child-song offers Mr. Harlan the same kind of an opportunity he had in Record 9562, "School Days." Both words and tune are far above the average for "popular" songs, and Harlan has unquestionably added another to his long list of "big sellers." Orchestra accompaniment. Music, Gus Edwards; words, Will Cobb; publishers, Gus Edwards Music Publishing Co., New York.

**9959 Beautiful Isle of Somewhere**

**Anthony and Harrison**

Many admirers of sacred songs have the entire lot of the Anthony-Harrison duets. Ever since their first duet Record, the famous "Glory Song" (made in July, 1905), these delightful duetists have worked together until they mastered the art of perfect Record making. Anthony's clear, sweet tenor notes are admirably balanced by the sonorous lower tones of Harrison's rich baritone. The present Record is one of those fine hymns that are more affecting on their one hundredth hearing than on their first. An accompaniment of bells and cathedral chimes adds to the impressiveness. Orchestra accompaniment. Music, J. S. Fearis; words, Jessie B. Pounds.

**9960 Patrol of the Scouts**

**Edison Symphony Orchestra**

A brilliant tone-picture that vividly depicts the scouts' patrol. The start is announced by faint drum taps heard away off. As the scouts approach, the music grows in volume, reaching a grand climax as they draw up for review. After some of the most delightful ensemble playing, the retreat begins, the music gradually softening until it is lost in the distance. The melody throughout is of the ear-tickling variety, the feature being a whistling refrain that is simply unforgettable. Composer, E. Boccalari; publisher, Carl Fischer, New York.

\*This selection will be illustrated on cover of the October Phonogram.

---

# 16 Edison Phonograph Monthly, August, 1908

---

## 9961 When It's Moonlight on the Silv'ry Rio Grande

James F. Harrison

Here is a song published in far-off Australia about our famed Rio Grande River. The writer, it seems, is a wanderer, with memories of a happy home there. The air is one of charming simplicity, not unlike Record 9428, "In the Evening by the Moonlight, Dear Louise." A bells obligato accentuates the effect of the pretty refrain, and Harrison's robust baritone voice is equally as pleasing as in his best known solos, "Heart Bowed Down," (Record 4914), and "In Old Madrid," (Record 7007). Orchestra accompaniment. Music, Joe Slater; words, Millwood and McAllister; publishers, D. Davis & Co., Sydney, N. S. W.

## 9962 Ah! So Pure

Frederic C. Freemantel

A new singer in an old, old favorite, "Ah! So Pure," from the opera "Martha." Mr. Freemantel has a sympathetic tenor of remarkable range, his tones in the upper register being especially pure and well sustained. His interpretation of Flotow's classic is masterly, to say the least, and will serve to emphasize anew its depths of romantic tenderness. Sung in English. Orchestra accompaniment. Composer, Frederick von Flotow.

## 9963 Matt Keefe's Yodle Song

Matt Keefe and George Stricklett

Something new and decidedly different in a yodle song. The song (by Stricklett) and the yodle (by Keefe) alternate throughout. There are no less than ten different yodling parts, some of them entirely unique. The wide demand last month for Keefe's first Edison Record proves that yodling is as acceptable as ever when well done. It is easy to understand Matt Keefe's success on the stage after hearing his latest yodle. His notes are as clear as a mocking bird's and reproduce perfectly. Song and words, Matt Keefe; not published.

## 9964 Wishes

Collins and Harlan

Collins and Harlan score again with a new duet that will fit right in with the best of their old-time successes. This one is a hodge-podge of foolishness, highly interesting and set to the merriest tune imaginable. There is not very much connection between the three different verses and choruses and the verbal tilts that are sandwiched in between them, but there is a keen contest on all the time as to which will win the most laughs. Orchestra accompaniment. Music, Ben M. Jerome; words, Irving B. Lee; publishers, F. B. Haviland Publishing Co., New York.

## 9965 If You Cared For Me

Frederic Rose

A new love ballad with an enticing waltz refrain, by those clever song writers, Rose and Snyder. If possible, Rose sings it more effectively than any of his earlier songs. His Record will do much to fulfill the prediction that the song will eventually be heard from coast to coast. In any event, it represents an added triumph for Frederic Rose, whose manly tenor voice has won him golden plaudits since he became a member of the Edison staff. Orchestra accompaniment. Music and words, Rose and Snyder; publishers, Rose & Snyder Co., New York.

## 9966 You Will Have to Sing an Irish Song

Ada Jones

This time Ada Jones is an Irish lass who is serenaded by an ardent Dutch wooer. She informs him without regret or sigh that he has no chance on earth to win her with that class of music. His Dutch music may sound fine, she tells him, but still it's Dutch to her Irish heart—"nuff ced." Then she gives him an illustration of a fine old Irish tune, sung with an excellent brogue, unaccompanied by the orchestra. The entire selection is from "Follies of 1908," the brilliant musical show of the Jardin de Paris roof garden, New York. Orchestra accompaniment. Music, Albert Von Tilzer; words, Jack Norworth; publishers, The York Music Co., New York.

## 9967 Ballet Music from "The Prophet"

American Symphony Orchestra

The ballet music from "The Prophet" is a noted feature of the great Meyerbeer opera. It is considered standard in the realm of ballet music and subsequent writers have not hesitated to borrow freely from its lilting measures. The American Symphony Orchestra (formerly the Edison Symphony Orchestra) has played the whole number just as the composer intended it should be played. Their performance will not suffer at all by comparison with that of the special opera orchestras of Berlin and Leipsic. Composer, Meyerbeer; publisher, Carl Fischer, New York.

## 9968 Pride of the Prairie

Billy Murray and Chorus

The past summer brought out some clever popular songs, but none to take the public fancy more than "Pride of the Prairie." It was heard in vaudeville, in illustrated songs at the moving picture shows; the bands took it up in the parks and passed it on to the orchestras on excursion boats. It is just the stripe of song that starts the gallery whistling. Billy Murray and chorus sing it with a whirlwind flourish that rivals the speed of the broncho on which Miss Mary and her cowboy lover rode away. Two verses and three choruses. Orchestra accompaniment. Music, George Botsford; words, Harry Breen; publishers, Jerome K. Remick Co., New York.



**9969 Ecstasy****Mr. and Mrs. Waterous**

This Record will recall the earlier success of the same singers in "O, Moment That I Bless," (Record 9731). This won them an ovation and led to a universal demand for another duet of the same class. H. Millard's English version of "Ecstasy" was finally chosen. This glorious semi-classic love song has a charm that constantly grows on one. The Record will prove a fine model for ambitious students of concerted singing. Orchestra accompaniment. Music and words, G. Alary (English version by H. Millard); publisher, G. Schirmer, New York.

**9970 Pat O'Brien's Automobile****Steve Porter**

A comic Irish descriptive sketch in which Mr. and Mrs. Pat O'Brien take their first automobile trip. It is also Pat's maiden effort as a chauffeur and his nerve is far in excess of his skill. Result, a thrilling runaway and smash-up. "Did ye pay for it?" asks Mrs. O'Brien, after it is over. "Not yit, I got it on trial." "Then tell the man we don't care for it." Incidental features include numerous admiring remarks by a crowd of neighbors, the turning of various cranks and levers, the chug, chug of the auto engine, and finally the head-on collision with an ice wagon. Original street scene; not published.

**9971 Genée Waltzes from "The Soul Kiss"****New York Military Band**

New York idolized Mlle Genée in "The Soul Kiss" last season. Genée's dancing was the feature of the production, which ran all season. The bewitching waltz melodies to which she danced are here combined in a fascinating medley, of which the band gives a highly artistic performance. The Record is played in even dance tempo, so can be used for dancing. Music, Maurice Levi; publishers, M. Witmark & Sons, New York.

---

## 5 Selections Made Over

We list below five selections that have been made over by the same talent. The October printed matter prepared for retail use will contain these selections. Jobbers should replace their stock of the original Records of these numbers with the new ones.

- 502 Angel's Serenade
- 6948 The Way to Kiss a Girl
- 8022 Nearer My God To Thee
- 8060 Home, Sweet Home
- 8591 Come Ye Disconsolate

**Edison Symphony Orchestra**  
**Arthur Collins**  
**Samuel Siegel**  
**Samuel Siegel**  
**Samuel Siegel**



*(The Methodist Episcopal Ladies' Aid Society, Gayville, S. D., listening to an outdoor Edison concert).*

An Edison Dealer at Monroe, N. C., writes us that he helped a school give a concert to secure funds for a library. He took a Phonograph and some Records over and entertained the audience for the best part of two hours.

He did not charge them anything for his trouble, but two of the hearers bought Standard Phonographs and Records the following week.

That is the way it will work out every time.

There are a certain number of lawn parties, picnics and church entertainments in your town during August. Get in touch with the ladies of the various churches who interest themselves in these affairs. You can get a lot of valuable free advertising by helping them out on the musical end of their programmes.

# Advance List

## New Hebrew and Norwegian Selections

**T**HE Records named below will be ready for shipment from Orange between September 1st and 10th. Samples of any or all of them will be shipped August 1st to such Jobbers as place orders for them. None will be shipped without orders. Jobbers' stock orders received by August 20th will be shipped as fast as possible, after September 1st. Care will be taken to make shipment at one time to all Jobbers in the same city. Separate supplements of each list will be shipped with Records to all Jobbers who request a supply. State quantity required of each kind.

### 15 Hebrew Records.

21000	Das Yussemil, from "Ben-Ami," <i>Goldfaden</i>	Simon Paskal
21001	Die Welt is Meschugge, <i>Friedsell</i> , Comic Song	Simon Paskal
21002	Die Goldene Hochzeit, from "The Golden Wedding," <i>Friedsell</i>	Simon Paskal
21003	Das Torale, from "Jacob and Esau," <i>Perlmutter &amp; Wohl</i>	Kalman Juvelier
21004	Shulom al Jisruel, from "Ben Hamelech," <i>Perlmutter &amp; Wohl</i>	Kalman Juvelier
21005	Dus Veigele, from "Black Jews," <i>Perlmutter &amp; Wohl</i>	Kalman Juvelier
21006	Jaffe, from "Jewish King Lear," <i>Perlmutter &amp; Wohl</i>	Kalman Juvelier
21007	Kabet Es owichu, from "House of David," <i>Perlmutter &amp; Wohl</i>	Kalman Juvelier
21008	Rosenkes mit Mandlen, from "Shulamith," <i>Goldfaden</i>	Kalman Juvelier
21009	I'm All Right, <i>Brody</i> , Comic Song	Solomon Smulewitz
21010	Das Kiduschin Ring, <i>Smulewitz</i> , Comic Song	Solomon Smulewitz
21011	Wart a Kappelle, from "Ben-Ami," <i>Goldfaden</i>	Solomon Smulewitz
21012	Dus Ferdil, from "Ben-Ami," <i>Goldfaden</i>	Solomon Smulewitz
21013	A Brivele der Mame, <i>Smulewitz</i> , Sentimental Song	Solomon Smulewitz
21014	Die Shulosh Regolim, <i>Perlmutter &amp; Wohl</i> , Comic Song	Solomon Smulewitz

### 13 Norwegian Records.

15768	Maximvisen, <i>Lehár</i>	Ingolf Schanche
15769	Af Maanens Sölverglöd, <i>Kjerulf</i>	Fru Cally Monrad
15770	Opslag, <i>Sfnx</i>	Brandt-Rantzau
15771	Ved Rondarne, <i>Grieg</i>	Fru Else Fröhlich
15773	General Bomssang, <i>Offenbach</i>	Johan Lövaas
15774	Viljalied, <i>Lehár</i>	Karoline Mork
15775	Barcarole, <i>Mon Schjelderup</i>	Fru Gerda Danielson
15777	Det var en dag, <i>Sig. Lie</i>	Fru Cally Monrad
15778	Den förste manden min, <i>Sfnx</i>	Brandt-Rantzau
15779	Lind, <i>Agathe Backer Gröndahl</i>	Fru Else Fröhlich
15781	Danebrogssang, <i>Halvorsen</i>	Operasanger Steen
15782	Prinsessen, <i>Kjerulf</i>	Fru Gerda Danielson
15783	Min Elskte jeg er bunden, <i>Kjerulf</i>	Fru Else Fröhlich

# Trade Bulletins

## *Suspended List, July 20, 1908*

### SUPERSEDING ALL PREVIOUS LISTS

This list is supplemental to the Suspended Lists printed in the Edison Phonograph Monthly for June and July, 1908, which are still in force and must be given the same consideration by the trade as if reprinted in full herewith.

- CAL., Chico—Moriss Kyrus (or Kryicus).  
The Postoffice News Stand.
  - COL., Ouray—C. C. Stratton.
  - CONN., Meriden—J. F. Malloy.  
\*New London—Smith Bros.
  - IOWA, Sidney—I. L. Morgan.
  - KAN., Cuba—Mrs. Frank Barnett.
  - MASS., Newburyport—Pertucket Phono. Store,  
M. H. McKinney, Prop.
  - MINN., \*Elgin—J. Watterson.
  - MIS., \*Sedalia—S. R. Payne.
  - N. J., \*Plainfield—L. Seisel.
  - N. Y., Brooklyn—A. Becker.  
Henry F. Staude.  
\*New York City—M. Greenberg, alias J.  
Greenburg.  
\*Rochester—A. J. Deninger.  
Watertown—L. A. Maxson.  
Byer & Susskind.
  - PENNA., Philadelphia—Eastern Phono. Co.,  
M. Futernik, Prop.  
\*Connellsville—Wright-Metzler Co.
  - TEX., New Braunfels—Ed. Gruene.
- REINSTATED.
- L. Luttenbacher & Co., New Haven, Mich.  
\*Added since June 20, 1908.

Copies of the complete Suspended List will be mailed on request. Jobbers and Dealers are asked not to supply any of the above named firms with our apparatus, either at addresses given or any other address.

## *Sales Department Bulletin No. 13, July 3, 1908*

### *Trade Information for Dealers*

Correspondence concerning this bulletin should mention its number and be addressed to the NATIONAL PHONOGRAPH COMPANY, SALES DEPARTMENT, Orange, N. J.

Your attention is called to an error in the prices of Model D Repeating Attachments on page 27 of our latest Phonograph Catalogue,

Form 1325. The prices are those that prevail in Canada. The United States prices are the same as before, as follows:

For Home, Triumph, Balmoral, Conqueror  
and Alva ..... \$ 7.50  
For Idelia ..... 12.50

If any of your retail customers should discover this error, kindly explain the matter as above.

NATIONAL PHONOGRAPH CO.

## *Legal and Agreements Department Bulletin No. 2, July 16, 1908 Trade Information for Dealers*

Correspondence concerning this bulletin should mention its number and be addressed to the NATIONAL PHONOGRAPH COMPANY, LEGAL DEPARTMENT, 10 Fifth Avenue, New York, N. Y.

Please take notice that we have this day suspended A. J. Deninger, 345 North street, Rochester, N. Y., for violating the Conditions of Sale forming part of our Jobbers' Agreement.

He is, therefore, no longer entitled to discounts or any advantages whatever under said Agreement.

NATIONAL PHONOGRAPH CO.

## *Legal and Agreements Department Bulletin No. 3, July 16, 1908 Trade Information for Dealers*

Correspondence concerning this bulletin should mention its number and be addressed to the NATIONAL PHONOGRAPH COMPANY, LEGAL DEPARTMENT, 10 Fifth Avenue, New York, N. Y.

It has come to our notice that Giles Bros., Quincy, Ill., which firm name appears on our Suspended List for violating the Dealers' Agreement, are endeavoring to obtain Edison goods by offering in trade merchandise or goods of other manufacture or nature, for Edison goods.

We herein notify all Dealers of Edison goods that if they accept any such proposition, they make themselves liable to suspension from the advantages and privileges of an Edison Dealer, inasmuch as they would not only be instrumental in making it possible for a Suspended Dealer to acquire a stock of Edison goods, but the acceptance of goods or merchandise of other make or nature in exchange as whole or part payment for Edison goods is distinctly prohibited by our Conditions of Sale.

NATIONAL PHONOGRAPH CO.



“Broadway Vaudeville at Perkins’ Corners”

**T**HE thing to consider in purchasing a sound-reproducing instrument is the fidelity with which it reproduces the human voice in songs or speeches and the musical notes of instruments. Until you have heard

## *The* EDISON PHONOGRAPH

you cannot appreciate how far Mr. Edison has carried his invention in this respect.

Every note of music and every syllable of a speech is not only clear and distinct, but also a perfect reproduction of the singer, band, orchestra or speaker who made the original Record.

The mechanical excellence of the Phonograph, its delicate reproducers, sensitive wax cylinder Records and smooth, indestructible reproducing point—all exclusive features—give the Edison a richness of tone and a faithfulness of reproduction of all sounds not to be found in any other type of machine.

**SEPTEMBER EDISON RECORDS READY AUGUST 25th.**

Hear them at the nearest Edison store and pick out those you like.

There's no end of fun in making your own records. Ask your dealer to show you how easily and cheaply this can be done in your own home with the Edison Phonograph and with Edison Record Blanks.

Ask your dealer or write to us for the new catalogue of Edison Phonographs, The PHONOGRAM, describing each Record in detail; the SUPPLEMENTAL CATALOGUE, listing the new September Records, and the COMPLETE CATALOGUE, listing all Edison Records now in existence.

National Phonograph Co., Lakeside Ave., Orange, N. J.  Thomas A. Edison

The Advertisement that will appear in the September Magazines.

# Edison Phonograph Monthly, August, 1908

## Jobbers of Edison Phonographs and Records

- ALA., Birmingham**—Talking Machine Co.  
Mobile—W. H. Reynolds.  
Montgomery—R. L. Penick.
- ARK., Fort Smith**—R. C. Bollinger.
- CAL., Los Angeles**—Southern Cal. Music Co.  
Sacramento—A. J. Pommer Co.  
San Francisco—P. Bacigalupi & Sons.  
Kohler & Chase, Inc.
- COLO., Denver**—Denver Dry Goods Co.  
Hext Music Co.
- CONN., New Haven**—Pardee-Ellenberger Co., Inc.
- D. C., Washington**—E. F. Droop & Sons Co.
- GA., Atlanta**—Atlanta Phonograph Co.  
Phillips & Crew Co.  
Waycross—George R. Youmans.
- IDAHO, Boise**—Eiler's Piano House.
- ILL., Chicago**—Babson Bros:  
Lyon & Healy.  
James I. Lyons.  
The Vim Co.  
Montgomery Ward & Co.  
Rudolph Wurlitzer Co.  
Peoria—Chas. C. Adams & Co.  
Peoria Phonograph Co.  
Quincy—Quincy Phonograph Co.
- IND., Indianapolis**—Indiana Phono. Co.  
Kipp-Link Phonograph Co.  
A. B. Wahl & Co.
- IOWA, Des Moines**—Hopkins Bros. Co.  
The Vim Co.  
Dubuque—Harger & Blish.  
Fort Dodge—Early Music House.  
Sioux City—Early Music House.
- KY., Louisville**—Montenegro-Riehm Music Co.
- LA., New Orleans**—William Bailey.  
National Automatic Fire Alarm Co.
- MAINE, Bangor**—S. L. Crosby Co.  
Portland—W. H. Ross & Son.
- MD., Baltimore**—E. F. Droop & Sons Co.
- MASS., Boston**—Boston Cycle & Sundry Co.  
Eastern Talking Mach. Co.  
Iver Johnson Sptg. Goods Co.  
Fitchburg—Iver Johnson Sptg. Goods Co.  
Lowell—Thomas Wardell.  
New Bedford—Household Furnishing Co.  
Springfield—Flint & Brickett Co.  
Worcester—Iver Johnson Sptg. Goods Co.
- MICH., Detroit**—American Phono. Co.  
Grinnell Bros.
- MINN., Minneapolis**—Thomas C. Hough.  
Minnesota Phono. Co.  
St. Paul—W. J. Dyer & Bro.  
Koehler & Hinrichs.  
Minnesota Phonograph Co.
- MO., Kansas City**—J. W. Jenkins' Sons' Music Co.  
Schmelzer Arms Co.  
St. Louis—Conroy Piano Co.  
Koerber-Brenner Music Co.  
Silverstone Talk. Mach. Co.
- MONT., Helena**—Frank Buser.
- NEB., Lincoln**—Ross P. Curtice Co.  
H. E. Sidles Phono. Co.  
Omaha—Nebraska Cycle Co.  
Shultz Bros.
- N. H., Manchester**—John B. Varick Co.
- N. J., Hoboken**—Eclipse Phono. Co.  
Newark—Douglas Phonograph Co.  
A. O. Petit  
Rapke Phono. Store.  
Paterson—James K. O'Dea.  
Trenton—Stoll Blank Book and Stationery Co.  
John Sykes.
- N. Y., Albany**—Finch & Hahn.  
Astoria—John Rose.  
Brooklyn—A. D. Matthews' Sons.  
Buffalo—W. D. Andrews.  
Neal, Clark & Neal Co.  
Elmira—Elmira Arms Co.  
Gloversville—American Phono. Co.  
Kingston—Forsyth & Davis.
- New York City**—Blackman Talking Machine Co.  
J. F. Blackman & Son.  
I. Davega, Jr., Inc.  
S. B. Davega Co.  
Douglass Phono Co., Inc.  
Jacot Music Box Co.  
Victor H. Rapke.  
Regina Co.  
Siegel-Cooper Co.  
John Wanamaker.  
Alfred Weiss.
- Oswego**—Frank E. Bolway.
- Rochester**—Mackie Plano, O. & M. Co.  
Talking Machine Co.
- Schenectady**—Finch & Hahn.  
Jay A. Rickard & Co.
- Syracuse**—W. D. Andrews.
- Troy**—Finch & Hahn.
- Utica**—Clark-Horrocks Co.  
Arthur F. Ferriss.  
William Harrison.  
Utica Cycle Co.
- OHIO, Canton**—Klein & Heffelman Co.  
Cincinnati—Ball-Fintze Co.  
Ilsen & Co.  
Milner Musical Co.  
Rudolph Wurlitzer Co.  
Cleveland—Eclipse Musical Co.  
Columbus—Perry B. Whitsit Co.  
Dayton—Niehaus & Dohse.  
Newark—Ball-Fintze Co.  
Toledo—Hayes Music Co.
- OREGON, Portland**—Graves & Co., Inc.
- OKLA., Oklahoma City**—Smith's Phono. Co.
- PENNA., Allentown**—G. C. Aschbach.  
Easton—William Werner.  
Philadelphia—Louis Buehn & Bro.  
C. J. Heppe & Son.  
Lit Bros.  
Musical Echo Co.  
Penn Phonograph Co.  
John Wanamaker.  
Western Talking Mach. Co.  
H. A. Weymann & Son.
- Pittsburg**—Pittsburg Phono. Co.  
Powers & Henry Co.  
Standard Talk. Mach. Co.
- Reading**—Reading Phonograph Co.
- Scranton**—Ackerman & Co.  
Technical Supply Co.
- Sharon**—W. C. DeForeest & Son.
- Williamsport**—W. A. Myers.
- R. I., Providence**—J. M. Dean Co.  
J. A. Foster Co.  
J. Samuels & Bro.
- TENN., Chattanooga**—J. H. Templeman Co.  
Knoxville—Knoxville Typewriter and Phonograph Co.  
Memphis—F. M. Atwood.  
O. K. Houck Piano Co.  
Nashville—Magruder & Co.  
Nashville Talking Mach. Co.
- TEX., Dallas**—Southern Talking Machine Co.  
El Paso—W. G. Walz Co.  
Fort Worth—Cummings, Shepherd & Co.  
Houston—Texas Piano & Phono. Co.  
San Antonio—H. C. Rees Optical Co.
- UTAH, Ogden**—Proudfit Sporting Goods Co.  
Salt Lake City—Clayton-Daynes Music Co.
- VT., Burlington**—American Phono. Co.
- VA., Richmond**—C. B. Haynes & Co.
- WASH., Seattle**—D. S. Johnston Co.  
Kohler & Chase.  
Spokane—Spokane Phonograph Co.
- WIS., Milwaukee**—Lawrence McGreal.
- CANADA, Quebec**—C. Robitaille.  
St. John—W. H. Thorne & Co., Ltd.  
Toronto—R. S. Williams & Sons Co., Ltd.  
Vancouver—M. W. Waitt & Co.  
Winnipeg—R. S. Williams & Sons Co., Ltd.

# Broaden Your Field

—and increase your sales. A dealer makes a serious mistake by selling records and instruments for amusement purposes alone. There is besides the amusement field the vast field of education from which can be reaped an abundant business. Here the dealer can increase the sale of records to those who already own phonographs, and can sell both instruments and records to a very large number of cash customers who would never think of buying a phonograph except for educational purposes. All this is made possible through

## I.C.S. LANGUAGE SYSTEM

WITH  
*Thomas A. Edison*  
PHONOGRAPH

There is a great opportunity for **you** to sell I. C. S. Language Outfits to people who are going abroad or who desire to learn a language for the sake of the knowledge of it alone; to those who desire to qualify for positions as translators and foreign correspondents; and to foreigners who wish to learn to speak English. No sledge hammer is needed to get it clearly into your head that this presents a sure way of broadening your field of work and increasing your sales. For the sake of good business sense, boom the I. C. S. Language feature of the business.

**International  
Correspondence Schools  
SCRANTON, PA.**

# The EDISON PHONOGRAPH MONTHLY

Vol. VI

September, 1908

No. 9

Two big ones this month



# The EDISON PHONOGRAPH MONTHLY

Published by the National Phonograph Co., Orange, N. J.

All communications to *The Phonograph Monthly* should be addressed to the Advertising Department, Orange, N. J.



## *Contents for Sept., 1908*

About the New Announcements . . . . .	1
Change of Officers . . . . .	2
Work off the Cut Outs . . . . .	2
Store Management . . . . .	3
Making the Taft Records . . . . .	4
Selling the Goods . . . . .	5
Suggestion for Postal Card . . . . .	7
Important Notice . . . . .	7
Important Printed Matter for Dealers . . . . .	8
What Bryan and Taft Advertising Means For You . . . . .	9
Lessons for Dealers . . . . .	9
Announcement Concerning Amberol Records, Attachments and New Types of Phonographs . . . . .	11
Price List of Parts for Model D Repeating Attachments . . . . .	12
Addenda to Dealers Agreement . . . . .	13
Suspended List . . . . .	14
Your Campaign for Bryan and Taft Record Sales . . . . .	15
Advance List of New Edison Records for November, 1908 . . . . .	16
Advance List of 12 Edison Records by William H. Taft . . . . .	19
Selling Force of National Phonograph Co. . . . .	21
First Advance List of Edison Amberol Record to be Issued October 1, 1908 . . . . .	22
Edison Records to be Withdrawn from Sale . . . . .	27
Advance List of Four New Edison Records by Harry Lauder . . . . .	29

NEW YORK: 10 FIFTH AVENUE.

NATIONAL PHONOGRAPH CO., LTD., VICTORIA ROAD, WILLESDEN, LONDON.

NATIONAL PHONOGRAPH CO. OF AUSTRALIA, LTD., 340 KENT STREET, SYDNEY, N. S. W.

MEXICAN NATIONAL PHONOGRAPH CO., AVENIDA ORIENTE No. 117, MEXICO CITY.

COMPANIA EDISON HISPANO-AMERICANA, VIAMONTE 515, BUENOS AIRES.

EDISON GESELLSCHAFT, M. B. H., SUD-UFER 24-25, BERLIN.

COMPAGNIE FRANCAISE DU PHONOGRAPHE EDISON, 42 RUE DE PARADIS, PARIS.



## No more important announcements concerning Edison Phonographs and Records have ever been made than those which appear in this issue of the Phonograph Monthly.

If you want to put new life into yourself and your business, Mr. Edison Dealer, read every word of them. Read them till you thoroughly understand them. Then act. Act promptly, too. Don't wait for your competitor. Be first to grasp the opportunity. Get ready to make your business jump to a greater volume than ever before.

The announcements concerning the Edison Amberol Record, the new combination Phonographs and the Attachments by which present Phonographs may play the new Record, represent more than two years' study and work by Mr. Edison and his assistants.

We believe in these new features and intend backing that belief with all the efforts of our selling organization and the expenditure of greater sums of money for advertising than ever before made by us or any other talking machine company.

But our enthusiasm alone is not enough. We must have your co-operation. We must make you fully as enthusiastic as ourselves. Therefore, we urge you strongly to inform yourself about the new Amberol Records, the new machines and the new Attachments. Then throw your whole energy and ability into the game.

The announcement prohibiting Edison Dealers from handling other cylinder goods will save your money. It will prevent you from being loaded up with goods that tie up your capital and bring you no profit. You will appreciate our course, when you think it over. Edison Phonographs and Records fill every demand for cylinder goods. So why handle others?

The announcement concerning the Edison Records made by Mr. Taft is also of great importance. We now have Records by Mr. Bryan and Mr. Taft, so that no matter how the November election may result we shall have Records by the next President. This makes new history. It indicates progress.

The Lauder Records and other features in the issue are worth your careful attention. Read the issue from cover to cover. Then take off your coat and go to work. The demand for new goods is already greater than we can supply. Order at once and get your supply at least as soon as your competitor.

## Change of Officers

[Copy of letter mailed to entire trade.]

Orange, N. J., July 29th, 1908.

At a meeting of the Board of Directors of this Company, held on July 23d, 1908, the following officers were elected:

Frank L. Dyer as President, and Carl H. Wilson as General Manager.

Mr. Dyer will continue to act as Chairman of Executive Committee and General Counsel.

The other officers of the Company remain unchanged.

NATIONAL PHONOGRAPH CO.,  
FRANK L. DYER,  
President.

---

Our new President, Frank L. Dyer, who succeeded Mr. Gilmore in that office on July 23, 1908, was born in Washington, D. C., on August 2, 1870. He was educated in the public schools at Washington and at the Columbian (now George Washington) University of that city.



PRESIDENT FRANK L. DYER.

He is a lawyer by profession. His father, Col. George W. Dyer, during his lifetime was a prominent patent lawyer, who, in 1878, became associated with Mr. Edison as his Patent Counsel. His elder brother, Richard N. Dyer, is also a patent lawyer of high reputation in New York, and represented Mr. Edison and the various Edison interests in a professional way from 1881 until 1903.

Leaving Washington in 1897 and coming to New York Mr. Dyer formed a partnership with his brother, which continued until April, 1903, when he moved his office to Orange. Since that time he has acted as General Counsel for

Mr. Edison and the various Edison companies, having charge of the extensive litigation in which those interests have been involved and doing much of the active work connected with them. This experience brought him into intimate relation with the commercial branches of the National Phonograph Co., and the various other Edison interests, so that he enters upon his new duties with a complete knowledge of the entire machinery under his control.

Mr. Dyer not only assumes the executive management of the National Phonograph Co., but also of the Edison Manufacturing Co., Edison Phonograph Works, Edison Storage Battery Co. and Bates Manufacturing Company. He is a Director and General Counsel of the Edison Portland Cement Co. and of the Pohatcong Railroad Co.

---

## Work Off the Cut-Outs

The cut out list printed in full on pages 27 and 28 has been issued in ample time to give Dealers plenty of opportunity to sell any stock of the cut out selections they may have on hand and thus avoid the necessity of returning them to us at some future day. While we are not ready to make any definite announcement concerning an exchange proposition, it is quite certain that one will eventually be made, taking care of cut out selections. In any event, it will be better and more profitable for Dealers to dispose of their stock of cut out Records and have none to return. This can readily be done, for all of the selections being dropped are still good sellers and should be quite as readily bought by the public as any others in our catalogue. Dealers are urged to tag their stock of cut out selections in such a manner that they and their clerks will make special efforts to sell them. It will pay Dealers to ask their customers to look over the hanger showing the cut outs and ask them if they do not want to take advantage of the last opportunity to get them.

---

The Austin Music Co., Dayton, Ohio, send two form letters, which they mailed to their list of Phonograph owners. The letters are about the new Edison Records and give the firm's opinion on the probable best sellers on the lists. Mr. Austin writes us that he gets out a letter every month to mail with the monthly supplement of new Edison Records, and it has resulted in large Record sales. One month as an experiment he left the letter out, and was literally swamped with kicks from all classes of customers.

# Store Management

A monthly comment on things Edison dealers have done with a few suggestions on what they should do to increase sales.

After all, there is not a great deal of difference between managing a store right and advertising. The way you manage your store, the way you and your clerks treat possible buyers, is all advertising.

You should always act as if you wanted to sell an Edison Phonograph. The Dealer or clerk who reluctantly gets out Records and plays them for a prospective purchaser, or who is not well posted on his stock, and on the subject of Records, who doesn't know all about the new Amberol Records and the attachment that makes it possible to play them on the old Edison Phonograph, who doesn't know that Bryan has made ten Records and Taft twelve, upon subjects that everybody is talking about, is not going to sell Edison Phonographs and Edison Records as often as he might.

Nobody ever got rich keeping store without working for it. It is not enough to simply open a store. There should be an atmosphere of selling goods about the store all day long. You should make people who come in so welcome that they will keep coming in. You should take special pains to get people in your store to hear the Records, whether they buy or not. You should have something in your window that will keep people looking in there all day long.

A window is a remarkably good advertisement. If your window is on a good street, it is worth as much as the number of people who pass it every day.

For instance, suppose your local newspaper has a circulation of one thousand every day, and your advertisement in the newspaper costs you twenty dollars a week, and suppose your store is on Main street, and five hundred people pass it every day. Then, judged by the newspaper cost alone, it would be worth at least ten dollars, because it reaches five hundred people, but even the biggest and best newspaper ad. cannot reach the people so effectively as a well-dressed window showing the goods with appropriate comments upon them.

It is a very easy matter to dress a window. The window should be changed every week.

Surely you or one of your clerks can get time each week to spend two or three hours in dressing up a window that will sell goods. If there is not time during the week, then do it out of hours. If you cannot do it yourself, pay one of your clerks something extra, and make it worth his while to study up window dressing—the kind that sells goods. If you have to pay a clerk a dollar an evening extra to dress a window, it will be one of the best investments you ever made.

See that it is done every week. There should be a fresh window every Monday morning. This doesn't mean a startling change—just something fresh and new each time—a new arrangement of the old goods, sometimes a window of Records, sometimes a window of Phonographs, sometimes both. The National Phonograph Company supplies you with enough cards and other things to help make your window inviting. We do everything we possibly can to help you, but the rest of it is up to you.

## *Dealers Attention*

There is one word we want to say to you, and that is that this is your department. We cannot tell you nearly so much about running a successful Edison Phonograph store as you can tell us. Everyone of you has done at least one thing that has been successful; has found at least one way to help sell Edison Phonographs and Edison Records. What is that way? Write and tell us your experience.

We want this department to have every month several suggestions from Dealers of things they have done and found successful, and which they are willing to pass on to Dealers in other towns.

Then we want you to tell us your troubles and ask us questions. What is there you want to know about the successful management of your store? What help do you want in window dressing, store dressing, displaying stock, getting people into your store, treating them right when you get them there, and all that? Ask us these questions, and we will answer them to the best

of our ability. We do not know everything, but we are the clearing house for thirteen thousand Dealers. We have the benefit of their experience as well as our own in selling goods through the trade for a dozen years, and all this experience is for your benefit if you will write and ask for it. Help us make this department of benefit to you and to every other Edison Dealer.

## Making the Taft Records

The 12 Edison Records, by William H. Taft, were made at Virginia Hot Springs, after Mr. Taft delivered his speech of acceptance at Cincinnati.

Walter H. Miller, manager of the Edison Recording Department, supervised the making of Records, assisted by George H. Werner.

They arrived at Hot Springs on Saturday morning, August 1st, at 8 o'clock, and engaged a small room in the Homestead, adjoining Mr. Taft's apartments, in which to make the Records.



WILLIAM H. TAFT.

Everything was quickly put in readiness and on Saturday afternoon Mr. Taft was ready to begin. At least, he thought so, but events proved that he wasn't.

He had a large scrap book in which newspaper copies of his speeches had been pasted. He had gone through these and marked the portions he wished to use in the Records.

It was so marked up, however, that he had difficulty following it. These were the first Records he had ever made and he remarked that it was a little different from what he had ex-

pected. So he gave one of his secretaries instructions to make typewritten copies of the marked portions.

"We had seen the distinguished Presidential candidate at work," says Mr. Miller, "and later in the afternoon we had a chance to see him at play. He was the center of a group of friends on the lawn and was easily the jolliest one there. Every now and then the famous Taft laugh would be heard above all as some one related an amusing incident. And he seemed to have an endless fund of jokes on tap himself.

"On Monday at 3 p. m. we got busy on the Records and by 5 o'clock had four completed. Mrs. Taft was very much interested to know how her husband's voice would sound in the Phonograph and was present while the first four Records were being dictated.

"At 5.15 p. m. Mr. Taft went for his regular horseback ride and gave us an appointment for that evening at 9. At that time he dictated two more speeches, which were all he had expected to make. He had become deeply interested by this time, however, and said, 'I'll give you another.' He kept 'giving us another' until we had twelve altogether.

"While Mr. Taft was dictating he concentrated his undivided attention on the work and seemed entirely oblivious of the presence of anyone else in the room.

"He appreciated that he was addressing millions of his countrymen and the earnestness of his speech and manner showed plainly how seriously he regarded the matter.

"The last of the Records was finished at 12 o'clock Monday night. We caught the first train out on the following morning and were at the factory with the Records Tuesday night, when the work of moulding the duplicates was begun.

"I was greatly amused, coming up from Washington on the Congressional Limited, at some scraps of conversation I overheard in the smoker. The morning papers were filled with accounts of Taft's 'canned speeches.' Everybody in the car was discussing them as well as the report that Mr. Bryan said the opposition had stolen his campaign thunder. They all seemed greatly interested in the part that the Edison is playing in the Presidential campaign. Of course no one imagined that the 'canned speeches of William H. Taft' were in my dress suit case at the moment."

**Because of the unusual quantity of trade notices this month, we have been compelled to make some changes in style and to omit the list of Jobbers and a lot of interesting matter.**

# Selling the Goods

ADVERTISING:—One of the most important and often one of the most neglected branches of a dealer's business.

Here is a time for every Edison Dealer to create considerable excitement. Never before has such a double attraction been offered to the trade as the Taft and Bryan Records for the regular Edison Phonograph and the new Amberol Records which play more than four minutes, or twice as long as the old Records. These two features should keep your store busy for the next six months.

Up till Election Day the Taft and Bryan Records will be big sellers. After Election, whichever candidate is elected, you will have a line of Records made by the President of the United States, something that has never been done before by any Phonograph Company.

Taking up first the Taft and Bryan Records:

Keep these in your window with appropriate cards.

Keep them ready to demonstrate on the Phonograph.

Advertise them in the newspapers, using our ready-made ads.

It is only by advertising that you can get all the sales out of these Taft and Bryan Records that are possible.

The newspapers are helping you. The free advertising given to the Taft and Bryan Records would cost us at least fifty thousand dollars if we had to pay for it. The fact that newspapers consider the making of Records by Taft and Bryan of such importance that they give it space in their telegraph matter, upon their editorial page, in their local news column and in their cartoons, is sufficient proof that the people in your town are interested in these Records and will buy them if you give them the chance.

Use newspaper space now, if you never did before, to tell people about the Taft and Bryan Records. You will find suggestions through this number of the PHONOGRAPH MONTHLY—ready-made ads, window cards, window displays and other suggestions—which will help you turn these Records into dollars.

The day after Election Day should be your big day. As soon as the winner is announced, put a good picture of him in every window that you

have, with a big pile of his Records in front, with a placard saying something like this:

"Records made by the President of the United States for sale here—35 cents."

While your entire town is interested in the results of election you should have a chance of disposing of a large number of Records made by the winning candidate.

Meanwhile, as if the Taft and Bryan Records were not enough, you will soon have the Amberol Records, Mr. Edison's greatest achievement of recent years.

The only criticism ever made upon the old Edison Record was that it was too short. There was not enough of a good thing. By careful experimenting Mr. Edison has found a composition upon which he can write twice as fine and, therefore, get twice as much music upon the same size of record as before.

This, in brief, is the new Amberol Record, a Record which will play between four and four-and-a-half minutes, making it possible to use music that we could not use before without cutting, making it possible to use the Records for dancing, and adding a great deal to their enjoyment and amusement.

In addition to this, the new composition makes the music clearer and better, giving a finer reproduction.

Your fall advertising campaign, in addition to the Taft and Bryan Records, should be based upon Amberol Records. Elsewhere in this paper we explain about the Records, the attachments and other things.

This department wants to impress on you that no good thing ever comes to the dealer who hides his light under a bushel. We know you have a good thing in the Amberol Records. We know that this is going to be the biggest winner in the Phonograph business this season.

It is up to you to get your share. Advertise the Amberol Records as soon as you get them; explain how easily the new attachments can be put on old machines; advertise the new machines

which play both Amberol and old Records; take space in the newspapers; get our window cards and put them in place, and especially get up an invited concert to hear these new Records, making a great deal of the fact that it is Mr. Edison's scientific achievement that makes them possible.

If the Edison dealers understood the wonderful power of judiciously applied advertising, not only would our business be doubled, but so would theirs. We cannot sell any more Phonographs and Records than the Dealers sell. We have no other avenue of outlet except through you. It is up to you to make the most of the market, and by just so much increase your profits.

The Dealer who doesn't believe that the Edison Phonograph and Edison Records are a good thing, and who does not express that belief in every kind of advertising, will not make the sales he could easily make.

Your business day is just so long. Your store is open only so many hours. You cannot add a minute to the working day, but you can make each minute of the working day earn a better profit by keeping your store full of buyers, your clerks busy and your stock turning over fast.

Nothing is so easy to sell as an Edison Phonograph, but to sell it you must make an effort and you must have buyers to work upon.

The only way to get the buyers to come to your store is by advertising. Advertising and advertising alone has built up the great business of such retailers as Marshall Field, John Wanamaker, Siegel-Cooper and others. Advertising makes it possible for every inch of their floor space to earn money, and every minute of the business day to sell goods. Advertising will do the same thing for you.

You never had better talking points than you have right now. The Taft and Bryan Records are timely subjects. Everybody is interested in politics. Newspapers are giving pages to it. Here are Records made by the candidates, expressing their sentiments. Even a wooden man could sell these Records. Then there will be the Amberol Records playing twice as long as the old ones, and very much better, offering a whole lot of new music never offered before, doubling the enjoyment of an Edison Phonograph, renewing the interest of every owner of an old Edison Phonograph, and offering an additional inducement to purchase a new one.

The only thing required of you is to advertise these things from your store and get a chance to show them to people who are only too anxious to buy them.

We are sacrificing most of our profit on the combination attachments, and ask Dealers to be satisfied with less than the usual margins, so that every owner of an Edison Phonograph can afford to invest in the attachment without delay. That will mean the biggest Record business ever dreamed of, for the Edison Amberol Record is grand value and everybody is going to want them.

Doesn't it make you feel good all over the way Edison Phonographs and Records are pushing ahead?

We have given you Edison Records by both Presidential candidates, and right in the midst of a red hot Presidential campaign.

And both Messrs. Bryan and Taft gave the Edison first choice for introducing their personal views into American homes.

Was ever such a compliment paid a talking machine?

The Republican and Democratic campaign managers know their business. Both they and the candidates realize that the Edison is "First in the hearts and the homes of the people." And they openly acknowledge that the Edison Phonograph and Records do justice to Bryan and Taft's oratorical powers.

And now, added to the Taft and Bryan Records comes the Edison Amberol Record, the greatest improvement since the Edison Gold Moulded Record and Model C Reproducer were brought out in 1902.

It looks as if the Edison Dealer will have the field all to himself from now on.

Let's everybody—Dealer, Jobber and Manufacturer—get together now and make all past achievements look puny by comparison.

## Do They Buy Records Regularly?

When Phonograph owners fail to call regularly to buy Records, what do you do about it?

An Edison Jobber outlines a very good plan of action. He suggests sending a man around to see if the machines are in good working order. If they are not, he puts them in order.

Some of the new Records are taken along to play while the Phonograph is being adjusted. The customer usually takes a few from hearing them played, and out of appreciation of the service done.

The salesman should not suggest a purchase, however, as his business is to fix the Phonograph. If he gives the impression that he called simply to sell Records, he may not be welcomed another time.

This campaign procession won't elect the president. Not a man in it is old enough to vote. They all came out of an ink bottle on Thursday of last week. But they will elect you if you say so. This is how.



Send a postal card to your list of Phonograph owners and prospective Phonograph buyers. On the front print this campaign procession. (If you will mail the post cards, we will send you the cut to print the illustration, free. It is No. 698.) On the back print:

"Among the twenty-two Edison Records by William Jennings Bryan and William Howard Taft are ten Edison Records personally dictated by the next President of the United States. Come and hear them."

Then add your name and address—and be ready to sell a lot of Records, not only Taft and Bryan Records, but as many other Records as your visitors hear in your store.

Any Dealer who set Smiling Sambo to rattling bones for him last month, on a postal card, is rattling bones of a different sort in his cash-drawer now, and will send for the election parade at once. If you missed Smiling Sambo last month, turn to page 10 of the last (August) issue of the Monthly and look over the opportunity you lost. To any Dealer so short-sighted that he didn't even read the August issue, we will send, on request, another copy of the August issue.

## Harry Lauder's New Records

The four new Edison Records by Harry Lauder, which are listed on page 29, include his latest song successes. They are in every way equal to the Lauder Records issued last February.

Judging from the way orders are pouring in the new lot will outsell the earlier one.

There is no Record artist whose songs at all resemble Lauder's. He is really and truly one of the world's cleverest entertainers.

## Important Notice

[Copy of letter mailed to entire trade.]

On and after October 1st, 1908, (unless extended as hereinafter provided), we will refuse to fill orders for Edison Phonograph and Records from Jobbers or Dealers who may handle other lines of cylinder machines and cylinder records, except such other cylinder machines as may have been taken in exchange for Edison Phonographs as permitted by our agreement.

In order that entire justice may be done to any Jobbers or Dealers who may have in stock considerable quantities, of other cylinder machines and cylinder records, we will, upon written application in any particular case, consent to an extension of this time to December 1st, 1908, in which to dispose of such stocks, but in no case will we supply Edison Phonographs and Records to Jobbers and Dealers who after October 1st, 1908, may continue to purchase other cylinder machines and cylinder records.

FRANK L. DYER,  
*President.*

August 1st, 1908.

The above letter to Edison Jobbers and Dealers requires no explanation. It is intended to benefit the trade as well as ourselves.

It will benefit the trade because it will make it impossible for Jobbers and Dealers to hereafter permit themselves to be stocked up with a lot of cylinder goods that have small sale and pay no profit. No longer will it be possible to play one Dealer against another and thereby compel one of them to put in a stock that he really does not want.

It will benefit us because it will make every new line build up its own business and not trade on ours, which has taken years of work and the expenditure of hundreds of thousands of dollars to establish.

We do not fear any competition that stands on its own merit and succeeds because of its own endeavors.

## Important Printed Matter for Dealers

We are getting out an unusual amount of printed matter for Dealers' use in this and next month. Jobbers will be supplied with all forms mentioned below and distribution will be made *exclusively through them*.

Order a supply of each form when you place your orders.

This is the most attractive line of supplements, hangers, etc., we have ever gotten out, and will be of immense help to you in your fall campaign. Mention the form number in writing to Jobbers about the printed matter.

### EDISON AMBEROL RECORDS AND COMBINATION ATTACHMENTS.

*Form 1415*—A four-page circular printed in two colors; contains an announcement of the Edison Amberol Record, the Combination Attachments and the new Combination Type Edison Phonographs, giving prices on each.

*Form 1421*—A twelve-page booklet with cover printed in three colors; contains list and descriptions of the 50 Edison Amberol Records.

*Form 1398*—A Bulletin on the Edison Amberol Records; gives list and short descriptions of the 50 Amberol Records. Printed in two colors, size, 22 by 28 inches.

*Form 1396*—A window and store hanger telling about the Edison Amberol Records. Printed in two colors; size, 22 by 28 inches.

*Form 1397*—A window and store hanger telling about the attachments for equipping Edison Phonographs to play both the Amberol and the two-minute Records. Printed in two colors; size, 22 by 28 inches.

### WM. H. TAFT RECORDS.

*Form 1410*—A four-page Supplement containing list and full descriptions of the 12 Edison Records by William H. Taft.

*Form 1391*—A Taft window and store hanger; contains a large picture of Mr. Taft and a list of the Taft Records. Printed in two colors; size, 22 by 28 inches.

### HARRY LAUDER RECORDS.

*Form 1401*—A four-page Supplement containing list and descriptions of the four new Edison Records by Harry Lauder.

*Form 1408*—Lauder window and store hanger; contains a large picture of Lauder with a list of his new Records. Printed in two colors; size, 11 by 28 inches.

### HEBREW AND NORWEGIAN RECORDS.

*Form 1394*—A four-page Hebrew Supplement; contains list and description of the 15 new Hebrew Records announced last month to go on sale between September 1st and 10th. Printed in Hebrew.

*Form 1384*—Hebrew window and store hanger listing the 15 Hebrew Records referred to above. Printed in Hebrew; size, 10 by 22 inches.

*Form 1395*—A two-page circular; contains list of 13 new Norwegian Records announced last month to go on sale between September 1st and 10th.

### NUMERICAL RECORD CATALOGUE.

*Form 1370*—New 128-page issue of the Numerical Catalogue of Edison Records. Includes Edison Records (American Selections) up to and including July, 1908, listed numerically and alphabetically. This catalogue is for trade use only. It is not being mailed to Dealers, as usual. Jobbers have been supplied and will be expected to provide Dealers with copies.

### MISCELLANEOUS MATTER.

The two pieces of advertising literature following are just the thing for general distribution by Dealers. They will be sure to create interest in the Edison Phonograph. Samples were mailed Edison Dealers August 20th. Your Jobber has a stock and can supply you.

*Form 1345*—"Tramp" Folder. A neat and original four-page folder printed in two colors. The front cover shows a tramp looking in at a barn window. Upon opening it up, the inside pictures a Phonograph show being given by a crowd of youngsters; good strong talk on the back cover and room for Dealer's imprint.

*Form 1320*—"Fun" Booklet. A miniature booklet on the Edison Phonograph. Each page is topped with a clever illustration, and contains a brief pointed reason for owning an Edison.

## What Bryan and Taft Advertising Means for You

For weeks the papers have been full of the fact that both of the Presidential candidates, Taft and Bryan, have made Records for the Edison Phonograph. The papers have taken this up and devoted columns to it as news matter. The cartoonists have treated it from all points of view, both seriously and humorously.

All of this means tremendous advertising for the Taft and Bryan Records—advertising of a kind which we could not buy, and which must affect your sales. To take advantage of this advertising be sure to have the Taft and Bryan Records in stock and be ready to demonstrate them at any time.

The making of Records by two Presidential candidates is the most remarkable thing that has happened in phonography in the last five years. Every Edison Dealer should take advantage of it.

An Edison Jobber on the Pacific coast writes that one of his Edison Dealers was induced about nine months ago to put in three machines and 150 records of another manufacturer. He still has the three machines and 80 of the records, although he has ordered \$2,000 worth of Edison goods during the past year. Don't this speak for itself?



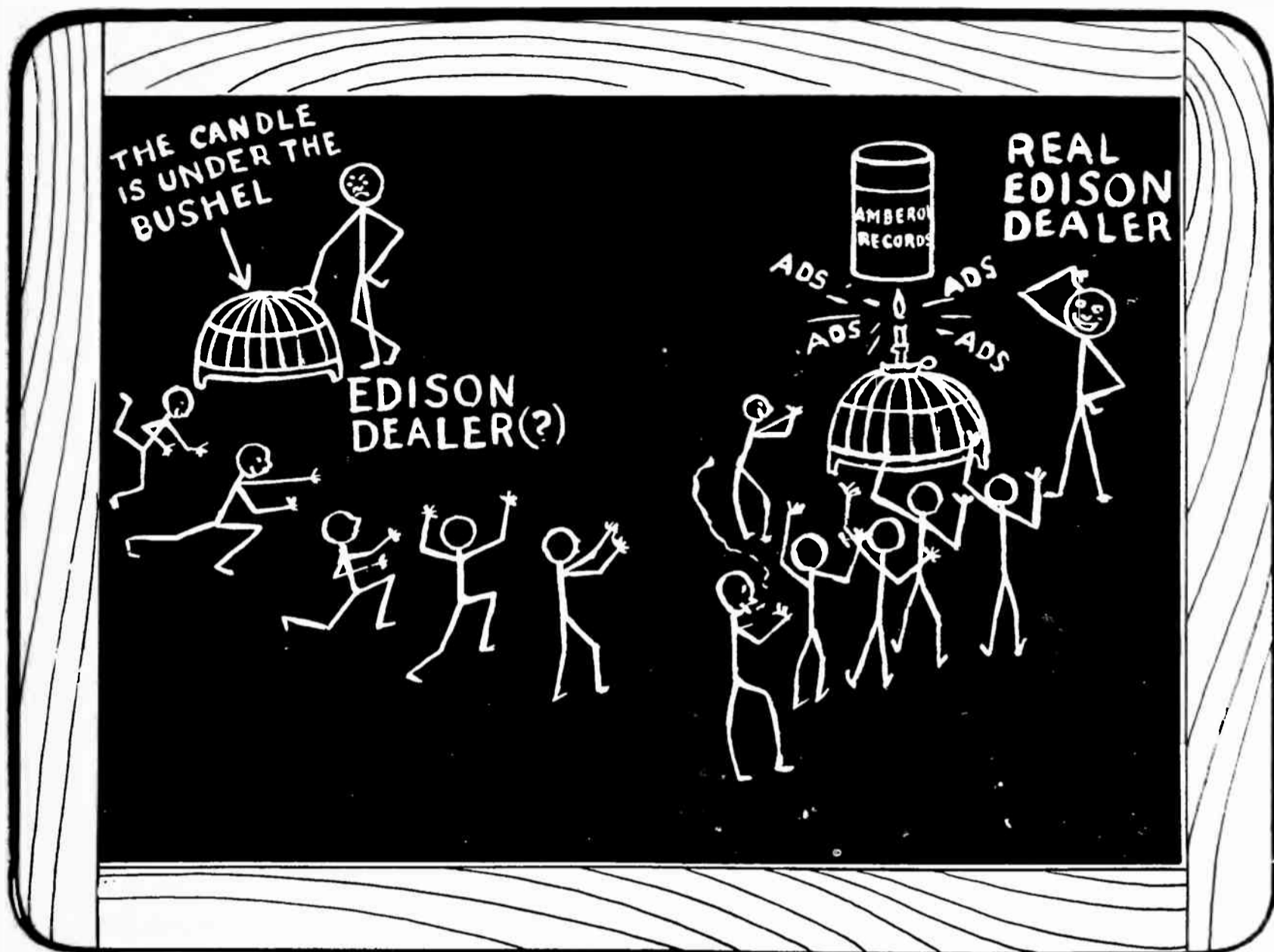

# Lessons for Dealers

## *Lesson II.*

There is a par-a-ble which ad-vises us not to hide our light un-der a bushel.

This par-a-ble was not spe-cial-ly writ-ten for the Pho-no-graph Month-ly as a trade help in sell-ing Edison Am-ber-ol Rec-ords, but its ap-pli-ca-tion is un-ques-tion-able.

Your cus-to-mers will want Am-ber-ol Rec-ords. You will have them.

Light your can-dle.

And put it where ev-er-y-one sees it.

*Selling Records Through  
Your Window*

How many people walk by your store daily?

You may not know—but your landlord knows. And when you pay rent, you pay him for the crowds that pass your window. That is why the rent for a corner is more than on a side street.

Now that you have paid for the crowds that pass your window, what are you going to do with them?

A good window display or a clever window card will make them stop and look. Then they'll come in to listen and buy.

Window cards need not be pretty pictures. The best window card the writer ever saw made him go in and buy an umbrella that he did not need—on a sunny day—and that window card was written on wrapping paper by a man who knew as much about printing signs as the office cat.

The point is, have something to say—then write, letter or print it the best way you can.

Here are some sentences that should help your window sell goods. Try them.

**BRYAN SPEAKS  
TO NIGHT  
IN AN  
EDISON PHONOGRAPH**

**THE ISSUES OF  
THE CAMPAIGN  
DISCUSSED BY THE  
PRESIDENTIAL CANDIDATES  
BY EDISON RECORDS**

**DONT TALK POLITICS  
GET A TAFT OR BRYAN  
RECORD AND LET  
IT DO IT FOR YOU**

35¢

**TAFT SPEAKS TO NIGHT  
IN AN  
EDISON PHONOGRAPH**

**4 NEW  
LAUDER RECORDS  
COME IN AND HEAR THEM**

**TAFT OR BRYAN?  
EDISON RECORDS  
WITH THE SPEECHES  
OF BOTH**

**LAUGH WITH  
THE NEW  
HARRY  
LAUDER  
RECORDS**

**COME IN  
AND HAVE A SMILE  
ON  
HARRY  
LAUDER**

Folded in this issue of the MONTHLY you will find two large portraits of Taft and Bryan. Everyone will know who they are, and the advantage of these big, brutal black-and-white pictures is that they will "carry" across the sidewalk. No one will need to put on glasses to see 'em. And no one will pass by without stopping to get acquainted.

Another advantage is that they are the same portraits that you will be running in your local newspapers. This will tie your store to your ad.

Cut out these two pictures, paste flat against the glass of your window, about four feet apart and high enough up to squarely meet the eye of a five-foot-seven man on the sidewalk. Then put a home-made Taft-and-Bryan window card or two, low in your window, among the Records and machines, and get ready with your silver-tongued oratory, and your genial smile to talk to Democrats and Republicans, and a Populist or two, and one Prohibitionist.

If you don't want to use the pictures as directed put them up as hangers in your store or windows. The important thing is to use them.

# Trade Bulletins

*Sales Department Bulletin No. 13, August 1, 1908*

TRADE INFORMATION FOR DEALERS.

*Correspondence concerning this bulletin should mention its number and be addressed to the NATIONAL PHONOGRAPH COMPANY, SALES DEPARTMENT, Orange, N. J.*

October 1st, 1908, will mark the beginning of a new era in the history of the Edison Phonograph. On that date we will put into effect a number of changes and improvements in Edison Phonographs and Records that will mean as much to the future of your business and ours as did the introduction of the Gold Moulded Record and the Model C Reproducer of 1902. The tremendous increase in the sale of Edison goods since that time is known to you all. The improvements then introduced have, we firmly believe, caused the sale of more Edison Phonographs and Records than the combined sale of all other makes of talking machines. Therefore, the changes and improvements to be placed before the public on October 1st next, will start with the prestige gained by six years of unexampled success. When to this success is added new conditions even more important than those that have gone before, we confidently believe that you will fully agree with our optimistic views regarding the future of the trade in Edison goods. The new feature will consist of the following:

1. A new Record made of a new composition, by a new process and playing an average of over four minutes, or about twice as long as our present Record.
2. A series of attachments by which at slight cost all present Phonographs except the Gem may be equipped to play the longer Record in addition to the present one.
3. Several new types of Edison Phonographs by which both the present and the new Record may be played at the pleasure of the operator.

## *1. The New Record*

This will be known as the Edison Amberol Record. Its most important feature is a recording thread of 200 lines to the inch, or twice as fine as the present Record of 100 threads. By this means twice the playing length is secured without increasing the length or diameter of the Record itself.

Since the finer thread required a smaller reproducing point it became necessary to find a new composition that would successfully resist the wear of the reproducer. The successful and accurate moulding of a 200 thread record formed of a much tougher composition, also necessitated changes and refinements in our moulding process.

More than two years were spent in experimenting to secure these results, the work of several experts being constantly directed and supervised by Mr. Edison.

The Edison Amberol Record is the most wonderful production of its kind that the world has seen. The engraved sound waves are so minute that the eye cannot follow them, and yet the sounds are reproduced even more clearly, more naturally, and more sweetly than by the present Record.

The present two-minute Record will be continued without change until further advised.

## *2. The Attachments*

With a Record of finer thread came the problem of devising a plan by which the Record could be marketed without compelling present owners of Phonographs to buy new machines. This was solved by the construction of attachments embodying the principle of the differential gear and including a new Reproducer with a smaller reproducing point. Attachments have been made for all Edison Phonographs except the Gem.

## *3. New Types of Phonographs*

On October 1st, we will place on the market, three new types of Phonographs to be known as the Standard Phonograph Combination Type, the Home Phonograph, Combination Type, and the Triumph Phonograph, Combination Type. These will be equipped to play both Records and will have two reproducers. They will be sold at slightly higher prices than the present Standard, Home and Triumph machines. At the same time we will supply the Idelia, Balmoral, Conqueror and Alva machines, equipped to play both Records, at no advance over present catalogue prices.

*Prices, Discounts, Etc.*

These are fully covered in the Addenda to the Dealers' Agreement on page 13. WE WOULD ESPECIALLY POINT OUT THE UNUSUAL PROFITS OFFERED TO THE TRADE BY THE PRICES ON THE NEW AMBEROL RECORD. The profits on attachments are less than those on machines. In order to keep down the retail price of the attachments and make it easy for owners to change over their machines, we are sacrificing most of our usual profit and are asking the trade to also make some sacrifice to the same end.

*How the Changes Will Be Made*

Salesmen will leave our factory about August 15th and call as rapidly as possible on all Jobbers in their respective territories. They will fully instruct the latter concerning the new attachments, etc. They will equip a Standard and a Home Phonograph in each Jobbers' stock so that Jobbers in turn may be able to fully instruct their Dealers on the subject. It is hoped in this way to get the entire trade fully informed by October 1st. Full instructions for putting attachments on all present Phonographs will be included with each attachment. It is also possible that copies of these instruction sheets will be sent to the entire trade by mail.

*How to Order*

The first list of Amberol Records will comprise 50 selections. The advance list is printed on page 22. This list has been made up of such a variety of selections as will make the widest appeal. It will be impossible to supply Jobbers with samples of these Records. We must ask Jobbers and Dealers to place advance orders without delay for such quantities as they may require. There will doubtless be a large and immediate sale for these Records, for we feel assured that hundreds of thousands of Phonograph owners will change their machines to play the new Record just as rapidly as they can have the work done.

Jobbers and Dealers are also urged to place orders for a quantity of the various attachments and of the new combination types of Phonographs. In fact, they should give every phase of the new conditions the most careful consideration, and anticipate their requirements so far as possible. We shall work our factory day and night for an indefinite time but we doubt if we shall be able to meet the demand for the Amberol Records, the Attachments, and the new Combination Phonographs. We feel confident that the sale will be enormous.

Additional lists of Amberol Records will be issued later, and they will be handled in the same manner as the present Record as soon as conditions make it possible.

*October 1st the Selling Date*

Shipments of Amberol Records, Attachments and Combination Type Phonographs will be made from Orange as fast as possible after orders are received, distant points getting attention first.

Under no circumstances will Jobbers or Dealers be permitted to offer for sale at retail, any Amberol Records, Attachments or Combination Type Phonographs before October 1st even though they may be received prior to that date. Jobbers may supply Dealers with Attachments or Combination Phonographs before October 1st, with the distinct understanding that they shall not be sold until October 1st. Amberol Records may be shipped to Dealers with October Records September 24th, but they must not be placed on sale until October 1st.

*In Conclusion*

Much more might be said about the new conditions and the great impetus that will be given the trade, but enough has been stated to arouse all concerned to the fullest enthusiasm. As good as the improvements are they cannot exploit themselves. They must have the most cordial co-operation of all Jobbers and Dealers and this, we believe, we shall have from every true Edison man.

[The foregoing, when mailed to the trade, was accompanied by original and duplicate copies of an Addenda to the Dealers' Agreement for the signatures of Dealers. The Addenda is given on the next page. Copies must be signed by all Dealers.]

*Sales Department Bulletin No. 15,  
August 20, 1908*

TRADE INFORMATION FOR DEALERS.

Correspondence concerning this bulletin should mention its number and be addressed to the NATIONAL PHONOGRAPH COMPANY, SALES DEPARTMENT, Orange, N. J.

*Price List of Parts for Model D, Repeating Attachment.*

Following are net retail prices on repair parts

for the Model D Repeating Attachment. Dealers' discounts are the usual discounts on Edison supplies and parts. This price list is not printed in any present Edison catalogue, so should be cut out and kept on file.

	Repair.	Supply.
Arm Clamp .....	.10	
Return Screw .....	1.50	
Return Screw Gear.....	.35	
Return Screw Gear Set Screw.....		.05
Return Screw Bushing.....		.15
Return Screw Bushing Set Screw.....		.05
Lifting Disc .....	.50	
Lifting Disc Key.....	.15	

	Repair	Supply		Repair	Supply
Lifting Disc Set Screw.....		.05	Lift Arm Plate.....	.10	
Return Screw Frame.....	1.25		Angle Plate .....	.10	
Return Screw Frame Screw (2) each....		.05	Return Arm Screw.....	.05	
Trip Rod .....		.10	Arm Adjusting Clamp Screws (3 to a set)		
Trip Rod Set Screw.....		.15	each .....		.05
Lift Lever Block.....	.75		Back Shaft Bearings, right and left, each	.35	
Lift Lever Pin.....		.05	Main Shaft Pulley, with Gear for "Home"	1.35	
Lift Lever Clamp Screw.....		.05	Main Shaft Gear, with Gear for "Triumph"	1.35	
Lift Lever Set Screw.....		.05	Main Shaft Pulley, with Gear for Concert		
Arm Casting .....	1.00		and Balmoral .....	1.85	
Arm Casting, with Lift Lever and Screws..	1.80		Main Shaft Pulley Set Screw.....		.05
Chain .....		2.50			

## Addenda to Dealer's Agreement

The Addenda referred to on pages 11 and 12 is as follows:

### ADDENDA TO DEALERS'

List Prices, Discounts, Net Prices, Terms, Conditions of Sale, and Agreements for United States of America, Issued October 1st, 1907.

SUBJECT TO CHANGE.

ISSUED BY

NATIONAL PHONOGRAPH CO., ORANGE, N. J.

*This Addenda must be signed by every Dealer now selling Edison Phonographs, Records, Blanks, Repair and Supply Parts, etc., and must be signed by every firm who may become Edison Dealers in future. It must be considered as of the same force and subject to the same penalties as the original Agreement.*

#### LIST PRICES OF COMBINATION TYPE EDISON PHONOGRAPHS.

Standard Combination Type.....	\$30.00
Home " " .....	40.00
Triumph " " .....	60.00
Idelia " " .....	125.00
Balmoral " " .....	70.00
Conqueror " " .....	85.00
Alva " " .....	85.00

All of the above machines subject to regular Dealers' discounts.

#### PRICES OF COMBINATION TYPE ATTACHMENTS COMPLETE.

	Dealers'.	List.
Standard .....	\$3.75	\$5.00
Home .....	6.25	7.50
Triumph .....	6.25	7.50
Idelia .....	6.25	7.50
Balmoral .....	6.25	7.50
Conqueror .....	6.25	7.50
Alva .....	6.25	7.50

#### PRICES OF EDISON AMBEROL RECORDS.

Dealers', \$ .28; List, \$ .50.

#### AMENDED SECTIONS ONE AND SIX OF CONDITIONS OF SALE.

1. *No Person, Firm or Corporation* will be recognized as a Dealer in Edison Phonographs or Parts, Edison Records or Blanks unless a Dealers' Agreement is signed, either direct with this Company or through an authorized Jobber, and no such Agreement will be accepted by this Company unless the Dealer signing same has an established place of business suitable for the display and handling of Edison Phonographs, Records, etc., and then only on condition that such Dealer purchase an initial quantity of at least three Edison Phonographs, each of a different type, and one hundred and fifty Edison Records. Unauthorized Dealers are not entitled to the discounts and net prices specified in the foregoing schedule. Any Dealer who fails to maintain a stock equal to the initial order may be removed from the list of authorized Dealers at the option of this Company. Dealers handling Edison Phonographs or Parts, Edison Records or Blanks,

SHALL NOT HANDLE ANY OTHER MAKE OF CYLINDRICAL sound reproducing Records or machines adapted for such Records.

6. *Exchanging* or tendering Edison Phonographs or Parts, Edison Records or Blanks, in whole or part payment for privileges of any character, or for advertising, or the exchange or acceptance of merchandise or goods (including sound reproducing machines and records) of any make or nature in whole or part payment for Edison Phonographs or Parts, Edison Records or Blanks, is not permitted. This does not prohibit the acceptance of an Edison Phonograph at full list price, if good as new, or less cost of repairs to make it good as new, in exchange for an Edison Phonograph sold at full retail list price, but does prohibit the acceptance of Records or Blanks of ANY KIND, AT ANY PRICE, in exchange for Edison Phonographs or Parts, Edison Records or Blanks.

## *Suspended List, Aug. 20, 1908*

### SUPERSEDING ALL PREVIOUS LISTS

This list is supplemental to the Suspended Lists printed in the Edison Phonograph Monthly for June, July and August, 1908, which are still in force and must be given the same consideration by the trade as if reprinted in full herewith.

**CAL., Chico**—Moriss Kyrous (or Kryicus).  
The Postoffice News Stand.

**COL., Ouray**—C. C. Stratton.

**CONN., Meriden**—J. F. Malloy.  
**New London**—Smith Bros.

**IOWA, Sidney**—I. L. Morgan.

**KAN., Cuba**—Mrs. Frank Barnett.

**MASS., Newburyport**—Pertucket Phono. Store,  
M. H. McKinney, Prop.

\***Needham**—J. L. Davis.

\***Northampton**—W. T. Risley.

\***Worcester**—J. G. Williams, Prop. Williams' Book Store.

**MICH., \*Marshall**—S. E. Cronin Estate.

**MINN., Elgin**—J. Watterson.

**MISS., Sedalia**—S. R. Payne.

**NEB., \*Alliance**—B. F. Lockwood & Co.

\***Geneva**—Geo. H. Nelson.

**N. H., \*Dover**—Dover Furniture Co.

**N. J., \*Bayonne**—Goldweber's Dep't Store, M.  
Goldweber & W. Goldweber.

**Plainfield**—L. Seisel.

**N. Y., \*Albany**—Albany Phono. & Sewing  
Mach. Co., Aaron Kent & W. H.  
Bernstein, Props.

**Brooklyn**—A. Becker.  
Henry F. Staude.

\***Lockport**—Floyd B. Serles, Prop. Lock-  
port Phono. Co.

**New York City**—\*Harry Cohen.  
M. Greenberg, alias J. Greenburg.

**Rochester**—A. J. Deninger.

**Watertown**—L. A. Maxson.  
Byer & Susskind.

**OHIO, \*Fremont**—Lorenz Henderson Piano  
Co.

\***Lima**—Henry Van Gunten, Van Gun-  
ten Music Store.

**PENNA., Philadelphia**—Eastern Phono. Co.,  
M. Futernik, Prop.

**Connellsville**—Wright-Metzler Co.

**TEX., New Braunfels**—Ed. Gruene.

**VA., \*Fries**—J. J. Crump.

**WASH., \*Krupp**—Ed. Long.

\*Added since July 20, 1908.

Copies of the complete Suspended List will be mailed on request. Jobbers and Dealers are asked not to supply any of the above named firms with our apparatus, either at addresses given or any other address.

## Phonograms Wanted

We are anxious to get copies of back numbers of the *Phonogram*, and will pay 2 cents a copy for any of the following issues: In 1904—July, August, September, October, November-December; in 1905—February, April and May; in 1906—March; and in 1907—January and May.

If you have any of the above-mentioned *Phonograms* and wish to dispose of them, please send them in to the Advertising Department.

## Cal Stewart Back Again

Cal Stewart is again back into the galaxy of Edison Record makers. Once more will his big, hearty and jovial voice be heard on Edison Records. Two of his selections appear in the first list of fifty Amberol Records. Others will follow. It is also our intention to shortly issue a number of Mr. Stewart's selections on the two-minute Records.



## “Fou the Noo”

You'll laugh. You'll laugh until you cry over Lauder—Lauder so “fou” that he does not “ken” what he has been celebrating—wedding, funeral or christening!

“Fou the Noo” is only one of four new Edison Records by Harry Lauder that we will be glad to play for you if you will drop in.

Lauder is making a big hit with his songs in New York. The Edison Phonograph is making a big hit with his Records all over the country. You cannot afford to miss hearing them. Come in today.

(Dealer's name and address)

An electro (Single Col. No. 696; Double Col. No. 697) of the above cut of Harry Lauder, supplied to Dealers who will insert an advertisement in their local newspaper and send us copies of the papers containing the advertisements.

## Your Campaign for Bryan and Taft Record Sales

should include two or three ads in your local newspaper. We will send, free, electrotypes of these portraits of Taft and Bryan to any Dealer who will insert an Edison Phonograph advertisement in his local newspaper and send us a copy of the paper in which it appears.



Single Col. No. 692  
Double Col. No. 693



Single Col. No. 694  
Double Col. No. 695

We have these cuts in one and two-column widths. Say which.

With these "cuts" in the newspapers and the "cut-outs" in your window you will link our advertising, your advertising and your store together with a chain that is bound to pull results for you. Here are two advertisements which your newspaper will set for you to use with the electrotypes.

### Taft and Bryan

What they say and how they say it will be interesting to hundreds of voters and to many others who may not hear either of them speak during this campaign.

This is not so great a loss as you might think since you can buy for 35 cents at this store Records made by both Taft and Bryan, giving their sentiments on public questions in their own voices and with their own inflections. You should buy both Taft and Bryan Records and compare them in your own home and to entertain your friends.

(Dealer's name and address)

### As the Campaign Grows Hot

interest in the two candidates for presidency deepens.

Think what it means to offer to your friends or to enjoy by yourself, by means of the

Edison Phonograph  
and the

Taft and Bryan Records  
not only the sentiments of the two candidates upon public questions, but also their actual voices and inflections.

Edison Taft and Bryan Records  
for sale here—35 cents each.

(Dealer's name and address)

The enterprising Dealer will readily see that this material is good not only for newspaper ads, but for postal cards and printed slips.

The electrotype offered on page 7 for use on a postal card would also make an excellent heading for a two-column newspaper ad.

# Advance List

## New Edison Records for November, 1908

**R**ECORDS listed below will be shipped from Orange in time to reach all Jobbers in the United States and Canada before October 25th, 1908, all things being favorable, and they may be reshipped to Dealers at 2 P. M. on October 24th. They must not, however, be exhibited, demonstrated or placed on sale by Jobbers or Dealers until 8 A. M. on October 25th. Supplements, Phonograms and Bulletins will be shipped with Records. These may be distributed to Dealers after October 20th, but must not be circulated among the public before October 25th. Jobbers and Dealers may, however, deposit Supplements and Phonograms in Mail Boxes or Post Offices after 5 P. M. on October 24th, for delivery on the following day. Jobbers are required to place orders for November Records on or before August 10th. Dealers should place November orders with Jobbers before September 10th to insure prompt shipment when Jobber's stock is received.

### 9972 The Love Kiss—Intermezzo

New York Military Band

Arthur Pryor's new intermezzo, which was so much in demand during the Pryor Band's last summer season at Asbury Park, N. J. Admirers of Pryor's "Razzazza Mazzazza" (Record 9233) and "Whistler and His Dog" (Record 9107) will concede, upon hearing "The Love Kiss," that his genius for original composition has ripened greatly since he gave us those earlier successes. The melody is of the easy-to-remember variety, and the time, slow waltz. Composer, Arthur Pryor; publisher, Carl Fischer, New York.

### 9973 Are You Sincere?

Byron G. Harlan

One of the most pleasing ballads of the day. It has often been remarked that when this song is on a vaudeville or other theatrical programme, the orchestra almost invariably repeats it at the end of the performance as the audience is leaving. It is certainly a very catchy and melodious ballad, which Mr. Harlan sings in his best voice. Orchestra accompaniment; music, Albert Gumble; words, Alfred Bryan; publishers, Jerome H. Remick & Co., New York.

### 9974 It's the Pretty Things You Say

Amy Butler

A new Edison singer in one of the catchiest songs brought out this season. Miss Butler's method is that of the typical Broadway musical comedy star. Her voice is most musical and she sings with a vivacity that can come only from an enthusiastic relish of her work. A Record that will tempt one to play it over a second and third time. Orchestra accompaniment; music, Ted Snyder; words, Al. Bryan; publishers, Ted Snyder Music Pub. Co., New York.

### 9975 Popular Straight Jigs

John Kimble

As the title indicates, this is a potpourri of straight, legitimate jigs. After hearing Kimble "tear off" such fine jig music from his magical accordion, one wonders why jigs are ever played on any other instrument. But then every accordion player is not a Kimble, nor is every accordion the equal of his in volume and power of musical expression. Piano accompaniment.

### 9976 When Highland Mary Danced the Highland Fling

Edward M. Favor

A jolly and highly diverting Record. The absorbingly interesting story of Highland Mary's adventures is sung to a melody that savors of the liveliest old Scottish airs and reels, especially when she "did the Highland Fling." Orchestra accompaniment; music, Harry Von Tilzer; words, Jack Mahoney; publishers, Harry Von Tilzer Music Pub. Co., New York.

### 9977 I'm Starving For One Sight of You

Manuel Romain

Manuel Romain gets one of the best opportunities he has yet had in Charles K. Harris' new love song. This selection is especially suited to Mr. Romain's method of singing, as there is an unusual number of the peculiar lingering notes, which add such a rare depth of tenderness to his sentimental songs. Part of the accompaniment is picked softly on the strings of the violins. Orchestra accompaniment; music and words, Charles K. Harris; publisher, Charles K. Harris, New York.

### 9978 I Think I See My Brother Coming Now

Arthur Collins

A remarkably novel comic coon song. The "cullud gemman" in the case became envious of the ease with which Joe Gans coins money prize-fighting. He decides to try his hand, declaring, "I'll fight 'til brother Bill comes home." (Brother Bill had been dead 27 years.) So he



fighters the "terrible Greek," gets knocked down nine times, and amid the laughs and jeers of the spectators, sings the great stuttering chorus, "I think (uh) I (uh) see m-m-m-y b-b-b-rother comin' home right now." Orchestra accompaniment; music, J. Fred Helf; words, Eddie Moran; publishers, Helf & Hager Co., New York.

**9979 Golden Blonde****American Symphony Orchestra**

A very ambitious concert number that displays wonderful feats of orchestration, especially with reference to flute and clarinet work. The introduction is showy, and is followed by a flute cadenza, which, in turn, leads up to a graceful mazurka movement. This Record is also a notable achievement in skillful recording. Composer, R. Eilenberg; publisher, Carl Fischer, New York.

**9980 When You and I Were Young, Maggie****Will Oakland**

Will Oakland is the sweet counter-tenor singer, who won a great personal triumph with his first Edison Record in the August list, (No. 9902). We predict that his Record of "When You and I Were Young, Maggie," will always be one of the best sellers in the Edison catalog. It belongs to that select class of good old songs that none of the good new ones seems to quite come up to. Orchestra accompaniment; music, J. A. Butterfield; words, George W. Johnson.

**9981 Just As I Am****Anthony and Harrison**

This month's sacred duet is a beautiful new arrangement of the grand old hymn, "Just as I Am." It would be difficult indeed to find two singers, whose voices blend so harmoniously as do Anthony and Harrison's. This is because they have been making Edison duet Records since 1905 and have long sung together in the choir of one of New York's largest churches. Orchestra accompaniment; music, Wm. B. Bradbury; words, Charlotte Elliott.

**9982 Evening Star****Thomas Chalmers**

This captivating aria is sung by Wolfrau in the third act, scene two, of Tannhauser. It is justly regarded as the gem of the great Wagnerian opera. Our Record presents the song in English by Thomas Chalmers, a new Edison artist, who is gifted with a rich, vibrant baritone voice. Orchestra accompaniment; composer, Richard Wagner; publishers, Oliver Ditson Co., Boston, Mass.

**9983 After Sunset—Intermezzo****Edison Concert Band**

A band concert piece by Arthur Pryor—rich in color and displaying the touch of a master-hand at instrumentation. It is in common time, and like Record No. 9972 of this month's list, has been demanded by nearly every audience that Pryor and his band have played before in several months past. The Edison Concert Band gives it a decidedly clever reading. Composer, Arthur Pryor; publisher, Carl Fischer, New York.

**\* 9984 I'm a Yiddish Cowboy****Edward Meeker**

A dandy new cowboy song with Western effects galore. Among them—the tom tom, cowboy chorus, cowboy and Indian yells, hoof beats, etc.—and all so plain and realistic that one can almost smell the alkali. Mr. Meeker sings this number with the spirit and fire that the unusual words and music call for—so plainly too that not a word is lost, even in the yiddish dialect portion. Orchestra accompaniment; music, Al Piantadosi and Halsey Mohr; words, Edgar Leslie; publishers, Ted S. Barron Music Publishing Company, New York.

**9985 It Looks Like a Big Night To-night****Collins and Harlan**

The comic song craze of the moment. Hubby packs wifey off to the seashore. No sooner is she gone than he is overwhelmed with self-pity because of his lonesomeness and plans to make "a night of it with the boys." Wifey turns up unexpectedly in the middle of it all. With prophetic vision he "sees his finish," and dolefully sings, "It looks like a big night to-night." The tune is extremely vivacious and is sung with genuine Collins and Harlan flourish. Orchestra accompaniment; music, Egbert Van Alstyne; words, Harry Williams; publishers, Jerome H. Remick & Co., New York.

**9986 Love Me Like I Like to be Loved****Ada Jones**

A leap year love song that is by long odds the best of the crop of new semi-rag coon songs. A certain dusky belle's "gemman friend" is far too slow to suit her fancy. Not only does she chide him about his lack of action, but goes further and describes the kind of action she would like. And, would you believe it!—the description frightens him away. This song reflects Ada Jones' happiest mood. Orchestra accompaniment; music, Geo. W. Meyer; words, Earle C. Jones and Alfred Bryan; publishers, Rose & Snyder, New York.

\*This selection will be illustrated on cover of November Phonogram.

**9987 Händel's Largo****Hans Kronold**

Handel's divine classic is in the same class as "Traumerei," by Schumann. Mr. Kronold has never done anything better than this entrancing 'cello solo. The piano accompaniment forms a suitable background, that does not in the least obscure the lovely, and at times, weird tones of the strings. Every one who loves music will appreciate this exceptional Record. Piano accompaniment; composer, George Friedrich Handel.

**9988 A Morning in Mrs. Reilly's Kitchen****Steve Porter**

A scintillating bit of Irish comedy. Mrs. Reilly resided in a flat where all the groceries, meat, ice, etc. were brought up on a dumb waiter. A shrill whistle would precede each trip of the waiter. On this particular A. M. the effect of the whistle was about as loud and long as at 1 A. M. New Year's morning, when all the steam whistles in town are turned loose and allowed to blow themselves out. A sample of Mrs. Reilly's ready wit: (whistle) "Oh, My! They call it a dumb waiter whin it's screechin' loike the divil from mornin' 'til night!" (whistle). A splendid Record. Original sketch, not published.

**9989 Take a Little Ride With Me****Dorothy Kingsley and Edward Meeker**

A breezy automobile flirting duet, which the writers call "A conversation with music." An automobilist (Ed. Meeker) meets with a fresh and pretty dairy maid (Dorothy Kingsley) and urges her to take a spin "O'er hill and dale." The tune is one of airy grace in tripping gavotte tempo. Both solo and chorus parts are capitally done and the record will prove an unusual seller. Orchestra accompaniment; music, Theodore Morse; words, Jack Drislane; publishers, F. B. Haviland Pub. Co., New York.

**9990 My Dream of the U. S. A.****Frederic Rose**

The latest addition to the list of patriotic songs of the U. S. A. A soldier lies dreaming of our past heroes who fought for American liberty and the words describe his vision. The melody is in stirring martial time with the orchestra introducing short phrases of well known patriotic airs. Orchestra accompaniment; music and words, Leonard Chick, Chas. Roth and Ted Snyder; publishers, Ted Snyder Co., New York.

**9991 Dancing Spirits****Albert Benzler**

What a storm of protests would be heard should the Benzler Bells solos fail to come out at regular intervals! This month's selection is a favorite composition by Carl Bohm, a celebrated writer of music. It is given an entirely new and original setting, and will undoubtedly make a very popular bells solo. Orchestra accompaniment.

**9992 Faded Roses****James F. Harrison**

Roma's new ballad is well named. It is really and truly as sweet and refined as the scent of a rose. It would seem as if the composer must have had Jas. F. Harrison in mind when he originated the bewitching waltz lento refrain, for Mr. Harrison sings it in a way to cause the listener to say instinctively, "Fine!" Orchestra accompaniment; music and words, Caro Roma; publishers, M. Witmark & Sons, New York.

**9993 Jim Jackson's Affinity****Ada Jones and Len Spencer**

This Record is filled with action. We are taken behind the scenes at a rag-time ball and given a glimpse of the belle and her ebon-hued affinity in a rapturous waltz, which far eclipses the "Merry Widow." The climax comes with "A Soul Kiss" that stops the music. Was there a scene when Jim's bona fide wife arrived just in time to witness the "Soul Kiss?" There was. She leads her (?) Jim off a captive, but Jim's "t'other fair charmer," evens up by singing "He's My Affinity." Original sketch, not published.

**9994 Come Where My Love Lies Dreaming****Knickerbocker Quartette**

An old standard song classic, by the composer of "Old Folks at Home" and "My Old Kentucky Home." This entrancing serenade as, sung by the Knickerbocker Quartette, has an original four-part setting. Each voice is heard in delightful contrast with the other, ending with a remarkably effective climax in which all four voices blend in splendid harmony. Unaccompanied; music and words, Stephen C. Foster.

**9995 The Crater March****Edison Military Band**

This martial band piece takes its name from the battle of "The Crater," fought in the civil war at Petersburg, Va. It will be a great seller, not for its historic associations alone, but because of its engaging military air. The Edison Military Band gives it a very spirited performance, which the Record adequately reproduces. Composer, Harry J. Lincoln; publishers, Vandersloot Music Publishing Co., Williamsport, Pa.

# Advance List

Twelve

## Edison Records by William H. Taft

*THE Taft Records will be ready for shipment from Orange about August 20th. For want of time samples will not be sent to Jobbers. Jobbers' stock orders will be shipped as fast as possible after August 20th, beginning with those received from Jobbers in the far West. Care will be taken to make shipments at one time to all Jobbers in the same city and shipments will be made to distant points first. Special supplements will be shipped with Records to all Jobbers who request a supply. State quantity required.*

**W**ILLIAM H. TAFT, Republican candidate for President, has made twelve Edison Records. The Records consist of the most striking portions of his Speech of Acceptance, which was delivered at Cincinnati, July 28th.

As Mr. Taft says, the Records give his "personal views on the leading political questions." And, we may add that they do this in a wonderfully lucid and concise manner.

They are splendidly recorded in Mr. Taft's most amiable voice and do full justice to the distinguished Ohioan's oratorical powers.

Now, for the first time, one can introduce the rival candidates for the Presidency in one's own home, can listen to their political views, expressed in their real voices, and make comparisons.

The National Phonograph Company is proud of having introduced this epoch-making novelty. We are proud that of all talking machines, the Edison was the first choice of both candidates for reaching the American public.

Edison Dealers! The Taft Records, coming right after the Bryan Records, present you with a talking point that should sweep all before it. Make the most of this golden opportunity to sell Edison Phonographs and Records.

The demand for the Taft Records is certain to be enormous. We earnestly urge Edison Jobbers and Dealers to coöperate with us by making their first orders large enough to cover their requirements up to Election Day, Nov. 3rd. We shall do our utmost to fill all orders, but the time until then is very brief and the trade should see to it that they do not lose sales of either machines or Records by running short of the Taft Records.

### 9996 Foreign Missions

Mr. Taft's views on the importance of foreign missions are here crystallized into a model sermonette. As the representative of this country, Mr. Taft spent much time in the Orient and had an unusual opportunity for studying his subject at close range. "It was not until then," says he, "that I realized the immense importance of foreign missions to the spread of civilization." This Record will probably stand as the ablest and most impartial exposition of this great subject that has ever been made.

**9997 Irish Humor**

This delightful talk on an every-day subject is certain to be very popular. It is of the after-dinner type, at which Mr. Taft has no superior, and is delivered in his most affable voice. "A sense of humor," says the speaker, "is like the bumpers in a solid train; like the air cushion of a modern field gun—it saves the jolt; it takes the recoil." He then repeats an apt and beautiful quotation from John Boyle O'Reilly and another from Kipling's poem, "An American." This Record will always be a great seller irrespective of Mr. Taft's political prominence.

**9998 Republican and Democratic Treatment of Trusts**

On the day after Mr. Taft delivered his powerful "Speech of Acceptance" the whole country was aroused by the newspaper reports of his remarkable allusion to the Trusts. The gist of those remarks is given in this Record. "Unlawful trusts should be restrained with all the efficiency of injunctive progress. And the persons engaged in maintaining them should be punished with all the severity of criminal prosecution in order that the methods pursued in the operation of business shall be brought within the law. This is the Republican view," exclaims Mr. Taft, and the exact tones of his voice are reproduced so perfectly true to life, the effect is the same as if the Presidential candidate stood before us.

**9999 The Rights of Labor**

A great battle is now being fought by the leading political parties on the labor question. Mr. Bryan's Edison Record on this subject led all of his other Records in sales. Now we have the chance to compare Messrs. Taft and Bryan's personal views on this engrossing subject. Mr. Taft's compelling argument in favor of labor unions is one that will find an enthusiastic echo in the heart of every union man. This Record will be a sensational seller.

**10000 Unlawful Trusts**

So important does Mr. Taft consider this subject that he decided to discuss it in a special Record. He rises to heights of true eloquence in denouncing monopolies that seek to control the market, raise prices and drive out competition. At the same time he makes it quite plain that legitimate business organization is needed to make possible reasonable prices and to promote prosperity.

**10001 Function of Next Administration**

One of the most engaging subjects Mr. Taft could have chosen. He pays a glowing tribute to the high standards of business operation forced upon the corporations and large business firms by President Roosevelt. He recites the most important ones and says, "The chief function of the next administration in my judgment, is to complete and perfect the machinery by which these high standards of Roosevelt may be maintained, by which law-breakers may be restrained and punished, but which shall operate with sufficient accuracy and dispatch as to interfere with legitimate business as little as possible."

**10002 Roosevelt Policies**

The mere mention of this title is sufficient to arouse universal curiosity. Everyone has decided views on the Roosevelt policies. Mr. Taft has been closer to President Roosevelt perhaps than anyone else. But many may not have guessed how deep seated and strong is his admiration of the man and his principles. Mr. Taft vividly pictures the conditions which necessitated the reforms advocated by President Roosevelt, and says, "The man who formulated the expression of the public conscience and who led the movement for popular reform was Theodore Roosevelt. He laid down the doctrine that the rich violator of the law should be as amendable to restraint and punishment as the offender without wealth and without influence." This speech is an oratorical gem.

**10003 The Philippines**

Without question Mr. Taft is better qualified to inform us about the Philippines than any other American. He was sent there by the U. S. Government at the most critical time in the Islands' history—just after the Spanish war—and was largely instrumental in establishing law and order out of chaos. He tells just what has already been accomplished there and asserts his belief that the Islands should be made independent when the people are able to govern themselves. This he thinks will take two generations. A splendid peroration is concluded with these ringing words, "It would be cowardly to lay down the burden until our purpose is accomplished."

**10004 Enforced Insurance of Bank Deposits**

This is the great national political question brought up by the recent business disturbance. It will be highly interesting to compare Messrs. Taft and Bryan's Records on this subject. Mr. Taft opposes in his most vigorous fashion the Democratic idea of government guaranty of bank deposits. "The idea is wholly impracticable," he says, "unless it is to be accompanied by a revolution in our banking system. If the proposal were adopted as proposed, it would break the whole banking system down in ruins." His closing remarks make a powerful plea for the regular government Postal Savings banks.

## 10005 Jury Trial in Contempt Cases

Another opportunity for comparing the private views of Messrs. Taft and Bryan on a great political issue. Mr. Bryan discusses jury trial in his Record on "The Labor Question." Here are samples of the "hot shot" with which Mr. Taft assails his opponent's position. "Under the provision of the Democratic platform a recalcitrant witness, who refuses to obey a subpoena, may insist upon a jury trial before the court determines that he received the subpoena. A citizen, summoned as a juror, and refusing to obey the writ, when brought into court, must be tried by another jury to determine if he received the summons. \* \* \* Never in the history of the country has such an insidious attack been made upon the judicial system."

## 10006 The Farmer and the Republican Party

This Record will make a powerful special appeal to those who live in the country districts. Mr. Taft enters fully into those subjects that are of first importance to every farmer, such as restraint of excessive railroad rates, enforcement of the pure food law, scientific agriculture, and increasing the comforts of country life by the extension of the rural free delivery and building of good country roads, more and more at the public expense, and less at that of the abutting property owner. No farmer or suburbanite, who is interested in these matters can afford to forego hearing Mr. Taft's personal word on the subject.

## 10007 Rights and Progress of the Negro

While the South is the center of interest on the negro question, still it is becoming more than ever a matter of national concern. If anything, Mr. Taft is more vehement in declaring his position on this question than on any other. Alluding to the declaration of the Republican party in favor of the 13th, 14th, and 15th amendments, and justice to all men without regard to race or color, Mr. Taft says, "It is needless to state that I stand with my party squarely on that plank of the platform."



SELLING FORCE OF NATIONAL PHONOGRAPH CO.

The above picture of the National Phonograph Company's salesmen was taken during their recent visit to the factory at Orange, N. J. President Frank L. Dyer, Manager of Sales F. K. Dolbeer and Manager of Salesmen E. H. Philips were also in the group.

The entire force was at headquarters from August 3rd to 10th, getting ready for the fall campaign. Under the supervision of Sales Manager F. K. Dolbeer and Mr. Philips, special attention was given to the equipment of regular style machines with the new attachments for playing both the two-minute and Edison Amberol

Records. The salesmen are now busily engaged calling on Jobbers and instructing them how to put the attachments on.

Looking from left to right the individuals in the above picture are: E. A. Neff, M. G. Kreuzsch, John H. Gill, Will P. Hope, J. Frank Stanton, W. H. King, A. H. Kloehr, A. V. Chandler, B. C. Barklow, J. W. Scott, F. W. Ewan, L. J. Kocher, F. K. Dolbeer, G. A. Renner, F. L. Dyer, C. D. Warren, E. H. Philips, G. H. Hedden, H. D. Clark, F. L. Fritchey, H. A. Turner, Mr. Carpenter.

## In Business for Himself

Archie Matheis, who for years has been manager of the talking machine department for Koehler & Hinrichs, St. Paul, Minn., has resigned his position and will engage in the retail business for

himself in Minneapolis, his company being known as the Talking Machine Company. He is located at 236 Nicollet avenue. He has been operating this store with the assistance of a manager for some time past. With his wide experience as salesman, both wholesale and retail, his success should be assured.

# First Advance List

## Of Edison Amberol Records to be Issued Oct. 1st, 1908

**R**ECORDS listed below will be shipped from Orange in time to reach all Jobbers in the United States and Canada before September 25th, 1908, all things being favorable, and they may be re-shipped to Dealers with October Two-Minute Records at 2 P. M. on September 24th. Amberol Records must not, however, be exhibited, demonstrated or placed on sale at retail by Jobbers or Dealers until 8 A. M. on October 1st. Supplements, Bulletins and special hangers will be shipped to Jobbers with Records. These may be distributed to Dealers with their orders for Amberol Records, but must not be circulated among the general public before October 1st. Jobbers and Dealers may, however, deposit Supplements in mail boxes or post offices after 5 P. M. on September 30th for delivery on the following day. Jobbers are required to place orders in the shortest time possible, so that shipments to all Jobbers in the same territory may be made at one time. Dealers should likewise place immediate orders with Jobbers to insure prompt shipment when Jobbers' stock is received.

- 1 William Tell Overture** **Edison Concert Band**  
 No more fitting selection could have been chosen with which to head the list of Edison Amberol Records than this famous operatic overture. The Record contains nearly the whole composition, including the majestic storm scene and the beautiful pastoral scene for flute and oboe. Composer, G. Rossini; publisher, Carl Fischer, New York.
- 2 Roses Bring Dreams of You** **Manuel Romain**  
 An exquisite love ballad. The Amberol Record makes it possible for Mr. Romain to sing with the utmost freedom of expression, just as he would on the stage. The singer's host of admirers will agree that he has never been heard to such good advantage. Orchestra accompaniment; music and words, Herbert Ingraham; publisher, Shapiro, New York.
- 3 Sextette from "Lucia"** **Edison Sextette**  
 The popularity of the wonderful "Sextette from Lucia" has continued unabated since its initial production in 1835. An adequate Record of this illustrious operatic number has not been possible heretofore, but we are at last treated to its every note from beginning to end. It is sung in English by soprano, alto, first and second tenors, baritone and bass. Orchestra accompaniment; composer, G. Donizetti.
- 4 Flanagan and "The Reillys" at a Baseball Game** **Steve Porter**  
 Over four minutes of solid fun. A spirited base ball game forms a highly interesting and exciting background. Flanagan and the Reillys landed seats in a hot-bed of enthusiastic "rooters," and Mrs. Reilly's ignorance of the game makes her the butt of much merriment. One of the most attractive features is the progress of the game, which is humorously pictured. Orchestra accompaniment. Original sketch, not published.
- 5 Love's Dream After the Ball** **Edison Venetian Trio**  
 "Returned from the ball, she falls asleep, and in a charming vision beholds him to whom she had given her heart that night." This is the engaging theme of this composition, which has won universal plaudits both here and abroad. It was originally written for string quintette, but is even more effective by the trio (violin, flute and harp). The principal theme is played in waltz tempo, 2/4 time, with tremolo to portray the dream. Composer, A. Czibulka; publisher, Carl Fischer, New York.
- 6 Memories of Mother** **Anthony and Harrison**  
 Our list of Four-Minute Records would not be complete without one or more gospel hymns by Anthony and Harrison. "Memories of Mother" is a favorite hymn of Evangelist Alexander, of "Glory Song" fame, and is often used by him in revival work. Added verses make this Record an improvement over the best previous efforts of these artists. Orchestra accompaniment; music, Robert Harkness; words, Fred P. Morris.
- 7 Don't Go Away** **Collins and Harlan**  
 Perhaps it is not possible to actually get enough of a fine Collins and Harlan rag time duet, but in this Four-Minute Record we come much nearer to that happy goal than was possible with the two-minute Record. The chief source of humor in their "latest" is the "dovey

dove" conversation of the coon and his "gal," when she questions the strength of his devotion. The melody is typical coon "rag," and never have these sterling artists done anything in which the rhythm and swing of the music was better emphasized. Orchestra accompaniment; words and music, Kendis and Paley; publishers, Jerome H. Remick & Co., New York.

- 8 Violets Waltz** **New York Military Band**  
 "It is to dance." Here is a four-minute Waldteufel waltz, loud enough and *long* enough for dancing. No composer of waltz music ranks above Waldteufel, and none of his compositions is better liked than "Violets," which is famed for its melody and perfectly marked dance tempo. The band has made an excellent Record—loud, clear, and in correct dance time. Composer, E. Waldteufel; publisher, Carl Fischer, New York.
- 9 Light as a Feather** **Albert Benzler**  
 By far the most elaborate bells solo ever attempted. The orchestration is quite remarkable, especially in the clarinet duet variations, through which the bells jingle merrily an attractive obligato. Orchestra accompaniment; music, T. H. Rollinson; publishers, Oliver Ditson Co., Boston, Mass.
- 10 The Holy City** **Reed Miller**  
 "The Holy City" needs no word of introduction. It is, and probably always will be, one of the most appealing sacred solos in the language. The entire selection is here given by Reed Miller, whose interpretation displays as much dramatic fervor as his famous rendition of Sullivan's "Lost Chord." Orchestra accompaniment; music, Stephen Adams; words, F. E. Weatherly; publishers, Boosey & Co., New York.
- 11 Uncle Josh and the Sailor** **Cal Stewart**  
 Cal Stewart says, "This is by far the longest record I ever made." And, we may add, it is easily one of the best. Uncle Josh is short of farm help, and hires a sailor, who said he knew it all and then some. But he insisted on sticking to the language of the sea. He yelled "starboard" and "port" to the team, and once he came up with a hatful of eggs. Said he found them on the hatchway. The climax came when the sailor-farmer wanted Uncle Josh to sit up nights and throw water against the side of the house so that he could go to sleep. Instead of doing so, Uncle Josh fired him.
- 12 The Message** **Harry Anthony**  
 Harry Anthony fairly revels in a harmonious semi-classic such as this. The words are romantically fanciful, and the music is of the type that the singer relates, was chosen to carry his message to his Love, in heaven. Mr. Anthony's thorough understanding of vocal art stands him in good stead in this class of song, and it is an artistic treat to listen to his well trained tenor voice. Orchestra accompaniment; music, J. Blumenthal; words, Miss Adelaide Proctor; publisher, G. Schirmer, New York.
- 13 Cavalry Charge (Descriptive Fantasie)** **Edison Military Band**  
 A powerful descriptive band piece that is a warm favorite with the leading band masters. Synopsis: Morning of the battle; infantry is heard approaching, with fife and drum corps; cavalry, infantry and artillery engage in fierce battle; defeat of the enemy; pursuit by cavalry. The Military Band gives a vivid portrayal of the moving armies and the swift action of the battle. Composer, G. Lüders; publishers, The John Church Co., New York.
- 14 Fol-the-rol-lol Limericks** **Edward M. Favor**  
 As a two-minute Record this has always been a famous seller because of the excruciatingly funny situations described in the verses and the strikingly "different" chorus. It is nonsense, of course, but the cleverest kind of nonsense that is an A 1 mirth-maker. The present Record gives 18 verses, while the old-style Record gives only 8. Orchestra accompaniment.
- 15 The Sinner and the Song** **James F. Harrison**  
 A distinctly unique semi-religious song that is certain to enjoy a wide vogue. A sinner sings the story of his wanderings and his conversion which resulted from hearing his favorite hymn sung by a church choir. To complete the scene, a mixed quartette is heard at intervals softly singing the verses of "Jesus, Lover of My Soul," accompanied by a church organ. Orchestra and organ accompaniment; music and words, Will F. Thompson.
- 16 The Stranded Minstrel Man** **Murry K. Hill**  
 One of the cleverest acts now in vaudeville, consisting of two very good humorous songs and a 400-word monologue. The monologist must of course knock somebody, and on this occasion, (1) the manager of a minstrel troupe, who left his company stranded, (2) the B. & O. Railroad and (3) the Inside Inn of the Jamestown Exposition—all "get theirs." It would be too bad if only a few of the "roasts handed them" were true. This Record is a whole show in itself. Orchestra accompaniment; original sketch, not published.
- 17 Humoreske** **Hans Kronold**  
 Anton Dvorak's illustrious concert number makes an ideal 'cello solo. The title, "Humoreske" means that the rendering is left to the musical fancy or feeling of the performer. Mr. Kronold's conception is the true artist's, and will be accepted as such by all who appreciate the best in music. Piano accompaniment; composer, Anton Dvorak.

## 18 The Preacher and the Bear

Arthur Collins

This comic coon song has run second in popularity to none in the list of Edison two-minute Records. The action, words and music are not only far above the ordinary, but are different from almost any other coon song. The story goes that a negro preacher went hunting on a Sunday morning and was (very properly) treed by a grizzly bear. The limb of the tree broke with him and there were "doings." Our new Amberol Record gives an extra verse, chorus and scene. Collins sings it even better than he sang the earlier Record. Orchestra accompaniment; music and words, Joe Arzonja; publisher, Jos. Morris, Philadelphia.

## 19 Trio from Faust

Metropolitan Trio

One of the sublimest passages in Gounod's musical adaptation of the immortal Goethe drama. The trio is sung at the end of the opera and portrays the death and redemption of Marguerite. The singing characters are Marguerite, Faust and Mephistopheles; the voices, soprano, tenor and baritone. Not a word or note is cut from the stage version, which is rendered with artistic finish by the Metropolitan Trio. Orchestra accompaniment; composer, Charles Gounod.

## 20 Asleep in the Deep

Gus Reed

This well known bass solo is now sung in proper tempo for the first time on any record. The vocalist, Gus Reed, a new Edison singer, has a truly remarkable voice and has produced a Record that has never been surpassed for fullness and depth of tone. Orchestra accompaniment; music, H. W. Petrie; words, Arthur J. Lamb; publisher, F. A. Mills, New York.

## 21 The Tales of Hoffmann—Selection

American Symphony Orchestra

Offenbach's most noteworthy operatic work. This opera was recently presented at the Manhattan Opera House, where it was most cordially received. Our Record gives the minuet and barcarole, which stand out prominently above everything else in the score. Composer, J. Offenbach; publisher, Carl Fischer, New York.

## 22 Daddy

Harry Anthony

There is no song that tugs at the heart-strings more than "Daddy." It paints the touching picture of a motherless little boy on his birthday night. In words brimming with pathos he prattles of "mother" until big tears fill "daddy's" eyes. The song is here given complete, which is not possible on any other talking machine record. Orchestra accompaniment; music, A. H. Behrend; words, Mary Mark Lemon.

## 23 Henny and Hilda at the German Picnic

Ada Jones and Len Spencer

One of the cleverest dialect acts that Ada Jones and Len Spencer have ever put on. Hilda promptly forgets that her escort is on earth when she spies her Henny of the band, proudly carrying his bassoon. Together they make a jolly round of the park attractions. Henny frequently gives vent to his exuberant feelings on the bassoon, and Hilda makes good with a number of short, catchy songs. 240 seconds of racy fun. Original vaudeville sketch not published.

## 24 The Sword of Bunker Hill

Knickerbocker Quartette

The inspiring patriotic song, which many recall as a prime favorite in their school days, when it was sung on all special occasions. Our new Amberol Record gives the four fine verses by Wallace, complete, so that the whole story of the veteran's dying gift to his son, is obtained. The Knickerbocker Quartette make an exceptionally good Record. Unaccompanied. Music, Covert; words, Wallace.

## 25 A Hunting Scene

Edison Military Band

This forceful descriptive musical scene opens with a pastoral movement portraying daybreak. The warbling of birds is heard and the stillness of early morn is otherwise broken by the echoing hunter's horn. The hunters prepare for the chase, singing merrily. The snap of the whip, clatter of horses' hoofs, and baying of hounds on the scent lead up to a climax when the game is run to earth amid cheers for the successful finish. The male chorus repeats the refrain, "A hunting we will go." Composer, P. Bucalossi; publisher, Carl Fischer, New York.

## 26 Pure as Snow

Edison Concert Band

A dazzling concert piece by Gustav Lange, that at once suggests some of the prettiest passages in his exquisite "Flower Song." The selection ranks as one of the most brilliant of a galaxy of old-world numbers that are equally in demand in this country. The arrangement played by the Edison Concert Band is a special one, featuring bells and chimes. Seldom has this organization displayed such able individual and ensemble work. Composer, Gustav Lange.

## 27 Belle Brandon

Manuel Romain

There are traces of tears in Romain's voice as he sings of "Little beauty, Belle Brandon, who sleeps 'neath the old arbor tree." He is simply immense in this grand old love ballad. Admirers of the sweet-singing minstrel tenor, who fail to secure this Record, will miss the best song that Mr. Romain has yet given us. Orchestra accompaniment; music, Francis Woolcott; words, T. E. Garrett.



## 28 Quartette from Rigoletto

Metropolitan Quartette

In point of brilliance and musical variety the Rigoletto Quartette represents the fruition of Verdi's genius. A marvelous exhibition of contrasted emotions is brought out by the four singers, the Duke, Magdalena, Rigoletto and Gilda, which makes this a very difficult selection to record. Our four-minute Record gives the famous quartette complete in English; and it will be accepted at once by opera lovers as the best operatic quartette Record yet produced. Orchestra accompaniment; composer, G. Verdi.

## 29 A Singer Sang a Song

Ed. Morton

Sam Bernard's big encore-winner in his new play "Nearly a Hero." We are introduced to all of the usual run of singers one hears at a "party," from the inevitable young lady, who has a cold when asked to sing, to Pat Casey, who could sing only "Harrigan." Morton works in some of the drollest imitations of the various singers, and gets many laughs for every line. Orchestra accompaniment; music, Seymour Furth; words, Will Wheelan; publishers, Great Eastern Music Publishing Co., New York.

## 30 Castilian Echoes

Samuel Siegel and Wm. Smith

Only one mandolin and guitar duet has previously been listed in the Edison Catalogue of American Selections. Two numbers are combined in "Castilian Echoes." The first has the languorous rhythm of the Spanish national dance, "Habanera," while the second is a rapturous waltz movement. Not only is this Record extremely good musically, but, as it is played by two of the leading performers of this country, it makes a safe model for students of the mandolin and guitar. Composer, Samuel Siegel.

## 31 The Palms

James F. Harrison

There are only a very few sacred solos in the same class with "The Palms." It is a surpassingly beautiful piece of vocal music, to which Mr. Harrison lends one of the ablest efforts of his long career as a singer of religious music. The sweet tone-quality of his robust baritone records perfectly and was never more delightful than in the Faure masterpiece, now given complete for the first time on any Record. Orchestra accompaniment; composer, J. Faure.

## 32 Nigger Loves His Possum

Collins and Harlan

Considered by many to be Collins and Harlan's best duet. This "classic" could not possibly have been left off the first list of four-minute Records. The scene is a Mississippi steamboat deck as the boat is about to leave with a crowd of typical southern darkies aboard. Between the "Mobile Buck" and other dances by star performers, a bunch of comic repartee, genuine negro shouts and peals of laughter, the clanging bell and tooting whistle of the boat and the great tuneful duet chorus by Collins and Harlan, we are treated to four minutes of the liveliest entertainment imaginable. Orchestra accompaniment; music and words, Paul Dresser; publishers, F. B. Haviland Pub. Co., New York.

## 33 You Can Look and You Can Listen, but M-U-M is the Word

Ada Jones

A new comic song that is being sung on all sides. Tom White, though newly wed, longed to get out with "the boys." His wife was "country," but far from simple, and his little lodge "gag" failed utterly to work. She follows him and finds that instead of treating the fellows to the "third degree," he is treating "the girl in blue" to champagne fizz. Naturally, a vivid scene ensues. The tune is a rollicking one, introducing a phrase of a well known Oriental air. Orchestra accompaniment; music and words, James Brockman; publishers, Helf & Hager Co., New York.

## 34 Always Gallant Polka

Albert Benzler

One of the most contagious things we have heard. It will not progress very far until you find yourself keeping time with its rhythm. A novel feature is included in an obligato and variations, played on the xylophone while the principal theme is played as a duet by cornets. Benzler performs with all of his accustomed dash and confidence and the true xylophone tone is perfectly reproduced. Orchestra accompaniment; composer, A. Fahrback, Jr.; publishers, J. Schott & Co., New York.

## 35 Rocked in the Cradle of the Deep

Gus Reed

Gus Reed's bass tones record better on the Amberol Record than was ever possible with any other singers on any other talking machine record. His voice is one that is a never-ending pleasure to listen to. The present Record offers the complete song, sung at the correct slow tempo. It is sure to revive interest in the famous bass solo on a very wide scale. Orchestra accompaniment; music, J. P. Knight.

## 36 I Would Still Love You

Ada Jones and Billy Murray

A capital love-duet with a generous flow of 18-karat comedy. Jones and Murray vie with one another in handing out the "airy persiflage" of love. The song smacks of "Kiss, Kiss, Kiss," and "Smile, Smile, Smile," two fine sellers among the two-minute Records, by the same singers. The Amberol Record gives twice as much entertainment, however, on account of being twice as long. Orchestra accompaniment; music, C. W. Murchy; words, Harriett Castling; publishers, Francis, Day & Hunter, New York.

**37 A Police Court Scene****Steve Porter**

A rich and rare vaudeville skit in which a witty Irish judge disposes of a docket of ten cases at one sitting. A liberal amount of uproarious fun is extracted from each case called. The last case was that of Danny Reilly who wiped out a Dutch colony because they said the Irish were no good. The judge recognizes him as an old friend, and adjourns court to join Reilly in a game of pinochle. Original sketch, not published.

**38 Semiramide Overture****Edison Concert Band**

The overtures that rank with this one can be counted on the fingers of a single hand. It is truly a musical inspiration, such as comes to the master composer but once in a lifetime. Nearly the whole selection is given, including the celebrated second movement, the Horn Quartette. The Edison Concert Band gives the overture a reading that will hold one's attention fast to the last note. Composer, G. Rossini; publisher, Carl Fischer, New York.

**39 I Was Roaming Along****Edward M. Favor**

Among the cleverest comic songs in Favor's repertoire. Roaming Bill was a happy-go-lucky individual, whose hardest task in life was "roaming here, roaming there." No matter how he tried, he could not avoid "easy money" and good fortune. It was simply handed out to him at every turn. Three verses and three choruses, the latter being set to a very roguish and unusual tune. Orchestra accompaniment; music, Joe Hollander; words, Arthur J. Lamb; publisher, Shapiro, New York.

**40 In the Sweet Bye and Bye****Edison Mixed Quartette**

Everybody loves this beautiful old song, handed down by our grandparents. Mechanically, this Record is better than "Good Night, Beloved, Good Night," by the Mixed Quartette. The four-minute feature also gives the advantage of hearing the song complete, three verses and three choruses. Every one of the four voices is heard with perfect distinctness, the female voices being especially good. Orchestra accompaniment. Music, Jos. P. Webster; words, S. Fillmore Bennett.

**41 A Bunch of Nonsense****Murry K. Hill**

Another crack-a-jack vaudeville sketch by Hill, which includes a couple of his latest song hits. The first is a neat parody on "Good Bye, Little Girl, Good Bye." The second, a parody on "Blue Bell." This is very funny. It tells the short life history of "Our hired girl, Sal," after she used coal oil for starting a fire. Another feature is a short recitation about a cake of cheese. This also is a remarkably "strong" feature. Orchestra accompaniment; original sketch, not published.

**42 Reels and Walk-Arounds****Leopold Moeslein**

An unique medley of the liveliest medleys and walk-arounds. The reels are played as a violin solo, by Mr. Moeslein, and the orchestra assists in emphasizing the walk-arounds. The following selections are played in the order named: Matinee, reel; Suwanee River, walk-around; Make Up, Susan, reel; Old Kentucky Home, walk-around; Army and Navy, reel; Annie Laurie, walk-around; Jaudas' Favorite, reel; Hear dem Bells, walk-around; Moeslein's Favorite, reel. Orchestra accompaniment.

**43 A Busy Week at Pumpkin Center****Cal Stewart**

Cal Stewart is "right down tew home" among the folks in this masterly talking Record. And his dry Yankee humor and quaint New England drawl were never more delightful. "There be times" when there are busy scenes at romantic Pumpkin Center, even if Stewart's talks do give the idea that it's mostly play down his way. For side-splitting comic description this four-minute Record will be voted one of the very best friend "Cal" has yet made. Sketch is original and not published.

**44 O That We Two Were Maying****Mr. and Mrs. Waterous**

As a two-minute Record by the same singers this selection won the distinction of being one of the most favored duets in the Edison catalogue. The song is now given complete, the singers are in better voice than when the two-minute Record was made, and the recording process has been greatly improved. The Record, therefore, is in every way better than its famous predecessor and should meet with a phenomenal demand. Orchestra accompaniment; music, Alice Mary Smith; words, Rev. Chas. Kingsley; publisher, G. Schirmer, New York.

**45 Waltz Medley****New York Military Band**

"On with the dance!" Here is just what is wanted for a merry waltz—a captivating waltz medley made up of the familiar refrains of the best waltz songs of the day "Just Some One," "When You Love Her and She Loves You," "O'Brien Has No Place to Go," "When It's Moonlight, Mary Darling, 'Neath the Old Grape Arbor Shade," "Are You Sincere," and "Take Me Out to the Ball Game." The time is perfect waltz and the Record runs a full four minutes.

- 46 Selections from Faust** Edison Symphony Orchestra  
 A truly wonderful orchestra Record, which gives the most beautiful airs from Gounod's opera, "Faust:" Grand Chorus (the Fair) Act 1; Romance, Act 3, (Siebel); Soldiers' Chorus, Act 3, and Finale of Act 4. This is considerably more of the opera than was ever before recorded at one time, and the Symphony Orchestra gives it a grand interpretation. Composer, Charles Gounod.
- 47 Silver Threads Among the Gold** Will Oakland  
 The most noted counter-terror song ever written. No matter how charming are Oakland's new songs in Dockstader's Minstrels, the audience will never allow him to retire until he sings "Silver Threads." The words are unsurpassed for appealing tenderness and the air is beautiful beyond description. Orchestra accompaniment; music, H. P. Danks; words, Eben E. Rexford; publisher, Hamilton S. Gordon, New York.
- 48 Santiago Flynn** Ada Jones and Len Spencer  
 An Irish maiden is courted by an Italian wooer. He plays the mandolin beneath her bower in true Romeo fashion and asks her to be his Irish Rosie, but she is able to make very little sense out of his "dago blarney." He asks her to cast her eyes on him and she answers sweetly that she has no cast in her eye. Santiago Flynn entreats her to take the name of Signora Santiago. "A fine name—for a five-cent cigar" she exclaims. The ending is happy, however, for Santiago convinces her that his father was Paddy Flynn, a good, true Irishman. She then agrees to have him to the accompaniment of "Killarney," on the mandolin. Several clever songs are introduced by Miss Jones. Orchestra accompaniment.
- 49 Blue Danube Waltz** Knickerbocker Quartette  
 The Blue Danube Waltz made Johann Strauss' fame. It is generally regarded as the finest waltz ever written. In our Record the irresistibly sweet melodies are arranged for a quartette by male voices. The Knickerbocker Quartette sings it in a manner which will cause the vocal arrangement to rival the instrumental in popularity. Orchestra accompaniment; composer, Johann Strauss; publishers, Oliver Ditson Co., Boston, Mass.
- 50 American Standard and the New Colonial Marches** Edison Military Band  
 This Record combines two of the best selling two-minute Records in the Edison catalogue. American Standard was the first selection ever played by the Edison Military Band. The New Colonial Marches are the best known work of the celebrated military march writer, R. B. Hall. The Edison Military Band gives a flawless performance. Composers, Frank R. Seltzer and R. B. Hall; publishers, Harry Coleman, Philadelphia, Pa.; and The John Church Co., New York, respectively.

# Edison Records

## To be Withdrawn from Sale

*THE 200 Edison Records named below will be withdrawn from our catalogue on December 1st, 1908. After December 1st, we will refuse to fill orders for any selections on the list, and any stock we may have on hand will be destroyed. These Records are being withdrawn solely because of the demand of the trade that the number of selections in our catalogue be reduced. They are equal in every respect to the selections retained, and would be continued in the catalogues were it not for the trade requirements. They have been and are still popular and large selling Records. Dealers should urge Phonograph owners, to look over the list and buy now any in which they may be interested. They will not be able to do so after December 1st next.*

50	Off to Camp March	Edison Military Band	8203	Watching and Waiting	Harlan & Stanley
657	Awakening of the Lion	Edison Military Band	8218	Down the Line with Molly	Collins & Harlan
1530	My Beautiful Irish Maid	MacDonough	8332	I'll Kill the Man Who Swiped My Can	Collins & Harlan
6105	What do You Think of Hoolihan?	Favor			
7328	Willow Grove March	Edison Military Band	8365	Then I'd Be Satisfied With Life	Favor
7425	Manisot March	Edison Military Band	8368	Monkey Shines on the Mobile Levee	Edison Military Band
7603	Sweet Antoinette	Harlan & Stanley			
7664	Coleville Coon Cadets	Collins	8419	In the Starlight	Morgan & Stanley
7722	Dancing with Ma Baby	Edison Military Band	8521	Won't You Kindly Hum Old Home Sweet Home to Me	Murray
7856	Olympia Hippodrome March	Edison Concert Band	8550	Bedelia	Murray
8043	Morning in Noah's Ark	Edison Military Band	8553	I'm Goin' to Leave	Collins & Harlan
8111	Imperial Edward March	Edison Concert Band	8564	Up in a Coconut Tree	Murray
8152	Molly Come Drive the Cows Home	Harlan	8574	Bedelia Medley	Edison Military Band
8153	Schultz on Christian Science	Kennedy	8613	Dear Old Girl	MacDonough
8165	Stay in Your Own Back Yard	Collins	8648	Barney Medley	Edison Military Band
8175	Nursery Rhymes	Collins & Harlan			

# 28 Edison Phonograph Monthly, Sept., 1908

8659	If I Were Only You	Harlan	9292	It's Up to You to Move	Collins & Harlan
8660	Bunch of Violets	Edison Symphony Orchestra	9295	Everybody Gives Me Good Advice	Roberts
8664	Breeze of the Night	Edison Male Quartette	9298	I Like Your Way	MacDonough
8666	Come Down From the Big Fig Tree	Collins & Harlan	9300	If Washington Should Come to Life	Murray
8668	Dear Sing Sing	Murray	9301	My Little Dutch Colleen Medley (Xylophone)	Benzler
8675	Cordalia Malone	Favor	9302	Here It Comes Again	Collins
8684	Good-bye My Lady Love	MacDonough	9303	Lonesome Little Maid	Gillette
8685	The Gondolier	Collins	9305	Dance of the Nile Maidens	Edison Concert Band
8686	The Irish, The Irish	Favor	9308	Baby Song—Chas. T. Ellis'	Watson
8707	The Goo-Goo Man	Collins	9309	Passion—Intermezzo	Edison Symphony Orchestra
8725	Starry Night for a Ramble	Edison Male Quartette	9314	Polonaise Militaire	Edison Concert Band
8730	Oysters and Clams	Collins	9318	After They Gather the Hay	MacDonough
8746	There's Nobody Just Like You	MacDonough	9320	Bill Simmons	Collins
8747	Where the Mocking Birds are Singing	Werrenrath	9321	Gen. Mixup U. S. A.	Edison Military Band
8753	I Can't Do the Sum	Edison Male Quartette	9322	Smile On Me	Gillette
8760	On Jersey Shore March	Edison Concert Band	9323	Daughter of Vanity Fair	Harlan & Stanley
8768	Everywhere Medley	Edison Military Band	9328	With the Robins I'll Return	Harlan
8779	A Bit o' Blarney	Favor	9329	I'm Up in the Air About Mary	Murray
8780	Karama (Banjo)	Ossman	9330	Baby Parade	Edison Concert Band
8791	Louisa Schmidt	Collins & Harlan	9331	Poor Old Man	Roberts
8792	Yarney's Ideal (Xylophone)	Benzler	9332	While the Old Mill Wheel is Turning	Anthony
8806	Valley of the Sunny San Joaquin	MacDonough	9337	Free Lance March	Edison Military Band
8807	Dreaming on the Ohio	Edison Male Quartette	9346	Give My Love to Dixie	Gillette
8826	The Chirpers	Edison Military Band	9348	Spoontime (Xylophone)	Benzler
8830	Save It For Me	Murray	9351	Jubilee Overture	Edison Symphony Orchestra
8840	Wedding of Barney and Bedelia	Collins & Harlan	9352	The Umpire is a Most Unhappy Man	Favor
8845	Down at the Baby Store	Harlan	9363	The Stars, the Stripes and You	Stanley
8857	There's a Dark Man Coming With a Bundle	Roberts	9364	When a Poor Relation Comes to Town	Collins
8860	Back, Back to Baltimore	Collins & Harlan	9370	Irish Hearts March	Edison Military Band
8864	Mr. Wilson—That's All	Murray	9373	Foolishness	Favor
8922	Let's All Go Up to Maud's	MacDonough	9374	La Balladora	Edison Symphony Orchestra
8923	Daddy Dear	Anthony	9375	Sweet Julienne	Thompson
8927	Port Arthur March	Edison Military Band	9376	Why Don't You Write When You Don't	Roberts
8942	Can't You See My Heart Beats All for You	Murray & Roberts	9378	Champagne Galop	Edison Concert Band
8979	Tammany	Collins & Harlan	9380	Come Take a Skate With Me	Murray
9012	Suzan Van Doozen	Roberts	9385	Chicken Chowder	Edison Military Band
9033	Shame on You	Tascott	9386	Bohemian Festival	Edison Concert Band
9034	Good-bye, Sweet Marie	MacDonough	9397	Happy Lena Polka (Xylophone)	Benzler
9037	Me an' de Minstrel Ban'	Murray	9401	Frau Louisa	Edison Concert Band
9046	Now What D'ye Think of That?	Roberts	9405	Golden Crown Overture	Edison Symphony Orchestra
9057	Who's There?	Collins	9406	Everybody Have a Good Old Time	Collins
9061	Violette	Harlan & Stanley	9411	O Leave Me Not Dear Heart	Anthony
9073	Now What d'ye Think of That Medley	Edison Military Band	9416	Meister's Musical Masterpiece	Spencer
9076	Making Eyes	Collins & Harlan	9418	Hottentot Love Song	Jones
9078	Waltzing With the Girl You Love	MacDonough	9419	Norma Darling	Gillette
9089	Through Battle to Victory March	Edison Concert Band	9423	Abraham Jefferson Washington Lee	Collins
9092	The Adieu	Narelle & Anthony	9424	Eternity	Anthony & Harrison
9105	A Picnic for Two	MacDonough	9425	Persia	Edison Concert Band
9114	My Word	Ada Jones	9427	Your Eyes So Dear	Thompson
9121	My Maryland March	Edison Military Band	9435	Just Because	Anthony
9124	On the Banks of the Rhine	Collins & Harlan	9436	Gwendolyn	Jones
9146	At the Old Grist Mill	Edison Concert Band	9442	Moses Andrew Jackson Good Bye	Collins
9147	Luna	Barrow	9444	Seems to Me I've Always Loved You	Gillette
9151	Lily White	MacDonough	9445	Hermosillo	Edison Symphony Orchestra
9161	With Flying Colors March	Edison Concert Band	9446	Why Can't a Girl Be a Soldier?	Thompson
9163	Short Stories	Frank Bush	9451	When Tommy Atkins Marries Dolly Gray	Murray & Chorus
9170	The Choristers	Edison Concert Band	9457	On the Rocky Road to Dublin	Edison Military Band
9187	Goodbye, Dixie Dear	MacDonough & Biehling	9458	A Garden Matinee	Edison Concert Band
9188	Yankee Boodle'	Murray	9468	Good Bye Sweet Maryland	Harrison
9190	Take Me to Your Heart Again	Barrow	9470	Night Time	Myers
9196	I'm a-Dreaming of You	Collins & Harlan	9471	Whistle It	Trix, Meeker & Murray
9200	It's a Good World After All	Roberts	9478	Because You're You	Hinkle & MacDonough
9210	Is Everybody Happy?	Maitland	9479	I'm Going Right Back to Chicago	Collins
9218	Gleaming Star	Edison Concert Band	9482	Uhlans' Call	Edison Concert Band
9223	Then I'd Be Satisfied With Life (parody)	Julian Rose	9483	Mountain King	Stanley
9230	I Lost My Heart Way Down in Alabama	MacDonough	9488	I've Got a Vacant Room for You	Roberts
9233	Razzazza Mazzazza	Edison Concert Band	9490	In a Chimney Corner	MacDonough
9234	What's the Use of Knocking?	Meeker	9494	Good Bye Nellie Darling	Thompson
9239	Pretty Desdamone	Collins	9497	Lalu My Lubly Queen	Edison Concert Band
9245	Cousins (Trombone and Cornet)	Clark & Zimmerman	9498	We'll Be Sweethearts to the End	Myers
9247	Where the Susquehanna Flows	MacDonough	9500	I'll Miss You in a Thousand Different Ways	Gillette
9248	I Would Like to Marry You	Hoy & Anthony	9504	Beauty's Eyes	Edison Male Quartette
9249	Target Practice March	Edison Military Band	9510	Farewell Killarney	Gillette
9257	Feather Queen	Edison Concert Band	9514	Far Away	Anthony
9258	We Parted as the Sun Went Down	Thompson	9518	That's What the Rose Said to Me	Le Baron
9260	When Mose With His Nose Leads the Band	Collins & Harlan	9529	My Mariuccia Take-a Steamboat Medley	Edison Military Band
9262	Songs the Bands Play	Meeker	9532	While I Have You	Gillette
9266	Everybody Works but Father	Edison Military Band	9535	Oh, Mister Brown	Collins
9268	Jessamine	Collins	9551	Ask Me Not	Denny
9274	Imperial Life Guard March	Edison Military Band	9557	Pretzel Pete (Banjo)	Ossman
9282	Anxious	Hoy & Anthony	9566	Monte Cristo	Roberts
9283	Good Bye, Sweetheart, Good Bye	Stanley	9573	Dainty Dames (Bells)	Benzler
9284	Dramatic Overture	Edison Symphony Orchestra	9574	Lulu and Her La, La, La	Trix
9290	Charge of the Hussars	Edison Concert Band	9576	Land League Band	Myers
			9610	Dearest, Sweetest, Best	Anthony
			9618	So Long, So Long	Collins
			9620	My Word! What a Lot of It	Denny

# Advance List

## Of Four New Edison Records by Harry Lauder

*The Lauder Records may be shipped to Dealers by Jobbers on September 23d, with the October two-minute Records, and sold at retail on the usual selling date, September 24th.*

**H**ARRY LAUDER, with his tuneful Scotch songs, his infectious laugh, his rolling r's, his quaint, side-splitting comedy is back again. Lauder has made four new Edison Records. The seven Lauder Records issued in February last were received with such enthusiasm that it was arranged to have him make four more Records of his latest song successes in London, England.

Lauder is a real genius of high-class comedy song. In London he is regarded as the king of music-hall artists. On this side of the Atlantic we know that this title is deserved, from the triumph he won during a four-weeks' engagement at the New York Theatre and from hearing him on the wonderful Edison Records.

The four new Lauder Records described below are in every way equal to his first lot and will probably outsell them, for he is better known now than when the first lot were issued.

### 13741 Hey Donal'!

Donal's sweetheart leads him right up to the point of popping the question and then has a sudden fit of shyness. However, when Donal' asks, "What about yer mither?" she answers that her "mither" took her "faither," and she'll take Donal'—and they lived happily ever after. The song is an old favorite and has been featured by Lauder ever since he first became the music-hall idol of London.

### 13742 The Weddin' O' Sandy Mac Nab

Lauder's latest hit. He sings of Sandy Mac Nab's having married in defiance of the confident predictions of his cronies that he never would. In the middle of the song he pauses long enough to relate a laughable incident of the wedding celebration, which was "a splendishus affair." The chorus is accompanied by a happy peal of wedding bells. It is said to be the most popular tune of the day in England. It is being hummed and whistled on every hand in the streets of London.

### 13743 Fou the Noo

Of all the droll songs in Lauder's repertoire this is the limit. He is "fou" (full) and he gives an imitation of a drunken man singing a song, that is so realistic it is hard to believe he is not some "three sheets under the wind" himself. There are the usual witty conversational passages and a coughing stunt that is simply great. Here are the happy concluding words:

"My name is Jock McGraw,  
And I dinna care a straw,  
For I've something in the bottle for the morning."

### 13744 When I Get Back Again tae Bonnie Scotland

A characteristic Scottish love song with more than one appealing touch of pathos. John's to be away from his bonnie lassie seven years. He consoles himself by singing, with delightful tenderness of her many charms. There is the usual Lauderesque conversational interlude, in which he describes the parting in a way to arouse pity in a heart of stone. A thoroughly charming Record.

# Broaden Your Field

—and increase your sales. A dealer makes a serious mistake by selling records and instruments for amusement purposes alone. There is besides the amusement field the vast field of education from which can be reaped an abundant business. Here the dealer can increase the sale of records to those who already own phonographs, and can sell both instruments and records to a very large number of cash customers who would never think of buying a phonograph except for educational purposes. All this is made possible through

## I.C.S. LANGUAGE SYSTEM

WITH  
*Thomas A. Edison*  
PHONOGRAPH

There is a great opportunity for **you** to sell I. C. S. Language Outfits to people who are going abroad or who desire to learn a language for the sake of the knowledge of it alone; to those who desire to qualify for positions as translators and foreign correspondents; and to foreigners who wish to learn to speak English. No sledge hammer is needed to get it clearly into your head that this presents a sure way of broadening your field of work and increasing your sales. For the sake of good business sense, boom the I. C. S. Language feature of the business.

**International  
Correspondence Schools  
SCRANTON, PA.**

# The EDISON PHONOGRAPH MONTHLY

Vol. VI

October, 1908

No. 10



A mildly humorous illustration of a decidedly serious article. See page 3

# The EDISON PHONOGRAPH MONTHLY

Published by the National Phonograph Co., Orange, N. J.

All communications to *The Phonograph Monthly* should be addressed to the Advertising Department, Orange, N. J.

## Contents for October, 1908

The Title of Edison Jobber or Edison Dealer as a Business Asset . . . . .	1
Our New Policies . . . . .	2
Success Assured . . . . .	2
Store Management . . . . .	3
Selling the Goods . . . . .	5
Points on Selling Attachments . . . . .	7
Don't Blame the Jobbers . . . . .	8
About Establishing Branch Stores . . . . .	8
Sign the Addenda . . . . .	8
Edison's Fame Secure . . . . .	9
Three More Lauder Records . . . . .	9
An Interesting Comparison . . . . .	9
Important Letter to Jobbers and Dealers . . . . .	10
The Muslin Banners . . . . .	11
No Electros of Attachments or Machines . . . . .	11
Advertising Amberol Records . . . . .	12
All Want Foreign Records . . . . .	12
Ready Made Ads . . . . .	14
Window Talk . . . . .	15
Lessons for Dealers, No. 3 . . . . .	16
Trade Bulletins . . . . .	17
Suspended List . . . . .	17
Advance List of Three New Records by Harry Lauder . . . . .	19
Advance List Edison Standard and Edison Amberol Records for December . . . . .	20
Our Magazine Advertisement for November . . . . .	24

NEW YORK: 10 FIFTH AVENUE.

NATIONAL PHONOGRAPH CO., LTD., VICTORIA ROAD, WILLESDEN, LONDON.

NATIONAL PHONOGRAPH CO. OF AUSTRALIA, LTD., 340 KENT STREET, SYDNEY, N. S. W.

MEXICAN NATIONAL PHONOGRAPH CO., AVENIDA ORIENTE No. 117, MEXICO CITY.

COMPANIA EDISON HISPANO-AMERICANA, VIAMONTE 515, BUENOS AIRES.

EDISON GESELLSCHAFT, M. B. H., SUD-UFER 24-25, BERLIN.

COMPAGNIE FRANCAISE DU PHONOGRAPHE EDISON, 42 RUE DE PARADIS, PARIS.



Is anything more needed to make the title of "Edison Jobber" or "Edison Dealer" a greater business asset?

First, Records by William Jennings Bryan; Second, Records by William H. Taft; Third, Edison Amberol Records, attachments to play them, and Combination Phonographs; Fourth, a policy that will prevent Dealers from being loaded up with unsalable cylinder goods of other manufacture; Lastly, (so far) a policy that will protect Dealers in their towns against the indiscriminate establishing of other Dealers in Edison goods.

These advantages do not take into account the present Edison Records and machines, all as salable as ever. Are not all of these enough to make every Edison Dealer anxious to retain his privileges?

### Our New Policies

The announcement made a month ago, that after October 1st, unless the time is extended by formal application in each case, Dealers who handle other makes of cylinder goods will not be permitted to sell Edison goods, needs no apology or defense. It has been widely discussed in the talking machine trade. The response which has come from both Jobbers and Dealers has been hearty, spontaneous and enthusiastic, and we have no doubt as to the complete success of the new arrangement.

Now, on top of the announcement of last month, comes another of even greater interest to Dealers. It is printed in full on another page. It means that we are going to regulate the matter of creating new Dealers and thereby prevent new ones from being established in places already properly covered.

It means that every Dealer who is pushing our line properly and is carrying an adequate stock of Edison goods will not be disturbed in his town. Seventy per cent. of our 13,000 Dealers at present have no competition in their towns and because of this later announcement 9,000 Dealers will continue without competition so long as they measure up to our reasonable requirements as to stock and energy.

Along with these two new policies we have in mind several plans designed to aid Dealers in making an even greater success of the Edison. The better discounts on the Amberol Record and the greater attractiveness of the new machines and attachments are among the things that cannot fail to make the privilege of being an Edison Dealer a valuable asset to every one possessing it. We confidently predict that the immediate future will make closer the co-operation between Jobbers, Dealers and the National Phonograph Co., and will inaugurate a period of unexampled prosperity for all.

---

### Success Assured

If ten times the space of this issue of the EDISON PHONOGRAPH MONTHLY were used for no other purpose, we could not repeat the laudatory comments that have been made, or complimentary letters written about the Edison Amberol Record, the attachments to play them on existing machines and the new types of Phonograph designed to play both the old and the new Records. The announcement concerning them came at the psychological moment. It has awakened a new enthusiasm and a renewed determination to push the Edison line as it has never been pushed before.

More expressive than words and letters has been the extent to which Jobbers have placed orders for the new goods. We believe that all orders have been more conservative than they would have been had the goods been on the market, and yet the total, for a time, has put us in the undesirable position of not being able to make more than part shipments. Our advance plans had provided for what we considered a big business, but we were too conservative. The first orders of Jobbers were large for a new product but before a single shipment had been made further orders were received from a large percentage of the Jobbers and they are still re-ordering. As their salesmen and our own salesmen get out among the Dealers they are meeting with the same reception that was accorded us by Jobbers when the announcement was made. The result has been a flood of orders that bids fair to swamp Jobbers and demonstrates that no first order placed by a Jobber will be large enough.

And the factory at Orange, N. J. After several months of a reduced force and shorter hours, it is a joy to see it running day and night, with one of the largest forces and pay rolls in our history. It is sweet music to hear every bit of machinery humming from early morning without cessation. In a commercial sense, it is a beautiful sight to see the immense concrete buildings, with their hundreds of thousands of feet of floor space, lighted at night from top to bottom. It is gratifying not alone for the profits to the trade and ourselves, that will result from this activity, but because it gives employment to many men and women who have done nothing for several months. Nothing is being left undone that will increase the output of the factory and thereby enable us to catch up and keep up with the demands of the trade. Because the conditions are new, we are more anxious to get Amberol Records, attachments and combination machines on the market.

No one connected with the Edison organization has at any time had any misgivings as to the success of the new Record, etc., and yet we rather expected the trade to find minor flaws that had been overlooked. But no such difficulties have been reported. The most expert men among the Jobbers have carefully gone over the new Record and the new attachments for the past month or more and have only words of praise for them. Nothing but getting a larger quantity of the new goods on the market seems to be wanting to consummate the final success of our work and this our splendid factory facilities will soon enable us to do.

# Store Management

A monthly comment on things Edison dealers have done with a few suggestions on what they should do to increase sales.

People hesitate to go into a store without a definite errand.

The advertisements contain a cordial invitation to call and see furniture, hear music or try this, that or the other thing.

Yet people hesitate.

Why?

Because so many stores confine their cordiality exclusively to their advertising.

"Come in and stay as long as you like," says an advertisement.

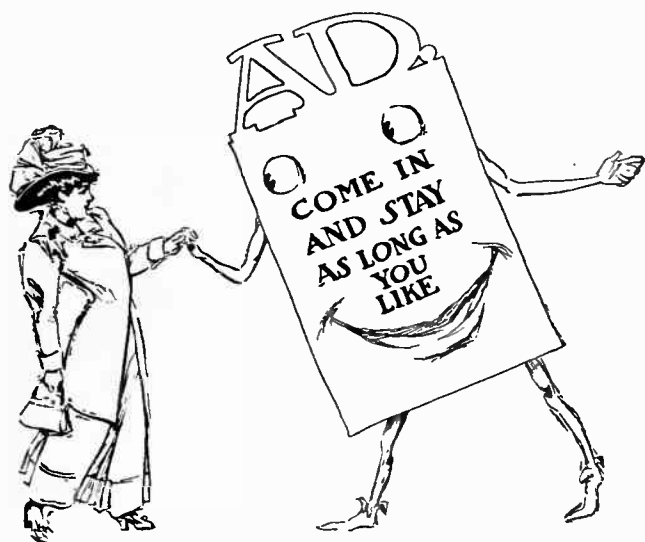

"It costs nothing to look," says another.

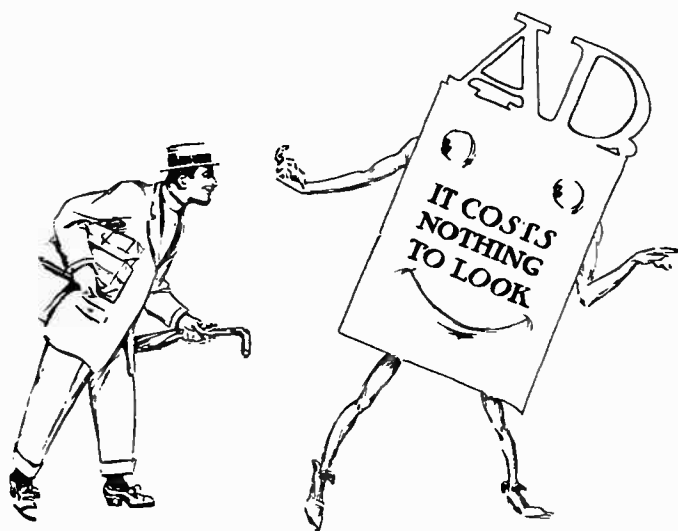

You go, you look, you listen, you ask questions, you take up a clerk's time, but the moment you give the least hint that you are not going

to spend any money at the time, a frost sets in,



the clerk's enthusiasm ebbs away, he loses interest in you, tries to close the interview and you gain the street feeling like an intruder.

This isn't always true, but it is true so often that hundreds of people, who really want something, prefer to look in windows rather than come inside and get helpful information.

How about your store?

Do you carry out your advertised promises?

When you announce the new Records and invite people to drop in and hear them, do you welcome all comers, make them comfortable, play through the entire list, explain the advantages of the Edison Phonograph and thank them, as they depart, for their interest, even though they buy nothing?

Or do you size them up as they come in, decide that certain ones are merely idly curious or are looking for a little free entertainment, play a Record or two, hand them a bunch of printed matter and excuse yourself?

In business you cannot discriminate. When you invite the public to your store and agree to do certain things, you must take the public as it comes.

You must consider every caller a possible purchaser or at least a future prospect.

A reputation for cordiality and courtesy is a big asset. Make people feel free to drop in when they like, regardless of what their errand

is, and you will find they will never drop in another store when they want what you sell.



If you are selling other things than Phonographs, make the Phonograph end a separate department.

Don't scatter.

A small stock of Phonographs makes a big showing if properly displayed.

But mix up Phonographs and Records with stationery, hardware, pianos, sporting goods and other merchandise and each line suffers.

The larger stores carrying Phonographs have a room for showing and demonstrating, where people may be taken away from the rest of the store and the noise of the street. There is a carpet on the floor and an easy chair to sit in. The surroundings are pleasant; the whole setting calculated to make the best impression.

This, of course, is not possible in the majority of stores selling Phonographs. But it is always possible to have some place where customers may be seated, away from outside noises and out of the way of other customers.

Even an Edison Phonograph cannot always inspire a possible purchaser who must listen to it standing in the main aisle, pushed here and there by passers-by, or leaning against the wall or hanging over a counter.



Get people away from the idea that Edison Records are delicate—that you must walk on

tip-toe when one is about or it will fly to pieces.

You can break an Edison Record with a hammer.

You can ruin the threads with your finger nail.

But they are by no means frail.

It is the very delicacy of the Edison Record that produces the faithful reproduction of sound and the clear, sweet tones for which the Edison is famous.

They should be handled with care, that's all—just ordinary care.

If this is done, they will last for years, as the wear on them from the reproducing point is almost imperceptible. An Edison Record will play with its original clearness and sweetness longer than any other record made.

That's the point for you to emphasize when the question of durability comes up.

Now come the new Amberol Records. Do not let their coming pass as merely an incident in your Phonograph business.

They are an event.



Nothing of so great importance has happened in the talking machine world since the discovery of the phonographic idea by Mr. Edison.

You can offer your trade a Record that plays, talks or sings as long as any two ordinary Edison Records.

You can offer them a Record that plays longer than any record of any kind on the market.

You should concentrate on these new Amberol Records. You should concentrate in displaying them, in advertising them and in talking them.

You should see to it that every Phonograph owner and every possible Phonograph purchaser not only knows about them, but hears them.

You should urge Phonograph owners to equip their instruments so that they can enjoy the Amberol Records.

They will cause a revival of interest in Phonographs that have been silent for years; they will give impetus to the sale of Records; they will make the Phonograph more necessary in the home than ever.

# Selling the Goods

ADVERTISING:—One of the most important and often one of the most neglected branches of a dealer's business.

## *Your Part in Our Advertising Campaign*

We want to have a few words with the Dealer who doesn't yet believe that advertising of his own will help to sell more Phonographs.

Retail advertising of the Dealer is next in importance to the national advertising of the manufacturer.

All that the National Phonograph Company can hope to do is to tell everyone who can read about the Edison Phonograph and how desirable it is.

The only way you can get this trade for your store is to let it know that you carry the Edison Phonograph. Of course, if you have no competition—if no one else in your neighborhood or territory sells Edison Phonographs—then everyone who wants a Phonograph so badly that he is willing to go out and hunt up a Dealer, will come to you, but how about the large number of people who are only half convinced, who have read our advertising and become interested, but who need your advertising to make them buy?

Selling any kind of goods is a matter of persuasion, but when it comes to selling a luxury, for, of course, the Phonograph is a luxury, you require more persuasion in the form of advertising than you do to sell flour, clothing or some actual necessity.

Nature insists that people shall eat; the law insists that people shall wear clothes, but the taste for amusement can be gratified in different ways.

What we want to do is to get at the people before they have spent their money for other things and in other stores and persuade them that no investment they can make will cheer them up so much as an Edison Phonograph.

Now if you could get these people into your store and talk to them face to face, you would soon convince some of them, but you cannot do that, so you must advertise—in your local papers, in your windows and by means of distributing

printed matter—and keep at it until you have sold a Phonograph to every inhabitant of your town who has the money to buy one and the inclination to hear one.

## *Have a Definite Plan for Advertising*

The work of advertising a store like yours is not so hard as you think.

First make up your mind that you will spend a certain amount of money in advertising in 1909.

Then find out just how much space you can get in your local newspaper for this money. If there are several papers in town and you have not money enough for all of them, pick out the best. If you cannot go in every day, go in twice a week. If you cannot go in twice a week, go in once a week. If your town papers are weeklies, then once a week is certainly often enough, but in a daily paper you ought to be in at least twice a week, and especially between now and the holidays, when people have more money to spend and more desire to spend it.

When you have found out the space that you can afford, then write to us for a set of the ready-made newspaper ads, which we have been showing in this magazine for months. We have enough ads to supply you with just as many as you can use. They are ready-made. That is, illustration and copy are all ready. If you have anything you wish to say in addition to what we have said for you, you can add it to these ads.

The idea of the ready-made ad service is to relieve the Dealer of the work of preparing copy. It takes a good deal of time to prepare advertising copy, even if you have the knack. It would cost you more for such illustrations as we give you than you could afford. We give you this advertising absolutely free in return for your co-operation to help sell Edison Phonographs. The only obligation there is on your part to use it is the obligation that every man in business has to make all the money he can.

You are not making all the money you can as long as you neglect to call the attention of every possible Phonograph buyer to the Edison Phonograph.

### *Follow Up Phonograph Sales*

After you have sold a Phonograph, do not strike that customer off your list. That is only the beginning. You ought to make a great deal more money out of selling Records to a customer than you did when you sold him his Phonograph. There are twenty-four new Records every month, and all of them are good. Of course, you cannot sell all kinds to everyone, but there is at least one example of every kind, and every customer you have ought to buy some new Records every month. They will if you go after them in the right way. If you let them know when the Records are there, if you invite them to come into the store and hear them, if you take pains to take out the kind of music they like when they are there, and if you are as good a salesman as we think you are, you should sell at least one new Record every month to every customer to whom you ever sold a Phonograph.

And here again advertising comes into play—our advertising. We send you a great deal of printed matter about the new Records—*The Phonogram*, the Record Supplement and various other things, calling attention to the new music. Send them out or distribute them. See that every single man in your town who owns a Phonograph hears about the new Records in time.

The only advertising that is successful is persistent advertising. It is not enough to advertise once, or one day or one week; it is advertising all the time that makes a business successful.

Surely you do not think that the big advertisers of the country—Wanamaker, Marshall Field, Rogers, Peet & Company and other retailers—made a success by any one splurge of advertising. They advertised every day. It is not necessary, however, for you to advertise every day, but you should advertise frequently and regularly. You must persist. You will not get your money back the first or second day. You will not get your money back until you get the people in the habit of coming to your store for the goods you sell. This is just as true whether you sell Edison Phonographs exclusively or whether you sell other kinds of goods. It is the advertising that sells the goods. Of course,

you must have a good store, careful clerks, the right goods, fair prices, and the like, but even with all these things you cannot make all the money you should make unless you advertise.

We want to make it as easy as possible for an Edison Phonograph Dealer to make money. We want to place every advertising help in his way that we can. Every month we are sending you good material, material which costs us a great deal of money, and which will bring you business if you will use it in the right way.

More than this, we want to get every Dealer to help us with his own experience. Send us the advertising you are doing for yourself. Send us sample ads from your newspaper. Tell us about your window dressing and how it worked out. Tell us about your sales and how you make them better. Tell us just what you are doing. Ask us any questions you like; bring us your selling or advertising problems, and we will try to help you.

We want to make this department an open court. We want the Dealer to consult our advertising department as often as he needs in order to do good work. We wish to assure you that there is nothing that we will not do to help you sell more Edison Phonographs and more Edison Records.

### *Making the Most of the Political Situation*

Now one more word about the Records made by the candidates.

In a month election will be over. You should sell a great many Records in that time. Remember that there is nothing in which men are now so interested as politics. You ought to be able to sell a full set of Bryan or Taft Records to every Phonograph owner in your town, and you ought to sell more Phonographs for the sake of hearing the Bryan and Taft Records.

Write letters to the leading politicians in your town. Get the chairmen of the Democratic and Republican Committees interested. Push these Records as they should be pushed, and you will do the biggest month's business on Records you ever did.

Then after election remember that you will have Records made by the President of the United States. Whichever ticket is elected, you will have the Records of the President. Advertise this fact. Make a big window display the day after election, showing the picture of the winning candidate surrounded by a heap of his own Records, with a card calling attention to the President's Records and the price.

## *Launching the Amberol Records*

The next big thing for the Edison Phonograph will be the Amberol Records, those Records which play more than twice as long as the old Records, the longest Records ever made for any Phonograph, and the best.

Our advertising for Amberol Records will be more liberal than any advertising we have ever done. We are going to cover the country with the facts about this great improvement.

You must make some sort of a hurrah in your store. You must emphasize the fact that Amberol Records are Edison's greatest discovery as far as the Phonograph is concerned, and the greatest improvement in the Phonograph that has been made in years.

We have special advertising for your newspapers for the Amberol Records, as well as matter to be distributed, window cards and posters. All these will be sent to you or are sent to you with this number of the PHONOGRAPH MONTHLY. Use them. You have got to use them if you wish to make them pay you.

Advertising made the National Phonograph Company what it is. Advertising created the Phonograph habit.

The only way you can get more business for Phonographs and Records is to advertise.

---

## Points on Selling Attachments

The success of Edison Amberol Records and the new attachments will largely depend upon the extent to which Dealers become proficient in adding the attachments to Phonographs now in the hands of their patrons. A Dealer can do nothing more important than to make himself familiar with the work of adding and properly adjusting these attachments. There is nothing about the mechanism itself, or the details of putting it on that any intelligent man cannot do, but he must first be shown. Our Jobbers, their salesmen and our own salesmen are now doing all they can to inform the trade. They will continue this work as fast as attachments can be shipped to Dealers by Jobbers. Dealers should make it a point to take advantage of this instruction whenever it becomes available, and if it does not come to them they should seek it by visiting the stores of their Jobbers. No live Dealer should ever let a customer see that he does not know how to put on the new attachments.

One of the important little points about adding attachments is the matter of adjustment so that the machine will run freely. Unless rightly adjusted there may be a bind that will cause the machine to run slow and thereby reproduce incorrectly. Nothing will disgust a customer more than this. If his machine does not run as well with the attachment on as it did before he will be dissatisfied and may want the attachment removed. His machine will run just as well with the attachment on, if properly adjusted, and Dealers should, therefore, pay particular attention to this feature.

---

Think what the sale of attachments is going to mean to the trade. It will mean a profit on the attachment itself, which, while not large, is worth having. It will mean the immediate sale of the Amberol Records with their handsome margin of profit. It will mean a revival of interest on the part of those who may have for the time lost interest in the Phonograph and who are not now buying Records of any kind. With their Phonograph changed over they will buy Amberol Records and will again buy the two-minute Records.

---

Then the Amberol Records are going to awaken a new interest in the Phonograph among people who, because of the shorter Record, have never bought a Phonograph at all. They will now buy combination machines and become purchasers of both kinds of Records.

---

Just as soon as they can get a supply of attachments, Dealers should make a thorough canvass among the owners of Edison Phonographs, for the purpose of getting them to change over their machines. If sales cannot be made for cash, Dealers who have the necessary capital should add the attachments and arrange to accept payments of fifty cents or a dollar a week. This plan will make the customer a patron for Amberol Records, and he will buy Records every time he comes in to make a weekly payment on the attachment.

---

It ought to be easy to sell attachments. The Dealer knows the names of all Phonograph owners in his territory and can reach them at once. He don't have to argue about the merits of the Phonograph, for the owner knows all about it. The owner has already felt a want for a larger Record and it needs no long explanation to convince him that the Amberol Record is a good thing. It really looks like an easy proposition to change his machine and get his money for the attachment and for Records later.

## Don't Blame the Jobbers

Dealers should not find fault with their Jobbers if for the next few weeks the latter cannot fill orders for Amberol Records, attachments and combination Phonographs, as they would like to have them filled. Jobbers will not be as much to blame as we are. Like many other important changes, it is easier to plan them than it is to carry them out as planned. The new product involves many difficulties and some of them have taken longer of solution and to properly work out than we anticipated. Because of difficult manufacturing problems we have been able to only make part shipments to the Jobbers, the total aggregating about twenty-five per cent. of the first order placed. Dealers will readily see, therefore, that Jobbers will not be able to fill more than twenty-five per cent. of their orders, this assuming that the Jobbers' first orders were large enough, which they were not, for more than half of them have since placed second and third orders.

We would not have delayed getting the new goods on the market could we have avoided it, for no one is more anxious than we to get them into the hands of every Phonograph owner. We are running the factory night and day, and doing everything possible to increase the output. The first partial shipments have been made to all Jobbers, and some further shipments have been made on the second round. We hope that another two or three weeks will make it possible to give Jobbers such quantities of goods that they will be able to take good care of Dealers.

It would have been a simple matter to put off the selling date another month, and then give the trade larger, if not complete shipments, but we believed that Jobbers and Dealers would rather make a start with smaller shipments than wait another month. This view has since been approved by the trade. We must ask Jobbers to be patient with us, and Dealers in turn must be patient with Jobbers. We are all doing the best we can. We will get the goods to Jobbers with the least possible delay and Dealers may be assured that Jobbers will only be too glad to turn them over as fast as received.

## Read Bulletin No. 15

The attention of Dealers is especially called to Sales Department Bulletin No. 15, printed in this issue. It contains information of vital interest to them.

## About Establishing Branch Stores

The following correspondence passed between a Western Jobber and General Manager of Sales F. K. Dolbeer. It covers a point that interests all Jobbers and some Dealers:

### THE QUESTION

The question has come up with connection with your ruling that Dealers shall only handle Edison Goods, whether it would be policy where a Dealer, who extensively dealt in the cylinder line of other manufacture than yours, to organize another company, carrying on their business in a store separate from the original one, and carrying the other line of goods in that store. Please let us know whether this would be looked upon favorably or unfavorably by your Company.

### THE REPLY

We would advise that the action of a Dealer in opening a branch store, for the handling of other cylinder lines, would not in itself be a violation of the terms of our agreement; that is, provided such Dealer did not make an attempt to display or sell Edison Phonographs or Records from the store in which he was handling the other cylinder lines, or that he did not carry any stock of cylinder phonographs or cylinder records other than those manufactured by us in the store where he was handling our goods.

Candidly, we feel that such action would only be a subterfuge, and where our attention was called to a transaction of this nature we would investigate it very carefully, and if we found that there was any attempt made to evade the terms of the Addenda to Dealers' Agreement, we would immediately take such steps as the case might warrant.

## Sign the Addenda

Another letter has just been mailed to such Dealers as have not signed the Addenda to the Dealers' Agreement. It has always been our experience that a certain per centage of Dealers cannot be induced to act upon the first notification. The letter above referred to and this copy of the PHONOGRAPH MONTHLY will both reach Dealers before October 1st, and all Dealers who have not yet signed the Addenda are urged to do so at once and forward a copy to the Agreement Department at 10 Fifth Avenue, New York City. The Addenda becomes effective October 1st, and not to sign promptly is to run the risk of being deprived of Dealers' privileges, now more valuable than ever before.

Dealers who do not fully understand the meaning of the Addenda are urged to write to us promptly.



## Edison's Fame Secure

[*Spokane Spokesman-Review*, September 7.]

Thomas A. Edison enjoys a privilege which comes into the lives of few men who achieve an enduring place in the Hall of Fame. While yet in the full flush of his marvelous powers, he is permitted to scan the future with a confident knowledge that his name and achievements will be famous in the distant ages.

That is a good fortune which falls to the inventor more often than to the great warrior, statesman, painter, author or musician. Contemporary estimates of the ability of genius of generals and statesmen are frequently not the verdict of history. Contemporary enthusiasm or partisanship may unduly laud the achievements of mediocrity, and, conversely, contemporary rancor and prejudice may deprive greatness in these fields of rightful honors which history will render.

And in art, literature and music we may never be sure that the tastes of one generation will be the tastes of succeeding generations.

But when Fulton made a success of the steamboat, Morse of the telegraph, Howe of the sewing machine and Edison of the electric light, their inventions were so revolutionary and entered so extensively into the lives and actions of the masses that it was instantly apparent that their fame would be secure through the centuries to follow.

Prior to Mr. Edison's success, the electric light had been no more than a laboratory experiment. He made it a practical, commercial reality. His Phonograph is another invention that would have given him enduring fame if he had contributed nothing else to the world's inventive wealth. So also his inventions of the duplex and later of the quadruplex method of

transmitting telegrams, by which it became the practice, first, for four operators to be employed on a single wire where previously only two could find employment, and later for eight operators to use instantaneously a single wire, were in themselves sufficient to give him high rank in the inventive world.

In addition to these brilliant and revolutionary inventions, Mr. Edison has given the world numerous other and minor inventions, such as moving pictures, the mimeograph, and attachments and improvements which added greatly to the service of Bell's telephone.

All in all, his has been an inspiring career, and surely none can begrudge him the pleasing reflection that long after his lifework is ended, millions will honor his memory and find life more pleasant by reason that he lived.

## Three More Lauder Records

An advance list of three more Records by Harry Lauder, the famous Scotch comedian, is given on page 19. These make a total of fourteen Lauder Records put out by this company. The reception that has been given the Lauder Records has been of the most cordial character and none are more popular. Mr. Lauder is about to make a tour of the principal cities of the United States, and with each appearance his Records will grow in popular favor. No Dealer can afford not to have a good stock of the entire fourteen selections.

## Error

In the Dealers' Order Blank for December, Record No. 10018, "I'm Glad I'm Married," is incorrectly given as being sung by Ed. Morton. It is sung by Billy Murray.

## An Interesting Comparison

EDISON AMBEROL RECORD, 4 MIN. 45 SEC., PRICE, 50 CENTS.

12-INCH DISC, 4 MIN. 22 SEC., PRICE, \$1.00.

6-INCH CYLINDER, 3 MIN. 25 SEC., PRICE, 50 CENTS.

10-INCH DISC, 3-MIN. 10 SEC., PRICE, 60 CENTS.

100-THREAD CYLINDER, 2 MIN. 10 SEC., PRICE, 35 CENTS.

7-INCH DISC, 2 MIN. 10 SEC., PRICE, 35 CENTS.

Table showing differences in playing lengths between Edison Amberol Records and all others on the market. The extreme length has been taken in every case. The average of all is a little less than given here. Note that the Amberol Record plays longer than its nearest competitor, and its cost is only half.

The following is a copy of a letter just mailed to every Edison Jobber and Dealer. Its purport is of the greatest interest to the trade, and Dealers especially should read it with the utmost care:

## To All Edison Jobbers and Dealers:

In response to what appears to be a general sentiment in the trade, we beg to announce that commencing December 1st, 1908, and before that date, if possible, we propose to institute a new system for establishing Dealers in the future, and on the details of which we have been working for the past year.

When the new arrangement goes into effect no Dealer will be established in any locality where our goods may be already satisfactorily represented.

Before a new Dealer is established at any point, a formal application must be presented, giving complete information from which, in connection with our own records, we may decide whether the applicant's territory is or is not properly represented; and, if not, whether the application should be granted.

In this way we will be able to prevent the indiscriminate appointment of Dealers in localities that may already be well represented, and in some instances over-represented. At the same time the arrangement will in no way interfere with the appointment of new Dealers in localities where a satisfactory field exists for the exploitation of the Edison Phonograph.

Pending the final announcement of the proposed plan we hope that our Jobbers will co-operate with us to the extent of not establishing new Dealers in localities where our present Dealers may now be handling our goods in a thoroughly satisfactory manner; but in any event, we shall not hesitate to decline to recognize new Dealers, who, in our opinion, may be unnecessary for the good of the trade.

NATIONAL PHONOGRAPH CO.

FRANK L. DYER, *President.*

## The Muslin Banners

No one is as sorry as we over the delay in getting to the trade the large muslin banners, about which so much has been said. These were promised us by the manufacturers by July 1st, and every Dealer should have had one in front of his store by this time. Part of the trade have already been supplied and we are daily following up the manufacturers for enough to supply the remainder. We hope to fill all orders within the next two weeks. The trade may rest assured that after an experience like this we will not again discuss another new piece of advertising matter with Jobbers and Dealers until the goods are in our hands.

We are already getting complimentary letters about these banners. F. M. Atwood, of Memphis, Tenn., writes: "The banners came to hand several days ago, and I immediately hung one over my front door on the outside, under my sign, and I can truthfully say that I never had anything in the way of advertising matter that brought as many people into my store as it has."

## Printed Matter

Conservative shipments of printed matter in connection with Amberol Records, attachments, combination Phonographs, etc., are purposely being made to Jobbers. The first shipment of Amberol Records, attachments, etc., will not much more than suffice to equip the machines in Dealers' stores and give them some Records for exhibition purposes. Until sufficient goods come through to make sales to the public possible there will be little use for printed matter. Jobbers are asked to use the quantities sent them in a manner to avoid waste and still leave some of it on hand for later uses.

Most Jobbers have been supplied with a quantity of the new catalogues of Grand Opera Records. Dealers carrying these Records should get a few and put them in the hands of their best customers—those who may be interested in the better class of music. The catalogue is attractively printed in two colors. Half-tones of the artists are features.

## A Jobbers' House Organ

The *Whitsit Monthly* is the name of an attractively printed house organ just issued by the Perry B. Whitsit Co., Edison Jobbers at Columbus, Ohio. Volume 1, No. 1, which is dated September, is largely devoted to a statement about the new Amberol Records, attachments, new type Phonographs, etc.

## He Goes After Business

H. S. Jones, Edison Dealer at Spencer, Iowa, sends a neatly printed booklet, containing a series of arguments concerning the Edison Phonograph, with a request for permission to put one in a farmer's home. Mr. Jones also writes:

"I enclose a small booklet, showing my method of getting the Edison Phonograph into the homes of the people. I do not sit down and wait for customers to call at my place of business, but I go for the trade in the way the booklet suggests. I mail fifteen or twenty of the booklets on rural routes, and in a few days I follow up with as many Phonographs as I may deem advisable, and place them on trial in the homes of those who have received the booklet. I find them pretty thoroughly canvassed up in this way and only too glad to try the Phonograph, which they have become interested in by the time I get around. Then I go around again about the time their enthusiasm is at high-water mark and sell the Phonographs. During this summer I have only had to take up three Phonographs and carry them further on for purchasers.

## Jobbers are Requested

Jobbers who may have received from Dealers signed copies of the Addenda to Dealers' Agreement are asked to send them to us at once. Not to do so may cause such Dealers much inconvenience. Jobbers are also asked to canvass their Dealers and make sure that all of them have signed the Addenda and sent it to us.

## No Electros of Attachments or Machines

It is not our intention to make any attempt to furnish the trade with electros of new attachments or the new combination type Phonographs. The attachments consist of a group of separate parts that would have no meaning to the public when used for advertising and the combination type Phonographs show no appreciable difference from the present machines. The differential gears are entirely covered by the guard and cannot be shown in an illustration. Electros of the present machines can readily be used as representing the new machines.

## Matter Omitted

The unusual quantity of matter concerning the new conditions and other important subjects has compelled us to omit much interesting trade information from this issue. For all such shortcomings, we ask the indulgence of our readers.

## Our Advertising of Amberol Records

With the appearance of the monthly magazines, between October 15th and November 1st, we shall begin a most extensive campaign of advertising for Edison Amberol Records, Edison Phonographs and new attachments. Double pages and single full pages will appear in the following standard magazines and weeklies: Collier's Weekly, Associated Sunday Magazines, Youth's Companion, American Magazine, Cosmopolitan, Everybody's, McClure's, Munsey's, Review of Reviews, Ladies' Home Journal, Woman's Home Companion, Ladies' World, Success, Pearson's, Sunset, Home Magazine, World's Work, Ainslee's, Puck.

The *Saturday Evening Post* for October 24th will contain two full pages devoted to a most attractively displayed and strongly written advertisement on the new conditions. This advertisement will occupy the two center pages and make such a striking presentation of the Amberol Record, etc., that none of the 900,000 readers of the *Post* can fail to see it. We would strongly urge every Dealer to get a copy, open it in the center and place it in his window. Attach a card to it, reading something like this: "This advertisement cost the National Phonograph Co. \$4,200.

A little later, as soon as the trade have sufficient Amberol Records, etc., to supply the public, we shall advertise them extensively in daily newspapers in most of the big cities of the country. We also expect to advertise largely in the important agricultural papers; also to have a campaign in Canada that will reach every possible Phonograph buyer in the Dominion. We shall spend in the aggregate, more money for advertising than ever before. We make the statement chiefly to show that our faith in the future of the Phonograph never was stronger. If the trade will in turn advertise locally, they and we will do a business that will put all past totals to shame.

---

## Good Talk

The Southern Phonograph Co., Edison Dealers at Princess Ann, Md., report that during their one year handling the Edison line they have purchased about \$1,500 worth of Phonographs and Records, and think so much of the line that they wouldn't take \$1,000 for their business.

This is the way Dealers talk who make a real effort to push the business. In another year this company will want a good deal more than a thousand dollars for the good will of their business.

## All Want Foreign Records

Here is an argument that will sell foreign Records to two of every three owners of Edison Phonographs: *The privilege of hearing the best music of all nations!*

Many of the foreign Records are irresistibly beautiful, and well they should be. Take Germany, Italy, France, Spain or most any of the foreign countries. They were busy building up their musical literature centuries before America and American music were ever thought of.

So that it is no wonder that many of their national hymns and characteristic concert and popular selections are ahead of almost anything we have to offer.

Even Chinese and Japanese music have a weird charm of their own. At any rate it is interesting and educational to know something of the music of the different countries of the world and a rare treat to be able to play it for one's friends, who likely never heard it before.

It matters not if the words are in a foreign tongue. Most grand opera is sung in Italian, German or French. But that has never affected grand opera's popularity.

The words do not count nearly so much as the melody to which they are set. Take the duet, "Miserere" from the opera "Il Trovatore." Nobody ever enjoyed that any less because it was sung in Italian. As a matter of fact the Italian language is softer and more melodious than our own.

You can see then that you have a double reason for carrying some of the Foreign Records—you can sell them both to foreigners and Americans.

Take the matter of Foreign Records up with your Jobber. Ask for the Foreign Catalogue and advice on the best selling Records.

---

## Because It Pays

We are now settled in our new quarters. We have a room 23 x 50, but strictly modern windows, cement basement, steam heat, good location and hope when things get straightened around to do a continued good business. Our purchases last year amounted to a trifle over \$10,000. As our entire store expenses were less than \$140 per month, you can readily see that one reason I like the Edison is because it is profitable. I have never been "stuck" yet. If you continue your business policy the same as in the past, I see no reason why I should do anything else than push your line.—*Portland Phonograph Agency, Portland, Ore.*

## What the Dealers Think

The letter printed below fairly represents the sentiments of fully ninety per cent. of the Edison Dealers. It was written by Henry L. D'Entremous, of \_\_\_\_\_, in reply to an invitation to join a Dealers' association for the purpose of combatting our new policy, and inspired by the manufacturers of another cylinder line:

Replying to your circular letter of yesterday's date, I would say that I am not in sympathy with the proposed Talking Machine Dealers' Association. As I deal only in Edison goods at present and as they always treated me fairly in the past, I have no apprehension of their doing any different in the future.

This move looks to me like the wailing of a few disgruntled Dealers who, in the parlance of the street, have been "stung" by stocking up with a lot of inferior talking machines and records that could not be sold, and will have less sale in the future. I have been "stung" myself, and bought goods I had to sell at less than cost to get rid of them.

Do you know of any Company that is treating their Dealers any fairer than the National Phonograph Co.? They make the goods that sell and will continue to do so, notwithstanding the idea conveyed in your letter, that other companies might place something on the market that would "outdo the National."

In conclusion, I would say that I signed the new agreement and mailed it back the same day I received it, and did so gladly.

## One Dealer's Experience

An Edison Dealer in the West thus summed up a condition in a letter recently written to us:

Some time ago you had an article pointing out the risk your Dealers incurred by adding a new line of Records. This lost its force then, as I was positively assured that I would be protected in the exclusive sale of the \_\_\_\_\_ product. I began in December, 1907, and dealt direct with manufacturers, with that understanding. When their Omaha Jobber was established, I was referred to them. Both gave me positive assurance. (It's to the Jobber's credit that I can find nothing to indicate but that he was not acting in good faith.) When practically every Edison Jobber in territory contiguous to \_\_\_\_\_ put in the \_\_\_\_\_ line, I felt uneasy. Wrote about the matter—reassured that I'd be protected.

When a local dealer secured \_\_\_\_\_ records, wrote again—but assured I'd come out O. K.—keep right on—territory for Jobbers would be divided, etc. But July 4th I received a letter exactly the reverse of the one received the week before. They can't protect me. Now, as I do not see how any Edison or \_\_\_\_\_ Dealer would want to put in a new line, except on the exclusive agency proposition, and that proposition is used to catch them (see Jobbers advertisements in the *Talking Machine World*), I

believe your Dealers should be posted as to what the final result will be. "In the soup,"—just as I am.

## Straws from Australia

On the arrival of the Massini picture, which you forwarded me through the New Century Talking Machine Co., Auckland, I placed it in one of the windows of my shop, along with an Edison Phonograph and a lot of Edison Records. Within a few minutes of doing so I sold the machine and a number of Records. I find my sales of Edison Phonographs and Records increasing, and the strange part is that each of my customers claims that their Edison Phonograph is the best ever sent out of my shop. They will take no other but Edison Records. —*Wm. Coad, Edison Dealer at Thames, New Zealand.*

I am glad that I have taken Edison goods. They increase my returns; profits and sales are far more than expected.—*H. Zellner, Australian Stores, Dalton, N. S. W.*

W. Chivers, Edison Jobber at Christchurch, N. Z., sends a photograph showing a terrace of six villas and a motor car, purchased, he says, out of the profits arising from his business as an Edison Jobber. Mr. Chivers is an enthusiastic Edisonite, and pushes Edison goods energetically, with good results to us both.

## An Odd Incident

To-day Mrs. Glegg had to fill a dying man's wish, and that was to play a certain sacred Record on the Phonograph as his body was being taken out of his late residence for burial. Further, as I had let him have the Phonograph many months ago, and nothing was paid on it, the man who was dying since last Saturday, and as he had got some money for a piece of land, he had the whole £6 wrapped up carefully under his pillow since then, and he made his wife declare she would pay the money to Mrs. Glegg or myself, by the side of his dead body before he was carried away. All this was carried out, the Phonograph playing "Shall We Gather at the River" as the coffin was carried out the door. No one ever heard of or saw any person with such a craving for the Phonograph as that man had, and when too ill to put the Records on, no one could do it right but Mrs. Glegg. That Phonograph is now sacred and not for sale.—*Extract taken from letter written by A. S. Glegg, Dealer of Gladstone, Queensland.*

THESE are the ready-to-print newspaper advertisements to be used by you in connection with the Amberol Records. The copy is set small here for lack of space. Give them more room in your newspaper. They are worth it. We furnish electrotypes of the illustrations free on request. Order by the numbers.



[Electro No. 698]

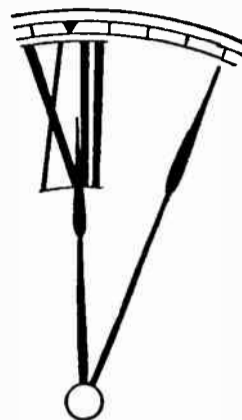

[Electro No. 699]

Edison Amberol Records

Edison Records are so sweet, clear and tuneful that you've often wished they were longer.

They are now. They play, sing or talk twice as long as the Edison Records you have, which means that there is more music on them than on any other Record made.

These double entertainers are called Amberol Records. Have you heard them? We have them for you to hear.

**SHARPS & FLAT**  
10 Main Street

Four Minutes

That is the running time of the new Edison Amberol Records.

It is twice as long as any Edison Standard Record. It is considerably longer than any Record of any kind.

This permits of entire selections rather than mere snatches—of music played or sung as it should be instead of being marred by being hurried.

Beautiful things, never before possible with sound producing machines, may now be enjoyed by Edison Phonograph owners.

Hear them at our store.  
**SHARPS & FLAT**  
10 Main Street

Twice as long.



[Electro No. 700]

Twice as long.



[Electro No. 701]

Twice as long.



[Electro No. 702]

Edison Amberol Records talk twice as long as Edison Standard Records.

If we talked twice as long as an Edison Amberol Record, we could not tell you all of their good points. Come in and hear an Amberol Record, but expect to stay twice as long as you intend to, for you will be twice as well entertained as you ever were before.

**SHARPS & FLAT**  
10 Main Street

Edison Amberol Records sing twice as long as Edison Standard Records.

Four minutes, the singing time of Amberols, is long enough to give *all* the song and *all* the chorus, not a verse or two, but all.

Come in and hear them.

**SHARPS & FLAT**  
10 Main Street

Edison Amberol Records play twice as long as Edison Standard Records.

This means better music for you as well as more music without changing Records. Selections heretofore too long for any record are now possible on the Edison. Nothing is lost by being cut or hurried.

Your Phonograph can be made to play Amberols. We have the attachment.

**SHARPS & FLAT**  
10 Main Street



# Window Talk

**T**HAT is what window cards are. Don't look at them from the viewpoint of a millionaire buying pictures. You are a seller of Phonographs and Records, not an artist. Between good looks and good talk in a window card, good talk always wins. Both are desirable, but because you cannot make a card artistic is no reason why you should leave your window speechless. It is what the cards say that counts, and here are some counters. Put them on paper or cardboard, as well as you can, with brush or pencil, but use them. Display one every day in the week and two on Sunday, when you don't work and your clerks won't work, but when advertising will work just as hard.

**DONT VOTE**  
UNTIL YOU HEAR  
BOTH SIDES.  
**TAFT AND BRYAN**  
**EDISON RECORDS**

**MONDAY**

**THE NEXT**  
**PRESIDENT'S VOICE**  
IS ON SALE.  
COME IN AND PICK  
IT OUT.

**TUESDAY**

**JOINT DEBATE**  
**BRYAN AND TAFT**  
COME IN  
AND HEAR IT

**WEDNESDAY**

**Edison Amberol**  
**Records**  
**Four Minute Concerts**  
**by New Stars**

**THURSDAY**

UNTIL YOU HEAR THE  
**EDISON**  
YOU HAVEN'T HEARD  
A PHONOGRAPH

**FRIDAY**

**AMBEROLIZE**  
YOUR  
**PHONOGRAPH**  
We have the  
attachments

**SATURDAY**

**Amberol -**  
A NEW  
**RECORD**  
WITH A  
**NEW RECORD**

**An AMBEROL**  
**RECORD at 50¢**  
Gives the same amount  
of entertainment as two  
regular **EDISON RECORDS**  
at 35¢

and

**SUNDAY**

# Trade Bulletins

*Sales Department Bulletin No. 16,  
September 24, 1908*

## *Trade Information for Dealers*

*Correspondence concerning this bulletin should mention its number and be addressed to the NATIONAL PHONOGRAPH COMPANY, SALES DEPARTMENT, Orange, N. J.*

The attention of Edison Dealers is called to the following information, the issuance of which has been made necessary by omissions from Bulletin No. 14, dated August 1, 1908, or by omissions and misunderstandings that have since arisen with reference to the prospective changes:

Some Jobbers and Dealers have obtained the impression that with the issuance of the new Record and the new Machine, the present two-minute Record and the present types of machines will be discontinued. This is incorrect. The new conditions will make no change whatever with the present type of Record or with the present Standard, Home or Triumph Machines. The two-minute Record will be continued and as great efforts made to improve it as heretofore. The present Standard, Home and Triumph Phonographs will be continued at the present prices.

Jobbers and Dealers having on hand any of the present types of Home and Triumph Phonographs will be permitted to equip them with the new attachments and sell them at the same prices as combination machines, namely, \$40 and \$60. It must be understood, however, that when sold separately the present Home Phonograph must be at \$35, the present Triumph Phonograph at \$55 and Attachments at \$7.50 each.

Bulletin No. 14 made no reference to the return of the main shaft and mandrel replaced on present machines with the new Home and Triumph Attachments. Jobbers and Dealers must get back these parts wherever a sale of new attachments is made. In other words, Jobbers will be expected to return to us an equal number of old-style parts for the new ones shipped them; they, in turn, will require Dealers to return these parts, and Dealers must get them back from retail customers. The new parts are being shipped in a special box, which should be used for the return of the old ones. Jobbers are asked to make freight shipments of old parts to us when a sufficient number have been accumulated to warrant the cost of transportation charges. The latter will be borne by us.

Jobbers who receive orders from Dealers for Amberol Records only should point out to such Dealers that they should also order a supply of attachments and new-style machines. Without these the Amberol Records will be useless. Jobbers should also caution Dealers against playing Amberol Records with a two-minute reproducer. It is also important that the four-minute reproducer shall not be played on two-minute Records.

The Model B Attachments for Standard, Home and Triumph Machines, now being shipped, are intended for machines that have been in general use for several years past. They cannot be attached to the special machines sold in New York State and known as Model C. The latter machines require a special attachment, and Model C attachments should be ordered when wanted for Model C machines. This paragraph applies only to the New York State trade, and to such Jobbers and Dealers in the States bordering New York as have bought some of these special machines.

## *Suspended List, Sept. 20, 1908*

### SUPERSEDING ALL PREVIOUS LISTS

This list is supplemental to the Suspended Lists printed in the Edison Phonograph Monthly for June, 1908, which is still in force and must be given the same consideration by the trade as if reprinted in full herewith.

- CAL., Chico**—Moriss Kyrous (or Kryicus).  
The Postoffice News Stand.
- CONN., Meriden**—J. F. Malloy.  
**New London**—Smith Bros.
- IOWA, Sidney**—I. L. Morgan.
- ILL., \*Charleston**—Frank Ricketts.
- KAN., Cuba**—Mrs. Frank Barnett.
- MASS., Newburyport**—Pentucket Phono. Store,  
M. H. McKinney, Prop.  
**Needham**—J. L. Davis.  
**Northampton**—W. T. Risley.  
**\*Roxbury**—Theo. Rothe and Mr. Price of  
Fuller Elec. Co.  
**Worcester**—J. G. Williams, Prop. Will-  
iams' Book Store.
- MICH., Marshall**—S. E. Cronin Estate.
- MINN., Elgin**—J. Watterston.
- MISS., Sedalia**—S. R. Payne.
- NEB., Alliance**—B. F. Lockwood & Co.  
**\*Alma**—Henry M. Dayton.  
**Geneva**—Geo. H. Nelson.  
**\*Sterling**—Dr. W. L. Heilman.



**N. H., Dover**—Dover Furniture Co.  
**N. J., Bayonne**—Goldweber's Dep't. Store, M. Goldweber & W. Goldweber.  
**Plainfield**—L. Seisel.  
**N. Y., Albany**—Albany Phono. & Sewing Mach. Co., Aaron Kent & W. H. Bernstein, Props.  
**Brooklyn**—A. Becker.  
 Henry F. Staude.  
**\*Collins Center**—A. P. Bolander, Jr.  
**Lockport**—Floyd B. Serles, Prop. Lockport Phono. Co.  
**New York City**—Harry Cohen.  
 M. Greenberg, alias J. Greenburg.  
**Watertown**—L. A. Maxson.  
 Byer & Susskind.  
**OHIO, Fremont**—Lorenz Henderson Piano Co.  
**Lima**—Henry Van Gunten, Van Gunten Music Store.  
**PENNA., Philadelphia**—Eastern Phono. Co., M. Futernik, Prop.  
**Connellsville**—Wright-Metzler Co.  
**TEX., New Braunfels**—Ed. Gruene.  
**VA., Fries**—J. J. Crump.  
**WASH., Krupp**—Ed. Long.

\*Added since August 20, 1908.

#### REINSTATED.

**COL., Boulder**—Bentley & Craig.  
**Ouray**—C. C. Stratton.  
**IOWA, Danbury**—J. W. O'Day.  
**N. Y., Rochester**—A. J. Deninger (Dealer's basis).

Copies of the complete Suspended List will be mailed on request. Jobbers and Dealers are asked not to supply any of the above named firms with our apparatus, either at addresses given or any other address.

## Give Free Concerts

The manager of one of the largest and most up-to-date retail Phonograph departments in the country says free concerts have been the main factor in the success of his business. He is right about it, too.

If a Dealer has a separate room in which to give free concerts he can rest assured it will pay him handsomely to do so regularly in the afternoons and occasionally at night. If no separate room is available it can be done in the regular ever most convenient.

Never run a newspaper advertisement without making prominent mention of the free concerts. This need not mean that there is something big and something special going on all the time, but should convey the impression that anybody can drop in any time and hear anything they like played upon an Edison. Make it plain in your announcements that visitors are not asked to buy. The better impression you can give that it is an entirely informal affair without the least obligation on your customers to buy the more freely handed them in the way of the new supplements, they will come. Let them feel that the pleasure

is yours, and that your recitals are strictly educational.

Put signs in your windows telling about the free concerts and have a number of advertising cards on your walls where your visitors can't help seeing them, telling how easy it is to own an Edison by the time-payment plan. Every caller should have some advertising matter etc., that will give particulars about the Edison Phonograph and Records.

They are your prospects for machine sales later on and should be treated as such. Take their names and addresses down when possible and mail them the monthly Supplements and other advertising matter that will keep their interest up until they buy. The special night concerts will draw crowds every time if neat invitations are sent out. This is a mighty good way to round your prospects up every now and then. So many people will come at night who find it inconvenient to call in the day. Often a man, or more likely, his wife, will come in the daytime, but a woman will want her husband to hear the machine before she decides to purchase. Both can arrange to attend at night.

The Phonograph is a sort of luxury, and many people do a lot of thinking and considering before they get to the buying point. Often there is something else they want at the same time, and it's an open question whether the Phonograph wins or the something else.

There is no way of selling an Edison so good as getting people to listen to it. You simply can not sell them any other way. So do the best you can in the free concert line. The people who come in to hear the Records will get the habit of buying other goods of you even if they hold back a while on buying a Phonograph. You may not have a whole lot of vacant space, but make the most of what you do have.

"The strenuous tones of a vaudeville tenor's song cut across the rattle of wheels in the street, and people turned to look. They came from the funnel of a talking machine, set near the open door of a new hardware store.

When the tenor had finished his effort to carry his voice to the end of the hall, a musical chime of bells followed. The next morning there was an orchestral march, to put spirit into the downtown procession; and in the evening the returning procession smiled in successive waves of understanding as the people came within earshot of 'Home, Sweet Home.'

It wasn't very long before the crowds that tramped up and down that street knew very well where to find a hardware shop when they needed something in that line. And the talking machine had neither said nor sung a word about business, either."—*Fame*.

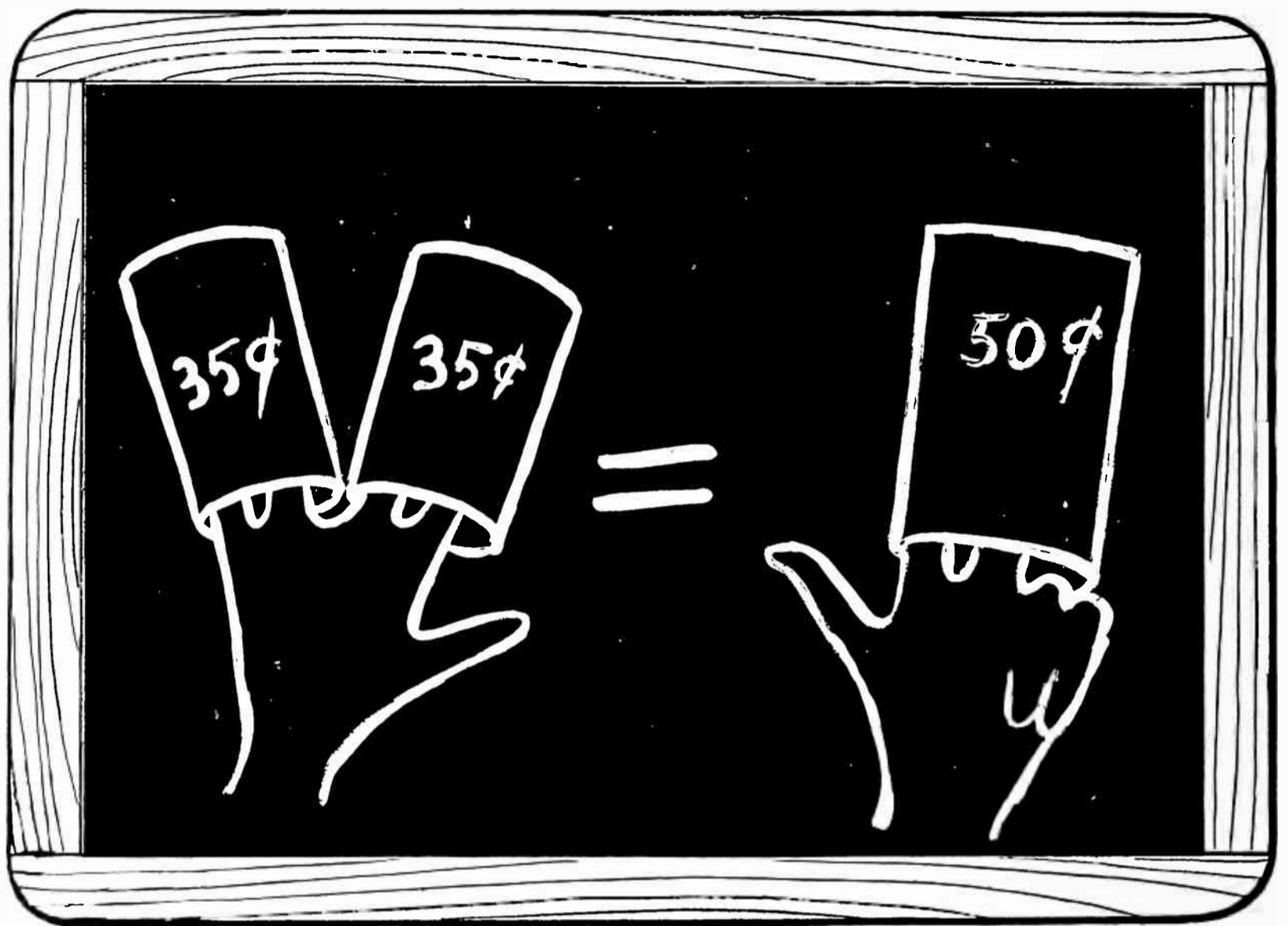

# Lessons for Dealers

## *Lesson III.*

Get next, *to solve*

Nit, *a contraction of not*  
Stung, *defrauded*

Come-back, *a saving*  
Tickle, *please*

Can you get next to this e-qua-tion? It means that one Edison Am-ber-ol Record will afford as much en-ter-tain-ment as two reg-u-lar Edison Records.

Two reg-u-lar Edison Records sell for 70c. One Am-ber-ol Record sells for 50c. This 20c come-back will tic-kle the cus-to-mer.

Are you stung? Nit. For Am-ber-ol Records will also tic-kle the cus-to-mer.

Instead of sell-ing one Am-ber-ol at 50c you will sell two at a dollar. This will tic-kle you.

# Advance List

## Of Three More Edison Records by Harry Lauder

**L**AUDER Records will be ready for shipment from Orange on or about October 10th. Samples will not be sent. Jobbers' stock orders received by October 5th will be shipped as fast as possible after October 10th. All first orders will go by freight. Because Mr. Lauder will first appear in New York and vicinity, the usual order of shipment to Jobbers will be reversed, that is, shipments will first be made to Jobbers nearest to New York City, those located farther away getting attention later. Shipments will be made at one time to all Jobbers in the same territory and it is hoped to complete the shipments within ten days. Special Supplements and Bulletins will be shipped with Records to all Jobbers ordering them. Lauder Records may be placed on sale by Jobbers and Dealers as soon as received.

**H**ARRY LAUDER, the famous Scotch comedian, will return to America in October and make a twelve weeks' tour of the principal cities, opening at a New York Theatre, on October 12th. This fact has induced us to put out three more of his Records. These are in addition to the four issued in September and the seven put out in February last. Mr. Lauder is already widely known in the United States and Canada, both because of his personal fame and the prominence gained by the tremendous sale of the Edison Records made by him. His salary of \$5,000 a week is one of the largest ever paid to a vaudeville star. His appearance in the principal cities here is going to create a new demand for his Records, and every Jobber and Dealer should see that his stock of Lauder selections is complete and ample.

### 13757 That's the Reason Noo I Wear a Kilt

This selection starts with an explanation by Lauder as to the reason for his wearing kilts. He admits that they are not fashionable, but recommends their wear to married men particularly. He says that when he wore breeches the pockets were exposed to too close inspection each night, while he was reposing comfortably under the quilts, with the result that he was stoney-broke every morning. How he made the discovery is told in his humorous way. The selection ranks as a favorite with Lauder—and worthily so.

### 13758 Inverary

Lauder tells in this delightful tuneful selection of his meeting with the "nicest lass that ever buttoned on a frock." He was enroute to Inverary at fair time, and the lass rushed into the same compartment of the train. After asking her name, Lauder invites her to go to Inverary. In the first part of the chorus he sings of how he got "spoony" with Mary and Mary got "spoony" with him. Lauder is unapproachable in the rendition of songs which contain a quaint confession of his "coorting the lass," and the present is a typical example from his repertoire, reminding one, particularly in the chorus, of his "I Love a Lassie."

### 13759 Callaghan

Callaghan was a tailor who made clothes for Lauder, taking his pay in small instalments each week. His work had always been most satisfactory until he made a pair of "pants" for Lauder. They evidently carried with them an evil charm of some kind, for as soon as Lauder began to wear them, his work fell off. He had had them for a "fortnight," when Callaghan called for his money. The scene which ensued is pictured in the chorus, which is a funny play on Callaghan's name.

## Lauder Records Previously Issued

13741 Hey Donal'!	19174 She's My Daisy
13742 The Weddin' O' Sandy Mac Nab	19175 Tobermory
13743 Fou the Noo	19176 We Parted on the Shore
13744 When I Get Back Again tae Bonnie Scotland	19177 The Safteft o' the Family
19173 Rob Roy Mackintosh	19178 I Love a Lassie
	19179 Stop Yer Ticklin', Jock

# Advance List

## Of Edison Standard (Two-Minute) and Edison Amberol (Four-Minute) Records for December, 1908

**T**HE Standard and Amberol Records listed below will be shipped from Orange in time to reach all Jobbers in the United States and Canada before November 25th, 1908, all things being favorable, and they may be reshipped to Dealers at 2 P. M. on November 24th. They must not, however, be exhibited, demonstrated or placed on sale by Jobbers or Dealers until 8 A. M. on November 25th. Supplements, Phonograms, Bulletins and Hangers will be shipped with Records. These may be distributed to Dealers after November 20th, but must not be circulated among the public before November 25th. Jobbers and Dealers may, however, deposit Supplements and Phonograms in Mail Boxes or Post Offices after 5 P. M. on November 24th, for delivery on the following day. Jobbers are required to place orders for December Records on or before October 10th. Dealers should place December orders with Jobbers before October 10th to insure prompt shipment when Jobbers' stock is received.

### Edison Standard (Two-Minute) Records.

- 10008 Christ is Come** **Edison Concert Band**  
 Special Christmas band number. This sacred song is given a most unique and charming setting, which includes a harmonious arrangement for band, a duet by Messrs. Anthony and Harrison, assisted by a mixed quartette in the refrain, and finally the joyous ringing of bells and chimes for Merry Christmas. Music, Sankey-Ecke; arrangement is special for our Record and not published.
- 10009 Always Me** **Byron G. Harlan**  
 Another "Why Don't They Play With Me," by Chas. K. Harris. A stepchild's "new papa" never pets, but always blames and scolds her. The affecting story of her childish hardships is set to a very wistful tune, which Mr. Harlan sings quite as finely as any of his earlier child-songs. Orchestra accompaniment; music and words, Chas. K. Harris; publisher, Chas. K. Harris, New York.
- 10010 Taffy** **Ada Jones**  
 We have all dealt in "taffy," giving or receiving it according to sex. Never mind—here is a Von Tilzer song that goes to the bottom of the question and tells what's what in the love game. One of the most "confectionery" things we have heard. Miss Jones has certainly added another to her list of serio-comic successes. Orchestra accompaniment; music, Harry Von Tilzer; words, Vincent Bryan; publishers, Harry Von Tilzer Music Pub. Co., New York.
- 10011 Petite Mignon** **Caesar Addimando**  
 A double novelty—an oboe solo by a new Edison artist, who is an acknowledged master of this sweet-toned instrument. This is the first oboe selection we have listed. Many prefer its quaint and dulcet tones to those of any other instrument. The selection is a dainty classical recitative number, more favored, perhaps, than any other for oboe work. Orchestra accompaniment; composer, M. Carman.
- 10012 When Darling Bess First Whispered Yes** **Manuel Romain**  
 A sentimental love ballad that seems to have been made on purpose to show off the reed-like tone quality of Mr. Romain's voice. The story told is reminiscent of sweetheart days, the hero and heroine being a lad in homespun and a lass in gingham. The Record will easily hold its own with Mr. Romain's best. Orchestra accompaniment; music, J. Fred Helf; words, Robert F. Roden; publishers, Helf & Hager Co., New York.
- 10013 My Brudda Sylvest** **Collins and Harlan**  
 One of the best of the Italian dialect songs that vaudeville singers are featuring at present. The irrepressible Collins and Harlan sing it to a rag-Italian tune—something new and decidedly fetching. If their hosts of admirers will ask to hear this Record, very few will miss the opportunity of taking it home. Orchestra accompaniment; music, Fred Fischer; words, Jesse Lasky; publishers, Fred Fischer Music Pub. Co., New York.
- \*10014 Everybody Knows It's There** **Edward M. Favor**  
 Mr. Favor affects the voice and manner of a boy in this unique comic song, and sings a jolly, lilting tune about the mischievous pranks he played on his father, his teacher and the family tom cat. There are three verses and three choruses. Each presents a novel and laughable situation in such a way that "Everybody knows it's there." Orchestra accompaniment; music and words, Dave Reed; publishers, M. Witmark & Sons, New York.

\* This selection will be illustrated on cover of December Phonogram.

**10015 Fun in a Barber Shop****Vess L. Ossman**

An original banjo conceit which presents Mr. Ossman at his best. The typical banjo tune is extremely infectious and is full sure to start a general patter of feet. The "fun" is supplied by ludicrous slide trombone effects introduced in the orchestral accompaniment. Orchestra accompaniment; composer, Jesse M. Winne; publisher, Walter Jacobs, Boston, Mass.

**10016 Uncle Josh's Arrival in New York City****Cal Stewart**

Uncle Josh has about the funniest experience of all his checkered career in New York. He started by losing his hat en route by leaning out the car window. His railroad ticket went with it and he had to buy another. But he got even with the railroad by buying a round-trip ticket and not using it to go back. His good looks made a great hit. When he got off the train he ran into dozens of cabmen, all of whom shouted at him, "Hansom, sir? Hansom?" Screamingly funny all the way.

**10017 The Widow Dooley****Ada Jones and Len Spencer**

This up-to-date dramatic sketch opens with a flute solo, "Sweet Molly Oh," announcing a visit by Larry Connor to court the widow Dooley, whose Mike has been dead only a month. The courtship is spicy and full of laughable scenes. By request the widow sings "Come All Ye," and Larry plays a reel on his flute, to which she dances. At the psychological moment he pops the question, but learns that he is too late, as Pat Murphy proposed and was accepted at the lamented (?) Mike's grave. Larry makes a sorrowful exit, whistling "Farewell Mavourneen." Orchestra accompaniment; original sketch, not published.

**10018 I'm Glad I'm Married****Billy Murray**

Here is a man that's glad he's married! Most of the matrimonial comic songs tell a different story. Even the singer makes his declaration with a comment that makes its sincerity doubtful. This Record is a worthy successor of Mr. Morton's Record 9949, "Don't Take Me Home," the Edison comic hit for October. He sings these comic songs with a gusto and flourish that carry all before them. There are three verses and three choruses, the latter set to that engaging two-four swing. Orchestra accompaniment; music, Al. Von Tilzer; words, Jack Norworth; publishers, York Music Co., New York.

**10019 In Lover's Lane****Edison Concert Band**

This naïve and winsome band number was inspired by the stroll of the West Point cadet with his best girl down Lover's Lane, the far-famed trysting place of Uncle Sam's future lieutenants, captains and generals. The most striking part is the air of the trio. This recalls instantly several of our prettiest Indian pieces, and will be continually recurring to everyone who hears it. The osculation effect makes a very happy and appropriate conclusion. Composer, Arthur Pryor; publisher, Carl Fischer, New York.

**10020 The Sons of Uncle Sam****Edward Meeker**

A new patriotic song written in Australia in honor of the American Battleship Fleet's recent visit to that country. The lines teem with heart-felt laudation of Uncle Sam's sailor boys, and the melody is one of those inspiring march airs that bring up mental pictures of a war fleet in action. Faint echoes of national airs are heard in the accompaniment, intermingled with lusty cheers for the Red, White and Blue. Orchestra accompaniment; music, L. L. Howarde; words, A. M. Rattray; publishers, W. J. Deane & Son, Sydney, Australia.

**10021 Last Day of School at Pumpkin Centre****Cal Stewart**

In this selection Uncle Josh treats us to some rich imitations. The first, is that of a typical Pumpkin Centre small boy reciting "I Like For to Live in the Country." Very amusing. Next is an imitation of Ezra Hopkin's youngest playing a mouth organ solo. Then comes the most ludicrous of all, a little German fellow in a thoroughly "Dutch" recitation of "Mary's Lamb."

**10022 My Rosy Rambler****Billy Murray and Chorus**

A new song of the far southwest by the writers of "Cheyenne" and "San Antonio." "Big Jim," the faro king, finds his heart's desire in a bewitching Spanish senorita. The tune has been styled the catchiest since "San Antonio," while Spanish color is given by the introduction of castinets and mandolin. Mr. Murray and chorus give the song the best interpretation it has ever had. Orchestra accompaniment; music, Egbert Van Alstyne; words, Harry Williams; publishers, Jerome H. Remick & Co., New York.

**10023 Kentucky Patrol****American Symphony Orchestra**

Patrols never fail to rank among the best sellers of the month in which they are issued. This one contains a number of engaging melodies, distinctly Southern in flavor, and is fully equal to "Patrol of the Scouts," (Record No. 9960). The whistling refrain, which was so widely praised in the latter, is eclipsed by a louder and even better one in the present Record. Composer, Karl Kaps; publishers, Francis, Day & Hunter, New York.

**10024 Yours is Not the Only Aching Heart****James F. Harrison**

Friedman's tenderly beautiful love song that is being sung everywhere. Words and music are fully as captivating as the well-chosen title would indicate. A past, but fondly cherished, love is the subject and the plaintive note that dominates the air is irresistibly sweet. Orches-

tra accompaniment; music, Leo Friedman; words, Beth-Slater Whitson and T. J. Quigley; publishers, Francis, Day and Hunter, New York.

**10025 Oh, You Coon!**

**Ada Jones and Billy Murray**

The coon song success of the newly organized Cohan & Harris Minstrels. The music represents the only George M. Cohan's idea of the new and popular semi-rag tune and is infectious to a degree. Miss Jones and Mr. Murray give it such a snappy Cohanesque interpretation that the Record will be a very big seller. Orchestra accompaniment; music and words, Geo. M. Cohan; publishers, Cohan & Harris Pub. Co., New York.

**10026 What You Goin' to Tell Old St. Peter?**

**Arthur Collins**

In Arthur Collins' new and sensational comic coon song the bone of contention has a decided chicken flavor. Parson Hammond, preaching "'bout the 8th Commandment," points out Ephraim White as a "bad nigger." He tells the congregation about tracing Ephraim's footsteps from Massa Jones' hencoop to his home. Ephraim retorts, "How come you round that coop?" The tune is a winner, especially in the chorus. Orchestra accompaniment; music and words, Ed. Rose; publishers, Rose & Snyder Co., New York.

**10027 Song of the Mermaids**

**Venetian Instrumental Trio**

This is the entrancing air sung by the maiden chorus in the finale of the second act of von Weber's tuneful opera, "Oberon." The instrumental arrangement used by the Venetian Trio makes one of the most beautiful numbers in their entire repertoire. Composer, C. M. von Weber.

**10028 I Don't Want the Morning to Come**

**Frederic Rose**

The long-expected companion piece to "I Am Tying the Leaves so They Won't Come Down" and by the same writers. An exceedingly fine ballad, which tells of a little sister's pathetic love for a dying brother. The doctor announces that he cannot live another day. In childish fashion she tries to keep the morning back by turning the hands of the clock and closing the window blinds. The refrain is in the effective waltz lento time with a strikingly original orchestra accompaniment. Music, J. Fred Helf; words, A. J. Lamb; publishers, Helf & Hager Co., New York.

**10029 So Do I**

**Knickerbocker Quartette**

A most unique quartette song. All of the singers, it seems, had flirtations with the same young lady. Singer No. 1 sings of her charms, saying, "I gave to her a diamond ring." Singer No. 2 replies, "So did I." Then the bass sings in deep sepulchral tones, "And she gave them both to me." Some clever conversational by-play is worked in between the verses and the Record will prove a phenomenal seller. Unaccompanied; adapted for our Record by **Gus Reed**.

**10030 Christmas Morning at Clancy's**

**Steve Porter**

This remarkable descriptive scene will make everyone get Christmas in his (or her) bones. Merry Christmas chimes are heard; Pat, Mary Ann and all the "childer" crowd around the tree and Pat distributes the presents amid happy shouts and peals of laughter. Danny plays his Jew's harp, Patsy his drum, also a piccolo. Then the old man gets out his fiddle and plays a lively jig while the others dance. Uncle Mike drives up in a sleigh, the kids pile in for a dash over the snow, and jingling sleigh bells are heard as they glide swiftly away. Original sketch.

**10031 Uncle Sam's Postman March**

**Edison Military Band**

At last Uncle Sam's faithful mail man gets his deserts musically. Lurvey has dedicated this rattling fine march to the postmen of the country. The postman's familiar whistle is heard in the trio. The time is 6-8 and it makes an admirable dance number for the new four-step dance, the more so as the Military Band has made a wonderful Record, both in point of volume and perfectly marked tempo. Composer, H. R. Lurvey; publisher, H. R. Lurvey, Lynn, Mass.

## Edison Amberol (Four-Minute) Records

**51 Overture, "The Year 1812."**

**Edison Concert Band**

The Overture Solennelle, "The Year 1812," was written for the consecration of a church at Moscow. Tchaikovsky, the great Russian composer, has depicted vividly stirring scenes of the Franco-Russian war during the year 1812. The majestic Russian hymn, "God, Preserve Thy People," is heard, after which there bursts terrifically the "Battle of Borodino." In this sanguinary contest the French "Marsellaise" is silenced by the Russian hymn. Only a few bands and orchestras, comprising the ablest performers, whose organization has been developed to a state of perfect efficiency, ever attempted this work. The Record runs considerably more than four minutes and includes all the most important parts of the selection. Composer, P. Tchaikovsky; publisher, Carl Fischer, New York.

**52 Ask Mammy**

Manuel Romain

One of the finest Records Mr. Romain has ever given us. The tune is bewitching and the well-chosen words tell a story of tender and absorbing interest. The subject is the love making of a couple of picaninies at a country stile. Bill's invitation to Lize to play in his yard is met with the teasing refrain, "Ask Mammy." Years pass and the couple are found at the same old stile, "Still making love, but on a larger plan." Bill asks if she loves him as of old. Again the charmingly tuneful refrain, "Ask Mammy." Orchestra accompaniment; music, J. F. Brymm; words, Daisy M. Braeson; publishers, Helf & Hager Co., New York.

**53 Miserere from "Il Trovatore"**

Miss Hinkle, Mr. Anthony and Chorus

We have hastened to give this wonderful duet complete in a four-minute Record, because of the ovation accorded the two-minute Record of the same selection in October. The entire Miserere scene is here given, just as it occurs in act 4 of "Il Trovatore." Here we not only have the duet complete, but have also the splendid chorus of male voices chanting the prayer, "Pray that peace may attend a soul departing," etc. Both duet and chorus are sung in English. Orchestra accompaniment; score, G. Verdi; libretto, S. Cammarano.

**54 A Few Short Stories**

Marshall P. Wilder

This Record introduces a distinguished new Edison artist, Marshall P. Wilder, the famous wit and theatrical monologist. Mr. Wilder is known throughout the English-speaking world as the foremost story teller of our times. His anecdotes are all new and extremely humorous and his droll method of telling them never fails to keep his audience in roars of laughter. There is something in the remarkable personality of the man that reaches out and grips an audience so as to make them see life through his eyes. In his stories he makes frequent humorous references to his small stature and is seldom on a stage for more than a minute or so before he establishes such a strong bond of sympathy with his hearers that they feel they have known him all their lives. The present Record gives a dozen of his best stories.

**55 When Grandma was a Girl**

Ada Jones

This novel song first won fame in Sam Bernard's musical comedy "Nearly a Hero." Later it was picked as one of the best songs of the year and featured in "Follies of 1908." In the most amusing and melodious lines it compares the modes of Grandma's day with those of to-day. Two special songs are introduced, a hit of fifty years ago and one of to-day, to show the contrast. Another comparison is an imitation of the car conductor of those happy times and the present. A decidedly clever admixture of song and comic monologue. Orchestra accompaniment; music and words, Ray Goetz; publishers, Jerome H. Remick & Co., New York.

**56 Spring, Beautiful Spring**

American Symphony Orchestra

The favorite European waltz by Paul Lincke. The music is standard in type and "Made to last." Like "Blue Danube" and similar waltzes, it will be as much admired in fifty years as it is to-day. The Symphony Orchestra is given a fine opportunity to show what it can do with the highest grade of composition. Composer, Paul Lincke; publisher, Carl Fischer, New York.

**57 Stories About the Baby**

Marshall P. Wilder

Mr. Wilder relates all of the noted "baby stories," on which his fame as our leading wit and raconteur largely rests. The one about his quest in the department stores for a supply of baby blue ribbons has never failed to "bring down the house." Each of the celebrated Wilder mannerisms and all of his deft little tricks of speech are reproduced as truly to life as though the speaker were present in the flesh.

**58 Grandma**

Byron G. Harlan

By long odds the leader among sentimental "Grandma" songs. It relates a simple story of affecting heart-interest founded on the devotion between grandma and her favorite grandchild. Mr. Harlan has no rival in this class of song. The Amberol Record gives it complete and enables him to greatly improve on all previous efforts. Orchestra accompaniment; music, Ted Snyder; words, Alfred Bryan; publishers, Ted Snyder Music Pub. Co., New York.

**59 The County Fair at Pumpkin Center**

Cal Stewart

There are 650 words in this breezy monologue, which most likely will be voted the funniest Yankee talk Cal Stewart has ever produced. Uncle Josh relates, in his own matchless way, all the incidents of the Pumpkin Center Fair, and it is certain no audience will ever tire of listening. He is great in his description of Salome's "Dance of the Seven Veils" and "The Dance of Venus," two side shows that played to "standing room only." Original sketch.

**60 I'm Afraid to Come Home in the Dark—Humoresque**

New York Military Band

This composition is attracting marked attention at concerts by all of the leading bands. It is a humorous paraphrase by Lampe on the popular song of the same title, arranged especially for large military bands. It requires a complete force of instrumentalists to interpret the score. The refrain of the song is taken for the theme and many humorous and fantastic effects are introduced by the various instruments. Composer, J. Bodewalt Lampe; publishers, Jerome H. Remick & Co., New York.



# EDISON AMBEROL RECORDS

are the new Phonograph Records that play twice as long as the regular Edison Records.

This is not done by making the Record larger or longer, but by engraving more than twice as many lines to the inch as on the regular Record.

Thus Amberol Records can be used in the standard sizes of Edison Phonographs by the addition of a simple attachment or gear.

These new Records not only play longer than any other Record now made, but they play better, their tone quality being richer, clearer and more delicate than has been possible in the past.

## **To Play Amberol Records on Your Present Phonograph**

requires an attachment comprising a change gear and a new reproducer. Your dealer has this attachment, will put one on your Phonograph at a moderate cost, and will explain it to you.

We will be glad to send to anyone, however, a booklet describing the new attachments, describing the Amberol Records, giving a list of the music now available on these Records and giving all the other information necessary to make it possible for you to get more than twice as much enjoyment out of your Edison Phonograph as you are now getting.

**NATIONAL PHONOGRAPH COMPANY, Lakeside Avenue, Orange, New Jersey**



# Edison Phonograph Monthly, Oct., 1908

## Jobbers of Edison Phonographs and Records

- ALA., Birmingham**—Talking Machine Co.  
**Mobile**—W. H. Reynolds.  
**Montgomery**—R. L. Penick.
- ARK., Fort Smith**—R. C. Bollinger.
- CAL., Los Angeles**—Southern Cal. Music Co.  
**Sacramento**—A. J. Pommer Co.  
**San Francisco**—P. Bacigalupi & Sons.  
Kohler & Chase, Inc.
- COLO., Denver**—Denver Dry Goods Co.  
Hext Music Co.
- CONN., New Haven**—Pardee-Ellenberger Co.
- D. C., Washington**—E. F. Droop & Sons Co.
- GA., Atlanta**—Atlanta Phonograph Co.  
Phillips & Crew Co.  
**Waycross**—George R. Youmans.
- IDAHO, Boise**—Eiler's Piano House.
- ILL., Chicago**—Babson Bros.  
Lyon & Healy.  
James I. Lyons.  
The Vim Co.  
Montgomery Ward & Co.  
Rudolph Wurlitzer Co.  
**Peoria**—Chas. C. Adams & Co.  
Peoria Phonograph Co.  
**Quincy**—Quincy Phonograph Co.
- IND., Indianapolis**—Indiana Phono. Co.  
Kipp-Link Phonograph Co.  
A. B. Wahl & Co.
- IOWA, Des Moines**—Hopkins Bros. Co.  
The Vim Co.  
**Dubuque**—Harger & Blish.  
**Fort Dodge**—Early Music House.  
**Sioux City**—Early Music House.
- KY., Louisville**—Montenegro-Riehm Music Co.
- LA., New Orleans**—William Bailey.  
National Automatic Fire Alarm Co.
- MAINE, Bangor**—S. L. Crosby Co.  
**Portland**—W. H. Ross & Son.
- MD., Baltimore**—E. F. Droop & Sons Co.
- MASS., Boston**—Boston Cycle & Sundry Co.  
Eastern Talking Mach. Co.  
Iver Johnson Sptg. Goods Co.  
**Fitchburg**—Iver Johnson Sptg. Goods Co.  
**Lowell**—Thomas Wardell.  
**New Bedford**—Household Furnishing Co.  
**Springfield**—Flint & Brickett Co.  
**Worcester**—Iver Johnson Sptg. Goods Co.
- MICH., Detroit**—American Phono. Co.  
Grinnell Bros.
- MINN., Minneapolis**—Thomas C. Hough.  
Minnesota Phono. Co.  
**St. Paul**—W. J. Dyer & Bro.  
Koehler & Hinrichs.  
Minnesota Phonograph Co.
- MO., Kansas City**—J. W. Jenkins' Sons Music Co.  
Schmelzer Arms Co.  
**St. Louis**—Conroy Piano Co.  
Koerber-Brenner Music Co.  
Silverstone Talk. Mach. Co.
- MONT., Helena**—Frank Buser.
- NEB., Lincoln**—Ross P. Curtice Co.  
H. E. Sidles Phono. Co.  
**Omaha**—Nebraska Cycle Co.  
Shultz Bros.
- N. H., Manchester**—John B. Varick Co.
- N. J., Hoboken**—Eclipse Phono. Co.  
**Newark**—Douglas Phonograph Co.  
A. O. Petit  
Rapke Phono. Store.  
**Paterson**—James K. O'Dea.  
**Trenton**—Stoll Blank Book and Stationery Co.  
John Sykes.
- N. Y., Albany**—Finch & Hahn.  
**Astoria**—John Rose.  
**Brooklyn**—A. D. Matthews' Sons.  
**Buffalo**—W. D. Andrews.  
Neal, Clark & Neal Co.  
**Elmira**—Elmira Arms Co.  
**Gloversville**—American Phono. Co.  
**Kingston**—Forsyth & Davis.
- New York City**—Blackman Talking Machine Co.  
J. F. Blackman & Son.  
I. Davega, Jr., Inc.  
S. B. Davega Co.  
Douglass Phono Co., Inc.  
Jacot Music Box Co.  
Victor H. Rapke.  
Regina Co.  
Siegel-Cooper Co.  
John Wanamaker.  
Alfred Weiss.
- Oswego**—Frank E. Bolway.
- Rochester**—Mackie Piano, O. & M. Co.  
Talking Machine Co.
- Schenectady**—Finch & Hahn.  
Jay A. Rickard & Co.
- Syracuse**—W. D. Andrews.
- Troy**—Finch & Hahn.
- Utica**—Clark-Horrocks Co.  
Arthur F. Ferriss.  
William Harrison.  
Utica Cycle Co.
- OHIO, Canton**—Klein & Heffelman Co.  
**Cincinnati**—Ball-Fintze Co.  
Milner Musical Co.  
Rudolph Wurlitzer Co.  
**Cleveland**—Eclipse Musical Co.  
**Columbus**—Perry B. Whitsit Co.  
**Dayton**—Niehaus & Dohse.  
**Newark**—Ball-Fintze Co.  
**Toledo**—Hayes Music Co.  
**\*Youngstown**—The W. E. Henry Co.
- OREGON, Portland**—Graves Music Co.
- OKLA., Oklahoma City**—Smith's Phono. Co.
- PENNA., Allentown**—G. C. Aschbach.  
**Easton**—The Werner Co.  
**\*Harrisburg**—Louis Buehn & Bro.  
**Philadelphia**—Louis Buehn & Bro.  
C. J. Heppe & Son.  
Lit Bros.  
Musical Echo Co.  
Penn Phonograph Co.  
John Wanamaker.  
Western Talking Mach. Co.  
H. A. Weymann & Son.
- Pittsburg**—Pittsburg Phono. Co.  
Powers & Henry Co.  
Standard Talk. Mach. Co.
- Reading**—Reading Phonograph Co.
- Scranton**—Ackerman & Co.  
Technical Supply Co.
- Williamsport**—W. A. Myers.
- R. I., Providence**—J. M. Dean Co.  
J. A. Foster Co.  
J. Samuels & Bro.
- TENN., Chattanooga**—J. H. Templeman Co.  
**Knoxville**—Knoxville Typewriter and Phonograph Co.  
**Memphis**—F. M. Atwood.  
O. K. Houck Piano Co.  
**Nashville**—Magruder & Co.  
Nashville Talking Mach. Co.
- TEX., Dallas**—Southern Talking Machine Co.  
**El Paso**—W. G. Walz Co.  
**Fort Worth**—Cummings, Shepherd & Co.  
**Houston**—Texas Piano & Phono. Co.  
**San Antonio**—H. C. Rees Optical Co.
- UTAH, Ogden**—Proudfit Sporting Goods Co.  
**Salt Lake City**—Clayton-Daynes Music Co.
- VT., Burlington**—American Phono. Co.
- VA., Richmond**—C. B. Haynes & Co.
- WASH., Seattle**—D. S. Johnston Co.  
Kohler & Chase.  
**Spokane**—Spokane Phonograph Co.
- WIS., Milwaukee**—Lawrence McGreal.
- CANADA, Quebec**—C. Robitaille.  
**St. John**—W. H. Thorne & Co., Ltd.  
**Toronto**—R. S. Williams & Sons Co., Ltd.  
**Vancouver**—M. W. Waitt & Co.  
**Winnipeg**—R. S. Williams & Sons Co., Ltd.

\*Added since September 1, 1908.

# Broaden Your Field

—and increase your sales. A dealer makes a serious mistake by selling records and instruments for amusement purposes alone. There is besides the amusement field the vast field of education from which can be reaped an abundant business. Here the dealer can increase the sale of records to those who already own phonographs, and can sell both instruments and records to a very large number of cash customers who would never think of buying a phonograph except for educational purposes. All this is made possible through

## I.C.S. LANGUAGE SYSTEM

WITH  
*Thomas A. Edison*  
PHONOGRAPH

There is a great opportunity for **you** to sell I. C. S. Language Outfits to people who are going abroad or who desire to learn a language for the sake of the knowledge of it alone; to those who desire to qualify for positions as translators and foreign correspondents; and to foreigners who wish to learn to speak English. No sledge hammer is needed to get it clearly into your head that this presents a sure way of broadening your field of work and increasing your sales. For the sake of good business sense, boom the I. C. S. Language feature of the business.

**International  
Correspondence Schools  
SCRANTON, PA.**

# The EDISON PHONOGRAPH MONTHLY

Vol. VI

November, 1908

No. 11



Helping Santa Claus Now and the  
Result. See page 3

# The EDISON PHONOGRAPH MONTHLY

Published by the National Phonograph Co., Orange, N. J.

All communications to *The Phonograph Monthly* should be addressed to the Advertising Department, Orange, N. J.

## *Contents for November, 1908*

Get Ready for the Holidays . . . . .	1
Addenda Must Be Signed Without Delay . . . . .	2
Edison Records Cannot Be Sold at Auction . . . . .	2
Going Some . . . . .	2
Store Management . . . . .	3
Lauder Records . . . . .	4
Everybody Enthusiastic . . . . .	5
Amberol Advertising . . . . .	5
A Phonograph Debate . . . . .	5
New Supplements and Bulletins . . . . .	6
Printed Matter . . . . .	6
Personal . . . . .	6
Christmas Records . . . . .	7
A Poster for your Window . . . . .	7
The Phonograph as a Political Factor . . . . .	7
Diverting Footsteps from the Beaten Path . . . . .	8
Little Local News Items . . . . .	9
Boosting Christmas Record Sales . . . . .	10
Tray System for Keeping Records . . . . .	11
Mr. Edison's First Public Record . . . . .	11
Attachments for Concert Machines . . . . .	11
Your Advertisement and Ours . . . . .	12
Some Short but Strong Holiday Ads . . . . .	13
Trade Bulletins . . . . .	14
List of Suspended Dealers . . . . .	15
Advance List Edison Standard and Edison Amberol Records for January . . . . .	16
Home Made Window Signs . . . . .	20

NEW YORK: 10 FIFTH AVENUE.

NATIONAL PHONOGRAPH CO., LTD., VICTORIA ROAD, WILLESDEN, LONDON.

NATIONAL PHONOGRAPH CO. OF AUSTRALIA, LTD., 340 KENT STREET, SYDNEY, N. S. W.

MEXICAN NATIONAL PHONOGRAPH CO., AVENIDA ORIENTE No. 117, MEXICO CITY.

COMPANIA EDISON HISPANO-AMERICANA, VIAMONTE 515, BUENOS AIRES.

EDISON GESELLSCHAFT, M. B. H., SUD-UFER 24-25, BERLIN.

COMPAGNIE FRANCAISE DU PHONOGRAPHE EDISON, 42 RUE DE PARADIS, PARIS.

Is your stock of Edison Phonographs and Records in good shape for the holiday trade?

Are you ready to get your share of the purchases that will be made within the next six weeks?

If not, then it is none too early to get busy. Christmas is only seven weeks away, a period all too short for Dealers who have not given much thought to the holiday season.

We have given up a large part of this issue to helpful holiday suggestions for Dealers and we commend them to every Dealer who wants to increase his business now or at any other time. These suggestions, however, will be worth nothing to Dealers who do not have a proper stock of Phonographs and Records. Unless you have such a stock on hand or intend to get it at once don't waste time or money for advertising or for any other holiday plans.

But bear this in mind, if you are the only Dealer in your town and you want to continue as the only one, you must do your part in taking care of your locality. We are going to make the title of EDISON DEALER worth more and more as time passes and we cannot afford to have Dealers occupy valuable territory if they will not carry an adequate stock and push the business.

If you find that the mail-order-houses are selling Edison goods in your vicinity, be as aggressive as they and you will have no reason to complain. The Amberol Record alone ought to wake you up to the new possibilities of the Phonograph business. Besides the possibilities for heavier sales the increased profits ought to appeal to you.

### Addenda Must be Signed Without Delay

A comparatively small number of Dealers have failed as yet to sign and send us the Addenda to our Dealers' Agreement. The effect of this Addenda is to commit Dealers to the sale of Edison goods as their only cylinder line. As was to be expected, a few of these Dealers will not sign at all, preferring to handle other lines, but the number is much smaller than we anticipated. In fact, we hardly realized our full strength in the trade, until we found thousands of Dealers eager to co-operate with us in this new policy. We fully believe that nine out of ten of the unsigned Dealers have failed to send us signed copies of the Addenda purely from carelessness or negligence. The following letter has been sent to unsigned Dealers and it will, we believe, bring the signatures of all Dealers who seriously intend continuing in business as talking machine Dealers:

Your name appears as one of the few Edison Dealers who have not yet signed the Addenda to our Dealers' Agreement.

It is important that we know at once your attitude concerning this matter. We want to put into effect the new plan of not permitting new Dealers to be established in localities where we are not properly represented, and until we hear from you we cannot tell what course to follow concerning your town. Then, too, we should regret it if we prevented your Jobber from supplying you with Edison goods and later found that you desired to continue as an Edison Dealer.

We enclose two copies of the Addenda. If you intend to continue as a Dealer, sign one, have your signature witnessed, and return to this office at once. *Retain the other for your files.*

If you have decided not to continue, sign the enclosed blank and mail it to us.

Requesting the favor of a prompt reply, we beg to remain.

---

### Edison Records Cannot Be Sold at Auction

In the early part of October a firm of auctioneers at Paterson, N. J., announced a sale of a lot of Edison Records. The National Phonograph Company heard of it in time and had a restraining order issued by a Federal Judge. The case was settled a few days later by the defendants consenting to the issuance of a permanent injunction against them. In a somewhat similar case at Woonsocket, R. I., a firm of pawnbrokers were restrained from selling a lot of Edison Records at less than retail prices.

### Going Some

Did you ever see a factory working with a daily force of 4,500 hands, running all night in some departments and part of the night in many others? Do you realize the number of Phonographs, Records and attachments such a force can turn out every week? Do you appreciate what it means to have a weekly payroll of \$50,000? If you do then you may form an idea of the efforts we are making to produce goods fast enough to supply the Edison trade. We have a force of 4,500 people; many departments are working night and day; they are making Phonographs and Records at a phenomenal rate, and it is costing \$50,000 a week to meet the cost of labor. Don't it seem likely that such a way of running a big factory must in a short time catch up with orders and then keep up with the demand?

Good progress was made last month toward catching up on the first orders from Jobbers for Amberol Records, combination Phonographs and attachments. Second shipments were made to all Jobbers. These in many cases completed the Jobbers' first orders. A few unusually large orders still remain to be filled. Many Jobbers have already placed second orders, which in not a few instances were larger than the first ones. The second shipments will ease up the situation a little and relieve the Jobbers of some of the strain to which they have been subjected in the past six weeks because of their inability to fill the orders of Dealers.

Although we are now making splendid progress in manufacturing goods it will not be out of place to make a statement that will aid the trade in appreciating some of the difficulties encountered in making the new Records, attachments and machines. To play the Amberol Record a reproducing point is required that is only one-quarter the size of the one used in a Model C Reproducer. Roughly estimated it is eight times as difficult to make one of these finer points and the percentage of imperfect work is proportionately large. To make these fine points required the breaking in of a large number of men and women. These hands have now become proficient. All the work is done under powerful microscopes. Because of the expense of these instruments and to increase the daily production the men work in three shifts of eight hours each, the department working without a stop from 7 o'clock Monday morning till 12 o'clock Saturday night. If the trade could have followed the details of building up this department it would fully appreciate at least one of the difficulties of the new conditions.

# Store Management

A monthly comment on things Edison dealers have done with a few suggestions on what they should do to increase sales.

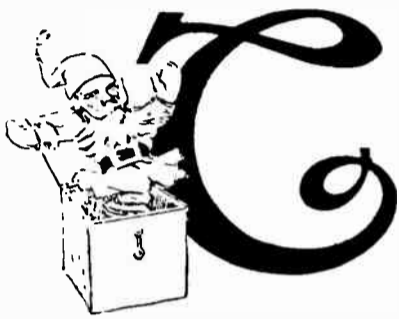

**C**HIS issue is our Christmas Special.

If it is a little bit ahead of its schedule, so much the better for you.

A suggestion for helping holiday trade is not of much value after the holiday trade has started.

You will probably do a good holiday trade without making any special effort. It is the time when people spend.

But the trade you get without effort is no credit to your store management and should not satisfy you when there is so much more to be had by going after it.

You will find in this issue a number of ideas that will bring you holiday trade that you would not otherwise get.

You cannot do these things at the eleventh hour and do them well. You cannot wait until the week before Christmas and do them effectively.

The only reason why the majority of people don't think about Christmas buying until well along in December is because nobody has suggested Christmas buying to them.

The holidays have been happening every year for hundreds of years, and yet most dealers have never acquired the habit of grasping time by the marcel wave and bringing about a six-weeks' buying season, instead of two.

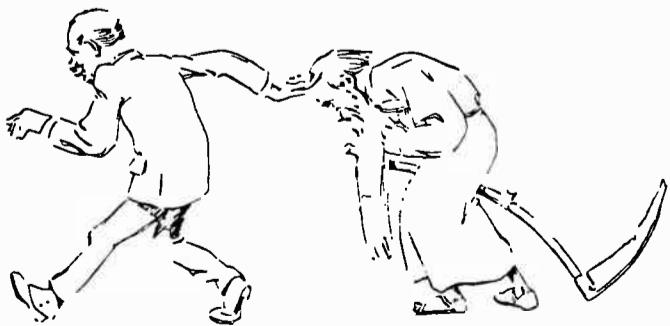

Once a pessimistic old farmer was asked about his crops.

"Well," he said, "they didn't turn out as well

as I thought they would and I hardly thought they would."

Your holiday trade in Phonographs and Records depend upon your belief in a big trade and your energy in backing up that belief.

If you do not expect an unusual demand and do not prepare for one, your summing up after it is all over will be just about like that of the old farmer.

The first step in preparing for the holiday trade should be to have sufficient goods in stock.

"Sufficient," in this instance, means a stock based upon the most optimistic outlook possible. It means a stock that will impress people with the belief that you intend doing the holiday business of your career.

And you will, if you begin early and set about it with that determination.

Holiday time is no time to clean out odds and ends. People are in a buying mood, and they



insist on spending their money at stores that have anticipated their wants.

If you do not believe there is going to be a good demand for Phonographs and do not prepare for such demand, there will not be any so far as your store is concerned.

With a stock of sufficient size to make the public believe that you believe that you have in Edison Phonographs and Edison Records the best Christmas proposition in the land (and you have) comes the next step, which is to impress this fact upon the minds of every man, woman and child in your locality.

Here is where advertising comes in, and here is where we want to direct you to the advertising suggestions offered in this issue.

In connection with these suggestions we have two requests to make. One is that you adopt them; the other is that you adopt them promptly.

As you read, this Christmas seems like a future event. So it is, but right now many people are thinking about it and trying to solve the question of what to give.

Why then wait until they make up their minds? Why not help them in deciding, and thus get the benefit of their decisions?

That is the purpose of early holiday advertising, and, in fact, the purpose of all advertising.

Advertising, even at holiday time, is not quick acting, unless it is bargain advertising.

You must start early in order to give your advertising time to work—otherwise, by the time it begins, the buying season will be all over.



Another advantage of early publicity or early effort of any kind is that it means a more evenly distributed trade, instead of three weeks of "nothing doing" and three days of grand last-minute rush.

You cannot sell Phonographs to a crowd, any more than you can sell pianos or automobiles to a crowd.

The Phonograph requires attentive, intelligent salesmanship, it calls for demonstrations, it needs a quiet atmosphere and it takes considerable time.

Cultivating an early-buying habit is very important to you.

---

If Phonograph and Record selling required only putting in a stock and putting up a sign, everybody would be in the Phonograph selling business.

There is some trade in your locality that is yours for the asking.

There is some that is yours without asking.

There is a whole lot that you must go out and pull in by the hair.

You go out after this trade in a number of ways. The Phonograph playing through your window or your door gets some of it; your window displays get some of it; your newspaper advertising gets some of it, and your direct advertising gets some of it.

Perhaps nothing you can do will get all of it, but no one thing you can do will get what all the things you can do will get.

Merely trimming up a window and letting it go at that is like picking apples one at a time, instead of shaking the tree.



If a certain scheme you work is good, keep on working it, but don't work it exclusively. Monthly concerts are very successful in attracting trade to your store. Mailing out lists of the new Records to Phonograph owners also brings trade that might otherwise become negligent.

But these trade-bringing efforts are not interchangeable, nor are they alternatives.

Each issue of this publication aims to give you several good ideas for pushing your goods. It isn't the plan to give you a choice. It is for the purpose of enabling you to have a number of things working at the same time.

---

## Lauder Records

Any one who doubts the tremendous popularity of Harry Lauder, the Scotch comedian, should have attended the performances in which he took part at the Lincoln Square Theatre, New York, during October. He was kept on the stage over an hour every night, and would have remained twice as long had it depended by the demands of his delighted audience. This is the kind of receptions he is going to get in every city in which he appears during his twelve weeks' stay in this country. It can only mean a great demand for the Edison Records made by him. Dealers should put in a good stock of the Lauder Records, get the latest Lauder bulletin from their Jobber and hang it up in their windows or some other prominent place. Then let the public know that they have Records by this popular comedian. In such cities as he appears Dealers should also advertise in the local papers. Just before coming to this country Mr. Lauder received a "command" from the King of England, and for seventy minutes delighted the King and a party of royal guests with his talent.



## Everybody Enthusiastic

From all sides come most enthusiastic commendations of the new Amberol Records and the attachments and combination machine for playing them. The Jobbers gave them their heartiest approval two months ago, when they were made acquainted with the details and were given demonstrations. The Dealers followed with glowing letters of praise as fast as they received the new goods from Jobbers. Now that owners of Edison Phonographs are equipping their machines to play the Amberol Records and others are buying combination machines, the trade and we are getting hundreds of letters of congratulation. Our own salesmen and those of Jobbers are doing a land office business in taking orders for the new goods and the reports they are making to headquarters all tell the same gratifying story. The new Records and the clever plans for playing them on existing Phonographs are everywhere proclaimed as one of the greatest advances ever made in the talking machine industry. In spite of the still adverse times, the entire trade has been aroused to a new interest, and to a man declare that if they can get the goods they will do a bigger and more profitable business than ever before. Many of them have already taken orders for large numbers of attachments subject to delivery when Jobbers can fill their orders. Viewed as a whole, the outlook for the future of the Edison trade never was as bright as at present. Then, too, the new policies of confining Edison Dealers to the sale of our goods as their only cylinder line, and of preventing the indiscriminate appointment of new Dealers have worked wonders in gaining the further good-will and co-operation of the trade. Nothing seems to be needed now but to get Edison goods in sufficient quantities to supply the demand of the public. We hope that this will not long be a cause for complaint, even though it may for a time be difficult to keep pace with the demand.

## Amberol Advertising

The standard magazines of largest circulations and the popular weeklies, like the *Saturday Evening Post* and *Colliers*, have already furnished ample evidence of the beginning of our big campaign for advertising Amberol Records and combination Phonographs. The cost of the month's advertising was the largest we have ever spent in a single month in this class of mediums, but the total for December

issues will be fully a third larger. One of the strong features of the list will be a full page in each of the Butterick trio—the *Delineator*, the *Designer* and *New Idea*. This order carries with it representation in a half-page advertisement that the publishers of the Trio will publish in 200 daily papers throughout the country, calling attention to the advertisers in the Trio. We shall also have the back covers of *American Magazine* and *McClure's Magazine*; a full page in the *Woman's Home Companion*; double pages in *Cosmopolitan*, *Everybody's*, *Munsey's* and *Review of Reviews*; full pages or proportionate space in the *Saturday Evening Post*, *Collier's*, *Associated Sunday Magazine*, *Youth's Companion*, *Ladies' Home Journal*, *Ladies' World*, *Outlook*, *Argosy*, *All Story*, *Railroad Men's Magazine*, *Red Book*, *Broadway*, *Metropolitan*, *Pacific Monthly*, *Human Life*, *National Magazine*, *World To-Day*, *Puck* and *Judge*. We also expect to begin the newspaper campaign in most of the large cities.

## A Phonograph Debate

One of the most unique affairs ever held in this country took place in Foster's Opera House, Des Moines, Ia., on October 9th. It was announced as "The First Phonograph Debate in History" and was, in fact, a joint debate between Mr. Bryan and Mr. Taft, carried on by means of Edison Phonographs. The affair was arranged by the *Des Moines Capital* and was carried out with the co-operation of Hopkins Bros., the Phonographs being operated by John Hopkins and D. F. Hopkins, of that firm. The Opera House was packed with an audience of 1,500 persons, all of whom seemed much pleased with the affair. The machines were plainly heard in all parts of the house. The debate was interspersed with vocal and instrumental music by local artists. At the close of the affair a number of miscellaneous selections were played on the Phonograph, including some of the Amberol Records. The event was voted a great advertisement for the Edison Phonograph.

Your letter to the Democratic Chairman, Mr. A. Hetfield, of this district, has enabled me to sell a Home, 10 Bryan Records, besides others. I therefore write you this letter to thank you very kindly for your aid. It would have been impossible to make that sale without you having written to him. Again thanking you very highly for your effort.—*Covington Supply House, Covington, Ky.*

## New Supplements and Bulletins

Beginning with the December issues, the Record Supplement and the Record Bulletin will be printed in a new and more attractive manner. Because of the necessity for including the ten Amberol selections with the twenty-four two-minute Records, it has been necessary to enlarge both forms. The Supplement will consist of six pages, instead of four, and be printed throughout in two colors. Small half-tones of a number of the Edison artists will be features of this and future Supplements. The Record Bulletin will be enlarged to 19 x 25. It will be printed in a new form, in two colors and on heavier paper. This size will be continued indefinitely and we would suggest that Dealers have frames made for enclosing the Bulletin as it appears each month. Such frames will not cost more than \$2, probably less, and would last a long time. In such a frame the Bulletin will be a fine advertisement, especially when placed in a show window.

---

## Printed Matter

We have in preparation a new catalogue of Edison Phonographs and a folder illustrating and describing the combination type Standard, Home and Triumph machines. The issuance of these has been purposely held up because of the delay in getting a sufficient supply of goods in the hands of the trade. The forms will reach Jobbers by or before November 20th, by which time we expect to be able to supply Phonographs and Records as fast as they may be wanted. The trade will then be in a position to make an aggressive campaign for business, which up to now has not been possible. We have printed a good sized edition of the folders for the purpose of saving the complete catalogues. The folders may be used for circularizing and the catalogues for store trade. We cannot supply machine catalogues in quantities large enough for use as circulars. They are too expensive. Don't ask your Jobber for large quantities for he won't have them to give you. Even the folders must be used carefully. They are intended for circularizing special lists, and for such use will be most effective. The catalogue is Form 1435 and the folder, Form 1434.

We'd like to talk about the merit of the muslin banners as advertising mediums, but these have "got us in so bad" that we hesitate about doing it. After most strenuous efforts we succeeded in getting the manufacturer to give us

enough to complete the shipments to Jobbers, and they have gone forward. Jobbers will take care of such Dealers as have asked for one. Those who haven't asked may get them from their Jobbers.

---

Jobbers have been supplied with Lauder Record Supplements and Bulletins with their orders for Lauder Records, and Dealers who carry these Records should ask for a Bulletin and a supply of Supplements. The latter is Form 1432 and the Bulletin is Form 1433.

It is idle for Dealers to ask for a large lot of electros without charge. We will not mail more than two or three at one time. Dealers who persist in asking for more will please indicate the order of preference so that we may easily determine which to send. We will supply electros for advertising purposes, but we insist upon knowing that they are so used when we send them. Before writing for more electros, Dealers should ask themselves if they have complied with our requirements and sent us papers showing the advertisements in which the previous ones were used. This will save a "turn down" and considerable useless correspondence. Don't write letters telling us how mean we are because we ask you to send papers or proofs. Such letters are not half as apt to get attention as papers showing how electros were used. What we ask of you is reasonable and just, and we shall continue the present plan of handling electros.

---

We have on hand a quantity of hangers of the Bryan and Taft Records, Forms 1361 and 1391 and will ship small lots to Jobbers on request, or we will mail one of each direct to Dealers who will use them.

---

## Personal

Eugene H. Philips, who a year ago became Manager of Salesmen for this company, has been promoted to the position of Credit Manager of the Edison Companies, including the National Phonograph Co. The latter's position has been filled by F. K. Dolbeer since the establishment of the office about seven years ago. Mr. Dolbeer will now devote his entire time to his duties as General Sales Manager of the National Co. He has held both positions for a year past.

H. T. Leeming, formerly traffic manager of the National Phonograph Company, has been made purchasing agent, vice John H. Moran, resigned. John T. Rogers, formerly assistant traffic manager, has been promoted to his former chief's position.

## Christmas Records

Early in November we are going to mail to every Edison Dealer a bulletin hanger, showing eleven Edison Records having a special bearing upon the Christmas season. The titles of the Records are given below. Dealers are urged to display the hanger, making sure in advance that they have the Records in stock, so as to meet any demand that may be created by the advertising. The list:

8270	Santa Claus Song	George P. Watson
8708	Old Jim's Christmas Hymn	Campbell & Harrison
8837	O Come All Ye Faithful (Adeste Fidelis)	Edison Male Quartette
8854	Ring the Bells of Heaven	Chimes
9156	Star, Beautiful Star	Anthony & Harrison
9168	Silent Night	Edison Male Quartette
9410	Joy to the World	Edison Concert Band
9431	Down on the Farm	Ada Jones & Len Spencer
9703	Ring Out the Bells for Christmas	Edison Concert Band
10008	Christ is Come	Edison Concert Band
10030	Christmas Morning at Clancy's	Steve Porter

## A Poster for Your Window

The poster enclosed carries the same illustration as our Christmas magazine advertising. This advertising will appear around the 20th of November.

About this time you should place the poster in your window. If you can surround it with a good Christmas display of Edison Phonographs and Records, so much the better.

The point is to show it just at the time we are showing it in the magazines, so that it may concentrate *our* advertising on *your* store.

Millions of people will see the "Christmas Matinee" in the magazines. We want these same millions to see it in the windows of our Dealers, so that when our advertising reminds them of an Edison Phonograph for a Christmas gift, the poster in the window will indicate a store where a Phonograph can be bought.

Just about everybody in your locality reads the magazines, so that our advertising will be seen and read by just about everybody. Holiday shopping will bring them by your window in crowds. The poster will bring them in.

## Trade Advertising of Amberol Records

We wish that we could give up the space necessary to acknowledge the receipt of the hundreds of pieces of printed matter, letters, etc., concerning the Amberol Records that have been

issued by enthusiastic Jobbers and Dealers in all parts of the country. We regret also that we cannot reproduce some of these forms. All of them show a marked degree of enthusiasm, but some are unusually clever in their presentation of the new conditions. Then, too, Dealers have extensively advertised the Amberol Records in their local papers, some of these advertisements filling a half page. All of this advertising activity on the part of the trade is a most encouraging sign of the times.

## The Phonograph as a Political Factor

It is now too late to accomplish anything politically from the sales of Phonographs and Bryan and Taft Records, but the following extract from a letter sent out by H. S. Martin, chairman of the Kansas State Democratic Committee, to all county chairmen, is quoted to show how seriously the Phonograph has been considered in the present campaign:

\* \* \* "I want to suggest to you the use of the Phonograph with the Bryan Records. The Phonograph has been used in a number of Kansas counties long enough to test it, and for a school-house meeting it is a great success. In every instance the report has been that where a Phonograph meeting has been advertised at a school house they have had an overflow meeting. A Phonograph, including the Records, can be secured for something less than \$30.00. In a good many cases you can find a Democrat who has a Phonograph you can borrow. The Bryan Records can be secured through regular Dealers, and I should like to have from one to three Phonographs in every county in Kansas."

In sending us the foregoing, the Santa Fé Watch Co., Edison Dealers at Topeka, Kas., wrote:

The enclosed letter is being sent by the State chairman to all of his county chairmen. A similar letter has been sent to all Republican chairmen. We had no trouble in getting the State chairman of both parties to do this. We also secured a list of all chairmen of both parties and wrote them personal letters. We are daily receiving orders from all over the State. There are 107 chairmen in each party in the State; 214 altogether. We are getting big returns for our trouble.

We have a few street car cards on hand that were used in the cars of New York city and now returned to us. They are in good condition. Dealers who want to do any street car advertising may have a small quantity, while they last, by agreeing to pay express charges from Orange.

## Diverting Footsteps from the Beaten Path



With the coming of the Holidays a throng of Christmas shoppers will pass your store.



The first step is to prevent their passing. A good window will do this for the Christmas shopper has time to shop, is out to see and is open to suggestion.

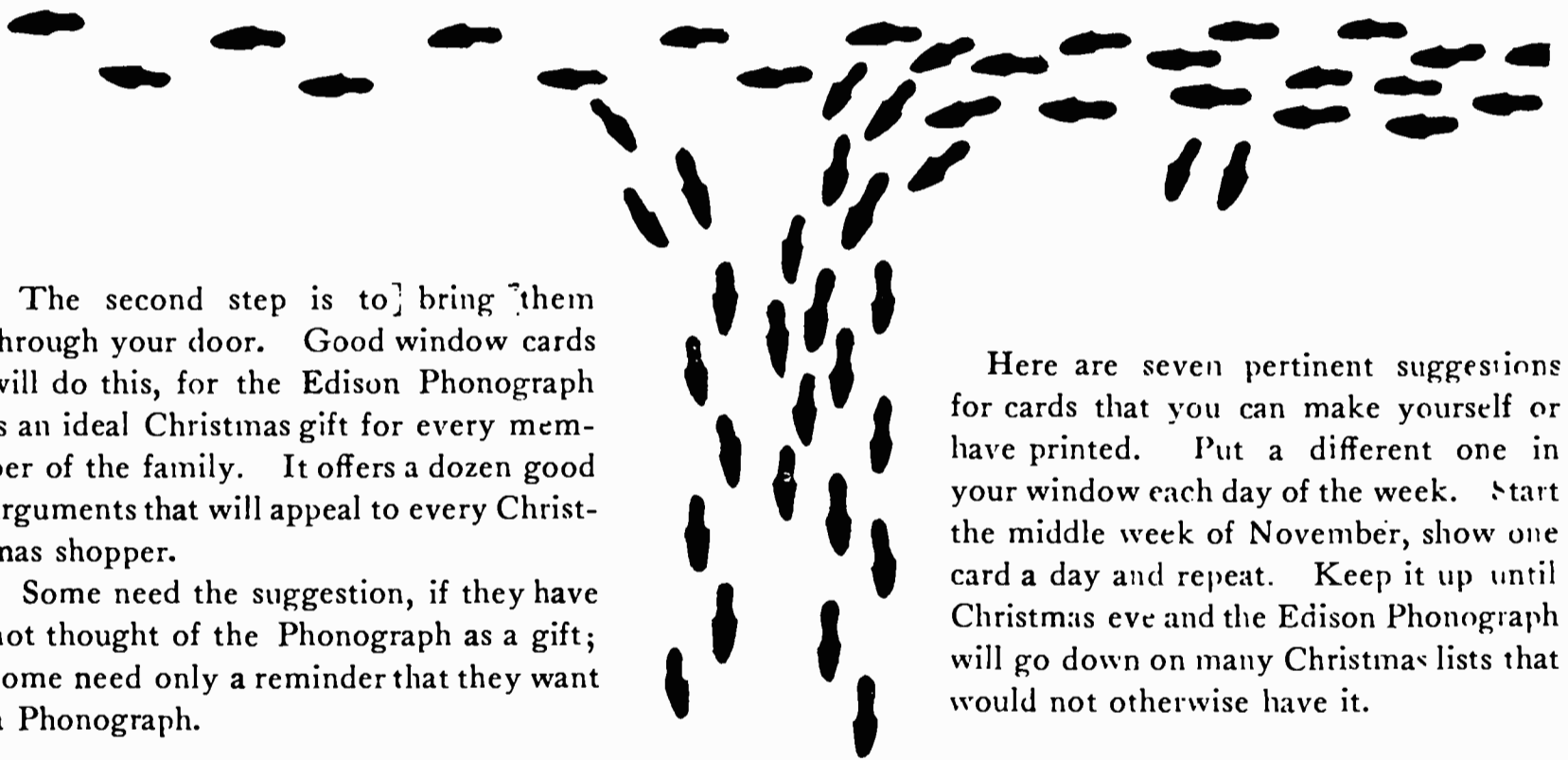

The second step is to bring them through your door. Good window cards will do this, for the Edison Phonograph is an ideal Christmas gift for every member of the family. It offers a dozen good arguments that will appeal to every Christmas shopper.

Some need the suggestion, if they have not thought of the Phonograph as a gift; some need only a reminder that they want a Phonograph.

Here are seven pertinent suggestions for cards that you can make yourself or have printed. Put a different one in your window each day of the week. Start the middle week of November, show one card a day and repeat. Keep it up until Christmas eve and the Edison Phonograph will go down on many Christmas lists that would not otherwise have it.

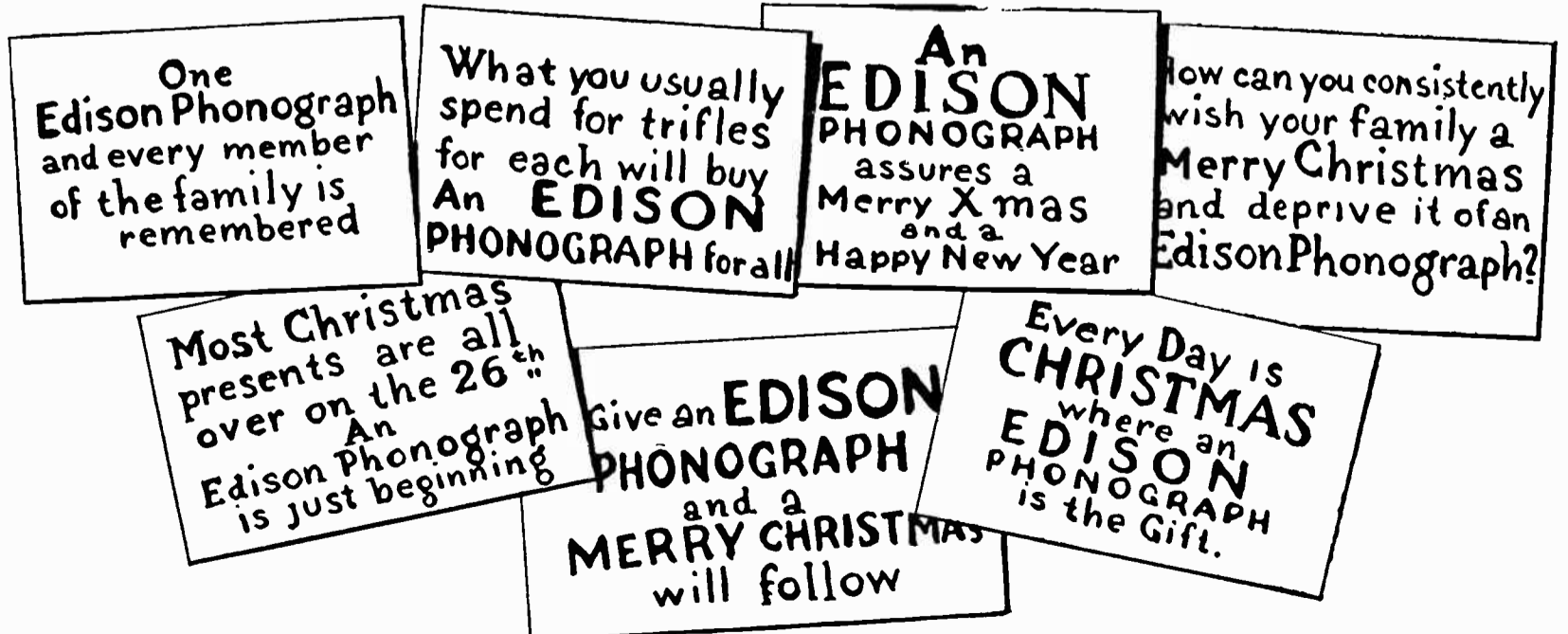



### Little Local News Items

Nearly every newspaper runs a column of news items each day, setting forth little local happenings.

Sandwiched in between these items are small advertisements that are usually pretty bad. Sometimes newspapers charge for inserting these advertising items, and sometimes they are given free to steady advertisers.

But whether they are free or paid for, they are of no value to the advertiser unless they are items that have a real news value.

They can have. An advertisement can be just as newsy as anything else that happens.

Our suggestion is that you run a reader in this local news column every little while, from now until Christmas.

Make the item a reminder that Christmas is only so many days off, that it is time to decide on a gift and that a Phonograph is the best gift, and why.

We reproduce in the opposite column a reader as it should be written and set. This reader should appear on December 1st, and should be followed at frequent intervals by others, copy for which we give, making sure to have the number of days right in each reader.

You can run one with the heading, "25 days to Christmas," in your newspaper of December 1st,

or you can run several in that issue with the same heading and repeat in later issues, changing the heading to correspond. Here are some suggestions for readers for this purpose.

One Edison Phonograph and every member of the family is remembered.

What you usually spend for trifles for each will buy an Edison Phonograph for all.

And Edison Phonograph assures a Merry Christmas and a Happy New Year.

How can you consistently wish your family a Merry Christmas and deprive it of an Edison Phonograph?

Most Christmas presents are all over on the 26th. An Edison Phonograph is just beginning.

Give an Edison Phonograph and a Merry Christmas will follow.

Every day is Christmas where an Edison Phonograph is the gift.

The best Christmas present is something for the home. The best thing for the home is an Edison Phonograph. Nothing makes home so inviting and so popular as this great and versatile entertainer.

The Christmas money goes farther if put into an Edison Phonograph—farther because the Phonograph goes farther, carries with it more pleasure for more people for a longer time than any gift you could select.

What a lot of Christmas gifts are thrown aside on the 26th. An Edison Phonograph carries the Christmas pleasure through the year and beyond.

The great difference between an Edison Phonograph and anything else you can think of, as a Christmas gift, is that people tire of anything else you can think of.

### An Apology

We regret that a press of other matter has made it necessary to omit Lesson IV of the series of "Lessons for Dealers."



## Boosting Christmas Record Sales

Edison Records make excellent Christmas gifts.

To a Phonograph owner nothing brings more pleasure, provided the Records are of the kind the owner prefers.

Selecting Records for others, however, is as risky as selecting neckties, cigars or anything else where personal likes and dislikes enter in.

Remove this difficulty and Record giving at Christmas time would become most profitably popular for the Dealer.

To enable Dealers to encourage this kind of giving we have prepared a Record Certificate, which is shown here in reduced size. It is attractively printed in several colors.

The Dealer sells these Certificates to those who wish to make presents of Records to their friends. The Certificates are filled out, showing the number of Records paid for and indicating whether regular Records or Amberols, or both.

The purchaser pays for the Records called for by the Certificate and gives the Certificate as a present. The recipient then presents the Certificate at the store issuing it and makes his own selections of Records.

We have printed a quantity of these Gift Certificates and will mail a limited number to Dealers at the rate of twenty-five for ten cents. This charge is for the purpose of regulating the demand and for mailing.

They should be advertised in the local newspapers, displayed in the windows, with window cards asking people to come inside and learn about them.

Any Dealer who takes these Certificates and makes a noise about them will do a record-breaking Record business throughout the holidays.

How many can you use? Order today from the Advertising Department. If you want to see how they look before you order, write for a sample copy.

## Tray System for Keeping Records

How many of the thousands of Edison Dealers who are carrying their Record stocks by what is known as the tray system, can repeat the name of the man who devised this system? It is Victor H. Rapke, of 1659 Second avenue, New York City, one of the first to become an Edison Jobber, and one of the most staunch friends of the Edison product. Mr. Rapke devised the Record trays and the labels used on them. For a time he was the only manufacturer of the trays, but the advantages of this tray system soon became generally known, and others entered the field of supplying the trade with trays. They are now made and sold by various Jobbers. Mr. Rapke has, however, retained control of the labels, and is to-day supplying them to the trade through Jobbers. He has sold thousands of complete sets and he has a large number of subscribers to his plan of furnishing labels each month as fast as new Edison Records are issued. At a cost of \$2 a year he is furnishing labels of all new Edison Records, including Standard and Amberol, as they appear. Dealers who are not carrying their Records in trays, properly labelled, should lose no time in taking the matter up with their Jobbers. The system is worth many times its cost in convenience and display. It is also a Record seller, for customers can read the names on the labels while Records are being played for them, and in this way they often buy many Records that they would not under other conditions.

---

## Mr. Edison's First Public Record

The Electrical Show, which is held annually at the Madison Square Garden, New York, was opened on October 3d with a Phonograph speech by Thomas A. Edison, Honorary President of the show. It was the first and only Record ever made by Mr. Edison for public use. He said:

Those of us who began our labors at the operator's key fifty years ago have been permitted to see and assist in the whole modern industrial development of electricity. Since the remarkable experiments of Morse in 1844 and the unsuccessful efforts of Field in 1858, there have come with incredible rapidity one electrical art after another, so that in practically every respect civilization has been revolutionized. It is still too early to stand outside these events and pronounce final judgment on their lasting value, but we may surely entertain the belief that the last half of the nineteenth century was as distinct in its elec-

trical inventions and results as the first was in relation to steam.

The lesson of the jubilee of the Atlantic cable of 1858 is one of encouragement to all who would add to the resources of our race and extend our control over the forces of nature. Never was failure more complete, never was higher courage shown, never was triumph more brilliant than that which since 1866 has kept the Old World moored alongside the New by pulsating cables of steel and copper—the "family ties" of the civilized world.

When I look around at the resources of the electrical field today as shown in this Exhibition, I feel that I would be glad to begin again my work as an electrician and inventor; and we veterans can only urge upon our successors, the younger followers of Franklin and of Kelvin, to realize the measure of their opportunities and to rise to the height of their responsibilities in this Day of Electricity.

There were also two-minute Phonograph speeches by Louis A. Ferguson, of Chicago, President of the American Institute of Electrical Engineering; W. C. L. Elgin, President of the National Electric Light Association; Vice President W. W. Freeman, President of the Associated Edison Illuminating Companies; E. G. Acheson, President American Electrochemical Association, and H. A. Lardner, President New York Electrical Society. Governor Hughes addressed the show in a two-minute Phonograph speech.

The opening exercises were held in the Concert Hall, the Records being played on an Edison Phonograph, partly hidden by a group of palms. It was the first great public function in which so prominent a part was taken by the Phonograph. The affair was voted a great success by all who attended.

---

## Attachments for Concert Machines

In response to a number of requests from the trade the following list and Dealers' prices have been fixed for combination attachments for Concert machines:

For the regular Concert machines, that is, those still containing the Concert mandrels, list \$9.75; Dealer \$8.00.

For Concert machines that have been changed over to play the Standard Record, list \$7.50; Dealer \$6.25.

---

Harger & Blish, Edison Jobbers at Dubuque, Ia., have also been appointed as Jobbers at Des Moines, being located at 707-711 Locust street. The Vim Company have discontinued their jobbing stock at Des Moines.

# Our Advertisement and Yours

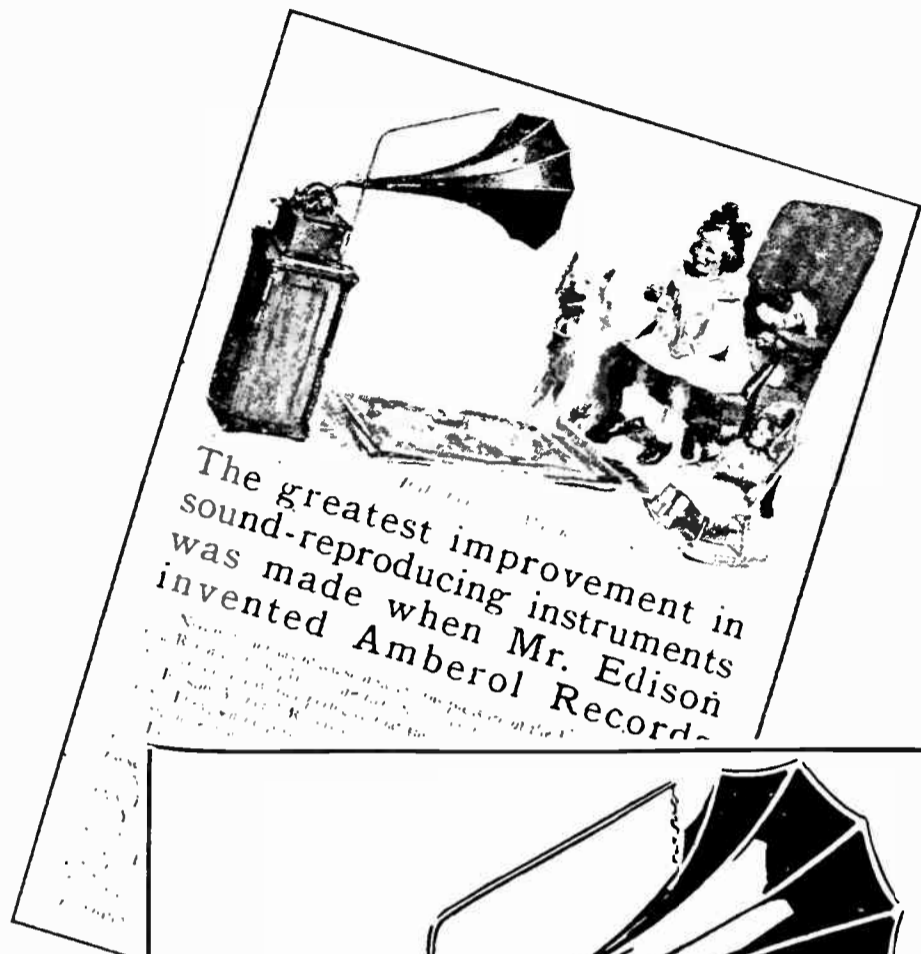

This large advertisement is for your local newspaper. The small ad is a reduction of the ad which we will run in the Christmas issues of all of the leading magazines. Run your ad about November 20th—that is when ours will be seen by your people. Then every bit of interest that our ad awakens in your locality will be centered on your store.



### The Edison Phonograph a Christmas Gift for the Whole Family from the Children Up

When you make the Edison Phonograph the home gift, no member of the family is neglected. For the baby it is a lasting diversion; for the young folks, wholesome and educational entertainment; for grow-ups a pleasure that never loses its popularity.

The Phonograph makes the home the most attractive spot on earth. It is a band, an orchestra, a concert, a soloist or a monologue artist as you wish. It is more than a Christmas gift for all; it is a gift for all time.

Before you decide on what the present will be, come in and hear the Phonograph. Seven models, \$12.50 to \$60.00.

**Symphony St.                      PUSH & PROSPER                      Symphony St**

Electro: Single Column No. 705: Double Column No. 706

This advertisement is a little larger than most dealers usually run, but this is an unusual time. It will be worth many times the space it takes. We furnish the cut free. Tear out the page, take it to

your newspaper and follow the style of type-setting. Schedule it for November 20th and if possible give it several insertions. It will bear repeating, for it is sure to bring you business.



Some Short but Strong Holiday Ads

A small ad can be so set that it will own the whole newspaper page. Here are four that will hold their own, if the newspaper sets them as they are set here. Take these ads to your newspaper and insist that the style of setting be followed. The cuts show the new Edison Phonograph with all of its improvements. An electrotype will be sent free. Order by the number. The number. The copy shown elsewhere for window cards will be equally forceful in your newspaper if this style of setting is followed.

**The Great Difference** between an Edison Phonograph and anything else you can think of, as a Christmas gift, is that people tire of anything else you can think of.

You have a choice of seven models:

**\$12.50 to \$60.00**

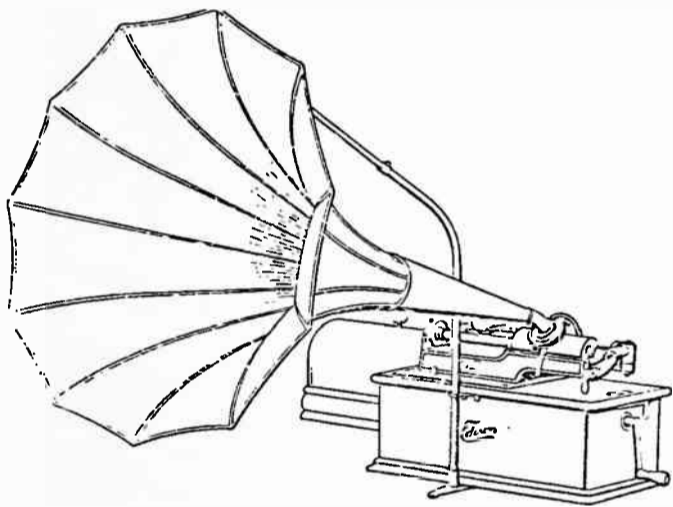

**PUSH & PROSPER**

10 Symphony Street

Cut is Electro No. 540

**The best Christmas present is something for the home.**

The best thing for the home is an Edison Phonograph. Nothing makes home so inviting and so popular as this great and versatile entertainer.

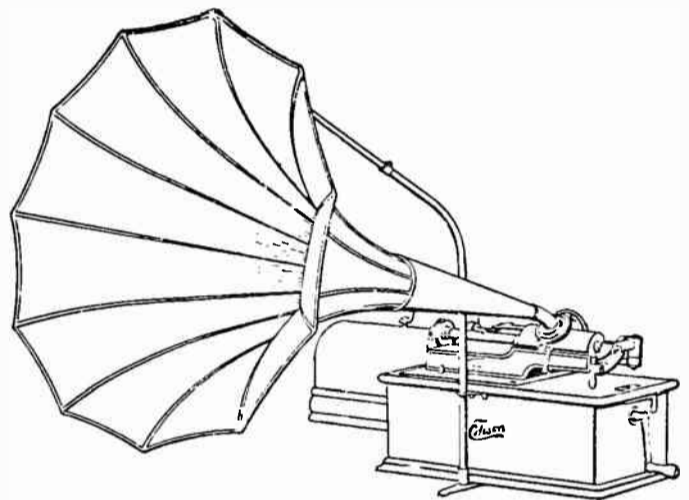

**\$12.50 to \$60.00**

**PUSH & PROSPER**

10 Symphony Street

Cut is Electro No. 540

What a lot of Christmas Gifts are thrown aside on the 26th. An **Edison Phonograph** carries the Christmas pleasure through the year and beyond.

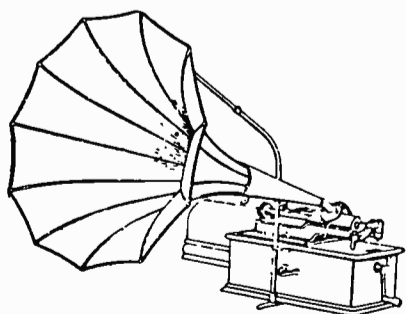

Seven Models

**\$12.50**

TO

**\$60.00**

**PUSH & PROSPER**

10 Symphony Street

Cut is Electro No. 541

The Christmas money goes farther if put into an **Edison Phonograph**

—farther because the Phonograph goes farther, carries with it more pleasure for more people for a longer time than any gift you could select.

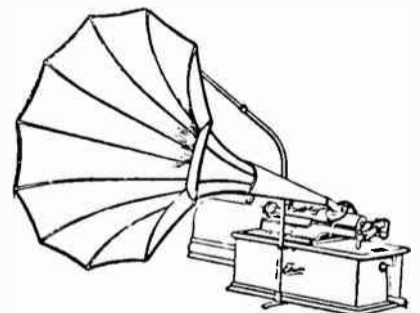

SEVEN MODELS

**\$12.50 to \$60.00**

**PUSH & PROSPER**

10 Symphony Street

Cut is Electro No. 541

Electros of Santa Claus on front cover are: single col. No. 703; double col. No. 704.

# Trade Bulletins

[COPY MAILED TO ALL DEALERS]

*Sales Department Bulletin No. 17,  
October 7, 1908*

## *Trade Information for Dealers*

*All correspondence concerning this bulletin should mention its number and be addressed to NATIONAL PHONOGRAPH COMPANY, SALES DEPARTMENT, Orange, N. J.*

Please file the enclosed Directions Sheets for adding the new Attachments to the Standard, Home and Triumph Phonographs. It is possible that sheets were not included with your order for Attachments and you may need them for reference. If you have not yet received your order for Attachments a study of the Direction Sheets will make it easier to apply the Attachments when they arrive.

You will find it profitable to learn how to apply the new Attachments quickly and accurately. The work can be done in a few minutes when you know how, and it is not difficult to learn. The Attachment yields a fair profit and every Phonograph that you change to play the Amberol Records, means the sale of many of the latter, which net a profit of 22 cents each, or 77 per cent. on the cost.

Don't these profits look good?

Get the names of every Phonograph owner in your vicinity (perhaps you already have them) and then persuade every one to equip his (or her) Phonograph with an Attachment and thus be able to play Mr. Edison's newest invention—the Edison Amberol Record.

Don't be discouraged because your Jobber is a little slow in filling your first order. We will soon be able to fill any order he can send. Take orders for as many Attachments as you can sell, promising deliveries as soon as the factory can fill orders. Let your customers know that those who order in advance will get your attention first. Getting orders in advance will also enable you to know how many to get from your Jobber. If you can afford to invest the money, sell Attachments on the fifty cents or dollar a-week plan to those who cannot pay cash. It will get such customers to buying Amberol Records and every time they make a weekly payment they will buy more Records. Many Dealers may find it pays to keep customers always in debt, for every time they come in they buy Records.

[COPY MAILED TO ALL DEALERS]

*Sales Department Bulletin No. 18,  
October 17, 1908*

## *Trade Information for Dealers*

*All correspondence concerning this bulletin should mention its number and be addressed to NATIONAL PHONOGRAPH COMPANY, SALES DEPARTMENT, Orange, N. J.*

It is important that Dealers should caution their customers to make certain that Model C Reproducers only be used on the Two-Minute Records, and Model H Reproducers only be used on Amberol Records, thereby obtaining proper results and avoiding the damage to Records occasioned by a disregard of this suggestion.

**STANDARD ATTACHMENT.** Users should also be instructed that in order to play the Standard, or Two-Minute Record, the sliding gear stud should be pushed away toward the right, or toward the cylinder, and the Model C Reproducer is to be used. To play the Amberol, or Four-Minute Record, the sliding stud should be pulled out to the left, and the Model H Reproducer is to be used.

**HOME AND TRIUMPH ATTACHMENTS.** To play Standard Two-Minute Records, the sliding clutch casing should be pushed close to pulley wheel, and Model C Reproducer used. To play the Amberol or Four-Minute Record, the sliding clutch casing should be pushed as far as possible toward main shaft, and Model H Reproducer used.

If these instructions are carefully followed, no injury to Records will result.

*Sales Department Bulletin No. 19,  
October, 25, 1908*

## *Trade Information for Dealers*

*All correspondence concerning this bulletin should mention its number and be addressed to NATIONAL PHONOGRAPH COMPANY, SALES DEPARTMENT, Orange, N. J.*

The forty-two British selections named below will be dropped by us on December 1st, after which date we will discontinue their manufacture and will fill orders only for such as we have in stock. They are being dropped because they have been cut out of our British Catalogue and we do not care to continue here any British Records not listed abroad.

12831	Selection from the "School Girl"	B. M. Band
12838	Salvage Man	Daniels
12846	Let Her Drown	Mackay

12847	O! the Business	Mackay
12849	Robin Adair	Reid
12850	Mary of Argyle	Reid
12852	Selection of Popular Songs No. 2	B. M. Band
12853	Selection of Popular Songs No. 3	B. M. Band
12855	I'll Be True	Hill
12856	Once	Hill
12858	Bonnie Dundee	Reid
12859	At the Seaside	Mackay
12860	Oh! Isn't It Singular	Mackay
12861	Recruiting Sergeant	Daniels
12862	Banks of Allan Water	Barry
12868	Life's Lullaby	Hill
12869	Jock O'Hazeldean	Reid
12870	There's Nae Luck Abcot the Hoose	Reid
12915	Selection of Popular Songs No. 4	B. M. Band
12919	Comin' Thro' the Rye	Reid
12920	Charlie is My Darling	Reid
12930	Bid Me to Love	Hill
12931	I've Got Something to be Thankful For	Mackay
12932	Fleeting Moments Galop	B. M. Band
12935	Am I in the Way?	Mackay
12936	I'm the Plumber	Mackay
12938	Selection of Popular Songs No. 6	B. M. Band
12939	Forget-me-not Intermezzo	B. M. Band
12940	Bundle of Mischiefs	B. M. Band
12951	Yo Ho Little Girls	Mackay
12957	Always in Jail	B. M. Band
12989	Banks of Allan Water	Reid
13049	Selection from "Pinafore"	B. M. Band
13050	Scots Wha Hae	Reid
13062	There's a Home for You With Me	Mackay
13063	Clown Polka	B. M. Band
13064	Miss Kelley	Daniels
13071	Selection of Popular Songs No. 5	B. M. Band
13073	Selection from "Falka"	B. M. Band
13075	Russian Dance	B. M. Band
13080	Pottergeister Galop	B. M. Band
13081	Selection from "Gypsy Life"	B. M. Band

N. Y., Albany—Albany Phono. & Sewing Mach. Co., Aaron Kent & W. H. Bernstein. Props.  
 \*Binghamton—Harlow & Co.  
 Brooklyn—A. Becker.  
 Henry F. Staude.  
 Collins Center—A. P. Bolander, Jr.  
 Lockport—Floyd B. Serles, Prop. Lockport Phono. Co.  
 New York City—Harry Cohen.  
 M. Greenberg, alias J. Greenburg.  
 \*Frank Prikowitz.  
 P. A. Rosenthal.  
 Watertown—L. A. Maxson.  
 Byer & Susskind.  
 N. C., \*Raleigh—Capital Typewriter Co. (John Harder, Mgr.)  
 OHIO., \*Akron—J. A. Mahaffey.  
 Fremont—Lorenz Henderson Piano Co.  
 Lima—Henry Van Gunten, Van Gunten Music Store.  
 OKLA., \*Guyton—J. C. Butts.  
 \*Weleetka—C. E. Dwinie.  
 Connellsville—Wright-Metzler Co.  
 PENNA., \*Oil City—James Fogle.  
 \*Gent & Eagen.  
 Philadelphia—Eastern Phono. Co., M. Futernik, Prop.  
 R. I., \*Providence—Kirby Piano & Music Co., (M. E. Kirby, Prop.), and at all points  
 \*Woonsocket—Donnelly & Fahey.  
 \*Kirby Piano & Music Co., (M. E. Kirby, Prop.), and at all points.  
 \*H. S. Oppenheimer.  
 TEX., New Braunfels—Ed. Gruene.  
 VA., Fries—J. J. Crump.  
 WASH., \*Wartsburg—J. B. Caldwell.  
 Krupp—Ed. Long.  
 \*Added since September 20, 1908.

## REINSTATED.

COL., Boulder—Bentley & Craig.  
 Ouray—C. C. Stratton.  
 IOWA, Danbury—J. W. O'Day.  
 N. Y., Rochester—A. J. Deninger (Dealer's basis).

## Suspended List, Oct. 20, 1908

### SUPERSEDING ALL PREVIOUS LISTS

This list is supplemental to the Suspended List printed in the Edison Phonograph Monthly for June, 1908, which is still in force and must be given the same consideration by the trade as if reprinted in full herewith.

CAL., Chico—Moriss Kyrous (or Kryicus).  
 The Postoffice News Stand.  
 \*Haywards—P. J. Federspiel; also Melrose.  
 \*Melrose—P. J. Federspiel; also Haywards.  
 CONN., Meriden—J. F. Malloy.  
 New London—Smith Bros.  
 \*Norwich—Shea & Burke.  
 IND., \*Decatur—Schaefer Hdw. Co.  
 \*Hammond—Paxton & Baker.  
 IOWA, \*Creston—H. W. Edaburn.  
 Sidney—I. L. Morgan.  
 \*Red Oak—A. C. Kelley.  
 ILL., \*Charleston—Frank Ricketts.  
 KAN., Cuba—Mrs. Frank Barnett.  
 MASS., \*Great Barrington—Rowe & Co.  
 Newburyport—Pentucket Phono. Store.  
 M. H. McKinney, Prop.  
 Needham—J. L. Davis.  
 Northampton—W. T. Risley.  
 Roxbury—Theo. Rothe and Mr. Price of Fuller Elec. Co.  
 Worcester—J. G. Williams, Prop. Williams' Book Store.  
 MICH., \*Coldwater—M. L. Brazie.  
 Marshall—S. E. Cronin Estate.  
 MINN., Elgin—J. Watterston.  
 MISS., Sedalia—S. R. Payne.  
 NEB., Alliance—B. F. Lockwood & Co.  
 Alma—Henry M. Dayton.  
 Geneva—Geo. H. Nelson.  
 Sterling—Dr. W. L. Heilman.  
 N. H., Dover—Dover Furniture Co.  
 N. J., Bayonne—Goldweber's Dep't. Store. M. Goldweber & W. Goldweber.  
 Plainfield—\*Chas. Greenwold.  
 L. Seisel.

Copies of the complete Suspended List will be mailed on request. Jobbers and Dealers are asked not to supply any of the above named firms with our apparatus, either at addresses given or any other address.

## A Series of "All Rights"

There are some Dealers who make it a point never to be pleased with any new trade condition or policy. They belong to the pessimists' club. A few of them have disagreed with our new policies. The following letter, however, written by Dusy & Sawrie, Inc., Edison Dealers at Selma, Col., represents, we believe, the views of 99 out of every 100 Edison Dealers in the United States and Canada; it is printed with the same emphasis as the original letter:

We desire to express our appreciation of your new selling policies.

For the Dealer who is not loyal enough to know a good thing, your policy of permitting him to handle only the Best (Edison Records) is a protection well designed to keep him right and to prevent him doubling his investment.

For the Dealers who are taking proper care of their trade and maintaining proper Edison stocks, your policy of not appointing new Dealers is an encouragement toward still more complete stocks and increased energy in disposing of the goods.

Your goods are all right, your policies are all right, you are all right, so that we now think it is up to the Dealer to be the same.

With our best wishes for your still greater success, we are.

# Advance List

## Of Edison Standard (Two-Minute) and Edison Amberol (Four-Minute) Records for January, 1909

*THE Standard and Amberol Records listed below will be shipped from Orange in time to reach all Jobbers in the United States and Canada before December 24th, 1908, all things being favorable, and they may be reshipped to Dealers at 2 P. M. on December 23d. They must not, however, be exhibited, demonstrated or placed on sale by Jobbers or Dealers until 8 A. M. on December 24th. (Date advanced on account of Christmas.) Supplements, Phonograms, Bulletins and Hangers will be shipped with Records. These may be distributed to Dealers after December 20th, but must not be circulated among the public before December 24th. Jobbers and Dealers may, however, deposit Supplements and Phonograms in Mail Boxes or Post Offices after 5 P. M. on December 23d, for delivery on the following day. Jobbers are required to place orders for January Records on or before November 10th. Dealers should place January orders with Jobbers before November 10th to insure prompt shipment when Jobbers' stock is received.*

### Edison Standard (Two-Minute) Records.

#### 10032 Nymph and Satyr

Edison Concert Band

A new characteristic number in which the composer takes for his subject an imaginary story concerning a nymph and a satyr, and works out a very melodious and interesting selection. The instrumentation is most attractive. Composer, T. H. Rollinson; publisher, Oliver Ditson Co., Boston.

#### 10033 Mandy Lane

Ada Jones

A coon love song in which "Mandy Lane in the old log cabin on the Suwanee shore" is the object of the dusky lover's serenade. The words are set to a quaint rag-time melody, which Miss Jones sings in a fetching way and with an echo of coon dialect. The chorus is catchy. Orchestra accompaniment. Music and words, William McKenna; publishers, Jerome H. Remick & Co., New York.

#### 10034 Uncle Josh's New Year's Pledge

Cal Stewart

Now that the inimitable Cal Stewart has returned to the ranks of Edison artists, there will be no let-up until every selection in his repertoire has been reproduced on Edison Records. In this selection Uncle Josh tells how he resolved on New Year's Day to abstain from the use of profanity. He bore up patiently under several provoking trials during the day without breaking his pledge, but when at night he fell down the cellar stairs with his arms full of eggs, molasses, flour, etc., and they mixed up in his hair, clothing, etc., it was all off. It is necessary to hear Mr. Stewart on the Record to know how laughable it really is.

#### 10035 The Yama, Yama Man

American Symphony Orchestra

An orchestra selection of the two popular songs, "The Yama, Yama Man" and "Cuddle Up a Little Closer, Lovey Mine," which are the song hits in the musical comedy, "The Three Twins." The oboe work is a feature. Composer, Karl L. Hoschna; publishers, M. Witmark & Sons, New York.

#### \*10036 When I Marry You

Frederic Rose

A selection on the order of "Are You Sincere," (our Record No. 9973) and by the same authors. Both songs are of the catchy waltz variety, which generally become very popular. The publishers expect this new song to become as popular as the preceding one. Orchestra accompaniment. Music, Albert Gumble; words, Alfred Bryan; publishers, Jerome H. Remick & Co., New York.

#### 10037 Honey Lou

Collins and Harlan

A comic coon song, with the customary rag-time melody. "Honey Lou" has an admirer who is so desperately in love with her that he threatens suicide if she refuses to marry him. Her funny responses in the chorus to his appeal for consideration make up an amusing feature of the song. The singing is done in conversational duet form. Orchestra accompaniment. Music, Tom Lemonier; words, Ed. Rose; publishers, Rose & Snyder Co., New York.

\*This selection will be illustrated on cover of January Phonogram.

**10038 Good Evening, Caroline**

**Billy Murray**

The latest effort of two of the most successful song writers of the day. This fact alone stamps it as one of the hits of the season. It is a typical coon serenade, with an air that catches on at once—just the kind of song in which Mr. Murray has made his greatest success as an Edison artist. Orchestra accompaniment. Music, Albert Von Tilzer; words, Jack Norworth; publishers, The York Music Co., New York.

**10039 Wild Cherry**

**New York Military Band**

A characteristic rag composition by the writer of "My Dream of the U. S. A.," "It's the Pretty Things You Say" and "Grandma." It is one of the brightest and sprightliest rag-time pieces brought out in many a day, and it makes an instant hit wherever played. Composer, Ted Snyder; publisher, Ted Snyder, New York.

**10040 Some Day**

**James F. Harrison**

This old-time popular ballad needs no description. Everyone familiar with popular music can recall its charming words:

I know not when the day shall be,  
I know not where our eyes may meet  
What welcome you may give to me,  
Or will your words be sad or sweet.

It may not be 'till years have passed  
'Till eyes are dim and tresses gray;  
The world is wide, but, love at last,  
Our hands, our hearts, must meet some day.

Mr. Harrison's cadenza at the end is a feature of the Record. Orchestra accompaniment. Music, Milton Wellings; words, Hugh Conway; publisher, G. Schirmer, New York.

**10041 Paulina, Otto and Fido**

**Ada Jones and Len Spencer**

A German vaudeville sketch in which the *dramatis personae* are: *Paulina*, a teasing German girl, who cannot decide whether she loves her dog or *Otto* the best, but mostly favors the dog; *Otto*, very much in love with *Paulina* and at odds with the dog; *Fido*, the dog. *Paulina* declares that if *Otto* loves her he must love her dog, too. The sketch has the usual amount of fun characteristic of the Jones and Spencer work. Original and not published.

**10042 Somebody Just Like You**

**Manuel Romain**

A sentimental ballad by the writers of "Ev'ry Ship Will Find a Harbor" (our Record No. 9732) and something on the order of "Just Some One" (our Record No. 9847). The chorus:

Somebody just like you, dear,  
Somebody just your size;  
Someone with heart so true, dear,  
Someone with your blue eyes.

Somebody's very lonely,  
Paddling his own canoe  
Somebody wants to share his heart  
With somebody just like you.

Mr. Romain sings it charmingly. Orchestra accompaniment. Music, Johann C. Schmid; words, Charles E. Baer; publisher, H. A. Weymann & Son, Philadelphia.

**10043 Father is a Judge**

**Edward Meeker**

Once again father is made the butt of a popular song, and if this one does not make as great a hit as "Everybody Works but Father" it will not be because it does not possess all the elements essential to popularity. It is being featured by the head-liners in vaudeville. Father's erudition was not known, even by his own family, until the Democrats discovered it and elected him Judge. Some of the things he did in his wisdom and the consequences that followed his acts form the theme of the song. The Record has three verses and three choruses, the latter being enlivened with a chorus of voices joining in at the end of each with "Has father." The comic interludes by the orchestra add to the fun. Orchestra accompaniment. Music, J. Fred Helf; words, Ed. Moran; publishers, Helf & Hager Co., New York.

**10044 You Can't Stop Your Heart from Beating for the Girl You Love**

**Byron G. Harlan**

A new sentimental waltz song that is attracting a great deal of attention. It is on the popular juvenile subject and tells of "Willie and May," who were playmates at school and also sweethearts. "School Days" was of this class of songs. Orchestra accompaniment. Music, George Christy; words, Bert Fitzgibbons; publishers, M. Witmark & Sons, New York.

**10045 Memories of Galilee**

**Knickerbocker Quartette**

A four-part arrangement of this well-known hymn, in which the solo part is sung by the tenor, and the responses are made by the entire quartette. Between the great popularity of the hymn and its splendid rendition by the Quartette, the Record cannot fail to be in wide demand. Unaccompanied. Music, H. R. Palmer; words, Robert Norris, LL.D.; publishers, Oliver Ditson Co., Boston.

**10046 Mary Ann O'Houlihan**

**Edward M. Favor**

An amusing song in Irish dialect. The subject is quite humorous. It reverses the usual order of things and the funny lines tell of man's faith and woman's perfidy. The melody is of the rollicking, jolly kind—just the kind one expects to find in an Irish song. Mr. Favor excels in songs of this sort, both on the stage and in making Records. Orchestra accompaniment. Music, Harry Von Tilzer; words, Vincent Bryan; publishers, Harry Von Tilzer Music Publishing Co., New York.

---

---

# 18 Edison Phonograph Monthly, Nov., 1908

---

**10047 Black and White Rag** **American Symphony Orchestra**

A composition fitly described by its name. It is written in the peculiar manner of rag-time selections and include some novel orchestral effects. A sure seller whenever played. Piano score published by Jerome H. Remick & Co., New York, but it is orchestrated especially for our Record and not published in this form.

**10048 Uncle Josh in a Roller Skating Rink** **Cal Stewart**

The title itself is enough to suggest the fun-making possibilities of this Record. Add to this Mr. Stewart's infectious laugh and the combination is complete. Any one who ever went to a roller skating rink can appreciate what happened to Uncle Josh when he put on the skates (he calls them "little automobiles") for the first time. His recital of his first efforts at skating is as funny as could be expected, even of Mr. Stewart.

**10049 Rainbow** **Ada Jones and Billy Murray**

This composition is sweeping the country from coast to coast and is destined to be as popular as "Hiawatha," which it resembles, being sung in Indian style and in much the same tempo. It is a bright and dashing two-step and a fascinating ballad. It is sung by Miss Jones and Mr. Murray in the conversational style that is always so interesting. Orchestra accompaniment. Music, Percy Wenrich; words, Alfred Bryan; publishers, Jerome H. Remick & Co., New York.

**10050 Sweet Girl of My Dreams** **Harry Anthony**

This charming ballad is sung with great success by Chauncey Olcott in his new production, "Ragged Robin." Its chorus:

Oh! sweet girl of my dreams, you have beauty so rare,  
Checks that resemble the roses so fair,  
Your eyes, love, sparkle; your smile brightly beams,  
To you I'm singing, sweet girl of my dreams.

The melody is in slow waltz tempo. Orchestra accompaniment. Music and words, Chauncey Olcott and Daniel J. Sullivan; publishers, M. Witmark & Sons, New York.

**10051 Love's Magic Spell** **Albert Benzler**

A bells solo of a catchy melody written in schottische tempo, on the song and dance order. Compositions of this kind are peculiarly well suited for bells solos, and in the hands of a musician like Mr. Benzler they make very attractive Records. Orchestra accompaniment. Composer, F. W. Meachan; publisher, Carl Fischer, New York.

**10052 Baby Doll** **Arthur Collins**

A coon song that is catching on rapidly and being sung everywhere. The words are set to a rag melody and tell of a darkey's delight when his lady-love calls him "Baby Doll." To him this is the dearest of endearing terms. Orchestra accompaniment. Music and words, Armstrong and Clark; publishers, Harry Von Tilzer Music Publishing Co., New York.

**10053 Darling Nellie Gray** **Metropolitan Quartette**

The old songs—the songs that won popularity in days of a generation or more ago—never lose their attractiveness. They seem to possess a charm that none of the later-day compositions can displace. "Darling Nellie Gray" is one of these. It is at least fifty years since it was written, sung and played. It has always been and is still a prime favorite at minstrel and vaudeville performances. The special arrangements for mixed voices give all the singers a chance to be heard in solos, duets and quartettes. Unaccompanied. Composer, B. P. Hanby.

**10054 Flanagan's New Year's Call** **Steve Porter**

Mr. Porter's Irish sketches continue to be one of the features of our monthly lists of new Records. His imitation of three voices is so clever that it is hard to believe three different persons are not carrying on the dialogue. Flanagan makes a New Year's call on Mrs. Reilly and the conversation that ensues makes up a very funny Record. This is Flanagan's New Year resolve: "I resolve never to take another drink—unless I am by meself, or with someone; and never to smoke—but one cigar at a time." Original sketch and not published.

**10055 On Parole March** **New York Military Band**

A spirited march of a true military character. One of the features is a bugle and drum effect in the trio. The composition is above the ordinary, just as our Band's rendition is of a superior character. Composer, W. J. Potts; publishers, W. J. Potts Music Co., Lisbon, Ohio.

## Edison Amberol (Four-Minute) Selections.

**61 Glow-Worm** **Edison Concert Band**

A selection from the operetta "Lysistrata." The composer styles it an "Idyl," a composition of a pastoral or tenderly romantic character. The Record gives the entire composition. It was written by Paul Lincke, a popular German composer, who is also musical director of the Apollo Theatre, Berlin, Germany. It has become a craze in this country, being featured in the programmes of all large bands. The principal melody or story has also been published as a song. Publishers, Joseph W. Stern & Co., New York.

## 62 Calvary

James F. Harrison

A well-known sacred song and one greatly favored by church singers. The two-minute Record gave it in an abbreviated form, but it is here given in its entirety. Mr. Harrison's fine baritone voice gives the song an unusually good rendition. There is nothing finer in sacred selections than the chorus of Calvary:

Rest, rest to the weary,  
Peace, peace to the soul,  
Though life may be dreary,  
Earth is not thy goal.

O lay down thy burden,  
O come unto me,  
I will not forsake thee,  
Though all else should flee

So impressive is this Record that it is certain to continue in the catalogue of Amberol Records as long as the Phonograph exists and will always be in demand. Orchestra accompaniment. Music, Paul Rodney; words, Henry Vaughn.

## 63 Aunt Dinah's Golden Wedding

Empire Vaudeville Co.

An unusually entertaining vaudeville sketch with the following cast of characters: *Aunt Dinah*, Byron G. Harlan; *Old Black Joe*, Arthur Collins; *Happy Jim*, Edward Meeker. The sketch opens with *Happy Jim* singing "De Golden Wedding," *Jim* and the boys call on *Aunt Dinah* for the purpose of celebrating the golden wedding of she and *Old Black Joe*. They are welcomed with open arms by *Aunt Dinah*, who tells them of the good "eatin's that's waitin' for them," and then sings, "O Dem Golden Slippers." *Joe* is then called in from the fields. He sings a phrase or two of "Old Black Joe" as he approaches, and on entering the house sings, "Hear Dem Bells." The splendid rendition of these old-time popular darkey songs will give this Record a heavy sale. Original arrangement.

## 64 Elks' Minstrels

The Amberol Record furnishes ample opportunity for making a minstrel selection, as this excellent example will prove. It is presented with the following cast of characters:

Mr. Tambo.....	Billy Murray
Mr. Bones.....	Edward Meeker
Mr. Middleman.....	Steve Porter
Our Popular Tenor (sings "Sweetheart").....	Harry Anthony
Old Man in Box (interrupts the performance).....	Steve Porter
His Wife (much embarrassed).....	Ada Jones
Musical Director.....	E. A. Jaudas

## 65 Selections from "Algeria"

American Symphony Orchestra

A Record containing six of the most popular numbers from Victor Herbert's new opera, "Algeria," which was given its initial presentation at the Broadway Theatre, New York, in September and has since scored a great success. The plot of this opera hinges upon the song, "The Rose of the World." The numbers are played in the following order on the Record:

General Petitpon's song: "I've Been Decorated."  
Zoradie's song: "Rose of the World."  
Millicent Madison, M.D.'s song: "Ask Her While the Band is Playing."  
Mr. and Mrs. Billings F. Cooing's song: "The Same Old Two."  
Captain De Lome's Song: "Love is Like a Cigarette," and  
"The Boule Miche."

Music by Victor Herbert; published by Charles K. Harris, New York.

## 66 A Comedy Dream

Murry K. Hill

It would be difficult to find a more nonsensical lot of matter than Mr. Hill repeats for this Record. It includes some of the brightest and best things picked from his several vaudeville acts. Features of "A Comedy Dream" are a funny recitation entitled, "A Court Room Scene" and a snappy song, giving the translation of a French bill of fare that he met in a restaurant. Orchestra accompaniment. Original sketch, not published.

## 67 Sing Me to Sleep

Miss Chapman and Mr. Anthony

This ballad, with its beautiful lines and sweet melody, is of the better class. The entire song is here given as a duet for soprano and tenor. A feature is the cadenza at the finish. The selection introduces a new artist in Miss Chapman, whose beautiful voice will win instant favor with owners of Edison Phonographs. Orchestra accompaniment. Music, Edwin Greene; words, Clifton Bingham; publisher, G. Schirmer, Jr., New York.

## 68 I Love My Love, Waltz

American Symphony Orchestra

A new waltz that in style and construction is like the popular French waltzes. It is the latest hit in Paris. It is introduced in "The Girls from Gottenberg," the musical play that has been presented for so long a time at the Knickerbocker Theatre, New York. Composer, Ivan Caryll; publishers, Chappell & Co., New York.

## 69 A Picture of Long Ago

Ada Jones and Len Spencer

A vaudeville sketch in which Samantha and Hezekiah indulge in reminiscences of bygone days. Samantha finds an old hymn book in the garret and, while playing one of the hymns

on the organ, Hezekiah reminds her that he gave her the book just before they were married, years ago. Then follows an exchange of sentiment, and they live over again the day of their marriage. It is a Record similar to "The Golden Wedding," by the same artists, which made such a hit on the two-minute Record. Original sketch and not published.

#### 70 Grand American Fantasia

New York Military Band

A tone picture of the North and South and a great favorite with the leading bands of the country. It never fails to arouse enthusiasm whenever played, for in it are intermingled the patriotic and favorite songs and tunes of the North and South. These are given in the following order: "Yankee Doodle," "Maryland, My Maryland," "Old Zip Coon," "Tenting To-night on the Old Campground," "Dixie," "Massa's in the Cold, Cold Ground" and "The Star Spangled Banner." Composer, Theodore Bendix; publishers, Oliver Ditson Co., Boston.

## Home Made Window Signs

The suggestions made in these pages for the past three months about the use of home-made window cards, have induced many Dealers to make and exhibit cards of this kind, and they are greatly pleased with the publicity they give them. F. M. Atwood, Edison Jobber at Memphis, Tenn., has worked out some cards of his own, and in inclosing two of them, said:

I am enclosing you copies herewith two original

Any One Can Buy  
A Phonograph!  
You Haven't Time?  
No Excuse.  
I Will give you Time.

show cards, which have attracted considerable attention in my windows. The one in regard to the "Two Bills" is displayed with one of your hangers of them on each side. This is the first time I have tried the roughly printed show cards, and am almost convinced they attract more attention than the artistic kind.

We print below, reproductions of the two cards Mr. Atwood sent in, just to show how simple the cards are:

Come in Here  
And Hear  
Them Speak!  
Who?  
The 2 Bills.

## How One Dealer's Business Grew

"It is with considerable pride that I call your attention to my business, which has been established now five years," writes Fred Becht, Jr., of 19 Alabama avenue, Brooklyn, N. Y. "When I began, my stock was about the usual one that the uninitiated start with. At the present time I carry the complete domestic list, as well as all the German selections, both vocal and instrumental, also British, Cuban, and Mexican instrumental Records. The space I occupied at the start was not more than 25 x 20. At the present time my business has grown with such rapidity that it was necessary to extend same, so alterations on my building have just been completed, and I have, at least for the present, ample space

to handle my rapidly growing business. It has always been a source of pleasure to me, as well as profit, in handling your product.

It is never a difficult task to impress the prospective customer with the superiority of your machines and Records and attending the demands of regular trade is easy indeed, when your stock is complete and you are thoroughly familiar with it.

That has helped me build up the business that I am proud of, and my success is further aided by the broad and generous principles as you apply them. Accept my wishes for long and continuous successful business. May the Edison lead them all always.

If you are one of the Dealers who have neglected to sign the Addenda, don't delay signing it any longer.



# Edison Phonograph Monthly, Nov., 1908

## Jobbers of Edison Phonographs and Records

- ALA., Birmingham**—Talking Machine Co.  
**Mobile**—W. H. Reynalds.  
**Montgomery**—R. L. Penick.
- ARK., Fort Smith**—R. C. Bollinger.
- CAL., Los Angeles**—Southern Cal. Music Co.  
**Sacramento**—A. J. Pommer Co.  
**San Francisco**—P. Bacigalupi & Sons.  
Kohler & Chase, Inc.
- COLO., Denver**—Denver Dry Goods Co.  
Hext Music Co.
- CONN., New Haven**—Pardee-Ellenberger Co.
- D. C., Washington**—E. F. Droop & Sons Co.
- GA., Atlanta**—Atlanta Phonograph Co.  
Phillips & Crew Co.  
**Waycross**—George R. Youmans.
- IDAHO, Boise**—Eiler's Piano House.
- ILL., Chicago**—Babson Bros.  
Lyon & Healy.  
James I. Lyons.  
The Vim Co.  
Montgomery Ward & Co.  
Rudolph Wurlitzer Co.  
**Peoria**—Chas. C. Adams & Co.  
Peoria Phonograph Co.  
**Quincy**—Quincy Phonograph Co.
- IND., Indianapolis**—Indiana Phono. Co.  
Kipp-Link Phonograph Co.  
A. B. Wahl & Co.
- IOWA, Des Moines**—Harger & Blish.  
Hopkins Bros. Co.  
**Dubuque**—Harger & Blish.  
**Fort Dodge**—Early Music House.  
**Sioux City**—Early Music House.
- KY., Louisville**—Montenegro-Riehm Music Co.
- LA., New Orleans**—William Bailey.  
National Automatic Fire Alarm Co.
- MAINE, Bangor**—S. L. Crosby Co.  
**Portland**—W. H. Ross & Son.
- MD., Baltimore**—E. F. Droop & Sons Co.
- MASS., Boston**—Boston Cycle & Sundry Co.  
Eastern Talking Mach. Co.  
Iver Johnson Sptg. Goods Co.  
**Fitchburg**—Iver Johnson Sptg. Goods Co.  
**Lowell**—Thomas Wardell.  
**New Bedford**—Household Furnishing Co.  
**Springfield**—Flint & Brickett Co.  
**Worcester**—Iver Johnson Sptg. Goods Co.
- MICH., Detroit**—American Phono. Co.  
Grinnell Bros.
- MINN., Minneapolis**—Thomas C. Hough.  
Minnesota Phono. Co.  
**St. Paul**—W. J. Dyer & Bro.  
Koehler & Hinrichs.  
Minnesota Phonograph Co.
- MO., Kansas City**—J. W. Jenkins' Sons Music Co.  
Schmelzer Arms Co.  
**St. Louis**—Conroy Piano Co.  
Koerber-Brenner Music Co.  
Silverstone Talk. Mach. Co.
- MONT., Helena**—Frank Buser.
- NEB., Lincoln**—Ross P. Curtice Co.  
H. E. Sidles Phono. Co.  
**Omaha**—Nebraska Cycle Co.  
Shultz Bros.
- N. H., Manchester**—John B. Varick Co.
- N. J., Hoboken**—Eclipse Phono. Co.  
**Newark**—Douglas Phonograph Co.  
A. O. Petit  
Rapke Phono. Store.  
**Paterson**—James K. O'Dea.  
**Trenton**—Stoll Blank Book and Stationery Co.  
John Sykes.
- N. Y., Albany**—Finch & Hahn.  
**Astoria**—John Rose.  
**Brooklyn**—A. D. Matthews' Sons.  
**Buffalo**—W. D. Andrews.  
Neal, Clark & Neal Co.  
**Elmira**—Elmira Arms Co.  
**Gloversville**—American Phono. Co.  
**Kingston**—Forsyth & Davis.
- New York City**—Blackman Talking Machine Co.  
J. F. Blackman & Son.  
I. Davega, Jr., Inc.  
S. B. Davega Co.  
Douglass Phono Co., Inc.  
Jacot Music Box Co.  
Victor H. Rapke.  
Regina Co.  
Siegel-Cooper Co.  
John Wanamaker.  
Alfred Weiss.
- Oswego**—Frank E. Bolway.
- Rochester**—Mackie Piano, O. & M. Co.  
Talking Machine Co.
- Schenectady**—Finch & Hahn.  
Jay A. Rickard & Co.
- Syracuse**—W. D. Andrews.
- Troy**—Finch & Hahn.
- Utica**—Clark-Horrocks Co.  
Arthur F. Ferriss.  
William Harrison.  
Utica Cycle Co.
- OHIO, Canton**—Klein & Heffelman Co.  
**Cincinnati**—Ball-Fintze Co.  
Milner Musical Co.  
Rudolph Wurlitzer Co.  
**Cleveland**—Eclipse Musical Co.  
**Columbus**—Perry B. Whitsit Co.  
**Dayton**—Niehaus & Dohse.  
**Newark**—Ball-Fintze Co.  
**Toledo**—Hayes Music Co.  
**\*Youngstown**—The W. E. Henry Co.
- OREGON, Portland**—Graves Music Co.
- OKLA., Oklahoma City**—Smith's Phono. Co.
- PENNA., Allentown**—G. C. Aschbach.  
**Easton**—The Werner Co.  
**\*Harrisburg**—Louis Buehn & Bro.  
**Philadelphia**—Louis Buehn & Bro.  
C. J. Heppe & Son.  
Lit Bros.  
Musical Echo Co.  
Penn Phonograph Co.  
John Wanamaker.  
Western Talking Mach. Co.  
H. A. Weymann & Son.
- Pittsburg**—Pittsburg Phono. Co.  
Powers & Henry Co.  
Standard Talk. Mach. Co.
- Reading**—Reading Phonograph Co.
- Scranton**—Ackerman & Co.  
Technical Supply Co.
- Williamsport**—W. A. Myers.
- R. I., Providence**—J. M. Dean Co.  
J. A. Foster Co.  
J. Samuels & Bro.
- TENN., Chattanooga**—J. H. Templeman Co.  
**Knoxville**—Knoxville Typewriter and Phonograph Co.  
**Memphis**—F. M. Atwood.  
O. K. Houck Piano Co.  
**Nashville**—Magruder & Co.  
Nashville Talking Mach. Co.
- TEX., Dallas**—Southern Talking Machine Co.  
**El Paso**—W. G. Walz Co.  
**Fort Worth**—Cummings, Shepherd & Co.  
**Houston**—Texas Piano & Phono. Co.  
**San Antonio**—H. C. Rees Optical Co.
- UTAH, Ogden**—Proudfit Sporting Goods Co.  
**Salt Lake City**—Clayton-Daynes Music Co.
- VT., Burlington**—American Phono. Co.
- VA., Richmond**—C. B. Haynes & Co.
- WASH., Seattle**—D. S. Johnston Co.  
Kohler & Chase.  
**Spokane**—Spokane Phonograph Co.
- WIS., Milwaukee**—Lawrence McGreal.
- CANADA, Quebec**—C. Robitaille.  
**St. John**—W. H. Thorne & Co., Ltd.  
**Toronto**—R. S. Williams & Sons Co., Ltd.  
**Vancouver**—M. W. Waitt & Co.  
**Winnipeg**—R. S. Williams & Sons Co., Ltd.

\*Added since October 1, 1908.

# Broaden Your Field

—and increase your sales. A dealer makes a serious mistake by selling records and instruments for amusement purposes alone. There is besides the amusement field the vast field of education from which can be reaped an abundant business. Here the dealer can increase the sale of records to those who already own phonographs, and can sell both instruments and records to a very large number of cash customers who would never think of buying a phonograph except for educational purposes. All this is made possible through

## I.C.S. LANGUAGE SYSTEM

WITH  
*Thomas A. Edison*  
PHONOGRAPH

There is a great opportunity for **you** to sell I. C. S. Language Outfits to people who are going abroad or who desire to learn a language for the sake of the knowledge of it alone; to those who desire to qualify for positions as translators and foreign correspondents; and to foreigners who wish to learn to speak English. No sledge hammer is needed to get it clearly into your head that this presents a sure way of broadening your field of work and increasing your sales. For the sake of good business sense, boom the I. C. S. Language feature of the business.

**International  
Correspondence Schools  
SCRANTON, PA.**

# The EDISON PHONOGRAPH MONTHLY

Vol. VI

December, 1908

No. 12



## Eleventh Hour Special

*Last chance for the Xmas Trade*

# *The* EDISON PHONOGRAPH MONTHLY

## *Contents for December, 1908*

Editorial Comments . . . . .	1
Store Management . . . . .	3
Last Notice About Signing Addenda . . . . .	4
Factory Activity . . . . .	5
Here's a New Year Resolution . . . . .	5
Let's Get Together . . . . .	6
Taft and Bryan Records . . . . .	6
Printed Matter . . . . .	7
About Branch Stores . . . . .	7
Wanted—Assistant Editors . . . . .	8
The Point is There . . . . .	8
A Neat Illustration . . . . .	8
Selling the Goods . . . . .	9
Making Concerts Pay . . . . .	9
The Story of the Good and the Bad Window Card . . . . .	10
Lessons for Dealers—Lesson IV. . . . .	11
Ready Made Ads . . . . .	12
Trade Bulletins . . . . .	14
Suspended List for November 20, 1908 . . . . .	15
Our Christmas Advertising . . . . .	15
A Better Proposition than Ever Before . . . . .	15
Advance List Edison Standard and Edison Amberol Records for February . . . . .	16
Sued for Violating Contracts . . . . .	20
Among the Jobbers . . . . .	20
Jobbers of Edison Phonographs and Records . . . . .	21

# The EDISON PHONOGRAPH MONTHLY

Published by the National Phonograph Co., Orange, N. J.

NEW YORK: 10 FIFTH AVENUE

NATIONAL PHONOGRAPH CO., LTD., VICTORIA ROAD, WILLESDEN, LONDON.  
NATIONAL PHONOGRAPH CO. OF AUSTRALIA, LTD., 340 KENT STREET, SYDNEY, N. S. W.  
MEXICAN NATIONAL PHONOGRAPH CO., AVENIDA ORIENTE No. 117, MEXICO CITY.  
COMPANIA EDISON HISPANO-AMERICANA, VIAMONTE 515, BUENOS AIRES.  
EDISON GESELLSCHAFT, M. B. H., SUD-UFER 24-25, BERLIN.  
COMPAGNIE FRANCAISE DU PHONOGRAPHE EDISON, 42 RUE DE PARADIS, PARIS.

---

All communications to *The Phonograph Monthly* should be addressed to the Advertising Department, Orange, N. J.

---

Vol. VI.

DECEMBER, 1908

No. 12

---

**D**AILY Newspaper Advertising—Lack of confusion in your store—these are the most important matters for you to take care of now that the siege of Christmas shopping is at its height—that is, if your Christmas sale of Edison Phonographs and Records is to be as large as it should be. We, of course, assume that you are well stocked with Edison goods, that you have been doing *some* advertising and that your Christmas window is an Edison window already performing its work.

Don't be satisfied to let the Christmas shopping whirl envelope your business, distort your plans and smother your good intentions until its force is spent. That isn't profiting by the experience of former years; nor is it benefiting by the hints we have given you in regard to "Store Management" and "Selling the Goods."

These two departments in the PHONOGRAPH MONTHLY, the contributions to which receive our best efforts, are only valuable to you to the extent that you take advantage of the suggestions contained in them. Only by your adaptation of these suggestions to your particular environment and individual requirements can you prove their worth.

Remember, there are two classes of Christmas shoppers—the people who know what they want and the people who do not know what they want.

Our magazine advertising is aimed to make people know that they want Edison Phonographs. Our Christmas magazine advertising is aimed to make people know that their families or friends, to whom they are to make Christmas presents, also want Edison Phonographs—or new Records in case Phonographs are already owned.

Now it is up to you—your duty to your busi-

ness—to use space in your local newspapers every day between now and Christmas for the purpose of leading people to your store for Edison goods. We have supplied you with sufficient ready-made newspaper ads for you to accomplish this end with little trouble.

It is further up to you—your duty to your business—to take care of the throngs that crowd through your store aimlessly during the Christmas season—the people who do not know what they want. To take care of them we mean convince them that an Edison Phonograph is the thing wanted—a simple matter once you have a possible customer in your store and in a buying mood at that, but difficult when your store is crowded with possible purchasers.

A smooth running, everything-in-its-place kind of a store, with a corps of intelligent, courteous-to-all clerks, is the store that captures the trade of the people who don't know what they want (when they come in).

---

In the February list of three-minute Records we are trying the experiment of putting out three new Records by Harry Lauder, the Scotch comedian, in place of three of the domestic selections. This is being done for two reasons: First, because we did not want to increase the total of the two-minute selections; and, second, to meet the views of many Jobbers and Dealers that more business will be secured for special Records like the three Lauders if included in the monthly list than if put out independently. According to the theories of advertising, the trade ought to be right and the advance sale for the Lauders ought to be larger than for any previous Lauder Records put out in a special manner. The regular advance list sent to the trade gets more careful consideration than a special one;

---

## 2 Edison Phonograph Monthly, Dec., 1908

---

the Dealers' order blank again calls attention to the titles; the monthly bulletin is put up in practically every store, where it is looked over regularly by all Phonograph owners, and finally the monthly supplement goes into 2,000,000 homes through the medium of thousands of special mailing lists maintained by Dealers. The *Phonogram* also helps, but then all special lists get the benefit of this little publication. We certainly hope that the experiment will show that the trade is right, not alone because of the increased business we shall get, but because it will have considerable influence upon the treatment of future special lists.

---

The name "Amberol," given to the new four-minute Edison Record, was not born until July, and is therefore only a little over four months old. It has been before the trade since August and before the public only since October 1st. In that short time, however, it has become known in the remotest parts of the United States and Canada and scarcely a Phonograph owner in those countries does not already know that the Amberol Record is the newest product of the Edison organization. The name already has a money value equal to a small fortune and promises in the near future to be one of the most valuable assets of the National Phonograph Co., just as the names Sapolio, Uneda, Pearline, etc., are worth millions to the companies controlling them. The name Amberol is this month being placed before the British public, and within three months more it will be a household word in every country where we have representation or the Edison Phonograph is known. What a testimony all of this is to the thoroughness and value of organization and advertising! A perfect trade organization backed by the expenditure of a comparatively small sum of money has in four months taken an unknown coined word, applied it to a new product and made both itself and the product known to millions of people.

---

It will be interesting to the trade to know that the word Amberol was originated by Mr. Edison and won out over a large number of others that were suggested by his associates in the laboratory and the officers and employees of the Edison Company. It naturally suggests a form of amber, and does in reality get its origin from the fact that one of the parts of the new composition of which Amberol Records are made was at one time in the prehistoric past amber of the palm tree. This amber found its way into

the earth and there underwent a change analogous to the process that transformed vegetable matter into coal. Still this matter is a far cry from what is generally known as amber, and this explanation about the origin of the name Amberol don't explain very clearly. It is enough, however, that the name is euphonious and that it stands for the greatest single advance ever made in the history of the Phonograph.

---

Whether existing Edison Dealers in small cities and towns shall have additional competition in their fields after December 1st, will depend entirely upon themselves. If they carry a fair stock, based upon the size of the towns; make a reasonable effort to push the business and make sales in proportion to the population of their towns, they will not be disturbed and no additional Dealers will be put in competition with them. Otherwise, we shall feel free to establish new Dealers. Our decision not to accept new Dealers where we are now properly represented, does not alone mean protection for existing Dealers. It means that we intend improving their standard and extending their business. We expect that the additional business we shall get from protected Dealers will more than offset the business that would be obtained from the initial orders of new firms and the additional business will be more profitable to those who do it. Consequently every present Edison Dealer who wants to keep out competition should see that his stock of Edison goods is in good shape, both as to quantity and condition and resolve to do a business that will be worth while. After all, why should a Dealer who carries a machine or two and from 100 to 200 Records and who makes no effort to sell goods want to continue in the business. He cannot make a profit worth the name, he is occupying space in his store that might be filled with more profitable goods, and he is occupying a town in which another firm might do a good Edison business. We are going to do our share toward making existing Dealers better Dealers. We are going to do everything we are now doing, including better and more widespread advertising, and besides are preparing plans that will aid Dealers in extending the business in their respective localities. We intend spending a considerable sum for direct trade work just as soon as we get some necessary information as to the status of Dealers. We expect to get into much closer relationship with the trade than ever before and anticipate that our plans will result in a general improvement all along the line, with greatly increased profits for the trade and ourselves.

# Store Management

A monthly comment on things Edison dealers have done with a few suggestions on what they should do to increase sales.



**W**HEN this issue of the PHONOGRAPH MONTHLY reaches you there will be about twenty-five days left in which to convince Santa Claus that his one best bet is an Edison Phonograph.

We trust that you have put some of the selling suggestions set forth in our Christmas Special into operation. We hope this—our Eleventh Hour Special—will encourage you to continue what you are doing and do more.

There will be more money put in circulation during the next three weeks than in any other three weeks in the year. You want to get your share of this money. Your share isn't any particular percentage. It isn't what you got last year at this time or the year before that. Your share is all you can coax from the pockets of Christmas shoppers by every possible means that the law permits.



It is better to do things at the eleventh hour than not at all. If you have waited until now before introducing the Christmas spirit into your advertising, your windows, your mail matter and your store, you certainly should wait not a day longer.

Don't think because you are an old, established dealer in Phonographs and Records that extra effort on your part is unnecessary.

Don't think because this is the season of spending that all you have to do is pass out the goods with one hand and take in the money with the other.

Though everybody in your community may know who you are, where you are and what you

sell, it is also true that these same people know other dealers in other lines and while you know and we know that there is nothing so acceptable to so many as a Phonograph for a Christmas gift, others don't know it and won't know it unless it is proved to them.

Look about you and see what the jeweler, the book seller, the stationer, the furniture man and the haberdasher is doing to get Christmas money.

These people do business all the year around just as you do; they are well known just as you are; yet at this time of year they do everything in their power to concentrate the Christmas spending on their stores.



Christmas doesn't call for any special lines of merchandise. People want at Christmas time only those things they want any time—the only difference being that at Christmas time they are better able or at least more willing to buy them.

You would not have to make any special effort to sell a Phonograph during the holiday season to a man or woman who has wanted one all the year.



Your effort is necessary, however, to convince the man who is hesitating between several things that the Phonograph is the best thing he can put his money into.

You undoubtedly believe it is. You know that if you can get such a man into your store you

can convince him that it is. You can get him in the store if you advertise in the newspapers or if you reach him at his home by mail, or if you stop him as he passes by means of a good window display.

When you get him in you need a well assorted stock, well arranged; you need at least one instrument of each price wound and adjusted so that it will do its best work while demonstrating; you need a supply of Records close at hand, embracing every kind of music and including selections or songs that have received the most popular approval.

Beyond this you should have a store that has about it the Christmas spirit; a store whose every-day appearance has been changed to that which Christmas shoppers expect. Edison goods properly demonstrated amid such surroundings will prove irresistible.

---

### *Inside the Store*

Interior arrangement should be considered from two points of view—convenience and effect.

Convenience includes not only your convenience in finding goods called for, but the convenience of your customers in buying.

Lack of system in arranging Records means lost time and frequently lost sales.

Poor facilities for demonstrating Phonographs does the Phonographs an injustice and discourages buyers.

Effect—that is, the impression created by a well arranged stock—is often sacrificed in the interest of convenience. It need not be and it should not be.

Surroundings often speak louder than the salesman and often more effectively. A poorly arranged store may undo the work of good advertising, good window dressing and good salesmanship. We show here some good examples of interior arrangements. They are splendid examples of convenience and effectiveness. Perhaps they will serve as suggestions to other Edison Dealers, who have not yet hit upon an arrangement and treatment that they are satisfied with.

---

### Have the Drop on all Others

We have your new machines and the full list of four-minute Records, and I take the liberty to say that both are a wonderful improvement over the old, and a great stride toward absolute perfection. Looks to me as though you had them all on your hip again. I don't think a man can be too enthusiastic in regard to this product, as it has the drop on all the others. With best wishes for the success of this product, I am.—*J. W. McCollum, Marietta, Ohio.*

### Last Notice About Signing Addenda

The letter sent in the latter part of October to such Edison Dealers as had not at that time signed the addenda to our Dealers' Agreement brought signed copies from probably all individuals or companies who intend to continue handling our goods as Dealers. A part of those who have not been heard from doubtless prefer some other cylinder line to ours and intend dropping Edison goods. It would be strange indeed if there were not some opposition to our policy and if some Dealers did not prefer other makes, although the number of our Dealers who have taken such a position is surprisingly small. The remainder of the unsigned are probably Dealers who have been doing so small a business that they do not intend to continue with the line. For fear, however, that there might still be Dealers who have not signed through neglect or carelessness and who would not want to lose their privileges as a Dealer, the following letter was mailed on November 18th to all who, according to our files, had not sent in signed addenda:

*Dear Sir:*— New York, Nov. 18, 1908.

We find that so far you have not signed the Addenda to the Dealer's Agreement, to which your attention has already been called.

It now becomes necessary to state that unless you do sign the Addenda on or before December 1, 1908, we will take it for granted that you do not purpose signing same and will immediately remove your name from our list of Dealers, notifying our Jobbers to refrain from filling your future orders for Edison goods of all description.

Hoping that you will not make this step necessary, we beg to remain,

Yours very truly,  
 NATIONAL PHONOGRAPH COMPANY,  
 F. K. DOLBEER,  
*General Manager of Sales.*

Copies of the Addenda have already been sent you. If you cannot find them, we will send others upon request. One copy should be sent to us, with your signature properly witnessed.

After December 1st those who have not signed will be considered as no longer an active Dealer, but it will take some time to remove their names from our files and mailing list and notify Jobbers of their removal, and those whose Addendas are received before this work is completed will be put back and omitted from the Jobbers' notification. Jobbers who know of any active Dealers who have not signed should communicate with them at once and urge them to forward the paper without delay.



## Factory Activity

As was to be expected, the tremendous efforts that have been put forth at our factory during the past three months resulted during November in making a marked gain on the orders in hand for combination Phonographs, Attachments and Amberol Records. The gain on combination machines was such that by the middle of December every order received prior to the first of the month will be filled complete. After December 15th we expect to keep up with machine orders unless there should be an unusually quick revival of general business throughout the country. Even then we shall have little trouble in meeting demands. Our factory organization is again back to its old efficiency and the weekly productions can be largely increased at short notice, if necessary. The trade will have little apprehension about our ability to fill machine orders fully and quickly, although it will not be wise for any Jobber to let his stock run low on this account. It should be borne in mind that business of all kinds is going to increase steadily and all should plan for a rising and not a falling market. Experience for several years past has shown us that after the January stock taking there comes a period of two to three weeks when the orders exceed our factory capacity. This may be the case in 1909, so don't bank too much on our output (large as it may be) to keep your stock replenished at short notice. Be on the safe side and keep ordering ahead.

Excellent progress was also made with the shipments of Amberol Records. The last shipments were made on the original orders and many additional orders were filled. For a time there was a doubt as to whether we could get out the orders for December Amberols on time, but luck and good management were on our side and the last of the December advance orders for both kinds of Records went out on November 21st. The last shipments went to New York and nearby points, so that the goods reached Jobbers in time for re-shipment to Dealers on November 24th. This is a closer schedule than we care to have, but it is heaps better than being late.

As more and more Phonographs are being equipped with attachments, and an increased number of combination machines get into the hands of the public, the demand for Amberol Records grows. More and more Dealers are

putting in a complete stock of Amberol Records and by playing them on their demonstration machines are making much enthusiasm among Phonograph owners. All of this is creating a demand for Amberol Records that is little less than remarkable considering the short time that the Record has been on the market. Strangely enough there has as yet been no falling off in the advance orders for two-minute Records. Judging by the total advance orders from Jobbers, the new Record is creating just so much new business.

The work of manufacturing attachments is not so satisfactory as the machine and Amberol situation. It is in this department that the extent of the interest of the public in the new Record is shown. During November as many as 3,000 attachments were made and shipped in a single day and the total shipment for the month reached figures that would not be credited if told. Yet the month closed with as many orders ahead as were on the books November 1st. This is likely to be the case for many months, possibly being more aggravated with the certain improvement in business conditions. The November shipments would have been greater than they were but for our inability to get additional machines for making certain parts and but for the trouble in making the fine point for the new Model H reproducer required to play the Amberol Records. All the work on these points is done under microscopes and the hands work in three shifts of eight hours each, the department working without a break from 7 o'clock Monday morning till midnight Saturday. The department is now the show place of the factory for activity, character of work and number of hands employed.

Taken as a whole our factory may be said to represent the advance guard of Phonograph optimism, for its present activity is but a reflection of what must be the condition of the entire trade within a few months.

---

## Here's a New Year Resolution

I will read the EDISON PHONOGRAPH MONTHLY every month and pass it on to the members of my sales force. And I will make use of all of the suggestions in it that will help increase my sales of Edison Phonographs and Records.

## Now Let's Get Together

What little dissatisfaction was manifested over our ruling that Dealers handling other cylinder goods will not be permitted to sell the Edison product (and it was indeed little) has wholly disappeared, the last of it dropping from sight with the issuance of the letter declaring our intention to protect Dealers from new competition in their respective localities. Now that it has become a settled policy, Dealers are practically unanimous in their approval of it. It has done much to simplify the talking machine situation.

There is no longer any necessity for a Dealer to push two or more cylinder lines. No matter which kind he sells—Edison or any other—he will bend all his energies to getting the most out of it. He will only have to carry one stock, which will require less capital than if he handled two or more. He can talk up the line to better advantage and with more certainty of making a sale, for it will no longer be necessary to withhold a good argument in favor of one machine because it might reflect upon another make also carried by the same Dealer. It is going to be easier to advertise one line and the advertising will do more good. When a Dealer can say, "I handle only Edison Phonographs and Records because in my judgment they are the best on the market," that fact alone is going to have a strong influence on a prospective purchaser.

The new policy is going to help the Jobbers in their collections. How many times have Jobbers found that Dealers, instead of paying their accounts, have used up their spare money by putting in another make of goods largely because of the talent of a clever salesman or because the discounts are a little better? How many times have Jobbers and Dealers seen these additional stocks handicap businesses so that they were kept continually behind in their accounts? There would be some recompense if Dealers made more money out of several lines than if they handled only one, but they don't. As a rule the extra lines are not advertised or pushed by the manufacturers, or if they are it is not to create a demand for the goods, but to deceive the trade.

Many other disadvantages of carrying more than one cylinder line might be named, but is it not necessary. They have now become a thing of the past. The future business of an Edison Dealer is going to be conducted on simpler, more pleasant and more prof-

itable lines, and every one is going to be greatly pleased over the new conditions. They are also going to make it possible for us to do many things to improve a Dealer's business than was possible before.

Watch everything we hereafter do. If you get any printed matter from us read it from beginning to end. If it don't seem clear, write us for further information. If it calls for a reply, make it at once. Read every issue and every page of the PHONOGRAPH MONTHLY. As fast as we find how we can make it more valuable to you we are going to do so. Our recent action has brought us very close together in a business way, and we want your co-operation in making it still closer as the months go by.

## Taft and Bryan Records

With the passing of Election Day the Edison Records made by Mr. Taft and Mr. Bryan take on an added value, and enterprising Dealers will not be slow to take advantage of it. The Taft Records are the first in the history of the world to be made by the head of a great government. After March 4th next the owner of one of these Records can say with no little pride: "This is a Record made by the President of the United States." As Mr. Taft takes hold of the duties of his office, as he gets deeper and deeper in the work and as he begins to do things that will keep him constantly before not only the people of the United States, but of the entire world, the Records of his voice will become more and more interesting, and they will have a value that could not be estimated if it were not possible to duplicate them.

The Bryan Records will lose none of their selling power because Mr. Bryan has again been defeated for the Presidency. Mr. Bryan is regarded by his friends and opponents alike as one of the most popular men and greatest orators that this country has produced, and it will always be a pleasure to listen to the Edison Records made by him. His "Immortality" and "An Ideal Republic" are not political in any sense, but are masterpieces of oratory and diction. Because of their political bearing the other eight Bryan Records may in time cease to be interesting, but these two must be sought after for years to come.

The Dealer who is disposed to believe that the day of the Taft and Bryan Records is past, simply because the election is over, is making a mistake, and he will make a worse error if he does not redouble his efforts to put the Records in every Phonograph collection.

## Printed Matter

Jobbers have been supplied with a quantity of a four-page folder for the purpose of stimulating Christmas trade. It is printed in red and green and is illustrated with the "Christmas Matinee" sketch that is the feature of all of our publications advertising for December. It is a handy folder for mailing lists, to hand out over the counter or to enclose with correspondence, bills, etc. Dealers should get some of the folders from their Jobbers and use them in such a way as will increase their Edison business.

The bulletin of special Christmas selections mailed to all Jobbers and Dealers last month should be hung in a prominent place in every Edison store, and it ought to make nice additional sales, for the special Christmas Records named on it. It is Form No. 1442.

The Christmas Record certificates, illustrated and described on page 10 of the November PHONOGRAPH MONTHLY, proved to be a popular form, but it ought to have been in greater demand than it was. It is not too late to get a few of them and sell them to your customers, properly filled in, for Christmas presents of Edison Records. We will mail you what you want at the rate of twenty-five for ten cents. Or if you want to see one before you order, ask us and we will mail one to you. If you don't know what the certificate is, look on page 10 of the November PHONOGRAPH MONTHLY.

How do you like the Record Supplement and the Record Bulletin in their new dresses? We think they're quite attractive and that they are going to help a whole lot in selling Edison goods. The little half-tones of the artists gives the Supplement a new interest, and the additional two pages gives space for more descriptive matter about the new Records. Then the Bulletin is bigger and more striking in appearance, and it ought to get considerable attention from the public if put up where it can be seen. This sheet will look fine in a frame, and the Dealer who will get a suitable frame to inclose it each month as it appears will have a business puller that cannot be beat. Both Supplement and Bulletin will be continued in this form for some time.

There is no decline in the popularity of the *Phonogram* as a means for increasing Record

sales. In spite of the times the edition has remained at 600,000 right through the year, showing conclusively that it stands well with the trade. It is not an elaborate piece of printed matter, but it does the work, and that's the real test of its merit. Possibly you don't know what the *Phonogram* cost the trade. Here's the schedule.

### ORDERED THROUGH JOBBERS.

Blank, per 1,000 copies.....	\$2.50
Smaller quantities pro rata.	
Imprinted, 500 copies .....	1.50
Imprinted, 1,000 copies .....	2.75
No orders filled for less than 500 copies requiring imprint, and all imprinting orders must be for multiples of 500.	

Jobbers will be glad to supply Dealers on the above basis.

### BY MAIL.

Single copies, per year.....	\$ .20
Five copies to one address, per year....	.40
Twenty-five copies to one address, per year .....	1.80
Fifty copies to one address, per year..	3.60

Unless they have open accounts on our books, Dealers ordering *Phonograms* sent by mail are requested to send cash or stamps with their orders. The amounts are too small to handle in any other way. *Phonograms* must be sold by the Jobber to his Dealers at the prices quoted above; any reduction of these prices will be considered as a violation of contract.

[Copy of letter mailed to all Jobbers and Dealers.]

## About Branch Stores

ORANGE, N. J., Oct. 26th, 1908.

To Edison Jobbers and Dealers:

On and after this date you must refrain from establishing any branch stores where goods of our manufacture are to be displayed for sale, without first obtaining our permission to do so.

This is in line with the protective policy which we purpose enforcing looking toward protecting the interests of loyal Edison Dealers, and we cannot permit a Dealer who is already carrying our goods to establish a branch where other Edison Dealers are already located to their detriment.

Should you desire to open a branch at any place in the country, we must respectfully request that you communicate with this office before so doing.

NATIONAL PHONOGRAPH Co.

F. K. DOLBEER,

Manager of Sales.

The wisdom of this decision will appeal to the entire trade. It is evident that if Jobbers and Dealers were permitted to establish branch stores at will we could not give Dealers protection in their towns as we have promised to do and are planning to do.

### Wanted—Assistant Editors

This is your paper. It hasn't any object on earth but to help you sell Edison Phonographs and Records.

Are you reading it every month? Do you get inspiration from reading of what other Dealers in the line are doing?

Do you notice the Trade Bulletins and keep posted on changes and other important factory news? Do you look over the lists of new Records so as to know what's coming?

Do you cut out the ready-made ads to run in your newspaper? In a word, do you get all that's coming to you in a business-helping way from this journal every month?

We want to make every Edison Dealer feel that he is a part owner of the EDISON PHONOGRAPH MONTHLY and to look for it eagerly the first of every month.

There is a coupon at the bottom of this page. Will you fill it out and mail it to the Advertising Department? We are particularly anxious to know what subjects you would like to see discussed in the PHONOGRAPH MONTHLY.

What feature of the business would you like to have some light on? Tell us what you think of the paper. Is it good? Is it better this month than usual? What's the best thing in it? The worst? We are just as glad to get roasts as compliments. Both will help us to make the MONTHLY *your* kind of a paper.

Will you not take a hand in running the PHONOGRAPH MONTHLY by setting us straight on these questions right away?

Jot down your thoughts on the blank now while you think of it. We want YOUR SUGGESTIONS.

### The Point is There

Since we began to fill orders for the new Amberol Records and the new attachments by which the Amberols may be played on the old machines, we have had several of the new Model "H" reproducers returned to us with statements that the sapphires were lacking. Investigation has proved in every case that these reproducers were complete and that the reproducing points were there.

To explain to those dealers who have had the wrong impression in regard to these reproducers, we would say that the new Model "H" button is much smaller than the one in Model "C" and since the settings differ it is much harder in the case of Model "H" to discern the sapphire with the naked eye. In cases of doubt use a microscope, or better, try the reproducer on an Amberol Record.

---

### A Neat Illustration

F. M. Atwood, Edison Jobber at Memphis, Tenn., uses the following illustration to show what the size and playing lengths of the Amberol Record are:

**SAME SIZE**  
██████████  
██████████  
**PLAYS TWICE AS LONG**  
████████████████████  
██████████  
**JUST THINK OF IT!**

---

Alonzo Wilkes, Edison Dealer at Amsterdam, N. Y., sends back to us a clipping of the article headed "A Series of 'All Rights'" from the EDISON PHONOGRAPH MONTHLY for November, and adds this comment of his own: "I think the same. My only wonder is that you did not do so before."

---

### Coupon

(Fill out and tear off.)

.....

Date.....

Editor EDISON PHONOGRAPH MONTHLY.

As a Dealer in Edison Phonographs and Records I would like to see you publish an article on  
..... in the PHONOGRAPH MONTHLY. The things I liked  
best in the November issue were.....

.....

Remarks.....

.....

Signed.....

.....

# Selling the Goods

ADVERTISING:—One of the most important and often one of the most neglected branches of a dealer's business.

## Making Concerts Pay

People buy the song hit of a musical farce between the acts or as they are leaving the theatre.

That is the psychological moment to sell them, because the people have just heard them, enjoyed them and are in the mood to possess them.

So with the Edison Phonograph Records.

The time to sell Records is when you have the people in your store listening to them.

Edison concerts, which have already been mentioned in these pages, bring a great many people to your store. If properly conducted, they become immensely popular and the attendance grows monthly.

It is at these concerts that people feel disposed to buy. Yet they cannot be canvassed or urged without feeling resentment.

The concerts are free. Everybody is invited. There is no obligation upon those attending. This must be the understanding or the public will stay away.

The thing to do is to make it convenient for those who wish to buy. This may be done very modestly, but effectively.

At the concerts there should be programs giving the list of new Records to be played.

Let this program suggest the purchase of Records and contain an order blank to be signed and left with you.

We show here a combination program and order blank which your printer can follow.

The advantage of this program is that the hearer can check off those of the Records which especially appeal to him as the concert progresses, so that when the concert is over he has a definite list of just the ones he prefers.

His signature and address at the bottom makes the purchase bona fide. He buys just what he wants without bother or waste of time and you deliver the day following.

A plan of this kind has proved very successful in many stores.

It will be yours.

It is certainly worth a trial, especially if you have never given concerts of this kind. If you do not care to print a program use the Record Supplement instead.

### EDISON PHONOGRAPH CONCERT

December 24, 1908

Conducted by THE SHARPS & FLAT CO.†

....10032	Nymph and Satyr	Edison Concert Band
....10033	Mandy Lane	Ada Jones
....10034	Uncle Josh's New Year's Pledge	Cal Stewart
....10035	The Yama, Yama Man	American Symphony Orchestra
....10036	When I Marry You	Frederic Rose
....10037	Honey Lou	Collins & Harlan
....10038	Good Evening, Caroline	Billy Murray
....10039	Wild Cherry	New York Military Band
....10040	Some Day	James F. Harrison
....10041	Paulina, Otto and Fido	Ada Jones & Len Spencer
....10042	Somebody Just Like You	Manuel Romain
....10043	Father is a Judge	Edward Meeker
....10044	You Can't Stop Your Heart from Beating for the Girl you Love	Byron G. Harlan
....10045	Memories of Galilee	Knickerbocker Quartette
....10046	Mary Ann O'Houlihan	Edward M. Favor
....10047	Black and White Rag	American Symphony Orchestra
....10048	Uncle Josh in a Roller Skating Rink	Cal Stewart
....10049	Rainbow	Ada Jones & Billy Murray
....10050	Sweet Girl of My Dreams	Harry Anthony
....10051	Love's Magic Spell (Bells)	Albert Benzler
....10052	Baby Doll	Arthur Collins
....10053	Darling Nellie Gray	Metropolitan Quartette
....10054	Flanagan's New Year's Call	Steve Porter
....10055	On Parole March	New York Military Band
<b>EDISON AMBEROL RECORDS</b>		
.... 61	Glowworm	Edison Concert Band
.... 62	Calvary	James F. Harrison
.... 63	Aunt Dinah's Golden Wedding	Empire Vaudeville Company
.... 64	Elks' Minstrels	
.... 65	Selections from "Algeria".	American Symphony Orchestra
.... 66	A Comedy Dream	Murry K. Hill
.... 67	Sing Me to Sleep	Miss Chapman & Mr. Anthony
.... 68	I Love My Love, Waltz	American Symphony Orchestra
.... 69	A Picture of Long Ago	Ada Jones & Len Spencer
.... 70	Grand American Fantasia	N. Y. Military Band

As the Records are played, check those you would like to buy in the square space to the left of the title. Then fill out the blank below and leave order at the door at the close of the entertainment. The Records ordered will be delivered promptly at your residence.

THE SHARPS & FLAT CO.,

Gentlemen: Please deliver to my address the Edison Records checked above.

Name \_\_\_\_\_

Address \_\_\_\_\_

*The Story of the  
Good and the Bad  
Window Card*



There was once a card in the window of a dealer's store which said: "Bring the children in here and the Christmas problem will be solved." Willie's father saw the card and took Willie in. They received a welcome and two seats. They heard all of the latest music, songs and jokes as only an Edison Phonograph can present them. They learned how to wind the instrument, how to adjust it and how to put in and take out the records. Willie had the time of his life and Willie's father wasn't bored by any means. Willie has an Edison and a lot of Records coming to him on the 25th prox.

There was such a card in another dealer's window. Tommie's father saw it and took Tommie in. The dealer was out back arguing with an expressman. Tommie and his father waited

twenty minutes, leaning up against the wall to rest. Tommie wandered around the store and the dealer growled at him for touching things. After much coaxing the dealer dusted off a Phonograph and tried to play a grand opera record, which, of course, was just what Tommie loved. When Tommie said something about band music the dealer said he had something of that kind but it was too hard to find. So Tommie and his father went out into the park to sit down and rest. Tommie decided he'd rather have a velocipede for Christmas.

The moral is that both window cards were good. Here are some other good ones. Put them in your window and then see that you help them make good.

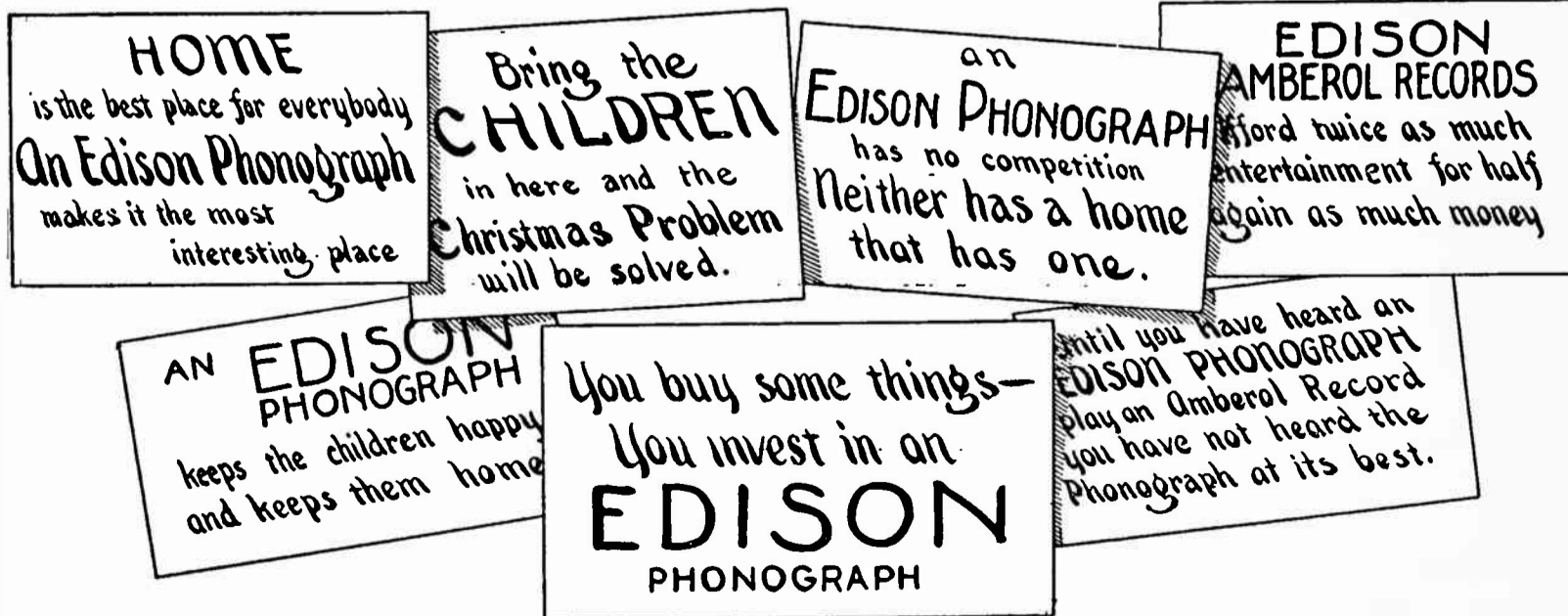

*Lessons for Dealers*

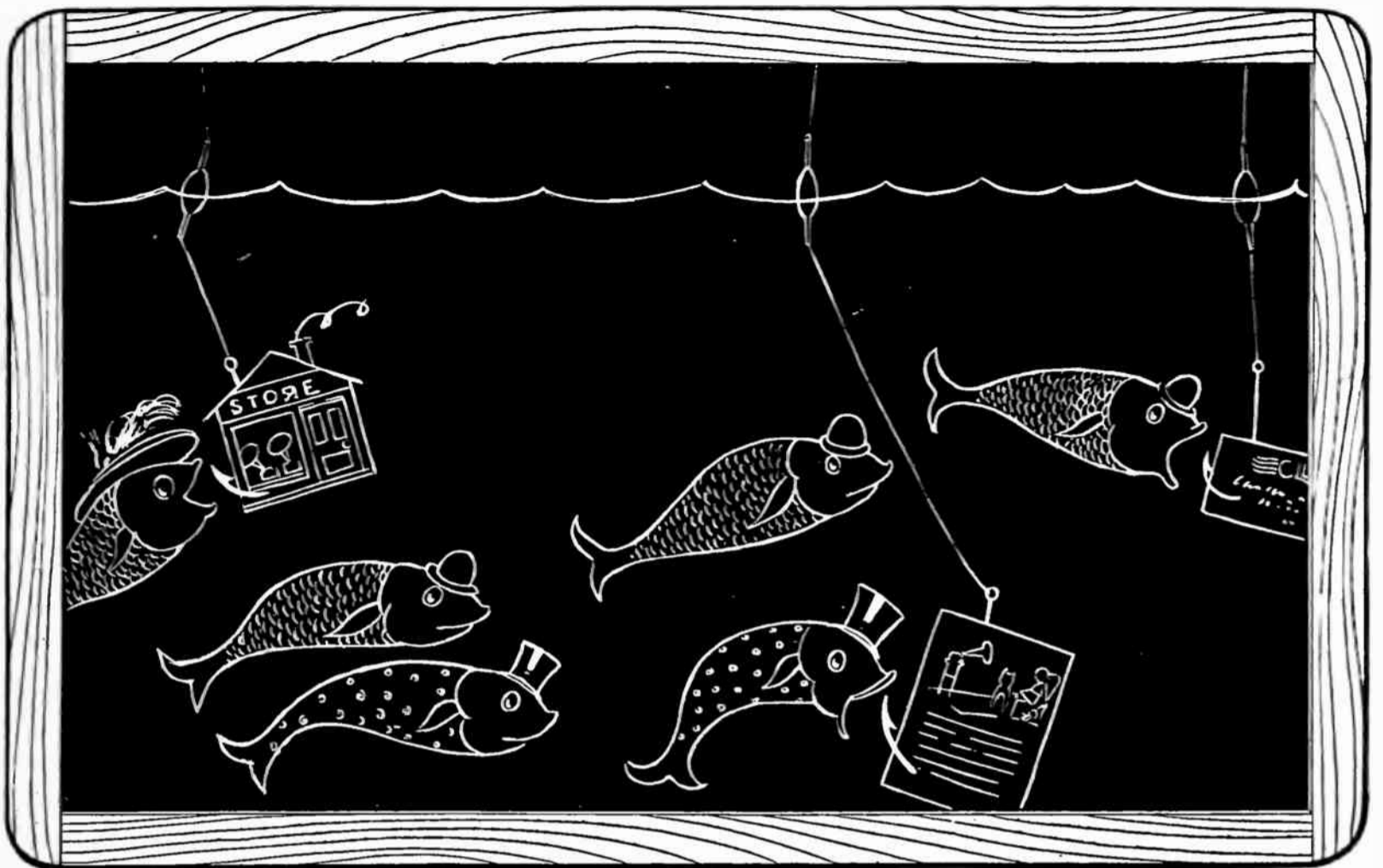

*Lesson IV.*

One cus-tom-er sees things in your win-dow that brings him in-side.

An-other cus-tom-er misses your win-dow but finds some-thing in your news-pa-per ad that brings him in.

Yet an-other cus-tom-er misses both your win-dow and your ad, but gets your let-ter or post-al. And that fetch-es him.

A nift-y win-dow, a strong ad and a bright line of mail mat-ter are all good bait, but if you use one and neg-lect two, you lose two cus-tom-ers for every one you land.

*Two Pages of Ready-Made Ads*

Ads for Your Local Newspaper

Your newspaper advertising between now and Christmas is important. You are, perhaps, too busy to give this end of the game the thought and time necessary to bring about the best results. We have anticipated your "eleventh hour" needs in this connection, and you will find here-with some suggestions for your use. There are three single-column ads. which we suggest your running every other day until Christmas, and a double-column ad. which we suggest your running alternately with the single-column ads. Two of the latter are Christmas ads., pure and simple—but to the point—the others being primarily to set forth the merits of Amberol Records and to show what they and the boxes they come in look like. If you will cut these ads. out and take them to your newspapers, the style of type and display can be accurately followed. To secure the best results insist upon this. We have the electros all ready to mail to you. We furnish them free. Order by number.



**Have You Heard an Amberol Record?**

Until you have, you haven't heard an Edison Phonograph at its best. The tone is beautiful and the selections by far the best ever heard on a talking machine

Amberol Records play, sing or talk twice as long as the Standard Edison Records and longer than any other Record of any kind.

If you have a Phonograph, we can equip it to play Amberol Records. If you haven't, we can sell you one on your own terms.

*(Dealer's name and address)*



**Four Minutes of Music Without Record Changing**

Amberol Records are the longest playing Records of any kind yet produced. Their length permits of music and songs heretofore impossible.

Their tone will give you an even greater appreciation of the Edison Phonograph. The variety of music offered will surprise you.

If you hear these Amberol Records you will want a Phonograph. If you have a Phonograph you will want the Amberol attachments. Let us let you hear them.

*(Dealer's name and address)*

Electros of above are: Single Column, 707; Double Column, 708.



## An Edison Phonograph on the Tree

Then a Christmas brightened by songs, music, dances and stories; then long evenings made short throughout the Winter by this same great entertainer

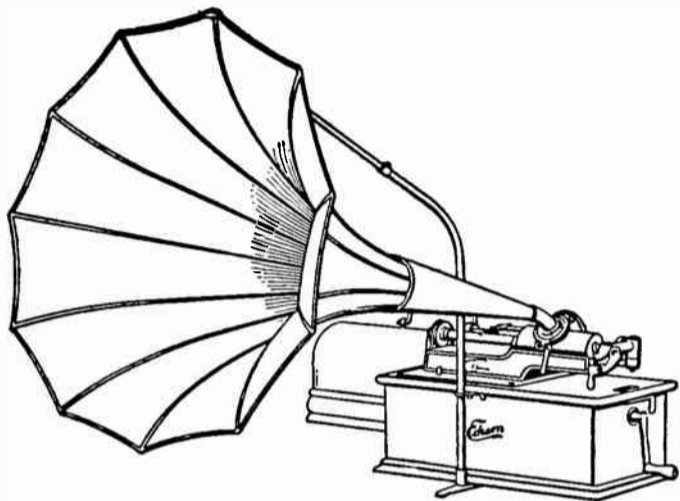

## THE EDISON PHONOGRAPH

A gift appreciated by all, from the baby up, from Christmas day on throughout the year and in other years.

Have you heard the new Amberol Records? They play four minutes. Come in early before the last-minute folks crowd the store. You can buy now for Christmas delivery.

*(Dealer's name and address)*

Cut is Electro No. 540

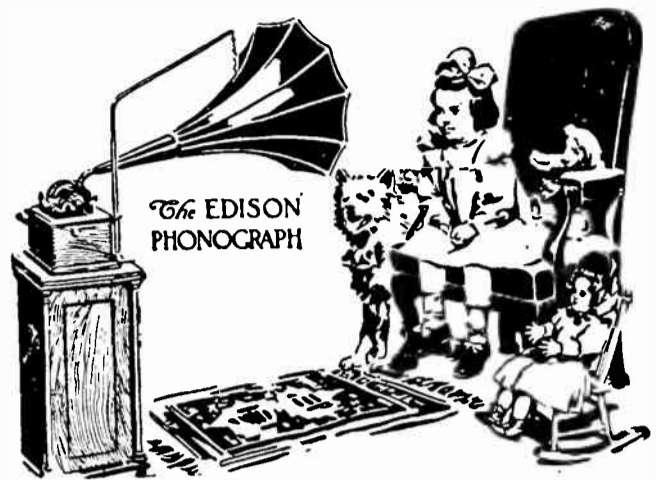

## The Children's Christmas

Christmas means more to the children than to any one else. This Christmas will mean more than any that have passed if an

## EDISON PHONOGRAPH

is among the gifts. It is something that will give them more real, wholesome pleasure for a long time than anything else you could buy.

Bring the children in to hear the Phonograph and let them decide. A full line of instruments and all the new Records.

*(Dealer's name and Address)*

Cut is Electro No. 705

## Put Them Up Outside

One of our own salesmen writes to the Advertising Department as follows:

I wish to call to your attention a detail in regards to our very fine and efficient outside display banner. Four dealers out of five are hanging them up in their stores instead of hanging them outside where the general public can see them. When these banners are put to proper usage they are *trade getters*, but when hung in the store their value as an advertising medium deteriorates.

Won't the Dealers who are hiding the light of this banner in their stores put them outside

where the public can see them and be induced to go inside to see and hear the goods?

## Who Wants Them?

We have on hand a limited supply of the 9x12 colored prints of the Massani painting of the old couple; and of the supplements and bulletins of the Harry Lauder Records. Forms 1433 and 1434 respectively. Until they are used up we will be glad to fill orders from Jobbers for redistribution to Dealers.

# Trade Bulletins

[COPY MAILED TO ALL DEALERS]

*Sales Department Bulletin No. 20,  
November 2, 1908*

## *Trade Information for Dealers*

*All correspondence concerning this bulletin should mention its number and be addressed to NATIONAL PHONOGRAPH COMPANY, SALES DEPARTMENT, Orange, N. J.*

### **Regarding Combination Attachments for Phonographs Fitted with Repeating Attachment**

The Home, Triumph, Idelia and Alva Combination Phonographs and Attachments can be arranged for driving Repeating Attachments, by using a special main shaft pulley.

All Combination Machines of these types, ordered with Repeating Attachments, will be equipped with special main shaft pulleys.

All orders for Combination Attachments, to be used on Phonographs containing Repeating Attachments, should specify for use with Repeating Attachment, in order that the special pulley may be furnished.

If any Phonograph owners have already purchased regular Combination Attachments from you for use on Phonographs with Repeating Attachments, they may return to us, direct or through you, the pulley with which the Attachment is now equipped, and we will supply, in place thereof, the special pulley required, no charge.

All Jobbers and Dealers should order and always carry in stock sufficient Combination Attachments for use with Repeating Attachments to take care of their requirements.

### **Combination Attachments for Concert Phonographs**

Combination Attachments for Concert Phonographs consist of the regular Triumph Attachment and a special diaphragm arm, the same as we have supplied with the regular Triumph cylinder shaft and mandrel for Concert machines to make them play the two-minute Record.

Combination Attachments for Concert Phonographs, which have already been equipped with small cylinder and special diaphragm arm, consist of the regular Triumph Combination attachment with a special reproducer.

We furnish no Combination Attachment for Concert Phonographs to play the Concert Record,

for we do not make a four-minute Concert Record.

The four-minute reproducers furnished with the Combination Attachments for Concert Phonographs must be fitted with special weight. The regular Model H reproducer cannot be used.

The following prices have been fixed for Combination Attachments for Concert machines:

For the regular Concert Phonograph, that is, those still containing the Concert mandrels, list \$9.75, Dealer \$8.00.

For Concert Phonographs that have been changed over to play the Standard Record, list, \$7.50, Dealer, \$6.25.

NATIONAL PHONOGRAPH COMPANY.

[COPY MAILED TO ALL DEALERS]

*Sales Department Bulletin No. 21,  
November 2, 1908*

## *Trade Information for Dealers*

*All correspondence concerning this bulletin should mention its number and be addressed to NATIONAL PHONOGRAPH COMPANY, SALES DEPARTMENT, Orange, N. J.*

### **Regarding Home and Triumph Attachments**

As some of the trade are under the impression that Combination Attachments for Home and Triumph Phonographs are the same, we feel compelled to advise that such is not the case. Although identical in design, they are not so in dimensions. The main difference is in the length of the feed screw, consequently the depression in shaft "T" for set screw "V" is not located in the same spot on both Home and Triumph main shafts. Furthermore, with the Triumph Attachment, it is necessary to furnish a belt, feed nut and spring assembled and feed nut washer, whereas with the Home Attachment, these parts are not necessary, consequently are not supplied. Also with the Home Attachment, we supply a back rod collar, which is not supplied, or cannot be used, with the Triumph Attachment.

From this information, you will note it becomes necessary for you to order Triumph Attachments for Triumph machines, and Home Attachments for Home machines.

All Home Phonographs equipped with swing arm and on which the cylinder shaft runs between centers, take one attachment, known as the Home D-B Attachment. The Model C Home machines, which have no swing arm, but on which

the cylinder shaft runs on a center bearing, the feed screw is slightly longer, and, therefore, these machines require the D-C Attachment.

In the Triumph Machine we have Model A, on which the swing arm is locked by the round spring lock knob, operated from the end; the Model B machine, on which the end gate is locked by the spring lock lever, operated from the front of the machine, and which has a combined body and top plate. A further distinction of these Model B machines is that they are assembled with the golden oak cabinet bearing the name "Edison." We also have the Model C type, which is the machine without the swing arm, and on which the shaft is mounted on the center bearing. The Model C machines, both Home and Triumphs, so far, have been sold only in the State of New York. These three types of Triumph machines vary slightly in length between the back bearings, and, therefore, the shafts and feed screws of the attachments for the three types vary in length. The feed screw sleeve for the D-A type is 4 27-32 inches long. The feed screw sleeve for the Model D-A attachment for the Model A type of Triumph is 5-32 of an inch shorter than the feed screw for the D-B attachment for the Model B Triumph. Both of these attachments are arranged to run between centers, and have a combination thrust and retaining collar between the screw sleeve and the cylinder. The feed screw sleeve for the Model D-C attachment for the New York State machines is one-quarter of an inch longer than the Model D-B screw sleeve, and is arranged to run on a center bearing, and is fitted up with a split bearing in addition to the retaining collar.

NATIONAL PHONOGRAPH COMPANY.

## *Suspended List, Nov. 20, 1908*

### SUPERSEDING ALL PREVIOUS LISTS

This list is supplemental to the Suspended Lists which appeared in the June, 1908, and succeeding issues of the EDISON PHONOGRAPH MONTHLY. These are still in force and must be given the consideration by the Trade as if reprinted in full herewith.

**GA., Savannah**—Knight Drug Co., Broughton St.

**ILL., Chicago**—Rudolph Heubsch, 5011 So. Ashland Ave.

**Olvey**—F. M. Borrell.

**IA., Clarksville**—L. Fowle.

**MONT., Missoula**—O. B. S. Orr Realty Co., P. O. Block.

**N. H., Colebrook**—Norman E. Parks.

**O., Ada and Lafayette**—H. P. Maus.

**OKLA., Weleetka**—C. O. Durnil.

**TEX., Clarksville**—Maxfield Music Co. (G. A. Maxfield), North Walnut St.

**VA., Norfolk**—H. Ginsburg, 296 Church St.

Jobbers and Dealers are asked not to supply any of the above named firms with our apparatus, either at addresses given or any other address.

## Our Christmas Advertising

The strongest proof of our confidence in Edison Dealers and our faith in Amberol Records may be evinced by a glance through the December monthly magazines and the late November issues of the large weeklies having national circulation. We have never before spent so much money in one month's advertising. We are bound that every possible purchaser of a sound reproducing instrument in the United States shall know that by the invention of Amberol Records the Edison Phonograph is placed upon a pinnacle of superiority never before reached by a Phonograph or talking machine.

Our quarter, half, full and double page ads, with color illustrations strongly suggestive of Christmas, which appear in thirty-two different publications, will be missed by few; and the Dealer who has not made himself known in his community as an Edison Dealer by identifying his local advertising with our national advertising will be the first to feel the results of our Christmas campaign.

If the Dealer's advertising efforts in behalf of Edison Phonographs and Records are in proportion to our own efforts his advertising expenditures will soon appear to have been good investments, as our tremendous outlays have always proved to be.

## A Better Proposition Than Ever Before

Whatever improves the Phonograph improves its selling possibilities. Whatever adds to its ability to entertain, increases its popularity, widens its field, raises its standard and broadens its scope, makes it just that much more inviting to those who are in a position to sell it.

Amberol Records afford more than a mere talking point. They represent an achievement in this kind of musical entertainment. They open up a new field of possibilities. Because of their length (playing over four minutes and longer than any other record of any kind) they permit of the reproduction of music never before possible and, with the way now open, more music of the better class will be the rule.

Amberol Records have a tone quality that is superior even to regular Edison Records and the possibility of getting over twice the entertainment afforded by regular Edison Records at little more than the old price is influencing Record sales far beyond what anything else in record-making has done.

The Dealer who now pushes Edison Phonographs will find a stimulated market in both instruments and Records.

# Advance List

## Of Edison Standard (Two-Minute) and Edison Amberol (Four-Minute) Records for February, 1909

*THE Standard and Amberol Records listed below will be shipped from Orange in time to reach all Jobbers in the United States and Canada before January 25th, 1909, all things being favorable, and they may be reshipped to Dealers at 2 P. M. on January 24th. They must not, however, be exhibited, demonstrated or placed on sale by Jobbers or Dealers until 8 A. M. on December 25th. Supplements, Phonograms, Bulletins and Hangers will be shipped with Records. These may be distributed to Dealers after January 20th, but must not be circulated among the public before January 25th. Jobbers and Dealers may, however, deposit Supplements and Phonograms in Mail Boxes or Post Offices after 5 P. M. on January 24th, for delivery on the following day. Jobbers are required to place orders for February Records on or before December 10th. Dealers should place February orders with Jobbers before December 10th to insure prompt shipment when Jobbers' stock is received.*

### Edison Standard (Two-Minute) Records.

**10056 Little Flatterer**

**Edison Concert Band**

"Little Flatterer" (Schmeichelkatzchen), is one of the earliest compositions by Richard Eilenberg, a popular European composer. It is well known and a favorite among his numerous concert numbers. It is written in gavotte tempo with bell effect, and has an introduction in which there is a cadenza for the flute. A very attractive band number. Publisher, Carl Fischer, New York.

**10057 Willie's Got Another Girl Now**

**Ada Jones**

A comic song by the writers of "Waiting at the Church" (our Record No. 9315) and "Poor John" (our Record No. 9531). It is one of the hits in "Fluffy Ruffles," a musical comedy that has had a long run in New York. Every time that Willie called on his girl the other members of the family "buted" in to such an extent that he was finally compelled to get another sweetheart. Orchestra accompaniment. Music, Henry E. Pether; words, Fred W. Leigh. Publishers, Francis, Day & Hunter, New York.

**10058 Uncle Josh in Society**

**Cal Stewart**

Uncle Josh pays a visit to an old friend in the city, who formerly lived in the country but who has become wealthy and now lives in a luxurious city home. It is not hard to imagine that some of the things that Uncle Josh did would not be considered good form in polite society. The funny way in which Uncle Josh tells about them is simply irresistible.

**10059 Sweetheart Town**

**Harlan and Stanley**

A new song by Theo. Morse, who wrote the famous "Blue Bell" song. It is similar in style and character to "Blue Bell," the refrain being in the popular march tempo. It is some time since Mr. Harlan and Mr. Stanley have sung together and the many admirers of their duet selections will welcome this addition to their repertoire. Orchestra accompaniment. Music, Theo. Morse; words, Jack Mahoney. Publishers, F. B. Haviland Publishing Co., New York.

**10060 Sullivan**

**Billy Murray**

A comic selection that is being sung with great success in George M. Cohan's "musical frivolity," "The American Idea." As its name suggests it is a song similar to "Harrigan," also a Cohan composition. It demonstrates that the good old Irish name of Sullivan meets all the requirements of the hall of fame. Big Tim, John L., and the man who wrote "Pinafore," are cited as illustrious examples. Orchestra accompaniment. Music and words, George M. Cohan. Publishers, Cohan & Harris Publishing Co., New York.

**10061 Schooners That Pass in the Night**

**Arthur Collins**

A comedy drinking song by the composer of "On the Banks of the Rhine with a Stein" (our Record No. 9124) and "Down Where the Wurzberger Flows" (our Record No. 8238), both successful drinking songs. It has a catchy air that will make it as popular as the two just mentioned. Orchestra accompaniment. Music, Harry Von Tilzer; words, Jack Mahoney. Publishers, Harry Von Tilzer Music Publishing Co., New York.

**10062 I Don't Like You****June Rossmore**

This serio-comic song introduces a new artist, who is well known on the vaudeville stage. Miss Rossmore sings for this Record in a style different from any singer now in our catalogues, introducing some of the effects that have made her such a success in vaudeville. It is one of those Records that improve with each hearing. Orchestra accompaniment. Music and words, Clare Kummer. Publishers, Jerome H. Remick & Co., New York.

**10063 Blessed Assurance****Edison Mixed Quartette**

One by one the best and most popular of the sacred selections are being added to the Edison catalogue. "Blessed Assurance" has been repeatedly asked for and its inclusion in this month's list will, therefore, please many Phonograph owners. Our Quartette has given it a rendition quite in keeping with the spirit of the hymn. Unaccompanied. Music, Mrs. Joseph F. Knapp; words, Fanny J. Crosby.

**10064 I Never Cared for Anyone the Way I Care for You****Byron G. Harlan**

A sentimental song that is fully described by its lengthy title. The writers of present day ballads aim to get names for their efforts that will furnish a fair idea as to their character. This one is entitled to a perfect score. The writers also produced "Somebody that I Know and You Know Too" (our Record No. 9822) and "When You Know You're Not Forgotten by the Girl You Can't Forget" (our Record No. 9544), both good examples of descriptive titles. Orchestra accompaniment. Music, J. Fred Helf; words, B. F. Barrett. Publishers, Helf & Hager Co., New York.

**10065 I'll Sing Thee Songs of Araby.****Thomas Chalmers**

The text of this song was taken from the poem "Lalla Rookh," by Tom Moore. "Lalla Rookh" was set to music by Frederic Clay, the well known English composer. It is a song of a high order and popular as a concert number. Mr. Chalmers' fine baritone voice makes it a Record of more than ordinary beauty. Orchestra accompaniment. Music, Frederic Clay; words, W. G. Wills. Publisher, G. Schirmer, New York.

**10066 Rainbow****New York Military Band**

This most popular Indian intermezzo was put out as a vocal solo by Ada Jones and Billy Murray, in the January list (it was Record No. 10049), but it is such an attractive composition that it will bear repetition as a band number, as all who get this Record will testify. "Rainbow" is similar in style to the famous "Hiawatha," and its popularity ought to be none the less enduring. In addition to some excellent work by the band, the Record includes solos by the xylophone and bells. Composer, Percy Wenrick. Publishers, Jerome H. Remick & Co., New York.

**10067 Down in Georgia on Campmeeting Day****Edward Meeker**

A coon song with a lively ragtime melody, and with words that are as full of action as the melody. The words are descriptive of the happenings at a darkey camp meeting in Georgia. Mr. Meeker enters into the spirit of the selection and makes a Record that is not only good musically, but is full of imitations of darkey mannerisms. Orchestra accompaniment. Music, Nathan Bivins; words, John Madison Reed. Publishers, Millbrook Music Publishing Co., New York.

**10068 I Wish I Had a Girl****Manuel Romain**

A song that has made a big hit in the West. It is being sung by Mr. Romain in vaudeville. The words tell of a young man's plaint that he is lonesome, very lonesome, without a girl and he wishes that he had one, just as the other fellows do. Mr. Romain, who by the way, has become one of the best selling Edison artists and, therefore, one of the most popular, sings the selection in a very attractive manner. Orchestra accompaniment. Music, Grace LeBoy; words, Gus Kahn. Publishers, Thompson Music Co., Chicago.

**10069 I Can't Say You're the Only One****Ada Jones and Billy Murray**

These are the words a young couple use in having a heart-to-heart confession concerning their past experiences in making love. There were others who kissed and said sweet nothings and both tell of it unblushingly. But those things are past history and both are now sure that the present love is "it." The song is from the English musical comedy "The Girls of Gottenberg" and is one of the hits in the production. Orchestra accompaniment. Music, Jerome D. Kern; words, C. H. Borill. Publishers, T. B. Harms Co. and Francis, Day & Hunter, New York.

**10070 Jim Lawson's Horse Trade****Cal Stewart**

Jim Lawson was a Yankee who was unusually clever in trading horses, but one day a gypsy proved too smart for him and he became the owner of a horse whose only fault was that he would sit down whenever he was touched on the side by his rider. This Record relates how Jim sold him to the Deacon as a hunting horse that would not only carry his owner but would "point" the game. A typical Cal Stewart Record in fun and rendition.

---

---

# 18 Edison Phonograph Monthly, Dec., 1908

---

## 10071 The Miner March

John Kimble

An accordion solo of one of the best marches in Mr. Kimble's repertoire. The popularity of Records made by the accordion would astonish those who are inclined to regard this instrument as commonplace. Of course, Mr. Kimble's excellent performances do much towards popularizing the Records. Piano accompaniment. Composer, Otto Kost.

## 10072 There's a Warm Spot in My Heart for Tennessee

Frederic Rose

A ballad by the writers of "Somebody Just Like You" (Record No. 10042 in the January list). The chorus:

There's a warm spot in my heart for Tennessee,  
There's a longing for your smile comes over me,  
And wherever I may roam,

I will call it home, sweet home,  
There's a warm spot in my heart for Tennessee.

The song is one that just suits Mr. Rose's voice and, therefore, the Record is a most pleasing combination of sentiment, music and singing. Orchestra accompaniment. Music, Johann C. Schmid; words, Charles E. Baer. Publishers, H. A. Weymann & Son, Philadelphia.

## 10073 Happy Mammy and Her Joe

Ada Jones and Len Spencer

An original Southern sketch. Mammy has a happy sunny disposition and she uses it effectively to cheer up her Joe, who is disposed to be low spirited because he's tired of the struggle for existence. She sings to him and induces him to shake the rheumatism out of his bones by dancing. The Record introduces Ed. Harrigan's and Dave Braham's old song "When de Trumpet in the Cornfield Blows."

## 10074 Policeman O'Reilly on Duty

Steve Porter

Another of Mr. Porter's clever street scenes, in which he continues his mirthful imitations of a conversation carried on by three individuals. Between the Italian peddlers, the newsboys and a fat woman who asks many questions, O'Reilly has his hands full. The way he handles every situation would make a New York policeman green with envy. It will certainly provoke many a smile.

## 10075 Alabama

Collins and Harlan

A comic ragtime coon duet song in the musical comedy "The Broken Idol." Mr. Collins carries the air in the verses, with responses by Mr. Harlan, and then they sing together in the choruses. One of those duet Records that have done so much to make Collins and Harlan popular. Orchestra accompaniment. Music, Egbert Van Alstyne; words, Harry Williams. Publishers, Jerome H. Remick & Co., New York.

## 10076 The Fairest of the Fair March

New York Military Band

The latest march by John Philip Sousa, the famous bandmaster. It has all the characteristic style and swing of his popular marches. It was written expressly for the Boston Food Fair and dedicated to the Boston Retail Grocers' Association. Publisher, John Church Co., New York.

## 13783 He Was Very Kind to Me

Harry Lauder

Jean's testimonial to the extreme kindness shown her by Sandy, her late spouse. After laying especial emphasis upon Sandy's kindness, Jean tells how she was confronted by a neighbor, who upon learning that Sandy was insured in the Prudential said that "eight poun'" and a dead "mon" was not so bad after all. A typical Lauder Record. Orchestra accompaniment.

## 13784 Rising Early in the Morning

Harry Lauder

A most excellent imitation of Jock's aversion to early rising and the efforts of his wife to get him out of bed. Mr. Lauder gives a most realistic presentation of the sleepy, yawning man who cares for nothing else so much as to stay in bed when he ought to get up and go to work. Orchestra accompaniment.

## 13785 The Weddin' o' Lauchie M'Graw

Harry Lauder

The things that took place at the wedding put the event in the same class as the far famed Donnybrook Fair. There was something doing every minute. So lively was the event that the singer declares that he'd sooner get mixed up in the wheels of a train than attend another like it. Orchestra accompaniment.

## Edison Amberol (Four-Minute) Records.

### 71 Selection from "Aida"

Edison Concert Band

"Aida," deemed by many to be Verdi's best opera, was written for the Khedive of Egypt and was given its initial performance at Cairo on December 24, 1871. On this Record are given the famous tenor solo, "Celeste Aida;" part of the ballet music and the grand finale of the second act. This is the most striking climax in the opera and very effective for military band performances. The Record must appeal strongly to those seeking some-

thing above ballads, coon songs and other selections of lighter vein. It is worth a place in the best collections of Records. Publisher, Carl Fischer, New York.

## 72 The Shipmates

Golden and Hughes

An original sketch in which this well-known team have made a great success on the vaudeville stage. With it they have entertained thousands from the Atlantic to the Pacific. Mr. Golden is the original "Billy" Golden, who was one of the early makers of Edison Records, and those coon shouts and songs are in every Record collection. The first half of the Record is taken up with a dialogue, in which nautical terms are used in a most original manner. Then follows the singing of a series of funny verses, with some good yodling by Mr. Hughes.

## \*73 Do You Know Mr. Schneider?

Ada Jones

One of the best things in the English musical comedy "The Girls of Gottenberg," which enjoyed a long run at the Knickerbocker Theatre, New York. It is written on different lines from any of the present day popular songs, a fact that adds much to its attractiveness. The entire song is given on the Record, comprising four verses and four choruses, each of the latter being different. Miss Jones' rendition of a perfect fac-simile of the stage performance. Orchestra accompaniment. Music, Lionel Monckton; words, Lionel Monckton and George Grossmith, Jr. Publishers, Chappell & Co., New York.

## 74 Popular Songs of 1908

American Symphony Orchestra

A potpourri of six of the most popular songs of 1908, as follows: "It Looks Like a Big Night To-night;" "Mandy Lane;" "Sweet Girl of My Dreams," from "Ragged Robin," Chauncey Olcott's new production; "Good Evening, Caroline;" "Once in a While," from "Marcelle," the new musical comedy by Pixley & Luders; "Down in Jungle Town." In the language of the department stores, it is unusual value for the money.

## 75 Uncle Josh Keeps House

Cal Stewart

Sarah Ann Martin was not at all anxious to go to town and leave Uncle Josh in charge of the house. She had several presentiments that Uncle Josh would not be a success as a housekeeper. But she felt compelled to make the trip and started off, after charging Uncle Josh with a list of things that he must not do during her absence. The Record tells with what success he carried out instructions, his efforts being more humorous than otherwise. Four and one-half minutes of clean, wholesome fun.

## 76 Mona

Edith Chapman

A love ballad of the better sort, the music being by Stephen Adams, the well-known English composer and writer of the famous "Holy City." The words by F. E. Weatherly are above the average in attractiveness. They are set to a charming melody. Miss Chapman's cultured soprano voice makes a delightful Record of the selection. Orchestra accompaniment. Publishers, White-Smith Music Co., New York.

## 77 By the Suwanee River

American Symphony Orchestra

A musical sketch by W. H. Myddleton that portrays an English composer's idea of a darkey's dream of the past. "Marching to the Camp Meeting" is the opening number. This has an approach and passing effect. The "Dance of the Old Folks" is played in a rollicking style and leads into a spirited coon dance, in which the shuffling of feet is heard. "Way Down Upon the Suwanee River," played with dreamy tremolo effect, defines a vision of the old folks at home and the finale is again a jolly dance melody. Publishers, Hawkes & Son, London.

## 78 Cohan's Pet Names

Ada Jones and Billy Murray

Another of the songs from George M. Cohan's new show, "The American Idea." It is a conventional duet between a young couple in which the young man nearly exhausts his vocabulary of pet names to find some that will please his lady love. The song is more striking because it is a departure from the style of the present day popular ditties. With it Miss Jones and Mr. Murray will again score, it being especially fitted to their duet work. Orchestra accompaniment. Music and words, George M. Cohan. Publishers, Cohan & Harris Publishing Co., New York.

## 79 Battle Hymn of the Republic

Miss Stevenson, Mr. Stanley and Chorus

A remarkably fine presentation of Julia Ward Howe's stirring national anthem. Mr. Stanley, baritone, sings the first verse; Miss Stevenson, soprano, the second verse; Mr. Stanley and Mr. Anthony, the third verse, and Miss Stevenson and Mr. Anthony, the fourth verse. The choruses between the verses are sung by the Mixed Quartette. The singers are accompanied by the New York Military Band, which also plays a number of original interludes, these being among the attractive features of the Record. It will be strange, indeed, if this does not prove one of the largest selling Records ever made for the Edison Phonograph.

\* This selection will be illustrated on cover of February Phonogram.

## 80 The Death of Custer

Edison Concert Band

A musical fantasy by Lee Johnson descriptive of the death of General Custer. A synopsis of the music is as follows:

1. Sioux Indian war dance—Night before the battle.
  2. Bugle calls in Custer's camp before forming the line of march.
  3. Custer's Cavalry on march to Sioux's camp, the sound of horses' hoofs in the distance.
  4. Approach of Cavalry with band playing "National Airs," the Indians responding with their customary war music.
  5. Battle of "Little Big Horn" June 25th, 1876, in which our great General lost his life.
  6. Indians rejoicing over the victory with scalp dance.
  7. Arrival of reinforcements, General Bentine and Cavalry.
  8. Custer's burial, volley of shots, muffled drums, and bugle sounding the last call, over General Custer's grave.
- Finale—"Nearer My God to Thee."

## Sued for Violating Contracts

The National Phonograph Co. recently obtained a preliminary injunction from the United States Circuit Court, western district of Pennsylvania, against Wright & Metzler, Connellsville, Pa., who are charged with infringing the patents of the Company. The defendants were enjoined from selling or advertising for sale Edison Phonographs or parts thereof, records or blanks, at less than current list prices, or violating in any manner whatsoever their license agreements of December 6, 1905, and October 26, 1907.

A final decree was also issued by the same court, October 13, against Gent & Eagen, Oil City, Pa., for violating the selling system of the National Phonograph Co. In this case the defendants were not authorized or signed Edison Dealers, and they claimed to have obtained the goods without notice of the restrictions. The Company waived an accounting and the defendants consented to a final decree and perpetual injunction. The defense, however, were assessed the costs and disbursements of the complainants in bringing the suit.

## Among the Jobbers

A. O. Petit, Edison Jobber at Newark, has bought out the Newark jobbing branch of the Douglas Phonograph Co., and now has the Newark field to himself, since the Rapke Phonograph store no longer handles Edison goods on a jobbing basis. Mr. Petit is one of the oldest Jobbers (from a business standpoint) in the country.

On November 1st the Standard Talking Machine Co., of Pittsburg, Pa., took over and bought out the entire stock of merchandise, fixtures and furniture of the Powers & Henry Co., and the Pittsburg Phonograph Co., both of Pittsburg. This deal involved some \$70,000 and combined with the Standard Talking Machine Co.'s \$60,000 worth of merchandise, gives them a combined stock of \$130,000, making the Standard Talking Machine Co. the fourth largest

talking machine jobber in the United States. It is the intention to run the business under the name of the Standard Talking Machine Co., with showrooms and main office at 435-437 Wood street, using the former Powers & Henry warehouse at 335-7 Second avenue. The combined Edison Record stock will aggregate 175,000 Edison Records. The former stockholders of the Standard Talking Machine Co. have not been increased by the addition of any outside parties, and none of the Power & Henry Co. or Pittsburg Phonograph Co. stockholders are at all interested in the Standard Co., they having gone out of the business entirely. The present officers of the Standard Company are: C. F. Haudenschild, president; M. S. Rocereto, vice-president, and J. C. Roush, treasurer and manager.

House publications continue to be popular in the talking machine trade. The newest addition is the *Wurlitzer Recorder*, No. 2 of which has just been issued by the Wurlitzer Company, of Cincinnati. It is full of bright and useful matter that cannot fail to interest its readers. Its editor is C. W. Page, Advertising Manager for the Wurlitzer Company. Mr. Page was formerly connected with the Advertising Department of this company.

## Courtesy Pays

Remember above all things, Mr. Dealer, that your business is dependent upon the public, therefore, when a person enters your place of business it is fitting and proper, and we will add necessary, that he or she be treated with the utmost courtesy. Don't get the foolish idea into your head that because a stranger drops into your store and gives you the impression he does not intend to buy, that he is not entitled to just as courteous treatment as the fellow who comes running in half breathless shouting he is going to buy. While on the face of it, it may not appear to you that the former is deserving of any attention, just the same, he is a good prospect and by making a friend of him he may do you a world of good indirectly.—*Whitsit Monthly*.



# Edison Phonograph Monthly, Dec., 1908

## Jobbers of Edison Phonographs and Records

- ALA., Birmingham**—Talking Machine Co.  
**Mobile**—W. H. Reynolds.  
**Montgomery**—R. L. Penick.
- ARK., Fort Smith**—R. C. Bollinger.
- CAL., Los Angeles**—Southern Cal. Music Co.  
**Sacramento**—A. J. Pommer Co.  
**San Francisco**—P. Bacigalupi & Sons.  
Kohler & Chase, Inc.
- COLO., Denver**—Denver Dry Goods Co.  
Hext Music Co.
- CONN., New Haven**—Pardee-Ellenberger Co.
- D. C., Washington**—E. F. Droop & Sons Co.
- GA., Atlanta**—Atlanta Phonograph Co.  
Phillips & Crew Co.  
**Waycross**—George R. Youmans.
- IDAHO, Boise**—Eiler's Piano House.
- ILL., Chicago**—Babson Bros.  
Lyon & Healy.  
James I. Lyons.  
The Vim Co.  
Montgomery Ward & Co.  
Rudolph Wurlitzer Co.  
**Peoria**—Chas. C. Adams & Co.  
Peoria Phonograph Co.  
**Quincy**—Quincy Phonograph Co.
- IND., Indianapolis**—Indiana Phono. Co.  
Kipp-Link Phonograph Co.  
A. B. Wahl & Co.
- IOWA, Des Moines**—Harger & Blish.  
Hopkins Bros. Co.  
**Dubuque**—Harger & Blish.  
**Fort Dodge**—Early Music House.  
**Sioux City**—Early Music House.
- KY., Louisville**—Montenegro-Riehm Music Co.
- LA., New Orleans**—William Bailey.  
National Automatic Fire Alarm Co.
- MAINE, Bangor**—S. L. Crosby Co.  
**Portland**—W. H. Ross & Son.
- MD., Baltimore**—E. F. Droop & Sons Co.
- MASS., Boston**—Boston Cycle & Sundry Co.  
Eastern Talking Mach. Co.  
Iver Johnson Sptg. Goods Co.  
**Fitchburg**—Iver Johnson Sptg. Goods Co.  
**Lowell**—Thomas Wardell.  
**New Bedford**—Household Furnishing Co.  
**Springfield**—Flint & Brickett Co.  
**Worcester**—Iver Johnson Sptg. Goods Co.
- MICH., Detroit**—American Phono. Co.  
Grinnell Bros.
- MINN., Minneapolis**—Thomas C. Hough.  
Minnesota Phono. Co.  
**St. Paul**—W. J. Dyer & Bro.  
Koehler & Hinrichs.  
Minnesota Phonograph Co.
- MO., Kansas City**—J. W. Jenkins' Sons Music Co.  
Schmelzer Arms Co.  
**St. Louis**—Conroy Piano Co.  
Koerber-Brenner Music Co.  
Silverstone Talk. Mach. Co.
- MONT., Helena**—Frank Buser.
- NEB., Lincoln**—Ross P. Curtice Co.  
H. E. Sidles Phono. Co.  
**Omaha**—Nebraska Cycle Co.  
Shultz Bros.
- N. H., Manchester**—John B. Varick Co.
- N. J., Hoboken**—Eclipse Phono. Co.  
**Newark**—A. O. Petit  
**Paterson**—James K. O'Dea.  
**Trenton**—Stoll Blank Book and Stationery Co.  
John Sykes.
- N. Y., Albany**—Finch & Hahn.  
**Astoria**—John Rose.  
**Brooklyn**—A. D. Matthews' Sons.  
**Buffalo**—W. D. Andrews.  
Neal, Clark & Neal Co.  
**Elmira**—Elmira Arms Co.  
**Gloversville**—American Phono. Co.  
**Kingston**—Forsyth & Davis.
- New York City**—Blackman Talking Machine Co.  
J. F. Blackman & Son.  
I. Davega, Jr., Inc.  
S. B. Davega Co.  
Douglass Phono Co., Inc.  
Jacot Music Box Co.  
Victor H. Rapke.  
Regina Co.  
Siegel-Cooper Co.  
John Wanamaker.  
Alfred Weiss.
- Oswego**—Frank E. Bolway.
- Rochester**—Mackie Piano, O. & M. Co.  
Talking Machine Co.
- Schenectady**—Finch & Hahn.  
Jay A. Rickard & Co.
- Syracuse**—W. D. Andrews.
- Troy**—Finch & Hahn.
- Utica**—Clark-Horrocks Co.  
Arthur F. Ferriss.  
William Harrison.  
Utica Cycle Co.
- OHIO, Canton**—Klein & Heffelman Co.  
**Cincinnati**—Ball-Fintze Co.  
Milner Musical Co.  
Rudolph Wurlitzer Co.  
**Cleveland**—Eclipse Musical Co.  
**Columbus**—Perry B. Whitsit Co.  
**Dayton**—Niehaus & Dohse.  
**Newark**—Ball-Fintze Co.  
**Toledo**—Hayes Music Co.  
**Youngstown**—The W. E. Henry Co.
- OREGON, Portland**—Graves Music Co.
- OKLA., Oklahoma City**—Smith's Phono. Co.
- PENNA., Allentown**—G. C. Aschbach.  
**Easton**—The Werner Co.  
**Harrisburg**—Louis Buehn & Bro.  
**Philadelphia**—Louis Buehn & Bro.  
C. J. Heppe & Son.  
Lit Bros.  
Musical Echo Co.  
Penn Phonograph Co.  
John Wanamaker.  
Western Talking Mach. Co.  
H. A. Weymann & Son.  
**Pittsburg**—Standard Talk. Mach. Co.  
**Reading**—Reading Phonograph Co.  
**Scranton**—Ackerman & Co.  
Technical Supply Co.  
**Williamsport**—W. A. Myers.
- R. I., Providence**—J. M. Dean Co.  
J. A. Foster Co.  
J. Samuels & Bro.
- TENN., Chattanooga**—J. H. Templeman Co.  
**Knoxville**—Knoxville Typewriter and Phonograph Co.  
**Memphis**—F. M. Atwood.  
O. K. Houck Piano Co.  
**Nashville**—Magruder & Co.  
Nashville Talking Mach. Co.
- TEX., Dallas**—Southern Talking Machine Co.  
**El Paso**—W. G. Walz Co.  
**Fort Worth**—Cummings, Shepherd & Co.  
**Houston**—Texas Piano & Phono. Co.  
**San Antonio**—H. C. Rees Optical Co.
- UTAH, Ogden**—Proudfit Sporting Goods Co.  
**Salt Lake City**—Clayton-Daynes Music Co.
- VT., Burlington**—American Phono. Co.
- VA., Richmond**—C. B. Haynes & Co.
- WASH., Seattle**—D. S. Johnston Co.  
Kohler & Chase.  
**Spokane**—Spokane Phonograph Co.
- WIS., Milwaukee**—Lawrence McGreal.
- CANADA, Quebec**—C. Robitaille.  
**St. John**—W. H. Thorne & Co., Ltd.  
**Toronto**—R. S. Williams & Sons Co., Ltd.  
**Vancouver**—M. W. Waitt & Co.  
**Winnipeg**—R. S. Williams & Sons Co., Ltd.

# Broaden Your Field

—and increase your sales. A dealer makes a serious mistake by selling records and instruments for amusement purposes alone. There is besides the amusement field the vast field of education from which can be reaped an abundant business. Here the dealer can increase the sale of records to those who already own phonographs, and can sell both instruments and records to a very large number of cash customers who would never think of buying a phonograph except for educational purposes. All this is made possible through

## I.C.S. LANGUAGE SYSTEM

WITH  
*Thomas A. Edison*  
PHONOGRAPH

There is a great opportunity for **you** to sell I. C. S. Language Outfits to people who are going abroad or who desire to learn a language for the sake of the knowledge of it alone; to those who desire to qualify for positions as translators and foreign correspondents; and to foreigners who wish to learn to speak English. No sledge hammer is needed to get it clearly into your head that this presents a sure way of broadening your field of work and increasing your sales. For the sake of good business sense, boom the I. C. S. Language feature of the business.

**International  
Correspondence Schools**  
SCRANTON, PA.