

# EDISON Phonograph Monthly

EXACT REPRODUCTION

By  
Wendell Moore

First Edition  
December 1976



NATIONAL PHONOGRAPH'S EXHIBIT AT ST. LOUIS.

*Reprinted By  
Pennant Litho, Inc.  
Louisville, Kentucky*

1904 - 05 - VOLUME II, NUMBER I

BOOK NUMBER 403

*Wendell Moore*

## PREFACE

March 1904 – Second year of the Edison Phonograph Monthly Bulletins. By now it is evident that E. P. M. is a success as a connecting link between the maker and the world wide sales organization, so let's look at some of the good news it has spread in the past year.

Of the 16 models of Edison phonographs mentioned in this issue, the Home, Standard, Gem and Triumph certainly were the most widely used – in the above order – and Mr. Edison, at this time, was evidently quite interested in improving all his products. For instance – the Concert machine was adapted to play small records, the Triumph mounting was improved and the machine was fitted with a new speed indicator, new Gold Moulded records have a new peg box, the Home machine has a new repeating attachment, and many tips are given on how to regulate the speed so performance will be more satisfactory. Also in this same time period he was working feverishly on new products – such as a new shaving machine and the Windsor and Majestic coin slots. We have no way of knowing how much time he spent on things that are not spoken of here, but it is apparent that he knew the importance of staying ahead of his competition.

History now proves that the talking machine industry eventually caught up with him, but this year and in many subsequent years, Thomas A. Edison was undoubtedly the leader in mechanically reproduced sound.

We have this as a matter of record – Because of one man – M. R. McMillion.

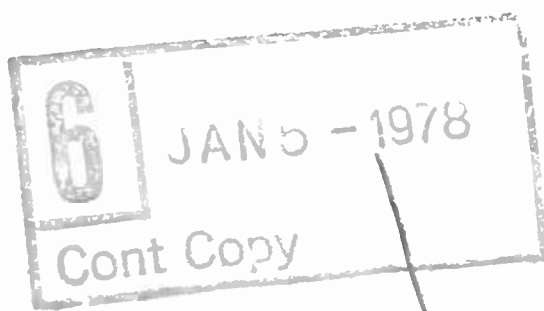

*This book is dedicated to M. R. McMillion and the thousands of phonograph collectors who are active in preserving the true Edison phonograph story – historically and mechanically.*

*My thanks also to William R. Rawson and Edward Orbann, of Thomas A. Edison Industries, for their favorable comment in their letter of October 15th, 1965.*

*Wendell Moore*

## TECHNICAL INDEX

Publication began March, 1904, so the index runs from March, 1904, through February, 1905, coinciding with the contents of book.

	MONTH	PAGE		MONTH	PAGE
	— A —			Dec . . . . .	6
Ajax Phono . . . . .	Aug . . . . .	3,10		Jan . . . . .	11
	— B —			Feb . . . . .	12
Bijou Phono . . . . .	Aug . . . . .	10	— Q —		
	— C —		— R —		
Concert Phono . . . . .	Mar . . . . .	5,10	Reproducers Model B. . . . .	Mar . . . . .	5,7
	Jun . . . . .	3,11		May . . . . .	5
	Aug . . . . .	11	Reproducers Model C . . . . .	Mar . . . . .	5,7
	Oct . . . . .	6,10		May . . . . .	5
	Nov . . . . .	3	Reproducers Model D . . . . .	Jun . . . . .	3
	Feb . . . . .	11		Mar . . . . .	5
Concert Records . . . . .	Aug . . . . .	1,3		May . . . . .	5
Conqueror Phono . . . . .	Aug . . . . .	3,11	Record Cabinets. . . . .	Jun . . . . .	3
	Oct . . . . .	10		Mar . . . . .	9,11
	Nov . . . . .	3		Jun . . . . .	5
Climax Phono . . . . .	Aug . . . . .	3,10	Recorder . . . . .	Sep . . . . .	11
	— D —			May . . . . .	4
	— E —			Jun . . . . .	12
Edison Excelsior Phono . . . . .	Aug . . . . .	10		Oct . . . . .	7
	— F —		Regal Phono . . . . .	Aug . . . . .	3,10
	— G —		Repeating Attachment . . . . .	Oct . . . . .	10
Gem Phono . . . . .	Jun . . . . .	7,11		Nov . . . . .	3
	Sep . . . . .	5	— S —	Jan . . . . .	10
	Oct . . . . .	6	Standard Phonos . . . . .	Mar . . . . .	7,9
	Nov . . . . .	6,8		Jun . . . . .	7,11
	Dec . . . . .	13		Sep . . . . .	3,5
	Jan . . . . .	12		Oct . . . . .	6,7
	Feb . . . . .	13		Nov . . . . .	6,10
Grand Opera Records. . . . .	Jul . . . . .	5		Dec . . . . .	13
	— H —			Jan . . . . .	11,12
Home Phono. . . . .	Mar . . . . .	4,7,12,13	Speed Indicator . . . . .	Feb . . . . .	13
	Jun . . . . .	3,4,7,10,11		Mar . . . . .	7,11
	Jul . . . . .	5,7		Jun . . . . .	6
	Aug . . . . .	13		Jul . . . . .	12
	Sep . . . . .	5,10,11	Shaving Machine . . . . .	Feb . . . . .	4
	Oct . . . . .	6,10		Mar . . . . .	10
	Nov . . . . .	3,6,8	— T —		
	Dec . . . . .	6,13	Triumph Phono . . . . .	Mar . . . . .	3,11,13
	Jan . . . . .	10		Jun . . . . .	3,7,11
	Feb . . . . .	13		Jul . . . . .	12
	— I —			Aug . . . . .	9,11
Imperial Phono . . . . .	Aug . . . . .	3,10		Sep . . . . .	5
	— J —			Oct . . . . .	5,6,10
	— K —			Nov . . . . .	6
	— L —			Dec . . . . .	13
	— M —			Jan . . . . .	10
Majestic Phono . . . . .	Aug . . . . .	3,10		Feb . . . . .	7
	— N —		— U —		
	— O —		— V —		
	— P —		Victor Talking Mach. Co. . . . .	May . . . . .	4
Phonogram. . . . .	May . . . . .	7		Oct . . . . .	10
	Jun . . . . .	5		Nov . . . . .	3
	Jul . . . . .	7	Victor (Edison) Phono . . . . .	Aug . . . . .	3,11
	Aug . . . . .	10	Vulcan Phono . . . . .	Aug . . . . .	3,10
	Sep . . . . .	3		— W —	
	Oct . . . . .	5,7	Windsor Phono . . . . .	Aug . . . . .	3,10
	Nov . . . . .	10		— X Y Z —	

**HIGHLIGHTS OF E.P.M. NO. 1, 1903-1904 PUBLISHED IN  
LIMITED EDITION OF 1,000 COPIES**

- No. 1 March First issue of E.P.M., Record list – April 1903.  
Portrait of Mr. Edison – December 27, 1902.  
Lambert loses suit to Edison.  
The Phonogram discontinued Dec. 1902.
- No. 2 April Purpose of E.P.M.  
Record list – May 1903.  
Dealers surplus of 14” horns.  
Solution to cure reproducer blast.
- No. 3 May Record list – June 1903.  
New reproducer lift for Standard model.
- Great issue! Dealer comparison – Disc versus cylinder.  
Reporter story – Edison’s favorite invention.
- No. 4 June Record list – July 1903.  
Editorial – What the world has lost.  
Future of the Phonograph.
- No. 5 July Record list – August 1903.  
New Megahorn approved – introduced in June.  
Why Bill Bailey returned home ???  
Worlds largest horn to date.  
Patents to date – 791!
- No. 6 Aug. Record list – September 1903.  
Process for making Edison Gold Moulded records.  
Cut-away drawing of C reproducer and recorder.
- No. 7 Sept. Record list – October 1903.  
Good! New style repeating attachment.  
Edison Kineoscopes and films.
- No. 8 Oct. Record list – November 1903  
Uncle Josh writes a book.  
One record played 1525 times.
- No. 9 Nov. Record list – December 1903.  
New style horn crane.  
8 pages of advertising.
- No. 10 Dec. Record list – January 1904.  
E.P.M. cancels all advertising.  
Record played 3000 times.
- No. 11 Jan. Record list – February 1904.  
A slap at disc machines.  
A device to play the Phonograph at sea.
- No. 12 Feb. Record list – March 1904.  
How about having a Phonograph party?  
Queen Victoria’s Phonograph message.  
Cotton wrapping discontinued - peg box instead.  
Mammoth Phonograph horn 21 ft long weight - 420 lbs.



# EDISON Phonograph Monthly

PUBLISHED FOR TRADE USE ONLY BY  
THE NATIONAL PHONOGRAPH CO.

VOL. II.

NEW YORK, MARCH, 1904.

No. 1.

*The National Phonograph Co.,*  
ORANGE, N. J.

NEW YORK: 83 CHAMBERS STREET.

CHICAGO: 304 WABASH AVENUE.

SAN FRANCISCO: 933 MARKET STREET.

NATIONAL PHONOGRAPH CO., LTD., 25 CLERKENWELL  
ROAD, LONDON, ENG.

## EDISON PHONOGRAPHS AND RECORDS.

All communications to THE PHONOGRAPH MONTHLY  
should be addressed to the Advertising Department,  
83 Chambers Street, New York.

### C O N T E N T S

About Trade in General.....	1
Advance List of Edison Gold Moulded Records for April.....	2
Imitation is Flattery.....	3
Sample Record Plan.....	3
A New Volume.....	3
Electros to be Dropped.....	3
227 Selections to be Cut from Catalogue...	4
February Records.....	4
Banquet to Mr. Edison.....	5
Concert Phonographs May be Changed to Play Small Records.....	5
Phonograph Effected the Sulu Treaty . . .	5
Phonograph Records of Emperor William's Voice.....	6
Here's a Plan Worth Copying.....	6
A New South Wales Way.....	7
Advertising the Greatest Essential.... .	7
Comments on April Records.....	8
Cabinet for Double Service.....	8
A New Shaving Machine.....	10
Supplement to Parts Catalogue.....	10
No Complaints About Edison Goods.....	11
Printed Matter... ..	11
Dealers' Experiences.....	12
Suspended List March 1, 1904.. ..	14
Jobbers of Edison Phonographs and Records	15

### ABOUT TRADE IN GENERAL.

"We never saw such a rush for Records as this month. Thought we had plenty, but calculations have not held good." This is the way the Penn Phonograph Co. of Philadelphia writes, and it fully represents the Record situation so far as Edison Gold Moulded Records are concerned. The steadily increasing demand for our Records shows that no matter how many cheap ones are put on the market, there will always be a sufficient number of buyers of the genuine Gold Moulded article to keep our Record-making plant running to its capacity. Dealers in all parts of the country are writing that the cheap Records are cutting no figures in their localities, and that customers who have been led by their price to buy a few are coming back, declaring that they are through with them. We ask nothing else from the public than that it will compare Edison Gold Moulded Records with any on the market—either cylinder or disc—and no matter by what talent they are made. Many of our Dealers have put in a line of cheap Records for the purpose of showing their customers the difference between them and Edison Gold Moulded Records. They report that almost invariably the comparison sells Edison goods.

In all that has been said and written during the past six months about the talking machine trade, it has been clearly demonstrated that the Edison Phonograph is the only high high grade machine of its type now being bought by the public. The only other cylindrical machine approaching its sale in quantity is one given away as a premium with newspaper subscriptions and equally cheap mail order propositions. The trade may be assured that the Edison Phonograph will never get into that class. When such a course seems necessary, the National Phonograph Co. will retire from the field.

(Continued on page 3.)

**THE ADVANCE LIST OF APRIL RECORDS APPEARS ON PAGE 2. ORDER FROM IT. NO OTHER ADVANCE LIST WILL BE ISSUED.**

# ADVANCE LIST OF NEW EDISON GOLD MOULDED RECORDS FOR APRIL, 1904

RECORDS listed below will be ready for shipment as near April 1st, as possible, at which time Jobbers' stock orders, if placed prior to March 15th, will be shipped. April Supplements will be forwarded to Jobbers with their stock order for Records. Retail Dealers should place stock orders with their Jobbers at once, to insure prompt shipment as soon as Jobbers' stock is received.

- |      |  |                                 |
|------|--|---------------------------------|
| 8649 | March of the Holy Grail<br><i>From Richard Wagner's sacred music drama "Parsifal"</i>  | Edison Military Band            |
| 8650 | The Man Behind<br><i>Comic male duet with orchestra accompaniment</i>  | Collins and Harlan              |
| 8651 | In Zanzibar (My Little Chimpanzee)<br><i>Song hit from "The Medal and the Maid" with orchestra accompaniment</i>   | Harry MacDonough                |
| 8652 | Birds of Spring Mazurka  | Edison Symphony Orchestra       |
| 8653 | Kiss Me Good Night, Dear Love<br><i>Sentimental song with orchestra accompaniment, as introduced in Eleanor Robson's great success "Merely Mary Ann"</i> | Byron G. Harlan                 |
| 8654 | Colored Major March<br><i>Banjo solo with orchestra accompaniment</i>  | Vess L. Ossman                  |
| 8655 | Blue Bell (March Song)<br><i>Male duet with orchestra accompaniment</i>  | Harlan and Stanley              |
| 8656 | Uncle Tom's Cabin (Flogging Scene)<br><i>Introducing the characters Uncle Tom and Simon Legree together with orchestra incidental music</i>              | Len Spencer                     |
| 8657 | Rosedale March   | Edison Military Band            |
| 8658 | You're Always Behind Like an Old Cow's Tail<br><i>Coon song with orchestra accompaniment</i>   | Bob Roberts                     |
| 8659 | If I Were Only You<br><i>A new waltz song by the writers of "Navajo" with orchestra accomp.</i>  | Byron G. Harlan                 |
| 8660 | Bunch of Violets (Flower Song)   | Edison Symphony Orchestra       |
| 8661 | I've Got a Feelin' for You<br><i>Coon song with orchestra accompaniment</i>  | Arthur Collins                  |
| 8662 | Robin and the Wren<br><i>Whistling and singing male duet with orchestra accompaniment</i>  | Harlan and Belmont              |
| 8663 | King Carneval Polka<br><i>Cornet solo with orchestra accompaniment, played by the composer</i>   | Bohumir Kryl                    |
| 8664 | Breeze of the Night  | Male Quartette Edison Quartette |
| 8665 | Llewellyn March  | Dulcimer solo Wm. A. Moriarty   |
| 8666 | Come Down from the Big Fig Tree<br><i>Male duet with orchestra accompaniment</i>   | Collins and Harlan              |
| 8667 | In a Nutshell (George Rosey's latest)<br><i>Xylophone solo with orchestra accompaniment</i>  | Albert Benzler                  |
| 8668 | Dear Sing Sing<br><i>Comic waltz song with orchestra accompaniment</i>   | Billy Murray                    |
| 8669 | Mr. Black Man (Cakewalk)<br><i>Introducing male chorus</i>   | Edison Military Band            |
| 8670 | General Hardtack—On Guard!<br><i>Humorous march song with orchestra accompaniment</i>  | Frank C. Stanley                |
| 8671 | The 17th of March<br><i>Comic Irish march song with orchestra accompaniment</i>  | Arthur Collins                  |
| 8672 | Georgia Minstrels<br><i>Introducing the coon song "Uncle Billy's Dream," sung by Len Spencer</i>   | Minstrels                       |
| 8673 | Navajo Medley<br><i>Introducing "Navajo," "Hannah Won't You Open That Door," "For Sale—A Baby" and "Maydee"</i>  | Edison Military Band            |

Edison Gold Moulded Records are made only in Standard size. Both Standard and Concert Records may be ordered from this list. Order by Number, not title. If Concert Records are wanted, give the number and letter C.



The difference between Records *actually* made from gold-lined moulds and those *claimed* to be so made is just the difference between Edison Gold Moulded Records and cheap imitations. The dealer in the latter must have smiled when the manufacturers told him only a month ago that they were "gold moulded." It was, doubtless, the first time that he had heard of it. It would have been interesting to have known just what the dealer thought of the claim, much as it may have amused him.

### A NEW VOLUME.

With this issue the EDISON PHONOGRAPH MONTHLY begins its second volume. Its publication has apparently been a success. We have found it a useful medium for advising the trade concerning many matters, and judging from the hundreds of letters of approval received from the trade during the year, it has been a success from a trade standpoint. This has been due in no small measure to the interest in it manifested by Jobbers and Dealers, who have contributed suggestions and experiences that have been interesting and valuable to others. We appreciate this support, and ask most sincerely for its continuance.

### IMITATION IS FLATTERY.

Ever since Mr. Edison invented the Gold Moulding Process for making Phonograph Records the term "Edison Gold Moulded Record" has been universally used in England. In September last the National Phonograph Company decided to also use the phrase in this country. It proved to be an excellent decision, for it furnished a distinctive name for a distinctively superior Record. It furnished a name that contrasted splendidly with "cheap." It was so good a name that another company is now claiming that its product is "gold moulded," which if true makes it a self-confessed infringer of Mr. Edison's patents. Imitation is most sincere flattery.

### ELECTROS TO BE DROPPED.

The following electros will not be supplied after our present stock is exhausted, and they will be omitted entirely when a new catalogue is printed: 305, 347, 351, 353, 354, 355, 364, 365, 372, 373, 374, 377, 378, 379, 383, 385, 386, 387, 388, 389, 391, 392, 396, 398, 399, 405, 407, 425, 426, 427, 428, 429, 458, 459, 460, 461, 462, 464, 465, 466, 468, 471.

Dealers are asked to cross out these numbers in their catalogues.

### SAMPLE RECORD PLAN.

The plan of sending sample Records to such Jobbers as ordered them was put into effect in February, the samples of March Records being shipped on February 5th. On the same day the following letter was mailed by the Sales Department to all Jobbers who had ordered sample Records:

We are shipping to-day, by express, from Factory, samples of March Records, as per your recent standing order. Please bear in mind that stock orders for these Records must be sent us on or before the 15th inst., in order to have shipment made at the same time it is made to other Jobbers. Any orders received after the 15th inst. cannot be shipped with first lot of stock orders.

Furthermore, a second stock order sent in by you, received after the 15th inst., with the request that it be included with your original orders received prior to the 15th inst., will have to be considered a second order, and cannot be shipped at the same time as original order.

At the same time a letter was mailed to Jobbers who had *not* ordered sample Records, as follows:

We will to-day or to-morrow make express shipments from factory of sample Records covering March list to such Jobbers as have placed standing orders with us. Inasmuch as you have placed no such order, you will, of course, not receive samples. We will, however, mail you to-day or to-morrow Advance List of these Records, and desire to advise that such stock order as you care to place for them, shipment of which you desire made at same time stock orders are shipped to other Jobbers, must be received by us not later than the 15th inst. Any orders received after this date will be somewhat delayed, and shipment cannot be made until after such orders as are received prior to the 15th inst. have been filled.

The new plan seemed to please all who took advantage of it. Many Jobbers at once issued an invitation to their Dealers to call and hear the sample Records played over as a guide in placing orders. As a result nearly every Jobber placed a larger order than usual, and every order showed by its varying quantity for each selection that greater discrimination than usual had been exercised in making out the order, each ordering more of such selections as would probably be the best sellers in his special territory. The future success of the plan will depend upon the judgment of the Jobbers in making up their orders. If they find that their judgment is borne out by sales, then the plan cannot fail to be popular. In any event, it enables a Jobber to place his orders with his eyes open concerning the merits of the Records themselves. The advance orders for March were the greatest in the history of the National Phonograph Co.

## 227 SELECTIONS TO BE CUT FROM CATALOGUE.

We have just mailed to the entire trade a list of 227 selections that will not appear in any catalogue after July 1st next. Of these, 39 are marked to indicate that orders for them cannot now be filled because we have no stock on hand and the moulds are out of commission. Orders for any of the others will be filled as long as our present stock lasts, or until the moulds become unfit for manufacturing. We want every Dealer to have a copy of this list of cut-out, and any one who did not receive it, enclosed with the new Numerical Catalogue, is asked to write the Advertising Department for another copy.

The principal factor in determining to cut these selections from the catalogue was the argument of many Jobbers that some steps should be taken to drop each year a number of titles nearly equal to the additions. The facilities of many Jobbers and large Dealers have been taxed to carry a stock of every selection, which must be done no matter how slow some may sell. With the addition of 300 domestic titles each year, to say nothing of the foreign selections, the Jobbers began to wonder how they could carry a stock a few years hence unless something was done toward cutting out some of the selections. This company accordingly decided to make a beginning in this direction, and after carefully going over the entire catalogue, and also asking many Jobbers for their views concerning slow sellers, this list of 227 was issued. It may not be as large as many Jobbers would like to see, but it could not be made larger without loss of business. All others in the catalogue are still selling too well to be omitted. In fact, there is not one among the 227 cut-out that is not ordered almost daily.

July 1st has been fixed as the date after which these selections will not be catalogued in order that the trade may have four months in which to work off such stock as they may have on hand, for it is not our intention to take them back for credit or replace them with other Records.

## THEY SWEAR BY THE PHONOGRAPH.

A Cincinnati resident recently bought a Home Phonograph and became so enthusiastic that he sent us the following letter:

We all swear by the Edison and likewise your Records. Our folks have got the craze in all its stages, and we have Records for breakfast, dinner and supper. It's Phonograph from morn till night, and we're all broke buying Records. We always talk, speak and recommend the Edison Phonograph to our friends.

## ANOTHER METHOD OF PLAYING BY TELEPHONE.

"I notice in the EDISON PHONOGRAPH MONTHLY for February, how A. E. Lauten plays Records by telephone," writes S. W. Corey, of Fort Dodge, Iowa. "I think I have an improvement on his method, and one causing less trouble. In the first place, I take a fourteen-inch horn and put the small end in the transmitter of the telephone. Then set my Phonograph on a stand a little lower than the telephone, so as to get both horns in line, with the bells of both horns about twelve to fourteen inches apart. By putting the receiver to your ear the distance can be regulated. I have run Records this way that have been heard fifty miles. In fact, I was informed by the manager of the telephone company that it was too strong for him. He could not cut it out. I am informed by persons that have listened to Records played over telephone that they are more distinct and louder than away from the telephone."

## FEBRUARY RECORDS.

Notwithstanding the most strenuous efforts on the part of our Record Department, we were not able to ship out the last of the February Records till February 20th. The demand for Records previously listed was so great that the department was unable to catch up on the February selections. Reference is made to the above facts in order that Dealers may know that the inability of their Jobbers to fill orders earlier in the month was not due to any fault of the Jobbers, but simply because they did not have the goods.

## RECORDS BY SCHOOL CHILDREN.

Many of the children in the Milwaukee public schools had the time of their school lives during January when they were marched in turn, singly and in classes, to the headquarters of McGreal Bros., 173 Third street, and talked and sang into an Edison Phonograph, and thus made Records for exhibition at the World's Fair. It was probably the first time that such a thing had ever been done in public school work and the youngsters greatly enjoyed the novel experiment.

## LOYAL MEXICAN DEALERS.

MONTEREY, N. L., MEXICO, Feb. 12, 1904.  
Suspended List January 1st to hand and noted. Will do all we possibly can to aid you in this mutual protection. Let shoddy makers use the shoddy methods to secure trade; Edison goods sell themselves without discounting.  
Yours truly,  
CROWN IMPORTING COMPANY.



**BANQUET TO MR. EDISON.**

Thomas A. Edison was the guest of the American Institute of Electrical Engineers at a Waldorf-Astoria banquet in New York City on the night of February 11th. The affair was a celebration of the twenty-fifth anniversary of Mr. Edison's invention of the electric light. Everybody of electrical prominence was there and enough interesting things were said and done to fill all the pages of the PHONOGRAPH MONTHLY. The function of this publication is not to act as a press agent for Mr. Edison, however, but to exploit one of his great inventions—the Phonograph. From this standpoint we reprint the following cablegram from Lord Kelvin:

"I join heartily with the American Institute of Electrical Engineers in gratitude to Edison for his great electric work *and for the Phonograph, a most exquisite and instructive scientific discovery*, and for his many other useful and well worked out inventions for the public good."

[The italics are ours.]

T. C. Martin, who acted as toastmaster, in his speech referred to Mr. Edison as "the deaf investigator at Menlo Park who wreaked unique retaliation on his affliction by preserving human speech forever with his Phonograph."

**A CHICAGO PROFESSOR'S ENDORSEMENT.**

The following endorsement of the I. C. S. Language Course by Prof. Jerome Hall Raymond, associate professor of sociology in the University of Chicago, was the result of a demonstration made by Atwater & Fullerton, Dealers in Edison Phonographs at Norwood, New York:

NORWOOD, N. Y., Jan. 29, 1904.

Mr. Atwater has shown me the Edison Phonograph, and I have listened to a number of International Correspondence School Records in French, German and Spanish. The pronunciation seems to me perfect, and the system of teaching most admirable. I wish I had had the advantage of such a method when I began to study French and German.

JEROME H. RAYMOND, PH. D.

**HIS RANGE OF VOICE.**

"Range?" repeated the young but compact baritone, "yes, indeed, I have a wide range. My voice is heard from the Atlantic to the Pacific."

In truth, he had made more Records than any other Phonograph soloist going.—*Newark (N. J.) Evening News.*

**CONCERT PHONOGRAPHS MAY BE CHANGED TO PLAY SMALL RECORDS.**

Here is an opportunity for live Dealers to work up some new business. We are now manufacturing a new diaphragm arm and a new main shaft and mandrel by which Concert Phonographs may be changed so as to play standard size Records. These parts are sold at \$7.95, subject to the usual repair discounts to the trade. The new parts may be applied by any one of ordinary intelligence. With these new parts the owner of a Concert machine will have one equal to a Triumph. Many Concerts are now unused because their owners do not care to make the sacrifice necessary to exchange them for other types. It is important to note, however, that only the Model B or Model D Reproducers can be used; Model C will not work. Dealers will do well to ascertain the names of owners of such Concert machines and get them to put on the new parts. The profit on the parts will not amount to much in itself, but the sale of Records should be considerable.

**PHONOGRAPH CONCERT INVITATION.**

Among the good things brought by the mails during the past month was the following from John E. Finney, a Dealer at Savannah, Ga.:

You are cordially invited to attend our daily concerts by the masterpiece of the inventive genius of

MR. THOMAS A. EDISON,  
"THE EDISON PHONOGRAPH,"

Every afternoon from four to five o'clock,  
and from eight-thirty to nine-

thirty on Saturday

evenings,

AT OUR STORE

BARNARD AND STATE STREETS,

SAVANNAH, GA.,

THE RAY CO.,

JOHN E. FINNEY,

Successor.

Wednesday afternoon Children's Matinee each week;

Recitations, Nursery Rhymes and special

music for the little ones.

**PHONOGRAPH EFFECTED THE SULU TREATY.**

It was a Phonograph that finally caused the Sultan of Sulu to make his famous treaty with the United States through the agency of General Bates in 1899. Just the effect that modern science had upon the mind of the semi-barbarians at this time is told by E. C. Rost in the *Scientific American*.

General Bates made his headquarters in the town of Jolo, and thither the Sultan and his staff came on several occasions to discuss the treaty.

Subsequently another visit was made to the *Charleston*. This time the mother of the Sultan accompanied the party. A Phonograph owned by one of the officers rendered very pleasing selections for the entertainment of



the guests. The aged dame sat entranced throughout the performance. It was not until the time came for her son to affix his signature to the treaty that she awakened. Under one condition only would she permit the Sultan to sign—the Phonograph must become hers at once.

For a time that Phonograph threatened to be the means of upsetting all of General Bates' well-laid plans for the amicable taking over of the islands. Fortunately, the owner was prevailed upon to part with the machine in the interests of his government, and the coveted music-producer changed owners at the signing of the treaty by the Sultan.

### PHONOGRAPH RECORDS OF EMPEROR WILLIAM'S VOICE.

The daily papers of February 4 contained the following cable dispatch:

BERLIN, Feb. 4, 1904.—A Phonographic Record of Emperor William's voice will be the first European deposit made in the phonetic archives that are to be kept at Harvard University and in the Congressional Library and National Museum at Washington. The Emperor, upon the application of Dr. Edward W. Scripture, the psychologist, of Yale University, through the United States Ambassador here, has given two examples of his voice for permanent preservation.

The Emperor received Dr. Scripture after the morning church service on Sunday. During the making of the Record His Majesty was alone with the Phonograph. He spoke twice into the apparatus. The first cylinder, made specially for Harvard University, contained observations on Frederick the Great. The other was a short disquisition on "Fortitude in Pain."

The Emperor's manner was kind and he showed interest in the matter. These archives of voices are said to be the first for historical purposes.

These Records of Emperor William's voice were made with a special Phonograph outfit furnished Dr. Scripture for this purpose by the National Phonograph Co.

### HERE'S A PLAN WORTH COPYING.

H. Schmidt & Son Co., of Muscatine, Ia., on February 1st mailed copies of our booklet "A Lasting Impression" to about 500 prospective customers in and about their city. The booklet was accompanied by a handsome circular printed in gold on bright red paper. This circular read as follows:

MUSCATINE'S PHONOGRAPH CENTER.

Feb. 1st, 1904.

DEAR SIR:—This red letter has some valuable news concerning the Edison Phonograph. Read the little story in the enclosed booklet entitled "A Lasting Impression." It's a pretty little story, and also shows the true worth of the unequalled Edison Phonograph with the Recorder.

The Edison Phonograph is always ready to play, sing or speak, and will furnish you some

of the sweetest music and most pleasant entertainment you ever enjoyed.

The Phonograph isn't a short-lived instrument, but is just as essential and durable as a piano. An Edison Phonograph in your home means pleasure, happiness and entertainment for all, old and young.

We cordially invite you to our store to hear this, "The World's Greatest Entertainer."

Respectfully yours,  
H. SCHMIDT & SON Co.

### PLANS FOR CARRYING RECORD STOCK

In sending its February advance list to Dealers the Penn Phonograph Company, of Philadelphia, included the following paragraph:

In calling on our trade we have frequently been surprised at the manner in which the Record stock is being carried. In many cases there is absolutely no attempt whatever to arrange the Records systematically.

This has made such an impression on our minds that we have decided to call your attention to the fact that by this indiscretion you are losing much time and money. Your stock should be so arranged that when a customer asks for a Record you can tell in a moment whether you have it in stock or not. In making up an order you will find it much easier if your stock is systematized. Several dealers to whom we have already spoken have adopted our suggestions and find their business has increased and requires less of their time.

Where a dealer is carrying only a small stock he could not conveniently use the same system as a dealer who carries a complete line. We cannot go into details here as to the best methods to adopt, but if any dealer is sufficiently interested in this matter to write us stating how he arranges his stock and about the quantity of Records he wishes to carry, we shall be pleased to advise him as to what we consider the best plan for him to adopt.

We hope you will give this matter your consideration as you will find the business more pleasing and profitable under improved conditions.

We should think that Dealers would take kindly to suggestions of this character.

### MORE PHONOGRAPH MUSIC BY TELEPHONE.

Hearing Phonograph Records by telephone was a boon to such residents of Otsego county, New York, as had telephones during the periods of heavy snows this winter. William Cushman, a farmer, bought an Edison Phonograph last summer and with it he entertained his neighbors at long distance. He called up the families on the circuit and they opened the receivers. Then he set the Phonograph up to the transmitter and started it going. Its Records were thus heard over miles of snow-bound country by a widely scattered audience.

### FINED FOR DUPLICATING EDISON RECORDS.

The *Talking Machine News*, published in England, in its February issue, reports the imposition of a fine of £10 upon a Londoner for duplicating Edison Gold Moulded Records and selling them as originals. The suit was brought on behalf of Thomas A. Edison. Such duplication is an infringement of Mr. Edison's patents and persons so offending will be vigorously prosecuted.

## ADVERTISING THE GREATEST ESSENTIAL.

It is evident that many small Dealers in Edison Phonographs and Records make little effort to push the line. They buy the quantity necessary to become a Dealer, put the goods in their stores and wait for buyers to come along. If these are slow in coming and the goods are not sold quickly, they eventually dispose of what they have and close the line, deciding that such goods are not profitable. Had they done some advertising, either in their weekly paper or with circulars, in all probability they would have sold their stock quickly and created a demand that would make it necessary to replenish. The life of business in these days is advertising, and every Dealer has it in his power to get as effective results from advertising as any business house in the land. No matter how small his town or how remote from a large city he may be, he can do effectual advertising. If he only places a small advertisement in his weekly paper he will get as proportionate results as the large advertiser who takes a page in a city daily. He will get even more attention, for the average country weekly is perused with greater care than any city daily. An expenditure of one dollar will secure from four to six inches in many weekly papers, and such an advertisement will be read by from 300 to 1,000 different families. And it will sell goods. If a town has no weekly paper, a Dealer can send out a circular or a catalogue to a selected list of families who should be interested in Edison Phonographs. An expenditure of \$100 in Edison Phonographs and Records will yield a profit of from \$75 to \$80 according to the types of machines bought, and we firmly believe that an expenditure of \$5 for advertising will sell goods to that amount: Too many Dealers regard such an expenditure as a loss, but the lack of courage necessary to make it is the most potent reason why they do not succeed in business. Go where you will, you will find that the successful men are the believers in advertising.

### A NEW SOUTH WALES WAY.

Peter Bacigalupi, Jobber at San Francisco, sends the following letter gotten out by one of his Dealers at Sydney, New South Wales:

100 WESTBOURNE ST., Petersham,

Jan. 8, 1904.

DEAR SIR OR MADAM—I have much pleasure in bringing under your notice that I have just landed two fine shipments, ex "Ventura" and "Persic," of Edison new Moulded Records for November. These Records are much improved, and a better lot has never been heard

in Sydney. The volume is greater and the tone is sweet. Edison has scored again, and has left his would-be imitators miles to the rear. Come early and judge for yourselves.

The shipments also include Standard and Home Phonographs, Recorders, C Speakers 21/-, Cement, Main Springs, all Duplicate Parts of Machines, Jewels for B and C Speakers and Recorders, Glass and Mica Diaphragms, Carrying Cases and Boxes for Records, Stands for Horns.

I would also draw your attention to the Speed Indicator for Phonographs. This is a great help to the machine, and enables the best results to be obtained from the Record when used.

The enclosed catalogue, together with the supplements, makes your list complete up to November.

Thanking you for your many past favors, and hoping to have the pleasure of an early call.

JAS. BLACKADDER.

### 13 OUT OF 16 CALLED IT A PHONOGRAPH.

One of the trials of manufacturers of other styles of talking machines is to get the public to realize that their particular machine is not the one invented by Edison. A Chicago young woman recently gave an advertising guessing party. She cut from magazines a series of well known advertisements and gave prizes to those guessing the greatest number correctly. One of the advertisements was that of a talking machine. Of the sixteen persons present, three guessed the advertisement correctly. The other thirteen called it a Phonograph.

### NOVEL ADVERTISEMENT.

A new and novel advertising scheme was successfully worked last Saturday for the Firemen's minstrels. J. B. Kennerdell, of the firm of Furnee and Kennerdell, agents for the Edison Phonographs, also a member of the fire department, made a record announcing the Minstrels on Washington's Birthday, and played it during the afternoon and evening, interspersed with popular songs, etc., from the second-story window of their store. It was certainly a good advertising scheme.—*Daily News, Kitanning, Pa.*

### A JOBBER'S INVITATION.

Following is the form of an invitation sent out by the S. L. Crosby Co., Bangor, Me.:

You are cordially invited to call at our new store, 186 EXCHANGE STREET, or at our branch store at 22 HARLOW STREET, and listen to a

CONCERT

by The National Phonograph Co., on next. . . . . afternoon and evening

Edison's latest improved Phonograph and all of this month's Gold-Moulded Records will be used. Any number on previous lists will be played on request. No Records offered for sale at this time. Come and bring your friends.

THE S. L. CROSBY COMPANY,  
Proprietors of THE BANGOR PHONOGRAPH CO.



**COMMENTS ON APRIL RECORDS.**

The list of Edison Gold Moulded Records for April contains several interesting novelties. There are the usual twenty-five selections, and, as becomes a list of the only high grade Record of its class now before the public, they are splendidly made. Each represents the most advanced progress in the art of making Records by Mr. Edison's corps of assistants at the Edison Laboratory. In arranging these monthly lists no effort is made to get out twenty-five Records that will please every individual. Cognizance is taken of the varying tastes of different persons and different sections and the lists made up so that every one will find from six to a dozen to suit him. Many Phonograph enthusiasts buy the entire twenty-five every month, but the large majority make selections from the list according to personal preference. A reference to each selection follows:

No. 8649, "March of the Holy Grail," is from Richard Wagner's sacred music drama, "Parsifal." This march is slow, stately and solemn. No more difficult music is written for Phonograph reproduction than that by Wagner. It is seldom that so much trouble is met in making a satisfactory Record as was experienced in making this selection. Had it not been for the high musical ability of the men who compose the Edison Military Band, we could not have made so perfect a Record as this one is. Unusual interest attaches to any music from "Parsifal," and we predict a great sale for this selection.

No. 8650, "The Man Behind," a male duet by Collins and Harlan, with orchestra accompaniment, tells in a most humorous way of the glory of the man behind,—how in battle the general gets the credit for he's "The Man Behind;" and the man with the baton is the man behind the tune. The words of this song are by Vincent Bryan and the music by J. J. Mullen.

No. 8651, "In Zanzibar," (My Little Chimpanzee.) is a song hit from "The Medal and the Maid," one of the comic opera hits of the New York theatres in the past season. It is sung by Harry MacDonough with orchestra accompaniment. The words of this song are by Will D. Cobb and the music by Gus Edwards. The air is attractive and Mr. MacDonough makes the Record with clear enunciation and good expression.

No. 8652, "Birds of Spring Mazurka," by the Edison Symphony Orchestra, is a Record that will be most timely for the opening of the spring season. It is filled with the warbling of birds and is very pretty throughout. The peculiar rhythm of the mazurka lends itself nicely to this style of Record. "Birds of Spring Mazurka" was in our old catalogue and is now made over in consequence of demands for it.

No. 8653, "Kiss Me Good-night, Dear Love," is a popular sentimental song from Eleanor Robson's great success, "Merely Mary Ann," which was one of the best things produced at

at the New York theatres this season. The song and refrain of this selection are by Malcolm Williams and the chorus by Israel Zangwill. It is sung by Byron G. Harlan and is accompanied by the orchestra. The combined features of a charming air from a popular comic opera success and Mr. Harlan's excellent rendition will make this Record a fine seller.

No. 8654, "Colored Major March," is a banjo solo by Vess L. Ossman with orchestra accompaniment. It was written by S. R. Henry. It is a fine ragtime Record and the accompaniment forms an excellent background for the banjo.

No. 8655, "Blue Bell," is a male duet by Harlan and Stanley and has orchestra accompaniment. It is a march song with a charming air, and the voices of the singers blend nicely. The words of the song are by Edward Madden and the music by Theodore F. Morse.

No. 8656, "Uncle Tom's Cabin," by Len Spencer, is certainly the most unique Record of the April list and one of the best of Mr. Spencer's productions. It represents the flogging scene in the fifth act of the play "Uncle Tom's Cabin," and introduces the characters of Uncle Tom and Simon Legree. The dialogue by Mr. Spencer is especially good and it is accompanied by incidental orchestral music. This should be a good selling Record and a seller also for a long period of time.

No. 8657, "Rosedale March," is a composition written by Frank L. Seltzer, who, with John Hazel, made a very clever cornet duet in the December list. This selection is made by the Edison Military Band, the prominent instruments being the cornet and the clarinet. It is an excellent band Record.

No. 8658, "You're Always Behind Like an Old Cow's Tail," is a coon song by Bob Roberts, with orchestra accompaniment; which tells how a lazy coon was always behind time. He celebrated Christmas on St. Patrick's Day and after loving a girl for fourteen years he finally told his love and the date was fixed for the wedding. He arrived two hours too late only to find that she had married Mose Levi Johnson. The verses of the song are interpolated with some very funny talk by Mr. Roberts. This song is the work of Farrell and Frantzen.

No. 8659, "If I Were Only You," is a waltz song written by the writer of "Navajo." It is sung by Byron G. Harlan with orchestra accompaniment. The words are by Harry G. Williams and the music by Egbert VanAlstyne. Waltz songs are always popular and this one will be no exception. It is sung rather rapidly, has a fine rhythm, and an excellent accompaniment.

No. 8660, "A Bunch of Violets," (Flower Song), made by the Edison Symphony Orchestra, is a composition by C. W. Bennet. It is played at a slow tempo and is one of the most delicate and charming airs imaginable. It has been finely rendered by the Edison Symphony Orchestra and is altogether a delightful Record.

No. 8661, "I've Got a Feelin' For You," sung by Arthur Collins, is a typical coon song and is made in the typical Collins' style. Funny talk between the verses and the chorus is a feature. The words of this song were written

by Edward Madden and the music by Theodore F. Morse.

No. 8662, "The Robin and the Wren," is a composition written by the late Frank P. Banta. It is a whistling and singing male duet by Harlan and Belmont with orchestra accompaniment. The composition is exceedingly clever and includes a duet between the robin and the wren in which the warbling of each bird is given in a surprisingly clear and artistic manner. All indications will fail if this Record is not extensively sold.

No. 8663, "King Carneval Polka," a cornet solo by Bohumir Kryl, with orchestra accompaniment, is Mr. Kryl's own composition. It introduces a very difficult and elaborate cadenza and is an excellent demonstration of Mr. Kryl's ability as a cornetist.

No. 8664, "Breeze of the Night," is sung by the Edison Quartette without accompaniment in deference to the taste of a large number of people who believe that quartette Records are more satisfactory when sung without accompaniment. This one is well rendered in every respect.

No. 8665, "Llewellyn March," by William A. Moriarty is the first dulcimer solo we have listed in a long time. We were induced to list another of these solos from the large sale of No. 8021, "Ain't Dat a Shame," made by Mr. Moriarty two years or more ago. This Record will appeal to all who are familiar with dulcimer music.

No. 8666, "Come Down From the Big Fig Tree," a male duet by Collins and Harlan with orchestra accompaniment, is one of the best Records of the April list. It is a song of the African country, telling of the love of the monkey and chimpanzee, but its music is quite unlike anything of the kind yet written. The words are by Edward Malden and the music by Theodore F. Morse. Sung by Collins and Harlan, it is a splendid Record.

No. 8667, "In a Nutshell March," xylophone solo by Albert Benzler, with orchestra accompaniment, is the latest composition by George Rosey, the writer of the well known "Honeymoon March," "The Handicap March," "Espanita Waltzes" and others equally popular. The music is especially adapted to the xylophone and the Record is a good addition to our list of these solos.

No. 8668, "Dear Sing Sing," is a comic waltz song by Billy Murray, with orchestra accompaniment, and tells in verse of the advantages of life in Sing Sing. The words were written by William Jerome and the music by G. Schwartz.

No. 8669, "Mr. Black Man," Arthur Pryor's new characteristic cakewalk, made by the Edison Military Band, is full of ragtime music. It also introduces a male chorus with whistling and excellent cornet work. Because of its unique character and general superiority it cannot fail to be a good selling Record.

No. 8670, "General Hardtack—On Guard," is the first solo Record that Frank C. Stanley has made for us in two months, he having just recovered from a severe attack of pneumonia. "General Hardtack—On Guard" is a humorous march song by Dave Reed, Jr. It is sung with orchestra accompaniment. This song has a striking air and Mr Stanley sings it with good articulation and his usual good voice.

No. 8671, "The 17th of March," is a comic Irish march song rendered by Arthur Collins. It is sung with orchestra accompaniment. The music resembles "Mr. Dooley" in its general character. This Record again shows that Mr. Collins can make Records of Irish songs as well as those of coon songs. "The 17th of March" is the work of Jack Drisbane and F. H. Shepherd.

No. 8672, "Georgia Minstrels," made by the Edison Minstrels, is one of the best of the kind that we have yet made. The principal fun in the Record is made by Len Spencer, who also sings "Uncle Billy's Dream." The things that Uncle Billy has dreamed about are too ludicrous for description. The singing is done by the Edison Quartette.

No. 8673, "Navajo Medley," is another of the very popular medleys now being made by the Edison Military Band. In addition to "Navajo," this medley introduces "Hannah, Won't You Open Dat Door," "For Sale—A Baby" and "Maydee." The cornets predominate in this Record to an extent that almost makes it possible to list it as a cornet solo. It follows that the work of the band is of a high class character.

#### CABINET FOR "DOUBLE SERVICE."

The modern Edison Phonograph demands a cabinet designed for double service—language study and amusement. Such a cabinet has been prepared by the International Correspondence Schools of Scranton, Pa., with the most careful attention to appearance, convenience and economy.

In the accompanying illustration the Edison Standard Phonograph is shown in the upper compartment, while directly back of it is a space for hearing tubes, speaking tubes and other accessories. Two sliding shelves hold fifty records; one shelf will contain a complete set of twenty-five Language Records, and the other shelf will accommodate twenty-five Amusement Records, furnishing entertainment for over an hour. Four bound textbooks and the horn may be placed below.

The cabinet is handsomely finished in weathered oak. When closed there is no objectionable display of drawers or instrument, making the cabinet an ornament in any home. Its outside dimensions are: 34 inches high, 18 inches deep, 13 inches wide.

When the student desires to use the Phonograph for language work, the simple action of raising the cover of the cabinet lifts the Phonograph into position, where it latches. The cabinet is also equipped with a convenient book rest.

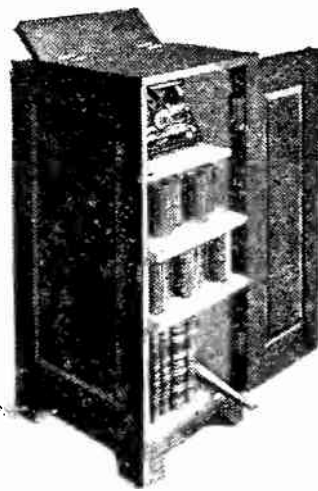



**A NEW SHAVING MACHINE.**

The National Phonograph Company is now putting on the market a new type of shaving machine for general use. It will be called the Edison Universal Shaving Machine and be sold at \$35. For trade discount, see discount sheet. It embodies many improvements over the old style machine or any other machine now made. Among the most important of these are a positive clamp for clamping the knife bar, an exhauster for exhausting the shavings, a cabi-

net containing a drawer for catching the shavings, etc., etc. The machine will shave either the four-inch regular blank or the six-inch business blank. This machine may be run by hand or motive power. The mandrel bearing has hardened steel centers, insuring perfect adjustment and running absolutely true. The mandrel runs at high speed when turning the crank at from 50 to 75 revolutions per minute. A high speed shaving knife is used on this shaving machine, which insures a perfect, smooth cut to the wax cylinder. The exhauster consists of a small exhaust fan with chip chute protruding through the top plate just below the knife and back of the wax cylinder. The shavings are instantly drawn down through this chute into the drawer below. There are no gears used on this machine. With it a six-inch blank may be shaved in from fifteen to twenty seconds. The following cuts and index of parts, taken from our direction sheet for operating the machine, will explain to the trade its construction and method of working:—

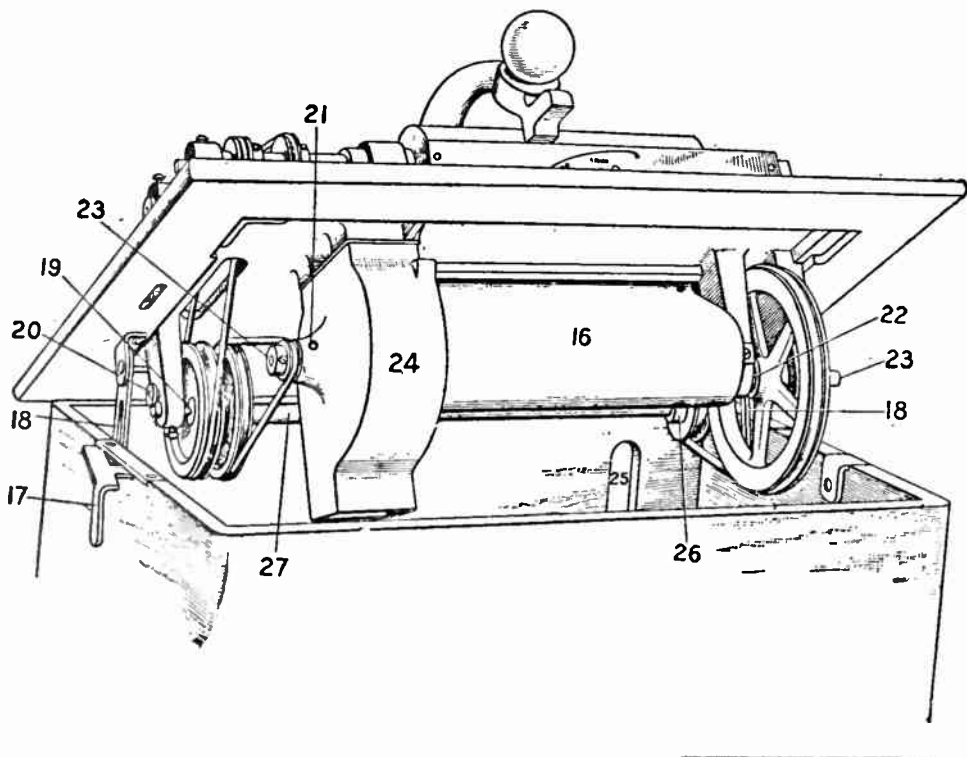
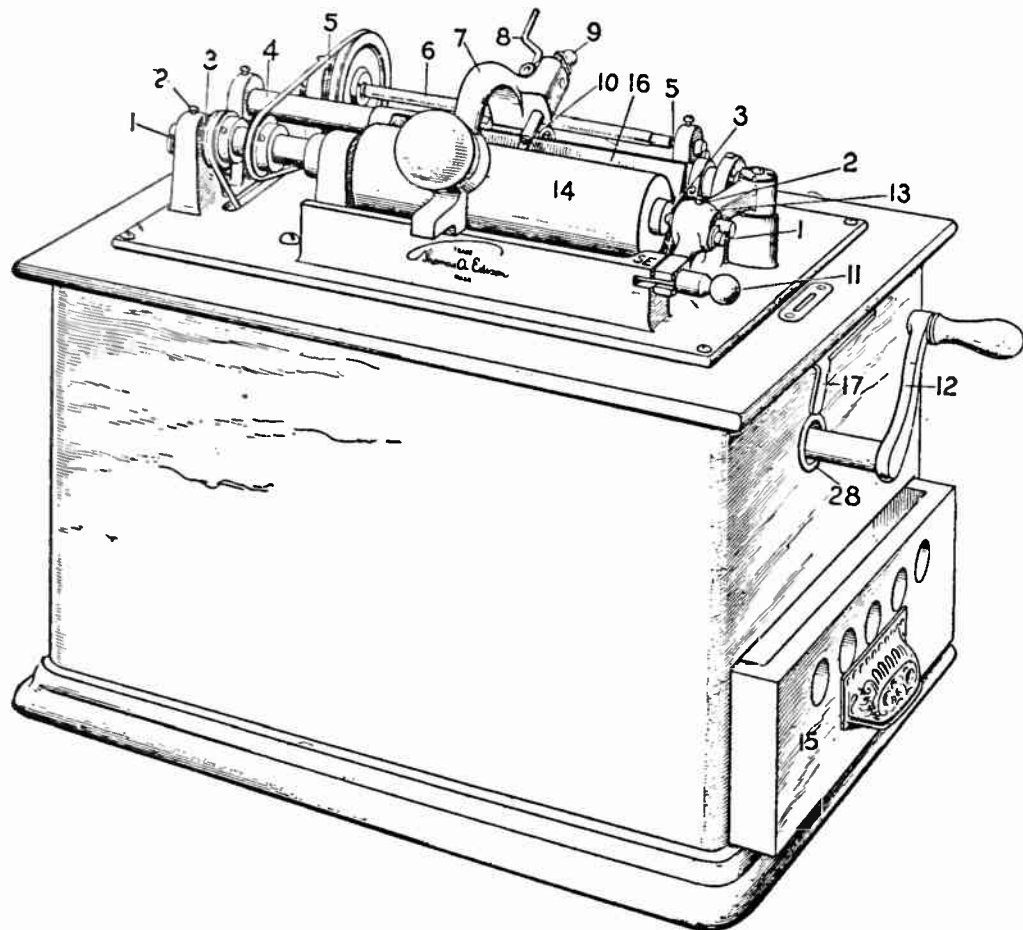

**INDEX OF PARTS.**

1. Main shaft center adjusting screw.
2. Main shaft center set screw.
3. Main shaft centers.
4. Back rod.
5. Feed screw centers.
6. Feed screw.
7. Knife bar arm.
8. Knife bar clamp lever.
9. Knife bar.
10. Sapphire knife.
11. Lock bolt knob.
12. Crank.
13. Swing arm.
14. Taper cylinder.
16. Chip chute.
15. Drawer.
17. Catch lever.
18. Supporting links.
19. Counter shaft centers.
20. Counter shaft center adjusting screw.
21. Fan case oil hole.
22. Crank shaft bearing.
23. Crank shaft.
24. Fan case.
25. Slot for motor belt.
26. Counter shaft pulley.
27. Counter shaft.
28. Crank hole thimble.

**SUPPLEMENT TO PARTS CATALOGUE.**

*Parts for changing Concert Phonographs so as to play standard size Records:*

New Diaphragm Arm (casting only).....	\$2.95
New Main Shaft and Mandrel.....	5.00
<b>Total.....</b>	<b>\$7.95</b>

Subject to usual Repair Discounts.

**TRADE ADVERTISING.**

It is out of the question, in the limited space of this publication, to mention the names of the Jobbers and Dealers who have sent copies of newspapers containing their advertisements and other advertising literature that they have issued. Their receipt is, however, appreciated by the Advertising Department. We are keeping scrap-books of trade advertising and will be glad to receive copies of everything issued that advertises Edison goods.



**NO COMPLAINTS ABOUT EDISON GOODS**

Symonds' London stores, one of our largest Jobbers in Great Britain, under date of February 6, writes to the PHONOGRAPH MONTHLY:

"We have a letter from one of our friends who visited your establishment in Orange, New Jersey, upon a letter of introduction given by us and he expresses the utmost delight at the greatness of your enterprise and general system prevailing in your works.

"We have sold, as you know, many thousands of dollars' worth of your goods which have been distributed by us through the United Kingdom and Colonies. They invariably give satisfaction and we may tell you in fact, that, although we handle all the leading lines, yours is the only one wherein we do not receive complaints more or less frequently on the matter of quality."

**ONE REASON FOR EDISON LOYALTY.**

"I to-day received the name of a prospective buyer from you, and followed same up, with following results: sold one Triumph, seventy-two Records, one seventy-two peg Record Case, one 42-inch brass horn, one Record Cabinet."

This is one of many letters constantly being received from Dealers in Edison goods. It is but one of the ways in which this company is seeking to benefit the trade of its Dealers. The fact that we have so many loyal and hustling firms handling Edison goods is due to just such things as these.

**ON SPEED REGULATION.**

A Phonograph Dealer at Ashburton, New Zealand, sends the following:

I notice in the PHONOGRAPH MONTHLY that one of your correspondents gave a hint for calculating the speed of a Phonograph. You will find no difficulty if you let the machine run for one and a quarter minutes with Record off and speaker arm down. If the machine has traveled two inches in that time, the speed is correct, namely 160 revolutions to the minute. The above method does away with complicated fractions, and is absolutely correct.

**PRINTED MATTER.**

Some Jobbers who get out a special advance list to send to their Dealers have asked to have a copy of our Advance List sent a few days prior to the shipment of sample Records each month, in order that they may send it to their printer and get their lists ready to mail when the sample Records are received. The request is reasonable and will be granted. Within two days after the Advance List is decided upon we will have copies printed of the second page of the PHONOGRAPH MONTHLY, and will mail one to each Jobber. This will be for printing purposes only. The PHONOGRAPH MONTHLY will be mailed on the same day that the sample Records are shipped.

We have had printed a neat four-page folder containing an argument on the reasons for the superiority of the Edison Gold Moulded Record. It is form No. 535. We want to get these into use at once, and are now sending to every Jobber with goods a quantity based on his monthly order for Record Supplements. Any Jobber who can use a still further quantity to advantage is asked to place an order after he receives the first lot. We will thank Jobbers if they will see that some of these folders are sent to such Dealers as have mailing lists, or will distribute them advantageously.

The somewhat belated Numerical Catalogue, Form No. 510, has just been mailed to every one in the trade who has signed our Agreement. Five copies were mailed to Jobbers and one to every Dealer. The edition printed will permit every Jobber to have a supply for new Dealers, but orders for large quantities cannot be filled. This catalogue is intended for store use only, and in printing it no provision is made for general circulation.

Judging by the demand, the little gold and black gummed stickers referred to in the February issue of the PHONOGRAPH MONTHLY have become popular, especially among Dealers who are unable to get advertising matter quickly. We still have a supply of these stickers on hand, and will be glad to mail a small quantity to any one in the trade who will use them.

We have had requests to publish a list of form numbers of catalogues and printed matter in the PHONOGRAPH MONTHLY. We began this some months ago, but found that by the time the numbers became known to the trade many of the editions were exhausted and orders could not be filled. It has since been thought inadvisable to print such a list.

**ADVERTISING PHRASES OF JOBBERS AND DEALERS.**

A little money will bring much happiness if invested in an Edison Phonograph.—*Douglas & Co., New York.*

Edison Gold Moulded Records are the best. A trial will convince. Fit any cylinder machine. Natural in Tone, Loudest and Clear—Moulded by a secret process and will not split on the mandrel. Not injured by handling—will outwear imitations.—*Eastern Talking Machine Co., Boston.*

The Edison Phonograph is the most marvelous of sound-reproducing inventions. It is a perpetual entertainment.—*Siegel-Cooper Co., New York.*

For home entertainment and for music-loving people the Phonograph has never been equalled, either in quality or price.—*Ackerman & Co., Prairie City, Ill.*

There is only one best Record. The Edison Gold Moulded Record is the best.—*Blackman Talking Machine Co., New York.*

Sell the Record which made the talking machine business.—*Penn Phonograph Co., Philadelphia.*

**DEALERS' EXPERIENCES.**

EAST AURORA, N. Y., Feb. 15, 1904.

I don't have much trouble with the ——— records. I keep some of them and play them in comparison with the Edison. Customers nearly always take the Edison. Last week a customer wanted an outfit. He liked the Home machine, but said he could get the ——— outfit for \$25. I happened to have one of the latter in the shop for repairs. I put on one of the sixteen-cent records and ran it for him. I then took the record off and put it on the Edison Home. He could see the difference. Then I put on the Edison Gold Moulded Records, Nos. 8574 and 8579 on the Home. When I was through he said: "That is the machine I will have." I sold him a Home, thirty-inch horn, two dozen Records, Record Case, half-dozen blanks, and horn crane. I shall stick to the Edison as long as they keep up the prices, and take care of their agents. I have sold the Edison goods for five years and have had very few repairs to make.

C. G. COE.

PHILADELPHIA, Jan. 13, 1904.

We have decided to handle only Edison goods, and although several of our competitors have put in a stock of ——— goods, our sales have not diminished apparently, as we sold more Records in December than in any previous month. Here is one of many of our experiences. A regular customer insisted upon having a few selections of ——— records, and said he could not understand why we did not keep them. He purchased three of them in the city, and after playing them at home, he informs us that the three are not equal in value to one Edison, and he now gives us credit for being wise enough to let them alone. We also find that where we were having a dozen ask for ——— records three months ago, we do not have two persons ask to-day. We also notice the people who ask for these goods are of a very illiterate class, who are satisfied with a quantity of noise of any kind.

HOWARD GEORGE.

PRAIRIE CITY, ILL., Feb. 6, 1904.

In November, 1903, a dealer in ——— disc machines, from Galesburg, Ill., made his appearance in Prairie City with two ——— machines, and a large supply of disc records. After playing an entire evening in a leading business house here, he condescended to inform the audience there was no machine but the disc worth having. The proprietor was very enthusiastic with the showing this instrument made, and remarked that it was the best talking machine he had ever heard. He had decided to purchase one of these ———'s, when we heard of the incident. We called at his place of business and told him we would like to have the opportunity to show the merits of the Phonograph, and after our concert we would let him be the judge.

He gave us the privilege, but said it remained to be seen whether we could make a

better showing than the disc machine. We took an Edison Home machine and seventy-two Gold Moulded Records to his store, and gave him a concert of five hours' duration. The first piece we played was the "Imperial Edward March," by the Edison Grand Concert Band. After playing this fine band selection his wife said her decision was already made. "And that in favor of the Edison Phonograph," and she would have no other, as there was no scratch or roar to the Edison Records, and the machine ran so smoothly. Her husband was of the same opinion; also the crowd which had collected. We sold him a Home Phonograph, and nine dozen Records; also a 36-inch spun brass horn. Since then they have purchased many dozens of Records.

This prompts us to again say there is no competition in the field with Edison goods. We find this to be true by experience extending over a period of three years; for, after hearing Edison goods, the verdict is universally for the same.

ACKERMAN &amp; Co.

SPOKANE, WASH., February 19, 1904.

Being so far West we do not get our Records as quickly as some Dealers, and have just lately received January Records. We consider this the best lot of Records up to date, and will predict if you keep this improvement up you will have the world of music at your feet. Every home in the land will have and will prize an Edison Machine to entertain themselves and their friends, and we are doing all we can to further this end. We see by the trade journal what are considered extra sales. We would like to speak of one. We have one customer to whom we sold a Home outfit, and within two months he has bought forty-three dozen Records, or 516, and has a standing order for everything that comes out. Can any one beat that? We are very pleased to learn of the new style box in contemplation and trust it will be in use as quickly as possible. We also note a reduction in freight rates on Western roads. The Western Dealer has considerable to contend with in these high freight rates.

FOSTER &amp; FOSTER.

SPARTA, Mich., Feb. 13, 1904.

I would like to relate a little incident which occurred recently. A gentleman came to me, and after purchasing some Records, I said to him: "I have a Record here which I admire very much. It is called 'The Little Boy in Blue.'" "Oh," he said, "I have a very good Record of that Number in the ———." I played ours for him, and he said, "I do not need two 'Little Boys in Blue,' but you may wrap that one up for me." While I am not doing a large business, my trade is steadily growing, and I am proud to be numbered among the Dealers who handle the goods that sell without price cutting.

HARRY N. HAGADONE.

RACINE, O., Feb. 8, 1904.

. . . I have been asked why I don't carry cheaper records and machines. I haven't time to waste with cheap trash, and when I sell a customer a machine or records, I don't want to be ashamed to meet him a few days afterward. I will handle no other goods but Edison goods.

ED. HARPOLD.



WASHINGTON, D. C., Feb. 13, 1904.

The great drawback to our trade in selling the Phonograph is the Disc or "Scratch-o-Graph." You talk to a person about a Phonograph and they will promptly tell you that they have heard the Phonograph, and when you ask them where they heard it, they will say over to "Smith's," when the fact of the matter is that "Smith" has a disc, which, of course, does not compare with the Phonograph. I must congratulate you on the fine Records you are putting out; for instance, the "New Colonial March," "Two of Us," "American Standard," "Any Rags," and so on, as I could name any quantity of them that never will be equalled by any other company.

One night a young man came to my place to buy a machine, and the gentleman who brought him had been speaking about a disc to him. I happened to have a disc in the house that belonged to a friend of mine, so put it up and played two pieces. I then started my machine. The result you can imagine. He bought the Edison and two dozen Records.

A gentleman came to my place, who owned a disc, for which he paid \$50.00, and \$60.00 for records, and said he wanted to hear the Edison. I played a few Records for him, with the result that he bought a Home machine, a fifty-six-inch horn and five dozen Records, and paid cash for the entire outfit. I have since sold him a six-dozen case and one dozen Records, notwithstanding the fact that there are \_\_\_\_\_ records in this city selling for twenty-five cents.

One of my customers, who had bought an outfit from me, bought a dozen of the \_\_\_\_\_ records, and one night afterward he came to my place in company with the customer to whom I sold the large outfit, and I had just received "Any Rags." I put it in on the machine, and when it had finished he said, "That is the best I have ever heard," and bought it. Another one of my customers, who had bought some \_\_\_\_\_ records, came to my place one evening to see about his reproducer, and I put the "American Standard March" on the machine to try his reproducer. Well, if you ever saw a surprised man in your life, that man was the one. After the Record had finished, he said, "I do not want any more \_\_\_\_\_ records."

I wish the public could understand that there is only one Phonograph, and that is the Edison.

OIL CITY, PA., Jan. 28, 1904.

A few evenings ago two brothers came in to price an outfit. One liked the cylinder machine best; the other preferred disc. We played eight different machines, from the cheapest to the best of the two disc makes. By using a Triumph we sold a Home outfit. The next morning this was returned, the customer saying that his mother would not pay his share unless they took a disc pattern. This we supplied. The next night he returned to secure the Home, saying that the family, after hearing the disc at home, preferred the Edison. People we could not interest before will stop and listen when we have a Triumph running, with a good Record. As we average from four to six hundred customers a day and have machines running most of the time, we are in a position to catch all classes. Local musicians pronounce

the reproduction as near perfect as could be expected.

FARRELL & LEROUX.

MARKDALE, Ont., Feb. 12, 1904.

I see by the PHONOGRAPH MONTHLY of February that M. Smith & Co., of Quebec, Can., have been giving outdoor exhibitions by means of a tube passing through the door to the Phonograph inside. I may say that I had the same device during Christmas week. The connection was made with a tin tube twenty feet long, from the door back to the counter. This town has a population of 1,200, and the Phonograph could be heard almost anywhere in town. My sales of Edison goods doubled after that.

T. F. WILSON.

JUNCTION CITY, KAN., Feb. 13, 1904.

I want you to know that I for one appreciate your way of doing business. I also handle the \_\_\_\_\_ records, not for the profit there is in them, for there is none, but to help sell Edison Records. If I had to sell \_\_\_\_\_ records alone, I would soon go out of the business. If a Dealer values his time any (as most customers want to hear a record before they buy) and knows by experience that there are some \_\_\_\_\_ records so poor that he will never be able to get rid of them, he will agree with me that there is no money in handling \_\_\_\_\_ records, but a Dealer has to keep a few in stock, so he will be able to compare them with the Edison.

E. L. WITZIG.

COLON, MICH., Feb. 15, 1904.

I have been a Dealer in talking machines for the past four years and my trade last year was double that of the year before. Have sold nothing lately but the Edison Phonograph. They seem to be the universal choice in this vicinity.

O. B. CULVER.

MONTOUR FALLS, N. Y., Feb. 10, 1904.

We are a village of a thousand, and another man has put in \_\_\_\_\_'s. A few of my customers some little time ago bought some of these records and now they are coming back to me and saying: "Either the \_\_\_\_\_'s were not good in the first place or are playing out." I first thought of putting in \_\_\_\_\_'s and cutting price, but now am keeping perfectly still, and am getting there all right.

E. W. HUBBARD.

BELMONT, W. Va., Jan. 18, 1904.

I will stick to you in upholding prices of Edison goods. Whenever we want to commit a crime among our fellow beings we will sell Grams or "Scratchaphones;" we would not give away (let alone sell) such trash, for the disgrace of it.

J. E. GREEN.

FREDERICK, MD., Feb. 10, 1904.

I am trying to knock out the \_\_\_\_\_ records. Very few people in Frederick will pay the twenty-five cents for \_\_\_\_\_ records, since I have been pushing the Edison. They say they would rather have one Edison than one dozen \_\_\_\_\_.

W. H. DYER.

KNOWLESVILLE, N. Y., Feb. 12, 1904.

My trade in Edison goods is better now than at any time during the past eighteen months, which proves that the Edison goods are gaining in popularity. People are realizing as never before the true worth of the Edison goods.

S. S. PRINGLE.

**BRITISH SELECTIONS COMPLIMENTED.**

The National Phonograph Company are to be complimented upon their latest list of British and French-Canadian selections of Gold-moulded Records. There are thirty-five titles in the British list, all of a highly popular character. These were recorded in London. Eleven of them are by the British Military Band. Mr. Leonard McKay, Miss Octavia Barry and Mr. Hamilton Hill are among the vocalists, whilst Miss Maud Dewey has two Records, remarkable imitations of British singing birds. We predict a big demand from English Dealers for these Records and an ever larger demand from the Englishmen abroad, since they will serve as a reminder of his native land. Of the thirty-seven French-Canadian selections, four

are by the famous Kilties' band of the 48th Highlanders. These four the National Company have sent us for review and we can conscientiously state that we have never heard clearer, better balanced, or more perfect band Records than these. One of these "The Blue Bells of Scotland," after a pianissimo opening, suddenly bursts into a full volume, the air being played by the treble and the trombones, and the basses playing a running staccato variation. The rendering of "The Cock of the North" is by both band and bagpipes, but all are of exceptional merit and attest the skill of the National Company's recording staff. By-the-way, as showing the conspicuous success of these Records, one factor alone, after a small trial order, gave "a repeat" for four thousand of them, and asked that they should be cabled for.—*Talking Machine News, London.*

**SUSPENDED LIST, MARCH 1, 1904.—SUPERSEDING ALL PREVIOUS LISTS.****COLORADO.**

BOULDER—BENTLEY &amp; CRAIG.

**KANSAS.**CLAY CENTRE—E. M. GOWENLOCK.  
LAWRENCE—BELL BROS.**MASSACHUSETTS.**LAWRENCE—LORD & CO., 314 Essex street.  
E. O. MOSHER, 420 Essex street.

MALDEN—A. T. FULLER.

NEW BEDFORD—H. B. DEWOLFF.

WOBBURN—OSBORN GILLETTE, or THE  
BOLTON JEWELRY COMPANY, L.  
F. MALONEY, Manager.**MICHIGAN.**DETROIT—F. J. SCHWANKOVSKY.  
SAGINAW—GEO. W. EMENDORFER.**MISSOURI.**

KANSAS CITY—THE WITTMANN CO.

**NEBRASKA.**LINCOLN—THE WITTMANN CO.  
OMAHA—THE WITTMANN CO.**NEW HAMPSHIRE.**

NASHUA—F. A. McMASTER &amp; CO.

**NEW JERSEY.**ATLANTIC CITY—SAMUEL D. WOLF, 32-34  
Arkansas avenue.

BAYONNE—I. WIGDOR, 450 Avenue D.

JERSEY CITY—W. L. HOFFMAN, 151 Mont-  
gomery street.NEWARK—R. L. CORWIN; also New York  
City.

PATERSON—CHAS. H. KELLY, 25 N. Main st.

PLAINFIELD—S. W. FRUCHT, or R.  
FRUCHT; also New York City.WEST HOBOKEN—EMIL HOLLANDER, or  
THE WEST HOBOKEN BICYCLE &  
PHONOGRAPH CO., 619 Spring street.**NEW YORK.**

BEDFORD PARK—GEO. H. TYRRELL.

Re-instated since February 1—FINCH &amp; HAHN, Albany and Schenectady, New York.

Jobbers and Dealers are asked to co-operate with us, FOR OUR MUTUAL GOOD, by being careful that they do not supply any of the above named firms with our apparatus, either at addresses given or any other address.

**NEW YORK—Continued.**

HOBART—F. H. MARSHALL.

NEW YORK CITY—A. T. ARMSTRONG, or  
AMERICAN PHONOGRAPH CO., 106  
Wall street.BRONX PHONOGRAPH CO., or DA-  
VID SWITKY, 506 Willis Avenue.

R. L. CORWIN; also Newark, N. J.

EAGLE PHONOGRAPH CO., or C.  
LOWENTHAL, 83 Nassau Street.EMPIRE PHONOGRAPH CO., 2 West  
14th street.S. W. FRUCHT, or R. FRUCHT, 7 Bar-  
clay st.; or 68 Cortlandt st.; also  
Plainfield, N. J.

O. HACKER, 2 Murray street.

HAWTHORNE & SHEBLE, 297 Broad-  
way; also Philadelphia, Pa.

N. HORN, 148 E. 58th street.

R. H. INGERSOLL & BRO., 67 Cort-  
landt street.

W. L. ISAACS, 114 Fulton street.

S. LEMBURG &amp; CO., 194 Broadway.

J. McELLYNNE, 202 Broadway.

RICHARD PEASE, 44 W. 132d st.

F. M. PRESCOTT, 44 Broad street.

SARATOGA—W. J. TOTTEN.

SARATOGA SPRINGS—MARVIN A. COTE.

**OHIO.**

CINCINNATI—J. L. ANDEM.

SPRINGFIELD—D. &amp; M. VANDERPOOL.

UHRICHVILLE—F. A. MAZURIE.

**PENNSYLVANIA.**PHILADELPHIA—A. R. CASSIDY, 2783 Em-  
erald street.HAWTHORNE & SHEBLE, 604 Chest-  
nut street, or Oxford and Wascher  
streets; also New York City.

PITTSBURG—A. LIPPARD, 615 Wylie avenue.

**RHODE ISLAND.**

PROVIDENCE—F. P. MOORE.

**WISCONSIN.**

MILWAUKEE—J. C. BLATZEK.



## JOBBERS OF EDISON PHONOGRAPHS AND RECORDS.

## ALABAMA.

**Birmingham**—The Ray Co., 2025 Second avenue.  
**Mobile**—The Ray Co., 54 Dauphin street.

## CALIFORNIA.

**San Francisco**—Peter Bacigalupi, 933 Market street.

## COLORADO.

**Denver**—Denver Dry Goods Co., 619 16th street.

## CONNECTICUT.

**Middletown**—Caulkins & Post Co., 406-408 Main street.  
**New Haven**—Pardee-Ellenberger Co., 155 Orange st.

## ILLINOIS.

**Chicago**—Oscar J. Junge, 245 E. Chicago avenue.  
 Kelley Cigar Co., 80-82 Wabash avenue.  
 James I. Lyons, 73 Fifth avenue.  
 The Ray Co., 90 Washington street.  
 Siegel-Cooper Co., State and Congress sts.  
 Talking Machine Co., 107 Madison street.  
 The Vim Co., 68 E. Lake street.  
 Montgomery Ward & Co., 111 Michigan ave  
**Peoria**—Peoria Phonograph Co., 314 S. Adams street.

## INDIANA.

**Indianapolis**—Kipp Bros. Co., 37 S. Meridian street.  
 The Ray Co., 234 Massachusetts avenue.  
 Wahl-Gaasch Co., 119 S Illinois street  
**Lafayette**—Wahl-Gaasch Co., 304 Main street.

## IOWA.

**Des Moines**—The Vim Co., 704 West Walnut street.

## KENTUCKY.

**Louisville**—The Ray Co., 640 Fourth avenue.

## LOUISIANA.

**New Orleans**—James I. Lyons, Theatre Arcade.  
 National Automatic Fire Alarm Co., 614  
 Gravier street.  
 The Ray Co., 111 Camp street.

## MAINE.

**Bangor**—S. L. Crosby Co., 186 Exchange street.  
**Portland**—W. H. Ross & Son, 207 Commercial street.

## MASSACHUSETTS.

**Boston**—Boston Cycle & Sundry Co., 48 Hanover street.  
 Eastern Talking Machine Co., 177 Tremont  
 street.  
 J. C. Haynes & Co., 451 Washington street.  
 Iver Johnson Sporting Goods Co., 163 Wash-  
 ington street.  
 Read & Read, 558 Washington street.  
**Fitchburg**—Iver Johnson Sporting Goods Co., 247 Main  
 street.  
**Lowell**—Ring Music Co., 112 Merrimac street.  
 Thomas Wardell, 111 Central street.  
**Worcester**—Iver Johnson Sporting Goods Co., 304 Main  
 street.

## MICHIGAN.

**Detroit**—American Phonograph Co., 106 Woodward  
 avenue.  
 Grinnell Bros. Music House, 219 Woodward  
 avenue.  
 The Ray Co., 168 Griswold street.  
**Saginaw**—Morley Bros.

## MINNESOTA.

**Minneapolis**—Thomas C. Hough, 714 Hennepin ave.  
**St. Paul**—Minnesota Phonograph Co., 37 E. 7th street.

## MISSOURI.

**Kansas City**—J. W. Jenkins' Sons Music Co., 1013-1015  
 Walnut street.  
 The Ray Co., 1021 Grand avenue.  
**St. Louis**—Conroy Co., 1115 Olive street.  
 The Ray Co., 923 Olive street.

## NEBRASKA.

**Lincoln**—H. E. Sidles Cycle Co., 1317 O street.  
**Omaha**—H. E. Fredrickson, 1502-1510 Capitol avenue.  
 Nebraska Cycle Co., 15th and Harney streets.

## NEW JERSEY.

**Hoboken**—Eclipse Phonograph Co., 205 Washington  
 street.  
**Newark**—A. O. Petit, New and Halsey streets.  
 H. J. Koehler Sporting Goods Co., 845 Broad  
 street.  
**Paterson**—James K. O'Dea, 117 Ellison street.  
**Plainfield**—Frank L. C. Martin Auto. Co., 810 Park  
 avenue.  
**Trenton**—Stoll Blank Book and Stationery Co., 30 E.  
 State street.

## NEW YORK.

**Brooklyn**—Chapman & Co., Fulton and Duffield streets.  
 A. D. Matthews' Sons, 394 Fulton street.  
 Price Phonograph Co., 1258 Broadway.  
**Buffalo**—P. A. Powers, 643 Main street.  
**Elmira**—Elmira Arms Co., 117 Main street.  
**Gloversville**—American Phonograph Co., 99 W. Fulton  
 street.  
**Kingston**—Forsyth & Davis, 307 Wall street.  
**New York City**—Barkeley & Co., 36 Vesey street.  
 Bettini Phonograph Co., 80 Chambers  
 street.  
 Blackman Talking Machine Co., 19  
 Beekman street.  
 J. F. Blackman & Son, 2654 3d avenue.  
 I. Davega, Jr., 802 Third avenue.  
 S. B. Davega, 32 E. 14th street.  
 Douglas & Co., 89 Chambers street  
 H. S. Gordon, 139 Fifth avenue.  
 Harry Jackson, 219 Bowery.  
 Jacot Music Box Co., 39 Union Square.  
 Victor H. Rapke, 1661 Second avenue.  
 Rosenfield Mfg Co., 587 Hudson st.  
 Siegel-Cooper Co., Sixth avenue and  
 18th street.  
 John Wanamaker, Broadway and  
 9th street.  
**Rochester**—A. J. Deninger, 347 North street.  
 Mackie Piano, O. & M. Co., 100 State street.  
 Talking Machine Co., 29 S. Clinton avenue.  
**Schenectady**—Jay A. Rickard & Co., 253 State street.  
**Syracuse**—W. D. Andrews, 216 E. Railroad street.  
**Troy**—James Lucey, 359-361 Fulton street.  
**Utica**—Clark, Horrocks Co., 54 Genesee street.

## OHIO.

**Canton**—Klein & Heffelman Co., 216 N. Market street.  
**Cincinnati**—Ilsen & Co., 25 W. 6th street.  
 The Ray Co., 143 West 5th street.  
 Wahl-Gaasch Co., 47 W. 5th street.  
 W. J. Roberts, Jr., 254-256 Arcade.  
**Columbus**—Perry B. Whitsit Co., 213 S. High street.  
**Dayton**—Niehaus & Dösche, 35 E. 5th street.  
**East Liverpool**—Smith & Phillips Music Co.  
**Toledo**—Hayes Music Co., 608 Cherry street.

## PENNSYLVANIA.

**Allegheny**—Henry Braun, 500 Federal street.  
**Allentown**—G. C. Aschbach, 539 Hamilton street.  
**Easton**—William Werner, 401 Northampton street.  
**Philadelphia**—C. J. Heppe & Son, 1117 Chestnut street.  
 Lit Bros., Market and 8th streets.  
 Penn Phonograph Co., 19 S. 9th street.  
 John Wanamaker.  
 Wells Phonograph Co., 41 N. 9th street  
 Western Electric Co., 931-933 Market  
 street.  
 H. A. Weymann & Son, 923 Market  
 street.  
**Pittsburg**—Theo. F. Bentel Co., Inc., 433 Wood street.  
 Kaufmann Bros., Fifth avenue and Smith-  
 field street.  
 H. Kleber & Bro., 221 Fifth avenue.  
 C. C. Mellor Co., 319 Fifth avenue.  
 Pittsburg Phonograph Co., 937 Liberty  
 avenue.  
**Reading**—Reading Phonograph Co., 809 Penn street.  
**Scranton**—Ackerman & Co., Coal Exchange Building.  
 Technical Supply Co.

## RHODE ISLAND.

**Providence**—J. M. Dean Co., 785-795 Westminster street.  
 J. A. Foster Co., Weybosset and Dor-  
 rance streets.  
 Household Furniture Co., 231-237 Wey-  
 bossett street.  
 Murray, Blanchard, Young & Co., 26-30  
 Pine street.  
 A. T. Scattergood & Co., 106-110 N. Main  
 street.

## TENNESSEE.

**Memphis**—The Ray Co., Lyceum Building, 2nd and  
 Jefferson streets.  
**Nashville**—The Ray Co., 30 The Arcade.

## TEXAS.

**Dallas**—C. B. Harris, Agt., 347 Main street.

## VIRGINIA.

**Richmond**—The Ray Co., 729 E. Main street.

## WISCONSIN

**Milwaukee**—McGreal Bros., 173 3d street.

## CANADA.

**Toronto**—R. S. Williams & Sons Co., Limited, 143  
 Yonge street.



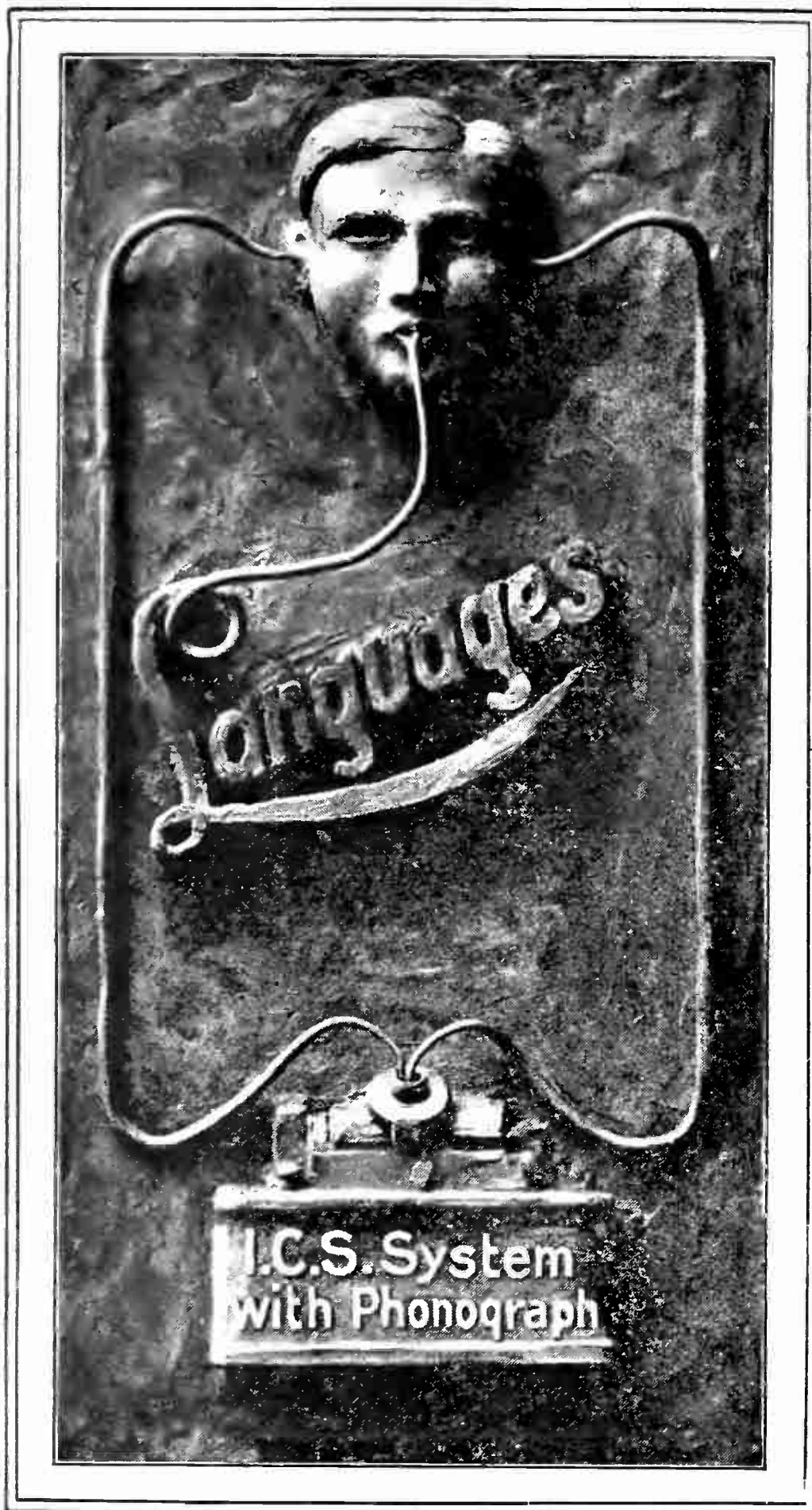

## Equip Yourself for Double Service

We will furnish any Edison dealer with I. C. S. literature and a demonstrating outfit consisting of 3 moulded Records with I. C. S. Textbooks in French, German, Spanish, delivered prepaid in the United States and Canada for

**\$1.50**

### Apply to the Following Jobbers of I. C. S. Outfits

PORTLAND, ME., W. H. Ross & Son  
 LOWELL, MASS., Thomas Wardell  
 BOSTON, MASS., Eastern Talking Machine Co.  
 BOSTON, MASS., J. C. Haynes & Co.  
 BOSTON, MASS., Boston Cycle & Sundry Co.  
 NEW HAVEN, CONN., Pardee-Ellenberger Co.  
 PROVIDENCE, R. I., Murray, Blanchard, Young & Co.  
 KINGSTON, N. Y., Forsyth & Davis  
 SYRACUSE, N. Y., W. D. Andrews  
 NEW YORK CITY, Blackman Talking Machine Co.  
 NEW YORK CITY, I. Davega, Jr.  
 NEW YORK CITY, Douglas & Co.  
 NEW YORK CITY, Jacot Music Box Co.  
 NEW YORK CITY, John Wanamaker  
 NEWARK, N. J., The Edison Co.  
 PLAINFIELD, N. J., F. L. C. Martin Automobile Co.

PHILADELPHIA, PA., Wells Phonograph Co.  
 EASTON, PA., William Werner  
 BUFFALO, N. Y., P. A. Powers  
 ROCHESTER, N. Y., Talking Machine Co.  
 COLUMBUS, OHIO, Perry B. Whitsit Co.  
 DAYTON, OHIO, Niehaus & Dohse  
 CHICAGO, ILL., O. J. Junge  
 CHICAGO, ILL., James I. Lyons  
 MILWAUKEE, WIS., McGreal Bros.  
 MINNEAPOLIS, MINN., Thos. C. Hough  
 OMAHA, NEB., Nebraska Cycle Co.  
 KANSAS CITY, MO., J. W. Jenkins' Sons Music Co.  
 ST. LOUIS, MO., The Conroy Co.  
 TORONTO, CAN., R. S. Williams & Sons Co.  
 SAN FRANCISCO, CAL., Peter Bacigalupi  
 NINETEEN STORES, The Ray Co.

# EDISON Phonograph Monthly

PUBLISHED FOR TRADE USE ONLY BY  
THE NATIONAL PHONOGRAPH CO.

VOL. II.

NEW YORK, APRIL, 1904.

No. 2.

## *The National Phonograph Co.,*

ORANGE, N. J.

NEW YORK: 83 CHAMBERS STREET.

CHICAGO: 304 WABASH AVENUE.

SAN FRANCISCO: 933 MARKET STREET.

NATIONAL PHONOGRAPH CO., LTD., 25 CLERKENWELL  
ROAD, LONDON, ENG.

## EDISON PHONOGRAPHS AND RECORDS.

All communications to THE PHONOGRAPH MONTHLY should be addressed to the Advertising Department, 83 Chambers Street, New York.

### C O N T E N T S

The Trade .....	1
Advance List of Edison Gold Moulded Records for May.....	2
Plans for Carrying Records.....	3
More British Selections.....	4
Record Playing by Telephone.....	4
Printed Matter .....	4
He Changed His Views.....	5
Record Shipments.....	5
Personal .....	5
The I. C. S. Display Rack .....	5
No Longer Antagonistic.....	6
Numbers for Record Stocks.....	6
A Phonograph Address.....	6
To Also Make Masters in New York.....	7
Not an American Tree.....	7
Comments on May Records.....	8
A Record Incident.....	9
Dealers, Read This!.....	10
A Historic Record.....	10
My Phonograph.....	10
Final Decrees in the Wittmann Cases.....	11
Injunctions Against Price Cutting.....	12
Suspended List.....	13
Jobbers of Edison Phonographs and Records	14
A Striking Comparison.....	15

## THE TRADE.

There is practically nothing new to say concerning the conditions of trade in Edison Phonographs and Edison Gold Moulded Records. Jobbers and Dealers everywhere report that business is excellent, and their reports are borne out by the orders being received and by the weekly output from our factory. Trade is better than Jobbers and Dealers expected, because for a time it was feared that the introduction of a cheap record might affect the sale of the Edison Gold Moulded Record. Now that experience has shown that such is not the case, a better feeling prevails, and less attention is being paid to the cheap record complication. It was predicted in these columns six months ago that the public would soon find out the difference between Edison Records and the imitation product, and time has shown the correctness of the prediction. No one disputes the claim that many cheap records are being sold, but they have created their own market and are being bought solely because of their price. The demand for Edison Gold Moulded Records remains unchanged. They are still eagerly sought by thousands of music loving owners of Phonographs, who regard the best obtainable as none too good. To supply this demand the output of Records at our factory is the largest in its history. Nor is there any doubt in any one's mind that this demand will continue to grow as it has grown since the National Phonograph Co. was organized.

This Company has never attempted to restrain a Dealer from handling other styles of talking machines or records. It has held to the belief that Edison Phonographs and Records would hold their own in comparison with any other kind sold and has been willing that Dealers should add to their profits by supplying the demand that other companies

(Continued on page 3.)

THE ADVANCE LIST OF MAY RECORDS APPEARS ON PAGE 2. ORDER FROM IT. NO OTHER ADVANCE LIST WILL BE ISSUED.



# ADVANCE LIST OF NEW EDISON GOLD MOULDED RECORDS FOR MAY, 1904

RECORDS listed below will be ready for shipment as near May 1st, as possible, at which time Jobbers' stock orders, if placed prior to April 15th will be shipped. May Supplements will be forwarded to Jobbers with their stock order for Records. Retail Dealers should place stock orders with their Jobbers at once, to insure prompt shipment as soon as Jobbers' stock is received.

- |      |  |  |
|------|--|--|
| 8674 | Fashion Plate March  | Edison Military Band                   |
| 8675 | Cordalia Malone<br><i>Irish waltz song with orchestra accom. from "Glittering Gloria"</i>  | Edward M. Favor                        |
| 8676 | My San Domingo Maid<br><i>Song hit from "The Yankee Consul," with orchestra accompaniment</i>  | Harry MacDonough                       |
| 8677 | You're the Flower of My Heart, Sweet Adeline<br><i>Tenor and baritone duet with orchestra accompaniment</i>  | Albert Campbell and<br>Fred'k Harrison |
| 8678 | Pop Goes the Weasel Medley<br><i>Violin solo with orchestra accompaniment, introducing "Pop Goes the Weasel," "Irish Washerwoman," "Tempest," "Speed the Plow," "Miss McCloud's Reel," and "D'Almaine's Favorite Reel"</i> | Charles D'Almaine                      |
| 8679 | Good-bye, Fedora<br><i>Comic Italian dialect male duet with orchestra accompaniment</i>  | Collins and Harlan                     |
| 8680 | In the Days of Old<br><i>Comic song, as sung by Raymond Hitchcock in "The Yankee Consul," with orchestra accompaniment</i>   | Bob Roberts                            |
| 8681 | Yaller Gal<br><i>An old time coon song</i>   | Billy Golden                           |
| 8682 | The Roses' Honeymoon (Reverie)   | Edison Symphony Orchestra              |
| 8683 | The Man in the Overalls<br><i>Song by the composer of "A Little Boy in Blue," with orchestra accompaniment</i>   | Byron G. Harlan                        |
| 8684 | Good-Bye, My Lady Love<br><i>Sentimental song with orchestra accompaniment</i>   | Harry MacDonough                       |
| 8685 | The Gondolier<br><i>Venetian love song with orchestra accom.</i>   | Arthur Collins                         |
| 8686 | The Irish, The Irish<br><i>Comic song with orchestra accompaniment</i>   | Edward M. Favor                        |
| 8687 | Dance of Honeybells  | Edison Military Band                   |
| 8688 | I'll do the Same for You<br><i>Descriptive march with orchestra accompaniment</i>  | Byron G. Harlan                        |
| 8689 | That is a Habit I Never Had<br><i>Coon song with orchestra accompaniment</i>   | Billy Murray                           |
| 8690 | California Minstrels<br><i>Introducing the ballad "I'm Going Home to Clo," sung by Harry MacDonough</i>  | Minstrels                              |
| 8691 | He Done Me Wrong (or the Death of Bill Bailey)<br><i>Coon song with orchestra accompaniment</i>  | Arthur Collins                         |
| 8692 | Down South (An American sketch composed in England)<br><i>Banjo solo with orchestra accompaniment</i>  | Vess L. Ossman                         |
| 8693 | What I Heard at the Vaudeville<br><i>Introducing Gus Williams' German dialect recitation, "Only a Lock of Hair," with orchestral embellishment</i>   | Len Spencer                            |
| 8694 | Idle Moments (Entr' Acte)  | Edison Symphony Orchestra              |
| 8695 | Nancy Lee<br><i>March song, male duet with orchestra accompaniment</i>   | Harlan and Stanley                     |
| 8696 | On a Good Old Trolley Ride ("Out With My Pearlie, My Steady Young Girlie")<br><i>A new summertime waltz with orchestra accompaniment</i>   | William M. Redmond                     |
| 8697 | 'Possum Pie (or the Stuttering Coon)<br><i>Coon song male duet with orchestra accompaniment</i>  | Collins and Harlan                     |
| 8698 | Turkey in the Straw Medley<br><i>Introducing "Turkey in the Straw," "Blue Bell," "In Zanzibar," "The Man Behind," and "General Hardtack—on Guard"</i>  | Edison Military Band                   |

Edison Gold Moulded Records are made only in Standard size. Both Standard and Concert Records may be ordered from this list. Order by Number, not title. If Concert Records are wanted, give the number and letter C.

(Continued from page 1.)

might create for their product. It is not pleasant, however, to have Dealers tell us that if it were not for Edison Phonographs and Records they could not remain in the business. They call or write apologetically in about this way: We handle cheap records simply because some of our customers want them—customers who do not care about quality so long as they can get the air of a song or instrumental selection. These customers admit that they are inferior and do not last as long, but say that they are good enough for their purpose. We feel compelled to carry a line for this reason, say the Dealers, but we don't make any money on them. The usual losses and the time it takes to play them eat up the margin of profit. If we did not do a profitable Edison business we could not sell them at all, and if Edison Records were sold at the same price we could not continue in the business.

This is about the tenor of the Dealers' apologies. Pleasant, isn't it, to have Dealers tell us that they must make money on our goods in order to be able to sell a cheaper product that yields them nothing.

As a matter of fact, these Dealers are wrong in believing that they must meet the demand for cheap records, and they are following a policy that is injuring instead of helping their business.

If their customers found that they did not carry cheap records, they would, in most instances, buy Edison Records, particularly when the difference in quality was properly explained to them. Many of our Dealers who have not put in a line of cheap goods state that such is the case with them. Once in a while a customer will refuse to pay the price for Edison Records and go elsewhere for cheaper ones, but most of them yield to argument and buy a Record that will always be a pleasure to them and give the Dealer a profit for his trouble.

The idea of selling something cheap or at a bargain price is all very well for a department store, but it will not be a success in the talking machine business. When the business is conducted on the same lines it will cease to be profitable. The salvation of the entire talking machine business to-day depends upon the National Phonograph Co. doing everything in its power to uphold prices. No one recognizes this more fully than the manufacturers of disk goods. Their greatest concern is that this company will cut its price on Records to meet the price of the cheaper product. Of all people in the business they are the most

anxious that we shall not do it. They know that if Edison Records are ever reduced in price it will bring down the price of disk goods to the same level, and the whole talking machine trade will suffer. Dealers especially will see their profits diminish.

The National Phonograph Co. has no doubt as to its ability to win out against any competition and to solve in its own way whatever difficulties may arise, but it does believe that it is the plain duty of every one in the talking machine business, whether manufacturer, Jobber or Dealer, and whether selling cylindrical or disk goods, to do everything that he can to maintain the present selling price of Edison Records. There never was a more short-sighted move in the history of the talking machine business than the putting out of a record at twenty-five cents. Time will prove this to every one's satisfaction. And the more that is done to discourage its sale the better it will be for the entire trade, including the manufacturers of the record under discussion.

We commend the subject to the thoughtful consideration of every enterprising Dealer.

The Kaiser has composed an essay on Frederick the Great, to be recited from a Phonograph at the prospective unveiling of the warrior King's statue in Washington, D. C.

#### PLANS FOR CARRYING RECORDS.

Charles B. Keim, a Dealer at Louisville, Ohio, sends a description of his plan of carrying his Record stock. He has a series of shelves  $7\frac{1}{2}$  inches apart and 7 inches deep. He then prints a special label,  $2\frac{3}{8} \times 4$  inches, one of which he puts on every carton. He has one color for band Records, another for orchestra, etc. In the upper part of each label he writes in the number and title of the Record. He then puts all band Records together, all orchestras on another shelf, etc. Mr. Keim only carries in stock what he considers the best selections and claims that his plan enables him to find any title readily or to quickly determine that it is not on hand.

J. S. Bowen & Co., Dealers at Cobourg, Ont., send the programme of a concert held in the local opera house on March 17, in which they furnished music with an Edison Phonograph between the two parts of the programme. Thirteen Records were played with great success.



**MORE BRITISH SELECTIONS.**

Twenty-eight new British selections of Edison Gold Moulded Records are listed herewith. They are placed before the trade principally because they will appear in the next edition of our catalogue of Foreign selections. Orders for any of them will be filled after April 1 and shipped with April Records. If there are sufficient requests for a special supplement of these Records, one will be issued for general circulation. An expression of opinion in the matter of a supplement is asked from Jobbers\*

- 12864 **Coronation Prize March**  
H. M. Grenadier Guards Band
- 12865 **Selection, "The Girl From Kays"**  
H. M. Grenadier Guards Band
- 12866 **Selection, "My Lady Molly"**  
H. M. Grenadier Guards Band
- 12867 **Overture to Zanetta** British Military Band
- 12868 **Life's Lullaby** Hamilton Hill
- 12869 **Jock O'Hazeldean** Thomas Reid
- 12870 **There's Nae Luck About the Hoose**  
Thomas Reid
- 12871 **That Old Sunny Window** Leonard Mackay
- 12872 **The Beef Eater (Dan Leno)** Fred T. Daniels
- 12873 **The Lecturer (Dan Leno)** Fred T. Daniels
- 12874 **The Jilted Shoeblick (Gus Elen)**  
Albert Whelan
- 12875 **Under the Deodar (From "Country Girl")**  
Miss Octavia Barry
- 12915 **Selection of Popular Songs—No. 4**  
British Military Band
- 12916 **Selection from "Belle of New York" No. 1**  
British Military Band
- 12917 **Boys of the Old Brigade**  
British Military Band
- 12918 **Overture to William Tell**  
British Military Band
- 12919 **Comin' Thro' the Rye (Scotch Song)**  
Thomas Reid
- 12920 **Charlie is My Darling (Scotch Song)**  
Thomas Reid
- 12921 **Girl Wanted There (George Lashwood)**  
Leonard Mackay
- 12922 **Good-Bye, Mignonette** Leonard Mackay
- 12923 **'E Grumbles (Gus Elen)** Albert Whelan
- 12924 **Mrs. Carter (Gus Elen)** Albert Whelan
- 12925 **I'll Sing thee Songs of Araby** Wilfred Virgo
- 12926 **The Miller's Daughter (from "Three Little Maids")** Miss Octavia Barry
- 12927 **Sons of the Brave March**  
British Military Band
- 12928 **Overture to Rienzi** British Military Band
- 12929 **Oh Dry Those Tears** Miss Octavia Barry
- 12930 **Bid Me to Love** Hamilton Hill

**AN ADVERTISING AUTO.**

A. O. Petit, Jobber at Newark, N. J., has a fine outdoor advertisement in an Oldsmobile runabout. He has constructed a box to represent a large Phonograph, which takes the place of the rear seat. This box is used as a receptacle for packages to be delivered. It has a huge gilt horn attached to it and the entire outfit is appropriately lettered for advertising purpose. Mr. Petit claims that as an advertising medium his auto ranks first.

**RECORD PLAYING BY TELEPHONE.**

"I notice many comments in regard to playing into a telephone," writes F. M. Barney, of Elm Creek, Neb. "I have long done the same. My method is to place Phonograph just under transmitter and put speaking tube on Phonograph, bending it up and fastening same to mouthpiece of transmitter with rubber bands. It is a perfect success. Also notice references on how to get correct speed. I take watch and adjust Phonograph so that mandrel will make thirteen revolutions in five seconds. This is quick and easy."

A. R. Quick, of Amityville, N. Y., writes: "There seems to be quite a number of ways to play the Phonograph over the telephone. Last night I took the receiver off the hook while the Phonograph was going and people on the line ten miles away say they could hear it. My telephone is twenty-five feet away from the Phonograph. The best way to play it so that people on the other end can hear it all over a small room, is to get a speaking tube and a mouthpiece for the transmitter. Put the mouthpiece of the transmitter in the mouth piece of the speaking tube and seal them with sealing wax. To play unscrew the mouthpiece on your telephone, screw on the one you have made and put Phonograph on other end. Record No. 8577, by Miss Morgan and Mr. Stanley, is a very fine one to hear over the telephone."

**PRINTED MATTER.**

The folder referred to in the March issue of the PHONOGRAPH MONTHLY as No. 535 should have been No. 540. No. 535 is another folder showing the four popular types of the Edison Phonograph on the inside pages and designed to succeed Form No. 414. Sample copies will shortly be sent out to the trade.

The new Catalogue of Domestic Record titles, Form No. 545, is now being used to fill all orders for Record catalogues. Copies will be mailed at the first opportunity. This catalogue has a much more attractive cover than any Record Catalogue issued by us in some time. It is printed in purple, green and gold. This catalogue contains all Records listed to and including March, 1904.

Among the most persistent advertisers of Edison Phonographs and Records is William H. Kellar, Scranton, Pa. He runs a double half column advertisement in three daily papers of his city almost constantly. It is no coincidence that he does a large and constantly increasing business in Edison goods.



**HE CHANGED HIS VIEWS.**

"I want to buy an Edison Phonograph," said a resident of Gloversville, N. Y., to the manager of the American Phonograph Company at that place, one day recently. "I will say frankly that a talking machine is about the last thing I ever expected to own. But I've changed my views, and I'll tell you why. My wife and I called at a friend's house last night and he brought out his Phonograph. It was an Edison machine, of course, although at the time I did not know what make it was and cared less. I said to my wife quietly, 'We'll stand this for a little while and then go home.' I had heard scratchy and harsh sounding talking machines and hated them cordially. It never occurred to me that there could be any other kind. Before my friend had finished the second Record I realized that I had not kept up to the improvements to the Edison Phonograph, and in fifteen minutes my wife and I were delighted with Phonograph music. Instead of leaving in a half hour, we stayed till 11 o'clock. My friend played all of the twenty-four Records that he had, and we insisted upon hearing most of them a second time. I decided then that I would buy an outfit at once." He did and is now one of the best Record customers of the American Phonograph Company. Nor will he have anything but Edison Gold Moulded Records.

**DEALERS' LETTERS.**

Interesting letters have been received from the following Dealers, lack of space making it impossible to publish them: John E. Finney, Savannah, Ga.; James Lawless, Millville, N. J.; Walter I. Prentiss, Worcester, Mass.; Herman Paetzell, Upper Black Eddy, Pa.; Willard L. Lathrop, Northport, Me.; John S. Smith, Philadelphia; Vaclav Kubes, West Hoboken, N. J.; W. C. Jones, Hammonton, N. J.; Amusement Machine Company, Green Bay, Wis.; C. W. Stokes, Byesville, O.; J. D. Kissenger, Tower City, Pa.; Howell & Boyer, Burlington Junction, Ind.; F. D. Stelzer, Frankfort, Mich.; Albert Palmer, Garrett, Ind.; J. F. Schaeberle, Ann Arbor, Mich.; C. T. Underwood, Weldon, N. C.; M. A. Hirdler, Kinsley, Kas.; Winfield S. Fisk, Philadelphia, and others.

**RECORD SHIPMENTS.**

A gain of five days was made in shipping March Records over the February shipments. It is hoped to do as well with the April Record shipments.

**PERSONAL.**

William E. Gilmore, President and General Manager of the National Phonograph Company, and Mrs. Gilmore, will sail for England on April 6 to be absent about two months.

L. Kaiser, well known in the Phonograph trade of the East, has been engaged by S. B. Davega, of Twenty-second street, New York, to manage the jobbing end of his Phonograph business.

E. B. Walthall, formerly with the Ray Company in Chicago, has been engaged as salesman by the National Phonograph Company. His first work for the company will be in the South.

Among recent visitors to the New York office of the National Phonograph Company from out of town were: C. A. Ray, Louisville, Ky.; George Ilsen, Cincinnati, O.; W. O. Pardee, New Haven, Conn.; J. A. Rickard, Schenectady, N. Y.; P. A. Powers, Buffalo, N. Y.; N. D. Griffin, American Phonograph Company, Gloversville, N. Y.; J. M. Linscott, Boston Cycle and Sundry Company; E. H. Dakin, S. L. Crosby Company, Bangor, Me.; W. H. Beck and E. F. Taft, Eastern Talking Machine Company, Boston; G. L. Ackerman, Ackerman & Company, Scranton, Pa.

**THE I. C. S. DISPLAY RACK.**

This is an illustration of the I. C. S.'s Display Rack offered free with sample language lessons on the back cover of this issue.

Besides holding the printed language lessons these racks would be useful to display the Edison bulletin or sheet music with words of a popular song played on the Phonograph.

The rack is detachable and fits securely in the cover clamps, and presents an attractive appearance.

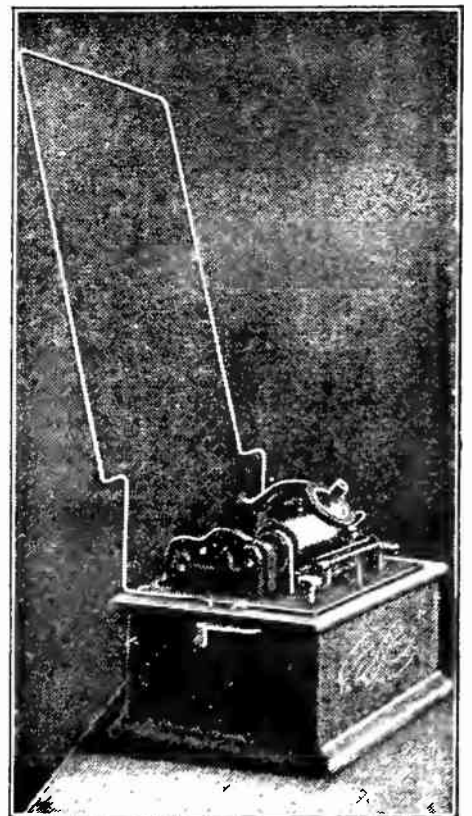
**UP TO DATE.**

The harp that once through Tara's halls  
The soul of music shed  
Is silent, for the Phonograph  
Now turns out tunes instead.

—Toronto Saturday Night.

### NO LONGER ANTAGONISTIC.

O. C. Thompson, a Dealer at New Albany, Ind., and also a member of Local No. II, of Louisville, Ky., American Federation of Musicians, writes that all professional musicians of his acquaintance now admit that the introduction of the Phonograph has increased the business of the professional musicians. The antagonistic feeling has given place to one of cordial approval. It has been found that the Phonograph has created a demand for popular songs and airs at dances and social affairs that only professional musicians can supply. There is such a variety of this popular music that the self-taught amateur, who plays by ear, cannot keep pace with it.

The National Phonograph Co. has seen a similar change of heart among musical people. At one time music publishers were in doubt as to whether or not they would permit the reproduction of their music on Phonograph Records. They are now convinced that it helps their business greatly. One publishing firm had a demonstration of this kind that won them completely. As a sort of test they furnished our Record Department with advance sheets of a coming song production, and our Record appeared almost immediately after the publication of the song. The firm at once began to get orders for sheet music of the song from all parts of the country, proving beyond a doubt that it had been caused by the sale of our Record. As a result, publishers of popular music are not only willing but anxious to have their compositions used for Record making purposes. Thousands of people who do not own a Phonograph or other style talking machine get their first knowledge of the attractiveness of a song or instrumental selection by having it played in this way, and buy sheet music in consequence.

### MORE APPROPRIATE.

A delay occurred early on a recent evening, and a long string of cars were stalled on Broad street between Orange street and Washington place for about ten minutes. A dealer in Phonographs on the east side of Broad street opened his front door and directed a big brass horn at one of the cars. The record he selected for the occasion was "Home, Sweet Home." The music was plainly heard on several of the cars, and an impatient girl remarked: "That man has a fine sense of humor, but why didn't he select 'We Won't Go Home 'Till Morning'?"—*Newark (N. J.) Sunday Call*, March 6, 1904.

### NUMBERS FOR RECORD STOCKS.

Many Dealers have at one time or another felt the need of good-sized and clearly printed figures with which to number their Record racks or shelves, but the cost of having a set printed or painted has been too heavy to consider. Victor C. Rapke, Jobber at 1661 Second avenue, New York, has set out to supply this want. Several of his Dealers wanted sets of numbers of this kind, and Mr. Rapke, believing that many others would also be glad to have them, decided to print a sufficient number of sets to supply his own and any other Dealers that might want them. These numbers are five-eighths of an inch high and

# 980

Size of letters.

can easily be read twenty-five or more feet away. They are printed on gummed paper,  $\frac{5}{8} \times 2\frac{1}{2}$  inches in size, and will be perforated. They are to be sold in sheets at \$1.50 for the entire set of about 2,200 numbers. The numbers will correspond to those in the catalogues of Edison Gold Moulded Records, with enough additional to last for Records that may be listed during the next six months. A discount on this price will be allowed to Jobbers. Since the getting out of these numbers is not a money making venture, Mr. Rapke states that money must accompany all orders. The trade is asked to correspond with Mr. Rapke on the matter.

### A PHONOGRAPH ADDRESS.

A novel and interesting feature of the annual meeting of the Credit Men's Association, of Grand Rapids, Mich., on March 15, was an address by William A. Prendergast, Secretary of the National Association of Credit Men, delivered by means of an Edison Phonograph. Mr. Prendergast was unable to attend in person and conceived the idea of talking to a Phonograph and sending the Records to Grand Rapids. He enlisted the interest of F. K. Dolbeer, manager of our Credit Department, who arranged to have the Records made at the Edison Laboratory. Mr. Prendergast's remarks filled four cylinders. The latter were forwarded to Grand Rapids and were enthusiastically received when played by the Credit Men's Association. All who know Mr. Prendergast easily recognized his voice. The Records were clear and distinct and plainly heard by every one present.



## TO ALSO MAKE MASTERS IN NEW YORK.

The National Phonograph Company has established a new plant for making Master Records at 65 to 69 Fourth avenue, New York. This is in addition to its present quarters at the Edison Laboratory, Orange, N. J. The new place is on the top floor and occupies the entire floor. It has been fitted up in the most complete manner and with the most approved apparatus and appliances for Record making. This move is the natural result of the determination of this company to leave nothing undone that will add to the popularity of Edison Gold Moulded Records. With this New York plant it will be possible to keep in the closest touch with the musical and theatrical world, upon which Record making depends for many of its artists. It is expected from time to time to make many additions to the "talent" because of the greater facilities afforded those desirous of making a name in the Phonograph world. Possession of the new quarters dates from April 1.

### JOBBER, ATTENTION!

**Jobbers will confer a favor by sending us from time to time the names of any Dealers whom they know are no longer selling Edison goods. Please look over your lists NOW and see if any of yours are out of business.**

### DOWN EAST HUSTLERS.

LYNN, MASS., March 8, 1904.

Under separate cover we mailed you copy of *Lynn Item*, dated March 7. Our "ad." speaks for itself. We are pushing Edison goods, *first, last and all the time.*

While we have some annoyance from our local competitors who are forcing the "Scratch Records" for any old price to the public, we find that those very "Scratch Records" find their way to our establishment in a very short time to be exchanged for an Edison 50c. Record. Within four weeks we have accumulated over two barrels full of traded "Scratch Records," for which we shall find a suitable dumping ground.

From time to time we are annoyed by another company with undesirable literature, threats and other annoying matter. As a rule such matter finds its way side by side with those "Scratch Records."

MENDLOW BROS.

### SEEMS LIKE AN INJUSTICE.

CONYERS, GA., March 17, 1904.

As we see no need of cutting prices on Edison goods, you may depend on us upholding prices. We have a few of the ——— records in stock which we are offering at fifteen cents each, but after a customer hears an Edison Gold Moulded we cannot very often induce him to take a ——— at any price, and we feel like we are doing our customers an injustice when we sell him one at all.

J. J. LANGFORD & SONS.

## TRADE ADVERTISING PHRASES.

For home entertainment and for music-loving people the Edison Phonograph has never been equalled, either in quality or in price.—*Ackerman & Co., Prairie City, Ill.*

When any advertiser tells you that the discarded records made for machines that were discontinued years ago are equal to the improved Edison Gold Moulded Records—it is ignorance that is talking. An advertiser should become familiar with what he is trying to sell.—*J. A. Foster & Co., Providence, R. I.*

The Edison Phonograph and the Edison Gold Moulded Records stand for First Quality.—*Penn Phonograph Co.*

## AN INVITATION IN RHYME.

Here's how the H. E. Sidles Cycle Co. of Lincoln, Neb., extended an invitation to its patrons to hear the February Records played:

*Dear Friend:*

A Phonograph Concert will be given for you, Our February Records are novel and new. Hear Harry MacDonough sing "Dear Old Girl,"

Make no mistake; this is a pearl. If you like something semi-morose, Hear our Phon' play for you, "The Bridal Rose."

"Marching Thro' Georgia" you all know is fine,

And also the song, "I Ain't Got No Time."

If you miss this you'll miss very much,

As we surely will spiel, "It Was the Dutch."

March 2d, thirty minutes of eight,

Sidles will give you this treat,

So do not be late.

## NOT AN AMERICAN TREE.

James H. White, manager of the National Phonograph Co., Ltd., London, under date of February 26, sends the following amusing incident:

I was running through yesterday some Records from the January supplement (which Records, by the way, are without doubt the finest I have ever listened to), and one of our largest factors from Manchester, England, happened to be in our show room. We were running the song "Under the Anheuser Bush." Our client, Joseph Richardson, was very much impressed with the Record, indeed, and, after listening to it intently, made the request that we play it a second time. We did this, and noticed that he paid particular attention to the words. When the song had finished he turned to me with rather a puzzled expression and said:

"I say, old chap. I always thought the Anheuser Bush was some particular sort of tree that grew in America."

When I explained to him that the Anheuser Busch was a very particular brand of American beer it created a great laugh, as we had several English people in at the time.



**COMMENTS ON MAY RECORDS.**

The May list of new Edison Gold Moulded Records contains more than the usual number of popular selections—songs and instrumental music that will soon be sung or played everywhere. In character the entire twenty-five selections are fully up to the Edison standard and a credit to the Record Department at the Edison Laboratory. The following necessarily brief comments do not in any case do justice to either the composition or the talent making the Record.

No. 8674, "Fashion Plate March," is a composition by W. P. English. It has an excellent and pleasing march air and is splendidly recorded by the Edison Military Band.

No. 8675, "Cordalia Malone," is one of the Irish waltz songs now so popular throughout the country. It is one of the features of the comic opera success "Glittering Gloria." It is sung by Edward M. Favor, with orchestra accompaniment, and is the first Record by Mr. Favor that we have had the pleasure of listening to in some time. He sings better than ever, and this Record cannot fail to add to his Phonographic popularity. The words of "Cordalia Malone" were written by William Jerome, and the music by Jean Schwartz.

No. 8676, "My San Domingo Maid," is one of the song hits from the "Yankee Consul," which was one of the most successful productions of the recent New York season. Harry MacDonough is the maker of this Record, and his fine voice and clear enunciation make it a most desirable addition to our list. This Record has an orchestra accompaniment. Henry N. Blossom, Jr., wrote the words of this song, and Alfred G. Robyn the music.

No. 8677, "You're the Flower of My Heart, Sweet Adeline," is a duet of unusually good quality. It is made by a new duet team, composed of Albert Campbell and Frederick Harrison. Mr. Campbell's tenor voice is too well known to need comment. Mr. Harrison has a noble baritone voice that will be much admired by all who hear this Record. Their voices blend perfectly in the chorus. The orchestra accompaniment adds much to the quality of the Record. The words of this song were written by Albert H. Gerard, and the music by Harry Armstrong.

No. 8678, "Pop Goes the Weasel Medley," is a violin solo, with orchestra accompaniment, by Charles D'Almaine. It introduces "Pop Goes the Weasel," "Irish Washerwoman," "Tempest," "Speed the Plow," "Miss McCloud's Reel" and "D'Almaine's Favorite Reel." As the name implies, this is a Record of just plain, old-fashioned violin music. We were induced to make it because of a repeated demand from the trade and from individuals in various parts of the country for a violin Record of this character. It is played in dance tempo and will be an excellent Record for a Virginia Reel or other dances of the same kind. We expect this Record to be a great seller.

No. 8679, "Good Bye, Fedora," is a comic Italian dialect duet by Collins and Harlan, and is sung with orchestra accompaniment. It introduces these two well-known singers in an entirely different role. Mr. Collins' Italian dialect is as good in its way as anything he has done in coon songs. It is an extremely funny selection. The words of this song were written by Harry Williams, and the music by Robert Adams.

No. 8680, "In the Days of Old," is the song with which Raymond Hitchcock made such a success in the "Yankee Consul." The air of this song was played by the orchestra upon the raising of the curtain, between the acts and as the audiences left the theatre at each presentation of this opera. By the time this Record is ready for the public this song will be widely known. Our Record is made by Bob Roberts, who sings it with excellent voice and distinct enunciation. Henry M. Blossom, Jr., wrote the words of this song, and Alfred G. Robyn the music.

No. 8681, "Yaller Gal," is another of Billy Golden's old-time coon songs. It needs no further comment than to say that it is made in Mr. Golden's inimitable style. The feature of the Record is Mr. Golden's laugh, and the listener cannot fail to be infected, unless too dyspeptic to laugh at anything.

No. 8682, "The Roses' Honeymoon" (a reverie), is a charming Record by the Edison Symphony Orchestra. Its music is somewhat classical in character; is delicate and refined, and cannot fail to meet the approval of all who admire Records of a better class of music. This composition is a credit to its composer, John W. Bratton.

No. 8683, "The Man in the Overalls," is a Record sung by Byron G. Harlan, with orchestra accompaniment. This song was written by Raymond A. Browne, the composer of "A Little Boy in Blue," and will certainly be well known everywhere in a short time. As its name indicates, it is a tribute to the workman. Mr. Harlan sings the selection finely.

No. 8684, "Good Bye, My Lady Love," is a sentimental song by Harry MacDonough, with orchestra accompaniment. Joseph E. Howard wrote both the words and the music. The air is extremely pleasing, and Mr. MacDonough sings it in a finished manner.

No. 8685, "The Gondolier," is a Venetian love song which was listed as a band selection in March. In making this Record Arthur Collins shows how versatile are his accomplishments as a singer. He has made so many good Records of coon songs that the public may have gained the impression that his best work was along that line. This will show, however, that he is equally good in others. "The Gondolier" is a charming and popular selection, and this Record is a fine one in every respect. Harry H. Williams wrote the words of the song, and W. C. Powell the music.

No. 8686, "The Irish, The Irish," is another selection by Edward M. Favor, who excels in Records of this character. This is a comic song with orchestra accompaniment, and tells

how the Irish set the pace for the rest of the world. An unusual feature of the Record is that it contains three verses and three choruses. This song is the work of Farrell and Trantzen.

No. 8687, "Dance of the Honeybells," is an attractive Record by the Edison Military Band. The music of the bells is a feature, but it is much less prominent than usual and not at all of a solo character. The music throughout is pleasing, and the Record artistically made. Simone Mantia is the writer of this composition.

No. 8688, "I'll Do the Same for You," is a descriptive march song by Byron G. Harlan, with orchestra accompaniment. The music is full of life, and Mr. Harlan does it full justice. Farrell and Trantzen are also the authors of this song.

No. 8689, "That Is a Habit I Never Had," is a splendid coon song by Billy Murray, with orchestra accompaniment. Mr. Murray's rendition is truly coonlike. Walter Wilson wrote the words and music.

No. 8690, "California Minstrels," is another of the popular series of minstrel Records which we regard as the best of the kind ever made for a talking machine. This one has the usual amount of fun and then introduces the ballad "I'm Going Home to Clo," with Harry MacDonough as the singer.

No. 8691, "He Done Me Wrong," is a coon song by Hughie Cannon, and is sung by Arthur Collins, with orchestra accompaniment. It tells in verse of the shortcomings of Bill Bailey, who in this song has apparently passed from the land of the living. Mr. Collins sings it in unusually fine voice, and to hear his imitation of a coon girl crying to the music of "Flee as a Bird" will bring a smile to the most solemn countenance.

No. 8692, "Down South," is a musical composition that has the unique distinction of being a negro cakewalk written by an Englishman, W. H. Myddleton, who never visited America or even saw the sunny South. He who hears it will agree that Mr. Myddleton has been most successful in his interpretation of Southern negro music. This Record is listed as a banjo solo by Vess L. Ossman, and has a very happy orchestra accompaniment.

No. 8693, "What I Heard at the Vaudeville," by Len Spencer, introduces Gus Williams' German dialect recitation "Only a Lock of Hair." It is accompanied by what is theatrically known as "shiver" music by the orchestra. This recitation is apparently pathetic, but it becomes extremely funny with the last line. This Record again shows Mr. Spencer's versatility in making records.

No. 8694, "Idle Moments" (Entr' Acte), is another delightful Record by the Edison Symphony Orchestra. The music is light and tuneful. The composition is the work of T. H. Rollinson.

No. 8695, "Nancy Lee," is a vocal duet by Harlan and Stanley, sung in march tempo. This is another instance in which an old name has been given to a new composition, this selection being quite different from the one so well known as "Nancy Lee." Messrs. Harlan and Stanley sing it in an exceedingly creditable

manner, Mr. Stanley's voice being unusually good. The words of this song were written by James O'Dea, and the music by Robert J. Adams.

No. 8696, "On a Good Old Trolley Ride,"  
"Out with my Pearlie, my steady young Girlie;  
This is the only time,"

is a new summer-time waltz song, with orchestra accompaniment, which it is expected will be as well known and as popular within another six months as "In the Good Old Summer Time." The music is of a striking character, and it would seem as if the predictions of the publishers concerning it could hardly fail to be verified. The Record is made by William H. Redmond, who has not sung for the Edison Phonograph for some time. Mr. Redmond's voice lends itself admirably to this character of song. Joseph C. Farrell wrote the words of this song, and Pat Rooney the music.

No. 8697, "Possum Pie" (or "The Stuttering Coon"), is a coon song, with orchestra accompaniment, by Collins and Harlan. It tells of Nicodemus Harrison Lee's difficulties in endeavoring to spell "Possum Pie." Messrs. Collins and Harlan make his efforts quite pleasing to the ear. The words of this song were written by Joseph C. Farrell, and the music by Hughie Cannon.

No. 8698, "Turkey in the Straw Medley," by the Edison Military Band, is a Record that can hardly fail to be as popular as was the Record made of this song by Billy Golden. The latter was a great selling Record. The medley by the Edison Military Band introduces "Turkey in the Straw," "Blue Bell," "In Zanzibar," "The Man Behind" and "General Hardtack—on Guard!" It is another instance in which the purchaser will get considerable musical variety on one cylinder. It will be hard to keep one's feet still while this Record is being played.

#### A "RECORD" INCIDENT.

Winfield S. Fisk, of 937 Silver street, Philadelphia, contributes the following:

*The Pretty Maiden and Dinah Jones took the Steamboat Leaving the Wharf for Finnigan's Jamboree. Being the Little Kinkies they sang the Pilgrim's Chorus for the Two of Us. Down on the Farm they saw the Moonlight on the Lake and the Spring Morning Serenade, Bird Imitations and the Birds of the Brook. We meet Happy Hobo and Old Black Joe at the Camp Meeting Jubilee. They Were All Doing the Same in Vaudeville Specialty; they were Always In the Way of the Laughing Coon, being Satisfied with Life; and In the House of Too Much Trouble they said I'm Going to Leave—I Want to Go To-Morrow to the Refuge, to see Jack Tar March, to hear the Fiddle Talk, and go to the Monologue Minstrels in the Holy City and take the Trolley Galop to Coney Isle to see the Rooster Dance and the Turkey In the Straw, Rocked In the Cradle of the Deep. The Battle of Manassas will be Busy All Next Week on Any Rags, and Bedelia will take a Coaching Party and Sleighride Party to hear the Anvil Chorus play It was the Dutch.*



**DEALERS READ THIS!**

Below is printed a letter received by the Perry B. Whitsit Co., of Columbus, O., from one of its Dealers. It should be read by every Edison Dealer in the land. Mr. Chandler is not the only Dealer who has been successful in consequence of putting in the entire line of Edison Gold Moulded Records. Many others have done equally well. Give it your careful consideration, Mr. Dealer. The letter follows:

CHILLICOTHE, OHIO, Feb. 29, 1904.

*Perry B. Whitsit Co., Columbus, Ohio:*

In enclosing herewith order for shorts in my stock I should like to state that I never made a better business move than when I put in the entire line of Edison Gold Moulded Records.

Previous to doing so I was in the habit of using my judgment as to what would sell. Since increasing my stock I find that I frequently sell Records that in my own opinion would never have sold. With the entire line it is so easy to fill your customers' wants. I used to have the experience of a customer dropping in and asking for something not in stock and then going away and not making any purchase at all. I find that where a customer makes his own selections from the catalogue that he will frequently take the Record that has been a slow mover.

With most dealers I believe that the tendency is to pick out the newest selections when playing for a customer. At least it has been so in my case. Now I let the customer do the selecting as much as possible, and I find it much more satisfactory.

I believe that I am safe in saying that my business has increased over one-third since putting in the entire list.

I realize the fact that I will likely have a few more Records on hand that I cannot dispose of, but this percentage is so small and the increased sales easily take care of this.

You will pardon the length of this missive, which I feel sure doesn't tell you anything new, but you will remember that I was very skeptical as to the advisability of making this move, and it is a good idea once in awhile to admit that you were wrong. I shall be glad to have you refer any Dealer to me in regard to this matter, and I can certainly convince him that it will pay him to do as I have done.

MARTIN G. CHANDLER.

**A HISTORIC RECORD.**

J. H. M. Davidson, manager of the New York Import Co., at Adelaide, South Australia, under date of January 25, wrote as follows:

Per same post I mail you copy of the *S. A. Register*, with notice of a speech made by the Governor-General, Lord Tennyson, into the Phonograph, and recorded by me.

This Record is the nucleus of a national historic collection of the voices of leading men in connection with the Australian Commonwealth, and I have been retained by the Pub-

lic Library Board to do the recording, for which purpose I am using an Edison Concert Phonograph.

The Record made by His Excellency was a portion of his farewell speech to Australians upon the occasion of his departure for England.

Lord Tennyson also wrote his signature with a stylus on the blank, thus authenticating the Record.

His Excellency is an admirable subject for the recorder, and is no stranger to the Phonograph, having in his possession one with which his late father, the great Poet Laureate, used to amuse himself and the members of his family. He expressed himself as satisfied with the result attained.

**MY PHONOGRAPH.**

Thou mysterious invention  
Brought so lately into the field  
Where wonders, more than we mention,  
From day to day are yet revealed;  
Thou hast a form so beguiling  
On thee we'd gaze some time or more  
Didst thou not force us to smiling  
At sounds from thee of ghostly lore.

What art thou and who gave thee right  
To make a record of my speech?  
Against which I with utmost might  
Dare not attempt thee to impeach.  
If I by chance should speak a word  
Into thy polished rubber ear,  
When meddling soul to thee referred,  
Shall I trust thee or stand in fear?

And can my friend with me to-day  
Record with thee some tender word,  
Ere to-morrow he pass away,  
His soul to God, as flies the bird,—  
Some words so clear and full of joy,  
For me to hear in coming days,  
Soothing my pain by thy employ,  
Thus know a glint of heaven's rays?

How will it be in future age,  
When ashes mine are scattered wide,  
Shall my own voice as printed page  
Speak unto those who here abide?  
And may my child, when I am dead,  
By thy fine art come near to me,  
And feel that I caress his head,  
Hearing my tones, my soul to see?

Thank God aloud that it be so,  
That mind of man is searching deep  
Into the truths we yet shall know  
Of mind and soul, in that great sleep;  
And while to us grim death alone  
Can solve the truth beyond the tomb,  
Speech from the dead may much atone  
And cheer the heart o'erpressed with gloom.  
—*Maxime, in an old issue of the Daily Re-*  
*public, Manhattan, Kas.*

**Dealers, are you doing any newspaper advertising or using other means to let the public know that you are selling Edison goods? If not, do it now. It will pay a handsome profit on the outlay.**

**FINAL DECREES IN THE WITTMANN CASES.**

Copies of the final decrees in the suits of the Edison Phonograph Co. against The Wittmann Co., and the National Phonograph Co. against The Wittmann Co., are given below. The Wittmann Co., were formerly Jobbers in Edison Phonographs and Records at Kansas City, Mo., and Omaha and Lincoln, Neb. About two years ago they had a disagreement with the National Phonograph Co., and violated their agreement by cutting prices. Then when we refused to supply them with goods, they bought surreptitiously from others and removed the serial numbers from Phonographs to avoid detection. Suits for price cutting and infringement of patents were brought against them and vigorously fought by this company, resulting in our favor

**United States Circuit Court, District of Nebraska**

EDISON PHONOGRAPH COMPANY } No. 101. Doc. V  
 Complainant. }  
 vs. } FINAL  
 THE WITTMANN COMPANY, } DECREE.  
 Defendant. }

This cause came on to be heard at this term, and was argued by counsel; and thereupon, upon consideration thereof, it was

ORDERED, ADJUDGED and DECREED as follows: That The Wittmann Company, defendant above named, and its associates, officers, managers, attorneys, servants, clerks, agents and workmen be, and they are hereby jointly and severally, perpetually and permanently enjoined from directly or indirectly using or causing to be used, advertising or offering for sale, selling or causing to be sold, any phonograph machines or apparatus described in the said complainant's Bill of Complaint herein, not licensed by or contrary to the license of the Edison Phonograph Company, complainant mentioned in the Bill of Complaint, embodying or constructed or operated in accordance with the inventions or improvements set forth in the Letters Patent mentioned, set forth and described in the said complainant's said Bill of Complaint.

\* \* \* \* \*  
 Dated this 30th day of December A. D. 1903  
 W. H. MUNGER, Judge.  
 ENDORSED: Filed December 30, 1903.  
 GEO. H. THUMMEL, Clerk.

UNITED STATES OF AMERICA, } ss.  
 District of Nebraska. }

I, Geo. H. Thummel, Clerk of the Circuit Court of the United States for the District of Nebraska, do hereby certify the above and foregoing to be a true and correct copy of the Journal Entry of the proceedings of said court, in the above entitled action as the same appears of record in my office.

Witness my hand and seal of said court at  
 [SEAL] Omaha, in said District this 5th day of  
 March A. D. 1904.  
 GEO. H. THUMMEL, Clerk.

Attached to said Copy of Order is Return of the U. S. Marshal, in words and figures following, to wit:  
 RETURN ON SERVICE OF WRIT.

UNITED STATES OF AMERICA } ss.  
 District of Nebraska. }

I hereby certify and return that I served the annexed order of court on the therein named The Wittmann Company by handing to and leaving a true and correct copy thereof with Otto Wittmann, as Vice President of the said The Wittmann Company, he being the highest officer found in my district, personally at Lincoln, in said District on the 7th day of March A. D. 1904.

T. L. MATHEWS, U. S. Marshal.  
 By JAMES WALLING, Deputy.

\* \* \* \* \*  
 Filed March 9, 1904.  
 GEO. H. THUMMEL, Clerk.

**United States Circuit Court, District of Nebraska**

NATIONAL PHONOGRAPH COMPANY, } No. 97.  
 Complainant, } Doc. V  
 vs. } FINAL  
 THE WITTMANN COMPANY, } DECREE.  
 Defendant. }

This cause came on to be heard at this term and was argued by counsel; and thereupon, upon consideration thereof, it was

ORDERED, ADJUDGED and DECREED as follows: That The Wittmann Company, defendant above named, its associates, officers, managers, attorneys, servants, clerks, agents and workmen be, and they are hereby jointly and severally permanently and perpetually enjoined from directly or indirectly advertising or offering for sale, and from directly or indirectly selling or causing to be sold, at prices less than the prices designated and fixed in the terms and conditions of the contract alleged and described and referred to in the above named complainant's Bill of Complaint, any and all phonographs, phonograph records or blanks furnished or sold by the said complainant, National Phonograph Company, to the said defendant, The Wittmann Company, and its predecessors, as alleged in the said Bill of Complaint.

\* \* \* \* \*  
 Dated this 30th day of December A. D. 1903.  
 W. H. MUNGER, Judge.  
 ENDORSED: Filed December 30, 1903.  
 GEO. H. THUMMEL, Clerk.

UNITED STATES OF AMERICA, } ss.  
 District of Nebraska. }

I, Geo. H. Thummel, Clerk of the Circuit Court of the United States for the District of Nebraska, do hereby certify the above and foregoing to be a true and correct copy of the Journal Entry proceedings of said court in the above entitled action as the same appears of record in my office.

Witness my hand and seal of said court at  
 [SEAL] Omaha, in said District, this 5th day of  
 March A. D. 1904.  
 GEO. H. THUMMEL, Clerk.

Attached to said copy of Order of Court is Return of U. S. Marshal in words and figures following, to wit:  
 RETURN ON SERVICE OF WRIT.

UNITED STATES OF AMERICA, } ss.  
 District of Nebraska. }

I hereby certify and return that I served the annexed Order of Court on the therein named The Wittmann Company by handing to and leaving a true and correct copy thereof with Otto Wittmann, as Vice-President of the said The Wittmann Company, he being the highest officer found in my district, personally at Lincoln, Nebraska, in said district on the 7th day of March A. D. 1904.

T. S. MATHEWS, U. S. Marshal.  
 By JAMES WALLING, Deputy.

\* \* \* \* \*  
 Filed March 9, 1904.  
 GEO. H. THUMMEL, Clerk.

**CALLS ON THE FARMERS.**

A Maine dealer writes: "I have a wide range of rural people to whom I shall carry my goods as soon as we get rid of our four feet of snow. I have sold goods to the people in this way for twenty years, and there are thousands of country folks who will buy Phonographs if they can only have them brought to them and played to them *at home*. When they go to the city their money goes before they get round to the Phonograph."

This Dealer has the right idea about push-

ing the sale of Edison goods. Nor does the plan apply to his territory alone. It can be followed with profit by any Dealer located in a farming or other sparsely settled country. When a Phonograph is taken into a farmer's home, where he and his family can hear and ask questions in their own way, it makes a much different impression upon them than it would if they called at a store to hear it. If they are at all interested in music they can hardly fail to become purchasers sooner or later. A Dealer will be doubly sure of his welcome if he arranges in advance for his visit.



**INJUNCTIONS AGAINST PRICE CUTTING.**

The United States Circuit Court, Southern District of New York, recently issued two injunction of importance to the Phonograph trade. Both were in favor of the National Phonograph Co. and against individuals who were selling Edison Phonographs and Edison Records at cut prices.

The first injunction was against Richmond Pease, who did business at 44 West 132d Street, New York City, against whom suit was brought for price cutting.

The second injunction was against David Switky, who formerly did business under the name of the Bronx Phonograph Company, 506 Willis Avenue, New York City, and later under the name of the Central Phonograph Company, at 160 East 42d Street, New York City, who was also sued for price cutting.

Neither Pease nor Switky had signed the agreement of this company, but were selling machines and Records secured surreptitiously through other parties. These injunctions by Judge Melville W. Fuller, of the Supreme Court of the United States, more firmly than ever establish our right to legal protection against price cutting. They show that even though dealers do not sign our agreement they cannot sell our goods at prices lower than those established by this company without infringing the Edison patents. The complete decisions are given below.

Every decision in our favor like these makes a precedent for other courts to follow and makes it easier to enforce our rights, a course that we shall continue to pursue against all individuals selling our goods illegally.

The decisions in full are as follows:

**U. S. Circuit Court, Southern District of New York**

EDISON PHONOGRAPH COMPANY and NATIONAL PHONOGRAPH COMPANY, }  
Complainants, }  
vs. } In  
RICHMOND PEASE, } Equity.  
Defendant.

(Seal.)  
*The President of the United States of America to Richmond Pease, and his servants, agents, attorneys, employees, workmen and confederates.*

**GREETING :**  
Whereas it has been represented to us in our Circuit Court of the United States for the Second Circuit and the Southern District of New York, that letters patent of the United States No. 382,418 were issued to Thomas A. Edison, in due form of law on May 8, 1888, for improvements in phonogram blanks, and that letters patent of the United States No. 386,974 were issued to Thomas A. Edison in due form of law on July 31, 1888, for improvements in phonographs, and that said letters patent Nos. 382,418 and 386,974 were duly assigned to the Edison Phonograph Company and that the National Phonograph Company is exclusive licensee of the said Edison Phonograph Company under said letters patent Nos. 382,418 and 386,974, and that you, the said Richmond Pease, have infringed the claims of said letters patent.

Now therefore, we strictly command and enjoin you, the said Richmond Pease, your associates, attorneys, servants, clerks, agents and workmen, from directly or indirectly using or causing to be used, selling or causing to be sold, any phonogram blanks or devices not licensed by the complainants embodying or constructed or operating in accordance with the inventions and improvements set forth in said letters patent Nos. 382,418 and 386,974.

Witness, the Honorable Melville W. Fuller, Chief Justice of the Supreme Court of the United States, at the City of New York, on the eighth day of February, 1904.

JOHN A. SHIELDS, Clerk.  
FRANK E. BRADLEY, Solicitor for Complainants.

Service of the above is hereby accepted.  
RICHMOND PEASE.  
Dated Feb. 8, 1904.

**U. S. Circuit Court, Southern District of New York**

EDISON PHONOGRAPH COMPANY and NATIONAL PHONOGRAPH COMPANY, }  
Complainants, } In  
vs. } Equity.  
DAVID SWITKY, } Defendant.

*The President of the United States to David Switky, and each and every person connected directly or indirectly with you, and your associates, attorneys, solicitors, clerks, servants and employees.*

**GREETING :**  
Whereas, it has been represented to us, in our Circuit Court of the United States for the Southern District of New York, in a certain case therein depending wherein Edison Phonograph Company and National Phonograph Company are complainants, and the said David Switky is defendant, that letters patent of the United States No. 386,974 were issued in due form of law, and that you, the said David Switky, have infringed said letters patent No. 386,974 and particularly the 24th and 27th claims thereof:

Now therefore, we strictly command and enjoin you, the said David Switky, and each and every person, firm or corporation connected directly or indirectly with you, your associates, attorneys, solicitors, clerks, servants, agents and employees, under the penalties that may fall on you in case of disobedience, that you forthwith, and until the further order of this court desist from directly or indirectly using or causing to be used, selling or causing to be sold, or advertising to sell, any apparatus, articles or devices embodying or constructed or operating in accordance with the inventions and improvements set forth in said letters patent No. 386,974 and particularly claims 24 and 27 thereof, or either of them, at prices lower than those at which they are authorized to be sold by said complainants as set forth in schedules 1 and 2 of the bill of complaint, viz:—Edison "Gem" Phonographs at ten dollars, Edison "Standard" Phonograph at twenty dollars, Edison "Home" Phonographs at thirty dollars, &c. or with the serial numbers thereof, partially or wholly obliterated or changed, or without the license of the said complainants.

Witness the Honorable Melville W. Fuller, Chief Justice of the United States, at the City of New York, on the 27th day of February, 1904.

JOHN A. SHIELDS, Clerk.  
FRANK E. BRADLEY, Solicitor for Complainants,  
290 Broadway, New York, N. Y.  
Borough of Manhattan.

**ANOTHER PHONOGRAPH NOVELTY.**

Peter Petersen, a Dealer at New Milford, Conn., has a novel device for calling attention to the Phonograph department of his music store. He has rigged up a life-size figure of a woman, similar to a dressmaker's dummy, and attired it with a full costume and hat.

Concealed in the figure is an Edison Phonograph, and, when Records are played on the machine, the music appears to come from the head, which is open at the top, the opening being covered by the straw hat. As soon as the weather is mild enough the figure will be placed in front of the store.

**STRAWS FROM JOBBERS.**

A Philadelphia Jobber recently wrote;

"We are greatly in need of Records on orders. Every Record on these orders is needed here now. Please rush. The demand is increasing. Many Dealers formerly handling \_\_\_\_\_ Records are coming back, and we were unprepared."

Ackerman & Co., of Scranton, Pa., wrote under date of March 12:

"We consider the March and April lists of Edison new Gold Moulded Records the finest ever produced, and will undoubtedly find that our March order placed with your firm will run short of supplying the demand, which these selections are bound to create."

**OTHERS HAD BETTER DISCOVER A NEW COUNTRY.**

PHILADELPHIA, March 13, 1904.

We beg to acknowledge the receipt of the Suspended List to date, March 1. Will say that we will do all in our power to aid in its good work. The February list was grand. The Gold Moulded Records are in a class by themselves, and all other records had better discover some new country where Phonographs are yet unknown, as they are fading from existence in the country of intelligence.

HAMMITT & COOK.

**SUSPENDED LIST, APRIL 1, 1904.—SUPERSEDING ALL PREVIOUS LISTS.****COLORADO.**

BOULDER—BENTLEY & CRAIG.

**KANSAS.**

CLAY CENTRE—E. M. GOWENLOCK.  
LAWRENCE—BELL BROS.

**MASSACHUSETTS.**

LAWRENCE—LORD & CO., 314 Essex street.  
E. O. MOSHER, 420 Essex street.  
MALDEN—A. T. FULLER.  
NEW BEDFORD—H. B. DEWOLFF.  
WOBBURN—OSBORN GILLETTE, or THE  
BOLTON JEWELRY COMPANY, L.  
F. MALONEY, Manager.

**MICHIGAN.**

DETROIT—F. J. SCHWANKOVSKY.  
SAGINAW—GEO. W. EMENDORFER.

**MISSOURI.**

KANSAS CITY—THE WITTMANN CO.

**NEBRASKA.**

LINCOLN—THE WITTMANN CO.  
OMAHA—THE WITTMANN CO.

**NEW HAMPSHIRE.**

NASHUA—F. A. McMASTER & CO.

**NEW JERSEY.**

ATLANTIC CITY—SAMUEL D. WOLF, 32-34  
Arkansas avenue.  
BAYONNE—I. WIGDOR, 450 Avenue D.  
JERSEY CITY—W. L. HOFFMAN, 151 Mont-  
gomery street.  
NEWARK—R. L. CORWIN; also New York  
City.  
PATERSON—CHAS. H. KELLY, 25 N. Main st.  
PLAINFIELD—S. W. FRUCHT, or R.  
FRUCHT; also New York City.  
\*ELSTON M. LEONARD.  
WEST HOBOKEN—EMIL HOLLANDER, or  
THE WEST HOBOKEN BICYCLE &  
PHONOGRAPH CO., 619 Spring street.

\*Added since March 1, 1904.

Jobbers and Dealers are asked to co-operate with us, FOR OUR MUTUAL GOOD, by being careful—that they do not supply any of the above named firms with our apparatus, either at addresses given or any other address.

**NEW YORK.**

BEDFORD PARK—GEO. H. TYRRELL.  
HOBART—F. H. MARSHALL.  
NEW YORK CITY—A. T. ARMSTRONG, or  
AMERICAN PHONOGRAPH CO., 106  
Wall street.  
BRONX PHONOGRAPH CO., or DA-  
VID SWITKY, 506 Willis Avenue.  
\*CENTRAL PHONOGRAPH CO., 160  
E. 42d street.  
R. L. CORWIN; also Newark, N. J.  
EAGLE PHONOGRAPH CO., or C.  
LOWENTHAL, 83 Nassau Street.  
EMPIRE PHONOGRAPH CO., 2 West  
14th street.  
S. W. FRUCHT, or R. FRUCHT, 7 Bar-  
clay st., or 68 Cortlandt st.; also  
Plainfield, N. J.  
O. HACKER, 2 Murray street.  
HAWTHORNE & SHEBLE, 297 Broad-  
way; also Philadelphia, Pa.  
N. HORN, 148 E. 58th street.  
R. H. INGERSOLL & BRO., 67 Cort-  
landt street.  
W. L. ISAACS, 114 Fulton street.  
S. LEMBURG & CO., 194 Broadway.  
J. McELLYNNE, 202 Broadway.  
RICHMOND PEASE, 44 W. 132d st.  
F. M. PRESCOTT, 44 Broad street.  
SARATOGA—W. J. TOTTEN.  
SARATOGA SPRINGS—MARVIN A. COTE.

**OHIO.**

CINCINNATI—J. L. ANDEM.  
SPRINGFIELD—D. & M. VANDERPOOL.  
UHRICHSVILLE—F. A. MAZURIE.

**PENNSYLVANIA.**

PHILADELPHIA—A. R. CASSIDY, 2783 Em-  
erald street.  
HAWTHORNE & SHEBLE, 604 Chest-  
nut street, or Oxford and Wascher  
streets; also New York City.  
PITTSBURG—A. LIPPARD, 615 Wylie avenue.

**RHODE ISLAND.**

PROVIDENCE—F. P. MOORE.

**WISCONSIN.**

MILWAUKEE—J. C. BLATZEK.



## JOBBERERS OF EDISON PHONOGRAPHS AND RECORDS.

## ALABAMA.

**Birmingham**—The Ray Co., 2025 Second avenue.  
**Mobile**—The Ray Co., 54 Dauphin street.

## CALIFORNIA.

**San Francisco**—Peter Bacigalupi, 933 Market street.

## COLORADO.

**Denver**—Denver Dry Goods Co., 619 16th street.

## CONNECTICUT.

**Middletown**—Caulkins & Post Co., 406-408 Main street.  
**New Haven**—Pardee-Ellenberger Co., 155 Orange st.

## ILLINOIS.

**Chicago**—Oscar J. Junge, 245 E. Chicago avenue.  
 Kelley Cigar Co., 80-82 Wabash avenue.  
 James I. Lyons, 73 Fifth avenue.  
 The Ray Co., 90 Washington street.  
 Siegel-Cooper Co., State and Congress sts.  
 Talking Machine Co., 107 Madison street.  
 The Vim Co., 68 E. Lake street.  
 Montgomery Ward & Co., 111 Michigan ave  
**Peoria**—Peoria Phonograph Co., 314 S. Adams street. .

## INDIANA.

**Indianapolis**—Kipp Bros. Co., 37 S. Meridian street.  
 The Ray Co., 234 Massachusetts avenue.  
 Wahl-Gaasch Co., 119 S. Illinois street  
**Lafayette**—Wahl-Gaasch Co., 304 Main street.

## IOWA.

**Des Moines**—The Vim Co., 704 West Walnut street.

## KENTUCKY.

**Louisville**—The Ray Co., 640 Fourth avenue.

## LOUISIANA.

**New Orleans**—James I. Lyons, Theatre Arcade.  
 National Automatic Fire Alarm Co., 614  
 Gravier street.  
 The Ray Co., 111 Camp street.

## MAINE.

**Bangor**—S. L. Crosby Co., 186 Exchange street.  
**Portland**—W. H. Ross & Son, 207 Commercial street.

## MASSACHUSETTS.

**Boston**—Boston Cycle & Sundry Co., 48 Hanover street.  
 Eastern Talking Machine Co., 177 Tremont  
 street.  
 Oliver Ditson Co., 150 Tremont street.  
 Iver Johnson Sporting Goods Co., 163 Wash-  
 ington street.  
 Read & Read, 558 Washington street.  
**Fitchburg**—Iver Johnson Sporting Goods Co., 247 Main  
 street.  
**Lowell**—Ring Music Co., 112 Merrimac street.  
 Thomas Wardell, 111 Central street.  
**Worcester**—Iver Johnson Sporting Goods Co., 304 Main  
 street.

## MICHIGAN.

**Detroit**—American Phonograph Co., 106 Woodward  
 avenue.  
 Grinnell Bros. Music House, 219 Woodward  
 avenue.  
 The Ray Co., 168 Griswold street.  
**Saginaw**—Morley Bros.

## MINNESOTA.

**Minneapolis**—Thomas C. Hough, 714 Hennepin ave.  
**St. Paul**—Minnesota Phonograph Co., 37 E. 7th street.

## MISSOURI.

**Kansas City**—J. W. Jenkins' Sons Music Co., 1013-1015  
 Walnut street.  
 The Ray Co., 1021 Grand avenue.  
**St. Louis**—Conroy Co., 1115 Olive street.  
 The Ray Co., 923 Olive street.

## NEBRASKA.

**Lincoln**—H. E. Sidles Cycle Co., 1317 O street.  
**Omaha**—H. E. Fredrickson, 1502-1510 Capitol avenue.  
 Nebraska Cycle Co., 15th and Harney streets.

## NEW JERSEY.

**Hoboken**—Eclipse Phonograph Co., 205 Washington  
 street.  
**Newark**—A. O. Petit, New and Halsey streets.  
 H. J. Koehler Sporting Goods Co., 845 Broad  
 street.  
**Paterson**—James K. O'Dea, 117 Ellison street.  
**Plainfield**—Frank L. C. Martin Auto. Co., 810 Park  
 avenue.  
**Trenton**—Stoll Blank Book and Stationery Co., 30 E.  
 State street.

## NEW YORK.

**Brooklyn**—Chapman & Co., Fulton and Duffield streets.  
 A. D. Matthews' Sons, 394 Fulton street.  
 Price Phonograph Co., 1258 Broadway.  
**Buffalo**—P. A. Powers, 643 Main street.  
**Elmira**—Elmira Arms Co., 117 Main street.  
**Gloversville**—American Phonograph Co., 99 W. Fulton  
 street.  
**Kingston**—Forsyth & Davis, 307 Wall street.  
**New York City**—Barkelaw & Co., 36 Vesey street.  
 Bettini Phonograph Co., 80 Chambers  
 street.  
 Blackman Talking Machine Co., 19  
 Beekman street.  
 J. F. Blackman & Son, 2654 3d avenue.  
 I. Davega, Jr., 802 Third avenue.  
 S. B. Davega, 32 E. 14th street.  
 Douglas & Co., 89 Chambers street  
 H. S. Gordon, 139 Fifth avenue.  
 Harry Jackson, 219 Bowery.  
 Jacot Music Box Co., 39 Union Square.  
 Victor H. Rapke, 1661 Second avenue.  
 Rosenfield Mfg Co. 587 Hudson st.  
 Siegel-Cooper Co., Sixth avenue and  
 18th street.  
 John Wanamaker, Broadway and  
 9th street.  
**Rochester**—A. J. Deninger, 347 North street.  
 Mackie Piano, O. & M. Co., 100 State street.  
 Talking Machine Co., 29 S. Clinton avenue.  
**Schenectady**—Jay A. Rickard & Co., 253 State street.  
**Syracuse**—W. D. Andrews, 216 E. Railroad street.  
**Troy**—James Lucey, 359-361 Fulton street.  
**Utica**—Clark, Horrocks Co., 54 Genesee street.

## OHIO.

**Canton**—Klein & Heffelman Co., 216 N. Market street.  
**Cincinnati**—Ilsen & Co., 25 W. 6th street.  
 The Ray Co., 143 West 5th street.  
 Wahl-Gaasch Co., 47 W. 5th street.  
**Cleveland**—W. J. Roberts, Jr., 254-256 Arcade.  
**Columbus**—Perry B. Whitsit Co., 213 S. High street.  
**Dayton**—Niehaus & Doshe, 35 E. 5th street.  
**East Liverpool**—Smith & Phillips Music Co.  
**Toledo**—Hayes Music Co., 608 Cherry street.

## PENNSYLVANIA.

**Allegheny**—Henry Braun, 500 Federal street.  
**Allentown**—G. C. Aschbach, 539 Hamilton street.  
**Easton**—William Werner, 401 Northampton street.  
**Philadelphia**—C. J. Heppe & Son, 1117 Chestnut street.  
 Lit Bros., Market and 8th streets.  
 Penn Phonograph Co., 19 S. 9th street.  
 John Wanamaker.  
 Wells Phonograph Co., 41 N. 9th street  
 Western Electric Co., 931-933 Market  
 street.  
 H. A. Weymann & Son, 923 Market  
 street.  
**Pittsburg**—Theo. F. Bentel Co., Inc., 433 Wood street.  
 Kaufmann Bros., Fifth avenue and Smith-  
 field street.  
 H. Kleber & Bro., 221 Fifth avenue.  
 C. C. Mellor Co., 319 Fifth avenue.  
 Pittsburg Phonograph Co., 937 Liberty  
 avenue.  
**Reading**—Reading Phonograph Co., 809 Penn street.  
**Scranton**—Ackerman & Co., Coal Exchange Building.  
 Technical Supply Co.

## RHODE ISLAND.

**Providence**—J. M. Dean Co., 785-795 Westminster street.  
 J. A. Foster Co., Weybosset and Dor-  
 rance streets.  
 Household Furniture Co., 231-237 Wey-  
 bossett street.  
 Murray, Blanchard, Young & Co., 26-30  
 Pine street.  
 A. T. Scattergood & Co., 106-110 N. Main  
 street.

## TENNESSEE.

**Memphis**—The Ray Co., Lyceum Building, 2nd and  
 Jefferson streets.  
**Nashville**—The Ray Co., 30 The Arcade.

## TEXAS.

**Dallas**—C. B. Harris, Agt., 347 Main street.

## VIRGINIA.

**Richmond**—The Ray Co., 729 E. Main street.

## WISCONSIN.

**Milwaukee**—McGreal Bros., 173 3d street.

## CANADA.

**Toronto**—R. S. Williams & Sons Co., Limited, 143  
 Yonge street.

## A STRIKING COMPARISON.

The following excellent presentation of the comparative selling quality of Edison Phonographs and other styles of talking machines appeared in the *Daily Evening Item*, of Lynn, Mass., on March 7:

<b>IN</b>	1900	we sold (3 months)	Edison Phonographs, 58;	all other makes, 2
	1901	we sold	Edison Phonographs, 426;	all other makes, 14
	1902	we sold	Edison Phonographs, 539;	all other makes, 18
	1903	we sold	Edison Phonographs, 637;	all other makes, 10
	1904	we sold (to date)	Edison Phonographs, 95;	all other makes, 1

## Edison Phonographs

Commanded the following prices in 1900:  
\$10, \$20, \$30, \$50 and \$75.

Edison Phonographs in 1904 at your service at  
\$10, \$20, \$30, \$50 and \$75.

All other kinds of Talking Machines at your own price. All kinds of  
of scratch records from 16c to 25c.

## Edison Records

In 1900, 50c each, \$5.00 per dozen.  
Edison Records in 1904, 50c each, \$5.00 per dozen.

The improvement of EDISON RECORDS and EDISON PHONOGRAPHS has enabled us to satisfy thousands of patrons. OUR TERMS: Complete outfit, with 12 Edison Records, \$5.00 upon delivery; balance in weekly payments of \$1.00.

## Mendlow Brothers

14 Central Avenue, Lynn, Mass.



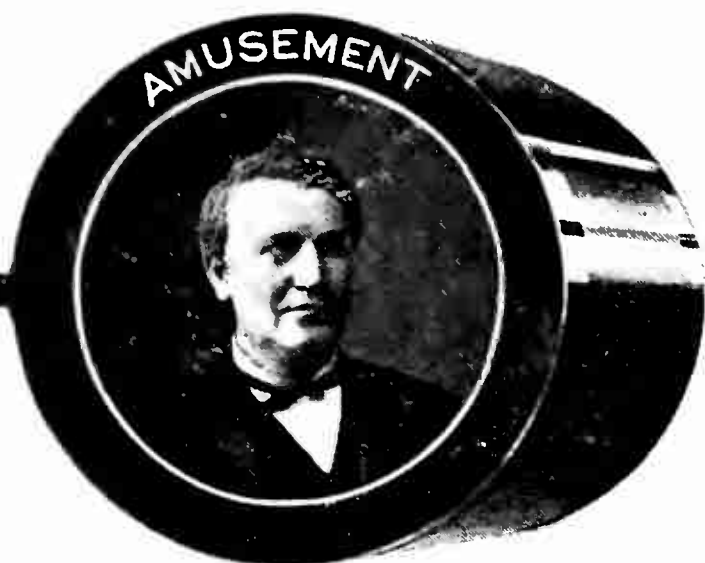

## TWO GREAT RECORDS

**Thomas A. Edison** The enduring popularity of the phonograph is one of the greatest monuments to Mr. Edison's genius. Not only is the inventor honored for the unique design of the apparatus (which immediately became a great commercial success), but also for the sterling qualities of the man, shown in two decades of indefatigable work and successive triumphs, maintaining the superiority of the original talking machine.

**The I. C. S.** With twelve years of earnest and successful effort in educational work, and with unlimited facilities to accomplish a great enterprise, it is very fitting and proper that a new method of learning languages should be given to the world by the International Correspondence Schools, of Scranton, Pa. The indorsement of thousands of Language Students and leading educators show that the collaboration of Mr. Edison and the I. C. S. has resulted in the best possible service.

**Double Service** for the Edison Phonograph means the employment of both of these great Records for Amusement and Language Study. Every dealer can increase his sales by demonstrating I. C. S. Language Lessons. A better or more attractive test for the perfect talking machine cannot be found.

### Special Demonstrating Outfit This Month

Edison dealers who order Sample Lessons in French, German, and Spanish, consisting of three Moulded Records and three 40-page Textbooks (price \$1.50 pre-paid in the United States), receive an additional demonstrating outfit free this month, as follows:

A unique and attractive Wire Rack for holding display cards of any description on the phonograph, with three large printed Language Lessons (14 × 22) for attractive store displays and demonstrating at entertainments.

#### Apply to the Following Jobbers of I. C. S. Outfits

PORTLAND, ME., W. H. Ross & Son  
 LOWELL, MASS., Thomas Wardell  
 BOSTON, MASS., Eastern Talking Machine Co.  
 BOSTON, MASS., J. C. Haynes & Co.  
 BOSTON, MASS., Boston Cycle & Sundry Co.  
 NEW HAVEN, CONN., Pardee-Ellenberger Co.  
 PROVIDENCE, R. I., Murray, Blanchard,  
 Young & Co.  
 KINGSTON, N. Y., Forsyth & Davis  
 SYRACUSE, N. Y., W. D. Andrews  
 NEW YORK CITY, Blackman Talking Machine Co.  
 NEW YORK CITY, I. Davega, Jr.  
 NEW YORK CITY, Douglas & Co.  
 NEW YORK CITY, Jacot Music Box Co.  
 NEW YORK CITY, John Wanamaker  
 NEWARK, N. J., The Edisonia Co.

PLAINFIELD, N. J., F. L. C. Martin  
 Automobile Co.  
 PHILADELPHIA, PA., Wells Phonograph Co.  
 EASTON, PA., William Werner  
 BUFFALO, N. Y., P. A. Powers  
 ROCHESTER, N. Y., Talking Machine Co.  
 COLUMBUS, OHIO, Perry B. Whitsit Co.  
 DAYTON, OHIO, Niehaus & Dohse  
 CHICAGO, ILL., O. J. Junge  
 CHICAGO, ILL., James I. Lyons  
 MILWAUKEE, WIS., McGreal Bros.  
 MINNEAPOLIS, MINN., Thos. C. Hough  
 OMAHA, NEB., Nebraska Cycle Co.  
 KANSAS CITY, MO., J. W. Jenkins' Sons Music Co.  
 ST. LOUIS, MO., The Conroy Co.  
 TORONTO, CAN., R. S. Williams & Sons Co.  
 SAN FRANCISCO, CAL., Peter Bacigalupi  
 NINETEEN STORES, The Ray Co.

# EDISON Phonograph Monthly

PUBLISHED FOR TRADE USE ONLY BY  
THE NATIONAL PHONOGRAPH CO.

VOL. II.

NEW YORK, MAY, 1904.

No. 3.

*The National Phonograph Co.,*

ORANGE, N. J.

NEW YORK: 83 CHAMBERS STREET.

CHICAGO: 304 WABASH AVENUE.

SAN FRANCISCO: 933 MARKET STREET.

NATIONAL PHONOGRAPH CO., LTD., 25 CLERKENWELL  
ROAD, LONDON, ENG.

## EDISON PHONOGRAPHS AND RECORDS.

All communications to THE PHONOGRAPH MONTHLY should be addressed to the Advertising Department, 83 Chambers Street, New York.

### C O N T E N T S

National Phonograph Exhibit at St. Louis..	1
Advance List of Edison Gold Moulded Records for June.....	2
Bicycle and Phonograph Popularity Compared .....	3
Dealers Should Have Catalogues .....	3
Criticism Wanted.....	3
An Important Decision .....	4
Dealers Get into a Rut .....	5
Printed Matter .....	5
Odds and Ends .....	5
Edison Records Can Not be Sold at Auction	6
I. C. S. Building at St. Louis .....	6
More British Records.....	6
Mr. Rapke's Printed Numbers .....	7
The Phonogram.....	7
Another Injunction Against Switky.....	7
Comments on June Records.....	8
Important Notice.....	9
What the Trade Says.....	10
After German Infringers .....	11
Keeping Record Stocks .....	12
A Jobber's Approval .....	12
Suspended List, May 1, 1904.....	13
New Border Electros .....	14
Jobbers of Edison Phonographs and Records	15

## NATIONAL PHONOGRAPH CO. EXHIBIT AT ST. LOUIS.

The exhibit of the National Phonograph Co. at the Louisiana Purchase Exposition, at St. Louis, will be one of purely Edison products. Nothing will be shown that was not made at the factory of the Company, Orange, N. J. It will be thoroughly representative of the Company's output. Even the booth itself was made at the Edison factory. The exhibit will be located in Block 74, Space 178, in the Liberal Arts Building. It will be very attractive. The backboard will be white enamel with gold trimmings and plate glass doors. On either side there will be a pyramid of Edison Gold Moulded Records, each surmounted by a number of highly polished Phonograph horns. At the foot of the backboard the different types of Phonographs will be artistically arranged. Some of these machines will be made very attractive by being gold plated, nickel plated and highly decorated. A large Concert Phonograph will stand in the center and be used for exhibiting the Records.

A most interesting feature of the exhibit will be the first public display of the new Edison Business Phonograph. The various types will be shown, and all interested will be given an opportunity of learning with what ease the Phonograph may be used for dictation purposes.

The exhibit will be in charge of Frank E. Madison. For the first two months he will have the assistance of C. L. Hibbard, who will have especial charge of the Business Phonograph. Edison Jobbers and Dealers who may visit St. Louis are invited to call and make the acquaintance of Mr. Madison and Mr. Hibbard. It is expected that some of the officials of the Company or department heads will be at the booth at different times during the summer.

**THE ADVANCE LIST OF JUNE RECORDS APPEARS ON PAGE 2. ORDER FROM IT. NO OTHER ADVANCE LIST WILL BE ISSUED.**



## ADVANCE LIST OF NEW EDISON GOLD MOULDED RECORDS FOR JUNE, 1904

RECORDS listed below will be ready for shipment as near June 1st as possible, at which time Jobbers' stock orders, if placed prior to May 15th, will be shipped. June Supplements will be forwarded to Jobbers with their stock order for Records. Retail Dealers should place stock orders with their Jobbers at once, to insure prompt shipment as soon as Jobbers' stock is received.

- |      |  |                              |
|------|--|------------------------------|
| 8699 | Ramona (Indian Intermezzo)   | Edison Military Band         |
| 8700 | All Aboard for Dreamland<br><i>Harry Von Tilzer's new "Summer" waltz song hit with orchestra accompaniment.</i>  | Byron G. Harlan              |
| 8701 | Evening Chimes (with Chimes)   | Mendelssohn Mixed Quartette  |
| 8702 | Awakening of Spring (Romanze)  | Edison Symphony Orchestra    |
| 8703 | The Ghost That Never Walked<br><i>Comic song from "Piff, Paff, Pouf" with orchestra accompaniment.</i>   | Bob Roberts                  |
| 8704 | Rube Haskins' Trip on His Airship<br><i>Flying over Ireland, Germany, Turkey, Port Arthur, the Philippines and return to America.</i>                        | Len Spencer and Parke Hunter |
| 8705 | My Little Love-Bird<br><i>Descriptive love song from "The Girl from Kay's" with orchestra accompaniment.</i>   | Harry MacDonough             |
| 8706 | Medley of Southern Patriotic Airs<br><i>Introducing "Dixie," "The Bonnie Blue Flag" and "Old Folks at Home."</i>   | Edison Military Band         |
| 8707 | The Goo-Goo Man<br><i>Comic song hit from "The Isle of Spice" with orchestra accompaniment.</i>  | Arthur Collins               |
| 8708 | Old Jim's Christmas Hymn<br><i>Introducing "Rock of Ages," tenor and baritone duet with chimes and orchestra accompaniment.</i>                              | Campbell and Harrison        |
| 8709 | Du Du Lichs Mir Im Herzen (or The Wearin' of the Green)<br><i>Comic descriptive Irish song with orchestra accompaniment.</i>                                 | Edward M. Favor              |
| 8710 | Slavery Days (Plantation Series No. 1)<br><i>Descriptive singing and talking selection.</i>  | Edison Male Quintette        |
| 8711 | Beauty's Cunning (Gavotte)<br><i>From the opera "May Queen."</i>   | Edison Symphony Orchestra    |
| 8712 | Down on the Brandywine<br><i>Coon love song male duet with orchestra accompaniment.</i>  | Collins and Harlan           |
| 8713 | The Prettiest Little Song of All (Schottische)<br><i>Bell solo with orchestra accompaniment.</i>   | Albert Benzler               |
| 8714 | Then and Now<br><i>Sentimental song with orchestra accompaniment.</i>  | James F. Harrison            |
| 8715 | Listen to the Mocking Bird<br><i>Contralto and basso duet of Septimus Winner's famous old song with orchestra accompaniment.</i>                             | Miss Morgan and Mr. Stanley  |
| 8716 | On the Wings of Love<br><i>Soprano and baritone duet with orchestra accompaniment.</i>   | Francelli and Lewis          |
| 8717 | Noisy Bill (Characteristic March)  | Edison Military Band         |
| 8718 | It's the Band<br><i>A spirited march song with orchestra accompaniment.</i>  | Byron G. Harlan              |
| 8719 | For de Lawdy Sakes Feed My Dog<br><i>Coon song with orchestra accompaniment.</i>   | Arthur Collins               |
| 8720 | I Love You All the Time<br><i>Descriptive love song with orchestra accompaniment.</i>  | Harry MacDonough             |
| 8721 | The Mule Song (Characteristic)<br><i>Descriptive male duet with orchestra accompaniment.</i>   | Collins and Harlan           |
| 8722 | Meet Me in St. Louis, Louis ("Meet Me at the Fair")<br><i>Waltz song with orchestra accompaniment.</i>   | Billy Murray                 |
| 8723 | Good Bye Fedora Medley<br><i>Introducing "Good Bye, Fedora," "On a Good old Trolley Ride," "Nancy Lee," "Cordalia Malone" and "The Man in the Overalls."</i> | Edison Military Band         |

Edison Gold Moulded Records are made only in Standard size. Both Standard and Concert Records may be ordered from this list. Order by Number, not title. If Concert Records are wanted, give the number and letter C.

### BICYCLE AND PHONOGRAPH POPULARITY COMPARED.

"The claim is occasionally made that the Phonograph is a fad, as was the bicycle a few years ago," recently said a New Yorker, who has been identified with the talking machine business for years and who is well known to the Eastern trade. "In my opinion there is no similarity between the two, and there is little likelihood of the Phonograph losing its popularity in the way that the bicycle did. In the first place the Phonograph is essentially a device for home amusement and its natural tendency is to keep the family at home and amused. The bicycle, on the contrary, takes one or more members away from the home and furnishes amusement for them only, those remaining behind having no part in their pleasure. The bicycle ceased to be a fad among the wealthy and better classes when they became so cheap that the poor could buy them, and when cycling ceased to be the fad of the fashionable, the many imitators of the latter also gave it up.

"The Phonograph never has been the fad of the wealthy and never will be. Money provides too many other means of gratifying musical tastes. Many wealthy families have Phonographs and enjoy them, but they also have pianos or other musical instruments, and they are constant patrons of the opera and theatre.

"The popularity of the Phonograph is greatest among the masses—people with less means and fewer opportunities for musical gratification. In thousands of homes—and good homes, too—it is the only musical instrument. In many homes that have pianos the Phonograph is the more popular instrument because no skill is required to play it. Then, too, there is always a new interest in the Phonograph due to the never-ending supply of new music. So long as songs and instrumental music continue to be popular, just so long will the Phonograph continue to grow in popularity. And who will care to fix a time when music will cease to be popular?

"For every person who tires of the Phonograph and puts it aside there are a hundred others who will eagerly buy one and enjoy it with even greater zest. The improvements constantly being made in the manufacture of Phonographs and Records are cutting down the number of persons who are tiring of them and are inducing many to take a renewed interest in the machines that they had put aside.

"If I were called upon to make a prediction I should have no hesitancy in declaring my

belief that the demand for Phonographs will be greater in the future than it has been up to the present time. I am unable to see how it can be otherwise. Certain it is that there is no similarity between the Phonograph and the bicycle, and the decline of the latter will never be duplicated in the Phonograph."

### DEALERS SHOULD HAVE CATALOGUES.

Occasionally we learn of a Dealer in our goods who hasn't a single catalogue in his store. Investigation shows that he is located some distance away from his Jobber and does not order goods frequently enough to keep supplied with catalogues. This is a condition that should not exist. We want every Dealer to have at least a few catalogues and while we are not anxious to send catalogues by mail, we would rather pay postage on a few than have prospective purchasers write that their Dealers cannot give them a catalogue. Dealers away from cities having Jobbers are therefore asked to write us if they cannot otherwise get a few catalogues.

### CRITICISM WANTED.

Jobbers receiving sample Records each month will do our Record Department a favor if they write a frank criticism of each list as a whole and singly, stating why they approve certain Records and do not like others. This department especially wants the views of Jobbers concerning the Records they do not think good. No other use will be made of these letters than to furnish information to the Record Department. Candid criticism and suggestion of this kind will be beneficial to the trade.

### RECORD SHIPMENTS.

We are continuing to gain on the shipments of new Records each month. The last of the orders for April Records were shipped on April 11. Unless the unexpected happens we will be even nearer the first of the month with May shipments.

### HINTS.

To maintain a good, lively interest among your trade, order new records each month. Secure the name of every talking machine user and send him the supplements as issued. Keep up your regular stock; order once a week, at least, and as early in the week as possible. Display the machines and supplies conspicuously—makes new trade.—*From the April Advance List to Dealers of the Penn Phonograph Co.*



**AN IMPORTANT DECISION.**

An important opinion was, on March 10th, handed down by Judge Van Devanter, of the United States Circuit Court of Appeals for the Eighth Circuit, in the suit brought by the National Phonograph Company against Christopher W. Schlegel and Thomas N. McNevin, doing business at Davenport, Iowa, under the name of Schlegel-McNevin Piano Company, for price cutting. Judge Van Devanter's opinion is concurred in by Judges Sanborn and Thayer of that court. The suit in question was originally decided by Judge McPherson, of the United States District Court for the Southern District of Iowa, who held that our agreement was "one that stifles trade," notwithstanding the fact that the agreement had been sustained in all the Circuit Courts east of the Mississippi. The Circuit Court of Appeals did not agree with this opinion of Judge McPherson's, and in the decision in question they reversed the decree and decided in our favor on all points, entering a decree enjoining defendant from violating our Agreement. We quote from the decision:

"An unconditional or unrestricted sale by the patentee or by a licensee authorized to make such sale, of an article embodying the patented invention or discovery passes the article without the limits of the monopoly and authorizes the buyer to use or sell it without restriction, but to the extent that the sale is subject to any restriction upon the use or future sale the article has not been released from the monopoly but is within its limits and, as against all who have notice of the restriction, is subject to the control of whoever retains the monopoly. This results from the fact that the monopoly is a substantial property right conferred by law as an inducement or stimulus to useful invention and discovery, and that it rests with the owner to say what part of this property he will reserve to himself and what part he will transfer to others, and upon what terms he will make the transfer. *Bement v. National Harrow Co.*, 186 U. S. 70; *Victor Talking Machine Co. v. The Fair* — C. C. A. —, 123 Fed. 424; *Dickerson v. Tinling*, 28 C. C. A. 139; 84 Fed. 192; *Heaton-Peninsular Button-Fastener Co. v. Eureka Specialty Co.*, 25 C. C. A. 267, 77 Fed. 288; *Cortelyou v. Lowe*, 49 C. C. A. 671, 111 Fed. 1005; *Edison Phonograph Co. v. Kaufman* 105 Fed. 960; *Edison Phonograph Co. v. Pike*, 116 Fed. 863; *Fowle v. Park*, 131 U. S. 88; *Garst v. Harris*, 177 Mass. 72. After mentioning limitations which attach to all property rights under the general law of the land, none of which is applicable to the facts of this case, it is said in *Bement v. National Harrow Co.*, supra pp. 91, 93:

"Notwithstanding these exceptions, the general rule is absolute freedom in the use or sale of rights under the patent laws of the United States. The very object of these laws is monopoly, and the rule is, with few

exceptions, that any conditions which are not in their very nature illegal with regard to this kind of property, imposed by the patentee and agreed to by the licensee for the right to manufacture or use or sell the articles, will be upheld by the courts.'

"The provision in regard to the price at which the licensee would sell the article manufactured under the license was also an appropriate and reasonable condition. It tended to keep up the price of the implements manufactured and sold, but that was only recognizing the nature of the property dealt in, and providing for its value so far as possible. This the parties were legally entitled to do. The owner of a patented article can, of course, charge such price as he may choose, and the owner of a patent may assign it or sell the right to manufacture and sell the article patented upon the condition that the assignee shall charge a certain amount for such article.

"It was urged in that case that the stipulation respecting the price to be demanded was violative of the act of Congress of July 2, 1900, 26 Stat. 209, upon the subject of trusts and unlawful combinations, but the court held otherwise, saying, p. 92:

"But that statute does not refer to that kind of restraint of interstate commerce which may arise from the reasonable and legal conditions imposed upon the assignee or licensee of a patent by the owner thereof, restricting the terms upon which the article may be used and the price to be demanded thereof. Such a construction of the act we have no doubt was never contemplated by its framers.'

"The condition against sales to retail dealers who do not sign a similar agreement governing sales by them was imposed by complainant in the legitimate exercise of its property right in the monopoly and for the purpose of rendering it valuable. The complainant had the same right to require that such an agreement be exacted from defendant's vendees that it had to demand it from defendants. Any sale by defendants outside of the terms of the under-license or contract was an invasion of complainant's lawful monopoly.

"The contract which the parties had made and which defendants were violating was a valid one, and upon the allegations of the bill, confessed by defendants and declared by the court to be not collusive, there should have been a decree for complainant."

**CALL ROLL BY PHONOGRAPH.**

An interesting incident of the meeting of the Society of Old Brooklynites, in Brooklyn on April 3d, was the recording by Phonograph of the names of the members present. The Phonograph will be used at the May meeting in calling the roll.

**ARE BEAUTIES.**

The March Records are beauties, and I think one of the finest lists gotten up since I have been handling Edison goods.

Los Gatos, Cal.

Z. J. LEFEVRE.

**DEALERS GET INTO A RUT.**

Too many of our Dealers get into a rut in selling Records. There is too much of a tendency to push one or two Records which appeal to the Dealer personally, or to his clerk, or whoever may be in charge of the Record stock. The result is that a demand is created for one or two selections each month at the expense of other selections equally good or better, and after a while the Dealer has accumulated a lot of Records which he calls slow sellers or unsalable Records, while to a very large extent the Dealer himself has created this very difficulty.

As an illustration I will cite the following: About one year ago I was calling upon one of our Jobbers who was waiting upon a retail customer. The customer had just purchased a Record of another make and was playing it on an Edison Phonograph. The Jobber turned to me and said: "Why don't the National Phonograph Company make that?" I looked at the record and found it a selection which we had had in our catalogue for a year or two and told him to hunt up our No. 521. He did so and played it, and his customer immediately bought it. The Jobber remarked to me: "Why, I didn't know that was in the catalogue!" Since then this Jobber has retailed over 100 of this selection alone. (Our 521, "Donan Wiebschen," the record referred to, was brought out by another company and called the Simplicius Waltz.)

Of course we all know that tastes differ, and that some records are naturally more popular than others; but the point is, that the Dealer is too prone to push what he personally likes, while the same amount of effort applied to the entire list would create a demand for many very fine records, which are now neglected.

GEORGE M. NISBETT.

[Mr. Nisbett is connected with our Chicago office.]

**PHONOGRAPH ENTERTAINMENT.**

"An Evening with the Phonograph, or Edison's Wonderful Talking Machine," was the title of an entertainment given under the auspices of the Oakland Culture Club, at Chicago, April 6. Mr. and Mrs. George M. Dugan furnished the machines and Records and gave the entertainment. In addition to playing nearly fifty different Records, Mrs. Dugan read a very interesting paper outlining the life of Thomas A. Edison, and Major A. W. Clancy gave a very interesting history of the Phonograph from earliest times to the present. It was a most enjoyable evening and appeared to be thoroughly appreciated by the large audience present.

**PRINTED MATTER.**

We have had printed a folder giving full information, with illustrations, for the adjustment or repair of Edison Models B, C and D Reproducers and the Edison Recorder. Jobbers and Dealers who find it necessary to have information of this kind are asked to write for a copy of Form No. 553.

It is expected to have a new catalogue of Foreign Records, Form No. 555, ready in May. Until it appears orders for Foreign Record Catalogues will be filled with small quantities of No. 381. The new catalogue will have an attractive cover of brown, light blue and gold. This cover and also that of the Domestic Record Catalogue, Form No. 545, will probably be used for two or more editions.

Dealers who can use to advantage Form No. 535 (folder showing four machines on inside pages) and Form No. 540 (folder on Records), should arrange to get them from their Jobbers. If orders are placed direct with this company, shipping instructions must be given that will make it unnecessary for us to pay transportation charges.

**ODDS AND ENDS.**

The *Talking Machine News*, of London, England, compliments the EDISON PHONOGRAPH MONTHLY by making liberal use of matter found in its columns each month, but it invariably forgets the trifling matter of credit.

The John M. Dean Company, Jobbers at Providence, R. I., sends a copy of its annual catalogue. A picture of its store appears on the cover, and the most prominent sign shown in the picture is one of Edison Phonographs. Two of the sixty-four pages in the catalogue are devoted to the Edison product.

Alfred K. Hobbs, Dealer at Manchester, N. H., announced the receipt of his stock of Edison Records for April with advertisements three columns wide and eight inches deep in two city papers. The advertisements gave the April list in full. The same course was pursued by William Keller, a Dealer at Easton, Pa. As a result of their progressiveness, both do a nice business in Edison goods.

A young lady at Asbury Park writes: "I have an Edison Home Phonograph, and am perfectly delighted with it. After hearing every variety of talking machines am satisfied that no such marvelous results could be obtained by any other than that bearing the name of Thomas A. Edison."



### EDISON GOODS CANNOT BE SOLD AT AUCTION.

The circumstances herewith show with what promptness the National Phonograph Company takes action when it learns of the intention of any one, whether he has signed an agreement or not, to sell our goods at cut prices.

Information reached our New York office on April 27th to the effect that at 10.30 A. M. on the following day a lot of Edison Gold Moulded Records and Edison Phonographs would be sold at auction at 2,212 Seventh avenue, New York city. Application was at once made to Judge Lacombe for an order restraining the owners of the goods in question and the auctioneers who were to hold the sale from disposing of the goods at less than retail prices. Judge Lacombe granted the order and it was immediately served, causing a postponement of the sale until the owners of the goods could show that it was their intention to comply with our patent rights.

### THE I. C. S. BUILDING AT ST. LOUIS.

The Edison trade who are interested in the subject of language study are cordially invited by the International Correspondence Schools of Scranton, Pa., to visit their handsome building at the Louisiana Purchase Exposition.

A large part of the building will be devoted to the demonstration of the languages, including French, German and Spanish, and an English course for some twelve foreign nations. This latter course opens up a greater field for the Edison Phonograph, and should be of considerable interest to the trade.

The attention of the trade is called to the desirability of using the I. C. S. building for a headquarters, especially if there are any ladies in the visiting party. The second floor is devoted to the comfort of the visitors, and here they may receive their mail, deposit their packages, and the ladies may enjoy the comforts of a special room with attendants.

### HEARING NEW RECORDS.

The plan of this company of sending sample Records to Jobbers each month has met with the approval of the entire number, all agreeing that it enables them to place orders with greater discrimination than before. In order that their Dealers may in turn be able to place orders with the same discrimination, a number of Jobbers now fix upon a night and invite their Dealers to call and hear the Records played. This has also resulted in enjoyable evenings for all hands, because of the opportunity of meeting one another and exchanging opinions.

### MORE BRITISH RECORDS.

Below are published twenty-eight additional British Records which have not yet been listed for use in the United States and Canada. Orders for any of them, if received by May 15th, will be shipped with June Records. Since the twenty-eight selections published last month and those listed below will appear in the next edition of Foreign Record Catalogues, Form 555, to be ready in May, no special list of British titles will be issued.

- 12931 I've Got Something to be Thankful for  
Leonard Mackay
- 12932 Fleeting Moments Galop British Military Band
- 12933 Bravo Dublin Fusiliers British Military Band
- 12934 Selection of Scotch Airs British Military Band
- 12935 Am I in the Way Leonard Mackay
- 12936 I'm the Plumber Leonard Mackay
- 12937 Viscount Nelson March British Military Band
- 12938 Selection of Popular Songs No. 6  
British Military Band
- 12939 Forget-me-not Intermezzo  
British Military Band
- 12940 Bundle of Mischief British Military Band
- 12941 Hot Stuff Cake Walk British Military Band
- 12942 Selection from Belle of New York No. 2  
British Military Band
- 12943 If I were King of England Albert Whelan
- 12944 The Coster Serenade Albert Whelan
- 12945 Here, There and Everywhere  
British Military Band
- 12946 Selection from Patience  
H. M. Grenadier Guards' Band
- 12947 What I Have I'll Hold Leonard Mackay
- 12948 The Passing of Ragtime British Military Band
- 12949 Overture to Massaniella  
H. M. Grenadier Guards' Band
- 12950 Has Anyone Been Asking for Me  
Leonard Mackay
- 12951 Yo Ho Little Girls (from A Country Girl)  
Leonard Mackay
- 12952 Kelvin Grove Thomas Reid
- 12953 My Flo from Pimlico Leonard Mackay
- 12954 La Reine de Saba British Military Band
- 12955 Selection of Irish Airs British Military Band
- 12956 Valse Bleue British Military Band
- 12957 Always in Jail Albert Whelan
- 12958 It's a Marvel 'ow 'e do it but 'e do  
Albert Whelan

### RECORD PLAYING BY TELEPHONE.

"I have been reading the articles about playing Records over the telephone," writes Harry Harmon, of Afton, Ia. "I have the long distance 'phone in the store, and on Sundays, and some other days, we have a concert. I have had a dozen or more towns on the line at the same time, and part of the towns had most of the patrons of their local switchboard on. We played to towns north, south, east and west, all at the same time. Some of the towns were over 100 miles away. They could hear every word distinctly. The way I work it is to put a thirty-inch brass horn on the machine and another one, about twenty-four inches, on the 'phone, with the small end in the transmitter to the telephone, leaving about sixteen inches space between the horns. It seems to me that every order of Records I get is better than the last one."

**THE PHONOGRAM.**

Beginning with July, we will republish *The Phonogram*. It will *not* take the place of the EDISON PHONOGRAPH MONTHLY, which is printed for trade use only, nor will it affect the printing of the Monthly Record Supplements. It will be issued for *retail trade use only*. Its subscription price to the public per year will be Twenty Cents; single copies, two cents. It will be the same size as before,  $3\frac{1}{2} \times 6\frac{1}{8}$  inches, 16 pages, and will go in a No. 6 $\frac{3}{4}$  envelope. It will weigh less than one ounce per copy. It will be neatly printed on smooth paper.

Each issue will contain a list of new Records for the month and "Comments" on the same, taken from the PHONOGRAPH MONTHLY. Another regular feature will be half-tone pictures of the "talent" making our Records. Special features from time to time will be articles on the care and operation of Phonographs, on making Records at home, on special lists of Records, references to Records of unusual merit, the words of a selection occasionally, and matters of general interest.

In a word, we hope to make it a publication that will assist in the sale of goods. It will interest the man who does not own a Phonograph and induce the Phonograph owner to continue to buy Records. No advertising of any kind will be accepted for it.

*The Phonogram* will be supplied to the trade at the rate of \$2.50 per 1,000, or 25 cents per 100, Blank. Postage extra.

It is expected that the *Phonogram* will take the place of the "Comments" on new Records, now being printed in sheet form, but the latter will still be printed for those who insist upon having them.

**ANOTHER INJUNCTION AGAINST SWITKY.**

In addition to the injunction recently granted, enjoining David Switky, of New York city, doing business as the Bronx Phonograph Company and the Central Phonograph Company, from selling Edison Phonographs at cut prices or with obliterated serial numbers, a second injunction has just been granted by Judge Lacombe, of the Circuit Court of the United States for the Southern District of New York, enjoining Switky "from directly or indirectly using or causing to be used, selling or causing to be sold, or advertising to sell any apparatus, articles or devices embodying or constructed or operating in accordance with the inventions and improvements set forth and claimed in said letters patent Nos. 382,462, 382,418 and 414,761 or either of them, at prices lower than those at which they are authorized by said complainants to be sold at retail, as set forth in schedules 1 and 2 of the bill of complaint, viz.: Edison Records (Standard size) at fifty cents apiece or five dollars a dozen, (if full dozen is sold at one time), Edison Concert Records at one dollar each, or twelve dollars a dozen."

**PERSONAL.**

John Otto, for the past eight years with Siegel, Cooper & Company, of Chicago, has entered the employ of the Chicago branch of R. Wurlitzer and Company, of Cincinnati, and will have charge of the retail Phonograph Department which they have just opened.

**MR. RAPKE'S PRINTED NUMBERS.**

The above cut shows how Victor H. Rapke, of 1661 Second avenue, New York, arranges his stock of Edison Gold Moulded Records, using the new numbers that he has just had printed for trade use. We regard Mr. Rapke's

enterprise as of benefit to the entire trade, and for this reason are printing in these columns what seems like advertising. The illustration shows how easily the numbers may be read and how readily missing Records may be determined.



### COMMENTS ON JUNE RECORDS.

Of excellent variety and unusual merit is the list of Edison Gold Moulded Records for June. The list comprises the customary twenty-five and an analysis of them shows the following: Four band Records, two orchestra, one bell solo, ten vocal solos, five vocal duets, one quartette, one quintette and one talking. Every Record, too, is representative of the progressive methods used by the Record Department of the National Phonograph Company. Most of the selections were made at the new Record plant in New York city. The following comments will give a scarcely adequate idea of the excellence of each:

No. 8699, "Ramona" (Indian intermezzo), by the Edison Military Band, is a composition by Lee Johnson, of San Francisco, which is widely known on the Pacific Coast and is rapidly growing in popularity in the East. It is being played by the more prominent bands. The music is intended to be of an Indian character. The Record is unique, and at the same time pleasing.

No. 8700, "All Aboard for Dreamland" is Harry Von Tilzer's new summer waltz song hit. It is sung by Byron G. Harlan, with orchestra accompaniment. The words were written by Andrew B. Sterling, and are suggestive of a Sunday outing in summer. Mr. Harlan makes the Record in good style.

No. 8701, "Evening Chimes," is a most attractive charming Record by the Mendelssohn Mixed Quintette. The voices of the singers blend most perfectly and the ringing of chimes is a pleasing feature. The music of this selection was written by L. O. Emerson.

No. 8702, "The Awakening of Spring" (romanze), is a fine Record of Bach's beautiful composition. The Record is made by the Edison Symphony Orchestra in a most artistic manner. The work of the violin is especially good.

No. 8703, "The Ghost That Never Walked," is a comic song now being featured in "Piff, Paff, Pouf." It is sung by Bob Roberts, with orchestra accompaniment. The "Ghost That Never Walked" is that creature of theatrical life who fails to make his appearance on salary day. The words of this song are by William Jerome and the music by Jean Schwartz. Mr. Roberts' good voice and distinct articulation make this a good Record.

No. 8704, "Rube Haskins' Trip on His Airship," is another of Len Spencer's clever talking Records in which he is assisted by Parke Hunter, as *Ezra*. The Record is a two-and-a-half-minute trip around the world by the airship, passing over Ireland, Germany, Turkey, Port Arthur, the Philippines, and over the Rocky Mountains back home. The whistling of the wind which might naturally accompany so rapid a trip is distinctly heard.

*Rube Haskins* has funny things to say about each country passed over and *Ezra* enlivens the trip with his whistling. This Record is an excellent addition to the Haskins' series.

No. 8705, "My Little Love-Bird," is a descriptive love song as sung by Hattie Williams in "The Girl from Kays." It is a song of the dove to his mate. The Record is made by Harry MacDonough with orchestra accompaniment, and is a good one in every respect, fully up to Mr. MacDonough's usual standard. The words and music of this selection were written by Maurice J. Stonehill.

No. 8706, "Medley of Southern Patriotic Airs," is a Record made in compliance with a request from some Southern admirers of the Phonograph that we should list something instrumental of a distinctly Southern character. We believe that this Record will meet the approval of our friends. It introduces "Dixie," "The Bonny Blue Flag," and "The Old Folks at Home." The Edison Military Band does the playing in a very satisfactory manner.

No. 8707, "The Goo Goo Man," is a song hit from the musical extravaganza, "The Isle of Spice." It is admirably sung by Arthur Collins, with instrumental accompaniment, the latter being very attractive. The music of this song was written by Paul Schindler and the words by Ben Jerome.

No. 8708, "Old Jim's Christmas Time," is a title that was most popular in the days of the wax Records, but which was not re-made by the new process. It is now being made over in the best possible manner. It is a Record that cannot fail to be popular, and it will be one of those Records that will continue popular for years. It is made as a tenor and baritone duet by Campbell and Harrison. It introduces "Rock of Ages," the playing of chimes, and has an orchestra accompaniment. The work of these two artists is delightful. William B. Gray wrote both the words and music of this almost classic selection.

No. 8709, "Du Du Lichs mir im Herzen" ("The Wearin' of the Green"), is a comic and yet clever mixture of Irish and Dutch dialect and singing. The title itself furnishes some idea of how funny the Record may be. It is excellently sung by Edward M. Favor with orchestra accompaniment. This composition is the work of Heelan and Helf.

No. 8710, "Slavery Days," is the first of a plantation series by the Edison Male Quintette. The series will comprise three Records, which together will tell an interesting story of slavery life in the South, although each Record will be complete in itself. No. 1 opens with a scene on a river wharf, with a steamboat about to leave. The darkies are singing "Down in Florida" as the boat is being loaded. The cry "All Ashore" is given when a slave overseer discovers that one of his slaves is missing. He threatens vengeance, when the lad appears, stating that he did not intend running away. The overseer starts to make good his threat when Uncle Jasper interferes on behalf of the boy and discharges the overseer. The slaves are given a holiday and the Record closes with their singing "Carve dat 'Possum."

Nos. 2 and 3 of the series will be given in later months.

No. 8711, "Beauty's Cunning," is a gavotte by Czibulka from the opera, "May Queen." It is played by the Edison Symphony Orchestra and is a delightful Record. The music is sweet and delicate and the instruments blend perfectly, the playing of the string instruments being particularly good.

No. 8712, "Down on the Brandywine," is a Record in which Collins and Harlan have produced some splendid duet effects. It is a coon slave song, reminding one forcibly of the plantation melodies of the South. The accompaniment is by the orchestra. Many will pronounce this Record one of the best on the June list. The words of this song were written by Vincent Byron and the music by J. B. Mullen.

No. 8713, "The Prettiest Song of All" (schottische), is a bell solo played by Albert Benzler, with orchestra accompaniment. Bells always make attractive Records, but this number is even better than the average. It will be a popular Record.

No. 8714, "Then and Now," is the first solo Record made for the Edison Phonograph by James F. Harrison. Mr. Harrison sang in a duet with Mr. Campbell in the May list, and his fine baritone voice was greatly admired. This solo Record by Mr. Harrison cannot fail to enhance the good impression made a month ago. His singing has the usual orchestra accompaniment. Louis Tocaben is the writer of the words and music of this song.

No. 8715, "Listen to the Mocking Bird," is beyond question one of the most beautiful Records ever listed by this company. It is a contralto and basso duet by Miss Morgan and Mr. Stanley, with orchestra accompaniment. Their delightful rendition of Septimus Winner's famous old song will be alike pleasing to the older ones who are familiar with it and the younger generation who have heard little of it.

No. 8716, "On the Wings of Love," is a soprano and baritone duet with orchestra accompaniment, which introduces new singers in Elma Francelli and Thomas Lewis. Their singing is quite unlike anything before put out by this company, and we predict a favorable reception for their effort. The words of this selection were written by Harry T. O'Brien and the music by H. O. Wheeler.

No. 8717, "Noisy Bill," is a characteristic march written by F. H. Losey, composer of the "Waldmere March," listed some time ago. It is well played by the Edison Military Band. Its unique character will make it popular.

No. 8718, "It's the Band," is a military march song, sung in a spirited manner by Byron G. Harlan with orchestra accompaniment. "It's the Band" that makes the soldier boys fight and die for their country. The words are by Andrew B. Sterling and the music by Max Hoffmann.

No. 8719, "For de Lawdy Sakes, Feed My Dog," is Arthur Collins' coon contribution for the month. This song is a coon's plea to have his dog fed even though he goes hungry

and thirsty himself. It is sung with orchestra accompaniment. The song is the work of Hughie Canon.

No. 8720, "I Love You All the Time," is a Record of the song sung with such success by Bessie Wynne in "The Wizard of Oz." This Record is admirably made by Harry MacDonough, with orchestra accompaniment. Will Anderson wrote the words and music.

No. 8721, "The Mule Song" (characteristic), is another clever descriptive male duet by Collins and Harlan. The feature of the Record is the dialogue between two coons. This song is the work of Robert Adams.

No. 8722, "Meet Me in St. Louis, Louis" ("Meet Me at the Fair"), is a waltz song with a swing that will carry it to popularity. It is well sung by Billy Murray, and has an orchestra accompaniment. The words are by Andrew B. Sterling and the music by Kerry Mills.

No. 8723, "Good-Bye Fedora Medley," is a continuation of our successful series of medleys. This number introduces "Good-Bye Fedora," "On a Good Old Trolley Ride," "Cordalia Malone," and "The Man in the Overalls." It is played by the Edison Military Band.

#### IMPORTANT NOTICE.

PRECAUTIONS THAT SHOULD BE TAKEN BY BUYER OR CONSIGNEE WHEN RECEIVING GOODS:

First. Before you give a receipt to a transportation company see that all the packages are in good order.

Second. If not in good order, state that fact (with particulars) on the receipt you give and take a copy of it.

Third. Goods that are crated and the contents of which can be easily looked over should be examined before receipt is given. If close examination cannot then be made, the right of later examination should be reserved. This also refers to goods shipped loose.

Fourth. All contents should be examined immediately and any damage should be reported at once to the transportation company, and claim made against it. This should be done promptly by you, as *all goods are shipped at buyers' risk.*

#### AN EDITOR'S KIND WORD.

The editor of the *Labelle* (Mo.) *Star* recently bought an Edison Phonograph and this is how he referred to the matter in the issue of April 8th:

The *Star* family is enjoying the evenings by listening to music from noted bands and musicians. This treat is due to the presence of an Edison Phonograph, purchased from L. G. Lamb, local agent. We do not think a better investment can be made than the purchasing of one of these wonderful machines. It adds to the pleasure of the home life and will keep your children at home at night, to say nothing of the pleasure we old people get out of the investment.



**WHAT THE TRADE SAYS.**

We are pleased to note the great increase of orders for Edison Records, not only for the new Records as they are issued each month but for the regular stock as well. Many Dealers who were selling the competitive record at twenty-five cents report their sales decreasing in that line and that their customers are expressing their choice for Edison Records. We hope those who are not already experiencing this change in the desires of the public may soon have that pleasure.—*May Advance List to Dealers of the Penn Phonograph Co., Philadelphia.*

Poor records make you apologize for the results. If you have an up-to-date Edison Phonograph and use Edison Gold Moulded Records, you can be proud of the results. *April Advance List of the Blackman Talking Machine Company, New York.*

Your article in April MONTHLY in regard to Dealers handling other than Edison goods just strikes me about right. While I am new in the business as a Dealer, I have had about six years' experience as a user of different records, and since I have become a Dealer I am more convinced than ever that Edison goods are far superior to any other, and then the people you sell to are of a better class.

Sidney, O.

H. O. WILES.

On Saturday nights I fix up my store and have a Phonograph concert. I play three or four Records and then I quote them prices on goods and give them a little talk on common topics. Also in the summer time on Sunday evenings I take a Phonograph to my house and put it on the porch and start it going. It is not long before I have a crowd of seventy-five to a hundred, and I think that is good for a small country village.

Ellsworth, N. Y.

E. L. DILLON.

Your methods of doing business are a continual source of pleasure and we often, when discussing the question of protecting the trade in connection with various other lines of goods we handle, point with pride to the methods of the National Phonograph Company and the Eastman Kodak Company. Gentlemen, you are doing the right thing, and the letters from various Dealers, published in the MONTHLY, evidence the fact that they appreciate the great amount of time and money you are expending annually to protect our mutual interests.

PICARD &amp; MOSS.

Jamestown, N. D.

Edison Records, like the Bank of England, are first with the intelligent public.

Prescott, Ont.

THOS. COATES.

Your method of selling goods is the right one, as every Dealer knows just where he is at. I do not think it a good plan to sell the cheap records, and for my part will handle none but Edison goods. I have invited some of the cheap machine advocates to bring in their machines and records and play them. When they were through I put up an Edison

Home and gave them some real music. I have not found one person but what says the Edison is so much ahead of any other that there can be no comparison.

Frankfort, Mich.

F. D. STELZER.

We will stand by Edison Phonographs and Records, and maintain prices with pleasure. Why not? The National Phonograph Company turns out (and always have) the best goods in the talking machine line in the world. Their plans of business as to maintaining prices and the quality of their output cannot help but be admired by the intelligent public.

THE C. F. JACKSON CO.

Norwalk, Ohio.

The Edison Gold Moulded Record is without a competitor when it comes to good music. Keep up the good work and I for one will try and dispose of all I can. I have never yet had a dissatisfied customer, as I handle no other make.

T. L. THOMAS.

Hazelton, Pa.

Your card of the 21st inst., referring to me, is at hand, and I have written him, giving as references a Home and a Standard Phonograph owner at that place, the latter outfit having been sold by me. I thank you for this favor, which, it is almost needless to say, is one of the features that encourage further the extension of the very best efforts to place Edison goods, the best on the market, from every standpoint, wherever a talking machine or records are bought. One of my Edison patrons, with a ———phone, ordered two of the new twenty-five cent records from Chicago and received but one of them. He expressed himself as thankful that the other did not come. He says: "Edison's are good enough for me, and I want that other title in one of them."

C. A. DODDS.

Sandoval, Ill.

The following is an extract from a letter from S. S. Sollee & Co., Dealers at Savannah, Ga., dated April 11, 1904: "The February and March Records have added new fame to the Edison Records, for no one could ask for better results, especially with regard to unmistakable improvement in tone."

How is this for an advertisement? I am agent for the Edison Phonograph, and I took this means to show the merit of Edison goods: I took an Edison Triumph Phonograph, with a good selection of Edison Gold Moulded Records and gave a free entertainment on the City Hall lawn. The consequence was that the next day I sold one Edison Standard and two Edison Gems, with five dozen Records. My machine could be heard for four blocks around. I think this is a very good scheme for my brother agents to adopt.

W. L. BROUSSARD.

New Iberia, La.

The other day a lady wanted me to call at her house and bring some Records. When I got there she told me that she had a dozen

of ——— records, but that she left them in a cold room and about all of them cracked. She asked me if the Edison Records would do the same. She bought a dozen of me. I saw her a week later, and she said they were as good as when she got them. She said she would always buy the Edison Records hereafter. I sell no other kind of record but the Edison, and I think that is the best way to get trade.

BERT G. SMITH.

Nichewaug, Mass.

The March Records are simply elegant. We are enclosing you a few of our advertisements in the State daily papers for our concert which we hold each month when we receive the Records. This has proven to be the best scheme for selling Records which we have ever had. Our store is large enough to hold 175 people, comfortably seated, and we have only had one night during the concerts when every seat in the house was not full, as well as standing room. One evening when the cold wind was blowing perhaps sixty miles an hour, our crowd only numbered forty persons. This all goes to show that the people of Lincoln appreciate Records which are sustained by their reputation and that are made with the clearness of tone that the Edison have.

H. E. SIDLES CYCLE Co.,  
Lincoln, Neb.

I don't know what to think of any dealer who cuts the price on Edison Gold Moulded Records. They are worth double the price asked for them. I sold a man two dozen Edison Records yesterday that has been buying the cheap records, and he said that he would not give ten cents apiece for any more of the latter. I think the Salt River will be full of the cheap records before very long. I will never keep any Records but the Edison Gold Moulded Records and the Edison Phonograph. I would rather go out of business than sell other records and talking machines.

W. H. DYER,  
Frederick, Md.

Your Gold Moulded Records for March, which I received a week ago, are certainly the finest that have ever come to this county, and I must congratulate you on your efforts in keeping the Edison in the lead. I don't handle cheap records simply for the reason that I want to give my customers their money's worth, and have no time for trash.

Crescent City, Cal. PETER DUFFY.

We are more than ever delighted with the Edison Records, and sincerely trust that you will not reduce the price. They are worth fifty cents now and for all time to come.—

WILLIAM H. KELLER, Easton, Pa.

"Hurrah for Edison Gold Moulded Records! Best in the world—either flat or cylinder makes."—E. N. WHITFORD, Great Cacapon, W. Va.

### AFTER GERMAN INFRINGERS.

The National Phonograph Company has been prosecuting in Germany infringers of the Edison patents in duplicating Edison Gold Moulded Records. It has already obtained some excellent decisions against individuals who have been copying its Records. The company published the following warning in the March 23d issue of the PHONOGRAPHISCHE ZEITSCHRIFT, published at Berlin, Germany:

#### WARNING.

The National Phonograph Company, hearing that worthless records are being sold in Germany and elsewhere under the appearance of genuine Edison Records, beg to bring the following warning before all concerned:

In English Courts of Justice certain persons have, within recent date, been condemned to severe punishments and have had to pay heavy costs for duplicating Edison Records and selling their duplicates.

Further, in Germany, has been lately decided against the defendant that the latter had no right to place Edison Records on the market, with the exception of those manufactured and sold by the National Phonograph Company, and at the same time a fine of Mk 500 was decided upon for each contravention of this decision.

We beg that any one, hearing of violation of our rights, will bring this to our notice.

NATIONAL PHONOGRAPH Co.,  
24-25, Suedufer, Berlin.

G. Croydon Marks, Representative of Thos. A. Edison for Europe.

### A UNIQUE ADVERTISEMENT.

L. R. Porter advertised the April list in the Brockton (Mass.) *Daily Enterprise* on April 16th, in this unique manner:

THE COLORED MAJOR in the BREEZE OF THE NIGHT met GENERAL HARDTACK ON GUARD in DEAR SING SING by UNCLE TOM'S CABIN. THE ROBIN AND THE WREN singing I'VE GOT A FEELING FOR YOU sat together IN A NUT-SHELL while the GEORGIA MINSTRELS down below sang KISS ME GOOD NIGHT DEAR LOVE and the band played LLEWELLYN MARCH. IN ZANZIBAR the MAN BEHIND, MR. BLACK MAN came DOWN FROM THE BIG FIG TEEE just as KING CARVIVAL passed by to the tune of ROSEDALE MARCH and NAVAJO MEDLEY holding a BUNCH OF VIOLETS which on THE 17th of MARCH you know are ALWAYS BEHIND LIKE AN OLD COW'S TAIL, and even BLUE BELL and the BIRDS OF SPRING as they marched to the HOLY GRAIL cried IF I WERE ONLY YOU!

### LANGUAGE COURSE DEMONSTRATION.

Yesterday afternoon a unique and delightful exhibition of the use of the Phonograph as an instructor was given at the Brooklyn Navy Yard in Building No. 23. Mr. Kelsey, who is the head of the department of phonography at A. D. Matthews' Sons, was in charge of the exhibition. A number of officers of the yard attended the exhibition, and appeared very much interested.

Professor Aol, who has been demonstrating the workings of the language phonograph at A. D. Matthews' Sons, for the past week, explained in a clear and comprehensive manner just how the instruction was accomplished.—*Brooklyn Citizen*, April 12th.



**KEEPING RECORD STOCKS.**

"I notice an article in your MONTHLY in reference to keeping stock," writes John P. Dougherty, Dealer at Chester, Pa. "I have found the best manner to be as follows:

"Have shelf boxes made about three inches wide, and twelve inches long, and three inches deep, so as to allow about two inches of second boxes to stand clear for easy handling. The Records will then stand above the boxes and show themselves, thus acting as an advertisement and relieving the monotony usually caused by a large number of box fronts. Then take the Numerical Catalogue and with a crayon marking-pencil mark the first box with the first four numbers and so on through catalogue, allowing four numbers to each box. I take it for granted, of course, that every man handling Records has shelving made for this purpose, twelve inches deep and five inches in the clear, to admit these stock boxes. Should any of your readers wish to try this system without incurring any expense for boxes, I am only too happy to inform them that every lady's furnishing store, where corsets are sold, throw out every week enough corset boxes of the exact size needed for Records, to supply all the dealers in the country, and will be only too glad to save them for any person who will take them out of their way.

"Another excellent thing in connection with this system is the ease with which orders can be made out. The Dealer never has to consult his catalogue numbers, being on his box-fronts he orders from his empties. Where he has several of a popular number he keeps one in his 'numericals' and the balance in an extra box or boxes, labelled 'Any Rags,' etc."

Do not think you have much to fear from the cheap record, as several of our customers who purchased them at first have turned in their entire lot. Our sales last week were one hundred and sixty-three Edisons against eight of the others—pretty near 16 to 1. Have noticed several methods of keeping Records. By ours, no matter how large the stock, you can have it on the machine the instant called for. We use the twelve-peg spindle box. Have these placed on slanting shelves all around the room at the right height to be handy. Keep each class of Record by itself; have one shelf for songs, one for band, one for instrumental solos, etc. We then arrange them in alphabetical order. For instance, some one asks for "Any Rags" song. We go to the shelf containing songs and find the Record in box A. In duets we label one box comic, one rube, one sentimental, and so on. We have found this the quickest and best way for you know right where the Record is and have no cotton to unwrap.

MUSICAL SUPPLY Co.

South Bend, Ind.

**A JOBBER'S APPROVAL.**

We can hardly find words to express our appreciation and approval of your article in the current issue of the EDISON PHONOGRAPH MONTHLY, relative to Edison Dealers handling the cheap records. We wish every Dealer

would read it carefully. If they would we are sure they would see the common sense of your argument. We have done all in our power to present good, plain arguments to the Dealer in favor of the Edison Record against the twenty-five-cent article, and in many instances we have been able to restrain the Dealer from handling the cheap product. During this week we have had several dealers express their pleasure at not having put in a stock of the cheap records and have thanked us for our advice. From interviews with a number of dealers in the past two days we know that they are doing all they can to induce the old and new trade to purchase Edison Records. We believe it is only a matter of time, and a short time at that, until the Dealers will handle only your Records. We hope the present prices will be maintained.

PENN PHONOGRAPH Co.,

Philadelphia.

**FROM TRADE ADVERTISEMENTS.**

Following are some phrases from a half-page advertisement by Thomas Wardell in the Lowell (Mass.) *Sunday Telegram*, of April 17th:

We have sold 1,000 Edison Phonographs in Lowell. Do you want any better proof of their superiority?

Talking Machines. No Pins to Change. No Scratches.

Edison Gold Moulded Records are in a Class by Themselves. They are much less brittle, and are never Harsh and Scratchy like cheap records.

Edison Records are Real Records. Edison Records played on an Edison Phonograph represent perfection.

An advertisement by L. R. Porter, of Brockton, Mass., in the Brockton *Daily Enterprise* of April 23d, contains the following:

If you want the Best talking machine in the world, buy this one, the Home. If you want the Best Records in the world, buy this kind, the Edison. (Cuts of an Edison Home Phonograph and an Edison Record accompanied these phrases.)

**BETTER THAN AN AUTOMATIC BANJO.**

Lowman & Hanford, Dealers at Seattle, Wash., send the following interesting incident:

A man came in our Phonograph Department and asked if we knew where he would be able to obtain an automatic banjo. He said he was very fond of banjo music, but played very little. We told him we did not think one was obtainable in the city, and asked him if he had heard any of the new banjo records on the Phonograph. He said he had not heard a Phonograph for two years. We put on the machine Record No. 8618, "Razzle Dazzle," banjo solo, and he was so pleased with the results that he did not look further for the automatic banjo, but bought a Home Phonograph with a \$10 horn and two dozen Records.

**A MONTANA DEALER'S EXPERIENCE.**

I received the EDISON PHONOGRAPH MONTHLY in this morning's mail, and I have read it from title page to back cover. I note where you state that many Dealers say that they could not continue in business if they didn't handle the Edison Phonograph. This is my case exactly. Without the Edison Phonographs and Gold Moulded Records I would have discontinued handling talking machines long ago. I do a great deal of canvassing all over Montana, and one day I carry a Phonograph, the next day a

phone. At many of the houses that I called at to exhibit the ————phone, I had one of the ———— machines, and when I stated that the price of same was \$20 the people would say: "Oh, I saw that very same ————phone advertisement in the ———— (some cheap monthly paper, published in the East), and the advertisement stated that if I would sell some bluing or soap, and forward the amount of \$3.60, I could have the ———— phone and a three-song record, etc." I beg to state that when I take along the \$20 Edison Phonograph I am never told that it can be had for selling soap, bluing or peanuts.

CHARLES S. MAGUIRE.

Walkerville City, Mont.

**SUSPENDED LIST, MAY 1, 1904.—SUPERSEDING ALL PREVIOUS LISTS.****COLORADO.**

BOULDER—BENTLEY & CRAIG.

**KANSAS.**

CLAY CENTRE—E. M. GOWENLOCK.  
LAWRENCE—BELL BROS.

**MAINE.**

\*BIDDEFORD—W. H. FIELD.

**MASSACHUSETTS.**

LAWRENCE—LORD & CO., 314 Essex street.  
E. O. MOSHER, 420 Essex street.  
MALDEN—A. T. FULLER.  
\*NANTUCKET—ARTHUR M. TAYLOR.  
NEW BEDFORD—H. B. DEWOLFF.  
WOBURN—OSBORN GILLETTE, or THE  
BOLTON JEWELRY COMPANY, L.  
F. MALONEY, Manager.

**MICHIGAN.**

DETROIT—F. J. SCHWANKOVSKY.  
SAGINAW—GEO. W. EMENDORFER.

**MISSOURI.**

KANSAS CITY—THE WITTMANN CO.

**NEBRASKA.**

LINCOLN—THE WITTMANN CO.  
OMAHA—THE WITTMANN CO.

**NEW HAMPSHIRE.**

NASHUA—F. A. McMASTER & CO.

**NEW JERSEY.**

ATLANTIC CITY—SAMUEL D. WOLF, 32-34  
Arkansas avenue.  
BAYONNE—I. WIGDOR, 450 Avenue D.  
JERSEY CITY—W. L. HOFFMAN, 151 Mont-  
gomery street.  
NEWARK—R. L. CORWIN; also New York  
City.  
PATERSON—CHAS. H. KELLY, 25 N. Main st.  
PLAINFIELD—S. W. FRUCHT, or R.  
FRUCHT; also New York City.  
ELSTON M. LEONARD.  
WEST HOBOKEN—EMIL HOLLANDER, or  
THE WEST HOBOKEN BICYCLE &  
PHONOGRAPH CO., 619 Spring street.

\*Added since April 1, 1904.

Jobbers and Dealers are asked to co-operate with us, FOR OUR MUTUAL GOOD, by being careful that they do not supply any of the above named firms with our apparatus, either at addresses given or any other address.

**NEW YORK.**

BEDFORD PARK—GEO. H. TYRRELL.  
HOBART—F. H. MARSHALL.  
NEW YORK CITY—A. T. ARMSTRONG, or  
AMERICAN PHONOGRAPH CO., 106  
Wall street.  
BRONX PHONOGRAPH CO., or DA-  
VID SWITKY, 506 Willis Avenue.  
CENTRAL PHONOGRAPH CO., 160  
E. 42d street.  
R. L. CORWIN; also Newark, N. J.  
EAGLE PHONOGRAPH CO., or C.  
LOWENTHAL, 83 Nassau Street.  
EMPIRE PHONOGRAPH CO., 2 West  
14th street.  
S. W. FRUCHT, or R. FRUCHT, 7 Bar-  
clay st., or 68 Cortlandt st.; also  
Plainfield, N. J.  
O. HACKER, 2 Murray street.  
HAWTHORNE & SHEBLE, 297 Broad-  
way; also Philadelphia, Pa.  
N. HORN, 148 E. 58th street.  
R. H. INGERSOLL & BRO., 67 Cort-  
landt street.  
W. L. ISAACS, 114 Fulton street.  
S. LEMBURG & CO., 194 Broadway.  
J. McELLYNNE, 202 Broadway.  
RICHMOND PEASE, 44 W. 132d st.  
F. M. PRESCOTT, 44 Broad street.  
SARATOGA—W. J. TOTTEN.  
SARATOGA SPRINGS—MARVIN A. COTE.

**OHIO.**

CINCINNATI—J. L. ANDEM.  
SPRINGFIELD—D. & M. VANDERPOOL.  
UHRICHVILLE—F. A. MAZURIE.

**PENNSYLVANIA.**

PHILADELPHIA—A. R. CASSIDY, 2783 Em-  
erald street.  
HAWTHORNE & SHEBLE, 604 Chest-  
nut street, or Oxford and Wascher  
streets; also New York City.  
PITTSBURG—A. LIPPARD, 615 Wylie avenue.

**RHODE ISLAND.**

PROVIDENCE—F. P. MOORE.

**WISCONSIN.**

MILWAUKEE—J. C. BLATZEK.



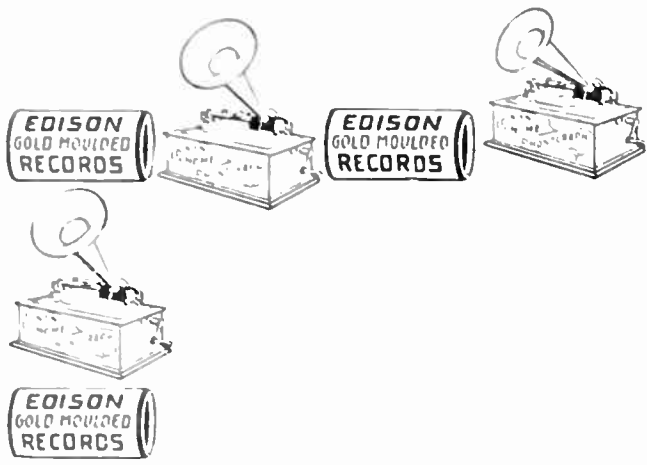

No. 476. 17c.

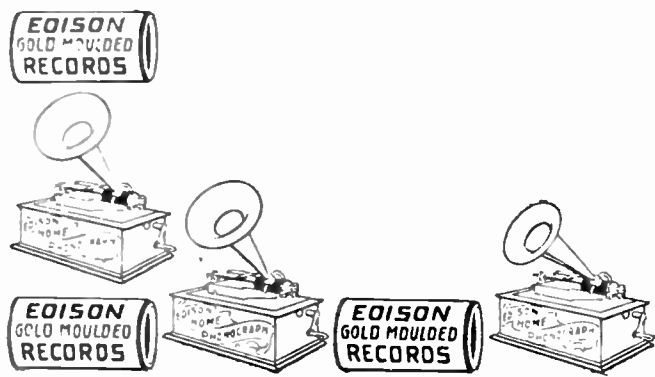

No. 477. 17c.

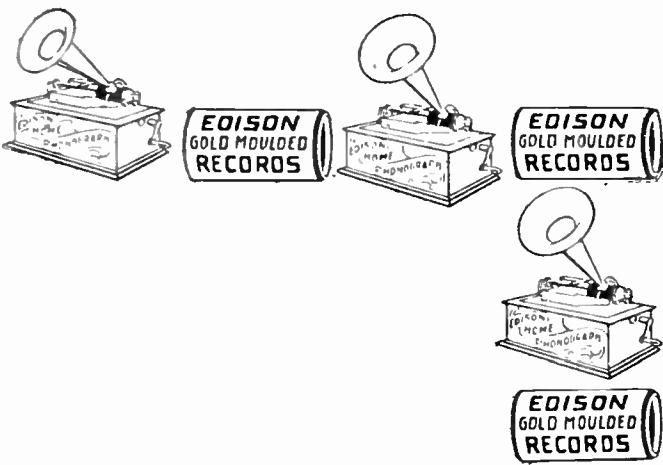

No. 478. 17c.

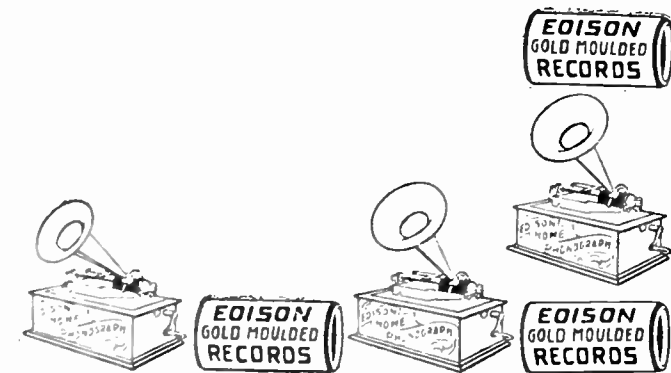

No. 479. 17c.



No. 475. 16c.

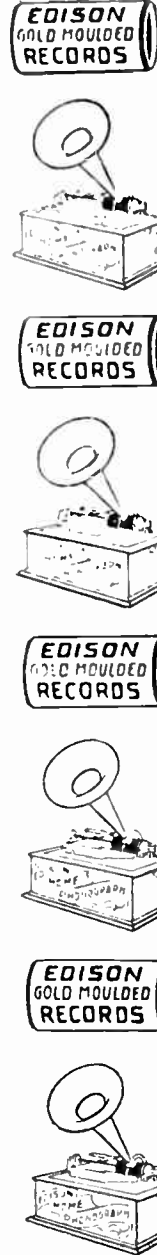

No. 473. 14c.



No. 472. 14c.

These electrotypes may be used to make any combination, and may be cut apart to make a border of any width or depth.

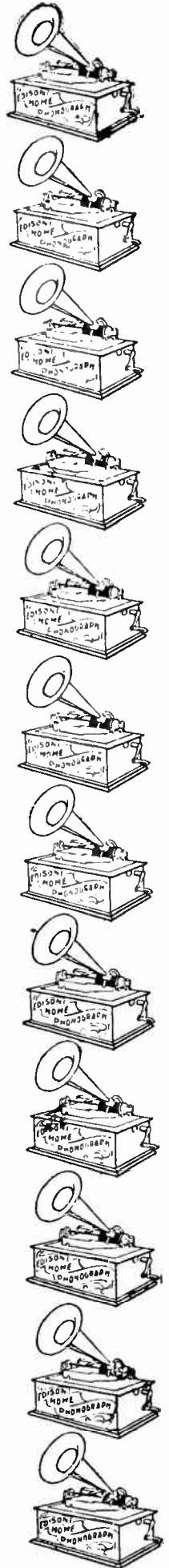

No. 474. 19c.

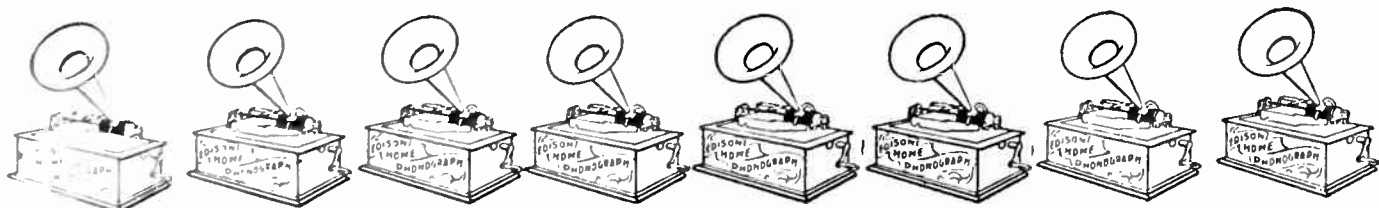

No. 480. 16c.

# NEW BORDER ELECTROTYPES.

## JOBBER OF EDISON PHONOGRAPHS AND RECORDS.

## ALABAMA.

**Birmingham**—The Ray Co., 2025 Second avenue.  
**Mobile**—The Ray Co., 54 Dauphin street.

## CALIFORNIA.

**San Francisco**—Peter Bacigalupi, 933 Market street.

## COLORADO.

**Denver**—Denver Dry Goods Co., 619 16th street.

## CONNECTICUT.

**Middletown**—Caulkins & Post Co., 406-408 Main street.  
**New Haven**—Pardee-Ellenberger Co., 155 Orange st.

## ILLINOIS.

**Chicago**—Kelley Cigar Co., 80-82 Wabash avenue.  
 James I. Lyons, 73 Fifth avenue.  
 The Ray Co., 90 Washington street.  
 Siegel-Cooper Co., State and Congress sts.  
 Talking Machine Co., 107 Madison street.  
 The Vim Co., 68 E. Lake street.  
 Montgomery Ward & Co., 111 Michigan ave.  
**Peoria**—Peoria Phonograph Co., 222 Bridge street.

## INDIANA.

**Indianapolis**—Craig-Jay Co., 234 Massachusetts ave.  
 Kipp Bros. Co., 37 S. Meridian street.  
 Wahl-Gaasch Co., 119 S. Illinois street.  
**Lafayette**—Wahl-Gaasch Co., 304 Main street.

## IOWA.

**Des Moines**—The Vim Co., 704 West Walnut street.  
**Fort Dodge**—Early Music House, 822 Central ave.

## KENTUCKY.

**Louisville**—The Ray Co., 640 Fourth street.

## LOUISIANA.

**New Orleans**—James I. Lyons, Theatre Arcade.  
 National Automatic Fire Alarm Co., 614  
 Gravier street.  
 The Ray Co., 111 Camp street.

## MAINE.

**Bangor**—S. L. Crosby Co., 186 Exchange street.  
**Portland**—W. H. Ross & Son, 207 Commercial street.

## MASSACHUSETTS.

**Boston**—Boston Cycle & Sundry Co., 48 Hanover street.  
 Eastern Talking Machine Co., 177 Tremont  
 street.  
 Oliver Ditson Co., 150 Tremont street.  
 Iver Johnson Sporting Goods Co., 163 Wash-  
 ington street.  
 Read & Read, 558 Washington street.  
**Fitchburg**—Iver Johnson Sporting Goods Co., 247 Main  
 street.  
**Lowell**—Ring Music Co., 112 Merrimac street.  
 Thomas Wardell, 111 Central street.  
**Worcester**—Iver Johnson Sporting Goods Co., 304 Main  
 street.

## MICHIGAN.

**Detroit**—American Phonograph Co., 106 Woodward  
 avenue.  
 Grinnell Bros. Music House, 219 Woodward  
 avenue.  
 The Ray Co., 168 Griswold street.  
**Saginaw**—Morley Bros.

## MINNESOTA.

**Minneapolis**—Thomas C. Hough, 714 Hennepin ave.  
**St. Paul**—Minnesota Phonograph Co., 37 E. 7th street.

## MISSOURI.

**Kansas City**—J. W. Jenkins' Sons Music Co., 1013-1015  
 Walnut street.  
 The Ray Co., 1021 Grand avenue.  
**St. Louis**—Conroy Co., 1115 Olive street.  
 The Ray Co., 923 Olive street.

## NEBRASKA.

**Lincoln**—H. E. Sidles Cycle Co., 1317 O street.  
**Omaha**—H. E. Fredrickson, 1502-1510 Capitol avenue.  
 Nebraska Cycle Co., 15th and Harney streets.

## NEW JERSEY.

**Hoboken**—Eclipse Phonograph Co., 205 Washington  
 street.  
**Newark**—A. O. Petit, New and Halsey streets.  
 H. J. Koehler Sporting Goods Co., 845 Broad  
 street.  
**Paterson**—James K. O'Dea, 117 Ellison street.  
**Plainfield**—Frank L. C. Martin Auto. Co., 810 Park  
 avenue.  
**Trenton**—Stoll Blank Book and Stationery Co., 30 E.  
 State street.

## NEW YORK.

**Brooklyn**—Chapman & Co., Fulton and Duffield streets.  
 A. D. Matthews' Sons, 394 Fulton street.  
 Price Phonograph Co., 1258 Broadway.  
**Buffalo**—P. A. Powers, 643 Main street.  
**Elmira**—Elmira Arms Co., 117 Main street.  
**Gloversville**—American Phonograph Co., 99 W. Fulton  
 street.  
**Kingston**—Forsyth & Davis, 307 Wall street.  
**New York City**—Bettini Phonograph Co., 80 Chambers  
 street.  
 Blackman Talking Machine Co., 19  
 Beekman street.  
 J. F. Blackman & Son, 2654 3d avenue.  
 I. Davega, Jr., 802 Third avenue.  
 S. B. Davega, 32 E. 14th street.  
 Douglas & Co., 89 Chambers street.  
 H. S. Gordon, 139 Fifth avenue.  
 Harry Jackson, 219 Bowery.  
 Jacot Music Box Co., 39 Union Square.  
 Victor H. Rapke, 1661 Second avenue.  
 Rosenfield Mfg Co., 587 Hudson st.  
 Siegel-Cooper Co., Sixth avenue and  
 18th street.  
 John Wanamaker, Broadway and  
 9th street.  
**Rochester**—A. J. Deninger, 347 North street.  
 Mackie Piano, O. & M. Co., 100 State street.  
 Talking Machine Co., 29 S. Clinton avenue.  
**Schenectady**—Jay A. Rickard & Co., 253 State street.  
**Syracuse**—W. D. Andrews, 216 E. Railroad street.  
**Troy**—James Lucey, 359-361 Fulton street.  
**Utica**—Clark-Horrocks Co., 54 Genesee street.

## OHIO.

**Canton**—Klein & Heffelman Co., 216 N. Market street.  
**Cincinnati**—Ilsen & Co., 25 W. 6th street.  
 The Ray Co., 143 West 5th street.  
 Wahl-Gaasch Co., 47 W. 5th street.  
**Cleveland**—W. J. Roberts, Jr., 254-256 Arcade.  
**Columbus**—Perry B. Whitsit Co., 213 S. High street.  
**Dayton**—Niehaus & Doshe, 35 E. 5th street.  
**East Liverpool**—Smith & Phillips Music Co.  
**Toledo**—Hayes Music Co., 608 Cherry street.

## PENNSYLVANIA.

**Allegheny**—Henry Braun, 500 Federal street.  
**Allentown**—G. C. Aschbach, 539 Hamilton street.  
**Easton**—William Werner, 401 Northampton street.  
**Philadelphia**—C. J. Heppe & Son, 1117 Chestnut street.  
 Lit Bros., Market and 8th streets.  
 Penn Phonograph Co., 19 S. 9th street.  
 John Wanamaker.  
 Wells Phonograph Co., 41 N. 9th street  
 Western Electric Co., 931-933 Market  
 street.  
 H. A. Weymann & Son, 923 Market  
 street.  
**Pittsburg**—Theo. F. Bentel Co., Inc., 433 Wood street.  
 Kaufmann Bros., Fifth avenue and Smith-  
 field street.  
 H. Kleber & Bro., 221 Fifth avenue.  
 C. C. Mellor Co., 319 Fifth avenue.  
 Pittsburg Phonograph Co., 937 Liberty  
 avenue.  
**Reading**—Reading Phonograph Co., 809 Penn street.  
**Scranton**—Ackerman & Co., Coal Exchange Building.  
 Technical Supply Co.

## RHODE ISLAND.

**Providence**—J. M. Dean Co., 785-795 Westminster street.  
 J. A. Foster Co., Weybosset and Dor-  
 rance streets.  
 Household Furniture Co., 231-237 Wey-  
 bossett street.  
 Murray, Blanchard, Young & Co., 26-30  
 Pine street.  
 A. T. Scattergood & Co., 106-110 N. Main  
 street.

## TENNESSEE.

**Memphis**—The Ray Co., Lyceum Building, and and  
 Jefferson streets.  
**Nashville**—The Ray Co., 30 The Arcade.

## TEXAS.

**Dallas**—C. B. Harris, Agt., 347 Main street.

## VIRGINIA.

**Richmond**—The Ray Co., 729 E. Main street.

## WISCONSIN.

**Milwaukee**—McGreal Bros., 173 3d street.

## CANADA.

**Toronto**—R. S. Williams & Sons Co., Limited, 143  
 Yonge street.





WE HELP INTRODUCE

## Double Service in the Homes

An Offer  
to the  
Edison Trade

DOUBLE SERVICE—Pleasure and Profit—Amusement and Language Study—Are you able to demonstrate the Edison Phonograph for both uses?

We want to coach you on the Language Proposition. There is nothing out of your pocket to learn a good talking point for the Edison Phonograph. And you might just as well handle your part of the thousands of I. C. S. Language Outfits that are sold every year.

REMEMBER; Edison Dealers are the only merchants who handle our Outfits, and they are protected by regular National Phonograph Company Agreements. Edison Jobbers in every part of the World carry our Outfits in stock and can fill your orders.

Write Us Today for Advice and Literature.

LANGUAGE DEPARTMENT

International Correspondence Schools

SCRANTON, PENNA.

# EDISON Phonograph Monthly

PUBLISHED FOR TRADE USE ONLY BY  
THE NATIONAL PHONOGRAPH CO.

VOL. II.

NEW YORK, JUNE, 1904.

No. 4.

*The National Phonograph Co.,*

ORANGE, N. J.

NEW YORK: 83 CHAMBERS STREET.

CHICAGO: 304 WABASH AVENUE.

SAN FRANCISCO: 786 MISSION STREET.

NATIONAL PHONOGRAPH CO., LTD., 25 CLERKENWELL  
ROAD, LONDON, ENG.

EDISON PHONOGRAPHS AND RECORDS.

All communications to THE PHONOGRAPH MONTHLY should be addressed to the Advertising Department, 83 Chambers Street, New York.

C O N T E N T S

Sixty Days Notice.....	1
Notice to Jobbers.....	3
An Important Improvement.....	3
Installing a Record Plant in Mexico.....	4
A British Columbia Enthusiast.....	4
The Whole World Its Field.....	4
Printed Matter.....	4
Gregorian Mass Sung Into Phonograph...	4
The New Phonogram.....	5
Shaved or Unshaved?.....	5
Mahogany Cabinets Made to Order.....	5
Wanted—Articles on Best Methods of Sell- ing Edison Goods.....	5
Phonograph is Pastor and Choir.....	5
Speed Regulator for Triumph.....	6
Stock Books for the Trade.....	6
Record Playing by Telephone in England..	6
Edison Branches at Berlin, Paris and Brus- sels .....	7
A Swindling Gang Broken Up.....	7
Comments on July Records.....	8
Keeping Record Stocks.....	10
Ex-Governor Hill and the Phonograph...	11
The Phonograph in British Columbia.....	11
Trade Notes.....	12
Western Fiction.....	12
Four Notable Injunctions.....	13
Suspended List.....	14
Jobbers of Edison Phonographs and Records .....	15

## SIXTY DAYS' NOTICE.

Orange, N. J., May 16, 1904.

Gentlemen:—Please take notice that 60 days from this date or thereafter, we purpose making changes in our price list, terms, discounts, conditions of sale and agreement.

Pending changes in question, we suggest that you use great care in placing your orders, and we especially caution you not to stock up with any style of Records, as the changes in question will, we believe, create radically different but entirely favorable trade conditions.

Kindly acknowledge receipt of this notice on appended form.

W. E. GILMORE  
President.

The above is a copy of a notice sent on the date given to every Jobber and Dealer in Edison goods in the United States and Canada. For the time being it simply means that we are carrying out a provision of our Agreement that requires us to give sixty days' notice before we can make any change in the prices of our goods or in the conditions under which they are sold.

Except that it will "create radically different but entirely favorable trade conditions," no statement can be made at present. Until July 16th at least the prices of Edison Gold Moulded Records will be 50 cents each or \$5.00 per dozen; and all other goods must be sold at existing prices. Price cutting will be as vigorously prosecuted as though the above notice had never been issued and the trade must continue to conform to all the stipulations of the agreement now in force.

We fully realize the depressing effect that this notice will have upon our trade until the new conditions go into effect, but we have no hesitancy in declaring our belief that the business done by all who handle the Edison pro-

(Continued on page 3.)

THE ADVANCE LIST OF JULY RECORDS APPEARS ON PAGE 2. ORDER FROM IT. NO OTHER ADVANCE LIST WILL BE ISSUED.



# ADVANCE LIST OF NEW EDISON GOLD MOULDED RECORDS FOR JULY, 1904

RECORDS listed below will be ready for shipment as near July 1st as possible, at which time Jobbers' stock orders, if placed prior to June 15th, will be shipped. July Supplements will be forwarded to Jobbers with their stock order for Records. Retail Dealers should place stock orders with their Jobbers at once, to insure prompt shipment as soon as Jobbers' stock is received.

- 8724 The Japs' Tattoo *Characteristic Japanese war march.* Edison Military Band  
 8725 Starry Night for a Ramble Edison Male Quartette  
*Popular waltz song with solo, duet and quartette chorus and orchestra accompaniment.*
- 8726 The St. Louis Rag Vess L. Ossman  
*Characteristic banjo solo with orchestra accompaniment.*
- 8727 My Kangaroo Miss Morgan and Mr. Stanley  
*Contralto and basso duet with orchestra accompaniment.*
- 8728 The Man with the Ladder and the Hose W. H. Thompson  
*(Dedicated to the Fire Heroes of the country) descriptive song with orchestra accompaniment.*
- 8729 Invitation to the Waltz (v. Weber) Edison Symphony Orchestra  
 8730 Oysters and Clams Arthur Collins  
*Descriptive huckster song with orchestra accompaniment.*
- 8731 An Interrupted Courtship on the Elevated Railway (Leander and Lulu) Campbell and Roberts
- 8732 Polly Prim March, by the composer of "The Colored Major" March Albert Benzler  
*Xylophone solo with orchestra accompaniment.*
- 8733 Just a Gleam of Heaven in Her Eyes Byron G. Harlan  
*Charles K. Harris' latest sentimental ballad with orchestra accompaniment.*
- 8734 My Old New Hampshire Home Campbell and Harrison  
*Descriptive tenor and baritone duet with orchestra accompaniment.*
- 8735 Sylvia (Scherzo) Frank S. Mazziotta  
*Piccolo solo with orchestra accompaniment.*
- 8736 Two Rubes at the Vaudeville Harlan and Stanley  
*Descriptive selection, introducing a scene at a vaudeville theatre, with Miss Daisy Boulais, serio-comic artist, and orchestra.*
- 8737 Hannah Coon song with orchestra accompaniment. Billy Murray  
 8738 Encouragement Overture Edison Symphony Orchestra
- 8739 Dream of Youth Violin and flute duet. Eugene A. Jaudas and Eugene C. Rose  
 8740 American Student's Waltzes Edison Military Band  
*(Recorded at a slow tempo for dancing) Introducing the college songs "My Love at the Window," "Dear Evelina," "The Spanish Guitar" and "Climbing, Climbing, Climbing."*
- 8741 Everywhere Comic male duet with orchestra accompaniment. Collins and Harlan  
 8742 A Bit o' Blarney Edison Concert Band  
*An Irish intermezzo and two-step.*
- 8743 Here's Your Hat, What's Your Hurry Bob Roberts  
*Coon song with orchestra accompaniment.*
- 8744 The Old Cabin Home (Plantation Series No. 2) Edison Male Quintette  
*Descriptive singing and talking selection.*
- 8745 Kryl's Favorite Cornet solo with orchestra accompaniment. Bohumir Kryl  
 8746 There's Nobody Just Like You Harry MacDonough  
*Sentimental song with orchestra accompaniment.*
- 8747 Where the Mocking Birds were Singing James F. Harrison  
*Sentimental song with orchestra accompaniment.*
- 8748 Down on the Brandywine Medley Edison Military Band  
*Introducing "Down on the Brandywine," "Meet Me in St. Louis, Louis," "My Little Love Bird," "The Goo-Goo Man," "Good Bye, My Lady Love" and "The Irish, The Irish."*

Edison Gold Moulded Records are made only in Standard size. Both Standard and Concert Records may be ordered from this list. Order by Number, not title. If Concert Records are wanted, give the number and letter C.

(Continued from page 1.)

duct will thereafter exceed their most sanguine expectations. Whatever loss may be occasioned by a quiet summer will be more than compensated for by a busy fall and winter. Jobbers and Dealers will do well to keep their stock of Records as low as possible during the next six weeks and at the same time to make arrangements to order and carry a larger stock than ever when the new conditions are announced.

No matter what changes may be made in prices or other conditions, there will be no change in the policy of this company in protecting the trade and prosecuting price-cutters.

Dealers who have overlooked the matter of signing the form, acknowledging receipt of our sixty days' notice, are urged to sign and return at once. It will benefit both them and us.

Every Edison Phonograph and every Edison Record and Blank is sold by the NATIONAL PHONOGRAPH COMPANY under restrictions as to the persons to whom and the prices at which such Phonographs, Records and Blanks are to be sold, and as to the removal or change in whole or in part of the serial numbers on such Phonographs. Any violation of such restrictions terminates the license to use and vend such Phonographs, Records and Blanks implied from the sale thereof, and any subsequent use or sale of such Phonographs, Records or Blanks is an infringement of the Edison Patents.

**NOTICE TO JOBBERS.**

In having sub Dealers sign agreement from now until July 16th, Jobbers should change the clause "subject to change on 60 days notice" to "subject to change on or after July 16th." This phrase occurs twice on each copy.

As an evidence that Edison goods were still in demand, one of our Jobbers recently pointed out that his business with us in the year ending March 1st was \$13,000 more than in the previous year; in fact, nearly double. We replied that, while his percentage of increase was high, every Jobber making an effort to push our goods made a handsome increase during the same year. Where increases were not shown the falling off was due to special causes.

**AN IMPORTANT IMPROVEMENT.**

In every Edison Triumph Phonograph now being shipped from our factory, springs are being used to hold the motor frame to the top plate, instead of the rubber washers heretofore in use. The cut herewith shows the springs in position. The effect of this change is to remove the last semblance of noise from the operation of the mechanism. It was practically noiseless before, but by getting close to it the whir of the governor could be heard. The use of springs in place of washers makes the mechanism absolutely noiseless. These springs will also be applied to all new Home and Concert machines. They may be applied to machines now in use by any good mechanic, the Home being the most difficult of the three. They will be listed in the next Repair Parts Catalogue as follows:

- FOR HOME PHONOGRAPHS.
  - 6 Motor Frame Springs..... 10 cents each
  - 3 Motor Frame Screw Nuts..... 5 cents each
  - FOR TRIUMPH AND CONCERT PHONOGRAPHS.
  - 6 Motor Frame Springs..... 10 cents each
  - 2 Motor Frame Screws..... 5 cents each
  - 1 Belt Tightening Screw..... 10 cents each
- Subject to Supply Discounts.

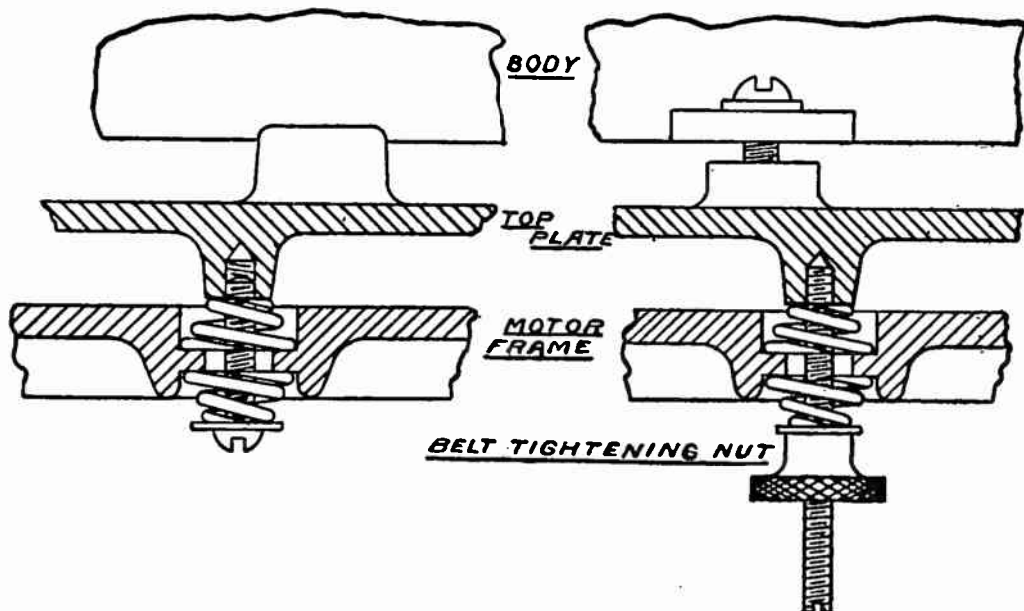

A set of these springs were recently sent to the owner of an Edison Phonograph at Elm Creek, Neb. He acknowledged their receipt as follows:

"The suspension springs arrived this morning and I put them in. 'Twas only a few moments work, and the result—Well! All I can say that I haven't felt so pleased in a long time over anything as with that *simple* cure and I want to congratulate you over your success. I consider this an improvement equal to the Model C and D Reproducer or Moulded Record. There is very little more to be desired in a machine at present, so far as I can see. I also want to thank you for your courtesy in ordering these springs sent me. Again I congratulate you."

**REMOVAL.**

Peter Bacigalupi, Jobber at San Francisco, has moved from 933 Market street to the five story building at 784-788 Mission street.



### INSTALLING A RECORD PLANT IN MEXICO.

The National Phonograph Company has just completed the installation of a Record plant at la Calle de Colon, No. 7, opposite the American Consulate, Mexico City, and have begun taking selections of Mexican vocal and instrumental music, executed by the highest class talent in the country. The Mexican repertoire will include all the popular national airs, as well as the favorite selections from zarzuelas, etc., sung by the most prominent artists.

The Master Records will be taken at the plant established in Mexico City. These will then be forwarded to the Edison Laboratory, at Orange, N. J., to be moulded by the well known Edison Gold Moulded process. George J. Werner, one of the Record experts at the Edison Laboratory, has been sent to Mexico to superintend the work.

The interests of the National Phonograph Company are represented in Mexico by Ralph Cabañas, who is well known among the English speaking residents of that city. Mr. Cabañas returned to Mexico some two months ago, and has been attending to the necessary preliminary arrangements in connection with the Record plant, as well as other details of the company's business in that country.

### A BRITISH COLUMBIA ENTHUSIAST.

Captain John Thompson, a pilot living at Victoria, B. C., finds much pleasure in his leisure hours in running his Edison Home Phonograph. He writes that since he bought it two and a half years ago he has owned 520 Records and has 300 on hand now. He has about 200 of the old style wax records, which he uses to make records when he desires to amuse his friends. "The outfit has cost me over \$500," he says, "and I must say that I have the loudest, finest and in every way the best Phonograph outfit in this city. Everybody says so that has heard it." He keeps his Records in a specially designed cabinet, built in his dining room and secured to the wall. This has two tiers of five drawers each at the bottom, with two tiers of four drawers each and one of three drawers above them, making twenty-one drawers. Each drawer holds a dozen Records. His Phonograph stands on another special cabinet, ornamented with paintings from his own brush and having a locker and shelf upon which to place a drawer of Records while playing them. His outfit includes five reproducers and two recorders.

### THE WHOLE WORLD ITS FIELD.

We are glad to advise the trade that the suits which were brought by the Columbia Phonograph Company against the National Phonograph Company and two of its Dealers in Washington, D. C., and Baltimore, Md., in 1901, for violating the territory to which the Columbia Company claimed to have exclusive rights, have been discontinued, and the injunctions which heretofore have prevented the National Phonograph Company from operating directly in that territory are no longer in force.

By this action there is now no place in the entire world where this Company cannot establish Jobbers and Dealers to whom goods can be supplied direct from Orange, and without danger of any possible legal complications.

### TESTIMONIAL TO MR. BANTA.

A testimonial entertainment and reception in remembrance of the late Frank P. Banta was given in Lyric Hall, Sixth avenue, New York City, on Wednesday night, May 10th. Mr. Banta was well known to owners of Edison Phonographs as a pianist of unusual ability. He was very popular with his Record making associates, many of whom took part in the entertainment.

### GREGORIAN MASS SUNG INTO PHONOGRAPH.

ROME, April 30.—At the request of the Pope, the singing of the Gregorian mass in St. Peter's on the occasion of the centenary of St. Gregory, which was executed by a chorus of 1,500 voices, has been perpetuated for the use and instruction of the churches outside of Rome. Arrangements were made with a Phonograph Company to take the Records of the most important parts of the execution and a special meeting of all the singers was held in the church to-day following the celebration. The making of the Records was perfectly successful and soon lovers of church music all over the world will be able to listen to the most perfect execution of Gregorian music.—*Chicago Record-Herald*.

### PRINTED MATTER.

A small edition has been printed of a supplement showing the British selections listed in the April and May issues of the PHONOGRAPH MONTHLY. It is Form No. 570 and limited quantities can be supplied to the trade.

### THE NEW PHONOGRAM.

The first issue of the new PHONOGRAM, which will appear about July 1st, will have an edition of from 80,000 to 100,000. Orders for about 75,000 have already been placed by Jobbers, all of whom are enthusiastic concerning its re-issue. All have agreed to pay the charge of \$2.50 per thousand for them. In order that the cost may not be burdensome to any one, Jobbers are urged to make a similar charge for such quantities as are ordered by their Dealers. We cannot insist upon this charge being made to Dealers, but Jobbers will consult their own welfare by declining from the start to furnish them without charge.

It is hoped to make the PHONOGRAM a useful assistant in selling Phonographs and Records. Every owner of an Edison Phonograph is more or less of an enthusiast. He is always eager to know about the new Records each month. He is ever anxious to be informed about the improvements being made in Edison Phonographs and in the processes for making Edison Gold Moulded Records. He is keen for news from the Edison Laboratory and concerning Mr. Edison's work. This interest in all things Edison made the old *Phonogram* much sought for all over the country. The new PHONOGRAM will endeavor to make itself even more in demand.

A feature that is expected to aid much in popularizing the new PHONOGRAM will be the publication each month of half-tone pictures of one or two of the talent who make Edison Records. We daily receive letters from Dealers and Phonograph owners, asking for pictures of the talent. We are so certain of the demand for the PHONOGRAM on account of these pictures that a considerable extra quantity will be printed each month to supply orders not on file.

Information will be given in the PHONOGRAPH MONTHLY next month as to the way Dealers may secure small quantities by mail.

### SHAVED OR UNSHAVED?

Jobbers and direct Dealers, in ordering blanks, should be careful to specify whether they are to be shaved or unshaved. The absence of this information either causes delay in shipment, by making it necessary to write for particulars, or wrong goods are shipped. The latter necessitates extra transportation charges, which must be borne by the parties who order the goods.

### WANTED—ARTICLES ON BEST METHODS OF SELLING EDISON GOODS.

The friends of the PHONOGRAPH MONTHLY cannot do us a greater favor than to send in for publication articles on the best methods of selling Edison Phonographs and Records. These will be published with or without credit as the writers may desire. We prefer always to give full credit, but will withhold names when so requested. Articles of this kind will be of much assistance to all Edison Dealers. Nor can they be detrimental to the business of the writer, for no one can affect his business except other Dealers in his own city, and they can easily find out in other ways how they sell goods.

### PHONOGRAPH IS PASTOR AND CHOIR.

In the lecture room of the Hudson City branch of the Young Men's Christian Association, in Central avenue, Jersey City, a Phonograph conducted religious services yesterday afternoon.

Promptly at 4 o'clock Dr. Henry A. Heath started the machine, and a voice called out: "We'll sing 'Wonderful Words of Life.'" There was a slight pause and then from the Phonograph a voice sang the well known gospel hymn, following with, "Some Time We'll Understand."

"What is your favorite hymn?" asked the machine in a matter of fact way.

"Saved by Grace," replied a young man in the congregation, and then all hands sang it with a will.

"Mr. Lewis Steck," said the Phonograph, as soon as the last strains had died away, "will lead in prayer." Then a new Record was set in motion and the words of a prayer, which had been spoken by Mr. Steck during the week, fell upon the ears of the congregation. Every head was reverently bowed.

Scriptural verses were recited by the Phonograph, and several hymns by W. S. Weedon, an evangelist, were sung. Several Gospel hymns, which had been sung to Records by the late John R. Sweeny seven years ago, were also reproduced. Mr. Sweeny has been dead five years.

The Phonograph asked three questions, which were answered by persons in the congregation, and then it sang "My Faith Looks Up to Thee," closing the meeting with a benediction.—*New York Herald*, May 9, 1904.

### MAHOGANY CABINETS MADE TO ORDER.

We are now prepared to make to order Phonograph Cabinets and covers (not Record Cabinets) of mahogany to match the mahogany Record Cabinets now in general use. Those interested are asked to write the Sales Department for information.



### SPEED INDICATOR FOR TRIUMPH.

We have fitted the Edison Triumph Phonograph with a speed indicator. It is now attached to all machines of this type. It is a simple device, consisting of a pointer attached to the body of the speed adjusting screw. There are three gilt lines marked on the top plate, indicating 120, 144 and 160 revolutions, respectively. The friction bracket and governor are so adjusted that the mandrel makes exactly 160 revolutions when the pointer points to the 160 mark; 144 revolutions when it points to the 144 mark and 120 revolutions when it points to the 120 mark. At the back of the screw is a stop pin which prevents the screw from being turned clear around and there is no chance of the speed being altered. Any one who reads the instructions that our Records are made at 160 revolutions per minute can readily adjust the machine to 160 revolutions.

### INFORMATION WANTED.

The editor of the PHONOGRAPH MONTHLY is anxious to own a file of the *Phonogram* published from January, 1890, to May, 1892, and edited by V. H. McRae; also of the *Phonograph*, published September, 1893, by a Mr. Johnston; also of the *Edison Phonographic News*, published at Cincinnati from May, 1894, to April, 1896; also the *Phonograph Record*, published from 1897 to 1900; also a copy of the *Echoes from the Talking Machine World*, issued May, 1900. Any information concerning the above, or of any other talking machine publications, that our readers may be able to send will be appreciated.

### STOCK BOOKS FOR THE TRADE.

All agreements signed by Jobbers contain this stipulation:

"Jobbers must keep a record of the serial numbers of all Phonographs sold by them to Dealers and furnish a copy thereof to the National Phonograph Company upon request."

Some two years ago we made up a number of blank books, with printed headings, for the use of Jobbers in keeping such records. They were listed at \$1.00 each and many Jobbers bought copies. For some reason they never were included in any catalogue and not a few Jobbers will now learn of them for the first time. These books comprise 150 ruled pages, headed "Phonograph Stock Book," and have special headings, as follows: "From Whom Purchased"; "Received"; "Machine Nos."; "When Sold"; "To Whom

Sold"; "Address"; "List or Dealer." They are bound in durable board covers. They are very convenient books for Jobbers and worth several times their list price, \$1.00. Dealers will also find them useful in keeping track of their machines.

### RECORD PLAYING BY TELEPHONE IN ENGLAND.

"I notice an article in the PHONOGRAPH MONTHLY for April having reference to playing Records by telephone," writes James H. White, of London, European Sales Manager for this company. "I have also read the various articles on this subject, and think I can give you a story which beats them all regarding the playing of Records over the telephone line.

"We have a customer in Manchester, England, which city is 200 miles from London. This customer frequently calls me up on the telephone to take up various questions in connection with the sale of our goods. While talking with him over the telephone a short time ago, he inquired as to the merits of one of the Records in our British Supplement No. 6, "Cavalleria Rusticana," No. 12854. He stated that if the Record was good he would want a large quantity of them. I happened to have the Record of this selection at hand, and told him to hold the line for a moment and I would let him hear it for himself. I then placed the Record on the Home Phonograph which sits within two feet of my desk 'phone, and, placing the receiver in the horn, started the Record. My factor in Manchester, 200 miles away, listened to the entire selection and stated that he heard every note clearly and distinctly; in fact, he was so pleased with the selection that he gave me an order then and there for 1,000 Records to be included in a large shipment which we already had in hand for him.

"I think this not only demonstrates the efficiency of the long-distance telephone service in England, but it is also a good pointer as to the possibilities of up-to-date Jobbers selling Edison Gold Mounted Records by telephone, and perhaps is an idea that might be adopted with profit by some of your up-to-date and hustling American Jobbers."

### "ARE GRAND."

FREDERICK, MD., May 23, 1904.

The new Records for the last three months are grand, and I expect to do a fine business this summer. W. H. DYER.

### EDISON BRANCHES AT BERLIN, PARIS AND BRUSSELS.

The National Phonograph Company has now established Recording plants at Berlin, Paris and Brussels. All of these plants are running successfully and furnishing Records, which are being sold on the Continent and in Great Britain. We have also established a selling office in Berlin, from which we supply German, Austrian, and Russian customers. The capacity of the Berlin plant is almost exclusively devoted to the supplying of Records for German, Austrian and Russian territory. The Paris plant will manufacture Records for sale within the French Republic; the Brussels plant is devoted to turning out Records for Belgium, Holland, and Great Britain. An office is about to be established in Paris to control the sale of Edison Phonographs and Records in France, Spain, and Portugal. One of the most interesting features in connection with the sale of Edison goods in Germany is the fact that the price agreement has recently been put into effect in that country and is working quite as satisfactorily as the agreements now in force in the British Isles. In addition to the above, permanent master-making plants have been established in Berlin, Paris, and Brussels, where our experts are constantly at work making new masters of the best European artistes obtainable. Within a reasonably short time we expect to collect a very large and valuable repertoire of French, German, Spanish, Russian, Austrian, Flemish, Dutch, and other selections.

### A SWINDLING GANG BROKEN UP.

Chiefly through the efforts of Victor H. Rapke, a Jobber in Edison goods on Second avenue, New York City, the local police have broken up a gang of men who for some time past have made a business of buying talking machines on the instalment plan, making the first payment thereon and then selling them at almost any price for cash. Mr. Rapke, having heard of the operation of the gang, set out to investigate a sale or two made by one of his branch stores. He soon learned that he had been victimized with the others. He obtained a lot of evidence against the gang, learned that the name of the man who had swindled him was Jack Greenfield and then presented all the facts to the District Attorney's office. He satisfied the assistant given charge of the case that a felony had been committed and detectives were assigned to make arrests.

Greenfield was located a few days later and committed to jail to await the action of the Grand Jury. As Mr. Rapke expects to spend the summer abroad, he induced some of the other victims to appear as complainants. The names of Greenfield's accomplices were ascertained and they will be arrested if they return to New York. The New York talking machine dealers feel very grateful to Mr. Rapke for the successful outcome of his efforts as an amateur detective.

Charles A. Miller, Dealer, in New York city, sends copies of a novel advertising leaflet. It is printed in imitation of a street car transfer. It advertises the song "A Good Old Trolley Ride," and announces that Edison Gold Moulded Records of the song may be had at Mr. Miller's store.

### WITH US TO THE FINISH.

A Dealer, who asks that his name and city be not published, writes as follows:

The article in the April number referring to Dealers handling different styles of machines and records along with the Edison make, hits the very chord that I have been sounding for the past six months. No better illustration can be found anywhere than exists right here. There are three firms in this city which sell cylindrical records. Two of these firms also carry a line of disk goods. At no time will you find more than one Edison machine nor more than three dozen Edison Records in stock at either of these places. They push the other goods. I have been in the Phonograph business about five years. I say Phonograph business for I have never carried in stock any other make machine than the National Phonograph Company's product. This also applies to Records. I carry in stock the Gem, Standard, Home and Triumph machines. I also have the two latter equipped with repeating attachment. I carry from 1,200 to 2,000 Records in stock. I have upward of 100 customers. I have my first machine to sell that has not given the very best satisfaction, in fact, each and everyone thinks that the machine they purchased is the best on earth. As to the Records, they are in a class by themselves. You are not only giving me the best goods that are made and allowing me the largest profit, but you are protecting me against the bargain-counter and the department store, and as long as you do this I am with you to the finish.

### THE HOME A WINNER.

Prospects are fine and we expect a fine business a little later. The Home is a winner, and will get home every time.

AINSWORTH MUSIC STORE.

Watertown, So. Dak.



### COMMENTS ON JULY RECORDS.

The July list of Edison Gold Moulded Records will be a delight to all interested in the Edison product, whether as a Dealer or a user. The initiated will find in them ample evidence of the monthly improvement being made by our Recording Department. Not only is the quality of the highest character, but the list abounds in variety. Of the twenty-five given, twenty-one are made by different combinations of talent. The only combinations having more than one are the Edison Military Band and the Edison Symphony Orchestra. The proportion of instrumental to vocal is eleven of the former to fourteen of the latter.

No. 8724, "The Japs' Tattoo," is a characteristic Japanese war march by the Edison Military Band. In view of the war in the Far East its issue now is timely. While the music of this composition is distinctly Japanese, it has enough Western musical flavor to make it melodious and tuneful. The composer of this selection is L. P. Laurendeau.

No. 8725, "Starry Night for a Ramble," is a popular waltz song with solo, duet, quartette chorus and orchestra accompaniment. It is made by the Edison Male Quartette. The title of this composition is that of a song well known many years ago and which is here written to new music and to a large extent new words. The chorus will be recognized for its similarity to the old song of the same name.

No. 8726, "The St. Louis Rag," is a composition written by Tom Turbin, and is quite *apropos* of the Exposition. It is played as a banjo solo by Vess L. Ossman with orchestra accompaniment. It is a typical banjo composition and one calculated to bring out the best effects of that instrument. "The St. Louis Rag" is being played by Sousa and other bands throughout the country. It will be one of the popular airs of the summer.

No. 8727, "My Kangaroo," is a remarkably fine contralto and basso duet by Miss Morgan and Mr. Stanley, with orchestra accompaniment. It is composed by Joseph C. Farrell and Charles Kohlman.

No. 8728, "The Man with the Ladder and the Hose," is a tribute to the fire fighting heroes of the country and is dedicated to them by its composer, T. Mayo Geary. It has an air that will make it popular. It is sung with splendid voice by W. H. Thompson and has an orchestra accompaniment.

No. 8729, "Invitation to the Waltz," is a record of von Weber's charming composition. It is splendidly made by the Edison Symphony Orchestra.

No. 8730, "Oysters and Clams," is a descriptive peddler's song that will remind all who hear it of that successful song, "Any Rags." Arthur Collins, whose excellent rendition did much to make the latter a success, also sings "Oysters and Clams." It is sung with orchestra accompaniment. Jack Drislane is the writer of the words and Theodore Morse the composer of the music.

No. 8731, "An Interrupted Courtship on the Elevated Railway," tells a humorous story of the efforts of *Leander* to propose to *Lulu* on an elevated railway train in New York City. A feature of the Record is the characteristic calling out of the stations by the guard, who, as usual, cannot be understood. This Record is made by Campbell and Roberts.

No. 8732, "Polly Prim March," is an instrumental selection written by S. R. Henry, composer of "The Colored Major March." It is a clever and well written composition and is played as a xylophone solo by Albert Benzler, with orchestra accompaniment. Mr. Benzler ably seconds the work of the composer.

No. 8733, "Just a Gleam of Heaven in Her Eyes," is Charles K. Harris' latest sentimental ballad and is sung in Byron G. Harlan's best manner. The combination of Mr. Harris' music and Mr. Harlan's singing make an unusually attractive sentimental Record.

No. 8734, "My Old New Hampshire Home" will require no introduction to Phonograph users. It is an old friend, but is presented in this Record in a new and attractive form. When listed before it was sung as a tenor solo. It is here given as a tenor and baritone duet by Campbell and Harrison, with orchestra accompaniment. The voices of the singers blend finely and, with the attractive air of the song, make a Record that will meet with universal popularity. The words of this song were written by Andrew B. Sterling and the music by Harry Von Tilzer.

No. 8735, "Sylvia," (scherzo) is one of the best piccolo solos by Frank S. Mazziotta that it has ever been our pleasure to get out. It is played with orchestra accompaniment. The composer is Ch. La Thiere.

No. 8736, "Two Rubes at the Vaudeville," is a descriptive selection introducing a scene at a vaudeville theatre. It is made by Harlan and Stanley, with the assistance of Daisy Boulais, a serio-comic artist, and the orchestra. From a recording standpoint this is one of the most ambitious Records ever made, although it may not so appear to the ordinary listener. The scene opens with two Rubes at the ticket office, asking for seats. They are told that there is standing room only. A ticket speculator induces them to buy two seats "way up front," and they enter the theatre. While they are buying their tickets the orchestra is heard playing on the inside. As the door opens to admit them, the full volume of the orchestra is heard. The seats "way up front" prove to be in the last row. The soubrette on the stage begins to sing the popular song, "Blue Bell." The loud talking of the two Rubes interrupts her until finally she refuses to sing until the noise is stopped. The crowd remonstrates and the Rubes are suppressed for the moment, only to again begin talking when the soubrette continues her song. She then gives it up in disgust, saying that if they are so smart they can sing it themselves. They then take the stage, get the orchestra to play and sing, "Don't Get Weary." The various effects are realistically carried out.

No. 8737, "Hannah," is a popular coon song. It is sung by Billy Murray, with orchestra accompaniment. This composition is the work of Farrell and Frantzen.

No. 8738, "Encouragement Overture," is a delightful selection by the Edison Symphony Orchestra. It was composed by E. Boettger.

No. 8739, "Dream of Youth," is another delightful violin and flute duet. It is played by Eugene A. Jaudas and Eugene C. Rose. The composer of this selection is G. Langer. It is fully as meritorious as any of the violin and flute selections heretofore listed.

No. 8740, "American Students' Waltzes," is a selection by the Edison Military Band. It was formerly listed in wax. It is recorded in slow tempo for dancing in consequence of a general demand for a greater number of dancing Records. This number introduces the college songs, "My Love at the Window," "Dear Evalina," "Spanish Guitar" and "Climbing, Climbing, Climbing." The composer is Jean M. Missued.

No. 8741, "Everywhere," is a comic male duet by Collins and Harlan, with orchestra accompaniment. The words and music are by Farrell and Frantzen. This song is just being issued by its publishers and our Record will be practically its first introduction to the American public. "Everywhere" is a song of the same character as "Oh! Didn't He Ramble," and will undoubtedly be as popular. The Record gives three verses and three choruses.

No. 8742, "A Bit o' Blarney," is an Irish intermezzo and twostep played by the Edison Concert Band. It was written by J. Fred. Helf. It is an original melody of an Irish character and worked in it is an occasional reminder of well known Irish airs. This Record will appeal strongly to those who are fond of Irish music.

No. 8743, "Here's Your Hat, What's Your Hurry?" is a clever and very funny Record by Bob Roberts. It tells of the hardships that befell a lovesick coon at the hands of his rival.

No. 8744, "The Old Cabin Home," is the second of the series of old plantation scenes. The first was listed in June under the title of "Slavery Days." This second selection is a continuation of the first. The latter closed with a 'possum feast. At the opening of this Record the 'possum feast is in progress and all the darkies are having a merry time. *Uncle Jasper*, however, discovers that his favorite boy, *Ephraim*, has disappeared and is afraid that the boy has run away to escape the vengeance of the overseer. The old man, however, maintains a cheerful appearance and asks the darkies to sing *Mammy's* favorite song, "Come Along, Chillun." They sing and then leave the cabin, their voices dying away in the distance. The old man then gives way to his fears for the safety of his boy. This Record is made by the Edison Male Quintette.

No. 8745, "Kryl's Favorite," is a fine cornet solo by Bohumir Kryl, an artist of the first rank. Mr. Kryl is now filling an important engagement at the St. Louis Exposition. This Record is made with orchestra accompaniment. Its composer is W. Paris Chambers.

No. 8746, "There's Nobody Just Like You," is a sentimental selection sung by Harry Mac-Donough, with orchestra accompaniment. It has a pretty air and is splendidly rendered.

No. 8747, "Where the Mocking Birds Were Singing," is a song that has been popularized through the efforts of a New York newspaper. Chimes and the singing of birds are introduced in the song, in a suggestive manner only. This Record is made by James F. Harrison with orchestra accompaniment. Mr. Harrison sings it in superb style. Harry J. Breen wrote the words of this song and T. Mayo Geary the music.

No. 8748, "Down on the Brandywine Medley," is the monthly medley contribution of the Edison Military Band. These medleys have become a strong feature of the usual list from the fact that each of them includes so many different airs. This one is even better than its predecessors in this respect, for it introduces "Down on the Brandywine," "Meet Me in St. Louis, Louis," "My Little Love Bird," "The Goo Goo Man," "Good-Bye, My Lady Love," and "The Irish, the Irish."

#### APPRECIATES PROTECTION.

Talking about cutting prices, why, I have been in all kinds of business. I am a watchmaker by trade, but that trade don't protect its dealers as the Edison does in cutting prices, for if any one gets any goods from the Jobbers then the Jobber is writing or sending catalogues to every Dick, Tom or Harry all around you, giving them the wholesale prices. When you think you have got a customer and you tell him the price of your goods he will answer: "Oh, I can get them at such a place (perhaps the very place you deal at) for so much. I get their catalogues." Now, such work disheartens any one and makes a dealer afraid to buy. But the Edisons don't deal that way, and I am proud of it. If they did I believe the business would soon go to pot. I handle Edison goods only.

WILLIAM HOBSON.

Vincentown, N. J.

#### DEALERS SHOULD STIMULATE THE SUMMER TRADE.

Customers buy fewer Records during the summer months because most of them look more for outdoor amusement or go away in the country or to the seashore, and leave their Phonographs at home.

If you want to stimulate your summer Record business, send a new list of Records each month to your customers and explain to them how fine the results are when Records are played in the open air on quiet summer nights. Also explain that the New Edison Gold Moulded Records are not affected by the summer heat, like the old wax Records or the cheap imitation so-called moulded records, but reproduce the music with full volume and brilliancy of quality and tone.—*From the June Order Blank of the Blackman Talking Machine Co.*



### KEEPING RECORD STOCKS.

"We have read many articles in the EDISON PHONOGRAPH MONTHLY written by Dealers regarding the way they keep their Records, and as none of their methods (in our opinion) seem to be very convenient, we beg to submit our plan," writes O. B. Daspit's Sons, of Houma, La.

"We use light wood boxes, from five to six inches deep, and large enough to hold from four to five dozen Records. We have these boxes lying flat upon a counter, placed next to one another, and place our Records in them, arranged in numerical order, and numbered on the cover of the Record box.

"Any Dealer who has made use of the numerical catalogue knows what little time it requires to find out the title of any Record number. The same applies to the above arrangement of keeping Records.

"A great many Dealers keep all of the band Records together in one box or section of shelving, and all of the songs in another, and so on. The trouble about this arrangement is that when your customer asks for a certain number, before you know what box or section to go to you must first find out the kind of Record, which necessitates looking over the catalogue before you can find the Record, whereas if they were kept in numerical order the Record could be found at once. The above arrangement may be changed from boxes to shelving to suit the Dealer."

### ALL FROM ONE MONTH'S LIST.

"As an illustration of the evenness of quality which your Records possess I send you an account of an incident which occurred in my store recently," writes William J. Killea, a Dealer at Albany, N. Y.

"A lady customer congratulated me on the politeness with which my clerk used customers, saying: 'She never tries to push any bad records on me. I have just purchased eighteen Records and they are very, very fine.'

"I asked her to let me see what Records they were and upon opening the package I found that she had eighteen Records from the April list. The clerk had simply played the April list through for her in rotation and the customer easily found 'eighteen delightful Records.'"

### OTHERS NOT IN THE RACE.

The Records for May are having a good sale. There are none finer than the Edison Records. I have sold none that were not satisfactory and hear nothing but praise for your Machines and Records. All of your agents should maintain prices. There is no cause why the price should be cut. Other makes are not in the race with the Edison.

F. C. DEVALANT.

Earlville, N. Y.

### STANDS BY THE EDISON.

I am still a lover of the Edison Phonographs and Records and your method of doing business. We got some ——— records, as we thought it would be a good plan to show them up beside the Edison. I knew they were not as good, but it is hard to tell a customer the difference. I have nearly all of them yet, but I am not sorry I got them, as I only had to show them to a customer once. Thereafter they stuck to the "old reliable," the Edison. A few days ago the ——— man was here. He wanted to put in a line of ——— machines. He claimed he had the *very best* machine on the market now (something new), and wanted to show it to me. I looked at it and he played it. I gave him the laugh. I set a little Standard beside it and beat him to death. There were several customers standing by, and they all gave him the laugh. A blind man could have told the difference. He was completely done up. He packed up and went his way, but did not leave town until he tried to sell to all the hardware stores, bicycle shops and gun stores, etc., in town. I stand by the Edison, as we stated in our ad the other day; "All others are inferior imitations."

F. J. COLLINGWOOD,

Mgr. Phono. Dept. C. F. Jackson Co.  
Norwalk, Ohio.

John J. Doyle, a Jersey City Dealer, relates a funny incident: He sold a customer a dozen Records. At home the latter took them out of the cartons and put them in a peg box. The box was accidentally dropped on the floor. Eleven out of twelve were either broken or cracked. The blue ticket fell out of the good one and in order to identify its title it was placed on the Phonograph. It proved to be No. 7875, "Ain't Dat a Shame?"

G. C. Aschbach, Jobber at Allentown, Pa., sends a neatly gotten up and nicely printed booklet advertising the lines of musical merchandise he carries. It is called "Aschbach Notes." A page is devoted to Edison Phonographs and Edison Gold Moulded Records.

### FROM CHILI.

The following letter was received by our Foreign Department from one of its customers in Chili:

For my part, I am more than pleased with the Edison Gold Moulded Records which, with the Home Phonograph and the large brass horn you supplied, give me excellent results.

Last week I gave an exhibition of the Phonograph in the club house here, and the members unanimously confessed that they had never heard anything to equal the Records that you forwarded to me with my Phonograph, and I only regretted that I ordered so few.

**THE I. C. S. BUILDING AT ST. LOUIS.**

The International Correspondence Schools, of Scranton, Pa., is represented at the Louisiana Purchase Exposition by a handsome building. The structure faces the Plaza in the Model Village, which is one of the most interesting features of the Exposition.

The lower floor of the building is devoted to a public exhibition of the plans and methods of the Schools, with specimens of the work of students. The second floor, furnished with all conveniences and comforts, is used as a post office, reading room, writing room, and, in fact, a rendezvous for I. C. S. students and their friends

**A "POETICAL" INVITATION.**

New Edison Records arrived to-day  
25 Selections for the month of May,  
Free Concert to-night from 7 to 9;  
Better Records are hard to find.  
They're 50c. each, \$5 per dozen.  
Come, bring your Uncle, Aunt and Cousin.  
—*Advertisement of L. R. Porter, 355 Centre  
St., Porter's Turnout, Brockton, Mass.*

**TRADE NOTES.**

Douglas & Co., Jobbers, of New York city, are showing a novelty in the way of a waterproof cover for Standard and Home Phonographs and for any style horns. It is made of mackintosh material.

Edgar B. Hyatt, proprietor of the Portland Phonograph Agency, Portland, Oregon, sends a miniature of a revolving table that he uses for displaying Edison Phonographs for his trade. The table in actual use will accommodate one Gem, two Standards, one Home, one Triumph and one Concert. The top revolves on a pivot, and the weight at the outer edges is borne by revolving castors placed on the under board. Attached to the latter board is a device for holding a 24 to 48-inch horn in a fixed position and at the proper height for reproducing, although it can be adjusted to any height. By revolving the upper board any style machine can be brought into position before the horn. Underneath the top boards is a shelf upon which to place the covers when removed from the machines. Mr. Hyatt is having printed a quantity of small booklets, giving in detail all the plans, dimensions, descriptions, etc., of this table, and will send a copy to any one interested for twenty-five cents. Even the above brief description will show that Mr. Hyatt has devised a useful and time-saving adjunct to any Phonograph business.

**WESTERN FICTION.**

Varney Russell, city ticket agent of the Wisconsin Central, is beginning to believe that landlords are as heartless as corporations. No sooner had Mr. Russell had his office at 230 Nicollet avenue fitted up in a sumptuous manner the past week than T. C. Hough rented the balance of what was the Wisconsin Central headquarters at 232 Nicollet for an Edison Phonograph parlor. The partition between the two offices is a thin wooden one, and the melodious tunes can be heard very distinctly in Russell's place of business.

Just as Miss Carrie came tripping into Mr. Russell's office a few days ago for the purpose of buying a railroad ticket a Phonograph next door started up, "Good Morning Carrie," and when she said that she had forgotten to bring her purse with her to pay for her ticket, another tune machine started, "Ain't That a Shame." Miss Carrie thought that some one was putting up a joke on her and left the office in high dudgeon, buying her ticket to Chicago the next day over another line.

While a couple of old gentlemen were sitting on the nice, new bench that Russell has recently placed in his office for the accommodation of prospective customers, one of the vindictive Phonographs began to play "On the Benches in the Park," while another soon commenced "They are Jays From Kansas."

Another man came in, ordered a ticket set aside for him, and while he was explaining that he would be in the next day and pay for it, one of the offending machines began to play, "When You Ain't Got No Money, Then You Needn't Come 'Round." The man never came back for his ticket.

While a well known temperance worker and a minister of the gospel were in the office discussing going to Chicago over the Wisconsin Central line, the Phonographs next door commenced playing with vigor, "We are Drunk and Out Upon a Spree," and "Down Where the Wurtzburger Flows." The good men decided to travel over some other road.

Just as a serious looking gentleman accompanied by three ladies was trying to explain to what point they desired to purchase tickets, a machine began to play "Hiawatha"—and they fled in terror.

When Mr. Russell was trying to telephone to Frank Towne a machine began, "Hello Central, Give Me Heaven"—a most ridiculous place to look for Towne.

When a man asked Russell where he could carry his dog on the train, a machine began "In the Baggage Coach Ahead."

Russell says that the machines have driven \$500 worth of business out of his office during the past week, and threatens to bring suit against the Phonograph man.—*From the Evening Tribune, Minneapolis, Minn., April 22d, 1904.*

In sending this clipping Mr. Hough wrote: "As we didn't take possession of the above place until May 1st you can understand what an impression we made."



**MORE EDISON PATENTS SUSTAINED.**

The patents granted to Thomas A. Edison which cover the use of sapphire jewels in Phonograph Recorders and Reproducers have been recently sustained by Judge Archbald, who on May 9th at Trenton, New Jersey, granted injunctions in four suits against Louis A. Chipot, of Newark, N. J., restraining him from infringing the claims of said patents. We print below the injunctions in full.

The defendant Chipot had been infringing these patents by manufacturing jewels similar in shape to those sold by the National Phonograph Company, though of inferior workmanship, and by regrinding or repolishing Edison jewels. Judge Archbald held both of these acts to constitute infringement and enjoined the defendant therefrom. The injunctions read as follows:

**INJUNCTION.**

UNITED STATES CIRCUIT COURT, DISTRICT OF NEW JERSEY.

EDISON PHONOGRAPH CO., Complainant,

VS.

LOUIS A. CHIPOT, Defendant.

*The President of the United States to:*

LOUIS A. CHIPOT, and each and every person, firm or corporation connected directly or indirectly with you, and your associates, attorneys, solicitors, clerks, servants, agents and employees, GREETING:

WHEREAS, It has been represented to us, in our Circuit Court of the United States in the District of New Jersey, in a certain case therein depending wherein National Phonograph Company is complainant, and you the said Louis A. Chipot are defendant, that Letters Patent of the United States, Nos. 430,278, 484,583 and 437,425 were issued in due form of law and that you the said Louis A. Chipot have infringed the claims thereof, and particularly claims 22, 23 and 32 of patent No. 430,278, which are as follows:

22. In a phonograph, a recording point having a cylindrical head provided with a cutting-edge and a shank or extension, substantially as set forth.

23. In a phonograph, a recording-point having a cylindrical head with its end hollowed to form a circular cutting edge, substantially as set forth.

32. In a phonograph, the combination of a recording-point having a curved cutting-edge and a reproducing point having a rounded bearing-surface, substantially as set forth. and claims 1, 2 and 3 of patent No. 484,583, which are as follows:

1. In a phonograph employing phonogram blanks of wax-like material, and in combination with a holder for such blanks, a jewel cutting-tool situated with relation to said holder, so as to operate upon the blank held thereby, substantially as set forth.

2. The combination, in a phonograph, with a phonogram blank of comparatively soft material, of a jewel recorder, substantially as set forth.

3. The combination, in a phonograph, with a phonogram-blank of a wax-like material, of a sapphire recorder, substantially as set forth. and claims 1 of patent No. 437,426, which is as follows:

1. A phonograph recorder having for its recording-point a cutting-tool with a cutting-edge in advance of the stock of the tool, which edge is made blunt to prevent the breaking of the recording material below the line of cutting, substantially as set forth.

NOW THEREFORE we strictly command and enjoin you, the said Louis A. Chipot, and each and every person, firm or corporation connected directly or indirectly with you, and your associates, attorneys, solicitors, clerks, servants, agents and employees, that you forthwith

and until the further order of this Court, desist from directly or indirectly making or causing or to be made, using or causing to be used, selling or causing to be sold, or advertising to make or sell any apparatus, articles or devices embodying or constructed or operating in accordance with the inventions and improvements of said claims, or either of them, or any devices like or similar to "Complainant's Exhibit Chipot Deep Cupped Stylus;" or from reconstructing any devices which embody the inventions of said claims, or either of them, by regrinding or repolishing said devices; or from infringing the said claims, or either of them, in any way whatsoever.

WITNESS the Honorable MELVILLE W. FULLER, Chief Justice of the United States, at the City of Trenton, on the 18th day of May, 1904.

S. D. OLIPHANT, Clerk.

Frank L. Dyer, Esq.,  
Orange, New Jersey,  
Solicitor for Complainants.

**INJUNCTION.**

UNITED STATES CIRCUIT COURT, DISTRICT OF NEW JERSEY.

EDISON PHONOGRAPH CO., Complainant,

VS.

LOUIS A. CHIPOT, Defendant.

*The President of the United States to:*

LOUIS A. CHIPOT, and each and every person, firm or corporation connected directly or indirectly with you, and your associates, attorneys, solicitors, clerks, servants, agents and employees, GREETING:

WHEREAS, It has been represented to us, in our Circuit Court of the United States in the District of New Jersey, in a certain case therein depending wherein National Phonograph Company is complainant, and you the said Louis A. Chipot are defendant, that Letters Patent of the United States, Nos. 430,278 and 484,584 were issued in due form of law and that you the said Louis A. Chipot have infringed the claims thereof, and particularly claims 11 and 12 of Patent No. 430,278, which are as follows:

11. In a phonograph, a reproducing-point whose bearing-surface is the surface of a portion of a sphere, substantially as set forth.

12. In a phonograph, a spherical reproducing-point, substantially as set forth. and claims, 1, 2 and 3 of patent No. 484,584, which are as follows:

1. The combination, in a phonograph, with a phonograph-blank of wax-like material, of a jewel reproducer, substantially as set forth.

2. The combination in a phonograph, with the phonogram-blank, of a rounded jewel reproducer, substantially as set forth.

3. A reproducer or bearing-point for phonographs, consisting of a jewel not affected by chemicals or chemical action of the wax-like material of a phonogram-blank, substantially as described.

NOW, THEREFORE we strictly command and enjoin you, the said Louis A. Chipot, and each and every person, firm or corporation connected directly or indirectly with you, and your associates, attorneys, solicitors, clerks, servants, agents and employees, that you forthwith and until the further order of this Court, desist from directly or indirectly making or causing to be made, using or causing to be used, selling or causing to be sold, or advertising to make or sell any apparatus, articles or devices embodying or constructed or operating in accordance with the inventions and improvements of said claims, or either of them, or any devices like or similar to "Complainant's Exhibit Chipot Reproducer Balls;" or from reconstructing any devices which embody the inventions of said claims, or either of them, by regrinding or repolishing said devices; or from infringing the said claims, or either of them, in any way whatsoever.

WITNESS the Honorable MELVILLE W. FULLER, Chief Justice of the United States, at the City of Trenton, on the 18th day of May, 1904.

S. D. OLIPHANT, Clerk.

Frank L. Dyer, Esq.,  
Orange, New Jersey,  
Solicitor for Complainants.

## INJUNCTION.

UNITED STATES CIRCUIT COURT, DISTRICT OF NEW JERSEY.  
EDISON PHONOGRAPH CO., Complainant,

VS.

LOUIS A. CHIPOT, Defendant.

*The President of the United States to:*

LOUIS A. CHIPOT, and each and every person, firm, or corporation connected directly or indirectly with you, and your associates, attorneys, solicitors, clerks, servants, agents and employees, GREETING:

WHEREAS, It has been represented to us, in our Circuit Court of the United States in the District of New Jersey, in a certain case therein depending wherein Thomas A. Edison is complainant, and you the said Louis A. Chipot are defendant, that reissued Letters Patent No. 11,857 were issued in due form of law and that you the said Louis A. Chipot have infringed the claims thereof, and particularly claim 7 of said patent, which is as follows:

7. As a new article of manufacture, an improved reproducer for phonographs, having a curved engaging edge, said edge being curved longitudinally of the record, in a smaller radius than at right angles thereto, substantially as set forth.

NOW, THEREFORE, we strictly command and enjoin you, the said Louis A. Chipot, and each and every person, firm or corporation connected directly or indirectly with you, and your associates, attorneys, solicitors, clerks, servants, agents and employees, that you forthwith and until the further order of this Court, desist from directly or indirectly making or causing to be made, using or causing to be used, selling or causing to be sold, or advertising to make or sell any apparatus, articles or devices embodying or constructed or operating in accordance with the invention and improvements of said claim, or any devices like or similar to "Complainant's Exhibit Chipot Button Balls;" or from reconstructing any devices which embody the invention of said claim, by regrinding or repolishing said devices; or from infringing the said claim, in any way whatsoever.

WITNESS the Honorable MELVILLE W. FULLER, Chief Justice of the United States, at the City of Trenton, on the 18th day of May, 1904.

S. D. OLIPHANT, Clerk.

Frank L. Dyer, Esq.  
Orange, New Jersey.  
Solicitor for Complainants.

## INJUNCTION.

UNITED STATES CIRCUIT COURT, DISTRICT OF NEW JERSEY.  
EDISON PHONOGRAPH CO., Complainant,

VS.

LOUIS A. CHIPOT, Defendant.

*The President of the United States to:*

LOUIS A. CHIPOT, and each and every person, firm, or corporation connected directly or indirectly with you, and your associates, attorneys, solicitors, clerks, servants, agents and employees, GREETING:

WHEREAS, It has been represented to us, in our Circuit Court of the United States in the District of New Jersey, in a certain case therein depending wherein Edison Phonograph Company is complainant, and you the said Louis A. Chipot are defendant, that Letters Patent of the United States, Nos. 393,967 and 393,968 were issued in due form of law and that you the said Louis A. Chipot have infringed the claims thereof, and particularly claim 1 of patent No. 393,967, which is as follows:

1. The method of recording sounds for reproduction, consisting in impressing sound-vibrations, upon a cutting recording-point and thereby cutting in the recording-surface the record corresponding to the sound-waves in contra-distinction to the formation of such sound-records by a scraping action. and claim 1 of patent No. 393,968, which is as follows:

1. A Phonograph-recorder having for its recording-point a cutting tool with a cutting-edge in advance of the stock of the tool, substantially as set forth.

NOW, THEREFORE we strictly command and enjoin you, the said Louis A. Chipot, and each and every person, firm or corporation connected directly or indirectly with you, and your associates, attorneys, solicitors, clerks, servants, agents and employees, that you forthwith and until further order of this Court, desist from directly or indirectly making or causing to be made, using or causing to be used, selling or causing to be sold, or advertising to make or sell any apparatus, articles or devices embodying or constructed or operating in accordance with the inventions and improvements of said claims, or either of them, or any devices like or similar to "Complainant's Exhibit Chipot Deep Cupped Stylus;" or from reconstructing any devices which embody the inventions of said claims, or either of them, by regrinding or repolishing said devices; or from infringing the said claims, or either of them, in any way whatsoever.

WITNESS the Honorable MELVILLE W. FULLER, Chief Justice of the United States, at the City of Trenton, on the 18th day of May, 1904.

S. D. OLIPHANT, Clerk.

Frank L. Dyer, Esq.  
Orange, New Jersey.  
Solicitor for Complainants.

## THE PHONOGRAPH IN BRITISH COLUMBIA.

REVILSTOKE, B. C., May 18, 1904.

With your permission and a little space in your valuable paper, I would like to tell some of your readers how easy it is to sell the Phonograph. I am a traveling salesman of the Edison Phonograph Department of the largest music house in Canada, the R. S. Williams Sons Co., of Toronto, and I have had long experience in handling talking machines as a dealer and traveler. I have sold all makes of machines, from a squeaky, nasal machine, with a sand dance on every record, to the only perfect machine on the market to-day and a leader that has gone through the many battles of competition and still stands unscathed and famous. I also want to say that the PHONOGRAPH MONTHLY is read with much interest, and they look forward to its appearance with pleasure on account of the valuable ideas derived from the same.

It does not take much energy to sell the Edison Phonograph. A practical demonstration of the wonderful reproducing and recording qualities that is unknown to any other imitation or so-called talking machines is all that is necessary. Customers are fascinated at once and place their orders readily. They cannot but recognize that the Edison Phonograph is a marvelous machine. Therefore it is not salesmanship that does the trick, but the Phonograph. It speaks for itself. I am doing everything possible to introduce the Phonograph to the people of this vast country, which takes ten months to cover. It is a blessing in the drawing rooms of the rich and a boon to the poor miners of the backwoods of Canada.

W. H. MATTHEWS.  
Toronto, Canada.



**SUSPENDED LIST, JUNE 1, 1904.—SUPERSEDING ALL PREVIOUS LISTS.**

**COLORADO.**

**BOULDER—BENTLEY & CRAIG.**

**IOWA.**

\***BURLINGTON—JOHN P. WEISS, 711 Jefferson street.**

\***SIoux CITY—HATTENBACH BROS.**

**INDIANA.**

**SOUTH BEND—\*EUGENE MARSH, 126 Vista avenue.**

\***SOUTH BEND BOOK BINDERY, Robert Lebolt, Prop., 203 North Michigan street.**

**KANSAS.**

**CLAY CENTRE—E. M. GOWENLOCK.**

**LAWRENCE—BELL BROS.**

**MAINE.**

**BIDDEFORD—W. H. FIELD.**

**MASSACHUSETTS.**

**LAWRENCE—LORD & CO., 314 Essex street, E. O. MOSHER, 420 Essex street.**

**MALDEN—A. T. FULLER.**

**NANTUCKET—ARTHUR M. TAYLOR.**

**NEW BEDFORD—H. B. DEWOLFF.**

\***SOMERVILLE—E. J. WINCHESTER, 32 Summit avenue.**

\***WOBURN—OSBORN GILLETTE, or THE BOLTON JEWELRY COMPANY, L. F. MALONEY, Manager.**

**MICHIGAN.**

**DETROIT—F. J. SCHWANKOVSKY.**

**SAGINAW—GEO. W. EMENDORFER.**

**MISSOURI.**

**KANSAS CITY—THE WITTMANN CO.**

**NEBRASKA.**

**LINCOLN—THE WITTMANN CO.**

**OMAHA—THE WITTMANN CO.**

**NEW HAMPSHIRE.**

\***MANCHESTER—A. E. DUMAS.**

**NASHUA—F. A. McMASTER & CO.**

**NEW JERSEY.**

**ATLANTIC CITY—SAMUEL D. WOLF, 32-34 Arkansas avenue.**

**BAYONNE—I. WIGDOR, 450 Avenue D.**

**JERSEY CITY—W. L. HOFFMAN, 151 Montgomery street.**

**NEWARK—R. L. CORWIN; also New York City.**

\***PASSAIC—I. HURWITZ.**

**PATERSON—CHAS. H. KELLY, 25 N. Main st.**

**PLAINFIELD—S. W. FRUCHT, or R. FRUCHT; also New York City. ELSTON M. LEONARD.**

**WEST HOBOKEN—EMIL HOLLANDER, or THE WEST HOBOKEN BICYCLE & PHONOGRAPH CO., 619 Spring street.**

**NEW YORK.**

**BEDFORD PARK—GEO. H. TYRRELL.**

**HOBART—F. H. MARSHALL.**

**NEW YORK CITY—A. T. ARMSTRONG, or AMERICAN PHONOGRAPH CO., 106 Wall street.**

\***BERN BEARWALD, 373 West 11th st. BRONX PHONOGRAPH CO., or DAVID SWITKY, 506 Willis Avenue.**

**CENTRAL PHONOGRAPH CO., 160 E. 42d street.**

**R. L. CORWIN; also Newark, N. J. EAGLE PHONOGRAPH CO., or C. LOWENTHAL, 83 Nassau Street.**

**EMPIRE PHONOGRAPH CO., 2 West 14th street.**

**S. W. FRUCHT, or R. FRUCHT, 7 Barclay st., or 68 Cortlandt st.; also Plainfield, N. J.**

**O. HACKER, 2 Murray street.**

**HAWTHORNE & SHEBLE, 297 Broadway; also Philadelphia, Pa.**

**N. HORN, 148 E. 58th street.**

**R. H. INGERSOLL & BRO., 67 Cortlandt street.**

**W. L. ISAACS, 114 Fulton street.**

**S. LEMBURG & CO., 194 Broadway.**

**J. McELLYNNE, 202 Broadway.**

**RICHMOND PEASE, 44 W. 132d st.**

**F. M. PRESCOTT, 44 Broad street.**

\***WINTHROP CYCLE CO., 2212 Seventh avenue.**

**SARATOGA—W. J. TOTTEN.**

**SARATOGA SPRINGS—MARVIN A. COTE.**

**OHIO.**

**CINCINNATI—J. L. ANDEM.**

**SPRINGFIELD—D. & M. VANDERPOOL.**

**UHRICHSVILLE—F. A. MAZURIE.**

**PENNSYLVANIA.**

**PHILADELPHIA—A. R. CASSIDY, 2783 Emerald street.**

**HAWTHORNE & SHEBLE, 604 Chestnut street, or Oxford and Wascher streets; also New York City.**

\***PENN NOVELTY CO., 15 South 9th street.**

**PITTSBURG—A. LIPPARD, 615 Wylie avenue.**

**RHODE ISLAND.**

**PROVIDENCE—F. P. MOORE.**

**WISCONSIN.**

**MILWAUKEE—J. C. BLATZEK.**

\*Added since May 1, 1904.

**Jobbers and Dealers are asked to co-operate with us, FOR OUR MUTUAL GOOD, by being careful that they do not supply any of the above named firms with our apparatus, either at addresses given or any other address.**

## JOBBERS OF EDISON PHONOGRAPHS AND RECORDS.

## ALABAMA.

**Birmingham**—The Ray Co., 2025 Second avenue.  
**Mobile**—The Ray Co., 54 Dauphin street.

## CALIFORNIA.

**San Francisco**—Peter Bacigalupi, 784-788 Mission street.

## COLORADO.

**Denver**—Denver Dry Goods Co., 619 16th street.

## CONNECTICUT.

**Middletown**—Caulkins & Post Co., 406-408 Main street.  
**New Haven**—Pardee-Ellenberger Co., 155 Orange st.

## ILLINOIS.

**Chicago**—Kelley Cigar Co., 80-82 Wabash avenue.  
 James I. Lyons, 73 Fifth avenue.  
 The Ray Co., 90 Washington street.  
 Siegel-Cooper Co., State and Congress sts.  
 Talking Machine Co., 107 Madison street.  
 The Vim Co., 68 E. Lake street.  
 Montgomery Ward & Co., 111 Michigan ave.  
**Peoria**—Peoria Phonograph Co., 222 Bridge street.

## INDIANA.

**Indianapolis**—Craig-Jay Co., 234 Massachusetts ave.  
 Kipp Bros. Co., 37 S. Meridian street.  
 Wahl-Gaasch Co., 119 S. Illinois street.  
**Lafayette**—Wahl-Gaasch Co., 304 Main street.

## IOWA.

**Des Moines**—The Vim Co., 704 West Walnut street.  
**Fort Dodge**—Early Music House, 822 Central ave.

## KENTUCKY.

**Louisville**—The Ray Co., 640 Fourth street.

## LOUISIANA.

**New Orleans**—James I. Lyons, Theatre Arcade.  
 National Automatic Fire Alarm Co., 614 Gravier street.  
 The Ray Co., 111 Camp street.

## MAINE.

**Bangor**—S. L. Crosby Co., 186 Exchange street.  
**Portland**—W. H. Ross & Son, 207 Commercial street.

## MASSACHUSETTS.

**Boston**—Boston Cycle & Sundry Co., 48 Hanover street.  
 Eastern Talking Machine Co., 177 Tremont street.  
 Oliver Ditson Co., 150 Tremont street.  
 Iver Johnson Sporting Goods Co., 163 Washington street.  
 Read & Read, 558 Washington street.  
**Fitchburg**—Iver Johnson Sporting Goods Co., 247 Main street.  
**Lowell**—Thomas Wardell, 111 Central street.  
**Worcester**—Iver Johnson Sporting Goods Co., 304 Main street.

## MICHIGAN.

**Detroit**—American Phonograph Co., 106 Woodward avenue.  
 Grinnell Bros. Music House, 219 Woodward avenue.  
 The Ray Co., 168 Griswold street.  
**Saginaw**—Morley Bros.

## MINNESOTA.

**Minneapolis**—Thomas C. Hough, 714 Hennepin ave.  
**St. Paul**—Minnesota Phonograph Co., 37 E. 7th street.

## MISSOURI.

**Kansas City**—J. W. Jenkins' Sons Music Co., 1013-1015 Walnut street.  
 The Ray Co., 1021 Grand avenue.  
**St. Louis**—Conroy Co., 1115 Olive street.  
 The Ray Co., 923 Olive street.

## NEBRASKA.

**Lincoln**—H. E. Sidles Cycle Co., 1317 O street.  
**Omaha**—H. E. Fredrickson, 1502-1510 Capitol avenue.  
 Nebraska Cycle Co., 15th and Harney streets.

## NEW JERSEY.

**Hoboken**—Eclipse Phonograph Co., 205 Washington street.  
**Newark**—A. O. Petit, New and Halsey streets.  
**Paterson**—James K. O'Dea, 117 Ellison street.  
**Plainfield**—F. C. L. Martin Auto Co.  
**Trenton**—Stoll Blank Book and Stationery Co., 30 E. State street.

## NEW YORK.

**Brooklyn**—Chapman & Co., Fulton and Duffield streets.  
 A. D. Matthews' Sons, 394 Fulton street.  
 Price Phonograph Co., 1258 Broadway.  
**Buffalo**—P. A. Powers, 643 Main street.  
**Elmira**—Elmira Arms Co., 117 Main street.  
**Gloversville**—American Phonograph Co., 99 W. Fulton street.  
**Kingston**—Forsyth & Davis, 307 Wall street.  
**New York City**—Bettini Phonograph Co., 80 Chambers street.  
 Blackman Talking Machine Co., 19 Beekman street.  
 J. F. Blackman & Son, 2654 3d avenue.  
 I. Davega, Jr., 802 Third avenue.  
 S. B. Davega, 32 E. 14th street.  
 Douglas & Co., 89 Chambers street.  
 H. S. Gordon, 139 Fifth avenue.  
 Harry Jackson, 219 Bowery.  
 Jacot Music Box Co., 39 Union Square.  
 Victor H. Rapke, 1661 Second avenue.  
 Siegel-Cooper Co., Sixth avenue and 18th street.  
 John Wanamaker, Broadway and 9th street.  
**Rochester**—A. J. Deninger, 347 North street.  
 Mackie Piano, O. & M. Co., 100 State street.  
 Giles B. Miller, 63 State street.  
 Talking Machine Co., 29 S. Clinton avenue.  
**Schenectady**—Jay A. Rickard & Co., 253 State street.  
**Syracuse**—W. D. Andrews, 216 E. Railroad street.  
**Troy**—James Lucey, 359-361 Fulton street.  
**Utica**—Clark-Horrocks Co., 54 Genesee street.

## OHIO.

**Canton**—Klein & Heffelman Co., 216 N. Market street.  
**Cincinnati**—Ilsen & Co., 25 W. 6th street.  
 The Ray Co., 143 West 5th street.  
 Wahl-Gaasch Co., 47 W. 5th street.  
**Cleveland**—W. J. Roberts, Jr., 254-256 Arcade.  
**Columbus**—Perry B. Whitsit Co., 213 S. High street.  
**Dayton**—Niehaus & Doshe, 35 E. 5th street.  
**East Liverpool**—Smith & Phillips Music Co.  
**Toledo**—Hayes Music Co., 608 Cherry street.

## PENNSYLVANIA.

**Allegheny**—Henry Braun, 500 Federal street.  
**Allentown**—G. C. Aschbach, 539 Hamilton street.  
**Easton**—William Werner, 401 Northampton street.  
**Philadelphia**—C. J. Heppe & Son, 1117 Chestnut street.  
 Lit Bros., Market and 8th streets.  
 Penn Phonograph Co., 19 S. 9th street.  
 John Wanamaker.  
 Wells Phonograph Co., 41 N. 9th street  
 Western Electric Co., 931-933 Market street.  
 H. A. Weymann & Son, 923 Market street.  
**Pittsburg**—Theo. F. Bentel Co., Inc., 433 Wood street.  
 Kaufmann Bros., Fifth avenue and Smithfield street.  
 H. Kleber & Bro., 221 Fifth avenue.  
 C. C. Mellor Co., 319 Fifth avenue.  
 Pittsburg Phonograph Co., 937 Liberty avenue.  
**Reading**—Reading Phonograph Co., 809 Penn street.  
**Scranton**—Ackerman & Co., Coal Exchange Building.  
 Technical Supply Co.

## RHODE ISLAND.

**Providence**—J. M. Dean Co., 785-795 Westminster street.  
 J. A. Foster Co., Weybosset and Dorrance streets.  
 Household Furniture Co., 231-237 Weybosset street.  
 Murray, Blanchard, Young & Co., 26-30 Pine street.  
 A. T. Scattergood & Co., 106-110 N. Main street.

## TENNESSEE.

**Memphis**—The Ray Co., Lyceum Building, and and Jefferson streets.  
**Nashville**—The Ray Co., 30 The Arcade.

## TEXAS.

**Dallas**—C. B. Harris, Agt., 347 Main street.

## VIRGINIA.

**Richmond**—The Ray Co., 729 E. Main street.

## WISCONSIN.

**Milwaukee**—McGreal Bros., 173 3d street.

## CANADA.

**Toronto**—R. S. Williams & Sons Co., Limited, 143 Yonge street.

Additions to list since May 1—Giles B. Miller, Rochester, N. Y.  
 Removals since May 1—Rosenfield Mfg. Co., New York; Ring Music Co., Lowell; H. J. Koehler Sporting Goods Co., Newark.



# Welcome to the Edison Trade

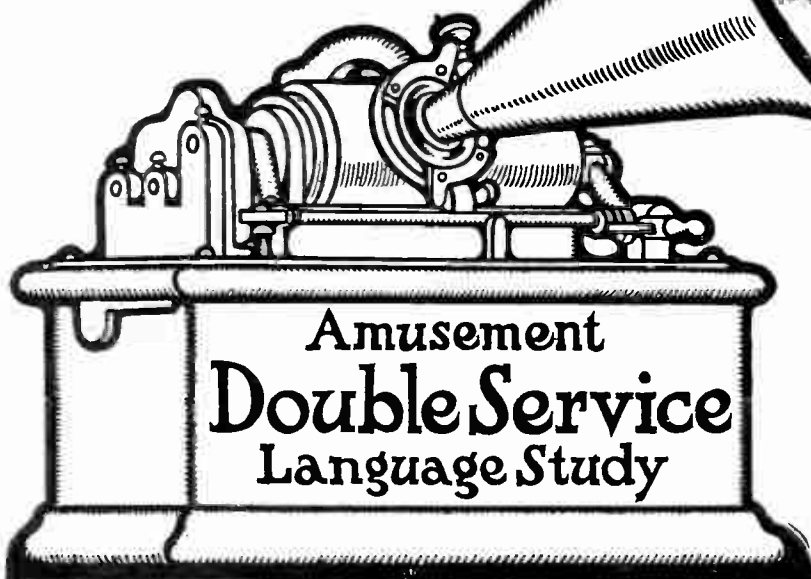

## World's Fair St. Louis, 1904

**Y**OU cannot miss our prominent building after passing through the main entrance to the Exposition. Here we will check your parcels and give you the best information about reaching the attractions. You may use our reading and writing room; and if there are any ladies in the party, they will appreciate the commodious room provided for their comfort in charge of a competent matron.

One entire wing of the building is devoted to the demonstration of the I. C. S. Language System. Thousands of visitors will be interested in the use of the Edison phonograph for "Double Service"—Amusement and Language Study. These people will question you on the subject when they return from St. Louis, for Edison dealers are the only merchants who can handle I. C. S. Language Outfits.

**Important.** Order sample demonstrating records for your store **now.** For \$1.50 we will send you, express prepaid, three Edison Moulded Language Records with sample textbooks and literature in French, German, and Spanish. Edison jobbers in all parts of the world carry our Outfits in stock and make deliveries for us.

**LANGUAGE DEPARTMENT**

**International Correspondence Schools**  
**SCRANTON, PA.**

# EDISON Phonograph Monthly

PUBLISHED FOR TRADE USE ONLY BY  
THE NATIONAL PHONOGRAPH CO.

VOL. II.

NEW YORK, JULY, 1904.

No. 5.

*The* National Phonograph Co.,

ORANGE, N. J.

NEW YORK: 83 CHAMBERS STREET.

CHICAGO: 304 WABASH AVENUE.

SAN FRANCISCO: 786 MISSION STREET.

NATIONAL PHONOGRAPH CO., LTD., 25 CLERKENWELL  
ROAD, LONDON, ENG.

EDISON PHONOGRAPHS AND RECORDS.

All communications to THE PHONOGRAPH MONTHLY  
should be addressed to the Advertising Department,  
83 Chambers Street, New York.

C O N T E N T S

Beginning of New Conditions.....	1
Advance List of Edison Gold Moulded Records for August, 1904 ... ..	2
Important Notice.....	3
Should be Easier to Fill Orders Quickly...	3
Trustee in Bankruptcy must also sell our Goods at List Prices.....	4
Best Ways of Selling Edison Goods.....	5
How About Supplements?.....	5
Use Catalogues and Printed Matter .....	5
Printed Matter.....	6
Personal. ....	6
The New Phonogram.....	7
A Bermuda Admirer.....	7
Comments on August Records .....	8
"Follow-up" Replies Requested.....	10
National Phonograph Co. in Great Britain.	10
Comments on British Records.....	11
More Business to Follow.....	12
Prayer vs. Benzine .....	12
Another Original Invitation.....	12
Another Way to Determine Speed.....	12
Ex-Governor Hill and the Phonograph ....	13
Suspended List, July 1, 1904.....	14
Jobbers of Edison Phonographs and Records	15

## BEGINNING OF NEW CONDITIONS.

NEW YORK, June 16, 1904.

In view of the numerous inquiries received, asking whether stock orders for July Records would be shipped prior to or after changes, referred to in our letter of May 16th, were made, we would advise that July Records will be shipped and invoiced at present prices just as soon after July 1st, as possible.

After changes are made, however, we will allow rebate in the shape of credit memorandum for whatever differences there may be between the present and new price. With this assurance, it is to your interest to place your stock order for July Records at once, so that shipment will not be delayed. Orders for these Records received after June 25th, will be subject to delay.

We would further advise that all orders for any Records placed on or after July 1st, will be subject to rebate, after changes are made, for the difference between present and new price. This arrangement is made in order that you may keep your stock in shape to take care of the increased demand, which is bound to come after changes are made.

Jobbers will please advise their Dealers that they will allow them rebates in the same manner.

Yours very truly,  
W. E. GILMORE,  
*President.*

This notice, sent to every Jobber and Dealer in Edison goods, has had a most salutary effect. The sixty days' notice sent out on May 16th, as was anticipated, caused a certain falling off in business, not only with this company but with competing companies as well. We suggested to the trade that they keep their stock low, consequently no orders were placed except for goods that were absolutely needed to keep their stock complete.

When the above notice was sent out on June 16th no decision had been reached concerning new prices, etc., and it was not possible to make any announcement concerning them. The notice, however, was an assurance from this company that it would protect the trade

(Continued on page 3.)

THE ADVANCE LIST OF AUGUST RECORDS APPEARS ON PAGE 2. ORDER FROM IT. NO OTHER ADVANCE LIST WILL BE ISSUED.



## ADVANCE LIST OF NEW EDISON GOLD MOULDED RECORDS FOR AUGUST, 1904

RECORDS listed below will be ready for shipment as near August 1st as possible, at which time Jobbers' stock orders, if placed prior to July 15th, will be shipped. August Supplements will be forwarded to Jobbers with their stock order for Records. Retail Dealers should place stock orders with their Jobbers at once, to insure prompt shipment as soon as Jobbers' stock is received.

- |      |   |                             |
|------|---|-----------------------------|
| 8749 | Dance of the Hours  | Edison Concert Band         |
|      | <i>Ballet music from "La Gioconda."</i>   |                             |
| 8750 | Good-Bye, Little Girl, Good-Bye ("For I'm Marching Away to be a Soldier")   | W. H. Thompson              |
|      | <i>The new march song hit with orchestra accompaniment.</i>   |                             |
| 8751 | Without Your Love, Ah, Let Me Die   | Miss Corinne Morgan         |
|      | <i>Sentimental song with orchestra accompaniment.</i>   |                             |
| 8752 | Pretty as a Picture   | Albert Benzler              |
|      | <i>Bell solo with orchestra accompaniment.</i>  |                             |
| 8753 | I Can't Do the Sum  | Edison Male Quartette       |
|      | <i>From "Babes in Toyland." Serio-comic song and chorus with orchestra accompaniment.</i>   |                             |
| 8754 | Belle of the West (Cornet solo played by John Hazel)  | Edison Military Band        |
| 8755 | I Want to Be a Soldier  | Byron G. Harlan             |
|      | <i>Descriptive song with orchestra accompaniment.</i>   |                             |
| 8756 | Michael Clancy as a Policeman (Transferred again)   | Campbell and Roberts        |
| 8757 | Katunka (Intermezzo)  | Edison Symphony Orchestra   |
| 8758 | Little Rustic Cottage by the Stream   | Harry Anthony               |
|      | <i>Descriptive song with orchestra accompaniment.</i>   |                             |
| 8759 | Gone, Gone, Gone  | Collins and Harlan          |
|      | <i>Coon male duet with orchestra accompaniment.</i>   |                             |
| 8760 | On Jersey Shore March   | Edison Concert Band         |
|      | <i>Arthur Pryor's new march</i>   |                             |
| 8761 | Don't You Cry My Honey  | Miss Morgan and Mr. Stanley |
|      | <i>Coon lullaby, contralto and basso duet with orchestra accompaniment.</i>   |                             |
| 8762 | Mississippi Mamie   | Harry MacDonough            |
|      | <i>Coon love song with orchestra accompaniment.</i>   |                             |
| 8763 | Great Big Chickapoo Chief   | Arthur Collins              |
|      | <i>Coon song with orchestra accompaniment.</i>  |                             |
| 8764 | Psyche (Scherzetto)   | Edison Symphony Orchestra   |
| 8765 | Alexander   | Billy Murray                |
|      | <i>Coon song with orchestra accompaniment.</i>  |                             |
| 8766 | Pompernickle's Silver Wedding (Vaudeville specialty)  | Len Spencer                 |
|      | <i>German dialect recitation with incidental music by the orchestra.</i>  |                             |
| 8767 | You're as Welcome as the Flowers in May   | Harlan and Stanley          |
|      | <i>Descriptive tenor and baritone duet with orchestra accompaniment.</i>  |                             |
| 8768 | Everywhere Medley   | Edison Military Band        |
|      | <i>Introducing "Everywhere," "The Man with the Ladder and the Hose," "Starry Night for a Ramble," "My Kangaroo" and "St. Louis Rag."</i>  |                             |
| 8769 | Minstrel Boy  | William Tuson               |
|      | <i>Clarinet solo, air and variations with orchestra accompaniment.</i>  |                             |
| 8770 | Two Eyes of Brown   | James F. Harrison           |
|      | <i>Sentimental song with orchestra accompaniment.</i>   |                             |
| 8771 | When the Coons have a Dreamland of Their Own  | Bob Roberts                 |
|      | <i>Coon song with orchestra accompaniment.</i>  |                             |
| 8772 | Wanderer's Return (Plantation Series No. 3)   | Edison Male Quintette       |
|      | <i>Descriptive singing and talking selection.</i>   |                             |
| 8773 | Two Rubes at the Circus   | Harlan and Stanley          |
|      | <i>Descriptive selection introducing the arrival of the two Rubes at the side show, their trip through the menagerie, the ring performance and band, concluding with singing and dancing by the two Rubes in the concert.</i> |                             |

Edison Gold Moulded Records are made only in Standard size. Both Standard and Concert Records may be ordered from this list. Order by Number, not title. If Concert Records are wanted, give the number and letter C.

(Continued from page 1)

in any changes that might be made, and orders at once began to come in at a surprising rate and for unusual quantities. First came advance orders for July Records, and then for stock Records. It is evident at this date that a splendid business in Edison goods is anticipated by Jobbers and Dealers and that many of them are getting ready for it by ordering enough goods to make their stock complete. Those Dealers who have not already done so, should look over their shelves and make up orders at once, for even with our present excellent facilities it is going to be difficult for a time to fill all orders at once. Those who get in early are going to get goods first and be ready the first for a demand that is certain to come.

#### IMPORTANT NOTICE.

To the Trade.

Beginning with the August list of Records, all new selections listed thereafter will have the title number and name of selection moulded in white in the bevelled edge of the Record. They will also be boxed in new style cartons. Beginning July 1st, selections already listed will be changed over to conform with these improvements as rapidly as possible, but as it will take several months to complete these changes on the entire list, and as it will be impossible for us to inform you what particular selections will be changed over from time to time, we will be compelled, and reserve the right, to fill any and all orders received in the meantime with Records both of the old and new styles marking, and boxed both in old and new style cartons.

Yours very truly,

C. H. WILSON.

Manager of Sales.

New York, June 28, 1904.

#### MR. HARLAN TAKES A WIFE.

Byron G. Harlan, so well known to tens of thousands of owners of Edison Phonographs, and whose picture appears in the July issue of the new *Phonogram*, was married on June 22 to Miss Ethel Van Horn, daughter of Mr. and Mrs. Harry Van Horn, of Flemington, N. J. The wedding took place at the Chelsea Hotel, New York city. The Rev. Dr. John F. Carson, of the Central Presbyterian church, Brooklyn, performed the ceremony. Only immediate relatives were present. Mr. and Mrs. Harlan spent their honeymoon at Point Independence, Mass. They will live in Orange, N. J.

#### SHOULD BE EASIER TO FILL ORDERS QUICKLY.

We recently sent a circular letter to a large number of persons who during several years past had asked us for catalogues of various kinds. Many interesting facts were gleaned from the hundreds of replies received from this letter. Of special interest to everyone selling Edison goods was the complaint of numerous writers from the rural districts that they were unable to get supplied with such goods as they wanted, because the Dealers in their towns carried but a small stock and were not able to fill orders without a delay of several weeks. There should be no occasion for such complaints as these. They do not occur where Dealers carry a full stock of Phonographs and Records, and they need not be heard concerning smaller Dealers if the proper amount of attention is given the subject. It is not feasible and probably would not be advisable for a Dealer in a small town to carry a large stock of Edison goods. The business he might do would not warrant it, even if he had the capital to invest in that way. He should, however, carry at all times a Gem, Standard and Home machine and at least 200 Records, the whole representing a very small investment. Two hundred Records, if carefully selected, will form a very fair nucleus with which to make sales. Among them can be found sufficient variety to satisfy most customers, even though they may prefer other selections in the catalogue. If a customer cannot make a choice from stock, then it should be possible to fill his order within a week. If he has not one already, every small Dealer should at once make an arrangement with his Jobber by which his order may be quickly filled. Few Dealers are so far away from their Jobbers that they cannot get goods in two days by express or in a week by freight. Paying express charges eats into the profits, but if a customer will not wait for freight trains it is better to pay expressage than to lose a sale entirely and send a patron away dissatisfied. In most cases, however, purchasers are willing to wait a reasonable time—long enough to get goods by freight if an order is put through at once.

It now needs the coöperation of the Jobber to complete the working arrangement suggested above. It is the duty of the Jobber to carry from five to twenty of every Record in the domestic catalogue if he expects to do a profitable jobbing business. Without such a stock a successful business cannot be con-



ducted. He should also carry a well selected lot of foreign selections, one or two of each will usually meet the requirements of his trade. A little observation will enable a Jobber to determine what kinds of foreign selections are best for his territory. It goes without saying that a Jobber should always have an ample supply of machines on hand. Jobbers with such a stock of machines and Records should rarely have trouble in getting goods in the hands of Dealers within a week. Only one other thing remains to be done, *i. e.* keep the stock up by looking it over daily and sending orders for Record numbers running low, or for machines if the stock is not ample.

Undoubtedly much of the delay in filling orders in the past has been chargeable to this company because the demand has exceeded our factory capacity. This has been changed in the past six months and factory enlargements will enable us to do much better in this respect. The new Record plant is now in operation, giving us double the capacity of the old one, which can still be used as a reserve. It is important that Jobbers should not let their stocks run too low before they order. Bear in mind that we are farther away from you than you are from your Dealers, and the larger volume of business renders it more difficult for us to serve all at once, especially when most orders must go by freight.

### TRUSTEES IN BANKRUPTCY MUST ALSO SELL OUR GOODS AT LIST PRICES

Below are printed copies of an injunction order and writ in a suit brought by the National Phonograph Company against Frederick B. Van Vleck as trustee in bankruptcy of the estate of Philip Marcus, a former dealer in Edison Phonographs and Records in Brooklyn. The injunction was granted after an extended argument before Judge Thomas. This decision is of unusual interest, for it is the first case on record where an attempt has been made to enjoin the sale of our goods under bankruptcy proceedings. Ordinarily, the trustee in bankruptcy is empowered to dispose of the bankrupt's estate at auction for the benefit of the creditors, but this injunction establishes a precedent under which the trustee is subject to the same conditions as any one else, so far as the sale of our goods is concerned. A singular feature of the case was that the defendant, Van Vleck, was appointed trustee by Judge Thomas, who later granted the injunction restraining his appointee

from selling our goods at less than the full list prices.

#### THE INJUNCTION.

*At a stated term of the Circuit Court of the United States held in and for the Second Circuit and Eastern District of New York at the United States Court Rooms in the City of New York, Borough of Brooklyn, on the 28th day of June, 1904.*

Present:

Hon. Edward B. Thomas, District Judge holding the Court.

EDISON PHONOGRAPH COMPANY and  
NATIONAL PHONOGRAPH COMPANY,

Complainants,

VS.

PHILIP MARCUS and  
FREDERICK B. VAN VLECK, personally and as trustee in bankruptcy of the estate of Philip Marcus.

IN EQUITY—Patents Nos. 382,418, 414,761.

A motion for a preliminary injunction herein having been made and brought on for argument, upon the bill of complaint, the affidavits of Carl H. Wilson and Delos Holden in support of said motion, and upon the affidavit of Frederick B. Van Vleck in opposition thereto, and after hearing Frank E. Bradley, Esq., in support of the motion, and George Brush, Esq., in opposition thereto, it is upon due consideration

ORDERED, that a preliminary injunction issue out of and under the seal of this court, strictly enjoining and restraining the defendant, Frederick B. Van Vleck, Trustee in bankruptcy of the Estate of Philip Marcus, his associates, attorneys, solicitors, clerks, servants, agents and employees until the further order of this court, from directly or indirectly using or causing to be used, selling or causing to be sold, or advertising to sell, any apparatus, articles or devices embodying or constructed or operating in accordance with the inventions and improvements set forth in Letters Patent Nos. 382,418 and 414,761, at prices lower than those at which they are authorized to be sold by said complainants as set forth in Schedules 1 and 2 of the Bill of Complaint, *viz.*:—Edison Records (standard size) at fifty cents a piece or Five dollars a dozen (if full dozen is sold at one time); Edison Concert Records at One dollar each, or Twelve dollars a dozen; or without the license of complainants.

And it is also

ORDERED that the suit be dismissed as to Frederick B. Van Vleck individually without costs each as to the other.

(Sgd) EDWARD B. THOMAS,

Form approved:

U. S. J.

Frank E. Bradley,

Solicitor for Complainants.

Geo. Brush,

Solicitor for Frederick B. Van Vleck, individually and as trustee of the estate of Philip Marcus.

#### THE WRIT.

*The President of the United States to:*

FREDERICK B. VAN VLECK as Trustee of the Estate of Philip Marcus, in bankruptcy, and every person connected directly or indirectly with you, your associates, attorneys, solicitors, clerks, servants, workmen, agents and employes, GREETING:

WHEREAS, it has been represented to us in our Circuit Court of the United States for the Eastern District of New York, in a certain case therein depending, wherein Edison Phonograph Company and National Phonograph Company are complainants and you, the said Frederick B. Van Vleck as Trustee of the Estate of Philip Marcus in bankruptcy, and Philip Marcus are defendants, that Letters Patent of the United States Nos. 382,418 and 414,761 were issued in due form of law, and that you, the said Frederick B. Van Vleck as Trustee in Bankruptcy of the said Philip Marcus, have threatened to infringe the claims of said Letters Patent Nos. 382,418 and 414,761,

NOW, THEREFORE, we strictly command and enjoin you, the said Frederick B. Van Vleck, Trustee in Bankruptcy of the said Philip Marcus, and your associates, attorneys, solicit-

ors, clerks, servants, agents and employes, that you forthwith until the further order of this court, desist from directly or indirectly using or causing to be used, selling or causing to be sold, or advertising to sell, any apparatus, articles or devices embodying or constructed or operating in accordance with the inventions and improvements set forth in Letters Patent Nos. 382,418 and 414,761, at prices lower than those at which they are authorized to be sold by said complainants as set forth in Schedules 1 and 2 of the bill of complaint, viz.:—Edison Records (standard size) at fifty cents apiece or Five dollars a dozen (if full dozen is sold at one time); Edison Concert Records at One dollar each or Twelve dollars a dozen; or without the license of complainants.

WITNESS, the Hon. Melville W. Fuller, Chief Justice of the United States at the City of New York, Borough of Brooklyn, on the 28th day of June, 1904.

B. LINCOLN BENEDICT, Clerk.  
Frank E. Bradley,  
Solicitor for Complainants.

### BEST WAYS OF SELLING EDISON GOODS

There is no trouble in selling Phonograph goods, but articles on best methods of selling Edison goods will certainly be of ample interest to salesmen and Dealers. There are many points that help the sale of Edison goods and will always increase it: no change of needle, no scratch, no Records that wear out, etc. While on the other hand Edison Records are "*natural as nature itself.*" They are durable, clear and distinct and good in many other respects. In showing up the Phonograph to an intended purchaser it is of some importance to know how to suit his musical taste. Playing the right Records will help a great deal in selling the Phonograph. Many times one will buy a machine for the love of a certain kind of music. I am often asked why the Edison people do not have grand opera Records like those made in the disk records. There are a great number of grand opera instrumental pieces on pages 3 and 4 of the domestic catalogue, and it should not be forgotten that there are fine Records sung in French, German and especially in Italian in the foreign catalogue which are beautiful reproductions of fine pages of grand opera music sung by good talent. We now carry a full stock of foreign Records and do a most satisfactory business in this line.

I have sold a few outfits, consisting of two Home Phonographs complete, a number of Records and blanks to people who use one of the machines here and send the other abroad for the purpose of exchanging Records of their voices across the ocean.

To sell Phonograph goods, compare them with other makes, carry a complete stock, advertise with public demonstrations in the store, lodges, etc., and look for customers among every class of people, as the love of music is as strong in the poor as in the rich and what cheaper way is there to gratify this taste than by the Phonograph?

H. F. Tosi.

With the Boston Cycle & Sundry Co., 48 Hanover street, Boston, Mass.

### HOW ABOUT SUPPLEMENTS?

Are you getting all the Record supplements that you can use to advantage each month, Mr. Jobber? Are you able to supply your Dealers with all they need? If not, write the Advertising Department. Can you use any more with benefit to your business, Mr. Dealer? If so, ask your Jobber for them. The most successful firms selling Edison goods are those who keep a list of all owners of Phonographs and send each of them a list of the new Records every month. Dealers who haven't such lists should lose no time in getting one up. A list of but fifty names would yield a nice business in a year, and it would only cost fifty cents a month to send them a monthly supplement.

### USE CATALOGUES AND PRINTED MATTER.

It is no coincidence that the most successful Jobbers and Dealers in Edison goods are those who get and use a liberal quantity of the catalogues and other printed matter issued by this company. We keep a record of all printed matter sent out, and the cards showing but few entries are invariably those of firms doing a limited business. We do not know just why this is so, but we would like to have such firms give the printed matter end more attention and see what effect it has upon their business. It is a form of advertising that costs little but pays handsomely. Be progressive and up-to-date. But don't get printed matter unless you can make it work effectively.

### AN OFT TOLD TALE.

A Philadelphia admirer recently wrote that he owned an Edison Phonograph and 200 Records or more and then related how he came to buy an Edison outfit. He took the advice given in our advertisements and asked a Dealer in his city to play different makes. The first style shown was not an Edison.

"After he had run about twenty records," continued the writer, "I got tired of the noise and then I asked him if he would run me one on the Edison Phonograph. He did, and when he had run one piece I told him I would not have one of them 'talking machines' if given me, for it was nothing in comparison to the Edison. I have had it a little over two years. I have got one of the finest selections of Records in Kensington. Also one of the finest Phonographs I have ever heard. A friend came to my house to hear my Phonograph. He said he didn't want his 'talking machine' any more. Hundreds have heard it, and they all say that it is the best they ever heard."



**PRINTED MATTER.**

No effort will be made to get out a new Record catalogue before August. This is because we want to use up the quantity of No. 545 now on hand. Orders will be filled in such a manner as to keep the trade supplied without having many on hand when the new edition appears. The delay in getting out a new catalogue will give the trade about two months more time in which to dispose of the selections which are to be cut out of the new edition.

Jobbers should look over their stock of catalogues and other printed matter and when ordering machines or Records state what they need to make their stock complete. Business in Edison goods is going to be fine this fall and it is not too early to make plans to take care of it when it comes. Jobbers will naturally look out for their machine and Record stock, but it is quite important to be able to give Dealers catalogues and advertising literature when they ask for it. We have none of this to waste but we want every Dealer to have all that he can use to advantage. We give below a list of current forms from which to make up orders. A good plan would be to send the Advertising Department an inventory of catalogues, printed matter, signs, etc., on hand, with another column showing what you want sent. We will then know just how to take care of orders, and possibly be able to send some forms that have not been carrying. We try to keep the trade advised as to what we have in this line, but once in a while we learn that a Jobber does not know of a form that has been in use for some time.

**CURRENT FORMS.**

- 291. Jingle Book.
- 390.            } Hangers.
- 391.            }
- 432.            }
- 433.            }
- 400. Supplement of Chinese Records.
- 409. Colored card of boy and hatchet.
- 425. Record order blank.
- 427. How to make Records at home.
- 464. Supplement of Japanese Records.
- 467. Four-page folder.
- 484. Accessories Catalogue (for trade use only).
- 485. Coin Slot Catalogue (for trade use only).
- 495. Record Supplement for April
- 496.       "       "       "       May.
- 497.       "       "       "       June.
- 498.       "       "       "       July.
- 500. Machine Catalogue ("A Lasting Impression").
- 509. Supplement of British Records No. 1.
- 570.       "       "       "       "       No. 2.
- 509.       "       "       "       "       French-Canadian Records.

- 510. Numerical Record Catalogue (for trade use only).
- 515. Repair Parts Catalogue (for trade use only).
- 535. Folder showing Gem, Standard, Home and Triumph Phonographs.
- 540. Folder on Edison Gold Moulded Record.
- 545. Domestic Record Catalogue.
- 555. Foreign       "       "

Individuals or firms now on our mailing list but who are no longer handling our goods are asked to advise us of the fact, so that we may remove their names.

Victor H. Rapke, of New York, has extended his series of Record numbers on gummed sheets from 8741 to 9020. There are 280 of these numbers and they are being sold at thirty cents for the set.

A number of Jobbers and Dealers have made excellent use of the new series of border cuts shown in the May issue of the PHONOGRAPH MONTHLY. Especially good were the advertisements of the Eastern Talking Machine Co., Boston, and Graves & Co., Portland, Oregon.

**PERSONAL.**

William E. Gilmore, President and General Manager of the National Phonograph Company, returned on June 11 from a two months' trip to England and Europe. He visited the new plants of the company at London, Berlin, Paris and Brussels. He was accompanied by Mrs. Gilmore.

James H. White, European Sales Manager of the National Phonograph Company, arrived from London on the *Bluecher* on June 19. He will return on July 7.

**LEADER GOES TO PRISON.**

Reference was made last month to the breaking up of a gang of men who made it a business to buy Phonographs on the installment plan from various New York Dealers and then sell them for half their value or less. We also told how Joseph Greenfield, the leader of the gang, was arrested, through the efforts of Victor H. Rapke. Greenfield later made a confession and gave the names of his confederates. He was brought before Judge McMahon, in the Court of General Sessions, New York city, on June 24, and was sentenced to three months in the penitentiary, the light sentence being due to his confession. Warrants have been issued for the arrest of the others in the gang and their apprehension is daily expected. Mr. Rapke has been warmly congratulated on his success in breaking up the gang.

### THE NEW PHONOGRAM.

The first issue of the new PHONOGRAM will be shipped with or just ahead of the July Records. It is especially requested that no effort will be made by either Jobbers or Dealers to send out the PHONOGRAM for retail use before the Records of the month have been received. It will contain a list of new Records each month and its distribution ahead of the receipt of the Records themselves would cause a demand that the Dealer cannot supply. A Phonograph owner, upon receiving a copy, would naturally assume that Records listed in it could be had and a useless trip to the Dealer's store would be an annoyance. It will be better for all if Jobbers will adopt a plan of sending PHONOGRAMS ordered by Dealers with their Records for the month, the same as they now do with Record Supplements. Those Jobbers who have PHONOGRAMS sent by express at their own expense may be able to beat out their competitors for a month or two in supplying Dealers a little sooner, but other Jobbers will quickly do the same thing, with the result that all will soon be incurring an expense that yields no advantage. We hope that all will see the force of this argument and will hesitate about beginning a plan that in the end will not benefit them.

Dealers who want a supply of the PHONOGRAM are urged to get them from their Jobbers, who will fill orders at the rate of 25 cents per hundred. This will yield the Jobber no profit but he will doubtless be glad to fill such orders as an accommodation and for the increased business that should result from the advertising gained through the publication. Dealers who cannot get copies in this way can have five or more copies *mailed to one address* by our Advertising Department at the rate of 8 cents per year for each copy. This will make five copies cost forty cents a year, most of which must be expended for postage, since publications of this kind cannot be mailed at publishers' rates. Twenty-five copies to one address will cost fifteen cents per month.

We do not expect that the first issue of the PHONOGRAM will meet the expectations of everyone in the trade, but rather expect to receive suggestions from Jobbers and Dealers that will make it a popular and useful medium for increasing business. The July issue will give half-tone pictures of Arthur Collins and Byron G. Harlan, and later issues will give one or two others of our Record making talent. This feature alone will, we believe, make the PHONOGRAM much sought

for by Phonograph owners. A copy of the PHONOGRAM will be mailed to the trade each month.

### ACOUSTICS TESTED BY PHONOGRAPH.

C. R. Zacharias, Dealer at Asbury Park, recently gave a practical demonstration of the excellent acoustic properties of the new Asbury Avenue Pavilion, recently built at Asbury Park. At the request of the Beach Commission, Mr. Zacharias played numerous selections in various parts of the building on a Concert Phonograph and both the musical and spoken Records were heard clearly and distinctly in all parts of the structure.

### A BERMUDA ADMIRER.

Luke Goins, an employe of the Hotel Frascati, Bermuda, recently bought a Home Phonograph and a lot of Records from our Foreign Department. In acknowledging the receipt of the outfit he wrote as follows:

I came down here a year ago from Boston, my home. Up in Hamilton there is a druggist who does a large business selling patent medicines, and he has a large machine in the store with a great big horn out the door, and of all the noises you ever heard "that's it." Well, crowds of people stand there every Saturday evening and listen to what they think is music and think it great. Of course you know what it sounds like. About a year ago a fellow came down here with some kind of a machine and gave concerts in different towns, and he put a damper on the talking machine, as his would break down every second, and something was the matter with it all the time. Now you cannot fool these folks down here, as they are wise and know a good thing from the start. I received my machine a couple of days after the boat arrived. They were thrown in the ware room like baseballs, but to my surprise not a thing was broken or damaged. Well, I fixed things up a wee bit, and then to get her a-going. This hotel overhangs the water, or at least the verandas do, and the Home rings out as clear as a bell. The first night not many knew of it, but the second and third evenings people came from every section. Every one who has heard it says that it is simply wonderful and they can hardly believe themselves. I ran the machine last night, which makes four nights I have run it, and so many people were out here and coming in on the grounds that I have concluded not to run it any more until I get a few more Records and give a few concerts and get back some of my money. I am going to give a concert next week, my first one, and I am all ready assured of good attendance. No doubt you will hear from parties down here in regard to buying machines. If you do, you can rest assured it is my good work that is doing it. In the meantime I am going to hustle and get the thing a-going, as I know there is money in it. It is the talk of the place already.



### COMMENTS ON AUGUST RECORDS.

The August list of Edison Gold Moulded Records will receive more than ordinary attention throughout the world from the fact that the twenty-five selections will be the first to be made with the titles engraved on the ends, and they will be packed in our new style Record box. These innovations will do away with the blue Record slip and will make it unnecessary to wrap the Records in cotton and paper. The new boxes will also bear a handsome new label in gold, red and black on white paper. The entire outfit will be unusually attractive. A notice to the trade on the new style Record and carton is printed on page 3 of this issue.

There is a preponderance of what is known as popular music in the August list and consequently it will be a profitable one for the Dealers, for, with all that is said about the better grades of musical compositions, the public as a mass demand songs with catchy airs, and rhythmic accompaniments, with still a strong leaning toward ragtime. The admirer of a higher class of music will, however, find much in the list to suit his taste. Another feature of the list, as in July, is the number of different artists whose names appear as makers of the Records.

No. 8749, "Dance of the House," is a Record of the ballet music from the opera "La Gioconda," by Ponchielli. It is one of the most popular instrumental numbers in the opera. While it is a standard or classical number, it is at the same time very pretty and tuneful, and easily understood. It offers full scope for the excellent soloists of the Edison Concert Band, and, particularly, in the beautiful little flute effects which intermingle so charmingly with the melody. Then in the broad, clear tones of the clarinets is at once heard the top notch of both the instrumentalists' and the recorder's art. The brilliant execution of these instruments in the spirited galop at the finale brings to a close a Record that is one of the gems of the Supplement.

No. 8750, "Good-bye, Little Girl, Good-bye," is a new march song by Cobb and Edwards. This song is somewhat similar to "Good-bye Dolly Grey" and has an equally pretty air. The introduction of bugles and an orchestra accompaniment of a martial character effectively carry out the phrase in the refrain: "For I'm Marching Away to be a Soldier." W. H. Thompson's rendition of this song is excellent.

No. 8751, "Without Your Love, Ah, Let Me Die," is a sentimental song by Charles K. Harris. It is by no means a new composition, but it is a charming tune and is admirably adapted to Miss Morgan's fine contralto voice. It is an unusually good Record of a female voice. It has an orchestra accompaniment.

No. 8752, "Pretty as a Picture," is a bell solo with orchestra accompaniment of T. B. Bishop's ever charming song and dance air. It is especially suited to the clear notes of the bells. All who hear it will recognize in it an old friend of the vaudeville stage. Albert Benzler makes the Record with his usual clever execution.

No. 8753, "I Can't Do That Sum," is a serio-comic song and chorus with orchestra accompaniment. It was one of the principle hits in the "Babes of Toyland," written by Glen MacDonough and Victor Herbert. The Record is made by the Edison Quartette. S. H. Dudley as the teacher puts the most ridiculous problems before the class and the quartette sings the chorus, giving a clever imitation of the scholars sitting on the wall and tapping their slates while singing:

"Put down six and carry two.  
Gee! but this is hard to do.  
You can think and think and think  
Till your brains are numb;  
I don't care what teacher says,  
I can't do that sum."

No. 8754, "The Belle of the West," is the second of a series of three compositions by A. Liberati which were formerly made in wax and are now being made by the Gold Moulded process. No. 8101, "The Belle of Kentucky," was listed some time ago, and "The Belle of the East" will follow. "The Belle of the West," listed this month, is a well played Record, with a cornet solo by John Hazel as its principal feature; in fact, it could have been equally well listed as a cornet solo with band accompaniment. There is an absence of frills in the cornet playing that is sure to please. The Record is made by the Edison Military Band.

No. 8755, "I Want to be a Soldier," is a descriptive song by William Cahill and is sung by Byron G. Harlan. In it a boy sings of his determination when he grows up to take his father's place and be a soldier. The orchestra accompaniment is of a military character with fifes, drums, etc. Mr. Harlan's work is fully up to his reputation as a Record maker of the highest order.

No. 8756, "Michael Clancy as a Policeman," is a talking and singing Record by Campbell and Roberts. It tells of the troubles of Clancy, includes the singing of "My Little Irish Canary" and closes with Clancy being found off his beat by the roundsman and "transferred again."

No. 8757, "Katunka," is an intermezzo written by Lee Olean Smith and is played by the Edison Symphony Orchestra. This composition has considerable character and a most attractive air. It is listed in response to calls from the West where it is now very popular. It will be equally popular wherever the Record is sold.

No. 8758, "The Little Rustic Cottage by the Stream," is another Record by Harry Anthony whose rendition of "I'm Longing for My Old Kentucky Home" in the March list made him one of our most popular artists. We have had many requests from Phon-

ograph users to have Mr. Anthony make other Records and have just succeeded in getting him to do so. "The Little Rustic Cottage by the Stream" is well adapted to Mr. Anthony's fine voice, and cannot fail to heighten the reputation he has already gained. The words of this composition are by M. H. Rosenfeld and the music by John and Otto Heinzman.

No. 8759, "Gone, Gone, Gone," a coon male duet by Collins and Harlan, with orchestra accompaniment, is one of the most popular Records of its kind in the August list. The chorus has an unusually catchy air. It will make it one of the leading songs of the season. Especially good is the singing of the opening and closing words in the chorus, "Gone, Gone, Gone." It is a ragtime song, pure and simple, and Collins and Harlan have made a splendid Record of it. The song was written by T. J. Farron, Jr., and the music by Joseph M. Hollander.

No. 8760, "On Jersey Shore March," played for our Record by the Edison Concert Band, is issued with the full confidence that it will be a big favorite, not only as a Record; but as a selection. It is Arthur Pryor's latest, and, we think, his best composition. The melody which begins the trio and concludes the march lingers in the memory, and the more it is heard the more it is enjoyed. We venture the opinion that this strain will be whistled from ocean to ocean.

No. 8761, "Don't You Cry, My Honey," is a coon lullaby and is sung as a contralto and basso duet, with orchestra accompaniment, by Miss Morgan and Mr. Stanley. Perfect blending of voices and excellent rendition make this a charming Record. This composition was written by Albert M. Noll.

No. 8762, "Mississippi Mamie," is a clever Record, sung with clear enunciation by Harry MacDonough. This is a coon love song and already has a wide popularity. It is made with orchestra accompaniment. The words are by Andrew B. Sterling and the music by Maxwell Silser.

No. 8763, "A Great Big Chickapoo Chief," tells how a darky minister, disguised as an Indian chief, was found robbing a neighbor's chicken coop. He denied that he was a colored man and claimed that he was an Indian chief, simply after feathers to decorate his head. His captor, however, declares that he is disillusioned by the kink in his hair. This coon song Record is made by Arthur Collins in his inimitable style and has the usual orchestra accompaniment. Edward Madden wrote the words of the song and Victor Morse the music.

No. 8764, "Psyche" (Scherzetto), played by the Edison Symphony Orchestra, is quite a remarkable Record, introducing as it does the staccato bowing of the violins, clear and distinct, and in perfect unison. The string harmony effects are strikingly well defined throughout the Record, and the 'cello passages are rich with the characteristic tones of this instrument. The playful character of the composition, in parts, admits of splendid

opportunities for the woodwind instruments, as does the crescendos, working up to double forte climaxes for the brass instruments. Harry Pabst, the composer, doubtless had no idea that his composition would find its way to the Phonograph, but had he written it specially for the purpose it could not have been better adapted.

No. 8765, "Alexander," is Billy Murray's monthly coon song contribution, with orchestra accompaniment. It is the plea of a colored girl to her lover to be taken back into his affections, and is a sort of "Bill Bailey" song with the conditions reversed. "Alexander" has already become widely known and is daily increasing in popularity. The words are by Andrew B. Sterling and the music by Harry Von Tilzer.

No. 8766, "Pompermickle's Silver Wedding," is Len Spencer's vaudeville specialty for the month. It is a German dialect recitation with incidental music. Pompermickle is supposed to be addressing an audience in a vaudeville theatre and telling them about his silver wedding. He hasn't been married twenty-five years, but he had the celebration because he "needed the silver." He then proceeds to tell about the good things that were served at the supper, the orchestra at the same time playing "Wouldn't That Make You Hungry." This is one of the best things Mr. Spencer has made in a good while.

No. 8767, "You're Welcome as the Flowers in May," is an exceedingly attractive tenor and baritone duet by Harlan and Stanley, with orchestra accompaniment. Many will agree that this is one of the best Records in the August list. The composition is by Dan J. Sullivan.

No. 8768, "Everywhere Medley," by the Edison Military Band, introduces "Everywhere," "The Man with the Ladder and the Hose," "A Starry Night for a Ramble," "My Kangaroo" and "The St. Louis Rag." The band execution of this Record is unusually good.

No. 8769, "The Minstrel Boy," is a clarinet solo by William Tuson, played in an artistic manner. The air is played with variations, and the clarinet is accompanied by the orchestra.

No. 8770, "Two Eyes of Brown," is a fine baritone Record by James F. Harrison, whose splendid baritone voice has made him one of the most popular of our Record making force. "Two Eyes of Brown" is a sentimental song and is given with orchestra accompaniment. The words were written by Edward Madden and the music by Stephen Howard.

No. 8771, "When the Coons Have a Dreamland of Their Own," is a coon song with orchestra accompaniment in which Bob Roberts tells of the wonderful things that will happen when this pleasure resort for colored people has been established. This will be a popular Record. The words and music are by Heehan and Helf.

No. 8772, "The Wanderer's Return," is No. 3 and the last of the Plantation Series. It is a descriptive singing and talking selection by



the Edison Male Quintette and tells how Ephraim returns to his father after an absence of fifteen years. The Record opens with singing by the darkies after which Ephraim appears on the scene, discloses his identity and states that he is rich enough to buy the freedom of Uncle Jasper. More singing follows and the Record closes with Uncle Jasper giving thanks.

No. 8773, "Two Rubes at the Circus," is another laughable Rube sketch by Harlan and Stanley. It gives their progress through the side show and menagerie, with funny remarks about the monkey, lion and the elephant. While they are in the latter place the band is heard playing in the distance; as they approach the ring performance the music increases in volume until they have entered the main tent. They witness the ring performance and attend the concert at the close, in which they are invited to sing and dance.

#### "FOLLOW UP" REPLIES REQUESTED.

Dealers who have recently had retail inquiries referred to them by this company have noticed that responses to them are requested by us. This is being done for the purpose of ascertaining whether or not Dealers are giving the inquiries proper attention. We will thank Dealers to endeavor to make a sale in each instance and at the end of three weeks to fill in the return card and mail it to us. We will then know whether or not it is desirable to send the inquirer a second letter.

#### NATIONAL PHONOGRAPH CO. IN GREAT BRITAIN.

*From the Talking Machine News, London.*

It was but the other day that the invasion of Great Britain by the National Phonograph Company took place. Not that the talking machine world was not well and favorably acquainted with them and their products long before. That was how the desire to become better acquainted came about. Hence the plant in the Gray's Inn Road for making masters, and hence, still more recently, the leasing of the fine premises at the corner of John street and City Road, Clerkenwell, appropriating, by-the-way, a goodly share of both thoroughfares. And, as Mr. James H. White, Managing Director, of the company, mentioned to me in the course of our chat, this new distributing center of theirs has in a few short months already become inadequate, so that they already contemplate a further extension. Yet there are seven floors to the present building, with a floor space of about seventeen thousand feet. Indeed, in going over the building in company with Mr. White, I felt as though I were doing the Grand Tour. We passed in rapid succession through the correspondence department, the invoicing depart-

ment, the credit department, the order department, the show room, the Record stock rooms, the packing and shipping rooms, the repair shop, and, last but not least, the agreement department. For the agreement is one of the special features of the National Phonograph Company's methods of business.

"We have," said Mr. White, to me, "upwards of eight thousand British agreements in operation. That is to say, of course, that we have that number of traders selling our goods all the time. In Germany we have about seven thousand agreements going."

"Can you give me an approximate idea of how many Edison Gold Moulded Records have been sold up to now?" I asked.

"That is rather a large order to fill at a moment's notice," replied Mr. White. "But I will look into the matter for you."

And the figures, as since forwarded me, stand at the pretty little total of about thirty millions.

"Since when," said I, "shall you date the figures?"

"Since August, 1901, when the Edison Gold Moulded -was first put on the market. It began to 'go big' in March, 1902, and has been going big ever since. There has not been a time since then when we have been able to fill all the orders which have come to hand. We are only just now beginning to catch up with the trade. That has come about as the result of the installation of our three manufacturing plants on the Continent, which are at the present time running continuously night and day. We have a plant in France, at 64, Rue de Cormeille, Levallois-Perret; a plant in Brussels, at 65, Quai du Halage; and a plant at Berlin—the principal one—at 24-25, Sud-Ufer. Brussels, however, was the first place where we laid down a plant."

"You do not anticipate having a plant this side the Channel?"

"Yes; we shall probably have one in going order in about eighteen months or two years from now. Meanwhile, we start another Record-making plant in Russia next year, and are making masters in Russia now."

"How long has your British repertoire been going?"

"Nine months, and we are adding to it month by month. Our master plant in the Gray's Inn Road is a permanent establishment for the manufacture of British selections. I may say that while we have had considerable success with them, it has not made the least difference to the sale of our American Records. The output has simply been increased all around. By the way, we are printing 500,000 of these booklet catalogues for the British trade."

It was an attractive little publication in gold, blue and green, labelled "Edison Gold Moulded Records. Domestic Selections," and contains all the selections listed up to, and including, March, 1904. This booklet will be a most useful little guide to buyers of records.

"The world staff of the National Phonograph must be pretty strong in point of numbers?" was my question.

"Yes, we employ between four and five thousand people, not reckoning the office force,

which would probably amount to a thousand more. That is directly; indirectly, through our agents, of course we employ many thousands more."

We made our way back through the stock rooms, with a capacity of 1,500,000 Records. And against the shelves, already crammed to repletion, there stood numberless cases waiting until there was room for them to disgorge their contents. Downstairs, in the basement, stood similar cases, tier upon tier and rank upon rank—each one holding three hundred Records. On the other side were stacks of machines, packed ready for delivery to the carrying companies. And yet all these by no means represent the business done in the Clerkenwell premises. For numbers of orders each year pass through the European headquarters only in a technical sense. That is to say, they are ordered from abroad, cleared in Clerkenwell, and sent on direct to the larger factors who have placed them, without so much as entering the Clerkenwell Road warehouse.

"Your readers," said Mr. White, next, "will be interested to hear that we are organizing a department for handling our increasing cinematograph business. At the present time our machines and films reach 'the showman' through other firms. When we have the new department in going order we shall sell direct."

#### COMMENTS ON BRITISH RECORDS.

The following comments from the *Talking Machine News*, of London, refer to Edison Gold Moulded Records made in Great Britain and called British Records. A few of them have already been listed in this country; the others will be listed later:

The National Phonograph Company's Records last month arrived too late for us to review the whole of them in our May issue. We have now had time to go carefully over the remainder, and cannot speak too highly of the excellent selection of band Records which this firm is turning out. The Grenadier Guards, in a selection from "Carmen," the "New Colonial March," a stirring and melodious march, and the waltz "Night Breezes," with its soft, stirring refrain, are all three good specimens of high-class band records, as also is the selection from *Les Cloches de Corneville*. In these Records the brasses ring out true and clear without blasting. This remark also applies to the selections by the British Military Band, whose selections embrace, "Here, There, and Everywhere," and the "Dublin Fusiliers." These two marches should go well. "The Passing of Ragtime," with a quaint trumpet effect, the "Happy Darkies Barn Dance," and the "Bundle of Mischief Cakewalk" are also three popular numbers, with plenty of life in them, whilst the "Fleeting Moments Galop" and "Forget-Me-Not Intermezzo" are well played, as also are the "Sons of the Brave March" and the "Rienzi Overture." Hamilton Hill's powerful voice in "Somebody's Sailor Boy," "Love's Proving," "When We Meet, Sunshine Above," "While Life Shall Last," "What Might Have Been," and the

"Anglo-Saxon Language," with orchestral accompaniment makes a very fine Record. Leonard Mackay gives us "My Flo," "Father's Footsteps," "What I Have I'll Hold," and "Yo, Ho, Little Girls," with much effect, while Miss Edith Manly's comic powers are clearly rendered in the "Piccadilly Johnny." Our Scotch friends would do well to obtain the Thomas Reid Records, given in the Scot's dialect. Among those sent are "Blue Bonnets over the Border," "Banks of Allan Water," "Kelvin Grove," "Duncan Gray," and "John Anderson." Fred Daniels in Dan Leno's famous patter song, with the eulogy on eggs, would be difficult to beat. It is one of the best comics that has been brought to our notice. The National this month sends us their special All Star Records, as per their list for June. The comic element is well to the fore. Ernest Shand contributes "Little Mary," "Bang went Saxpence," "Don't Mention It, Please," "I Only Meant to be Polite," and "More Trouble in Store for Someone." T. E. Dunville, the well known music hall comedian, gives us "Three Stages of Woman," "Nine Gallant Highlanders," "Enquire Within," and the "Volunteer Fireman." Phil Ray, who is as usual up-to-date, is heard to advantage in "Let Her Drown," "I'll Risk It," "Nonsense," "The Restless Wife," "I'm Not a Coon," "Only Seventeen," "The Mad Wife," and a humorous recitation, "The Parting." Gus Elen's coster Records show a marked improvement on any we have before heard by him. They comprise "Who Could be Happier than Me," "The Postman's Holiday," "The Lucky Treasure Seeker," "The New Perjama 'At," and "The Faithless Donah." George Bastow sings "I Didn't Know What to Do," "Varmer Giles," "Muvver's Nursery Rhymes," and "Let Us Pause amid Life's Pleasures;" and Lloyd Morgan is responsible for that quaint nigger melody, "I'se Awaiting for You, Josie." Dutch Daly, who has for so long held high place not only as a "patter" artist, but for his inimitable business with the concertina, is well reproduced in "Stories" and "A Few Words on Love." They are laughable in the extreme. His concertina solos, "American Airs," "The Carnival" and "Imitations" are unique examples of what can be done with the concertina. In our opinion, two of the best Records sent us are by Joe O'Gorman, whose brogue in "Flanagan's Hotel Expenses" and "Flanagan at the Front" is not only rich, but at the same time quite distinct. He also contributes "What Did Patsy Do?" "Three Men Went out a-Hunting," and the ever popular "Bedelia." Amongst the serious contributions we have Bruno Hesse in the Norwegian songs, "Sol-feste," "Eg Elskla," "Gamle Mor," and "Ved Rundarne;" and Hamilton Hill in "Who Goes For a Sailor," "Pansy Faces," "Good Luck to Japan," "The John Bull Store," and "No Alien Need Apply." No list would appear to be complete without some songs by Hamilton Hill. He certainly makes excellent Records. The British Military Band is responsible for Popular Songs, No. 7, with its catch waltz refrain on the reeds, "The Duchess of Dantzic," Nos. 1 and 2, "The Overture to Oberon," "The Orchid," and the "Earl and the Girl."



**MORE BUSINESS TO FOLLOW.**

We, also, wish to add our tribute to your Gold Moulded Records. To say that they are superb is putting it mildly.

We, as you are well aware, have had an uphill row to hoe with machines and records on all sides being sold at any price to get rid of them, and of course many people buy who do not appreciate the difference between the sweet music produced by the Edison and the scratchy, noisy, so-called music produced by various other machines because they could be bought for little or nothing. However, we have done much missionary work and some business and looks like much more to follow, especially when your contemplated changes are made.

Then, too, your method of protecting your agents is very commendatory. We always know that we are just as good as some one else.

Each month's list seems to be a little improvement over the last. Right here we wish to suggest that "Rock of Ages," sung by Campbell and Harrison, would seem to us to be a winner from the fact that the portion of this hymn sung in No. 8708 is the finest we have ever heard, and that is the sentiment of all who heard it.

SMITH & MOYER.

Dixon, Ill., June 13, 1904.

**ANOTHER ORIGINAL INVITATION.**

H. Schmidt & Son Co., Dealers at Muscatine, Ia., sends another bit of original printed matter in the shape of the following invitation to a Phonograph concert:

**SATURDAY IS "RECORD DAY."**

We cordially invite you to attend the concert given on that day by the world's most wonderful musician, "The Edison Phonograph."

Our Record shelves are filled with "Edison's Gold Moulded Records," the only Records that embody "PERFECTION" and "LASTING QUALITIES," everything that is good, new and up-to-date, including the June selections. 2,500 Records in all have been received for this "Record Day."

We trust that you will accept this invitation so that you may hear what the "Edison Phonograph, with Gold Moulded Records" can do. It is the only playing machine that possesses lasting qualities and will furnish music and other amusement for years to come.

Saturday is the day, don't forget it.

H. SCHMIDT & SON Co.

Muscatine, Iowa, June 9, 1904.

**BEST THEY EVER HEARD.**

I handle nothing but Edison machines and Records and have no trouble to get my price for them. I have had hundreds tell me that I have the best machine they ever heard. It's because I have nothing but new Records and they are the best.

LEOPOLD J. SCHREIBER.

Plymouth, Mass., June 12, 1904.

**PRAYER VS. BENZINE.**

A. C. D. Loucks, manager for Douglas & Co., of New York, sends the following:

The following story may interest readers of the MONTHLY. Some weeks since we received from a Brooklyn customer, a letter demanding the prompt attendance of one of our repair men to adjust his Triumph Phonograph. We sent the man, who, on his return, told the following story:

The owner took him up into a second story room, uncovered the instrument and to demonstrate the requirements of the occasion, placed "Lead, Kindly Light" Record on the mandrel, but the light would not lead, nor the machine run. The owner then spread a paper in the center of the room, placed the instrument carefully thereon, and asked the repair man to kneel down, while he asked the blessing of the Great Spirit on their work. The prayer proved a lengthy one and the position an unaccustomed one to the visitor. After ten minutes of exhortation the latter stealthily removed his benzine and oil cans and applied their contents to the Phonograph. After five minutes more of exhortation it was found that the Phonograph operated without trouble. The owner stated that the sending of such a nice Christian man on the part of Douglas & Co. bespoke the standing of the house. The prompt answer to prayer was a perfect manifestation of the Spirit's power. The repair man being a somewhat wild youth, states he has an idea it was more the work of the Devil and a can of benzine.

**ANOTHER WAY TO DETERMINE SPEED.**

"I have tried several devices for determining the speed of Phonographs," writes J. A. Bedworth, a Dealer at South Boston, Mass., "but they do not give satisfaction. I have had great success with a little scheme of my own. I take any record or blank and make a mark from one end of the record to the other. By putting this record on the machine and standing in front or any where near the horn, I find it much easier to count the required revolutions by hearing the click through the horn than to hold the finger on the set-screw. It also gives you the correct number of revolutions a machine makes in doing actual work. Most people retard the motion of the machine when putting their finger on the set-screw."

**WITH APOLOGIES TO ANANIAS.**

Philadelphia, Pa., June 23.—[Special.]—A runaway horse attached to a sewing machine wagon on Park drive was stopped to-day at the Falls of the Schuylkill by a Phonograph playing at the window of Samuel MacWhinney's residence near the drive. The horse had run from Main street and Walnut lane, Manayunk, nearly two miles, when the Phonograph sang out through a megaphone attachment the old song:

"Hey, Nellie, Hi, Nellie, listen unto me."

The horse, which happened to be named Nellie, pricked up its ears and stopped and the driver soon arrived and took charge of it.—*Chicago Tribune.*





NATIONAL PHONOGRAPH'S EXHIBIT AT ST. LOUIS.

### EX-GOVERNOR HILL AND THE PHONOGRAPH.

Some time ago there appeared in many of the New York daily papers in prominent positions, a news item, headed "PHONOGRAPH BOTHERS GOVERNOR HILL." As many of the trade may have read this article, which was incorrect, I write to give you a correct version of the affair. Ex-Governor Hill occupies the office adjoining my Phonograph Concert Room. As I sell Edison Records it is of course unnecessary to state the store is busy all the time. There never was the ghost of a kick from Mr. Hill, who enjoyed the delightful music from our Edison Phonographs, until one day we had occasion to play a disk machine. (We don't have much call for them, anyway.) Then the trouble began. He would not stand for that.

As a result I have decided not to handle the disk goods. I want a machine and records to sell that are good enough for an ex-Governor of New York State. I have decided that that machine is the Edison, and the establishment is now being run with the aid of Edison goods only. All is harmony now, as far as talking machines are concerned.

W. J. KILLEA,  
Albany Phonograph Headquarters.

### NO GRAPHS OR GRAMS.

We sell nothing but Edison goods. We do not sell buzz saws. We sell Edison Phonographs in homes where they have other kinds of talking machines. They always want to trade their graph or gram in part payment for an Edison, but we tell them nixy.

C. C. THOMPSON & SON.  
Baraboo, Wis., June 22, 1904.



**SUSPENDED LIST, JULY 1, 1904.—SUPERSEDING ALL PREVIOUS LISTS.****COLORADO.**

BOULDER—BENTLEY &amp; CRAIG.

**IOWA.**

BURLINGTON—JOHN P. WEISS, 711 Jefferson street.

SIOUX CITY—HATTENBACH BROS.

**INDIANA.**

SOUTH BEND—EUGENE MARSH, 126 Vista avenue.

SOUTH BEND BOOK BINDERY,  
Robert Lebolt, Prop., 203 North Michigan street.**KANSAS.**CLAY CENTRE—E. M. GOWENLOCK.  
LAWRENCE—BELL BROS.**MAINE.**

BIDDEFORD—W. H. FIELD.

**MASSACHUSETTS.**LAWRENCE—LORD & CO., 314 Essex street,  
E. O. MOSHER, 420 Essex street.

\*JOHN E. O'NEIL.

MALDEN—A. T. FULLER.

NANTUCKET—ARTHUR M. TAYLOR.

NEW BEDFORD—H. B. DEWOLFF.

SOMERVILLE—E. J. WINCHESTER, 32 Summit avenue.

WOBBURN—OSBORN GILLETTE, or THE  
BOLTON JEWELRY COMPANY, L.  
F. MALONEY, Manager.**MICHIGAN.**

DETROIT—F. J. SCHWANKOVSKY.

SAGINAW—GEO. W. EMENDORFER.

**MISSOURI.**

KANSAS CITY—THE WITTMANN CO.

**NEBRASKA.**

LINCOLN—THE WITTMANN CO.

OMAHA—THE WITTMANN CO.

**NEW HAMPSHIRE.**

\*HILLSBORO BRIDGE—E. M. BARNES.

MANCHESTER—A. E. DUMAS.

NASHUA—F. A. McMASTER &amp; CO.

**NEW JERSEY.**ATLANTIC CITY—SAMUEL D. WOLF, 32-34  
Arkansas avenue.

BAYONNE—I. WIGDOR, 450 Avenue D.

JERSEY CITY—W. L. HOFFMAN, 151 Mont-  
gomery street.NEWARK—R. L. CORWIN; also New York  
City.

PASSAIC—I. HURWITZ.

PATERSON—CHAS. H. KELLY, 25 N. Main st.

PLAINFIELD—S. W. FRUCHT, or R.  
FRUCHT; also New York City.  
ELSTON M. LEONARD.WEST HOBOKEN—EMIL HOLLANDER, or  
THE WEST HOBOKEN BICYCLE &  
PHONOGRAPH CO., 619 Spring street.**NEW YORK.**

BEDFORD PARK—GEO. H. TYRRELL.

HOBART—F. H. MARSHALL.

NEW YORK CITY—A. T. ARMSTRONG, or  
AMERICAN PHONOGRAPH CO., 106  
Wall street.BERN BEARWALD, 373 West 11th St.  
BRONX PHONOGRAPH CO., or DA-  
VID SWITKY, 506 Willis Avenue.CENTRAL PHONOGRAPH CO., 160  
E. 42d street.

R. L. CORWIN; also Newark, N. J.

EAGLE PHONOGRAPH CO., or C.  
LOWENTHAL, 83 Nassau Street.EMPIRE PHONOGRAPH CO., 2 West  
14th street.S. W. FRUCHT, or R. FRUCHT, 7 Bar-  
clay st., or 68 Cortlandt st.; also  
Plainfield, N. J.

O. HACKER, 2 Murray street.

HAWTHORNE & SHEBLE, 297 Broad-  
way; also Philadelphia, Pa.

N. HORN, 148 E. 58th street.

W. L. ISAACS, 114 Fulton street.

S. LEMBURG &amp; CO., 194 Broadway.

J. McELLYNNE, 202 Broadway.

RICHMOND PEASE, 44 W. 132d st.

F. M. PRESCOTT, 44 Broad street.

WINTHROP CYCLE CO., 2212 Seventh  
avenue.

SARATOGA—W. J. TOTTEN.

SARATOGA SPRINGS—MARVIN A. COTE.

**OHIO.**

CINCINNATI—J. L. ANDEM.

\*COSHOCOTON—BURNS &amp; GOSSER.

SPRINGFIELD—D. &amp; M. VANDERPOOL.

UHRICHSVILLE—F. A. MAZURIE.

**PENNSYLVANIA.**PHILADELPHIA—A. R. CASSIDY, 2783 Em-  
erald street.HAWTHORNE & SHEBLE, 604 Chest-  
nut street, or Oxford and Wascher  
streets; also New York City.PENN NOVELTY CO., 15 South 9th  
street.

\*PHOENIXVILLE—KEINARD BROS.

PITTSBURG—A. LIPPARD, 615 Wylie avenue.

**RHODE ISLAND.**

PROVIDENCE—F. P. MOORE.

**WISCONSIN.**

MILWAUKEE—J. C. BLATZEK.

\*Added since June 1, 1904.

Jobbers and Dealers are asked to co-operate with us, FOR OUR MUTUAL GOOD, by being careful that they do not supply any of the above named firms with our apparatus, either at addresses given or any other address.

## JOBBERERS OF EDISON PHONOGRAPHS AND RECORDS.

## ALABAMA.

**Birmingham**—The Ray Co., 2025 Second avenue.

## CALIFORNIA.

**San Francisco**—Peter Bacigalupi, 784-788 Mission street.

## COLORADO.

**Denver**—Denver Dry Goods Co., 619 16th street.

## CONNECTICUT.

**Middletown**—Caulkins & Post Co., 406-408 Main street.  
**New Haven**—Pardee-Ellenberger Co., 155 Orange st.

## ILLINOIS.

**Chicago**—James I. Lyons, 73 Fifth avenue.  
 The Ray Co., 90 Washington street.  
 Siegel-Cooper Co., State and Congress sts.  
 Talking Machine Co., 107 Madison street.  
 The Vim Co., 68 E. Lake street.  
 Montgomery Ward & Co., 111 Michigan ave.  
**Peoria**—Peoria Phonograph Co., 222 Bridge street.

## INDIANA.

**Indianapolis**—Craig-Jay Co., 234 Massachusetts ave.  
 Kipp Bros. Co., 37 S. Meridian street.  
 Wahl-Gaasch Co., 119 S. Illinois street.  
**Lafayette**—Wahl-Gaasch Co., 304 Main street.

## IOWA.

**Des Moines**—The Vim Co., 704 West Walnut street.  
**Fort Dodge**—Early Music House, 822 Central ave.

## KENTUCKY.

**Louisville**—The Ray Co., 640 Fourth street.

## LOUISIANA.

**New Orleans**—James I. Lyons, Theatre Arcade.  
 National Automatic Fire Alarm Co., 614 Gravier street.  
 The Ray Co., 111 Camp street.

## MAINE.

**Bangor**—S. L. Crosby Co., 186 Exchange street.  
**Portland**—W. H. Ross & Son, 207 Commercial street.

## MASSACHUSETTS.

**Boston**—Boston Cycle & Sundry Co., 48 Hanover street.  
 Eastern Talking Machine Co., 177 Tremont street.  
 Oliver Ditson Co., 150 Tremont street.  
 Iver Johnson Sporting Goods Co., 163 Washington street.  
 Read & Read, 558 Washington street.  
**Fitchburg**—Iver Johnson Sporting Goods Co., 247 Main street.  
**Lowell**—Thomas Wardell, 111 Central street.  
**Worcester**—Iver Johnson Sporting Goods Co., 304 Main street.

## MICHIGAN.

**Detroit**—American Phonograph Co., 106 Woodward avenue.  
 Grinnell Bros. Music House, 219 Woodward avenue.  
 The Ray Co., 168 Griswold street.  
**Saginaw**—Morley Bros.

## MINNESOTA.

**Minneapolis**—Thomas C. Hough, 714 Hennepin ave.  
**St. Paul**—Minnesota Phonograph Co., 37 E. 7th street.

## MISSOURI.

**Kansas City**—J. W. Jenkins' Sons Music Co., 1013-1015 Walnut street.  
 The Ray Co., 1021 Grand avenue.  
**St. Louis**—Conroy Co., 1115 Olive street.  
 The Ray Co., 923 Olive street.

## NEBRASKA.

**Lincoln**—H. E. Sidles Cycle Co., 1317 O street.  
**Omaha**—H. E. Fredrickson, 1502-1510 Capitol avenue.  
 Nebraska Cycle Co., 15th and Harney streets.

## NEW JERSEY.

**Hoboken**—Eclipse Phonograph Co., 205 Washington street.  
**Newark**—A. O. Petit, New and Halsey streets.  
**Paterson**—James K. O'Dea, 117 Ellison street.  
**Trenton**—Stoll Blank Book and Stationery Co., 30 E. State street.

Removed since June 1, 1904, Kelley Cigar Co., Chicago; F. C. L. Martin Auto Co., Plainfield, N. J.

## NEW YORK.

**Brooklyn**—Chapman & Co., Fulton and Duffield streets.  
 A. D. Matthews' Sons, 394 Fulton street.  
 Price Phonograph Co., 1258 Broadway.  
**Buffalo**—P. A. Powers, 643 Main street.  
**Elmira**—Elmira Arms Co., 117 Main street.  
**Gloversville**—American Phonograph Co., 99 W. Fulton street.  
**Kingston**—Forsyth & Davis, 307 Wall street.  
**New York City**—Bettini Phonograph Co., 80 Chambers street.  
 Blackman Talking Machine Co., 19 Beekman street.  
 J. F. Blackman & Son, 2654 3d avenue.  
 I. Davega, Jr., 802 Third avenue.  
 S. B. Davega, 32 E. 14th street.  
 Douglas & Co., 89 Chambers street.  
 H. S. Gordon, 139 Fifth avenue.  
 Harry Jackson, 219 Bowery.  
 Jacot Music Box Co., 39 Union Square.  
 Victor H. Rapke, 1661 Second avenue.  
 Siegel-Cooper Co., Sixth avenue and 18th street.  
 John Wanamaker, Broadway and 9th street.  
**Rochester**—A. J. Deninger, 347 North street.  
 Mackie Piano, O. & M. Co., 100 State street.  
 Mackie B. Miller, 63 State street.  
 Talking Machine Co., 29 S. Clinton avenue.  
**Schenectady**—Jay A. Rickard & Co., 253 State street.  
**Syracuse**—W. D. Andrews, 216 E. Railroad street.  
**Troy**—James Lucey, 359-361 Fulton street.  
**Utica**—Clark-Horrocks Co., 54 Genesee street.

## OHIO.

**Canton**—Klein & Heffelman Co., 216 N. Market street.  
**Cincinnati**—Ilsen & Co., 25 W. 6th street.  
 The Ray Co., 143 West 5th street.  
 Wahl-Gaasch Co., 47 W. 5th street.  
**Cleveland**—W. J. Roberts, Jr., Erie and Huron streets.  
**Columbus**—Perry B. Whitsit Co., 213 S. High street.  
**Dayton**—Niehaus & Dohse, 35 E. 5th street.  
**East Liverpool**—Smith & Phillips Music Co.  
**Toledo**—Hayes Music Co., 608 Cherry street.

## PENNSYLVANIA.

**Allegheny**—Henry Braun, 500 Federal street.  
**Allentown**—G. C. Aschbach, 539 Hamilton street.  
**Easton**—William Werner, 401 Northampton street.  
**Philadelphia**—C. J. Heppe & Son, 1117 Chestnut street.  
 Lit Bros., Market and 8th streets.  
 Penn Phonograph Co., 19 S. 9th street.  
 John Wanamaker.  
 Wells Phonograph Co., 41 N. 9th street.  
 Western Electric Co., 931-933 Market street.  
 H. A. Weymann & Son, 923 Market street.  
**Pittsburg**—Theo. F. Bentel Co., Inc., 433 Wood street.  
 Kaufmann Bros., Fifth avenue and Smithfield street.  
 H. Kleber & Bro., 221 Fifth avenue.  
 C. C. Mellor Co., 319 Fifth avenue.  
 Pittsburg Phonograph Co., 937 Liberty avenue.  
**Reading**—Reading Phonograph Co., 809 Penn street.  
**Scranton**—Ackerman & Co., Coal Exchange Building.  
 Technical Supply Co.

## RHODE ISLAND.

**Providence**—J. M. Dean Co., 785-795 Westminster street.  
 J. A. Foster Co., Weybosset and Dorrance streets.  
 Household Furniture Co., 231-237 Weybosset street.  
 Murray, Blanchard, Young & Co., 26-30 Pine street.  
 A. T. Scattergood & Co., 106-110 N. Main street.

## TENNESSEE.

**Memphis**—The Ray Co., Lyceum Building, 2nd and Jefferson streets.  
**Nashville**—The Ray Co., 30 The Arcade.

## TEXAS.

**Dallas**—C. B. Harris, Agt., 347 Main street.

## VIRGINIA.

**Richmond**—The Ray Co., 729 E. Main street.

## WISCONSIN.

**Milwaukee**—McGreal Bros., 173 3d street.

## CANADA.

**Toronto**—R. S. Williams & Sons Co., Limited, Yonge street.



**A new force  
at work**

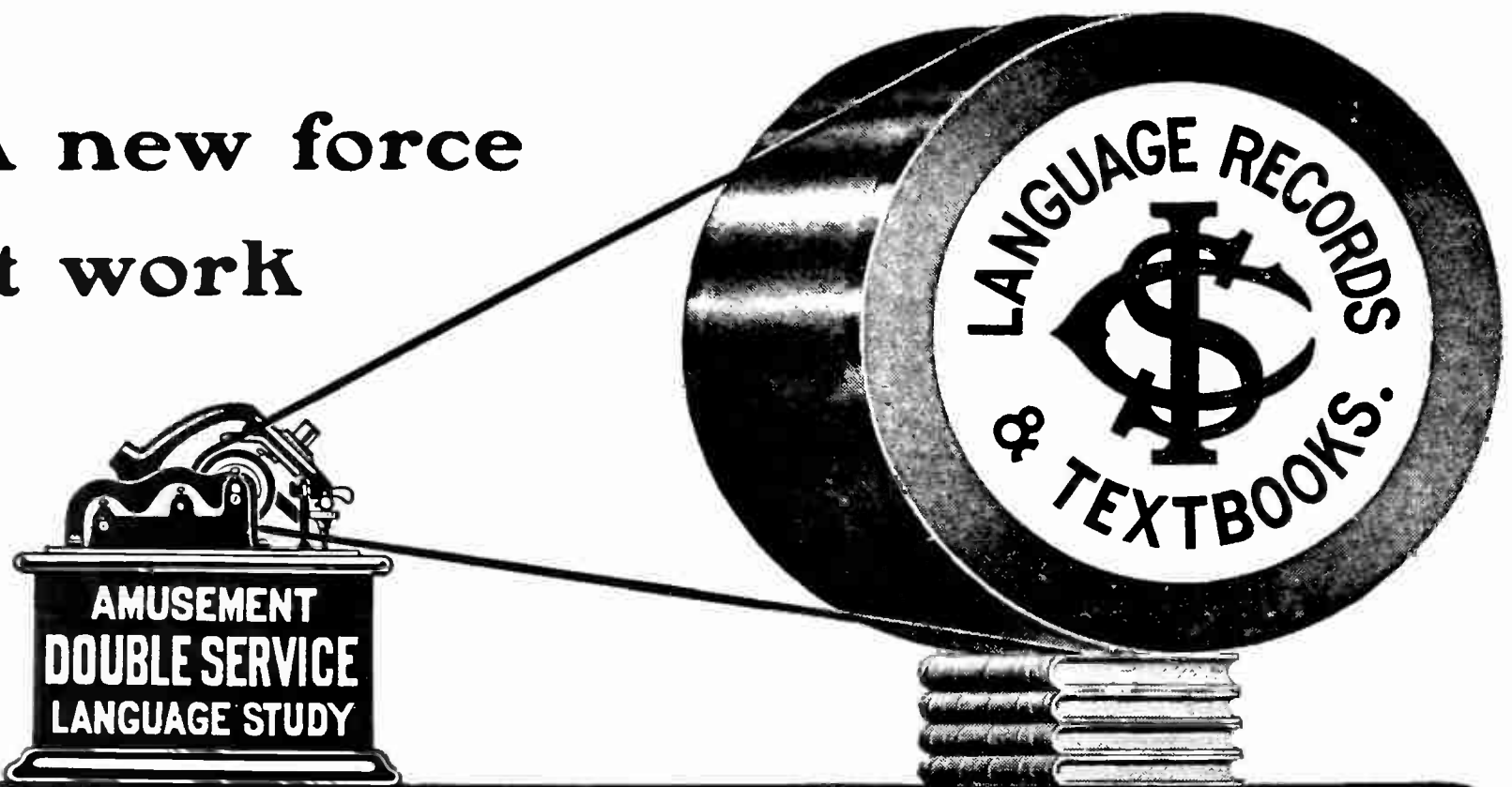

## The Power of Education

**A**N I. C. S. Language Outfit gives the Edison Phonograph power to teach a foreign tongue in the most convenient and practical manner. It cost \$50,000 to produce this instruction—an amount invested for you, Mr. Edison Dealer, should you care to represent “double service”—amusement and language study.

Do not underestimate the importance of this great educational movement. The moulded language record alone marks an advancement as distinct in its character as the invention of printed books; here we have permanent metal moulds “printing” pronunciation on the wax for the ear just as the type prints the textbooks for the eye.

The public is quick to grasp the value of a *standard language*, both oral and written, printed from the same masters that have supplied instruction to leading colleges and thousands of successful students.

**\$25.00 Pays for a Complete Language**

*(Liberal Discount to the Trade)*

An Outfit in either French, German, or Spanish, includes 25 Edison Gold Mould Language Records, reproducing 9,000 words; and four handsomely bound I. C. S. textbooks of over 2,000 pages.

**Demonstrations Prove the Value.** We have prepared a special demonstrating outfit for the Edison trade (furnished without profit) to introduce I. C. S. Language Outfits; contains 3 Moulded Language Records and Textbooks in French, German, and Spanish, with special literature for dealers' imprint. Price, \$1.50 complete, delivered in U. S. and Canada. **SEND NOW.**

**LANGUAGE DEPARTMENT**

**International Correspondence Schools**  
**Scranton, Pa.**

# EDISON Phonograph Monthly

PUBLISHED FOR TRADE USE ONLY BY  
THE NATIONAL PHONOGRAPH CO.

VOL. II.

NEW YORK, AUGUST, 1904.

No. 6.

*The* National Phonograph Co.,

ORANGE, N. J.

NEW YORK: 83 CHAMBERS STREET.

CHICAGO: 304 WABASH AVENUE.

SAN FRANCISCO: 786 MISSION STREET.

NATIONAL PHONOGRAPH CO., LTD., 25 CLERKENWELL  
ROAD, LONDON, ENG.

## EDISON PHONOGRAPHS AND RECORDS.

All communications to THE PHONOGRAPH MONTHLY should be addressed to the Advertising Department, 83 Chambers Street, New York.

### C O N T E N T S

A Great Future Ahead.....	1
Advance List of Edison Gold Moulded Records for September.....	2
The New Agreement.....	3
How to Determine Imitation Air Holes in Records .....	5
Composers Names Added.....	5
The Whole Trade Awake and Hustling..	5
New Carton and New Style Marking....	6
Dealers Should Sign Promptly.....	6
How to Handle New Agreements.....	7
Where to Send Orders and Correspond- ence .....	7
Printed Matter.....	7
A Word to Canadian and Foreign Dealers	7
Comments on September Records.....	8
Coin Slot Phonographs.....	10
The Phonogram .....	10
New Record Catalogue.....	10
Change Catalogues to New Prices.....	11
Get Ready for Fairs.....	11
A Striking Sign.....	12
Our St. Louis Booklet.....	12
Suspended List, August, 1, 1904.....	14
Jobbers in Edison Phonographs and Records .....	15

## A GREAT FUTURE AHEAD.

As premised by the sixty days' notice sent out on May 16th, the price of Edison Gold Moulded Records was on July 18th reduced to 35 cents each and are now being sold all over the United States at that price. Owing principally to the duty, the retail price in Canada has been made forty cents. Edison Concert Records have been reduced to 75 cents each, the same price prevailing in Canada. The impetus given to orders by the rebate letter sent out in June was very satisfactory, but was almost nothing as compared to the orders received since the lower prices were formally announced. The advance orders for August Records fully equals those for the same month of last year and the orders for stock Records have been phenomenal. It was only because of our belief that a largely increased business would follow that a decision was reached to reduce prices. Had our Record making facilities been no greater to-day than they were a year ago, it is quite unlikely that a lower price would have been seriously considered, at least not for a long time. But within the past year, finding ourselves unable to fill orders in a manner satisfactory to the trade, because of inadequate factory facilities, and anticipating a rapid and steady increase in the demand for Edison Records, we built and completely equipped an entirely new Record making plant. The plant and equipment represents an expenditure of many thousands of dollars.

With more than double the Record making capacity that we had a year ago, we determined to get the business necessary to keep it busy. We did not doubt that even with Edison Records at 50 cents each, we could get such a business in time, but we wanted it now, and have, therefore, set out to get it. We con-

(Continued on page 3.)

**THE ADVANCE LIST OF SEPTEMBER RECORDS APPEARS ON PAGE 2. ORDER FROM IT. NO OTHER ADVANCE LIST WILL BE ISSUED.**



## ADVANCE LIST OF NEW EDISON GOLD MOULDED RECORDS FOR SEPTEMBER, 1904

RECORDS listed below will be ready for shipment as near September 1st as possible, at which time Jobbers' stock orders, if placed prior to August 15th, will be shipped. September Supplements will be forwarded to Jobbers with their stock order for Records. Retail Dealers should place stock orders with their Jobbers at once, to insure prompt shipment as soon as Jobbers' stock is received.

- 8774 Algonquin March (*Seltzer*) Edison Military Band  
*With bells and conducted by the composer, Frank R. Seltzer.*
- 8775 Tippecanoe (*Van Alstyne*) Bob Roberts  
*Comic song as sung by Wm. Gould in "The Southerners", with orchestra accompaniment.*
- 8776 How Can I Leave Thee (*Cramer*) Miss Morgan and Mr. Stanley  
*Contralto and basso duet with orchestra accompaniment.*
- 8777 The Russian Story (*Wilder*) Edison Symphony Orchestra
- 8778 Please Come and Play in My Yard (*Morse*) Byron G. Harlan  
*Descriptive song with orchestra accompaniment.*
- 8779 A Bit o' Blarney (*Helf*) Edward M. Favor  
*A popular Irish song with orchestra accompaniment.*
- 8780 Karama (*Vivian Grey*) "A Japo-Rhapsody" Vess L. Ossman  
*Banjo solo with orchestra accompaniment.*
- 8781 Old Folks at Home (*Foster*) W. H. Thompson  
*The old standard song accompanied by the Edison Military Band*
- 8782 Why, Hello Bill, Who's Your Friend? (*Brown*) Arthur Collins  
*Coon song with orchestra accompaniment*
- 8783 On Tiptoe (*Hosmer*) Characteristic selection Edison Concert Band
- 8784 Dixie (*Dan Emmett*) "'Way Down South in Dixie" Harlan and Stanley  
*Male duet with orchestra accompaniment*
- 8785 Old Mother Goose (*Jerome*) Billy Murray  
*Characteristic song from the comic opera "The Royal Chef" with orchestra accompaniment*
- 8786 Forsaken—Verlassen (*Koschat*) Edison Brass Quartette
- 8787 Back Among the Clover and the Corn (*Petrie*) James F. Harrison  
*Descriptive song with orchestra accompaniment*
- 8788 Down in the Vale of Shenandoah (*Harris*) Harry MacDonough  
*Charles K. Harris' latest descriptive song with orchestra accompaniment*
- 8789 Blulette (*La Rose*) *Piccolo solo with orchestra accompaniment* Frank S. Mazziotta
- 8790 In the Gloaming (*Harrison*) Edison Male Quartette
- 8791 Louisa Schmidt (*Von Tilzer*) Collins and Harlan  
*Comic Dutch male duet with orchestra accompaniment*
- 8792 Yarney's Ideal (*Stimson*) Negro sketch Albert Benzler  
*Xylophone solo with orchestra accompaniment*
- 8793 The Bloom is on the Rye (*Bishop*) George Seymour Lenox  
*An old Scotch ballad with orchestra accompaniment*
- 8794 Scissors to Grind (*Allen*) Arthur Collins  
*Character song by the composer of "Any Rags," with orchestra accompaniment.*
- 8795 Yale College Life March (*Reed*) Edison Military Band
- 8796 Stories Adam Told to Eve (*Jerome and Schwartz*) Edison Male Quartette  
*Solo and chorus with orchestra accompaniment*
- 8797 A Rheumatism Cure in Jayville Center Harlan and Stanley  
*Comic Rube talking and singing male duet*
- 8798 I Want to be a Soldier Medley Edison Military Band  
*Introducing "I Want to be a Soldier," "Good-Bye Little Girl, Good-Bye" and "Mississippi Mamie"*
- 8799 The Maple Leaf Forever (*Muir*) W. H. Thompson  
*National song of Canada with orchestra accompaniment*

Names of Composers are given in italics and parentheses following the titles.

Edison Gold Moulded Records are made only in Standard size. Both Standard and Concert Records may be ordered from this list. Order by Number, not title. If Concert Records are wanted, give the number and letter C.

(Continued from page 1.)

fidently believe that at 35 cents we shall in a very short time practically occupy the entire cylindrical record field. We certainly shall so far as the trade is concerned. At 50 cents each, Edison Gold Moulded Records were universally admitted to be worth their price. At 35 cents each they represent the greatest value possible, and we know that the public will so regard them. They are of such marked superiority that the difference between their price and that of cheap goods will not be considered by Phonograph owners. We haven't the first doubt that our Record business will inside of two months be double that of any time in the past. The conditions are ripe and a business of this magnitude is as certain as anything of the future can be.

More than this, with Edison Gold Moulded Records being sold at 35 cents each, the Edison Phonograph is going to increase in popularity by leaps and bounds. After all has been said a talking machine is the musical instrument of the masses. A comparatively few will pay high prices for machines and records, but tens of thousands of others look at the cost carefully and buy the best they can get for the least money. Edison Phonographs and Edison Gold Moulded Records will fill this situation to the fullest extent. Thousands have not bought a Phonograph because of the cost of Records. The price of the machine has been no bar, but they have realized that a stock of Records must be had and that additions must be made to it all the time to get the proper benefit from the machine. Then when they figured up the total cost they have found it more than they could stand. Edison Records at 35 cents will bring the expenditure within their means and their long cherished desire to own an Edison Phonograph will then become an established fact.

This increase in the sale of Edison goods is going to be the Dealer's recompense for the lower discounts on Records made necessary by the reduced prices. He is not only going to sell many more Records and sell them more easily, but his sales of Phonographs, upon which discounts are unchanged, are going to increase handsomely. Every Dealer who carries an adequate stock of Edison goods and makes a reasonable effort to sell them is going to be more than satisfied with his business in the coming year. Not even general business depression or Presidential year causes can prevent it. It's in the air. It must come.

**Stock up. Be ready.**

### THE NEW AGREEMENT.

The reduction in price of Edison Gold Moulded Records became an established fact on July 18th, at the expiration of the sixty days' notice required by our Agreement with Jobbers and Dealers. The first announcement concerning possible new conditions was sent out on May 16th. On July 16th a telegram was sent to every Jobber in the United States advising him that on the 18th the price of Edison Records, standard size, would be reduced to 35 cents each. At the same time a letter of similar purport and a copy of the new Agreement, Form No. 585, was also sent to every Jobber. Since then a supply of Retail Dealers' Agreements, Form No. 590, has been sent to all Jobbers and they are now being laid before Dealers for their signature. Most of the Jobbers have already signed the new form and no opposition to it has been manifested. Dealers' Agreements are also being freely received, showing that the new conditions are being received in the proper spirit and that they will receive the hearty coöperation of the entire trade.

In the new Agreement changes are made in the price list, the discounts, the terms and the conditions. The price of standard size Records is reduced from 50 cents to 35 cents each, or \$4.20 per dozen, no lower price being permitted when a dozen is purchased at one time. Concert Records are reduced from \$1.00 to 75 cents each, or \$9.00 per dozen.

Edison standard Blanks are reduced from 20 cents to 15 cents each when unshaved, and from 25 cents to 20 cents each shaved. Concert Blanks are reduced to 50 cents each.

The price of the Edison Victor Phonograph is increased from \$60.00 to \$65.00 and that of the Edison Conqueror Phonograph is increased from \$75.00 to \$80.00.

Radical changes have been made in the styles, prices and discounts of Coin Slot Phonographs. The Imperial, Regal, Climax, Ajax and Vulcan types have been cut out and will no longer be furnished. Two new styles, the Windsor and Majestic, have been substituted, with new list prices and special discounts. The Windsor is a new style battery current machine, and the Majestic is operated by 110 volt direct current. The list price of the Windsor is \$80.00 and of the Majestic \$90.00. Discounts of a special character have been made on these two new types. They are given in full and the reason for them, in an article on Coin-Slot Phonographs on page 10.

The discounts on all but Windsor and Ma-



jestic Phonographs remain as before. Standard size Records are placed at net prices to Jobbers and Dealers, and the discounts on Concert Records and Blanks have been reduced. (See new Agreement for these discounts.)

Several changes have been made in the conditions under which Edison goods must be sold. In addition to having an established store, a Retail Dealer must at all times carry a sufficient stock of Edison Phonographs and Records for exhibition and sale purposes. Dealers must get full prices for all articles sold as part of an outfit with an Edison Phonograph. This is done to prevent the cutting of prices on accessories in order to sell an Edison Phonograph and is entirely in the interest of the Dealers themselves. Clause No. 1, of the Conditions, also prohibits the disposition of Edison Phonographs or parts thereof, Records or Blanks as premiums, or by lottery, raffle or game of chance, or in other ways by which such goods may be obtained at less than full current list prices. Clause No. 2 prohibits giving trading stamps or other premiums with Phonographs, Records or Blanks. Clause No. 4 prohibits the acceptance of records of any kind, at any price, in exchange for Edison goods. Clause No. 7 prohibits the sale of Edison Phonographs, Records or Blanks outside of the United States or for export except at full list prices. The new Conditions of Sale, in full are as follows:

#### CONDITIONS OF SALE.

All Edison Phonographs, Records and Blanks are sold at Orange, New Jersey, under the license of Thomas A. Edison, the Edison Phonograph Company, and others, subject to the following conditions:

No. 1. *Retail Dealers must not give away or sell or offer for sale, either directly or indirectly, Edison Phonographs or parts thereof, Records or Blanks at a discount, or at less than current list prices, nor to Dealers who are on our suspended list, nor include with a machine at list price any extra material or supplies not listed to go with same as a regular outfit. When other goods are included with an Edison Phonograph or Records and are advertised or sold as an outfit at a special or fixed price, the price of the Phonograph or Records or both, also of each and every other article in the outfit, not listed as part of the regular Phonograph outfit, must be given and must be the same whether included in an outfit or sold separately. Edison Phonographs or parts thereof, Records or Blanks must not be disposed of as premiums, nor by lottery, raffle or any game of chance, nor in any other way whereby any person or persons may acquire such goods for less than the full current list price.*

No. 2. *Giving away or selling other goods at less than current prices or giving away trading stamps or premiums of any kind in order to induce the sale of Edison Phonographs or parts thereof, Records or Blanks, will be a violation of the conditions hereof.*

No. 3. *All Edison Phonographs bear a serial number; all Edison Records are boxed and ticketed with copyright and registered tickets and labels, and any Retail Dealer, selling or offering for sale an Edison Phonograph the serial number upon which has been removed or changed, or an Edison Record without the copyright and registered label and ticket, infringes the patents under which Phonographs and Records are sold, and will be considered as having violated his AGREEMENT.*

No. 4. *Exchanging Edison Phonographs or parts thereof, Records or Blanks in whole or part payment for advertising privileges, or for goods of some other make or nature; or the acceptance of goods or merchandise of other make or nature in whole or part payment for Edison Phonographs, or parts thereof, Records or Blanks, is contrary to the conditions hereof. This does not prohibit the acceptance of a talking machine at full list price, if good as new, (or less cost of necessary repairs to make good as new) in exchange for an Edison Phonograph sold at full retail list price; but does prohibit the acceptance of Records or Blanks of any kind, at any price, in exchange for Edison Phonographs Records or Blanks.*

No. 5. *The selling or offering for sale of Edison Phonographs, or parts thereof, Records or Blanks that have become shopworn, or in any way damaged, or have been taken in exchange, as second-hand Phonographs, or parts thereof, Records or Blanks, at reduced prices, will be considered a cutting of prices and will not be allowed.*

No. 6. *Exchange between Dealers. Authorized Dealers, in case of emergency, will be allowed to borrow from any other authorized Dealer, provided the goods so borrowed are actually replaced with goods of the same style and make. In case a sale takes place between two Dealers, it must be at full list prices.*

No. 7. *Edison Phonographs, or parts thereof, Records and Blanks are sold to Jobbers and Dealers in the United States with the express reservation that such goods shall not be sold to Jobbers and Dealers outside of the United States, nor for export from the United States except at full list price.*

No. 8. *Dealers violating any of the above conditions, or failing to pay accounts due the National Phonograph Company, may be at once cut off from any further supply of goods and placed on the suspended list.*

No. 9. *ALL EDISON Phonographs, Records and Blanks are covered by United States patents and are sold under the condition that the license to use and vend them, implied from such sale, is dependent on the observance of the foregoing conditions; upon the breach of any of said conditions the license to use or vend said Phonographs, Records and Blanks immediately ceases and any vendor or user thereafter becomes an infringer of said patents, and may be proceeded against by suit for injunction or damages, or both.*

No. 10. *No variation of these terms and conditions, and no representations or agreements made by any employee of the National Phonograph Company, will be valid unless ratified in writing by its President or Secretary.*

The foregoing matter refers only to goods sold in the United States. In Canadian territory Records will be sold at 40 cents each and all other goods will be subject to an additional charge for duty.

#### GREATEST NIGHT OF FUN.

We gave a concert on an Edison Home machine to a prominent young men's club, known as the Y. M. L. A., last Wednesday evening, July 13, 1904. We played the complete July list for them. They went wild over it, for when we played No. 8742, "A Bit o' Blarney," they marched all over the parlors and threw their hats into the air. They say it was the greatest night of fun they ever had, and want us to give them another one when the August Records arrive.

SCHARPEN BROS,  
Jersey City, N. J.

July 18, 1904.

## HOW TO DETERMINE IMITATION AIR HOLES IN RECORDS.

The information given below has been prepared by experts at our factory and is offered as a guide to Jobbers and Dealers in determining to their own satisfaction whether or not Records returned by their customers as defective on account of air holes (heretofore commonly termed pin holes) appearing on the surface, are caused in the process of manufacture or are the result of intentional injury with a sharp pointed instrument, such as a pin, needle or lead pencil.

A genuine blow or air hole which appears on the surface before the Record has been played appears under a glass to have regular edges and is of an oval or elliptical form, and invariably appears lengthwise of the Record, the cavity beneath the surface being larger than the opening at the surface and the bottom of the cavity is not discernible.

After the reproducer button has passed over this opening a number of times the edges become ragged and irregular in form and the sapphire carries the minute particles of wax which have become detached from the edges over the track of the Record, causing a scar which can be plainly seen.

The hole that has been made in imitation of an air hole does not show any of the above characteristics; on the contrary the edges have a burred appearance, the wax being forced above the surface of the Record, the cavity appears in circular form, the walls of the hole present a shiny appearance and converge to a point at the bottom of the cavity, which can be easily seen. In a great many instances the hole shows the marks of the instrument with which the injury was made and a number of cases show that the insertion of the instrument has raised and slivered or chipped the wax.

In the examination of these Records where the use of a microscope is not available we suggest the use of a jeweler's glass, and feel assured that when the trade becomes familiar with the characteristics of the genuine and imitation air holes further impositions of this nature will cease.

---

## COMPOSERS' NAMES ADDED.

A new feature of the forthcoming Domestic Record Catalogue will be the addition of the composers' names to the various titles. These have been inserted without making it necessary to omit any of the matter heretofore contained in the Record Catalogue. The com-

posers' names have been added wherever it has been possible to get them, and efforts will be made to supply the missing ones from time to time in the future. The present Record Catalogue Form No. 545 contains the titles of the Records that have been cut out, and Jobbers and Dealers will find it advantageous to continue their use for the sale of these Records as long as their present supply lasts. The new catalogue will contain all titles listed to and including August. The omission of five months' titles does not materially affect the value of the present catalogue, especially when the new titles can be supplied by Supplements. We must cut down orders for Record Catalogues as they come in until the middle of August in order that the trade may not have on hand many of the present edition when the new one appears. Jobbers may send in orders at any time for the new catalogue, but it will not be possible to send large quantities to them at one time, and we must reserve the right to make partial shipments on such orders.

---

## THE WHOLE TRADE AWAKE AND HUSTLING.

Most gratifying was the up-to-date and progressive manner in which the Jobbers and Dealers in Edison goods throughout the country appeared before the public with advertisements of the reduced price of Edison Records as soon as they were advised of the fact. The notice of the change was sent out on July 16th and the following day the papers in all the large cities in which the Jobbers are located contained striking advertisements announcing the reduction. The papers in other cities contained the announcement on the following Monday and they have since been appearing with surprising regularity in most of the daily papers. It is doubtful if to-day many users of the Phonograph are not aware of the reduced price of Edison Records. Many Dealers have gotten out printed matter in various styles. Cards, folders, blotters, circular letters and many other forms have been employed to advise the public of the new price. It is apparent that Jobbers and Dealers are determined to do a largely increased business under the new conditions. We should like to acknowledge individually the receipt of the papers and literature that have been sent to us by Dealers advertising the new price, but the list is too large; it includes the names of nearly every progressive Edison Dealer throughout the country.



### NEW CARTON AND NEW STYLE MARKING.

The samples of the August Records sent to all Jobbers early in July were packed in the new style Record carton. They were also lettered on the end with the new style marking. The entire outfit has been warmly commended by Edison Jobbers everywhere. One or two imperfections in the making of the box have been pointed out and will be remedied. The entire list of the August selections will be shipped out in the new boxes and with the new style marking. The new box is slightly over  $2\frac{3}{4}$  inches in diameter and is  $4\frac{5}{8}$  inches long. The cover and bottom are countersunk so as to hold the Record firmly in place when placed over the spindle inside. The new box

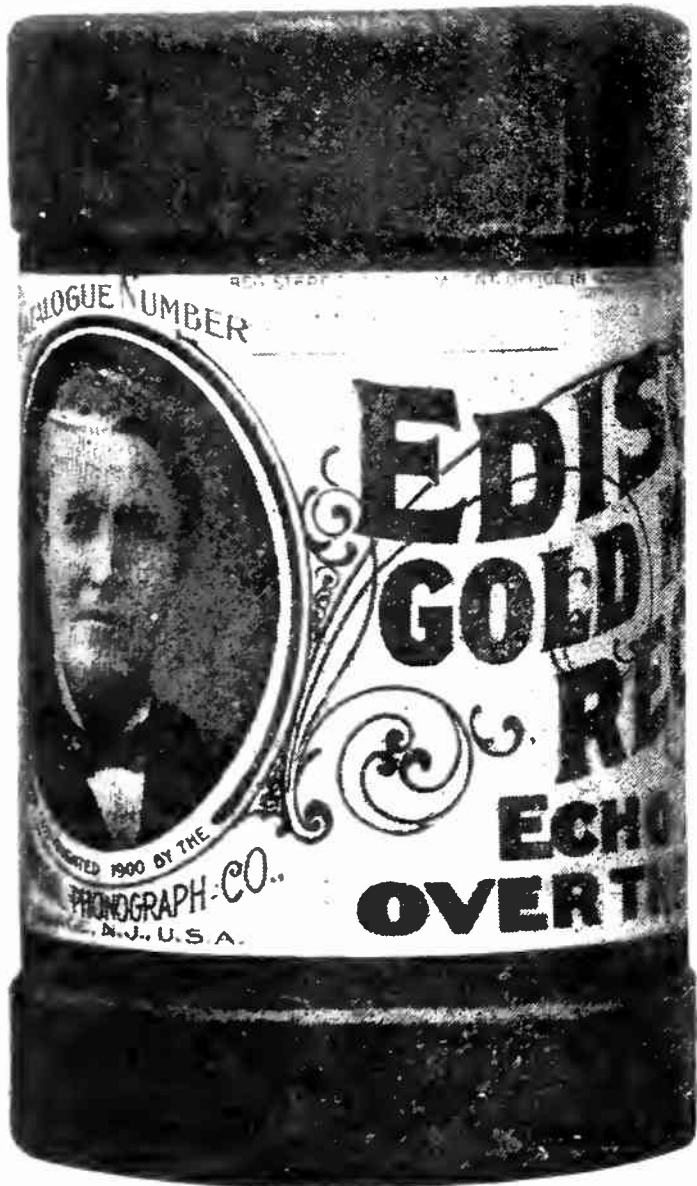

bears a handsome new style label printed in black, red and gold and has a small circular label on the lid upon which is placed the number of the Record. The number is also shown on the side label.

As announced last month, selections already listed will be changed over to conform with the new improvements as rapidly as is possible, but it will take several months to complete the changes on the entire list. It will be impossible to inform the trade what particular selections will be changed over from time to time and we will be compelled, therefore, to reserve the right to fill any and all orders

received in the meantime with Records both of the old and new styles of marking and boxed in the old and new style cartons.

### DEALERS SHOULD SIGN PROMPTLY.

The supply of the new Retail Dealers Agreements, Form No. 590, sent to all Jobbers is sufficient to permit them to re-sign all of their present Dealers and have a quantity on hand for new business. A further supply may be had for the asking. No index cards are being sent with the Agreements and Jobbers will *not* be required to fill out and return one except in the case of a new Dealer or an old one signing under new conditions, such as new address, etc. Dealers will keep themselves on our mailing list and will accommodate their Jobbers and ourselves by signing the new Agreement as soon as they receive it and returning the proper copies without delay. Before doing so carefully read the Agreement and the notice attached to it. Make sure that every clause is fully understood. After sufficient time has elapsed the name of every present Dealer who has not signed the new Agreement will be removed from our files and mailing list. To get names restored after this has been done will cause extra trouble to every one. Jobbers are urged to see that all of their Dealers are able to meet the conditions requiring them to have an established store and to carry a stock of Edison goods sufficient for exhibition and sale purposes. Without a proper store and a suitable supply of Phonographs and Records a satisfactory and profitable business cannot be done, and in making this clause even stronger than it was in the present Agreement, we are seeking to advance the interest of all concerned, the Dealer himself most of all. Dealers who sign with us direct are asked to sign and mail the proper copies of the Agreement sent them, addressing it to New York or Chicago according to the territory in which they are located. Business in Edison goods in the next six months is going to break all records and Dealers should leave nothing undone to get their share. So sign the new Agreement at once.

Owing to the duty, a special Agreement is necessary for Canadian Dealers, and it will be a little later in reaching the trade there than the United States Agreement reaches Dealers here. Until Dealers have had an opportunity to sign the new Agreement the old Agreement remains in force except in the matter of prices.

**HOW TO HANDLE NEW AGREEMENT.**

**Dealers:** When the new agreement reaches you, read it carefully, date and sign each copy and have your signature **WITNESSED**. If you deal through a **Jobber**, return to him the copies marked "Original" and "Duplicate." Retain the copy marked "Triplicate" for your future reference. If you deal direct with this **Company** send the copy marked "Original" to office from which it was mailed, and return "Duplicate."

**Jobbers:** When dealers return **Original** and **Duplicate** copies to you, send us the **Original** and retain the **Duplicate** for your files. Be sure that they are properly dated and witnessed before returning **Original** to us.

**WHERE TO SEND ORDERS AND CORRESPONDENCE.**

All Dealers in Indiana, Illinois, Michigan, Wisconsin, Minnesota, Iowa, Missouri, Kansas, Nebraska, Wyoming, Colorado, North Dakota, South Dakota, Oklahoma Territory, New Mexico and Indian Territory who are buying goods direct from this company are asked to send all orders and address all correspondence to our Chicago office. All of the direct business in these States is handled at Chicago, and to send orders or address correspondence to any other place involves a loss of time, for all papers if received at New York are returned to Chicago. Time will be saved by sending them direct to Chicago.

Dealers in Washington, Oregon, Nevada, Montana, Idaho, California, Utah and Arizona should send orders and address correspondence to Peter Bacigalupi, 786-788 Mission street, San Francisco. Orders can be filled from there with great saving in freight charges, and correspondence will have better attention.

Direct Dealers in all other States of the Union should send orders and correspondence to the New York office. Jobbers should also send orders to New York office. It is a mistake to think that orders will receive better attention if sent to the factory at Orange, N. J. Every order sent there is returned to the New York office and causes a loss of time rather than a saving. Orders sent to the New York office get the best possible attention. We have an open telephone wire between the fac-

tory and the New York office four times daily, and send a messenger from New York to the factory at noon and night, every day. No matter how urgent an order may be, it will have immediate attention. Our system requires that all orders shall pass through the New York office, and the trade will get better service if they bear this fact in mind.

**PRINTED MATTER.**

We have just mailed to the entire trade a hanger announcing the reduced price of Records and a number of circulars of the same purport. The hanger is for temporary use by Dealers. We have also sent to every Jobber throughout the country a large supply of these circulars and a show card printed on cardboard, both of which we are asking them to distribute to their Dealers. Being printed on cardboard the show cards cannot be mailed.

The circulars are of an inexpensive character and were intentionally printed in this way in order that they might be used in liberal quantities by all Dealers. The number of these sent to each Jobber is sufficient to allow him to distribute them freely. Dealers are urged to get a supply of these circulars and at least one of the show cards and see that every one in their territory knows that the price of Edison Gold Moulded Records has been reduced to 35 cents. Now that the price has been reduced we want the fullest possible publicity concerning it. Along with the above circulars and hangers we have mailed a new lithographed hanger, Form 573. It is not a work of art, but is designed to catch the eye of the public and call their attention in another way to the Edison Phonograph. A reasonable additional number of these copies will be supplied to Jobbers upon request. They should know, however, that a copy has been mailed to every Dealer and they will only need a supply for such of their Dealers as need an extra copy or two and for new Dealers.

**A WORD TO CANADIAN AND FOREIGN DEALERS.**

Matter published in the **EDISON PHONOGRAPH MONTHLY** is prepared for the trade in the United States. Canadian Dealers should always bear in mind that an amount equal to the duty into their country should be added to any prices that may appear in these columns. Dealers in foreign countries, who may receive or see copies of this publication, should also remember that unless otherwise written it treats only of trade conditions here.



**COMMENTS ON SEPTEMBER RECORDS.**

In the advance list of Edison Gold Moulded Records for September, published in full on page two and referred to in detail below, there are many interesting and attractive selections, notwithstanding that July (the month in which the list was made up), is the mid-season month in the matter of musical attractions. The light opera and musical comedy companies have not yet begun their fall season and the music publishers are not yet ready to put their new compositions before the public. Consequently there is not the same amount of material to select from that there will be two months hence. Advantage has been taken of this fact to put out a few selections for which our patrons and the trade have been asking for some time. Among these are "Old Folks at Home," "Dixie," "In the Gloaming," and "The Maple Leaf Forever." To thousands of Phonograph owners these selections will appeal more strongly than most songs of the present day. They belong to the class of music that never loses its hold upon the public, no matter how old the songs may be. At the same time our Recording Department has listed a varied lot of new music. The entire list is made in the best style of this department, which never stands still but ever improves.

No. 8774, "Algonquin March," is a composition written by Frank R. Seltzer, leader of the Edison Military Band, by whom the Record is made. The selection includes a bell solo and is notable for the tuba and trombone execution. It is a bright clear Record. It gets its name from the Algonquin Club of New York City.

No. 8775, "Tippecanoe," is a comic song in which William Gould has made a great success in "The Southerners." It is sung for our Record by Bob Roberts, and has an orchestra accompaniment. This song and Record are destined to have wide popularity. Harry H. Williams is the writer of the words and Egbert Van Alstyne is the composer of the music.

No. 8776, "How Can I Leave Thee?" is a charming contralto and basso duet of Cramer's well known ballad by Miss Morgan and Mr. Stanley. An orchestra accompanies the singers. The duet Records of these artists are greatly admired.

No. 8777, "The Russian Story," is a unique composition that will meet the approval of lovers of fine music. It is played by the Edison Symphony Orchestra. This selection was written before the present war was begun and therefore has no connection with it; in fact, the music is quite different from anything of a warlike character. A 'cello solo is a feature. The composer is George H. Wilder.

No. 8778, "Please Come and Play in My Yard," is a descriptive sentimental song, with orchestra accompaniment, by Byron G. Har-

lan. It tells how two little girls, one rich and the other poor, who lived in adjoining houses, became acquainted and invited each other to play. Mr. Harlan sings it splendidly. The words of this song are by Edward Madden and the music by Theodore Morse.

No. 8779, "A Bit o' Blarney," was given in the July list as a selection by the Edison Concert Band, being played as a twostep. This number is a vocal selection by Edward M. Favor and has an orchestra accompaniment. No more charming selection in Irish dialect has ever been made for the Phonograph. "A Bit o' Blarney" is a delightful composition. It is written in an artistic manner, and the words are as satisfactory as the music. The words and music of this song were written by Heelen and Helf. It is now being sung with marked success in "A Little of Everything," a New York City success.

No. 8780, "Karama," is a selection by Vivian Grey (Miss Mabel McKinley), who calls it a Japo-rhapsody. Miss McKinley is well known as the composer of "Anona," and "Little Dolly Driftwood." "Karama" is played as a banjo solo by Vess L. Ossmann, who is without a peer on this instrument. It has an orchestra accompaniment.

No. 8781, "Old Folks at Home," is remarkable for the unusual volume of tone. It is sung by W. H. Thompson, and he is accompanied by the Edison Military Band. The introduction is played with full band volume and the band is unusually strong through the entire Record. It is not loud enough, however, to affect the fine quality of Mr. Thompson's singing. This old Southern song was written by Stevens Collins Foster. It is put in the catalogue in response to many requests. These old songs are renewing their popularity and we predict that the demand for this number will be unusually large.

No. 8782, "Why, Hello, Bill, Who's Your Friend?" is a coon song with orchestra accompaniment. It is sung by Arthur Collins in his inimitable manner. It tells how one coon "butts in" on his friend and asks to be introduced to his girl. Harry Brown is the composer of this song. It makes an excellent Record.

No. 8783, "On Tiptoe," by L. Hosmer, is what may be properly styled a "swell" Record. As its name indicates, the music is light, airy and graceful and is notable for the flute and clarinet work. It is made by the Edison Concert Band.

No. 8784, "Dixie," is the late Dan Emmett's ever popular Southern air. It is sung as a male duet by Harlan and Stanley, with orchestra accompaniment. This is another Record for which there has been great demand. Mr. Emmett, the composer, died recently.

No. 8785, "Old Mother Goose," is a characteristic song from the comic opera, "The Royal Chef." It is sung by Billy Murray, with orchestra accompaniment. It is styled a "scare" song. Ben M. Jerome is the composer. In the opera the singer gathers around him a lot

of little colored children and tells them that old Mother Goose is around. He tells them to

Run to your little bed,  
Cover up your kinky head.  
Don't you let her in the room,  
Or you'll take a ride on the broom.  
She will take you far away,  
Up in the clouds they say.  
Sh! Sh! Do you hear that sound?  
She's a comin' round,  
She'll steal you by de light of de moon.

No. 8786, "Forsaken" (Verlassen) is a folk-song of one part of Germany, but the air is so well known that most hearers will think it of American origin. The Record is made by the Edison Brass Quartette, composed of two cornets and two trombones. This music is written in slow time and because of this fact is most suitable for brass quartette work. "Forsaken" was composed by T. Koschat.

No. 8787, "Back Among the Clover and the Corn," is another fine baritone Record by James F. Harrison. It is a descriptive selection by H. W. Petrie, and has the usual good orchestra accompaniment. This song will be one of the features of the first part in Dockstader's Minstrels in the coming season. The air somewhat resembles "Love's Old Sweet Song."

No. 8788, "Down in the Vale of Shenandoah," is a well executed Record by Harry MacDonough, of Charles K. Harris' latest descriptive song. Mr. MacDonough is accompanied by the orchestra.

No. 8789, "Blurette," is a piccolo solo by Frank S. Mazziota, with orchestra accompaniment, that cannot fail to delight every one. The music is pretty and it reproduces clearly and sweetly. A catchy air runs through the composition. "Blurette" was written by L. La Rose.

No. 8790, "In the Gloaming," is an artistic rendition by the Edison Male Quartette of A. F. Harrison's old time ballad. It is sung by the quartette without accompaniment, in deference to the taste of a large number of people who claim that male quartettes are better when sung without accompaniment.

No. 8791, "Louisa Schmidt," is a comic song given as a male duet by Collins and Harlan, with an orchestra accompaniment. In spite of the dialect, the words are unusually distinct and can be easily understood. Andrew B. Sterling wrote the words of the song and Harry Von Tilzer the music. The Record is unusually well rendered.

No. 8792, "Yarney's Ideal," is listed as a negro sketch and is played as a xylophone solo, with orchestra accompaniment, by Albert Benzler. A very clear and well played Record. This composition is the work of F. W. Stimson.

No. 8793, "The Bloom is on the Rye," an old Scotch ballad by Henry R. Bishop, is a tenor solo by George Seymour Lenox. Mr. Lenox sings it in an artistic manner and is accompanied by the orchestra.

No. 8794, "Scissors to Grind," is a character song by Thomas S. Allen, who wrote "Any Rags." It is sung by Arthur Collins, who made such a success of "Any Rags." His work in this Record is equally good. The

Record can hardly fail to be a great seller. Between the verses are given some funny remarks. When solicited for scissors to grind the old lady says, "The last pair you ground for me were very dull." The grinder's reply is simply "So's business." It is not so much the remarks themselves as the way in which Mr. Collins says them that make them so funny.

No. 8795, "Yale College Life March," is a composition written by F. Herbert Reed and played by the Edison Military Band. The music is of a rollicking character, typical of college life, and has a good rhythm. The air is carried by the tubas, the treble instruments playing the accompaniment.

No. 8796, "Stories Adam Told to Eve," is a song that made a big hit in "Mother Goose." It is sung by the Edison Male Quartette, with solo, chorus and orchestra accompaniment. It is an excellent Record. William Jerome wrote the words of this song and Jean Schwartz the music.

No. 8797, "A Rheumatism Cure in Jayville Center," is a still further addition to Harlan and Stanley's Rube sketches. Ezra (Stanley) is confined at home with rheumatism. Zeb (Harlan) calls upon him with Jim Martin's boy. In the conversation that follows Ezra asks which of the medical schools Zeb thinks is the best, allopath, homeopath or osteopath. Zeb, in his characteristic manner, replies, "All paths lead to the grave." Among the bits of news that Zeb discusses is one about a neighbor, whom he says is getting so high-toned that he goes after the cows in a carriage. Jim Martin's boy then plays "Pop, Goes the Weazel" on the violin and Ezra gets so excited that he forgets his rheumatism and dances with his neighbor. The violin quality in the Record is unusually loud and clear.

No. 8798, "I Want to be a Soldier Medley," introduces that song together with "Good-bye, Little Girl, Good-bye," and "Mississippi Mamie." The Record is made by the Edison Military Band and in arranging the music it has been given a military character, the drums and fifes being heard at each change in the melody. The cornet is prominent throughout the Record.

No. 8799, "The Maple Leaf Forever," is a Record of the national song of Canada, sung by W. H. Thompson in his usual fine voice, accompanied by the orchestra. This composition was written by Alexander Muir, B. A., and is too well known in the upper part of the United States and Canada to need any comment. It will unquestionably find a large sale in those sections.

#### NEW MOTOR SUSPENSION SPRINGS ARE FINE.

I want to congratulate you over the success of the motor frame springs, for I got some yesterday and put them on a Triumph Phonograph and the result was way beyond my expectations. I think they are just fine. So, wishing you success over all rivals, I remain,

G. W. HINSHAW,

July 14, 1904.

Carmel, Ind.



**COIN SLOT PHONOGRAPHS.**

With the withdrawal of the Edison Imperial, Regal, Climax, Ajax and Vulcan Coin-Slot Phonographs and the introduction of the Windsor and the Majestic, the National Phonograph Company has decided to adopt an entirely new plan in selling these types of coin-slot machines. It has been found that to instal coin-slot Phonographs and keep them in satisfactory operation requires more attention than the average Dealer can afford to give to them. It was therefore decided that the proper exploitation of coin-slot machines could only be secured by having them handled by the company direct and a special department has been organized for that purpose. The company will solicit this class of business direct, will instal machines with its own men and will see that they are started in a proper manner. While it will not be formally responsible for the machines after they have been thus installed, and proper instructions given concerning their care and operation, it will always stand ready to remedy any serious trouble that may arise. Briefly, it is intended that Edison Coin-Slot Phonographs shall have the attention that their merit warrants and the growing demand for them demands.

At the same time it was decided not to take the matter out of the hands of the trade entirely, but to allow discounts that would enable the larger Dealers to still handle them. The Windsor type is operated by battery current and will be sold at \$80.00. The Majestic type is equipped for 110 volt direct current and will be sold at \$90.000. These prices will be subject to discounts as follows:

Less than 10 machines.....	no discount
10 machines.....	10 per cent. off List
25 ".....	15 per cent. off List
50 ".....	20 per cent. off List
100 or more machines.....	25 per cent. off List

Discounts on Windsor and Majestic types are not confined to Jobbers or Dealers, but are open to any purchaser. They are not cumulative nor does one purchase establish a discount on future orders. In each and every case orders must be placed for quantities above specified or discount quoted cannot be allowed.

Bijou and Excelsior Coin-Slot Phonographs, both of which are spring-motor types, will be sold at the same prices and same discounts as before.

In Canada an amount equal to the duty must be added to the selling prices of Coin-Slot Phonographs as well as to those of all other goods.

**THE PHONOGRAM.**

The re-issue of THE PHONOGRAM seems to have met the approval of the trade and the public. It was found necessary to increase the first edition to 100,000 copies. We have printed 110,000 copies of the second edition and the orders already on file will take the entire lot. Time is the real test of the merit of a publication of this character, but we hope that with a little assistance from the trade and the public we shall be able to make THE PHONOGRAM an interesting little pamphlet and one that will be looked for each month. We would again point out to Jobbers that we cannot imprint THE PHONOGRAM in smaller lots than 500 copies and multiples of that number, and to do this we must have an order at least one month in advance and be continued for at least several months. Unless Dealers will pay express charges, it will be necessary for them to get a supply of Phonograms through their Jobbers. They are too heavy to send in quantities by mail. THE PHONOGRAM will be shipped to the trade with the new Records each month. This will make its date of publication each month somewhat uncertain, and Dealers should explain to their patrons why the time of publication varies.

**NEW RECORD CATALOGUE.**

The new Domestic Record Catalogue will be ready for the use of the trade about the middle of August. It will probably be sent out with the August Records to such Jobbers as find it necessary to have a supply about that time. It will be Form No. 600, and will succeed the present Form No. 545. It will have the same purple cover as No. 545, but the phrase "Domestic Selections" will be changed to read "American Selections." This phrase has been changed because we find it necessary to use many of these catalogues in foreign countries and to them the term "domestic selections" does not have the proper meaning. The new catalogue will contain only American selections. The British selections have been cut out entirely and will appear only in the foreign catalogue. When it is found necessary to print a new edition of the Foreign Record Catalogue the phrase "Foreign Selections" will be changed to read "British, European, French-Canadian, Asiatic." This change will make it possible to use the present Foreign Catalogue either in this country or any other country and have the title comprehensive in each. This Foreign Catalogue will include all Records except American selections.

**CHANGE CATALOGUES TO NEW PRICES**

Jobbers and Dealers are asked to correct with a pen the Machine and Record Catalogues they are now using so that they will contain the proper prices. The following table shows the changes that have been made under the new Agreement. Jobbers cannot be expected to make these changes in catalogues that they furnish to Dealers, and the latter, therefore, should give the matter their own attention.

NEW PRICES IN EFFECT JULY 18, 1904.

*Change in prices of Edison Phonographs.*  
Edison Victor Phonograph, new price, \$65.00.  
Edison Conqueror Phonograph, new price, \$80.00.

*Change in prices of Edison Records.*  
Standard size, reduced to 35c. each, \$4.20 per dozen.  
Concert size, reduced to 75c. each, \$9.00 per dozen.

*Changes in prices of Edison blanks.*  
Standard size, rough, reduced to 15 cents each.  
Standard size, shaved, reduced to 20 cents each.  
Concert size, shaved, reduced to 50 cents each.

John S. Smith, a Philadelphia Phonograph Dealer, sends an official membership card in the "National Society of Butters In." It bears his business card on one side and the following matter on the back:

NATIONAL SOCIETY OF BUTTERS IN  
NATIONAL SOCIETY OF BUTTERS IN  
MEMBERSHIP CARD.

Good for One Season.

This is to certify that M.....  
Is privileged to Butt in on all Conversations  
both Private and Public.

Signed,  
Billy Butt, Pres. Angora Butt, Sec'y.  
Nanny Butt, Treas.

*Butt if you want a Talking Machine or Records  
Butt In.*

**GET READY FOR FAIRS.**

It is about time to consider the matter of getting literature for use in connection with exhibits at county fairs. The fair season opens in September and there is no better way to advertise Edison Phonographs and Records than exhibits at these fairs. We have several forms of printed matter suitable for this purpose.

These are No. 291, one of the Jingle Book series; No. 409, the lithographed card in colors showing boy with hatchet looking for the band; No. 467, the four-page folder on the merits of the Phonograph; No. 535, a four-page folder showing four different styles of the Phonograph on the inside pages; No. 540, a four-page folder. Dealers contemplat-

ing making exhibits at county fairs should place an order with their Jobbers for any printed matter they require and have it forwarded, provided the latter cannot supply it out of their own stock. This literature cannot be imprinted with the Dealer's name and address. It will be necessary for a Dealer to imprint it himself or do the printing with a rubber stamp.

**BETTER THAN ANTICIPATED.**

The Pardee-Ellenberger Co., of New Haven, Conn., send the following letter from one of their customers:

I have put the suspension springs I obtained from you in my Triumph phonograph and the results were even better than I anticipated. All noise is now eliminated and I am sure no Phonograph owner would be without them were he to ever see the difference demonstrated. The "Triumph" is triumphant now in every respect. My neighbors count it a pleasure living in close proximity to the best talking machine in the world.

S. N. WING,  
Shelburne Falls, Mass.

**ROVE AWAY THE BLUES.**

Our Foreign Department recently sold a Concert Phonograph and a supply of Concert Records to a customer in Mexico. In acknowledging their arrival, he wrote:

I received the Concert Phonograph and Records in good shape. I am very highly pleased with the Phonograph. It is perfect. I had the "blues" at my mines when the Phonograph arrived. I immediately set it up and played several Records on it, when the "blues" were forgotten. It simply saved my life. Wishing you unbounded success, I am.

**ITS TONE THE MOST NATURAL.**

I played before a party of expert musicians lately and they were all agreed that the Edison machine brought out the natural tone more fully than any other they had ever heard. I have noticed several articles in the EDISON PHONOGRAPH MONTHLY on determining the speed of a machine. Here is my method: I do not use a speed indicator, nor make a scratch on the Record and count the revolutions from the clicks. I put on a Record and change the speed until I get the correct tone. That I am successful is proved by the fact that one of the musicians mentioned above declared that I was one of the few whom he had ever seen operating a machine, who regulated the speed in a manner which brought out the exact natural tone of the instrument or voice. But I wish to state right here that I have tried the same thing on other machines and failed every time.

H. N. HAGADONE,  
Sparta, Mich.



### A STRIKING SIGN.

Eugene Zimmerman, manager of the Peoria Phonograph Co., Peoria, Ill., sends a photograph of what he calls "the livest sign in town." It is a circular sign over five feet in diameter and is so arranged that it is attractive at all times. At night it is illuminated on the inside so that the white letters stand out strong on the dark background. Red, white and blue incandescent lights are placed on the outer edge of the drum. The bell of a brass horn appears in the center and from it Phonograph music is issuing during all business hours. In the center of the bell is a green light. Lettered on the sign are the words, "Edison Phonographs, \$10 up. Simple, Durable. Peoria Phonograph Co., E. Zimmerman, manager." Mr. Zimmerman writes: "The effect is great. It is the best single advertisement we have. Frequently we have a hundred or more persons in the audience, for the sign is visible to thousands who pass on three lines of street cars crossing within one hundred feet of our place."

### OUR ST. LOUIS BOOKLET.

We are giving out to the public at our exhibition at the St. Louis Fair an attractive little sixteen-page booklet printed in two colors and entitled "Just Airs." On the first page is an airy young lady dressed in the top of the fashion and holding a prize bull-dog by a chain. Inside on the right hand pages are a series of illustrations showing six beautiful girls each typical of as many different countries. The countries portrayed are America, France, England, Spain, Germany, Italy. Above the girl in each picture appears the coat of arms of the country and below is a bar of music of the national hymn of each country. The quantity that we have had printed of this booklet will probably make it possible to allow a number of them to be distributed by Jobbers and Dealers to their customers in the fall. If this is done, the trade will be advised in the usual channels. Six of the pages in the booklet bear a series of arguments on the advantages of owning a Phonograph. These are so good that we have considered it worth while to reproduce them here. They are as follows:

#### THE EDISON PHONOGRAPH. ITS SATISFYING QUALITY.

"Let me make the music of a country and I care not who makes its laws." Music moves man; and thousands of dollars are paid to hear music *once*. How the longing to hear the same sweet strains again has gone unanswered in every heart. Who is *satisfied* with *one* hearing of music he likes?

When Mr. Edison invented the Phonograph, he provided the first fulfilment of this desire.

The Phonograph plays each piece till you are satisfied—till you have learned the strains and made them *your own*. The scratching and the shrill notes of the old-time Records and machines have been done away with by the Gold Mould Process by which all Edison Records are now made. A Reproducer has been invented that is exactly adapted to these marvelous Records, and that fits every Phonograph however old.

You may sit in your home and hear the thrilling tones that appeal to the hidden chord within,—full, rich, and pure—not the "imitation of sound" of the past, but a real *reproduction*.

The Phonograph requires no skill—in five minutes you can master it. The Phonograph takes up no room—it stands on the table when playing, and rests under it when idle.

The Phonograph and a supply of Records cost half the price of a mechanical piano player and a decimal of the price of a piano. Yet the Phonograph sings as sweetly and as clearly as the singer, and renders perfectly the voices of the various instruments of the orchestra or band, with their indescribable beauties of combination, of contrast, and of harmony.

#### A WELCOME DIVERSION.

Who has not felt the need of some unflinching diversion for entertaining company? Some visitors are always hard to amuse. Some gatherings, however carefully planned, will not "mix," and things go wrong. Every caller is a new problem.

The Phonograph is the perfect solution of every such difficulty in every home. The loud, clear, rich-toned instrument of to-day is a welcome diversion to every guest. Classical music or rag-time, songs or marches, minstrels or orchestras, and funny stories, are sure to divert and entertain those who cross your threshold, and few companies fail to "get together" in delightful unity at the first hearty laugh, or the first thrill of pleasure shared together.

Then think of the fun when you are alone—the long evenings when there is no company, and perhaps those at home are on the verge of getting tired of one another. It is an inexhaustible amusement. There are *always* new ones—twenty-five every month, embracing the latest popular music, with additions to the classical, the grave, the gay, and every time a novelty of some kind.

Few can resist the charms of that monthly list of new Records. It's like the monthly magazine, except that you "read the stories" over and over, finding each time some new delight—adding each month some permanent pleasure—teaching the youngsters a new appreciation of the greatest art in the world—the art of music.

#### IN THE COUNTRY.

You who live away from the towns—do you ever envy the townsmen the countless diversions of concert, theatre and lecture—the educating influence of hearing something new each day? The invention is here that takes these pleasures and advantages to you in your home however isolated. No other instru-

ment is so inexpensive; no other joy so endless in variety; no other servant so tireless.

Do you like a piece of music? It will play and play until you are *satisfied*—till you have learned words and tune, should you desire—and always just as clearly and sweetly as the very first time. Have you heard a song till you tire of it? You can get another. Do you want to know the latest popular hit? It will play it with the lilt and swing that made it popular, while your neighbor's daughter is thumping it on her piano minus its good points. Without a Phonograph none except trained musicians can hear the music they like, played as they like it, as often as they like it.

Would you hear a funny story? It knows hundreds. Would you learn a foreign tongue? Languages are taught by the I. C. S. System on the Phonograph.

You will never be lonesome with it. You will never grow tired of it, for new Records are added monthly—twenty-five at a time. You will never fail to entertain a friend or a houseful of visitors. Your children will like to stay at home. Your whole family will grow closer together in their mutual enjoyment.

Do you want to know more about it? Hear it. Buy it.

#### IN TOWN.

And you, Mr. City-man, have you learned how tiresome it is to sit through a long evening of old jokes, painted faces, and gaudy costumes, just to hear a song or two that you really like? Have you ever struggled to remember that catchy tune of which a phrase or two haunts you? Have you ever missed your cigar, your smoking jacket, and your slippers on these occasions.

Then remember the Phonograph, on which you can play that haunting tune till you know it—words and music. Remember the Phonograph which alone plays like the orchestra itself.

Perhaps you have heard a "talking machine" in a ferryhouse waiting room, or possibly your neighbor rouses the whole vicinity on summer evenings with a screaming noise, and you think you don't want one. Think again. These are imitations, and old—obsolete—styles. Any "talking-machine" will reproduce the notes and the noise; but the sweetness and expression for which you prize music are reproduced only by the modern Edison Phonograph with Edison Gold Moulded Records. Dealers everywhere will assure you that this is true, and prove it on the spot.

The greatest home entertainer the world has ever seen is waiting for a trial which will prove to you that you cannot do without it; that rainy evenings need not be lonesome evenings; that home has some attraction for your children; that your wife can have happy diversion if she does stay home with the baby so much; that she needs the Phonograph, and that you want it.

Be fair; go and hear it.

#### FOR DANCING.

Did you ever dance to the Phonograph? NO? Then you have no idea what perfect time it keeps, how smoothly it swings you over the floor, fairly carrying you along with

the rhythm of its clear, vibrant tones. And oh, the fun of having a rich band or sweet orchestra to dance to at home, instead of hopping around to an amateur pianist's efforts, while you regret the necessity that keeps the prettiest girl in the room tied to the piano stool, or prevents your hostess from sharing your pleasure. How many times have you had a little company who would have liked so much to dance but for these things.

Perhaps you have no piano. Perhaps the cost looms up alongside the grocer's bill or the doctor's fees that put it out of the question. The first instalment on that piano will buy you the sweetest Phonograph that ever played, with dozens of Records, and it will let you dance, take you to the theatre, instruct you in a foreign language, transport you to the minstrels, carry you back to the Wagnerian opera, play "rag-time," sing songs that touch the heart, and play marches that rouse the soul—all between dinner and bed-time.

No other instrument will do this with charm and sweetness, for these qualities distinguish the Edison Phonograph from its imitations. See that you get the genuine Edison Gold Moulded Records, and don't forget that every month there are twenty-five new Records, to take the place of the ones you are tired of.

#### MAKING RECORDS.

Did you ever make a Record of your voice on the Phonograph? If not, you have a new experience before you. Perhaps your friends may some day place a value on that Record that you little dream of when in the fulness of strength you amuse yourself in the making.

But it is not a sad process. Some of the heartiest laughs ever heard have resulted from hearing ourselves as others hear us, and often the results obtained would not be parted with for gold. Your friend who sings that song which no one else can sing to suit you, will rarely refuse your request to "put it on record."

And then the children: some of their pretty sayings—most of them—are lost forever unless you have a Phonograph. But *if* you have it, you are ready at a moment's notice to have them "say it again" while it is fresh in the memory; and then you have not only the quaint expression, but the childish voice as well, safely stored away. There is always the chance that some day *that* will be *all* you will have. Then *how much* would that Record be worth?

#### FROM THE STRAITS OF MAGELLAN.

Following is an extract from a letter received by our Foreign Department from one of its customers in Punta Arenas, Straits of Magellan:

I am glad to say that your machines and Records continue to give great satisfaction. The manager of the bank at Tarapaca was here recently, going all around the sheep farms, and heard the Edison Home. He says he has traveled a great deal but never heard a better or more clear machine in any part of the world.



**SUSPENDED LIST, AUGUST 1, 1904.—SUPERSEDING ALL PREVIOUS LISTS.****COLORADO.**

BOULDER—BENTLEY &amp; CRAIG.

**IOWA.**

BURLINGTON—JOHN P. WEISS, 711 Jefferson street.

SIOUX CITY—HATTENBACH BROS.

**INDIANA.**

SOUTH BEND—EUGENE MARSH, 126 Vista avenue.

SOUTH BEND BOOK BINDERY,  
Robert Lebolt, Prop., 203 North Michigan street.**KANSAS.**

CLAY CENTRE—E. M. GOWENLOCK.

LAWRENCE—BELL BROS.

**MAINE.**

BIDDEFORD—W. H. FIELD.

**MASSACHUSETTS.**BOSTON — \*CONCLAVE PHONOGRAPH  
CO., S. Katz, manager, 93 Stamford St.  
\*T. SINGER, 60 Leverett St.LAWRENCE—LORD & CO., 314 Essex street,  
E. O. MOSHER, 420 Essex street.

JOHN E. O'NEIL.

MALDEN—A. T. FULLER.

NANTUCKET—ARTHUR M. TAYLOR.

NEW BEDFORD—H. B. DEWOLFF.

SOMERVILLE—E. J. WINCHESTER, 32 Summit avenue.

WOBBURN—OSBORN GILLETTE, or THE  
BOLTON JEWELRY COMPANY, L.  
F. MALONEY, Manager.**MICHIGAN.**

DETROIT—F. J. SCHWANKOVSKY.

SAGINAW—GEO. W. EMENDORFER.

**MISSOURI.**

KANSAS CITY—THE WITTMANN CO.

**NEBRASKA.**

LINCOLN—THE WITTMANN CO.

OMAHA—THE WITTMANN CO.

**NEW HAMPSHIRE.**

HILLSBORO BRIDGE—E. M. BARNES.

MANCHESTER—A. E. DUMAS.

NASHUA—F. A. McMASTER &amp; CO.

**NEW JERSEY.**ATLANTIC CITY—SAMUEL D. WOLF, 32-34  
Arkansas avenue.

BAYONNE—I. WIGDOR, 450 Avenue D.

JERSEY CITY—W. L. HOFFMAN, 151 Montgomery street.

NEWARK—R. L. CORWIN; also New York  
City.

PASSAIC—I. HURWITZ.

PATERSON—CHAS. H. KELLY, 25 N. Main st.

PLAINFIELD—S. W. FRUCHT, or R.  
FRUCHT; also New York City.  
ELSTON M. LEONARD.WEST HOBOKEN—EMIL HOLLANDER, or  
THE WEST HOBOKEN BICYCLE &  
PHONOGRAPH CO., 619 Spring street.**NEW YORK.**

BEDFORD PARK—GEO. H. TYRRELL.

HOBART—F. H. MARSHALL.

NEW YORK CITY—A. T. ARMSTRONG, or  
AMERICAN PHONOGRAPH CO., 106  
Wall street.BERN BEARWALD, 373 West 11th St.  
BRONX PHONOGRAPH CO., or DA-  
VID SWITKY, 506 Willis avenue.CENTRAL PHONOGRAPH CO., 160  
E. 42d street.

R. L. CORWIN; also Newark, N. J.

EAGLE PHONOGRAPH CO., or C.  
LOWENTHAL, 83 Nassau Street.EMPIRE PHONOGRAPH CO., 2 West  
14th street.S. W. FRUCHT, or R. FRUCHT, 7 Bar-  
clay st., or 68 Cortlandt st.; also  
Plainfield, N. J.

O. HACKER, 2 Murray street.

HAWTHORNE & SHEBLE, 297 Broad-  
way; also Philadelphia, Pa.

N. HORN, 148 E. 58th street.

W. L. ISAACS, 114 Fulton street.

S. LEMBURG &amp; CO., 194 Broadway.

J. McELLYNNE, 202 Broadway.

RICHMOND PEASE, 44 W. 132d st.

F. M. PRESCOTT, 44 Broad street.

WINTHROP CYCLE CO., 2212 Seventh  
avenue.

SARATOGA—W. J. TOTTEN.

SARATOGA SPRINGS—MARVIN A. COTE.

**OHIO.**

CINCINNATI—J. L. ANDEM.

COSHOCTON—BURNS &amp; GOSSER.

SPRINGFIELD—D. &amp; M. VANDERPOOL.

UHRICHSVILLE—F. A. MAZURIE.

**PENNSYLVANIA.**PHILADELPHIA—A. R. CASSIDY, 2783 Em-  
erald street.HAWTHORNE & SHEBLE, 604 Chest-  
nut street, or Oxford and Wascher  
streets; also New York City.

\*A. KROUSE, 832 Arch street.

PENN NOVELTY CO., 15 South 9th  
street.

PHOENIXVILLE—KEINARD BROS.

PITTSBURG—A. LIPPARD, 615 Wylie avenue.

**RHODE ISLAND.**

PROVIDENCE—F. P. MOORE.

**WISCONSIN.**

MILWAUKEE—J. C. BLATZEK.

\*Added since July 1, 1904.

Jobbers and Dealers are asked to co-operate with us, FOR OUR MUTUAL GOOD, by being careful that they do not supply any of the above named firms with our apparatus, either at addresses given or any other address.

## JOBBER'S OF EDISON PHONOGRAPHS AND RECORDS.

## ALABAMA.

**Birmingham**—The Ray Co., 2025 Second avenue.

## CALIFORNIA.

**San Francisco**—Peter Bacigalupi, 786-788 Mission street.

## COLORADO.

**Denver**—Denver Dry Goods Co., 619 16th street.

## CONNECTICUT.

**Middletown**—Caulkins & Post Co., 406-408 Main street.

**New Haven**—Pardee-Ellenberger Co., 155 Orange st.

## ILLINOIS.

**Chicago**—James I. Lyons, 73 Fifth avenue.

The Ray Co., 90 Washington street.

Siegel-Cooper Co., State and Congress sts.

Talking Machine Co., 107 Madison street.

The Vim Co., 68 E. Lake street.

Montgomery Ward & Co., 111 Michigan ave.

**Peoria**—Peoria Phonograph Co., 222 Bridge street.

## INDIANA.

**Indianapolis**—Craig-Jay Co., 234 Massachusetts ave.

Kipp Bros. Co., 37 S. Meridian street.

Wahl-Gaasch Co., 119 S. Illinois street.

**Lafayette**—Wahl-Gaasch Co., 304 Main street.

## IOWA.

**Des Moines**—The Vim Co., 704 West Walnut street.

**Fort Dodge**—Early Music House, 822 Central ave.

## KENTUCKY.

**Louisville**—The Ray Co., 640 Fourth street.

## LOUISIANA.

**New Orleans**—James I. Lyons, Theatre Arcade.

National Automatic Fire Alarm Co., 614

Gravier street.

The Ray Co., 111 Camp street.

## MAINE.

**Bangor**—S. L. Crosby Co., 186 Exchange street.

**Portland**—W. H. Ross & Son, 207 Commercial street.

## MASSACHUSETTS.

**Boston**—Boston Cycle & Sundry Co., 48 Hanover street.

Eastern Talking Machine Co., 177 Tremont

street.

Oliver Ditson Co., 150 Tremont street.

Iver Johnson Sporting Goods Co., 163 Wash-

ington street.

Read & Read, 558 Washington street.

**Fitchburg**—Iver Johnson Sporting Goods Co., 247 Main

street.

**Lowell**—Thomas Wardell, 111 Central street.

**Worcester**—Iver Johnson Sporting Goods Co., 304 Main

street.

## MICHIGAN.

**Detroit**—American Phonograph Co., 106 Woodward

avenue.

Grinnell Bros. Music House, 219 Woodward

avenue.

The Ray Co., 252 Woodward avenue.

**Saginaw**—Morley Bros.

## MINNESOTA.

**Minneapolis**—Thomas C. Hough, 714 Hennepin ave.

**St. Paul**—W. J. Dyer & Bro., 21-23 West 5th street.

Minnesota Phonograph Co., 37 E. 7th street.

## MISSOURI.

**Kansas City**—J. W. Jenkins' Sons Music Co., 1013-1015

Walnut street.

The Ray Co., 1021 Grand avenue.

**St. Louis**—Conroy Co., 1115 Olive street.

The Ray Co., 923 Olive street.

## NEBRASKA.

**Lincoln**—H. E. Sidles Cycle Co., 1317 O street.

**Omaha**—H. E. Fredrickson, 1502-1510 Capitol avenue.

Nebraska Cycle Co., 15th and Harney streets.

## NEW JERSEY.

**Hoboken**—Eclipse Phonograph Co., 205 Washington

street.

**Newark**—A. O. Petit, New and Halsey streets.

**Paterson**—James K. O'Dea, 117 Ellison street.

**Trenton**—Stoll Blank Book and Stationery Co., 30 E.

State street.

## NEW YORK.

**Brooklyn**—Chapman & Co., Fulton and Duffield streets.

A. D. Matthews' Sons, 394 Fulton street.

Price Phonograph Co., 1258 Broadway.

**Buffalo**—P. A. Powers, 643 Main street.

**Elmira**—Elmira Arms Co., 117 Main street.

**Gloversville**—American Phonograph Co., 99 W. Fulton

street.

**Kingston**—Forsyth & Davis, 307 Wall street.

**New York City**—Bettini Phonograph Co., 80 Chambers

street.

Blackman Talking Machine Co., 19

Beekman street.

J. F. Blackman & Son, 2654 3d avenue.

I. Davega, Jr., 802 Third avenue.

S. B. Davega, 32 E. 14th street.

Douglas & Co., 89 Chambers street

H. S. Gordon, 139 Fifth avenue.

Harry Jackson, 219 Bowery.

Jacot Music Box Co., 39 Union Square.

Victor H. Rapke, 1661 Second avenue.

Siegel-Cooper Co., Sixth avenue and

18th street.

John Wanamaker, Broadway and

9th street.

**Rochester**—A. J. Deninger, 347 North street.

Mackie Piano, O. & M. Co., 100 State street.

Giles B. Miller, 63 State street.

Talking Machine Co., 29 S. Clinton avenue.

**Schenectady**—Jay A. Rickard & Co., 253 State street.

**Syracuse**—W. D. Andrews, 216 E. Railroad street.

**Troy**—James Lucey, 359-361 Fulton street.

**Utica**—Clark-Horrocks Co., 54 Genesee street.

## OHIO.

**Canton**—Klein & Heffelman Co., 216 N. Market street.

**Cincinnati**—Ilsen & Co., 25 W. 6th street.

The Ray Co., 143 West 5th street.

Wahl-Gaasch Co., 5 Arcade.

**Cleveland**—W. J. Roberts, Jr., Erie and Huron streets.

**Columbus**—Perry B. Whitsit Co., 213 S. High street.

**Dayton**—Niehaus & Dohse, 35 E. 5th street.

**East Liverpool**—Smith & Phillips Music Co.

**Toledo**—Hayes Music Co., 608 Cherry street.

## PENNSYLVANIA.

**Allegheny**—Henry Braun, 500 Federal street.

**Allentown**—G. C. Aschbach, 539 Hamilton street.

**Easton**—William Werner, 401 Northampton street.

**Philadelphia**—C. J. Heppe & Son, 1117 Chestnut street.

Lit Bros., Market and 8th streets.

Penn Phonograph Co., 19 S. 9th street.

John Wanamaker.

Wells Phonograph Co., 41 N. 9th street

Western Electric Co., 931-933 Market

street.

H. A. Weymann & Son, 923 Market

street.

**Pittsburg**—Theo. F. Bentel Co., Inc., 433 Wood street.

Kaufmann Bros., Fifth avenue and Smith-

field street.

H. Kleber & Bro., 221 Fifth avenue.

C. C. Mellor Co., 319 Fifth avenue.

Pittsburg Phonograph Co., 937 Liberty

avenue.

**Reading**—Reading Phonograph Co., 809 Penn street.

**Scranton**—Ackerman & Co., Coal Exchange Building.

Technical Supply Co.

## RHODE ISLAND.

**Providence**—J. M. Dean Co., 785-795 Westminster street.

J. A. Foster Co., Weybosset and Dor-

rance streets.

Household Furniture Co., 231-237 Wey-

bossett street.

Murray, Blanchard, Young & Co., 26-30

Pine street.

J. Samuels & Bro., 154 Weybossett street.

A. T. Scattergood & Co., 106-110 N. Main

street.

## TENNESSEE.

**Memphis**—The Ray Co., Lyceum Building, and and

Jefferson streets.

**Nashville**—The Ray Co., 30 The Arcade.

## TEXAS.

**Dallas**—C. B. Harris, Agt., 347 Main street.

## VIRGINIA.

**Richmond**—The Ray Co., 729 E. Main street.

## WISCONSIN.

**Milwaukee**—McGreal Bros., 173 3d street.

## CANADA.

**Toronto**—R. S. Williams & Sons Co., Limited,

143 Yonge street.





**YOU CAN TEACH ENGLISH!**

To the **GERMAN** To the **FRENCH**  
**ITALIAN** **POLISH**  
**LITHUANIAN** **RUTHENIAN**  
**SLOVAK** **SPANISH**  
**RUSSIAN, ETC.**

*With 25 Standard English  
Records in the*

## **New I. C. S. Series**

The "stranger in a strange land" will now, more than ever, bless the Edison phonograph. His entertainer at once becomes his teacher in the English language, which he must know if he is to live and prosper in America.

It is so easy to learn by the I. C. S. Method. The familiar language of the foreigner is printed side by side with the English translation, and these he follows with the eye while he hears the pronunciation on the phonograph. The English expressions he learns in private today, he uses at his work tomorrow, and so progress is rapid and his pronunciation correct.

English people may also learn **French, German, and Spanish** through complete sets of I. C. S. Records and Textbooks.

### **DEALERS MUST DEMONSTRATE**

We send samples of I. C. S. Moulded Records and Textbooks in French, German, Spanish, and English to Edison Dealers in the United States or Canada, express prepaid, \$2.00 net; or one English Record with assortment of foreign textbooks, express prepaid, 75 cents net.

Write today for prices, discounts, and literature.

*Address, LANGUAGE DEPT.*

**International Correspondence Schools**  
**Scranton, Pa.**

# EDISON Phonograph Monthly

PUBLISHED FOR TRADE USE ONLY BY  
THE NATIONAL PHONOGRAPH CO.

VOL. II.

NEW YORK, SEPTEMBER, 1904.

No. 7.

*The National Phonograph Co.,*

ORANGE, N. J.

NEW YORK: 83 CHAMBERS STREET.

CHICAGO: 304 WABASH AVENUE.

SAN FRANCISCO: 786 MISSION STREET.

NATIONAL PHONOGRAPH CO., LTD., 25 CLERKENWELL  
ROAD, LONDON, ENG.

## EDISON PHONOGRAPHS AND RECORDS.

All communications to THE PHONOGRAPH MONTHLY should be addressed to the Advertising Department, 83 Chambers Street, New York.

### C O N T E N T S

Phenomenal Business .....	I
Advance List of Edison Gold Moulded Records for October .....	2
The Phonogram .....	3
Three Talkers .....	3
Our "Follow Up" System .....	4
New Record Carton and Marking .....	4
Mail Supplement to Machine Owners ....	4
Machine Improvements .....	5
Stock Up .....	5
Printed Matter .....	5
Talent Statistics .....	6
Play Over the Older Titles .....	6
Made Over With Different Talent .....	7
Sign and Return at Once .....	7
Comments on October Records .....	8
Phonograph an Aid in Teaching the Deaf.	10
A Quick Sale .....	10
Phonograph Music on Donkey Back .....	11
Dealers and Advertising Literature .....	12
Suspended List, September 1, 1904 .....	14
Jobbers of Edison Phonographs and Records .....	15

## PHENOMENAL BUSINESS.

The reduction in price of Edison Gold Moulded Records and Edison Concert Records has brought an increase in business beyond our most sanguine expectations. The new conditions were decided upon because largely increased facilities made it possible to manufacture a much greater number of Records than ever before, and it was believed that the lower prices would soon make it necessary to run the plant to its fullest capacity. That the limit would be reached at once was scarcely thought of. Since July 18, however, the orders have been coming in at a most astounding rate and at this writing they have not only reached the capacity of our Record plant, but they are compelling us to operate it nights as well as days. Even at this, the orders accumulate faster than Records are being turned out. Consequently we have fallen somewhat behind with Record shipments. We desire to assure the trade, however, that nothing is being left undone to overcome this. We hope in a short time to have the situation well in hand and to be able to fill orders promptly.

No more popular move was ever made by the National Phonograph Company than the reduction in price of Edison Gold Moulded Records to 35 cents each in the United States and 40 cents in Canada. It has now become widely known in both countries and in spite of the midsummer season, a presidential campaign and other conditions usually considered unfavorable to business, the public are buying Edison Records as they never before bought them or any other kind. They have developed a hunger for Edison Records that has made inroads upon the stock carried by Dealers, and that has compelled the latter to send rush orders to their Jobbers for a

(Continued on page 3.)

**THE ADVANCE LIST OF OCTOBER RECORDS APPEARS ON PAGE 2. ORDER FROM IT. NO OTHER ADVANCE LIST WILL BE ISSUED.**



# ADVANCE LIST OF NEW EDISON GOLD MOULDED RECORDS FOR OCTOBER, 1904

RECORDS listed below will be ready for shipment as near October 1st as possible, at which time Jobbers' stock orders, if placed prior to September 15th, will be shipped. October Supplements will be forwarded to Jobbers with their stock order for Records. Retail Dealers should place stock orders with their Jobbers at once, to insure prompt shipment as soon as Jobbers' stock is received.

- |      |   |  |
|------|---|--|
| 8800 | Ballet Music from Coppelia ( <i>Delibes</i> )   | Edison Concert Band                                    |
| 8801 | Con Clancy's Before Election Speech<br><i>Descriptive of a ward political meeting and introducing a drum corps,<br/>brass band and other incidental effects.</i>            | Len Spencer  |
| 8802 | Star of My Life ( <i>Corliss</i> )<br><i>Sentimental song with orchestra accompaniment.</i>   | W. H. Thompson   |
| 8803 | One Heart One Mind ( <i>Strauss</i> )<br><i>Poika Mazurka, bell solo with orchestra accompaniment.</i>  | Albert Benzler   |
| 8804 | Teasing ( <i>Von Tilzer</i> )   | Coon song with orchestra accompaniment. Bob Roberts    |
| 8805 | Battle Cry of Freedom ( <i>Root</i> )<br><i>Rallying song, tenor and baritone duet with orchestra accompaniment,<br/>introducing cheers, bugles and drum corps effects.</i> | Harlan and Stanley                                     |
| 8806 | In the Valley of the Sunny San Joaquin ( <i>Dewey</i> )<br><i>Descriptive song with orchestra accompaniment.</i>  | Harry MacDonough                                       |
| 8807 | Dreaming on the Ohio ( <i>Brill</i> )<br><i>Descriptive song and quartette chorus with orchestra accompaniment.</i>   | Edison Male Quartette                                  |
| 8808 | Seminole ( <i>Van Alstyne</i> )<br><i>A new Indian ballad by the writers of "Navajo," with orchestra<br/>accompaniment.</i>   | Harry Tally  |
| 8809 | Wilhelmina Waltzes ( <i>Hall</i> )<br><i>Recorded at a slow tempo for dancing.</i>  | Edison Military Band                                   |
| 8810 | Down Where the Sweet Potatoes Grow ( <i>Von Tilzer</i> )<br><i>Coon male duet with orchestra accompaniment.</i>   | Collins and Harlan                                     |
| 8811 | Sweet Sixteen Waltz   | Cornet solo with orchestra accompaniment. Bohumir Kryl |
| 8812 | Cupid's arrow ( <i>Eno</i> )  | Banjo solo with orchestra accompaniment. Fred Van Epps |
| 8813 | Sylvie ( <i>O'Connor</i> )<br><i>Sentimental song with orchestra accompaniment.</i>   | Byron G. Harlan  |
| 8814 | What Colored Eyes Do You Love ( <i>Jerome</i> )<br><i>Contralto and baritone duet from "The Royal Chef," with orchestra<br/>accompaniment.</i>                              | Miss Nelson and Mr. Stanley                            |
| 8815 | Selection from The Royal Chef ( <i>Jerome</i> )<br><i>Introducing "Let Me Go Back," "It's a Way They Have in Chicago"<br/>and "Old Mother Goose."</i>                       | Edison Concert Band                                    |
| 8816 | It's Great to be Crazy ( <i>Bowers</i> )<br><i>Comic song from "The Maid and the Mummy," with orchestra<br/>accompaniment.</i>  | Arthur Collins   |
| 8817 | Bye and Bye You Will Forget Me ( <i>Huntley</i> )<br><i>Sentimental male duet with orchestra accompaniment.</i>   | MacDonough and Biehling                                |
| 8818 | My Old Kentucky Home ( <i>Foster</i> )  | Fantasia Edison Concert Band                           |
| 8819 | Does You Love Me as You Used to, Miss Jane ( <i>Smith</i> )<br><i>Coon male duet with orchestra accompaniment.</i>  | Collins and Harlan                                     |
| 8820 | I Fell in Love with Polly ( <i>Carle</i> )<br><i>Serio-comic song with orchestra accompaniment from<br/>"The Maid and the Mummy."</i>                                       | Harry MacDonough                                       |
| 8821 | She Was a Good Old Soul ( <i>Morse</i> )<br><i>Descriptive song with orchestra accompaniment by the composer of<br/>Dear Old Girl."</i>                                     | Frank C. Stanley                                       |
| 8822 | Bridal Tour Overture ( <i>Enhaes</i> )  | Edison Symphony Orchestra                              |
| 8823 | Old Black Joe ( <i>Foster</i> )   | unaccompanied. Edison Male Quartette                   |
| 8824 | Here's My Friend ( <i>Snyder</i> )<br><i>Coon song with orchestra accompaniment.</i>  | Bob Roberts  |
| 8825 | Royal Italian March   | Edison Military Band                                   |

Names of Composers are given in italics and parentheses following the titles.

Edison Gold Moulded Records are made only in Standard size. Both Standard and Concert Records may be ordered from this list. Order by Number, not title. If Concert Records are wanted, give the number and letter C.

(Continued from page 1.)

replenishing stock. The Jobbers were unprepared for such a flood of business as the Dealers have sent them and their stocks have been inadequate. They in turn are "putting it up" to us. Like the Dealers and Jobbers, we hardly expected so much and so soon, and as we get the accumulated force of the demand throughout the United States and Canada, we are for a short time unable to "make good." As already stated, we feel sure that by running our Record plant to its fullest capacity day and night we will soon handle orders to the entire satisfaction of the trade.

The demand for Records already listed, or "stock" Records as they are better known, has not only been extremely heavy, but the orders for the September list exceed by many thousands the highest number ever before received for any month's list in the history of this company. This is partly due to the forethought of Jobbers in placing orders, and partly because the September list is one of unusual merit.

Another feature of interest is the fact that nearly a dozen large firms have become Jobbers in Edison goods since the new conditions went into effect. Most of these have done so almost without solicitation, and because their business judgment told them that a great future lies before the Edison Phonograph and Edison Records.

Then, too, hundreds of firms have taken up the line during the past month; firms who have never handled Phonographs before. At the same time reports come to us from all parts of the country of Dealers who have dropped other makes of cylindrical records entirely or are seeking to get rid of their stocks as fast as possible. They state that their patrons will have nothing but Edison Gold Moulded Records and that no demand exists for any other.

### THE PHONOGRAM.

The *Phonogram* for September will contain half-tones of Bohumir Kryl, cornetist, and Frank S. Mazziotta, piccolo player, both well known for their clever work in making Edison Records. The September edition will be 135,000 copies, a fairly convincing evidence of the popularity of the little publication. This popularity is largely due to the great curiosity of Phonograph owners to see the pictures of the men and women whose voices they know

so well. The trade should know that the forms of the *Phonogram* close five weeks in advance of its time of shipment, which will explain to all why any matter cannot be published in its columns for so long a time after its receipt. This time is required to get the publication printed, bound and packed for shipment.

In spite of the information printed in the EDISON PHONOGRAPH MONTHLY for July, giving the cost of the *Phonogram* to the trade, we still get frequent letters from Dealers asking for prices on it. The cost is as follows:

In quantities from Jobbers, 25 cents per 100. Single copies by mail, 20 cents a year.

Five copies by mail to one address, 40 cents a year.

Twenty-five copies by mail to one address, \$1.80 per year.

Unless they have open accounts on our books, Dealers ordering *Phonograms* sent by mail are requested to send cash or stamps with their orders. The amounts are too small to handle in any other way.

### "THREE TALKERS."

An amusing mailing card comes to us from "The 'Little' Repair Shop" at Keene, N. H. Mr. Little has succeeded in getting out a card that cannot fail to attract attention and provoke a smile. It is headed "Three Talkers." At the left and right, near the top, Mr. Little has printed pictures of his two children. Under one is the inscription "Earl Wildridge Little. This one talks well but 'breaks occasionally, and can talk cross.'" Under the other are the words "Albert Isham Little. This one is indistinct, 'breaks' with sometimes a little cross talk." Farther down on the card is a picture of an Edison Standard Phonograph and inscribed "This one is distinct with an even tone and without cross talk." Between the three pictures is the following "All well made and growing in popularity (two wound up all the time and never run down—I would not sell either of these for a million dollars). If you have neither of them buy yourself an Edison Talking Machine. Hear all the popular music and songs of the day in your own home."

### HAD ENOUGH.

"Some disc records and machines less than cost, to clean them out. Will trade for bicycles or Edison machines." This is an extract from the advertisement of one of our Dealers. And there are others.



### OUR "FOLLOW UP" SYSTEM.

Almost daily the mails bring letters from Edison Dealers in various parts of the country referring with pleasure to the benefit derived from our system of "following up" inquiries for catalogues of Edison Phonographs and Records. Many of these letters tell of satisfactory sales of our goods—sales that would not have been possible had we not referred the inquirer's names to the Dealers. Frequently we get inquiries from small towns where we have no Dealers and where we might be justified in endeavoring to make a sale direct. By referring the matter to a Dealer in nearby towns, however, we are able to put the business into the hands of a regular Dealer. Our advertising endeavors to induce the public to first go to the stores of Dealers for catalogues and information, but if this is not feasible then we want them to write to us direct. Our "follow up" system then puts the inquirer and Dealer in touch with each other.

In order to make it more certain that we were getting the best results from catalogue inquiries, we recently enlarged our "follow up" system in a manner that requires more co-operation on the part of Dealers. Upon receipt of an inquiry for catalogues we send those requested and accompany them with a typewritten letter, referring to the merits of our goods and stating that we have asked a nearby Dealer to give him such further attention as he may desire. We enclose a return mailing card upon which we ask him to advise us if he has heard from the Dealer to his satisfaction. A similar course is pursued with one or more Dealers in the vicinity in which the prospective customer lives. They are asked to give him all the attention possible and to advise us on return mailing cards whether or not a sale has been made. If satisfactory replies from the first series of letters sent out are not received within one month another series is sent out, which in nearly all cases completes the transaction.

The maintenance of this department is somewhat expensive and we feel that the least that Dealers can do is to give the inquiries their careful attention and supply the information we ask for. We notice that some Dealers return the mailing cards at once, and before they have been able to see or hear from the inquirer. These should not be filled out and returned until enough time has elapsed to know whether or not a sale has been or can be made. When a sale has been effected,

Dealers should fill in and return the cards at once. If none takes place in three weeks that fact should be noted on the cards and the latter mailed to us. This gives us another opportunity to write the inquirer. We continue to refer inquirers to Dealers as long as they do their part, both in "following up" and advising us. When they persistently neglect both, we stop referring to them and find some one else who will co-operate better. Such cases, however, are few in number.

We so thoroughly have the good will of the entire trade that it is almost like carrying coals to Newcastle to refer to this "follow up" system as one of the numerous things being done by this company to get business for Dealers. We have abundant evidence that our efforts on their behalf are thoroughly appreciated. In few lines of business are the relations between manufacturer and the trade more cordial, a fact that gives us much satisfaction.

### NEW RECORD CARTON AND MARKING.

By this time the new box and new style of marking Edison Gold Moulded Records have become known to owners of Edison Phonographs everywhere in the United States and Canada. Many Records were bought just to see the new conditions, both of which have been warmly commended. The work of making over the moulds of selections previously listed is going on as rapidly as possible, considering the phenomenal demand for Records, and in a few months all Records made at our factory will go out in the new box and marked on the end. Each new monthly list hereafter will be so marked and packed.

### MAIL SUPPLEMENT TO MACHINE OWNERS.

Nothing that a Dealer can do will bring better results than the mailing each month of a supplement of new Records to owners of Phonographs. Hundreds of Dealers are doing it now and the number is rapidly growing. We are printing and sending out 500,000 of these supplements each month, but will gladly print double the quantity if the trade will use them properly. Jobbers should encourage Dealers to get up mailing lists and call upon us for larger quantities of supplements if they need them.

**The great Edison family will not be complete without you, Mr. Dealer. Sign new Agreement and stay in the fold.**

**MACHINE IMPROVEMENTS.**

We continue to receive many complimentary letters in reference to the new suspension springs that are being placed in the Triumph and Home machines and which may be attached to any of these machines now in use. Everyone who has attached them has expressed the greatest delight at the results secured. The speed indicator with which the Triumph and Home are also equipped is another improvement that is being favorably commented upon. This speed indicator has been carefully tested and will meet all the requirements of those who do not find it easy to keep their machine running at the proper speed.

**A BUSINESS CARD.**

Following is a reprint of a neat little card gotten out by an Ohio Dealer:

**CHARLES MILLER,**

Agent for

**EDISON PHONOGRAPHS,**

Records Etc.

**MUNGEN, OHIO.****Our Leaders.**

Edison Gem, \$10; Standard, \$20; Home, \$30;  
Triumph, \$50.

Terms: One-half down, balance \$5 per month.  
Records 35c. each, bills for Records must be  
paid every 30 days.

A young man loved a young lady,  
That's his business.  
A young lady loves a young man,  
That's her business.  
Soon they'll be married,  
That's their business.  
If the young man wishes to buy  
An EDISON PHONOGRAPH,  
That's his business.  
Read the top of this card,  
That's our business.

**STOCK UP.**

At no time in the history of the business will the trade find it more important to carry a full stock of Edison Phonographs and Edison Records than in the coming four months. Those who do so are going to do a most gratifying business. Those who neglect it or think that there is still plenty of time will regret their procrastination. Many things are combining to make a great business in Edison goods and wise Dealers will climb into the wagon and go along with the crowd.

**Sign new Agreement, Mr. Dealer, and keep in good standing. We want your signature, your good will and your business.**

**A NOVEL RECORD CABINET.**

A Phonograph owner at Narragansett Pier, Rhode Island, sends a photograph of a Record cabinet that he has made for his own use. It is made in the form of a table, with a drawer in the base, which is enclosed on all sides. Above this base are four carved legs. These support the upper leaf upon which the Phonograph rests. Between the four posts is a circular enclosure. In the latter is a revolving drum with spindles for Records projecting at intervals all around and from top to bottom. The circular enclosure has an opening at one side through which the Records are reached. The cabinet is at once novel, useful and attractive.

**PRINTED MATTER.**

The new Record catalogues, Form No. 600, is now being sent to the trade as fast as the printer can supply them. It includes August Records. With the exception of changing the phrase on the outside from "Domestic Selections" to "American Selections," the cover is the same as on Form No. 545. This cover was so satisfactory that it was decided to continue its use on the new edition.

At the first opportunity we shall mail to the entire trade a copy of our St. Louis booklet and when received Jobbers will know that if they desire a limited quantity for careful circulation we will take pleasure in filling their orders. We want every Jobber to see a copy before ordering, for a page of the booklet is given up to a list of Jobbers (without street addresses) who were in business when it was printed, and some Jobbers might object to distributing anything containing the names of his competitors. It was originally intended to distribute this booklet only at the St. Louis Fair, and for that reason the names of all Jobbers were included in it. We think the arguments in the booklet sufficiently convincing to make it a good medium for advertising.

**PRISONERS AND THE PHONOGRAPH.**

"I had the pleasure recently of entertaining the prisoners at the Albany Penitentiary with an Edison Phonograph," writes Charles Van Epps, of Albany, N. Y., under date of August 6. "There were about 1,100 in all. The expressions on the faces of some of them was well worth seeing, for a great many had never heard a Phonograph before."



### TALENT STATISTICS.

Domestic Record Catalogue No. 600, now being sent out to the trade, contains 1,150 selections, divided as follows: Bands, 178; orchestral, 116; bagpipe, 5; banjo, 35; bells, 9; brass quartettes, 4; bugle calls, 2; chimes, 2; clarinet, 14; cornet, 20; cornet duets, 2; cornet and trombone duet, 1; dulcimer, 2; field music, 6; flute, 1; mandolin, 9; piano, 1; piccolo, 10; trombone, 2; violin, 17; violin and flute duets, 7; whistling, 8; xylophone, 15; zither, 6; vocal solos, 421; mixed trios, 1; male quartettes, 54; male quintets, 3; mixed quartettes, 7; sextettes, 1; duets, 100; talking and singing, 19; duo-logues, 8; minstrels, 5; talking and musical, 3; talking only, 54.

The number of selections made by each individual or groups of individuals are as follows: Edison Concert Band, 120; Edison Military Band, 58; Edison Symphony Orchestra, 58; Peerless Orchestra, 57; Hungarian Orchestra, 1; James C. MacAuliffe, 5; Vess L. Ossman, 19; Fred Van Epps, 7; Ruby Brooks, 9; Edward F. Rubsam, 3; Albert Benzler, 6; brass quartette, 4; A. L. Sweet, 2; chimes, 3; William Tuson, 14; Bohumir Kryl, 15; A. Librati, 4; John Hazel, 1; John Hazel and Frank S. Seltzer, 2; Bohumir Kryl and Leroy Haines, 1; William A. Moriarty, 2; U. S. Marine Fife and Drum Corps, 5; First Regiment N. G. N. J. field music, 1; Charles Molé, 1; Samuel Siegel, 9; Frank P. Banta, 1; Frank S. Mazziotta, 10; Leo Zimmermann, 2; Charles d'Almaine, 17; Eugene A. Jaudas and Louis Atz, 6; Jaudas and Eugene C. Rose, 1; Joe Belmont, 8; J. F. Hopkins, 13; Albert Benzler, 2; D. Wormser, 6; Harry Anthony, 2; Albert Campbell, 3; Arthur Clifford, 13; Arthur Collins, 53; Will F. Denny, 28; S. H. Dudley, 13; Ed. M. Favor, 26; J. J. Fisher, 6; Billy Golden, 9; James F. Harrison, 3; Byron G. Harlan, 47; William F. Hooley, 8; George W. Johnson, 2; William H. Kenney, 1; George Seymour Lenox, 3; J. Aldrich Libbey, 4; Harry MacDonough, 55; Miss Corrinne Morgan, 5; Billy Murray, 14; J. W. Myers, 4; Joe Natus, 10; Frank North, 3; Dan W. Quinn, 15; William M. Redmond, 5; Miss Louise Roberts, 1; Rob Roberts, 8; Julian Rose, 6; Andrew Schneider, 3; Frank C. Stanley, 22; Cal Stewart, 2; George M. Stricklett, 2; Harry L. Tally, 2; William H. Thompson, 30; Francklyn Wallace, 10; George P. Watson, 11; Harry West, 1; Walter Wheatley, 1; Metropolitan Mixed Trio, 1; Edison Male Quartette, 44; Invincible Quartette, 8; Lotus Quar-

tette, 2; Edison Male Quintette, 3; Mendelssohn Mixed Quartette, 7; Edison Sextette, 1; Campbell and Harrison, 3; Miss Chapell and Mr. Stricklett, 3; Collins and Natus, 12; Collins and Harlan, 39; Francelli and Lewis, 1; Harlan and Belmont, 6; Harlan and Stanley, 30; MacDonough and Biehling, 1; Miss Morgan and Mr. Stanley, 11; Schneider and Wallace, 1; Thompson and Campbell, 3; Spencer and Girard, 6; Campbell and Roberts, 2; Edison Modern Minstrels, 5; Spencer and Hunter, 3; Frank Kennedy, 4; James H. White, 4; Len Spencer, 19; Harry Spencer, 1; Cal Stewart (talking), 26.

### PLAY OVER THE OLDER TITLES.

A mistake too frequently made by some Dealers is to play only Records from the latest supplements and pay no attention to those in the regular catalogues. It is a mistake to think that the newer selections are the most desirable. There are hundreds of titles in the regular catalogue that are most desirable, but many Phonograph owners know little about them because Dealers have fallen into a habit of showing the latest titles first. Dealers should remember that many of the old and familiar airs are in the main catalogue. These are the songs that really never grow old but have as strong a foothold upon the public as they did years ago. The playing of these old songs will oftentimes awaken pleasant memories of the past in the minds of hearers and make sales that would not otherwise have been possible. The wise Dealer is he who is keen enough to size up his prospective customers and who puts on Records that seem most likely to please him. A careful study of the whole catalogue will benefit many Dealers.

### ADVERTISING NEW PRICES.

Some notable advertising of the reduced prices of Edison Gold Moulded Records was done by the National Phonograph Company in the latter part of July and early part of August. This included half pages in the *Saturday Evening Post*, *Collier's* and proportionate space in a score or more of other publications of national circulation. This advertising, supplemented by that of the trade, made the new prices known throughout the entire United States and Canada in a surprisingly short time.

**Dealers who desire to continue the sale of Edison goods must sign new Agreement without delay.**

**MADE OVER WITH DIFFERENT TALENT**

The march of progress in the manufacture of Edison Gold Moulded Records renders it necessary from time to time to make over certain selections, listed in the catalogues. When this is done, as much or even more care is taken by our Recording plant to make them up-to-date as is exercised with any monthly list of Records. The talent is sometimes changed and all hands strive to see how much better they can make the new Record over the old. Below we give a list of Records which have been made over since Catalogue No. 545 was issued in March. The trade will find them as good as any we have ever made.

Formerly by Edison Band; now by Edison Military Band:

- 8235 Rajah March (*Lonka*).
- 8107 Semper Fidelis March (*Sousa*).
- 93 Stars and Stripes Forever March (*Sousa*).
- 7722 Dancing with Ma Baby (*Anthony*).
- 8261 Don't be Cross Waltz (*Zeller*).
- 8376 Symphia Waltzes (*Holzmann*).
- 8128 Wedding of the Winds Waltz (*Hall*).
- 8213 In the Good Old Summer Time (*Evans*).
- 8317 I've Got My Eyes on You (with bells).
- 8049 Lizard and the Frog (*Morse*).

Formerly by Edison Orchestra; now by Edison Military Band:

- 7787 Intermezzo from Naila (*Delibes*).
- 664 At the Circus.
- 523 Down on the Suwanee River (*Foster-Banta*).

Banjo solos now made with orchestra accompaniment:

- 2607 Darkies Awakening.
- 2625 Nigger in a Fit.
- 7666 San Toy Selections (*Monckton*).

Clarinet solos now made with orchestra accompaniment:

- 3608 L'Estudiantina Waltz (*Waldteufel*).
- 8769 Minstrel Boy (air and variations).
- 3615 Nellie Gray (with variations).
- 8024 Robert C. Diable (*Meyerbeer*).

Piccolo solos now made with orchestra accompaniment:

- 7168 Blue Bird Polka (*Mazziotta*).
- 2804 Gem Polka (*Cox*).
- 2806 Irish Reel (*Mazziotta*).

Violin solo now made with orchestra accompaniment:

- 8099 Mocking Bird (*Winner*).

Changes in singers:

- 8340 While the Convent Bells Were Ringing (*Witt*) now made by W. H. Thompson instead of Fischer.

**PRICES OF EDISON RECORDS.**

Edison Gold Moulded Records, standard size, are sold in the United States at 35 cents each, and in Canada at 40 cents each. The Canadian price is higher because of the duty. Edison Concert Records are sold at 75 cents each in both countries.

**SIGN AND RETURN AT ONCE.**

We desire to again call the attention of Jobbers and Dealers to the matter of signing and returning the new Agreement. We want to receive this month the signed Agreement of every Dealer who desires to continue the sale of our goods. On October 1st we shall remove from our files and mailing list the names of all who have not signed. The following paragraph is reprinted from the August issue of the EDISON PHONOGRAPH MONTHLY:

**DEALERS:** When the new agreement reaches you, read it carefully, date and sign each copy and have your signature WITNESSED. If you deal through a Jobber, return to him the copies marked "Original" and "Duplicate." Retain the copy marked "Triplicate" for your future reference. If you deal direct with this Company send the copy marked "Original" to office from which it was mailed, and return "Duplicate."

**JOBBERS:** When Dealers return "Original" and "Duplicate" copies to you, send us the "Original" and retain the "Duplicate" for your files. Be sure that they are properly dated and witnessed before returning "Original" to us.

**DEALERS' ADVERTISING.**

Hayward & Garratt, of Dunedin, New Zealand, send a copy of their house catalogue, in which they devote three pages to illustrations and descriptions of Edison Phonographs.

Most of the advertising done by William H. Kellar, of Easton, Pa., outside of newspapers, is in the form of an owl. The latest form taken by the bird is an aluminum bookmark, one of which has been received. Mr. Kellar's slogan is "Wise people buy at Kellar's."

Albert A. Magwire, of the Springfield Music Rooms, Springfield, Vt., sends a series of circulars showing that twice each week during August he gave outdoor evening concerts with an Edison Phonograph, and he expects to continue it during September.

**A GOOD RECORD RECORD.**

I have been handling Edison goods for about one year after trying to sell all other makes of talking machines without much success. I think I have made a record, selling thirty machines and a Record for every person in the town. Edison goods were never sold here before and we have but 2,000 population.

GEORGE A. LEWIS,  
Ridgefield, Conn.

**CANNOT SELL ANY OTHERS.**

Since the cut in your Records we cannot sell any others. We are glad of it, too.

DEAN & HEBERT,  
Manchester, N. H.



### COMMENTS ON OCTOBER RECORDS.

Twenty-six new titles were included in the September list of Edison Gold Moulded Records and a like number are issued for October. This has been done to make the numbers end more even. For some time past the monthly list has ended with 23, 48, 73 and 98. Putting in two extra selections has brought up the list so that it now ends with 25, 50, 75 and 00. This will make it easier to keep the numbers in mind as long as twenty-five new titles are issued each month.

The October list is replete with interesting things and fully up to the Edison standard in quality and variety. The entire twenty-six will make an excellent assortment for he who is just buying a Phonograph and even the old time enthusiasts can hardly fail to commend all of them.

No. 8800, "Ballet Music from Coppelia," by the Edison Concert Band is a selection from the ballet "Coppelia," composed by Delibes. It introduces the Allegretto movement in two-four time in which the clarinet section's work appeals to the listener at once. A crescendo working up to double forte with a sudden pause concludes the movement, giving a very pleasing effect to the moderato movement of six measures that follow. The climax is the Allegro-Vivace movement at the finale of the selection. Beginning piano, but spiritedly, honors are even between the brass and reed sections. The different parts of the musicianly arrangement at all times reproduce clearly and well defined as the sprightly theme goes forward, now soft, now swelling out loudly in its clever and interesting modulations.

No. 8801, "Con Clancey's Before Election Speech," by Len Spencer, is an excellent Record, describing in a most humorous manner a ward political meeting and introducing a drum corps, a brass band, cheering and other pre-election effects. Mr. Clancey makes himself solid with the boys by promising to give all of them offices or five dollars a day or free beer or other things dear to the heart of the average voter.

No. 8802, "Star of My Life" (written by Corliss), is a fine baritone solo by W. H. Thompson. It is a sentimental song and has an orchestra accompaniment.

No. 8803, "One Heart One Mind," is a bell solo by Albert Benzler, with orchestra accompaniment, of Strauss' well known composition. The saying "clear as a bell" is at once suggested by the remarkable quality of this Record.

No. 8804, "Teasing," is a new coon song by Albert Von Tilzer. It is sung by Bob Roberts with orchestra accompaniment. In it a coon tells of the troubles he has with his girl who is always teasing him. It is a well-made Record, clearly spoken and will be a big seller.

No. 8805, "The Battle Cry of Freedom," is a Record that will arouse the patriotism of all Americans, especially the old ones who have served in the Civil War. It is made in a manner similar to the Record, No. 8606, "Marching Through Georgia," and it was because of the success of the latter Record that this was made. It includes a tenor and baritone duet with orchestra accompaniment and introduces cheers, bugles and drum corps effects. It is made by Harlan and Stanley, who made such a success of No. 8606.

No. 8806, "In the Valley of the Sunny San Joaquin," sung by Harry MacDonough, is a pleasing new song written by James G. Denny (music) and J. Gordon Temple (words). The words are very appropriate and the music quite captivating. Mr. MacDonough was accompanied by the orchestra when he made this Record.

No. 8807, "Dreaming on the Ohio," (written by Edwin S. Brill) is a descriptive song and quartette chorus by the Edison Male Quartette, and is sung with orchestra accompaniment. It is an excellent Record of a charming selection.

No. 8808, "Seminole," is a new Indian ballad written by the composers of "Navajo," and the music is of the same attractive character. The Record is made by Harry Tally with orchestra accompaniment. The words of this song were written by Harry H. Williams and the music by Egbert Van Alstyne.

No. 8809, "Wilhelmina," (composed by John T. Hall) is a Record made at slow tempo for dancing. It was made by the Edison Military Band. The music is attractive and has a good swing for waltzing.

No. 8810, "Down Where the Sweet Potatoes Grow," is a coon duet by Collins and Harlan with orchestra accompaniment. The artists do the song full justice and the Record will be a popular one. Andrew B. Sterling wrote the words of this song and Harry Von Tilzer the music.

No. 8811, "Sweet Sixteen Waltz," is another of Bohumir Kryl's fine cornet solos with orchestra accompaniment. Few cornet soloists can compare with Mr. Kryl in execution.

No. 8812, "Cupid's Arrow," is a banjo solo with orchestra accompaniment by Fred Van Epps, which shows clearly that Mr. Van Epps constantly improves as a soloist on this instrument. The accompaniment of the orchestra is more subdued than in many other banjo selections, a feature that will meet the approval of those who feel that banjo Records for the most part should have no accompaniment. "Cupid's Arrow" was listed in the catalogue of wax Records and is made by the moulded process in response to many calls for it.

No. 8813, "Sylvie," is an unusually charming sentimental song, written by Laurence B. O'Connor (music) and C. E. Billings (words). It is sung by Byron G. Harlan and has an orchestra accompaniment. This song is very popular in the New England States and our well-made Record of it will do much to in-

crease its popularity in all parts of the country.

No. 8814, "What Colored Eyes Do You Love," is a contralto and baritone duet of one of the most popular hits in "The Royal Chef," which opened in New York City on September 1st. It is made by Miss Nelson and Mr. Stanley. Miss Nelson is a new singer for Edison Records, but we feel that this introductory song will gain for her voice the approval of all Edison admirers. The music of this selection was written by Ben M. Jerome.

No. 8815, "Selection from The Royal Chef," played by the Edison Concert Band, introduces "Let Me Go Back," "It's a Way They Have in Chicago" and "Old Mother Goose." This Record takes the place of the usual monthly medley and we hope that it will be quite as popular.

No. 8816, "It's Great to be Crazy," is a Record of one of the most unique songs that we have put out in some time. It is sung by Arthur Collins and is bound to be a big success. This song is from "The Maid and the Mummy," and its words, its music and the orchestra accompaniment are as crazy as its name. Every collection of Phonograph Records should include this one. The words of the song were written by Richard Carle and the music by Robert Hood Bowers.

No. 8817, "Bye and Bye You Will Forget Me," is a sentimental duet by MacDonough and Biehling, and is sung with orchestra accompaniment. These artists sing well together and, combined with the music of the song, make a very desirable Record. Arthur W. French is the writer of the words and William A. Huntley the music.

No. 8818, "My Old Kentucky Home, Fantasia," is an adaptation of Stephen Collins Foster's ever popular Southern air by Otto Langey. It is made by the Edison Concert Band with special work by the brass quartette, flutes and clarinets.

No. 8819, "Does You Love Me as You Used To, Miss Jane," is one of Collins and Harlan's characteristic coon duets, with orchestra accompaniment, in which Mr. Collins sings the solo parts and Mr. Harlan makes the responses of Miss Jane, and joins in the chorus. It is a very clear Record. Avery and Hart wrote the words of this song and Chris Smith the music.

No. 8820, "I Fell in Love with Polly," is a serio-comic song from "The Maid and the Mummy," and is sung by Harry MacDonough with orchestra accompaniment. The violin work of this Record is attractive, and after the song is completed the latter part of the Record is taken up with a charming little dance music, making an unusually good finish to the Record. The writer of this song is Richard Carle.

No. 8821, "She Was a Good Old Soul," is a descriptive song written by Raymond A. Brown and Theodore Morse, the composers of "Dear Old Girl." The Record is made by Frank C. Stanley, and is the first one of this

kind that we have listed. Mr. Stanley has not heretofore made sentimental Records, but after hearing this one all will admit that he can make them as well as anything else that he does. This Record is made with the usual orchestra accompaniment.

No. 8822, "The Bridal Tour Overture," is played by the Edison Symphony Orchestra, is a sort of companion piece to "The Bridal Rose," although not written by the same composer. Characteristic features of the selection are the music by the bassoons and the cornets. It is a Record that cannot fail to please. The composer is August Enhaes.

No. 8823, "Old Black Joe," Stephen Collins Foster's well known song, is another unaccompanied Record by the Edison Male Quartette. This selection will be a favorite as long as the Phonograph is known.

No. 8824, "Here's My Friend," is a coon song Record made by Bob Roberts, with orchestra accompaniment. In the song a coon declares that his best friend is his pocket-book. The words are by Ed Rose and the music by Ted Snyder.

No. 8825, "The Royal Italian March," by the Edison Military Band, is an air that will at once be recognized everywhere as the principal band selection at all Italian celebrations. We expect this Record will find a large sale among the Italians, but its all-round merit will cause it to find many purchasers among lovers of band music.

#### SAND DANCE AND SONG.

One of our largest dealers in Melbourne recently advised us that on account of the demand for disc machines, he very reluctantly placed a number in his stock. We quote as follows from a letter just received, giving his experience with them:

"I would like to mention that I imported some disc ———, and I have decided to place them with any house in Melbourne who will take over the stock. I am quite satisfied with my experience so far. Some of the records are very good, others are damnable, and one gets a sand dance and song all at once. I feel sure that if the Japanese had a few of these machines and some of the records, no shot nor shell would be required, for the Russians would depart rather than remain and hear the tortuous sounds rendered by these scratchophones."

#### BURIED.

Trade very good. Everybody satisfied. Cheap records buried with no hope of resurrection. Many holding their orders till the new boxes come.

L. B. SPAULDING.

Buckfield, Maine.

**Dealers who want to keep on our files and mailing list should sign new Agreement at once.**



## PHONOGRAPH AN AID IN TEACHING THE DEAF.

Superintendent E. W. Walker, of the Wisconsin School for the Deaf, has made a series of successful experiments showing by a powerful Phonograph just how much improvement in articulation a deaf pupil is making from time to time.

He is making tests of a child's voice on the same cylinder, allowing a given time to elapse between the tests. Several tests having been made, the cylinder is placed on the Phonograph, which will ring out the same sentence uttered by the pupil at different stages of his education. The picture shows a primary pupil seven years old talking into the Phonograph. [Picture not reproduced here.] He is speaking the words that are written on the blackboard, his teacher standing beside him. Professor Walker explains the object of his plan as follows:

"It sometimes happens that in working out things of this nature one does accidentally discover something of real value, and it is not unlikely that when I have upon the same cylinder records of the speech of the same child taken at different periods of his school career some helpful suggestions as to the training of the deaf children may develop.

"There is a second purpose. I am convinced that the education of the deaf, as it is carried on in this country, is based quite as much on sentiment as on judgment. This is due probably, first, to a feeling of keen sympathy which every one entertains for the afflicted, and, second, to the failure to appreciate that there are three distinct types of the so-called deaf persons:

"The totally and congenitally deaf. Included in this class are those who have suffered entire loss of hearing during years of infancy.

"Those who are congenitally and partially deaf. In this class are those who have suffered a partial loss of hearing during years of infancy.

"Those who lost their hearing after learning speech and receiving something of an education. It is difficult to draw an age line marking off this third class, but eight years will suggest where the line should be drawn as near as it can be settled upon.

"It is customary to speak of all of these classes as deaf people. This leaves the public to class them all together for the purpose of instruction, and, indeed, leads the parents of deaf children to do likewise. I wish we might call persons who belong to class one, deaf people; to class two, hard of hearing; to class three, lost hearing. The possibilities for the education of these three classes are markedly different. Within the last few weeks I have witnessed a public exercise of deaf children and sat beside the mother of a totally deaf child. There was on the programme a young

woman of eighteen who lost her hearing at fifteen. Of course she talked in a normal voice and with a distinctness approximate to that of a hearing person. The good mother who sat beside me felt confident that her daughter, who was attending the same school, would be able to talk as this young woman did. All who are acquainted with the teaching of the deaf know this to be absolutely impossible.

"Briefly, as I see it, the fundamental thing with all of these classes is to give each as much mind development as possible. The purpose of education here does not differ from that of an ordinary school. The means used, methods of approach, etc., only are different. While giving this general education it is to be borne in mind that for members of class one to be taught speech and lip reading (and many of them may be so taught) is a valuable thing indeed. Speech, however, for this class should not be sought at the expense of an education. In most cases their articulation will be metallic and unnatural.

"Pupils belonging to the second class, that is, with defective hearing, should not be treated as though they were deaf. If they are taught as deaf are taught—that is, without the use of what little hearing they have—they will lose that little. To strengthen rather than to weaken the defective faculty should be the purpose of the school, and this class should have different treatment from that of class one.

"Persons belonging to class three form another distinct class. Their speech will be good and great emphasis in their education should be placed upon lip reading, and of course to build upon the education they have already obtained by means of their former state."—*Chicago Tribune*.

## A QUICK SALE.

"Thinking that you would like to hear from us in regard to our Phonograph business, we send a short story telling about a quick sale we made recently," writes Fred Pfau, manager of Christy's Music Store, San Jose, Cal., under date of July 28. "We have been kept very busy selling Edison Phonographs and Records and we already see a bright future for them.

"A few days ago a man was passing our store, and being attracted by our fine display of Edison goods in the window, stopped to take a hurried glance. He paused a long while, looking at the various styles of talking machines and finally he turned around and entered the store. He asked if he could hear some of them, but at the same time saying he had not much intention of buying one then. I began by playing a disc machine, but he did not seem a bit satisfied with the results. I then placed an Edison Gold Moulded Record on the Home Phonograph and started playing it. When the music ceased, he became so enthused that he wanted me to play some more. I finally put on a medley march by the Edison Military Band, and this piece alone proved that the Edison machine was superior to all

others. He listened attentively all through the Record and he was so satisfied that he said he'd take the Phonograph. He afterwards remarked, 'It ought to be a rare treat to any person to have an opportunity of hearing such beautiful music. I am proud of my new Phonograph.' I selected two dozen of our choicest Records for him, and altogether the sale was made in twenty minutes. I will say this is but one of the few incidents that happen constantly. Our Edison Record trade has built up immensely since the new changes have taken place. We have increased our stock of Records and ordered more Phonographs and supplies, as we found that we could not meet the demands of the people unless we did so."

### PHONOGRAPH MUSIC ON DONKEY BACK.

Our Mexican representative sends the following paragraph concerning a recent experience:

"While wandering around the public square, or "plaza," of a nearby Indian village, where a fair was being held, I noticed upon approaching the outskirts of the grounds at several places, the familiar strains of American band pieces played by a Phonograph, and as it seemed rather too small an assembly of people to warrant so large a number of exhibitors (although one, or even two are not uncommon on such occasions), I was rather curious to see whether they were all doing a profitable business, not having gotten a glimpse of any of the machines, owing to the thickly packed "puestos" or booths, gambling tents, etc., which formed a barrier around the fair grounds proper.

"The sight that met my eyes when I had worked my way to the edge of the crowd, made me wish I were a camera crank, with the ever ready kodak. Perched upon the back of a little Mexican donkey or "burro" was an Edison Home Phonograph, equipped with one of the high way-rails used by exhibitors in this country, elaborately festooned and otherwise ornamented with paper flags, spangles, etc., while beside this stood the exhibitor in the full "charro" costume of the lower classes. Sticking straight out behind the donkey was a 24-inch brass horn, through which the immediate crowd was enjoying a Spanish comic duet, while the burro tranquilly moved his ears to and fro, but otherwise didn't move a muscle. Evidently the audience didn't seem productive of cash, for the exhibitor then started the "American Standard March," and the outfit moved away, followed by a rather motley crowd; the slow, even gait of the donkey not interfering in the least with the reproduction.

"This fully explained the seeming large number of Phonographs, and was certainly a very unique method of 'going after trade.'"

**Keep in the Edison ranks, Mr. Dealer, by signing new Agreement. Do it now.**

### CABINET FOR STORING PHONOGRAPH RECORDS.

Phonograph Records being ordinarily made of wax, are very fragile and must be preserved with considerable care, and when many are to be provided for it becomes a matter of difficulty to do this and at the same time have them accessible for ready selection. A cabinet has been invented by Mr. Edgar Krom, of 538 West 159th street, New York City, which provides for the safe keeping of a large number of records. The cabinet is formed with two swinging doors pivoted centrally at the top and bottom. The inner face of each door is provided with a number of pins upwardly inclined, on which the Records are supported. On the upper end of each pin is printed or written the name of the particular Record thereon supported. The cabinet is preferably of such height as to furnish a convenient support for the Phonograph. In use the cabinet will be preferably placed at sufficient distance from the walls of the room to permit swinging of either door upon its central pivots. When the doors are thus opened all the pins and supported Records may be seen, and any of the latter desired may be removed without disturbing the others. It will be seen that this cabinet provides for the storing of a great number of Records in a comparatively small space, renders each freely accessible, and does away with any danger of injuring the one removed or those about it. At the same time it is comparatively inexpensive to construct, and furnishes an ornamental and convenient support for the instrument in connection with which the Record is to be used.—*Scientific American*.

**Get ready for the fall and the holidays. Stock up.**

### AN UP-TO-DATE CANADIAN.

S. M. Brown, a Dealer at Picton, Ont., sends a photograph of his new Phonograph showroom. It is nicely carpeted and furnished with chairs for his patrons. The shelves show that he carries a large stock of Edison goods and two Phonographs, each with a large bell, are used to play Records. Mr. Brown occasionally gives concerts from the windows of his store. Of one of these concerts a local paper said:

Last evening about 9 o'clock the stillness of the business portion of Main street was interrupted by a Phonograph concert from the studio windows of S. M. Brown. The machine used was the celebrated Edison, producing clear, sweet tones, and perfect pronunciation. The June Records comprise all that is new and up-to-date in vocal and instrumental music and were much enjoyed by the large audience in listening upon the street, as their hearty applause attested.



### DEALERS AND ADVERTISING LITERATURE.

We again want to point out to Dealers buying through Jobbers that we would much prefer that they shall get printed matter from their Jobbers and not write direct to us for it. We occasionally get letters from sub-Dealers simply asking for a supply of printed matter. Nothing is said about method of shipping and what quantity is wanted. Such requests are hard to comply with for two reasons. In the first place we do not know anything about the amount of business a sub-Dealer is doing and cannot tell whether to send him much or little. Then the quantity we might send would not make a freight shipment and we cannot send by express at our own expense, for it is too costly. We are afraid to send by express collect without the authorization of the Dealer, for past experience has shown that this sometimes meets with a refusal to receive the goods and we have express charges to pay two ways to get them back. All of this makes it necessary to write a letter to the Dealer and explain the situation, causing a loss of time quite annoying to a progressive Dealer.

Dealers should ask their Jobbers to send them what they want. If the latter cannot supply, get them to endorse and forward the order to us, specifying how shipment shall be made so that we are not compelled to pay express charges. Our system of doing business makes it desirable to have Dealers look to Jobbers for everything they need in the way of advertising literature, as well as goods, and we prefer to remedy any shortcoming that may exist in the system than to change it. Jobbers who find that Dealers need more printed matter than they can supply should write to us and ask for an increased quantity. We may not be able to meet a largely increased demand all at one time, but we will arrange to order larger quantities until we can do so. At the present time, except when the edition of one catalogue is running out and another is about due, we are filling all orders for printed matter, and few Jobbers can say that they do not get all they ask for.

We expect to get out catalogues, etc., to meet every reasonable demand. It makes the business go and grow, and we believe in it. We don't want it wasted, however. We don't think that a machine catalogue, costing \$10 a thousand, should be used for street or house to house distribution, and it hardly pays to send out Record catalogues to people who don't own a Phonograph and who cannot tell one type of machine from another. In rare cases it might arouse an interest and cause a man to become a machine purchaser, but a well written letter or folder would be much more effective. Few Dealers would use catalogues in this way if they paid the printer and we feel that they should be equally care-

ful when furnished by us. We get out a line of cards, folders, etc., that should be useful for preliminary work, and these are printed in quantities which permit their liberal use.

While on the subject of printing and distributing, we want to state that in our opinion the most effective work is that done through the mails. Phonographs cannot be sold like groceries by means of circulars thrown around the street or on the stoops of city houses, or in the yards of suburban country homes. A neatly printed circular letter, accompanied by a folder giving information about the goods and mailed to a carefully selected list of names, will do more to get business than any method of advertising. This should also be supplemented by an advertisement in the local papers. The letter should be written so as to get a reply asking for catalogues. Then, if followed up with tact, sales will be made.

### EXPECTS TO DOUBLE HIS BUSINESS.

It is with great pleasure that I write to inform you that my sales this year to date (seven months) in Edison Phonographs and Records have exceeded my sales of the preceding twelve months. In view of the fact, that since March I have had as a competitor a branch of the ——— Company, I think this record is worth recording. It shows the Edison Dealer, if he will show up his goods properly, that a certain kind of competition will help him along. I expect to almost double my business this year. Great is the National Phonograph Company.

THOMAS WARDELL.

Lowell, Mass, Aug. 1, 1904.

### EDISON—A SYNONYM FOR BUSINESS.

G. L. Ackerman, of Ackerman & Company, Jobbers, at Scranton, Pa., recently went on a trip through the State for his house and on July 29 he wrote to us as follows:

"We are pleased to note that the ——— record is being entirely weeded out by all dealers we have so far met on this trip, and considering the time of year, general business conditions, etc., writer finds very much gratification with the results of our first trip to this section. The old adage "A new broom sweeps clean" does not apply at this time. The success lays in the fact that the people want the best goods obtainable, and now that the price is a popular one, in reach of all, there is only one way to explain matters fully—in short, in one simple word—"Edison."

### ONE OF MANY.

I have much pleasure to inform you that since the reduction in price of the Edison Records my sales have increased 150 per cent. The Records need no recommending, as they speak for themselves. My Saturday's sale was 84 Edisons and four ———'s, which jump is a phenomenon in Record selling this time of the year.

W. KOHLHOFF.

Camden, N. J.

**WORLD'S GREATEST ENTERTAINER.**

H. Schmidt & Son Co., of Muscatine, Iowa, always get out some original literature when they go after business. This is the way they informed their patrons about the new price of Edison Gold Moulded Records:

We beg to announce that the National Phonograph Co., of New York, have reduced the price of the "Edison Gold Moulded Records" from 50 cents to 35 cents each, or \$4.20 per dozen. This news will be as welcome as "food is to the beggar," for hundreds of people have been without this wonderful entertainer, "The Phonograph," owing to the price of Records. But now since the price of 35 cents has been established no one need be without a Phonograph in their home.

The "Edison Gold Moulded Record" is admitted to be the finest and most durable Record on earth. Other Records in three months will show signs of wear-out—Edison Records won't in three years. Every Record is guaranteed to be free from any blemishes or defects.

The "Edison Phonograph, with the Gold Moulded Records," make the greatest team for entertainment that money can buy. The Edison Phonograph will improve any record, the Edison Records will improve any machine, but in using Edison Records on the Edison Phonograph you have the best.

We cordially invite you to our store at any time to hear this, the "World's Greatest Entertainer," as we have just received a large shipment of Records, so that we can play most any piece you might call for from the catalogue.

Hoping to see you soon, we remain ever ready to answer any inquiries. Respectfully yours,  
H. SCHMIDT & SON Co.

**IN THE BERKSHIRE HILLS.**

One of our advertising friends spent part of his vacation at Garfield, in Rensselaer County, New York, and this is the report of Phonographic conditions as he found them there:

In this village of twelve dwellings there are four Edison Phonographs and one — in constant use. In the evenings if you stand in the village street it reminds you of Douglas' selling booths or a block of Harlem flats. The new lists are looked for each month, yet they have to drive twelve miles and cross a mountain 2,240 feet (that means 1,440 foot climb) to buy Records. Talk about enthusiasm."

**EDISON RECORDS ARE SUPREME.**

Stockton, Cal., March 15, 1904.

Accept my thanks for latest literature sent me. Edison Records speak for themselves. Let them be heard and the cheaper record is crushed. Edison Records are supreme.

H. W. MOSIER.

**ONE DEALER'S REGRET.**

Have sold several Phonographs, but at present I haven't an Edison in stock. I have five — and one — in stock and I am trying hard to get rid of them. I do not want to handle anything but the Edison Phonograph, for I consider it the only talking machine and musical instrument in existence. There is no use to think of selling the machines I have in stock as long as the Edison is kept along with them, for the Edison will sell itself, but the others are stayers, or stickers, or scratchers and are not to be compared with the Edison when it comes to smoothness and sweetness of tone. I am sorry I ever took up anything but Edison goods, and just as soon as I can get rid of these other machines I intend to stock up again with the Edison.

I wish you would propose some kind of a plan so I can dispose of them in short order. Any information you can give me on the subject will be thankfully received. I want you to understand that I am for the Edison every time, for I think it is the only talking machine made; others are the poorest kind of imitations.

**A LETTER FROM WALES.**

I never before knew how superior the Edison Machines, etc., are over *all* others until this month. As you know I deal a lot with the —. About a month ago I asked that firm (by letter) if they thought the — phone was better than the Standard (Edison) allowing for the difference in price, 2 gns. They answered: Yes, decidedly. I ordered one and have returned it to-day because I am certain I could never sell it. My opinion, and my customers', is that it cannot be in the same street as the Standard if it was the same price. I give you my word, I will never sell another Phonograph or anything else except the Edison manufacture. I never was more convinced of the superiority in my life.

F. E. HUGHES,  
Owestry, Wales.

[The above letter was written to our London office.]

**A COINCIDENCE.**

We have been greatly interested in the PHONOGRAPH MONTHLY, as are all Edison people, and a story in this month's issue brings to mind an incident which happened in our store last winter. This is absolutely true.

We were playing the Record "Firemen's Duty" for a customer, and just as the fireman says "Box 32, let her go, Bill," the fire-gong on the tower at the central station struck 32. As this box is located near the Adventist Sanitarium it created some excitement, but the customer stayed right by the Edison till the Record was played through.

We have a good business on Edison lines.  
CURRIE & MILLS.  
Battle Creek, Mich.



**SUSPENDED LIST, SEPTEMBER 1, 1904.—SUPERSEDING ALL PREVIOUS LISTS.****COLORADO.**

BOULDER—BENTLEY &amp; CRAIG.

**INDIANA.**

SOUTH BEND—EUGENE MARSH, 126 Vista avenue.

SOUTH BEND BOOK BINDERY,  
Robert Lebolt, Prop., 203 North Michigan street.**IOWA.**

BURLINGTON—JOHN P. WEISS, 711 Jefferson street.

SIOUX CITY—HATTENBACH BROS. CO.

**KANSAS.**

CLAY CENTRE—E. M. GOWENLOCK.

LAWRENCE—BELL BROS.

**MAINE.**

BIDDEFORD—W. H. FIELD.

**MASSACHUSETTS.**BOSTON—CONCLAVE PHONOGRAPH CO.,  
S. Katz, manager, 93 Stamford St.  
T. SINGER, 60 Leverett St.LAWRENCE—LORD & CO., 314 Essex street,  
E. O. MOSHER, 420 Essex street.  
JOHN E. O'NEIL.

\*LYNN—ELIAS DE YOUNG.

MALDEN—A. T. FULLER.

NANTUCKET—ARTHUR M. TAYLOR.

NEW BEDFORD—H. B. DEWOLFF.

SOMERVILLE—E. J. WINCHESTER, 32 Summit avenue.

WOBURN—OSBORN GILLETTE, or THE  
BOLTON JEWELRY COMPANY, L.  
F. MALONEY, Manager.**MICHIGAN.**

DETROIT—F. J. SCHWANKOVSKY.

SAGINAW—GEO. W. EMENDORFER.

**MISSOURI.**

KANSAS CITY—THE WITTMANN CO.

**NEBRASKA.**

LINCOLN—THE WITTMANN CO.

OMAHA—THE WITTMANN CO.

**NEW HAMPSHIRE.**

HILLSBORO BRIDGE—E. M. BARNES.

MANCHESTER—A. E. DUMAS.

NASHUA—F. A. McMASTER &amp; CO.

**NEW JERSEY.**ATLANTIC CITY—SAMUEL D. WOLF, 32-34  
Arkansas avenue.

BAYONNE—I. WIGDOR, 450 Avenue D.

JERSEY CITY—W. L. HOFFMAN, 151 Montgomery street.

NEWARK—R. L. CORWIN; also New York  
City.

PASSAIC—I. HURWITZ.

PATERSON—CHAS. H. KELLY, 25 N. Main st.

PLAINFIELD—S. W. FRUCHT, or R.  
FRUCHT; also New York City.  
ELSTON M. LEONARD.WEST HOBOKEN—EMIL HOLLANDER, or  
THE WEST HOBOKEN BICYCLE &  
PHONOGRAPH CO., 619 Spring street.**NEW YORK.**

BEDFORD PARK—GEO. H. TYRRELL.

HOBART—F. H. MARSHALL.

NEW YORK CITY—A. T. ARMSTRONG, or  
AMERICAN PHONOGRAPH CO., 106  
Wall street.BERN BEARWALD, 373 West 11th St.  
BRONX PHONOGRAPH CO., or DA-  
VID SWITKY, 506 Willis avenue.CENTRAL PHONOGRAPH CO., 160  
E. 42d street.

R. L. CORWIN; also Newark, N. J.

EAGLE PHONOGRAPH CO., or C.  
LOWENTHAL, 83 Nassau Street.EMPIRE PHONOGRAPH CO., 2 West  
14th street.S. W. FRUCHT, or R. FRUCHT, 7 Bar-  
clay st., or 68 Cortlandt st.; also  
Plainfield, N. J.

O. HACKER, 2 Murray street.

HAWTHORNE & SHEBLE, 297 Broad-  
way; also Philadelphia, Pa.

N. HORN, 148 E. 58th street.

W. L. ISAACS, 114 Fulton street.

S. LEMBURG &amp; CO., 194 Broadway.

J. McELLYNNE, 202 Broadway.

RICHMOND PEASE, 44 W. 132d st.

F. M. PRESCOTT, 44 Broad street.

WINTHROP CYCLE CO., 2212 Seventh  
avenue.

SARATOGA—W. J. TOTTEN.

SARATOGA SPRINGS—MARVIN A. COTE.

**OHIO.**

CINCINNATI—J. L. ANDEM.

COSHOCTON—BURNS &amp; GOSSER.

SPRINGFIELD—D. &amp; M. VANDERPOOL.

UHRICHSVILLE—F. A. MAZURIE.

**PENNSYLVANIA.**PHILADELPHIA—A. R. CASSIDY, 2783 Em-  
erald street.HAWTHORNE & SHEBLE, 604 Chest-  
nut street, or Oxford and Mascher  
streets; also New York City.

A. KROUSE, 832 Arch street.

PENN NOVELTY CO., 15 South 9th  
street.

PHOENIXVILLE—KEINARD BROS.

PITTSBURG—A. LIPPARD, 615 Wylie avenue.

**RHODE ISLAND.**

PROVIDENCE—F. P. MOORE.

**WISCONSIN.**

MILWAUKEE—J. C. BLATZEK.

\*Added since August 1, 1904.

**Jobbers and Dealers are asked to co-operate with us, FOR OUR MUTUAL GOOD, by being careful that they do not supply any of the above named firms with our apparatus, either at addresses given or any other address.**

## JOBBER'S OF EDISON PHONOGRAPHS AND RECORDS.

### ALABAMA.

**Birmingham**—The Ray Co., 2027 Second avenue.  
The Talking Machine Co.

**Mobile**—W. H. Reynolds, 167 Dauphin street.

### CALIFORNIA.

**San Francisco**—Peter Bacigalupi, 786-788 Mission street.

### COLORADO.

**Denver**—Denver Dry Goods Co., 619 16th street.

### CONNECTICUT.

**Middletown**—Caulkins & Post Co., 406-408 Main street.

**New Haven**—Pardee-Ellenberger Co., 155 Orange st.

### DISTRICT OF COLUMBIA.

**Washington**—E. T. Droop & Sons Co., 925 Pennsylvania avenue, N. W.

S. Kann, Sons & Co., 8th and Pennsylvania avenues.

### ILLINOIS.

**Chicago**—James I. Lyons, 73 Fifth avenue.

The Ray Co., 90 Washington street.

Siegel-Cooper Co., State and Congress sts.

Talking Machine Co., 107 Madison street.

The Vim Co., 68 E. Lake street.

Montgomery Ward & Co., 111 Michigan ave.

The Rudolph Wurlitzer Co., 302 Wabash ave.

**Peoria**—Peoria Phonograph Co., 222 Bridge street.

### INDIANA.

**Indianapolis**—Craig-Jay Co., 234 Massachusetts ave.

Kipp Bros. Co., 37 S. Meridian street.

A. B. Wahl & Co., 119 S. Illinois street.

**Lafayette**—A. B. Wahl & Co., 304 Main street.

### IOWA.

**Des Moines**—The Vim Co., 704 West Walnut street.

**Fort Dodge**—Early Music House, 822 Central ave.

### KENTUCKY.

**Louisville**—The Ray Co., 640 Fourth street.

### LOUISIANA.

**New Orleans**—James I. Lyons, Theatre Arcade.

National Automatic Fire Alarm Co., 614

Gravier street.

The Ray Co., 111 Camp street.

### MAINE.

**Bangor**—S. L. Crosby Co., 186 Exchange street.

**Portland**—W. H. Ross & Son, 207 Commercial street.

### MASSACHUSETTS.

**Boston**—Boston Cycle & Sundry Co., 48 Hanover street.

Eastern Talking Machine Co., 177 Tremont street.

Iver Johnson Sporting Goods Co., 163 Washington street.

Read & Read, 558 Washington street.

**Fitchburg**—Iver Johnson Sporting Goods Co., 247 Main street.

**Lowell**—Thomas Wardell, 111 Central street.

**Worcester**—Iver Johnson Sporting Goods Co., 304 Main street.

### MICHIGAN.

**Detroit**—American Phonograph Co., 106 Woodward avenue.

Grinnell Bros. Music House, 219 Woodward avenue.

The Ray Co., 252 Woodward avenue.

**Saginaw**—Morley Bros.

### MINNESOTA.

**Minneapolis**—Thomas C. Hough, 714 Hennepin ave.

**St. Paul**—W. J. Dyer & Bro., 21-23 West 5th street.

Minnesota Phonograph Co., 37 E. 7th street.

### MISSOURI.

**Kansas City**—J. W. Jenkins' Sons Music Co., 1013-1015 Walnut street.

The Ray Co., 1021 Grand avenue.

**St. Louis**—Conroy Co., 1115 Olive street.

The Ray Co., 923 Olive street.

### NEBRASKA.

**Lincoln**—H. E. Sidles Cycle Co., 1317 O street.

**Omaha**—H. E. Fredrickson, 1502-1510 Capitol avenue.

Nebraska Cycle Co., 15th and Harney streets.

### NEW JERSEY.

**Hoboken**—Eclipse Phonograph Co., 205 Washington street.

**Newark**—A. O. Petit, New and Halsey streets.

**Paterson**—James K. O'Dea, 117 Ellison street.

**Trenton**—Stoll Blank Book and Stationery Co., 30 E. State street.

### NEW YORK.

**Brooklyn**—Chapman & Co., Fulton and Duffield streets.

A. D. Matthews' Sons, 394 Fulton street.

Price Phonograph Co., 1258 Broadway.

**Buffalo**—P. A. Powers, 643 Main street.

**Elmira**—Elmira Arms Co., 117 Main street.

**Gloversville**—American Phonograph Co., 99 W. Fulton street.

**Kingston**—Forsyth & Davis, 307 Wall street.

**New York City**—Bettini Phonograph Co., 80 Chambers street.

Blackman Talking Machine Co., 19 Beekman street.

J. F. Blackman & Son, 2654 3d avenue.

I. Davega, Jr., 802 Third avenue.

S. B. Davega, 32 E. 14th street.

Douglas & Co., 89 Chambers street.

H. S. Gordon, 139 Fifth avenue.

Harry Jackson, 219 Bowery.

Jacot Music Box Co., 39 Union Square.

Victor H. Rapke, 1661 Second avenue.

Siegel-Cooper Co., Sixth avenue and 18th street.

John Wanamaker, Broadway and 9th street.

**Rochester**—A. J. Deninger, 347 North street.

Mackie Piano, O. & M. Co., 100 State street.

Giles B. Miller, 63 State street.

Talking Machine Co., 29 S. Clinton avenue.

**Schenectady**—Jay A. Rickard & Co., 253 State street.

**Syracuse**—W. D. Andrews, 216 E. Railroad street.

**Troy**—James Lucey, 359-361 Fulton street.

**Utica**—Clark-Horrocks Co., 54 Genesee street.

Arthur F. Ferriss, 89 Washington street.

### OHIO.

**Canton**—Klein & Heffelman Co., 216 N. Market street.

**Cincinnati**—Ilsen & Co., 25 W. 6th street.

The Ray Co., 143 West 5th street.

A. B. Wahl & Co., 5 Arcade.

The Rudolph Wurlitzer Co., 121 E. 4th st.

**Cleveland**—W. J. Roberts, Jr., Erie and Huron streets.

**Columbus**—Perry B. Whitsit Co., 213 S. High street.

**Dayton**—Niehaus & Dohse, 35 E. 5th street.

**East Liverpool**—Smith & Phillips Music Co.

**Toledo**—Hayes Music Co., 608 Cherry street.

### PENNSYLVANIA.

**Allegheny**—Henry Braun, 500 Federal street.

**Allentown**—G. C. Aschbach, 539 Hamilton street.

**Easton**—William Werner, 401 Northampton street.

**Philadelphia**—C. J. Heppe & Son, 1117 Chestnut street.

Lit Bros., Market and 8th streets.

Penn Phonograph Co., 19 S. 9th street.

John Wanamaker.

Wells Phonograph Co., 41 N. 9th street

Western Electric Co., 931-933 Market st.

H. A. Weymann & Son, 923 Market st.

**Harrisburg**—S. K. Hamburger, 12-14 N. Market sq.

**Pittsburg**—Theo. F. Bentel Co., Inc., 433 Wood street.

Kaufmann Bros., Fifth avenue and Smithfield street.

H. Kleber & Bro., 221 Fifth avenue.

C. C. Mellor Co., 319 Fifth avenue.

Pittsburg Phonograph Co., 937 Liberty avenue.

**Reading**—Reading Phonograph Co., 809 Penn street.

**Scranton**—Ackerman & Co., Coal Exchange Building.  
Technical Supply Co.

### RHODE ISLAND.

**Providence**—J. M. Dean Co., 785-795 Westminster street.

J. A. Foster Co., Weybosset and Dorrance streets.

Household Furniture Co., 231-237 Weybosset street.

Murray, Blanchard, Young & Co., 26-30 Pine street.

J. Samuels & Bro., 154 Weybossett street.

A. T. Scattergood & Co., 106-110 N. Main street.

### TENNESSEE.

**Memphis**—The Ray Co., Lyceum Building, and Jefferson streets.

**Nashville**—The Ray Co., 13-15 The Arcade.

### TEXAS.

**Dallas**—C. B. Harris, Agt., 347 Main street.

### VIRGINIA.

**Richmond**—The Ray Co., 729 E. Main street.

### WISCONSIN.

**Milwaukee**—McGreal Bros., 173 3d street.

### CANADA.

**Toronto**—R. S. Williams & Sons Co., Limited,  
143 Yonge street.



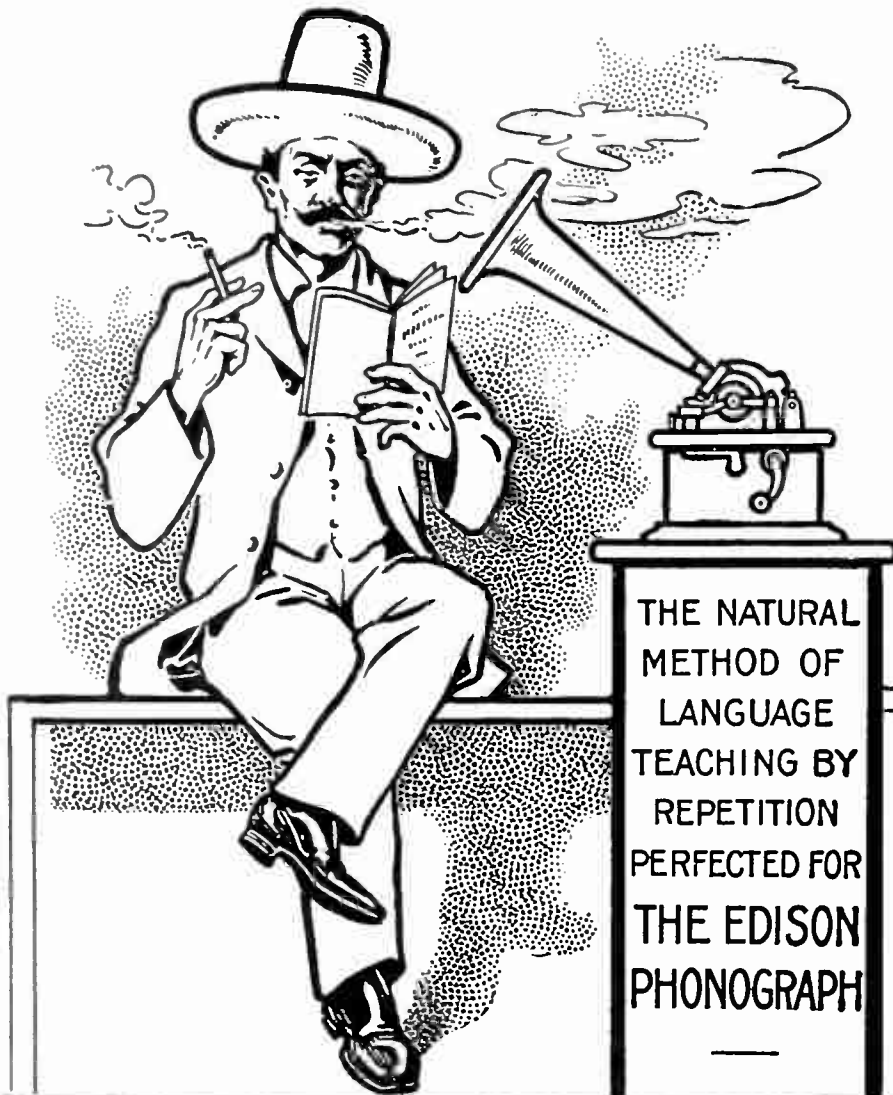

# Language Lessons for Pan-Americans

THE NATURAL  
METHOD OF  
LANGUAGE  
TEACHING BY  
REPETITION  
PERFECTED FOR  
THE EDISON  
PHONOGRAPH

SPANISH-ENGLISH  
ENGLISH-SPANISH

## How Dealers Unite Two Continents

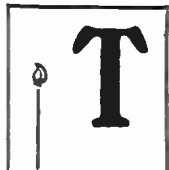

THE Spanish-American war has made the Spanish language the most useful to Americans, and the reverse is true for South Americans, who are waking up to the necessity of learning English. The Edison dealers, through the sale of the I. C. S. Courses, will be the principal agency for this exchange of languages so essential to the expansion of trade and commerce.

Mr. L. L. Lewis, Superintendent, Sun Life Insurance Company, of Canada, writes us from Monterey, Mexico, as follows:—"Since coming here I have opened a new branch, have perfected myself in Spanish by your method, and in June, stood second in new business for the whole western foreign field of my Company."

I. C. S. Records and Textbooks are arranged to teach *French*, *German*, and *Spanish* to English people, and *English* to nine foreign nations.

### SAMPLE LESSONS FURNISHED AT COST

*We send samples* of I. C. S. Moulded Records and Textbooks in French, German, Spanish, and English to Edison Dealers in the United States or Canada, *express prepaid, \$2.00 net*; or one English Record with assortment of foreign textbooks, *express prepaid, 75 cents net*.

Write today for prices, discounts, and literature. Address:

**LANGUAGE DEPARTMENT**  
**International Correspondence Schools**  
**Scranton, Pennsylvania**

# EDISON Phonograph Monthly

PUBLISHED FOR TRADE USE ONLY BY  
THE NATIONAL PHONOGRAPH CO.

VOL. II.

NEW YORK, OCTOBER, 1904.

No. 8.

*The National Phonograph Co.,*  
ORANGE, N. J.

NEW YORK: 83 CHAMBERS STREET.

CHICAGO: 304 WABASH AVENUE.

SAN FRANCISCO: 786 MISSION STREET.

NATIONAL PHONOGRAPH CO., LTD., 25 CLERKENWELL  
ROAD, LONDON, ENG.

## EDISON PHONOGRAPHS AND RECORDS.

All communications to THE PHONOGRAPH MONTHLY  
should be addressed to the Advertising Department,  
83 Chambers Street, New York.

### C O N T E N T S

The Demand for Edison Goods Beyond All Expectations.....	1
Advance List of November-December Records .....	2
No Records of Other Tongues Just Now..	4
Notice to the Trade.....	4
A Profitable Second Hand Stock.....	4
Change in Western Manager.....	4
Why Jobbers Cannot Fill Orders.....	5
Phonograms to the Trade.....	5
Learn to Make Records.....	5
Those Cut Outs.....	5
Pike Injunction.....	6
Greater Demand for Better Styles.....	6
Use Order Sheets for Records and Order Books for Machines.....	6
To Change Over Concert Machines.....	6
Appreciative English Actors.....	6
Printed Matter.....	7
No Let Up in Effort.....	7
Dealers' Printed Matter.....	7
Comments on November-December Records	8
Model D Repeating Attachment.....	10
President Diaz's Birthday Gift.....	11
Two from Great Britain.....	12
New Record Numbers.....	13
Unsigned Dealers To Be Removed.....	13
An Advertising Record.....	13

## THE DEMAND FOR EDISON GOODS BE- YOND ALL EXPECTATIONS.

It is with a combined feeling of pride and regret that we address Jobbers and Dealers in Edison goods this month. We justly feel proud in being able to say that no such demand for Edison Phonographs and Records has existed since Mr. Edison gave the Phonograph to the world. We regret that our facilities, unequalled as they are by any other similar plant in the world, are not adequate to enable us to properly and promptly fill the orders sent us by the trade; we feel the situation more keenly than the public would credit. When a large manufacturing company sends out salesmen, advertises extensively and puts forth every effort to sell its goods, those who place orders with it have every reason to expect that they will be filled completely and within a reasonable time. Not to be able to do so is a great disappointment to us.

A year ago a somewhat similar situation prevailed at our factory in Orange. The demand for Phonographs and Records for many weeks exceeded the output, although we put forth unusual efforts to keep ahead of orders. With a determination that such a state of affairs should not occur again, we began to increase our manufacturing facilities in every department and on July 1st had a capacity, as we thought, ample for a long time to come. Then came the decision to increase the Record business by reducing the price to 35 cents each. That this action would bring more orders than could be easily taken care of was not considered possible. Such has been the result, however, and there is no apparent let up in the situation.

We naturally expected the flood of orders that came in immediately after the new prices were announced. We knew that the entire

(Continued on page 3.)

**THE ADVANCE LIST OF NOVEMBER-DECEMBER RECORDS APPEARS ON PAGE 2.  
ORDER FROM IT. NO OTHER ADVANCE LIST WILL BE ISSUED.**



NEW EDISON GOLD MOULDED RECORDS.  
COMBINED ADVANCE LIST FOR  
NOVEMBER - DECEMBER, 1904.

RECORDS listed below will be ready for shipment as near **November 20th** as possible, at which time Jobbers' stock orders, if placed prior to **October 20th**, will be shipped. November-December Supplements will be forwarded to Jobbers with their stock order for Records. Retail Dealers should place stock orders with their Jobbers at once, to insure prompt shipment as soon as Jobbers' stock is received.

- |      |  |   |                             |
|------|--|---|-----------------------------|
| 8826 | The Chirpers ( <i>Frank</i> )                        | <i>Morceau characteristic</i>   | Edison Military Band        |
| 8827 | Shine On, Oh Stars ( <i>Sawyer</i> )                 | <i>Song-Romanza, Orch. acc.</i>   | Irving Gillette             |
| 8828 | My Heart's Desire ( <i>Shelley</i> )                 | <i>Sentimental song, Orch. acc.</i>   | W. H. Thompson              |
| 8829 | Blue Bell ( <i>Morse</i> )                           | <i>Bells and xylophone duet, Orch. acc.</i>   | Benzler and Hager           |
| 8830 | Save It for Me ( <i>Cole</i> )                       | <i>Comic song, Orch. acc.</i>   | Billy Murray                |
| 8831 | Has Your Mother Any More Like You ( <i>Keiser</i> )  | <i>Miss Nelson and Mr. Stanley</i><br><i>Contralto and baritone duet, Orch. acc.</i>  |                             |
| 8832 | Feast of Lanterns Overture ( <i>Bennett</i> )        |   | Edison Symphony Orchestra   |
| 8833 | Make a Fuss Over Me ( <i>Morse</i> )                 | <i>Coon song, Orch. acc.</i>  | Arthur Collins              |
| 8834 | What Shall the Harvest Be ( <i>Bliss</i> )           |   | Mendelssohn Mixed Quartette |
| 8835 | Imagination ( <i>Muller</i> )                        | <i>Comic topical song, Orch. acc.</i>   | Arthur Collins              |
| 8836 | Pepita Maguire ( <i>Mullen</i> )                     | <i>Comic song, Orch. acc.</i>   | Edward M. Favor             |
| 8837 | O Come All Ye Faithful ( <i>Adeste Fidelis</i> )     | <i>Unaccompanied</i>  | Edison Male Quartette       |
| 8838 | Jovial Joe ( <i>Ringleben</i> )                      | <i>Slow drag cakewalk</i>   | Edison Concert Band         |
| 8839 | Rock of Ages ( <i>Hastings</i> )                     |   | Campbell and Harrison       |
|      |  | <i>Tenor and baritone duet, Orch. acc.</i>  |                             |
| 8840 | The Wedding of Barney and Bedelia ( <i>Rogers</i> )  |   | Collins and Harlan          |
|      |  | <i>Comic Irish male duet, Orch. acc.</i>  |                             |
| 8841 | I've Got a Feelin' for You ( <i>Morse</i> )          | <i>Banjo trio</i>   | Ossman Banjo Trio           |
| 8842 | Hail! Smiling Morn ( <i>Spofforth</i> )              |   | Edison Male Quartette       |
|      |  | <i>Christmas carol, unaccompanied.</i>  |                             |
| 8843 | There's Nothing New To Say ( <i>Robyn</i> )          |   | Harry MacDonough            |
|      |  | <i>Sentimental song, Orch. acc.</i>   |                             |
| 8844 | Down Tennessee Barn Dance ( <i>Cruger</i> )          |   | Edison Symphony Orchestra   |
|      |  | <i>Introducing chorus of male voices with banjo acc.</i>  |                             |
| 8845 | Down at the Baby Store ( <i>Von Tilzer</i> )         | <i>Descriptive song, Orch. acc.</i>   | Byron G. Harlan             |
| 8846 | Little Boy Called Taps ( <i>Morse</i> )              |   | Byron G. Harlan             |
|      |  | <i>March song by the composer of "A Little Boy in Blue," Orch. acc.</i>   |                             |
| 8847 | I May Be Crazy but I Ain't No Fool ( <i>Rogers</i> ) |   | Bob Roberts                 |
|      |  | <i>Coon song as sung by Williams and Walker in "In Dahomey," Orch. acc.</i>   |                             |
| 8848 | The Village Maid ( <i>Hoffmann</i> )                 |   | Collins and Harlan          |
|      |  | <i>Duet as sung by The Rogers Brothers in Paris, Orch. acc.</i>   |                             |
| 8849 | Our National Airs—Patriotic poem                     |   | Len Spencer                 |
|      |  | <i>Talking selection with incidental music by band and orchestra.</i>   |                             |
| 8850 | Medley of War Songs                                  |   | Edison Military Band        |
|      |  | <i>Introducing "Marching thro' Georgia," "Tramp, Tramp, Tramp, etc.," "Glory Hallelujah," "The Battle Cry of Freedom," "Kingdom Coming" and Finale.</i> |                             |
| 8851 | My Little Canoe ( <i>Stuart</i> )                    | <i>From "The School Girl"</i>   | Edison Symphony Orchestra   |
| 8852 | Birthday of a King ( <i>Neidlinger</i> )             | <i>Christmas song, Orch. acc.</i>   | Frank C. Stanley            |
| 8853 | Star of Bethlehem ( <i>Adams</i> )                   |   | Irving Gillette             |
|      |  | <i>Song by the composer of "Holy City," Orch. acc.</i>  |                             |
| 8854 | Ring the Bells of Heaven ( <i>Root</i> )             |   | Chimes                      |
| 8855 | Deed of the Pen March ( <i>Moret</i> )               |   | Edison Concert Band         |
|      |  | <i>By the composer of "Hiawatha"</i>  |                             |

Edison Gold Moulded Records are made only in Standard size. Both Standard and Concert Records may be ordered from this list. Order by Number, not title. If Concert Records are wanted, give the number and letter C.

(Continued from page 1.)

trade had held back orders for several weeks in anticipation of the new conditions, and it was a moral certainty that they would want to replenish their stock. These orders at once made deep inroads on our reserve facilities. Then came a record-breaking demand for the August Records. The list was excellent, they were to be packed in the new boxes and have the titles engraved on the end, and Phonograph owners everywhere wanted some of them. Still the stock orders continued to come, and Jobbers who had already had stock orders filled began to come back for a further supply. Next came a series of orders for the fine September list that overtopped the aggregate for August. And with every order for the new list came orders for selections already listed. All this time our Record plant was running to its limit and night work, with different crews and full hours, had been resorted to.

When it was decided to make 35 cents the selling price of Edison Gold Moulded Records, it was believed that the lower price would greatly increase the demand for Phonographs. The reduction in price of another make of cylindrical record had caused a larger demand for Edison Phonographs and we felt sure that a 35 cents price for our own superior Record would make a still greater demand for them. During the summer, when, by our advice, the trade was keeping stocks low and placing few orders, we kept right on making thousands of machines ahead and holding them in stock. This course was most fortunate. No sooner were the new conditions made known than heavy machine orders began to flow in and they have continued to come at a rate that has fully kept pace with Record orders.

Up to this time this prosperous state of affairs had no other effect upon the officials of the company than a glowing feeling of self complacency. It was coming our way to even a greater extent than we had anticipated and we were in for the business of our lives as a company.

The advance list for October was sent out. It was declared by the trade to be the best yet, and they backed the declaration with phenomenal orders. Stock orders for Records and orders for machines showed no signs of decreasing and early in September all hands suddenly realized that we were face to face with a situation that would require heroic treatment. A meeting of the officers of the company and all department heads was called to discuss the subject. A rounding up of

reports showed that the facilities we thought equal for immediate contingencies must be further enlarged at once and added to constantly. The stock of machines that we had accumulated during the summer had melted away and orders on hand for machines were as much behind as orders for Records. Fortunately we were so situated that increased facilities could be had in a short time and steps were at once taken to secure them the utmost despatch. Orders were issued to continue to run the entire plant day and night; directions were given to buy machinery in every department in which the daily output did not equal the maximum; men were sent in every direction to expedite the shipment of raw materials and machinery already on order, and general instructions were given to spare neither time nor money to increase the product.

To further relieve the situation it was decided to combine the November and December advance lists of twenty-five titles each and get out but one list of thirty titles, this combined list to be ready for shipment so as to reach the trade prior to December 1st. A more detailed announcement concerning this list is printed elsewhere.

We now ask the trade to be as patient as possible until the full effect of our efforts to increase our output can be realized. It does not seem possible that we shall not then be able to catch up and keep ahead. As before stated, we are to-day making more Phonographs and more Records than ever before, and we will, by making partial shipments, do all we can to keep the trade supplied until all orders can be filled complete.

#### UNSIGNED DEALERS TO BE REMOVED.

**This copy of the EDISON PHONOGRAPH MONTHLY will be the last printed matter or advertising literature we shall mail to Dealers who have not signed the new Agreement, Form No. 590. During the next two weeks we will remove from our mailing list all but such Dealers as have complied with the requirements of our system. There is nothing in the new Agreement that is not calculated to benefit the trade and there is no reason why it should not be signed by every Dealer who desires to continue the sale of our goods. We will, therefore assume that those who have not signed are no longer interested.**

**Edison goods were never in greater demand. Don't drop the line now. Sign the new Agreement at once.**



## NOTICE TO THE TRADE.

### NOVEMBER AND DECEMBER LISTS TO BE COMBINED.

Owing to the large and unprecedented orders received to date, and with a conservative estimate of orders that will be received up to December 1st, we find that it will be impossible to issue lists of 25 new selections each for both November and December, and furnish the December list in time for the holiday trade. For this reason we have decided to combine November and December lists into one, and instead of 25 the list will contain 30 selections.

The selections will be shipped to Jobbers on or about November 20th so as to be in the hands of Dealers about December 1st.

NATIONAL PHONOGRAPH CO.

C. H. WILSON, Manager of Sales.

October 1st, 1904.

Below is given a copy of a letter mailed to every Jobber on October 1. It is published in full in order that Dealers may see how important it is that Jobbers have their coöperation in making up their orders and getting them in early. The demand for these thirty selections is going to be unusually heavy and those Jobbers who fail to get their orders in on time will probably be delayed in getting their supply. Dealers will, therefore, assist the Jobbers by placing orders in good season. The letter to Jobbers follows:

NOTICE TO JOBBERS.

NEW YORK, Oct. 1, 1904.

Dear Sirs:—

Owing to the large and unprecedented orders received to date, and with a very conservative estimate of orders that will be received up to December 1st, we find it will be impossible to issue lists of twenty-five new selections each for both November and December, and furnish the December list in time for the holiday trade. For this reason we have decided to combine November and December lists into one, and

instead of twenty-five the list will contain thirty selections.

If you have a standing order with us for the sample Records, samples of this combined November and December list will be sent you on October 10th. Stock orders for such quantity of them as you desire must be mailed us not later than October 20th. We will then exert every effort to make shipment of such stock orders on or about November 20th. This will place in your possession a stock of November and December Records December 1st, or about the time you would receive the November Records, if list was issued separately. We trust this arrangement will meet with your approval.

**Please do not forget that in order to make shipment of stock orders about November 20th, your order must be mailed us not later than October 20th. Any orders sent us after that date will have to follow shipment of those sent us by that time.**

NATIONAL PHONOGRAPH CO.,

C. H. WILSON,

Manager of Sales.

### A PROFITABLE SECOND HAND STOCK.

One of our Western Jobbers who does a large retail business was recently asked if he did not find it somewhat of a handicap to sell only Edison goods. He replied:

"It is hardly fair to say that I sell only Edison goods. It is true that I am not the authorized agent for any other line, but I have in my store every type and style of every talking machine made in this country. They are machines that I have taken in exchange for Edison Phonographs, from people who have tired of them and wanted an Edison. Odd as it may seem, having all styles aids in selling Edison outfits. When a customer enters my store we first ascertain what style of machine he wants, provided he has decided upon a choice. If he wants a machine other than an Edison we explain that we haven't a new machine of that style, but have one

that we have taken in exchange for a Phonograph. We assure him that it will play as well as a new machine; that we guarantee to keep it in good order for several months, and that we will be glad to play records on it for him. If he calls what he thinks is a bluff on our part, we make good and show just what the machine will do. We then get him to listen to an Edison Phonograph. The contrast is so great and so pleasing to him that we seldom fail to sell him an Edison machine. My stock of second-hand machines represent quite some money, but they pay a handsome interest as object lessons."

### CHANGE IN WESTERN MANAGER.

George M. Nisbett has succeeded J. E. Garvin as manager of the Chicago office of the National Phonograph Company. Mr. Nisbett has been connected with the Chicago office since it was first established.

**WHY JOBBERS CANNOT FILL ORDERS.**

Dealers who buy Edison goods through Jobbers and who find that the latter are not filling their orders completely and promptly are asked to give the article on trade conditions printed on the first page of this issue their careful consideration. The facts there set forth are the simple truth. No effort has been made to exaggerate. It is not necessary. Owing to the unparalleled demand for our goods we are unable to make complete shipments, except for the monthly supplement, to any Jobber. If the latter does not get the goods he can only partially fill the orders of his Dealers. Therefore if your Jobber tells you that he is doing the best he can he probably is.

We must ask the forbearance of both Jobbers and Dealers for a short time. We are working our factory to its absolute limit night and day; we are constantly adding new machinery and putting on more help, and although the new orders still exceed the output we fully believe that we shall soon have facilities that will enable us to catch up and keep ahead of all demands.

**No Phonogram for November.**

**Owing to the combining of the November and December Lists of Edison Gold Moulded the Records in to one list, no separate issue of Phonogram will be published for November.**

**That month and December will be combined into one number, and will be shipped with the November-December Records. Those who have paid for subscriptions to the Phonogram, will have the date of expiration extended one month.**

**LEARN TO MAKE RECORDS.**

We doubt if many Dealers appreciate the selling value of the fact that Records can be so successfully made with the Edison Phonograph, for we know that many of them pay no attention to this feature. Others have taken the pains to learn how to get good results and they report that it pays them handsomely right along. An illustration of this

was given us recently by a Jobber in one of the large Pennsylvania cities. This Jobber enjoys the acquaintance of many of the prominent officials and politicians of his State. One day, a few weeks ago, one of the most prominent Democratic United States Senators in the country came into his place with some political friends. Our Jobber asked him to make a Record. The Senator consented, but instead of speaking into the horn he sang a song, to the great delight of all present. The Senator was so pleased with the reproduction of his vocal efforts that he ordered a Triumph machine and a complete outfit sent to his home, although he had no thought of making a purchase when he entered the place. Incidentally it might be said that the Senator's Record is much prized by our Jobber friend.

Other cases might be cited where this ability to make a Record has so pleased the maker that he has ordered an outfit at once. Dealers who have given this feature of the business little attention should spend some time in getting posted.

**THOSE CUT OUTS.**

The fact that we do not purpose taking back from the trade any of the 227 selections omitted from the present Record catalogue has caused a little comment from a few Jobbers, who have some on hand. Under all the circumstances we do not think that we should be expected to take them back. The selections in question were dropped at the solicitation of the Jobbers, the claim being made that something should be done to keep down the list on account of the large stock that it compelled them to carry. A letter was sent to many Jobbers, asking their opinions as to the least popular selections. These opinions and our own books were used as the basis for deciding upon the cut-out list. The omitted selections, therefore, were those of which the Jobbers had the smallest number on hand. So far as possible our action had the endorsement of the Jobbers. Then the cut-out list was issued in April and they were included in the Record catalogue until August, allowing Jobbers over four months in which to work off their stocks. And most of them did so to a large extent.

If Jobbers and Dealers still have some on hand they should not consider them as dead stock. Most of them are still desirable selections and many of them would please some people better than the later selections. A little judgment in playing them for customers will assist materially in disposing of most of the stock.



**PIKE INJUNCTION.**

THE PRESIDENT OF THE UNITED STATES TO WILLIAM A. PIKE, and every person connected directly or indirectly with you, and your associates, attorneys, servants, clerks, agents and workmen, GREETING:

WHEREAS, it has been represented to us in our Circuit Court of the United States for the District of Massachusetts, in a certain case therein depending, wherein Edison Phonograph Company and National Phonograph Company are complainants, and you, the said William A. Pike, are defendant, that Letters Patent of the United States Nos. 382,418 and 386,974 were issued in due form of law and that you, the said William A. Pike have infringed claims 9, 11, 13, 14, 15, 24, 27, 28 of said Letters Patent No. 386,974, and claims 1 and 2 of said Letters Patent No. 382,418.

NOW THEREFORE, we strictly command and enjoin you, the said William A. Pike and your associates, attorneys, servants, clerks, agents and workmen from directly or indirectly using or causing to be used, selling or causing to be sold, or advertising to sell any apparatus, articles or devices not licensed by complainants and embodying or constructed or operating in accordance with the inventions and improvements set forth in the said claims or either of them, and particularly from directly or indirectly selling or causing to be sold or advertising to sell any Edison Phonographs, Records or blanks at less than the prices at which they are licensed by complainants to be sold.

WITNESS, the Honorable Melville W. Fuller, Chief Justice of the United States at the City of Boston, on the 25th day of August, 1904.

L. C. TUCKER,  
Deputy Clerk.

Service of copy of within admitted August 25, 1904.

WILLIAM A. PIKE,  
Defendant.

A true copy:

Attest: L. C. Tucker,  
Deputy Clerk.

**GREATER DEMAND FOR BETTER STYLES.**

One of the agreeable surprises of the early fall has been the great increase in the sale of Triumph machines. The sale at present is double what it was a year ago and is growing steadily and rapidly. This increased demand is not to be wondered at, for with its suspension springs and speed indicator it is certainly an ideal Phonograph. It is quite evident that the trade is talking up the better grades of Phonograph, for the increase in the sale of the Standard, Home and Triumph types is very much greater than the Gem. It is a benefit to a prospective purchaser to get him to take as good a machine as he can afford, for it will give him greater satisfaction in the end. Incidentally it pays the Dealer a better profit.

**USE ORDER SHEETS FOR RECORDS AND ORDER BOOKS FOR MACHINES.**

Jobbers and others ordering goods direct from this company are again urged to make out all orders for Records on the special sheets furnished by us for the purpose. These sheets contain numbers corresponding with the numbers in the catalogues, and they render it an easy and simple matter to make up an

order for Records. They also reduce to a minimum the liability to error in getting orders filled at our factory. Those who have been sending orders to this office on plain sheets and without making an effort to have the numbers come in sequence are asked to use the printed order sheets if they have them, or send to us for a supply if they have none on hand. Orders for machines should be made out on the order books, also furnished by us.

**TO CHANGE OVER CONCERT MACHINES.**

Dealers should bear in mind that we furnish a device at \$7.95 list by which Concert Phonographs may be made to play the small Record. If you know of any one who now has a Concert machine that he is not using much, get him to change it over to play the standard size Record. You will not only make a profit on the device itself, but every Concert changed over in this way means the sale of more Records. If you don't know about this device write our Sales Department.

**APPRECIATIVE ENGLISH FACTORS.**

The National Phonograph Company, Ltd., has taken up in England the plan pursued by the parent company in this country of sending to its Jobbers (they are called Factors in England) samples of each monthly list of new Records. The plan has been found to work as successfully as in "the States." At the same time the London company is getting out some remarkably fine British selections. Below are given copies of three telegrams recently received at London from leading Factors of Great Britain. They refer to List No. 10, British selections, just issued:

Shore Rd., Douglas, Manchester.

Congratulate you on the 10th List. Every one a success.

CHRISTIAN DUWE.

Thomas St., Manchester.

Tried No. 10, British List, last night. Congratulate you upon the excellency of Records and choice of selections.

RICHARDSON'S.

Clerkenwell Green, London.

Have tested samples of No. 10, British supplement. Consider them the best British issued by you. Ordering largely to-day.

MURDOCH & Co.

**PRICES OF EDISON RECORDS.**

Edison Gold Moulded Records, standard size, are sold in the United States at 35 cents each, and in Canada at 40 cents each. The Canadian price is higher because of the duty. Edison Concert Records are sold at 75 cents each in both countries.

**PRINTED MATTER.**

Orders for Record order sheet, Form No. 425, have been cut down for some weeks past, but we are now in better shape to fill moderate orders.

New Discount sheets are being prepared for the use of the trade. As soon as ready copies will be mailed to all Jobbers and Dealers. These sheets have been held back awaiting decisions on certain small matters. They will not contain any new discounts or make any changes in existing ones.

With the present demand for Edison Records it is not surprising that there should be a heavy demand for Record catalogues. While we expected a great business this fall, we were hardly prepared to have it begin so soon or to be so heavy. The demand for Record catalogues began before the new edition was ready, and even by making partial shipments we have not been able to get catalogues from the printer fast enough to keep the trade satisfied. By continuing the plan of making partial shipments we hope to make the present edition last until another can be got ready. The new edition will include September and October and possibly the combined November and December list.

Jobbers and Dealers are urged to use their present supply of Phonograph catalogue No. 500 for regular purposes only and not send them out for circularizing. We have but a few on hand and will only be able to fill small orders until the new edition is ready. We shall begin to get copies of the new edition in about two weeks. In the new catalogue the story feature will be eliminated, the various goods listed being treated in much the same style as Catalogue No. 375, which preceded No. 500. The interior view of several styles of Phonographs will be omitted as tending to confuse the uninitiated, and the machines will be shown a little larger. The catalogue will be printed in two colors. The illustrations and type work will be in black, and each page will be surrounded by an artistic border of gray. It will be a creditable piece of work.

**JULY AND AUGUST PHONOGRAMS.**

We are anxious to get back some copies of the *Phonogram* for July and August. Any Jobber having a few left over will confer a favor by advising the Advertising Department of the fact.

**Sign new Agreement at once and keep in good standing.**

**NO LET UP IN EFFORT.**

A Dealer recently wrote that he found the August list of Edison Gold Moulded Records even better than when they were sold at 50 cents each. He seemed surprised that such should be the case. We should regret very much to find that any one had looked for a deterioration in quality because our Records had been reduced to 35 cents, for the contrary will be the case. Not only will there be no let up, but increased efforts will be put forth and more money expended to make each new list better than the month before. We realize that with their present high quality this is cutting out a considerable task for our Recording Department, but we know that they will "make good."

**PARDON US.**

The Advertising Department, which is responsible for the EDISON PHONOGRAPH MONTHLY and the *New Phonogram*, has again made trouble for the trade by publishing incorrect information. On page 5 in the PHONOGRAPH MONTHLY for September we said that Home Phonographs are now being equipped with speed indicators. Such is not the case. We are experimenting with such a device, but it is not likely that it will be put on the Home for some time. Proper notice will be given when it is done.

On page 16 of the *New Phonogram* for September we said that the Standard Phonograph is equipped with an Edison Recorder, when every one in the trade knows that it is not.

**DEALERS PRINTED MATTER.**

G. C. Aschbach, Jobber at Allentown, Pa., sends a copy of his fall booklet called "A Leader of Music." It is neatly printed in red and black. It treats on the various musical instruments carried by Mr. Aschbach, including the Edison Phonograph.

A neatly printed folder in three colors comes from L. C. Miller, a Dealer at Waverly, N. Y. The first page announces Mr. Miller's monthly concert of Edison Records. The second page shows a list of the September Records; the third page invites the recipient to attend the concert, and on the fourth page is an enumeration of the goods carried by Mr. Miller.

**It will be easier to keep on our mailing list by signing new Agreement now than to get your name restored after it has been removed.**



### COMMENTS ON NOVEMBER-DECEMBER RECORDS.

In the opinion of the officials of the National Phonograph Company, who have heard them played over, the combined list of thirty selections gotten out for November-December is decidedly the best ever produced by our Recording Department. As usual, the list is sufficiently diversified to suit all tastes. For the holiday season there are two distinctively Christmas hymns and five others of a religious character. There are three selections that will appeal strongly to the patriotic and lovers of martial music. Those partial to instrumental Records will find in the list four by the bands, three by the Edison Symphony Orchestra, and two fine novelties, one a bells and xylophone duet and the other a banjo trio. Among the vocal selections are six of popular songs and several ballads of an attractive character. Several Records include new features in the art of recording and all are made in a manner that shows even a greater percentage of advance than ever before attained in one month. The following brief comments do not do justice to the list:

No. 8826, "The Chirpers," is a characteristic selection written by Charles Frank and played by the Edison Military Band. A novel feature of this Record is the whistling done by a number of artists to represent the chirping of birds. Other features are excellent work by the clarinets and bells. The entire selection is very pretty and the Record will be much in demand.

No. 8827, "Shine On, Oh Stars," is a ballad of the higher order in which Irving Gillette makes his bow to the Phonograph public. Mr. Gillette has a cultivated voice of a fine tenor quality as all who hear this Record will admit. This composition is called a "Song-Romanza" and was written by Frank E. Sawyer. The Record has an orchestra accompaniment.

No. 8828, "My Heart's Desire," is another charming ballad of a sentimental character and it is sung with orchestra accompaniment by W. H. Thompson. The accompaniment is very pretty. "My Heart's Desire" was written by Harry Rowe Shelley, whose symphonies, string quartettes, organ music and church anthems have made him prominent in the entire music world. He is organist and choirmaster of the Fifth Avenue Baptist church, New York city, and is one of those who were invited to play the great organ at the St. Louis Fair.

No. 8829, "Blue Bell," is something new in the way of a Phonograph Record. It is a bells and xylophone duet by Albert Benzler and Frederick W. Hager, with orchestra accompaniment. This is a most excellent Record of one of the most popular airs published in some time. The tune is carried by the bells, the xylophone plays a variation of the air and back of this is a fine orchestra accompaniment.

We predict that this Record will sell as well as the vocal Record of the same selection, the demand for which has exhausted our capacity to manufacture it ever since it was listed. The composer of "Blue Bell" is Theodore F. Morse.

No. 8830, "Save It For Me," is Billy Murray's comic song for the month. This is a song of a topical character and treats of several subjects in a witty manner. It has an orchestra accompaniment. The words are by James W. Johnson and the music by Bob Cole.

No. 8831, "Has Your Mother any More Like You," is a charming selection written by Robert A. Keiser. It has an air that is especially suited to a duet for contralto and baritone voices. This Record is nicely sung by Miss Nelson and Mr. Stanley, with orchestra accompaniment, the voices of the singers blending well together.

No. 8832, "The Feast of Lanterns Overture," written by C. W. Bennett, is perhaps the most artistic Record in the list. It is made by the Edison Symphony Orchestra. Little effort has been made to get volume, this feature being subordinated to make the selection sweet and delicate. Very pretty effects are obtained by a number of crescendos throughout the composition. Those of advanced musical taste will find this Record extremely pleasing.

No. 8833, "Make a Fuss Over Me," is Arthur Collins' coon song for the month and is sung in his usual clever manner. He is accompanied by the orchestra. The words of this song were written by Edward Madden and the music by Theodore F. Morse.

No. 8834, "What Shall the Harvest Be," the music for which was written by P. P. Bliss and the words by Mrs. Emily S. Oakey, is a nicely rendered selection by the Mendelssohn Mixed Quartette. It is listed in response to many inquiries that we have received ever since Edison Records were made by the moulded process. It cannot fail to please those who desire Records of sacred music.

No. 8835, "Imagination," is an unusually well rendered Record of this well known and popular topical song. It is sung by Arthur Collins with orchestra accompaniment. The Record has the unusual feature of giving four different verses and four choruses. These refer to various timely topics. "Imagination" was written by Bryan and Mullen.

No. 8836, "Pepita Maguire," is a comic song written by J. B. Mullen and sung by Edward M. Favor with orchestra accompaniment. The air is an amusing combination of Mexican and Irish music. Maguire has married a pretty Mexican girl and he sings in sorrowful tones of her cigarette smoking proclivities, as well as the other habits of her native country. The selection has an attractive air and Mr. Favor sings it in good style.

No. 8837, "O Come, All Ye Faithful" (*Adeste Fidelis*), by the Edison Male Quartette, is an excellent unaccompanied Record of this well known hymn. This is another Record for which there have been many requests.

No. 8838, "Jovial Joe," is a composition written by Justus Ringleben and is played by the Edison Concert Band. It is a slow drag cakewalk and is written in the general style of "Southern Smiles" and "Peaceful Henry," both of which achieved great popularity. Considerable public favor is expected of "Jovial Joe."

No. 8839, "Rock of Ages," is sung as a tenor and baritone duet, with orchestra accompaniment, by Campbell and Harrison. Ever since these artists made the Record "Old Jim's Christmas Hymn" we have had many requests from Dealers and Phonograph owners asking to have these artists make a complete Record of "Rock of Ages," a part of which is given in "Old Jim's Christmas Hymn." We feel sure that this Record will satisfy not only those who have wanted the selections, but all who desire music of this character. The music was specially arranged for this Record, the second verse being differently sung than the first, although Dr. Hastings' old familiar tune is retained throughout. This is one of the best religious Records that we have ever put out.

No. 8840, "The Wedding of Barney and Bedelia," is a cleverly sung Irish male duet by Collins and Harlan and it has the usual orchestra accompaniment. This song was written by Ed Rogers, and has the attractive swing characteristic of the two songs "Barney" and "Bedelia," although the air is unlike either.

No. 8841, "I've Got a Feelin' For You," is another special feature of the November-December list. It is played as a banjo trio by the Ossman Banjo Trio, composed of Messrs. Ossman, Hunter and Farmer. Beyond question this is one of the best banjo Records ever made. Even those who do not ordinarily care for the music of this instrument cannot fail to like this Record. The air of the selection is very attractive and one especially adapted to the banjo.

No. 8842, "Hail! Smiling Morn," is a Christmas carol by Reginald Spofforth and is sung by the Edison Male Quartette without accompaniment. It is an artistic presentation of a timely composition.

No. 8843, "There's Nothing New to Say," is a sentimental song, the theme of which is "I love you; there's nothing new to say." It is sung in a delightful manner and with clear enunciation by Harry MacDonough and has an excellent orchestra accompaniment. The words of this song were written by Harry H. Luther and the music by Alfred G. Robyn.

No. 8844, "Down Tennessee Barn Dance," by Dox Cruger, is a very ambitious Record. It is played by the Edison Symphony Orchestra and introduces choruses of male voices with banjo accompaniment. The Record opens with the playing of orchestra music and then the male voices join in singing an original plantation melody. At the same time the orchestra music gradually dies away and the banjos take up the accompaniment. The Record closes with singing, darkies shouting and orchestra and banjo music. Mr. Hunter plays the banjo.

No. 8845, "Down at the Baby Store," tells a

pretty story of a little lad whose baby sister has been taken away and who seeks to find another sister. Seeing some children playing at an orphan home, he enters, picks out a little golden-hair lassie and takes her home to his mother, telling her he found her "Down at the Baby Store." It goes almost without telling that the Record is made by Byron G. Harlan, and he sings it most satisfactorily. Harry Von Tilzer wrote the music and Alfred Bryan the words of this song.

No. 8846, "A Little Boy Called Taps," is a new song by Theodore F. Morse, who wrote "A Little Boy in Blue," which achieved such wide popularity. Byron G. Harlan's well rendered Record of this composition will do much to make it equally popular. The Record is sung with orchestra accompaniment. The song is of a patriotic nature and the music includes bugle calls, etc. A novel effect is introduced at the end by the bugles sounding taps, accompanied by violin music. This is a new feature and one that will be found most pleasing.

No. 8847, "I May Be Crazy, but I Ain't No Fool," is Bob Roberts' contribution to the list. As usual with him, his enunciation is so clear that every word of the song can be understood the first time. This selection was written by Alexander Rogers and was sung by Williams and Walker in "In Dahomey." The singer is accompanied by the orchestra.

No. 8848, "The Village Maid," tells the story of Dolly Dimple as sung by the Rogers Brothers in their latest success, "The Rogers Brothers in Paris." Dolly Dimple was a simple village maid, but she soon acquired city ways when she came to town. The Record is made by Collins and Harlan and they have seldom sung better together. "The Village Maid" was written by Max Hoffmann.

No. 8849, "Our National Airs," is another novel Record by Len Spencer, with incidental music by the band and orchestra. It is a patriotic poem in which a verse is devoted to "Marching Through Georgia," "Dixie," "Yankee Doodle Dandy" and "The Star Spangled Banner." Mr. Spencer recites a verse and at its close the band and orchestra play the airs referred to. This Record cannot fail to appeal strongly to all who are fond of patriotic music.

No. 8850, "Medley of War Songs," is a splendidly executed Record by the Edison Military Band. It introduces "Marching Through Georgia," "Tramp, Tramp, Tramp," "Glory Hallelujah," "The Battle Cry of Freedom" and "Kingdom Coming." The finale is especially good.

No. 8851, "My Little Canoe," is a selection from "The School Girl," played by the Edison Symphony Orchestra. This song was sung by Edna May and was one of the most delightful features of the opera. It is the kind of song in which the verses are sung as a solo and responses are made by the chorus. The music is unusually sweet and attractive in character. The composer is Leslie Stuart, who wrote the music for "Florodora."

No. 8852, "The Birthday of a King," is a fine baritone solo with orchestra accompani-



ment of W. H. Neidlinger's Christmas song, the soloist being Frank C. Stanley. This is another Record especially suited to the holiday season.

No. 8853, "The Star of Bethlehem," is a composition written by Stephen Adams, the composer of "The Holy City." It is sung by Irving Gillette, referred to above as a new tenor singer, who is accompanied by the orchestra. Mr. Gillette makes a fine Record of this selection.

No. 8854, "Ring the Bells of Heaven," is the first Record that we have made with the Chimes in some time. It is one of the best of its kind that we have put out.

No. 8855, "A Deed of the Pen March," is a selection that typifies the signing of the Declaration of Independence. Intermingled with the music are phrases from various patriotic songs. This composition was written by Neil Moret, widely known as the composer of "Hiawatha." The Record is made by the Edison Concert Band in a manner that does the composition full justice.

#### MODEL D REPEATING ATTACHMENT.

We have just perfected a new style repeating attachment, which will be known as Model D. This attachment is designed primarily for coin-slot Phonographs, but it can be readily attached

to the inch, ratchet shaped, and is driven by means of a spur gear which engages a similar gear on the main shaft pulley, thus dispensing with a belt or chain. An adjustment is provided at each end of the bracket to suit the beginning and the end of the Record. The adjustment for the end of the Record is accomplished by rotating the disk which is carried on the return screw. This disk also carries the pin which acts on the lift lever block to raise the diaphragm arm and engage the block with the threads of the return screw. This lifting action also disengages the feed nut from the thread of the main shaft and the return screw of the attachment takes the reproducer arm back to the starting point. The return movement takes about 1-25th of the time to play the Record. All parts of the return device subject to wear are hardened.

#### HOW TO ATTACH MODEL D REPEATING ATTACHMENT TO THE HOME PHONOGRAPH.

The following directions and illustrations apply to the Home Phonograph only. The directions for attaching the device to other types differs principally in the method of fastening the attachment arm to the back rod.

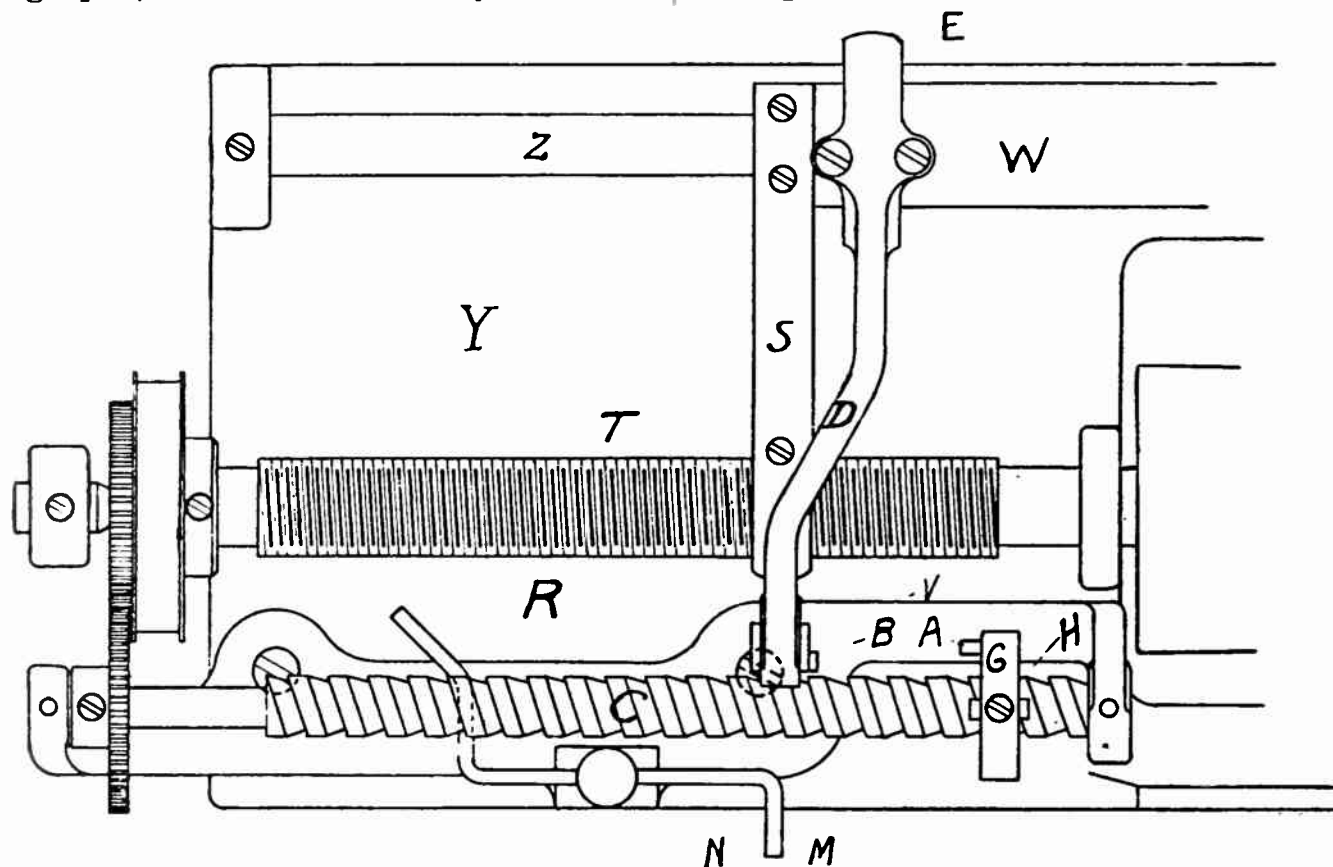

Fig. 1.

to the Home, Triumph, Concert, Victor and Conqueror Phonographs. It is remarkable for its simplicity and effectiveness. Its principal features are the return screw and lifting lever block. The screw is mounted on a cast bracket which is fastened with two screws to the Phonograph body in front of the cylinder shaft. These two holes for fastening bracket are the only holes to be drilled and tapped to fasten attachment. The lifting lever block is carried by an arm which is clamped to the back rod sleeve. The return screw has four threads

Drill and tap the body for the two 8-32 screws (R-R)  $\frac{1}{2}$  inch and  $3\frac{1}{2}$  inches respectively from the end of the body (Y) and parallel with and 3.54 inches from the center of the back rod (Z) (Fig. 1).

Remove the back rod (Z) and the speaker arm (W) from the machine and place the repeating attachment arm (D) over the speaker arm (W). Then replace the speaker arm and back rod on the machine having the arm (D) next to the feed nut spring (S). The clamp (P) should be placed in the arm

(D) with the bent end at the front or back of the speaker arm (W), either side that will allow the block (V) to hang in a vertical position when just touching the return screw (C) (Fig. 2).

Adjust the arm (D) for height by means of the adjusting screw (F) and set screws (E-E)

so that the lifting pin (A) clears the projector (B) by 1-64 inches (Fig. 2) when the feed nut (X) engages with the main shaft thread (T).

The lifting disc (G) may be moved in either direction by rotating on the return screw (C) after loosening the set screw (H) and the trip rod (M) by the thumb screw (N).

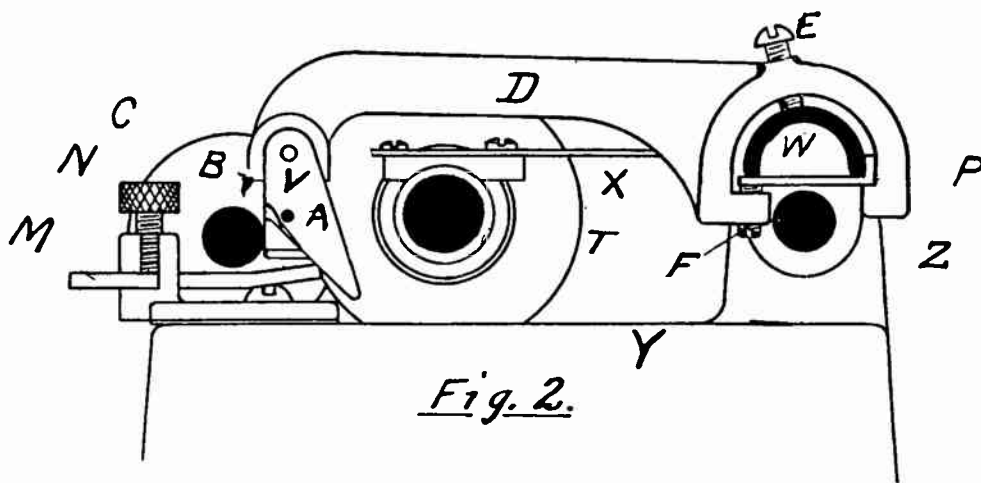

### PRESIDENT DIAZ'S BIRTHDAY GIFT.

President Diaz, of Mexico, celebrated the seventy-fourth anniversary of his birth on September 15. In honor of the event Thomas A. Edison presented him with a handsome gold mounted Phonograph and a choice selection of Mexican Records just made in Mexico City by the National Phonograph Company. The Phonograph bore the following inscription:

"Fonógrafo Especial Presentado por Thomas Alva Edison á su Excelencia el Señor General Porfirio Diaz, Presidente de los Estados Unidos Mexicanos, Septiembre Quince, de mil novecientos cuatro."

("Special Phonograph presented by Thomas Alva Edison to his Excellency Señor General Porfirio Diaz, President of the United States of Mexico, September fifteenth, nineteen hundred and four.")

The present was accompanied by a personally signed letter from Mr. Edison, as follows:

September 2, 1904.

His Excellency General Porfirio Diaz,  
President of the United States of Mexico.

Dear Sir:—On this, the fifteenth day of September, when all your countrymen are participating in the celebration of your birthday, I likewise wish to commemorate same, in presenting to you, through my representative, one of my latest model Phonographs, together with an assortment of Vocal and Instrumental Gold Moulded Records, recently made by prominent artists in Mexico City, and it is my desire that you should receive the first copies.

I beg you to accept this gift as a token of my esteem for Mexico's most honored man and trust that this instrument will afford you many moments of pleasure.

That many returns of this happy day be granted you, is the sincere wish of

Very truly yours,

THOMAS A. EDISON.

President Diaz has replied to Mr. Edison, as follows:

MEXICO, September 19, 1904.

Señor Thomas A. Edison,  
Llewellyn Park, N. J., U. S. A.

My Esteemed Sir:—Señor Don Rafael Cabañas handed to me the elegant Phonograph, together with a select and a beautiful assortment of Gold Moulded Records, you had the kindness to send me, making your delicate gallantry and your gift coincide with the date of my birth. I received it with great pleasure, not only on account of the moments, that, as you very well say, I will enjoy, but mainly coming as it does from one of the most notable inventors of the nineteenth century, whom I admire, and whose phrases of friendship and benevolence bestowed upon me, do me a great deal of honor.

Your servant and friend,

PORFIRIO DIAZ.

The presentation to President Diaz was made by Rafael Cabañas, representing Mr. Edison and the National Phonograph Company in Mexico. Mr. Cabañas was introduced to President Diaz by General Powell Clayton, United States Ambassador.

The Records presented to President Diaz are part of a series of about 300, the masters for which were made under the direction of George J. Werner, one of the experts from our Recording Department, who spent four months in Mexico carrying on this work.

On the day before the presentation the representatives of the Mexican city newspapers were invited to inspect it and also to hear some of the new Mexican selections. All of the papers represented, next day contained long accounts of this affair, one of these, from the *El Correo Español* is reprinted below:



## THE MARVELS OF THE PHONOGRAPH.

## A PRESENT TO SENOR GENERAL DIAZ.

Kindly invited by Sr. Rafael Cabañas, General Representative at this Republic of that notable inventor Edison and his National Phonograph Company, and Edison Manufacturing Company, we visited yesterday afternoon the salons of the enterprise, situated on Colon First Street, which is intended for the recording of the Phonograph Records, to be present at the proof of many of these, made with a magnificent apparatus installed there.

The visit was a most enjoyable one. The apparatus, manipulated by Mr. George J. Werner, one of the most skilful experts of the Edison Laboratory, made us hear, reproduced with the amazing naturalness of tone, and without the slightest hint of mechanical noise, recitations in verse and prose by eminent orators and poets of this country, pieces of Mexican and Spanish music, etc., all performed with the inflections and peculiarities of each instrument, (when it referred to instrumental music,) and a surprise volume that filled the vast hall.

The voice of the singers kept all its natural sound and clear intonation; and thus we admire Chole Coyzueta as if we were before the stage listening directly to the songstress, and applauded Juan de Dios Peza reciting admirably his verses and a speech made in praise of Edison.

Our admiration reached the utmost when we heard from the Phonograph, as if we were at the Bull Fight arena, all that confused noise made by the crowd during the most interesting period of the fight.

Acceding to kind invitations, some of those in the audience placed themselves before the talking machine, whereupon we recorded several Records moulded in wax, and immediately tried same on the Phonograph, repeated our own voices and expressions with incomparable genuineness. It is impossible to ask more from this apparatus, a model of absolute perfection.

Messrs. Cabañas and Werner have recorded in this country about three hundred Records, repeating the proofs whenever it was necessary so as to obtain an absolute preciseness. These Wax Cylinders, recorded with small sapphires which we examined with a microscope, are the Masters to be used in the manufacture of Gold Moulded Records.

The above gentlemen received a splendid Phonograph purposely made for Señor General Diaz to be presented to him to-day in honor of his birthday. It is a very handsome instrument, entirely gold plated, and placed in a beautiful golden box.

**BETTER THAN WHEN SOLD AT 50c.**

We are pleased to inform you that we found the August list of Records even better than when the price was fifty cents, and we enjoyed a very excellent trade in consequence. We are perfectly satisfied with Edison goods, and as long as they give such good satisfaction we will handle no others.

HOWARD GEORGE,  
Frankford, Phila.

## TWO FROM GREAT BRITAIN.

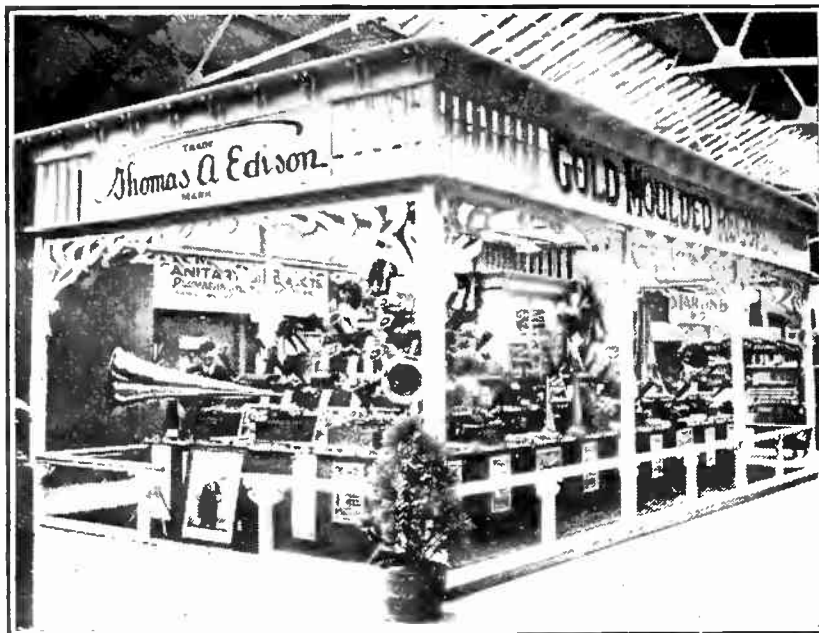

EDISON PHONOGRAPH EXHIBIT, NOTTINGHAM, ENGLAND.

The above half tone is from a photograph of an exhibit of Edison Phonographs and Records made by the National Phonograph Company, Ltd., at the Midlands' Exhibition, Nottingham, England, from May 14 to October 8. The exhibit was thirty feet long by fifteen feet wide, and it was conceded to be the finest show of talking machines ever seen in England. Nottingham has a population of 250,000, and is one of the largest cities in the Midlands' counties of England.



A CAMP SCENE IN ENGLAND.

The above photograph shows an Edison Home Phonograph in operation at the annual camp of the Yorkshire Artillery at Scarborough, England. The instrument was the property of one of our English factors, who is a lieutenant in the regiment named.

**IT AIDS THE BUSINESS.**

Permit me to express my appreciation of Form No. 573. It catches the eye, and elicits much praise. Your method of sending the latest literature to Dealers is just the thing to build up a business.

H. W. MOSIER,  
Stockton, Cal.

**NEW RECORD NUMBERS.**

It is against our rule to publish anything that will appear like advertising, but we feel that it would be withholding from the trade a bit of useful information if we did not refer to the new set of Record numbers that Victor H. Rapke, of 1661 Second avenue, New York, is getting out for trade use. These numbers are printed on white ground paper, 2x3 $\frac{5}{8}$  in size. The following is an exact reproduction of one of them:



Mr. Rapke expects to get out these numbers for all Edison Records issued to date and then to get them out each month as we issue a new list. He intends to sell these numbers to Jobbers and allow them a discount on those sold to Dealers. Mr. Rapke states that he will send a set of the October numbers to all Dealers who write him concerning them during October.

**AN ADVERTISING RECORD.**

A Connecticut Dealer recently wrote: "While exhibiting at the ——— county fair two weeks ago I felt the need of a good talking record that would dilate upon the merits of your Phonographs and Records. While a crowd would soon disperse if I talked to them personally, it seemed as though a good loud argumentative Record would hold their attention because of the very novelty of being addressed in this manner. Why do you not get out something of this kind?"

The suggestion is by no means a new one. It has not had serious attention for two reasons: The demand for goods has held up this, as well as other new matters; and there has been a wide difference of opinion among Dealers as to what matter should be given on a Record of this kind. As a basis for reaching a decision in the near future, we shall be glad to receive from the trade suggestions as to what such a Record should say to a crowd of listeners.

**BRITISH BAND RECORDS.**

I have found your British band Records net a neat little profit when handled in the right way. For instance, a plan which is worked in my store is to play Record No. 12945, "Here, There and Everywhere," for every person who calls for Records, after they have selected what domestic Records they wish to buy. This invariably results in their purchasing this British Record in addition to those they already selected. We do not put the Record on until they have purchased all the domestic Records they want, so you can see it does not interfere with the sale of our regular stock. I have sold about 400 of Record No. 12945, and it has netted me quite a profit, not to speak of the new customers it has sent my way from people hearing the Record on my customer's machines. If the customer takes to the British Records I then run in the entire list, which I keep in stock constantly, in addition to every Record on your domestic catalogue. Douglas & Co., J. A. Rickard & Co. and W. D. Andrews, Jobbers, can testify to the way I have called for this Record, and, indeed, I have had to get about a hundred direct from you. I keep twenty-five of it in stock at all times.

W. J. KILLEA,  
Albany, N. Y.

**"ONE THAT IS IN A CLASS BY ITSELF."**

A little over two years ago Lawrence E. McGreal and his brother, Hugh J. McGreal, engaged in the talking machine business at 173 Third street, Milwaukee. They seemed exactly fitted for the business and the success was almost instantaneous and has increased with every year. Its extent may best be understood when it is considered that at the time they had some misgivings in placing an order for fifty instruments and 1,800 Records to be delivered in one consignment, whereas but a few days ago, without any second thought, they placed an order for 2,000 instruments and 30,000 Records.

"The talking machine is no longer a fad," said Lawrence E. McGreal, the other day. "It has passed the experimental stage and has become almost a necessity. It will be used more and more in business and probably the time is coming when we shall write our letters on records and transmit these through the mails.

"Our success is due principally to the fact that we handle a high grade article—one that is in a class by itself. Almost as important a factor has been our publicity campaign. We have been the first dealers in talking machines to use large space in the newspapers. Many of our ads. have been copied throughout the country."—*Music Trade Review*.

We might complete the above article by saying that the "high grade article—one that is in a class by itself," referred to by Mr. McGreal, is the Edison Phonograph.

**Last Call:— Sign new Agreement at once if you want to remain on our mailing list.**



**SUSPENDED LIST, OCTOBER 1, 1904.**

SUPERSEDING ALL PREVIOUS LISTS.

**COLORADO.**

Boulder—BENTLEY &amp; CRAIG.

**INDIANA.**

South Bend—EUGENE MARSH, 126 Vistula avenue.  
SOUTH BEND BOOK BINDERY,  
Robert Lebolt Prop., 203 North  
Michigan street.

**IOWA.**

Burlington—JOHN P. WEISS, 711 Jefferson street.  
Sioux City—HATTENBACH BROS. CO.

**KANSAS.**

Clay Centre—E. M. GOWENLOCK.  
Lawrence—BELL BROS.

**MAINE.**

Biddeford—W. H. FIELD.

**MASSACHUSETTS.**

Boston—T. SINGER, 60 Leverett street.  
Lawrence—LORD & CO, 314 Essex street.  
E. O. MOSHER, 420 Essex street.  
Lynn—ELIAS DEYOUNG.  
Malden—A. T. FULLER.  
Nantucket—ARTHUR M. TAYLOR.  
New Bedford—H. B. DEWOLFF.  
Somerville—E. J. WINCHESTER, 32 Summit avenue.  
Woburn—OSBORN GILLETTE, or THE BOLTON  
JEWELRY CO., L. F. Maloney, Manager.

**MICHIGAN.**

Detroit—F. J. SCHWANKOVSKY.  
Saginaw—GEO. W. EMENDORFER.

**MISSOURI.**

Kansas City—THE WITTMANN CO.

**NEBRASKA.**

Lincoln—THE WITTMANN CO.  
Omaha—THE WITTMANN CO.

**NEW HAMPSHIRE.**

Hillsboro Bridge—E. M. BARNES.  
Manchester—A. E. DUMAS  
Nashua—F. A. MCMASTER & CO.

**NEW JERSEY.**

Atlantic City—SAM'L D. WOLF, 32-34 Arkansas ave.  
Bayonne—I. WIGDOR, 450 Avenue D.  
Jersey City—W. L. HOFFMAN, 151 Montgomery st.  
Newark—R. L. CORWIN; also New York City.  
Passaic—I. HURWITZ.  
Paterson—CHAS. H. KELLY, 25 N. Main street.

Plainfield—S. W. FRUCHT, or R. FRUCHT; also  
New York City.

ELSTON M. LEONARD.

West Hoboken—EMIL HOLLANDER, or THE WEST  
HOBOKEN BICYCLE & PHONO-  
GRAPH CO., 619 Spring street.

**NEW YORK.**

Bedford Park—GEO. H. TYRRELL.

Hobart—F. H. MARSHALL.

New York City—A. T. ARMSTRONG, or AMERI-  
CAN PHONOGRAPH CO., 106  
Wall street.

BERN BEARWALD, 373 W. 11th st.  
BRONX PHONOGRAPH CO. or  
DAVID SWITKY, 506 Willis ave.  
CENTRAL PHONOGRAPH CO.,  
160 E 42d street.

R. L. CORWIN; also Newark, N. J.  
EAGLE PHONOGRAPH CO., or C.  
LOWENTHAL, 83 Nassau street.  
EMPIRE PHONOGRAPH CO., 2 W.  
14th street.

S. W. FRUCHT, or R. FRUCHT, 7  
Barclay street, or 68 Cortlandt  
street; also Plainfield, N. J.

O. HACKER, 2 Murray street.

HAWTHORNE & SHEBLE, 297  
Broadway; also Philadelphia, Pa.

N. HORN, 148 E. 58th street.

W. L. ISAACS, 114 Fulton street.

S. LEMBURG &amp; CO., 194 Broadway.

J. McELLYNNE, 202 Broadway.

RICHMOND PEASE, 44 W 132d st

F. M. PRESCOTT, 44 Broad st.

WINTHROP CYCLE CO., 2212 Sev-  
enth avenue.

Saratoga—W. J. TOTTEN.

Saratoga Springs—MARVIN A. COTE.

**OHIO.**

Cincinnati—J. L. ANDEM.

Coshocton—BURNS &amp; GOSSER.

Springfield—D. &amp; M. VANDERPOOL.

Uhrichsville—F. A. MAZURIE.

**PENNSYLVANIA.**

Philadelphia—A. R. CASSIDY, 2783 Emerald street.

HAWTHORNE & SHEBLE, 604 Chest-  
nut street, or Oxford and Mascher  
streets; also New York City.

A. KROUSE, 832 Arch street.

PENN NOVELTY CO., 15 South 9th st.

Phoenixville—KEINARD BROS.

Pittsburg—A. LIPPARD, 615 Wylie ave.

**RHODE ISLAND.**

Providence—F. P. MOORE.

**WISCONSIN.**

Milwaukee—J. C. BLATZEK.

Jobbers and Dealers are asked to co-operate with us, FOR OUR MUTUAL GOOD,  
by being careful that they do not supply any of the above named firms with our  
apparatus, either at addresses given or any other address.

## JOBBERERS OF EDISON PHONOGRAPHS AND RECORDS.

## ALABAMA.

**Birmingham**—The Ray Co., 2027 Second avenue.

The Talking Machine Co.

**Mobile**—W. H. Reynolds, 167 Dauphin street.

## CALIFORNIA.

**San Francisco**—Peter Bacigalupi, 786-788 Mission street.

## COLORADO.

**Denver**—Denver Dry Goods Co., 619 16th street.

## CONNECTICUT.

**Middletown**—Caulkins & Post Co., 406-408 Main street.

**New Haven**—Pardee-Ellenberger Co., 155 Orange st.

## DISTRICT OF COLUMBIA.

**Washington**—E. F. Droop & Sons Co., 925 Pennsylvania avenue, N. W.

S. Kann. Sons & Co., 8th and Pennsylvania avenues.

## ILLINOIS.

**Chicago**—James I. Lyons, 73 Fifth avenue.

The Ray Co., 90 Washington street.

Siegel-Cooper Co., State and Congress sts.

Talking Machine Co., 107 Madison street.

The Vim Co., 68 E. Lake street.

Montgomery Ward & Co., 111 Michigan ave.

Rudolph Wurlitzer Co., 302 Wabash ave.

**Peoria**—Peoria Phonograph Co., 222 Bridge street.

## INDIANA.

**Indianapolis**—Craig-Jay Co., 234 Massachusetts ave.

Kipp Bros. Co., 37 S. Meridian street.

A. B. Wahl & Co., 119 S. Illinois street

**Lafayette**—A. B. Wahl & Co., 304 Main street.

## IOWA.

**Des Moines**—Hopkins Bros. Co., 620 Locust street.

The Vim Co., 704 West Walnut street.

**Fort Dodge**—Early Music House, 822 Central ave.

## KENTUCKY.

**Louisville**—The Ray Co., 640 Fourth street.

## LOUISIANA.

**New Orleans**—James I. Lyons, Theatre Arcade.

National Automatic Fire Alarm Co., 614

Gravier street.

The Ray Co., 111 Camp street.

## MAINE.

**Bangor**—S. L. Crosby Co., 186 Exchange street.

**Portland**—W. H. Ross & Son, 207 Commercial street.

## MASSACHUSETTS.

**Boston**—Boston Cycle & Sundry Co., 48 Hanover street.

Eastern Talking Machine Co., 177 Tremont street.

Iver Johnson Sporting Goods Co., 163 Washington street.

Read & Read, 558 Washington street.

**Fitchburg**—Iver Johnson Sporting Goods Co., 247 Main street.

**Lowell**—Thomas Wardell, 111 Central street.

**Worcester**—Iver Johnson Sporting Goods Co., 304 Main street.

## MICHIGAN.

**Detroit**—American Phonograph Co., 106 Woodward avenue.

Grinnell Bros. Music House, 219 Woodward avenue.

The Ray Co., 252 Woodward avenue.

**Saginaw**—Morley Bros.

## MINNESOTA.

**Minneapolis**—Thomas C. Hough, 714 Hennepin ave.

**St. Paul**—W. J. Dyer & Bro., 21-23 West 5th street.

Minnesota Phonograph Co., 37 E. 7th street.

## MISSOURI.

**Kansas City**—J. W. Jenkins' Sons Music Co., 1013-1015 Walnut street.

The Ray Co., 1021 Grand avenue.

**St. Louis**—Conroy Co., 1115 Olive street.

The Ray Co., 923 Olive street.

## NEBRASKA.

**Lincoln**—H. E. Sidles Cycle Co., 1317 O street.

**Omaha**—H. E. Fredrickson, 1502-1510 Capitol avenue.

Nebraska Cycle Co., 15th and Harney streets.

## NEW JERSEY.

**Hoboken**—Eclipse Phonograph Co., 205 Washington street.

**Newark**—A. O. Petit, New and Halsey streets.

**Paterson**—James K. O'Dea, 117 Ellison street.

**Trenton**—Stoll Blank Book and Stationery Co., 30 E. State street.

## NEW YORK.

**Brooklyn**—Chapman & Co., Fulton and Duffield streets

A. D. Matthews' Sons, 394 Fulton street.

Price Phonograph Co., 1258 Broadway.

**Buffalo**—P. A. Powers, 643 Main street.

**Elmira**—Elmira Arms Co., 117 Main street.

**Gloversville**—American Phonograph Co., 99 W. Fulton street.

**Kingston**—Forsyth & Davis, 307 Wall street.

**New York City**—Bettini Phonograph Co., 80 Chambers street.

Blackman Talking Machine Co., 19 Beekman street.

J. F. Blackman & Son, 2654 3d avenue.

I. Davega, Jr., 802 Third avenue.

S. B. Davega, 32 E. 14th street.

Douglas & Co., 89 Chambers street

H. S. Gordon, 139 Fifth avenue.

Harry Jackson, 219 Bowery.

Jacot Music Box Co., 39 Union Square.

Victor H. Rapke, 1661 Second avenue.

Siegel-Cooper Co., Sixth avenue and 18th street.

John Wanamaker, Broadway and 9th street.

**Rochester**—A. J. Deninger, 347 North street.

Mackie Piano, O. & M. Co., 100 State street.

Giles B. Miller, 63 State street.

Talking Machine Co., 29 Clinton avenue, S.

**Schenectady**—Jay A. Rickard & Co., 253 State street.

**Syracuse**—W. D. Andrews, 216 E. Railroad street.

**Troy**—James Lucey, 359-361 Fulton street.

**Utica**—Clark-Horrocks Co., 54 Genesee street.

Arthur F. Ferriss, 89 Washington street.

William Harrison, 41 Columbia street.

Utica Cycle Co., 31 Columbia street.

## OHIO.

**Canton**—Klein & Heffelman Co., 216 N. Market street.

**Cincinnati**—Ilsen & Co., 25 W. 6th street.

The Ray Co., 143 West 5th street.

A. B. Wahl & Co., 805 Vine street.

Rudolph Wurlitzer Co., 121 E. 4th st.

**Cleveland**—W. J. Roberts, Jr., Erie and Huron streets.

**Columbus**—Perry B. Whitsit Co., 213 S. High street.

**Dayton**—Niehaus & Dohse, 35 E. 5th street.

**East Liverpool**—Smith & Phillips Music Co.

**Toledo**—Hayes Music Co., 608 Cherry street.

## PENNSYLVANIA.

**Allegheny**—Henry Braun, 500 Federal street.

**Allentown**—G. C. Aschbach, 539 Hamilton street.

**Easton**—William Werner, 401 Northampton street.

**Philadelphia**—C. J. Heppe & Son, 1117 Chestnut street.

Lit Bros., Market and 8th streets.

Penn Phonograph Co., 19 S. 9th street.

John Wanamaker.

Wells Phonograph Co., 41 N. 9th street.

Western Electric Co., 931-933 Market st.

H. A. Weymann & Son, 923 Market st.

**Harrisburg**—S. K. Hamburger, 12-14 N. Market sq.

**Pittsburg**—Theo. F. Bentel Co., Inc., 433 Wood street.

H. Kleber & Bro., 221 Fifth avenue.

C. C. Mellor Co., 319 Fifth avenue.

Pittsburg Phonograph Co., 937 Liberty avenue.

**Reading**—Reading Phonograph Co., 809 Penn street.

**Scranton**—Ackerman & Co., Coal Exchange Building.

Technical Supply Co.

## RHODE ISLAND.

**Providence**—J. M. Dean Co., 785-795 Westminster street.

J. A. Foster Co., Weybosset and Dor-

rance streets.

Household Furniture Co., 231-237 Wey-

bossett street.

Murray, Blanchard, Young & Co., 26-30

Pine street.

J. Samuels & Bro., 154 Weybossett street.

A. T. Scattergood & Co., 106-110 N. Main street.

## TENNESSEE.

**Memphis**—The Ray Co., Lyceum Building.

**Nashville**—The Ray Co., 13 15 The Arcade.

## TEXAS.

**Dallas**—C. B. Harris, Agt., 347 Main street.

## VIRGINIA.

**Richmond**—The Ray Co., 729 E. Main street.

## WISCONSIN.

**Milwaukee**—McGreal Bros., 173 3d street.

## CANADA.

**Toronto**—R. S. Williams & Sons Co., Limited, 143 Yonge street.



# The Problem of the Christmas Gift

Solved by the Edison Trade Who Demonstrate  
"DOUBLE SERVICE" to Old and Young

Mr. Dealer, the illustration on this page must appeal to you as an attractive way to present the Edison Phonograph. Then why not advertise and demonstrate "Double Service"—Amusement and Language Study—remembering that it's the women, by a large majority, who direct the Christmas purchases?

"Double Service" *attracts and proves*. The Christmas buyer is attracted by this unique combination of fun and seriousness. The dealer proves the superiority of the Edison product by an I. C. S. Language Demonstration, calling for the highest type of talking machine.

Be wise and enterprising, and offer "Double Service" Christmas bargains in Edison Phonographs this year. We will help you with advice, price, and literature.

**\$2.00 Holiday Demonstrating Outfit \$2.00**

We supply a Holiday Demonstrating Outfit at cost to the trade, including Moulded Records and Special Text-books in FRENCH, GERMAN, SPANISH, and ENGLISH. Price, \$2.00 net, express prepaid in the United States or Canada. Address:

**LANGUAGE DEPARTMENT**  
**International Correspondence Schools**  
**SCRANTON, PA.**



WHEN THE LANGUAGE LESSON'S DONE  
THEN THE CHILDREN HAVE THEIR FUN

COPYRIGHT

Copyright, 1904, by International Textbook Company

# EDISON Phonograph Monthly

PUBLISHED FOR TRADE USE ONLY BY  
THE NATIONAL PHONOGRAPH CO.

VOL. II.

NEW YORK, NOVEMBER, 1904.

No. 9.

*The National Phonograph Co.,*  
ORANGE, N. J.

NEW YORK: 83 CHAMBERS STREET.

CHICAGO: 304 WABASH AVENUE.

SAN FRANCISCO: 786 MISSION STREET.

NATIONAL PHONOGRAPH CO., LTD., 25 CLERKENWELL  
ROAD, LONDON, ENG.

## EDISON PHONOGRAPHS AND RECORDS.

All communications to THE PHONOGRAPH MONTHLY should be addressed to the Advertising Department, 83 Chambers Street, New York.

### C O N T E N T S

Trade Facts .....	1
Advance List of November-December Records (reprinted from October)...	2
Don't Insist Upon the New Style.....	3
Model D Repeating Attachment, \$7.50....	3
No Records in Other Tongues Just Now..	3
Handle Only Edison Goods Now.....	4
One Selling Method.....	4
Phonograms to the Trade.....	4
For the Equal Benefit of All.....	4
Printed Matter .....	5
One More Chance.....	5
Phonograph Clubs .....	6
Tried It and Bought.....	6
When American Titles Were Listed.....	7
Value of Three Original Records.....	7
Western Aggressiveness .....	8
About an Advertising Record.....	8
Police Superintendent and Phonograph...	9
Two Phonograph Don'ts for Dealers.....	9
To Debate by Phonograph.....	10
The Phonogram in German.....	10
Dealers' Doings .....	11
Reduction Not Necessary.....	11
Opinion of Connoisseur.....	11
November Magazine Advertisement.....	13
List of Suspended Dealers, Nov. 1.....	14
Jobbers of Edison Phonographs and Records .....	15

## TRADE FACTS.

The steps taken by the National Phonograph Company early in September to increase the output of its factory at Orange, N. J., are bearing excellent fruit. An increase of fully thirty-five per cent. has already been secured, and it is expected that by December we shall be able to manufacture at least fifty per cent. more Phonographs and Records than were made in September under what we considered very favorable conditions for turning out large quantities of both. Orders continue to be as numerous and for even larger quantities than ever before, but we are steadily gaining on them, and expect by December 1st to have the situation well in hand.

The decision to drop one month's list and get out a combined list of thirty selections for November-December has been cordially approved by the trade. We are gratified to find that such was the case, for we had some misgivings as to how it would be received and would not have decided upon such a course had it not seemed impossible to do otherwise.

The judgment of the officials of this company, in believing that the combined November-December list is the best ever issued by the National Phonograph Company, has been most emphatically approved by the trade. The number of titles is only twenty per cent. larger than the usual list of twenty-five, but the advance orders were nearly fifty per cent. greater than the October advance orders, which exceeded any previous month in the history of the company. Two months ago it would have been impossible, with other work, to get these ready in one month, but our present facilities will enable us to have the entire lot of advance orders in the hands of the trade before December 1st. The trade may rely upon this and make arrangements for holiday business accordingly. At the same time stock orders

(Continued on page 3.)

**THE ADVANCE LIST OF NOVEMBER-DECEMBER RECORDS APPEARS ON PAGE 2.  
ORDER FROM IT. NO OTHER ADVANCE LIST WILL BE ISSUED.**



# NEW EDISON GOLD MOULDED RECORDS. COMBINED ADVANCE LIST FOR NOVEMBER - DECEMBER, 1904.

**Dealers who have not yet placed their orders for these Records should do so at once. The demand for them is already phenomenal, and it will be greater as the holiday season draws nearer. They will be ready for shipment to Jobbers about November 20th.**

- |      |   |                             |
|------|---|-----------------------------|
| 8826 | The Chirpers ( <i>Frank</i> ) <i>Morceau characteristic</i>   | Edison Military Band        |
| 8827 | Shine On, Oh Stars ( <i>Sawyer</i> ) <i>Song-Romanza, Orch. acc.</i>  | Irving Gillette             |
| 8828 | My Heart's Desire ( <i>Shelley</i> ) <i>Sentimental song, Orch. acc.</i>  | W. H. Thompson              |
| 8829 | Blue Bell ( <i>Morse</i> ) <i>Bells and xylophone duet, Orch. acc.</i>  | Benzler and Hager           |
| 8830 | Save It for Me ( <i>Cole</i> ) <i>Comic song, Orch. acc.</i>  | Billy Murray                |
| 8831 | Has Your Mother Any More Like You ( <i>Keiser</i> ) <i>Miss Nelson and Mr. Stanley</i><br><i>Contralto and baritone duet, Orch. acc.</i>                                    |                             |
| 8832 | Feast of Lanterns Overture ( <i>Bennett</i> )   | Edison Symphony Orchestra   |
| 8833 | Make a Fuss Over Me ( <i>Morse</i> ) <i>Coon song, Orch. acc.</i>   | Arthur Collins              |
| 8834 | What Shall the Harvest Be ( <i>Bliss</i> )  | Mendelssohn Mixed Quartette |
| 8835 | Imagination ( <i>Muller</i> ) <i>Comic topical song, Orch. acc.</i>   | Arthur Collins              |
| 8836 | Pepita Maguire ( <i>Mullen</i> ) <i>Comic song, Orch. acc.</i>  | Edward M. Favor             |
| 8837 | O Come All Ye Faithful ( <i>Adeste Fideles</i> ) <i>Unaccompanied</i>   | Edison Male Quartette       |
| 8838 | Jovial Joe ( <i>Ringleben</i> ) <i>Slow drag cakewalk</i>   | Edison Concert Band         |
| 8839 | Rock of Ages ( <i>Hastings</i> ) <i>Tenor and baritone duet, Orch. acc.</i>   | Campbell and Harrison       |
| 8840 | The Wedding of Barney and Bedelia ( <i>Rogers</i> ) <i>Comic Irish male duet, Orch. acc.</i>  | Collins and Harlan          |
| 8841 | I've Got a Feelin' for You ( <i>Morse</i> ) <i>Banjo trio</i>   | Ossman Banjo Trio           |
| 8842 | Hail! Smiling Morn ( <i>Spofforth</i> ) <i>Christmas carol, unaccompanied.</i>  | Edison Male Quartette       |
| 8843 | There's Nothing New To Say ( <i>Robyn</i> ) <i>Sentimental song, Orch. acc.</i>   | Harry MacDonough            |
| 8844 | Down Tennessee Barn Dance ( <i>Cruger</i> ) <i>Introducing chorus of male voices with banjo acc.</i>  | Edison Symphony Orchestra   |
| 8845 | Down at the Baby Store ( <i>Von Tilzer</i> ) <i>Descriptive song, Orch. acc.</i>  | Byron G. Harlan             |
| 8846 | Little Boy Called Taps ( <i>Morse</i> ) <i>March song by the composer of "A Little Boy in Blue," Orch. acc.</i>   | Byron G. Harlan             |
| 8847 | I May Be Crazy but I Ain't No Fool ( <i>Rogers</i> ) <i>Coon song as sung by Williams and Walker in "In Dahomey," Orch. acc.</i>  | Bob Roberts                 |
| 8848 | The Village Maid ( <i>Hoffmann</i> ) <i>Duet as sung by The Rogers Brothers in Paris, Orch. acc.</i>  | Collins and Harlan          |
| 8849 | Our National Airs—Patriotic poem <i>Talking selection with incidental music by band and orchestra.</i>  | Len Spencer                 |
| 8850 | Medley of War Songs <i>Introducing "Marching thro' Georgia," "Tramp, Tramp, Tramp, etc.," "Glory Hallelujah," "The Battle Cry of Freedom," "Kingdom Coming" and Finale.</i> | Edison Military Band        |
| 8851 | My Little Canoe ( <i>Stuart</i> ) <i>From "The School Girl"</i>   | Edison Symphony Orchestra   |
| 8852 | Birthday of a King ( <i>Neidlinger</i> ) <i>Christmas song, Orch. acc.</i>  | Frank C. Stanley            |
| 8853 | Star of Bethlehem ( <i>Adams</i> ) <i>Song by the composer of "Holy City," Orch. acc.</i>   | Irving Gillette             |
| 8854 | Ring the Bells of Heaven ( <i>Root</i> )  | Chimes                      |
| 8855 | Deed of the Pen March ( <i>Moret</i> ) <i>By the composer of "Hiawatha"</i>   | Edison Concert Band         |

Edison Gold Moulded Records are made only in Standard size. Both Standard and Concert Records may be ordered from this list. Order by Number, not title. If Concert Records are wanted, give the number and letter C.

(Continued from page 1.)

for Phonographs and Records will have their full share of attention. Dealers who are delaying placing stock orders with their Jobbers should get busy, for with the passing of Election Day trade is going to be even better than it is now. The demand for Edison Phonographs and Records continues to grow by leaps and bounds, and the Dealers who do not keep up their stocks will have much to regret.

The reduction in the price of Edison Gold Moulded Records to thirty-five cents cannot alone account for the remarkable demand for Edison goods, for the sale of machines is fully as great as that of Records and no change has been made in the price of machines. It shows beyond cavil that the public are more and more recognizing the superiority of the Edison Phonograph and with the fullest opportunity of trying all others are choosing Mr. Edison's invention. It must be admitted, however, that the high standard of quality of Edison Gold Moulded Records has much to do with the popularity of the Phonograph.

#### **DON'T INSIST UPON THE NEW STYLE.**

Occasionally an order is received from a Jobber for stock Records with the direction that it be filled only with the new style cartons and the new style marking on the end. The Jobber has probably been induced to make out his order in this way because his Dealers have made a similar stipulation. Since it is impossible, at present, to fill such an order in its entirety, part of it is returned to the Jobber, with a letter explaining the situation. The Jobber in turn passes the information on to his Dealers. In this way much time is lost in getting goods.

A word of explanation will aid the trade in understanding why we cannot as yet fill all orders for the new style box and marking. When these changes were decided upon we at once began to make over all the moulds of the titles already listed. There were over 1,100 of these in the domestic catalogue alone. This work has progressed steadily and is constantly going on, notwithstanding the great demand for Records. As fast as moulds are changed over all orders for such titles are filled with Records marked on the end and put up in the new box, and this will be continued whether so stipulated in the orders or not. It will, however, be two or three months more before the work of changing the moulds will be completed, at which time we will advise the trade of the fact. Until then it will be useless to direct that orders *must* be filled

under new conditions. Such insistence will only cause correspondence and delay. There is no objection to a preference being expressed and it will be followed as far as possible.

Whether marked on the end in the new style or not, we are packing as many Records in the new boxes as we can get boxes for, the demand for boxes exceeding the capacity of the manufacturer to turn them out. We have had some inquiries from the trade to know whether a quantity of the new boxes could be purchased. This will not be possible until the manufacturer can make a greater number daily than at present.

#### **MODEL D REPEATING ATTACHMENT, \$7.50.**

The retail price of the new Model D Repeating Attachment, fully described in the October issue of the EDISON PHONOGRAPH MONTHLY, has been fixed at \$7.50, subject to the same trade discounts as repeating attachments previously listed. Considering the great superiority of the Model D over anything else of the kind on the market, this price is unusually low, and it should be followed by a large and widespread sale. Every progressive Jobber and Dealer should get at least one, and learn how to attach it to either the Home, Triumph, Concert, Victor and Conqueror Phonographs, or have it attached to a machine coming from the factory, and use it to exhibit the peculiar effectiveness of the device. It is fascinating to watch it in operation and it is hard to realize that it is not guided by human hands. Almost any ingenious Dealer can attach the device from the directions furnished. In ordering, state what type of Phonograph the device is wanted for. Hundreds of Phonograph owners would be glad to get a repeating attachment, if they knew how little it costs and how cleverly it works. Properly attached it will not fail to operate and give satisfaction at all times.

#### **NO RECORDS OF OTHER TONGUES JUST NOW.**

We have had inquiries from Dealers and correspondents for Swedish, Slavish, Portuguese and other foreign Records, and the hope expressed that we might soon make Gold Moulded Records in those languages. Inability at present to meet the demand for Records in the languages spoken by the greater number of persons is the only reason why every language is not represented in the catalogue of Edison Gold Moulded Records. We expect some day to make our Records in every tongue spoken by a large number of persons. but at present we cannot do so.



### HANDLE ONLY EDISON GOODS NOW.

The mails daily bring letters from Dealers stating that they are now handling only Edison goods, and similar reports are made by our salesmen from all parts of the country. Since July hundreds of Dealers have disposed of their stock of other goods, and increased their supply of Edison Phonographs and Records and declared their purpose of handling only the Edison line hereafter. Others state that they will do the same thing as soon as they can get rid of other goods they have on hand. Edison Phonographs and Edison Gold Moulded Records meet every demand for quality and price and a Dealer makes no mistake when he handles them alone and bends all his energies to pushing their sale. Once in a while a customer may ask for another style machine and for other records, but when the merit of the Edison product has been pointed out to him, it is seldom that he is not willing to buy an Edison Phonograph. Once an owner of an Edison outfit he is glad that the difference was made clear to him. He then becomes an enthusiast and not only thinks that the Edison Phonograph is far ahead of other types, but he freely asserts that his particular machine is the best one ever made.

### ONE SELLING METHOD.

One of our Jobbers, who requested that his name should not be published, recently gave us an interesting account of one of the methods used by his firm to sell Edison Phonographs. His house carries several other lines and has a number of men on the road all the time. These men get into sections where a traveling salesman is almost unknown. "One of our men will go into a country store," said he, "and get permission to play a few Records. It is only too willingly granted, for the proprietor has his own curiosity and then he knows that it will bring the neighbors into his store. The word that 'one of Edison's talking machines' is down at Brown's is quickly passed around and in a surprisingly short time our man has a good sized crowd listening to the music and his comments on the merits of the machine. Finding that he is going to remain some time, the women and children are sent for and they too listen with every sign of pleasure. It is seldom that one of these seances does not result in the sale of one or more machines, paying a handsome profit over all the expenses of our man, who has also sold the proprietor a nice line of goods."

### PHONOGRAMS TO THE TRADE.

Following is a schedule of prices at which *Phonograms* may be obtained by the trade:

#### DELIVERED WITH GOODS.

Blank, per 1000 copies.....	\$2.50
Smaller quantities pro rata.	
Imprinted, per 500 copies.....	1.50
Imprinted, per 1000 copies.....	2.75
No orders filled for less than 500 copies requiring imprint, and all imprinting orders must be for multiples of 500.	

#### BY MAIL.

Single copies, per year.....	\$ .20
Five copies to one address, per year.....	.40
Twenty-five copies to one address, per year.....	1.80
Fifty copies to one address, per year.....	3.60

Unless they have open accounts on our books, Dealers ordering Phonograms sent by mail are requested to send cash or stamps with their orders. The amounts are too small to handle in any other way.

Orders requiring imprinting or changes in imprint must be placed four weeks in advance of the month desired. We do not aim to carry a stock of blank copies and cannot promise to fill orders unless placed in advance. The July, August and September editions were sold out before the printer had completed deliveries.

### FOR THE EQUAL BENEFIT OF ALL.

"After reading your article, 'Our Follow Up System,' in the September PHONOGRAPH MONTHLY, I am prompted to write and ask *why* I have received none. I am the only dealer in \_\_\_\_\_ which is surrounded by large towns, that should send you many inquiries. I do not buy goods direct, but suppose that makes no difference."

Thus wrote a Connecticut Dealer on September 13th. We replied that the reason why no inquiries had been referred to him was because none had happened to come from his vicinity. We assured him that the system was operated for the benefit of all Dealers, whether buying direct or through Jobbers, and so long as Dealers coöperated with us in following up no one would be overlooked. No sale is ever made by us direct in territory where our goods are sold by Dealers, except where customers insist upon our filling their orders. This seldom occurs where Dealers carry a proper stock of our goods. The trade has our first consideration at all times, but if Dealers cannot supply our goods they should not find fault with customers who send their orders to us, or write us for filling them.

### PRICES OF EDISON RECORDS.

**Edison Gold Moulded Records, standard size, are sold in the United States at 35 cents each, and in Canada at 40 cents each. The Canadian price is higher because of the duty. Edison Concert Records are sold at 75 cents each in both countries.**

**PRINTED MATTER.**

We have on hand a quantity of Form No. 516, the folder gotten out in December of last year, and will fill reasonable orders for it as long as the supply lasts. It is just as useful for interesting prospective customers as it was a year ago, and can be used to advantage by progressive Jobbers and Dealers. We will mail a copy to any Jobber not familiar with the form.

Owing to the failure of the printer of the cover of Record Catalogue No. 600 to make deliveries as promised, we have been compelled to reprint part of the August edition of this catalogue with a less attractive cover. We deemed it better to do this than to ask Jobbers to wait till the regular covers could be obtained. The catalogues now going out bear this special cover. Jobbers who receive them will understand that except for the covers they are the same as all Record catalogues issued since August 1st.

We shall have ready for the trade about November 20th an attractive four-page folder in two colors for use in connection with holiday season. It will be Form No. 611. It will have special reference to Christmas and if put into circulation at once should favorably affect holiday trade. The edition being printed will permit us to fill orders for liberal quantities. We should like to have Jobbers place orders at once and arrange to pass some of them along to their Dealers. As far as possible Jobbers' orders will be shipped with the November-December Records. Sample copies will be mailed early in November.

Occasionally a Dealer suggests that we get out the monthly list of new Records in the form of a post card instead of the present form. Superficially the idea seems good. The trade would simply have to address them, put on a one cent stamp and mail them. From our side the plan has too many objections to be feasible. In the first place the present form is satisfactory to ninety per cent. of the trade and fully one half would prefer it to a post card. To meet the views of all it would be necessary to get out two styles, with the almost endless trouble of finding out which wanted which and the heavy waste consequent upon doing so, to say nothing of the duplication of quantities with two kinds, where one style now suffices. Allowing for the sake of argument that all would use a post card, the increased cost of using card board instead of paper must be considered. At a low estimate this difference would be \$1,500 a year. Then the list each

month would crowd an ordinary size post card so that there would be no room for the incidental advertising possible with the present style and no room for Dealers' names and addresses. If the card was made large enough to permit this, it would cost at least another \$1,000 a year for the extra stock. There is no likelihood, therefore, of anything being done with the post card suggestion for some time.

Following is a list of the active printed matter forms of the National Phonograph Co.:

- 400. Chinese Record Supplement.
- 409. Card showing boy and hatchet.
- 425. Record Order Blanks (Sheets A to D for American selections; sheets E to G for Foreign selections).
- 427. Pamphlet on Art of Making Phonograph Records.
- 464. Japanese Record Supplement.
- 484. Accessories Catalogue.
- 508. British Record Supplement.
- 515. Parts Catalogue.
- 516. Four-page Holiday Folder (only a limited number on hand).
- 535. Four-page Machine Folder.
- 550. St. Louis Souvenir Booklet.
- 555. Foreign Record Catalogue.
- 570. British Record Supplement.
- 581. September Record Supplement.
- 582. October Record Supplement.
- 583. November-December Record Supplement (Cannot be furnished till November-December Records are out.)
- 600. Domestic Record Catalogue.
- 611. Four-page Christmas Folder. (Ready November 20.)
- 625. New Machine Catalogue.

Forms previously listed and not given here are either out of print or the quantities on hand will only permit the filling of small orders. Jobbers who find that their orders for these forms are not filled will understand that it is because none are in stock.

**ONE MORE CHANCE.**

**In beginning to remove from our files and mailing list the names of Dealers who had not signed the new agreement we found that the agreements of several of our good friends had not reached us, owing to some error or oversight. Fearing that there might be others in the same way, we mailed on October 31st a special letter to every old Dealer who had not re-signed, calling his attention to the fact and giving him until November 7th in which to return his agreement through his Jobber or direct to us. After that date we will consider that those who do not sign are no longer interested in the business and will remove their names. To again become a Dealer after this is done it will be necessary to purchase the initial quantity over again.**

**Jobbers will please check up the names of their Dealers and follow up those whom they know are still in business and intend continuing in it. A little attention now will save much trouble and correspondence later.**



### PHONOGRAPH CLUBS.

One of the most comprehensive pieces of Phonograph literature that we have received in some time is a large four-page circular sent us by Alfred K. Hobbs, a Dealer at Manchester, N. H. It is headed "How to Obtain a Phonograph for Your Home," and explains in detail how to purchase an Edison Phonograph by joining one of his Phonograph Clubs. Because of the admirable arguments presented by Mr. Hobbs, we take pleasure in reprinting part of the circular, as follows:

#### OUR CLUB PLAN.

That everybody may enjoy the Phonograph is the aim of the Edison Phonograph Club. Probably you have given the matter of its purchase some consideration, and possibly decided that while you would like the Phonograph you do not care to make the spot cash outlay necessary for its possession. Our club plan solves this problem for you. By joining one of our clubs you have the use of the outfit while paying for it in small weekly sums which you will not feel. Three, five or ten dollar membership fees are amounts within everybody's purse, and the weekly dues of seventy-five cents to three dollars will not be missed from your income. We deliver the club outfit to you at once upon payment of membership fee. One week from the day you receive your outfit the first weekly dues are payable and each week after until the specified number of payments have been made. We then give you a receipt in full and you are the owner of your outfit.

There are four popular styles of the Phonograph, and each style is handled by a separate club, explanation of which you will find in detail on pages following. Each club includes a Phonograph complete with Records and every requisite for its immediate use and your entertainment.

#### HOW TO BECOME A MEMBER.

Mail to me the amount of membership fee corresponding to the special club which you wish to join and I will deliver to you the outfit F. O. B. Manchester. Or to convenient, call at my Phonograph Parlors, 1070 Elm street, Manchester, N. H., and make arrangements there. One of our club representatives will call at your home if you so request by mail or telephone. Telephone number 242.

You may feel certain of liberal and courteous treatment and reasonable leniency in case of sickness or inability to meet your dues for any special reason.

#### WHAT THE PHONOGRAPH IS.

Almost everybody has heard the Phonograph, but few have heard it at its best, and few appreciate its true value as an entertainer. It gives you at your pleasure, the singing and speaking voice, instrumental solos or full band, just as clear, just as sweet, as the original tones, and with sufficient volume for the home. It makes it possible for you to hear in your own parlor the finest talent in any line which is at the service of the public at concert or theatre. It is superior to all other instruments because of its endless variety. For the home it stands absolutely alone and at the head.

#### AS AN ENTERTAINER.

To be able to have at your command and pleasure, in your own home, the best music, instrumental, vocal or band, is the privilege of the Phonograph owner. You have the choice of any style of instrument and the newest and best things produced for the public's pleasure can always be obtained—obtained, too, while they are new. When the long cold winter evenings make home staying dull, the Phonograph helps to agreeably pass the hours. It entertains your friends as well as yourself, and keeps the family circle complete by adding an interest to the home. You can have a waltz in your own parlor to the finest music through the Phonograph or give a Phonograph party and have your friends make records which can be reproduced while they wait.

#### A RECORD.

Sound waves recorded on little wax cylinders for your pleasure at will is what a Phonograph record means. Not the least of all pleasure will be found in making records—You can record any instrument as well as the voice. Blank cylinders sell for 25 cents each.

#### A LAST WORD.

If there is any further information which you would like, write me, or call at my sales-room, and I will give it. In ordering by mail be careful to write name plainly, and give your street and number and town in which you live. The time to join a club is now, and so have the full benefit of the club at once.

Then follows a detailed reference to each club. The Gem Club, including a Gem outfit and five Records, costs \$15, with membership fee of \$3 and 75 cents weekly dues for sixteen weeks. The Standard Club, including a Standard outfit and five Records, costs \$25, with a membership fee of \$5 and \$1 weekly dues for twenty weeks. The Home Club, including a Home outfit and six Records, costs \$36, with a membership fee of \$10 and \$1.50 weekly dues for eighteen weeks. The Triumph Club, including a Triumph outfit and twelve Records, costs 65, with a membership fee of \$25 and \$3 weekly dues for fourteen weeks.

#### TRIED IT AND BOUGHT.

W. Hobson, an Edison Dealer at Vincetown, N. J., writes about an interesting experience in selling an Edison Phonograph recently. One of his customers had another style machine but was buying Edison Records. One day Mr. Hobson took a Standard Phonograph to his customer's house and asked if he could not leave it there till he returned, consenting to having it used in the meantime. A few days later the man brought the Standard back himself. Mr. Hobson hoped that he had had a pleasant time with it, but did not urge him to buy it. "In less than a week," wrote Mr. Hobson, "he came back for it. I have since sold him ten dozen Records, besides a large horn and a Record-gr. Now he says that his machine is the best in the world and Edison Gold Moulded Records are his choice."

#### ENTERTAINMENT AND BUSINESS.

NEW YORK, October 17, 1904.

It is with pleasure that we write these few lines and relate our experience with Edison goods. A certain political club asked us to give an entertainment at one of their meetings. We picked out six dozen Records and a Home. We started with "Stars and Stripes Forever," and wound up with "Home, Sweet Home," and the sensation was a grand surprise. The audience was spellbound. We had to play several pieces over and over. And the best success of all was that we sold four Home machines and nine dozen Records the same evening. Keep it up.

BRONX AIR LIGHT Co., INC.

### WHEN AMERICAN TITLES OF EDISON GOLD MOULDED RECORDS WERE LISTED.

The manufacture of Edison Records by the wax process was discontinued in 1902, being superseded at that time by the Gold Mould process now used. In the early part of the year catalogue No. 350 was issued, giving 678 selections made by the new process. In June, 1902, the first regular monthly list of Gold Moulded Records was issued. It began with 8004 and ended with 8033. In the same month announcement was made that five wax selections had been made over by the new process. In July, 1902, another regular list was issued, beginning at 8034 and ending at 8063. At the same time it was announced that a number of old style selections had been made over by the Gold Mould process and given new numbers. These ran from 8064 to 8076. Announcement was also made seven old style selections had been made over with no change in their numbers. The regular August list ran from 8077 to 8098; old style selections were made by the new process and given numbers from 8099 to 8109; and two old styles were made over with no change in numbers. The regular September list included numbers 8110 to 8125; new numbers running from 8126 to 8158 were given to thirty-three old styles made over; and announcement was made of fifty-two selections made over with no change in numbers.

In October, 1902, only the regular list was issued, and this has continued in unbroken order up to the present, only regular lists being issued each month. The following table shows the numbers gotten out since the beginning of this regular system and the months in which they were listed:

NOS.	MONTHS ISSUED.
8159 to 8207 inclusive (49)	October, 1902.
8208 to 8245 inclusive (38)	November, 1902.
8246 to 8281 inclusive (36)	December, 1902.
8282 to 8314 inclusive (33)	January, 1903.
8315 to 8346 inclusive (32)	February, 1903.
8347 to 8376 inclusive (30)	March, 1903.
8377 to 8391 inclusive (15)	April, 1903.
8392 to 8403 inclusive (12)	May, 1903.
8404 to 8423 inclusive (20)	June, 1903.
8424 to 8448 inclusive (25)	July, 1903.
8449 to 8473 inclusive (25)	August, 1903.
8474 to 8498 inclusive (25)	September, 1903.
8499 to 8523 inclusive (25)	October, 1903.
8524 to 8548 inclusive (25)	November, 1903.
8549 to 8573 inclusive (25)	December, 1903.
8574 to 8598 inclusive (25)	January, 1904.
8599 to 8623 inclusive (25)	February, 1905.

8624 to 8648 inclusive (25)	March, 1904.
8649 to 8673 inclusive (25)	April, 1904.
8674 to 8698 inclusive (25)	May, 1904.
8699 to 8723 inclusive (25)	June, 1904.
8724 to 8748 inclusive (25)	July, 1904.
8749 to 8773 inclusive (25)	August, 1905.
8774 to 8799 inclusive (26)	September, 1904.
8800 to 8825 inclusive (26)	October, 1904.
8826 to 8855 inclusive (30)	Nov.-Dec., 1904.

### VALUE OF THREE ORIGINAL RECORDS.

The question of what value can be placed upon a Phonographic record of a dead sister's voice will be the question to be decided by the Cherry Sisters, whose notoriously rank show has made a success solely for the reason that it is the most ludicrous attempt at acting ever put before the American people in sincerity.

Manager Higley, of the Grand Theatre, received a communication from the Cherry Sisters, now at Cedar Rapids, Iowa, inquiring as to the identity of the party here who took the record of their little sister Jessie's voice. Manager Higley has learned that the party is a former attache of the Grand and now in the newspaper work here.

The holder of the three records has opened negotiations with the sisters and has asked them to place a figure on the three records. He will hold them at \$100, although advised to make the price \$500, one man agreeing to take up the negotiations on a commission of all over \$100.

The records of little Jessie's voice are probably worthless to the present holder as far as their use is concerned, but to the Cherry sisters, who desire to hear once more the voice now stilled in death, they would be invaluable, hence the feeling on the part of the owner that they are worth at least \$100.

If the Cherry sisters have laid aside any of the good coin handed over by those who have laughed themselves sore at a performance intended to be serious, they may be in a position to meet the demands of the individual monopoly.

While the mere mention of the name of the Cherry sisters and "Little Jessie" brings a smile to regular patrons of the theatre, there is an element of pathos in the desire to hear a dead sister's voice that cannot be ignored, and it is to be hoped that the milk of human kindness will not be soured in the progress of negotiations for the Phonographic records.

The holder of these records says he has no desire to gouge the sisters, even though they have been doing that for the public for a number of years, and under such circumstances could not be expected to resort to poetic justice.—*Portsmouth (Ohio) Daily Blade.*

**Dealer: If you have not yet signed the new agreement and intend remaining in the Phonograph business, sign at once. It will save you trouble later.**



### WESTERN AGGRESSIVENESS.

Some especially fine advertising of Edison goods is being done by McGreal Brothers, Jobbers at Milwaukee, Wis. It is being done in the daily papers of that city, moderate space being used on week-days and large space on Sundays. Most of this advertising is in the form of specially illustrated plates. One of these announcements occupied a space of five columns wide and a half column deep. It showed a circular panel in the center and square panels in each of the four corners. In the upper left-hand panel was a fac-simile of the first order placed by the firm on August 12th, 1902. This was for 75 Standards, 15 Homes, 10 Gems and 5,000 Records. The upper right-hand panel showed a fac-simile of the acceptance of C. H. Wilson, manager of sales of the National Phonograph Co. In the lower left-hand panel was a reproduction of the order placed by the firm August 31st, 1904, for 1,200 Standards, 600 Homes, 200 Gems and 27,000 Records. Opposite to this was a fac-simile of Mr. Wilson's acceptance of the order. In the center panel was the following:

DRAW YOUR OWN CONCLUSION.

Compare our first order of August, 1902, with the one of August 31, 1904. Why have we sold nearly 8,000 Edison Phonographs and over 200,000 Edison Gold Moulded Records within this short time? We think we can tell you.

*Because the Edison Phonograph is a machine of merit and every time we sell one we make a friend.*

Any person who will look into the matter of talking machines carefully when ready to buy will select the Edison. It is *the* machine.

Our policy of extending credit has also helped our business. We are proud of our record. We are thankful to our friends and customers.

McGREAL BROS.,  
173 Third St.

Another striking advertisement of McGreal Brothers showed an Edison Phonograph standing in a niche in a wall, illustrating the phrase "In a Niche by Itself."

### ABOUT AN ADVERTISING RECORD.

WAUSEON, O., Oct. 14, 1904.

I notice in the PHONOGRAPH MONTHLY for October, page 13, under caption "An Advertising Record," something which reminds me of my experience at our county fair, where we gave an exhibition, and where, as stated in this article, I, too, felt the need of a talking record for advertising purposes. In fact, I felt the need before I went out, and therefore, as *Mrs. Partington* says, "I took time by the fetlock," and provided myself with a good recorder and several blanks, and said the things to the machine which I wished to say to the people, and let it repeat it to them, and I

did not fail to have a large crowd about me at all times. I even heard some of them say: "Oh, that was already made on the record," but I took that idea out of their heads by inviting them to tell me what to say. I think this method better than to use a regular stock Record for the purpose, as you will be able to secure more interest in that way and incidentally do a little private advertising that would be impossible with a stock Record. Of course a person should not attempt such a thing unless he knows that everything is O. K. and he is sure of good results.

EUGENE ALDRICH,

Of Aldrich & Richmond.

Mr. Aldrich's letter points out one of the chief difficulties in the way of getting out a stock advertising Record. In the past several suggestions have been made to us as to what would be suitable for a Record of this kind, but no two have been alike. On the contrary, they have shown the widest variance. After all, any Dealer who finds the need of an advertising Record can easily make one himself and have it make an announcement unlike that of any one else.

### A GOOD RECORD A STIMULUS TO TRADE.

I think from all indications here that the trade will be very heavy during the next four or five months. Am now selling many of your Records, considering the size of the place, and some machines. Have some cylinder records of another make which I handled before your reduction in prices to meet the demand for cheap records, but since your reduction to 35 cents I have not sold as many as a dozen, and guess I am "stuck." However, I am glad you have reduced your price, as it is more satisfactory to sell a good record than a poor one. A good record acts as a stimulus to trade, while a poor one has a depressing effect. Almost invariably when a party has been using records of an inferior kind and buys a few of the Edison he comes back in a few days for more Edisons.

E. T. GASSETT,  
Cerro Gordo, Ill.

### NONE ON EARTH BUT THE EDISON.

BOWLING GREEN, O., Oct. 15, 1904.

I am greatly interested in the Edison goods and am trying hard to cooperate and conform to all your rules and methods. I made an exhibit of the Edison at our fair here last month, and am surprised and delighted with the business I am doing in these goods. In my estimation of merit there is no talking machine on earth but the Edison.

R. V. SLAUSON.

### GOOD ENOUGH.

PLYMOUTH, MASS., Sept. 26, 1904.

Edison Records and machines take the prize here. Can't sell any other and don't care to try, as they are good enough for me. Yours for more business.

LEOPOLD J. SCHREIBER.



#### WINDOW DISPLAY OF THE OUTLET COMPANY, PROVIDENCE, R. I.

The above half-tone shows a fine window exhibition of Edison Phonographs and Edison Gold Moulded Records made by the Outlet Company, of Weybosset street, Providence, R. I., conducted by J. Samuels & Bro. The exhibit is marked by unusual taste and ingenuity. This enterprising department store has

been handling Edison goods only a year, but it has been most successful in building up a large business on the cash and easy-payment plan. It has a separate room for its jobbing business. The firm has a force of salesmen who travel all over New England.

#### POLICE SUPERINTENDENT AND PHONOGRAPH.

At a garden party at the house of the German Chancellor of the Exchequer, Count von Buelow, the Superintendent of Police in Berlin, Herr von Borris, spoke the following characteristic sentences into an Edison Phonograph which had been prepared for it:

"The principal duty of a police constable is to act in accordance with his calling; that is to say, he should work for the protection and safety of the public. This he will find an easier task when the public recognizes his office and ceases to regard him as a public enemy. His duty will be easily performed when he is sure of public support, and it is to be hoped that he will be able to reckon on this more and more in the future."

"It would be a good plan," remarks the *Berliner Tageblatt*, "to make many duplications of this record and to have same played in every police station. The public would thus be made acquainted with the wish of the Superintendent."—*Berlin Phonogramm*.

#### TWO PHONOGRAPH DONT'S FOR DEALERS.

Don't hold back your orders for Phonographs and Records. No matter from whom you buy, get your orders in early. Anticipate your wants and have the goods on hand when your trade wants them.

Don't fail to make up mailing lists of probable customers and send some printed matter to them regularly. Have one list of individuals who do not own Phonographs and make a regular effort to interest them. Have another list of Phonograph owners in your territory and send them a list of new Records each month.

It is probably not a mere coincidence that the demand for Record Supplements has been quite as heavy as the demand for Records in the past three months. Dealers are making up lists of Phonograph owners and sending them a Supplement each month. They are finding it an excellent way to get business.



### TO DEBATE BY PHONOGRAPH.

To have debates with clubs in distant cities without visiting them, John F. Macklin has organized the Wachusett Debating Club, and will negotiate with societies in Boston, Springfield, Hartford, Providence and other New England towns to arrange debates by means of Phonograph records.

It is Macklin's intention to have a certain subject chosen, then picked debaters are to speak into receivers and the records will be exchanged. Upon a given night each club is to meet in their respective cities and turn on the flood of oratory. Judges at each end will give decisions and by letters the winners are to be made known.

After explaining how it was intended to carry on the debates, Mr. Macklin said:

"One advantage of giving a debate with Phonographs, is that it gives the timid orator a chance. After he has his speech prepared he can give it in seclusion. He will not be troubled with stage fright. He can face the record and put in his speech all the fervor and enthusiasm he is capable of. He can listen to it and if not satisfied with it, reel off another one.

"Another advantage is that it limits the speaker. He has a certain time in which to talk, and knows he must advance his best points. He realizes this, and the listeners are not forced to hear a lot of meaningless rhetoric. It will be a great help to those who wish to learn how to condense arguments. It will urge them to practice, and that makes perfect.

"The average debater will not find it as easy as it looks to debate by Phonograph. The old way is simpler. By that method he can say what he pleases, and his time is not limited. He can talk all night to explain his meaning, if he wishes.

"This cannot be done by the Phonograph system. Brevity counts. A verbose speech will lose the debate. Every unnecessary word, no matter how fine it may sound, must be eliminated. Facts have to be boiled down."—*Wachusett (Mass.) Telegram.*

### THE PHONOGRAM IN GERMAN.

The Edison Gesellschaft, M. B. H., which is the name of the Berlin, Germany, branch of the National Phonograph Co., began on September 15th the publication of *The Phonogramm* in German. It is in no particular, however, a reprint of the *New Phonogram*, but is original throughout. The Preface to the first issue was as follows:

The genuine Edison Phonograph is not a toy, neither does it serve only as a pastime, nor simply for an interesting amusement. It is rather the means for the greatest enjoyment of art.

Music of the first order, in order to hear which it has hitherto been necessary to visit the

opera or the concert room, at great expense, has now by means of the Edison Phonograph been brought into the home and the family circle. The most celebrated singers, whose ringing notes are paid by untold gold; the most wonderful orchestras, to whose concerts enraptured crowds are ever thronging, are ready to let their glorious tones ring through our home.

The most costly musical treasures of which all mankind is proud pour with perfect harmony and clearest purity, from the horn of this wonderful machine.

Each possessor of a genuine Edison Phonograph has secured Terpsichore for his personal friend. Nevertheless in the end one would be sure to tire of even this if it were necessary to listen again and again to the same works.

For this reason the Edison Gesellschaft is working untiringly to separate the best from all good works and to include the most costly pearls of music in the wonderful collection of Edison Records.

The object of this Journal is to keep possessors of Edison Phonographs always *au courant* as regards this continual work of obtaining the very latest works of art. We are not an advertising journal, and these pages will therefore not be distributed among the general public, but only to the friends of ours, who have given proof of this denomination by their possession of a genuine Edison Phonograph. To such this page is intended to give in the fullest and clearest manner information about all the novelties in the Phonograph line. But this is not all. The "Phonogram" will give the most exhaustive instructions for making of records, in this manner appreciably increasing the pleasure obtainable from the genuine Edison Phonograph. In conclusion the Phonogram is intended for the making known of many points of interest to the Phonographic trade in general. Every possessor of an Edison Phonograph has a certain pride—which is fully justified—namely, the pride of possession. It is not every one who is the possessor of a machine capable of giving noblest form of amusement, for it is not to be wondered at that everything connected with the realm of the Phonograph, serious or light, good or bad, great or small, awakes interest and it is for this interest that it is our intention to cater. It is, then, the object of this, our Phonogram, to keep awake in every reader the interest and appreciation for his Edison machine. We wish to increase and magnify it, and in this manner to form a friendly circle in connection with the Edison Gesellschaft and its clientele.

### CONGRATULATIONS.

Oct. 13, 1904.

We wish to congratulate you most sincerely on the samples for the November-December list, recently received. The character of the selections is far above the average, and the manner in which they are produced will commend the entire list to all Phonograph owners, besides contributing as a great help in selling machines. Wishing you every success, we are,

C. J. HEPPE & SON,  
Philadelphia, Pa.

**DEALERS' DOINGS.**

Among copies of newspaper advertisements of Edison goods, received from Dealers during the month, was one from H. Schmidt & Son Co., of Muscatine, Iowa, which occupied a third of a page in the *Muscatine Journal*.

F. N. Green, an Edison Dealer at Willimantic, Conn., has again received a special award at his county fair for the superiority of his exhibit of Edison Phonographs and Edison Gold Moulded Records over all others.

Albert A. Magwire, Dealer at Springfield Vt., sends a programme of a Phonograph concert that he gave in Ludlow Town Hall on the night of October 25th. An admission fee was charged. A selected list of Edison Gold Moulded Records was played and the Phonograph was assisted by two young lady pianists.

The Outlet Company, of Providence, R. I., gave a most thorough demonstration of the satisfactory manner in which records may be made with an Edison Phonograph, at their store, on October 7th and 8th, when they had Arthur Collins and Byron G. Harlan make special master records for the patrons of the Phonograph Department.

**A REDUCTION NOT NECESSARY.**

The organization of the National Phonograph Co., Ltd., in England and the prosecution of an adequate campaign for the sale of Edison goods had the same effect upon competition in Great Britain that the demand for Edison Phonographs and Records had in "the States"—it compelled competing manufacturers to reduce the prices of their records to lower prices than Edison Records, as the only alternative to being driven out of the field. The reductions led to rumors that the National Phonograph Co., Ltd., contemplated a similar reduction in the price of Edison Gold Moulded Records, and made it necessary to get out a circular letter on the subject and send it to the trade. It was as follows:

TO DEALERS IN GENUINE EDISON PHONOGRAPHS  
AND GOLD MOULDED RECORDS.

Having received a number of inquiries of late as to whether or not we intend reducing the price of genuine Edison Gold Moulded Records during the present or coming season, we beg herewith to notify all our trade that we have no intention whatever of reducing the retail price of our product.

We wish, furthermore, to state that in our opinion nothing which has occurred of late makes it in any way necessary for us to reduce the price at which the Genuine Edison Record will be sold to the public.

The superiority of the Edison Record is an acknowledged fact, and our bookings for delivery up to January 1st, 1905, are already almost

100 per cent. heavier than at this time last year, so that at the present time the indications are that we shall have more orders than we can fill.

We wish to impress upon Dealers the necessity of placing their orders for their season's supply with our factors at the earliest possible date, as we fully believe the demand for our Records will greatly exceed the supply during the two months before Christmas.

Very truly yours,

NATIONAL PHONOGRAPH COMPANY, LTD.

This announcement was received with expressions of approval by the entire trade. Among the many letters received was the following from a Dealer at Lincoln, England:

September 28, 1904.

We thank you for circulars to hand *re* price reduction. We are quite convinced there is absolutely *no necessity* to reduce the *price* of your Records. Since other companies have reduced their prices we have found the sale of your Records have doubled. People will have them and no other. We intend shortly opening a wholesale warehouse. Can you please quote us factor's prices for your Records and machines?

LINCOLN TALKING MACHINE CO.

**THE OPINION OF A CONNOISSEUR.**

The following letter was recently received at our Berlin branch:

"I have for a short time been in possession of an Edison Standard with about three dozen Edison Gold Moulded Records and a large quantity of \_\_\_\_\_, \_\_\_\_\_ and \_\_\_\_\_ records, besides the \_\_\_\_\_ with seventy of the best disks. The reason I bought an Edison Phonograph was because I wish to make records myself of a musical and rhetorical nature, which I have succeeded in doing with the aid of various horns and dispositions. My efforts have been crowned with no small measure of success. By chance I tried several Gold Moulded Records and was astonished to find that this small article used with the concert horn gave results which were in every way equal in purity and clearness of reproduction to those of the \_\_\_\_\_ with best disks. Selected Edison Records appear to me indeed to be superior to selected \_\_\_\_\_ disks, inasmuch as the reproduction is in no way interfered with by disagreeable sounds, and is at the same time more agreeable, more natural and more melodious.

"The final victory of the Edison Phonograph with its solid construction and perfect reproducing apparatus, together with the practical shaving attached over the scratching needle-grinding disk machines should come as a matter of course."

**HAS HAD WONDERFUL SUCCESS.**

TURNER'S FALLS, MINN., Oct. 17, 1904.

I would like to say that I think your policy is the right one. I have found wonderful success in your line. Since I took it on my sales have amounted to about \_\_\_\_\_ per month, while the past year on other makes I failed to make even a start.

G. A. GOVE.



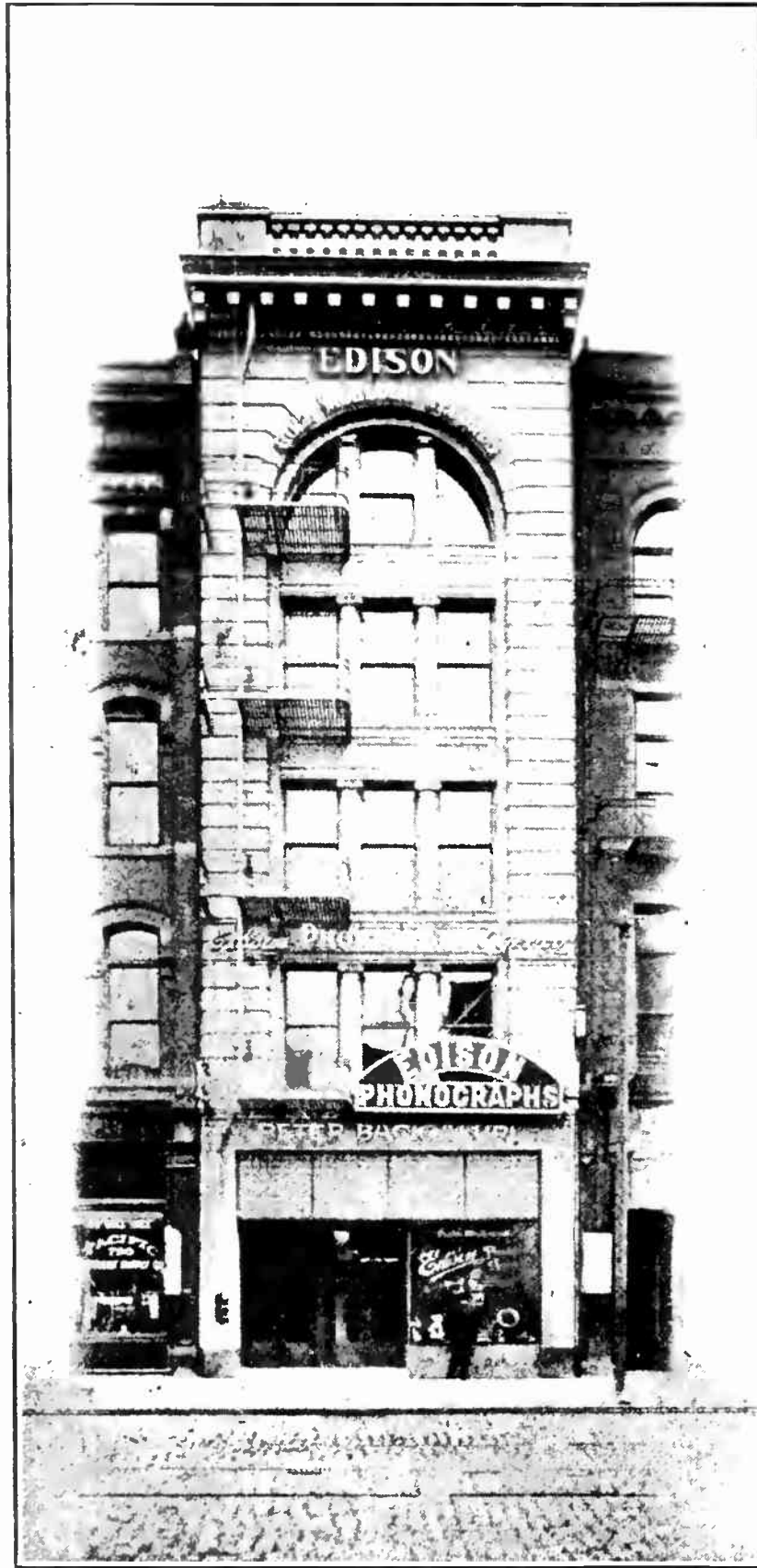

**HEADQUARTERS OF PETER BACIGALUPI, 784-786 MISSION STREET, SAN FRANCISCO, PACIFIC COAST JOBBER IN EDISON GOODS.**

#### **DIFFERENCE BETWEEN CLAIMS AND FACTS.**

This is the first time I've had an opportunity to write to you concerning my sales of your Phonographs and Records. It is about eighteen months that I've handled your goods exclusively. The first few months I had only three machines and about 200 Records, and had met with quite some disappointments. So I then thought it would be wise to put in a complete stock. I now have a complete stock of your Gold Moulded Records and a few machines of each type except the Triumph and the higher

priced machines of which I have one of each.

I had some calls for disk machines and Records, so I just put in a line of disk machines and records. But I find that it increases the sales of Edison Phonographs and Records fifty per cent., for no one can tell me that a disk machine is better than an Edison. The moment a customer says so, I immediately put up a disk record and then an Edison Gold Moulded Record. When he hears the difference between the disk machine which he said was best and the Edison which is the best that settles all arguments.

**LOUIS LIPCHITZ,**  
Passaic, N. J.



# THE EDISON PHONOGRAPH

## A Most Acceptable Holiday Gift.

It is the most useful instrument in any home. Its power to amuse makes entertaining easy. It plays for dancing. It keeps the young folks home at night. It brings the hits of all the shows to you in town or country.

Edison Gold Moulded Records, price 35 cents each, contribute largely to its marvelous results by their unapproached perfection. Dealers everywhere will be glad to prove this wonderful superiority. If there is no dealer near you, send to us for catalogue.

NATIONAL PHONOGRAPH CO., Orange, N. J.

New York.

Chicago.

San Francisco.

London.

I. C. S. LANGUAGE COURSES TAUGHT BY EDISON PHONOGRAPH.



**SUSPENDED LIST, NOVEMBER 1, 1904.**

SUPERSEDING ALL PREVIOUS LISTS.

**COLORADO.**

Boulder—BENTLEY &amp; CRAIG.

**INDIANA.**

South Bend—EUGENE MARSH, 126 Vistula avenue.  
SOUTH BEND BOOK BINDERY,  
Robert Lebolt, Prop., 203 North  
Michigan street.

**IOWA.**

Burlington—JOHN P. WEISS, 711 Jefferson street.  
Sioux City—HATTENBACH BROS. CO.

**KANSAS.**

Clay Centre—E. M. GOWENLOCK.  
Lawrence—BELL BROS.

**MAINE.**

Biddeford—W. H. FIELD.

**MASSACHUSETTS.**

Boston—T. SINGER, 60 Leverett street.  
Lawrence—LORD & CO, 314 Essex street.  
E. O. MOSHER, 420 Essex street.  
Lynn—ELIAS DEYOUNG.  
Malden—A. T. FULLER.  
Nantucket—ARTHUR M. TAYLOR.  
New Bedford—H. B. DEWOLFF.  
Somerville—E. J. WINCHESTER, 32 Summit avenue.  
Woburn—OSBORN GILLETTE, or THE BOLTON  
JEWELRY CO., L. F. Maloney, Manager.

**MICHIGAN.**

Detroit—F. J. SCHWANKOVSKY.  
Saginaw—GEO. W. EMENDORFER.

**MISSOURI.**

Kansas City—THE WITTMANN CO.

**NEBRASKA.**

Lincoln—THE WITTMANN CO.  
Omaha—THE WITTMANN CO.

**NEW HAMPSHIRE.**

Hillsboro Bridge—E. M. BARNES.  
Manchester—A. E. DUMAS  
Nashua—F. A. McMASTER & CO.

**NEW JERSEY.**

Atlantic City—SAM'L D. WOLF, 32-34 Arkansas ave.  
Bayonne—I. WIGDOR, 450 Avenue D.  
Jersey City—W. L. HOFFMAN, 151 Montgomery st.  
Newark—R. L. CORWIN; also New York City.  
Passaic—I. HURWITZ.  
Paterson—CHAS. H. KELLY, 25 N. Main street.

Plainfield—S. W. FRUCHT, or R. FRUCHT; also  
New York City.

ELSTON M. LEONARD.

West Hoboken—EMIL HOLLANDER, or THE WEST  
HOBOKEN BICYCLE & PHONO-  
GRAPH CO., 619 Spring street.

**NEW YORK.**

Albany—\*G. LINDE, 353 S. Pearl street.

Bedford Park—GEO. H. TYRRELL.

Hobart—F. H. MARSHALL.

New York City—A. T. ARMSTRONG, or AMERI-  
CAN PHONOGRAPH CO., 106  
Wall street.

BERN BEARWALD, 373 W. 11th st.  
BRONX PHONOGRAPH CO. or  
DAVID SWITKY, 506 Wi lis ave.  
CENTRAL PHONOGRAPH CO.,  
160 E. 42d street.

R. L. CORWIN; also Newark, N. J.  
EAGLE PHONOGRAPH CO., or C.  
LOWENTHAL, 83 Nassau street.  
EMPIRE PHONOGRAPH CO., 2 W.  
14th street.

S. W. FRUCHT, or R. FRUCHT, 7  
Barclay street, or 68 Cortlandt  
street; also Plainfield, N. J.

O. HACKER, 2 Murray street.  
HAWTHORNE & SHEBLE, 297  
Broadway; also Philadelphia, Pa.

N. HORN, 148 E. 58th street.  
W. L. ISAACS, 114 Fulton street.

S. LEMBURG & CO., 194 Broadway.  
J. McELLYNNE, 202 Broadway.

RICHMOND PEASE, 44 W 132d st.  
F. M. PRESCOTT, 44 Broad st.

WINTHROP CYCLE CO., 2212 Sev-  
enth avenue.

Saratoga—W. J. TOTTEN.

Saratoga Springs—MARVIN A. COTE.

Syracuse—\*SPALDING &amp; CO.

**OHIO.**

Cincinnati—J. L. ANDEM.

Coshocton—BURNS &amp; GOSSER.

Springfield—D. &amp; M. VANDERPOOL.

Uhrichsville—F. A. MAZURIE.

**PENNSYLVANIA.**

Philadelphia—A. R. CASSIDY, 2783 Emerald street.  
HAWTHORNE & SHEBLE, 604 Chest-  
nut street, or Oxford and Mascher  
streets; also New York City.

A. KROUSE, 832 Arch street.

PENN NOVELTY CO., 15 South 9th st.

Phoenixville—KEINARD BROS.

Pittsburg—A. LIPPARD, 615 Wylie ave.

**RHODE ISLAND.**

Providence—F. P. MOORE.

**WISCONSIN.**

Milwaukee—J. C. BLATZEK.

\*Added since October 1, 1904.

Jobbers and Dealers are asked to co-operate with us, FOR OUR MUTUAL GOOD,  
by being careful that they do not supply any of the above named firms with our  
apparatus, either at addresses given or any other address.

## JOBBERERS OF EDISON PHONOGRAPHS AND RECORDS.

## ALABAMA.

**Birmingham**—The Ray Co., 2027 Second avenue.

The Talking Machine Co.

**Mobile**—W. H. Reynolds, 167 Dauphin street.

## CALIFORNIA.

**San Francisco**—Peter Bacigalupi, 786-788 Mission street.

## COLORADO.

**Denver**—Denver Dry Goods Co., 619 16th street.

## CONNECTICUT.

**Middletown**—Caulkins & Post Co., 406-408 Main street.

**New Haven**—Pardee-Ellenberger Co., 155 Orange st.

## DISTRICT OF COLUMBIA.

**Washington**—E. F. Droop & Sons Co., 925 Pennsylvania avenue, N. W.

S. Kann, Sons & Co., 8th and Pennsylvania avenues.

## ILLINOIS.

**Chicago**—James I. Lyons, 73 Fifth avenue.

The Ray Co., 90 Washington street.

Siegel-Cooper Co., State and Congress sts.

Talking Machine Co., 107 Madison street.

The Vim Co., 68 E. Lake street.

Montgomery Ward & Co., 111 Michigan ave.

Rudolph Wurlitzer Co., 302 Wabash ave.

**Peoria**—Peoria Phonograph Co., 222 Bridge street.

## INDIANA.

**Indianapolis**—Craig-Jay Co., 234 Massachusetts ave.

Kipp Bros. Co., 37 S. Meridian street.

A. B. Wahl & Co., 119 S. Illinois street.

**Lafayette**—A. B. Wahl & Co., 304 Main street.

## IOWA.

**Des Moines**—Hopkins Bros. Co., 620 Locust street.

The Vim Co., 704 West Walnut street.

**Fort Dodge**—Early Music House, 822 Central ave.

## KENTUCKY.

**Louisville**—The Ray Co., 640 Fourth street.

## LOUISIANA.

**New Orleans**—National Automatic Fire Alarm Co., 614

Gravier street.

The Ray Co., 111 Camp street.

## MAINE.

**Bangor**—S. L. Crosby Co., 186 Exchange street.

**Portland**—W. H. Ross & Son, 207 Commercial street.

## MASSACHUSETTS.

**Boston**—Boston Cycle & Sundry Co., 48 Hanover street.

Eastern Talking Machine Co., 177 Tremont street.

Iver Johnson Sporting Goods Co., 163 Washington street.

Read & Read, 558 Washington street.

**Fitchburg**—Iver Johnson Sporting Goods Co., 247 Main street.

**Lowell**—Thomas Wardell, 111 Central street.

**Worcester**—Iver Johnson Sporting Goods Co., 304 Main street.

## MICHIGAN.

**Detroit**—American Phonograph Co., 106 Woodward avenue.

Grinnell Bros. Music House, 219 Woodward avenue.

The Ray Co., 252 Woodward avenue.

**Saginaw**—Morley Bros.

## MINNESOTA.

**Minneapolis**—Thomas C. Hough, 714 Hennepin ave.

**St. Paul**—W. J. Dyer & Bro., 21-23 West 5th street.

Minnesota Phonograph Co., 37 E. 7th street.

## MISSOURI.

**Kansas City**—J. W. Jenkins' Sons Music Co., 1013-1015 Walnut street.

The Ray Co., 1021 Grand avenue.

**St. Louis**—Conroy Co., 1115 Olive street.

The Ray Co., 923 Olive street.

## NEBRASKA.

**Lincoln**—H. E. Sidles Cycle Co., 1317 O street.

**Omaha**—H. E. Fredrickson, 1502-1510 Capitol avenue.

Nebraska Cycle Co., 15th and Harney streets.

## NEW JERSEY.

**Hoboken**—Eclipse Phonograph Co., 205 Washington street.

**Newark**—A. O. Petit, New and Halsey streets.

**Paterson**—James K. O'Dea, 117 Ellison street.

**Trenton**—Stoll Blank Book and Stationery Co., 30 E. State street.

## NEW YORK.

**Brooklyn**—Chapman & Co., Fulton and Duffield streets

A. D. Matthews' Sons, 394 Fulton street.

Price Phonograph Co., 1258 Broadway.

**Buffalo**—P. A. Powers, 643 Main street.

**Elmira**—Elmira Arms Co., 117 Main street.

**Gloversville**—American Phonograph Co., 99 W. Fulton street.

**Kingston**—Forsyth & Davis, 307 Wall street.

**New York City**—Bettini Phonograph Co., 80 Chambers street.

Blackman Talking Machine Co., 19 Beekman street.

J. F. Blackman & Son, 2654 3d avenue.

I. Davega, Jr., 802 Third avenue.

S. B. Davega, 32 E. 14th street.

Douglas & Co., 89 Chambers street.

H. S. Gordon, 139 Fifth avenue.

Harry Jackson, 219 Bowery.

Jacot Music Box Co., 39 Union Square.

Victor H. Rapke, 1661 Second avenue.

Siegel-Cooper Co., Sixth avenue and 18th street.

John Wanamaker, Broadway and 9th street.

**Rochester**—A. J. Deninger, 347 North street.

Mackie Piano, O. & M. Co., 100 State street.

Giles B. Miller, 63 State street.

Talking Machine Co., 29 Clinton avenue, S.

**Schenectady**—Jay A. Rickard & Co., 253 State street.

**Syracuse**—W. D. Andrews, 216 E. Railroad street.

**Troy**—James Lucey, 359-361 Fulton street.

**Utica**—Clark-Horrocks Co., 54 Genesee street.

Arthur F. Ferriss, 89 Washington street.

William Harrison, 41 Columbia street.

Utica Cycle Co., 31 Columbia street.

## OHIO.

**Canton**—Klein & Heffelman Co., 216 N. Market street.

**Cincinnati**—Ilsen & Co., 25 W. 6th street.

The Ray Co., 143 West 5th street.

A. B. Wahl & Co., 805 Vine street.

Rudolph Wurlitzer Co., 121 E. 4th st.

**Cleveland**—W. J. Roberts, Jr., Erie and Huron streets.

**Columbus**—Perry B. Whitsit Co., 213 S. High street.

**Dayton**—Niehaus & Dohse, 35 E. 5th street.

**East Liverpool**—Smith & Phillips Music Co.

**Toledo**—Hayes Music Co., 608 Cherry street.

## PENNSYLVANIA.

**Allegheny**—Henry Braun, 500 Federal street.

**Allentown**—G. C. Aschbach, 539 Hamilton street.

**Easton**—William Werner, 401 Northampton street.

**Philadelphia**—C. J. Heppe & Son, 1117 Chestnut street.

Lit Bros., Market and 8th streets.

Penn Phonograph Co., 19 S. 9th street.

John Wanamaker.

Wells Phonograph Co., 41 N. 9th street.

Western Electric Co., 931-933 Market st.

H. A. Weymann & Son, 923 Market st.

**Harrisburg**—S. K. Hamburger, 12-14 N. Market sq.

**Pittsburg**—Theo. F. Bentel Co., Inc., 433 Wood street.

H. Kleber & Bro., 221 Fifth avenue.

C. C. Mellor Co., 319 Fifth avenue.

Pittsburg Phonograph Co., 937 Liberty avenue.

**Reading**—Reading Phonograph Co., 809 Penn street.

**Scranton**—Ackerman & Co., Coal Exchange Building. Technical Supply Co.

## RHODE ISLAND.

**Providence**—J. M. Dean Co., 785-795 Westminster street.

J. A. Foster Co., Weybosset and Dorrance streets.

Household Furniture Co., 231-237 Weybosset street.

J. Samuels & Bro., 154 Weybossett street.

A. T. Scattergood & Co., 106-110 N. Main street.

## TENNESSEE.

**Memphis**—The Ray Co., Lyceum Building.

**Nashville**—Nashville Talking Machine Co., 510 Church street.

The Ray Co., 13-15 The Arcade.

## TEXAS.

**Dallas**—C. B. Harris, Agt., 347 Main street.

## VIRGINIA.

**Richmond**—The Ray Co., 729 E. Main street.

## WISCONSIN.

**Milwaukee**—McGreal Bros., 173 3d street.

## CANADA.

**Toronto**—R. S. Williams & Sons Co., Limited, 143 Yonge street.



# What "Double Service" Means to the Edison Christmas Trade

"Double Service" means amusement and language study—recreation and education—fun and seriousness—combined to make the Edison Phonograph the most attractive holiday gift that an exacting public could wish.

I. C. S. Language textbooks represent an expenditure of \$50,000 to standardize the languages in Edison Gold Moulds or in other words to "print" pronunciation and revolutionize language teaching.

There is nothing deep or impracticable about the I. C. S. language method. Any dealer can demonstrate it as easily as he plays an amusement record. One prominent merchant had a salesman give trial lessons in his Edison Phonograph Department and sold over one hundred I. C. S. Outfits during the holidays.

Let us equip **you** for "Double Service." Send \$2.00 for dealers' demonstrating outfit (expressage prepaid); includes four sample moulded records in French, German, Spanish, and English with corresponding I. C. S. textbooks for instructing Americans and Foreigners. Special holiday circulars and catalogues are now ready for the trade to push "Double Service."

Write to-day.

Address,

**LANGUAGE DEPARTMENT**

**International Correspondence Schools,**

**SCRANTON, PA.**

# EDISON Phonograph Monthly

PUBLISHED FOR TRADE USE ONLY BY  
THE NATIONAL PHONOGRAPH CO.

VOL. II.

NEW YORK, DECEMBER, 1904.

No. 10.

*The* National Phonograph Co.,

ORANGE, N. J.

NEW YORK: 83 CHAMBERS STREET.

CHICAGO: 304 WABASH AVENUE.

SAN FRANCISCO: 786 MISSION STREET.

NATIONAL PHONOGRAPH CO., LTD., 25 CLERKENWELL  
ROAD, LONDON, ENG.

## EDISON PHONOGRAPHS AND RECORDS.

All communications to THE PHONOGRAPH MONTHLY should be addressed to the Advertising Department, 83 Chambers Street, New York.

### C O N T E N T S

Get Ready for the Holidays.....	1
Advance List Edison Gold Moulded Records for January, 1905.....	2
Special Advance List Edison Gold Moulded Records for Dancing.....	3
More British Selections.....	4
Use Record Order Blanks.....	4
Dealers' Names Removed.....	5
The Dance Supplement.....	5
A High Water Mark.....	5
Among the Jobbers.....	6
Clever Advertisements.....	6
The Phonogram.....	6
Many Thanks.....	6
More Prompt Shipments.....	7
Printed Matter.....	7
Comments on January Records.....	8
Berlin Branch Advertisement.....	10
Model "Copy".....	10
Testimony and Prophecy from Australia..	11
The Right to Regulate Prices.....	11
A Patriotic Record.....	12
A Great Success.....	13
Talking Machine Development.....	13
New Style Shelving.....	13
List of Suspended Dealers December 1....	14
Jobbers of Edison Phonographs and Records	15

## GET READY FOR THE HOLIDAYS.

The closing month of the year offers little new to say with regard to the business in Edison Phonographs and Edison Gold Moulded Records. The demand for them continues unchanged. It is as great now as at any time in the past and shows no signs of abatement. In spite of the greatly increased factory output the new orders still keep ahead of those being filled. It would surprise even those familiar with the business of this company to know how many Phonographs and Records are being made at our Orange, N. J., factory each week. Nothing like it has ever been reached by any other company. What is still more gratifying is the fact that this entire output is sold absolutely; not a dollar's worth can be returned or exchanged for other goods and not a single machine or Record is put out on consignment. The demand for Edison goods is not only phenomenal among Jobbers and Dealers who have been handling them for years, but nearly a score of firms have been made Jobbers and hundreds of others have become Dealers in the past five months.

Now that the election and Thanksgiving have passed, the eyes of the retail trade are turned toward the Christmas season and all are anticipating a splendid business. From the manufacturing standpoint it cannot be said that the Presidential campaign and election had any effect upon business. We could not have turned out any more goods under any circumstances. It is possible, however, that it had some effect upon the retail trade. If so, it has passed away with the announcement of the result, and all Dealers have been hard at work preparing for the holiday season. The trade should not be carried away with the belief that the popularity of the Edison product will alone bring them customers who will forthwith buy their entire stock. It is quite the duty of

(Continued on page 4.)

**THE ADVANCE LIST OF JANUARY RECORDS APPEARS ON PAGE 2. ORDER FROM IT. NO OTHER ADVANCE LIST WILL BE ISSUED.**



# NEW EDISON GOLD MOULDED RECORDS. ADVANCE LIST FOR JANUARY, 1905.

RECORDS listed below will be ready for shipment as near **December 20th** as possible, at which time Jobbers' stock orders, if **received** prior to **December 8th**, will be shipped. January Supplements will be forwarded to Jobbers with their stock order for Records. Retail Dealers should place stock orders with their Jobbers at once, to insure prompt shipment as soon as Jobbers' stock is received.

- 8856 The Auto Race (*Missud*) *A descriptive piece.* Edison Concert Band
- 8857 There's a Dark Man Coming with a Bundle (*Leighton*), Bob Roberts  
*Lew Dockstader's great coon song, Orch. accom.*
- 8858 My Little Canoe (*Stuart*), Miss Grace Nelson  
*Contralto song, as sung by Edna May in "The School Girl," Orch. accom.*
- 8859 Make a Fuss Over Me (*Morse*) *Trio of Banjos,* Ossman Banjo Trio
- 8860 Back, Back, Back to Baltimore (*Van Alstyne*) Collins and Harlan  
*Coon male duet, Orchestra accompaniment.*
- 8861 Sing Me to Sleep (*Greene*), *Ballad, orchestra accompaniment,* Irving Gillette
- 8862 Laces and Graces (*Bratton*), Edison Symphony Orchestra  
*A Novelette by the composer of "In a Cosy Corner."*
- 8863 Why Don't They Play with Me? (*Harris*), Byron G. Harlan  
*Descriptive song by the writer and composer of "Always in the Way," Orch. accom.*
- 8864 Mr. Wilson, That's All (*Van Alstyne*), *Comic song, Orch. accom.* Billy Murray
- 8865 Royal Trumpeters March (*Seltzer*), *Conducted by the composer,* Edison Military Band
- 8866 Little Tommy Went a Fishing (*Macy*), *Male quartette,* Criterion Quartette
- 8867 The Girl Who Cares for Me (*Edwards*), *Waltz song, Orch. acc.* Harry MacDonough
- 8868 Yankee Girl (*Lampe*), Albert Benzler  
*Xylophone solo, orchestra accom., by the composer of "Creole Belles."*
- 8869 Countess of Alagazam (*Cole*), *Comic song, orchestra accompaniment,* Bob Roberts
- 8870 I'm Trying So Hard to Forget You (*Harris*), Harlan and Stanley  
*Sentimental male duet by the writer and composer of "I'm Wearing My Heart Away for You," orchestra accompaniment.*
- 8871 Loving Hearts (*Tobani*), Edison Instrumental Quintette
- 8872 Just Before the Battle, Mother (*Root*), MacDonough and Biehling  
*Descriptive male duet, orchestra accompaniment.*
- 8873 Abraham (*Von Tilzer*), Arthur Collins  
*Coon song by the writers of "Alexander," Orch. accom.*
- 8874 Come Take a Trip in My Airship (*Evans*), Billy Murray  
*Serio-comic waltz song, orchestra accompaniment.*
- 8875 Sweet Thoughts of Home (*Edwards*), W. H. Thompson  
*Song as sung by Madame Schumann-Heink in the comic opera, "Love's Lottery," orchestra accompaniment.*
- 8876 By the Old Oak Tree (*Hoffman*), Miss Morgan and Mr. Stanley  
*Contralto and basso duet from "The Rogers Brothers in Paris," Orch. accom.*
- 8877 Tales from the Vienna Woods (*Strauss*), *Concert waltz,* Edison Symphony Orchestra
- 8878 The Darkies' Dream (*Lansing*), *Descriptive selection.* Edison Military Band
- 8879 Dr. Jekyll and Mr. Hyde (*Stevenson*), Len Spencer  
*The Transformation Scene, with orchestra and all the incidental effects.*
- 8880 Teasing Medley, Edison Military Band  
*Introducing "Teasing," "Save It for Me," "Alexander," and "I've Got a Feeling for You."*

Edison Gold Moulded Records are made only in Standard Size. Both Standard and Concert Records may be ordered from this list. Order by number, not title. If Concert Records are wanted, give the number and letter C.

# SPECIAL ADVANCE LIST OF EDISON GOLD MOULDED RECORDS FOR DANCING.

WE list herewith a special Supplement of 32 Edison Gold Moulded Records for dancing. This list will be handled in the same manner as the Monthly Supplement. Samples will be shipped to Jobbers about **December 10th**, and they will be asked to place advance orders to reach us not later than **December 20th**. All orders so placed will be shipped at the same time and **as early in January as circumstances will permit**. Printed Supplements will be shipped with Records, the quantity being proportionate to the standing orders for supplements. A special Record Bulletin will also be issued. Dealers should assist their Jobbers in deciding how to order by placing their advance orders as early as possible.

### LANCERS

8247	U. S. Army Lancers	( <i>Tobani</i> ), with calls,	1st Figure, Edison Military Band
8248	U. S. Army Lancers	" " "	2d " " " "
8249	U. S. Army Lancers	" " "	3d " " " "
8250	U. S. Army Lancers	" " " 1st half Last	" " " "
8251	U. S. Army Lancers	" " " 2d half Last	" " " "
8881	Hedge Roses Lancers	( <i>Weingarten</i> ) without calls,	1st Figure, Edison Military Band
8882	Hedge Roses Lancers	" " "	2d " " " "
8883	Hedge Roses Lancers	" " "	3d " " " "
8884	Hedge Roses Lancers	" " " 1st half last	" " " "
8885	Hedge Roses Lancers	" " " 2d half last	" " " "

### QUADRILLES

8886	Good Humor Quadrille	( <i>Wiegand</i> ) without calls,	1st Figure, Edison Military Band
8887	Good Humor Quadrille	" " "	2d " " " "
8888	Good Humor Quadrille	" " "	3d " " " "
8889	Good Humor Quadrille	" " "	4th " " " "
8890	Good Humor Quadrille	" " "	5th " " " "

### WALTZES

8891	Over the Waves Waltz	( <i>Roses</i> ) <i>Sobre Las Olas</i> ,	Edison Military Band
8892	Impassioned Dream Waltz	( <i>Roses</i> ),	" " "
8128	Wedding of the Winds Waltz	( <i>Hall</i> ),	" " "
8623	Daughter of Love Waltz	( <i>Bennet</i> ),	" " "
8740	American Students Waltz	( <i>Missud</i> ),	" " "
8809	Wilhelmina Waltz	( <i>Hall</i> ),	" " "

### TWO-STEPS

8549	Southern Smiles Two-Step	( <i>Kelly</i> ),	Edison Military Band
8893	National Two-Step	( <i>Seltzer</i> ),	" " "
8894	Thoroughbred Two-Step	( <i>Fahrbach</i> ),	" " "
8895	For Love and Honor Two-Step	( <i>Alberti</i> ),	" " "
8896	High Pride Two-Step	( <i>Heed</i> ),	" " "

### OTHER DANCES

8897	Don Juan Minuet	( <i>Mozart</i> ),	Edison Concert Band
8898	Here! Chick, Chick Polka	( <i>Gauwin</i> ), <i>Viens Poupoule</i> ,	Edison Military Band
8899	Love's Spell Mazurka-Yorke	( <i>Strauss</i> ),	" " "
8900	My Little Sweetheart Schottische-Gavotte	( <i>Seltzer</i> ),	" " "
8901	Club Galop	( <i>Laurendeau</i> ),	" " "
8902	Virginia Reel	( <i>Bennet</i> ),	" " "

Edison Gold Moulded Records are made only in Standard Size. Both Standard and Concert Records may be ordered from this list. Order by number, not title. If Concert Records are wanted, give the number and letter C.



(Continued from page 1.)

Dealers to let the public know that they carry the goods. The appropriation of this company for Christmas advertising is the largest in its history; it includes adequate space in more than a score of the most widely circulated publications in this country and the advertising appeals to the public to go to the Dealers to hear and buy.

But of what avail will it be if Dealers simply put in a stock and wait with folded hands? The public cannot be expected to go around with a searchlight trying to find Dealers. It will, however, go to the man who makes himself known and it will buy his goods. This admits of no contradiction; it has been clearly proven too many times. The men to-day who are making the greatest successes of the Phonograph business are those who advertise; who take advantage of the general publicity given Edison goods and who say to the public, "We keep them; they're the best; come hear them." Then they carry the stock and make good to the public and their own pockets.

#### MORE BRITISH SELECTIONS.

The British selections made at our London recording plant and already listed for use in this country have found many admirers among Phonograph owners. More of them would have been put out before this had it not been for the great demand of the past four months for domestic selections. Now that our Record making facilities have been increased we take pleasure in advising the trade that we are ready to receive orders for thirty-two new titles as given below. These Records are made by British talent and under the direction of experts familiar with all the up-to-date methods of the Edison Laboratory. These titles will be included in the next edition of the Foreign Record Catalogue. The last British selections were issued in May.

- |       |                                  |                       |
|-------|----------------------------------|-----------------------|
| 12989 | Banks of Allan Water,            | Thomas Reid           |
| 13047 | Dormas March,                    | British Military Band |
| 13048 | I Love You Still,                | Hamilton Hill         |
| 13049 | Selection from Pinafore,         | British Military Band |
| 13050 | Scots Wha Hae,                   | Thomas Reid           |
| 13051 | Farewell March,                  | British Military Band |
| 13052 | Rowan Tree,                      | Thomas Reid           |
| 13053 | Petrosa March,                   | British Military Band |
| 13054 | I Felt Sorry for the Fellow,     | Leonard Mackay        |
| 13055 | Under Freedom's Flag,            | British Military Band |
| 13056 | My Love Is Like a Red, Red Rose, | Thomas Reid           |
| 13057 | Punjaub March,                   | British Military Band |
| 13059 | Belphegor March,                 | British Military Band |

- |       |   |                       |
|-------|---|-----------------------|
| 13061 | Kaiser Frederick March,                         | British Military Band |
| 13062 | There's a Home for You with Me,                 | Leonard Mackay        |
| 13063 | Clown Polka,                                    | British Military Band |
| 13064 | Miss Kelly,                                     | Fred T. Daniels       |
| 13065 | Austria March,                                  | British Military Band |
| 13066 | Peace, Peace,                                   | Leonard Mackay        |
| 13068 | Just in a Motherly Way,                         | Leonard Mackay        |
| 13069 | With Sword and Lance March,                     | British Military Band |
| 13071 | Selection of Popular Songs No. 5,               | British Military Band |
| 13072 | It's the Finest Flow of Language<br>Ever Heard, | Albert Whelan         |
| 13073 | Selection from Falka,                           | British Military Band |
| 13075 | A Russian Dance,                                | British Military Band |
| 13077 | Selections from Pirates of Penzance,            | British Military Band |
| 13078 | Iolanthe,                                       | British Military Band |
| 13079 | Drink,  | Leonard Mackay        |
| 13080 | Pottergeist Galop,                              | British Military Band |
| 13081 | Selection from Gypsy Life,                      | British Military Band |
| 13083 | Overture to Zampa,                              | British Military Band |
| 13084 | Overture to Poet and Peasant,                   | British Military Band |

#### USE RECORD ORDER BLANKS.

It will greatly facilitate the work of handling Record orders if Jobbers will always make them out on the regular order blank furnished by us. If you haven't a supply or don't know what they are, send to us for some. The form is No. 425. Sheets A to D include all domestic numbers and sheets E to G cover the foreign numbers.

#### DEALERS NAMES REMOVED.

On November 7th the names were removed from our files and mailing list of all Dealers who did not sign the new Agreement. Such Dealers were regarded as being no longer interested. This statement will only interest Jobbers who may receive complaints from some of their Dealers that they no longer receive mail matter.

#### SPEECHES BY PHONOGRAPH.

Making speeches by means of Phonograph Records is becoming quite popular. Some months ago we noted how the Secretary of the National Association of Credit Men sent a speech to a Western Association. On October 27th the Dallas, Texas, branch of the Commercial Telegraphers Association held a meeting and smoker, and among its features were addresses by Phonograph from the President and Secretary of the National Association, both of whom live in Chicago.

### THE DANCE SUPPLEMENT.

On page 3 we present for the consideration of the trade a special list of dance Records, which we confidently expect will be one of the most popular features ever put out by the National Phonograph Company. The matter of issuing this dance supplement has been under consideration for several months, and it would have been out early in the fall had not the demand for other Records been greater than we could supply. Even now, with a greater increased capacity it will not be easy to fill orders, but it was decided that if a dance supplement was to be put out at all this winter it could not be longer deferred.

This dance supplement was made under the direction of William Pitt Rivers, of the Knapp Mansion, Brooklyn's most fashionable dancing academy, and one of the foremost instructors of dancing in this country. When Mr. Rivers entered upon his task he would accept only five Records from our regular catalogue as being suitable for dancing. These were No. 8623, Daughter of Love Waltz; No. 8740, American Students' Waltz; No. 8809, Wilhelmina Waltz; No. 8128, Wedding of the Winds Waltz, and No. 8549, Southern Smiles, a two-step. These were declared by him to have been made at the proper tempo. The other twenty-seven were made anew. The United States Lancers, Nos. 8247 to 8251 inclusive, listed in the regular catalogue and made by the Edison Symphony Orchestra, were made over by the Edison Military Band. This set of Records is made with calls. As the lancers is more frequently danced without being called off, another set, the Hedge Roses Lancers, Nos. 8881 to 8885 inclusive, was made without calls. The entire supplement is made in perfect dancing time and according to the most approved terpsichorean methods.

From a recording standpoint, they are equal to any selections ever put out by this company. Aside from their merits for dancing, every one is a gem. The waltzes, two-steps and other dances will be found to be most delightful and entitled to places in every collection. Nothing better has ever been issued in a regular supplement. The truth of this will be apparent to every Jobber who hears the samples.

### A HIGH WATER MARK.

The advance orders for the November-December Records reached the high-water mark for one month's supplement. The total was not only the greatest for a single month but the average number of each selection ordered has never been equaled.

### AMONG THE JOBBERS.

The Price Phonograph Co., of 1258 Broadway, Brooklyn, has opened a jobbing and retail branch store in Poughkeepsie. This company now has five stores.

Harry Jackson, of 219 Bowery, New York, has opened another branch store in Hartford, Conn. He now has five Phonograph stores.

The Rudolph Wurlitzer Co., of 805 Vine street, Cincinnati, were burned out on November 20th. Its loss was given at \$250,000.

Among those who have become Jobbers in Edison goods in the past few months are the Talking Machine Company, Birmingham, Ala.; W. H. Reynolds, Mobile, Ala.; E. F. Droop & Sons Co., and S. Kann Sons & Co., Washington, D. C.; Rudolph Wurlitzer Co., Cincinnati and Chicago; Craig-Jay Co., Indianapolis; Hopkins Bros. Co., Des Moines, Ia.; Early Music House, Fort Dodge, Ia.; Knoxville Typewriter and Phonograph Exchange, Knoxville, Tenn.; Nashville Talking Machine Co., Nashville, Tenn.; W. J. Dyer & Bro., St. Paul, Minn.; Giles B. Miller, Rochester, N. Y.; A. F. Ferriss, William Harrison and Utica Cycle Co., Utica, N. Y.; S. K. Hamburger, Harrisburg, Pa.; William Bailey, New Orleans, La.; H. M. Holleman Co., Houston, Texas; O. K. Houck Piano Co., Memphis and St. Louis.

The firm of Douglas & Co., of New York, has been incorporated, and will hereafter be known as the Douglas Phonograph Co.

### FROM THE FROZEN NORTH.

"I am using an Edison Phonograph in my place of business," writes G. D. Hitchcock, of Sunrise, Alaska, "and no one can appreciate more fully the great enjoyment we derive from it. We are shut in about six months in the year here in the frozen North, but the machine and Records greatly help to relieve the monotony in delivering the latest songs and pieces of music, which are so loud, clear and of good tone. I have used a much-advertised, lower-priced record, but find it a very inferior quality to the Edison."

### A GOOD UNDERSTUDY.

A well known actor recently promised to give a speech at a dramatic club on a New Jersey tour, but found at the last hour that he had a prior engagement of urgent importance in Boston. He went to a friend who possessed a Phonograph, delivered his address into the machine, and was sixty miles away when the Phonograph reproduced his characteristic effort to a delighted audience at the seaside club that night.



**CLEVER ADVERTISEMENTS.**

E. F. Droop & Sons Company, Jobbers in Edison Phonographs and Records, at Washington, D. C., send us copies of some advertisements that they have been running recently. Two of these were cleverly written and illustrated so as to get some publicity out of the recent Presidential election. One was headed "The People's Choice," and the illustration showed Uncle Sam, a large elephant, and a small bear dancing to the music from a huge Edison Home Phonograph placed on the porch of the White House. Below the cut were the words:

"And you never will want to 'lose me' if you once place me in your home! I'm there to stay! Not for one or two short terms, but 'for ever and a day!' You'll never tire of my administration! I bring joy, music, and genuine entertainment into the home. I'm the Edison Phonograph and have been accorded first place by unanimous vote of the people!"

The second one was headed "Strenuous Music," and showed Uncle Sam and the bear being entertained by the music of two Edison Home Phonographs. Explanation of the illustrations were these words:

"Notice the joy depicted on our old Uncle Sam's face! And the Bear! He's having every kind of a good time! There's a lot of 'Hot Air'—music from the 'band' wagons—issuing from each of these Edison machines! Musical selections are interspersed with inspiring oratorical efforts! (Lots of that going on just now!)

"The Voice of the Land Proclaims the Edison Phonograph the Choice of the People."

In view of the fact that this company sell all makes of talking machines, the following extracts from one of their advertisements are quite gratifying:

"Edison Phonographs—Absolutely the most perfect machine on the market. *No rasping—no harsh sounds! The Edison Phonograph makes music and affords constant and genuine pleasure.*"

More developments of the "language student's companion" side of the talker! Some missionaries who went to Tripoli to learn the language took a machine with them. They succeeded in speaking the Lord's Prayer, the Creed, the Ten Commandments and certain other sentences in Haussa into the Phonograph. The cylinders were sent home, and intending missionaries will now be able to learn the native pronunciation before leaving America.—*Exchange.*

**It is good policy to advertise at all times, but it is especially profitable to advertise at the holiday season. Try it.**

**THE PHONOGRAM.**

The November-December number of the *Phonogram* contains half-tones of Len Spencer and Edward M. Favor. The edition of this little publication holds its own nicely, and as every copy ordered by the trade is partially paid for, it would appear as if it was regarded as an excellent medium for selling Edison goods. A copy is being mailed to every Jobber and Dealer on our lists in addition to the PHONOGRAPH MONTHLY. The November-December issue went out November 21, with the shipment of December Records, and it is expected to send out the January issue about December 20th. Following is a schedule of prices at which *Phonograms* may be obtained by the trade:

**DELIVERED WITH GOODS.**

Blank, per 1000 copies.....\$2.50  
Smaller quantities pro rata.  
Imprinted, per 500 copies..... 1.50  
Imprinted, per 1000 copies..... 2.75

No orders filled for less than 500 copies requiring imprint, and all imprinting orders must be for multiples of 500.

**BY MAIL.**

Single copies, per year.....\$ .20  
Five copies to one address, per year..... .40  
Twenty-five copies, one address, per year. 1.80  
Fifty copies to one address, per year..... 3.60

Unless they have open accounts on our books, Dealers ordering *Phonograms* sent by mail are requested to send cash or stamps with their orders. The amounts are too small to handle in any other way.

**MANY THANKS.**

Speaking of the National Phonograph Co., popularly known as the Edison people, a rival concern had this generous comment to make: "We find it the hardest work to capture an Edison dealer. They stick like wax, and for the reason that the company take mighty good care of their trade. They are a fine house to have connection with."

This paragraph appeared in a recent issue of the *Music Trade Review*. We do not know the name of our generous competitor, but we feel glad to know that our efforts are so regarded by the trade. Our aim first and last is to improve the business of our Jobbers and Dealers and if we fail at any time it is not because of desire on our part.

**PRICES OF EDISON RECORDS.**

**Edison Gold Moulded Records, standard size, are sold in the United States at 35 cents each, and in Canada at 40 cents each. The Canadian price is higher because of the duty. Edison Concert Records are sold at 75 cents each in both countries.**

**FOR MORE PROMPT SHIPMENTS.**

The coöperation of Jobbers and Dealers is asked in an effort to make more prompt shipment of new Records each month. Too many times in the past, owing to a number of causes, it has been six weeks after the new list was sent out to the trade before the Records were in the hands of Dealers. It is now proposed to cut this time down to less than a month. The last orders for the November-December list were shipped from the factory on November 21st. On November 23d copies of the January advance list were mailed to all Jobbers, with a statement that samples would be shipped November 29th; that Jobbers' orders must be received on or before December 8th; that shipments would be made before the holidays, and that orders received after December 8th would be considered as second orders. It will be seen that this is a comparatively close schedule and if it is to be carried out it needs coöperation all along the line. Dealers should place their orders at once so that Jobbers may be able to get a line on the situation and get their orders to us before December 8th. The factory has already begun to manufacture January Records, but it cannot do more than hold them until Jobbers' orders come in. As soon as these orders arrive the Records can be packed for shipment.

This plan of making more prompt shipments has involved a considerable rearrangement of our manufacturing schedule, and we feel that the trade will sufficiently appreciate its benefits to do all it can to assist in successfully carrying it out by ordering more quickly than before.

**PRINTED MATTER.**

A new discount sheet, Form No. 609, has just been mailed to every Dealer who has signed the new Agreement. Jobbers will need only a few additional copies for new Dealers and these will be supplied upon request.

A quantity of the four-page Christmas folder was shipped to every Jobber in the latter part of November. This folder showed Santa Claus with an Edison Home Phonograph in his arms which he is about to present as a Christmas gift to the family, saying: "Here's one for the whole family. I could think of nothing that will give such pleasure." Suitable argument is made on the other pages. The printing is in green and red ink on purple paper, a typical Christmas combination. Additional orders will be filled as long as the supply lasts.

Beginning with January we will mail two Record bulletins (large lists) to every Dealer

on our lists. This will be done to enable each Dealer to hang one in his show window and have a second copy for use inside. Jobbers who find an occasional Dealer asking for still another copy may have a small supply shipped with their orders for new Records each month by advising the Advertising Department in advance. Dealers will confer a favor by displaying one of these bulletins prominently in the show windows of their stores. Incidentally they will find this an excellent means of selling Records.

A copy of the new machine catalogue, Form 625, has just been mailed to each Jobber and Dealer. The supply of the previous catalogue, Form 500, is now exhausted and all orders for this form will be filled with Form 625. In addition to the matter included in Form 500, this new catalogue contains illustrations and descriptions of the Model B Reproducer, the new Model D Repeating Attachment and of the Gold Moulded Record.

A new Foreign Record catalogue will be issued within a month and in the meantime we will take the liberty of editing any large orders sent in for the present edition. The only change in the new catalogue will be the listing of a lot of Mexican Records and a few more British Records. The cover will be the same design as before but printed in different colors.

**TOOK THE PLACE OF "SUPERS."**

The latest recruit to stage mechanics is the Phonograph, which has recently been introduced in Berlin. It proved a grand success, the first attempt being made in Shakespeare's "King Henry V.," a drama in which the din of battle is especially prominent. One who was present declares that not a soul noticed that in place of human voices a piece of pure mechanism was at work. Instead of thirty "supers" crowded together and blocking up each other's way behind the wings there was a little table with an apparatus which could be shifted from one place to another at a moment's notice. And how faithful to his task was this new colleague! No disturbance now would arise owing to awkwardness or to the fault of some malevolent super or untimely wag. The innovation is likely to spread, and will surely prove a considerable economy for the smaller theatre, where the outlay on stage noises of the human and musical sort is no trifle.—*Strand*.

S. M. Brown, of Picton, Ont., sends two photographs of a Phonograph exhibit made by him and R. S. Williams & Sons Co., of Toronto, at the Picton Fair in October.



### COMMENTS ON EDISON GOLD MOULDED RECORDS FOR JANUARY, 1905.

The list of Edison Gold Moulded Records for the opening month of the new year comprises twenty-five delightful selections, made in the unequalled style of the Recording Department of the National Phonograph Company. They are so attractive that more than the usual amount of space is herewith given in commenting upon them.

No. 8856, "The Auto Race," by the Edison Concert Band, is a composition by Jean M. Missud, the well known director of the famous Salem Cadet Band, of Salem, Mass. An auto race is well described in the music, but in addition our Recording Department has introduced a scene at the beginning and end of the Record that makes it very realistic. The occasional toot-toot of auto horns helps out the scene.

No. 8857, "There's a Dark Man Comin' with a Bundle," is a typical coon song by Bob Roberts. The success that Lew Dockstader and other prominent comedians are meeting with in singing this song leads us to predict that Phonograph owners will welcome this Record as one of the best in the January Supplement. A laughable situation is when the colored woman sees her "old man" staggering home full of gin and understands it to be the "comin' true" of the "fortune tellin' man's" prophecy of "There's a Dark Man Comin' with a Bundle." The gin is the "bundle."

No. 8858, "My Little Canoe," is a contralto solo by Miss Grace Nelson. "My Little Canoe," by Leslie Stuart, was listed last month as an orchestra selection. Owing to the growing popularity of the canoe song—the most talked about musical number in "The School Girl," in which it was sung by Edna May—we have selected it to introduce Miss Nelson as a soloist to the Edison family of Phonograph lovers. Miss Nelson has a very pleasing contralto voice, combined with an exceptionally clear articulation. Her style of delivery is well fitted to this particular kind of song. We give the words of the chorus:

Mamie, I've a little canoe,  
Room for me, my Mamie, and you.  
I'll paddle along and rock you in my cradle—In my  
little canoe.  
Mamie you'll have nothing to do,  
And when I've told my worries to you,  
Then, Mamie we might "canoodle" we two  
In my little canoe.

No. 8859, "Make a Fuss Over Me," is another fine selection by the Ossman Banjo Trio. It is a coon song written by Theodore F. Morse, who wrote "I've Got a Feelin' for You," which was listed last month as a banjo trio. The three banjos are plainly heard. The Record is well played, as is to be expected from such well known artists as Messrs. Ossman, Hunter and Farmer.

No. 8860, "Back, Back, Back to Baltimore," is a coon song duet by Collins and Harlan. Not always does the so-called "coon" song have in it a situation so genuinely comic. The colored troupe has "busted," and two of its stranded erstwhile stars are lamenting their fate while awaiting a "freight" back to Balti-

more—many miles back. Their idea of the cause of their troubles is best told on the Record. Collins and Harlan sing the song and handle the coon parts well. Harry Williams and Egbert Van Alstyne are the writers of the song. The Record is made with orchestra accompaniment.

No. 8861, "Sing Me to Sleep," by Irving Gillette, is a ballad by Clifton Bingham (words) and Edwin Greene (music). Mr. Gillette was introduced to the Phonograph public in the last Supplement with two selections, "Shine On, Oh Stars," and "The Star of Bethlehem." This month's offering is of the same high order but of a different character. The accompaniment is orchestral. All three will grow in favor the more they are heard.

No. 8862, "Laces and Graces," played by the Edison Symphony Orchestra, is a composition by Bratton that has been very much in evidence in orchestral performances during the last year, fully equaling in popularity his well known "Cosey Corner Girl." It adapts itself readily to Record making requirements, and will doubtless be much appreciated by those who enjoy orchestra selections.

No. 8863, "Why Don't They Play with Me?" sung by Byron G. Harlan, is a descriptive song by Charles K. Harris, and it is sung with orchestra accompaniment. "Papa," said the child, "write mamma to come back so that they will play with me." This is the theme upon which Mr. Harris has built his new song. It is as full of human interest as "Always in the Way." The melody is both tuneful and appropriate, and admits of a fine orchestra accompaniment. Mr. Harlan is particularly fitted to render this kind of song, and in this one it will be admitted that he excels himself.

No. 8864, "Mr. Wilson, That's All," is a Record by Billy Murray. Just which is the most comic or interesting point brought out in this really comic coon song had best be left to the listener's own impression. Suffice it to say that Mr. Wilson has plenty of trouble, but sometimes has the "best of it." Harry Williams and Egbert Van Alstyne, the writers, have ejected lots of comedy in the verses and plenty of spirit in the melody with which Billy Murray finds himself perfectly at home. He is accompanied by the orchestra.

No. 8865, "Royal Trumpeter's March," played by the Edison Military Band, is a composition by Frank R. Seltzer, conductor of this band. As its title implies, it introduces trumpets. All the different sections of the band are kept busy, with a result fully up to the standard of any of Mr. Seltzer's fine military band marches. As Mr. Seltzer personally conducted the band for this piece it is unnecessary to say that it was played to his satisfaction.

No. 8866, "Little Tommy Went a-Fishing," is sung by the Criterion Quartette. We take pleasure in calling attention to this quartette of male voices, and we feel assured that their work in this Record will gain for them many friends. The selection is one well adapted to show their voices, organization and school. The story is no doubt familiar to many of how little Tommy, who while fishing on Sunday

without any luck, was told by the minister, who came along, how wicked it was to catch fish on Sunday. Little Tommy replied, "Who's catching any fish? Haven't had a bite all day." The musical setting is by J. C. Macy, and is fitted effectively to the story.

No. 8867, "The Girl Who Cares for Me," by Harry MacDonough, is a serio-comic sentimental waltz song, sung with orchestra accompaniment. It was written by the well known song writers, Cobb and Edwards. It is original in words and melody and makes a splendid Record in the hands of Mr. MacDonough. One of the verses follows:

There's a girl who cares for me,  
Every curl she curls for me,  
Every smile she smiles for me,  
She for me, me for she.  
She's my sweet forget-me-not  
I'm her Johnny on the spot,  
And I'll tell you what,  
If she'll share my lot,  
For the rest I care me not.

No. 8868, "Yankee Girl," is Albert Benzler's best xylophone solo. The character of the piece is such as to admit of this result. The drum solo introduced into the orchestra accompaniment is something new. J. Bodewalt Lampe, the composer, is also the composer of "Creole Belles" and many other popular selections. The "Yankee Girl" is his latest and one of his best works.

No. 8869, "The Countess of Alagazam," sung by Bob Roberts, is a comic song of one verse and five different choruses set to a rollicking air and sung with orchestra accompaniment. Written by Bob Cole. In each chorus the Countess has the last syllable of her name changed in a most amusing way. Requires a hearing to be appreciated. In the fourth chorus she is the "Countess of Alagazi" and the words chronicle her sad finish as follows:

The Countess of Alagazi. The maid with the dreamy eye,  
One day when the circus was passing by,  
She happened to get too dangerously high;  
With the elephant she got fly, and he boosted her to the sky,  
And the choir it sang, "In the sweet bye and bye,"  
O'er the Countess of Alagazi.

No. 8870, "I'm Trying so Hard to Forget You," is a duet Record by Harlan and Stanley, of Charles K. Harris' latest sentimental ballad. They thoroughly interpret Mr. Harris' meaning of the song. It is said that Mr. Harris had a romance in his early life. Be this as it may, considerable color is given to the suggestion by the beautiful ballads, "I've a Longing in My Heart for You, Louise," and "I'm Wearing My Heart Away for You," followed by this last song, for which the same popular welcome is predicted.

No. 8871, "Loving Hearts," by the Edison Instrumental Quintette a new organization designed to perform selections of the violin and flute order. Its initial performance is Theo. Moses-Tobani's charming composition. It is presented with confidence that both selection and the new organization will find many admirers.

No. 8872, "Just Before the Battle, Mother," is a fine duet by MacDonough and Biehling, of George F. Root's famous old-time war ballad. It is now listed on account of repeated

requests from many Phonograph enthusiasts, and also because it makes an unusually good Record. Mr. Root wrote a great number of popular songs during the civil war times.

No. 8873, "Abraham," is Arthur Collins' coon song contribution for the month. This song is on the order of "Alexander." Andrew B. Sterling and Harry Von Tilzer wrote them both. Mr. Collins introduces a little character acting between the verses in his inimitable style. As with all of our new vocal selections, "Abraham" is accompanied by the orchestra.

No. 8874, "Come Take a Trip in My Air-Ship," by Billy Murray, is a serio-comic song that has recently become very popular. The theme is a new one as will be seen from the chorus:

Come, take a trip in my air ship,  
Come, take a sail 'mong the stars,  
Come, have a ride around Venus,  
Come, have a spin around Mars  
No one to watch while we're kissing,  
No one to see while we spoon.  
Come, take a trip in my air-ship  
And we'll visit the man in the moon.

George Evans, composer of "In the Good Old Summer Time," wrote the melody and to its catchy swing may be attributed its quick jump into popular favor. The story and words are Ben Shields' inspiration. Billy Murray does both writers full justice with his fine phrasing and distinct articulation.

No. 8875, "Sweet Thoughts of Home," is a splendid solo Record by W. H. Thompson. This song was written by Stanislaus Stange and Julian Edwards and is sung by Madame Schumann-Heink in "Love's Lottery." This is perhaps the most enjoyed musical number sung by the Madame in this successful comic opera. Mr. Thompson who sings it for our Record is a member of the "Love's Lottery" company, playing one of the principal parts. Listening to this song nightly Mr. Thompson has caught the secret of Madame Schumann-Heink's irresistible rendition and has placed it upon our Record in a manner second only to that of the great singer herself.

No. 8876, "By the Old Oak Tree," by Miss Morgan and Mr. Stanley, is an exceptionally good contralto and baritone duet of this popular song from "The Rogers Brothers in Paris." It is one of the most pleasing selections in the programme. It has a very catchy melody written along new lines. The following words of the chorus give an idea of the somewhat humorous story:

The dove said "Coo! Coo! won't you come along  
and woo, woo!"  
The crow said "Caw! Caw! you're the worst I ever  
saw, saw."  
But the rural lovers smiled with glee,  
For she loved he and he loved she,  
And they kept on a-loving just as happy as could be,  
By the old oak tree.

No. 8877, "Tales from the Vienna Woods," by the Edison Symphony Orchestra, is Johann Strauss' well known composition. It is played as a concert waltz. A flute cadenza and a violin and flute duet precede the waltz, giving a variety of movement and tone color. The whole is an artistic rendering of a beautiful and standard composition and should be an immense favorite.



No. 8878, "The Darkies' Dream," by the Edison Military Band, is a selection formerly made on the old style Record and played by the orchestra. It is re-listed because of numerous requests. It is now made by the Military Band and is a much finer Record. The dialogue at the beginning has been added to and the Record is thereby made much more realistic and entertaining. "The Darkies' Dream" is of the "never die out" kind, or as one of our clear-sighted dealers puts it, "As staple as flour, salt and sugar in a grocery store."

No. 8879, "Dr. Jekyll and Mr. Hyde," is a unique Record by Len Spencer. In this Record the transformation scene of the play is given true to life and with care to details, of which there are many. The orchestra, organ and chimes in the distance, the discovery of Mr. Hyde after breaking in the door to Dr. Jekyll's laboratory give great realism to the scene. For years the play was the strongest attraction in Richard Mansfield's repertoire.

No. 8880, "Teasing Medley," by the Edison Military Band, introduces "Teasing," "Save It for Me," "Alexander," and "I've Got a Feelin' for You." The Military Band medleys that we have listed from time to time have been exceedingly popular throughout the country. The one listed this month will be found to equal any of them in attractiveness. It consists of four big favorites, while the song for which the medley is named is especially popular at the present time.

#### BERLIN BRANCH ADVERTISEMENT.

Following is a translation of an advertisement of our Berlin branch, published in a trade paper:

THOMAS A. EDISON,

To whose genius the world owes the wonderful invention of the reproduction of sound, made in the beginning of the year 1902 two important improvements to the Phonograph, which make it superior to all other talking machines. To-day the Edison Phonograph is therefore the most perfect talking machine. These improvements were the new Edison Gold Moulded Records and a new reproducing device.

Edison Phonographs are constructed on scientific principles. Edison Phonographs are not only reproducing apparatus, but they can always be adapted for recording purposes. Half the pleasure in the possession of the Phonograph is the making of one's own records.

Edison Gold Moulded Records are the result of many years' inventive work and lavish expenditure. They are of astonishing tone and purity, exempt from all disturbing sounds, and they wear to a very small extent. They furnish real music for the connoisseur.

The Edison Gesellschaft protects its dealers against price cutting, and insures them a stipulated high profit on their Phonographs and Records, owing to its sales system.

The Edison Gesellschaft only supplies Dealers, and does not enter into competition with the latter, either openly or secretly by means of retail shops. The Edison Gesellschaft is in

a position to deliver promptly, considering the splendidly organized factories established in three European capitals—Berlin, Paris, and Brussels—and Orange, America. Three necessary features for a pleasant and profitable business relationship with dealers.

Genuine Edison Phonographs and Gold Moulded Records bear the registered trademark.

Catalogues, prices and terms through our factors or direct.

EDISON GESELLSCHAFT, m. b. H.  
Berlin, Südufer 23.

#### MODEL "COPY".

For the benefit of Dealers who may want some good "copy" for an advertisement, we take pleasure in reproducing the following argument from a large advertisement published by the American Phonograph Company in the Detroit daily papers:

EDISON PHONOGRAPHS AND RECORDS.

There is no doubt, no question of the vast superiority of Edison Phonographs and Edison Gold Moulded Records. They are the very finest in the world. Edison, that wonderful wizard in invention, perfected the Phonograph, until the tones of the human voice in all the various modulations are reproduced so naturally that you recognize at once who is speaking or who is singing. Edison Gold Moulded Records stand alone in the perfect reproduction of sound. Be it a band of sixty-two pieces; be it a comic minstrel with his banjo; be it a recitation, humorous or tragical; be it the finest singer in the world—the Edison Gold Moulded Record reproduces, by the aid of the Edison Phonograph, absolutely, naturally.

Now, then, why be tortured or annoyed with rank imitations? Why submit to imperfect reproduction? Why take a "bundle of noise" and discord, when you can enjoy a perfect reproduction without any extra expense?

Nothing gives such conclusive evidence as your own personal comparison and experience. Therefore, we invite you, we urge you, to visit our store and let us give you a practical demonstration of the beauty and perfection of the Edison Gold Moulded Records with the Edison Phonograph.

Why buy from the followers, when you can enjoy the efforts of the originators without extra expense.

We have for years been the State headquarters for Edison Phonographs and Edison Gold Moulded Records. So sweetly perfect. No hiss, no scratch, no discord, but perfection in the reproduction of sound. Edison Phonographs cost no more than the commonplace sorts, and we make very easy terms—\$1.00 a week if you like.

Edison Gold Moulded Records are the only perfect Records, and we are now selling the regular 50c. qualities for 35c.

Just think of the coming holidays and how charming a Christmas offering to your family or friends a good Edison Phonograph will be.

Anyway, drop in and be entertained for a while.

## TESTIMONY AND PROPHECY FROM AUSTRALIA.

The following interesting article on the present and future of the Edison Phonograph appeared in the *Times* of Sydney, New South Wales, Australia, on October 9th:

Only those who have chanced to hear them can commence to realize the revolution that has taken place in talking machines within this last two years. Most persons have heard the old Edison Phonograph with its voice talking, or singing, down a chimney. It was wonderful, startling, but on the whole more curious than practical. Very few were anxious to have more than a small instalment of its performances. But quite lately nearly all the old defects have been swept away. It is an actual fact that on a good machine you can now hear the human voice in song or speech so exactly reproduced that the absence of the living mouth can be detected by the eye alone. Together with this increase in quality, the price of machines and Records has so fallen as to be within the reach of every purse. The great fillip to the trade was the invention of the Moulded Record. That is, once you get a good master Record and make a mould, it is possible to reproduce duplicates at a nominal cost of material by the hundred thousand. Already it is a distinct and lucrative branch of the musical profession to perform exclusively for the record-maker.

It is now only a question of time, and a short time, too, when a talking machine will be indispensable to every household; and that not only as a source of amusement, but as a help in numberless other directions. On the cheap and perfect record now in sight the politician will speak his condensed speech, and post a copy to every constituent; the parson will post his sermon after preaching it in his study. The shopkeeper will post that enticing speech by which you are induced to buy the latest thing in bootware, hatware, or backware, as the case may be. No one will write letters to anybody; it will be so much easier "to graph." The school teacher can so model his system that nearly all can be done by record instruction. Newspapers will give as supplements records in the voice of the famous persons of the day. And it takes no great stretch of fancy to imagine the newspaper itself superseded by the daily record. Certainly as a means of correspondence even the typewriter will be obsolete when record making is further simplified and cheapened. What lover would not rather talk to the loved one and hear her voice than see her pen marks? What friend will not rather hear the friend's voice than read a lifeless note on paper? The prospect of development is boundless. For teaching purposes universities may be abolished; a trained body of professors can send their lectures to students at the end of the world, and by the same means the student may send replies and questions. The wholesale house of the future will find in the morning's mail not a stack of letters, but records. It will be the duty of clerks to hear these records and dictate an answer on another record. It will thus arise that the future gold medal clerk

will not be he who writes a good hand or is swift with the typewriter, but the one with a clear, distinct voice, competent to make a good record. The customer going into a large store will not need to find a shopman at each counter to describe the merits of a line of goods. He will touch a button near at hand, and a mechanical talker will tell him all he wants to know.

The Governor of a State, already largely a figurehead, will be quite unnecessary; his speeches of congratulation on opening a public building or laying a foundation stone are of necessity of such a sameness that one of a baker's dozen of original speeches from King Edward himself, properly recorded, would be a grateful substitute. Better the voice than the shadow of royalty. In law courts the evidence of witnesses and parties in the case will be taken on records with a great saving of time. In the railway carriage every stoppage will announce the name of the station and duration of stop. The business man will not personally interview ordinary callers, who now fritter away his time. In an ante-room a small boy with a stock of appropriate records, made by the principal, will have a reply for everybody.

One great blessing of the new era that many of us may shortly see is the tendency it will have to compress speech; the windy person will be a waste to so much valuable record space. Our politicians, parsons, and public men will have to learn to blue pencil their remarks.

Already the talking machine is the greatest blessing that ever came to the bushman or the dweller in lonely places. By the mere winding of a key he is put in touch with the world's best in the way of music or song. And no one now should learn to play or sing unless possessed of great natural aptitude for at their best they will always be so inferior to the machine.

## THE RIGHT TO REGULATE PRICES.

Regulating the selling price of a patented article as an inherent right of the inventor has been firmly established in connection with talking machines, said the *Music Trade Review* in a recent issue. As to the trend of recent or modern decisions on the question of the power and right of patentees to regulate the prices and terms of sale of their patented articles, through and by their licensees, the Federal courts have recently, in several judicial pronouncements, found and held that patentees have such right; that they may prescribe the price and lay down the terms of sale which their licensees shall charge and impose in selling to the general trade the patented articles covered by the patents under which the license is granted.

This was determined by the Supreme Court of the United States in May, 1902, in the case of Beamant against the National Harrow Company and in several other instances enumerated below. In this case the court, after ana-



lyzing the conditions of the license, said in referring to the rule of the laws on this subject: "The very object of these laws is monopoly, and the rule is with few exceptions that any conditions which are not in their very nature illegal with regard to this kind of property, imposed by the patentee and agreed to by the licensee for the right to manufacture or use or sell the article will be upheld by the courts. The fact that the conditions in the contracts keep up the monopoly or fix prices does not render them illegal."

In June, 1902, in the District of Massachusetts, Judge Lowell decided the case of the Edison Phonograph Company against Pike, reported in Volume 116 *Federal Reporter*, at page 1863, in which he sustained the validity of a similar contract. The contract before him was one by which the owner of certain patents granted licenses to use and vend the patented articles, the licensees agreeing not to sell such articles for less than the price fixed by the licensor, and not to sell to any one who did not sign a similar agreement. The contract contained a further condition that as to any of the patented articles sold in violation of its terms, the license should be void, and that any vendor or user of such articles thereafter should be an infringer of the patents. The court held that such condition was valid and that the sale or use of the patented articles by one who purchased them from the licensee, with knowledge of the terms of the contract, and without signing the agreement required by the contract, constituted an infringement. Thus the court, recognized the right of the patentees to impose the price at which the licensee shall sell the licensed articles, and the further right of the patentees to require the licensee not to sell to any one as his customer who will not sign a similar agreement. The point in the case was whether one who had purchased the patented article of the licensee and had sold them in disregard of the terms of the license to the licensee, was an infringer. The court held that such customer so ignoring the terms of the license under which the licensee sold the goods to him, was an infringer.

In April, 1903, the Circuit Court of Appeals for the seventh district, which sits in Chicago, decided the case of the Victor Talking Machine Company against The Fair, which case is reported in Volume 123 *Federal Reporter*, at page 424. In this case the court laid down the right of the patentee to fix the selling price of the licensed article in broad terms. The court decided that the "owner of a patent who manufactures and sells the patented article may reserve to himself, as an ungranted part of his monopoly, the right to fix and control the prices at which jobbers or dealers buying from him may sell to the public, and a dealer who buys from a jobber with knowledge of such reservation, and resells in violation of it, is an infringer of the patent." The court also added: "Within his domain the patentee is a czar. The people must take the invention on the terms of his dictates or let it alone for seventeen years." Judges on other circuits have since reaffirmed this decision, so that it is now enforced in all parts of the country.

Thus it may be affirmed that the time has

been reached and passed in the progress of judicial pronouncement when a patentee or owner of a patent may lawfully regulate the price and terms of sale, both as between himself and a jobber or dealer, and between the latter and the public to whom they sell.

#### A PATRIOTIC RECORD.

Record No. 8849, "Our National Airs," by Len Spencer, listed in December, will appeal so strongly to every patriotic American that space is here given to a more detailed description of it than was possible last month. The words were written by Howard Taylor Middleton, of Philadelphia. As Mr. Spencer recites them soft music is played by the orchestra. At the close of the third verse the band plays "Marching Thro' Georgia"; after the fourth verse, "Dixie"; after the fifth verse, "Yankee Doodle Dandy," and at the end "Star Spangled Banner." The words:

#### OUR NATIONAL AIRS.

When journeying through some foreign clime,  
Away from home and friends,  
If we hear an air from our native land,  
We bathe in the peace it sends.

All of our homesickness is gone  
And in its place there comes  
A thrill of pride, a sense of joy,  
For we're America's sons.

The air that marked the time so oft'  
When marched the boys in blue  
Down through Georgia's sunny fields;  
It thrills us through and through.  
Band: "Marching Thro' Georgia."

The southern anthem, too, we love  
That led the boys in gray;  
Those gallant sons of Dixie land  
May Dixie live alway.  
Band: "Dixie."

Then comes that lively ringing strain  
That always comes so handy  
To stir the blood, to clear the head,  
Old "Yankee Doodle Dandy."  
Band: "Yankee Doodle Dandy."

But best of all we love the one  
That lauds our flag so brave;  
The flag that has never known defeat.  
So may she always wave.

Hurrah! for the flag. Hurrah! for the air  
Heard through battle clamor,  
The greatest flag, the grandest air,  
Our own Star-Spangled Banner.  
Band: "Star-Spangled Banner."

Well, a Phonograph may not sing as well as a girl, but the crowd doesn't have to coax and flatter the Phonograph two hours to make it sing five minutes.

**If you have the stock for a holiday business advertise the fact. It will pay.**

**A GREAT SUCCESS.**

In an advertisement in the Bangor, Maine, papers of November 19th the S. L. Crosby Co., Jobbers in Edison goods in that city, printed a copy of the following letter from C. H. Wilson, manager of sales of the National Phonograph Company:

New York, Nov. 15, 1904.

The S. L. Crosby Company, 186 Exchange Street, Bangor, Maine.

Dear Sirs:—We beg to acknowledge receipt of your orders of November 14th, 1904, calling for 200 Standard, 35 Gem and 35 Home Phonographs, to be shipped December 1st; 24,000 Records to be shipped immediately, and advertising matter as per specifications given, all of which will have our prompt and careful attention, and for which kindly accept our thanks.

Since October 1st, 1904 we have shipped you 35 Gem, 170 Standard, 35 Home and 5 Triumph Phonographs. To-day's order in addition thereto, makes a total of 70 Gem, 370 Standard, 70 Home and 5 Triumph Phonographs ordered by you since October 1st.

We congratulate you upon your success as Jobbers in Edison Phonographs and Records.  
C. H. WILSON,  
Manager of Sales.

This letter speaks for itself. The advertisement also contained the following paragraphs:

Talk about your home entertainers! There isn't anything on the market to-day that is half so versatile, half such "good fun" for all ages and at all times, as the Phonograph. You may have been thinking of buying one; DO IT NOW while the winter evenings have but just begun, and make home merry not only for yourself but for the whole family and all your friends.

Since the recent important improvements have been introduced in Phonographs, the makers have not been able to keep up with orders, even though they have greatly increased their factory force, and DOUBLED their output. DOES THIS LOOK AS THOUGH THE PHONOGRAPH WAS LOSING POPULARITY? Far from it!

**TALKING MACHINE DEVELOPMENT.**

When the talking machine first appeared it was looked upon as a novelty, the demand for which would be fleeting, and to have proclaimed that its stay would be permanent and have an ever-widening demand, would have seemed preposterous.

In the light of later development it must be conceded that the talking machine has not only lived down its early detractors, but it has advanced to such a position that it cuts no small part in the music field of to-day.

There has been remarkable developments in the perfection of the talking machine, with the result that to-day it is conceded to be an educational force with ever growing possibilities. Well equipped music stores throughout the

land feature their departments with talking machines and many have fitted up special rooms in which great varieties of machines are exhibited. Attendants are always in evidence to test records and otherwise entertain shoppers.

The demand for these special products is world-wide, and in recording the steadily growing foreign demand for talking machines we may say that the value of talking machines sent abroad during 1904 in dollars exceeds that of pianos and other musical instruments.

It is an industry to-day of no mean proportions, and there are new specialty factors springing up which will undoubtedly form a greater impelling power.

The talking machine has come to stay, and exercise a growing influence in not only the life of America, but it will assist greatly in the business offices as well.—*Music Trade Review.*

**NEW STYLE RECORD SHELVING.**

A new method of constructing shelving for carrying stocks of Edison Records comes from Victor H. Rapke, a New York city Jobber, who is constantly devising new plans for conducting his business. Mr. Rapke suggests that Record shelves be built with a pitch of about twenty degrees, so that when Record boxes are placed on their sides they will always roll to the front. The advantages of this plan are obvious. As long as there is a single Record on the shelf it is always at the front and its absence tells the Dealer that the stock of that selection is depleted. From the middle of the floor the Dealer can tell just what numbers are missing, and, as the boxes lie a little above each other, he can see by a glance in each compartment just how many of each number he has in stock. This style of shelves need only be built far enough apart to permit the boxes being placed in the compartments easily. In fact, each box can be placed in front and used to press back any others that may be in the compartment. A strip across the face of the shelves acts as a stop to keep the boxes from rolling out and affords a suitable place to display the number and even the name of the selection. The depth of the shelves may vary according to the number of each selection that it is desired to carry in stock.

**Mr Dealer: Take a last look over your stock and make sure that you are fully prepared for the holiday trade.**



**SUSPENDED LIST, DECEMBER 1, 1904.**

SUPERSEDING ALL PREVIOUS LISTS.

**COLORADO.**

Boulder—BENTLEY &amp; CRAIG.

**INDIANA.**

Marion—\*Butler Music Co.

South Bend—EUGENE MARSH, 126 Vistula avenue.  
SOUTH BEND BOOK BINDERY,  
Robert Lebolt, Prop., 203 North  
Michigan street.**IOWA.**

Burlington—JOHN P. WEISS, 711 Jefferson street.

Sioux City—HATTENBACH BROS. CO.

**KANSAS.**

Clay Centre—E. M. GOWENLOCK.

Lawrence—BELL BROS.

**MAINE.**

Biddeford—W. H. FIELD.

**MASSACHUSETTS.**

Boston—T. SINGER, 60 Leverett street.

Lawrence—LORD &amp; CO., 314 Essex street.

E. O. MOSHER, 420 Essex street.

Lynn—ELIAS DEYOUNG.

Malden—A. T. FULLER.

Nantucket—ARTHUR M. TAYLOR.

New Bedford—H. B. DEWOLFF.

Somerville—E. J. WINCHESTER, 32 Summit avenue.

Woburn—OSBORN GILLETTE, or THE BOLTON  
JEWELRY CO., L. F. Maloney, Manager.**MICHIGAN.**

Detroit—F. J. SCHWANKOVSKY.

Saginaw—GEO. W. EMENDORFER.

**MISSOURI.**

Kansas City—THE WITTMANN CO.

**NEBRASKA.**

Lincoln—THE WITTMANN CO.

Omaha—THE WITTMANN CO.

**NEW HAMPSHIRE.**

Hillsboro Bridge—E. M. BARNES.

Manchester—A. E. DUMAS

Nashua—F. A. McMASTER &amp; CO.

**NEW JERSEY.**

Atlantic City—SAM'L D. WOLF, 32-34 Arkansas ave.

Bayonne—I. WIGDOR, 450 Avenue D.

Jersey City—W. L. HOFFMAN, 151 Montgomery st.

Newark—R. L. CORWIN; also New York City.

Passaic—I. HURWITZ.

Paterson—CHAS. H. KELLY, 25 N. Main street.

Plainfield—S. W. FRUCHT, or R. FRUCHT; also  
New York City.

ELSTON M. LEONARD.

West Hoboken—EMIL HOLLANDER, or THE WEST  
HOBOKEN BICYCLE & PHONO-  
GRAPH CO., 619 Spring street.**NEW YORK.**

Albany—G. LINDE, 353 S. Pearl street.

Bedford Park—GEO. H. TYRRELL.

Hobart—F. H. MARSHALL.

New York City—A. T. ARMSTRONG, or AMERI-  
CAN PHONOGRAPH CO., 106  
Wall street.BERN BEARWALD, 373 W. 11th st.  
BRONX PHONOGRAPH CO. or  
DAVID SWITKY, 506 Willis ave.  
CENTRAL PHONOGRAPH CO.,  
160 E. 42d street.R. L. CORWIN; also Newark, N. J.  
EAGLE PHONOGRAPH CO., or C.  
LOWENTHAL, 83 Nassau street.  
EMPIRE PHONOGRAPH CO., 2 W.  
14th street.S. W. FRUCHT, or R. FRUCHT, 7  
Barclay street, or 68 Cortlandt  
street; also Plainfield, N. J.

O. HACKER, 2 Murray street.

HAWTHORNE & SHEBLE, 297  
Broadway; also Philadelphia, Pa.  
N. HORN, 148 E. 58th street.

W. L. ISAACS, 114 Fulton street.

S. LEMBURG &amp; CO., 194 Broadway.

J. McELLYNNE, 202 Broadway.

RICHMOND PEASE, 44 W. 132d st.

F. M. PRESCOTT, 44 Broad st.

WINTHROP CYCLE CO., 2212 Sev-  
enth avenue.

Saratoga—W. J. TOTTEN.

Saratoga Springs—MARVIN A. COTE.

Syracuse—SPALDING &amp; CO.

**OHIO.**

Cincinnati—J. L. ANDEM.

Coshocton—BURNS &amp; GOSSER.

Springfield—D. &amp; M. VANDERPOOL.

Uhrichsville—F. A. MAZURIE.

**PENNSYLVANIA.**

Philadelphia—A. R. CASSIDY, 2783 Emerald street.

HAWTHORNE & SHEBLE, 604 Chest-  
nut street, or Oxford and Mascher  
streets; also New York City.

A. KROUSE, 832 Arch street.

PENN NOVELTY CO., 15 South 9th st.

Phoenixville—KEINARD BROS.

Pittsburg—A. LIPPARD, 615 Wylie ave.

**RHODE ISLAND.**

Providence—F. P. MOORE.

**WISCONSIN.**

Milwaukee—J. C. BLATZEK.

\*Added since November 1, 1904.

**Jobbers and Dealers are asked to co-operate with us, FOR OUR MUTUAL GOOD, by being careful that they do not supply any of the above named firms with our apparatus, either at addresses given or any other address.**

## JOBBERS OF EDISON PHONOGRAPHS AND RECORDS.

## ALABAMA.

**Birmingham**—The Ray Co., 2027 Second avenue.  
The Talking Machine Co.

**Mobile**—W. H. Reynolds, 167 Dauphin street.

## CALIFORNIA.

**San Francisco**—Peter Bacigalupi, 786-788 Mission street.

## COLORADO.

**Denver**—Denver Dry Goods Co., 619 16th street.

## CONNECTICUT.

**Middletown**—Caulkins & Post Co., 406-408 Main street.

**New Haven**—Pardee-Ellenberger Co., 155 Orange st.

## DISTRICT OF COLUMBIA.

**Washington**—E. F. Droop & Sons Co., 925 Pennsylvania avenue, N. W.

S. Kann, Sons & Co., 8th and Pennsylvania avenues.

## ILLINOIS.

**Chicago**—James I. Lyons, 73 Fifth avenue.

Siegel-Cooper Co., State and Congress sts.

Talking Machine Co., 107 Madison street.

The Vim Co., 68 E. Lake street.

Montgomery Ward & Co., 111 Michigan ave.

Rudolph Wurlitzer Co., 302 Wabash ave.

**Peoria**—Peoria Phonograph Co., 222 Bridge street.

## INDIANA.

**Indianapolis**—Craig-Jay Co., 234 Massachusetts ave.

Kipp Bros. Co., 37 S. Meridian street.

A. B. Wahl Co., 119 S. Illinois street.

**Lafayette**—A. B. Wahl Co., 304 Main street.

## IOWA.

**Des Moines**—Hopkins Bros. Co., 620 Locust street.

The Vim Co., 704 West Walnut street.

**Fort Dodge**—Early Music House, 822 Central ave.

## KENTUCKY.

**Louisville**—The Ray Co., 640 Fourth street.

## LOUISIANA.

**New Orleans**—\*William Bailey, 600 Frenchman street.

National Automatic Fire Alarm Co.,  
614 Gravier street.

The Ray Co., 111 Camp street.

## MAINE.

**Bangor**—S. L. Crosby Co., 186 Exchange street.

**Portland**—W. H. Ross & Son, 207 Commercial street.

## MASSACHUSETTS.

**Boston**—Boston Cycle & Sundry Co., 48 Hanover street.

Eastern Talking Machine Co., 177 Tremont street.

Iver Johnson Sporting Goods Co., 163 Washington street.

Read & Read, 558 Washington street.

**Fitchburg**—Iver Johnson Sporting Goods Co., 247 Main street.

**Lowell**—Thomas Wardell, 111 Central street.

**Worcester**—Iver Johnson Sporting Goods Co., 304 Main street.

## MICHIGAN.

**Detroit**—American Phonograph Co., 106 Woodward avenue.

Grinnell Bros. Music House, 219 Woodward avenue.

The Ray Co., 252 Woodward avenue.

**Saginaw**—Morley Bros.

## MINNESOTA.

**Minneapolis**—Thomas C. Hough, 714 Hennepin ave.

**St. Paul**—W. J. Dyer & Bro., 21-23 West 5th street.

Minnesota Phonograph Co., 37 E. 7th street.

## MISSOURI.

**Kansas City**—J. W. Jenkins' Sons Music Co., 1013-1015 Walnut street.

The Ray Co., 1021 Grand avenue.

**St. Louis**—Conroy Co., 1115 Olive street.

\*O. K. Houck Piano Co., 1118 Oliver street.

The Ray Co., 923 Olive street.

## NEBRASKA.

**Lincoln**—H. E. Sidles Cycle Co., 1317 O street.

**Omaha**—H. E. Fredrickson, 1502-1510 Capitol avenue.  
Nebraska Cycle Co., 15th and Harney streets.

## NEW JERSEY.

**Hoboken**—Eclipse Phonograph Co., 205 Washington street.

**Newark**—A. O. Petit, New and Halsey streets.

**Paterson**—James K. O'Dea, 117 Ellison street.

**Trenton**—Stoll Blank Book and Stationery Co., 30 E. State street.

## NEW YORK.

**Brooklyn**—Chapman & Co., Fulton and Duffield streets  
A. D. Matthews' Sons, 394 Fulton street.

Price Phonograph Co., 1258 Broadway.

**Buffalo**—P. A. Powers, 643 Main street.

**Elmira**—Elmira Arms Co., 117 Main street.

**Gloversville**—American Phonograph Co., 99 W. Fulton street.

**Kingston**—Forsyth & Davis, 307 Wall street.

**New York City**—Bettini Phono. Co., 80 Chambers street.

Blackman Talking Machine Co., 19

Beekman street.

J. F. Blackman & Son, 2654 3d avenue.

I. Davega, Jr., 802 Third avenue.

S. B. Davega, 32 E. 14th street.

Douglas Phonograph Co., 89 Cham-

bers street

H. S. Gordon, 139 Fifth avenue.

Harry Jackson, 219 Bowery.

Jacot Music Box Co., 39 Union Square.

Victor H. Rapke, 1661 Second avenue.

Siegel-Cooper Co.

John Wanamaker.

**Rochester**—A. J. Deninger, 347 North street.

Mackie Piano, O. & M. Co., 100 State street.

Gilès B. Miller, 63 State street.

Talking Machine Co., 29 Clinton avenue, S.

**Schenectady**—Jay A. Rickard & Co., 253 State street.

**Syracuse**—W. D. Andrews, 216 E. Railroad street.

**Troy**—James Lucey, 359-361 Fulton street.

**Utica**—Clark-Horrocks Co., 54 Genesee street.

Arthur F. Ferriss, 89 Washington street.

William Harrison, 41 Columbia street.

Utica Cycle Co., 31 Columbia street.

## OHIO.

**Canton**—Klein & Heffelman Co., 216 N. Market street.

**Cincinnati**—Ilsen & Co., 25 W. 6th street.

The Ray Co., 143 West 5th street.

A. B. Wahl Co., 805 Vine street.

Rudolph Wurlitzer Co., 121 E. 4th st.

**Cleveland**—W. J. Roberts, Jr., Erie and Huron streets.

**Columbus**—Perry B. Whitsit Co., 213 S. High street.

**Dayton**—Niehaus & Dohse 35 E. 5th street.

**East Liverpool**—Smith & Phillips Music Co.

**Toledo**—Hayes Music Co., 608 Cherry street.

## PENNSYLVANIA.

**Allegheny**—Henry Braun, 500 Federal street.

**Allentown**—G. C. Aschbach, 539 Hamilton street.

**Easton**—William Werner, 401 Northampton street.

**Philadelphia**—C. J. Heppe & Son, 1117 Chestnut street.

Lit Bros., Market and 8th streets.

Penn Phonograph Co., 19 S. 9th street.

John Wanamaker.

Wells Phonograph Co., 41 N. 9th street.

Western Electric Co., 931-933 Market st.

H. A. Weymann & Son, 923 Market st.

**Harrisburg**—S. K. Hamburger, 12-14 N. Market sq.

**Pittsburg**—Theo. F. Bentele Co., Inc., 433 Wood street.

Kaufmann Bros., Fifth avenue and Smith-

field street.

H. Kleber & Bro., 221 Fifth avenue.

C. C. Mellor Co., 319 Fifth avenue.

Pittsburg Phono. Co., 937 Liberty avenue.

**Reading**—Reading Phonograph Co., 809 Penn street.

**Scranton**—Ackerman & Co., Coal Exchange Building.

Technical Supply Co.

## RHODE ISLAND.

**Providence**—J. M. Dean Co., 785-795 Westminster street.

J. A. Foster Co., Weybosset and Dor-

rance streets.

Household Furniture Co., 231-237 Wey-

bossett street.

J. Samuels & Bro., 154 Weybossett street.

A. T. Scattergood & Co., 106-110 N. Main

street.

## TENNESSEE.

**Knoxville**—\*Knoxville Typewriter and Phonograph

Exchange, 311 Clinch street.

\*O. K. Houck Piano Co., 359 Main street.

**Memphis**—The Ray Co., Lyceum Building.

**Nashville**—Nashville Talking Machine Co., 510 Church

street.

The Ray Co., 13-15 The Arcade.

## TEXAS.

**Dallas**—C. B. Harris, Agt., 347 Main street.

\*Houston—H. M. Holleman & Co., 715 Main street.

## VIRGINIA.

**Richmond**—The Ray Co., 720 E. Main street.

## WISCONSIN

**Milwaukee**—McGreal Bros., 173 3d street.

## CANADA.

**Toronto**—R. S. Williams & Sons Co., Limited,  
143 Yonge street.

\* Added since November 1, 1904.





“**D**DOUBLE SERVICE” extends the full Edison hand to the Trade with heartiest good wishes for a prosperous Holiday Season. The best favor we can do for you is to recommend one of our Holiday Demonstrating Outfits to strengthen your arguments and increase your December business. Let us send you this outfit *today*.

**DESCRIPTION:** 4 Complete Lessons consisting of French, German, Spanish, and English Moulded Records and sample textbooks, posters, and holiday literature. **Price, \$2.00, net, Prepaid.**

For Domestic and European Sales, address:  
**International Correspondence Schools,**  
 Language Dept., Scranton, Pa.

For Foreign Sales, address:  
**National Phonograph Co., Foreign Dept.,**  
 83 Chambers St., N. Y. City



# EDISON Phonograph Monthly

PUBLISHED FOR TRADE USE ONLY BY  
THE NATIONAL PHONOGRAPH CO.

VOL. II.

NEW YORK, JANUARY, 1905.

No. 11.

*The National Phonograph Co.,*

ORANGE, N. J.

NEW YORK: 83 CHAMBERS STREET.

CHICAGO: 304 WABASH AVENUE.

SAN FRANCISCO: 786 MISSION STREET.

NATIONAL PHONOGRAPH CO., LTD., 25 CLERKENWELL  
ROAD, LONDON, ENG.

## EDISON PHONOGRAPHS AND RECORDS.

All communications to THE PHONOGRAPH MONTHLY should be addressed to the Advertising Department 83 Chambers Street, New York.

### C O N T E N T S

Trade Notes .....	I
Advance List Edison Gold Moulded Records for February, 1905 .....	2
Please Fill Out Cards.....	3
Not Guilty .....	3
Selling Suggestions .....	3
Seventy-one Mexican Records .....	4
Printed Matter .....	5
New Duty on Talking Machines .....	5
The Reason Why .....	6
Fac-Simile of Letter Declining Award at St. Louis .....	7
Comments on February Records .....	8
Among the Jobbers .....	10
Trade Devices .....	10
Model D Return Attachment .....	10
It Does Pay .....	10
Trade Holiday Advertising .....	11
From Australia .....	12
I. C. S. Language Outfits .....	12
Cold Weather Idea .....	12
The Phonogram .....	12
Window Display of John M. Dean Co... ..	13
Interior of Store of Peter Bacigalupi.....	13
List of Suspended Dealers, January 1....	14
Jobbers of Edison Phonographs and Records .....	15

## TRADE NOTES.

In the October issue of the EDISON PHONOGRAPH MONTHLY reference was made to a meeting held in September of the officials of this company and department heads, at which the unusual trade conditions were discussed and means considered whereby the factory output might be increased. Those in charge of the mechanical department made what they deemed was a careful canvass of the situation and declared their ability within a few weeks to increase the output sixty per cent. This increase was not only equalled on time, but, owing to the remarkably increased demand for goods, it was exceeded week after week until in the week ending December 17th the output was more than one hundred per cent. greater than that of any week in September. To reach the output referred to it was necessary to run our factory night and day. This fact is cited as showing the state of business in Edison Phonographs and Edison Gold Moulded Records at the present time. It is not expected that this great demand will continue indefinitely, but at the present writing there is no sign of a let up in orders, either for Phonographs or Records. The demand will probably be unchanged for some time because there will be a general re-stocking among the Dealers on account of their holiday sales.

The advance orders received from the special supplement of Dance Records are even greater than we anticipated when the list was sent out. The total sales of these Records, however, will be very much greater in the next few months than these advance orders, for as soon as the public realize how good they are, they are going to buy them largely. Aside from their merit for dancing purposes, they are a splendid lot of Records and they are going to find more favor among people who have

(Continued on page 3.)

**THE ADVANCE LIST OF FEBRUARY RECORDS APPEARS ON PAGE 2. ORDER FROM IT. NO OTHER ADVANCE LIST WILL BE ISSUED.**



# NEW EDISON GOLD MOULDED RECORDS. ADVANCE LIST FOR FEBRUARY, 1905.

RECORDS listed below will be ready for shipment as near **January 23d** as possible, at which time Jobbers' stock orders, if **received** prior to **January 9th**, will be shipped. February Supplements will be forwarded to Jobbers with their stock order for Records. Retail Dealers should place stock orders with their Jobbers at once, to insure prompt shipment as soon as Jobbers' stock is received.

- 8903 Hunting Scene (*Bucalossi*) Edison Military Band  
*Descriptive selection with male chorus and effects.*
- 8904 My Dreams (*Tosti*) Sentimental song, Orch. accom. Irving Gillette
- 8905 By the Watermelon Vine—Lindy Lou (*Allen*) Edison Male Quartette  
*Coon love song, Male quartette, Orch. accom.*
- 8906 Dreamy Moments (*Ehrich*) Violin and Flute duet. Jaudas & Rose
- 8907 Coax Me (*Von Tilzer*) Coon song, Male duet, Orch. accom. Collins & Harlan
- 8908 Good Bye, "Sis" (*Morse*) Harry MacDonough  
*March song by the composer of "Blue Bell," Orch. accom.*
- 8909 Original Fantasia (*Picchi*) Simone Mantia  
*Euphonium solo, accompanied by the Edison Concert Band.*
- 8910 Yankee Doodle Boy (*Cohan*) Billy Murray  
*Song hit from "Little Johnny Jones," Orch. accom.*
- 8911 Those Songs My Mother used to Sing (*Smith*) Fred G. Rover  
*Descriptive song, introducing "Believe Me if All Those Endearing Young Charms"  
and "The Last Rose of Summer," Orch. accom.*
- 8912 Monastery Bells (*Wely*) Benzler & Nesbit  
*Chimes and Bells duet, Edison Military Band accom.*
- 8913 Dan, Dan, Dan-u-el (*Rogers*) Coon Male duet, Orch. accom. Murray & Roberts
- 8914 Mamma's Boy (*Helf*) March song, Orch. accom. Byron G. Harlan
- 8915 Hear Me, Norma (*Bellini*) Hazel & Tuson  
*Clarinet and Cornet duet from "Norma", Orch. accom.*
- 8916 Juanita (*Norton*) Miss Morgan and Mr. Stanley  
*Contralto and Basso duet, Orch. accom.*
- 8917 Gimme de Leavins' (*Cole*) Coon song, Orch. accom. Arthur Collins
- 8918 Skeleton Dance (*Lepaige*) Edison Concert Band
- 8919 I've Got My Fingers Crossed, You Can't Touch Me (*Maxwell*) Byron G. Harlan  
*Descriptive song, introducing children's voices singing "London Bridge is  
Falling Down," etc., Orch. accom.*
- 8920 Louisiana Minstrels Minstrels  
*Introducing the characteristic Darkey song, "Keep a Climbin'," By Len Spencer.*
- 8921 Glowworm—Idyl (*Linke*) Edison Symphony Orchestra
- 8922 Let's All Go up to Maud's (*Mills*) Harry Mac Donough  
*Serio-comic waltz song, Orch. accom.*
- 8923 Daddy Dear (*Cliff*) Descriptive song, Orch. accom. Harry Anthony
- 8924 Diplomat March (*Sousa*) Edison Concert Band
- 8925 Rare Old Bird (*Morse*) Comic song, Orch. accom. Bob Roberts
- 8926 When the Bees are in the Hive (*Mills*) Edison Male Quartette  
*Sentimental Male quartette, Orch. accom.*
- 8927 Port Arthur March (*Seitz*) Edison Military Band

Edison Gold Moulded Records are made only in Standard Size. Both Standard and Concert Records may be ordered from this list. Order by number, not title. If Concert Records are wanted, give the number and letter C.

(Continued from page 1.)

no interest in dancing than any other Records that we have issued. Even the Records for the square dances are fine band selections, fully equal to any similar Records gotten out by this company. Jobbers and Dealers who have not provided themselves with an adequate stock of these Records will certainly disappoint their customers.

#### PLEASE FILL OUT CARDS.

Jobbers and Dealers who receive letters from us asking them to follow up retail inquirers will confer a favor if they will fill out the cards which accompany the letter. Where it is necessary to write letters about these inquiries, please refer to the name of the inquirer or to the number on the card that accompanies our letter. The principal object of these cards is to determine whether it is advantageous to follow up inquirers to any further extent. If they have made purchases, we do not want to send them any more letters. We desire Dealers to make such effort as will tell them whether or not the parties are interested in our goods and then return the post cards to us with the blanks filled out. We should like, however,, to get these back in about three weeks after their receipt by the Dealer.

#### NOT GUILTY.

Wholesale musical merchandise houses—not the little concerns, but the “big toads in the puddle”—are complaining bitterly of the alleged unfair manner in which they are being treated by the talking machine companies. They are all on the jobbing list of the manufacturer whose line they “plug,” and their business is supposed to be supplying the regular music trade, but their complaint is that they often find the Dealer is on the same buying footing as themselves. A Jobber is classed as one who stipulates to buy at least \$5,000 stock of goods annually; but the small goods gentlemen aver they are often put up against a Dealer who does not pretend to handle a third or less quantity, but are getting the Jobber’s discount just the same. Therefore they declare the talking machine proposition to them is “stuffed with sawdust,” hence unsatisfactory. These houses are good people and as distributors of musical goods of all kinds are important factors in the trade.—*Music Trade Review*.

The shoe don’t fit and we don’t put it on in referring here to the above paragraph. Lest, however, some one might think it refers to this company, we want to say that Jobbers’ discounts are allowed no one who does not purchase Jobber’s quantities and do a certain amount of business each year to entitle him to a continuance of the discounts. The system of this company provides a protection for Dealers not equalled by any other business in this country.

#### SELLING SUGGESTIONS.

From observation we are led to believe that many Dealers neglect to make proper use of their window space and are losing the benefit of their best and cheapest advertising medium. Merchandise well displayed is half sold. First of all, have your windows absolutely clean outside and inside; then make your display so attractive that people will stop to admire it and you will have the first evidence of a successful merchant. Nothing succeeds like success, and an attractive window display indicates success. The outside appearance of your store may be made a great factor toward inducing prospective customers to step inside where they should find at least samples of all the best selling types of machines, and any Record at any time listed in the catalogue. This means a large stock of goods, or what appears a large stock to Dealers in small towns; but we are strong advocates of and firm believers in the advisability of all Dealers carrying a complete stock of all domestic selections catalogued. You may be successful without all of them, but you are certain to be more successful if you have them.

Edison Records are as staple as any article of merchandise. Don’t be afraid to invest the few dollars necessary to complete the list.

Next in importance to a large stock of goods neatly arranged and properly displayed is the necessity of intelligent demonstration to prospective customers. Allow us to offer a few suggestions along this line. Don’t forget that the Edison Phonograph is a recording as well as a reproducing machine. We believe Dealers are neglecting to make use of one of the strongest features of the machine when they fail to show how easily Records can be made by users. You should learn how to make Records yourself so you can use the recorder with confidence. Memorize a few lines that call attention to the fact that the owner has an instrument that will record his voice and reproduce it again at any future date and as many times as desired. Make this *the* feature of your demonstration and play a few Records afterwards. Always show the higher priced machines first, but do not name the prices until your customer asks for them. Most salesmen begin by saying: “This machine is \$10; this one, \$20; that one, \$30; the other, \$50,” and so on. This method is machine-like and radically wrong. Defer quoting the price until you have shown the superiority of the Edison over all other types and convince your customer that this is an article that will afford diversified and unlimited entertainment to himself and friends.



**SEVENTY-ONE MEXICAN RECORDS.**

We list herewith 71 Mexican Records, 37 of which are included in the new Catalogue of Foreign Records, Form No. 640, now ready for the use of the trade. These Records were made in Mexico City under the direction of experts sent from the Recording Department of the National Phonograph Co. They are, therefore, made according to the most approved methods of this company. Large numbers of them have been sold in Mexico and have been pronounced by natives of that country as being remarkable for their quality, naturalness, volume and clearness. The vocal Records are made in Spanish and by famous Mexican singers. The instrumental Records are made by the leading Mexican bands and orchestras. A number of the titles are accompanied by the guitar.

**Baritone Solos by Senior Jose Torres Ovando.**

- 18501 "AMOR" DANZA. Acompañamiento de Orquesta.  
 18502 "DICEN QUE NO" DANZA. Acompañamiento de Orquesta.  
 18503 "VIVIR SIN TI" DANZA. Acompañamiento de Orquesta.  
 18504 "PERJURA" DANZA. Acompañamiento de Orquesta.  
 18505 "TRISTEZAS" DANZA. Acompañamiento de Orquesta.

**Baritone Solos by Sr. R. Herra Robinson.**

- 18508 "JARABE TAPATIO." Cancion Popular.  
 18510 "EL DESCARRILAMIENTO," 1a. Parte Corrido. Cancion Popular.  
 18511 "EL DESCARRILAMIENTO," 2a Parte Corrido. Cancion Popular.  
 18512 "IGNACIO PARRA," 1a Parte Corrido. Cancion Popular.  
 18513 "IGNACIO PARRA," 2a Parte Corrido. Cancion Popular.  
 18514 "A ELENA," Corrido. Cancion Popular.  
 18515 "HERACLIO BERNAL," Corrido. Cancion Popular, acompañamiento de Guitarra.  
 18518 "JESUS LEAL," Corrido. Cancion Popular.  
 18519 "A MI MARIA" DANZA. Cancion Popular.  
 18521 "EL RENTROY," DANZA. Acompañamiento de Guitarra.  
 18522 "EL PAJARITO" DANZA, Cancion Popular.  
 18528 "MARIA" (Si algun ser). Cancion Popular, acompañamiento de Guitarra.  
 18530 "EN MI SOLEDAD" MAZURCA. Cancion Popular, acompañamiento de Guitarra.  
 18531 "QUE HARE SIN TI" DANZA. Cancion Popular, acompañamiento de Guitarra.  
 18532 "AL TRISTE ARRULLO" DANZA. Cancion Popular, acompañamiento de Guitarra.  
 18533 "EL CIELITO LINDO," Tango Tapatio. Cancion Popular, acompañamiento de Guitarra.  
 18534 "ANTONIA DE LAS CALABAZAS." Cancion Popular, acompañamiento de Guitarra.  
 18537 "EL MATRIMONIO" SCHOTTISCH. Cancion Popular, acompañamiento de Guitarra.  
 18539 "ORALIA" SCHOTTISCH. Cancion Popular, acompañamiento de Guitarra.

**Soprano Solos by Snra. Esperanza Dimarias**

- 18540 "CANCION DE LA SARABIA," en la zarzuela "La Cuarta Plana." Acompañamiento de Orquesta.

**Soprano Solos by Snra. Soledad Goyzueta.**

- 18542 ROMANZA EN LA ZARZUELA "MARINA." Acompañamiento de Orquesta.  
 18544 ROMANZA EN LA ZARZUELA "LOS DIAMANTES DE LA CORONA." Acompañamiento de Orquesta.  
 18546 VALSE EN LA OPERETA "BOCCACIO." Acompañamiento de Orquesta.  
 18547 ROMANZA EN LA ZARZUELA "EL JURAMENTO." Acompañamiento de Orquesta.  
 18548 POLACA EN LA ZARZUELA "EL BARBERO DE SEVILLA." Acompañamiento de Orquesta.

**Baritone Solos by Sr. Felipe Llera.**

- 18549 "CANCION DEL GALLEGO," en la zarzuela "Chateau Margaux." Acompañamiento de Orquesta.  
 18550 "YA SOY FELIZ" DANZA. Acompañamiento de Orquesta.  
 18551 "LO QUE ES AMOR" Romanza. Acompañamiento de Orquesta.  
 18552 "LOS BESOS QUE TE DI" DANZA. Acompañamiento de Orquesta.  
 18553 "ASI TE ADORO" DANZA. Acompañamiento de Piano.  
 18554 "RECUERDO" DANZA. Acompañamiento de Piano.

**Mezzo-Soprano Solos by Srta. Beatriz Franco.**

- 18555 "LAS GOLONDRINAS DE BECQUER," Romanza. Acompañamiento de Orquesta.  
 18558 HABANERA EN ZARZUELA "NINA PANCHA." Acompañamiento de Orquesta.  
 18559 "EL ALMA ENAMORADA," Romanza en la zarzuela "Boccacio." Acompañamiento de Orquesta.

**Mezzo-Soprano and Baritone Duets by Srta. Franco and Sr. Llera.**

- 18562 DUO DE "LOS PATOS" en la zarzuela "Marcha de Cadiz." Acompañamiento de Orquesta.  
 18563 DUO EN LA ZARZUELA "EL BATEO." Acompañamiento de Orquesta.

**Banda de Zapadores de Mexico.**

- 18564 "EL 23 DE JULIO" MARCHA.  
 18569 "CUPIDO Y VENUS" DOS DANZAS.  
 18793 CAKE-WALK ("BUNCH O' BLACKBERRIES") en la zarzuela "Chin Chun Chan."

**Banda de Estado Mayor de Mexico.**

- 18572 "EL CONGRESO PAN AMERICANO" MARCHA.  
 18573 "DULCE RECUERDO," SCHOTTISCH.  
 18576 "ALMA Y CORAZON," DANZAS.  
 18577 "VIVA EL REY," PASO DOBLE.  
 18578 "VALSE POETICO," (Obligado de Saxofon.)  
 18579 "OH! ILUSION MIA!" GAVOTA.  
 18580 JOTA EN LA ZARZUELA. LA MADRE DEL CORDERO.  
 18581 "UN RECUERDO A EDISON," PASO DOBLE.  
 18583 "BILBAIMA," BOLERO.  
 18625 "LAS MARIPOSAS," Gavota en la zarzuela "Instantaneas."

**Orquesta Tipica Lerdo.**

- 18585 "CONSENTIDA," VALSE.  
 18590 "EL RATONCITO," DANZA TANGO.  
 18629 "LA DANZA DE LOS APUROS."

**Tenor and Baritone Duets by Snrs. Abrego and Picazo**

- 18592 "LAS ESTRELLAS," DANZA. Cancion Popular.  
 18593 "ADIOS A MI AMADA." Cancion Popular, acompañamiento de Guitarra.

- 18594 "A JUANITA." Cancion Popular, acompanamiento de Guitarra.
- 18595 "LAS TRES CARTAS." Cancion Popular, acompanamiento de Guitarra.
- 18596 "ADIOS, ADIOS." Cancion Popular, acompanamiento de Guitarra.
- 18597 "MI LIRA," DANZA. Cancion Popular, acompanamiento de Guitarra.
- 18598 "LA CELOSA EMBARANDA." Cancion Popular, acompanamiento de Guitarra.
- 18599 "LAS SOMBRAS DE LA NOCHE." Cancion Popular, acompanamiento de Guitarra.
- 18600 "TUS OJOS," DANZA. Cancion Popular, acompanamiento de Guitarra.
- Tenor and Soprano Duets by Snra. Herrera and Sr. Rosete.**
- 18601 "DUO DE LOS PARAGUAS," en la zarzuela, "En Ano Pasado por Agua," acompanamiento de Orquesta.
- 18602 DUO EN LA ZARZUELA "LA SENORA CAPITANA." Acompanamiento de Orquesta.
- Soprano Trios by Snrs. Herrera and Sedano and Srta Bereaud.**
- 18676 "CHIN CHUN CHAN" Coplas de los Polichinelas, acompanamiento de Orquesta.
- 18677 "EL TELEFONO SIN HILOS." Gavota en la zarzuela "Chin Chun Chan," acompanamiento de Orquesta.
- Tenor Solo by Sr. Braulio Rosete.**
- 18694 DANZA DE LA ZARZUELA "CHIN CHUN CHAN." Acompanamiento de Orquesta.

#### PRINTED MATTER.

In placing orders for Records, Jobbers are again requested to make them out on Record Order Sheets, Form 425. Sheets A to D cover Domestic Records and E to G, Foreign Records. It is also advisable to furnish them to Dealers who are ordering Records in any considerable quantity. Jobbers who do not have a supply are asked to have some sent with their next goods.

We still have on hand quite a supply of our St. Louis Booklet, Form 550, and will be glad to furnish them to Jobbers who can use them to advantage for their own trade, or who can furnish them to Dealers where they will be circulated with good results.

The demand for Form 611, Christmas Folder, was so great that the edition was entirely exhausted early in December, making it necessary to disappoint a number of Jobbers who wanted a further supply.

With the January Records we mailed two of the large Bulletins to each Dealer in addition to the usual number sent to each Jobber. Dealers are asked to place one of these in their show windows and to use the other inside their stores for the sale of Records.

A new Record Catalogue, Form 630, containing all Records to and including December, has just been mailed to the entire trade and has been used to fill all orders for the past month. This catalogue only differs from the previous edition in having four months' Sup-

plements added to it, and we would like Jobbers who have on hand a supply of the August edition to use them up before sending for the latter issue.

A new Numerical Catalogue, Form 620, has just been sent out to the entire trade, five copies having been mailed to all Jobbers and one to each Dealer. This contains all Records to and including December. In printing this two errors crept in. No. 8274 on Page 22 has been printed as No. 8287, and on the same page No. 8281 has been printed as No. 7281.

Dealers are again urged to adopt the plan of mailing a Record Supplement each month to such owners of Phonographs or other cylinder machines as they can get the names of. Hundreds of Dealers are already doing this and we believe that this plan has had much to do with increasing the demand for Records. Other Dealers are mailing copies of the *Phonogram*, finding that the more detailed references to new Records contained in it had induced many persons to buy Records who would not be interested in titles alone. It is certainly not a mere coincidence that the increase in the use of Record Supplements and the issue of the *Phonogram* have been followed by a large increase in the sale of Records.

We continue to get letters from Dealers who buy through Jobbers, asking to have a supply of printed matter sent to them direct. Even if Dealers are willing to pay express charges on catalogues, etc., we still prefer that they shall get it from their Jobbers. The latter should be able to supply it without incurring express charges, and they also know what quantities can be used advantageously. If Jobbers are not getting large enough quantities to enable them to take care of their Dealers, we want them to write us. If the editions now being printed are not large enough to do this properly we will increase them. Catalogues, etc., are a most potent factor in selling goods and we want every Dealer to have at least a small supply on hand at all times.

#### NEW DUTY ON TALKING MACHINES.

In the new tariff which is now being prepared by the Philippine authorities, there will be a change on the rate of duty on talking machines which, imported into the Philippines at the present time, have to pay a duty of \$4 each. Under the revised Philippine tariff act the rates on Phonographs and similar machines, including detached parts and Records therefor, will be changed to thirty per cent. ad valorem.—*Music Trade Review*.



### THE REASON WHY.

For the benefit of Edison Jobbers and Dealers who may wonder why Edison Phonographs and Edison Gold Moulded Records did not receive the highest award at St. Louis, we print on the opposite page a reduced facsimile of a letter written by William E. Gilmore, President of the National Phonograph Company, declining an award on behalf of our exhibit at the Fair. For the purpose of showing that we did not take the position because the first prize was not awarded to us, we desire to refer to some incidents that occurred long before any decision had been reached by the jury.

Our exhibit at the Fair was in charge of Frank E. Madison. On August 18th at the request of the Department officials, he forwarded to Mr. Gilmore blank forms to be filled out for submission to the Jury of Awards. To this Mr. Gilmore replied under date of August 26th:

"Referring to your favor of the 18th, in which you enclose forms to be submitted to the Jury of Awards, I desire to say that it is not our intention to enter into competition in any way, shape or form. If you are approached by any of the St. Louis people, simply tell them that it is not the intention of this company to exhibit our apparatus for the purpose of obtaining any award."

On August 31st Mr. Gilmore telegraphed to William Pelzer, a representative of the company, who was then in St. Louis, as follows:

"See Madison and arrange we do not enter competition for award. Never intended to do so. He tells us that rules compel us to enter."

Under the same date Mr. Gilmore telegraphed to Mr. Madison:

"See Pelzer about entering competition. There is no reason for us to do so. Do not consider any demonstration necessary."

On September 2nd Mr. Gilmore received a copy of the rules and regulations governing the system of awards and again telegraphed Mr. Pelzer as follows:

"If possible want to avoid competing. You are authorized to fill out form if imperative. We care nothing about medals or prizes."

In spite, however, of the protests of Mr. Madison and Mr. Pelzer, the department officials insisted upon our exhibiting our apparatus. This was done in a perfunctory manner by Mr. Pelzer and Mr. Madison before the group jury, less than a half hour being occupied in doing so. Notwithstanding this fact, we were awarded a gold medal for our exhibit. The awards were made by a system of points, grand prizes being given to those who achieved from 95 to 100 points and gold medals being given to those receiving 85 to 94

points. It was evident, therefore, that to have received a gold medal our exhibit must have been given more than 85 points. Not having our exhibit ready on the opening day caused a loss of 10 points which, added to the number given us, would have entitled us to a grand prize. This, too, notwithstanding the fact that no effort was made on our part to get any prize.

In view of all that is being said concerning the awards of the St. Louis Fair, we are more than gratified at our course in not only putting forth no effort to gain prizes, but in protesting against rules which compelled us to compete.

The following matter is reprinted from the official rules for the purpose of informing the trade how the awards were decided upon:—

- a—Value of the product, process, machine or device, as measured by its usefulness, its beneficent influence on mankind in its physical, mental, moral and educational aspects.  
Counting not to exceed 25.
- b—Skill and ingenuity displayed in the invention, construction and application.  
Counting not to exceed 25.
- c—Merits of the installation as to the ingenuity and taste displayed, the cost and value as an exposition attraction.  
Counting not to exceed 10.
- d—Magnitude of the business represented, as measured by the gross sales during the calendar year preceding the opening of the Exposition.  
Counting not to exceed 10.
- e—Quality or cheapness, with reference to the possession by the exhibit of the highest possible quality, or the fact that the article is sold at so low a price with reference to its quality as to make it a valuable acquisition to the purchaser.  
Counting not to exceed 10.
- f—For completion of installation within required time and for excellence of maintenance.  
Counting not to exceed 10.
- g—Length of time the exhibitor has been in business as showing whether exhibit is a development of original invention or is an improvement on the work of some prior inventor.  
Counting not to exceed 5.
- h—Number and character of awards received from former expositions.  
Counting not to exceed 5.

### PRICES OF EDISON RECORDS.

**Edison Gold Moulded Records, standard size, are sold in the United States at 35 cents each, and in Canada at 40 cents each. The Canadian price is higher because of the duty. Edison Concert Records are sold at 75 cents each in both countries.**

W. E. GILMORE,  
PRESIDENT & GENERAL MANAGER

ADDRESS YOUR REPLY TO THIS COMMUNICATION TO ORANGE, N. J.

J. F. RANDOLPH,  
SECRETARY & TREASURER

## NATIONAL PHONOGRAPH CO.

ORANGE, N. J.

EDISON PHONOGRAPHS & RECORDS.

83 CHAMBERS STREET, NEW YORK.  
304 WABASH AVENUE, CHICAGO.

LONDON.  
PARIS  
BERLIN.  
BRUSSELS

TRADE  
Thomas A. Edison  
MARK

IN REPLYING ADDRESS THE COMPANY NOT  
THE INDIVIDUAL AND MENTION THESE INITIALS.

CABLE ADDRESS  
"ZYMOTIC, NEW YORK"

*Orange, N. J.* Oct. 11, 1904.

Hon. David R. Francis,

President Superior Jury, Universal Exposition,

St. Louis, Mo.

Dear Sir:

We are in receipt of a notification stating that we have been awarded a Gold Medal in Group 21 on our exhibition of Phonographs.

At the time we made out our application for space it was our intention not to enter any competition and our application was signed with this idea. When we received notice that the Jury would examine our apparatus, our representative called the attention of Col. Ockerson to our position, stating that we had no intention of entering any competition and giving our reasons therefor. Col. Ockerson stated that under the rules it was compulsory upon us to exhibit our apparatus to the Jury, and we therefore permitted our representative to exhibit our apparatus. He was instructed to inform the Jury, and did inform the Jury, that we had no intention of competing and had no desire at that time to do so, but that inasmuch as the rules compelled us to do so our apparatus was there for that purpose.

It is our policy not to enter any competitions and not try for awards of any character. In view of the position that we took, and in view of our policy, we therefore must decline, with all due respect to the Jury, any award that has been granted to us.

Yours respectfully,

*W. E. Gilmore*  
President.

REDUCED FAC-SIMILE OF LETTER DECLINING AWARD AT ST. LOUIS FAIR.



### COMMENTS ON EDISON GOLD MOULDED RECORDS FOR FEBRUARY, 1905.

This list of February Records comprises nine instrumental and sixteen vocal selections. In the former are four bands, one orchestra, three instrumental duets and one instrumental solo. The vocal part includes ten solos, three duets, two quartettes and one minstrel. This is sufficient variety for all tastes. The new features are an euphonium solo by Simone Mantia, a solo by Fred G. Rover, a new singer with a fine tenor voice; a chimes and bells duet by Messrs. Benzler and Nesbit, a duet by Messrs. Murray and Roberts, and a clarinet and cornet duet by Messrs. Hazel and Tuson.

No. 8903, "A Hunting Scene," by the Edison Military Band, is a composition by P. Bucalossi that was formerly listed in the old style Records and is now made over in response to many requests. It is descriptive of a hunting scene, with hounds and chorus of male voices. Those familiar with the selection made on a wax Record will appreciate the wonderful advances made in recording after hearing this Record by the gold mould process.

No. 8904, "My Dreams," sung by Irving Gillette, is one of the standard sentimental ballads, being sung by the best singers throughout the country. The music was written by F. Paulo Tosti and the words by Frederic W. Weatherly. It is charmingly sung by Mr. Gillette with orchestra accompaniment.

No. 8905, "By the Watermelon Vine (Lindy Lou)," made by the Edison Male Quartette, is a coon love song by Thomas S. Allen. It was published in Boston and has had considerable popularity throughout New England. The air is tuneful and catchy. Excellent work was done by the Edison Quartette in making this Record and its attractiveness is enhanced by a delightful orchestra accompaniment.

No. 8906, "Dreamy Moments," by Jaudas and Rose, is another sweet violin and flute duet, similar to those previously listed, but even more tuneful. The Record shows that Messrs. Jaudas and Rose are artists of the first rank.

No. 8907, "Coax Me," is a male duet by Collins and Harlan, with orchestra accompaniment, of another popular coon song by Harry Von Tilzer and Andrew B. Sterling. All who are familiar with the singing of Messrs. Collins and Harlan will realize what an attractive Record they can make of a song, in the chorus of which the dusky maiden says to her lover:

"Coax me, go on and coax me,  
If you love me madly, want me badly,  
Coax me; go on and coax me.  
I'll be your toot-sie woot-sie,  
If you'll coax me."

No. 8908, "Good Bye, Sis," sung by Harry MacDonough, is a brand new sentimental song by Theodore Morse and Will D. Cobb, and just published by the F. B. Haviland Publishing Company, New York. It is catching on in public favor very fast, and seems destined to be one of the hits of the day. It

is sung with orchestra accompaniment. The melody is built on more original lines than most of the ballads of the day. Mr. Cobb is well known as the author of "Good Bye, Little Girl, Good Bye" and "I've Got a Feeling for You." The chorus of this song follows:

"I've come to say good bye, 'Sis,' before I sail away.  
Your lips have said you loved me, but your eyes have told me 'No.'  
On deck a sailor murmurs, 'It was the only way.'  
On shore there stands a maiden as she cries across the bay,  
'Come back, my sailor lover,' but the billows answer 'Nay,' I am going to sail away, sail away."

No. 8909, "Original Fantasia," is an euphonium solo by Simone Mantia, accompanied by the Edison Concert Band. This is something entirely new. Mr. Mantia's execution of this difficult selection on this most difficult of instruments is marvelous. He has the reputation of being able to execute clearly passages of such rapidity as to tax the capabilities of the finest cornet soloists. Mr. Mantia will be remembered as the soloist of the band which played on the beach at Asbury Park in the past summer.

No. 8910, "The Yankee Doodle Boy," Billy Murray's solo for the month, was written by George M. Cohan and is being sung in Mr. Cohan's latest play, "Little Johnny Jones." It is a comic song of the spirited march order. It introduces suggestions of "Yankee Doodle," "Dixie" and "Star Spangled Banner," into an original and tuneful melody. The chorus:

"I'm a Yankee Doodle Dandy,  
A Yankee Doodle, do or die;  
A real live nephew of my Uncle Sam's,  
Born on the Fourth of July.  
I've got a Yankee Doodle sweetheart.  
She's my Yankee Doodle joy,  
Yankee Doodle came to London  
Just to ride the Ponies;  
I'm the Yankee Doodle Boy."

No. 8911, "Those Songs My Mother Used to Sing," serves as an introduction to the Phonograph public of Fred. G. Rover, who has a cultivated tenor voice particularly suited to the rendition of descriptive songs. The song refers to and introduces "Believe Me If All Those Endearing Young Charms" and "The Last Rose of Summer." The music is of a pathetic character and in keeping with the subject. The Record is made with orchestra accompaniment.

No. 8912, "Monastery Bells" is a chimes and bells duet by Benzler and Nesbit, and rendered with accompaniment by the Edison Military Band. This selection cannot fail to please those fond of Records made by bells and similar instruments, and even those not ordinarily partial to them will pronounce it attractive. The chimes are of an extra fine quality of tone. The band accompaniment is especially good for this combination. This is the first Record ever made by chimes and bells. "Monastery Bells" was written by L. Wely.

No. 8913, "Dan, Dan, Dan-u-el" is a fine Record by Murray and Roberts. The success achieved by Messrs. Murray and Roberts in this their first duet will be a source of pleasure to the friends of both of these popular singers. The song is a typical "coon" selection and on the order of "Alexander." It

cleverly illustrates a dialogue between a dusky belle and her lover, Mr. Roberts representing the latter and Mr. Murray making the responses for the girl. The voices of both singers are admirably adapted to selections of this kind, and we know that this Record will be a big seller. The singers are accompanied by the orchestra. This song was written by Ed. Rogers.

No. 8914, "Mamma's Boy," by Byron G. Harlan, is another of those popular march songs so well suited to Mr. Harlan's voice, and splendidly sung by him, with orchestra accompaniment. Written by J. Fred Helf and Harry Sinclair. A wee little lad comes home to his mother crying because the older boys don't allow him to play soldier, calling him "Mamma's Boy." To which his mother replies in the chorus:

"Don't you mind what they call you, darling,  
And don't let your heart grow sad,  
Some day you may be a soldier,  
A hero like your dear old dad.  
Then perhaps in some famous battle,  
I will read of your name with joy,  
Then those who sneer, will be the first to cheer,  
They'll be proud of "Mamma's Boy."

No. 8915, "Hear Me, Norma," is a clarinet and cornet duet by Hazel and Tuson, of this selection from Bellini's opera, "Norma." Played with orchestra accompaniment. The clarinet and cornet make fine solo Records, but played as a duet they are even more pleasing. In the hands of such artists as John Hazel and William Tuson they are made to blend perfectly, and with an artistic orchestra accompaniment as a background, they make a Record of more than usual merit. The air of the selection is very pretty and familiar to thousands who do not know the opera in which it is sung.

No. 8916, "Juanita" is another charming contralto and basso duet by Miss Morgan and Mr. Stanley, the selection being Caroline Norton's old Spanish melody. The work of these singers is too favorably known from the Atlantic to the Pacific to need further commendation.

No. 8917, "Gimme de Leavins," by Arthur Collins, is a new but popular coon song and rendered up to the usual clever standard of Mr. Collins' work. Written by Bob Cole and J. W. Johnson and sung with orchestra accompaniment. This song is part of the repertoire of Cole & Johnson, and Lew Dockstader.

No. 8918, "Skeleton Dance," by the Edison Concert Band, is a composition by Charles Lefraige. It is not at all like Record No. 8290, "Dance of the Skeletons," but written on equally unique lines. This is a new composition and difficult to play.

No. 8919, "I've Got My Fingers Crossed, You Can't Touch Me," is a unique Record by Byron G. Harlan. It is a descriptive song by Joe Moxwell and most attractively sung by Mr. Harlan, with orchestra accompaniment. A new idea is presented in this song by introducing children's voices singing "London Bridge Is Falling Down," "Water Water Wild Flower," "Miss Jinny Ann Jones," "Ring a Ring a Rosey" and "Lazy Mary." The chorus is as follows:

"Don't you wish you could join the fun,  
As you watch the youngsters play?  
Don't you wish you could still be one of that  
jolly crowd to-day?  
Take your cue from the youngsters too,  
And at trouble shout with glee,  
I've got my fingers crossed, you can't touch  
me."

No. 8920, "Louisiana Minstrels" is a new Record by the Edison Minstrels. Minstrel Records always find favor with Phonograph owners because of their variety, including as they do orchestra music, jokes and singing, the latter usually by a soloist and quartette. This one is even better than usual. It opens with an orchestra selection. Len Spencer at one end of the semi-circle tells Billy Murray at the other how he got two glasses of beer without buying them. He went into a saloon, ordered three glasses, drank two and left the third to "settle." Mr. Spencer then sings the darkey song "Keep a Climbin," the Edison Male Quartette singing the chorus.

No. 8921, "Glowworm—Idyl" is made by the Edison Symphony Orchestra. It is Paul Linke's pretty composition engraved on wax in a manner that makes its reproduction fully as entertaining as if heard from an orchestra direct. In fact it is doubtful if for home entertainment the selection played direct would be as good as this reproduction, for the recording has softened the music without losing any of its beauty. The flute and clarinet effects are fine.

No. 8922, "Let's All Go Up to Maud's" sung by Harry MacDonough, is a popular serio-comic, descriptive waltz song being sung on the vaudeville stage. It was written by Kerry Mills and Joseph C. Furrell. Sung by Mr. MacDonough, with orchestra accompaniment. It has this chorus:

"Let's all go up to Maud's,  
We'll have a jubilee;  
Make love to all her sisters, boys,  
But please leave Maud to me;  
Her Ma don't mind the noise,  
Her Dad's one of the boys.  
If you're a bit handy,  
You'll be all the candy.  
Let's go up to Maud's."

No. 8923, "Daddy Dear," by Harry Anthony, is a descriptive song written by Lall Cliff and Nat Clifford. Sung by Mr. Anthony in an artistic manner and with orchestra accompaniment. The theme is a child's prayer to her dead father, as follows:

Daddy dear, can you hear  
The voice of your baby boy?  
Come back to Mamma, her heart is sad.  
We feel so lonely without you, Dad;  
And if you can't come down  
Tell me, dear Daddy, do."

No. 8924, "Diplomat March," by the Edison Concert Band, is a "swell" Record of Sousa's latest composition. When we made this Record the composition had been heard in New York only ten days, but it had already "caught on" and has since been rapidly climbing into popularity. Everything put out by Sousa is a success and "The Diplomat March" will prove no exception.

No. 8925, "A Rare Old Bird," by Bob Roberts, includes two verses and two choruses of this extremely funny song, rendered in Mr. Roberts' clear and distinct voice. As a singer of topical and comic songs Mr. Roberts has no



superior. One verse of "A Rare Old Bird" tells of the bridegroom's dismay at finding that false limbs, false hair, etc., constituted a large part of the make-up of his bride. The other describes the stunts that Auntie did when the automobile stopped suddenly. The Record is made with orchestra accompaniment. Theodore Morse wrote the music and Edward Madden the words of this song.

No. 8926, "When the Bees Are in the Hive," by the Edison Male Quartette, is a sentimental song by Kerry Mills and Alfred Bryan and given with orchestra accompaniment. A very desirable quartette Record, the work of the singers being effectively done. This song is one of the hits of Lew Dockstader's Minstrels this season.

No. 8927, "Port Arthur March," by the Edison Military Band, is a composition suggestive of gunpowder and battle, but cannot be termed descriptive. It is, however, well written and is artistically played by the Military Band. Its composer is Roland F. Seitz.

#### AMONG THE JOBBERS.

The Rudolph Wurlitzer Company, of Cincinnati, "Phoenix" like, arose from the ashes of its fire in November and at once secured new quarters at 10 and 12 West Fourth Street. So quickly was this done that their Phonograph business was scarcely interrupted. They at once drew upon their Chicago branch for a supply of goods, immediately placed orders with the manufacturers, and with Phonographs and Records already on their way they were able within three days after the fire to ship goods to Dealers as though nothing had occurred. They are now well stocked with Edison Phonographs and Records and their Dealers are getting the usual good service of this firm.

#### TRADE DEVICES.

Every Dealer in Phonographs who has a repair shop has often been troubled to devise a method of keeping a supply of small parts in a way easily accessible when wanted. The popular method has been to put them in envelopes. To meet this want L. Kaiser, who is connected with S. B. Davega, 32 East 14th Street, New York, has devised what he terms the "Kaiser Handy Pack." It consists of thirty small vials with corks and labels. These vials are made in three different sizes and stand up in a flat oak board 10x14, in which holes of proper size have been bored about two-thirds the way through. The price of \$1 for the outfit will be appreciated quite as much as the latter's advantages.

#### IT DOES PAY.

In an editorial on the value of newspaper advertising the *Daily Evening News* of Fall River, Mass., on November 29, said:

"Incidentally, the testimony of W. D. Wil-

not as to the results of his daily Phonograph advertisements in the *News*, may be of interest. He is selling this year, in the face of the long-drawn out strike and consequent dullness of business in general, three times as many talking machines as he did last year, when there was no strike and he was not advertising these machines. What is your opinion? Does it pay to advertise?"

Mr. Wilmot is a constant user of large space in the Fall River newspapers and it consequently is not strange that he does a large and increasing business in Edison goods.

#### MODEL D RETURN ATTACHMENT.

The Return Attachment now being sold for use on Edison Phonographs is remarkable for its simplicity and effectiveness. Its principal features are the return screw and lifting lever block. The screw is mounted on a cast bracket which is fastened with two screws to the Phonograph body in front of the cylinder shaft. These two holes for fastening bracket are the only holes to be drilled and tapped to

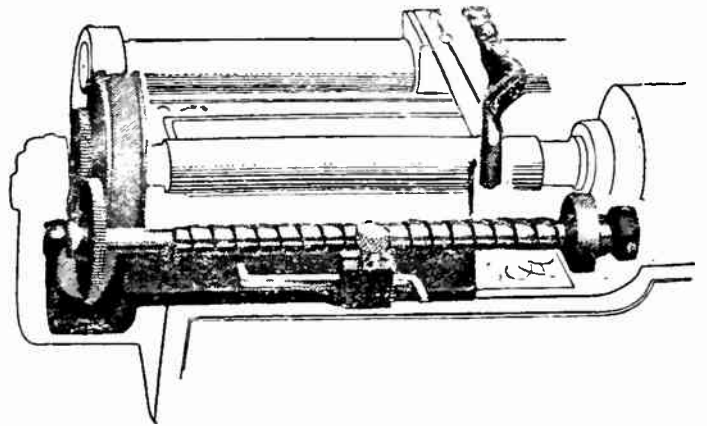

fasten attachment. The lifting lever block is carried by an arm which is clamped to the back rod sleeve. The return screw has four threads to the inch, ratchet shaped, and is driven by means of a spur gear which engages a similar gear on the main shaft pulley, thus dispensing with a belt or chain.

An adjustment is provided at each end of the bracket to suit the beginning and end of the Record. The adjustment for the end of the Record is accomplished by rotating the disk which is carried on the return screw. This disk also carries the pin which acts on the lift lever block to raise the diaphragm arm and engage the block with the threads of the return screw. This lifting action also disengages the feed nut from the thread of the main shaft and the return screw of the attachment takes the reproducer arm back to the starting point. The return movement takes about one-twenty-fifth of the time to play the Record. All parts of the return device subject to wear are hardened.

The list price of Model D Return Attachment is \$7.50. It may be attached to the Home, Triumph, Victor, Conqueror, Concert, Opera and Orators' Phonographs. In ordering state style of Phonograph.

**TRADE HOLIDAY ADVERTISING.**

The advertising in newspapers and other mediums done by Jobbers and Dealers in Edison goods in the past six weeks is most convincing evidence of their faith in the present and future of Edison Phonographs and Edison Gold Moulded Records. A notable feature of this advertising was the size of the space used, indicating that the pulling power of large space is being more and more recognized as time passes. Firms doing adequate advertising of this character are those doing the largest business in their respective cities. Their belief in the efficacy of local advertising as an adjunct to the general publicity concerning Edison Phonographs has enabled them to build up a large business, and as nothing succeeds like success they are keeping it up. We know that hundreds of Dealers in Edison goods are regular advertisers and that they used newspapers liberally during the holiday season, but their modesty prevented them from sending us copies of their announcements. Consequently we are unable to mention many of them.

Perhaps the most notable of all the advertisements came from McGreal Brothers, of Milwaukee. It occupied six full columns of the *Milwaukee Sentinel*, December 11th. In the center of the space was a half-tone illustration showing a boy pointing at an Edison Home Phonograph and saying, "Oh, Papa, that's what I want for Christmas." Surrounding this illustration was a half-column talk on the merits of Edison Phonographs and Edison Gold Moulded Records, a list of 200 titles of late Edison Records and a list of the Dealers of McGreal Bros. throughout Wisconsin, Michigan and Minnesota. Another attractive advertisement of the same firm appeared in the *Milwaukee Sentinel* December 2d. It was printed in black and red and showed Santa Claus carrying an Edison Home Phonograph in his arms and saying: "Here is something for all the family." This advertisement included a coupon worded:

If any little boy or girl will fill out this coupon and send or bring it to our store, we will do our best to induce Santa Claus to leave an Edison Phonograph at their home Christmas.

McGREAL BROS., 173 THIRD STREET, CITY.

My Name is .....

My Papa's Name is .....

I Live at .....

A large number of these coupons were returned and in each case McGreal Bros., at once "got next," to papa with a special letter. Still another striking advertisement of McGreal Bros., appeared in the *Milwaukee Sentinel* December 18. Six half columns were filled with a fac-simile reproduction of handwriting and made to look as if it had been written across the face of the paper with a broad pencil.

The most noticeable series of Dealers' advertisements came from the C. M. Cochran Company, Erie, Pa. These were half page advertisements and they were run in four different papers. If these did not bring business to the Cochran Company advertising is not the lever we consider it.

Well arranged and convincing was the half page advertisement of the Eastern Talking Machine Co., in the Boston dailies on December 18th.

The Werner Music House, Easton, Pa., ran some full pages during December along with smaller spaces.

The H. M. Holleman Company, new Jobbers at Houston, Texas., send a series of large advertisements showing that they mean to get a good slice of Edison business in the Lone Star State. A feature of this advertisement was their offer to call with a Phonograph upon any lady who could visit their store and give a demonstration of its merits. The "copy" presented forcible arguments.

Advertisements were also received from the C. C. Mellor Co., Pittsburg; E. T. Gossett, Cerro Gerdo, Ill.; Bump Bros., Binghamton, N. Y.; L. R. Porter, Brockton, Mass.; Wilmot Sport and Toy Store, Fall River, Mass.; Finch & Hahn, Schenectady and Albany, N. Y.; Penn Phonograph Co., Philadelphia; Pardee-Ellenberger Co., New Haven, Conn.; A. O. Petit, Newark, N. J.; E. S. Oliver, Newark, N. J.; American Phonograph Co., Detroit, Mich.; American Phonograph Co., Gloversville, N. Y.; Peoria Phonograph Co., Peoria, Ill.; Thomas Wardell, Lowell, Mass.; Peter Bacigalupi, San Francisco; Alfred K. Hobbs, Manchester, N. H.; Furnee & Kennerdell, Kittingan, Pa.; C. A. Freeman, Bloomington, Ill.; Wells Phonograph Co., Philadelphia; Blackman Talking Machine Co., New York City; Douglas Phonograph Co., New York City; S. L. Crosby Co., Bangor, Me.; C. C. Thompson & Son, Barbaboo, Wis.

**FROM AUSTRALIA.**

Avoca, Victoria, Australia,

Oct. 14, 1904.

I beg to enclose postal order for subscription to *Phonogram* which you are kindly sending. The photos of the "talent" are very interesting. A friend of mine here, through an advertisement, sent all the way to England for a talking machine. He was at my place some time ago and heard my Edison Standard. Since then he has put away his and purchased an Edison Standard. This friend has also a magic lantern and I lent him my first *Phonogram* with the photos of Arthur Collins and Byron Harlan. Being a good amateur photographer, he has taken copies of these two gentlemen and fixed them on his lantern slides. He now shows the pictures on his lantern and then announces that Mr. Collins or Harlan, as case may be, will give a song on the Phonograph. He is going to fix up Mr. Stanley and Miss Morgan. He also shows a picture of King Edward and then announces that Mr. Stanley will sing "God Save the King."

My friend is a great church man and does all this for sake of the Church. He makes a small coin admission and then hands over proceeds to Church people. I have written this fully thinking it might interest you. It's a good advertisement for the Edison Company, and the Edison deserves it. Wishing you every success,

JOHN RESUGGAN.



### I. C. S. LANGUAGE OUTFITS.

The International Correspondence Schools of Scranton, Pa., sent out a four page folder, printed in green and red ink on green paper, as a Christmas greeting to Edison Dealers, as follows:—

To the Edison Trade:

The Dealer who knows "Double Service"—Amusement and Language Study—for the Edison Phonograph strengthens his arguments and increases his Holiday business.

The latest development is a set of twenty-five English Records with different textbooks to teach eight classes of foreigners the English language. Twenty (\$20.00) Dollars is the very small price for one language, and thousands of Phonograph owners will avail themselves of this practical instruction.

It costs the trade only \$2.00 net to represent "Double Service." We send prepaid four Edison moulded Records in French, German, Spanish and English with large printed posters and Textbooks, arranged in a very unique demonstrating outfit. Our literature is the finest, as you will note from the enclosed, and may be had in quantities to produce the proper sales.

Trusting that we may be allowed to add to your prosperous Holiday trade, and with best wishes, we remain,

Very truly yours,

NELSON C. DURAND.

Mgr. Language Department.

P. S.—We sell to the Edison trade under National Phonograph Company Agreements, covering I. C. S. Language Outfits, excluding all other merchants and guaranteeing standard prices. Retail Dealers should purchase through Jobbers wherever possible.

Accompanying the folder was a series of booklets, folders and cards supplied to I. C. S. Dealers for the purpose of extending their business in language study outfits.

### A COLD WEATHER IDEA.

Most of the musical stores which make a specialty of Phonographs kept their doors open and one of the instruments going in the summer to attract the public. When the cold weather set in, however, most of them found it too cold to leave the doors open and stopped the practice. A dealer uptown devised a scheme to keep his machine going so that the passerby can hear it and the doors be shut at the same time. He bored in the frame of the door a hole large enough for the neck of the horn of the Phonograph to slip through and with the horn outside and the instrument on the inside he still draws the crowds to his window.—*New York Sun*.

This idea did not originate with the New York Dealer, for it has been used by Edison Dealers in various parts of the country for the past two or three winters.

### BEST FOR DANCING.

Henry G. Hines, of Wilkesbarre, Pa., sends his business card, on which he announces that he will furnish dance music and other entertainment for dancing and parties by means of the Edison Phonograph and the latest Gold Moulded Records. On the Reverse side he says: "Have you heard the Phonograph lately? If you haven't you should do so, for this most marvelous invention has been brought to such a height of perfection that it is truly wonderful. It furnishes the best kind of music for dancing at parties and other private gatherings."

### THE PHONOGRAM.

Following is a schedule of prices at which *Phonograms* may be obtained by the trade:

DELIVERED WITH GOODS.

Blank, per 1000 copies ..... \$2.50  
Smaller quantities pro rata.

Imprinted, per 500 copies ..... \$1.50

Imprinted, per 1000 copies ..... \$2.75

No orders filled for less than 500 copies requiring imprint, and all imprinting orders must be for multiples of 500.

BY MAIL.

Single copies, per year ..... \$ .20

Five copies to one address, per year.... .40

Twenty-five copies to one address, per year ..... 1.80

Fifty copies to one address, per year.... 3.60

Unless they have open accounts on our books, Dealers ordering *Phonograms* sent by mail are requested to send cash or stamps with their orders. The amounts are too small to handle in any other way.

### KIND WORDS FROM THE CITY OF PRUNES.

San Jose, Cal., December 6th, 1904.

Your PHONOGRAPH MONTHLY and Suspended List reaches us regularly and you may be sure we find it a great source of satisfaction, not alone in the feeling of security and content in handling a one-price article and the "clean-ness" consequent thereunto, but also that a retailer's efforts are appreciated and will be supported at every turn. It makes one feel like getting out and expending every effort, and, like the skirmisher in battle feeling that the artillery is supporting him, so we retailers feel that the head office will support our every move in the right direction. May your business continue to grow in the future as it has in the past, for along with it grows ours, and rest assured that in one store in this city of "Prunes," the Edison goods have warm friends and supporters.

G. R. BENT & SON.

### EDISON GOOD FAR AHEAD.

"A firm made me an offer a few days ago on \_\_\_\_\_ Said he had the best machines made and wanted me to handle his machines. I wrote him that I handled the best, the Edison, and that the only way he could convince me of the superiority of his machine over the Edison was to send me one on approval; one that he considered the best, let me examine it and play it beside the Edison, and if it proved to be better I would handle them. He sent me one of the \$40 machines with all the latest attachments. I gave it a fair trial. Well I returned it. This is enough said. My \$20 Standard was far ahead of his \$40. Well there is just about as much difference—as there is in the Gem and Standard. Edison can't be beat."

E. P. DILLON.





WINDOW DISPLAY OF THE JOHN M. DEAN COMPANY,  
PROVIDENCE, R. I.

In sending the above photograph this firm wrote:

"We are, as you know, a strictly Edison store in the talking machine line. Have repeatedly tried other makes, but had no success

whatever with them. We are looking forward to a very large Christmas trade on Edison machines and records. They are perfection." We have since learned that their Christmas trade was all they expected.

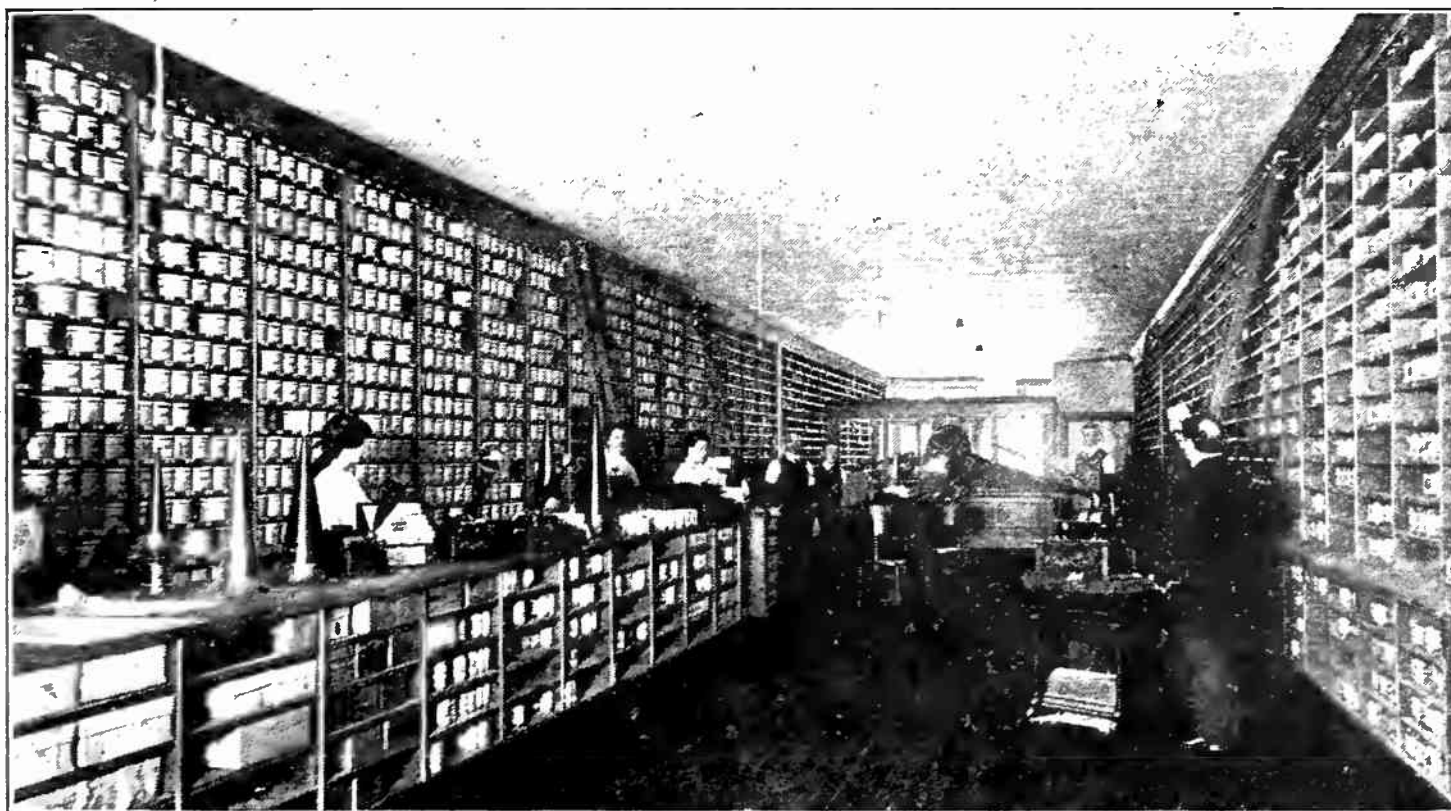

INTERIOR OF STORE OF PETER BACIGALUPI, 786 MISSION STREET,  
SAN FRANCISCO.



**SUSPENDED LIST, JANUARY 1, 1905.**

SUPERSEDING ALL PREVIOUS LISTS.

**COLORADO.**

Boulder—BENTLEY &amp; CRAIG.

**INDIANA.**

Marion—Butler Music Co.

South Bend—EUGENE MARSH, 126 Vistula avenue.  
SOUTH BEND BOOK BINDERY,  
Robert Lebolt, Prop., 203 North  
Michigan street.**IOWA.**

Burlington—JOHN P. WEISS, 711 Jefferson street.

Sioux City—HATTENBACH BROS. CO.

**KANSAS.**

Clay Centre—E. M. GOWENLOCK.

Lawrence—BELL BROS.

**MAINE.**

Biddeford—W. H. FIELD.

**MASSACHUSETTS.**

Boston—T. SINGER, 60 Leverett street.

Lawrence—LORD &amp; CO., 314 Essex street.

E. O. MOSHER, 420 Essex street.

Lynn—ELIAS DEYOUNG.

Malden—A. T. FULLER.

Nantucket—ARTHUR M. TAYLOR.

New Bedford—H. B. DEWOLFF.

Somerville—E. J. WINCHESTER, 32 Summit avenue.

Woburn—OSBORN GILLETTE, or THE BOLTON  
JEWELRY CO., L. F. Maloney, Manager.**MICHIGAN.**

Detroit—F. J. SCHWANKOVSKY.

Saginaw—GEO. W. EMENDORFER.

\*JAMES V. CALAHAN, 217 Genessee st.

\*TIERNEY BROS., 217 Genessee st.

**MISSOURI.**

Kansas City—THE WITTMANN CO.

**NEBRASKA.**

Lincoln—THE WITTMANN CO.

Omaha—THE WITTMANN CO.

**NEW HAMPSHIRE.**

Hillsboro Bridge—E. M. BARNES.

Manchester—A. E. DUMAS

Nashua—F. A. MCMASTER &amp; CO.

**NEW JERSEY.**

Atlantic City—SAM'L D. WOLF, 32-34 Arkansas ave.

Bayonne—I. WIGDOR, 450 Avenue D.

Jersey City—W. L. HOFFMAN, 151 Montgomery st.

Newark—R. L. CORWIN; also New York City.

Passaic—I. HURWITZ.

Paterson—CHAS. H. KELLY, 25 N. Main street.

Plainfield—S. W. FRUCHT, or R. FRUCHT; also  
New York City.

ELSTON M. LEONARD.

West Hoboken—EMIL HOLLANDER, or THE WEST  
HOBOKEN BICYCLE & PHONO-  
GRAPH CO., 619 Spring street.**NEW YORK.**

Albany—G. LINDE, 353 S. Pearl street.

Bedford Park—GEO. H. TYRRELL.

Hobart—F. H. MARSHALL.

New York City—A. T. ARMSTRONG, or AMERI-  
CAN PHONOGRAPH CO., 106  
Wall street.

BERN BEARWALD, 373 W. 11th st.

BRONX PHONOGRAPH CO. or

DAVID SWITKY, 506 Willis ave.

CENTRAL PHONOGRAPH CO.,

160 E. 42d street.

R. L. CORWIN; also Newark, N. J.

EAGLE PHONOGRAPH CO., or C.

LOWENTHAL, 83 Nassau street.

EMPIRE PHONOGRAPH CO., 2 W.  
14th street.

S. W. FRUCHT, or R. FRUCHT, 7

Barclay street, or 68 Cortlandt

street; also Plainfield, N. J.

O. HACKER, 2 Murray street.

HAWTHORNE &amp; SHEBLE, 297

Broadway; also Philadelphia, Pa.

\*HOLOBER BROS., 350, 421 and 491  
West st.

N. HORN, 148 E. 58th street.

W. L. ISAACS, 114 Fulton street.

S. LEMBURG &amp; CO., 194 Broadway.

J. MCELLYNNE, 202 Broadway.

RICHMOND PEASE, 44 W. 132d st.

F. M. PRESCOTT, 44 Broad st.

WINTHROP CYCLE CO., 2212 Sev-  
enth avenue.

Rome—\*CHARLES TUTTLE.

Saratoga—W. J. TOTTEN.

Saratoga Springs—MARVIN A. COTE.

Syracuse—SPALDING &amp; CO.

**OHIO.**

Cincinnati—J. L. ANDEM.

Coshocton—BURNS &amp; GOSSER.

Springfield—D. &amp; M. VANDERPOOL.

Uhrichsville—F. A. MAZURIE.

**PENNSYLVANIA.**

Philadelphia—A. R. CASSIDY, 2783 Emerald street.

HAWTHORNE & SHEBLE, 604 Chest-  
nut street, or Oxford and Mascher

streets; also New York City.

A. KROUSE, 832 Arch street.

PENN NOVELTY CO., 15 South 9th st.

Phoenixville—KEINARD BROS.

Pittsburg—A. LIPPARD, 615 Wylie ave.

**RHODE ISLAND.**

Providence—F. P. MOORE.

**WISCONSIN.**

Milwaukee—J. C. BLATZEK.

\*Added since December 1, 1904.

**Jobbers and Dealers are asked to co-operate with us, FOR OUR MUTUAL GOOD, by being careful that they do not supply any of the above named firms with our apparatus, either at addresses given or any other address.**

## JOBBERS OF EDISON PHONOGRAPHS AND RECORDS.

## ALABAMA.

**Birmingham**—The Ray Co., 207 Second avenue.  
The Talking Machine Co.  
**Mobile**—W. H. Reynolds, 167 Dauphin street.

## CALIFORNIA.

**San Francisco**—Peter Bacigalupi, 786-788 Mission street.

## COLORADO.

**Denver**—Denver Dry Goods Co., 619 16th street.

## CONNECTICUT.

**Middletown**—Caulkins & Post Co., 406-408 Main street.  
**Hartford**—Harry Jackson, 300 Asylum street.  
**New Haven**—Pardee-Ellenberger Co., 155 Orange st.

## DISTRICT OF COLUMBIA.

**Washington**—E. F. Droop & Sons Co., 925 Pennsylvania avenue, N. W.  
S. Kann, Sons & Co., 8th and Pennsylvania avenues.

## ILLINOIS.

**Chicago**—James I. Lyons, 73 Fifth avenue.  
Siegel-Cooper Co., State and Congress sts.  
Talking Machine Co., 107 Madison street.  
The Vim Co., 68 E. Lake street.  
Montgomery Ward & Co., 111 Michigan ave.  
Rudolph Wurlitzer Co., 302 Wabash ave.  
**Peoria**—Peoria Phonograph Co., 222 Bridge street.

## INDIANA.

**Indianapolis**—Craig-Jay Co., 234 Massachusetts ave.  
Kipp Bros. Co., 37 S. Meridian street.  
A. B. Wahl Co., 119 S. Illinois street.  
**Lafayette**—A. B. Wahl Co., 304 Main street.

## IOWA.

**Des Moines**—Hopkins Bros. Co., 620 Locust street.  
The Vim Co., 704 West Walnut street.  
**Fort Dodge**—Early Music House, 822 Central ave.

## KENTUCKY.

**Louisville**—The Ray Co., 640 Fourth street.

## LOUISIANA.

**New Orleans**—William Bailey, 600 Frenchman street.  
National Automatic Fire Alarm Co.,  
614 Gravier street.  
The Ray Co., 111 Camp street.

## MAINE.

**Bangor**—S. L. Crosby Co., 186 Exchange street.  
**Portland**—W. H. Ross & Son, 207 Commercial street.

## MASSACHUSETTS.

**Boston**—Boston Cycle & Sundry Co., 48 Hanover street.  
Eastern Talking Mach. Co., 177 Tremont st.  
Iver Johnson Sptg. Goods Co., 163 Washington street.  
Read & Read, 558 Washington street.  
**Fitchburg**—Iver Johnson Sptg. Goods Co., 247 Main st.  
**Lowell**—Thomas Wardell, 111 Central street.  
**Worcester**—Iver Johnson Sptg. Goods Co., 304 Main st.

## MICHIGAN.

**Detroit**—American Phono. Co., 106 Woodward ave.  
Grinnell Bros. 219 Woodward ave.  
The Ray Co., 252 Woodward avenue.  
**Saginaw**—Morley Bros.

## MINNESOTA.

**Minneapolis**—Thomas C. Hough, 714 Hennepin ave.  
**St. Paul**—W. J. Dyer & Bro., 21-23 West 5th street.  
Minnesota Phonograph Co., 37 E. 7th street.

## MISSOURI.

**Kansas City**—J. W. Jenkins' Sons Music Co., 1013-1015 Walnut street.  
The Ray Co., 1021 Grand avenue.  
**St. Louis**—Conroy Co., 1115 Olive street.  
O. K. Houck Piano Co., 1118 Olive street.  
The Ray Co., 923 Olive street.

## NEBRASKA.

**Lincoln**—H. E. Sidles Cycle Co., 1317 O street.  
**Omaha**—H. E. Fredrickson, 1502-1510 Capitol avenue.  
Nebraska Cycle Co., 15th and Harney streets.

## NEW JERSEY.

**Hoboken**—Eclipse Phono. Co., 205 Washington st.  
**Newark**—A. O. Petit, New and Halsey streets.  
**Paterson**—James K. O'Dea, 117 Ellison street.  
**Trenton**—Stoll Blank Book and Stationery Co., 30 E. State street.

## NEW YORK.

**Brooklyn**—Chapman & Co., Fulton and Duffield streets.  
A. D. Matthews' Sons, 394 Fulton street.  
Price Phonograph Co., 1258 Broadway.  
**Buffalo**—P. A. Powers, 643 Main street.  
**Elmira**—Elmira Arms Co., 117 Main street.  
**Gloversville**—American Phonograph Co., 99 W. Fulton street.  
**Kingston**—Forsyth & Davis, 307 Wall street.  
**New York City**—Bettini Phono. Co., 80 Chambers street.  
Blackman Talking Machine Co., 19 Beekman street.  
J. F. Blackman & Son, 2654 3d avenue.  
I. Davega, Jr., 802 Third avenue.  
S. B. Davega, 32 E. 14th street.  
Douglas Phono. Co., 89 Chambers st.  
H. S. Gordon, 139 Fifth avenue.  
Harry Jackson, 219 Bowery.  
Jacot Music Box Co., 39 Union Square.  
Victor H. Rapke, 1661 Second avenue.  
Siegel-Cooper Co.  
John Wanamaker.  
**Poughkeepsie**—Price Phonograph Co., 203 Main st.  
**Rochester**—A. J. Deninger, 347 North street.  
Mackie Piano, O. & M. Co., 100 State street.  
Giles B. Miller, 63 State street.  
Talking Machine Co., 29 Clinton avenue, S.  
**Schenectady**—Jay A. Rickard & Co., 253 State street.  
**Syracuse**—W. D. Andrews, 216 E. Railroad street.  
**Troy**—James Lucey, 359-361 Fulton street.  
**Utica**—Clark-Horrocks Co., 54 Genesee street.  
Arthur F. Ferriss, 89 Washington street.  
William Harrison, 41 Columbia street.  
Utica Cycle Co., 31 Columbia street.

## OHIO.

**Canton**—Klein & Heffelman Co., 216 N. Market street.  
**Cincinnati**—Ilsen & Co., 25 W. 6th street.  
The Ray Co., 143 West 5th street.  
A. B. Wahl Co., 805 Vine street.  
Rudolph Wurlitzer Co., 10-12 W. 4th st.  
**Cleveland**—W. J. Roberts, Jr., Erie and Huron streets.  
**Columbus**—Perry B. Whitsit Co., 213 S. High street.  
**Dayton**—Niehaus & Dohse, 35 E. 5th street.  
**East Liverpool**—Smith & Phillips Music Co.  
**Toledo**—Hayes Music Co., 608 Cherry street.

## PENNSYLVANIA.

**Allegheny**—Henry Braun, 500 Federal street.  
**Allentown**—G. C. Aschbach, 539 Hamilton street.  
**Easton**—William Werner, 401 Northampton street.  
**Philadelphia**—C. J. Heppe & Son, 1117 Chestnut street.  
Lit Bros., Market and 8th streets.  
Penn Phonograph Co., 19 S. 9th street.  
John Wanamaker.  
Wells Phonograph Co., 41 N. 9th street.  
Western Electric Co., 931-933 Market st.  
H. A. Weymann & Son, 923 Market st.  
**Harrisburg**—S. K. Hamburger, 12-14 N. Market sq.  
**Pittsburg**—Theo. F. Bentel Co., Inc., 433 Wood street.  
Kaufmann Bros., Fifth avenue.  
H. Kleber & Bro., 221 Fifth avenue.  
C. C. Mellor Co., 319 Fifth avenue.  
Pittsburg Phono. Co., 937 Liberty avenue.  
**Reading**—Reading Phonograph Co., 809 Penn street.  
**Scranton**—Ackerman & Co., Coal Exchange Building.  
Technical Supply Co.

## RHODE ISLAND.

**Providence**—J. M. Dean Co., 785-795 Westminster street.  
J. A. Foster Co., Weybosset st.  
Household Furniture Co., 231-237 Weybosset street.  
J. Samuels & Bro., 154 Weybosset street.  
A. T. Scattergood & Co., 106-110 N. Main street.

## TENNESSEE.

**Knoxville**—Knoxville Typewriter and Phonograph Exchange, 311 Clinch street.  
**Memphis**—O. K. Houck Piano Co., 359 Main street.  
The Ray Co., Lyceum Building.  
**Nashville**—Nashville Talking Mach. Co., 510 Church st.  
The Ray Co., 13-15 The Arcade.

## TEXAS.

**Dallas**—C. B. Harris, Agt., 347 Main street.  
**Houston**—H. M. Holleman Co., 706 Main street.

## VIRGINIA.

**Richmond**—The Ray Co., 729 E. Main street.

## WISCONSIN.

**Milwaukee**—McGreal Bros., 173 3d street.

## CANADA.

**Toronto**—R. S. Williams & Sons Co., Limited,  
143 Yonge street.





Start right. Present language study with amusement.  
A proposition exclusively for the Edison Trade. Write today for samples, prices, and literature.

FOR DOMESTIC AND EUROPEAN SALES, ADDRESS:  
**INTERNATIONAL CORRESPONDENCE SCHOOLS**  
LANGUAGE DEPT., SCRANTON, PA.

For Foreign Sales, address: National Phonograph Co., Foreign Dept., 83 Chambers Street, New York City.



# EDISON Phonograph Monthly

PUBLISHED FOR TRADE USE ONLY BY  
THE NATIONAL PHONOGRAPH CO.

VOL. II.

NEW YORK, FEBRUARY, 1905.

No. 12.

*The National Phonograph Co.,*

ORANGE, N. J.

NEW YORK: 31 UNION SQUARE, COR. BROADWAY  
& 16TH STREET.

CHICAGO: 304 WABASH AVENUE.

SAN FRANCISCO: 786 MISSION STREET.

NATIONAL PHONOGRAPH CO., LTD., 25 CLERKENWELL  
ROAD, LONDON, ENG.

## EDISON PHONOGRAPHS AND RECORDS.

All communications to THE PHONOGRAPH MONTHLY  
should be addressed to the Advertising Department,  
Orange, N. J.

C O N T E N T S

Trade Status .....	1
Advance List Edison Gold Moulded Rec- ords for March, 1905.....	2
Advance List 24 Hebrew Selections.....	3
Removal of New York Office.....	4
Co-operation Spells Success.....	4
Learn to Regulate Speed.....	4
Advertising the Thing.....	4
Schedule for Record Shipments.....	5
Dance Records .....	5
Removal of Advertising Department.....	5
It Helps Business.....	6
Hebrew Records .....	6
Printed Matter .....	6
Task Not Finished.....	6
Helps Sell Music.....	7
A Great Business.....	7
Phonograph Publications in Mexico.....	7
Send Orders to New York.....	7
Patent Infringement in London.....	7
Comments on March Records.....	8
In the Phonograph Palace.....	10
Phonograph Music by Telephone.....	11
A Remarkable Occurrence.....	12
Reproducer Exchange .....	12
A Record Made by Australian Aborigines	13
List of Suspended Dealers, February 1, 1905 .....	14
Jobbers of Edison Phonographs and Rec- ords .....	15

## TRADE STATUS.

The expected did not materialize. Owing to the custom of many firms of taking account of stock after the holidays, and the general need of "straightening out" store affairs, we rather looked for a falling off in the demand for goods in the early part of January, but the falling off did not come. On the contrary, the January orders have exceeded those for December, and they have increased each week as the month progressed. The advance orders for February Records were decidedly larger than those for January Records, the average for each selection almost equalling the phenomenal sale of the combined November-December list. It is evident that Edison goods are keeping farther to the front than ever; that in spite of the extravagant claims of others, the merits of the Edison Phonograph and its wonderful Gold Moulded Record are universally recognized wherever they have an opportunity of proving their qualities. The Edison Phonograph asks for nothing more than an opportunity of being played against any similar device now made, and we hope that all Dealers who handle any other line will at least play both, and let their patrons choose for themselves.

One of the most gratifying things in connection with the business of the National Phonograph Company is the number of firms who are taking up the sale of Edison goods. Since the new conditions went into effect last July, more than a score of firms have become Jobbers and an average of more than fifty firms each week have become Dealers. This has been done without granting special favors to any one. In each and in every case the goods have been bought outright and in accordance with our agreement. Every one that has become a Dealer in Edison goods has been treated the same as all others, and no better.

 SPECIAL ATTENTION IS CALLED TO REMOVAL NOTICES ON PAGES FOUR AND FIVE.



## NEW EDISON GOLD MOULDED RECORDS. ADVANCE LIST FOR MARCH, 1905.

RECORDS listed below will be ready for shipment as near **February 25th** as possible, at which time Jobbers' stock orders, if **received** prior to **February 10th**, will be shipped. March Supplements will be forwarded to Jobbers with their stock order for Records. Retail Dealers should place stock orders with their Jobbers at once, to insure prompt shipment as soon as Jobbers' stock is received.

- |      |   |                           |
|------|---|---------------------------|
| 8928 | A Sprig o'Shillalah ( <i>Helf</i> )<br><i>An Irish Intermezzo by the composer of "A Bit o'Blarney."</i>   | Edison Concert Band       |
| 8929 | Oh Promise Me ( <i>De Koven</i> ) <i>Sentimental song, Orch. accom.</i>   | Irving Gillette           |
| 8930 | Never ( <i>Rogers</i> ) <i>Comic song, Orch. accom.</i>   | Bob Roberts               |
| 8931 | Come Take a Trip in My Air-Ship Medley<br><i>Xylophone solo. Orch. accom. introducing "Come Take a Trip in My Air-Ship,"</i><br><i>"Please Come and Play in My Yard," "Let's All Go Up to Maud's,"</i><br><i>and "I've Got My Fingers Crossed, You Can't Touch Me."</i> | Albert Benzler            |
| 8932 | It Makes Me Think of Home, Sweet Home ( <i>Bryan</i> )<br><i>Descriptive song, Orch. accom.</i>   | Byron G. Harlan           |
| 8933 | The Troubadour ( <i>Powell</i> ) <i>Intermezzo</i><br><i>The 1905 annual instrumental number of the popularizers of "Hiawatha,"</i><br><i>by the composer of "The Gondolier."</i>   | Edison Concert Band       |
| 8934 | The White Swan ( <i>Stults</i> )<br><i>By the composer of "Birds and the Brook."</i>  | Edison Symphony Orchestra |
| 8935 | Oh, Oh, Sallie ( <i>Leonard</i> ) <i>Coon male duet, Orch accom.</i>  | Collins & Harlan          |
| 8936 | Mexico ( <i>Cole &amp; Johnson</i> )<br><i>Song hit from New York's big "Humpty Dumpty" spectacle, Orch. accom.</i>   | Harry MacDonough          |
| 8937 | Darkie Tickle ( <i>Hunt</i> )<br><i>Descriptive selection and characteristic dance.</i>   | Edison Military Band      |
| 8938 | Marguerite ( <i>White</i> ) <i>Sentimental duet, Orch. accom.</i>   | MacDonough & Biehling     |
| 8939 | The Bingville Band ( <i>Billings</i> ) <i>Comic song, Orch. accom.</i>  | Arthur Collins            |
| 8940 | Evening Star from Tannhäuser ( <i>Wagner</i> ) <i>'Cello solo, Piano accom.</i>   | Hans Kronold              |
| 8941 | Hans Krausmeyer and His Dog Schneider<br><i>A humorous German dialect sketch, introducing a conversation between</i><br><i>Hans and his dog.</i>  | Len Spencer & Alf Holt    |
| 8942 | Can't You See My Heart Beats All for You ( <i>Morse</i> )<br><i>Coon male duet, Orch. accom.</i>  | Murray & Roberts          |
| 8943 | The Wren Polka ( <i>Damare</i> ) <i>Piccolo solo, Orch. accom.</i>  | Frank S. Mazziotta        |
| 8944 | Won't You Fondle Me ( <i>Kendis &amp; Paley</i> )<br><i>Serio-comic coon love song, Orch. accom.</i>  | Arthur Collins            |
| 8945 | Tell Me With Your Eyes ( <i>Von Tilzer</i> )<br><i>Male quartette, Orch. accom.</i>   | Edison Male Quartette     |
| 8946 | Ye Ancients March ( <i>Reeves</i> )   | Edison Concert Band       |
| 8947 | Tommy (Tell Me True) ( <i>Ramsay</i> )<br><i>Sentimental male duet, Orch. accom.</i>  | Harlan & Stanley          |
| 8948 | My Carolina Lady ( <i>Hamilton</i> ) <i>Sentimental song, Orch. accom.</i>  | Miss Ada Jones            |
| 8949 | Mildred ( <i>DeWitt</i> ) <i>Bells solo, Orch. accom.</i>   | Albert Benzler            |
| 8950 | When the Harvest Moon is Shining on the River ( <i>Henry</i> )<br><i>Descriptive song, Orch. accom.</i>   | Harry Anthony             |
| 8951 | Tennessee Minstrels<br><i>Introducing Len Spencer and Billy Murray as end men, and the minstrel ballad,</i><br><i>"My Love Remains the Same," sung by Harry MacDonough.</i>   | Minstrels                 |
| 8952 | There's a Dark Man Coming With a Bundle Medley<br><i>Introducing "There's a Dark Man Coming With a Bundle," "Mamma's Boy,"</i><br><i>"I'm Trying so Hard to Forget You" and "The Yankee Doodle Boy."</i>  | Edison Military Band      |

Edison Gold Moulded Records are made only in Standard Size. Both Standard and Concert Records may be ordered from this list. Order by number, not title. If Concert Records are wanted, give the number and letter C.

## SPECIAL ADVANCE LIST HEBREW SELECTIONS EDISON GOLD MOULDED RECORDS.

THESE special Hebrew selections will be ready for shipment as near February 10th as possible. All orders received prior to February 1st will be shipped at that time. These selections have been made in the best manner of our Recording Department and will be found entirely satisfactory to all who desire Hebrew music.

- |  |                         |
|--|-------------------------|
| 18804 Overture Gavriel ( <i>Friedsell</i> ),   | Edison Military Band    |
| 18805 Chanuke Licht Benshen ( <i>Schnurmacher</i> ),                                   | Goldin Hebrew Quartette |
| 18806 Isrulik Kim a Heim ( <i>Meyerowitz</i> ), <i>Lied mit Orchester begleitung</i> , | David Meyerowitz        |
| 18807 Lechu nerannenu ( <i>Schnurmacher</i> ),   | Goldin Hebrew Quartette |
| 18808 Zimblen ( <i>Tanzman</i> ), <i>Comisches Lied mit Orchester begleitung</i>       | Hyman Cornfeld          |
| 18809 Bifroach reshuim ( <i>Blumenthal</i> ),  | Goldin Hebrew Quartette |
| 18810 Mutter's Gebeth ( <i>Arenstein</i> ),  | Edison Military Band    |
| 18811 Adojnoj sechurunu ( <i>Schestorpol</i> ),  | Goldin Hebrew Quartette |
| 18812 Aufjener Seit ( <i>Moguleski</i> ), <i>Lied mit Orchester begleitung</i>         | Meyer Goldin            |
| 18813 Ufchein jiskadosh ( <i>Goldstein</i> ),  | Goldin Hebrew Quartette |
| 18814 Gott un Sein Mishpet is Gerecht ( <i>Meyerowitz</i> ),                           | David Meyerowitz        |
| <i>Lied mit Orchester begleitung.</i>  |                         |
| 18815 Hashkivenu ( <i>Wohl</i> ),  | Goldin Hebrew Quartette |
| 18816 Sisi Wesimchi ( <i>Friedsell</i> ),  | Edison Military Band    |
| <i>Aus der Oper "Die Gebrochenen Herzen."</i>  |                         |
| 18817 Die fier Chsidym ( <i>Goldin</i> ),  | Goldin Hebrew Quartette |
| 18818 Brechen Die Beiner ( <i>Tanzman</i> ),   | Hymen Cornfeld          |
| <i>Comisches Lied mit Orchester begleitung.</i>  |                         |
| 18819 Eitz Chaim ( <i>Sulzer</i> ),  | Goldin Hebrew Quartette |
| 18820 Die Seider Nacht ( <i>Brody</i> ),   | Meyer Goldin            |
| <i>Lied aus "Teibele" mit Orchester begleitung.</i>                                    |                         |
| 18821 Hajom Haras ojlom ( <i>Schor</i> ),  | Goldin Hebrew Quartette |
| 18822 Chardas  | Edison Military Band    |
| 18823 Weshomru ( <i>Sulzer</i> ),  | Goldin Hebrew Quartette |
| 18824 Mismor Le David ( <i>Brody</i> ),  | Herman Suchovisky       |
| <i>Lied aus "Gott, Mensch und Teufel," mit Orchester begleitung.</i>                   |                         |
| 18825 Kwojdoj ( <i>Schnurmacher</i> ),   | Goldin Hebrew Quartette |
| 18826 Die Awojde ( <i>Belzer</i> ),  | Goldin Hebrew Quartette |
| 18827 Masil toff ( <i>Moguleski</i> ),   | Edison Military Band    |

Edison Gold Moulded Records are made only in Standard Size. Both Standard and Concert Records may be ordered from this list. Order by number, not title. If Concert Records are wanted, give the number and letter C.



## REMOVAL OF NEW YORK OFFICE.

The New York office of this Company will on February 1 be removed from 83 Chambers Street to 31 Union Square, corner Broadway and 16th Street, (fourth floor, Bank of the Metropolis Building.) This change to larger quarters has been made necessary by the growth of our business. All orders and correspondence intended for our New York office should hereafter be sent to the new address.

NATIONAL PHONOGRAPH CO.

### CO-OPERATION SPELLS SUCCESS.

The year 1904 was the most prosperous in the history of the National Phonograph Company. It was a great year for the sale of Edison Phonographs and Edison Gold Moulded Records. Not only was the foreign business greatly extended and increased, but the domestic business made greater strides than in any other twelve months of the company's career. The result is a source of much satisfaction to every officer and employee of the company whose work assisted in making it possible. The ever increasing strength of the Edison product upon the public has had much to do with this success, but we do not forget that no small part of it has also been due to the Jobbers and Dealers. Without the good will and cordial co-operation of the trade the same success could not have been possible. It will not do to say that Jobbers and Dealers only sell what the public demands and that the manufacturer has but to popularize his product to make the trade sell it, for this is not entirely so. Take away the element of good-will and the volume of business would suffer. We, therefore, desire at this time to express to all Jobbers and Dealers our appreciation of their efforts in 1904, and give voice to the hope that we shall have their co-operation to even a greater extent in 1905. Everything points to a most prosperous year and it only requires working together all along the line to make the promise of to-day a reality in December next. So let us all touch glasses to the toast "Edison and the Phonograph."

### ADVERTISING THE THING.

The magazine advertising that we have been doing in the past year has been more extended and more adequate than ever before. In spite of its cost, it has been most profitable, for it has played no small part in the great increase

of our business. If we did not believe that every Edison Dealer in the country has seen this advertising in some form, we would reprint some of the advertisements. It has occupied full pages in a score or more magazines, and all dealers must have seen it. In every advertisement the public has been asked to call at Dealers' stores and hear the Edison Phonograph and Edison Gold Moulded Records. Dealers can get much benefit from this advertising by using space in their local papers to tell the public that they carry the goods. Every Dealer who has made a success in selling the Edison product has been a liberal user of advertising space, and the business of all would be increased by advertising in one or more of its various forms.

### LEARN TO REGULATE SPEED.

Our salesmen report that one of the commonest things in their daily experiences is to find Dealers exhibiting Records on a Phonograph running either too fast or too slow, thereby causing customers to have unfavorable impressions when a contrary effect is desired. Every Dealer should make it his first duty to learn how to properly regulate the speed of all styles of Phonographs. It is really the most important factor in the sale of machines. The direction sheet packed with each Phonograph, except the Gem, gives careful instructions for determining a speed of 160 revolutions a minute, and by giving them a little study every Dealer may know when his machines are running at the right speed. On the Gem machine the Dealer may make a chalk mark on the rim of the pulley or some other mark of that nature that can be seen, and count the revolutions of the mandrel in ten or fifteen seconds. In ten seconds it should be from twenty-six to twenty-seven, and in fifteen seconds it should be forty.

**SCHEDULE FOR RECORD SHIPMENTS.**

Because of the ample facilities that we now have at Orange, N. J., for the manufacture of Edison Gold Moulded Records, it has become possible to announce a definite and fixed schedule in connection with the shipment of new Records each month. Unless otherwise advised, samples will be shipped on the 1st to each Jobber ordering them. Advance orders must be received by the 10th. Shipment of orders received at that time will be made about the 25th, the date not varying two days one way or the other. Those received after the 10th will be regarded as second orders. Shipments by the 25th will make it possible to have the new Records in the hands of all Dealers by the first of the month given on the supplement. It is only within the past three months that it has been possible to carry out a fixed schedule of this kind, and it only needs the co-operation of the Jobbers to make it a standard feature of the business.

**THE DANCE RECORDS.**

The reports being sent in covering the instant success of the dance Records shipped early in January, are no surprise to the experts who supervised their recording, or to those whose duty it is each month to hear or approve all Records before they are placed before the public. The splendid tonal qualities and full volume were known to them, and they would have been grievously disappointed had these dance Records been anything but a success. Before they passed inspection they were compared with similar Records of other companies and found to surpass them on every point. The advance orders were more than half those for the monthly supplement, and many Jobbers have already placed second orders. They are going to be steady sellers for months, or until something better is made, and no Dealer's stock will be complete without most of them. Every Dealer should have them, for few Phonograph owners will be without a representative selection.

When the five Records, Nos. 8247 to 8251, "U. S. Army Lancers," were made over by the Edison Military Band, "Mr. Nightingale's" whistling specialty was omitted from No. 8248; "Squire Hawkins'" Rube monologue was omitted from No. 8249, and the singing and whistling duet by "Mr. Nightingale" and "Mr. Hightone" was omitted from No. 8250. All orders for this set of Records are now being filled with the new series. These Records still include the calls.

**REMOVAL OF ADVERTISING DEPARTMENT.**

On February 1 the Advertising Department of the National Phonograph Company will be moved to the main office and factory of the Company at Orange, N. J.

Ever since the Company has been in business its Advertising Department has had its headquarters at the New York office. There all the work of planning, ordering and checking was carried on, and all mailing to the trade was done. The bulk of the catalogues and printed matter has, however, been carried at the factory in Orange, from whence shipments were made to the trade.

It has been decided that more efficient service can be rendered the trade by having the department and its stock under one roof. Therefore its removal to Orange.

The department will occupy a one-story brick building, 25x100 feet in size and 20 feet in height. The building is one formerly occupied by Mr. Edison for experimental purposes, and its walls have witnessed the working out of many parts of his inventions. Had the building been constructed especially for the department it could not have been better adapted for the work. Although located in the middle of the factory grounds, and surrounded by the buildings in which Edison Phonographs and Records are made, and by Mr. Edison's Laboratory and experimental buildings, it stands apart from them all, free from the turmoil and confusion incident to a large manufacturing plant.

Correspondence intended for the Advertising Department only should hereafter be addressed to Orange, although it will reach it without material loss of time if sent to the New York office.

In its new quarters, the aim of the department will be to study more closely than ever the needs of Jobbers and Dealers in the matter of catalogues and other advertising literature. Being in close touch with the Shipping Department will make it possible to send out printed matter without delay, when not necessary to hold for shipment with merchandise. On the whole we believe that the removal will be a benefit to the trade and ourselves.

I wish to say a few words in praise of the Edison Phonograph. Have one here which has been in constant use for three years selling Records. There has never been anything wrong with it, and I have only had to put on one new belt.—*From a Dealer at Sydney, New South Wales, Australia.*



### IT HELPS BUSINESS.

"Don't the sale of cheap premium talking machines make inroads on the demand for Edison Phonographs and Records," we were recently asked, and the inquirer was quite surprised when we informed him that the contrary was the case; that they have been a benefit to the Edison Dealers in every city where the premium plan has been carried on. These Dealers report that they have at once increased the demand for Edison Records, and have served to whet the appetite of the owner for a better machine. The premium machines are so imperfect and so unsatisfactory that few people use them long without getting disgusted. This feeling extends in a large degree to all machines of the same name and having a stock of cylinder Records, they look around for a better machine to play them. Then the Edison Dealer has an inning and scores right along. Dealers whose cities have not yet been struck by the premium scheme need not fear its coming, but rather welcome it, for with a little judicious advertising of their own it will bring them much business.

### HEBREW RECORDS.

The twenty-four Hebrew selections listed on page 3 of this issue were made at our New York Recording plant, under the direction of the experts who have made the fame of the Edison Gold Moulded Record, and they are up-to-date in every respect. The selections are all of a popular character. It is certain that every Hebrew owner of an Edison Phonograph will want the entire list. A limited edition of supplements for these Records is being printed. It will be Form No. 649, and Jobbers placing orders for the Records are asked to order a few supplements shipped with them. Mailing these supplements to a selected list of names will not only sell Records, but induce many non-owners to purchase Phonographs.

### THE TASK NOT YET FINISHED.

Orders for Records are occasionally received directing us to fill them only with the Records of the new style marking, and packed in the new style carton. The trade should know that it is still not possible to comply with these requests with all selections. Although we have been steadily at work making over the Records to conform to new conditions, the task will not be completed for some months to come. Until that time we shall be compelled to supply a certain number of titles in the old style. The number of these selections will steadily decrease, and eventually disappear.

### PRINTED MATTER

Form No. 618, a hanger showing the prices and discounts under which Edison Phonographs are sold, was recently mailed to the entire trade. We trust that all Dealers will hang this form in a conspicuous place so that they will be able to explain to their customers why they are compelled to sell Edison goods at uniform prices. In printing this form an error was made in giving the price of the Victor Phonograph as \$60, when it should have been \$65. We will thank Dealers to make this correction on their copies.

We still have on hand a quantity of our St. Louis Booklet, Form 550, and will be glad to fill orders for it from Jobbers who can use it to advantage.

All orders from the trade for price cards are now being filled with a new style card, Form 641. This card is 7 1-3 x 9 inches in size, and a different color is being used for each of the four machines. The colors are bright and will enhance the appearance of any window display in which they are used.

A copy of Form 619, Accessories Catalogue, was recently mailed to the entire trade. This catalogue is intended only for trade distribution, and cannot be supplied to anyone in large quantities.

Beginning with this issue, we shall mail with each copy of the EDISON PHONOGRAPH MONTHLY an order blank to be used by Dealers in ordering new Records each month. This will make it unnecessary to use the second page of this MONTHLY, or write a lot of numbers. Spaces will be left for the names of Jobbers and the signatures of Dealers. Only enough will be printed each month to mail one to each Dealer. It will not be supplied in quantities.

### DEATH OF CHARLES MOLE.

Charles Molé, who made Edison Record No. 8513, "Le Tremelo," died in New York City on January 8. For two years he had been connected with Damrosch's orchestra as first flute player. Previous to that he was flute soloist for the Boston Symphony. For many years he was an instructor in the Paris Conservatory of Music.

### APPRECIATED.

Dealers all over the country should thank you for your efforts in their behalf. It is good to know that a company like yours stands by its Dealers. Accept my best wishes for further success and a prosperous 1905.

LESTER CHARLES RIEMER.

### HELPS TO SELL SHEET MUSIC.

A Dealer who has been handling talking machines exclusively states that he recently put in as a side line a stock of sheet music. In selecting same, care was taken to buy such as were popular in Records. The idea of hearing a song sung, instead of being played on a piano, as is usually done, appealed to purchasers of sheet music, and he now has the best trade in his city in this line. Naturally his complete stock brought in many who were prejudiced against a Phonograph, and were surprised at the wonderful improvement in Record making.

We found that the latter statement was especially true. Many piano players are prejudiced against a Phonograph by dealers who handle pianos exclusively; and, too, by the belief that the Phonograph is machine-made music like the piano players.—*Chandler Phonograph Company, Chillicothe, O.*

### A GREAT BUSINESS.

The following letter was written from Boston to the editor of the PHONOGRAPH MONTHLY by our New England salesman:

In calling on the Boston Cycle and Sundry Co. yesterday, they requested me to point out to you the wonderful business that they are doing in Edison goods. For your information they placed orders with me on the 7th inst. for nearly 19,000 Stock Records and over 17,000 from the February list. I also received their regular weekly order for 100 Phonographs. They will receive over 12,000 Dance Records during the coming week. It is now up to our company to give them a good send off in the MONTHLY.

Mr. Scott has stated the situation so nicely that we felt that we can not do better than print his letter in full. It is needless to say that we take great pride in the conditions which make it possible to print such a letter.

### PHONOGRAPH PUBLICATION IN MEXICO.

Our Foreign Department is in receipt of the first issue of *El Boletín Fonográfico*, a monthly published in Mexico City, Mexico, in the interests of the Phonograph. Following the publishers presentation of the magazine is a short biographical sketch of Mr. Edison and a well-written article setting forth very strongly the leading position occupied by the Phonograph among the inventions of the nineteenth century. The publishers of *El Boletín Fonográfico* promise to keep the Mexican public closely in touch with all improvements in connection with the Phonograph, as well as to furnish other information of interest to Phonograph enthusiasts; and it is to be hoped that their efforts will be rewarded with unqualified success.

### PATENT INFRINGEMENT IN LONDON.

The following is a report of proceedings against Messrs. A. W. Gamage, Ltd., heard before Justice Kekewich at the Royal Courts of Justice, London, on Friday, December 2nd, 1904, when A. J. Walter appeared for the Plaintiffs; M. D. Warmington and J. C. Graham appeared for the Defendants.

Mr. Walter, on behalf of the Plaintiffs, The National Phonograph Co., Ltd., stated that the action was brought to restrain infringement of Edison's Letters Patent. The articles were sold by the plaintiff company under what is known as a Limited License, under which they could only be resold under certain conditions. They were resold by the defendants contrary to the conditions, and an action for infringement had been brought. A defense had been put in denying infringement, and denying the validity of the patents but the defendants now through their Counsel sought leave to withdraw their defence and an injunction was therefore sought to restrain the defendants, their servants and agents during the life of the Letters Patent from infringing the said or either of the said Letter Patent. The injunction as asked for was granted.

### SEND ORDERS TO NEW YORK.

The attention of the trade is again called to the desirability of sending all orders for Phonographs, Records and supplies direct to our New York office. All orders must pass through the Sales Department, which has its headquarters in New York, and although the orders will reach this department no matter how addressed, they will get attention quicker by sending them direct to New York.

### A FINE LOT.

Your January Records are a particularly fine lot and we trust you will continue to supply songs, etc., of the same good quality. Wishing you a successful New Year.

THE TORONTO MUTOSCOPE Co., LTD.

### NOT IN THE SAME CLASS.

Don't conflict the Edison Phonograph with the "Scratchophone" machines on this market whose only virtue is that they make a lot of noise. The Edison Phonographs are free from that scratching sound and don't require needles after each record is played, but the music is reproduced by the aid of a sapphire point that lasts a life time.—*Extract from advertisement Danforth & Carter, Augusta, Ga.*

I have a Triumph Phonograph which I purchased from you, and of all the machines I have tried, there is none that can compare with yours, as the workmanship is all that is desired.—*From a correspondent at Christchurch, Canterbury, N. Z.*



### COMMENTS ON EDISON GOLD MOULDED RECORDS FOR MARCH, 1905.

The March list of Edison Gold Moulded Records is essentially one of popular airs and up-to-date music; just the kind of selections that are wanted by ninety-nine persons out of a hundred. Records of grand opera music by high class talent appeal to one man and afford good talking points for the manufacturer, but the Records that reach the heart of the other ninety-nine and get the business are those of the high, catchy, rhythmic songs of the day. On this basis the demand for the March list will be phenomenal. The following references to each will afford some information about these Records, but every Phonograph owner should hear them played at a Dealer's store:

No. 8928, "A Sprig o' Shillalah," by the Edison Concert Band, is a timely selection, listed in the month of St. Patrick's Day. "A Sprig o' Shillalah" is styled by its composer, J. Fred Helf, as an Irish Intermezzo. Mr. Helf is the composer of "A Bit o' Blarney," and while his newer selection does not resemble it, the style of the composer will be readily recognized as being similar. "A Sprig o' Shillalah" is in every respect as fine a selection as "A Bit o' Blarney." Our Record of it is made in a musicianly manner by the Edison Concert Band.

No. 8929, "O Promise Me," sung by Irving Gillette, is one of the best ballads of later days that was not made over when the gold mould process of making Records was introduced by Mr. Edison. The demand for it, however, has been so constant that it has been decided to list it as part of our March Supplement. This song is, beyond question, the most popular thing that Mr. De Koven ever wrote and our Record of it by Mr. Gillette is the best that the latter has yet made for Phonograph use. The singer is accompanied by the orchestra.

No. 8930, "Never," is another topical song by Bob Roberts, without which the Monthly Supplement of Edison would not be complete. Each one that he sings always seems to be better than the one previously listed. This is true of "Never," the words and music of which were written by Alexander Rogers. The Record includes three verses, each one of which leads up to an amusing situation cleverly brought out by the chorus. The Record is made with orchestra accompaniment.

No. 8931, "Come Take a Trip in My Airship Medley," played by Albert Benzler, is an unusually fine xylophone solo with orchestra accompaniment, introducing the songs "Come Take a Trip in My Airship," "Please Come and Play in My Yard," "Let's All Go Up to Maud's" and "I've Got My Fingers Crossed, You Can't Touch Me." The cornet variation on the theme for which the medley is named is a very effective part of the Record. In this medley of popular waltz songs there is "something doing" throughout the entire selection.

No. 8932, "It Makes Me Think of Home, Sweet Home," is a new descriptive song, sung by Byron G. Harlan, written by Frank D. Bryan and one that is destined to be very popular. In it the singer refers to the "Star Spangled Banner" as the song that stirs up his American blood and makes him think of "Home, Sweet Home." Mr. Harlan, as usual, sings the song finely and in his work has the assistance of the orchestra.

No. 8933, "The Troubadour," played by the Edison Concert Band, is an intermezzo by W. C. Powell, composer of "The Gondolier," the \$5,000 instrumental hit, published by the popularizers of "Hiawatha." "The Troubadour" was the instrumental number selected by these people to feature during the present season, and the success it has met with in the past few months justifies the wisdom of their choice. Our Record does the composition full justice.

No. 8934, "The White Swan," is a selection by the Edison Symphony Orchestra, written in schottische tempo. It is of the same character and by the same composer,—R. M. Stultz,—as "Birds and the Brook," our Record, No. 7860, one of our most popular orchestra Records. "The White Swan" has the same elements of success.

No. 8935, "Oh, Oh, Sallie," is another fine duet by Collins and Harlan. This selection has a sub-title "I'll Love You Till I Die" and the story is built on this line. The music is tuneful and full of character, and offers excellent opportunities for the duetists, Collins and Harlan, to entertain their many friends. The words of this song were written by Rogers and Frantzen and the music by Eddie Leonard. The Record has an orchestra accompaniment.

No. 8936, "Mexico," sung by Harry MacDonough, is Miss Maud Lillian Berri's great hit in Klaw & Erlanger's New York production of the Drury Lane spectacle, "Humpty Dumpty." This song is the most talked-of number in the show and is rapidly climbing to a high point of popularity. The Record is made with orchestra accompaniment. Its composers are Cole and Johnson. In the song the Mexican lover sings:

Mexico! My dark-eyed Mexico!  
Though years may come and go I'll constant be,  
Oh! Mexico, I dearly love you so!  
And I would like to know if you love me.

No. 8937, "Darkie Tickle," made by the Edison Military Band, is a characteristic dance composition by E. B. Hunt already listed in our catalogue as a banjo solo by Vess L. Ossmann. In its new form it will doubtless be more popular than ever. This selection introduces a humorous coon dialect, dancing and other incidental effects.

No. 8938, "Marguerite," sung by MacDonough and Biehling, is a fine Record of C. A. White's old song, which is popular everywhere. Very few melodies equal it and none surpass it. It was especially arranged for MacDonough and Biehling as a duet and has never before been heard in the form now offered to Edison Phonograph owners. The orchestra accompaniment provides an attractive embellishment.

No. 8939, "The Bingville Band," by Arthur Collins, is a distinctly comic song descriptive of the Band of Bingville in which some amusing effects are introduced. The music has a characteristic swing and is full of action from beginning to end. Mr. Collins is accompanied by the orchestra. The music of this song was written by C. F. Billings and the words by F. M. Dean. It is a Record that cannot fail to please Mr. Collins' many admirers.

No. 8940, "Evening Star," is the first violoncello solo that we have listed. It is played by Hans Kronold, who is one of the best violoncello players of the present day. Being able to have him make a Record of this beautiful selection from Wagner's "Tannhauser" is a bit of enterprise in which we take much pride. It is one of the most artistic Records from a musical standpoint that it has been our good fortune to issue. In order to detract as little as possible from the 'cello, Mr. Kronold was accompanied by the piano instead of the orchestra. Particular attention is invited to the steady, sustained bowing of Mr. Kronold, which is perfectly recorded. At the time this Record was made Mr. Kronold expressed himself as delighted with the reproduction of his work.

No. 8941, "Hans Krausmeyer and His Dog Schneider," is a unique talking Record by Len Spencer and Alf Holt. So cleverly do Mr. Spencer and Mr. Holt make this Record that one can all but see Krausmeyer carrying on the soliloquy with his dog and the latter wagging its tail and barking in reply. Krausmeyer's "talk" is very funny.

No. 8942, "Can't You See My Heart Beats All for You?" by Murray and Roberts, is a coon love song now being sung in the best vaudeville performances of the country. The first duet Record made by these artists and listed in February made an instant hit and caused an immediate demand for other Records by the same people. The following dialogue is appropriately introduced:

ROBERTS—What's the matter with, girl? Haven't I treated you all right? Didn't I take you to the ice cream festival?

MURRAY—Yes, but you only had car fare one way and I had to walk back home.

The Record is made with orchestra accompaniment. The music is by Theodore Morse and the words by Bert Fitzgibbon.

No. 8943, "The Wren Polka," is a piccolo solo played by Frank S. Mazziotta, with orchestra accompaniment. The tonal quality of this selection is superior to any previous Records made by this instrument. The composition is replete with brilliant and difficult execution, yet withal, tuneful and capable of ready appreciation. This selection was composed by E. Demare.

No. 8944, "Won't You Fondle Me?" is a serio-comic love song by Arthur Collins, which is very popular among vaudeville singers generally. It has somewhat of the rag-time rhythm, and Mr. Collins' work in making a Record of it is up to his usual high standard. The orchestra accompanies the singer. This song was written by Kendis and Paley. Its chorus:

Won't you fondle me, won't you fondle me,  
Throw your loving arms around me in that loving way,  
Tell me that you love me and you're going to stay,  
I'll stop flirting too, 'cause it's hurting you,  
Keep my heart's affection burning all for you,  
If you only fondle me.

No. 8945, "Tell Me With Your Eyes," is another fine Record by the Edison Male Quartette. This selection was specially arranged, introducing in the verse part a solo by the second tenor, a duet by the two tenors, a trio by the tenors and baritone, and finishing with a quartette chorus, or refrain. The entire Record is accompanied by the orchestra. The music of this selection was written by Albert Von Tilzer and the words by Arthur J. Lamb. Its refrain follows:

Tell me with your eyes  
All I want to know.  
Tell me with your eyes, my dear,  
That you love me so;  
Though your love's conferred  
In your heart's tender sighs,  
More than all the sweetest words  
Tell me with your eyes.

No. 8946, "Ye Ancients March," played by the Edison Concert Band, is another popular Record made by the wax process, but not until now made by the gold mould process. It introduces a number of old time melodies, characteristic of the title. The reed section plays an important part in the fife and drum effects, introducing in it this march by the composer. This selection was dedicated to the Ancient and Honorable Artillery Company of Boston by its composer, the late D. W. Reeves, bandmaster of the American Band of Providence, R. I., who succeeded to the directorship of Gilmore's Band at the death of Patrick Sarsfield Gilmore.

No. 8947, "Tommy (Tell Me True)," made by Harlan and Stanley, is a sentimental song written by Don Ramsey and Tell Taylor, and cleverly sung by these two well known artists. The music is written in schottische tempo, which is kept up throughout the Record, giving a fine swing to the selection, which is very pleasant to hear. The singers are accompanied by the orchestra.

No. 8948, "My Carolina Lady," served as an introduction to the Phonograph public of another new singer in Miss Ada Jones, who has a charming contralto voice. Miss Jones sings this selection in a style all her own, with a dainty coon dialect and expression, that claim your interested attention at once. The music of this song was written by George Hamilton and the words by Andrew B. Sterling. A part of one verse follows:

At night I dream I'm back in Carolina,  
With the little Southern girl I dearly love,  
At night I pray that naught will come to harm her,  
That angels will watch o'er her from above.

No. 8949, "Mildred," is a bells solo by Albert Benzler, written in the song and dance or schottische tempo, with a melody fully as catching as any of Mr. Benzler's entertaining bell numbers. It is played with orchestra accompaniment. The composer of this selection is Len O. De Witt.

No. 8950, "When the Harvest Moon is Shining on the River," sung by Harry Anthony, is a new ballad by S. R. Henry and Arthur J.



Lamb, the music of which forms a very pretty setting to the story as told in the words. It attracts the first time it is heard, which accounts for the rapid growth in popularity that it has met with since its first publication a short time ago. Mr. Anthony sings it in a remarkably fine manner. It has the usual orchestra accompaniment. The theme is the old love story about—

The nightingales are singing in the valley,  
The stars like shining jewels deck the skies,  
As still beside the garden gate they linger,  
And whisper of a love that never dies.

No. 8951, "Tennessee Minstrels," by the Edison Minstrels, is another excellent addition to our list of Minstrel Records. It begins with the regular minstrel scene and the opening overture is "Maud S." Then are introduced the end men, Billy Murray and Len Spencer, and the interlocutor in a bright and funny "gag." Harry MacDonough sings the minstrel ballad "My Love Remains the Same," with chorus by the Edison Male Quartette. All are accompanied by the orchestra.

No. 8952, "There's a Dark Man Coming With a Bundle Medley," played by Edison Military Band, includes "There's a Dark Man Coming With a Bundle," "Mamma's Boy," "I'm Trying So Hard to Forget You," and "The Yankee Doodle Boy," four of the very latest popular successes.

#### EDISON LINE ALL HE WANTED.

"Attached you will find a letter from——," wrote George E. Mickel, manager of the Nebraska Cycle Co., Omaha, Neb., on December 31st. "This is the party we had sign a Retail Dealer's Agreement about six weeks ago. Before he went into the talking machine business, the writer tried to induce him to take up the Edison line, and later I called on him and found he had taken up a line of —— . In November I had him put in a line of Edison goods, and this letter explains the result: Nebraska Cycle Co.

"I must say I am highly pleased with the Phonograph, so much so I would like to dispose of my stock of ——, consisting of three instruments, and handle your goods exclusively. Could you not take them off my hands? I presume you could dispose of them better than I can. Let me know what you think of such a thing."

The Douglas Phonograph Co. have established a branch of their business at 1525 First Avenue, New York City, in charge of Alfred Weiss. This will place at the disposal of the uptown dealers a large stock of Edison Phonographs and Records, etc. The uptown branch will be open every day and evenings, which will enable dealers to obtain goods of them at all times.

#### IN THE PHONOGRAPH PALACE.

It says "Admission Free" over the door of the penny in the slot Phonograph palace, and apparently there are some who think that that applied to the machines as well.

A woman came in, carrying an armful of bundles, which she deposited on top of a Phonograph case, picking up, then, the tubes and applying them to her ears, clearly expecting to hear, right off, the music. But it didn't come.

She shook the tubes, and looked at them, and joggled the music box itself, and then put the earpieces up to her ears again, and listened hard, but still no music. And then:

"Madam," said a man standing at the next Phonograph, listening to its music, a man who couldn't help witnessing her efforts, and who now ventured to address her respectfully, "madam, I think if you would drop a penny in the slot you would find it will work better."

But instead of doing this she dropped the earpieces and gathered up her bundles and departed. Didn't it say "Admission Free" over the door?

But if it seemed strange that anybody should think the machines were free, it seemed stranger still to encounter somebody that didn't know how the machines worked. But there are such.

Up to a man who had a pair of tubes glued to his ears walked a woman who, as a matter of simple fact, was at once handsome, graceful in bearing and elegantly attired, a woman of evident cultivation and refinement, and who was accompanied by her daughter, a young woman handsomer still than herself. But neither knew how the penny in the slot Phonographs were operated, and when the man whom they had approached had dropped the earpieces up spoke the elder of the two visitors, with:

"Will you please tell me how they work?"

Which the gentleman was indeed pleased to do; and straightway the mother and daughter, from a home in some fine old town that might be one of wealth and of great natural beauty, but one evidently not yet boasting of a Phonograph parlor, began putting cents in the hopper.

All sorts of people visit the Phonograph palace, including men as well as women and children; and grown up men appear to enjoy the music as much as anybody does. Two men may be seen, or two young women, or a young man and a young woman, or two children often are listening to the same Phonograph, each holding a single earpiece; and sometimes one man may be seen, listening with a single earpiece, not using the other at all. Perhaps he is deaf in the other ear, but anyway he uses only one earpiece.

Mothers hold little children up in their arms and themselves listen with one earpiece and place the other at the ear of the child. They do this sometimes with infants so young that it would seem impossible for the little ones to realize that what they were hearing was a con-

cord of sweet sounds, but the mothers seem to enjoy giving the infants a chance to hear; they like to divide the music with them.

Of all those who drop a penny in the slot and put up the earpieces some listen gayly, while some plant their elbows on the box over the machine, and hold the earpiece to their ears lightly, and listen in an attitude of rapt enjoyment; and some people hum the tune as they listen to it. Many of the listeners seem to have made strange selections. For instance:

You may see gray haired but alert men, with earpieces up, listening to the stirring strains of "Marching Through Georgia" or of "Dixie," and it is easy to imagine as to them that they are veterans to whom these songs bring back vividly recollections of the days when, on one or the other side, they performed the man's part. It is easy to account for their selections. And there is the swarthy man with the pointed beard drinking in his selection from the opera—it seems natural that he should have made this selection; and the same is true of the young people to be seen listening to love songs, or perhaps to rollicking comic ditties.

But how shall we account for the people who are drawn to the Phonograph that plays "Down Where the Sweet Potatoes Grow," people who may have about them nothing whatever bucolic in appearance? It may be simply idle curiosity, but it seems strange.

And why should people put up the earpieces of "Dear Sing Sing," people of wholly innocent appearance, people who from their looks would seem never to have had any further acquaintance with Sing Sing than that to be gained by riding past it on the railroad. Why should they be interested in "Dear Sing Sing?" And you may see people whom you would never pick out as being of a deeply devotional nature listening with manifest interest to "The Holy City" or to the notes of "Onward, Christian Soldier."

And so on all along the line, so that one is inclined to repeat to himself as he looks at the listeners, "You can't always judge a man by his looks." Curious and interesting and peculiarly modern is the penny in the slot Phonograph palace, and of interest, as well, are the people to be met in it.—*New York Sun*.

#### A HIGH COMPLIMENT.

Rudolph, O., Jan. 9, 1905.

I wish to relate an incident which occurred in our store this evening, which I considered the highest compliment that has ever been paid to a talking machine. I was exhibiting a Home, with a 24-inch silk horn. Among other Records, I put on No. 8656, The Flogging Scene from "Uncle Tom's Cabin." When the Record was ended, a man sprang out of his chair, wiped the tears from his eyes, and said, "I'd give ten dollars for the privilege of hitting that damned slave driver just once." Has any other talking machine ever been complimented any higher? The Edison is taking our community by storm.

THE BUCKEYE MUSIC Co.,  
J. C. Friend, Manager.

#### PHONOGRAPH MUSIC BY TELEPHONE.

Sleighting parties from New Rochelle and the Bronx had an impromptu dance at a City Island Bridge hotel Christmas eve, in which two mice and a Phonograph twelve miles away played most important parts. Thomas Jordan, proprietor of the hotel, which is in Pelham Bay Park, found his house full of gay young people Saturday evening, and when they suggested a dance he had his dining room cleared, a big fire started and all was in readiness. Miss Clara Forsyth, of New Rochelle, sat down to the piano to furnish music for the dancers, but her first notes were discords, and were accompanied by a piercing squealing and scratching from the interior of the piano.

"Rats!" somebody shrieked, and Miss Forsyth climbed on top of the piano stool, while the other young women mounted chairs and window sills. Mr. Jordan opened the back of the piano to investigate, and a little mouse leaped out and scurried around the floor to a chorus of shrieks. There was another mouse still in the piano, and after cautiously poking around with a stick among the wires, Mr. Jordan decided not to endanger the instrument by such proceedings, and went to the telephone to call up a musician in Fordham, not far away, intending to order two or three musicians sent to the hotel.

He got a crossed wire and listened to a brass band concert reproduced from a Phonograph in the home of Albert E. Lauten, a musical instrument dealer at No. 1934 Amsterdam avenue, Manhattan, about twelve miles from City Island. Mr. Jordan broke in at the end of the march and talked to Mr. Lauten. As a result he made a megaphone of cardboard and his patrons danced to the telephone music of the Phonograph for two hours.—*New York Herald*.

#### ASSIST HER, OF COURSE.

Mr. \_\_\_\_\_ writes us, saying "he has just received one dozen Records and finds 'The Girl I Love in Sunny Tennessee' is broke, what shall I do?" We replied, "If you love her, send some money." What would you do?—*Thomas C. Hough, Edison Jobber at Minneapolis, Minn.*

#### DANCE RECORDS FINE.

I received the Dance Records to-day, and they are fine. Any one who could not dance to such music will not try any other kind. I have a 72x28 brass horn and a Concert Phonograph changed to play the Standard Records. I have never heard its equal, not excepting the \_\_\_\_\_, of which I also have one.

We have a local band here and I am going to take some Records in some future time. Last winter I got some chimes on the Concert Phonograph that were fine, also some violin solos. They were my first attempt to make Records.

Z. J. LE FEVRE.



**A REMARKABLE OCCURRENCE.**

Mansfield, Ohio, Dec. 21, 1904.

Herewith we enclose a copy of an "ad" which we had in our leading daily paper, the *News*, in the issue of December 19th and 21st. The occurrence there portrayed actually took place in our store last week. The name of the man is properly given and the story is not in the least over-drawn. He actually wept, prayed and swore.

W. T. GELTZ.

**THE PSYCHIC POWER OF THE PHONOGRAPH.**

Reader, what would you give to again live over, in all its realism, the most momentous period of your life, especially if that time had been a great history making epoch?

Uncle Dan Frankhouser, who served over four years in the Great American Conflict, can tell you what it means. He can tell you what it is to again march to the strains of martial music and that wonderful necromancy which can call sleeping battalions from the silence of the grave, to hurl themselves into the awful vortex of war's fire and blood—the clash of contending armies. Ask Uncle Dan of the marvelous mesmeric potency of the old war song, "Marching Through Georgia," as sung by Harlan & Stanley:

"Bring the good old bugle, boys, we'll sing another song;  
Sing it with a spirit that will start the world along.  
Sing it as we used to sing it, fifty thousand strong,  
While we were marching through Georgia."

Ah! you should see the old warrior's nostrils dilate and his eye take on the fire of battle. The veteran is again back on the famous march from Atlanta to the sea. His arms swing and his feet beat time to the inspiring rhythm of the song while his entire being is aquiver with the thrill which soldiers alone can feel. Then play for him "The Battle Cry of Freedom," by the same duo:

"We are springing to the call of our brothers gone before,  
Shouting the battle cry of freedom!  
And we'll fill the vacant ranks with a million freemen more,  
Shouting the battle cry of freedom!"

Strange anomaly! Inexplicable paradox of the human soul; he weeps and great hot tears roll down the furrows which the years have laid into his cheeks. The heart of the rough old fighter is as tender as a maiden's. His lips again move with the prayers that were murmured before the charge, and then, obvious to all present surroundings, carried forward in the irresistible current of the strife, he swears terrible oaths invoking the war god's vengeance upon the heads of his country's enemies. Was it real? Ask him.

In the brief period of ten or fifteen minutes the panorama of "The Great Rebellion," with all its sounds and sights; its comedies and tragedies has passed before his eyes and filled his ears. Nay! More: He has been taken into it and lived it all over again as he did in all its ghastly reality more than forty years ago.

The Edison Phonograph was the magic medium that marshaled the spirits of a dead past to re-enact the drama of war.

The Edison Phonograph, Mysterious of Sound, capable of portraying every passion of the human heart and every mood which can be made manifest to the ear. Yet there are people who affect a dislike for this child of the brain of the "Wizard of Menlo Park." For them there can be but one verdict: A necrosed mentality, an atrophied soul; a being wholly animal in its selfishness and dead to every attribute that is noble.

However, we may be unjust in our judgment. Perhaps those people who have a dislike for what are commonly called "Talking Machines" have never heard a genuine Edison Phonograph. If you have not, or, even if you have, come to our store this week and hear the Wonderful New "Home Phonographs" we have just put on exhibition. They will indeed be a revelation to your ears and hearts as well. The most acceptable Christmas gift you can possibly make to any one, except a deaf person. Every machine which comes into our house is thoroughly tested and warranted in every way.

GELTZ'S CASH STORE.

**THE PHONOGRAM.**

Following is a schedule of prices at which *Phonograms* may be obtained by the trade:

**DELIVERED WITH GOODS.**

Blank, per 1000 copies.....	\$2.50
Smaller quantities pro rata.	
Imprinted, per 500 copies.....	\$1.50
Imprinted, per 1000 copies.....	\$2.75

No orders filled for less than 500 copies requiring imprint, and all imprinting orders must be for multiples of 500.

**BY MAIL.**

Single copies, per year.....	\$ .20
Five copies to one address, per year....	.40
Twenty-five copies to one address, per year .....	1.80
Fifty copies to one address, per year....	3.60

Unless they have open accounts on our books, Dealers ordering *Phonograms* sent by mail are requested to send cash or stamps with their orders. The amounts are too small to handle in any other way.

**REPRODUCER EXCHANGE.**

That there are still many of the old style Edison Reproducers in use is shown by the number that find their way back to our factory for repairs. For the benefit of those who have become Dealers in Edison goods in the past two years we would point out that the exchange proposition in connection with reproducers is still in force. This proposition permits Dealers to allow \$2 on an old reproducer when a new style one is bought at full list price. A similar allowance, less usual discounts, is made to Dealers when they return old style reproducers and order new ones.

### A RECORD MADE BY AUSTRALIAN ABORIGINES.

Edward C. Watts, of Albany, West Australia, under date of November 3, 1904, wrote to our Foreign Department as follows:

"Accompanying this note I am sending a somewhat unique Record made by the telegraph operators at the Eucla transmitting station. Eucla is situated on the border line of West and South Australia. Record was made on an Edison Gem which I sent to the boys. Eucla is about 300 miles from anywhere and the machine is a great source of amusement to the operators and helps to beguile many hours which would otherwise be weary. I have myself a Standard which is the clearest and best I have up to date heard. Record is an imitation of Australian Aborigines' Corroboree, made by three natives. The second part is a Corroboree solo. The Corroboree, I should, I suppose, explain, is a sort of war dance, or rejoicing amongst the blacks to celebrate a big day's hunting or any occasion. The male blacks paint themselves as many different colors as possible with clay, or mud or anything they can get hold of. The more hideous they can appear the better they are pleased (although they are ugly enough at any time.) They light a big fire around which the Lubras (females) sit and crone and hit two sticks together, the males dance and jump about and carry on a lot of gibberish which no one seems to understand and I am doubtful if they understand it themselves. This record is not an extra good one, as the man who took it had some difficulty in getting the blacks close to the trumpet. They were not too pleased with the looks of the machine and kept jumping back as you will notice at intervals the sounds get very faint. Of course the man could not get the Lubras and sticks in, but did the best he could under the circumstances. I should think this is the first of its kind made. You are at liberty to make what use you like of the Record. I thought, perhaps, you would like to hear it; it will run fairly on a Standard machine. The Record is an old one shaved down, the only one the boys could get where they were."

Unfortunately the Record was broken in transmission.

### NEW ZEALAND CONGRATULATIONS.

Following are extracts from a letter addressed to Mr. Edison and written by S. F. Boler, Tauhoa, Auckland, N. Z., under date of November 15th:

"Permit me on behalf of many friends here to offer my hearty congratulations on the perfection to which your marvelous invention, the Phonograph, has attained. The pleasure it gives to thousands in this colony alone bears testimony to its excellence.

"Personally, I have exhibited all through the Island as a hobby and the result has been most gratifying. \* \* \* I am still as deeply in-

terested as when I listened to the first little machine brought here, although quantities have passed my hands since then."

### PERSONAL.

Among the out-of-town Jobbers attracted to New York by the automobile show January 16-21 were H. E. Fredrickson, of Omaha, Neb.; W. D. Andrews, Syracuse, N. Y.; N. D. Griffin, of the American Phonograph Co., Gloversville, N. Y.; P. A. Powers, Buffalo, N. Y.; S. K. Hamburger, Harrisburg, Pa.; J. M. Linscott, of the Boston Cycle and Sundry Co., Boston; William Werner, Easton, Pa.; Louis Buehn, of the Wells Phonograph Co., Philadelphia; C. A. Ray, Louisville, Ky.; H. L. Ellenberger, New Haven, Conn.; John N. Willys, of the Elmira Arms Co.

### WINS CASE BY PHONOGRAPH.

London, Jan. 21.—The Phonograph has appeared as a witness in a case tried in the Berlin Second Civil Court. Herr Jakobsen claimed a debt from Herr Gerson on the strength of a verbal agreement which the defendant denied on oath. Thereupon Herr Jakobsen produced a Phonograph and set it in motion. It repeated the conversation between the two men, their voices being clearly recognized. Judgment was immediately given for Jakobsen.—*New York Sun*.

### WANTS DIVORCE OR SOME NEW MUSIC.

One of the acts of cruelty assigned by a Portland, Oregon, woman in her suit against her husband for a divorce is that "defendant some time ago purchased a Phonograph and will not buy new music, but sits by the hour and plays the same pieces over and over again, late into the night, so plaintiff cannot sleep."

The Reading Phonograph Co., Reading, Pa., in one of their recent newspaper advertisements printed cuts of the Gem, Standard and Home Phonographs, and under them ran these neat captions:

A REAL "GEM,"  
\$10.00.

THE "STANDARD"  
OF  
EXCELLENCE, \$20.00.

A DELIGHTFUL "HOME"  
ENTERTAINER, \$30.00.

GOLD MOULDED RECORDS	} Perfection of	} TONE QUALITY FINISH
35 CENTS EACH.		



## SUSPENDED LIST, FEBRUARY 1, 1905.

SUPERSEDING ALL PREVIOUS LISTS.

### COLORADO.

Boulder—BENTLEY & CRAIG.

### INDIANA.

Marion—BUTLER MUSIC CO.; also Wabash, Ind.  
 South Bend—EUGENE MARSH, 126 Vistula avenue.  
 SOUTH BEND BOOK BINDERY,  
 Robert Lebolt, Prop., 203 North  
 Michigan street.  
 Wabash—BUTLER MUSIC COMPANY; also Marion,  
 Ind.

### IOWA.

Burlington—JOHN P. WEISS, 711 Jefferson street.  
 Sioux City—HATTENBACH BROS. CO.

### KANSAS.

Clay Centre—E. M. GOWENLOCK.  
 Lawrence—BELL BROS.

### MAINE.

Biddeford—W. H. FIELD.

### MASSACHUSETTS.

Boston—T. SINGER, 60 Leverett street.  
 Lawrence—LORD & CO., 314 Essex street.  
 E. O. MOSHER, 420 Essex street.  
 Lynn—ELIAS DEYOUNG.  
 Malden—A. T. FULLER.  
 Nantucket—ARTHUR M. TAYLOR.  
 New Bedford—H. B. DEWOLFF.  
 Somerville—E. J. WINCHESTER, 32 Summit avenue.  
 Woburn—OSBORN GILLETTE, or THE BOLTON  
 JEWELRY CO., L. F. Maloney, Manager.

### MICHIGAN.

Detroit—F. J. SCHWANKOVSKY.  
 Saginaw—GEO. W. EMENDORFER.  
 JAMES V. CALAHAN, 217 Genessee st.  
 TIERNEY BROS., 217 Genessee st.

### MISSOURI.

Kansas City—THE WITTMANN CO.

### NEBRASKA.

Lincoln—THE WITTMANN CO.  
 Omaha—THE WITTMANN CO.

### NEW HAMPSHIRE.

Hillsboro Bridge—E. M. BARNES.  
 Manchester—A. E. DUMAS  
 Nashua—F. A. McMASTER & CO.

### NEW JERSEY.

Atlantic City—SAM'L D. WOLF, 32-34 Arkansas ave.  
 Bayonne—I. WIGDOR, 450 Avenue D.  
 Jersey City—W. L. HOFFMAN, 151 Montgomery st.  
 Newark—R. L. CORWIN; also New York City.  
 Passaic—I. HURWITZ.  
 Paterson—CHAS. H. KELLY, 25 N. Main street.

Plainfield—S. W. FRUCHT, or R. FRUCHT; also  
 New York City.

ELSTON M. LEONARD.

West Hoboken—EMIL HOLLANDER, or THE WEST  
 HOBOKEN BICYCLE & PHONO-  
 GRAPH CO., 619 Spring street.

### NEW YORK.

Albany—G. LINDE, 353 S. Pearl street.  
 Bedford Park—GEO. H. TYRRELL.  
 Hobart—F. H. MARSHALL.  
 New York City—A. T. ARMSTRONG, or AMERI-  
 CAN PHONOGRAPH CO., 106  
 Wall street.  
 BERN BEARWALD, 373 W. 111th st.  
 BRONX PHONOGRAPH CO. or  
 DAVID SWITKY, 506 Willis ave.  
 CENTRAL PHONOGRAPH CO.,  
 160 E. 42d street.  
 R. L. CORWIN; also Newark, N. J.  
 EAGLE PHONOGRAPH CO., or C.  
 LOWENTHAL, 83 Nassau street.  
 EMPIRE PHONOGRAPH CO., 2 W.  
 14th street.  
 S. W. FRUCHT, or R. FRUCHT, 7  
 Barclay street, or 68 Cortlandt  
 street; also Plainfield, N. J.  
 O. HACKER, 2 Murray street.  
 HAWTHORNE & SHEBLE, 297  
 Broadway; also Philadelphia, Pa.  
 HOLOBER BROS., 350, 421 and 491  
 West st.  
 N. HORN, 148 E. 58th street.  
 W. L. ISAACS, 114 Fulton street.  
 S. LEMBURG & CO., 194 Broadway.  
 J. McELLYNNE, 202 Broadway.  
 RICHMOND PEASE, 44 W. 132d st.  
 F. M. PRESCOTT, 44 Broad st.  
 WINTHROP CYCLE CO., 2212 Sev-  
 enth avenue.

Rome—CHARLES TUTTLE.

Saratoga—W. J. TOTTEN.

Saratoga Springs—MARVIN A. COTE.

Syracuse—SPALDING & CO.

### OHIO.

Cincinnati—J. L. ANDEM.

Coshocton—BURNS & GOSSER.

Springfield—D. & M. VANDERPOOL.

Uhrichsville—F. A. MAZURIE.

### PENNSYLVANIA.

Philadelphia—A. R. CASSIDY, 2783 Emerald street.  
 HAWTHORNE & SHEBLE, 604 Chest-  
 nut street, or Oxford and Mascher  
 streets; also New York City.  
 A. KROUSE, 832 Arch street.  
 PENN NOVELTY CO., 15 South 9th st.

Phoenixville—KEINARD BROS.

Pittsburg—A. LIPPARD, 615 Wylie ave.

### RHODE ISLAND.

Providence—F. P. MOORE.

### WISCONSIN.

Milwaukee—J. C. BLATZEK.

Jobbers and Dealers are asked to co-operate with us, FOR OUR MUTUAL GOOD, by being careful that they do not supply any of the above named firms with our apparatus, either at addresses given or any other address.

## JOBBERERS OF EDISON PHONOGRAPHS AND RECORDS.

## ALABAMA.

**Birmingham**—The Ray Co., 207 Second avenue.  
The Talking Machine Co.  
**Mobile**—W. H. Reynolds, 167 Dauphin street.

## CALIFORNIA.

**San Francisco**—Peter Bacigalupi, 786-788 Mission street.

## COLORADO.

**Denver**—Denver Dry Goods Co., 619 16th street.

## CONNECTICUT.

**Middletown**—Caulkins & Post Co., 406-408 Main street.  
**Hartford**—Harry Jackson, 300 Asylum street.  
**New Haven**—Pardee-Ellenberger Co., 155 Orange st.

## DISTRICT OF COLUMBIA.

**Washington**—E. F. Droop & Sons Co., 925 Pennsylvania avenue, N. W.  
S. Kann, Sons & Co., 8th and Pennsylvania avenues.

## GEORGIA.

**Atlanta**—\*Atlanta Phonograph Co., 49 Peachtree St.

## ILLINOIS.

**Chicago**—James I. Lyons, 73 Fifth avenue.  
Siegel-Cooper Co., State and Congress sts.  
Talking Machine Co., 107 Madison street.  
The Vim Co., 68 E. Lake street.  
Montgomery Ward & Co., 111 Michigan ave.  
Rudolph Wurlitzer Co., 302 Wabash ave.  
**Peoria**—Peoria Phonograph Co., 222 Bridge street.

## INDIANA.

**Indianapolis**—Craig-Jay Co., 234 Massachusetts ave.  
Kipp Bros. Co., 37 S. Meridian street.  
A. B. Wahl Co., 119 S. Illinois street.  
**Lafayette**—A. B. Wahl Co., 304 Main street.

## IOWA.

**Des Moines**—Hopkins Bros. Co., 620 Locust street.  
The Vim Co., 704 West Walnut street.  
**Fort Dodge**—Early Music House, 822 Central ave.

## KENTUCKY.

**Louisville**—The Ray Co., 640 Fourth street.

## LOUISIANA.

**New Orleans**—William Bailey, 600 Frenchman street.  
National Automatic Fire Alarm Co.,  
614 Gravier street.  
The Ray Co., 111 Camp street.

## MAINE.

**Bangor**—S. L. Crosby Co., 186 Exchange street.  
**Portland**—W. H. Ross & Son, 207 Commercial street.

## MASSACHUSETTS.

**Boston**—Boston Cycle & Sundry Co., 48 Hanover street.  
Eastern Talking Mach. Co., 177 Tremont st.  
Iver Johnson Sptg. Goods Co., 163 Washington street.  
Read & Read, 558 Washington street.  
**Fitchburg**—Iver Johnson Sptg. Goods Co., 247 Main st.  
**Lowell**—Thomas Wardell, 111 Central street.  
**Worcester**—Iver Johnson Sptg. Goods Co., 304 Main st.

## MICHIGAN.

**Detroit**—American Phono. Co., 106 Woodward ave.  
Grinnell Bros. 219 Woodward ave.  
The Ray Co., 252 Woodward avenue.  
**Saginaw**—Morley Bros.

## MINNESOTA.

**Minneapolis**—Thomas C. Hough, 714 Hennepin ave.  
**St. Paul**—W. J. Dyer & Bro., 21-23 West 5th street.  
Minnesota Phonograph Co., 37 E. 7th street.  
Thomas C. Hough, 392 Wabasha street.

## MISSOURI.

**Kansas City**—J. W. Jenkins' Sons Music Co., 1013-1015 Walnut street.  
The Ray Co., 1021 Grand avenue.  
**St. Louis**—Conroy Co., 1115 Olive street.  
O. K. Houck Piano Co., 1118 Olive street.  
The Ray Co., 923 Olive street.

## NEBRASKA.

**Lincoln**—H. E. Sidles Cycle Co., 1317 O street.  
**Omaha**—H. E. Fredrickson, 1502-1510 Capitol avenue.  
Nebraska Cycle Co., 15th and Harney streets.

## NEW JERSEY.

**Hoboken**—Eclipse Phono. Co., 205 Washington st.  
**Newark**—A. O. Petit, New and Halsey streets.  
**Paterson**—James K. O'Dea, 117 Ellison street.  
**Trenton**—Stoll Blank Book and Stationery Co., 30 E. State street.

## NEW YORK.

**Albany**—\*Finch & Hahn, 92 State street.  
**Brooklyn**—Chapman & Co., Fulton and Duffield streets  
A. D. Matthews' Sons, 394 Fulton street.  
Price Phonograph Co., 1258 Broadway.  
**Buffalo**—P. A. Powers, 643 Main street.  
**Elmira**—Elmira Arms Co., 117 Main street.  
**Gloversville**—American Phono. Co., 99 W. Fulton st.  
**Kingston**—Forsyth & Davis, 307 Wall street.  
**New York City**—Bettini Phono. Co., 80 Chambero street.  
Blackman Talking Machine Co., 19 Beekman street.  
J. F. Blackman & Son, 2654 3d avenue.  
I. Davega, Jr., 802 Third avenue.  
S. B. Davega, 32 E. 14th street.  
Douglas Phono. Co., 89 Chambers st.  
H. S. Gordon, 139 Fifth avenue.  
Harry Jackson, 219 Bowery.  
Jacot Music Box Co., 39 Union Square.  
Victor H. Rapke, 1661 Second avenue.  
Siegel-Cooper Co.  
John Wanamaker.  
**Poughkeepsie**—Price Phonograph Co., 203 Main st.  
**Rochester**—A. J. Deninger, 347 North street.  
Mackie Piano, O. & M. Co., 100 State street.  
Giles B. Miller, 63 State street.  
Talking Machine Co., 29 Clinton avenue, S.  
**Schenectady**—Jay A. Rickard & Co., 253 State street.  
\*Finch & Hahn, 456 State street.  
**Syracuse**—W. D. Andrews, 216 E. Railroad street.  
**Troy**—James Lucey, 359-361 Fulton street.  
\*Finch & Hahn, 7 Third street.  
**Utica**—Clark-Horrocks Co., 54 Genesee street.  
Arthur F. Ferriss, 89 Washington street.  
William Harrison, 41 Columbia street.  
Utica Cycle Co., 31 Columbia street.

## OHIO.

**Canton**—Klein & Heffelman Co., 216 N. Market street.  
**Cincinnati**—Ilsen & Co., 25 W. 6th street.  
The Ray Co., 143 West 5th street.  
A. B. Wahl Co., 805 Vine street.  
Rudolph Wurlitzer Co., 10-12 W. 4th st.  
**Cleveland**—W. J. Roberts, Jr., Erie and Huron streets.  
**Columbus**—Perry B. Whitsit Co., 213 S. High street.  
**Dayton**—Niehaus & Dohse, 35 E. 5th street.  
**East Liverpool**—Smith & Phillips Music Co.  
**Newark**—\*Hoover-Ball Co., Inc.  
**Toledo**—Hayes Music Co., 608 Cherry street.

## PENNSYLVANIA.

**Allegheny**—Henry Braun, 500 Federal street.  
**Allentown**—G. C. Aschbach, 539 Hamilton street.  
**Easton**—William Werner, 401 Northampton street.  
**Philadelphia**—C. J. Heppe & Son, 1117 Chestnut street.  
Lit Bros., Market and 8th streets.  
Penn Phonograph Co., 19 S. 9th street.  
John Wanamaker.  
Wells Phonograph Co., 41 N. 9th street.  
Western Electric Co., 931-933 Market st.  
H. A. Weymann & Son, 923 Market st.  
**Harrisburg**—S. K. Hamburger, 12-14 N. Market sq.  
**Pittsburg**—Theo. F. Bentel Co., Inc., 433 Wood street.  
Kaufmann Bros., Fifth avenue.  
H. Kleber & Bro., 221 Fifth avenue.  
C. C. Mellor Co., 319 Fifth avenue.  
Pittsburg Phono. Co., 937 Liberty avenue.  
**Reading**—Reading Phonograph Co., 809 Penn street.  
**Scranton**—Ackerman & Co., Coal Exchange Building.  
Technical Supply Co.

## RHODE ISLAND.

**Pawtucket**—\*Pawtucket Furniture Co., 39 N. Main St.  
**Providence**—J. M. Dean Co., 785-795 Westminster street.  
J. A. Foster Co., Weybosset st.  
Household Furniture Co.  
J. Samuels & Bro., 154 Weybossett street.  
A. T. Scattergood & Co., 106 N. Main st.

## TENNESSEE.

**Knoxville**—Knoxville Typewriter and Phonograph Exchange, 311 Clinch street.  
**Memphis**—O. K. Houck Piano Co., 359 Main street.  
The Ray Co., Lyceum Building.  
**Nashville**—Nashville Talking Mach. Co., 510 Church st  
The Ray Co., 13-15 The Arcade.

## TEXAS.

**Dallas**—C. B. Harris, Agt., 347 Main street.  
**Houston**—H. M. Holleman Co., 612 Fannin street.

## VIRGINIA.

**Richmond**—The Ray Co., 729 E. Main street.

## WISCONSIN.

**Milwaukee**—McGreal Bros., 173 3d street.

## CANADA.

**Toronto**—R. S. Williams & Sons Co., Limited,  
143 Yonge street.

\*Added since January 1, 1905.





**The Edison Trade** are the only merchants allowed to sell I. C. S. Language Outfits. Send \$2.00 for Agent's Sample Outfit and instructions for representing "Double Service," including sample moulded records in French, German, Spanish, and English. *Write today!* Address:

LANGUAGE DEPARTMENT

**INTERNATIONAL CORRESPONDENCE SCHOOLS  
SCRANTON, PA.**

For Foreign Sales, address: Foreign Dept., National Phonograph Co., 83 Chambers St., New York City.