

LINK HOUSE PUBLICATION

August 1987

US \$4.00 £1.50

STUDIO SOUND

AND BROADCAST ENGINEERING

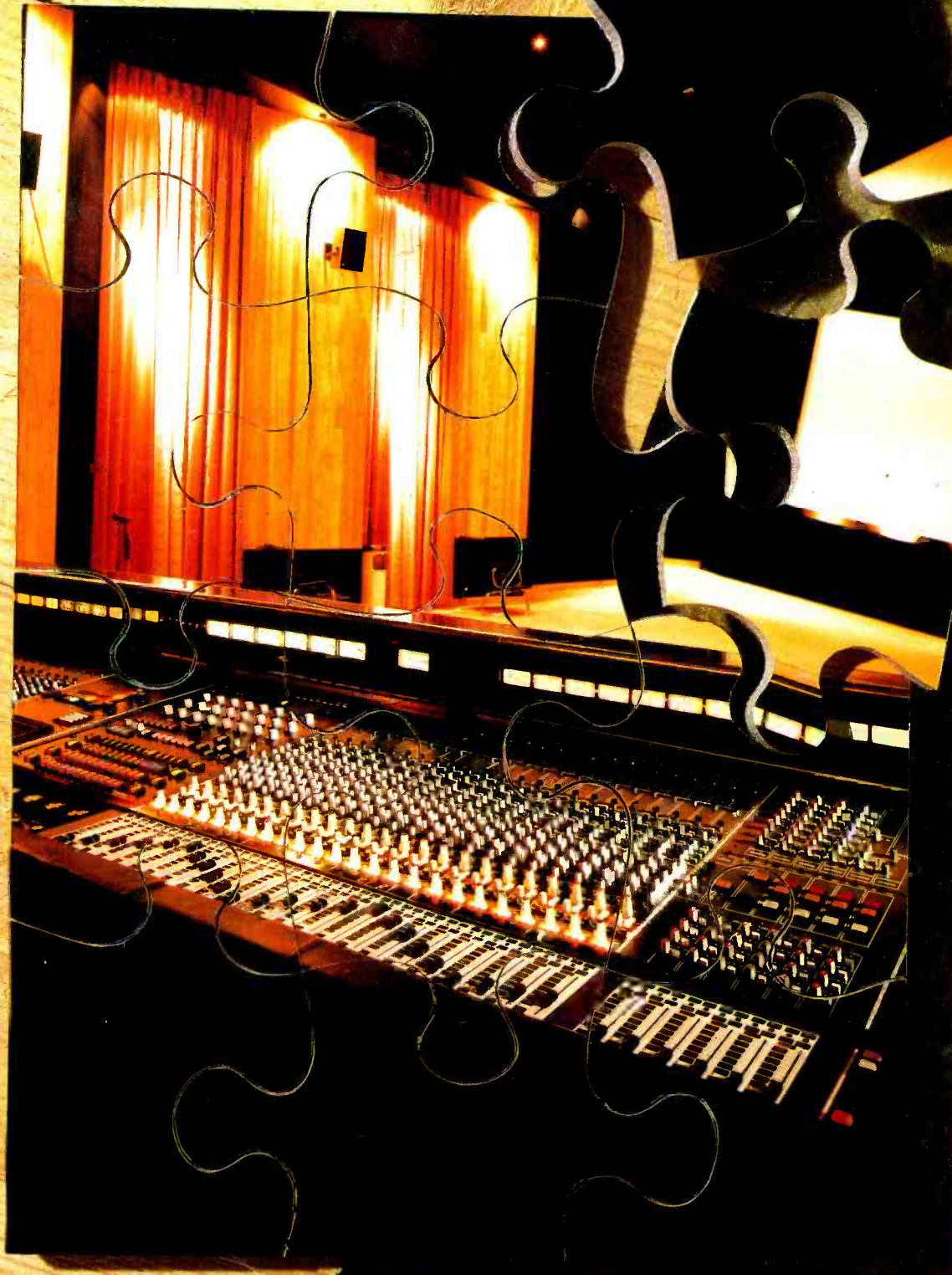

STUDIO DESIGN

This is the mixing console that will cause a revolution in 24 track studios.

The world's first Dual Mode mixing console.

With the advanced features and performance of a desk you'd expect to cost a great deal more than it actually does, it's a remarkable achievement. Take Dual Mode.

When you record with the TS12, its in-line monitoring means you create a control room mix on the main faders.

In mixdown this becomes the basis for your master mix. Saving time and helping you keep a train of thought as to how the final mix will sound.

Unlike other in-line desks, though, the TS12 also allows true stereo subgrouping on long-throw group faders.

In this mode the routing matrix offers either six stereo groups or four extra auxiliary sends – totalling ten sends – plus four stereo groups.

No other console in the world provides such versatility.

The TS12 is an open-ended investment, with optional disc-based SMPTE automation for faders, mutes, EQ in/out and auxiliary on/off. Again, at the price it's unique.

And fittingly, audio performance is superb.

Recent Soundcraft advances in summing amp technology, and in grounding and decoupling systems, make the TS12 one of the cleanest and quietest consoles ever.

The mic amplifiers, a critical factor in console quality, create less than 0.01% distortion at 10kHz at 70dB of gain (Easily exceeding 16-bit digital specifications)

Standard features are impressive, to say the least. Six auxiliary sends, seven stereo line inputs or effects returns, a 'musician friendly' headphone mix, an extensive 19" metal frame patchbay – and the option to create a massive total of 102 inputs.

Quite a line-up.

Attention to detail is equally stringent with modular PCBs, no dual concentrics and a clear, logical layout that belies the sophistication inside.

But the most remarkable feature of the new TS12 is without doubt the price.

We suggest you call us today to find out just how remarkable.

ALL THE FEATURES YOU'D EXPECT IN A £30,000 CONSOLE, EXCEPT ONE. THE PRICE.



STUDIO SOUND

AND BROADCAST ENGINEERING

CONTENTS

- 5** **Editorial:** Keith Spencer-Allen reviews trends in studio design
- 10** **General news:** Windmill Munro Design... Bandive sale complete... Carlton acquires Simmons... Forthcoming events... In brief... People... Change of address... Agencies... Stolen equipment... Record bids... Literature received... Contracts
- 16** **Product news:** Crest Audio 8001 amplifier... Kahler Human Clock... Applied Creative Technology DB8 DI box... Atlas microphone stand... BGW model GTA amplifier... API 3124/3124m mic preamp/mixer... Trident series 80 update... Otaritech TC-50 timecode/FM processor... Sony K-1149 delay board... In brief
- 24** **Sam Toyoshima:** Keith Spencer-Allen talks to one of Japan's top studio designers, while Carl Snape visits the Toyoshima-designed Sound Valley studio in Tokyo
- 32** **Helmuth Kolbe:** Acoustician Helmuth Kolbe is featured here in a discussion with Terry Nelson, along with two Swiss studios, Ebony and Studio 60, that have taken advantage of Kolbe's expertise
- 44** **Rhett Davies:** Producer Davies talks to Ralph Denyer about life with Roxy Music, Eno and Fripp
- 52** **Smokehouse—an in-house approach:** Jim Betteridge discovers from Jeff Ward that hard work and sound marketing are still the keys to making a success out of a newly formed studio
- 58** **Designing a practical monitor:** Sean Davis gives some inside information on his monitor design principles
- 62** **Business:** Barry Fox writes on a 'one-copy' copycode and Dolby v Thomas Dolby settlement, and reviews some light reading
- 64** **Perspective:** US correspondent Martin Polon reviews the first half of 1987
- 70** **Master Rock:** Janet Angus visits a London studio built in an old cinema

Sound Valley (see page 28)

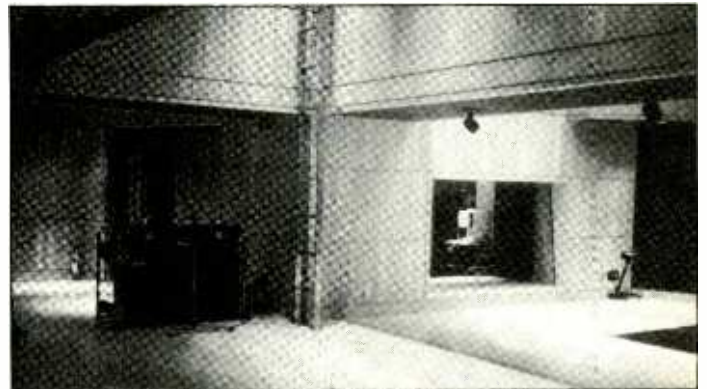

Ebony (see page 34)

Studio 60 (see page 34)



THE ADVANTAGES OF A STUDIO CONDENSER WITHOUT A SOUND OF ITS OWN



For all of its virtues, the typical studio condenser imparts a definite character to any recording. These impositions are often considered inevitable technical imperfections: accepted, ignored or tolerated by audio engineers.

Characteristic anomalies of condenser performance such as exaggerated high end response or distortion have even been rationalized as compensation for the high frequency losses inherent in typical analog formats. Nowadays, however, they are increasingly viewed as unnecessary intrusions in critical analog and digital recording situations.

A Condenser For The Digital Era: The Difference is Nothing. The increased dynamic range of digital recording is perfectly complemented by the self-effacing nature of the MC 740. The microphone is virtually inaudible. No coloration, no self-noise — no sonic footprint, not even a fingerprint. All

five of its pickup patterns are equally uniform, identically transparent. We feel your prior experience with large diaphragm condensers will confirm this as a unique achievement.

An Atypical Approach To Condenser Sound. Beyer has never relied on conventional technical solutions. A manifestation of this kind of thinking, the MC 740 eliminates the icy, stride at quality typical of most condensers to reproduce voices and instruments with warmth and intimacy. It's no coincidence that these are characteristics often ascribed to our ribbon microphones.

The MC 740's freedom from exaggerated sibilance or graininess and its greatly reduced distortion are immediately apparent to critical listeners. European and American engineers have already commented on the startling accuracy of the 740, and the way it reveals the subtle differences between instru-

ments and ambient environments.

Accuracy And Versatility Without Compromise. Uniform (<2 dB: from actual machine specs, not just published specs) frequency response curves for all five polar patterns may seem a remarkable breakthrough. To Beyer, this is simply a design criterion for the microphone. Similarly, there is no contradiction in the fact that the 740 is exceptionally sensitive, yet also withstands extreme SPLs (up to 144 dB with the 10 dB attenuator in circuit).

Hear What You Could Be Missing. The MC 740's unconventional design offers a clear alternative. The best way to evaluate the difference the MC 740 can make is to work with it in your studio. To arrange a hands-on audition of this remarkable new audio instrument, contact your Beyer dealer or write to us: Beyer Dynamic (GB) Ltd., Unit 14, Cliffe Industrial Estate, Lewes, East Sussex BN8 6JL.

ACCURACY IN AUDIO

Canada: ELNOVA 4190 rue Sere, St. Laurent, Quebec H4T 1A6
Tel: (514) 3 41 69 33 Telex: 5824086

USA: beyerdynamic U.S., 5-05 Burns Avenue
Hicksville, NY 11801 Tel: (516) 935-8000

Great Britain: beyerdynamic Ltd., Unit 14, Cliffe Industrial Estate
Lewes, Sussex BN8 6JL Tel: 0273-479411

Germany: Eugen Beyer Elektrotechnische Fabrik GmbH & Co., Theresienstrasse 8,
Postfach 13 20, D-7100 Heilbronn Tel: (07131) 617-0 Telex: 728771

beyerdynamic))))

STUDIO SOUND

AND BROADCAST ENGINEERING

August 1987
Volume 29 Number 8
ISSN 0144-5944

EDITORIAL

Editor: Keith Spencer-Allen
Deputy Editor: Carl Anthony Snape
Staff Writer: Jonathan Kaye
Production Editor: Ann Horan
Production Assistant: Carrie Love
US Commentator: Martin Polon
Secretary: Cecilia Farrelly

ADVERTISEMENTS

Sales Manager: Mark Walsh
Display Sales: Andrew Knox
Production Manager: Jacky Pearce

Japan and Far East Agent: Media Sales
Japan Inc, Tamuracho Bldg 3 3 14,
Shimbashi Minato-Ku, Tokyo, Japan
USA Agent: Joe Statuto, Rt 1, Box 40A,
Montague, TX 76251, USA. Tel: (817)
894-6923

Commercial Manager: Phil Guy
Director: Douglas G Shuard

CIRCULATION

Circulation Manager: Sally White

Editorial and advertising offices: Link House,
Dingwall Avenue, Croydon CR9 2TA, UK
Tel: 01-686 2599
International tel: +44 1 686 2599
Telex: 947709
E-mail: 78:DGS1071
IMC: STUDIOSOUND-UK/US
Fax: 01-760 0973

CIRCULATION ENQUIRIES

Controlled circulation: Controlled Circulation
Dept, Studio Sound, Link House Magazines Ltd,
Central House, 27 Park Street, Croydon CRO
1YD, UK

Paid subscriptions: Subscription Dept, Studio
Sound, Link House Magazines Ltd, 120-126
Lavender Avenue, Mitcham, Surrey CR4 3HP,
UK

2nd class postage paid New York, NY: Postmaster
please send address corrections to Studio Sound
c/o Expeditors of the Printed Word Ltd, 515
Madison Avenue, New York, NY 10022, USA

© Link House Publications plc 1987 all rights
reserved
Printed in England

 A LINK HOUSE
PUBLICATION

Studio Sound and Broadcast Engineering
incorporates Sound International and Beat
Instrumental

Studio Sound is published on the second Friday
of the month preceding the cover date. The
magazine is available on a rigidly controlled
requested basis, only to qualified personnel (see
back page for terms)

Annual subscriptions are available for non-
qualifying personnel or where more than two
copies are required in a studio or small
organisation as follows:

UK £18.00
Overseas surface mail £24.50
Overseas airmail £46.50

 MEMBER OF THE AUDIT
BUREAU OF CIRCULATIONS

Total average net circulation of 14,686 per issue
during 1986. UK: 6,094. Overseas: 8,592
(ABC audited)

EDITORIAL

This month we focus on studio design. A couple of years ago we were experiencing some major new innovations in design approach. Syn-Aud-Con's *LEDE* concept was controversial although the first certified rooms were proving popular with those who were prepared to live with any limitations that the early designs had. We saw the appearance of spin-off technology from Manfred Schroeder's work that was realised through companies like RPG Designs with their diffusors and more recently their Abfusors. We have seen the approach taken by Tom Hidley in recent designs where the monitor wall contains a mountain of concrete to increase rigidity. There has been a move towards acoustic control techniques that try to avoid the use of large trapping areas: ASC's absorbing tubes; the membrane absorbers of Sam Toyoshima and the use of resonators by other designers. We have seen designers borrowing from methods that were not allied to their own specific line of design and there has generally been a mellowing of the lines between design philosophies.

This issue sees the start of a short series of articles on studio designers. It is intended to look at some who may not have had a great deal of coverage so far and take a fairly in-depth look at their ideas. We kick off this month with Sam Toyoshima of the JVC Acoustic Design Center who has been quietly making a name in the UK and more naturally in the Far East.

There is a tendency to think that all the interesting new facilities are being built in the main recording locations of the world: London, New York and Los Angeles. Over the next few months we hope to prove that this is not the case at all. I recently had the chance to visit Nashville and in this relatively small city of just over ¼ million people there are facilities within a few blocks of each other that are as adventurous as you will find in any of the major centres. As examples Masterfonics has a magnificently large mix room designed by Tom Hidley—his first completed operational 20 Hz room together with a pair of identical mastering rooms built to a similar standard. Soundstage a few doors along the street has two rooms, the largest of which is also a Hidley design but without a wall between the control room and the studio area. The monitors are mounted on hydraulic stands in front of the console but the rest of the area is completely open—and apparently it works. Their other room is a slightly more conventional design by Russ Berger based on *LEDE* principles but with many clever ideas, particularly in the layout of the musicians' area, approach hall and the machine room to fit a lot into a comparatively small area.

Still in Nashville, two blocks up Music Row, there is the Welk building with Welk's own Champagne studio that was originally designed for in-house work but is attracting some enthusiastic response from external clients. This is due to its Bob Todrank *LEDE*-type/soft dome monitoring design that gives a very accurate and impressive monitoring environment. In the same building is Norbert Putnam's Digital Recorders which takes a quite different approach using a prefabricated glass panel construction that creates a hemispherical gold fish bowl control room that allows close contact with musicians and vice-versa.

The Toyoshima article will show the kind of studios being built in Tokyo and other Far Eastern cities. Subsequent articles will also often feature 'out of the way' facilities that have adopted an interesting approach. Any insular feelings about the continued unchallenged strength of the established recording centres is rather misplaced and constancy will undoubtedly have to be earned rather than being a right.

Equally on the cosmetic side there have been some very interesting developments that I would like to see continue. We are also beginning to see some facilities that may have taken the design cosmetics rather over the top and frightened clients away rather than attracting them but everyone has their own taste.

It is encouraging, however, to see that even the more limited budget facilities are beginning to take care with their appearance. Indeed, it may be the more established facilities that will have to consider their appearance rather more strongly. Recently I have been in some studio areas that still sport the purple, orange and green painter panels that wowed us in the '60s and have remained that way since. Even if money is tight may I suggest a short trip to Woolworth's for a couple of tins of white gloss?

Finally on a completely different topic I would like to say goodbye to my deputy editor Carl Snape. Carl has been a very valuable member of the editorial team for the last two and a half years and has contributed much to the department of the magazine. His abilities are not lost totally to us as he has become editor of our sister publication *One to One* aimed at professionals in mastering, pressing and duplicating. We wish him good luck. □

Keith Spencer-Allen

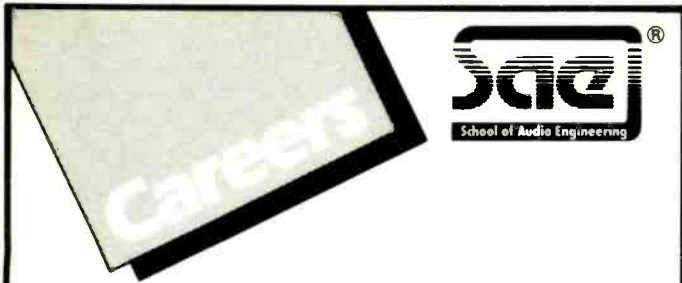

SOUND ENGINEER COURSE

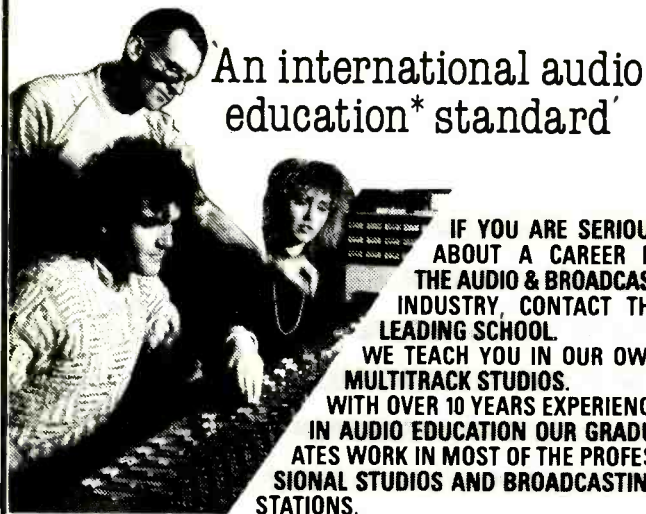

An international audio education* standard

IF YOU ARE SERIOUS ABOUT A CAREER IN THE AUDIO & BROADCAST INDUSTRY, CONTACT THE LEADING SCHOOL. WE TEACH YOU IN OUR OWN MULTITRACK STUDIOS. WITH OVER 10 YEARS EXPERIENCE IN AUDIO EDUCATION OUR GRADUATES WORK IN MOST OF THE PROFESSIONAL STUDIOS AND BROADCASTING STATIONS.

- ★ 14 SCHOOLS ★ SINCE 1976 ★ JOB PLACEMENT ★ 1 YEAR
- ★ OUR OWN STUDIOS ★ OVERSEAS STUDY POSSIBILITIES
- ★ GOV. LICENSED COURSE ★ RECOGNIZED DIPLOMA ★



LONDONSt. Marks Building Chillingworth Road (off Holloway Road) London N7 8QJ. Tel 01-609 2653

MUNICHWeissenburger Str. 19 RGB 8000 Munich 80 West Germany. Tel 089/48 71 45

FRANKFURT ..Tanusstr. 44 RGB 6000 Frankfurt/Main 1 West Germany. Tel 069/23 61 79

VIENNAMayerhofgasse 6 A-1040 Wien. Tel 222-652 718 Austria

AUSTRALIA...Head Office: Sydney 6997931

SAE LONDON - MANCHESTER - MUNICH - VIENNA - FRANKFURT

SONEX CONTROLS SOUND.

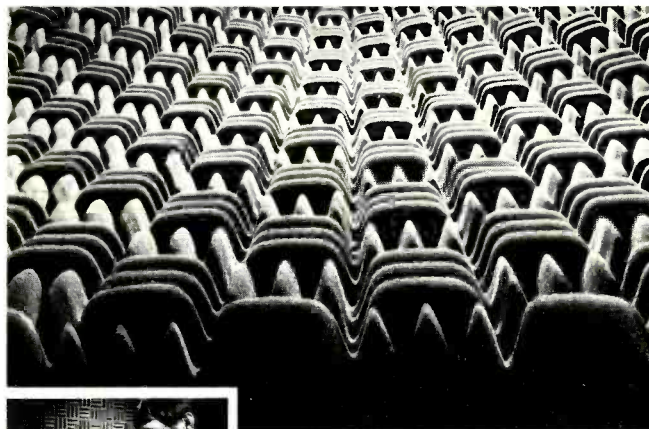

With its patented anechoic foam wedge, SONEX absorbs and diffuses unwanted sound in your studio. And it can effectively replace traditional acoustic materials at a fraction of the cost. SONEX blends with almost any pro audio decor and looks clean, sharp, professional. Check into this attractive alternative for sound control. Call or write us for all the facts and prices.

SONEX is manufactured by Illbruck and distributed exclusively to the pro sound industry by Alpha Audio.

Alpha Audio

2049 West Broad Street
Richmond, Virginia 23220 USA (804) 358-3852
Telex 469037 (ALPHAUD CI)

Acoustic Products for the Audio Industry

Media Products

Our new range of BPO audio jackfields are of the highest quality and economically priced, from £150.

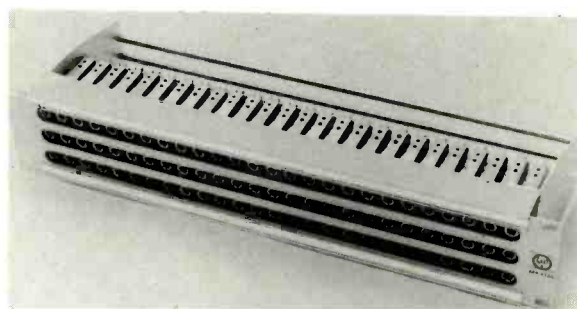

Featuring Mosses & Mitchell 5-point palladium contact gauge B jacks, the jackfield occupies just 2U, of rack space. Standard versions are 2 or 3 row in 20, 24 and 26 ways. Please contact us today for information on our range of audio and video systems equipment.

'It's in the name'

Media Products Limited
Unit 4,
Chiltern Enterprise Centre,
Station Road, Theale,
Reading, Berks., RG7 4AA
United Kingdom.

Phone (0734) 303800
Telex 858893 FLETEL G
Fax (0734) 509262 (G2/3)

**Every Instrument
you've ever dreamed of...**



SEE THEM!...HEAR THEM!...PLAY THEM!
BRITISH MUSIC FAIR
OLYMPIA LONDON

Trade only: 28th, 29th, 30th July
Trade and Public: 31st July, 1st, 2nd August 1987

Organised by Philbeach Events Ltd., Earls Court Exhibition Centre. 01-385 1200 Ext. 359.

www.americanradiohistory.com

CLARITY BEYOND BELIEF

Sennheiser studio microphones have long stood for quality, being widely used by studios throughout the world. With the increase in digital recording the need for a microphone with extremely low inherent noise and capable of accepting high sound pressure levels with low distortion is required. The MKH 40 with its cardioid response has been designed to meet these requirements.



MKH 40 P 48

“ The clarity of this mic is astonishing . . . ”

Simon Croft *Sound, February 1986*



SENNHEISER

Hayden Laboratories Ltd, FREEPOST, Hayden House, Chiltern Hill,
Chalfont St Peter, Bucks SL9 9BS. Tel. (0753) 888447



Sennheiser manufactures an extensive range of audio products. Please tick the appropriate box if you would like information on the following.

Dynamic mics Electret condenser mics Tie clip mics
Studio condenser mics Radio mics Infra-red sound
transmission Headsets Headphones

Please send me further information on the Sennheiser range of Dynamic microphones.

NAME

ADDRESS

.....

.....

NEUTRIK Audio Measuring Systems

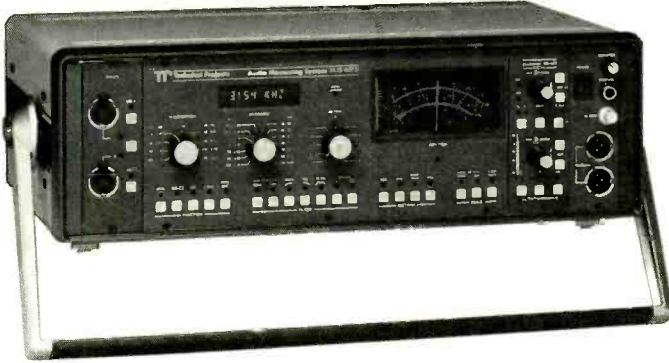

The TP401 is a high performance general purpose test instrument comprising generator (10HZ to 300KHz) and analyser (10HZ to 100 KHz), for measuring noise level, THD, IMD/TIM, W&F, cross talk and frequency.

THD, IMD and W&F are totally automatic, generated by an internal CPU and controllable via an IEEE 488 BUS.

Dimensions:- 47cm (18.5") wide, 14cm (5.5") high and 39cm (12.5") deep including handle.

The Audiograph 3300 is a modular extremely compact measuring system for acoustic and audio applications, which is expandable from a chart recorder to a complete audio test set.

Applications include measurement of all hi-fi and professional audio equipment, level, cross-talk, impedance, frequency response, tape recorders, pick-up cartridge, loudspeakers and room acoustics. Automatic synchronized multiple plots. Wide variety of Modules available.

Frequency range:- 20HZ to 40KHZ \pm 0.5dB.

Dimensions:- Main Frame 3302, Input Module 3312 and Output Module 3322:- 30cm (11.75") wide, 8.5cm (3.33") high and 21.0cm (8.25") deep.

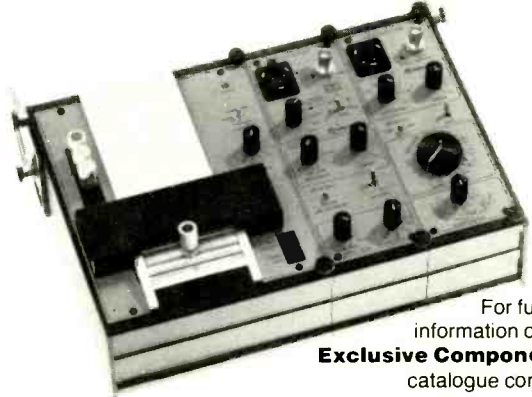

For further information or our Exclusive Components catalogue contact:

Sole Agent U.K.

Eardley Electronics Ltd

Eardley House, 182-184 Campden Hill Road, Kensington, London W8 7AS
Telephone: 01-221 0606/01-727 0711 Telex: 23894 Telefax: 01-727 9556

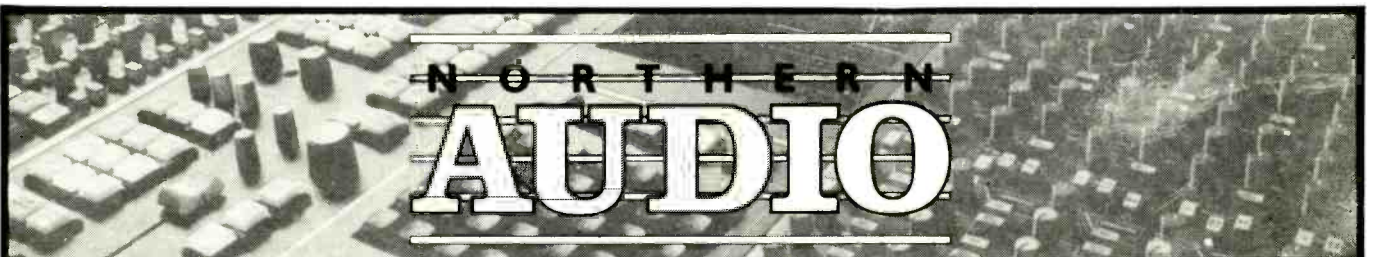

PROFESSIONAL USED STUDIO EQUIPMENT

STOCK LIST AVAILABLE

SECOND HAND CONSOLES

SSL 6000E 6 months old 56 frame, 40 mono fited and 8 stereo inputs, patch bay and producer desk extra centre section light meters and total recall with the latest software available immediately. P.O.A.
SSL 6000e 48 frame with Plasma and Total Recall 32 channel: fited with Adam Smith Synchroniser Master Transport Selector and all interfaces Video switch and distribution. Events controller 26" colour Monitor Stopwatch 12 months old in very good order. Available end of May 87 £125,000.00
SSL 4000e 40 frame with Plasma and Total Recall 32 channels fited with two extra stereo channels. Patchbay on the right and producer desk left side Commissioned July 1984 in good order available July 87 £87,500.00
M.C.I. 556D 56 fited, 1980, lots of updates, very clean console £50,000.00
Amek 2500 40 frame 40 fited with Alison auto 65 k prog. 4 years old in very good condition £31,000.00
Harrison 32/32 56 frame 56 fited with Alison 65k programmer 6 years old in superb condition £34,000.00
M.C.I. 628 with JH50 Auto Light meters 4/5 yrs £25,000.00
Neve 8108 32 frame with 5 yrs from private studio nice condition £37,500.00
M.C.I. 636 Af VU 36 fited full parametric E/Q 9 returns and phase meters JH 50 automation £30,000.00
Neve 8128 48 frame fited 48 with penthouse this console is new and ready to deliver £99,000.00
Amek 2500 console 15/16/8/2 pa console £7,000.00
Amek 2500 40 frame 36 fited Alison Automation 6 years old in very good order available March 87 £28,500.00
M.C.I. 636 36 fited with JH50 auto 5/6 years old £29,500.00
Soundcraft 1600 24/8/16mon patch and stand £4,500.00
Trident T.S.M. 32/24/24 in good condition £20,000.00
Amek Angela 28/24 full patch new fids 4/5 yrs £11,000.00
Harrison 40/32 frame 40 fited with Alison 65k programmer and Alison VCA Fader faders 6 years £27,500.00
Trident 'A' series 28/24 1974c good condition £12,500.00
3M 32/4 track and editor complete dig system £50,000.00

M.C.I. JH 10 4 inch and 1/2 inch master £2,000.00
Studer A80 Mk3 16 Track recorder 100 hours use £11,500.00
Sony 3324 Digital machine (as New) £85,000.00
Studer A80 Compact 24 track remote and Auto £11,500.00
Studer A80 Mk2 24 track 6 years old narrow £14,500.00
Studer B87 in console and penthouse (mic) £2,250.00
Lyrec TSR 24 track spare 16 track headblock Autolocator 11 4,000 hours £11,500.00
Studer A80 1/4" master machines £3,500.00
Ampex ATR 102 master machine with spares (mint) £3,500.00
Ampex 1/4" master machines 2 in stock (each) £4,500.00
Studer A80 Mk2 24 track no auto 7 years old £14,500.00
Studer A800 Mk1 new heads auto and remote £21,000.00
Studer A80 wide body Mk2 24 track auto £15,500.00
Studer A80 narrow body Mk1 auto remote £13,500.00
Studer A810 1/4" in console penthouse 6 months £4,500.00
Ampex ATR 700 1/4" master £2,500.00
Studer B87 1/4" master 4 years old 'nice nic' £2,650.00
Lexicon Prime Time £650.00
Fairlight 11X with midi and S.M.P.T.E. updates in Fairlight cases superb condition £12,000.00
PPG System: 2.3 Wave Version Wavetern "B" 16 bit pages two revision discs All PPG discs Version 3 Aprons £9,995.00
Oran DP 4050 C2 Cassette copy 1 master two slaves 8 times 36 c60 per hour 2 in stock (each) £2,000.00
Oran MTR12 master 1/4 inch, two years old £3,500.00

WE ARE CONSTANTLY ON THE LOOKOUT FOR USED EQUIPMENT. . .

NOTICE

We also act for studios as selling agents, let us handle the hassle of getting rid of unwanted items, it does not matter where you are in the world, why not drop us a line listing your equipment or ring us on the numbers below for the best rates. We assure you of our best attention and service plus the utmost confidentiality at all times.

FOR A COMPLETE STOCK LIST WRITE OR RING TONY BAYLEY ON

061-483 9563/4299

4 CHEVIOT ROAD, HAZEL GROVE, STOCKPORT, CHESHIRE SK7 5BH. TELEX: 666597 NAUDIOG.

In brief

● Mark Five Studios and Sandcastle Recording, both in Greenville, South Carolina, have merged to form Mark Five/Sandcastle. The new owners, Eddie Howard, Rick Sandidge and Chris Cassels are now offering full service audio and video production/duplication facilities with a 24-track room and a 16-track MIDI room.

● Brooke Siren Systems, part of the EdgeTech Group, have recently changed their name to BSS Audio Ltd.

● Otari have announced that due to the agreement reached between themselves and King Instruments, the company will immediately recommence sales of their full line of video and audio tape loading, leadering and tailoring equipment in the US. Additionally, Otari announced the imminent opening of a new Chicago-based regional sales office.

● An honorary CBE has been awarded to Gisela Burg, founder and managing director of Expotus Ltd, for her outstanding contribution to British exports, especially pro-audio equipment. Miss Burg came to London at the age of 20, set up Expotus in 1968, was named Young Exporter of the Year in 1972, and became Business Woman of the Year in 1981. In 1976, Miss Burg became chairman of the Federation of British Audio and in 1979 its vice-president. In the same year she was appointed as a member of the National Economic Council's Consumer Electronic Economic Development Committee.

● Robertson Taylor Insurance Brokers have announced their further expansion with the development of a specialist department for recording studios and hire companies. They've put together a 'package'-style policy offering wide coverage in easy-to-understand terms. Robertson Taylor Insurance Brokers, Millard House, Cutler Street, London E1 7DJ. Tel: 01-283 3951.

● Knurr AG of Munich, manufacturers of 19 in enclosures for electronic equipment, have acquired the Alloy Oak manufacturing facility near Cambridge, who are sheet metal designers and manufacturers of enclosures for the telecomms and electronics industries. It will be renamed Oak Engineering (Cambridge) Ltd, and be a sister company to Daturr Ltd of Camberley, Surrey, another wholly owned subsidiary of Knurr AG. Oak Engineering (Cambridge) Ltd, Denny End Industrial Estates, Waterbeach, Cambridge CB5 9PB, UK. Tel: 0223 862326.

● MRI, the North-West-based radio production facility, are expanding into studio installation. They have

installed several in Europe, and claim to have a working studio for as little as £10,000, and can be on-air for £18,000. Both recording and on-air facilities are catered for.

● The first studio-laboratory in Spain dedicated exclusively to editing, copying and live recording in the digital domain, has been established in Madrid. Prosound SA use all Sony equipment, including the DMR-2000 and 4000, PCM-1630 and the DAE-1100A. Prosound SA, Avda de San Luis, 93 Bajo H, 28033 Madrid, Spain. Tel: 202 72 04.

● Yamaha-Kemble Music (UK) Ltd have launched their European Research and Development Centre in Conduit Street in London, which Yamaha hope will become a meeting point for Europe's top professionals. The centre houses a complete Eastlake-designed 24-track recording studio featuring all Yamaha's up-to-date musical and recording equipment, and some prototypes will be available for early trials and evaluation.

● The Ampex Magnetic Tape Division have launched a multi-million dollar investment programme at its Opelika, Alabama, manufacturing and R&D facility, beginning with the ground-breaking for a new warehouse and distribution centre.

● Soundtracs have expanded their R&D department with the aim of designing and developing up to six new products every 12 months. The new facility includes additional CAD design and plotting stations, ATE stations for evaluating new circuit designs, and a wealth of new computer hardware for developing digital control systems.

Meanwhile, in Surrey, Soundtracs have expanded their Surbiton manufacturing facility to cope with the demand for their recently introduced modules. The new facility will produce the CP6800 series and FM/FMX/FME series of consoles. The expansion also means additional jobs with emphasis on recruiting young people to participate in Soundtracs' training school.

● A new concert production company, Sound+Light Productions, has been formed by John Denby and Jan Goodwin, ex-management team of Entec, the sound and lighting company. Sound+Light Productions, 53 Northfield Road, London W13 9SY, UK. Tel: 01-579 2748.

● Yorkshire and Humberside Independent Radio Ltd have announced the formation of a specialist technical engineering subsidiary, Audionics Ltd. Besides their work with the Yorkshire Radio Network, Audionics expect to expand to design and build equipment for other broadcasting stations. Radio Hallam, PO Box 194, Hartshead, Sheffield S1 1GP, UK. Tel: 0742 766766.

NEWS

Windmill Munro Design

Dublin-based Windmill Lane Group and London-based Munro Associates have announced the recent formation of Windmill Munro Design as a joint venture to offer a complete international design service to video and TV facilities houses. Under the new arrangement, Windmill Munro Design will co-ordinate all the

acoustic/music studio projects of Munro Associates from the company's recently acquired London offices at 26 Soho Square, London W1. The company currently has design work in progress on major projects in UK, US, France, Norway, Eire, Italy and Turkey.

Bandive sale complete

Harman International Industries Inc finalised the acquisition of Bandive Ltd on May 28th, 1987. Bandive's directors Andy Bereza and Ivor Taylor continue their marketing and technical roles, while Andy Szeliga of

Harman UK becomes sales director. The combination of the Harman and Bandive makes it one of the largest and most diverse pro-audio companies in the UK.

Carlton acquires Simmons

UK-based manufacturer of electronic percussion equipment, Simmons Electronics Ltd, have announced its acquisition by Carlton Communications plc. Carlton comprises 23 separate group companies engaged in the operation of TV facilities, video production, manufacture of digital TV equipment,

satellite TV and digital audio. Simmons say they are now able to implement plans for further expansion and diversification of product range. One of the first changes has been the acquisition of the assets of its US distributor Group Centre Inc and the establishment of Simmons Electronics (USA) Inc.

Forthcoming events

September 3rd to 7th SIM-HI-FI-IVES, Milan, Italy.

September 24th 12th Sound Broadcasting Equipment Show, Albany Hotel, Birmingham, UK.

October 14th to 17th Broadcast '87, Frankfurt, West Germany.

October 16th to 19th AES 83rd Convention, New York, USA.

November 23rd to 26th Digital Information Exchange '87, Private Member's Suite, London Zoo, UK.

November 5th to 8th The Institute of Acoustics' Reproduced Sound 3 (in

collaboration with the AES, ACSE, EMAS and APRS), Windermere Hydro Hotel, Windermere, UK.

1988

March 1st to 4th AES 84th Convention, Palais des Congrès, Paris, France.

March 9th to 13th Frankfurt Musik Messe '88, Frankfurt, West Germany.

September 23rd to 27th International Broadcasting Convention '88, Metropole Conference and Exhibition Centre, Brighton, UK.

Pure ingenuity



Much of what we see today was shaped by tools. And by ingenuity. When the two come together, the result is often a universal, all-in-one device. Now Studer presents the multi-purpose tool for audio: powerful, compact, and affordable. Constructed on a rugged die-cast aluminum chassis, this remarkably fast machine features servo controlled spooling motors, a brushless DC capstan motor, a shuttle controller, and one-hand cueing. All tape deck and audio functions are microprocessor controlled, including digitally controlled, phase-compensated audio electronics and audio alignment through D/A converters. Among other features, the A807 provides switchable NAB/CCIR equalization, phantom-powered microphone inputs, monitor speaker, parallel remote control, serial RS232 port, and vari-speed.

Studer A807 – professional ingenuity in the 19" rack format.



STUDER INTERNATIONAL AG

Althardstrasse 10, CH-8105 Regensdorf

Sales Offices:

Australia, North Sydney 4064700. **Austria**, Vienna 4733 09 / 4734 65. **Belgium**, Hasselt (011) 229 664. **Canada**, Toronto (416) 423-2831. **Denmark**, Gentofte 451652340. **Finland**, Helsinki 80/742133. **France**, Paris (1) 45 33 58 58. **Germany**, Löffingen 07654-8030. **Great Britain**, London/Herts. 01-9530091. **Hong Kong** 5-441-310 / 5-412-050. **Italy**, Milano (02) 25390121. **Japan**, Tokyo 03-320-1101. **Netherlands**, Gennep 08851-96300. **Norway**, Oslo (02) 356110. **Singapore** 2507222/3. **Spain**, Madrid 2317840. **Sweden**, Solna 08/7340750. **USA**, Nashville (615) 254-5651. **Worldwide**: Studer International AG, Regensdorf, Switzerland, +41 840 2960. a

NEWS

People

- At Syco, Mike Kelly will relinquish his co-directorship to concentrate more on Cristofori's role as pianoforte distribution outlet, while continuing his involvement with Syco's marketing.
- Soundtracs have announced the appointment of John Carroll as sales and marketing director.
- Wulf Gray has taken up the position of chairman of Amber Technology who have moved to new headquarters in Frenchs Forest, Sydney, Australia (see 'Change of address').
- Neotek have announced two new executive staff members. Susan Gosstrom has been appointed sales manager, while David Ruttenberg has been named director of

marketing.

- Mike Paige has joined Syco as director of technical services. He will have responsibility for service, installation and custom engineering and will head up a team of five in-house engineers and other sub-contractors.
- Kazunori Kurata has been named president of Sony Professional Products Company (SPPC), New Jersey, USA, where he will be responsible for the manufacturing and engineering operations.
- Martin Sweeting, formerly a full-time keyboard player, and vocalist, has joined Toa's Pro-Sound division as part of their sales team. He is responsible for the company's retail dealer network in the North of England and Scotland.

Change of address

- Amber Technology (formerly the audio division of Rank Electronics Pty Ltd) have moved to new national headquarters at: Unit 6, Forestview Park Estate, Frenchs Forest, NSW 2086, Australia. Tel: (02) 975 1211.
- Rainhill Tape Specialists from Merseyside have moved house. The new address is: Music House, 369 Warrington Road, Rainhill, Prescott, Merseyside L35 8AD, UK. Tel: 051 430 9001.
- Agfa-Gevaert officially opened their new US corporate headquarters building on May 6th, a 9-storey, 137,000 ft² facility in Ridgefield Park, New Jersey, just a stone's throw from their original

headquarters whose 225,000 ft² will now serve as the company's distribution centre and equipment service department. Agfa-Gevaert Inc, 100 Challenger Road, Ridgefield Park, New Jersey, USA.

- As of May 5th, Martin Levan Sound Design Ltd's new address is: 70A Berwick Street, London W1V 3PE, UK. Tel: 01-437 9187.
- Crest Audio have established a new European headquarters in Britain, whose general manager will be ex-founder of Rauch Precision, Jerry Mead. Crest Audio (UK) Ltd, PO Box 36, Royston, Herts SG8 7RQ, UK. Tel: 076 382465.

Agencies

- Earley Electronics has recently been appointed UK distributor for three German manufacturers: KACO/BACH GmbH, whose range includes both relay and connector products; Buschel, whose products include LF and RF connectors; and Polytronik, who produce a range of toroidal mains transformers.

- Thandar Electronics Ltd have appointed Cirkit Distribution as UK distributor for their range of electronics test equipment.
- Martin Sound & Light Ltd of London have announced their appointment by Celestion International as distributors of the new SR system.

Stolen equipment

● Spaceward Ltd of Cambridgeshire were robbed on the night of May 24th, 1987. Officer manager Rachel Harvey doubts the equipment will be recovered, and offers words of warning about the professionalism of the break-in.

"The thieves forced their way through the front door and then proceeded to gain entry into the control room, which is protected by a 3 in thick door, with a Chubb lock and metal strips.

"Having done this, they then removed about half our outboard gear and nearly all our microphones; all this is worth approximately £30,000 and we are in no doubt that if they had not been disturbed by an engineer asleep in one of our bedrooms on the premises, they would have cleared us out totally.

"Despite help from the local police force and CID, we don't really think that we'll get the stuff back, however, we think that the rest of the industry should be warned as, judging by the job done, these people know a great deal about studio gear, how to remove it carefully, what's most expensive, etc, and also in case anyone might hear something through the grapevine."

Included in the long list of equipment stolen are:

- * AMS *DMX15-80S* digital delay with keyboard controller (1919)
- * AMS *RMX16* reverb unit (1361)
- * Sony *PCM F1* digital processing unit (650128)
- * Two Neumann *U87s* (40625, 30046), two *KM84s* (26227, 24099), and one *U47* (4339)
- * Two Schoeps *CMC54Us* (mics 9174, 2175; capsules 20062, 27121)
- * Revox *B710* cassette deck (12384)
- * Two Lexicon reverbs
- * Two Eventide *HarmoniZers*, and one flanger
- * Tascam *122* cassette deck
- * Three Beyer dynamic mics
- * Four AKG mics
- * Roland tape echo unit
- * Fender *Stratocaster*.

If anyone does have some information to pass on, the address is: The Old School, Stretham, near Ely, Cambridgeshire CB6 3LD, UK. Tel: 0353 741222.

- On or about June 1st Peter Downey had stolen from his Middlesex studio a Nagra 4S (serial No. 0603998). Any information should be forwarded to 01-568 0037, or DC Brown at Brentford CID on 01-577 1212.

Record bids

Christie's, the London auction house have incorporated a 'fourth-generation' 22-channel voice logging system from Philips that records incoming telephone and auction room bids as well as the auctioneer's voice, providing an accurate record of sales in progress and giving Christie's the ability to resolve any disputes of bids quickly and efficiently. The £24.75 million paid for Van Gogh's *Sunflowers* was one of the first bids logged on the system.

The electronics in the system are duplicated, each tape on the dual

deck runs for 24 hours, and recording is automatically switched to the second deck at the end of the tape, and if the tape breaks. A microprocessor-controlled timecode generator registers the time on the tape at every second, and it's programmed to run to the year 3000. Key protection of the essential recorder functions is provided, preventing any unauthorised access, and Philips claim that tampering with the operation of the system is impossible.

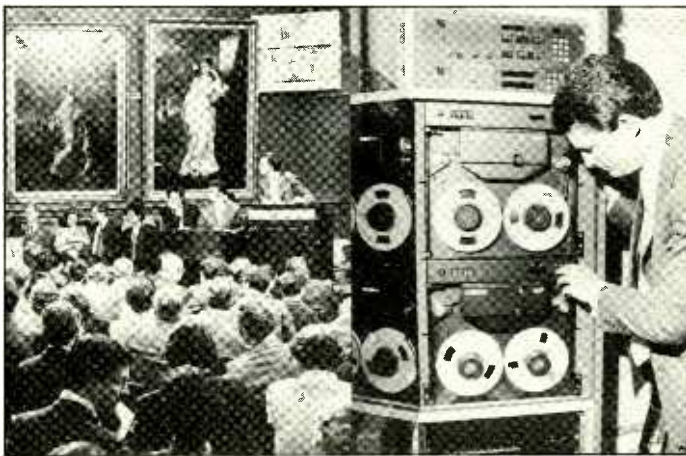

The Boss™ Display

How To Keep An Eye On The Boss.™

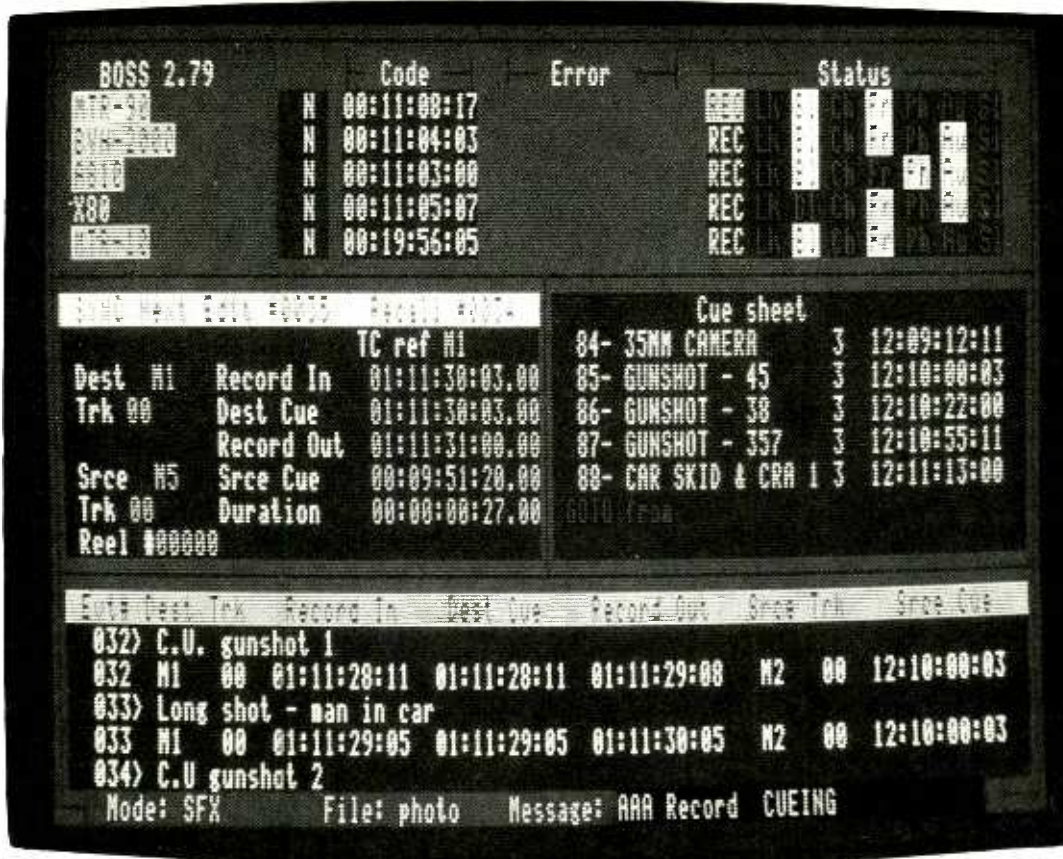

What shows on The Boss screen really says it all. You get to see exactly what you've done, what you're doing, and what you will do. In color. So, instead of one step and only one step at a time, you can create limitlessly in any direction.

The Boss screen is divided into several lists which describe your equipment, your editing script, even your recording media. As Boss operations change, one list will be highlighted to help you focus on what you're doing. But like a good map, The Boss keeps everything right in front of you.

At the top left of the screen you will see descriptions of your studio gear—every machine The Boss controls. Next to that is the time code and status information from each device.

The lower portion of the screen contains the active work area and various lists. Information from the active work area is accumulated in the audio decision list below. A "library" list displays a catalog of your tape library.

The Boss display was designed by audio engineers for audio engineers. Each area of the screen adds to your awareness of the editing

process, so you can see new opportunities for creativity and make the most of them.

The Boss. It'll change the way you look at editing.

Alpha Audio. 
Automation Systems

A Division of Alpha Recording Corporation, 2049 West Broad Street, Richmond, VA 23220, 804/358-3852, TLX: 469037 (ALPHAAUD CI)

The Boss and Alpha Automation are trademarks of Alpha Recording Corporation.

 **Stirling** 

1 Canfield Place, London NW6 3BT. Tel. 01-625 4515.
Fax. 01-372 6370. Tlx. 946240 CWEASYG. Ref. No. 19014280.

AEG Nederland N.V.
Prof. Audio Dept.
Aletta Jacobslaan 7
1066 BP AMSTERDAM
THE NETHERLANDS

AEG
Phone Number: 020-5105486
Fax (3): 020-5105240

GEXCO TECHNOLOGY INTERNATIONAL INC.



317 St. Paul's Ave., Jersey City, NJ 07306/USA. Tel. (201) 656-7466. Tlx. 285261 GEXCI. Fax. (201) 653-2386.
Gexco Technology International Inc. is the worldwide distributor of the Alpha Audio BOSS and other high quality products for the recording, broadcast and postproduction industries.

Contracts

● Eastlake Audio are currently involved in several new projects in music recording, film-dubbing and broadcast facilities. The 5-theatre film dubbing complex Les Auditoriums de Joinville, Paris, has been under construction at the same time as a London video dubbing theatre, designed and constructed over six weeks, for Malcolm Bristow Studios, Soho Square.

Musigrama Studios in Madrid recently underwent a rebuild and enlarging of its studio facilities and work is about to commence on a post-production music recording facility for K2000 SA, also in Madrid. Eastlake broadcast projects have included an enlarged sound facility for TV-am in London and a sound control room for Yorkshire Television, Leeds. Also in London, work is currently underway on construction of a live studio for Studio Soundtracks Ltd's audio production facility.

● Otari have announced the supply of two more BTR-10J2SN 2-track recorders to NHK, the Japan Broadcasting Corporation, bringing the total to three. This follows Otari's supply of 10 MX-70 multitracks to NHK.

● S W Davies have been awarded a contract to design and supervise the construction of a residential studio

for Spitzbergen Studios in Groningen, Holland, while in London, a new mastering/CD preparation room is under construction for Richard Goldblatt and Ray Staff of Side FX. Recent Davies projects include a new mastering room at CBS Studios in London, and a rock/orchestral studio for Ace Studios in Aartselaar, Belgium.

● Yellow Two Studios in Stockport have announced the purchase of a Mitsubishi X850 multitrack, an X80 and a Sony F1 mixdown. These, combined with their V series Neve console, makes them the first fully digital studio in the North of England.

● API Audio Products of Springfield, Vermont, have sold their first motorised fader system to Tommy Boy Records in New York. The system, consisting of 32 API 940M faders and Disk Mix, will be installed into an older API console.

● Focusrite have announced a further order for an add-on console, this a 12/8 mixer going to West Side Studios at Hook End Manor in Checkendon, UK.

● Sam Therapy studios have placed an order with Syco for a 52-channel GML moving fader automation system to be installed in their DDA AMR24, the first time a GML system has been fitted to a DDA. □

NEWS

Literature received

● Bruel & Kjaer (UK) have issued a 32-page brochure, *A World of Applications* that outlines 12 application areas for the company's 2032 and 2034 dual channel FFT analysers. Aimed principally at the 'modern engineering industry', it hopes to assist engineers to understand the benefits of FFT analysis in solving design and maintenance problems. Vibration, acoustics, servo-systems analysis and materials testing, among other topics, are comprehensively covered, and there are application notes on time windows, scaling of spectra and the Hilbert Transform.

● Clare Instruments of Worthing,

manufacturers of test instruments for electrical safety, have made available their 1987 catalogue. The freely available 12-page publication contains specifications and black & white pictures of the company's complete range of instruments and services, including general purpose units, special test stations, high voltage flash testers and portable appliance testers, all of which meet required standards. For the catalogue and further information, contact Rod Walker at: Clare Instruments Ltd, Clare Works, Woodway, Goring-by-Sea, Worthing, West Sussex BN12 4QY, UK. Tel: 0903 502551.

Source or sampling?

"There is no better sampling" *)



The TC 2290 is the first sampler/delay in the world to give you 100% accurate sampling up to 32 seconds. Make an A/B comparison with any analog or digital master tape or compact disc, and you will notice there is no difference.

The new TC 2290 digital delay is based on a totally new converter principle. With a linear frequency response up to 20KHz +0/-0.5

dB an additional roll-off up to 33KHz and a unique 100 dB dynamic range, the TC 2290 is very warm, transparent, crystal-clear, musical... with absolutely no noise. It has 18 bit resolution - better sound quality than a compact disc, and many new innovative effects.

Ask your dealer for a demonstration of the new world standard of delay + programmable sampling. Just a few features are: delay with

ducking, chorus and delay simultaneously, automatic panning 100 presets and MIDI feature making it possible to control the TC 2290 from a computer.

Big studios will like the extras, small studios will love the price

*) "There is no better sampling" is a quote from Bob Schwall - Right Track Studio in N.Y.C.

OF DENMARK

t.c. electronic

U.K.: STATE OF THE ART DISTRIBUTION
HIGH LANE VILLAGE, NR. STOCKPORT SK6 8AA
PHONE: 0663 62442

WEST GERMANY: 081577677. DENMARK: 06262800. GREAT BRITAIN: 010456262800. SWEDEN: (031) 134950. NORWAY: (033) 26798. HOLLAND, BELGIUM, LUXEMBURG: 003110-4588166. AUSTRIA: 004981577677
ITALY: (02) 50841. FRANCE: (91) 498728. SPAIN: 91-4426426. USA: (201) 384-4221. CANADA: (416) 727-1951. JAPAN: (03) 329-8051. AUSTRALIA: (03) 6992388. FINLAND: 90-814133. GREECE: 01-3628541. SWITZERLAND: 073/226616.



The fact that we don't want to mention digital recording in this advert is no reflection on its undoubted merits, or the merits of Brüel & Kjær Series 4000 Professional Microphones.

The thing is, we've seen enough adverts claiming that the ultimate microphone for digital recording has arrived; too many in fact. To paraphrase Shakespeare, "methinks they do protest too much". And he was acknowledged as a genius without mentioning digital recording once....

All we'd like to say is: don't listen to us, listen to our microphones. They speak for themselves.

SERIES 4000 PROFESSIONAL MICROPHONES

Brüel & Kjær 

Brüel & Kjær (UK) Ltd

Harrow Weald Lodge · 92 Uxbridge Road · Harrow · Middlesex · HA3 6BZ · Telephone: 01 954 2366

Australia (02) 736-1755 · Austria 02235/563 0 · Belgium 02/241-8982 · Brazil 11-2468149 · Canada (514) 695-8225 · Finland (90) 8017044
France (1) 6457 2010 · Federal Republic of Germany (04106) 4055 · Great Britain (01) 954-2366 · Holland 03 402-39994 · Italy (02) 5244 141
Japan 03-435-4813 · Republic of Korea 02-793-6886 · Norway 02-846360 · Spain (91) 268 1000 · Sweden (08) 711 27 30
Switzerland (01) 860 67 05 · Taiwan (02) 7139303 · USA (617) 481-7000 · Local representatives and service organisations world-wide

86-348

NEWS

Crest Audio 8001 amplifier

Crest Audio have introduced the model 8001 professional power amplifier. Power output is rated at 750 W/channel into 8 Ω , 1200 W/channel into 4 Ω and 1500 W/channel into 2 Ω . Peak power is said to be 2000 W/channel (4 Ω) and 4000 W/channel (2 Ω).

New circuits in the 8001 include a completely discrete front end, 'Auto-Mute' signal ramp, IGM impedance

sensing and an RMS clip meter. The model 8001 is 3U high and 15 in deep and like all Crest amplifiers is completely modular with rear to front forced air cooling.

Crest Audio, 150 Florence Avenue, Hawthorne, NJ 07506, USA. Tel: (201) 423-1300.

UK: Crest Audio, PO Box 36, Royston, Herts SG8 7RQ. Tel: 0763 82465.

Kahler Human Clock

Developed by Kahler, the *Human Clock* is designed to 'listen' to a rhythmic analogue input, accurately calculate the tempo and then convert the output to MIDI clock data. The unit allows the synchronisation of drum machines and sequencers to live musicians either on stage or during recording.

The *Human Clock* eliminates MIDI

delay and can also be used to sync drum machines and sequencers to tapes without a sync track or to replace lost or damaged sync tracks.

Kahler, APM, PO Box 9305, Anaheim, CA 92802, USA.

UK: John Hornby Skewes & Co Ltd, Salem House, Garforth, Leeds, West Yorkshire LS25 1PX. Tel: 0532 865381.

Applied Creative Technology DB8 DI box

Applied Creative Technology have developed an 8-channel active DI box specifically for connecting up keyboards and drum machines. Line level, unbalanced inputs are connected via 1/4 in jacks; outputs are via male XLRs. The transformerless unit is 1/2U high, has a frequency

response of 10 Hz to 25 kHz (± 0.2 dB), a maximum input level of +10.5 dB and a signal-to-noise ratio greater than 93 dB. A clip LED indicator is provided for each input and the front panel also includes a power on/off switch.

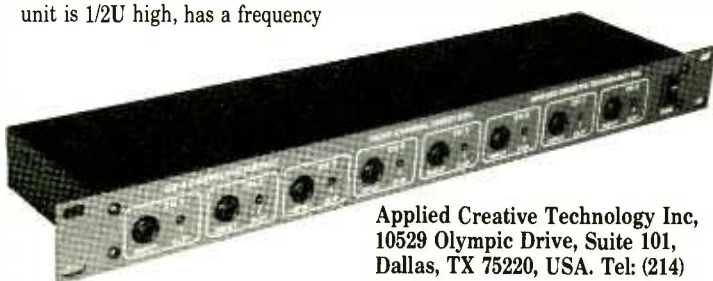

Applied Creative Technology Inc, 10529 Olympic Drive, Suite 101, Dallas, TX 75220, USA. Tel: (214) 358-4800.

Atlas microphone stand

Atlas Sound have introduced a new microphone stand, *MSX-10CE*, with patent pending 10 in diameter cast iron base weighing 11.4 lb. The two position base can be set vertically when the stand is not in use for more convenient storage and transportation.

The tube assembly extends from 34 to 61 in and is terminated with a standard 5/8 in thread. The stand is finished in baked epoxy and non-glare ebony.

Atlas Sound, 10 Pomeroy Road, Parsippany, NJ 07054, USA. Tel: (201) 887-7800.

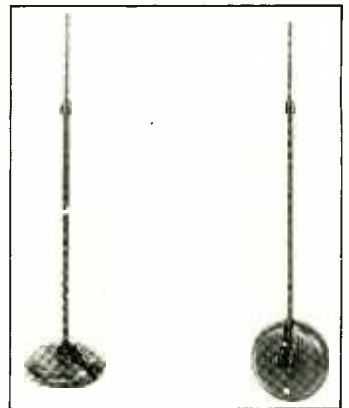

BGW model GTA amplifier

The BGW *GTA* (Grand Touring Amplifier) is constructed on a single piece welded steel chassis and essentially comprises two independent units each with its own power supply, power cord and magnetic circuit breaker.

Abbreviated specifications include FTC power outputs of 1800 W (minimum, bridged 4 Ω); 900 W (minimum sine wave/channel into 2 Ω); 600 W/channel (4 Ω) and 350 W/channel (8 Ω).

Design features include enormous energy reserves, compact size (3U high), low feedback discrete circuitry,

compatibility with BGW crossover cards, high performance active balanced inputs (70 dB common mode rejection), gold plated 5-way binding posts and modular construction.

Other features include optional transformer isolated inputs, oversized panel indicators and built in DC speaker protection.

BGW Systems, 13130 South Yukon Avenue, PO Box 5042, Hawthorne, CA 90251-5042. Tel: (213) 973-8090.

UK: Britannia Row, 35 Britannia Row, London N1 8QH. Tel: 01-226 3377.

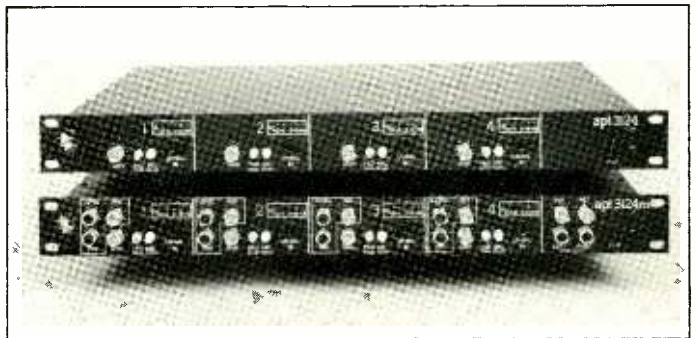

API 3124/3124m mic preamp/mixer

API have introduced two rack mounted versions of their 312 mic preamp, used in all API consoles. The 3124 has four mic preamps with XLR-type mic inputs (Jensen transformers, 150/600 Ω); balanced XLR outputs (+30 clip) and balanced 1/4 in outputs (+22 clip). Front panel features include individual channel gain control, 20 dB pad, Mic/Line switch, 5-segment LED level indicators and a 1/4 in unbalanced high impedance mic level connection.

An alternative mixer version (3124m), in addition to the above

features, also includes a stereo and aux bus with mix level control, panpot, aux send and insert point on each channel together with a master left/right, aux send and stereo return controls.

Options include external phantom powering, external battery power supply and Jensen output transformers. A twin channel unit (expandable to four) is also available. **API Audio Products Inc, 7953 Twist Lane, Springfield, VA 22153, USA. Tel: (703) 455-8188.**

WE DIDN'T REACH No.1 BY BEING OUT OF STOCK OR EXPENSIVE!



TRADE COUNTER OPENS
8.30am - 5pm Mon-Friday.

Today's
orders through
your door, Today
or Tomorrow

The UK's largest supplier of
MICS + TAPES + CABLES
PLUGS + EFFECTS UNITS
CASSETTES + RECORDERS
ACOUSTICAL TREATMENT
MIXERS + ACCESSORIES
Wholesale prices all items

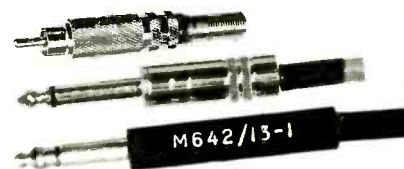

Save time - phone
STUDIO SPARES

first

TRADE COUNTER
Open 8.30am - 5pm (Mon - Fri)
TELEPHONE ORDERS: 01-482 1692 ADMIN: 01-485 4908
16 Stucley Place, Hawley Crescent, Camden Town, London NW1 8NS

Please send free 56 page catalogue
Please send account application form

NAME _____

ADDRESS _____

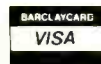



The M20 from AEG sets new standards for professional tape recorders in the studio.

This professional machine is right at the cutting edge in terms of technology, ease of operation, reliability and ergonomics.

The M20 is the latest development from the inventor of the magnetic tape recorder in a successful line stretching back 50 years.

It has every impressive feature the professional could ever desire. The latest microprocessor technology.

Sync amplifier for monitoring with the recording head during electronic editing. Electronic and storable automatic bias adjustment for different types of tape, with all sorts of equalization (such as NAB and IEC), and that at all 4 speeds. Incorporation in computer-controlled systems via standard interface. Timecode option. Built-in or portable for studio and mobil operation. Optimal operating in horizontal or vertical position. Continuous vertical and horizontal adjustment of Variostand allows perfect ergonomics for any operator. Suitable for 19" plug-in systems.

The M20 represents the ultimate combination of state of the art electronics and high-precision mechanics. For higher demands and new applications, e.g. in conjunction with computer-controlled editing systems or stereo television. It's tomorrow's answer to today's sound studio.

Please forward further information about the new Magnetophone M20 from AEG.

Name _____

Company _____

Street _____

Post Code/City _____

AEG Aktiengesellschaft
 Professional Tape Recorder Branch
 Bücklestrasse 1-5
 D-7750 Konstanz
 West Germany
 Phone: (07531) 862370
 Telex: 733233

K2_WAK_3619 E

AEG

NEWS

Sony K-1149 delay board

Sony have introduced the *K-1149* delay board for use with the *PCM-1630* processor. Fitting into the 'auxiliary' slot on the *1630* card frame it is capable of delaying the analogue or digital outputs by up to 2.972 s, switchable to the nearest millisecond. Using existing timecode links, the accuracy of the delay enables lip-sync audio to video. Other applications include correcting

audio timelag on simulcast satellite transmission and the mastering of Laservision and CD Video discs. UK: Sony Broadcast Ltd, Belgrave House, Basing View, Basingstoke, Hants RG21 2LA, UK. Tel: 0256 55011. USA: Sony Corporation of America, Professional Audio Division, Sony Drive, Park Ridge, NJ 07656. Tel: (201) 930-1000.

In brief

- Soundtracs have announced the availability of the *CMS3*, enabling the update of the *CM4400/CMS2* and *CP6800* automation systems to include the control of external MIDI equipment. Features include MIDI clock generation in sync with internal or external timecode sources, generating SMPTE/EBU timecode from video, restriping, timecode generation at 24, 25 or 30 frames/s, MIDI program changes stored or read from the console automation mix memory. These new features are being offered as either a factory fitted option or retrofit kit for existing consoles. Soundtracs plc, 91 Ewell Rd, Surbiton, Surrey KT6 6AH. Tel: 01-399 3392.
- CB Electronics have introduced a range of timecode products. Among the first releases are a generator/reader/insertor with full video wipe and countdown facility for cueing in ADR and full cue editing. CB Electronics, 4 Brandon Avenue, Woodley, Reading, Berks RG5 4PU. Tel: 0734 694512.
- Audio Kinetics will shortly release a disk storage system for the *Eclipse* audio editor. A simple interface to IBM PC-compatibles is in the offing. Amek have chosen to fit AK's *MasterMix* digital grouping interface to their new 2520 console as standard, and have developed their own VCA fader specifically.
- A set of 10 royalty-free sound

- effects LPs (also available on 7½ or 15 in/s ¼ in tape) has been produced jointly by Chappell RML and Molinare. Details from Chappell Recorded Music Library, Chappell Music Ltd, 129 Park Street, London W1Y 3FA.
- Sony have launched a new range of U-matic tapes. Two types are available: *BRS* (Broadcast Standard) and *XBR* (Mastering Standard) and both are claimed to offer improved audio and video performance.
- Two new automatic resetting clocks for broadcast use are available in the UK. Manufactured by Torpey Controls of Toronto the more advanced unit (*CLK 5*) has a single switch for automatic summertime advance/retard. Further details in the UK from Canford Audio, Crowther Road, Washington, Tyne & Wear NE38 0BW.
- Audio Developments are to manufacture the 6-channel, fully computerised Micro Dub sound dubbing system developed at Border TV. The system is claimed to reduce sound dubbing time by up to a half and be totally error free.
- 3M have developed a new digital audio U-matic tape packaged in 60- and 75-min lengths. Designed for CD, record and cassette production, the new tape features a complete antistat system and a claimed tape life of up to 2000 passes.

Trident series 80 update

Trident Audio Developments have introduced the series 80C. The new console has been completely restyled and features a new monitor section with dual line input facility providing up to 48-track monitoring. The new modules also feature full 4-band equalisers and long throw conductive plastic faders. During

mixdown, inputs and monitors are effectively identical providing up to 56 fully equalised inputs from the standard 32/24/48 frame.

Trident's moving fader and VCA-based automation systems are also now available for the 80B and 80C consoles.



Trident Audio Developments Ltd, Trident House, Rodd Industrial Estate, Gcvt Avenue, Shepperton, Middlesex TW17 8AQ, UK. Tel: 0932 224665. USA: Trident (USA) Inc, 652 Glenbrook Rd, Stamford, CT 06906. Tel: (203) 357-8337.

Otaritech TC-50 timecode/FM processor

The first product to be released under the Otaritech name is the *TC-50* centre-channel timecode/FM processor. The unit can be retrofitted to the Otari *MX-5050* 2-track machines such as the *B*, *BII*, *MkII-2*, *MkIII-2* or any other 4-head position tape recorder, and enables ¼ in stereo 2-track machines to be synchronised to film or video as an alternative to the conventional ½ in 4-track standard.

Three tape speeds are time compensated for coincident timecode and audio track recording and

playback. Front panel LEDs show timecode levels at the input and output and a *NagraSync*-compatible FM pilot signal demodulated output is provided.

Otari Electric Co, Otari Building, 4-29-18 Minami, Ogikubu, Suginamiku, Tokyo. Tel: 03 333-9631.

UK: Otari Electric (UK) Ltd, 22 Church Street, Slough, Berks SL1 1PT. Tel: 0753 38261.

USA: Otari Corporation, 2 Davis Drive, Belmont, CA 94002, USA. Tel: (415) 592-8311.



Soundtracs' *CMS3* screen display



What does it take to pro-audio centre

It takes more than a warehouse full of the best audio equipment.

We've got that of course.

Names like Amcron – we have every

Our directors started out building sound systems for rising stars, and

the staff all have very similar

backgrounds.

We've found that customers from way back are still regulars – like Phil Collins, who we knew when he was just a drummer.



model. Yamaha – we're the biggest pro-audio stockist in the UK. Sony – we launched low-cost digital in this country.

It also takes experience: at HHB you won't find slick salesmen, just a team that knows its business inside out.

You'll also find everyone at HHB has a one-track mind. (Or 24 track if you want to see our range of Amek TAC consoles and Sony recorders!)



It takes space for facilities: while you're exploring our demo room, you can be sure that our service and hire



be the best equipped in the country?

departments are hard at it to preserve our reputation for the best back-up in the business.

Our enlarged digital editing suite now includes AMS Audiofile, as well



as Sony CD mastering.

It takes comfort: we realised that the hair shirt was out of fashion



and so in our new premises you'll find a high level of comfort that extends throughout the building.

And of course to make your visit more palatable we're always happy to offer you suitable refreshments.

We feel that, with our unmatched technical expertise, approachability and reputation – and our new premises – we've earned the right to call ourselves the first pro-audio –

centre in the country.





**Buy one,
get four
free.**

Symetrix

They say you get what you pay for. Indeed, the 528 Voice Processor proves the point. Five high performance signal processors in a single rack space, for about what you'd expect to pay for each. Mic Preamp, De-esser, Compressor/Limiter, Downward Expander, Parametric EQ/Notch Filter. Even 48v phantom powering and a balanced line input. No compromises, nothing left out.

The 528 Voice Processor is the ideal mic input system for sophisticated recording and high level sound reinforcement systems. Control annoying sibilance, optimize spectral balance. Set overall signal levels. Reduce noise. And, eliminate resonances and ring frequencies with the 528's extremely selective EQ and filtering.

Get what you pay for, and then some. Get the 528 Voice Processor. Call or write for a detailed spec sheet.

In the UK:

SOUND TECHNOLOGY, LTD.
6 Letchworth Business Centre
Avenue One, Letchworth
Herts SG6 2HR
Telephone: 0462 675675

Exclusive International Representation:

E & E INSTRUMENTS INTERNATIONAL, INC.
PO Box 1313
Laguna Beach, CA 92653, USA
Telephone (714) 494-0231
Telex 182291 EASTMAN LGNH

Signal processing at its best

Subscribe. Now.



JOIN THE AUDIO PROFESSIONALS

You're obviously interested in professional audio.



You want to know what's going on in the world of professional sound, be it in music recording, new equipment, techniques or live sound reinforcement.

There's only one answer, subscribe to
STUDIO SOUND.

STUDIO SOUND gives you the hard facts, techniques and opinions which cannot be matched by any other publication in the field.

**Keep in touch
Subscribe to Studio Sound Now
The International Publication for the
Professionals in Sound**

Please send me _____ magazine for 12 issues.
I enclose a cheque/postal order/International Money Order
payable to LINK HOUSE MAGAZINES for £18.00 UK or
£24.50 Overseas. US rates: \$40 surface, \$75 airmail.

Or debit my credit card account    
(please tick box)

CREDIT CARD NO. _____

SIGNATURE _____  Credit card holders can order
simply by ringing 01-760 0054,
quoting your credit card number

NAME _____

ADDRESS _____

(please print in block capitals)

Commencing with the _____ issue I understand that I am
committed to one year's subscription to the above magazine, and should I wish to
cancel my subscription, no refund will be made.

To:
The Subscriptions Department, Link House Magazines Ltd.,
120-126 Lavender Ave., Mitcham, Surrey CR4 3HP.

PLATINUM LEVEL IV



THE USER FRIENDLY CONSOLE

ARE YOU A HAVE, OR HAVE NOT?

- IN LINE MONITORING ON EVERY CHANNEL
- VU METERING ON EVERY CHANNEL
- 6 INDIVIDUAL AUXILIARY SENDS
- STEREO SOLO IN PLACE
- PATCH POINTS+DIRECT OUTPUTS ON EVERY CHANNEL, GROUP & MASTER
- 4 BAND SEMI PARAMETRIC EQ
- SEPARATE MIC & LINE GAIN CONTROLS ON EVERY CHANNEL
- INSTRUMENT INPUT FOR DIRECT INJECTION OF LINE LEVEL INPUTS
- 100 mm STUDIO FADERS
- 48 INDIVIDUALLY CONTROLLABLE LINE INPUTS

HAVE



HAVE NOT



ARE YOU A HAVE NOT?

NOT FOR LONG, PLATINUM DESKS ARE AVAILABLE NOW.

AND NOW THE GOOD NEWS FOR HAVE NOTS.

THE PLATINUM PRICE

**PLATINUM
159 PARK ROAD
KINGSTON-UPON-THAMES
SURREY
01-549 9130
TLX 889294 MIXER G**

TOYOSHIMA

Japan has become an important contributor to the pro-audio industry over the last decade but this has mainly been restricted to hardware development. It is therefore interesting to look at a Japanese studio designer who has been finding increasing acceptance outside his own country. Keith Spencer-Allen spoke to Sam Toyoshima in London while Carl Snape toured a Japanese designed facility with him, to produce the following articles

While we are looking increasingly towards Japan for many aspects of pro-audio hardware, the idea of turning in that direction for studio design may seem somewhat unusual. But Sam Toyoshima has already completed three major studio projects in the UK (Townhouse 4, Park Gates and Genesis' Fisher Lane Farm) and another is currently under construction (Virgin's refit of the old Olympic studios facility). He has work in

progress in the US Can Am (LA) and projects in Australia (Rhinoceros, Sydney), Korea (JIGU and Seoul Studios, Seoul) and the Palace Hall of the Republic of Russia, Moscow. This is not to mention a large number of Japanese facilities such as Aoyama, Onkio Haus, Smile Garage, Shangri-La, Nichion, Sound Inn and Sound Valley.

One obvious question was does his being Japanese mean he has a unique approach to design that would explain the large amount of

interest shown in his designs so far? The answer is both yes and no and hopefully the reasons for this will become clear later on.

Sam M Toyoshima graduated with a Masters degree in Acoustic Engineering from the Waseda University, Tokyo, in 1954. After joining JVC, his work included monitor speaker design as well as acoustic design for concert halls and recording studios. His current position is that of manager of the JVC Acoustic Design Office, which in turn is part of the Research and Development Division. This is not a one-man operation—there are around 10 people employed all having a background in acoustics with a range of associated expertise that enables virtually all aspects of design and measurement to be handled in-house. The department started about 12 years ago initially to design and build stage one of JVC's own studio complex. Since that time they have designed the acoustics for almost 40 concert halls and auditoriums and more than 50 studio facilities (70+ rooms), the latter currently being about 70% of their work. Sam was originally introduced to the UK by Alan Douglas of The Townhouse.

It is often difficult enough for a client and the studio designer to communicate on the finer points of sound, even when they both speak the same language and I was a little apprehensive about discussing design criteria with Sam due to the language problem. There was, however, little to worry about because he speaks reasonable English and understands very well. He normally works closely with Hiroaki Suzuki, assistant engineer from the design office, who also speaks good English. In discussion you realise just how universal the language of rock'n'roll technology has become and the basic needs for successful recording are fully understood. Any communication problems were punctuated with a devastatingly sharp sense of humour that totally removes the stiffness often present when we westerners expect the Japanese to converse with us in English.

Basics of design

Most designers have certain aspects that they see as fundamental to their design approach, accepting that the laws of physics need to be accommodated first. In Sam Toyoshima's opinion the control room is far more important than the studio area and few would disagree with this. It is the control room where all the important quality decisions are made and therefore accurate design is fundamental.

"The control room must have some similarities with a standard home listening environment. If the monitoring environment is very different it becomes difficult to know what effect adjustment in sound made in the control room will have on the sound in the home."

While Sam is ready to admit that reverb time is not the most perfect way of expressing the performance of a room it is a universally accepted parameter. He feels that the RT of a control room must be a little smaller than the 'conventional listening room' whose value he quotes as 0.3 s, giving an ideal value for the control room of 0.2 s. All his control room designs fall between 0.15 and 0.25 s.

Other basic design philosophies include the desire to maintain consistency of sound characteristics throughout his designs while keeping design flexibility to accommodate clients' specific needs. Keeping a constancy of sound is not, he feels, just down to adjustment of monitor



systems or minor acoustic treatment but is fundamental within the acoustic design. To this end he normally considers the acoustic aspects of the control room in three frequency bands: low, mid and high with the low response being the more important area for control.

At low frequencies his designs aim to remove standing waves and control LF room energy by making at least one out of every two opposite surfaces absorbent to LF. These may be the front and rear ceiling and floor or side walls but the baffle area around the monitors in the front wall must always remain a hard material that is heavy enough to provide a good 'baffle effect'. His basic design always requires that the rear wall is absorbent while the front is largely live. He feels that maintaining diffusion at low frequencies from a rear wall is impractical enough to render it too difficult to prevent standing waves.

In the mid range, problems are not so great with design largely being based upon proper geometric control—avoiding parallel surfaces, etc. It is especially important to consider early reflections in this frequency range (2 to 4 kHz) where there might be a secondary reflected signal path that is close to the direct signal path leading to many problems at the monitoring position.

In terms of the high frequency signals he generally finds that surface treatment is all that is required provided the other design criteria have been met. Generally the treatment is applied in a fairly random fashion to produce a similar soundfield to that found in a domestic living room. Toyoshima designs often use variable sized wooden slits randomly distributed throughout the room with widths under 10 cm. Occasionally absorbency will be applied to the surfaces of the monitor wall. Sam likes to stress that listening tests are essential to fine tune aspects of the room that cannot be predicted in design and this applies particularly to the HF end.

His stated aim, as with many designers, is perhaps one of the greatest problems—that of achieving a wide monitoring area within the control room to meet the escalating demands of increasing amounts of equipment and the trend for musicians and synthesisers to be in the control room. The need for these additional players to also have accurate monitoring has further complicated the equation.

Sam believes that the separation of machine rooms from the control room is now an important design consideration so as to remove some of the bulkier items and to reduce noise, heat output and reflected sound from hard surfaces.

Finer points

Many designers are aligning themselves with particular types or brands of monitors. Does he agree with this approach?

"We can work with almost any type of monitor but we are very accustomed to Westlake systems. We normally use the 3-way *TM3* with the *HR-1* being requested in the UK. We have also used JBL and UREI systems as well. Our first step would be to measure the proposed system in our anechoic room so that we can decide the shapes and angles in the front of the room."

Sam admits to a personal preference for soft dome monitors but has so far found problems with the available SPL, although the HF dispersion is beneficial. They design for no monitor EQ, the systems running flat but very occasionally they may decide to use 2 or 3 dB in the low frequencies to compensate for change in the room.

As with most designers he states a preference

for being involved in a project as early as possible so he can have some say in site selection although this does not often happen. With increasingly high noise insulation requirements he has a horror of underground trains, low flying aircraft and helicopters. The challenges of building a demanding complex in downtown Tokyo are probably greater than anywhere else in the world.

There are places he feels where it would really be impossible to build a studio but his requirements in terms of space are fairly flexible. He needs a gross structural height in the control room area of at least 3.5 m. He is prepared to work with less but would expect to start making compromises in performance.

His techniques for acoustic control are also tailored to experience: "It is very easy to introduce large traps to give good absorbency. But we usually do not have such a large area to work with so we have developed other techniques."

These are membrane-type absorbers constructed from standard sized plywood of 1×2 m with glass fibre of 50 mm thick attached to both surfaces. These are then fixed by their edges parallel to the rear wall. These units can be tuned quite accurately to produce a relatively narrow band of resonance (hence absorption) that depends on variables including the elasticity of the plywood, the stiffness of the air behind the unit and the weight of the materials. Many different sized panels are needed to get an even response.

The studio design is handled back at the main offices in Japan although on European projects they are working with British architect John Flynn where extensive building requirements are added. Part of the design process is completed with a CAD system running in-house written programs that allow easy calculation of angles and multiple path reflections, etc.

What I believe to be quite unique with Toyoshima's work is the use of mock-ups for precise acoustic design.

"When consoles are large they affect the acoustics and they can influence your design quite a lot. It is difficult to calculate the acoustic parameters of a console. So we make a mock-up of the console in wood almost full size and place it in the control room under construction to help with the final design stages. You also have to be very careful with the positioning of the axis of the monitoring system and this way will help us reduce HF reflection from the console."

Monitor positioning is determined by experiments in the anechoic chamber on different models and also practical listening tests with recording engineers. The idealised monitor position would be with the junction of the monitor axes at the engineer's head. In practical terms this is wasting a great deal of the possible good

monitoring area, which with the larger control room and more 'listeners' is much needed. Their experience has shown that with monitor positions of 3 m apart a shift in the mixing position of 30 cm forward or back makes very little difference to stereo imaging. It is also possible to increase the horizontal angle for the monitors by an average 10° as shown in Fig 1 (x) the actual amount varying with the type of monitor used, the 'tolerable angle' being determined by listening tests. The vertical monitor angle is determined in a similar way. Obviously the height of the control room window is a factor but with an average window height of 1.5 m and the seated engineer having an ear height of about 1.2 m, experience has shown that typical vertical angles are between 5° and 10° (see Fig 2).

The studio area

Most of the Sam Toyoshima rooms that we have seen so far are large predominately wooden-finished areas. They appear to be quite usable for most types of music recording. He believes that the multipurpose studio is quite possible with the aid of variable acoustics. In the UK this was seen in his design for Townhouse 4 (see *Studio Sound* June 1986) but the amount of variable control did not really look enough to create any real change within the room although they did appear to be very carefully placed.

"It is often very difficult to distinguish any changes by ear but if you use a microphone it will sound quite different. The mic is far less directional than the ear. If you turn every one of the rotating variable acoustic units then the ear can hear it but with just two or three you can't. We have used this system quite a lot particularly in the JVC studios."

I was particularly interested in any differences between the approach to studios in Japan as compared with the West. Had Sam noticed anything?

"In Japan we have been very influenced by sounds from Europe and the US, studios such as Townhouse 2 and the Power Station. This means that there has been a trend towards live rooms. However, we usually still have a number of small booths within the studio, an average of four would be normal. In Europe there used to be a live and a dead end approach to the studio area but that appears to be gone and they just want a unique sound quality. This is something we are beginning to see in Japan."

Sam made the point that the acoustic separation between the studio area and the control room showed a difference of approach.

"In Europe we consider a separation of 60 to

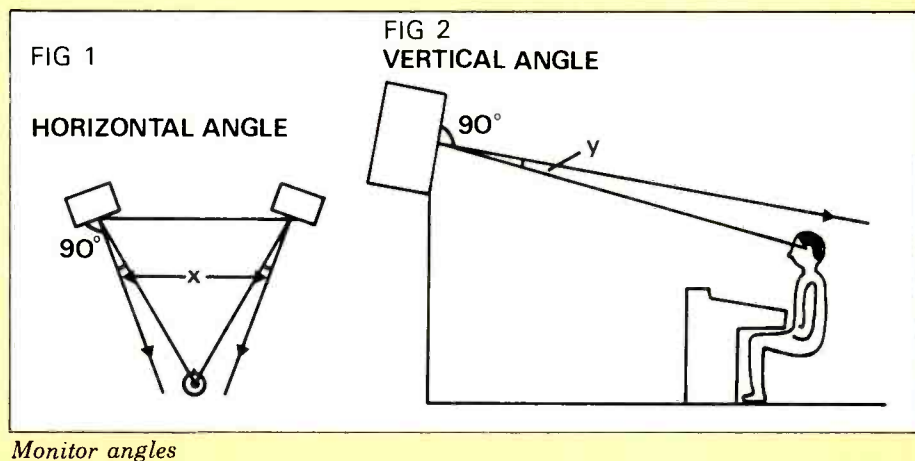

TOYOSHIMA

70 dB at 500 Hz to be enough. In Japan we have to have more. Japanese singers sing very quietly and with a loud monitoring we may get howlround." (All said with a completely straight face.)

Cosmetic design

Looking at the rooms designed by Sam Toyoshima

they all appear to look quite different—mostly with a lot of wood but still different. They do not usually undertake the cosmetics themselves preferring to hire in expertise. They also try to use local materials in the area and normally this presents no problem.

"But you do not have such a good handle for the soundproofed door. We have a very good handle in Japan."

There does not appear to be a specific

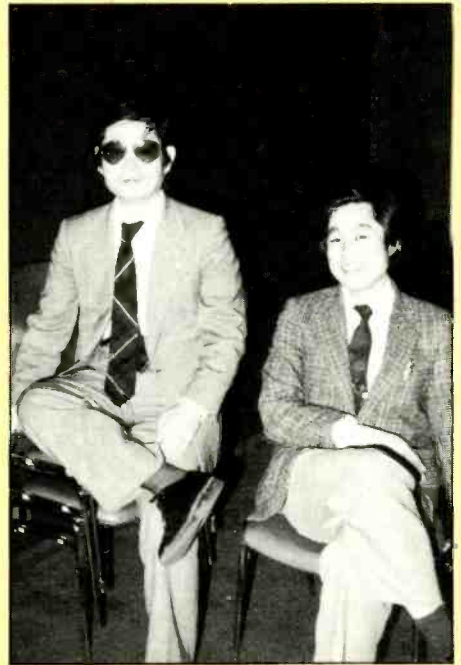

Sam with Hiroaki Suzuki

Toyoshima look but the rooms all appear to have a pleasant balance between being attractive environments while retaining a work place type of ambience.

Designing for the future

What of future requirements for the studio? Sam is very aware of future needs. Currently they have developed a design for digital mastering suites that is capable of producing a linear acoustic response with a very high dynamic range. They are claiming a design capable of operating with 200 dB even though there are no monitoring systems with anything like that capability.

On a slightly more practical note he believes that the first step will be the machine room as long as some of the problems this causes can be solved fully. He also has a philosophy of big control rooms and a philosophy of supplying high quality sound to all the people who are in the control room not just a favoured few in a particular location. As control rooms get larger this assumes increasing importance in his design.

"Also we see increasing numbers of musicians in the control room and we will need a big area behind the desk to house the digital music systems. In my personal opinion we may need a semi-separated room behind the engineer listening to the main monitors and with no glass. This will be my future control room."

He went on to elaborate that this could be a structure that rises from the floor and down from the ceiling when needed in a similar way to some drum booths that he has designed for Japanese studios that appear on the middle of the open studio floor when required and disappear into the ceiling when not.

If we return to our question at the beginning of whether his being Japanese is the reason that he is getting the work, you can see why this is not answerable. Yes he does have a different approach and yes the studios do look different but I really don't think that this has anything to do with being Japanese but rather more clients looking for a slightly different input to their facility. □

the 'mix' consoles

MULTIMIX 19" rack mount 16:2:1 12:4:2:1 and 16:4:2:1
 * 3 band eq. * 2 aux sends * 48V p.p. * line inputs
 * RIAA inputs * direct outs * 100mm faders * 2 way LED displays * peak LEDs

STAGEMIX 19" rack mount 12:6 rack mount monitor console
 * inputs: mic split, trans balanced, 3 band eq., peak LEDs
 * outputs: trans balanced, 4 band eq., 12 way LED displays

SOUNDMIX 24:4:2:1 and 16:4:2:1
RAKMIX 19" rack mount 8:4:2:1
 * 4 band eq. * 4 aux sends * 4 aux returns * 48V p.p. * patch points * direct outs * +4dBm or -10dBu outputs * pfl metering * 12 way LED displays on groups and outputs

Total Audio Transparency



Hill Audio Ltd., Hollingbourne House, Hollingbourne, Kent ME17 1QJ England
 (062 780) 555 Tlx 966641 HILL

Hill Audio Inc., 5002B N. Royal Atlanta Dr. Tucker, GA 30084 USA (404) 934-1851 Tlx 293827 HLAD

Neve V Series – when only the best is good enough.



PHOTO: PRT STUDIOS LONDON

“ We were delighted by the exceptionally clean response of the console and the ease of operation of the Necam system during mixing.”

GEOFF CALVER & CHRIS CAMERON (Producer/Engineer & Producer/Arranger)

“ ...without doubt the finest console I have worked on.”

BOB MALLET (Resident Engineer PRT Studios)

NEVE ELECTRONICS INTERNATIONAL LIMITED, CAMBRIDGE HOUSE, MELBOURN, ROYSTON, HERTS, SG8 6AU TEL: 0763 60776 TELEX: 81381 FACSIMILE: 0763 61886
RUPERT NEVE INC, BERKSHIRE INDUSTRIAL PARK, BETHEL, CONNECTICUT 06801 TEL: (203) 744 6230 TELEX: 96-9638 FACSIMILE: (203) 792 7863



SOUND VALLEY



Control Room A

What do you do when your car repair business isn't making enough money to justify the real estate it's sitting on? Call Sam Toyoshima. Far fetched? Far from it, for that's exactly what one enterprising Japanese businessman did when looking at the costs per square metre and the return he was getting from his garage business. Out went the car ramps and oil drums and in came the builders, electricians and carpenters. The complete project, from start to finish, took roughly a year.

Studio Sound Valley, as the name might suggest, is not located in some idyllic mountain setting. It's below street level in a hectic part of central Tokyo. Buses and lorries trundle overhead, and a few metres away the local underground railway transports daily commuters in and out of the area—in many ways a studio designer's nightmare. But the problems didn't end there as Sam Toyoshima found out when he originally surveyed the site.

Access to the studio is at street level, down a flight of stairs to the first level and down again to the second. Available height was very restricted and the location was peppered with load bearing structures supporting the office block above. In this space he had to find room for two studios, reception, lounge, catering facilities, storage, office, shower and two toilets.

Centrepiece of the design is Studio A which effectively covers most of the lower level. The control room is very large and extensive use of glass (four sections on the studio side and five in the control room) provide excellent visibility across the entire studio area.

The SSL console (*SL4048/40/VU*) sits in the middle of the room, well back from the monitors giving the control room a spacious, uncluttered feeling. Most of the wiring is totally concealed. Access to the room is to the right of the console through a special, carefully sealed door. Roughly 3 in thick, the door weighs about 300 kg yet opens at the slightest touch. As with all the work in the studio, the quality, even the small details, is superb. Identical doors are used throughout Studio Sound Valley for access to studio areas and control rooms.

Much of the space along the back wall of the control room is taken up by low level seating. Multitrack and mastering machines are also in the control room, along the left-hand wall. On the other side of the wall is the vocal booth. Entry is directly from the studio rather than the control room. A triple glazed window into the control room, however, provides good visual contact.

In order to get to the studio from the control room it is necessary to go through the sealed door, walk down the hallway, then in through a second sealed door. One interesting touch in the

hallway is the 'dumb waiter' set into the wall. It goes up to street level and is ideal for getting instruments and equipment in and out of the building with the least amount of fuss.

It's another world once you walk into the studio. After the craziness of the Tokyo traffic it's the stillness of the place that first hits you. That, and the vast expanse of wood to be seen in every direction. Almost all the walls are clad in American pine (as it is known in Japan) and the floor is maple. Then, as you start to walk across the studio floor, you're immediately aware of just how lively the acoustics are. Certainly from a musician's point of view, it is very easy to imagine just how responsive the room would be.

And for the engineers too, no two aspects of the studio are quite the same so there's an endless variety of permutations for experimenting with mic placement and instrument layout. In almost every direction there are interesting nooks and crannies. This is due in part to the fact that in some areas of the studio, only the single storey height has been used (the basic floor to ceiling dimensions are 4 m, the finished room height is 2.7 m) whilst elsewhere, with the original upper floor removed there's a much greater volume of air (constructionally 7 m, finished 5 m) above your head. Basically this larger area occupies the main central block of the studio and complete with sloping ceiling extends back to the rear wall.

Across the main span of the room is yet another interesting feature—a 'mic gallery'. In fact this is a neat solution to disguising a massive structural beam. Boxed in with extended sides and panelled to match the rest of the room, the 'gallery' is an excellent place for mounting overhead mics. About 1.2 m wide and with a removeable ladder for access, the beauty of the system is that if you want to leave your mics in exactly the same position throughout a session and yet still clear the floor area from time to time the 'gallery' provides the ideal solution.

In addition to the 'central area' there are six other roughly defined recording areas. These are all 'single storey' areas surrounding the central 'core'. Down either side and towards the rear of the studio are two isolation booths. The left room, looking down the studio from the control room, is a piano booth (Yamaha) and the larger room on the right is the drum booth. As with the other recording areas, both have identical wall cladding and flooring to that used in the main studio area. The remainder of the left and right walls form open plan areas (quite different in shape and size incidentally) under the low, single storey ceiling. A similar low ceiling area runs across the front of the studio, immediately in front of the control room window. Finally there is the vocal booth. This is located on the left side, tucked in adjacent to the control room.

Sam Toyoshima explained some interesting aspects of the construction. The floating floors are made of a concrete and rubber sandwich (the rubber being in the middle). Above the concrete base is a wooden floor system which comes from Denmark (apparently it is very popular in Scandinavian homes). No joists or battens are used to support the flooring: it is simply assembled and held together by interlocking metal components. It is easy to construct and in the case of Studio Sound Valley the floors that would normally take three days to complete were installed and in use within half a day.

Overall the studio has quite a live sound with a long reverberation time (0.6 s). Carpets are available but the floor is very reflective and usually the studio is used as it is. Microphones available include the usual range of Neumann,

The Producers Story

When producer Barry Andrews came into the console buying market he chose the Soundtracs CP6800 for its sound, its flexibility, its computer facilities and its exceptional value for money.

A freelance producer of many successful years standing, Barry's recent work has included recording the Radio One Janice Long sessions featuring such varied talents as Howard Jones, China Crisis and The Christians.

Towards the end of 1986 he became involved with major London publishing company, Peer Southern in Denmark Street. The company's recent chart successes include Walk Like an Egyptian by The Bangles and Freddie Mercury's The Great Pretender.



Barry Andrews's role at Peer Southern is that of Manager over the Professional, Creative department and Production company and to this end one of his first tasks was the complete rebuilding and re-equipping of the company's recording studio. The facility, now re-opened and hard at work, has the potential to grow and diversify into any of the many areas a music company may pursue in future years. This flexibility has been achieved with the installation of a Soundtracs CP6800 mixing console as the central piece of equipment.

Barry Andrews explained that, having worked extensively behind Radio One's SSL consoles he particularly wanted to find a desk within the company's budget which could offer wide ranging flexibility and quality of sound.

'The Soundtracs CP6800 is a wonderful desk. I had used a Soundtracs CM4400 previously at another studio and I really liked the sound. For this studio we really need the computer facilities such as automated patching, subgrouping and all the other excellent facilities the CP6800 offers. You can get a lot more complicated with your mixing when you have the help of the computer. It makes 12" mixes much easier; we do a lot of those here.'

'I just love the flexibility of the console and I love the sound – it's wonderful. Also, if we want to get into video at a later date, we can do that with the CP6800 unlike other consoles which maybe out of date in a year's time.'

Call now to arrange a full demonstration
27 GUILDFORD STREET, LUTON, BEDS. LU1 2N
TEL: (0582) 450066



SOUND VALLEY



Studio A

Sennheiser, AKG and Shure. Dynamic mics are normally stored in the studio mic cupboard but the vocal booth contained a useful item—the Chemy *Drykeeper*. This is a small auto desiccator specifically made for condenser mics, the object being to keep the microphones in good condition and help to reduce unwanted noise. Inside the box were a collection of Neumann *U87* and *U47*, an Amcron *PZM* and power supply, Schoeps *CMC5*, AKG *451* and Shure *SM7* (dynamic).

Other unusual items around the studio included a sophisticated portable cue system—six channels (four mono, one stereo) all with pan and level controls, each system feeding four sets of cans and a Takasago mic stand. (This latter item is normally found in TV studios.) The solid base (on wheels) and two-section construction allows mic placement high above the musician.

Studio A officially accommodates up to 40 musicians but no sooner had the studio opened when one, now famous, recording session for a film soundtrack had no less than 70 musicians playing in the studio!

Upstairs, above the control room and the front section of Studio A, is Studio B. This is the remix suite basically but the studio, which is usually used for vocal overdubs, will accommodate seven or eight musicians. Most of the work is remixing sessions from Studio A but about 25 to 30% of the work is from outside.

“The main point of Studio B,” explained Sam

Toyoshima, “is that it has a larger than normal control room because we need more space for synthesisers. Usually we have as many as 10 people behind the engineer so we made a bigger room.” Interestingly both control rooms occupy the same floor area and are roughly the same shape. The most obvious difference in Studio B is the smaller control room window which has only three sections facing each room.

Equipment-wise the two control rooms are also similar. Unlike Studio A, Studio B is equipped with a Solid State Logic *SL6048/48/VU* console but both rooms have identical monitoring systems (Westlake *TM-3* and Amcron *PSA-2X*, *MT-1000* for main monitoring and Yamaha-*NS-10Ms*—with tissue paper for nearfield). According to Sam Toyoshima the sound in both control rooms is pretty closely matched. No monitor EQ is required.

Control room acoustics are carefully tailored. “The low frequency absorbers behind the wall fabric are made with glassfibre and plywood,” explained Sam Toyoshima. “In conventional studios the absorbers are side-on to the monitors. In this room they face the monitors.”

In Studio B most of the walls are fabric covered effectively hiding the acoustic treatment. “In some parts of the control room we have conventional systems with a line of traps on the surface. Behind the ‘solid’ panels you can feel, is a further sound trap. I would like to have put

sound traps on the ceiling but we did not have enough room so we just put a panel system on the ceiling with glassfibre on top. It sounds good and many people like the sound of this studio.”

Most of the outboard equipment is housed in two low level 19 in racks at the side of the console. For the most part the equipment is the same in both control rooms and includes: *EMT-140* (plates located in a service corridor and mounted on special rubber suspension in order to provide isolation from the nearby subway) reverberation system; AMS *RMS-16* and *DMX 15.80S*; Lexicon *224XL*; Neve *33609* compressor; UREI *LA-4* and *1176*; Keepex *II*; Roland *SDE-3000*, *SDE-2500* delay units and *SDD-320* chorus; Songbird *TSC-1380S* (stereo chorus splitter) and *FS-1*; Jensen *T-DB-2E* and *T-DB-2ES* DI units and Orban *536A* compressor/limiter. Also additionally in Studio B are a Publison *Infernal Machine*, Apex *II*, Yamaha *REV7* and Lexicon *200*.

Tape machines are pretty well standardised with each control room having a Sony *PCM-3324* digital multitrack, Studer *A80* mk IV 24-track (Dolby *SP-24* noise reduction) and *A820* ¼ in machines. Studio B also has a second (½ in) Studer *A820* and the JVC *DAS-900* digital mastering system. Both rooms have JVC *AV-28s* and Sony *PCM-1630s*.

Finally there is a very interesting staff arrangement at Studio Sound Valley, “The studio is very independent and when I was asked to design it the owner Mr S Haketa, was interested in having a nice group of people dealing with the studio. Some people formerly with JVC’s own studios made a very nice mixer/engineer team. Originally about 20 engineers were working in the group. The group is very, very successful now and it is that team that runs this studio. At the moment I can’t say exactly how many people are working for this studio.

“Sound Valley usually runs with three or four engineers and five tape ops. There are no maintenance engineers. We have so many representatives from UK and European companies—Studer and SSL for example—that when we have some problem with the equipment it is easy to repair just by making a phone call to the representative.”

All in all the studio appears to do very well. It attracts some of Japan’s top producers and during my visit for example, the producer using the studio had 11 hits, of the then current Top 50, to his credit.

Memories of Studio Sound Valley? I have two I’ll always remember. The superb quality of the workmanship even when you looked close up (Japanese craftsmen were making beautiful things in traditional materials long before the transistor had been invented) and Sam’s comment about the ceiling in Studio B.

I’d been curious about the cutouts and wondered whether they were cosmetic or part of the acoustic design. It turned out that neither of my suggestions was right. In the first stage of construction the ceiling was flat. It was also pretty low due to the height restraints between floors and it didn’t take long to realise that some Japanese vocalists get pretty energetic whilst singing with the result that their head would go crashing through the ceiling at the crucial moment. It was never made clear whether the engineers were worried about the singer’s head or just the horrendous noise the impact made on the vocal track. In any event with the strategically placed cutouts now everyone can leap around to their heart’s content. □

The ultimate *MIDI* automated console

Series II features include:

- * MIDI controlled muting of input channels and auxiliary returns. Tri-colour LEDs indicate channel status
- * 6 pre/post auxiliaries with fully routable, MIDI controlled returns. Effects return to foldback function
- * 4 band parametric equalisation
- * Individual channel 48V phantom power
- * Phase reverse
- * Insert points on all inputs and outputs
- * Two separate 2-track returns
- * Built-in talkback condenser microphone. Talkback to groups and studio foldback
- * 100mm ALPS faders
- * LED metering of all outputs and SOLO in unique meter pod (pod also contains talkback mic)
- * Rack mountable external power supply Type EP3
- * Available as 16.4.2, 16.8.2, 16.16.2
- * Input and Tape Monitor expanders for building consoles up to 40.16.24.2

Update: From August 1987, a major SERIES II MIDI update will be available. The new MCM (MIDI controlled muting) board uses Note ON/Note OFF and Note Value implementation for easy programming from a sequencer via a keyboard. It can "Read" mutes when instructed to by MIDI and allow recording of mutes in real-time onto the sequencer.

To complement the new MCM board, a hardware based sequencer will be available as an add-on to the console. It can record up to 2500 events in internal memory (with battery backup). Saving data to disk is possible. An SMPTE generator/reader is incorporated for logging events to. Additionally, Program Change/Number information can be entered to control external MIDI equipment such as effects.

Contact your Studiomaster dealer or us direct for further details:

STUDIOMASTER Studiomaster House, Chaul End Lane, Luton, Bedfordshire LU4 8EZ. Telephone: 0582 570370 Telex: 825612 STUDIO G Fax: 0582 570242.
U.S.A.: STUDIOMASTER INC. 1340-G Dynamics Street, Anaheim, California 92806 U.S.A. Telephone (714) 524 2227 Fax: (714) 524 5096.

Series II

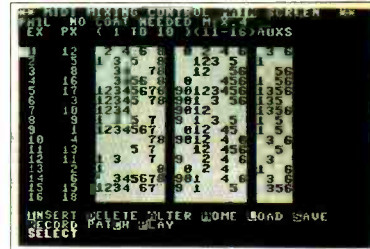
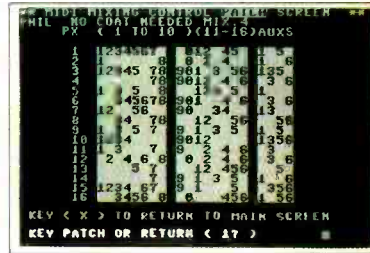
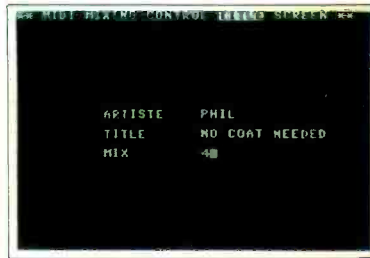

STUDIOMASTER

KOLBE

Terry Nelson finds out how Hellmuth Kolbe became involved with studio design and how his philosophy is put into practice in Studio 60 and Ebony

Acoustician Hellmuth Kolbe studied electronics, physics and mathematics at Zug in Switzerland and went to Vienna at the end of the war to study music and musical science. His main subject was orchestral conducting together with 'cello and double bass. He also had his own jazz band playing mainly for service men's clubs in Switzerland and Austria.

He went to work as an independent engineer for the radio station RWR which was part of the broadcast network for the forces in Europe.

"We were two Americans, two Swiss and 17 Austrians and we were heard all over Europe. My department was jazz and modern classical, together with being involved in the design of the studios. We also did a lot of live concerts including one a week from the large concert hall in Vienna, where we used just one microphone (a Shure modified with an AKG capsule) and it sounded wonderful!

"The autumn of 1953 saw us getting the first stereo Ampex recorder in Europe and we immediately started recording in stereo—which meant we aimed for a proper stereo image rather than the 'ping-pong' style that was popular in the early days (everything on the left or on the right and no middle)."

When the allied occupation of Austria ended in 1955, Kolbe started his own recording company in Vienna and found immediate success with such US labels as Vox and Vanguard.

"At that time the rate of exchange of the dollar to the Austrian schilling was very favourable and American companies soon found it well worth their while to record in Vienna."

The following year Karlheinz Stockhausen founded his first electronic studio with Hellmuth Kolbe as engineer and together they elaborated the first electronic music 'scores' which consisted of frequency vs time graphs: "There was no way you could use traditional notation."

It was soon time to move on and in '57 Kolbe returned to Switzerland and started the Wintherthur Phonag recording company at Lindau (which still exists). This also marked the beginning of a fruitful period as a freelance engineer for Columbia Records, where considerable globe-trotting was involved in the making of classical recordings. Highlights of this period were the heady days of quad (SQ) and a Grammy for his recording (on 3-track) of Mahler's 8th with Leonard Bernstein and the LSO.

"By the time the '70s came around I was

getting tired of living out of a suitcase and I wanted to spend more time with my family.

"In a way, everything came together: operas were starting to be recorded on 24-track and at this stage I felt that the technology was moving in and the music moving out! Also there was a general slump for classics so I was able to cut down on recording and move back to my first studies which was acoustics. After all, I had recorded in the best—and the worst—halls in the world and had amassed considerable experience. Whenever I was able to, I measured the halls and began to compile a file on hall acoustics.

"I started a consultancy service for concert halls, theatres, industrial buildings, domestic, etc, that dealt with all aspects of acoustics such as reverberation, isolation, and so on."

Though acoustics encompasses many areas from noise abatement to recording studios, Hellmuth Kolbe has strong thoughts on the qualifications required for the latter.

"I am convinced that in order for anyone to be an acoustic engineer in a musical environment, he has to be a musician. You have to understand the sort of environment that musicians require in a studio, control room or concert hall. Most of us have come across situations in theatres or halls where the orchestra can either hear everybody or each musician is straining to hear his neighbour just to stay in tune.

"It's the same situation with console manufacturers—the best builders are also users because they know what is required out in the real world."

Hellmuth Kolbe was an early member of Synergetic Audio Concepts and is often involved with the Syn-Aud-Con seminars.

"The development of TDS by the late Richard Heyser is, in my opinion, one of the greatest steps



forward in acoustics since the work by Sabine. One of the important aspects of it is that you can now prove to a client that what you are doing actually works. Before, he just had to take your word for it.

"Heyser also has to be credited for the work he did in loudspeaker development.

"We are involved in studio construction all over the world and anywhere it is rare to be able to build a studio from the ground up—but that's the challenge!

"For me the important thing is to make the control room as big as possible—you need space in order to be able to have an uncoloured sound. With today's recording techniques most of the music is done in the control room which means that you need space both for the instruments and the sound.

"Design criteria are always on the move and I have modified the LEDE concept to include the Reflection Free Zone (RFZ) manner of design. This gives the most uncoloured sound possible in a given situation and provides a natural sound that can be the reference point. Of course, some of the original LEDE principles are still very valid such as the asymmetrical outer shell and completely symmetrical inner shell.

"The goal is to achieve as natural a sound as possible so that things such as equalisation can be used as an effect, rather than as an attempt to compensate for colouration and/or bad acoustics. The moment you have a neutral reference point I find that EQ settings tend to become less drastic and are often of the order of several dB or so. When I visit studios I always steal a glance at the settings on the console and almost invariably those which have settings of ± 18 dB (for example) have problems with their acoustics; good rooms usually show ± 2 dB settings.

"As a studio designer I feel it is my duty to provide a neutral reference point; you then need a good engineer with good ears—and one who listens!"

What of the balance between equipment and acoustics?

"You need space—which means money! It is important to have a proper balance in the budget between the cost of the studio acoustics and the equipment that is going into it. However, I always point out that you can buy the equipment as you go along—changing the acoustics afterwards is a lot more expensive."

Although studio design forms an important part of Kolbe's interests, much of his time is taken up with the design—or re-design—of theatres and concert halls, industrial acoustics and the like ("though noise abatement is really boring!"). Projects that are presently underway include a new control room for the SFB concert hall in Berlin, a new concert hall with variable acoustics in Thun (Switzerland), AGV audio/visual studio in Bern and a reference control room for the East German broadcast organisations. The latter studio embodies LEDE and RFZ principles complete with Schroeder diffusors (which Kolbe designs himself—"you mean the computer does"); control of the bass frequencies requiring diffusors cast in concrete. "You need mass to properly control the bass."

With the new advances in recording technology, studio design is more important than ever before. If the sound is not right to start with, it is a losing battle from then on. Though Hellmuth Kolbe has surrounded himself with all the new tools for studio design—TEF, TDS, etc, this is combined with a deep knowledge of music and its requirements, which, after all, is what it's all about.

The Sony MXP-3000 is so quiet we asked a panel of experts to test it



You'll need more than a keen pair of ears to pick up any unwanted noise from the new Sony MXP-3000.

It's probably the quietest audio mixer ever made.

Our proprietary hybrid circuits, oxygen free interconnect cabling and gold plated connectors throughout the audio path ensures the ultimate purity in analogue signal processing.

The MXP-3000 is more than compatible with the latest digital recording methods.

No other console is built like it or sounds like it.

A unique range of five equalisers gives you total control over the sounds you want – with none of the sound you don't.

For more information send the coupon to:

Marketing Services, Sony Broadcast Ltd.,
Belgrave House, Basing View,
Basingsoke, Hampshire RG21 2LA.
Telephone (0256) 55011

Name _____ Position _____

Company _____

Address _____

_____ Tel: _____

SS/8/87

SONY[®]
THE LEADER IN DIGITAL AUDIO.

STUDIO SIXTY

Studio 60 in Lausanne has evolved over several years and, like many other studios even the name reflects a previous address. The present studio is very close to its former location, in what could be loosely termed the commercial centre of Lausanne, and is situated on the second basement level of a modern industrial building. In terms of basic construction there are, of necessity, thick concrete walls and solid foundations, and the studio is well isolated from ground-borne vibrations and exterior traffic noise. Fortunately, there is no underground railway nearby.

Studio 60 began as an 8-track (Tascam) demo studio belonging to a local group, whose sound engineer, Wolfgang Ehrlich, ran the equipment. They soon found themselves doing demos and local release records/cassettes for other people, which in turn enabled the facilities to be improved gradually. The studio then became a separate entity and ended up as a fully-fledged 24-track professional recording studio. As the original address had now grown too cramped, when the opportunity to move arose it was taken.

The studio area now consists of Studio A, which is the fully professional facility, and Studio B, which is primarily a demo/budget studio. The next step will be to convert the rest of the space available into a comfortable reception and lounge area—though as the studio is in Switzerland, one is never far from a bistro!

Studio A

Helmuth Kolbe designed the control room firmly around the *LEDE* concept.

Basement studios often tend to have a height problem and though not exactly a gothic

cathedral, the ceiling is—at 3.5 m with an interior maximum of 3.1 m—more than enough to keep out claustrophobia. Though the room is quite small, it has been laid out for maximum efficiency and it is quite easy to move around in.

The front of the room—just over a third of the total—is completely non-reflective and features Sonex tiles on the walls and ceiling. The ceiling slopes up from the front wall to drop down slightly at the rear and the front side walls 'waist' inwards before splaying out to the rear in order to present irregular surfaces to the first reflections.



Wolfgang Ehrlich, engineer at Studio 60

EBONY

Ebony Recording Studios are situated in the small town of Wohlen, just outside Zurich. The setting is suitably rural and low-key, with an abundance of good restaurants and watering holes.

The studio is in a country-style house that blends in with the rest of the local architecture and is set back from the main road. Access is easy and there are private parking places belonging to the studio.

Running Ebony is Bernhard Staub (otherwise known as Bernie), who took over the studio from the previous owner in 1983.

"I was originally a musician and often had a hard time getting the sounds I wanted in the studio. I felt that probably the best way to remedy this would be to learn the job myself and I took an engineer's course at the Recording Workshop in Los Angeles. I was then able to gain a lot of practical experience by working as second engineer at the Chateau Studio in Santa Monica before coming back to Switzerland.

"At that time the studio here was called Spectrum and I was engaged as studio engineer to help oversee the construction and installation. The owner then wanted to concentrate more on A/V work so I took the studio over and changed several things (such as the console and the name) to fit in better with my own ideas."

The acoustic design has been a joint effort, with

the control room and some of the studio being done by Hellmuth Kolbe and the rest in-house.

The construction of the building meant that the acoustics had to be built around it—taking out the large wooden beams would have had undesirable consequences—but on the positive side this has added to the charm of the studio atmosphere.

The control room measures 80 m³ and has been

designed around *LEDE* principles. "I like the *LEDE* concept, which is why we asked Hellmuth to do the design. I feel that the liveness in the rear of the room makes the sound more natural and true-to-life—and thus more comfortable to work with. We often have long sessions in here without getting fatigued and this is very agreeable.

"The combination of Tannoy *Super Red* monitors with the *LEDE* acoustic seems to work very well—both for us and our clients."

The front end of the control room features the absorbent, padded surfaces typical of *LEDE* rooms with the live end consisting of splayed wooden



Bernhard Staub, owner of Ebony Studios

SOUND ENGINEERING

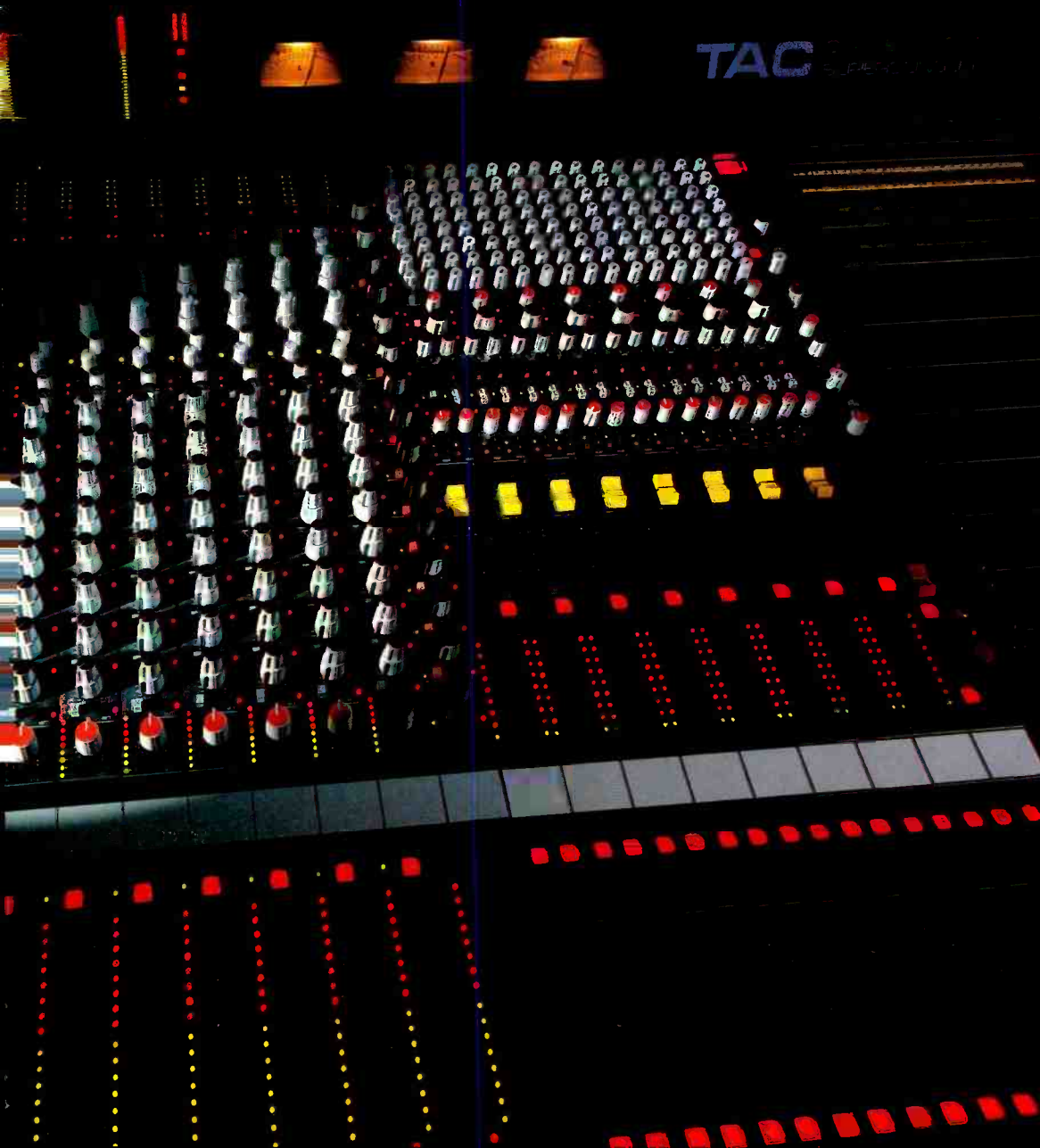

Sound Engineering in the eighties demands more from the console than ever before – the SR9000 is the engineers response to those demands.

Features include:

- ★ 42 Inputs
- ★ 16 Aux sends
- ★ 16 Subgroups
- ★ 8 VCA groups
- ★ 8 Mute groups
- ★ 16x8 Output matrix
- ★ 4 Band parametric EQ
- ★ Comprehensive jackfield
- ★ In-place solo system
- ★ Optional input extenders

S · R · 9 · 0 · 0 · 0
SUPERCONSOLE



TAC

TOTAL AUDIO CONCEPTS

Sales and Factory
TOTAL AUDIO CONCEPTS
Unit 17, Bar Lane Industrial Park
Bar Lane, Basford,
Nottingham NG6 0HU
Tel: 0602 783306
Telex: 37329 AMEKN1 G
Fax: 0602 785112
E-Mail: DGS 1947

In the USA
AMEK CONSOLES INC.
10815 Burbank Blvd
North Hollywood, CA 91601
Tel: 818 508 9788
Telex: 662526 AMIK USA
Fax: 818 508 8619
E-Mail: AMEK@S

STUDIO SIXTY

The live part of the room consists of wooden panelling on the walls and ceiling together with Schroeder quadratic diffusors on the rear wall flanked on either side by large plexiglass deflectors. The diffusors operate over two overlapping frequency bands to ensure a smooth, broad range response. The upper frames are inclined down into the room, the lower set remaining vertical.

The treatment behind the external surfaces consists of tuned resonators and low frequency absorbers, with the whole structure being fully isolated and floating from the main building. The floor is parquet with the exception of a carpeted area in front of the console.

A slightly unusual feature of Studio A is that though the control room wall is next to the studio, there is no window—just two TV monitors linked to several cameras installed in the studio. Was there any particular reason for this?

“Yes,” laughed Wolfgang, “it was a lot cheaper than a window! The dividing wall is thick reinforced concrete and it would have cost a fortune to pierce and install a window. The other reason is that we have found over the last couple of years that 95% of the work is in the control room so the expense of a window was not really warranted.

“In fact, working with CCTV has provided more positive benefits than anything else. First of all, the isolation is much better between the two rooms—virtually to the point that there is no leakage—and secondly, we have found that the

musicians actually like it. Without the window, they feel less distracted and can get on with playing. I always found a problem with ‘friends of the band’ coming in during sessions; the musicians tended to end up playing for the gallery rather than getting on with the job in hand. The layout here means they can work in peace and when they want to hear the result through the monitors they can take the few steps round to the control room.”

The monitoring system has been custom-designed and built by the Swiss company, PSI, with a lot of input from the studio. The system is 3-way and features a special crossover with active sections between the bass and mid-frequencies and passive filtering for the mids and highs. There is also a passive protection circuit that works on heat sensing and shuts off the system when the temperature is just under danger point.

“However,” Wolfgang explained, “unlike some protection systems, the signal does not pass through the protection circuit and suffer from the associated problems such as impedance changes, resistive load, etc. This way it stays untouched—or turned off!”

The enclosures are vertical monitors with an RCF 15 in (38 cm) bass driver, ATC mid range dome driver and Cabasse tweeter with the components phase-aligned both mechanically and electrically. Frequency response is quoted as 30 Hz to 22 kHz ± 2 dB.

Power for each speaker system is provided by a Yamaha 2200 amplifier mounted just underneath

the enclosure thus providing the shortest possible cable run.

“The monitors are the result of a lot of R&D work and sleepless nights. From the start I wanted to have a system with dome drivers and an extended frequency range. We have certainly been very pleased with the result—and so have our clients.”

Listening to some CDs showed the sound in the control room to be very even and peak-free, standing up or sitting down, and capable of quite high pressure levels without strain.

“It is clear that the diffusors do serve a very real purpose in making the room sound bigger than it really is and thus a lot more comfortable. We did try it without them and the room sounded very small in comparison!”

Secondary monitoring is available in the form of a pair of NS-10s (with the obligatory tissue paper) mounted on the console overbridge, though Wolfgang noted, “We tend to use the main monitors far more than the Yamahas. People are realising more and more that the monitors are designed to work with the room and we are using the nearfield less and less.”

The main equipment in Studio A consists of an MCI 628 28-channel console with automation, Otari MTR-90 24-track recorder and Otari MTR-12 master machine equipped with Dolby SR. Digital mastering is also available in the form of a Sony PCM 701 processor with Betamax VCR. Copying and other general duties are taken care of by a Revox PR99 and Alpine cassette recorder (“one of the best cassette machines on the market”).

The outboard equipment is mounted in a quad 19 in rack behind the console; rather in the same manner as in film re-recording studios. The top provides a handy surface for keyboards, drum

EBONY

panelling on the side and rear walls and the rising ceiling. The floor is carpeted at the front and parquet at the rear.

The Ebony control room is probably a good contender for the title of ‘largest in Switzerland’ and has a very spacious feel about it that makes the equipment look rather small and inconspicuous. The colour scheme of wood-brown and beige fabric makes for a restful atmosphere and it would be difficult to feel cramped: “We often have five or six musicians in here without the place feeling crowded!”

The Tannoys are powered by a Rauch 250 amplifier (“we went through several amplifiers and the Rauch just seems to do the job”) and equalised via a Klark-Teknik 360 graphic.

“Most of the time we are bypassing the equaliser. However, some clients like what we call a loudness curve, which is basically a bump in the bass, as a reference.”

Secondary monitoring consists of JBL 4313s situated underneath the Tannoy monitor bridge on stands and powered by a BGW 750 and Revox and Auratone speakers powered by a Pioneer hi-fi amplifier. (I must confess that on playback of some material recorded at the studio, I have never heard Auratones sound better!)

Recording centres around a Harrison MR-2 console (40-channel frame fitted with 28) with Allison automation and a Studer A-800 MkIII multitrack.

Mastering facilities consist of Studer A-80 and A-810 recorders with Dolby SR, plus Nakamichi

and Alpine cassette recorders.

“The Dolby SR has proved very popular with clients—even though we have only had it for a short time. As far as multitrack recording is concerned, we try to run the A-800 at 30 in/s as much as possible and this combined with the SR mastering gives results every bit as good as digital.

“This is not to say that we are not interested in digital, however, prices will have to be more affordable before we can consider it and at the moment we are getting very good results anyway.

“At the moment we are getting more requests for 48-track than for digital and people say they are prepared to pay for the added facility. As far as digital is concerned, clients would obviously like it but they are not prepared to pay the extra rates that would have to be imposed. Digital is just too expensive at the moment for us to absorb the cost—and why should we, anyway? However, we are glad that there is SR.”

Most of the outboard equipment has been installed in an angled rolling rack and the rest sits in a rack against the rear wall. The Lexicon 224 XL remote sits on the console. Effects available include a Yamaha REV7 and two SPX 90s, Lexicon PCM-42 digital delay, Eventide Harmonizer, MXR delay/flanger/phaser/chorus, Roland SDD 320 chorus and phaser, Aphex B Exciter and Compellor compressor, UREI LA-4 and 1176 compressor/limiters and 545 parametric equaliser, BSS compressor/limiter and Valley People rack with Kepex II, Gain Brain and Maxi-Q modules.

The studio measures 320 m³ and is essentially live with a 3-sided dead area that is open to the studio and features a lowered floor and integral corner drum booth.

The studio has an irregular floor plan and the surfaces are wood panelling, parquet floor and stone walls painted white. The reflectiveness of the latter can be attenuated by drawing heavy drapes, and large isolation screens enable the studio area to be reduced. The atmosphere of the room is very pleasant and the large wooden beams contribute to the rustic feel.

The isolation room features a mixture of absorbent surfaces and wood-faced slat absorbers that keep the sound bright while remaining damped. The drum corner is all absorbent with a reflective panel overhead for the cymbals and the area can be further isolated if necessary with low screens.

Microphones are Neumann U89, KM84, KM56 (valve), Schoeps, AKG (including *The Tube*), Shure (“I like the SM7 for drums a lot though it is a good all-round microphone”), Sennheiser and Electro-Voice. The studio also has a hire arrangement with one of the local distributors in order to meet the needs of musicians.

“The live sound of the main studio is very popular as it makes the instruments come to life and musicians can get a very good ensemble feel in the room. In spite of this the separation is very good and it is rare that we have to put up screens. People tend to comment especially on the piano and drum sound that we are able to get.”

The foldback system enables musicians to have stereo mixes from the control room and they can modify it themselves with a D&R monitor mixer that is installed in the studio. “Rather than someone saying can they have more of this and/or

A STAR IS BORN!



X-86

2 TRACK
DIGITAL AUDIO

The X-86 digital 2-track is the first system compatible digital mastering machine. Experience gained in producing and delivering over 300 digital audio machines over the past three years, and our recent advances in high density recording and LSI technology have resulted in a leap into the second generation of digital 2-track audio.

The X-86 is the key to total self-sufficiency in digital mastering, all functions can be carried out without any external equipment, and we've built in a performance capacity so advanced that it'll be in a class of its own for many years.

With frequency response flat from 20Hz to 20KHz, dynamic range of more than 90dB, distortion of 0.05%, the X-86 will virtually outperform any other machine on the market. Unique features include 14" reel



capacity, tach or SMPTE counter, built-in autolocator, external sync input, two analog cue tracks, time code track and auxiliary digital track, ideal for recording sub-code information during CD mastering. Simple razor splice editing, low power consumption and easy servicing complete an unbeatable specification.

With the new 16 channel X-400 multitrack now available, the cost of high quality PD compatible digital audio throughout the whole recording process is becoming increasingly affordable. Compared to other 2-track digital systems available, the X-86 is highly cost-efficient, and, considering its technological advances, is surprisingly close in price to the best analog machines on the market.

To get a little Mitsubishi into your professional life, phone Adrian Bailey at Mitsubishi Pro Audio and ask for a demonstration.



MITSUBISHI PRO AUDIO GROUP
DIGITAL ENTERTAINMENT CORPORATION

Headquarters: 225 Parkside Drive, San Fernando, CA 91340 • Phone (818) 898-2341 • Telex: 311786
New York: Suite 1530, 555 W. 57th Street, New York, N.Y. 10019 • Phone (212) 713-1600 • Telex: 703547
Tennessee: 104 Eastpark Drive, Suite 306, Brentwood, TN 37027 • Phone (615) 371-6602 • Telex: 510617477
Canada: 260 The Esplanade, Toronto, ONT. M5A 1J2 • Phone (416) 365-3363 • Telex: 06219839
United Kingdom: Unit 13, Alban Park, Hatfield Road, St Albans, Herts. Phone 0727 40584 Fax 0727 67684 Telex 826542



STUDIO SIXTY

machines, etc and the front of the racks is sloped for better visual contact, as well as to reduce unwanted acoustic reflections.

Equipment at the time of our visit included Apex *Compellor*, Audio+Design 760-RS *Compex* compressor/limiter, Lexicon *PCM-60*, Yamaha *D-1500* digital delay, three Teletronix *LA-2* limiters, *UTP 1* valve (tube) preamplifier, ADA *Pitchraq* pitch transposer, Roland *SDF-325* stereo flanger and *SRV-2000* digital reverb, Yamaha *REV7*, Lexicon *Prime Time*, Roland *SDE-2000* DDL and a *Dimension D*, Rebis rack with compressor, gate and autopan modules, Publison *Fullmost*, *REV7*, Roland *SMX-880* line mixer (8/2) used as effects mixer for the reverb and echo units, mic patch panel, Ibanez *GE-3101* graphic equaliser, TC Electronic *TC 2240* dual 4-band parametric, Furman *PQ6* dual 3-band parametric and two Unit 8 27-band graphics.

The number of digital effects is completed with a Lexicon *224X* and *224XL* which shares its *LARC* remote controller with a *480L*.

Studio 60 also have quite a comprehensive MIDI setup based around an Atari *1040 ST* computer/Steinberg *24* complete with Steinberg *SMP24* timecode unit featuring four MIDI output channels.

"The Atari/Steinberg combination is very flexible and easy to use, as well as having a lot of possibilities. For any studio that is getting into MIDI for the first time—or even upgrading—it is well worth consideration."

The studio uses the space available to the maximum advantage. The feature immediately noticeable is that one wall consists of a massive wooden Schroeder diffusor ("four tons of wood in all") that increases the apparent size of the room quite dramatically.

The studio area features a completely asymmetrical floor and ceiling plan and is divided into three distinct areas: a live part bounded by the diffusor and wood-faced slat absorbers, with a wood ceiling and parquet floor; an overdub area with parquet floor, absorbent ceiling and bounded on one side by a wooden wall and on the other by glass; a drum corner with carpeted floor and small dais, absorbent side walls and small overhead wooden diffusor. The drum area can also

be closed off from the rest of the room by two curtains.

The sound is very much under control in each of the different areas; the overdub section retained a bright sound with a short reverberation time. A tinkle on the Yamaha mini-grand confirmed the acoustic characteristics of the live area while the drum corner remained suitably non-reflective without being dead.

Studio B

"This is intended as a low cost room where clients can come in and do the engineering themselves—although we can provide staff if necessary. The room is quite sufficient for making demos, tracking or publicity work such as jingles, etc. As much as anything it allows groups to get recording experience—as well as being a training ground for future engineers—with professional equipment.

"We now have the situation where anyone with a Tascam or a Fostex considers he has a studio and charges absurdly low prices in order 'to be in the business'. In order to counter this we have installed Studio B: we do charge what is admittedly a very low price but we find that we are benefiting in several ways. Firstly, people are coming in to do demos which often turn out better than they expected and they end up by booking Studio A for the mixdown. We are now doing a lot of work for local radio and advertising agencies and this can easily be done in B which means that A is free for other work.

"Another positive reaction is that musicians are meeting each other on common ground. As a general rule, the Swiss keep very much to themselves but the barriers are starting to come down a bit now which will be very good for the local music scene."

Studio B is a small rectangular studio with minimal treatment, though it does actually sound quite good, and a small control room.

At the time of our visit the Dynamix console was living out its last days and by the time this is in print will have been replaced by a Soundcraft *TS12* 32-input frame fitted with 24.

Multitrack is an Otari *MX-80* 24-track with mastering on an Otari *MX-5050*. Other machines include a Revox *B77*, Otari NAB cartridge recorder and Alpine cassette.

Outboard equipment consists of a Teletronix *LA-2* limiter, MXR *Pitch Transposer*, Psionics 4-channel noise gate, Tascam dual parametric, Fostex stereo compressor/limiter, *REV7*, *PCM-60* and *EXR Exciter*. Monitoring is PSI with Yamaha amplification.

Future developments

Studio 60's clientele is not just local and they have productions coming in from France and as far afield as the USA, which puts them firmly in the international league.

"People do like working here," said Wolfgang, "and we are very keen to develop the international side of our activities. Bookings for the rest of the year are very good and I am very confident about the future.

"The next step will be to change the console. The MCI has been very good and never once given any trouble. However, we are finding that we are getting short of channels now and we are starting to look at possible replacements."

And digital multitrack?

"I tend to have a phone call each week from the distributors of the various systems—and each time the price gets lower! Maybe if I wait long enough they will give us one. Seriously, I think the introduction of the double standard has done far more harm than good and is holding everything back. Digital is still very expensive and now that we have *SR* there is another compatible option open to us. Certainly the results obtained on mastering with *SR* have been great and a lot of clients prefer it to digital. I think we are also going to see a rapid advance in hard disk editing systems and these will also be a viable alternative. I am certainly not going to buy a digital multitrack that may be half the price in six months time! If a client wants digital we can hire it in without any problem."

Switzerland had never been exactly an international recording centre, no doubt due in part to the relatively inactive local music scene. Studio 60 have managed to throw a stone into the pond and perhaps the ripples will stir things up even further.

Studio 60, rue de la Vigie 3, 1003 Lausanne, Switzerland. Tel: 021 22 63 32.

EBONY

less of that and modifying the main foldback mix, they can just add in to their own feed and not disturb anybody else."

In addition to the studio area, the house also contains two more rooms that can be used as separation rooms, rehearsal rooms or whatever. One room is about 4x7 m and features slat absorbers on the walls for a fairly bright acoustic that is not too reverberant. The room is flanked on one side by a smaller room that can serve as an overdub booth or mini-control room for the second room, with a window system between the two. The larger room also has a window that can look through into the dead area of the main studio.

"We are still in the process of equipping these rooms but they can serve several purposes. For instance, the large room can be used as a control

room for either the drum booth or the adjoining booth; either that or as a studio/rehearsal room with the booth serving as a control room. The acoustics of both rooms are similar in conception and give us just that extra bit of flexibility."

Listening to some tapes done in the studio revealed a very open, uncluttered sound—the music breathed—which made a welcome change from the welter of sound that one is often faced with.

I found the stereo image stable throughout the length of the console and the sound did not change noticeably from a standing/sitting position; the same applied when varying the volume from soft to loud to soft. The bass remained well-defined at all levels and indicated a good monitor-to-room interface.

Ebony tend to do a variety of productions

ranging from hard rock (Chris von Rohr of Krokus recently recorded his solo album there) through to jazz and chamber music. Looming on the horizon is also some A/V work and the studio will be installing a U-matic with a synchronising system (as yet undecided) during the summer for some upcoming projects. Ebony also have a good track record as regards the Swiss charts and May saw three of their clients in the Swiss top 30.

"We would like to expand our international clientele and working for companies such as Polygram and Teldec has brought in custom from outside."

Though not a residential studio, accommodation can easily be arranged in Wohlen at reasonable prices (another advantage of being outside Zurich) and a 'producer's office', complete with telephone and telex, can be quickly installed in the studio.

A last but not insignificant feature of Ebony is the very pleasant garden at the back of the house where clients can relax with a cool drink between takes.

Ebony Recording Studio, Parkweg 8, 5610 Wohlen, Switzerland. Tel: 057 22 73 72. □



IT DOESN'T MAKE A BAD STUDIO GOOD. IT MAKES A GOOD STUDIO BRILLIANT.

Otari's new DTR 900 digital multitrack recorder isn't the first digital recorder on the market.

But it's undoubtedly one of the most advanced.

For a start, it includes Otari's legendary pinch-rollerless transport.

It combines outstanding sonic performance with utter practicality for the operator.

And best of all, it's ready to work with complete reliability, 365 days a year, from the first day it's installed in your studio.

If that sounds like a machine your studio could use, we'd be delighted to send you a fuller description of it, in our literature.

Alternatively, we'll be happy to arrange a complete demonstration.

But first, we'd like to warn you that the DTR 900 sells for a fairly serious sum of money. And no recording machine – even one as advanced as ours – will make an average studio better than it is.

But all we can say is that if your people have the skills, the DTR 900 will make them shine as never before.

THE OTARI DTR 900. DIGITAL FOR PROFESSIONALS.

Otari Electric (UK) Limited
22 Church Street, Slough, SL1 1PT, Berkshire.
Telephone: (0753) 822381. Telefax: (0753) 823707
Telex: 849453 OTARI G

Otari Corporation,
2 Davis Drive,
Belmont, California 94002
Telephone: (415) 592-8311
Telefax: (415) 591-3377
Telex: 910-376-4890 OTARICORP BLMT

Otari Electric Co Ltd,
4-29-18 Minami-Ogikubo,
Suginami-ku
Tokyo 167
Telephone: (03) 333-9631
Telefax: (03) 331-5802
Telex: J26604 OTRDENKI

Otari Singapore Pte Ltd,
625 Aljunied Road,
07-05 Aljunied Ind,
Complex Singapore 1438
Telephone: 743-7711
Telefax: (743) 6430
Telex: RS36935 OTARI

Otari Electric Deutschland GmbH,
Rudolf Diesel Strasse 12,
D-4005 Meerbusch 2
West Germany
Telephone: 010 49/2159/50-861, -862 or -863
Telefax: 010 49 2159 1778
Telex: 8531638 OTEL D

New sounds only change what we hear.

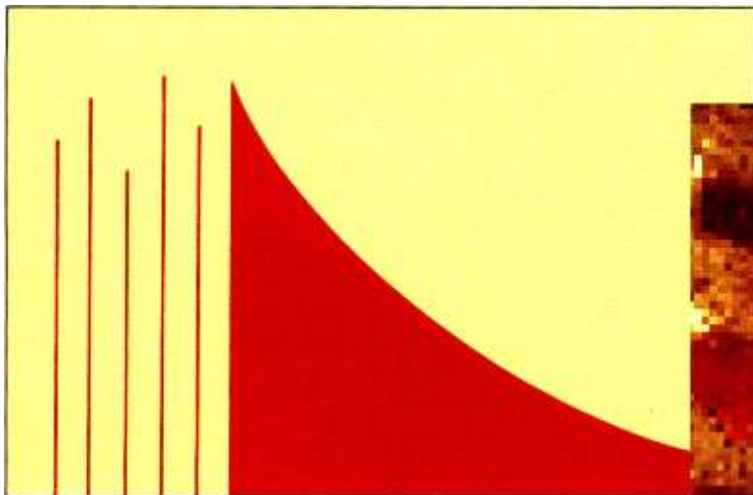

Digital reverb sounded like this.

First generation digital reverb offers control over a few discrete pre-echos. These are followed by the exponentially decaying reverb envelope typical of plates or small chambers.



New approaches to ambience, imaging and sampling

The new 480L digital effects system from Lexicon was created to produce more accurate room simulations. However, within its innovative software and hardware are possibilities that extend far beyond the limits of realism: combinations of plate, gated and ambient reverbs, unique cascaded time-based effects, sampling. Personal settings can be stored and transported on RAM cartridges.

Controlled from the familiar LARC, the 480L's multiple high speed processors operate in several configurations. Samples can be processed with reverb and time-based effects, all in the digital domain. Two control rooms can use one 480L. Or two 480Ls can be connected through their digital I/O ports. A 480L can even be connected to a 224XL and both units operated from a single LARC.

Moving forward by looking back

The 480L is a generation beyond other digital processors in both hardware and software. Yet many of its advances were conceived in centuries-old con-

cert halls. Close analysis uncovered basic flaws in the usual digital techniques of ambient simulation.

In real halls, the rate of the first 15 dB of decay is crucial to the perception of spaciousness and ambience. For many listening positions, this initial decay is longer than the measurement of total reverb time would suggest. To emulate these fine old halls, it is necessary to control the initial decay independently of the overall reverb time.

Hall programs of unprecedented realism

The initial reverb envelope defines apparent room size and ambience to the ear. In real spaces, this buildup and decay is gradual, with a complex, non-exponential profile. The use of digital pre-delays does increase apparent room size, but adds unnaturally defined attacks that make the sound artificial. The 480L's SHAPE and SPREAD parameters emulate the complex profile of natural reverb. SHAPE affects the contour of the reverb envelope, while SPREAD controls the time factor for that contour. When balanced with SIZE (reverb density) and RT60 MID, SHAPE and SPREAD create deep, warm, spacious ambience without excessive decay times.



Unit B, 346 Frenchs Forest Road Frenchs Forest NSW 2086, Australia, PO Box 942, Brookvale NSW 2100, Australia, Sales (O2) 975 1211 Service (O2) 975 1255 Accounts (O2) 975 1477 Fax (O2) 975 1368

 **ELECTORI CO., LTD.**

MONDO BLDG 1-19-3 KAMIOCHAI SHINJUKU-KU TOKYO JAPAN (163)
TELEPHONE *TOKYO/03/1950 6266 TELE *2723116 CABLE ADDRESS *ROHICHEL ECT TOKYO



GRISBY MUSIC PROFESSIONAL s.r.l.
Via delle Industrie, 4
60022 CASTELFIDARDO (Ancona) - Italy
Phone (071) 781714-5-6 - Fax (071) 7819048

Only new ideas change the way we listen.

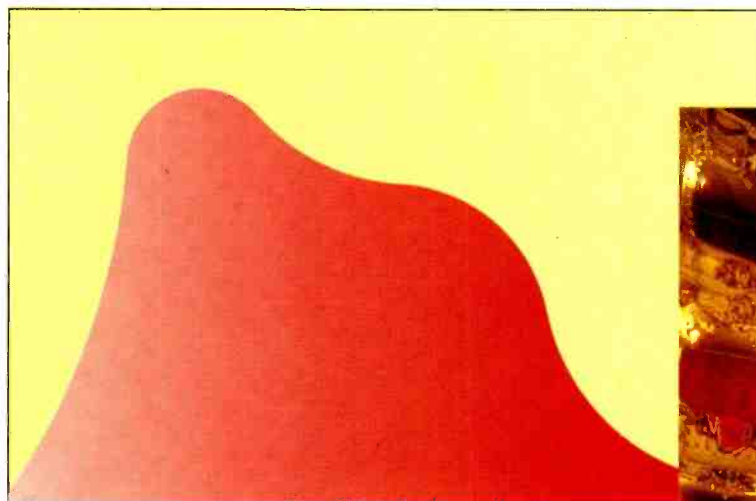

Now we have a clearer picture.

The 480L's innovative SHAPE and SPREAD controls continuously adjust the diffused reverb profile to match the ideal ambience characteristics of a real hall — with uniquely natural pre-delay.

Digital processing for digital production

The 480L is engineered for the unforgiving all-digital audio environment, with its higher standards of accuracy and dynamic range. The PCM 1610/1630 compatible *digital I/O interface* lets you add true stereo ambience and sampling, *all in the digital domain*. 18 bit linear internal architecture and converters produce a wet signal dynamic range of 98 dB. Now you can add reverb without adding noise — even on a digital master.

The next stage — and beyond

Right now, the 480L is a powerful and dramatic step forward in digital signal processing technology. Yet its present software doesn't strain the architecture, which is itself designed for future hardware additions. If you need continually expanding creative options more than disposable packages of cliché sounds, experience new possibilities. Treat your ears — and your imagination — to an hour with the new 480L Digital Effects System from Lexicon.



Gexco International Inc. is the worldwide distributor of the Lexicon 480L and other high quality products for the recording, broadcast and postproduction industries

lexicon

Stirling I/A

1 Canfield Place, London NW6 3BT, Tel. 01-625 4515
Fax: 01-372 6370, Tlx: 946240 CWEASYG, Ref. No. 19014280

interSONIC

Box 421 33, S-126 12 STOCKHOLM

GEXCO

GEXCO
INTERNATIONAL

317 St. Paul's Avenue, Jersey City, NJ 07306/USA
(201) 653-2383 Telex 285261 GEXCO



MASTER CLASS FOR CLASS MASTERS

Analogue it may be, performance it most definitely has, with lower noise than 16 bit digital playback, having a dynamic range in excess of 100dB, packed with features, and looks to match.

- Fully modular ● 24 Bus ● Split and in-line configurations ● Capacity for 60 modules, + producers desk option ● Fader automation ready ● Dual operating levels on separate connectors ● SSR Remote as standard, giving MIDI synced muting ● Balanced inputs and outputs ● Silent FET mute switching ● Gold on gold edge connector system

The list of well designed, and expertly engineered features goes on and on. For complete information on the SIGMA 24 console range, make contact NOW.

 *Mixing Art with Science*

Allen & Heath Brenell Ltd, 69 Ship Street, Brighton. BN1 1AE. UK Tel: (0273) 24928. Telex: 878235 MBI AHB G.

AHB USA. 5 Connair Road, Orange, Connecticut 06477 USA. Tel: (203) 795 3594.

RHETT DAVIES

Ralph Denyer goes to Chelsea and finds out why Rhett Davies regards himself as the practical way to an artist's dreams

Since the late '70s the name of Rhett Davies has been synonymous with several influential bands and artists handled by the London-based EG Group of companies, who also manage Rhett. He engineered Roxy Music's *Manifesto* before going on to co-produce *Flesh & Blood* and *Avalon* with the band. He co-produced Roxy frontman Bryan Ferry's enigmatic *Boys And Girls* album. He co-produced *Another Green World, Before And After Science* and *Music For Films* with ex-Roxy member Brian Eno. Through Eno he met Roxy guitarist Phil Manzanera and engineered his *801* and *801 Live* albums.

He co-produced the King Crimson '80s rebirth albums *Discipline* and *Beat*. Other credits include the B-52s, Russ Ballard, Huang Chung, OMD and the Starjets. He produced 'Til,

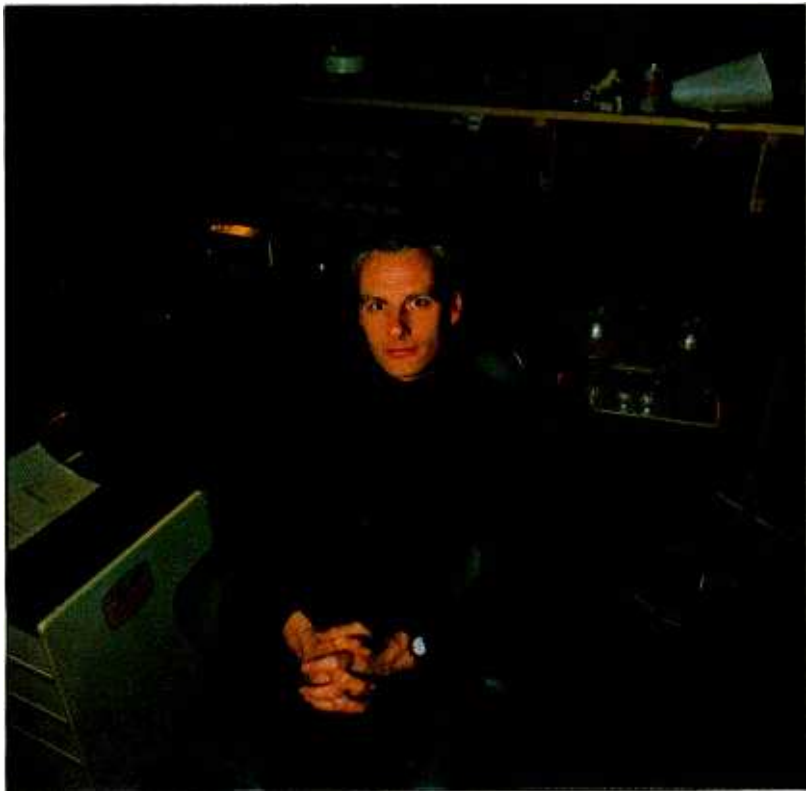

44 Studio Sound, August 1987

Tuesday's recent *Welcome Home* album and has one in the can with American singer Nancy Shanks.

The interviews took place in a studio owned by EG, tucked away amongst Chelsea's immaculate white-painted houses festooned with well-trained greenery.

Rhett's first interest in music was stimulated by his father Ray: "In the '60s he was the top session trumpet player. Every time you hear a British '60s record with a trumpet solo on it, it's my Dad. I was keen on the trumpet and studied the instrument during any school holidays and I went on to Trinity College of Music when I was 16 or 16-plus. My father used to take me along to recording sessions he was doing which I found very interesting."

Rhett thought the lot of the '60s session player—spending a great deal of time sitting in the studio reading a paper waiting for a take—very boring. "The musicians would be called upon once in every blue moon to play a couple of notes and I thought that didn't look very interesting. One particular session my father took me along to was with my idol at the time, Burt Bacharach. I'd just seen a TV documentary on him and I wanted to be a songwriter. That was it—I wanted to be a songwriter. We went along to a studio where he was doing the music for *What's New Pussycat*. I was really bored but I knew that my hero was in this dark room at the end of the studio. Eventually I got to go in and meet him and that was the first time I'd been in a control room. I thought: This is where it's all happening, not out there in the studio. This is where the seat of power is—in this room."

Rhett's interest in the trumpet began to wane. "I didn't even know what a recording engineer was but that appealed to me. Mind you, I must admit *then*, I still wanted to be a songwriter."

While driving a van for a living, he scoured the ads for jobs in the London *Evening Standard*. He eventually found one for a tape-op at Island Records' Basing Street Studios and called studio manager Penny Hanson who asked his age. He said he was 22 and was told they weren't interviewing anyone over 21.

"I put the phone down feeling very dejected, went and had a cup of tea, phoned straight back and said I was 21 and got the interview. Another six months of bashing on their door and they gave me a job."

By the end of the following six months he was engineering the occasional session. He was popular with studio clients who would ask to work with him, forcing the pace at which he progressed from tape-op to engineer. "Studios don't turn down business and tell clients they can't have the engineer they want for a particular project. These were only small projects—singles, mixing and things like that. But within a year or 18 months I was made a fully-fledged engineer."

His first complete album project as an engineer was for a "weird character" he had seen around the studio. That was Eno and the album was *Taking Tiger Mountain (By Strategy)*. There was no designated producer on the album which Eno had written and extensively demo'ed with Phil Manzanera.

"At the end of that album Eno phoned me up and said that he was so impressed with the work that he would like me to co-produce his next album. I couldn't believe it. I mean, my first fully-fledged engineering job, the first record I make, and the guy's offering me co-production on the next one. So it just snowballed from there."

It seems many successful producers have a relatively short period as an engineer before moving on to production.

"I don't think the job is that tough at all. It's a very easy job once you get the basic hang of it, which really doesn't take more than a few months. Obviously, it takes years to gain the experience and you have to make all the mistakes to know what's right and wrong. Being a good engineer is more than just doing the job well. I think character has an awful lot to do with it. The way a person behaves in the studio, the way he gets on with people, what his general outlook and personality is like. That's all as important as the actual job they do technically."

"As regards the technical side of what goes on in the studio, I'm not the best equipped at it and I really don't know half of what I'm doing half the time. But what I have been blessed with is a good set of ears. I know what I like, I know when something sounds right. A lot of the times on my early records when I was engineering, I had *no* idea what I was doing. Technically it was a mess but the end products sounded right. I might have bent the needles or whatever, I may have got

everything wrong, got all my limiting thresholds wrong but the sound, the output, was what was wanted so I got away with it.

"Working with Eno we struck up a very good working relationship. He taught me an awful lot about how *not* to make records. When I say that I mean that his approach was totally different to anyone else that I'd ever met or been involved with.

"His whole idea was to discard every normal route you would take to making a record: there had to be a more interesting way of making records. And we failed lots of times. I remember one instance when we spent a whole day creating a piece and at the end of the day he walked in and made me slam all 16 tracks into Record and just erase the whole thing. I thought it was a whole day's work gone but it was disposable to him. If it didn't work, get rid of it and the next day, another clean sheet. But while making those albums I did with him, we would do 30, 40 or 50 sketches of music from which eventually the album would be compiled. When we finished one of the records we said: 'What are we going to do with all this stuff that's left over?'"

"So we spent a week just going through the whole lot and doing very weird mixes. Like half-speed mixes, like leaving all the main instruments and just featuring all the background instruments. We compiled that and made up what was his first *Music For Films* album, which was distributed to all the TV and film companies throughout England—a free copy was sent to all of them—and from that he got so much TV work. He was so surprised by the success—and the money he got from that—that his whole 'Ambient Music' thing emerged. So it was a good way of getting rid of reject stuff."

This must have been about the time that Eno launched his Oblique Strategy Cards on an unsuspecting world? "Yeah, that came about when we were making *Another Green World* I seem to remember. Yes, we used those a lot during the recording. I still have a few sets at home and tend to bring them out when I work with a new client, just for a laugh."

The theory behind the Oblique Strategy Cards is that when a session is lacking in creativity and momentum, deal out a card from the pack. Each card gives an instruction which should be followed, no matter how bizarre it may seem. "The fun," Rhett explained, "is actually to use them. And some strange things can happen. On one particular track on one of Eno's own records we pulled out the cards and one said: 'Listen to the radio'."

"We went upstairs to the maintenance room or wherever and the first thing we heard was Sandy Nelson playing *Let There Be Drums*. So we went straight down to the studio and put some drums down and it worked. It's a crazy way to approach making records but my philosophy has always been that if you're stuck for an idea, then just try *anything!* The worst thing is sitting around and not doing anything, killing time or just fiddling around with what you've already got. So the cards—anything like that is good inasmuch as it will motivate you in one direction and you will instantly see if that is the right direction or not. There's a starting point."

It was during the mid '70s, while still an engineer at Basing Street that Rhett co-produced the Eno records and was happy to engineer Phil Manzanera's solo albums *801* and *801 Live*. He produced acts for other people but noted a distinct difference between EG projects and many others: EG saw that he was paid his promised production points. If he had counted on royalty points promised on other projects that he also engineered, he would have been in dire straits. EG's record for being totally sympathetic to an artist's personal direction—even with left fielders such as Fripp and Eno—speaks for itself.

Listening to Nancy Shanks' debut album (soon to be released) and Bryan Ferry's mysterious *Boys and Girls* back-to-back, the difference in production in terms of mood, performance and sound—from backing tracks to lead vocals—was vast. Though Rhett says some people claim to be able to recognise his production work, these albums have totally different moods and atmospheres.

"I always like to think that I can capture an atmosphere not just on an album but also on a particular song. I like to deal with each track or song individually. And if I think a really cheap snare drum sound is going to work on a particular song, it doesn't worry me that it's not the greatest snare drum sound in the world. I guess the mood thing comes from working with Eno and also carrying that work on with Roxy Music and Bryan Ferry because they were very much atmosphere orientated records. We started with an atmosphere and built the song

around that atmosphere, more so on the later records that I made with them. I don't consciously go into making a record thinking that it must be atmospheric or moody. I don't have a set way of working at all. Working with a band, they have a particular way in which those songs were conceived, written or even played. You do actually find the odd band that goes out and plays songs before they go into the studio these days!"

"My first job when starting is to work out the best way to work with that particular band. With Bryan it would always be a clean sheet and building up from a single note, a chord or just atmosphere. Then a very laborious process just building a song out of that. With the Nancy Shanks album, most of the songs were pre-written. I was delivered a tape that had 10 or 12 songs on, two or three of which I really liked."

Of course, the general circumstances surrounding the Ferry and Shanks albums are different to say the least. Ferry—a major figure and innovator in popular music—was a man in search of something musically different and was able to set his own pace. Nancy Shanks has vast experience as a session singer, yet as a new act had to deal with some constraints regarding budget.

The credits for musicians on Ferry's album were such that at one point it was suggested that it might be easier to list people who had *not* played on the record. Luminaries involved included Andy Newmark, Nile Rodgers, David Sanborn and Tony Levin—musicians who might be expected to play in a tight and traditional sort of way. Yet the album has a prevailing atmospheric collage approach. Instruments appear momentarily and disappear, or move tantalisingly around in the mix. The Shanks album has far more of an orthodox 'band' sound.

The approach to making the two records was totally different: "The guy she co-wrote the songs with had them all programmed on an *MC500* which made it very easy for me to change the arrangement and move things about. We spent two weeks in LA with just a rhythm box and keyboards getting the arrangements, tempos and keys right for her voice. Then when we came to England with Nancy and the tapes the musicians walked in and could actually see a chart of the song, which is a very different state of affairs from *Boys And Girls*. Why Bryan's thing worked in its own way was we again cut 20 or 30 atmospheric pieces of music. Sometimes they would have to be speeded up to an enormous degree—sometimes as much as a tone—to make a song out of them. Because Bryan and I would just sit and twiddle around, I would come up with a groove on the drum machine, he would come up with some nice chords on a keyboard, and a stretch of tape with some music would emerge.

"The next stage would be for Bryan to sing on those tapes—any sort of scat vocal, lah-de-dah or whatever—to see which pieces of music would take vocals and what melodic possibilities there were. We would end up with 15 or so out of the original 30 pieces of music that were potential songs. We would then start to wheel in the musicians one by one, over a long period. Here, you are not assembling the likes of Andy Newmark, Neil Jason, Neil Hubbard or Chester Kamin to all play together. They are walking in—they don't even have a blank tape. They have a stretch of tape that has music on it, which has atmosphere on it. And they respond to what is on the tape, which is Bryan. He admits himself, he's not technically good enough to play along with the band in the studio. He'd much rather have his idea, his form, down on tape and then let the musician react to that, be it badly or well."

As well as top session players, several major name musicians—including Dave Gilmour, Mark Knopfler and Nile

It's a crazy way to approach making records but my philosophy has always been that if you're stuck for an idea, then just try anything!

RHETT DAVIES

If there is a relevant delay that works for the part and works for the song, I print it when I record the instrument

Rodgers—also played on *Boys And Girls*. “Somebody might come in and spend a whole day doing guitar parts and the week after we might decide we don’t really like that guitar because it’s taken the track in a wrong direction. We’ll get rid of it but there’s that one phrase in the second verse that is worth keeping. And somewhere on the outro he played a line that was really nice. Maybe we can stick it in the AMS and use it in a few other places. So that is how *Boys And Girls* was made over a very long period of two years, off and on. There were lots of breaks in between but that is how, over a long period of time, you end up with all these little bits everywhere. One of them was maybe recorded during the first month of making the record, another one might have been done in New York at the Power Station eighteen months later. It’s a total mishmash but it works. And I must say it’s a very enjoyable way of doing it, even if you do pull your hair out at times, because you do end up with something which is unique.”

For most of the recording of *Boys And Girls*, it was just Bryan and Rhett working away in The White House Studio. No other musicians, no tape-ops nor anyone else. The Trident desk was moved into the studio and there the two of them worked, most of the time in splendid isolation.

“I think that during the making of *Boys And Girls* we both realised—especially towards the end of the project—that we had exhausted and abused the system beyond belief and a new way had to be found.”

Rhett has no doubts about the fact that—although he loves

Over a long period of time you end up with all these little bits everywhere. It’s a total mishmash but it works. And I must say it’s a very enjoyable way of doing it, even if you do pull your hair out at times, because you do end up with something which is unique

Ferry’s working methods—two years is too long to spend making any album. He feels that when such a long period of time is spent aiming for perfection, music is in great danger of becoming stale through being overworked—not to mention the relationship between producer and artist.

“At the end of *Boys And Girls* I did another single, *Is Your Love Strong Enough* for him for the *Legend* movie, that took two months to do. One single, you know? I just realised then—and we had already started to cut some new songs for the next album—I thought: no, I can’t do another one.

“Bryan was no longer listening to me, unfortunately, and he does need some help and guidance. For me I needed to get out into the big bad world, with some other bands and some new people and to start enjoying making some records again, if you like.”

It was through Roxy that Rhett became involved with Bob Clearmountain who mixes their records and Ferry’s. “Bob always seems to have a great feel for the stuff I put on tape. I would always be interested to see how he would pan things compared with how I had panned them during general playbacks. Ninety-nine times out of the 100 he would do exactly the same but he had a great talent for making the hundreds of things we had on those tracks all work in a mix.

“*Boys And Girls* was doubly tough because we had worked 48-track and I must admit the experience of slaving up on that record put me off 48-track for ever. Obviously I’d worked that way before but never to that extent. There were so many things going in and out on *Boys And Girls* it was a nightmare to sort it out. Thank God for Mitsubishi.”

Though he admits to only having tried one other digital multitrack for a single day, Rhett felt the system did not offer significant enough gains above using analogue to warrant going digital. Through producing half of the Icehouse *Measure To Measure* album he met Andy Hilton who had engineered and produced their previous record. Hilton offered to let Rhett hire one of his Mitsubishi X850 multitracks for a couple of days on the understanding that if he found the machine as unappealing as the other digital multitrack he had tried, he would not be charged a penny of the hire fee.

“I’ve got to say that within an hour of using the machine, I was in love with it. I love the sound working digital with the Mitsubishi and I know going back to analogue now would be terrible. I would just hate it. I did one transfer on analogue not so long ago and I thought I was listening to a duff cassette. I could really hear that much difference when I listened back to the analogue copy. But I’ve got to say mainly I love the 32 tracks. It’s a great format, not having to slave up. Today if you are working with a band and you’re cutting a Linn 9000, DMX or whatever, the basic drum things that you’re putting down gobble up eight tracks straight away. OK, you can condense them and mix them down later or you can always have them running off SMPTE but I don’t like that. I like to have everything on tape that is going to be on the record. Any echo or delays, I print on to tape.

“Obviously, normal plate echo and stuff like that I leave for the mix but a special effect reverb or delays on guitars, that I print. If it’s right when you record something, it works.”

Rhett operates on the basis that if you listen to his tapes at any point in recording, the sound you hear is that which is intended to be on the final record. If a guitar is not to be used on a chorus, get rid of it. If he feels there’s only an outside chance of wanting to use something, he records it on a slave copy and puts the reel to one side.

“Obviously sometimes you don’t have as much space or you have more space than you thought you were going to have on a mix. But I very much like to keep my house in order as I go along. I think it’s very important. I don’t do any mixing myself these days, or very little. When I present that tape to the mixing engineer I know that there are no decisions for him to make as regards bouncing down, performances, all that has been taken care of.

“If there is a relevant delay that works for the part and works for the song, I print it when I record the instrument. Because you know from experience that you’ll never get it back the same. It could be the same equipment, everything could be the same but it never sounds the same and that starts to give you head problems. You begin to think something’s not right with the track. I like all the decisions to be made on tape as we go

THE NEW INTELLIGENCE.....STUDIOMASTER IDP1



The **STUDIOMASTER IDP1** represents a new "intelligent" approach to dynamics processing. In a 1U 19" rack mount package, it combines features and effects only previously realised by the use of multiple effects units.

The **IDP1** has two identical channels of dynamics processing, which may be used totally independently of each other, or quickly linked for true stereo operation.

Each channel may be configured to give one of the following effects:

- 1 Compressor
- 2 Expander
- 3 Limiter
- 4 Noise Gate
- 5 Inverse Gating (Ducking)

- 6 MIDI Triggered Gating/Ducking
- 7 Manual Futo-fading
- 8 MIDI Triggered Auto-fading
- 9 MIDI Pitch-Bend Fading
- 10 MIDI Controlled Amplitude

As a bonus, each channel has an extra function expander gate, which may be used simultaneously with the current effect to reduce any unwanted background noise, tape hiss etc...

The unique **DELAY** parameter in Compressor mode can be used to drastically reduce low frequency distortion, a factor prominent in virtually all other compressors.

The **IDP1** employs an incredibly easy editing system, one parameter - one key,

as opposed to other "page" type systems where parameters may be tucked away in the depths of the software.

For a full colour brochure, contact:

STUDIOMASTER

STUDIOMASTER, -Studiomaster House,
Chaul End Lane, Luton, Beds LU4 8EZ
Telephone: 0582 570370 Telex: 825612
STUDIO G Fax: 0582 570242

STUDIOMASTER INC., 1340-G Dynamics
Street, Anaheim, California 92806, U.S.A.
Telephone: (714) 524 2227 Fax: (714)
524 5096

RHETT DAVIES

along, that's basically what I'm saying. I'm a very neat person—be that good or bad.”

Rhett feels that his neat and organized approach to recording has been behind his success in producing Eno, Roxy, Ferry and other EG acts whom he describes as “very spontaneous artists who like to quickly throw ideas down when they feel hot at certain moments.” Rhett says it is essential to respond immediately to those moments; just get them on tape. “But then I like to take as long as it takes to sort those spontaneous moments out into a structured performance. So that's why it takes a long time to make records with that sort of person.”

Rhett's first experience of having tracks he worked on mixed by a specialist was when Bob Clearmountain did 12 inch remixes of *Angel Eyes* and *Dance Away* from the *Manifesto* album. “Obviously, we are talking about the greatest remix engineer in the world, as he's classified. But I suddenly realised what a joy it was not to be burdened with the technical aspects of having



I'm the straight man of the comedy team if you like

to mix a track I have spent I don't know how many months working on.”

Rhett found that not having to juggle with “a million-and-one pieces of technical junk in your brain” allowed him to concentrate more on the actual sound of the performance and how to best project that performance.

“The last few projects I've done have been with a mixing engineer called Bruce Lampcove. You have to have confidence in the guy, obviously. It's no good getting uptight on the day and panicking everybody. So I like to give the mixdown engineer as much freedom as possible in terms of getting the track together. I don't like to be there when they're getting the sound together, for example. I don't like to know what they've done and what is going on on the desk. Obviously because I come from engineering I only have to look around the studio and desk to know what is going on but I don't like to know. If I come in and listen and think there's a technical problem, then I can obviously isolate that problem very quickly. I would rather be free from the desk and outboard equipment—because there is so much these days—and just *listen* when I'm mixing.

“Now I still do like to engineer the records I produce but obviously that is limiting, especially with today's equipment. I found that with the Nancy Shanks album a large part of it was just a question of sampling drum sounds, overdubbing sounds and overdubbing musicians one at a time, then vocals. In that position I like to be in total control. I don't even like to have tape-ops about. In the situation here at The White House there is just no point in talking to an engineer saying: “That doesn't sound right—go back to the chorus.” Rhett can do it faster himself? “Exactly. You can make a cup of tea quicker yourself in most studios in London.”

When Rhett produced 'Til Tuesday's *Welcome Home* album last year, his working methods were different again. They made the record at Bearsville, New York State, one of Rhett's favourite studios and the workplace of Bob Clearmountain. Rhett and the band rehearsed the songs in the large barn Bearsville have for that specific purpose.

“We spent two or three weeks rehearsing with the band and then we cut the record live in the studio. Now that suited that band. There was no way they wanted to cut things to rhythm boxes and overdub everything. They wanted to cut at least the drums, bass and a lot of guitars live. We did guide keyboards, obviously overdubbing keyboards and vocals later. Live vocals were put down on some tracks. I had Bruce Lampcove engineering the basic tracks and was totally confident about him and how the sound would be in the control room, which enabled me to actually spend a large proportion of the time in the studio with the band as they were cutting the tracks. I enjoyed it and I'm sure the band enjoyed it, that I was in there with headphones on, dancing around motivating the band on the studio floor. I knew—because Bruce was engineering—that we could just walk into the control room and it would sound great. We would then reach a stage when it was down to fixing goofs on the basic tracks, doing keyboards, guitar overdubs, vocals, which are one-to-ones again. So that's when I get back behind the desk, eliminate the waffle and get down to it.”

Considering that the albums Rhett has made with the '80s Roxy Music are highly regarded as extremely well-crafted records, some would find it surprising that a great deal of the recording was carried out on a basic Trident console. This came about because Phil Manzanera acquired one for his private studio about 10 years ago and much of the band's recording was done there. Rhett points out that because the desk is relatively simple to operate, it is useful when he's working 'one-to-one', because he can operate virtually on auto-response with regard to technicalities and concentrate on musical aspects of production.

“We did the whole of *Flesh & Blood* on Phil's desk which was one of the first Trident series 80s on the market. They do sound good, I must admit. If you want a bit of treble it's very simple, there's no messing about. You have to kick them a bit but in terms of producing and engineering they're a doddle, which is a great boon. The last thing I want to worry about is twiddling any knobs. That side of it has to be automatic, like driving a car. So that's why the desk is here, because Phil had one and it had worked for *Flesh & Blood* and *Avalon*. And those records—mixed on an SSL—ended up sounding pretty good. Any noises we had got through the Trident were got rid of on the SSL.”

If Rhett were to buy a desk now he says there are many

FME SERIES MIXERS

SOUNDTRACS

A British company dedicated to the design and manufacture of one of the broadest ranges of mixing consoles in the World. We offer ten individual models in over fifty versions to suit your specific requirements.

The choice is yours.

Applications:	Video Post Production
	Broadcast Production
	Multitrack Recording
	Sound Reinforcement
	Broadcast "On Air"
	Stage Monitoring
	Theatre

Options:	Stereo Inputs
	Remote switching
	Former balancing



Soundtracs plc. 91 Ewell Road. Surbiton, Surrey,
 KT6 6AH, England Telephone: 01-399 3392
 Telex 8951073/STRACS/G Fax: 01-399 6821
 U.K.: Studio Equipment Distribution (0582) 452495



"Soundtracs and the indicative  are trade marks of Soundtracs PLC."

RHETT DAVIES

superb models available. But given the choice he is in no doubt which manufacturer's console—any vintage—he'd use for recording: "Neve is my number one favourite for recording. Trident, I'm happy with."

Rhett often structures a final studio recording around the way the original demo was put together.

"Whenever I work with any artist I like to find out how the songs were written and conceived. To me that always should be the starting point of how I approach the recording of that song. If something hit me out of the demo that I thought was really good then let's do it that way. Then again, if the band can routine it and come up with something better, then I'm game for that as well. So while I don't have a set pattern for my



I am unfortunately a very neat and tidy person and I don't like loose ends. I'm the housewife of the recording industry!

productions, a way emerges that is natural. It's always a case of finding the easiest route. Making records should be fun. It should be relatively painless and easy."

Rhett has recorded a wide variety of guitarists including Dave Gilmour, Mark Knopfler, Phil Manzanera, Robert Fripp and Adrian Belew. Vastly different sounding though some of them are, Rhett's approach to the technical side of getting them down on tape is simple to say the least.

"It's just one of those things. You bung up a mic and you get on with it. You know how to get a good guitar sound and you know what works. Just get on with the job and do the normal thing. It doesn't matter who the guitarist is, how big a name they are or how big their amplifier is. You know, it's the same old mics that do the same good old job, so just press on. You usually find that the people who have the most complicated equipment set up generally get the worst sound, you'll have the most problems from them. The guys that walk in with one nice little amp, they know its limitations but they get a good sound out of it—they are often the best."

Discussion of precise recording techniques does not really say a great deal about Rhett's production methods. "I can't honestly think of anything that I do that is so interesting or so different technically that is really worth mentioning. It's all pretty much on automatic.

"I visualise myself as the straight man in any set up with an artist. Most of the people I work best with, the weirder they are the better I can counteract them and the better the end result will be. Looking back, it *seems* to be like that. If you take someone like Bryan who's got some pretty strange ideas, or Eno who's got some pretty strange ideas and is always pretty weird. I'm the straight man of the comedy team if you like. And I can keep them on the tracks, get the job done, whilst visualising their dreams or ideas on the outside. I think that's where I work best. I am unfortunately a very neat and tidy person and I don't like loose ends. It's just the way I am. I'm the housewife of the recording industry!"

What are Rhett's general feelings about the way the available technology is moving?

"Well, I kind of like the way things are going and the pace they are moving at because I was brought up working on tape. When I started it was 8- and 16-track and I'm still used to working on tape, sitting behind a solid desk. I know that within 10 years I'll probably just have one little unit the size of a telephone at my side that I'll do all my recording on and there will just be a little drawer underneath with hard disks. This is fair enough, at its own pace, but I don't want it thrust upon me now and have to completely change things that I'm used to, things that I know are safe. In terms of using the digital equipment and the X850, I like the fact that it has two spools with tape on that go around the machine because I'm used to seeing that. I'll take it day by day."

Rhett is quite pleased that—albeit in response to a more competitive market place—audio companies have much less of a holier-than-thou attitude in recent times and actually take input from professional users in terms of ergonomics.

"My one regret about the way studios are going—it has its plus points inasmuch as you can go anywhere in the world and they'll all look and sound the same—is I don't like the way that Solid State Logic consoles are everywhere. I would like to see some other desks. I don't particularly like the sound of SSL. A horrible thing to say. It's a great computer and I wouldn't mix on anything else. I don't like recording on SSLs and generally don't book studios that have them for recording. There are plenty of great recording desks. The SSL is a great mixing tool and I can't imagine mixing on anything else at this stage."

Working at Bearsville—where they have a semi-vintage Neve in one room and an SSL in the other—Rhett says he can take a day or two to adjust to the comparatively flat response of the SSL. "On a Neve it's just a lovely warm sound. Then on an SSL, suddenly everything's brighter, harder and harsher. But as I say, the SSL is the industry standard at the moment and you've got to go with that."

As I prepared to leave, his Oberheim DMX drum machine arrived having just had a MIDI retrofit. "One of the best investments I ever made buying this. This and the 808 rhythm machine are the only rhythm boxes I've got but I use them all the time. You see, I say I'm not into the gear but I love fiddling with it all." □

THE ULTIMATE DIGITAL PROCESSING EQUIPMENT



AUDIO LOGIC and DOD
The best in digital delays, graphics equalisers
and sound processing.

YET MORE



6 Letchworth Business Centre, Avenue One, Letchworth, Herts SG6 2HR
Telephone 0462 480000. Fax: 0462 480800. Telex: 826967
DOD International, 10 Cindy Drive, Nashua, NH 03062. Phone: 603-888-5230. Fax: 603-888-6750

THE SMOKEHOUSE AN IN-HOUSE APPROACH

Many studios are put together on an informed hunch. London based, The Smokehouse carried out a lengthy market analysis before starting and then also handled design in house. Jim Betteridge talked to Jeff Ward in the studio

In 1979, at the age of 18, Jeff Ward entered the music business as a tape-op at Rak Recording Studios. A year later he left, having recognised that tape operating probably wasn't going to be his most effective path to studio ownership or the position of creative freedom he desired. He spent the next five years working in computers and ended up as a highly paid systems analyst for a large bank in the City of London. During this time his aim was always to amass enough money and financial credibility to start his own studio, and he filled his evenings and weekends playing keyboards in various bands, and engineering in smaller studios around London.

In 1985, he and his wife decided it was time to make their

move toward studio ownership, and teamed up with fellow directors Dave Stewart and Cliff Wells to launch an extensive market research project in order to discover that much sought-after phenomenon—the hole in the market. They think they found one, and it is on the basis of their discoveries that The Smokehouse has been built. At the time of writing, they had only been open for a little over three months, and that period had been virtually booked solid, even to the extent of having to force a two week semi-closure to allow the final stages of building to be completed. At a time when mid-priced 24-track studios are going under at an alarming rate, it is encouraging to think that good business sense, careful planning and some natural flair might have triumphed over what sometimes seem to be difficult odds.

Analysis

Jeff Ward: "We drew up a list of studios we considered to be our potential competition: 24-tracks and well known 16-tracks in and around the London area, going out at £45/hr (\$70/hr) or less. The list totalled about 170 studios in all. Dave and I took the week off work, and spent it on the telephone getting brochures and information on their operations. That was a great lesson in itself. With many of the studios we called we just didn't get the professional telephone response we were after, and often there'd be no reply and no answering machine. Of those we did get to speak to, only about 50% responded at all with brochures. Many of those would promise to send us more stuff on in a few days, and didn't; or they'd promise a colour brochure, and we'd end up with a poor photo copy. On the other hand, some people responded really efficiently and the full information would arrive the next day, which was very impressive. Once we'd got all the brochures in it became apparent that a lot of the studios just weren't making sense. The prices quoted were often largely irrelevant, because a stated rate of £45/hr would come straight down to £25/hr (\$40/hr) even for a small amount of time. That also struck us as unprofessional, in that you couldn't look at the piece of paper and know how much the job was going to cost.

"That was the first stage. Around May '85 we drew up a short list of about 35 studios, including some of those who didn't respond but looked particularly interesting. By this time we'd narrowed it down to 24 tracks who were actually taking £35/hr after discounts, and Dave made appointments to go and see them as a potential client, and indeed as he was working in management at the time, he could well have been one."

Grading system

"We drew up a list by price, and devised a grading system for each major item of the studio so that if they had an SSL they'd get three points, and if it was a secondhand budget console with half the modules missing, it would get 0. The same with tape recorders, outboard gear and other important considerations such as did they have daylight in the studio or the control room, did they have recreational facilities, did they have a good professional attitude, etc. By this system, if a studio had everything they'd get 36 out of 36, whereas if they were an unkempt, ill-equipped, ice-cube of a place, they'd get 0. Then we graded them points against price, and it made no sense at all; The Fitz on Charlotte Street, for instance, has relatively low cost basic equipment but they're such a nice studio. It's obvious as soon as you walk in, they're nice people to deal with and they've taken care of the place; it's none of this 'run by musicians for musicians' nonsense. Musicians are often the worst people to have running a business, that's why managers are so successful!

"Of course, it's actually very difficult to find out just how well a studio is going, because they're almost bound to give you bullshit. If it's a limited company the accounts will be published and it would theoretically be possible to go through them. But there again books can be cooked and some studios are part of much larger organisations and are partly there as a tax loss—so it's all a matter of getting as much information as possible and intuiting how you think a place is really doing. I've got *Studio Sound* and other magazines going back five years, and from press coverage you can get a good idea of a studio's history. One



AKG

ACOUSTICS

THE C414 B-ULS
UNMARKED SOUND + TECHNOLOGY FOR YEARS TO COME



ADV 355/1/E



Digital recording techniques call for
high quality microphones and audio
processors.

We supply the microphones.

Get more information from your dealer or directly from

AKG AKUSTISCHE U. KINO-GERÄTE GESELLSCHAFT M.E.H. Brunhildengasse 1, A-1150 Vienna/AUSTRIA Tel. (222) 95 65 17-0, Tx: 131839 akgac a, Fax: (222) 92 34 58
AKG ACOUSTICS LTD., Catteshall Wharf, Catteshall Lane, Godalming, Surrey GU7 1JG/GB Tel: (4868) 25 702, Tx: 859013 akgmic g, Fax: (4868) 28 967

www.americanradiohistory.com

THE SMOKEHOUSE AN IN-HOUSE APPROACH

of the questions we asked was, 'How much notice would we have to give you for a booking?', and again we graded the answer. Some people would say they were a bit busy this month but if we booked now they could fit us in next, which obviously meant they were doing well. More often, though, they'd avoid the question altogether and say, 'Come on down and we'll talk about price', which wasn't what we were asking."

Hole in the market

All this information was collected together into a business plan, a 35-page bound document divided into six sections: Introduction; Market, Basic Income and Expenditure; Other Products and Expansion; Capital; Budget and Cashflow; and Premises. Through the various points systems and general comments they'd written on each studio, a clear picture of the industry was drawn up, and in it they found their niche.

Jeff Ward: "From the business plan we were able to see where the hole was, we could see what we needed to be able to offer and at what price to be positively competitive. It turned out to be very simple: we had to take business away from the basement sweat shops in the West End, especially around Soho. Nobody feels comfortable or creative in some poky studio where there's damp coming through the walls, there's tatty old carpet on the floor and they're continually popping cards all over the place trying to keep 23 of the 24 tracks working. They're all discounting like crazy, sometimes putting out 24-tracks for £18/hr. We wanted to build a studio so that when customers walked in they'd feel immediately at home, know they're dealing with people who understand the business and know that they're not wasting their money. I'm quite sure that people are prepared to pay the going rate for that kind of reliable service, and that once they've talked to us and seen the studio, there won't be any unnecessary haggling over a few pounds an hour.

"We all know that under-pricing is what kills most studios. It means they can't make enough money to keep the studio up to date and in good condition, therefore people aren't prepared to pay full rates, and so starts the downward spiral. From studying press cuttings, we saw several examples of extraordinarily rapid decline. In the space of three years, one West End multi-studio complex went from rave reviews and full page colour ads, to being up for sale for £150,000 the lot. We thought about buying it but finally decided it would have cost too much to refurbish all three suites. There were other studios developing in the opposite direction, having started out as 16-tracks and moved up to 24-tracks but then I wonder why they changed something that was obviously doing well. If we do become very successful here, we won't be buying an SSL, because we'll be doing well at what we're doing well at. What's the point in changing, investing umpteen thousands of pounds in more equipment, raising your hourly rate and losing your entire client base?"

Are the profits not larger, then, as the operation gets bigger? Jeff Ward: "Generally, I think not. The overheads rocket upward and the profit margin becomes tighter. Places like The Manor or Jacobs can offer much more than just a studio—there's

nothing like getting up at five in the morning and chasing a few sheep before the session—they're just great places to work, and so it becomes viable. But the last thing in the world I'd like to be doing now is trying to sell a London SSL suite."

Importance of position

No one would argue that many West End studios aren't a little tatty but could it be that what they lack in cosmetics and ambience they make up for in convenience of location?

Jeff Ward: "We're not in the West End but we are much closer than people might think. I live just off Baker Street, I drive in every day through the West End and it takes me no more than 20 minutes, regardless of the traffic. We have none of the West End's problems—there's plenty of parking, plenty of space and no heavy traffic noise. In about six months time, when they finish Tobacco Dock just over the way, there'll be 140,000 ft² of retail, leisure, wine bars and restaurants, etc. We'll be right in the middle of the new London. Once you're on that embankment it's only five minutes from the West End; it's obviously dead easy from East London; once they've finished the Rochester Relief Road, it should be easy from South London; Kent is very quick straight up through the Blackwall Tunnel; and it's not too bad for North London, although that's probably the most inconvenient place. So we're really Central London, without the Central London headaches. I don't believe that being in the West End is a prerequisite for serving West End customers. We're offering so much in terms of service, equipment, acoustics and comfortable surroundings, people will come to us; a lot of musicians would come here just for the daylight in the control room and the studio alone!

Having established such a precise studio points system, how would the finished Smokehouse rate?

Jeff Ward: "Out of a possible total of 36 we get about 32 or 33, and we've pitched ourselves at an hourly rate just under the studios that would match that. Of all the studios we looked at there were only a few that come into that category: places like Hollywood—although they're a little over the top—E-Zee, Terminal 24 and Eel Pie 2. We were very surprised when they closed Eel Pie 2 down because it did seem to be making money but Pete Townshend wanted to put his energies elsewhere and instructed his staff to have the place clear by a certain date. Hence we bought their UREI 813B monitors and their Otari MTR90 24-track for a very reasonable price. Actually, we ended up selling the Otari because we preferred our Studer A80 but the UREIs are fabulous.

"We had originally designed the monitor shelves for a pair of Tannoys, which were all we could afford in the original budget, but the 813s were offered to us at £1,000 each. This is still roughly twice the cost of the Tannoys but it seemed like an offer we couldn't refuse. We ended up rebuilding the monitor shelves three times to accommodate the larger cabinets before we were satisfied with the result, but now the sound is excellent.

"That was quite a typical situation, actually, and it turned out that at each stage of the process, as the options became clearer, we always wanted to do it a little better than had been planned. It's been a very idealistic project from the start. We scheduled the building work to take four months and the total project to cost £93,000. It's taken us nine months to get to this stage at a cost of approximately £150,000—that includes everything. We wanted to make sure that, once it was all finished, there was nothing we felt uncomfortable about, or that we had to apologise to clients over. So we always did it 'properly', and now it's a real pleasure to work here and to show prospective clients around.

"In addition to the vital updating of equipment, we've built into the cashflow projection enough money to keep the place in good decorative order. There are so many studios that were obviously lovely when they built them but which haven't had any money spent on them for anything but racking equipment for the past five years; they have great gear but there's gaffa tape all over the carpet, everything's tatty, and you just don't feel good sitting in them. If an artist is doing an album, he or she can virtually buy a basic 24-track set-up and install it at home. Offering the equipment isn't enough—the rooms, the design and the comfort are all vital components too. The whole project has been based around providing that total environment,



The NFA-1
The right answer
to most
audio test problems

The NFA-1 is the simple, easy and reliable way to do audio tests. 30 measurement modes, max. frequency 200 kHz.

High versatility: ★ selective and wide-band level meter ★ phase and frequency meter ★ noise level meter ★ distortion and difference frequency meter ★ wow & flutter ★ runup time and rumble-voltage meter ★ signal generator. No need to bother with piles of equipment and masses of cable.

Easy operation: Due to menu control and memory for up to 49 complete front panel setups. Paired, balanced inputs and outputs. IEC/IEEE bus.

Wandel & Goltermann, VMW, Postfach 12 62, D-7412 Eningen Fed.-Rep. of Germany, Tel. +(49) 71 21-86-0, Tlx. 7 29 833

- I would like
 an NFA-1 colour brochure
 a visit from a sales engineer

Name

Company

Street

Town

Tel. E 6369 KF

SS 8/87

THE SMOKEHOUSE AN IN-HOUSE APPROACH

and in fact we only went a few thousand over budget on equipment, most of the extra cost was in the building itself. All the rooms have independent, fully silenced ventilation and air conditioning, which cost a fortune but which we think is very important. It's very hard to retrofit systems like those. We originally budgeted for a type of linoleum studio flooring but we realised that all the studios we liked had wooden studio floors, and so we stretched ourselves to parquet. Most of the things that impressed about other studios, we've included here."

Acoustics

At school Jeff had studied Fourier Analysis and acoustics to scholarship level (slightly above A-level). Combining this understanding with his practical experience of studios and his knowledge of computers, he created his own computer program



56 Studio Sound, August 1987

to aid him in the acoustic design of The Smokehouse.

Jeff Ward: "I've actually devised my own concept of acoustic design and treatment, which I can't say too much about because I do intend to market it and get into that side of the business as a designer. One of the main problems with accurate acoustic design is the huge amount of number crunching that has to be done. I've taken an existing financial modelling software package for my Amstrad PCW and rewritten it to do all the acoustical calculations. It uses all the existing acoustical data on available building materials, and the three main reverberation time formulae plus various other formulae for room modes, etc, and lays out the results in such a way that I can make my own final judgments regarding the best combinations of treatments."

What did the process entail in practical terms?

Jeff Ward: "Before we signed the lease on the building, Dave and I took a close look at its acoustic isolation properties and the level of ambient noise, so that we were satisfied we had something tenable to start with. We hired a spectrum analyser and a noise source and spent a weekend measuring sound transmission coefficients for all the rooms. We put the noise generator through a powerful amplifier and took octave-band measurements in the studio, and then repeated the operation with the meter on the roof; and, of course, it was freezing cold and it rained! We had no access to power, so we hired a generator and positioned it on a long lead down at the other end of the street; that was also useful as a noise source. From the start we knew that we couldn't afford a fully isolated room-within-a-room construction but we've done a great deal to increase isolation, and structure-borne noise hasn't been a problem. Our neighbours aren't particularly noisy: we have a textile store, a tool hire shop, a printing company and a garage. We've put 5 tons of *Rockwool*, 2 miles of 4x2 in timber and 7 tons of plasterboard into the building, and that's very effectively dealt with most foreseeable problems. The only interruption we've had from ambient noise was during the height of the Rupert Murdoch News International disputes when a police helicopter hovered about 100 ft above us for five minutes. The sound didn't get in but the motion of the blades set up a very low frequency resonance. Hopefully, that won't be a problem for the future!

"The control room was originally a heat-insulated cool room for the salmon smokers and its existing structure gave us a good place from which to start. Its outside walls are brick, then there's 8 in of polystyrene, then the internal concrete walls, 1½ in of rendering and finally 2x2 in battening. The floor is 1½ in of concrete on 8 in of cork, and the ceiling is 8 in polystyrene with a thin layer of plaster. In terms of transmission loss, the polystyrene is virtually like thin air but at least it creates a multiple structure which is effective for isolation. Initially, we covered all the surfaces with 2x2 in battening, and on top of that pinned 2 in of *Rockwool*. For the outside walls we then erected 4x2 in studs spaced apart from the previous *Rockwool* and infilled with a further 4 in of *Rockwool*. This was covered by two sheets of ½ in plasterboard and finally plastered. So any sound coming in has to go through a completely dead void between the two layers of *Rockwool*, and this was basically the principle I used for all the sound isolation. The ceilings are constructed in a very similar way."

For the rear and side walls of the control room, the plaster was the final finish, save for a coat of paint. The front wall and the ceiling, however, were made more absorbent.

Jeff Ward: "The rear 4 ft of the ceiling is an assortment of Helmholtz and panel bass absorbers. In front of these, above the desk, is a system of wooden slats backed with *Rockwool*, to both absorb and diffuse the sound above the engineer's head at the necessary frequencies. Forward of these are 4 in *Rockwool* slabs positioned about 1 ft 6 in below the soundproof ceiling which makes it very dead. The front wall is also very absorbent and there are panel bass absorbers below the monitor shelves. The floor is simply 2x2 in battening, infilled with *Rockwool*, and covered with ¾ in chipboard. It works very well."

Fabric finish

In its finished state, the control room measures nominally 15 ft front to back and 29 ft side to side, although all the walls are slightly off-square to avoid standing waves. The ceiling and most

of the front wall are covered to a very high standard of finish by an almost seamless salmon-pink fabric. How was that achieved?

Jeff Ward: "The fabric is transparent up to 15 kHz and the great thing about it was that we could play around with the acoustic treatment until we got it absolutely right, and then say, 'Right, cover it'. Rather than stapling the material directly to a wooden frame, as most studios do, we used a tracking system called Fabtrak, available over here through Hayden Davis Ltd who have the sole UK licence for its sale and installation. (See *Studio Sound*, March 1987.) The track is fixed to the frame, and the material is folded into the track with a special tool. This means that there are no staples showing, and also that any time we like, we can take the material down, wash it, and have it put back up again without any difficulty. Again, it's much more expensive than simply using staples but Hayden Davis did a really superb job, it looks great and it's undoubtedly a very good long term investment.

"The control room is a quasi-Live End Dead End design, but the depth of the room doesn't comply with the requirements of that definition. No doubt some people will say that we should have problems with early reflections from the rear wall but, in fact, we don't. The room is completely linear in terms of both frequency response and decay time between 125 Hz and 8 kHz, with a decay time of 0.48 s. There is a minute bass lift below that and at 63 Hz the decay time is up by 0.2 s but in practice that's really nothing. To get rid of that we'd have needed a bigger room and more bass trapping than there's actually space for. But it's very marginal and we certainly don't consider it worth using graphics, with all their own problems and distortions, just to alter its spot response on an analyser. It's all really rather academic and the subjective effect would probably be an adverse one. The room sounds very good, music recorded here also sounds great on the average hi-fi or car stereo and everyone who's been here has loved the sound, so we're happy."

The walls and ceiling of the studio area are finished in plaster in a similar manner to the rear and side walls of the control room. Modular panels, designed and constructed in-house and consisting simply of a 4x2 in frame, with a 2 in *Rockwool* infill and fabric covering, are then suspended from a wooden rail

running around the walls above head height to offer broad band absorption. What was the intention here?

Jeff Ward: "Whilst it's very important to have an accurate control room acoustic, I think it's less relevant for the studio area. People ask me if the studio is flat but I'm really not sure if that's a pertinent question. Obviously we've made sure there are no strong room modes but in terms of its sound I think it's more important to offer a range of musical acoustic responses, which is what we've achieved with the combination of removeable panels, parquet flooring, removeable carpet and the totally dead isolation booth. The decay time of the main studio can be varied between about 0.6 and 2.6 s at 500 Hz, which is a considerable swing. Using the Audio Kinetics screens, we can divide the room in two, with one end dead and the other live, so there's a great deal of scope and flexibility. It's also ideal for chamber music and we've installed a 1972 harpsichord for that purpose."

This interview took place in February during a two week closure in which a large recreational area was being completed, to include hi-fi, video and cooking facilities. After all the research, calculations and plain hard work, it's nice to be able to report that the studio did look, feel and sound very good, and that the attitude of the proprietors is friendly, competent and professional.

The Smokehouse, 120 Pennington Street, London E1 9BB
UK. Tel: 01-488 3904.

Studio facilities

Monitors: UREI 813B/Yamaha NS10M

Console: Trident series 80B

Multitrack: Studer A80, 24-track

Mastering: Sony PCM-701/Studer B67 with Dolby A

Processing: AMS 15.80S, Klark-Teknik

DN780 digital reverberator, Yamaha

SPX90, Aphex Type C Aural Exciter,

Drawmer gates and compressors, dbx de-essers, MXR 01a digital reverberator, Korg SDD-3000 digital delay

Microphones: include AKG, Electro-Voice, Neumann, Sennheiser, Shure, Tandy

Instruments: Yamaha C3 6 ft grand piano, single manual harpsichord

Drawmer

Ingenuity

A
FAMILIAR
FACE...



DRAWMER DISTRIBUTION LTD.

CHARLOTTE STREET BUSINESS CENTRE
CHARLOTTE STREET
WAKEFIELD - WEST YORKSHIRE
WF1 1UH ENGLAND

Telephone: 0924 - 378669 Telex: 556649



THE DS 201 OFTEN EMULATED STILL UNSURPASSED

DESIGNING A PRACTICAL MONITOR

Designer Sean Davies describes the background and implementation of a new monitoring system

During the late '70s it became increasingly evident that high quality, low power domestic speaker systems had overtaken the studio monitor in some areas, notably distortion, phase accuracy and the associated effects of stereo imaging detail and lower listener fatigue.

An investigation began into the high power systems, while design objectives were defined:

- High SPL (>120 dB)
- No loss of detail at high levels
- Low listener fatigue
- Suitability for all kinds of music (eg classical, rock, etc)
- Low failure rate of drivers, without recourse to protective devices
- No need for narrow band equalisation*
- All driver units to be user replaceable without special tools

*The phase shift usually introduced by narrow band equalisers is extremely damaging to transient response, stereo perspective and general clarity unless restricted to frequencies below, say 300 Hz. When used to compensate for room modes and/or reflections, the equaliser can only introduce a steady state correction whereas the room deficiencies will have associated time effects. Nevertheless, some very carefully used LF equalisation may be applied where it is not practical to correct the room itself.

ON AXIS +15° LAT

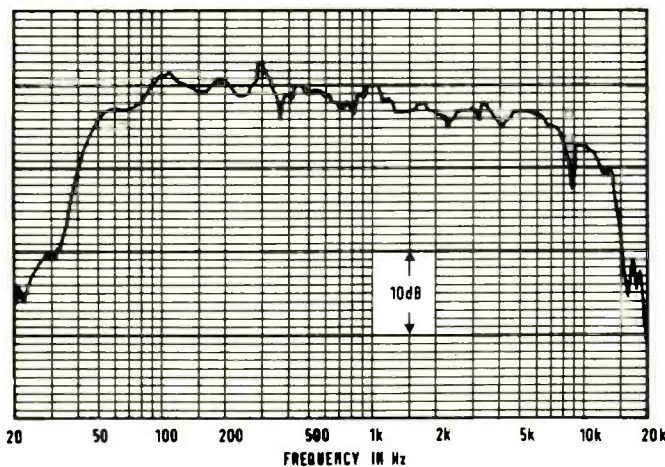

ON-AXIS (Flat) RESPONSE

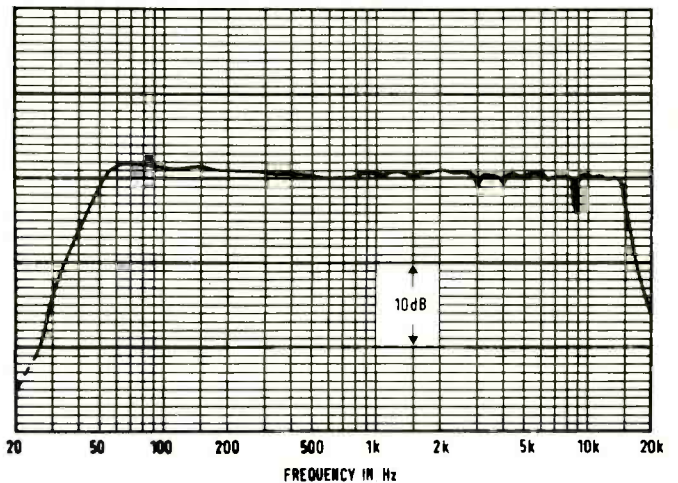

ON AXIS + 25° LAT

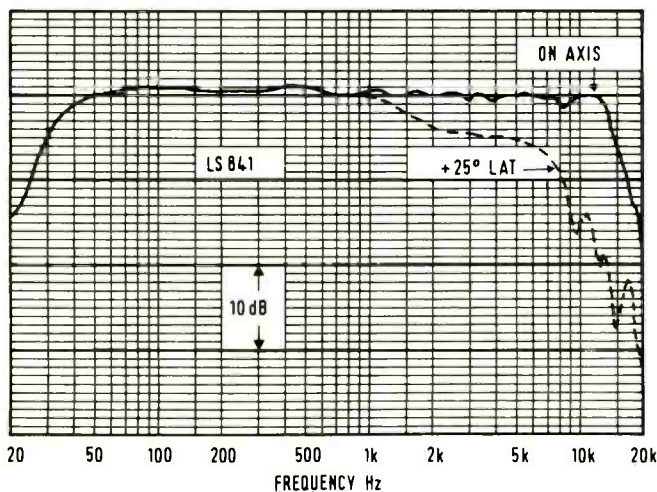

HF ROLL OFF

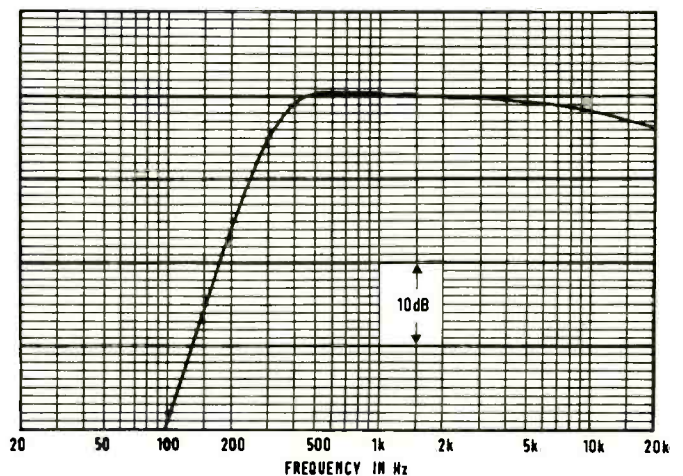

It quickly became apparent that a horn loaded midrange unit had a number of undesirable features:

- Non-linearities caused by compression of the air in the throat of the horn
- Phase shifts associated with the above
- The difficulty in designing a horn with good polar patterns and optimum driver loading—witness the continuing appearance of new horn shapes
- The unsatisfactory crossover point(s) dictated by the horn

Most midrange horns cannot function below 800 Hz because of horn dimensions and driver diaphragm excursions. This usually means that the LF unit (typically one or two 15 in cone drivers) have to operate up to this frequency. Apart from the difficulty in making such a driver there will inevitably be Doppler distortion of the lower mid frequencies whenever the LF cone has significant excursions. Of course this effect will be both programme and level dependent—both highly undesirable.

Some guidance as to the desired crossover point and midrange performance may be obtained from the well known hearing sensitivity curves originally published by Fletcher and Munson. The maximum sensitivity occurs in the region 1 to 6 kHz. This suggests that if we consider the 2nd and 3rd harmonics as the predominant driver distortion products, then the driver's performance in the range 300 Hz to 3 kHz is critical.

It appears that the 300 Hz region would be a good LF/MF crossover point since at this frequency cone excursions, even at high levels (around 120 dB), are small and a well-designed 15 in LF unit has a good performance in this range.

Since we have rejected a horn loaded diaphragm driver for the midrange the choice is between a dome-type direct radiator, a cone driver or an electrostatic membrane. The latter offers high performance qualities but is easily damaged by accidental overdriving. It is also costly in both development and manufacture. A dome-type direct radiator offers good performance at first sight but suffers from two drawbacks. Firstly, at high levels the dome tends to break up into resonant modes which are difficult to control. This would yield a change in subjective quality according to level. Secondly, even at 300 Hz the excursions at high levels could lead to premature failure in those commercially available units which were tested. This would force the crossover frequency higher than desired.

The second option seemed worth further exploration. Work at the BBC by Harwood showed that certain modern polymer compounds had distinct advantages over paper as cone material, particularly in the low-to midrange. Further study confirmed that polypropylene had excellent self

damping qualities and this has been used in the BBC LS5/8 monitor speaker manufactured by Swisstone Electronics (Rogers).

Richard Ross and Andrew Ball of Swisstone took an immediate interest in the project and undertook a development programme to investigate the suitability of the company's 12 in polypropylene coned driver as a high level midrange unit (the unit in question was designed as an LF to 2.5 kHz driver). A modified version was found to give excellent results with levels in excess of 120 dB in the desired frequency range. The large radiating area reduces excursions so even at the highest levels distortion is very low and the fact that the basic unit was designed to handle LF implies extremely low stress leading to high reliability. The choice of crossover frequency at 300 Hz allows the inter driver spacing to be less than a wavelength at crossover thus only one frontal lobe is produced on the polar diagram; this avoids irregularities in the off-axis response. An exclusive licence was granted by Swisstone for the unit to be incorporated in the eventual systems.

The range above 2.5 kHz is handled by the Celestion T50, an annular driver with phase correcting slug.

To date three versions of the integrated system have been manufactured. The LS 821 BS employs two JBL 15 in units type 2235H in a brick built infinite baffle enclosure of 14 m³ with the MF and HF units in a sealed enclosure within the brick wall. The LS 821 R employs the same components as the 821BS but with the LF units mounted in reflex enclosures (separated for each driver). The system SPL is increased by 6 dB at the expense of the response below 30 Hz. The LS 841 consists of one 15 in bass driver with MF and HF as above, the system contained in one cabinet with a separate reflex compartment for the LF.

The reflex design utilises a QB3 alignment after Thiele and Small. The systems are bi-amplified, the LF/MF crossover utilises the findings of Linkwitz *et al*, and a CAD passive crossover is used between MF/HF. A variable HF control is placed in the active crossover allowing an adjustable roll of above 5 kHz.

The choice of power amplifier has been left to the customer although not less than 200 W RMS into 8 Ω is required per output. The 841 system has been tested with amplifiers of 500 W RMS per output and shows no ill effects.

The subjective effects of the system indicate that the desired objectives have been achieved. The front-to-back perspective in a mix is well preserved and listener fatigue is very low. A good correlation is achieved with the smaller high quality speakers often used in control rooms. An interesting effect always remarked upon is that new listeners do not think that they are listening very loud until they try to converse and realise they can't!

FOON NEW SYSTEM

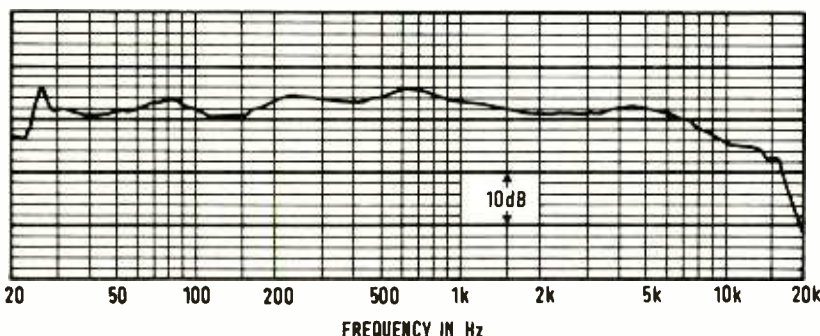

**AT LAST — A SMPTE
READER/GENERATOR/MIDI
CONVERTER FOR UNDER
£300. FEATURES INCLUDE
SONG POINTERS & MIDI
MERGE. UNBELIEVABLE?
GIVE US A RING & FIND
OUT ABOUT THE NOMAD
SMC10 — ONLY
£299 + VAT**

SOME OF OUR SECONDHAND & EX-DEMONSTRATION STOCK

Eventide 949 Harmoniser excellent condition	£600
Fostex model 80 8-track, 3 months old	£1,250
RSD Series II 16,16,2 — mint	£2,600
BEL BDE 3200, 32 sec, 99 window super-sampler, as new, silly price	£999
3M M79 + Full autolocate — excellent	£9,500
TAC Matchless 26:24:8:2 + patchbay + stand, 9 months old	£8,500
Yamaha SPX90 (New)	£325
Akai MG 14D rack mounted 14 track ex-demo	£2,500
Sony PCM 501 (new)	£495
BOKSE USB Universal synchroniser	£245
Q.Play programmable remote for E16, B16 + M80	£99
Selection of ex-demo Yamaha power amps	Phone
Fostex E16 w/remote — 3 months old	£3,600
Tascam 3340	£500
Slapback scintillator (exciter)	£150
Yamaha 31 band graphic eq. (2 only)	£160 each
Symetrix quad expander gates	£325
Ashly stereo gates	£199
Drawmer DS221 compressor/limiter	£275
AHB Keymix computer mix down system	£999
(fits any desk — routing & mixing — 16T)	
Akai 5900 Super Sampler	£1,250
Roland MC500 Sequencer	£650
Hill 32 x 24 (40 way Frame)	£5,000
24 channels Bel Noise Reduction	£1,000
Revox B77 as new	£650
Electrospace time Matrix Multitap Delay	£699
Tannoy SRM 12X Monitors (Big little Reds!)	£700
Aphex Compellor	£750
Yamaha NS10's	£160
Drawmer DS201 Gates	£245
Tascam 32 half Track	£500
Two Track DBX Noise Reduction	£150
Tascam 38 (Mint)	£1,200
Symetrix 511 Noise Reduction	£350
MXR 31 Band Graphic	£175
Aphex Dominator	£850
Digitech 1900 delays 2 seconds full bandwidth	£165
JBL 4430 Monitors immaculate	£1,500
Seck 18/8/2	£975

Plus loads more — give us a ring!
All prices exclude VAT

Special offer 8-track starter package (M80, MTR 1282
plugs, cables, patchbay)

New Amazing Korg DRV 3000/Reverb, Harmoniser Delay,
plus loads more all at incredible 20 Khz bandwidth including
infra red remote control, only

Just some of the new products we stock
Akai S900, S700, X7000 and the brand new 24-track
Yamaha — RX5, DX7II, TX81Z, SPX90II
plus
RSD series II desks, TAC Matchless and Scorpion, Fostex E16,
Tascam, Tannoy and loads more.

From Fostex to Neumann, TAC to Yamaha, we are main
dealers for all the latest high quality products, most of it on
permanent demonstration in our 3 24-track studios.

IF you have any audio requirements, give us a ring

Axxeman at last a No Noise Studio Quality Guitar Processor
with chorus, filters, ADT, overdrive, compression and gate.
Money back if not satisfied — £260 + VAT

Special offer computer package. Atari 1040 Steinberg
Pro-24 and Nomad SMPTE/Midi reader generator —
£1,050 + VAT

• EXPORT • FULL CREDIT FACILITIES AVAILABLE • MAIL ORDER •



**Thatched
Cottage Audio**

Telephone Dave on
Cambridge (0223) 207979 (3 lines)

Thatched Cottage Audio,
North Road, Wendy, Nr. Royston, Herts.



A MARRIAGE OF CONVENIENCE BRINGING TOGETHER THE BEST ANALOG DIGITAL PRODUCTION TOOLS AVAILABLE

NEW



Editron 500A

Control of up to 15 audio, video or film transports.

Multiple mixed frame-standards can run simultaneously.

999 Events.

Programmable VCA control.

A, B loop for machine sharing in multiple locations.

Unique software driven architecture allows easy machine changes – no dedicated hardware.

Simple change of floppy disc and keyboard turns system into Video Editor.

Video edit-list stripping option.

Full colour graphics give critical information at a glance.

10 user soft keys for customised operations.

Session set-ups stored on disc for easy retrieval/editing.

20 comparators for external devices, repeat fireable.



Lexicon PCM 70

Lexicon Digital effects set world standards for sonic quality.

The PCM 70 offers the essence of Lexicon sound as well as being the only digital reverberator to have Dynamic MIDI™ for control of all reverb and effects parameters.

OGUE AND BLE



dbx 150X

The dbx 150X features two separately powered, simultaneous encode/decode channels of dbx Type 1 noise reduction giving up to 40 dB improvement in signal to noise ratio using analogue tape.

The 150X can be mounted singly or in pairs in 1U of rack space – full rack mount kit included as standard.

The 150X outperforms its best selling predecessor, is more flexible and breaks a new price/performance barrier.

We know it sounds too good to be true but assure you it's for real.

To prove to yourself that digital signal to noise ratios are attainable for well less than two hundred pounds, call Scenic or a stocking dealer soon.



Despite being deceptively simple in appearance and very affordable, the PCM 70 has a specification which puts it in the top rank of professional digital signal processors.

Call us for the name of your nearest stocking dealer.

D

FOR 15 YEARS SCENIC SOUNDS HAS SOUGHT OUT AND DISTRIBUTED PRODUCTS WHICH OFFER THE BEST TECHNOLOGY OR BEST VALUE OF THEIR KIND.

WE ENJOY DEALING WITH OUR CLIENTS DIRECT, ADVISING AND LEARNING FROM THEM, BUILDING UP LONG TERM RELATIONSHIPS.

WE ALSO RECOGNISE THAT YOU MAY PREFER A LOCAL SOURCE OF SUPPLY, SO WE HAVE CREATED A NETWORK OF DEALERS TO ENSURE THAT MOST OF OUR PRODUCTS ARE EASILY ACCESSIBLE WHEREVER YOU ARE BASED.

DO CONTACT US FOR DETAILS OF OUR RANGE AND OUR DEALERS.

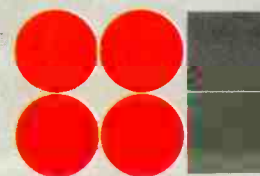

SCENIC SOUNDS EQUIPMENT LIMITED
Unit 2, 12 William Road, London NW1 3EN
Tel: 01-387 1262, 01-734 2812
Telex: 27939 SCENIC G

BARRY FOX'S BUSINESS

The Copycode plot is now as thick as soup. Philips of the Netherlands have come up with an ingenious idea that pulls the rug from under Copycode. It allows one copy from a disc to DAT but no more. Unlike Copycode, there is no need to tamper with the original sound.

Apparently oblivious of the political problems, because its wholly-owned subsidiary has publicly committed itself to using Copycode, Philips unveiled 'one-copy' in London on April 29th. Peter Plompen made a flying visit from the research laboratory in Eindhoven to speak at a seminar organised by the Copyright Unit of the European Economic Community. Ironically, he was filling a gap in the timetable left when CBS refused to demonstrate Copycode.

Already DAT recorders cannot dub in digital domain from CD because of deliberate mismatch of the sampling frequencies (44.1 kHz for CD and 48 kHz or 32 kHz for domestic DAT). And the CD data stream already has room for a copy-inhibit flag which does the same trick. The current industry squabble, and push for Copycode, is to stop A/D dubs. Once the dub is made it can be copied digitally without further quality loss.

"The awesome thing about digital taping is that it isn't just taping, it's cloning," says George Martin in an IFPI handout. "However many copies you make the product is just as good as you get in the studio."

Plompen's plan is to stop cloning. The DAT recorder will put a copy-inhibit flag on any recording made through the line inputs. So the first dub is perfect. Thereafter any attempt at copying the copy fails.

Clearly Plompen's lecture has embarrassed Philips. The EEC seminar was open to anyone who was willing to pay £110 to attend. Those who did were promised a written copy of Plompen's text. But Philips said lamely the "English was not good enough to release" and after six weeks had still failed to polish it. In the meantime, Polygram—the record company now wholly owned by Philips—have issued a statement which explains why this may be. Polygram "calls for appropriate legal action by governments enforcing the inclusion of the Copycode system in all DAT machines" and promises to use Copycode on its own recordings. Clearly the Philips proposal for a one-copy system conflicts with Polygram's plans for Copycode. The plot gets even more confused now that Jan Timmer has been moved over from running Polygram to overseeing all Philips' consumer electronics activities. The IFPI names Hans Tenderbo of Philips/Polygram as the adviser who gave Copycode the thumbs-up.

It seems that CBS declined the invitation from the European Copyright Unit to demonstrate Copycode at the EEC London seminar on April 29th, fearing that it would steal thunder from the

IFPI's demonstrations scheduled for a couple of weeks later. As it turned out, those London dems were disastrous.

As reported last month, the Copycode notch proved as audible as the laws of physics had predicted. Many people with a professional interest in audio and music have since objected that they were not invited by either the IFPI or CBS. Many of those present had gatecrashed after hearing about it on the grapevine. When the results of the London demonstration were reported in America, during US Government hearings, CBS accused the media of "biased and inaccurate reporting". David Stebbings, Mr Copycode, went so far as to read a letter into the official Government records.

"The claim that a roomful of engineers could tell when the Copycode was in use or not has been flatly contradicted by numerous attendees," claims Stebbings. "The London demonstrations... made it clear that not even the most expert audience can detect the Copycode with any degree of accuracy".

Interestingly, CBS then climbs down a few steps.

"The issue here is not whether a test can be devised in which the CBS Copycode may be detectable to some listeners," says Stebbings. "The issue is whether the CBS Copycode, properly used, can protect copyrighted material without reducing the audio quality of the music encoded. Once again, we have demonstrated that it can."

Those who were present at the London demonstrations may well now start wondering whether CBS has a notch in its memory as well as its music.

Meanwhile, IFPI President Nesuhi Ertegun (who was *not* present at the Abbey Road demonstrations) has been having his say. Ertegun has accused "so-called hi-fi experts who have been against the Copycode system from the very beginning and much before they actually heard it" of "campaigning and agitating against the system". But Ertegun has already climbed down. He says in a recent IFPI release: "Yes, certain musical notes and forms could be hurt by careless encoding, but the skilled encoding engineer can specifically avoid such sensitive passages."

Ertegun says that in his opinion "this is an organised plot to discredit a perfectly valid system as I have listened to it with great care on several occasions". Ertegun feels sure that "we will be able to overcome these baseless and prejudiced objections".

Whether the IFPI can re-write the laws of acoustics and physics remains to be seen.

Obviously Bart Locanthi, president of the Audio Engineering Society, thinks not. Locanthi has now gone on record saying that the Copycode proposals are "ludicrous", they "castrate music" and that tests have shown that "the discerning ear can hear the notch".

It's holiday time folks. The time of the year when busy studio persons take a few hours off to learn the names

of their children and fly off somewhere sunny. It's at times like these that most people's thoughts turn to a good book. And UK health minister Edwina Currie advises "a good book" as companion for those who haven't got time for a holiday and are flying off to work in some lonely foreign city. Hence, herewith a few suggestions, many of which would doubtless make Ms Currie's hair curl.

Beginning at the low end of the tack scale, both volumes of Kenneth Anger's *Hollywood Babylon* are now available. *Babylon 2* came to Britain first, because *Babylon 1* was for years suppressed by the threat of libel actions. Irresistibly intrusive, both volumes rake through America's colourful history of show biz scandal. If you enjoy the *Babylons*, don't miss *Wired*, Bob Woodward's biography of John Belushi, through *Saturday Night Live* to the Blues Brothers band, film and recordings.

In a similar low life vein, watch out for the excruciatingly tasteless *Only The Good Die Young*, Robert Duncan's collection of essays on every rock star who OD'ed, fell off a bike, crashed a plane or shot himself. *Rock Wives* is by Victoria Balfour, and *Babylon* author Kenneth Anger recommends it. The title says it all but the fact that the book is written by a woman, with sympathy, makes it different.

Moving up class, Philip Norman's *The Road Goes On For Ever* is a collection of ex-*Times* essays on rock and pop encounters, from Lionel Bart ("how I helped Bertrand Russell") through a Barry White tour ("a major triumph of opportunism over content") to a one-nighter with Joe Loss (trouserless in the intermission to preserve the creases). Norman has plenty on the Beatles of course. I'm deliberately skipping *Beatle books* from this listing because there are far too many. I still prefer George Martin's *All You Need Is Ears*. Martin gives credit where it is due, for instance to Geoff Emerick's *Beatle* work and slaps off EMI something rotten. In the halcyon early '60s Martin was still earning under £3,000 a year.

If you want to talk managers try *Expensive Habits*, Simon Garfield's book on "The dark side of the music industry". It's a bit tedious but if you can stick with the lengthy extracts from legal contracts, there are some fascinating insights into record company rip-offs, chart hyping, crooked audits and contractual theft. Gilbert O'Sullivan, MAM, Elton John, Sting, The Kinks, Alan Klein and The Who all feature heavily. The Hazel O'Connor chapter should be required reading for every schoolkid with hopes of becoming a star.

For jazzers, I note that Jim Godbolt's earlier book *All This And 10%* on British jazz and pop (he worked with the Bron agency for a while) has been reargutated, and revised as *All This And Many A Dog*. Some of the best sections of the earlier book, on squabbles with the Musicians' Union, have been hived off into *A History Of Jazz In Britain 1919-1950* by the same author.

Godbolt's catalogue of how the MU blocked the performance of American jazz greats in Britain in the '40s and '50s is well worth reading, especially as the MU now seems to be trying to rewrite history with the claim that American jazz greats were only banned from Britain because British jazz greats were banned from America.

Even non-jazzers will enjoy John Fordham's *Let's Join Hands And Contact The Living*, the story of Ronnie Scott and the Scott club. Even if,

like me, you find today's Scott club an unfriendly and unwelcoming place to hear music, the Scott book makes a thoroughly enjoyable read.

The film and recording industries are tightly entwined. For a fascinating insight into modern Hollywood, try William Goldman's *Adventures In The Screen Trade*. Goldman wrote the screenplays for *Butch Cassidy* and *Marathon Man*, and walked out of *The Right Stuff*. If you think record producers have a tough life, read about scriptwriters.

David McClintick's *Indecent Exposure* tells the extraordinary story of how David Begelman, who ran Columbia Pictures, forged a Cliff Robertson expense cheque, and triggered a Wall Street crash. In Hollywood studio life, fact is far stranger than script fiction. If you want confirmation read Leonard Mosley's biography of *Darryl F Zanuck*, the last of the Hollywood tycoons. He had affairs like most people have breakfast, and ended up in a bitter studio power struggle with his son Richard.

Perhaps most riveting of all of all the film studio books, is Stephen Bach's *Final Cut*. It's the gripping story of what went wrong when Michael Cimino persuaded United Artists to let him make *Heaven's Gate*. It was budgeted at \$7.5 million, ended up costing \$36 million and sank the studio. The way Bach tells it, Cimino was worse than a pop group given a year in the studio to make one album.

As a bonus, one of the early chapters in Bach's book deals with 'The Trust'. Early in the century, the firms which had invented motion picture technology pooled their patents to form the Motion Picture Patents Company. This was known as The Trust. They had a vice-like grip on the industry. No films could be legally made or shown unless licensed by The Trust. Kodak only sold film to Trust licensees. Legal eagles and thugs ran unlicensed film-makers out of town. Anti-trust laws put an end to vicious monopolies like this—which is why if you shout 'anti-trust' at anyone in the American entertainments industry today, they will scuttle for cover behind a lawyer.

That little lot should be enough for even the longest working trip or holiday. Doubtless some titles are now out of print. Book publishers, like record companies, have little interest in longevity. But you can always try your local library.

Owners of pets and kids called Dolby beware. I see reports in the American press that the legal dispute between Dolby Labs and Thomas Dolby, born Thomas Morgan Robertson has been settled. The musician has had to admit that he is infringing Dolby's much-prized trademark and taken a licence to use his acquired name in a limited way. He can go on calling himself Dolby but only if he always uses the forename Thomas.

It looks lucky for Robertson that he didn't take the word Dolby as a forename, because he could never have got too friendly with anyone. They would risk being hit for trademark infringement if they called him by his first name alone.

All very complicated and how odd that Dolby Labs, knowing of my interest in the case (and previously saying that they couldn't comment while it was still undecided), didn't think to tell us of the outcome. If there is someone, somewhere, inside the Dolby HQ in San Francisco who is paid to communicate with the press, perhaps they could borrow an atlas. The world does not stop at Newfoundland. □

AUDIO TEST AUTOMATION THE EASY WAY

COMPREHENSIVE AND COMPETENT: Audio Precision's System One fills audio production test needs -- at industry - leading performance levels. System One measures: harmonic, inter-modulation (including dynamic), quantization distortion and SINAD; wideband or selective amplitude and noise; phase; frequency; wow and flutter; dc Volts and resistance. Guaranteed performance <0.001% total system distortion; 0.05 dB flatness; 1.5 microvolts noise.

PAINLESS SOFTWARE: Software ease and speed may outrank performance. Tests set up in minutes via on-screen instrument panels. Acceptance limits created in minutes. Tests linked together into procedures in minutes, without knowledge of programming languages. Complete test procedures are thus done in minutes-to-hours, not weeks-to-months typical with other test systems.

PRODUCTION ORIENTED: Audio Precision's signal switchers let you test up to 192 inputs and outputs of single or multiple devices. System One supports prompts to the operator, control of device under test or external devices, graphic or tabular hard copy of test results or error tags, disk storage of test data in formats compatible with most other software.

AFFORDABLE: Best of all, System One is priced competitively with lower-performance, slower audio test systems. The savings in software development alone pay for the whole system in the first few months. If your goal is testing products rather than writing software, System One gets you there!

Call or write Audio Precision today for complete technical data and prices on System One.

Audio precision

P.O. Box 2209, Beaverton, OR 97075
503/627-0832 1-800/231-7350



MARTIN POLON'S PERSPECTIVE

In many ways, the first half of 1987 has been a banner year for the professional audio industry. Sales are brisk for many lines of products and the 'home studio' revolution is adding new customers and merging MIDI devices with established studio products. As always, new (and usually young) talents will establish themselves in studios, in sales, in design and in maintenance. At the same time, another batch of 'old timers' will shuffle off to park benches; there to heatedly debate the virtues of SR v digital, whether CDs are really superior to optimum pressed LPs and if transistors do provide a more transparent 'sound' than vacuum tubes (valves) for all applications. Of course, some 'old timers' never realise that they are out of 'vogue' and continue to create new innovations in audio engineering *ad infinitum*.

Sadly, not all the 'old timers' are old and not all of them shuffle off. The ranks of audio professionals have been diminished this year by the passing of Hugh Ford and Richard Heyser, to name just two. Aside from sorrow, chagrin and the private sense of the fleeting nature of mortality expressed by many, there remains a greater question of the lasting value of all of us in and to our industry. One could paraphrase Hemingway: 'Ask not for whom the bell tolls; the bells toll for me and the knowledge we have all lost.'

What is unfortunate with any passing is the usual flurry of anguished activity to find someone to write or contribute to the listing of that

person's life achievements. In a specific sense, Ford and Heyser were pioneers in bringing the profession of audio to the level of technology we have today. Trying to find out about what was pioneered is much more difficult than trying to prepare a decent obituary that truly honours the individual. But the ultimate question becomes that of what we have all really lost besides the good companionship of that man or woman.

It is a curiosity of our industry that we have discarded our collective technical past without so much as a fare-thee-well. Our industry has adopted the computer and computer technologies with a flourish unseen in any other aspect of the electronics industry; even including the computer industry itself.

One wry observer of both industries commented recently on the place of history in the audio and the computer businesses. "I had a chance to think about the way we look at technological history and those who have made that history. In audio, someone who pioneered a given technology 10 years ago is viewed as a relic. Witness the number of times some 'old timer' is given an award at an AES banquet and then is thoroughly ignored by the 'bright young things' for the rest of the banquet. I was recently at a banquet for Admiral Grace Hopper, the Navy computer software expert. Even though Hopper retired at close to 80 years of age and had been instrumental in developing modern software—especially COBOL—she was given a reception that was awesome and that continued well into the night. The point here is that the computer industry has reverence for those who made it

what it was; the audio industry rarely shows such respect."

Now, gentle readers, I am not endorsing that position *per se*. As with everything else in life, it is not that simple. What we seem to have in terms of countless interviews I have conducted in the course of forecasting this industry, is a vivid sense of what is now, not what has been. The audio industry has a feel to its practitioners of a total revision of technique and technology every so many years and as technology moves faster, this proverbial 'shedding of our technical skin' seems to occur more frequently. We have moved in recent history from recording on 2-track tape to 4-, 8-, 16-, 24- and finally to 32 tracks. We have done all this with the concomitant increase in console size and capacity. We have gone from analogue to digital. We have made the transition from vinyl to cassette tape to digital disc. We have seen musical instruments that have not changed basic concepts in two centuries being replaced by computer music machines using synthesis, emulation, sampling, MIDI and other technologies. Countless studio owners are complaining today that they cannot realise their investments in current equipment because their entire studio becomes obsolete before they can pay for it.

In short, the old has been left by the wayside. In the world of computers, we have achieved progress in many cases by building on an existing technological base or manufacturing hardware that performs existing tasks with greater speed and efficiency at a lower cost and requiring significantly less space. The basic concepts of computing remain in place as the building blocks of computer advancement. Books on computer history sell out of their publishing runs. Tell me the last time you saw a book about any aspect of audio history.

However, this is not a bladder elimination match between the computer business and the professional audio industry. What it is about is the relevance of past practices, developments and techniques of the sound studio. Does this historical base matter? Can we learn from the past and especially from the past experiences of those who pioneered the studio recording of audio? And if this information is important, how can we save it?

The crucial issue is the acceptance of the fact that we can still learn from our audio history and from the people who made that history. There are numerous examples of this 'historical transfer'. The underlying principles of vacuum tube audio technology are still with us and the so-called 'tube' sound is very much in demand for applications ranging from condenser microphones to power amplifiers. Even in terms of using semiconductors to create the 'warmth' associated with the tube sound; knowledge of the desired effect has to come from experience.

Transformers are still with us in audio for specific isolation and/or impedance matching applications. The past wealth of information on the audio use of transformers for the last 50 years does provide some insights as to what to do and conversely what not to do. The successful range of transformer products available today from such companies as Jensen and Sowter are based on what transpired previously in transformer design and practice.

The continuing quest for the key to the psychoacoustic phenomenon of stereophonic localisation by researchers could be greatly enhanced by a complete reference to the activities of audio researchers past such as Harry Olsen and Ben Bauer. The current development in

10 OUTLET DISTRIBUTION AMPLIFIER 4



A compact mains-powered unit with one balanced input and ten AC and DC isolated floating line outputs; Further noise level reductions.

- Exemplary R F breakthrough specifications giving trouble free operation in close proximity to radio telephones and links.
- Excellent figures for noise, THD, static and dynamic IMD
- Any desired number of outlets may be provided at microphone level to suit certain video and audio recorders used at press conferences.
- Meets IEC65 2, BS415 safety and I. B. A. signal path requirements.

Also available as a kit of parts less the case and all XLR connectors for one or ten outlets.

Broadcast Monitor Receiver 150kHz-30MHz * Stereo Disc Amplifier 3 and 5 * Moving Coil Preamplifier * Illuminated PPM Boxes * PPM Drive Boards and Ernest Turner Movements * Stabilizer and Frequency Shifter Boards * Peak Deviation Meter * Programme and Deviation Chart Recorders * Stereo Microphone Amplifiers * Advanced Active Aerial.

SURREY ELECTRONICS LTD., The Forge, Locks Green, Cranleigh, Surrey GU6 7BG Telephone 0483 275997

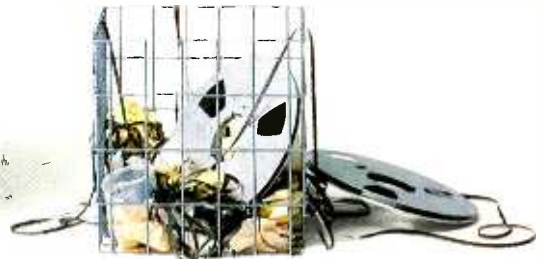

TRUTH...

OR
CONSEQUENCES.

If you haven't heard JBL's new generation of Studio Monitors, you haven't heard the "truth" about your sound.

TRUTH: A lot of monitors "color" their sound. They don't deliver truly flat response. Their technology is full of compromises. Their components are from a variety of sources, and not designed to precisely integrate with each other.

CONSEQUENCES: Bad mixes. Re-mixes. Having to "trash" an entire session. Or worst of all, no mixes because clients simply don't come back.

TRUTH: JBL eliminates these consequences by achieving a new "truth" in sound: JBL's remarkable new 4400 Series. The design, size, and materials have been specifically tailored to each monitor's function. For example, the 2-way 4406 6" Monitor is ideally designed for console or close-in listening. While the 2-way 8" 4408 is ideal for broadcast applications. The 3-way 10" 4410 Monitor captures maximum spatial detail at greater listening distances. And the 3-way 12" 4412 Monitor is mounted with a tight-cluster arrangement for close-in monitoring.

CONSEQUENCES: "Universal" monitors, those not specifically designed for a precise application or environment, invariably compromise technology, with inferior sound the result.

TRUTH: JBL's 4400 Series Studio Monitors achieve a new "truth" in sound with

an extended high frequency response that remains effortlessly smooth through the critical 3,000 to 20,000 Hz range.

And even extends beyond audibility to 27 kHz, reducing phase shift within the audible band for a more open and natural sound. The 4400 Series' incomparable high end clarity is the result of JBL's use of pure titanium for its unique ribbed-dome tweeter and diamond surround, capable of withstanding forces surpassing a phenomenal 1000 G's.

CONSEQUENCES: When pushed hard, most tweeters simply fail. Transient detail blurs, and the material itself deforms and breaks down. Other materials can't take the stress, and crack under pressure.

TRUTH: The Frequency Dividing Network in each 4400 Series monitor allows optimum transitions between drivers in both amplitude and phase. The precisely calibrated reference controls let you adjust for personal preferences, room variations, and specific equalization.

CONSEQUENCES: When the interaction between drivers is not carefully orchestrated, the results can be edgy, indistinctive, or simply "false" sound.

TRUTH: All 4400 Studio Monitors feature JBL's exclusive Symmetrical Field Geometry magnetic structure, which dramatically reduces second harmonic

distortion, and is key in producing the 4400's deep, powerful, clean bass.

CONSEQUENCES: Conventional magnetic structures utilize non-symmetrical magnetic fields, which add significantly to distortion due to a nonlinear pull on the voice coil.

TRUTH: 4400 Series monitors also feature special low diffraction grill frame designs, which reduce time delay distortion. Extra-large voice coils and ultra-rigid cast frames result in both mechanical and thermal stability under heavy professional use.

CONSEQUENCES: For reasons of economics, monitors will often use stamped rather than cast frames, resulting in both mechanical distortion and power compression.

TRUTH: The JBL 4400 Studio Monitor Series captures the full dynamic range, extended high frequency, and precise character of your sound as no other monitors in the business. Experience the 4400 Series Studio Monitors at your JBL dealer's today.

CONSEQUENCES: You'll never know the "truth" until you do.



JBL Professional
8500 Balboa Boulevard
Northridge, CA 91329

MARTIN POLON'S PERSPECTIVE

England of a stereophonic television broadcast system based on the principles of Ambisonics seems to refer regularly to pioneering work done by Michael Blumlein. How much have we learned about microphone placement and usage from Lou Burroughs? And the list goes on and on.

No one can work on improving the quality of motion picture sound without a firm grasp of the industry's technological past, including the involvement of: the Academy of Motion Picture Arts and Sciences and their 1938 'Curve' that dominated theatre acoustics and the film sound recording process for nearly 40 years; Altec Lansing in theatre speaker design; the Bell Telephone Laboratories and RCA in optical soundtrack development; ERPI as the 'bastard' offspring of Western Electric in improving theatre sound installations; Dolby Labs and Eastman Kodak in the creation of the improved stereophonic soundtrack; not to mention a myriad list of others too numerous to mention.

As to the specific terms of the contributions of Hugh Ford and Richard Heyser, who can really account for what we have all lost? Hugh had certainly reached the point in equipment testing where he was setting the standards for techniques and the technology to perform such tests. Less known to many was that one of his real interests was the improvement of audio recording techniques in the analogue vein. Conversely, we all know of Richard Heyser's countless innovations in testing the interaction of loudspeakers with the space they occupy, but less know of his usage of sound as an exploration tool for the ocean depths and his expressed hope to produce a similar audio 'sonar' to allow the precise 'charting' of spaces used for performance and listening.

To me, the real loss of both these gentlemen was their bringing of wisdom mixed with humour to various situations far too grim without their interactions. How many times did Hugh stop an AES Education Committee meeting from becoming a boring conundrum? And I cannot count the number of Hollywood Sapphire Group meetings when Richard's presence made the camaraderie that much more vital.

What can we do about this? We will all inevitably follow the simple philosophy espoused on a popular British television programme: 'Life is hard; then you die'. That much is given for all of us. To deal with that and, much more important, to pass vital knowledge to all members of the audio industry, this industry must begin to

follow the lead of businesses and disciplines around the world and undertake to operate an active oral history programme. Not with a morbid sense of collecting the thoughts from some 'old geezer' before he passes but with the purpose of capturing vital ideas now when they can help.

An oral history programme modelled on, say, the efforts of the United States Naval Institute or of similar programmes in Great Britain would conduct interviews with myriad individuals who have contributed to the progress of the industry or who have innovated techniques or operating practices. Talking to Ray Dolby about noise reduction or to Robert Moog about synthesisers is obvious but so is a discussion with James Lock about recording classical music or with Bill Porter about the recording of Elvis Presley's music. In concept, we focus on all those who have made a contribution to the recording of sound and advancement of audio reproduction; no matter what role they fill in our industry.

Where to house such a programme poses a vexing problem and has prevented this idea from reaching functionality before. The most successful model for an oral history programme requires a very small staff and operates with volunteer assistance. All that is really necessary is a coordinator who identifies potential interviewees (with the assistance of a volunteer executive council) and a secretary/transcriber to produce hard copy of the interviews. Volunteers around the world can be used to record the actual interviews. The hard copy mode has been proven the most effective way to disseminate the output of such a programme. People will read a transcript where they simply will not sit down to hear a 3- or 4-hour audio tape.

In a practical sense, we currently have the intellectual machinery of AES, APRS, ASA, EIA/CES, EIAJ, IBC, IEE, IEEE, NAB, NSCA, SMPTE and SPARS geared to the production of a multitude of reports about the future of audio. A small contribution from each trade organisation or professional society would help to fund an industry-wide oral history programme geared to saving audio's past. Such a programme could be ensconced on an academic campus with modest funding. But the organisational strategy we ultimately adopt is less important than the simple act of faith of starting to record interviews and cataloguing those recordings already done. It is time we began to capture our collective history so that in the knowledge necessary to moving forward in audio is available to all. □

No additives.
No artificial
flavours or
colouring.

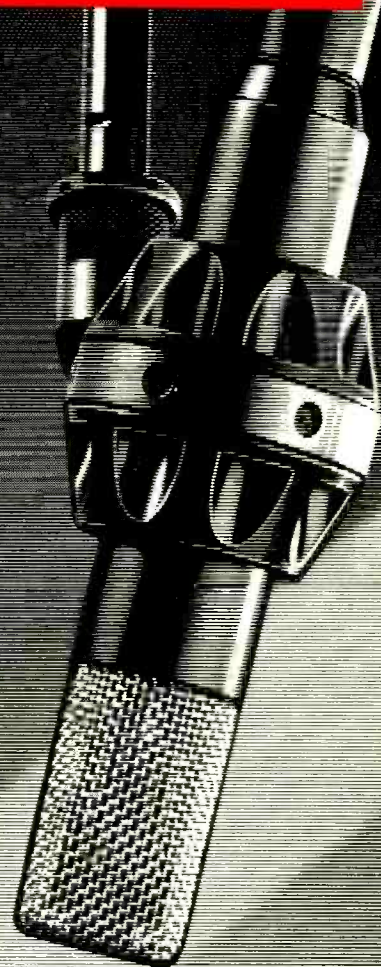

Just pure sound.
Like it was meant
to be heard.

DC-96B by Milab.
Try it, and hear
the evidence.

Milab

Court Acoustics Sales Ltd
29 Beethoven Street
London W10 4LG
Telephone: 01 950 8176

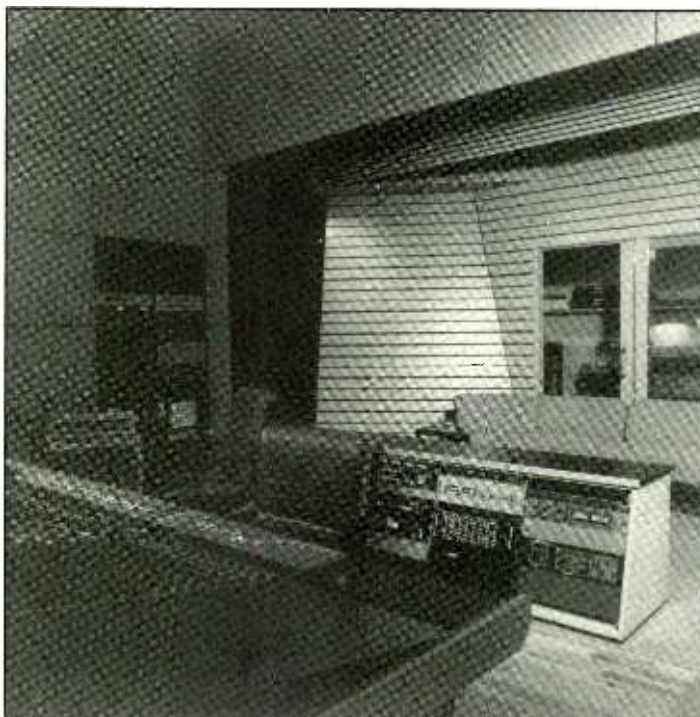

'SYNERGY'

sýn'ergý, n. The combination of resources such that the whole is greater than the sum of the individual parts.

sýn'erget'ic, a. Working together, sharing information and experience.

WMD provide a fully independent design and project management service to Audio and Video Broadcasters and Facilities.

With proven experience and success in over 200 projects worldwide, the WMD team can produce guaranteed results which are both cost effective and uncompromising.

Advanced CAD and Critical Path Analysis ensure each project is commissioned on time, on budget and to the highest technical standards.

Acoustics, Architecture, Electronics and Services are integrated by a single team into a synergetic force with total responsibility.

WMD are qualified, experienced professionals who work to only one international standard — the best.

Call Andy Munro or Jim Butler in London or write for our industry overview

The Future of Sound and Vision.

Windmill Munro Design Ltd

26 Soho Square, London W.1.V 5FJ Tel. 01 434 0011

Fax 01 434 9625 Tx 942111 COPSND G

Exciting. **INNOVATIVE**. State of the Art.
So why DON'T we sell it?

REJECT

PASSE



Many 'leading edge' ideas which arrived to fan-

fares now lie in cobwebs.

At Syco we greet every new development with a critical eye. We assess, we consider, we use our judgement.

And since we introduced the first digital music production technology back in 1980, our products have been increasingly influential in changing music production techniques.

With our experience of both digital and analogue technologies we've been able to successfully integrate the two in various ways, creating a wide variety of music production environments.

Our Technical Services Department, for example, experienced at installing analogue and digital audio, MIDI systems and Local Area Networks (LANs) for computers, frequently designs custom interfaces for specific installations.

We also produce new products to solve problems which are not being addressed by other manufacturers. (The Sycologic M16 Midi-Matrix is one example.)

Our knowledge and experience has helped us identify the major new trends in music production, and the products that will accompany them.

Syco will be introducing this technology. A quality of product and service which will establish new standards. Helping you build a more efficient and creative production environment.

So not only will our new technology be exciting, innovative and state of the art. You can also be assured that it'll meet our own high standards.

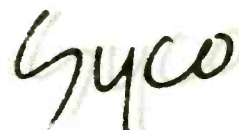

TECH/KNOWLEDGE/Y

Syco: Conduit Pl. London W2 Tel: 01-724 2451. Tlx: 22278 Fax: 01-262 6081.

MASTER ROCK

Master Rock is located in Kilburn, a little north of central London. The two owners have firm ideas about what they want in a studio. Janet Angus visited

Master Rock is one of those studios whose name seems to have been around for years, whereas in fact the studio only opened in January 1986. Owners Steve Flood and Stuart Colman, who is also a producer, had both already worked in the industry for years when a chance meeting led to the idea for Master Rock.

It is a facility with a purpose rather than one aiming to be all things to all men. Both Colman and Flood knew what they wanted and since these ideas coincided they felt they might just as well do it together. Flood was looking for a partner who was actively involved in buying studio time in order to ensure meeting that market. With a background of many years on the

road and eventually moving into the 16-/24-track studio market, Flood had decided to go for the top. For his part Colman, like so many other record producers, simply wanted to own his own studio. But the Colman connection is not emphasised since studios tied up with producers are sometimes misinterpreted by potential clients.

The studio was finally built in a 1910 cinema in Kilburn, North London. Flood had been looking for three years and seen over 300 buildings before he found his answer.

"When they closed the cinema down it became a rag trade sweat shop. The point is that it was just a huge, clear open space."

Over the years Colman had recorded numerous albums at a Ken Shearer-designed studio where he was very comfortable and so it was he they chose to build Master Rock. The facility was to consist of a large control room with a separate large machine room and a large recording room.

Flood: "Ken's design brief for the studio was a bright live room and that's exactly what we got. We wanted a room that could record drums although around that time everyone else was building cupboards. We have also started doing string work, for example on the string parts on the Paul O'Duffy tracks. It's not an area in which we have particular experience but we would like to cultivate it. String rooms are disappearing—like Olympic; that will just become another Virgin rock & roll studio. We are basically a track laying studio here but there seems to be a market for string rooms. I find it odd that we are generating work in that area."

The bright lively room has also gained a reputation for its drum sound, RT being about 1.5 s. From the ceiling there is suspended a series of hanging diffusers à la Albert Hall which Flood described as a very cost effective method of diffusion.

"We have been toying with the idea of motorising them so that you could lower the whole lot and alter the reverb time but it will be very expensive."

The studio floor is polished woodblock, the walls concrete blockwork with Ken Shearer membrane bass trapping around the room.

"There is a nice, tight bottom end to the room. We have some JBL 4430s for talkback but we also have Jimi Hendrix's old PA system for rebuilding bass drums on the mix. We tend to use the room on mixdown to put the ambience back into a mix."

As with any studio all the various corridors and nooks and crannies are put to work when different acoustics are sought but Master Rock has more nooks and crannies than most because of its past uses.

"There is a wonderful old gents toilet out the back—it works wonderfully as a brass echo chamber!"

Next to this is a half finished dead room—witness to the ever changing face of the facility. The projection room functions today as maintenance workshop.

Building Master Rock was a relatively simple task given the vast empty space from which it was constructed.

"We just laid a concrete floor in the open space and built two separate buildings."

The front monitor wall in the control room consists of a "... standard hanging baffle arrangement. The side and rear walls are a combination of bass absorbers and removeable absorptive (*Rockwool*) and reflective panels. The beauty of the system is that you can change it without any downtime. The ceiling is essentially a broad band bass absorber."

The Quested monitoring arrangement was changed earlier this year. Originally the monitors were free-standing: "There was a good reason for that; it meant that there was no pumping of room nodes although it was lacking in the low end. The only answer was to build them into the wall."

For this Andy Munro was called in: "He has a reputation for sorting monitoring out. Munro vastly improved the monitoring but cut down the space with a new monitor stud wall. To build a concrete wall would have meant a month's downtime. As it was the whole thing was done in seven days."

Although the control room is sizeable, about 6.5×6.5 m, it was never intended to be one of the new breed of synthesiser control rooms as such. "Actually, I think it looks old fashioned which is what I wanted. Why? Because I appreciate the old values of studios—traditions which should be kept in the industry such as professionalism and sound quality. I just get the feeling that there are no new people coming through the industry. Most

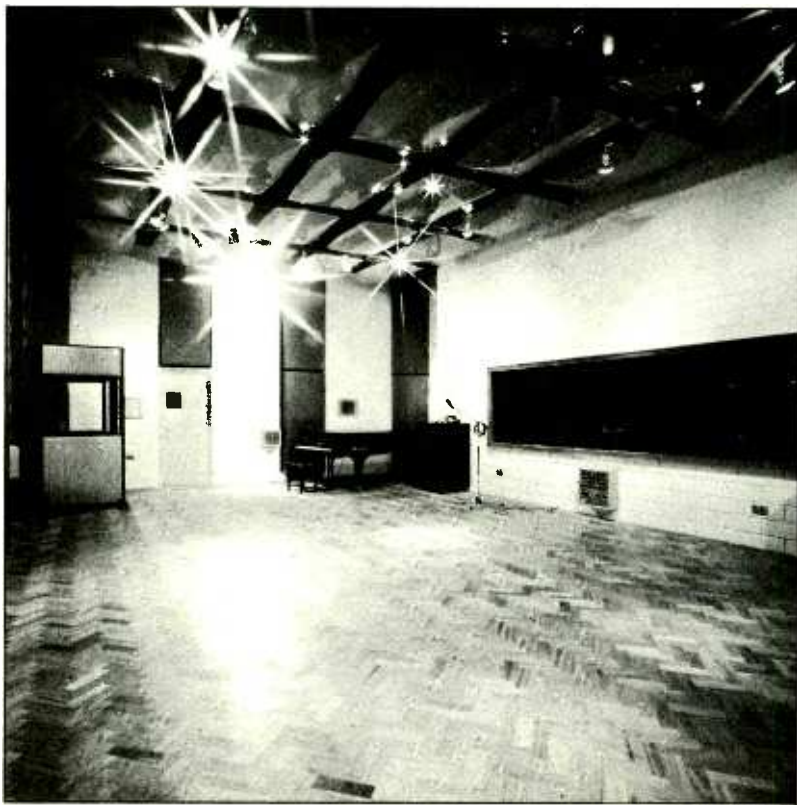

Stereo

Broadcast

Mixer

SBM



EELA AUDIO SBM:
 a complete, fully modular
 on air radiodesk with flexible layout
 and all necessary functions and
 facilities.
 Extreme reliable by intensive use of
 solid-state switching and VCA faders.

eela audio

Hondsruglaan 83a, 5628 DB Eindhoven Holland, Tel: 040 -424455, Telex: 5928 BOLLE NL.

Audio and Design U.K. Tel.: (0992) 468674
Telefax — 093140 428925

AUDIO JACKFIELDS & JACK SOCKETS

Plasmec Systems are the largest manufacturer of Audio Jacks and Jackfields in the UK. We are approved suppliers to the BBC, British Telecom, Pye Telecommunications and many other major telecommunication companies throughout the world. We manufacture a complete range of Audio Jacks and Jackfields and offer a design and manufacturing service geared to meet your specific requirements. For further information and technical data on our products contact:

MOSSES & MITCHELL

Plasmec Systems Limited
Weydon Lane Farnham Surrey GU9 8QL Telephone: Farnham (0252) 721236 Telex: 858820

D&R Dayner Series Console

Totally modular in-line, split in/out, monitor modules or patchpanels allow unlimited expandability with unparalleled compactness. Individual led metering, 4 band eq. with sweepable mids, and 8 aux buses are all standard. The DAYNER has a welded steel chassis and a superb styling.

8 fully floating subgroups: allow routing any input (or group) to any multitrack channel(s) without repatching. In addition, since any I/O module can become a subgroup master, subgroups can be equalized, fed to auxiliaries, muted or grouped.

Discrete mic pre-amps and proprietary circuit design: yield outstanding headroom, audio transparency, and transient response.

Modular dual function tape monitors: allow monitor capacity to be individually determined and expanded. Monitor channels also double as returns for effects, samplers, and sequenced synthesizers on mixdown.

Precision engineered and manufactured by D&R Electronica: recognized the world over as a leader in professional audio. Priced to make value an understatement.

Call or write to D&R Electronica B.V., Rijnkade 15B, 1382 GS Weesp, The Netherlands. Tel. 02940-18014, tlx 18503 dr nl.

Call or write to D&R USA, 1720 Chip N Dale Drive, Arlington, TX 76012, Tel. (817) 548-1677, tlx 758666, or contact one of



Dayner Series Beyond Comparison



AUSTRALIA, AUDIO & RECORDING, 2019 Sydney, 36-38 Daphne St. Botany tel: 61-26669935
AUSTRIA, KUHNL & WURZER, A-4020 Linz, Waldeggstrasse 68 tel: 43-732668125 **BELGIUM**,
A.S.E. pvba 2800 Mechelen, Kon. Astridlaan 216 tel: 32-15421152 **CANADA**, J MAR M4H 1E9
Ontario, 6 Banian Drive, Toronto tel: 1-4164219080 **DENMARK**, POWER PLAY MUSIC APS. DK
2200 Copenhagen, Norrebrogade 125a tel: 45-1244048 **ENGLAND**, STUDIO SPARES, NW 6NS
London, 16 Stuckley Pl., Camden Town tel: 44-14854908 **FINLAND**, SAHKOLIIKKEIDEN OY
01301 Vantaa 30, P.O. Box 88, Sahkometsa tel. 358-908381 **FRANCE**, METTLER AUDIO, 75009
Paris, 1-3-5 Blvd de Clichy tel: 33-148782911 **GERMANY**, SOUND SERVICE 1000 Berlin 15, Fasa-
nenstrasse 45 tel: 49-308834262 **ITALY**, PROFESSIONAL EQUIPMENT 20142 Milano, V. le Fama-
gosta 37 tel: 02-817839 **NORWAY**, JON VEDUM ELEKTRONIKK N-1381 Heggedal, Aamotveien
2 tel: 47-2798990 **SPAIN**, BOSE SA 28027 Madrid, Arisoteles 3 tel: 34-4050611 **SWEDEN**, MON-
TEZUMA RECORDING 10265 Stockholm, Kocksgatan 17 tel: 46-8436291 **SWITZERLAND**, ISLER
AG 8048 Zurich, Badenerstrasse 808-810 tel: 41-14321444.

engineers have no idea about mic technique.

"Where are the old engineers? Old engineers are not operating within the industry anymore. One of the major problems in studios is the staffing levels. It is reflected in the institutions—the Airs and the Abbey Roads of this world. London should be full of Americans at the moment and it's not. If you walk into an American studio you will find proper tape operators not trainee tea boys. Where you traditionally used to have a balance engineer, a producer and a tape op in the studio you now have an engineer/producer and a tape op. A lot of producers are ex-engineers and have trouble finding engineers so they do it themselves.

"We have been very lucky not to have the 'How do you mic up a drum kit?' problem here. We do a lot of live acoustic recording because we saw a space in the market. The modern requirement is to be a facility to cover both live and keyboard work so we have lots of room. You have to be able to do everything but you can't say 'We're a synth studio' unless you take the 'I'm sitting here with my Fairlight' route."

The mixing console is a 48-channel SSL 4000E.

"Why SSL? There is no other console to buy in terms of being a friendly flexible tool. My attitude at the moment is that I'll build another room when someone builds another console. As for the new computer, we'll all buy them. There's no choice is there? It's a great idea. Wonderful marketing.

"We recently bought four Focusrite EQs because they sound wonderful. The original Focusrite modules were too large but now they drop straight into the SSL. The place for EQ is in the console."

Master Rock was the first studio in this country to buy the Lynx synchroniser, chosen because: "It works, and it's simple with fast lock-up (between 1 and 3 s to link up two Studer A800s). It's idiot proof which is a great advantage. For straight lock up nothing else compares.

"Same thing with Focusrite: Rupert Neve and Massenburg are the only people who understand analogue audio—they are both exceptional sounding products."

As no doubt you have gathered the multitrack machines are Studer A800s. These were decided on as opposed to Otari MTR90s because: "They are nice. Studer and Otari are roughly the same price but it's like comparing a Volkswagen Golf with a Mercedes 190. The Golf is marginally cheaper and faster, but the Mercedes has got more class. You either come from a Studer or an Otari background.

"Studer is a substantial company too. We ran the two machines side by side and chose Studer. It looks nicer anyway! So what if the Otari handles tape 1 s faster? Studers work—they go round and round and make a noise, what else do you want? They don't cause any grief and the backup is wonderful. But then again, you could say the same thing about Otari. It's just a personal thing.

"Anyway, the best tape machine is still the Ampex but they don't make them any more and reliability is a problem, but in terms of sheer sound quality, they win. We felt Studer was the next best thing.

"For mastering, now, the only practical decision is the A820—it sounds so much better than the A80." Master Rock has an A820 ½ in and an A810 ¼ in plus Sony F1.

"Digital multitrack? Yes we had one of those in here for a day once. Record companies are interested in spending £600 a day less, not more. It took five years for 48-track to catch on. Digital multitrack is not here yet. It's an interim medium anyway and doesn't justify the investment especially when you see studios that did buy them now selling them because the work doesn't exist."

Nearfield monitors on the console are Yamaha NS10s, AR 18s and Auratones. All outboard effects are mounted in a rack behind the console between the operator and the keyboard/visitors area at the back of the room. Reverbs include Lexicon 224X, AMS RMX16, Yamaha REV7 and EMT 140 valve plate. Digital delays are the AMS DMX15.80S and Bel BD80. Other equipment includes Bel BF20 stereo flanger, Eventide H910 Harmonizer, UREI 1176 limiters, ADR FX760, Drawmer noise gates, dbx 160s, Pultec-type valve equaliser, Orban stereo parametric, ElectroSpace Spanner, SRC and Quark MIDI link and MIDI loops.

"We have lots of microphones including some old Neumann valve 47 and 67s plus a good complement of everything else. It's

MASTER ROCK



not as good a collection of vintage microphones as they have at Abbey Road but then I haven't been in business for 30 years. I've been thinking about getting some TLM 170s and Briel & Kjaer mics. But the only mic I have had to hire in is the C24 so we are on the lookout for some of them. Anything that we rent in on a repeat basis should become part of the studio."

The studio has a Bosendorfer Imperial (9 ft 6 in) grand piano.

Creature comforts are more than adequately catered for with a 24 hour bar and a restaurant that handles everything from breakfasts and snack lunches to three-course dinners. "I have eaten too many fast food meals off the console in my time. What happens outside the control room is as important as what happens inside."

Pool and tennis tables as well as a lounge with television, video and stereo relieve the boredom.

Master Rock was recently joined by Robyn Sansone, formerly of Green Street Recording and Unique Recorders in New York. Her official title is studio manager although she describes herself as 'House Mother', while urging a very exhausted looking engineer to go home to bed. Steve Flood describes himself as technical director. The studio also employs two engineering assistants; Roland Herrington and Helen Woodward. No house engineer? "I've been looking for a house engineer for 15 months. They all want to be freelance and earn more than the studio."

Obviously a man who knows what he wants, Steve Flood plunged the studio straight in at the deep end when it first opened.

"Most studios' proving sessions are just a couple of instruments aren't they? Well our proving session was Cliff Richard and the Young Ones. Not only did we have all these personalities, we had a 40-man film crew to cope with! It was hair raising with all those personalities and equipment. That told me we must have done something right."

Master Rock Studios, 248 Kilburn High Road, London NW6. Tel: 01-328 9605. □

PROFESSIONAL VIDEO

INTERNATIONAL YEARBOOK 1987/88

TENTH EDITION PUBLISHED BY
BROADCAST-SYSTEMS-ENGINEERING

10 YEARS SERVING THE PROFESSIONAL BROADCAST INDUSTRY

A must for your bookshelf!

For 1987 the Professional Video International Year Book is published in the popular A4 magazine format. With its successful editorial coverage of equipment and services covering the international broadcast industry with 1,000's of listings by manufacturers, brand-names and in many cases their UK and Overseas distributors, plus a summarised text of product lines.

All this invaluable information is classified under sections, ranging from aerials antennae and masts to video cassette storage and cases, therefore ensuring that looking for the equipment you need can be found in our comprehensive easy to use publication.

Published in association with Broadcast Systems Engineering the international magazine for the broadcast industry.

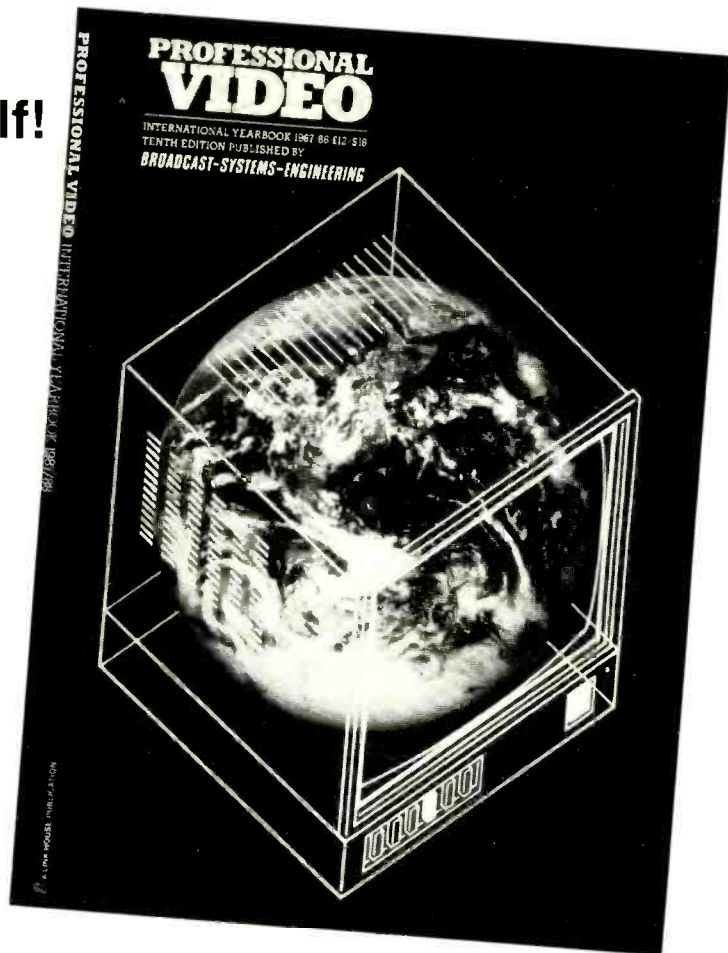

Professional Publications Group, Link House Magazines Ltd, Dingwall Avenue, Croydon CR9 2TA, United Kingdom.

Please send me copies of
Pro Video International Year Book 87/88.

£14.00 (UK) £16.00 Europe \$27 USA Airmail
£19.00 World Airmail. *Includes Postage and Packing.*

I enclose a cheque/postal order/International money order
payable to **Link House Magazines** for the amount _____

Or debit my credit card



Credit card No.

Credit card holders can order by simply ringing 01-686 2599
ext 550, quoting credit card No.

Signed _____

Name _____

Address _____

(please print)

Please return the completed order form enclosing full
remittance (including delivery) or giving your credit
card number to **Professional Publications Group,
Link House Magazines Ltd, Dingwall Avenue,
Croydon, CR9 2TA, United Kingdom.**

Please allow 28 days delivery in Britain, extra overseas depending on
country and delivery method.

Gateway

SCHOOL OF RECORDING
MUSIC TECHNOLOGY
AND
MEDIA STUDIES

EUROPE'S LEADING MUSIC

INDUSTRY SCHOOL

Courses for 1987:-

- *Primary and Advanced Multitrack Recording*
- *Sampling and Midi Workshops*
- *Composing and Producing Radio and T.V. Commercials*
- *The Synthesizer Week, FM/DX Programming Weekends*
- *Synchronisation, using codes (SMPTE/EBU) Music to Picture*

For complete Brochure and Prospectus Call:-
Gateway School of Recording
and Music Technology
1A Salcott Road, London SW11 6DQ. 01-350 0340

We give a Certificate of Recognition for each completed Course.

Gateway Courses should not be confused with
ANY others offered . . .

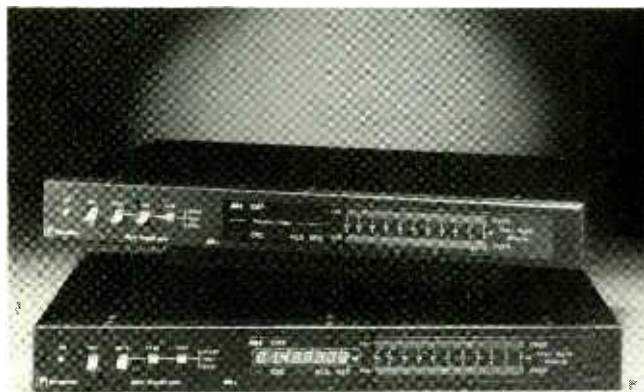

DBM-1A

**Comprehensive remote digital metering
unit for the
Sony PCM-1630/1610 systems**

Owners include:

Tape One Studios (4)	Nimbus
Abbey Road Studios (2)	Island Records
ICM Switzerland (2)	Digipro
Genesis	Mullard
HHB	N.O.S. Holland

TOTALSYSTEMS



Weller Eggar House,
High Street, Hartley Wintney, Hants RG27 8NY
Tel: 0251 26 4757

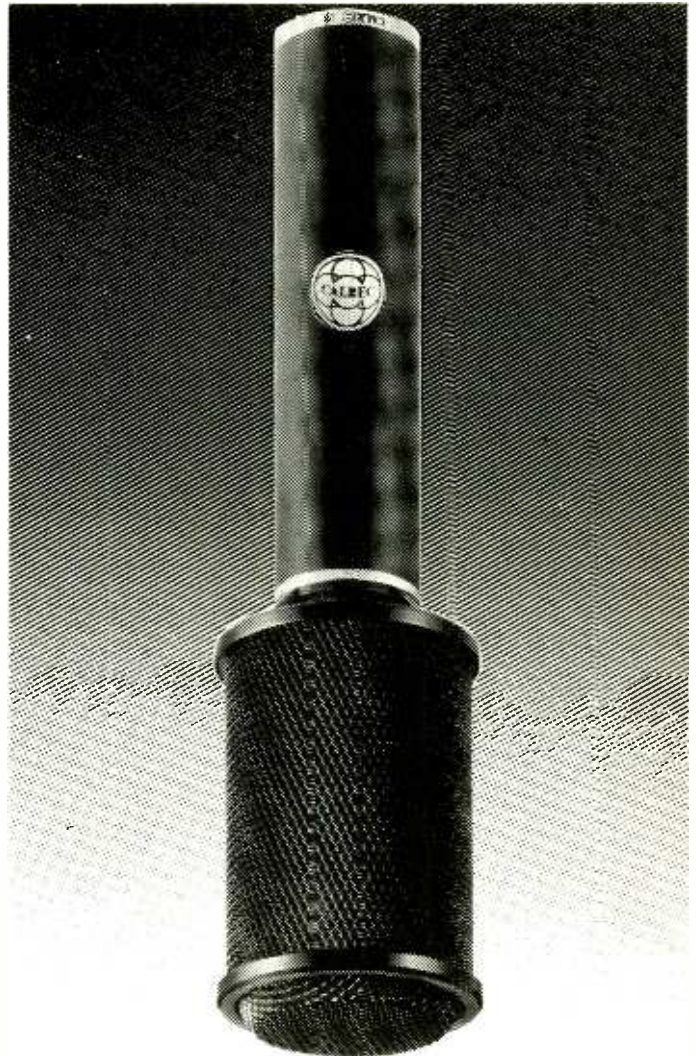

We'll take it from here!

Ask any studio owner, engineer or client . . . when only the best is good enough . . . AMS has the answers.

From the world's number one microphone, the Calrec Soundfield, to Audio File, the world's most versatile digital recording, editing and mastering system.

From a range of digital reverberators and audio processors to the Calrec UA8000 music recording console, now available with The AMS Studio Computer.

In our digital age when audio quality matters, from microphone to master, whatever stage you're at, AMS has the best.



The Queen's Award for Export Achievement to Edendeck Ltd.
1984/85 and AMS Industries plc 1986.
In July 1985, Edendeck Ltd. became AMS Industries plc.

ams

ADVANCED MUSIC SYSTEMS

AMS Industries plc, Burnley, Lancs. BB11 5ES, England
Tel: (0282) 57011. Telex: 63108 AMS-G. Fax: (0282) 39542

Harris Sound Inc.
6640 Sunset Blvd., Suite 110, Hollywood, CA 90028, U.S.A.
Tel: (213) 469-3500

STUDIO SOUND'S

PRO-AUDIO DIRECTORY 1986/7

From the publishers of the world's leading professional recording magazine **Studio Sound**, comes the latest edition of their sister publication, **The Pro-Audio Directory**.

This unique and vital reference source has been completely updated and revised to provide in one volume information on every aspect of the professional recording industry; From Acoustic Materials to Tape Recorders; From Mixing Consoles through to Synthesisers.

In addition to its forty extensive hardware sections are chapters covering Dealers in the UK, USA and Worldwide. Pin-pointing which equipment can be brought where – anywhere in the world.

The ultimate section is the extensive address listing featuring the full details of over 3,000 companies mentioned in the directory, including key contact names. Also there is a cross reference listing of Worldwide Distributors detailing international availability of any given product. This information is not available in any other publication.

The Pro-Audio Directory has all the information you need, and to make sure it is straight forward to use, this edition sees a complete redesign with an even greater emphasis on clarity.

To ensure you stay in touch with the expanding, rapidly changing world of professional recording order your copy of the specialised **Pro-Audio Directory** now.



Professional Publications Group, Link House Magazines Ltd, Dingwall Avenue, Croydon CR9 2TA, United Kingdom.

Please send me copies of
Pro Audio Directory 1986/7.

£13 (UK) £14.00 Europe \$25 USA Airmail
£16.50 World Airmail. *Includes Postage and Packing*

I enclose a cheque/postal order/International money order
payable to **Link House Magazines** for the amount _____

Or debit my credit card



Credit card No.

Credit card holders can order by simply ringing 01-686 2599
ext 550, quoting credit card No.

Signed _____

Name _____

Address _____

(please print)

Please return the completed order form enclosing full
remittance (including delivery) or giving your credit
card number to **Professional Publications Group,
Link House Magazines Ltd, Dingwall Avenue,
Croydon, CR9 2TA, United Kingdom.**

Please allow 28 days delivery in Britain, extra overseas depending on
country and delivery method.

CLASSIFIEDS

Advertisements for this section must be pre-paid. The rate is 60p+VAT per word, minimum £15.00+VAT. Box Nos. £5.00+VAT. VAT (UK only) \$ rate \$2.00 per word, minimum \$50.00, Box No. \$10.00 extra. Semi-display rates on application. Copy and remittance for advertisements in **OCTOBER** issue must reach these offices by **26th AUGUST** addressed to: The Advertisement Manager, **Studio Sound**, Link House, Dingwall Avenue, Croydon CR9 2TA. Cheques made payable to Link House Publications (Croydon) Ltd. **Note:** Advertisement copy must be clearly printed in block capitals or typewritten.

Replies to Box Nos. should be addressed to the Advertisement Manager, Studio Sound, Link House, Dingwall Avenue, Croydon CR9 2TA, and the Box No. quoted on the outside of the envelope. The district after Box No. indicates its locality. **SEX DISCRIMINATION ACT 1975:** No job advertisement which indicates or can reasonably be understood as indicating an intention to discriminate on grounds of sex (e.g. by inviting applications only from males or only from females) may be accepted, unless (1) the job is for the purpose of a private householder or (2) it is in a business employing less than six persons or (3) it is otherwise excepted from the requirements of the Sex Discrimination Act. A statement must be made at the time the advertisement is placed saying which of the exceptions in the Act is considered to apply.

The attention of advertisers is drawn to "The Business Advertisements (Disclosure) Order 1977", which requires that, from 1st January 1978, all advertisements by persons who seek to sell goods in the course of business must make that fact clear. From the above date consumers therefore should know whether an advertisement relates to a sale by a trader or a private seller.

SERVICES

<h1>MRC</h1> <p>A ZONAL COMPANY</p>	<p>The Magnetic Recording Company, a subsidiary of Zonal, Britain's leading manufacturers of professional magnetic sound recording products, offer you cassette duplication of music, speech and data using Gauss loop bin, as well as the best equipment for winding, printing onbody labels and inlay cards.</p> <p>You will get the service and quality that is expected of a company that has been in the magnetic products business for over 30 years.</p>	<h3>MAGNETIC RECORDING COMPANY</h3> <p>Holmethorpe Avenue, Redhill, Surrey, RH1 2NX. Tel: 0737-67171 Telex: 946520 Fax: 0737-67610</p>
-------------------------------------	---	--

TRANSPORT PROBLEMS? Look no further! Technical Transport Ltd have available experienced sound and video technicians driving latest vehicles to transport your equipment where you want, when you want. We can also help with installation and operation. Phone Richard Guy on 01-698 0099.

HIGH SPEED COPIERS SALES AND SERVICE. Real time cassette copying. Blank cassettes. Audio Visual supplies and servicing. Contact: Sound Marketing on 0603 667725. (O)

THE COMPLETE SERVICE. Disc cutting, pressings, duplicated cassettes and blanks. Bin Masters. Location Recording. Free Brochure. Tam Studio, 13a Hamilton Way, London N3 1AN. Tel: 01-346 0033. (X)

REAL-TIME cassette copying, high quality, reliable, very economical, using cassette, 1/4" or digital masters. Master preparation and editing service. Digital mobile recording. Steve Pontin Audio Services 01-398 7933. (O)

SMALL-RUN PRINT SERVICE of audio cassette labels using high-quality daisywheel printer. S.A.E. for price list. 50 pairs £5.45 for 4 lines of text. First Impressions, P.O. Box, Leeds LS7 4HQ.

QUALITY CASSETTE COPYING AND PROCESSING, any quantity. Video duplication. PAL-NTSC-SECAM systems transfers. While-you-wait-service. Open 24 hours, 7 days a week. Central London, W2. GWBB Audio Vision. (01) 723 5190.

100 C-60 cassettes beautifully copied in stereo from **£59.50** (plus VAT)
We can copy from 100 to 5,000 high quality cassettes on our high speed loop-bin system, load them precisely into top-class shells. Price includes library case and all production work from your 1/4" in edited master. Any length C 5 to C 90. Ring for price check.

STUDIO REPUBLIC 
47 High Street, Pinner 01-868 5555 01-866 5555

STUDER REVOX

WE ARE THE TAPE MACHINE SPECIALISTS. WE PROVIDE PROMPT EFFICIENT SERVICE AND REPAIRS FOR THE WORLD FAMOUS RANGE OF STUDER REVOX MACHINES. WE ALSO HANDLE TEAC/TASCAM+NAGRA RECORDERS IN OUR WELL EQUIPPED WORKSHOPS WITHIN EASY REACH OF LONDON.

★ WHEN YOU RELY ON YOUR EQUIPMENT, YOU CAN RELY ON US!

3M OFFICIAL UK SERVICE CO.
SPARES *Service Calls Save Time!*

153A VICTORIA STREET, ST. ALBANS
Telephone: 58977 (0727)

THE SOUND & VISION WORKSHOP LIMITED

CASSETTE DUPLICATING:
GAUSS Loop-Bin / TELEX In-Cassette
High Quality Blanks / Label Printing
OPEN REEL DUPLICATING
(ANY SPEED - ALSO TO BROADCAST SPEC.)
SPEECH RECORDING
(VOICE-OVERS; LANGUAGES; AUDIO-VISUALS)

SPEECH-PLUS RECORDINGS LTD.

UNIT 32, NO. 19, PAGES WALK, LONDON SE1 4SB. TEL: 01-231 0961

CLASSIFIEDS

SERVICES

REAL TIME CASSETTE COPYING

All work carried out on Nakamichi machines to the highest standard. Normal or chrome tape available.

We also supply blank cassettes wound to length.

AGFA and BASF Chrome tape available

GATEWAY CASSETTE SERVICES
1 GAUDEN ROAD, LONDON SW4 6LR
TEL: 01-627 4758



THE CASSETTE DUPLICATING SPECIALISTS

Real time & high speed loop bin duplication, printing & packaging. Blanks wound to length

TEL: 061-973 1884

SELECTA



SOUND

AUDIO
CASSETTES
04024 53424

REAL TIME AUDIO CASSETTE DUPLICATION

on the latest equipment

• Quality superior to high speed copying. • No mastering charges • Any quantity at very competitive prices • Fast delivery. All work guaranteed. **BLANK CASSETTES (C1-C100)**.
• Highest quality screwed or welded housings • Ferric or Chrome tape • **LIBRARY CASES • LABELS • INLAY CARDS** • Phone or write for immediate quotation.

AUDIOCOPY (Dept SS3), Unit 3
Buslingthorpe Green, Meanwood Road,
Leeds LS7 2HG. Tel: (0532) 625650



CASSETTE DUPLICATION

Quality Cassette Duplication, High-Speed and Real Time. From 1/4", PCM-FI or Cassette Masters, Overwrapping, custom wound blank cassettes, labels and inlays

Tel: Leicester (0533) 602064

ACCURATE SOUND LIMITED
QUENIBOROUGH (Ind. Est.) MELTON ROAD
QUENIBOROUGH, LEICESTER LE7 8FP

FOR SALE—PRIVATE

UHER 4200 HALF-TRACK STEREO. Portable with rechargeable NiCads, carrying case. £550 no VAT.

AKG CONDENSER RIFLE MIC. C451 + CK9 + B46 pistol grip etc. £150 no VAT hardly used hence mint condition—bereavement forces sale. Phone: 01-534 3290.

STUDIO BOOM STANDS—AKG type ST212. Very good condition. 4 available at £30 each no VAT. Phone: 01-534 3290.

YAMAHA REV 1 Reverb 6 months old mint condition £2,750 + VAT. Mercedes sports coupe 450 SLC 52,000m full service history 1979 private no. all electric beautiful car throughout. Bargain £8,995. Phone: (031) 440 1084.

24T STUDIO SALE. Tape machine/remote £4,500, 32 channel mixer £4,500. NR/Ancillary equipment. All excellent condition. Phone for list/details: (0757) 638812.

3M M56 16-track with remote control and varispeed. Good condition. £4,250 o.n.o. Bristol 662932.

MCI JH100 16 TRACK. 2" tape recorder full remote control with auto locate just had extensive overhaul £4,950. Phone: (0622) 859331 or (0622) 859547.

SONY 1610 DIGITAL PROCESSOR, 2 Sony BVU200 NTSC U-Matic Video Recorders, £11,500—but might sell separately. Phone Adam: 01-226 4867.

NEUMANN VALVE MICROPHONE U67 with PSU plus cables, very good condition £1,350. Phone Andrew/Fiona: 01-960 4455.

Check It Out...

DIRECT FROM OUR MODERN U.K. PRESSING PLANT

- CUTTING · PRESSING
- TEST PRESSING
- LABELS · SLEEVES
- CASSETTES
- ARTWORK
- COMPETITIVE PRICES

MARKET LEADERS

SRT

01-446 3218

SPEEDY REVOX SERVICE

Plus **TEAC/TASCAM, FOSTEX, UHER**, most Mixers. Amplifiers. Effects. Priority Bookings taken. Collection/Delivery arranged.

A personal service by experienced engineers.

34 Danbury Street, London N1 8JU
Telephone 01-359 9342/3030

RAPER & WAYMAN

CLONE 01-351-4895

Real time high quality cassette copying from digital Sony 701, r/r or cassette format (Agfa, TDK, BASF), labels and inlays fully typed. Analogue editing facilities.

UNIT C, CHELSEA STUDIOS, 92 LOTS RD, LONDON SW10 0RN

CASSETTE DUPLICATORS

Specialists in the supply and service of cassette duplicators, bulk custom wound cassettes, and accessories

GRAFF SONY TELEX WOLLENSAK

Main Dealers UK and Export

SOUND CASSETTE SERVICES LIMITED
BODEN STREET, CHARD, SOMERSET

0460 67237

NATIONWIDE

NEW HEADS FOR OLD!

All makes relapped

TAPETEK: 01-254 5203 or
0836 215900 (car)

APPROVED BY



jbs records

MUSIC-SPEECH-DATA

REAL-TIME/HIGHER-SPEED Quality Cassette
Duplication and Blanks from 1 1000 . Computer printed
Labels. Solo, 1/4" reel. Sony Betamax recording.
Fast security Delivery service
FILTERBOND LTD jbs records div. FREEPOST
19 SADLERS WAY, HERTFORD SG14 2BR. 0992-500101

REAL TIME CASSETTE DUPLICATION

USING AIWA AD F770 CASSETTE DECKS
FROM 1/4" AND PCM F1 MASTERS

- Custom wound blank cassettes
- Shape MK10 and ICM-CO's
- Inlay card and label printing

TEL 0222 554195
BACKYARD RECORDING
STUDIO LTD



CLASSIFIEDS

**STUDIO DESIGNERS
AND CONSULTANTS**

INSTALLATIONS
Audio, Video & Electrical Contractors
Complete project management
Prefabrication off-site
Elliott Bros
0865 249 259

FOR HIRE

WORKING IN THE USA?

"THE BEST THAT MONEY CAN RENT"
Complete selection of pro audio equipment for hire.
Outboard Equip ★ Digital Recorders ★ Walkie Talkies
599 Eleventh Avenue, New York, NY 10036
Phone (212) 582-4400

FOR SALE—TRADE

BRAND NEW SONY PROFESSIONAL studio condenser microphones. C-36 £75 (SRP £218); C37/38 £115 (£287); ECM64 £45 (£132); ECM969 £95 (£144); Sony BVU200B NTSC umatic for PCM1610, almost new, £1,350 (£6,500 new). (048 632) 455.

USED PROFESSIONAL RECORDING EQUIPMENT: Buy, Sell, Trade. Dan Alexander Audio. USA 415-474-1625 or 213-660-5719.

TAPE HEADS

TAPE HEADS

REWORK SERVICE, relap and reprofile often same day or even quicker.

REPLACEMENTS, from the U.K.'s leading Pro Audio head maker.

BRANCH & APPLEBY Ltd. Stonefield Way, Ruislip, Middx HA4 0YL 01 864 1577

AUDIO AMPLIFIERS

TURNER ELECTRONICS IND (Est 1966)

POWER AMPLIFIERS 100-700 Watts. 2u, 3u, 4u rackmount. High stability, ultra low noise and distortion. Flat response. Linear class AB1, 70% Efficient triples complementary circuitry design by our engineers from Plessey, Fluke, Dolby and Mullard. No noisy fans, thermal limiting of Mosfets, mechanical relays, fuse blowing or overload trips one million watts. In use by artists and sound establishments. Sales, service, export engineering advice and sales of most UK electronic audio products.
PO Box 49, Etchingham, East Sussex TN19 7NZ (STD) 0435-882581.

35 BRITANNIA ROW LONDON N1 8QH

**BRITANNIA
ROW** 01 226 3377

**Multitrack, 2-Track
& Studio Effects**

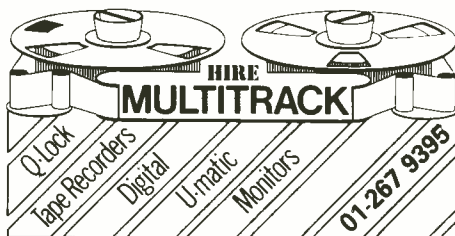

QUESTED 212 MONITORS with three way crossover, £2,500 o.n.o. Amber 4400 multi-purpose audio test set, OFFERS. Tequipment dual beam oscilloscope type D1011, £200. Contact Terry at Utopia Studios on (01) 586 3434.

STUDIO EQUIPMENT FOR SALE due to 24T upgrade. TAC/AMEK Matchless in-line console 26/24/8/2. 18 months old v.g.c. 8K o.n.o. Lyrec 16T, 2" low hours v.g.c. 8K o.n.o. Otari 8T 1" (7300) New Heads 2K o.n.o. Otari 1/4" Stereo (MX5050) £750 o.n.o. Phone: (061) 236 7530.

AMEK/TAC 'Matchless' in-line console 26/24/8/T. 18 months old v.g.c. £8K o.n.o. Lyrec 16 track 2" low hours £8K o.n.o. Otari 8 track 1" New heads £2K o.n.o. Otari MX5050 Stereo £750 o.n.o. Phone: (061) 236 7530.

DISC CUTTING EQUIPMENT and systems bought, sold, installed and manufactured (under licence from ORTOFON). TAM/ENGLAND, 13a Hamilton Way, London N3 1AN. Telephone 01-346 0033. (X)

TEAC 244/34/38 discounts and HP and leasing. Erricks VCD, Brighouse 722121 (Bob) (X)

PPM METERS (Earnest Turner) and drive amps £18 + VAT each. Penny & Giles faders PGF1520 5klog £12 + VAT each. 4.5KVA Petrol 240V generator £150 + VAT. (01) 995 5432 (Mike).

LOCKWOOD, TANNOY, etc., new and used equipment always available and wanted. Lockwood Audio Sales 01-866 0671. (X)

HIGH SPEED DUPLICATING EQUIPMENT. Loop bin, master, 6 slaves, winders and all master room equipment, offers around £15,000 o.n.o. to clear quickly. 01-981 6933.

TASCAM/SENN/BEYER, trade counter. Erricks VCD, Brighouse 722121. (X)

HUGH FORD'S LAB EQUIPMENT SALE

Ampex ATR102 4 speed 2 track recorder in console with extra pad nets.....	£3,250
Nagra IV S stereo with case, mains p.s.u., charger, leads, sync head.....	£2,750
Amcron DC300A amplifier.....	£450
Dolby A 360.....	£300
H.P. 86 computer, 3.25 inch discs (dual), interfaces, Epson FX80 Printer, Biodata microlink 3 etc.....	£1,500
Philips 6652 Programmable timer counter.....	£500
Datron 1065 Auto cal. D.M.M.....	£500
B and K 1902 I.M.D./Harmonic analyser.....	£2,000
B and K 2010 Osc./Wave analyser.....	£3,500
B and K 2305 Level chart recorder with 10dB, 50dB, and 2 linear pots and accessories.....	£850
B and K 5675 Delay unit.....	£100
B and K 2971 Phase meter.....	£500
B and K 2426 Auto range millivoltmeter, reads peak, R.M.S. or Average.....	£500
B and K 2206 Precision Sound level meter.....	£250

Phone 01-349 0511 or write enclosing S.A.E. for full list of additional equipment to:

ANGUS MCKENZIE

57 Fitzalan Road, Finchley, London N3 3PG

CLASSIFIEDS

FOR SALE—TRADE

SECOND-HAND

Recording Equipment

Call now for full Computerised List	
2 TRACKS:	£ Sterling
MCI/CCIR, 15/7.5-4 POSIT AUTO.ZEROL.METERS/MONS	1,700.00
CONSOLES/24T PACKAGE:	
AMEK M2500 36/24 + OTARI MTR90 MK II	59,000.00
DIGITAL DELAY:	
AMS DMX 1580S.6.4 + 6.4 STEREO SAMPLING/PITCH	4,750.00
MULTITRACKS-16T:	
STUDER A80 VU CLOSEPROX HEADS. NARROW. 15/30	8,500.00
MULTITRACKS-24T:	
SOUNDCRAFT SCM 762 AUTOL + REMOTE. 15/30 + 16T HB	10,750.00
STUDER A800 WITH AUTO-LOCATE AND REMOTE	19,500.00
OUTBOARD:	
SCAMP RACK + 2xS05 GATE: 2xS06: 2xS01 L/C: PAN: ADT	1,750.00
SYNTHESISERS:	
SYNCLAVIER II. 56K WINCHESTER. SAMPLING	19,500.00

JACKSON MUSIC GROUP

STUDIO PROPERTIES & PACKAGES

SHIPPING & INSTALLATION

+44 923 772351/720060

FAX 0923 774713 Telex 262284 Ref 1728G
The Studios, Rickmansworth, Herts, England WD3 2XD

STUDIO CONDENSER MICROPHONES. Sony C36P Cardioid pencil mikes. Applications—vocals, drums, acoustic instruments (new) £120. List price £230. Steve Pontin Audio Services 01-398 7933.

RAINDIRK S2000 "Concord" (In Line) 36/28/2 Console, master status switching, submix module, extra patchbay, 76 inputs in remix: 5 way eq: 9 stereo aux in remix. Customisations: 10K/14K treble switching, phase reversal, pre/post auxiliary switching, 2nd foldback facility, 4 way speaker switching, 1-16 line up pots, 2 spare modules. Excellent working condition and very well maintained. Please call Graham Sharpe—01-481 8615.

WHO SAYS YOU DON'T NOTICE THESE SMALL ADS! For as little as £13.75 + VAT you too could be getting your service message across. For more details contact Andrew Knox at STUDIO SOUND. Tel: 01-686 2599.

AMCRON DC300a POWER AMP £350 + VAT. (01) 995 5432 (Mike).

			
NEUMANN	J.B.L.	LEXICON	SOUNDCRAFT
SENNHEISER	TANNOY	DRAWMER	STUDIOMASTER
SHURE	REVOX	D.B.X.	B.E.L.
BEYER	TASCAM	YAMAHA	APHEX
UREI	QUAD	AMPEX	APPLIED MICROSYSTEMS
TRIDENT	ROLAND	AKG	AUDIO KINETICS

18-42 Charlotte Street, WAKEFIELD, W. Yorks. WF1 1UH
Tel: (0924) 371786. Export Enquiries welcome. Telex: 556649

STUDIO FOR SALE

STUDIO FOR SALE. 4 Bedroom house with all facilities. Lounge, kit/diner, bathroom, garden. Lower ground floor fitted out as 8T-Otari based recording studio. Ideal for part-time business/songwriter/musician. Equipment separate. Negotiation Freehold £47,500. Phone Folkestone (0303) 59953.

AMEK M2500 32/24 console. Trident Series 65 24/16/2. Console. Soundcraft 2" 16 track tape machine. Lyrec 1/2" TR55 2-track tape machine. Bell BDE 2400 (24 second sample and delay).

Contact Anita on 01-607 9495

AUDIO LEADS

Cable Technology
PRO AUDIO CABLES & SYSTEMS

IMPORTERS OF KLOTZ PROFESSIONAL AUDIO CABLE, CABLE SYSTEMS AND CONNECTORS FOR THE MOST DEMANDING USE IN RECORDING, BROADCAST, AUDIO VISUAL AND P.A.
72-74 EVERSHOLT STREET, LONDON NW1 1BY
TEL: 01-387 5783 TELEX: 28159 MUSLAB G

WANTED

ACOUSTIC SCREEN, quality 24T and 2T machines. Quality mic's/ancillary. Private buyer—0757-638812.

SITUATIONS VACANT

ilea Working in Education

LEARNING RESOURCES BRANCH

Television & Publishing Centre, Thackeray Road, London SW8 3TB.

Sound Recordist

£10,335-£11,487 inc.

A sound Recordist is required to assist in a range of sound recording activities on location and in the television studio which is equipped to colour broadcast standard.

This post is suitable for job share.

For further details and an application form, to be returned by 24th July 1987, write to PER/PS4a, Room 362a, The County Hall, London SE1 7PB. Please enclose sae.

Inner London Education Authority

ILEA IS AN EQUAL OPPORTUNITY EMPLOYER

CLASSIFIEDS

SITUATIONS VACANT

POWER PLANT STUDIOS

seek

SENIOR TECHNICAL & MAINTENANCE ENGINEER

with major studio experience, to work with Nick Clarke in running current three studio complex (SSL and Harrison desks) and to assist in future expansion.

Thorough knowledge of all latest technology essential

Please contact

Callie Mather on 01-451 3727 or write with full CV to Power Plant Studios 169-171 High Road, Willesden, London NW10

TRIDENT RECORDING STUDIOS REQUIRE A MAINTENANCE ENGINEER. PREVIOUS STUDIO EXPERIENCE PREFERRED. SALARY NEGOTIABLE. PHONE GLENN CREW ON 01-734 9901

EXPERIENCED MAINTENANCE ENGINEER required to maintain equipment in comprehensive film/video sound post production studios. Applicant must be conversant in the setting up of magnetic tape recorders, sprocketed and non-sprocketed, and also all the necessary interfaces. Box No. 951.

MANUFACTURING MANAGER

£12K base (to £20K with bonus)

Production management/supervisory experience within electronics company essential. Location N. England.

SALES MANAGER

c£20K package

Major distributor based in London.

BASE SERVICE ENGINEER

c£11K

Experience of tape machines and microphones required.

Contact Mike Jones

PROFESSIONAL AND TECHNICAL APPOINTMENTS (0256) 470704

FOR DETAILS OF HOW TO ADVERTISE IN THIS SUCCESSFUL SECTION PLEASE CONTACT ANDREW KNOX 01-686 2599

SITUATIONS WANTED

FREELANCE ENGINEER

International/SSL Experience Interesting Projects Required For Late 87/88 BOX NO. 952

***EXPERIENCED MATURE SOUND MAINTENANCE/RECORDING ENGINEER** sick of London ratrace seeks post with good remuneration in South/South West England. Excellent refs, Phone Graham 01-864 9287.

***YOUNG SOUND ENGINEER** passed course at School of Sound Recording (Manchester). Experience with hot musicians, seeks assistant engineer's vacancy. Will travel (Manchester or London preferable). Phone: Chris (0565) 830246.

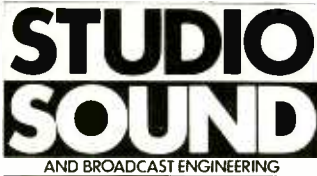

CLASSIFIED ADVERTISEMENTS ORDER FORM

Please use this coupon for all your sales and wants. Rates: 60p + VAT per word. Min £15.00 + VAT. Box Nos. £5.00 + VAT extra. VAT (UK only) \$rate \$2.00 per word, minimum \$50.00, Box No. \$10.00 extra

PLEASE PRINT IN BLOCK CAPITALS

To: STUDIO SOUND, please publish the above advertisement for insertions under the heading Cheque/P.O. to be made payable to LINK HOUSE PUBLICATIONS LTD, LINK HOUSE, DINGWALL AVENUE, CROYDON CR9 2TA. Is a Box No. required Yes/No. If no, please include remittance to cover name and address and/or tel. no.

Name Address

AUDIO SERVICES

Professional Audio & Audio for Video Equipment

Phone and ask for our latest list - more bargains are coming in daily!

NEW HIGH TECHNOLOGY EQUIPMENT

- From JELLINGHAUS of W. Germany comes a major breakthrough. A cost effective fade automation system called the C-Mix system. Which is retrofitable into virtually any mixer from a 16 to 64 inputs utilizing the capabilities of the now well established ATARI 1040 ST. The C-Mix can bring real time automation to many smaller studios. Example price for 32 Faders £2,600 + Computer. Write or phone for details.
- Sony PCM 601 The New Digital Audio Processor. Available from stock. £750
- T.C. Electronic of Denmark. Professional parametric equalisers and spatial expander. The parametrics are of the highest standard electronically and construction-wise. The spatial expander has to be heard to be believed. Please phone for a demonstration.
- Steinberg Research SMP-24. In essence a similar function unit to the Bokse SM-9. This unit comes into its own when used in conjunction with the PRO-24 Sequencer. All song timing information may be stored on the Atari computer along with the corresponding sequence and then subsequently stored onto disc. Also a 'Midi Merge' facility is provided to enable the sequencer to receive both note input and MIDI clock information. Price £799
- Rebs Mid Gate - A very useful production tool. Acts like a Drawmer DS-201 but with a few extra tricks like trigger mask, trigger delay key filter may be used on audio plus a midi output which sends note on and key velocity dependent on audio amplitude information. Price £485
- Yamaha DMP-7 Digital Effects and Mixer Coming Soon - Watch This Space!
- Amazing Alesis Microverb in stock now. 16 bit linear processing only 5 1/2" wide. Slick three together like jumbo Slickie bricks and rack mount. Price each £216. Special three deal + rack kit £599
- 24-track sequencer package, comprising: ATARI 1040 ST, monochrome monitor, mouse, word processing & language software plus STEINBERG RESEARCH Pro 24 software. All ready-to-run. Demonstration arranged by appointment. **New Low Price £825**
- The superb TANTEX M4000 Master Matrix micro-processor based signal routing patchbay. Now in stock. Send for colour brochure

SECOND HAND, EX-DEMO & NEW EQUIPMENT

TAPE RECORDERS

STUDER A-80 2 inch 16TK	£9,500
STUDER A80 MK11 24 Trk Approx 6 Yrs Old	£12,750
STUDER B62 Stereo, Lovely Condition	£795
OTARI MX-5050 XHD 4TK - little use	£1,200
TEAC 80-8 c/w dBx, Vari-Speed & Remote. Brand New!	£1,650
TEAC 3440 - As New	£925
TASCAM MS 16 + dBx + Autolocate + Console Stand - Showroom Model	£9,250
TASCAM ATR-60 1/2" Eight Track Professional + Console + Overbridge	£4,950
TASCAM 480B New	£3,445
TASCAM 32 - New Ex-Demo	£875
TASCAM 38 - New shop Soiled	£1,450
TASCAM 34B - As New	£950
TASCAM 38B - Ex Showroom	£1,826
FOSTEX E2 1/4" Stereo + Centre Track	£2,400
FOSTEX Model 80 - New	£1,295
FOSTEX E 16 - From Stock	£90 A
FOSTEX A 8 - 2 (16 S/H)	£895
REVOX B77 II - 1 Yr Old	£895
REVOX B77 II	£1,095
REVOX PR-99 II	£1,695
REVOX A77 MK III - Perfect Condition	£450
UNHER 4200 c/w. Case & Mics	£595
2 x AKAI MG-14D + AUDIO KINETICS Pacer (24 Trk Recording)	£7850
AKAI MG-14D - New From Stock	£3,042
AMPEX ATR-700 2 Trk - Immaculate	£895
OTARI MX5050 2 Trk/4 Trk - Mint	£895
BRENEL L Min 8 c/w Remote & Timer	£1,295

MIXING CONSOLES

AHB Sigma 4/24 Automation Ready - On Demonstration	£12,960
AHB System 8 MK II 16B - S/H	£1,200
AHB System 8 MK III 24 16 with JELLINGHAUS Automation	£4,895
AHB CMC 24 MK I (24 16) - New	£1,950
AHB CMC 16 MK II (16 8) - New	£1,395
AHB CMC 24 MK II - New	£3,100
AHB Studio 12 For Broadcast or Disco Applications	£1,895
AHB S 62 Production Desk	£250
SOUNDTRACS MR Series 24 8 16	£5,100
SOUNDTRACS PC/Midi Series 16 Input version	£4,045
RSD Studiomastrer 16 8 2 - New, Ex-Demo	£1,150
PLATINUM Level IV 32/8/32	£5,500
BEL 24 16 2 Modular - 2 Yrs Old	£1,850
TASCAM M312 (12 4 8) - New, Ex-Demo	£1,395
TAC Matchless - New, To Order	£90 A
TAC Scorpion	Prices From £2,950
SECK 18 8 2 - New,	To Clear £895
FOSTEX 450 16 Chan - New,	£1,995
FOSTEX 350 + 3060 Meterbridge As New,	£2,000
M & A Custom Console 26 16 2 5 Band Eq, 5 Aux - Impressive Board	£1,895
SOUNDCRAFT 400B 16 4 2 + 8 + 8 Mtrs	Bargain @ £5,000
TWEED AUDIO 24 16 Console, Patchbay & Stand, All PPM's & P - G. Cost 26K New	£3,000

OUTBOARD GEAR ETC

AMS RMK-16 Latest Software 9 Months Old	£3,900
AMS DMX-180B 6 Secs + 1/6 Sec Dual Pitch Change DE-G	£3,950
LEXICON 224 XL With Larc - 18 Months	£6,000
T.C. ELECTRONICS 2290 with 32 Secs Sampling - New	£2,735
AUDIO KINETICS O-Lock 310 with various interlaces - As New	£4,500
YAMAHA SPX-90 II - New	£545
YAMAHA DMP-7 Digital Reverb/Mixer Motorized Faders, Midi, etc. - New	£2,600
YAMAHA R-1000 boxed - As New	£150
ROLAND DEP-5 - New	£545
ALESIS Microverb - New	£216
3 x ALESIS Microverb Inc Rackmount Kit - New	£599
ALESIS Microverb II - New	£373
AKG BX-20E Perfect	Bargain £295
DIGITECH RDS 3600 (36) Secs - New	£320
REBIS RA701 Midi Gate - New	£495
APHEX Compeller - Less than 1yr old	£795
AUDIO + DESIGN Gemini Dual Comp/Lim - New	Special Offer £250
AUDIO + DESIGN Panscan Auto Panner - New	£375
AUDIO + DESIGN Complex Stereo - S/H	£750
AUDIO + DESIGN F700RS - As New	£495
AUDIO + DESIGN Transdynamic + 3 + Express Limiters	£1,500
DRAWMER DS-201 Noise Gate	(Quantity Discounts) £295
DRAWMER DL-221 Comp/Lim	(Quantity Discounts) £345
DRAWMER LX-20 Comp/Exp	(Quantity Discounts) £225
REBIS Rack 2 Comps, 2 Gates, RIAA Pre-Amp, P Bay + PSU	£550
REBIS Rack 2 De-ess, 4 Gates, P Bay + PSU	£550
Boss DE200 Delay - Boxed As New	£95
DBX 150 - S/H (2 Avail)	Each £175
DOLBY M16 - Perfect	£5,000
OTARI Remote/Locator for MX-5050 8 Trk - S/H	£250
YAMAHA G C2020B Balanced	New £245
TANTEX M4100 Master Matrix Automated Signal Routing	£766
T.C. ELECTRONIC 1210 Spatial Expander	£735
T.C. ELECTRONIC 2240 HS 4 Band 2 Chan Parametric	£575
T.C. ELECTRONIC 1140 HS 4 Band Mono Parametric	£345
T.C. ELECTRONIC 1220 2 Ban Stereo Parametric	£265
HARRISON GP215 2 x 15 Graphic	£362
HARRISON GP130 Mono 31 Band	£473
HARRISON GP230 2 x 30	£583
FENDER STRAT Reg. Maple Neck - Trem. Custom Electronics	£395
FENDER RHODES Stage 73 - Good condition	£250
GIBSON LES PAUL De-Luxe Black c/w Hard Case	£395
EMULATOR 1 - Mint Condition	£895
LINN DRUM LM2 - With Expanded Memory	£699
OSBERHEN DMX - New Condition	£499
ROLAND MSQ 700 - Used Mint!	£105
JBL 4350 Monitors Mint with JBL X-Over	£1,500
MICROPHONES New & Second Hand Used From: NEUMANN, AKG, SENNHEISER, BEYER, SHURE	
AKG C414 EB - S/H (2 Avail)	Each £425
AKG C422 Comb - Mint	£995
MONITORS From JBL (Full Range In Stock) TANNON, YAMAHA, UREI	
AMPLIFICATION By HARRISON, UREI, YAMAHA, QUAD & RAUCH	

Loads more equipment in stock - we have gear coming in all the time. Please note: the prices above do not include VAT

STUDIO HOUSE All major credit cards accepted. LONDON
High Lane Village 4 Wellington Road,
Stockport SK6 8AA St. John's Wood,
Tel: 06636 4244. Telex: 665721. Fax: 06636 2328 London NW8 Tel: 01-586 3167

Normal opening hours are 9.30 am to 6.00 pm Monday to Friday; 10.00 am to 2.00 Saturdays. If you intend to call at either of our premises we recommend you make an appointment first.

INDEX TO ADVERTISERS

AMS Industries plc	75
AEG Aktiengesellschaft	18
AKG	53
Allen & Heath/Brenell	42
Alpha Audio	6, 13
Amek Ltd	35
Audio Precision	63
Audio Service Co	82
Beyer Dynamics	4
British Music Fair	7
Bruel & Kjaer A/S	15
Court Acoustic Sales Ltd	66
D & R Electronics	72
DOD Electronics Corp	51
Don Larking Audio	29
Drawmer Distribution Ltd	57
Eardley Electronics	9
Eastlake Audio	43
Eela Audio	71
FWO Bauch Ltd	11
Gateway	75
Hayden Laboratories Ltd	8
HHB Hire & Sales	20, 21
Hill Audio Ltd	26
J.B.L.	65
Lexicon	40, 41
Media Products Ltd	6
Mitsubishi Pro Audio Group	37
Mosses & Mitchell Ltd	71
Munro Associates	67
Neve Electronics Labs Ltd	27
Northern Audio	9
Otari	39
Platinum	23
Scenic Sounds Equipment	60, 61
School of Audio Engineering	6
Sony Broadcast Ltd	33
Soundcraft Electronics	IFC, OBC
Soundtracs plc	49
Studer	11
Studiomastrer	31, 47
Studio Spares	17
Surrey Electronics	64
Syco Systems	68, 69
Symetrix	22
T C Electronic	14
Teac UK	IBC
Thatched Cottage Audio	59
Total Systems	75
Wandel & Goltermann	55

Studio Sound is available without charge to qualified readers: these are directors, managers, executives and key personnel actively engaged in sound recording in any part of the world. The Publisher reserves the right to refuse applications considered inappropriate and restrict the number of free copies sent to any one company or organisation. Non-qualifying readers can buy Studio Sound at an annual subscription of £18.00. All enquiries to: Subscription Department, Link House Magazines, 120-126 Lavender Avenue, Mitcham, Surrey CR4 3HP. Published by the proprietors Link House Magazines Limited, Link House, Dingwall Avenue, Croydon CR9 2TA and printed by Lawrence-Allen Ltd., Gloucester Street, Weston-super-Mare, Avon BS23 1TB.

24 TRACKS - 24 HOURS A DAY TASCAM PROVES THE WAY TO WORK

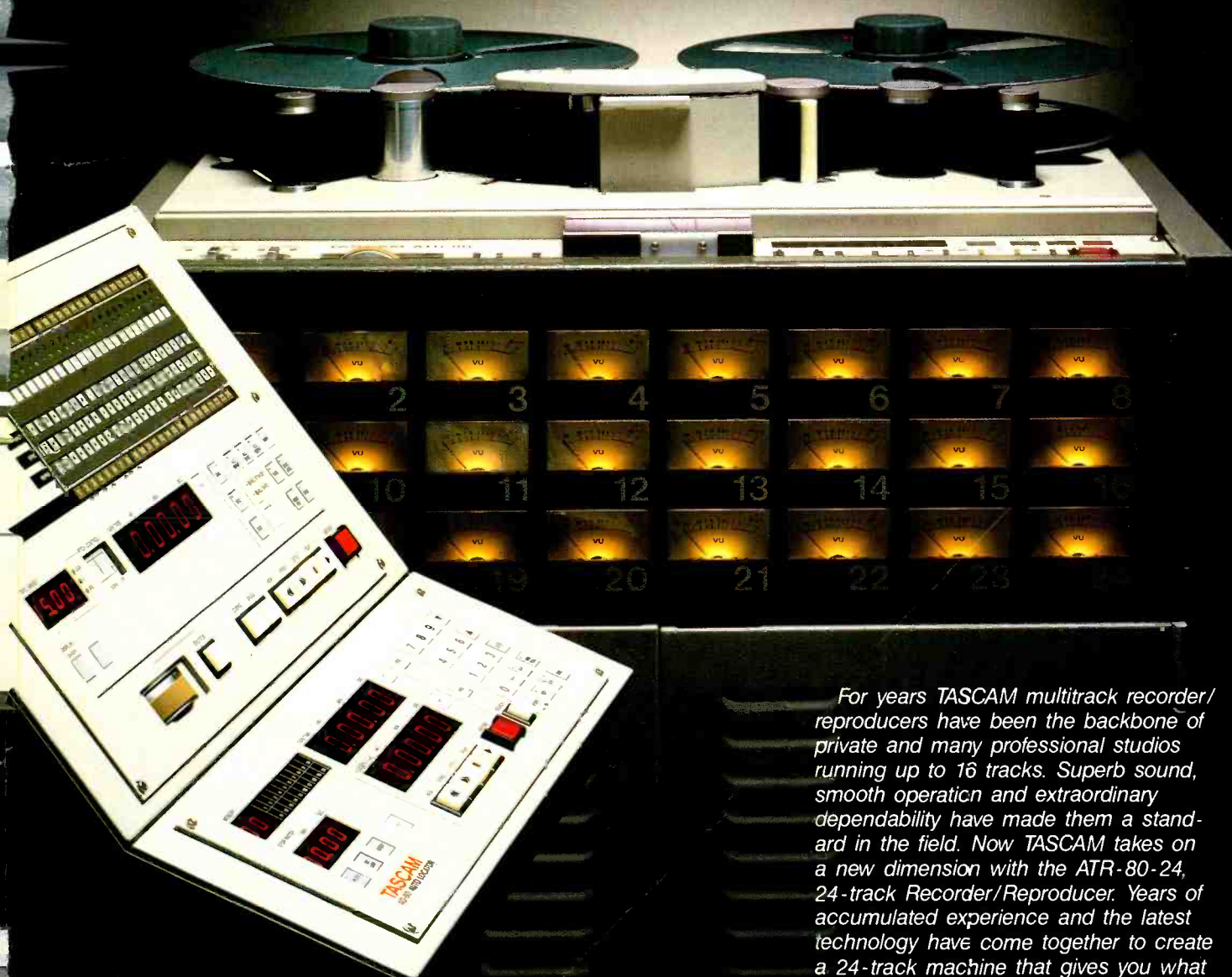

TASCAM PROFESSIONAL ATR-80-24 2-inch Recorder/Reproducer

For years TASCAM multitrack recorder/reproducers have been the backbone of private and many professional studios running up to 16 tracks. Superb sound, smooth operation and extraordinary dependability have made them a standard in the field. Now TASCAM takes on a new dimension with the ATR-80-24, 24-track Recorder/Reproducer. Years of accumulated experience and the latest technology have come together to create a 24-track machine that gives you what you need to compete.

If you're going 24-track, now is the time to go TASCAM.



This machine is a major advance in analogue multitrack recorders.

It took five designers three years to develop it. A multitrack to match or beat Studer and Otari machines. But with many powerful, exclusive new innovations.

Tape handling is probably the most important function of any machine.

The Saturn's unique 'COLT' (Calculated Open Loop Tension) transport handles tape like no other multitrack using computer-linked motion sensors and bi-directional heavy-duty spool motors.



DESIGNED TO COMPETE WITH THE BEST IN THE WORLD.

Conventional closed loop systems rely on the critical alignments of mechanical tension arms. COLT replaces them with more accurate and reliable electronic calculations. The result is virtually constant tape tension through all modes from end to end of the tape.

The tape is always brought to play speed before the pinch roller is engaged, and the pinch roller/capstan system ensures "extraordinarily low wow and flutter," (Sound Engineer and Producer November 1986) with rapid acceleration and high wind speeds. In short, precision tape handling that's as smooth as it is fast.

It also reflects the no-compromise long-term reliability we've built in at all stages.

The audio electronics have a response that's virtually flat to 27kHz, and a superb S/N ratio. Allied to Dolby SR, this new analogue purity means performance to beat 16-bit digital.

Even from the mix position, Saturn looks way ahead. The revolutionary Total Remote console stores all auto-alignment parameters, a major benefit in any busy studio.

It also provides digital control over every function, allowing cueing and editing with great accuracy.

Among its facilities are three fully programmable function keys, four monitor status memories and a sophisticated record/rehearse system. And much more.

It's time to take a look at a major new name in professional multitrack.

The Soundcraft Saturn.