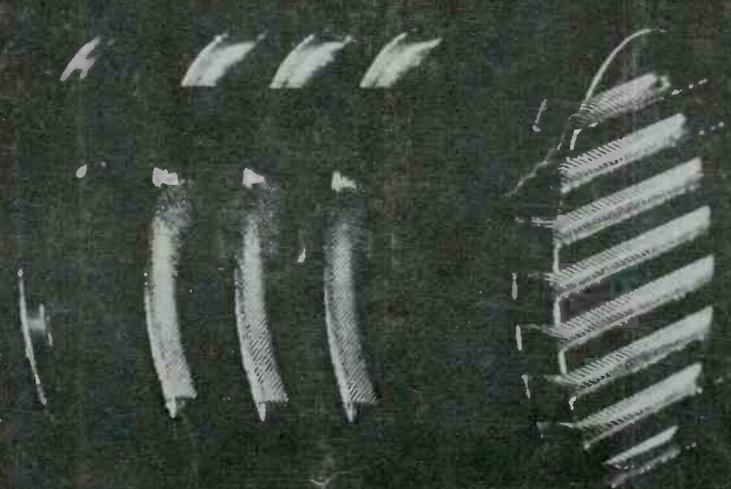


# studio sound

AND BROADCAST ENGINEERING

FREQUENCY  
SHIFTER FOR  
HOWLROUND  
REDUCTION



# Making a Big Decision?

We are always pleased when engineers compare consoles critically instead of blindly accepting what the manufacturer promises; who form their own opinions instead of following others; who make a cool assessment of systems engineering and cost; who know what they want precisely.

A good look at Cadac makes the choosing easy.

## cadac

The established leaders in music recording  
consoles and techniques.

Cadac (London) Ltd.

141, Lower Luton Road Harpenden Herts AL5 5EL

☎ Harpenden (STD 05827) 64351 Telex 826323

# studio sound

AND BROADCAST ENGINEERING

EDITOR DAVID KIRK  
DEPUTY EDITOR MICHAEL THORNE  
EDITORIAL PRODUCTION DRUSILLA DALRYMPLE  
ADVERTISEMENT MANAGER RICHARD WESTBROOK  
MAGAZINE SALES MANAGER DON BAILEY



THE LINK HOUSE GROUP

Editorial and Advertising Offices: LINK HOUSE, DINGWALL AVENUE, CROYDON CR9 2TA. Telephone: 01-686 2599

© Link House Publications Ltd 1974. All rights reserved.

## CONTENTS

### FEATURES

IBC—LIST OF EXHIBITORS	30
POLITICS AND BROADCASTING By John Dwyer	32
FREQUENCY SHIFTER By Trevor Brook	44
SURVEY: TAPE CARTRIDGE MACHINES	48
MICROPHONE AND LOUDSPEAKER ARRANGEMENTS FOR TETRAPHONY By R. Condamines	54

### COLUMNS

LETTERS	24
NEWS	26
CLEANFEED	38
PATENTS	40

### REVIEWS

PANDORA DELAY LINE, TECHNICS SL 110 By Hugh Ford	60
---	----

### SUBSCRIPTIONS

STUDIO SOUND, published monthly, enables engineers and studio management to keep abreast of new technical and commercial developments in electronic communication. The journal is available without charge to all persons actively engaged in the sound recording, broadcasting and cinematographic industries. It is also circulated by paid subscription to manufacturing companies and individuals interested in these industries. Annual subscription rates are £3 (UK), or £3.30 overseas.

STUDIO SOUND is published on the 14th of the preceding month unless that date falls on a Sunday, when it appears on the Saturday.

### CORRESPONDENCE AND ARTICLES

All STUDIO SOUND correspondence should be sent to the address printed on this page. Technical queries should be concise and must include a stamped addressed envelope. Matters relating to more than one department should occupy separate sheets of paper or delay will occur in replying.

### BINDERS

Loose-leaf binders for annual volumes of STUDIO SOUND are available from Modern Bookbinders, Chadwick Street, Blackburn, Lancashire. Price is £1.25 (UK) and (overseas). Please quote the volume number or date when ordering.

OCTOBER 1974 VOLUME 16 NUMBER 10

A GLOSSARY OF technical terms used in television production was recently agreed upon by the Video Tape Production Association, New York. Although much shorter than might have been expected, it provides a much-needed source of distinction between such terms as dub (verb) and dupe (noun), between cassette (enclosed reel-to-reel) and cartridge (enclosed single reel). It does not, however, appear to differentiate between a reel and a spool, between a rotary head and a head drum, or indeed go beyond the most superficial items of jargon in the magnetic recording bag.

It could be argued that the jargon of sound recording, in Britain at least, is sufficiently stabilised not to require further formalisation. We all think we know the difference between wow, wow-and-flutter, and flutter. But do we? Too often, the generic wow-and-flutter is contracted into wow—introducing the possibility of confusion. And is a flutter-meter merely a device for measuring flutter or will it register frequency fluctuations occurring less than 15 times per second?

Our concern with the small matter of jargon was aroused some months ago when we were shown what can only be called a cas-sartridge. Don't believe it? Then what else can one call a Philips Compact Cassette deprived (by Philips) of its usual innards and fitted with the single cyclic reel found in most 6.25 mm tape cartridges? Perhaps it doesn't really matter. Perhaps we can all muddle on until such time as sound recording becomes solely a matter of button pushing, whereupon the needs to distinguish between several hundred petty components should disappear.

Meanwhile, who accepts the responsibility for standardising technical jargon within the sound recording industry? Ideally the industry itself, perhaps through the medium of the Association of Professional Recording Studios. Alternatively the industry can work to the cumbersome dictates of the British Standards Institution. Problems even there, however. STUDIO SOUND has waved the metrication flag for several years, achieving a less than 100 per cent conversion of Imperial minds. And this with the easily memorised 76, 38, 19 and 9.5 cm/s multiples employed at least nominally by most European tape machines. What hope have the BSI of hearing 76.2, 38.1, 19.05 and 9.53 cm/s used in everyday studio conversation. Precious little.

This journal has never tried to project itself as a tin god of the recording industry (except, forgive it, where metric is concerned) and has consequently refrained from making its own inventive additions to the industry's vocabulary. Yet the temptation is strong. Why not wobble as a generic for speed fluctuation. Existing mechanical connotations? Then what about jitter? Quadraphony and pseudo-quadraphony have brought their share of obscure expressions. Is stereo now to mean solely and simply 'two-channel' instead of its former 'solid' and, if so, what precisely is meant by 'quadraphonic stereo'.

Perhaps we should sit back and allow advertisement copywriters to dictate the progress of audio jargon. In which case we have at least a name for the result. Cacophony.

### Cover

Photography: Tim Bishopp. Equipment: AKG, Tannoy.  
Many thanks.



Total average net circulation of 7,641 per issue during 1973.

MEMBER OF THE AUDIT BUREAU OF CIRCULATIONS

# TRINIDAD TO BANGKOK- TORONTO TO MEXICO CITY

**Auditronics, Inc. sound mixing consoles  
are in use around the world.**

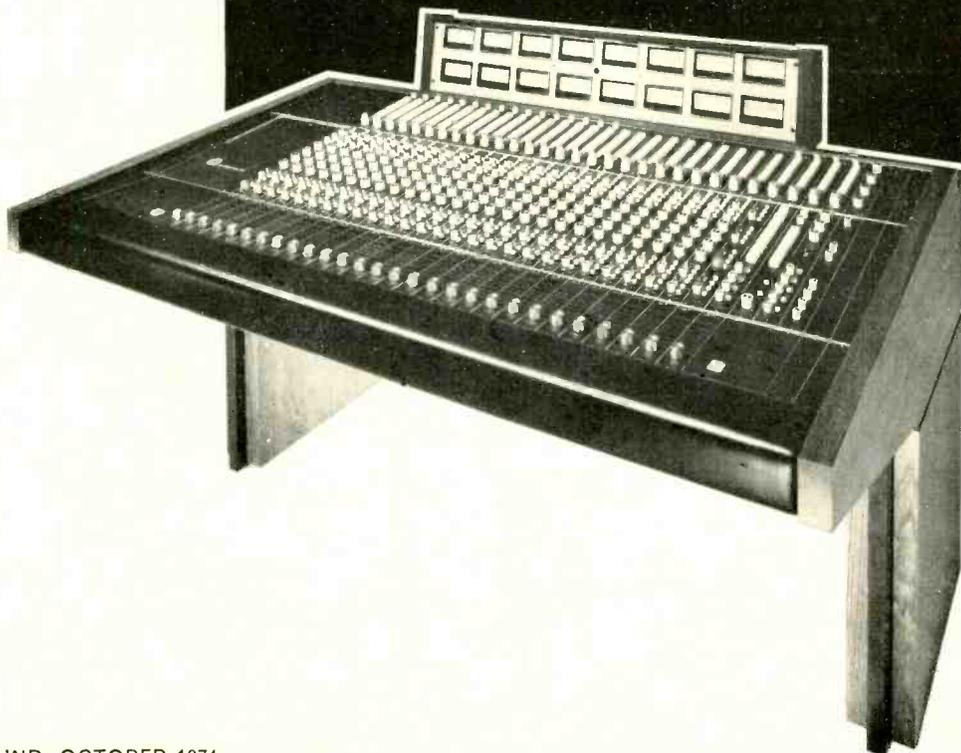
**More than 60 studios depend on Audi-  
tronics systems and equipment for ease  
of installation, reliability, performance,  
and quality.**

**Now is the time to find out what makes  
Auditronics products accepted worldwide  
in professional audio.**



**auditronics, inc.**

P.O. Box 12637 • Memphis, Tenn. 38104  
901/276-6338



# REVOX

## REVOX A77 SERIES

Available in a wide variety of configurations, inc.  $\frac{1}{2}$  track, full track,  $\frac{1}{4}$  track. Choice of tape speed.

Backed by ITA Service

**IMMEDIATE DELIVERY—  
ALL MODELS**

**(ALSO AVAILABLE FOR HIRE)**



## THE NEW REVOXA-700 SERIES

3 tape speed configurations  
Full deck logic  
Four inputs  
Crystal servo control  
Tape footage counter  
Servo tape tension

Write for full information

**IMMEDIATE DELIVERY—  
ALL MODELS**

**(ALSO AVAILABLE FOR HIRE)**

Scotch 207 LOWEST UK PRICES

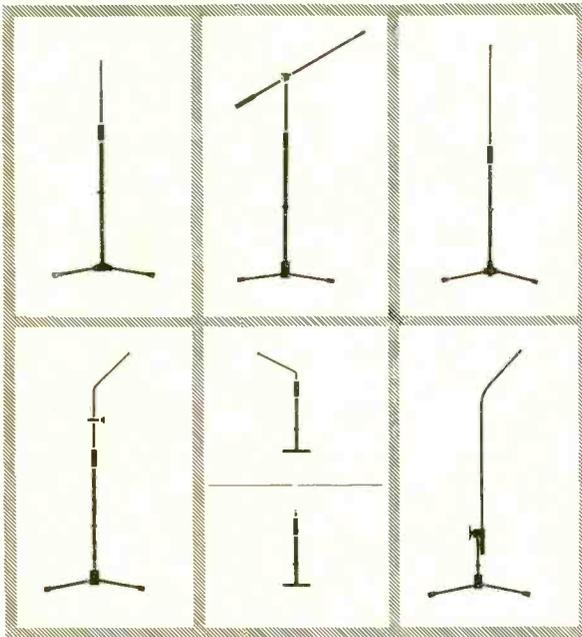
**NOTE NEW ADDRESS~**



**Industrial Tape Applications  
5 Pratt Street, London NW1 OAE. Tel: 01-485 6162 Telex: 21879**

**p+n**

**stands for  
good mike  
support**



**a good mike  
stands for  
nothing better  
than** **p+n**

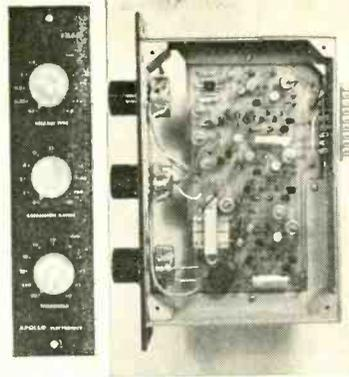
*Please write for complete catalogue*

**Peter-Nicholas Engineering Co Ltd**

TONTEG ROAD TREForest INDUSTRIAL ESTATE GLAMORGAN  
Telephone: Treforest (044385) 2453

**PROFESSIONAL  
AUDIO  
PLUG-IN UNITS**

- ★ Superb performance and reliability at moderate cost
- ★ Specially designed, 190 x 45 x 115mm, very rigid and lightweight castings house the electronics most effectively
- ★ McMurdo 16-way red range rear connector for all units
- ★ Supply voltage required 24VDC negative earth



MA80 input amplifier, Gain 0-80db\*cont. adj., 4 pos. low cut filter.  
 PE16 tone equalizer, Treble and Base  $\pm 1$  db, 7 Pres. freq. 0 to  $\pm 16$ db.  
 CL36 compressor limiter, Max. compr. 36db, comp. ratio 1:1 to 1:72.  
 EX60 expander, for 0 to 60db reduction of noise, crosstalk and interf.  
 LA26 line output amplifier, Gain 0-26db, Zout. 50 ohms balanced.  
 PA10 monitor amplifier, 10V RMS into 8 ohms load, 32 VAC Supply req.  
 EPF4 echo send, pan-pot, foldback monitoring, for sound mixing desks.  
 TB90 mic. amp., Built-in dyn. mic., Gain 90db, press-to-talk switch.  
 MI12 I2 input to single output summing amplifier, unity overall gain.  
 MC12 complete input channel for professional sound mixing desks.  
 MCX7 compressor-limiter-expander with built-in extra facilities.  
 MP62 magn. P-U amplifier, 4 equalisations, sensitivity and 2 filter sw.  
 TH68 tape relay amplif., single NAB equal, but adj. from 1 and 7/8 to 15 IPS.  
 TRP1 tape replay amplif. and monitor amplif., dual NAB, A-B monitoring.  
 TRR1 tape record amplif. and bias amplif., dual NAB, record/safe/sync. sw.  
 TRE1 tape erase amplifier with erase kill switch.  
 TRB1 tape bias oscillator, can drive up to 24 pairs of TRR1 and TRE1.  
 PS24 power stabilizer, input 30VAC, output 24VDC/1A short circ. prot.  
 SG56 wien bridge oscill., 5 spot freq., 6 levels -72 to +6dBm.

**APOLLO ELECTRONICS**  
**96 MILL LANE, LONDON NW6 1NQ**  
Telephone: 01-794-8326

HOLLAND REP: A. R. C. DE VRIES, Florence Nightingale St., 112 HAARLEM.  
Trade enquiries welcomed.

**0.002% THD  
100 watt  
per channel  
power amplifier**

0.002% THD at all levels up to 10 watts and all audio frequencies. Less than 0.02% THD at all frequencies and all levels up to 50 watts, typically 0.004% at 1kHz and 50 watts. Intermodulation distortion is less than 0.03%.

The amplifier is unconditionally stable and does not ring even into a 2µF capacitor.

The two channels are power limited at 120 watts rms and a tracking short-circuit cut-off protects each of the four power supplies. There is also a thermal cut-out.

Both channels will deliver continuously more than 100 watts into a 4 ohm load or 70 watts into an 8 ohm load.

The frequency response is within 1dB from 10Hz to 20 kHz and the noise is more than 100dB below 70 watts into an 8 ohm load.

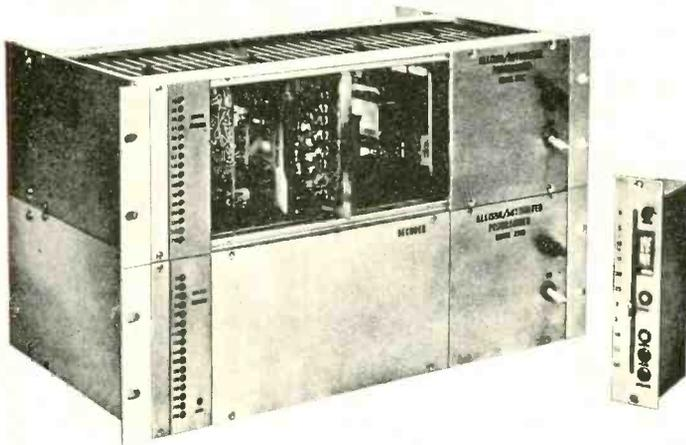
The case size is 430mm x 300mm x 76mm.



**naim audio**

The price of the NAP200 Amplifier is £172 + VAT.  
15 CHURCHFIELDS RD · SALISBURY · WILTS · SP2 7NH · Tel: 3746

# Automated Mixing is NOW!



Functional...useful automation, whether for music, film or commercials, requires that the mixing console or separate mixdown console, self-program all relevant control functions in real time. In other words, the equipment must be capable of normal manual operation, but with the additional capacity to remember what was done, when it was done, and how it was done. It must then be able to precisely re-create the original mix any number of times without degradation while individual controls are readjusted to alter or improve any portion of the recording.

#### MODEL 256 PROGRAMMING UNIT

At the heart of the system is the Programmer, designed to avoid obsolescence by being capable of encoding up to 256 channels for recording on any conventional tape recorder. The Programmer contains independent Encoder and Decoder units, each of which employs state of the art analog and digital circuitry. This approach achieves the infinite resolution (stepless) control associated with analog systems while maintaining the error detection capability of digital circuitry.

The Model 256E Encoder consists of a 5 1/4" x 19" card frame, and is supplied with the Master Encoder module, one Model 16E switching card for 16 functions, and the required power supply modules.

The Model 256D Decoder, a separately packaged card frame with the same dimensions as the Encoder, contains the Master Decoder module, one Model 16D switching card for 16 functions, and the required power supply modules.

Both units can be expanded at any time in multiples of 16 functions by simply plugging in additional 16E and 16D switching cards. The expanded system will continue to decode tapes made prior to expansion. No other adjustment is necessary on either the programmer or the tape machine. In fact all tapes and programmers are interchangeable without adjustment so that tapes made in one studio may be played in any other studio having similar equipment.

#### MODEL 256 PROGRAMMER SPECIFICATIONS

**NUMBER OF FUNCTIONS:** 16 to 256 expandable in groups of 16 by means of plug-in circuit cards.

**UPDATING RATE:** 800 Micro sec/function.

**ACCURACY:** ± .2 dB, 0 to -40  
± 2 dB, 0 to -60  
+ 0 - inf @ -80

**BANDWIDTH REQUIRED:** 5 kHz (35 dB S/N)

**RECORDING LEVEL:** -20 to -5 (actual level or level variations have no effect).

**DROP-OUT AND SPLICE PROTECTION:** Any such occurrence of sufficient magnitude to cause decoding error causes device to hold prior information until error signal is removed.

**COMPATABILITY** (System to System/Studio to Studio, etc.): Compatible within ±1 dB. Decoder automatically senses the number of encoded functions present and adjusts its cycling rate accordingly. Decoder also displays (via LED array) the number of encoded functions as an aid to determining the degree of automation on tape of unknown origin.

**PACKAGING:** Decoder and encoder separately packaged for remote control applications.

Decoder: 5 1/4" x 19" rack panel.

Encoder: 5 1/4" x 19" rack panel.

Both units: 10" deep. Self powered.

#### MODEL 940 AUTOMATED FADER

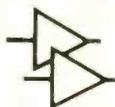
The Automated Fader is a self-contained channel level control module capable of either manually or automatically setting audio levels. It contains all the electronics and front panel controls necessary to record, play back, and update channel fader settings. In addition, it may be used as an automated master fader, or may be externally controlled for gate or mute functions. An Auto/Manual switch is provided, which allows the module to operate as a normal audio fader, bypassing the automation electronics entirely. The module incorporates a conductive plastic slide attenuator of the same quality and reliability that has made our Model 440 and 475 faders so popular.

The Model 940 Automated Fader fits in the space normally occupied by a conventional fader so that no additional console panel area is required in retro-fit applications.

Electrical performance characteristics are compatible with the Model 256 Programmer. Power requirements are as follows: ±15V @ 50mA, +5V @ 10mA, and lamp power of 5 to 6V @ 30mA.

Mounting Dimensions are: 7" high x 1 1/2" wide x 3 3/4" deep over mating connector.

You can automate your studio NOW with the Model 256 Programmer and the Model 940 Fader Modules, or with a pre-wired, ready-to-use 16 or 24 channel automation console... and there's more to come!



**AUTOMATED PROCESSES, INC.**  
80 MARCUS DRIVE, MELVILLE, NEW YORK 11746 • 516-694-9212

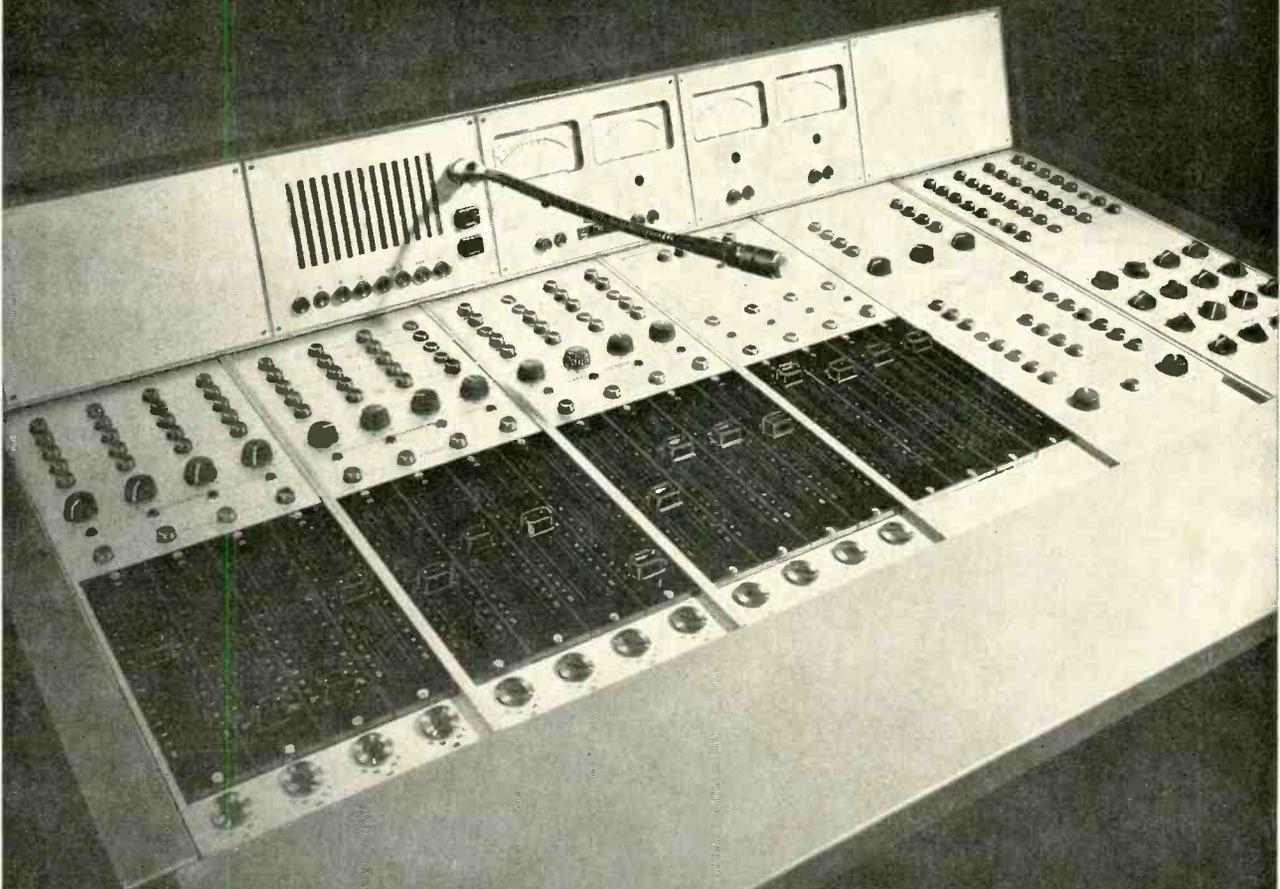
# It needn't break the bank.

The Philips MD is a range of high performance standard mixing desks at realistic prices.

They have been used all over the world for years and years, which just proves their reliability and excellent quality.

A kind of all risks insurance. So keep it in mind.

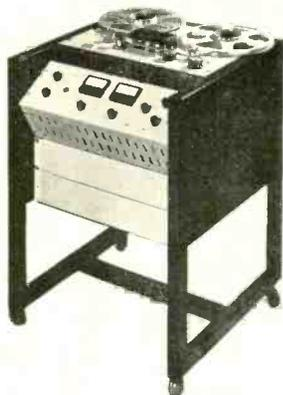
You need more information? Contact Mr. Jan Gerrits or Mr. Bram Potappel, N.V. Philips' Gloeilampenfabrieken Electro-Acoustics (ELA) Division, Broadcast Equipment, Building SAQ II, Eindhoven - The Netherlands. Tel. 040-733793 or 732645, Telex 51121.



## PHILIPS



# CAN WE HELP YOU?



In these days of rising prices and galloping inflation it becomes more important than ever to carefully equate the cost of a professional recorder to its performance and reliability. That's where we can help you, follow the example of many commercial radio stations and recording studios. Buy British, Buy Bias for years of hard usage at prices that won't cause a coronary.

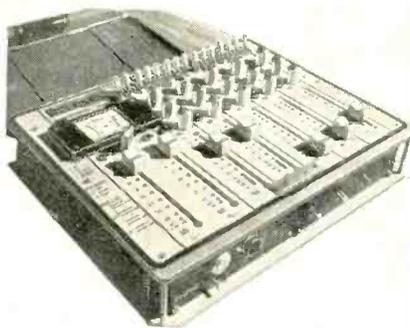
**BIAS ELECTRONICS LTD.**      01-540 8808  
572 KINGSTON ROAD, LONDON SW20 8DR



**GRAMPIAN REPRODUCERS LTD**  
HANWORTH TRADING ESTATE  
FELTHAM, MIDDLESEX  
TELEPHONE 01-894 9141

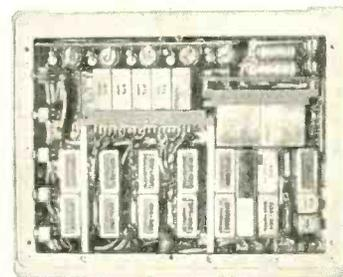
# mixing with the best

In order to fill the need for a small versatile truly professional mixer, Stellavox have designed the ultra modern Mixer type AMI 48. Using the same principles as the well known Stellavox professional tape recorder type SP7, the AMI 48 is : very rugged, with a die-cast chassis; very light and small, but with perfect operational comfort; battery operated, for use anywhere.



Being comprehensive, it offers not only the classical facilities of conventional big studio consoles, but many exclusive circuits: *powering for any condenser microphones* (parallel or phantom fed 12 V, phantom fed 48 V); very accurate *880 Hz tuning fork reference oscillator*; and the new *limiting circuits type SIL on all inputs and outputs*, allowing easy use of **STELLAMASTER** technology for extremely low noise recordings.

# STELLAVOX



**A. V. Distributors (London) Ltd.**  
26 Park Road, Baker Street,  
London NW1 4SH.  
Tel.: 01-935 8161.

Please send me further Stellavox details.

Name .....

Address .....

.....

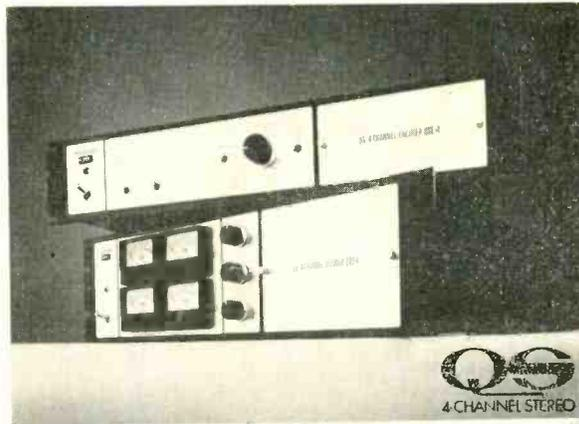
.....

.....

SS10/74



# Within 2 years, 4-channel sound will be the rule. Sansui QS system puts you 2 years ahead.



Now your listeners can enjoy the extra depth of 4-channel sound with the minimum of 2-channel conversion costs on your behalf.

Thanks to the Sansui QS 4-channel system. Now available for the first time in the United Kingdom.

## Keep your equipment

The Sansui QS 4-channel system is used with all current stereo transmitters/receivers, cutting equipment and hardware. So there's no need to upgrade. The listener only requires a 4-channel receiver and 4 speakers to obtain astounding quadrasonic effects.

## Excellent separation

Both encoding and decoding matrices are symmetrical. Together with the new QS Vario-Matrix in the decoder, an inter-channel separation of 20dB or more is no problem.

## Maintains present hi-fi standards

High standards are maintained. Because of a unique phase shift technique, the quality as

well as the quantity of input information is preserved. In fact it gives better stereo perspective than conventional 2-channel sources.

## Proven performance

In both Japan and the United States where 4-channel sound is becoming the rule rather than the exception, QS type matrixing is standard.

Listen to this remarkable equipment at the London showroom of Sansui.

It's right next to the GPO tower. Our technical experts are ready and willing to give advice on specifications and prices. Or send in this coupon for full information.



Vernitron Ltd., Thornhill Southampton SO9 QF England

Sansui Audio Europe S.A., Diacem Building, Vestingstraat 53/55 - 2000 Antwerp Belgium

Sansui Electronics Corporation 55-11 Queens Boulevard, Woodside, N.Y. 11377, U.S.A.

Sansui Electric CO., Ltd. 14-1, 2-chome, Izumi, Suginami-ku, Tokyo 168, Japan.

To: Sansui London Showroom,  
39/41 Maple Street, London W1P  
5FU (Freepost) Telephone: 01-580 5353

Please forward all technical and price details on the new QS 4-channel encoder and decoder.

My name: \_\_\_\_\_

My address: \_\_\_\_\_

Postal code: \_\_\_\_\_



Sansui equipment is distributed in the United Kingdom by Vernitron Ltd., Thornhill, Southampton.

# REW AUDIO CONTRACTS

LONDON'S LEADING CONSULTANTS AND DISTRIBUTORS FOR P.A., STUDIO AND PROFESSIONAL AUDIO EQUIPMENT



### TEAC 3340

The Teac A 3340 professional model is a very high quality, 4 track (separate) recorder. Operating at 7½ and 15 i.p.s. with full built-in sel-sync facility. Potential 8 input source (4 line and 4 mic) incorporating separate mixing controls on front panel. In stock.

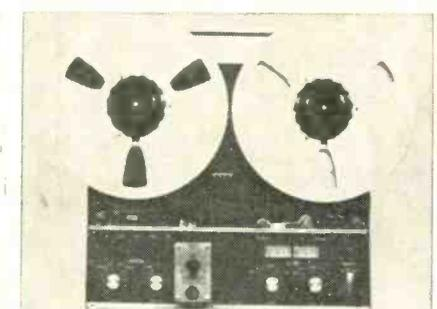
NETT PROFESSIONAL PRICE ON APPLICATION



### AMCRON

The long awaited Amcron tape deck and latest addition to the REW Audio Contracts Family of mini-studio high quality recorders. REW are able to offer this 800 and 700 series of decks with choice of CX or SX electronics.

NETT PROFESSIONAL PRICE ON APPLICATION

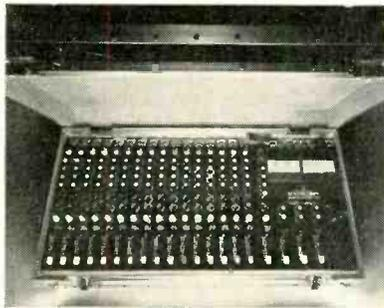


### REVOX A77

The world famous A77 1102 Series III semi-professional recorder, available in 3¾ and 7½ i.p.s. or 7½ and 15 i.p.s. speeds + sel-sync and varipitch conversions. This machine proves a long standing favourite with the REW Audio Contracts range of mini-studios. In stock.

NETT PROFESSIONAL PRICE ON APPLICATION

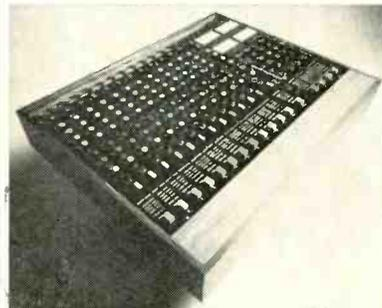
## MIXERS BY SOUNDCRAFT ELECTRONICS



### SOUNDCRAFT 16/2

New 16/2PA. Complete in flight case incorporating 16 mic channels, stereo output channels, foldbacks output plus two echo return channels. Full monitoring facilities; pfl; balanced input; 4-band eq; f/b send; echo send; channel switch; pan pots and faders. Input and output XLR sockets plus 37 way socket for multicore connection.

NETT PROFESSIONAL PRICE  
£992 + VAT

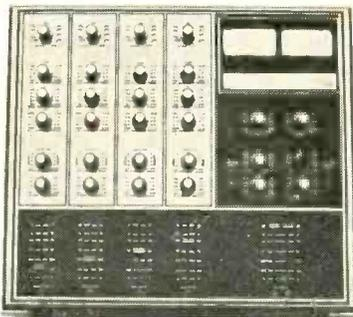


### SOUNDCRAFT 12/4

Just arrived—12/4 Recording Console which is built into a teak case, incorporating 12 input and 4 output channels, output limiters, and full monitoring facilities. All input and output connectors are Switchcraft (XLR equiv.) except line input which are ¼" jack. 200 ohm mic inputs are balanced. 4 band E.Q.; f/b send; echo send; pfl; channel switch; pan pots and faders.

NETT PROFESSIONAL PRICE  
£875 + VAT

## SCOTCH 207 at very competitive prices.



### LAMB PML 420 MIXER

This high quality inexpensive 4/2 mixer incorporating 3 band e.q.; pan pots; faders; limiters and echo send controls make it a good starting point for the basic mini studio set-up.

NOW IN STOCK

NETT PROFESSIONAL PRICE ON APPLICATION

REW Audio Contracts are able to offer the following microphones at professional prices (subject to stock) to bona-fide pro users.

AKG	AKG	SHURE	CALREC	BEYER	RESLO
D190	D707	5155A	CM652	M160	S80
D160	D900	588SA	CM655	M500	CABARET
D109	D1200	545		M260	S91
D12	D2000	565		M101	
D90	D202E1	548	Available in		
D200	D224E	SM57	DIN or CANNON (XLR) connectors.		
D202	C451*	SM58			

\*VERY SPECIAL PRICE WHILE STOCKS LAST

ALL PRICES ON APPLICATION Full range of mic stands and accessories by KMAL.

ALL PROFESSIONAL AUDIO EQUIPMENT AT

**REW Audio Contracts, 146 Charing Cross Road, London WC2. Tel: 01-240 3883**

VIDEO, INDUSTRIAL AND STUDIOS AT

**REW Video Contracts, 10-12 High St., Colliers Wood, London SW19. Tel: 01-540 9684/5 Telex 896194**

\*NOTE REW Audio Contracts and REW Video Contracts are registered trade names and are part of The REW Group of Companies.

# AMCRON

## 800 SERIES RECORDER

- \* Computer Logic Control. Prevents tape breakage by providing fool-proof operating controls.
- \* Feather touch push-button mode controls.
- \* Photo-cell, automatic shut-off in all modes.
- \* Take-up reel motor shut-off switch for editing.
- \* Motor shut off switch (electronics remain on).
- \* Cue lever for controlling tape-to-head contact.
- \* Professional styling and colour combinations.
- \* Fully remote controllable.
- \* Patented electro-magnetic brakes.
- \* Plug-in modules for all functions: mic modules optional.
- \* Built in remote record (CX-800's) for no thumps on tape at beginning or end of record mode.
- \* Echo controls built in.
- \* Front panel bias adjustment.
- \* 3-speed equalization.
- \* Treble and bass controls with "flat" detents.
- \* Available with 600 or 250 ohm balanced XLR cannon inputs and outputs as an accessory.

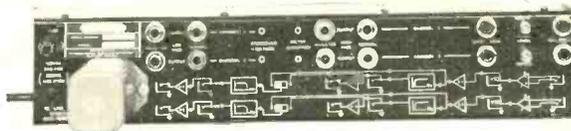


AVAILABLE IN  
MONO, STEREO, OR  
FOUR TRACK IN-LINE

**NEW!**

## VFX-2 DUAL CHANNEL CROSSOVER/FILTER

The Amcron VFX-2 provides continuously variable filters which can be used to perform either crossover or band pass functions. The dual channel unit employs two filters per channel, each continuously variable from 20 Hz to 20k Hz. Filter rolloff is at a fixed 18dB/octave.



Our London stockists for all AMCRON equipment are REW (Audio Visual) Ltd., 146 Charing Cross Road, London WC2. Tel. 01-240 3883, and also at 10-12 High Street, Colliers Wood, London SW19. Tel. 01-540 9684.

or Direct to sole agents:



**MACINNES LABORATORIES LTD.**

**MACINNES HOUSE, CARLTON PARK INDUSTRIAL ESTATE,  
SAXMUNDHAM, SUFFOLK IP17 2NL  
TEL: (0728) 2262 2615**

this is Otari

## Otari DP4050

Ideal for 1 cassette copy or 10,000

From Japan's biggest manufacturer of Tape Duplication equipment, the DP4050 reel to cassette copier.

Foolproof operation for non-skilled personnel.

Eight times copy speed.

Automatic cycle through Record-Rewind-Stop.

Absolute consistency in manufacture through large volume production.

Modular construction.

Servo-controlled direct capstan drive.



# O/TARI/I

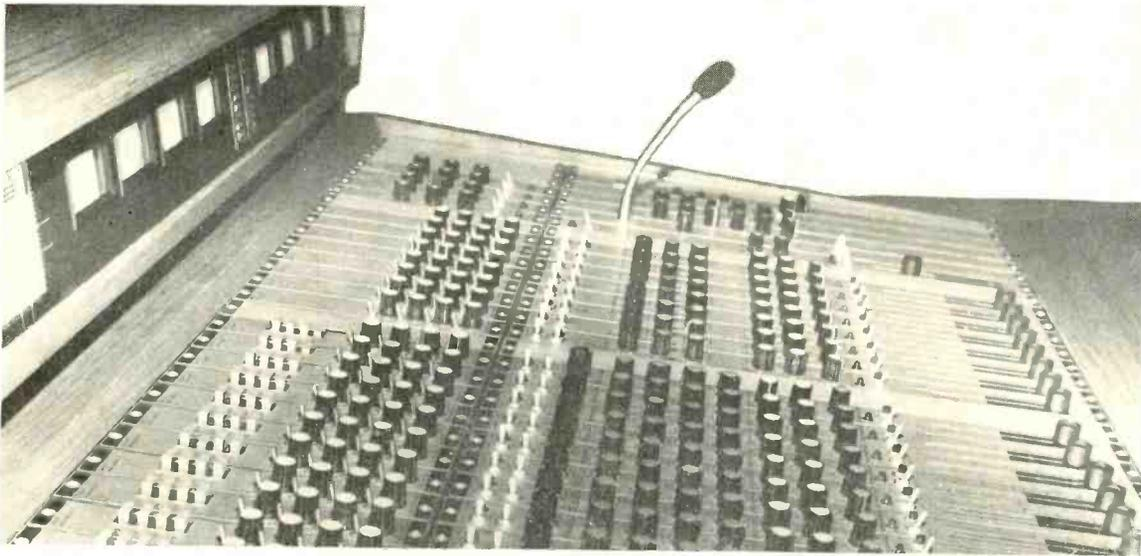
**NOTE NEW ADDRESS-**

Industrial Tape Applications

5 Pratt Street, London NW1 OAE. Tel: 01-485 6162 Telex: 21879

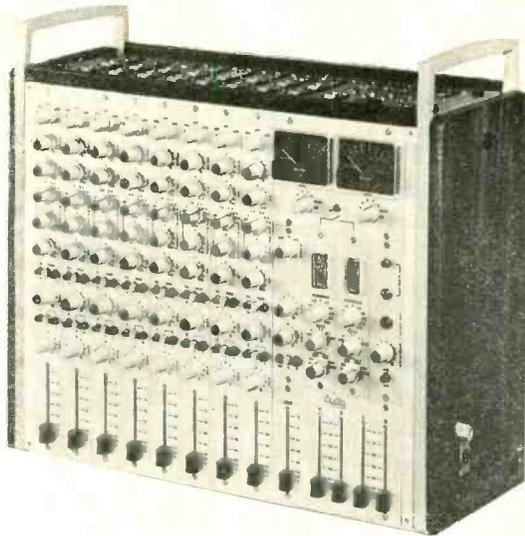
# ITA

## *Alice* AM-Adaptable Modular



*Alice* (Stancoil Limited) Alexandra Road, Windsor, Berks.

Tel. Windsor 51056



### AD 007 PORTABLE MIXER

The Mini Mixer with the professional qualities and the professional performance.

- Battery or external power supply operable.
- 8 Inputs 4 Outputs all balanced into XLR connectors.
- 2 Compressors with stereo link.
- 2 Peak Programme Meters switchable to all channels and groups.
- Auxiliary send and returns.
- Modular construction is used to promote serviceability.
- Inputs extendable to 18 via the Ten Input Extension Unit.

Other facilities include insertion points in each channel and group, a line up oscillator and cue facility. The Extender Unit can also incorporate Talkback and Monitoring at the exclusion of input modules.

Customers so far supplied have been full of praise for the mixer. They include people in broadcasting studios and the live entertainment field.



Hall Lane  
Walsall Wood  
Staffs WS9 9AU

Tel. Brownhills 5351

## SESCOM'S NEW CABLE TESTER

TESTS FOR:

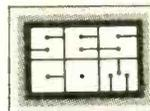
- Continuity
- Opens
- Shorts
- Phasing



MODEL CT-1

Just plug a standard cannon type 3 pin male to female extension cord into box, depress three push buttons. Compact cast aluminum box. Uses standard 9V transistor battery. Professional Net \$21.50.

Send for Spec Sheet



*Quality Engineered Sound Products*

**SESCOM, INC.**

P.O. Box 590 Gardena, CA 90247 U.S.A.  
Telephone (213) 770-3510 · TWX 910-328-6189

## STUDIO ACCESSORIES

WE SUPPLY HEADPHONE BOXES, MIC. BOXES, WALL BOXES, LEADS, SWITCHING BOXES, OR ANY SMALL CUSTOM BUILT BOXES TO ORDER.

WE SPECIALIZE IN SUPPLYING, SERVICING AND MODIFYING REVOXES.

We also supply mic. cable in 10 colours (ex-stock), and all other studio equipment.

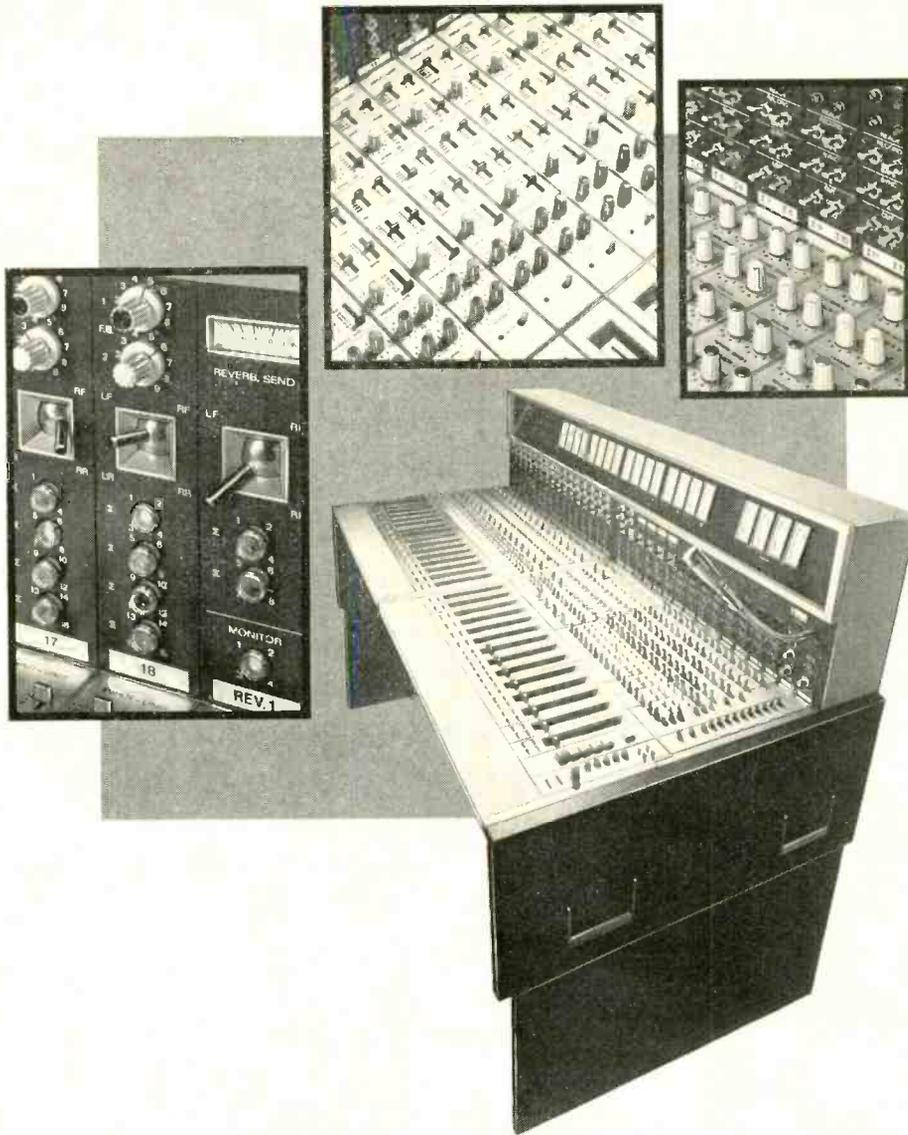
**RADIO RECORDINGS 01-722-7574**

### \* Dolby A361 for hire \*

- \* REVOX A77 Mk III Recorders, standard and high speed model in stock. Sel-Sync model available.
- \* New REVOX A700 1372 and 1374 now available.
- \* NEAL 102 professional cassette deck from stock.
- \* All leading equipment at competitive prices including A.K.G., Beyer, Ferrograph, Teac A3340, Quad, Tannoy, Spondor, Uher 4000/4200/4400, Report IC, and CR210 cassette recorder with facility for chrome tape.

131 The Parade, High Street, Watford WD1 1NA  
Tel. Watford 34644

# BAILEYS



## The Studer 189 Quadro Makes Sound Sense (and sense of sound)

- \* No fuss and bother about specification
- \* Realistic Price
- \* Instant Delivery
- \* Renowned Studer Quality
- \* Any Questions?

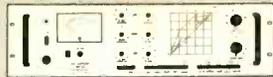
*All the details have already  
been worked out for you  
Due to streamlined Production  
2 - 6 Weeks  
Ask anyone  
Phone or write*

STUDER

F.W.O.Bauch Limited  
49 Theobald Street, Boreham Wood,  
Hertfordshire. Tel:01-953 0091

# The Big PDM-Compressor

## EMT 156



# has inspired a new Family of Console Components:



### EMT 256 II

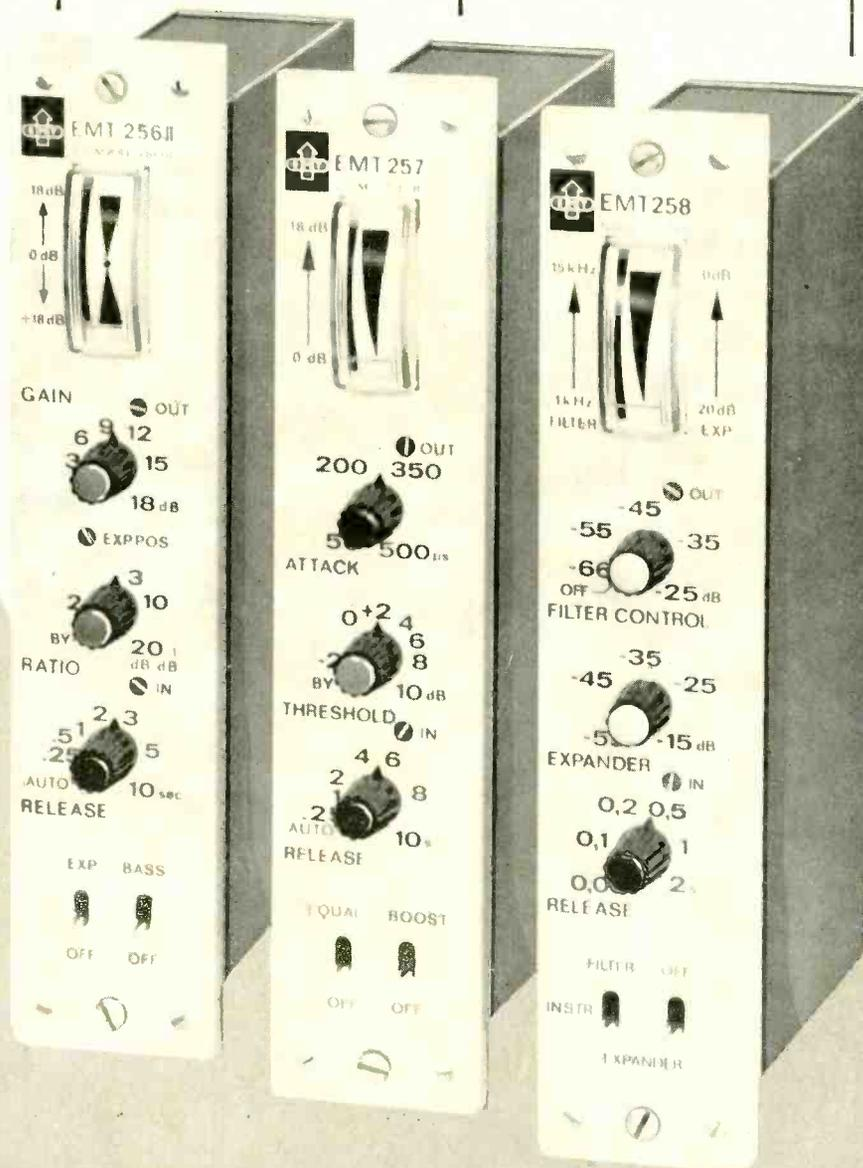
Compact compressor with program dependent release time, low level noise reduction by expander, and compression gain and ratio adjustable over wide range. Uniquely applicable for all types of music and speech program material; directly insertable in the microphone input channel.

### EMT 257

Compact limiter featuring adjustable attack times to 50 microseconds and loudness dependent release time. For automatic, low distortion limiting of program peaks.

### NEW: EMT 258

Automatic noise filter, featuring program controlled low-pass cut-off frequency and dynamic expander function. A highly up to date circuit principle for suppression of background noise and improvement of signal-to-noise ratio.



EMT 258 delivery: beginning mid 1975

#### Additional export program:

- Reverberation units
- Studio turntables and pickup cartridges
- Specialized tape machines for endless loop cassettes and logging purposes.
- Digital audio signal delay units
- Auditorium microphone winch systems
- Electronic tuning fork and polarity tester
- Test equipment for wow and flutter measurement

**FRANZ** Vertriebsgesellschaft m.b.H.  
D-763 LAHR 1, P. O. BOX 1520, West Germany



# audix

SOUND SYSTEMS AND ELECTRONICS

## B100 SERIES AUDIO MIXING CONSOLES

Model B101, 10 channel 2 group audio mixing console — part of a new and flexible range of mixing equipment — each mixer having an interchangeable selection of control modules designed to enable your exact requirements to be met. Other mixers within the B100 series range from 4 input, 1 output O.B. units to multi channel consoles — all custom built with no compromise electronics to meet the highest broadcast and studio standards.



# audix

**MANUFACTURERS OF  
SOUND SYSTEMS AND  
ELECTRONICS**

**AUDIX LIMITED STANSTED ESSEX CM24 8HS  
TELEPHONE : BISHOP'S STORTFORD 813132  
(4 lines) (STD 0279)**



# Now and Forever

## Today

With a Quad 33, any pickup can be properly matched to give the finest performance of which that pickup is capable (1).

## Tomorrow

The Quad 33 pickup is uniquely placed to meet the needs of the future (2).

- 1 (a) Equivalent input noise at the exceedingly low figure of 0.5  $\mu$ V.
- (b) An input load which is a pure resistance at all frequencies. 5° 0-20 KHZ.
- (c) An input dynamic range of close on 100dB, 30dB better than the finest recordings now available.
- (d) Provision to place the pickup dynamic range (60-70dB) in proper relation to the amplifier range so there need be no compromise between overload requirements and low noise.
- 2 Digital mastertapes for disc cutting and further refinement of the pickup cartridge will lead to lower noise and less distortion, and may make a major contribution to better sound in the next decade. The Quad 33 can do full justice to each and all of these possibilities.



Send postcard for illustrated leaflet to Dept. SS  
Acoustical Manufacturing Co. Ltd., Huntingdon PE18 7DB.  
Telephone (0480) 52561.

**QUAD**  
Products of  
**The Acoustical Manufacturing Co. Ltd.**  
for the closest approach to the original sound  
QUAD is a Registered Trade Mark

**This** is a book:  
 contents: approximately 100,000 words.  
 50 illustrations  
 reading time, 5-6 hours  
 It can be read by any literate person  
 (2 out of 3 adults). It's probably the  
 greatest invention since the wheel.



**This** is a video cassette:  
 contents: approximately 200,000 words,  
 two languages. 90,000 pictures  
 in colour  
 reading time: 60 minutes  
 It can be read by a child of 3 or an  
 illiterate peasant. It's probably the  
 greatest invention since the book.

## ...and this

is a teacher, entertainer and salesman all rolled into one—with a difference. It'll work 24 hours a day (weekends too), needs no paid holidays or Christmas bonuses, and if it goes sick it is instantly replaceable. It will never replace people, but it is a good understudy.

The U-Matic video cassette system offers a wider range of options than any other. This, coupled with fantastic performance and great reliability, make it the ideal video cassette system for all serious users of CCTV. Blank cassettes cost less than £14 and give a full 60 minutes playing time and may be used time and time again. Recordings can be made from any TV camera, off the air, or from existing film material and can be played back on any monochrome or colour monitor or TV set. We are compiling a pre-recorded library too.

If you feel you could use an addition to your staff Action Video can help you (with some assistance from Sony, National Panasonic & Nivico).

Complete and return the coupon for full details of the U-Matic video cassette system.

Please send me details of the U-Matic video cassette system. I am particularly interested in:

\_\_\_\_\_

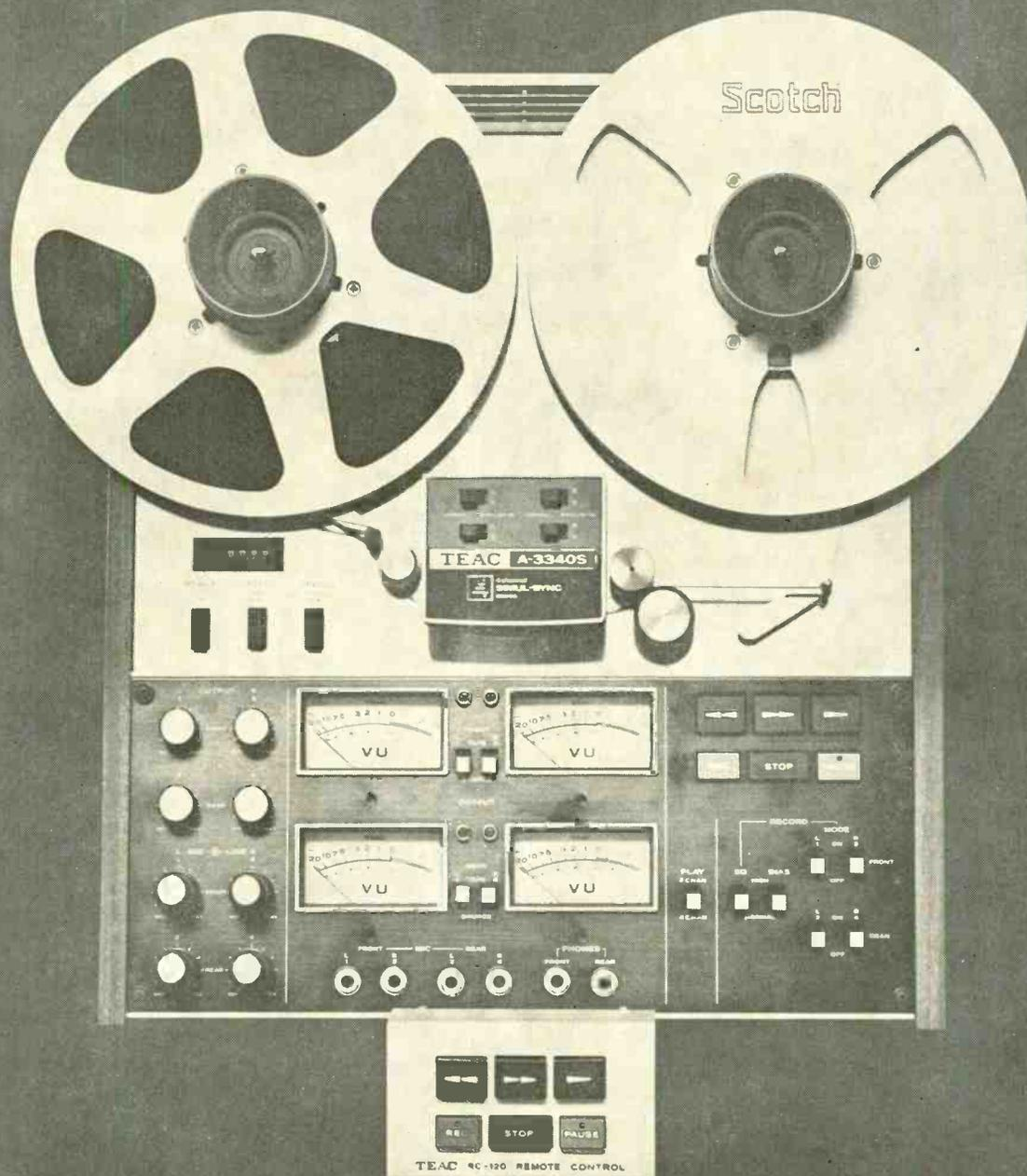
\_\_\_\_\_

Name \_\_\_\_\_ Position \_\_\_\_\_

Address \_\_\_\_\_

**ACTION VIDEO LTD** 45 Great Marlborough Street, London W1 01-734 7465

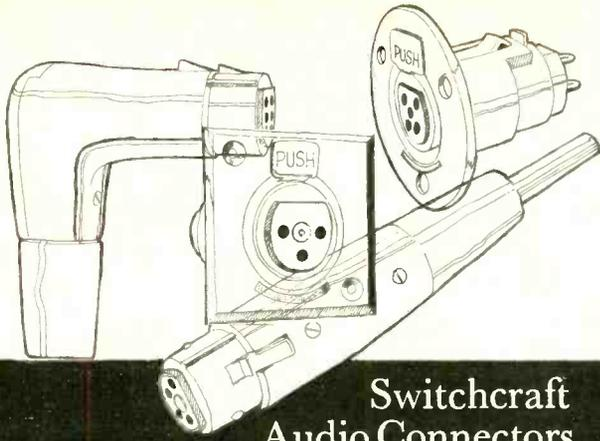
# THE NEW TEAC A3340S



**TESTED CHECKED AND SUPPLIED ONLY BY**

**TAYLOR  
HUTCHINSON  
LTD**

105 HIGH STEET ETON BUCKS SL4 6AF PHONE WINDSOR 51403/53014



## Switchcraft Audio Connectors

Complete range of Switchcraft audio connectors for all studio and ancillary equipments.

**Versatile**— 3, 4, 5, or 6 pole; wide variety of matching plugs receptacles adapters; readily interchangeable with other leading makes.

**Streamlined**— simple positive snap-in connection; cable clamping and latch lock.

**Safe**— self-polarisation; captive insert screw provides rigid assembly and electrical continuity; pin and contact insulation eliminates hum and noise problems.

**Low Cost · Ex-stock · Quantity Discounts**

*Write now for free descriptive literature.*

Sole U.K. Agent for Switchcraft QG Connectors

**F. W. O. BAUCH LIMITED**

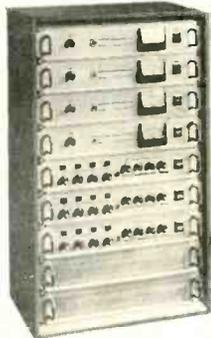
49 Theobald Street, Boreham Wood, Herts. WD6 4RZ Telephone: 01-953 0091



**“sounds perfect”**

AT LAST your search is over. If second best just will not do, you should be using our range of high reliability equipment which includes power amplifiers, 100v. line transformers, microphone transformers, rack cabinets, and some superb electronic lighting control units. Delivery— usually ex-stock.

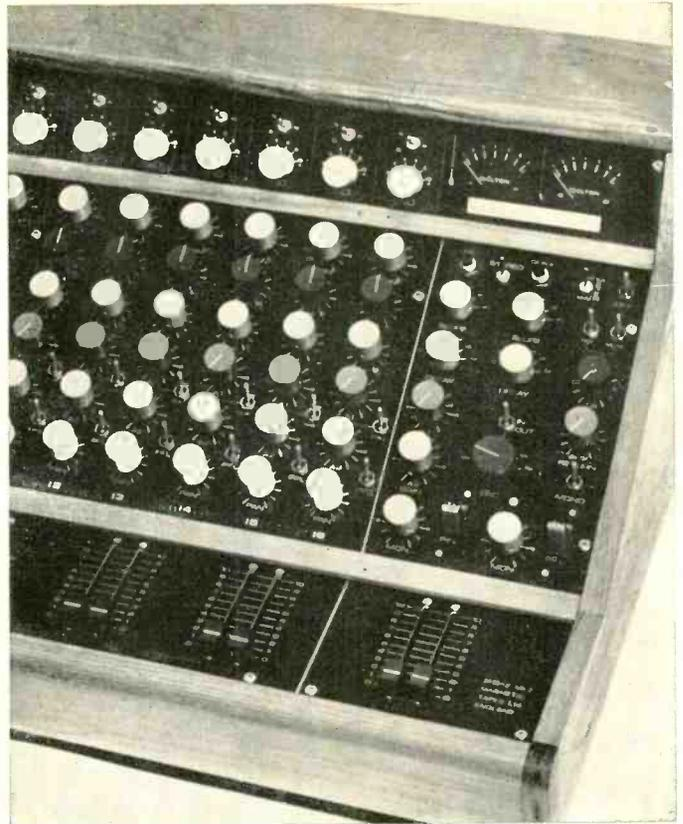
Write now for the full details.



**MUSTANG  
COMMUNICATIONS**

NELSON STREET · SCARBOROUGH  
YORKSHIRE · YO12 7SZ

Telephone (0723) 63298



## WHY CHILTON MIXERS?

We are manufacturers in the true sense of the word; producing Teak Cabinets, Sheet Metal Work, Tooling, Front Panel and Printed Circuit Artwork etc., our products are accurate with an attention to detail that is second nature to us.

The popular M10/2 (10in 2out) portable mixer shown is supplied as a basic unit with 10 Line inputs inc PPM, Oscillator, LF/HF Equalisers, 1 Aux and PFL. You choose the number of Microphone or Gram inputs, the channels to have Presence, Switchable HF/LF Filters or Ducking. In addition a 2nd Aux channel, Talk-Back, and/or Compressors can be fitted.

Ring or write for full information, if however our standard range is unsuitable it may be possible to modify one to suit your requirements.

M10/2 Mk3 BASIC .....	£295.00 + VAT
16 input version .....	£455.00 + VAT
12 in 4 out .....	£515.00 + VAT

MAGNETIC TAPES Ltd., Chilton Works,  
Garden Rd., Richmond, Surrey, TW9 4NS

Telephone 01-876 7957

## SPECIALIST IN PORTABLE MIXING

### ADO 31 MICRO MIXER



**Special Features:**

- ★ 8 MIC/LINE Inputs
- ★ 2 Main Groups
- ★ 1 Sub Group
- ★ Auxiliary Output
- ★ Channel Overload Indicator
- ★ Size 440 x 330 x 105 mm
- ★ Weight 10 kg

# Audio

Developments

Hall Lane  
Walsall Wood  
Staffs WS9 9AU

Tel. Brownhills 5351

## AUDIO CONNECTORS

BROADCAST PATTERN JACKFIELDS, JACKCORDS PLUGS & JACKS, QUICK-DISCONNECT MICROPHONE CONNECTORS. AMPHENOL (TUCHEL) MINIATURE CONNECTORS WITH COUPLING NUT. HIRSCHMANN BANANA PLUGS & TEST PROBES. XLR COMPATIBLE IN-LINE ATTENUATORS. LOW COST SLIDER FADERS BY RUF.

**FUTURE FILM DEVELOPMENTS LTD.**

90 Wardour Street W1V 3LE

01-437 1892/3

## CART' WORK !!

- ★ N.A.B. and "Q"-8 repairs
- ★ Reloading, Rewinding and Phasing
- ★ Copies, Duplicating and Distribution
- ★ Machines overhauled and Commissioned
- ★ All work in our own labs to N.A.B. and I.B.A. specs
- ★ Precision head replacement and lapping service, 24 hours

**1 OLDERSHAW MEWS  
MAIDENHEAD, BERKS.**

Tel. Maid 0628-33011 24 hours.



## Altec Sound Equipment by Theatre Projects



9846B Biampifier Studio Monitor Speaker System

For further information on the Altec range of sound equipment please fill in the coupon below and return to:

**Theatre Projects/Sole UK Agents**  
10 Long Acre London WC2E 9LN  
Telephone 01-240 5411



Please send me further information on the Altec range

Name: \_\_\_\_\_

Address: \_\_\_\_\_  
\_\_\_\_\_

Telephone Number: \_\_\_\_\_

I am particularly interested in: \_\_\_\_\_  
\_\_\_\_\_

# Response

A & B Series Mixers for those people who want just a little more.



For further details  
contact  
DICK CULLUP,  
SULAMOSS Ltd.  
5 Wall Park Close,  
Newnham Road,  
Plympton,  
Plymouth,  
Devon.  
Tel: (0752) 30494  
Telex: 45623

*The BM 104*

# Condenser Microphones... at greatly condensed prices

Yes it's true! Unisound Electret Condenser Microphones are capturing the sound and the interest of the amateur and professional recordist, for at last the condenser microphone price barrier has been shattered and without any loss of performance.

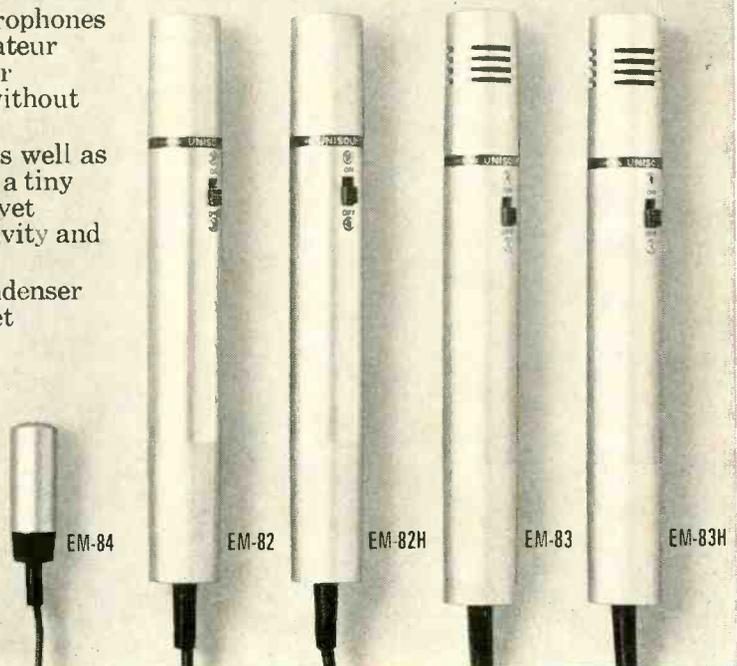
The range includes Omni and Uni-Directional as well as Tie-Tack lapel models. The unique design employs a tiny UM-3 battery making bulky power packs obsolete yet providing sufficient power to maintain high sensitivity and a wide response ratio.

Get to know more about Unisound Electret Condenser Mikes - we have a very interesting technical leaflet available on request.

## Condor

The fastest bird in the business  
Condor Electronics Limited,  
100 Coombe Lane, London, SW20 0AY  
Telephone: 01-946 0033 (4 Lines)

*Distributors of cartridges, styli, condenser  
microphones and headphones. Guaranteed  
24-hour dispatch service*



## Bose 1801 power amplifier review

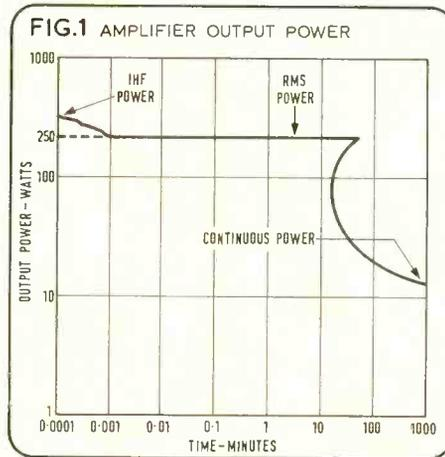
Dear Sir, I would like to make some comments on the review of the Bose 1801 power amplifier which appeared in the June issue of *STUDIO SOUND*. We feel that the review adopts a rather negative tone, in part due to philosophical differences and in part due to minor misunderstandings. Having just visited the Bose Corporation in America, I left a copy of your magazine with Joseph Verantz, a member of the Bose design team. I would like to relay to you a recent letter I have received from Mr Verantz which I hope will clear up any doubts as to the performance of the 1801:

'First, let me clarify the Bose specification philosophy as it relates to distortion. Mr Ford takes exception to the statement that harmonic distortion above 10k Hz is unimportant, but the argument he gives to support his position relates to intermodulation distortion. I am in complete agreement with Mr Ford's view of the importance of intermodulation distortion. In fact, the experiments we have performed indicate that any level of intermodulation distortion greater than 0.5 per cent may audibly affect the performance of an amplifier. The Bose literature states this fact, and when it cites audibility criteria for harmonic distortion, intermodulation distortion, frequency response, noise, damping factor, overload recovery, and input impedance, the intended meaning was that all of these criteria must be met for audible perfection, not just some of them.

To elaborate further, let me postulate an amplifier with an inherent 20 per cent non-linearity. This amplifier would be unacceptable for quality music reproduction. However, it could be improved by employing feedback to suppress all error (distortion) components in the output to less than 0.5 per cent. If the feedback operated only over the range from 20 Hz to 20k Hz, all audible distortion would be eliminated, and the intermodulation distortion would be less than 0.5 per cent even for two high-frequency signals whose difference fell into the audio range. This would be an audibly perfect amplifier, though its 10k Hz harmonic distortion could be as high as 20 per cent.

Mr Ford notes that the im distortion of the 1801 is as high as 0.11 per cent, which is much worse than some competitive products. This statement is also true, yet I will stand by the fact that distortion even four times this great is inaudible. Bose Corporation has attempted to establish this fact through the use of a demonstrator which allows one to compare the input and the output of the 1801 through a system of much 'better' specifications. There is no audible difference. Therefore, any effort devoted to the improvement of distortion in the 1801 would be a poor allocation of resources and offer no benefit to the consumer.

The issue of thermal capability of the 1801 is probably a more important one, and certainly much harder to resolve, since it is much harder to make an experimental determination of the average power requirements for music than to determine the audible levels of distortion. Since



applications vary widely, we feel that the only cost-effective solution is to make different thermal options available for different requirements.

The amplifier which was reviewed by Mr Ford was the 1801, or consumer version which, as he states, is certainly not suitable for professional applications. This unit is intended for convection cooling only, and if data is recorded for time of operation till cutout for a given sinewave output power, the results are as shown in fig. 1. Though the continuous output capability is only 15W per channel, this has been established to be more than adequate for home music reproduction where the music has a typical crest factor of 15 dB. Mr Ford determined that though the amplifier could handle 16W continuous, it was capable of reproducing Radio Two programming only up to a level of 40W peak. This is a crest factor of only 4 dB, which is the most incredible amount of compression I have ever heard of, and which I have certainly never encountered in the USA.

For professional applications, Bose manufactures another version of the amplifier called the 1800. This amplifier may be purchased for convection cooling also, with only a slightly modified internal heat coupler for improved thermal performance. However, no amplifier of this power level is capable of operating at half-power without forced-air cooling, and the 1800 is no exception. For this reason, several cooling options are available.

Where the requirements are moderate, the 1800 may be used in its transit case, which contains two fans and provides adequate cooling for pa applications and music with crest factors as low as 10 dB. For very extreme operating conditions, the 1800 may be fitted with an optional fan kit, which provides adequate cooling for all types of music and speech.

The cooling requirements of the 1800 may appear to be quite severe. This is not due to a lack of efficiency relative to other Class B amplifiers in this power range. Instead, it is due to the high power capability of the amplifier, resulting in higher dissipation for a given

output level, and the low thermal-cutout temperature. The 1800 uses a thermal-cutout temperature of 65°C, which results in almost twice the cooling requirements of an amplifier whose thermal cutout activates at 95°C. We believe that the extra reliability associated with the lower temperature is well worth the additional cooling effort.

I hope that this discussion has cleared up some of the major questions addressed by Mr Ford, and that he will have an opportunity sometime in the near future to review an 1800. (Signed) Joseph L. Verantz.

I hope that this will answer any problems that you have with the performance of the 1801.

Yours faithfully, N. A. Pierce, Sales Director, Acoustico Enterprises Ltd, Unit 7, Space Way, North Feltham, Middlesex TW14 0TZ.

While I appreciate the trouble taken by Mr Verantz in replying to my review of the Bose 1801, I'm afraid that much of what he says only goes to endorse my opinion of the Bose 1801.

It should first be understood that Acoustico Enterprises supplied the Bose 1801 for the specific purpose of a review by me in *STUDIO SOUND*. No mention was made that the amplifier supplied was a 'consumer version' and in fact the Acoustico Enterprises representative was somewhat surprised at the very poor power handling capability of the amplifier.

Rightly, Mr Verantz takes me to task about the performance when amplifying Radio Two—I would however suggest that the figure of only 4 dB may have been brought about by the type of peak metering used. If my memory serves me correctly I used the amplifier's led display as opposed to my extremely fast Bruel & Kjaer peak meter.

In spite of this I think that it is agreed that the power handling capacity of the Bose 1801 is quite unacceptable for professional work without extra cooling. Other high power amplifiers do not suffer from this problem.

Reverting to the subject of distortion I think that we agree that both harmonic distortion at medium frequencies and also intermodulation distortion as measured by both the SMPTE method and the CCIF methods are important. The measurement of both harmonic and intermodulation distortion performance is important because contrary to popular opinion they are not necessarily related.

I am however of the opinion that harmonic distortion at high frequencies is equally important in a wide band system where the available bandwidth extends well beyond the upper limit of audibility. In such a system it is quite clear that the harmonics of high frequency signals will be within the passband of the system and that when more than one fundamental is present the resulting harmonics will produce beat notes that are not normally harmonically related to the fundamental.

The simple solution to this problem is to reduce the closed loop gain of the system outside the audio frequency band, which will also have the desirable effect of reducing noise. **Hugh Ford**



# Just how good is the Philips 'Electronic'?

That Philips make Hi-Fi of the highest quality as well as good domestic audio equipment is most clearly demonstrated by the GA212 'electronic' record deck.

This shows technological innovation of a high order, resulting in genuinely better standards of record reproduction.

Its two speeds (33 $\frac{1}{3}$ , 45 rpm) can be adjusted precisely, using the built-in stroboscopic rings and fine-speed controls, and are accurately maintained by a tachogenerator that keeps wow and flutter to less than 0.1%.

Speed selection is by 'skin-sensitive' controls that light-up when touched.

Floating suspension of the turntable and pick-up arm gives excellent insulation against shocks and vibration, resulting in very low rumble and very accurate cueing. Turntable and pick-up arm have been mounted on a sub-chassis which is suspended from the rigidly mounted main chassis. Considerably more flexible springs can therefore be used. And as the motor is independently mounted underneath the main chassis, the pick-up arm is doubly insulated against vibrations from the motor.

The tracking error of the



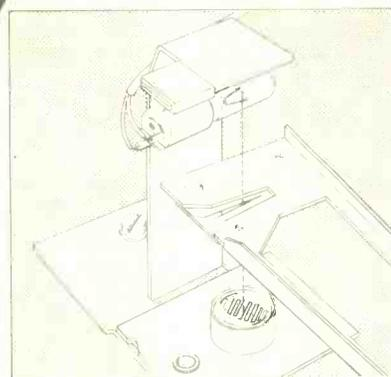
virtually frictionless low-resonance pick-up arm is exceptionally low. Side-thrust may be compensated at all playing weights for both conical and elliptical styli.

The Philips slide-in carrier accepts virtually any pick-up cartridge with fixing centres to the  $\frac{1}{2}$ " international standard. A Philips GP400 Super M magneto-dynamic cartridge is supplied.

Switching on and off is done silently through a bi-stable multivibrator, operated by relay-type switches.

Autostop at the end of a record is not effected by mechanical means, but electronically. When the rate of interception of a light-beam striking

a photo-sensitive cadmium sulphide cell exceeds a certain value, a bi-stable multivibrator is triggered, cutting off the motor supply voltage. Hence 'thumping' and groove jumping cannot occur. The pick-up can be lowered precisely into any groove, even close to the run-out, without premature switch-off.



Your Philips Audio Specialist will be pleased to demonstrate this top-quality record deck, which sets new high standards in record reproduction.

For a free 36-page Audio Guide, write now to Philips Electrical Ltd., Dept SP, Century House, Shaftesbury Avenue, London WC2H 8AS.

**Simply years ahead.**



**PHILIPS**

## High quality line amp

**SPECTRA SONICS** has developed a modular amplifier that is claimed to produce less than 0.01% total harmonic distortion at +21 dBm from 20 Hz to 20k Hz, noise being -127 dBm equivalent input over the same range. The *110* model finds applications in preamps, line boosters and mixer amplifiers.

Supplied by  $\pm 24V$  dc power, the *110* is contained on a card 65 x 130 x 13 mm and is available from stock. Price: \$72.

Spectra Sonics, 770 Wall Avenue, Ogden, Utah 84404, U.S.A. Phone: (801) 392 7531. Sun Recording Services, 35 Edgcombe Park Drive, Crowthorne, Berkshire. Phone: Reading (0734) 63724.

## Stolen

**WINTHROP LABORATORIES**, of Winthrop House, Surbiton - upon - Thames, Surrey, has asked for assistance in tracing a Uher *4000 IC* stolen from a house in Iver, Bucks. The serial no is 1412016090. Any information to A. Todd at the above address.

## Professional tape recorder

**MCI** HAS added a new model, the *JH 120*, to the range of professional machines. This is a two-track unit available in 6.25 mm and 12.5 mm format, and incorporates 'sophisticated' circuitry with digital control of tape transport.

Hamilton Brosious, Audio Techniques Inc, 142 Hamilton Avenue, Stamford, Connecticut 06902, USA.

## IBA local radio contracts

**THE IBA** HAS awarded two local radio contracts. The Teesside contract goes to Sound Broadcasting (Teesside) Ltd. Enquiries to the chairman, Mr J. B. Robertson. Phone: 0642 780436.

The Nottingham contract goes to Radio Trent. Enquiries to the chairman, Mr Ashton Hill. Phone: 0602 46651.

## Macinnes monster mash

**AGREEMENT** HAS been reached for Macinnes to market exclusively loudspeakers from RTR of the USA. As well as manufacturing high quality loudspeaker systems, RTR produce a wide range of speakers including a high efficiency 65 cm model with a 15 cm voice coil. A similar arrangement has been reached with CTS, formerly Magnavox, to supply their wide range of speakers.

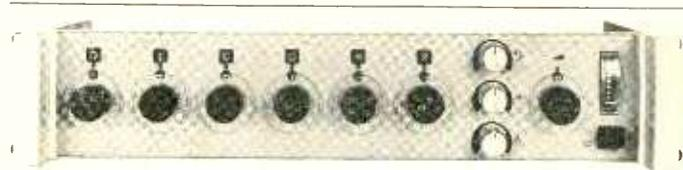
Macinnes has received an order for eight Amcron *DC300As* to be supplied to the CBS London studios, and were also contracted to supply the sound system for the tenth Annual Cambridge Folk Festival.

Amcron recently introduced the *VFX-2* electronic crossover providing two variable filters per channel with two separate channels; these can have either crossover or band-pass functions. Range is from 20 Hz to 20k Hz with roll off fixed at 18 dB octave. Output level is 10V, gain 15.5 dB, with hum and noise typically 113 dB below rated output from shorted unity gain input. Im distortion of the unit is claimed less than 0.01% at rated output. An inverted output enables two power amplifiers to be driven in mono mode without modification. Power requirements are 115 or 240V ac. Price is £145.

Macinnes Laboratories Ltd, Macinnes House, Carlton Park Industrial Estate, Saxmundham, Suffolk IP17 2NL. Phone: Saxmundham (0728) 2262/2615.

## Soft drinks, soft music

**THE SPARTA ELECTRONIC** Corporation has announced the sale to Colombia's major radio broadcast organisation, Radio Cadena Nacional, of broadcast transmitting equipment valued at £200,000. Radio Cadena Nacional, headquartered in Medellin, is owned by Postobon, the nation's largest soft drinks manufacturer. Sparta is a subsidiary of Computer Equipment Corporation, El Monte, California. Sparta Electronic Corporation, 5851 Florin-Perkins Road, Sacramento, California 95828, USA.



Millbank *MEX6* mixer

## Digital delay

**LEXICON** HAS introduced a second generation of delay units, the Delta T model *102* series. These claim a dynamic range of 90 dB and a  $\pm 2$  dB 20 Hz to 15k Hz response at 14 dB below limiting. Basic main-frame delay is 320 ms (models *102A/B*) and 128 ms (model *102C*) with capability to 3.2s with additional modules. The headroom below limiting is displayed by leds spaced at 10 dB intervals. Total noise and harmonic distortion is claimed to be 0.2% at limit and 0.3% at 34 dB below limiting level. Lexicon Inc, 60 Turner Street, Waltham, Massachusetts 02154. Phone: (617) 891 6790.

## Independent NE local radio

**THE FIRST INDEPENDENT** local radio station in NE England started programmes on July 15. Estimated coverage is about 1,600,000 people in the Tyne and Wear districts. The station will transmit on 261m medium wave, and on 97 MHz in stereo using circular polarisation.

Metropolitan Broadcasting, in accordance with the IBA charter, is made up from many local interests including newspapers and employers. The chairman and chief executive of the company is Sir John Hunter, chairman of the Swan Hunter shipbuilding group, and his programme controller is Mr Geoffrey Coates.

## AR loudspeakers

**DESIGN CHANGES** have been made to the *AR 3a* resulting in a claimed improvement in spectral linearity of output. The model title now becomes *AR 3a/improved*. An addition to the range is the *AR*

*MST*, a compact unit that is offered for use in monitor applications. Although not specified, the *MST* is claimed to have a power handling capability with a flatness of response suitable for this duty. Acoustic Research International, High Street, Dunstable, Bedfordshire LU5 2BR. Phone: 0582-603151.

## More Millbank

**TO MEET** a growing worldwide demand, the Millbank Electronics Group is restructuring its operating companies and introducing new facilities which will lead to a doubling of production later this year. With effect from August 1, the existing companies of the Millbank Group became wholly owned subsidiaries of a new holding company, Millbank Electronics Group Ltd. The managing director of the new company is Mr A. E. Walker, with Mr E. L. Walker as chairman.

Delivery is now being effected on a four-week schedule on most products with amplifiers available within 14 days. The group has recently introduced upgraded versions of their *MEX 6* and *MEX 6P* six input sound mixers. The output stage of each model now incorporates a transformer to provide a floating output at line level, eliminating the danger of hum loops and hum pickup. Available for use with these mixers is a series of plug-in modules of different characteristics. The *MEX 6P* model incorporates an electronic override priority system operating automatically on three of the input circuits. Prices are: *MEX 6* £85.48, *MEX 6P* £102.47.

Millbank Electronics Group, Bellbrook Estate, Uckfield, Sussex. Phone: 0825 4166.

#### Internavex 74

INTERNAVEX, THE annual exhibition of the audio visual aids industry, was staged at the National Hall, Olympia from July 16 to July 19, in parallel with a conference on the application of av techniques in education.

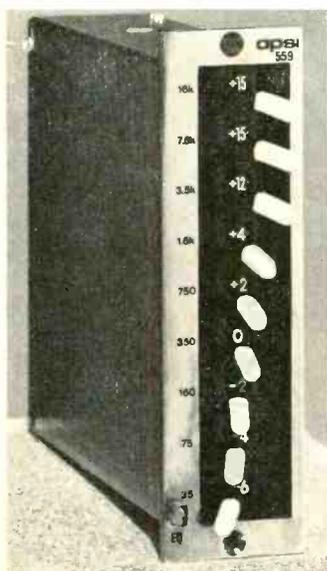
Of interest was an unusual use of polarised light to provide a high quality 3D slide show. A double projector beamed two stereoscopic images on to a conventional screen. In the path of each beam was placed a polaroid filter arranged so that its plane of polarisation was at right angles to the other filter. This produced a single image composed of two, encoded by polarised light. To decode the image to 3D, the observer wore a pair of polaroid spectacles with lenses polarised in the correct aspect to allow each eye to see only the relevant polarised image on the screen.

■ Closed circuit tv predominated, greatest interest being shown at the cost-conscious end of the market. In video cassette recording, the system battle rages unabated. The main combatants are Sony, with their Umatic, and Philips with their N1500 system; in the salvos fired at the show, the visitor was bombarded with stockcars, Walt Disney and sex lessons.

#### Sansui QS

TO EXPLAIN THE principles of its quadraphonic system, Sansui has published a booklet 'A Guide for Recording Engineers — Under-

APSI Nine band graphic equaliser 559.



standing the QS Regular Matrix Four Channel System'. This is available from Masaya Ishikawa, Sansui Audio Europe S.A., 39/41 Maple Street, London W1P 5FU. Phone: 01-580 5353.

#### Home built high fidelity

WIRELESS WORLD Publications has issued 'High Fidelity Designs', a tome which collects the most frequently requested reprints on the subject from the magazine. It contains collected articles by authors such as John Linsley Hood, Nelson Jones and Arthur Bailey. It is available now at £1 from most booksellers and news-agents.

#### Small graphic equaliser

THE AUDIO PROCESSING Systems 559 equaliser provides nine - band graphic equalisation in a compact console or rack mountable module. Leverwheel switches are used to provide -12 dB to +15 dB of control in bands centred on 35, 75, 160, 350, 750, 1.6k, 3.5k, 7.5k and 16k Hz. It has been worked out that there are 'over 5 x 10<sup>9</sup> potential frequency contours available'. A pushbutton switch, led illuminated, activates the equalisation circuits. Dimensions: 37.5 x 136 x 150 mm. Noise: -90 dBm, distortion at full output: 0.25%, thd at +24 dBm.

The 559 is available direct from Audio Processing Systems Inc, 98 Woodland Road, Southbro, Massachusetts 01772, USA. Phone: 617-481 6656; and through Automated Processes Inc, Melville, New York, and is fully compatible with Automated's model 550A equaliser.

#### Tape record

IN THE QUARTER ended March 31, home sales of prerecorded cassettes and cartridges totalled 3,313,519 and 1,663,884 units respectively. Compared with the corresponding quarter in 1973 the figures are up 51% for cassettes and 94% for cartridges. The statistics are compiled by the European Tape Industry Association from information supplied by the country's major prerecorded tape distributors. A projection of this growth

suggests a market potential of up to £35M in 1974.

#### High quality beam tetrode

A NEW HIGH quality Eimac tetrode for broadcasting transmitter applications has been introduced by EMI-Varian. The tube, designated 4CX250BC/8957 is a premium quality direct replacement for the existing 4CX250B. By the use of a new cathode structure, the life has been considerably extended. EMI-Varian Ltd, Blyth Road, Hayes, Middlesex.

#### Improved faders

A REDESIGNED VERSION of the Penny & Giles 1800 series wire-wound fader is now available. The new instrument claims high performance at moderate cost and incor-

porates a high precision track giving a resolution of better than 0.06%, producing level changes of less than 0.1 dB. Tracking is by a twin noble metal wiper assembly to improve reliability and contact noise; typical quoted levels are better than 65 dB down on input. Tracking accuracies from 0 to 25 dB down are ±1 dB with linear and log law outputs available. Standard instruments are available from stock.

Andrew Salanson, Penny & Giles Potentiometers Ltd, Mudeford, Christchurch, Dorset BH2 4AT. Phone: 042 52-71511.

#### More bop for Torbay

BECAUSE THE RADIO One relay transmitter has been resited and boosted in power with a change of frequency, it will be necessary for listeners in the Torbay area to retune their radios to 202m to take advantage of Tony Blackburn at higher signal strength. This will enhance the lives of 120,000 people in South Devon. 28 ▶

# APRS

MEMBERS AND  
AFFILIATES  
SAVE TIME AND  
MONEY BY JOINING  
COPYRIGHT  
SCHEME

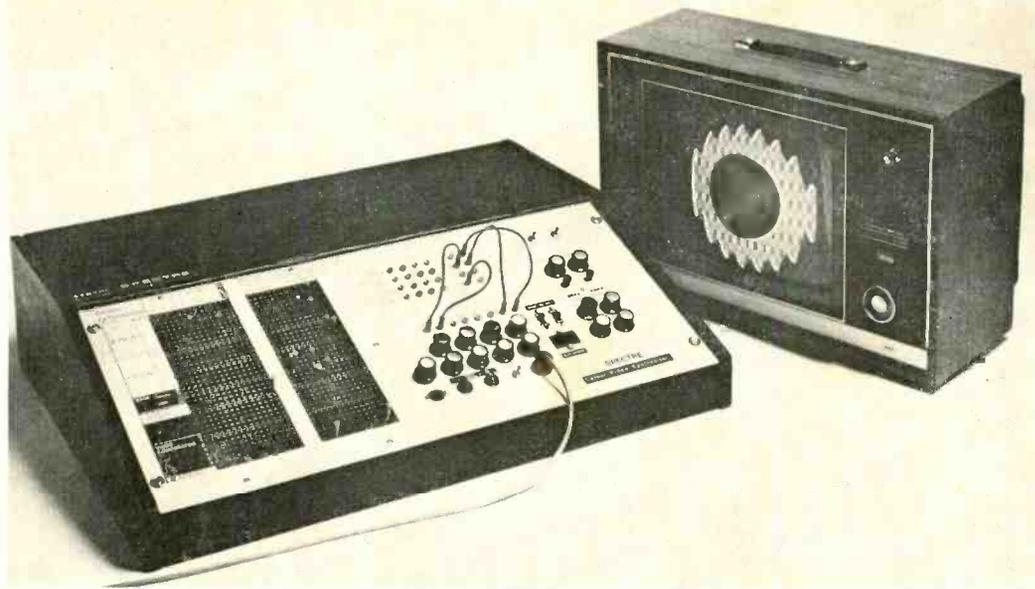
Details from:

**APRS SECRETARY**  
**E L MASEK**  
23 Chestnut Avenue,  
Chorleywood,  
Herts WD3 4HA

**Schlumberger sound equipment**

SCHLUMBERGER INSTRUMENTS and Systems has received a major contract for the supply of sound equipment for broadcast, television and cinema studios in Kinshasa, Zaire. The contract is believed to be worth more than £2M and will cover more than 25 sound mixing desks, over 200 magnetic recorders and turntables, with associated equipment including line amplifiers, and a talkback communications network. The main contractors for the whole operation is the French company Sodeveg Engineering, with video equipment supplied by Thomson CSF.

The new centre will house all the information services of Kinshasa including the Ministry of Information and the National Press Agency (AZP), together with administrative services and the Commissariat d'Etat à l'Orientalion Nationale.



Pre-production model of the EMS Spectre colour video synthesiser system.

**EMS go video**

EMS, INTERNATIONALLY known for its range of music synthesisers, has introduced the world's first video equivalent. It is possible that their video synthesiser, known as *Spectre*, may do for colour tv graphics what the electronic music synthesiser has done for sound. The designer of *Spectre* is Richard Monkhouse, a development engineer with EMS. The potential uses of the synthesiser are graphic design, special effects for video recording and tv broadcasting, and kinetic art.

*Spectre* controls the interaction between colour and brightness of an image that has been generated internally, or externally from a black and white camera or video tape recorder. The result is displayed on a colour tv monitor. The graphics are derived either directly from logic signals or from analogue function generators controlled by logic. This enables the synthesiser functions to be set up on a patch board operating with digital signals, overcoming problems of noise and signal interaction.

To generate patterns, the output from binary dividers are added together through AND gates which have their inputs brought out to a matrix pin board on the front panel. This produces a chequerboard pattern which may have outputs from the analogue generator superimposed upon it. The bars of the chequerboard can have a variable mark/space ratio and a variable

distance between them, depending on which outputs from the binary dividers have been patched in. The colour of the image can be dependent on the luminance level; there are 64 different combinations programmed by digital 'words' set up on the patch board. The luminance is controlled by 16 digital combinations. To create spheroids and triangles, dual ramp generators are used, with the intersection of two voltages producing a visible locus. These function generators have characteristics defined by dc control voltages allowing modulation by internal oscillators or external music to create random or pseudo-random pattern changes.

An input from an external video signal source may be processed by analysing the amplitude of the individual picture elements. The video amplitude is split into seven discrete levels by a seven-stage comparator, each level having an assigned colour. On addition of the luminance signal to the frame, a separated coloured image is created. This facet of *Spectre* may find an application in X-ray recognition. Also, it is possible to create the equivalent of acoustic feedback by focussing the camera on the screen of the monitor, resulting in a moving pattern; every time that the signal travels around the loop, it modifies the image.

The EMS video synthesiser can be produced to any video standard and is capable of operating from internal or external sync. The recommended package consists of: *Spectre*, a Sony bw camera and a

modified Sony monitor. The cost of the basic synthesiser is £3,000, the complete package £4,000.

Electronic Music Studios (London) Ltd, 277 Putney Bridge Road, London SW15 2PT. Phone: 01-788 3491/2.

New York: 408 East 78th Street, NY 10021. Phone: 212-734 7344.

radio. Political balancing has again produced a balance between commercial and state-run broadcasting, this time in radio.

**Commercial radio cut**

AS PREDICTED, THE government has cut back the number of commercial radio stations to 19. The final number was to have been 60. Twenty-seven have already been announced of which 13 have been allocated and six more were to have been allocated during the next two years. The cutback to those stations already operating or planned for is said to be pending the report of the Annan Commission.

The IBA, strangely, have welcomed the decision, though they have said it might be difficult to open the remaining stations—in Bradford, Ipswich, Portsmouth, Wolverhampton, Belfast and Reading—by the end of next year. Cardiff, Brighton, Coventry and Leeds have been proposed as alternatives.

Until the Conservative election victory of 1970 the BBC had planned to open 60 stations, too. After the election the number was cut down to the stations already existing and new plans, outlined above, were laid for commercial

**Audio courses**

FROM OCTOBER 31 to December 12 the Polytechnic of North London is offering courses in 'Sound Studios and Recording' and 'High Quality Sound Reproduction and Measurement'. The purpose is 'to provide the student with a knowledge of both the fundamental principles and the techniques . . . to the standard required by the City and Guilds' subject 271 Part III'. Details from the Course Organiser, Audio and Acoustics Group, Department of Electronics and Communications Engineering, The Polytechnic of North London, Holloway Road, London N7 8DB.

**Sorry B & K**

DUE TO OUR printers taking it upon themselves to swop one block for another, and our blindness at page passing stage, the Bruel & Kjaer 2209 sound level meter was not printed in the September issue as stated on p64.

## Tannoy

THE 13 COMPANIES in the Tannoy group are to be enveloped by a large holding company, and Harman International Inc is to take a 76 per cent stake in that company. The other 24 per cent will continue to be held, for the time being, by the Fountain family, but Harman has an option to buy the shares at a later date.

The amount involved in the deal is a closely-guarded secret but, in the absence of any confirmation or denial by Tannoy, it is reasonable to assume that the deal involves some '£½ million, including an injection of fresh capital'. The rather low price for a group of companies said to have a turnover of £2 million a year can be explained by their difficulties as a result of a fire earlier this year at one of their major suppliers. The hold-up in supplies coincided with the three-day week, and the combination was enough to make the major shareholders in Tannoy, Midland Bank Ltd, begin to look for a buyer in April this year.

Harman has an associated company, Jervis, which is said to be the largest supplier of car wing mirrors to the American car market. Harman International is more well-known here, however, as manufacturers of the Harman Kardon range of hi-fi equipment. Their turnover last year was 76 million dollars. Mr Guy Fountain founded Tannoy in 1926. He has not been well since he suffered a heart attack at Christmas, though he has maintained control over what continues as a paternalistic company.

## Operating threshold

AN AMIABLE BINGE on July 17 in the presence of Sir Edward Lewis officially opened Threshold Record's new studio, although two Moody Blues were already in and working on a solo project, and had been until about three the previous morning. Producer Tony Clark had been looking for some time for a location around the Threshold offices in Cobham, Surrey, but an arrangement was reached with Decca whereby they would function within the West Hampstead complex in what was formerly Studio One. Bookings are handled separately, but the studio obviously benefits from the wider amenities of the Decca operation.

The studio is now completely refurbished and has one of the most comprehensive collections of

equipment in the world. It is one of few London studios with 24 track quadrasonic reduction, which is far from being the only notable innovation. Although ten channels of Dolby A noise reduction are provided, the emphasis is on the 32 channels of Dbx which are the standard for internal use. For external interfacing with cutting and other equipment, either transportable units or internal tie lines are used. Tony Clark explained his enthusiasm for the units, apologising in the process for sounding like a hard sell commercial.

The control room acoustics were designed by Westlake Audio, the desk by Automated Processes. Basic configuration is 32 in, 16 out with 24 track monitoring. Four echo channels feed a Cooper Time Cube acoustic delay unit, a Pandora digital delay (see reviews this month) together with two EMT 240 plates and two AKG BX20s. Foldback is lavish, with four systems mixable to requirements by a small subsidiary mixer on the studio floor.

Real time checking of the control room characteristics is facilitated by a B & K measuring microphone suspended in the centre of the room about 1m above the engineer's head. This feeds a Hewlett Packard real time analyser which can give a continuous display of the frequency spectrum at the microphone. Monitoring is via Amcron DC 300As and four Westlake Audio Studio Monitors, which incorporate JBL drive units. Since the view from the control room is fairly restricted, the studio floor being invisible from the desk positions, four camera-tv monitor links are installed, possibly the nicest toys there.

The studio is now fully operational, and we hope to make an Official Visit shortly.

## Cadac introduce thick film gyrator

CADAC, INTERNATIONALLY known for mixers, has produced a thick film microcircuit gyrator specifically for audio use. Known as the 550, the gyrator is expected to find use in circuits requiring inductive elements of both large and small values.

The basic gyrator is a device which has, typically, two ports and is capable of synthesising at its input the inverse resistance characteristics of an element connected to its output. If the element connected to the output is reactive in nature, then the characteristics of the input

port will also be reactive but with the voltage/current relationships transposed; if the output port is capacitive, then the input port will be inductive. This property enables circuits that use inductors to be fabricated from RC networks without the bulk or expense of wire-wound components; an inductor gyrator bandpass circuit for 20 Hz has about the same bulk as the identical circuit for 20k Hz.

The 550 microcircuit is manufactured from a discrete design that Cadac has been using successfully in their mixers over a long period of time, and they claim that the device will generate inductance values from 10 mH to 100H simply by changing the values of a resistor and a capacitor connected across the output port. It is possible to alter the generated inductance over a range of 16:1 by alteration of the value of the output port resistor alone. Although most modes of reactance can be created with the 550, the most usual for audio is the series resonant circuit that provides a low impedance at resonance. In this format, a simple graphic equaliser capable of  $\pm 10$  dB control at  $\frac{1}{2}$  octave separation may be constructed without any wire-wound inductors. It is equally possible to design bandpass and notch filters as well as waa-waas and phasers.

The main limitation in use of the device is that one side of the input port must be earthed. This means that the simulated circuit element must have one terminal grounded and the other isolated through a series capacitor; in the series resonant mode, this is the ideal arrangement for the 550. In other designs, it is often possible to rearrange the circuit to take advantage of the other properties of the gyrator. As with any 'active' circuit, there are noise penalties in

comparison to purely passive components. In practice, these amount to equaliser designs producing noise levels of about 85 dB which is generally acceptable for studio use.

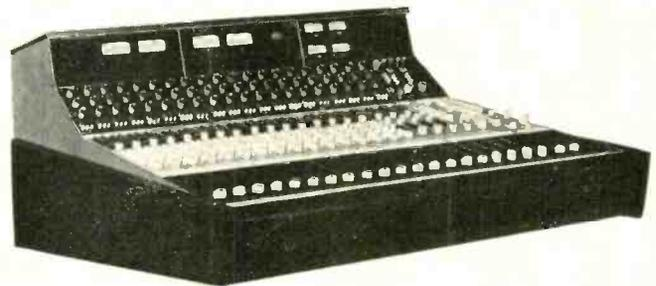
The 550 gyrator is available now priced at about £4 for one-off quantities. It can be obtained direct from Cadac (London) Ltd, 141 Lower Luton Road, Harpenden, Hertfordshire AL5 5EL. Phone: 05827-64351.

## New modular mixer

The 1604 control console from Automated Processes Inc offers performance options selected from plug-in modules with a variety of interchangeable equalisers also available. It will accommodate 16 inputs, four echo channels, two foldback circuits, four output channels, four submaster, four speaker monitors, slate, tone and intercom circuits, and audition and cue facilities. For broadcast applications, the 1604 has the necessary foldback, audition and programme interlock features, and may be equipped with optional modules offering remote control of tape machines and turntables or remote input selection.

For ease of installation, external connections are by standard connectors. The model 1604 may be table-top mounted or free standing. Subsequent rapid system expansion is facilitated by factory prewiring. Don Richter, Automated Processes Inc, 80 Marcus Drive, Melville, N.Y. 11746, USA. Phone: (516) 694 9212.

UK agents: 3M United Kingdom Ltd, 3M House, Wigmore Street, London W1A 1ET. Phone: 01-486 5522. 36 ▶



Automated Processes Inc. Audio control console 1604.

Sales Executive,  
ADB/CCT,  
11 Manor Road,  
Wallington,  
Surrey.

The Director,  
AKG Equipment Ltd,  
182/4 Campden Hill  
Road,  
Kensington,  
London W8 7AS.

Dipl. Ing. P. Albrecht,  
Elektronik,  
D8540 Schwabach,  
Alte Rother,  
Strasse 16.

The Director,  
Allotrope Ltd,  
90 Wardour Street,  
London W1V 3LE.

E. H. Sadeler Esq.,  
Ampex GB Ltd,  
Acre Road,  
Reading,  
Berkshire.

The Sales Manager,  
Aston Electronic  
Developments Ltd,  
125/7 Deepcut Bridge  
Road,  
Deepcut,  
Camberley,  
Surrey GU16 6SD.

The Director,  
Audix Ltd,  
Stansted,  
Essex.

A. J. M. Chalcroft Esq.,  
Ballancroft Film & TV  
Equipment Co Ltd,  
292 Worton Road,  
Isleworth,  
Middlesex.

The Director,  
FWO Bauch Ltd,  
49 Theobald Street,  
Boreham Wood,  
Hertfordshire.

A. M. Daniell Esq.,  
Head of Engineering  
Publicity,  
Engineering  
Information Dept,  
The British Broad-  
casting Corporation,  
Broadcasting House,  
London W1A 1AA.

A. J. Pallas Esq.,  
Berkey Technical,  
PO Box 5,  
Burrell Way,  
Thetford,  
Norfolk.

Sales Promotion  
Manager,  
Bosch Ltd,  
PO Box 166,  
Rhodes Way,  
Watford, WD2 4LB.

Managing Director,  
Broadcast Electronics  
Inc.,  
24/30 Park Lane,  
Poynton, Cheshire.

Managing Director,  
Cepak Europe  
Ltd,  
Princess House,  
Eastcastle Street,  
London WIN 7AP

European Sales  
Director,  
Cetec UK,  
Shaftesbury Street,  
High Wycombe,  
Bucks. HP11 2NA.

The Manager,  
Alexander Cole Ltd,  
257 Cranbrook Road,  
Ilford, Essex.

P. W. Herke Esq.,  
Managing Director,  
Computer Equipment  
Co Ltd,  
Shaftesbury Street,  
High Wycombe,  
Bucks. HP11 2NA.

Michael Cox Esq.,  
Managing Director,  
Michael Cox  
Electronics Ltd,  
67a Holly Road,  
Twickenham,  
TW1 4HF.

C. R. Webster Esq.,  
The Director,  
Crow of Reading Ltd,  
PO Box 36,  
Reading,  
RG1 4QD,  
Berkshire.

Managing Director,  
Decca Radio and  
Television,  
Ingate Place,  
Queenstown Road,  
London SW8 3NT.

S. F. Giddings,  
Deputy Managing  
Director,  
Dynamic  
Technology Ltd,  
Zanal House,  
Alliance Road,  
Acton,  
London W3 0BA.

D. W. Griffiths Esq.,  
Sales Manager,  
Electrocraft  
Instruments Ltd,  
Coombeswell,  
Farnham Lane,  
Haslemere, Surrey.

G. Bailey Esq.,  
European Manager,  
Electrohome Ltd,  
23 Hampton Pier Ave.,  
Herne Bay,  
CT6 8EW, Kent.

Elektroimpex,  
1392 Budapest Pf. 296,  
Munich Ferenc u.21,  
Hungary.

General Director,  
Elektromechanikai  
Vallalat,  
1502 Budapest, Pf. 94,  
Hungary.

## IBC 74

LISTED ON THIS page are the prospec-  
tive exhibitors for The International  
Broadcasting Convention to be held at  
Grosvenor House, Park Lane, London W1  
from September 23 to September 27.

On Monday September 23 the conven-  
tion is to be formally opened at 14.00 hours  
and a welcome speech given by Mr. J. D.  
Tucker, chairman of the IBC management  
committee. The convention will remain  
open until 18.00 hours. Between 18.30 and  
20.00 hrs a champagne reception will be  
held at Banqueting House, Whitehall  
(tickets are available from the organisers  
of IBC but numbers are limited). For the  
remaining three days the convention will  
be open from 09.30 until 18.00 hrs.

For the accompanying ladies (and  
gentlemen?) who have interests other  
than the International Broadcasting Con-  
vention, the chairman has arranged for  
them to visit various factories, places of  
historical interest and a publishing house.

The convention will cover the most  
recent additions and alterations to broad-  
cast equipment in both sound and vision.  
A programme of technical sessions has  
been scheduled but unfortunately the  
sessions are arranged such that they  
overlap. A number of people from the  
television world will be giving speeches  
in connection with television, e.g. video,  
satellite tv and radio.

J. Bailey Esq.,  
Director,  
Electronic Visuals  
Ltd,  
PO Box 16,  
Staines, Middlesex.

The Exhibitions  
Officer,  
EMI Ltd,  
135 Blyth Road,  
Hayes,  
Middlesex. UB3 1BP.

P. M. Kingsley Esq.,  
Director,  
Engineering Designs  
& Supplies Ltd,  
Cores End Road,  
Bourne End,  
Bucks.

N. E. Knight Esq.,  
Publicity Manager,  
English Electric Valve  
Co Ltd,  
Waterhouse Lane,  
Chelmsford,  
Essex.

R. E. Milner Esq.,  
Publicity Manager,  
Evershed Power-  
Optics Ltd,  
Bridge Wharf,  
Bridge Road,  
Chertsey,  
Surrey. KT16 8LJ.

S. G. Griffiths Esq.,  
Director,  
Ferrograph Co Ltd,  
Auriema House,  
442 Bath Road,

Cippenham,  
Slough,  
Bucks.

P. R. Consultant,  
The Guild of  
Television  
Cameramen,  
12 West View,  
Bedfont,  
Feltham, Middlesex.

The HEIS,  
The Independent  
Broadcasting  
Authority,  
Crawley Court,  
Crawley,  
Winchester,  
Hampshire.

H. G. Wilkinson Esq.,  
Sales Promotion  
Manager,  
IMHOF-BEDCO Ltd,  
Colne Way Trading  
Estate,  
By-Pass  
Watford, WD2 4NE.

The Director,  
International Video  
Corporation (UK)  
Ltd,  
Liverpool Victoria  
House,  
Cheapside,  
Reading, Berkshire.

K. Saxton Esq.,  
Exhibition Officer,  
ITT Components  
Group Europe,  
Edinburgh Way,

Harlow, Essex.

J. C. Millar Esq.,  
Regional Sales  
Manager,  
Laboratoire General  
Des Telecommuni-  
cations,  
16 Rue du Moulin des  
Bruyeres,  
92404 Courbevoie,  
France.

The Sales Manager,  
Lee Engineering Ltd,  
Ashley House,  
Ashley Road,  
Walton-on-Thames,  
Surrey.

Link Electronics,  
Prowest Electronics  
Autocue and Neve,  
Co-ordinator for above  
companies, Market-  
Link Public  
Relations Ltd,  
403 London Road,  
Camberley,  
Surrey.

J. Pool Esq.,  
Exhibition Manager,  
Marconi Communi-  
cation Systems Ltd,  
Marconi House,  
New Street,  
Chelmsford,  
Essex.

Exhibition Officer,  
Marconi Instruments  
Ltd,  
Longacres,  
St Albans,  
Hertfordshire,  
AL4 0JN.

The Design Studio  
Manager,  
Matthey Printed  
Products Ltd,  
William Clowes St.,  
Burslem,  
Stoke-on-Trent,  
ST6 3AT.

The Director,  
Mercury Electronics,  
6 Rockingham Wharf,  
Rockingham Road,  
Uxbridge,  
Middlesex.

P. Cowan Esq.,  
Southern Area Sales  
Manager,  
Micro Consultants  
Ltd,  
Interace House,  
Croydon Road,  
Caterham,  
Surrey.

Product Manager,  
NERA A/S,  
Pilestredet 75c,  
PO Box 7033H,  
Oslo 3,  
Norway.

J. M. Etheridge Esq.,  
Marketing Executive,  
The Rank  
Organisation,  
38 South Street,

London W1A 4QU

George C. Sekula Esq.,  
Administrator Inter-  
national Advertising  
& Promotion,  
RCA Communicatons  
Systems Division,  
Front and Cooper  
Streets, Building,  
2/5 Camden,  
New Jersey 08102,  
USA.

The Manager,  
Europe, M/East and  
Africa,  
Richmond Hill  
Laboratories Ltd,  
Pinewood Studios,  
Pinewood Road,  
Iver,  
Bucks. SL0 0NH.

Sales and Marketing  
Director  
System Video Ltd,  
24 Guildford Street,  
Chertsey,  
Surrey. KT16 9BQ.

European Marketing  
Manager,  
Tektronix Ltd,  
Beaverton House,  
PO Box 69,  
Harpenden,  
Herts.

D. Hughes Esq.,  
Marketing Manager,  
Telemation  
International,  
37 Great Portland St.,  
London W1.

R. M. Hammond Esq.,  
Exhibitions Officer,  
Thorn Lighting Ltd,  
Thorn House,  
Upper Street,  
St Martin's Lane,  
London WC2H 9ED.

The Sales Engineer,  
N. Tønnes Pedersen  
A/S,  
Theklavej 44,  
DK-2400 Copenhagen  
NG,  
Denmark.

A. T. Baldwin Esq.,  
Managing Director,  
Video Electronics Ltd,  
Gibfield Works,  
Atherton,  
Manchester,  
M29 0RH.

The Sales Director,  
W. Vinten Ltd,  
Western Way,  
Bury St Edmunds,  
Suffolk.

Mr Seale-Finch,  
Data Vision Ltd,  
79 London Street,  
Reading,  
Berks.

J. Arolinna Esq.,  
O Y Stromberg AB,  
PL 118, SF 00101,  
Helsinki, 10.

# SPARTA

Broadcasting equipment

VEGA wireless microphones

JAMPRO antennas



## I.B.C.'74 STAND B28

23-27 September

IEC/CCIR tape cartridge machine

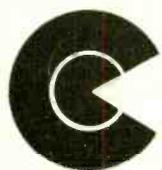
680/1 FM transmitter

Centurion 8/12 channel stereo/mono mixer

GT 123/Y custom turntable



For further information ring:  
Mike Angelou on (0494) 37529



**C.E.C. LTD., BROADCAST DIVISION**  
Shaftesbury Street, High Wycombe, Bucks.

A division of the Cetec Corporation of El Monte, California

*Besides the establishment of the Annan Committee of Inquiry into Broadcasting, the Conservative and Labour parties have both recently issued virtual policy statements on their respective attitudes.*

## Politics and Broadcasting

John Dwyer

**THE NAMES OF** the members of the Annan Committee of Inquiry into broadcasting were given in a written reply to a Commons question on July 12. There are 16 members plus the chairman, Lord Annan. Seven of them have some claim to being able to offer expert advice, to a greater or lesser extent. These are:

Professor Hilde Himmelweit, who was a director of the Nuffield Television Enquiry from 1954 to 1958. Otherwise she is a professor of Social Psychology at the London School of Economics.

Mr Tom Jackson was a governor of the BBC from 1968 to 1973, when his place was taken by Lord Feather. He is a member of the Press Council, the TUC General Council and General Secretary of the Union of Post Office Workers, in which capacity he may be regarded as a moderate trade union leader.

Mr Anthony Jay was with the BBC from 1955 to 1964. He edited the 'Tonight' programme, which was regarded as a revolution in television journalism at the time (from 1962 to 1963), after which he was head of television features until he left the BBC to become a freelance film and television writer, producer and consultant. One of his well-known books is 'Corporation Man'.

Marghanita Laski has appeared on the radio. 'Who's Who' describes her as a novelist, critic and journalist but she may safely be described as the first two.

Professor G. D. Sims will be able to give the benefit of his advice as Professor and Head of Electronics at Southampton University. He is also Vice-Chancellor designate of Sheffield University. He is a Fellow both of the IEE and the IERE and has written 'numerous papers on microwaves, electronics and education in learned journals'.

Mr Phillip Whitehead has been Labour MP for Derby North since 1970 and was a BBC producer from 1961 to 1967, after which he edited Thames's 'This Week' until he became an MP. He was awarded the Guild of Television Producers award for factual programmes in 1969. He was a founder of the 76 group for broadcasting reform, along with many of those who left London Weekend as a protest against the sacking of Michael Peacock. He is a member of the executive committee of the Media Society and a member of the National Union of Journalists.

Sir Marcus Worsley was a programme assistant with the BBC's European Service between 1950 and 1953 although, strangely, this fact was not mentioned in the brief biographical details of each member handed out to the press. He's an Eton and Oxford man and has been MP for Chelsea since 1966. At Oxford he gained honours in modern history.

Those are the members who have some claim, however slight, to knowledge of the problems of broadcasting. The rest are as follows:

The chairman, Lord Annan, is the provost of University College London. He is a life peer (not a Labour peer as we said in June) and a director of Covent Garden Opera House.

Mr Peter Goldman has been director of the Consumers' Association since 1964 and a member of the Community Relations Commission since 1970. He joined the Conservative research department in 1946, contested West Ham South for the Conservatives in 1959, and

was the Conservative candidate Eric Lubbock beat at Orpington in 1962. None of this was stated in the press release, though it was mentioned that he was a director of the Conservative Political Centre from 1955 to 1964.

Mrs H. M. Lawrence is a member of the Stevenage Development Corporation and she was an alderman on the Hertfordshire County Council until March this year when local government was reorganised.

Mr A. Dewi Lewis is chairman of the Dyfed Area Health Authority. He is also a former headmaster of an Aberystwyth Grammar School and a member of the council of University College of Wales.

Sir James McKay is a former member of the Highlands and Islands Development Board and the Countryside Commission for Scotland. He has also been in the Ministries of Defence and Aviation and the Home Office.

Mrs Charles Morrison was a member of Wiltshire C.C. for ten years up to 1971, since when she has been vice-chairman of the Conservative Party. She is also vice-chairman of the National Council of Social Service and married to the Conservative MP for Devizes, who has been such since May 1964. He, in turn, is vice-chairman of the Game Conservancy; his hobby is shooting. Mrs Morrison was the daughter of the second Viscount Long of Wraxhall.

Mr Dipak Nandy is a specialist in race relations, a member of social and community planning research, a director of the Runnymede Trust between 1968 and 1973, a member of the Council of the Institute of Race Relations 1966 to 1972 and of the Home Office Advisory Committee on Race Relations research from 1971 to 1973. He has lectured at Essex and Kent Universities.

Mr G. J. Parkes is bereft of all distinction that we can discover other than that of his position of chairman of the Unilever Merseyside Committee.

Mr John D. Pollock is the former chairman of the Scottish Labour Party and is General Secretary Designate of the Educational Institute of Scotland.

Just before the names of the committee were announced a spokesman for the Standing Committee on Broadcasting, which claims to represent the views of academics and trade unions in the industry, was quoted as saying: 'Our anxiety is that the committee will be a sell out. We want to see people who are independent of the existing broadcasting organisations on it. We do not want it packed with actresses and bishops' wives and other standard lay characters.'

Looking at the list confirms that they had cause to worry. There were reports of some difficulty in finding people for the job—not that there weren't enough people but that there weren't enough people of the right kind.

The difficulties of selection arose because of arguments among ministers about the choice of members. This was partly because the BBC seem to have been conducting a massive undercover campaign to get a committee which would constitute no threat to it.

It's interesting to speculate just on what basis the members of the team were selected. There are some intriguing possibilities: Lord Annan has published an essay in an anthology of Kipling's work. The essay was called



'Kipling's Place in the History of Ideas'. One of Marghanita Laski's latest series of broad-casts has been Kipling's 'English History'—the story of Victorian England through Kipling's poems.

The Standing Committee on Broadcasting was worried about just this. It submitted its own list of names, among which was that of Anthony Smith, author of 'The Shadow in the Cave', a book which challenged the assumption of broadcasters that the medium was meant to be for a few addressing many, not an attitude likely to appeal to the BBC or the establishment. Nevertheless Smith, a former BBC producer of 'many highly controversial television programmes'—he used to edit '24 Hours'—who is now at St Anthony's College Oxford, would have been an excellent choice.

At the very least his choice would have been obvious, which is more than can be said of that of the good Mr Parkes, or Dewi Lewis. The nearest they got to Smith was Anthony Jay, whose biography is similar to Smith's but who would be regarded as much safer. He is a long-time associate of David Frost. Not mentioned in Jay's biography is that Jay wrote the sycophantic commentary to the Royal Family documentary.

Peter Goldman's Consumers' Association ran one project with the BBC which Anthony Sampson described in 'The New Anatomy of Britain' as follows: 'The BBC, as the only sector of the mass media which is independent of advertising, should be well-placed to give honest information about travel, detergent or cars; but a short-lived programme, called *Choice*, collapsed from timidity; and the BBC motoring programmes are full of long-winded bores extolling the cars they have been lent by the manufacturers'. Goldman's tenuous connection with the BBC could, therefore, put the 'experts' up to eight.

Then you notice the oddest thing about the rest. There is, in Whitehall, a collection of loose-leaf pages in a row of folders called disrespectfully by some of the younger pin-stripes 'The Book of the Great and the Good'. Sampson again: '[Civil servants] have a large influence on quasi-government appointments . . . and on the process of talent-spotting and approval of all the hundreds of men from outside the civil service who serve on committees and commissions. A secret tome of the Great and the Good is kept in the civil service department listing everyone who has the right qualifications of worthiness, soundness, and discretion.'

A cynic could be forgiven for concluding that in choosing the members of the Annan committee the civil service department had reached for 'L to P'.

The first session of the Annan committee was held on July 18, after which a press conference was held. Lord Annan defended the choice of membership of the committee by saying: 'We are dealing with a public service and we are trying to represent the public, looking at broadcasting from the public's point of view'. Could amateurs out-manoeuvre the entrenched vested interests in broadcasting? 'We must tax the broadcasting authorities with the mass of evidence that we collect, and don't forget we have not only our own resources, our own research department, but also the resources of the civil service'.

The committee will take a year to collect all the evidence, and a further year and a half to produce its report. During the course of the conference Lord Annan confided that he had two televisions and a radio and another radio in his car. Lord Annan also stressed that he wanted to hear the opinions of the public as to what they liked and disliked in broadcasting and why.

The address to write to is:

The Committee on the Future of Broadcasting,  
Waterloo Bridge House,  
Waterloo Road,  
London SE1 8UA.

Mrs Mary Whitehouse has complained that the Annan inquiry shows every sign of being an 'established exercise'. Mrs Whitehouse, who is honorary general secretary of the self-styled National Viewers and Listeners Association, said the lack of a representative of her association showed that the government was insensitive to public concern about broadcasting standards.

No one in broadcasting is very enthusiastic about the Annan Inquiry according to Mr John Freeman, chairman of London Weekend. Mr Freeman has just been succeeded as chairman of the network programme committee of the IBA by Mr Bruce Gynnell. The committee decides the broad pattern of commercial television strategy, and this year's chairman is likely to be the most important giver of evidence to the Annan committee on behalf of ITV.

Freeman said such committees as the Annan Committee 'consume a vast amount of time and add to the feeling of uncertainty people have about the future'. He hoped it would be the last such committee for ten years 'so those of us making television programmes are allowed to do it with as little interference as possible'.

Three months to the day after the setting up of the Annan Commission, and three days before the names of the members of that commission were named, the Labour Party published a document setting out their attitude to broadcasting and the press, with recommendations for changes in the structure of each.

Labour have called their study 'The People and the Media'. It was prepared by a committee of 29 party workers and MPs chaired, until the last election, by Mr Tony Benn. The committee sat from May 72 until May 74, so the last chairman, Mr John Grant, who had been opposition spokesman on broadcasting and other media, only chaired the last few meetings.

The study was to have been published as a green (discussion) paper by the government, but to have done so would have pre-empted the work of the Annan committee, not to say embarrassed it, so the document has only the status of a party pamphlet and is not official party policy.

It's none the less devastating for that, and revives some of the discarded proposals of the Pilkington Committee. Among its recommendations are that there should be 'central and adequate funding of broadcasting (including the collection and distribution of advertising revenue) with independence from political and commercial pressures assured', the separation

of advertising revenue from programme making and scheduling, 'the introduction of real internal democracy within the framework of public accountability' and elected representation on broadcasting management bodies at local, regional and national level. An essential element in the proposals is a large measure of workers' control.

As leaked from the committee earlier in the year, the present IBA and BBC would be scrapped, to be replaced by two television corporations, each of which would be responsible for running one national and one local television station, and there would be one or two radio corporations. Among the throwaway remarks scattered throughout the document was 'We see no future for commercial radio as such'. In a radio interview on LBC Mr John Grant explained that this was not as drastic as it sounded: 'This would probably mean that we would freeze commercial radio at its present state but that we would extend public service radio'.

The other crucial proposals are the setting up of a communications council and a public broadcasting commission. The communications council would keep the operation, development and interrelation of all the media, press, radio and film, under permanent review 'and make its findings publicly available, in order to encourage and assist public debate'. The council would be run on government money, and among the projects which the study recommends it should undertake is the possibility of investigating issues involving more than one medium 'such as possible subsidy of one medium by funds levied from another'. It could also give independent technical advice where major vested interests were involved.

The second function of the council would be to invite and investigate complaints from the public: 'In this capacity the council would have the right to demand air time or column space for the correction of errors of fact or redress of grievances'. The composition of the council would 'include' elected representatives from the unions, local or regional government and MPs, and other national bodies. The document suggests that the council should be organised at once to survey communications problems 'and to provide, in a narrower focus, additional research facilities for the Annan Commission's inquiry'.

The Public Broadcasting Commission would control the finance of television and radio, and would take ultimate responsibility for administration 'of all matters within the orbit of public policy decision'. The PBC would recommend to the government, once every five years how much would be needed from the treasury, and this amount would be supplemented by advertising revenue. The PBC would then allocate all the funds collected by these two methods.

The other main function of the PBC would be to lay down guidelines for broadcasting practice, such as advertising times and so on. It could also commission the production of special programmes. Again, the membership of the Commission would include elected representatives from public life. The study suggests that the basic membership would be of elected representatives of the broadcasting organisations and local government, plus members of parliament and nominees from important national organisations. The meet-

## ■ POLITICS AND BROADCASTING

ings of the PBC would be in public and 'all key decisions actively publicised'.

The committee propose to scrap the licence fee. The licence, they say, may have the advantage of preserving the broadcasters from government interference but is 'a clumsy and regressive tax'. They propose that the licence should be phased out, beginning with its abolition for pensioners.

The most valuable and well thought out part of the Labour Party document is the introduction, which amounts to a comprehensive summary of the fears of many who work in broadcasting and publishing. 'A few people are in a position to impose their taste upon the masses, or to prevent the expression of certain views . . . The potential quite clearly exists for a form of censorship every bit as undesirable as the more blatant variety utilised by some governments. In the present situation the absence of participation both internal and external has meant closed decision making by unrepresentative cliques.'

The study remarks that government is surrounded by unnecessary secrecy: 'Information is jealously guarded by a number of small elites that would be unthinkable in Sweden or the USA. Worse than this, our broadcasting structures mirror this closed system of government. The actions of these organisations, which were established to promote the public interest in broadcasting, show more concern with keeping the public at a safe distance.'

The document emphasises that it does not wish to bring about government control: 'It should be reiterated that the Labour Party absolutely rejects any policy for the mass media, or any system for operating it, that is based upon government censorship or central control'. It proposes the abolition of the Official Secrets Act and its replacement by a Freedom of Information Act that would protect individuals, newspapers and broadcasters who sought official sources of information, obliging the public authority to justify withholding information, a policy that is very sensible and very unlikely to be implemented. It must be pointed out that the Labour governments over the years have had a somewhat worse record of overuse of the Official Secrets and D Notice mechanisms than the Conservatives.

'The People and the Media' makes a useful contribution to the arguments for overhauling the BBC and IBA. The diagnosis of the disease leaves little to be desired. The problem is that the cure they advocate might kill the patient. There would be direct control of the papers and radio and television by the public purse, and with such control you don't need censorship. Until now the licence fee has kept the BBC fairly independent of government even if the Corporation has chosen to make government interference unnecessary. The advertising revenues have made the commercial companies similarly independent, even if they have tended to make the programmes so venal that matters of controversy rarely arise.

The trouble is that, in the course of outlining their proposals for the solution of the problems, the committee has made little adjustments in the drafting of them that give rise to anxiety.

The passage quoted earlier stating that the communications council would oversee all the means of mass communication and make all its findings public 'in order to encourage public debate' leads one to wonder where and how this public debate is to be conducted without the council holding meetings and giving judgements on how the reports of its own affairs have been reported and criticised. How and by whom are the elected representatives on the various bodies to be elected and who are going to be the other nominees? Which 'national bodies' are to be represented, and on what basis—could one exclude, say, the RSPCA from a truly representative committee? The Commission can only *recommend* to the government of the day how much money broadcasting needs. If all the meetings of the PBC are held in public why is it only the *key* decisions that can be publicised?

The reasons for suggesting these measures, which extend even more into the independence of the press since that independence has traditionally been greater than that of broadcasting, are not hard to discover. In the case of the press, battle was joined in February 1967 when Chapman Pincher revealed in a *Daily Express* story that copies of all cable messages to and from the British Isles were collected from the cable companies' offices by van and taken to the Ministry of Defence for vetting, to be returned two days later. That was the start of the D Notice row.

In the case of broadcasting the painful memory of 'Yesterday's Men' is even fresher in the minds of Harold Wilson and his senior colleagues. The programme went out on the first anniversary of the election they lost in June 1970. It was a caricature of the leaders of the Labour Party, who subsequently claimed that they had been misled in the preparation of the programme as to its intentions. They said that the editing of the programme had been such as to make them look ridiculous. There was, indeed, a public outcry not just from the politicians concerned, particularly Wilson and the late Richard Crossman, but from the press and public.

The BBC Board of Governors held their own inquiry into 'Yesterday's Men' and concluded that the programme and its preparation had had minor faults but had been essentially fair. Thus they exonerated themselves, for the Board of Governors had seen the programme before its transmission, deleting only one sentence, and were thus responsible for its showing. More protests followed the decision, and chorus demanding a complaints commission swelled until one was set up in October 1971 and started work in the following January. The BBC paid the commission's staff and gave them premises. In the first year it heard three cases. The IBA, too, have since set up a Complaints Review Board chaired by the deputy chairman of the IBA.

These two bodies are unsatisfactory in one very important respect, which is that they have been set up by the organisations over which they are supposed to be adjudicating, and are thus open to accusations of partisanship. It has been persuasively argued that these two complaints committees only exist because the IBA and the Board of Governors have failed in their original task, which was to represent the public in directing the two bodies. The fact that there is a governing body for each

broadcasting organisation has tended to make the members of those bodies less representative of the public than defenders of their particular organisation against criticism by the other and, ultimately, by the very public whose interests they should represent. In the absence of any corrective influence on the public's behalf this cannot work in the nation's interest.

As things stand the appointment, ironically by Harold Wilson, of a chairman of the BBC Board of Governors of an individual determined to act, unconstitutionally, as an executive—Lord Hill—continues to bear on the relationship between broadcasters and the public. Many politicians, not just some of the Labour party, are concerned that the broadcasters are no longer accountable. Some politicians and others have advocated a broadcasting council on the lines of the press council which would intercede for aggrieved members of the public. To this the two sets of broadcasting bodies reply that such a council would usurp their sole function, even though this is the vital function they have abandoned. As it is, the BBC Complaints Commission has a poor record—the Swedish Broadcasting Council heard 626 complaints in 64 meetings in its first three years—and the complaints commission's deliberations are held in secret.

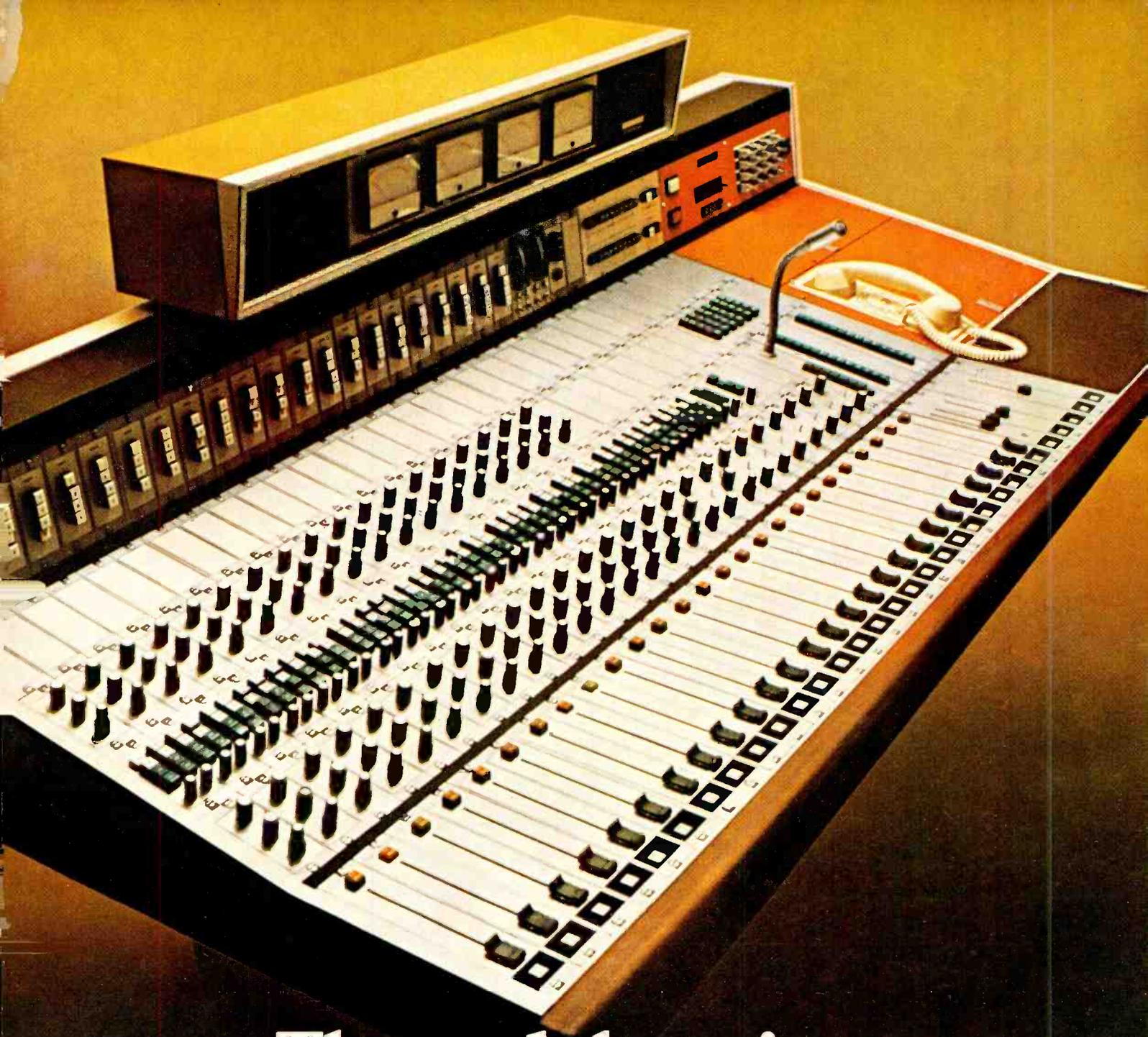
But understanding why the Labour Party feel as they do to the media is not to make any valuable assessment of the value of any criticisms the Labour Party or any other party may make. Indeed, though the Labour Party may have any number of little pinpricks inflicted by the BBC or the IBA that they can point to, there is something else which they are not so able to express or, more likely, are unwilling to express because the tune has been heard so often before: that is, that the media are run by an 'establishment' and are hostile to any party of the left.

This is an immensely difficult charge to either establish or refute. At least it would have been but for the publication, a week after the Labour Party's media document appeared, of the Conservative Party's Campaign Guide 1974. This is a survey of every aspect of contemporary politics from the Conservative point of view, a handbook for party workers in arguing Conservative philosophy before an election. Its 700-plus pages have a five-page section on broadcasting which is fascinating to compare with the Labour Party document.

The BBC and IBA have always claimed that they have as many complaints of bias from the right as they receive from the left, and that on that basis they are maintaining impartiality. To some extent this is true—the MP who, after 'Yesterday's Men', argued most strongly for a complaints commission was Julian Critchley, a Conservative MP.

But if we make allowances for the over-reaction of Labour to press and broadcasting criticism, and for the under-reaction of the other side due to a certain security of tenure they possess regarding their influence in society, that still leaves us to wonder about the uncritical satisfaction with the broadcasting system displayed in the Conservative document: 'The Conservative Party's Election Manifesto promised to ensure that the BBC should be able to make its essential public contribution . . .'

Again, in regard to the financing of the BBC and IBA the document draws attention to the



# The modular mixer

Take a good look at this mixer. Under that eye-catching console is a system that reflects the technical expertise gained from years of experience in the studio sound business.

Here, at last, is a mixer tailor-made to your requirements, but costing no more than a standard production model.

It's the Schlumberger UPS 4000, giving you real state-of-the-art technology at your fingertips. Fully modular, with plug-in units made of die-cast aluminium alloy to ensure highest accuracies, it's the system that has everything - integrated circuits, field-effect transistors, printed circuit cabling.

And modularity means you get the facilities you need now . . . with the flexibility you could need later.

Just specify your system requirements, and leave the rest to us. We custom-build the mixer *you* want. At a price you can afford. With filters, reverberation, foldback and much, much more.

Find out about this new concept in studio mixers. Contact Schlumberger, now.

**Schlumberger**

**Schlumberger Instruments and Systems, 296, Avenue Napoleon Bonaparte,  
92500 - Rueil - Malmaison, France. Tel. 977 92 23. Telex Labophy 26 649**

## ■ POLITICS AND BROADCASTING

Conservative government's role in saving the broadcasting organisations from insolvency in February 1971 by cutting the advertising levy by £10 million and increasing the licence fee to the BBC by £1.

The document also refers directly to 'Yesterday's Men', as follows: 'Features like the "Yesterday's Men" incident have from time to time led to pressure on ministers to intervene in the content of BBC or IBA programmes. Conservative ministers have always declined to interfere with the programme content of the BBC or IBA and would only do so if it were clear beyond doubt that the

Corporation or the Authority was infringing its legal powers.' Also: 'Conservative Ministers have also resisted proposals to impose a broadcasting council on the BBC, on the grounds that this would undermine the position of the Governors who have the task of both managing and answering to the public'.

These statements, by themselves, could be interpreted, and certainly have been by Labour supporters, as an indictment of the BBC's impartiality and that of the IBA. But taken with Sir John Eden's rejection, also recounted in the Campaign Guide, of an inquiry into broadcasting as suggested by the Select Committee on Nationalised Industries, they represent proof that the Conservative Party has nothing to fear from the broadcasters.

It's a far different thing to know that some-

thing is wrong from knowing a remedy. The study group proposals are best regarded as one possible suggestion for a correctly analysed series of problems. They seem extreme, as perhaps they are, but the system needs to be changed, not just tinkered with, and the Labour Party document is a courageous effort to embrace new ways of administering these crucial public institutions.

When the Annan committee object to these proposals on the basis that they would produce government control of the media, it is to be hoped they will also realise that the present system produces such control far more effectively than anything the study group has proposed. For the present system works behind closed doors and inflicts its control on a public convinced that no such control exists.

## ■ NEWS

### Spectra Sonic UK

THE RANGE OF Spectra Sonics equipment is to be imported into the UK by Sun Recording Services. Although in the USA the range extends over a wide area, Sun say that they intend to concentrate on the smaller units because they see the market as being more encouraging to these items. The mixing consoles will, nevertheless, be available to special order and one may be imported for demonstration next year.

Of interest is the Model 901 slider unit, which is available in one, two and four gang format. Fixing centres are 38 mm and stroke length 93 mm; prices are £23, £26.75 and £40 respectively ex-stock, with quantity discounts. A cylindrically-

shaped quad pot is offered at £82.50, also fitting on 38 mm centres, with connection via an Amphenol seven-pin socket on the bottom. Two pots are available as a module which does the same job; less convenient, but cheaper. The Model 610 Complimiter provides the usual range of slope and release times to give limiter or compressor characteristics dependent on set up. The Model 502 microphone/programme equaliser is available for desk mounting, being 38 mm wide. Sun Recording Services, 35 Edgumbe Park Drive, Crowthorne, Berks. Phone: Reading (0734) 63724. Spectra Sonics, 770 Wall Avenue, Ogden, Utah 84404, USA. Phone: (801) 392 7531.

The first tape recording of a public concert was made on this AEG K3 portable tape recorder in 1935.



## HIGH PERFORMANCE P.A. AND STUDIO MIXING CONSOLES.

Per Input Meter, Mic/Off, Gain, 3 band Eq., Echo Send, Reverb Send, 2 or 4 Foldback Sends, PAN, PFL, Fader.

**Other Standard Facilities** Talk back, internal Reverb Unit, Echo Return (with Eq.) Reverb Return (with Eq.) Headphone Monitoring of Foldback Channels, PFL of Echo, Reverb, Inputs, Tape output, Cannon Sockets per Channel plus Multipin Connector, Arm Rest.

10 into 4  
15 into 4  
23 into 4

£906  
£1183  
£1577

31 Station Road, London SE25 5AH  
Telephone: 01-653 6018/8483.





Studio - Motoring Broadcasts Limited

## professionally speaking you hear...

... and the professional knows well the sound standard set by Beyer Dynamic — it starts with the elite in microphone engineering and ends with a true conversion in the headset — Artists too perform with confidence when Beyer Dynamic is to hand.



*Beyer Dynamic speak as  
professionals in sound*

## BEYER DYNAMIC

BEYER DYNAMIC (GB) LIMITED  
1 Clair Road, Haywards Heath, Sussex. Tel: Haywards Heath 51003

## QUADRAPHONICS

by  
SPECTRA SONICS



Model 904P Pan control can be mounted on 1.5" centres

Model 901 straight line attenuator. Available in 1, 2 & 4 gang. Active electrical element sealed to prevent dirt.



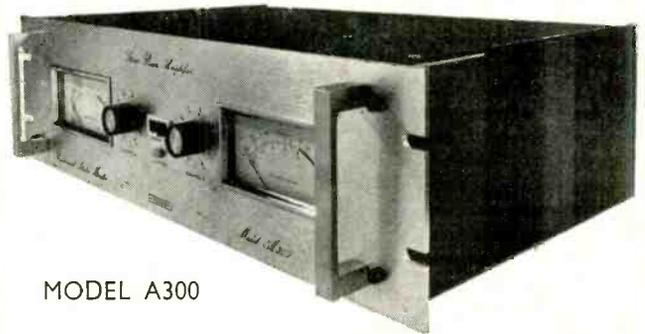
For further details contact  
MARTIN MAYNARD

## SUN RECORDING SERVICES LTD.

35 Edgecombe Park Drive, Crowthorne, Berks

—TURNER—

## STUDIO AMPLIFIER



MODEL A300

A professional stereo power amplifier designed and manufactured to a very high standard, achieving the maxima of technical, artistic and purposeful parameters.

- Power output:** 150+150 watts R.M.S. into 4 ohms  
100+100 watts R.M.S. into 8 ohms  
60+60 watts R.M.S. into 15 ohms
- Power response:** ±0.1dB 20Hz-20kHz at 75W. 8 ohms
- Frequency response:** ±0.1dB 20Hz-20kHz at 1W. 8 ohms
- Distortion:** Less than .01% at full rated output into 4, 8 or 15 ohms (typically .003% at 75w. into 8 ohms)
- Hum and Noise:** 110dB below rated output 20Hz-20kHz (unweighted)
- Crosstalk:** 100dB below rated output 20Hz-20kHz
- Damping Factor:** 400 at 1kHz 8 ohms



Mixers by —TURNER—

May we build a Mixer to  
your requirements?

TURNER ELECTRONIC INDUSTRIES LTD  
175 Uxbridge Road, London W7 3TH

Tel: 01-567 8472

**VAT 74:** HM Customs has 'nearly completed' discussions with leading trade associations on the potential problems of introducing variable rates of VAT. Such a system as some practised by our EEC partners could have attractions for a Chancellor of the Exchequer desperately trying to regulate the economy. France, for example, has a bewildering range of rates, one for 'non-essential luxuries' as high as 33 per cent, and this includes gramophone records. Ireland has a system so complicated as to be only vaguely understood by a minority of the Irish. The worry for us is two-fold. For a very unmusical and square Chancellor recorded music might well be a non-essential luxury. Then again can you imagine the nightmare of the small shopkeeper selling a range of goods from fags through ball-points to records, all with a different rate of VAT? Studios have found the burden of VAT onerous enough even under the existing simple two-tier system. The recent tiny reduction in our standard rate from 10 per cent to 8 per cent can be cautiously welcomed, although it is slightly more difficult to calculate with a shop full of people, and it is not easy to be accurate with the change when relating 8 per cent to a metric coinage. However, we have to be grateful to British Phonographic Industries Ltd (BPI) for presenting a persuasive argument that, for the record business, the two-tier system should be left the way it is, if we have to have it at all. One tiny snag to bear in mind. A studio collecting in VAT over three months to pay out in the fourth month by alteration in the rate has effectively had its liquidity reduced by 2 per cent of 10 per cent. Ask your accountant.

**Bargain:** The other day at Christie's auction rooms a hand driven Berliner disk gramophone, the 1892 model, changed hands for £1,111. How about that for inflation? And it was only a mono version.

**A hard day's night:** EMI owns a large area of property bounded by the north side of Oxford Street and the west side of Tottenham Court Road extended to form a rough rectangle of 3½ acres. Most of it was purchased as a block from Southbank Estates for £5.8 million and additional leases for an undisclosed sum. The original intention was to redevelop the whole site, changing the local geography quite a bit, to provide offices for the entire EMI Group at present scattered over no less than 21 different locations in and around London. As well as offices the scheme was to include shops, pubs, 'leisure amenities', maybe a cinema or two, car parking, a recording studio complex (to replace Abbey Road?), and, wait for it, flats for people to live in and at subsidised rents. Sounds a pretty good idea on the face of it you might think. The area for the most part is tatty to say the least. A nice new, pleasant to look at and good to work and live in, building would buck the place up no end. EMI can be relied upon not to put its name to one of those hideous

monstrosities standing like tombstones to commemorate the death of art in architecture. And there would be flats for people to live in.

Well, why not get on with it then? Ah, but not yet. Property development has got a bad name and it would only be surprising if it hadn't. The Borough of Camden, the local authority concerned, is even more than usually concerned and has hesitated to grant planning consent. Westminster City, also involved, is worried about giving the go-ahead for such a large scheme. Looming over the site from just across the street is a certain, long vacant, tower block which has become a symbol of property development and a target for protest. So there have been discussions and compromises, alterations to the plans and two public enquiries, a protest by local tradesmen and still no decision, and still no flats for people to live in. To be fair there are so many interests to be served, not least those of the ratepayers who already live in the affected area, and as the result of a wrong decision will be there for all to see and suffer for many a long year to come, it is little wonder progress is slow not to say tedious. Every month that goes by costs EMI another £80K in interest charges just to service the value of the undeveloped property and you have to sell a pile of albums to earn that kind of bread. And there are still no flats for people to live in.

**Silly question:** Fifteen minutes is allowed and it is worth a maximum of four pints of electric soup.

*A* builds a recording studio. The control room is adapted from a previous control room which had been used originally for a different purpose. The adapted control room is never acoustically checked or voiced but offered for hire all the same. *B*, a customer, hires the facilities of the studio including the control room in good faith believing the acoustics to be of a standard comparable with any other professional studio charging the same rates. *B* takes the tape recorded in *A*'s studio to another studio of high repute and is disturbed to find the tape sounds not only different but disappointing. *B* decides that there is nothing to do about it except never to use *A*'s studio again. However, about 18 months later *A* discovers that his control room acoustics are way out, and have always been way out, and takes hasty steps to try to rectify matters. Now all that time *A* has been offering for hire a facility purported to be of top professional standard. He has been charging as such and it has not been so. *B* spent a lot of money on something which he did not get and it may have cost him a great deal more than just the hiring charge in lost opportunity even to the ultimate possibility of damage to his reputation as a record producer.

What action should *B* take?

Answers should be confined to no more than a High Court writ. Of course, this sort of thing couldn't really happen. Come on, it's just unbelievable, isn't it? Well . . . . you'd be surprised!

**Red light:** Since the re-organisation of Local Government the authorities are finding themselves desperately short of money (so what's new?). All the usual reasons are given for this deplorable state of affairs and one of the more obvious results has been the staggering increase in rates. This means studio overheads going up again and ways have to be found to make up the difference. That's one of those business problems we all have to face while we carry on smiling. At the same time the local authorities are trying to find means of balancing their books without making too drastic a cut in services, putting up the rates still higher, or extending the begging bowl to a Government which hasn't any money to spare either, though you might be forgiven for thinking otherwise. Now one of the things happening because of all this is that local authorities are taking a more detailed than usual interest in all that goes on in their areas. Maybe, they reason, some premises are rated as X when they should be rated as Y and produce more revenue. So, if you do happen to be operating a recording studio for which there ain't no planning consent . . .

**Oodaf?:** A recent exciting development has been the first AGM of a public company held as a 'phone-in. Organised very successfully by London Broadcasting, perhaps it will establish a precedent and an extension of shareholder democracy. At last the shareholders will be able to ask those searching questions they have always wanted to ask but have been daunted by journey or stage-fright. Maybe they will even get answers. Now, when we have fourth channel telly, can you imagine the mounting drama of the zoom-in on the Chairman's look of consternation as some intrepid shareholder asks about his account in the Cayman Islands—or—'Who was that lady I saw you with at MIDEM?' ('That was no lady. That was my attorney').

**Wishful thinking:** Funny how something said half as a joke can come true, if enough people say it. At the last APRS exhibition it was being bandied about in the bar that next year, instead of showing us a lot of tantalisingly beautiful equipment costing a great deal of money (and worth every penny) wouldn't it be a groovy idea to organise a show to encourage customers to spend more money in studios. Then studios could afford to buy all that lovely equipment . . . see? And what do you know? Looks like in '75 we are to have our very own MIDEM-equivalent. Just what is needed. Bringing the music publishers, recording studios, management companies, record companies, advertising and promotion, hardware manufacturers, Uncle Tom Cobley and all together under one roof at one time is just the job. From September 2 to September 6 London will be the centre of the music world as it is at any other time we like to think. What with the AES Convention in March and this thing in September there will hardly be time for Ascot.

# WHO'S WHO IN SOUND

RUPERT NEVE

Anyone who is anyone in sound knows, if professional audio control and distribution equipment is to do its job, only the best is good enough. They know what they want. The highest standards of quality and reliability and technical performance as near the theoretical limits as possible. Plus the fact that Neve equipment is custom built to individual requirements and tailored to fit neatly into limited studio space. Naturally it all goes to produce a very impressive list of Neve customers.

**Here's a list of some of their 1973 customers:**

**Radio and TV:** RTV Romania; Link Electronics; B.B.C.; Marconi; Granada Television; Radio Luxembourg; Tyne Tees Television; Damascus Radio; HTV Ltd.; Radio Telefis Eireann; Greater Manchester Radio; Gospel Radio Fellowship; HSV7, ATN7, ATVO, Australia; B.F.B.S. (British Forces Broadcasting Service); R.T.V. Singapore; Yorkshire Television; Capital Radio; Ampex; Rediffusion; London Weekend Television; I.B.A.; Radio Sofia; Nigerian Broadcasting; United Evangelistic Church; WGBH; WRMF; Encounter Ministries; KBYU; KHOF TV; WSM; WBZ; CBC.  
**Theatres:** Royal Opera House; Congress Hall, Bucharest.  
**Communications:** Pye Business Comms.; Fernseh GmbH.  
**Film:** Shepperton Studios; Felix Acaso; Pinewood Studios; Consolidated Film Industries; Imperial War Museum; Zaar Films.  
**Recording:** J. Albert; Metronome Records; Preview Sound; R.C.A.;

Radio Triunfo; C.T.S. De Lane Lea; Federal Records; CBS-Sony, Japan; Cockatoo Sound; R.G. Jones; Music for Pleasure; Pye Records; Weir Sound; Polydor; West of England Studios; Maritime Studios; EMI; Festival Records; Bavaria Atelier; Arne Bendiksen; Gallo; Belter Records; Carbo; Elliot Mazer; CBS Records; Decca;

Iyanda Records, Nigeria; Multi-Media; Creative House; Caribou Ranch; Eastman Kodak; Harcourt Brace; His Masters Wheels; PAC Inc.; Sound City; Track Recorders; Whitney Recording; Griffith Gibson; Les Productions Paul Baillargeon; Marc Productions; Mercey Brothers; Jeff Smith Interchange; Linkage Sound; Studio Marko; Studio 3; Intervideo; Mahogany Rush; Sound Toronto; Chatham Square; Neil Young; Belafonte Enterprises; Air Studios.

**Universities and schools:** Syracuse University; University of Surrey; Plymouth Polytechnic; Yale School of Music.



**Neve** internationally sound people

Rupert Neve, Cambridge House, Melbourn, Royston, Herts. Telephone: Royston (0763) 60776. Or Cambridge (0223) 53454. Telex 81381.  
Cables Neve Cambridge. 2719 Rena Road, Malton, Ontario L4T 3K1, Canada. Telephone: 416 677 6611. Telex 0696 8753.  
Berkshire Industrial Park, Bethel, Connecticut 06801, U.S.A. Telephone: (203) 7446230. Telex 969638. Hollywood Office: Telephone: (213) 465 4822.

**THE FOLLOWING** list of Complete Specifications Accepted is quoted from the weekly *Official Journal (Patents)*. Copies of specifications may be purchased (25p) from the Patent Office, Orpington, Kent BR5 3RD.

## July 3

**1362975** Sony Corporation.  
FM receivers.

**1363060** Bosch Fernschanlagen GmbH, Robert.  
Television circuit.

**1363079** Marconi Co Ltd.  
Directional aerial systems and apparatus.

**1363156** International Computers Ltd.  
Scanning apparatus.

**1363197** Bosch Fernschanlagen GmbH, Robert.  
Correcting colour television signals.

**1363268** International Business Machines Corporation.  
Magnetic recording and/or reproducing apparatus.

**1363269** International Business Machines Corporation.  
Magnetic recording and/or reproducing apparatus.

**1363315** Standard Telephones & Cables Ltd.  
Telephone instruments.

**1363320** Vockenhuber, K., and Hauser, R.  
Strip handling apparatus.

**1363381** Magnavox Co.  
Selectively energising facsimile receivers.

**1363463** Western Electric Co Inc.  
Communications switching systems.

**1363483** Matsushita Electric Industrial Co Ltd.  
Means for indicating a balance position between the channels of a four-channel stereophonic system.

**1363487** Philips Electronic & Associated Industries Ltd.  
Switching device for tape recorder.

**1363490** Sony Corporation.  
Colour image pickup device.

**1363517** Industrial Research Products Inc.  
Delay system for audio signal processing.

**1363519** Standard Telephones & Cables Ltd.  
Acoustic surface wave device.

**1363550** International Business Machines Corporation.  
Electro-acoustic transducer device.

**1363701** RCA Corporation.  
Non-interacting optical system for a colour encoding camera.

**1363723** Amplivox Communications Ltd.  
Earphone assemblies.

**1363759** Faser - Und - Kunst - Stoff - Presswerk Romen KG.  
Loudspeaker apparatus.

**1363771** Tocquet, B., and Personnic, M.  
Electroacoustic transducers.

## July 5

**1363841** Mccaffrey, R. G., and Mccaffrey, M. J.  
Coding and decoding of information.

**1363861** Marconi Co Ltd.  
Aerial systems and apparatus and radars incorporating the same.

**1363882** International Computers Ltd.  
Display devices.

**1363885** Westinghouse Electric Corporation.  
Light beam polarisation modulator.

**1363924** Texas Instruments Inc.  
Digital data processing system having a signal distribution system.

**1364045** EMI Ltd.  
Duplication of magnetic recordings.

**1364151** Eidophor AG.  
Cathode ray tube for a projection television system.

**1364179** Intersound Ltd.  
Record player.

**1364217** Grundig EMV.  
Tape mechanism for tape recorders.

**1364254** Central Electricity Generating Board.  
Ultrasonic inspection.

**1364264** Soc Italiana Telecomunicazioni Siemens.  
SPA APCM transmission system including a monitoring system.

**1364268** Ampex Corporation.  
Electronic editing system for video tape recorders.

**1364274** Thomson-CSF.  
Electrically-controlled modulator systems with chromatic polarisation.

**1364346** King Instrument Corporation.  
Apparatus for use in tailoring two sections of tape.

**1364348** Compagnie Internationale Pour L'Informatique.  
Magneto-resistive devices.

**1364373** International Business Machines Corporation.  
Cylindrical magnetic domain display system.

**1364414** General Electric Co.  
Light-modulating medium for image projection apparatus.

**1364428** Pye Ltd.  
Television transmitters.

**1364432** Hughes Aircraft Co.  
Gain controllable image intensification system.

**1364480** Soc Italiana Telecomunicazioni Siemens.  
SPA PCM transmission system.

**1364504** Philips Electronic & Associated Industries Ltd.  
Device for centering disc records on the turntable of a record player.

**1364545** Agfa-Gevaert AG.  
Sound on sound recordings.

**1364553** Gretag AG.  
Film splicer.

**1364569** Nippon Kogaku KK.  
Cine camera.

**1364576** RCA Corporation.  
Fabrication of liquid crystal devices.

**1364586** Cables De Lyon-Alsacienn Geoffroy Delore.  
System for the transmission of signalling and communications currents for railway traffic.

**1364069** Queffeulou, J.-Y., and Vautrin, G.

Speech detector for a communication system.

**1364634** Patelhold Patentverwertungs & Elektro-Holding AG.  
Apparatus for automatically checking pulse-distortion correction in a signal channel.

## July 10

**1364706** Bell & Howell Co.  
Image display from continuously moving image carrier.

**1364718** Cosmocord Ltd.  
Phonographic record cleaning devices.

**1364729** Barnes & Mullins (MFG) Ltd.  
Joint for a musical wind instrument.

**1364776** Metrosound MFG Co Ltd.  
Cleaning of contaminants from gramophone records.

**1364808** Sendai Television Broadcasting Corporation.  
Simultaneous radio communication system.

**1364863** International Computers Ltd.  
Magnetic heads.

**1364864** Textilipari Kutato Intezet.  
Method of and device for analysing an electrical signal into its component frequencies.

**1364904/5/6** International Business Machines Corporation.  
Disc dictation machines.

**1364907** International Business Machines Corporation.  
Cartridge for laminar record members.

**1364976** Sadorus, G. P.  
Picture frame and sound producing mechanism.

**1365019** Matsushita Electric Industrial Co Ltd.  
Leader tape guiding apparatus.

**1365131** Matsushita Electric Industrial Co Ltd.  
Magnetic heads.

**1365231** Sony Corporation.  
Tape cassette.

**1365232** Sony Corporation.  
Magnetic tape recording and reproducing apparatus.

**1365314** Ted Bildplatten AG AEG-Telefunken-Teldec.  
Method and device for recording high-frequency signals and more particularly video signals on signal carriers.

## July 17

**1365456** Barnes Eng Co.  
Multiple line rotating polygon scanner.

**1365521** Emerson Electric Co.  
Method and antenna means for transmitting or receiving beam of electromagnetism.

**1365566** Stromberg Components Ltd.  
Mounting devices for mounting a reflector upon the boom of a uhf aerial.

**1365638** Marconi International Marine Co Ltd.  
Radio receiving arrangements.

**1365716** Seeburg Corporation of Delaware.  
Musical devices.

**1365851** Ljudmirsky, M. L., Forshtator, G. M., and Shkurovich Y. S.  
Test record and method of test for magnetic recording equipment.



# TRANSFER YOUR ASSETS

film-to-film and  
tape-to-film  
transfer  
equipment



If you count good recordings among your assets, you'll be glad to know that KEM think the same way. The excellent KEM range of sound equipment is based on a modular concept allowing for expansion from single to multi-transport combinations; or for coupling the transfer and dubbing machines for simultaneous use.

**FILM-TO-FILM TRANSFER:** the machines are designed for dubbing, recording and transfer operations. Each film transport has a main drive motor, with two film winding motors. Sound scanning units achieve sound stability within 3 seconds (without strain on film). Fast rewind is standard. Optional extras include: automatic film stop; automatic switchover to reverse run; and automatic film recording insertion process. All machines can be equipped

to interlock with external equipment such as the KEM TV Scanning Unit or Studio Projector.

**TAPE-TO-FILM TRANSFER:** machines are designed to transfer from 1/4" tape to 16mm or 35mm perforated film with, or without, pilot sound control. Two models are available: the 3-motor BS15 and 4-motor BS20; both of these feature a double-speed transfer facility, saving both time and money. And both have very precise winding motors to maintain an even wind.

If you want sound equipment that's good enough to match your talents. A system that's precision-engineered to the most exacting specifications. An after-sales service that's backed up by factory-trained personnel. Then please contact us today because you want KEM!

Please visit us in Hall 11, Stand 57 at Photokina, 27 Sept.—3 Oct. 1974



**KEM ELECTRONIC MECHANISMS LTD**

24 VIVIAN AVENUE · LONDON NW4 3XP Tel.: 01-202 0244

## PATENTS

MR LIVY OF EMI draws reader's attention to his British Patent 612,163 (long since expired, of course). The world of science and technology is at serious risk of sinking under the dead weight of paper information available on library shelves and letters such as Mr Livy's help ensure that publications which are relevant to modern technology are not lost and forgotten simply because they are old. It is a sobering thought that since 1948, when the Livy patent was published, around three quarters of a million British patents have been published in the UK alone, with comparable numbers from every other developed country in the world!

The patent Office records show that not even the 1955 searches carried out by the USA Patent Office Examiner (to whom the Hamann patent 2,849,540 was referred) unearthed the Livy patent. However, it is of course for a court, in this case a USA court, to say whether or not the Livy patent invalidates the Hamann patent.

Students of four channel technology and the patent battles which will doubtless erupt over the next few years (basic matrixing theory was after all disclosed by Blumlein as far back as 1933 in British Patent 394,325) will be interested in the proposals for discrete discs made in the mid 40s both by Livy and RCA in the USA.

RCA, USA patent 2,536,664, suggested in 1945 a means of imposing two separate channels of sound on a single channel transmitting medium such as a gramophone record. The signal from one source was trimmed into the band 50 Hz to 8k Hz and the signal from the other source trimmed into the band 50 Hz to 5 k Hz. An oscillator signal at 13k Hz was used to convert the 50 Hz to 5k Hz band of signals into a band of 8k Hz to 13k Hz. The resultant two bands (the original 50 Hz to 8k Hz and the converted 8k Hz to 13k Hz) were then recorded together and the upper band demodulated on playback.

According to Livy a year or so later (see fig. 1) programme source 1 was to be trimmed to the band 0 to 6k Hz and amplified, while the signals from programme source 2 were similarly trimmed (0 to 6k Hz) and amplified, but modulated by an oscillator (like RCA) running at 13 k Hz. The modulated signal was subsequently filtered to produce a band of 7 to 13k Hz which was mixed with the untouched band of 0 to 6 k Hz from source 1. The mixed signal was then further amplified and recorded. On playback (fig. 2) the mixed signal was amplified and filtered with the band 0 to 6k Hz fed direct to an amplifier and loudspeaker. The filter also produced a second band of 7 to 13k Hz which was modulated by an oscillator running at 13k Hz and filtered to produce a band of 0 to 6k Hz which was then amplified and fed to a second loudspeaker. But the Livy patent additionally suggests that this basic technique was well known in the UK by 1946 and that in practice it was hard to keep the oscillators at the record and playback stage accurately synchronised; difficulties also arose if there was any fluctuation in the turntable speed on reproduction. In his patent Livy claimed that the problem could be overcome by recording some of the carrier frequency oscillations (13k Hz) and using these oscillations to control the frequency

FIG. 1

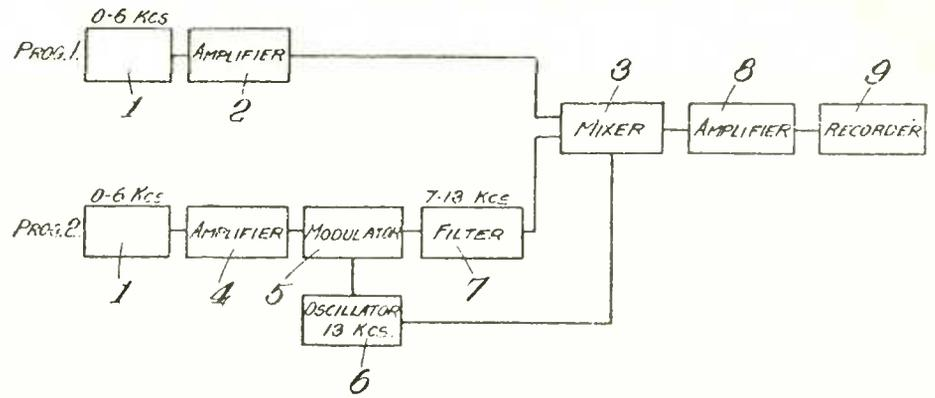
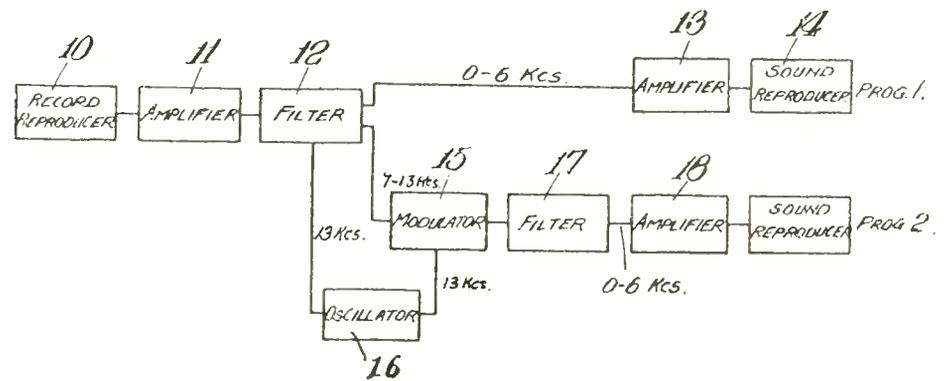


FIG. 2



of the playback oscillator; the patent drawings show this.

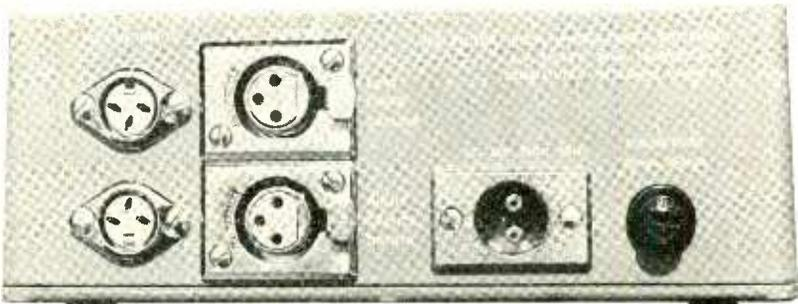
In the JVC Nivico system, the CD-4 disc carries on the inner groove wall cuts which represent the Front Left plus Rear Left channels together with a 30k Hz carrier wave frequency modulated by the difference signal Front Left minus Rear Left. Similarly the outer groove wall carries Front Right plus Rear Right and a 30k Hz carrier frequency modulated by Front

Right minus Rear Right.

Although it is now becoming very clear that the basic concept of multiplexing a pair of audio signals together into one disc groove or one wall of one disc groove, is in the public domain and no longer protectable by patents, this is unlikely to prevent JVC Nivico from patenting the modern technology which has made the CD-4 disc a reality.

Adrian Hope

### LOOKING FOR A REAR PANEL LIKE THIS?



- \*RIAA with 2% components.
- \*Large output transformers with excellent L.F. performance.
- \*Lock-DIN input sockets.
- TO IBA SPECIFICATIONS FOR DISC REPLAY EQUIPMENT

**SURREY ELECTRONICS**  
The Forge, Lucks Green, Cranleigh, Surrey  
GU6 7BG  
STD 04866 5997

# Cuemaster's plus NAB tape cartridge systems

Laminated NORTRONICS heads — 'dummy' record head fitted to replay deck ensures even loading of the cartridge pressure pads.

Select FAST FORWARD manually and drop back to play speed without going through the STOP mode — for editing, previewing or selecting a particular item.

\*FAST FORWARD (57 cm/sec) with either automatic (aux. cue 1) or manual selection.

\*Miss-cue of programme is eliminated as operator cannot select START unless READY indicator shows correctly loaded cartridge.

Cue-track ERASE — erases cuetones independent of recorded programme — no need to bulk erase. Erase of all tracks automatic in RECORD.

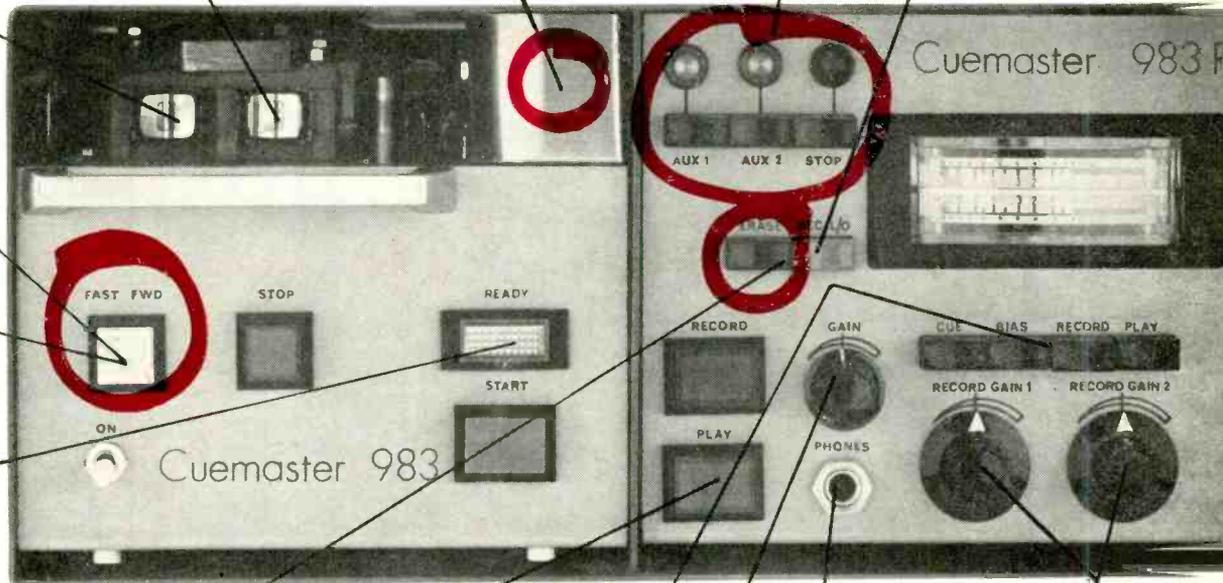
Precision milled head mount — triple tape guides and positive azimuth adjustment.

Machined 13 mm thick anodized aluminium deck with positive cartridge location.

Air-damped, full travel solenoid — no cartridge pre-load or eject necessary.

\*All three cuetones (1 KHz, 150 Hz, 8 KHz) may be recorded during either PLAY or RECORD. Indicators monitor off-tape to verify correctly recorded cuetone.

\*Record lock-out prohibits RECORD selection.



Record/monitoring module connections.

All regular features plus those marked\* are available at the module remote control outputs.

Automatic FAST FORWARD override.

Custom built housing configurations.

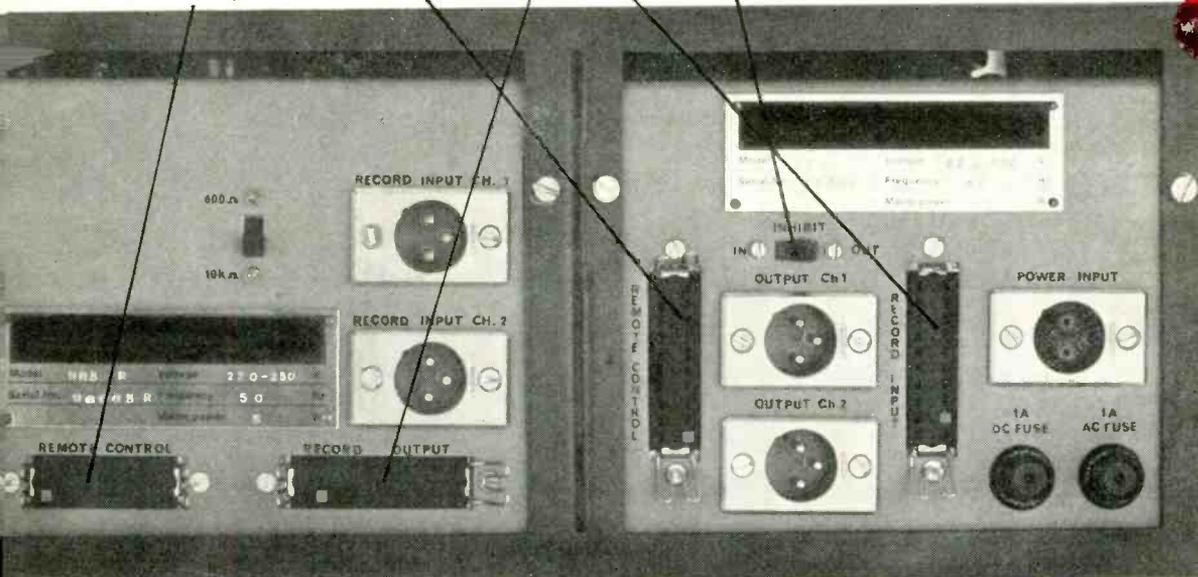
Completely self-contained deck modules.

Modules available with all functions operational facilitating in-situ adjustment or bench-test.

Two speed switchable pole direct drive hysteresis synchronous capstan motor custom designed for 220-250V, 50 Hz mains input.

Plug-in printed circuit boards designed for optimum noise, crosstalk and distortion performance.

Three modules to choose from in either stereo or mono — replay, record/replay and record/monitor.



# Cuemaster

Cepak Europe Limited, London 580-1204.

UK. Crow of Reading Ltd (0734) 595025. Reslosound Ltd. (70) 61926. FRANCE, BELGIUM, LUXEMBOURG N.V. Delta Equipment S.A. Brussels 376.60.34. NETHERLANDS,

WEST GERMANY Inter Electronics B.V. Arnhem 61.32.06. EASTERN EUROPE Convair Import and Export Ltd. London 244.8899.

*The recent availability of linear multiplier integrated circuits has greatly simplified the design of high performance frequency shifters for audio. Full circuit diagrams of the units which are commercially available are given along with discussion of the principles of operation and use.*

## Frequency shifter

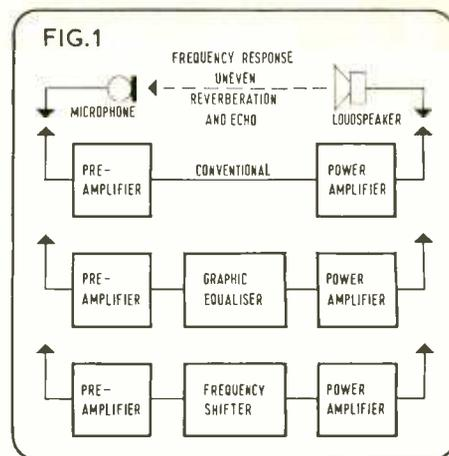
TREVOR BROOK

**THE CONCEPT** of shifting, by a few hertz, the audio spectrum fed to the loudspeakers in public address systems has been around for some time, but its realisation at an economic price has awaited the introduction of linear multiplier integrated circuits.

In any public address situation in which the microphone and loudspeakers are in the same vicinity, **fig. 1**, the output of the microphone includes, besides the required sound, a replica of the loudspeaker signal but with colorations of the frequency response and multiple reverberations. If the amplification is raised beyond the critical value, where the gain around this loop is unity, then oscillation occurs. Frequency response unevenness results from room resonances and imperfections in both microphone and loudspeaker responses. The amplitude of reverberation picked up by the microphone is a function of the directional characteristic of the microphone, room design and, to some extent, loudspeaker positioning. To reduce the problem of howl-round in any installation firstly use microphones and loudspeakers with smooth frequency responses and appropriate directional characteristics. Beyond this, extra gain may be utilised by fitting a graphic frequency response equaliser in the amplifier chain. This would be adjusted to reduce system gain at the particular frequencies most prone to howling, and increase gain at other frequencies. Though a useful increase in gain may be possible this method has the drawback, particularly for music, of spoiling the flat frequency response earlier achieved by good quality microphones and loudspeakers. It is also only able to compensate for the general trends in room response and cannot help with the irregular peaks and troughs occurring every few hertz through the audio band.

If, instead, the entire spectrum picked up by the microphone is shifted by a few hertz, before being fed back into the room via the loudspeakers, those frequencies that were accentuated by the room response will now go through the loudspeaker-microphone path at a frequency which is not so accentuated while, similarly, frequencies which were previously not accentuated may now be. The effect of this shifting process then is to average the room response and thus allow more gain to be used before howling occurs.

At the eventual howl-round point with a shifter in use there is an objectionable warbling effect, but if the system is operated below this point there is an absence of the ringing colorations found in conventional systems, just below their feedback point. The choice of frequency shift is governed principally by its perceptibility if it is too large, and by its ineffectiveness in reducing howl-round if it is too small. Though shifts up or down of as much as 10 Hz are quite difficult to detect on speech, a smaller value is necessary for music. For large halls a shift of 2 or 3 Hz is probably optimum (ref. 1) though smaller halls with lower reverberation times may require around 5 Hz for best results (ref 2). An available increase in gain of four to eight decibels may be expected, along with a reduction of coloration effects, and the loss in extra gain when a shift, not exactly optimum, is used, is only around one decibel. A shift of +5 Hz has been chosen for the standard units, being a reasonable compromise between perceptibility and effectiveness in halls of various sizes. If a shift of 5 Hz is tried out in a small



room, say four metres square, with a corresponding small microphone-speaker separation, then the gain increase available generally falls to only one or two decibels.

A problem occasionally arises in sound reinforcement applications when an instrument producing sustained low frequency notes, such as organ or electric guitar, is involved. Listeners at the front of the audience may hear beating between the direct sound and the shifted version from the loudspeakers and caution is needed when using the device in such situations where the two sounds can have approximately the same loudness. The audibility of beating effects is, however, surprisingly low and this has been accounted for by the inevitable small delay between the direct sound and the amplified version, being enough to destroy coherence and virtually eliminate beats; laboratory experiments showing that a delay of only three milliseconds is sufficient (ref 2).

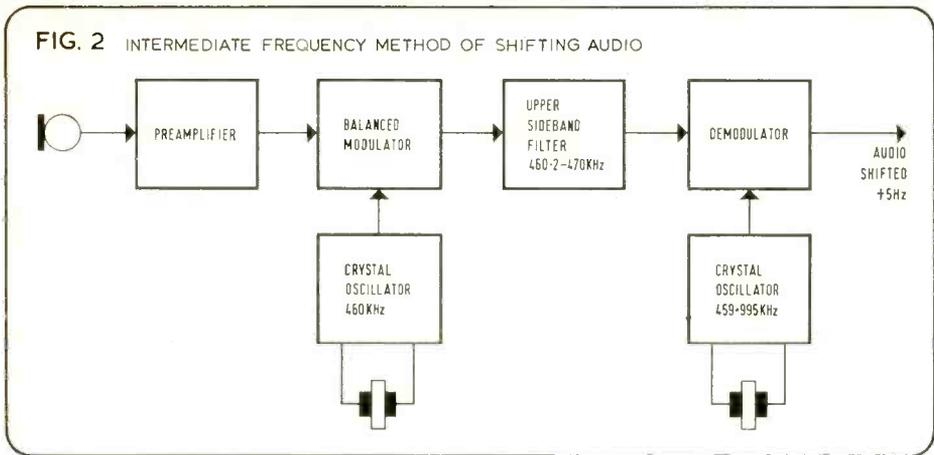
When a frequency shifter is installed and operated skilfully the audience should remain unaware that any unusual treatment has been applied to the sound.

### Methods of shifting audio

Until recently audio frequency shifts were typically produced in the following way, **fig. 2**. A frequency stable suppressed double sideband signal is first generated at a convenient intermediate frequency, usually in the 450k to 480k Hz region. This is fed through a filter allowing only one sideband to pass, and is then demodulated by a carrier reinserted at a slightly different frequency to give the original audio but with a shifted spectrum. This system has several performance limitations: to achieve harmonic distortion better than around one per cent demands modulator and demodulator design of great complexity. This also applies to intermodulation distortion performance. Frequency response ripple of around two decibels results when using a practical filter design with the good stop-band rejection necessary to prevent beating effects from the unwanted sideband. If the unwanted sideband does leak through it produces in the output an audio spectrum shifted in the opposite direction to that required. The slope of the filter must have reached its maximum attenuation around the carrier frequency and also causes some inevitable loss of lower frequencies in the wanted sideband.

The shifter board now available, **figs. 3 and 4**,

FIG. 2 INTERMEDIATE FREQUENCY METHOD OF SHIFTING AUDIO



is for the basic circuit developed by Dr M. Hartley Jones at the University of Manchester Institute of Science and Technology and published with full circuit explanation in July 1973 (ref. 3). The basic principle of operation is that quadrature sine waves of the shifting frequency, along with phase shifted versions of the audio input, are fed into two multiplier integrated circuits and a shifted audio output derived.

**Shifter circuit**

IC3 and IC4 together form an oscillator at the desired shifting frequency,  $\Delta f$ , determined by C2, C3, C10, and R3, R6, R9. The function of this oscillator is to produce two sinewave outputs of low distortion, stable amplitude and accurately in quadrature, fig. 5. The zeners, along with the preset R10, determine the amplitude of oscillation. One of these outputs,  $\sin 2\pi\Delta ft$ , is fed to the Y+ input of one multiplier (pin 4), and the second output,  $\cos 2\pi\Delta ft$ , is fed to the other multiplier's Y+ input. Both Y- inputs are returned to dc offset adjustment presets, R35, R40, to allow setting for zero input voltage to the multiplier to yield no output.

Audio passes through IC1, a conventional amplifier, and IC2, an inverter, and the out of phase outputs of IC1 and IC2 are applied to two broad-band phase shifting circuits, R7, R8, C4, C5, and R11, R12, C6, C7. The outputs from these networks, maintained in reasonable quadrature over the audio frequency range, are fed to the X+ inputs of the multipliers (pin 9). Again both X- inputs go to dc offset presets, R31, R38. If a single frequency audio input,  $f_t$  is considered, the phase shifter network outputs are  $\sin 2\pi f_t t$  and  $\cos 2\pi f_t t$ . These, as the X inputs to the multipliers, along with the shifting frequency Y inputs give the products  $\sin 2\pi f_t t \cdot \cos 2\pi\Delta ft$  and  $\cos 2\pi f_t t \cdot \sin 2\pi\Delta ft$ . With  $\Delta ft = 5\text{ Hz}$  and  $f_t = 1\text{ k Hz}$  these appear as fig.6 at pin 14 of IC5 and IC6. These two outputs pass through a balance preset, R33, into IC7, arranged as a virtual earth adder with variable gain, R39. The products added,  $\sin 2\pi f_t t \cdot \cos 2\pi\Delta ft + \cos 2\pi f_t t \cdot \sin 2\pi\Delta ft$  are equivalent to  $\sin (2\pi f_t t + 2\pi\Delta ft)$ , the required shifted input signal.

R39 may be omitted on the printed circuit board as its connections are brought out on to the edge connector allowing an external gain control to be used. The 470 nF output coupling capacitor, C15, may be replaced on the board

by two 33  $\mu\text{F}$  10V tantalum bead capacitors, back-to-back to allow feeding loads down to 2 k $\Omega$  without loss of low frequency response. The shifter board also includes straightforward ac rectifiers and regulated power supplies, IC8 and IC9, providing outputs of plus and minus 15V. Using the transformer supplied (or the similar RS components 'Min Trans 20V') up to 80 mA at  $\pm 15\text{ V}$  may be drawn from pins seven and eight of the circuit card for external use.

The noise level at the output of the shifter is -60 dBV (mean reading meter 40 Hz to 10k Hz); and is determined by the inherent noise of the multiplier ics. As the overload point of the board is +12 dBV the normal way of operating the device is to include it between the preamplifier and power amplifier, and use an input from the preamplifier sufficiently high enough in level for the preamplifier noise to just overcome the shifter noise, so the signal-to-noise ratio of the system is still limited by the equipment preceding the shifter. If it is more convenient to provide extra input gain on the shifter board itself this can be done by adding C22 and R66 to reduce the feedback around IC1. Making R66 = 15k  $\Omega$  raises the shifter gain to +26 dB which, in conjunction with a -26 dB output attenuator, allows use directly in microphone lines. Though adequate for public address the signal-to-noise will not be particularly outstanding; 741s are not exactly the best microphone preamplifiers! Raising the gain by 10 dB (R66 = 120 k $\Omega$ ) is generally useful when involved with DIN domestic line levels, around 200 mV.

Fig. 7 shows the residual modulation on a processed 1k Hz sinewave signal, and this depth of residual modulation (less than 0.5 dB peak-to-peak) remains constant at all levels up to the clipping point, when it greatly increases. Fig. 8 shows the output with the shifter well into clipping. At lower and higher frequencies the residual modulation performance deteriorates due to departures from exact quadrature of the two audio signals produced by the phase shifting networks. Fig. 9 shows the treatment of 1k Hz squarewaves, figs. 10 and 11 the performance with sinewaves of 100 Hz and 20k Hz respectively. This is not objectionable in practice and, for normal applications, does not justify the increased complexity of more accurate phase shifting networks. A recent article has described tests to assess the audibility of phase distortion introduced by all pass phase shift networks of the kind used here (ref. 4).

FIG. 4

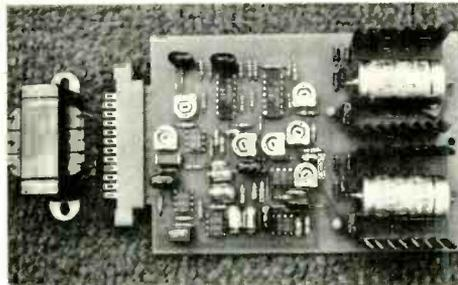


FIG. 5

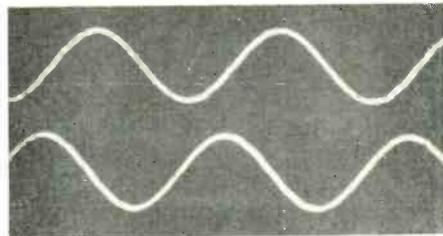


FIG. 6

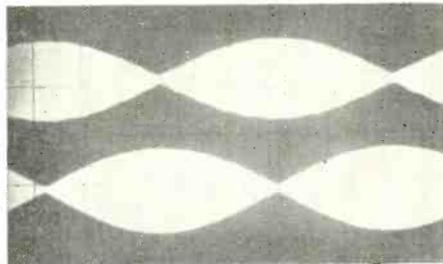


FIG. 7

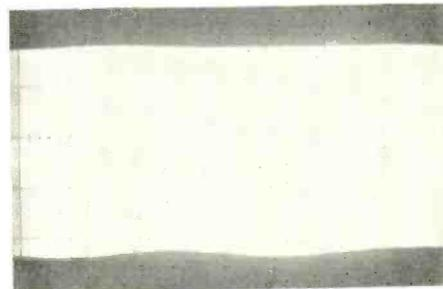


FIG. 8

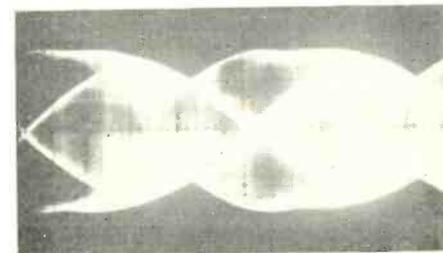


FIG.12 PERIPHERAL CIRCUITS

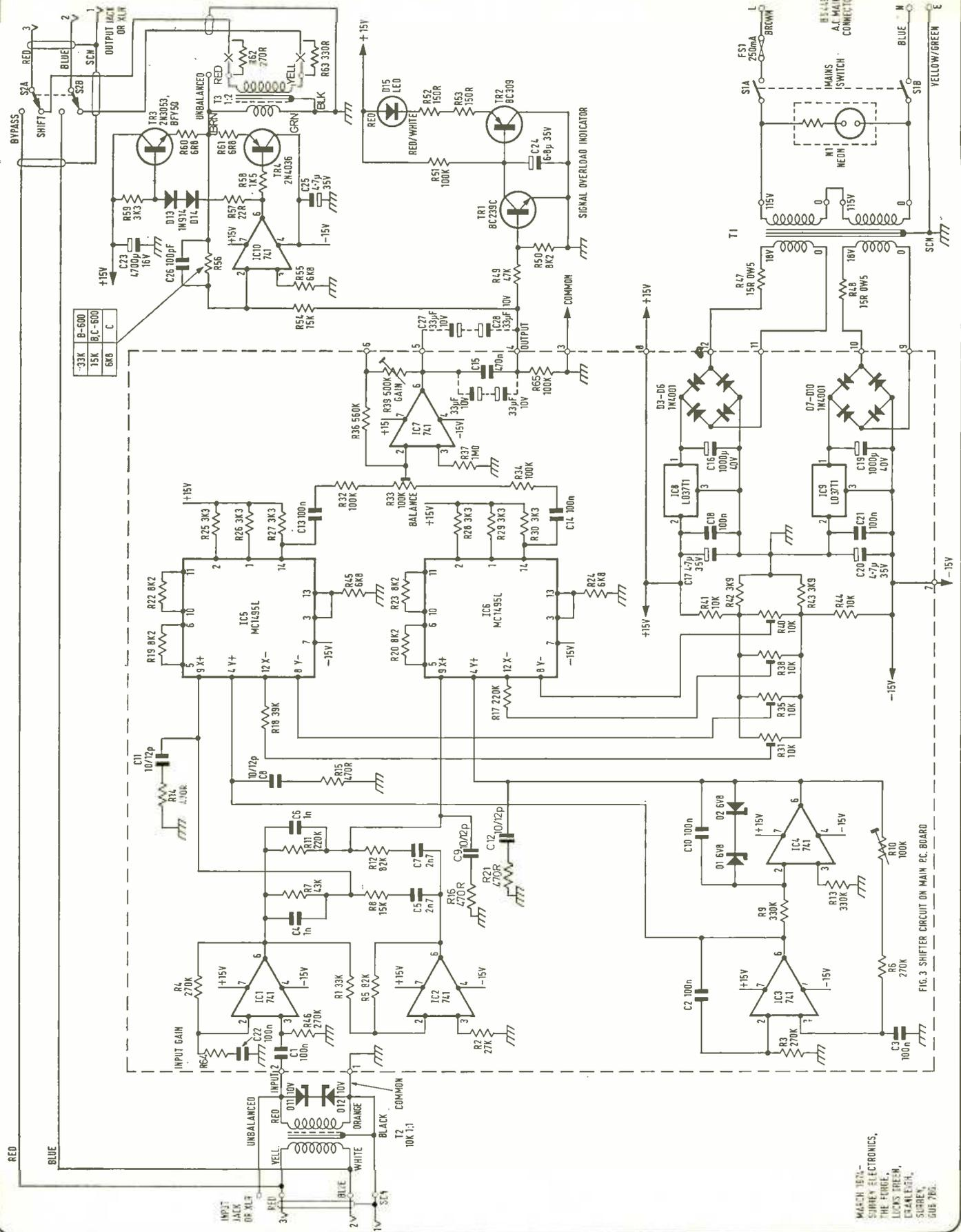


FIG. 3 SHIFTER CIRCUIT ON MAIN PC BOARD

MADE IN THE  
 SURETY ELECTRONICS,  
 THE FORCE,  
 LUCAS, FRESH,  
 CEAL, EIGHT,  
 SURETY,  
 608 761.

## FREQUENCY SHIFTER

Total harmonic distortion of the shifter for 1k Hz at a level of +11 dBV is less than 0.1 per cent.

### Peripheral circuit

I discovered that adding a large capacitor, C23, decoupling the positive 15V supply reduced the treble noise output of the shifter considerably. The improvement is generally about 4 dBA and Dr Hartley-Jones has suggested that possible causes are positive feedback originating in the finite supply impedance or rf components in the regulator output being demodulated in the multipliers.

At the board input D11 and D12 are 10V zeners back-to-back to prevent damage to IC1 by possible high voltage pulses from valve equipment. T2 is a high quality Sowter 10 kΩ bridging transformer used for balanced line systems. The overload indicator consists of TR1 and TR2 driving the front panel light emitting diode, D15. This circuit has attack and decay time constants approximately the same as for peak programme meters, but to avoid great complexity only detects positive audio peaks. In practice this is immaterial as the overload indicator should not light at all during normal use, it should serve only as an alert to grossly incorrect signal levels. By putting the timing capacitor, C24, between TR2 base and the 0V supply line the led flashes every time the unit is switched on, thus providing confirmation that at least some positive supply is present within the unit. With a sine-wave input signal, the indication level is arranged so that the led just starts glowing above +8 dBV and is fully lit at +10 dBV, two decibels below the +12 dBV overload in the shifter.

As positive and negative 15V supplies are available it is convenient to incorporate an ic in a dc coupled line driving amplifier. Unfortunately at present there are no ics reliably available which are capable of driving low impedance loads with low distortion, so a complementary pair of T05 output transistors are used in conjunction with a 741 ic. D13, D14, and R57 set the quiescent current and R59 feeding these base biasing components also causes the 741 to supply some current even in no signal conditions, and thus prevents crossover distortion from the 741's own output stage when handling small signals. For driving balanced lines a 1:2 ratio output transformer allows an overload point for the line driver of +21 dBV at 1k Hz when feeding a 600Ω load. Figs. 13 and 14 show the squarewave performance of the line driver and transformer combination at 1k and 10k Hz.

FIG. 9

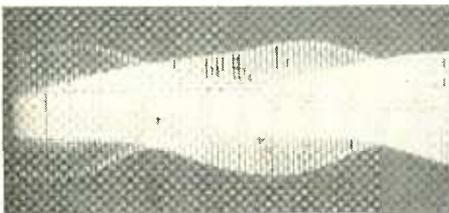


FIG. 10

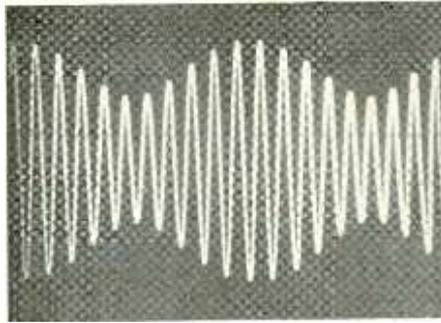


FIG. 11

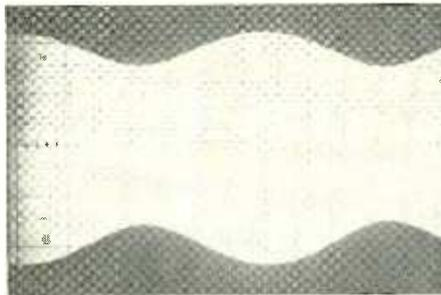


FIG. 13

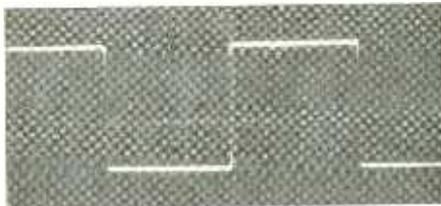
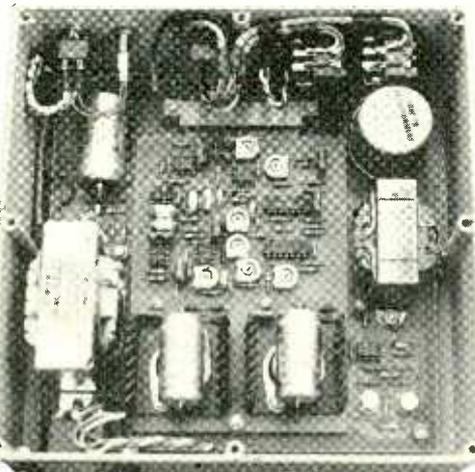


FIG. 15



The shift-bypass switch connects the input and output sockets directly together. This arrangement is made possible by the fact that the shifter is designed as an overall unity gain device, and has the advantage of quickly removing the unit entirely from the audio system in the case of mains or unit failure. This also allows instant howl reduction and signal degradation comparisons.

The mains input is standard double pole switched, fused at a 20 mm fuse holder on the back panel and fed to a series-parallel primary on the mains transformer allowing for 115 or 230V mains supplies. The rear panel also carries a BS4491 mains connector which, along with the Cannon XM series, is one of the most sensible and reliable mains connectors I have come across.

### Variations

If a frequency decrease is desired it is easy to change the circuit by swapping the phase shifted audio inputs to the two multipliers. This is done on the printed board by changing R7 for R11 and R8 for R12. Very natural results have been reported in two channel sound reinforcement systems when using a frequency increase in one channel and a decrease in the other (ref. 2).

Different shifting frequencies are possible by changing C2, C3 and C10 in the quadrature oscillator and very strange musical effects are possible by using much higher shifting frequencies.

The frequency shifter is an interesting device that sound engineers may find helpful where good installation practice has already been followed and a further increase in gain or reduction in colorations is still required. It should not be used as an excuse for avoiding proper planning of installations in the first place.

The shifter units described are manufactured by Surrey Electronics under a royalty agreement with the University of Manchester Institute of Science and Technology. Circuit boards alone are also available for manufacturers to build into their own equipment.

Finally my thanks to Dr M. Hartley Jones for general help and suggestions, to Hugh Ford for help with facilities for the oscilloscope photographs and to Joe Cosham for the circuit board photographs.

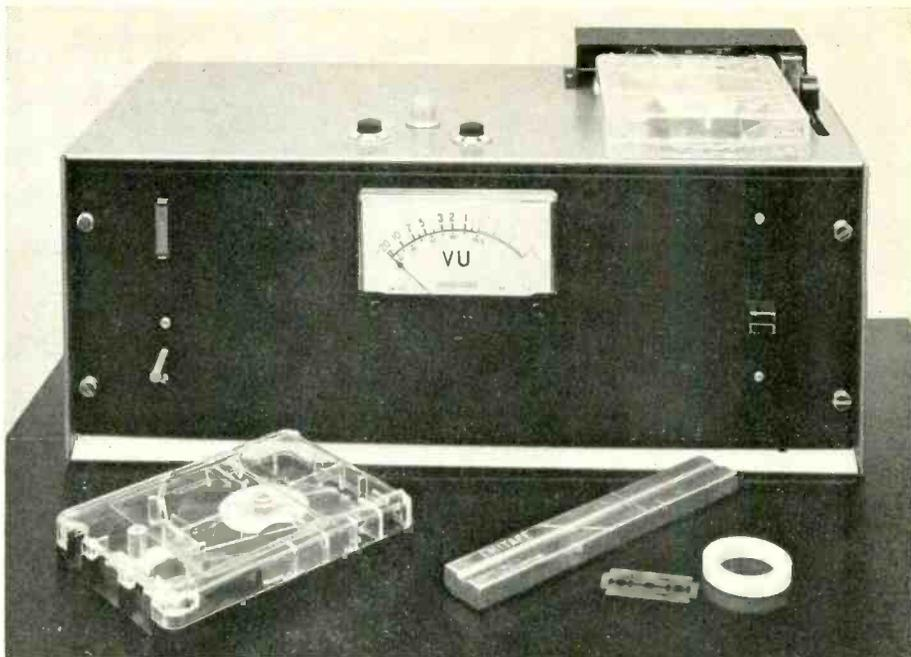
### References

- 1 Harwood H. D. *Wireless World* Vol 79 No 1455 (Sept 1973) letters.
- 2 Hartley Jones M. Private communication. August 1973.
- 3 Hartley Jones M. 'Frequency shifter for howl suppression'. *Wireless World* Vol 79 No 1453 (July 1973).
- 4 Bauer B. B. 'Audibility of phase distortion'. *Wireless World* Vol 80 No 1461 (March 1974).

FIG. 14



# Survey: tape cartridge machines



Air Check

## AIR CHECK

Sound Audio, Electronic and Video Techniques, 1 Oldershaw Mews, Maidenhead, Berkshire.  
Phone: 0623-33011.

## NAB 11P

Format: mono playback, mono record/playback, stereo record/playback.  
Tape speed: 38, 19, 9.5 cm/s optional.  
Play time: 10.5 minutes.  
Cartridge: NAB A size.  
Cue tones: 1k Hz stop, 150 Hz and 8k Hz aux.  
Equalisation: NAB, CCIR or IEC optional.  
Frequency response: 45—14,000 Hz  $\pm$  2 dB at 19 cm/s. 50—13,000 Hz  $\pm$  2 dB at 9.5 cm/s.  
Crosstalk: -54dB.  
Signal-to-noise ratio: 57 dB stereo, 61 dB mono.  
Wow and flutter: 0.2% at 19 cm/s. 0.3% at 9.5 cm/s.  
Start/stop time: 60 ms.  
Weight: 16.4 kg.  
Price: £260 (mono playback). £345 (mono r/p). £480 (stereo r/p).

## AMITY

Amity Shroeder Ltd., 3/4 New Compton Street, London WC2.  
Phone: 01-836 7811.

## Broadcast Cartridge Machine

Format: mono or stereo record/playback or playback only.

Tape speed: 19 cm/s.  
Play time: 10.5 minutes.  
Cartridge: NAB A size.  
Cue tones: 1k Hz stop, 150 Hz aux.  
Equalisation: NAB.  
Frequency response: to NAB.  
Crosstalk: to NAB.  
Signal-to-noise ratio: to NAB.  
Wow and flutter: to NAB.  
Start/stop time: to NAB.  
Dimensions: 305 x 275 x 140 mm.  
Price: £445 mono play. £485 mono r/p. £475 stereo play. £525 stereo r/p.

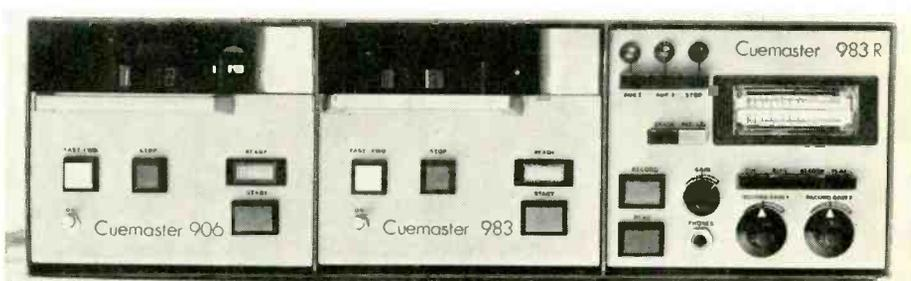
## CCA

CCA Electronics Corporation, 716 Jersey Avenue, Gloucester City, New Jersey 08030, USA.  
Phone: 609-456 1716.  
UK agents: Industrial Tape Applications, 5 Pratt Street, Camden Town, London NW1.  
Phone: 01-485 6162.

## Citadel

Format: mono or stereo playback.  
Tape speed: 19 cm/s.  
Play time: 10.5 minutes.  
Cartridge: NAB A size.  
Cue tones: 1k Hz stop, 150 Hz aux. 8k Hz aux (optional).  
Equalisation: NAB adjustable.  
Frequency response: 50—15,000 Hz  $\pm$  2 dB.

Right: Consolidated Electronics (Cepak)  
Below: Amity





# New from

# AMITY SHROEDER

## Top quality equipment for recording studios . . .

### AMITY TAPE TRANSPORTS

For studios wishing to supply their own electronics.

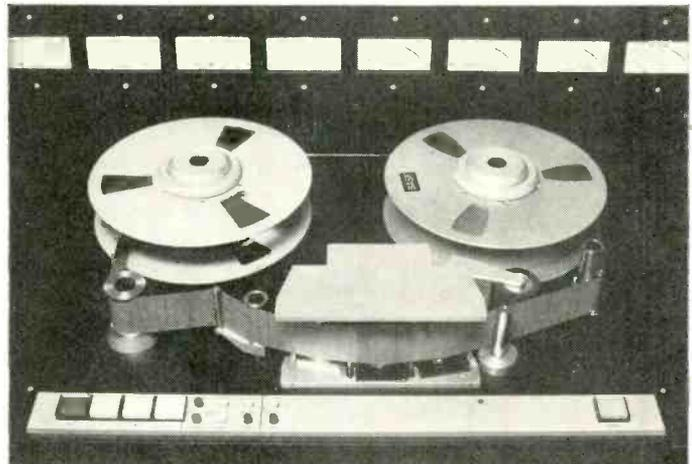
#### SPECIFICATIONS

Max. spool diameter	10½"
Operating speeds	15/30 i.p.s.
Rewind time for 2400' tape	90 Sec
Wow & flutter (din weighted)	·05%
Speed stability	-1%
Dimensions (ins) Width	25½
Depth	19½
height above deck	4
height above deck*	13½

\*Allowing room to tilt deck up through 90° for service.

Decks are normally supplied with undrilled head plates and two guides.

Delivery 6-8 weeks from receipt of order.



Tape transport for 1" tape      £2490 + VAT  
 Tape transport for 2" tape      £2760 + VAT  
 Prices include all control circuits and power supplies, but exclude heads.

## . . . and broadcasting stations



Stereo Record/Play	£525 + VAT
Stereo Play only	£475 + VAT
Mono Record/Play	£485 + VAT
Mono Play only	£445 + VAT

### AMITY BROADCAST CARTRIDGE MACHINES

Meets or exceeds all N.A.B. specifications. Normal operating speeds 7½ I.P.S. Cue speed 15 I.P.S. 1 kHz and 150 Hz tone generators and sensors provide automatic fast cue operation with manual override. Papst outside rotor capstan. Solenoid operated pull-up and start mechanisms for fast, one-handed operation. Hinge top lid for access to heads and audio circuits. Socket provided for remote control working. Rear mounted switch enables cue tone oscillators to be switched off for recording of continuous background music cartridges.

## AMITY SHROEDER LTD.

3 NEW COMPTON STREET,  
 LONDON WC2 H8DD  
 01-836 7811      TELEX: 23197

Please send me immediately full details of  
 AMITY SHROEDER TAPE TRANSPORTS   
 AMITY BROADCAST CARTRIDGE MACHINES

Name \_\_\_\_\_

Address \_\_\_\_\_

## ■ SURVEY

**Signal-to-noise ratio:** 55 dB mono, 50 dB stereo.  
**Wow and flutter:** 0.2%  
**Start/stop time:** 0.1s.  
**Dimensions:** 130 x 335 x 146 mm.  
**Weight:** 7.5 kg.  
**Price:** from £327.

**CONSOLIDATED ELECTRONIC**  
 Consolidated Electronics Industries, Melbourne, Australia.  
**UK Agents: Cepak (Europe) Ltd.,** Princess House, East Castle Street, London W1.  
**Phone:** 01-580 1204.

### 900

**Format:** 986 playback, 983 record/playback, 983R record module. All models mono or stereo.  
**Tape speed:** 19 cm/s or 57 cm fast cue.  
**Play time:** 10.5 minutes.  
**Cartridge:** A size.  
**Cue tones:** 1k Hz stop, 150 Hz, 8k Hz.  
**Equalisation:** CCIR-IEC-NAB.  
**Frequency response:** 40—15,000 Hz.  $\pm 2$  dB.  
**Crosstalk:** -55 dB.  
**Start/stop time:** 0.1s.  
**Dimensions:** 146 x 133 x 330 mm.  
**Weight:** 11.5 kg.  
**Price:** 986 £767, 983 £927, 983R £284. (Stereo models)

### GARRON

Garron Electronics Inc., 1216 Kifer Road, Sunnyvale, Calif. 94086, USA.  
**Phone:** 408-736 8737.  
**UK Agents: Hayden Laboratories Ltd.,** Hayden House, 17 Chesham Road, Amersham, Bucks HP6 5AG.  
**Phone:** 02403-5511.

### Rapid Q series

**Format:** Available in mono and stereo.  
**Tape speed:** 19 cm/s standard. 9.5 and 38 cm/s optional.  
**Cartridge:** NABA, B, C options.  
**Cue tones:** 1k Hz stop, 150 Hz and 8k Hz aux tones available on some models.  
**Equalisation:** NAB standard.  
**Frequency response:** 50—15,000 Hz  $\pm 2$  dB.  
**Crosstalk:** better than 55 dB.  
**Signal-to-noise ratio:** 57 dB.  
**Wow and flutter:** 0.2%.  
**Start/stop time:** 50 ms.  
**Dimensions:** depends on specification.  
**Weight:** depends on specification.  
**Price:** depends on specification.

### GATES

Harris-Intertype Corporation, 123 Hamp-

shire Street, Quincy, Illinois 62301, USA.  
**UK Agents: Lee Engineering Ltd.,** Ashley House, Ashley Road, Walton-on-Thames, Surrey KT12 1JE.  
**Phone:** Walton-on-Thames (98) 28783/4.

### Criterion 80 Series

**Format:** mono or stereo, playback or record/playback.  
**Tape speed:** 19 cm/s.  
**Cue tones:** 1k Hz stop, 150 Hz and 8k Hz aux optional.  
**Equalisation:** NAB standard.  
**Frequency response:** 50—15,000 Hz  $\pm 2$  dB.  
**Crosstalk:** -50 dB approx.  
**Signal-to-noise ratio:** 45 dB stereo, 48 dB mono at NAB standard reference.  
**Wow and flutter:** 0.2%.  
**Start/stop time:** 0.1s.  
**Dimensions:** 102 x 340 x 320 mm.  
**Weight:** 5.5 kg.  
**Price:** £475.

### Criterion Compact:

**Format:** mono or stereo playback only.  
**Tape speed:** 19 cm/s.  
**Play time:** 10.5 minutes.  
**Cartridge:** NAB A, B size.  
**Cue tones:** 1k Hz stop, 150 Hz and 8k Hz aux optional.  
**Equalisation:** NAB standard.  
**Frequency response:** 50—15,000 Hz  $\pm 2$  dB.  
**Crosstalk:** -50 dB approx.  
**Signal-to-noise ratio:** 45 dB stereo, 48 dB mono NAB standard reference.  
**Wow and flutter:** 0.2%.  
**Start/stop time:** 0.1s.  
**Dimensions:** 142 x 220 x 320 mm.  
**Weight:** 9 kg.  
**Price:** from £365.

### Criterion Compact III three machine tandem.

**Format:** mono or stereo playback.  
**Tape method:** 19 cm/s.  
**Play time:** 10.5 minutes.  
**Cartridge:** NAB A size.  
**Cue tones:** 1k Hz stop, 150 Hz and 8k Hz aux optional.  
**Equalisation:** NAB standard, CCIR optional.  
**Frequency response:** 300—15,000 Hz  $\pm 2$  dB. 50—300 Hz -2, +3 dB.  
**Crosstalk:** -50 dB approx.  
**Signal-to-noise ratio:** 55 dB mono, 52 dB stereo.  
**Wow and flutter:** 0.2%.  
**Start/stop time:** 0.15s.  
**Dimensions:** 285 x 225 x 485 mm.  
**Weight:** 17 kg.

### INTERNATIONAL TAPETRONICS

International Tapetronics Corporation, 2425 South Main Street, Bloomington, Illinois 61701, USA.  
**Phone:** 309-828 1381.

**UK Agents: Lee Engineering, Ashley House,** Ashley Road, Walton-on-Thames, Surrey KT12 1JE.  
**Phone:** Walton-on-Thames (98) 28783/4.

### RP series

**Format:** mono or stereo record/playback.  
**Tape speed:** 19 cm/s.  
**Play time:** 31 minutes.  
**Cartridge:** NAB A, B, C size.  
**Cue tones:** 1k Hz stop, 150 Hz and 8k Hz aux optional.  
**Equalisation:** NAB adjustable.  
**Frequency response:** 50—15,000 Hz  $\pm 2$  dB.  
**Crosstalk:** -50 dB.  
**Signal-to-noise ratio:** 55 dB mono, 50 dB stereo.  
**Wow and flutter:** 0.2%.  
**Start/stop time:** 0.1s.  
**Dimensions:** 445 x 280 x 136 mm.  
**Weight:** 18 kg.  
**Price:** from £733.

### SP/WP series

**Format:** mono or stereo playback.  
**Tape speed:** 19 cm/s.  
**Play time:** 16 minutes.  
**Cartridge:** NAB A, B size.  
**Cue tones:** 1k Hz stop, 150 Hz and 8k Hz optional.  
**Equalisation:** NAB adjustable.  
**Frequency response:** 50—15,000 Hz  $\pm 2$  dB.  
**Crosstalk:** -50 dB.  
**Signal-to-noise ratio:** 55 dB mono, 50 dB stereo.  
**Wow and flutter:** 0.2%.  
**Start/stop time:** 0.1s.  
**Dimensions:** SP series 215 x 280 x 135 mm. WP series 445 x 280 x 135 mm.  
**Weight:** SP series 10.5 kg. WP series 12.7 kg.  
**Price:** SP from £408. WP from £450.

### 3D series three machine tandem

**Format:** mono or stereo playback.  
**Tape speed:** 19 cm/s.  
**Play time:** 16 minutes.  
**Cartridge:** NAB A, B size.  
**Cue tones:** 1k Hz stop, 150 Hz and 8k Hz aux optional.  
**Equalisation:** NAB adjustable.  
**Frequency response:** 50—15,000 Hz  $\pm 2$  dB.  
**Crosstalk:** -50 dB.  
**Signal-to-noise ratio:** 55 dB mono, 50 dB stereo.  
**Wow and flutter:** 0.2%.  
**Start/stop time:** 0.1s.  
**Dimensions:** 215 x 325 x 270 mm.  
**Weight:** 18.6 kg.  
**Price:** from £940.

### SIS

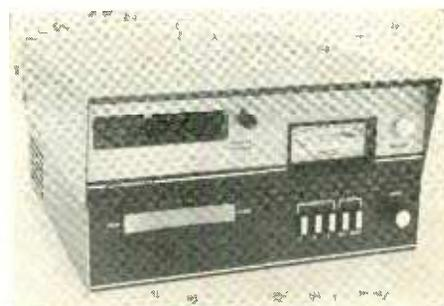
SIS Recording Studios Ltd., 12 Military Road, Northampton.  
**Phone:** 0604 32965.

### S100/s Mk2

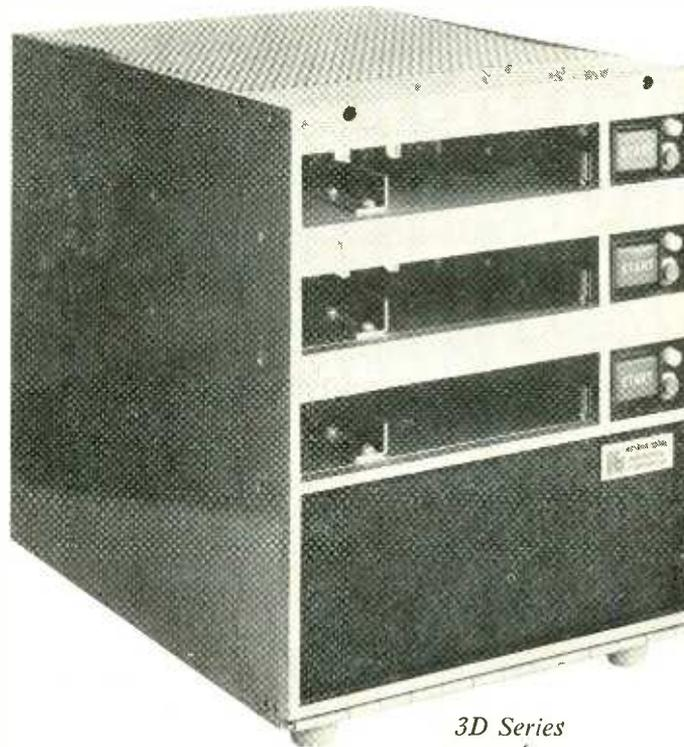
**Format:** Mono playback.  
**Tape speed:** 9.5 cms.  
**Play time:** 21 minutes.

Left: Garron

Right: Sparta



*Lee Engineering have supplied tape cartridge equipment to over 50 recording studios, the BBC and 9 out of 11 commercial radio stations in Britain, can provide full service and repair facilities and carry over 5000 cartridges in stock for immediate delivery.*



*3D Series  
reproducer*

*Need we say more?*



**LEE ENGINEERING LTD**

ASHLEY HOUSE, ASHLEY ROAD, WALTON-ON-THAMES, SURREY KT12 1JE  
WALTON-ON-THAMES 28783/4      Telex: 928475      Cables: LEETECH

## SURVEY

**Cartridge:** NAB A size.  
**Cue tones:** 1k Hz stop.  
**Equalisation:** NAB adjustable.  
**Frequency response:** 50—11,000 Hz  $\pm$  2 dB.  
**Crosstalk:** -70 dB.  
**Signal-to-noise ratio:** 45 dB.  
**Wow and flutter:** less than 0.35%.  
**Start/stop time:** 0.5s.  
**Dimensions:** 270 x 200 x 95 mm.  
**Weight:** 3.2 kg.

### S100/h Mk2

**Format:** Mono playback.  
**Tape speed:** 19 cm/s.  
**Play time:** 10.5 minutes.  
**Cartridge:** NAB A size.  
**Cue tones:** 1k Hz stop.  
**Equalisation:** NAB adjustable.  
**Frequency response:** 50—13,000 Hz  $\pm$  2 dB.  
**Crosstalk:** -70 dB.  
**Signal-to-noise ratio:** 48 dB.  
**Wow and flutter:** less than 0.3%.  
**Start/stop time:** 0.5s.  
**Dimensions:** 270 x 200 x 95 mm.  
**Weight:** 3.2 kg.

### S150

**Format:** mono playback (S150A stereo).  
**Tape speed:** 19 cm/s.  
**Play time:** 10.5 minutes.  
**Cartridge:** NAB A size.  
**Cue tones:** 1k Hz stop, 150 Hz aux.  
**Equalisation:** NAB.  
**Frequency response:** 50—14,000 Hz  $\pm$  2 dB.  
**Crosstalk:** -70 dB.  
**Signal-to-noise ratio:** 50 dB.  
**Wow and flutter:** 0.4% rms weighted peak level.  
**Start/stop time:** 0.1s.  
**Dimensions:** 270 x 200 x 95 mm.  
**Weight:** 3.5 kg.

### SPARTA

Sparta Electronic Corporation, 5851 Florin-Perkins Road, Sacramento, Calif. 95828 USA.  
 Phone: 916-383 5353  
**UK Agents:** Computer Equipment Company Ltd., Shaftesbury Street, High Wycombe, Bucks HP11 2NA.  
 Phone: 0494 34641.

### Century Series

**Format:** Mono, stereo record/playback.  
**Tape speed:** 19 cm/s.  
**Play time:** 10.5 minutes.  
**Cartridge:** NAB A size.  
**Cue tones:** 1k Hz stop 150 Hz aux tone optional.  
**Equalisation:** NAB adjustable.  
**Frequency response:** 50—15,000 Hz  $\pm$  2 dB.  
**Signal-to-noise ratio:** 55 dB mono. 52 dB stereo.  
**Wow and flutter:** 0.2%.  
**Dimensions:** 300 x 380 x 152 mm.  
**Price:** From £250 to £650 depending on specification.

### SPOTMASTER

Broadcast Electronics Inc., 8810 Brook-vill Road, Silver Spring, MD. 20910.  
 Phone: 301-588 4983.  
**UK Agents:** CRS (World) Productions Ltd., Caroline House, 24/30 Park Lane, Poynton, Cheshire.  
 Phone: Poynton 6401.

### Ten/70

**Format:** mono or stereo record/playback.  
**Tape speed:** 19 cm/s.  
**Play time:** 10.5 minutes (NAB A size).  
**Cartridge:** NAB A, B size.  
**Cue tones:** 1k Hz stop, 150 Hz aux, 8k Hz aux.



Sparta

**Equalisation:** NAB or IEC.  
**Frequency response:** 50—15,000 Hz  $\pm$  2 dB. 30—18,000 Hz  $\pm$  4 dB.  
**Crosstalk:** -55 dB.  
**Signal-to-noise ratio:** 57 dB.  
**Wow and flutter:** 0.2%.  
**Start/stop time:** 0.1s.  
**Dimensions:** 140 x 220 x 310 mm.  
**Weight:** 7 kg.  
**Price:** £779.09 (mono).

### 303D three machine tandem

### 305D five machine tandem

**Format:** mono or stereo playback.  
**Tape speed:** 19 cm/s. 9.5 cm/s optional.  
**Play time:** 10.5 minutes.  
**Cartridge:** NAB A size.  
**Cue tones:** 1k Hz stop, 150 Hz and 8k Hz aux optional.  
**Equalisation:** NAB standard.  
**Frequency response:** 50—15,000 Hz  $\pm$  2 dB. 30—18,000 Hz  $\pm$  4 dB.  
**Crosstalk:** -55 dB.  
**Signal-to-noise ratio:** 55 dB.  
**Wow and flutter:** 0.2%.  
**Start/stop time:** 0.1s.  
**Dimensions:** 370 x 142 x 450 mm.  
**Weight:** 19 kg.  
**Price:** £1708.18 (305 stereo). £1318.63 (303 stereo).

### 500 series

**Format:** record/playback (500D) playback only (505D). Mono.  
**Tape speed:** 19 cm/s.  
**Play time:** 31 minutes.  
**Cue tones:** 1k Hz stop, 150 Hz, 8k Hz aux optional.  
**Equalisation:** NAB standard.  
**Frequency response:** 50—12,000 Hz  $\pm$  2 dB. 40—

15,000 Hz  $\pm$  3 dB.  
**Signal-to-noise ratio:** 50 dB.  
**Wow and flutter:** 0.2%.  
**Start/stop time:** 0.1s.  
**Dimensions:** 270 x 330 x 170 mm.  
**Weight:** 8 kg.

### 400 series

**Format:** record/playback (400B) playback only (405B).  
**Tape speed:** 19 cm/s.  
**Play time:** 31 minutes.  
**Cue tones:** 1k Hz stop, 150 Hz and 8k Hz aux optional.  
**Equalisation:** NAB standard.  
**Frequency response:** 50—12,000 Hz  $\pm$  2 dB.  
**Signal-to-noise ratio:** 50 dB.  
**Wow and flutter:** 0.2%.  
**Start/stop time:** 0.1s.  
**Dimensions:** 270 x 330 x 170 mm.  
**Weight:** 8 kg.

### Three/70

**Format:** mono playback.  
**Tape speed:** 9.5, 19 cm/s optional.  
**Play time:** 21, 10.5 minutes.  
**Cartridge:** NAB A size.  
**Cue tones:** 1k Hz stop, 150 Hz and 8k Hz optional.  
**Equalisation:** NAB or IEC.  
**Frequency response:** 50—15,000 Hz at 19 cm/s.  
**Crosstalk:** -55 dB.  
**Signal-to-noise ratio:** 55 dB.  
**Wow and flutter:** 0.2% NAB unweighted at 19 cm/s.  
**Start/stop time:** 0.1s.  
**Dimensions:** 135 x 146 x 320 mm.  
**Weight:** 5.5 kg.  
**Price:** £300.

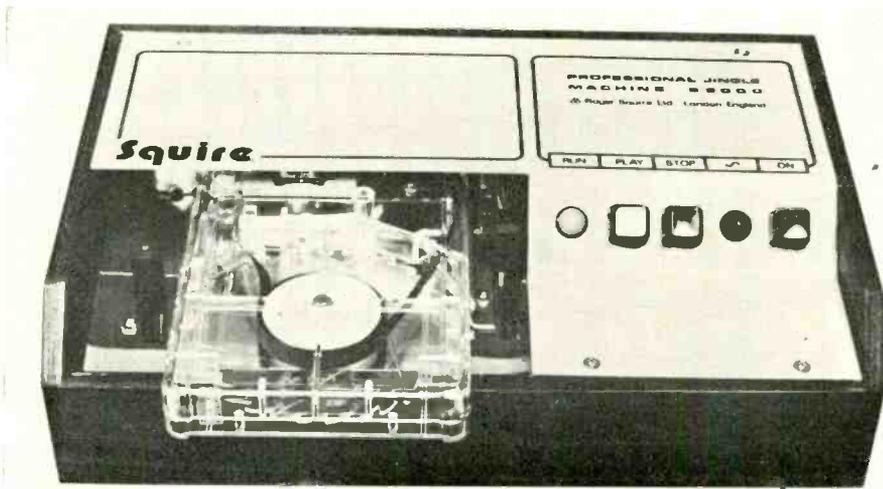
### ROGER SQUIRE

Roger Squire DJ Studios, 55 Charlbert Street, St Johns Wood, London NW8 6JN.  
 Phone: 01-722 8111

### S2000

**Format:** mono playback.  
**Tape speed:** 19 cm/s.  
**Play time:** 10.5 minutes.  
**Cartridge:** NAB A size.  
**Cue tones:** 1k Hz stop.  
**Equalisation:** NAB.  
**Frequency response:** 50—10,000 Hz  $\pm$  3 dB.  
**Crosstalk:** -45 dB.  
**Signal-to-noise ratio:** 50 dB.  
**Wow and flutter:** 0.3%.  
**Start/stop time:** 0.13s.  
**Dimensions:** 305 x 200 x 80 mm.  
**Weight:** 3.5 kg.  
**Price:** £139.

Squire



**QRK**

IS THE STANDARD EQUIPMENT OF THE AMERICAN BROADCAST AND RECORDING INDUSTRY. THERE IS NO EQUAL. CHECK OUR HIGHLY COMPETITIVE PRICES.

this is **QRK**  
Broadcast Equipment



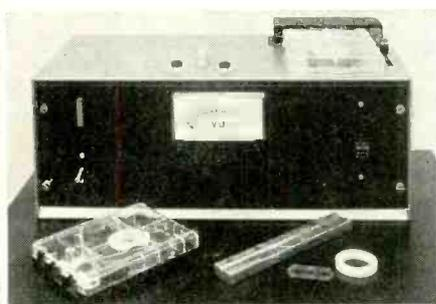
**QRK** 12C BROADCAST TURNTABLE

**QRK** STEREO CARTRIDGE BROADCAST RECORDER

**ITA**

**Industrial Tape Applications**

5 Pratt Street, London NW1 OAE. Tel: 01-485 6162 Telex: 21879



**"AIR CHECK"**

**MACHINES & CARTRIDGES**



I OLDERSHAW MEWS MAIDENHEAD, BERKS.

Possibly the least expensive, Probably the best!

- ★ Phone us your cart problem
- ★ Ask for Iain Webb, 'the Cart King' Tel. 0628-33011 24 hours.

**BE Spotmaster**

**Broadcaster's Supermarket**

One-stop shopping for outstanding values in Spotmaster® cartridge tape equipment and other broadcast products and accessories. Just check the boxes and send us this advertisement with your letterhead. We'll speed complete information by return mail.



**Single Cartridge Equipment**

Ten/70 Stereo Record-Play

Record-play & playback models, mono & stereo, compact & rack-mounted.

- The incomparable Ten/70®
- The low-cost "spacesetter" Three/70®
- Delayed programming models

**C. R. S. (World) Productions Ltd.**

24/30 Park Lane, Poynton, Cheshire  
Tel: Poynton 6401

**NOW UNDER ONE ROOF!**

- ★ Audio Cassette Duplication Services
- ★ Tape and Cassette Recorder Rentals
- ★ Video Tape Sales
- ★ System design and installation

**MAGNEGRAPH Recording Co. Ltd.,**

8 Hanway Street, London, W.1 (junct. Oxford Street/Tottenham Court Road) Tel. 01-323 0888

The research carried out in the ORTF research laboratory is summarised in the context of acoustic ambience recreation. Considerable improvement in the quality of the tetraphonic perspective is related to the nature of the sound field and its perception.

# Microphone and loudspeaker arrangements for tetraphony

\* R. CONDAMINES

It is not out of place here, as a preface, to recapitulate briefly that evolution which, starting with monophony, has brought us now to tetraphony and which will bring us in due course to polyphony. We shall make a distinction (fig. 1) between S, the sound input and recording facilities, which constitute a sound transmitter in the most general sense; R, the sound reproduction facilities, which include the listening room and the observer; and T, the transmission facilities linking them. In the case of monophony, whatever may be the actual number of microphones and loudspeakers, T consists of one single channel; the microphones and loudspeakers are coupled together in groups both acoustically and electrically. In the case of stereophony—or 'biphony'—T consists of two electrically distinct channels; the microphones and the loudspeakers respectively are, of course, coupled acoustically within S and within R—that is indeed the condition for the very existence of the system. Tetraphony is the natural extension of this technique to four electrically distinct channels (fig. 1).

At the present time, a great deal of publicity is being devoted to recording and reproducing processes employing matrices. In these processes, T may be divided into three stages,  $T_1$ ,  $T_2$  and  $T_3$ , consisting of four, two and four channels respectively, whereby  $T_2 = MT_1$  and  $T_3 = M_1T_2$ , wherein  $M_1$  M is a matrix which is not orthogonal. Under those conditions,  $T_2$  does not reconstitute  $T_1$ , and each of the four channels of  $T_3$  depends on the four channels of  $T_1$ . In addition, as the capacity of each of the two channels of  $T_2$  is no greater than that of each of the four channels of  $T_1$  or  $T_3$ , an inevitable loss of information occurs as well as the above-mentioned crosstalk. The matrix processes, therefore, do not constitute true tetraphony.

In this present paper, we shall assume that T is non-degenerate and thus consists of four separate channels, each of them being equivalent to a conventional high-quality monophonic transmission channel.

### Subjective sound-space

In order to introduce our subject, we will first briefly summarise the theory of the sound-space, which is a generalisation of that of the 'cone of presence' described by G. von Békésy<sup>1</sup> and J. Bernhart<sup>2</sup>. In fact, we shall discuss here a subjective space, a conventional notion in psychology which can concern not only sensory phenomena, but also the more developed categories of instinct and intelligence. The application of these principles to a subjective sound-space makes it possible to represent in a synthetical fashion all the phenomena of psychoacoustics; here we shall apply them to tetraphony.

Let us assume that, by some unspecified process, an observer can indicate the direction and position in the sound-space of the perceived sounds, making use of the conventional methods of reproduction for the more complex qualities corresponding to the tonal quality. The observer will build up in that fashion an application of the perception space on to the physical space; and thus, a representation of the subjective sound-space is obtained (fig. 2). It is essential to note that, in such an operation, the observer must consider the perceptions as

FIG. 1 SCHEMATIC REPRESENTATION OF THE THREE PARTS CONSTITUTING A TETRAPHONIC CHAIN

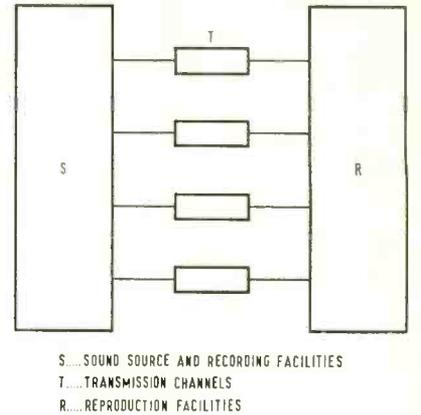


FIG. 2 REPRESENTATION OF THE SOUND-SPACE EXPERIENCED BY AN OBSERVER. THE DENSITY OF THE SHADING CORRESPONDS TO THE INTENSITY OF THE PERCEPTION.

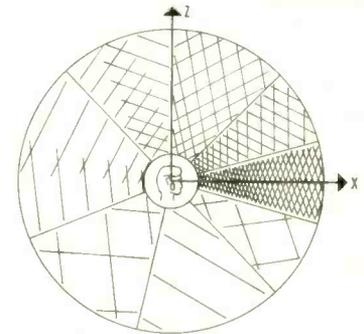
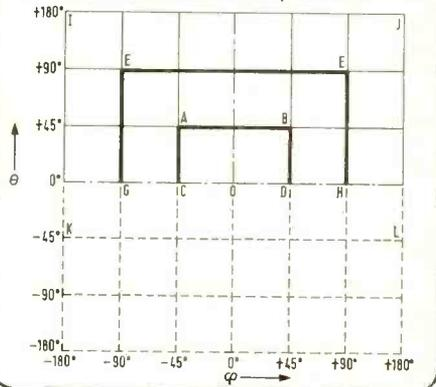


FIG. 4 TWO DIMENSIONAL REPRESENTATION OF THE COORDINATES  $\theta$  AND  $\varphi$  IN FIG. 3



\* Dr. Condamines is Chief Telecommunication Engineer and Head of the Acoustic Laboratory of the Office de Radio-diffusion-Télévision Française

such, and not their significance as manifestations of real sound sources. For example, the reverberation in a concert hall seems to come from the forward hemisphere. Notwithstanding that it is, in theory, homogeneous and isotropic.

A diagram which the author has published several times previously<sup>3</sup> is reproduced here as fig. 2. The perceptions seem to be closer in the immediate psychological environment of the observer (also termed 'more present'), in proportion to their nearness to the horizontal axis OX and to the observer. On that basis, the density of interest is represented by the density of shading. A 'cross-section' by a plane perpendicular to OX makes it possible to represent the sound-scene, which leads to the notion of stereophonic perspective.

If the observer receives a multiplicity of impressions, the most substantial appear spontaneously within the cone of presence. The observer can analyse the sound-space by means of a cone of vigilance of smaller aperture, which will enable him to 'fix' his attention on this or that feature. This is the phenomenon of selective listening, which may be studied within the framework of the theory of the detection of signals.<sup>4</sup> It is sometimes termed intelligent listening.<sup>3</sup> But that term does not take account of the artistic or merely informative aspects of the operation; moreover, it seems fairly probable that some animals are capable of very developed selective listening, so that this must therefore be considered to be on the level of instinct rather than that of intelligence.

It is necessary to give a two-dimensional representation of that subjective space, and in fig. 3 the angles  $\theta$  and  $\varphi$  of elevation and azimuth respectively are indicated; together with the distance, they make it possible to localise any spatial perception. The greater or lesser fineness of the perspective, that is to say, the 'compactness' of the sounds or the sensation of real physical presence, the illusion of which is sometimes created by true stereophony, may be represented by more or less dense shading.

#### Tetraphonic perspective

It is convenient to discuss this on the basis

of the conventional graphical representation depicted in fig. 4. The angle  $\theta$  is scaled positively upward and the angle  $\varphi$  increases to the right.

The cone of vigilance would be represented by a small circle located in the area IJKL; when the attention is particularly attracted, it tends towards the centre of the space of presence within ABCD. The values of  $\theta$  between  $-10^\circ$  and  $+30^\circ$ , and those of  $\varphi$  between  $\pm 45^\circ$  thus play a preferential role, characterising what has been termed the front space.

In practice, conventional stereophony makes it possible to re-create the subjective impressions occupying two-thirds of the area ABCD. Tetraphony is intended to do better than that.

It happens that the psychophysical properties of the subjective space are very diverse, depending upon the region considered. The most interesting of those sub-divisions are indicated in fig. 4. It may be said, in outline, that the effects of presence and occupation to which the intellect is sensitive decrease with increasing distance from the area ABCD. The regions for which  $\theta$  is less than  $-30^\circ$  are subjectively of little importance; the same applies, although to a lesser degree, in the case of values of  $\varphi$  such that  $|\varphi| > 90^\circ$  (hearing from the rear).

These considerations, set out in greater detail in fig. 3 and represented by an obvious convention in fig. 2, do not apply wholly to alarm signals, whose direction and subjective importance are not correlated. In the presence of any sound field, however, the general rule is the following: the observer directs his attention and (possibly) tends to turn himself so that the space of effective perception has the same structure as the reference space (fig. 2). It is thus that we turn the head in response to a point stimulus coming from behind.

In consequence, one of the criteria of high-quality listening which leaves the listener, in terms of his personal parameters<sup>4</sup>, the freedom of filtering the global information received by him, is the construction of an acoustic field responding to the conditions of reference. Otherwise his attention would be perpetually attracted toward the back, the right and left, and high and low, in an imperative manner and without—other than exceptionally—any aesthetic justification. For example, the process

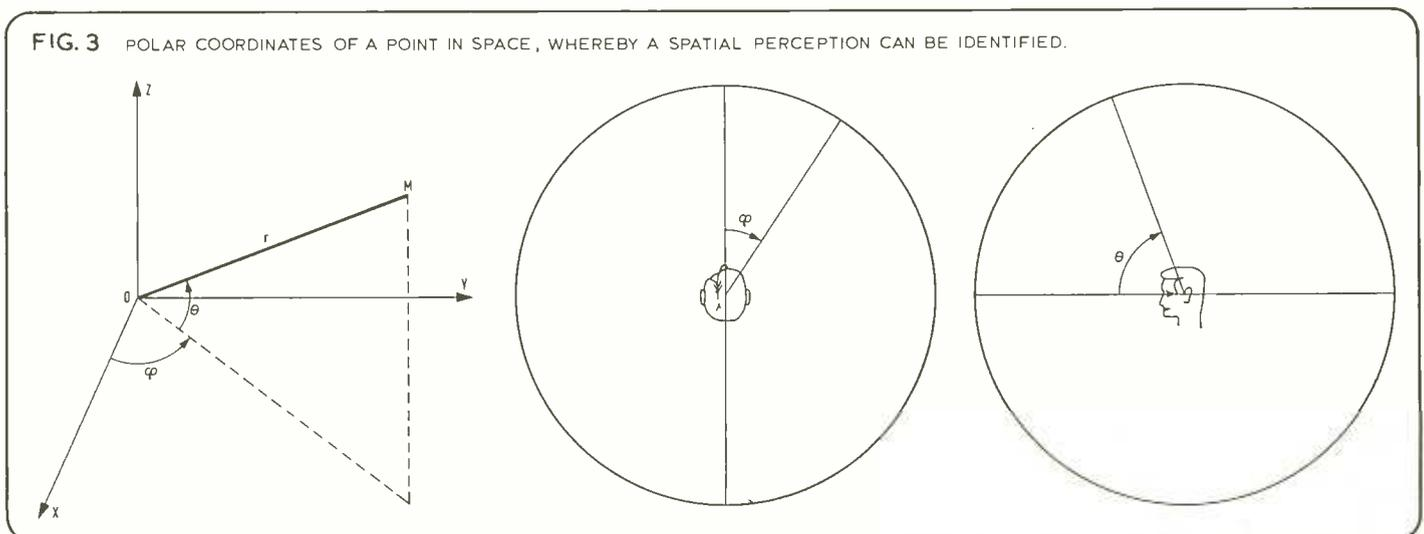
depicted in figs. 5a and 5b which represent the first steps in tetraphony, seeks to reproduce the ambience of a large hall by picking up the reverberation at the far end of the hall and reproducing it at the far end of the listening room. In that form it is doomed to failure because either the sound from the loudspeakers C and D is masked by that from A and B and their effect is slight, or it is not so masked and they are perceived as quasi-point sources attracting the attention, tending to cause the observer to turn round. In any case, the actual reverberation in a concert hall is perceived in the subjective front space.

To sum up, the target which we shall propose for tetraphony is a first generalisation of biphony (or dual-channel stereophony). To advance from the known to the unknown will be a process of increasing the magnitude or the extent of the sound-stage, by going beyond the boundary of the cone of presence in a two-dimensional representation (fig. 4). We shall, if possible, reach the area EFGH; that is to say, the forward and upward space. The sound should, moreover, retain that particular quality of true stereophony, 'compactness,'<sup>5</sup> which gives the illusion of a real although invisible physical presence of the sound sources. That sensation forms part of the range of possibilities of true stereophony and should be maintained, or even augmented, in the case of tetraphony.

#### The space-time correlation

An overall classification of sound may be based on their perspective, which is a spatial magnitude of a subjective nature. The time-scale of the perceptions is another factor, associated with the time of arrival  $t$  of the physical sound waves. Because every sound phenomenon occupies space and time, the resultant impression is a synthesis which cannot be reduced to any simple psychological operation. In particular, the subjective time-scale and the perspective are intimately linked, and it is valid to introduce the notion of subjective sound space-time. The representation depicted in figs. 2 and 4 can then no longer be applied directly. The time variable will be taken into account by its influence on the perspective.

56 ►



## TETRAPHONY

At this point we shall briefly introduce certain rather unconventional notions about the acoustics of halls. A comprehensive survey<sup>6</sup> of the work carried out throughout the world has recently demonstrated to what extent the physical parameters now used in the study of room acoustics are inadequate. Let us limit ourselves, for example, to the concepts of direct and reverberant sound. We could give them evident physical significance, but such an analysis is no longer directly valid from the point of view of perception. The direct sound in the physical sense is the source of only the 'dead' sensations experienced in the anechoic chamber. Listening in free space always involves a certain amount of reflection or diffusion resulting from temperature gradients in the surrounding medium. In actual listening, and more particularly in listening in a concert hall, we break down the sound field into the sound perceived in a living and direct manner, constituting the nucleus of the sonic phenomenon, and a halo, or aureole, giving an impression of a wider ambience. The nucleus involves the first reflections and the halo the later reflections up to a certain fraction of the reverberation time.

The sound nucleus is characterised by a mean time of arrival  $t_1$ , the halo by a time  $t_2$ . The definitions of those factors might be determined on the basis of the theory put forward by H. Mertens,<sup>7</sup> and by taking account of the space distribution of the waves. Thus it would appear that  $t_1$  takes account of the first reflections and  $t_2$  of the global characteristics of the hall. Nucleus and halo also have 'geometric' significance of the centre of a sound phenomenon in that space; the functions  $n(r_1, \theta_1, \varphi_1, t_1)$  and  $h(r_2, \theta_2, \varphi_2, t_2)$ , relative to the two subjective components, could be made to correspond to any sound whatever. Thus, the perception of any sound can be represented (in fig. 4) by a point at which one value, the time, is assigned.

Conversely, it would be necessary to assign a time of arrival whose magnitude would depend on the nature of the sound phenomenon to every point in the subjective space. Two

functions,  $N(r, \theta, \varphi, t)$  and  $H(r, \theta, \varphi, t)$ , in the subjective space-time  $E$ , which is therefore subjective in space and objective in time, would thus be defined.

To every point in the subjective space there corresponds a time of arrival of the sensations (taking as the origin the instant of arrival of the direct sound at the ears of the observer); the nucleus occupies the cone of presence, and the reverberant sounds are further delayed as the distance increases. A sound reproducing installation should, therefore, take account of these 'natural' relationships, otherwise it may produce results which, although perhaps not being entirely without interest, will be quite incapable of recreating concert-hall listening conditions.

Moreover, in a listening room the observer is submerged in a defined sound field in a physical space-time completely different from that existing in the concert-hall. The reproducing equipment, that is to say the loudspeakers, behave as relatively point-like sound sources in any case and in no way analogous to the reverberation. The relative delays of the waves arriving at the ears of the observer are functions of the concert-hall and the listening-room and not of the loudspeakers. Let us consider, for example, the layouts of loudspeakers for tetrachophony and functioning according to the following principle (fig. 5). The ambience microphones set up at the back of the concert hall (fig. 5a) pick up the reverberation, which is reproduced for the observer by the loudspeakers installed at the back of the listening-room (fig. 5b). In that case, the loudspeakers C and D provide a relatively point-like image which, in a normal subjective space, corresponds to average values of  $t$  that are shorter than the value  $\bar{t}$  of the sounds picked up by the microphones. In brief, the function  $S(r, \theta, \varphi, t)$  representing the sound field  $N+H$  in the space-time, is not physiological and cannot correspond to a mode of normal reception by the observer. Tetrachophony of this type is not satisfying to an isolated observer. This leads to the layout of fig. 5c, which greatly improves the diffusion with slightly increased value of  $\bar{t}$ ; however, that diffusion is uncontrollable, and the arrangement is rather closely related to pseudo-

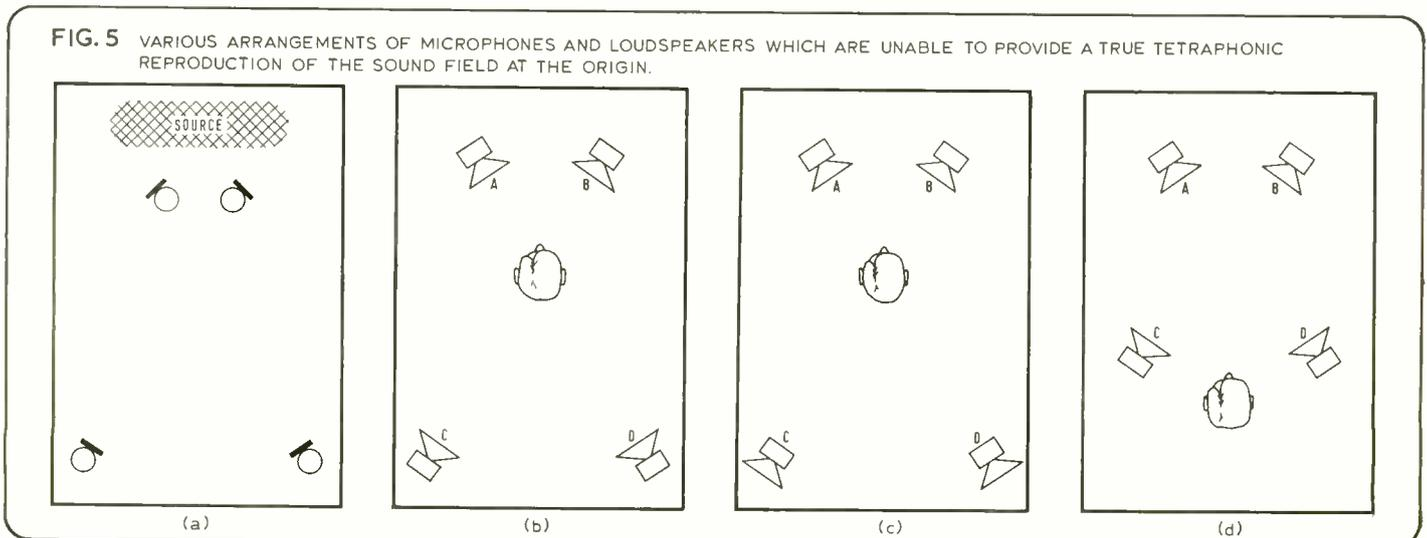
tetrachophony. Finally, the layout in fig. 5d attempts to increase the diffusion and also the value of  $\bar{t}$ , by positioning the centre of the sound-scene in front of the observer, which partly redistributes the listening to a favourable area. Again, and for the same reasons as in the last case, such an arrangement results in perceptions intermediate between those obtained from true and pseudo-tetrachophony.

Let us reiterate once again what has always been our guiding principle: the qualifications true and pseudo have no laudatory or pejorative meaning. True tetrachophony is simply the only system capable of re-creating sounds giving a subjective impression of presence, of 'compactness' closest to the perception of the original sound field. Pseudo-tetrachophony, which allows the four channels to be mixed electrically, gives diffuse perceptions, at the back at least. When true tetrachophony is modified by increasing the acoustic coupling of the back channels the subjective impression tends to present those characters (figs. 5c and 5d). Let us mention in passing that we have found by listening to installations using those two last layouts that they seem to be extremely useful in widening the sound-scene, but they cannot give the range of possibilities which we shall now discuss and which constitute the principal object of our research.

### Studies in the laboratory

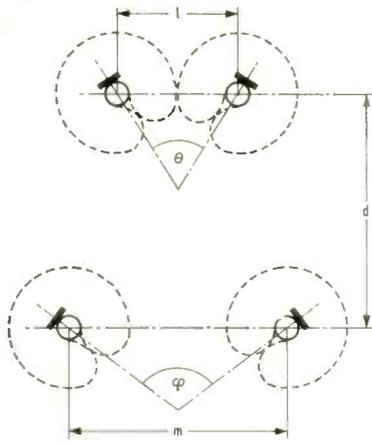
Following the statement of the premises summarised above, the studies undertaken in the laboratory were aimed at the determination of the properties of the tetrachophonic quadruplet as depicted in fig. 6. Four microphones having cardioid directivity were arranged in two pairs (l,  $\theta$ ) and (m,  $\varphi$ ), separated by a distance  $d$ . It will be observed that it would be possible to arrange those microphones as four different pairs, and this must certainly be taken into account as it could have a definite influence on the listening results. This technique renders the solutions based on two stereophonic pairs (17 cm, 110°), themselves 17 cm apart, of little interest, and one of the objectives was precisely to arrive at a coupling that was neither too tight nor too loose.

The positions of the loudspeakers and the observer are equally important, because their

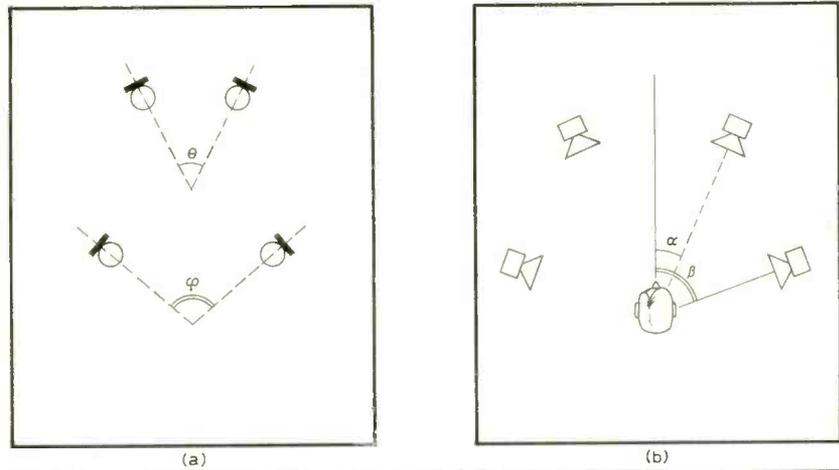




**FIG. 6** PLAN SHOWING THE TETRAPHONIC QUADRUPLLET FORMED WITH FOUR CARDIOD MICROPHONES



**FIG. 7** THE ANGLES DEFINING THE ARRANGEMENT OF TETRAPHONIC MICROPHONES AND LOUSPERS UNDER DISCUSSION



heights and the angles ( $\alpha$ ,  $\beta$ ) (fig. 7) have a direct influence on the pair ( $\theta$ ,  $\phi$ ), and the spacing on  $r$ . A series of experiments was undertaken on the listening conditions for this arrangement in conjunction, of course, with the microphone positions.

We shall not describe in this paper the practical details of those experiments which, it may be mentioned, covered the very large number of quadruplets which could be included in a sphere of radius 20 cm up to being outside a sphere of radius 3m for productions in studios of average size. On the other hand, we feel that it is indispensable to give a few brief indications regarding one of the most interesting of the possibilities that came to light, namely space-time compensation. We shall adopt for that a practical terminology, which might be transposed by means of the space-time functions  $N$  and  $H$ .

Let us consider a stereophonic pair (17 cm,  $110^\circ$ ). Let us now assume that we move the microphones further apart; the sound-scene then becomes rapidly more and more vague and occupies spatially a larger area. If the distance between the microphones exceeds a certain value, we observe a 'hole in the middle' and the impression of merging of the loudspeakers decreases. The effect is similar if the corresponding loudspeakers are moved further apart while the pair ( $l$ ,  $\theta$ ) is maintained constant. The two operations may be combined. Closely-spaced microphones correspond to a small value of  $\bar{t}$  and give an image whose extent  $e$  is greater if the loudspeakers are located in the subjective space in a region outside the cone of presence, corresponding to a greater value of  $\bar{t}$ . Conversely, wider-spaced microphones correspond to rather higher values of  $\bar{t}$  and, if they feed closely-spaced loudspeakers, the corresponding global image will be narrower and more precise, thus demonstrating the existence of compensation between space and time.

For us, the problem was to arrive at a system of compatible tetraphony (fig. 8). We started with a stereophonic pair AB (17 cm,  $110^\circ$ ), which gave a low value of  $\bar{t}$  and a fairly low value of the image  $e$ , the image being located between the two loudspeakers. In order to

obtain tetraphonic perspective, we progress from the known to the unknown, from the direct to the indirect, from the cone of presence to the regions of the subjective space that surround it, and then further and further away from it. In other words, tetraphony will make it possible to 'utilise' a great part of the front space and bring about an improvement, compared with dual-channel stereophony, of about the same magnitude as that between monophony and dual-channel stereophony.

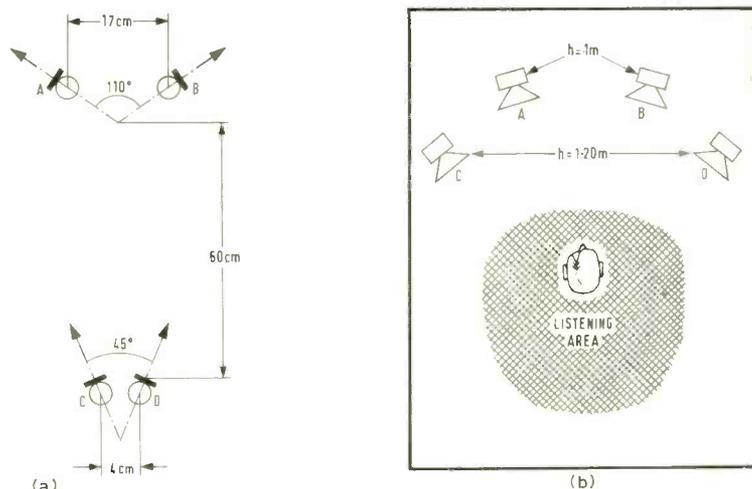
We wish to obtain an extent  $e'$  which is greater than the extent  $e$  given by biphony. Closely-spaced microphones C and D feeding relatively widely-spaced loudspeakers C and D (fig. 8) will give a sound image corresponding to a value of  $\bar{t}$  fairly appropriate to the position ( $\theta$ ,  $\phi$ ) of the image in the subjective space, with a hole in the middle, in which are placed the microphones A and B. Of course, such an argument is only indicative, because of the effects of the couplings AC, AD, BC and BD,

as well as of the triplet ABC and other parameters. The distance  $d$  would have to be several tens of centimetres, if such parasitic effects are to be avoided. The development of a system of this kind can obviously only be effected in an empirical fashion; it leads to very considerable variations of the image depending on the positions of the microphones and, to a lesser degree, of the loudspeakers. It was, moreover, the same in the case of conventional stereophony.

As an example fig. 8 depicts a quadruplet ABCD and the corresponding listening arrangements which, under certain conditions, produce genuine compact tetraphonic perspective, the logical generalisation of stereophonic perspective. The sound-scene appears really to be in the space delimited by the loudspeakers and contrary to certain opinions (including that held by the present author some years ago), at least as much is gained by changing from two

58 ►

**FIG. 8** ARRANGEMENTS OF THE MICROPHONES AND LOUSPERS MAKING POSSIBLE AN IMPROVEMENT OF THE QUALITY OF THE TETRAPHONIC PERSPECTIVE USING THE SPACE-TIME COMPENSATION PRINCIPLE.  $h$  = HEIGHT OF THE LOUSPERS FOR A SEATED OBSERVER.



## TETRAPHONY

to four channels as by changing from one to two channels.

The advantages of this arrangement, termed space-time compensation, are similar in magnitude to those of true stereophony. Although the area of optimum listening quality is reduced, the area of very good quality is considerably increased—in particular, the compactness of the sound is noticeable outside that area and even in the next room.

A certain amount of adjustment remains to be effected in each particular production. It may be desired that the pairs AB and CD do not remain within exactly the same plane, or within parallel planes, and that adjustments are made to the distance between them and to their position as an entity. The directivity may be adjusted also, at least in the case of the rear pair. Moreover, the very principle of space-time compensation implies that the system is dependent on the dimensions of the sound source, the room in which it is situated, and the listening room. The experience gained with stereophony where in the same manner a conventional pair should depend on the same variables, but is found to be in fact fairly stable, shows that fear is not well founded, if one remains close to the cone of presence. If one goes slightly away from it, which is the case of

our tetraphony, it may reasonably be hoped that because the attention is then less concentrated, a single quadruplet could be suitable for all routine situations.

### Conclusion

The revelation of the correlation and the possibility of space-time compensation appears to constitute a valuable step forward in the studies not only of tetraphony, but also of polyphony. Without exaggeration, it can now be seen how the use of a number of pairs AB, CD etc., where  $d$ ,  $\varphi$  and  $m$  are variables, could make it possible to shift the predominant nucleus sounds into the regions of the subjective space naturally reserved for the halo, in order to increase further the extent of the sound space. With regard to the compatibility, it exists strictly and inherently with AB stereophony. Moreover, as the channels A and D, B and C etc, are not coupled, and AB takes advantage of a certain priority, such systems are also fairly compatible, if it is taken for A+C and B+D stereophony (compatibility 2/4), A+C+E+G and B+D+F+H stereophony (compatibility 2/8), and so on.

To sum up, starting from theoretical considerations and from practical listening experiments, it ought to be possible to achieve further substantial progress. It is to that end that the Acoustics Laboratory of the ORTF is making its modest contribution.

### BIBLIOGRAPHICAL REFERENCES

1. von Bekesy, G: Experiments in hearing. McGraw-Hill, New York, 1960.
2. Bernhart, J: Traite de prise de son (Studio technique). Editions Eyrolles, Paris, 1953.
3. Condamines, R: La stéréophonie (Stereophony). *Revue du Son*, No. 167, March 1967, pp. 91-96; No. 172-173, August-September 1967, pp. 341-344; No. 174, October 1967, pp. 373-377; No. 177, January 1968, pp. 1-4; No. 179, March 1968, pp. 89-93.
4. Condamines, R: Thèse de Doctorat ès Sciences appliquées (These principale): Contribution à l'étude de la régulation du niveau sonore dans la prise de son (Thesis for Doctorate in Applied Sciences (Main thesis): Contribution to the study of the control of the sound volume in broadcasting), pp. 294-300, Paris, December 1972.
5. Condamines, R: De la monophonie à la polyphonie (From monophony to polyphony). *Revue du Son*, No. 234, October 1972, pp. 424-427.
6. Condamines, R: Thèses de Doctorat ès Sciences appliquées (Thèse complémentaire): Les critères physiques de la qualité acoustique des salles (Thesis for Doctorate in Applied Sciences (Complementary thesis): The physical criteria of the acoustic quality of concert halls), Paris, December 1972.
7. Mertens, H: Directional hearing in stereophony Theory and experimental verification. *EBU Review*, No. 92-A, August 1965, pp. 146-158.
8. Condamines, R: Le problème de la compatibilité (The problem of compatibility). *Revue du Son*, No. 242, June/July 1973, pp. 41-43.

## LETTERS

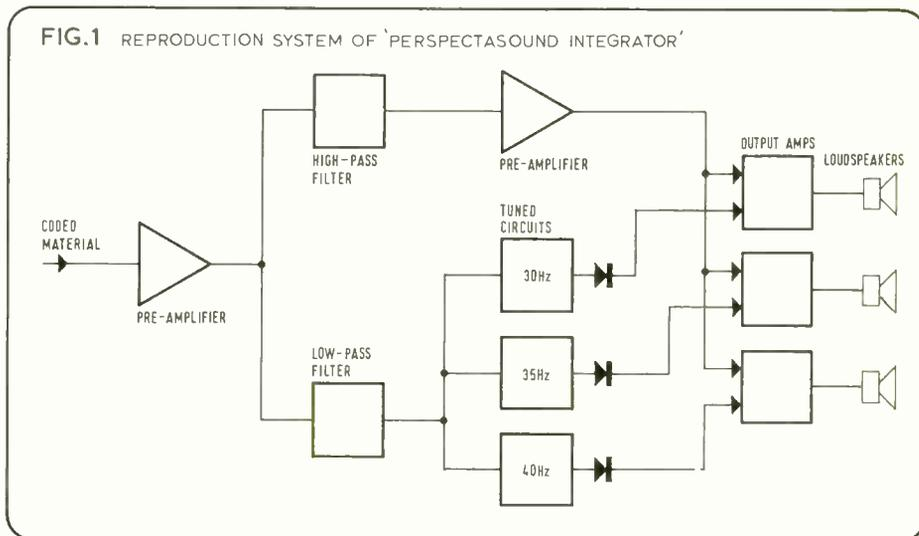
### Perspectasound encoding

Dear Sir, I was very interested to read in the Patents section of July 1974 *STUDIO SOUND* about the patent published in 1958 concerning a method for coding two channels so that only one storage channel was necessary, thus making possible the storage of four channels on two channels, and so on. This system, or a version of it, was in fact used by the Rank Organisation in several of their Todd AO productions, notably 'Around the World in 80 Days', and the instrument was given the name 'Perspectasound Integrator'.

Rather than using very high frequencies, this instrument appears to have utilised the frequencies 30, 35 and 40 Hz in the three-channel system shown in the schematic in fig. 1. The tuned circuits separate the marker frequencies, which are then each rectified and produce a dc voltage proportional to the marker concerned. These are then used to control automatically the output of each amplifier. Thus, the three outputs become mutually independent, in a 3-1-3 audio system. In fact this system is very amenable to adaption for experimental recording by the amateur, using two marker frequencies on each channel, giving four-channel sound encoded on to two channels or a 4-2-4 coding system. Some loss of very low frequencies is inevitable, but the overall sound should be very satisfactory and worthy of further experimentation.

Yours faithfully, James Crabbe, B.Sc., M.Sc., A.R.I.C., 39 West End Avenue, Harrogate, Yorkshire.

*My understanding of Perspecta sound (gleaned from the really excellent Focal Press book Wide Screen Cinema and Stereophonic Sound by Michael Wysotsky), is that it was very much a*



*pseudo-stereophonic system. The control signals of 30, 35 and 40 Hz imposed on the mono track (of which the bass end is clipped at 63 Hz) were used on playback to pan the mono sound automatically between three banks of speakers behind the screen. So despite its name the system offered no true perspective of sound!*

*This wasn't the only odd thing about early Todd AO—the first few films were shot at 30, rather than 24, frames per second. When the National Film Theatre tried recently to screen 'Around the World' in its original 70 mm form they found the print required projection at 30 fps and were thus forced to screen a 35 mm print instead.*

Adrian Hope

### Disc patents

Dear Sir, In the July 1974 issue of *STUDIO*

*SOUND* on page 28 you published a rather extensive coverage of a United States patent (2,849,540) applied for in 1954 and published in 1958.

I would like to draw your attention to the British Patent (612.163) in my name, applied for in 1946, and the complete specification accepted in 1948.

The British patent therefore invalidates the US patent which was published ten years later and which appears to be identical to mine, with only the frequency range increased in accordance with the progress of disc recording and reproduction at the later date.

Yours faithfully, W. H. Livy, Chief Engineer, EMI Recording Studios, 3 Abbey Road, St John's Wood, London NW8 9AY.

\*See Patents, page 40.

*an introduction to*



**TWEED  
AUDIO**



20 CHANNEL 8 TRACK  
MUSIC RECORDING  
CONSOLE.

WE DESIGN AND  
DELIVER CUSTOM BUILT  
AUDIO EQUIPMENT TO  
PROFESSIONAL  
STANDARDS INCLUDING  
LIMITOR COMPRESSORS  
MONITOR POWER  
AMPLIFIERS AND  
DISTRIBUTION AMPLIFIERS.



**TWEED AUDIO**

ELECTRONICS  
2 ROXBURGH STREET, KELSO, ROXBURGHSHIRE,  
SCOTLAND. TELEPHONE 2983 STD 057 32

**AN ANNOUNCEMENT OF IMPORTANCE  
TO ALL THOSE CONNECTED WITH  
FILMS, TELEVISION, MUSIC AND  
RELATED INDUSTRIES.**

**STUDIO FACILITIES AVAILABLE ON A  
DAILY BASIS OR LEASE AT THE 20  
ACRE SHEPPERTON STUDIO CENTRE.  
SHEPPERTON HAS BEEN COMPLETELY  
REORGANISED.**

Film Producers can rent the big scale stages without incurring overheads which are associated with traditional big time studios. Service companies, producers, directors, writers, composers, etc. can rent stages, workshops, offices, cutting rooms, post production facilities, etc. and so be based where the action is!

**FULL TIME MANAGEMENT STAFF ARE  
BASED AT THE STUDIOS TO LOOK  
AFTER TENANTS AND PROVIDE CENTRAL SERVICES.**

**SHEPPERTON STUDIOS HOME OF  
MANY FAMOUS PRODUCTIONS IS  
IDEALLY SITUATED IN A PLEASANT  
ENVIRONMENT 18 MILES FROM THE  
CENTRE OF LONDON, 6 MILES FROM  
LONDON AIRPORT AND M.4 AND ONLY  
2 MILES FROM THE M.3.**

**Quotes:**

'A modern and realistic approach to film making' Director David Butt of BBRK Ltd.

'I can recommend it' Jules Levy producer of 'Brannigan' with John Wayne.

**THESE ARE OPPORTUNITIES NOT TO  
BE MISSED. COME TO SHEPPERTON.**

**Contact:**

The Estates Manager,  
The Shepperton Studio Centre, Squires  
Bridge Road, Shepperton, Middx

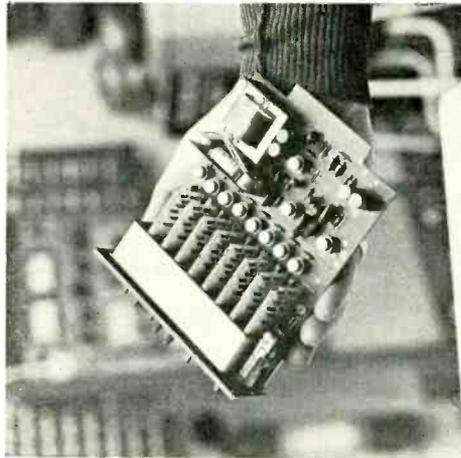
**Tel: Chertsey 62611**

## PANDORA DELAY LINE

By Hugh Ford

### MANUFACTURERS' SPECIFICATION

**Format:** 12 bit offset binary digital code.  
**Maximum delay:** 449 ms (with full delay module complement).  
**Minimum delay:** 1 ms.  
**Frequency response:** dc to 14k Hz ( $-3$  dB at 14k Hz from 18 pole active filter).  
**Range:** 72 dB (without accessory noise reduction).  
**Distortion:** less than 0.1% (maximum output level).  
**Sampling rate:** 40k Hz.  
**Flutter:** Unmeasurable.  
**Timing accuracy:** Internally adjustable to less than 1%.  
**Nominal input level:** +4 dBm switchable to  $-2$  dBm.  
**Input impedance:** 600 $\Omega$ , unbalanced (balanced optional).  
**Nominal output level:** +4 dBm.  
**Output impedance:** 600 $\Omega$ , unbalanced (balanced optional).  
**Level indication:** front panel overload indicator.  
**Dimensions:** 133 mm standard retma rack mounting, depth 279 mm.  
**Weight:** 11.5 kg maximum weight for fully loaded unit.  
**Power:** 120/230V ac, 50/60 Hz, 100W.  
**Connectors:**  
 Signal: Cannon XLR's.  
 Power: International standard.  
**Price:** Basic unit with one input module, two delay modules and one output module £1350. Extra delay modules £220 each. Extra output modules £250 each. As tested £2260.  
**Manufacturer:** Pandora Systems, Inc, PO Box 964, Nashville, Tennessee 37202.  
**UK Agent:** Feldon Audio Ltd, 126 Great Portland Street, London W1.



OVER THE last couple of years there has been much talk about using digital methods for recording and processing audio and television signals, and while digital standards converters and other equipment have been in use in the television field for some time practically no useful digital audio equipment has appeared in the market place. The reason for this situation is not in my opinion related to the engineering techniques which are necessary for handling digitised audio, but simply is a result of the complexity and consequent cost of potential techniques for handling digitised audio.

Before proceeding with the evaluation of the Pandora Time Line I propose to remind readers of a few of the fundamental matters which dictate the performance of any digital

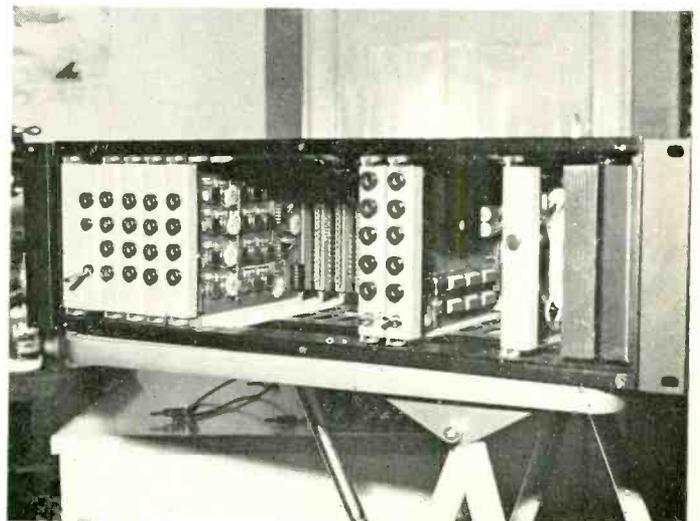
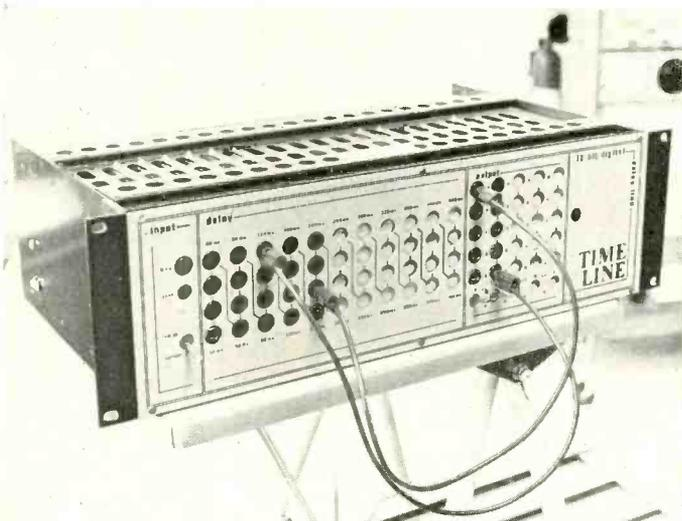
audio system, and I hope that those readers who are familiar with digital techniques will forgive the repetition of such basic information, but its understanding is essential if the reason for the performance limitations of digitised audio devices is to be appreciated.

### The fundamentals of digitised audio

Any number may be converted into a digital coded number provided that an adequate number of digital bits are available, the largest number that can be held by a digital store being  $(2^n - 1)$  where  $(n)$  is the number of digital bits in the store. If the number zero is included, the capacity of a digital store is  $(2^n)$  and the resolution of the store in terms of the smallest difference between numbers that it can store is  $(1)$ . If we assume that electrical signals are stored as a number proportional to the voltage it becomes apparent that the potential signal-to-noise ratio of a digital store increases 6 dB per bit of storage.

There are a number of ways of considering the actual signal-to-noise ratio of a digital store, but the simplest approach is to compare the maximum number that can be stored with the potential error of the store which is  $\pm \frac{1}{2}$  bit—this leads to a signal-to-noise ratio of  $2^n:1$  (i.e. 72 dB for a 12 bit store). The potential error of  $\pm \frac{1}{2}$  bit is known as the quantising error and in the above calculation we have taken the peak quantising noise in relation to the peak signal; it can be appreciated that the theoretical rms signal-to-noise ratio measured by the conventional audio methods will be a little better than our figure calculated by these simple means. It is however clear that high quality audio dictates the use of at least 12 bits of digital storage in order to give a really good signal-to-noise ratio.

The next audio parameter of particular

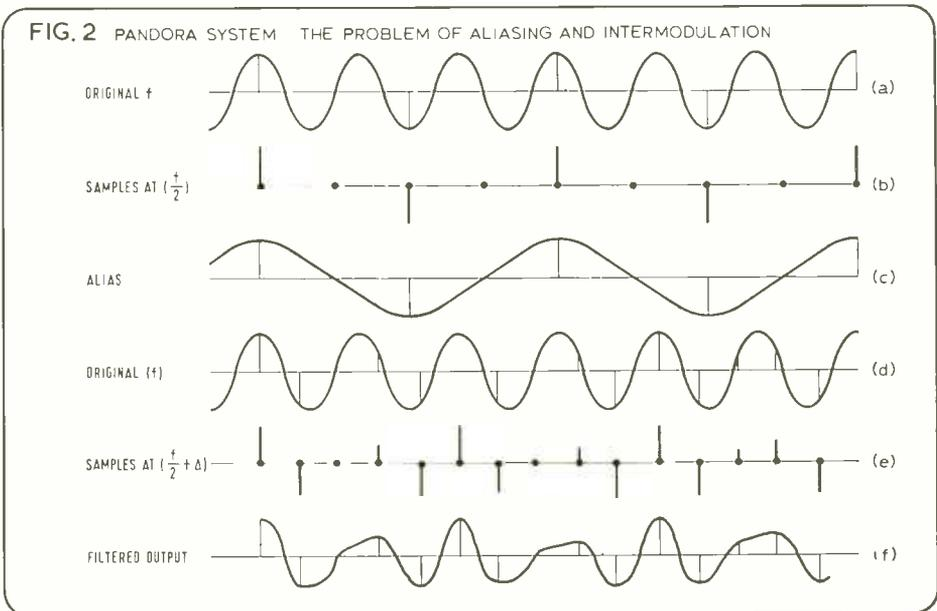
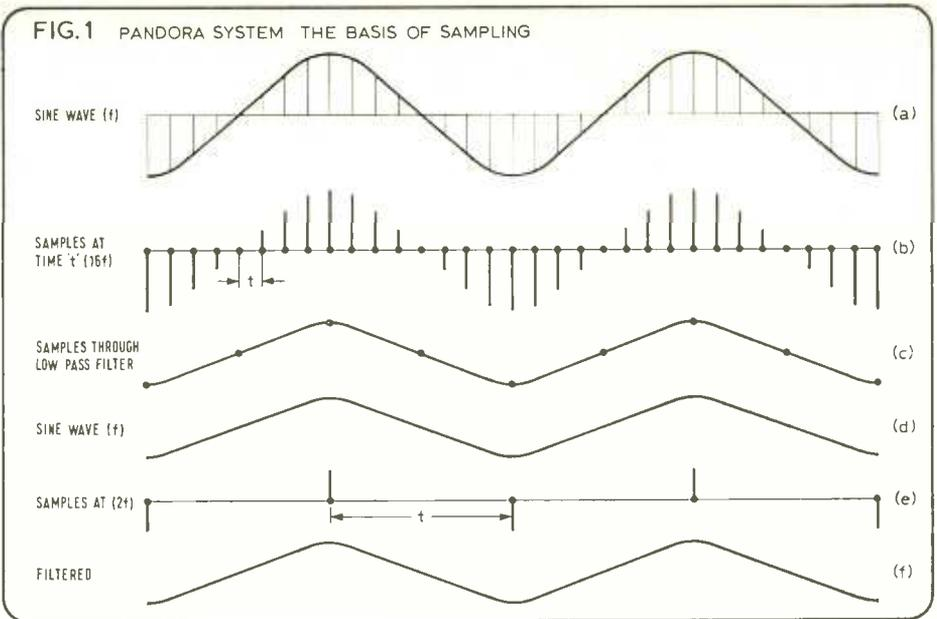


interest is the frequency response of a digital system which is a rather more complicated matter than the signal-to-noise ratio. An audio signal is converted into digital form by periodically sampling the amplitude. Reference to fig. 1 (a) shows a sinusoid, which when sampled at regular intervals spaced by time 't' gives a series of voltage samples shown in fig. 1 (b)—it is this series of voltage samples that is stored in digital form in a series of individual stores. When the store is replayed (read) the series of voltage samples will appear in the form in which it was stored (fig. 1 (b)), and if this waveform is passed through a low-pass filter with the right characteristic the samples will disappear and the original sinusoid will be reconstructed.

Reference to fig. 1 (d, e and f) shows that in order to reconstruct the original sinusoid, the sampling frequency must be at least twice the input frequency, and this requirement is shown mathematically by the sampling theorem. The situation where the input frequency is excessive is illustrated in fig. 2 (a, b and c) from which it can be seen that a reconstructed frequency (in this case) of one half the original frequency will appear; this is known as an 'alias' and of course represents audio distortion. It is therefore vital that excessively high audio frequencies must not appear at the input to a digital device, and this situation is avoided by the incorporation of anti-aliasing filters in the form of multipole lowpass filters at the inputs to digital audio devices. There is a further phenomenon which dictates the use of an anti-aliasing filter on the output of audio digital devices. It can be shown that as the audio frequency approaches half the sampling frequency (known as the folding frequency) an alias is being generated either side of the sampling frequency and one of these aliases is approaching the folding frequency. If really effective anti-aliasing filters are not used on the output of the digital device, the alias will appear as distortion which is not harmonically related to the original fundamental unless the fundamental happens to be a sub-multiple of the sampling frequency.

There is one remaining matter which can have serious consequences if the audio frequency can approach the folding frequency—half the sampling frequency. This occurs when the audio frequency is close to the folding frequency and is shown in fig. 2 (d, e and f) from which it can be seen that the recovered original frequency may be amplitude modulated by a frequency which is the difference frequency between the audio and the folding frequency. As is well known, an amplitude modulated waveform contains sidebands at the carrier frequency  $\pm$  the modulating frequency, and in audio terms this effect will appear as intermodulation distortion.

From the above fundamentals it should be quite clear that the mere processes involved in digitising audio are perhaps not as foolproof as has been suggested at times, and that like conventional audio systems there are a number of compromises that have to be made between performance, complexity and cost; there are however substantial advantages to be had because there is no degradation of the audio quality when material is transmitted or copied by reliable digital means, and other manipulations are possible without any deleterious effects.



#### The 'time line'—what it does

The basic function of the time line is as an analog/digital converter which is followed by a digital store of variable length, and then by a digital/analog converter; it therefore is possible for the time line to delay audio signals by a selected time depending upon the chosen size of the digital store.

Fig. 3 shows a simplified block diagram of the time line, from which it is to be seen that the digitised signal is fed to a parallel/serial converter converting the digitised audio signal into a series of digital bits which only require a single wire for their transmission. This means that serial shift registers can be used as the delay storage, and that by selecting any position along the shift register with a

single wire, any length of delay may be chosen within the range of the shift register capacity. Furthermore, a number of outputs with different delays can be obtained.

In fact the time line is of modular construction incorporating high quality plug-in printed circuit boards for everything except the main power supplies, the power regulator being a plug-in board. The main chassis is designed to accept one input module which contains the input circuitry as far as the parallel/serial converter, up to 11 delay modules each of which provides up to 40 ms delay with output taps at 10 ms intervals, and up to five output modules each of which provides a further 9 ms delay in 1 ms movements and contains all the

## PANDORA DELAY LINE

decoding circuitry and output circuitry.

The selection of the required time delay is achieved by patching between the delay modules and the output modules, each of which has a series of standard banana sockets which are clearly labelled in terms of delay time. In addition to this selection of delay there is a toggle switch on each output module which can add a further 1 ms delay in that particular module. This layout provides a most versatile system with the possibility of driving more than one output module with the same delay by stacking the patch cords, or driving all output modules with different delays, the only programming restriction being that an output module must not be driven from more than one delay module tapping.

The only remaining control is a toggle switch on the input module for increasing the input sensitivity by 6 dB from the normal nominal input of +4 dBm. All inputs and outputs are xlr connectors in the rear panel which houses the mains input socket, voltage selector and fuse.

### Inputs and outputs

Both the input and the outputs are unbalanced nominal 600Ω terminations with the option of balanced terminations on request. As is common with American equipment the specified impedances could be misleading as the measured output impedance was 131Ω and the measured input impedance 787Ω. While the output impedance is sensibly low, it is perhaps inconvenient that the input impedance is not somewhat higher for conveniently bridging 600Ω lines.

The maximum input level before the onset of serious distortion was found to be +14.5 dBm which virtually coincided with the overload light on the input module being illuminated. This level was decreased by a very accurate 6 dB when the input sensitivity switch was set for the available 6 dB increase in sensitivity. It will be appreciated that the specified input of +4 dBm (or -2 dBm at increased gain) refers to a zero VU indication with a VU meter!

When operated into a high impedance the insertion loss of the time line was 1.6 dB at 1k Hz, but as is to be expected from the output impedance the insertion loss rose to 3.3 dB when operating into a 600Ω load.

### Frequency response and noise

Fig. 4 shows the overall frequency response of the time line when operating into a 600Ω load, the response over the audio band being identical into a high impedance load, but the infrasonic fall-off shown in the figure appearing as a small boost around 6 Hz. The high frequency 3 dB point occurs at the specified 14k Hz, but the kink in the fall-off at 20k Hz does suggest that there might be a degree of misalignment in the anti-aliasing filters which will be referred to later. As should be expected, the frequency response is completely unaffected by the selected delay time or the combination of modes of operation that may be selected.

Noise was measured in relation to the maximum output before clipping with the time line terminated into 600Ω, and gave the follow-

FIG. 3 PANDORA SYSTEM BLOCK DIAGRAM (SIMPLIFIED) OF TIME LINE.

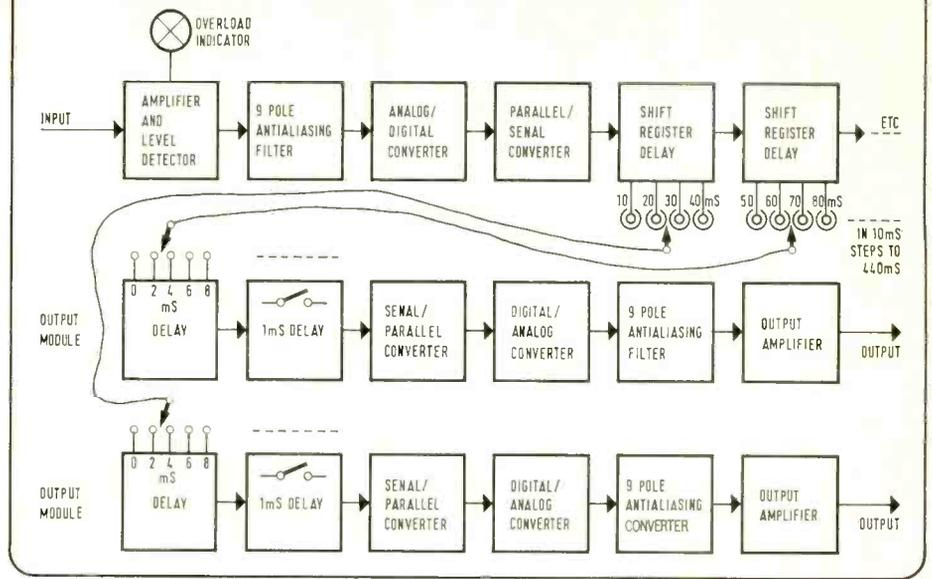


FIG. 4 PANDORA SYSTEM FREQUENCY RESPONSE

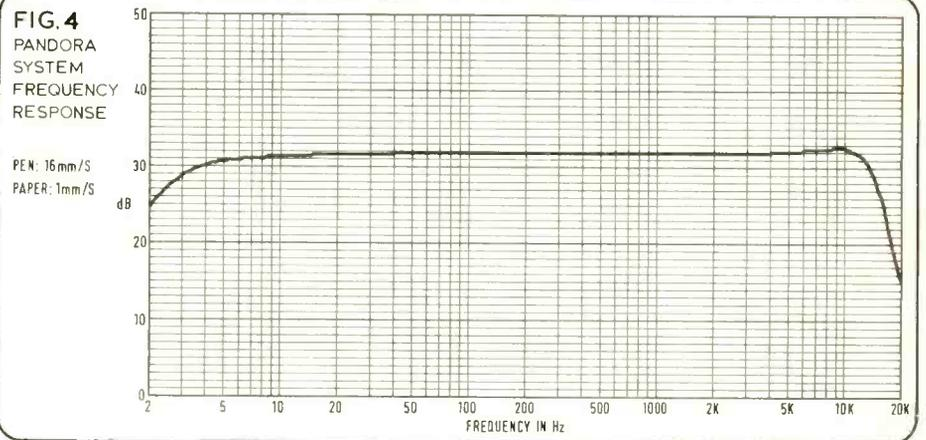
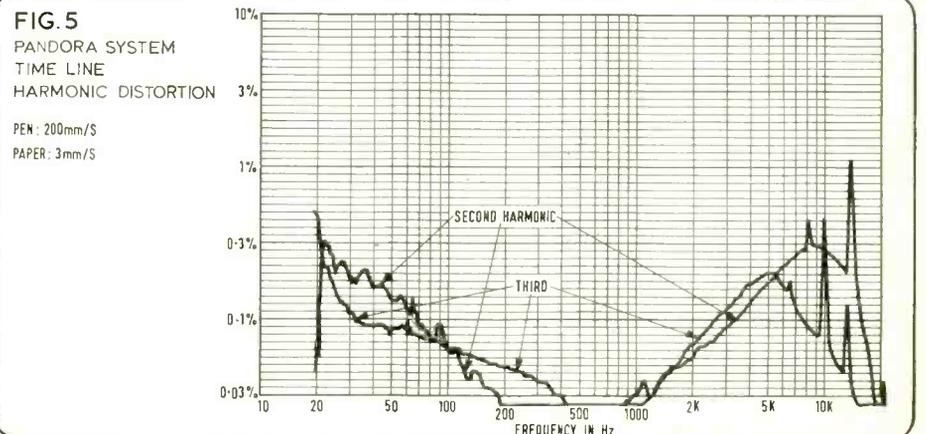


FIG. 5 PANDORA SYSTEM TIME LINE HARMONIC DISTORTION



# How much of IBC 74 will be the same as IBC 72?

Every time IBC comes around, you go along in the hope of seeing something new.

As it turns out, you've usually seen most of it before. Right?

This year we're going to change that.

We're Elektroimpex. It's our first time at IBC. Even though we already have quite a few customers in Europe, the Americas, the Middle and Far East.

We build sound systems and virtually nothing else.

Complete sound systems for TV studios, equipment for OB Vans, Master Control Centres . . . we'll be showing so much equipment, we've had to take three stands to squeeze it all in.

Drop in and see us on stand B3.

Or Stand B4.

Or Stand B5.



Perhaps the only equipment at IBC that you haven't seen before.

Elektroimpex, 1392 Budapest 62. P.O.B.296. Telegrams: Elektro Budapest. Telex: ELIMP-H 22-5771.

## ■ PANDORA DELAY LINE

ing results confirming that much of the output noise is high frequency quantising noise, expected in a digital system and is outside the audio band.

Measurement	Maximum signal to noise ratio
Unweighted 2 Hz to 200k Hz	72.7 dB
Unweighted 20 Hz to 20k Hz	88.2 dB
'A' weighted	90.2 dB

Certainly the noise output is satisfactorily low and the level of the quantising noise is most satisfactory and most unlikely to give any trouble.

### Distortion

The first matter of interest as far as distortion is concerned is the setting of the input level, for once the upper limit of the input at +14.5 dBm is exceeded there is an extremely rapid rise in harmonic distortion which is typical of digital devices. The peak indicating lamp on the front panel of the input module proved to be very rapid acting and to give a good visual indication when +14 dBm input was exceeded by even one cycle at 10k Hz; however it is a rather tight margin having only an indication when one hits 0.5 dB below severe clipping. Furthermore, the provisional instruction manual suggested that this lamp should be flashing regularly for optimum operation; such a condition produced pronounced distortion during listening tests.

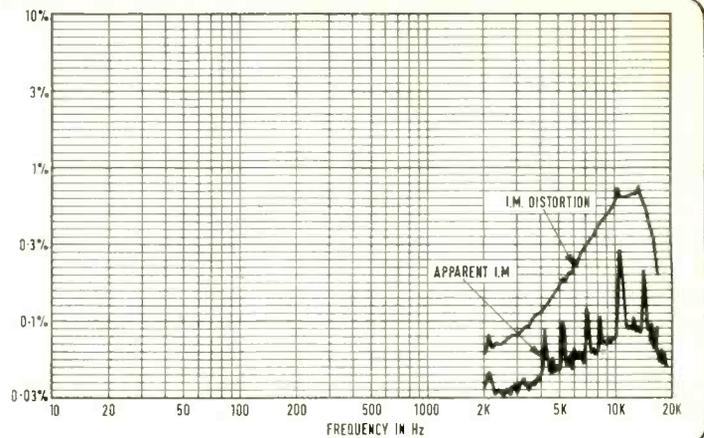
It follows that as things stand, considerable care must be taken to avoid overload—but the signal-to-noise performance is such that under driving is quite safe. I would however prefer to see a second peak indicating lamp adjusted to operate somewhere around 6 dB below the input clipping level.

Fig. 5 shows the relation between second and third harmonic distortion and frequency at an input level of +4 dBm, which is similar to the performance found at +14 dBm. The individual harmonics are generally below 0.1 per cent in the audio band below 3k Hz, above which the harmonics increase in intensity and show distinct peaks when the harmonics of the input frequency coincide with the sampling frequency which is nominally 40k Hz and practically measured at 39.6k Hz. This pattern is typical of a digital system with a sampling frequency which is relatively low, but improvements in the anti-aliasing filter in the output module would decrease these harmonics. However, the harmonics are largely above the audio band and will not be particularly objectionable if the subsequent equipment does not suffer from intermodulation distortion.

This leads to the subject of the intermodulation distortion of the time line. As measured

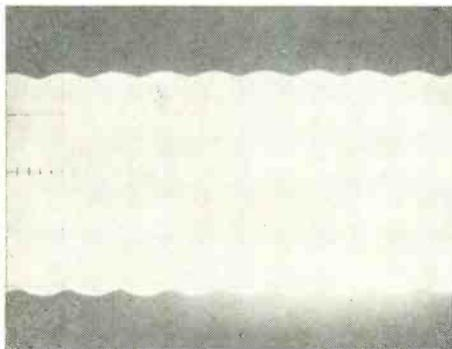
FIG. 6  
PANDORA SYSTEM  
I.M. DISTORTION

PEN: 200mm/S  
PAPER: 16mm/S



by the SMPTE method the intermodulation distortion was generally in the order of 0.3 per cent at input levels down to 20 dB below the clipping input when using 50 Hz and 7k Hz signals in a 4:1 ratio. However, mention has been made of both the potential beat effects when the high frequency input is a subharmonic of the sampling frequency, and also the possible misalignment of the anti-aliasing filters. Both these effects may account for the upper curve in fig. 6 which shows the relation

FIG. 7



between SMPTE intermodulation distortion and the high frequency test signal. While the former effect accounts for the lower curve (which shows the intermodulation caused by this effect when the low frequency test signal from the intermodulation distortion testgear is not present), the type of waveform associated with the measurement is shown in fig. 7, and this type of performance is fundamental to digital systems unless an extravagantly high sampling frequency is used.

### Other matters

Allowing for an inherent system delay of

about 120  $\mu$ s, the delay calibration was generally accurate and no apparent degradation of the throughput signal occurred with increased delays (as is to be expected of a digital system).

The power supplies operated satisfactorily over a very wide range of mains voltage inputs with no degradation of the performance when the incoming mains was dropped to below 200V and caused insignificant hum levels at the output.

The instruction manual provided gives due warning about the provision of adequate ventilation, and operation of the unit on the bench confirmed that this is a very necessary warning; in fact, there is a suspicion that the time line could be unduly temperature sensitive.

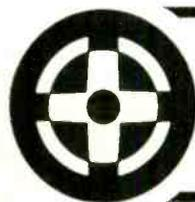
### Summary

A device such as the time line, offering delays from virtually zero to almost half a second in one millisecond increments, can find many interesting applications which were not available before, and also replace magnetic tape or drum delays in many applications, particularly in the field of sound reinforcement. Albeit expensive, the digital delay is much more reliable and offers a far better performance than electromagnetic delay systems.

A few of the other possible applications are delayed echo effects to simulate very large halls, generation of pseudo stereo and quadraphonics, and data storage during the start time of a tape recorder.

The performance of the time line is generally good but it does demonstrate the limitations of any audio/digital system and the severe problem of the cost/performance ratio of digital techniques.

My main complaint about the time line is the inadequate level setting facilities; in other respects (allowing for American matching impedances) it works very well and has a performance which is likely to be superior to that of the equipment with which it is to be used.



**TEKNIK GRAPHIC EQUALISERS**  
**GIVE UNEQUALLED PERFORMANCE**  
TEKNIK M.O.S. Industrial Site Summerfield Kidderminster Tel. 64027





# TECHNICS SL 110 TRANSCRIPTION UNIT

By Hugh Ford

## MANUFACTURERS' SPECIFICATION

**Type:** Direct drive system.  
**Turntable platter:** Aluminium die-cast, 35 cm diameter. 320 kg cm<sup>2</sup> inertial moment. 2 kg weight.  
**Turntable speeds:** 33 $\frac{1}{3}$  and 45 rpm.  
**Motor:** 20 poles (rotor)—15 poles (stator) ultra low speed dc brushless motor.  
**Power supply:** 50/60 Hz, 110/120/140/220V, 4W.  
**Speed change method:** Electronic change.  
**Variable pitch control:** Individual adjustment by variable resistor,  $\pm 5\%$  adjustment range.  
**Wow and flutter:** Less than 0.03% wrms.  
**Rumble:** Better than -65 dB DIN(A), -70 dB DIN(B).  
**Build-up time:** Within  $\frac{1}{2}$  rotation at 33 $\frac{1}{3}$  rpm.  
**Dimensions (wxdxh):** 51 x 39 x 19.5 cm.  
**Weight:** 13 kg with dust cover.  
**Player case:** Aluminium die-cast with audio insulated legs.  
**Price:** £154.95 including VAT.  
**Manufacturers:** Matsushita Electric Trading Co Ltd, PO Box 288, Central Osaka, Japan.  
**UK Agents:** National Panasonic (UK) Ltd, Whitby Road, Trading Estate, Slough, Bucks.

**THE INSPIRATION** for this review came from my efforts to find a really first-class turntable for use in the laboratory where it is essential to have the very highest standard of performance for measuring the performance of test discs (among other things) and also the ability to fit a variety of arms and cartridges.

In addition to these requirements, it is of course essential that all performance parameters shall be consistent over a long period of time, and it is this particular requirement that eliminates the use of the common mechanical drive systems and weighs strongly in the direction of direct motor drive.

These laboratory requirements are of course identical to the requirements for the very best reproduction of records in any environment, but do not necessarily meet the added facilities so important to the broadcast industry where there are those of rapid start time and cueing facilities.

Inspection of the adjacent specification shows that the Technics *SL-110* is on paper an outstanding turntable which furthermore sells at a very high price which is exceeded by few others; it should therefore be in the very top class in all respects.

### The mechanical construction

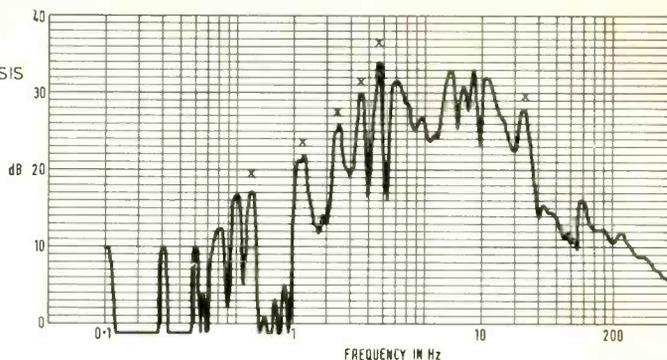
The first thing that strikes you about the unit is its solid construction, the top of the unit and its sides being a single aluminium die-casting and the under cover (which in most units is made of plastic) being a further aluminium die-casting. The whole is supported by four anti-vibration legs which are all adjustable in height and fitted with large (in diameter) feet, but perhaps surprisingly no spirit level is fitted.

Pickup mounting is on a separate wooden board which is secured to the top surface by

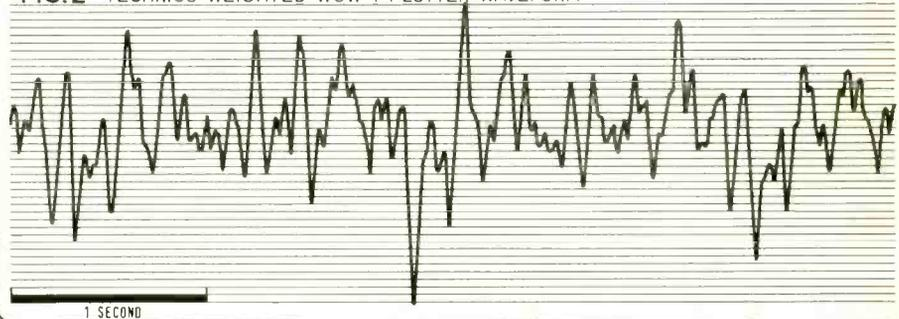
**FIG. 1**  
TECHNICS  
NARROW BAND ANALYSIS  
OF DIN (W)  
WOW + FLUTTER

WR SPEED... 32 mm/S  
PAPER SPEED... 1 mm/S

x PEAKS COMMON TO ALL  
TEST DISCS



**FIG. 2** TECHNICS WEIGHTED WOW + FLUTTER WAVEFORM



eight machine screws and therefore readily removable and easily interchanged for boards with alternative cutouts. As a convenience, the boards are printed with radial lines and diameters from the turntable centre. Ready-cut boards are, of course, available from the UK agent for such pickup arms as the SME.

The turntable is another machined aluminium die-casting which simply slips over the central locating pin, resting on what is effectively the motor shaft with a pleasantly close fit. Strobe dots for 33½ rpm and 45 rpm at either 50 Hz or 60 Hz surround the periphery of the turntable, and are illuminated when a pushbutton switch is operated on the plug-in strobe illumination device. The combination of this really bright neon light and the good finish of the strobe dots on the turntable leads to easy checking of the precise turntable speed even under high ambient lighting. Furthermore, the strobe dots are accurately placed so that there is no wander of the dots as the turntable revolves; however, the identity of the four sets of dots is by means of a rather unclear stick-on label.

The remaining controls are a three-position lever switch for selecting the speeds of 33½ rpm or 45 rpm with a central off position (with associated pilot light), two-speed setting potentiometers and two pushbuttons which start or stop the turntable.

One particularly nice feature of the *SL-110* is the facilities for wiring the signal leads: internally, adjacent to the pickup mounting, there are two 'phono' sockets and an earth terminal which are wired to external 'phono' sockets and an external earth terminal which is isolated from the chassis. A second external earth terminal is fitted for earthing the chassis. This means that not only can the pickup leads be wired internally, but also that individual earths can be arranged for minimum hum induction.

Removal of the under cover reveals that there is only one moving part, this being the very compact motor. The servo electronics for the motor are mounted on a single printed board which plugs into edge connectors and is directly mounted on to the main chassis casting.

#### The mechanical tolerances

The main mechanical tolerances of direct interest are the turntable runout and the basic dimensions of the central locating pin. Measurement of the pin diameter gave consistent results of 7.127 mm which is an ideal fit for records made to either the NAB Standard or to the current British Standard, allowing a pin clearance of only 0.086 mm in the worst case.

Runout of the centre spindle with reference to the pickup mounting board was extremely small at ±0.010 mm, while the vertical runout at the turntable edge measured at ±0.020 mm is a sign that great trouble has been taken in the mechanical tolerances.

#### Wow and flutter and speed

Using a number of different test discs the best recorded wow and flutter was 0.05% DIN weighted, which is to my belief far better than the specification for any of the normal test discs. The rms unweighted figure was similarly determined at 0.04% total wow and flutter, comprising 0.03% wow and 0.015% flutter.

Fig. 1 shows a narrow band spectrum analysis of the DIN weighted wow and flutter using one of the better test discs; however, all test discs did have certain consistent peaks which are identified in the figure. It should, however, be noted that the frequencies of these peaks do not appear to correspond to any of the natural frequencies of the turntable unit.

Because the turntable speed is controlled by a servo system the actual speed is not affected by the incoming mains frequency with the result that the apparent speed indicated by the stroboscope discs is not a true indication if the mains frequency varies. As a result of this factor the speed stability was checked by means of a constant frequency test disc in conjunction with a timer/counter. The resulting speed stability was beyond reproach, even when the incoming mains voltage was lowered from its nominal 240V to as low as 180V where the speed varied by 0.16%. The speed setting potentiometers provided a very fine control of precise speed together with a possible variation of +7.4% -5.8% at 33½ rpm or +6.9% -6.4% at 45 rpm.

Disc modulation did not appear to have any measurable effect upon the speed, and the application of a well lubricated Watts 'dust bug' caused a shift of 0.38%.

The start time at 33½ rpm to the rated wow and flutter was certainly less than the specified half turn of the turntable, and was measured in terms of time from when the start button was pressed as 1.5s—it is this parameter that makes the Technics *SL-110* a doubtful runner in the broadcast business, but does not in any way deter from its performance as a very high quality turntable for any other purposes.

#### Rumble

As with all the other parameters an SME arm with a Shure V15 series III cartridge was used for the evaluation of rumble. As with the wow and flutter measurements, the outcome of the exercise was that different test discs gave different and very low results when measuring to the DIN standard method. I can say with some confidence that the turntable is equal to or better than the Bruel & Kjaer Test Disc type *QR2011* which is specified at 50 dB to the DIN 'A' curve or 65 dB to the DIN 'B' curve, both of which figures are to a very high standard. However, I would be interested to know how the manufacturers manage to measure their specified figures with confidence, because such a performance implies the most exhaustive care in cutting a test disc.

#### Summary

I have no hesitation in recommending this turntable for any applications where a really fast start time is not essential. Its overall finish and performance are superb and the only complaints that I do have are of a very minor nature.

Wow and flutter is better than any other turntable that I have come across, and I consider the rumble to be unmeasurable: these two factors do great credit to the direct drive design.

Furthermore, while I have not mentioned the performance of the turntable suspension, this is so good that at reasonable volume levels the turntable can be operated on the same table as a loudspeaker without acoustic feedback!

## AB Pearl Mikrofon- laboratorium.



DC21.

48 volt, cardioid, miniature.  
Also available as omni-  
directional DC20.

For further information on the complete range of Pearl microphones, contact:

**Allotrope Limited**

90 Wardour Street, London W1V 3LE.  
Telephone: 01-437 1892. Telex: 21624.

U.K. Representatives for:

**AB Pearl Mikrofonlaboratorium - Sweden**, Microphones & accessories.

**HES Electronics - Brussels**, TSV series telephone balancing units, and studio equipment.

**Inovonics Incorporated - Campbell California U.S.A.**, Audio electronics.

**Roland Zeissler Werk Für Elektro Mechanik - Cologne**, Racks and instrument housings.

# Classified Advertisements

Advertisements for this section must be pre-paid. The rate is **8p** per word, minimum **80p**. Box Nos. **20p** extra. Semi-display rates on application. Copy and remittance for advertisements in **NOVEMBER 1974** issue must reach these offices by **16th SEPTEMBER 1974** addressed to: The Advertisement Manager, **Studio Sound**, Link House, Dingwall Avenue, Croydon CR9 2TA.

**NOTE:** Advertisement copy must be clearly printed in block capitals or typewritten. Replies to Box Nos. should be addressed to the Advertisement Manager, Studio Sound, Link House, Dingwall Avenue, Croydon CR9 2TA, and the Box No. quoted on the outside of the envelope. The district after Box No. indicates its locality.

## FOR SALE—TRADE

★Nagra III and IV and SN models available. Immediate delivery. Write or phone J. J. Francis (Wood Green) Ltd., Manwood House, Matching Green, Harlow, Essex. Tel. Matching 476.

**Studer A80**  
Stereo two track  $\frac{1}{4}$ "  
**£1,500**  
0480 52561

★A.K.G. D25 £30, A.K.G. D24 £25, A.K.G. D12 £15, A.K.G. D19 £10, S.T.C. 4021 £10, S.T.C. STICK £15, R.C.A. 10002 £40, Neuman KM254C £80, Neuman KM56 £65, Neuman KM54A £70, Electro Voice 668 £45, Electro Voice 10001 £95, Electro Voice Gun Mike £60, Audio Radio Mikes RMS £70, Sony Rover Video Camera, Recorder, Colour Monitor £450, Braun TG1000 (new) £230, Leavers-Rich Console £60, Leavers-Rich Portable £40, Leavers-Rich Stereo Portable £200, Perfect Tone Mixer £400, E.M.T. Mixer £280. All goods plus V.A.T. J. J. Francis (W.G.) Ltd., Manwood House, Matching Green, Harlow Essex CM17 0RS. Tel. Matching 476.

★A new dB tamer from Cathedral . . . Compressor/Limiter module CLA 1, £15.50 post and VAT paid. Low distortion oscillator module OSC/2 £15.50 post and VAT paid. Quantity discounts available. S.A.E. details Cathedral Sound, Fourways, Morris Lane, Halsall, Lancs. L39 8SX.

Building Mixers?

**zero88**  
**AUDIO MODULES**

offer high quality at competitive prices

Contact Richard Brown at Zero 88,

115 Hatfield Road, St. Albans, Herts

AL1 4JS Tel: 63727

★Revox A77 sold, serviced and modified, accessories supplied. Full range of modifications that only we carry out. Ring 01-586 0064 for details.

## RAC MIXERS

Custom-built mixers for groups, P.A., hospital broadcasting, recording, discos, etc. RAC plug-in audio modules for building your own mixers.

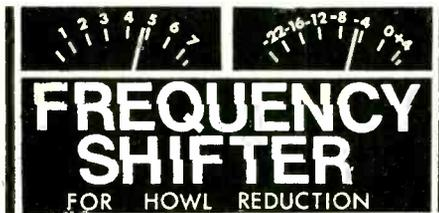
Sony, Akai, TEAC, Tandberg, Marantz, Lux, Nikko, Dual, Quad and Armstrong dealers. Shure, Calrec, AKG mikes and stands, etc. APRS Manufacturing members.

**RUGBY AUTOMATION CONSULTANTS**  
19 Freemantle Road, Bilton, Rugby,  
Warwickshire CV22 7HZ  
Tel. 0788-810877 (Rugby)  
Call, write or phone us

★Ten different colours of 14/0076 x 2 braided mic cable in stock. Phone 01-586 0064.

## PEAK PROGRAM METERS TO BS4297

also 200KHz version for high speed copying:  
Drive circuit, 35 x 80mm, for 1 ma L.H. zero meters to BBC ED 1477. Gold 8-way edge con supplied.  
4 off 10 off 50 off  
Complete kit £10.00 £9.50 £9.00 £8.50  
Built and aligned £14.00 £13.30 £12.60 £11.90  
ERNEST TURNER PPM meters. Below scalings stocked  
Type 642, 71 x 56mm £10.90; 643, 102 x 79mm £12.90  
TWIN MOVEMENT, scale 86 x 54mm £31.00.



**PUBLIC ADDRESS : SOUND REINFORCEMENT**  
In any public address system where the microphones and loudspeakers are in the same vicinity acoustic feedback (howl-round) occurs if the amplification exceeds a critical value. By shifting the audio spectrum fed to the speakers by a few Hertz the tendency to howling at room resonance frequencies is destroyed and an increase in gain of 6-8dB is possible before the onset of feedback.  
SHIFTERS IN BOXES with overload LED, shift/bypass switch, BS4491 mains connector and housed in strong diecast boxes finished in attractive durable blue acrylic. Jack or XLR audio connectors.

Type	A	B	C
Input impedance	200Kohm	200Kohm	10Kohm Balanced
Output impedance	2Kohm	20or600ohm	20or600ohmBAL
PRICE	£58	£68	£84

SHIFTER CIRCUIT BOARDS FOR VW July 1973 article  
Complete kit and board £21 Including p.s.u. and Board built and aligned £28 mains transformer  
DESIGNER APPROVED

## SURREY ELECTRONICS

The Forge, Luckes Green, Cranleigh, Surrey GU6 7BG  
(STD 04866) 5997  
CASH WITH ORDER less 5% U.K. post free, add VAT

★Audiofact No. 1!! You can build 8 Cathedral Complimiters into your mixer for LESS than the cost of one medium price competitor. P.S. Ask about our new Graphic Equaliser. Cathedral Sound. Tel. Halsall 328.

## STUDIO FACILITIES

### TAPE ELECTRONICS

High quality professional electronics as used in our own professional recorders are now available.

Ideal for updating Studio and Film Recorders with valved electronics.

**BIAS ELECTRONICS LIMITED**  
572 Kingston Road, London, SW20 8DR  
01-540 8808

★Fanfare Records. Tape-disc pressings, demo's, masters, any quantity. Studio/mobile Neumann disc cutter. S.A.E. brochure. 1 Broomfield Close, Rydes Hill, Guildford. Tel. 0483 61684.

★County recording service stereo and mono masters and lacquer discs from your tapes. Telephone Bracknell 4935. London Road, Binfield, Bracknell, Berks.

### RECORDS MADE TO ORDER

DEMO DISCS MASTERS FOR RECORD COMPANIES	VINYLLITE PRESSINGS
Single discs, 1-20, Mono or Stereo, delivery 4 days from your tapes. Quantity runs 25 to 1,000 records PRESSED IN VINYLLITE IN OUR OWN PLANT. Delivery 3-4 weeks, Sleeves/Labels. Finest quality NEUMANN STEREO/Mono Lathes. We cut for many Studios UK/OVERSEAS. SAE list.	
<b>DEROY RECORDS</b> PO Box 3, Hawk Street, Carnforth, Lancs. Tel. 2273	

### S.G.S. RECORDING STUDIO

DEMOS AND MASTER PRESSINGS  
MULTITRACKING FACILITIES 01-778 0450  
Complete studio service. Mobile studio service engineers. Music publishing. Independent production Group P.A. and amps serviced and sold. Disco equipment installed.  
**131A ANERLEY ROAD, LONDON S.E.20**  
Studio 01-778-0450 Messages 01-688 0728

★J & B Recordings. Tape to disc—latest high level disc cutting, all speeds. Master pressings, studio, mobile. 14 Willows Avenue, Morden, Surrey. MITcham 9952.

★Sound News Productions. Britain's oldest full-time Tape/Disc/Tape transfer service. Direct transfers, pressings for private and for the trade. Fund raising advisory service for societies, choirs, bands. 18 Blenheim Road, London W4. Tel. 995 1149.

## STUDIO FACILITIES (Continued)

### COMPACT CASSETTES

#### PROFESSIONAL HIGH-SPEED DUPLICATION

Dolby B—compression and equalisation available—competitive prices on small runs—full productions undertaken—music and language specialists.

Contact Chris Sands

**AUDIO EDUCATION COMPANY**  
01-723 6635

## WANTED

★All Nagra Equipment urgently required for cash. J. J. Francis (W.G.) Ltd., Manwood House, Matching Green, Harlow, Essex CM17 0RS. Tel. Matching 476.

★Scully 8-Track Model 280 Series with Syncmaster. Would consider purchasing electronics only. Tel. 01-229 4477.

## SITUATIONS VACANT

### STRAWBERRY STUDIOS

We at STRAWBERRY STUDIOS are looking for another 1st class Engineer to join our happy family. Applicants must have a thorough knowledge of 16 and 24 track recording. Musical ability and personality are essential and technical knowledge would be an asset.

Wage by negotiation. Please write or ring.

#### PETE TATTERSALL

Strawberry Studios, 3 Waterloo Road,  
Stockport, Cheshire  
Tel: 061-480 9711/2

## AUDIO ENGINEERS SENIOR PROJECT AND COMMISSIONING ENGINEER

Should have good theoretical training in electronics plus actual experience of professional audio equipment in broadcasting, recording or with a specialist manufacturer

o o o

### Also required: ASSISTANT DESIGN ENGINEER

Apply in writing to:

**MR. R. W. SWETTENHAM**  
**HELIOS ELECTRONICS LTD.**

**161 High Street, Teddington, Middx. TW11 8HT**

## WANTED (Continued)

### GLENN MILLER

Private collector requires recordings taken from BBC broadcasts during 1944-45 of THE AMERICAN BAND OF THE A.E.F. who were stationed in the UK during this period, I am particularly interested in complete broadcasts by the full Orchestra & various sub-units under the titles of:- "Swing Shift", "Swing Sextet", "Uptown Hall", "Johnny Desmond Sings", "Strings With Wings", "The American Band of the AEF", plus any 16" Transcriptions, "Air Checks" & "V" Discs etc. in any condition tape copies acceptable but will pay very good price for original discs or will exchange from my collection.

Also requires AAF band from "Uncle Sam", "I Sustain the Wings" show & AFRS & OWI Transcriptions plus his civilian band broadcasts & GMMs Transcriptions. All letters answered.

**A. J. HIBBERD**

59 Waverley Rd., The Kent, Rugby, Warks.  
or phone 6473 daytime 71066 eve.

## FOR SALE—PRIVATE

★For sale going 8 Track—16/2 studio valve mixing console built by Hollick & Taylor Recording Company. Most facilities, equalisers, echo, talk back, cue lights, etc. Delivery and H.P. if required, £450. Also Gramplan Disc Cutter and Head, no amps, £110. Profile Records, 213 Hatfield Road, St. Albans, Herts. Tel. 058283 3334.

★EMI RE301C stereo tape recorder, VGC £125 o.n.o. EMI L4 portable, mint, with charger and Gramplan DP4, £70 o.n.o. Martin Castellan, Lane Cottage, Wootton, Ashbourne DE6 2GW.

★E.M.T. 927A turntable £45. Ferrograph 4A £30. Also Series 4 Deck. Wanted: Stereo Tuner. Phil or Steve, tel. 01-892 2545.

★E.M.I. BTR/2, ex-BBC, good working order. Ideal for conversion. Best offer secures. Tel. 0603 713141.

## SITUATIONS WANTED

★Studio Manager/Chief Engineer 8-Track W.1 studio requires similar position in more progressive studio, London/South. Box No. 684.

★Freelance Sound Engineer, PA, recording, requires contract work. Travel no object. Box No. 683.

## MISCELLANEOUS

★Tape and Cassette Recorder Repairs by Specialists. The Tape Recorder Centre, 82 High Holborn, London, W.C.1.

**AMCRON IN EDINBURGH**  
2 years free service

**HI-FI**  
**CORNER**  
—clearly better hi-fi.

1 Haddington Place, Edinburgh EH7 4AE  
Telephone 031-556 7901

## TAPES

★We have the very best equipment in the country for the duplication of recordings on magnetic tape. Our newly-equipped plant with its clinical atmosphere reflects our dedication in offering the finest and most competitive duplication service currently available. Please send for full information on tailored blank cassettes; C. zero cassettes; Duplitape facilities. Duplitape, 5 Pratt Street, London NW1. Tel. 01-485 6162.

## THE OPEN UNIVERSITY AUDIO-VISUAL AIDS DEPARTMENT TECHNICAL MANAGER

Applications are invited for the post of Technical Manager in the Audio-Visual Aids Department of the Open University, based at Walton Hall.

The person appointed will supervise the work of the staff in the Department, be responsible for the co-ordination and progressing of production of discs, tapes and equipment required in connection with course material, the maintenance of audio-visual hardware, technical liaison with the BBC, evaluation of audio-visual hardware systems and advising on the updating of equipment used on Campus.

A sound knowledge of audio-visual hardware systems would be required, and a minimum of five years relevant experience, after qualification, preferably including appointment in industry. Formal qualification as a Registered Technician Engineer (CEI) will be required.

The post carries Non-academic F.S.S.U. Terms and Conditions of Service. Salary scale (with effect from 1st October 1974) £2580-£3636 per annum.

Application forms and further particulars are available from the Personnel Manager, The Open University (AT2), P.O. Box 75, Walton Hall, Milton Keynes, MK7 6AL. Applications should be returned as soon as possible.

# ARE YOU ADAPTABLE ENOUGH FOR THIS POSITION?

Wanted! Sound Recordist to assist in the production of sound tapes for Audio Visual Programmes and movie films.

A knowledge of live recording, studio recording, mixing and an understanding of linking sound with visuals required.

This is an interesting and challenging position within a rapidly expanding Audio Visual and Film Production Company. We are willing to train where necessary. Salary by negotiation according to age and experience.

## FIDELITY FILMS LIMITED

Oak Ends Way, Gerrards Cross, Bucks.

Telephone: Gerrards Cross 84646 & 86521

## TAX-FREE HOSPITAL OPPORTUNITIES in SAUDI ARABIA with Whittaker

The Whittaker Corp. represents one of the largest companies in the U.S.A., which has diversified internationally into health care and environmental projects. We have been awarded a multi-million dollar contract to staff and manage three newly-built hospitals in Jiddah (60 beds), Tabuk (135 beds) and Khamis Mushayt (135 beds). The hospitals have been built to top U.S. standards. Equipment is the latest and best from U.S.A. and Europe, covering the full range of medical and surgical treatment.

There are immediate opportunities on a two-year contract basis for:

### Audio Visual Specialist up to \$8,400

With G.C.E. 'O' level education and at least one year's experience in a similar job operating and maintaining film and overhead projectors, tape recorders and training aids (ref 66).

In addition to a tax-free salary, benefits include free housing, return passages for employees and families, generous baggage allowance, household storage provision and 30 days' annual holiday.

**ACTION — To meet our initial staffing requirements, this post must be filled quickly. Please write immediately with telephone number/s and full biographical details, quoting appropriate reference number to J. S. Coulson, Whittaker Corp., c/o**

**MSL ADVERTISING SERVICES LTD.,**  
17 Stratton Street, London W1X 6DB.

## NEVE ELECTRONIC LABORATORIES LTD

leading manufacturer in the field of professional sound control consoles for the broadcasting, recording, and film industries has an immediate vacancy in our Research and Development Laboratory for an

## AUDIO DESIGN ENGINEER

experienced in the design and development of audio amplifiers, filters, equalizers, limiters, and other related audio devices. This is a challenging position for an individual with moderate or better experience in audio circuit engineering and team leadership capabilities.

Salary is fully commensurate with experience, ability and qualifications. Excellent working conditions. Company transport from Royston and Cambridge areas. Canteen and pension scheme.

Contact:

**MRS PAT WYTHE**

**Neve Electronic Laboratories Ltd.,  
Cambridge House, Melbourn, Royston, Herts**

Phone: Royston 60776

## cadac

The company specialises in the design and production of sound control equipment to the recording industries.

With the continued expansion of the company, vacancies arise for the following:—

## SALES ENGINEER SENIOR TEST ENGINEER

Applicants should have a theoretical knowledge of electronics and/or experience in studio engineering techniques and practices.

The Sales Engineer should have experience in the audio industry.

It would be preferable that the Senior Test Engineer has had studio experience.

Salaries by negotiation and to be commensurate with that of the position.

Apply to:—

**CADAC (London) LTD.,  
141 Lower Luton Road,  
Batford,  
Harpenden,  
Herts.  
Tel. Harpenden (STD 05827) 64351**

## TEAC 4-CHANNEL INDUSTRIAL RECORDER

The complete mobile recording studio  
4 totally independent channels.

Sel sync on all channels.  
Mixing facilities 63dB signal to noise ratio.  
Wide flat band width.

Backed by ITA Service

**SOLE SUPPLIER**



SEMI-PRO "S" VERSION NOW AVAILABLE IN 240V

## ITA 10-4 MODULAR MIXER

Now in use in 15 countries throughout the world.

Ten inputs.

4 output groups.

4 limiters. Base, mid, treble EQ.

Balanced inputs.

Modular construction.

Headphone monitoring.

**£590 + V.A.T.**

IMMEDIATE DELIVERY



**NOTE NEW ADDRESS~**

**ITA**

Industrial Tape Applications

5 Pratt Street, London NW1 OAE. Tel: 01-485 6162 Telex: 21879

Our warranty records show that on average only one Revox buyer in six has never had a tape recorder before.

The remaining five have all owned one or more makes previously. Since our warranty application invites comment, we are frequently told how happy our customers are with their Revox, especially when they compare it with their previous purchases.

But too often we hear the lament:

# I WISH I'D BOUGHT IT SOONER



**The incomparable  
Revox A77**

Save yourself the cost of experimentation in tape recording. Select a recorder that will neither add nor detract from the original.

Choose the A77 - and if your finances don't quite run to a new machine, try to find one second hand - in standard condition it will out perform other makes of new equipment at the same price.

# REVOX

Buy it first - it's built to last

**Revox**  
C. E. Hammond Co. Ltd.  
Lamb House  
Church Street  
Chiswick  
London W4 2PB  
England

**Revox Corporation**  
155, Michael Drive  
Syosset  
N.Y. 11791  
U.S.A.

**Revox Corporation**  
3637 Cahuenga Boulevard West  
Hollywood  
California 90068

**Revox Sales & Service  
in Canada**

**Revox International**  
Regensdorf 8105 ZH  
Althardstrasse 146  
Switzerland

Please tell me where I can see and buy

Name  Revox  A77  
 Revox  Good used machines\*  
 Revox  A100

Name .....  
Address .....

\*As and when available

BIW