

# Recording T.M. ENGINEER/PRODUCER

The Technical Journal for Audio Professionals

\$4.00

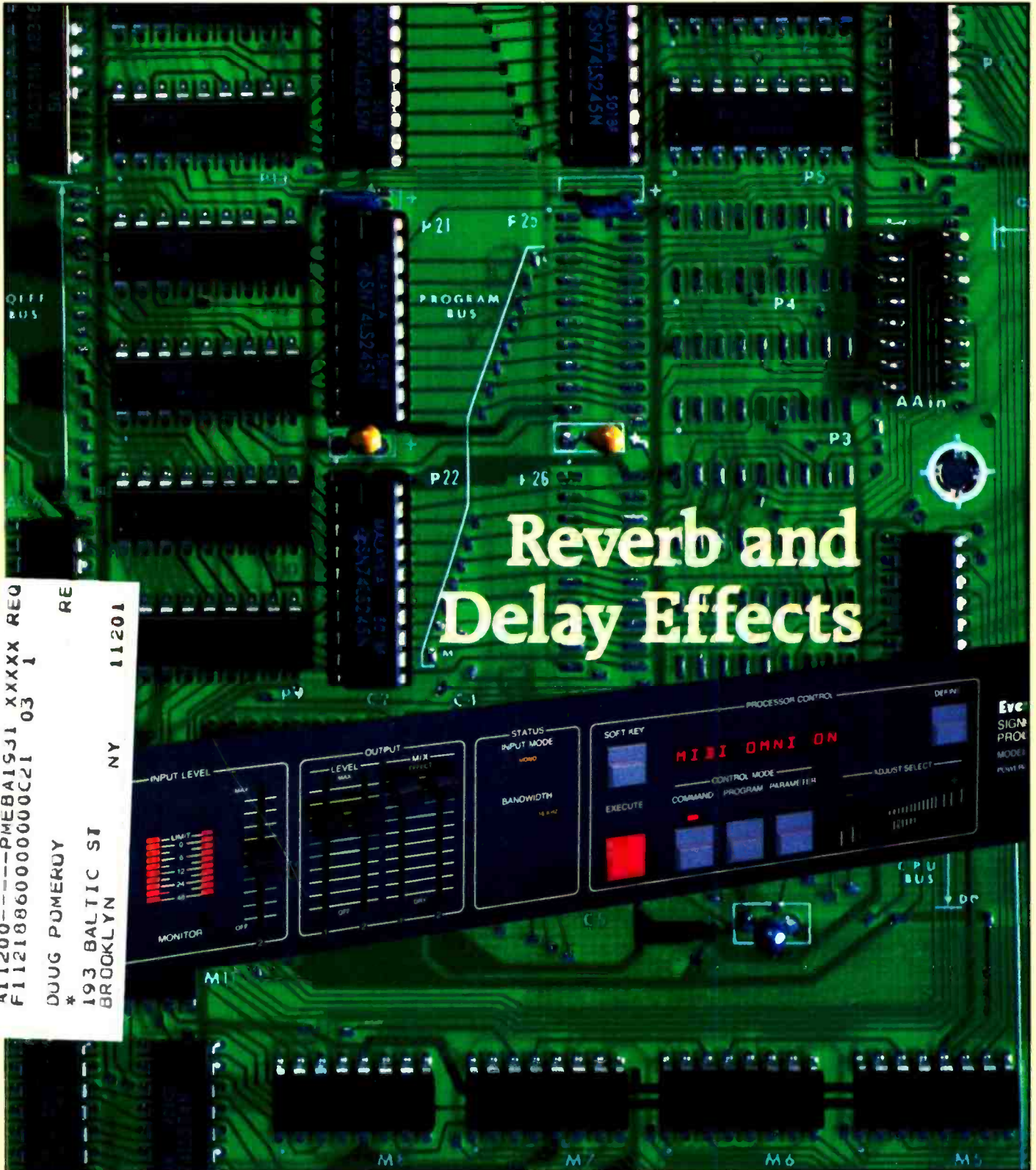

# CLEVER TRICK

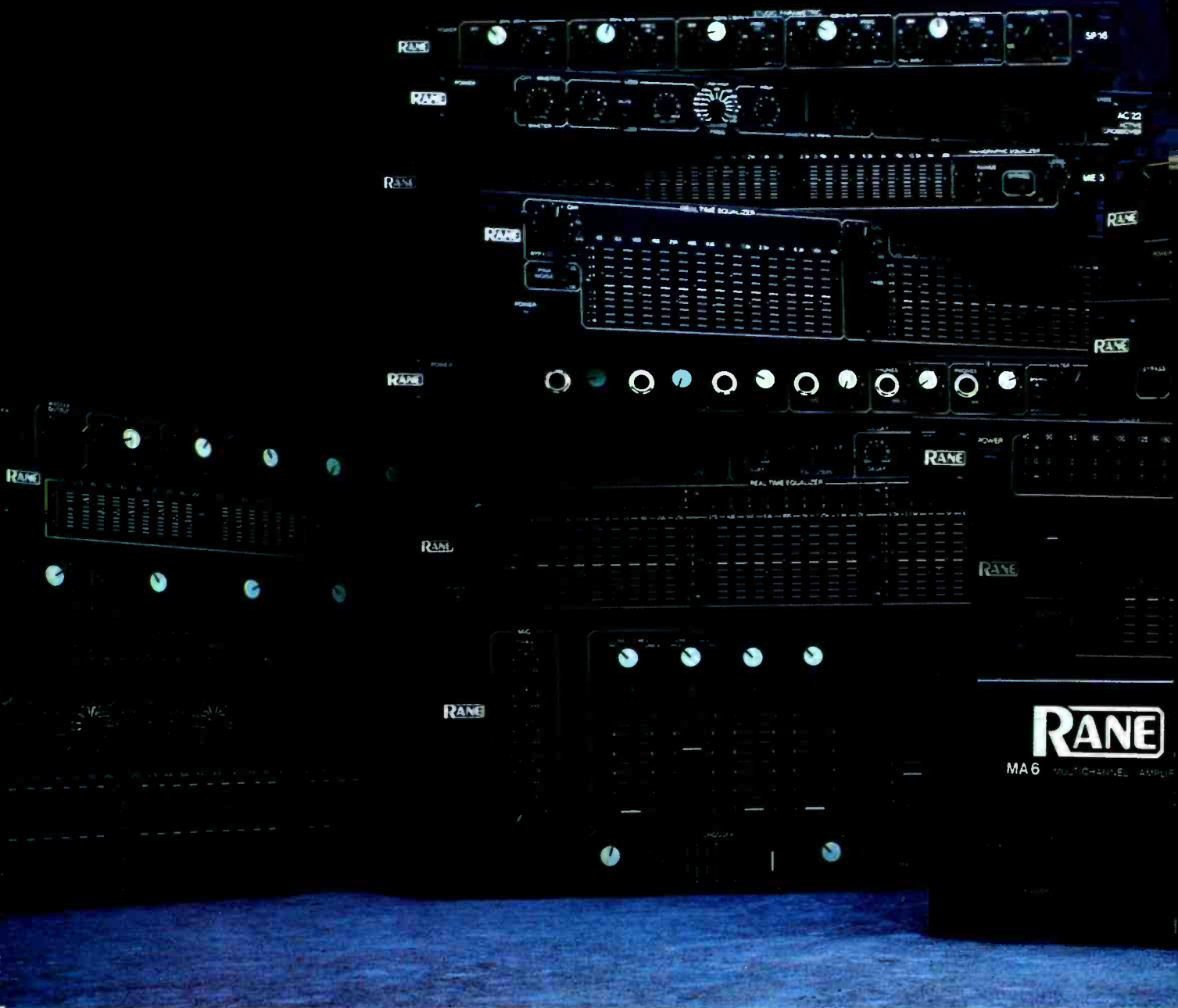

**H**ere you go. The whole bag of tricks from Rane. As you can see, where innovation is concerned, we'll stop at absolutely nothing.

From time-correcting crossovers to constant-Q

graphics to ultra-flexible program mixers, each Rane instrument is conceived as an aggressive and innovative breakthrough in its category.

Nothing frivolous, useless or complicated. No trivial



# S F R O M R A N E .



bells or whistles. Just prodigious technological design to give you unprecedented capability. And to give our competition fits.

to your sound system. Rane Corporation, 6510 216th Southwest, Mountlake Terrace, WA 98043. For information call 206/774-7309. Internationally distributed by E and E

Get a leg up on the status quo. Add a few Rane tricks

Instruments, 714/494-0231 Telex 182291.



Circle (1) on Rapid Facts Card

# Contents

# Recording

## ENGINEER/PRODUCER

February 1987    Volume 18    Number 2

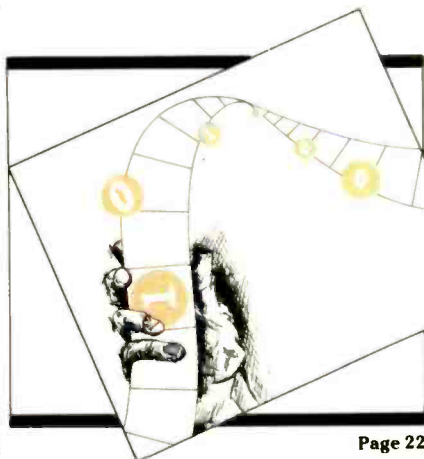

Page 22

### Reverb and Delay Effects

The modern generation of digital reverb and delay units available to recording and production engineers has opened up new areas of creativity in the studio.

### MIDI Control of Delay, Reverb & Special Effects

With the growing application of MIDI in recording and production studios, external control of delay and reverb units can add creative flexibility.

By *Tony Gambacurta* ..... 22

### Engineer's Guide to Reverb & Delay

Various types of delay and reverb processing have become increasingly important as creative tools.

By *Denis Degher* ..... 28

### Evolution of Artificial Reverberation

To create natural sounding artificial ambience requires that an engineer has an understanding of the acoustical power responses of different instruments.

By *John Eargle* ..... 34

### Other Features

### Test and Measurement Equipment Part Two

What are the important measurements you need to make on recording and pro-



Page 56

duction equipment, and what type of test equipment should a facility look for?

By *Richard C. Cabot* ..... 44

### Health Insurance:

#### An RE/P Guide for Production Staff and Facilities

Knowing the basics can make it easier to find suitable coverage.

By *Dan Torchia* ..... 50

### The Singing Christmas Tree

Operators can enhance the quality of live-performance events by taking advantage of outside rental companies.

By *David Scheirman* ..... 56

### Hands On:

Dolby Cat. No. 280 Spectral Recording module.

By *John Eargle* ..... 62

### Facility Spotlight:

#### Master Sound Astoria

More studios are electing to diversify into serving audio for video and film post-production.

By *Kathleen White* ..... 66

### The Final Link

Advances in analog disk cutting and Compact Disc pre-mastering have affected the ways recording and production engineers prepare master tapes for consumer release.

By *Kathleen White* ..... 74



Page 66

### Selecting an In-Cassette Duplication System

What electrical, mechanical and economic factors should be considered prior to selecting a duplication system?

By *Kenneth A. Bacon* ..... 78

### Departments

Editorial .....	4
News .....	6-8
Managing MIDI .....	10
Sound on the Road .....	12
Film Sound Today .....	14
Living with Technology .....	16
SPARS On-Line .....	20
Studio Update .....	85
New Products .....	88
Final Stage .....	94
Classified .....	95
Advertiser's Index .....	96

### On the Cover

This month's cover shows the front panel features and internal circuitry of an Eventide SP2016 digital reverb and special effects processor. Photo by David Emberling.

RECORDING ENGINEER/PRODUCER—Volume 18, No. 2—(ISSN 0034-1673) is published monthly by Intertec Publishing Corporation, 9221 Quivira Road, P.O. Box 12901, Overland Park, KS 66212-9981. Second-class postage paid at Shawnee Mission, KS and additional mailing offices. POSTMASTER: Send address changes to Intertec Publishing Corporation, P.O. Box 12901, Overland Park, KS 66212-9981.





# THE LEGEND CONTINUES

When you're in the studio, tape that's good enough is not enough. Which is why for ten years Ampex has continued pushing the potential of recorded sound. Through a decade of increased fidelity and reliability, Grand Master® 456 remains an audio tape obsessed with performance. Which is why more top albums are recorded on Ampex tape than any other tape in the world. For Grand Master 456, the beat goes on.

**AMPEX**

Ampex Corporation, Magnetic Tape Division, 401 Broadway, Redwood City, CA 94063, 415/367-3809 Ampex Corporation • One of The Signal Companies 

**AND THE BEAT GOES ON**

Circle 47 on Reader Service Card

## Vocal Dexterity

Despite the growing emphasis being placed on digital recording, and the creative potential offered by today's arsenal of signal processors, I would suggest that one fundamental production technique runs the severe risk of passing into the realms of audio memorabilia.

To my mind, accurately capturing vocals in both live performance and in recording sessions is rapidly becoming something of a lost art. Too many times during recent concert performances and while listening to album releases on both black vinyl and Compact Disc, I have been surprised at the poor quality of vocal tracks. (I won't even begin to describe my reaction to vocal and dialogue quality being produced by network and local TV stations; the degree of compression and signal processing currently being used by many of them would need to be covered in a subsequent editorial.)

A strange situation, you may ponder, given the number of high-quality dynamic, condenser, ribbon and electret models we have at our disposal. In live-performance there is a quite natural reluctance to place an expensive condenser or ribbon vocal mic in what often proves to be such a hostile environment. However, even when such mics are used during audio/video shoots or live album sessions under more carefully controlled conditions, the end result is quite often little better than what could be achieved with a dynamic model.

And in the studio, breath noises and pops are all too prevalent on today's recordings, not to mention distortions caused by excessive EQ and compression. That the reverse is true when dealing with background vocals may point to a possible cause: artist are being allowed to work too close to the microphone, and/or engineers have forgotten how to use adequate pop shields and filters.

I wonder if the key to successful solo vocal micing lies in fully appreciating the dynamics of harmony sections. After all, several vocalists working around a mono, coincident-stereo or spaced-mic array are pretty much forced to keep a respectable distance between themselves and the transducer.

Several factors contribute to this phenomenon, including an appreciation of the space in which each member has to work, and the collective consciousness that is fundamental to the working of a true harmony section.

Just as with a string or horn section, a vocal group possesses an intimate "inter-

nal balance" that causes the individuals to function as a cohesive entity, rather than a collection of individuals. Part of that cohesion results from an appreciation of the section's collective sound, and how the individual voices are blending together in the volume of air they currently occupy.

Contrast the situation for a lead vocalist. In the studio, most solo vocals are recorded as overdubs, often long after the basics were tracked. Apart from the problem of singing into the previously recorded tracks can we expect any soloist to give their best performance in such a relatively bizarre environment?

Aside from discussions about how engineers and producers should inspire a convincing performance from a lead vocalist, the primary consideration here is the studio environment itself. Gone are the days of excessive isolation in studios—if only because we are, at long last, beginning to appreciate the creative options provided by reasonably live acoustics, and are not too worried about sound leakage between instruments. (And, in these days of direct-inject everything, studio acoustics present even less of a problem.)

If you do have access to a reasonable live acoustic, why not take advantage of it? Position the vocal mic array reasonably near the control-room window for improved visual communications, screen off any areas of the room that may cause acoustic problems, and then use all your mental faculties to persuade the artist to keep a respectable distance from the mic.

A few of us even resort to occasional bouts of trickery, by maybe putting up a couple of mics in front of what you choose to designate as a "room ambience" mic. I'm sure we can all live with a white lie, if the result to be gained from using a vocal mic several feet back provides the sound we're after.

If the vocalist is hip to such trickery, experiment with large-scale windshields, which, by their very size, force the artist to maintain a reasonable distance.

In addition, check out the mic for frequency response aberrations at different orientations. I've seen some strange positioning of cardioid microphones used for vocal sessions, simply because the engineer knows that a certain side produces a more linear and smooth response over the frequency range of interest.

Mel Lambert  
Editor



## N/DYM means better sensitivity

N/DYM design means more microphone signal to cut through the electrical noise of mixers and processors for system "signal-to-noise" that equals even expensive studio microphones.

## N/DYM means lower distortion

Neodymium, the rare earth supermagnet at the heart of every N/DYM mic, not only creates an enormous magnetic field within the gap, the "fringe" flux outside the gap is also intense, surrounding the voice coil with a uniform magnetic field for lower distortion even during peak SPL's.

# New N/DYM™ microphones break every Electro-Voice tradition but one. Excellence

When was the last time you used a microphone that performed so well you actually did a double take? You actually said, "Wow! This thing is fantastic."

Chances are it hasn't happened in years. It hasn't happened because even though microphones have been modified and improved gradually over the years, there hasn't been any real breakthrough for over two decades.

The new N/DYM™ microphones are going to make you say "Wow!" This innovative series of vocal and instrument dynamics represents the first genuine advance in microphone performance in nearly a quarter century.

At the heart of this Electro-Voice breakthrough is N/DYM, a totally new microphone technology. N/DYM aligned design uses a rare earth supermagnet that is four times more powerful than conventional dynamic microphone magnets. The power and presence of these N/DYM microphones is anything but traditional. They convert more sound energy into usable

signal than any other dynamic microphone. *That's 6 dB hotter than the most popular!*

But the proof is in performance. We know it's not the components but the sound that equates to excellence in your mind. See your Electro-Voice dealer for a demonstration before your next performance.



## N/DYM means high end sizzle

With 50 percent more surface area than other designs, the larger N/D diaphragm intercepts *more sound waves* and converts this energy into *more output*. Reinforced to prevent "breakup," the diaphragm reliably couples high-frequency pressures and voice coil movements all the way to 20,000 Hz.

## N/DYM means less feedback

Our supercardioid pattern rejects more unwanted off-axis sound than the usual cardioid. And the *unique geometry* of the N/DYM magnetic structure *keeps our pattern supercardioid at all frequencies*.



To learn more about N/D Series microphones, see your Electro-Voice dealer or write Electro-Voice, Inc., Dept. N, 600 Cecil Street, Buchanan, MI 49107.

a MARK IV company

Circle (5) on Rapid Facts Card

# News

## Soundtracs appoints

### AKG Acoustics as U.S. distributors

The Stamford, CT-based company is now distributing Soundtracs products in the United States beginning January, 1987.

Both companies intend the transition to be as smooth as possible and, therefore, there are no immediate plans to change either the existing rep or dealer networks that AKG hopes to assimilate in full.

## Fairlight Australia buys controlling interest in U.S. distributor

Fairlight Instruments Pty, Ltd., the Sydney, Australia-based manufacturer of the CMI series III, recently acquired a controlling interest in its U.S. sales and service organization, Fairlight Instruments, Inc.

The U.S. corporation was formed in 1983 as a joint venture by Fairlight Australia and George Hormel Enterprises, Inc. The Hormel company will

continue as a major stockholder, although Fairlight Instruments, Inc. now technically becomes a subsidiary of the Australian manufacturer. A new chief executive officer, Paul Broucek, has also been appointed.

According to Kim Ryrie, managing director of Fairlight Australia, "We are particularly pleased about the appointment of Paul Broucek as CEO, and the establishment of much closer links between our research and development and service facilities and our extensive base of users in the United States."

## Syco Systems introduces Sycologic line to U.S. market

Although known primarily in the UK and Europe, Syco System's Sycologic products will be distributed in the United States through Los Angeles-based Creative Dimensions.

Initially, two products will be introduced, including the M16-Digital MIDI matrix. The M16 comprises a 16x16 patch matrix controlled by a remote

keypad. Up to 32 matrix patches may be edited, stored or recalled.

The second product is the M16x-MIDI matrix expander, which contains a 16x16 matrix to expand the M16's capabilities to 16x32 or 48. More destinations are supported than sources, to allow a greater number of MIDI voice modules and MIDI-controlled effects to be connected than MIDI controllers.

For further information on Sycologic products, contact Rita Lambert at Creative Dimensions, P.O. Box 6010-817, Sherman Oaks, CA; 818-907-7816.

## Stop Press

The SPARS studio business conference scheduled for March 28-29 at UCLA, Los Angeles, has been changed to April 25-26. The date has been changed to avoid conflict with the National Association of Broadcasters (NAB) convention, March 29-April 1 in Dallas.

For more information contact the SPARS national office: 818-999-0566.

# Recording

ENGINEER/PRODUCER

## EDITORIAL

Mel Lambert, *Editor*  
Dan Torchia, *Managing Editor*  
Sarah Stephenson, *Associate Editor*  
Alisa Carter, *Editorial Assistant*  
Irma Allread, *Editorial Assistant*

## ART

Kevin Callahan, *Art Director*  
Noelle Kaplan, *Graphic Designer*

## BUSINESS

Cameron Bishop, *Group Vice President and Publisher*  
Stephanie Fagan, *Promotions Manager*  
Cynthia Sedler, *Marketing Coordinator*  
Dee Unger, *Advertising Supervisor*  
Gloria Shanahan, *Advertising Coordinator*

**Sales offices: see page 96**

## ADMINISTRATION

R.J. Hancock, *President*  
John C. Arnst, *Circulation Director*  
JoAnne DeSmet, *Circulation Manager*  
Dee Manies, *Reader Correspondent*

## TECHNICAL CONSULTANTS

Larry Blake, *Film Sound*  
Bob Hodas, *Evaluations and Practices*  
Douglas Howland, *Broadcast Production*  
Paul Di Lehrman, *Electronic Music*  
David Scheirman, *Live Performance*  
Stephen St. Croix, *Technology Developments*

**RECORDING ENGINEER/PRODUCER** is edited to relate recording science to recording art to recording equipment, as these subjects, and their relationship to one another, may be of value and interest to those working in the field of commercially marketable recordings and live audio presentation. The editorial content includes: descriptions of sound recording techniques, uses of sound recording equipment, audio environment design, audio equipment maintenance, new products.

## CORRESPONDENCE

*Advertising and Subscription:*  
9221 Quivira  
Overland Park, KS 66215  
913-888-4664  
Telex: 42:4156 Intertec OLPK  
Fax: 913-888-7243

*Editorial:*  
Suite 220  
1850 N. Whitley Ave.  
Hollywood, CA 90028  
213-467-1111  
Fax: 213-856-4895  
IMC Email: REP-US

## SUBSCRIPTIONS

*Qualified:*  
**United States (Domestic Only) . . . . \$24.00**  
**Foreign . . . . . \$45.00**  
*Non-qualified:*  
**United States (Domestic Only) . . . . \$30.00**  
**Foreign . . . . . \$60.00**  
Optional airmail for non-qualified readers is also available for an additional \$75.00 per year. Foreign subscriptions are payable in U.S. funds only by bank check or money order. Adjustments necessitated by subscription termination at single copy rate.

**Recording Engineer/Producer** is not responsible for any claim by any person based on the publication by **Recording Engineer/Producer** of material submitted for publication.

## BPA Membership applied for December 1986

Photocopy rights: Permission to photocopy for internal or personal use is granted by Intertec Publishing Corporation for libraries and others registered with Copyright Clearance Center (CCC), provided the base fee of \$2.00 per copy of article is paid directly to CCC, 21 Congress St., Salem, MA 01970. Special requests should be addressed to Cameron Bishop, group vice president. ISSN 0034-1673 \$4.00+\$0.00.

**INTERTEC**  
PUBLISHING CORPORATION

© 1987. All rights reserved.



# THE AUDIO/POST SOLUTION

FILM/VIDEO SCORING  
SOUND DESIGN  
SMPTE, MIDI,  
SCSI CONTROL  
HARD DISK RECORDING  
USER FRIENDLY

## CMI

## SERIES



Dennison Advertising

*Fairlight*

- **Los Angeles**  
Fairlight Instruments, Inc.  
(213) 470-6280
- **New York**  
Fairlight Instruments, Inc.  
(212) 219-2656
- **Chicago**  
Gand Music & Sound  
(312) 446-4263
- **Miami**  
Limelite Video  
(305) 593-6969
- **San Francisco**  
AIC  
(415) 686-6493
- **Australia**  
Fairlight Instruments, Pty. Ltd.  
(02) 331-6333
- **Canada**  
Computer Music International  
(416) 964-1885
- **U.K.**  
Syco Systems, Ltd.  
(01) 724-2451

**THE COMPANY  
BEHIND YOUR  
SUCCESS**

Circle (6) on Rapid Facts Card

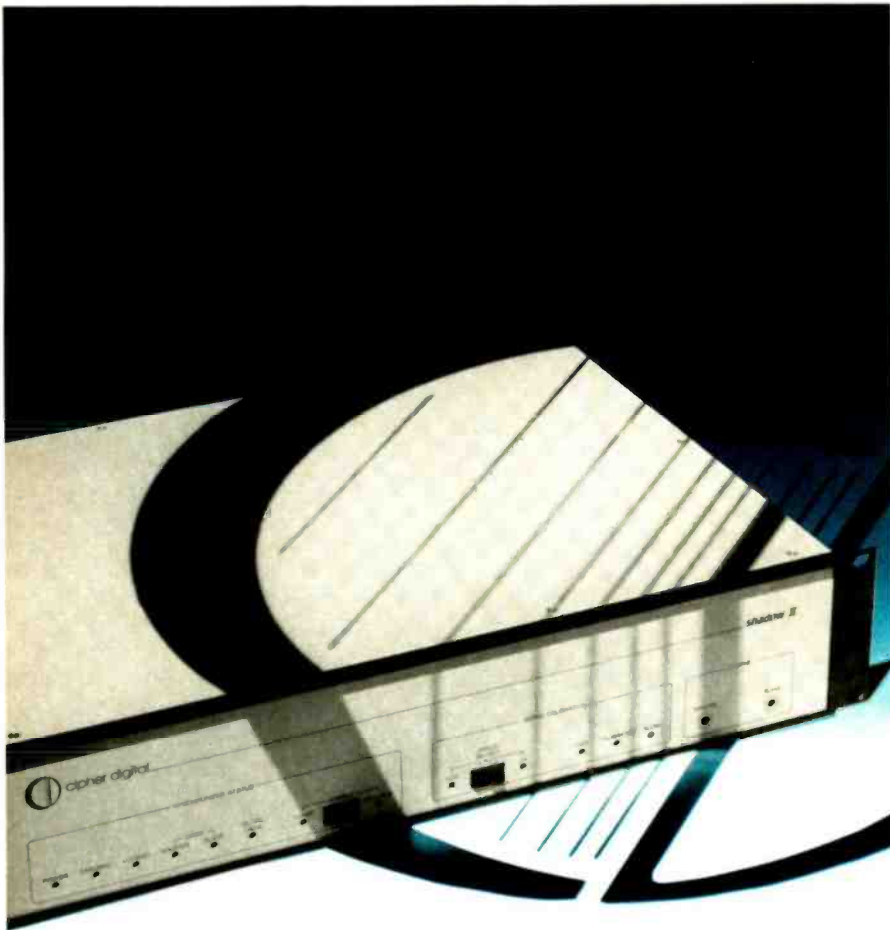

## The Shadow Knows

The new CDI-4800 SHADOW II™ synchronizer/controller with universal transport capability knows how to control virtually any audio, video or film transport on the market. Completely redesigned to reduce cost and increase reliability, the CDI-4800 Series features an improved time code reader, an enhanced code only master, RS-232/422 interface control, master record-in, and a more powerful microprocessor.

And the all new SHADOW II™ performed with even greater versatility, yet is completely compatible with its predecessor.

The SHADOW II™ provides the ultimate in production flexibility for complex edits. And it's affordably priced for today's professional.

Each unit carries a 3 year warranty.

For more details contact CIPHER Digital today. Call (800) 331-9066.



cipher digital, inc.

P.O. BOX 170/FREDERICK, MD 21701  
(301) 695-0200 TELEX: 272065

*Timely today, consistent with tomorrow.*

Circle (8) on Rapid Facts Card

## News

### Alpha Audio announces three sales of Boss editing systems

According to David Walker, director of marketing for Alpha Audio, recent sales of Boss systems have been made to Walt Disney Imagineering (WED), Glendale, CA, Soundtrack, Boston and New York, and Production Masters, Pittsburgh.

"We've certainly seen great results from the two fall trade shows, both AES and SMPTE," Walker says. "These shows first seemed to legitimize the audio-editor market; they further served to provide an arena of comparison for us and our competitors."

Alpha has been marketing the Boss system since January, 1986, after a 2½-year Beta-test phase.

The system has been recently expanded to include routines for MIDI-triggering, multitrack track select and direct control of video decks.

### Munro Associates set to build several European facilities

The design company, based in London, reports several new design contracts for studios due for completion in 1987.

Markant Studios in Eindhoven, Holland, will be building a new control room to full Munro specification, including M series monitoring. The construction will involve complete Techron TEF analysis to guarantee integrity of the electro-acoustic room interface.

Other rooms scheduled to be designed to this specification include: Sweet Silence Studios, Copenhagen; Eggars Hill Studios, Aldershot; Leroy Street Studios, London; Solid State Logic, Oxford; Berwick Street Studios, London; Sans Souci Studios, London; and other projects in Cornwall and Ireland.

Recently completed projects include Windmill Lane 3 and Music Works 2, both with Munro M3 monitor systems, Konk Studios 2, London, Great Linford Manor Studios, London University and Bermudasound, Bermuda.

### People

**David Deranian** has been named professional products sales manager at **Celestion Industries**, where he will coordinate the company's rep network for professional and MI products.

**Jack Letscher** has been appointed president of **TimeLine**, manufacturer of the Lynx and Lynx VSI interface/synchronization products. Prior to joining the company, Letscher was vice president of operations at Lexicon. **REP**





**\$395...**  
**PRO-Verb**  
**The Leader**  
**in Digital**  
**Reverberation.**

- **100 Presets**
    - 50 Natural Reverb
    - 10 Gated Effects
    - 10 Reverse Effects
    - 10 Chorus Effects
    - 10 Echo Effects
    - 10 Delay Effects
  - **1 High Rack Mount Case**
  - **Professional Phone Jacks**
  - **Midi Interface**
  - **Wide Range of Algorithms**
- Suggested Retail  
**\$395**

It Has To Be A Work Of . . .

**ART**

Applied Research & Technology  
215 Tremont Street  
Rochester, New York 14608  
716-436-2720  
Telex: 4949793 ARTFOC  
Circle (7) on Rapid Facts Card

# Managing MIDI

By Paul D. Lehrman

When keyboard players press a key, they expect something to happen right away. A hammer hits a string, a valve opens and lets air into a pipe, or a contact closes and starts an electrical circuit oscillating. Having recorded a track, during every playback they expect to hear the music exactly as he/she performed it.

When keyboard players are dealing with MIDI, however, there can be a lot of intermediary stages between an action and the resultant sound. Long after the player has recorded a MIDI data track, things can happen to it. Sometimes, what occurs in those intermediary stages and to that recorded track is the result of deliberate action. Sometimes, however, what occurs is a strange, unpredictable variation in timing. Such a variation is often the result of what's commonly known as MIDI delay.

MIDI delay can be caused by a number of things. For example, some synthesizers process MIDI data faster than others. The slower ones can run into trouble when confronted with a lot of notes played at high speed. (Sequencer developers like to test their products by firing bursts of notes at different synthesizers and seeing which one is the last to finish.)

Other times, MIDI delays are caused by what happens between the data generator (keyboard or sequencer) and the sound generator. Unlike analog sound, when MIDI data is processed it doesn't simply pass through filters, A-to-D converters, or what have you, with maybe only a little phase shift as a by-product.

Whenever MIDI goes through *any* device, it is regenerated. Sometimes the regeneration is straight ahead, as in a synthesizer's Thru jack, but sometimes it

can be much more complicated, such as in a device that filters out or changes controller information.

The nature of the operation being performed, as well as the quality of design of the device doing the work, will determine how seriously the regenerated code will lag behind the original—and sometimes it can be serious indeed. Chain a bunch of these devices together, and the problem is compounded.

It can get even worse if a computer sits at the center of your setup. If your master keyboard isn't directly connected

---

## *With these kind of MIDI timing delays, the music starts to lose sync with itself.*

---

to any synthesizers, but instead feeds the computer, which then feeds the synths, you have to take into account the MIDI-to-computer-bus conversion process, the computer's internal processor, the software controlling it, the computer-bus-to-MIDI converter, and *then* the interpreting speed of the target synth.

The result of these kinds of delays is that the music can lose sync with itself. The basic beat is okay, but different voices don't line up properly, or a certain rhythmic "feel" gets lost. Sometimes the effect is obvious, and sometimes the effect is subtle.

There's another far more serious form of delay, that crops up in multichannel, multisynth setups: MIDI choke, or overload of the data stream itself. A common source of overload is excessive controller data. A single sweep of a pitchbend wheel, for example, can generate 128 discrete events. Run that on several different channels within the space of a quarter second or so, and you've soon exceeded MIDI's bandwidth. Sometimes controller data is "invisible": some popular synthesizers put out aftertouch constantly, whether it's needed or not, and that huge amount of data gets passed around the system and recorded in the sequencer.

The result is that notes can get delayed, while the controller data gets

taken care of, and then they are played too fast, in an attempt to catch up. At a low level, the effect is a certain rhythmic "mal de mer;" in more severe cases the music will actually halt and then spurt ahead. In the worst cases, data can be lost, which can wreak havoc with tracks, particularly if a note-off or controller-to-zero command is among those dropped.

As long as MIDI has a finite bandwidth, delay problems will never be eliminated. Their effects can be minimized, however, with the application of a little common sense. First of all, always filter out unnecessary controller information. If you're using a sequencer that doesn't filter out keyboard aftertouch automatically on input, then get an external device that does, or else be prepared to manually edit out the data after each recorded pass.

Secondly, keep paths from controllers to synthesizers as short as possible and, more importantly, keep them *consistent*. If a player experiences a uniform 20mS delay between key press and the onset of sound, he will unconsciously adapt his playing style to compensate, quickly and with no fuss. But if the delay is 5mS on one synth and 60mS on another, it'll make it impossible to record decent tracks. Don't use Thru jacks on synths. Instead, use Thru boxes, so that every synth is the same distance *electrically* from the controller.

Third, keep things consistent from day to day; don't go moving around everything in your studio between sessions. If you rewire your MIDI setup, you may end up changing the relative delay times between instruments, which will make all previously recorded tracks sound a little off.

Finally, don't ask MIDI to do more than it's capable. Don't try to send banks of patches to a synthesizer while you're playing a sequence. Don't put pitchbend on 16 tracks of a sequencer and expect it to stay in sync. If you're building up MIDI tracks and you hear things start to break down rhythmically, recognize that you've reached the limit of the medium, and make other plans. Record what you've already got to tape, laying down a sync track at the same time, and use a fresh sequence, locked to tape, for the remaining tracks.

Someday, we'll have MIDI tools that will allow a higher information density, and can forget about all of these petty cautions. But until then, as long as we know what we're dealing with, we can still do just fine.

**R·E·P**

---

Paul D. Lehrman is a free lance writer, electronic musician, synthesist, producer and a regular RE/P contributor.

---



You ain't heard nothin' yet.  
There are new sounds in  
creation and they are ema-  
nating from the new 480L  
Digital Effects System.  
It goes beyond the 224XL.  
But can work with it, too.  
Hear "Varoom" (and over  
40 other new programmed  
effects) now. For front row  
seats call (617) 891-6790.

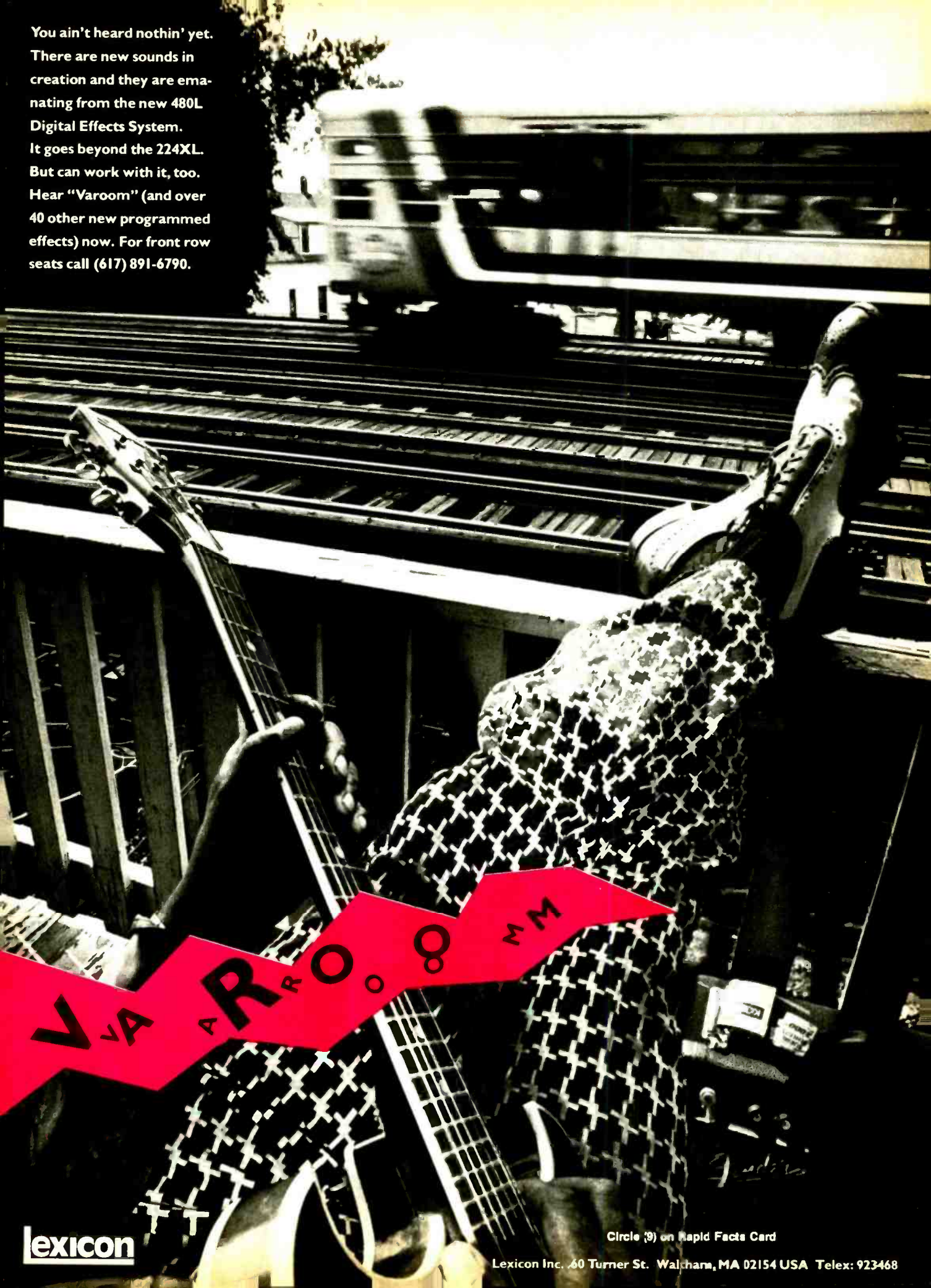

**VAROOM**

**lexicon**

Circle 9 on Rapid Facts Card

Lexicon Inc., 60 Turner St., Waltham, MA 02154 USA Telex: 923468



# Sound on the Road

By David Scheirman

In early days of live-performance sound, few dedicated products were commercially available for road technicians to use in combining the variety of stage microphone inputs into an artistically mixed output signal. Small 6-channel, rack-mounted mixers were often ganged together for this purpose; early touring sound systems featured custom roadboxes housing three or more such devices.

As recording and production technology brought about the creation of consoles, or integrated soundmixing panels offering greater audio control and flexibility in a horizontal format, live-sound systems began to incorporate the new designs.

Consoles that were originally designed for use in a recording or broadcast-production studio had the ability to combine and pass good, clean audio signals, but oftentimes the board's "ins and outs,"

and features such as equalization and signal re-routing, were not optimum for live sound. For this reason, many early sound companies developed their own mixing boards, along with the fact that both the purchase and modification of studio consoles often could not be justified economically.

Today, there is a wide range of mixing consoles available for use in concert-sound applications. Commercially available products, created by market-responsive manufacturers, can now be had off-the-shelf that once were only a dream in the mind of a touring-sound technician. Whereas a 16-channel mixer was once considered extravagant, and a stereo main output a luxury, products are available today that offer 40 inputs and more, with in excess of eight auxiliary outputs and extensive main program output capabilities.

With development of these expanded mixing capabilities, of course, has come an expanded price. The choice of consoles is an area of major concern to touring-sound firms. The cost of a

separate house and monitor-mix boards for a given portable system represent a major percentage of the capital investment required—yet consoles are most likely to become obsolete in today's fast-paced technological climate, with a shorter life expectancy than amplifiers or speaker systems.

Within the past two years or so, several different price categories seem to have emerged. These include: the under-\$20,000 bracket (24 and 32 inputs); the under-\$40,000 bracket (32 and 40 inputs); and the \$40,000 and up group of consoles (to 52 inputs). While the number of inputs is certainly not the only indicator of quality or price, it's not difficult to see why you don't find any 52-input consoles priced at \$9,500; as the quality of parts used in such a low-cost unit would not be professionally acceptable.

In like manner, smaller-frame 24-input devices are not often available with such added features such as programmable mute groups and VCAs. (A new Japanese design is available in a 24-input version and, for that reason, has become a popular unit for permanent installation systems.) Products from several console manufacturers have experienced good market acceptability, and a host of other companies are now also introducing large-frame mixing boards for portable use.

While production-line desks from many companies are dominating the scene, by virtue of affordable price and easy availability, a market still exists for high-end, custom made products. Many of them represent the "cutting edge" in live-performance design for some of today's aggressive concert sound companies.

Although several examples exist, one in particular is hand-crafted on a limited-production basis and boasts 56-input modules. Because each module measures 0.9 inches wide, a console takes up just about the same amount of physical space as most commercially available 40-channel desks. Made-for-audio op-amps, hand-selected, 1% tolerance parts and a component list that looks like a NASA inventory check-off sheet make the console one of the most unique products available today for live-sound applications.

Two boards have already been sold to Sound On Stage, Brisbane, CA, and Stage Sound, Phoenix, AZ. A 56-input configuration, beaucoups outputs and quiet as a mouse? No problem! Just be ready to peel off a cool \$100,000.

REP

David Scheirman is president of Concert Sound Consultants, Julian, CA, and REP's live performance consulting editor.

## api —a reputation of quality—

- distribution amplifiers
- custom products
- microphone pre-amps
- equalizers
- replacement parts
- the 2520 OP-AMP

Plus these new products:

- 5502 Dual Four Band Rack Mount 550A EQ



- 940M Motorized Servo Fader
- 318a distribution amplifier

let's  
be  
discrete

### api audio products, inc.

7953 Twist Lane, Springfield, VA 22153  
(703) 455-8188 tel: 510-6001-898

Use  
CAD/CAM

western representative

EVERYTHING  
AUDIO

16055 Ventura Blvd., Suite 1001  
Encino, California 91436  
(213) 276-1414

eastern representative

studio consultants, inc.  
321 West 44th Street, New York, NY 10036  
(212) 586-7376

Circle (42) on Rapid Facts Card



# The Affordable Alternative

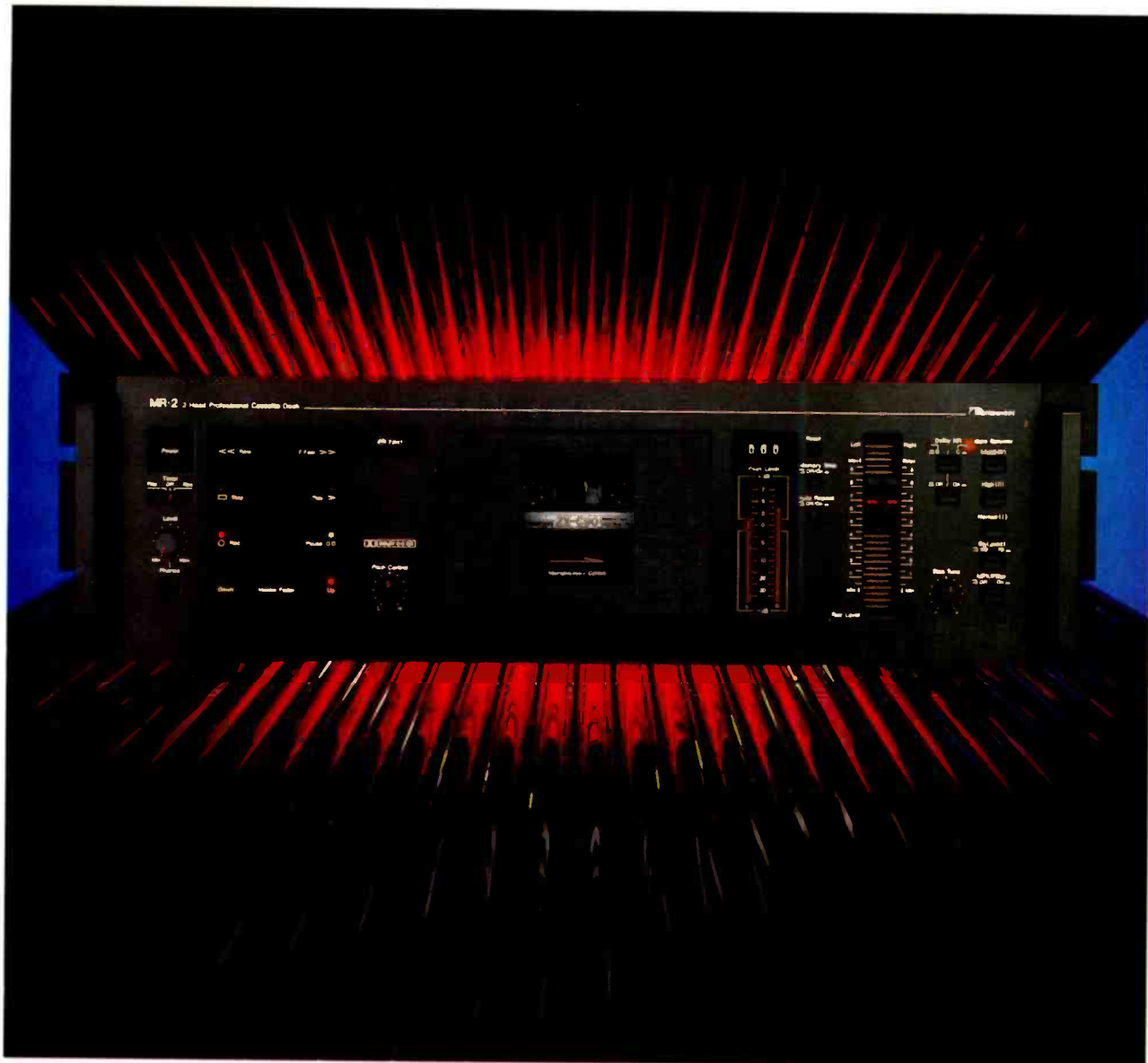

Why settle for a consumer deck when you can afford  
The Nakamichi MR-2 Two Head Professional Cassette Deck!  
Whether you operate a recording studio,  
a broadcast station,  
or a real-time tape-duplication facility,  
you'll find the MR-2 ideal for the job.

The MR-2 embodies the essentials of Nakamichi Technology...  
a "Silent Mechanism" transport that banishes vibration-induced flutter,  
Nakamichi tape heads that yield smooth response from 20 Hz to 20 kHz,  
low-noise/low-distortion electronics with exceptional dynamic range,  
and legendary Nakamichi quality control.

And, the MR-2 brings you such professional features as...  
Variable output for operation in -10 dBV or +4 dBm environments,  
RCA and 1/4-inch input/output jacks,  
Copy Out and Remote Input/Output ports for real-time tape duplication,  
Dual-Speed Master Fader, EIA rack mounting and more.

The Nakamichi MR-2—the Affordable Professional Alternative!



Nakamichi U.S.A. Corporation 19701 South Vermont Ave., Torrance, CA 90502 (213) 538-8150

Circle (10) on Rapid Facts Card

# Film Sound Today

By Larry Blake

It doesn't take a genius to figure out that the coming computer-based improvements in film-sound technology will lead to changes in the "who-does-what" issue. In this month's column, I'd like to speculate about how the talent in today's film-sound community might be best combined with the potential of tomorrow's technology.

It has been suggested that, in the best of all worlds, one person should be responsible for a film's entire soundtrack: all of the recording, editing and mixing. Except for the occasional music-only film, where one person has indeed handled virtually the whole job, I don't believe that a single POV is in a film's best interest. First, let's consider dialogue.

Product sound mixers working at U.S. facilities rarely participate in re-recording and *vice-versa*. I can't imagine any improvement in recorder or microphone technology that would change what's been required of production-sound teams since *The Jazz Singer* 60 years ago achieve a good, clean dialogue recording with minimal background noise. In fact, many would argue that the last major improvement in production sound technology, portable 1/4-inch recorders, in fact has *lowered* the quality of production sound tracks.

Why? Simply because such machines are extremely easy to use. As a result there are many people out there recording location sound who have no business being on a set. This is the considered opinion of many veteran sound editors and re-recording mixers, in light of the rudimentary, silly mistakes made by production crews, not to mention the overall low standard of the tracks they have to deal with today.

Quality production recording is an almost totally non-technical pursuit. Instead, it's a function of the experience and wits the boom operator and mixer bring to the film; fancy equipment and technical knowledge don't go very far.

Similarly, only years at a dubbing console can teach a re-recording mixer how

to blend a patchwork of production and ADR tracks into the appearance of a single take. The blinding speed exhibited by top dialogue mixers in knowing how to EQ, gate, compress and process tracks is a motor skill not picked up overnight.

Spending half one's time in production and the other half in re-recording would compromise the end product, and the mixer's overall effectiveness. There is also the fact that some people just aren't up to the physical demands of location shooting, while the pressure of tying

---

***Sound editors of the future will, in effect, have already cut the sound for the temp dub before the producer asks them to.***

---

everything together on the dubbing stage would be too much for others.

In many European countries, whose films are mostly "dialogue shows," and don't involve extensive sound effects or music, it's common practice for the production mixer to go on to handle the final re-recording. I'd like to hear from anyone whose positive experience with this arrangement would lead them to disagree with me.

Sound effects, on the other hand, can be handled by one person with no great harm (and much benefit, some might argue) to the track. Because of the computer-based nature of the coming technology, there will be less need for sound editorial crews to wait until the picture is in "fine cut" form and black-and-white sound dupes are made.

Working with a random-access digital editing system, a supervising sound editor can start laying in effects against picture on the first day of picture editing. Because the effects are not physical 35mm units, but instead are simply numbers in an EDL that note where each effect starts and stops, there is no need for manual re-conforming.

Thus, when working with a large central, disk-based sound archive, not only will a sound editor be able to quickly audition, say, bird backgrounds, but any

decision will automatically conform to subsequent changes in the picture cut.

When a film is finally in fine-cut form, the sound editor will have been working since the first day of shooting, and the effects for the film will have been refined over perhaps a six month period. This time frame will also allow the sound editor to record a goodly amount of fresh effects. Even some basic work on dialogue clean-up will be sketched out, with attention paid to trouble spots.

Today, film studios often spend a great deal of money on "temp dubs," hiring sound crews to come in and prepare the tracks for a quick, 3-day mix. Not only do these people cost money but, because of subsequent picture changes, their work will be all but useless in the final dub. Sound editors of the future will, in effect, have already cut the sound for the temp dub before the producer asks them to, because they are always preparing for the final dub. (Think about it.)

We're talking big savings here; again, because no sound is ever transferred, there will be no need for the armies of sound editors and assistants used on today's big features. Once the picture is locked, an editor or two will be hired for a few weeks to fine tune the supervisor's ideas. Today, on expensive features, it is assumed that each editor will spend roughly one week cutting the dialogue and one week cutting the effects for a 10-minute reel. This adds up to 24 sound editor weeks per film!

The reason why other editors are sometimes hired at this point is that the supervisor might be on the re-recording stage, mixing the tracks he's been working on for the past six months. This process will allow a single viewpoint to be carried through to the end. However, some supervisors might choose to leave the mixing to another set of ears, so that they can devote all their attention on the dub stage *listening* to the effects.

The idea of starting the supervising sound editor on the first day of shooting is anything but original; it's standard practice in England. Although, like us, English film-sound editors deal with 35mm mag, giving this person a head start on preparing the soundtrack results, by Hollywood standards, in very small crews.

Next month I'll outline what has to happen in technology before working procedures can change. In addition, I'll hazard a guess as to when and where all of the above speculations will become reality.

**REP**

Larry Blake is REP's film sound consulting editor.



# REINFORCEMENT: *THE NEXT GENERATION*



## *When the Music Store Mixer Won't Cut It*

The simple fact is, all the other PA consoles available today lack the processing, monitoring, and routing capabilities that today's touring acts have grown to expect in the studio. The WHEATSTONE MTX-1080 is the reinforcement console that PA mixers have been asking for. It's loaded with features, like programmable muting; 8 effects send controls (each with pre, post and off functions, programmable to pre-fader or pre-EQ); four-band sweepable equalization with switchable Q and peak/shelf modes; tunable HPF; separate electronically balanced mic and line inputs (transformer balanced option available);

XLR direct channel outputs; and channel, subgroup and main output insert points. Of course, the console also has eight 11x1 input matrix mixes (up to 16 are available using optional matrix expander modules). Mainframe size, module complement, group placement and aux zone control modules are configured per client specifications.

Now in our 10th Anniversary Year—ten years experience building Audioarts Engineering and Wheatstone custom consoles. The WHEATSTONE MTX-1080 Console: built by professionals . . . for professionals.

---



Wheatstone® Corporation

---

6720 VIP Parkway, Syracuse, NY 13211 (315-455-7740)

Circle (11) on Rapid Facts Card

# Living with Technology

By Stephen St. Croix

You know what a problem it is when you are working hard on a mix, and various people in the control room insist on having a conversation at the same time. You tell them to be quiet, so they stop for three minutes, and then slowly resume in a horrible strained whisper that is worse than before.

Some studios have dealt with this problem with a sort of "You talk, You walk" policy, while most others have isolated the traditional couch or provided sedatives to spectators. Recently it has become less of a problem. Maybe these people are simply growing up.

Well, get ready for more conversation in the control room and studio than ever before. It will happen in your studio, or you will not be able to compete.

A great deal of your equipment will be talking this year, loudly and incessantly, and no doubt right in the middle of your mix. All this conversation will significantly reduce setup time and provide more musical precision and versatility than ever before possible.

But it *is* conversation, and you *don't* want to hear it; but you will if you're not very careful.

Synthesizers will be talking to other synthesizers and computers will be forcing their will on all of them. Drum machines and digital signal-processing devices will cruise through the mix locked in relentless slavery to other computers, while still more computers are busy loading new voice patches into the synths, and actual digitized voices into slaved samplers.

Digital reverbs, equalizers and compressors will change parameters perfectly, on every bar; on every *note* if desired; all locked to a few tracks of specialized score running across the master sequencing computer's screen.

All this is just the MIDI conversation.

The master computer will be locked to the real, physical world via a time code interface. Several tape machines will chase or lead flawlessly, while separate MIDI-to-time code interfaces will happily convert timing locations into bars and beats for humans.

Stephen St. Croix, RE/P's technology developments consulting editor, is president of Lightning Studios and Marshall Electronic, Baltimore.

Automation systems will speak their own language over long cables. Digital processors will listen to remote controls talk still other languages over even longer cables. You get the picture.

All this is pretty neat. There will be more digital conversation in a modern studio in one month than any studio has had in all previous time combined!

But with power comes *noise*, and it will be up to you to keep it under control. Take all those data formats and send them over long cables at differing speeds; add multiple ground potentials;

---

## ***This may be a very good time for everyone to stop and study the basic rules of "Respecting the Common Ground."***

---

add several video monitors...you soon see that it's not going to be easy.

All of this becomes even more of a problem when you consider that we can no longer hide under that wonderful 70dB noise floor. We are beginning to ship 90dB product, and the end user will actually have a 90dB playback system.

Take three parts digital ground-loop hum combined with two parts high-frequency data hash; add one part clock-beat birdies; four parts sideband-induced transient intermodulation distortion; a pinch of good old RF-induced, least-significant-bit correlation noise; and you have the secret recipe for finding yourself on the street looking for a job selling Datsuns.

Or take care to avoid potential ground-loop and RF problems and produce the tightest, most impressive work you have ever turned out. Your choice.

This may be a very good time for everyone to stop and study the basic rules of Respecting The Common Ground. Now wait, I know that you know all about this stuff: don't wire both ends of a cable ground and then plug 48 of them into one machine. But, with the incredibly broadband RF in the air from this new gear, and the significant currents needed for long-wire digital communication, your current grounding scheme has little chance of getting the job done.

While it is beyond the scope of this column to provide you with all the details,

perhaps I can jog your memory in an area that you may have forgotten, and you can follow up as needed.

- Keep all digital and analog grounds separate! *Real separate*. If you can, sneak into your neighbor's yard late at night to sink your digital ground.
  - Watch chassis ground loops. Mounting a digital device in a grounded metal rack (or even an ungrounded one that has other equipment in it) can cause very interesting looping artifacts through the audio connection's grounds. This can be much worse than with a simple analog device.
  - Brush up on the proper practices for the grounding status of all input and output audio cable combinations to each piece of gear, including the newer concepts of capacitively or resistively decoupled cable grounding for problem units.
  - Now is the time to really study that single-point ground approach in earnest for your analog ground. It works.
  - Make your decisions about the grounding schemes that you want to use for your patch bays, and adhere to them without fail. This is obvious, but additional care and even some mu-metal shielding may be needed today.
  - Nothing is ideal; you know that. But do you know how far from ideal your cables and connectors might be? Cables with high internal resistance or questionable shield construction that, in the past, may have been quiet enough, won't be now. Loose-fitting connectors can cause intermittent artifacts at the worst time, while just a little corrosion in the right place can cause distortion that sounds amazingly like amplifier garbage, and can take hours to sort out. Some of the new anti-corrosion compounds really do work.
  - Don't run digital-data and audio cables near each other. The twist pitch in today's audio cables is for 60Hz rejection, not RF. No cable is good enough to overcome this kind of abuse.
  - Balanced, differential...whatever you call it...you need it on *every* bay and *every* cable. Ground looping and RF are actually two different problems. Running true differential cables, with real balanced drivers and receivers is critical to rejecting this new digital RF. The other part of this is the inverse: Shield all digital cables and connectors as well.
- All of which may seem a strange subject for my column, but it's all I had time for; I'm busy rewiring the grounds in my studio.

RE/P



# L.A.'s LARGEST PRO AUDIO DEALER

- ▷ Sales people experienced in the equipment and techniques of audio/video production,
- ▷ Factory-trained service technicians who are fast, courteous, and dependable.
- ▷ Over 200 different brands of professional audio/video equipment. Better selection of consoles and tape machines than anyone else in southern California.

L.A.'s largest pro audio dealer is

# EVERYTHING AUDIO



Sales • Service • Design

**ea** **Everything Audio**  
*Advancing with Technology*

16055 Ventura Blvd., Suite 1001 • Encino, California 91436  
Phone (818) 995-4175 or (213) 276-1414 • TWX 5106017338

Circle (12) on Rapid Facts Card



The background is a large, stylized graphic of a CD or tape reel. The outer ring is red, and the inner area is yellow and orange. A large black circle in the center contains a red and white gradient. Silhouettes of a band (bassist, drummer, guitarist, and singer) are positioned around the bottom edge of the reel. The 3M logo and the number 250 are prominently displayed in the upper right quadrant.

# 3M

---

# 250

## **One Tape Sounds True.**

Because capturing all the music is all that matters, we've created the world's finest music mastering tape. 3M 250 Recording Tape. Designed to deliver the greatest dynamic range and best signal-to-noise ratio of any tape in the world. To give you the truest sound.



# TO THOSE WHO PUT A RANGE OF MUSIC ON A ROLL OF TAPE, ONE TAPE IS TRUE.



## **One Tape Stands True.**

Helping you capture all the music...that's what we've been doing since we introduced recording tape back in the '40s.

That's why we stand by you—with the largest support force in the field.

And we stand behind you—with some of the most advanced research in the industry. All to keep our standing—as number one in the world of the pro.

***NUMBER ONE IN THE WORLD OF THE PRO***

Circle (13) on Rapid Facts Card

**3M**

Worldwide Sponsor  
1988 Olympic Games



# SPARS On-Line

By Gary Helmers

The dilemma facing today's studio owner, with regard to outboard equipment, is dreadful. Given the wide array of peripheral devices now available, how can you anticipate what the client may request to achieve a specialized sound? And how can you determine whether the client will be willing to pay for additional gear? Is the device going to be used only once, or is it something that will have long term value for the studio?

When you get that booking call you've been eagerly awaiting, the killer line is: "And I assume, of course, that the room comes with 'XYZ' at no extra charge?"

One of the essential keys to survival in the recording studio business is choosing the "toys" carefully. Profit margins are slim and all purchases must be justified. Two questions are important. First, will it improve the quality of the music produced at your studio? Second, will the client pay the extra charges, either as a rental item or as an increased hourly rate?

The logistics require you to determine the actual cost of the item, and then calculate how you can afford it. If it's a high-cost device, you might want to include it in a lease package, along with those new microphones and the second multitrack you've been considering. Even with the new tax laws that do away with investment tax credit, the cost of new equipment can be recouped in a number of ways.

A simple first step is to rent before you buy. If the client demands a special widget, you can explain that the studio rate does not include that particular piece of gear. Offer to rent it from your local studio rental company, and have it billed directly to the client. By taking this initial course, you will be able to determine whether the item will be a common request, or just a one-time whim. Most im-

Gary Helmers is the executive director of SPARS.

portantly, there is no cost to your studio.

If it turns out to be an item that's commonly requested, you can then proceed to purchase it, knowing whether you will be able to charge for it or absorb its cost in your present studio rate. The question: "Is it cost effective?" The answer: "Will the client pay for it?"

Having chosen either to rent the device, or to purchase it and charge it back to your client, you'll be in a better position to consider establishing your own in-house equipment rental company.

Test the market. Before the session,

---

***The goal is to remain competitive without having to purchase every new toy that comes along.***

---

tell the client which items are included in the hourly rate, and which items carry an additional charge.

We can learn a valuable lesson from our video post-production colleagues who stack their racks with outboard gear and say, "The XYZ is available, but if you turn it on, you pay for it." This is a very effective approach, because it shows even the most sophisticated client that while you have the latest toys, they must be paid for.

How much can you realistically charge the client for such hardware? What does it cost you? The formula is simple: 1½% of your total purchase is the minimum daily rental. Above that is how much the traffic will bear which, in turn, is determined by what the competition is charging. Another good rule of thumb is to charge for it until you have paid for it, and then give it away if you have to. You can judge by the resistance of clients to pay any extra charges and for how long they are willing to do so.

Another simple and effective method is to share costs with fellow studios, by setting up a co-op rental group. If your XYZ is booked for a session and you need another, call up another studio and see if their's is available. If it isn't, they will probably be willing to rent it for a percentage of their normal charge; anything is better than letting the XYZ sit on a shelf. Agree to insure its safety, and

pay in a reasonable period of time. (You'll also help them pay for that exotic gear they bought for their favorite client.)

A formula that encourages a client to indulge in new gear is to decrease the charges for extended use. Maybe charge them four days for a week's use, or three weeks for a month's rental. In this way the client gets a rate even better than your fair charges, and can enjoy the toys throughout the project. It works; try it.

Pitfalls: If you get involved in the rental of large pieces of equipment, such as consoles, tape machines and exotic signal processors, then you must consider cartage—yet another studio expense. Be sure the client knows of the additional cartage costs, and any damage costs. In return, if it doesn't work when delivered, there is no charge, and you pick up the cartage tab.

Axiom: To avoid embarrassment, never put a rental item in the studio until you have checked it out *thoroughly*. Additionally, if the gear is being charged to you, and you must bill the client, charge the standard 15% for handling to cover paperwork, and the time lag before you are paid back.

The situation is clear: Don't buy a piece of equipment unless you can justify its cost through increased revenue. If you cannot afford it, rent it and pass the cost along to the client. If the competition is giving it away, then you can either absorb the cost of renting/buying, or drop the hourly rate so that the rental charges combine for a competitive overall rate.

To determine which items you should consider renting or purchasing, look at the kind of equipment the local rental company has in stock and find out what it charges. Don't be the first kid on the block to purchase the new XYZ. If the device is in demand, consider a re-rental agreement with other studios or, if it looks wise, buy it.

The goal is simple: Remain competitive without having to purchase every new toy that comes along. Rent when advisable, and re-rent your own gear to other studios to offset costs. You can survive and prosper. What else matters? Except to make better music.

In closing, I'd like to express my gratitude to Chris Stone, president of the Los Angeles Record Plant and a founding member of SPARS, for his contributions to this month's column. He shared with me valuable hardball economic wisdom gained from years of experience in the big leagues.

**R-E-P**



Today's tougher audio requirements demand a new choice

# Telex *Pro Series* 6120 XLP

A new duplicator with 8X speed and tougher specs.

Improved frequency response plus less distortion and crosstalk are just a few of the technical gains achieved in the new Telex Pro Series duplicator. This means that you'll make duplicates that are truer to the master than with any comparable tape duplicator on the market today.

Yes, here's a system with all the advantages of the famous 6120 high speed duplicator plus enhanced specifications. Features that made the 6120 popular such as compact size, unlimited expandability, track select, audio

level monitors and easy one-button operation remain distinct Telex advantages. But, by developing the 6120XLP with 8X speed, Telex gives you the advantage of improvements in many important professional specifications such as distortion, frequency response, speed accuracy and crosstalk. And, the new cassette transport speed allows you to duplicate directly from 15 ips open reel masters for the ultimate in quality and convenience.

The Pro Series 6120 uses a newly developed, highly effi-

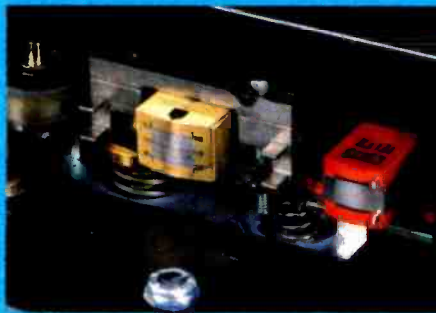

New XL LIFE cassette head.

cient XL LIFE<sup>®</sup> cassette head featuring ultra-hard physical characteristics for extra long life (10X normal) plus a satin smooth surface that resists excessive oxide build-up preventing the need for frequent maintenance. Its advanced engineering, precision design and painstaking manufacturing techniques contribute immensely to the Pro Series improved specs including an unmatched frequency range of 50 to 13KHz. For further technical details and the name of your nearest 6120 dealer, call or write Telex Commu-

nications, Inc., 9600 Aldrich Ave. So., Minneapolis, MN 55420.

### Up to 12 months to pay with no interest!

The entire Telex 6120 duplicator series is available with special NO INTEREST financing through participating Telex dealers. Yes, with only 10% down and up to 12 months to pay, you could be eligible for special NO INTEREST financing. Think of it! You could pay for your 6120 out of the savings or income generated.



## TELEX<sup>®</sup>

Call Toll Free in U.S. 800-828-6107 • In Minnesota Call (612) 887-5531

Circle (14) on Rapid Facts Card

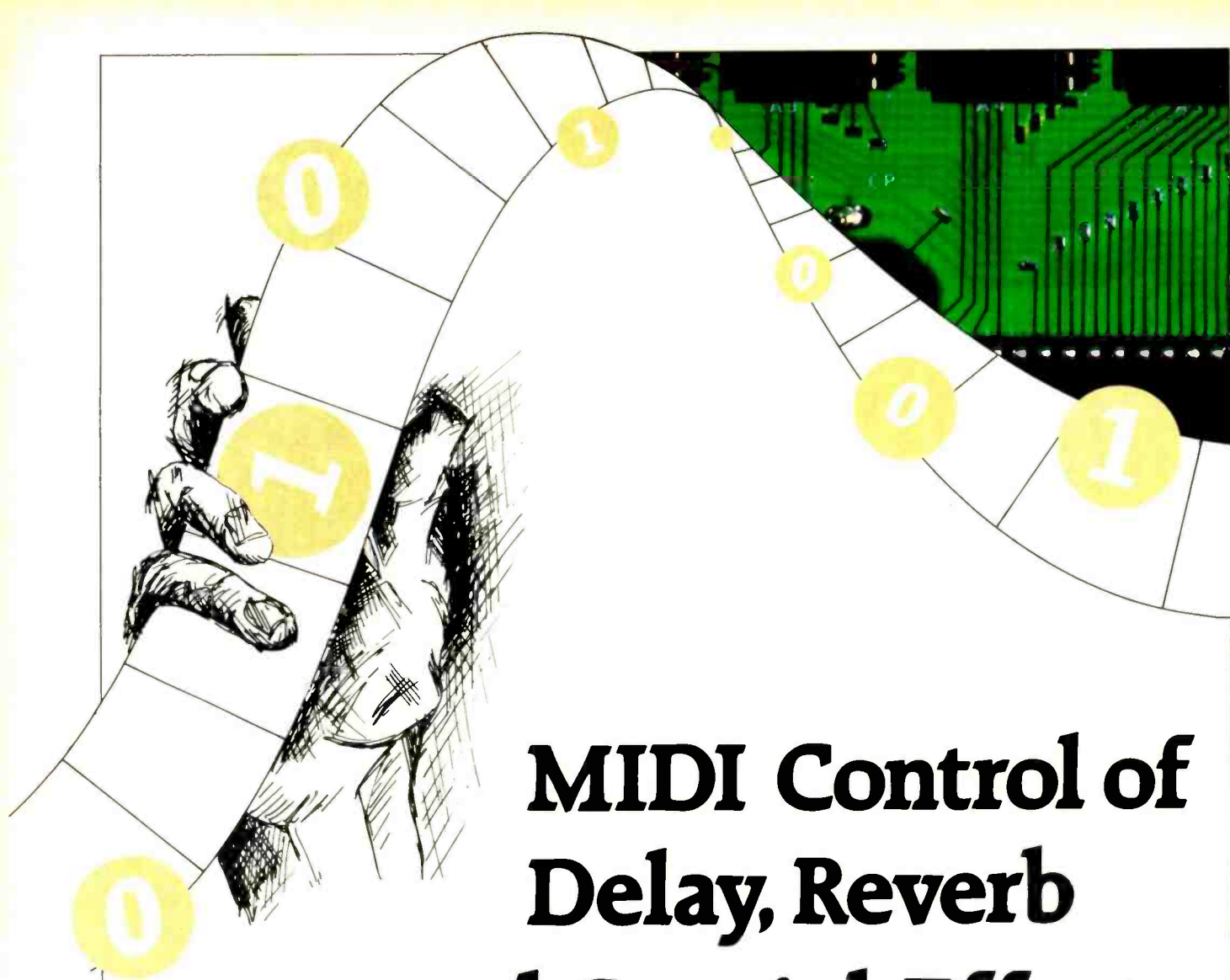

# MIDI Control of Delay, Reverb and Special Effects

By Tony Gambacurta

**With the growing application of MIDI in recording and production studios, external control of delay and reverb units can add creative flexibility to today's increasingly complex sessions.**

**I**n the past couple of years, a growing number of special-effects devices have become available that allow both static and real-time changes to be made to control settings via MIDI messages, a capability that has opened up new opportunities for expression in various areas of

audio production and recording. This article addresses some of the technical aspects of using MIDI for program and real-time control of delay and reverb units, with a slant toward the specific needs and applications of recording engineers and producers.

Until quite recently, external control of signal processors and effects devices has relied on a dedicated remote-control unit, or a proprietary protocol scheme using one of the standardized interfaces, such as RS-232C, RS-422 or IEE-488.

Generally speaking, such interfaces have been costly to implement, and require a dedicated computer or microprocessor-controlled remote to drive them. In addition, making real-time changes to control settings—for example, reverb time, EQ center frequency or compression threshold—is usually impossible without noticeable artifacts being produced.

The use of a standardized MIDI interface and commands, however, enables static and real-time control of outboard signal-processing devices to be made

Tony Gambacurta is vice president of engineering at Applied Research and Technology (ART), with primary responsibilities for new product design and development. He also serves on the executive board of the MIDI Manufacturers Association.



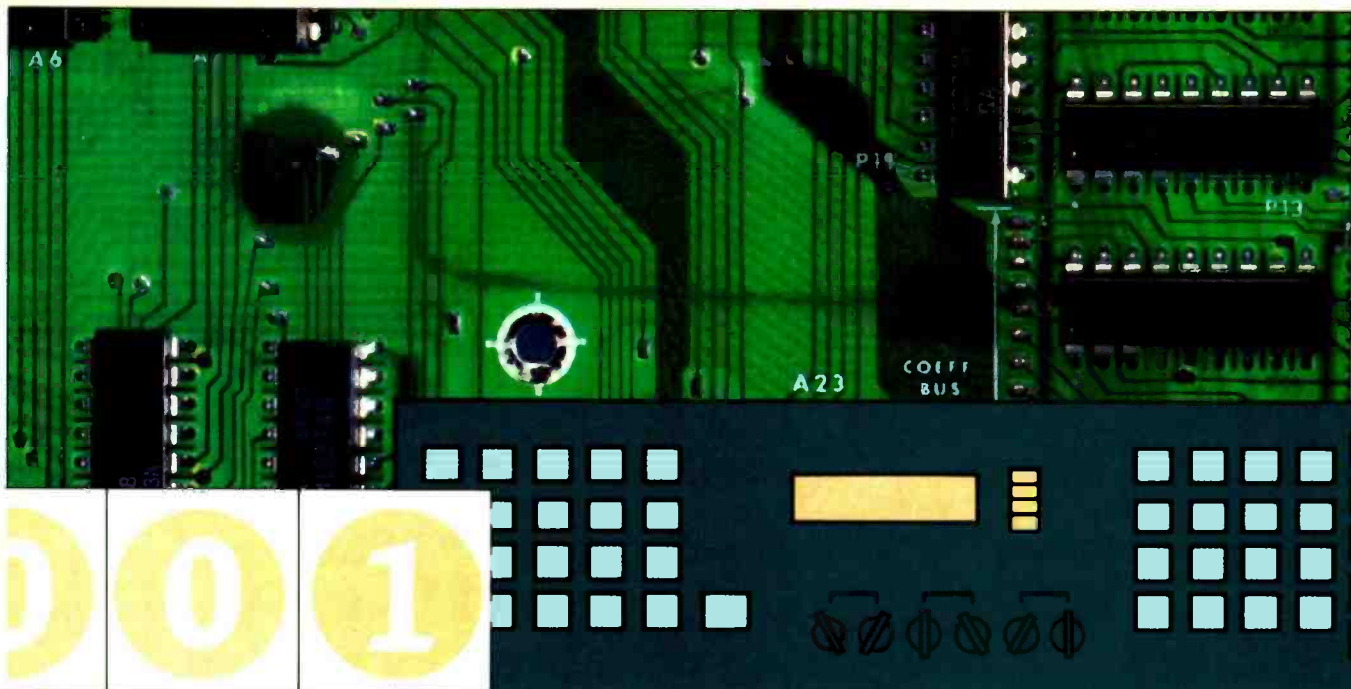

from any MIDI-capable music instrument or similar device. In this way, we can use the performance information from one synthesizer, for example, to control special-effects devices that are processing not only the sound of that instrument, but also the sound of any other source.

In addition, the entire process of special-effects control can be easily automated via an external MIDI sequencer and/or time code interface, with repeatable and precise results.

MIDI has helped to make all of this a practical reality in the studio. By now a well-established standard throughout the music industry, MIDI is low-cost interface yet, because of its speed and resolution of control, it offers very good performance for real-time control.

An increasing number of outboard effects processors, including delay and reverb units, now come equipped with MIDI interfaces. In addition to musical instruments such as synthesizers, guitars, electronic drums and percussion sets, MIDI capability is now being included in sequencers, message modifiers, devices to link MIDI with time code systems, as well as customized interfaces that allow personal computers to handle tasks such as sequencing, preset storage and patch editing. MIDI applications are also expanding now that new features such as MTC (MIDI time code) are being developed for simultaneously sending time code information and MIDI data between equipment.

Changes we need to make to special-effects units fall into two, complimentary categories: program changes and parameter changes. MIDI-capable effects

devices may lack the ability to perform real-time changes, but will respond to program-change messages to recall presets stored in internal memory. Preset changes allow various front-panel "snapshots" or setups to be activated at various points in time when the unit receives a MIDI program-change message.

On many MIDI-capable devices, the receipt of a preset-change message causes the output to mute temporarily while a new delay or reverb processing algorithm is set up for the new effect. Because of this short mute period, if an external MIDI sequencer is being used to send the MIDI command to change presets, the message may need to be triggered a few beats before the processing change is actually needed. In this way, the unit has time to alter its internal processing algorithm prior to its being required on a particular instrumental or vocal track.

The presets being selected via MIDI control can either take the form of a manufacturer-designed set of parameters that define a particular delay or reverb effect, or user-designed presets. Parameter changes often allow modifying an effect without changing all of the parameters that define a preset, and do so without muting the output signal.

It is worth noting that not all special-effects devices mute the output when preset changes are made via MIDI. Certain units determine whether or not to mute, based on the difference between the control parameters of the old and the new preset. On one well-known outboard unit, for example, if the only difference between the old and new presets

on a particular reverb algorithm is the amount of low- or high-frequency damping, no mute will occur.

Most of the processing parameters normally altered or modified via a unit's front-panel controls can be changed under external MIDI command. For a reverb processor, these parameters might consist of decay time ( $RT_{60}$ ), high-frequency damping or listener position, while for a DDL they may comprise settings such as delay time, output panning or the amount of regeneration/feedback.

#### Creating real-time messages

The first device needed for real-time MIDI control is a means of generating continuous rather than intermittent control messages. MIDI-capable keyboards work well for this application; they may be either keyboard-based synthesizers or MIDI master keyboards. Also now appearing on the market are stand-alone devices capable of generating continuous and static MIDI messages, and which do away with the need for a dedicated keyboard in the control room.

Conventional, MIDI-capable keyboards allow a number of possibilities for generating control messages. Control sources include modulation wheel (or lever), pitch wheel (or lever), foot pedals, note-on number, note-off number, note-on velocity, note-off (release) velocity, and after-touch messages of poly-key pressure and channel pressure. However, not all keyboards produce every one of these MIDI messages.

When selecting a controller, be aware that each has their own unique characteristics. Most synthesizers will output

MIDI messages for the performance controls that they produce, even if the synthesizer isn't using them. For example, if the particular synthesizer is equipped with note-on velocity, but this function is temporarily turned off or defeated, the note-on messages coming out of the synthesizer's MIDI jack will still contain velocity information. The same is usually true of all of the synthesizer's performance controls, such as modulation wheels, key pressure, etc.

Modulation wheels and pitch wheels are continuous controls and may be used as one might use knobs on a front panel. Pitch wheels are often spring loaded toward their center position. Modulation and pitch wheels are useful because their function is intuitive: the more you move the controls, the greater the change, and their operation is somewhat repeatable.

A potential problem with some MIDI-capable keyboards is that their modulation wheels produce messages without being touched. Normally, one would expect a MIDI message to be sent only when the wheel position changes. What appears to happen, however, is that the

wheel is located on the edge of discrete two values. As a result, a type of MIDI noise is generated as these two values are sent alternately. Such an output of MIDI commands may waste space in a sequencer, and cause the delay or reverb parameter being controlled in real time to modulate, with audible results.

Foot pedals share many of the properties of modulation wheels, but allow the use of a limb that might not be busy doing something else.

Note-on number works well as a MIDI message source, even when the keyboard is not being used to create actual musical notes. Its operation is very repeatable and predictable.

Note-off number has characteristics similar to note-on. Some keyboards do not send this MIDI message at all; instead, they simply output a note-on message with a velocity set to zero, which is acceptable within the MIDI specification.

Although note-on velocity has the properties of being intuitive, it is not as repeatable as modulation wheels, note-on or note-off number. It can be very ex-

pressive, however, especially in the hands of a good keyboard player.

Note-off (release) velocity is not as common as note-on velocity. It is less intuitive than the latter, and even keyboard players generally don't have the "touch" for release velocity that they have for note-on velocity.

Channel pressure is usually the amount of pressure a player exerts on the entire keyboard, even if the instrument in question is a polyphonic synthesizer. Poly-key pressure is the pressure exerted on individual notes, and is less common. Although intuitive, as with velocity information, the use of poly-key pressure isn't as repeatable as modulation wheels or key number. Poly-key pressure also has the property of generating a stream of messages once the keyboard pressure exceeds a threshold value. The space between the messages is too small for each to be processed before the next message is received.

As a result, the external effects device being controlled via MIDI must throw away or discard some of the messages to prevent the data overflowing its receive buffer.

It may also be possible to have the effects device itself generate MIDI messages. If a sequencer is being used to record messages for later playback, and the sequencer does not filter out MIDI system exclusive messages, then the effects device may be used to originate the desired messages. In some cases, it is possible to set the unit into a master mode, whereby each control change will generate a MIDI message such that a sequence of control changes may be precisely repeated.

Tables 1 and 2 provide summarized listings of MIDI sources and messages.

**Table 1. Typical MIDI messages and sources useful for controlling effects.**

**1A: Channel voice messages that are not classified as a controller:**

Description	Hex Message
Note off key <sup>5</sup>	8nh 0..7Fh (key) 0..7Fh (velocity)
Note off velocity	8nh 0..7Fh (key) 0..7Fh (velocity)
Note on key <sup>5</sup>	9nh 0..7Fh (key) 0..7Fh (velocity)
Note on velocity	9nh 0..7Fh (key) 0..7Fh (velocity)
Poly key pressure	Anh 0..7Fh (key) 0..7Fh (pressure)
Channel pressure	Dnh 0..7Fh (pressure)
Pitch bend (14 bit)	Enh 0..7Fh (1sb) 0..7Fh (msb)

**1B: 14-bit controllers:**

Description	(Control number)	Hex Message
Mod wheel	(1,33)	Bn 01 0..7F (msb) Bn 21 0..7F (lsb)
Breath controller	(2,34)	Bn 02 0..7F Bn 22 0..7F
Unassigned	(3,35)	Bn 03 0..7F Bn 23 0..7F
Foot controller	(4,36)	Bn 04 0..7F Bn 24 0..7F
Portamento time	(5,37)	Bn 05 0..7F Bn 25 0..7F
Data Entry	(6,38)	Bn 06 0..7F Bn 26 0..7F
Main volume	(7,39)	Bn 07 0..7F Bn 27 0..7F
Balance	(8,40)	Bn 08 0..7F Bn 28 0..7F
Pan	(10,42)	Bn 0A 0..7F Bn 2A 0..7F
Expression pedal	(11,43)	Bn 0B 0..7F Bn 2B 0..7F

**1C: 7-bit controllers:**

Description	(Control number)	Hex Message
Hold pedal	(64)	Bn 40 0..7F
Portamento	(65)	Bn 41 0..7F
Sostenuto	(66)	Bn 42 0..7F
Soft pedal	(67)	Bn 43 0..7F

**Applications of real-time messages**

Real-time MIDI commands can be recorded on a MIDI-capable sequencer, or used directly at the time they are generated. Real-time effect control may be done during the initial recording of a track or during subsequent mixdown.

One problem encountered when using a sequencer to replay recorded and edited MIDI data to control a delay or reverb unit is that some performance controls (such as modulation wheels) can fill up sequencer memory very quickly. Consequently, if sequencer memory space is a problem, some performance data is best suited for use while it is being generated rather than during sequencer playback.

The most creative part of real-time control lies in the selection of effects parameters to be modified. In the case of reverberation, we can change such



# MEYER SOUND



## A LITTLE ABOVE ALL THE REST

Accuracy. Consistency. Reliability. Characteristics prized by audio professionals—and with good reason. Meyer Sound looks at the real needs of the working audio professional. We engineer solutions to those needs. And we offer our solutions to the industry... to stand or fall on their own merit. Why are Meyer Sound products known as the standard by which all others must be measured? Because they are simply the best. Meyer Sound Laboratories, 2832 San Pablo Avenue, Berkeley, California 94702.

Circle (15) on Rapid Facts Card



parameters as the apparent distance from the sound source, the brightness of a room, and the reverb decay time ( $RT_{60}$ ). Although I don't have sufficient space in this article to provide details of how to set up every parameter that can be modified under real-time control, a few notes are in order.

Once it has been decided which particular external controller or MIDI message will alter which effects unit parameter, the next step is to set the center point and scaling. It's usually easiest to do this by first working on the control's two end points. For example, consider the case of setting note-on velocity to adjust  $RT_{60}$  decay time. Let's say that when we hit a synthesizer key harder, we want to reduce the decay time to bring the sound out front into a less reverberant sound field. (The opposite setting is also interesting.)

The shortest decay time we'll want is probably around 0.1 seconds (a dry-sounding room), and the longest five seconds. Having set the center  $RT_{60}$  setting on the reverb unit to somewhere half way between these values, adjust the scaling until you reach a point at which hitting the keyboard really hard

produces a reverb time of 0.1 seconds, and when played softly the room expands to  $RT_{60}$  of five seconds. Once this is done, the center often takes care of itself and if it feels right, you're done.

Some combinations of MIDI messages and effects parameters do not work too well, or may produce unexpected results. If you try to change a delay time in an echo effect or pre-delay in a reverb program with something like a modulation wheel, a "zipper" effect occurs. What's happening is an instantaneous change in delay time, which has the effect of splicing the signal by skipping segments of the signal. The modulation wheel is sending a rapid number of MIDI commands that result in a series of signal discontinuities—hence the zipper sound.

Because the anomaly can only be as loud as the signal itself, the zipper effect is only heard while there is a signal there to be processed. (The zipper effect is either a bad artifact or a great effect, depending on what you are trying to achieve in the mix.)

There is sometimes a delay between the time the MIDI command is received by an effects unit and the effect changes. It takes a finite time for the delay or

reverb unit's microprocessor to make the necessary calculations and send them to the internal digital signal processor. Under some conditions, this timing delay may be perceptible.

The worst case happens when the parameter change is so drastic that the output signal must be muted while the DSP is being reprogrammed. As mentioned previously, this artifact typically occurs when the effects algorithm actually changes, such as in the case of a reverb pattern being modified from a hall to a plate.

The audio mute usually only occurs when preset changes are being made. With parameter changes such as "position," for example, the changes are so fast that no perceivable processing delay occurs. (Indeed, the time it takes to process the change is less than the time it takes for the signal to make its way through the DSP.)

There are a few things that could occur in the future of real-time effects control using MIDI. As computers become more prevalent in recording studios and production facilities, they can aid in the setting up and control of external delay and reverb devices. Indeed, front panels and dedicated controls for outboard effects could become completely redundant.

Another possibility is to build additional processing capability into the effects units themselves. One example might be to use the new MIDI time code standard currently being developed. MTC allows time code data to be transmitted along with MIDI commands. In this way, an effects unit could be preset to change delay settings or reverb programs at certain points in time, in response to a predesignated MTC message.

Both of the above situations will become realistic and more practical when central controllers are used in control room. The controller could take care of simply sending MIDI timing information to the effects, or be a complete controller for an effects, or be a complete controller for an effects device with a blank front panel.

A few final notes: Experiment, experiment, experiment! MIDI control of delay and reverb units is a whole new area in audio effects, and its limits have not begun to be found. Real-time MIDI control of effects has been used by keyboard players, but there is no reason why recording and production engineers shouldn't exploit these new areas of creativity. (Why should keyboard players have all the fun?) After all, the vast majority of audio effects have been discovered through the creative input of studio and live-sound engineers.

**R·E·P**

**Table 2.** Parameters that may be controlled by MIDI. [Note: The contents of this table are specific to the ART DRI digital effects processor.]

Reverberation Effects:	
Description	Value range
Pre delay	0 to 200 mS
Decay time	0.1 to 25.0 secs
HF damping	0 to 19
Position	0 to 9
Diffusion	0 to 9
Output	ON/OFF
Infinite decay	ON/OFF
Digital Delay Effects:	
Description	Value range
Left delay time	0.01 to 1.00 secs
Right left delay time	0.01 to 1.00 secs
Regeneration delay time	0.01 to 1.00 secs
HF rolloff	0 to 19
Regeneration amount	0 to 19
Output	ON/OFF
Infinite decay	ON/OFF
Flanger-Chorus	
Description	Value range
Left starting delay	0 to 100 mS
Right starting delay	0 to 100 mS
Left sweep width	0.1 to 8.0 mS
Right sweep width	0.1 to 8.0 mS
Sweep speed	1 to 25
Regeneration	0 to 19
Output	ON/OFF



# TURN EVERY SESSION INTO A GOLDEN OPPORTUNITY

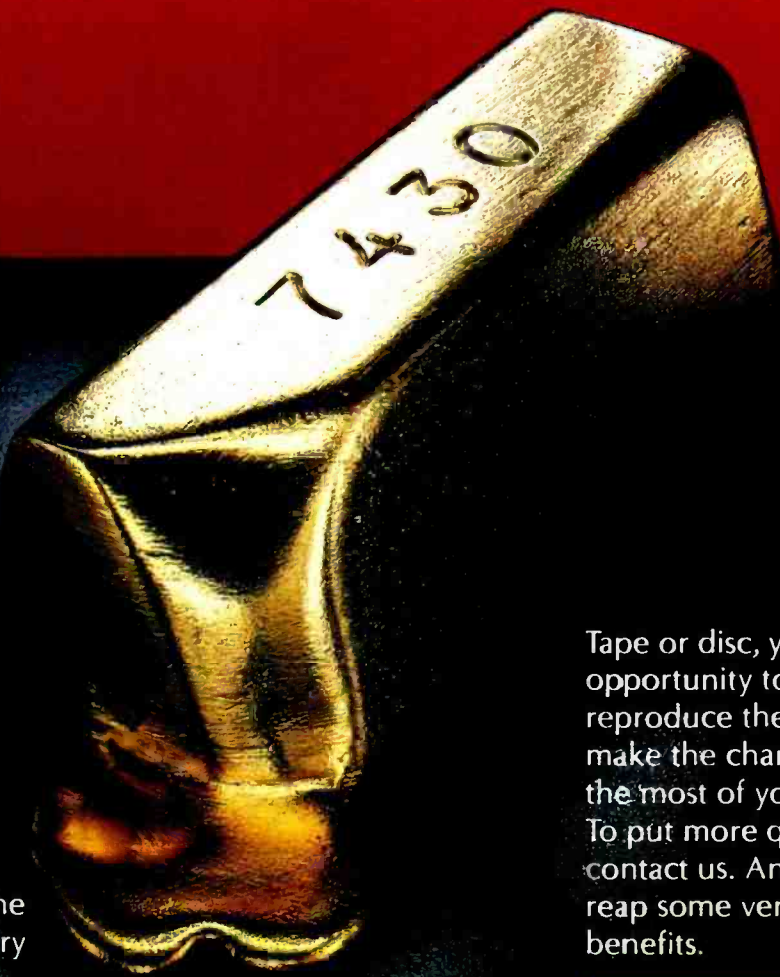

## Gold!

Gold bar—or gold record—it's a precious and much sought after commodity. Yet opportunities to achieve the excellence the metal implies can be every day occurrences in your studios. Simply blend your sound abilities and our superbly-designed, industry-preferred components and you're on your way to golden results.

One session after another, one mix after another, you can rely on the precise performance of our thousands of electrically and mechanically verified standard and miniaturized audio parts. Stereo phono jacks or patch panels, plugs or power cords—whatever you need—we offer the exceptional selection and remarkable recording and playback qualities that give you the outting edge. If you have any technical questions, just call on our backup team of support engineers.



Tape or disc, you'll have more opportunity to produce and reproduce the sounds that make the charts by making the most of your new system. To put more quality into it, contact us. And get ready to reap some very golden benefits.

### Send me information on your quality components:

- Please have a representative contact me.
- Please send me your Short Form Catalog covering the complete Switchcraft line.

My area(s) of interest is:

- Switches  Connectors
- Power Cords  EAC Receptacles
- Jacks/Plugs  Patch Panels
- Molded Cable Assemblies

My application is  Current  
 Future  (date) \_\_\_\_\_

Name \_\_\_\_\_

Company \_\_\_\_\_ Title \_\_\_\_\_

Address \_\_\_\_\_

City \_\_\_\_\_ State \_\_\_\_\_ Zip \_\_\_\_\_

Telephone ( \_\_\_\_\_ ) \_\_\_\_\_

Mail To: Marketing Communications Dept.,  
 Switchcraft, Inc.  
 5555 N. Elston Ave.,  
 Chicago, IL 60630

R2-87

## Switchcraft

A Raytheon Company

5555 N. Elston Ave.  
 Chicago, IL 60630

(312) 732-2700 Circle (16) on Rapid Facts Card

# Engineer's Guide to Reverb and Delay

By Denis Degher

Various types of delay and reverb processing have become increasingly important as creative tools for today's recording and production engineers.

Today's sound-enhancement techniques were developed in an attempt to recapture the ambience and directionality originally found on true stereo recordings. Stereo was considered an improvement over mono, because of its ability to create a convincing time-space image. Certain sounds would reach one microphone earlier than the other, simulating the ear's ability to determine directionality of sound by differences in arrival time.

During stereo recordings using spaced or coincident microphones, the sound from instruments in the rear of an orchestra would arrive at the mic position one millisecond later for every 13½ inches of separation between them and instruments down front. If, for example, sound would arrive nearly 27mS later, thereby creating a real-time depth effect.

For the same reason, left/right imaging occurs to varying degrees, depending upon the distance between the microphone pair. Additional factors that affect stereo perception include phase difference and intensity of sound arriving at each ear.

Close-miced recordings are devoid of any time-space directionality and, in many cases, consist of individually recorded mono sounds that are stacked and layered in the mix. Utilizing three basic parameters—amplitude, frequency content and panning—such sounds are placed left to right in an electronically created panorama we have come to refer to as "stereo."

To compensate, recording engineers

Denis Degher is a Hollywood-based free lance engineer, and a regular contributor to RE/P.

and equipment manufacturers have created various types of effects utilizing delay, reverberation and other time and phase-related devices to recreate some semblance of ambience, directionality and movement within a mix.

Although the general categories of special effects themselves are not complex, it is the engineer's skill at blending them together that creates an identifiable sound. It is the engineer's perception and creativity that eventually determines how to recapture the ambience, directionality and spatial effects missing from the original, close-miced recording that ultimately determines the final sound.

## Synthetic ambience

Room or ambient sounds can be achieved via distant micing to add space, depth and possibly direction to close-miced instruments. Bear in mind that, because of the higher percentage of reflected to direct sounds, the room's size and acoustic characteristics will have a large impact on the overall sound.

All sounds are basically composed of attack, sustain and decay. The attack is the leading edge of the sound wave that initially sets the air molecules in motion. The sustain reinforces this action, and is determined by the individual characteristics of the sound itself. The decay is the ambience factor comprised of random reflections (echoes) from various room surfaces that follow the original discrete attack and sustain.

As the discrete reflections move closer and closer together, forming a denser

## Session Examples From a Recent 24-track Remix

Listed here are my notes from a recent 24-track mixdown session, of a song in 4/4 time at a tempo of 120 bpm with annotations of the type of delay and reverb effects that I used. Obviously, your multitrack tapes will contain different instrumentations, but the listing should at least point you in the right direction.

- **Kick Drum:** use a stereo gated-plate reverb with an external digital delay line set at 30mS pre-delay, and a short decay time ( $RT_{60}$ ) between 0.6 and 0.8 seconds.

- **Snare drum:** use another stereo gated-phase reverb with an external DDL set 60mS pre-delay, and a longer decay time from 1 to 1.5 seconds. By adding some top-end EQ to the reverb returns, you can pull in a lot more snare wire sound. An additional digital reverb set to a large hall program ( $RT_{60}$  about 3 seconds) blended with the other effects can add some "air" to the snare.

- **Snare room mic** is compressed and added to mix for ambience.

- **Hi-hat:** do not use discrete delay or reverb processing, because the hi-hat will be picked up via the drum overhead mics.

- **Stereo toms:** use a digital reverb setting for a small hall with an  $RT_{60}$  of between 1 and 1.2 seconds, and a 125mS pre-delay. Also, add a longer or larger hall program for ambience.

- **Stereo drum overheads:** because the overhead tracks feature mainly



# THE BLUE CHIPS.

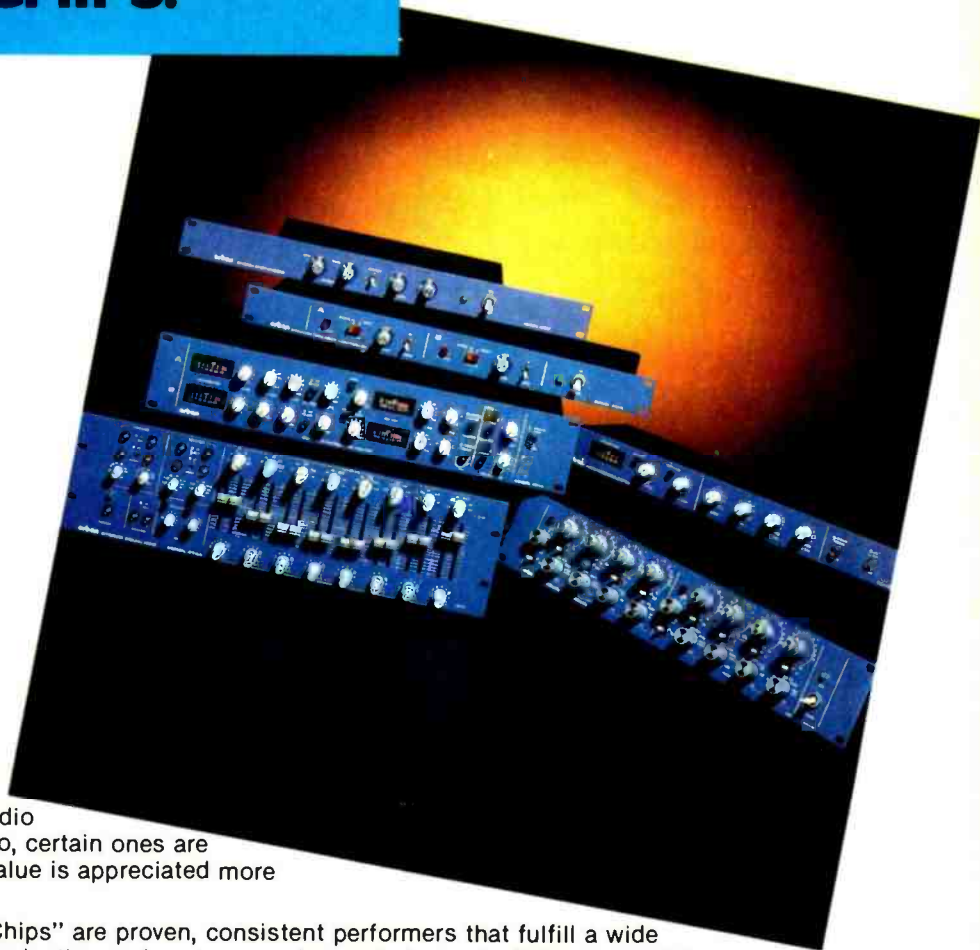

While trendy audio products come and go, certain ones are timeless. Their true value is appreciated more year after year.

Orban's "Blue Chips" are proven, consistent performers that fulfill a wide variety of essential production and system requirements in top facilities worldwide.

**622B Parametric Equalizer:** The standard by which all others are judged. Sonically and musically pleasing. Can be used as combination 4-band EQ and notch filter. A real job saver.

**672A/674A Graphic Parametric Equalizers "The Paracrossalizer":** Combines eight bands of parametric EQ with tunable high and lowpass filters. A uniquely versatile production tool. Also quickly becoming the smart choice for room and system tuning because it eliminates ringing and phase shift problems. Can be used as full electronic crossover plus EQ in one cost-effective package.

**536A Dynamic Sibalance Controller:** Around the world, Orban de-essers are the salvation of vocal sessions. Quick set up and easy operation.

**422A/424A Gated Compressor/Limiter/De-Esser "The Studio Optimod":** The most flexible, cost-effective level control system available. Orban compressors are known and appreciated for their smoothness. No pumping, no breathing; they work for you, not against you in tough applications.

**412A/414A Compressor/Limiter:** Transparent level control delivers the punch without the bruise. Very cost-effective. Ideal for installations and reinforcement work.

**245F Stereo Synthesizer:** Magical stereo effects from mono synths, drum machines, or any mono source. Perfect for extending capability of smaller format multi-track systems—the 5th, 9th, 17th, or 25th track. Inexpensive.

Orban also manufactures the reliable 111B Dual Spring Reverb as well as attractive acrylic security covers which fit all standard 19" rack mount products.



**Orban Associates Inc.**  
645 Bryant St. San Francisco, CA 94107  
(415) 957-1067 Telex: 17-1480

Circle (17) on Rapid Facts Card

sound, the amplitude decreases and the envelope blends together into a reverberant sound field. A live reverb or acoustic echo chamber can also be used to retrieve ambience, by placing a monitor speaker in a highly reflective room without parallel surfaces. The reflected, reverberant sounds are then extracted from the chamber via a microphone pair to create a "quasi-stereo" effect according to the varying arrival time of sound reaching the mics. (In essence, this technique can be viewed as "after-the-fact" ambience micing.)

Another variation of this theme is to use the studio itself as an acoustic chamber during mixdown. Various sounds from the mix can be routed through the studio monitors, the ambience being picked up by several microphones placed strategically in the room.

It is also possible to vary these effects in several ways. By using a digital delay ahead of the speaker feed, the resultant pre-echo can tune the beginning of the reverb pattern to a particular beat or time signature, thereby creating in-

teresting slapback effects. By delaying the attack of the reverb, the source sound can also be more clearly defined before the reverb pattern begins.

Another variation is to use tape delay before the reverb, thereby creating an analog-type of delay sound. By placing a delay *after* the reverb source, a post-echo can be created. There are also many variations of this effect, including compressing an echo send or compressing the returns. By selecting a release time that causes the track to pump or breathe, a "swelling" effect can be accomplished. The swelling can also be set up either pre- or post-echo, and pre- or post-delay.

By utilizing a loudspeaker-style driver element and two contact pickups attached to a steel sheet, the resultant plate reverb can be used to simulate an acoustic chamber. The advantages of a plate reverb over a live chamber include adjustable decay time via a damper system, and compactness (most plates can fit into a 2'x4'x8' space.) Plates have as much individuality as live chambers,

with many of them sounding great and many sounding poor; no two ever seem to sound the same.

In fact, the left and right returns from stereo plates rarely, if ever, sound the same, thus creating a sound differential or movement. At times, this effect can be beneficial, while at other times it can be a hindrance. (I've often wondered if manufacturers do this intentionally, or whether it's an uncontrollable, or unnoticed quirk.)

Digital reverbs have advanced a long way over the past few years in both cost-effectiveness and versatility. The lowering price of RAM and A-to-D converters means that digital reverbs and other effects have become more and more inexpensive. Today, such units have become the most commonplace of all types of reverb, due in no small part to their incredible versatility.

As is probably well known, digital reverb systems comprise of input A-to-D converters, a dedicated microprocessor and software, followed by output D-to-A converters. Having digitized the input signal, the reverb unit can manipulate the data to mimic the way sound is reflected off various surfaces of the "rooms" constructed or modeled by the software programs supplied with the device. Parameters such as surface reflectivity (which affects the low- and high-frequency content of the reverb pattern), decay time (RT<sub>60</sub>) and room dimensions can all be varied in real time by adjusting front-panel controls.

### Delay lines

The common usage of the word "echo" is akin in studio jargon to the operation of a delay line, in that it repeats a sound after the source has stopped. Used properly, an analog or digital delay line is one of the best tools for creating time/space effects within the mix. By creating various delays from left to right, or center to side, etc., a great deal of movement and excitement can be created in an otherwise static sound field.

Other types of time-domain processing, such as flanging, phasing and chorus, add very short delay times, usually of the order of 1-10ms.

### Reverb and delay examples

For years, simple reverb from a plate or live chamber was the primary source effect for **drums**. Today, as our effects and horizons have expanded, the list of tricks we take for granted keeps multiplying. Depending on how the chamber itself sounds, soaking a complete drum kit, less kick, in live reverb can create a soft, "pastel" sound, or a hard, crashing effect. If the room is plastered with a very hard, glossy finish,

*cymbals, yet also pick up the entire drum kit, any processing added here can have a large effect on what was previously added to the rest of the kit. Try and match ambience and reverb programs.*

*Straight room reverb on drum overheads, used in moderation, can often expand the entire sound of the kit; too much will wash out the entire kit, making it sound distant and weak. The key to adding effects to the drum kit is more a matter of blending together all of the different reverbs, noise gates used on the various drums and their respective levels into a coherent and musical sound that fits the song being mixed.*

• **Electric bass:** no time-based processing is normally required, except in the bridge where a little small hall program might be added for effect.

• **"Clean" rhythm guitar:** to add depth, double the track with a DDL set at 62.5mS and placed behind the source in the mix. A touch of room reverb is then fed from the DDL output to help spread out the sound a little.

• **"Dirty" guitar:** use a large-hall program, normal room reverb plus the 62.5mS DDL panned to the opposite side; this combination will help enlarge the sound and bring out the "crunch."

• **Sampled synth strings:** use lots of large-hall program with pre-reverb delay, and doubled with a 250mS delay panned opposite in the mix. The double is also laden with large hall in the post-fader position. For additional ambience, feed the tracks into the studio monitors and mic for room

sound.

• **Cello as part of live string quartet:** because this must be a highly defined line, no reverb or delay is added.

• **Two violins and a viola as part of live string quartet:** use a touch of small-hall program for enhanced ambience.

• **Chorused synth bells:** use a DDL set at 250mS with several decaying repeats for an one-eighth-note repeat, and panned to the opposite side for space. (Actual delay time selected will be dependent on the time signature of the synth line and the tempo of the track.) For extra depth, a large-hall program can also be added to source and a small hall to the DDL output.

• **Flugelhorn in bridge:** since the part comprises long, sustained notes, utilize a long digital plate-reverb program and a DDL set for a 500mS one-quarter-note slap. Pan the return to the same side of the mix as the source, but slightly harder to create a little move movement and depth.

• **Piccolo trumpet in bridge:** since this part is played against the flugelhorn, but in double time, use an one-eighth-note 250mS DDL setting, plus the shorter small-hall reverb program.

• **Lead vocal:** use a tape slap with VSO on the vocal, the other channel of the 2-track slap tape machine being used to delay a plate reverb with a 2 second decay time. To add a unique sound, use a closer echo from another digital reverb set to an inverse-room program with a 0.6 second decay time.

• **Lead vocal, 2-part harmony** is processed in the same way as the lead vocal is processed.



# The digital effects.

COMPRESSOR RELEASE = 525ms	PARAMETRIC EQ. MID FRQ = 500 Hz	AUTO PAN DIRECTION= L+R
TRIGGERED PAN PANNING = 525ms	FREEZE A REC MODE= AUTO	FREEZE B OVER DUB
PITCH CHANGE A BASE KEY = C 3	PITCH CHANGE B 1 FINE = + 8	PITCH CHANGE C L DLY = 0.1
PITCH CHANGE D F.B. GAIN= 10 %	ADR-NOISE GATE TRG. MSK= 5ms	SYMPHONY MOD. DEPT
STEREO PHASING MOD. DLY= 3.0ms	CHORUS A DM DEPTH= 50 %	CHORUS B AM DEPT
REV 1 HALL REV TIME= 2.6s	REV 2 ROOM DELAY = 20.0ms	REV 3 PLATE HIGH = 0.7
REV 4 PLATE HIGH = 0.7	EARLY REF. 1 TYPE = RAND	EARLY REF. 2 TYPE = RAND
STEREO FLANGE A MOD. DEPTH= 50 %	STEREO FLANGE B MOD. DEPTH= 50 %	STEREO FLANGE C MOD. DEPTH= 50 %
DELAY L,R Lch DLY = 100.0ms	DELAY L,R Lch DLY = 100.0ms	DELAY L,R Lch DLY = 100.0ms
GATE REVERB LIVENESS = 5	GATE REVERB LIVENESS = 5	GATE REVERB LIVENESS = 5

**YOURS FREE!**  
**SPX90 Applications and Programming Guidebook**  
 Featuring programs and data from famous  
 artists, engineers and producers.  
 For your free copies write:  
 SPX90  
 P.O. Box 227  
 Winona, MN 55987

## Without the expensive side effect.

If you want highly cost-effective, extremely versatile digital sound processing, you may not need anything more than the new SPX90 Digital Multi-Effect Processor. Or want anything less.

Built into its rack-mountable chassis are 30 preset effects specifically designed to suit a wide range of studio and live performance applications.

All the preset effects have up to nine user-programmable parameters. So you can further individualize them for your particular need and store them in any of the 60 on-board RAMs for instant recall using the front panel keys, optional remote control or footswitch.

The SPX90 offers MIDI-compatibility including the ability to make program changes during live performance via MIDI. Some effects can even be actuated

**\$775.**

\* by a change in input level during performance.

So whether you're a studio or sound reinforcement engineer, keyboard player, guitar player,

bass player, even home recording enthusiast, the SPX90 can add incredible creativity to your music. At a very credible price.

See your Yamaha Professional Audio dealer. Or write: Yamaha International Corporation, Professional Audio Division, P.O. Box 6600, Buena Park, CA 90622. In Canada: Yamaha Canada Music Ltd., 135 Milner Avenue, Scarborough, Ont. M1S 3R1.

\*U.S.A. suggested retail price subject to change without prior notice. Canadian price will vary.



Circle (18) on Rapid Facts Card

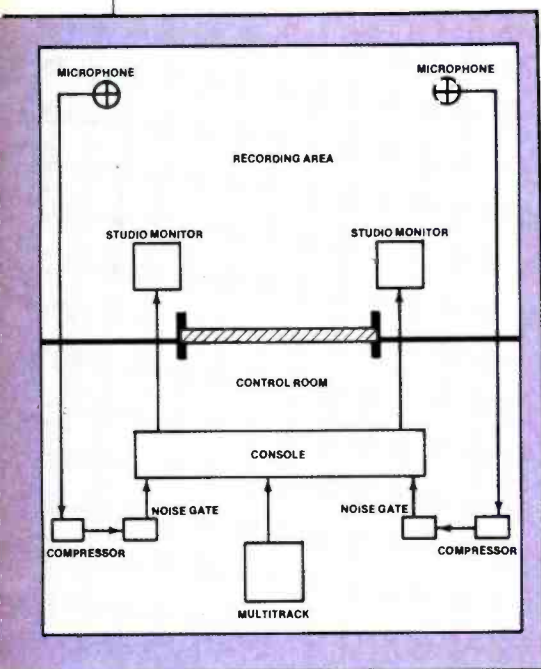

**Figure 1.** A more dense ambience can be achieved with the studio recording area serving as a live acoustic chamber. The miced sound is compressed and gated prior to being added to the stereo mix. Plate, spring or digital reverb units can be substituted for the studio or live chamber.

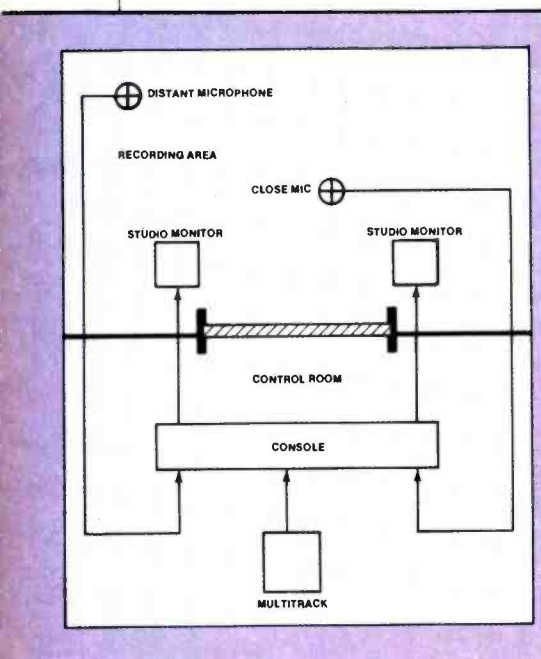

**Figure 2.** Air and depth can be added to synthesizer string parts by using close and distant micing in a studio recording area, or a live chamber. Conventional backline instrument amplifiers can be used in place of the studio monitors.

and is rather small in size, the mids and highs will be enhanced.

This type of reverb can add a shimmering "brilliance" to drums and reduce the top-end equalization necessary to attain a "cracking" or "cutting" sound. On the other hand, if the chamber is larger and walled in a more porous concrete, a warmer softer sound will result.

In the past, various studios were utilized because of the sound of their live reverb which, in many cases, helped define the studio's sound. Plates also have signature sounds and can attract a clientele of their own. In fact, certain older tube plates are still sought by certain producers and engineers for that elusive "warmth" tubes are thought to possess.

By processing drum kits through a tube plate, a sound analogous to a "softer" room sound might possibly be obtained. Utilizing a newer, solid-state plate a "tougher," more "brilliant" sound might be replicated.

One distinct advantage of using plates over live chambers is their variable decay time. Sound dampening materials may also be inserted into a live chamber, although the process involves, however, a great deal of trial and error.

Digital reverb units provide even greater flexibility on drums. The majority now offer programs that duplicate rooms, inverse rooms, gated reverb, reverse-gated reverb, spring reverb, taps, multitaps, etc. Many of today's newer devices even provide variable control of room sizes and types (large and small halls), with decay time related to the size of the room being fabricated in the digital domain.

First-reflection times can be adjusted to determine when the reverb effect is activated. Pre-delay can also be utilized to push back the onset of the reverb effect. Diffusion characteristics can be modified to create a high or low diffusion effect, which will impact the frequency range of the eventual reverb envelope.

High- and low-pass filters may be inserted, and the crossover frequency manipulated to further contour the program's characteristics.

Gated reverb on drums has become a very popular effect over the last few years. Utilizing a gate to chop off the end of a decay pattern from a plate or live chamber can create a very dense, yet short reverb pattern. The process can be used to great effect on snare, toms or even a bass drum. It adds size and "power" to the kit, without giving it a washed or pastel effect that occurs with long decay times. Gated reverb is featured on many digital reverbs; additional parameters such as hold and release time allow for great flexibility.

Further enhancing this effect is the reverse-gated program available on many digital reverbs, whereby the unit samples, holds and flips over the sampled envelope. With the decay coming first, followed by the attack, a sucking or "pulling" effect is created.

Another twist on this effect is to compress the reverb pattern, thereby creating a denser sound. Compressing and gating room ambience provides another interesting effect, utilized either during the tracking or mixdown (Figure 1).

Utilizing an outboard delay either pre- or post-reverb, or a pre-echo delay built into the reverb unit, can further change the effect's outcome. Delaying one side of the stereo send and/or return more than the other can create a very interesting sound, while side-to-side movement may be realized if the effect's panning is set hard left and right.

**Electric bass** does not usually require plate or live reverb. Added to a fretless base, however, reverb can produce a very "silky," smooth sound that is particularly effective when utilized with melodic passages. **Synthesizer bass** can be similarly treated. Other time-based processing, such as chorus and phasing, can be very effective for adding sparkle to lower-frequency sounds.

**Synthesizer sounds**, being of an artificial nature, can be easily processed with live reverb, plate reverb or ambience to create air, depth and to compensate for direct-inject recording. By feeding **synth strings** back in to the studio during mixdown via the studio monitors (Figure 2), the sound can be greatly enhanced and made more real. Another variation of this theme is to mic a backline amp cabinet during recording with various close and distant mics, to capture room ambience.

Both of these techniques do not have to be limited to string sounds; they can be applied to all types of synthesizer sounds to create depth and space.

Utilizing reverb on a string-synth sound helps float it in the mix, rather than placing it directly "in your face." The reason that reverb enhances strings so well is because, in most cases, it's the natural room ambience that creates the "lush" sound we associate with a live string section. (Strings often sound fabulous on film soundtracks, because they're normally recorded on large, live-sounding scoring stages, using distant micing.)

If the section had been recorded in a small or not particularly good sounding room, washing **live strings** in a chamber or plate reverb can also enhance the sound. By delaying the reverb with tape slap, the sound can be warmed up further still; adding a doubl-



ing effect also makes the section seem larger. The use of tape regeneration (feeding the off-tape output back into itself) can create another twist by compounding the delay affect; utilizing a digital delay line with feedback before the plate or reverb unit will also create a similar affect.

**Guitar amplifiers** were one of the first devices to be equipped with a built-in spring reverb, which consequently helped define the sound of many early rock records. (Can you imagine a Sixties surf guitar without that "slippery," washed out sound?) Today, with all of the various plate and digital reverbs we have available in the studio, it's pretty much impossible to improve on this vintage sound, if that's what you're after.

In other ways though, modern signal-processing toys have allowed the guitar to evolve in many new and exciting ways. Tape-based delay is still frequently used today, although to a lesser extent that it was before the advent of digital delay units. By panning the source to one side of the mix, and delaying to the other side, a simulated video stereo effect can be created.

Fast tape speeds create a tighter doubling affect, while slow speeds with longer delays can create an "answering" sound. Utilizing regeneration, which is similar to feedback on a digital delay, can provide multiple repeats to yield a trailing or falling-off sound.

Digital delays can be used to create most of the same effects, although with a slightly different sound text. Using a pair of DDLs with a source sound can yield many interesting effects. By panning a guitar to the center, delaying one to the left with Xms and to the right with 2Xms, the resultant sound will seem to move quickly across the stereo image (Figure 3.) This type of sound can be used with either **lead** or **rhythm guitars**.

Another variation is to feed delay line 2 from the output of delay line 1 and utilize identical delay-time settings. Other variations on this theme depend on different panning positions, such as source right, delay 1 center and delay 2 left, or source right, delay 1 and delay 2 center. Obviously, any feedback factors will have to be figured into this equation, and can be used creatively to further enhance the effect.

Room ambience can be used to create interesting stereo imaging by panning a close-miced guitar to one side and the distant mic to the other, thereby creating a spatial effect. Heavy compression of the room-mic output with a slow release time can create a delayed, "swelling" effect from the room mic and thereby enhance the panning effect. Room and plate reverbs can be added to set the

sound back into the mix and add depth.

Various digital reverbs can also be employed, thereby adding virtually unlimited possibilities by adding varying amounts of different sounds to the source. Combining many different sounds, such as gated and ambience program, plate and ambience sounds, chorusing reverb via a DDL, flanging a DDL, or delaying a flange, etc., can add myriad possibilities limited only by ones creativity. **Acoustic guitar** can use many of the same effects to successfully enhance sounds.

**Horn sections** can be electronically doubled with DDLs to fatten up the sound (use approximately 40ms or less, of delay). Longer delays on horn sections can occasionally be used for long, sustained parts, but are usually not appropriate for staccato "hits" or "punches." (The key word here is "usually" because sometime, somewhere, someone has probably use long delay on horn parts with great success.)

Long delays can be used successfully with **sax, trumpet, flute or flugelhorn solos**; by also adding reverb, a "dreamy," "ethereal" sound can be created. Again, the key factors in using delays are the level of the delay, the tempo of the song related to the delay, and the song itself.

Because there are so many different types of **percussive instruments** being used on sessions today, drawing any specific conclusion may be difficult. By using digital delay on staccato sounds (**woodblock, triangle, sticks, etc.**) a "bouncing" movement between speakers can easily create motion and interest within the mix.

Digital delays can also create rhythmic effects, such as triplets,  $\frac{1}{4}$ -note,  $\frac{1}{2}$ -note repeats, etc., by timing the delay to match the song tempo. The approximate delay can be calculated by computing the number of quarter notes per second, and then dividing 1,000 by this value to find the millisecond value of each quarter-note. From there, one-eighth, one-sixteenth and one-thirty-second note intervals can be computed and utilized for various rhythmic effects.

Live, plate or digital reverb can enhance many other close-miced sounds, including **vibes, marimbas, congas, bongos, shakers, rattles, tambourines, steel drums, etc.** An interesting effect can be achieved by using a reverb, or one side of a stereo reverb, and panning the output to the other side of the mix so that the reverb pattern moves across the stereo image.

Panning reverb behind the source, or panning the source off-center and the reverb hard to one side, can also create the illusion of depth.

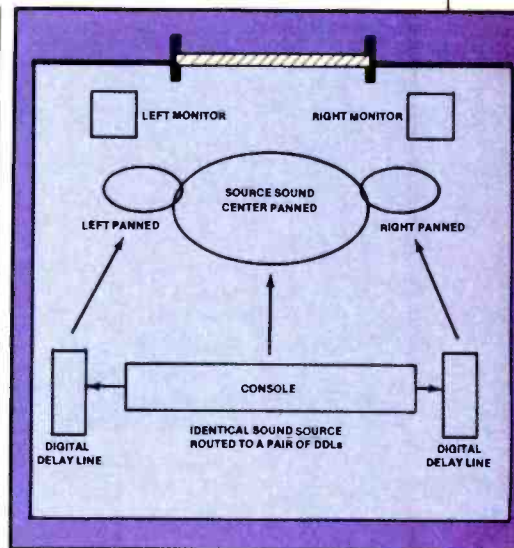

**Figure 3.** A cross-delay effect in the mix works particularly well for guitar parts. By using twice the delay time on the right as on the left, the resultant sound will appear to move rapidly across the stereo sound field.

**Acoustic piano** is sometimes placed in the percussion family, mainly because of the percussive-type sound of hammers hitting the strings. Various reverbs can often help expand the sound of a small acoustic piano, or one that was recorded in a small or dead-sounding room. If the piano was recorded as an overdub with ambient micing, care must be taken to try to maintain correct stereo imaging, simply because the ambient mics will diffuse the directionality.

In the last few years, **lead** and **background vocals** have become highly treated sounds, with the advent of digital delays, digital reverbs, chorusing, flanging, compression, expansion, etc. In the past, vocals were, for the most part, kept fairly natural; a touch of reverb, or perhaps tape slap in conjunction with reverb, was added to enhance the sound. Today, vocals have become very specialized sounds that are sometimes easily identifiable because the effects have become an inherent part of an artist's sound. Besides adding depth and movement to the modern mix, such effects have helped the evolution of contemporary records.

For all intents and purposes, the field of reverb and delay is as broad as the collective consciousness of the musical community's creativity. As a result, any attempt to codify it would by definition, be incomplete.

I hope this article will shed some light on the subject and enable talented and creative people to further expand the creative aspects of the studio world.

**REP**

# Evolution of Artificial Reverberation

By John Eargle

**To create natural sounding artificial ambience requires that an engineer has a basic understanding of the acoustical power responses of different instruments in a reverberant recording area.**

**R**everbation, equalization, and dynamic-range control are usually considered to comprise the "big three" of signal processing. While equalization and dynamic range control are often used in subtle ways by recording and production engineers—and are usually intended not to be heard as such—rever-

beration is often added to change program character in a profound way. Even the manner in which it is typically implemented draws attention to this special character.

The earliest studio implementation of reverberation probably dates from motion picture sound re-recording in the late Thirties, where first were seen Cinema Engineering schematics for a console with the ubiquitous Pre/Post switching of "Reverb Send" around an input fader, as shown in Figure 1. In nor-

mal use, the Reverb Return function took place at the line-amp stage and wasn't especially easy to manipulate or adjust. Further, Reverb Send bus switching usually followed program bus switching; via some cumbersome patching, however, this state of affairs could be changed, as shown in Figure 2.

The "normalled" control of reverb described here was adequate in those days of monophonic reverberation chambers. It underscored the use of reverb basically as a special effect, rather than any attempt to duplicate the natural ambience that today's better reverb units afford. The wisdom behind Pre and Post switching is that it allowed the mix engineer to ride individual input levels, while maintaining a fixed ratio between direct and reverberant elements (*Post*), or to maintain a fixed global reverberant signal component with the direct sound seeming to move closer or farther away, at the command of the mixer. Both effects were useful in the motion picture theater.

Does all of this sound familiar? It should, since the same console topology was adopted in most recording and production studios during the Fifties and Sixties. The advent of stereo put a few strains on the system because it had originally evolved for mono only. Cross-patching of mono reverb with or without tape delay came first, followed by true stereo reverberation. With the rise of multitrack recording for rock music, the number of Pre/Post send channels rose quickly, mainly because they had found

*Continued on page 38*

John Eargle is president of JME Consulting Corporation, and has consulted for a variety of equipment manufacturers. He also manages to find time for regular jazz and classical sessions.

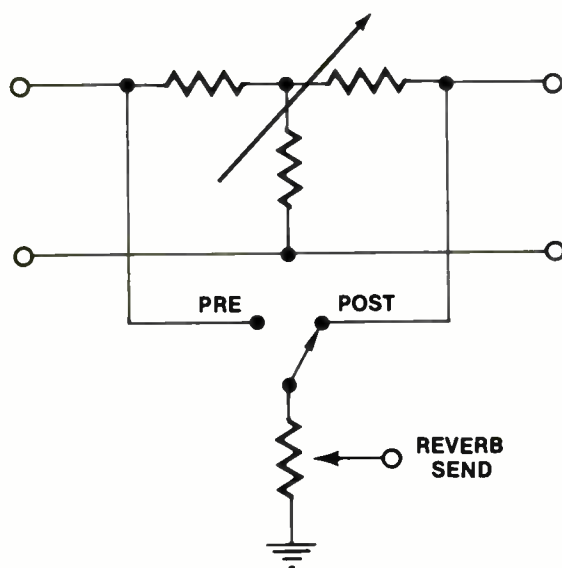

**Figure 1.** Block diagram of a traditional reverb send, with pre- and post-fader switching.



# It's like holding an isolation booth in your hand!

Compared to older microphone designs, the ATM63 is far better at rejecting sounds from the sides and rear. Even with a stage full of monitors and amplifier stacks. And as you get farther from unwanted sound, the ATM63 advantage sharply increases when compared to the others.

Only the vocal comes through loud and clear, making both monitor and house mixes cleaner and far more controllable. With the punch and clarity that is the very definition of a great vocal microphone.

But the ATM63 works

for more than vocals. Around a drum kit, for instance, the ATM63 provides outstanding bleed-through rejection to greatly reduce troublesome phase cancellation. Both musicians and engineers have more freedom...and more control.

If your "old reliable" microphones have reached their limit, reach for the new ATM63 from Audio-Technica. It's a far better sound value...for just a little more.

Learn all the facts from your nearby Audio-Technica sound specialist today.



# ATM63



**audio-technica.**

Audio-Technica U.S., Inc.  
1221 Commerce Dr., Stow, OH 44224  
(216) 686-2600

Circle (29) on Rapid Facts Card



# "Digital has final



Sony Communications Products Company, Professional Audio Division,  
1600 Queen Anne Rd., Teaneck, NJ 07666. © 1987 Sony Corporation of America.  
\*Sony is a registered trademark of Sony Corporation.



# y adapted to me."

Sit down at a Sony PCM-3202 2-channel digital recorder and you'll notice something strange.

Mainly, that it's *not* strange.

You can rock its reels, splice the tape, in fact, you can do everything you're used to doing with a studio-quality analog recorder. But still get great digital sound.

And since it's Sony digital, you'll find that it's not only easier to work with, it's also easier to master with. Because the 3202 makes *direct* digital transfers to the world standard PCM-1630 CD mastering system.

So if you've been waiting for a great tape machine that happens to be digital; don't wait. Contact your Sony Pro-Audio representative for a demonstration.

For more information on the PCM-3202 and the PCM-3102 (7½ ips version) call the Leader in Digital Audio at (201) 833-5231.

**SONY.**  
**PRO AUDIO**

Circle (21) on Rapid Facts Card

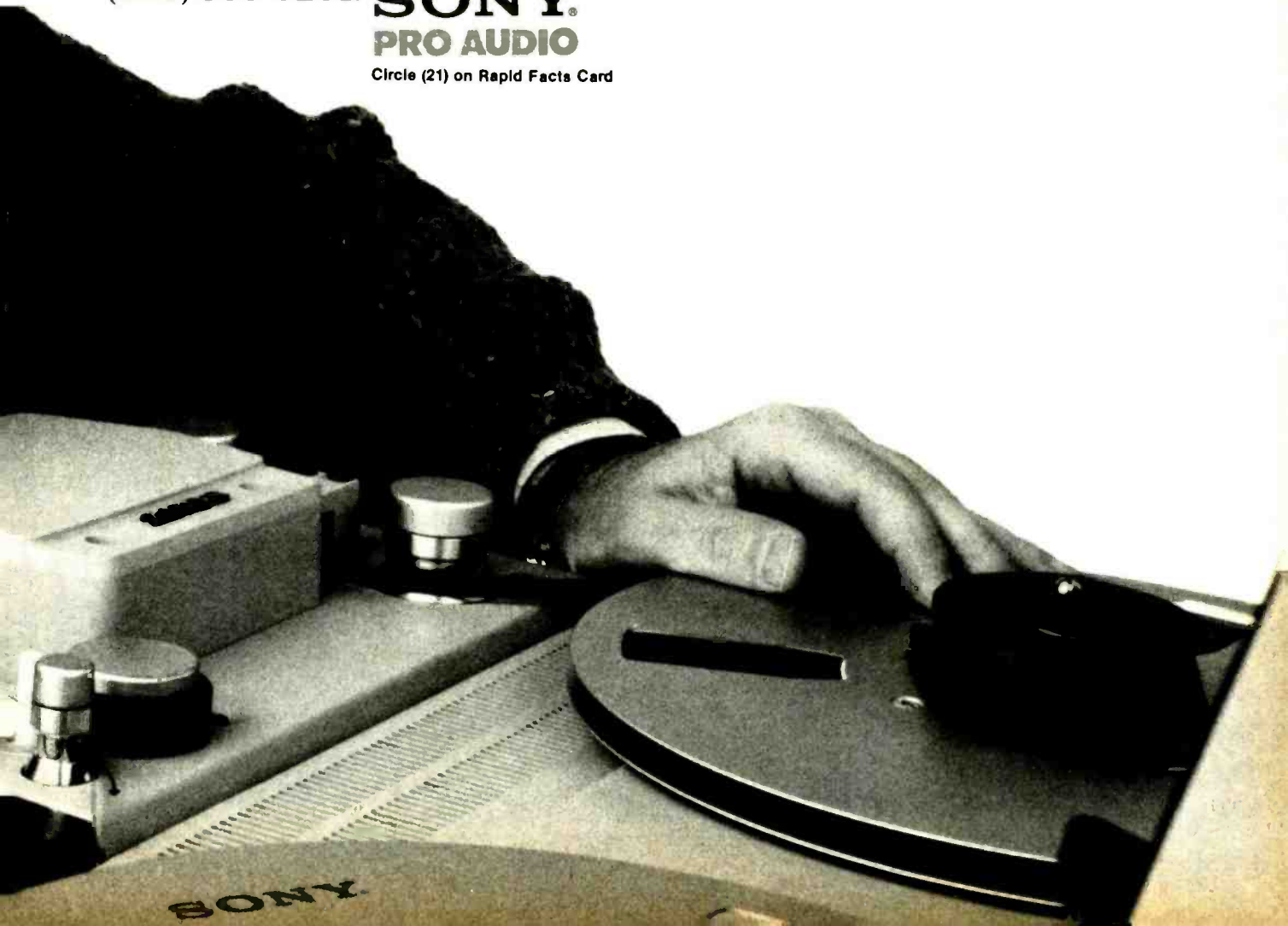

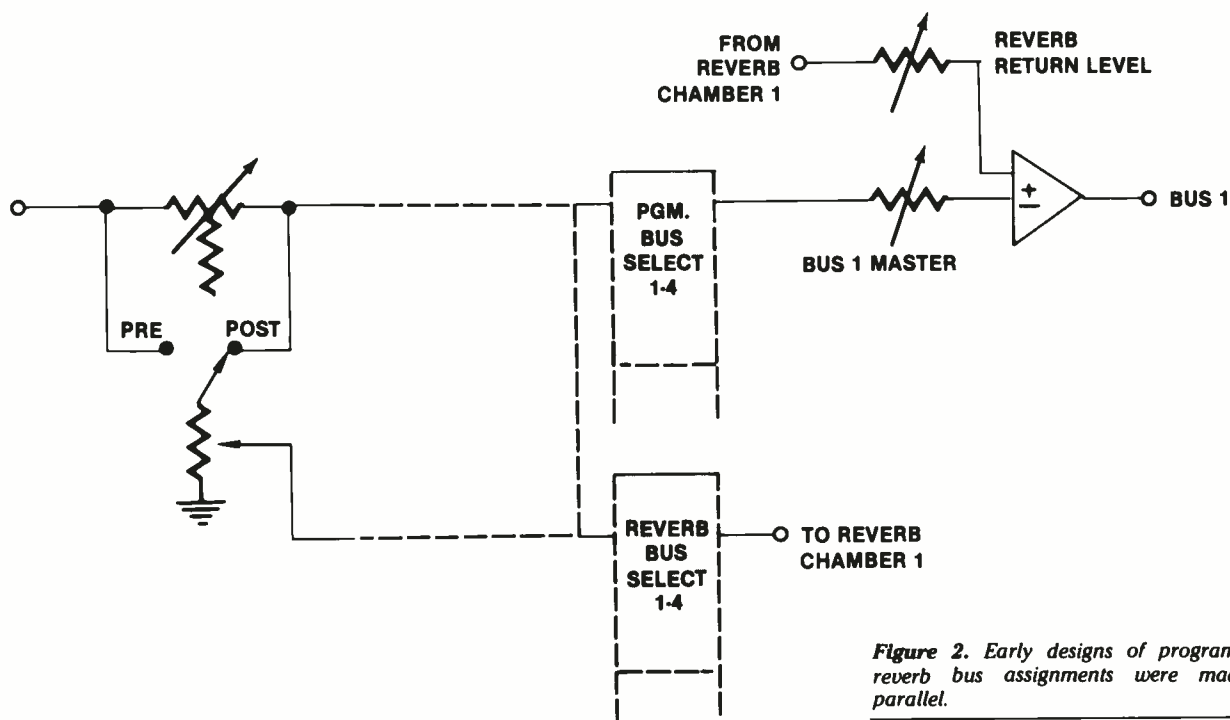

Figure 2. Early designs of program and reverb bus assignments were made in parallel.

Continued from page 34

a new application: headphone monitoring during tracking and overdubs.

The names changed and these auxiliary buses were variously labeled Cue, Send and Foldback. Some were grouped in stereo pairs with panning, and they had all become independent of normal program bus assignment—in a sense representing a “console within a console.”

Things are pretty much the same way today, and only current in-line consoles, or those with very comprehensive monitor sections, offer a significantly different way of handling reverberation. In these cases, the session engineer and producer have the ultimate luxury of storing each input separately and monitoring with all effects added, while not committing themselves to final balances until long after the sessions. This is a legitimate way to go for a lot of music, but it is a very expensive approach and one often implemented when it serves no real musical purpose.

#### Special effects or true ambience?

Today's console topology favors the implementation of reverb as a special effect, rather than evocation of true ambience. Some would even ask the question whether *true* ambience is possible, when different groups of instruments are recorded at different times. The answer is *yes*, and ambience is being used more

and more.

In an increasing number of studios, you often see mounted about 10 or 12 feet high a pair of omnidirectional microphones, spaced perhaps six to eight feet apart. These mics are often used on big band dates that will require little, if any, subsequent sweetening. The purpose of these spaced omni microphones is to pick up room sound that consists of the following components:

- Delayed sound from all acoustical sources in the room, as determined by distances from those sources to the microphones and by the acoustical output levels of the sources.
- An ensemble of early room reflections of the above, as determined by room boundary characteristics.
- Largely uncorrelated stereo (left-right) program information.

If the signals from the two room microphones are carefully mixed into the composite stereo program, either at the time of the session or in later remix of a multitrack recording, they will lend to it a sense of space and increased density. One may not be aware of an increase in reverberation as such, inasmuch as the studio, full of musicians and baffles, may be unable to support a true diffuse reverberant field. But the listener will sense an added degree of depth and lateral spread, which goes past anything that can be done with panpots and conventional reverberation.

One important aspect of the above im-

plementation of natural room sound is that the *relative* levels from the various sources are in *direct* proportion to their acoustical power outputs, regardless of the proportions that will be evident in the final mixdown of the master tape.

Stating it somewhat differently, in the final mixdown the trumpets, trombones and saxophones might all be mixed at pretty much the same level. However, noting the relative output levels of these instruments, the acoustical “power response” in the room will be another picture. Some indication of the diversity the power output levels of various instruments can be seen in Table 1.

Thus, with the setup described above,  
*Continued on page 42*

Table 1. Peak acoustic output level for various instrument sound sources. (Derived from data measured by Bell Labs.)

Source	Peak power	Level (Reference: 10 <sup>-10</sup> W)
Clarinet	0.05W	87dB
Bass viol	0.16W	92dB
Piano	0.27W	94dB
Trumpet	0.31W	95dB
Trombone	6.0W	108dB
Bass drum	25.0W	114dB



Professional audio equipment number one supplier

# Westlake Professional Audio



### Sales:

Westlake's sales staff is ready to supply you with up-to-date information regarding new equipment, its features, availability and competitive prices.

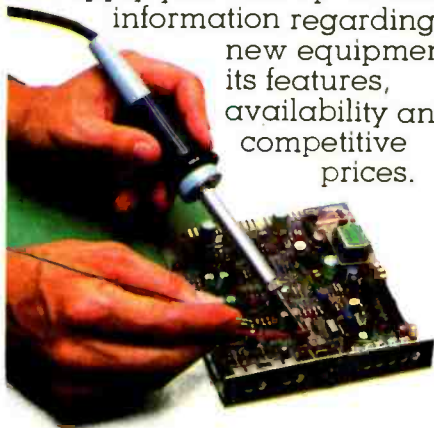

### Demonstration Facilities:

Unequaled in the industry are Westlake's demonstration facilities—from Audio/Video sweetening to demo production, broadcast to world class studio equipment.

### Service:

*Before and after* the sale, Westlake's technical staff is at work to assure a professional interface of the equipment to your system. Our staff is familiar with all of the various technologies in use today.



Ampeg, 3M, MCI/Sony, Otari, Soundcraft, JBL, U.R.E.I., Westlake Audio, Aphex, AKG, Neumann, Sennheiser, Shure, White, Eventide, Lexicon, Crown, BGW, A.D.R., Yamaha, BTX, Valley People, DBX, Bryston, Studer/ReVox and many other professional lines.

from acoustic design  
to down beat...

## Westlake Audio

Professional Audio Sales Group  
7265 Santa Monica Boulevard  
Los Angeles, California 90046  
(213) 851-9800 Telex: 698645



**SERIESTEN** Nothing is quite so disappointing as an unfulfilled expectation. For fifteen years the people who make sound mixing desks have told you that they were going to build you a fully automated mixing desk. Just the thoughts of such a machine are enough to get your creative juices flowing.

Remember...instead of what you've asked for, others have only given you fader and mute automation. No one but Harrison has ever given you more. Some have lulled you with complex machine control systems. Others have tantalized you with preliminary DSP systems. Many have offered you no more than a fast line and a low price.

Now, Harrison offers you something refreshingly different. It's absolutely what you have asked for, what you've been

promised, and we're calling it Series Ten. Series Ten is the world's first fully automated mixing desk. Everything is automated, dynamically, with frame accuracy.

Harrison has redefined the way mixing desks are made in order to accomplish what others have been unwilling even to attempt.

The front panel controls are inputs for a unique and powerful multiple processor system in each Series Ten module. Your commands from the front panel update a comprehensive data base which controls all parameters of the signal handling system of the Series Ten.

Because the Series Ten is always controlled from this data base, we can accurately reproduce even the most subtle nuance of your work anyplace there is a Series Ten mixing





# ABSOLUTE

desk, anytime.

There are no VCAs in a Series Ten mixing desk. We found it necessary to develop a whole new family of audio control devices and techniques to accommodate the extraordinary requirements of Series Ten.

The signal handling system is capable of giving you back your mix exactly as you originally heard it on any Series Ten mixing desk. It accomplishes this without ever passing your precious signal through anything other than state-of-the-art amplifiers and digitally-controlled attenuators, ever.

Series Ten from Harrison—it's what you wanted.

*imagine*  Harrison

Circle (22) on Rapid Facts Card

Harrison Systems, Inc. • P.O. Box 22964  
Nashville, TN 37202 • Telephone (615) 834-1184 • Telex 555133

# Test and Measurement Equipment

By Richard C. Cabot, Ph.D.

**What are the important audio measurements you need to make on recording and production equipment, and what type of test equipment should a facility look for?**

Part 1 of this article, published in the January issue, dealt with making level, noise and distortion measurements. In this conclusion, I'll be considering phase, frequency and wow and flutter measurements, as well as taking a look at the correct procedures for connecting test equipment in the studio.

When a signal is applied to the input of a device the output will appear some time later. For the case of a sinewave excitation this delay between input and output may be expressed as a proportion of the sinewave cycle, usually in degrees. This measurement is illustrated in Figure 1, where the phasemeter input signal 2 is delayed from, or is said to be lagging, input 1 by 45°.

Most instruments measure phase directly by measuring the proportion of one signal cycle between zero crossings of the signals. As shown in Figure 1, this can be achieved with an edge triggered set-reset flip-flop whose output will be a signal that goes high during the time between zero crossings. By averaging the amplitude of this pulse over one cycle, a measurement of phase results.

Phase is typically measured and recorded as a function of frequency over the audio range. For most audio devices, phase and amplitude responses are closely coupled; any change in amplitude that varies with frequency will produce a corresponding phase shift. A device that has no more phase shift than what is re-

quired by the amplitude response variation with frequency is called minimum phase.

A fixed time delay will introduce a phase shift that is a linear function of frequency. This time delay can introduce large values of phase shift at high frequencies of no significance in practical applications. It will not distort the waveshape of complex signals, and will not be audible in any way. If we subtract out the absolute time delay from a phase plot, the remainder will represent the audible portion of the phase response. There can be problems from time delay when the delayed signal will be used in conjunction with an undelayed signal. (This would be the case if one channel of a stereo signal was delayed and the other was not.)

Another useful expression of an audio device's phase characteristics is group delay, which is the slope of the phase response and expresses the relative delay of complex waveform's spectral components. It describes the delay in the harmonics of a musical tone relative to

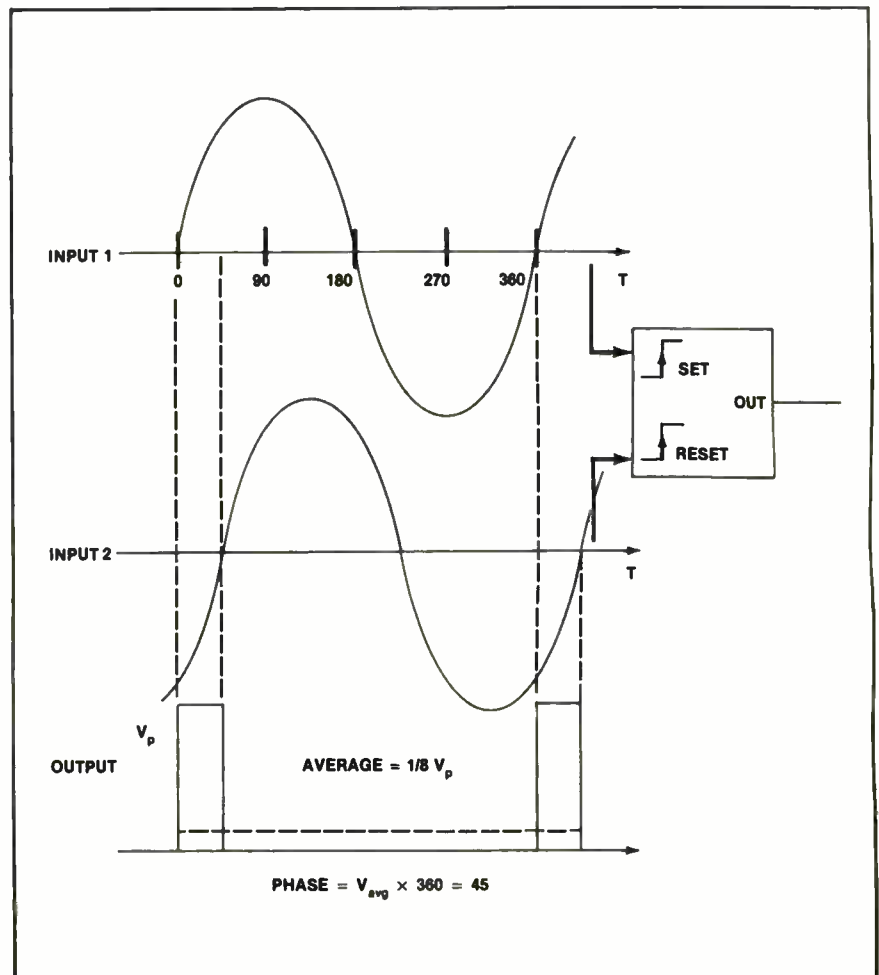

Figure 1. Signal comparison for basic phase measurements.

Richard Cabot is vice president and principal engineer at Audio Precision, Beaverton, OR.



the fundamental. If group delay is flat, all components will arrive together; peak or rise in the group delay indicates that those components will arrive later by the amount of the peak or rise.

Group delay is computed by taking the derivative of the phase response vs. frequency:

$$\text{Group Delay} = \frac{\text{phase at } f_2 - \text{phase at } f_1}{(f_2 - f_1)}$$

The most common application of phase measurement in a studio is aligning tape machine heads. If a multitrack head is tilted relative to the direction of tape travel (an azimuth error) the signals in each channel will be slightly delayed, resulting in a phase shift on sinewaves. Since azimuth error results in a fixed time delay, the phase error will increase with increasing frequency. At a sufficiently high frequency the phase error may exceed 360°. Because sinewaves repeat every 360°, a phasemeter will not be able to detect that this has occurred and the readings will be in error.

To avoid this, first measure the phase at a mid-frequency where it will be less than 360°, such as 1kHz. Increase the frequency to about 3kHz and remeasure, then increase it again to 10kHz. Head azimuth is adjusted for a minimum phase reading at 1kHz, and then fine tuned at 3kHz and again at 10kHz. By measuring

the phase shift at several frequencies, head misalignment becomes easy to see and correct.

If an automatic measurement set is being used, the procedure becomes very simple. The graph in Figure 2 is the result of a 3-point sweep of phase on the two outside tracks of a ½-inch 8-track. The test equipment repeats this sweep several times per second, allowing essentially real-time display of head alignment.

Frequency is a fundamental characteristic of periodic signals and is simply the number of times per second that the signal being measured repeats its pattern. An alternate way to specify this parameter is the period of the signal: the time taken for one cycle of the pattern to occur.

Care should be taken not to confuse pitch and frequency. Pitch is essentially the perceived frequency. Indeed, for complex waveforms, such as narrow-band noise or FM modulated sinewaves, frequency is difficult to define. For example, what is the "frequency" of a signal consisting of 2kHz, 3kHz, 4kHz and 5kHz sinewaves? When this signal is heard, the brain will "insert" the missing 1kHz fundamental and perceive a 1kHz pitch. Pitch, though not always obvious from electrical measurements, is readily apparent to a listener.

Frequency measurement has ad-

vanced greatly since the development of digital logic circuits. Early designs used digital counters to count the number of zero crossings during a fixed time window. For ease of design, these time windows (called gates) were decimal fractions or multiples of one second. For example, if the gate is open for one second while measuring a 1kHz tone, the counter will accumulate 1,000 counts, a value that is then displayed on a suitable readout. For most audio purposes, however, resolution of this technique is very limited. To obtain a 4-digit accurate readout of the frequency of a 10Hz tone would require a 1,000-second (15-minute) gate.

Newer designs take advantage of microprocessors and measure period, reciprocating the result to obtain a frequency value. To perform this measurement both a high-frequency reference clock and the input signal are counted during the gate interval, as illustrated in Figure 3.

The frequency of the input signal may then be computed by the formula:

$$F = (f_c \times N_s) / C$$

Where  $f_c$  = clock frequency  
 $N_s$  = number of signal cycles  
 $C$  = count

Note that the gate interval does not

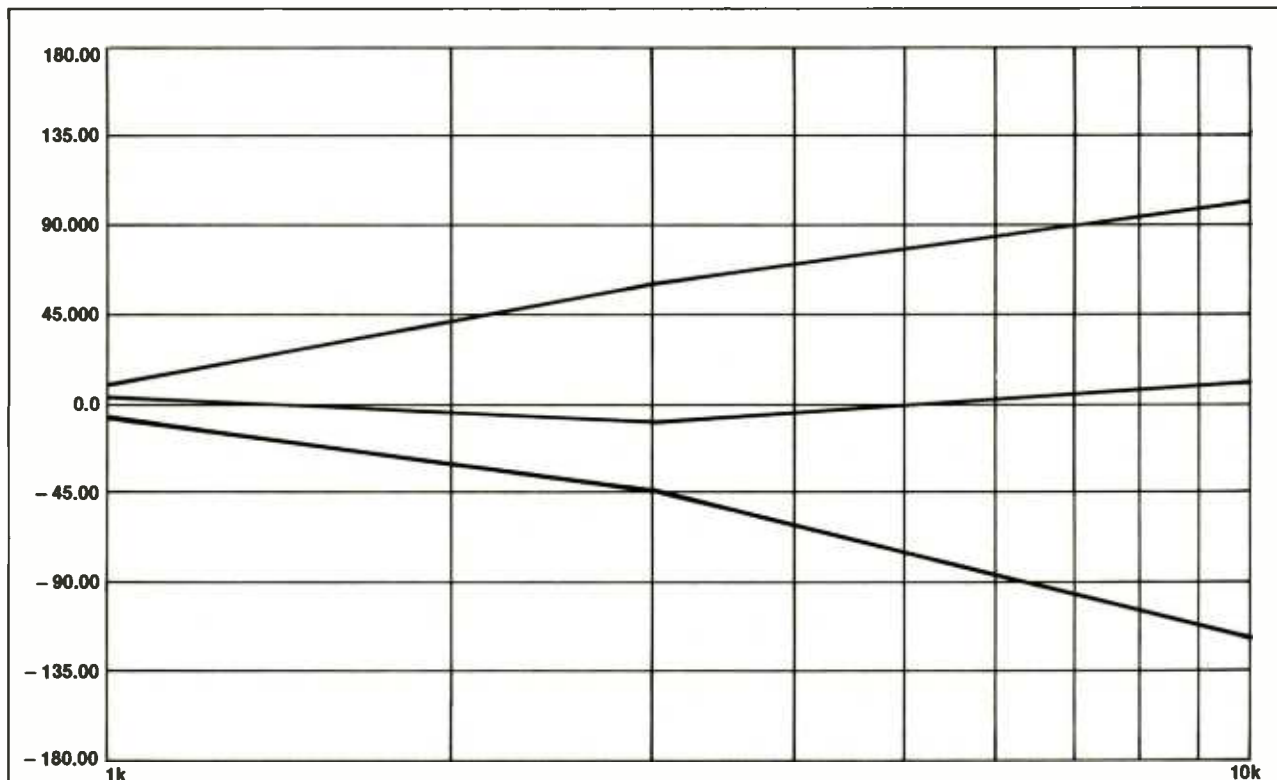

Figure 2. Phase comparison of two outside tracks from a ½-inch 8-track tape machine.

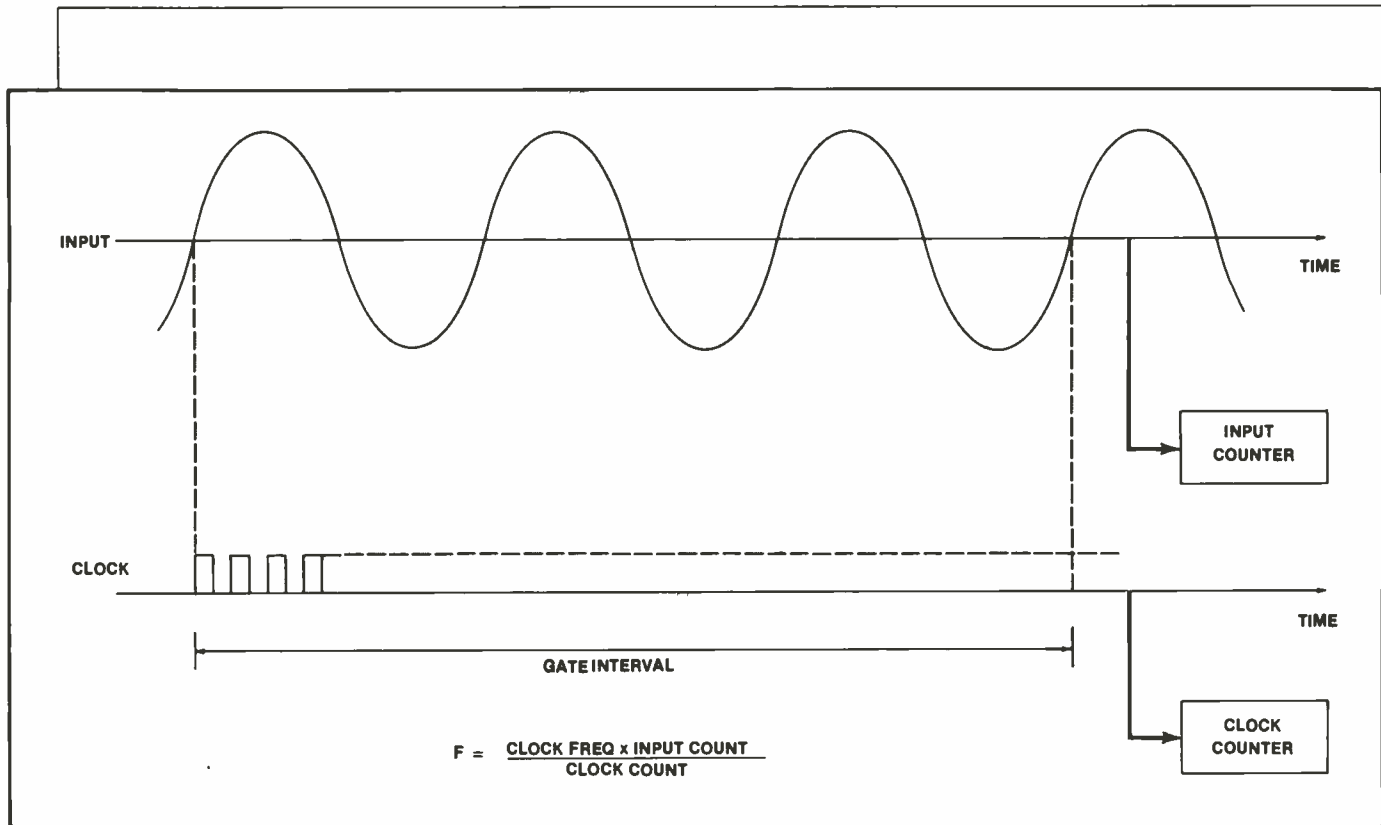

Figure 3. Basis of frequency measurement technique using high frequency reference clock.

enter into the calculation, and may be chosen based on the speed of measurements desired. Longer gate intervals and higher clock frequencies will result in higher resolution measurements. However, it is necessary that the gate interval be an integer multiple of the input signal period, which is easy to ensure with appropriate logic circuitry.

For the fairly typical case of a 10Hz signal, a 0.1 second gate and a 10MHz clock, we would have a one cycle gate and a count of:

$$(10\text{MHz} \times 1 \text{ cycle}) / 10\text{Hz} = 10^6$$

Giving a resolution of six digits. A

1-second gate would allow 10 cycles of input signal, giving a count of  $10^7$ .

Another scheme is sometimes used for measuring low frequencies quickly, and to high resolution. This involves locking a voltage-controlled oscillator to a multiple of the input frequency, usually 100, with a phase-lock loop. The counter then counts the VCO output and obtains the factor of 100 improvement in resolution for the same gate time. The technique requires many input cycles for the PLL to acquire and lock to the input. Because of oscillator instability and tuning range problems, increasing the multiplication factor much above 100 is difficult. Although the factor of 100 improvement

is substantial, period-based measurement schemes achieve even better resolution, yet are quite inexpensive.

#### Wow and flutter

Wow and flutter is the undesirable frequency modulation of an audio signal due to instantaneous speed variations in an audio storage medium, such as a tape machine or phonograph. Such speed variations may be caused by mechanical imperfections in the device, noise in the servo mechanisms or external influences such as floor vibration.

Measurements are made by playing back a tape containing a pre-recorded tone, usually at 3.15kHz. The repro-

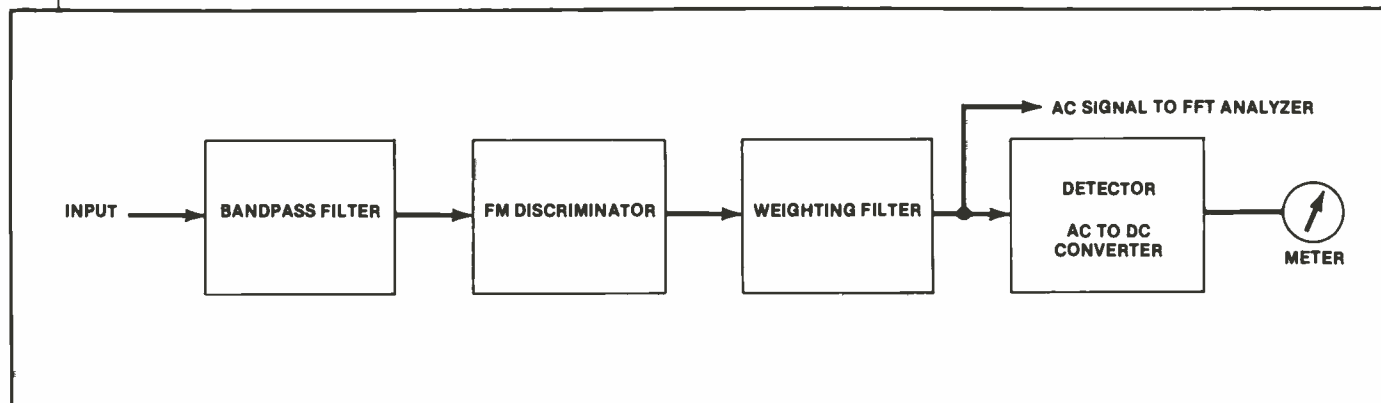

Figure 4. Block diagram of wow and flutter meter.





# COMPLETE 16-TRACK AUDIO POST SYSTEMS FROM \$14,600.

Here's your very best buy in the latest high-tech audio sweetening hardware, complete from input to output. It's tailor-made for film and video post production, a completely integrated system. No other manufacturer can offer you all this, all ready for on-line operation.

We even offer automated audio assembly exiting as an option. It's called F.A.M.E., for Fostex Automated Media Editing, and it lets you program edit decision lists so that all your dialog, effects, music and cues are synchronized right on the money.

Your investment in Fostex gear pays for itself. Just take a look at what you spent last year for outside audio post work, and see how much sense a Fostex system like this makes:

- Model E-16, 16-track recorder with integral noise reduction. No need to leave a guard band for the SMPTE stripe. **\$7000.**
- Model E-2, 2-track recorder with center channel SMPTE track. Full compatibility with standard half-track tapes. **\$3600.**
- Model 4030 Synchronizer with Model 4035 Remote Controller. Allows you to control up to one master recorder and up to three slaves with chase and pre-roll; also resolves to film. **\$2000.**
- Model 450-16 Recording Console. 16 x 4 x 2 with phantom powering, parametric EQ, solo and in-line monitoring. **\$2000.**
- Fostex also makes a complete line of microphones (including a unique M/S Stereo Mic), monitors

(point-source, phase coherent), the hot tip in headphones (Model T-20), signal processors — even the interconnecting cables and all the other Necessarys™ you need to remain on-line.

So check with your Fostex dealer today and join the fast-growing list of professionals who are producing popular records, videos, TV show themes and movie soundtracks on Fostex equipment.

Also check out our Autolocator and SMPTE generator/reader. Model 4050 lets you lock MIDI to SMPTE for even greater automation and flexibility. Trust Fostex for all of your on-line audio needs.

## Fostex

ON-LINE AUDIO  
FOR OFF-LINE VIDEO

15431 Blackburn Ave., Norwalk, CA 90650 (213) 921-1112

Special cables and interface units may be required, depending on other hardware. Not all products are available at all dealers. Prices and specifications are subject to change without notice.

Circle (24) on Rapid Facts Card

duced tone is fed to a wow and flutter meter, which contains an FM discriminator whose output is proportional to the instantaneous frequency deviation of the test tone. For most applications the flutter components are weighted, based on their frequency, according to the ear's sensitivity to them. The block diagram of a wow and flutter meter is shown in Figure 4.

The bandwidth of wow and flutter meters with the weighting filter turned off usually extends from about 0.5Hz to 200Hz, the range where problems occur in rotating components such as idler wheels, capstans, pulleys, motors, etc. Variations in tape speed can also be caused by frictional effects of the tape moving over guides or the heads themselves. These effects are referred to as scrape flutter, and produce FM components as much as 5kHz away from the signal.

Modern servo-motor transports can also exhibit FM products substantially above the 200Hz top end of conventional wow and flutter meters. Such high-frequency FM products are perceived more as added noise, "grit" or "harshness," than the wavering sound usually associated with wow and flutter.

To measure this form of flutter it is necessary to use a test-tone frequency higher than the usual 3.15kHz. A test tone frequency of 12.5kHz allows a 5kHz bandwidth in the measurement, if the tape machine bandwidth is at least 17.5kHz. Because of the test's wide-band nature, a weighting filter is not used.

For typical professional tape machines with a scrape flutter idler, the scrape flutter measurement of components above 200Hz will read approximately as high as the conventional wow and flutter measurement. For lesser-quality machines, the scrape flutter reading will be much higher, indicating the presence of excessive tape motion instability.

Some manufacturers prefer to follow the NAB flutter standard, which specifies measuring with a "flutter-free" test tape on playback. The IEC flutter standard specifies that testing shall use a tape that has been recorded on the machine undergoing test. This cannot be done during simultaneous record/playback mode, because the time delay resulting from the physical separation of the record and playback heads will cause a comb-filter response that cancels some flutter components. The tape must be recorded, rewound, and played back.

To truly see the effects of varying tape tension and wrap throughout the reel of tape, measurements according to either method should be performed at several points through the reel.

To identify the source of the wow and flutter in the machine under test, the AC output from the wow and flutter meter may be analyzed with a low-frequency spectrum analyzer. Because typical wow and flutter has components down to 0.5Hz, it is extremely slow and tedious to do this with a sweeping filter type of analyzer. The speed of an FFT approach is essential in getting accurate information in a reasonable measurement time.

The high-frequency resolution provided by an FFT analyzer also helps in separating components that may be relatively close in frequency, such as a 4Hz capstan eccentricity and a 4.5Hz servo resonance. The sweeping filters available in some wow and flutter meters have too wide a bandwidth to distinguish these components.

An interesting example of the use of spectrum analysis of wow and flutter came during the Watergate tape recording investigation. By analyzing the wow and flutter spectrum on the hum products during the famous 18-minute gap,

# CLEAR REASON

**For the music studio owner, no decision is more critical than choosing a console.** Both financially and creatively, the success of your operation may well depend on the capabilities and quality of the system you select, and the company that supports it. Clear reason, we suggest, to consider the SL 4000 E Series Master Studio System from Solid State Logic. But certainly not the only reason.



plus switchable phantom power, patchfree audio subgrouping, AFL and PFL monitoring, fader start for external devices,

Consider, for instance, that only SSL has built-in track remotes on every channel, integrated with the industry's most versatile monitor fader and foldback facilities. Or that SSL alone provides pushbutton signal processor routing for each channel's noise gate and expander, compressor/limiter, high and low pass filters, and parametric equaliser —

and stereo modules with balance and Image Width controls.

Consider that SSL makes the industry's only comprehensive studio control system — with integral synchronisation of up to five audio/video machines, concise English commands,



tape location by timecode, foot/frames, cue numbers or key words, and complete session list management. And that SSL alone offers extensive fader, group and mute automation and mix manipulation plus optional programmable parametric equalisation and panning, multi-repeatable Events Control, and Automatic Dialogue Replacement.



it was possible to identify the machine used to make the erasure.

Surface irregularities in tape will result in high-frequency amplitude variations. These result in amplitude modulation which will raise the noise floor of a SMPTE IM measurement. (Recall that SMPTE IM measures the amplitude modulation of an HF tone by a low-frequency tone.)

By recording an HF tone with no LF component present, a conventional SMPTE IM analyzer may be used to measure the effect. This makes an excellent test of tape quality, and is used by some recording and production studios to test incoming tapes prior to use.

Another important measurement to be made on recording devices is speed accuracy and drift. This is measured with a standard test tape or disc on which a stable frequency has been recorded. Changes in speed will produce a change in frequency, which can be measured with a frequency counter. The frequency is monitored on playback as a function of time, and the percentage difference between the measured and recorded values represents the percentage speed error. Changes in this value over the length of the tape are the speed drift.

### Balanced vs. unbalanced inputs/outputs

Balanced inputs and outputs are used in audio to eliminate ground loops and reduce interference; it is even *more* important to maintain balanced operation when connecting to audio test equipment. Use of a balanced differential input on a voltmeter or distortion analyzer is essential to accurate readings, and to verification of today's low distortion and noise levels. It is important to ensure that the input on the test equipment is fully balanced and differential.

Some test equipment manufacturers, in an effort to save money, have produced inputs that can only accept a few volts on the low terminal. Although such inputs allow reduction of ground loops from unbalanced sources, they do not permit connection to balanced lines. A good rule of thumb is that you should be able to plug the input into the wall without blowing fuses or melting silicon.

A differential input is also valuable for eliminating noise when measuring unbalanced lines. If an additional ground is introduced by the connection of an unbalanced meter to the studio patchbay, it may introduce hum that was not previously there. A differential input

allows the monitoring of unbalanced lines without introducing any additional ground paths.

Similar concerns about balanced operation apply to the signal source. When a balanced system is unbalanced by connection to a grounded generator, there may be hum introduced if the common mode rejection ratio (CMRR) of the system under test is inadequate. With an unbalanced generator driving an unbalanced line, it will be impossible to separate the hum introduced by connection to the generator from that inherent in the system.

If measurements are made in a high RFI (radio-frequency interference) field, such as the inside of a digital tape machine, it is essential to maintain balanced operation. Most inexpensive pieces of test equipment will not operate properly in such environments. Using such devices will certainly result in hours of wasted time fighting with shields and filters, or recording incorrect data.

Audio measurements are important for verification of proper studio operation. If they are approached with knowledge and the right equipment, they are easy, informative and well worth the time.

**RED**



Then consider that SSL's Studio Computer alone goes beyond mixing automation to provide Total Recall™ — a unique system, completely independent of the audio path, which stores all I/O module settings after each session.

The new TR AutoScan function makes it faster than ever to recreate headphone and monitor mixes, equalisation, or entire console setups with quarter dB accuracy and rapid verification. And SSL alone offers data-compatibility with more than 300 installations — in over 80 cities around the world.

Finally, consider a company whose record of practical innovation, ongoing development and in-depth technical support has earned repeat orders from many of the world's toughest customers — a company that other manufacturers use as a standard for comparison. We join them in urging you to compare. Our 40 page colour brochure on the SL 4000 E Series is a good place to start. It's yours for the asking, and it just might make your difficult decision a whole lot easier. Clear reason, may we suggest, to write or call us today.

## Solid State Logic

Begbroke, Oxford, England OX5 1RU • (08675) 4353  
200 West 57th Street • New York, New York 10019 • (212) 315-1111  
6255 Sunset Boulevard • Los Angeles, California 90028 • (213) 463-4444



# Health Insurance:

## An RE/P Guide for Production Staff and Facilities

By Dan Torchia

Although choosing health insurance can be a complex and time-consuming process, a knowledge of the basics can make it a great deal easier to find suitable coverage.

### Basic Insurance Terms

**Benefits:** what your policy covers.

**Co-insurance:** an arrangement where you and the company pay for treatment. This is often expressed in numbers, such as 80/20, which would mean that the company would pay for 80% of the expenses and you would pay for 20%.

**Deductible:** what you pay before the policy's coverage takes over. Generally, deductibles are \$100, \$250, \$500, \$1,000, \$2,500 and \$5,000, although sums will vary. Paying a higher deductible usually means that your premium will be lower.

**Exclusions:** specific items not covered in a policy, such as cosmetic surgery or eyeglasses.

**Pre-existing condition:** a health problem you had before your policy was issued. Policies will not cover pre-existing conditions or will have a waiting period imposed (see definition below), say for six months or a year, before you get benefits.

**Premium:** the amount that you pay for the policy. Generally, you pay semi-monthly, quarterly, semi-annually or annually. Sometimes you have a choice, sometimes you don't. Frequent payments usually mean higher premiums.

**Stop-loss provision:** a cap on what you pay in a co-insurance arrangement. For example, in an 80/20 arrangement, the company will pay 100% of eligible expenses when your out-of-pocket expenses reach a set amount, such as \$2,500.

**Waiting period:** a specified time you must wait between when the policy is issued and when payment of benefits begins. This could mean that there is a delay when the policy is issued and when your coverage begins. It could also apply to a pre-existing condition, such as heart trouble, and you would have no benefits for a specified period of time.

Let's face it, health insurance is not the most fun thing to think about. It's complex, there's a lot of arcane language and the health care industry is going through major changes.

You are, in essence, buying something intangible—security—and you can't take out just one policy and be covered.

If you take out car insurance, for example, you buy a policy for the entire car. You don't have to take out another policy on the engine if your first policy doesn't cover it.

Likewise, if you have a policy covering studio equipment, you have it for the entire contents of the studio, not one for the console and another for the patch bay. So it's relatively easy.

Not so with health insurance. Different policies cover different things, and you may have to take out more than one to be fully covered. You have all sorts of options to consider, each of which will affect how much you pay.

And we're talking about a gamble—

you're paying money now to insure that you don't have to pay much more later. If you don't have insurance and never have a major illness, you've won. But if you become sick and don't have insurance, you could pay for the rest of your life.

Remember that health care costs keep rising. According to a recent report from the federal government, the average cost of a semi-private hospital room was \$233.85 as of January 1986. If you're in the hospital, the cost of a couple of Tylenol can approach what you have paid for a decent meal not too many years ago.

If you ever get seriously ill, the cost of your care could easily be more than \$50,000. Don't be caught short if you can't pay it out of your savings.

A disclaimer about the following information: it applies only generally to the health insurance industry. It doesn't apply to all companies and organizations nor to all areas of the country.

### For More Information

Although the world of health insurance is often complex, there are a variety of publications that can assist you in sorting out the various options.

Two booklets are available from the Health Insurance Association of America. The first, "What You Should Know About Health Insurance," discusses basic policies and includes a list of terms.

The second booklet, "What You Should Know About Disability Insurance," deals with this important insurance consideration. Although disability is not health insurance per se, you should consider it as part of a total protection package.

Both booklets are available from the HIAA at 1850 K St. NW, Washington, DC 20006.

"The Health Insurance Fact and Answer Book," by Geri Harrington, was a valuable resource in researching this article. Published by Harper and Row, it surveys the entire scope of

health insurance, from group and individual policies to Medicare.

Although the scope may be broad, it has individual chapters on choosing a policy and how to read one. You can order it from a bookstore, or look for it at your local library.

From the Small Business Administration, "Insurance and Risk Management for Small Business" covers all types of insurance, but does include a section on health insurance. Its small business perspective could be helpful if you're self-employed or run a studio. Published by the SBA's Office of Business Management, it is available for loan from a government documents depository (if you have access to one at a local library) or if for sale from the Superintendent of Documents.

Remember that these sources deal with general information only; if you have a question about a specific company or policy, contact the appropriate agent.



Basic terms are defined in an accompanying sidebar and additional resources listed in another. If you need answers concerning a specific policy or a company, contact a qualified agent.

There are two basic types of health coverage. The first is *basic* protection, also called hospitalization. As its name implies, it covers the basics: room and board, regular nursing services, and other hospital services, depending on your policy.

With a basic policy, you need to check out a couple of things. First, see if your policy has "inside limits" that cover only part of the cost of your hospital room or any surgery. If it does, you will have to make up the difference.

Second, if your insurance entitles you to service benefits, which is a plan designed to pay bills in full, payment is made on what is considered "reasonable" charges.

The operative word here is *reasonable*. What your company will pay may be below the actual cost on your bill. As with any aspect of insurance, check to see what will be paid and what won't be.

Major medical is the second level of coverage, for long-term illness or injury. The deductible is higher than for a basic policy, but the protection is greater.

There are a variety of major medical policies to choose from. Some supplement a basic policy. Others are more comprehensive and may be able to function as sort of a dual policy.

With this type of policy, there are two provisions, co-insurance and stop-loss, that follow the basic insurance premise of paying now to save later. Co-insurance means that you pay a percentage of the costs along with the company; stop-loss means that you will quit paying after you reach a specified dollar amount and your company will pay 100%.

Another important provision is the lifetime maximum. This is a specified amount in your policy. After your annual out-of-pocket expenses reach the stop-loss level, the insurance company will pay 100% up to the maximum. Many insurance experts recommend a \$1 million maximum, not an outrageous sum considering today's health costs.

But there is one important point to check out. Some policies provide the maximum for all illnesses for the rest of your life; others pay for only one illness. Check to see what type of coverage your policy will provide.

#### HMOs

Health maintenance organizations,

Dan Torchia is managing editor of RE/P. A free lance guitarist/keyboardist, he recently co-produced his own album.

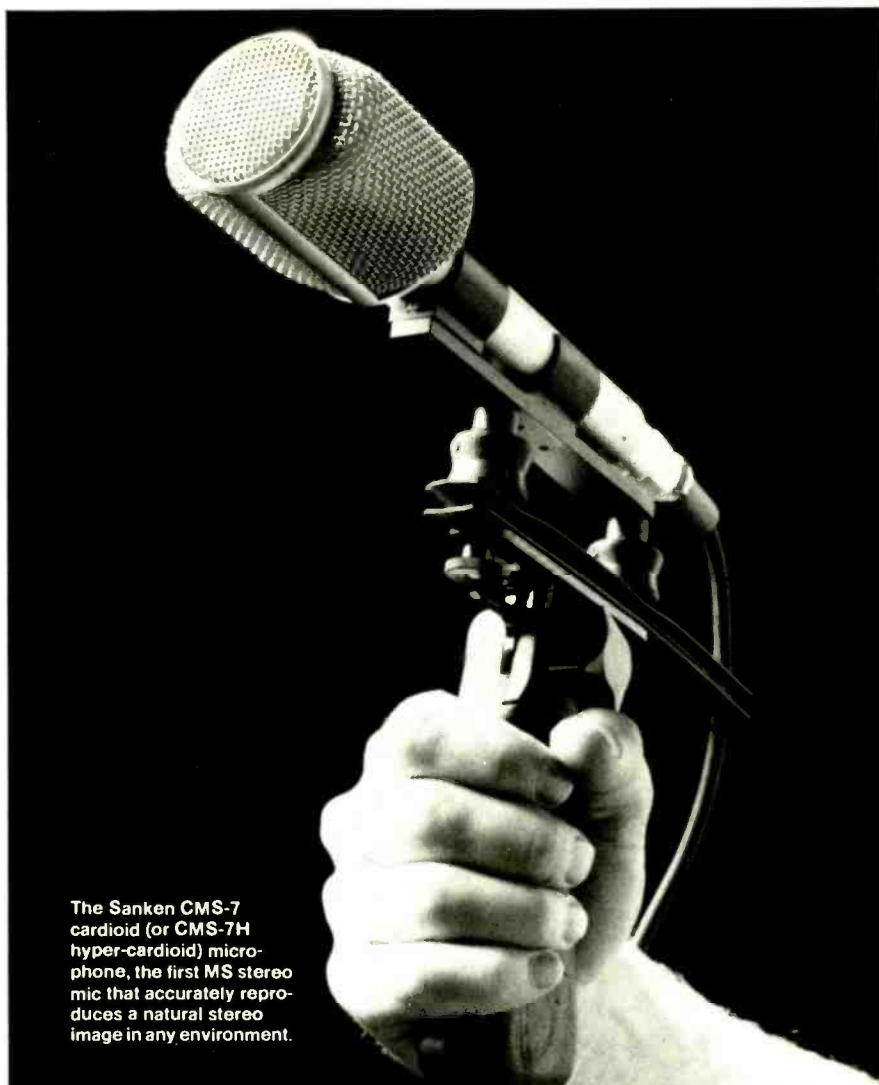

The Sanken CMS-7 cardioid (or CMS-7H hyper-cardioid) microphone, the first MS stereo mic that accurately reproduces a natural stereo image in any environment.

## TRUE STEREO IN A PORTABLE MICROPHONE!

Sanken, maker of the world-acclaimed CU-41 CD-recording microphone, is pleased to announce the new CMS-7, the first portable MS stereo condenser mic that accurately captures a natural stereo perspective in *any* environment. Ideal for TV and radio broadcasting, motion picture making and studio recording. Its corrosion-free titanium diaphragm is immune to temperature and humidity changes, and performs superbly in adverse conditions. Battery power supply/switchable matrix box, which clips to your belt, carries an aperture control for focusing the stereo perspective. For more information, please contact:

**LOS ANGELES** Audio Intervisual Design Tel: (213) 469-4773

**NEW YORK** Martin Audio Video Corp Tel: (212) 541-5900

**NASHVILLE** Studio Supply Co., Inc. Tel: (615) 366-1890

**CANADA** Gould Marketing, Inc. Tel: (514) 342-4441

**sanken**

Japan's most original microphone maker

Sole export agent Pan Communications, Inc.  
Azabu Heights, Suite 607, 1-5-10, Roppongi, Minato-Ku, Tokyo, 106, Japan  
Telephone 03-505-5463/Telex 2423934 KNMPCM  
Telefax 03-505-5464/Cable Address PANCOMMJPN

Circle (25) on Rapid Facts Card

although not a policy in the traditional sense, is a health care option that might be suited to you.

Basically, an HMO is a prepaid form of health insurance. You pay a monthly premium, and in return you get comprehensive hospital, medical and other expenses at little or no cost no matter how many times you use the service.

Although you may lose some flexibility (HMOs provide only local coverage and you're limited to the choice of doctors on staff), the emphasis on preventive medicine may lower your health costs.

With an HMO, it is important to check all the features and compare them against a traditional policy. If you're an individual, you may have trouble joining one; some accept only groups.

#### Disability insurance

Not only do you need to look at immediate or short-term medical needs, you also have to look at the long-term. What if you become disabled for months or years and cannot work? That's where disability insurance comes in.

Disability insurance technically isn't health insurance, but you should consider it as part of your total health plan. If you become sick or injured and cannot

work, disability will help you in your long-term needs.

Coverage begins after a specified period of time, usually 30 days, 60 days, 90 days, 180 days or a year, depending on the policy. Once benefits start, you are covered for two or five years or to age 65, again depending on your policy.

#### Individual policies

If there is a rule of thumb to follow when you're looking for an individual policy, it might be this: try to get into a group policy such as a plan taken out by several members of a production facility. Failing that, secure the best individual policy that you can.

What makes insurance work is the large numbers involved; if a company insures many people, coverage can be better and cost less.

The numbers just aren't there for a company writing individual policies, and if you have to go that route, you'll pay more for less coverage. But investigate things first; even if you're alone, you may be able to get a group policy. More about that in the following section.

#### Group coverage

Group policies come in two kinds—

those for less than 10 people, and those for more than 10 people. If you can get into a group plan, you'll be better off than going alone. The coverage will be better, the premium will cost less and there may not be a medical screening.

If you work for a studio that has a health plan, look at the coverage. If you think it's adequate, you're in good shape. If you think there is something lacking, look into a supplemental policy. If you belong to a union, you can also check out the union's policy.

If you are self-employed, you still might be able to get group coverage. Check out the policies for groups totaling less than 10. Even if you're a company of one, you may qualify for some sort of group policy.

The same thing is true if you own a small studio or hire company with fewer than 10 employees or if you're a 1-person operation with a lot of freelance people working there. If you get together with them, you can secure some sort of group policy that will be better and cheaper than if you secured coverage on your own.

If you have a group with fewer than 10 people, it is likely that you'll have to fill out some sort of medical questionnaire.

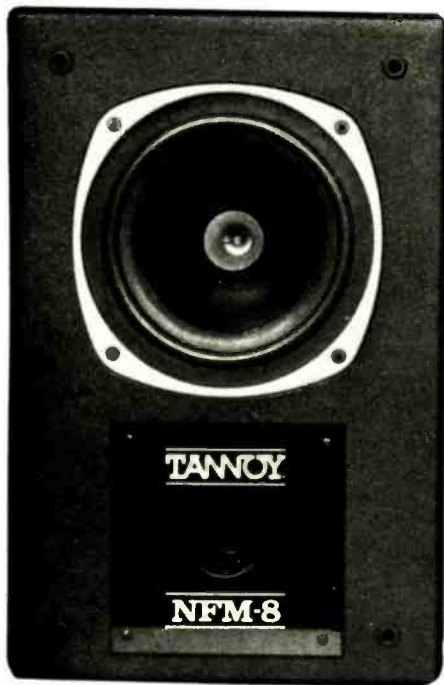

## "NO TISSUE" REQUIRED



POINT SOURCE-PHASE COHERENT MONITORING

By **TANNOY**

Join the Gold Rush at  
your nearest Tannoy Dealer

Tannoy North America Incorporated, 300 Gage Ave. Unit #1, Kitchener, Ontario, Canada, N2M2C8. Telephone (519) 745-1158.

Circle (26) on Rapid Facts Card



and there is a possibility that you could be rejected.

If that concerns you, check into a guaranteed issue policy, which means that you cannot be rejected for any reason. But be aware that the premiums will be higher and the coverage will be limited.

#### Hints and tips

Whether you are an employer looking for group coverage or self-employed and looking for your own coverage, there are some guidelines to follow to help you keep your costs down and ensure that you have adequate coverage:

- Make sure that your policy covers major expenses. Your policy should cover a broad range of services and also adequately cover the cost.
- Pay as much deductible as you can afford. The more deductible you choose, the lower your premiums will be.
- Be sure of what your policy covers and what it doesn't. Assume nothing; make sure everything is in writing.
- Don't overlap your coverage to make a profit. You're only wasting money, as most policies have a duplication of benefits clause that will limit benefits from two policies to 100% and no more.

- Make sure that you have 24-hour coverage if you need it. This is especially important if you're self-employed, because you're not covered under workman's compensation. If you're with an employer's plan, make sure that your employer is paying into workman's comp. If not, you also need 24-hour coverage. If you're injured on the job and there is no workman's comp or 24-hour coverage, you won't be covered.

- Don't lie when answering medical questions. If you have a pre-existing condition, don't disclose it and then file a claim for it, you won't be covered. Tell the truth. At worst, if you need treatment for the condition and it falls into the exclusion period, you'll be out some money. Then if you have a claim after the period is over, you'll be covered. But you need to disclose it from the beginning.

- Make sure your policy covers people in the industry. People in the pro-audio industry are not entertainers, but they are in a support industry. The difficulty that entertainers have in getting insured may extend to you. If you do road sound, or travel extensively because you freelance or consult, this may affect your securing coverage. Make sure the com-

pany knows exactly what you do, so that you will be properly covered.

- Don't jump from policy to policy. You may be trying to save money, but you probably won't. With a new policy, you will have new waiting periods and exclusions. Adding to your present policy or getting a supplemental one is a better way to go.

- Review your policies to keep them up to date. Just as you don't want to switch too often, you also don't want to be stuck with out-of-date and, therefore, financially inadequate policies. Make sure that you have enough. Some sources suggest that you review your coverage annually.

One last word—remember what you're buying. It's security, the peace of mind in knowing that you can weather a major medical crisis and come out of it financially intact.

So make sure you have enough, pay your premium on time and hope that you're never sick enough that you have to use it. But if you ever do face a medical crisis, at least you'll be prepared.

**REP**

Acknowledgment: Thanks to Total Concepts Financial Planning, Prairie Village, KS, for information and assistance.

# GLM™



Advancing technologies can move at such a rate a new product may blur by without offering the true explanation of why it was developed in the first place.

Quite simply the new GLM is a superior studio quality microphone that incorporates all the benefits of its larger more conventional predecessors.

Crown technology has always ignored the conventions of new product development and recognized no limits in achieving the ultimate in professional quality.

See your nearest Crown dealer. Find out how this incredibly small microphone achieves such a high level of performance.

Crown International, Inc., (219) 294-8000  
1718 W. Mishawaka Rd., Elkhart, IN 46517

 **CROWN®**



**NSCA ELECTRONIC CONTRACTORS EXPO '87**  
 • WORKSHOPS • EXHIBITS • AND MORE  
 FAIRMONT HOTEL • NEW ORLEANS

**MARK YOUR CALENDAR**

**APRIL '87**

S	M	T	W	T	F	S
		1	2	3	4	5
6	7	8	9	10	11	12
13	14	15	16	17	18	19
20	21	22	23	24	25	26
27	28	29	30			

**HERE'S A WORKING VACATION WORTH CLOSING UP SHOP FOR**

*designed by Contractors — for Contractors*

**1 NEW PRODUCT EXHIBITS AND DISPLAYS**

Hundreds of Exhibitors  
— Thousands of Products

**2 WORKSHOPS, SEMINARS TECH PAPERS**

Technical Topics • Management Subjects • CCTV Topics • Training Programs for New Sales People

**3 WORK AND EXPERIENCE EXCHANGES**

Talk to Other Electronic Contractors from All Over the Hemisphere

*"The Industry Event of the Year!"*

**REGISTRATION/BADGE INFORMATION**

Company Name \_\_\_\_\_

Address \_\_\_\_\_

City, State, Zip \_\_\_\_\_

Telephone \_\_\_\_\_

- Contractor       Representative       Manufacturer  
 Consultant       Trade Press       Other

\_\_\_\_\_  
Name/Title

\_\_\_\_\_  
Name/Title

\_\_\_\_\_  
Name/Title

**EXPO Registrations:** On-Site Administrative Fee ..... \$5.00

**WORKSHOP Registrations:**\* Member Companies      3 Days ... \$75/Person

\*Non-members: Add \$100 per company      1 Day ... \$30/Person

(may be applied to membership dues)

\_\_\_\_\_  
Name/Title

\_\_\_\_\_  
Name/Title

Check for \$\_\_\_\_\_ enclosed as payment for \_\_\_\_\_ conference registrants.

(Make checks payable to NSCA Contractors Expo.)

- NSCA Member       Non-member



Mail checks to:  
**NSCA CONTRACTORS EXPO '87**  
501 WEST ALGONQUIN ROAD  
ARLINGTON HEIGHTS, ILLINOIS 60005-4411



# BUILT FOR THE DEMANDS OF PRODUCTION.



**I**n the production business, quality plus speed equals success.

That's why the TASCAM ATR-60 Series is engineered for those who make their living with recorders. All five share a design philosophy stressing function over flash; an overriding concern for performance without complication; a thoughtful integration of features which respond to the needs of the professional.

— On every ATR-60, the deck plate won't flex. Ever. So you won't be compensating for flex-induced phase or wow and flutter in post production.

— The unique Omega-Drive puts less stress on your tape, so the cumulative tension of a thousand start/stop passes won't reach your tape.

— Heads designed and man-

ufactured by TASCAM means Sync frequency response equals Repro, so you don't have to rewind and change modes to make critical audio decisions.

— Sync Lock and the most responsive servo control in the business will keep you working instead of waiting for a machine to lock up.

— Time Code Lock keeps code coming from the Sync head, regardless of the audio monitor mode, so your synchronizer won't get confusing double messages when modes are switched.

— Input Enable/Disable allows you to monitor any source without repatching or changing mixer settings, avoiding a common cause of aborts.

— Long cable runs don't bother a TASCAM ATR-60, since +4 dBm, +8 dBm and even +10 dBm levels are available.

There are five ATR-60 recorders: the ATR-60-2T (IEC Standard) Center Track Time Code; ATR-60-2N/2D Quarter-inch Mastering; ATR-60-2HS Half-inch High Speed Mastering; ATR-60-4HS Half-inch 4-Track High Speed Mastering or Multitrack; and the ATR-60-8 Half-inch Production Quality 8-track.

To see, hear and feel them, visit your nearby TASCAM dealer, or call TASCAM for the name of the dealer nearest you.

Production is a demanding business. And the ATR-60's are built to meet the demand.

Pure Performance  
**TASCAM**  
TEAC Professional Division

7733 Telegraph Rd. • Montebello, CA 90640  
Telephone: (213) 726-0303



**Figure 1.** Compact loudspeaker enclosures were hidden throughout the stage set for use as area monitors. Shown here: a Fender model 2821 sprinkled with artificial snow.



**Figure 2.** A total of 18 hanging condenser microphones were brought in and out of the stage set on flylines. Sennheiser model 405 and AKG C-568-EB mics with foam wind-screens were used.

## Producing Live-Performance Sound for "The Singing Christmas Tree"

By David Scheirman

**Operators of fixed-installation sound systems can enhance the quality of live-performance events by taking advantage of the skill and equipment experience of outside rental companies.**

Much has been written about the improvements in sound quality made in the contemporary concert industry within the past two decades. Not only has the available equipment (microphones, mixers, amplifiers and speakers) started to fall into alignment with user needs, but sound system operating technicians, as a group, have been fine-tuning their skills and techniques, the result being better-sounding concerts than ever before.

The same is true with public events of all types. Theatrical productions, symphonic concerts and civic musical events have all benefitted from the closer attention to detail paid by sound departments in recent years to auditoriums and arenas. While some public buildings have yet to upgrade their existing sound reinforcement systems, many facilities now own or have access to truly modern mixing and processing equipment, and

auditoriums in most major cities are beginning to integrate road-veteran system operators as part of their technical staffs.

The *Singing Christmas Tree*, the 24th annual celebration presented on Dec. 11-14 at the Portland Civic Auditorium, Portland, OR, serves as a good example of how excellent audio results can be obtained for civic events through collaboration between a house sound department and an outside sound equipment rental contractor. Featuring the choirs of Portland's Rolling Hills Community Church and produced and directed by Pastor of Worship Jim Bohner, last December's *Singing Christmas Tree* drew sellout crowds to each performance in the 3,000-seat Civic Auditorium. The production featured a 200-voice choir and a 30-piece orchestra.

### Advance audio planning

Without doubt, planning audio-system requirements can mean the difference

between success and failure for any complex stage production. A stage full of sets and people makes placement of both microphones and monitor loudspeakers critical. Fortunately, the production format of the *Singing Christmas Tree* has been fine-tuned during the past few years. Sound system designer David Cutter, of Sundown Sound, Portland, has been involved with the show for the past 11 years.

"For past performances, nearly every possible approach has been tried for the sound of this event," Cutter notes. "We put mics *everywhere* one year, and did a complete reinforcement mixdown of the entire symphony, and then moved to a very spartan setup the next year when things weren't quite right. We eventually found a good balance, and have worked the past couple of years on refining certain techniques.

"The show is a very delicate balance of natural stage sound and amplified music; it takes a fine touch on the board after doing some very sensitive mic placement and equalization adjustments to deliver the particular blend that this audience expects to hear."

Cutter collaborated with lighting and set designer Gene Dent, of Illumino Limited, Portland, for monitor and microphone placement. Although some stage fill speakers were available from the auditorium's sound department stock, Cutter also planned to bring in additional items from his own rental stock. Blueprints showing audio device placement were drawn up for use during the 3-day equipment load-in and setup. Small enclosures were hidden around the stage (Figure 1).

The hanging plot for scenic and lighting equipment was written up to include the placement of 18 separate condenser microphones on eight pipes, with flylines being set for 8, 10, 12, 14, 16 and 22 feet off the deck for optimum voice pickup from risers of various heights in the stage set (Figure 2).

A Clear-Com communications system

David Scheirman, RE/P's live-performance consulting editor, is president of Concert Sound Consultants, Julian, CA.





**Figure 3.** The conductor in the orchestra pit communicated with the sound mixing positions by means of a handset and belt-pack.



**Figure 4.** Pace Landmaster III radio communicators were specified to facilitate sound-crew communications during setup.



**Figure 5.** A large artificial Christmas tree was the most prominent feature of the stage set. Approximately 120 choir members stood on the tree's seven levels for up to one hour at a time.

was specified to link the house sound control room, the temporary stage and audience mix locations and the conductor's position in the orchestra pit (Figure 3). In addition, to facilitate the lengthy and complex setup of the sound system prior to the dress rehearsal, Cutter planned to make use of hand-held radio communicators (Figure 4). The radios were not used during the performances for several reasons, including audience distraction and the susceptibility of the sound reinforcement consoles used for the event to RF interference.

Scaled blueprints of the stage set and backstage area were used to estimate cable length requirements, and inventory equipment lists for the show were tabulated in advance, down to the spare batteries and rolls of tape that would be required. Early coordination with the auditorium's sound department helped in determining what in-house equipment resources could be used.

#### Initial setup

Equipment load-in took place on a Sunday in anticipation of a Tuesday evening production run-through. A dress rehearsal was planned for Wednesday. Sundown Sound and auditorium sound technicians coordinated the placement, hook-up and testing of microphones and loudspeakers.

"This type of production is not like a rock concert, where you throw everything up, ring it out, do the show, pack it and leave," says Bill Gardner, monitor system operator for the *Singing Christmas Tree*. "With this type of production, the placement of each mic and speaker cabinet is dependent on many other things. As you start to fill up the stage with the set, the room to work with gets tighter. The same is true in the orchestra pit. Having the time to make sure everything is in the right spot and working correctly can spell the difference between a smooth show and trouble."

The primary stage set piece that captured the audience's attention when the

curtain went up was a large Christmas Tree fabricated of wooden truss beams and artificial foliage. Designed by a structural engineer, the massive set piece was intended to hold more than 120 people (Figure 5). Bass, baritone, tenor, alto and soprano vocalists were evenly distributed throughout the tree's seven different levels.

There is no room for microphone stands in such a crowded environment; the visual aspect had to be considered as well. Cutter's solution to this challenge, in addition to a flying brace of shotgun microphones, has been to hide miniature condenser microphones throughout the branches of the tree. Fifteen different units were distributed, with microphone cables being routed underneath the wooden flooring structure of the tree and gathered into multipair cables for the run over to the monitor mix position and the main splitter box (Figure 6).

Fender M1 microphones were chosen for this application. These miniature condenser mic capsules (Figure 7) come with a separate pocket-sized pre-amp box with belt clip that is connected to the capsule by an ultra-thin cable. The M1 is a "phantom-priority"/battery supply microphone powered by 48V supplies in professional mixing consoles, but which keeps working on its own internal battery if the board's phantom power supply should ever fail. Built-in tunable notch filters (from 50Hz to 320Hz) and a frequency response switch (flat or bass roll-off position for voice) add to its versatility (Figure 8).

During rehearsals, conductor Jim Boehner listened carefully to the choral vocal blend and rearranged the vocalists' standing positions within the tree as needed to achieve an optimum balance between the different sections, with strong singers given placement priority in front of the tiny microphones.

Portable floor-slant monitor speakers were installed behind and beneath the choral sections on wooden support platforms inside the Christmas tree set-piece.

These cabinets were used primarily to supply piano and orchestral music as a reference to the singers in the tree (Figure 9).

"The singers in the tree were quite a distance from the conductor in the orchestra pit," says Bill Gardner, monitor system operator. "They needed to hear the piano for their pitch. However, if it came up too much, there was bleed-through into the vocal microphones located in the tree, and it gave an unnatural sound to the house mix. I relied on comments from the singers in the tree and the house engineers to stay with the right level on this mix as the show progressed."

#### Microphone placement

In addition to the 15 tree mics and 18 hanging mics, four AKG C-568-EB shotgun microphones were used as "foot" mics to pick up soloists and children's voices downstage (Figure 10). These pre-polarized, short shotgun condensers were placed strategically behind some of the hundreds of potted Christmas poinsettias used to decorate the stage. Thus, not one single microphone stand was visible to the audience throughout the production; flylines brought mics in and out during the different acts to cover areas of the stage not served by the forward shotguns.

With the exception of two hand-held wireless microphones used by soloists and announcers, all vocal input to the system was achieved with hidden microphone placement.

#### Stage monitor system

A custom-modified, 32-input Soundcraft series 400B formed the heart of the stage monitor mixing system (Figure 11). Eight separate outputs were used, as detailed in Table 1. Monitor enclosures included the previously mentioned Sundown Sound bi-amplified floor slants with JBL components, JBL model 4602 compact floor slants supplied by the auditorium's sound department for use



**Figure 6.** Microphone cables were gathered underneath the tree's wooden flooring and carried to the splitter box area at the monitor mix position on multipair runs.



**Figure 7.** Miniature Fender M1 condenser mics were hidden throughout the tree.

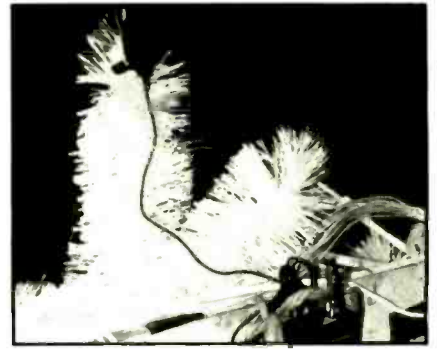

**Figure 8.** The M1 miniature condenser is equipped with a separate belt-pack power supply, attached here to the wooden walls of the Christmas tree.

on the front apron (Figure 12) and Fender model 2821 enclosures.

The 2821 is a small (23 $\frac{3}{4}$ "x15"x12 $\frac{1}{4}$ ") unit with a quoted frequency response of 70Hz to 15kHz. Each box has an internal 1.5kHz passive crossover, and the enclosure offers 90°x40° dispersion. A 12-inch low-frequency cone speaker and 0.94-inch throat high-frequency compression driver are used. Several of these enclosures were placed atop portable Ultimate Support stands for choral section coverage on stage left and right risers (Figure 13).

The stage monitor position was located stage left, within view of all on-stage vocalists. Klark-Teknik graphic equalizers, TDM Design electronic crossovers and Panasonic Ramsa power amplifiers were housed in aluminum-framed electronics racks for transport and protection. In addition, a spare Soundcraft power supply was located at the mix position.

"This production did not have a tremendous amount of fader-moving ac-

tivity," recalls monitor system operator Bill Gardner. "Getting the vocal blends and the right sound levels on different areas of the stage was the primary task. Compared to rock shows, this is very subtle work. This event is the biggest show that a choir like this one may do in the course of a year; they are not used to sophisticated stage monitoring systems, and working out exactly what will please a large group of people is a challenge."

#### House mix position

Located at the edge of the first balcony in the center of the seating area, the house mix position included a pair of Soundcraft consoles, with an 800B-32 being used as the primary console and a 400B-24 as submixer (Figure 14). Seats were removed to allow the temporary installation of consoles and electronics racks (Figure 15).

Outboard gear included seven White series 4000 third-octave filter sets, three dbx model 160X stereo compressors with noise gates, a Lexicon Prime Time

digital delay (used to "fatten" the sound of the orchestra's violins) and a Klark-Teknik DN-780 digital reverb for spatial enhancement (Figure 16).

"With such a large number of open vocal microphones hanging everywhere, notch-filtering is needed to get enough available gain before feedback in addition to just the console's input channel EQ," explains sound designer David Cutter. "We group-insert the Whites on the different submasters serving the different area hanging mics and, after ringing out each individual mic for feedback problems, we then boost the gain and notch out the most prominent problem frequencies that crop up when the whole submaster group is summed together. Then, we take the gain back down to a normal operating level, and we have a headroom factor to actually work with during the performance."

During the production and dress rehearsals, two main board operators adjusted and set levels of inputs and microphone submaster groups. Hanging microphone adjustments were made to improve area vocal pickups as needed, and then the corresponding re-equalization took place to accommodate the changes. By the time the first performance was successfully completed, the sound system operation had become a one-man job, with very few actual input or EQ changes required during the show; the primary system operating activity became the activation and muting of different inputs as the show's numbers made use of audio "scenes."

#### Auditorium control room

Portland's Civic Auditorium is unique in one respect: a sophisticated monitoring system enables the house sound technicians to mix shows from the sound control room, located backstage. Only portable sound system setups that travel with road shows use the audience-area mix location.

Five separate custom speaker enclosures, each housing a JBL LE-8H speaker and tweeter, are suspended in

	Program	Output Devices
Output #1:	M1 mics in tree, piano	Four bi-amplified SDS-200 wedges, located inside tree
Output #2:	M1 mics in tree, orchestra mix, tape playback, solos	Two bi-amplified SDS-200 wedges, hanging overhead centerstage on an electric pipe
Output #3:	Solo mics, tree mics, music	Four JBL model 4602 floor monitors on front apron
Output #4:	Solo mics, tree mics, hanging area mics	Three Fender model 2821 speakers, located in orchestra pit for conductor, pianist and drummer
Output #5:	Solo mics, music, tape playback	Two Fender model 2821 on speaker stands, stage right
Output #6:	Solo mics, music, tape playback	Two Fender model 2821 on speaker stands, stage left
Output #7:	M1 mics in tree, orchestra, tape playback	JBL-component large sidefills, located offstage left and right
Output #8:	Tree mics 1-15, mixes down for choral blend	To input channel on console for assignment to mixed 1-7 as needed

**Table 1.** Monitor console output assignments.





**Figure 9.** [Top] Sundown Sound's SDS-200 biamplified slant floor monitors were placed inside the Christmas tree to provide vocal and piano reinforcement to the choir.



**Figure 10.** [Center] AKG C-568-EB short shotguns were positioned on the front apron of the stage for use as "foot" mics.



**Figure 11.** [Right] The monitor mix position featured a Soundcraft 400B-32, Klark-Teknik equalizers, TDM Design crossovers and Ram-sa amplifiers.

the air above the auditorium's Yamaha PM-2000-32 mixing console. A relay-based routing matrix enables the system operator to assign output signals to any of the five overhead monitor speakers; if desired, the five monitors can pass the same signals that are going to the five different main proscenium overhead speaker clusters. In this manner, the board operator who becomes used to the relation between his backstage control room monitors and the corresponding house sound level can control a show from this room.

For the *Singing Christmas Tree*, auditorium staff technicians were present in the control room to monitor the event and observe the functioning of the in-house loudspeaker system, which was used as the sole reinforcement system for the audience area on this show. A tape playback device was housed in the backstage control room, and triggered by a pushbutton located at the conductor's stand in the orchestra pit. The audio signal was routed up to the portable mix position in the audience area.

#### House speaker system

Above the stage area, five overhead cluster arrays are built into the sound bridge. Each of the five arrays comprises three 15-inch JBL D-140 bass speakers and two, 1-inch throat JBL model 2470 drivers mounted on small multicell horns. The system was installed in 1968, and is still powered by solid-state James B. Lansing Transducer Energizers.

"This system was pretty advanced for its time," says engineer Cal Perkins, who helped bring the early transistor amplifiers from the drawing board to the production line as an engineer with JBL more than 20 years ago. Perkins, now a

# A FEW WORDS ABOUT SOUNDMASTER™ AND TIME

In the time it takes you to read this ad, you can learn how to execute your first Soundmaster edit, flawlessly.

In the time it takes to call and arrange for a personal demonstration, your Soundmaster system can be up and running.

In the time it takes you to pull together the financing for one of our cost-effective systems, Soundmaster can profitably lay down the tracks for a half hour program.

In the time it takes you to compare Soundmaster to our competitors, you can leapfrog your competitors in one sound business decision.

Soundmaster. The fully integrated editing system designed to perform perfectly time after time after time after time...

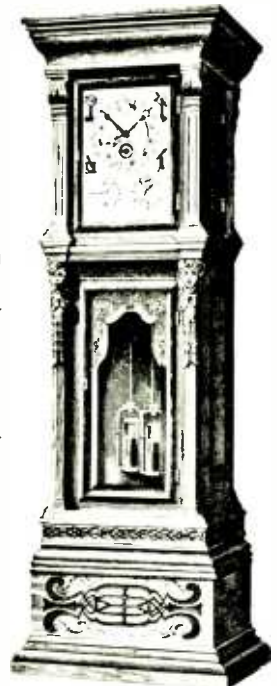

**NAB BOOTH #2780**

soundmaster

Soundmaster International, Inc., 306 Rexdale Boulevard, Unit # 5  
Toronto, Ontario, Canada M9W 1R6, (416) 741-4034 - Telex 06-963548

NEW YORK • LOS ANGELES • CHICAGO  
TORONTO • MONTREAL • SYDNEY • TOKYO • PARIS

Circle (54) on Rapid Facts Card



**Figure 12.** JBL model 4602 compact floor monitors were supplied by the Civic Auditoriums' sound department.



**Figure 13.** A Fender 2821 speaker enclosure suspended from an Ultimate Support stand for use as an area monitor near a choral riser.



**Figure 14.** A Soundcraft 800B-32 served as the primary house soundmixing console.

design engineer for Fender Musical Instruments, admitted to being proud that all of the original power amplifiers were still working in the building's racks when he dropped in to observe the setup.

"When they were correctly engineered and installed, a lot of these early civic facility sound systems were perfectly capable of lasting for two or more decades," he confides. "They may not put out the SPL or frequency response that is now specified for modern systems, but many are still a credit to their designers as a functioning audio system."

Sundown Sound's portable mix position used three of the overhead house clusters (left, center and right) for the production. Additionally, sidewall-mounted, special effect line-array speakers were used to enhance the climax of the "Hallelujah Chorus" from Handel's *Messiah*, which was the production's finale.

"I'd certainly rather have our own contemporary modular speaker system suspended in an overhead central array," Cutter says. "However, it might be a visual distraction for this particular event, and it wouldn't work logistically for the production. The installed house system is adequate for the marginal volume levels of this show. It's a case of subtly blending the reinforced audio in with the natural sound of the chorus onstage, rather than trying to overpower the room with amplified sound."

#### **Orchestra section**

In the orchestra pit, a full symphony complete with string, woodwind, brass and percussion sections was gathered around the conductor. A drum set, electric bass and grand piano comprised an additional rhythm section to add a "pop" musical texture. Cutter elected not to use any reinforced audio on the bass guitar amp or drums; brass instruments were also not reinforced.

Miniature AKG clip-on microphones were supplied to the four first and four second violinists, four violas and four cellos. The mics were left clipped to each musician's stand, and attached by the

string players upon entry into the orchestra pit (Figure 7). A sound system technician was in place to assist in this process.

During the performance, overall level of the show was determined by the intensity at which the drummer and bassist played; when the orchestral balance was layered over the natural rhythm section sound audible in the audience area, choral textures could then be brought in.

"With a show like this one, it is very important that the conductor have a good handle on the level at which the rhythm section plays," Cutter advises. "If they start to run away with the volume, the sound of the whole production will deteriorate. Just continuing to turn up the choir mics is *not* the answer."

In the orchestra pit, monitor reinforcement was confined to a small amount of piano and a choral mix for the conductor and rhythm section players. Other orchestra members relied on a natural, open listening environment from which to play their parts. The large number of open mics both in the pit and on the stage made low monitor levels a priority.

#### **Production comments**

Achieving a smooth, natural-sounding mix from 200 voices and a symphony orchestra is a delicate task. Like a surgeon, the sound system operator must deftly cut out those parts of the whole that are not working for the good of the entire production; on different nights, in different performances, this meant that some mic inputs worked better than others, depending on the strength and on-key singing of different individuals.

The most challenging part of this particular production, with its 37 open choral and area mics, was attempting to give the singers, who were spread out across the stage, sufficient instrumental reference material, without generating sound that would bleed back into the open microphones. The choir had a difficult time singing the uptempo contemporary numbers if sufficient orchestral accompaniment was not audible; the house-sound system operator had a difficult time controlling the sound of the

show if this stage sound level was too high.

Being able to drop banks of area choral mics in and out with flylines made a tremendous difference in the show's clean look. We did find that written cues were helpful with this aspect of the sound; if hanging microphones were not muted as they went up into the ceiling, unwanted backstage noises and low-frequency rumble build-up could result.

Consoles with programmable muting would have been helpful in this respect. Fortunately, this feature is starting to become commonly available on the better mixing consoles, after being a common fixture for lighting system operators for years.

One of the most valuable tools for use in operating a sound system such as this over the course of repeated performances was an open mind. After each show, members of the audience (who had an approximate median age of 50 years) would invariably come by the mixing position with comments. These were almost entirely all positive, and often sprinkled with a few clues that could lead to the improvement of the next show's mix.

Many people were repeat audience members; some had been to every annual production for the past 24 years. As an audience ages, so can its taste in musical styles. Attempting to please this same crowd year after year has been no small feat, according to David Cutter.

"These are familiar songs, and most people like to be able to understand those words even from the highest balcony," he says. "The large number of microphones does not represent a need to make things get loud, but is intended to give us the greatest amount of flexibility we can have in pulling in those voices from all over the stage.

"There is a lot to watch for. If the kids get on stage and crowd too close to the front, they will overshoot the shotgun mics. If the choir in the tree gets restless, they start making too much body movement noise during the quiet passages. It's certainly *not* just your average gig."



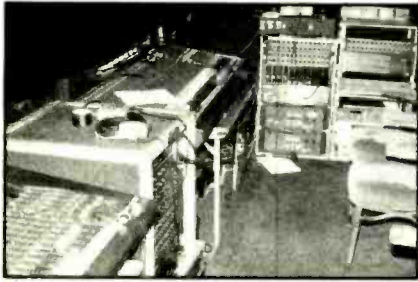

**Figure 15.** The house mix position in the audience area.

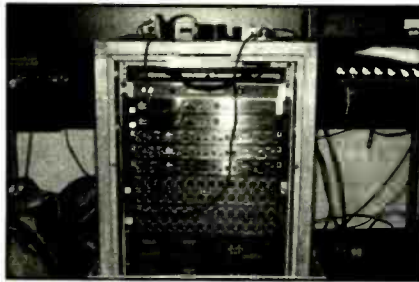

**Figure 16.** Portable electronics racks housed White filter sets and dbx compressors.



**Figure 17.** AKG clip-on mics were supplied to the orchestra's string sections.

### Civic event sound is improving

It is perhaps safe to say that, 20 years ago, dozens of condenser microphones and 56 audio inputs were not considered to be necessary for a choral music production in a 3,000-seat civic auditorium. Are they necessary today? That question is best answered by anyone who could step into a time machine and jump forward two decades, hearing the same show (such as a Singing Christmas Tree!) one night as it was done in the Sixties and then as it is treated in 1987.

The improvement in sound for public events has been very, very gradual, and has been marked by certain highlights

that point to specific innovations. The first placement of the mixing console out in the audience area; the first separate on-stage monitor mixing position; the expansion of input capabilities to incorporate enhanced mixing flexibility—each trend has brought live sound for public events closer to whatever point of perfection sound-system operators have always been reaching for.

As older installed systems are upgraded with new components, and as modern sound system technology is introduced to civic facilities by portable system operators, the audio quality of the shows being held in our civic buildings will con-

tinue to improve. Event promoters no longer question the need for high-quality sound systems; the paying public *does* know the difference. In the hands of knowledgeable system operators, the combination of outside rental equipment with sound system resources that are already installed can provide audiences with excellent sound.

**RE/P**

Author's note: The mention of specific products in this article is not to be taken as an endorsement by RE/P or Intertec Publishing Corp. The system has been detailed for the purpose of satisfying reader interest and educational needs.

Photos by David Scheirman.



**Buy one,  
get four  
free.**

**Symetrix**

*They say you get what you pay for. Indeed, the 528 Voice Processor proves the point. Five high performance signal processors in a single rack space, for about what you'd expect to pay for each. Mic Preamp, De-esser, Compressor/Limiter, Downward Expander, Parametric EQ/Notch Filter. Even 48v phantom powering and a balanced line input. No compromises, nothing left out.*

*The 528 Voice Processor is the ideal mic input system for sophisticated recording and high level sound reinforcement systems. Control annoying sibilance, optimize spectral balance. Set overall signal levels. Reduce noise. And, eliminate resonances and ring frequencies with the 528's extremely selective EQ and filtering.*

*Get what you pay for, and then some. Get the 528 Voice Processor. Call or write for a detailed spec sheet.*

4211 24th Avenue West  
Seattle, Washington 98199, USA  
Telephone (206) 282-2555  
Telex 703282

Signal processing at its best

Circle (30) on Rapid Facts Card

# Dolby Cat. No. 280 Spectral Recording Module

By John Eargle



**T**he history of analog recording is intimately bound up with pre- and post-equalization. Unlike digital recording, which has an inherently flat power bandwidth, each analog recording medium has its own non-linear characteristics. Because of noise problems at high frequencies and modulation space requirements at low frequencies, the LP vinyl disc has the most drastic pre- and post-equalization scheme, some 34dB.

Analog tape recording at 15ips requires a relatively small amount of pre- and post-equalization, no more than about 8 to 10dB, depending on the kind of tape used and specific characteristics of the heads.

The biggest determinant in setting up the pre- and post-equalization plan for a given analog medium is the specific spec-

trum of the program to be recorded. When most of the present analog recording standards were developed just after World War II, it was generally observed that most musical material exhibited an overall spectral signature that rolled off at high frequencies.

As music changed over the years, high-frequency spectral requirements have increased and, all else being kept equal, this has required a general lowering of recorded levels, because of HF power bandwidth limitations in the medium. This, in turn, raised the noise floor relative to the program, a problem to be attacked directly 20 years ago by encode/decode noise-reduction systems.

Just about all readers of *RE/P* understand, at least in broad terms, the workings of compansion-based noise reduction such as those manufactured by Dolby, and dbx. The program is compressed before recording and then expanded upon playback. The compressed signal is allowed to ride well above the medium's noise floor, and complemen-

tary expansion of the program during playback restores the original program dynamics—while the medium's inherent noise floor fluctuates below it.

The real art in designing a noise-reduction system is to render this fluctuation of the medium's noise floor virtually inaudible, through attention to masking phenomena and attack and release time constants.

Another requirement of these systems is that the compression/expansion action be sufficiently complementary so that no dynamic artifacts are present in the overall processed signal.

Traditionally, any signal-processing scheme of the type described above was known simply as *noise reduction*, since the main purpose was to increase the effective dynamic range of a given medium. Such systems did not flatten the power bandwidth of the tape-recording medium; in fact, high-frequency power bandwidth was further sacrificed in some of these systems as a result of HF boosting during the record/encode process.

Noise reduction has had a very successful 20 years. The advent of digital recording, however, at least its implementation in original 2-channel recording and in stereo mixdown for LP and CD preparation, has pretty much displaced analog noise reduction as the preferred technology at the 2-track operational stage. Analog noise reduction's strength has remained in areas of multi-track recording, where the digital alternative is still too expensive for most recording and production studios.

John Eargle is president of JME Consulting Corporation. He also manages to find time for regular jazz and classical sessions.



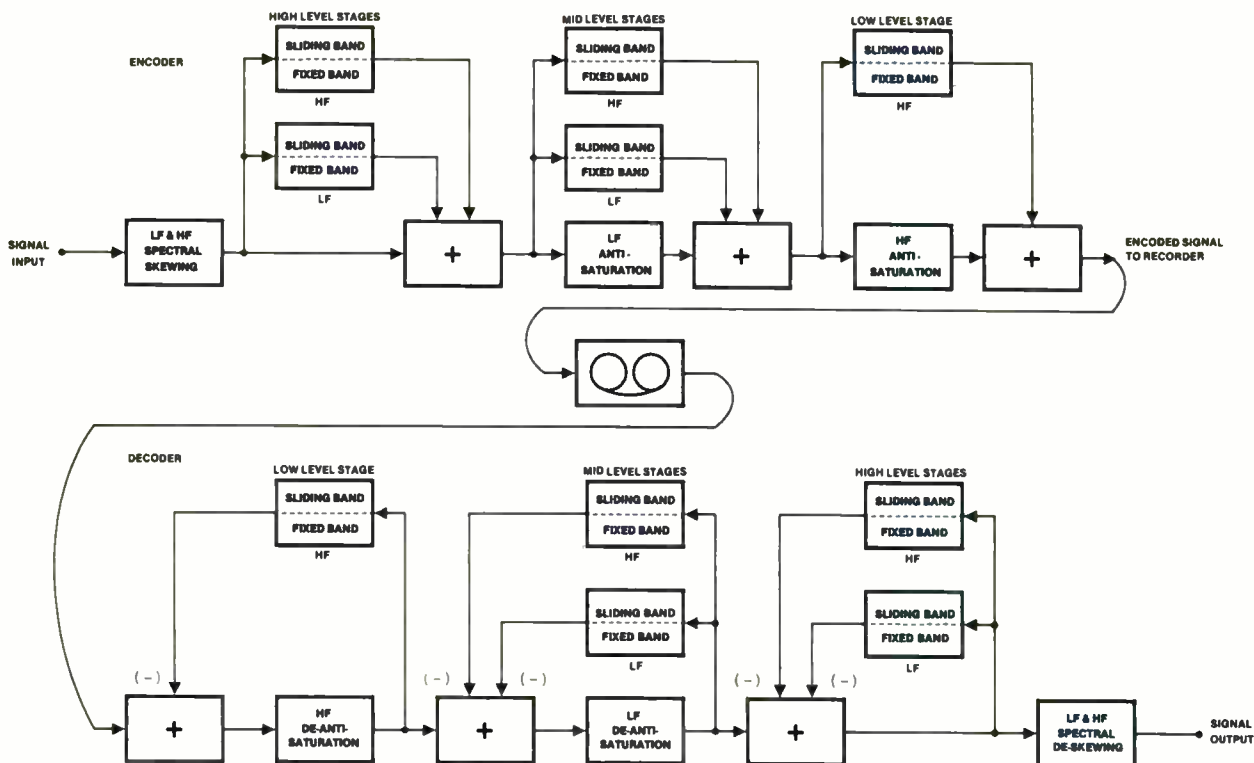

Figure 1. Simplified block diagram of the Spectral Recording encoder and decoder circuitry.

An "ideal" recording channel with finite signal-to-noise capability may be conceived as one that continuously monitors the program and establishes an appropriate pre- and post-equalization scheme, both as a function of signal frequency and level. Such a system would further take into account the natural limits of a given storage medium, at both frequency and dynamic extremes, shaping the signal to avoid both audible noise and overload, regardless of the type of program at hand. The Dolby Spectral Recording system was designed with these aims in mind.

#### System configuration

The SR modules retrofit directly into Dolby A-type models 360, 361 and M-series units, effectively widening the performance limits of a magnetic recording channel.

The Cat. No. 280 SR module has the same switching topology as a standard A-type unit: a feed-forward path in recording, switching the same processors into a negative feedback link during playback. This action is apparent from an examination of the system block diagram, shown in Figure 1.

The module is just slightly thicker than the A-type Cat. No. 22 module. A switch on the back edge of the module customizes it for either 360, 361, or M-series application; otherwise, there are no adjustments.

The front of the module contains an LED that lights up when the Dolby tone

## Technical Specifications

#### Input:

680K $\Omega$  unbalanced, 300mVrms for reference level.

#### Peak encode input level:

3Vrms (20dB above reference level).

#### Peak decode output level:

3Vrms from output 1;  
5Vrms from output 2.

#### Line amplifier:

When mounted in interference frame, maximum output +22dB into bridging load, +21dB into 600 $\Omega$  (0dB = 0.775Vrms).

#### Overall frequency response:

$\pm$  1dB, 20 Hz to 20kHz (encode/decode).

#### Bandwidth limitation:

Internal filters: 10Hz to 50kHz.

#### Overall total harmonic distortion:

0.2% 2nd and 3rd harmonic at 3dB below peak level, 20Hz to 20kHz.

#### Overall dynamic range:

105dB clipping level to CCIR/ARM noise level; 93dB clipping level to CCIR Rec. 468.2 weighted noise level; 108dB clipping level to NAB; A weighted noise level; 105dB clipping level to unweighted noise level, 20Hz to 20kHz.

#### Dynamic range:

90dB to 95dB, typical at 15ips.

#### Signal delay:

16ms overall, encode/decode.

#### Phase difference, SR in/out:

less than 2 degrees, 20Hz to 20kHz overall, encode/decode.

#### Control inputs:

External +18 to +30V to actuate record mode provided in interface frame; external single-pole switch for process in/out (provided in interface frame); external single-pole switch for Dolby noise mode (provided in interface frame). Internal 3-position switch to adjust operating logic to model 360, model 361, or M-series interface frame.

#### Dimensions:

7.5" x 6.1" x 0.8".

#### Weight:

18 oz.

#### Power requirements:

SR circuits +20 to 28V, 100 to 140mA; line amplifier + 18 to +36V, 13mA to 17mA.

Circle (141) on Rapid Facts Card

# Basis of the Spectral Recording Process

SR processing employs three thresholds set at -30dB, -48dB and -62dB. As the signal level drops below each of these levels, a separate gain-control stage is invoked, a process referred to as "action staggering." The sum of the actions of the separate stage produces the overall effect of the system on low-level noise and non-linearity. The higher two stages operate in

separate high- and low-frequency sections, separated at 800Hz, while the lowest-level stage operates only at frequencies above 800Hz.

Each of the five frequency bands incorporates a fixed and a sliding-band filter, which interact to achieve an optimal configuration (action substitution). Overall, the circuit is said to adaptively construct a virtually infinite

set of spectral transmission characteristics to optimally protect the signal. (Refer to Figures 2, 3, and 4.)

Two additional circuits operate to increase headroom for high-level signals (anti-saturation), and to de-sensitize the system to frequency response and level anomalies in the tape and recorder combination (spectral skewing).

**Table 1.** Anti-saturation action of the SR system. Input is held constant with frequency. (Nominal zero-level input.)

Frequency (Hz)	Output of module (dB)
31.5	-7.5
40	-5
50	-4
63	-3
80	-2.5
100	-2
125	-1.5
160	-1
200	-.75
250	-.5
315	0
400	0
500	0
613	0
800	0
1k	0
1.25k	0
1.6k	0
2k	0
2.5k	0
3.15k	-.5
4k	-1.5
5k	-2
6.3k	-2.5
8k	-3.5
10k	-5
12.5k	-7
16k	-10
20k	-12

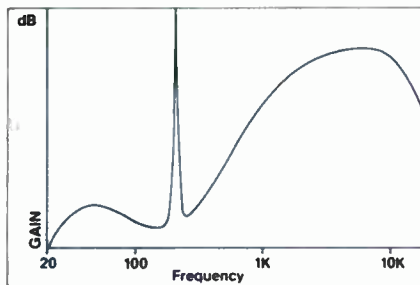

**Figure 2.** A simplified representation of the SR processing contour of an input signal with primary energy in the 200Hz region, showing the spectral transmission characteristics.

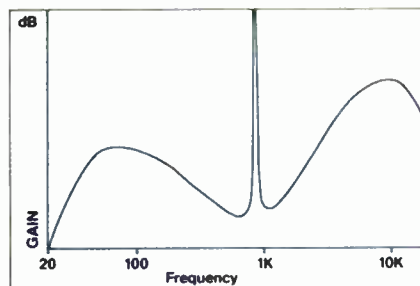

**Figure 3.** As Figure 2, but for an input signal with primary energy in the 800Hz region.

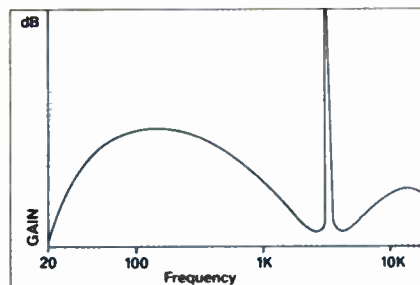

**Figure 4.** As Figure 2, but for an input signal with primary energy in the 3kHz region. By comparing the spectral transmission characteristics of Figures 2, 3, and 4, it can be seen that the degree of noise reduction is tailored to suit the primary frequency content of the input signal, thus forming a protective "gain surface" around the program material.

button is pressed on the mainframe. The calibration signal is pink noise, however, rather than the familiar Dolby Tone. Two additional LED's are used in playback mode in an Auto-Compare function, which alternates between the recorded pink noise and the pink-noise reference signal, thus allowing a quick aural check on the system's overall alignment.

System alignment is essentially the same as with the Cat. No. 22 module. In the case of the present product evaluation, the SR modules simply replaced the Cat. 22 units with no further adjustments.

Recording tests were made using an Ampex AG-440 recorder, such a machine being typical of the class of older recorders in the field that will benefit from the SR upgrade. In initial tests at 15ips, I was amazed at the virtual elimination of modulation noise on isolated sine waves. For such input conditions, the signal analyzing circuits are able to define frequency-dependent record gain structures, such as those shown in Figures 2, 3 and 4. Upon playback, the inverse is carried out and inherent system noise and modulation noise substantially reduced.

In recording piano, the Ampex/SR combination was extremely clean and transparent, with no trace of breakup, even at peak input levels well in excess of VU readings of zero (corresponding to a flux level of 185nW/m).

Although, because of its overall transparency, piano input is demanding on any recording system, it does exhibit a rolled-off HF spectrum and thus may not tax the system at high frequencies. Further tests with a variety of percussive effects demonstrated the anti-saturation nature of SR signal processing. This function actually reduces both high- and low-frequency signals at high modulation levels and, of course, restores them upon playback. Since the roll-offs are taking place well above the medium's noise threshold, the boost in playback can be accomplished with no audibility as such.

*Continued on page 93*



# THE STRONGEST LINK

Otari's new EC-101 synchronizer module, when combined with the MTR-90 audio machine, creates an entirely new audio post-production system that uses a time-code-only link, via mic cable, with the master. This unique "pre-engineered" combination offers performance well beyond that of any other audio tape recorder.



- Bi-directional frame-lock from 0.2X to 2X play speed
- Typical parking accuracy of *zero* frame offset.
- Phase-lock over a  $\pm 50\%$  play speed range.
- Wideband time-code reading
- RS-232C interface port with optional RS-422 SMPTE/EBU and VITC reader/master interfaces available

So if your studio must stay current into the 1990's, or if your facility is now expanding into post-production, your timing is perfect. The breakthrough technology that gives you the best performing tape recorder in the world is here. And if you already own a MTR-90-II, an EC-101 is available as a plug-in option. From Otari: The Technology You Can Trust. Contact your nearest Otari dealer for a demonstration, or call Otari Corporation, 2 Davis Drive, Belmont, CA 94002 (415) 592-8311 Telex: 9103764890



**OTARI**

Circle (55) on Rapid Facts Card





# Facility Spotlight: Master Sound Astoria

By Kathleen White

**By locating the 2-room facility within a major entertainment complex, Master Sound has chosen to both serve and educate a wide range of clients in the growing importance of high quality audio.**

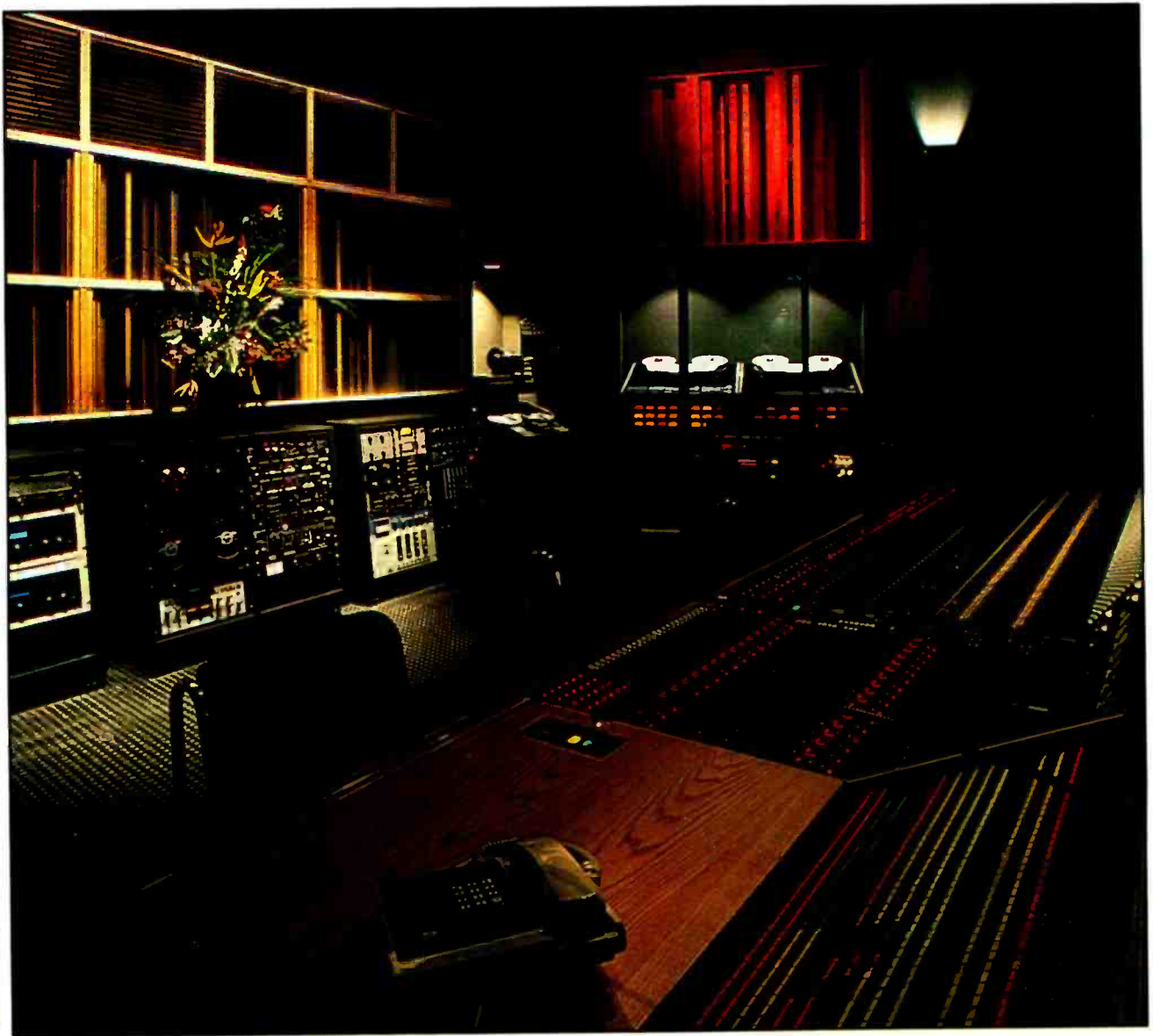

Photo by Ken Howard



Control Room A1 houses a 48-input automated Trident TSM console, two Ampex ATR-124 analog multitracks with full remote control, various analog and digital mastering machines, plus a full complement of outboard signal processors. A pair of Sony PCM-3324 DASH-format digital multitracks are also available for use in both Studio A1 and the recently renovated Studio A2.

The recording area of Studio A1 during an early construction stage.



In the Eighties, the recording and production industry finds itself in a continual debate over such topics as how to survive and prosper in today's highly competitive, high-tech marketplace. For example, the availability of computer-based synthesizers and sequencers with multitrack recording and MIDI capabilities has enabled composers and musicians, among others, to set up personal use studios in their homes.

These days, commercial facilities have to offer quite a bit more than just tape tracks, be it in the form of the latest new outboard equipment, acoustic design or digital transports. But equipment and facility upgrades form only part of the picture. Technological developments have spawned new approaches to recording and production, and have brought about shifts in the marketplace.

The good news is that despite the various changes and upheavals, audio production is still very much in demand. Music is an increasingly important feature of entertainment and communication industry productions. Film soundtracks often gross more than the film itself and the "original Broadway cast album" is often released long before the show opens.

Recording and production studios are responding in a variety of creative ways to these changes. For many facilities, ongoing upgrades have become a fact of life. Some studios have found it useful to focus their attention toward a specific

Kathleen White is a Boston-based free-lance writer, musician and composer, and a regular contributor to RE/P.

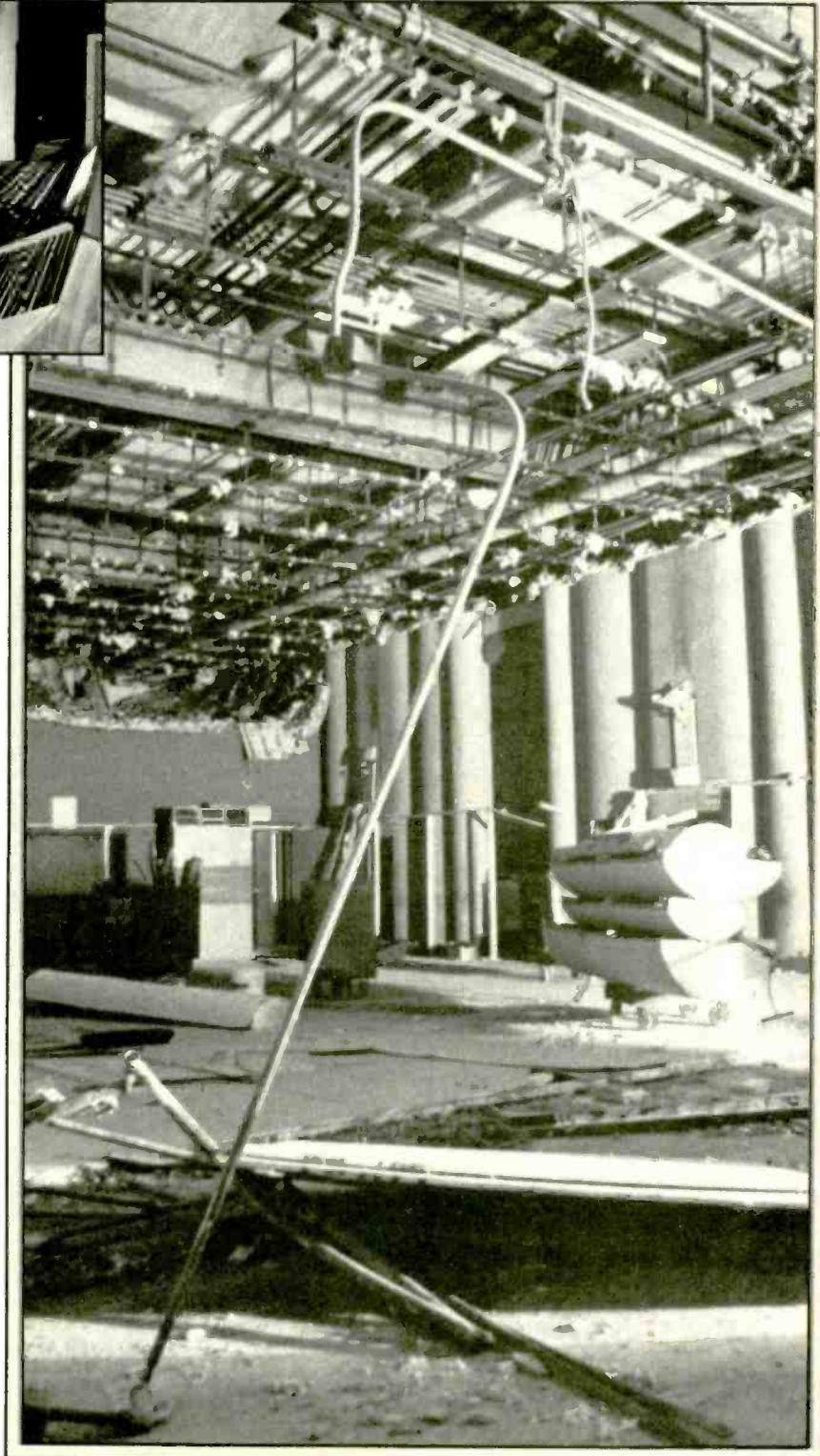

## Equipment List: Studio A1

**Console:** Trident TSM with 48-input channels, 24-output groups, a 32-track monitoring section with 4-band EQ (for a total of 80-line inputs during mix-down), and console automation.

**Multitracks:** Two Sony PCM-3324 digital and two Ampex ATR-124 analog 24-tracks.

**Monitors:** JBL model 4435s, powered by Macintosh model 2500 amps strapped for mono. The amps are located two feet away from the monitor cabinets and connected with Monster Cable leads.

**Mastering:** Digital—Sony PCM-1630

and F1 2-track processors; two Sony PCM-3302 Twin-DASH machines; Analog—Ampex ATR-102 and 104 machines, plus Sony APR-5003 stereo transport with center-track time code.

**Reverb and delay:** One live chamber; EMT 251, AMS RMX-16 and Lexicon 224XL digital reverbs; two Lexicon PCM-70s; two Yamaha REV-7s; two Yamaha SPX-90s.

**Outboards:** UREI 1176, UREI LA-4, dbx model 160 and Audio-Design compressors; Orban stereo and API mono limiters; GML, UREI, Orban and Pultec equalizers.

market, while others are diversifying into a wide range of services to meet their client's more specialized needs, including MIDI-equipped pre-production rooms, specialist "mix rooms," and video and film post-production facilities.

Yet as studios become more business and technology-oriented, they face another dilemma: how to maintain an atmosphere supportive of the creative and artistic efforts of engineers and musicians alike.

Master Sound Astoria, New York, has developed its own solution to the vagaries and complexities of the pro audio industry. By locating its studios within the Kaufman Astoria Studio film complex, Master Sound has become the focal point for a variety of audio and music productions.

The Kaufman Astoria complex, located in Queens just over the Queensboro Bridge from midtown Manhattan, opened in 1981 on the site of the old Paramount Pictures Studios. It now houses more than 80 communications and entertainment related industries, along with six film stages. The latter are among the East Coast's largest, and serve the pre-production, shooting, and post-production needs of feature film, video and TV commercial producers.

### Facility origins

Master Sound, owned by husband and wife team Ben Rizzi and Maxine Chrein, moved into the complex in 1985. What the two had in mind was an audio facility

capable of recording and mixing music for a variety of media. To this end, they built two 48-track studios: Studio A1, the larger of the two, has been up and running since October 1985; Studio A2 came on-line earlier this year.

The pair of studios were designed and equipped to handle all analog and digital track formats, electronic music production, film and video scoring plus lighting shoots. Both areas are fully equipped for time code synchronization, and have been permanently wired via audio and video tielines to the main shooting stages within the complex. In addition, the studios are hard-wired to a satellite uplink station.

Chrein and Rizzi started out in the early 1970s with a modest 4-track facility on Long Island. Rizzi's background was as a musician and engineer; Chrein's as a singer with experience in administration and financial planning.

In its early days, Chrein recalls, the studio catered to the local band market.

"We cultivated a diverse client base from the start," she says. "Doing small label work for all sorts of clients—jazz, ethnic and rock music groups, even children's music. Because we reinvested everything back into the studio, by the late 1970s we had upgraded in increments to a 46-track facility."

The partners also found that being located a fair distance from Manhattan, and out of the New York's mainstream studio population, other services were not available locally for their clients. As a

result, Master Sound branched out into high-speed cassette duplication, 35mm mag transfer and off-line videotape editing. Eventually, the studio expanded to offer production services for industrial films, slide shows and videos.

"Even back then," Chrein adds, "the idea was not to just be the world's 'best' recording studio, we wanted to expand our business activities well beyond the studio itself."

By the early 1980s, she says, word began to circulate about the Kaufman Astoria complex.

"When we saw the proposed facilities, we jumped—it was a golden opportunity to be at the center of an entertainment and music complex. And, at the time, the handwriting was on the wall for our existing facility. We were over-equipped, too high-tech and expensive for the market. The smaller studios were into price-slashing wars, as they are often wont to do.

"Both Ben and I felt that a mid-sized, independent studio was no longer viable, and that the market was heading toward a mix of large, multiservice facilities and a variety of specialized and home-grown studios."

The history of the Kaufman Astoria complex itself reaches back to the early days of the filmmaking industry: Paramount Pictures opened the facility in 1920 and shot most of its early silent films at the complex. When the film industry moved west in the 1940s, the U.S. Army took over and set up the Army Pictorial Center. Following the Army's departure about 15 years ago, the building fell into disrepair and plans were made to raze the site.

In 1976, the Astoria Motion Picture and TV Foundation, with the help of business, labor and local and federal government agencies, saved the studios from demolition. The foundation reopened the main filmstage and, in 1981, gave the development rights to George S. Kaufman, a luminary in the New York real-estate business. Kaufman assembled a group of investors from the entertainment industry, and proceeded to build what may now be considered a world-class production and office center to serve the TV, film and music industries.

Since 1981, the complex has grown from five acres with one main building to a 15-acre complex. The existing film stage was renovated and two new stages constructed. Each soundstage is now flanked by production offices, makeup, dressing rooms, wardrobe departments and carpentry and scenic shops. In reality, the complex is like a self-sufficient city, with a bank, lawyer's offices, a florist, 24-hour security service and a commissary.





To the right of the console during the 72-track AT&T digital remix sessions were located three Sony PCM-3324 multitracks synchronized via their individual remote control units. The pair of PCM-3324s pictured right are owned by Master Sound Astoria, and the unit to the left was rented for the session from AT Scharff, New York.

## Why do Jensen Transformers have Clearer Midrange and Top End?

The high frequency rolloff of a *Jensen Transformer* is optimized, by computer analysis, to fit the *Bessel Low Pass Filter* response. This means *minimum overshoot and ringing* and *flat group delay* for best *time alignment* of all spectral components of the musical waveform.

In other words, the harmonics arrive at the same time as the fundamental frequency.

The result is a clear midrange and top end without the harsh, edgy sound which has been one of the most objectionable sonic complaints about transformers.

There's no "midrange smear."

Only *Jensen* has this benefit of hi-tech computer optimization.

*Visitors by appointment only. Closed Fridays.*

10735 BURBANK BOULEVARD • NORTH HOLLYWOOD, CA 91601  
(213) 876-0059 • Telex via WUI 6502919207 MCI UW

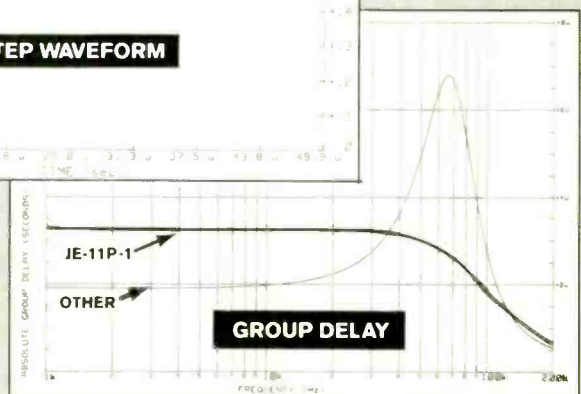
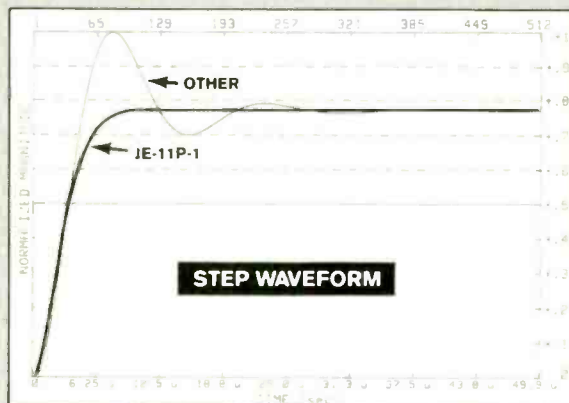

**jensen transformers**  
INCORPORATED

Circle (28) on Rapid Facts Card



*Pictured in Master Sound Studio A1 during a recent 72-track session for AT&T using three, interlocked Sony PCM-3324 DASH-format digital multitracks (from left-to-right): producer Andy Behar, staff engineer Gene Paul, tape operator and second engineer Corky Stasiak (rear), chief engineer and studio owner Ben Rizzi, and assistant engineer David Acetta.*

### Studio design concepts

The two Master Sound studios and offices occupy more than 14,000-square feet of space in the basement of the complex's main building. Large hallways and freight elevators have been provided for easy access to clients and their session instruments. The sheer amount of space gave Rizzi a free hand in designing the facility. Over a period of a year, Rizzi and acoustician Charles Bilello planned every detail of construction and acoustical design.

Studio A1's studio floor consists of an 18-inch concrete slab that sits on 25-foot pilings run into bedrock. The control room floor is a floating platform filled with 15 tons of sand. Walls and ceilings are double constructed and sealed in lead, with a 4-inch airspace between each wall.

The studio's main power supply, separate from that of the complex, consists of two transformer-isolated systems using hospital-grade ac outlets and a star grounding scheme. Belden cable was used for line-level runs, with Star Quad low-capacitance used on the microphone lines. As an extra precaution, the control room was Faraday-shielded to keep out RF interference.

At the rear of the recording area are two large isolation booths, also Faraday-shielded. (This latter feature, however, is courtesy of the U.S. Army, which originally built the booths for use as control rooms.)

Located above the isolation booths is a large projection booth; a projection screen is hung on the wall at the opposite end of the studio. On the ceiling is a lighting grid, powered by its own 600A electrical supply.

"Both studio and control room are airtight and absolutely quiet," Rizzi says. "We installed two separate air-conditioning systems to provide 10 changes of air per hour."

Acoustically, the control room is a certified Live-end/Dead-end design, to which Rizzi added some of his own ideas.

"We first started by choosing monitors [a pair of JBL model 4435s] and then built the room around them.

"The front half of the room is non-reflective, with surfaces covered with an upholstery fabric. The rear half of the room is reflective with plaster surfaces and a panel of RPG diffusors mounted on the back wall. The floor behind the console is covered with computer vinyl, while the area in front of the console is carpeted and furnished with seats."

The room, measuring 32' x 27', is dominated by an automated 48-input Trident TSM console with 32-track monitoring. Two Sony PCM-3324 DASH-format digital multitracks and two Ampex ATR-124 analog 24-tracks are discreetly tucked away in pairs in glass booths located on the rear wall. Three equipment racks slide out from beneath the wall diffusors, and two portable rollaround racks hold outboard gear.

"This is the only Syn-Aud-Con certified room in New York," Rizzi says. "Although it is officially an LEDE design, I prefer to call it a 'reflection-free control room', with a stable stereo image wherever you sit.

"The sound environment is so good that musicians could record in here if they wanted. It's big enough to accommodate musicians, engineers, synthesizers, etc., without crowding everyone

The recording area's design principle was well-defined from the start. Measuring 42' x 60', with a ceiling height ranging from 18' to 23', the studio proper can accommodate a large-size orchestra.

"We wanted to build a small concert hall," Rizzi says.

Studio walls are plain white with four groups of RPG diffusors per side. In addition, four sets of rotating panels per side are reflective on one side and absorptive on the other. Floors are polished oak, with Persian area rugs.

"We can quickly adjust the reverberation time from 1.5s to 3s by adjusting the panels. Often we find musicians starting at 1.5s RT<sub>60</sub>, and then opening the room up to 3s because they like the sound so much," Rizzi says.

Studio A1 has been running around the clock since it opened, Rizzi reports, with a diverse clientele. Sessions have included a variety of album projects, including La La producing a Glen Joanes album; Julius La Rosa recording his recent album, *Don't Go To Strangers*; and



Placido Domingo. Eddie Roynesdal, keyboardist for the Joe Jackson Band, and Mark Sherman have also used the room for their respective recording projects.

Larger sessions have included a digital 72-track to 6-channel mix for an AT&T multiscreen presentation on the history of the world, now on permanent exhibition at the Info Quest Center in New York.

"This could have been one of the biggest digital mixes ever," Rizzi says. "We locked together three 3324s and a Sony BVU-800 [plus PCM-1630 digital processor], along with an analog 4-track as a backup. We set up both studio and control rooms for a 6-channel mix, to simulate the Info Quest auditorium."

Extra staff was called in to assist on the recording of two Broadway musical cast albums: Rupert Holmes' musical, *The Mystery of Edwin Drood*, with full orchestra, and more recently, the cast of the yet-to-be-produced English musical, *Secret Garden*, tracking vocals in the studio.

Other sessions have included a commercial for Renault, with voice-overs by George C. Scott, and Honey Cole taping his way through a Suntory

Whiskey commercial.

"We set up some Sanken mics and a pair of Crown PZMs and let him dance," Rizzi says. "I was a bit worried about the floor getting scratched up, but it worked out well!"

#### Electronic music studio

The second studio, A2, has the same construction and acoustic features as A1, but on a smaller scale. Measuring 21' x 28' in the control room, and 25' x 18' in the studio, the new facility is geared toward electronic music production. Equipment matches that found in Studio A1, and the purchase of a computer-based synthesizer is under consideration, possibly a New England Digital Synclavier. At the time of writing, Studio A2 houses an Automated Processes console, although this may be used later for mobile dates and replaced with a Neve V series board.

Additional equipment in Studio A2 includes an Ampex ATR-124 24-track, LATR-102 2-track and ATR-104 1/2-inch 4-track, plus a Sony PCM-1630 digital audio processor and companion U-Matic videocassette deck.

According to Rizzi, "We wanted a smaller room available for our clients,

and right now we've got people waiting in line to get in there."

Staffing for the facility is provided by two full-time engineers—Rizzi and Gene Paul, formerly of Atlantic Studios—plus a full-time maintenance engineer. Several assistant engineers are on call for larger sessions. Chrein manages the business and administrative end of the operation with the help of an assistant.

#### Future diversification

With the facility now consolidated at one location, Chrein and Rizzi have been able to take advantage of Master Sound forming an integral part of the film complex as well. "The computer allows people from all areas of the music and entertainment industry to get together and exchange ideas," Chrein says. "Our own of-fshoots are thriving here. We've just formed a company called Music Graphics, in partnership with Joe Bilella, which specializes in music-related film projects and music videos. At the moment, Joe is developing a series of 'live' concert shows to be filmed and recorded in Master Sound, and then sent out via the satellite uplink station."

The proximity of a satellite uplink has given rise to a number of possible ideas,

# DON'T LET STEREO PHASE YOU!

## AM-3B PHASE MONITORS make it easy!

The totally new AM-3B PHASE MONITOR gives you all of the features you have come to expect from B & B SYSTEMS. Complete monitoring of your stereo audio signal via the AM-3B's unique X/Y CRT display shows you, in realtime, the in-phase/out-of-phase relationship of the actual audio signal. Mono compatibility, stereo phase and correct level are now easily maintained.

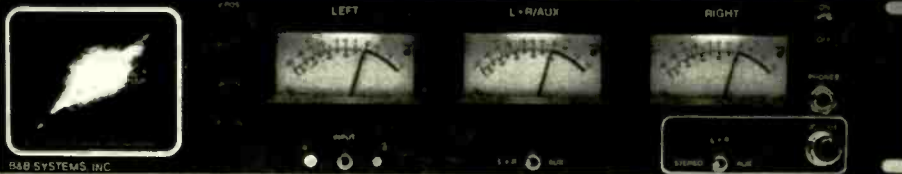

With two independent sets of three channel inputs, selectable A/E, and a built-in power amplifier with headphone and speaker outputs, the AM-3B is the ideal tool for all MTS and BTSC applications.

*Creative tools for stereo audio.*

## B & B SYSTEMS, INC.

28111 NORTH AVENUE STANFORD, VALENCIA, CA 91355

IN CALIFORNIA 805-257-4853

OUTSIDE CALIFORNIA TOLL FREE 800-345-1256

*Call to arrange a hands-on demonstration!*

Circle (33) on Rapid Facts Card





For the 72-track AT&T digital session, six close-field loudspeakers were used to monitor the final 6-track mix. In addition to three monitors arranged as left, center and right atop the Trident TSM console's meter override, three smaller, rear-channel monitors can be seen here above the outboard equipment racks.

# Source or sampling?

"There is no better sampling" \*)



The TC 2290 is the first sampler/delay in the world to give you 100% accurate sampling up to 32 seconds. Make an A/B comparison with any analog or digital master tape or compact disc, and you will notice there is no difference.

The new TC 2290 digital delay is based on a totally new converter principle. With a linear frequency response up to 20KHz +0/-0.5

dB an additional roll-off up to 33KHz and a unique 100 dB dynamic range, the TC 2290 is very warm, transparent, crystal-clear, musical... with absolutely no noise. It has 18 bit resolution - better sound quality than a compact disc, and many new innovative effects.

Ask your dealer for a demonstration of the new world standard of delay + programmable sampling. Just a few features are: delay with

ducking, chorus and delay simultaneously, automatic panning 100 presets and MIDI feature making it possible to control the TC 2290 from a computer.

**Big studios will like the extras, small studios will love the price**

\*) "There is no better sampling" is a quote from Bob Schwall - Right Track Studio in N.Y.C.

OF DENMARK

## t.c. electronic

T.O. BOX 5039, 52 WOODBINE STREET, BERGENFIELD, N.J. 07621, PHONE: (201) 384-4221

WEST GERMANY: 04157/7677, DENMARK: 06262804, GREAT BRITAIN: 010456263/800, SWEDEN: (031) 134950, NORWAY: (033) 26798, HOLLAND, BELGIUM, LUXEMBURG: 003110-4588166, AUSTRIA: 00496157/7677, ITALY: (02) 5084.1, FRANCE: (91) 498728, SPAIN: 91-4426424, USA: (201) 384-4221, CANADA: (416) 727-1951, JAPAN: (03) 329-8051, AUSTRALIA: (03) 6992388, FINLAND: 90-814133, GREECE: 01-3628541, SWITZERLAND: 073/226616.

Circle (38) on Rapid Facts Card



Chrein explains: "We could use it for live performance broadcasts or private teleconferencing. The latter would be a great time and money saver for companies with offices spread around the world. Also, because it's possible to send in excess of 24 tracks of digital audio on the satellite transponders, it could be a good solution to the problems of transporting multitrack or stereo master tapes."

Other ideas have been sparked by the close proximity of two local radio stations, WHN-AM and WAPP-FM. A series of live, weekly concerts from the studios and a host of promotional activities are under consideration.

"We have to be careful in developing our off-shoots," Chrein cautions. "We get hit with at least 10 viable ideas a day here, whereas at the old facility we might consider three a month. At this point, we are moving slowly and carefully, so as not to end up trying to do too much too quickly."

Master Sound is also expanding its audio production areas. A separate voice-over room is currently under consideration, and Studio C, an area the size of Studio A1, lies in its original condition directly behind the studios.

"We are still debating what to do with this space," says Chrein. "We may turn it into a mixing theater for film and video post-production work. Because we intend to meet the needs of the people in the complex, it will depend on how things shape up there; it's a continually evolving situation, as new companies move in."

The Kaufman Astoria complex has its own expansion plans. Since the main filmstage opened in 1977, almost 30 feature films have been shot in the complex, along with many TV commercials.

Long-range plans include expanding its video capabilities by building video-production stages and adding post-production facilities. Also in the works is a plan to attract more independent low-budget film production companies, thereby making the facility available to every level of filmmaker, rather than just the larger feature-film producers. Eventually, the complex would like to produce in-house motion pictures.

"We have ongoing discussions with the Kaufman Astoria board about future developments," Chrein says, "especially since everything is interrelated here. The presence of Master Sound on the complex has drawn a lot of musical activity—music videos are being shot here more and more, and bands are starting to discover it as a tour and lighting rehearsal space.

"We intend to expand into music production and recording, which could lead

to our own record company. Film soundtracks are a great, low-risk way to launch new artists, and from this we could consider developing another spinoff, perhaps a pop label."

If Master Sound sounds like a self-perpetuating entertainment machine, Chrein wouldn't disagree.

"The whole point of a place like Kaufman Astoria is to generate its own work, and thus provide an outlet for the talents of the whole cadre of entertainers—composers, arrangers, studio musicians, etc.

The only limit of what you can do here is your imagination."

For the moment, Master Sound's owners are content with their current creation.

"We are first and foremost a music studio, and that means doing music for whatever medium, be it film, albums, live concerts, video, radio or whatever," Chrein says. "What I most enjoy is the look on the face of musicians as they start playing in the studio, and hear how they sound in that room." **REP**



## The acoustic analysis system that means business.

TEF System 12 utilizes TDS technology and determines areas of reflection within parts of an inch. With this kind of accuracy you may never have another call-back.

In addition, TEF System 12 substantially ignores ambient interference. That means you'll schedule jobs when it's convenient for you. And, you'll schedule more jobs than ever before.

### An investment in professionalism.

An analyzer with pinpoint accuracy, documentation and impressive displays. Software that reduces the need for other bench and field instruments. Software that reduces analysis time to seconds. Training programs and a helpful newsletter. All designed to enhance your reputation as a professional sound contractor. All designed to help you increase sales.

For more information, call or write.

**TECHRON**

1718 W. Mishawaka Road, Elkhart, Indiana 46517 • (219) 294-8300

Circle (31) on Rapid Facts Card



# The Final Link: Developments in Disc and CD Mastering Techniques

By Kathleen White

**Recent advances in analog disk cutting and Compact Disc pre-mastering have affected the way in which recording and production engineers need to prepare master tapes for consumer release.**

In every area of audio production, the drive toward perfect recording, playback and storage systems has resulted in a proliferation of sophisticated signal-processing equipment, both analog and digital. Consumers now have a wide choice of media—black vinyl, cassette and Compact Disc—with R-DAT looming upon the not-too-distant horizon.

For disc mastering, the final step in the analog recording chain from master tape to consumer, the latest technical developments correspondingly fall into both the analog and digital domains. Direct Metal Mastering (DMM), introduced by Teldec in 1981, is considered by many mastering engineers to possibly represent the final improvement in

analog disc cutting—especially for those who expect Compact Disc and R-DAT to dominate the consumer market within the next decade or so.

For CD mastering, an entire “subindustry” has emerged to serve the stringent requirements of the new medium, with digital systems for recording, editing and mastering under continuous development. As with any new technology, however, considerable confusion has resulted between studio recording and mastering engineers.

Recording engineers now must prepare master tapes for subsequent release on analog vinyl, compact cassette and CD; gone are the days of the flat transfer to acetate discs.

This article will consider both DMM and current CD mastering procedures, and how the changing technology is affecting the preparation of master tapes.

## **Analog metal mastering**

The Teldec/Neumann Direct Metal Mastering process first appeared in Europe and has made its way to U.S. cutting facilities during the past couple of years. A total of 25 DMM lathes are now installed in mastering facilities worldwide, with five of them in this country.

In brief, the DMM system uses a diamond stylus to cut into a copper-coated disc, from which stampers can then be made directly. In contrast, during the conventional cutting process several more production steps are required before a metal master is ready for making the stampers used to press vinyl discs. [A complete description of the DMM process can be found on page 58 of the October 1985 issue of *RE/P—Editor*.]

The DMM system offers a number of advantages over the conventional cut-

Kathleen White is a Boston-based free lance writer, musician and composer, and a regular contributor to *RE/P*.





Mastering engineer Bob Ludwig, of Masterdisk, New York.



For CD pre-mastering, Masterdisk uses a Sony PCM-1630 digital processor (lower rack-mounted unit), and a companion 3/4-inch U-matic VCR (top). A Harmonia Mundi bw102 system, comprising a sampling-frequency converter and digital EQ module (center), enables transfers and signal processing to be made in the digital domain from Mitsubishi X-80/86-encoded material to 1630-format.

ting process, as Bob Ludwig of Masterdisk, New York, explains: "It gives us a closer representation of what we want in the first place. There is less groove echo, and the inner bands retain more high-frequency information. The system also makes very efficient use of the space on the disc, which means you can put more music onto a single or an album."

On a conventional, non-DMM disc, 21 minutes of music per side is considered the practical limit. Using DMM, however, it's possible to cut up to 40 minutes per side Ludwig says, although this is usually only done for special program material.

For material containing a large amount of dynamics, including rock albums, 26 minutes per side represents the practical limit for DMM after which the cutting engineer needs to reduce the level.

To summarize, Direct Metal Mastering is a higher-quality option to conventional acetate mastering, and can save time and money on recuts. In addition, recording engineers and producers do not need to alter the way in which they prepare master tapes; the techniques used now for conventional cutting are perfectly adequate for copper mastering.

#### Compact Disc mastering

Mastering for CD, however, involves a completely different set of criteria. CD manufacturing usually involves the preparation of a standard format,

digitally encoded, 3/4-inch U-matic videocassette recorded at a sampling frequency of 44.1kHz using a Sony PCM-1610 or 1630 processor. [It should also be stressed that several CD pressing plants around the world can handle Mitsubishi PD-Format X-80/86, Sony DASH-Format PCM-3102/3202 and JVC VP-90 encoded CD master tapes. Because the majority of optical CD cutting lathes are set up to handle 1610/30-encoded masters, a digital-to-digital conversion will be required for "non-standard" master tapes—*Editor*.]

Obviously, the transfer from stereo master (be it analog or digital) to 1610/30-format is of critical importance. Particular attention must be paid, in the case of analog masters, to correct azimuth, noise-reduction alignment levels and headroom. Once the program material is transferred, the U-matic videocassette is edited for length and musical sequence, and the PQ codes and index points added. PQ codes mark the time code start and end points in the program material; indexing involves adding further references to specific locations on each CD track. If all is satisfactory, the completed tape is dispatched to the CD pressing plant to be cut onto the glass master used for manufacturing Compact Discs.

For recording engineers accustomed to the limitations of vinyl mastering, the

Compact Disc allows greater freedom and flexibility. Given the medium's enhanced capability for handling a wider dynamic range (up to +90dB) less compression and EQ are required than with conventional masters.

It is worth noting, however, that the CD medium is an especially revealing medium; glitches, pop, sibilance, hiss and high-frequency tape saturation reproduce beautifully via CD. Clearly, the quality of the source material used to press a Compact Disc is of crucial importance.

In readying stereo masters for CD release, a few general guidelines are in order. The CD master tape should be taken from a non-equalized version, free of any noise or distortion. Dennis Drake, director of studio and technical operations at Polygram Records, offers the following advice: "Monitor everything very carefully—listen closely to get a good uniform tonal balance, and be sensitive to the ambient recording characteristics of the sound.

"With CDs, it's possible to mix for a better room sound plus finer nuances and detail, because you know that they won't be lost during the pressing.

"The recording must be of highest quality to be worthy of the medium—CDs should sound *substantially* better than an LP or compact cassette.

"Staying in the digital domain helps maintain the quality: mixdown to digital 2-track will save an additional analog-to-digital generation."

The transfer process from 2-track master to 1610/30-format is often referred to as the "pre-mastering" stage, and is handled by many disc-mastering houses, studios, CD plants and specialist pre-mastering houses. Many mastering engineers prefer to have the producer, artist, and/or A&R person participate in the pre-mastering stage.

Various items of hardware are now available for use during the transfer process, including sampling frequency converters, digital EQ and compressor units. Their use enables dynamics and equalization changes, where appropriate, to be made in the digital domain.

When working with an analog master, any leveler EQ adjustments should be made before or during the first transfer



Available for use throughout Sterling Sound for disc and CD mastering are a Sony DAE-1100 digital editing system (right) and a Mitsubishi X-86 PD-Format digital 2-track (to the right of main equipment rack).



Ted Jensen, chief engineer of Sterling Sound, New York, in one of the facility's five disc and CD mastering rooms.

to 1610/30-format; otherwise it's back to analog again, and also another generation loss.

All-digital systems for mixing and editing are gradually appearing on the market, although their high cost makes them a rare commodity in all but the most financially well-endowed mastering houses.

[An overview of Digital Audio Post-Production for disc and CD pre-mastering rooms was provided in an article beginning on page 64 of the January issue of *RE/P—Editor*.]

During the pre-mastering stage, a log is created of all the audio, PQ and indexing information relevant to the master tape; CD plants are notorious for sending back

masters containing unaccounted-for noises, which can mean delays in the release date. The log should contain artist name, date, record company, engineer, total program time and a list of frame-accurate start and end time code locations for all songs. In addition, frame-accurate location of any anomalies or noises should be logged.

Various aesthetic decisions can also be made regarding how the program material should be linked. Songs can be faded or cut in; between songs there can be digital silence ("digital black"), room ambience or even a touch of analog tape hiss. In the case of a live-performance recording, crossfades and applause should be noted in the log.

For those engineers and producers who want to send their EIAJ-format tapes to overseas CD pressing plants, bear in mind that VHS, Beta and U-matic VCRs conform to local video standards: NTSC in the United States and Japan, PAL in England, most of Europe and Australia, and SECAM in France and Russia. Because none of these formats is compatible with another, the best solution at the moment is to check ahead and master to the appropriate format.

Thus far, our discussion has been limited to preparing CD master tapes of new releases; the preparation of older material for CD pressing is a subject worthy of an entire article. Put briefly, most of the difficulties involve tracking down the original stereo master tape, preferably a non-EQ version. In some cases, it has been necessary to get back to the original multitrack master and remix to stereo. Using second-, third- or even fourth generation copies is not a good idea, because the CD may not sound as good as the original LP release.

If you're wondering why all this effort is being put into Compact Disc production, consider a few statistics: In 1981, albums and EPs out sold pre-recorded compact cassettes by 295 million units to 137 million units. By 1985, cassettes out sold albums by 339 million units to 167 million units; in the same year CD sales totaled 22 million units. Currently, there is a shortage of CD production capacity, a situation that will change dramatically by mid-year when the many new CD plants around the world will fully come on-line.

#### Other factors

There are other considerations to be born in mind while mastering for CD, as Ted Jensen of Sterling Sound explains: "Producers and engineers should be rethinking their final markets. Often, a mix is set up for FM radio play, and that's not what you want on a CD. A good radio mix and a good CD mix are not always compatible—the wider dynamic range of the CD can drive the meters crazy at a radio station."

Which does indeed raise yet another issue for Compact Discs: radio stations are used to receiving various kinds of special mixes and promo items from record companies. The cost of producing CD versions of these extended and



dance-single mixes is currently prohibitive for such a small market.

As is always the case in audio, what sounds good will determine the development of CDs and their place in the market. Consumer R-DAT is just around the corner, and new developments are already planned in CD mastering. Teledac, for example, recently announced a new Direct Metal Mastering process for cutting CD masters. The system, which uses an embossing method rather than a laser technique, is said to eliminate the need for a clean room during the mastering process. Rumors are already circulating that the DMM system, due for release in a year or so, can be used to cut direct-to-CD and from analog or digital sources.

At the moment, the question of offset time between the actual audio start time, and that entered into the PQ code, is the subject of hot debate. (An offset is often subtracted from the actual starting time of program material to allow a CD player to find the appropriate disc location, load its buffer and start outputting audio.)

Ideally, this offset should be around two to five time code frames. However, as many as 15 to 20 frames are sometimes specified to accommodate the

slower cuing speed of inexpensive CD players. Excessive offsets can be annoying, especially for CDs used in production studios or sound-effects libraries, where instant replay from a cue point is essential. Better to provide *absolute* timings, and allow the CD pressing plant to modify them accordingly.

#### CD master formats

The 1610/30-format U-matic master must be made at a 44.1kHz sampling frequency, and must contain continuous, newly generated, non-drop (30fps) time code. Two minutes of digital video black level, with time code, are required at the beginning of the tape; 30 to 90 seconds are recommended at the tape's end.

It is standard practice to record time code information on audio channel 2, with channel 1 being reserved for PQ subcode data. The U-matic's control, time code track and PQ subcode tracks must be phase-locked to the same video-sync source; otherwise you run the risk of encountering some truly extraordinary phase problems during mastering.

Many producers are now using 14/16-bit EIAJ-format digital processors to master album sessions, recording the PCM-encoded data to ½-inch VHS, Beta

or ¾-inch U-matic VCRs. First off, make sure that the VCR being used is in good condition; dropouts can lead to massive amounts of error correction, and thus sound degradation. An extra processor and/or VCR should be used for backup, and take care to maintain videotape heads and transports in correct alignments.

A few problems arise in the transfer from EIAJ-format to 1610/30-format, including pre-emphasis and dc offset. Pre-emphasis is not well-regarded by many in the field, and the presence of dc offset on a recording will result in the CD player producing a pop during replay. Fortunately, both pre-emphasis and dc offset can be removed with various accessories during the transfer stage.

EIAJ-format tapes also suffer from a phase problem: Because a single, switched digital converter is used in the processor, left and right channels will be separated by a time delay of 11.34µs during digital transfers. Although small, this time delay can cause high-frequency cancellation during playback of a CD in mono. If the transfer is being made in the digital domain, ensure that you use an accessory box that corrects for the delay.

**REP**

# Perfection!

## MPA-SERIES MONITOR AMPLIFIERS

by



... and now, the **MPA-2300** with the **BIG WATTS** for the **BIG SYSTEMS**

#### PERFORMANCE SPECIFICATIONS of MPA-SERIES:

FR= 1Hz to 100 KHz (Flat) • Slew Rate >450V/µS (8 Ω) • Damping Factor > 500 (up to 20KHz) • Power: 200 to 500W/600 to 1300W

INFORMATION CONTACT: JIM RHODES, LENC O, INC. / phone: 1-800:325-8494 / P.O. 348, JACKSON, MO 63755 (TWX 910/760-1382)

MPA-2100 MPA-2300

Circle (35) on Rapid Facts Card

# Selecting an In-Cassette Duplication System

By Kenneth A. Bacon

Now that an increasing number of recording and production facilities are installing in-cassette duplicators, what electrical, mechanical and economic factors should be considered prior to selecting a duplication system?

*"Price, Speed, Quality—  
Choose Any Two."*

This sign hangs in the lobby of a cassette duplicator I visited recently. While the sign referred to the end cassette product, it pretty well sums up the trade-offs one faces in choosing the equipment to duplicate cassettes.

This article will explore not only the electrical and mechanical specifications usually found in the manufacturers' brochures, but also some of the economic and application considerations that are important in selecting a particular cassette duplicator for use by a recording or production facility. We'll touch on some subjective tests that are useful in evaluating equipment, and provide some formulae that can help the user

determine how much equipment is needed for a given production volume or, conversely, how much production can be expected from a particular installation.

The first order of business, before looking at specifications, is to give serious thought to the market you intend to serve. A spreadsheet for your specific potential customers or customer types, such as that shown in Table 1, can be expanded as far as desired, and can serve to organize these thoughts.

In analyzing the intended market, consider the needs of each customer. For example: high-performance stereo equipment is not needed for instructional tapes. Demo tapes for musicians must be

of highest quality; they are usually needed instantly and are generally low-volume runs. Tapes for talking books should be clear but don't need a flat frequency response beyond 10kHz.

Producing tapes for a local market will usually involve low-volume runs of many titles. As a result, the flexibility of doing several jobs simultaneously may be important. Producing tapes for national distribution will more than likely require large-scale equipment utilizing high-speed loop bin systems.

Such an analysis may produce some surprises about what your most profitable market really is, and help you avoid purchasing equipment that is either overkill or underkill for your particular business.

## Electrical specifications

Electrical specifications are usually the first take listed. The basic decision is: mono or stereo? If the greatest portion of the expected business is voice (instructional material) then it makes sense to start with a mono system. If most of your work will be with musicians, however, a stereo system is a must. It will also handle mono duplication, although at a slightly higher per unit amortized equipment cost.

• *Frequency response.* The human voice, male or female, has little energy content beyond 10kHz. Most in-cassette, high-speed duplicating equipment was developed originally for instructional applications. For the average duplicator, this voice market is many times larger than the music market, so there is little incentive or need to extend frequency response in mono equipment. A further 16:1 duplicator, operating at a tape speed of 30ips, with a frequency specification of  $\pm 3\text{dB}$ , 50Hz to 10kHz must have a flat frequency response between 800Hz and 160kHz.

The bias oscillator frequency needs to be eight to 10 times the upper value, over 1MHz, to avoid audible beating with harmonics of the material being recorded. If the frequency response in an in-cassette duplicator is to be extended, it is more cost-effective to lower the duplication speed than to increase the bandwidth and the bias frequency.

To take advantage of these trade-offs, duplicators are made that operate at 30ips (16:1), 20ips (10.67:1), 15ips (8:1), 7.5 ips (4:1), 3.75 ips (2:1) and even 1 7/8 ips (real-time). Several examples of equipment spanning this range are shown on accompanying pages.

Not too long ago, cassette tape, housings and even most players could not do justice with music. During the past few

Kenneth Bacon is president of KABA Research and Development, Novato, CA.

Customer name and/or Customer type	Stereo	Response to	Average quantity per title	Master type	Most important variable	Order frequency
Musician demo	Yes	20kHz	25-50	Reel	Quality	2-3/week
High school bands	Yes	16-18kHz	150-500	Reel	Quality	6/year
Ad agencies	No	12-14kHz	50-250	Reel	Speed	2/month
Cassette newsletters	No	10kHz	250	Cassette	Speed	3/month
Children's toys	No	10kHz	25,000	Reel	Price	2/year
Hobby music groups	Yes	20kHz	50	Reel	Quality	2/year
Religious instruction	No	10kHz	50-150	Cassette	Price	3/week
Language instruction	No	10kHz	500	Cassette	Price	1/month
Record companies	Yes	20kHz	1,000	Reel	Quality	2/month
Training tapes, etc.	No	10kHz	5,000	Cassette	Price	4/year

Table 1. Market analysis spreadsheet of customers.





A KABA in-cassette duplication system capable of real- and 2-times ratios, installed recently at AT&T, Los Angeles.

years, however, all of these components have improved so much that now music tapes can be made that will faithfully reproduce frequencies up to 21kHz, well beyond the hearing ability of all but a very select few.

So, if most people can't hear frequencies above 146Hz to 166Hz, why spend any money to record them? Simply because although you may not be able to hear an individual tone at these frequencies, the energy content of harmonics in these ranges is responsible for the timbre that distinguishes one instrument from another.

- **Noise specifications** are sometimes expressed as being within a certain number of decibels of the master tape, or of the background noise present on bulk-erased tape. Sometimes the specification is given as a signal-to-noise ratio. Sometimes it is a nominal value; sometimes a minimum value. The spec sheet may or may not tell you whether the value is weighted, what reference flux was used, and whether a DIN, JIS or NAB standard was used.

The bottom line is that you cannot draw up a table of comparative specifications and look for the highest or lowest number as an indication of which machine has the best performance in that area. Later in this article, I'll move on to discuss some subjective tests that can help alleviate this problem.

- **Crosstalk** is the amount of signal that bleeds over from one side of the tape to the other. If you recorded just the A side, then turned the tape over and listened to the B side and heard the A side faintly playing backward, that would be

crosstalk.

Crosstalk, if present, can be attributed to misaligned heads in either the master or slave transport, or in the customer's cassette deck. The duplicator manufacturer's specification assumes there is no such problem, and only refers to crosstalk contributed by electrical or magnetic coupling in the relevant circuitry. Typical crosstalk rejection values are 40dB to 50dB.

No matter how high the crosstalk rejection figure, if you have high-energy material on one side of a tape and on the opposite side a space between selections, you'll be able to hear crosstalk at high replay levels. The question is: Under what circumstances does it become objectionable? What may be unacceptable on a meditation tape may not even be audible on a rock and roll tape.

- **Channel separation** is similar to crosstalk, except that it exists between the left and right channels of each side. Channel separation normally will be 5dB to -10dB lower than crosstalk. Because both left and right channels normally carry the same program material, however, its effect is much less noticeable.

- **Wow and flutter.** Wow results from a speed change occurring at a very low rate, typically from one to a few hertz. Flutter is also a periodic speed change, but of a much more rapid nature. Wow is generally caused by mechanical eccentricities, whereas flutter is usually a function of tape vibration.

Because the cassette shell forms an integral part of the tape transport in an in-cassette duplicator, if objectionable wow

and flutter are experienced, it is well to first look at the shell or C-O as a possible culprit. When cassettes are duplicated cassette-to-cassette—in other words from a cassette master—any mechanical problems in the master shell are added to those in the shell of the copy tape, as well as the wow and flutter contributions of the two transports involved.

This is one reason why a reel-to-cassette duplication system can be expected to produce a better quality product. The fact that the track width on a reel master can be much wider than the track width on a cassette master means that the signal-to-noise ratio can be much improved/another reason to expect a higher quality product from the reel-to-cassette system.

It is generally considered that a 0.5% W & F spec is acceptable for duplicated speech. However, a system should have no frequency components above 0.1% if it is to be used for music reproduction. Wow and low frequency flutter are particularly objectionable where sustained piano or other instrumental tones are involved.

- **Harmonic distortion.** For distortion specifications to be comparable, they too must be based on the same measurement standards. Harmonic distortion is a measure of the way in which a system's amplifiers change the waveform of a particular frequency sine wave. Terms that describe the effect distortion has on duplicated material include the following: slurring, muddiness, frizziness, harshness, raspiness and loss of high-frequency clarity.

Unless you are well versed in the applicable measurement theory, and have the instrumentation to make such

measurements, you can make a better evaluation of wow and flutter and distortion performance by just listening to material duplicated on the equipment being considered, and comparing it with the master from which it was made.

Mechanical specifications and considerations include duplication speed, head life, transport design and life, speed regulation, size, weight, construction and convenience features.

• *Duplication speed.* As mentioned previously, in-cassette duplicators are available from real-time up to 16:1 duplicating ratios. While it is obvious that higher speed results in more cassettes per hour per machine, it does not necessarily mean that the cost per cassette will be correspondingly lower. In some situations—for example, on-site duplication at a conference—speed may be the most important consideration. In

another application, a machine fast enough to not allow an operator time to accomplish anything else between cycles, could be less efficient than a slower unit that would enable one person to do several other tasks.

If quality is the most important consideration, speed will most likely have to be sacrificed. If cost is a prime consideration, an analysis should be made of such factors as production capacity, equipment cost, life, maintenance, cost of invested capital and labor.

• *Head life* is not usually quoted as one of the specifications, because it is partially dependent on the characteristics of the tape used and the care given the equipment. However, head alignment and replacement is a major maintenance item and should be considered. Heads made of ferrite and Sendust have longer lifetimes than those made of other materials.

Head accessibility and mounting method are also important characteristics to consider. Heads must be solidly mounted, or they will need to be frequently adjusted. As they wear, heads must be realigned and screws should be easily accessible and able to be locked down once properly set.

*The Otari DP-4050 series is available with a choice of reel-to-reel or cassette master transports. Duplicating ratio is 8:1.*



# Moving?

**Take us with you.**

Just peel off the subscription mailing label and attach it to the address change card located at the front of this issue. Please allow 6-8 weeks to process your address change.

**Recording**  
ENGINEER/PRODUCER





As part of a 5-year equipment upgrade program, Recording for the Blind, headquartered in Princeton, NJ, has begun to install Telex model 6120 systems. The reel-to-reel master tape is recorded in a special 8-track format to enable a pair of 4-track cassettes to be copied simultaneously at a 16:1 duplication ratio. As each pair of cassettes complete the duplication cycle, they are moved to a pair of rewind transports that operate simultaneously with the duplication transports. The RFB's facility is capable of producing over 3,000 textbook cassettes per day.

• *Transport life* is another characteristic rarely provided in specifications. Because of the larger number of transports involved in an installation, it is of greater significance to real-time duplicators. Transport life is primarily a function of bearing and motor wear. Ball bearings have longer life, but are expensive. Sleeve bearing are more widely used because they cost less and, when new, have better runout characteristics that translate to lower wow and flutter.

When a high-quality consumer deck is used for real-time duplication, one of the main problems is transport maintenance and replacement—the decks are not designed for continuous commercial use.

While most high-speed, in-cassette duplicators have been designed for continuous use, there are low-cost, light-duty units on the market. If your needs are for only a few voice-quality cassettes per week, such equipment may be ideal. As with most other products, in general, you get what you pay for.

• *Speed regulation.* Typical speed regulation specifications will fall between 0.1% and 1.0%. Usually, a particular transport will run a little slow or a little fast within the manufacturer's spec; more rarely, a transport might exhibit a gradual speed change as a cassette is being recorded.

The significance of a transport running 1% fast is twofold. For example, 1% of 30 minutes is 18 seconds, which means that a C-60 duplicated in such a transport would finish 18 seconds before the master, if the master transport were exactly on speed. If the master transport were running 1% slow, the copy would finish 36 seconds short. This makes it necessary, therefore, to either overload the copy cassettes with enough tape to compensate for a worst-case condition, or to always make the master correspondingly shorter than the copies.

The other effect of speed regulation is a change in pitch. Some people can detect a 1% change, which could be reason for a demanding customer to reject a job.

It should be noted, however, that under operating conditions speed variations are more likely caused by main-

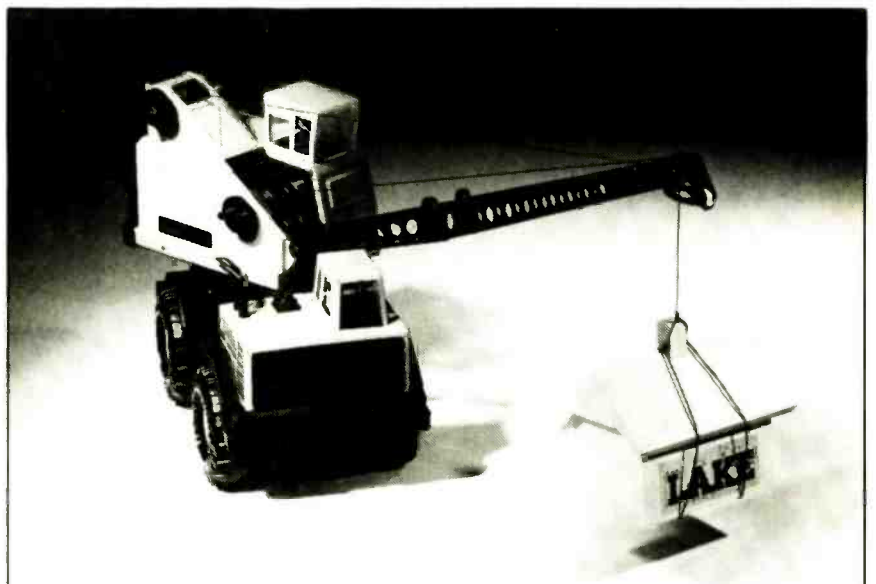

## WE'VE MOVED

New England's largest professional supplier for recording equipment, broadcast, video and sound reinforcement.

Adams-Smith	Calzone	Fostex	Neotek	Soundcraft
ADM	Convergence	Grass Valley	Neumann	Soundtracs
AGFA	CRL	Harrison Systems	Otari	Sound Workshop
AKAI	Crown	IEM	Orban	Studer/Revox
AKG	dbx	JBL	Orban Optimod	t.c. electronics
AMS	Dolby	Lexicon	QSC	Timeline
Aphex	Drawmer	3M Scotch	Ramsa	Tram
ATI	Electro-Voice	Monster Cable	Sennheiser	Trident
Beyer	Emu Systems	MRL	Shure	UREI
Broadcast Electronics	Eventide	Nagra	Sony	Valley People
Bryston	Fidelipac	Nakamichi	Sony Broadcast	with over 250 more...

Competitive prices with professional service all over the world.

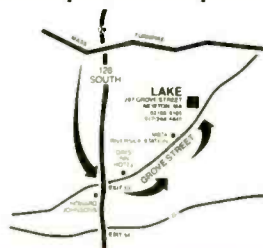

**LAKE**  
THE AUDIO COMPANY

287 Grove Street  
Newton, MA 02166, U.S.A.  
(617) 244-6881  
in N.E., PA, NJ and NY  
1-800-848-4890

Circle (37) on Rapid Facts Card

tenance problems than by design characteristics. Oxide on the capstan increases its diameter and makes the transport run fast. Cotton fibers in the capstan bearing from careless cleaning of the capstan will slow it down. If the capstan is belt-driven, a twist in the belt, a loose or tight belt, or whether a replacement belt is square or round, it will all affect transport speed. If holdback tension is accomplished by a friction device, wear, humidity and temperature may affect recording speed.

• *Convenience features.* There are many

*Examples from the Infonics range of in-cassette duplicating systems and reel-to-reel master transports.*



different convenience features on various duplicator makes and models, including:

The ability to use both reel and cassette masters;

Auto and manual rewind selection;

Auto eject at end of cycle;

Automatic stop at end of audio;

Bias select switch to allow recording on normal (ferric) and hi-bias (chrome dioxide and metal) tapes;

Jammed cassette transport disengage function;

Master transport EQ switch;  
Rack mountability;  
Record-level meters, moving coil or LED;  
Short or jammed cassette indicator light;  
Track selection and switching;  
2-speed recording capability; and  
Variable master transport speed

#### Subjective tests

Although comparing manufacturer's specifications provides a good starting point, when it comes to deciding which duplicator to purchase, there is no substitute for testing the equipment. Unfortunately, most prospective users have neither the equipment nor the testing know-how to confirm performance to specification; the next best thing is to carry out some subjective tests.

• *Ear tests.* The easiest, and probably the most meaningful, test is to take a master reel or cassette typical of what you expect to duplicate, and have copies made on the equipment you plan to purchase. Have all copies made from the same master on the same type of cassette (length, C-O and tape), so the only variable is the equipment, and then A-B compare the result. Your ears will give

## Naturally we're MIDI. We have a reputation to live up to.

You expect up-to-the-moment technology at L.D. Systems. In this industry, that means MIDI. So of course we have the gear. But as you'd expect, we went further than "MIDI-izing" our showroom. We brought on a MIDI expert. He *knows* computers, software, sampling, accessories, applications—anything MIDI. That's why we hired him.

**So we can maintain our reputation.**



467 West 38th Street, Houston, Texas 77018  
(713) 695-9400

Professional Sound and Lighting Sales, Services, Rentals

J.L. Cooper  
Garfield  
360 Systems

A complete line  
of software and  
peripherals for:

Atari  
Commodore  
IBM  
Macintosh  
Apple—IIc  
IIe  
GS

...and much more

## Want More Information on Advertised Products?

Use the  
Rapid Facts Card  
in the back  
of this issue!

Circle (38) on Rapid Facts Card



you a very good idea of the quality of the recording electronics.

• *Visual inspection.* If possible, have the prospective vendor open the unit so that you can inspect the mechanical construction, circuit-board layout, modularity, wiring and connector types. Is the frame plastic, stamped sheet metal or machined? Do things look flimsy or solid? Are circuit boards neat and clean? How do the solder connections look? Is it laid out so that you or a service person has easy access to the transport for head adjustment or replacement, cleaning and demagnetizing, replacing belts (if used),

*The Alpha 2000 series 16:1 duplicator is available in a road-case configuration for on-site duplication at conferences and similar functions.*

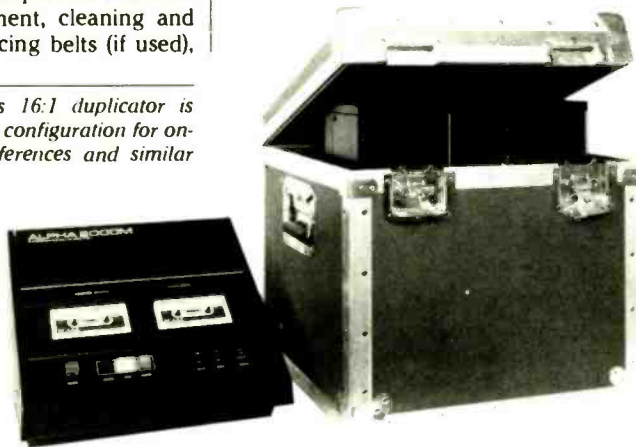

and adjusting potentiometers that control levels, bias and EQ?

A simple visual inspection will tell you a lot about how much thought and care the manufacturer has put into the design and construction, particularly after you have looked at several different brands.

It is always a good idea to contact a few users and solicit their comments. While the manufacturer or vendor usually will give you some references, you can

get more potentially unbiased information by looking in a trade directory for studios or duplicators listing the brand of equipment you are considering.

Finally, when you have made what you believe to be a good selection, ask the vendor if you can return the equipment if it does not meet your needs. Most reputable dealers will give you a few days to make such a determination and, at most, charge you for shipping and perhaps a small restocking fee to cover inspection and recalibration of the equipment.

#### Economic considerations

The economic considerations involved in the selection of a duplication system include initial cost, long-term cost, productive capability, spatial efficiency and peripheral equipment requirements.

Initial cost is an obvious factor; long-term cost includes maintenance and the cost of borrowing or tying up the capital used for the purchase. Productive capability is the number of cassettes per hour that you can expect the system to produce. Spatial efficiency concerns productive capability per square foot of floor area, while peripheral equipment requirements relates to other hardware needed to support the duplication opera-

## The art of shaping sound.

SONEX is a high-performance acoustical foam that upgrades your studio inexpensively. Ideal for a temporary isolation booth, it can also eliminate slap echo and harsh resonances in the main room or silence noisy tape equipment in the control booth.

Write for our color brochure today.



**Alpha Audio**

2049 West Broad Street  
Richmond, Virginia 23220 USA  
(804) 358-3852  
FAX: (804) 358-9496  
Telex: 469037 (ALPHAUD CI)

Acoustic Products for the Audio Industry

Circle (39) on Rapid Facts Card

## The Mic Preamp you've been wishing for is here!

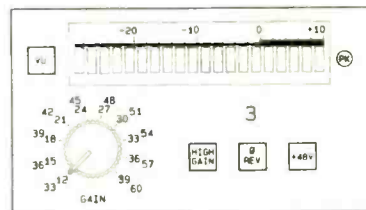

### The M-1 Mic Preamp

The John Hardy Company M-1 Mic Preamp gives you superior quality of sound at a very affordable price. Features include:

- 990 discrete op-amp
- Jensen JE-16-B mic input transformer
- DC servo circuitry



THE JOHN HARDY COMPANY

The Manufacturer of High-Quality Audio Equipment

P.O. Box AA631  
Evanston, IL 60204

(312) 864-8060

TELEX: 910-380-4670  
(JOHN HARDY CO)

Circle (40) on Rapid Facts Card

**Table 2.** Production formulae used in the calculation of production capacity of a duplication system.

**Definitions and assumptions:**

- C = Total length of cassette in minutes (both sides).
- P = Number of copy positions.
- D = Number of cassette decks (real-time systems).

All systems, except consumer decks used for real-time duplication, copy both sides on one pass.

Rewind time = 0.0194C minutes. (70 seconds for C-60 is an average, but it will vary with system.)

Load, and reload time = 4 seconds per copy position.

Load turnover, unload and reload time for consumer-type, real-time decks = 12 seconds per deck, no rewind time.

- Cassettes per hour at 30ips (16X) =  $60P / (0.0506C + 0.067P)$ .
- Cassettes per hour at 20ips (10.6X) =  $60P / (0.0664C + 0.067P)$ .
- Cassettes per hour at 15ips (8X) =  $60P / (0.0819C + 0.067P)$ .
- Cassettes per hour at 3 3/4 ips\* (2X) =  $120D / (0.2694C + 0.133D)$ .
- Cassettes per hour at 1 7/8 ips\* (1X) =  $(120D) / (0.5194C + 0.133D)$ .
- Cassettes per hour at 1 1/8 ips (1X) =  $60D / (C/60 + 0.2D)$ .

**Note:** Further details on the derivation of these formulae, and tabular printouts of production as a function of both variables, are available from the author at no charge. Please enclose a stamped, self-addressed envelope with your request, and mail it to Kenneth Bacon, 24 Commercial Blvd., Novato, CA 94947.

\*Applies only to KABA dual-transport, 4-track real-time system.

tion, including mastering equipment, QC and monitoring equipment, rewinders, degaussers, loaders, labelers, packaging equipment, etc.

Other than the formulae provided in Table 2 for calculating productive capability, the other items mentioned in the economic considerations listed above relate to a specific piece of equipment and to the interest rates and terms involved with the purchase. Suffice it to say that they should be considered as part of the business decision being made.

**Summary**

Selecting an in-cassette duplication system for a recording or production facility is a process that should begin with an analysis of the intended market and its needs. The electrical and mechanical characteristics necessary to meet these needs are not necessarily selectable from the manufacturer's printed specifications. Listening tests and visual inspection of the equipment construction, coupled with seeking the opinion of other users, will go a long way toward helping make good buying decisions and give you a positive start toward an enjoyable and profitable business.



# The clear choice...

## ORATOR III Wireless microphone system

Combines ease of operation with high performance at an affordable price. Its new audio processor provides very high signal-to-noise ratio and wide dynamic range. Operation is clean and clear up to 1000 feet, line of sight.

**FEATURING:**

**TO-93 bodypack transmitter**  
Long battery life (up to 10 hours on a 9-V alkaline battery).

**Power on/off switch**  
Recessed.

**Mic level control**  
Screwdriver adjustment.

**Mic on/off switch**  
Silent "no pop" operation.

**Miniature XLR mic connector**  
Allows use of most lavalier mics.

**Extra rugged case**  
High-impact Cyclocac.



**106X mic**  
Other lavalier mics are available.

**Terminal strip**  
Line-level output.

**XLR connector**  
Switchable mic-level and line-level audio outputs (internal switch).

**RO-95 receiver**  
Easy to set up.

**Rugged steel case**



REAR VIEW

**LED indicators**  
Transmitter on, audio overload, and power. For fast, simple setup.

**Power switch**

Also available is the TO-92A hand-held transmitter. The ORATOR III operates on a clear VHF high-band frequency. It is rugged and dependable, and is manufactured in the United States by...

## Cetec Vega

... the world's leader in wireless mics  
9900 Baldwin Place  
El Monte, California 91731  
(818) 442-0782 TWX: 910-587-3539

Circle (34) on Rapid Facts Card



# Studio Update

## Northeast

**Greene Street Recording** (New York) recently upgraded with the installation of an **AMEK APC-1000** console.

**Steve Loeb**, owner of Greene Street, notes that the APC-1000 was selected for its application in film and commercial work. "The fact that it responds to a time code track for setup and status changes, gives it enormous flexibility." 112 Greene St., New York, NY 10012; 212-226-4278.

**Photomag Recording Studios** (New York) announces that **Terry Mader** has joined the staff as post-production mixer.

Mader's background is in broadcast production and special-effects mixing. She joined ABC Television five years ago as a post-production mixer on the network's *20/20* and ABC's *Wide World of Sports* series, and was awarded her first Emmy for a *Wide World of Sports* special. 300 E. 34th St., New York, NY 10016; 212-683-9672.

**University of North Dakota's Center for Aerospace Sciences Atmospherium** (Grand Forks, ND) has completed installation of a 6-channel sound system. The Audio Systems Division of Peirce-Phelps, (Philadelphia, PA) installed the system.

The 6-channel playback system is enhanced with a sub-woofer system and is said to be capable of reproducing sound from 15Hz to 20,000Hz at sound pressure levels up to 115dB. The system interfaces with existing multichannel video systems through a Tascam 512 console. Box 8216, University Station, Grand Forks, ND 58202; 701-777-2791.

**Music & Sound Design Studio** (Bridge-water, NJ) has expanded its music and sound effects libraries to include the **Associated Production Music** library and the **Sound Ideas** effects library.

"By the end of 1987, we will have more than 10,000 music selections and more than 6,500 sound effects available in-house for our clients," says **Bill Milbrodt**, studio owner. 1425 Frontier

Rd., Bridgewater, NJ 08807, 201-560-8444.

**Digital Audio Disc Corporation** (Terre Haute, IN) has installed a **Sony PCM-1630** processor and **DMR-4000** video recorder.

"With the new 1630, we have unquestionably, one of the finest CD mastering facilities in the world," says **Jim Frische**, executive vice president, DADC. "The new system will significantly improve the bit-error correction rate for the audio discs and give us greatly increased audio monitoring capabilities." 1800 N. Fruitridge Ave., Terre Haute, IN 47804; 812-466-6821.

**Trod Nossel Recording Studios** (Wallingford, CT) has taken delivery of a **Sony JH-24** analog multitrack.

In addition, control room acoustics were restructured and monitor tuning upgraded by **Steve Blake** of **Lake Systems-Boston**. 10 George St., Wallingford, CT 06492; 203-269-4465.



*Fader/VCA  
Packages  
Available  
Soon!*

## Affordable AUTOMATION

Finally there is an inexpensive, simple-to-operate, flexible modular Automation System to retrofit any console. SAM™ (SMPTE Automation Manager) and MIDI MUTE truly constitute a breakthrough in console automation. Now you can automate your studio starting for as little as \$549 for full mute automation, or \$1398 for a full SMPTE self-locked automation system. And, like all JLCOOPER products, these grow with you — up to 24 channels. Best of all, SAM and MIDI MUTE require no modification of your console, just plug them in and you're ready to go.

**JL COOPER ELECTRONICS**

1931 Pontius Avenue • West Los Angeles, CA 90025  
(213) 473-8771 • TLX: 5101001679 JL COOPER

# Studio Update

**Airwaves Audio Productions** (Manchester, NH) has relocated to 342 Lincoln St., the former **Kevin Tracey Productions** studio.

**Joel Schwelling**, manager and co-partner of the company, says that the New Hampshire advertising community is accustomed to having quality radio and commercial music produced locally. "We very much want to see that trend continue," he says. 342 Lincoln St., Manchester, NH 03101; 603-627-2774.

## Midwest

**River City Studios**, (Grand Rapids, MI) has updated Studio A with a **Sound Workshop Series 34-B** console equipped with 32 channels of **ARMS** automation, a **Sony JH-24** multitrack and **UREI 815** Time Align monitors.

Studio B's upgrades include a **JM-24** with synchronizer, two **Yamaha SPX-90** digital effects units, Yamaha room equalizers and a customized **Audiotronics 501** console resited from Studio A. 147 Goodrich, S.E., Grand Rapids, MI 49503; 616-456-1404.



River City Studios, Studio A, Grand Rapids, MI.

## Mountain

**Colorado Sound Recording** (Westminster, CO) has purchased an **AKG C24** stereo mic, four **AKG C414** mics, a

**Studer A-80** 2-track and a **Lexicon PCM-70** digital effects unit. 3100 W. 71st Ave., Westminster, CO 80030; 303-430-8811.

**Luxury Audio Workshop** (Las Vegas, NV) has added an **Adams-Smith model 2600** time code sync/generator system. Also added are a **Lexicon PCM-70** and **Yamaha SPX-90** digital effects, **Aphex Type C Aural Exciter**, **Roland DEP5** digital processor, **Ensoniq Mirage** sampling keyboard system, **Yamaha DX-7**, and two **Oberheim DX** drum machines. 2570 E. Tropicana #19, Las Vegas, NV 89121; 702-451-6767.

**Denver Center for the Performing Arts** (Denver, CO) has installed a **Sony PCM-3202** DASH-format digital 2-track. The transport features a built-in synchronizer that allows interlocking with other audio and video recorders via time code. 1245 Champa St., Denver CO 80204, 303-893-4000.

## Southern California

**Golden Goose Recording**, (Costa Mesa, CA) has added an **Ampex MM-1100** 24/16-track for time code interlock with the facility's **Spectra Sonic/API 32/32** console, which will be updated with a new 32-channel monitor section. 2074 Pomona Ave., Costa Mesa, CA 92627; 714-548-3694.

Please send Studio Update announcements to: RE/P: Studio Update, 1850 N. Whitley Ave., Suite 220, Hollywood, CA 90028.

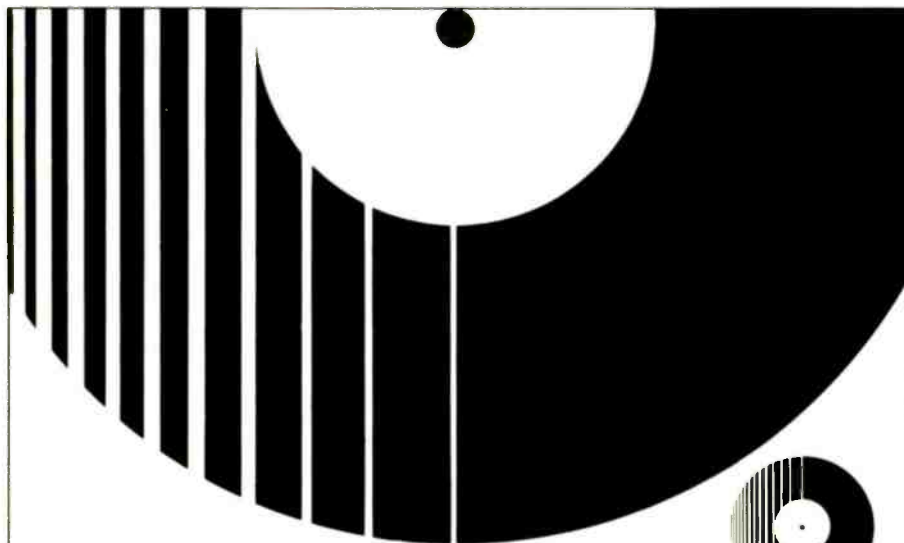

**FUTURE DISC  
SYSTEMS**

INCORPORATED

COMPLETE ANALOGUE & DIGITAL MASTERING SERVICES

FOR COMPACT DISC, RECORD & CASSETTE MANUFACTURING

3475 CAHUENGA BLVD. WEST, HOLLYWOOD, CALIFORNIA 90068  
(213) 876-8733

Circle (46) on Rapid Facts Card



# Studio Update



Canyon Record's recent addition of the Soundcraft series 200B, Tokyo, Japan.

## Northwest

Audio Production Studio and Rainbow Recording have merged to form Sound Innovations (Anchorage, AK) and will feature what it describes as Alaska's first multistudio recording complex with two 8-track control rooms and studios. 5520 Lake Otis Parkway, Suite 104, Anchorage, AK 99507; 907-563-8273.

## Pacific

Sea West Productions, (Hauula, HI) announces that David Locksley has joined its creative staff.

Previously he was production assistant for the Dance Theatre of Harlem and a staff producer/arranger for John King Studios in New York. Box 729, Hauula, HI 96717; 808-293-1800.

## Japan

Canyon Record (Tokyo, Japan) has recently purchased two Soundcraft Series 200B consoles for use in two new CD mastering rooms.

The record company is a member of the Fuji Sankei Group, a communications network including TV, radio and newspaper operations. Tokyo, Japan. **R-E-P**

## THE VERY HEART OF YOUR TAPE MACHINE

Can you trust it to just anyone?

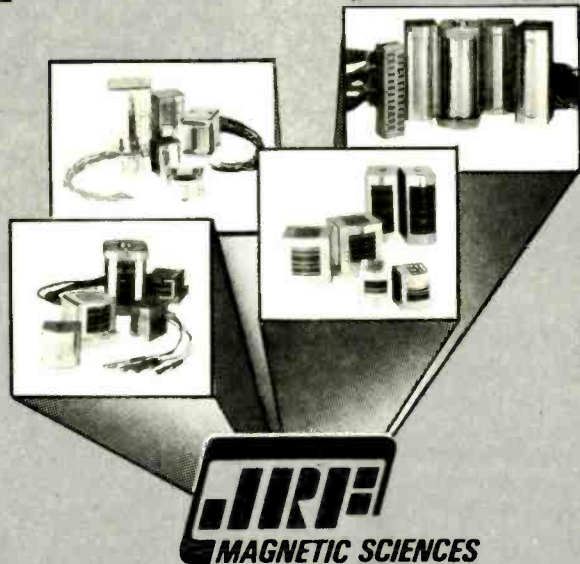

**JRI**  
MAGNETIC SCIENCES

The audio magnetic professionals with the track record to prove it.

Complete lab facilities • Over 20-years of in-depth experience

Specializing in restoring worn, unserviceable magnetic heads for a fraction of the replacement cost.



Kennedy Rd. • P.O. Box 121 • Greendell, NJ 07839 • (201) 579-5773 • Telex: 325-449

Circle (45) on Rapid Facts Card

# New Products

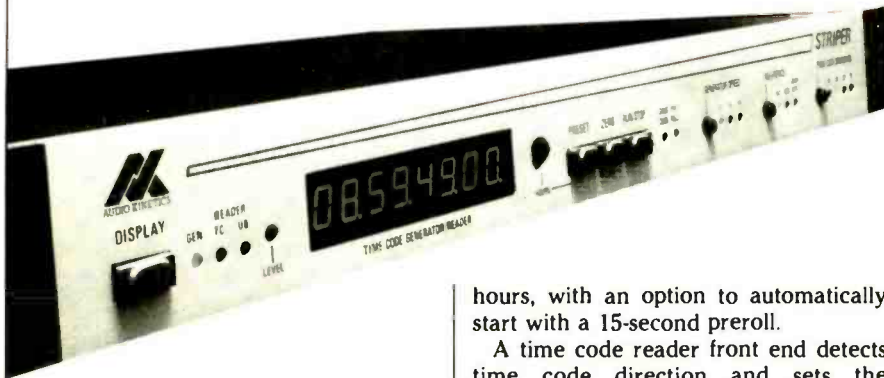

## Audio Kinetics Striper time code generator

The unit can be used to record time code at a quoted two or four times normal speed, the company claims. The generator time base can be referenced to an internal crystal or external pulse, and time preset to any hour start from 0-10

hours, with an option to automatically start with a 15-second preroll.

A time code reader front end detects time code direction and sets the generator direction to the same when the JAM command is given. The code stream can be generated backward to extend code at the start of material for synchronizer preroll.

Input capability is quoted at  $-30\text{dB}$  to  $-10\text{dBm}$  balanced XLR.

Circle (120) on Rapid Facts Card

## Soper Sound series XII Music Library

The new series features a range of music, including avant garde fusion and soft jazz sounds.

"Series XII was produced in response to requests from many producers who already use our library," Dennis Reed, president, says. "They were looking for music similar to that released by Windham Hill and other limited distribution labels."

The series is available on a 2-album set, reel-to-reel tapes or on cassette.

Circle (132) on Rapid Facts Card

## Crown GLM-100/D microphone

Designed for broadcast applications, the dual lavalier, omnidirectional condenser microphone features a quoted frequency range of 50Hz to 18kHz, omnidirectional polar pattern and a balanced impedance of 240 $\Omega$ .

Other features include a sensitivity of  $-73.5\text{dBV}$  per microbar, self-noise of 28dBa, maximum SPL of 150dB and dual XLR-type output connectors.

The flat-profile mic is formed to hide under a tie when the mic is clipped on.

Circle (130) on Rapid Facts Card

## Crest FA800 power amplifier

Rated at 240W into 8 $\Omega$ , and 400W into 5 $\Omega$ , the unit also features back to front cooling, modular construction, full-load

protection and active balanced inputs.

The unit occupies two 19-inch rack spaces and is durably designed, the company claims.

Circle (126) on Rapid Facts Card



## Electro-Voice model 2710 graphic equalizer

The third-octave graphic equalizer uses constant range filters, XLR-type connectors and a transformer-isolated output with an input transformer option.

Other features include a high-pass filter with a quoted 18dB per octave slope and variable low-pass filter with a 6dB per octave slope, plus an integral pink-noise generator.

Circle (124) on Rapid Facts Card

## PPG America announces Realizer digital synthesizer

The synth incorporates digital sound production, processing, recording and sequencing. Sound is produced using eight software-controlled signal processors and converted to audio via 16-bit D/A converts operating at a sampling frequency of 44.6kHz. Echo, delay, phasing, chorus, flanging and pitch shifting effects can also be produced.

An integral 170Mbyte hard disk provides 24 minutes of mono, 12 minutes of stereo or 5 minutes of 4-track storage at 44.6kHz sampling. Up to six tracks can be played back simultaneously.

Circle (143) on Rapid Facts Card

## Ariel introduces data acquisition processor for IBM PC

Comprising a complete signal acquisition, synthesis and processing system, the DSP-16 plug-in card provides two channels of input/output conversion plus a large data buffer. Potential applications include digital sampling, signal processing and waveform synthesis.

An on-board TI TMS32020 microprocessor with a throughput of 5 million instructions per second (5 MIPS) enables complex processing and analysis of the acquired signal in real time, freeing the host PC for set-up and control of custom software display of the processed signal, data storage and retrieval.

The DSP-16 can buffer up to 256K samples of incoming or outgoing data, or up to one megasample with optional memory expansion. It operates both channels of input and output with 16-bit precision at a maximum sampling rate of 50kHz. The accompanying PC Sampler software package consists of a program development system and five software application programs: Data Acquisition, Digital Audio Effects, Storage Oscilloscope, Audio Loop Editor and Waveform Synthesizer.

Circle (144) on Rapid Facts Card



# New Products

## Beyer MC736/MC737 shotgun mics

Designed for film, video and broadcast production, the new mics feature a pre-amp design that accepts any 12V-48V phantom power supply.

The MC736 is a short shotgun with a lobed polar pattern above 2kHz and a cardioid pickup pattern below 2kHz for a long pickup range.

The MC737 long shotgun design produces a lobed pattern for immediate off-axis rejection and accurate voice pickup, the company says.

Switchable 12dB attenuation and low-frequency roll-off functions prevent pre-amp overload at frequencies below 200Hz.

Circle (135) on Rapid Facts Card

## Crown PZM-20RG microphone

Designed for permanent flush mounting on a conference table, the mic fits in a square hole routed in the table, or in a standard 4"x4" electrical outlet box.

The unit is powered by 12V-48V phantom powering and features a quoted frequency range of 20Hz-15kHz, a hemispherical polar pattern, an impedance of 240Ω balanced, and a sensitivity level of -65dBV per microbar.

Circle (122) on Rapid Facts Card

## Cerwin-Vega SSM-200 midbass speaker system

The unit features a bent horn design for an extended 3-foot path, plus a built-in passive crossover.

The 2-way unit utilizes an M-162 mid-bass compression driver capable of handling 150W and delivering 108dB - 129dB sound levels, the company claims. The unit also features a JMN-1 1-inch throat MF compression driver, and a high-frequency auto resetting relay protection.

Circle (138) on Rapid Facts Card

## Yamaha QX5 MIDI recorder

The 8-track, 16-channel sequencer is capable of recording MIDI data from any MIDI-equipped keyboard, complete with touch response, function parameters and program changes.

The system will also allow real-time parameter changes to be performed on the KX-76 and KX-88 keyboards, and recorded as part of the sequence. DX/TX voice data may also be recorded.

Up to 16 separate instruments can be controlled over a single MIDI cable, and the unit will store and play back indepen-

dent data for all 16 channels in each track.

Recording modes include realtime, punch-in or step. Edit functions include relative tempo, remove, shift quantize, transpose, velocity, gate time adjustment, crescendo and create. Other edit functions comprise extraction, clock move (shifting an entire track backward or forward) and thin out (deleting every other continuous controller message). Data capacity is 20,000 notes.

Circle (133) on Rapid Facts Card



# MegaMix™

## FINALLY!

A High Quality, Professional AUTOMATION System at an AFFORDABLE Price.

Easily interfaces to your existing console.

- Full fader automation
- Mute and solo
- 8 Subgroups
- Real time and step edit
- Mix merge
- Copy, bounce, delete fades
- SMPTE compatible
- Runs on IBM and compatibles and
- Macintosh 512 & Plus

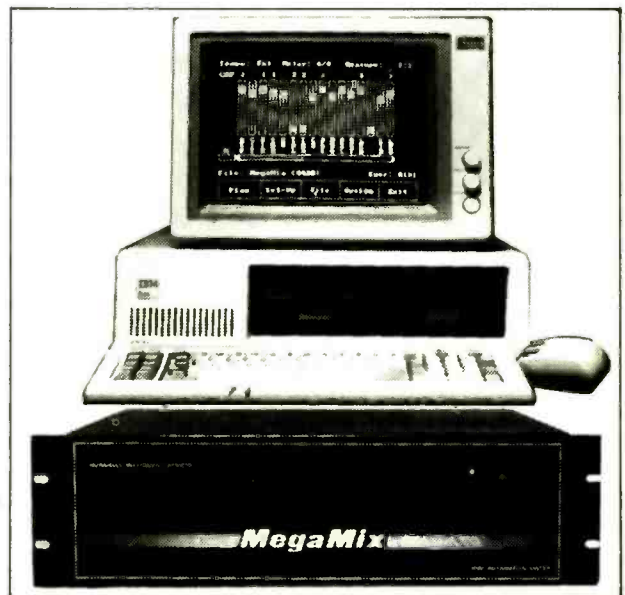

PATENT PENDING

## MIDI BASED MIXING BOARD AUTOMATION ON YOUR PC

Musically Intelligent Devices  
3 Brian Street, Commack, NY 11725

516 864-1683

Circle (47) on Rapid Facts Card

# New Products

## **Klark-Teknik PMC402 portable mixer**

Each of the four input channels features a built-in limiter, -20dB pad, HF filter and a pan pot. The choice of a microphone powering including 12V or 48V phantom and DIN A-B is available.

The unit is powered by 12 AA cells providing about eight hours of operation. Direct connection to a NAGRA portable tape machine is made possible via an external interface connection. A separate mains power supply is also available.

Circle (129) on Rapid Facts Card

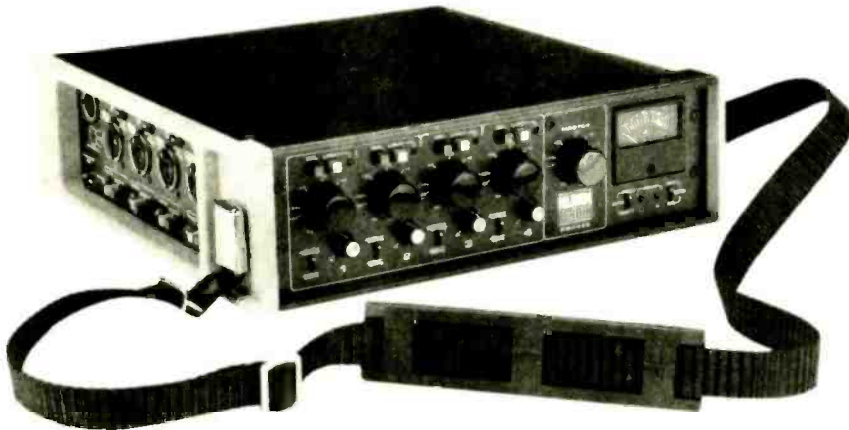

## **Fender 2235 power amplifier**

Designed to withstand rugged use, the amplifier is cased in aluminum alloy rack which serves as structural components of the chassis. Each handle joins with part of the 14 gauge steel chassis to form a steel/aluminum sandwich construction mounting flange that's over 0.32 inch thick.

Each channel has its own front panel 14 detented precision gain control and two LED status indicators are associated with each gain control. A separate "Peak" LED allows the amplifier to clip the signal peaks for a period of time before it turns on.

The unit is rated at 350W into a 4Ω impedance, with audible clipping at about 625W of continuous power (5% THD).

The model 2235 incorporates a 2-speed fan that draws in air from the front and exhausts it out the rear of the unit, with replaceable air filters.

In large multiple-amplifier systems, channel B is internally normalled to channel A for simultaneous dual-channel, mono operation until a plug is inserted in the channel B input. A small, recessed mono-bridge configuration switch prevents accidental actuation. 1% metal film resistors are used throughout for accurate and repeatable performance specifications, Fender says. Low-loss metal film capacitors and silver mica capacitors are used for all circuit functions.

Circle (139) on Rapid Facts Card

## **Alesis Microverb digital reverb processor**

The 16-bit MIDI-capable processor features 16 switched programs and sounds ranging from small rooms and plates to halls and large cavernous spaces. Decay time, tonal coloration and

depth characteristics vary with each program.

The unit can handle input signals from low-level instruments to the +4 pro-audio levels and has a quoted 90dB dynamic range.

The processor is constructed in an aluminum case and dimensions are one-third rack space wide by 1 rack space high. It can be mounted singly or with two other units in a 19-inch rack adapter.

Circle (123) on Rapid Facts Card



## **Trident 24 multitrack console**

Available in 28- and 36-input frames with 24-output buses and 24-track monitoring, the console features separate mic and line inputs with phase reversal, 4-band EQ with variable hi-pass filter and eight auxiliary sends.

Other features include auto muting, solo-in-place, monitor fader reverse, direct outputs and four echo returns.

Circle (131) on Rapid Facts Card



# New Products

## ADA MQ-1 MIDI equalizer

The MIDI-capable stereo equalizer features 99 programs and 14 bands per channel with 12dB boost or cut, 102dB minimum EIN, two transformerless balanced inputs and a 20Hz to 20kHz bandwidth.



The LED readout displays boost/cut, MIDI channel or memory selection.

A security lockout system prevents tampering with front-panel controls, while the optional MC-1 MIDI foot controller provides remote access.

Circle (121) on Rapid Facts Card

## Charvel GTM6 guitar-to-MIDI converter

The Charvel GTM6 guitar-to-MIDI converter features a specially designed bridge with six individual Piezo pickups—one on each of the bridge feet which eliminates tracking errors.

The converter has a built-in sequencer capable of storing up to 1,000 notes or chords for live performances. It also features three different pitch bend modes, step, quantized or bend, each adjustable up to eight semitones.

Each string has its own sensitivity level to individually adjust and is assigned to its own MIDI channel, allowing each string to independently control separate synthesizers.

A detachable remote control unit can be placed on a belt pack or on a stand next to the guitar for control of the sequencer, program changing, program assigns, MIDI assigns and pitch bend assign.

Circle (145) on Rapid Facts Card

## Yamaha GC2020B compressor

The dual-channel compressor/limiter features a quoted 20Hz to 20kHz frequency range and less than 0.05% total harmonic distortion.

Each channel features a noise gate with variable threshold level for eliminating background noise and hiss.

The front panel includes a link switch

for dual, mono or stereo modes, compressor in/out switch and LED, a 5-segment level meter and compression ratio control.

The rear panel includes 3-pin male XLRs for connection to balanced 600Ω lines, and two 1/4-inch phone jacks for unbalanced 10kΩ lines.

Circle (136) on Rapid Facts Card

# SOFT TECHNOLOGY

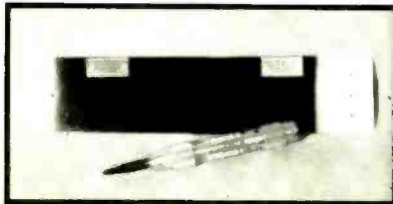

"A tool that performs more work with less energy input through a simpler, more sophisticated design is considered to be SOFT TECHNOLOGY."

CONNECTOR TEMPLATES make fabrication of XLR-type connector panels SWIFT, ACCURATE, and EASY! All the tedious drafting of the odd decimal dimensions of the connectors is done for you. The precision work is built into the TEMPLATES. This spring tempered stainless steel tool gives consistent, precise connector mounting without all the work.

SWIFT, ACCURATE, and EASY! An excellent example of Soft Technology.

1 set (1 male, 1 female) - \$17.00

# BLACK AUDIO DEVICES

P.O. BOX 4573 - GLENDALE, CA 91202  
(818) 507-8785

Circle (48) on Rapid Facts Card

# HOLDS UP ON THE ROAD

## TYPE 85 FET DIRECT BOX



# COUNTRYMAN ASSOCIATES INC.

424 STANFORD AVE. - REDWOOD CITY, CA. - 94063 - PHONE 415-364-9988

Circle (49) on Rapid Facts Card

# New Products

## Atlas Sound MSX-10CE mic stand

Designed for stability and convenient set up, the 10-inch diameter base mic stand features a cast-iron base weighing 11.4 lbs.

It can be positioned parallel to the floor during use, and raised to an upright position for transportation and storage.

The vertical tube assembly height extends from 34 to 61 inches.

Circle (134) on Rapid Facts Card

## Furman TX-Series electronic crossovers

The TX-324, TX-424 and TX-524 series of electronic crossovers feature 24dB per octave slopes, output limiters on each band and wide range tuning controls.

In addition, a field-select switch allows the user to choose between filter types suitable for close-field and far-field loudspeaker focusing.

Circle (125) on Rapid Facts Card

## Audio Precision A-Version test system

The enhanced test system, designed for use with an IBM PC or compatible, is



able to make simultaneous amplitude measurements on two channels that can be displayed as analog bar graphs or the decibel difference between the channels for balance adjustments. Crosstalk and stereo separation can also be displayed.

Additional filter capability is added by a fifth internal option socket and provisions for external filters.

The system's distortion is a quoted 0.0015% maximum, 20Hz-20kHz in the 80kHz bandwidth.

Circle (128) on Rapid Facts Card

## The Stewart Electronics ADB-4

Four Channel Active Direct Box  
Four transparent, reliable direct boxes in one chassis.



List Price \$349.00

### Each Channel Features:

Hi Z inputs on front and rear of chassis • Ground lift switch • Instrument/line/speaker level input selector • Lo Z balanced output with XLR connector • Mic/line Lo Z output level selector • Operates on Phantom Power or auxiliary power supply • Optional rack kits allow rack mounting of up to 8 channels in a single rack space • May be mounted forward or reverse—allowing terminations to be made on front or rear of rack.

Dealers Inquiries Welcome

**Stewart Electronics**  
P.O. Box 60317, Sacramento, CA 95860  
(916) 635-3011

Circle (44) on Rapid Facts Card

# GET OUT OF THE DARK.



Open your eyes and see just how many subjects are covered in the new edition of the Consumer Information Catalog. It's free just for the asking and so are nearly half of the 200 federal publications described inside. Booklets on subjects like financial and career planning; eating right, exercising, and staying healthy; housing and child care; federal benefit programs. Just about everything you would need to know. Write today. We'll send you the latest edition of the Consumer Information Catalog, which is updated and published quarterly. It'll be a great help, you'll see. Just write:

**Consumer Information Center**  
Department TD, Pueblo, Colorado 81009

U. S. General Services Administration



Continued from page 64

During these tests, an EIAJ-format PCM digital processor and companion Beta II 1/2-inch VCR were operating in parallel operation using 16-bit mode. The nominal analog reference level of 185nW/m was matched at 1kHz to -15dB in the PCM system. During some of the percussion tests, the PCM system, because of its 10dB pre/de-emphasis, readily went into signal clipping, while the Ampex/SR system was coasting.

Both PCM and SR systems were inherently so low in self noise that the only noise that ever intruded during these tests was signal input noise or self-noise in the microphones. These were readily apparent during console fades, at which time the noise floor of each system dropped to near inaudibility.

There are few meaningful measurements that can be made on a dynamic system such as SR, inasmuch as the system's action at any instant is a function of both frequency spectrum and level. However, in order to see the effect of the high- and low-frequency anti-saturation circuits, a spot frequency run was made at nominal zero input level.

The results are shown in Table 1. Note that the low-frequency rolloff is fairly

gentle (matching the NAB low-frequency record boost below 50Hz), while the high-frequency rolloff is more substantial, allowing for the increased high-drive levels necessary for flat NAB response from the tape recorder.

The SR system is claimed to be more tolerant of small level mismatches than Dolby A-type. In order to get some indication of this, we observed the output of the module in record function as a 1kHz tone was reduced from zero level. For each decibel of input reduction, the output of the module dropped approximately 0.5dB. This action was observed over an input range from zero to approximately -40dB.

This effective 2:1 compression ratio is indicative of the system's relative insensitivity to level mismatching, and also an indication of the overall 20dB extension of dynamic range the system provides in the 1kHz region. I hasten to add that the 2:1 action observed is not the result of a simple compressor, but rather is due to a multiplicity of sliding and fixed-band compression actions based on a number of thresholds.

As good as SR is, I expect it to make a significant impact on the current recording scene. It will not have an effect on

2-channel mixdown or direct-to-stereo recording for records, since that industry is now clearly driven by Compact Disc. (It is only sensible to get to the 2-channel digital medium as early as possible.)

However, SR may well have a significant impact on the film industry, inasmuch as there is no imminent digital standard on that industry's horizon. Dolby has already outfitted many theaters with A-type systems, and the conversion to SR is a cinch.

For the present at least, one of the greatest opportunities for SR may be in multitrack recording, where it can easily upgrade 16- and 24-track machines to performance standards that are effectively the match of digital. Many of these machines have already been outfitted with A-type noise reduction. An SR conversion can be had for a price that may be only one-eighth that of a multitrack digital machine.

As long as multitrack mixdown takes place through analog consoles, there is absolutely nothing wrong conceptually with having analog input. Only when digital consoles become commonplace (and that may be a long time in the future) will there be a real need for multitrack digital recorders. **RE/P**

## coming in March:

### Audio Production for Broadcast

To coincide with the forthcoming NAB Convention in Dallas, **RE/P** will spotlight recent developments in the expanding world of audio production techniques for broadcast.

#### Production Techniques for Stereo TV

Discusses studio micing and production techniques for Fox Television's stereo broadcast of "The Late Show starring Joan Rivers."

#### Commercial Production

Explores electronic music, sampling and multitrack techniques for stereo commercial production.

#### Understanding Circuit Principles

A semi-technical overview of circuit elements used in consoles and peripheral equipment.

#### Maintenance and Service Contracts

Explains what a studio should expect in the way of preventative maintenance and repair contracts from independent service companies.

#### NAMM Anaheim Replay

Spotlights recent developments in recording and production equipment unveiled at the January NAMM show.

## Recording

ENGINEER/PRODUCER

#### Plus our regular departments

- Managing MIDI
- Sound on the Road
- Film Sound Today
- Living with Technology
- SPARS On-Line
- News and People
- Letter to the Editor
- Studio Update
- New Products

# The Better Bass Driver

The New RCF L18/851K 18-inch low frequency driver from EAW utilizes state-of-the-art technology to set new standards for output and reliability. No matter what you're using for bass drivers today, upgrading to the RCF L18/851K will improve your system's low frequency definition and reliability.

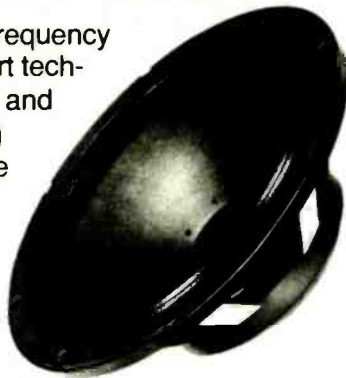

Check out these features:

- ✓ RCF's use of a kevlar (the material used in bullet proof vests) spider and proprietary chemical treatment of the cloth surround virtually eliminate suspension fatiguing, enabling **1000 watts AES power handling**.
- ✓ Unmatched thermal capabilities of **400 watts (100 hour sine wave)** due to the large 100mm (4-in) diameter state-of-the-art voice coil and Kapton former with die cut vent holes.
- ✓ High efficiency of **100 dB SPL 1w @ 1m** combined with the L18/851K's exceptional power handling result in unmatched maximum output capabilities of **130 dB SPL peak @ 1 m**.
- ✓ More definition and lower distortion are the result of advanced European cone and suspension with a new optimized geometry magnetic circuit.

For more information on the L18/851 and the complete range of RCF drivers call EAW at 617 - 620 - 1478.



Circle (43) on Rapid Facts Card

Mogami, Plus!

**One Call** **800-522-7377**  
in NY **212-585-1645**  
**Gets It All.**

- **Cable** — Hi quality bulk, featuring Mogami.
- **Connectors/Adaptors** in stock.
- **Custom cable assembly/repair.**
- **Tools/Accessories.**

**Plus** **FREE**

Engineering assistance/  
 quotes/catalog for  
 Audio — Video —  
 Data — Communications  
 Systems.

Ask For Our New  
 1987 Catalog

**BI-TRONICS, INC.**  
 Box 125, Tuckahoe, NY 10707

Circle (41) on Rapid Facts Card

# Final Stage

*The R-e/p*  
 Buyer's Guide  
 of Cutting and  
 Mechanical Services

- **MASTERING**
- **PRESSING**
- **TAPE DUPLICATION**
- **PACKAGING**
- **CD PREPARATION**

*R-e/p's* Unique Directory Listing of Disk Cutting and Tape Duplication Services — the kind of services all recording production facilities require as the "Final Stage" in the preparation of marketable audio products.

**FUTURE DISC SYSTEMS**

COMPLETE ANALOGUE & DIGITAL  
 MASTERING SERVICES FOR COMPACT DISC,  
 RECORD & CASSETTE MANUFACTURING

3475 CAHUENGA BLVD. WEST  
 HOLLYWOOD, CA 90068 (213) 876-8733

## Sound Off Two Ways



**For Studio Demos or Retail Sales**

**SOUNDSHEETS:** Flexible vinyl discs sound great, won't break!

**AUDIO CASSETTES:** Send for your free "Cassette Talk" newsletter complete with latest prices.

**EVA-TONE** TOLL FREE 1-800-EVA-TONE  
 P.O. Box 7020-R, Clearwater, FL 33518

# Moving?

**Take us with you.**

Just peel off the subscription mailing label and attach it to the address change card located at the front of this issue. Please allow 6-8 weeks to process your address change.

**Recording**  
 ENGINEER/PRODUCER



THE MOST COMPLETE  
SELECTION OF

# AUDIO TEST TAPES

All formats including cassettes  
Write or phone for free catalog

## STL

STANDARD TAPE LABORATORY, INC.  
26120 Eder Landing Road #5, Hayward, CA 94545  
(415) 786-3546

Circle (51) on Rapid Facts Card

## COMING TO WEST GERMANY?

### audiorent

#### GERMANY'S NO. 1 RENTAL COMPANY

Offers you a complete selection of pro audio equipment for hire

OUTBOARD EQUIPMENT - DIGITAL RECORDERS

Fully equipped **SONY DIGITAL** editing suite  
Including DAQ-1000 CD - Subcode editor and DTA-2000  
tape analyser

For further details please contact Peter Wolff or Stephan  
Behrens at

AUDIORENT, Kurtfuerstenwall 11, D-4350 Recklinghausen 1  
Phone: 2361-59494. Telex: 829772 wolff d

Circle (52) on Rapid Facts Card

#### FREE 32pg Catalog & 50 Audio/Video Applic.



Circle (53) on Rapid Facts Card

# Classified

Advertising rates in Classified Section  
are:

\$1.00 per word per insertion. Initials and  
abbreviations count as full words.  
"Blind" ads \$25.00 additional. Minimum  
classified charge \$20.00. Classified is  
also available at \$112 per inch. Order  
must be accompanied by payment to en-  
sure publication.

Classified columns are not open to  
advertising of any products regularly  
produced by manufacturers unless used  
and no longer owned by the manufac-  
turer or distributor.

Classified Advertising should be sent  
to RE/P, Advertising Department, 9221  
Quivira Rd., Shawnee Mission, KS 66215.

## FOR RENT



"The Audio Rental People"  
DIGITAL RECORDERS • CONSOLES  
TIMECODE • WIRELESS MIKES  
SYNTHESIZERS • EFFECTS  
1619 Broadway, NY NY (212) 582-7360

## FOR SALE

24 TRACKS—\$19,800 That's no misprint, that's  
your total price for a brand-new 24 track deck! The  
ACES Co. of England makes a complete line of  
studio gear, built to rugged, top-quality standards,  
all available at unheard of prices. 32 input in-line  
console, \$13,780! This board has all the features  
at the right price. Why even consider semi-pro or  
used 24 track equipment, when you can have  
brand-new, full featured gear, all with a 2 YEAR  
WARRANTY! Call or write, and find out how. YOU  
CAN GO 24-TRACK TODAY! FACTORY DISTRIBU-  
TOR, ROCK STUDIO SUPPLY, Box 5997, Norman,  
OK 73070, (405)329-8431 2-87-61

## IN OUR CONTINUING EFFORTS TO SERVE YOU...

From time to time, Intertec Publishing Corp. makes its subscriber lists  
available to carefully screened companies or organizations whose products,  
services, or information may be of interest to you. In every case, list users must  
submit their promotional material for approval. They may use the list only once.  
No information other than name and address is ever divulged, although names  
may be selected by segments to which the particular offer might appeal.  
We are confident that the majority of our readers appreciate this controlled use  
of our mailing lists. A few people may prefer their names not be used.  
If you wish to have your name removed from any lists that we make available to  
others, please send your request, together with your mailing address label to:

Direct Mail Mgr.  
Intertec Publishing Corp.  
P.O. Box 12901  
Overland Park, KS 66212

*For fast, accurate service,  
please remove the peel off  
label used to address your  
magazine, and attach it to  
the Reader Service Card,  
the Address Change Card  
or to any correspondence  
you send us regarding  
your subscription.*

# SAVE TIME

# Advertiser's Index

	Page Number	Rapid Facts Number	Advertiser Hotline		Page Number	Rapid Facts Number	Advertiser Hotline
Allen & Heath Brenell	IBC	2	416/361-1667	Lenco	77	35	800/325-8494
Alpha Audio	83	39	804/358-3852	Lexicon, Inc.	11	9	617/891-6790
Ampex Corp.	3	4	415/367-3809	3M	18-19	13	
API Audio Products, Inc.	12	42	703/455-8188	Meyer Sound Labs	25	15	
Applied Research & Technology	9	7	716/436-2720	Musically Intelligent Devices Inc.	89	47	516/864-1683
Audio-Technica U.S., Inc.	35	20	216/686-2600	Nakamichi USA Corp.	13	10	213/538-8150
Audiorent	95	52		Opamp Labs	95	53	213/934-3566
B&B Systems	71	33	800/345-1256	Orban Associates Inc.	29	17	
Bacon, Kenneth Assoc.	43	19	800/231-TAPE	Otari Corp.	65	55	
Bi-Tronics Inc.	94	41	800/522-7377	Rane Corp.	IFC-1	1	714/494-0231
Black Audio Devices	91	48	818/507-8785	Sanken Microphone Co.	51	25	
Cetec Vega	84	34	800/322-2537	Solid State Logic	48-49		212/315-1111
Cipher Digital Inc.	8	8	301/695-0200	Sony Broadcast Products Co.	36-37	21	
Cooper, J.L. Electronics	85	32		Soundmaster Intl.	59	54	416/741-4034
Countryman Associates	91	49	415/364-9988	Standard Tape Laboratory, Inc.	95	51	415/786-3546
Crown International	53	27	219/294-8000	Stewart Electronics	92	44	916/635-3011
Eastern Acoustic Works	94	43	617/620-1478	Studer Revox/America	BC	3	615/254-5651
Electro-Voice, Inc.	5	5		Switchcraft	27	16	312/792-2700
Everything Audio	17	12		Symetrix	61	30	206/282-2555
Fairlight Instruments US	7	6	213/470-6280	T.C. Electronics	72	36	201/384-4221
Fostex Corp. of America	47	24	213/921-1112	Tannoy North America Inc.	52	26	519/745-1158
Future Disc Systems	86	46	213/876-8733	Tascam Div./TEAC Corp.	55	29	213/726-0303
Hardy Co.	83	40	312/864-8060	Techron	73	31	219/294-8300
Harrison Systems, Inc.	40-41	22	615/834-1184	Telex Communications, Inc.	21	14	612/887-5531
Jensen Transformers	69	28	213/876-0059	Westlake Audio	39		213/851-9800
JRF Magnetic Sciences, Inc.	87	45	201/579-5773	Wheatstone Broadcast Group	15	11	203/393-0887
Lake Systems	81	37		Yamaha Intl. Corp.	31	18	
LD Systems, Inc.	82	38	713/695-9400				

# Sales Offices

## OVERLAND PARK, KS

Mary Tracy  
913-888-4664  
P.O. Box 12901  
Overland Park, KS 66212  
Telex: 42-4256 Intertec OLPK

## SANTA MONICA, CA

Herbert A. Schiff,  
213-393-9285  
Jason Perlman  
213-458-9987  
Chris Woodbury  
213-451-8695  
Schiff & Associates  
501 Santa Monica Blvd.  
Santa Monica, CA 90401

## NEW YORK, NY

Stan Kashine  
212-687-4128  
212-687-4652  
630 Third Ave., Eight Floor  
New York, NY 10017

## NORWOOD AUSTRALIA

Hastwell, Williamson  
Rouse Pty. Ltd.  
P.O. Box 419  
Norwood, Australia  
Phone: 332-3322  
Telex: AA87113

## TOKYO, JAPAN

Haruki Hirayama  
EMS, Inc.  
Sagami Bldg., 4-2-21, Shinjuku  
Shinjuku-ku, Tokyo 160.  
(03) 350-5666  
Cable: EMSINCPERIOD  
Telex: 2322520 EMSINCJ

## LONDON, ENGLAND

Nicholas McGeachin  
Suite 460, Southbank House  
Black Prince Road,  
London SE1 7SJ  
Telex: 295555 LSPG  
Telephones: 01-582-7522  
01-587-1578



# CMC SYNCHRONISED MIDI MIXING



## THE MIXERS

Advanced in-line consoles — High sonic quality — 32 Programmable on-board memories for input and monitor muting and input to track routing — 6 effect sends — Wide-range EQ — Extensive foldback and talkback systems — 8 re-routable subgroups — Genuine solo-in-place

## THE FORMATS

CMC24 — 24:16:2 — 16 track monitoring — 40 inputs at remix  
CMC32 — 32:16:2 — 24 track monitoring — 56 inputs at remix

## THE CONTROL OPTION

For system expansion — The CMR revolutionary MIDI-intelligent programmer — 100 routing memories — 100 muting memories — 100 MIDI programs — 1000 event 10-song sequencer, 100 steps per song — Step or real-time event programming — MIDI song position pointer implementation — Interchangeable RAM-pack memory

## THE COMPUTER OPTION

The expansion alternative — CMI64 and CMS64 interfaces for CBM64/128 computers — Channel index — Track sheet — 56 routing memories — 1024 muting memories — 2048 event sequencer — Tape synchronisation

## THE INFORMATION

A colour brochure — Write, telephone or telex



AHB-USA, 5 Connair Road, Orange, CT (203) 795-3594. In Canada — GerrAudio Distribution Inc. (416) 361-1667  
Allen & Heath Brenell Ltd., 69 Ship Street, Brighton BN1 1AE, UK. Tel: (0273)24928 Telex: 878235 MBI AHB G

mbi AHB

*Mixing Art with Science*

Circle (2) on Rapid Facts Card





# Top Notch for Your Bottom Line

A top-notch performer, the new Studer A807 has the features and sound quality you need for demanding production applications. And, as the lowest-priced Studer, it also looks good on your bottom line.

**The Fruits of "Trickle-Down" Technology.** Over the past five years Studer has developed a whole new generation of micro-processor-controlled ATRs. Now, with the A807, budget-minded pros can find this new technology in a compact, ingeniously engineered package.



## A Summary of Top-Notch Features:

- Digital setting and storage of audio alignment parameters
- Tape shuttle wheel
- Zero locate, autolocate, start locate, and loop functions
- Multiple timer modes
- Programmable keys for additional locator addresses, fader start ready, or lifter defeat
- Backspace (momentary rewind to play), library wind, varispeed, and reverse play
- Three tape speeds
- Microphone input with phantom powering
- Complete monitoring facilities
- RS 232 port for external computer control
- ...and the list goes on!



**Sonically Superior.** For superior high frequency dynamics the A807 audio electronics incorporate advanced phase compensation and Dolby HX Pro.<sup>TM</sup> You won't sacrifice the top end of your sound to enjoy a great bottom-line price.

**Tough Stuff.** The A807 is 100% Studer, with a die-cast chassis and head-block, rugged AC spooling motors, and a new brushless DC capstan motor. Manufactured with Swiss precision, this ATR is designed to get the job done faithfully—even in adverse outdoor remote assignments.

**Suit Yourself.** The rack-mountable A807 may be ordered with optional wooden side panels and handles, or in a roll-around console with padded armrest. A wide range of remote controls and options make it suitable for practically any application.

To find out more about this new top-notch performer, call or write for complete information and the name of your nearest Studer Professional Products dealer.



## STUDER REVOX

STUDER REVOX AMERICA, INC.  
1425 Elm Hill Pike, Nashville, TN 37210 (615) 254-5651