

**Christmas
Buying Guide**

Audio

THE AUTHORITY MAGAZINE ABOUT HIGH FIDELITY NOVEMBER 1975 \$2.50
47425



U0803760 0476 30725005P0101212
DON L HUNTER
2608 CENTRAL BLVD
EUGENE OR 97403

**Do You Really Hear in Quadraphony?
Update: Musings on the Four-Channel Scene**

The reason Pioneer's tuners and amplifiers keep getting better.

To achieve improved linearity and transient response, plus absolute stability, each amplifier has a 3-stage, direct-coupled equalizer-amplifier section, as well as a first stage differential amplifier. By using low noise transistors in the critical first stage of the equalizer (an FET, in the SA-9500), an exceptional level of phono performance, heretofore unattainable in integrated amplifiers, is attained. See Table 1 for Pre-amplifier section highlights.

Tape-to-tape duplicating and monitoring

Two tape monitor circuits are incorporated in each model and include tape copying switch positions for dubbing from one deck to another while listening to another program source.

Advanced chassis layouts for improved performance and increased reliability

Input and output terminals on the SA-9900 and SA-9500 are segregated from each other by being located at opposite sides of the chassis. More important, the full rear of the chassis serves as a heat radiating surface and reduces the length of internal shielded wires. The result is less attenuation of high frequency audio signals. Pioneer's new amplifiers provide

power output for every audio requirement and a maximum number of inputs and outputs to go with it. See Tables 2 and 3.

The Tuners: TX-9500, TX-7500

Truly new in styling and appearance, these Pioneer tuners are loaded with circuit refinements that finally allow you to realize the full static-free, high fidelity potential of FM and stereo FM. They even receive AM reception.

The FM front end — key to sensitivity and noise-free reception

In the TX-9500, three dual-gate MOS FETs combined with a linear 5-section variable capacitor reject all forms of interference by an incredible 110dB. Desired signals of as little strength as 1.5 microvolts are received with noise and distortion sufficiently suppressed to make them listenable.

Phase Lock Loop (PLL) circuitry for stable stereo FM separation

The Phase Lock Loop circuit used in both new tuners insures optimum separation of all audio frequencies. Completely drift-free, this PLL circuit requires no alignment — ever. A sharp low-pass filter lets you tape FM programs without interference from audible "beats".

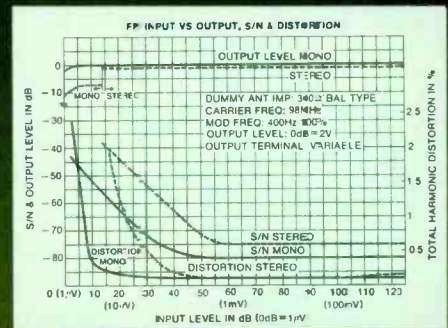

8-stage limiters

High selectivity and good capture ratio are vital with today's crowded FM radio band. Pioneer's TX-9500 IF section, with its seven ICs, four ceramic filters and 8-stage limiter provides outstanding capture ratio and selectivity. You hear the station you want — and nothing else.

Unique muting controls

The two-position variable muting control on the TX-9500, as well as the muting switch on the TX-7500, employ electronic switching. Both utilize a silent, reed-relay which eliminates noises of turn-on or popping and interstation tuning.



TX-7500

SA-7500

*The values shown are for informational purposes only. The actual resale prices will be set by the individual Pioneer dealer at his option. Optional cabinets are available for all models shown and are constructed with wood grained walnut veneer top and side panels.

Dedication.

And it's the kind of dedication that gives you the opportunity to own high fidelity components that offer more power, sensitivity and features at better values. Components that not only meet, but exceed the challenges posed by changes and improvements in current broadcasting and recording technology.

Pioneer recognizes that high fidelity enthusiasts are also a dedicated group. That's why we invite you to examine the new Pioneer tuners and amplifiers now.

The Amplifiers: SA-9900, SA-9500, SA-8500, SA-7500

The power amplifier section

Each model is direct-coupled in all stages for lower distortion and wider frequency response. The SA-9900 uses a 2-stage differential amplifier and optimized negative feedback from output to input for improved stability and transient response. A newly developed bias system compensates for any temperature drift; while an automatic electronic protection circuit

prevents current overload and guards against speaker shorts. A thermal detection circuit protects power output transistors in each model.

The control amplifier section: twin stepped tone controls and selectable turnover for precise tonal tailoring

With Pioneer's exclusive twin tone control system (SA-9900, SA-8500), you can make the most critical and precise bass and treble adjustments with ease. 5,929 tonal variations are possible on the SA-9900.



Twin stepped tone controls. (SA-9900, SA-8500)



Selectable turnover tone controls. (SA-9500, SA-7500)

You can select thousands of individual tone settings on the SA-9500, SA-8500 and SA-7500, too. A tone defeat switch on all models instantly restores wideband flat frequency response.

Tone control settings are calibrated for precise repeatability in discrete 1.5dB steps on the SA-9900. All four models feature low and high frequency filters (with multiple settings for each on the SA-9900 and SA-9500). The master volume control on the SA-9900 and SA-9500 is a 22-step professional attenuator. It is complemented by a selectable muting switch for lowering sound levels without altering master volume settings. This feature also permits easy settings of the master volume control regardless of program source levels.

High phono overload capability for unprecedented dynamic range

Good phono sensitivity in a phono equalizer is not enough to insure distortion-free reproduction of high transient musical peaks. Until now, a 150 millivolt overload capability was considered to be quite good for a phono preamplifier-equalizer circuit. Pioneer's SA-9900 remarkable equalizer-amplifier can handle peak signals as high as 500 mV. That's 46 dB greater than its nominal 2.5 mV input sensitivity.



SA-8500

SA-9900



Why would Pioneer change the world's best-selling tuners and amplifiers?

The entire world of high fidelity acknowledged that Pioneer's SA-9100 integrated amplifier and TX-9100 stereo tuner were the best products of their type and value ever built. They established new standards for high fidelity performance. In fact, people recognized their greatness by buying more of them than any other tuners and amps in the world. Why then would Pioneer want to change these top-performing, top-selling components? There can only be one answer:

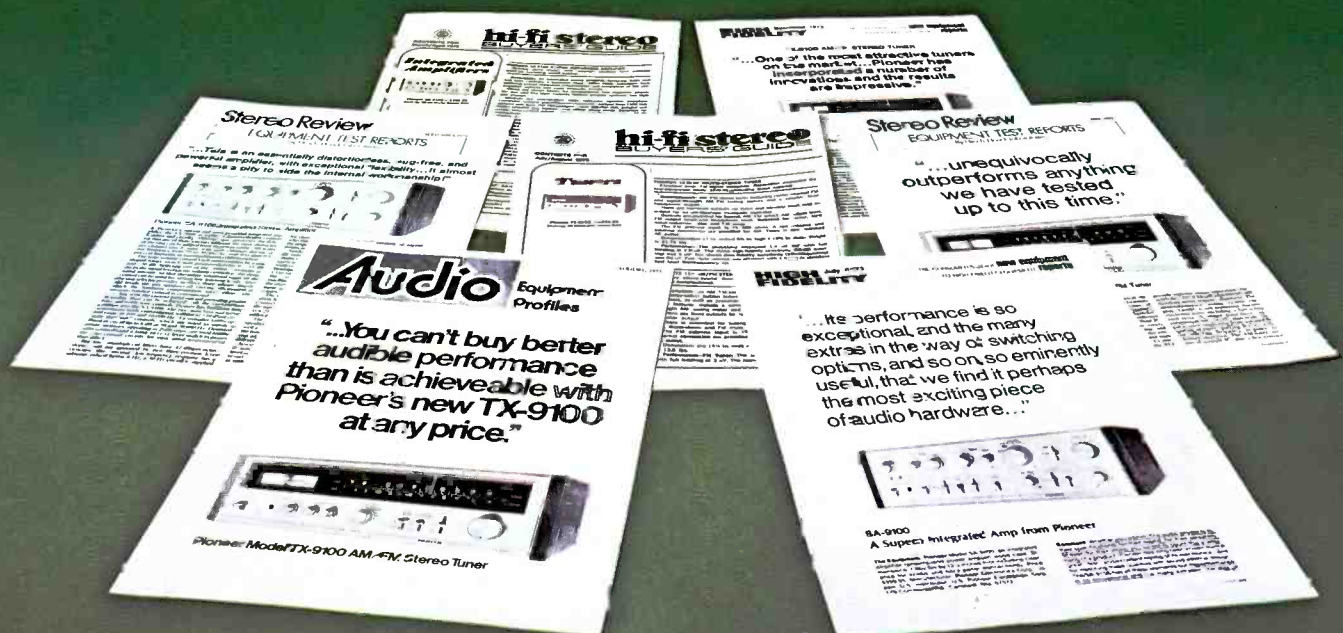

State-of-the-art features

Of course, both new Pioneer tuners have selectable deemphasis (25 μ S or 75 μ S), a must for listening to the newer Do by FM and stereo FM broadcasts. Both have separate fixed and variable output terminals, too, for adjusting listening level to match other program sources. In addition to the signal-strength and center-of-channel meters, both tuners feature separate output terminals which can be connected to an oscilloscope. This permits visual tuning for best reception and lowest multipath interference.

The TX-9500 has a built-in recording signal level check. Use it to set recording levels on your tape deck for best results before you start recording.

For the great specs that make great performance, see Table 4.

This new series of tuners and amplifiers is unquestionably the most technically advanced ever developed. It represents the high fidelity industry's most outstanding values in performance, features, precision and versatility. And visually, it carries Pioneer's traditional handsome styling.

Here, these magnificent components at your local Pioneer dealer.

U.S. Pioneer Electronics Corp.,
75 Oxford Drive, Moorachie,
New Jersey 07074
West: 13300 S. Estrella, Los Angeles 90248
/ Midwest: 1500 Greenleaf, Elk Grove
Village, Ill. 60007/Canada: S.H. Parker Co.

PIONEER
when you want something better

(1) Amplifiers: Preamplifier section

	SA-9900	SA-9500	SA-8500	SA-7500
Phono Overload	500/1000 mV	250/500 mV	200/400 mV	200 mV
S/N Ratio	70dB	70dB	70dB	70dB
Dynamic Margin	46dB	40dB	38dB	38dB
RIAA Accuracy	± 0.2 dB	± 0.2 dB	± 0.3 dB	± 0.3 dB
Input Impedance	35K, 50K, 70K, 100K, selectable	35K, 50K, 70K, 100K, selectable	50K	50K

(2) Amplifiers: Inputs and outputs

No. of Inputs	S/N Ratio	SA-9900	SA-9500	SA-8500	SA-7500
Tape Monitor		2-95dB	2-90dB	2-90dB	2-90dB
Phono		2-70dB	2-70dB	2-70dB	2-70dB
Auxiliary		2-95dB	2-90dB	1-90dB	1-90dB
Microphone		1-65dB	1-65dB	1-65dB	1-65dB
Tuner		1-95dB	1-90dB	1-90dB	1-90dB

Outputs

Speakers, Headsets	2+1	2+1	2+1	2+1
Tape Decks	2	2	2	2

(3) Amplifiers: Power output specifications

	SA-9900	SA-9500	SA-8500	SA-7500
Min. RMS power/channel, both channels driven, 8 ohms	110 watts	80 watts	60 watts	40 watts
Min. RMS power/channel, both channels driven, 4 ohms	110 watts	100 watts	75 watts	45 watts
Max. total harmonic distortion	0.1%	0.1%	0.1%	0.3%
Power band	20Hz-20kHz	20Hz-20kHz	20Hz-20kHz	20Hz-20kHz
Priced under *	\$750.	\$500.	\$400.	\$300.

(4) Tuners: Specification highlights

	TX-9500	TX-7500
FM Sensitivity (IHF), mono	1.5 μ V	1.9 μ V
50dB Quieting Sensitivity, mono (stereo)	2.5 μ V (35 μ V)	4 μ V (50 μ V)
Selectivity	85dB	80dB
Capture Ratio	1.0dB	1.0dB
S/N Ratio mono, (stereo)	80dB (75dB)	73 dB (68dB)
Image, IF & Spurious Rejection	110dB	85dB, 90dB, 9CdB
Stereo Separation 1kHz (50Hz-10kHz)	40dB (35dB)	40dB (35dB)
Distortion, mono 1 kHz (10 kHz)	0.15% (0.15%)	0.2% (0.2%)
Stereo	0.2% (0.5%)	0.3% (0.6%)
Priced under *	\$400.	\$250.

TX-9500

SA-9500



Check No. 33 on Reader Service Card



The Precision Cleaning Instrument for Today's Styli

Today's advanced styli are remarkably sensitive, and every manufacturer specifies that cleaning is essential for maximum performance.

Introducing SC-1.

The SC-1 is a graceful walnut handle from which you can push a small tang. At the end of this tang is a calculated-density brush of black nylon with enough rigidity to clean waxy deposits—yet with enough "give" to eliminate cantilever damage. There is also a silvered mirror that magnifies the stylus, cantilever, and cartridge mounting for total

MAGNIFYING
SIDE

BRUSH SIDE perception of your pickup system.

All of this retracts into the walnut handle for elegant protection.

The new SC-1 for only \$6.00, at audio specialists nationwide that carry Discwasher products.



discwasher GROUP
DISCWASHER, INC.
909 University
Columbia, Mo.

Audio

November, 1975

"Successor to **RADIO** Est. 1917"

Vol. 59, No. 11

Feature Articles

- 34 Up-Date: Musings on the Four Channel Scene/George W. Tillett
- 44 What Do You Really Hear in Quadraphony?/Daniel Shanefield
- 54 Christmas Buying Guide

Equipment Profiles

- 58 Phase Linear 4000 Preamplifier/Leonard Feldman
- 62 Nakamichi 500 Cassette Deck/George W. Tillett
- 66 EPI One Power Amplifier/Bascom H. King
- 71 Pickering XUV/4500Q Phono Cartridge/B.V. Pisha
- 72 Pioneer CT-F7171 Cassette Deck/Howard A. Roberson

Record Reviews

- 75 The Column
- 88 Classical Reviews/Edward Tatnall Canby
- 98 Jazz & Blues

Audio In General

- 6 Audioclinic/Joseph Giovanelli
- 12 Tape Guide/Herman Burstein
- 16 Audio ETC/Edward Tatnall Canby
- 22 Behind The Scenes/Bert Whyte
- 32 Dear Editor
- 42 What's New In Audio
- 78 Advertising Index
- 102 Classified Advertising

EDITOR Eugene Pitts III
ASSOCIATE EDITOR Edward Tatnall Canby
ASSOCIATE EDITOR Bert Whyte
ADVERTISING PRODUCTION Lynn Lyons

PUBLISHER Jay L. Butler
MARKETING DIRECTOR Sanford L. Cahn
DESIGN Janet Lee
CIRCULATION MANAGER Jean Davis

Contributing Editors: Herman Burstein, Martin Clifford, Fred De Van, Leonard Feldman, Martha Sanders Gilmore, Joseph Giovanelli, Richard C. Heyser, Bascom H. King, C.G. McProud, B.V. Pisha, Donald M. Spoto, George W. Tillett.

AUDIO (title registered U.S. Pat. Off.) is published monthly by North American Publishing Co., Irvin J. Borowsky, President; Frank Nemeyer, and Jay L. Butler, Vice Presidents; R. Kenneth Baxter, Vice President/Production; Nate Rosenblatt, Promotion Director; Mary Claffey, Circulation Director.

RATES—United States only: 1 year for \$7.00, 2 years for \$12.00, 3 years for \$17.00; outside the U.S.: 1 year for \$9.00, 2 years for \$16.00, and 3 years for \$23.00. Printed in U.S.A. at Columbus, Ohio. All rights reserved. Entire contents copyrighted 1975 by North American Publishing Co. Second class postage paid at Philadelphia, Pa. and additional mailing office. Back issues, \$2.00 each. World Library Congress number: ISSN 0004-752X. Dewey Decimal number: 621.381 or 778.5.

REGIONAL SALES OFFICES: Jay L. Butler, Publisher and Sanford L. Cahn, Marketing Director, 41 East 42nd St., New York, N.Y. 10017, telephone (212) 687-8924.

Jay Martin, 2525 West 8th St., Los Angeles, California, 90057, telephone (213) 385-2917.

REPRESENTATIVES: Continental Europe: John Ashcraft, 12 Bear St., Leicester-Square, London W.C.2, telephone 930-0525. For Benelux and Germany: W.J.M. Saunders, Mgr., Herengracht 365, Amsterdam, Holland, telephone 24.09.08. Japan: Japan Printing News Co., Ltd., No. 13.2 Chome Ginza Higasi, Chuo-ku, Tokyo, telephone 541-5795.

AUDIO Editorial and Publishing Offices, 134 N. 13th St., Philadelphia, Penna. 19107
Postmaster: Send Form 3579 to the above address



For the advanced enthusiast or professional, Ferrograph Super 7 makes sound sense.

The new Ferrograph Super Seven takes its place alongside the finest high fidelity components in the world. Admittedly, it's not for everyone. Just the limited few who are able to recognize and appreciate its unexcelled capability for professional performance in the home.

The Super Seven achieves new heights in innovative tape recording with more than thirty advanced features including:

Exclusive variable speed wind and rewind—10½-inch reels—3 speeds: 1⅞, 3¾, 7½ ips or 3¾, 7½, 15 ips—Dolby B (on request with either speed configuration)—professional electronic editing—

instant slur-free starts in record/playback—bias adjustment on front deck—pushbutton tape/source comparison—bias reading and tape track transfer.

The choice of professional broadcasters and musical perfectionists the world over, Ferrograph Super Seven is not merely the best of its kind—it's the only one of its kind.

A visit to your Ferrograph dealer will convince you. Or write to: Elpa Marketing Industries, Inc., New Hyde Park, New York 11040 / 7301 East Evans Road, Scottsdale, Arizona 85260.



New Super Seven Ferrograph

Total versatility with tape.

Four questions you multiple-play

1. Does it perform as well as any single-play turntable?



There are some who believe that a single-play turntable is somehow inherently better than a multiple-play unit. All right—the Z2000B *is* a single-play turntable. Its capacity to function as a multiple-play unit offers convenience with no compromise of performance. The *automatic* mechanism which gently indexes the arm, lifts it at the end of play, returns it to the arm rest and shuts off the motor—is completely disengaged during record play. A 2-position control sets the proper vertical tracking angle for single or multiple play. The Z2000B can truly be called the automated, single-play turntable with multiple-play capability.

2. Does it have belt-drive and variable speed?

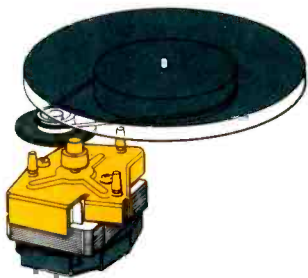

Garrard engineers have attained remarkable results by combining the world famous Synchro-Lab motor and an inventive belt/idler drive combination. A 5 lb., die-cast, dynamically balanced platter is rotated via a flexible belt. Not only are the tiniest fluctuations of speed smoothed out, but an extraordinary -64dB rumble is only one example of the impressive specifications achieved. A variable speed control corrects out-of-pitch recordings and an illuminated stroboscope provides optical confirmation. The Z2000B combines all of these elements to achieve the main goal of Garrard engineering: superior performance at reasonable cost.

3. Does it handle records gently?

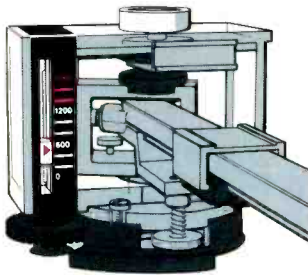

All responsible turntable manufacturers are concerned with protecting your records. With Garrard, it's an obsession. The Z2000B boasts an array of features designed solely to prolong the life of your records. In addition to the exclusive, articulated tonearm, it incorporates an exceptionally accurate magnetic anti-skating device. Cueing is viscous damped in *both* directions. The ingenious built-in automatic record counter keeps track of how many LP sides the stylus has played. And unlike some of the highest priced changers that support records only at the center hole, the Z2000B supports them at the hole *and* edge, and the release mechanism operates at *both* points. Protection for your records indeed!

4. Does it eliminate tracking error?



The grooves of a record are cut by a stylus that travels in a straight line. Conventional playback tonearms move in an arc. The difference between these two paths is called "tracking error." Simply stated, tracking error launches a cycle of distortion and record wear. In good design, the error is averaged over the record so that distortion is minimal. But such compromise was unacceptable in the Z2000B. What Garrard engineers did about it was summed up by High Fidelity Magazine which described the Zero Tracking Error Tonearm as "... the best arm yet offered as an integral part of an automatic player." The Z2000B is the *only* automatic turntable in the world without tracking error.

For your free copy of the New Garrard Guide, write to Garrard, Division of Plessey Consumer Products, Dept C, Plainview, New York 11803.

must ask about any turntable.



The Garrard Z2000B. Yes. Yes. Yes. Yes.



\$229.95

Check No. 34 on Reader Service Card

Garrard
The Automatic Choice

Audioclinic

Joseph Giovannelli

More Power?

Q. I am driving a pair of speakers with a Marantz 1060 amplifier. I am highly satisfied with my equipment except for what now seems to be a universal problem: I want more power.

Will I be able to increase the power output of my 1060 by placing a 4-ohm resistor across the speaker terminals?—Mark A. Collins, Powell, Tenn.

A. You can extract more power from an amplifier by shunting its output with a resistor, if the amplifier can handle this load in addition to the speaker which is already connected to it. This extra power output, however, will be completely wasted. It will be dissipated as heat in the resistor. The

speakers themselves will receive no more power than they would if this added load was not present. In fact, they will probably receive less power than with no resistor added.

Rather than wasting power as heat, why not add additional speakers to the amplifier? This would give you two speakers per channel and would increase the acoustical efficiency of the system. The result would be more volume, an improvement in low frequency response, and possibly better overall "presence."

Volumes with Audio Tapers

Q. Volume controls generally have audio tapers (including input level set controls on power and preamplifi-

ers). Is there any reason for this so far as proper circuit operation per se is concerned?

I am thinking specifically of the case where one fixes maximum possible gain by setting the input level control of the preamplifier.—(Name Withheld), Los Angeles, Cal.

A. Audio taper pots are used only because of the desirable volume change versus the amount of shaft rotation. If a linear pot was used for audio volume control service, you would find that most of the action of the pot will occur at the lower one quarter of its rotation. By the time the pot is halfway up, there would be only six dB more to go between this point and the fully clockwise position of the pot. This 6 dB is not very much when you stop to think of it. You can see, therefore, that all of the action would be confined to a small portion at the lower end of its rotation, making volume adjustments most difficult.

This is true whether we are discussing input (level set) controls for preamplifiers, the main volume control on a preamplifier or the volume control found on some power amplifiers. Try substituting a linear pot for a pot having an audio taper. Note the action. You will quickly replace the original unit.

Aside from the peculiar action of a linear pot, no other circuit problems will be encountered by the use of such a pot.

Why any cartridge (even ours) with an elliptical stylus must be considered just a bit old-fashioned.

As a premium stylus, elliptical designs have only one real advantage over a Shibata stylus: lower cost. Which is why we still offer them.

But when it comes to performance, a Shibata stylus is far, far better. It provides the small scanning radius needed to track highs (up to 45 kHz for CD-4), but without the penalty of requiring extremely low stylus force settings.

In fact, even when tracking at up to 2

grams, a Shibata stylus is easier on your records than an elliptical stylus trying to track at 1/2-gram! New records last longer, old records sound better, and you can play every kind of two or four-channel record made.

All Audio-Technica Universal Series cartridges have genuine Shibata styli. Anything less would be false economy for you...and out-dated technology for us. Prove it to yourself today.



audio-technica® INNOVATION / PRECISION / INTEGRITY

© AUDIO-TECHNICA U.S., INC., Dept. 115A, 33 Shiwasee Ave., Fairlawn, Ohio 44313
Available in Canada from Superior Electronics, Inc.

Check No. 3 on Reader Service Card

If you have a problem or question on audio, write to Mr. Joseph Giovannelli, at AUDIO, 134 North Thirteenth Street, Philadelphia, Pa. 19107. All letters are answered. Please enclose a stamped, self-addressed envelope.

ABOUT THE COVER: It seems awfully early to begin thinking about Christmas gifts, but audio buffs can be so persnickity that sometimes it takes quite a while to choose the proper gift. Our cover this month shows a present for a Fifties-Fan, the classic RCA Victor 45 record player, courtesy of Larry Robin.

60% of BOSE Owners Changed Our Mind

While we enjoy talking about the technology that distinguishes the BOSE 901[®], and about the unprecedented series of rave reviews by leading critics, the purpose of an advertisement is to increase sales by introducing more people to the product.

A surprising result of a customer survey changed our mind as to the most effective use of advertising funds. It revealed that 60% of the people who select the BOSE 901 do so at the recommendation of a 901 owner! This told us that the best advertisement is the product, and the best salesman is the enthusiastic owner.

We concluded that an excellent use of advertising funds would be to help set up an absolutely phenomenal music system in as many owners' homes as possible. Known as the SUPER BOSE SYSTEM, it consists of the 1801[™] power amplifier and two pairs of 901 speakers. One pair of 901s is placed to reflect sound off a front wall, and the second pair reflects off side walls, producing sound with spatial realism and presence that is simply astounding.



Our program in setting up these systems in owners' homes is to provide the **SECOND PAIR OF 901s FREE** to all those serious enough to purchase a component system consisting of the 1801 amplifier and a pair of 901s. We have allocated sufficient advertising funds to cover all purchases made from October 15, 1975 to January 15, 1976.

We believe that the SUPER BOSE SYSTEM is the best music system available today.

And we believe that its owners will be the best BOSE salesmen tomorrow.

One equalizer is required for the Super Bose system, and accordingly the second pair is supplied without equalizer.

This offer is good in continental U.S.A., Alaska and Hawaii only.

901 cabinet is walnut veneer.

BOSE[®]

The Mountain, Framingham, MA 01701

Get inside digital electronics!

Bell & Howell Schools now offers you two fascinating learn-at-home programs that can equip you with professional know-how in the expanding field of digital technology!

The world of electronics is an astounding place—a world that, in the short span of 70 years, has taken us from a simple mechanical age into an age where electronic sophistication has actually helped man set foot on the lunar surface.

One area of this space-age technology that has been successfully harnessed for consumer and industrial use is digital electronics. It is this breakthrough that has given us such remarkable new products as tiny pocket calculators and digital-display wristwatches. And now, you can learn about some of the many extraordinary applications of digital electronics in two special learn-at-home programs from Bell & Howell Schools.

Start your exploration of electronics at home!

With these exciting home learning adventures from Bell & Howell Schools you'll experience the true thrill of discovery as did such electronic pioneers as Thomas Edison and Dr. Lee DeForest. And think about this... they didn't discover electronics in a classroom, and you don't have to either!

Whichever program you choose, test new electronic theories as you build and experiment with the exclusive Electro-Lab® electronics training system!

With your very first lesson you'll receive a special Lab Starter Kit, so you'll be able to see how basic electronic principles actually work in practice. Then, step by step, as your understanding of electronics increases, you'll actually be able to perform your own experiments and work on fascinating projects from "scratch"—like building the exclusive Electro-Lab® electronics training system. This important project helps you learn electronic skills through "hands on" experience with professional testing equipment. The Electro-Lab® system consists of a **design console** to help you learn how to hookup circuits—a **digital multimeter** for measuring electrical voltage, current and resistance. And a **solid-state "triggered sweep" oscilloscope** that, among other things, you'll use to analyze the operation of tiny integrated circuits. The "triggered sweep" feature locks in signals for easier reading.

I. HOME ENTERTAINMENT ELECTRONICS Learn how digital technology is being applied to home entertainment products—build and experiment with the new generation 25" diagonal color TV with digital features!

To learn the most advanced electronics technology you must work with up-to-date training tools. That's why



you'll build Bell & Howell Schools' 25" diagonal color TV with digital features as part of your training. Step by step you'll learn about the many exciting applications of the most up-to-the-minute electronics technology. And you'll have the confidence in knowing that the advanced skills you're learning will be valuable for years to come.

"Hands on" training will help you understand advanced applications of digital technology!

Your "hands on" training will give you a professional's understanding of how this advanced technology works. How features such as on-screen, digital display channel numbers and a digital time readout in hours, minutes and seconds are possible. You'll learn to program an automatic channel selector so that it skips over dead channels and "homes-in" on the channels of your choice.

And, how "state-of-the-art" integrated circuitry and the 100% solid-state chassis add immensely to your understanding of circuit theory and TV servicing techniques. You'll also become thoroughly familiar with the technology behind features such as digitally-automated tuning, and the outstanding color clarity of the Black Matrix picture tube.

By actually building and experimenting with this exceptional equipment, you'll gain the occupational skills, specialized knowledge—and the self-confidence that could open up exciting new directions for you!

II. DIGITAL INDUSTRIAL ELECTRONICS

Our exclusive digital trainer will help you discover today's exciting applications of digital electronics in industry.

Industry is constantly finding new applications for digital technology. Today, this technology is helping to set new standards of accuracy and providing a more precise method of control in refining, food processing, transportation and in manufacturing plants.

Now Bell & Howell Schools has a learn-at-home program that could get you involved in the industrial uses of this challenging technology. The program provides a solid background in basic electronic principles and the

opportunity for you to experiment and learn with the Bell & Howell digital trainer. This remarkable piece of equipment lets you set up and examine a range of complex digital circuits like those in use in industry today. You will work with circuitry which has many of the numerical

and process control applications used in a number of today's most sophisticated manufacturing operations.

Bell & Howell Schools is with you every step of the way!

You'll be pleased to know that, throughout all of these dynamic Bell & Howell Schools' programs, you're just a toll-free phone call away from expert assistance should you need it.

For even more personal attention...Bell & Howell Schools has a truly unique idea—

You can attend in-person help sessions scheduled in over 50 major cities at various times throughout the year, where you can meet and talk with fellow students and receive additional assistance from an instructor.

Once you've completed this program, your skills in electronic troubleshooting could lead you in exciting new directions. While we cannot offer assurance of income opportunities you can use your training: to seek out a job in the electronics industry, to upgrade

your current job, or as a foundation for advanced programs in electronics.



Now... audio/quadrasonics... first home program of its kind!

It's another first from a leader in home learning. Bell & Howell Schools proudly introduces America's first learn-at-home program in audio electronics featuring the exploration of quadrasonics. It's the 4-channel "wrap-around" sound system that has opened a new era in audio technology! You'll actually build Bell & Howell's 4-channel audio center including amplifier and FM-FM Stereo receiver as a part of the development of professional know-how in this exciting and promising new field. Get more details now...check the appropriate box on card and mail today!†

Why not aim yourself in an exciting new direction today—just check the Bell & Howell Schools' program you're interested in and...

Mail the postage-free card right away!

We'll see that you get more details! Taken for vocational purposes, these programs are approved by the state approval agency for Veterans' Benefits.

†Cabinet and speakers available at extra cost.

Simulated TV picture/test pattern.

"Electro-Lab®" is a registered trademark of the Bell & Howell Company.



If card has been removed, write:

An Electronics Home Study School
DeVRY INSTITUTE OF TECHNOLOGY



ONE OF THE
BELL & HOWELL SCHOOLS

4141 Belmont, Chicago, Illinois 60641

THE FIRST! PREAMP BY BGW

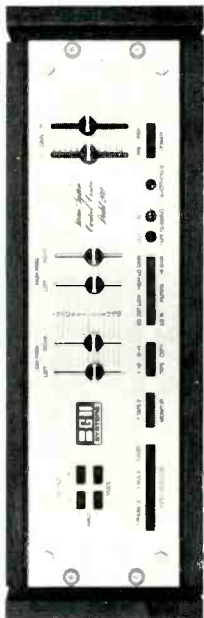

THE BGW 202 HAS —

- Dual discrete OP amp phono stage for unprecedented accuracy
- Active tone controls using sliding step switches
- Active 18-dB/OCT. High and low pass filters
- Two phono inputs plus accessory socket for moving coil pre-preamp converter
- Separate power amp switching
- Remote AC switching unit accessory available

Guaranteed specifications:

Phono stage: Gain=42-dB, \pm 25-dB of RIAA, S/N=82-dB, THD=.01%.

Tone controls: Active baxandall controls add virtually no distortion. \pm 18-dB at 50-Hz and 15-kHz in 3-dB steps.

High and low pass filters: Active 3-pole, 18-dB/OCT. Low frequency at 40-Hz, high frequency at 12-kHz.

Maximum output voltage: At line output, 8-volts RMS into 600-ohms (+20-dBm). Phono at tape output, 10-volts RMS into 5-kohms. Rated output, 4-volts RMS into 5-kohms.

Total harmonic distortion: Less than .01% at rated output, 20-Hz-20-kHz.

Write for the location of your nearest dealer.



in Canada...

BGW Systems
P.O. Box 3742
Beverly Hills
CA 90212
(213) 973-8090

Recrion, Limited
105 Denison St.
Markham, Ont.
(416) 495-0880

Check No. 11 on Reader Service Card

Tape Guide

Herman Burstein

Open-Reel or Dolby Cassette?

Q. I'm planning to purchase my first tape recorder, which I will use to build up a tape library. I can't decide whether to get an open-reel deck or a cassette deck which includes Dolby noise reduction. Some people tell me that the open-reel machines have lower wow and flutter, less distortion, and wider frequency response, and that I can always add Dolby to any machine later. Others claim that cassette decks using Dolby and chromium dioxide tape can have just as good frequency response, equally low distortion, and wow and flutter as good as most open-reel decks (except those with three separate motors, which cost a lot more). In addition, of course, there's the convenience of cassettes.

I've also heard that cassette will replace discs before long. Which is most likely to be around longest, and which will offer the best fidelity?—Stephen P. Sherman, West Hartford, Conn.

For years people have been repeating stories that tape would largely outmode the phonograph disc, but discs are as strong as ever. Similarly I doubt that cassettes will drive out the open-reel decks in the foreseeable future. As for chromium tape, it does make more improvement in cassettes, with their 1-7/8 ips speed, than in open-reel decks running at 7 1/2 ips, because the open-reel at the speed doesn't need chrome tape. Even though cassettes are very good, the best open-reel machines are better. Too, there's more recording headroom with open-reel, so you can make recordings more reliably with open-reel than with cassettes.

Wants to Replace Heads

Q. About five years ago I purchased the Norelco Continental 401 four-track tape recorder. When I checked on replacement heads and transport components at North American Philips, I learned that my machine has been discontinued. Can you advise on the feasibility of a separate transport to be used with my existing

electronics, or is this impossible, unreasonable, or just not worthwhile?—Robert J. Galligan, Niantic, Conn.

A. I don't know of any separately available transports. If a surplus mechanism such as is sometimes offered in the classified pages were purchased, you'd have some job matching it with the electronics for equalization, audio record current, bias current, erase current, and calibration of the record level meters. I don't think it's a practical idea. However, you can get replacement heads for just about any tape recorder ever made by writing to Nortronics Co., Inc., 8101 W. 10th Ave. North, Minneapolis, MN. 55427.

Cassette Production

Q. Who manufactures tape machines that will take a master tape and produce a number of cassette copies?—Frank J. McDonald, Baldwin, N.Y.

A. I suggest that you query the following companies which are involved in tape duplication: (1) Ampex Corp., 401 Broadway, Redwood City, CA., 94063. (2) Sony Corp. of America, 9 West 57th St., New York, N.Y. 10019. (3) Telex Communications, Inc., 9600 Aldrich Ave., S., Minneapolis, Minn. 55420.

Recording Troubles

Q. I have a problem with my Ampex 1100. After taping a selection from a record, I play back the tape and find that the left channel decreases in volume and the high frequencies fade into the background in many places on the tape. This happens at the same place every time I play the tape. I have tried to retape the selections several times, and the problem occurs in different places along the tape (but not throughout the entire tape). The volume comes back to normal after a few seconds, and then it decreases again. I

If you have a problem or question on tape recording, write to Mr. Herman Burstein at AUDIO, 134 North Thirteenth Street, Philadelphia, Pa. 19107. All letters are answered. Please enclose a stamped, self-addressed envelope.



**If you've never heard music on BASF tape before,
turn the page and see how it sounds.**

Check No. 9 on Reader Service Card

keep the heads demagnetized and cleaned. I also have trouble when I want to record a reverse signal. It doesn't record all the time, and when it is on the tape it doesn't always activate the reverse mechanism.—Eva Barkovich, Detroit, Mich.

A. I suspect that your difficulty is what is known as left-channel dropout and is due to inadequate contact between the tape and the upper gap of the head, in your case, the record head. The reason for inadequate contact may lie in the tape guides, in tape tension exerted by the supply and take-up reels or in the nature of the tape path. Another possibility is a fault in the record electronics, causing the audio signal to wax and wane. Your problems calls for the services of a qualified technician.

Deck-to-Deck Hookup

Q. In my hobby of creating electronic music I use two tape recorders, a Harman-Kardon TD-3, which has three heads, and a Realistic 300-D, which has two heads. With the Realistic I can record on one channel while listening to the other. However, using the Harman-Kardon, this is not practical because the playback head is separate from the record head, caus-

ing the channels to be out of timing when played back. Is it possible to route the wires which lead to the heads to a switching panel so that either channel of either head could be operated in the playback or record mode independently of the other channels? If this is possible, what problems would there be?—Bruce R. Gerow, Liverpool, N.Y.

A. If you wish to use the same record head for either recording or for playback, and the same for the playback head, the likelihood you'll run into trouble is great. Usually the record and playback heads are of different design to optimize the performance of each. Consequently each head has different impedance and gap width. However, you could use your switching scheme if you can sacrifice treble response while monitoring. Another idea is to substitute a new playback head for the record head, but this requires adjusting the bias current, the audio record current, and calibrating the record level indicators.

Surplus Tape Transport

Q. I have acquired a tape transport that was originally part of a computer tape memory. The unit was manu-

factured by Ampex and is in such good condition that I would like to convert it to an audio machine. I would like to know whether or not the flutter and wow of this type of machine is low enough to make such a conversion possible. The capstan motor is a hysteresis motor, which is fine, but the spooling motors are d.c. units and are switched off and on by two tensioning arms. There is also a vacuum loop that I would like to remove. Also, what speed does this machine operate at normally, and are the present heads in the machine any good for audio purposes?—Alan Hoffman, Lyndhurst, Ohio.

A. My guess is that the motion characteristics of your tape transport are excellent. I have no information about the speed and head characteristics. This kind of information must be sought from the manufacturer. (The speed is likely to be much too fast—computer tapes usually run at 100 or 200 ips). The heads are 1/2 inch wide, and not suitable for audio use. A skilled development technician could convert such a deck into a good four- or eight-track audio machine, but it would take a great deal of research and design effort. It's unlikely that a tape enthusiast could successfully complete such a project.

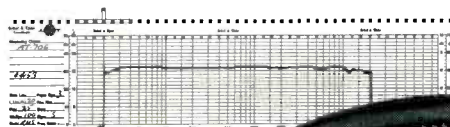

**MODEL AT-706
electret condenser
headphones**

20 to 22,000 Hz \pm 2 dB*

**"...this is
nothing
short of
incredible."**

— LEN FELDMAN

*Mr. Feldman, reporting in *Tape Deck Quarterly*, Spring, 1975 noted that the AT-706 response varied no more than \pm 2 dB from 20 to 22,000 Hz. He also stated, "What we heard corresponded with what we had plotted..." Hear the incredible new AT-706 headphones at Audio-Technica dealers everywhere.



audio-technica

AUDIO-TECHNICA U.S., INC., Dept. 115A, 33 Shiloh Avenue, Fairlawn, Ohio 44313
Available in Canada from Superior Electronics, Inc.

Check No. 4 on Reader Service Card

AM Radio Interference

Q. I own an Astrocom/Marlux 407 deck. During the daytime when AM stations broadcast, their signals are picked up by my tape deck. I have this trouble only in playback mode because recordings made at the same time don't have the radio signals mixed in. I tried grounding the front panel of the tape transport section to my amplifier chassis and the noise was cut down a little, but it still is noticeable. What can I do?—John F. Wood, Huntsville, Ala.

A. The first amplifying stage of your playback preamplifier has very high gain and is picking up the radio signals, rectifying them at the same time that it amplifies them. Sometimes the problem can be eliminated by placing a small capacitor at the input of the first amplifier stage. Experiment to see what the smallest value capacitor is which will kill the undesired signal. Often something between 10 and 50 pF will do the job. If this fails, you will have to experiment with extra shielding of various parts of your system, possibly grounding it (and the entire system) to a water pipe or other good earth connection.



BASF sound is so clear and true, nothing comes between you and the music.

What you experience when you listen to music you record on BASF tape is simply this: the music. Pure and clear.

How does BASF make this phenomenal clarity happen? By polishing the tape. Literally.

When tape is made, it has thousands upon thousands of tiny bumps and ridges that can cause background noise. By getting rid of most of them, we get rid of most of the noise as well.

And to make sure the sound you *do* hear is all there, we give the tape incredible range and response by

using a highly magnetizable dense oxide coating.

Of course, when you listen to music this rich and clear, you don't just hear it. The music happens. (Which may come as a surprise if what you've been experiencing until now is background noise.)

Now if all this sounds too good to be true, there's something we'd like to point out. BASF invented audio tape in the first place. Giving us lots of time to perfect it.

So it isn't surprising we sound so much like the original. You see, we are the original.

BASF. We sound like the original because we are the original.



Check No. 9 on Reader Service Card

Audio ETC

Edward Tatnall Canby

AD MUSIC! You probably laughed last month when I suggested that, some day, some ad music might even aspire to "classical" status. Could be. But definitely not if our audio engineers continue treating music as they too often do now. So much senseless noise, to be slashed and hacked and mutilated any old way, just so long as the stuff lets the much more important SPOKEN word get through. Music—what's that?

We never hack up the spoken words of an ad, do we? Throttle the announcer in the middle of a sentence, cut off his wind as he opens his mouth, fade him away right in the middle of his punch line. Not a chance! But these things we do to music, and much worse, with a vengeance. My ear tells me that 90 percent of the people who deal with ad music must be stone tone deaf. Or maybe it's their bosses. To these operators, music isn't even there. They don't listen. Frankly, I get furious at this sort of treatment. I don't care what sort of music it is—the very definition of music, in the large, is a sound that carries some sort of meaning or expression. And it hurts me to see the crassness of people who simply ignore that meaning because their ears are tin, and well corroded.

Of course, if we could just eliminate this particular form of background noise, we would immeasurably improve the clarity of the precious ad message. Think of the S/N! Velvety silence behind every word. But for some obscure reason, the powers decree that there shall be music in almost every broadcast ad. (Could it be that music is known as a potent persuader?) Anyhow, from the tin-ear viewpoint, if you can't get rid of the stuff then at least you can harass it. And are the people good at harassment!

As we all should know by this time, words and music can indeed live together amicably and helpfully, not only in ads on the air but in film and TV and even in classical music commentary—such as my own for some 30 years. But this depends on mutual respect and equality, words and music both. There are two ways in which music may be tailored (and words tai-

lored) for this kind of joint action and the oldest, most honorable of these techniques, already in use for a half century, is often enough highly effective, though it can be hideously crude when the tin-ears get to work.

Write To Fit

The older technique, by now a sophisticated, matured means for combining words and music, is the fade and cut-to-fit system (for lack of a better name) with which we are all familiar. The music fades down, under the spoken words, continuing at a low but audible level, then fades up at the ends of sentences, at the close either fading out or ending with appropriate musical punctuation. Like some evolutionary animal, music has adjusted itself beautifully to this arrangement—music of every imaginable sort. It can be directly composed to fit, as it is in both ads and film, or it can be smoothly adapted from works already composed, using the natural shapes of that music to effect the joining. It is a good technique and communicative, because the two types of sound, music and words, are so different in audio spectrum that our ears can in fact take in both at once, hearing the words, following the musical line at the same time—assuming a proper job in the combining.

There are plenty of ads on the air which continue this harmonious relationship, music and words treated with equal respect. And in all truth the music—given a chance on its own—does just as much selling as the words themselves. Why not? Words tend to drone along monotonously. Nobody listens. Music livens, catches the ear, sets the tone, delivers the punch. Why say more? It's obvious. That is—again—*when music is respected for itself*. Delta is Ready when You Are. We Did it Before, We'll Do it Again. Sometimes You Need a Friend (bank commercial). Hey, America. These are the words; you know the music. Of course it isn't Grrreat music (yet). But neither is it maltreated.

Slice To Fit

Yet when the slobs and the tin-ears

take over, how crude the very same technique becomes! Blast out the music, then fade it abruptly any old place, right in the middle of a loud chord (wait a quarter second and it would fade itself, naturally). Fade DOWN—and out. Lost! No more music. But when the words end, up comes the music, still going, as though you'd been following it right along. Crude. But by far the worst is the sliced ending. It happens a million times a day and never fails to burn me up. Just close your pot when ready, on cue. Don't ever *listen*. Slice to fit, anywhere. In the middle of the final chord. Throttle a phrase, strangle a clarinet, axe a singing voice, guillotine-like. Bring the music up loud and kill it right in the middle of its climax, stone dead. Or chop it down a half second *before* its natural ending, plop. (And all that money put into commissioning and recording the music!)

This burns me up because I do NOT like to hear musical sense ignored, no matter what that sense may be. Why not wait out that extra half second and let the music end on its own? Why? Because up there in the ad control booth nobody is listening. Nobody gives a damn. Fade out on cue. Tin ears. I am just as distressed at the lowliest 30-second ad, throttled in mid-music, as I am when I hear a Beethoven symphony unceremoniously hacked off in the middle of the last chord. Easy enough to do. Just a flick of the wrist.

But this isn't the half of it. There's the other and newer way of music treatment, the music-destroying circuit. Suddenly in the last year or so these deadly devices have sprung up on everybody's air right and left—you can't get away from them. Compressor-type circuitry deliberately designed to squeeze music into a meaningless pulp, in favor of some fancied improvement in the word transmission. Automatic mayhem, replacing intelligent human control. It's murder, no less, and the evidence is right before your ears, if you ever notice it, 24 hours the day and night. Smash that music into a bloody mess, crush it into sonic hamburger. Plaster the remains on the air. It's a musi-



The Empire 598 III Turntable

Created by concentrating our total effort on a single superb model.

The Motor

A self-cooling, hysteresis synchronous type with an inside out rotor, drives the platter with enough torque to reach full speed in one third of a revolution. It contributes to the almost immeasurable 0.04% average wow and flutter value in our specifications.

The Drive Belt

Every turntable is packaged only when zero error is achieved in its speed accuracy. To prevent any variations of speed we grind each belt to $\pm .0001$ inch.

The Platter

Every two piece, 7 lb., 3 inch thick, die cast aluminum platter is dynamically balanced. Once in motion, it acts as a massive flywheel to assure specified wow and flutter value even with the voltage varied from 105 to 127 volts AC.

The Main Bearing

The stainless steel shaft extending from the platter is aged, by alternate exposures to extreme changes in temperature, preventing it from ever warping. The tip is then precision ground and pol-

ished before lapping it into two oiled, self-lubricating bearings, reducing friction and reducing rumble to one of the lowest figures ever measured in a professional turntable; -63 dB CBS ARLL.*

The Suspension

Piston damped, 16 gauge steel coil springs cradle the arm and platter. You can dance without your stylus joining in.

The Tonearm

The aluminum tubular design boasts one of the lowest fundamental frequencies of any arm, an inaudible 6 Hz. Acoustic feedback is unheard of, even with gain and bass turned all the way up. The vertical and horizontal bearing friction is 1 milligram. This allows the arm to move effortlessly, imposing only the calibrated anti-skating and tracking force you select.

The Cartridge

Empire's best, the 4000D/III, wide response cartridge is a standard feature. The capabilities of this cartridge allow you to play any 4 channel or stereo record at 1 gram or less. And the frequency response is an extraordinary 5-50,000

Hz, with more than 35 dB channel separation.

The Controls

The coordinated anti-skating adjustment provides the necessary force for the horizontal plane. It is micrometer calibrated to eliminate channel imbalance or unnecessary record wear.

Stylus force is dialed with a calibrated clock mainspring more accurate than any commercially available stylus pressure gauge.

A true-vertical cueing control floats the tonearm up or down from a record surface bathed in light.

At Empire we make only one model turntable, the 598III, but with proper maintenance and care, the chances are very good it will be the only one you'll ever need.

*Independently tested and recorded in High Fidelity's 1974 Test Reports.

Write for your free catalogue:
EMPIRE SCIENTIFIC CORP.
Garden City, N.Y. 11530

Mfd. U.S.A. **EMPIRE**

Check No. 18 on Reader Service Card

Incredible.

How else would you describe a preamplifier with:

- A **Peak Unlimiter** that restores dynamics lost in recording to closely approximate the original.
- A **Downward Expander** that reads "gain riding" and expands dynamics down to precisely the intended level.
- An **AutoCorrelator** that makes record/tape hiss and FM broadcast noise virtually vanish without affecting musical content.
- Plus an **Active Equalizer** that gives you flat energy distribution over the full audio spectrum, Joystick Balance and Step Tone Controls that allow precise music tailoring to your listening environment *and* SQ* and Phase Linear differential logic for Quad Sound.



The 4000 is an advanced stereo preamp that actually puts back in what recording studios take out . . . lets your music (at last) reach life-like levels without distortion . . . lets you (for the first time) hear your music from a silent background. It is, in a word, incredible. Ask your dealer for an audition.

Warranty: 3 years, parts & labor.

Phase Linear 4000

THE POWERFUL DIFFERENCE

PHASE LINEAR CORPORATION
P.O. Box 1335 • Lynnwood, Wash. • 98036

*SQ is a trademark of CBS, Inc.

Check No. 31 on Reader Service Card

cian's torture chamber to suit an Edgar Allen Poe.

The idea is beautifully simple as simple as the guillotine in the Revolution. As I understand are merely limiter-compressor which the voice signal level is modulate or control the music inversely. The voice goes up, the music goes down. If there are any gain controls, they don't often get used tell you. Maximum position. Right, this type of device was first used as an aid to sportscasting, to overcome the ever-present crowd noise and allow the voice to get through. It was a good idea. But now it is the music that gets the crowd treatment. Instead of being longer is it merely faded down to become inaudible. An absolutely horrible sound, such as an easy way to devastate the vestige of musical communication. Unbelievable that we tolerate it everywhere we listen.

Perfectly respectable music, as advertised by these circuits, comes out of a Disney character flattened by a caterpillar tractor, only it isn't funny. I find it even less funny when the music is wrecked on good construction. Do you think our friends make any musical distinction between the shredder, the hamburger, right along with the rest of the classical soundburger. But the worst of all this has me speaking (well, almost). My God, would you believe it, they use this hamburger circuitry to advertise the very music they are destroying. Multilated right in front of the customer, like at the high class butchery!

The Metropolitan Opera. Yes—the Met. *The actual sound of it.* Was that the glorious climax of a Verdi opera? I couldn't be sure; the corpse was unidentifiable. Yet there it was, the golden effulgence mashed into heaving fragments of nonsense—and the message? *Go hear that very music.* (Well, at least you would hear it live and intact.) Or take the Philharmonic, the Anonymous Philharmonic, for the moment. "Thrill to the splendid music of Piotr Tchaikovsky!" intones the announcer, and there he is, Tchaikovsky himself, gasping in agony, something the shark mangled and then spewed out again. Is this the way we honor the great art of music? Is this the way we want to treat our advertisement music?

A Choir Burger

The Valley Forge Military Academy . . . on the air. They wanted music for

246 pages of Erotica for only \$1⁰⁰?



SEE OTHER END OF THIS TAB →

meat grinder just the way it went into. As music. Well . . . we can always hope.

A brief P.S. Reading an earlier version of the above, our Editor wondered whether I could not also get into the similar music compression so widely used in pop music broadcasting, notable on AM but also via FM. I dislike that sound, myself, almost as vehemently as the vomit sound of ad music. But the situation there is a bit different.

On the pop air, you are hearing music alone, by itself, for its own sake. The message, no matter how it is maltreated by circuitry, *is music*, in terms of function, and is so accepted by a very wide audience, for better or worse. And no matter that the technical reasons for compression have nothing at all to do with musical sense. A later installment on this interesting subject.

Ten years after the revolution.



1966

In 1966, Sony brought you the world's first commercially available turntable with a DC servo motor. This effectively slowed motor speeds from 1800 to 33 1/3 RPM, producing the lowest rumble figures measured till then. The servo system also drastically reduced wow and flutter, thus giving you a chance to hear what 33-1/3 records sound like at 33-1/3. Quite a revolution.

But we haven't been sitting on our laurels since then. Introducing the PS-4750.

Overlooking the fact that the PS-4750 is so pretty we could sell it through interior decorators, here are its technical innovations. It has a direct drive servo motor that gives you incredibly low rumble, wow and flutter levels.

Plus total immunity from linear velocity and frequency variations. That's because the PS-4750 has a unique system that, in essence,



1975

consists of a sensitive magnetic head (with eight gaps instead of the normal one) which monitors platter speed by picking up a magnetic coating on the outside of the platter. This speed data goes through a small computer connected to the motor, instantly compensating for variations.

The PS-4750 is also ultra insensitive to outside vibrations (which causes intermodulation distortion and acoustic feedback). Sensitivity to outside vibration shows as "G." And the PS-4750 has a platter and case made of SBMC, a Sony developed compound which has one third the "Q" of aluminum or zinc.

We've even done something

about the resonance caused by warp in the record itself. Those round doohickies on the platter are rubber suction cups that actually provide greater contact surface, reducing the longitudinal vibration caused by warp. The end result is a cleaner sound.

So, all in all, our engineers think the PS-4750 is pretty nifty. But don't take our word for it. Just stop into your Sony dealer and show your independence by listening for yourself.

SONY®

©1975 Sony Corp. of America, Sony, 9 W. 57 St., N.Y., N.Y. 10019.
SONY is a trademark of Sony Corp.

Check No. 54 on Reader Service Card

Behind The Scenes

Bert Whyte

A FEW WEEKS ago I was rearranging tapes and adjusting shelves, in the never-ending quest for more space to cope with my always expanding library, when I came across "old number one" itself.

This is what the "ancient order of audiophiles" fondly calls the first pre-recorded stereo tape ever issued by a major record company, RCA's 1954 release of Fritz Reiner conducting the Chicago Symphony Orchestra in Richard Strauss' **Also Sprach Zarathustra**. This justly famous tape was, and is, a great performance and a sonic spectacular. It was in half-track stereo, of course, two channels in line, covering the full width of the 1/4-in. tape, with tape speed at 7-1/2 ips.

I played this 21-year-old tape and was pleased to note that it had gained its majority gracefully, with but a slight "cupping" of the tape and minimum shedding of oxide. Sure, it was hissy...but the sonics were still re-

markable for their lucidity, general cleanness, overall rich sonorities, and the splendid orchestral balances the engineers achieved in the superb acoustics of Chicago's Orchestra Hall. This was one of the great recording halls in the world, before the lamentable reconstruction in 1966, which henceforth ruined it as a recording venue.

Listening to this tape, a lot of memories bubbled to the surface, and I recall the cynics and skeptics of that time saying things about stereophonic sound that have a familiar ring today, "It's just for you far-out hi-fi freaks," "It will never get off the ground," "It's too expensive," "Who needs it?" etc. The more reasonable types said, "Yes, it's great...no question about that...but it will never be a factor in the market until you can give us the same stereo on a phonograph record." As we all know, it took four long years until, in 1958, Westrex came up with its 45/45 system, and we had a stereo disc. But only the most charitable would say that it was a quality product. In truth, it left a great deal to be desired, with much development work necessary to achieve the fidelity of reproduction acceptable to critical audiophiles. There had to be improvements in the stereo cutterhead and cutting amplifier, etc., to say nothing of the improvements needed in stereo playback cartridges. It must also be remembered that most engineers had little or no experience in recording stereo and, for many engineers, old ideas and procedures died hard...and learning this new recording philosophy was often a prolonged and painful affair.

As With Stereo

Obviously, this stereo scenario sounds very similar to what has been happening with quadrasonic sound since its introduction. It was in 1969 that Seymour Solomon and his Van-

guard Record Co. ushered in the quadrasonic era by releasing discrete four-channel, open-reel tapes. Needless to say, this new sound was enthusiastically condemned by the usual intra-industry mossbacks and doom-sayers. Their epithets were of the same pungent variety that were leveled at stereo, "Too impractical," "Too damned expensive," etc. One could hardly argue with them with respect to expense, since a four-channel tape machine, four channels of amplification, and four loudspeakers added up to a very costly package. The quadrasonic tapes were expensive too, ranging from \$12 to \$18 per 7-in. reel, and there were not many titles available, a situation which unfortunately has only marginally improved today.

It was apparent that to make quadrasonic sound more accessible to the consumer, it would be necessary to develop a means of reproducing this great new sound from a phonograph record. From any technical viewpoint, this was obviously going to be a most formidable task, far more so than was the case with stereophonic sound. (After all, we did have the 1933 stereo experiments of Dr. Blumlein of EMI as at least some sort of an approach to the problem.) A four-channel disc had to be a venture into totally uncharted areas of phonograph record technology. There was first of all the question of compatibility of such a four-channel disc with existing stereo and monophonic equipment. The idea of reproducing four channels of sound for a single record groove was mind-boggling; believe it or not, there even were experiments using specially cut discs with parallel-tracking stereo cartridges, a la Emory Cook in the old binaural days!

In 1970, Peter Scheiber startled the industry with a demonstration of a four-channel disc, utilizing what came to be known as a 4-2-4 matrix encoding process. The output of a four-

In my report on the June CES, I inadvertently left out of my coverage of the special British exhibit the name of Celestion, which is now being distributed in North America by the Canadian firm, Rocelco. Celestion is, of course, one of the oldest and most respected loudspeaker manufacturers in Britain, and if you read The Gramophone or Hi-Fi News and Record Review, the two pre-eminent English audio magazines, you will have seen ads for Celestion's Ditton speakers many times. Rocelco will be handling both Celestion's Ditton range and their new UL range of speakers through a much expanded dealer network, and in many parts of the country, the Celestion speakers are already appearing in selected audio shops.

Drop in a Fuji



and you'll drop all the others...

There is a new cassette on the market. The FUJI FX, a Pure Ferrix cassette that soon will be the standard of excellence for top quality, truly high fidelity reproduction. It already is in many parts of the world.

FUJI FX gives you the music you want, the way you want your music. Clear, crisp sound over the entire audio frequency range without perceptible distortion. A signal-to-noise ratio of better than 58db. No hiss. Virtually failure-proof. The finest music at your fingertips without

the need for any special bias. Drop in at your FUJI dealer today; then drop in a FUJI and hear music as you have never heard it before.

FUJI FX cassettes come in lengths of 46, 60 and 90. Also available, a full line of FUJI FL Low Noise cassettes in lengths of 30, 60, 90 and 120 minutes.

FUJI Photo Film U.S.A., Inc.
The Empire State Building,
New York, New York 10001.



FUJI FILM

**THE TAPE THAT'S HEARD
AROUND THE WORLD**

Crown The Known Value...

at an uninflated price!

An honest value isn't hard to find, if you know an honest supplier. CROWN's reputation for providing more recorder value for your dollar is as old as our company. Nothing would ever cause us to change that.

CROWN recorders offer you day-in, day-out worry-free reliability, plus brilliant performance. Both result from simple, rugged design, with only a few moving parts. The CROWN belt drive and massive flywheel almost completely isolate the capstan drive from any vibration or rumble.

CROWN electronic circuits are carefully designed for maximum reliability, and electronic components are thoroughly tested before assembly. Oversize meters and easy-to-handle-controls make operation simple. The result? A professional tape deck, used to produce quality recordings in many a studio.

Each CROWN transport has undergone 100 hours of testing. Each CROWN recorder has its own performance report, signed, not stamped, by a CROWN inspector. And each CROWN recorder is backed by a one-year full warranty on parts and labor; and an additional two-year limited warranty on parts only. We put the CROWN name on these recorders proudly - we believe they've earned it.

Why not talk to your nearby CROWN dealer about the long-term values of a CROWN recorder. And the uninflated price. It could be the year's best buy.

Write us for his name. CROWN, Box 1000, Elkhart, IN 46514



CROWN
WHEN LISTENING BECOMES AN ART

Check No. 15 on Reader Service Card

channel discrete tape was fed into a special "encoder" which matrixed (mixed) and phase-shifted the four signals in a precise mathematical relationship, reducing them to two channels. In playback, the two signals were fed into a decoder, where complementary dematrixing circuitry restored the signals to the four-channel mode, purportedly the equivalent of the original quadrasonic input signals. Critics were quick to point out that "You just can't mix four colors of paint together and then separate them back into their original hues." The analogy was crude, and they did not take into account psychoacoustic factors at work in the playback process, which helped to "deceive" the ears into apparent restoration of the original sound field. Nonetheless, the devotees of discrete quadrasonic tapes considered the matrix, at best, a compromise. In spite of this, Pete's matrix idea stimulated a great deal of interest and, in short order, we had the Scheiber/Feldman-Fixler/Electro-Voice joint involvement in the 4-2-4 system. Then came Ben Bauer and Columbia Records with their SQ matrix disc, followed by Sansui with their QS matrix disc. This set the stage for a long period of development and refinement of matrixing technology. However, to complicate matters, the Victor Company of Japan entered the four-channel disc sweepstake with their CD-4 quadrasonic disc, whose principal virtue was that there was no "mixing" of the original four-channel tape signals, as each of the 4 channels on the disc remained "discrete" and precisely localized in their respective quadrants.

At first glance, this CD-4 system seemed to satisfy the requirements of a true discrete quadrasonic tape/phonograph record interface. But the CD-4 system was such an ultra-sophisticated, technically complex affair, that although the discs made with it indisputably reproduced discrete quadrasonic sound, there were many problems within the system that adversely affected some basic playback parameters.

New Cutting Gear

All the foregoing has been a rather long preamble to the "meat" of this column, to wit: The ongoing development of the CD-4 system, including a visit with John Eargle in Los Angeles, and a tour of the JVC CD-4 Cutting Center and RCA's Hollywood studios, wherein I saw the new JVC Mark-3 Modulation System and its RCA

counterpart known as the "Quadrulator." John is a consultant for all of the CD-4 record manufacturers, and conveniently, his JME Associates office is in the same building as the JVC Cutting Center and the RCA studios.

I think it is safe to say that some time ago the SQ and QS matrix systems have reached a level of technological maturity. In SQ, the various logic aids to channel separation have been reduced to IC chips, and there are highly sophisticated decoders in the Paramatrix of CBS Labs, the Tate DES design, and the Shadow Vector unit from Audionics. Sansui's QS has its advanced Vario-Matrix decoders and a commanding lead in terms of synthesizer functions.

On the other hand, as noted, the sheer complexity of the CD-4 system has revealed problems which have somewhat slowed its development. Diligent research and experience with the system have gradually resolved these problems. It is the thrust of this article to discuss the breakthroughs represented by the new jointly developed JVC and RCA CD-4 modulation systems, and the resultant high quality of discrete quadrasonic sound that has been achieved.

In the CD-4 discrete quadrasonic disc system, four audio signals are fed into a signal processor and are converted into sum signals, left-front plus left-back and right-front plus right-back, and difference signals, left-front minus left-back and right-front minus right-back. The difference signals are used for angular modulation of a 30-kHz carrier, and then superimposed on the sum signals before going to the lathe cutter head. The 30-kHz carrier is FM (frequency modulated) from 30 to 800 Hz, phase modulated from 800 Hz to 6 kHz, and is again frequency modulated from 6 kHz on up. High frequency range in the system extends to 45 kHz, hence the need for playback cartridges with response to 50 kHz.

The name of the game in CD-4 performance is base-band or normal stereo response in combination with the carrier-band response. Ideally, nothing should interfere with the recovery of the 30-kHz carriers. In the earliest days of CD-4, there were numerous problems, total playing time was about 22 minutes per side, overall levels were down 4-5 dB from normal stereo levels, bass response was restricted. All this mainly as a result of the frequency response and crosstalk characteristics of the cutterheads available at that time. This was also one of the reasons for cutting

The Monster



The new BA 5000 Power Amplifier from Sansui

The most dramatic component in Sansui's new "DEFINITION" Series, the BA 5000 solid-state power amplifier is capable of 300 watts min rms per channel into 8 ohms, both channels driven, from 20 to 20,000 Hz, with no more than 0.1% harmonic distortion in the stereo mode. What's more, the BA 5000 can be strapped for mono operation to deliver 600 watts rms under the same conditions.

A true monster amplifier.

But that's not all. Unlike other solid-state amplifiers, the BA 5000 has a huge, laboratory-quality output transformer, enabling it to deliver rated power into 2, 4 or 8 ohms plus 25 volt line

output in stereo and 4, 8 or 16 ohms plus 70 volt line output in mono. A rating of 600 watts into a 16 ohm mono load with no more than 0.1% harmonic distortion, 20 to 20,000 Hz, is simply unprecedented in transistor equipment.

The "DEFINITION" series also includes the BA 3000, our Junior Monster, and the CA 3000 a very high quality low distortion preamplifier.

For professionals, sophisticated audiophiles and monster lovers everywhere. See it and touch it if you wish at your nearest Sansui franchised dealer or write for complete literature.

SANSUI ELECTRONICS CORP.
Woodside, New York 11377 • Gardena, California 90247
SANSUI ELECTRIC CO. LTD. Tokyo, Japan • SANSUI AUDIO EUROPE S.A. Antwerp, Belgium
ELECTRONIC DISTRIBUTORS (Canada) B.C.
Check No. 42 on Reader Service Card

Sansui

Feast your ears



If you're starving for great sound, it's time to move up to MAGNEPLANARS. Our technical features will turn even ordinary ears into audio gourmets.

We give you:

- * woofer, tweeter, diaphragm and voice grids all in the same plane for excellent phase response.
- * 500 square inch midrange/bass radiating area
- * purely resistive amplifier load
- * no cabinet resonance
- * high power handling
- * no external power supply
- * unmatched reliability and value

MAGNEPLANARS are eye-pleasers, too. Sleek, six foot panels, they're only one inch thick.

So, have a banquet on us.
MAGNEPLANAR

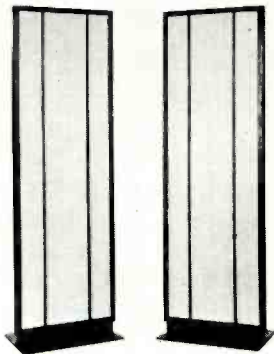

*MG-II \$625 per pair

MAGNEPLANAR
MAGNEPLANAR® PRODUCTS
P.O. BOX 8642, WHITE BEAR LAKE, MINNESOTA 55110

the lacquer master at approximately one-third normal speed. The limited inside cutting diameter of about six inches (across the center hole) and subsequent time reduction was also caused by the contour of the cutting stylus and width of the burnishing facets. Presently, styli that are used for CD-4 cutting have back angles of 35 degrees, rather than the usual 45 degrees, and burnishing angles are now close to 30 degrees. Burnishing facet width has been appreciably reduced and all this adds up to the ability to cut to diameters of less than five inches, with satisfactory carrier information over the 20- to 45-kHz range.

Distortion Reduced

Another problem frequently encountered was certain kinds of distortion, mainly the result of interaction between the base-band and the carriers. "Type One" distortion can be described as carrier erasure due to excessive levels and subsequent heavy base-band modulation, and it shows up audibly as sharp, crackling sounds. When the one-third cutting speed was commonly used, it was "suggested" to avoid Type One distortion that tape masters not exceed +2 VU. At the present half-speed cutting, tape levels of +6 VU can be used with minimum Type One distortion. The use of the aforementioned new contour cutting styli also reduces this kind of distortion. It should be mentioned here that demodulators like the Technics SH-400 have a special high speed muting circuit, which effectively masks the sound of carrier dropout. Type One distortion can also result from too low a tracking force (Shibata styli and 2 gram force are recommended) and from excessive harmonic distortion in the playback cartridge which might appear in the carrier frequency and confuse the demodulator.

"Type Two" distortion really is a form of intermodulation or "beat" distortion, generally caused by rear channel information leaking into the front channels, or vice versa, and this insufficient carrier separation produces a "buzzing" sound, particularly affecting low frequencies like bass notes. Type Two distortion is almost totally a product of the playback cartridge and not the CD-4 cutting system. Cartridges with but 10 - 12 dB of separation in the carrier range would be suspect.

All this talk of distortion sounds horrific, but it must be noted they were problems uncovered in the first operational period of CD-4 technolo-

gy. Either through improvements in the cutting system, in playback equipment, or on current CD-4 recordings, these Type Two distortions have virtually disappeared.

In 1970, the first CD-4 cutting modulation system was housed in three large racks, with myriads of controls, and the cutting speed was one-third of normal. In 1974, the JVC Mark-2 CD-4 system was introduced, and had shrunk to a single rack and cutting speed had gone to half normal (16 rpm).

When I walked into the JVC Cutting Center in Los Angeles in May of this year, John Eargle showed me the new JVC Mark-3 modulation system, housed in an attractive console 40 in. H by 52 in. W by 34 in. D. Among the major features of the unit are reduced cost, now at a level that independent cutting studios can easily acquire one; new signal conditioning equipment, using a new phase modulation principle; the ability to interface with any cutting system on provision of input/output switching; wider dynamic and frequency range of the modulator, thus lowering distortion; automatic signal conditioning of both low and high frequencies to optimize transfers for any kind of program material; a new type of carrier level control, which does not require an extra set of advance heads on the tape transport, and automation which reduced operational controls from 65 on the Mark-2 to just 15 on the Mark 3.

In the same building in the RCA studios, Joe Wells proudly showed me their new CD-4 Quadulator. Since the new phase modulation system is the result of a joint RCA/JVC/Matsushita project, the same system is used in the JVC Mark-3 and the RCA Quadulator. The Quadulator occupies only 13 in. of space in one standard 19 in. rack. While the Quadulator performs the same functions as the JVC Mark-3, it is even simpler to operate and is especially set up to interface with equipment normally used in RCA studios. It is good to know that the RCA New York studios will soon receive a Quadulator, and we can then expect some really fine CD-4 recordings.

The item of major importance in the JVC Mark-3 and the RCA Quadulator is the use of a special selected frequency divider type of phase-locked loop, instead of the serrasoidal modulator used in the previous systems. In the JVC Mark-3, the PLL has simplified the circuitry, eliminated the delay time, and widened the dynamic range. Among other important ad-

The Finest Four-Channel Receivers

KENWOOD KR-9940 and KR-8840

Why settle for less?

The outstanding KENWOOD KR-9940 and KR-8840 four-channel receivers reproduce every existing 4-channel program source without the need for separate adaptors or awkward plug-ins. Both have a sophisticated control center for an elaborate 4-channel system. But most important of all to your total enjoyment of 4-channel is the fact that KENWOOD's advanced engineering and meticulous craftsmanship deliver the same superb 4-channel reproduction through years of constant listening pleasure

- Built-in CD-4 Demodulator
- Built-in SQ with Full Wave-Matching and Variable Blend Logic
- Built-in RM Decoder for Regular Matrix and Synthesized 4-channel
- Big Power
- Full 4-channel Controls

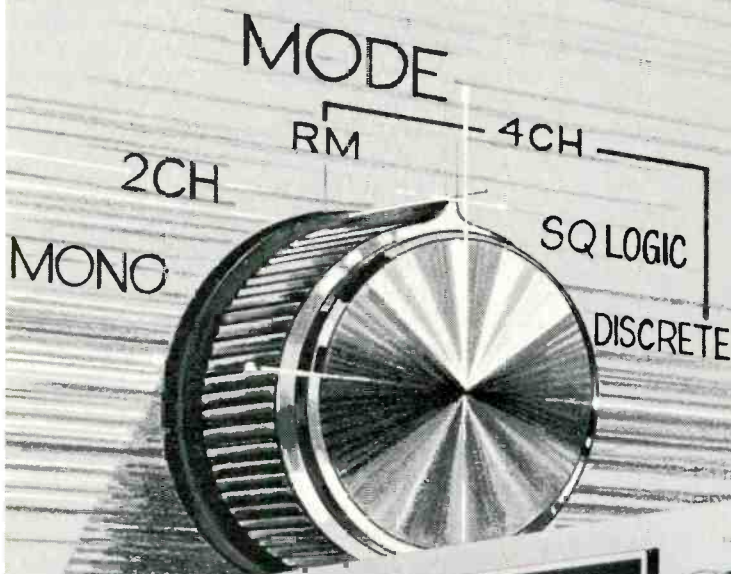

KR-8840 ... 40 watts per channel, Minimum RMS at 8 ohms, at any frequency from 20 Hz to 20 kHz, with no more than 0.5% Total Harmonic Distortion

KR-9940 ... 50 watts per channel, Minimum RMS at 8 ohms, at any frequency from 20 Hz to 20 kHz, with no more than 0.5% Total Harmonic Distortion

For complete information, write ...

KENWOOD 15777 S. Broadway, Gardena, CA 90248 • 72-02 Fifty-first Ave., Woodside, N.Y. 11377 • In Canada: Magnasonic Canada, Ltd.

Check No. 23 on Reader-Service Card

Three Compacts

Bozak quality sound for modest-sized rooms

It's a fact of physics that the larger the loudspeaker enclosure, the more realistic the bass reproduction.

Yet, room size and amplifier power limitations sometimes dictate the use of smaller-than-optimum loudspeakers. For these applications, Bozak, whose reputation for providing the truest possible bass spans more than a quarter century, has developed three compact speaker systems, each of which offers fidelity in bass response far beyond what might be expected from an enclosure of its size.

Rhapsody

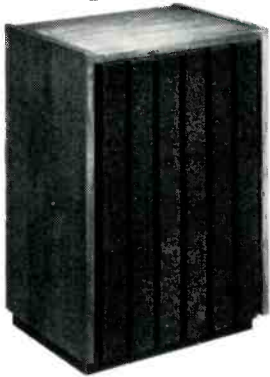

The ideal loudspeaker for a medium-size room, the Rhapsody is a three-way system providing a full spectrum of true sound from natural bass through clear midtones to the highest shrill-free treble. Waterproof finish lets the Rhapsody double as an end table without fear of spotting. A three-position brightness control permits matching the speaker system to room acoustics. Sculptured foam grille enhances the true walnut surfaces.

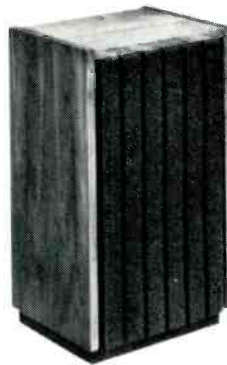

Tempo III

Bozak's smallest three-way system has been acoustically designed to reproduce currently popular music with its emphasized bass. A ducted enclosure helps bring discotheque sound into the living room. Cabinet finish is waterproof, so there's no fear of ordinary liquids marring the surface. Grille is of modern acoustical fabric. Available in free-standing or bookshelf models.

Sonora



Although the smallest Bozak speaker, the Sonora caused *Popular Science* magazine to say "you can get really good sound from an under-\$100 speaker . . . While no speaker is perfect in reproducing lows, it was exactly this solid, rich sound that made the . . . Bozak speakers stand out." To which we add, the crystal clarity of its highs are equally important to the success of this finest of compact bookshelf speakers.

If you buy any compact speaker, regardless of your room size or budget, without first listening to the Bozak compacts, you'll be doing your music system an injustice. We'll gladly send you the names of dealers in your area where you can hear them for yourself.



Bozak, Inc., Box 1166, Darien, Connecticut 06820

vantages in the Mark 3 is that in the previous systems the four audio signals were processed by limiter circuits, where as they now are first converted into sum and difference signals, and then these signals are processed by the signal conditioners which automatically control the level of the signals. The sum-signal conditioner controls its level so that non-linear distortion due to over-amplification does not occur in playback; the carrier band signal conditioner prevents over deviation.

Another item which contributes greatly to higher quality CD-4 discs is the use of the new Ortofon DSS731 and Neumann SX-74 cutterheads that have diamond cutting styli, rather than the usual sapphire styli. Their use is said to provide discs with much smoother frequency response, better S/N ratio, and with fewer variations in group delay characteristics. Lasting up to 10 times longer than sapphire types, the diamond cutting styli also give higher lacquer production rates with less down time.

As a result of all these improvements, we now have a CD-4 disc of superb quality. There are no longer any playing time limitations and recorded levels are within 2 dB of regular stereo discs. The new, harder, lubricated, anti-static CD-4 pressing compounds are capable of producing really quiet discs. One looks forward to their use in regular stereo discs. The concomitant improvement in CD-4 playback equipment, new generations of phono cartridges, like the Pickering XUV/4500 . . ., which can track CD-4 discs at one gram with superb separation, and the aforementioned Technics SH400 demodulator which incorporates PLL, high speed muting, easy meter locking and calibration of separation and carrier signals—combine to make CD-4 listening a real pleasure.

I have two experimental CD-4 discs made with the RCA Quadulator, Carly Simon's **Hot Cakes** and **Stephan Michael Schwartz** (dig that title), and I have the same recordings made with the previous modulation system. The difference is absolutely startling. The new discs are virtually noiseless, gone is the sense of "strain," as if you were expecting to hear some distortion at any moment. Everything is wide open and "airy," the sound is very clean, levels are up, bass is deep and solid, and dynamics much wider. This certainly is impressive audible evidence that the CD-4 system has come of age. . . a viable quadrasonic product, and discrete to boot!

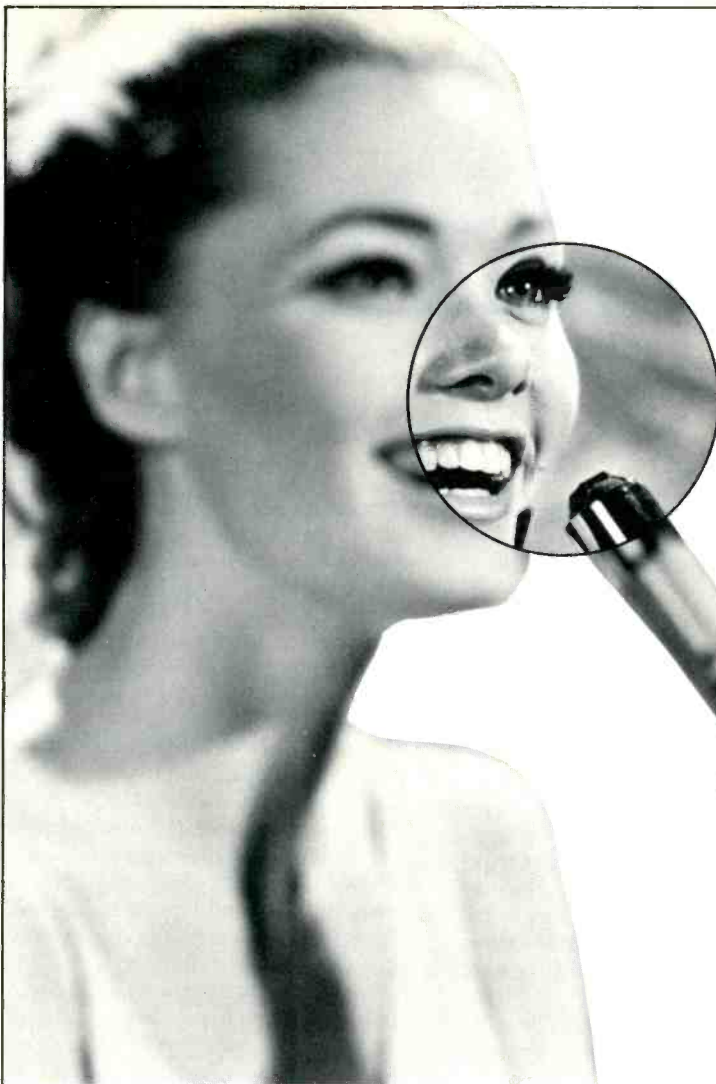

SONUS

STEREO PHONO CARTRIDGE

**suddenly there is
the definition
you have never been
able to get before!**

AH! DEFINITION—That elusive quality of clearness and accuracy never quite attainable before. (If you can't extract it at the point of contact with the record, the rest of your equipment won't deliver it to you.)

The design philosophy of the SONUS cartridge is to use the latest refinements in material and techniques to convert the motion of the record groove into a precise electrical replica, thus assuring the highest possible sonic accuracy and definition.

The electromagnetic structure of the cartridge is exceptionally efficient and has been arranged in such a way that the point of transduction is placed as close as possible to the record surface. This enables the distance from the stylus tip to the energized armature to be kept extremely short, thereby minimizing the chances of the motion being significantly changed, and/or extraneous resonances introduced. It further enables the moving element to be kept exceedingly light and rigid. Indeed, we believe the total moving structure to be lighter than that of any other magnetic cartridge of which we are aware.

Great care has been taken with the cartridge geometry, not only to minimize vertical tracking error but also to ensure accurate transmission of the stylus motion to the generating armature. This has been

achieved by (among other things) positioning the stylus tip on the same axis as the armature so that none of the stylus motion is lost in rotation or affected by any possible rotational resonances.

The stylus pivot is located at the dynamic center of rotation of the moving system and is fabricated from material having optimum elastomeric properties, providing an extremely linear and highly compliant suspension.

In sum, we have a transducer system characterized by reproduction of exceptional accuracy, clarity and definition, and capable of perfect tracking and tracing at very low stylus forces.

Write to SONUS customer service for full line catalog and the name of the franchised dealer nearest you.

Your franchised dealer will be happy to demonstrate the superior qualities of this cartridge.



SONIC RESEARCH INC.

27 Sugar Hollow Rd., Danbury, Ct. 06810

Represented in Canada by:
PACO Ltd. 45 Stinson St.
Montreal, Quebec

Check No. 47 on Reader Service Card

Dear Editor:

More Toolmakers

Dear Sir:

Thank you for publishing the article on Syn-Aud-Con in the September issue. We felt that your readers might be interested to know who the latest Syn-Aud-Con sponsors are:

United Recording Electronics Industries
General Radio Co.
Shure Bros., Inc.
Sunn Musical Equipment Co.
Sescom, Inc.
Emilar Corp.

Syn-Aud-Con puts a lot of emphasis on their sponsors because they give wholehearted support of this advanced education and because of the important services they offer the industry in their own right.

Carolyn Davis
Syn-Aud-Con
Tustin, Calif.

Real Loads for Amps

Dear Sir:

I would like to express my pleasure in reading the article by Mr. De Marinis "How Valid is the FTC Preconditioning Rule?" in the September issue. I would like to point out that so far none of the articles on this subject has mentioned that all the amplifier tests, as well as preconditioning, are done with resistive loads, 8 ohms in most cases, while amplifiers are designed to operate into a complex impedance load. Most speaker systems are complex loads, commonly showing phase shifts of 60 degrees in the lower frequency range, where a good portion of the audio information is contained.

Dissipation in the output section of the amplifier can be considerably higher while driving such speaker loads than while driving resistive loads. This, in turn, means higher

heatsink temperatures than indicated by the measurement with resistive loads under program source conditions.

Based on the fact that for a reduction of 10° C of the transistor junction temperature, life of the transistor will approximately double, and the fact that a 25° C decrease in case temperature excursion will increase thermal cycling ratings almost an order of magnitude, depending upon the type of transistor used and operating conditions, I don't think that the FTC rule is all that unreasonable. It is true that consumers are paying slightly more, but in my opinion improvement from a reliability standpoint could be well worth the additional cost.

Miroslav Glogolja
Hillsborough, N.J.

The author replies:

I basically agree with Mr. Glogolja. A couple of times in the article I mentioned that reliability considerations were an entirely different matter, and I tried to avoid confusing that subject with the matter of an FTC test for OUTPUT POWER capability.

The problem for designers of good, reliable amps becomes horrendous when you realize that we have no control over what the user will connect to the output or input of our product, how he will set the controls, or how much air circulation will be available. More heat sinking certainly helps, but there are other ways to address the problem. Sensitive thermal protection is one approach which has been made very difficult by the FTC ruling.

The various engineering solutions to this maze of problems is one of the factors which determine amplifier quality and cost. It's an important part of a competitive free market. Freedom of design should not be distorted by the side effect of a government ruling. This discussion, if allowed to run

its course, would fill several issues of Audio magazine, but thanks for the opportunity to comment.

Joseph De Marinis
GTE Sylvania
Batavia, N.Y.

Gee, Thanks

Dear Sir:

I couldn't help writing to tell you what a "Godzilla" of a magazine your September issue was. First, a review of Ampzilla that reveals how an amp sounds as well as looks on paper. (Jim Bongiorno, please keep those prices down, at least until I get ahold of your amp!) Then, an excellent article by Joseph DeMarinis that reveals the FTC preconditioning requirement is as ridiculous as requiring the welterweight boxing champion to do 10 rounds with a heavyweight, and then immediately defend his title in another match. The article on bi-amplification was concise and informative, and revealed little bias in the direction of any manufacturer's products. George Tillet's piece on cassette decks (and their relation to open-reel) was refreshingly different from the approach the "other" stereo magazine would take to the same subject—and it was concise and informative. Only the last paragraph revealed a little of the consumeristic approach, but perhaps it was written in response to an editorial request to keep the article under X words but still have a pretty ending. Finally, Ed Canby gave me some new binaural thought, not too "techno-freakish."

By the way, please have fun-loving (Datsun 260Z?) Richard Heyser review the Dahlquist DQ-10 and the Magneplanar soon. (If you have to edit this letter for space, please leave in the last sentence, for I respect Heyser's reviews, and would like to compare my findings against his really accurate ones.)

Bob Katz
Hartford, Conn.



In response to the needs of the recording and broadcast industries, Stanton creates the new calibration standard ...the 681 TRIPLE-E...

A definite need arose.

The recording industry has been cutting discs with higher accuracy to achieve greater definition and sound quality.

Naturally, the engineers turned to Stanton for a cartridge of excellence to serve as a primary calibration standard in recording system check-outs.

The result is a *new* calibration standard, the Stanton 681 TRIPLE-E. Perhaps, with this cartridge, the outer limits of excellence in stereo sound reproduction has been reached.

The Stanton 681 TRIPLE-E offers improved tracking at all frequencies. It achieves perfectly flat frequency response to beyond 20 kHz. It features a dramatically reduced tip mass. Actually, its

new ultra miniaturized stylus assembly represents an important advance in stereo cartridge design and construction, with substantially less mass than its predecessor. And this stylus assembly possesses even greater durability than had been previously thought possible to achieve.

The Stanton 681 TRIPLE-E features a new design of both cartridge body and stylus; it has been created for those for whom the best is none too good.

Each 681 TRIPLE-E is guaranteed to meet its specifications within exacting limits, and each one boasts the most meaningful warranty possible: an individual calibration test result is packed with each unit.



For further information write Stanton Magnetics, Inc., Terminal Drive, Plainview, N.Y. 11803.

Check No. 32 on Reader Service Card

Update:

Musings on the Four-Channel Scene

George W. Tillett

IN THE EARLY days of stereo, audio shows reverberated to the sound of trains steaming past, clanking and hooting; seals splashing about in pools, barking and yapping, and ping pong matches on tables that sounded as big as tennis courts, and so on. Motion in sound was then quite a novelty, and an ex-

citing one at that, but this phase (no pun intended) fortunately did not last very long. Soon record companies were using the new dimension to make better and more musical recordings. Quadraphonic sound, or so it seems to me, is now truly entering that stage probably because most of us are no longer impressed

with violins, or what-have-you, playing in all four corners of the room.

It's true that many musical (and unmusical) trivialities are still being recorded (or remixed) but there are encouraging signs that artists and producers are beginning to realize the potentialities of this intriguing medium. Sales of rock and popular stereo records are relatively much greater than classical, and to some degree this situation also holds true for quadraphonic recordings. Much present day pop and rock music is well suited to surround-sound presentation, and some items are quite excellent with this sort of presentation.

However, it should not be assumed that the more serious kinds of music have been denied four-channel release. Opera lovers have reveled in *La Boheme*, *Tosca*, *Thais*, and several others including not one, but two versions, in CD-4 and SQ, of *La Navarraise*. We have had a great number of symphonic works from Brahms and Beethoven to Tchaikovsky and Bartok, not to lose sight of the glorious recordings of two Mahler symphonies from RCA. Jazz has not been forgotten nor has the organ. In fact, the whole range of classical music—choral, and leader, orchestral and electronic—is represented at one or another point in the four-channel record catalog. No longer does one have to search in vain through the four-channel record stacks for a particular type of music.

Some of these recordings convey a spacious sense of concert hall ambience, while others attempt to create special dramatic effects by arranging the performers in a circle or semi-circle. Figure 1 shows a typical arrangement used by Columbia for SQ recordings made in Avery Fisher Hall. Figure 2 is an example of a different technique used by Andrew Kazdin in his fabulous SQ recording of Carl Orff's *Carmina Burana* in Cleveland's Masonic Auditorium. Purists, who are sometimes unaware of multi-

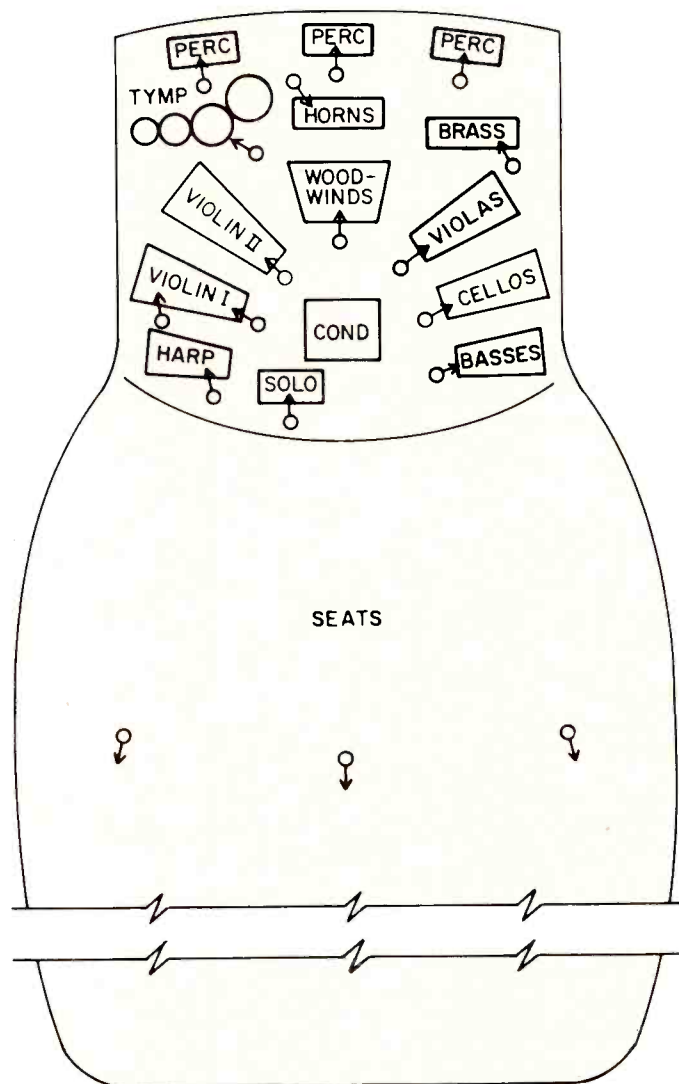

Fig. 1—Typical arrangement used by Columbia for SQ recordings made in Avery Fisher Hall.

FIVE OUT OF SIX TAPE RECORDER BUYERS WIND UP PAYING MORE THAN THEY NEED FOR PROFESSIONAL TAPE RECORDING QUALITY

Reason: They bought one or more makes before choosing Revox.

Our warranty records show that on average only one Revox buyer in six has never had a tape recorder before.

The remaining five have all owned one or more makes previously.

Since our warranty application invites comment, we are frequently told how happy our customers are with their Revox, especially when they compare it with their previous purchases.

But too often we hear the lament: "I wish I'd bought it sooner"

Save yourself the cost of experimentation in tape recording.

Select a recorder that will neither add nor detract from the original.

Choose the New Revox A700 or the A77 as your needs befit - and if your finances don't quite run to a new machine try to find one secondhand - in standard condition it will outperform other makes of new equipment at the same price.

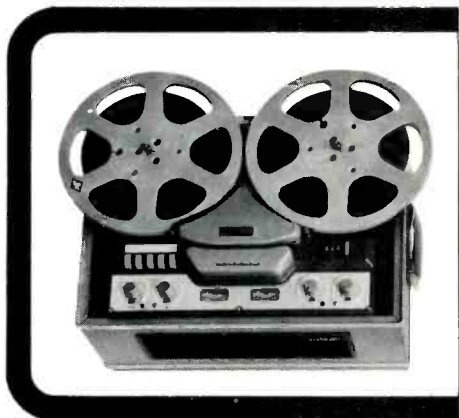

Revox Discontinued Model 36
Price: Less than \$450



Revox Current Model A77
Price: \$899 - \$1623



Revox Current Model A700
Price: \$1800

REVOX

BUY IT FIRST
IT'S BUILT TO LAST.

Revox Corporation
155 Michael Drive
Syosset, N.Y. 11791
U.S.A.

Revox International
Regensdorf 8105 ZH
Althardstrasse 146
Switzerland

Revox
C.E. Hammond Co, Ltd.
Lamb House
Church Street
Chiswick
London W42PB
England

Revox Canada, Ltd.

Please tell me where I can see and buy

Revox A700
Revox A77
Revox

Illustrations may contain optional extras.

Good used machines*

Name.....
Address.....

*As and when available
from our dealers

BFS

track techniques, might well be shocked by Kazdin's method of recording, but I am certain that if a person who was not familiar with this work listened to the recording more than once, he would find the stereo version dull and uninspiring.

Would the composer have "approved?" Andrew Kazdin believes he probably would, and I am inclined to agree. I am sure Bach would revel in the spatial possibilities; so would Moussorgsky. Listen to Tomita's incredible electronic version of *Pictures At An Exhibition* and you will understand.

Records and Radio

At the present time, there are over 1,000 quadrasonic records available in the U.S. Of these, some 350 are CD-4 types but more have been released in Japan. One company, Victor Musical, has no less than 510! Columbia reports that 47 SQ discs have achieved solid gold status, which these days means that they have sold more than half a million copies each. More than 400 FM stations broadcast SQ discs and 55 have SQ encoders. Sansui has been concentrating on FM stations, and they say that over 75 now have QS encoders and that another 75 will have them by early 1976. CD-4 records cannot of course be broadcast, but in spite of this handicap, sales of quadratics have been most impressive, with a surprising number achieving high places on the charts. JVC long ago decided that the best way to inform the public about CD-4 was to form Quadracenters at co-operating dealers, and there are now more than 60 such in operation throughout the country. The company also has dealer education programs—something badly needed.

Meanwhile, behind the scenes, yet another system is attracting a good deal of interest—especially in Japan and Europe. This is the Nippon-Columbia UD-4 system which first ap-

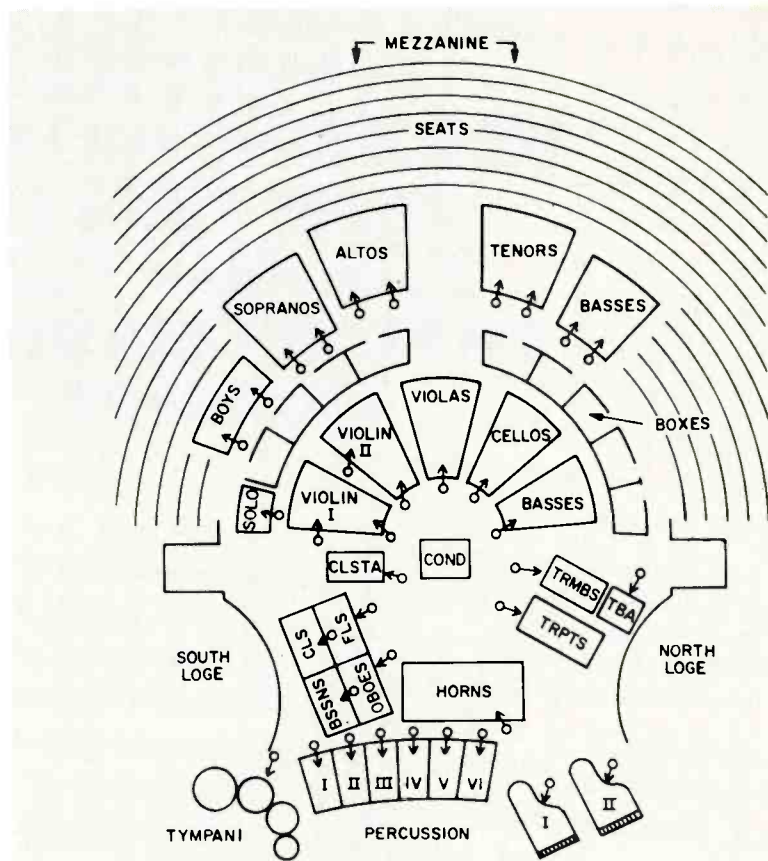
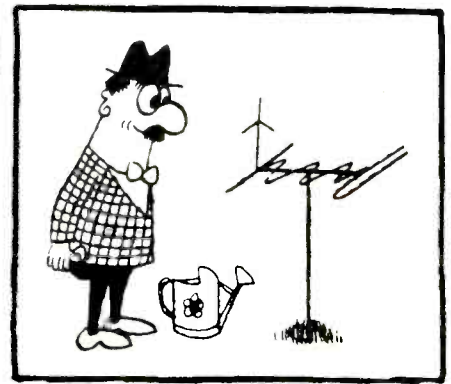
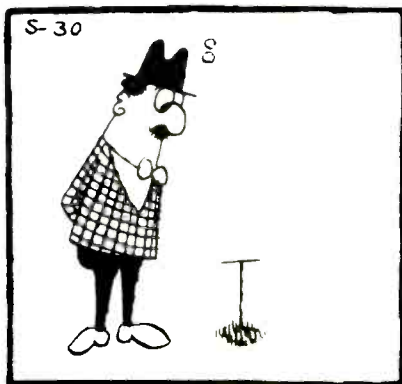

Fig. 2—Surround sound arrangement for recording *Carmina Burana* at the Masonic Auditorium, Cleveland.

peared in 1971 but has yet to find a major record company willing to sponsor it. One of its inventors, Dr. Duane Cooper of the University of Illinois, well known to *Audio* readers, says that the basic system, BMX, is more symmetrical and accurate than any other. However, separation still leaves something to be desired with this basic system, and the later, more sophisticated QMX version is far superior. (See Figs. 3A and B.) This kind of polar pattern can be achieved by certain logic systems, but what intrigues many engineers is the way the results are achieved. A carrier system is used to supplement the BMX matrix by providing a difference signal to increase

separation by phase cancellation. Records made in this way can be played via a simple matrix decoder or a more elaborate discriminator decoder. In practice, the ordinary compact or console would use the simple matrix decoder, while the audiophile's hi-fi system would contain the more sophisticated system. Such records have been released in Japan under the Denon name, and I understand that they will be available here in the near future. As a matter of interest, a pulse code modulation system is used for recording these discs, as well as others, thus improving the signal-to-noise ratio without resorting to special noise-reduction circuitry.



The end of the war between art and engineering.



*Console shown is optional.

There is performing and there is engineering. Art and signal. Both are important and both can suffer when you have to do both. Especially when your music and the machine that records it are making heavy demands on your concentration.

Our new 1140 lets you focus more on your music and worry less about how it's getting there.

Take sync. The 1140's simplified automatic sync control is a more logical approach to the function than anything you've used before. It frees you from that "Where the hell am I" frustration when you're building tracks.

It also lets you punch in (and when you punch in you're automatically switched from sync to source).

Sync level is the same as playback level, too, in case you don't have a third arm available for gain control.

The 1140 has built-in bias with the bias controls up front so you don't have to tear the electronics apart every time you change tapes. Plus a 200 kHz bias frequency for further noise reduction and one of the few heads around capable of erasing those exotic new formulations.

Then there's program memory, motion-sensing circuitry for anti-

spill tape handling, peak level indicators and an optional floor-standing console that makes the 1140 even easier to work with.

For all that and more the 1140 costs \$1199.95, about 45¢ more than Teac's A3340S. But if you spend that extra half-a-buck with us, you can spend more time with your music.

DOKORDER



	TEAC A3340S	DOKORDER 1140
Wow and Flutter 15 ips	0.04%	0.04%
Frequency Response at 15 ips	±3 dB, 35-22K	±3 dB, 30-23K
Signal-to-Noise Ratio	65 dB WTD	60 dB WTB
Front Panel Bias Controls	No	Yes
Built-in Test Generator	No	Yes
Mic/Line Mixing	Yes	No
Peak Indicator Lamps	No	Yes
Motion Sensor	No	Yes
Manufacturer's suggested retail price	\$1199.50	\$1199.95

Features and specifications as published by respective manufacturers in currently available literature

54301 csecrans Avenue Lawndale, California 90260

Check No. 53 on Reader Service Card

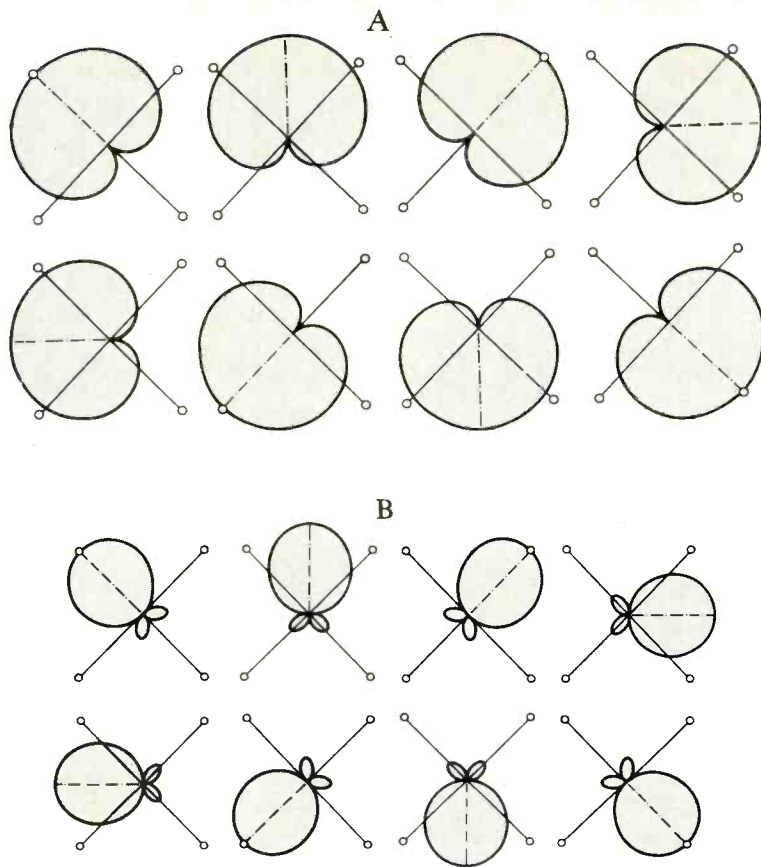

Fig. 3—A, speaker feeds with BMX matrix; B, speaker feeds with QMX matrix.

QMX is one of the five systems submitted to the National Quadraphonic Radio Committee (NQRC) for approval, and it is expected that their report will be made public early next year. However, there is a snag. Like CD-4 records, those made by the QMX system cannot be broadcast without contravening the present FCC regulations because of the wide bandwidth requirements. Figure 4A shows the present FM stereo frequency distribution, and the QMX arrangement is shown in Fig. 4B. As it is far from certain that the FCC will change the regulations, an alternative proposal has been submitted. This is designated TMX and the difference signal of this proposal uses a restricted bandwidth for the fourth channel, the effect being slightly reduced separation. In a series of tests, the differences between the two systems were found to be surprisingly small—probably because the most important locating frequencies, so far as listeners are concerned, 500 to 3000 Hz, still have good separation. Figure 4C shows the TMX distribution, and Fig. 4D shows the Quadracast or Doreen system. Bandwidth is sufficient for CD-4 records with the Quadracast system, but the FCC might not approve of the SCA's new home at 95 kHz.

Our System



takes the Noise out of your system.

Not all of it maybe, but up to 10 to 14 dB. And that's usually enough to have your signal emerge so clear and pure you will never again want to listen to your favorite music without the Burwen Noise Reduction Unit, the DNF 1201. Just add the DNF 1201 to your Hi-Fi system; the results from any tape, radio or record source will amaze you.

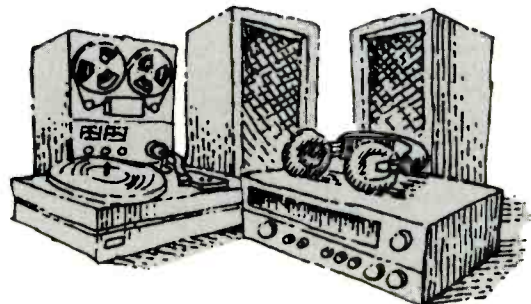

Burwen LABORATORIES
 DIVISION OF OHMTEC CORPORATION
 209 MIDDLESEX TURNPIKE, BURLINGTON, MASS. 01803 (617) 273-1488

Check No. 14 on Reader Service Card

Now - from the new RCA Quadraphonic Club!

Quadraphonic

Records or Tapes

Compatible, Discrete CD-4

Any 4 for only 99¢

plus postage & handling

Worth \$31.92 at regular Quadraphonic Club prices!

You merely agree to select 4 more hits at the regular Quadraphonic Club price in the next year from hundreds to be offered.

ARTHUR FIEDLER/BOSTON POPS 04468
Greatest Hits Of The '70s [RCA RED SEAL]

SEALS & CROFTS 20102
Summer Breeze [WARNER BROS.]

HENRY MANCINI 33413
Return Of The Pink Panther [RCA]

JONI MITCHELL 23669
Court And Spark [ASYLUM]

More Hits to Choose!

- Bread: Baby I'm 23710
- Jefferson Starship: Dragon Fly 13512
- Arlo Guthrie: Brooklyn Cowboy 13675
- The Guess Who: #10 24007
- Perry Como: Perry 20152
- Isao Tomita: Snowflakes Are Dancing 20045
- Nilsson: Duit On Mon Def 24194
- Gordon Lightfoot: Sundown 33176
- Hair: Original Cast 03292
- Floyd Cramer: Super Country Hits 23305
- Virgil Fox: The Entertainer 23294
- José Feliciano: Compartments 23605
- Hugo Montenegro: Neil's Diamonds 13641
- Tchaikovsky: Symph. #6 Patheque 23246
- Best Of The New Seekers 23720
- Carly Simon 23722
- Black Sabbath: Paranoid 04222
- Ronnie Milsap: Pure Love 04463

ARTHUR FIEDLER/BOSTON POPS 23626
Greatest Hits Of The '70s, Vol. 2 [RCA RED SEAL]

SPINNERS 23668 [ATLANTIC]

CARLY SIMON 23724
No Secrets [ELEKTRA]

CITIZEN KANE 24326
Gerhardt/Nat'l. Phil. Orch. [RCA RED SEAL]

The Souther • Hillman • Furay Band 23688 [ASYLUM]

EUGENE FODOR 33809
Tchaikovsky Violin Concerto [RCA RED SEAL]

THE BEST OF THE DOORS 13719 [ELEKTRA]

HUGO MONTENEGRO 13639
Scenes & Themes [RCA VICTOR]

HENRY MANCINI 10246
Henry Mancini Salutes Sousa [RCA VICTOR]

THE GUESS WHO 04443
ROAD FOOD [RCA VICTOR]

ORMANDY/PHILA. ORCH. 32488
Tchaikovsky Sleeping Beauty Suite [RCA RED SEAL]

DONNY HATHAWAY 23703
Extension Of A Man [ATCO]

HUGO MONTENEGRO 13631
Love Theme From "The Godfather" [RCA VICTOR]

HANGIN' OUT WITH HENRY MANCINI 24019 [RCA VICTOR]

DOLLY PARTON 31351
Bubbling Over [RCA VICTOR]

BLACK OAK ARKANSAS 23700
Raunch 'N' Roll [ATCO]

VIRGIL FOX 23660
Heavy Organ At Carnegie Hall [RCA RED SEAL]

TONY RLANDO/DAWN He Do "I Love You (Like I Love You)" 23627 [ELEKTRA]

BETTE MIDLER 14130
The Divine Miss M [ATLANTIC]

ROBERTA FLACK 13541
Killing Me Softly [ATLANTIC]

HUGO MONTENEGRO 04571
Hugo In Wonder Land [RCA VICTOR]

SEALS & CROFTS 23501
Unborn Child [WARNER BROS.]

ALICE COOPER 23629
Billion Dollar Babies [WARNER BROS.]

DANNY DAVIS & THE NASHVILLE BRASS 14317
Latest & Greatest [RCA VIC TOP]

THE BEST OF BREAD 23693 [ELEKTRA]

FRANK SINATRA'S GREATEST HITS VOL. 2 13874 [REPRISE]

THE BEST OF THE GUESS WHO, VOL. 2 20071 [RCA VICTOR]

THE FANTASTIC PHILADELPHIANS Ormandy/Phila. Orch. 14299 [RCA RED SEAL]

CHARLEY PRIDE 20076
Pride Of America [RCA VICTOR]

JAMES TAYLOR 22232
One Man Dog [WARNER BROS.]

JUDY COLLINS 23709
The Best Of Judy Collins (Colors Of The Day) [ELEKTRA]

DEEP PURPLE 13813
Machine Head [WARNER BROS.]

ALICE COOPER 23586
Muscle Of Love [WARNER BROS.]

CASABLANCA 14084
Gerhardt/Nat'l. Phil. Orch. [RCA RED SEAL]

VIRGIL FOX/ORMANDY Saint-Saëns Symph. No. 3 13670 [RCA RED SEAL]

SUNSET BOULEVARD 14354
Gerhardt/Nat'l. Phil. Orch. [RCA RED SEAL]

PERRY COMO 20207
And I Love You So [RCA VICTOR]

THE DOOBIE BROTHERS 33452
What Were Once Vices Are Now Habits [WARNER BROS.]

HENRY MANCINI 14319
Brass, Ivory & Strings [RCA VICTOR]

ORMANDY/PHILA. ORCH. 23664
Tchaikovsky Symph. No. 4 [RCA RED SEAL]

Your RCA Quadraphonic Club Brings You Top Hits at Top Savings!

Start Saving Now! Take any 4 Quadraphonic Records or Tapes for only 99¢ with trial membership in the RCA Quadraphonic Club. Indicate the 4 selections you want on the coupon; mail it today!

Colorful Magazine! Free Choice! Every four weeks MEDLEY brings news of dozens of Quadraphonic selections and features a "Selection of the Month" in your favorite music category. In all, you will have 17 purchase opportunities in the course of a year. No need to buy a selection every time. You merely agree to purchase four more hits in the next year at regular Quadraphonic Club prices (usually \$7.98). Choose from top labels like RCA, Warner Bros., Reprise, Atlantic, Elektra, Asylum . . . and more.

Automatic Shipments! To get the regular "Selection of the Month," do nothing; it will be sent automatically. If you want other selections, or none, advise us on the card always provided and return it by the date specified. You always have at least 10 days to decide. But, if you ever have less than 10 days to decide, you may return your automatic selection to us at our expense for full credit.

Cancel whenever you wish after completing your membership agreement by writing to us. If you remain a member, choose 1 selection FREE for every 2 you buy at the regular Quadraphonic Club price. (Postage and handling charge is added to each shipment.)

Free 10-Day Trial! If not satisfied, return your 4 hits after 10 days and owe nothing. Mail coupon today!

SEND NO MONEY - MAIL COUPON TODAY!

Mail to: RCA Music Service Quadraphonic Club
P.O. Box RCA 1, Indianapolis, Ind. 46291

Please accept my trial membership in the RCA Quadraphonic Club and send me the 4 hits I have chosen for 99¢. I agree to buy as few as four more at the regular Quadraphonic Club price in the next year, after which I may cancel my membership. I understand I may refuse the automatic shipment of each "Selection of the Month," order other selections, or none, by returning the dated card always provided. (Postage and handling charge is added to each shipment.)

1 SEND MY SELECTIONS ON (check one only):

8-Track **QUADRAPHONIC CARTRIDGES** **CD-4 RECORDS**

2 RUSH ME THESE 4 SELECTIONS (indicate by number):

3 I am most interested in the following type of music - but I am always free to choose from every category (check one only):

Today's Sound (Rock/Soul/Folk) **Classical**

Easy Listening (Instrumental/Vocal)

4 Mr. Mrs. Miss _____ Please Print

Address _____

City _____ State _____

Phone (_____) _____ Zip _____

Area Code

RCA Limited to new members; continental U.S.A. only; one membership per family. Local taxes, if any, will be added. **B-D6 T2**

Check No. 37 on Reader Service Card

Future Developments

CBS Laboratories is field testing the SQ Paramatrix decoder system, demonstrating it at recent audio shows. It is a very sophisticated system, using fast switching gates to achieve separation on the order of 30 to 40 dB.

Figure 5 shows the basic concept. A signal applied to the LT terminal only, without the logic action, results in the generation of a unity signal at LF'' and 0.71 signals at LB'' and RB''. The logic action, in this instance, causes the voltage-controlled switches (A and B)

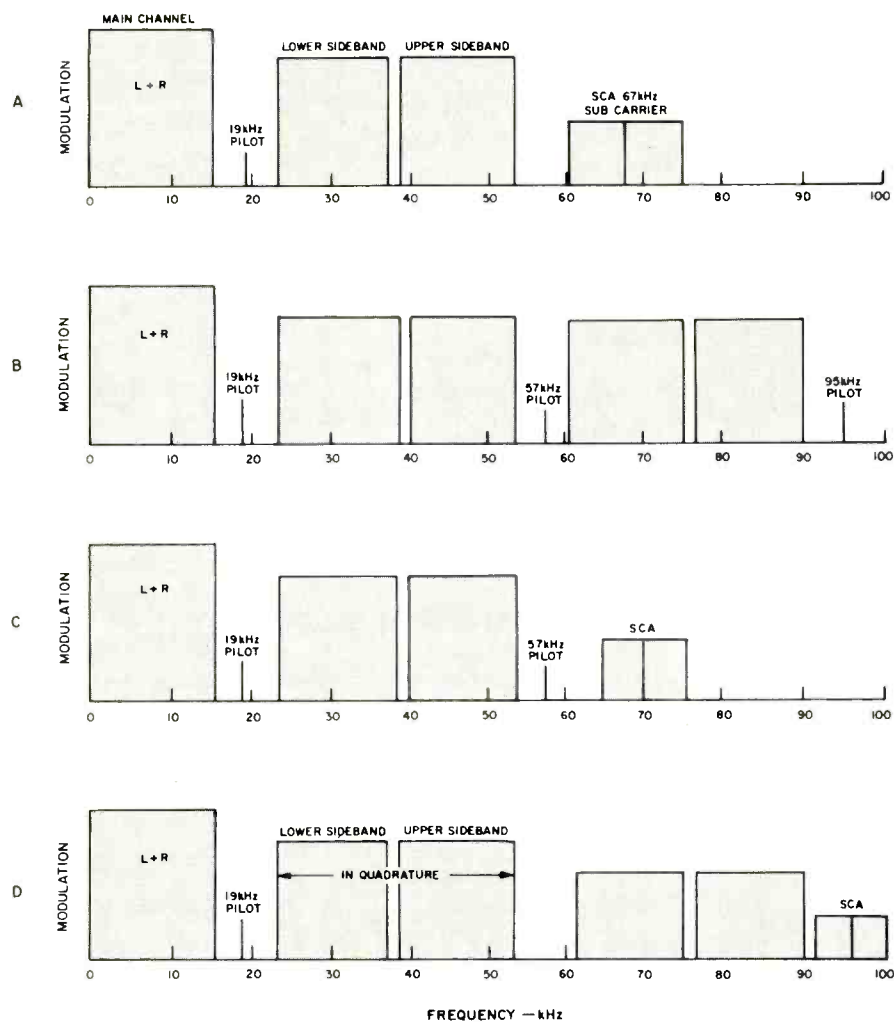

Fig. 4—A, present FM stereo frequency distribution; B, QMX proposal for distribution; C, TMX proposal for distribution, and D, Quadracast or Dorren proposal for distribution.

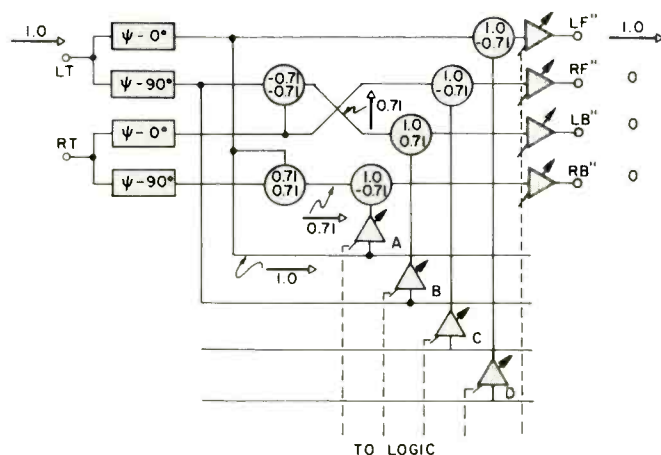

Fig. 5—Signal flow scheme of SQ Paramatrix decoder.

to become fully conductive, conveying equal and opposite signals to LB'' and RB'' and thus resulting in cancellation. At the same time, the level of the LF'' is raised 3 dB to retain the power balance. Other signal combinations and cancellation circuits work in a similar manner. Because the scheme uses selective cancellation, rather than gain control, it is possible to provide very short attack times, which translates into high degrees to cancellation or separation. It will be noticed that there are some similarities with QMX, and I agree with most critics that the results can be most impressive.

Audionics is now marketing yet another unit, using a system called Shadow Vector decoding. This professional-grade unit sells for \$1250.00, and reported sales are over 30. Relatively few details of the system have been made public, though the results of the demonstrations have been very impressive here as well. While the Tate Directional Enhancement System (DES) was not being shown at the most recent hi-fi shows, its return is to be expected. Results with the latest version of the Tate DES were as different from those of the Audionics Shadow Vector as both were from the CBS Paramatrix. Which is best? Well, all are very impressive, with imaging rather subtly different, so that making an absolute choice here is rather like successfully choosing a wife for someone else—possible but difficult.

Over in Great Britain, the BBC is testing various systems (including QMX), and work is still proceeding on the Ambisonic concept. With this last, the object is to create or rather recreate the sound field as heard at the listener's ears, and a special tetrahedral array of cardioid microphones is employed. Research has been undertaken by the University of Reading in Britain, in conjunction with the National Research Development Corp., but so far none of the record companies have shown any great interest—possibly because of the lack of flexibility.

Back home, the big question still concerns the NQRC and the FCC. If a system is approved, then we will see an immediate race to bring out suitable receivers. Many manufacturers already have prototypes in the lab, and Kenwood demonstrated a receiver at the spring audio show in Washington, D.C. that could work happily with four out of the five possible systems. However, the FCC might not approve any system or might just put off the decision for the time being. We must wait and see.

All cartridges are not created equal. Here's proof.

“...Tracking ability at low and middle frequencies was exceptional...the high level required half the tracking force of most other cartridges...One of the best 2-channel stereo cartridges and better than most CD-4 types.”

HI-FI NEWS AND RECORD REVIEW

Our new Super XLM MK II (\$125.) is the finest cartridge available. It was engineered solely for the true audiophile and the serious music listener who own the very finest components.

It embodies principles found in no other cartridges, as evidenced by our U.S. Patent. It features a unique “induced magnet” whereby the magnet is fixed and the magnetism is induced into a tiny hollow soft-iron collar. This collar in turn moves between the pole pieces thereby allowing for a major reduction in the mass of the moving system. This LOW MASS permits the Shibata type stylus to trace the most intricate modulations of stereo and CD-4 record grooves with a feather-light tracking force—as low as $\frac{3}{4}$ of a gram.

This results in super-linear pick up especially at the higher frequencies of the audible spectrum, which other cartridges either distort or fail to pick up at all. This low tracking force also assures minimal erosion and a longer playing life for the records.

This family of LOW MASS Cartridges is also offered with elliptical diamond stylus for stereo play exclusively—the XLM MK II (\$100) and VLM MK II (\$75).

For detailed specifications, write ADC.



U.S. PAT. NO. 3294405

ADC Super XLM_{MK II}



**AUDIO
DYNAMICS
CORPORATION**

A BSR Company • New Milford, Conn. 06776

What's New in Audio

Stanton Gyroiose Turntable



This turntable features magnetic suspension of the 12-in. aluminum platter for reduced bearing wear as well as lower rumble. The arm has a single pivot point for both lateral and vertical movement. Viscous-damped cueing control is included, and drive

is via belt from a 24-pole synchronous motor. Supplied with base, dust cover, and Stanton cartridge. With the TT681 stereo pickup, the Model 8004-I costs \$199.95. With a TT780 4-channel pickup, the Model 8004-IV costs \$224.95.

Circle No. 90 on Reader Service Card

Sony PS-8750 Turntable



The PS-8750 direct-drive turntable uses a quartz crystal-controlled oscillator, yielding speeds said to be 99.997% accurate. Rumble, flutter, and wow are claimed virtually non-existent. Carbon fiber arm and pickup shell provide minimum resonance level and low tracking mass. A photoelectric cell replaces the usual mechanical tripping at the end of the disc; a separate motor then powers arm lift-off and return to rest position. The price, including base and dust cover, is \$580.

Check No. 92 on Reader Service Card

SAE Mark XXV Power Amplifier



This stereo power amplifier from Scientific Audio Electronics provides 300 watts per channel at less than 0.1% THD from 10 Hz to 30 kHz and less than 0.05% IM distortion. S/N ratio is said to be 100 dB below rated output. SAE states their unique PSO (paralleled-series-output) circuit, which uses 16 output devices, can

drive highly reactive loads, such as electrostatic speakers, over a greater-than-usual safe-operating area. Professional version of this amplifier is in rack-mount panel with handles, labelled Model 2500. Both versions have forced-air cooling and are priced at \$1250. Five year SAE warranty is transferable.

Circle No. 91 on Reader Service Card

Swiftcraft Dolby De-emphasis Compensator

There are increasing numbers of stations in metropolitan areas (30 at last count) going over to Dolbyized broadcasts because it can increase their effective range considerably, for Dolbyized listeners. For those people who have a tape recorder with Dolby but whose FM stereo tuner has the previously-standard 75 microsecond de-emphasis network at its output, this compensator provides an easy way to change the tuner's output over to the newly approved 25 microsecond de-emphasis network (for Dolby). It works with any separate Dolby unit. The Model 621 is a small box with two cables for its output and two jacks for input from the tuner. Passive network inside is switchable for either 25 or 75 microsecond circuit. Price is \$12.95.

Check No. 93 on Reader Service Card

The \$750 alternative.

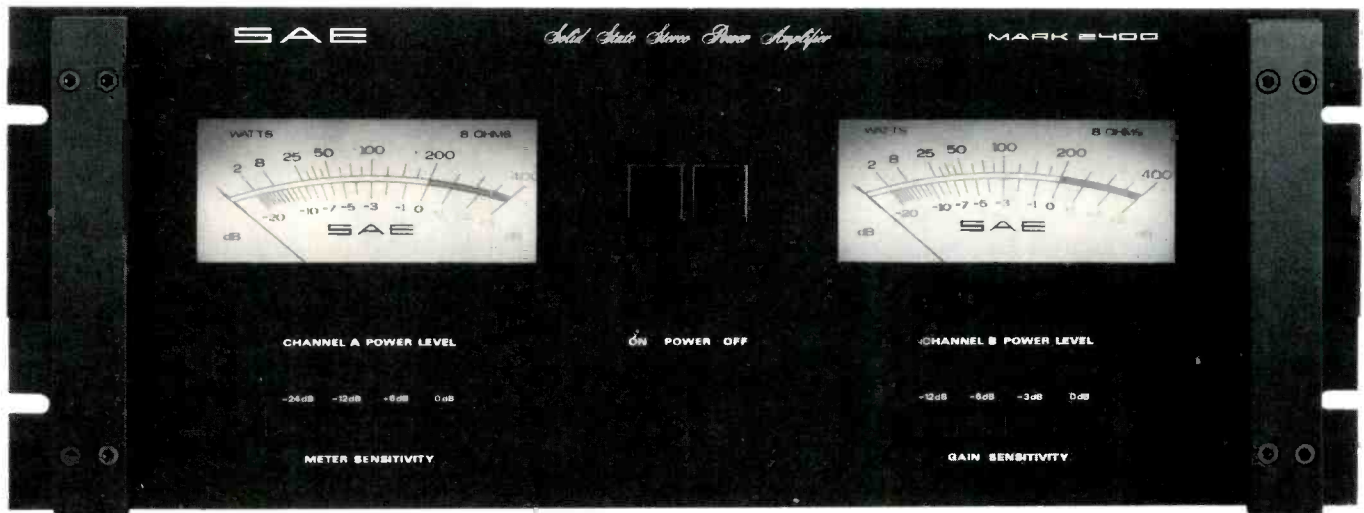

SAE 2400 Professional Dual-Channel Power Amplifier

The 2400 Professional amplifier—SAE's \$750 alternative. We give you maximum power, performance, reliability, and versatility for your dollar.

POWER—200 watts RMS, per channel, both channels driven into 4 or 8 Ohms from 20Hz to 20kHz at no more than 0.05% Total Harmonic Distortion.

PERFORMANCE—The 2400 is built to typical SAE specifications which include extremely low IM Distortion and low noise, as shown by the following graphs and specifications:

2400 INTERMODULATION DISTORTION @ 8 OHMS, FULL POWER 40V RMS BOTH CHANNELS DRIVEN

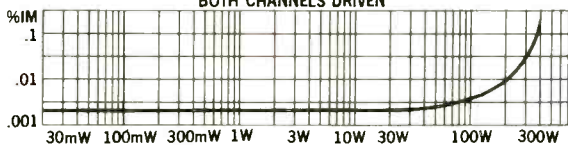

2400 TOTAL HARMONIC DISTORTION @ 8 OHMS, FULL POWER 40V RMS BOTH CHANNELS DRIVEN

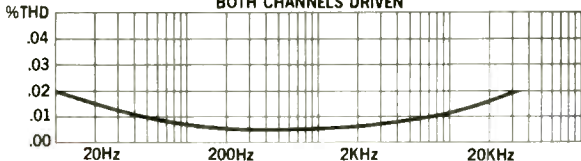

Other Specifications:

IM Distortion from 200mW to rated power at 4 or 8 Ohms with any 2 mixed frequencies between 20Hz and 20kHz at 4/1 voltage ratio..... 0.05% Max.
 Input Sensitivity..... 1.5 volts, RMS
 Frequency Response at rated power..... ± 0.25 dB, 20Hz to 20kHz
 Noise..... Greater than -100dB below rated power
 Transient Response of any Square Wave..... 2.5 μ sec. rise and fall time
 Slew Rate..... 40 V/ μ sec.
 Dimensions..... Front panel: 19"Wx7"H, Chassis: 11"D
 (excluding handles, controls and connections)

Specifications comply with FTC requirements for power amplifiers.

Check No. 43 on Reader Service Card

RELIABILITY—Series-Output circuitry assures high current capability without loss of wide power bandwidth, low leakage current or super high slew rate. High demand reliability is built in through the use of 8 triple diffused output transistors.

VERSATILITY—The 2400 is a very efficient power package, weighing less than 42 lbs. and having a depth of only 11". Available in black rack mount (as shown) or our traditional satin gold and black.

OTHER FEATURES—Dual relay disconnect circuits, plug-in board modules, feedback level control, direct power reading VU meters and forced air cooling—features normally associated with power amplifiers costing considerably more than the SAE 2400.

COMMENT—You'd have to look a long time to find a power amplifier that delivers so much value. Superb power, superior performance and total reliability makes the SAE 2400 truly the \$750 alternative.

Components for the connoisseur.



Scientific Audio Electronics, Inc.
 P.O. Box 60271
 Terminal Annex
 Los Angeles, California 90060

A 11/75

Please send me the reasons (including available literature) why the SAE 2400 Professional Amplifier is the "\$750 Alternative."

NAME _____

ADDRESS _____

CITY _____ STATE _____ ZIP _____

Four-Channel Sound: What Do You *Really* Hear?

Daniel Shanefield

AT SOME TIME or other, most high-fidelity enthusiasts have flipped a switch back and forth between *mono* and *stereo* and observed the striking difference in the sounds which were perceived. The present article analyzes this difference into several attributes which can be demonstrated by simple experiments. Then, going on to quadraphonic the difference between it and stereo is explored in a parallel manner. Several kinds of quadraphonic and pseudo-quadraphonic sound are discussed.

Mono Versus Stereo

The most obvious attribute of stereophonic sound, when compared to monophonic sound, is *directionality*—the abil-

ity to give the listener the perception that a sound is coming from an identifiable direction. Stereophonic equipment provides for differences in volume between the left and right channels, and also differences in phase, and each of these contributes to the directionality effect. Of course, these differences are not present in a mono system.

(Another word, *separation*, has often been used in other discussions, but it has somewhat different meaning. While *separation* refers to an objective difference in volume alone, the word *directionality* as used here refers to a subjective illusion, caused by differences in volume, phase, and possibly additional factors.)

A second attribute is *spaciousness*—that is, the perception that a sound source is spread out over a long line or a large area. Sounds that seem to emanate from several different directions will provide a spacious feeling to some degree, but there is more to it than that. Even if a soloist is performing at a single spot, and directionality is therefore not involved, the listener can still be given the feeling that there is a large stage around the soloist.

Part of this spacious feeling can be generated by one channel being out of phase with the other. If a mono music recording is played through speakers or headphones, and the phase of one channel is suddenly reversed, the music will seem to spread out toward the left and right. There are several ways to do this. The simplest is to reverse the wires at one speaker (or headphone). To get quick AB comparisons while the music is playing, one can wire a DPDT switch into one channel.

There is another method which is probably easier for most people to accomplish, since it does not require the addition of a switch. In this method, one uses an amplifier or equalizer which has an odd number of inverting stages, thereby changing the phase, and only one channel is passed through it (see Fig. 1). The Bose 901 equalizer is an example of such a

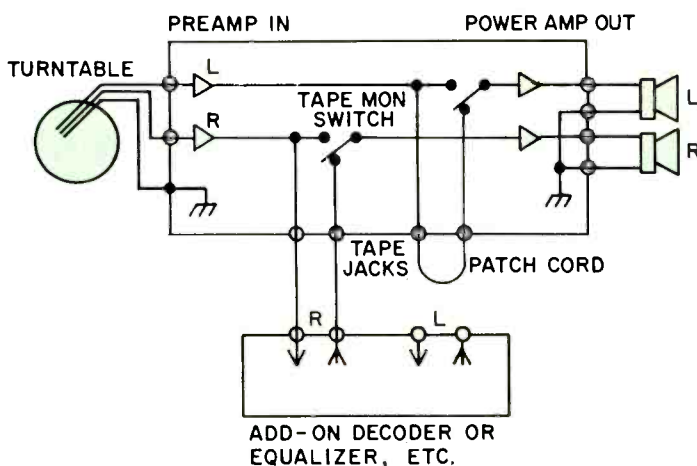

Fig. 1—Reversing the phase (inverting) one channel. Tape monitor switch can be used for fast AB comparisons.

TWICE AGAIN, HISTORY REPEATS ITSELF.

Carrying on the innovative tradition of our almost
ninety year involvement in music,
Yamaha announces a double breakthrough in all-FET technology.

Yamaha's C-1.

At \$1800, you've never seen a preamplifier like this before.

It's so different we call it the Master Control Center. You'll call it well worth waiting for.

From input to output, it's the first to use advanced FET's exclusively throughout the signal path.

Yamaha's C-1 is made for perfectionists who appreciate the superb clear tonality and exceedingly low distortion that only FET's can bring.

For advanced audiophiles who want the complete control over literally thousands of audio variables that only the most advanced circuits and features can offer.

A built-in oscillator.

Consider the C-1's unique built-in oscillator with level control, a professional test instrument that's usually found only in sophisticated audio labs.

By generating both random "pink" noise as well as the four most useful test tones (70 Hz, 333 Hz, 1 kHz and 10 kHz), the C-1's oscillator can be put to a variety of tasks:

Determining the precise phono impedance loading, checking the frequency response of speakers, A-B speaker comparisons, setting up a tape deck, balancing the output level of an entire system, and balancing room acoustics. You'll discover more and more uses as you go along.

(A word of caution: because the C-1's oscillator can be used externally, all your audiophile friends will want to use it to test their own components.)

Where most other manufacturers use a negative feedback design in their phono equalizer amplifiers, Yamaha specified the more sophisticated passive interstage equalizer (CR-type). The results were worth it:

Greater stability, lower distortion, superior tonality.

In our all-out effort to reduce noise at all preamp output levels (not just at

maximum output), the C-1 features a unique four-gang volume control that simultaneously adjusts inputs and outputs.

You're totally in control.

With the C-1's selectable equalization controls for presence and acoustic balance, you enjoy the equivalent of a separate equalizer. For those occasions when you don't want to use equalization controls, the C-1's special circuitry lets you bypass them completely.

Another unique feature that sets the Yamaha C-1 Master Control Center apart from other so-called state-of-the-art preamplifiers:

Six-position selectable phono impedance that allows your cartridge to be precisely loaded for optimum high frequency performance.

The Yamaha C-1's absolute control over sound also includes a pair of extra wide-range (-50 db to +6 db) peak reading meters. Electronic damping provides both faster peak readings and slower decay, assuring precise monitoring. You can also use the C-1's meters to monitor any external component that doesn't have meters.

Writing in *Audio* about our unique metering system, Bascom H. King stated:

"...by far the most accurate and meaningful of any meter set-up seen thus far."

Individual level controls let you balance the input from all signal sources, except the tuner. (Yamaha's companion tuner, the CT-7000, has its own variable output level adjustment.) So the volume level stays the same when you switch, for example, from tape to phono, tuner to aux, etc.

And there's more.

Enough that once you hear the Yamaha C-1, you'll never be satisfied with another preamplifier again.

Yamaha's B-1.

At \$1600, it's already redefined state-of-the-art amplifier performance in a lot of people's minds. Yours might be next.

Revolutionary Vertical-FET design produces a completely different kind of sound. Clean, open and transparent. With a richness that goes beyond the best vacuum tube amplifiers.

And, up to now, unavailable.

Worth the wait.

As late as a few years ago, there existed only two types of transistors: bipolar and horizontal FET. Each operated in a completely different manner.

The bipolar device uses input current to control output current. On the other hand, the horizontal FET uses input *voltage* to control output current—a more suitable audio technique that's quite similar to vacuum triode tube design. (Both use input voltage to control output current; both have sharp cut-off characteristics which eliminate high-order harmonics and notch distortion.)

Only there was a small problem.

Because current passage was restricted to a single path, the horizontal FET didn't produce enough power to be used in the output stages of a power amplifier.

Then, in 1971, Prof. Nishizawa of Tohoku University drastically changed the FET's internal structure. The shape of the voltage-controlled constriction was altered to let the current take an almost infinite number of paths.

And so, the Vertical-FET was born.

During the past three years, working exclusively with Prof. Nishizawa, Yamaha's engineers have brought the Vertical-FET to the forefront of audio technology, where it serves as both driving and output devices in our new B-1 amplifier.

The B-1's rated 150 watts per chan-

nel (20 Hz to 20 kHz, less than 0.1% THD) are produced by only two Vertical-FET output devices per channel.

Compare that with the minimum of six to eight output devices per channel found on most other amps!

Yamaha knows that fewer output devices minimize the distortion caused by out-of-balance output devices during transistor switching cycles. And maximize tonality.

People are talking.

Here's what Julian Hirsch of *Stereo Review* had to say about the power-handling capacity of Yamaha's new Vertical-FET:

"Each of the FET's is about the size of an ordinary power transistor, but it can dissipate 300 watts!"

Audio's Bascom H. King observed that the B-1's power output at visual onset of clipping for an 8-ohm load was 220 watts—46% over spec!

So you can see that our 8-ohm rating of 150 watts is quite conservative indeed!

Because the B-1 is used as a reference amp by many of our dealers, we supply an optional control unit that can A-B up to five pair of speakers and balance them for efficiency at the head amp. Without the insertion of T-pads that degrade low-end response by decreasing damping characteristics.

It's called the UC-1. It costs \$250. And you don't have to be a Yamaha audio dealer to own one.

Besides speaker switching, the UC-1's extra wide-range peak delay meters, with faster peak and slower decay like those on the C-1 (but calibrated in both dB's and watts of power output), offer an extremely precise monitoring capability to your system.

Yamaha's C-1 and B-1. \$3650 the pair, with the UC-1 control unit.

After you hear them together, you'll never be satisfied with anything less.



International Corp., P.O. Box 6600, Buena Park, Calif. 90620

Check No. 52 on Reader Service Card

component. Or, instead of an equalizer, one could use just the right *front* channel of most types of SQ decoder or decoder-amplifier, switched to stereo (not SQ). Also, many tape recorders switched to *source* will accomplish this. However, some equipment such as the BSR Metrotec FEW-2 equalizer does not change the phase in the manner needed here and would not serve this purpose.

To test a given component to determine whether it can be used for the experiment, place the left and right speakers close to each other. Pay particular attention to low-pitched sounds. If the sound volume decreases when the component is switched into one channel, then the phase is being reversed properly. But if no large change in bass volume occurs, then a different type of component should be sought for the experiment.

If the sound volume *increases*, then the speakers were improperly phased in the first place, and the wires leading to one speaker should be reversed. The component is doing its job, however, and it can be used for the experiment.

The *synthesized spaciousness* experiment consists of listening to music through the circuit of Fig. 1 and switching the *Tape Mon* switch in and out quickly. If loudspeakers are used instead of headphones, the listener should be equidistant between the speakers. When the 180° phase reversal is switched in, the apparent source of sound should seem to spread out.

To make use of this effect, several new types of headphones have switches to change the phase of one channel to various degrees. Examples are the Koss Phase/2+2 and the Audiotec Electrostatics.

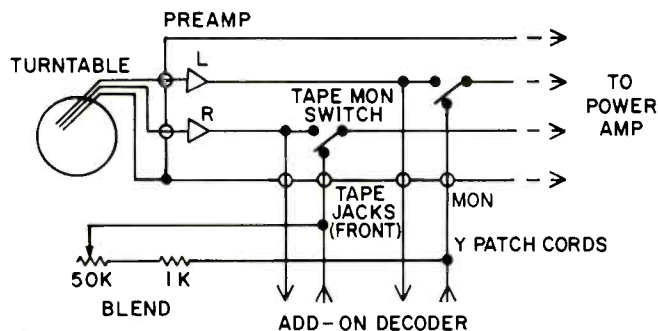

Fig. 2—Blend potentiometer for front channels. If add-on unit is not used, a built-in decoder can be blended by attaching pot to *Tape Out* instead of *Tape In*.

Unfortunately, a constant phase difference of 180° gives the illusion of a hole in the middle of the performing stage. Switching to true stereo provides a much stronger effect of directionality and spaciousness, and it does so without the hole in the middle. The reason is that true stereo includes a variety of complex phase differences, and this has a better effect than one simple phase difference.

Turning now to a different effect, *headphones* operated in the stereo mode sometimes produce an illusion that the instruments in an orchestra are spread out *more* than they were in the actual performance. To correct such exaggerations, blend devices are offered commercially which mix mid-bass frequencies to a controllable degree, restoring realistic dimensions. A simplified version of such a device is

shown in Fig. 2. All frequencies are affected equally, which is usually a satisfactory arrangement.

It is interesting that a quadrasonic decoder/synthesizer can give a good illusion of stereo spaciousness when it is used to change the left (or right) channel phase of signals coming from a mono source. This can be demonstrated as follows. While playing a 2-channel stereo recording through a 4-channel matrix system, turn off the right-front and right-back speakers. Switch the decoder/synthesizer to stereo, so that the synthesizer (sometimes called *Composer* circuit) is not operating. Of course, you will now be hearing only the left channel, which is monophonic sound played through two loudspeakers. Face the left wall and note that the sound seems to emanate from a spot in the middle, in typical mono fashion. Switch the decoder/synthesizer to either *SQ* or *Synthesize*, and note that the sound seems to spread out over the whole wall, with a much increased feeling of spaciousness.

A synthesizer changes the phases of different sounds in a fairly complex manner, and it also changes the volumes. The question immediately comes up, "Will a synthesizer therefore create a good illusion of front-to-back spaciousness in a four-speaker system playing stereo records?" This will be discussed in a later section.

Another illusion of spaciousness using a mono source is obtainable by turning one (but only one) of the loudspeakers around to face the wall. It should be about 1-1/2 ft. away and aimed at a slight angle, to reflect the sound to the listener. For the two channels, sounds of various wavelengths will be out of phase by different amounts. Also, this system introduces complex reflections. The illusion is pleasant and can enhance the enjoyment of mono recordings.

Recent reissues of old mono records are often modified by the record companies to provide "electronically reprocessed stereo." One of the possible methods involves a "Madsen tube," (1) which delays the sound of one channel by passing it through the air between a loudspeaker and a microphone. Reverberations similar to those of a concert hall can also be added by this means, to generate quadrasonic effects, although purely electronic reverb is more commonly used.

While we are dealing with out-of-phase but otherwise mono sounds, it should be remembered that 180° reversed phase signals, when 100% combined electrically, cancel out and leave zero signal. (Other words which are sometimes used to describe this are "mixing" or "adding" to give "destructive interference.") The interesting fact is that if the signals are combined in your head, as in the 180° phase reversal experiment described above, there is no cancellation.

In commercial mono recording, it is common to mix several microphone channels electrically. Is there significant cancellation of out-of-phase sounds in mixed mono? If so, something in stereo which we could call *richness* would be lost in mono. (Once again, this might have a bearing on quadrasonic sound.) However, it happens that it is quite possible to mix channels with little net loss, because cancellation is compensated by new waves which are added only slightly out of phase and do not cancel. What is lost just about equals what is gained.

Experiments may be made to test for loss of richness in mono, as follows. Hook up both the left and right speakers (or phones) in parallel, with both connected to the left channel amplifier output. Select a particularly noise-free stereodisc recording, having practically no sound in the spiral grooves which run between the recorded bands, and play it in stereo. Of course, you will hear only the left channel. Listen for complex music which might be described as rich. Now switch back and forth between stereo and mono. In



THE INNOVATORS. BY BOSE.

The only Direct/Reflecting® loudspeaker systems.

The Bose 901, 501 and Model 301. The only speaker systems that meet the two basic requirements for preserving the qualities of live music in reproduced sound: the proper balance of reflected and direct sound for spaciousness and clarity; and flat power radiation to assure correct frequency balance and accurate reproduction of instrumental timbre in an actual listening environment.

The internationally acclaimed 901® system utilizing nine full range drivers with an active equalizer to provide the ideal balance of reflected to direct sound at all frequencies, setting the standard for lifelike music reproduction in the home.

The unconventional 501 incorporating an exceptionally linear 10" woofer and two rearward facing tweeters to furnish many of the performance advantages of the 901 system, but at substantially lower cost.

The new Model 301 offering a unique combination of features: Asymmetrical Design, a Direct Energy Control and a Dual Frequency Crossover™ network. This achieves reflected and direct sound with flat power radiation in a bookshelf enclosure, producing a sound quality that is extraordinary from so compact a speaker at so low a price.

The innovative speakers. From Bose. Each unique in concept and design to provide the maximum musical enjoyment for your home. One of them will ideally meet your requirements.

Shown above, left to right, 501, 901, and Model 301. For information, write to us at room AS.

Model 301 Patents Issued and Pending

BOSE®

The Mountain, Framingham, MA 01701

the mono mode, the L and R channels are combined, and any significant cancellation will be heard during the AB comparison.

You can repeat this with a noisy record and observe the cancellation of noise when you switch to mono this time. This is due to the way the two transducers are wired in the pickup cartridge, whereby pure vertical motion results in left *minus* right signals, which amount to nearly zero. A large percentage of the noise (caused by dirt and defects) leads to the cancelled vertical motion of the needle. But with a quiet record, the musical vibrations are not purely vertical. Adding the right channel (by switching to mono) puts in just as much new recorded sound as it cancels, so no significant richness is lost.

It should be noted that a small amount of noise can give a mistaken illusion of better high frequency response, (2) so a good, noise-free record is essential for a true test of richness. With such a record, there is practically no loss-of-richness effect.

Stereo Versus Quad

Let us consider *directionality* again, but this time from a front-to-back standpoint. For a strong effect it requires the additional channels of quadrasonic sound. Some newer serious music, such as Leonard Bernstein's *Mass*, is being arranged specifically for quadrasonic, and much popular music is also. For these the directionality of quadrasonic is necessary for fidelity to the original.

Since the older music which we call "classical" is not meant to be performed behind the listener, it might seem as though front-to-back directionality would be superfluous for that kind of music. However, it turns out that the illusion of reverberations with long time constants can be generated in the listening room if suitably-delayed sounds are added at the back of the room. Thus, directionality can be useful in creating another dimension of spaciousness. But let us explore further into the directionality effects themselves.

Much literature has already been published on the accuracy of directionality achievable with various kinds of matrix decoders. (3) Here are a few additional points.

Front-to-back directionality (or the illusion of "separation") can be improved in some older types of SQ decoders by blending the left-front and right-front channels. These decoders allow considerable leakage of the back channels into the front, and vice versa. The leakage is particularly noticeable in the front, since more of the listener's attention is usually concentrated there. The leaked back signal which shows up in front is often out of phase between the left and right channels. A blend pot such as the one described in Fig. 2 tends to cancel this signal. While some L to R separation is lost by this means, it is often exaggerated in matrixed records anyhow, and more is usually gained than is lost by front L+R blending. (Some types of decoders blend the back channels, in a variable manner. However, with only a fixed resistor, front blending appears to be more effective.)

It should be remembered that only *slight* differences in volume and phase are necessary to provide a rather strong feeling of directionality. Listeners are often disappointed when they turn off three speakers and listen to just one, and the sounds which should be coming from four different directions seem to be playing at nearly constant volume from that one speaker. Variations in volume and phase are not impressive from one speaker, but they are sufficient to provide plenty of the directionality illusion when all four speakers are operating.

Regarding quadrasonic headphones, you can tell front from back with some of the new quad phones. Doubters should try the following in any hi-fi showroom. Play music in

the stereo mode in which front and back channels are coming from the same source, undecoded. Turn the front channel on and the back channel off, and then vice versa, for a fast AB comparison. While the best phones have definite front-to-back directionality, it is not as strong an effect as with speakers. Comparative reviews of some quadrasonic phones have been published in *Audio*. (4)

For many readers the *spaciousness* aspect of quad will be the part of this discussion which is of the most interest, particularly if much of their listening is to classical music. When 4-channel spaciousness is demonstrated, the quadrasonic system usually beats stereo by at least as wide a margin as stereo provides in exceeding mono. Typically, a classical SQ disc, such as the Vanguard VSQ-30021 recording of *Petrouchka*, is played with a quadrasonic system. Then the back channels are switched off and a stereo record is played. No contest.

However, the listener should say immediately, "That was not a fair contest in the first place." For one thing, the same record was not used for both tests. The addition of back speakers can give a strong spaciousness effect, even without the decoding.

As with the mono-versus-stereo tests, we can estimate the effectiveness of two channels versus four channels with an AB test. Most 4-channel amplifiers have a switch marked 2-CH/4-CH with which you can make the comparison. Keep the back speakers on all the time, and use a quadrasonic recording.

If the 2-CH position cuts off the back speakers, as it usually does with discrete tape systems, leave the switch in the 4-CH position to operate all four speakers continuously. Connect patch cords to the 4-channel tape monitor jacks, and touch the hot leads of the front and back channels together to hear the effect of only two signal channels playing through four speakers. If the circuit diagram of the tape monitor does not show at least 1000 ohms of series resistance at its output in the preamps involved, add 1K resistors in series for protection.

With the four-speaker setup (with the front and back channels combined, as above) there is still another problem in trying to make a fair test comparison of four separate channels. When the two channels are playing through the four speakers, there is an unpleasant phenomenon which has been called "the flat radiator" effect (5), in which the sound seems to be coming from the middles of the left and right walls. By comparison, true quadrasonia has blended, complex phase mixtures which spread the apparent sound sources similarly to the way stereo does when compared to mono. The difference in the degree of blending tends to mask other effects which are of more interest.

The arrangement shown in Fig. 3 eliminates this problem, by blending during the 2-channel part of the test. In addition, the sound will reflect back and forth from left to right several times before working its way to the listener's ears. This causes the apparent reverberation time to be longer than that usually heard in household rooms, thus providing some of the feeling of a large concert hall.

Some of the author's friends call the configuration of Fig. 3 the "Shanefield speaker setup," or "S-cubed." Other acquaintances call it "quadrasony." Regardless of the name, it will give true quadrasonic some pretty tough competition, with classical music.

Another mode of creating quadrasonic effects from stereo recordings is the electronic *Synthesizer* or *Composer* circuit built into many matrix decoders. The wiring diagrams of several popular models indicate that these use the decoders themselves, with a few attenuating resistors added, to change the phases of the back channels in a complex way.

Would you recommend your turntable to your best friend?

If not, you need a Dual.

If you were to replace any of your present components, would you know exactly what its successor would be? And then buy it without further consideration? Perhaps. But we think it more likely that you would look for more information, either in a music/equipment magazine or from a knowledgeable friend. Probably from both.

Which brings us to turntables . . . and Dual.

Each year we hear from a sampling of Dual owners in response to a lengthy questionnaire. A high percentage tell us they're now on their second Dual. An even higher percentage formerly owned manual turntables. And nearly all rate their Duals as either "excellent" or "good."

Although there are other fine turntables, few match Dual's reputation for quality performance and reliability, and none match Dual's operational versatility. For example, if you want to be able to play records in sequence, you have four single-play/multi-play Duals to choose from. If you simply want fully automatic convenience in a single-play-only turntable, you have two to choose from. And there is now a semi-automatic Dual.

The way a tonearm is moved to and from the record is not critical. Nor is the type of drive system. What is critical is how faithfully the tonearm permits the stylus to follow the contours of the groove and how accurately and quietly the platter rotates. To compromise with quality in these respects can risk damage to your precious records and produce sounds which were never recorded.

Every Dual, from the 1225 to the CS701, provides more precision than you may ever need. Which is why more component owners—audio experts, hifi editors, record reviewers and readers of the music/equipment magazines—own Duals than any other turntable.

There's no better recommendation we can offer you. Or that you can offer to your best friend. Unless you happen to own a Dual yourself.

Dual 1225. Fully automatic, single-play/multi-play. Viscous damped cue-control, pitch-control. 10 $\frac{1}{2}$ " platter. \$139.95, less base.

Dual 1226, with cast platter, rotating single-play spindle, \$169.95.

Dual 1228, with gimballed tonearm, synchronous motor, illuminated strobe, variable tracking angle, \$199.95.

Dual 1249. Fully automatic, single-play/multi-play. Belt drive. 12" dynamically-balanced platter. \$279.95, less base. Full-size single-play models include: Dual 510, semi-automatic, \$199.95; Dual 601, fully automatic, \$249.95. (Dual CS601, with base and cover, \$270.)

Dual CS701. Fully automatic, single-play. D.C. brushless, electronic direct drive motor; tuned anti-resonance filters. \$400, including base and cover.



Dual 1225



Dual 1249



Dual CS701

Check No. 17 on Reader Service Card

United Audio Products, 120 So. Columbus Ave., Mt. Vernon, N.Y. 10553
Exclusive U.S. Distribution Agency for Dual

Dual

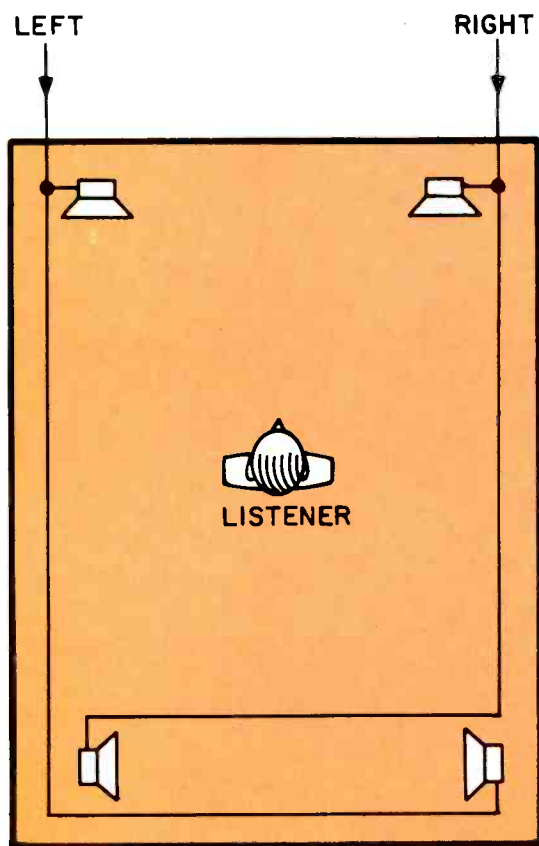

Fig. 3—Reflected-sound synthetic 4-channel arrangement, to increase the spaciousness illusion of stereo classical music. This provides blend, reverb, and complex phase changes.

For completeness, it should be mentioned here that simple, 180° phase reversal in the back speakers has no effect on the overall feeling of spaciousness. Very complex phase changes are required in the back in order to have even a minimal effect.

Now we come to matrix decoding of four-channel recordings. This appears to give another slight improvement in spaciousness, compared to the above mentioned modes. There are some sections of some records where the effect on classical music is quite pronounced. For an example, listen to the pulsating drums in the Vanguard *Petrouchka*, VSQ-30021, 2/3 in on side 2 (49 mm from the beginning of the recorded grooves). With a full-logic decoder, these beats create vibrant excitement which cannot be conveyed in words.

The pulsation frequency is about 3 Hz, and it is not to be confused with "pumping" or "breathing" effects occurring at about 1.0 or 0.5 Hz in poorly-designed logic decoders. By contrast, these pulsations are in the recording itself, as determined by microscopic examination and by the fact that they are slightly audible with no decoder. Similar vibrant, pulsating sounds are evident in drum beats and plucked bass string notes in other quadrasonic recordings.

But here is an important question. Is this fidelity to the original performance? In view of the fact that studios are known to add reverb to records(6), a bit of skepticism might be appropriate here. The author has never heard anything

like this in a concert hall, although it is admittedly a pleasurable effect.

When it comes to four-channel discrete tapes, the improvement in spaciousness over SQ is rather small, and in many cases it seems to be zero. Some parts of some tapes really show an unmistakable difference—but, once again, is it fidelity? The discrete Q8 cartridge version of Boulez conducting the Bartok *Miraculous Mandarin* (Columbia MAQ-31368) is a good example. At the beginning and end of track 2 there are drum beats in which the sound transient begins at the front of the room and decays to the center or back. If you face the side wall, you can hear and feel the booms sweeping across you. This is exciting but probably inaccurate.

For a comparison with matrix decoding, listen to the SQ disc version of this performance (Columbia MQ-31368). The effects are not quite as strong as in the Q8 version.

The above examples should not be taken as an assertion that all the really strong effects in quadrasonic recordings are artificially enhanced. There are many examples in each of the quadrasonic formats in which quite natural realism is provided. And even the occasional effects which sound suspicious are at least lots of fun.

Now we have to wrap up several other questions which are suggested by the mono-stereo analyses discussed earlier. Do quadrasonic headphones enhance spaciousness more than quad loudspeakers? As previously reported in *Audio*(4), the answer is "No." The probable reason is that the headphones lack reverberation, while loudspeakers make full use of the listening room. The partial L+R blend setup of Fig. 2 is recommended, but only between the front channels.

For AB comparisons of two versus four channels heard through four-channel phones, be sure that the degree of blend is the same in both modes. Otherwise, an unfair test will result, somewhat analogous to the discussion leading to Fig. 3. Headphone listening is particularly sensitive to blending, and this alone can improve the sound to some extent.

What about richness? Is significant music cancelled when the front and back channels are mixed and not decoded? Experiments similar to the L plus R mixing tell us there is no audible loss, at least with regard to the richness itself (not considering spaciousness, etc.).

A bonus with quadrasonia comes from the fact that the addition of two back speakers definitely contributes to the efficiency of coupling to the air, and also, more amplifier power is ordinarily used in a four-channel system. The low-bass transients really sock you when they are generated by four speakers at the corners of the room.

How does it all add up? For some listeners only the best of everything will be good enough. For others the use of various synthesizing or decoding systems will suffice, especially as an interim arrangement while a more complete system is being accumulated.

References

1. Cooper, D.H., "Construction of a Madsen-System Delay Tube," *Audio*, April 1971, p. 18; cont. May 1971, p. 48.
2. Hirsch, Julian D., "Some Thoughts on High Frequency Response," *Stereo Review*, Jan. 1974, p. 31; Arthur Shifrin, "Rx for 78s . . . Tape Them," *Audio*, April 1974, p. 34.
3. Tillet, G.W., "Quadrasonic Progress Report," *Audio*, June 1973, p. 20.
4. Anon. (staff report), "Quadrasonic Headphones," *Audio*, June 1973, p. 28.
5. Canby, E.T., "The New Stereo Bonanza," *Audio*, May 1974, p. 14.
6. Anderton, Craig, "Electronics in Modern Studios," *Popular Electronics*, April 1974, p. 66.

Heath introduces a timeless new concept in component music system versatility.

MODULUS™



Modularity for flexibility.
The system that expands, adapts.
The system that is what you want it to be – always.

Module I – Tuner/Control Center

A superb AM/FM tuner with digital readout, an exceptional 2+2 preamplifier with a headphone amplifier, tape dubbing facilities, and unusually versatile controls. All in one. Unique. Unmatched. The heart of the MODULUS system.

The Tuner – quality you can hear. Four 1/2" LEDs display broadcast-only frequencies measured by its digital counter. Careful AM design with 6 μ V sensitivity, over 60 dB selectivity. Purely superb FM with 1.7 μ V sensitivity, digital discriminator for less than 0.3% distortion, LC filter for over 100 dB selectivity, adjustable muting, PLL Multiplex, multipath outputs.

2+2 Preamplifier – the quiet one. Distortion levels below 0.05% at full output; hum and noise as low as 80 dB below full output; new phono section design with over 94 dB dynamic range. Amplification for 2 or 4 channel headphones. Tape dubbing for 2 or 4 channel recordings. Full 4-channel capability in every section.

Versatile Control Center. Complete command. Functions are selected by twenty-one pushbuttons – each with lighted tip to show which are activated. They select output, 8 inputs, 5 modes, plus hi & lo filters, loudness, tone flat, squelch defeat, FM Dolby, and Power. Controls include: separate Baxandall bass and treble controls for front and rear channels, separate level controls for each channel, master volume, and tuning. Meters include: 4 output meters with 40 dB dynamic range and peak-reading capability; signal-strength and center-tune meters. Speaker protection.

Modular kit construction. 14 circuit boards, 4 wiring harnesses, 28 ICs, 134 transistors, 55 diodes, built-in test meter. Space for plug-in SQ, FM Dolby, CD-4.

Module I – for what it is, what it can be, surprisingly low cost – 599.95

Modules II & III – Stereo Power

Expand your MODULUS system with your choice of stereo power amplifiers. Module II, 35 watts per channel. Module III, 60 watts per channel. 35 or 60 watts: min. RMS, per channel into 8 ohms at less than 0.1% total harmonic distortion from 20-20,000 Hz.

Front panel Main and Remote speaker switching; lighted Power Button; rear panel level controls, and Heath's unique polarized speaker connectors end phasing problems. Easy to build.

Both amplifiers are styled to match Module I. And unlike others, these look so good you'll want people to see them. Diecast front panel, massive side-mounted black heat sinks, and simulated walnut-grain metal side accents.

Add one of either power to make a MODULUS Stereo Receiver. Add two of either power to make a MODULUS 4-Channel Receiver. Module II, 159.95. Module III, 179.95

Module IV – FM Dolby.

To enjoy the reduced noise and increased dynamic range of specially-encoded Dolby FM broadcasts, add this option. It fits inside the Module I Tuner/Control. Module IV, 39.95.

Module V – CD-4 Demodulator.

Add the spacious quadrasonic sound of CD-4 discrete 4-channel recordings with this option. And no external black boxes as it slips securely inside Module I. Module V, 79.95.

Module VI – SQ Decoder.

Sophisticated circuitry with full logic and variable blend enhancement for excellent quadrasonic separation from matrixed records, tapes and FM broadcasts. Like the others, it fits inside Module I. Module VI, 49.95.

MODULUS – today and tomorrow.

MODULUS – as you like it.
To change as you wish.
A Digital AM/FM Tuner/2-4 Ch.
Preamp/Control Center



A Stereo Receiver – high or medium power



A 4-Channel Receiver – high or medium power



Sophisticated Optional Capabilities



For information on MODULUS send coupon below.

HEATH Schlumberger	Heath Company Dept. 41-11 Benton Harbor, MI 49022
Please send information on the new MODULUS music system.	
NAME _____	
ADDRESS _____	
CITY _____	STATE _____ ZIP _____
PRICES & SPECIFICATIONS SUBJECT TO CHANGE WITHOUT NOTICE. MAIL ORDER PRICES, FOB FACTORY. HF-299	

Check No. 22 on Reader Service Card

Fine amplifiers produce excellent square waves.

SAE Mark 3C

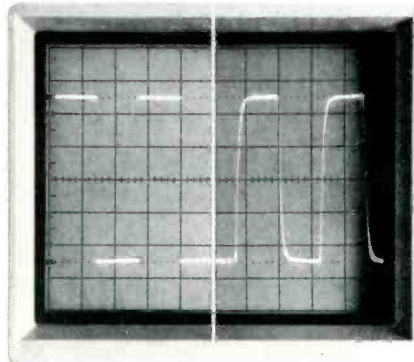

20 Hz

20 kHz

The finest separate power amplifiers produce excellent square waves. Quality oriented designers and engineers know that square wave response is profoundly useful because it is a precise projection of musical quality.

Not only does the square wave "mirror" the quality of

HARMAN KARDON CITATION 16

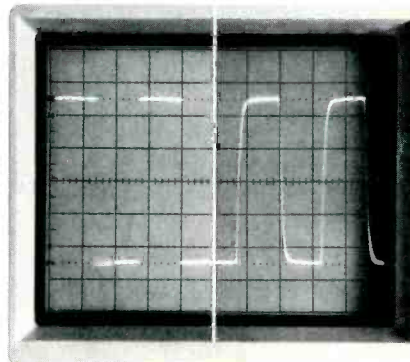

20 Hz

20 kHz

sound, but it is, in a unique way, sound itself. The square wave possesses the complexity of a musical wave form. Both have a fundamental and a series of harmonics that have a set relationship to one another. The square wave must be able to pass through the amplifier without damage

if the musical wave is to pass through undamaged.

Square wave measurements do not replace conventional methods of testing components. Yet it can be said that an instrument which fails to produce excellent square waves is limited in musical authenticity.

All square wave measurements 10V peak to peak

harman/kardon

One receiver matches the square waves of fine amplifiers.

HARMAN KARDON 430

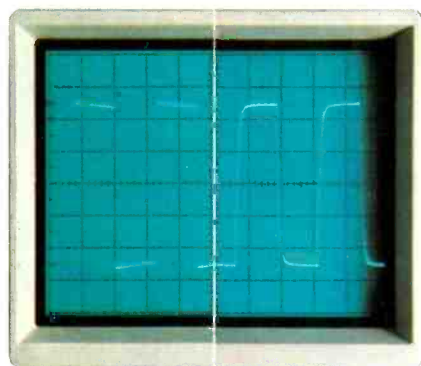

The implication of a comparison with conventional receivers is obvious.

The square wave reproduced here is not that of the 430 power amplifier section alone. Amazingly, it is the square wave achieved by the 430 amplifier and preamplifier operating together!

The 430 AM/FM tuner is consistent with the outstanding performance quality of the amplifier and preamplifier. It is sensitive, receiving even distant stations with ease and without distortion. The tuner is also characterized by excellent selectivity and signal-to-noise ratio.

The 430 functions with two separate power supplies,

one for each channel—the Harman Kardon “twin-power” concept. No matter how much energy is called for by dynamic music passages, performance of one channel is not affected by the other.

At Harman Kardon, technical advances are pursued not for their own sake, but as methods of predicting and improving music quality. It is in this context that we have prepared our literature on the 430 as well as our booklet: Square Wave Analysis of Audio Amplifier Performance. Your Harman Kardon specialist dealer can supply both. Or write to us directly at Harman Kardon, 55 Ames Court, Plainview, N.Y. 11803.

The new Harman Kardon 430 receiver displays square wave response that is indistinguishable from the finest power amplifiers. A listening test will reveal that the 430, in all but absolute power levels, is the sonic equivalent of any individual component system your dealer can demonstrate.



Christmas Buying Guide

Infinity Servo-Static 1A and DSP Switching amplifier



Lux M4000 power amplifier



Shure V-15 III phono cartridge



Supere TL-3 headphones

TEAC A-3340S



Marantz 5420 cassette deck



Crown DC-300A amplifier



JVC 4VR-5446X receiver



Hartley Zodiac '75 speaker



Buying presents for the choosy audiophile can be quite a chore for those who aren't "into" the field as deeply as he is. While Joe Audiophile knows exactly what hot, new piece of gear will make his Christmas Day, his relatives and friends usually need some prompting. Here then are a few suggestions, one of which is certain to satisfy Joe. And if you're Joe, just leave this spread open in some strategic spot, with a circle around what would make your Christmas merry!

The component look.

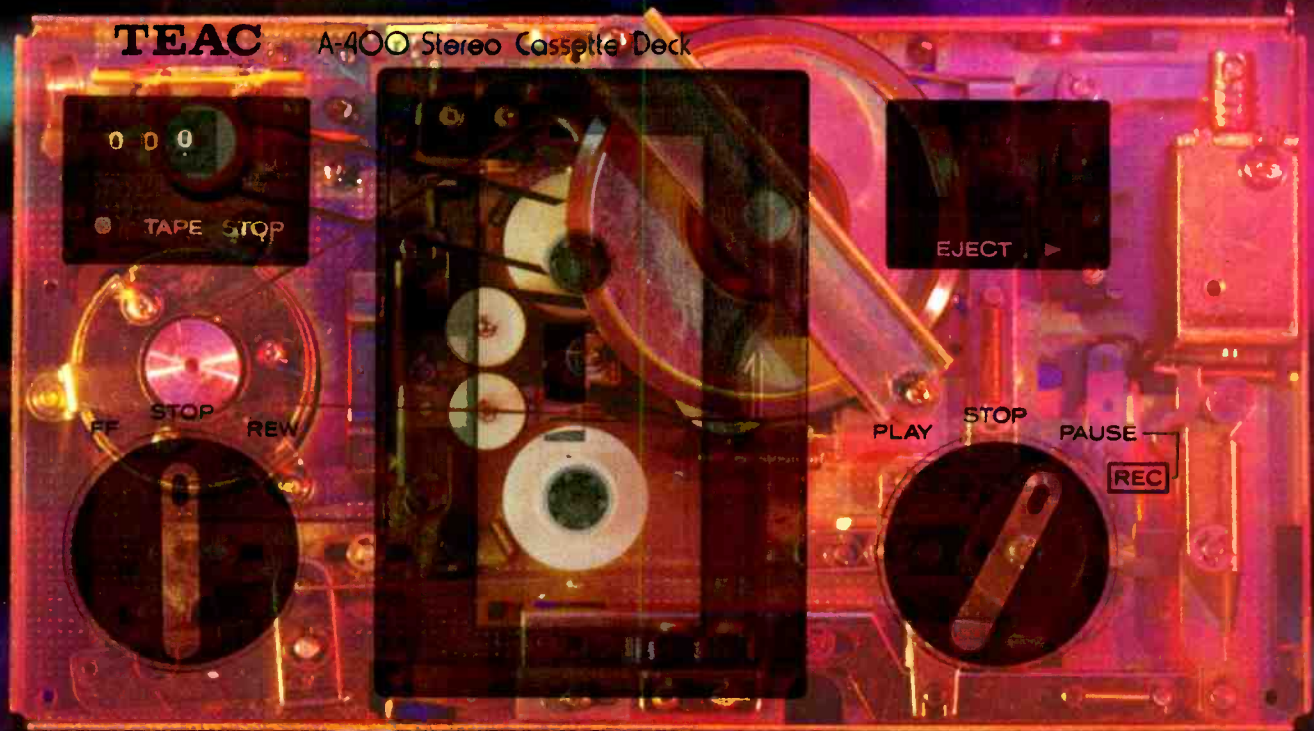

By design.

A-400

The 450 redefined the cassette deck as a true high fidelity component. That remarkable transport design generated a new found measure of respectability for the cassette format.

Our engineers then determined that a vertical transport was best



suited for a front load application. In terms of overall design integrity and mechanical stability. So rather than adapt one transport design to fit another need, we produced a completely new, highly streamlined mechanism. From the inside out. It's called the A-400.

Twin rotary levers control the transport functions with smooth, positive cam action. Which means unnecessary mechanical linkages have been eliminated. You get peace of mind instead, because fewer moving parts assure greater reliability and long term dependability.

Since the cassette loads vertically into the A-400, the adverse effect of

gravity on the cassette package itself is eliminated. So tape jams are prevented and smooth, even tape packs are predictable.

If new design concepts superbly executed appeal to you, put an A-400 through its paces. Just call (800) 447-4700* toll free for the name and location of your nearest TEAC retailer. You'll find that the A-400 delivers definitive TEAC performance with the added convenience of a front load component. All by design.

*In Illinois, call (800) 322-4400.

TEAC®

The leader. Always has been.

TEAC CORPORATION OF AMERICA 7733 Telegraph Road, Montebello, Calif. 90640

©TEAC 1975

Check No. 50 on Reader Service Card

Equipment Profiles

Phase Linear 4000 Preamplifier

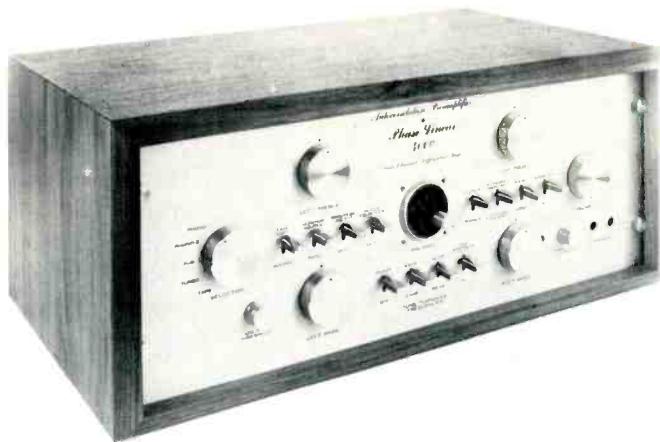

MANUFACTURER'S SPECIFICATIONS

Frequency Response: Phono, within ± 1 dB of RIAA from 20 Hz to 20 kHz; High Level, within ± 1 dB from 20 Hz to 20 kHz. **Gain:** Phono, 65 dB; High Level, 15 dB. **Input Impedance:** Phono, 47 kOhms from 20 Hz to 20 kHz; High Level, 50 kOhms. **Noise Level:** Phono, 82 dB below full output; High Level, 95 dB below full output. **Output voltage:** Full output 8 volts rms; better than 2.0 volts into 4.7 kOhm or greater. **Total Harmonic Distortion:** Less than 0.25%; typically 0.02%. **Tone Control Range:** Bass, ± 8 dB at 20 Hz (selectable hinge points at 40 or 150 Hz); Treble: ± 8 dB at 20 kHz (selectable hinge points at 2 and 8 kHz). **Active Equalizer Response:** 6 dB/octave boost below 50 Hz. **Peak Unlimiter Attack Time:** 0.5 dB/microsecond for 6 dB peak unlimited action. Downward Expansion: Begins at -35 dB to -41 dB limit. **Autocorrelator Noise Reduction Action:** High Frequency, begins at 2 kHz (for 3-dB noise reduction), reaching 10 dB noise reduction from 4kHz to 20 kHz; Low Frequency, begins at 200 Hz, reaches 20 dB at 20 Hz. **Sub-Sonic Filter Rejection:** -35 dB at 5 Hz.

General Specifications

Power Switching Capability: Up to 25 amperes for associated equipment. **Power Consumption:** (Preamplifier only) 40 watts. **Dimensions:** 19 in. W x 7 in. H x 10 in. D (including cabinet). **Weight:** 18 pounds. **Price:** \$599.00; cabinet, \$37.00.

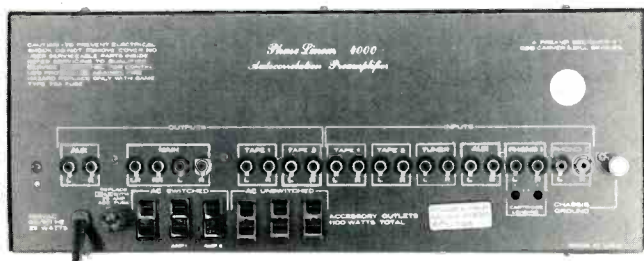

Fig. 1—Rear panel of the 4000 preamplifier.

There are two schools of thought when it comes to preamplifiers. There are those who believe that a preamplifier should simply amplify and do nothing else to the program signals applied to it. Purists who take this position often forget that, at the very least, a preamplifier had better impart anything but flat response to the signals applied to its phono inputs from a magnetic cartridge—else one would hear reproduction devoid of all bass response and with screaming highs (thanks to the RIAA recording curve). Some purists concede that moderate-acting tone controls are a necessary evil, but should generally be bypassed by a defeat switch in the interest of "true high fidelity."

Then there are those audiophiles who believe that anything that can be done in the design of a preamp to improve S/N ratios (even response-destroying high- and low-cut filters), expand dynamic range (which has been compressed in the medium, be it FM radio or phonograph discs) or even subtly fill in that octave or so that loudspeakers generally ignore, is well worth the effort. I confess that I was somewhat of a purist—up until recently. Such niceties as Dolby, dbx, ANRS (as used in CD-4 recording to reduce noise), Burwen, and now, the Phase Linear 4000 Autocorrelator Preamplifier helped change my mind.

The moment this large, impressive preamp comes out of the carton you know that you're not dealing with just another preamplifier. Its circuitry and features are, in fact, more sophisticated than those of any other preamplifier we have ever tested.

The massive looking front panel sports the now familiar joystick balance control located right in its center. Why a joystick balance control? Simply because the Phase Linear 4000 is a sort of hybrid 4-channel device that incorporates an SQ decoder circuit with front-back logic and therefore has four outputs. This, however, is its only 4-channel attribute, since all high level inputs and other outputs are strictly intended for stereo use. For example, the four massive tone controls symmetrically positioned about the panel are for individual control of bass and treble, of left and right channels. The other two large metal-turned knobs are for program selection (at the left) and master volume control (at the right). Of the four elegant and easy-to-finger toggle controls below the joystick, one turns on power to the unit,

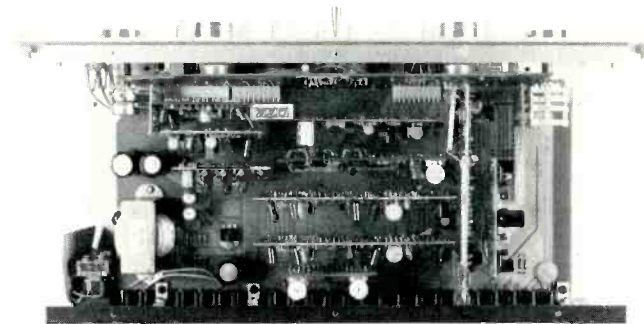

Fig. 2—Internal view.

while the remaining three select turnover points for the bass control (150 Hz or 40 Hz) and treble control (2 kHz and 8 kHz) and permit total bypassing of the tone controls altogether (for the benefit of those purists). Nestled between the left bass and treble controls are four more lever switches. Two of these are involved in the tape monitoring functions and permit monitoring of *Tape 1*, *Tape 2* or copying of tape to tape while listening to yet another program source. The third lever in this area activates what Phase Linear calls an *Active Equalizer*, which adds a slight amount of boost at the extreme low and high ends of the audio spectrum. This feature is not to be confused with a so-called loudness control, since the degree of boost is fixed regardless of volume settings.

The fourth lever in this area introduced one of the unique circuits incorporated in the Phase Linear 4000. It is called a *Peak Unlimiter and Downward Expander*. When activated, it introduces a sophisticated volume expansion system that actually provides different degrees of expansion depending upon instantaneous program levels. The threshold level of the expansion system can be varied by means of a small control knob below and to the right of the selector knob and when the circuit is working properly, an adjacent LED indicator flashes on peak signals. But wait! The best feature of all is yet to come. The four additional lever switches located between the right channel bass and treble controls provide for stereo/mono switching, audio muting of about 20 dB, insertion of the 4-channel SQ logic decoder and Phase Linear's incredible "autocorrelator" circuit. The autocorrelator is a noise reduction scheme that is one-sided in its operation. That is, it does not require specially-encoded program sources (as do Dolby and dbx) to reduce random noise which it does by as much as 10 dB. A brief description of this amazing circuit is supplied by the manufacturer. As they explain it, signals in the 200 to 2000 Hz region are sensed to determine whether the signal content is discrete (or musical) as opposed to random, wide-band noise. Discrete or musical program content in this frequency region, when detected, causes "windows" to open up in the preamplifier's 2000 to 20,000 Hz response range at harmonics of the musical frequencies while the rest of that spectrum (where most objectionable noise is heard) is shut down, dynamically, excluding noise components not harmonically related to the program material. In actual use, the small correlation threshold knob, located to the right of the right bass control is rotated counterclockwise while listening to program material until the noise takes a noticeable drop. Musical highs are unaffected unless the control is turned considerably past that operating threshold. More about this unusual circuit and how it performed during our listening tests later on.

The rear panel of the 4000, shown in the photo of Fig. 1, contains the usual array of input and output jacks. One of the two phono input pairs is equipped with screwdriver-adjustable controls which help match cartridge characteristics to the input load of the preamplifier. Outputs include the 4-channel quartet, an auxiliary pair of stereo outputs, and outputs for the *Tape 1* and *Tape 2* monitor circuits. The auxiliary outputs are duplicated on the front panel in the form of phone jacks for feeding other amplifiers in your system. The panel also contains six convenience a.c. outlets, three of them unswitched. The switched outlets are relay-controlled and can therefore handle more current (up to 25 amperes total) than if they were switched directly by the preamplifier's own on/off power switch.

An internal view of the Phase Linear 4000 is pictured in Fig. 2. All of the vertically-oriented, glass-epoxy circuit boards are well supported mechanically and further cushioned by plastic foam which adheres to the unit's cabinet

wrap and applies cushioning pressure to the tops of the boards when the wrap is reinstalled. A good portion of the circuitry visible in the photo of Fig. 2 is devoted to the complex autocorrelator feature previously described. In fact, this circuit alone uses some twenty-odd transistors and about a hundred diodes.

Laboratory Measurements

Before attempting to measure performance of some of the "special" circuits of the Phase Linear 4000, we decided to test it first as a conventional preamplifier. Figure 3 plots tone control range for bass and treble controls when turnover frequencies are set to 150 Hz and 2 kHz and the range provided is similar to that of conventional tone controls. By switching to the 40 Hz and 8 kHz turnover points, it becomes possible to trim the extremes of the audio range without materially affecting mid-frequency response. Range of bass and treble controls in this mode is plotted in Fig. 4.

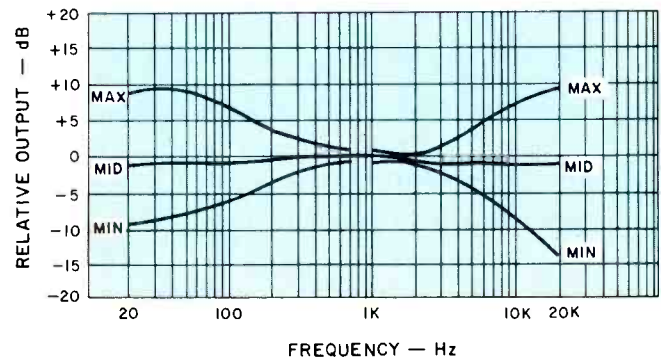

Fig. 3—Range of bass and treble controls, set at 150 Hz and 2kHz turnover points, respectively.

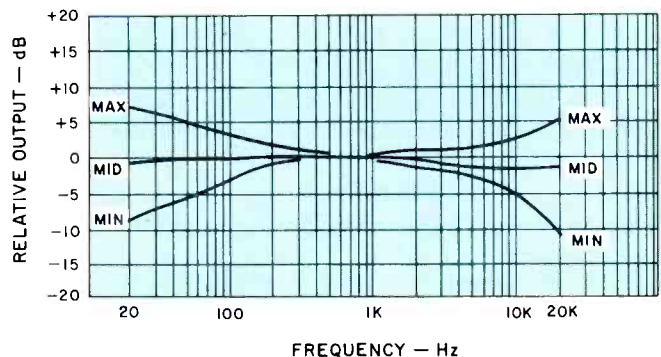

Fig. 4—Range of bass and treble controls, set at 40 Hz and 2 kHz turnover points, respectively.

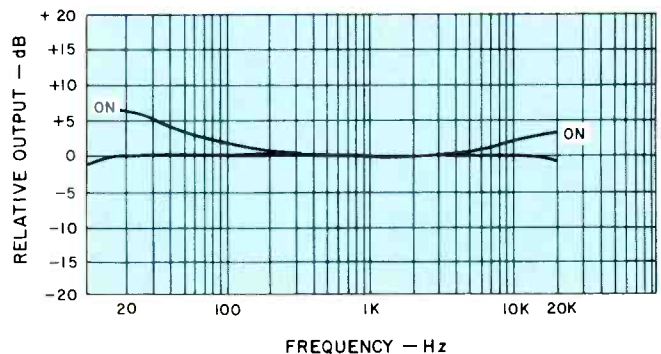

Fig. 5—Response of active equalizer.

Figure 5 shows response of the preamplifier when the *Active Equalizer* is turned on. As described by the manufacturer, this circuit simply adds a moderate amount of boost at the extreme low end (about 5 dB at 30 Hz) and even less boost at the extreme highs (2 dB at 10 kHz; 3 dB at 20 kHz), adding just a needed bit of life to woofers and tweeters that have given up at these frequencies.

Harmonic distortion was well under 0.1% for all output levels up to 3 volts (only 0.03% at a nominal 1 volt output level), while IM reached 0.25% at just over 3 volts output and hovered around the 0.1% mark at more typically-used output levels (1 volt and below). Results of these distortion measurements are plotted in Fig. 6.

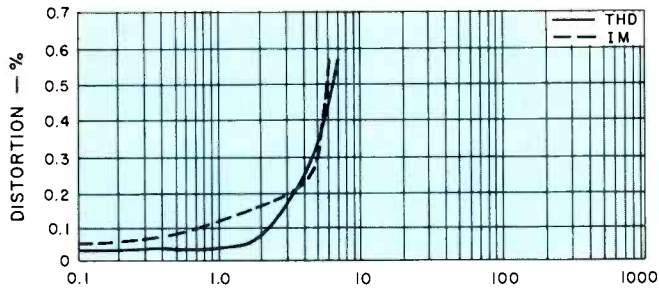

Fig. 6—Harmonic and IM distortion characteristics.

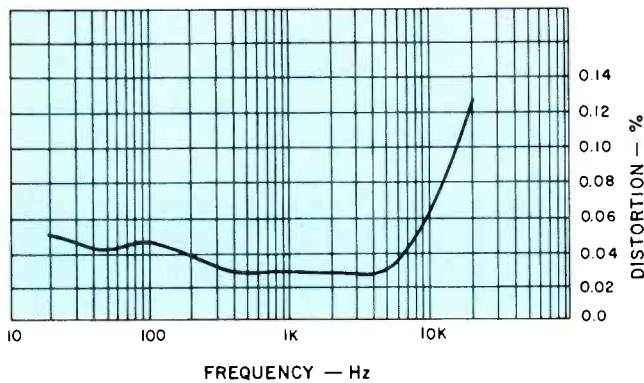

Fig. 7—THD versus frequency at 1 V output, 1 V input.

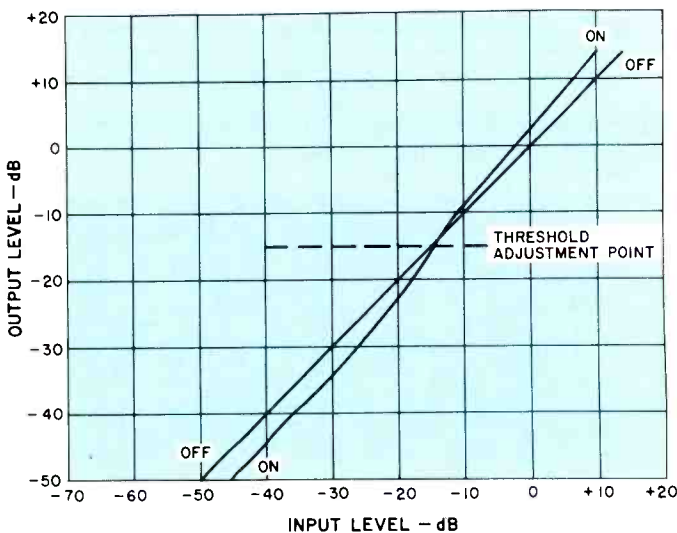

Fig. 8—Action of peak unlimiter circuit.

The extremely low distortion of the 4000 is not limited to mid-frequencies. We measured THD at all audio frequencies for an output level of 1 volt and the results are shown in Fig. 7. Even at 10 kHz (where THD is rather academic, since the second harmonic will not be heard), THD was still a mere 0.06%.

Other basic preamp performance measurements included phono input sensitivity of just over 2.0 millivolts for 1 volt output, high-level input gain of 10 dB, 180 mV input sensitivity for the high level inputs, and phono overload capability of 120 mV. Output overload occurred before any earlier stage distorted, at a level of about 8 volts out. Unweighted S/N in phono (referred to 10 mV input, 1 V out) measured 66 dB. When using the A-weighting network, the number improved to better than 75 dB. For the high level inputs, unweighted S/N measured 75 dB (referred to 1 V output) and increased to 87 dB with A weighting. RIAA equalization was accurate to within 0.5 dB at all frequencies from 30 Hz to 15000 Hz.

It was at once apparent to us that the *Dynamic Peak Unlimiter* and *Downward Expander* was a most worthwhile circuit, because it restored what sounded like about 8 to 10 dB of dynamic range to otherwise-compressed program material when it was switched into the circuit. Indirectly, this circuit also contributes toward improved signal-to-noise ratio, for if quiet passages are made quieter, and louder passages are made louder still, the net effect is that the low-level noise recedes further into the background. Since the circuit does operate dynamically, it was difficult to graphically depict its full effect. Nevertheless, recognizing the limitations imposed by static, sine-wave testing, we plotted input-versus-output for a particular threshold setting, and the results are shown in Fig. 8. Even under this static test, it is obvious that levels above the threshold are increased in intensity, while levels below the threshold (-15 dB in our graph) are further attenuated.

The most exciting feature of the 4000 is the autocorrelator. One has to hear it in action to appreciate how well it is able to clean up noisy program sources. Properly adjusted, it worked just about as well as Dolby B noise reduction systems. However, it is used with ordinary material that already had noise content as part of the program—something that Dolby just cannot help. It worked well with old records and it even worked with weak-signal FM reception. We were

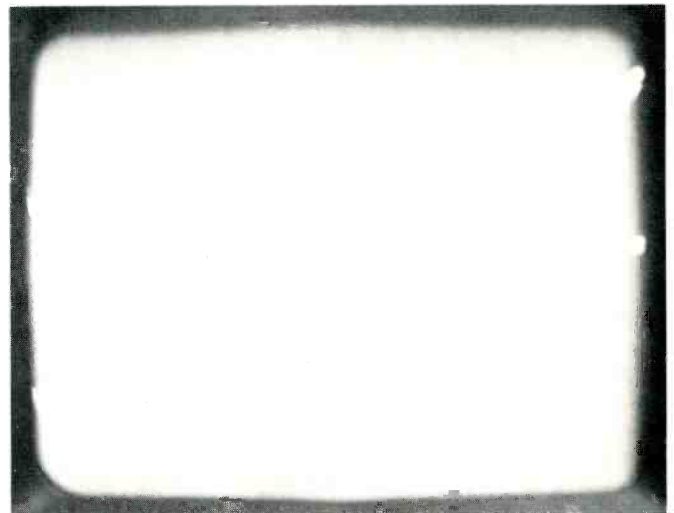
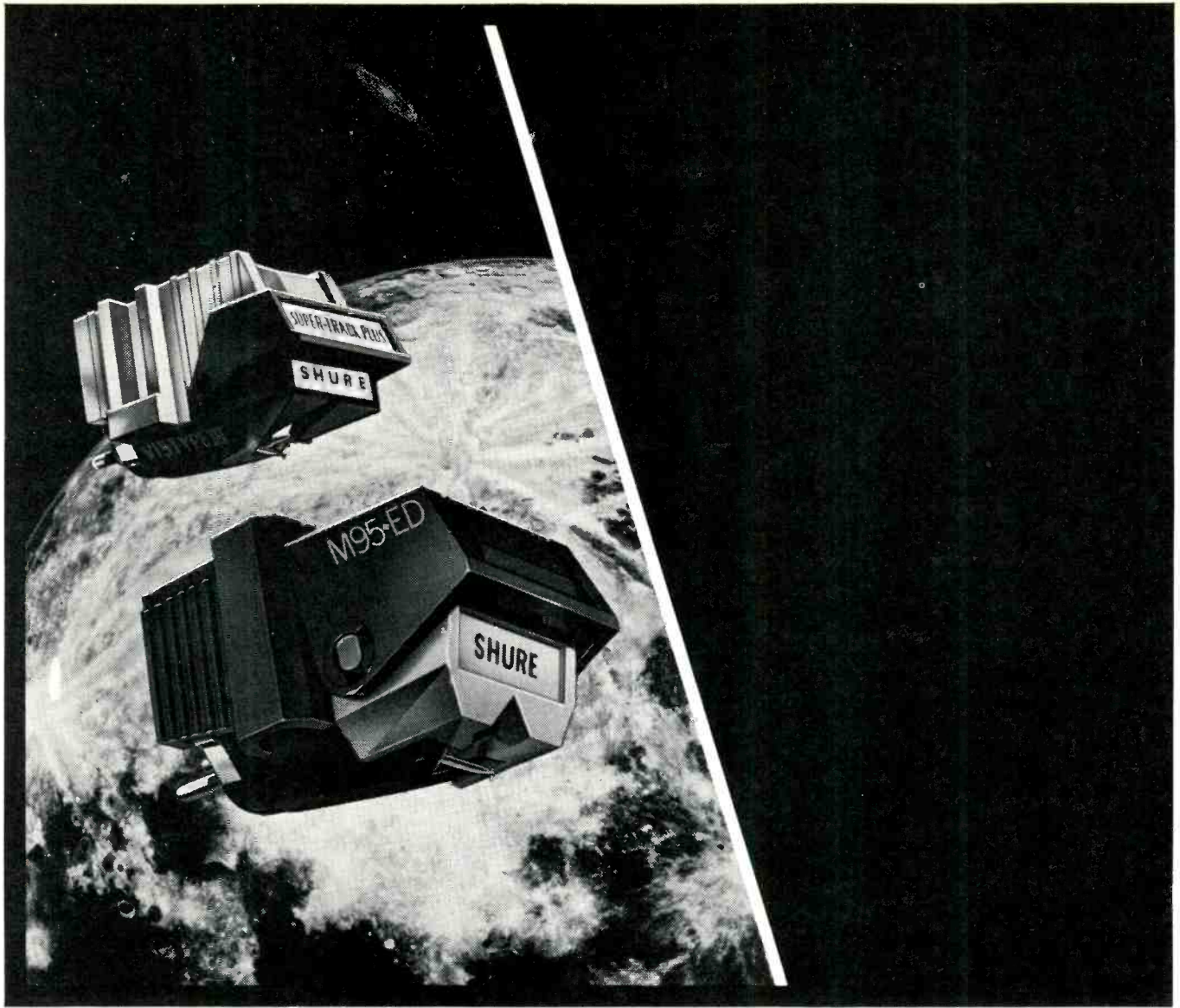

Fig. 9—Upper trace, weak-signal FM at tuner output (note ragged random noise content); lower trace, same signal after processing through Autocorrelator circuit.



II'nd only to the III.



FREE!!
1976 Stereo
Directory &
Buying Guide if
you purchase this
cartridge before
December 31.
(see details
below)

The new Shure M95ED phono cartridge combines an ultra-flat 20-20,000 Hz frequency response and extraordinary trackability with an utterly affordable price tag! To achieve this remarkable feat, the same hi-fi engineering team that perfected the incomparable Shure V-15 Type III cartridge spent five years developing a revolutionary all-new interior pole piece structure for reducing magnetic losses. The trackability of the M95ED is second only to the Shure V-15 Type III. In fact, it is the new "Number 2" cartridge in *all* respects and surpasses much higher priced units that were considered "state of the art" only a few years ago. Where a temporary austerity budget is a pressing and practical consideration, the M95ED can deliver more performance per dollar than anything you've heard to date.

Shure Brothers Inc.
222 Hartrey Ave., Evanston, IL 60204
In Canada: A. C. Simmonds & Sons Limited



* FREE! 1976 Stereo Directory & Buying Guide with the purchase of a Shure V-15 Type III, or the M95 series, M75 Type II or M91 series of cartridges. Simply send us your warranty card with the notation "Send Free Buying Guide" before Dec. 31, 1975. (Offer subject to supply and may be withdrawn at any time.)

Check No. 46 on Reader Service Card

most anxious to record its operation graphically, somehow, but were at first at a loss as to how to demonstrate the action statically. Finally, we resorted to our FM generator which we use in measuring tuners and receivers. We applied a weak signal to the antenna terminals of a tuner we had on hand. Since we could regulate the FM program signal strength at will, we reduced signal strength until the output waveform (500 Hz) from the tuner was loaded with the raggedy kind of noise that is typical of weak-signal reception. This waveform was displayed on the upper trace of our dual-trace oscilloscope. Using a Y-connector from the tuner's outputs, we also connected the "received" signal to the tuner inputs of the Phase Linear 4000, and displayed its output as the lower trace on the 'scope. We activated the autocorrelator circuit, and adjusted its threshold to a point that did not attenuate a 10 kHz signal. There we had it, for all to see! The lower trace, adjusted to the same amplitude as the direct-from-

the-tuner audio, had *visibly* much less noise content than the untreated, recovered audio. While you have to examine the 'scope photo of Fig. 9 fairly closely to see the cleaner appearance of the lower waveform, audibly the difference is astounding.

I have only one criticism to level against the people at Phase Linear, and it's one they doubtless encountered before. Why oh why did they wait so long before bringing out the magnificent autocorrelator circuit as a separate add-on unit? What were those of us who had otherwise fine pre-amplifiers supposed to do, throw away our control units to take advantage of the noise reduction and peak-unlimiting features of the 4000? Well, it's all academic now since Phase Linear has introduced its Model 1000 with the autocorrelator and downward expander circuitry.

Leonard Feldman

Circle No. 80 on Reader Service Card

Nakamichi 500 Dual-Tracer Cassette Recorder



MANUFACTURER'S SPECIFICATIONS

Frequency Response: 40 Hz to 17 kHz ± 3 dB, Nakamichi EX tape; 40 Hz to 16 kHz ± 3 dB, CrO₂ tape; 40 Hz to 15 kHz ± 3 dB, low-noise tape. **Wow and Flutter:** Less than 0.13% WTD peak. **Signal-to-Noise Ratio:** Better than 58 dB, CrO₂ tape; better than 55 dB, Nakamichi EX tape (both W rms, 400 Hz, 3% THD, Dolby). **THD:** Less than 2% at 1 kHz. **Erase:** Better than 60 dB at 1 kHz. **Crosstalk:** Better than 60 dB at 1 kHz. **Dimensions:** 15 in. W. x 10 in. D. x 4½ in. H. **Weight:** 15½ lbs. **Price:** \$399.00.

The Nakamichi folks were pioneers in the tape recorder industry, and they have made cassette recorders and component parts for many well-known companies all over the world. It is still a family concern, and during the past three years or so they have built up quite an excellent reputation for well-engineered, top-quality cassette decks, both for home and for studio use. Their top-of-the-line model, the 1000 Tri-Tracer, which we reviewed in March, 1974, is a pro-

fessional-grade, state-of-the-art machine with three heads, two noise reduction systems, head alignment facility, and a host of other very intriguing and worthwhile features. At \$1,295.00, it is quite expensive, as cassette recorders go, but it has to be with all its features. However, it was soon followed by the Model 700, which retained the three-head system and the alignment facility and cost considerably less at \$849.00.

More recently, Nakamichi has introduced the Model 500, a two-head machine, at the very competitive price of \$399.00. It does not have all the features and refinements of the 1000 and 700 models, but it does have some innovations of its own, including a focused gap head, and naturally includes Dolby. And, most importantly, in terms of the basic performance parameters, such as frequency response, distortion, signal-to-noise ratio, and so on, the 500 compares very favorably as we shall see.

Styling of the 500 is unlike most American or Japanese recorders, being more European in concept, with a matte black panel with just a touch of chrome to make a very pleasing contrast to the white end pieces. The two VU meters are mounted on an inclined panel at the back, and the neat, uncluttered scales make them seem even larger than they really are—which is quite large indeed. Note that the calibration is from -40 dB to +5 dB, but more about these meters later.

There are six controls keys at the front of the machine towards the left for the standard functions, *Record*, *Rewind*, *Eject-Stop*, *Play-Record*, *Fast Forward*, and *Pause*. Just to their right, at the front of the machine, are four lever switches. The first pair is for selection of bias and equalization for either CrO₂, EX or Normal. The EX position is for high output, fine grain tapes, such as the Nakamichi EX or Maxell UDZ tape. Next in the row of switches comes the Dolby *In/Out/Tone* lever, after which comes the limiter *On/Off* switch.

Behind the row of switches is a group of six slider controls that, reading from the left, control the blend mike, left and

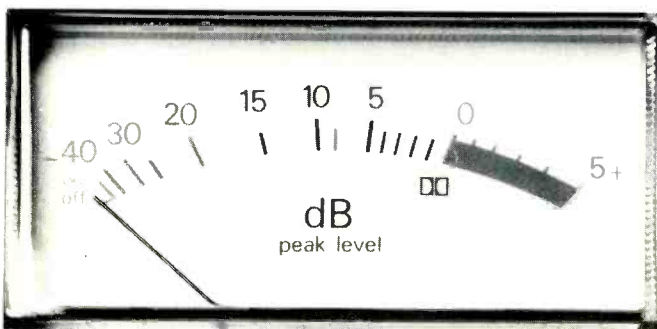

Fig. 1—Close up of one meter.

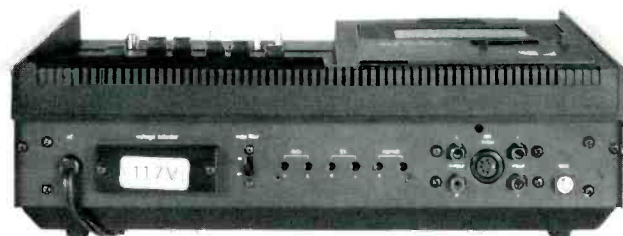

Fig. 2—View of back, with nameplate removed.

THE ART ADVANCES



Maxell introduces UD-XL.
The world's first cobalt/ferric/
crystal cassette.

The UD-XL is the only cassette ever to win an Audio Grand Prix. Here's why:

Epitaxial formulation We combined the unsurpassed low/middle range abilities of gamma-ferric Hematite with the high frequency performance of cobalt in a single crystal. Distortion, for all practical purposes, simply doesn't exist. No special bias or equalization necessary.

The shell, perfected We made the UD-XL shell a full 40 per cent closer to absolute tolerance. You get the truest head-to-tape contact and running reliability ever attained.

Convenience engineered UD-XL has a five-second non-abrasive, head cleaning, leader/timer on each end. Plus replaceable peel-and-stick labels for easy indexing.

Look for our Audio Grand Prix Champion, the Maxell UD-XL, at better audio dealers nationwide, the home of our premium Ultra Dynamic and economical Low Noise cassettes.

Maxell Corporation of America,
130 West Commercial Avenue, Moonachie,
New Jersey 07074. Also
available in Canada.

maxell®

For professional recordings
at home.



© Maxell Corporation of America, New Jersey

Check No. 28 on Reader Service Card

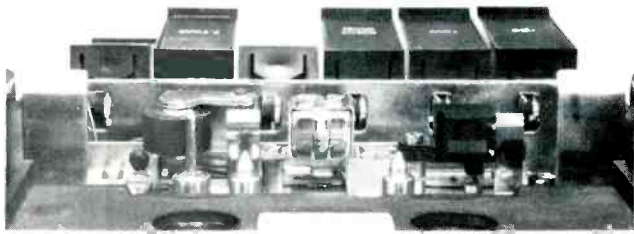

Fig. 3—Close up view of transport and heads from behind the machine. Pinch roller and capstan are at left, record-playback head at center, and erase head on right.

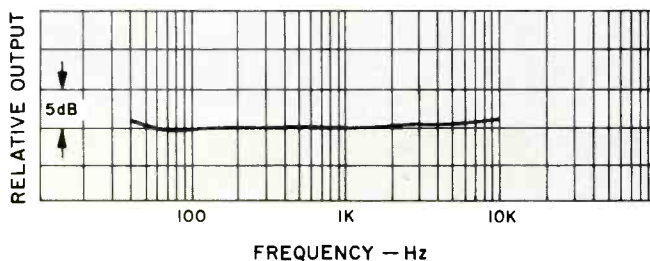

Fig. 4—Response from standard test tape.

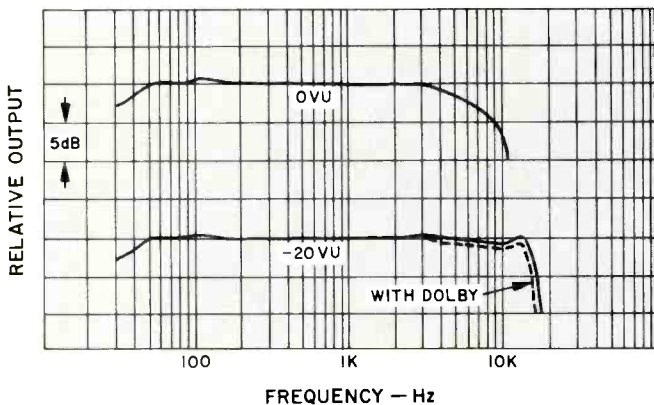

Fig. 5—Record-replay response with Nakamichi CrO₂ tape.

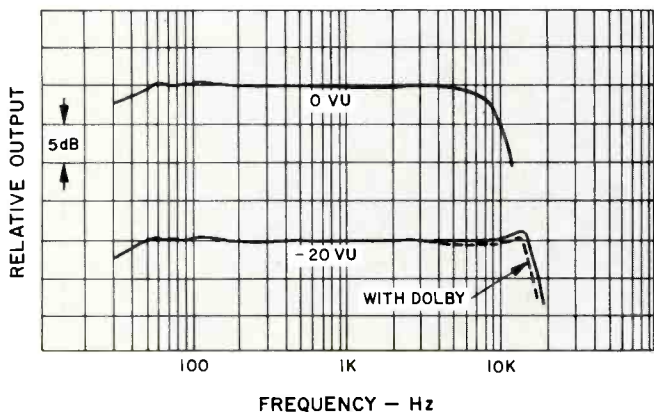

Fig. 6—Record-replay response with Nakamichi EX tape.

right mikes, line inputs, and the ganged output. The power switch is at the lower right-hand corner, while the *Record* and *Dolby* indicator lights are between the two VU meters. A digital counter and a memory rewind switch are both located to the left of and behind the cassette compartment. The three microphone input jacks, left, right, and blend, are located on the short, vertical front panel, together with a headphone jack.

On the rear of the machine is a multiplex filter switch, an a.c. voltage selector, the input and output sockets, a DIN socket, and Dolby calibration controls. There are six of these last named controls tucked away under a nameplate (removed for the photo), two for each kind of tape. Now, *that's* perfection for you! The Dolby switch on the front panel has a third position, marked *Tone*, which gives a 400-Hz reference signal at 0 VU, so you can adjust the calibration controls accordingly.

The standard Dolby level of 200 nanowebers per meter corresponds to 0 VU on these meters, instead of +2 or +3 as with some other recorders. Since their scale is non-linear (actually semi-logarithmic), the usable range is much greater than usual. Furthermore, the meters are peak-reading instruments with a fast attack time of 150 mS and a slow decay time of nearly two seconds, so they give a very accurate indication over a wide dynamic range.

The record-replay head uses a new technique of manufacture to produce a 1.5 micron head gap, whose effective magnetic gap width is kept at that width by careful control of the manufacturing stresses. Nakamichi calls this a focused-gap head, and it controls the lines of force in the magnetic field to provide optimum results and a minimum compromise between the conflicting playback and recording requirements. Figure 3 shows the transport mechanism and head layout, viewed from the back of the machine. The pinch roller and capstan are on the left, the record-playback head in the center, and the erase head on the right. The motor is a d.c. type and is servo controlled.

Measurements

Replay response from a standard test tape is shown in Fig. 4, and record-replay response with Nakamichi CrO₂ tape is shown in Fig. 5. The next graph, Fig. 6, shows the response with Nakamichi EX tape, and it will be seen that the 3-dB down point is at 18.5 kHz, as compared with 18 kHz for CrO₂. Headroom is slightly better too—but note that the meter's zero point corresponds to +2 of the DIN standard. Figure 7 shows the response with the bias and equalization set at *Normal* for the recommended TDK ED tape. The -3 dB point is at 18 kHz with a slight rise from about 5 kHz.

The next step was to check the Dolby system. Tracking at -20 dB on the meter was excellent, with a deviation of less

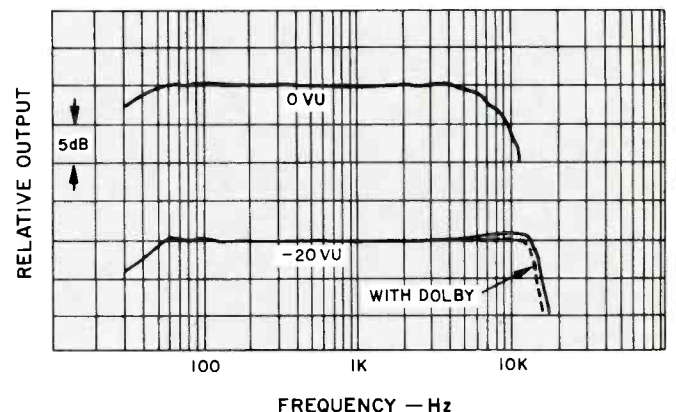

Fig. 7—Record-replay response with TDK ED tape.

INVISIBLE SOUND, SMALL AND BEAUTIFUL.

You probably know ADS for its complete line of high performance home loud-speaker systems. Our studio monitors, for instance, have rapidly become favorites among dedicated audiophiles and professionals. Now the unmatched open clarity and exact response to the most subtle musical detail, the famous 'Invisible Sound', has been extended into a miniature package!

The new ADS 2001 speaker system brings 'Invisible Sound' into your car, boat, plane, camper, mobile recording van – or wherever music reproduction of the highest quality is needed, space is limited, and only 12 Volt DC is available.

No existing mobile music system can be remotely compared to the high power, bi-amplified ADS 2001!

Engineering breakthroughs begin with the drivers: ADS engineers succeeded in developing a 4" precision woofer, which compares in overall power handling and its ability to move air to a good 6" woofer. This tiny superdriver is matched with a 1" soft-dome tweeter derived from the uniformly excellent model installed in the entire ADS line.

Sophisticated electronics were necessary to give these speakers their stunning performance. A minimum of 160 W of sinewave power, provided by four independent Darlington power amplifiers, is available for the woofers and



tweeters, coupled with electronic cross-over networks (active filters), equalizers, and opto-electronic limiters.

The power-supply is a high frequency DC-DC switching converter operating at 25,000 Hz; it provides over 350 watts of electrical power to the amplifiers from an ordinary 12 V battery.

All three components of the ADS 2001 system are enclosed in precision metal cabinets, finished in black. The 12" x 9" x 4" power supply/amplifier box can be installed virtually wherever a sufficiently large space is available (trunk, under hood, boat-peak, etc.). The 7" x 4" x 4" speaker cabinets have multiple provisions for optimum mounting.

You can experience the 'Invisible Sound' of the ADS 2001 system at over two hundred authorized ADS dealers across the United States. Find out why the ADS 2001 is so powerful yet 'invisible', just like all ADS speakers for home and studio high fidelity systems.

For additional information, data sheet DSC 2001, and test reports, see your local ADS dealer or write to: Analog & Digital Systems, Inc., 64 Industrial Way,

Wilmington, Massachusetts 01887.

2001C-76 PG

THE ADS 2001

than 1 dB. Channel matching was very close, being within 0.3 dB over most of the range. Distortion at 1 kHz for the three tapes can be seen in Fig. 8, while distortion versus frequency is shown in Fig. 9. Signal-to-noise ratio (with ANSI A weighting) was 56, 52, and 49 dB for CrO₂, Nakamichi EX, and TDK ED tapes, respectively. With the Dolby system switched in, the figures were 64, 60, and 57 dB. All the figures are at 0 VU. If the reference point is the 3% distortion level, then these figures should be increased by 3 dB.

Input voltage required for 0 VU indication was 70 mV for line inputs and 0.18 mV for the mike inputs. Maximum output was then 1.13 volts. The erase-MPX filter, which prevents the 19-kHz FM carrier from interfering with the Dolby operation, had an attenuation of 29 dB at 19 kHz with a 2-dB peak

at 15 kHz. Erase efficiency was better than 65 dB, and cross-talk measured 65 dB at 400 Hz. Wow and flutter was exceptionally low, measuring only 0.08% using the DIN-weighted standard for record-replay. Tape speed was less than 1% fast, and the *Fast Forward* speed was slower than usual at 1 min, 50 sec. for a C-60 cassette.

It will be seen that all the specifications were met or exceeded by a comfortable margin, and it appears that the focused-gap head is obviously more than an advertising gimmick—it really works.

Listening and Use Tests

Tests were carried out over a period of several weeks, and I must say that I was particularly impressed with two of the features—the absolute quietness of the transport system and those incredible meters. I knew that the machine was pretty quiet when I tested it in the lab, but I did not realize just how quiet until I moved it into the listening room! I liked that logarithmic scale on the VU meters and the fast response of the meter's ballistics was unusually accurate, better in fact than that of some meters used in expensive open-reel machines.

A number of tapes were made, both with and without the benefit of Dolby, and on one occasion a small group was recorded using the blend position for a center microphone. Nakamichi, incidentally, has recently published a good booklet describing the three-point microphone technique, which can add a good sense of depth or space to a recording that is not easily obtained with a standard two-point system. Some care should be taken to avoid overloading the front end of this recorder, and an attenuator might be necessary with some high output microphones.

All in all, the Nakamichi 500 is a well-engineered, very versatile cassette recorder which will appeal to those who want above-average performance at the lowest possible cost. Are there any criticisms? Well, yes, a small one. I found the *Eject-Stop* key a little difficult to get used to; it works by the double pressure principle, and sometimes the tape ejected when I only wanted it to stop. But I am probably being hypercritical (or just plain ham-fisted) because my wife never had the slightest difficulty!

There is also another two-head cassette deck available from Nakamichi, the Model 550, which is a portable model using batteries. This unit has higher headphone output, about 300 mW, and includes a preset timer, an alarm to signal the end of the tape, and a switch to permit use of the recording level meter to test the condition of the battery. Dimensions are 12-1/4 in. W x 13-3/4 in. D x 3-1/2 in. H; weight, 11-1/4 lbs less batteries, and price is \$499.00.

Circle No. 81 on Reader Service Card *George W. Tillett*

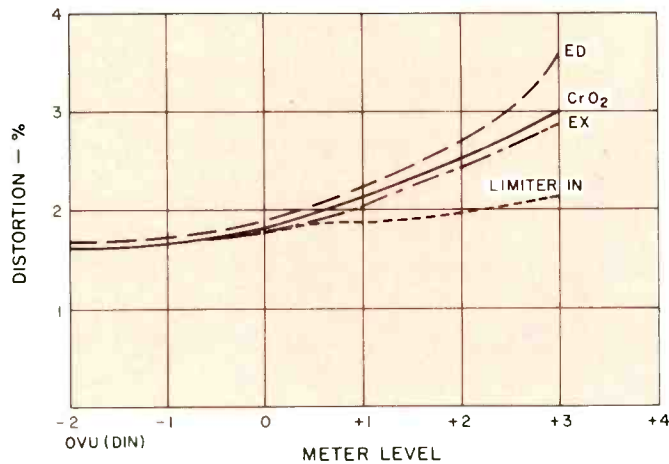

Fig. 8—Distortion versus meter level at 1 kHz for three tapes and showing effect of the limiter.

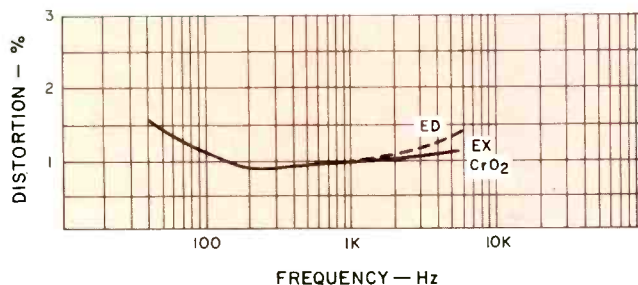

Fig. 9—Percentage THD versus frequency at -5 dB meter level for three tape formulations.

Epicure Model One Power Amplifier



MANUFACTURER'S SPECIFICATIONS

Power Response: 125 watts rms into 8 ohms, both channels driven 20 Hz to 20 kHz at or below 0.2% total harmonic distortion or intermodulation distortion from full power or below 117 V a.c. (typically over 150 watts). **Frequency Response:** 10 Hz to 100 kHz .05 dB. **Power Bandwidth:** 10 Hz to 52 kHz at 0.2% THD. **Damping Factor:** 100 or greater. **Rise Time:** Better than 1.5 μ s. **Slewing Rate:** Greater than 17 V/ μ s. **Signal-To-Noise Ratio:** Greater than 100 dB. **Input Impedance:** 100k Ohms. **Input Sensitivity:** 1 V for 125 watts. **Dimensions:** 18 1/2 in. W x 12 1/2 in. D x 7 1/2 in. H; 19 in rack mount kit available. **Weight:** 58 lbs. **Price:** \$649.00.

The Model One is the first electronic product of the Epicure Corp. of Newburyport, Mass., which has been producing speakers since 1967. The unit looks to be quite solidly constructed (see Fig. 1) and has a front-panel appearance rather different from most power amplifiers. Nearly all of the front panel area is dark when the amp is turned off;

Celestion



loudspeaker

specialists

since

1924

New Celestion UL6. Tiny enclosure provides 35 Hz-28 kHz overall response; ± 3.5 db 80 Hz-20 kHz. Power handling 20 watts continuous RMS sine wave. Can be used with amplifiers up to 80 watts RMS per channel.

UL6

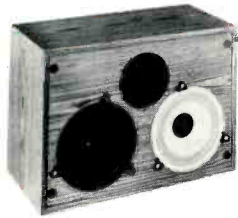

New Celestion Ditton 33. Overall response 40 Hz-28 kHz; ± 3 db 60 Hz-20 kHz. Power handling 33 watts DIN continuous.

DITTON 33



New Celestion UL8. Overall response 30 Hz-28 kHz; ± 3 db 70 Hz-20 kHz. Power handling 25 watts continuous RMS sine wave. Can be used with amplifiers up to 100 watts RMS per channel.

UL8



Ditton 44 Monitor. Power handling 44 watts DIN continuous. "It could take 100 watts (at 300 Hz on a steady-state basis) to produce an output of 106 db, and a power pulse of 486.5 watts (973 watts peak) to yield an output of 116 db. These figures attest to both the Ditton's robustness and to its excellent dynamic range . . ." —High Fidelity, June 1973.

DITTON 44



New Celestion UL10. Overall response 20 Hz-40 kHz; ± 2 db 40 Hz-20 kHz. Power handling 50 watts continuous RMS sine wave. Can be used with amplifiers up to 200 watts RMS per channel.

UL10



Ditton 66 Studio Monitor is top of Celestion Ditton Series and has received rave reviews worldwide. Appointed "Reference Standard" by "Revue du Son" of France. Features 16 Hz-40 kHz overall response, ultra-low distortion, high efficiency. Power handling 80 watts DIN continuous.

DITTON 66



**Also available: Ditton 15 "Bookshelf Classic"
Ditton 25 floor standing luxury loudspeaker**

The following quality drivers, used in the 8 models listed above, were totally researched, designed, and built by Celestion—Britain's most experienced loudspeaker manufacturer.

- HF2000 3/4" pressure-dome supertweeter specified for B.B.C. monitors.
- HD1000 New 1" pressure-dome tweeter ensures extended treble response, excellent dispersion and complete freedom from listener fatigue.
- HD700 New 2" pressure-dome midrange unit.
- MD500 2" soft-dome midrange unit covers 500 Hz-5kHz with very low distortion, exceptional dispersion. Extremely powerful magnetic field ensures critical damping and high power handling.
- MC5 New 5" midrange unit with low mass fibrous cone for outstanding transient response.
- MC6 6" plasticized midrange unit in damped hermetically sealed transmission line.
- BASS UNITS UL bass units have 1.5" voicecoil, massive magnet system and specially treated Bextrene diaphragm. Ditton bass units have specially plasticized fibrous cone to prevent resonances; neoprene roll front suspension permits long linear axial movement for low distortion bass reproduction.
- ABR's Auxiliary bass radiators ensure excellent bass response, raise sensitivity, and reduce distortion to negligible limits.

Sole North American Distributors:

ROCELCO INC. 160 Ronald Dr. Montreal, Canada H4X 1M8 Phone(514) 489-6842

Los Angeles: (213) 985-5707 Chicago: (312) 381-4559 New York: (516) 938-4057

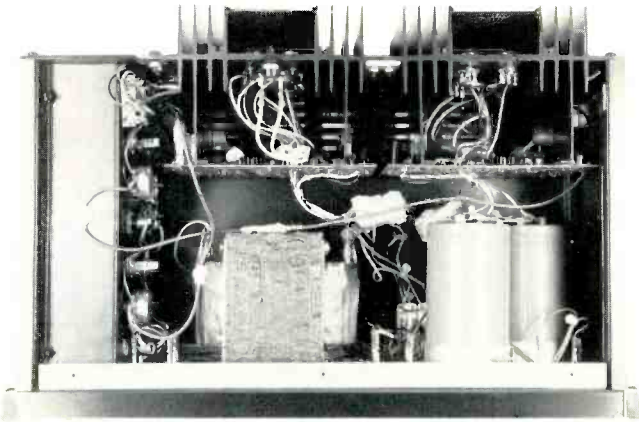

Fig. 1—Interior view of the Epicure Model One.

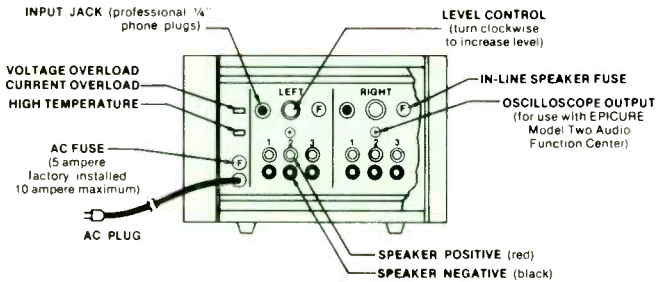

Fig. 2—Controls and jacks on side panel.

when powered, the word *Epicure* appears in white at the upper right-hand corner. There are three red lights per channel that spell out left or right *Current Limit*, *Voltage Limit* or *Hi Temp* when these conditions occur; these lights are in two vertical columns.

The front panel has a push-button power switch and three push-button speaker switches, which permit any or all of three separate speaker systems to be selected. Epicure states in their operating manual that it is okay to have three 8-ohm speakers powered at once, as long as the amp isn't driven consistently hard enough to overheat and thereby trip the thermal breakers. There isn't much said about three 4-ohm systems in parallel, but it is doubtful that the amp would drive three *inefficient* speaker pairs to any truly satisfactory volume without causing current limiting, distortion, and/or thermal overload.

The access to the input and output connections is through the left side of the unit, behind a panel which slides forward and out; see Fig. 2. There are three pairs of output post connectors, two input phone jacks, two input level controls (10 k), power cord, line fuse, and two slide switches for testing the overload indicator bulbs. There are no connections on the rear of the unit, as that section of the amp is occupied by the large heat sinks.

The front panel is the mechanical base for the unit, having a large power transformer, two 20,000 μ F/75 V filter caps, the seven indicator bulbs, and the speaker and power switches mounted upon it. Extruded corner pieces interconnect the rear panel to the front. The recessed left side panel with the a large power transformer, two 20,000 F/75V filter capacitors,

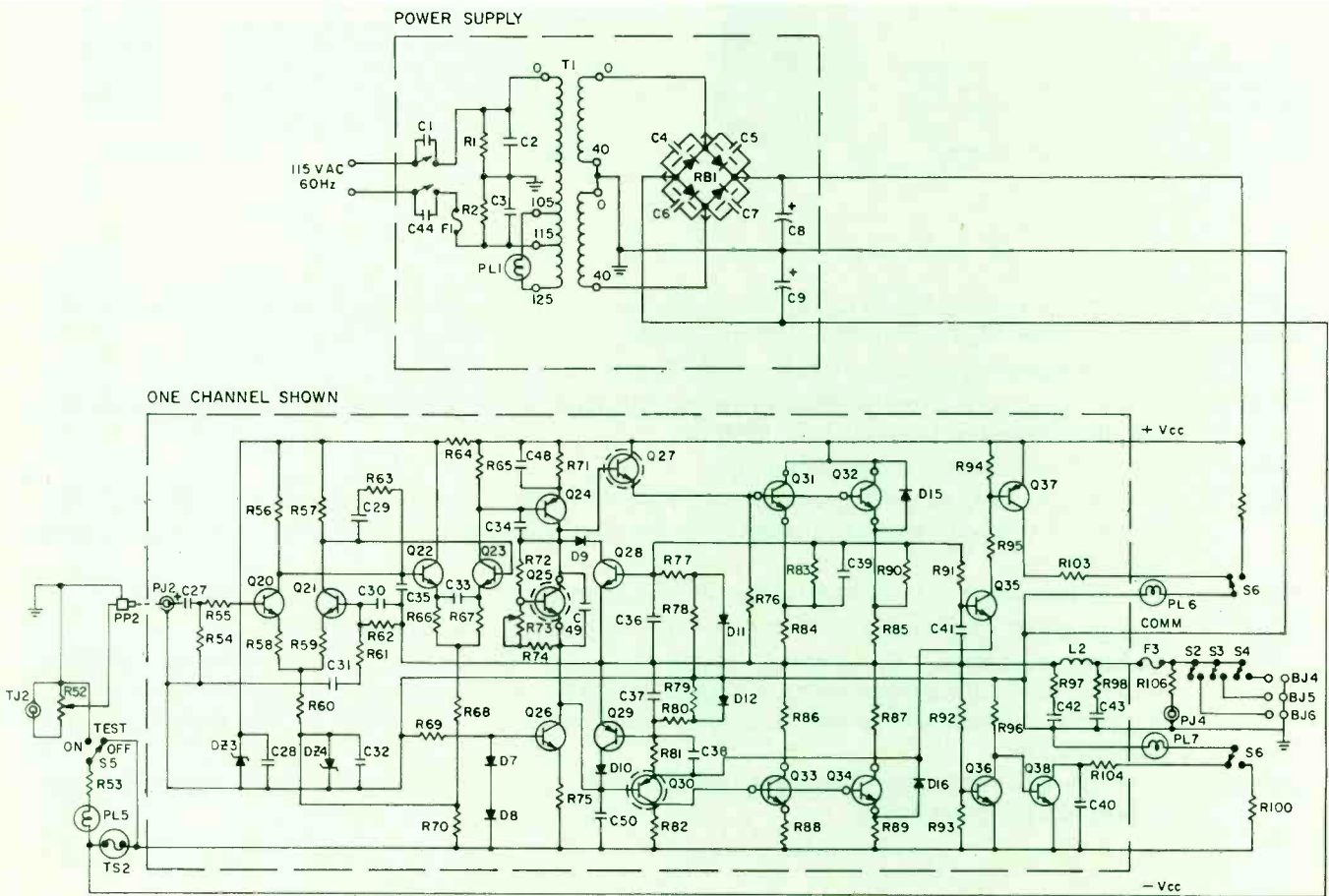

NOTE:
ALL COMPONENTS LOCATED WITHIN DASHED LINE ARE
PC BOARD MOUNTED EXCEPT Q25, Q31, Q32, Q33 & Q34.

Fig. 3—Schematic of one channel and power supply.

top and bottom cover plates serve to stiffen and strengthen the unit as a whole. One PC board per channel is mounted on an extended fin about 3 in. off the inner side of each heat sink. Four TO-3 power output devices, two plastic drivers, the bias regulator transistor, and a thermal cutout are all mounted directly on each sink. Each amplifier module thus formed has an RCA phono jack on the PC board and a Molex line connector to allow easy disconnection for servicing. All in all, it's a very nice package.

Circuit Description

A circuit diagram of one channel is shown in Fig. 3. The circuit topology of this amplifier, when compared to other amplifiers, is most like that of a Phase Linear 400 or 700, containing an NPN bipolar differential pair direct coupled to a second NPN bipolar differential pair. One collector of the second differential pair drives an inverting PNP stage that forms the predriver. The collector of the predriver drives the output stage plus base drive line and proceeds downward (schematically speaking) through one transistor bias regulator to the lower base drive line and the collector of a constant current source made of an NPN transistor. The output stage is a quasi-complementary emitter follower, consisting of plastic NPN and PNP drivers and four RCA 410 NPN output devices. When output voltage gets within a few dB of clipping, the first NPN turns off and the bulb driver turns on, illuminating the *Voltage Limit* indicator.

This circuit is unusual in that it uses emitter degeneration resistors in both differential amplifiers, which reduces the low frequency open-loop gain and improves the linearity of these stages. Further, a capacitor connected between the emitter of the second differential amplifier provides some lead compensation in the overall open-loop shaped response.

VI limiting is accomplished in the usual way, by sensing current and voltage in the output drives and shunting away the driver base drive when voltage and/or current are considered excessive. The base-emitter junction of an NPN transistor is connected across the plus and minus current sensing resistors and is biased to turn a few dB below the point where actual current limiting takes place. When this transistor turns on, it turns on a PNP based to the positive supply voltage drive, which in turn illuminates the *Current Limit* front panel indicator. Output voltage of the amplifier is divided down to an NPN device based to the minus supply voltage. This device is normally biased on and thus keeps a second NPN turned off. The collector load of this second NPN is the *Voltage Limit* indicator. These indicators of voltage and current limiting are a good idea and do a good job of informing the user when the amp is being pushed. The circuit constants are arranged so that the relative intensity of the indicators is a good measure of the relative severity of the limiting. For instance, if the *Voltage Limit* indicator only lights, the speaker impedance is in the normal range of greater than 4 ohms and voltage peaks are being clipped. If the *Current Limit* indicator flashes, the speaker impedance is probably below 4 ohms and is unusually reactive. When both current and voltage indicators occasionally flash, the amplifier is being most efficiently utilized.

Listening Test

Overall impression of this amplifier is that it sounds about as good as anything previously tested as long as output is kept below clipping. Considerable listening was done with the Model One driving the reviewer's own equalized arrays, which are quite efficient and ordinarily tend to utilize the

low end of an amp's power range. The Model One was considered excellent in this use, having very good definition, tight and solid bass response, and an open, airy high end, with a relatively low amount of grit and high frequency edginess or irritation. Measurements aside, this amplifier sounds very, very good.

Further considerable listening was done with Stax SRX Mk-II electrostatic phones, Sony C-500 mikes, and an Ampex MR-70 recorder for monitoring during live recording and later playback. The Model One was considered quite good in this use as well, though not up to a pair of specially modified Marantz 9 tube amps and an experimental class-A transistor design.

More limited listening was done on Magnepan 2167F speakers, which use a great deal more power. The conclusion here was that the Model One was again quite good for this use so long as it wasn't overdriven, a condition which was readily observable with the front-panel indicators. If the amplifier was overdriven hard at high frequencies, then the misbehaviors noted in the measurements taken later do become audible as a harshness not apparent in other amps that clip more cleanly with difficult loads.

Measurements

The Model One was first run at one-third rated power into 8-ohm loads for one hour with a test signal of 1 kHz. The unit operated without thermal cutout but did get hot, as would be expected.

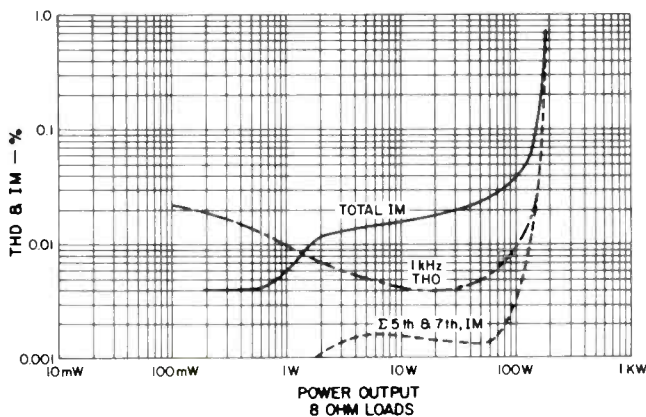

Fig. 4—THD and IM versus power output.

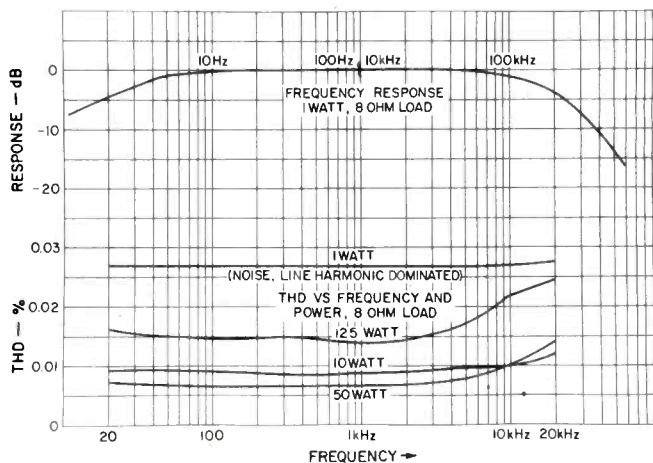

Fig. 5—One-watt frequency response and THD versus power. (Note break in frequency response curve from 100 Hz to 10 kHz.)

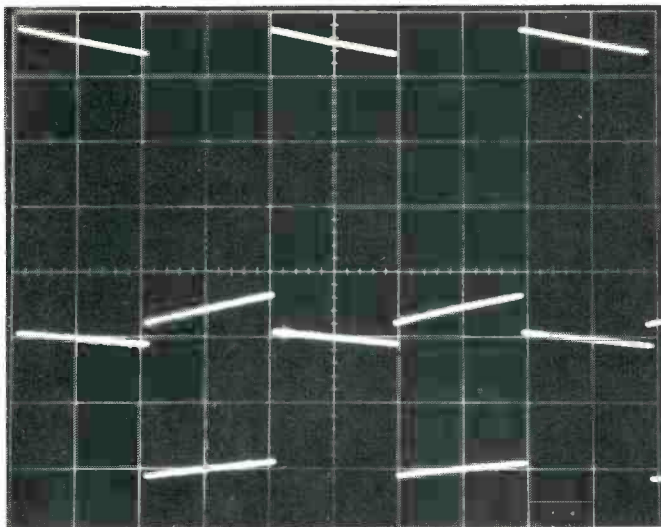

Fig. 6—50-Hz square waves with 8-ohm loads. Top, approximately 200 watts (scale: 20 V/cm, 5 mS/cm); bottom, 3.12 watts (scale: 5 V/cm, 5 mS/cm).

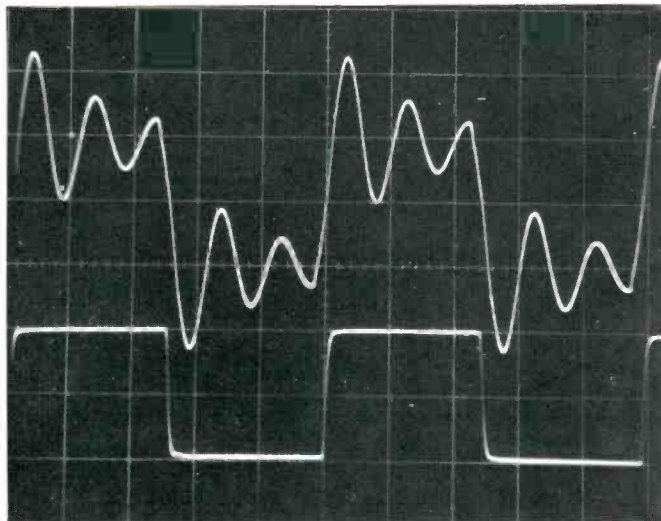

Fig. 7—10-kHz square waves into, top, 2 μ F loads and, bottom, 8-ohm loads. (Scales for both: 5 V/cm, 20 μ S/cm.)

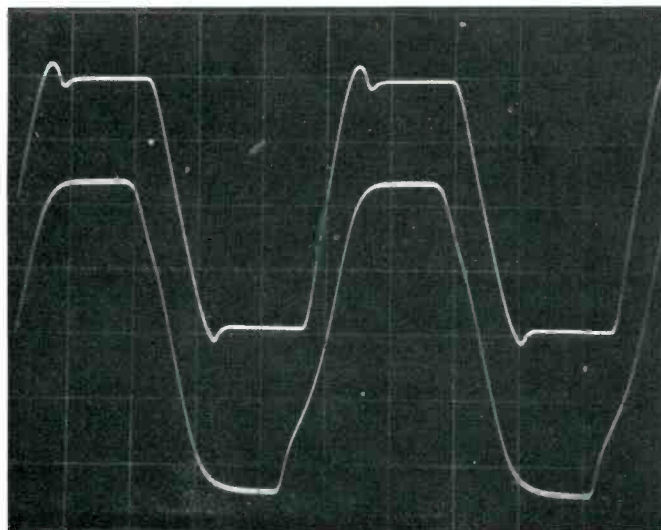

Fig. 8—Top, 20-kHz square wave, 8-ohm load; bottom, 20-kHz sine wave, 2 dB overdrive into 8-ohm load. (Scales for both: 20 V/cm, 10 μ S/cm).

Voltage gain was measured at 1 kHz into 8-ohm loads and found to be 32.5X and 32.0X for the right and left channels respectively. These gains translate to 30.24 and 30.1 dB. Input sensitivity for rated power into 8-ohm loads is therefore about 1 V rms.

Harmonic distortion at 1 kHz and IM distortion as a function of output power are shown in Fig. 4. (Note that this graph is plotted on log-log paper rather than the semi-log paper used in past reviews. This allows greater resolution in reading the distortion magnitudes.) Measured distortion is satisfactorily low for the Model One. THD vs. power and frequency is shown in Fig. 5 along with the 1-watt frequency response. The 1-watt distortion is dominated by 60-Hz line harmonics, which suggests that the output noise of the Model One isn't quite what it could be. The output noise is shown in Table I below.

The 20 Hz-20 kHz noise is mostly line harmonics, somewhat higher than with other amplifiers, and it could be heard on the reviewer's efficient speaker arrays but wouldn't be bothersome on less efficient speakers. It is believed that the problem is a ground loop in the way the amp is internally grounded and/or in the signal-lead dress near the power transformer of the shielded leads connecting the gain control pots to the amplifier circuit board inputs. It is entirely possible that later production units don't have as much output noise. At any rate, figures more like 100-200 μ V are achievable with other designs and should be the design goal sought after by new designs.

Scope photos of response to various signals and loads are shown in Figs. 6 to 9. Fig. 6 shows the amount of 50 Hz tilt at about 3 and 200 watts, which is a result of the low-frequency rolloff illustrated in Fig. 5. Also, the amplifier doesn't have any change in LF tilt or phase response as a function of power which is both normal and desirable. Fig. 7 shows the 10V p-p, 10 kHz, square-wave response for an 8-ohm and 2 μ F loads. Risetime is typical of most solid-state amps, although the ringing caused by the RLC buffering network is noticeably less damped than with other amplifiers.

Table I—Output Noise, μ V

Bandwidth, Hz	Left		Right	
	CCW	CW	CCW	CW
20-20k	550	600	380	620
400-20k	115	122	130	215

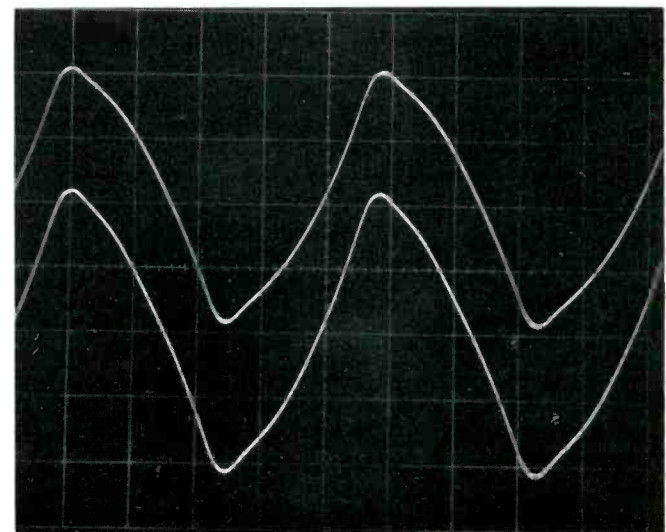

Fig. 9—Effects of 1 μ F load on, top, 20-kHz square wave and, bottom, 20-kHz sine wave (scales for both: 20V/cm, 10 μ S/cm).

Fig. 8 is for a large signal 20-kHz square wave into 8 ohms and with a 2 dB overdrive beyond the onset of visual clipping with a 20 kHz sine wave. The slew rate for plus and minus transitions of the square wave isn't equal and recovery from slewing isn't as clean as the very best designs. The measured rise time for a 60 V p-p output into 8 ohms which is fairly close to rated power, was 3.6 μ s for the plus transition and 6 μ s for the minus transition which works out to a slew rate of 13.3 and 8 V/ μ s respectively. "Sticking," which was explained in the September issue review of Ampzilla, is rather severe on this unit as the waveform is distorted and visibly nonsinusoidal on the slopes. The last scope picture is for 20-kHz square and sine waves into a 1 μ F load. These last pictures aren't as good as other fine amps that have been recently reviewed here, as this amp will not deliver much current (necessary for fast voltage change on a step transition) and its sine wave output "latches" into a nonlinear mode when the amplitude is raised much beyond 20 V rms. (Latching means that the output jumps up to a certain level and wave shape, as shown; when in this state, further input drive doesn't increase the output, and reduction of input ampli-

tude holds this wave shape and level until suddenly the output collapses back to a lower level sine wave.)

The particular test signals and loads used here are admittedly quite difficult, and the Model One's performance with them are a departure from what an ideal would be expected of or perfect amplifier. The whole question is, perhaps, academic, since the amplifier sounds extremely good, and that is what really counts in the final analysis.

Damping factor was measured at about 100 from 20 Hz to 1 kHz, decreasing smoothly to about 17 at 20 kHz. Power at visual onset of clipping with a 1-kHz sine wave was 200, 175, and 100 watts for 4-, 8-, and 16-ohm loads respectively, with both channels driven.

In summary, the Epicure Model One is a well-built, rugged appearing unit that sounds very good when not pushed hard into clipping at high frequencies. It would be an excellent choice for use where speaker efficiency is moderate to high and the user doesn't want to have "blow your head off" rock volume.

Bascom H. King

Check No. 82 on Reader Service Card

Pickering XUV/4500Q



MANUFACTURER'S SPECIFICATIONS

Stylus Type: Quadrahedral. **Stylus Tracking Force:** One gram optimum. **Output:** 3.4 mV nominal re 5.5 cm/sec. **Channel Balance:** $\pm 1\text{-}1/2$ dB maximum. **Separation:** 35 dB at 1 kHz, 25 dB at 30 kHz. **Frequency Response:** 10 to 50,000 Hz $\pm 1\text{-}1/2$ dB base bands, ± 2 dB carrier bands. **Cartridge D.C. Resistance:** 600 ohms. **Cartridge Inductance:** 290 mH. **Weight:** 6-1/2 grams, including 1 gram brush. **Load Resistance:** 100 kOhms for four channel; 47 kOhms for two channel. **Load Capacitance:** 100 pF including arm leads, cables, and amp for four channel; 275 pF for two channel. **Price:** \$139.95.

In 1973, Pickering's sister company, Stanton Magnetics, introduced the first American-made CD-4 cartridge, the 780/4DQ, which had a Shibata-like stylus shape called Quadrahedral. Experience with their first CD-4 cartridges and continuing research has led to a new design which retains the diamond Quadrahedral stylus tip. Like its predecessors, the cartridge comes equipped with a Dustamatic brush; for our tests, this brush was removed. The stylus assembly is easily replaced by pulling the assembly straight forward, separating it from the cartridge body.

The XUV/4500Q has a remarkably flat response from 20 Hz to 30 kHz, +1, -2 dB, and a separation averaging 23 dB from 20 Hz to 30 kHz. Separation at 20 kHz is 25 dB and 22.5 dB at 30 kHz, which is quite impressive. Pickering recommends a tracking force of one gram plus or minus one-half gram, and we found the optimum tracking force to be 1.15 gram for the cartridge tested, with an optimum anti-skating force setting of 1.25 gram. Square waves indicate that the resonant frequency of the cartridge is about 32 kHz,

with a fast rolloff. Its ability to track warped records with minimal distortion is good.

The Pickering XUV/4500Q ranks among the top cartridges for stereo, SQ, QS, and CD-4. The sonic clarity is exceptionally good, with superb transient and applause response, and good definition, particularly in the low bass region.

Measurements

As is our practice, measurements are made on both channels, but only the left channel is reported. During the test period, temperature was 73° F $\pm 1^\circ$ and the relative humidity 55% $\pm 2\%$.

Frequency response is flat within +1, -2 dB from 20 Hz to 30 kHz, -7.5 dB at 40 kHz, and -5 dB at 50 kHz. Separation is 25 dB at 1 kHz, 23 dB at 5 kHz, 24 dB at 10 kHz, 25 dB at 20 kHz, 22.5 dB at 30 kHz, 17 dB at 40 kHz, and 19.25 dB at 50 kHz. Channel balance is within a quarter dB and trackability is very good. A state-of-the-art CD-4 cartridge should produce more than 0.7 mV at 30 kHz from the JVC-1004 test record, where the 30-kHz monophonic signal is recorded at the 5.5-in. diameter with a peak velocity amplitude of 5 cm/sec. The XUV/4500Q output at 30 kHz was 0.95 mV. On a test record designed by this reviewer (AEL-100), which contains tracking velocities from 7 cm/sec. to 70 cm/sec. at 1 kHz, lateral cut, peak velocity, the XUV/4500Q tracked just under 28 cm/sec. Signal output is 0.68 mV/1-cm/sec.

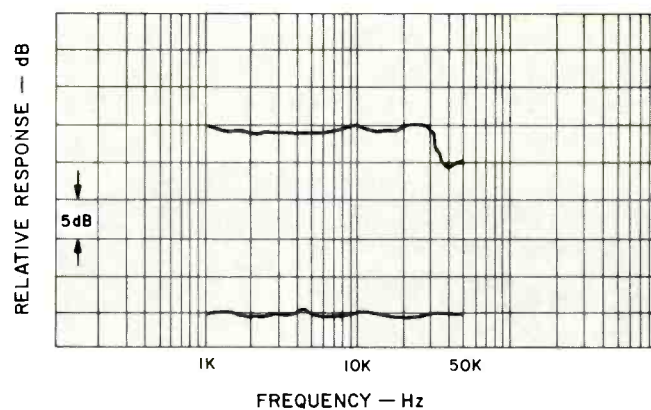

Fig. 1—Frequency response and separation of the Pickering XUV/4500Q with the JVC TRS-1005 test record.

The following adjustment and test records were used in making the reported measurements: JVC 4DE-205; WEA PR186; Shure TTR-197, TTR-103, TTR-110; Columbia STR-100, STR-112; JVC TRS-1004, TRS-1005; Stereo Review SR-12; B & K QR-2009, Deutsches Hi Fi No. 2; Panasonic SPR-111; Denon (UD-4) ST-5003; Ovation (QS) OVQS/4000; Columbia (SQ) SQT-1100, and AEL-100. Both the square wave photograph and 4:1 IM test were made using the new CBS Laboratories Professional Test Record, STR-112.

Wt., 5.59 g.; d.c. res., 591 ohms; Ind. 269 mH; Opt. tracking force, 1.15 g.; Opt. anti-skating force, 1.25 g.; Output, 0.68 mV/1-cm/sec; IM dist. (4:1) + 9 dB lateral, 200/4000: 2.1%, +6 dB vertical, 200/4000: 3.2%; Crosstalk, -28 dB; Ch. Bal., 0.25 dB; Trackability: High Freq. (10.8 kHz pulsed) 24 cm/sec.; Mid-freq. (1000 + 1500 Hz lat. cut) less than 20 cm/sec; Low freq. (400 + 4000 Hz lat. cut) 19 cm/sec;

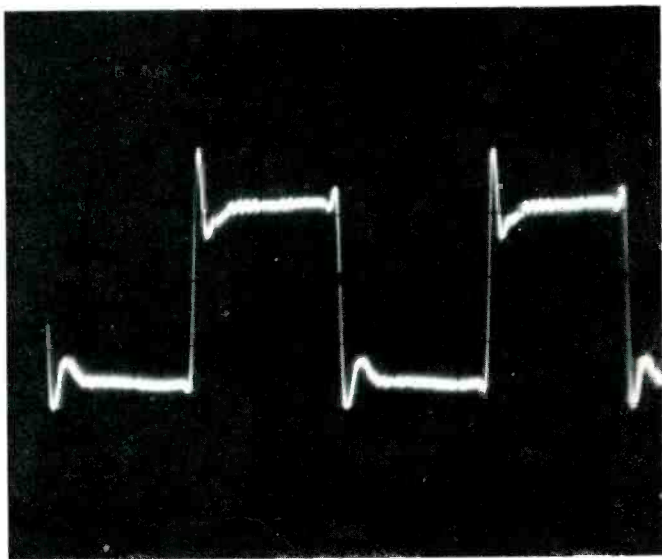

Fig. 2—Square wave response of the Pickering XUV/4500Q with the CBS Labs STR-112 test record.

30 kHz mono signal, 0.90 mV. Passed all bands of the Shure Audio Obstacle Course Era III test record. Cartridge-arm resonance (using Audio-technica AT-1009 arm) was less than 10 Hz.

Listening Evaluation

We have used the XUV/4500Q cartridge with the following CD-4 demodulators in the listening evaluation: Technics SH-400, Panasonic SE-405, JVC 4DD-5, Harman/Kardon +44, and the Denon (UD-4) UDA-100, which also includes CD-4, SQ, and QS. Separation and 30-kHz carrier-signal adjustments (where required) were easily accomplished. Two

Phase Linear 4000 preamplifiers and a pair of Crown D-150 amplifiers drove the speakers, primarily four Micro-Acoustics FRM-1's. A Technics SP-10 turntable with the Audio-technica AT-1009 tone arm was used for all tests, as well as the listening evaluation. A Janis Audio Associates W-1 subwoofer was used in combination with a Crown VFX2 crossover to reproduce all frequencies below 100 Hz.

A rigorous listening evaluation of the Pickering XUV/4500Q was made in both the stereo and quadraphonic mode, using all the records listed in *Audio*, March 1974, p. 39, those mentioned in *Audio*, September 1975, p. 60, and the following additional quadraphonic records which demonstrate the capabilities of this cartridge:

- Yuri, Furi, Suri*—JVC CD-4B5040
- Steven Michael Schwartz—RCA Experimental Record, RL-1890 (mastered with the RCA Quadulator)
- Carley Simon: *Hotcakes*—RCA Experimental Record, RL-1885 (mastered with the RCA Quadulator)
- Levine Conducts Mahler—*Symphonies Nos. 1 and 4* - RCA CRD3-1040
- Captain Blood*—RCA ARD1-0912
- Anthony Newman: *Organ Orgy (A Wagner Sound Spectacular)*—Columbia MQ 33268
- Chicago III*—Columbia C2Q 30110
- Orff: *Carmina Burana*—Columbia MQ 33172
- Schoenberg: *Gurre-Lieder*—Columbia M2Q 33303

Most cartridges have a difficult time reproducing the last half-inch of Side A, Debussy: *LaMer* (RCA ARD1-0029). The Pickering XUV/4500Q reproduced this portion of the record with excellent clarity and definition, without the usual shattering sound. RCA recently produced two records for experimental use, Steven Michael Schwartz (RL-1890) and Carly Simon's *Hotcakes* (RL-1885), by mastering them with the new RCA Quadulator. Aside from the fine results brought about by the Quadulator, the XUV/4500Q reproduced the two recordings superbly. A remarkable Japanese recording, *Yuri, Furi, Suri*, presents Japanese musical instruments playing Japanese music. The recording is full of sharp transients that this cartridge was able to faithfully reproduce. To the best of our knowledge, Wagner's operatic music has never been recorded in modern times on a pipe organ. Columbia's *Organ Orgy* (MQ 33268) is played on the great Aeolian Skinner Organ of St. John the Divine, N.Y.C., by Anthony Newman. Despite all the sharp transients, very low pedal bass, and the usual Wagnerian fire and fury, the XUV/4500Q reproduced the recorded organ music faithfully, particularly the pedal bass, which not infrequently was below 30 Hz. The nine-ft. concert bass drum in Columbia's *Carmina Burana* was taken in its stride by the XUV/4500Q cartridge.

To sum up, we can recommend the Pickering XUV/4500Q cartridge without reservations, based upon our laboratory and listening tests.

B. V. Pisha

Check No. 83 on Reader Service Card

Pioneer CT-F7171 Cassette Deck



MANUFACTURER'S SPECIFICATIONS

Frequency Response: Std. tape, 40 to 12,000 Hz; CrO₂ tape, 40 to 13,000 Hz. **S/N Ratio:** 48 dB, std. tape; 58 dB w/Dolby; 4.5 dB improvement with CrO₂ tape. **Harmonic Distortion:** Less than 2% for 333 Hz at 0 VU. **Input Sensitivity:** Line, 60 mV at 470 kOhms; mike, 0.2 mV at 20 kOhms. **Output Level:** Line, 300 mV; phones, 40 mV into 8 ohms. **Wow & Flutter:** 0.1% W rms. **Fast Forward And Rewind Time:** 80 sec., C-60. **Dimensions:** 17 in. W x 5 1/2 H x 12 1/4 D. **Weight:** 18.8 lbs. **Price:** \$369.95.

The Pioneer CT-F7171 cassette recorder has been on the market for a while and is one of the earliest of the growing group of front-load units. The opening for insertion and removal of cassettes is at the left of the front panel. The tape-

drive mechanism is inclined at an angle within the opening to facilitate inserting cassettes. A spring-loaded tray receives the cassette and then latches down in playing position. When released the cassette is ejected onto an inclined shelf at the bottom of the opening. The *Memory On-Off* switch is on the front panel to the left, with the counter and its reset button just inside. An interior convenience light for observing tape motion and cleaning heads, has its lever switch on the front panel to the right. A transparent plastic door can be let down to cover the drive mechanism for dust protection.

Below the cassette-access opening and to the left is the *Power On-Off* switch. Next to the right is the spring-loaded push-to-operate *Skip* button, which advances the tape at twice normal speed in *Play* for cue purposes. Then there is a series of levers to control *Record*, *Rewind*, *Play*, *Fast Forward*, *Pause* and *Stop/Reject*. Next is the button that releases the door to drop down in front of the cassette well. The door snaps into a retaining latch when pushed upward.

The level meters on the right side of the front panel are of good size and well illuminated. The scale markings are very legible and are noticeably expanded above 0 VU, an aid to detecting excessive record levels. Between the two meters are the *Record* and *Peak* indicator lights. Located below the meters are a row of four button switches for *Dolby NR*, *Tape Bias* and *Equalization*, and *Record Limiter*. With the *Bias* switch, selection can be made for *Normal* or *Chrome* tapes. *Equalization* can be set for normal tape (and older chrome) or for the new 70-microsecond chrome. The *Input* (record) and *Output* (play) level pots are identical in construction, with knobs for each channel mounted on concentric shafts. Friction between the sections allows the levels to be adjust-

ed individually or simultaneously, as desired. A plastic ring with a red indicator line located behind each set of pots provides a level reference.

There are three phone jacks at the very right of the front panel—two for microphones and one for stereo headphones. Plugging into the microphone jacks disconnects the associated line inputs. On the rear panel are the input and output phono jacks, paired to facilitate connection to other equipment. A DIN socket provides input/output connections for systems with DIN plugs. The back panel also includes a ground terminal, an a.c. convenience outlet (unswitched) and the fuseholder.

With the top cover removed the electronic assemblies are visible. At the top left is a small board with three fuses, which indicates unusual attention to protection of the system components. One 500 mA fuse is in series with the pilot lamps in the meters, an 800 mA fuse protects the B+ line, and a one-amp fuse is in series with the unswitched a.c. convenience outlet on the rear panel.

Performance

Response from standard tapes was tested first, and playback response from a standard DIN tape was within 2 dB to over 4 kHz, 5 dB down at 10 kHz. With the CrO₂ test tape, the response was within 2 dB to 10 kHz, 5 dB down at 12.5 kHz. The channel B record/playback response was the better of the two and is reported here. Good results were obtained with Maxell UD, which provided very flat response and 3-dB down points at 30 Hz and 12.7 kHz at the -20 VU level without Dolby, superior to Pioneer's specs. The -20 VU response with Dolby was also very close, indicating excellent

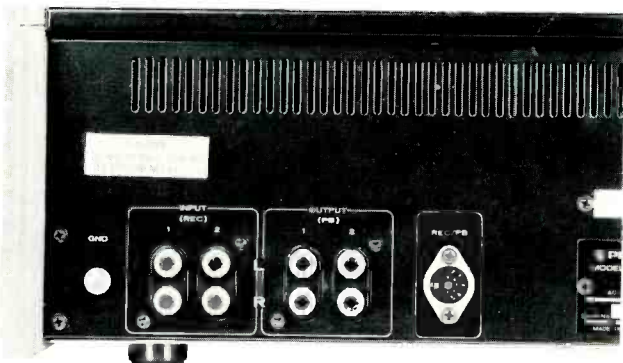

Fig. 1—Rear panel of Pioneer CT-F7171 deck.

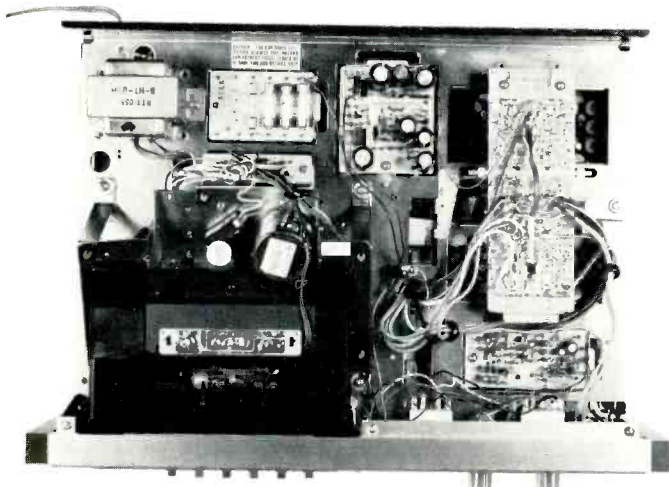

Fig. 2—Inside view of cassette deck with top cover removed.

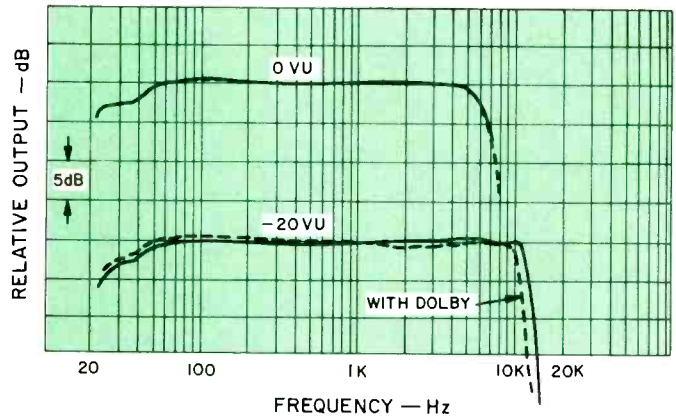

Fig. 3—Record/Playback response, Maxell UD tape, with and without Dolby, recorded at Zero VU and at -20 VU.

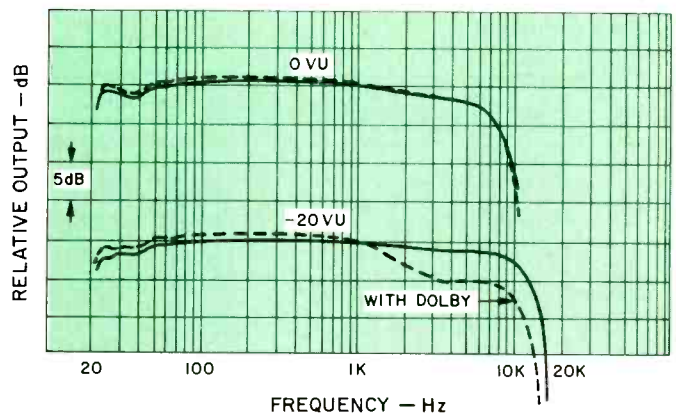

Fig. 4—Record/Playback response, TDK KR (chromium dioxide) tape, with and without Dolby, recorded at Zero VU and at -20 VU.

tracking of the Dolby circuits with the flat-response inputs. Results with Memorex MRX₂ and Capitol Music tape were also quite good, while the deck showed some high-frequency droop with other tapes. The CT-F7171 reached 10.8 kHz with TDK KR, the better of two chrome tapes tested. With Dolby On, at -20 VU with this same tape, response was 7 dB down at 10 kHz.

A spectrum analyzer was used to measure distortion generated by a 1-kHz signal at record levels from -1 to +10 VU. Distortion was commendably low with the low-noise tapes, which averaged 0.20 percent at 0 VU without Dolby, and 0.14 percent with Dolby. Distortion with the chrome tapes averaged 0.85 and 0.50 percent. With Memorex MRX₂ the distortion was a very low 0.06 percent at 0 VU, 0.05 percent with Dolby. The 2 percent distortion reference was not exceeded with a number of the low-noise tapes until approximately +10 VU. The chrome tapes showed 2 percent distortion at about +5 VU. See Fig. 6.

Minimum distortion over a range of frequencies from 30 Hz to 10 kHz was at 500 or 1000 Hz, and depended on the tape type. At 10 kHz, careful analysis proved that the high-level "harmonic" was actually a beat note between the eighth harmonic of the test tone and the bias oscillator. The average signal-to-noise ratio for three low-noise tapes was very close to 48 dBA (A-weighted) which is as specified. With a two percent distortion reference, the average was 57 dBA. With Dolby On, the averages for all low-noise tapes were 55 dBA at 0 VU and 65 dBA at 2 percent distortion. With the two chrome tapes the results were slightly better at 0 VU, but slightly worse at 2 percent distortion.

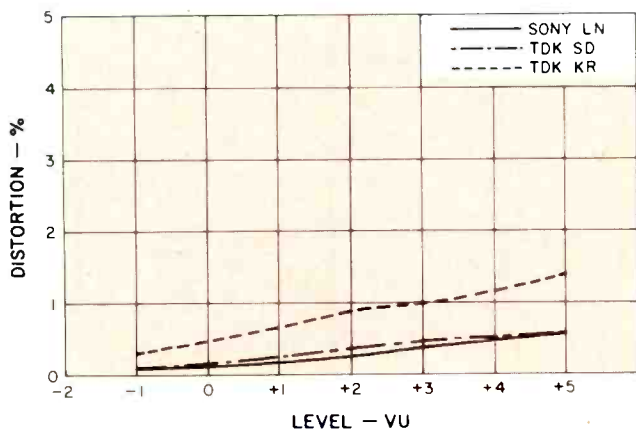

Fig. 5—Harmonic distortion at 1 kHz, three tapes, with Dolby noise reduction.

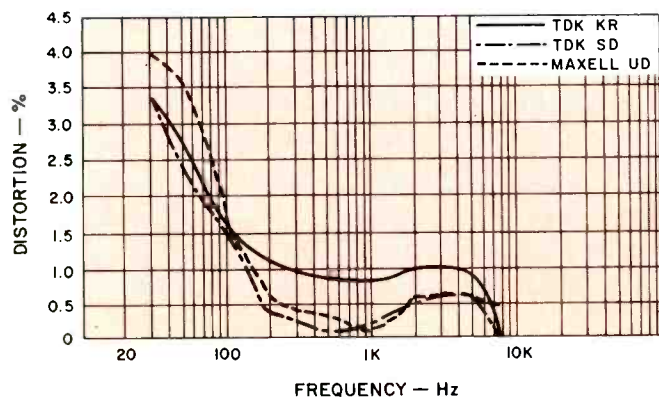

Fig. 6—Distortion versus frequency for three tapes.

A 1000-Hz tone at 0 VU was erased to at least 72 dB down. Cross-talk from channel to channel was -41 dB, quite satisfactory. Crosstalk to the channel of opposite-play direction was at least 70 dB down. The lowest flutter was 0.06%, with an average of 0.19%, both for DIN-weighted peak. These figures would be approximately 0.03% and 0.09% on A-weighted rms basis and thus within the specified 0.1%. Average rewind time for 77 seconds, better than the 80 seconds specified. Tape speed was slightly high, 2.0% fast, but was very consistent, regardless of changes in the line voltage.

At 0 VU the output to headphones was 450 mV across 8 ohms, much greater than the specified 40 mV. Microphone input sensitivity was 0.19 mV and line sensitivity was 50 mV, both better than stated. The limiter showed its effect above 0 VU and reduced a 20-dB increase in the input to just +4 VU. Response time was about 20 milliseconds.

The output at 0 VU is specified at 300 mV. In record, it measured 315 mV. Some of the tapes tested met this level in playback, although the standard level on the DIN test tape indicated +3 VU. Testing with tone bursts of varied duration showed the meter response close to the VU standard, which many do not. The peak indicator began to flash when fed a 10-millisecond burst at a +4 VU level.

In-Use Tests

The front-loading scheme is well designed in its basic components, with easy loading and smooth ejecting. Demagnetizing and cleaning the heads, as well as head alignment, is somewhat difficult. Ejecting a cassette while the door was down, admittedly an improper action, but nevertheless something a new owner might easily do until he became familiar with the machine, required a bit of care to clear. Tape drive controls were well interlocked, but the Record lever required more force to actuate than seemed convenient. The front panel has a nice, subdued look, a plus factor for some people. The Dolby indicator is relatively small, and the operator should remember to be certain of the status of the tape type switches. The level pots worked very well in controlling both channels simultaneously, but the high friction between sections made initial balancing difficult. On the other hand, the reference level rings were looser, allowing them to be moved more easily.

The instruction book provides all details required for using the deck, and the schematic is quite acceptable. Access to the interior is gained by removal of just four screws holding the top enclosure. The bottom is shielded and protected by a rigid metal plate. Construction is of good quality with helpful labels on the circuit cards.

Listening tests were performed by copying portions of Walter Carlos' *Switched-on Bach* and a Haydn *Sinfonia Concertante*. A minor difficulty experienced was that the peak indicator was hard to see until the ambient light level was reduced. The CT-F7171 provided very satisfactory listening on playback with Maxell UD, both with and without Dolby, the lower-noise Dolby version being slightly better. Memorex MRX₂ and Capitol Music Tape showed up very nearly as well, with a slight loss of brightness with Dolby. The poorer high-frequency response on channel A was probably the cause of a subtle deterioration of the stereo effect. The treble loss with chrome tapes caused their playback to be relatively duller, with strong apparent bass. It appears possible that this machine could be adjusted for optimum response with the various chrome formulations, though the user might not wish to have this done. We obtained best performance with Maxell UD, Memorex MRX₂ and Capitol Music Tape.

Howard A. Roberson

Circle No. 84 on Reader Service Card

The Column

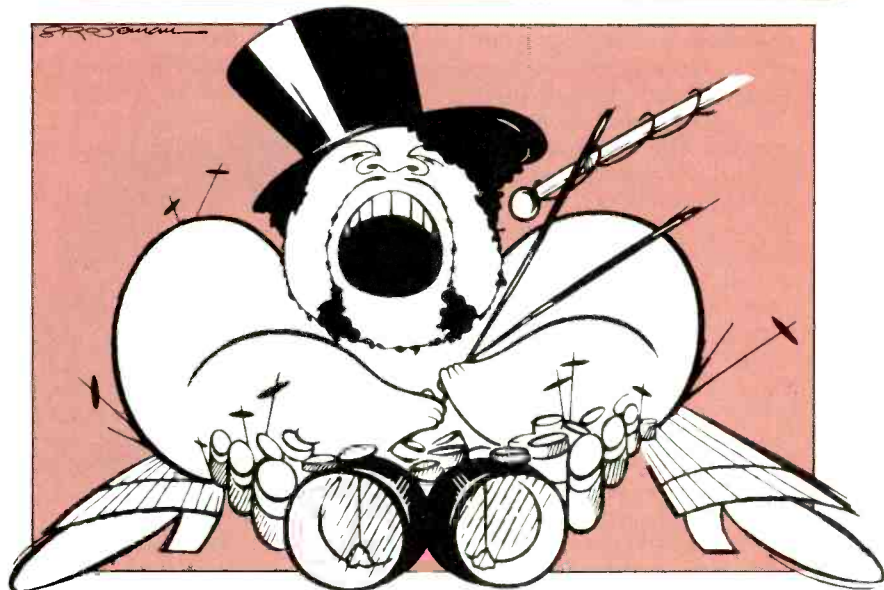

All The Faces: Buddy Miles
Columbia KC-33089, stereo \$5.98.

Buddy plays disco? Well, why not! He does it okay, and besides he has done almost everything else. He has recorded with Jimi Hendrix, Paul Butterfield, Mike Bloomfield, the Electric Flag and a jillion others, besides having made 10 albums of his own. The best of the lot is the nearly-extinct **Them Changes**, on Mercury. Buddy Miles is a better-than-average rock drummer, yet strangely, Buddy's drumming does not appear on this record. Edward Green handles drums in the standard Earl Young manner and that establishes the total sound for this record, just as Young does for all the Philly sound that is now the dominant style of Black R&B music.

That's right, Buddy not only plays disco, he duplicates much of the basic Philadelphia International-Tom Bell-Linda Creed-Kenny Gamble-Leon Huff sound of the mid-70s. His vocals, aimed at the mass audience, sound good for the type, but mediocre for Buddy Miles. It is not a bad record, just a workmanlike, professional job of making very average music, neither an artistic *milestone*, nor a horrible mess.

But if you are addicted to the Spinners, O'Jays, Whispers, The Three Degrees, Intruders, Blue Notes, et. al., then, the many faces of Buddy Miles

will be special, because he brings some of his other musical personalities into this restricted area. Even the weakest songs are consistent with the current (and ever-changing) Buddy Miles Express band (their last two albums are of dubious merit). Once this record gets rolling, it does hold you and builds up, a bit here, a bit there. But let's give credit where it's due—to the folks from Philly. If you're not familiar with these people and groups (mentioned above), they are representative of a whole family of practitioners who you might like. Give them a listen.

Even as they do, Buddy Miles exceeds the ordinary on occasion, but the personal tastes of the listener do count when judging music. That feeling is a little contradictory I know, but it does say Buddy Miles on the cover, which makes me expect more. The disco style limits him, because this is a concept album, with a small c, and a big C too. The small c is the style and its limitations. The big C is CASH. A good record in this style produces cash. It sells well, not to the Buddy Miles cult who will be disappointed, but to the masses who will dance, bop, and party until they have worn the disc white. Maybe we are missing the point. A steady diet of this kind of album is not going to offend anyone, for it may well be the background music of our time.

more than one revolution started in MASS- A·CHU- SETTS

and one of them is
still going on here
where we started
the hi-fi revolution
in 1947.

The Scott revolution contributed enough firsts to fill this page, including the first successful stereo FM tuner, the first all-solid-state components, the first digital tuner, the first four-channel components, and many more.

Start a little revolution of your own by upgrading your music system with a new Scott tuner, amplifier, receiver or speakers from the revolutionaries at Maynard, where innovation has been a tradition for over a quarter of a century. To fire the first shot, circle reader service number or contact us for complete product information and list of dealers where you may see and hear Scott stereo components demonstrated.

W SCOTT[®]
where innovation is a tradition
H.H. Scott, Inc., 111 Powdermill Road, Maynard, Mass. 01754
Check No. 44 on Reader Service Card

FREE!

the 1976 Lafayette Electronics Catalog

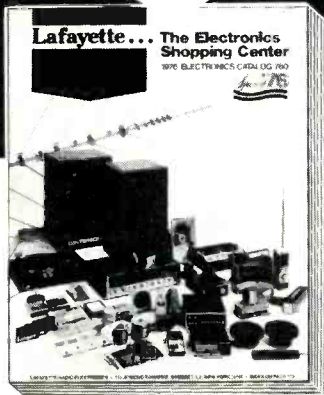

Offering the **FINEST** in
Home Entertainment
Products

Akai • Audio Technica • B.I.C. •
BSR • Burwen • dbx • Dokorder
• Dual • Dyna • Empire • ESS
• Garrard • Hitachi • Koss •
Meriton • Micro Acoustics •
Onkyo • Ortofon • Panasonic •
Philips • Pickering • Sanyo •
Sennheiser • Scotch • Shure •
Sony • Stanton • Teac • Technics •
TDK • Venturi • Wollensak

Plus **EXCLUSIVE**
LAFAYETTE
AUDIO PRODUCTS

Lafayette

the electronics shopping center

Mail Coupon
Today!

FREE

Dept. 27115

Lafayette Radio Electronics
111 Jericho Turnpike
Syosset, L.I., N.Y. 11791

Send me your FREE 1976 Catalog.

Name Apt.
Street
City State

Zip

Send a 1976 Catalog to my friend.

Name Apt.
Street
City State

Zip

Check No. 24 on Reader Service Card

This brings up another problem with the album. Although the songs, background singers, orchestra, horns, and rhythm band are fine, I can't help wondering (since the Sound of Philadelphia is for hire—Joey Heatherton even did an album there) why did Buddy Miles duplicate it in Hollywood? I strongly feel that real Philly would have put this over the top and made it a blockbuster. Earl Young and Norm Harris would provide a tighter, more inventive bottom. Philly's Three Degrees do background vocals not only in tune, but with spunk and a bit of sex. And M.F.S.B. is one of the most flexible 27-man studio orchestras in the world. They and their space-age studio can be stronger than the world economy will ever be again. The sound is very good, but Joe Tarshia and his Sigma Sound section of the Philly music factory can't be outdone by anyone.

This is a better Buddy Miles record than some of his previous albums, but not at all a Buddy Miles record (pun intended). It's an R&B record of unexpectedly good quality—not a masterpiece of any kind—still nothing to be ashamed of. For all the things this record lacks, grab a copy of the reincarnated Electric Flag's new album, **The Band That Kept Playing**, Atlantic AT-18112. There Buddy shines in a form far more familiar.

The sound of this disc is good, but never spectacular. Smooth as glass and as dealed as necessary, but the real Sound of Philadelphia could have turned it around.

Fred De Van

Sound: A Performance: B

Destiny: Felix Cavaliere
Bearsville BR 6958, stereo, \$6.98.

When Felix released his first solo album many moons ago, people called it the comeback-of-the-year. Not so. Felix has been making records for quite a while, though he started making them less frequently several years ago when the Rascals stopped aiming for the AM charts. He later dropped the tag "Rascals," though the music was unchanged. The Rascals, neé The Young Rascals, were never anything but a rock 'n roll outfit doing Felix' bidding. In their later days they sounded unlike their hit-single selves, but splinter group Bulldog proved that Gene Cornish and Dino Danelli were Felix's players, not "The Soul of Greater Long Island."

What makes these recent albums different is that Felix no longer is afraid to make songs which sound like

hit singles. AM artists don't have the bad name they once did, and there's no pressure to maintain a cool, calm, adult, FM exterior (play songs which last at least 6½ minutes). So, with **Destiny** we get 10 new Cavaliere tunes (we hope all become singles). The new Felix is on the cover, with longish hair and beard, still a Rascal at heart.

The songs are good, particularly *Never Felt Love Before*, and the voice is very much intact. The thing which always struck home with The Young

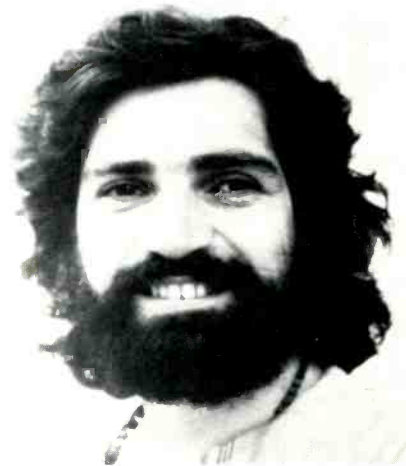

Rascals and established their sound was the smile in the throat of Mr. Cavaliere, who's smiling just as brightly today as ever. He is older (his lyrics at times show it but his voice does not).

It's only natural that he use the best musicians money can buy, so various members of the East Coast jazzoid ensembles provide the back-up sounds, including the Brecker Bros., Leslie West, Laura Nyro, and even Paul McCartney-lookalike Dino Danelli (on drums).

Where his last album, produced by Todd Rundgren, had a brighter sound and sported a few really special tracks, **Destiny** keeps an even level of musical quality throughout. Old Rascallions should find the album a delight. I hope Bearsville will be able to make at least one of these songs into a hit single to put Felix on the AM, where he belongs.

Jon Tiven

Sound: B+ Performance: B+

War Child: Jethro Tull
Chrysalis CH4 1067, CD-4, \$6.98.

The next time the Ian Anderson and Jethro Tull aggregation is in your neck of the woods, get a copy of this or **Aqualung** (Chrysalis CH 4 1044), and take the record with you to the arena. After the concert play the record. It is almost impossible to appreciate or even understand most of the album without seeing Jethro Tull live at least once. Twice is better, since the first

time will be a total wipe-out. Unless you are 16 you will feel out of place at first, but after about 20 minutes you will look at the faces about you and feel like they know something that you don't. Best of all is seeing the honest happiness and joy all around the hall.

The form is almost Harlequin, a jester from the 14th century playing basic forms in a 1970's rock band. When they rock, they remind you of Led Zep—when they solo, the best jazz musicians. When they reach into the darker reaches of our social history they send you back centuries, musically, mentally, and nearly physically. I don't think it's really possible to get a firm fix on the Jethro Tull concept without having it spread out in front of your eyes and ears. Not until I saw the performance could I bear more than one cut of **War Child** in one day. I neither understood nor liked the record originally (and to some degree still don't), but I really enjoyed it repeatedly after the concerts. **Aqualung** is far easier to get into. In my view it's a better record. **War Child** is, like all Tull albums, an amalgam of times, music, and sensibilities of England today and of 700 years ago. But the musicianship is pure Today. Ian Anderson may indeed be one of the most capable musicians alive. Musically he takes a back seat to no one. His flute is incredible. He absolutely is one of the finest flautists playing any kind of music. His voice is strong and distinctive. His writing is unique. His energy is limitless. His head is in another place.

Jethro Tull has neither substitutes nor imitators. You either like or hate them, or both. They do not play Rock and Roll as I understand it. They are so much a form unto themselves that they are almost impossible to criticize. Understanding what they are doing takes a bit of work, more than is justifiably demanded by any other group. But after all, who else is doing electric madrigals?

Fred De Van

Sound: A Performance: B

No Doubt About It: Graham Central Station
Warner Brothers BS 2876, stereo, \$6.98.

Given that most Black, rock music groups around (Ohio Players, B.T. Express) are just as anonymous as the majority of white hard rock bands (Bachman Turner Overdrive, Rush, Mahogany Rush), Graham Central Station must surely be the Led Zeppe-

lin of R&B. They are a monster group, quickly becoming the most popular group on the soul charts, and for good reason—they embody what party music should be without losing their uniqueness, their musicality, and their sense of humor. And all of these factors are as essential to GCS as Jimmy Page's brains/fingers, John Bonham's point-me-at-it-and-I'll-hit-it drumming, and Robert Plant's sultry vocal delivery are to Zeppelin. The parallel goes even further—Larry Gra-

ham came out of Sly's Family Stone, a late 60s group which was all to Black music until Sly's energies started to dissipate. Larry got out right before the going got rough, and took what he'd learned with him, starting what he conceived as the Ultimate R&B Bash. So also did Jimmy Page leave the Yardbirds as their initial supernova fizzled, grabbing his tools of knowledge (weaned at the unlikely breasts of Mickie Most and Andrew Oldham)

(Continued on page 83)

Soundcraftsmen THE PERFECT PRE-AMP

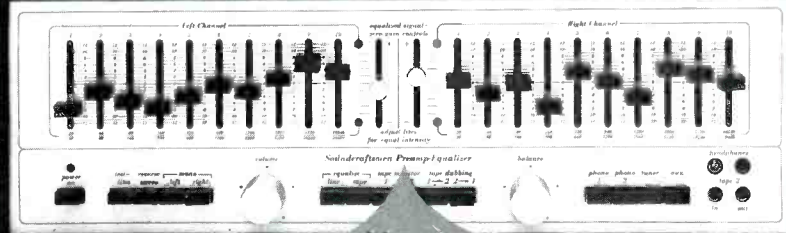

FOR THE GREAT NEW SUPER POWER AMPS!
For a SUPER-SYSTEM, match the 2217 with any of these TRUE "State-of-the-Art" amps—

• PHASE LINEAR • SAE • CROWN • DYNACO • AUDIO RESEARCH • CITATION •
• ESS • MARANTZ • SONY • KENWOOD • BOSE • QUATRE • BGW •

"FANTASTIC! I CAN HARDLY BELIEVE MY EARS... VERY VERSATILE & CLEAN-SOUNDING AND I REALLY LIKE THE SWITCHABLE PATCHING."

(CUSTOMER COMMENT CARDS ARE ON FILE AT SOUND-CRAFTSMEN)

FANTASTIC! I CAN HARDLY BELIEVE MY EARS... VERY VERSATILE & CLEAN-SOUNDING AND I REALLY LIKE THE SWITCHABLE PATCHING.

Fantastic unit! I'm glad my first audio review feature is in a central.

Great functional response!

It's fantastic & we would for own one!

Please list any suggested improvements, changes, or
YOU MUST BE KIDDING!

SPECIAL FEATURES

- ALL PUSHBUTTONS INTERLOCKED to prevent inadvertent program destruction
- DISCRETE-OCTAVE EQUALIZATION CONTROL of ten octaves on each channel, ± 12 db each octave
- FULL-SPECTRUM LEVEL CONTROL for each channel
- AUTOMATIC CONTINUOUS MONITORING by light-emitting diodes for visual warning of overload in output circuits
- VISUAL ZERO-GAIN EQUALIZATION BALANCING on music, white noise or pink noise
- SELECTION of TEST LITES on or off
- TAPE DUBBING BETWEEN TWO MACHINES, with optional simultaneous equalizing and monitoring
- DOUBLE-DUBBING into two recorders simultaneously
- SEPARATE SYSTEM-SELECTION enables full use of all other functions during the dubbing operation
- LINE OR TAPE equalization selector
- AUTOMATIC EQUALIZER-BEFEAT when line or tape equalizer is not in use
- FRONT PANEL TAPE input-output jacks for easy 2nd and 3rd tape recorder hookup access
- TAPE MONITORING of either tape at any time
- TWO stereo headphone jacks
- MONO SELECTOR for left, right or both channels to both outputs
- REVERSE-STEREO mode
- TWO low-level phono inputs
- FOUR independent phono preamps
- SIX A/C outlets, 4 switched, 2 unswitched
- ELECTRO-PLATED FERROUS CHASSIS—(eight sections)—provides optimum shielding to minimize magnetic field-coupling
- SINGLE-POINT system ground connector minimizes ground-loops
- TWO REGULATED power supplies

SOUND-CRAFTSMEN EQUALIZERS

NOW YOU CAN MAKE YOUR SYSTEM SOUND EXACTLY THE WAY YOU WANT IT TO SOUND! In a few minutes, YOU can accurately "tune" the frequency response of YOUR stereo system and room environment to a flat ± 2 db! All you need are YOUR OWN EARS and the Soundcraftsmen Equalizer (WITH ITS STEP-BY-STEP INSTRUCTION RECORD) to transform any stereo system and room environment into an acoustically perfect concert hall. Or, to provide any special acoustical effects you desire! The Soundcraftsmen Equalizer enables YOU to instantly compensate for frequency response variations, IN SYSTEM AND ROOM.

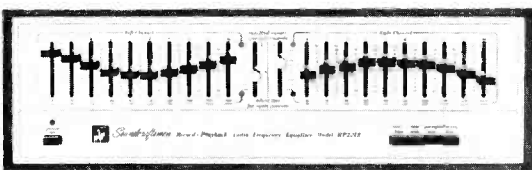

GUARANTEED to enhance and improve any fine system!

Just plug 2 cables into your receiver's tape monitor jacks, and you are ready to enjoy a new experience in musical enjoyment!

2212 Illustrated above... **\$349.50**

20-12 Same specs as RP2212, except no L.E.O.'s, no Tape Equalize on front... **\$299.50**

Both models include cabinet or rack mounts.

GUARANTEED SPECIFICATIONS

FREQ. RESPONSE — Hi level: $\pm 1/2$ db, 5 Hz to 100 KHz
FREQ. RESPONSE — Phono: $\pm 1/2$ db, 20 Hz to 20 KHz
THD: less than .05% at 1 volt (Typ. .01% at 1 volt)
IM: less than .05% at 1 volt (Typ. .01% at 1 volt)
PHONO INPUT CAPABILITY: 100mv
SIGNAL-TO-NOISE — Hi level: 100 db below full output
SIGNAL-TO-NOISE — Phono: 84 db below a 10mv input
SIGNAL-TO-NOISE — Equalizer: 90 db below a 1 volt input
GAIN — Hi level: 63 db
GAIN — Hi level: 23 db
OUTPUT IMPEDANCE: 600 ohms
EQUALIZER LEVEL: Zero-gain controls for left and right continuously variable, for unity gain compensation
EQUALIZER RANGE: 12 db boost and 12 db cut, each octave at 30, 60, 120, 240, 480, 960, 1920, 3840, 7680 and 15,360 Hz
MAX. OUTPUT SIGNAL: Variable master volume control allows adjustment of optimum output to match amplifier
COLD SWITCHES: All contacts are gold plated for low-noise, long life, and resistance to oxidation and corrosion
CIRCUIT BOARDS: Military grade G-10 glass epoxy
RESISTORS: Low-noise selected carbon-film
CABINET SIZE: 7 1/4" x 20" x 11 1/2" deep
SHIPPING WEIGHT: 20 lbs.
MADE IN U.S.A. includes cabinet or rack mounts

PE2217 — \$499.50

FREE!

THE "WHY'S AND HOW'S OF EQUALIZATION," an easy to understand explanation of the relationship of acoustics to your environment. This 8 page booklet also contains many unique ideas on "How the Soundcraftsmen Equalizer can measurably enhance your listening pleasures." "How typical room problems are eliminated by Equalization," and a "10-point self-rated Equalization Evaluation Check-List."

Soundcraftsmen
1721 NEWPORT CIRCLE, SANTA ANA, CA 92705

Advertising Index

ADVERTISER	PAGE	ADVERTISER	PAGE	ADVERTISER	PAGE
Acoustical Manufacturing.....	89	Discount Music Club.....	106	Radio Shack.....	96, 100
Quad Components		Samples		Amplifier	
Write Direct to Advertiser		Write Direct to Advertiser		Check No. 35 on Reader Service Card	
Aries.....	99	Discwasher.....	2	Catalog	
Synthesizer Kit		Record Cleaning Devices		Check No. 36 on Reader Service Card	
Check No. 1 on Reader Service Card		Write Direct to Advertiser		RCA.....	39
Audioanalyst.....	96	Dokorder.....	37	Record Collection	
Loudspeakers		Tape Recorders		Check No. 37 on Reader Service Card	
Check No. 2 on Reader Service Card		Check No. 53 on Reader Service Card		Revox.....	35, 90, 97
Audio Dynamics Corp.....	41	Dual.....	49	Record Cleaning Device	
Cartridges		Turntables		Check No. 38 on Reader Service Card	
Write Direct to Advertiser		Check No. 17 on Reader Service Card		Hi-Fi Components	
Audio Research.....	102	Empire Scientific Corp.....	17	Check No. 39 on Reader Service Card	
Record Collection		Cartridges		Rhoades.....	104
Write Direct to Advertiser		Check No. 18 on Reader Service Card		Teledapter	
Audio Technica.....	6, 14	Elpa.....	3	Write Direct to Advertiser	
Headphones		Hi-Fi Components		Rocelco.....	67
Check No. 3 on Reader Service Card		Write Direct to Advertiser		Speakers	
Headphones		Fidelitone.....	98	Check No. 40 on Reader Service Card	
Check No. 4 on Reader Service Card		Record Washer		Ruxton.....	100
Audonics.....	101	Check No. 19 on Reader Service Card		Collector's Catalog	
Hi-Fi Components		Fuji.....	23	Check No. 41 on Reader Service Card	
Check No. 6 on Reader Service Card		Cassettes		SAE.....	43
Hi-Fi Components		Check No. 20 on Reader Service Card		Amplifiers	
Check No. 7 on Reader Service Card		Harmon-Kardon.....	52, 53	Check No. 43 on Reader Service Card	
Auraton.....	109	Hi-Fi Components		Sansui.....	25
Speakers		Write Direct to Advertiser		Hi-Fi Components	
Write Direct to Advertiser		Hartley Products.....	83	Check No. 42 on Reader Service Card	
Avid Corp.....	90	Speakers		Saxitone.....	105
Speakers		Write Direct to Advertiser		Cassettes	
Check No. 5 on Reader Service Card		Heath Co.....	51	Write Direct to Advertiser	
BASF.....	13, 15	Hi-Fi Components		Schwann.....	86
Tapes		Check No. 22 on Reader Service Card		Record & Tape Guide	
Check No. 9 on Reader Service Card		Kenwood.....	27	Write Direct to Advertiser	
Bell & Howell.....	8, 11	Hi-Fi Components		Scott.....	75
Correspondence Course		Check No. 23 on Reader Service Card		Hi-Fi Components	
Write Direct to Advertiser		Lafayette.....	76	Check No. 44 on Reader Service Card	
BES.....	87	Catalog		Sherwood.....	Cover 4
Hi-Fi Components		Check No. 24 on Reader Service Card		Hi-Fi Components	
Check No. 10 on Reader Service Card		Lee West.....	88	Check No. 45 on Reader Service Card	
BGW.....	12	Music Chairs		Shure.....	61
Hi-Fi Components		Check No. 26 on Reader Service Card		Hi-Fi Components	
Check No. 11 on Reader Service Card		Magnepan.....	26	Check No. 46 on Reader Service Card	
BML.....	84	Loudspeakers		Sonic Research.....	31
Loudspeaker System		Check No. 27 on Reader Service Card		Cartridges	
Check No. 12 on Reader Service Card		Marantz.....	110, Cover 3	Check No. 47 on Reader Service Card	
Bose Corporation.....	7, 47, 99	Hi-Fi Components		Sony.....	21
Hi-Fi Components		Write Direct To Advertiser		Reel-to-Reel Tape Deck	
Write Direct to Advertiser		Maxell.....	63	Check No. 54 on Reader Service Card	
Bozak.....	28	Cassettes		Soundcraftsmen.....	77
Loudspeakers		Check No. 28 on Reader Service Card		Hi-Fi Equipment	
Write Direct to Advertiser		McIntosh.....	97	Check No. 49 on Reader Service Card	
Braun.....	65	Catalog		Stanton.....	33
Speaker Systems		Check No. 29 on Reader Service Card		Cartridges	
Write Direct to Advertiser		PAIA.....	100	Check No. 32 on Reader Service Card	
BSR.....	101	Amplifiers & Synthesizers		Tapco.....	85
Turntables		Check No. 30 on Reader Service Card		Hi-Fi Components	
Check No. 13 on Reader Service Card		Phase Linear.....	18	Check No. 48 on Reader Service Card	
Burwen Labs.....	38	Preamp		TEAC.....	56, 57
Hi-Fi Components		Check No. 31 on Reader Service Card		Cassette Deck	
Check No. 14 on Reader Service Card		Pioneer.....	Cover 2, 1	Check No. 50 on Reader Service Card	
Crown International.....	24	Hi-Fi Components		Warehouse Sound.....	95
Tape Deck		Check No. 33 on Reader Service Card		Catalog	
Check No. 15 on Reader Service Card		Plessey.....	4, 5	Check No. 51 on Reader Service Card	
		Turntables		Yamaha Audio.....	45
		Check No. 34 on Reader Service Card		Hi-Fi Components	
				Check No. 52 on Reader Service Card	

(Continued from page 77)

and forming the Rock Supergroup to outheavy everyone. We need go no further—it's obvious that Larry Graham's Central Station will outdistance and outlast all his contemporaries (except possible Hot Chocolate, a new but strong contender) and be playing the Madison Square Gardens of the world in no time at all.

But what of this album? The songs at times remind one of mid-period Sly (expected). The lyrics are his best ever (who can argue with a title like *Ain't Nothing But A Warner Brothers Party?*) The playing is always outstanding but not enough so to get in the way of the music, and the production (Graham's) is superclean/tight. The only complaint this writer has is that when the pace slows down, the band's interest level drops to nil. When Chocolate sings *I Can't Stand The Rain* (a great song), the band loses its identity as GCS, and the listener is tempted to jump right to side two. It's fine that they chose this song, but they fall short of even Humble Pie's rendition of it. GCS shouldn't leave room for mistakes.

But such mistakes are the slips of creative souls, and at least they dare to set foot in the wrong place. This is a hot record despite its occasional failings. GCS are the only R&B group who can reproduce the energy of a live performance in the studio. They are a group that will grow, and they know it. They're going to be so big that no one will be able to avoid them pretty soon.

Jon Tiven

Sound: B+ Performance: B

Cunning Stunts: Caravan
BTM 5000, stereo, \$6.98.

Caravan is a cultural enigma: they come out of perhaps the haven for English progressive artists, an area of the Mother Country known as Canterbury. From Canterbury came jazz-nicks such as the Soft Machine, Gong, Kevin Ayers, and David Allen, to name but a few. All of these artists were heavily grounded in new wave rock, totally disavowing pop music in terms of Chart Items. And just a few years ago, Caravan fit in quite well with this bunch, indulging in the instrumental rambling common to the Canterbury crowd—I was quite prepared for them to stay put and appeal to the cults forever, sticking strictly to what is known among the FM radio crowd as "progrock."

Needless to say, I was surprised when I heard this latest album because it exposes Caravan's soul to be at heart no less AMish than, say, **Rhi-**

nestone Cowbcy by Glen Campbell and no less commercial. Caravan is a completely self-contained pop music group that at their best uses their keyboard array and violin not to wail away pointlessly but instead to melliflously provide a layer of sound to vocalize over. All of the members play their instruments with ability and verve, true, but unlike their closest cousins, Yes (close in terms of musical lineup), they never let their axes get in the way of their music... the songs come first.

On side one, Pye Hastings (guitar/vocals) comes through as the strongest writer in the group (*Stuck in a Hole*) although Mike Wedgewood shines in this department too (*Lover*). Side two, however, is a pretty melodic suite penned entirely by Dave Sinclair, and exposes the more progressive side of this group. Since Dave Sinclair has left the group after the record was made, the group will most likely turn toward the style of side one. Not to downgrade side two, which is excellent, I'd rather get my

Please don't pass this on to a friend.

Almost no one knows Hartley speakers and we'd like to keep it that way.



Hartley Products Corporation

56 North Summit Street, Tenafly, New Jersey 07670
(201) 371-3442

Hooks and Infectious Choruses on each song rather than have to listen for them in the context of an entire side of a record. I hasten to add that most listeners also listen to songs and to pieces of music whose length depends on the duration of the discs. If you had told me two years ago that Caravan would be a singles group two years later I wouldn't have believed it; currently that fact is indisputable, and welcomed.

I like **Cunning Stunts** an awful lot as

is, but even more likeable about it is its obvious direction—a return to *the song*. This may upset a lot of diehard Caravan fans who thought they could hold Pye, Richard, Geoff, Dave, and Mike close to their breasts as their very own and will soon find Caravan to be a group they'll have to share with the public at large. I suppose that's a cross Caravan will have to bear, but I can't think of a better one.

Jon Tiven

Sound: _____ Performance: A

Kokomo: Kokomo
Columbia PC 33442, stereo, \$6.98

If there is one new British band that deserves more than a cursory audition, Kokomo is it. This nine-member group is really exciting. A warm blend of almost all the influences prevalent in popular dance music today, almost like an expanded Average White Band, Kokomo surrounds its economically tight disco-rhythm base with five capable voices, the most notable being the dusty baritone of keyboard player Tony O'Malley, though the other four don't really lack much. The instrumental work is first-rate, and the tunes are more than adequate for a band that has not yet fully developed its identity. Using both male and female voices gives texture to the elemental exuberance and excitement that is kept in check and perspective by the medium-slow, back-beat rhythm that is the heart of disco this season.

The reason Kokomo needs a second chance is because the production is inferior to the other elements in this album. It starts off weak and climbs to, at best, medium quality on side two. The spotty, nearly mind-blowing sonics are discouragingly distracting and act as a veil between the listener and the details of the music when the band really romps. Sometimes Kokomo manages to surmount even these obstacles to let you know they are a bit special. I saw them live and came away convinced that their second album will surpass what you will get out of this one. Time and repeated listening will mitigate the failings of this album.

Fred De Van

Sound: _____ Performance: B+

Blue Jays: Justin Hayward and John Lodge.

Threshold THS 14, stereo, \$6.98.

Days after hearing a performance of the Blue Jays live, I found out that many of my colleagues from the hi-fi press got stuck with lousy seats in the second balcony, which made lots of standing waves and other gremlins assault their ears. Nevertheless, the people I spoke to were, despite the sound they heard at the concert, still very pleased with the sound of this Blue Jays album. Indeed, when you play it on a good home system, it is marvellous. At home I found that the sound level in the concert hall had been too low, as the disc needs to be played at a high sound level.

This music is magnificent, by any standard. The lyrics are universal in

Tracer II - \$174.00
Tracer I - \$112.00

Dealer inquiries invited
(AC 312) 271-7755

BML Acoustics, Inc.
Acoustics Division
P.O. Box 711
Wheeling IL 60090

What are the characteristics of the perfect loudspeaker system? 1. Linear and efficient response. 2. Absolute absence of coloration and distortion. 3. Unexcelled power handling capabilities. 4. Perfect transient response. 5. Ultra wide dispersion.

Finding a speaker system with all of these characteristics has been impossible. Impossible, that is, until BML introduced *Tracer* - the line of loudspeakers that has fulfilled this impossible dream.

Tracers utilize the most advanced techniques in speaker design . . . dual phase coupling, (our amplitude modulating transmission line) . . . solid state tweeters that do not have the harsh, peaky effect found in other systems . . . crossover elimination, not even a capacitor, and no tweeter level control . . . no insertion loss and no phase distortion. Treat your ear to Tracer's auditory excellence! Perception? They just might be!

"It just might be perfection!"

Check No. 12 on Reader Service Card

feeling and meaningful in content. As usual with any Moody Blues/Tony Clarke production (Hayward and Lodge and Tony Clarke have been together as 3/5 of the Moody Blues for 10 years), the voice is used totally as a musical instrument that also happens to possess the capability of speaking English. The result is stunning. Blue Jays is difficult to listen to casually, although it will be welcomed as it becomes more familiar. It is an awesome experience to just sit down and listen to the whole thing at anywhere near its proper level (LOUD!).

The dynamics are indeed awesome because the music is so rich and full. The sound of the record is part of the music. The performance is a construction of seemingly limitless dimension and subtlety, and it's difficult to deal with one without mention of the other. The words are eloquent in concept, meaning, and delivery, yet as songs would take on different character and impact without the specifically-ornate music that they dwell within. This interdependence of elements is what makes the music what it is.

The entire thing is an immense orchestration. Neither Dimitri Tiomkin nor any other Hollywood spectaculars composer has done lush orchestral string flourishes, yet this record never becomes maudlin in any way. Despite its epic proportions, producer Clarke make the myriad pieces mold themselves into magnificence. All the words and music are by Hayward and Lodge. Their songs (and that's SONGS, in the classical sense) are lovely. A loveliness replete with breathy pipe organs playing against a counterpoint which sounds like 20 perfectly in-tune, bowed basses, against a woodwind choir with three full sections of strings supplying a wailing rhythm, at times augmented by distant trumpets—all this surrounding Graham Deakin's drums. All this plus sonorous guitars from Justin and a string quartet made up by John Hayward, bass; Jim Cockey, violin; Tim Tompkins, cello; Tommy Tompkins, viola. Yet Kirk Duncan still has room to play his fluid, punctuating piano. What's more, there is the multitude of voices. It all works. It all fits. This is fine contemporary music. It doesn't fit into any category. It could be a 1975 equivalent of the *Songs* of Bartok, or *Greensleeves*, or the *Mickey Mouse Song*. All have roots in the everyday music of their time and society. **Blue Jays** of has a bit of George Antheil, Bach, Debussy, the Beatles, Beach Boys, Chuck Berry, Larry Coryell, Vivaldi, and others, all playing mix-and-match. The lyr-

AUDIO • NOVEMBER, 1975 85

ics/sonnets are a bit of the same sort of ragout, set into poetry. The Blue Jays owe much to the Moody Blues, of course, to those 10 years of working together. That's readily apparent in their interplay, and in their awareness of each other's artistic needs.

I Dreamed Last Night, complete with symphonic orchestration was recorded in one take, though it seems hard to believe. And *Who Are You Now?* is said to include no overdubbing. I can accept that only because of those 10 years of rehearsing, and because they have the world's

best studio in which to record. At least, it must be that for them (the best studio in the world).

This recording has about as good sound as I've heard on records. It has a very quiet, silent background, engineered by Kent Duncan of Kendun Recorders in California, and the rainbow-surfaced vinyl is in itself a work of art, flawless. It sounds almost as good as a 15 ips half-track tape. This is one of the few records I've listened to in recent months which hasn't required use of a noise reduction system for protracted listening. That

When you're buying a mixer, read the small print first.

We're talking, of course, about the specs. Because they'll tell you right away just how good a mixer really is. And that's especially important when you've already got a quality recorder. Our Tapco 6200 has bass and treble controls on every channel. Complete stereo panning on every channel. Line outputs from every channel for quad recording. Line inputs on every channel for quad mixdown. 82 dB signal to noise ratio on balanced Low Z mike inputs. There's actually a lot more. Like the 6200's AutoPad automatic padding that virtually eliminates overload problems. And for complete recording studio capability at home, check the Tapco Graphic Equalizer and Reverberation System, too. The small print reads just as good.

TAPCO

2200 Graphic Equalizer
289.00

4400 Reverberation System
389.00



Check No. 48 on Reader Service Card

6200 Mixers From \$349.00

TAPCO, 405 Howell Way, Edmonds, Washington 98020 (206) 775-4411

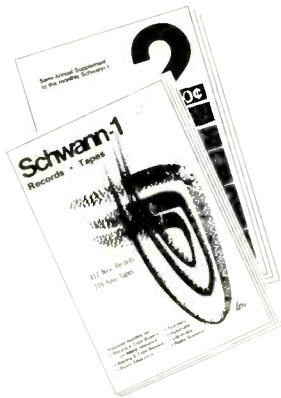

Goldmine

If the recorded music you purchase and listen to is important in the way you enjoy life . . . you ought to know about a goldmine of helpful information for every record collector.

Schwann Record & Tape Guide

is a compilation of information about records and tapes of many classifications. This wonderfully useful catalog uncovers titles you didn't know were available, helps you select versions by conductors and artists whose work you prefer . . . shows you money-saving reprints on budget labels . . . and much, much more.

More than 65,000 records and 8-track and cassette tapes are listed in the monthly *Schwann-1* and its semi-annual companion, *Schwann-2*. All are available through your record dealer if you ask for them by Schwann title and number. Schwann opens up rich rewards in your record collecting hobby. See your record dealer for latest copies.

Schwann-1 Monthly. Lists the month's new releases in every category. Also nearly 45,000 available recordings on 702 record labels, 231 tape labels, 82 quadrasonic labels, in classical, recent popular, rock, jazz, musical shows, country, opera, ballet, electronic, etc. \$1.00 at your dealer's.

Schwann-2 The semi-annual companion catalog for specialized categories: pop more than two years old, classic jazz, classical classics of the pre-stereo era, also the great re-issue catalogs; international pop & folk on domestic labels, spoken, educational, religious, etc. 90c at your dealer's.

SPECIAL PRICE SAMPLE OFFER

If your favorite store doesn't carry Schwann, order samples by mail, but please try your dealer first. Prices include postage and handling.

- Latest Schwann-1 (monthly).....\$1.60
- Latest Schwann-2 (semi-annual).....\$1.40
- Combination Offer: latest Schwann-1 (monthly) and latest Schwann-2 (semi-annual).....\$2.75
- Newly revised Basic Record Library booklet.
Lists 1,000 suggestions in classical music by musical periods for your enjoyment. Send 50c for cost of handling and postage.

I enclose \$.....for the items checked above.

Name _____

Address _____

City _____ State _____ Zip _____

Dealer's Name & Address. _____

Schwann Record & Tape Guide

137 Newbury Street, Boston, Mass. 02116

AU

means it's a really silent record.

The mix and monitoring in the studio were done in four-channel (Tony Clarke says that quadrasonics have been fully used by him, and the Moody Blues for some time now). If you don't have four-channel already, take a copy of this to your local quadrasonic shop and listen—it might make you a believer. Warm, honest, lovely, sophisticated. Superbly-crafted, wonderful music, perfection. Bravo, Blue Jays, bravo! *Fred De Van*

Sound: A+ Performance: A+

Anvil Chorus:The Kids
ATCO 36-114, stereo, \$6.98.

Despite what their promoters would have you believe, The Kids are guys who spent time taking some kind of music lessons, and who are now trying to make a buck. They pay oblivious attention to the basics and succeed in playing very English, very hard, very basic rock. They're definitely not for everyone, but if you want to feel like 14 again, listen to The Kids for a while. This record is not terrible, not offensive, and it even rocks pretty well. It's an innocuous change of pace for serious listeners, a cream puff for the *aficionados*, and a few bucks for a bunch of guys who at least try to do it right. *Fred De Van*

Sound: C+ Performance: C+

Supernatural: Ben E. King
Atlantic SD 18132, stereo, \$6.98.

Fall and the holidays that follow are times for parties and celebrations. They give us all a chance to play disc jockey even though party rock is not normal fare for most of us. This record is one of the very best that I can find, musically and sonically, for partying. Hold onto your hats and hear the best of today's big beat! It's time to get down with the disco sound!

This strong album is great disco without sonic frenzy. It bashes rhythm at you for sure, just as good disco should, but still manages to stay down a bit from the 100% hysteria level. Which means you won't tire of hearing it for quite a while. In fact, it works out just fine if you listen while seated or even prone. Which means that **Supernatural** is a better album than I expected it to be. Good disco does not have to be great music; this is *Great disco!* Even the words are fun.

P.S. Save your live performance money to buy this record. King is 10 times tighter in the studio than in person. *Fred De Van*

Sound: A+ Performance: Disco A

They're only 3¾ inches thin.
They range from only \$129 to \$499.
And they're the only true 360°
omnidirectional speakers you can buy;
you hear the same wide-response,
distortion-free stereo sound *wherever*
you sit.

That means anywhere. Horizontally,
vertically or diagonally. In back, in front,
to the sides, above or below them.

Furthermore, these are speakers
without enclosures, without baffles,
without cones. And without equal.

It appears that Prof. Jose Bertagni's
22 new U.S. and foreign patents have
created a rather dramatic new
technology.

Like everyone else, you probably
won't believe it when you see them.
So hear them.

The New B.E.S. Geostatic™ Speakers

Hear them. The excitement is growing.



**Bertagni
Electroacoustic
Systems**

345 Fischer Street, Costa Mesa, California 92626
©1975 by Bertagni Electroacoustic Systems, Inc.

Check No. 10 on Reader Service Card

the great Escape



Cue up your favorite record, sit back, relax . . . suddenly you're surrounded by total sound. A spectacular and utterly different musical experience —

The Lee Music Chair.

The Lee Music Chair is a new version of the famous Lee Sound Chambers. Designed on the principle of the sound engineer's anechoic (echoless) chamber, it's the ideal relationship between listener and sound source.

Inside the chair, you enjoy full volume sound in an acoustically perfect environment. No speaker system in the world gives you such a sense of involvement. The world stays outside. Your sound stays inside. Family and neighbors remain undisturbed.

Best of all, the new Lee Sound Chair with ottoman is available factory direct to save you money. Total cost, chair and ottoman is only \$399 including shipping. Ask about our money back guarantee and 10 day free trial. Plan your escape, send now for an illustrated brochure on the Lee Music Chair.



LEE WEST, INC.

2824 Metropolitan Place
Pomona, California 91767
714/593-3531

name _____

address _____

city _____ state _____ zip _____

Check No. 26 on Reader Service Card

Classical Reviews

Edward Tatnall Canby

The Great Mozart Conductors (1934-49). Symphonies Nos. 35, 36, 39, 40 and 41. With Beecham, Klemperer, Toscanini, Walter, Kleiber and Böhm. **Vox Turnabout THS 65033-35** 3 discs, mono, \$11.94.

I spent a happy evening of reminiscence with this thoughtfully assembled, six-sided set of 78-period reissues, for I was carried back by the startlingly familiar sound, as from my formative listening years. Not that I knew all these. But in the days before LP, in an era when orchestral music was being documented in electrical recording for the first time ever, we did not yet have a choice of versions; we marveled when a single recording, the first-and-only, became available and standard, to be played and played until every note, every tick and scratch, was memorized, along with the abrupt 4-minute per side breaks in mid-movement which became so much a part of the music that we kept "hearing" them in every later performance, live or LP. So it was with conductors, too. Beecham, Stokowski, Bruno Walter, Toscanini! Their ways of making music became our second nature.

Of these six late Mozart symphonies, the standard ones of that time, Bruno Walter's grand old E Flat, No. 39, made me break into a dance of joy across the floor in spite of myself. Such strength, such irresistible rhythm! A legacy indeed. The early Klemperer (he was on Vox long before his great late days on Angel) is similar, perfectly Viennese and energetic too. Sir Thomas Beecham, who did dozens of Haydns and Mozarts on 78, is as impeccably, astonishingly accurate and persuasive as I always remember him, a great orchestral disciplinarian with a sense of humor as well. See his recent mono Columbia reissues and the later stereos on Capitol/Angel. Toscanini—ah, Toscanini! That familiar strident, thin sound, recorded in a vacuum, no doubt the famed Studio 8-H of the earlier NBC Symphony broadcasts—even, here, unto the inevitable loud cough just before a movement begins. They used

silk programs to reduce studio noise but they never controlled those coughs nor edited them out either. Toscanini always managed to play just a bit faster than anyone else would dare, at tempi in fact scarcely playable, amid a general feeling of nervousness on the edge of musical hysteria. Nope, I never could take the latter Toscanini in his NBC days. Just try his earlier, calmer N.Y. Philharmonic recordings if you want to hear the difference.

I didn't then know Karl Böhm and Erich Kleiber, recorded here in 1946 and 1949. Kleiber's No. 40, the G Minor, is curiously unphrased and flat, all shapeless legato in a blurred and distant liveness. Not good, and an abominable low rumble like an earthquake intrudes from one end to the other—couldn't this have been reduced? As for Böhm's No. 41, the *Jupiter*, you will find it rather mannered, with curious ritardandos and upslidings of strings, as of maybe 1910. Interesting but disturbing for our different ears.

All of these conductors used the then-standard larger orchestra for Mozart, sounding thicker and heavier than the small classic ensembles now, correctly, used. All the recordings, except Kleiber, seem relatively dead acoustically, as of the then-normal recorded sound. (Kleiber's liveness was probably more an accident of circumstance than a stab into the future of recording technique.) And all the recordings have that familiar (if you are over 45) and not unpleasant ringing sound of the old 78 electric, clear enough in the soft parts, turning megalic, if brilliant, in the loud passages. We took this for granted and didn't really mind. The music got through.

I listened, of course, via quadraphonic array—I always do. In mono, SQ is out of its depth, even with logic; not enough to go on. QS does somewhat better in spreading things around, but much better still is Sony's useful "2-4" enhancement matrix ("two channels into four"), which is splendid for mono. I could imagine

the ecstasy this sound would have brought me, back in the days when these recordings were brand new.

American Contemporary Electronic Music/Priscilla and Barton McLean. CRI SD 335, stereo, \$6.98.

Composers Recordings has documented electronic music right from the beginning, and this is one of several recent discs in that genre, a husband/wife team working in the same medium but separately. Interesting.

Priscilla McLean's *Dance of Dawn*, the work on side 1, seems to me to be the stronger, more original of the pair of pieces on the record, one by each; also the less fussy in detail. Too many electronic composers bog down in vast electronic complexities, saying not very much. Not this lady! She is spare. She takes her time, and she knows how to build sonic tension and coherence over a long haul, a full LP side. With all respect to the male sex, I find her husband's *Spirals*, side 2, both more elaborate and more conventional, with a definite sense, for my ear, of his professional training out of Eastman and Indiana. A hint of the academic. Curious, because the two

works are clearly related in sound, out of the same technical resources, the composers' careers having been joined in their more recent electronic experience and training. Play and you will hear for yourself.

Any judgment on electronic music must be tentative, the medium being so new and in the process of defining itself in its own terms. We too easily read into its music things that perhaps are irrelevant. Keys, thematic organization—who knows? Curious, too, then, that in both these works those very elements appear, diatonic (keyboard scale) sounds, consonant and dissonant, even hints of key and harmony as structure. Oddly, I find this disturbing, because it stirs up the wrong things in me—for this music. But that is no negative criticism, merely a personal reaction. Surely, it is always OK to integrate the old and the new!

Mahler: Symphony No. 6; Symphonies Nos. 5, 10 (Adagio). Utah Symphony Orch., Abravanel. Vanguard **Everyman SRV 323/4 SD** (2 discs); **SRV 321/2 SD** (2 discs), stereo, \$7.96 each.

Mahler: Symphonies Nos. 1, 4. London/Chicago Symphony Orchs., Levine; Judith Blegen, sopr. **RCA CRD3 1040** (3 discs), CD-4 quadraphonic, \$20.94.

The bigger Mahler symphonies are an evening's listening apiece unless you prefer economy at 45. Even the pair of short ones here run on to three sides in RCA's quadraphonic gatefold. So, much—given a reasonably professional orchestra—depends on mood (yours) and interpretation (legitimate conductorial differences) and a review can only attempt to describe and opine. A critic should properly be humble in the face of this music, reserving his "good" and "bad" for the extremes.

No extremes here! Abravanel, a good European working with success in deep America, has had plenty of kudos for his Mahler already, the complete series of 9-plus huge works, now appearing on the low-cost Everyman label. Needless to say, they were not all recorded in a few quick sessions. Dates are missing, as usual, but we can assume a large spread at minimum, what with vast choruses to



Now and Forever

Today

WITH A QUAD 33, ANY PICKUP CAN BE PROPERLY MATCHED TO GIVE THE FINEST PERFORMANCE OF WHICH THAT PICKUP IS CAPABLE (1)

- 1.(a) Equivalent input noise at the exceedingly low figure of 0.5uV.
- (b) An input load which is a pure resistance at all frequencies. 5° 0-20 KHZ.
- (c) An input dynamic range of close on 100dB, 30dB better than the finest recordings now available.
- (d) Provision to place the pickup dynamic range (60-70dB) in proper relation to the amplifier range so there need be no compromise between overload requirements and low noise.

Tomorrow

THE QUAD 33 PICKUP INPUT IS UNIQUELY PLACED TO MEET THE NEEDS OF THE FUTURE (2).

2. Digital mastertapes for disc cutting and further refinement of the pickup cartridge will lead to lower noise and less distortion, and may make a major contribution to better sound in the next decade. The Quad 33 can do full justice to each and all of these possibilities.

Send postcard for illustrated leaflet to
Acoustical Manufacturing Co. Ltd.,
Huntingdon PE18 7DB, England

QUAD

Products of
the Acoustical
Manufacturing Co. Ltd.

for the closest approach
to the original sound.

QUAD is a Registered Trade Mark

The Avid 103.

Few people would expect more in a loudspeaker.

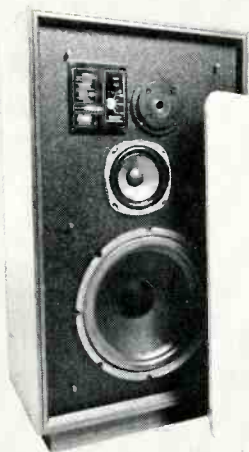

For most people, the Avid Model 103 really is the ultimate speaker.

Not that you can't pay more for a speaker. You can. A lot more.

But, for most audio enthusiasts any difference between the Avid 103 and more expensive speakers just isn't going to justify the added cost. As it is, the 103 clearly outperforms speakers costing up to twice their price.

The Avid 103.

You owe it to yourself to find out why it is rapidly becoming the popular new reference standard for 3-way systems. For your nearest Avid dealer, please write:

AVID
CORPORATION

10 Tripps Lane, East Prov., R.I. 02914

Sound products for Avid listeners.

Check No. 5 on Reader Service Card

There's more to great sound than meets the ear.



When dust, dirt and static build up on your record, it can't possibly sound like it's supposed to sound. **Groov-Kleen**® is a specially designed component that removes dust and dirt, so you hear exactly what is recorded on your record — and nothing else.

An attractive chrome and steel armature, **Groov-Kleen**® mounts permanently on your unit. Its sable tracking brush and velvet roller lift dust and dirt out of record grooves and collect residue. All you have to do is sit and listen. And **Groov-Kleen**® also reduces stylus wear.

There's a **Groov-Kleen**® for every record player, manual or automatic. What's more, **Groov-Kleen**® has height and balance adjustments to insure that it can be used on any record without causing speed variation. So see your record or audio dealer and find out about **Groov-Kleen**®.

Remember, when there's more to a record than you've been hearing, give a listen with **Groov-Kleen**®.

Bib® **Groov-Kleen**®

Bib® Hi Fi Accessories 155 Michael Drive, Syosset, N.Y. 11791

Check No. 38 on Reader Service Card

train, soloists to garner, extra players and so on. So my reaction to two albums (two evenings) is this. I found No. 6 incredibly exciting and wonderful—both in the clean, lovely sonics and in the music itself. Was it the roast beef and red wine that night?? Have to allow for that, and so would you. Also—I did not know No. 6 very well—it was a new musical experience, without much previous comparison in the mind's ear. No. 5—was it a rainy, foggy night?—fared worse; I found it dull, lacking in tension and subtlety, and the single adagio movement of the unfinished No. 10 was even more sadly lacking. But I know both of these works, and especially No. 10 in the incomparable old version with Szell conducting, an unforgettable, unparalleled listening experience, as though from beyond the grave, which the music in all truth almost was. Abravanel, by comparison, is merely prosaic.

The young James Levine, new sensation on the recording scene, could not at his age produce the sage, seasoned music of a George Szell no matter how good he might be but, all things considered, he does a lot more here than merely wave his arms imperiously. His two Mahlers tend to rip along at new fast tempi, notably faster than the accepted classic versions by older men. Not bad! Some of the Viennese-type dances stop galumphing and really move. I like his faster movements. But in the very slow movements he is often lost; tension departs and the spell is broken. The notes are being played as indicated, period. Floundering, though accurately.

Just for check, I got out a Bruno Walter slow movement (Mahler Ninth). Such a difference! There is the true tension, the spun-out line, the ever-alive surge of real music. It takes a lifetime to learn that sort of conducting.

Oh yes—quadraphonic. Though RCA says "surround sound" and provides circle diagrams, I would suggest that it is unwise to fuss about where you hear the glockenspiel or the violins—in any case, both these layouts, two different orchestras, wisely compromise with tradition, placing the strings, for instance, more or less in the expected positions and mixing ambience/rear effects along with specific directionality, the whole bathed in the over-all big liveness we cannot do without. All in all, PR stuff or no, this is a useful and musical double try in the direction of new sounds for old music. If (when) you have CD-4, this is a big album to buy very soon. 

Orff: Der Mond. Rundfunkchor and Rundfunk-Sinfonie-Orchester Leipzig, Kegel. **Philips 6700 083** 2 discs, stereo, \$15.96.

Aha! After the Orff **Carmina Burana** from Columbia, this one at least takes Carl Orff back into a legitimate "classical" area and a good and amusing one, very much of modern Germany whether East or West. This is one of those allegorical, semi-children's, pseudo-peasant operas, very much in the spirit of some of Hans Werner Henze's lighter works—notably the little fables about the frogs, the crows and so on, so delightfully narrated and sung. This is a fable opera, all about the moon that got stolen and put up in a tree to light a small village, and it has that timeless simplicity and profundity that can only be achieved when modern sophistication is superimposed on the roots of folk art.

The simple harmonies and the rhythmic repetition of **Carmina Burana** are here, too, but in moderation rather than excess. (It makes a fine follow-up for those who would like to explore further after **Carmina**.) The story is quaintly presented and timelessly; the performance in German is stunningly communicative, perfection itself in technique and styling, but minus a trace of show-off ostentation. The English translation keeps the rapid-fire German (both spoken and sung) under easy control as you listen. A fine little morality play with music, even unto four whole sides of Philips' most extraordinarily fine recording.

Spaced-Out Bach. The Orbiting Harpsichord of Joseph Payne. RCA ARD1 0439, CD-4 quadrasonic, \$6.98.

It isn't easy to find legitimate classical-music fare for "surround sound" quadrasonic—the real thing, that is, minus front and back, the music coming from any direction, equally. Both CD-4 and SQ technicians have muffed the idea often enough already, either via too much liveness and no real discrete directionality or via the opposite, arbitrary and capricious discreteness for no solid musical reason. Here's a fine example, though, of what can be done, rightly and musically, and don't be fooled by the flip title. Joseph Payne is a fine musician and a knowledgeable, fleet-fingered harpsichordist who knows his Bach extremely well. Spaced out or no.

The idea here is to separate the well-known Bach "voices" in the strictly constructed fugues and the like into the four quadrasonic

sources, like so many separate players. Not arbitrarily, thank the Lord, not dogmatically, but with imagination and musical taste, thanks again. Also, to space out the whole larger range of Bach ideas, the rhythmic motives, chords, patterns, which we so much enjoy in good Bach. It works! Bach comes through with impact and strength. You are "inside" a spread-out harpsichord, a collection of harpsichords (including the pedal harpsichord for big bass), a reversed harpsichord-orchestra, like an inside-out stocking. I liked it, all of it. By means of this sonic array, I heard things in the dense Bach textures that I wanted to hear, that are in fact there, and the space strengthened them, intact, in fine style. What more can you ask? Bach himself did precisely this when he wrote out his keyboard works for instrumental ensembles or played them on the organ.

The job is very sophisticated, easily up to pop standards, whether via simple panpotting (plus a bit of quick editing) or, more often, via the laying down of tracks, one after the other, the standard pop procedure applied to the far more difficult classical art. You don't have to be a Bach fanatic to enjoy *this* Bach! And if you are too pure, you can always play it in mono.

Mozart: Violin Concerto No. 2 in D, K. 211; Rondo in C, K. 373, B Flat, K. 269, Adagio in E, K. 261. Pinchas Zukerman; English Chamber Orch., Barenboim. **Columbia MQ 33206**, SQ quadrasonic, \$6.98.

Greensleeves. (Vaughan Williams, Walton, Delius.) Pinchas Zukerman; English Chamber Orch., Barenboim. **Deutsche Grammophon 2530 505**, stereo, \$7.98.

Well, what have we here! A comparison I hadn't hoped to discover. Some months back I played Columbia's Mozart, with Zukerman and Barenboim and the English Chamber Orchestra, found it an ugly, coarse, loud cutting, always on the edge of overload distortion, and put it aside for a second trial, maybe with a different stylus, just to be sure. Sometimes I wonder what Columbia thinks it is doing. No amount of SQ encoding is going to help this outrageously crude job of record making! Are they trying for a classical juke box trade?

Anyhow, here comes our European friend D-G with different music but the selfsame performers, to a man. Now we have merely stereo, but what a difference! The level is right, the sound is clean, and via the selfsame SQ decoding *this* music sounds ever so nice in four speakers. Moral: if you

EAROTIC NEW CATALOG

That's right. . . our tantalizing new hi-fi catalog is hot off the press! And more than ever, we offer earotic music systems and single components from all the best brands—at huge discounts. Call me, Brillo Bob, or any of the guys and you'll get friendly advice and low price-quotes right over the phone. . . **805 / 544-9700**

Drop us the envelope at left and you'll quickly receive our 96-page color-wonder, free! Include \$1 for postage, and we'll also zip you the 1976 Music Machine Almanac: it's a full-color, 150-page reference guide to hi-fi equipment complete with photos and specs on over 37 different brands! PS. If the envelope's missing, just write me directly: Brillo Bob, P.O. Box "S", San Luis Obispo, CA 93405.

WAREHOUSE SOUND CO.

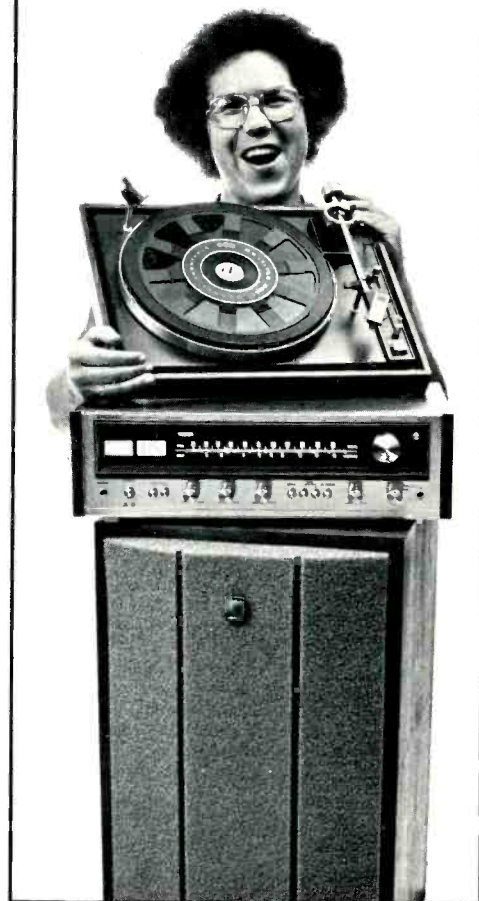

Check No. 51 on Reader Service Card

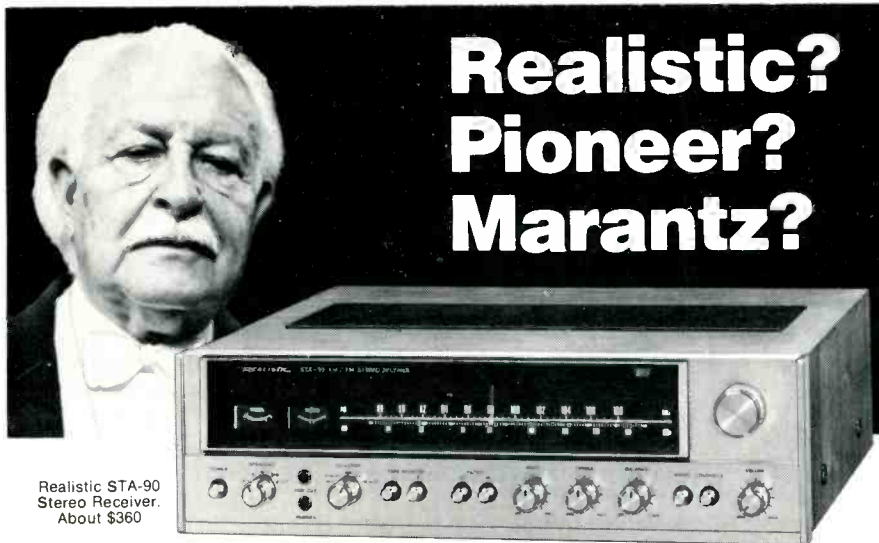

Realistic? Pioneer? Marantz?

Realistic STA-90
Stereo Receiver.
About \$360

Who's got the most customers?

Ask a funny question — get a surprising answer. Realistic* wins hands-down in North America. Because our famous audio brand also goes onto other kinds of sound equipment. Such as Citizens Band and powerful radios. In 1974 over 3,000,000 units of Realistic gear got sold to customers who knew whom to bet on in a tough year.

But music lovers have been fed so many claims about quantity and quality, we'll just say this: it's obvious Realistic & Competition are great music machines. So if more people are coming our way there must be a reason. Come see if it's lower prices. Or exclusive features. Or both!

Radio Shack^{*} Great sound since 1923

Over 4000 Stores/Dealers in the USA, Canada, England, Australia, Belgium, Germany, Holland
Check No. 35 on Reader Service Card *Registered Trademark

ABOUT OUR STEREO IMAGE

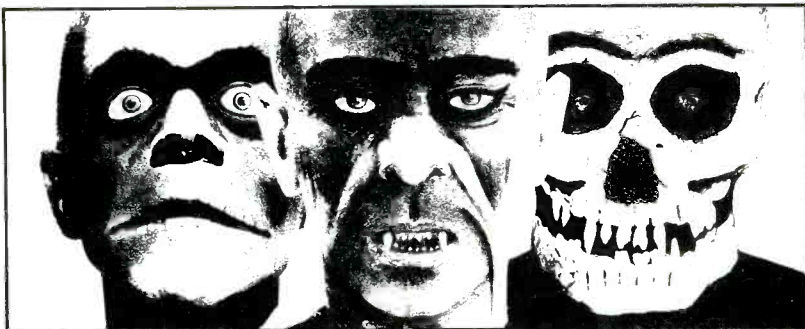

Our fiendishness about quality control is being widely recognized. We, therefore, wish to thank all responsible, from our Spectrum Analyzer and Non-Reflecting Chamber to the Ears with which we test every single component and driver.

Stereo Review has called our product "Superb": Low Density Woofer Cones treated front and back for super-smooth response and Wide Dispersion Tweeters, resulting in exceptional

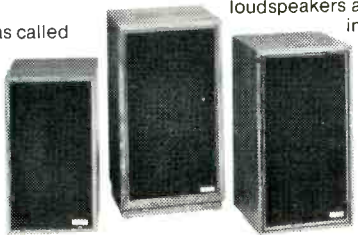

stereo imaging, make the Audioanalysts sound magnificently accurate. That's what our sales tell us, despite our selective distribution which we intend to keep limited. So, we'll continue to torture each and every one of our loudspeakers and maintain our image. Beauty, after all, is in the ears of the beholder.

Audioanalyst
P.O. Box 262, Brookfield, Conn. 06804
Monstrous About Perfection

Distributed in Canada by Superior Electronics, Inc.
European & Middle East Distributors: Argo Hellas GmbH Frankfurt 6056 Heusenstamm 44 Industrie Strasse/West Germany

Check No. 2 on Reader Service Card

are going to SQ, Columbia, please watch your Ps and Qs.

Musically, the Mozart is good, now that the young Zukerman has overcome his earlier treacly tone color in favor of a sturdier and purer sound, and friend Barenboim has toned down his own stridencies into a more mature and effective approach. If Columbia would re-cut (and remix?) this disc, it could be very good. As for the British music of the soft-soap period, it remains juicy and overripe to a degree but the sound of Delius, not to mention Walton and old V-W, is coming back into style and these somewhat fulsome tone poems, including the famous *First Cuckoo in Spring* as well as some film music fragments (Walton) and opera bits (Delius), make very acceptable high-class party music for today. Or serious listening music, if you will.

Mozart Serenades, Vol. 4. Willi Boskovsky, Vienna Mozart Ensemble. London STS 15301, stereo, \$3.49.

One of the more refreshing types of British candour is in the indication of copyright. Whereas U.S. reissues in all their thousands are always dated as of the present, English imports put down the original copyright date—and this one, reissued at the low, low price, is as recent as 1971. Now how's that for positive thinking? Don't suppose it isn't good, either. It is excellent. Willi Boskovsky remains in my memory as a first-rate interpreter of Viennese waltzes by the hundreds; his Mozart is just as rightly styled from Vienna. These works, the *Serenade No. 1*, K. 100 and the humorous *Musical Joke*, K. 522 (a counterpoise for the ineffable *Eine Kleine Nachtmusik*, K. 525, of the same time), are done with just the right small combos of string and wind instruments and the right sound, the first piece an excellent background for dinner with wine (which was its original function), the second a sophisticated take-off of bumbling amateur composers and players, 18th century style. If you like these, there are more volumes of the same in the series.

Benjamin Britten: War Requiem (1962). Lawrence, Altmeyer, Sells, Wm. Hall Chorale, Columbus Boychoir, Vienna Festival Orch., Hall. **Klavier KS 544** (2 discs), stereo, \$13.96.

This second recording of a major Britten work brings an unknown (mostly) masterpiece to a West-Coast-style American performance of music that is uniquely British in every measure. Miraculously, it works. I don't have the original recording—led by

Britten himself—but, for all the stellar brilliance of its cast under the composer's direction, I expect that this alternative, beautifully recorded, will prove just as enduring. It is a careful, well-produced, moving performance in every detail, just as it is, equally, totally American in style, without a trace of imitation British. Remarkable. Indeed, I wouldn't have thought it possible.

Where? Who knows, these days. The only alien element is the Vienna orchestra, obviously used for the standard financial reasons. Which mountain came to Mohamet? Was the recording done in Vienna (on tour), or maybe in Columbus, Ohio (on tour)? No matter! This is the way things are, these days, in our international world, and what counts is the product, not the locale. The product, here, is American, even to the Viennese players. American, first of all, in the sound and the singing style of the three soloists, Douglas Lawrence, Jeannine Altmeyer, and Michael Sells, who could not possibly be imagined to be typical Benjamin Britten voices—whose public "acclaim" (the usual PR word) is highly West Coast orientated. And secondly it's American in the choral voices, the very American chorus and the angelic little boys—who sound as aetherial (and are as devilishly ingenious) as little boys always can be, when well trained.

A combination of a Latin mass and a setting of apposite English poetry, this isn't an easy work for the outsider who is new to Britten. But let me say, this man is one of today's genuine musical geniuses, whatever you may think of his relatively conservative style. He is *real*. It shows here.

Essay for Orchestra. Samuel Barber, Thomas Schippers, New York Philharmonic. **Columbia Odyssey Y 33230,** stereo, \$3.98.

A lot of people enjoy Samuel Barber's restrained modern Romanticism and a million people swoon over the too-famous Adagio for Strings, opus 11. Well, the Adagio is here, and a lot more of the same or similar—the sprightly Overture to "The School for Scandal" and the Second Essay for Orchestra, plus a later ballet work, *Medea's Meditation and Dance of Vengeance*. All this is just what you are looking for if you are the swooning type, or if you enjoy Romantic music for big orchestra written the day before yesterday. This is a reissue of an LP that was originally on the CBS label, not Columbia. Don't ask me why.

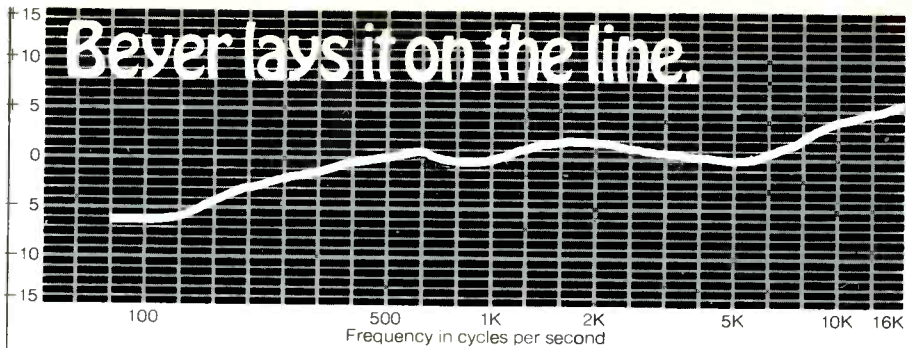

For the demanding professional, some mike manufacturers furnish a frequency print out as proof of performance.

Unfortunately, when it comes to low cost mikes for home use that practice is not only costly, but could prove embarrassing. Besides, you shouldn't expect a guarantee with an inexpensive mike.



Or should you?

You can if you buy the new Beyer 550.

At only \$42.50, the Beyer 550 provides authenticated performance at a price you can afford.

And what performance. In one elegant package you get smooth, wide frequency response, omnidirectional pickup pattern, low distortion and high signal-to-noise ratio.

Finally, you get the most generous warranty in the industry and that's another way Beyer lays it on the line.

Another innovation from Beyer Dynamic, the microphone people. Revox Corporation, 155 Michael Drive, Syosset, N.Y. 11791

Check No. 39 on Reader Service Card

FREE McIntosh CATALOG and FM DIRECTORY

Get all the newest and latest information on the new McIntosh Solid State equipment in the McIntosh catalog. In addition you will receive an FM station directory that covers all of North America.



MX 113

FM/FM STEREO - AM TUNER AND PREAMPLIFIER

SEND TODAY!

McIntosh Laboratory, Inc.
East Side Station P.O. Box 96
Binghamton, N.Y. 13904
Dept. 1

NAME _____

ADDRESS _____

CITY _____ STATE _____ ZIP _____

If you are in a hurry for your catalog please send the coupon to McIntosh. For non rush service send the *Reader Service Card* to the magazine.

Check No. 29 on Reader Service Card

Jazz & Blues

Smithsonian Collection of Classic Jazz: The great jazzmen. Selected and annotated by Martin Williams. Div. of

Performing Arts, Smithsonian Inst., Wash., D.C. 20560, six LPs with 36-page booklet, \$23.00 postpaid.

Williams rightly omits the widely-available Benny Goodman, important as he is, in favor of several tracks by Fletcher Henderson, who paved the way for B.G.'s great success.

An absolutely stupendous gathering into one bundle of many of the pivotal masterpieces of early, classic, and modern jazz by one of the (possibly *the*) best-qualified critics in the field. Martin Williams taught English for some years and wrote many articles and books on jazz (his *Where's The Melody?*, Pantheon, is the best book anywhere on the subject). He's worked hard and long spreading the Jazz Word, and three years ago was made Director of the Jazz Program of the Smithsonian's forward-looking Division of Performing Arts.

Martin Williams has been thinking about how to teach people about jazz for a long time. In addition to his own writings, he co-edited (from 1957 to about 1960) with Nat Hentoff *The Jazz Review*, regarded by many as the best periodical concerned exclusively with this music yet to appear. He initiated, and for several years taught an introductory course on jazz at New York's New School (where his successor, Dick Katz, one of the few musicians from a white middle-class background who's earned the respect of the important jazzmen, uses these records and the booklet as his text).

In addition to presenting an unprecedented series of concerts in Washington under the august aegis of the Institution, Williams somehow wangled, cajoled and badgered the various record companies who own the rights to these 86 important recordings into letting him present them as an introduction to and museum of the most-important musicians and movements in this music. Some might say that not all historically-significant selections are here, but no one could deny any here their inclusion. (This observer would have put in at least one of the six Vocalion recordings of the explosive band Roy Eldridge propelled in the late 30s at Chicago's famed after-hours club, The Three Deuces—*Wabash Stomp*—as well as at least one track from Eldridge's 50s/60s collaboration with tenor giant Coleman Hawkins. They were both senior statesmen then past their prime but still swinging furiously to show the kiddies how jazz should be played.)

Starting back before it was jazz, with Scott Joplin's *Maple Leaf Rag* (prophetically prior to the current Joplin-rag vogue), Williams takes us through each major phase of jazz (mercifully sparing us the Original Dixieland Jazz Band's unconscious parody of the real jazzmakers). Every major, and most of the important lesser figures up to the 60s is presented, with emphasis on the work of the masters. He concentrates on the key innovators, Jelly Roll Morton, Armstrong, Ellington, Basie, Lester Young, Charlie Parker, and Thelonious Monk, encountering most of the other seminal figures along the way, but these seven form the backbone of the collection, both on the records, and in his tightly-organized booklet.

It also seems to me that one or more of the Monk cuts (six), or Duke or Louis (eight each) selections, or Parker gems (five) might have been abbreviated to make room for a little more Earl Hines, some fully-realized Fatha, instead of just the young Hines, who appears here only with Louis (*West End Blues* and *Weatherbird*), those masterpiece collaborations of the budding trumpeter with the already-mature pianist who so strongly influenced each other.

The booklet is authoritative, yet accessible to non-students of jazz. It includes the best brief history of jazz yet (10 pages) and 30 pages describing and picturing the artists and selections. An unusually good bibliography of books on jazz and a few good places to buy jazz records (world-wide) are included.

This stunning set is invaluable for anyone who wants to learn about jazz from B-Flat up, and even for those who already know a great deal. This reviewer, fairly knowledgeable (friendly with most of the great musicians included who are still living) found he'd never heard at least 10 of



- Most effective cleaning system
- Easy... Thorough... Safe
- Cleans 'em all... LP's, 45's, 78's
- Removes static... Leaves no residue
- No electricity... You Spin & Clean Records
- Special concentrated Record Wash solution
- Gentle plush scrubbing pads get deep into grooves... remove for easy cleaning
- Only \$19.95, suggested list price.

After years of research with all types of record cleaning gadgets, gizmos and gimmicks, Fidelitone came up with a simple, direct solution... the Record Washer! Now you can wash your records quickly and easily with this unique Spin & Clean system. Gets out dirt deep down in the record groove... gives you maximum performance from your old records. Comes complete with special cloth and enough Fidelitone Record Wash Concentrate to wash up to 1,000 records!

FIDELITONE[®]
 207 N. Woodwork Lane Palatine, IL 60067
 THE TOUCH OF MAGIC
 in Phonograph Needles, Cartridges,
 Record Care, and Audio Accessories

Check No. 19 on Reader Service Card

the selections included here. What a treasure! Thank you, Martin!

Jonathan Graham

Sound: variable Performance: A

Piano Giants, Vol. 1: Various Artists

Musicians and Selections: Duke Ellington, *Cottontail*; Earl Hines, *My Monday Date*; Art Tatum, *Please Don't Talk About Me When I'm Gone*; Erroll Garner, *White Rose Bounce*; Thelonious Monk, *Little Rootie Tootie*; Bud Powell, *Jubilee*; Lennie Tristano, *Subconscious-Lee*; Al Haig, *Opus Caprice*; George Shearing, *Darn That Dream*; John Lewis, *Concorde*; Horace Silver, *Four*; Hampton Hawes, *Hamp's Paws*; Bobby Timmons, *Moanin'*; Oscar Peterson, *Walkin' My Baby Back Home*; Phineas Newborn, *Our Delight*; Ahmad Jamal, *Wave*; Red Garland, *Billy Boy*; Wynton Kelly, *I Want A Little Girl*; Bill Evans, *Come Rain or Come Shine*; Herbie Hancock, *Black Narcissus*; Chick Corea, *Song of the Wind*; Joe Zawinul, *In A Silent Way*; Keith Jarrett, *Yaqui Indian Song*; McCoy Tyner, *A Silent Tear*.

Prestige P-24052, mono and stereo, \$6.98.

Subtitled "an informal history of modern jazz piano, from sometime before its birth in the Forties through the mid-Seventies, by means of examples selected from the work of 24 of the most talented and influential keyboard artists, "this two-record set is indeed all that.

Culled from the rich Prestige and Riverside/Milestone catalogs, with some clever (authorized) borrowing from Impulse, Atlantic, ECM, and the old Black & White label to fill certain gaps, this is a fascinating compilation, about as good as this sort of thing can be.

Some artists are better served than others, and in some cases, as compiler Orrin Keepnews conscientiously points out, the selections are chronologically quite out of historical sequence (Shearing, Peterson, Jamal). Such things are inevitable, given the circumstances, but better samples of Silver than the relatively brief spot on Miles Davis' *Four* can be found in the Prestige catalog, and when so many good examples of Zawinul as pianist are extant on Riverside, why pick something from At-

lantic that features him primarily as a composer and secondarily on electric piano, duetting with Herbie Hancock? Hancock's own selection, from a Joe Henderson date, also spots him on electric piano, an instrument that doesn't allow much individuality in touch and sonority; even if one disagrees, it is indisputably a different instrument from the acoustic piano on which the other 22 artists herein express themselves.

But there are masterpieces here, and the average is very high indeed. For novices, an excellent introduction to a subject rich in detail, and for seasoned listeners, quite a few rarities and pleasant surprises. The only serious omission, especially with other seminal figures as Hines, Ellington, and Tatum present, is Teddy Wilson, who probably has the best claim to the title "Father of Modern Jazz Piano." Surely a slice of Wilson could

ARIES - KITS!

ARIES INCORPORATED
119 FOSTER STREET
PEABODY MASS
01960
(617-532-0450)

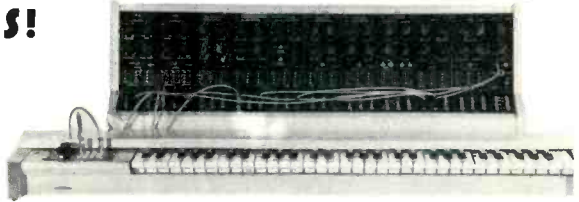



A NEW ELECTRONIC MUSIC SYNTHESIZER KIT
 *Standard 1 Volt/Octave, 10 Volt range scale factor
 *Fully compatible with the products of other manufacturers
 *Five octave, two voice high quality keyboard
 *Fully modular, professional construction
 *Priced at a fraction of other units
 *Available in kit or wired form
 *WRITE, OR CHECK READER REPLY FORM FOR INFORMATION ON THIS, AND OTHER ARIES ELECTRONIC KITS

Check No. 1 on Reader Service Card

take advantage

Don't settle for just any professional power amplifier. Take advantage of the BOSE 1800.

Advantages like high power, ruggedness, reliability, serviceability, LED power indicators, and a full 5-year warranty. The 1800 gives performers the advantage by providing them with all the power they need to handle the dynamics of their music.

BOSE 1800 pro power amp: designed to be taken advantage of.



BOSE 1800

Please send information on the BOSE 1800 to:

Name _____

Address _____

City/State/Zip _____

BOSE, The Mountain, Framingham MA 01701
(617) 879-7330 Dept. AP

Get your new Radio Shack catalog at one of our 3500 stores today!

FREE! 1976 EDITION

**OVER 2000 PRODUCTS
EXCLUSIVES ON EVERY PAGE
BEAUTIFUL FULL COLOR**

**164 pages of the finest
in home and hobby
electronics**



**Save! Our Prices
Are Within 1% of
Our July, 1974 Prices!**

**Hi-Fi • CB • Kits • Parts
Phonos • Recorders • Tape
Radios • Antennas • Tubes
Auto Tuneup • Much More**

See what's really new. It's the most-wanted, most popular catalog in electronics, and loaded with our own exclusive nationally advertised brands: Realistic, Micronta, Archer, Science Fair, others — you've seen them advertised on TV. Come in for your free copy today!

**AVAILABLE BY MAIL TOO —
JUST SEND US THIS COUPON**

To: **Radio Shack** 584
P.O. Box 1052, Ft. Worth, TX 76101
Rush me your 1976 catalog.
(Please Print)

Name _____ Apt. # _____
Street _____
City _____
State _____ ZIP _____

Check No. 36 on Reader Service Card

THE DYNAMIC DUO!



**Pygmy Portable
Amplifier
\$39.95**

**GNOME
Micro-Synthesizer
\$48.95**

If you're into electronic music, PAIA's Pygmy Portable Amp and GNOME Micro-Synthesizer are a pair that's hard to beat. And now we offer them together, as a package, at a price that can't be beat — \$84.50 plus 10 lbs shipping — catalog #3741.

DEMO LINE—Use Ma Bell's low night rates to get a one minute demo of PAIA Synthesizers. Our recording equipment also takes catalog requests, charge orders, etc. (405) 843-7396.

— FREE CATALOG —

PAIA ELECTRONICS, INC.
Dept. 41-A
1020 W. Wilshire Blvd.
Oklahoma City, OK 73116

Check No. 30 on Reader Service Card

the sound build-up

Professional results — the basis of our home constructor speaker and amplifier kits.

Genuine walnut veneer cabinets plus the finest component parts, make our kits outstanding value for money.

A 50% saving over built-up units. Send for free catalog now!

NAME _____
ADDRESS _____
CITY _____
STATE _____ ZIP _____

**ruxton
electronics**

P.O. Box 30312 Santa Barbara
California 93105

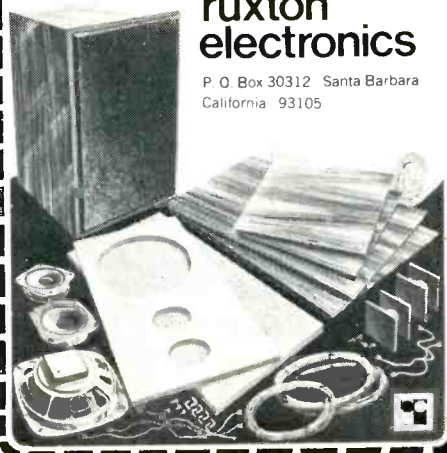

Check No. 41 on Reader Service Card

have been somewhere procured, or if not, his absence explained and regretted?

Good remastering from a variety of sound sources, ranging from excellent to adequate, and a concise guide to the contents by Grover Sales.

Dan Morgenstern

Sound: see above Performance: A

In the Beginning: Dizzy Gillespie **Prestige PR-24030**, two discs, mono \$7.98.

Dizzy Gillespie, Vols. One and Two Archive of Folk & Jazz Music FS 237, 272, stereo, \$5.98.

For the most part these two Gillespie releases offer the same material. Twenty of the titles on the Prestige pair and all of the numbers on the two Archive discs with a grain of salt; were originally recorded in 1945 and 1946 on Guild and Musicraft 78-rpm discs. Both labels have long since died, and there is some confusion about the ownership of the masters. (In great Britain, another label, Saga, has also issued the same titles.) No matter who has the legal rights to re-issue these masterpieces, the collector comes out ahead. He can buy the Prestige "twofer," which, though it tacks on three 1950 Gillespie sides of lesser importance, offers the clean, monaural sound some jazz purists prefer, or, he can buy the Archive budget lps. (Take the \$5.98 list for the Archieve discs with a grain of salt; they are discounted to \$2.50 and even \$2.00 at most record shops and are tremendous buys.) The Archive reproduction is in "simulated stereo," anathema to many jazzniks, but, in this instance, the sonic padding gives these recordings depth and body, particularly on the small combo sides that I found quite exciting.

As for the performances, the dozen combo cuts have achieved classic status. Here are the most important of the young bop musicians, including Charlie Parker, Dexter Gordon, Sonny Stitt, Al Haig, Milt Jackson, and Kenny Clarke. These were brilliant virtuosi, and their taut, crisp playing and incredible manipulation of their instruments remains dazzling after 30 years. On *Blue N'Boogie*, *Shaw 'Nuff*, *Dizzy Atmosphere*, and *Salt Peanuts*, all the jolts of excitement one initially received from Gillespie's and Parker's playing are still there. One listens awestruck as these monstrous talents drive forward, punching with tremendous energy and swing. These are definitive statements by the young radi-

cals who revolutionized jazz and changed the sound of American music.

There are eight Gillespie big band tracks included in both the Archive and Prestige collections that are equally innovative as they had tremendous influence on the direction of big band music after 1946. The big bands, previously rooted in swing concepts, were infiltrated by young bop musicians and arrangers whose new chord progressions, voicings, and capricious rhythms perplexed and eventually alienated the mass audience. Indeed, bop turned the big bands away from dance music and, in doing so, helped push them off the center stage of American entertainment.

A special word of praise for the sonics on the Prestige set. Kudos to Fantasy engineer Mike Reese for skillful remastering that has made it possible to hear things on these 30-year-old discs one did not hear on the badly pressed originals. One also missed these things on the numerous redubbings and dubbings-on-dubbings that were made as these recordings made the rounds over the years.

John Lissner

Sound: A Performance: A+

World's Greatest Jazz Band With Guests Bobby Hackett and Maxine Sullivan

World Jazz WJLP S-4, stereo, \$5.95.

This is an inauspicious 1974 WGJB concert, saved by Maxine Sullivan's three vocals. The collective spark was not ignited that night at Carnegie Hall; the band's playing obviously lacked cohesion, although there were some good solo moments by trumpeter Yank Lawson. Even cornetist Bobby Hackett remained a disappointment, only coming to life behind Miss Sullivan, whose three splendid tracks, *One Hundred Years From Today*, *I've Got a Right to Sing The Blues*, and *Keeping Out of Mischief Now* are worth the price of the album.

Maxine Sullivan in her charming, soft-voiced way proves that there's more to singing than strident hollering. Her faultless articulation and warm phrasing stem from a school of jazz singing that reached its apex with the late Mildred Bailey. For some reason the recording balance seems best on the three Sullivan selections; many of the other numbers sound muffled. This may be due either to Carnegie Hall's peculiar acoustics or to an indifferent engineering job. John Lissner

Sound: B+ Performance: B

Introducing the BSR Silent Performer

The only rumble from this belt-drive turntable comes from our competitors.

For years expensive manual record-playing devices have used belt-drive as a smooth, trouble-free—and most important—silent method for transmission of power. Now, our engineers have integrated a highly-refined belt-drive system into more affordably-priced turntables, with features and performance not available in even more expensive competitive models. We call them Silent Performers.



Model 20 BPX is a fully automated single-play turntable with a precision machined platter, high-torque multi-pole synchronous motor, tubular "S" shaped adjustable counter-weighted tone arm in gimbal mount, viscous cueing, quiet Delrin cam gear, dual-range anti-skate and much more. With base, dust cover, and ADC K6E cartridge.

Consumer Products Group
BSR (USA) Ltd.
Blauvelt, N.Y. 10913



Check No. 13 on Reader Service Card

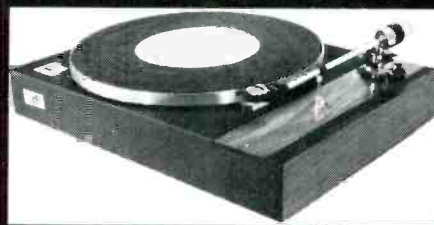

At last! A precision tonearm/turntable combination that saves you money.

ERA manual turntables, now available in the U.S., are renowned in Europe for their quiet 48-pole synchronous motors. Grace cartridges and tonearms are renowned around the world for their consistently excellent quality. Together, the ERA and Grace fully realize the potential of two great performers.

The ERA Mk6 is a slow-speed belt-drive design with a mounting board for your choice of precision tonearm. Our recommended choice is the Grace 707, for which a pre-drilled board is available. The 707 accommodates any of the outstanding Grace cartridges, plus many others.

The ERA Mk6 and Grace 707 offer you the best audiophile performance cost value.

ERA precision
turntables
AUDIOINCS, INC.
1033E NE Sandy/Portland, OR
97220 Check No. 6

GRACE cartridges
tonearms
SUMIKO, INC.
P.O. Box 5046/Berkeley, CA
94705 Check No. 7

Classified

FOR SALE

IMF LOUSPEAKERS. Monitors featured. Transcriptors turntables. Levinson, Burwen, C/M, Futterman tubed electronics. Bohn Omnitrex SR1 portable calculators, only \$75. Sheffield recordings. John Coates sensational jazz piano recording \$7.48. Fidelity Research cartridges. Beam-Echo rare English mono tubed amplifier, new \$195. Hartley 210-MSG speakers, mint, \$235. RTR 400E electrostatic speakers, mint \$235 each. DUAL 1218 turntable. w/base/cover \$100. Jensen Fives loudspeakers, mint, \$290 pair. Trades accepted. Audiocraft, name changed registered — GOLDEN EAR, South Rockwood, Michigan 48179. (313) 379-9945.

TRADE IN YOUR KLH 9's, QUADS, & MAGNEPLANARS: Incomparable Fulton J-Modular Speaker Systems are now available, generous trade-ins, especially on Marantz tube equipment. We serve the discriminating audiophile with the finest equipment available, both new and pre-owned. Come and hear the J's or write us for advice and a quote on all your audio needs, list your trade-ins. NATURAL SOUND, 1021 Claremont Street, Lincoln, Neb. 68508, (402) 475-DEAL, and E-7 Institute and Einhorn-WPI, Worcester, Mass. 01609. (617) 755-1461.

COMPLETE SYSTEM - Phase Linear 700-B, BIC 980 turntable, with Empire 5000 cartridge. One pair Acoustic Research LST's; Yamaha CT-7000 tuner; Phase Linear 4000 preamplifier; Soundcraftsman equalizer, model PE2217; TEAC 450S cassette deck; TEAC reel to reel model A-2300SD. \$3000 - must sell, going into Army. Donald Jacobs, 64 Wilson Ave., Westbury, N.Y. 11590.

DYNACO-A-R, transistors, repairs-boards & units, speaker service. Send for prices & details: BEAR ELECTRONICS, 177-R Hillcrest Road, Mt. Vernon, N.Y. 10552.

ND GIMMICK! JBL, Marantz, Pioneer discounted 60%! Amazing details FREE. John Peterson, Box 8014A, Canton, Ohio 44711

AUDIO BREAKTHROUGHS

"We're closing the gap on perfection"

Long Island's finest audio dealer. The incredible Lux M-6000 now you can hear what a \$3,000 amplifier sounds like! See the original Transcriptors turntable with new fluid damped arm; complete selection of ultra-fidelity records; Sheffield, Levinson, Fulton, Jonas Miller and more! Just arrived; the new elliptical Decca Mk V, Audiocraft and Grace damped tonearms. Satin "ultimate" cartridge, plus Paoli tube amplifier, Magneplanar, Linn Sondek, Lux turntable, B&W, KEF speakers and drivers, Yamaha (CT-7000, B-1 and NS-1000M!), Supex, M&K super woofer. IAD ultra-low distortion dynamic range expander! Levinson, new Polk, IMF and the list goes on... AUDIO BREAKTHROUGHS, 1681 Northern Blvd., Manhasset, N.Y. 11030. (516) 627-7333.

DON'T PAY THE HIGH MAIL ORDER PRICES. THIEVES WAREHOUSE OF FT. WALTON BEACH, 652-D BEAL PARKWAY, N.W., FT. WALTON BEACH, FLORIDA 32548

FOR SALE

AUDIO RESEARCH MAGNEPLANARS and Electronics, ESS, Infinity, Ohm, Dahlquist, EPI, Audionics, Radford, Crown, Citation, BGW, Transcriptor, Linn-Sondek, Keith Monks, ERA, Connoisseur, SME, Supex, Decca, Grace, Sony, Spectrum Scanning Tuner, Epicure Amplifier, Marantz 500, DBX, ADC, Nakamichi, B&O, Tandberg, Celestion, Marc Levinson, Stax, Dayton-Wright, others. THE GRAMPHONE LTD., 757 Asp St., Norman, Okla. 73069. 405-364-9477.

ANTI-SKATING for AR TURNTABLES!! Proven counterweight design of nickel steel & aluminum construction. Install yourself in minutes. \$7.00 postpaid. (Dealer inquiries invited.) AUDIO INNOVATIONAL PRODUCTS, P.O. Box 137, Ballardvale Station, Andover, Mass. 01810.

SUPER — ORTOFON — OTHER MOVING COIL CARTRIDGE OWNERS; Send for free literature on our Micro-Preamp Super performance at \$99.95. Huntington Electronics, Box 2009-A, Huntington, Conn. 06484

ELECTRONIC CROSSOVERS — ALL TYPES. Updated definitive booklet describes applications; how to improve speaker systems; \$7.50 postpaid, credited to first purchase. Huntington Electronics, Box 2009-A, Huntington, Conn. 06484.

LOWEST DISCOUNT PRICES ANYWHERE on audio equipment. All major brands discounted. Write for quotes, K&L Sound Services, 75 N. Beacon St., Watertown, Mass. 02172.

DIAMOND NEEDLES and Stereo Cartridges at Discount prices for Shure, Pickering, Stanton, Empire, Grado and ADC. Send for free catalog. LYLE CARTRIDGES, Dept. A, Box 69 Kensington Station, Brooklyn, New York 11218.

THE MONEY SAVER! Write STEREO SPECTRUM, Box 1818, Miami Beach, FL 33139.

WANT TO GO BI-AMP?

DeCoursey Electronic Dividing Networks are available from \$89.10 (Monaural bi-amp) to \$205 (Stereo tri-amp). Price includes plug-in Butterworth filters; 6, 12, or 18 db. per octave at any desired cutoff frequency. Write for brochure. DeCoursey Engineering Laboratory, 11828 Jefferson Blvd., Culver City, California 90230.

STEREO CO-OP. Now purchase stereo components directly from a manufacturer co-op, and realize substantial savings. Members include Advent, EPI, Pioneer, Sansui, Dual, Garrard, and others. Write for specific price quotations. Stereo Co-op, 1629 K St. N.W., Suite 5088-Dept. A, Washington, D.C. 20006.

JBL L-200 \$825, pair; Revox A-76 tuner \$425; Mark Levinson JC-1 \$100. (203) 387-6473.

SYNTHI 100 Synthesizer, complete, with extras. Excellent condition. Must sell. Way below cost. Barton McLean, 58412 Locust Rd., South Bend, Ind., Phones 219-287-7540, or 219-237-4101.

CROSSOVERS - Custom designed; fully tested; guaranteed quality. Free brochure. Write: Networks, Box 458, Placentia, Calif. 92670.

SCTOCH — TDK — MAXELL — MEMOREX — CAPITOL — AMPEX. Blank tape. Lowest Prices S & P Enterprises, Box 101, Elk Grove Village, Ill. 60007.

FOR SALE

DON'T LET VOLTAGE TRANSIENTS ZAP YOUR HI-FI. Solid State Equipment Protector. Plugs into outlet. Check or money order \$6.95. Kopp Sales & Service, 1650 William St., Buffalo 14206. Free brochure—send SASE.

RECORDING TAPE CLOSEOUT: Dozen reels 2400', \$12.00. Dozen 1200', \$8.00. 24 reels 900', \$6.00. 24 600', \$5.00. Postpaid Guaranteed. Mitchell, Box 132A, Flushing, N.Y. 11367.

ONE STOP for all your professional audio requirements. Bottom line oriented. F.T.C. Brewer Company, P.O. Box 8057, Pensacola, Florida 32505.

DON'T PAY THE HIGH MAIL ORDER PRICES. THIEVES WAREHOUSE OF SARASOTA, 6564 GATEWAY AVENUE, SARASOTA, FLORIDA 33581.

BUILD YOUR OWN SPEAKERS AND SAVE UP TO 50%. You can assemble your own high quality, multi-element stereo speakers in a few hours and save up to half the cost of comparable speakers. Send for our free 32-page catalog of speaker kits, raw speakers and accessories. SPEAKERLAB, Dept. A2, 5500—35th N.E., Seattle, WA 98105.

ILLINOIS, WISCONSIN, MINNESOTA AUDIOPHILES. Dahlquist, Decca, Dynaco (Modified), Ferrograph, Fulton J, Lecson, IMF, Quad, Quintessence, SAE, Satin, Stax, Technics, Transcriptor, Ampzilla, and many others. Sales, Service, and Installation. AUDIOPHILES SOUND STUDIO 7459 Elmwood Ave. Middleton (Madison) Wis. 53562 (608) 836-3807

OPERA TAPES. Historical performances of past 40 years. Unbelievable treasures and rarities. ALSO LP RECORDS. Free catalog. Ed Rosen, 66-33 Saunders St., Rego Park, N.Y. 11374.

WESTCHESTER AND FAIRFIELD COUNTY AUDIOPHILES TAKE NOTE! THE AUDIOPHILE, 231 BEDFORD STREET, STAMFORD, CONN. specializes in equipment for the connoisseur. Ampzilla, ADC, Citation, Crown, Dahlquist, Dyna, Epicure, Infinity, Koss Model One, Phillips, SAE, SME, Stax, TEAC, Technics, Thorens and many more. (203) 348-3551 (Closed Mondays).

DISKO MIX-MASTER I for disco use and/or preparation of disco tapes. Mixes two stereo phono inputs with self-contained cueing amplifier. Literature available. \$129.00 Dealer inquiries invited. BERKSHIRE AUDIO PRODUCTS, Box 35, Great Neck, N.Y. 11021

CONNECTICUT: Yamaha, Celestion, IMF, Infinity, Braun, Revox, Stellavox, Thorens, ESS, Mark Levinson, Supex, BGW. Will ship prepaid. AUDIOCOM, 177 Sound Beach Avenue, Old Greenwich, Conn. 06870. (203) 637-3621.

RABCO MOD: elegant oiled redwood cartridge shell plus 35% overall arm mass reduction, \$50. Data sheet. AUDIO-ETC., Box 55, Lansing, Iowa 52151

STERED TIMER AND ELECTRONIC DIGITAL CLOCK. P.C. Board with instructions \$9.95. Kit with box \$99.95. Assembled unit \$149.95. Wake up and fall asleep to strains of your favorite AM/FM, record, or tape. This product will be an attractive addition to your stereo equipment. Switches up to 1200 watts. Cosmos Electronics, Dept. A2 P.O. Box 33278, Seattle, Wash. 98133.

Rates: 35¢ per word per insertion for noncommercial advertisements; 60¢ per word for commercial advertisements. Frequency discounts as follows: 3 times, less 10%; 6 times, less 15%; 12 times, less 20%. Closing date is the FIRST of the second month preceding the date of issue. Payment must accompany all orders. Use the handy self-addressed, postage paid card at the back of this issue. When replying to Audio box number ads, send letters c/o Audio, 134 North 13th Street, Philadelphia, Pa. 19107. For more information about classified advertising, circle Reader Service Card #135.

FOR SALE

ATTENTION: LATIN AMERICAN AUDIOPHILES

ATTENTION: VACATIONERS VISITING THE MIAMI AREA

ATTENTION: RESIDENTS OF SOUTH FLORIDA

SOUND COMPONENTS, INC. is THE place for state of the art stereo. Some of our products include:

LOUDSPEAKERS — SPENDOR BCII and BCIII, Audio Research Corporation Magnaplanars, Quads, Magneplan, Allison I and II, Bowers & Wilkins, FMI including the J System, Gale, M&K Sub-Woofers, Dayton Wright XG-8 Mark III, IMF Small Monitor, IMF Studio IIB, IMF Super Compact

TURNTABLES — Linn-Sondek, The Michell Engineering Co. Transcriptors, B&O 3000-2 and 4000-2, and Yamaha

PICKUPS AND TONEARMS — Ultimo DV38/20A, Denon 103-S, Satin M15 Conic, Supex 900 and 901, Ortofon SL-15E Moving Coil Pickups, SME, Audicraft, KMAL, Grace 707 Tonearms, Dayton Wright 535 Infrasonic Cartridge Pre-amp, Denon Transformers, Ortofon Transformers, and Hoffmann Transformers

ELECTRONICS — Audio Research, Lecson, Quad, BGW Ampzilla, Dayton Wright, Paoli, Yamaha, B&O Citation, Stax, Radford

RECORDINGS — A range of selected British, French, and German pressings. Also, the Fulton and Sheffield discs.

All of the above products are in stock and on demonstration in our 1100 sq. ft. showroom.

Hours: 10 - 6 Monday through Saturday.

We accept Master Charge and BankAmericard

We ship mail order in continental U.S., prepaid.

SOUND COMPONENTS, INC.

2710 POUNCE DE LEON BLVD.
CORAL GABLES, FLORIDA 33134

Telephone: 305-446-1659 TWX: 810-848-7627

Superb Products For The Discriminating Audiophile and Music Lover.

CANADIANS — DYNACO COMPONENTS AT TREMENDOUS DISCOUNTS. Write En-Jay Sales, Hornepayne, Ontario.

TUNED ROCK P.A.'s. Customized high intensity touring/permanent installation sound systems, including narrow band (5 Hz) feedback suppression, detailed regenerative response. Acousta-Voicing/environmental equalization (+1dB at your ears), room design/measurement/treatment, v15% articulation loss of consonants, 1000's of customized professional products including . . . fiberglass horns, consoles, comp/rms/peak limiters, 18db continuously variable electronic crossovers, digital/acoustic delays, omnipressors, phasers, reverb, echo, doubling/tripling effects, P.A. noise reduction, piezo transducers, frequency shifters from . . . J.B.L./Altec Pra, Tascam, U.R.E.I., Eventide, Gately, Studer, Beyer, Crown, Community Light/Sound, Mom's Audio, McIntosh, Bozak, Allen Health, Gauss, Cetec, Scully, Multi-track, etc., etc. All shipped prepaid/Insured. Music & Sound Ltd. 11 1/2 Old York Rd., Willow Grove, Pa 19090 (215) 659-9251.

DEALERS!! CONSUMERS!!

Write for quotes on all medium and many High End lines. We need campus reps and people seriously interested in hi-fi to properly demonstrate a fantastic loudspeaker line. Liberal compensation for qualified individuals. Write: Audio P.O. Box 36 Salsberry, Indiana 47459, or call (812) 825-9750 or (812) 332-4252.

VIDEO EQUIPMENT-LOW PRICES

PANASONIC-cameras, monitors, vtrs

RCA-cameras (low light), monitors

GYRR-time lapse vrt

Many accessories; new vidicons

Write or call your needs.

ELECTRONIC EYE

9044 Eldora Drive

Cincinnati, Ohio, 45236

(513) 891-9044

SAVE TIME AND MONEY!

We have 15 years experience selling over 60 major brands. Save up to 50% off. We get the best deals from the manufacturers you get the best deals from us! Call now (212) 338-8555 or write, S.C.A. Dept. AM, 2122 Utica Ave. Brooklyn New York 11234.

FOR SALE

GRAPHIC EQUALIZER PLANS: Novel circuit very effective/inexpensive, requires no inductors. Ten knobs (octave bands) compensate your Hi-Fi/Tape providing better listening. Complete plans rushed only \$3.49. GREEN BANK SCIENTIFIC, Box 100C, Green Bank, WVa. 24944.

COMPETENCE IN AUDIO SINCE 1928!

Qualified service, custom installations
Klipsch, Sequerra, SAE, McIntosh, Levinson,
SME, Ortofon, Fidelity Research, Ampex
Professional, Tandberg.

We buy and sell quality used gear.

THE MUSIC BOX, INC., 58 Central Street,
Wellesley, Mass. 02181. (617) 235-5100.

SIGHT & SOUND LTD.

Catering to the audiophile who desires the absolute in sound, equipment, service and professionalism.

OUR LINES

Ampzilla, ADS/Braun, AKG, B&O, Beyer, Bose, Crown, Dahlquist, DBX, Linn Sondek/MAL, Magneplan, McIntosh, Micro Acoustics, Ortofon, Revox, Soundcraftsman, Tandberg, Yamaha

OUR STAFF

Engineers, physicists, musicians, teachers — all devoted audiophiles dedicated to providing the epitome in experience, patience and service.

OUR LOCATION

Campus Hills Shopping Center, Five miles northeast of Bel Air, Maryland 21014 on Route 22. Phone 1-301-838-2100.

SONY TC-854-4S; (2) SB-200; (2) SB-300; RM-16; PS-2251; NR 335; Sansui AU999. Best offer! Andy Sommersberger, 2219A So. 15th, Sheboygan, Wisc. 53081. Phone (414) 458-9559.

NOTICE

NOW AVAILABLE . . . FAMOUS REFLECTING SYSTEM'S 4 1/2" REPLACEMENT DRIVERS. \$7.98 POSTPAID. BIG QUANTITY DISCOUNTS. FREE SPECIFICATIONS. AURATONE, BOX 580-25A DELMAR, CALIFORNIA 92014.

THE AUDIO RESEARCH ROOM. The complete line of Audio Research equipment on display under ideal listening conditions. AUDIO SYSTEMS & DESIGN, 5421 South 84th St., Lincoln, Nebraska 68516 (402) 489-9888.

AMPEX TAPE—NEW 1800' on 7" reel 12 for \$18 POSTPAID; 1200' 12 for \$13 POSTPAID—free list—WIDE RESPONSE. 6114A SANTA MONICA BLVD., HOLLYWOOD, CA 90038.

ELECTROENCEPHALOPHONE: brainwave monitor, Professional biofeedback instruments. J&J 8102-A, Bainbridge, WA 98110.

JAPANESE TRANSISTORS, Kit \$23.44 contains 24 most widely used transistors, including 14 power transistors. Over 500 types available. Free catalog **WEST PACIFIC ELECTRONICS,** Box 25837, W. Los Angeles, Calif. 90025.

HIGHEST QUALITY USED EQUIPMENT: McIntosh MC 2300, \$900; Marantz 500, \$860; Marantz 4400, \$800; Bose amplifier, \$700; Dahlquist DQ-10, \$310 ea.; JBL Sovereign S8R, \$750 ea.; IMF ALS-40A, \$250 ea.; SAE MK VII eq., \$365; Revox A77 MK III, \$675; Revox A77 MK III HS, Variable Speed, \$700; IMF Studio, \$325 ea.; B&W OM70C/A \$450 ea.; Thorens 125/SME, \$300; Thorens 125/TP-60, \$300; Ampex AG-500, Quad tube system and more . . . all guaranteed 90 days parts and labor. Audio Consultants, 517 Davis St., Evanston, Illinois 60201. (312) 864-9565.

10 1/2" RECORDER SPECIALISTS: Fresh new Scotch L/N 3600 ft. on new 1/4" NAB metal reels five for \$35.00. New Ampex GRANDMASTER tape on 10 1/2" metal reel, six for \$73.00. New 4 channel 8-track blank cartridge loaded with 40 minutes Scotch L/N tape, \$23.00 per dozen. Reconditioned NAB metal 10 1/2" reels, \$24.00 per dozen. 10% on above for postage. Sound Investment, POB 88338, Dunwoody, Ga. 30338.

CENTRAL NEW YORK HI-FI ENTHUSIASTS—Britain's finest loudspeakers on demonstration—THE IMF STUDIO AND ALS40—as well as Marantz, Pioneer, Revox, Beyer, Epicure (3 lines), Thorens, Ortofon, XLM, Discwasher . . . THE SOUND SHOP, 96 Seneca Street, Geneva, N.Y. 14456 (315) 781-0215.

FOR SALE

ANTIQUE: Webster Wire Recorder Model 7 plus three yards wire. No other accessories \$225.00 or best offer. Truse, 6 James Saranac Lake, New York 12983.

DYNACO TRANSFORMERS - A-441 (output), P-782 (power), Dykehouse, 2322 Romence, Portage, Mi. 49081

AR-1W (WOOFER), Wharfedales 8 and 5 (tweeter) - 2 each, 6550-MP tubes. Dykehouse, 2322 Romence, Portage, Mi. 49081.

CALIFORNIA'S UNIQUE AUDIO SHOP proudly presents: ADC, Allison Acoustics, BGW, Burwen, Decca, Dynaco, ESR, Harmon Kardon, Linn Sondek, Quad, Soundcraftsman, Transcriptors, etc. AUDIO TECHNIQUES, 351 South Baywood, San Jose, California, 95128. Phone 408-984-6655 weekdays 11-8, weekends 12-6.

MCINTOSH C-28 \$425, MC-2300 \$1,250, both \$1550. Like brand new, original ctms, etc. Newman, 9512 Woodbine, Baton Rouge, La, 70815.

SEATTLE, WASHINGTON

Audio Research

Quintessence

Magneplaner

Polk Audio

Cambridge

Ampzilla

Radford

Fulton

Yamaha

Sonex

Decca

Supex

Denon

Stax

Koss

Lux

SME

IMF

Fidelity Research

Audio Technica

Mark Levinson

Linn Sondek

Nakamichi

Audionics

Technics

Philips

Quatre

Dtari

Grace

Paoli

Gale

Quad

KMAL

ERA

M&K

C/M

DEFINITIVE AUDIO

3414 NE 65th

Seattle, Wash. 98105

(206) 524-6633

open 12-8 Tues-Fri 10-6 Sat

THE FIRST (1962) and most durable of the "underground" subscriber-supported audio publications, STEREOPHILE has proven itself the most reliable source of information available to the perfectionist who can hear differences between the top amplifiers, pickups, etc.

There are good reasons why the latecomers have modeled themselves after STEREOPHILE. To learn some of them, write for our free blurb sheet or send \$7 for 4 issues of the real thing. Address to STEREOPHILE, Box 49, Elwyn, Pa. 19063

CYBERACOUSTIC LABS presents the new RTR DR-1 DIRECT DRIVE ELECTROSTATIC TRANSDUCER SYSTEM!L

DRIVEN by its own internal servo-feedback amplifier!

MORE musical than any tube or fet system ever devised! ITS uncanny realism is totally unequaled by any other electrostatic system, including headphones!

THE first true non-directional (360°) electrostatic system! GATHER your most precious records or master tapes and call for an appointment today!

Cyberacoustics by Barclay-Philadelphia's Exclusive RTR Distributor
503 Haverford Ave., Narberth, Pa. 19072
1-215-667-3048

WHARFEDALES SPEAKERS Model W90D walnut mint. (401) 943-4222 after 7:00 PM EDT.

MARANTZ 7 (c), 7 (T), 8 (B), 15, SLT-12. All mint. (401) 943-4222 after 7:00 PM EDT.

JBL HARTSFIELD & pair JBL C-37 with 001 system all mint. (401) 943-4222 after 7:00 PM EDT.

STUDER A-80 professional recorder, new condition. Walker, 323 Grove St., Montclair, N.J. (201) 746-2794.

CONTROL 1 - Audio activated automatic power shut-off for component systems. \$49.95. Details: Electromedia Design, Inc., Box 26 Livingston, N.J. 07039.

Listen to TELEVISION IN STEREO



The TE-200 TELEDAPTER EASILY CONNECTS TO ANY TV & STEREO SYSTEM. Using our coupling and matrix circuit, teledapter takes a low impedance output from the television and delivers two HIGH IMPEDANCE CHANNELS OF SIMULATED STEREO, to drive any amplifier. Frequency response is maintained so you can hear the trinkle of bells or booming bass sounds as it happens on TV. With service warranty and hookup instructions \$16.95 ppd. Guaranteed to make your TV 100% more enjoyable.

OUR NEW TE-300 VHF-UHF HI-FI TUNER IS NOW AVAILABLE. A complete and self contained 110 volt tuner, VHF-UHF antenna connections. Recording and amp output jacks. Five year service warranty \$149.95 ppd. From our factory.

SEND: CHECK MASTER CHARGE NO. for TE-200 TE-300 or \$5.00 for C.O.D. TO: RHOADES NATIONAL CO. DEPT AD P.O. BOX 817 HENDERSONVILLE, TENNESSEE 37075

NAME _____

ADDRESS _____

CITY _____ STATE _____ ZIP _____

SEND COMPLETE CATALOG

FOR SALE

DON'T PAY THE HIGH MAIL ORDER PRICES. THIEVES WAREHOUSE OF BETHESDA, P.O. BOX 34251, WEST BETHESDA, MD. 20034.

ALLISON ACOUSTICS LOUSPEAKERS have stabilized Radiation Loading. Years of intensive research by Roy Allison (formerly of Acoustic Research, Inc.) on the interaction between loudspeakers and room boundaries has yielded a new high standard of uniform bass performance. New Convex Diaphragm Mid-Range and High Frequency drivers achieve phenomenal wide dispersion (—3db 90 degrees off axis at 20kHz!) Literature and price information available upon request.

SUFFOLK AUDIO, INC.
1105 Mass. Avenue
Cambridge, Mass. 02138
Ph. (617) 868-1080

BALTIMORE-WASHINGTON AREA AUDIOPHILES REJOICE! At last a store for you. Come to Myriad Sound and hear the finest in state of the art audio equipment. Featuring the complete Audio Research line, Polk Audio Model Nines, ESS Heils, Janszen, S.A.E., Altec, Citation, R.T.R. B&O, Thorens, S.M.E. etc. all accompanied by Fred Huggins himself. Main store at 9619 Reisterstown Rd., Garrison, Md. 21055 (2 miles North of Balt. Beltway exit 20) (301) 363-1733.

ENGINEERED ENCLOSURE & CROSSOVER DESIGNS — free w/purchase of our J.B.L., Gauss, Altec, and Community raw drivers and horns. Music & Sound Ltd., 11-1/2 Old York Road, Willow Grove, PA 19090 (215) 659-9251.

Loudspeaker Reconciling Labs

PROPRIETARY CUSTOMIZED MOOS reduce tone arm friction, damp spurious resonances, minimize torsional forces, improve tracking, and reduce hum and record wear. For S.M.E.'s—\$30.00* For Rabco SL-8(E)—\$100.00. For Transcriptors—free * (*with purchase).

NOW

LISTEN to our calibrated Satin/Denon/F-R/Ortofon/Supex moving coils, B&O/Grace/Micro-Acoustics. From the laboratories of Music & Sound Ltd., 11 1/2 Old York Rd., Willow Grove, Pa. 19090 (215) 659-9251.

Levinson & Stax Cartridge Preamp

NORTHERN N.J.'S FINEST AUDIO STORE, 20 minutes from NYC. Ampzilla, Avid, Bozak, B&O, Dahlquist, DBX, Dual, IMF, Kenwood, Magneplanar, Micro-Acoustics, Ortofon, Phase Linear, Pioneer, Quintessence, Thorens. Write or call-University Stereo, 57 E. Ridgewood Ave., Ridgewood, N.J. (201) 447-5700.

CROWN SX-724, IC-150, D-150, Burwen, RTR HPR-12 Magnums, Nakamichi 700. (215) 942-2161.

UTAH'S OLDEST, FINEST AUDIO SPECIALISTS

McIntosh	Levinson
Infinity	Bozak
Servo Statik IA	JBL
DSP Amp	Pioneer
B&O	Supex
Yamaha	Stanton
Tandberg	AKG
Nakamichi	DBX

WINTERTON'S AUDIO

Salt Lake — 2164 Highland Drive
Provo — 83 North University
Price — 20 North Carbon

FOR SALE

ATTENTION... LUCKY OWNERS OF:
OYNA STEREO 70
RABCO SL8(E)
OYNA PAS-3(X)
INFINITY 2000A
DECCA MKV AND "EXPDRT"
DYNA MARK III
SHURE SME and
other tubular tonearms

THE DKL LABORATORY, INCORPORATED HAS DEVELOPED UNIQUE MODIFICATIONS ENGINEERED SPECIFICALLY FOR THESE COMPONENTS. NOW YOU CAN GREATLY IMPROVE THE SOUND QUALITY TO "ULTRA DEFINITION".

PRICED FROM \$25.00 TO \$170.00. OUR MODIFICATIONS OFFER VAST AUDIBLE IMPROVEMENTS AT REASONABLE COST.

FOR MORE INFORMATION CONTACT:

DKL LABORATORY, INCORPORATED
BOX 683
SEVERNA PARK, MARYLAND 21146
OR CALL: (301) 588-6257
MONDAY, WEDNESDAY, THURSDAY,
SATURDAY 2-8 PM

WE SPECIALIZE IN ONLY THE FINEST SOUND COMPONENTS—ALLOW OUR STAFF OF AUDIO EXPERTS TO HELP YOU CREATE YOUR "ULTRA DEFINITION" SOUND SYSTEM. CHOOSE FROM THE WORLD'S FINEST COMPONENTS LIKE:

AUDIO RESEARCH—electronics and speakers
BGW—power amplifiers
OBX—noise reduction systems, dynamic range enhancers
"HAND-TUNED" DECCA MKV—cartridges
DYNACO—tube electronics
FULTON—regular and MODULAR speakers
HK CITATION—amps, tuners
IMF—"MONITOR-ORIENTED" speakers, kits, sub-woofers
LINN—SONDEK—turntables
MAGNEPAN—speakers
M & K—sub-woofers, matrix systems
PAOLI—tube amplifiers
RABCO—turntables
RTR—electrostatic speakers
SOUNDCRAFTSMEN—pre-amps, equalizers
STAX—electrostatic headphones
"SUPER SHURE" SME—tonearms
TANDY—turntables, speakers

AND SCORES MORE.

WASHINGTON O.C., MARYLAND, VIRGINIA
AREA RESIDENTS TAKE NOTE—
YOUR "STATE-OF-THE-ART" DEALER IS:

DKL SOUND LAB
943 BONIFANT

SILVER SPRING, MARYLAND 20910
Hours: MONDAY, WEDNESDAY, THURSDAY,
SATURDAY 2-8PM FRIDAY BY
APPOINTMENT ONLY, CLOSED TUESDAY
(301) 588-6257

STATE-OF-THE-ART comes to NORTH-CENTRAL FLORIDA, serving you with: **AUDIO RESEARCH**, Citation, Crown, Dahlquist, Denon, Dynaco, Fidelity Research, DBX, G.A.S. Co., Hartley, Infinity, Magneplanar, Mark Levinson, Ortofon, Rabco, Revox A-700, S.M.E., Supex, Thorens, Transcriptors, and \$10,000 worth of test equipment for in-store audio analysis. We maintain a mobile recording van and sell professional recording equipment. **AUDIO, ETC., INC.**, 1999 N.W. 43rd Street, Gainesville, Florida, 32605. 1-904-377-4107.

TEAC 1/2 TRACK tape deck model 7030 GSL, mint. \$700 firm. You pick up in R.I. (401) 766-6019.

MINT USED EQUIPMENT. Citation 11a Preamp w/case \$290; Citation 12 Amp \$225; CM Labs CC-2 Preamp w/case \$175; SAE Mk IVc Amp \$350; Audio Research Tympani III Tweeter-Midrange \$600; Audio Research Dual 51 Amp \$500; Audio Research EC-3 Crossover \$475; Audio Research Tympani III complete \$1050; Marantz 7c Preamp \$225; Panasonic SP-10 Turntable \$310; Shure SME 3009 Tonearm \$100. **SOUND ADVICE**, 536 State Road, Emmaus, PA 18049. Hours: Daily 6-9:30; Sat 10-6.

FOR SALE

AN IMPORTANT ANNOUNCEMENT

Parnassus Audio is now producing a full Class A (not AB) stereo power amplifier capable of relatively high output power.

The amplifier additionally satisfies the theoretical criteria for completely eliminating transient intermodulation distortion.

The difference in sound quality between this amplifier and conventional amplifiers is easily audible, even to the inexperienced.

We welcome requests for a descriptive brochure. Dealerships will be limited.

Address all inquiries to: **PARNASSUS AUDIO, 2918 Harper Street, Berkeley, California.**

MCINTOSH MX-110 tubed preamp-tuner with Mullards and case, \$350. Levinson JC-1, \$150. Supex SD900, \$75. Shure M64 preamp \$30. (617) 648-4191.

MINNEAPOLIS — High Quality Audio Has Finally Arrived! Audio Research, Bang & Olufsen, Klipsch, Audionics, Radford, Revox, Bozak, Crown, DBX, Sequerra and others... **THE SOUND ENVIRONMENT**, Butler Square, Suite 114, 100 North Sixth Street, Minneapolis, Minn. 55403, (612) 339-4641.

DYNACO RACK MOUNTS for pre-amps, tuners, integrated amps. \$24.95 postpaid, \$22.50, three or more. **AUDIO BY ZI-MET**, 1038 Northern Blvd., Roslyn, N.Y. 11576 (516) 621-0138

PROFESSIONALLY SPEAKING... Klipsch, Nakamichi, Crown, Yamaha, SAE, Bose, Burwen, DBX, Soundcraftsmen, Transcriptor, Microacoustic, Teac, Sonab, Dokorder, Supex, Grace, JBL. For that extra personalized service visit — **HAL'S STEREO SOUND CENTER, INC.**, RT. 1 & Texas Ave., Trenton, N.J. 08638. 609-883-6338.

MCINTOSH 2105 \$550.00, **JANSZEN TWEETERS MODEL 130's** \$275.00/PR. PRICES NEGOTIABLE (615/693-4874)

LOW NOISE RESISTORS — 1/4W, 5% carbon film from 10-3.3 Megohm for 3 1/2 each. Fifty per value is \$1.25. 1N4004, 1N4148 diodes. Postage 75c. **COMPONENTS CENTER**, Box 134A, New York, N.Y. 10038.

ABSOLUTELY THE LOWEST PRICES on name brand stereo components. Send for our free catalog to **BOSTON AUDIO EXCHANGE**, 1589 Commonwealth Avenue, Brighton, Massachusetts 02135.

MUST SELL AKAI GX2800SS Tape Deck. Original carton and manufacturer's warranty. Never used. No reasonable offer refused! Larry Riley, 4A Couch Street, Plattsburgh, N.Y. 12901. (518) 563-2102

MARANTZ 10-B. Complete set of spare tubes \$750. Glenn English, (512) 478-2054.

TDK C-90 Dynamic Cassettes. BASF 90 minute 8-tracks \$1.49 — over nine \$1.29. Postage Paid. 10 1/2" Fiberglass Reels \$7.50 for 30. Pete Kuruzovich, 24575 Donover Rd, Warrensville Hts. Ohio 44128 216-292-2864

BURGLAR alarm dialing unit automatically calls police. \$29.95. Free literature. S&S SYSTEMS, Box 12375H, North Kansas City, MO 64116.

AMPZILLA — THAEDRA

Sound Advice, 536 State Road, Emmaus, Pa. 18049. Hours: Daily 6-9:30; Sat. 10-6.

RUMBLESEAT RECORDS - new label — Big Band Era. Send for free catalogue. Rumbleseat Records, P.O. Box 233, Irvington, N.Y. 10533

ATTENTION

WESTERN NEW YORK AUDIOPHILES

The word is getting around!! Our personalized, honest service and quality equipment make a winning combination. In addition to the incomparable **AUDIO RESEARCH** line, (T-1B's black/natural in stock), we carry **AMPZILLA**, SAE, Phase Linear, Yamaha, Quintessence, **LEVINSON**, B&O, IMF, **MAGNEPAN**, M&K Subwoofers, Hegeman, Infinity, RTR, ESS, **DAHLQUIST**, Fulton Music, **QUATRE**, Onkyo, Connoisseur, Technics, Thorens, Dynaco, Transcriptors, Cerwin Vega, Soundcraftsmen, Supex, Ortofon, ADC, Micro-Acoustics, Damped S.M.E. Linn Sondek, **KMAL**, Naim Audio, etc. The Stereo Emporium, 3407 Delaware Ave., Buffalo, N.Y. 14217. (716) 874-3372.

FOR SALE

N. CALIFORNIA'S CUSTOM IMF DEALER is now offering: **IMF SMALLER MONITOR** — Smaller version of the world-acclaimed MDNITOR!

IMF MODEL R!! Flat to 20 Hz. Stunning transient attack! Uses new version of KEF flat woofer. At \$330 — extraordinary!

IMF SUB-WOOFER KIT — Dual transmission line system flat to 6 Hz — \$250!!

STUDIO IIB and MONITOR MK IV — Both newly "impulse" revised!

Custom demonstrations in The IMF Listening Room. For information and/or listening appointment, write or call Russ Goddard, **CUSTOM IMF DEALER**, 1171 W. Latimer, Campbell, California 95008. (408) 374-4697.

Mail order customers: For your convenience, all orders are shipped prepaid and insured, by air!

BUY DIRECT FROM ENGLAND'S HI-FI MAIL ORDER SPECIALISTS! Save on B&O, Celestion, Decca, Tandberg, Revox, Transcriptor, Jordan-Watts, Lowther, KEF, Rogers, SME, Ariston, HPD, Sugden, Radford, Neal, Ferrograph, etc. Shipping lists free or send \$3.00 bills to include literature. Goodwin Ltd., 7 Broadway, Woodgreen, London N.22. Phone 01-888-0077. Visitors welcome.

SURPRISE! SURPRISE! Digital Piano Tuning Device tunes musical instruments Accurately! Perfectly! Inexpensively! Construction-Instruction Plans Complete \$12.95 Airmailed Postpaid! Moonlighting quickly repays \$40 electronics investment! **GREEN BANK SCIENTIFIC**, Box 100E, Green Bank, WV. 24944

Dayton-Wright SPS pre-amp, Epicure "1" Power amp. Technics SL-110A with improved SME Tonor arm with ADC-XLM & Super XLM cartridges. Advent FBC equalizer, Kenwood 6005 Tuner and Infinity Monitors. All Equipment 6 months old with warranty cards. Call Gordon 216-637-9199

NORTHWEST'S FINEST — Audio Research, Audionics, Braun, BGW, Burwen, Crown, Dahlquist, Dayton Wright, Decca, Fidelity Research, FMI, GAS, Hartley, IMF, Infinity, Linn Sondek, Mark Levinson, Nakamichi, Quad, Quatre, Quintessence, Radford, Sequerra, Supex, Tandberg, Transcriptor, Yamaha, also Custom Designed Superwoofers, and many more. **HARTLEY ELECTRONICS**, 1502 Butternut, Richland, WA 99352. (509) 946-4459 until 6:00 PM, then 947-5026 evenings.

SOUNDCRAFTSMAN RP2212, \$275.00, **ADVENT 100**, \$175.00, **ORTOFON ARM**, \$50.00, **SPEAKERS** — **PIONEER CS33's**, \$120.00 pair, **AR4X's**, \$110.00 pair (615/693-4874)

ST. LOUIS' LEADING QUALITY AUDIO DEALER—Featuring the following equipment:

AUDIO RESEARCH	
ACCUPHASE	PHILIPS
AKG	QUAD
ALTEC PRO	QUINTESSENCE
B & O	REVOX 700
BOZAK	RTR
CITATION	SCULLY
DECCA	STANTON
EPICURE	STAX
KMAL	TANDBERG
LINN SONDEK	TECHNICS
NAKAMICHI	UHER
PHASE LINEAR	YAMAHA

and others

Equipment tested before being shipped prepaid.

J.C. Gordon Company
2831 Hampton Avenue
St. Louis, Missouri 63139
(314) 647-8866
Since 1927

NEW GENERATION Crown Amplifiers, Cleanest, Smoothest sound ever produced - Crown D1200/HP1200, on demo only at Barclay Recording, 503 Haverford Ave., Narberth, Pa. 19072. (215) 667-3048.

FLORIDA AUDIOPHILES! Phase Linear, I.M.F., B&O, H/K, Marantz, Quatre, Thorens, Sony, Klipsch, Revox, Barzilay cabinets. Sales and expert repairs. **INTERIORS PLUS SOUND**, 3038 N. Federal Highway, Ft. Lauderdale, Florida 33306. (305) 566-3511.

FOR SALE

BERKELEY, CALIFORNIA

speakers & headphones	ADS FMI M&K Gale Polk Stax Braun Beyer Fulton Quatre Magnepan Quad ESL Audionics Cambridge Dahlquist Sennheiser Beveridge ESL	electronics	ADS GAS Quad Hervic Quatre Radford Ampzilla C/M Labs Audionics Cambridge Parnassus Quintessence Mark Levinson
----------------------------------	---	--------------------	---

tape-recorders, processors, & accessories	ARK Dbx Lamb Beyer Braun Revox Sheffield Vac-o-rec Nakamichi Quintessence	record-playing equipment	SME BSR KMAL Dual Grace Supex Win Labs Connoisseur Keith Monks Linn-Sondek Mark Levinson Fidelity Research
--	--	---------------------------------	---

STEREO WORKSHOP
2985 College Avenue
Berkeley, California 94705
(415) 843-5836

new hours
Tues-Sat 12-5 PM
6-10PM
Sun-Mon closed

open for browsing
private appointments for auditions & consultation

DYNA STEREO 70 MOD KIT. Tighter bass, improved transient response, higher definition. Complete instructions, schematics, parts list, \$5.00. With parts kit, including all new tubes, \$58.00. Or we will modify \$105.00 all postpaid. Audio Designers, Box 122, Ledyard, Conn. 06339.

Audio Research Quintessence Techniques Oahlquist Hartley Quatre Braun SME SAE	M & K Gale KMAL Supex Yamaha Win Labs Audionics Nakamichi Linn Sondek	Fidelity Research Mark Levinson Connoisseur Magnepan Sequerra Fulton Grace Stax DBX
---	--	---

GARLAND AUDIO, INC.
2960 Stevens Crk. Blvd.
San Jose, California 95128
(408) 244-6724

TRANSIENT OUTPUT MONITOR for audio amplifiers. I.E.D. readout indicates 1/4 to 1000 watts average and transient power output. Hand assembled, calibrated, tested, \$100. Free literature. Analogic Design, P.O. Box 7753, Phila., Pa. 19101.

ROGERS B.B.C. MONITOR, B&W Ltd., Celestion, Radford, Decca, ERA, Connoisseur, Audionics TL-90, Goldring, Revox, Beyer, Lamb and more. Custom design and modifications. **SUFFOLK AUDIO, INC.** 1105 Mass Ave., Cambridge, Mass. 02138 (617) 868-1080.

WESTCHESTER AND FAIRFIELD COUNTY AUDIOPHILES TAKE NOTE! THE AUDIOPHILE, 231 BEDFORD STREET, STAMFORD, CONN. specializes in equipment for the connoisseur. Ampzilla, Audio Research, ADC, Citation, Crown, Dahlquist, Dyna, Epicure, Infinity, Philips, SAE, SME, Stax, TEAC, Technics, Thorens and many more (203) 348-3551 (Closed Mondays).

CASSETTE LABELS

Plain white cassette labels, Norelco cleaners, Norelco type plastic box, famous brand cassettes. Send for open reel and cassette discount catalog.

	1-9	10-99	100	1000	10M
Cassette Labels (Multiples of 10)	.02	.015	.01	.006	
Norelco Cassette Cleaner	.65	.60	.55	.50	.45
*Scotch Cassette SC90HE	2.72	buy 2 get 1 free			
*10 1/2 metal reels used	1.00	1.00	.90	.80	.70
Plus Postage by Weight and Zone					Minimum Order, \$5.00

OPEN REEL STEREO TAPE BUYERS!

At last! An open reel catalog, including titles, songs, etc. of 95 long play, 2-3 hour albums, by American Airlines or Ampex 4 track stereo tapes. Send \$1.00—and we will also mail you a 140-page Harrison stereo tape guide—so you'll get both for \$1.00—and this \$1.00 is refundable on your first \$10.00 purchase of open reel stereo tapes at our 30% discount.



SAXITONE BICENTENNIAL TAPE SHOPPE

1776 Columbia Rd., N.W., Wash., D.C. 20009

FOR SALE

FREQUENCY EXTENDER-EQUALIZER

Model EQ3200. New! In limited production. Ask your dealer or contact Burwen Laboratories, Dept 11, 209 Middlesex Turnpike, Burlington, Massachusetts, 01803 Tel. 617-273-1488

TRAVELING TO ENGLAND?

Then visit Guildford HiFi for the finest audio equipment including Accuphase, AKG, Gale, B&W, Decca, Dual, Stax, Quad, Linn Sondek, Nakamichi, Supex, SME, Sugden, Teac, KMAL, Technics, Watts, Yamaha, Zerostat, etc. Only 25 minutes from London. 270 High Street, Guildford, Surrey. (0483) 71534

LOUDSPEAKER MOUNTING KITS

— Includes 4 die-cast clamps, 4 plated 1/4-20 screws, 4 - tee nuts and gasket. \$4.00 ppp. Minimum order 6 kits. Please specify speaker size. LTC Audio, 14244 Vanowen Street, Van Nuys, Calif. 91405.

IMPROVE SIGNAL TO NOISE RATIO

on tape equipment by actually measuring any damaging magnetic residuals, then really demagnetizing with the powerful, sine wave Hand-Mag. Professional Hand-D-Kit \$58.50 delivered USA on prepaid orders. Literature and Article reprint available. ANNISCO, 1103 N. Delaware, Indianapolis, Ind. 46202. Phone (317) 637-9282.

AUDIOPHILES WANTED!!

Put your knowledge to use, earn an excellent spare time income. We need campus representatives to sell name brand stereo equipment at substantial discounts in your area. No investment necessary. For information and application please write: ABCO, Dept. CR, 915 Grand Avenue, New Haven, Conn. 06511

CAROLINA'S ONLY AUDIOPHILE CENTER

— Infinity Servo-Statiks, Switching amp, Ampzilla, Dahlquist, Magnepan, FMI, Ortofon, Crown, Accuphase, SME, Decca, Hegeman, Klipschorn, Technics, Teac, Marantz, Harmon Kardon on demonstration.

Vickers Audio
210 West Franklin St.
Chapel Hill, N.C. Carolina 27514
(919) 929-4554

YELLOW PAGES OF AUDIO

— Comprehensive reference to professional as well as consumer audio products and manufacturers. FREE classified advertising information and copy form available with each issue. \$1.50. Box 94, Colmar, Pa. 18915.

LOOKING FOR HIGH QUALITY "PREVIOUSLY OWNED" MERCHANDISE?

Referral/resale service for industrial and professional audio equipment. All merchandise guaranteed to meet manufacturer's specification for 12 months (parts, labor, and round trip shipping included). Call or write OH-RWERKE, 40 High Street, Guilford, Conn. 06437, (203) 453-5285.

MAKING HIS MOVE

— Mel Schilling, formerly of Willow Grove, Pa., has taken his knowledge of music and sound to California, where he will continue to serve a select nationwide clientele devoted to ultra state-of-the-art stereo. All shipments prepaid and insured. Write or call — 20929 Ventura Blvd., Woodland Hills Village, Woodland Hills, Calif. 91364. (213) 348-4600

FOR SALE

FREE details... A DIFFERENT KIND OF RECORD CLUB

Discounts up to 73%, no "agree-to-purchase" obligations. All labels, Schwann catalog of thousands of titles; classical, pop, jazz, country, etc. Discount dividend certificates. Newsletter; accessories; quick service. 100% iron-clad guarantees. Write for free details.

DISCOUNT MUSIC CLUB, INC. DEPT. 14-115
650 Main Street, New Rochelle, N.Y. 10801

AKG, ALTEC, AUDIO RESEARCH, Beyer, CROWN, DAHLQUIST, DBX, DECCA, INFINITY, KLH 9s, Koss, Mark Levinson, Nakamichi, Ortofon, PHASE LINEAR, PML, REVOX, SAE Sennheiser, Sequerra, Sony, Stanton, Stax, Supex, Tandberg, TASCAM, Technics, Thorens, etc.

HI-FI HAVEN

28 Easton Ave.
New Brunswick, N.J. 08901
201-249-5130

LOW NOISE STEREO PREAMPLIFIER.

Model SP5200. New! In limited production. Ask your dealer or contact Burwen Laboratories, Dept 11, 209 Middlesex Turnpike, Burlington, Massachusetts, 01803 Tel. 617-273-1488

INFINITY 2000A speakers \$190, each Citation 12 Amplifier \$200, Kenwood Audio Scope \$150, Braun Changer \$200, Stax Headphone \$95, Electrovoice Outdoor Speakers \$50, pair, Dr. D.S. Konicoff, 120 W. Palmetto Park Rd., Boca Raton, Fla 33432.

PIEZO SUPER HORN TWEETERS \$7.95 P.P. Cont. U.S.A. Daily Mfg. Co. (Mfr. of quality loudspeaker systems since 1951), 100 Liberty St., Rockwell, N.C. 28138.

CANADIANS: Shure M91ED \$24.88; Dynaco A25 \$68.00; Pioneer SX424 \$179.95; Dual 1216 \$119.00; Leak Delta 75 \$289.00; Garrard Mini changer \$13.99. Free Hi-Fi discount catalog. Etc (Au), Box 741, Montreal H3C 2V2.

NAME BRAND RECORDING TAPE, custom loaded. Available in cassettes, reels, and cartridges. Huge savings direct from manufacturer. MJS, 516 Brooks, San Jose, Calif. 95125.

SHOP AROUND — Listen to every speaker available — then come to Cyberacoustic Laboratory and hear RTR's New Direct Drive Electrostatic DR-1 speaker system at Philadelphia's exclusive distributor — by appointment — 503 Haverford Ave., Narberth, Pa. 19072. (215) 667-3048.

DEALERS: We will buy your excess stock. ALL lines, no quantity too large or small. Cash paid immediately. Call M. Gasman 617-924-0561.

SAL-A-THON - Bring cash today and take it away. Low prices on used test equipment. Subject to prior sale FOB, Brockton: Simpson Handiscope 100 KHz, \$55.00; HP 120AR w/PII 200 KHz mod., \$95.00; HP 202A F.G. .008-1200 Hz, \$95.00; HP 400D AC VTVM 10Hz-4MHz, 1mv-300v, \$75.00; Tek 105 sq. wave gen. 25Hz-1MHz, \$75.00; Tek 181 time mark gen., \$95.00; GR 1330A bridge osc. 5k-50MHz, \$375.00; GR 1021A 40-250 or 250-900 Mhz, \$275.00; HP 523D counter 1.2MHz, per TIM, \$120.00; Decade .1 ohm-111megohm 9 decades, \$49.00. **WALLEN ELECTRONICS CO., INC.**, 46 No. Manchester Street, Brockton, Mass. 02402. (617) 588-6440, (617) 472-0244

DON'T PAY THE HIGH MAIL ORDER PRICES THIEVES WAREHOUSE OF TAMPA, 1531 SOUTH DALE MABRY, TAMPA, FLORIDA 33609.

TORONTO AREA FM FANS: Get the full story on local programming, new products, dealers, record reviews. The FM Guide, 122 Davenport Road, Toronto M5R 1H9. One year, \$7.00.

ORIGINAL TRANSDUCTOR HYDRAULIC REFERENCE TURNTABLE (do not confuse with smaller "Skeletal" table/Vestigal arm package from Ireland) now available direct from U.S. importer. Magnificent turntable complete with silicone-damped Unipivot arm, \$498.00 freight prepaid. Without arm, including blank arm-mounting board or one cut for SME, \$398.00. Send \$100.00 down for COD shipment. Audiophile Imports, 10 East Erie, Chicago, 60611. (312) 787-0754.

West Michigan Audiophiles—Paoli, Ampzilla, Transcriptors, Magnepan, Fulton. Available at Music Center/Equinox, (616) 457-2117, or Box 333, Grandville, Michigan 49418.

FOR SALE

CROWN IC-150, \$280.00; Crown DC-300A, \$650.00. Excellent - must sell. Tim Bulgrin, Box 397, Owen, Wisc. 54460.

THE AUDIOPHILE

At last! An audio dealer in the Washington, D.C. Metropolitan area serving the sound purist. Audition the new DB Systems preamp - absolutely the finest sound available today, tube or transistor. Listen to your favorite records through the Stax SRX Mk II electrostatic headphones or Quad ESL's with M&K sub-woofer. The sound may surprise you. 582 N. Frederick Ave., Gaithersburg, Md. 20760. (301) 948-2999. Where quality is foremost.

GATELY PROKIT SM-6 mixer, EQ-6 equalizer, EK-6 reverb. Excellent. \$550. Nelson Wright, 617-767-0493 evenings.

PHILA'S IMF ROOM - Separate facilities to hear the exquisite sound of IMF loudspeakers. (215) 667-3048

JBL D61 S7R's (2), \$400 each; AR32's (2), \$150 each; Advent Frequency Balance Control, \$100; Dual 1229 with Shure V-15II, base & dust cover, \$125.00; AR-XA with Empire 999, \$60; Kenwood KA5002, \$110; Koss E9 headphones, \$125; Kenwood KT-6005, \$200. (606) 272-6896.

STEREOPUS - The quarterly equipment review journal that gives you the straight word on the latest in stereo components, in-depth interviews, comment on the current audio scene. First issue off the press, second imminent. Don't miss a word. \$9.00/year (first class add \$2.00). Foreign \$12.00. P.O. Box 269, Fort Walton Beach, Florida 32548.

SHURE 16" MODEL 3012 II tonearm. List price \$120.00, closeout \$75.00. Limited quantity. Shipping prepaid. HiFi Haven, Inc., 28 Eastern Avenue, New Brunswick, N.J. 08901.

TWO SENNHEISER MKH 405 condenser microphones, \$400 (\$200 each). Charles O'Flynn, 300 South 2nd Street, West Monroe, La. 71291.

ONLY THE BEST

Audio Research, B&O, Braun, B&W, Cambridge, Dahlquist, Decca, Dynaco, Epicure, Grace, IMF, Keith Monks, Koss Electrostatic, Linn Sondek, Mark Levinson, MicroAcoustics, Nakamichi, Ortofon, Paoli, Quatre, Revox A-700, SME, Sony, Stax, Supex, Tandberg, Thorens, Transcriptors, Vestigal, Yamaha, and more...

Audio Workshop, Inc., Latham, N.Y.

(518) 783-9810 private consultation (518) 783-9810

SAE MARK 1M preamp with cabinet, mint. \$410. Call (518) 783-6890, evenings.

CROWN CX-822, mint \$1700; DC-300A, case, \$600; Shure M-67 mixer, \$100, Robert Busk, 1203 N.W. 4th Ave., Gainesville, Fla. 32601. (904) 373-3043.

AMPLIFIERS AND REEL DECK. Tube 1961 Scott model 299-C, very few hours. Marantz 1200, 4 yrs. old. Both mint. Scott has homemade walnut cabinet but looks sharp. Marantz in factory walnut cabinet. First certified check for \$750 plus shipping takes both. May split to right offer. Also Teac reel deck 4010SL in excellent condition, \$350 plus shipping. Phone evenings 406-797-3291. Jim Henderson, Route 1, Box 18, Anaconda, Mont. 59711.

DAHLQUIST, Rabco ST-7, Crown DC300a, Accuphase - Reasonable. (515) 244-5816.

MAGNEPLANAR TYMPANI IA, \$625; Stax SR-3/SRD-5, \$70. Mark Zenon, 2301 Jefferson Davis Hwy., Apt. 1231, Arlington, Va. (703) 557-7505.

TWO SHURE DYNAMIC MICROPHONES, model 55S Unidyne, excellent condition, \$50 each. Write or call Sam Benjamin, 108 E. 53rd Ave., Merrillville, Indiana 46410. Ph. 219-887-0057.

B&D 4002 TURNTABLE, Harman Kardon Citation 16, Soundcraftsman 2217, Magnepan - Reasonable. (515) 274-1092.

FOR SALE

FROM GERMANY - New male perfume oil -5. Fresh, clean scent. \$10.00 to Robert Veal, 412 15th Ave., Paterson, N.J. 07504. (201) 279-4976.

LET STEREO ONE bring a new excitement to your listening pleasure. Stereo One is at 1229 Post Rd., Fairfield, Conn. 06430. For the discriminating listener we offer: McIntosh, Mark Levinson, Braun ADS, Quatre, Nakamichi, Revox, Thorens, Supex, Dahlquist, Ortofon, B&O, Denon, F-R, JBL, Yamaha, Phase Linear, Jecklin Float, & Bi-Amplified Bozak Speakers. We ship pre-paid. For competent, professionally objective advice call:

STEREO ONE
1229 Post Road
Fairfield, Conn. 06430
Phone 203-255-5939

"BLANK PROFESSIONAL series metal cassettes. Ends binding and jamming. 60, 90, 120 minutes. Also new cassette storage units for home, auto, boat. Write Audio Recording Center, P.O. Box 194, Pittsford, New York 14534. Dept. A.

CAR STEREO - all major brands. Lowest prices. Audio, Suite 47, 947A Dyer Avenue, Cranston, R.I. 02920.

CROWN DC150 SAE Mark III CM, Audio Research SP-3 Preamp - \$1450.00 firm. Will consider offers on individual pieces. Call (615) 226-2139, ask for Larry.

INFRA WOOFER™ world's largest, deepest, most powerful sub-woofer system can be had only at Music and Sound, Ltd. 50 dB per octave crossover, bandpass 16 Hz. \$1495.

DAHLQUIST, F.M.I., I.M.F., HARTLEY SUB-WOOFERS, for the closest approximation to dipole definition \$132 up! Shipped prepaid/insured. Music and Sound, Ltd., 11 1/2 Dld York Road, Willow Grove, Pa. 19090 (215) 659-9251.

+ Free PassiveX-over Design w/Purchase +

CYBERACOUSTIC LABORATORY is a research and development center combined with the most scientifically advanced audio/acoustics lab; featuring Crown, IMF, Mark Levinson, Nakamichi, Burwen, UREI, RTR, DBX, Ortofon, Decca, HK-Rabco, AKG, and more. Crown tape recorder specialists. Send for free catalog! 503 Haverford Avenue, Narberth Pa. 19072. (215) 667-3048.

SOUNDAMERICA — Northern Minnesota's finest Audio dealer. Crown, SAE, Infinity, Yamaha, Ortofon, Shure, Thorens, Pioneer, Sony, Kenwood, E-V, Teac. Finest selection — will ship prepaid. **SOUNDAMERICA** 2116 Maple Grove Rd., Duluth, Minn 55811

TARZAC

Cassette-cartridge labels: custom-blank. Capitol Cartridges: 28 through 100 minutes. Cassettes, Storage Boxes. 638 Muskogee Avenue, Norfolk, Virginia 23509.

FLORIDA'S LARGEST AUDIO RESEARCH DEALER. Full Audio Research Systems on display SP3-A-1 Dual 76A/Dual 150/Dual 52/Magneplanar Tympani I C/Tympani IV. Plus AR B&O, Crown, Denon, Fulton, IMF, Magnepan, Marantz, Mark Levinson, Nakamichi, Paoli, Phase Linear, Revox, Russound, SAE, Satin, Sequerra, Sherwood, Shure, Stax, STR, Supex, Tandberg, Technics, Transcriptors, Uher, Yamaha. **SOUND AND SIGHT, INC.** 20 N. Federal Highway, Boca Raton, Florida 33432, (305) 391-1843.

DON'T PAY THE HIGH MAIL ORDER PRICES. THIEVES WAREHOUSE OF MOBILE, 1770 BELTLINE HIGHWAY, MOBILE, ALABAMA 36609.

TUBE EQUIPMENT: McIntosh, Marantz and Dynaco. Klipsch speaker wanted. 4430 Wheeler, Houston, Texas. (713) 747-4682.

CERWIN-VEGA PRODUCTS
(312) 581-7436

STEREO COMPONENTS: Over 50 brands & accs. List 50¢ refundable Custom Audio c/o Dick Walen 4226 Robert St. Red Wing, Minn. 55066

MAGNEPLANAR TYMPANI 3-A's, mint, neutral fabric, with bass screens. Call (919) 449-4132.

FOR SALE

A TOTALLY NEW AUDIO EXPERIENCE, the Video Image Programmer produces vivid color images on color TV receivers from stereo program material. Attaches directly to stereo and TV antenna input. \$99.00 complete. Dealer inquiries invited. For complete information, write to OSI, P.O. Box 374, Hudson, Ohio 44236.

ALAN AUDIO OF INDIANA

ADVENT, AOS/BRAUN, AVID, CITATION, CROWN, FULTON, GALE, LINN-SONDEK, NAKAMICHI, OHM, ORTOFON, REVOX, SHURE, SME, SUPEX, TANNON/MICRO, YAMAHA, Amplifier & tuner testing; cartridge comparisons; fully instrumented factory authorized service

Alan Audio, 310 S. Washington, Bloomington, Indiana 47401; 812-332-2192

Open Sunday, Closed Saturday.

MIDWESTERNERS - Write for COMPONENT AND RECORDING TAPE DISCOUNT PRICE LIST. AUDIO, Box 477, Notre Dame, Indiana 46556.

INFINITY 2000A's (electrostatics) with stands, exc. cond. \$400 pr. McIntosh MA5100 \$175; SP-10 w/ Shure SME arm, perfect cond., \$200; Harmon Kardon HK-1000, \$180; Soundcraftsmen 20-12 equalizer \$160; Sherwood SEL-300 digital tuner w/cabinet \$300, all exc. cond. J. Moccia, 4705 H.H. Pkwy Riverdale #1C NYC 10471 or call evenings (212) 884-4319.

YOUR ROOM IS THE MISSING LINK

A state of the art system is usually junk in the typical poor listening environment, and therefore a rip-off. Our acoustical consulting division will have a calibrated "reverberation curve vs. frequency" measurement performed in your room, and our engineering dept.'s plan of correction, loudspeaker placement, and room equalization, all at no cost with your purchase or upgrade. Music & Sound Ltd., 11 1/2 Old York Rd., Willow Grove, Pa. 19090. (215) 659-9251.

CONSIDER YOUR SOURCE FOR SOUND

I. Credentials

College instructors in audio /acoustics, Inventors/graduate electrical engineers, Recording & disc mastering engineers; Members: United Inventors & Engineers Acoustical Society of America
Institute of Electronic Engineers

II. Facilities

Anechoic Chamber: .9a working floor
\$50,000 research laboratory
Factory authorized "A" warranty stations
Loudspeaker Reconciling Lab

III. Our Distinguished Suppliers

Audio Research, Sequerra, Satin/Denon/F-R, Transcriptors, F.M.I./R.T.R., Linn Sondek, Nakamichi, Dayton Wright, Dahlquist, Crown, Infinity, I.M.F., London Decca, Quad, Rogers, Spendor, Stax, B&O, Grace, Supex, Micro Acoustics, Custom Rabco, Braun, Revox A-700, Ortofon, Damped S.M.E., Scully, Mark Levinson, Koss-ELS, Yamaha.

+

1000's of PROFESSIONAL products (see Tuned Rock P.A. ad).

Music & Sound Ltd., 11 1/2 Old York Rd., Willow Grove, Pa. 19090. (215) 659-9251.

Whom Would You Trust?

THOUSANDS OF LIKE NEW LP's and prerecorded tapes. Catalogue \$1.50. House of Records, Hillburn, New York 10931.

AUDIO RESEARCH, AUDIOINICS, BANG & OLUFSEN, BOZAK, CROWN, OBX, KLIPSCH, KMAL, LINN SONDEK, NAKAMICHI, PHASE LINEAR, RADFORD, REVOX, SEQUERRA, STAX, TANDBERG, BEYER, SENNHEISER, and other fine instruments for the reproduction of music. Send for list of used equipment **AUDIO SYSTEMS AND DESIGN**, 5421 South 84th St., Lincoln, Nebraska 68516 (402) 489-9888... and 4408 Capital Ave., Omaha, Nebraska 68131. (402) 556-7559.

CONN. AND WESTERN MASS—FRED LOCKE STEREO offers Accuphase, Epicure, Crown, Quatre, Audio Research, Phase Linear, SAE, Citation, Mark Levinson, Soundcraftsman, ESS (including bi-amped Towers), Magneplanar, Thorens, Technics, SME, Ortofon, Supex, Fidelity Research, Revox, Tandberg, Teac, Transcriptors, DBX, Beyer, Stax, AKG, Nakamichi, Sequerra, Burwen, Hartley woofers, and others Avon 203-678-1797; East Hartford 203-528-9479; New Haven 203-787-0183; Waterbury 203-757-9296; Fairfield 203-366-5246; Springfield, Mass. 413-782-7111.

FOR SALE

CANADIANS: Best Hi-Fi discounts on over 96 leading Hi-Fi brands. Many exclusive factory closeout and special deals. Quotations via return mail. Nationwide mailorder service. FREE catalogs jam pack with bargains in: Hi-Fi equipment, tape and recording accessories, calculators, telephones and accessories, kits, parts, etc. Hundreds of factory and government surplus specials too! American inquiries welcome. Rush free catalog request to: ETCO, Dept. AUA, Box 741, Montreal H3C 2V2.

COMPONENTS FOR THE CONNOISSEUR

LOUDSPEAKERS: Audio Research T-3A, 1B, Braun LV 1020, Dahlquist DQ10, Dayton-Wright XG-8 MK11B, ESS, Fulton J Modular System, Hartley Concert Master, Hegeman 1A, & 2, Magneplanar MG2167-F, RTR 280 DR, ESR 6, 15. **COMPONENTS:** Audio Research, BGW, Burwen, Connoisseur, Dayton-Wright, Hercul, Linn-Sondek, M&K super woofers and crossovers for T-3ATM, 1B, etc., Mark Levinson Products, Ortofon, Panasonic SP 10, Quad, Quintessence, Radford, SAE, Shure, SME, Supex, Thorens Transcriptor and SEQUERRA. Brochures available.

PAUL HEATH AUDIO
354 STATE STREET
ROCHESTER, N.Y. 14608
(716) 232-2828

HONG KONG, TAIWAN, JAPAN, Asia Directory. World products information. Mail-orders, bulk-orders. Listings. Directory and Information \$1.00 today. World Trade Inquiries. Box 6224, Spokane, Wash. 99207.

HIGH PERFORMANCE HIGH FIDELITY WITHOUT THE "HYPE". Suffolk Audio takes a rational, no nonsense viewpoint on high performance audio equipment. Our advice and opinions are based in objective fact, not mythology and folklore. All equipment is pre-tested for maximum performance. Our distinguished suppliers include: Allison Acoustics, Bowers and Wilkins, Quad, Linn Sondek, Decca, Mark Levinson, Revox (incl. A-700 series), KMAL, Ortofon, BGW Systems, Radford, Beyer, Connoisseur, and much, much more. Call or write for information.

SUFFOLK AUDIO, INC.
1105 Mass. Avenue
Cambridge, Mass. 02138
Ph. (617) 868-1080.

PROTECT YOUR LP's. Poly sleeves for jackets 8c round bottom inner sleeves 6c Poly lined paper sleeves 15c White jackets 35c Postage \$1.25. House of Records, Hillburn, New York 10931.

NEW YORKERS—WE ARE COMMITTED!

Consult with us about your audio needs. We have what you want, we offer FULL service.

IMF, BGW, SAE, OHM, INFINITY, KLIPSCH, ORTOFON, THORENS, SME, LEVINSON JC-1, STAX, AOS-BRAUN, TECHNICS, PIONEER, KENWOOD, CROWN, MARANTZ, TANNON, KEF, IAS, DBX, REVOX and Many Others.

INNOVATIVE AUDIO
129 DeGraw Street
Brooklyn, NY 11231
(212) 596-0888
Call For Appointment

THE JANIS WOOFER IS ABSOLUTELY FLAT TO 30 Hz.!

The specifications can only hint at the effortless, ultra-clear and detailed bass reproduction to the limits of hearing. Typical response 30 - 100 Hz. + 1/2dB, distortion about 1% max. About 60 W is enough to drive this speaker. Elegant in size (22"x22"x18" high) and appearance. Full details: Janis Audio Associates, Inc., Box 88 Throgs Neck Station, New York, N.Y. 10465.

CROWN IC-150 preamp with case, \$215. Kenwood 6005 tuner, \$150. Kenwood 6060A labscope, \$115. Call (518) 561-2555.

CUSTOM BUILT SPEAKER SYSTEMS, enclosures, kits, foam grills, crossovers. Raw speakers. Low prices, high quality. CSS, 8460 Marsh, Algonac, Mich. 48001.

FOR SALE: RCA RT-16, 6 deck multitrack cartridge tape playback unit. New condition, still in factory carton. Originally \$2500; will sell for \$1000. Contact Chief Engineer, WCUZ Radio, #1 McKay Tower, Grand Rapids, Michigan 49502. (616) 451-2551.

FOR SALE

STEREO NEEDLES AND CARTRIDGES—ADC, B&O, GRADO EMPIRE, MICRO-ACOUSTIC, PICKERING, ORTOFON, SHURE, STANTON, SUPEX, SONY, PANASONIC, RCA, BSR, and others. Write for FREE CATALOG. NEEDLE IN A HAYSTACK, INC., P.O. Box 17436, Washington, D.C. 20041.

NOW IN PRODUCTION: World's heaviest 12" woofer, 17Hz resonance. Over 200 watts RMS. Sand cast frame, \$59.00 delivered U.S.A. Rockwell Systems, Inc., 100 Liberty St., Rockwell, N.C. 28138. NOW THE BIG MIO-RANGE: 3" dome, 3" voice coil, 96 watts RMS sine wave power at 1000Hz. Over 120 degrees dispersion 500 to 5000 Hz. Weight 12 1/2 pounds. \$99.50 postpaid USA.

AR-3A - like new, walnut stands plus glass tops. \$250. (804) 282-5918.

WESTCHESTER HEADQUARTERS for the great sounds in the world. Quad, Cambridge, Dahlquist, Bose ESS, Braun, SAE, EPI, Crown, Phase Linear, Tandberg, Thorens, Yamaha, Nakamichi, Technic, BGW, Qual, Revox, Leak, B&O, OBX, Burwen, We stock Ampzilla. The listening Room, Inc. 590 Central Ave. Scarsdale, N.Y. 10583 (914) 472-4558.

IMF MONITOR Mk III's, perfect condition. (814) 238-5016; evenings call (814) 238-7883

OHM F SPEAKERS, purchased new in April but never placed in use. Still in boxes. Perfect condition. \$695. (301) 681-7462.

TASCAM MODEL 10, 12 in. 4 out, Quad pan, mic and line transformers, plywood case - \$2500.00. Contact Phil Hartshorn, P.O. Box 1118, Trenton, New Jersey 08625. (609) 259-3093.

TWO CERWIN-VEGA 432R highlevel studio monitors 300 rms - 130 dB out; 2 JBL LE-85, 2 LX-5, 2 HL-91. Equipment in excellent condition. Best offer. Serious inquiries only. J. Plagman, 63-61 99 St., Rego Park, N.Y. 11374. (212) 275-2530 evenings.

AUDIO'S HI-FI HANDBOOK

Complete reference guide to over 1,000 components, including prices and specs. All arranged in tabular form for easy comparison. Plus over 30 outstanding articles on audio topics, trends and advances. State-of-the-art reading for audiophiles. Only a limited quantity available. Over 200 pages. Send \$3.95 (includes shipping and handling) to: Jean Davis, Audio Hi-Fi Handbook, 134 N. 13th St., Phila., Pa. 19107.

MILWAUKEE & WISCONSIN'S only audiophile dealer. Specialists in components by Crown, Dahlquist, Transcriptors, Integral Systems, Epicure, Nakamichi, Bozak, Citation, Ohm, SME, Ampzilla, DBX, Infinity, SAE, RTR, ESS, Revox, Phase Linear and 50 others. Wisconsin's only Audio Research dealer with the entire product line on demonstration. WACK ELECTRONICS INC., 5722 W. North Ave., Milwaukee 53208. 414-442-3441.

—SPEAKER CATALOG—

Up to date. Top quality drivers. Hop-up the speakers you have or build new ones. Transmission-line speaker plans \$5.00—Foam damping material. E&E Audio, 2816 Church Ave., Brooklyn, New York 11226. 212 462-0984

MICRO-ACOUSTICS QDC-1e, new, \$55.00. (919) 383-5729.

SP-10 WITH SME non-detachable, ADC XLM Mk II, \$500; Stax SRX-II, \$185; Quintessence preamp, \$400 - all 5 months old, mint with warranty cards, packing. 413-586-4132.

HI-FI ENTHUSIASTS WANTED!! Earn more than just spare money in your spare time. We need campus representatives to sell name brand stereo components at discount prices in your area. High commission, no investment required. Serious inquiries only, please. Contact: Alan Weisberg, K&L Sound Services Co. 75 N. Beacon St., Watertown, Mass. 02172.

SUPERIOR PRODUCTS AT LOWER PRICES: B&W, Decca, EMT, IMF, Leak, KMAL, Naim, Quad, Linn Sondek, Spendor, Stax, many others. THE SOUND AFFAIR, 364 Mission Court, St. Louis, MO 63130 (314) 863-6037

FOR SALE

CURRENT AND RECOMMENDED:

SDNEX speaker. Originally developed as a mix down monitor, a piezoelectric has been added for dispersion. The result is a very efficient, accurate reproducer with very good power handling. \$185 each.

ORCA/DNAUGHT power amps by Dunlap Clarke. Absolutely stable, superior protection. Despite other claims this is the first solid state amp we have heard which is as good or better than the best tube equipment we have heard. We used to have to specialize depending on what the amplifier was to be used for. This is the amp for super-woofers or any part of a bi or tri amp system, or for PA or band use. Models 500 and 1000, \$800 and \$1200. These amps will also be available under the Sequerra name with different cosmetics.

SUPEX SMM5 moving magnet cartridge. Not the best but exceptionally smooth. Nothing can touch it for \$50.

GRACE 940 oil damped, uni-pivot tone arm. \$149.

FIDELITY RESEARCH cartridge and transformer. The best moving coil yet. Highly regarded even by resident Decca freak. Great depth of image and detail. Also variety of preamps. Cart. \$130, Toroidal transformer \$150.

CAMBRIDGE AUDIO P50 and **P140** integrated amplifiers with toroidal power supply and state of the art preamp. \$350 and \$550. Also **TL 200** transmission line speakers.

DECCA BRUSH. Over a million conductive bristles eliminate need for liquids and reduce static. \$15

OECCA CLEAN-UP. The ultimate dust bug. Same bristles as brush, conductive shaft and ground wire. \$15

also: **GAS Ampzilla**, **Dayton Wright**, **C/M Labs**, **Sony**, **Lux**, **BGW**, **Audionics**, **Lexson**, **Revox**, **Otari**, **Nakamichi**, **Neal**, **FMI**, **Celestion**, **IMF**, **Linn Sondek**, **ERA**, **Micro 700**, **Oval**, **Decca**, **Ortofon**, **Supex**, **Sennheiser**, **Beyer**, **Sequerra**.
Shipped free anywhere in U.S. and Canada.
GREENWOOD SOUND, INC.
P.O. Box 2069
Portland, Ore. 97202
503 235-1776

SOUND ADVICE MAGAZINE — the second issue includes comparative reviews of amplifiers: **Audio Research Dual 76A**; **C/M Labs 912**; **Electro Research Class A**; **Luxman 4000**; **Naim NAP160**; **SAE 2500**; **Stax High Powered FET Class A**; and **Technics SE9600**. Preamps include **Audio Research SP3a-1**; **Crown IC-150**; **Dayton Wright Sps**; **Dynaco PAT-5**; **ESS** preamp; **Harman Kardon Citation 11a**; **Levinson JC-2**; **Luxman C-1000**; **McIntosh C-28**; **Naim NAC12**; **Phase Linear 2000**; **Radford**; **Soundcraftsman 2217**; **Stax FET**; and **Technics SU9600**. Cartridges reviewed: **Audio Technica AT20SLa**; **Decca V Elliptical**; **Empire 4000D/III**; **Shure V15 Type III**; and **Stanton 681EEE**. Some extra goodies: **Keith Monks Tonearm**; **Linn-Sondek turntable**; **IAD Dynamic Range Expander**; **Dayton Wright** and **Levinson Jc-1-AC** moving coil preamps. Much more. Four issues — \$9 (\$11 first class; \$12.50 foreign — sent airmail). **Sound Advice**, 225 Kearny, No. 200M, San Francisco, Calif. 94108.

THE BOTTOM END, as reviewed in the April *Stereophile*. A new compact super bass speaker that retails for around \$200.00. A no-compromise performer with smooth response below 20 Hz. Ideal for use with Magnaplanars. Quads, Oahquist, ESS, or any system deficient in low bass, because of room placement. **BOTTOM ENO CROSSOVERS** permit the use of one woofer, no bi-amping, one amplifier does it all. Model X1 for all Magnaplanars. Model X2 for all others. Literature and information available upon request, dealer inquiries invited. Consumers write for the name of your nearest dealer. **M & K Sound Inc.**, 8719 Wilshire Blvd., Beverly Hills, Calif. 90211.

DON'T PAY THE HIGH MAIL ORDER PRICES

THIEVES WAREHOUSE OF PENSACOLA

3731 NAVY BOULEVARD, PENSACOLA, FLORIDA 32507

MINT SONY PREAMP 2000, \$185; **Sony SQ Decoder SQD2020**, \$135; **Kenwood Audio-Denoiser KF8011**, \$140; **Pioneer SA900** amp, 120 watts rms, \$175. (919) 578-0655, A. Blanchard, P.O. Box 2034, Burlington, N.C. 27215.

SPEAKERS

SAVE 50%. Construct speakers and save money. Send for free catalog and instructions. **Speaker Kit**, Box 12A, Menomonie, WI 54751.

RECORDS

SOUNDTRACKS/OC, JAZZ/PERSONALITY — FREE NEWSLETTER! **RTSA**, 3700 S. Plaza Drive, Bldg F/211, Santa Ana, California 92704.

OLD RADIO LIVES AGAIN! Catalog with big selection available for \$1.00. **R.R. Schurch**, 9370 Urban Dr., La Mesa, Calif. 92041.

SOUNDTRACKS - JAZZ - POP. **Vincent**, Box 5202, Long Island City, N.Y. 11105.

QUADRAPHONIC RECORDS AND TAPES - World's largest selection - all labels, over 1000 titles - at discount prices! For your free illustrated quad catalog, write: **SOUND CONCEPTS**, 2713 West Radan, Dept. C11 Peoria, Illinois 61604.

SOUNDTRACKS — MOVIES, TV, BROADWAY, RELATED, RARE. \$1.00 FOR CATALOG, REFUNDABLE. "MR. SOUNDTRACKS," 59-359 PUPUKEA RD., HALEIWA, HAWAII 96712.

SHOW ALBUMS — Rare. Out of Print LP's. 52 page list 50c **Broadway/Hollywood Recordings** Georgetown, Conn. 06829.

5,000,000 SURPLUS Records, Tapes—100 new LP's major labels \$65.00; 60 8-track prerecorded, all major labels \$90.00; 40 prerecorded cassettes, major labels, new \$50.00; 25 open reel prerecorded, all major labels, new \$49.50. Catalogue available \$1.00 refundable with first order. **Surplus Records & Tapes**, Box 496, Lone Pine, Calif. 93545.

OLD RADIO PROGRAMS at low rates, high quality! Six hour reel: \$6.50 - cassette: \$2.50/hour. Catalog \$1.00. **BRC Quality Dubs**, 17173 Westbrook, Livonia, Michigan 48152.

PERFECTLY CLEAR™ ultra hi-fi record **Burwen Laboratories BL-2**. The East Bay City Jazz Band — Big Bear Stomp, Oriental Strut, Louis-i-an-a Blues My Naughty Sweeties Gives to Me. Dans Le rue d'Antibes, etc. \$10.50 each postpaid \$70.00 postpaid in lots of 10. Send check or money order Massachusetts residents add 3 sales tax Dealers wanted. **Burwen Laboratories Inc.** 209 Middlesex Turnpike, Burlington, Massachusetts 01803 617-273-1488.

SOLD @ AUCTION: COLLECTORS RECORDS, LP's; Jazz, Soundtracks, Personalities, Original Casts, Country/Western, Blues. Indicate which list from: **Ray Macknic**, (or) **Theo's**, P.O. Box 7511, Van Nuys, Calif. 91406

FREE 200-PAGE CATALOG, 1,400 New Stereo Recordings. Renaissance, Baroque, Classical, Romantic, Modern Music. Not sold in stores. Not listed in Schwann's. Highest quality! Budget label prices! Available only by mail. **MUSICAL HERITAGE SOCIETY**, Box 932 AU, New York, N.Y. 10023.

MUSICAL SPEAKERS REPAIRED

ALTEC WARRANTY STATION

Hughes Electronics Service

45 Dunn St., Asheville, N.C. 28806

Selling Entire Collection of Records LP's, 45's on Auction **Basis Sam Blank**, 3545 Woodward Ave., Seaford, NY 11783

COLLECTORS: "MIDWEST GROOVE" newsletter and record exchanger is here. Subscription info send 10c **Hydra Productions**, Box 792, Palatine, Ill. 60067

RECORD COLLECTORS' CONTACT GUIDE. Dealers, magazines, societies, Handbooks and directories listed. \$3.00. **Jackson**, 1506 W. Barker, Peoria, Ill. 61606.

OLDIES — 45 RPM Original hits. Catalog 50c **C&S Record Sales**. Box 197, Wampsville, N.Y. 13163.

WHILE YOU WERE LOOKING for out-of-print records, you should've been looking for us. Discontinued, 216 N. Rose, **Burbank**, California 91505.

FILM-STAGE SOUNDTRACKS. Large free list. **A. Lutsky**, P.O. Box 557342, Miami, Fla. 33155.

CATALOGS. Broadcasts, soundtracks, Personalities of Thirties, Forties. Box 225, New York, N.Y. 10028

TAPE RECORDINGS

RENT Open Reel or Cassette Prerecorded tape. All labels. Catalog \$1.00. **Tape & Time**, P.O. Box 740, Hopkins, Minn. 55343.

EVERYTHING ON OPEN REEL! Prerecorded classical/popular tapes. Latest releases. **Dolby Quad**, 96-page catalogue \$1. **Barclay-Crocker**, Room 857A, 11 Broadway, NYC 10004.

AMBIPHON'S RECORDS AND TAPES — Quad and stereo. Highest quality available anywhere! Send stamped, addressed envelope to: **Ambiphon Records**, Dept. A, P.O. Box 341, Kingsbridge Station, Bronx, New York 10463.

SHORTWAVE

HEAR POLICE FIRE Dispatchers. Catalogs show receivers; exclusive directories of "confidential" channels. Send 10c stamp. **Communications**, Box 56AU, Commack, New York 11725.

RADIO PROGRAMS

1930-1962 RADIO PROGRAMS, Reels, \$1.00 hour! Cassettes, \$1.00 show! **Mammoth catalog** \$1.25. **AM TREA-SURES**, Box 192 AU, Babylon, New York 11702.

RENT RADIO SHOWS - Make your own copies or just listen. Great way to build your collection reasonably. Catalog \$1 refundable. **OTR Rental**, Box 465, Livermore, Ca. 94550

YESTERDAY'S RADIO PROGRAMS ON TAPE. Reels, cassettes - fast reliable service. Catalog \$1.00 refundable with first order. **ADVENTURES**, 1301-A North Park Avenue, Inglewood, California 90302.

RENT OLD RADIO PROGRAMS as low as 50c per reel week.

GOOD OLD RADIO

P.O. Radio

Lone Pine, Calif. 93545

OLD RADIO PROGRAMS ON TAPE. Thousands available. Low prices, finest quality, immediate service. Catalogue 25c. **Nostalgic Radio**, Box 29K, Peoria, Ill. 61601.

RADIO AS IT WAS — Rag time, Honky-Tonk, etc. others. Reel, Cassette, Cartridge, Custom discs. Our package or recorded to your order from our library. Sample cassette and list \$1.25, Refundable. **Nostalgic Enterprises**, P.O. Box 3786, St. Louis, Mo. 63122.

OLD TIME RADIO PROGRAMS on cassette. Catalog \$1.00. **MB/JB Enterprises**, Box 724, Spencer, Iowa 51301.

GOLDEN AGE RADIO - your best source for radio tapes. Box 25215-0, Portland, Oregon 97225.

PLANS & KITS

CONSTRUCT YOUR OWN speaker enclosure. Send \$2.00 for drawing to: **Creightney Sounds**, 140-25 169th Street, Jamaica, N.Y. 11434.

MUSICAL INSTRUMENTS

UP TO 60% DISCOUNT. Name brand instruments. Catalog. **Freeport Music**, 455R Route 110, Melville, N.Y. 11746.

40% DISCOUNTS. Huge Stock of Name Brand Instruments. Free Catalog. **Gracin's** 110 Dept. A, 606 Route 110, Huntington, N.Y. 11746.

WHOLESALE Musical Instruments, accessories. **Allied**, 573, Route 17, Paramus, N.J. 07652.

COMMUNICATIONS

MAKE NEW FRIENDS using your tape recorder. A new experience in Communications. **Tapexchange**, Box 372-A, Murray, Kentucky 42071.

SITUATION WANTED

FORMER OJ would like to return to radio in a similar position or as a Program Director. I have a third class broadcast endorsed license, 2 years college, 2 years experience. Contact: **Ooug Galliher**, 3907 Angol Place, Jacksonville, Florida 32210. (904) 771-7386.

SERVICES

CONSUMERS - We recommend components and systems and make your needs and budget to the best performance available. Satisfaction guaranteed. Send \$3.00 to: FSC 219 E. 17th St. Bloomington, Indiana 47401.

CUSTOM RECORDING SERVICE, Tapes, discs, and cassettes. Stereo and mono. Live and copies. Editing. Masters and pressings. High quality at reasonable rates. Joseph Gliovaneli, Audio-Tech Laboratories, 2819 Newkirk Ave., Brooklyn, N.Y. IN9-7134.

MASS PRODUCTION-CUSTOM REPRODUCTION — 8-Track, cassette & Reel to Reel. We specialize in corporate meetings. Call or write T.S. Recording/o T.C. Shearer, 385 Ocean Blvd., Suite 5C, Long Branch, N.J.07740, (201) 870-2952.

COMPLETE CUSTOM RECORDING SERVICE — Record pressing, cassette duplication — editing — location recording. Omega Audio, 25520 Graham, Detroit, Mich. 48239.

ULTIMATE DUPLICATION (10 up) from your program source to Maxell UD tapes & cassettes at amazingly low prices. DBX, Dolby available. Box 3065, Seattle, Washington 98114.

THE NEW YORK AUDIO SOCIETY INC. is a unique, non-profit, member supported hi-fi club featuring interesting monthly meetings about sound and the latest audio techniques. We invite all N.Y. area audiophiles to attend one of these sessions as our guest. Details about meetings and membership available. Write Box 5889 Grand Central P.D., N.Y.C. 10017. Call 212-722-2781.

STEREO MASTERS, RECORDS AND ALBUMS. Check our prices. Newest type high level cutting equipment featuring: Neumann VMS 70 Computer control lathe, Parametric Equalization, Dolby, DBX, and the new SX74 Cutting System by Neumann. Special package prices on pure vinyl album and single record production. 1000 45 RPM stereo singles \$273.00 including mastering. 100 LP albums \$436.00 including printed jackets. Write or call for brochure. A & R Record Manufacturing Corp., 902 N. Industrial Blvd., Dallas, Texas 75207. (214) 741-2027.

SONGWRITERS

Present your songs to publishers like professionals. By mail or in person, find out the correct way. Also find out where to get the right business contacts. Write for this valuable and informative booklet. Send \$3.00 to:

SUNSOUND

256 S. Robertson, Dept. 1558
Beverly Hills, Ca. 90211

TAPE RECORDER HEADS brought back to spec. Wear removed. Brilliant finish. \$10.00 each. One day service. E. Maher, 5 Evans Place, Orinda, Calif. 94563.

DON'T PAY the high mail order prices. Thieves Warehouse is coming to your area. Franchises available. Thieves Warehouse, P.O. Box 8057, Pensacola, Florida 32505.

IF YOU'RE INTO AUDIO, you'll want to look into StereoOpus. The new quarterly equipment review journal that won't make you read between the lines. \$9.00/year (first class add \$2.00). Foreign \$12.00. P.O. Box 269, Fort Walton Beach, Florida 32548.

HIGH FIDELITY SPEAKERS REPAIRED

AMPRITE SPEAKERS SERVICE

655 Sixth Avenue, New York, N.Y. 10010
212-CH3-4812

NASHVILLE RECORD PRODUCTIONS WILL PRESS HIGH QUALITY PURE VINYL RECORDS FROM YOUR TAPES. SEND FOR SAMPLE RECORD AND PRICE LIST. ALSO FINEST DISC MASTERING. 469 Chestnut St., NASHVILLE TENNESSEE 37210.

COMMUNICATION EQUIPMENT

CB — MARINE — SCANNERS — HAM Buy Below Wholesale. Save up to 50%. Buy Direct From Factory Warehouse. Guaranteed Lowest Prices Anywhere. Catalog \$1.00: WHITLOCK INTERNATIONAL, P.O. Box 131, Wayne, Michigan 48184

AUTO ACCESSORIES

SANDBLASTERS - \$39.50-\$839.50. Free Catalog. Truman, 1330A Market, Youngstown, Ohio 44507.

CORVAIR Parts — 1,000 Different parts. Catalog \$1.00. Clark's Corvair Parts, Shelburne Falls, MA 01370

INSTRUCTION & EDUCATION

DIGITAL ELECTRONICS! Design and understand Digital Circuits. Increase technical competence. Complete and guaranteed course is highly effective. \$10.00. Free literature. DYNASIGN, Box 60AM, Wayland, Mass. 01778.

THINK Metrically with U.S. Metric Conversion Chart, only \$1.95. Keehn, Dept. 126, P.O.B. 261, Elkhart, IN 46514.

IN SEARCH OF Economic Fundamentals? \$10—Correspondence Course. Money back guarantee. Henry George School, 1318A Beacon Street, Brookline, MA. 02146.

PROFESSIONAL HI-FI COURSE—Instructors include Len Feldman, Julian Hirsch, Larry Klein, and Larry Zide. Home study course also available. Send \$1.00 for audio primer and full information or visit HI-FI EXPO, 393 5th Ave., New York City 10016.

BE A SPEED READER! Finish books in one sitting. Immediate results! Send \$4.00 for proven successful instructional manual. Speed Read Foundation, P.O. Box 2735, Toledo, OH 43606.

FREE EDUCATIONAL ELECTRONICS CATALOG. Edukits Workshop, Department 503FK, Hewlett, New York 11557.

FREE LESSON - "Learn Chord Playing." Piano, organ, guitar. Davidsons, 6727SW Metcalf, Shawnee Mission, Kansas.

EQUIPMENT WANTED

CASH FOR Mint Ips & prerecorded reel tapes. Records, Box 323, Hillburn, New York 10931.

SPENDOR BC1, BC11; Rogers BBC Monitor; Gale GS401A. (919) 275-5839. 908A Oillard St., Greensboro, N.C. 27403.

MCINTOSH 275. Call collect (313) 331-0453.

SONY 377 MICROPHONE Clyde G. Hollinger, RD 1, Manheim, Pa. 17545

NEED ACRO 300 Ultra Linear Output transformer new or good condition. Will pay fair price. Maathuis, 510 16th St., Ogden, Utah 84404.

WANTED: WHARFEDALE W60 speaker and base. A.C. Steiner, 211 W. George St., Milford, Pa. 18337.

WE MUST HAVE YOUR USED COMPONENTS

Premium Trade or Cash for:

McIntosh tube (pre) amps & tuners, Marantz tube (pre) amps 7 tuners, Marantz 7(T), 15, 16 (B), Futterman H-3, J.B.L. 400, 500, 600 series electronics, J.B.L. Hartsfield, L-101, Metrogon, Minigon, Music & Sound Ltd., 11 1/2 Old York Rd., Willow Grove, Pa. 19090. (215) 659-9251.

WANTED: HARMAN-KARDON Citation V tube power amp. Please state condition and bottom price. Charles Buland, 130 Johnson Street, Fairmont, Minn. 56031.

CASH PAID for distressed audio/video components or tape. any consumer electronics closeouts for foreign markets. Call 617-643-3111 or send information to Opus One Inc., 7 Medford St., Arlington, Mass. 02174.

MCINTOSH MC-30, C-22. mint only. (919) 383-5729

WANT TO BUY Revox-A77 Deck, used but good condition. Will pay up to \$500. Tom Stone, 130 East 18th Street, Apt. 2-U, New York, N.Y. 10003. (212) 777-2029.

WANTED: Reel to Reel Tape Deck, Cassette tape deck with speakers and headphones by Soundesign. Write: Hubert Woods, 162 Curry Court, Talladega, Al. 35160.

TAPE & TAPE RECORDERS

AURATONE®

5C SUPER-SOUND-CUBE™

RECORDING INDUSTRY'S FAVORITE
MIXDOWN MONITOR SPEAKERS
AT YOUR DEALERS OR FACTORY DIRECT!

\$49.95 PAIR POSTPAID

Satisfaction Guaranteed or Your Money Back!

AURATONE • BOX 580-A3 • DEL MAR • CA 92014
— DEALER INQUIRIES INVITED —

SCOTCH RECORDING TAPE, lowest prices TAPE CENTER Box 43058, Washington, D.C. 20012.

SCOTCH, CAPITOL. Blank cassettes, cartridges, reels. Discount prices. Lawson's, Box 510, Livermore, CA 94550

SCOTCH AND MAXELL TAPE DISCOUNTED. Write and Save. N.A.B. Audio, Box 7, Ottawa, IL 61350

RECORDING TAPE: Custom Loaded, 8 track, reel, cassette. Prices on request. DICK WALEN, 4226 Robert St., Red Wing, Minn. 55066

TDK, BASF, Memorex, Maxell, cassettes, reels, 8-tracks. Lowest Prices. Guaranteed. New. S&S Audio P.O. Box 56039 Harwood Heights, IL 60656

HIGH FIDELITY

DYNAKITS, IAD, lowest prices, Underground HI-FI Sales, 324 Broadwater Road, Arnold, Md. 21012. (301) 647-0919.

NOTICE

NOW AVAILABLE... FAMOUS REFLECTING SYSTEM'S 4 1/2" REPLACEMENT DRIVERS. \$7.98 POSTPAID. BIG QUANTITY DISCOUNTS, FREE SPECIFICATIONS, AURATONE, BOX 580-23, DEL MAR, CALIFORNIA 92014.

BUSINESS OPPORTUNITIES

BUSINESS INVESTIGATOR DISCLOSES jealously guarded mail order trade secrets. Helps beginners make \$600.00 weekly. Giant free report! Futuristics, 1311 Berkshire, Austin, Texas 78723.

\$500/1000 stuffing envelopes. Nothing to buy or sell. Circulars supplied free! Rush stamped addressed envelope to: K. Heinrich, Box 123-SAJ, Hayes Center, NB. 69032.

EARN EXTRA MONEY in your spare time mailing commission circulars. Rush stamped, addressed envelope for details. Treasure, Drawer E-1, Millbrook, AL 36054.

\$100 WEEKLY POSSIBLE — Stuffing, mailing circulars for advertisers. Home - spare time. Information — Send stamped envelope. Opportunities, Box 721 - AQ, Lynbrook, N.Y. 11563.

DO SIMPLE ADDRESSING — Mailing. Keep \$8.00 profit. Receive \$12.95 orders. Details — Rush stamped envelope. Distributors, Box 9 — AO, East Rockaway, N.Y. 11518

EARN \$100.00 NIGHTLY PLAYING RECORDS. DISCOTHEQUES ARE IN. COMPLETE DETAILS, DDS, DONS, PHOTOS, DESCRIPTIONS, ETC. SEND \$5.00 TO "DYNAMIC UNO," P.O. Box 8116, CORPUS CHRISTI, TEXAS 78412.

DIRECTED TO YOU, Mr. Moneyed Audio Activist. Individualist. Self-Confident, with a haunting desire to get into the speaker game with an edible "MUSHROOM" - here is your chance, flood-tide. Acquire an enclosure UNIQUELY DIFFERENT in two crucial points, and patented. At your leisure come up to my studio and listen to my ACOUSTIC TONE EQUALIZING MUSIC SYSTEM. In a class with the best of the brood. Nothing beats a trial but a failure - to act - even on a hunch. Call for appointment: MERCKO - 212-WY 2-1674

PHOTOGRAPHY

'75 CATALOG, listing 10,000 super slides plus 5 sample slides. \$1.00. Oolan's Colorslides, Box 1193, Studio City, Calif. 91604, Dept. AM.

"Marantz is just about the only component manufacturer around that's devoted to system interfacing."

In August, 1974, sound engineers and audiophiles were invited to examine and discuss the new Marantz professional component line featuring the 3800 Preamp, the 510M Power Amp and the 150 Tuner. The following comments were taken from that taped discussion.



The 3800 Preamp

"When you build a phono preamp, you never know what you're going to plug it into. But the Marantz 3800 can interface with the outside world. Whatever amplifier you hang on it won't affect the operation of the preamp one iota. The 3800 will drive any amp on the market — even the super amps."

"Let's say you use three Sony reel-to-reels with the nearest competitive preamp. You'd wipe out the bottom end. Not with the 3800. It'll actually drive a load as low as 1000 ohms at a reasonable level and maintain full frequency response."

"Until now you had to shell out over \$1000 to accomplish that with a preamp. This unit goes for what... \$599.95?"

"Then there's the fact that the 3800 is virtually the quietest preamp going. Not only in specifications, but in perceived noise. Eight-tenths of a microvolt specified."

"Another thing about systems planning — the 3800 has variable frequency turnover tone controls. Designed to complement both speakers and listeners. What that'll let you do is bring up a string bass and leave the viola alone."

"Or if you use the mic feature, like in a live recording, and you're playing your string guitar and you want that nice ring you hear in recordings. You just put the tone controls in the four kiloHertz position and run the treble control up and you've got it."



"It's just one of the most versatile preamps in the world. Not only does it include a full-process Dolby®* Noise Reduction System, but also the tone controls can be used for tape equalizing."

"Maybe you want to listen to something else while you're making tape copies. You just let one tape recorder talk to the other — one recorder is playing back and one is recording. And you can use the Dolby in that loop. Then you keep yourself entertained by listening to a regular FM or AM station at the same time. And the same preamp is available without Dolby for \$100 less. That's the Marantz 3600."



The 510M Power Amp.

"This is a locomotive when it comes to power. Delivers 256 watts minimum continuous power per channel at 8 ohms with no more than 0.1% total

harmonic distortion and a power band of 20 Hz to 20 kHz."

"The whole package is smaller. Heat dissipation is one reason why. That's where this baby really moves ahead... Marantz has implemented a new method of heat dissipation. It's based on turbulent air flow."

"They call it a staggered finger heat dissipator. It was originally developed for the computer industry where they really have heat problems. What it does is break up the air flow. It's aero-dynamically designed to eliminate stratification and create vortices."

"Efficiency can be up dramatically compared to a convection system. And you do it all in a smaller, lighter package."

"There's one competitive unit that weighs over 140 pounds. The 510M weighs 43."

"It's got gain controls — two of them. Meter range switches with the advantage of not being part of the limiting circuit. And peak/overload indicators that are really sensitive to the fluctuations of line voltage."



The 150 Tuner

"Biggest advantage to the Marantz 150 tuner is the ease of tuning. You can go 60 to 80 kHz of detuning with little change in distortion or separation characteristics. Tuning's less critical because good performance is obtained over a wider segment of the pass band."

"The Model 150, in stereo, performs for almost all conditions with FM distortion under 0.2%. In mono it's around 0.1%. And this is right down to test equipment residuals. You'd have to spend a lot of money for a tuner to match that."

"The 150's 18-pole linear phase I.F. filters give you this excellent performance and long-term stability of alignment. It'll be right-on five years from now without alignment."

"I'd go so far as to say it exceeds the performance of the original Marantz 10B and the 10B was the ultimate tuner in my estimation."

"Gives performance so high in quality that if there's a problem with the signal you tend to question the source, not the tuner."

"Phase lock loop. Of course. Even with multipath and antenna problems shown on the oscilloscope, it sounds cleaner than virtually any tuner around."

"All this is accomplished through the use of the linear phase I.F. filter system — a system composed of three filter blocks of four poles and one block of six poles. Eighteen poles in all."

"Of course, we can't forget the five gang front end with dual gate MOSFET RF amplifier and mixer. Gives the best image and spurious rejection I know of, combined with the best available sensitivity."

The Marantz 3800 Preamp, 510M Power Amp and 150 Tuner are just part of the exciting new Marantz component line. There are ten Marantz components in all, starting as low as \$199.95. Each of them reflects the kind of technical expertise and engineering excellence that has made Marantz the choice of professionals world-wide. Stop by your local dealer and see the exciting Marantz line. Or send for a free catalog.

Marantz. Ask an expert.

marantz®
We sound better.



*Dolby System under license from Dolby Laboratories, Inc. © 1975 Marantz Co., Inc., a subsidiary of Superscope, Inc., 8150 Vineland Ave., Sun Valley, CA 91352. In Europe: Superscope Europe, S.A., Brussels, Belgium. In Canada: Superscope Canada, Ltd., Ontario. In the Far East: Marantz Far East, Tokyo, Japan. Prices and models subject to change without notice. Consult the Yellow Pages for your nearest Marantz dealer.

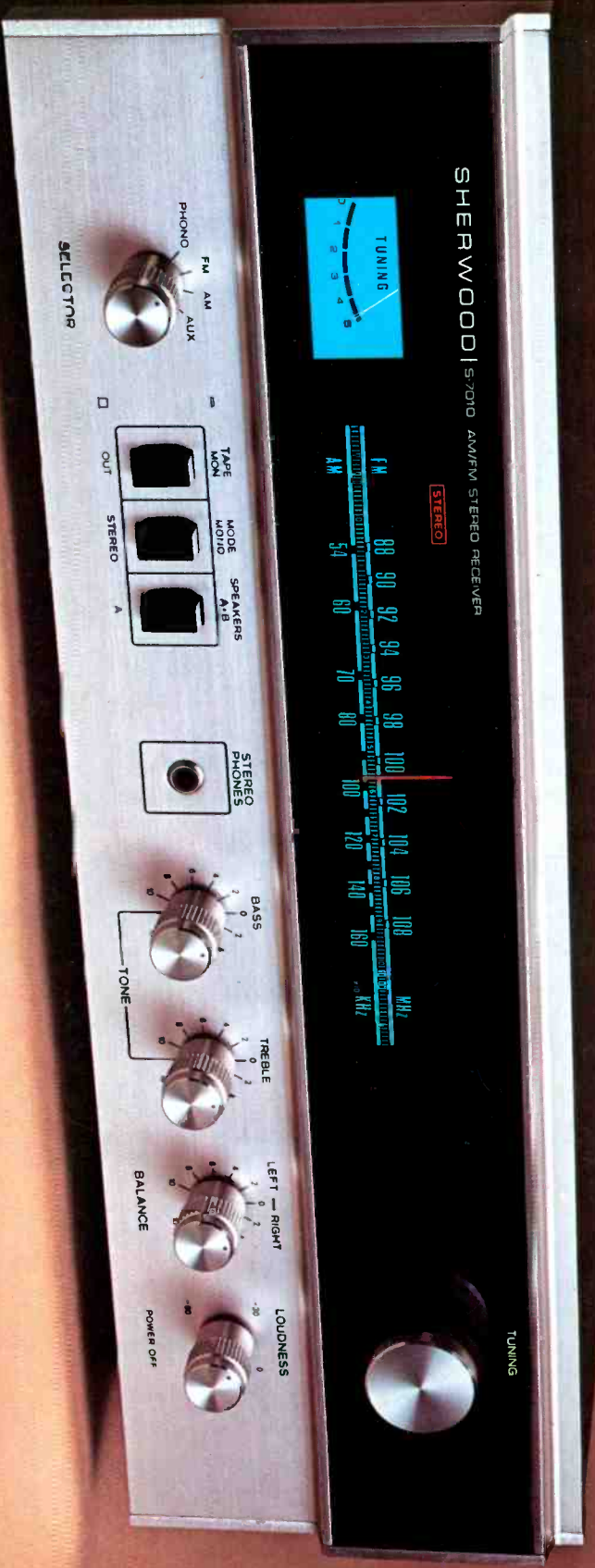

Extravagant praise for a budget receiver.

A recent Hirsch-Houck appraisal of Sherwood's Model S7010 stereo receiver (*Stereo Review*, September '75):

"It would be an understatement to say we were impressed with the Sherwood S7010... It is a thoroughly competent little receiver that gratifyingly sells for a fraction of the price of many of the stereo receivers we have seen in recent months.

"Very little has been sacrificed in performance to achieve the unit's low price. In the important areas of effective sensitivity, noise and distortion (to say nothing of uniform channel separation across the audio

frequency range), the (S-7010's tuner) ranks with some of the most highly regarded tuners and receivers. "... a lot of receiver for the money. It sounds good, looks good, feels good, and the price is right."

For a complete, unedited copy of this review, send us a self-addressed envelope.

For a complete, unedited sample of the unit that prompted these words of praise, visit any Sherwood dealer.

MINIMUM RMS POWER OUTPUT:
10 WATTS PER CHANNEL [@ 8
OHMS, 40-20,000 Hz.; MAXIMUM
TOTAL HARMONIC DISTORTION,
NO MORE THAN 0.9%]

Provision for two sets of speakers.
The latest integrated circuitry.
2.6 μ V FM Sensitivity.
Solid-State Ceramic FM IF Filters.
Complete with case*

Sherwood Electronic Laboratories
4300 North California Avenue
Chicago, Illinois 60618



SHERWOOD
The word is getting around.

*The cabinet shown is constructed of plywood with a simulated woodgrain vinyl cover.
Check No. 45 on Reader Service Card