

AUDIO ENGINEERING

OCTOBER
1951
35c

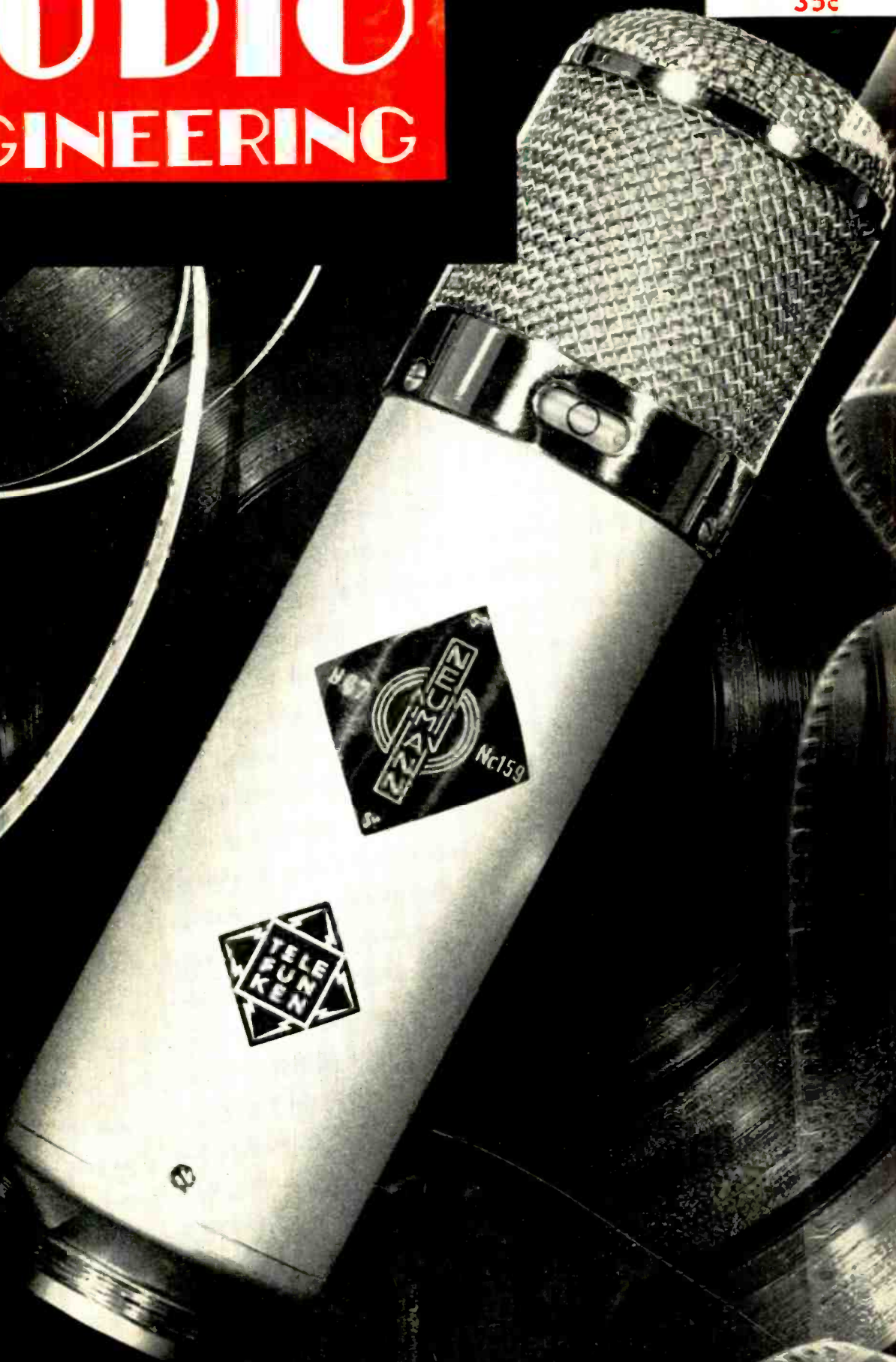

Published by RADIO MAGAZINES, INC.

www.americanradiohistory.com

Here's the
RECORD-MAKING COMBINATION



that brings fine music to millions

audiotape^{*}
 for the
 original sound

audiodiscs[®]
 for the
 master recording



Today's trend to high fidelity phonograph reproduction demands higher quality than ever before—in both the original sound recordings and the masters from which pressings are made. And the country's leading manufacturers of fine phonograph records have found that Audiotape and Audiodiscs are the ideal combination for meeting these exacting requirements.

Master Audiodiscs—the choice of record-makers for more than a decade—are now used for the *vast majority* of all phonograph records produced in this country. That's because their outstanding performance is a matter of record—known throughout the industry for consistent uniform quality, freedom from humidity effects, and exceptionally low surface noise at all diameters.

Although magnetic recording is relatively new in the record-making field, Audiotape is already widely used for recording the original sound. Here, too, its preference is the result of proved performance. For professional recordists know that they can always depend on Audiotape for the finest in magnetic recording—with unequalled uniformity and minimum distortion at maximum output.

... and you get the same unsurpassed performance when you use Audiotape and Audiodiscs in your recording work

There's nothing special about the Audio products used by the phonograph record industry. Except for size, Master Audiodiscs are exactly the same as the Red Label Audiodiscs used anywhere else—with the same superior lacquer, applied by the same precision coating process and meeting the same exacting standards of flawless perfection. And the Audiotape used in record making is *identical* to that which is available for general use by all sound recordists.

If it's *quality* you want, Audiodiscs and Audiotape speak for themselves. Remember, too, that Audiotape, in both 1250 and 2500 foot reels, is guaranteed splice-free!

AUDIO DEVICES, Inc.

444 Madison Avenue, New York 22, N. Y.

Export Dept.: 13 East 40th St., New York 16, N. Y., Cables "ARLAB"

^{*}Trade Mark

audiodiscs ● **audiotape** ● **audiofilm** ● **audiopoints**



All new

RCA Limiting Amplifier BA-6A

For high-fidelity AM and FM speech input systems

FEATURES

- No matched tubes required
- Choice of single or dual time constant
- Greater reliability—push-pull stages
- High gain—Low noise level
- Adjustable T-pad in output
- Standard plug-in mounting—for new handling convenience

SPECIFICATIONS

- Output level at verge of limiting, 30 dbm
- Gain, 54 db
- Noise level—down 83 db at verge of limiting
- Frequency response ± 1 db, 30-15,000 cycles
- Distortion (12 db gain reduction), 1%
- Takes only $8\frac{3}{4}$ inches of rack space. Weighs only 37 pounds.

This represents the ultimate in useful performance...at lower cost

Save yourself hundreds of dollars when you buy your limiting amplifier. Specify a BA-6A. For complete details, call your RCA Broadcast Sales Engineer. Or write Dept. PA-19, RCA Engineering Products, Camden, N. J.



AUDIO BROADCAST EQUIPMENT
RADIO CORPORATION of AMERICA
 ENGINEERING PRODUCTS DEPARTMENT, CAMDEN, N. J.

In Canada: RCA VICTOR Company Limited, Montreal

www.americanradiohistory.com

Wide Range Reproduction For the Home



* Triad Hi-Fidelity Amplifier Kit...

The Triad HF-10 Amplifier, from a circuit designed in cooperation with J. N. A. Hawkins, prominent sound engineer, has been produced especially for those who like to build their own sound reproducing systems. When used with the high quality speakers, tuners, turntables, and pick-ups now available, a system can be built that will meet the requirements of even the most critical music lover. The Triad HF-10 kit supplies the basic engineering and solves the most difficult mechanical layout problems. With 18 db. of feedback, affording a reflected impedance of less than 2 ohms to the 16 ohm speaker tap, within 1 db. linear frequency response from 20 to 20,000 cycles, and with a minimum of distortion over this same range, the HF-10 is worthy of use in the very finest home music installations.

* Features...

- Wide Frequency Response:** Within one db. from 20-20,000 cycles.
- Low Distortion:** Less than 2% from 50-18,000 cycles at full 10 watts output. Less than 1% from 20-20,000 cycles at 5 watts.
- Heavy Speaker Damping:** Reflects less than 2 ohms to speaker from 16 ohm tap.
- Equalization:** Continuously variable to +12 db. or -30 db. at 50 or 8000 cycles.
- High Gain:** 74 db. from crystal microphone or radio receiver; 96 db. (equalized for magnetic pickup) through preamplifier.
- Low Noise:** Hum and other noise 60 db. below maximum output. A-74J equalizing coil has 70 db. shielding.
- Beautiful Appearance:** Gray hammertone chassis with ivory silk-screened lettering, matching gray Triad transformers.

* Prices

- HF-10 Kit**—Includes S-31A, R-14A, A-74J, and C-10X Triad transformers, chassis, prints and assembly instructions. List Price \$43.00
- HF-10A Kit**—Same as above except for substitution of HS-81 output transformer for S-31A. List Price \$63.50

Also available with 500/250/150 ohm secondary output transformers. Write for Catalog TR-51.



2254 Sepulveda Blvd.
Los Angeles 64, Calif.



AUDIO PATENTS

RICHARD H. DORF*

DIRECT-COUPLED AMPLIFIERS are more or less passé these days in audio work, probably largely because they were so difficult to adjust and keep in adjustment, what with the complex power-supply bleeder systems commonly used and the high B-voltage necessary. There is still, however, a distinct need for d.c. amplifiers in many instrumentation applications and some audio men are still enamoured (and justly so) with the bass response they make possible.

One way to avoid the complicated bleeder is to supply B-plus to each stage, in the usual R-C-amplifier manner, through a load resistor and ground the cathode, but place a battery between the plate of one stage and the grid of the next to cancel the positive voltage transfer. This requires a number of batteries or independent voltage sources and is too cumbersome. Raymond A. Minzer of Watertown, Mass., has come up with a system which uses this basic philosophy but uses only one, or at the most, two power supplies for the entire amplifier. His simple

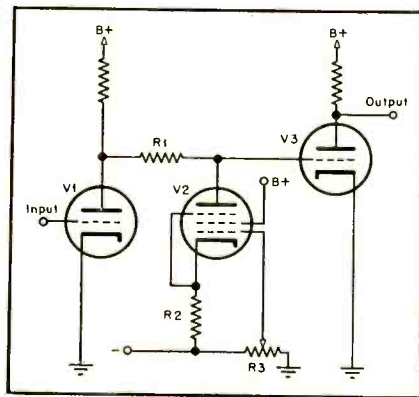

Fig. 1.

circuit, the subject of Patent No. 2,554,469, is diagrammed in Fig. 1.

V_1 , the first amplifier stage, is conventional, using any convenient bias method (not shown) and having a plate-load resistor connected to B-plus. V_2 , the second stage, is also conventional. R_1 is placed in series between the two stages.

V_2 is a pentode, called the "d.c. level changer." Its cathode is connected to a source of negative power, which may either be separate from the main B-supply or may be obtained by a standard bleeder system. Current in V_2 passes from the negative supply through the tube, R_1 , the load resistor of V_1 , and back to ground through the B-plus supply. In passing through R_1 , which may have a high value, it creates a d.c. voltage drop which makes the grid end of R_1 negative with respect to the plate

end. The value of R_1 and the positive grid bias for V_2 (adjusted with R_2) are made large enough so that the net potential at the plate of V_2 —and therefore the grid of V_3 —is actually somewhat negative with respect to ground, thus giving V_3 the correct operating bias.

All this, however, does not cause any appreciable audio voltage loss, for the combination of R_1 - V_2 does not act as an audio voltage divider. The reason is that V_2 , being a pentode with constant screen and control-grid potentials, is essentially a constant-current device. The audio-voltage variations at its plate do not produce appreciable variations of current. Thus the current through R_1 remains unvaried and there is no a.f. voltage drop across it. Both because R_1 may have a rather high value and because the plate resistance of a pentode is high, the arrangement does not appreciably shunt V_1 to reduce its gain. The result is direct coupling with all its advantage, with, at the same time, conventional operation of the amplifier stages.

As many stages as necessary can be handled in exactly this same way, a level-changer tube being inserted between each pair, all operated from the same negative supply. In operation, the only adjustment is setting R_2 for the correct bias on V_2 . A triode may also be used for V_2 , with a value for R_2 of 0.5 to 1.0 meg. With the pentode, R_2 is present to introduce some degeneration to make the circuit more stable; the high value used with a triode, normally a constant-voltage source, makes it the equivalent of the constant-current pentode.

Calibrating Sound-Level Meters

Building and using sound-level meters is among the more frustrating aspects of the

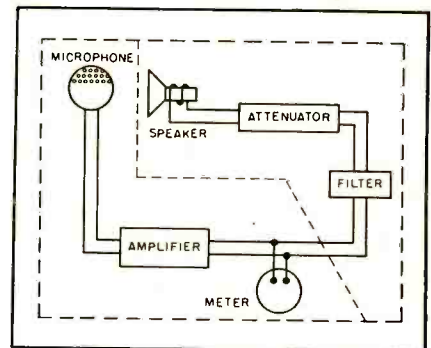

Fig. 2.

audio art, largely because calibration of the instrument as a whole is so difficult. Microphones (especially the crystals ordinarily used) and amplifiers vary in sensitivity and gain with weather and age, and unfortu-

[Continued on page 4]

* Audio Consultant, 255 West 84th St., New York 24, N. Y.

AUDIO ENGINEERING

Successor to **RADIO**

Established 1917



C. G. McProud, Editor

Ladd Haystead, Publisher

Harrie K. Richardson, Associate Editor

Luci Turner, Production Manager

S. L. Cahn, Advertising Director

Lucile Carty, Circulation Manager

H. N. Reizes, Advertising Manager

Editorial Advisory Board

Howard A. Chinn

John D. Colvin

C. J. LeBel

J. P. Maxfield

George M. Nixon

Representatives

H. Thorpe Covington, Special Representative
677 N. Michigan Ave., Chicago 11, Ill.

Sanford R. Cowan, Mid-West Sales
67 W. 44th St., New York 18, N. Y.

James C. Galloway, Pacific Coast Sales
816 W. 5th St., Los Angeles 17, Calif.

Technical Book & Magazine Co.
297 Swanston St., Melbourne, C. I.
Victoria, Australia

CONTENTS OCTOBER, 1951 Vol. 35, No. 10

Audio Patents— <i>Richard H. Dorf</i>	2
Letters	6
Editor's Report	8
Equivalent Circuits to Simplify Feedback Design— <i>Richard S. Burwen</i>	11
Expressions for the Reduction of Distortion and Output Impedance in Terms of db of Feedback— <i>William J. Kessler and Sydney E. Smith</i>	13
Square Wave Testing Simplified— <i>Harold E. Bryan</i>	14
More About Mismatching— <i>Robert M. Mitchell</i>	16
Audio—Big Business	17
The Ciné Cruiser	18
Simple Attenuator Calculations— <i>Jack D. Gallagher</i>	20
Technique of Record Processing— <i>Lewis S. Goodfriend</i>	21

AUDIO engineering society SECTION

The Measurement of Audio Volume—Part 2— <i>H. A. Chinn</i>	24
Record Revue— <i>Edward Tatnall Canby</i>	28
New Products	38
Audio in England— <i>H. A. Hartley</i>	40
Employment Register	52
New Literature	53
Industry People	55
Advertising Index	56

COVER

The Telefunken Type U47 condenser microphone, although introduced in this country only recently, is receiving marked acceptance among major recording studios and broadcast stations. This interesting study was photographed at Reeves Sound Studios, New York.

RADIO MAGAZINES, INC., 342 MADISON AVE., NEW YORK 17, N. Y.

AUDIO ENGINEERING (title registered U. S. Pat. Off.) is published monthly at 10 McGovern Ave., Lancaster, Pa., by Radio Magazines, Inc., D. S. Potts, President; Henry A. Schober, Secretary-Treasurer. Executive and Editorial Offices: 342 Madison Avenue, New York 17, N. Y. Subscription rates—United States, U. S. Possessions and Canada, \$3.00 for 1 year, \$5.00 for 2 years; elsewhere \$4.00 per year. Single copies 35c. Printed in U. S. A. All rights reserved. Entire contents copyright 1951 by Radio Magazines, Inc. Entered as Second Class Matter February 9, 1950 at the Post Office, Lancaster, Pa. under the Act of March 3, 1879.

AUDIO ENGINEERING • OCTOBER, 1951

REK-O-KUT Specialists in Sound Equipment for Broadcasting and Public Use! The World's Finest!

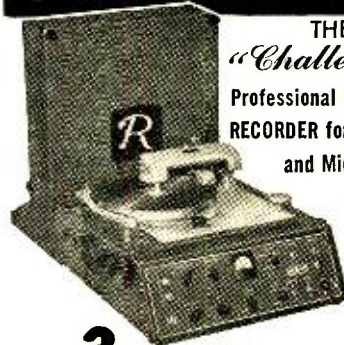

THE "Challenger"
Professional 13 1/4 DISC RECORDER for Standard and Micro-Groove Recording

3 INSTRUMENTS IN ONE

1. A Professional Recorder
2. A High-Fidelity Phonograph
3. A High-Fidelity P.A. System

The Challenger, America's finest 13 1/4 Disc Recorder, is built to meet the respective needs of the professional recordist, musician, educator and recording enthusiast who wants to make permanent, professional recordings. Embodies the most advanced design, engineering and production techniques in the disc recording industry. The Challenger's many exclusive operating features simplify and improve the art of disc recording. NOTE: Tape recording enthusiasts need the "Challenger" to re-record their finished tape after it has been edited... input jack available, no special attachments required.

RECORDS disc from 6" to 13 1/4" masters.
PLAYS back disc from 6" to 16" transcriptions, standard or micro-groove.
With heavy duty synchronous motor..... **\$439.95**

★ ★ ★ ★ ★ ★



CONTINUOUSLY VARIABLE-SPEED TURNTABLE OF BROADCAST QUALITY

Plays at ANY speed from 25 to 100 R.P.M. ... without distortion. Ideal for record collectors, musicians, singers, disc jockeys, music schools, dance studios, general schools, broadcast studios, etc., wherever controlling pitch and tempo is required.

Model CVS-12, (illustrated) chassis, motor and turntable, assembly..... **\$84.95 net**

Model CVS-12P, mounted in portable case with 16" dual stylus pick-up..... **\$124.95 net**

★ ★ ★ ★ ★ ★



MODEL LP-743 3-SPEED 12 INCH TRANSCRIPTION TURNTABLE

Recommended by leading sound critics. Induction type motor, designed for smooth, quiet, vibration-free operation. Instantaneous speed changes—78, 45 and 33 1/3—without stopping turntable or removing disc.

\$54.95 net.

See...hear...compare REK-O-KUT products at leading music stores, audio-visual dealers and radio parts jobbers... or write for literature.

REK-O-KUT CO.

38-01 Queens Boulevard
Long Island City 1, N. Y.

* MAGNECORDER Sound Performance

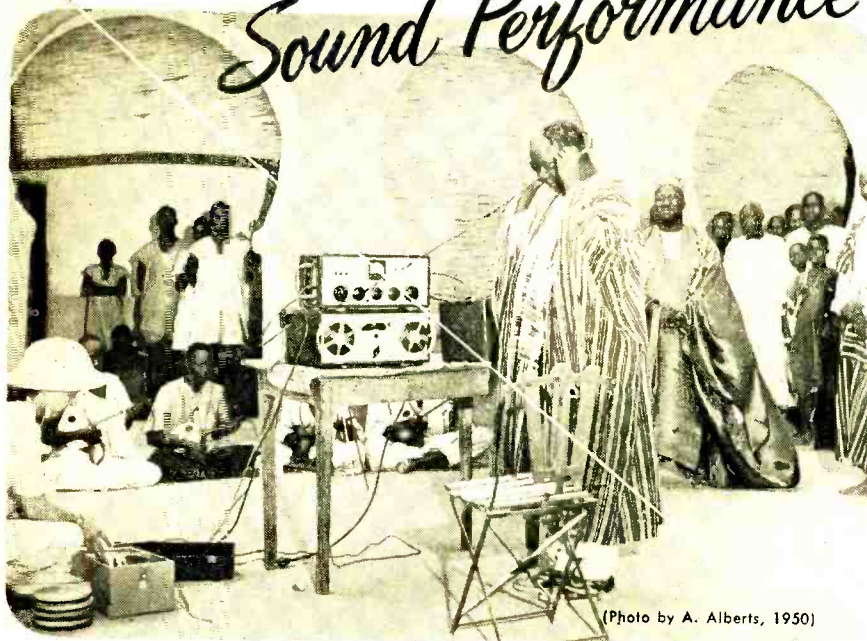

(Photo by A. Alberts, 1950)

.. from "Studio A" .. to TIMBUKTU! *

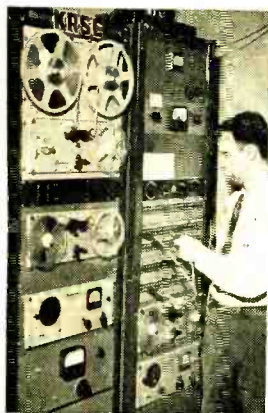

The famed traveler, Art Alberts, recently used Magnecorder Tape Recorders in his search for African tribal music — never before recorded. His Magnecorders underwent 140 degrees temperature, relative humidity ranging from 8 to 99, and 5,000 miles of grueling, jouncing desert and jungle trails. Operating perfectly all the way, Magnecorders brought home faithfully accurate reproductions from the court of the Mossi Emperor, south of Timbuktu.

Whether in Timbuktu or in Studio A at KRSC, Seattle, Wash., Magnecorders handle delayed programs and "on location" recordings with constant dependability. Easy portability, precision and fidelity make Magnecorder the first choice of radio engineers everywhere.

MORE FEATURES

PT7 accommodates 10½" reels and offers 3 heads, positive timing and pushbutton control. PT7 shown in console is available for portable or rack mount.

GREATER FLEXIBILITY

In rack or console, or in its really portable cases, the Magnecorder will suit every purpose. PT6 is available with 3 speeds (3¾", 7½", 15") if preferred.

HIGHER FIDELITY

Lifelike tone quality, low distortion, meet N.A.B. standards — and at a moderate price. PT63 shown in rack mount offers 3 heads to erase, record and play back to monitor from the tape while recording.



WRITE FOR NEW CATALOG
Magnecord, INC

360 North Michigan Avenue
Chicago 1, Illinois, Dept. A-10

Send me latest catalog of Magnecord equipment.

Name.....

Address.....

City..... Zone..... State.....



nately there is almost no reliable way of recalibrating except with a standard sound source in a completely dead room. This is done at the factory but is usually impossible for the user.

Augustus H. Fiske, Jr., assignor of Patent No. 2,558,550 to General Electric, has attacked the field recalibration problem in a neat and simple way, as *Figs. 2 and 3* illustrate. A measure of the sensitivity and gain of an entire system involving amplification is the threshold of oscillation. As *Fig. 2* shows in block manner, an ordinary sound-level meter consists of a microphone, amplifier, and level indicator. When the microphone has a certain sensitivity and the amplifier a certain gain, the meter is calibrated to indicate sound levels in decibels (or phons in elaborate instruments). Mr. Fiske adds a calibration circuit consisting of a dynamic speaker connected through an attenuator and possibly a filter to the amplifier output, in parallel with the meter.

With the microphone and speaker tightly coupled acoustically, the system will begin to oscillate when the combined sensitivity of the microphone and amplifier is at a certain point. If a gain control is provided in the amplifier, and if it is set during each calibration so that the system just begins to oscillate, the total sensitivity of microphone and amplifier to measured sounds will always be the same, assuming (with justice) that the efficiency of the speaker and the loss in the attenuator do not change appreciably. The filter, tuned to a single frequency, may be inserted for greater calibration accuracy.

In use, then, the microphone, amplifier, and meter are initially calibrated at the factory against a standard sound source in the usual way. Then the microphone and speaker are coupled and the attenuator is adjusted so that the system just breaks into oscillation. In the field, the system can be recalibrated whenever the operator wishes, simply by coupling microphone and speaker and adjusting the amplifier's gain control so that oscillation begins. This is a calibration of the whole meter, since any change in microphone sensitivity—or of amplifier gain—will be offset by the adjustment of amplifier gain. The speaker and attenuator can be expected to keep their initial characteristics for a good long time, so remain reliable.

Figure 3 shows how the microphone and

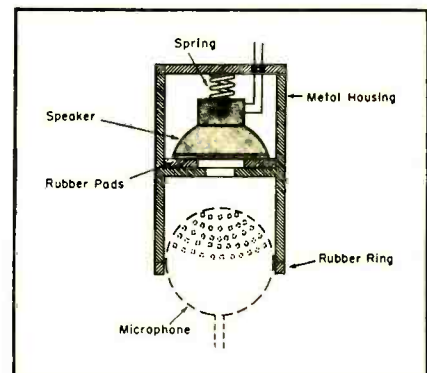

Fig. 3.

speaker can be coupled acoustically for full sound transfer, uniform from one time to the next, and eliminating any effects of surrounding acoustics. A metal housing with a shelf holds the speaker upside down, with the rim of the speaker lying on rubber pads and being held by the spring. The microphone is inserted in the bottom of the

[Continued on page 51]

**Brain power,
experience,
superb facilities**
all in one package at

**GRAY
RESEARCH**

- Television
- Video and display systems
- Audio and communications
- Teleprinter techniques
- Precise electro-mechanisms
- Aeronautic control devices
- Data transmission and recording
- Facsimile

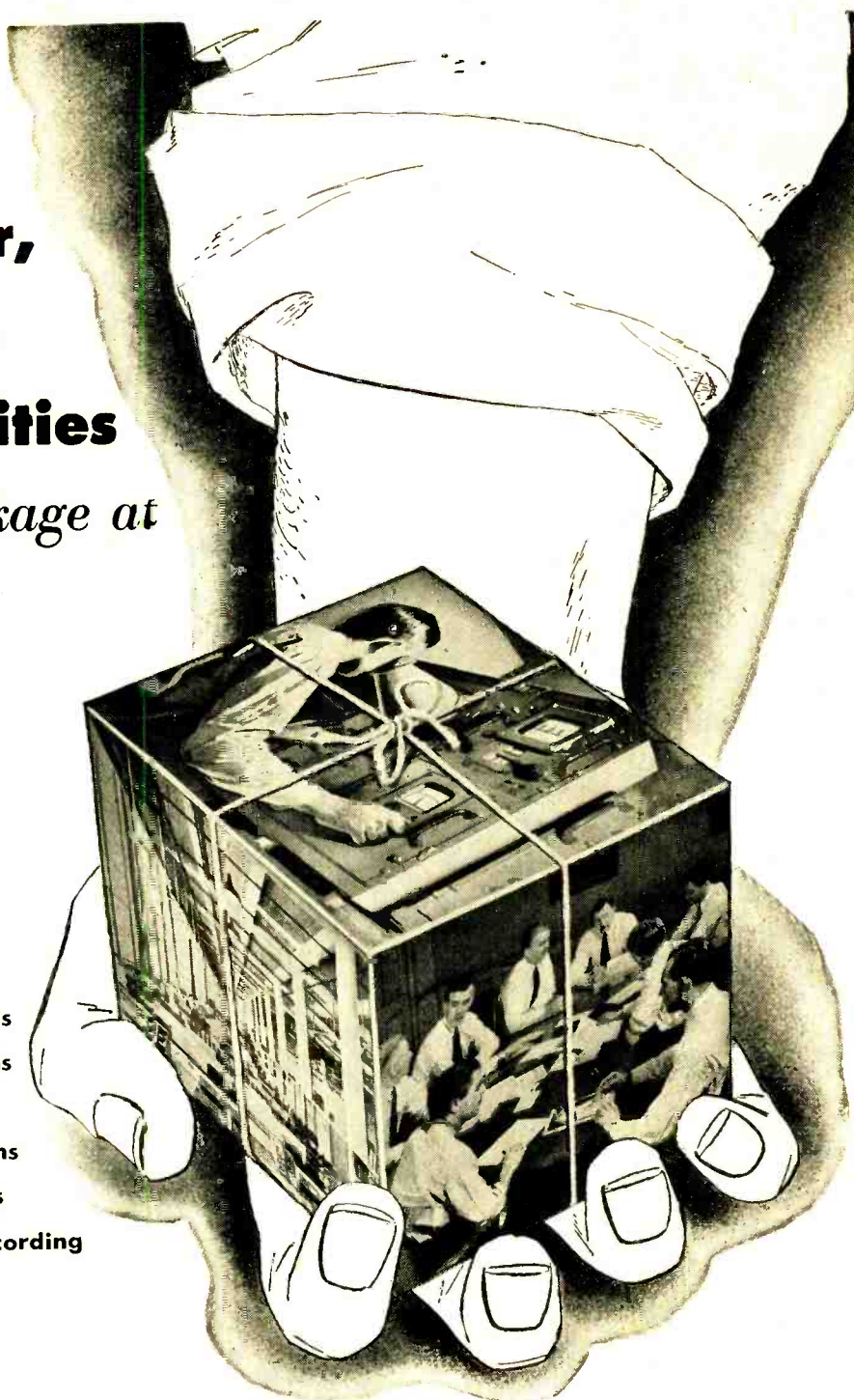

In each of the defense-important fields listed here, the Gray organization has recently solved important problems. These facilities are available to prime contractors and to the military services as our contribution to the national effort in furtherance of communications, engineering or electro-mechanical designing. A booklet telling more of the Gray story will be sent for the asking.

● Please write for Bulletin RA-10 describing the above equipment

GRAY RESEARCH

AND DEVELOPMENT CO., INC., 16 ARBOR ST., HARTFORD 1, CONN.
Division of The GRAY MANUFACTURING COMPANY—
Originators of the Gray Telephone Pay Station and the Gray Audograph



Melvin E. Ottaviano
President



High Fidelity

THE NEW MAGAZINE FOR AUDIO-PHILES*
*People who enjoy fine Audio reproduction

shows latest improvements in the remarkable

F·A·S AUDIO SYSTEM

IT'S HARD TO BELIEVE...NEVERTHELESS, IT'S TRUE!

An amazing improvement in the reproduction of sound ... including full 20-cycle response from a speaker people can't see ... or locate

One expert after another has listened to the FAS Audio System, and summarized its performance as one of the greatest advances since headphones and mechanical phonographs were superseded by loudspeakers and electrical pickups. Since the original Fowler-Allison-Sleeper design was first announced thousands of hi-fi enthusiasts have built FAS systems, using standard parts, readily available. Next, HIGH-FIDELITY will describe important further improvements.

<p>Typical comments (with explanatory notes) from those who heard FAS performance for the first time ...</p>	<p>HI-FI ENTHUSIAST: "The bass doesn't drop out when the volume is turned away down. Now I can enjoy music late at night without waking the baby, or disturbing folks in the next apartment." (You don't have to crank up the volume to hear bass in the FAS system)</p>	<p>AUDIO CONSULTANT: "I'm satisfied that the only speakers in this room are the 12-in. and tweeter types set up in plain view, but it's impossible for them to deliver the quality I am hearing!" (There is more to the FAS than meets the eye)</p>
<p>MUSIC CRITIC: "I can feel the vibration from low organ notes just as I do in the big churches." (That is quite true, down to the 32-ft. pipes) "And I still feel them with the volume just above audibility." (An important feature of FAS performance)</p>	<p>VIOLINIST: "This is the first time I have been able to distinguish reproduction of a violin from a viola." (That realism, plus an amazing presence effect are characteristic of the FAS)</p>	<p>ORCHESTRA CONDUCTOR: "Ordinary radio and phonograph music always tired me very quickly. I have listened to the FAS all evening. There is something decidedly different about it." (You, too, will enjoy that difference)</p>
<p>AUDIO ENGINEER: "You must have a new kind of speaker with flat efficiency down to 20 cycles, or an amplifier with enormous bass boost." (Only standard speakers are used, with no bass boost at any part of the system)</p>	<p>RADIO MANUFACTURER: "This is luxury performance. Few people can afford such installations." (The cost is as pleasingly low as the quality is surprisingly high)</p>	<p>CUSTOM DESIGNER: "I can sell any number of jobs like this. Is it difficult to get the parts?" (They are readily available from your local parts jobber, or by mail)</p>

A complete review of experiments and construction details to enable you to build your own FAS system

Complete data on the construction and installation of the FAS System, including the out-of-sight Air-Coupler, was published in the Summer Issue of HIGH-FIDELITY. (You can still get a copy if you subscribe at once.) The Fall Issue, with a 13-page section on tape, is being mailed now. The Winter Issue, mailed November 15, will show the improved FAS Reflex Air-Coupler. **ORDER NOW!**

A large-size magazine, with over 100 illustrations, handsomely printed on fine paper

High Fidelity

Published by Milton B. Sleeper
 15 Audio Building, Great Barrington, Mass.

Mr. Charles Fowler, Editor, High-Fidelity
 15 Audio Bldg., Great Barrington, Mass.
 Please enter my subscription to High-Fidelity:

\$6.00 for three years (SAVE \$6.00)
 \$3.00 for one year (SAVE \$1.00)
(Published Sept. 15, Nov. 15, Feb. 1, Apr. 15)

Name.....
 Address.....
 Add 50¢ per year in Canada, \$1.00 foreign

LETTERS

Record Lists

Sir:

I would like to express my appreciation for the abbreviated evaluation of new records which now appears in Mr. Canby's column. By all means continue and expand this work. When audio is a serious hobby, the demand for good records also becomes serious, for a good system is of little value without good records as source material.

At some time in the future, may we have a listing of suitable recordings for "background music"? There are many of us whose devotion to symphonic music does not include 100 per cent of our listening time, and it is difficult to select this type of music simply from titles in catalogues. In order to obtain even a dozen such records, I have already procured over fifty and I am still unsatisfied. I would like a library of records of the type used by the wired music services—those with no great crescendoes or changes of tempo which would distract a person's attention from other occupations.

Neil MacCoull,
 Fishkill, New York

Intelligent Correction

Sir:

Permit me to call your attention to a mistake in Jerome Goodman's article "Music and Mass Production" (*Æ*, Sept. '51). In this article, the author gives the impression that I.Q. is measured in per cent. The letters *I. Q.* are an abbreviation for *intelligence quotient*, or the ratio between mental age and chronological age. This ratio, multiplied by 100, gives the I.Q., which we in the social sciences usually term an index of brightness. Perhaps this is a minor point, but I think it important that technical terms, whether native to one's field or not, be used correctly. The probable unfamiliarity of most readers with this technical definition of I.Q. makes it all the more important that any discussion of it be correct to preclude any further misconception about the notion.

D. E. Clark

(*Thus isn't mental age a percentage of chronological age?* Ed.)

Credit to Co-Author

Sir:

Many thanks for your presentation of the article on the Space Charge Amplifier (*Æ*, Sept. '51). While I am grateful for the "plug" in the sub-heading, but I feel it is only fair to call attention to the true status of the work on the original Musician's Amplifier. The bulk of the layout and arrangement work was done by David Sarser, while I contributed suggestions and ideas to eliminate some of the troubles encountered in adapting it to American parts. Therefore, I feel that Mr. Sarser is entitled to equal recognition or possibly even sole recognition for his work in making the amplifier the success that it has become. Dave and I have always worked together as a team and it is not my intention that he be slighted in any way.

Melvin C. Sprinkle,
 Altec Lansing Corp.,
 161 Sixth Ave.,
 New York 13, N. Y.

(*That's one on us—we wrote the subhead.* Ed.)

tape it...

with a **PRESTO**

PRESTO has been a byword of discriminating broadcast and recording engineers for almost two decades. Recognized as the designer and builder of the finest tape recorders available today, PRESTO stands behind this reputation with a complete guarantee of satisfaction on every instrument sold. For smooth operation, for minimum maintenance, for best results... tape it with PRESTO, the best buy in tape recorders today.



PRESTO AMPLIFIER 900-A2

The recommended amplifier for the RC-10/24 tape recorder, has a frequency response of 50 to 15,000 cps., a low level three mike mixer and a bridging input. Five-way switch for recording, playback, remote, erase current and bias current.

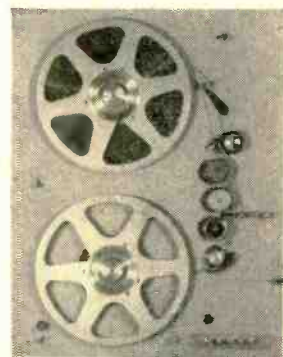

PRESTO MODEL RC-10/24

World favorite for relay rack mounting. Accommodates 10½" reels, three magnetic heads, push-button controls, response up to 15,000 cps. Panel size 19" x 24½". Also available in console unit.

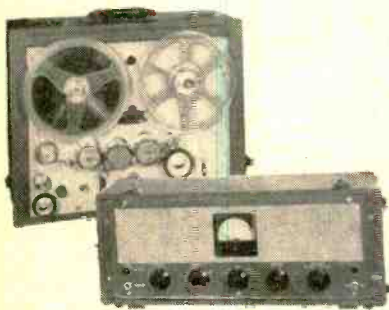

PRESTO PORTABLE PT-920

Brand new and improved successor to the famous PT-900. Three motors, no friction clutch or tension adjustments. Fast forward and rewind speeds, instantaneous monitoring from tape. Compact case contains 10 watt amplifier, two speakers, power supply.



PRESTO PORTABLE RC-10/14

Portable version of the RC-10/24 with smaller panel size (19" x 14") and rotary switch selector. Weighs only 68 lbs. Superb audio quality, speed control and reliability.

PRESTO RECORDING CORPORATION
PARAMUS, NEW JERSEY

Export Division: 25 Warren Street, New York 7, N. Y. Canadian Division: Walter P. Downs, Ltd., Dominion Square Bldg., Montreal

WORLD'S LARGEST MANUFACTURER OF PRECISION RECORDING EQUIPMENT AND DISCS

EDITOR'S REPORT

THE PACIFIC ELECTRONIC EXHIBIT

HELD IN CONJUNCTION with the 1951 Western Convention of the Institute of Radio Engineers, the 7th Annual Pacific Electronic Exhibit has come and gone—and a bang-up exhibit it was. Excellently attended, and in a convention hall admirably suited to such an affair, it was somewhat of a surprise to those of us who have succumbed to the average New Yorker's provincialism. The many booths were crowded from opening to closing for the three days of the show, and it was necessary to darken the hall to get the visitors to go home on the final evening. And with nearly sixty papers on a wide variety of subjects—presented in thirteen sections in eight periods so that no one could possibly attend all of the papers—the convention itself was a huge success.

We consider ourselves fortunate to have been able to attend this convention and exhibit for a number of reasons—we were able to meet and discuss audio with many old friends, we saw and heard a number of new developments, and we learned that the Pacific Coast is well on its way toward besting the East in electronic developments.

THE AUDIO FAIR

While the AES Convention is held at the same time as the Audio Fair, it is the Fair which attracts the greatest attention and attendance. For the benefit of those who are not professionally engaged in the Audio profession, the convention papers which are of greatest interest to this group—the hobbyists—are scheduled for the session on Saturday morning, November 3, beginning at 10:00 a.m. Friday morning's session will be devoted to industrial aspects of audio, and the afternoon session on the second day will cover recording. The opening day's sessions will be devoted to components, instrumentation, and related subjects.

Two floors of Hotel New Yorker—the fifth and sixth—will be filled with exhibitors with all types of devices of interest to anyone whose vocation or avocation involves audio. Several new speakers are due to be unveiled—both woofers and tweeters; new amplifiers will make their debut; magnetic recorders, both professional and non-professional will be watched with interest. Above all, the Audio Fair will permit these developments to be *heard*, as well as seen. It is this one feature which has made the Fair of nation-wide interest in so short a time. Audio as a separate industry and a separate profession has certainly become recognized.

This year, for the first time, wives of audio people are being recognized. Announcements of the convention being sent to members list a number of activities available for those wives who may wish to accompany their husbands to New York for the gala affair. This addition will probably bring out some who would not otherwise come—and *vice versa*.

INTERNATIONAL STANDARDIZATION

The Sixth Plenary Assembly of the International Radio Consultative Committee (C.C.I.R.) met in Geneva, Switzerland during the month of June and made considerable progress toward standardizing recording characteristics for radio programs destined for international exchange. Departing from the AES recommendation that no disc recording characteristic be standardized—only that for a standard playback system—the committee presented for further study a number of existing recording characteristics with the recommendation that such compromises be made by the various countries represented as would permit complete agreement upon one standard curve.

The proposed compromise characteristic provides for a 450-microsecond curve below 1000 cps and a 50-microsecond curve above 1000 cps. This corresponds to a low-frequency turnover of approximately 360 cps and a high-frequency turnover of approximately 2800 cps, as compared to the AES Playback Characteristic of 400 and 2500 cps respectively. While our preference still remains for the AES curve—both as to frequency of turnover and as to its specification as a *playback* characteristic instead of a recording standard—it appears that the proposed curve would fall within the tolerance allowed by the AES curve and would thus provide satisfactory reproduction when played on equipment engineered to AES standards. The Society's recommendations have already been forwarded to Neal McNaughten, the member of the Preparatory Group from the U. S., and it is to be hoped that his influence may help to swing the other members more closely to our already-adopted standard.

The C.C.I.R. standardization is not intended to apply to any recording intended purely for use in the individual countries, but only to those programs which are intended for international distribution or exchange. However, it is felt that if the equipment is made to satisfy the standards for programs in the exchange category, it is probable that it would be used without change for the locally consumed recordings, with consequent benefit to all who use them for any purpose whatsoever.

ELECTRONICS OFFICERS, AIR

Recent communications from the Public Information Office of First Air Force Headquarters indicate that men with a university degree and suitable qualifying experience in electrical, communication, radio, or electronics engineering may possibly step directly from civil into military life with a commission in the Air Force Reserve.

Depending upon age, commissions from second lieutenant to major may be granted those who qualify. A master's degree in one of the specified fields, or a bachelor's degree followed by at least a year of experience are prerequisite.

In Every Way, You Get SOUND VALUE at **TERMINAL**, the Headquarters for New York's Audio Fans!

RCA 15" DUO-CONE SPEAKER

with full weight ALNICO V magnet

This full-size 15" RCA loudspeaker provides the listener with full depth of bass and clear natural upper register. The unique magnetic structure and Duo-Cone arrangement with two voice coils accounts for its smooth frequency response from 40 to 12,000 cycles. Power capacity is 25 watts. 16 ohm input impedance. Weighs 15 lbs. RCA 51551.

29⁹⁵ NET



frequency response from 40 to 12,000 cycles. Power capacity is 25 watts. 16 ohm input impedance.

RADIO CRAFTSMEN RC-10 FM-AM TUNER with Built-in Preamp

Compensated for G.E., Pickering and crystal phono cartridges. Continuously variable bass and treble controls with flat response from 20 to 20,000 cycles. Automatic frequency control entirely eliminates station drift.

131⁵⁰ Net

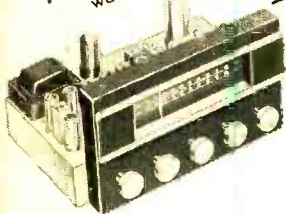

Companion unit for the RC-10 AM-FM tuner, or any high fidelity application. Over 10 watts output with less than 1% distortion. 20 to 20,000 cycles frequency response.

RC-2 Wide Range Amplifier

42⁹⁰ Net



NEW!
Model A-800

INPUT AMPLIFIER

Here in one compact unit is a four-stage preamplifier with inputs for fine wide-range phono cartridges such as G.E., Pickering and Collaro; radio tuner input and crystal cartridge. Has separate bass and treble tone controls. Especially designed for high quality amplifier power stages, such as the famous Williamson.

37⁵⁰ Net

UTC-WILLIAMSON Amplifier Kits

Incomparable audio reproduction in an easy-to-build style! Chassis are drilled and punched for all components. Only UTC's famous linear standard transformers used in audio section. Wired sample on demonstration in our Sound Department. Chassis and transformer kit priced at

44¹⁰ Net

Instruction manual **25[¢]**

PERMOFLUX Royal Blue 8" PM Speaker

Model 8T-8-1. The magnificent speaker that amazed visitors at the Audio Fair! Response is 50 to 12,000 cps, 8 watts. Efficiency high, distortion low! 8" diameter, 8 ohm voice coil.

13²³ Net

UNIVERSITY 6201 12-inch Coaxial Speaker

Full-range 25 watt coaxial speaker, 45 to 15,000 cps. Complete with 2000 cycle cross-over network and high frequency attenuator. A wonderful buy!

44¹⁰ Net

FREE!

Sylvania stroboscope to test the speed of your phono turntable! Sorry, no mail or phone orders on this item!

Have you heard of Terminal's P.D.Q.? Send for Terminal's P.D.Q. Bulletin!

COLLARO RECORD CHANGERS Now Available in U.S.A. at **TERMINAL!**

The mechanical perfection and smooth performance of the Collaro changer will startle the most critical record listener. Even the new Collaro crystal cartridge, which requires no preamplifier, has an amazing fidelity usually associated with the best magnetic types. Mounting space required: 15" x 12 1/2", 2 1/2" below and 4 3/4" above base plate.

CHOICE OF CARTRIDGES

HFH-01 High fidelity magnetic pickup head. High impedance. Permanent sapphire needle for microgroove records (33 1/3 and 45 R.P.M.). . . . **8.31**

HFH-03 Same as HFH-01 except for 78 R.P.M. records. **8.31**

CRY-01 Crystal pickup head for microgroove (33 1/3 and 45 R.P.M.) records. . . . **8.31**

CRY-03 Same as CRY-01 except for 78 R.P.M. records **8.31**



3RC511

3-Speed Automatic
A non-mixer changer, will play up to nine 12", 10" or 7" records automatically. Pickup arm returns to rest and motor is automatically switched off after last record on the stack has been played.

38⁸¹ Net

3RC512 3-Speed Mixer

Will play a total of nine 12" and 10" records mixed in any order. 7" records must be stacked separately. Other features same as model 3RC512, including ease of stacking, operation and the automatic shut-off after last record is played.

46³¹ Net

TERMINAL'S new UTILITY KORNER-KABINETS

Terminal's Korner-Kabinets will make an amazing improvement in the reproduction of any loud-speaker. The full size enclosed reflex chamber uses the walls of the room as a gigantic horn extension for enhanced bass response. Sturdy construction of 1/2" thick plywood throughout, properly reinforced to eliminate resonance and give true tone. Unfinished exterior, ready for painting. Supplied with movable speaker mounting board, sound absorbing pads and hardware.

KK-8 For 8" speakers. 24" high, 32" across, 23" each side. **18.00**

KK-12 For 12" speakers. 36" high, 32" across, 23" each side. **21.00**

Also available for 15" speakers

All equipment furnished for operation on 105-120 volts, 60 cycles AC.

VISIT
TERMINAL'S
FAMOUS
SOUND
DEPARTMENT!

PRICES
SUBJECT TO
AUTHORIZED
CHANGES

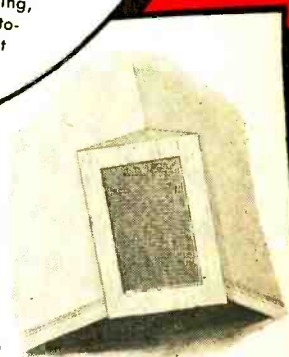

Terminal Radio Corp.

85 CORTLANDT STREET, NEW YORK 7, N.Y.
Worth 4-3311

Your voice

in Davy Jones' locker

To strengthen voices in the newest submarine cables between Key West and Havana amplifiers had to be built right into the cables themselves. With the cables, these amplifiers had to be laid in heaving seas; and they must work for years under the immense pressure of 5000 feet of water.

For this job, Bell Laboratories engineers developed a new kind of amplifier — cable-shaped and flexible, with a new kind of water-tight seal.

To serve far beyond reach of repair, they developed electron tubes and other parts, then assembled them in dust-free rooms.

The two cables — each has but two conductors — simultaneously carry 24

conversations as well as current to run the electron tubes.

With these deep-sea amplifiers, submarine cables carry more messages . . . another example of how research in Bell Telephone Laboratories helps improve telephone service each year while costs stay low.

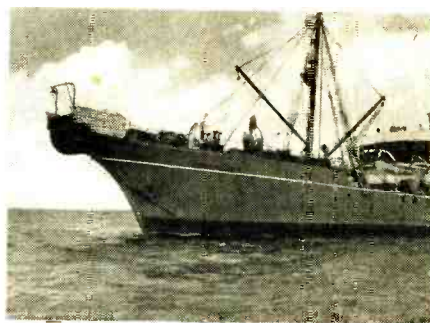

Cutaway view of deep-sea amplifier. Tubes and other elements are housed in plastic cases then enclosed in interleaved steel rings within a copper tube. Layers of glass tape, armor wire and impregnated fiber complete the sheath. Cable ship, shown right, payed out cable over large sheave at bow.

BELL TELEPHONE LABORATORIES

• Exploring and inventing, devising and perfecting, for continued improvements and economies in telephone service.

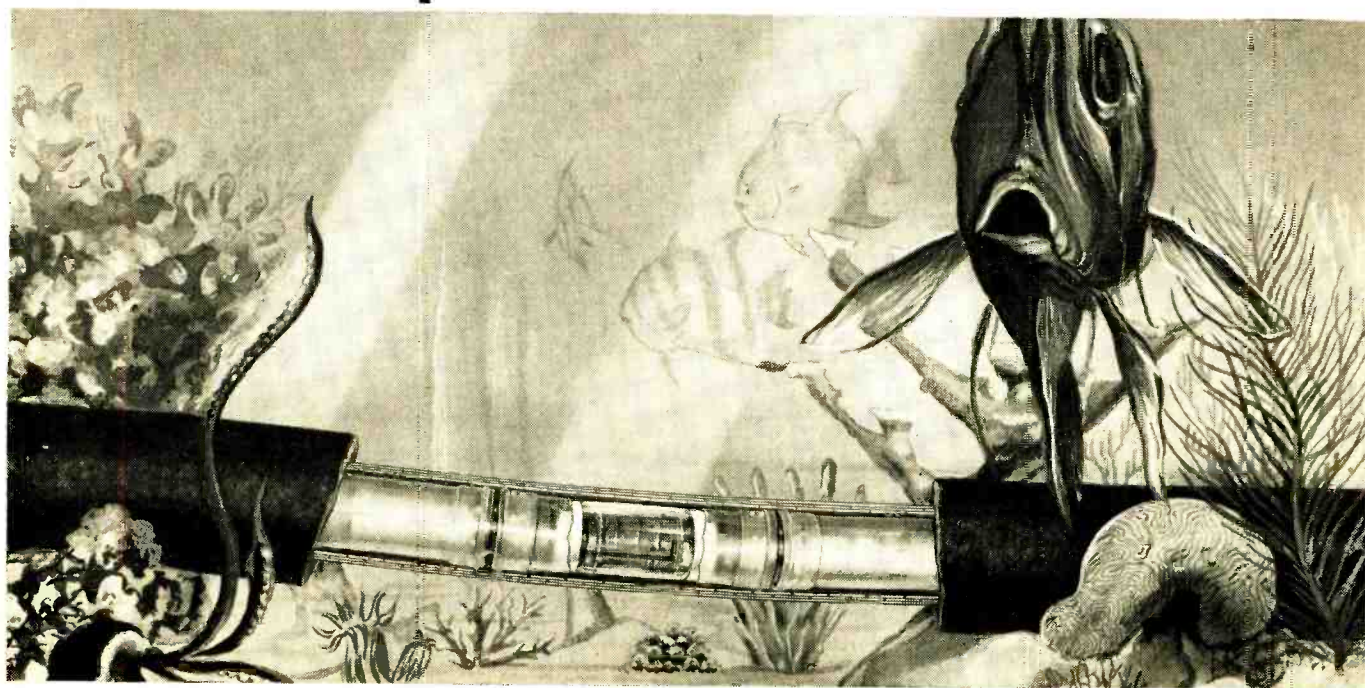

feedback. The second is a direct path from input to output through Z_1 and Z_2 by-passing the tube. (These effects may be observed by disconnecting the grid of the tube from the circuit and grounding it.) Almost every feedback amplifier has such a path. Usually it is neglected because the amount of signal at the output coming directly through the feedback network is very minute compared to the signal from the tubes.

To take these two factors into account, the equivalent non-feedback circuit has been drawn in two parts, as at (B). The signal is first attenuated in the left circuit by the factor $Z_2/(Z_1 + Z_2)$, giving a new input voltage E_{in}' . Next the signal voltage E_{in}' is amplified and fed into an interstage equalizer derived from Fig. 1. The additional branch consisting of a series arrangement of Z_1 , Z_2 , and a generator E_{in} takes care of the direct path from input to output and the plate loading due to $Z_1 + Z_2$.

Note that in (B) of Fig. 3 the voltage

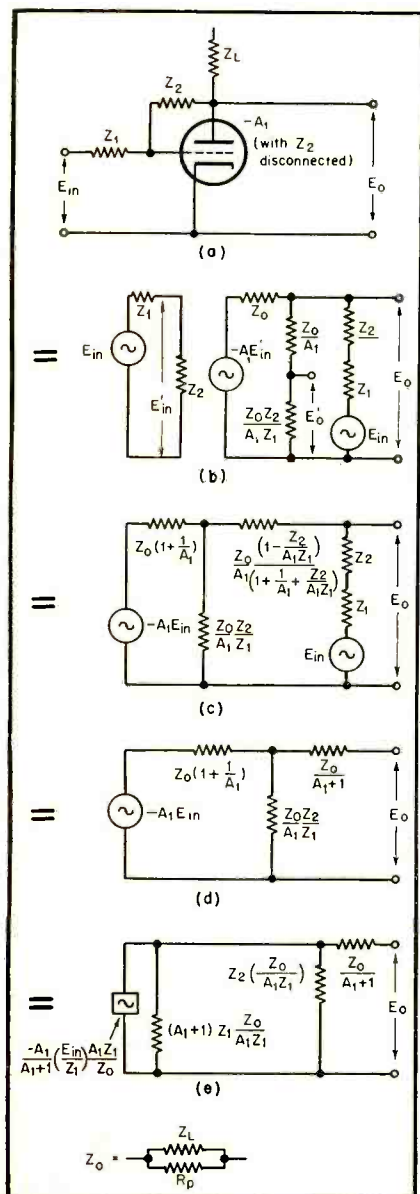
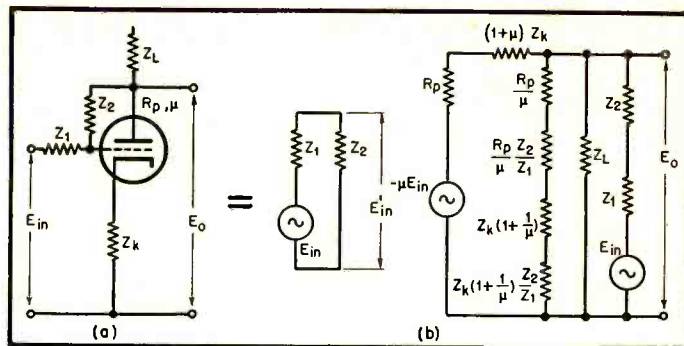

Fig. 3. Equivalent circuits for plate-to-grid feedback.

Fig. 4. Combined grid and cathode feedback equivalent circuit.



$E_{o'}$ is just $E_o Z_2 / (Z_1 + Z_2)$. By taking $E_{o'}$ as the output voltage, then, the left portion of (B) can be eliminated. (C) in Fig. 3 shows the resulting circuit. Another branch has been added for the purpose of correcting the output impedance Z_o' back to its proper value as seen at the output terminals in (B).

Frequently the internal impedance of the balance of the circuit is so small compared to $Z_1 + Z_2$ that the loading effect of $Z_1 + Z_2$ on the output and the amount of signal fed directly through are negligible. In this case the circuit can be reduced to a simple T network, as at (D). The impedance $Z_o' / (A_1 + 1)$ is an approximation of the corresponding branch in (C). In calculations of open-circuit frequency response this branch can be completely disregarded. It serves only to indicate the minimum internal impedance when Z_2/Z_1 becomes very small.

The approximate equivalent circuit using a constant current generator is shown at (E).

Combined Grid and Cathode Feedback

The circuit equivalent to a triode with both plate-to-grid voltage feedback and cathode current feedback is shown in Fig. 4. On account of the complexity of this circuit, however, it is frequently easier to consider the two types of feedback separately.

This is the case when Z_L and Z_K are pure resistances. The procedure is to consider first the triode with cathode current degeneration as (A) in Fig. 2. The circuit is then reduced to a generator $-A'E_{in}$ with an internal impedance Z_o' as at (C) in Fig. 2, which can now be redrawn in the form of the original circuit, (A), but with new circuit constants. The cathode impedance Z_K is zero; the plate load Z_L is replaced by Z_o' (which combines the effects of plate resistance R_p , degeneration across Z_K , and plate load impedance Z_L); and μ is replaced by $-A'$.

The final portion of the procedure is to add the plate-to-grid voltage feedback, making the circuit the same as (A), Fig. 3, which can then be reduced to one of its simpler forms such as (D) or (E) of Fig. 3.

In all of the previously mentioned circuits the stray circuit capacitances are combined whenever possible into the impedances shown; otherwise they are neglected. For example, grid-to-plate capacitance can become a parallel element in Z_2 .

The practical advantage of using a

selective feedback amplifier over a conventional amplifier followed by an interstage equalizer is immediately evident from a comparison of (A) and (D) of Fig. 3. In the former case, the tube has to supply only the output voltage E_o while in the latter case, the tube has to supply several times E_o to make up for loss in the equalizer. Operation at a lower level causes the tube in the feedback amplifier to have less harmonic distortion by a factor of several times. In addition this lower distortion is further reduced by feedback. The internal impedance Z_o' of the feedback amplifier is likely to be lower than that looking back into the equalizer, which has to be kept at a high impedance level in order that the tube will have a sufficiently high plate-load impedance for low-distortion operation. Hence the feedback amplifier has greater freedom from the effects of external loads.

The disadvantages of using a feedback amplifier whose feedback varies with frequency response is more dependent upon the gain of the tube and may change with age. The response, however, can be stabilized to any desired degree by using enough feedback.

Effect of a Small Amount of Feedback on Beam Power Amplifiers

Circuit (B) of Fig. 1 and the related formulas show the effect of a small amount of feedback on the performance of a pentode or tetrode power amplifier. Without feedback, an 8-ohm loudspeaker may look back into as much as 80 ohms internal impedance due to the high plate resistance of the pentode. This means that if the load impedance were disconnected the output voltage would rise 20.8 db. If we were to apply just 6 db negative voltage feedback measured with the load connected, the loudspeaker would look back into something less than 8 ohms. This would be true even if the loudspeaker had originally looked back into 80 megohms.

The reason is plain from observation of the shunt impedance $Z_o' / -A_o\beta$. (The $-A_o\alpha$ and α/β impedances are zero.) When negative voltage feedback is applied it is the loading effect of this impedance that reduces the output voltage. To reduce the output voltage to one half its value before feedback the value of this impedance must be equal to Z_o in parallel with Z_L . Therefore, with 6 db of feedback the loudspeaker looks back into less than its own impedance. This is because 6 db feedback with the

[Continued on page 42]

Expressions for the Reduction of Distortion and Output Impedance in Terms of db of Feedback

WILLIAM J. KESSLER* and SYDNEY E. SMITH*

The authors simplify the calculation of amplifier characteristics by employing easily measured parameters.

DURING THE PAST DECADE, it has become increasingly common to express the degree of inverse feedback employed in audio output amplifiers in terms of the gain reduction due to the addition of the feedback loop rather than the feedback factor $A\beta$. In many feedback applications the value of β cannot be readily determined unless the feedback signal is derived from a divider network where the values of all the impedances are known. In contrast, the degree of inverse feedback expressed in decibels may be readily determined simply by measuring the reduction in output level due to the addition of the feedback loop. This measurement may be made at any frequency; however it should be noted that the expressions for the reduction of distortion and output impedance are usually applicable only for the frequency corresponding to a single measurement, or the frequency range over which the measured gain reduction is substantially constant. Accordingly, it appears desirable to rewrite the well-known expressions for the reduction of distortion and output impedance due to the use of negative voltage feedback to eliminate the often indeterminate $A\beta$.

The conventional expression for the effective output impedance of a power amplifier¹ incorporating negative voltage feedback is:

$$R_o = \frac{R_p}{1 - \mu A_1 \beta} \quad (1)$$

where R_p is the plate resistance of the output stage without feedback, μ the amplification factor of the output tube, A_1 the voltage amplification included between the feedback point and the grid of the output stage and β is the feedback fraction expressed as a decimal less than one. A similar expression for the reduction of distortion due to the use of negative voltage feedback is:

$$D' = \frac{D}{1 - A\beta} \quad (2)$$

where D is the total harmonic distortion in the absence of feedback, D' the residual distortion with feedback, and A

* *Engineering and Industrial Experiment Station, University of Florida, Gainesville, Fla.*

¹ *Radio Engineers Handbook*, Frederick Emmons Terman, p. 402.

the total amplification included within the feedback loop.

The net amplification of an amplifier incorporating negative feedback is known to be:

$$A' = \frac{A}{1 - A\beta} \quad (3)$$

Expressing the change of amplification in terms of decibels yields:

$$db = 20 \log (1 - A\beta) \quad (4)$$

Combining this equation with equation (2) yields the following expression for the residual distortion in the presence of feedback free of the feedback factor $A\beta$:

$$D' = \frac{D}{\log^{-1} (db/20)} \quad (5)$$

where db is the degree of inverse feedback expressed in decibels and D the initial total distortion.

In a similar manner, combining equations (1) and (4) results in an expression for the effective output impedance also free of $A\beta$ as follows:

$$R_o = \frac{R_p}{1 + \frac{R_p + Z_L}{Z_L} \{[\log^{-1} (db/20)] - 1\}} \quad (6)$$

where Z_L is the recommended load impedance and R_p the plate resistance of the output stage in the absence of feedback. In the event the voltmeter used for making the level measurements before and after the addition of the feedback loop is not calibrated in terms of decibels, the ratio of the two voltage readings may be substituted for $\log^{-1} (db/20)$ in equations (5) and (6).

It should be observed that the value of R_p published in the tube manuals is reliable only for the class of operation specifically stated. The values of R_p for class AB₁ and AB₂ are seldom given, particularly when cathode bias is employed, because the actual plate resistance varies throughout the audio cycle. Under such circumstances, a more reliable "average" figure may be calculated from the expression:

$$R_p = Z_L [\mu / A_o - 1] \quad (7)$$

where Z_L and μ are as previously defined and A_o is the large-signal ampli-

fication of the output stage.² A_o may be obtained by dividing the peak voltage corresponding to maximum grid power output by the recommended grid bias. For push-pull operation the peak plate-to-plate voltage should be divided by twice the recommended grid bias.

The magnitude of the effective output impedance R'_o reflected to the secondary of the output transformer can be verified by a simple and straightforward method previously outlined by Richter.³ This output impedance, in terms of the open-circuited and properly-loaded output voltage, is then:

$$R'_o = R_L \left[\frac{e_o - e_L}{e_L} \right] \quad (8)$$

where R_L is the recommended load resistance across the secondary of the output transformer. A speaker can be employed as a suitable load; however, it is recommended that a noninductive resistance be employed to remove doubt regarding the value of R_L . It is observed that the reciprocal of the bracketed quantity in equation (8) constitutes an experimental determination of the damping factor (R_L/R'_o) of the output stage.

² For push-pull operation, Z_L , R_p , and R_o can be regarded as the plate-to-plate values.

³ Walter Richter, "Simple method of determining internal resistance," *AUDIO ENGINEERING* vol. 32, no. 10, pp. 19-20, October 1948.

New York AES Meeting:

Demonstration Record Committee Presents List of Selections

At the first fall meeting of the New York AES group, R. D. Darrell, chairman of the Test and Demonstration Record Committee, presented a list of selected records deemed suitable for demonstrating the performance of home music systems. Many of the choices were played on Mr. Darrell's own system, and brief descriptions of the music and what the records were intended to demonstrate were given. Selections ranged from full orchestra to individual instruments, from heavy classics to popular. Mimeographed lists of the records were presented to all present.

Square Wave Testing Simplified

HAROLD E. BRYAN*

The determination of the practical response limits of an amplifier is reduced to a few simple statements relating to the reproduced wave shape from a given square-wave frequency.

ASK THE AVERAGE engineer why he doesn't use square waves in making tests of an amplifier and he will probably say something like, "Square waves? Oh yes. They make those pretty pictures on the 'scope, and I always wonder what they mean. It's a waste of time—I'll run the curves." Of course, running the curves point-by-point is perfectly legitimate, and is highly desirable in some cases.

But square waves do have their place in testing equipment. They make it possible to obtain the necessary information on frequency and phase response of the amplifier quickly and with reasonable accuracy. Nor is the equipment expensive or hard to build—a good "square-waver" can be constructed very simply.¹ In addition, square waves will give information on the transient response of the amplifier that cannot be obtained from point-by-point curves. Less testing time is required than it normally takes to obtain one or two points on the usual curve.

Single-Stage RC-Coupled Amplifiers

Since no matter what type of coupling is used it involves time constants, the following analysis is based on the RC coupling.

At low frequencies, the amplifier is essentially a high-pass device, as illustrated in Fig. 1. It has often been stated that a square wave test provides no information on the characteristics of the amplifier at frequencies below the square wave fundamental. This is not strictly true. According to Fourier's theory, a symmetrical square wave contains a sinusoidal fundamental, at the repetition rate of the rectangular wave, and odd harmonics thereof. On the face of things it might therefore be said that since there are no frequencies involved which are lower than the fundamental of the test wave, there can be no information available about the performance at such lower frequencies.

A look at the coupling circuit from another angle, however, will show that there are indeed possibilities for lower-than-fundamental information. The ideal symmetrical square wave rises instantaneously to its maximum value, remains at that point for one half its period, and then drops immediately to its maximum negative value, where it remains for the duration of the cycle. In order for the

amplifier to pass the wave as it is generated—remember we're considering low frequencies now—the coupling circuit must pass the flat top of the wave without alteration. This will be possible only if the time constant of the circuit is long compared with the time of the flat top. If this is not true, the top will slope off instead of remaining at a constant value.

Suppose it is assumed that if the top slopes down to no less than 95 per cent of the maximum value the response is sufficiently good. Let's see what this would mean in terms of the amplifier.

If a d.c. voltage is applied to the coupling circuit, which is essentially what is happening in the flat top of the wave, the voltage across the resistor will be determined by the equation

$$e_o = E e^{-\frac{t}{T}}$$

where t is the time at the point of measure
 T is the time constant of the circuit.

In an RC circuit the time constant is equal to the product of resistance and capacitance. In the example above, where the final voltage is 95 per cent of the maximum,

$$\text{whence } e_o/E = 0.95 = e^{-\frac{t}{T}} \\ \frac{t}{T} = .051$$

This simply says that in order to meet the requirements set up the time con-

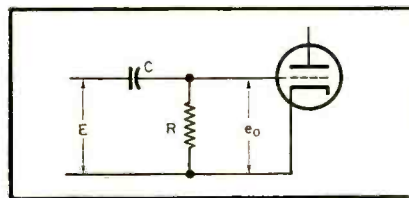

Fig. 1. Simplified equivalent circuit of amplifier at low frequencies.

stant of the circuit must be $1/.051$ or 19.5 times the flat-top time, which is t in the equation.

From the information so supplied we can determine the frequency at which the response is down 3 db, assuming normal phase shifts, and in general the response at any other frequency in between if desired. In this type of circuit the frequency for 3-db attenuation is that at which the reactance of the ca-

pacitor equals the coupling resistance. That is,

$$f_o = \frac{1}{2\pi RC} = \frac{1}{2\pi T}$$

$$\text{From above, } T = 19.5t \\ = 9.75(2t) = 9.75/f$$

where

t is the half-cycle, or flat-top time

f is the frequency of the square wave

Then, with this information, by substitution the 3-db frequency

$$f_o = \frac{1}{2\pi T} = \frac{1}{2\pi \left(\frac{9.75}{f} \right)} \\ = \frac{f}{61.3}$$

In other words, the frequency for 2 db attenuation is obtained by dividing the 95 per cent slope square-wave frequency by 61.3.

At a frequency approximately equal

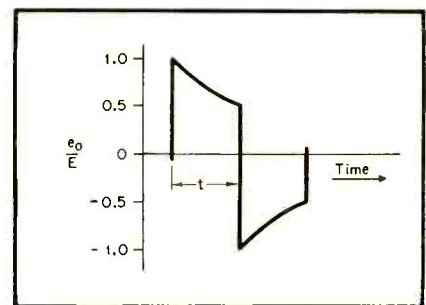

Fig. 2. Typical output signal showing square wave with 50 per cent slope.

to one-tenth the applied frequency (roughly six times the 3-db frequency) the reactance will be one-sixth the resistance of the circuit and the amplifier response will be down only 1.3 per cent.

Thus if the square wave obtained at the output of the amplifier is as good as pictured here, the amplifier—unless it is unusual in some other particular—will have good response down to one-tenth of the test frequency and will be down 3 db at approximately one-sixtieth of that frequency. The phase response will also be good over the same range.

Practical Aspects

While the foregoing analysis is perfectly valid, it may be slightly hard to apply, since it is difficult to determine accurately when a 95-per cent slope was realized. However, if the square wave

* 552 Fern Glen, La Jolla, California.

¹ See REFERENCE 1.

has a good flat top, it is apparent that the amplifier will be reasonably flat to one-tenth of the test frequency.

In order to make it easier to determine the actual frequencies involved, it is desirable to use something greater than a 95 per cent slope. It is also desirable to apply the square wave at a frequency where the response of the amplifier is still good. As a starter, let us assume that the test frequency is applied where the amplifier is down only 2 per cent.

Working backward from the fundamental equation for the amplifier response

$$e_o/e = 1/(1 - jf_o/f)$$

we find that for $e_o/e = 0.98$,
 $f_o = f/4.9$

or the test frequency is 4.9 times the 3-db frequency. From this figure we can find the actual slope of the flat top. We know that

$$T = \frac{1}{2\pi f_o} = \frac{4.9}{2\pi f}$$

$$= \frac{9.8t}{2\pi}$$

whence

$$t = 0.64T$$

Substituting this value in the equation

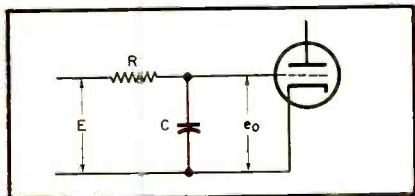

Fig. 3. Simplified equivalent circuit of amplifier at high frequencies.

for the voltage across the coupling resistance,

$$\frac{e_o}{e} = e^{-0.64}$$

$$= 0.5275$$

So under these conditions the flat top will slope down to 52.75 per cent of maximum in the half cycle time. This is illustrated in Fig. 2. Thus in practice the frequency of the square wave is adjusted until a slope of approximately 50 per cent is realized. The 3 db frequency is then calculated by dividing the resulting test frequency by 4.9.

High-Frequency Response

The high-frequency response of the amplifier is handled in much the same manner, although it is somewhat easier. In this case, the coupling circuit is essentially that of Fig. 3, a low-pass device. The voltage output rises exponentially according to the relation

$$\frac{e_o}{E} = 1 - e^{-t/T}$$

where t is any time after application of the pulse. A typical case is illustrated in Fig. 4. When the measurement time is equal to the time constant of the circuit the output has risen to 63.7 per cent

of its maximum value. At high frequencies, therefore, the leading edge of the wave will be rounded due to this exponential rise of voltage. By spreading the wave out on the scope it is possible to determine a 64 per cent rise time with reasonable accuracy in terms of the half-cycle time. From this the actual time in seconds is obtained.

At the high frequencies the amplifier is down 3 db when the reactance and resistance are equal. This is the same equation as before, but the resistance and reactance involved are different. Thus again

$$f_o = \frac{1}{2\pi T}$$

Since the time for 64 per cent rise of voltage is the time constant T , the 3 db frequency is easily calculated.

Multistage Amplifiers

Since the foregoing analysis is based

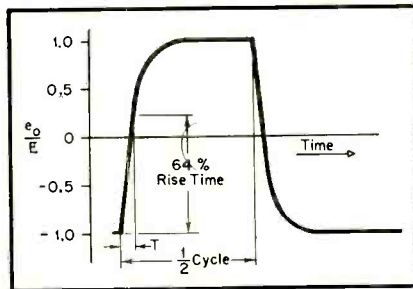

Fig. 4. Typical output signal showing deterioration of square wave due to reduced high-frequency response.

on a single coupling circuit, its value may be questioned. But it is the basis for the considerations in multistage amplifiers.

Consider a two-stage amplifier with identical coupling circuits, isolated by a tube. This can be considered at low frequencies as a single circuit whose time constant is one-half that of each of the original couplers. It would therefore appear that the 3-db frequency would be twice that of one stage, since the effective time constant is half as great as a single circuit. We find, however, that the response of the two circuits to sinusoidal signals is *not* down 3 db at this frequency. Instead,

$$f/f_o = 1.55$$

which means that the 3-db frequency is 1.55 times that of a single stage, instead of twice. The frequency calculated from the 50 per cent slope frequency, by dividing by 4.9, will not therefore be the true 3-db frequency. It is instead a frequency equal to twice the 3-db frequency for a single stage. To determine the value for the two stages, this latter value must be divided by two and multiplied by 1.55. Summed up, for a two-stage amplifier

$$f_{3db} = f \times \frac{1.55}{2 \times 4.9}$$

$$= 0.158f$$

where f is the frequency for a 50 per cent flat-top slope.

For three stages, the considerations

are the same. The ratio turns out to be 1.96 instead of 1.55 and the 3-db frequency

$$f_{3db} = f \times \frac{1.96}{3 \times 4.9}$$

$$= 0.133f$$

For four stages,

$$f_{3db} = 0.116f$$

For more than four coupling circuits the same reasoning applies. However, the factor by which the 50 per cent slope frequency is multiplied approaches a limit and it is doubtful if the extra work is worth the effort. For example, on a test amplifier, which actually contained four coupling circuits plus an output transformer, the 50 per cent frequency was 350 cps. By assuming that the amplifier contained only two stages, the 3-db frequency was calculated to be 55.4 cps. For three stages it was 46.6 cps and for four stages, 41 cps. The true 3-db frequency, by measurement, was 43 cps. Thus little practical error is involved if the estimate of the number of stages is wrong and there seems to be no point in going beyond four stages.

The high-frequency response is analyzed in the same manner, but the calculations are somewhat more involved. It can be shown that the equivalent single stage, for a two-circuit amplifier, has a time constant 1.585 times that of each individual circuit. The frequency for 3-db attenuation of sinusoidal signals is 0.643 times that for one stage. Since the reciprocal of 0.643 is 1.55, there is not much point in attempting to obtain an accurate expression. If the difference is ignored the result is still within 2 per cent. This is closer than the time can be read on the oscilloscope screen.

Similar results are obtained for more stages. In the test amplifier, the 3-db frequency was calculated as 70 kc, and by actual measure was 65 kc.

Other Considerations

When transformers appear in the amplifier, as they often will, other things may have to be taken into account. These may or may not invalidate the results obtained by the above analyses, depending upon how good or how bad the transformers are. Generally speaking, if such tests are undertaken on an amplifier it is because the owner considers it to be a pretty good one and wants a "quick and dirty" method of finding out how good it actually is. With reasonably good transformers no particular trouble should be experienced.

Response peaks usually due to transformers will produce transient effects, appearing as damped waves on top of the square wave. These may make the high-frequency response determinations difficult. Another effect which may be noticed in some cases will appear the same but at a very low frequency. This will probably be due to insufficient damping of a loudspeaker load. It is doubtful if this will be experienced, however, since the test frequency probably will not be low enough to show it up.

[Continued on page 46]

More About Mismatching

ROBERT M. MITCHELL*

A discussion of the manner in which a change in the load presented to an amplifier can affect gain, frequency response, distortion, and other characteristics.

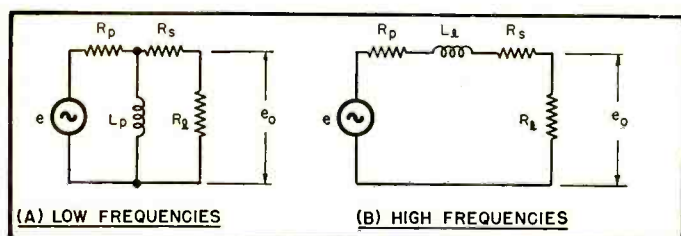

Fig. 1. Simplified equivalent circuits of output transformers at low frequencies (A), and at high frequencies (B).

ADVICE CONCERNING the matching of loads to audio amplifiers was provided in these pages some months ago.¹ The large number of questions about this problem shows it to be one of the major concerns of audio constructors. Many of these questions concern power output capabilities, and have been answered in the article cited. Many others, however, concern performance characteristics of the amplifier or system as a whole, aside from power capabilities. These are questions of quality rather than quantity, and involve frequency response, distortion, hum, damping, gain, and stability. These characteristics will each be briefly treated in respect to their relationships to load changes.

Damping

The damping factor of an amplifier is the ratio of the load resistance R_l to the plate resistance r_p of the output stage, both referred to the same side of the output transformer.

$$D = \frac{R_l}{r_p}$$

- (1) Obviously, if a higher than rated load impedance is used, the damping is improved.
- (2) If a lower load is used, the damping is poorer.

Frequency Response

Figure 1 shows the simplified equivalent circuits of an output transformer at low and at high frequencies. At (A), for example, the value of the primary inductance L_p is chosen by the designer so as to make the output e_o at a frequency f_L 3 db below its mid-frequency value when a load R_l is connected to the output. If the transformer is manipulated by mismatching so as to make R_l smaller, the frequency at which L_p will produce this same loss in output is re-

duced. Consequently, the low-frequency response is improved.

Just the opposite is true for the high-frequency end. Diagram (B) in Fig. 1 shows that as R_l is decreased, more and more of the voltage is developed across the leakage inductance L_p and less and less across R_l . Consequently, the high-frequency response is made poorer. The lumped primary resistances R_p and sec-

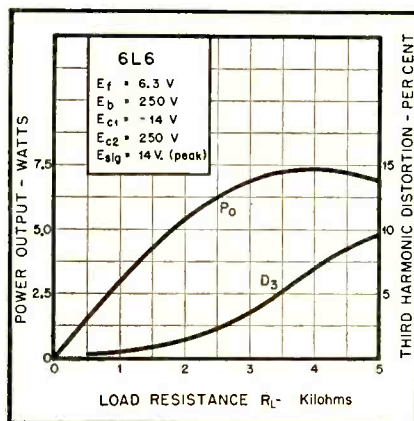

Fig. 2. Curves showing the effect of changing load resistance has upon power output and distortion in a typical beam power tetrode—the 6L6.

ondary resistances R_s are assumed to be small for both cases. We may summarize these results as follows:

- (1) Connecting a load impedance lower than the rated load shifts the frequency characteristic downward, resulting in better low-frequency response and poorer high-frequency response.
- (2) Connecting a higher impedance shifts the frequency characteristic upward, resulting in poorer low-frequency response and better high-frequency response.

Distortion

If a push-pull amplifier is involved, as is almost always the case, the even-order harmonics of the output tubes appear considerably reduced in the output if not

completely canceled. The third harmonic, however, is not reduced by push-pull connection, and consequently, must be considered when mismatching.

Figures 2 and 3 show the variation of third harmonic distortion as the load is changed for two representative types of tubes. The increase of distortion with load impedance shown in Fig. 2 for the 6L6 is typical of beam power tubes and pentodes. With triodes, however, the change is in the opposite direction, as Fig. 3 shows for the WE 300B. Designers sometimes take advantage of this relationship to reduce the distortion in triode amplifiers when the loss in power is not significant. It is often possible to obtain a considerable reduction in distortion with only a slight loss in power. This was done in the well-known Williamson amplifier, for example, where a plate-to-plate load of 10,000 ohms was used for tubes whose rated load as given by the manufacturer was much lower (4,000 ohms).

(1) Connecting a higher than rated load tends to increase distortion for beam power tubes.

(2) Connecting a higher load tends to decrease distortion for triodes.

The gain of the output stage is given by the relation

$$A = \mu \frac{R_l}{R_l + r_p} = \mu \frac{1}{1 + \frac{r_p}{R_l}}$$

The ratio of gains with different loads is then

$$\frac{1 + \frac{r_p}{R_{l1}}}{1 + \frac{r_p}{R_{l2}}}$$

[Continued on page 54]

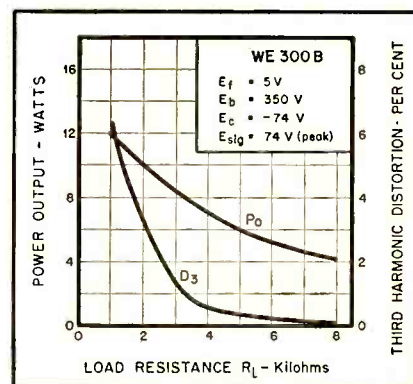

Fig. 3. Load resistance vs. power output and distortion for a typical triode—the 2A3.

* Circuit Applications Engineer, United Transformer Company, New York.

¹ S. J. White, "How far can I mismatch?" AUDIO ENGINEERING, Jan. 1951.

Audio—Big Business

LEON WARTMAN

From an unfamiliar word to a profession, to the Society, to the Audio Fair—Audio has become one of our fastest growing industries.

IT PROBABLY IS America's youngest industry and in spite of that has already grown to be a $\frac{3}{4}$ billion dollar enterprise. It's the "sound" industry. Its members call it "audio." The word "audio" is still described in modern dictionaries as an adjective but its followers refer to it as a proper noun, "Audio." It is defined as the science of the production and reproduction of sound through electro-mechanical techniques. It's the design, manufacture, processing, and distribution of equipment, and the actual playing back of recorded music, speech and other sounds. It's the production of equipment for making tape and wire recordings. It's the design, manufacture and sale of microphones, amplifiers, loudspeakers, and recordings. It is the putting together of these devices into an integrated system for the sheer pleasure and esthetic delight of listening to the supernatural reproduction of music. It even extends to other industries such as furniture, where thousands of cabinets are scientifically custom-made to contain this equipment most attractively. It is an industry that caters to the ears of lovers of music, from Bach to BeBop. The Audio Industry gives employment directly to an estimated 100,000 persons in the United States alone. No one can estimate the number of people who derive pleasure from the industry's efforts.

The Great Leveller

Rich man, student, and wage earner are on one level—and none objects—when they meet at the local equipment supply houses to see and hear the latest audio devices which are being offered for sale. There they find a certain camaraderie, a mutual and rabidly devoted interest where, surrounded by woofers, tweeters, pickups, turntables, tuners, amplifiers, equalizers, and recordings, they can express their personal preferences and discuss the relative merits of one device over the other. One debater may have an Audio outfit in his home costing thousands of dollars. Another, a youth still on a weekly allowance, may have, over a period of time, accumulated a hundred or so dollars worth of merchandise. One may have hired an Audio Consultant to design and construct the electronic portions and an Interior Decorator for the cabinets and loudspeaker box. The other may have designed his by copying from magazine articles, "horse-trading" for the components, hand-building and home-making what he didn't have the cash for. One is just as proud as the other and can justify the choice made for each unit of his Audio "system."

So enthusiastic are these Audio enthusiasts that several magazines completely out of the technical field are recogniz-

ing this growing factor of the buying public and are devoting new pages and sections to it.

Too, a new type of music critic has been created, one who not only must be qualified to comment on a recorded musical performance, but who can comment on the microphone placement, auditorium acoustics, and other technical aspects. This new critic reviews the record *en toto* and, should he betray an unfamiliarity with the technical aspects, he might be swallowed up by a sea of indignant Audio enthusiasts, as well as by those among his readers who are professional musicians.

The AES is Formed

In 1948 a society of Audio enthusiasts was formed by a group of engineers, business men, an editor, and an attorney. They drew a constitution and became the Audio Engineering Society (AES) for the "diffusion and increase of educational and scientific knowledge in Audio Engineering, the promotion and advancement of this science and its allied arts in both theoretical and practical application . . . the encouragement of the interchange and intercourse of ideas. . . ."* A Board of Governors was created and the temporary officers appointed. Within less than a year, a general election was held and officers were democratically installed by direct-mail ballot. The society now has seven active sections holding monthly meetings in four states. Ten foreign countries are represented in the AES Directory of Members.

In addition to the monthly meetings of the local chapters, the Society holds a national meeting once each year. The first convention, held in October of 1949 at the Hotel New Yorker, lasted three full days and drew so enthusiastic a response that the AES immediately reserved space for October 1950 for the second annual convention. As is customary for convention times, a manufacturers' exhibit of equipment is held concurrently. The exhibit held concurrently with the AES convention is called the Audio Fair, and is managed by Harry N. Reizes, a member and general counsel for the Society.

In 1949, the year of the first convention, the manufacturers responded with mild enthusiasm, stating that they had to attend too many conventions which already stretched the budget. Yet enough manufacturers responded to lease two-thirds of the rooms on the sixth floor of the Hotel New Yorker for the three day convention period. The AES convention and the Audio Fair were both freely publicized by the industry in a joint effort. Paid advertisements

* AES Constitution; excerpt from Article II, "Objects."

were taken in the trade press by the Audio Fair management. The AES membership responded loyally. But the biggest surprise of all came from the general public. Students came in groups, Audio enthusiasts and the inevitable convention go-ers came singly or brought friends who quickly caught the enthusiasm and, in turn, became Audio enthusiasts.

In October of 1950, the second annual convention and the Audio Fair were again held at the Hotel New Yorker. Publicity was extended to the daily newspapers, literary magazines, and the radio. So many manufacturers, publishers, and distributors of audio components expressed their desires to participate in the Audio Fair that the entire sixth floor and half of the fifth floor had to be leased. Attendance was double that of 1949 and enthusiasm increased immeasurably.

The 1951 Convention

The third annual convention of the AES and the Audio Fair are to be held this November 1, 2 and 3 at the Hotel New Yorker. It is expected that the attendance will double that of 1950 and the visitors will see the exhibits of about 200 members of this 750 million dollar infant industry, still growing apace with its younger and bigger brother, Television. The visitors will see items ranging in cost from a few pennies to thousands of dollars. The manufacturers', publishers', and distributors' attendants will discuss and demonstrate their wares in their private rooms to an excited public for three days with little more than time out for coffee and doughnuts. This time the entire fifth and sixth floors of the Hotel New Yorker have been leased by the Audio Fair Management.

A friendly sort of rivalry for the visitor's attention has grown among the exhibitors. All sorts of novel gimmicks and wholesome attention-getters are used. One enthusiastic exhibitor is publicizing a "Golden-Ear" contest. Each visitor to this exhibitor's room will be given a hearing quality test with a Bell Laboratories "Audio-Meter." The results will be recorded on a "Golden-Ear" lapel tag for the visitor and in a scoring book retained by the exhibitor. This will continue during the three days and valuable prizes of Audio equipment will be given to about twenty of those who have hearing which is considered closest to the ideal.

Exhibitors who complained they were already attending too many conventions have dropped out of others in favor of the low-cost Audio Fair which gives its small profits, after all salaries and expenses are deducted, to the Audio Engineering Society for the "encouragement of the interchange and intercourse of ideas."

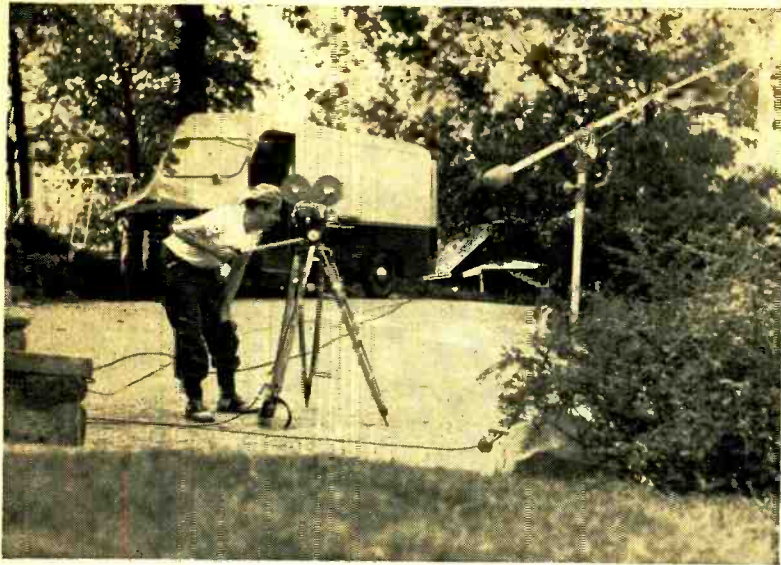

C. Robert Fine, designer and builder of the "location" unit, is shown using the synchronous 16mm magazine loading Maurer camera which is being used for color work. A Telefunken microphone is at the end of the boom. The microphone and camera are equipped with 200' of extension cables. Since the recording truck can operate 600' from the generator trailer, it is thus possible for the microphone to be as far as 800' from the generator. This is quite useful for work done in the narrow winding streets which are characteristic of numerous historical European towns and villages. Remote controls enable one man to operate all equipment that is inside the truck while he is at the camera or microphone boom.



The microphone and audio mixer is a Magnecord PT6-P. It can be operated inside or outside the truck. Below the Magnecord mixer can be seen a small Jensen bass-reflex baffle equipped with long extension lines so that it can be placed near the subject being photographed.



The driver and his co-pilot are provided with seats at the front cab of the truck. The seats fold forward and out of the way to allow as much floor space as is possible. The entire truck and trailer can be operated while in motion.

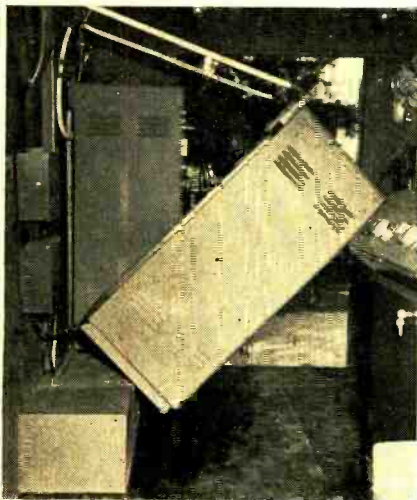

The two racks of equipment shown in the block diagram are mounted against the bulkhead opposite the Magnecord mixer location. The racks are hinged at the bottom and secured at the top with wing nuts and bolts so that they can be made to swing forward and rest against the restraining chains, exposing their interiors for service and inspection.

For recording sound tracks, all equipment is normalled through jacks. Inputs and outputs of the separate units in the system can be lifted and multiples are also provided. For wide-range recording, the dialog equalizer and the mid-range equalizer are "patched around."

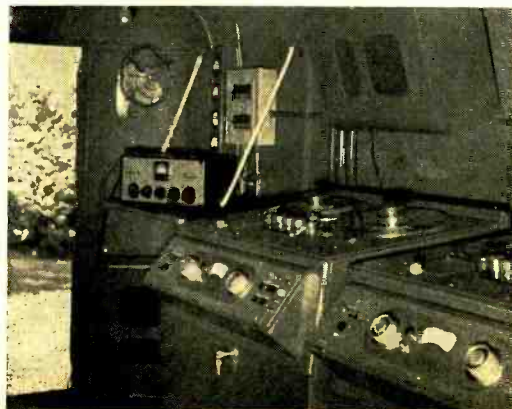
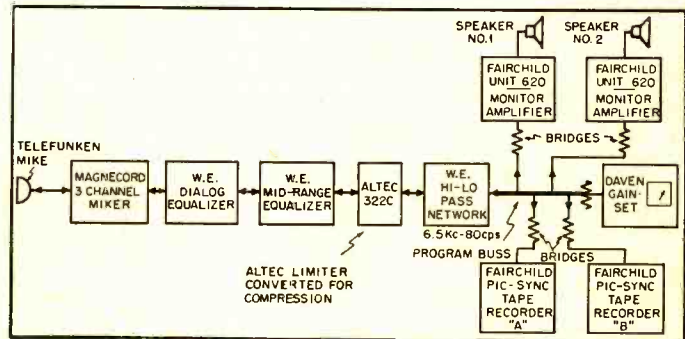

All sound tracks are recorded on two Fairchild Pic-Sync Magnetic Tape Recorders, operating simultaneously for an original and a safety. The monitor speaker is secured to the bulkhead of the truck and just above the Fairchild Tape Recorders. The tape equipment is mounted on Barry shock-mounts. Heavy coil springs, secured to the outsides of the recorder cabinets, insure that they will not "room about" the floor of the truck while travelling. At the same time, these springs do not inhibit the effectiveness of the shock-mounts.

Meet the Cinécruiser

New mobile location unit provides synchronous magnetic tape facilities for recording motion picture sound tracks.

MANY MEMORIALS to great people and great places have been carved in granite, put to canvas, and in other ways immortalized. Too often, it has been complained, they are artists' conceptions and usually idealize the mien, pose, poise and relative stature of their noble subjects. But no medium portrays as realistically as does the motion picture camera. Nothing else preserves the great mortals for posterity more completely than does the motion picture with its sound track.

The Jerome Hill Foundation, a philanthropic organization, is sponsoring a project to immortalize the great through the medium of cine-sound. Toward this end, the foundation engaged the services of C. Robert Fine, a prominent audio engineer. Mr. Fine's assignment was to design and construct a completely mobile "location unit." With a thirty day deadline, the unit described and illustrated on these pages was designed and constructed, laboratory and road tested, and driven aboard a freighter bound for Europe and its first assignment. By the end of October 1951, both Mr. Fine and the "location" unit will have returned to the States and left for their second "assignment for immortality" in California.



The "location" unit (it hasn't been christened with a name as yet) consists of a 1-ton, 6-cylinder Chevrolet truck with an aluminum body. It is equipped with an extra gas tank to take care of those long stretches between European re-fuelling stations. All of the operating equipment is contained inside the truck which has sufficient space for two operators to move about without crowding or stooping. There is adequate floor space for sleeping cots, in case of emergencies.



The meter panel monitors both splits of the power line feed from the trailer. Each line is metered for voltage, current load and frequency. Should the power line frequency fall below 59 cycles, an alarm is tripped which warns the operator that there is danger of out-of-sync operation. There are twelve main-power outlets. Each is protected by an individual magnetic circuit breaker. By selecting the proper outlets, or by manipulating the circuit breakers, the loads on the split-line feed can be kept in balance, one side of the line with the other. For camera, truck and trailer intercommunication, a Masco system is provided.



The two wheel trailer contains the power generating equipment and can be quickly hitched or unhitched by one man. It is equipped with electric brakes and signal lights. The louvers, which can be seen on the front of the trailer, pivot freely. Behind them is a large ventilating fan. When the generator is started, power is supplied to the fan motor and the louvers open automatically and are raised by the air stream. This makes certain that they will be closed when the equipment is idle, keeping out dust and rain.

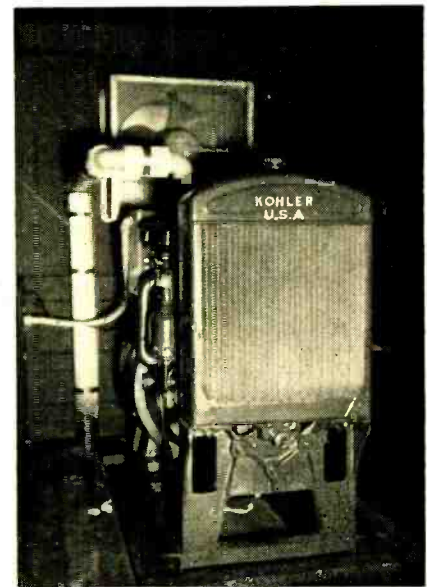

The power generator, contained inside the trailer, is a 10kw Kohler driven by a 4 cylinder gasoline engine. The trailer carries its own gasoline supply tank. The output of the generator is 220 volts a.c., 60 cycles. The 220 volt line is split to 110-0-110, so that all American and some of the European equipment encountered can be operated from the one source. The ventilating fan can be seen just above the generator, at the rear. Six hundred feet of cable, in six 100' lengths, enable the generator to be adequately sound-separated from the truck.

Simple Attenuator Calculations

JACK D. GALLAGHER*

Using only algebraic methods, the author presents a simple approach to determining resistor values for T pads.

DESIGN OF ATTENUATORS for the reduction of voltage, current, or power in pre-determined amounts is often necessary in the adjustment of audio systems, impedance matching circuits, and other applications.

One of the most commonly used attenuators is the "T" pad as shown in Fig. 1. The computations for solving the values of the resistive components of the "T" pad involve the use of hyperbolic functions as indicated by the associated formulas.

The value of θ is the value of the image transfer constant, or the loss in the network in nepers—this quantity being equal to the loss in decibels divided by 8.686.

There are other formulas which can be used to solve for the resistive components of the network, but they also involve the hyperbolic functions of the image transfer constant. Perhaps the only cumbersome feature of these formulas is that a table of hyperbolic functions must be used in their solution, or a vector slide rule must be used if one is available. However, this is not the only objectionable feature of these formulas, for there is no method of pre-determining whether or not one of the resistive elements will become less than zero with a desired loss until the formulas in Fig. 1 have been solved. Thus, effort is wasted in computing values for a non-existent T pad.

Algebraic formulas for the solution of a T-pad network are shown in Fig. 2.

In the formulas for c and b , the value of P is always less than 1, and is equal to the antilog of the quotient of the desired loss in decibels divided by 20, or

$$P' = \text{antilog}_{10} \left(\frac{db}{20} \right)$$

If the right side of the equation for P' comes out greater than 1, the reciprocal of P' is used as P in the above formulas; if P' is less than 1, use P' for P in the formulas. Thus, if the desired loss is 40 db, P would be 0.01, and if the desired loss is 10 db, P would be .316.

It can be shown that a simple approximate formula for determining the least loss for which a T pad can be designed is given by the following expression:

$$\text{Least loss in db} \cong 20 \log_{10} \left[0.5 \sqrt{\frac{Z_1}{Z_2}} \right]$$

If the quantity in the brackets is less than 1, use the reciprocal of this value in solving for the least loss.

Examples

The use of the formulas can be illus-

* 5438 McCommas Ave. Dallas 6, Texas.

trated by choosing a practical example. Suppose that $Z_1 = 225$ ohms, $Z_2 = 625$ ohms and the required loss is to be 25 db. The first step in the solution is to determine if the T pad can be designed for a 25 db loss.

Using the approximate formula previously given for determining the least loss in db, we find it to be

$$db \cong 20 \log_{10} 0.5 \sqrt{\frac{225}{625}}$$

Since the value of the constant and radical expression is less than 1, the reciprocal must be used; thus

$$db \cong 20 \log_{10} 2 \sqrt{\frac{625}{225}} \cong 10.4$$

Since this value is less than 25 db, the design can continue with the assurance that one of the resistive components of Fig. 2 will not become less than zero. The exact value of the least loss as computed by a slightly more cumbersome formula was found to be 9.54 db.

Continuing with the design, the value of P in the formulas for c and b is determined.

$$P' = \text{antilog}_{10} \left(\frac{25}{20} \right) = 17.75$$

But, since P' is greater than 1, the reciprocal must be used; that is, $P = 0.0564$. Substituting this value in the algebraic formulas for c and b , the values of the resistive components in the network of Fig. 2 are: $c = 42.8$ ohms, $b = 600.2$ ohms, and $a = 183.6$ ohms.

If, in the example, the required loss were 8 db, the solution of the approximate formula for the least loss in db would indicate that a T pad could not be used with the impedances in the example, and no further calculations need be made.

If the designer is frequently confronted with T-pad problems, it is convenient to make a table of least losses

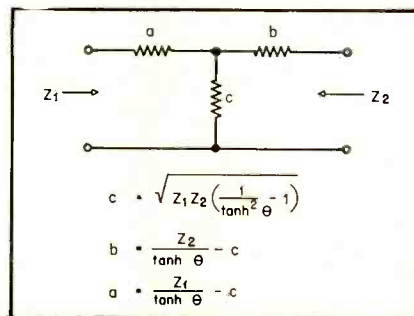

Fig. 1. Formulas for determining resistor values for T pads, using hyperbolic functions.

from the approximate formula previously given so that useless computations will be avoided. If the exact least loss is desired, the following formula can be used to compute this loss.

$$\text{Least loss in db} = 20 \log_{10} \frac{\sqrt{Z_2 + \sqrt{Z_2^2 - Z_1}}}{\sqrt{Z_1}}$$

In this formula, Z_2 is the larger of the two impedances.

The use of hyperbolic tables or a vector slide rule is not necessary in the foregoing discussion; however, a slide rule containing enough scales to solve square roots, determine logs, and to accomplish simple multiplication and division is almost a necessity.

If a T pad is designed using the value or least loss as given by the formula above, the resulting network will be an L pad which will match the terminal impedances.

REFERENCE

F. E. Terman: "Radio Engineer's Handbook," McGraw-Hill, New York.

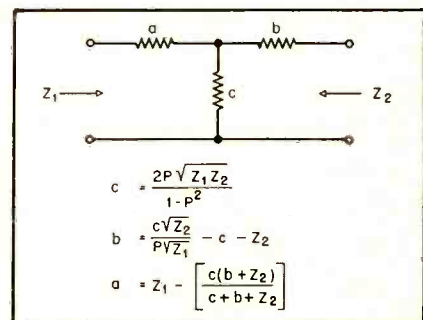

Fig. 2. Formulas for determining resistor values for T pads, using only the impedances and the term P which is derived from the pad loss.

Neat Suite

The extent to which high-quality audio has achieved recognition in the business world is well exemplified in the new Manhattan offices of MacManus, John & Adams, Inc., Detroit advertising agency.

Designed and built under the direction of v.p.-manager Ernest A. Jones, an audio hobbyist himself, the suite represents tasteful coordination of esthetic and functional influences with superb reproduction of sound for auditioning purposes.

Equipped with Altec Lansing amplifiers and speakers, Rek-O-Kut turntables, and Pickering reproducers, the installation offers a graphic glimpse of what may be expected among prime amenities in the office of tomorrow.

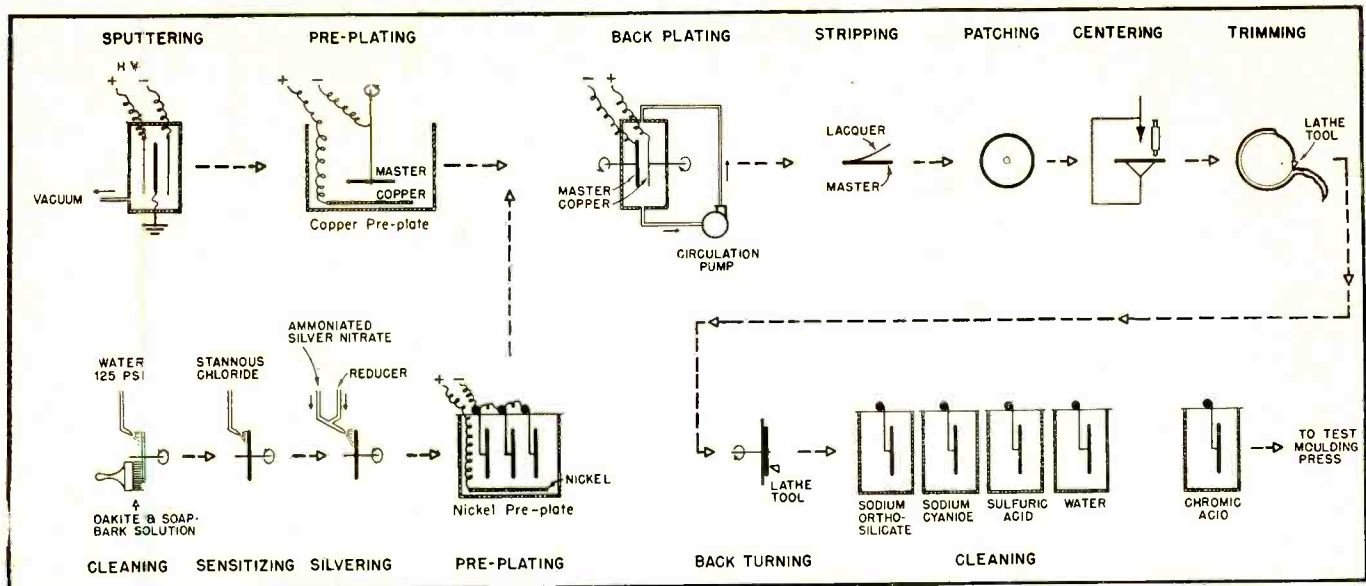

Fig. 1. Flow chart for record processing in modern plant equipped for high-quality record or transcription manufacture.

Technique of Record Processing

LEWIS S. GOODFRIEND*

A review of the methods employed in the making of high-quality transcriptions, from lacquer master to finished platter.

THE GENERAL TECHNIQUE for making modern phonograph record matrices has been discussed at length, and its application in one of the country's most modern plants will be described here.¹ The key to high-quality phonograph reproduction is in the manufacture of phonograph records. Bad recordings and pressings can never be made to produce good quality. The discs even when perfect have already lost some detail, and in order to produce as fine a disc as possible great care must be taken.

Lacquer masters or wax masters are received at the pressing plant in dust-proof boxes which are not opened until the disc is ready for metalizing. The operator removes the disc from the box, inspects it, and if it is without defects it is processed. The plant of the K. R. Smith Division of Allied Record Mfg. Co., to be described here, uses both gold sputtering and silvering processes for metalizing. Since the former is used almost nowhere else in this country it will be considered first. The entire processing operation is diagrammed in Fig. 1.

The object of the metalizing is to produce a metallic surface on the lacquer master so that a heavy metal backing may be plated on the impression of the grooves. After inspection in an air conditioned sputtering room the lacquer master is placed in the sputtering chamber, Fig. 2, which is then sealed and

evacuated. When the proper vacuum is reached the high voltage is turned on and the lacquer is sputtered with a layer of gold only three molecules thick. This process takes from 12 to 20 minutes depending on the lacquer volatile content. After the sputtering is completed the voltage is removed and the

pressure in the chamber returned to atmospheric. The disc is then removed and immediately placed in the copper pre-plate room. The pre-plating is done in a tank in which the gold-plated master is the cathode and copper bars in the bottom of the tank form the anode. The disc is washed with distilled water just



Fig. 2. Operator removes the gold-sputtered master from one of the three vacuum sputtering units.

* 404 Riverside Dr., N. Y. 25, N. Y.

¹ Harold Harris, making phonograph record matrices." *AUDIO ENGINEERING*, July 1948, p. 14.

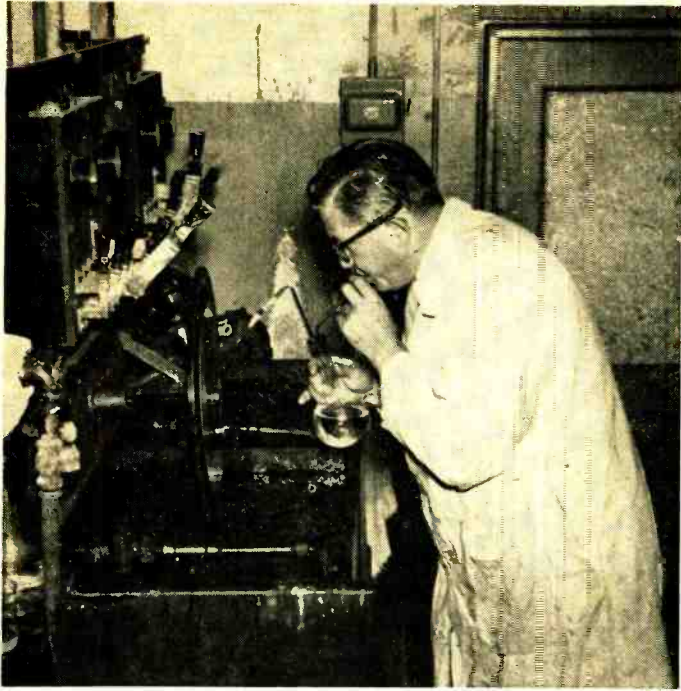

Fig. 3. K. R. Smith demonstrates the washing of a master between the sputtering and pre-plating processes.

prior to being immersed in the acid copper bath, Fig. 3, and is rotated in the bath in order to increase the chemical activity. The current density during this pre-plating is low, about 25 amperes per square foot. The thickness of the pre-plate is about .0015 in., and is deposited in about 30 minutes. Following the pre-plating the disc is placed in one of the high-speed platers which deposits a .055-in. back plate of copper in about four hours at a current density of at least 250 amperes per square foot, requiring about 1200 ampere-hours. The bank of nine high speed platers is shown in Fig. 4. The heavy braided copper leads carry the high plating current while the pipes permit high-speed circulation of the plating solution.

Silvering

When the process reaches the back-plating stage both silvered and gold sputtered masters follow the same processing, as the flow chart indicates. So a quick review of silvering will show what has been happening to the discs that customers ordered processed by the silvering method.

On passing inspection, the disc is scored on the back through to the metal base, in a circle about a quarter of an inch from the edge, and the edges are scraped free of lacquer. By doing this, the operator assures that the silver film will not peel near the edge. Then the disc is placed on a slowly turning table in a plating booth and degreased with a solution of soap bark and Oakite and washed in a water spray under 125 psi pressure. The lacquer surface is sensitized by a spray of stannous chloride which slightly penetrates the surface. After further washing the disc is sprayed by a dual jet nozzle, Fig. 5, which simultaneously feeds ammoniated silver nitrate and a reducing agent, either formaldehyde or dextrose. When they come in contact with the sensitizer

they form a very thin layer of metallic silver on the lacquer surface. In spraying any of the solutions the spray is always done from the outside in, in order to obtain good bonding at the edges.

Following the spraying and final washing, the discs are placed vertically in a nickel pre-plating tank. This tank does not have rotating electrodes, because too much agitation may cause separation of the silver film from the disc. After 15 to 20 minutes in the pre-plating bath, the disc is ready for the high-speed back plating operation. Figure 6 shows the operator closing the first three high-speed platers after reloading. The solid copper anode may be seen in the plater at the left.

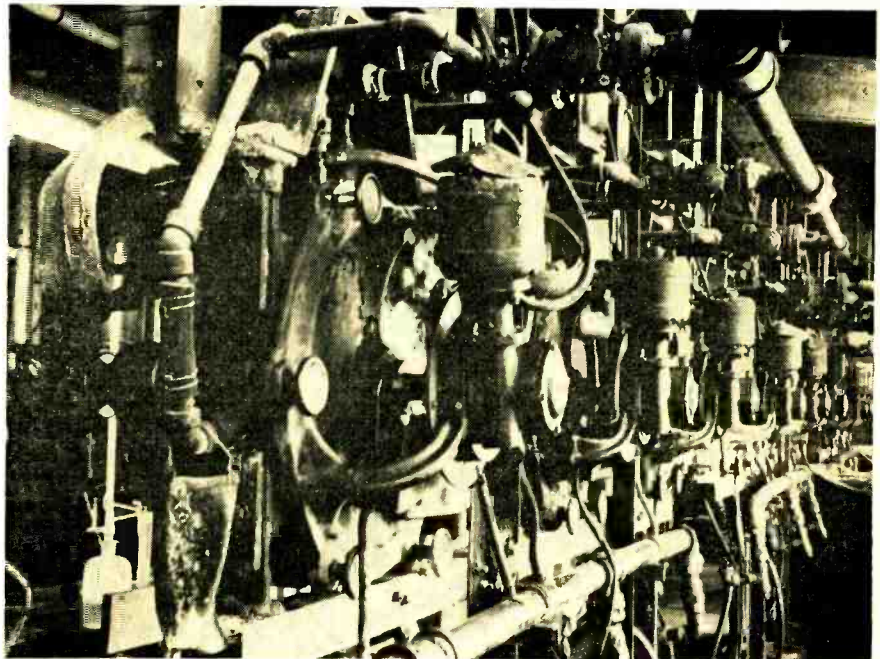

Fig. 4. Back view of the high-speed plating machines. These motors rotate the solid copper anodes, while similar motors on the front of the machines rotate the master discs. Note the heavy braid leads necessary to carry the high plating current.

Up to the end of the pre-plating operation the processing has included metalizing the original lacquer master and adding thicknesses of various metals. At this point the success or failure of the plating operations is determined. The lacquer master and the metal impression are separated at the stripping table. This is a hand operation and depends on the skill of the workmen. When the metal layers are stripped off, the soft gold or silver layer is outermost and any sliding of the lacquer over the soft metal may damage the raised groove impressions of the *metal master*. To strip the master, a knife blade is inserted between the lacquer and the metalized layer and carefully used as a lever to pry the two masters apart. In a pressing plant the metal master is known as *the master* while the lacquer original is known as the *lacquer master*. The master has raised impressions of the original recorded groove surfaces, and inspection of the master at this point tells whether the metalizing and pre-plating operations were successful.

Fabrication

Following stripping and inspection, the original center hole of the disc is filled in with a patch. Usually the plating around the hole has not been even so a small section is cut away and a small piece of copper soldered into the center in its place. Even if the original hole had been reproduced accurately it is usually not desirable to use it. Many recording tables have worn or undersized center pins, and manufacturers allow a tolerance in the size of the center hole of the lacquers that they supply. These two factors combine to permit an original center hole with an eccentricity of .003 to .004 in. An accurate center is located on a centering table by rotating the disc and watching the grooves with a mi-



Fig. 5 (left). Silvering a master with a dual-jet nozzle.

Fig. 6 (below). Operator preparing to close three high-speed platers.

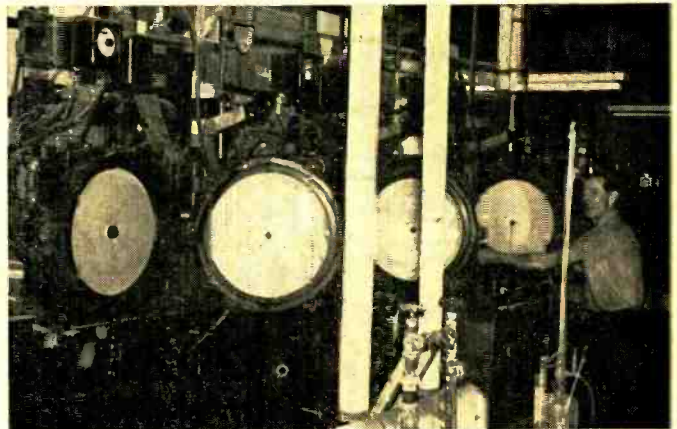

roscope. The edge of the disc is tapped lightly until one groove spiral may be traced each revolution. The punch is then operated and a new and accurate center is in the master.

After centering, the master is placed on a trimming turntable, *Fig. 7*, which has a tight fitting center pin. A circular knife blade is closed on the rim of the disc and the disc turned slowly. With each revolution the knife pressure is increased until the rim is cut. This provides the edge of the master which is gripped by clamps in the molding presses. All that remains now is the back turning. This operation illustrated in *Fig. 8* is performed on a lathe which has a rubber sealing ring on a soft paper-faced vacuum chuck. The rubber prevents air leakage and the paper prevents damage to the groove faces while the vacuum holds the master tightly without clamps or screws. The back of the master is turned until the total thickness is forty thousandths of an inch. It is then ready for the final set of chemical baths required to plate a thin layer of tough chromium over the gold or

silver face of the metal master. The chromium is strong enough to resist plastic flow under the high pressures in the stamping press.

Chrome Plating

After the fabrication has been completed the disc must be thoroughly cleaned. First grease is removed in an electric caustic bath of sodium orthosilicate. It then goes to a sodium cyanide dip which neutralizes the alkali and brightens the gold. After this it is given a sulfuric acid dip that precludes contamination of the chromate both by cyanide or alkali. Following the chemical treatment the master is washed and placed in the chromic acid plating solution. It is usually mounted with another disc for this part of the process. Two sixteen inch masters are first given a 1500-amp. "jolt" for 15 seconds, followed by nine minutes at a current of 600 amps. When the discs are then removed, washed, and dried, they are finished masters.

When it is desired to make more pressings than a single stamper can pro-

duce, a *mother* is made. The mother is a metal replica of the lacquer master. That is, the grooves are now in the disc rather than raised from the surface as in the master and stamper. In this plant the method of producing mothers is to make a test pressing from the master, and on approval of this pressing repeat the process starting with the master. That is, the master is gold sputtered over the chrome on the master. The rest of the mastering process is followed giving a mother which separates from the master between the gold-chrome interface. The process may be repeated starting with the mother this time and ending with a stamper. Several stampers may be made from each mother.

Another more common process to obtain mothers is to remove the silver from silvered masters by a chromic acid bath. This leaves the nickel surface. The nickel surface is now cleaned and treated by a separating agent or stripping solution, usually sodium or potassium dichromate. This *pacifies* the nickel and forms a thin crystalline oxide which is

[Continued on page 46]



Fig. 7 (above). Trimming of the master follows accurate locating and punching of center hole.

Fig. 8 (right). A vacuum chuck is used to hold the master during the back-turning operation.

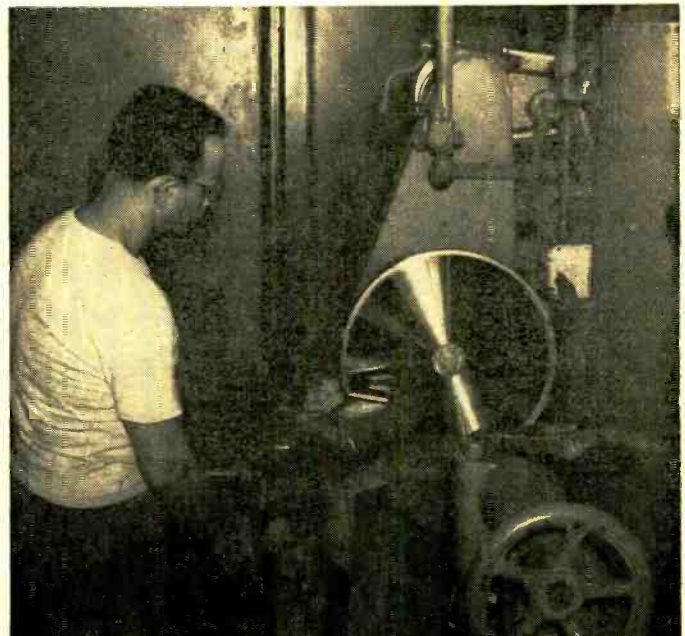



Audio Engineering Society,
Box F, Oceanside, N. Y.

AUDIO engineering society

Containing the Activities and Papers of the Society, and published monthly as a part of AUDIO ENGINEERING Magazine

OFFICERS

John D. Colvin President	Bob Hugh Smith Western Vice.-Pres.
C. G. McProud Executive Vice-Pres.	Lawrence Shipley Central Vice.-Pres.
Norman C. Pickering Secretary	Ralph A. Schlegel Treasurer

The Measurement of Audio Volume

H. A. CHINN*

Part II—A comprehensive discussion of the problems involved and the instruments employed to indicate program level and sine-wave tones in broadcast and recording circuits.

A THOROUGH COMPREHENSION of the connotations of the term "reference volume" is fundamental to any studio engineering endeavor. Unfortunately, experience has shown that this subject is often completely misunderstood. It is hoped that the following will dispel the vague understanding that sometimes surrounds this simple subject.

It is important to appreciate that reference volume is a practical and useful concept, but one which is quite arbitrary and not definable in fundamental terms. As already mentioned, it cannot be expressed in any single way in terms of the ordinary electrical units of power, potential, or current. Reference volume is describable only in terms of the electrical and dynamic characteristics of an instrument, its sensitivity as measured by its single-frequency calibration, and the technique of reading it. In other words, reference volume may be defined as that level of program which causes a standard volume indicator, when calibrated and used in the accepted way, to read zero vu.

The sensitivity of the standard volume indicator is such that reference volume corresponds to the indication of the instrument when it is bridged across a 600-ohm resistor³ in which is flowing one milliwatt of sine-wave power.

It is especially cautioned that *reference volume should not be confused with the single-frequency power used to calibrate the zero volume setting of the volume indicator.* If a volume indicator

* Columbia Broadcasting System, 485 Madison Ave., New York 22, N. Y.

³ A standard impedance of 600 ohms was chosen originally since, keeping in mind the telephone plant, there was more audio equipment designed to this impedance than to any other.

is calibrated so as to read zero vu on a sine wave power of, say, one milliwatt in a stated impedance, a speech or program wave in the same impedance whose intensity is such as to give also a reading of zero vu will have instantaneous peaks of power which are several times one milliwatt and an average power which is only a small fraction of a milliwatt. It is therefore erroneous to say that reference volume is one milliwatt.

Moreover, it should be emphasized that although it is convenient to measure the performance of amplifiers and systems by means of single frequencies there is no *exact* universal relationship between the single-frequency load-carrying capacity indicated by such measurements, and the load-carrying capacity for speech and program waves expressed in terms of volume level. This relationship depends upon a number of factors such as the rapidity of cutoff at the overload point, the frequency bandwidth being transmitted, the quality of service to be rendered, and similar factors.

The question may well be raised why reference volume has been related to a calibrating *power* rather than to a cali-

brating *voltage*, inasmuch as a volume indicator is generally a high-impedance, voltage-responsive device. A reference level could conceivably be established based on voltage and the unit of measurement might be termed "volume-volts." However, volume measurements are a part of the general field of transmission measurements, and the same reasons apply here for basing them on power considerations as in the case of ordinary transmission measurements using sine waves. If the fundamental concept were voltage, apparent gains or losses would appear wherever impedance

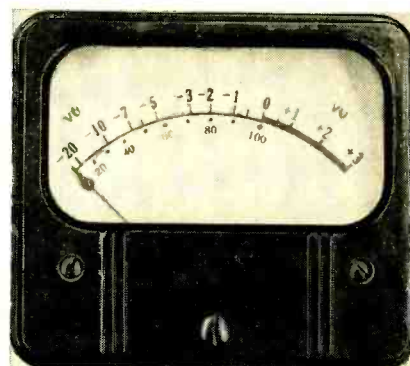

Courtesy General Electric Co.

Fig. 2. The "A" type standard volume indicator scale emphasizes the VU markings and has an inconspicuous voltage scale. This type of scale is commonly used for transmission measuring sets.

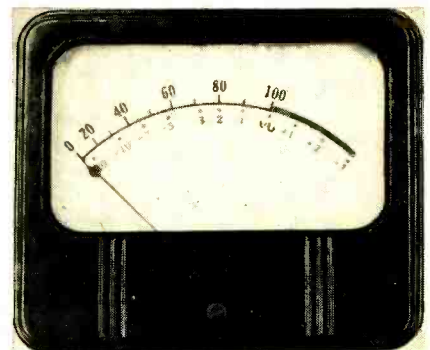

Courtesy General Electric Co.

Fig. 3. The "B" type standard volume indicator scale emphasizes the percentage scale. This scale is used extensively for program transmission applications.

transforming devices (such as transformers) occur in a circuit. This difficulty is avoided by adopting the power concept, making suitable corrections in the readings when the impedance is other than 600 ohms.

Volume Measurement Terminology

(a) VU. The terminology that is used to express volume measurements was created to avoid confusion as to the type of volume indicator used and the reference level. The term "vu" (pronounced "vee-you") is used; the number of vu

Responsibility for the contents of this paper rests upon the author, and statements contained herein are not binding upon the Audio Engineering Society.

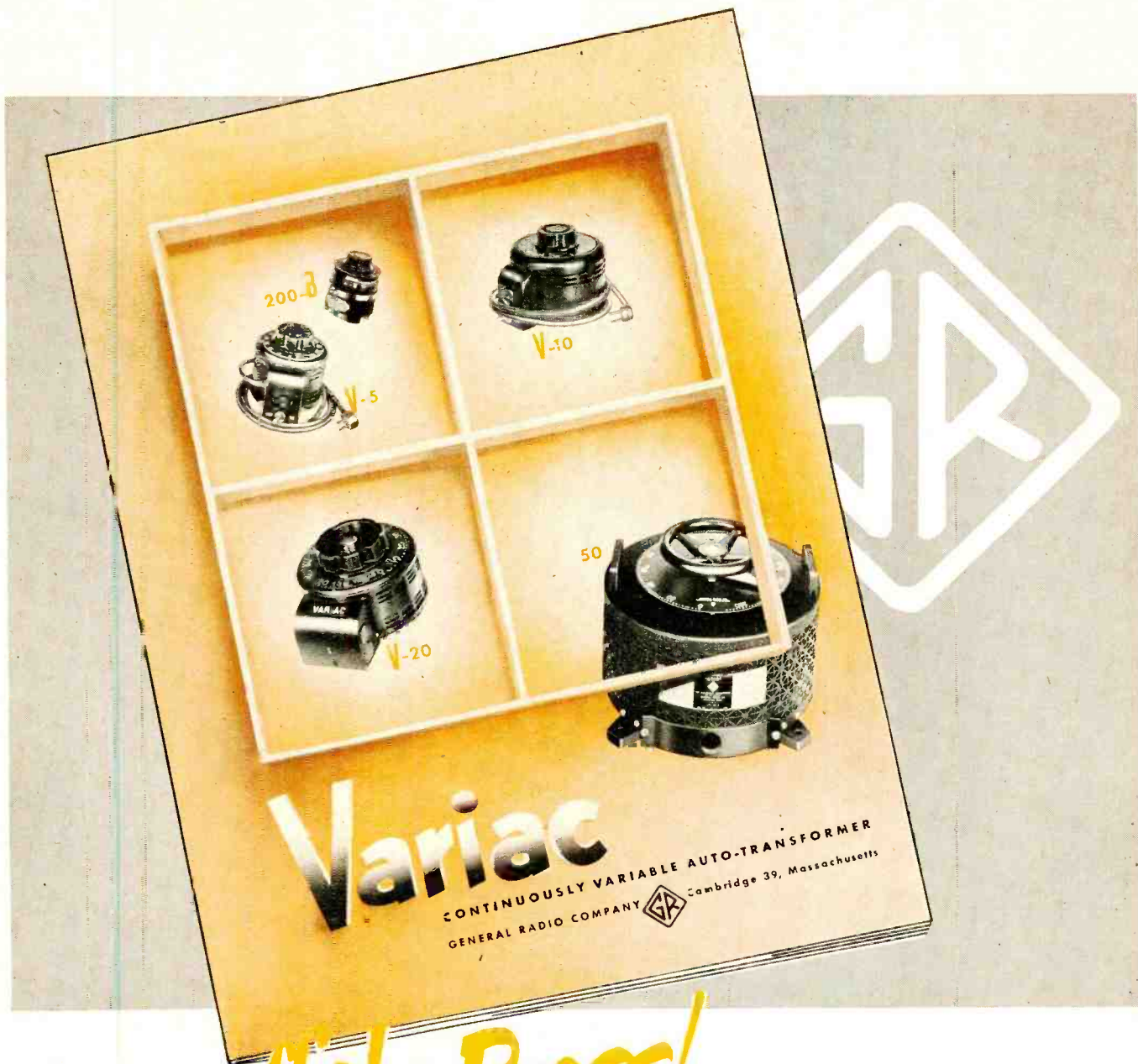

Just off the Press!

NEW Variac BULLETIN — Write for Your Copy

New models . . . more detailed electrical and mechanical specifications . . . complete table of all standard single, ganged and polyphase VARIACS are described in this profusely illustrated, complete VARIAC Bulletin, now ready for mailing.

We know you'll want a copy. Fill in and mail the coupon below.

GENERAL RADIO Company
 275 Massachusetts Avenue, Cambridge 39, Mass.



30 West St. NEW YORK 6
 320 S. Michigan Ave. CHICAGO 5
 1000 N. Seward St. LOS ANGELES 38

SEND ME THE NEW VARIAC BULLETIN



Name _____

54

Street _____

City _____ Zone _____ State _____

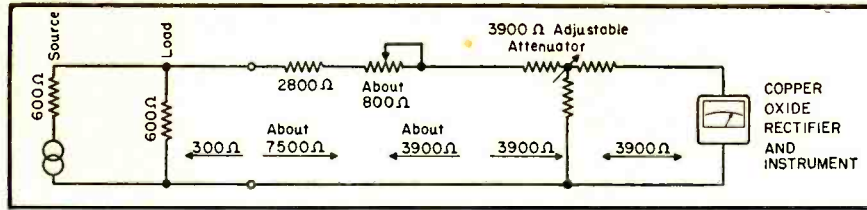

Fig. 4. The basic circuit for the standard volume indicator has an input impedance of 7500 ohms. For maximum sensitivity the loss in the adjustable attenuator is reduced to zero, but in order to maintain proper dynamic characteristics the indicating instrument itself must always face approximately 3900 ohms.

being numerically the same as the number of *db* above or below the reference volume level. The use of this term is restricted to the ASA standard volume indicator described herein. A volume level reading can be correctly expressed in terms of *vu* only when it has been made with an instrument having the electrical and dynamic characteristics described.

(b) *DBM*. For steady-state measurements a reading in "*vu*" would denote a specific single-frequency audio power, for dynamic program indications "*vu*" denotes only a volume level. This dual meaning of "*vu*" is avoided by the use of the term "*dbm*" for all steady-state measurements. As defined, a reading expressed in "*dbm*" at once indicates the power level of a steady, single-frequency signal where the number of "*dbm*" is equal to the number of decibels above or below a reference power of 1 milliwatt.

(c) *DBM vs. VU*. It is to be noted that a "*vu*" reading can be made only on a standard volume indicator whereas *sine-wave* power measured with the standard volume indicator or with any other suitable a.c. instrument can be expressed in "*dbm*".⁴

DBM is a unit of finite power whereas "*vu*" is a measure of volume level and, as already discussed, has no connotation of finite power level. Thus no direct relationship between "*dbm*" and "*vu*" can be established.

From a practical standpoint, however, some relationship is desirable between

⁴ H. A. Chinn, *AUDIO ENGINEERING*, Vol. 32, No. 3, p. 28, March 1948

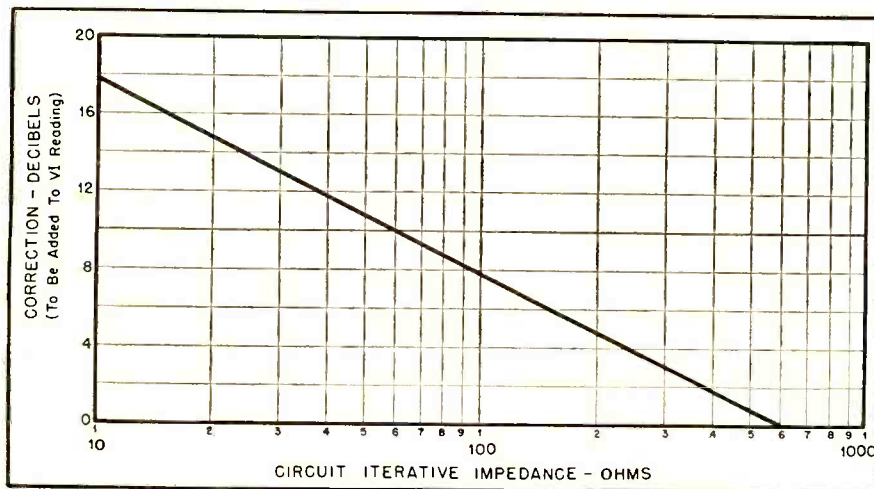

Fig. 5. Volume indicator correction factors (to be added to volume indicator reading) for use when instrument is bridged across circuits having iterative impedances other than 600 ohms.

the "*vu*" level used for program transmission peaks and the "*dbm*" level used for system measurements. In practice it has been found that with typical program material of a given crest amplitude, the standard volume indicator reaches an indication 8 to 14 *db* below that reached with a steady tone of the same crest amplitude. To nominally take into account this 8 to 14 *db* difference in response, the established practice is that

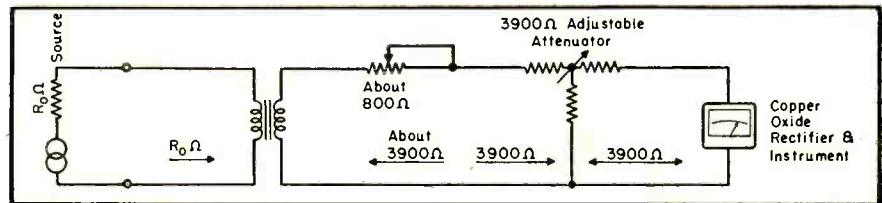

Fig. 6. Volume indicator circuit having low input impedance which terminates source and also provides increased volume indicator sensitivity.

performance requirements must be met at a single-frequency test-tone level that is at least 10 *db* higher than the normal program peaking level (for example, in a system that is to transmit program material at +8 *vu*, all single-frequency measurements would be made at +18 *dbm* test-tone level). This procedure reasonably insures that system performance is within standards under normal operating conditions.

Reading the Volume Indicator

Since program material is of a rapidly varying nature, a reading of a volume indicator cannot be obtained instantly. Rather, the gyrations of the needle must be watched for an appreciable period of

time, the length of time depending upon the program material. For speech a 5 to 10 second period of observation may be sufficient whereas for symphonic music 1 to 2 minutes may be necessary. During this time the adjustable attenuator, which is a part of the volume indicator, is adjusted so that the extreme deflections of the instrument needle just reaches the reference point; i.e., a scale reading of zero on the *vu* scale or 100 on the percent voltage scale (see *Figs. 2 and 3*). The volume level is then given by the designations numbered on the attenuator. If, because of the coarseness of the adjustments provided or for other reasons the deflections cannot be brought exactly to the 0 *vu* or 100 per cent mark, the reading obtained from the setting of the attenuator may, if desired, be corrected by adding the departure from 0 shown on the *vu* scale of the instrument. In the interests of accuracy the steps on the adjustable attenuator should not ex-

ceed 2 *db*, so that the departure from the reference point never need exceed this amount. Particular attention is called to the fact that, unlike almost any other electrical indicating instrument, the volume indicator reading is determined primarily from the setting of the associated range switch and, in effect, only a secondary correction is obtained by observing the deviation of the needle from exact coincidence with the reference point on the scale.

Features of the Standard Volume Indicator

The volume indicator that has been described has the stature of an American Standard.⁵ In the many years since it was first placed into service there have been no changes, whatsoever, in either the fundamental requirements or the specific features of the instrument that was developed to meet the basic needs. Because of the importance and the widespread use of the instrument some of the detailed characteristics that are of concern to the design engineer are presented below.

(a) *Response vs. Frequency Characteristic*. The sensitivity of the volume indicator instrument shall not depart from that at 1000 cps by more than 0.2 *db* between 35 and 10,000 cps nor more than 0.5 *db* between 25 and 16,000 cps.

(b) *Input Impedance*. The impedance of the volume indicator arranged for bridging across a line is about 7500

[Continued on page 48]

⁵ Volume measurements of electrical speech and program waves, American Standards Association C16.5-1942

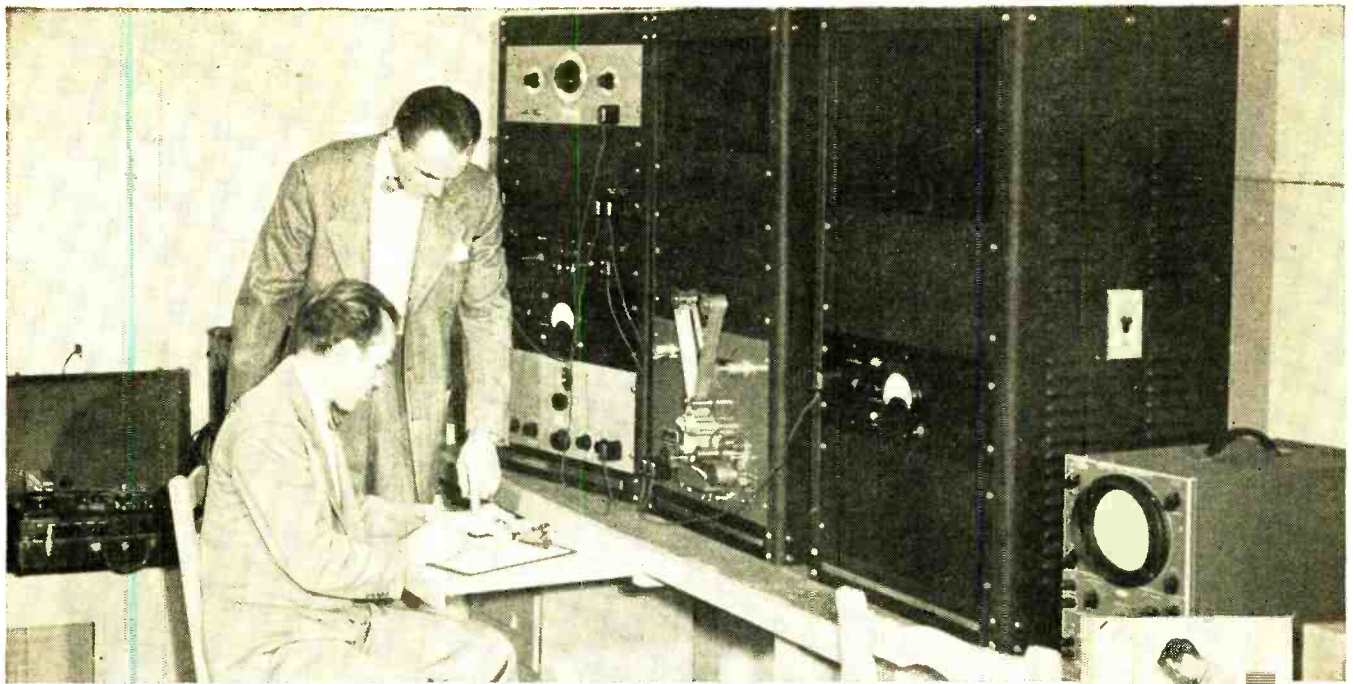

SOUND RECORDING TAPE engineers at work in the 3M Hollywood Engineering Laboratory.

Ask one of our 3M Service Engineers

FOR A "SOUND SOLUTION" TO ANY TAPE RECORDING PROBLEM

Eighty 3M engineers in the field—backed by twenty technical experts in the 3M laboratories—stand ready to help you with any tape recording problem.

This 3M Service Organization works daily with radio station engineers, electronic engineers and industries using tape recordings in process or quality control. The same electronic and engineering know-how that produced and perfected the famous "SCOTCH" Sound Recording Tape offers you technical assistance on every phase of sound recording.

If you are using sound recording equipment in your radio station, laboratory or business, call upon the 3M Service Representative in your community. He'll be glad to help you make better recordings—more easily. If you are contemplating the use of tape recordings, he'll be glad to analyze your requirements and aid in the selection of equipment.

Call him today—or, if you prefer, write directly to Minnesota Mining & Mfg. Co., Dept. AE-101, St. Paul 6, Minn. No obligation, of course.

"SCOTCH" Sound Recording Tape gives you these EXTRA construction features...

- **REEL TO REEL UNIFORMITY**—controlled coating assures consistent output.
- **THINNER CONSTRUCTION**—resists temperature and humidity changes.
- **NO CURLING OR CUPPING**—tape lies flat on recording head unaffected by humidity.
- **UNIFORM TAPE SURFACE**—no "dropouts" on recordings due to surface irregularities.
- **LONGER TAPE LIFE**—special lubricating process reduces friction.
- **GREATER SENSITIVITY**—more output on your present machine setting.



The term "SCOTCH" and the plaid design are registered trade-marks for Sound Recording Tape made in U.S.A. by MINNESOTA MINING & MFG. CO., St. Paul 6, Minn.—also makers of "Scotch" Brand Pressure-sensitive Tapes, "Underseal" Rubberized Coating, "Scotchlite" Reflective Sheeting, "Safety-Walk" Non-slip Surfacing, "3M" Abrasives, "3M" Adhesives. General Export: Minn. Mining & Mfg. Co., International Division, 270 Park Avenue, New York 17, N. Y. In Canada: Minn. Mining & Mfg. of Canada, Ltd., London, Canada.

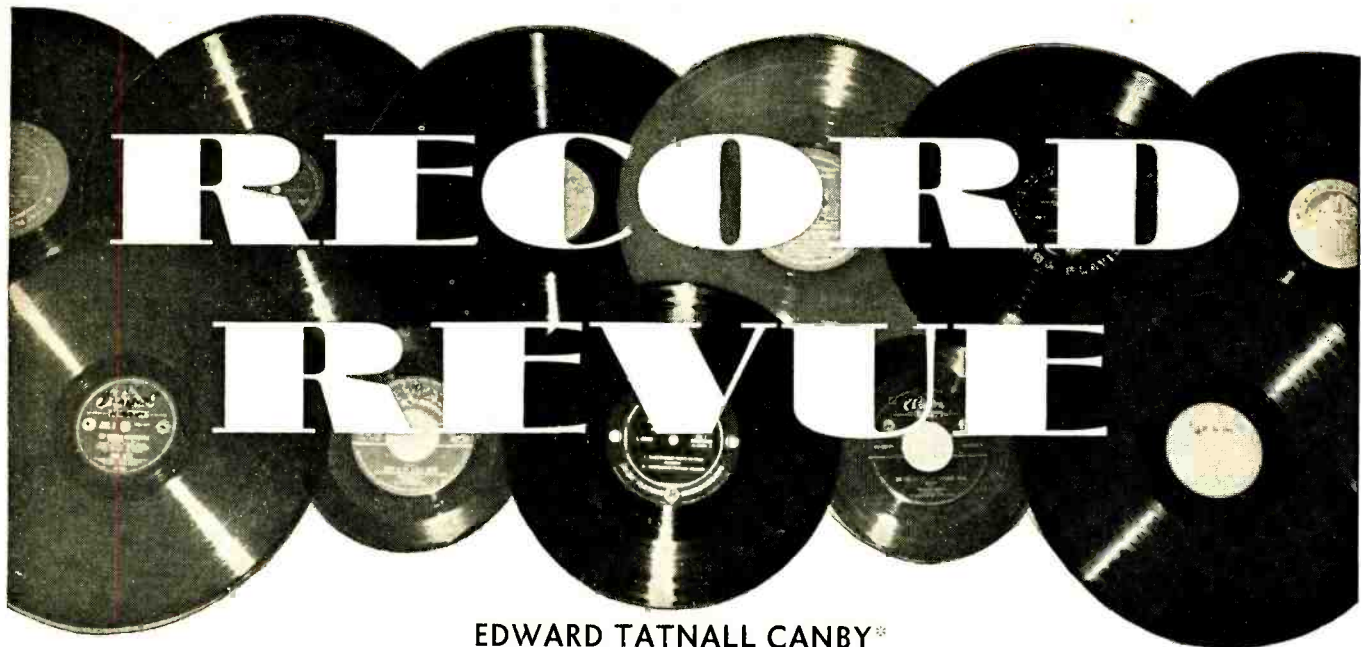

EDWARD TATNALL CANBY*

The RJ Speaker

A COUPLE OF ISSUES back I made some cryptic remarks about a new speaker enclosure system I had seen and heard, small enough with a 15 in. speaker in it for "your wife to sit on with a tight skirt." That somewhat risqué analogy was used deliberately (after I had discarded plenty of others!) to indicate that it was small—but not how small. The basic idea behind this new speaker system is so simple that—at this writing still—I simply cannot believe it. Either it's true and we have here something quite revolutionary in its practical significance; or else the whole thing is a large bubble of hot air. I'm willing to take a risk, anyhow; but until this appears, it will not have been fair to the designers of the equipment to give the "secret" away, since protection was not yet secure, and hence in my first mention I was as vague as could be.

Is Bigness Necessary?

The trend in the last year or so in speaker enclosures as we all know has been towards the monstrous. "Bigger and Better" is a rather accurate description of many of the new horn-assisted systems. Yet in most other phases of electronics and audio, the trend has been mercifully towards smaller and smaller. The basic elements of a phonograph system have shrunk astonishingly since before the war—styli, pickups, arms, motors, amplifiers and their tubes and capacitors, even speakers; for the potent-magnetized PM speaker gives more music for less size than most pre-war electro-dynamics. Records too. The decrease in size-per-minute of music is of course the biggest development of all. Which only serves to isolate the speaker enclosure as the glaring exception to the happy rule of the miniature.

And the worst part of it is that with a huge and heavy enclosure necessary for good sound in an audio system, the rest might just as well take up space too. Things as a whole, then, remain overly big partly because it just isn't worth fussing too much with miniature problems. And so we have two general alternatives these days in the larger audio field: put out bulky equipment and get the best in sound; or put out portable, modestly proportioned stuff—and sacri-

fice heavily in the quality. Both lines of thought are being followed assiduously. What we need, however, is to have this particular cake and eat it. If we could have a small outfit that at the same time gave top quality, include the all-essential good bass response, then we would have a bonanza-producer. The answer to a hundred thousand dealers' prayers. And a million record owner's equally insistent dreams. It looks to me as though *maybe* those dreams and prayers could be answered, by the new speaker enclosure which I shall call, for lack of an official name, "RJ", after Frank Robbins and William Joseph (Sales Engineer, Milo Electric) the team who have worked it out.

RJ—for the Tight Skirt

Perhaps you will see why I have been enthusing over RJ these several months when I give you the bare essentials. Take a standard high quality two-way speaker system, 15-in. woofer plus tweeter. Mount the 15 and the tweeter both together into an RJ enclosure that is *roughly 18 inches square*. Measure the output of the system and discover for yourself that you are hearing sound with a cleaner, flatter "curve," with far better transients than the average reflex box, with bass response flat down to below the best in standard reflex arrangements, there is no peak whatsoever. And all this at a sacrifice of about 3 db in output efficiency, since only the frontal output of the speaker is used.

Look at it differently. Here, coming out of this 18-in. square box, is sound that can match or surpass the sound from the largest and heaviest of bulky systems in a number of ways. Perhaps, from the professional's viewpoint, it will not rate as *the* finest system in all respects. But enough that it rates among the better systems—and takes up such an incredibly small space! What more can you ask?

Still another angle. Take a quality 8-in. speaker and tie it to a 6-in. as a tweeter. Mount these two in an RJ box *9 inches square*. (I was going to say a hat box—but that's too big; call it a pill box.) You will thereupon achieve flat bass response down in the 70's or so, equivalent to response of many a far larger, full-sized cabinet and surely better than any of the

usual commercial open-backed arrangements, "consoles," as they are so euphemistically called. How about a "console" that will sit happily on a dinner plate? This one I've heard, in a sort of pilot hand-made arrangement and am hoping to have one built as soon as practicable. Hearing's believing, with me.

Exact figures are not important in this sort of discussion—my intention is to give you the general idea of this—in case it proves to be as good as it looks and sounds. Size for size all the way up and down, the RJ type of cabinet enclosure will give you excellent bass response and smooth over-all response equal to enclosures that simply dwarf it. If this principle works, then we *can* have our cake and eat it.

RJ's Innards

Engineering not being my profession, I make no pretense of giving a proper technical description of the RJ principle. I can give you plenty to go on with yourself, from this point—the device now being adequately protected. Back of it is the Helmholtz resonator. To be more exact, the RJ Enclosure is a modified form of Helmholtz resonator, according to the Helmholtz principle of bass response. The back wave of the woofer is not used—hence both the 3 db loss in efficiency and the smooth response, minus the interference peaks and valleys of systems using combined front and back wave projection, most commonly found in the bass reflex. Both sides of the cone are loaded—not just the back, as in most enclosures.

Work on both sides of the cone, back and front. Load up the back side, as in the conventional fully-enclosed baffle, damping out the back wave. But load up the front too, and the pressure is equalized. With the front also loaded, the rise in resonant frequency that normally occurs with smaller and smaller enclosed air space behind a speaker is eliminated. Thus one can use a far smaller air volume—and a small space. No big box full of air. In fact, RJ has almost no rear space at all, to speak of, and the cubic measurement is no longer a crucial factor in the response. It figures instead in the tuning.

How to load up the front, yet let through

[Continued on page 30]

* 279 W. 4th St., New York 14, N. Y.

only you can decide

that's what the man says...

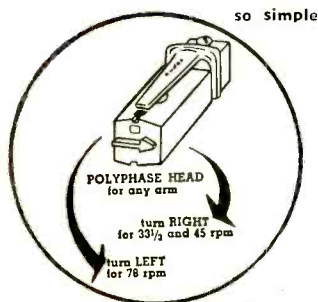

One single magnetic unit plays all records—
Replaceable Sapphire or Diamond styli.

Special models for radio stations, in-
cluding Vertical-Lateral units.

You are cordially invited to
visit us at the Audio Fair
Nov. 1, 2, and 3.

“... thanks for shipping the stylus. It is now in use, and serves as a constant reminder of the *electronic magic* . . . wrought in the POLYPHASE pickup. I am gratified, but not surprised. Mr. Weil's sensible views on sound reproduction, quoted in April “Atlantic Monthly”, lead one to expect . . . artistically satisfying music, which one actually gets from POLYPHASE . . . it is refreshing to possess at least ONE unit designed with more than electrical efficiency in mind.”

(from a letter)

Audax POLYPHASE reproducers

*“The Standard by which Others
are Judged and Valued”*

have won the acclaim of thousands of users everywhere—Never before such EAR-QUALITY, such FAITHFUL REPRODUCTION but . . . after all the reams are written about kilocycles and other laboratory data—when the chips are down—you and only you can decide what sounds best and most pleasing to your ears. Therefore . . . SEE and HEAR POLYPHASE—and you be the judge.



Available with the new Compass-pivoted Audax Arms—and for Record Changers.

Write for editorial reprints
on POLYPHASE principles—
PHONO FACTS from your favorite store

AUDAX COMPANY

500 Fifth Avenue New York 18

*“Creators of Fine Electro-Acoustical Apparatus
for Over 25 Years”*

Here's why
those in the know
—demand

CANNON PLUGS

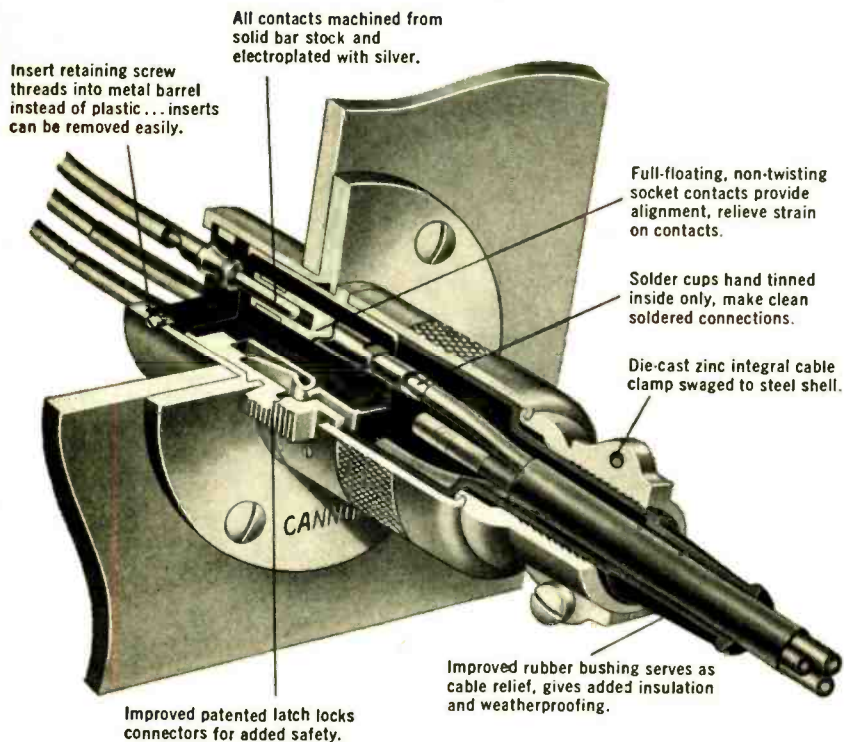

If you talk to sound technicians anywhere you'll find Cannon Type P connectors are the accepted standard of quality... taking a beating day in day out where frequent changes in circuits are required on all kinds of jobs up to 30 amp. capacity.

The close attention to important details called out in the above illustration is typical of the care used in the design and construction of all Cannon Plugs—the world's most complete line.

The above type series is distributed through selected franchise distributors. The line is fully described in the Type P Bulletin. Engineering bulletins describing each of the many basic types of Cannon Plugs will be sent on request.

Type P insert arrangements include 2-3-4-5-6 and 8 contacts. All contacts are 30 amp. capacity except those in P-8 layout which are 15 amp. Full scale layouts, front view pin insert, engaging side, shown at right.

CANNON ELECTRIC

Since 1915

CANNON ELECTRIC COMPANY
LOS ANGELES 31, CALIFORNIA

Factories in Los Angeles, Toronto, New Haven. Representatives in principal cities. Address inquiries to Cannon Electric Company, Department 109, P. O. Box 75, Lincoln Heights Station, Los Angeles 31, California.

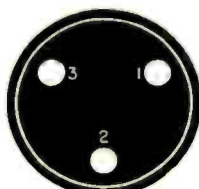

P-3



P-8

RECORD REVUE

[from page 28]

the sound? That of course is the whole simple, ingenious trick. In the design I've seen, the woofer is mounted facing down. It speaks into a carefully designed rectangular duct. (It took months of theoretical work, after the system was actually working, to derive the necessary all-over formulas to fit every possible situation.) As I get it, the duct measurements are calculated to tune with the cavity behind the speaker. Sound issues from a slot extending across the base of the enclosure—there is, I gather, some horn loading on the way from the duct to the outside slot, but it is not of importance in increasing efficiency.

And thereby hangs a short tale. The slot principle is a very ancient one in musical instruments, though remarkably seldom used in the audio field. (Some of the recent very high range tweeters use it.)

Slots

The finest way to achieve real sound distribution through a wide angle is to use a slot. Sound issuing from a horizontal slot curves sharply upward and downward in a sort of fan-shaped "spray". The most telling example is the organ pipe—which achieves a fabulously good distribution of sound from a relatively tiny slot, even in the largest and most majestic bass pipes hardly thicker than your thumb and the length of your hand. Apply that to the RJ (which could, theoretically, use an opening of any shape, as long as the area were correctly calculated) and the bass, coming from what seems to be a very thin and unimpressive slot, fills a room to perfection, distributing itself most effectively. Point-source is virtually eliminated.

The same idea may be used at the tweeter end, though the RJ principle is applied only to the woofer. I have seen a six-inch speaker used as an inexpensive tweeter which was thus mounted behind a solid piece of wood with no more than a slot across it. The sound distribution was excellent. In some projected models of the RJ enclosure the tweeter sound will also issue from a slot, possibly mounted in the "roof," facing upwards, or alternatively at the upper section of the front face, the bass slot occupying the bottom segment.

Enough said about RJ's insides—most engineers will be able to take over from here and do their own opining, pro or con. There *must* be something wrong or it would have been done before. And yet—is there? I mean fundamentally wrong, wrong enough to out-balance the absolutely inestimable advantage of enormously diminished enclosure size? That is the question. I grant that for the professional perhaps this matter of size is not of top importance. But think of the larger "market" for the entire range of audio equipment, from the hi-fi record collector and engineer right on down to the buyer of a miniature portable radio. Size is a vital thing for all of these people. Bulky equipment is tolerated and even welcomed by a good many, because it has been an unalterable rule that quality requires bulk. And if it is quality or nothing, then bulk is OK. But once you have so much as hinted that the eternal rule has been dented, even by ever so little—and anything may happen!

Applications

Let me for a moment take it for granted that the RJ enclosure is as good as it seems

Engineering Data
on **ARNOLD TAPE-WOUND CORES**

PROPERTIES OF...

DELTAMAX
4-79 MO-PERMALLOY
SUPERMALLOY*

* Manufactured Under License Arrangements with Western Electric Co.

BULLETIN TC-101
August 15, 1951

THE ARNOLD ENGINEERING COMPANY

SUBSIDIARY OF ALLEGHENY LUDLUM STEEL CORPORATION

General Office & Plant: Marengo, Illinois



WRITE FOR YOUR COPY

W&D 3611

HARVEY Features the Finest Brands



MAGNECORD SERIES 6 RECORDERS AND AMPLIFIERS

PT6-JA Recorder and Amplifier . . . the only combination that offers such high professional quality at such a low price. Includes PT6-A Recorder plus Amplifier with low impedance microphone and bridging inputs, 10 watt audio amplifier with monitor, speaker and jack for external speaker, 600 ohms balanced line output terminal.

PT6-JAH—Magnecord Combination with high speed forward	\$564.00
PT6-AH—Recorder with high speed forward	316.00
PT6-J—Amplifier	248.00
PT6-P . . . Lightweight Portable Amplifier, including a record playback remote amplifier and power supply for use with the PT6-A Recorder	\$462.00

McINTOSH AMPLIFIERS

We have McIntosh Amplifiers in stock for immediate delivery. Full information on request, or come in (if you're in town) for a demonstration.

20 W-2 Amplifier	\$149.50
50 W-2 Amplifier	249.50
AE-2-A Equalizer Pre-Amp	74.50



Complete Line of CANNON Plugs and Connectors carried in stock for immediate delivery.

CANNON plugs have been standard equipment for more than 15 years wherever a high quality connector is required for low level sound transmissions or for general electrical and electronic use. You'll find them in quality microphones, sound systems, radio and TV stations, etc. CANNON is definitely a "must" for you. Write for literature and prices for connectors to fit your requirements.

WILLIAMSON HR-15 AMPLIFIER KIT

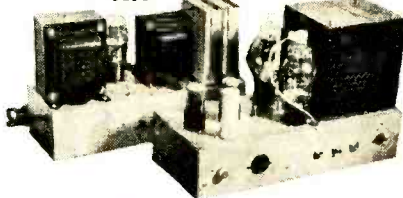

The famous Williamson HR-15 amplifier circuit . . . now available with the original Partridge transformers built to Williamson's specifications. Build this kit in 3 hours or less, and enjoy sound of a quality you never heard before. The HR-15 is a 2-Chassis power amplifier for use with tuners or other front ends having own volume and tone controls. All American triodes, 2-6SN7GY, 2-807, or 6BG6G in PP output, 5V4G rectifier. Response $\pm .5$ db, 10-100,000 cycles. Output impedances 1.7 to 109 ohms in 8 steps. Absolute gain 70.8 db. 20 db. of feedback around 4 stages and the output transformers. Kit is complete with Tubes, Punched Chassis, Pre-wired Resistor Board, Sockets, Genuine Partridge Output Transformer, and All Necessary Parts. **\$75.00.**

As Above, with CFB Transformer. **\$85.00**

PARTRIDGE OUTPUT TRANSFORMER WWFB, as used in above Kit, available separately \$24.50

Now in Stock! New Partridge CFB Series



Frequency response 3db down at 3 cycles and 95,000 cycles. Power rating 30 to 30,000 cycles at 60 watts with less than 1% distortion without negative feedback. Write for descriptive literature.

\$35.00. net

WILLIAMSON KIT, with all TRIAD Transformers, using potted output transformers. **\$75.00**

As Above, with Hermetically Sealed Output Transformers **\$85.00**

WESTERN ELECTRIC 755-A 8" PM SPEAKER

Will handle 8 watts of power. Uses a very heavy magnet. This speaker has built into it more loudspeaker quality than has been available in a unit of this size, power and cost. Only 3 1/8" deep, therefore, it offers extremely small space requirements for full range frequency coverage and wide angle distribution of high frequencies. **\$24.60**



CARTER SUPER CONVERTERS

Wherever 115v line voltage is not available or hard to get, Carter Converters supply dependable AC power supply to make on-location recordings. Operates from storage batteries. Recommended by Brush and Magnecord. . . . one model operates both Brush and Magnecord equipment. Used by leading networks. Delivers clean 60 cycle AC power. Available for 6, 12, 24, 28, 32, 64 and 115v input voltage. Write for price list and complete information.

TRANSFORMER PRODUCTS

Transformers for all applications—High Fidelity Audio Components, "Trijets"—Hermetically Sealed Midgets, Power Transformers, Replacements, Filters, Reactors, etc. . . . for the laboratory, industrial, servicing, public address and radio amateur fields. Complete stocks of all components are on hand for immediate delivery.



VISIT THE
AUDIO-
TORIUM

Come in and visit our new sound department . . . all these items and many more on working display at all times.

Telephone: **3-1300** LUXemburg 2-1500

HARVEY
RADIO COMPANY INC.

103 West 43rd St., New York 18, N. Y.

See us at The Audiofair, Room #631, November 1, 2 and 3.

NOTE: In view of the rapidly changing market conditions, all prices shown are subject to change without notice and are Net, F.O.B., N.Y.C.

to be, that it will rank technically well up with others, that it can be exploited. In other words, let me assume (as I think is the case) that here we have a very large saving in size for any attainable degree of quality. An improvement from any size-versus-quality basis.

Take the hi-fi area. The bigger RJ—the biggest being the small 18-in. cube or its approximate—will take any type of single woofer speaker. Fifteen-inch speakers give more efficiency and it may well be needed; but 12-inch speakers give remarkably good performance too. The tweeter section is adaptable as per convenience; it may be built in wherever ingenuity or convenience dictates. Needing no air space of its own, the usual tweeter unit can be included within the cube or near-cube framework of the woofer enclosure, for good looks and good centering of sound source. At present, the RJ proponents are concentrating on this aspect of the RJ development—for the best possible quality with quality components.

(Note one disadvantage of sorts: the RJ enclosure will not take a coaxial speaker system, since the tweeter would then be inside the box. Highs would be attenuated.)

In the hi-fi area, the RJ enclosure may prove of tremendous importance to those buyers of high-quality equipment who have sumptuous but none-too-big living rooms and tend, even against engineering advice, to order those dreadful combination "armchair console" arrangements which sacrifice so much in acoustical response in favor of smaller size. The RJ enclosure can be used as a chair or a coffee table or a chairside stool; it beats any chairside conventional arrangement all hollow—and gives far superior quality. With such a speaker the objection to a separate box is largely nullified. Amplifier and controls—possibly remote—could then be stowed away with the greatest of ease. I see extraordinary possibilities here, in the ultra-custom department.

Medium-fi

But, though the RJ partners have been too busy to extend their experiments yet, I have a strong feeling that the RJ principle may be even more useful in the less expensive areas. Take the medium-fi area—the cheaper separate-unit arrangements and the huge number of "console type" manufactured phonographs that people insist on buying. RJ can't improve their amplifiers and their distortion in the high end. But—build an RJ enclosure into any old console and you'll improve the bass response tremendously. I can't see anything that that would make this sort of enclosure prohibitively expensive. I can easily envision a whole line of machines such as Philco, RCA, Zenith or the like which, featuring "Magic Bass" or something equally evasive, might actually provide a kind of true bass response such as has never before been heard in a standard console.

But far more important than the console radio-phonograph is the table model. As every engineer will have to admit, grudgingly enough, 99 per cent of the people want, first of all, a table model—either a sit-up or a true portable. They want it so much that they will pay outrageous sums for phonographs with 5-inch speakers and a speaker enclosure several inches long.

RJ has not actually been tested yet to see what sort of improvement can be had in the way of better bass with the small speakers and tiny space in the millions and millions of such small portable machines—which are anything but low-priced. My hunch is that some extraordinary sounds might be caused to emit from those ordinarily bass-less horrors. Heaven only knows just where the

New 1952 HEATHKITS

Heathkit
TELEVISION
GEN. KIT \$39.50

Heathkit
ELECTRONIC
SWITCH KIT \$19.50



Heathkit
AUDIO GEN.
KIT \$34.50



Heathkit
CONDENSER
CHECKER KIT \$19.50



Heathkit
R. F. SIGNAL
GEN. KIT \$19.50



Heathkit
A.C. VOLTMETER
KIT \$29.50



Heathkit
SQUARE WAVE
GEN. KIT \$29.50



Heathkit
INTERMODULATION
ANALYZER \$39.50



Heathkit
AUDIO FREQ.
METER KIT \$34.50

Heathkit 5" OSCILLOSCOPE KIT

- New "spot shape" control for spot adjustment — to give really sharp focusing.
- A total of ten tubes including CR tube and five miniatures.
- Cascaded vertical amplifiers followed by phase splitter and balanced push-pull deflection amplifiers.
- Greatly reduced retrace time.
- Step attenuated — frequency compensated — cathode follower vertical input.
- Low impedance vertical gain control for minimum distortion.
- New mounting of phase splitter and deflection amplifier tubes near CR tube base.
- Greatly simplified wiring layout.
- Increased frequency response — useful to 5 MC.
- Tremendous sensitivity .03 RMS per inch Vertical .6V RMS per inch Hor.
- Dual control in vernier sweep frequency circuit — smoother acting.
- Positive or negative peak internal synchronization.
- Multivibrator type Wide Range Sweep Generator.

A brand new 1952 Heathkit Oscilloscope Kit with a multitude of outstanding features and really excellent performance. A scope you'll truly like and certainly want to own.

The kit is complete with all parts including all tubes, power transformer, punched and formed chassis, etc. Detailed instruction manual makes assembly simple and clear — contains step-by-step instructions, pictorials, diagrams, schematic, circuit description and uses of scope. A truly outstanding value.

MODEL 0-7
SHIPPING WT. 24 LBS.

\$43.50

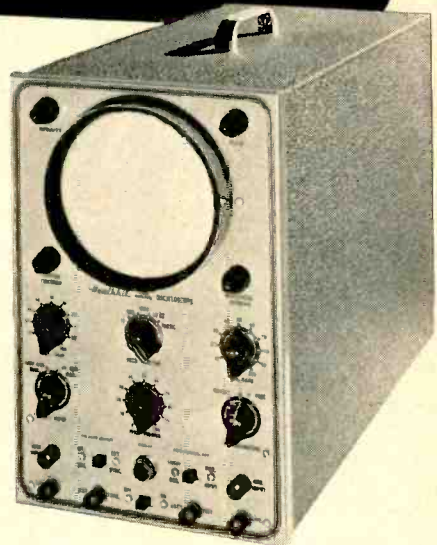

Heathkit VACUUM TUBE VOLTMETER KIT

- New styling — formed case for beauty.
- New truly compact size — Cabinet 4 1/8" deep x 4-1/16" wide x 7 3/8" high.
- Quality Simpson 200 microamp meter.
- New ohms battery holding clamp and spring clip — assurance of good electrical contact.
- Highest quality precision resistors in multiplier circuit.
- Calibrates on both AC and DC for maximum accuracy.
- Terrific coverage — Reads from 1/2V to 1000V AC, 1/2V to 1000V DC, and .1 to over 1 billion ohms resistance.
- Large, clearly marked meter scales indicate ohms, AC Volts, DC Volts, and DB — has zero set mark for FM alignment.
- New styling presents attractive and professional appearance.

The 1952 Model Heathkit Vacuum Tube Voltmeter! Newly designed cabinet combines style and beauty with compactness. Greatly reduced size to occupy a minimum of space on your work-bench. Covers a tremendous range of measurements and is easy to use. Uses only quality components including 1% precision resistors in multiplier circuit for greatest accuracy. Simpson 200 microamp meter with easy to read scales for fast and sure readings.

All parts come right with kit, and complete instruction manual makes assembly a cinch.

MODEL V-5
SHIPPING WT. 5 LBS.

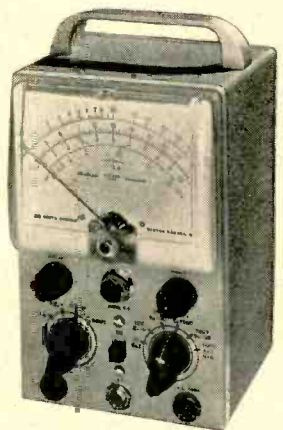

\$24.50

YOU SAVE BY ORDERING DIRECT FROM MANUFACTURER

EXPORT AGENT
ROCKE INTERNATIONAL CORP.
13 E. 40th ST.
NEW YORK CITY (16)
CASE# AR-10-NY

The **HEATH COMPANY**

... BENTON HARBOR 25, MICHIGAN

world's toughest transformers

CHICAGO

"SEALED-IN-STEEL" New Equipment Line

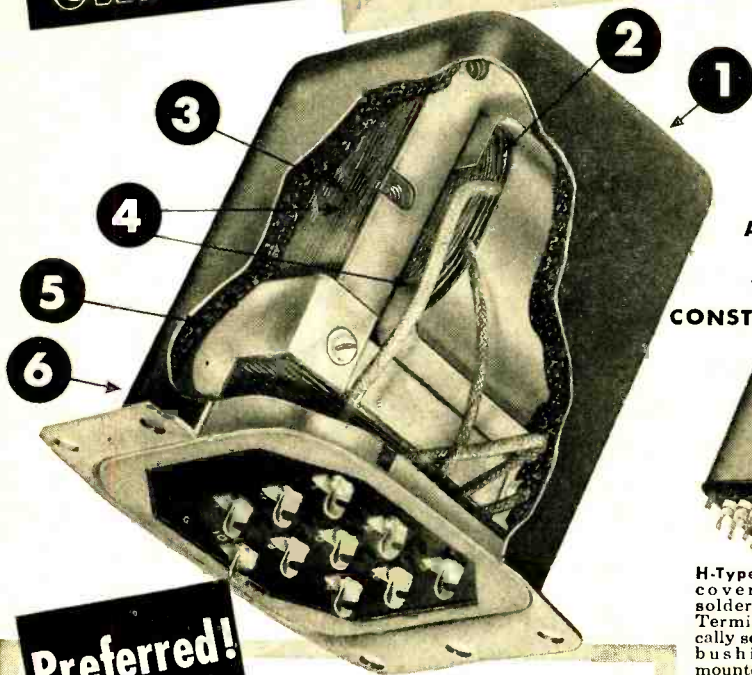

AVAILABLE
IN THREE
VERSATILE
CONSTRUCTIONS

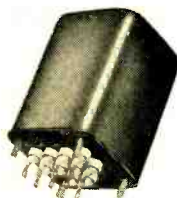

H-Type. Steel base cover deep-seal soldered into case. Terminals hermetically sealed. Ceramic bushings. Stud-mounted unit. Meets MIL-T-27 Specifications.



S-Type. Steel base cover fitted with phenolic terminal board. Convenient numbered solder lug terminals. Flange-mounted unit.



C-Type. With 10" color-coded stripped and tinned leads brought out through fibre board base cover. Flange-mounted unit.

Preferred!

the INSIDE STORY tells why!

The proof of toughness is on the inside—the actual proof that demonstrates why CHICAGO Transformers are preferred by engineers, why they fully meet the express requirements of today's tubes and circuits. Here are the "inside facts" of CHICAGO "Sealed-in-Steel" design:

- 1 Exclusive one-piece drawn-steel case, unsurpassed for strength, moisture-resistance, better electrostatic and magnetic shielding, mounting ease, and streamlined appearance.
- 2 Uniformly-wound precise coil structures—cooler operation and better electrostatic shielding in power units—minimum leakage, optimum coupling in audio units.
- 3 Core of high-grade non-aging silicon steel brought to high efficiency by scientific heat-treating in CHICAGO'S own annealing ovens.
- 4 Core and coil vacuum-impregnated with varnish. Final high-temperature baking achieves a perfectly impregnated coil and core locked against vibration.
- 5 All internal free space is filled by special, moisture-resistant compound. Prevents corrosion and helps maintain far cooler operation than in conventional air-surrounded mountings.
- 6 Checked by quality controls at every stage of manufacture, rigidly inspected, "torture-chamber"-tested to insure long, dependable life in actual service.



SEND FOR "NEW EQUIPMENT LINE" CATALOG

You'll want the full details on CHICAGO'S New Equipment Line—the famous Sealed-in-Steel line that offers advanced engineering design to fit today's circuits. Lists units for all purposes: Power, Bias, Filament, Filter Reactor, Audio, MIL-T-27, Modulation, Stepdown and Isolation. Write for your FREE catalog today—or get a copy from your distributor.

CHICAGO TRANSFORMER

DIVISION OF ESSEX WIRE CORPORATION

3501 ADDISON STREET • CHICAGO 18, ILLINOIS



bass ceases to exist on such systems—but if a bass "floor" of 200 cps could be stretched down to 100, results would be, relatively speaking, sensational. You may laugh, but keep in mind that the great majority of present record owners, many of them plenty cultured and knowledgeable, own just such machines.

I can also conceive of a simple RJ front-loading system, perhaps stamped out of plastic, that might well revolutionize the tiny plastic radio sold by the millions. But now I'm becoming astronomical!

New style custom sets?

I suppose my chief asset is my unbridled imagination—set a'rolling by prospective new devices such as this. Can't quite stop yet. My fondest hope, since I've been following RJ's progress these last few months, has been that out of this might come what I have always wanted to see, a really good medium-priced type of semi-custom outfit that would fall in that large gap between real "hi-fi" equipment and commercial manufactured stuff. Something that would take advantage of the price differential, that would also take advantage of every bit of engineering ingenuity, to achieve a really useful, small-sized, inexpensive, portable, flexible phonograph system for the great majority of ardent record collectors who can't manage present hi-fi either as to cost or as to bulk.

As an experiment in this direction I'm working now on having a little system set up, just for my own observation. It will have a special aluminum small-size Columbia LP player (hand made, for the beginning of LP) with an Astatic U-J crystal with the FL-33 arm and filter. A miniature-tube push-pull amplifier, transformerless, goes underneath, with flush volume and roll-off controls of solid aluminum; the whole unit is about 7 x 9 x 2½ in., with one end curved. This will feed into an RJ enclosure approximately 9-in. square, probably to contain two Permoflex speakers, or equivalent, an 8-in. "woofer" and a 6-in. "tweeter", working through a slot. The whole outfit will stand on a small typewriter table or can be carried under your arm. I expect—and hope—to get smooth bass down to as low as most bass-reflex cabinets for 12-in. speakers will give, if not better, and with better acoustical performance. Though not professionally hi-fi, the player-amplifier-speaker combination will be far in advance of most fairly expensive commercial large-size consoles.

I might add, to close, that RJ (so named by me) is here announced for the first time—and at my own risk, for the whole thing might be an utter frost, though I can hardly think so. It is not yet publicly on sale, but will probably be shown at the Audio Fair, as of present (August) plans. So far RJ has been applied to a Stephens 15-in. woofer, a University 12-in. 6200, a Western Electric 754A, and a Permoflex 8-in.-6-in. combination, with various associated tweeters. The entire speculation herein included is my own, not in any way necessarily approved by RJ's two designers.

And so I cross my fingers.

RECORD LIST

Try these on your hi-fi outfit

(Note: The August issue carried listings without performer identification; the September issue, sacrificing some compactness, gave brief performer information, and this would seem to me to be a good compromise. Reader reaction has been decidedly favorable to these brief surveys and they will be continued. E. T. C.)

*Outstanding over-all sound.

HUDSON

RADIO & TELEVISION CORP.

FORMERLY NEWARK ELECTRIC CO., INC. (OF NEW YORK)

*has Everything for the Finest
Reproduction of Broadcast and Recorded Music!*

ALL FAMOUS MAKE COMPONENTS
ULTRA-MODERN SOUND STUDIOS
EXPERT TECHNICAL ADVICE
LOWEST POSSIBLE PRICES

HUDSON is an ideal place to get your High Fidelity Equipment, for Professional or Home Installation. We carry a Complete Stock of All the Famous Instruments... and our facilities for demonstrating them are unparalleled! Both our Great Stores in New York City have elaborate Sound Studios... our uptown salesroom, adjoining Radio City, features the most advanced installation of its kind available anywhere. Under conditions simulating your own living room or studio, you can relax in an easy chair and select and operate ANY combination of world-famous high fidelity components by Push-Button Remote Controls. All speakers are mounted in identical baffles so their true performance can be honestly compared! Every music lover, engineer, sound technician and high fidelity enthusiast will be fascinated by this new, ingenious approach to audio-comparison.

FAMOUS Concertone TAPE RECORDER



*The Only True High Fidelity—High Performance
Tape Recorder in the Popular Price Field!*

We're proud to add this fine Magnetic Tape Recorder to our Great Stock of Famous High Fidelity and Electronic Equipment. The Concertone Has Every Feature of the Most Expensive Professional Instruments! By Any Standard of Comparison It Is The Best Buy in the Tape Recorder Field!

The Concertone meets all professional requirements, yet is priced Exceptionally Low! Equalization conforms to NAB Recommended Broadcast Standards. Extended Frequency Response is 50 to 15,000 cps \pm 2 db at 15" per second speed. Tape Noise down to random level. Also has 7.5" per sec. Speed. Pre-aligned heads quickly interchangeable for Dual or Single Track Recording. Total Harmonic Distortion less than 2% at normal maximum signal level. Has 3 dynamically balanced motors, separate heads for recording, erase, and playback. Simultaneous monitoring from tape while recording. Instant choice of 7.5" or 15" per second speeds, Fast Forward, Rewind, and Reverse (2500 ft. per min.). All controls are interlocked to prevent spillage or tearing of tape. Size of basic recorder: 22 x 14 x 5" mtg. depth below panel. Use with any good quality amplifier.

AVAILABLE AS BASIC UNIT WITH CARRYING CASE
OR CONSOLE CABINET

BASIC RECORDER, 1401D: Drive mechanism, power supply, erase, record, and playback preamplifiers, mounted on base plate, ready for installation. **\$345.00**
With Dual Track Heads. No. A16147... Net
Model 1401S, Same with Single Track Heads.....Net \$345.00
Console Tray 503, base for basic recorder.....\$14.95
CARRYING CASE, 501 (Illustrated): With monitoring amp., hi-fi 8" spkr., connections for portable system.....Net \$82.50
CARRYING CASE, 502: Less spkr. and amp.....Net \$47.50
CONSOLE CABINET, 702: All metal, with rack panel for complete sound system. Fully Enclosed.....Net \$97.50

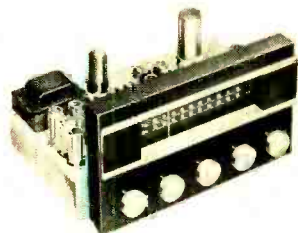

RADIO CRAFTSMEN AM-FM TUNER

The Most Popular High Fidelity Tuner! Flat Frequency Response of 20-20,000 cps, 5 microvolt sensitivity on both AM and FM, full output with less than 1% distortion, AFC eliminates drift and simplifies tuning. 10 Kc AM Filter, Bass and Treble Controls for boost or cut, Built-in Preamplifier for magnetic cartridges. 12 Tubes including rectifier. Built-in loop and FM antenna. 13 1/2 x 9 1/2 x 7" H. **\$131.50**
No. A10955.....Net

RADIO CRAFTSMEN RC-2 MATCHING AMPLIFIER. True high fidelity performance! Full 10 watts output with less than 1% distortion. Response: \pm 1 db from 20-20,000 cps. 7 x 10 x 6" H. **\$42.90**
No. A10952.....Net

Sensational Tuner Value!

FAMOUS COLLINS FM TUNER

High Fidelity At Its Best!

Formerly **\$59.50**
\$87.55



All the technical skill, craftsmanship and quality possible have been incorporated into Collins Audio Products. This model FM-11 was a great buy at \$87.55. And now, at \$59.50 it's really sensational! Genuine Armstrong circuit uses 11 tubes and stable permeability tuning. Has Tuned RF stage—3 IF Amplifiers and Dual Cascade Limiters... No Frequency Drift! IF Frequency is 10.7 Mc. Image ratio 300 to 1. Sensitivity 10 microvolts for complete limiting. Built-in power supply, phono switch. High impedance output. Tubes: 6J6, 6C4, 6AK5, 3-6AG5, 2-9001, 6AL5, 6X5 rect. and 6AL7GT Tuning Eye. 19 1/4 x 12 x 7 1/4" H. **\$59.50**
No. A3001, 10 lbs.

BROWNING TUNER

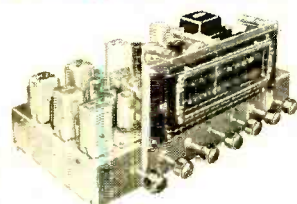

Famous AM-FM Model RJ-20A. Armstrong FM circuit, 20 db quieting with 6 1/2 microvolts, AFC on FM, with on/off switch. 15-15,000 cps \pm 1 1/2 db. Power Supply, Tuning Eye, 7 1/2 x 17 x 9" D. **\$175.18**
No. A2009.....Net

ALTEC-LANSING AMP. and PRE-AMP.

A superb new dual-amplifier system that sets new standards in performance, versatility, and reliability. Consists of 20-watt power amplifier with compact pre-amplifier and control unit. Controls include Volume Level, Choice of Response and Quality (bass rise and droop, and treble rise and droop), Record Xover Frequencies, Equalization, 3 1/2 Filter, Input Selector, plus conventional controls. Power Amplifier: 20 watts with less than 2% harmonic distortion. Response: Flat, \pm 0, - 1 db 20-20,000 cps. Excellent quality!
A-433A Pre-Amp.: 11L x 4 1/4" H. **\$75.00**
No. A20001
A-333A Power Amp.: 13 1/2" L x 7 1/4" H x 6 1/4" D. 21 lbs. No. A20000 **\$111.00**



RADIO CRAFTSMEN 500 AMPLIFIER

Williamson All-Triode Circuit
99.999% Distortion-Free

Terrific Performance! This new 12-watt "Ultra-Fidelity" amplifier uses the famous Williamson All-Triode circuit to set a new high in audio fidelity. Frequency response: \pm 0.1 db, 20-20,000 cps. \pm 2 db 5 to 100,000 cps. 12 watts \pm 2 db, 10 to 50,000 cps. Total harmonic distortion less than 0.01% at average listening level below 1 watt. Tubes: 2-6SN7GTA, 2-KT66, 5V4G rectifier. One chassis, uses the finest component to produce unexcelled listening quality with practically no distortion. At this price there's nothing better!
\$99.50
No. A10964, List \$166.00.....Net

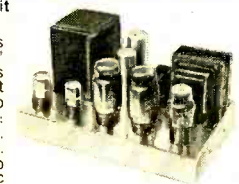

JENSEN G-610 TRI-AXIAL SPKR.



Finest loudspeaker ever built! 15" 3-way system achieves closest approach to actual "presence." Reaches well above 18,000 cps. 3 individually driven elements with xover and control network. 35 watts, 16 ohms **\$224.91**
#A20144

ALL FAMOUS MAKES IN STOCK

GE S1201D 12" High Fidelity Speaker... Net \$19.95
Western Electric 728B 12" Speaker... Net 35.70
RCA 515S1 15" Duo-Cone Speaker... Net 35.57
RCA 515S2 15" Duo-Cone Speaker... Net 48.50
Altec-Lansing 604B 15" Dia-Cone Spkr. Net 140.00
Altec-Lansing 603B 15" Dia-Cone Spkr. Net 75.00
University 6201 12" Coaxial Speaker... Net 44.10
New Bell 2122A Amplifier.....Net 49.45
New Bell 2145A Amplifier.....Net 175.52
Brook 12A3, 10 Watt Amplifier.....Net 198.00
All Preamps, Equalizers, Cartridges, Arms in Stock!

WE STOCK AND DEMONSTRATE ALL STANDARD MAKES OF ELECTRONIC AND AUDIO EQUIPMENT... High Fidelity Tuners, Amplifiers, Speakers, Pickup Arms and Cartridges, Accessories, Record Changers, Tape and Disc Recorders, Cabinets, Replacement Parts, Tubes, Television Chassis and Components, etc. by such famous names as...ALTEC-LANSING, ASTATIC, AUDAK, BELL, BOGEN, BROOK, BROWNING, COLLINS, CLARKSTAN, ELECTRO-VOICE, ESPEY, GARRARD, GE, GRAY, HALLICRAFTERS, JENSEN, MARKEL, MASCO, PICKERING, RCA, RADIO CRAFTSMEN, REK-O-KUT, H. H. SCOTT, STEPHENS, UNIVERSITY, WEBSTER, W. E., etc.

HUDSON

RADIO & TELEVISION CORP.

Formerly Newark Electric Co., Inc. (of New York)

Main Office, Store and Warehouse
48 West 48th St. • New York 19, N. Y.
Downtown Store: 212 Fulton St., New York 7, N. Y.
Phone: Circle 6-4060



"For those who demand the highest standard of fidelity and sensitivity..."

Permoflux dynamic HEADPHONES



Ray Block
Orchestra Conductor



Permoflux High Fidelity Dynamic Headphone — Model DHS-17 with Model No. 1505 Ear Cushion.

"I have used the Permoflux Headphones on many of my programs. This has given me an opportunity to test them thoroughly before reporting on their performance.

I now can say that the Permoflux High Fidelity Dynamic Headphones exceed in every way any other phones I have ever used. We, in the music profession, who have to insist upon perfection, are perhaps more critical than other users and the equipment we require must be the best. For those reasons, I would recommend the Permoflux earphones to any one who demands the highest standard of fidelity and sensitivity from such equipment."

Unsurpassed for Broadcasting, Television and Recording Uses!

New developments in the Permoflux Dynamic Headphone design make possible the use of these units in applications heretofore not covered in the electronic field. Flat frequency response of from 100 to 7000 ~ is assured in the Permoflux High Fidelity Dynamic series and up to 4500 ~ in the standard series. Permoflux offers the finest headphones made for broadcast, television and recording uses as well as monitoring, audio metric work and auditory training.

Send today for the new Permoflux catalog #J203 for the latest information on Permoflux's new "Champion" line of Speakers and Dynamic Headphones.



TRADE MARK
PERMOFLUX
"SOUND IN DESIGN"

PERMOFLUX CORPORATION

4902-J W. GRAND AVE., CHICAGO 39, ILL. • 236 S. VERDUGO RD., GLENDALE 5, CALIF.
Canadian Licensee—Campbell Mfg. Company, Toronto, Canada

Small instrumental groups—hi-fi

Older music

- *Bach, Das Musikalische Opfer (Vuataz arr.), soloists cond. Scherchen. Westminster WL 5070
- *Telemann, Trio in E Minor; Quartet in D Minor (Tafelmusik). Loeillet, Trio Sonata in B Minor. Westminster WL 5076
- Pergolesi, Concertino in F Mi. Respighi, Ancient Airs and Dances (Suite #3). Stuttgart Ch. Orch., Munchinger. London LLP 312
- *J. Haydn, Divertimento in C (Winds and Strings); *Four Military Marches. M. Haydn, Divertimento in C (Strings). Boccherini, Flute Quintet in D Flat. London Baroque Ensemble, etc. Westminster WL 5080

"Romantic"

- ¹ Beethoven, Trio in E Flat, Op. 3. Pasquier Trio. Allegro ALC 3023
- Brahms, Violin Sonata #1 ("Rain"). Stern-Zakin. Columbia ML 2193
- ² Brahms, String Quartet #1, Op. 51, #1. Budapest. Columbia ML 2191
- Brahms, String Quartet #1, Op. 51, #1. Amadeus. Westminster WL 5084
- Sibelius, String Quartet ("Voces Intimae"). Criller. London LLP 304
- ³ Beethoven, Violin Sonata in C Mi., Op. 30, #2. Schneiderhan, H. Berg. Remington 149-35
- Beethoven, Violin Sonata in C Mi., Op. 30, #2. Rostal, Osborn. London LLP 162
- *Beethoven, Variations on themes by Handel, Mozart. J. Graudan, pf., N. Graudan, cello. Vox VL 6150
- ⁴ Beethoven, Trombone Sonata, Op. 17; Three Equali. Shumann Brass Choir. Renaissance X 31
- Matyegka-Schubert, Quartet for Flute, Guitar, Viola, Cello. Period SPLP 518
- ^b Debussy, Sonata #3. Heifetz, violin; Bay piano. RCA 45: WDM 1515 (2)
- Johann Strauss, J. Lanner: Waltzes. Alexander Schneider String Ensemble (Quintet). Columbia ML 2179
- ¹ Beethoven, String Quartets, Op. 127, 130. Pascal Quartet. Concert Hall CHS 1209, 1210

Modern

- ^c Milhaud, Madrigal, Pastorale. Berezowsky, Wind Quintet Suite, Op. 11. Fine, Wind Partita. New Art Wind Quintet. Classic CE 1003
- ² Sessions, Violin Sonata #2. Ives, Violin Sonata #2. Patricia Travers, Otto Herz, pf. Columbia ML 2169
- *Martinu, Three Madrigals for Violin & Viola. Mozart, Duo #2. J. Fuchs, vl., L. Fuchs, vla. Decca DL 8510

¹ Nice microphoning; some distortion in LP.
² Close-to, steely miking, in large space.
³ Marches have excellent drums and snares.
^b Bass is thin.
^c Close, rather dead hi-fi recording.
⁴ Some surface hiss.
^d Dull music, but top trombone recording.

WHAT

OTHERS

SAY

about

ORRadio

irish
BRAND

MAGNETIC RECORDING TAPE

“**SWEETEST** quality I’ve ever heard”

“Irish Magnetic Tape is the **BEST** I’ve used”

“Orradio Magnetic Tape **RINGS THE BELL** with me”

“I **LIKE** Orradio Irish Tape because it’s so easy to use”

“**CONGRATULATIONS** on your extended frequency performance”

“I use Irish Magnetic Tape because it gives me **EVERYTHING I WANT**
in good quality recordings”

“I am **IMPRESSED** with the fine service of the Orradio organization, as well as the quality of their products. It’s Orradio Tape for me”

From Alaska to South America—from Israel to Korea—words of praise and appreciation for the fine quality of ORRADIO Magnetic Tapes tell the story of what can be accomplished by a small company regardless of overwhelming odds in a competitive market, when users have faith—this is The Spirit that makes America, AMERICA!

To our countless friends all over the world, we say “THANK YOU” for the tremendous part you have played in helping us to produce a commodity that has received such magnificent approval.

Your choice of 2 fine magnetic tapes:

NEW 211RPA Plastic Backing for Professional Users \$5.50 list (1270 feet)

NEW 195RPA Plastic Backing for Slow Speed Recorders \$3.50 list (1270 feet)

THE NEXT TIME YOU need magnetic recording tape — ask for ORRADIO IRISH TAPE at your Electronic Distributor or Photo Supply Shop. Distributors everywhere.

ORRADIO INDUSTRIES, INC. — OPELIKA, ALABAMA

NEW PRODUCTS

● **Williamson-Amplifier Components.** Availability of low-cost transformers and choke for the Williamson amplifier circuit has been announced by Standard Transformer Corporation, 3580 Elston Ave., Chicago 18, Ill. Type designations are output transformer A-8054, power transformer

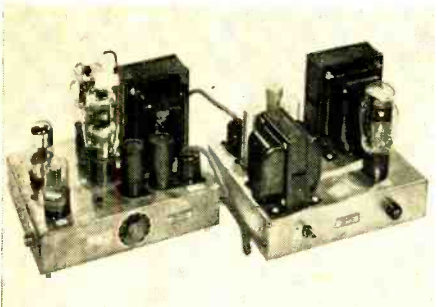

PC-8412, and filter choke C-1411. Laboratory tests of an amplifier built from the new Stancor components showed frequency response virtually flat at 8 watts output. Intermodulation measured 3 per cent. Harmonic distortion was negligible. Stancor will supply on request Bulletin No. 382, which describes construction of the Williamson amplifier, and includes chassis drawing, schematic, and complete parts list.

● **Crystal Cartridge.** Low cost and high output are combined in the new Astatic Model L-12 crystal for standard 78-rpm records. Output is rated at approximately 4.0 volts at 1000 cps on the Audiotone 78-1 test record. The pickup is designed to

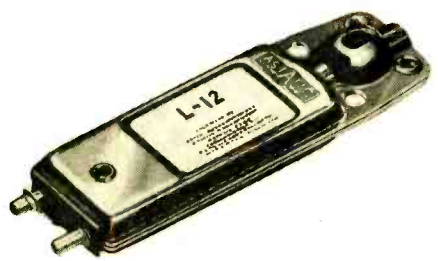

operate with a needle pressure of one ounce and has a total weight of 18 grams. Crystal element is coated against moisture and housing is stamped steel. The unit is supplied without stylus and has a universal chuck for use with standard type needles. Manufactured by The Astatic Corporation, Conneaut, Ohio.

● **High-Quality Amplifier.** Remarkable characteristics are claimed for the new Craftsman 500 audio amplifier, an all-triode unit based on the well-known Williamson circuit. It incorporates an output transformer of exceptional quality, and 20 db of inverse feedback around the entire amplifier. Characteristics supplied by

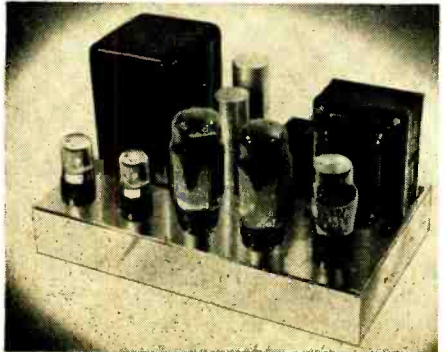

the manufacturer are: Total harmonic distortion, less than 0.1 per cent at mid-frequency; Intermodulation, less than 0.5 per cent at 10 watts; Frequency response, ± 0.1 db, 20 to 20,000 cps; Power response, ± 1 db, 10 to 50,000 cps. Manufactured by The Radio Craftsmen, Inc., 4401 N. Ravenswood Ave., Chicago 40, Ill.

● **Portable P.A. System.** Audio quality considerably better than average for portable p.a. equipment is featured in the Newcomb Model H-1512R. Containing two 12-in. speakers and a 17-watt amplifier in

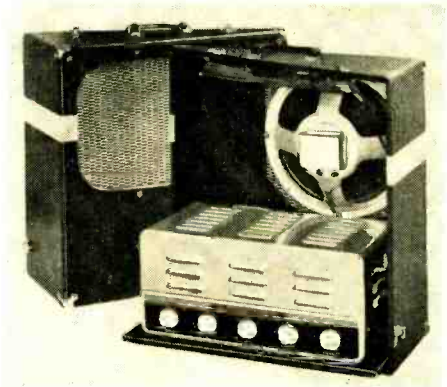

a split case, the system provides inputs for two microphones and a turntable, and includes individual bass and treble tone controls. The equipment is housed in a fabricoid-covered plywood case with metal fittings and kickproof speaker grills. Over all dimensions are $11\frac{1}{2} \times 20\frac{1}{2} \times 21$ ". Total weight is $44\frac{1}{2}$ lbs. Manufactured by Newcomb Audio Products Co., 6824 Lexington Ave., Hollywood 38, Calif.

● **Noise-Suppressor-Preamplifier.** Flexibility and performance of many home music systems, both new and existing, can be improved extensively with the new Scott Model 112-B "Dynaaural" preamplifier. Circuit features the original Scott dynamic noise suppressor, high gain for magnetic-type pickups, variable turnover control to compensate for various recording characteristics, adjustable record-distortion

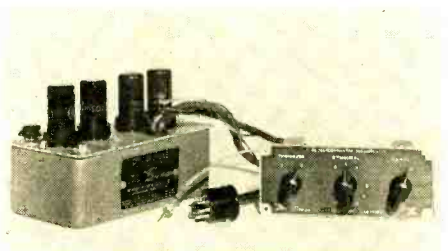

filter, and input level adjustment. Usable frequency response is 20 to 20,000 cps. The unit can be attached to most basic amplifiers by means of three standard plug-in connections. Remote control panel is handsomely finished in etched bronze. Bulletin will be mailed on request to Hermon Hosmer Scott, Inc., 355 Putnam Ave., Cambridge 39, Mass.

● **Fluid-Drive Pickup.** "Fluid Sound" is the trade mark applied to a unique new pickup cartridge now being marketed by the Lindberg Instrument Co., 830 Folger Ave., Berkeley 10, Calif. The device consists, essentially, of an actuating arm on which is mounted a conventional sapphire stylus, a plastic housing which contains three cells filled with an electrolytic, non-toxic, conducting fluid, and a rubber diaphragm. In operation, direct current flows through the three cells in series and is modulated by the stylus as it tracks the recording. The current modulations thus

produced cause an output voltage to appear at the center cell electrodes, which is fed in conventional manner to an audio amplifier. Stylus-record contact is used only to modulate the externally supplied d.c. voltage as it flows through the fluid. It is stated by the manufacturer that the



Fluid Sound pickup reproduces fundamentals as low as 20 cps. Upper frequency limit is quoted as being 10,000 cps. The cartridge requires no bass boost and no special compensation of the highs. Tracking pressure range is $3\frac{1}{2}$ to 10 grams, depending on the tone arm used, and output is 0.8 volts. Priced extremely low.

● **Phono-Radio.** Tasteful cabinet design, compactness, and good audio quality are all inherent in the "Vermont", a new table model phono-radio recently announced by Audar, Inc., Pasadena 18, Calif. Traditional Early American in appearance, the cabinet

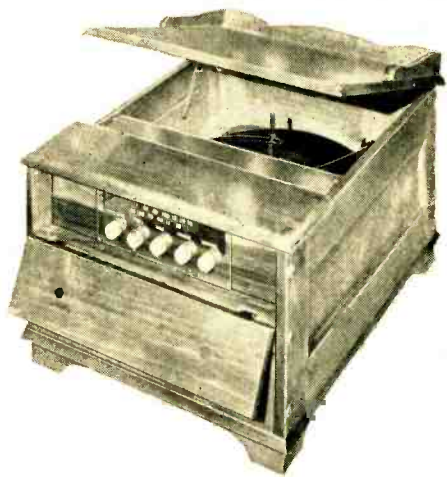

is made of solid birch with hand-rubbed maple finish. The 7-tube chassis features separate bass and treble controls, push-pull power output, and an 8-in. speaker. Chairside stands and record cabinets in matching finish are available as accessories.

● **High-Temperature Insulation.** Refrasil is a fibrous silica insulation which provides both thermal and electrical insulation at temperatures up to 1800° F. De-



veloped originally in batt form for use in jet aircraft, the material is now fabricated in both sleeve and tape for a wide range of electrical applications. Flexibility is not affected by continued exposure to high temperature which, together with light weight, minimum bulk, and ease of slip-on installation, makes the material ideally suited for wiring electronic equipment where both resistance to heat and high dielectric efficiency are required. Further information about Refrasil may be obtained from The H. L. Thompson Company, 1733 Cordova St., Los Angeles 7, Calif.

• **Magnetic Recording "Rubber."** A special Neoprene base, into which has been incorporated a uniform pigmentation of magnetic oxide, is a new recording material recently announced by The Brush Development Company, 3405 Perkins Ave., Cleveland 14, Ohio. Also included in the base material is a permanent lubricant

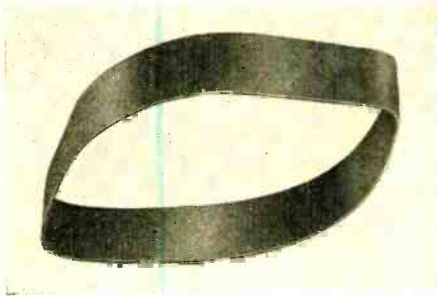

which virtually eliminates wear of both medium and the recording head with which it is used. Designed for use when stretched over a supporting drum, bands of the material can be supplied in various sizes and shapes to meet special requirements. Requests for information should be addressed to Division D-4.

• **Corner Speaker Baffle.** Designed for use with eight-inch speakers, the new Permo-flux corner cabinet affords good audio performance with remarkably low space requirements. Sturdily constructed of four-layer plywood, the baffle is attractively finished in maroon leatherette. Dimensions are 14 in. wide, 24 in. high, and 9 1/2 in. deep. Tests, according to the manufacturer, indicate that the effect of corner radiation is more pronounced, relatively speaking, with this compact enclosure than with cabinets considerably larger in size. Permo-flux Corporation, 4902 W. Grand Ave., Chicago 33, Ill.



• **Self-Holding Test Prods.** The New Klipzon Type H heavy-duty test prods and leads are designed for clipping to conductors and are suitable for many applications in electronic power supplies, public utility systems, and in electrical manufacturing and testing. Self-holding points



are needle-sharp for piercing insulation and will maintain effective contact until removed. Flexible leads are equipped with spade terminals, are four feet long, and consist of 16 strands of No. 30 B & S gauge copper heavily insulated. Manufactured by United Technical Laboratories, Morristown, N. J.

The Discriminating Eventually Come to Leonard's!

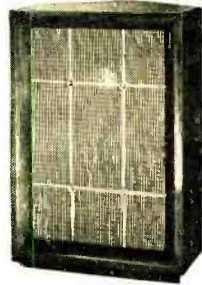

Maximum Performance at Minimum Cost!

THE ARISTOCRAT

Utilizing the famous Klipsch principle which employs the corner of the room as an extension of the exponential-acoustic-horn air-load, the ARISTOCRAT provides, for the first time, purity of extended bass never achieved before in a cabinet of this size. At least one full octave of added bass range is disclosed on first listening!

Beautifully styled, with its mahogany veneer hand-rubbed to mirror-like finish, it is the ideal enclosure for 12" full range speakers. Height — 29 1/2", width — 19", depth 16 1/2", over-all.

NET, mahogany finish . . . \$59.70
In bleached blond finish . . . \$63.60

ELECTRO-VOICE COAXIAL SPEAKER · SP-12B

Thrill to the dynamic impact of true, fundamental bass, the tinkling clash of cymbals! Utilizing a heavy-ribbed, straight-sided low-frequency driver cone for medium transient distortion, and with the high-frequency propagator decoupled from the bass reproducer by a mechanical crossover, the RADAX 12 gives you maximum performance at a cost well within the most modest budget. Frequency Response when used with ARISTOCRAT CORNER BAFFLE—35 to 13,000 cps. Power Rating—20 watts. Impedance—8 ohms.

NET \$26.46

ANNOUNCING THE NEW GROMMES "LITTLE JEWEL"

Here at last is a quality amplifier priced to meet the most modest of budgets! Appropriately named "LITTLE JEWEL," it is a welcome addition to the now famous GROMMES family. Will deliver 8 watts with 2% distortion. Response—± 1.0 db 40 to 15,000 cps., 3 inputs—magnetic or crystal phono, and radio. Bass control gives 0 to ± 10 db.

Treble control gives +10 db or 20 db variation. Output—4, 8, and 16 ohms. Tubes—6SC7, 6SL7GT, 2-6V6GT, and 5Y3GT. Beautifully finished in brown hammerloid.

BUILT-IN PREAMPLIFIER

NET \$33.00

Mail orders accepted. Visit our sound studios and hear these truly remarkable components. Audio Fair Headquarters—Suite 536.

WRITE FOR OUR LATEST
HI FI CATALOGUE

TELEPHONE: CORTLANDT 7-0315

Leonard Radio inc.

the house
built on
SERVICE

69 CORTLANDT ST., NEW YORK 7, N. Y.

APPROVED • ASTATIC • ATLAS • AUDAK • AUDIO DEVELOPMENT • BELL • BOGEN • BOZAK • BROOKS • BROWNING • BRUSH • CHALLENGER • ELECTRO-VOICE • JENSEN • ESPEY

PENTRON • PICKERING • RACON • RADIO CRAFTSMEN • REK-O-KUT • H. H. SCOTT • SHURE • SONAR • UNI-MODE • UNIVERSITY • V-M • WEBSTER • CHICAGO • WEBSTER ELECTRIC



HOW LEADING NETWORKS USE Carter CONVERTERS

Photo above shows NBC's Tommy Bartlett and Universal Recording Company engineers making transcriptions from STORAGE BATTERY POWER by means of Carter Frequency Controlled Converter.

Wherever 115v. line voltage is not available, or hard to get, Carter Converters supply dependable AC power to make on location recordings. Operates from storage batteries. . . . Used by leading networks, broadcast stations, and program producers.

Recommended by Brush and Magnecord

One model operates both Brush and Magnecord equipment. Delivers clean 60 cycle AC power. Requires no filtering. Frequency control feature compensates for 10% input voltage variation. Available for 6, 12, 24, 28, 32, 64, and 115v. DC input voltage. Size 8 1/4" x 5 3/8" x 7 1/2" high. Weight only 15 1/2 lbs. Performance Guaranteed!



MAIL COUPON FOR FREE CATALOG

New Converter catalog illustrates entire line of Carter Rotary Converters for recording, TV, sound projection and transcription players. SELECTOR CHART included tells model to suit your purpose. Mail Coupon now for your copy and name of nearest Carter distributor.



Carter MOTOR COMPANY

2648 N. MAPLEWOOD AVE., CHICAGO 47

Carter Motor Co.
2648 N. Maplewood Ave.,
Chicago 47, Ill.

Please send catalog #349 with information on Frequency Control Converters, and name of nearest distributor.

Name

Station or
Company

Address

Audio in England

The 1951 Picture

H. A. HARTLEY

THE 1951 NATIONAL RADIO EXHIBITION offers an appropriate time to discuss developments in this country, of which there have been mighty few since my last contribution. In fact the only direction in which there seems to have been any progress is in TV, and the feature of this year's show is the arrival of the 12-inch tube. Please do not think I am trying to be funny. You who are accustomed to really big tubes in television sets cannot understand how Britain has so completely lost her leadership in TV. I think it is only fair to say that British television on any sort of mass scale was the first in the world, but now, when we read of what you have done, we look on our present situation with dismay. This is no fault of the industry, but simply due to the fact that TV is run as a sort of erring offspring of sound broadcasting, and given no chance of showing that it is an entirely new art. And, of course, there is no competition. We have to take what is given us whether we like it or not, and as many of us don't like it we don't bother buying TV sets, and as we don't buy sets in sufficient numbers to make full scale research and design in the factories a paying proposition, our receivers are not so imaginative as yours.

Audio

In the old days before the war we used the phonograph as a stop-gap because of what were, in those days, very good transmissions of music. Now we endorse what Ross Snyder said in his article in the August issue of *Æ* "Non-professional high-fidelity enthusiasts, we find, are more interested in good record-playing equipment than in anything else. Radio is most often regarded as an accessory, to be used for incidental listening, but not as a primary source of serious musical entertainment." How true that is.

We find the B.B.C. goes to some trouble to broadcast good orchestral concerts; we find no one takes the trouble to see that the technical quality of those transmissions is acceptable to a musical listener. Some of these broadcasts are so bad that they have to be heard to be believed. I have listened to transmissions and adjusted the controls of a carefully calibrated tone-control amplifier to reach some sort of conclusion as to the frequency response actually broadcast. One twiddles the controls to find how far one can go without adding or subtracting quality or absence of quality, and I have found orchestral stuff broadcast with a response apparently about 15 db up at 100 cps and a complete cut-off at 2500. Much of the output has nothing above 5000 and the extreme possible limit at the present day is just about 8000. I have taken this up with the B.B.C. engineering staff several times, and most of the blame is laid to the land lines. These are admitted to be bad by Post Office engineers, although there is always talk that new lines are on the way.

The musical enthusiast therefore turns to records which have improved enormously since pre-war days, and the advent of LP has, of course, revolutionized phonograph technique. No real hi-fi listener would ever

have a record changer, and LP has killed the bugbear of having to change the records manually. But LP has introduced a whole host of attendant troubles and a good deal of dissatisfaction has been aroused in this country about the indifferent results that have sometimes been obtained after spending considerable sums of money.

Letters

One of the things that pleases me so much is the ever increasing number of letters I get from *Æ* readers. I find these interesting, informative, and thoughtfully and sensibly written. They prove to me that the intellectual and technical level of the readership of this magazine is quite exceptionally high. I have had a good deal of information on the shortcomings of various makes of American LP's, and as it is not my job to comment on the American scene I can rejoin with some comments on British. Still we have only Decca, although it is now commonly rumoured that the E.M.I. outfit, realising at last that LP has come to stay, are coming in too. The story goes that since the Gramophone Co. (H.M.V.), having committed themselves by announcing that they would give six months' notice if they introduced LP, will not do so for the moment, but will introduce 45's *a la* Victor; but, since they (E.M.I.) will be forced to produce LP's, these will come out with Columbia labels. I cannot vouch for the accuracy of this gossip, for it is just rumour; all I can tell you is that our only LP's (apart from some pops by one of the small companies) are Decca.

I am told that, except for your Columbia's and those Capitol's which are not dubbed from Telefunken, the besetting sin of many American LP's is pre-emphasis of lows and highs in no sort of system at all. This may be, but the besetting sin of the early Decca's was, without a shadow of aural doubt, pre-emphasis of the highs. Decca never made any secret of the fact that their 78 firr had a rise of 3 db per octave at the top end of the characteristic, and this certainly made them sound as though they had more top than the usual run of discs. And firr sounded better on an ordinary radio-phonograph than did records which were recorded flat.

But it was another story altogether on a real high-fidelity outfit, for the top pre-emphasis did exactly what one would expect it to do—reproduce the harmonics out of proportion to the fundamental. And if you sought to counteract this pre-emphasis by a corresponding cut in the amplifier it did not appear to restore the harmonics to their pre-recorded value. The consequence was that all compound notes rich in harmonics, particularly the upper register of the violin, were harsh. In fact, they had harmonic distortion which we all try to eliminate in our reproducing system. What came to be considered "characteristic firr violin tone" always suggested a tissue-paper and comb effect. Not all Decca records did have this defect, which suggests that not all firr's had top pre-emphasis, but a large proportion of the earlier LP's sounded just like pre-emphasized 78's, ex-

cept that as there was more top on the LP's it sounded worse.

I started what was almost a public campaign about this, pointing out that it was the height of folly to damn this new development by making it sound beastly on high-fidelity equipment. I was on pretty sure ground too, because many of my American correspondents wrote to me pointing out this paper-splitting top on certain Decca LP's, and asking if I had any explanation. It wasn't wrong tone-correction in my equipment, for I was able to reproduce American Columbia to perfection. I don't know what eventually was done in the Decca recording menage, but it can be said that modern releases are of a consistently higher quality, and I am hopeful that they are adhering to the N.A.B. characteristic.

Against this background of "audio source," poor broadcasting, some good 78's and fairly consistently good Decca LP's, you will realize that we are not too well fed, as engineers, with the raw material of our trade. But against this background the statement that the 1951 Radio Show had practically no interest for the audio engineer will not appear surprising. Speaker and phono equipment demonstrations were non-existent except for the one show put on by Wright and Weaire who were demonstrating their tape-deck on a British-made Klipsch. This and the Simon tape-deck are considered as good as can be obtained in this country; they are two-speed, $3\frac{1}{2}$ and $7\frac{1}{2}$ inches per second, and at the latter speed claim flat response from 50 to 10,000 cps. The "Wearite" demonstration was short and cautious, some speech, a violin, woodwind (carefully omitting the oboe), and with no brass, percussion, or full orchestra, in fact nothing that would give one the real low-down on what can be got out of tape. (By the way I should very much like to hear from any of you who can be bothered to write, what can be got out of tape, but as I shall be at the Audio Fair, perhaps I shall be able to hear for myself.)

The usual wide range of speakers by Rola, Goodman, W.B., and Gramman were in evidence, but all of these wholly admirable companies are mainly concerned with big-scale production of moderate priced speakers for set makers. Indeed one or two of them find the high-fidelity market such a nuisance from their angle that they very generously pass over their high-fidelity orders and enquiries to your humble correspondent (the British characteristic is ever to live and let live). Decca showed their corner indirect radiator, but no opportunity was found to hear it, if indeed such opportunity actually existed.

A small range of amplifiers of sound if unexciting design were on display, but again could not be heard working, and so I left the show with nothing learned except that the piped sound of every radio show there has ever been is worse than ever, though now so negligible that it hardly makes its presence felt.

In the outside world there is virtually nothing to report. The postwar epidemic of "high-fidelity" manufacturers of small dimensions has gradually faded out, for those who thought that all that is needed to click the high-grade market is to tack on the label "hi-fi" have not been able to make the grade, and the large manufacturers who turn out a luxurious-looking pantechmicon sell only to those who have money and no taste (and today more than ever are these two conditions poles apart). The real thing is left to the few firms who work on a personality basis, who really try to turn out something good and

New LABORATORY INSTRUMENTS for Precision Measurement at Moderate Cost

INTERMODULATION METER

Highest Professional Flexibility at Reasonable Cost

Model 165 IM Meter is especially suited for laboratories, broadcasters, recording studios. Has signal generator, analyzer, voltmeter in single compact case. Reads %IM, amplifier output directly on meter. Provides for use of oscilloscope to analyze and cure IM causes: full graphic instructions supplied. Wide range of low and high test frequencies: 60 cps internally, 40-200 cps externally; standard 2, 7, 12 kc internally, 2-20 kc externally. Only 0.1% residual IM due to accurate bridge-type mixing circuit for 2 tones and special analyzer wave filters. Voltage ratio choices: for LF testing, 4:1; for more accurate HF testing, 1:1. $8\frac{3}{4} \times 19$ " rack-type panel; $8\frac{1}{2}$ " deep. Price \$250.00.

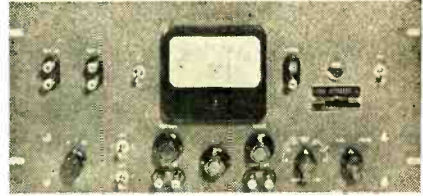

GALVANOMETER PROTECTOR

New Model 170 increases speed and convenience of use of Wheatstone Bridge. Adjusts itself automatically and continuously during balancing operation. Galvanometer retains enough sensitivity to indicate balancing effect at all settings, yet is completely protected against damage. Uses network of non-linear and linear resistors. Price \$24.50.

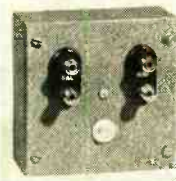

Negligible loading with the BRIDGER

In bridging measuring instruments across high-Z circuits, lowest possible circuit loading is vital. Model 100A's newly improved cathode follower and special double-shielded cable reduce cable capacitance and circuit leakage to the insignificant. Input Z: 70 megs, 5 mmf, with 3 ft. cable. Output Z: 200 ohms. Output/input voltage ratio: 0.99. Usable to several hundred kc. Price \$88.50.

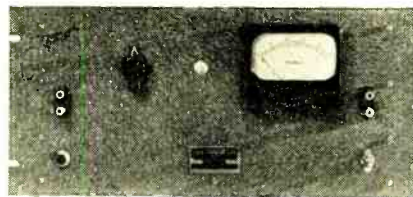
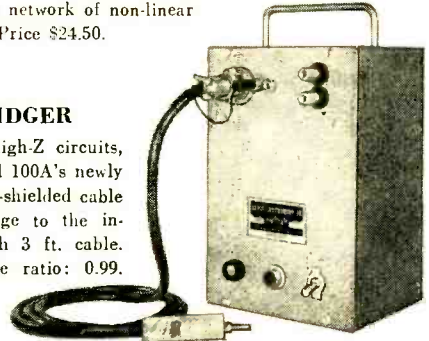

ULTRA-SPEED RECORDING with the LOGGER

For reverberation tests, experimental phonetics, propagation tests, other fast-changing phenomena. This new technique employs a stable Logger, feeding a direct-writing oscillograph. Convenient low-cost inked chart. Recording speed 10 to 20 times faster than usual high speed level recorders.

Loggers shown provide new stabilized logarithmic converter, linear rectifier and oscillograph-driving DC amplifier. Utmost stability: no thermostats, clutches or motors. Adjustable pen speed. Model 124: 50 db scale. Model 124W: 60 db range.



MINIATURE PREAMPLIFIERS for Kellogg and other Condenser Microphones

Makes stability, low noise level of best condenser microphones inexpensively available. Models for acoustical laboratory, sound recording. Models 12, 12R, 14, 14R, 16.

KELLOGG MIDGET CONDENSER MICROPHONES

Performance-proved for over 15 years. Exceptional calibration stability. Unaffected by humidity variations. Rugged construction. Reasonable cost. Prompt delivery. Calibrated if you wish. We are authorized dealers for these excellent microphones and are glad to advise you on their use. Just phone or write us.



INTERMODULATION SET

For the first time—here is intermodulation distortion measurement at low cost. With Model 162, and your own audio oscillator and oscilloscope, you read per cent of IM directly on your scope image—in just seconds. Complete with graphic instructions for adjusting equipment for best performance. Price \$88.50.

Write NOW for Catalog A.

SEE US AT THE AUDIO FAIR.



Audio INSTRUMENT COMPANY INC.
 Dept. 133 WEST 14th STREET, N. Y. 11, N. Y.

TAPE EDITORS—SOUND MEN

splice tape faster...
easier with the new

EDITALL

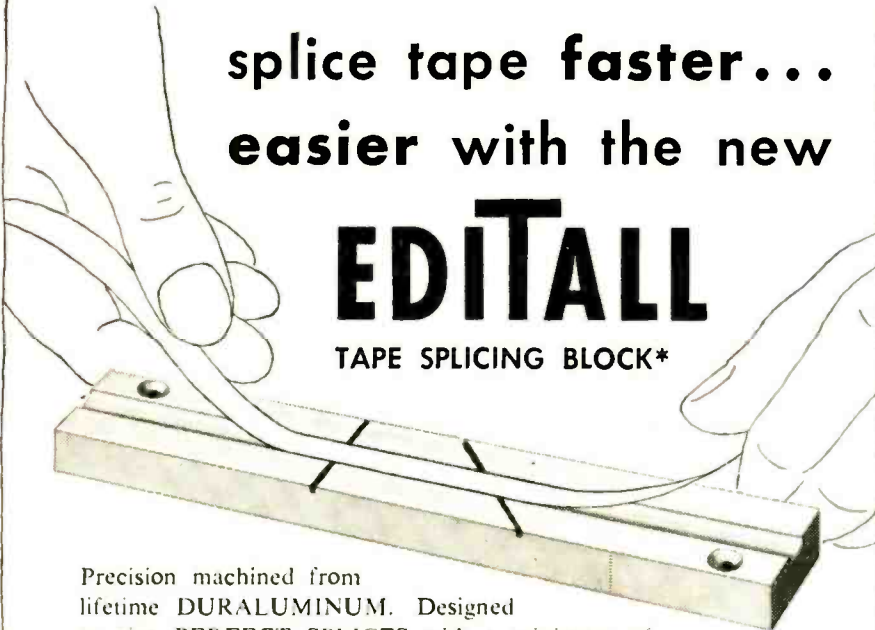
TAPE SPlicing BLOCK*



Precision machined from lifetime DURALUMINUM. Designed to give PERFECT SPLICES with a minimum of time and effort. Can be used in conjunction with any tape recorder using standard tape. Simple to use—no clips or mechanical devices to go out of order.

Price
\$6.50

DEVELOPED by Joel Tall, famous tape editor of C.B.S.; Instructor of Tape Editing at N.Y.U.

RECOMMENDED by Minnesota Mining and Manufacturing Co.

USED on the Famous Ampex Tape Recorder.



(Photo—Courtesy of Audio and Video Products Corp., New York)

• Ask for it at your local distributor

Manufactured exclusively by

TECH LABORATORIES, INC.

Box 148, Palisades Park, N. J.

New York Distributor: HARVEY RADIO CO.

*PAT. APPLIED FOR

who, it is sad to report, have a supreme contempt for all the others. This is not altogether without some reason, for I notice one firm that has professedly catered for the "music-conscious" market for many years offers, in the advertisement pages of one of our *technical* journals, a variable filter which steeply cuts "at any selected frequency between 4000 and 8000 cps" and then go on to say "specially valuable for use with new microgroove records". And I leave you to sort that one out for yourselves.

Examining the products of these various high-fidelity manufacturers I find there is absolutely nothing new at all. The twin-unit speakers in more or less elaborate cabinets continue as before, but with ever increasing prices, although I notice a slowly increasing consciousness on the part of the would-be customer that it seems impossible to achieve either complete merging of the sound of the two units, or completely smooth passage through the cross-over frequency. In Britain, of course, we have no speakers of the concentric tweeter-woofer type like your Altec's, Stephen's, Jensen's and University's. I do not know what these sound like, but I shall, as I have already told you. Meanwhile I continue to plough my lonely furrow of pinning my faith to a single highly specialized diaphragm, even if the metaphor ought to be blocked. The problem that now has to be solved by all us audio engineers is to find a way of getting good sound uniformly propagated throughout the auditorium, even though the "auditorium" is the usual somewhat restricted living room.

For the rest I promise you, at the editor's kind invitation, a complete list of the best British recordings of 1951, and all the British L.P.'s. That list will appear very early in the new year.

FEEDBACK DESIGN

[from page 12]

loudspeaker connected is equal to 21.6 db feedback with the loudspeaker disconnected.

Thus it is evident that in the case of a pentode it would be decidedly advantageous to place part of the plate-load impedance in the cathode circuit to provide some 10 db of local feedback. The ordinary 16-ohm loudspeaker winding is sufficient to provide 6 db of feedback over a single-ended stage. A local feedback loop of this type should make it possible to use more feedback than the usual 10 or 15 db around a loop from the voice coil to a preceding stage, since changes in the load impedance will have a much smaller effect on this loop. With enough of the plate winding in the cathode circuit to provide 10 db of feedback, a pair of pentodes is likely to require less driving voltage and less input power, and to have less distortion and lower output impedance than triodes with the same power output.

Independent Control of Gain and Internal Impedance

It will be noted also from (B) of Fig. 1 that positive current feedback decreases the output impedance since it adds $-A_{oa}$ to Z_o . If in the case of the pentode enough positive current feedback were applied from the cathode of

the output tube to the cathode of the driver to increase the gain 20.8 db, measured with the load connected, then the output E_c would be the same whether the load were connected or disconnected and $Z_o - A_o\alpha = 0$. If in addition we apply negative voltage feedback so the shunt arm $(Z_o - A_o\alpha) / -A_o\beta$ comes into play and reduces the gain by 20.8 db, then we have reduced the output impedance to zero without changing the gain at all. The harmonic distortion also remains unchanged. By combining current and voltage feedback the internal impedance can be made any desired value—positive, negative, or zero; at the same time the gain can also be made any desired value.

Illustrative Phonograph Preamp Design

To illustrate the practical use of these circuits, suppose we wish to design a preamplifier stage that will equalize a magnetic phonograph pickup to the standard playback curve for Columbia LP records. Let us assume the pickup is flat on a velocity basis. The tube will be one high- μ triode section of a 12AX7 in the circuit of Fig. 4; and let us suppose that for reasons of economy the cathode bypass capacitor is omitted.

The frequency response curve we intend to create is that derived from the inverse of the Columbia preemphasis network¹ in Fig. 5. Its inverse with respect to an arbitrary resistance R_o is shown at (A) in Fig. 6 together with three equivalent circuits having the same response. Figure 7 shows the straight-line approximation to the play-back response curve.

To achieve this response all the impedances in Fig. 4 will be made pure resistances except for Z_2 . By using a large coupling capacitor, Z_1 over the audible range can be considered to be made up of the plate resistor and the following-stage grid resistor in parallel. One can see from (D) of Fig. 3 that if there were a very large amount of feed-

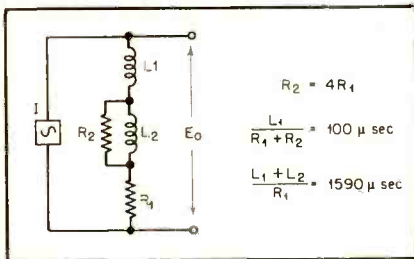

Fig. 5. Columbia LP pre-emphasis network.

back at all frequencies the gain would be simply Z_2/Z_1 and we could get the required response by making Z_2 the network of (A), Fig. 6. In this case we intend to use only about 6 db of voltage feedback at low frequencies and so the network will have to be modified. We shall see that the response obtained with a limited amount of feedback is the same as that obtained with infinite feedback when a resistance is shunted across Z_2 . This effective shunt resistance may be

¹ "Columbia LP microgroove records," AUDIO ENGINEERING, August 1948, p. 24.

There's a NEW SILHOUETTE on the Microphone Horizon...

THE NEW ULTRA-CARDIOID DYNAMIC

MODEL 55s

"THE PERFECT PERFORMER"

SMALL Unidyne

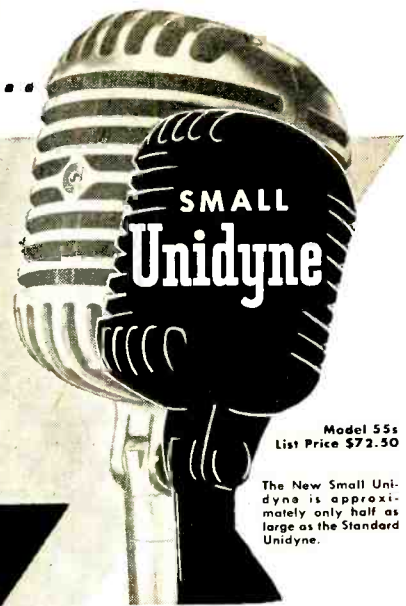

Model 55s
List Price \$72.50

The New Small Unidyne is approximately only half as large as the Standard Unidyne.



Model 55s
Small
Unidyne

"not 2 but 4!"

Model 55s Small Unidyne
Model 556s Small Broadcast
Model 55 Standard Unidyne
Model 556 Standard Broadcast

Code: RU00T List Price: \$72.50
Code: RU00V List Price: 100.00
Code: RUMUL List Price: 72.50
Code: RUMUB List Price: 100.00

Patented by Shure Brothers, Inc.

► Eliminates Feedback Problems

► Permits performer to stand farther from the microphone

THIS MIGHTY, though little, Microphone, is the *only* small-size, uni-directional moving-coil dynamic microphone—all the important directional qualities are retained. The 55s is actually a new Microphone retaining all the highly desirable features that made the Model 55 "Unidyne" world-famous.

Model 55s offers superior performance, featured in a streamlined, small, functionally-designed case. The moving-coil system has a high overall efficiency and smooth frequency response. A large air-gap clearance and a rugged coil construction provide immunity of the moving-coil system to abnormal atmospheric conditions and severe mechanical shocks.

The New Small "Unidyne," Model 55s and 556s, are not replacements for the current Models 55 and 556 "Unidyne." The Standard "Unidyne" are not being discontinued. You now have four outstanding, feedback-killing dynamic microphones from which to choose for the most severe acoustic applications.



SHURE BROTHERS, Inc.

★ MANUFACTURERS OF MICROPHONES AND ACOUSTIC DEVICES

225 W. Huron St., Chicago 10, Illinois

● Cable Address: SHUREMICRO

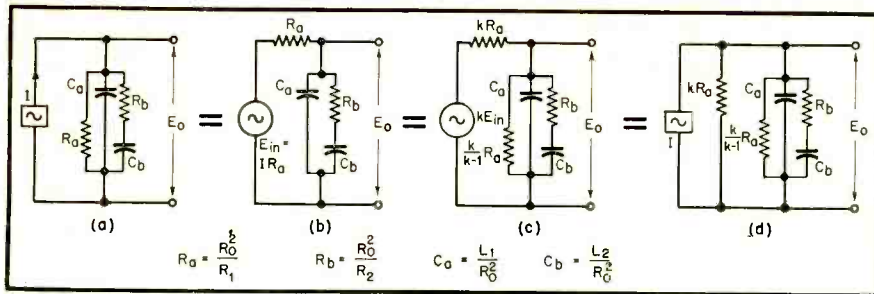

Fig. 6. Playback network for LP records.

included in the network as a part of R_a . Our first task is to consider the amplifier stage with cathode degeneration alone and no plate-to-grid feedback.

From tube data² we find that one section
² RCA Tube Handbook HB-3, Resistance-Coupled Amplifier Charts.

of a 12AX7 has a gain of 68 and is capable of putting out 79 volts peak with the following circuit constants: plate supply, 300 volts; bypassed cathode resistor, 3100 ohms; plate-load resistor, 0.22 meg; and following-stage grid resistor, 1.0 meg. From a guess at the operating point the curves indicate an amplification factor of 95. Combining this with a gain of 68, a Z_L of 180,300 ohms and $Z_K=0$ in the circuit of (B), Fig. 2, we find that $R_P=71,600$ ohms. When the cathode bypass capacitor is removed we find that we have a gain $A'=31.1$ and an internal resistance Z_o' of 122,200 ohms.

We have thus reduced the triode with 6.8 db of cathode current degeneration to a generator of voltage $-31.1 E_{in}$ with an internal impedance Z_o' as in (C) of Fig. 2. Had we made a poor guess at the mu of the tube we would still have arrived at the correct answer for gain with feedback, although the internal impedance would have been somewhat in error.

Next we proceed to reduce the complete stage, which can now be drawn as at (A), Fig. 3, to its approximate equivalent, (E). Comparing (E) of Fig. 3 and (D) of Fig. 6, we see that they can have the same frequency response if Z_1 is a resistor and Z_2 is a four-element resistance-capacitance network. If for the moment we disregard the factor $[Z_o/A_1Z_1]$ (E) of Fig. 3, which simply determines the impedance level of the entire circuit without affecting the open-circuit response, we see that the gain-versus-frequency is directly proportional to the combined impedance of Z_2 in parallel with the resistor $(A_1+1)Z_1$.

In short, returning to (A) of Fig. 3, we find that the gain-versus-frequency is simply Z_2'/Z_1 where Z_2' consists of Z_2 in parallel with a resistance $(A_1+1)Z_1$. This rule for computing the response also applies when Z_1 is a complex network. It holds whenever Z_1+Z_2 is so large that it does not load the output circuit appreciably or cause any appreciable amount of signal to feed directly through from input to output.

To determine the loading and direct feed-through we examine the response curve, Fig. 7, and find the minimum value that Z_1+Z_2 can reach within the audible range. Since we have decided that the gain reduction at low frequencies is to be 6 db, this means that at 15,900 cps the gain will be down 34 db more or only 0.31. At this frequency and above, Z_2 has become so small that the

A Sound INVESTMENT IN FINE MUSIC

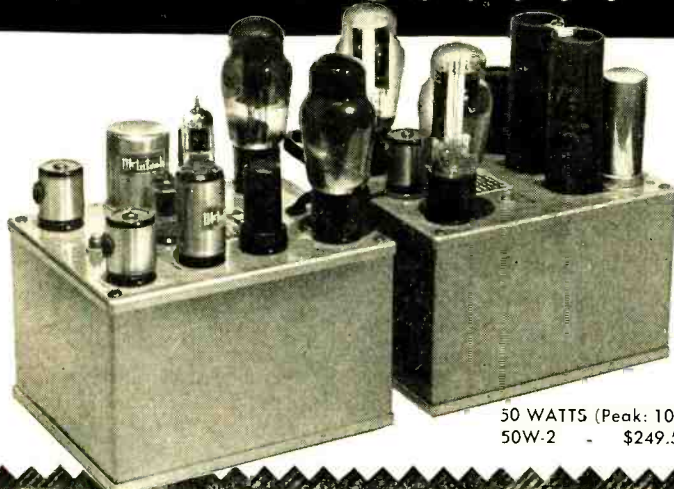

50 WATTS (Peak: 100)
50W-2 - \$249.50

McIntosh

WORLD'S FINEST AUDIO AMPLIFIER

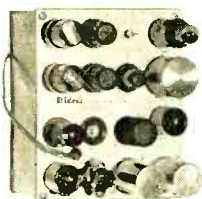

20 WATTS (Peak: 40)
20W-2 - \$149.50

Unequaled for quality reproduction of any sound source, the McIntosh is the most advanced amplifier of the day. Its unique, compact design offers: HIGHEST EFFICIENCY —over 65%; LESS THAN 1% DISTORTION AT PEAK POWER; DYNAMIC RANGE: OVER 70 db; FREQUENCY RESPONSE: 20-20,000 cps.

AE-2 Amplifier
Equalizer - \$74.50



SEND FOR *Free* CATALOG Dept. A-3

McINTOSH ENGINEERING LABORATORIES, Inc. 320 WATER STREET BINGHAMTON, N. Y.

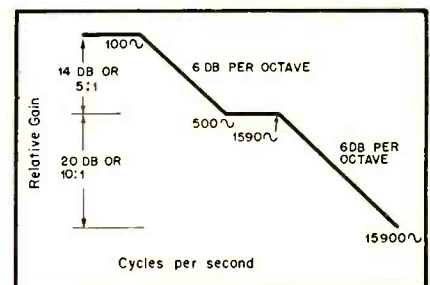

Fig. 7. Asymptotes to LP playback curve.

loading and direct feed-through are determined almost entirely by Z_1 and the internal impedance with feedback. According to (C) of Fig. 3, at high frequencies where Z_2 approaches a short circuit, the internal impedance approaches $Z_0/(A_1 + 1)$ or 3780 ohms. If we choose Z_1 about 100 times this value, then the loading and direct feed-through will cause an error of less than 0.1 db up to 20,000 cps.

This low value of internal impedance at high frequencies makes the amplifier quite immune to the capacitance effects of adding a following stage or an output cable.

The effective parallel resistance $(A_1 + 1)Z_1$ across Z_2 is now identified with the resistance KR_a of (D), Fig. 6. It is convenient to set this value at 12 megohms, making Z_1 equal 374,000 ohms. Since we want to have 6.02 db of gain reduction at extreme low frequencies, amounting to 5.80 db feedback and 0.22 db loss due to input voltage division between Z_1 and $(Z_2 + Z_0)$, Z_2' must be just half its no-feedback value, or 6 megohms. This means that Z_2 , which approaches the resistance $KR_a/(K - 1)$ at low frequencies, must be 12 megohms. Putting together the relationships $KR_a = 12$ megohms and $KR_a/(K - 1) = 12$ megohms determines the value of R_a as 6 megohms. The remainder of the network can be found from the relationships in Fig. 5 and (A) of Fig. 6.

Figure 8 shows the completed circuit. In order to maintain the best possible low-frequency response, the coupling capacitor has been included in the feedback path. It was chosen for 0.1 db loss at 20 cps without feedback. Also the 80 μmf grid-to-plate capacitor has been made 3.3 μmf smaller than calculated to allow for tube and wiring capacitances. Such a preamplifier would be suitable for use with a Pickering cartridge which would provide the d.c. grid return to ground. To maintain the flat velocity response required at the input terminals of the preamplifier, this particular pickup should have a 27,000 ohm re-

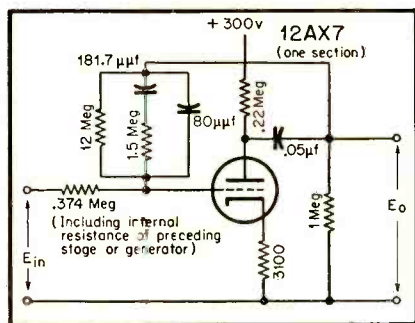

Fig. 8. Complete phonograph amplifier.

sistor connected across it. Other resistor values are required for different types of magnetic cartridges.

Extension to Multistage Amplifiers

The use of equivalent circuits stemming from (B), Fig. 1, is not limited to the cases illustrated where the only frequency discrimination occurs in the

external feedback path. Ordinary multistage feedback amplifiers can be treated similarly. In general, the generator voltage $A_0 E_{in}$ is a function of frequency and so it becomes necessary to add the response curve of the network in db to the response curve of the amplifier without feedback A_0 . When the total phase shift in the negative feedback lops exceeds 90 deg., at least one of the elements of the network will be a negative resistance.

New Hudson Consultant

One of the more remarkable figures in the audio field, Robert W. Gunderson, has

been retained as consultant by the Hudson Radio & Television Corp., New York, to assist customers in solving technical problems.

Although totally sightless since birth, Gunderson, who is 32 years old, has achieved national prominence as an engineer, and because of his efforts to assist others who are similarly afflicted.

He is radio instructor at the New York Institute for Education of the Blind, from which he himself graduated in 1937, and has prepared hundreds of students for employment in industry, also many for ham licenses.

While Gunderson takes great pride in his own station W2JIO, his pet project is the Braille Technical Press, a radio and electronics guide for the blind which he publishes monthly at his own expense.

Save Time
Save Money
with these...

New STANCOR REFERENCES

The big new Stancor 1951 Mid-Year Catalog lists 441 Stancor transformers... the most complete catalog line in the industry. All transformers, including television components, are classified and indexed so you can easily locate the unit you need. Each listing includes electrical specifications, dimensions, weight and list price. Clear illustrations show each mounting type in detail.

The 8th Edition of the Stancor Television Catalog and Replacement Guide provides you with quick, easy-to-read replacement information on 1511 TV models and chassis made under 79 brand names. All manufacturers are listed alphabetically and the models and chassis are listed in numerical order. A separate section lists all Stancor TV transformers and related components by part number.

Both of these up-to-date references are now stocked by your Stancor distributor, or write Stancor directly for your free copies.

AUDIOPHILES—Use Stancor transformers to build the famous Williamson High Fidelity Amplifier. Circuit diagrams and complete parts lists are available in Stancor Bulletin 382 at your Stancor distributor.



Most Complete Line
in the Industry

STANDARD TRANSFORMER CORPORATION

3594 ELSTON AVENUE, CHICAGO 18, ILLINOIS

9205 DEGAUSSER

Demagnetizes magnetic tape and film to erase recording and residuals. Accommodates 5400 foot reels of 1/4" tape; 1000 foot, 35mm. Write for Catalogue. Net Price \$69.50



CINEMA ENGINEERING COMPANY
1510 WEST VERDUGO AVENUE, BURBANK, CALIFORNIA

Export Agents: Frazar & Hansen, Ltd. • 301 Clay Street • San Francisco, Calif., U. S. A.

You Are Invited to Attend the Third Annual

AUDIO FAIR

Sponsored by the
AUDIO engineering society

in conjunction with its
Annual Meeting and Convention

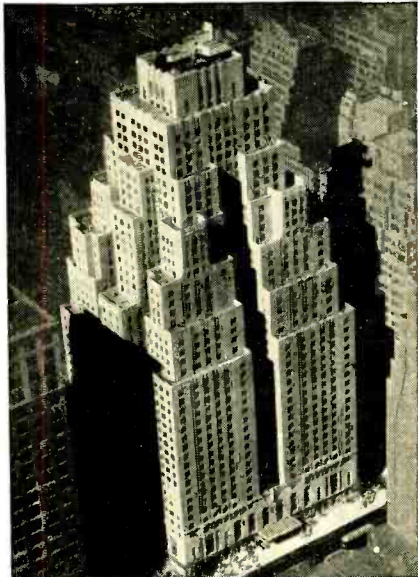

AUDIO on the contemporary SCENE

of utmost interest and importance to government and military agencies, Broadcast Engineers, Recordists, Sound-on-Film Men, Public Address Operators, Audio Hobbyists, Dealers and Distributors, and lovers of high-quality music reproduction

YOU WILL SEE and HEAR

industry-wide displays and demonstrations of the latest and best audio equipment, components, and accessories

AGAIN UNDER ONE ROOF

REGISTRATION FREE
for all Exhibits

Hotel New Yorker, New York City, November 1-2-3, 1951

Fifth and Sixth Floors



ANNUAL CONVENTION BANQUET

Thursday Evening, November 1, 7:30 p.m.

For further information and reservations,
write

Fair Manager, Room 920, 342 Madison Avenue, New York 17, N. Y.

SQUARE WAVE TESTING

[from page 15]

As the test frequency is raised, the picture obtained on the 'scope gradually changes from a square to an approximate sine wave. This is because the test frequency is approaching the amplifier cut-off point and its harmonics are greatly attenuated. If the amplifier has a sharp cut-off, such as might be experienced with a low-pass filter, the wave at some frequency may appear double humped because of the presence, primarily, of the fundamental and third harmonic only, the fifth and higher harmonics being attenuated to the point where they have little if any effect. Thus a rough measure of the sharpness of cut-off may be obtained.

In making these tests, the low-frequency square wave must be sufficiently low that the high-frequency effects are not noticeable, and vice versa. In a narrow-band amplifier this may not be possible, but it is doubtful if anyone will want to make these tests on a narrow-band amplifier anyway.

Conclusions

The method given here makes possible the easy and rapid determination of the practical response limits of an amplifier. Also, if a good reproduction of the original square wave is obtained, these figures show that the amplifier response is good down to approximately one-tenth the test frequency. It can also be shown that the response under such conditions is also good up to about ten times the test frequency.

REFERENCES

1. Louis E. Garner, "Wide frequency range square-wave clipper" *Radio & Television News*, March 1950, p. 36
2. Gilbert Swift, "Amplifier testing by means of square waves" *Communications*, Feb. 1939
3. A. V. Bedford, "Transient response of multistage video-frequency amplifiers" *Proc. I.R.E.*, April 1939
4. L. B. Arguimbau, "Network testing with square waves" *General Radio Experimenter*, Dec. 1939
5. L. B. Arguimbau, "Transient response of a broadcast system" *General Radio Experimenter*, April 1940
6. Philip M. Seal, "Square wave analysis of compensated amplifiers" *Proc. I.R.E.*, Jan. 1949, p. 48

RECORD PROCESSING

[from page 23]

conductive, but which prevents permanent adhesion of the metal. The master thus treated is now pre-plated with copper or nickel, back plated and separated between the copper-nickel or nickel-nickel interface. Again to get a stamper from a mother the mother process is repeated as many times as necessary, starting with the mother and yielding

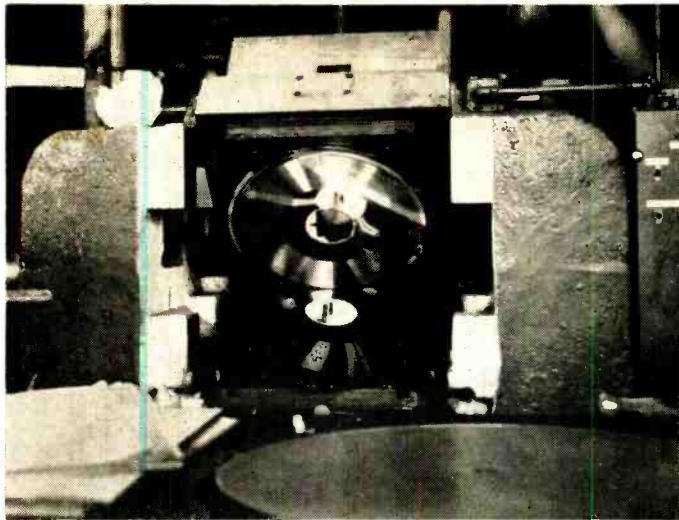

Fig. 9. Finished transcription being removed from one of the molding presses.

stampers. The stampers are finished by the chrome plating process outlined above.

After the stampers are completed they are sent to the press room where they are placed in the test press. A pre-heated, 240 to 260° F, square preform of the right weight of vinyl plastic, is placed on the master which has been heated to 300° F, and the press is closed. After about 5 seconds, pressure of 1700 to 1800 psi is applied for 40 seconds and cold water is circulated to cool the die. The press is opened after pressure is released and the test pressing removed. The three steps involving the press are called *cycling*. After the disc is pressed, the excess material at the edge—flashing—is removed, and the disc is inspected and delivered to the customer. On his approval the stampers, Fig. 9, are run until the order is filled.

For the run, two masters are usually required and are placed facing each other in the press, the labels are placed with their faces against the stampers, the preform placed on the bottom one and the press cycled. Inspection for air bubbles, blisters, and proper filling of the grooves then precedes the packaging and shipping.

Some of the headaches of processing include the \$1500 gold foil sheets, lasting only two months, used in each of the gold sputtering chambers. Fifty cents worth of gold is used in the making of each master. To have the gold reclaimed would require 15 tons of old masters if the reclamation were to pay for itself. Direct current is used for the plating, of course, and to obtain the high current required six motor generators with a total a.c. power consumption of 25 kw are needed. The plant must generate its own steam, and must provide a large quantity of distilled water.

To supply the highest quality pressings the plant also manufactures wax masters for use by its pressing customers. This is the only plant in the country handling wax masters commercially.

High-quality vinyl pressings demand close control of the chemical processes and mechanical operations. No polishing or other degradation of the master is permitted. The process as outlined is the one now used to produce frequency test records which cover the audio range from 50 to 20,000 cps.

The author wishes to acknowledge the cooperation of K. R. Smith and the staff of the K. R. Smith Division of the Allied Record Mfg. Co. in the preparation of material for this article.

ERRATUM

The schematic of a vacuum-tube phase shifter described in the *Audio Patents* section of the August issue of *EE*—Fig. 4, Page 49—shows the plate resistor R_2 shorted and the output capacitor connected to B+.

It is to be hoped that the patent on the device is more valid than was *EE*'s diagram illustrating its performance.

Sorry.

TWIN CONE AXIOM 150

This 12-in. high fidelity unit has a twin-curvilinear diaphragm (British patent No. 451754). A carefully designed magnet assembly using anisotropic material provides a total flux of 158,000 maxwells on a 1½-in. pole. The back centering device is a dustproof bakelised linen disk with concentric corrugations. The combination of these features gives this precision-built instrument an outstandingly wide coverage from 40 to 15,000 c.p.s. free from bass modulation effects. An ideal high fidelity reproducer for the record enthusiast and the connoisseur of wide range musical reproduction, it gives exceptionally fine transient and frequency response.

U. S. NATIONAL SALES WILLGOLD ELECTRONICS SALES CORP.

350 Fifth Avenue, New York, N. Y.

New England Office
Harold A. Chamberlin
31 Milk St., Boston 9, Mass.

Pacific Coast Office
Perlmuth-Colman & Associates, Inc.
1335 Flower St., Los Angeles, Calif.

Chicago Office
Harry Halinton Co.
612 N. Mich. Ave., Chicago 11, Ill.

Canadian Office
A. C. Simmonds & Sons, Ltd.
100 Merton St., Toronto 12, Can.

Manufactured by:

GOODMANS INDUSTRIES LIMITED
WEMBLEY MIDDLESEX ENGLAND

SPECIFICATION

Frequency Coverage
40/15,000 c.p.s.
Overall Diameter
12 in.-31.3 cms.
Overall Depth
6 in.-17.6 cms.
Fundamental Resonance
55 c.p.s.
Voice Coil Diameter
1¾ in.-4.4 cms.
Voice Coil Impedance
15 ohms at 400 c.p.s.
Maximum Power Cap.
15 Watts Peak A.C.
Flux Density
14,000 gauss
Net Weight
12 lbs. 13 ozs.
(5810 grs.)
Finish—Grey Rivelling
Enamel.

\$65.
LIST

for flawless reproduction
**NO OTHER CARTRIDGE CAN
 PERFORM LIKE A PICKERING**

Pickering *patented design*
 provides **DYNAMIC COUPLING***
throughout the entire audible range

*** DYNAMIC COUPLING ASSURES**

- constant stylus contact with the record grooves over the entire audio spectrum (20-20,000 cps)
- full frequency response
- full transient response

**NO RESONANCES
 NO MISTRACKING
 NO GRINDING OF GROOVE WALLS**

Well-informed engineers and technicians, schooled in the science of electro-mechanics, know that only wide-range frequency response provides full transient response; the electronic phenomena which enables the reproduction of orchestral music with all the subtle sounds that give each musical instrument its individual character.

Pickering engineers and designers have but one objective . . . to produce products that will please the music lovers' insatiable appetite for the flawless recreation of recorded music . . . for the utmost in quality insist upon Pickering Audio Components.

Pickering Cartridges transmit all of the sounds in the musical spectrum, without loss of definition, just as a fine optical lens passes all of the colors in the rainbow.

For literature address Dept. A
 See us at the Audio Fair Nov. 1, 2, 3, Room 624, Hotel New Yorker, N. Y. C.



AUDIO VOLUME MEASUREMENT

[from page 26]

ohms when measured with a sinusoidal voltage sufficient to deflect the pointer to the 0 vu or the 100 per cent scale marking. Of this impedance, 3900 ohms is in the meter and about 3600 ohms must be supplied externally to the meter, this value of series resistance being required in order to meet the above dynamic characteristics.

(c) *Sensitivity.* The application of a 1000-cps potential of 1.228 volts r.m.s. (4 db above 1 milliwatt in 600 ohms) to the instrument in series with the proper external resistance (3600 ohms) causes a deflection to the 0 vu or 100 point on the scale. The instrument, therefore, has only sufficient sensitivity at its normal reference point (0 vu or 100) to indicate a volume level of +4 vu. It has not been found possible to design more sensitive instruments while meeting other requirements.

There should be no confusion because the instrument deflects to a scale marking of 0 vu when a level of +4 vu is applied to it. The 0 point on the vu scale is merely an arbitrary point at which it is intended nominally to read the instrument, and the rest of the vu scale represents deviations from the 0 point. The volume level is read, not from the scale, but from the indications on the associated sensitivity control when the latter is set so as to give a scale deflection of zero (as detailed in a foregoing section).

(d) *Overload Capacity.* The instrument is capable of withstanding, without injury or effect on calibration, peaks of 10 times the voltage equivalent to a deflection to the 0 vu or 100 scale point for 0.5 second and a continuous overload of 5 times the same voltage.

(e) *Presence of Magnetic Material.* It should be cautioned that the presence of magnetic material near the movement of the instrument may affect its calibration and dynamic characteristics. This is because, to obtain the desired sensitivity and dynamic characteristics, it has been necessary to employ more powerful magnets than usually required for such instruments, and any diversion of flux to nearby magnetic objects effectively weakens the useful magnetic field beyond the point where these characteristics can be met. The instruments should not, therefore, be mounted on steel panels. (The effect is only slight, however, if they are mounted on 1/16-in. steel panels with the mounting hole cut away as far as possible without extending beyond the face of the meter case.)

In the instruments as now available, the deviation of the sensitivity with temperature is less than 0.1 db for temperatures between 50° F. and 120° F., and is less than 0.5 db for temperatures as low as 32° F.

The instrument by itself does not con-

MIDGET CONDENSER MICROPHONE
 For Precision Sound Measurements and High Quality Sound Recording

- **RUGGED CONSTRUCTION**
- **EXCEPTIONAL CALIBRATION STABILITY**
- **UNAFFECTED BY VARIATIONS IN HUMIDITY**

Built to give years of service without change in calibration. Even without dessicators, Kellogg Midget Condenser Microphones show no detectable drift in laboratory service. Proven in use for optimum performance for more than 15 years.

PRINCIPAL CHARACTERISTICS

	MODEL A	MODEL B
RESPONSE (Referred to 1 volt/ dyne/cm ²)	-59 db	-55 db
FLAT TO WITHIN	± 3 db from 20 to 11,000 cps. for closed cavity without grille.	± 4 db from 20 to 15,000 cps with or without grille for perpendicular incidence in free field.

Users Include government laboratories, universities, audio development laboratories, sound studios and industrial plants manufacturing sound equipment.

SEND FOR FULL SPECIFICATIONS TODAY! WRITE DEPT. 27-J

KELLOGG SWITCHBOARD AND SUPPLY COMPANY
 Established 1897

6650 South Cicero Avenue, Chicago 38, Illinois

MIDGET CONDENSER MICROPHONE

stitute a complete volume indicator but must have certain simple circuits associated with it. The basic form which this circuit takes is illustrated in Fig. 4. This is a high-impedance (7500-ohm) arrangement intended for bridging across low impedance lines. As noted above, about 3600 ohms of series resistance has been removed from the instrument and must be supplied externally in order to provide a point where the impedance is the same in both directions, for the insertion of an adjustable attenuator. A portion of the series resistance is made adjustable as shown by the slide wire in the diagram. This is for the purpose of facilitating accurate adjustment of the sensitivity to compensate for small differences between instruments and any slight changes which may occur with time.

The maximum sensitivity possible with this, the simplest circuit, is +4 vu for indications at the 0 vu or 100 per cent mark when placed across 600-ohm line. The maximum sensitivity occurs, of course, when the loss in the adjustable attenuator is zero. The upper limit to the range of measurement is limited only by the amount of loss introduced by the adjustable attenuator, its power handling capacity and that of the two series resistors.

The volume indicator of Fig. 4 can be bridged across circuits of other than 600 ohms, of course, but when this is done a correction factor must be applied in order to determine the true level. Figure 5 shows the magnitude of the correction factor. It is to be noted that the basic volume indicator circuit (Fig. 4) has an input impedance of 7500 ohms and should not be bridged across circuits of appreciably higher than about one-tenth of this impedance if undue loading of the circuit is to be avoided. On the other hand, when used across circuits of less than the normal 600 ohm value, the sensitivity of the instrument is reduced, as indicated by Fig. 5.

Figure 6 shows an arrangement in which, by adding a transformer, the sensitivity has been increased at the expense of decreasing the input impedance to a low value. The circuit is designed so that the impedance facing the instrument itself is the same as in the basic circuit (Fig. 4). Thus the correct dynamic characteristics are obtained. The input impedance, on the other hand, is low, hence the device cannot be bridged across a through line but must be used to terminate the circuit. In practice, approximately a 10 db increase in sensitivity may be obtained by this arrangement.

In high-fidelity audio systems the use of a 150-ohm circuit impedance is becoming common practice.⁶ However, when the basic volume indicator circuit is used with 150-ohm circuits a loss in sensitivity of 6 db results. Therefore, on a 150-ohm circuit the instrument is ca-

⁶ Monroe and Palmquist, *Proc. I.R.E.*, Vol. 36, No. 6, p. 786 (June 1948).

Air-Tone

HEADQUARTERS FOR **Magnecord**



↑ **MAGNECORD PT6-JAH RECORDER & AMPLIFIER**
Complete Systems from \$564.00

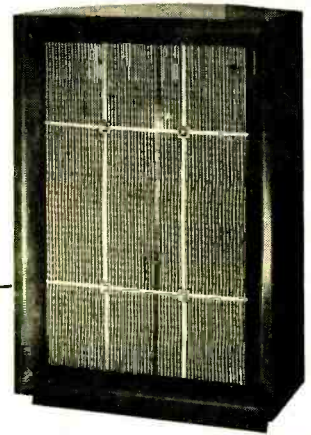

→ **ARISTOCRAT SPEAKER**
Direct front radiation of high frequencies for 12" full range driver. At least 1 full octave of added base range at full efficiency. Mahogany finish. Immediate delivery—in stock NET PRICE.. \$59.70
SAME IN BLEACHED BLONDE FINISH
Immediate delivery—in stock NET PRICE.. \$63.60

Air-Tone

HIGH FIDELITY SYSTEMS ON DISPLAY AT OUR SHOWROOMS

SOUND & RECORDING COMPANY
1527 CHESTNUT ST., PHILA. 2, PA. — RI. 6-8388

Sylvania Offers FULL-LINE of High Quality Sockets

Sylvania now offers a full line of sockets for military and civilian requirements, manufactured in accordance to JAN and RMA specifications. Available in General Purpose and Low Loss Phenolics and Steatite, with any combination of contact materials.

Available types include 7- and 9-pin Miniature, Turret, Octal, Duo-Decal, etc., sockets. For complete descriptions write today for new illustrated catalog to: Sylvania Electric Products Inc., Dept. A-1310, Parts Sales Division, Warren, Pa.

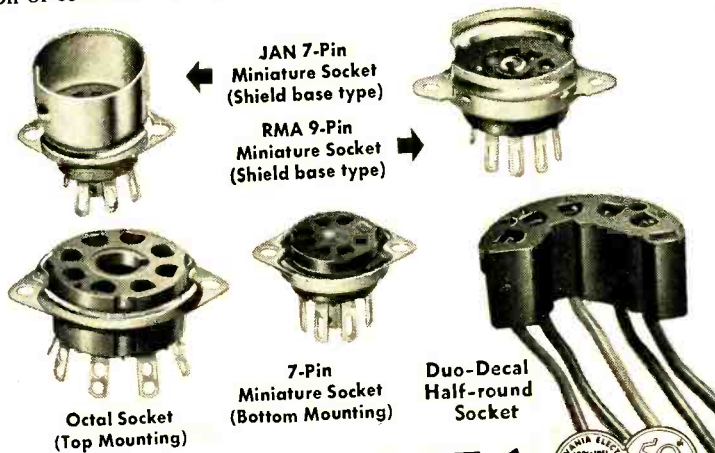

SYLVANIA

RADIO TUBES; TELEVISION PICTURE TUBES; ELECTRONIC PRODUCTS; ELECTRONIC TEST EQUIPMENT; FLUORESCENT TUBES, FIXTURES, SIGN TUBING, WIRING DEVICES; LIGHT BULBS; PHOTOLAMPS; TELEVISION SETS

SYLVANIA ELECTRIC PRODUCTS INC. 50th ANNIVERSARY 1907-1957 FIVE DECADES OF PROGRESS

MEET THE FINEST audio amplifier ever built, at any price. Its name: the Craftsmen 500, with the famous Williamson all-triode circuit. We had to invent a new word to describe its 99.99%* distortion-free performance. The word is ULTRA-FIDELITY. Hear the "500" and you'll know why.

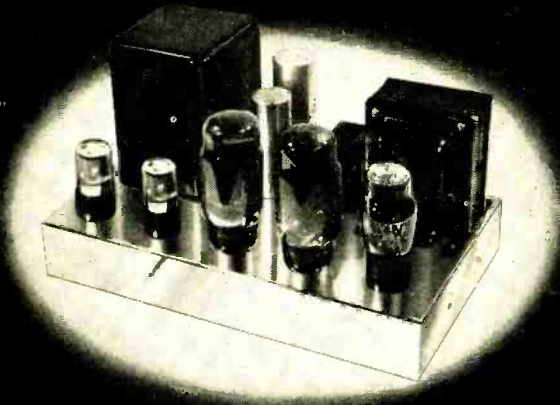

C500 Amplifier Features

- Freq. response: ± 0.1 db., 20 cps to 20,000 cps; ± 2 db., 5 cps to 100,000 cps.
- Power response: 12 watts ± 2 db., 10 cps to 50,000 cps.
- Tube complement: (2) 6SN7GTA; (2) KT66 power output: 5V4G rectifier.
- Total H Distortion: Less than 0.1% at 10 watts, at mid-freqs.
- *0.01% at av. listening level below 1 watt.

for information, write

THE RADIO **craftsmen** INCORPORATED

Dept. A-10, 4401 N. Ravenswood Ave., Chicago 40, Ill.

Still the Best at Any Price!

\$3.75

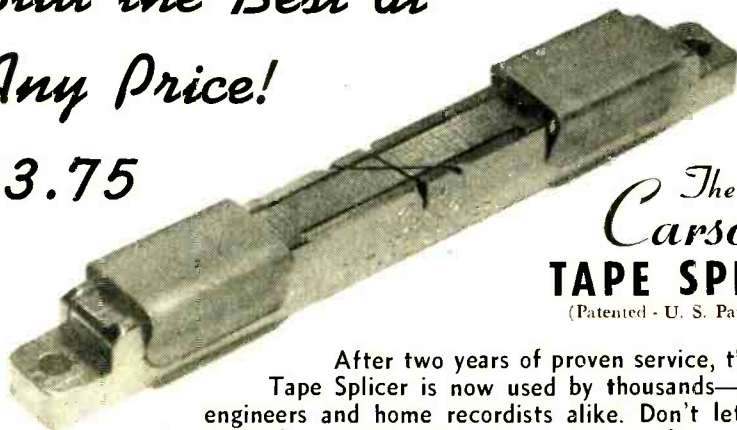

The **Carson** TAPE SPLICER
(Patented - U. S. Patent Office)

After two years of proven service, the Carson Tape Splicer is now used by thousands—recording engineers and home recordists alike. Don't let the low price mislead you. This splicer is a quality product guaranteed for results and yet at an amazingly low price for such a precision machined device. A Carson Tape Splicer along with a razor blade and No. 41 splicing tape are all you need for fast perfect splices.

Look at just three of the many special features engineered into this splicer:

- | | |
|----------------------------------|--|
| 1. Positive Clamping | Tape cannot slip while you are making your splice, assuring even splices. |
| 2. Trimming of the Splicing Tape | Surplus splicing tape can be trimmed without removing tape from splicer. |
| 3. Nickelplated Brass | Long wearing and non-magnetic—Indefinite life—No soft aluminum to be cut and nicked by a cutting edge. |

It will pay you to investigate. Sold at all leading dealers and distributors.

INQUIRIES WELCOMED BY:

MAGNECESSORIES, BOX 6960, WASHINGTON 20, D. C.

EXPORT SALES OFFICE: Norpat Sales Inc., 45 W. 45 St., New York 19, N. Y.

pable of reading levels only down to +10 vu. The loss in sensitivity in situations such as this can be avoided by utilizing a circuit similar to Fig. 6 except that the step-up ratio of the transformer is made only great enough to overcome its own losses and that which results from the existence of lower voltage (for a given volume level) on a circuit of lower impedance. In the particular instance cited a step-up ratio of slightly more than 1:2 would be necessary if the transformer were without losses and slightly greater than this in a practical case.

The input impedance of the volume indicator (7500 ohms in the basic circuit) will be reduced under these circumstances by a factor equal to the square of the turns ratio. This is not a serious disadvantage, however, since the impedance of the circuit being bridged has also been reduced by essentially this same factor. Therefore the ratio of the circuit impedance to the bridging impedance remains approximately the same. For the particular example cited, namely a 150-ohm circuit, practical volume indicator transformers, when terminated in a standard volume indicator, have input impedances of about 1700 ohms.

Transmission Level Practices

The volume levels that are used for the transmission of speech and program waves may be determined upon in a number of ways depending upon the communications service involved. For example, in a system employed for voice communication, where loss of naturalness of the speaker's voice is not a factor, the relative audio levels might be maintained as high as possible without loss of intelligence. Another criterion might be the transmission of voice and music at the same loudness. On this basis, using the standard volume indicator, voice would be peaked 2 or 3 db below music.¹ Still another possible basis for determining relative transmission level is the appearance of aural distortion caused by overloading of the particular facility involved. Determinations of this kind are usually made on an A-B test basis¹ and the results will depend to a large extent upon the shape of the overloading characteristic of the system involved. Transmission practices based upon this criterion ensure the maximum use of the facility concerned while avoiding detectable aural distortion. For this reason it has great appeal, from a purely technical standpoint, for high-fidelity broadcasting and sound recording applications. However, it does not take into consideration the listener's preferences.

Program transmission practices, where listening for pleasure is concerned, may well be determined on the basis of the average listener's wishes. A study⁷ made with this criterion de-

¹ Chinn, Gannett and Morris; *Proc. I.R.E.*, Vol. 28, No. 1, p. 9, Jan. 1940.

² *Loc. cit.*, pg. 4.

⁷ Chinn and Eisenberg, *Proc. I.R.E.*, Vol. 35, No. 12, p. 1547 (Dec. 1947).

veloped that on the average, listeners prefer to hear broadcast music and speech at about the same peak levels as read on a standard volume indicator. Furthermore, listeners like to hear broadcast music and speech at the same relative levels, regardless of the absolute sound level that is individually preferred.

The Columbia Broadcasting System is following this practice with considerable success. The measure of success in this instance being the almost complete absence of listener complaints concerning the relative loudness of speech and music. A few complaints continue to be received of course, but when specific cases are investigated it is almost always found that either (a) the recommended transmission practices were violated because of some special circumstance or (b) that the program originated on another network.

AUDIO PATENTS

[from page 4]

housing and is insulated acoustically (and positioned) by a foam rubber ring. Sound travels through a hole in the shelf.

Transconductance Tester

The same principle of checking gain by oscillation threshold is used by La Verne R. Philpott in his Patent No. 2,555,368 to find the transconductance of vacuum tubes. The patent contains the formulas by which actually calibration of the dial in micromhos is made possible, but the unit is also a simple and effective service tester for amplifier tubes.

As Fig. 4 indicates, the basis of the in-

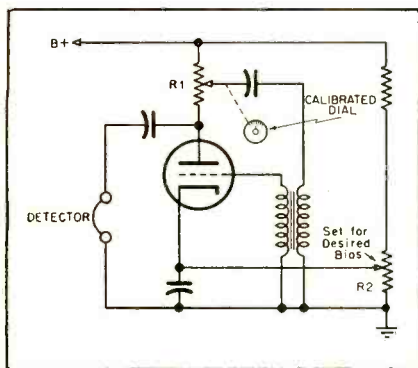

Fig. 4.

vention is an ordinary transformer-coupled audio oscillator with feedback adjustable through the setting of the arm on R_1 , the plate load resistor of the tube. The amount of feedback necessary for the circuit to reach oscillation is determined by the G_m of the tube. To use the invention, a tester can be made up with the usual variety of tube sockets and switches for connecting the various leads to the right elements. Tubes known to be good are then inserted and biased as desired with the aid of R_2 , part of a divider across the power supply. The calibrated dial is adjusted so that the circuit just breaks into oscillation, as indicated by

see the latest

PICKERING DEVELOPMENTS

at the

AUDIO FAIR



November 1, 2, 3

Room 624, Hotel New Yorker, N.Y.C.

Pickering components are created for listening pleasure by Audio Engineers who know music and who have but one objective . . . to produce products that will please the music lovers' insatiable appetite for the flawless recreation of recorded music . . . for the utmost in quality, insist upon Pickering Audio Components.

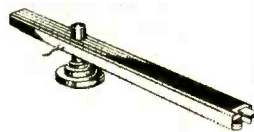
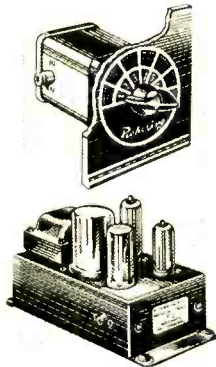

RIGHT!

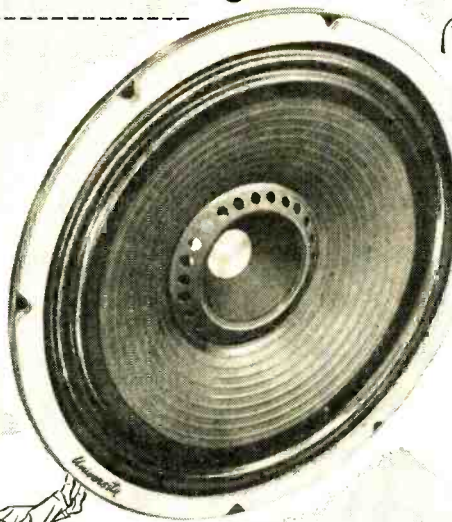

— from any angle

A challenging answer to low cost, wide-angle high fidelity reproduction. Diffusicone-12 is a newly engineered speaker with exclusive dual concentric cone design, which diffuses the normally beam-like high frequencies. Results in exceptionally uniform response . . . assures full range reception over the entire listening area.



Write today for Bulletin 62N73 — address inquiries to Desk 13.



THE NEW

University DIFFUSICONE-12

An Engineering Achievement of

UNIVERSITY LOUDSPEAKERS INC.
80 So. Kensica Ave., White Plains, New York

Distinguished by BRILLIANT PERFORMANCE

Recording engineers have learned to rely on Ampex for top performance in both the audio and instrumentation fields. Mechanical flexibility and reliability, incorporated into Ampex Recorders, are a bulwark to their unequalled performance. Through long gruelling hours of continuous service the precision built Ampex delivers reliable performance with minimum upkeep time . . . that's why Ampex has unchallenged leadership.



**SERIES
300**

- **CONSOLE**
- **PORTABLE** in twin cases
- **RACK MOUNTING**

MODEL 300
15 & 7 1/2 Ins. Per Sec. For audio recording to 15,000 cycles.

MODEL 301
30 & 15 Ins. Per Sec. For frequencies to 15,000 cps. Simplifies program editing.

MODEL 307
60, 30 & 15 Ins. Per Sec. For instrumentation uses to 100,000 cps.

Complete Specifications and other useful information is available without obligation on request.



Exclusive INTERCHANGEABLE TAPE Feature

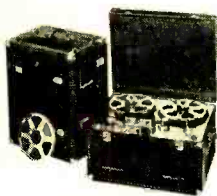

How well Ampex has learned to build unrivaled accuracy into its products is well proven by the interchangeable tape feature. Ampexed tape plays back on any Ampex Recorder with the same timing and response as it would on the machine that made the original recording!

STANDARD OF THE GREAT RADIO SHOWS

AMPEX



MAGNETIC TAPE RECORDERS
AMPEX ELECTRIC CORPORATION • Redwood City, Calif.
Distributors in Principal Cities

AX-57

headphones, an electron-ray tube, or some other detector, and the dial reading is noted. Thereafter tubes of the same type which require the arm of *R_i* to be set nearer to the plate end have less gain, how much less being indicated by the dial setting. Pentodes can, of course, be tested as well if voltage is provided for the screen.

Readers interested in investigating any of these patents further may obtain copies for 25 cents each from the Commissioner of Patents, Washington 25, D. C.



Employment Register

POSITIONS OPEN and AVAILABLE PERSONNEL may be listed here at no charge to industry or to members of the Society. For insertion in this column, brief announcements should be in the hands of the Secretary, Audio Engineering Society, Box F, Oceanside, N. Y., before the fifth of the month preceding the date of issue.

★ Positions Open • Positions Wanted

★ **Wanted:** Network caliber audio technician as chief engineer of large recording installation, New York area. Draft exempt preferred. State salary. Box 1001, Audio Engineering.

★ **Audio Engineers:** One amplifier and circuit designer. One audio with good mechanical background. Exceptional long-range opportunity in recording and business machine field. Permanent non-defense work in Connecticut. Send resumes to P. O. Box 29, Hartford 1, Conn.

★ **Mechanical Design Analyst:** For work in a small research group. Drafting and letter-writing background required with at least two years' experience designing small electro-mechanical mechanisms. A knowledge of audio and recording patents preferred. Permanent non-defense work in Connecticut. Send resumes to P. O. Box 29, Hartford 1, Conn.

★ **Sales Engineer** wanted by leading distributor of professional tape and disc recorders, playbacks, and all accessories. Man selected will be paid for knowing his stuff. Box 1002, Audio Engineering.

★ **Engineer:** experienced in vacuum tube circuit design and construction. Knowledge of audio frequency instruments and a.c. measurement techniques also required to fill position in test and development laboratory. Box 1003, Audio Engineering.

★ **Engineer:** to engage in development and construction of audio frequency circuits. Must be able to conduct investigations independently and to write up results in good technical style. Box 1004, Audio Engineering.

• **Recording Engineer,** American, with impressive English film background; familiar with all phases of film production from studio floor to laboratory, both aural and visual; desires connection in films or live television, USA or abroad. For details write or wire: John F. Higgins, 57 Juniper Road, Port Washington, New York.

We're not saying you MUST have AUDIO ENGINEERING You could undoubtedly live without it if you had to.*

BUT our many readers think of AE as a sort of institution, a necessity for their interests and way of thinking. Our readers tell us they think AE is worth its price and much more.

IF YOU ARE interested in Audio (and who isn't, these days?), you know that AE IS THE ONE MAGAZINE DEVOTED TO AUDIO AND NOTHING BUT AUDIO.

IF YOU WANT to know what is happening in your field of work or how to better the sound equipment you are making for your living room, you'll want every issue of AE.

SO, before you miss one of the stimulating issues we have scheduled for the winter months ahead, fill out the coupon below. That one back issue you need most is generally sold out.

* At last count, only one subscriber had widowed his wife because he forgot to renew his subscription.

AUDIO ENGINEERING

342 Madison Avenue, New York 17, N. Y.

Enclosed is my check money order for \$..... for my subscription to AUDIO ENGINEERING FOR 1 yr 2 yrs.

Subscription Price in U. S. A. and Canada and Pan American Union: 1 yr—\$3; 2 yrs—\$5. Add \$1. per year for foreign subscriptions.

Name (please print)

Address

City Zone State

Occupation (give title and department)

Firm name

NEW LITERATURE

● **Society of Motion Picture and Television Engineers**, 40 W. 40th St., New York 18, N. Y. announces the publication of "High Speed Photography", Volume 3. The 160-page book is an anthology containing reprints of articles of special interest to the general field of photography in engineering and research, which first appeared in the SMPTE Journal from January 1950 through January 1951. Copy may be obtained from Society headquarters upon remittance of two dollars.

● **Milo Radio and Electronics Corp.**, 200 Greenwich St., New York 7, N. Y. has assembled a remarkably complete listing of industrial and special-purpose electronic tubes in a new 28-page catalog which is being mailed on request. All major manufacturers are represented in the booklet, and technical specifications and prices are shown for all items listed.

● **Westinghouse Electric Corp.**, Box 2099, Pittsburgh 30, Pa., is publishing a 30-page booklet on the selection of electrical measuring instruments. Complete lines of portable, switchboard, panel, recording, and socket instruments are described and illustrated, and functions of each are explained. Requests for copy should specify Booklet B-4696.

● **Society of Women Engineers**, 103 Park Ave., New York, N. Y., has begun publication of a new official organ known as the "Journal of the Society of Women Engineers." The 16-page quarterly booklet will report on the activities of Society members and carry articles of general engineering interest.

● **Allied Radio Corp.**, 833 W. Jackson Blvd., Chicago 7, Ill., has surpassed even its own fine efforts of previous years with its new 1952 catalog of electronic equipment. Containing 212 pages with hundreds of illustrations, the catalog well exemplifies its title, "Everything in Radio, Television, and Industrial Electronics." This book should be considered a must by everyone, consumers and industrial users alike, involved in the buying of electronic parts and supplies. Will be mailed on request.

● **The Astatic Corporation**, Conneaut, Ohio, is now distributing a new general catalog which covers all products made by the company for civilian markets. Handily indexed on the front cover, the booklet is printed in three colors and contains illustrations of all items listed. Helpful for readers in the audio field is the practice of showing beside each phonograph cartridge a picture of the stylus it contains. Requests should be addressed to the Sales Department and should specify Catalog No. 51.

● **The International Nickel Company**, Development and Research Division, 67 Wall Street, New York 5, N. Y., is now issuing a new technical booklet on the resistance welding of nickel and high-nickel alloys. For anyone interested in this subject, the Inco booklet will be of great value. It contains 32 pages of worthwhile technical information, and is illustrated throughout by drawings and photographs. Will be mailed without charge. Address Technical Service Section and ask for Bulletin T-33.

● **International Resistance Co.**, 401 N. Broad St., Philadelphia 8, Pa., continues to maintain its high standard of technical publishing with Bulletin B-1, a 12-page booklet containing comprehensive data on characteristics and specifications of Advanced Type BT fixed composition resistors. There is no technical information a buyer could desire which is not included in this catalog which is to be commended for its excellence.

● **Rigidized Metals Corporation**, 662-P Ohio St., Buffalo 3, N. Y. has available an interesting 8-page booklet on the subject of metal conservation. Will be helpful to designers. Must be requested on company letterhead. Address Dept. A.

● **Insulation Manufacturers Corporation**, 585 W. Washington Blvd., Chicago 6, Ill. has compiled complete descriptive information and technical data on Dieflex tubings and sleeves in a new 8-page bulletin which will be mailed free on request. Will be of substantial interest to engineers and designers concerned with insulation of leads and wires in all types of electrical and electronic equipment. Address Publications Department and ask for Bulletin No. 250A.



IT'S ALLIED FOR RCA



Electron Tubes for Industry

Quick, Expert Service on RCA Tubes

ALLIED maintains in stock for quick shipment, the world's largest distributor inventory of RCA special-purpose tubes—of all types. We specialize in supplying the needs of industrial, broadcast, governmental and other users. To save time, effort and money—phone, wire or write to ALLIED. Fill all your needs quickly from the complete, dependable electronic supply source.

ALL TYPES IN STOCK

- Vacuum Power
- Thyratrons
- Vacuum & Gas. Rect.
- Ignitrons
- Cold-Cathode
- Phototubes
- Oscillograph Tubes
- Camera Tubes
- Monoscopes
- Special Types

FREE Interchangeability Directory

Valuable guide to selection of proper RCA tube type replacements. Lists 1600 tube types. Write for FREE RCA Guide No. 37-046.

See Your 1952 ALLIED Catalog

Refer to your ALLIED Catalog for all electronic supplies—parts, tubes, test instruments, tools, audio amplifiers, accessories—available from the world's largest stocks. Write today for your FREE copy of the complete 212-page ALLIED Catalog.



FREE! Send for it now

ALLIED RADIO

833 W. Jackson Blvd., Dept. 17-K-1, Chicago 7, Ill.

Everything in Electronics from ONE Source

ANNOUNCING

Unusual Opportunities in SOUTHERN CALIFORNIA

Senior men with degrees and several years of proven accomplishment may achieve further personal growth by working with some of the nation's outstanding scientists in the West's largest laboratories.

CHALLENGE AND OPPORTUNITY

for physicists and engineers in the fields of electron tubes, computers, precision electronics, solid state, system analysis, servo-mechanisms, radar, guided missiles, microwaves.

HUGHES LABORATORIES OFFER

- New Air-Conditioned Buildings With the Finest Modern Laboratory Facilities and Equipment.
- Solid Long-Range Plans For a Continuing Future.
- Intriguing Vital Defense Projects Plus a Strong Program For Advanced Development of New Peacetime Products.
- Company-Sponsored Program For Advanced Education.
- Excellent Employee Benefits.
- Frequent Salary Reviews.

AMPLE GOOD HOUSING AVAILABLE

Send Resume To

HUGHES RESEARCH AND DEVELOPMENT LABORATORIES
Culver City, Calif.

**NOW...
CUSTOM QUALITY**

enters low price field



CLARKSTAN MAGNETIC PICKUP

At last a quality variable reluctance, balanced armature magnetic pickup at low cost. The Clarkstan Model 204 features removable and replaceable stylus to permit use with all recordings, LP microgroove, and commercial pressings. Change the size of the sapphire ball point as desired without altering fine performance. Weighs $\frac{1}{2}$ an ounce and plays all popular record changers having standard mounting holes $\frac{1}{2}$ " between centers. Encased in a beautiful transparent case $1\frac{1}{2}$ " overall length. Velocity responsive (flat +2 db) from 50 cps to 12,000 cps. Delivers .030 volt from average record. **PRICE:** #204 cartridge only with sapphire needle \$9.00 list. #204 cartridge only with diamond needle \$35.00 list.

See your jobber or write for Bulletin 5A

CLARKSTAN
CORP. ELECTRONICS DIVISION 5A
11921 W. PICO BOULEVARD
LOS ANGELES 64, CALIFORNIA

THE **BROOK**

... *High Quality* ...

AUDIO AMPLIFIER . . .

ALL TRIODES

Distortion and intermodulation extremely low

Wide frequency range, flat from 20 to 20,000 cycles within .5 db

Attractive remote-control pre-amplifier

Compensation for various inputs; Phono, Tuner, Television or Microphone

Exclusive BROOK circuits and transformers



YES, ALL THESE FEATURES . . . but primarily LISTENING PERFORMANCE heretofore not achieved

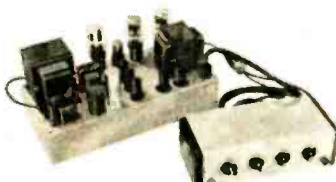

Write for free Technical Bulletin, detailed Distortion Analysis & booklet "Better Listening"

BROOK ELECTRONICS, INC.
34 DUMART PLACE, ELIZABETH 2, NEW JERSEY Dept. AK-1

MISMATCHING

[from page 16]

Substituting appropriate values for r_p and R_l the following results are obtained. The 6L6 and the 2A3 are used as representative tubes of a type.

For the 6L6, the connection of a load impedance 100 per cent higher than rated load causes an 83 per cent increase in gain. For the 2A3 the gain increase is only 14 per cent.

The connection of a load of 50 per cent of the rated value gives a 48 per cent decrease in gain for the 6L6 and a 20 per cent decrease for the 2A3.

The reason for the tremendous difference in behavior is, of course, that the plate resistance is much larger than the load in the case of the 6L6 and, consequently, the gain is determined by the load. The load is larger than the plate resistance in the case of the 2A3, and, therefore, the load has less control over the gain.

Effect upon Feedback

Many modern amplifiers, especially those of high quality, employ negative feedback to improve the performance, and manipulation of the load brings up problems which do not exist in ordinary amplifiers.

Negative feedback reduces the gain of the amplifier by the factor

$$F = 1 - A\beta_0$$

where β is the fraction of the output voltage fed back and A_0 is the total gain of the amplifier. This factor is also the factor by which the distortion, hum, and noise of the amplifier are reduced by negative feedback. As the load (and therefore, the gain) of the final stage varies, the over-all gain A_0 will vary in proportion, and, consequently, the gain reduction factor F will also vary. The amount of variation will depend on whether the output tubes are beam power or triodes and how large β is.

From the above it may be seen that changing the load value will also change the distortion, the hum, and the noise. Making the load impedance lower than its rated value will reduce the feedback, and, therefore, increase the distortion, hum, and noise for the same output. Making it higher will increase the feedback, and, consequently, reduce these non-signal components.

For example, two amplifiers have exactly the same gain A_0 and the same β , but one has 6L6 output tubes and the other has 2A3's. The gain reduction factor with the correct load is 10, corresponding to 20 db of feedback. An increase in load impedance of 100 per cent will cause an increase in F of 73 per cent for the 6L6 amplifier, and of 12 per cent for the 2A3 amplifier. The distortion of the 6L6 unit will be reduced by 57 per cent and that of the 2A3 unit by 8.5 per cent. It must be remembered, however, that the initial distortion of the 6L6's has been increased, and that of the 2A3's reduced, due to the increase

CLASSIFIED

Rates: 10c per word per insertion for noncommercial advertisements; 25c per word for commercial advertisements. Rates are net, and no discounts will be allowed. Copy must be accompanied by remittance in full, and must reach the New York office by the first of the month preceding the date of issue.

CUSTOM WILLIAMSON AMPLIFIER. Finest overrated components, 2 chassis, power take-off for preamplifier, \$110. Hi-Fi. Hallcrafters S47C AM-FM, 3 bands SW, PT-6V6, 12 watts—perfect condition. Best offer over \$125. Dr. Paul R. Nicely, Kenron Theatre Bldg., Kenton, Ohio.

GOOD BUYS in surplus audio and recording equipment. Write for list. Southwest Recording Service, 903 Salmon Drive, Dallas, Texas.

STROBOSCOPE DISCS for 78 r.p.m. records and VARIABLE speed turntables. Every speed synchronous with 60-cps light from 60 to 110 r.p.m.—80 different speeds! Records can be played instantly to predetermined pitch, metronome or duration by the use of these discs. Write for information. Lewis Serven, 24 S. Portland Ave., Brooklyn 17, N. Y.

AUDAX TUNED-RIBBON LM73 studio model microgroove record reproducer, 200 ohms, never used, \$40 or best offer. Duane Mrohs, 701 Marquette St., Flint 4, Michigan.

PRESTO 90-A three-channel recording and playback amplifier. Original cost \$500; will sell for \$250. Reco-Art, 1305 Market St., Philadelphia, Pa.

PRESTO PT-900 tape recorder, with three microphone channels; like new, \$795. Reco-Art, 1305 Market Street, Philadelphia, Pa.

HELP WANTED

Loud Speaker Design Engineer

Nationally known manufacturer of sound equipment for schools, churches, hospitals, industry has excellent opportunity for experienced loud-speaker design engineer. Will offer salary commensurate with experience. Best living conditions in cultural home city. If interested in a lucrative career with an expanding old-line company write, giving full particulars, to J. Leo O'Toole, Employment Manager, Stromberg-Carlson Company, 100 Carlson Road, Rochester, New York.

PROFESSIONAL DIRECTORY

C. J. LeBEL

AUDIO CONSULTANT

Development, Test, Custom Equipment, Complete Laboratory and Shop Facilities

133 WEST 14TH STREET
NEW YORK 11, N. Y.
CH 3-8082

Custom-Built Equipment

U. S. Recording Co.

1121 Vermont Ave., Washington 5, D. C.
Lincoln 3-2705

PREVIEW FOR '52

TWIN-TRAX* TAPE RECORDERS

Just out! Our new 1952 catalog, featuring the most advanced-design and widest variety of tape recorders ever offered. More than 20 popular recorders, including models for the broadcaster, technician, experimenter, and high-fidelity enthusiast.

*Trade Mark
Reg. U. S. Pat. Off.

Write today for your free copy of Catalog #5272.

AMPLIFIER CORP. of AMERICA
398 BROADWAY • NEW YORK 13 N. Y.

Tired of leafing through that stack of magazines for the issue you want?

Solution: order your AUDIO ENGINEERING binder. It is of DuPont Fabricord, stain-proof and washable, with a rigid backbone, a built-in metal support with a center channel to keep magazines securely in position. Well worth the price of \$2.75! You may have the year stamped in gold at no extra cost if you like.

Foreign orders please add 50¢ per binder.

AUDIO ENGINEERING
342 Madison Ave., N. Y., N. Y.

- INDISPUTABLY
- UNQUESTIONABLY
- UNDOUBTEDLY

The 1951 Audio Fair will be the most impressive display of fine audio equipment ever assembled under a single roof.

November 1, 2, 3

Hotel New Yorker New York City

in load and, consequently, the above figures do not tell the whole story.

It has been shown that change in the load impedance will produce changes in both frequency response and mid-frequency gain. In a negative feedback amplifier the gain vs. frequency response characteristic must be closely controlled in order to ensure that the feedback be negative at all points where the gain is unity or greater. The designer generally chooses a margin of stability in order to allow for gain changes due to all causes. A common minimum value for this margin is 6 db, which means allowing for a total variation of 2 to 1. A 100 per cent change in load may change the frequency response at either end by almost this much, thus practically eliminating the margin of stability. In better-designed amplifiers this margin is considerably more, and mismatching may be done much more safely from the stability point of view.

In general, within the limitations of power output discussed in the cited reference, mismatching may be quite readily accomplished. If deterioration of performance is to be avoided, the above factors should all be taken into consideration before any changes are made.

Industry People...

Dr. Albert Charles Walker of Bell Telephone Laboratories has been awarded Louis Edward Levy Medal by The Franklin Institute . . . **Leonard Carduner** of British Industries Corp. in England for a look-see at new audio developments—expects to return in time for The Audio Fair . . . **James M. Valentine**, former TV engineering head of ABC's Central Division, named an executive in TV field engineering group by Federal Telecommunication Laboratories—will headquarter in Buenos Aires.

Heckert Parker justly commended by re-appointment as manager of Annual Pacific Electronic Exhibit . . . Appointment of **Howard W. Bredlow** as Chicago district manager is newest step in expansion of Hoffman Radio Corp. into Eastern markets . . . **Bernard Hecht** moves from RCA-Victor to Starrett Television Corp. as General Manager . . . **Miss Beatrice Hicks** re-elected president of Society of Women Engineers—other officers are Miss Lillian Murad, vice-president; Mrs. Hilda Edgecomb, treasurer; Mrs. Barbara Cain, recording secretary, and Mrs. Phyllis Evans Miller, corresponding secretary.

Eugene F. Haines retiring as assistant treasurer of RCA Victor Division of RCA after serving 50 years with Division and predecessor companies . . . **Lester Klein** tops years of activity in radio merchandising business with new position as manager of downtown branch of New York's Hudson Radio & Television Corp. . . . **Ralph Schlegel** busy installing new equipment for WOR Recording . . . **Coleman London** upped to manager of electronics service for Electronics and X-Ray Division of Westinghouse . . . **George C. Mercer** and **W. J. Topmiller** become Director of Purchasing and Purchasing Agent respectively as result of promotions by P. R. Mallory & Co., Inc., Indianapolis.

Miriam Simpson, vice-president of Mark Simpson Mfg. Co., announces formation of Masco Electronic Sales Corp. to handle distribution of all Masco products . . . **George E. Faustman** has been named factory general manager of the Bendix Radio Division of Bendix Aviation Corp. to succeed Edward F. Kolar who becomes general manager of company's Red Bank Division . . . **Fred Harvey**, Sylvania ad manager, back on the job after a session in uniform . . . **Charles Ray**, Sound Department manager for Arrow Electronics, New York, busy building unique display centered around a "Then and Now" theme for The Audio Fair . . . **Bob Hertzberg**, pioneer technical writer and editor, has set up shop as consultant to manufacturers and advertising agencies.

AMPERITE

Studio Microphones at P.A. Prices

Ideal for
BROADCASTING
RECORDING
PUBLIC ADDRESS

"The ultimate in microphone quality," says Evan Rushing, sound engineer of the Hotel New Yorker.

• Shout right into the new Amperite Microphone—or stand 2 feet away—reproduction is always perfect.

• Not affected by any climatic conditions.

• Guaranteed to withstand severe "knocking around."



Models
RBLG—200 ohms
RBHG—Hi-imp.
List \$42.00



"Kontak" Mikes
Model SKH, list \$12.00
Model KKH, list \$18.00

Special Offer: Write for Special Introductory Offer, and 4-page illustrated folder.

AMPERITE Company, Inc.

561 BROADWAY • NEW YORK 12, N. Y.
Canada: Atlas Radio Corp., Ltd., 560 King St. W., Toronto



Plays all speeds
GARRARD
"Triumph"
**WORLD'S FINEST
RECORD CHANGER**

Fully automatic with automatic stop
Easily installed in your present set.

Write for FREE literature

GARRARD SALES CORP., Dept. 10E
164 Duane St., New York 13

Gentlemen:

I am interested in learning what to look for when purchasing a 3-speed record changer. Please send me, without obligation, your FACT SHEET.

NAME
ADDRESS
CITY ZONE STATE



ACHIEVING REALISTIC REPRODUCTION

A few years ago in Britain we started a campaign to differentiate between realism and high fidelity, and met with a good deal of success. But we find we are slipping and go on talking about hi-fi. So we are going to talk about realism again.

Our considerable American correspondence is always intelligent and interesting, and we find that what you want is what we have always thought real music lovers do want—an illusion of the real thing in contrast to a formula of db's and cps, of curves and figures. Obviously, first class equipment cannot be designed without technical knowledge, but technical knowledge alone cannot design first class equipment. The designer must also heed room acoustics and know so much about what an orchestra really sounds like that he must apply correction factors to what his mathematics tell him must be done. In other words, a designer must be an artist as well as a technician. And how many are?

The technique of Hartley-Turner reproduction is in some respects a flat contradiction of what the engineers think should be done, but our business has been built up on faith in how we think and what we do. A few engineers who bought the 215 speaker don't like it because it sounds different from what they think high-fidelity should sound; but we have never met a man who, primarily interested in music, did not like it. On the contrary, he is vastly intrigued at the new sound which strikes him as realism, whether it is high-fidelity or not.

Actually, the 215 is high-fidelity plus all those things which are necessary for realism, and a very large number of you have taken a chance and are very glad you bought the speaker. But we are reasonable people, and we don't expect all of you to have the same faith in what we say as we have, so we are going to make it easier for you to form your own opinion as to whether our unusual approach to the subject is realistically sound or just advertising ballyhoo.

H. A. Hartley and Hartley-Turner equipment will be at the Audio Fair, and Mr. Hartley will be very glad indeed to meet as many of you as care to come and argue with him, listen to his designs, and (dare we hope?) go away convinced. At least he can say that he has concentrated on the attainment of realism since 1927 and has no other radio or audio interest.

Those 24 years of specialised experience are completely at your service at no cost to you.

A word of warning, however. We have foreshadowed a price increase in the 215 and that is likely to happen before November. For a very limited period we can still supply the 215 at \$48.00.

Illustrated literature free on request, but do get on to our permanent mailing list for technical and other information. Just send one dollar bill to find out that our originality does not stop at technicalities.

H. A. HARTLEY CO. LTD.

152, Hammersmith Road
London W.6, England

ADVERTISING INDEX

Air-Tone Sound & Recording Co.	49
Allied Radio Corp.	53
Amperite Co., Inc.	55
Ampex Electric Corp.	52
Amplifier Corp of America	55
Arnold Engineering Co., The	31
Audak Company	29
Audio Devices, Inc.	Cover 2
Audio Fair	46
Audio Instrument Co.	41
Bell Telephone Labs	10
Bogen, David Co., Inc.	56
Brook Electronics, Inc.	54
Cannon Electric Dev. Co.	30
Carter Motor Co.	40
Chicago Transformer Co.	34
Cinema Engineering Co.	46
Clarkstan Corp.	54
Classified Ads	54
Daven Co., The	Cover 3
Garrard Sales Corp.	55
General Radio Co.	25
Goodman Industries, Ltd.	47
Gray Manufacturing Co.	5
Hartley, H. A. Co., Ltd.	56
Harvey Radio	32
Heath Co., The	33
High-Fidelity Magazine	6
Hudson Radio & Television Corp.	35
Hughes Res. & Dev. Labs	53
Kellogg Switchboard & Supply Co.	48
LeBel, C. J.	54
Leonard Radio Co.	39
Magnecessories	50
Magnecord, Inc.	4
McIntosh Engineering Lab., Inc.	44
Minnesota Mining & Mfg. Co.	27
Orradio Industries, Inc.	37
Partridge Transformers Ltd.	56
Permoflux Corp.	36
Pickering & Co., Inc.	48, 51
Presto Recording Corp.	7
Professional Directory	54
Radio Corp. of America	1
Radio Craftsmen, Inc., The	50
Rek-O-Kut Co.	3
Shure Brothers, Inc.	43
Standard Transformer Corp.	45
Stromberg-Carlson	54
Sylvania Electric Products, Inc.	49
Tech Labs	42
Terminal Radio Corp.	9
Triad Transformer Mfg. Co.	2
U. S. Recording Co.	54
United Transformer Co.	Cover 4
University Loudspeakers	51

PARTRIDGE WILLIAMSON OUTPUT TRANSFORMER BUILT TO THE ORIGINAL SPECIFICATION

De-luxe potted model now available from stock from all important Radio Stores throughout the U. S. A. (Price \$26.00 duty paid)

This transformer is now accepted as the most efficient in the world. According to "Audio Engineering," Nov. 1949, there is no U. S. equivalent.

Thousands already sold in the United States. A "must" for every high fidelity enthusiast.

New York Stockists:

Harvey Radio Co. Inc.
103 West 43rd Street

Terminal Radio Corporation
85 Cortlandt Street

If you are unable to purchase Partridge transformers in your city, write to us and mention the name of your dealer.

Fullest data, including square wave tests, distortion curves, etc., together with list of U. S. stockists rushed Air Mail to you.

PARTRIDGE TRANSFORMERS LTD.
TOLWORTH, SURREY, ENGLAND

new Bogen H 623

23 WATT UNIVERSAL
MOBILE AMPLIFIER



- FOR 6 VOLT DC AND 115 VOLT AC
- SIX POSITION MULTI-RANGE TONE CORRECTOR
- "CRISP" POSITION FOR IMPROVED OUTDOOR PERFORMANCE
- SPECIAL MOBILE PHONOGRAPH PICKUP
- REMOTE CONTROL OF PLATE SUPPLY
- CONSTANT VOLTAGE OUTPUT
- UNDERWRITERS' LABORATORIES APPROVED

Address Inquiries to Dept. A-10

David Bogen



CO., INC.

663 BROADWAY, NEW YORK 12, N. Y.

AMPLIFIER SYSTEMS & ACCESSORIES

Write for literature

DAVEN

Electronic Voltmeter Type 170-A

Vastly Improved

with

3

important, new features



1.

Input stages of the amplifier are shock mounted to reduce microphonics.

2.

The amplifier is completely shielded to prevent hum pick-up.

3.

The power supply is completely shielded to prevent hum radiation in adjacent equipment.

Write

for completely detailed catalog data.



THE DAVEN CO.

185 CENTRAL AVENUE
NEWARK 4, NEW JERSEY

The New Daven Electronic Voltmeter, Type 170-A

is a superior, portable instrument, ideal for general laboratory and production use. It is built with typical Daven precision to measure accurately A.C. sinusoidal voltages over a frequency range from 10 to 250,000 cycles and a voltage range from .001 to 100 volts.

- Large, easy-to-read, illuminated, meter scale on which all readings may be made.
- Accuracy $\pm 2\%$ over entire frequency range.
- Output jack and separate volume control for using Voltmeter as wide-range, high-gain amplifier.
- Construction permits readings independent of normal power line variations.
- Meter scale has both voltage and decibel ranges.



FOR MINIATURIZATION

The miniaturization of transformers has been a UTC specialty ever since the development of the Ouncer series in 1937. The importance of this engineering "know how" is reflected by the large number of UTC Miniature components in present military equipment. Some examples of this engineering leadership are illustrated below

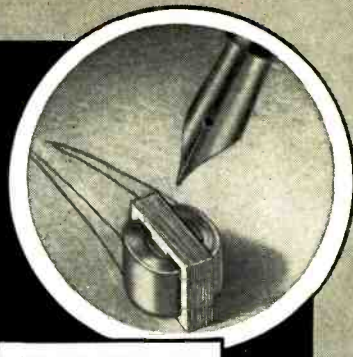

SM Unit ACTUAL SIZE
— As photographed
with normal pen for
comparison.

DC CONTROLLED OSCILLATOR INDUCTORS

The curves below illustrate oscillator frequency variation using two types of RF inductors varied by the amount of DC through the controlled windings. These units are available in ounce size and smaller.

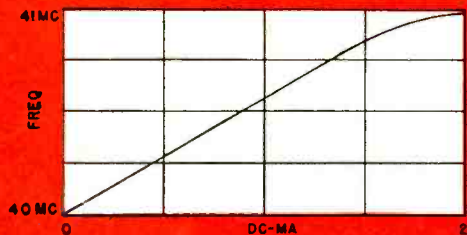
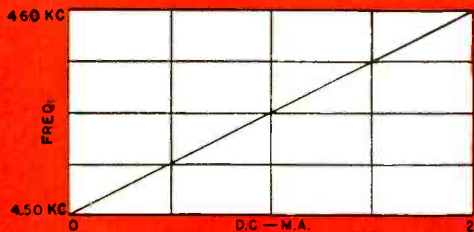

MINIATURIZED AIRCRAFT FILTERS

The standard 90-150 cycle aircraft filters have been reduced in size and weight in UTC's miniaturization program. The curves below illustrate the frequency characteristics of these units.

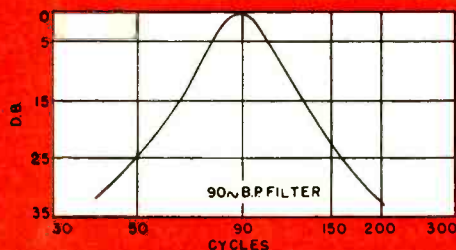
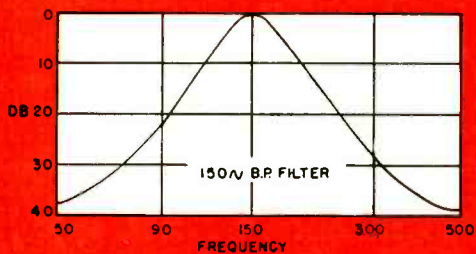

Ouncer case, non hermetic, is 7/8" diameter x 1 1/8" height. Weight — .06 lb..



Ouncer case, hermetic, is 15/16" diameter x 1 3/8" height. Weight — .11 lbs.



Miniaturized filter case is 1 11/16" x 13/16" x 1 3/8" height. Weight — .3 lbs.



SM sub-miniature audio components, 7/16" x 1/2" x 7/16" height. Weight — .009 lbs.

OUNCER FILTERS

Filter miniaturization is a specialized art. The curves below show a low pass filter and a high pass filter being supplied in the UTC ounce case.

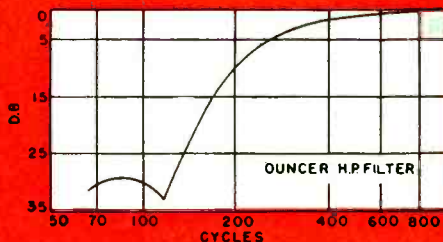
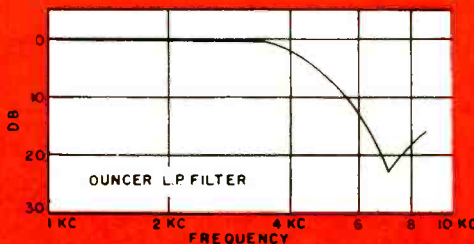

EXTREME MINIATURIZATION

Through the use of specialized materials, extremely compact designs are possible. The curve below illustrates the Q characteristics of a 7500 hy. low frequency reactor housed in the UTC ounce case.

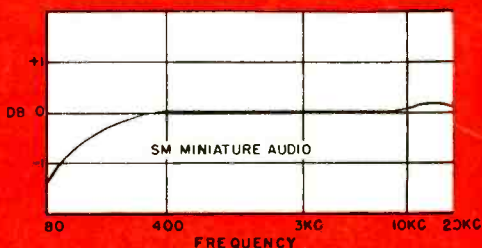
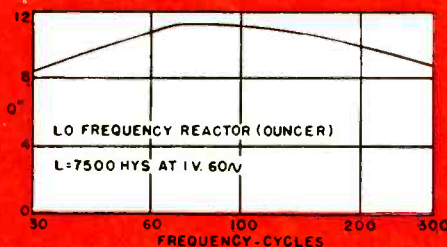

The sub-miniature audio transformer whose frequency curve is shown above, weighs less than one-seventh of an ounce yet provides wide range frequency characteristics. Its impedance ratio is 500 to 50,000 ohms for operation into a 1/2 meg. loaded grid.

United Transformer Co.

150 VARICK STREET NEW YORK 13, N. Y.
EXPORT DIVISION: 13 EAST 40th STREET, NEW YORK 16, N. Y. CABLES: "ARLAR"