

SET UP
YOUR
OWN
HI-FI

SET UP YOUR OWN HI-FI

A
Beginner's
Guide

A Beginner's Guide

R. H.
Warring

R. H. Warring

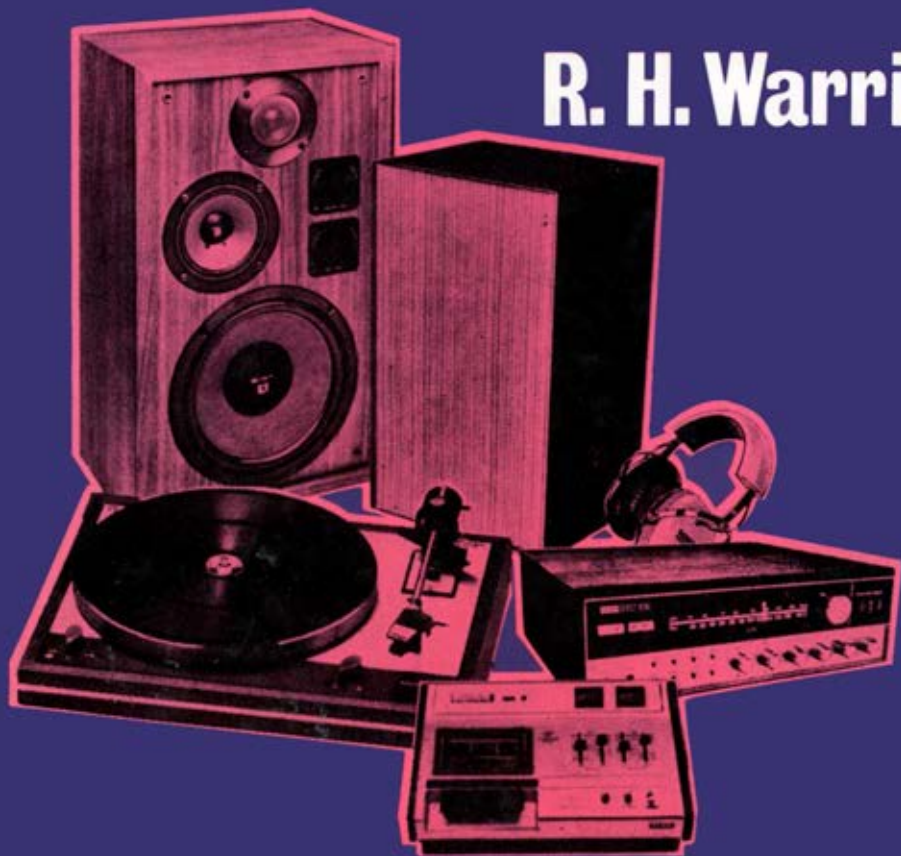

**SET UP YOUR OWN HI-FI
A BEGINNER'S GUIDE**

SET UP YOUR OWN HI-FI
A BEGINNER'S GUIDE

by

R. H. WARRING



LUTTERWORTH PRESS
GUILDFORD AND LONDON

First published 1974
Second impression 1976

ISBN 0 7188 1984 5

COPYRIGHT © 1974 R. H. WARRING

Printed in Great Britain by
Cox & Wyman Ltd.
London, Fakenham and Reading

CONTENTS

| <i>Chapter</i> | <i>Page</i> |
|------------------------------------|-------------|
| 1. HI-FI SYSTEMS AND SOURCES | 7 |
| 2. DEFINING HI-FI | 13 |
| 3. COMPLETE SYSTEMS | 31 |
| 4. UNIT AND CIRCUIT CONSIDERATIONS | 42 |
| 5. DISCS, DECKS AND PICK-UPS | 52 |
| 6. TAPES AND TAPE MACHINES | 60 |
| 7. LOUDSPEAKERS | 72 |
| 8. TUNER DESIGN | 87 |
| 9. AMPLIFIER CIRCUITS | 96 |
| 10. MICROPHONES | 108 |
| <i>Appendices</i> | |
| I. BBC TEST-TONE TRANSMISSIONS | 113 |
| II. BBC VHF RADIO TRANSMISSIONS | 115 |
| III. RADIO FREQUENCY WAVELENGTHS | 120 |
| IV. WAVELENGTH OF SOUND WAVES | 121 |
| V. CUT-OFF FREQUENCIES | 122 |
| VI. PLUG AND SOCKET CONNECTIONS | 123 |
| INDEX | 125 |

CHAPTER 1

HI-FI SYSTEMS AND SOURCES

HIGH fidelity sound reproduction—popularly known as hi-fi—has in recent years become immensely fashionable as well as offering the discerning listener greater enjoyment. On the technical side it has led to a vast improvement over earlier types of both sound recording and sound reproducing equipment. Sources of material suitable for reproduction by this means are the radio, gramophone records and tape recordings. On radio, only VHF/FM (Very High Frequency/Frequency Modulated) broadcasts can give satisfactory hi-fi results with suitable equipment. Programmes on the ordinary broadcast wavelengths—long, medium and short—are usually subject to interference, fading and other failings, and are also limited by the lack of audio frequency range.

The gramophone record established itself as a hi-fi medium with the advent of the low-noise vinyl plastic disc, which replaced the older (and more abrasive) shellac disc in about 1948. Not only was fidelity of recording improved substantially, but playing time was greatly increased by virtue of the lower speeds which could be brought into use. Great advances have also been made both in the mounting and drive of turntables used on record players, and in the pick-up cartridge and its stylus. It remains essentially a mechanical system in that electronic signals are converted into surface irregularities in the record groove during manufacture, and these irregularities are used to excite a stylus into mechanical movement which can be converted back into corresponding electronic signals on playing.

Tape recorders work on the principle of storing electronic signals on a magnetic strip. Originally the strip material was magnetic wire or ribbon, but in the early 1940's paper and plastic-based tapes coated with a ferro-magnetic material were developed. The only real changes in bringing magnetic tapes to near-perfection as a recording/playback medium have been the materials. Plastic tapes are obviously preferred to paper as a base material—acetate plastic originally being preferred on account of its stable quality (i.e. because it does not stretch), and its

SET UP YOUR OWN HI-FI

good adhesion to the ferro-magnetic coating. The chief limitations with acetate, however, are an affinity to absorb moisture (which can cause it to wrinkle), and a tendency to become brittle with age. PVC and polyester tape base materials are thus now preferred, although these are rather more stretchable. The high strength of polyester has made possible the use of thinner tapes, and thus extended playing times.

The original ferro-magnetic material was ferric oxide in finely powdered form, specially treated to give it magnetic properties. The main development has been in the 'tailoring' of the particles to produce better magnetic properties, and in the smoothing of the surface to reduce inherent residual 'noise' or 'hiss'. Such refinements have made it possible to provide excellent frequency response at relatively low tape speeds. More recently the potential frequency response has been further increased by the introduction of chromium dioxide (CrO_2) as the magnetic medium.

Apart from the fact that the complete record-store-playback cycle is electro-magnetic at all stages, tapes have a certain advantage over discs (gramophone records) in that multiple-channel facilities are readily provided with good mutual separation, making stereo working relatively simple. The gramophone record, however, also has its own advantages and, equally, a long established popularity. If direct comparisons are to be made then it is better to regard records and tapes as being complementary, rather than one having superiority over the other and leading to the eventual obsolescence of one system.

The first tape recorders/players were reel-to-reel devices, a system which offers both the greatest versatility and the highest fidelity possibilities. They are also standard for professional work, the majority of such recordings now being made on tape rather than on discs.

In addition to reel-to-reel systems, which can offer the highest in hi-fi requirements, tape systems also embrace *cassettes* and *cartridges*. The cassette, or compact cassette as it is correctly termed, is a commercial development by Philips, which first appeared in 1963. Originally it was intended primarily for voice record/play systems for office use, and for compact playing systems of ordinary (non hi-fi) quality, with the convenience of simple rewind, etc., and enclosed tape storage. Only recently has it achieved true hi-fi quality in performance possibilities, due primarily to the introduction of dynamic noise limiting circuits and the wider frequency range made possible by improved tape forms,

HI-FI SYSTEMS AND SOURCES

overcoming the basic limitation of low tape speed performance with compact cassettes.

The cartridge system appeared in 1965, developed in America by Lear-Jet, specifically for service in cars. Using a similar tape size and speed to a reel-to-reel system, the tape is endless and fully enclosed in a cartridge, offering continuous-play systems. Also the width of the tapes readily permitted the recording of 8 tracks on a single length of tape—usually in the form of four (2-track) stereo recordings.

Again the considerable advances in tape performance, and the performance of cartridge players, means that the cartridge system is capable of true hi-fi reproduction—more readily so than the compact cassette, in fact, because of the greater tape speed. To some extent, however, this is offset by limitations which may be imposed by the mechanical system necessary to handle the cartridge. Basically, in fact, the cartridge system is probably best suited to the reproduction of continuous background music—which can be of hi-fi quality if required, with suitable equipment. The compact cassette system is considerably more flexible and adaptable both to semi-continuous play (e.g. with automatic release, or a mechanical cassette changing system), and for single or selected passage playing, as with a reel-to-reel system.

Compared with a reel-to-reel system, however, both the compact cassette and cartridge systems have limited facilities for editing (the cartridge system has virtually no such facility).

Reel-to-reel, compact cassette and cartridge are now all established tape systems with standardized tapes and speeds, and in the case of cassettes and cartridges, incorporate standardized transport systems within standard cases. There have been other systems, notably those developed by Garrard, and Grundig and Telefunken. The Garrard was a cassette system, introduced in 1959, employing standard tape and two 5-inch spools. The system developed by Grundig and Telefunken became known as the DC International and employed miniaturized cassettes and narrow tape, only slightly larger in size than the Philips cassette. It was not compatible with the Philips system since the tape ran at a speed of two inches per second, but it survived as a competitor for some time.

Stereo

Stereo means simply stereophonic sound or extra-directional reproduction and has nothing to do with *quality* of reproduction, or hi-fi. Its

SET UP YOUR OWN HI-FI

virtue is based on the fact that a person is used to listening to sounds with two ears, and thus has two different sources of received sound which the brain interprets with a certain *directional* quality.

Basically, therefore, sounds emanating from a single speaker are somewhat unnatural since they lack 'directional' information. Much, however, depends on the nature of the sounds involved. Sound from a single instrument, or a single voice, is fully realistic coming from a single speaker. The directional qualities of sounds from two instruments or two voices, are covered by two separate speakers. To appreciate the sound of an orchestra, the logical arrangement should be a row of speakers, each replaying sounds at the individual points of the orchestra—Fig. 1.

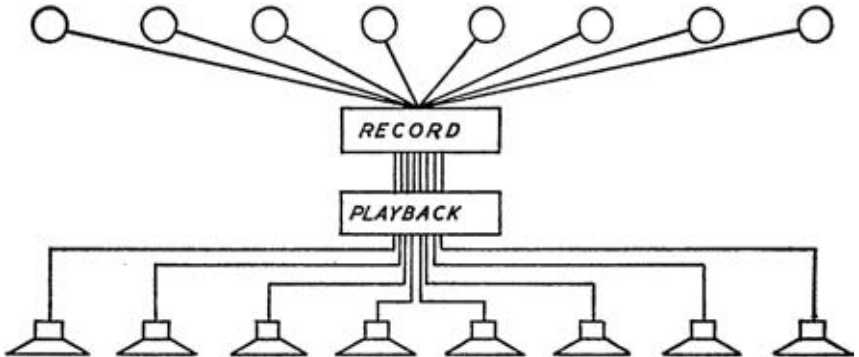

Fig. 1 TRUE STEREO RECORDING IS BY MULTIPLE MICROPHONES AND PLAYBACK THROUGH A CORRESPONDING NUMBER OF INDIVIDUAL SPEAKERS

In practice, sufficient 'directional' information to create at least a considerable difference compared with a single speaker or monophonic system can be obtained by splitting the whole sound content into two channels, each containing logical or selected 'directional' content, each channel then being played back through its own speaker, suitably located relative to the listener for optimum effect—Fig. 2. This is what has become popularly known as a *stereo system*, and the additional 'directional' information conveyed by such a system can be enhanced by suitable 'tricks of the trade' (or acoustic engineering!) in the making of the recording.

There are many other factors which finally govern the subjective

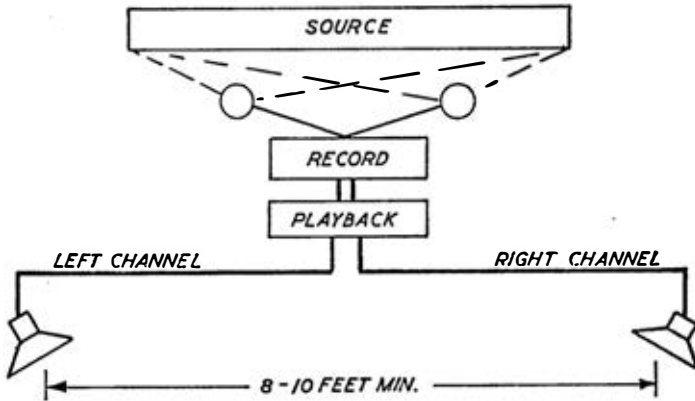

Fig. 2 STEREO IN THE POPULAR MODE IS BASED ON TWO-CHANNEL RECORDING AND PLAYBACK

assessment of the sounds heard, however, but two-channel stereo can be most effective without unduly complicating the recording/playback system requirements. Stereo information can be applied separately to the two sides of a record groove, or on separate tracks on a tape. In point of fact a three-channel stereo system would probably be more effective, and adequately cover most requirements for adding 'directional' information to a recording, but this is not an attractive technical proposition for domestic systems.

'Quad Sound' or 'quadrophonic sound' is the latest system to emerge in the domestic field, where the sound content is split into four separate channels, each playing back through its own speaker. The listener is thus 'surrounded' by sound—Fig. 3. The fidelity of such a system is questionable, as in natural circumstances a listener is not *surrounded* by sources of sound when listening to an orchestra, etc. However, it can duplicate the sounds likely to be heard in an auditorium including the natural sound reflections; but any gains in this respect can all too readily be lost by the poor acoustic properties of the average room in which the sounds are finally reproduced.

Stereo is well established and now virtually accepted as a standard adjunct to hi-fi. In other words, virtually all hi-fi equipment now produced is based on two-channel working for stereo reproduction through two speakers. Quadrophonic sound is too new to assess on long-

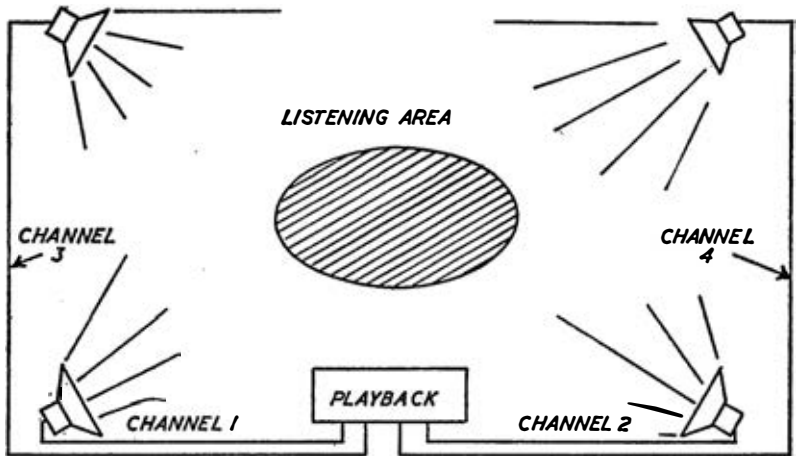

Fig. 3 'QUAD SOUND' ILLUSTRATED DIAGRAMMATICALLY

term merit. But for general enjoyment it would appear that the additional complication of accommodating two extra channels (and the additional expense) is unlikely to be justified, unless associated with a listening room designed specifically to exacting acoustic requirements. 'Quad sound' does, however, offer scope to reproduce echo, reverberation and other 'big hall' effects—far more so than stereo—and so has obvious attractions for the enthusiast seeking the ultimate in reproduction fidelity.

Stereo Headphones

The use of stereo headphones rather than twin loudspeakers for listening to stereo programmes provides 'complete' channel separation and isolation from echo or reverberation, which can be said to detract from hi-fi quality. Nevertheless, many enthusiasts find this a very satisfying method, using high-quality headphones with a good sound range and sufficient controls to compensate for the essentially artificial listening conditions. In general, it is desirable to reduce the channel separation with headphone listening via an adjustable cross-mixing circuit, but the degree to which this is felt necessary is purely subjective and can vary widely from individual to individual.

CHAPTER 2

DEFINING HI-FI

HI-FI, which, as we said at the outset, is short for 'High Fidelity', is the popular description for equipment capable of reproducing original sounds with a high degree of faithfulness. Because any reproduction is artificial, perfection in this respect is impossible, so there are varying degrees of hi-fi, depending on the quality of the equipment covered.

Unfortunately, as yet, there are no universally recognized standards for defining hi-fi in scientific terms, and by which equipment performance can be measured and assessed. Such measurements can be made, but the 'pass' or 'fail' levels are largely based on personal opinions, authoritative or individual, both of which can vary considerably. There is, however, a German (DIN) specification established as a standard for measurement of hi-fi performance, but in fact this permits a lower standard than would be expected or demanded in many respects, by the true hi-fi enthusiast. For other less critical listeners, this standard, or even a lower quality, may well be regarded as hi-fi. (The minimum requirements of this standard are set out at the end of this chapter.)

To draw a complete picture it is necessary to look into the various factors which go to make hi-fi reproduction, and the effect of 'quality level' and human response. The first and most important—but by no means the sole criterion of hi-fi—is *frequency response*.

The human ear is capable of hearing sounds ranging in frequency from about 30 Hz (cycles per second) to some 16,000–20,000 Hz, although the ability to hear higher frequency sounds (above 12,000 Hz) varies with the individual and also deteriorates with age. All sounds, apart from 'pure' notes, are mixtures of frequencies. The main frequency content of human speech is between 50 and 5,000 Hz, the female voice having a larger measure of higher frequency content than that of the male. Orchestral music may contain frequencies ranging from 30–40 Hz up to 15,000 Hz, or higher.

The typical domestic transistor radio may have a frequency response of 100–5,000 Hz, i.e. it can only reproduce frequencies within this range.

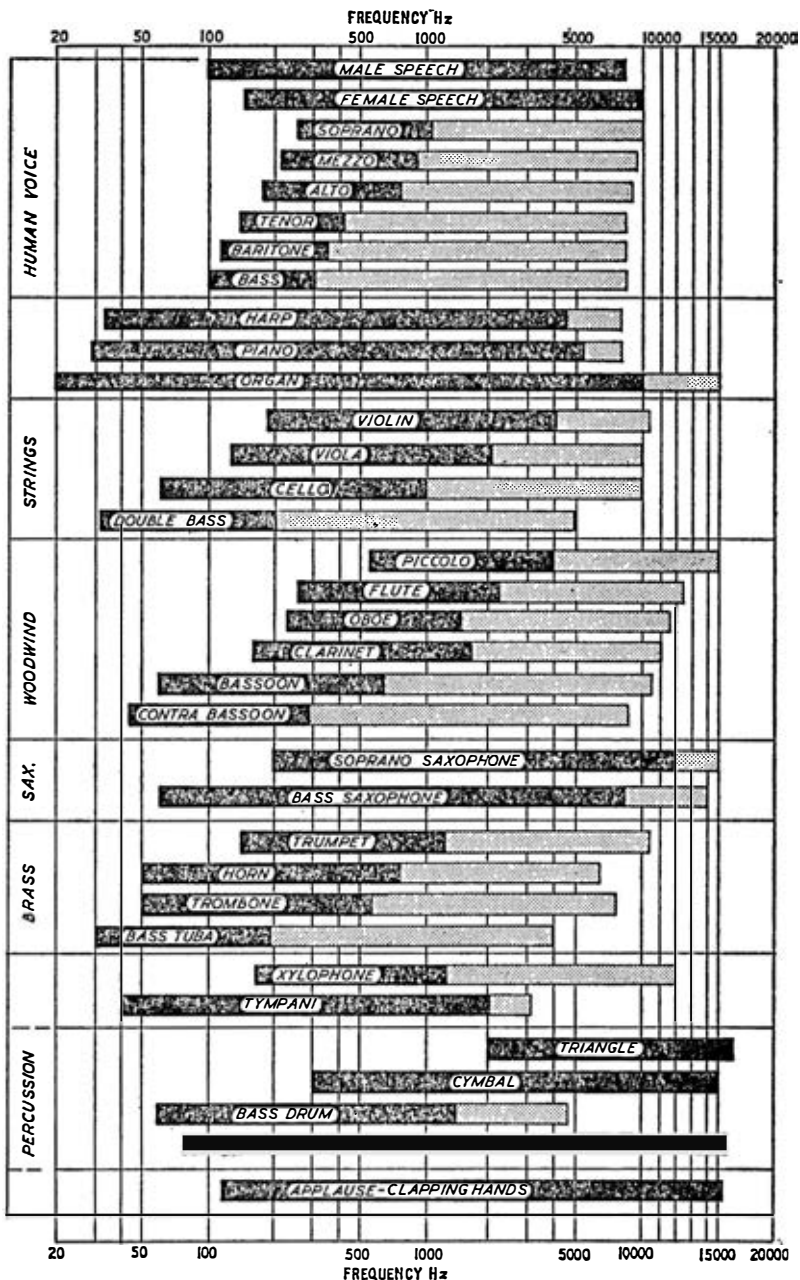

Fig. 4 FREQUENCY RANGE OF THE HUMAN VOICE AND TYPICAL INSTRUMENTS. The bold panel represents the fundamental range, the faint panel the extension of the range via harmonics and overtones

DEFINING HI-FI

It will thus more or less cover voice reproduction (although the quality of the reproduction may be degraded by other factors), but will literally cut off higher frequencies of music reproduction. It is thus definitely low-fi. The quality of reproduction may be improved by other means, such as tone control, but it cannot attempt to reproduce faithfully orchestral sounds because its frequency range is restricted.

This can still be quite satisfactory for general listening, especially if other 'quality' factors are incorporated in the system, as the bulk of enjoyable sound lies in the lower and mid-frequency ranges, although the *overtones* which add subtleness and extra quality to the sound may be lost.

Fig. 4, for example, shows the frequency ranges of sounds produced by a variety of different instruments, showing the range both for fundamental tones and overtones in each case. Chopping off the ability to reproduce frequencies above 4-5,000 Hz, considerably reduces the fidelity of reproduction possible.

Theoretically, at least, as far as frequency response is concerned the equipment should have the full range of the audible spectrum—30 to 20,000 Hz. In practice hi-fi frequency response can be considered as covering a frequency range of about 60-10,000 Hz as a *minimum* requirement—which could probably be called 'mid-fi', although to many people it would sound like hi-fi. True hi-fi would aim at a considerable improvement, particularly at the upper end of the range.

The Decibel

Frequency response alone, however, has little meaning in defining hi-fi. What is far more important from the listening point of view is the *relative loudness* of the different sounds in the frequency range covered, and how far these deviate from the original sounds.

Sound levels are described in units known as the *decibel* which is not a true unit of sound at all but a *ratio* between two power levels (in this case sound levels). Also it is not a simple arithmetical unit, like other straightforward measurements, but is 'calculated' on a *logarithmic* scale, starting from the lowest level of audible sound.

What this means in effect is that the whole range of sound 'loudness' is covered by a range of 120 decibels—from the threshold of hearing, to sound so intense that it is becoming feeling (and painful at that!) rather than sound. And every step or difference of 6 decibels represents

SET UP YOUR OWN HI-FI

a ratio of sound pressure of 2:1 or 1:2, i.e. a doubling or halving of the *sound pressure level*, on which the loudness of a sound is judged.

A complete specification of frequency response would include figures for comparative sound levels at different frequencies, i.e. deviations above or below the original sound level at those frequencies, expressed in decibels. To the trained ear a deviation of one decibel (1 dB) may be detectable, and most people can detect a difference of 3 dB. Any greater deviation would represent a considerable departure from high fidelity.

Commonly such performance figures are expressed only for deviation at a single reference level—usually 333 Hz or 315 Hz (the latter being more or less standard for cassette equipment). A more complete specification would include a response curve, showing performance over the full range of frequencies.

Dynamic Range

The difference between the softest and loudest sounds in a presentation is called the dynamic range, and again this is expressed in decibels. In the case of an orchestral work the dynamic range may be as great as 60–70 dB, implying a ‘loudness’ difference of some ten times or more. In actual recordings, however, this may be compressed to 60 dB or even less. Other types of music—and particularly pop music—may deliberately have a very much lower dynamic range.

The significance of this is that for true hi-fi reproduction of these sounds the difference between the maximum power output of the equipment and the residual noise level in the system must be at least equal to the dynamic range of the original, otherwise part of the dynamic range will be lost. This available range is expressed as Signal-to-Noise ratio, or S/N ratio.

Such a figure for S/N ratio would normally be quoted for any hi-fi equipment, and also a separate S/N ratio for re-recording on tape (where applicable), commonly expressed as *erase ratio*. Generally acceptable figures are at least 50 dB S/N ratio for play, and at least 60 dB for erase, although such performances are usually improved upon by modern hi-fi equipment.

Unfortunately a single S/N ratio figure is no complete guide to dynamic performance since the human ear responds differently to different frequencies. Basically it tends to be increasingly less sensitive to sounds lower than a frequency of 1,000 Hz; rather more sensitive to sounds

DEFINING HI-FI

above 1,000 Hz up to 4,000 Hz, and then increasingly less sensitive again. In fact, to sound *equally loud*, the *sound pressure levels* for different frequencies need to vary considerably, as shown graphically in Fig. 5.

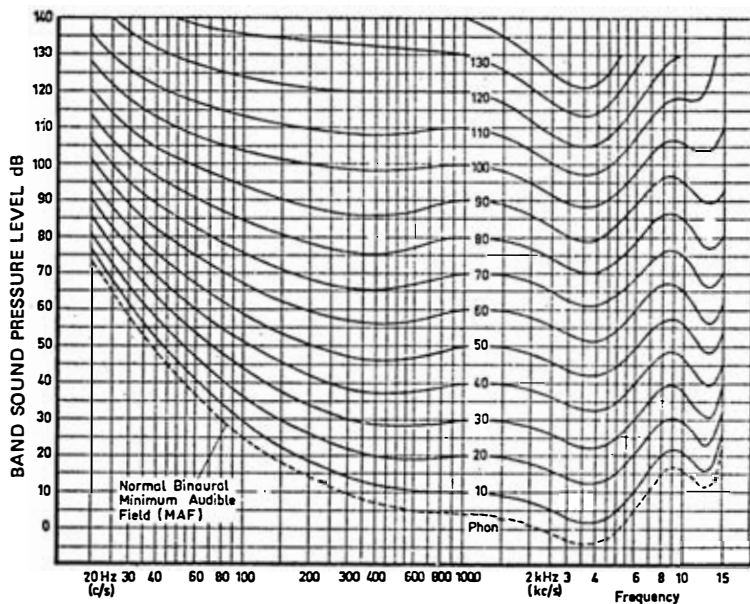

Fig. 5 EQUAL LOUDNESS SOUND CONTOURS. This shows how the subjective response to sound varies with frequency, and to a lesser extent with sound level

Such variations are most noticeable at low loudness levels and become increasingly less as the loudness level is raised. Thus a signal-to-noise measurement at a single frequency may have quite different meaning as far as listening is concerned, taken at different frequencies.

This particular difficulty of relating measured performance to subjective response can be overcome by 'weighting' the measured noise. What this really means is that some form of additional circuitry is included in the measuring instrument to bias or 'weight' the readings obtained at different frequencies so that the overall reading of sound pressure level measurement corresponds to the response of the human ear. The most commonly used is A weighting, discriminating markedly against the lower frequencies as shown in Fig. 6, but capable of provid-

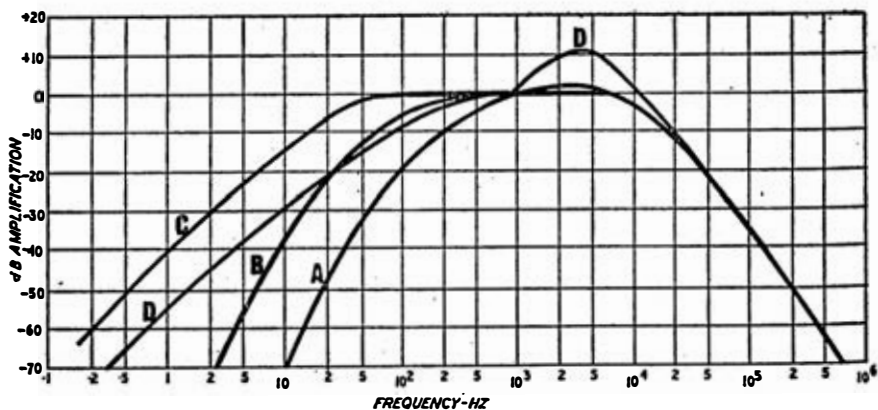

Fig. 6 INTERNATIONAL WEIGHTING CURVES FOR SOUND LEVEL MEASUREMENT. The A weighting curve is the most widely used. B, C and D weightings are used for industrial sound measurement

ing a single S/N ratio reading matching closely the response of the human ear over the whole of the frequency range covered. Such a value may be referred to as weighted, or A-(or A-scale) weighted; and the measured figure given the unit dBa (implying A-weighting).

Distortion

When sound levels are increased there is always the possibility of spurious extra frequencies being produced, particularly when the sound is being rendered in the form of electrical signals during recording or playback. These additional, and unwanted, constituents of the sound contribute distortion which can be measured directly as a percentage distortion of the true signal. This is usually expressed as a total distortion, but the actual figure is dependent on the sound level of measurement. Comparative figures for distortion, therefore, are only valid at the same or a common *reference level*. Without that, distortion figures measured could be 'adjusted' up or down by increasing or decreasing, respectively, the sound level at which the measurement is taken. Also distortion level can vary with different frequencies, so for complete comparison a further standard of measurement is required. The one commonly taken is third harmonic distortion of a 315 Hz tone recorded at reference level.

DEFINING HI-FI

The ability to identify distortion varies widely with individuals, and is also influenced by comparison. For example, distortion of 5 per cent or more might not be appreciated without any immediate comparison with the undistorted original sounds, even by the most ardent hi-fi enthusiast. Thus 'under 5 per cent distortion' is commonly quoted as hi-fi quality (e.g. this figure is given in the DIN specification). In practice the trained ear should be capable of detecting distortion of the order of 3 per cent down to 2 per cent and ideally the aim of *hi-fi* equipment should be to better these figures at a suitable level of listening.

Background Noise

Any recording and/or playback system is likely to be subject to inherent noise which must be suppressed or isolated as far as possible in hi-fi equipment so that it does not swamp or obtrude on the quietest passages of music and 'quiet' intervals. The three main sources of noise are:

- (i) Electronic noise or a high-pitched hiss, inherently generated in all electronic circuits.
- (ii) Mains hum, or a 'breakthrough' sound pitched at the frequency of the mains supply, i.e. 50 Hz, together with harmonics—100 Hz, 150 Hz, etc.
- (iii) Rumble, or a low pitched sound associated with the rotation of drive motor and/or bearings carrying rotating spindles, etc.

Mains hum and rumble are distinct from electronic noise taken into account in determining S/N ratio, and all true hi-fi equipment should be designed to keep the level of this inherent noise below the threshold of audibility.

'Wow' and 'Flutter'

Any departure from a constant speed when a recording is being played will produce a pitch change, or a departure from fidelity of reproduction. This effect is popularly described as 'wow' and 'flutter'. 'Wow' is the result of a fairly brief speed change, or more accurately a brief loss of speed stability, which has the effect of producing a 'wobbling' effect on sustained notes. 'Flutter' is an even more brief speed change (very brief loss of speed stability), which can produce higher frequency 'fluttering' of notes and sounds.

In more technical terms, 'wow' is a spurious low frequency variation

SET UP YOUR OWN HI-FI

superimposed on the original sound, and 'flutter' a higher frequency variation, produced as a result of speed variations. 'Wow' frequency is sub-audio, and 'flutter' frequency is within the audible range. Neither is *heard* as a sound, only the *effect* causing a pitch change in a 'wobbling' or 'fluttering' manner, respectively.

Performance in this respect is usually defined in terms of a single measurement of 'wow and flutter', which to be realistic must be related to a reference standard of measurement. The two standards commonly used are a weighted peak measurement (DIN standard) or weighted Root Mean Square (RMS) measurement, both of which are a specific measurement of the actual degree of 'wobble', expressed as a percentage. The two reference standards do not, however, give the same arithmetical figures for the same performance, that of the DIN standard being approximately from 2.0 to 2.8 times greater than the corresponding RMS measurement.

Synchronous speed between recording and playback is also important. If a recording is played at a different speed to the one at which it was recorded it will have the effect of 'tuning' the presentation up or down. It is therefore important that all hi-fi disc or tape players or decks should have accurately governed and correctly speeded play rates, e.g.

33 r.p.m. or 45 r.p.m. for discs.

$3\frac{3}{4}$ inches per second (9.52 cm/sec) for tapes and cartridges.

$1\frac{7}{8}$ inches per second (4.75 cm/sec) for cassettes.

VU (Volume Level)

Volume level is commonly indicated by an electronic 'magic-eye', or now more usually by fast-acting, damped pointer type meters (VU meters). Unfortunately although the latter provide direct indication it is not always apparent whether the meters indicate true peak values or quasi-peak values. This is probably of little significance to the average operator but can influence test results of Signal-to-Noise ratio and distortion. For example, distortion is measured by third harmonic distortion of a 315 Hz tone at 0 VU indicated by the meters on playback. Unless the meter circuit functions strictly as a true VU indication this loudness level may, in fact, be considerably below the standard reference level, yielding a flatteringly low distortion figure as a consequence.

Measurement of the 'value' or representative amplitude of a complex wave form, such as a sound wave, can be done in various ways. Thus

DEFINING HI-FI

taking the waveform shown in Fig. 7, a meter could measure the true peak, or an 'average peak' over a short period, or perhaps just some 'nominal average' over a slightly different time interval. All three would represent different values.

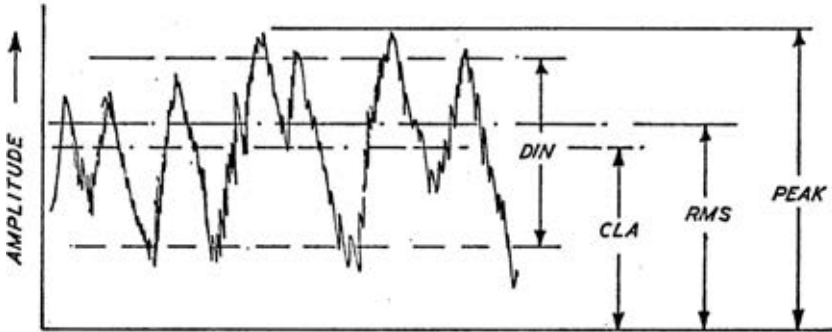

Fig. 7 THE AMPLITUDE OR 'STRENGTH' OF SOUND SIGNALS CAN BE MEASURED IN VARIOUS WAYS. The figure shows in simple diagrammatic form four different systems

There are 'standard' methods for specifying truly representative values, the most widely used of which is the root mean square (RMS) equivalent of an irregular waveform. This is a truly representative *average* value. The CLA average is also based on a similar principle of measurement, but yields a value which is usually some 10 to 20 per cent less than the RMS value for the same waveform. Then there is the DIN value which is a measure of the displacement between two nominal tangents to the peaks and troughs. Meter readings are thus not necessarily as informative as they might appear, unless it is known what they are reading!

The method of designating a reference level as 0 VU or 0 dB is responsible for the negative value commonly quoted for Signal-to-Noise ratio. With the reference level loudness set at 0 dB, the noise in the system is measured as so many decibels below that level, e.g. -30 dB, -40 dB, etc.

The principal use of the volume control during recording is to set the average modulation level high enough to give a good Signal-to-Noise ratio, but not so high as to provide overloading and consequent distortion. Volume-limiter circuits may also be incorporated—and are

generally desirable—to enable high recording levels to be maintained with automatic protection against overloading.

Pitch Control

Some decks may incorporate a speed-change control whereby the speed of record/playing can be varied by, typically, plus or minus 5 per cent. This is, in effect, a *pitch control* and is generally specified as such. The object is to provide a facility for tuning up or tuning down, with the effect as previously described.

This can be a particularly useful feature on tape recorders (although it is more often found on high quality turntables), since it can compensate for slight accelerations and decelerations which may be produced by tape dubbing, as well as being used as an overall pitch control. A further possibility is the use of pitch control (speed-change control) to synchronize sound to vision when a tape is used in conjunction with a cine projector, rather than the more usual procedure of adjusting cine speed to tape to obtain synchronization.

Equalization

Since no electronic circuit can be 100 per cent efficient, certain losses in recording and playback, which can result in a modification of frequency response, are inevitable. This is particularly apparent on tape where there is inherently a varying frequency response on recording, dependent also on the tape speed. This effect can be compensated on playback by equalizing circuits (playback equalization), the degree of compensation differing for different tape speeds. Fig. 8 shows standard recording curves indicating the naturally rising response or *pre-emphasis*, and the corresponding 'equalizing' playback curves.

In the case of gramophone records, equalization requirements are slightly different (although basically similar to those for the higher tape speeds). Virtually all modern gramophone records are recorded with pre-emphasis to improve the Signal-to-Noise ratio, defined by the three time constants 3180, 318 and 75 microseconds. Older records (pre 1954 and 78 rpm records) generally have different recording curve characteristics and require different equalization on playback. Without knowing the recording characteristics it may be difficult, or impossible, to achieve satisfactory hi-fi playback on even the most sophisticated modern equipment.

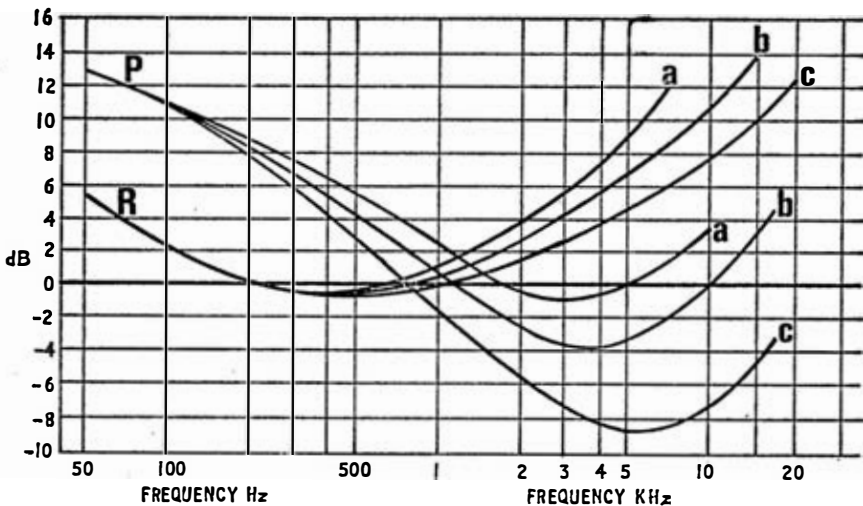

Fig. 8 EQUALIZATION CURVES. R for recording and P for playback. The lower case letters refer to tape speeds, a = $1\frac{1}{8}$ inches per second (4.75 cm/sec) b = $3\frac{3}{4}$ inches per second (9.5 cm/sec) and c = $7\frac{1}{2}$ inches per second (19 cm/sec)

It also follows that to accept alternative programme sources, a hi-fi amplifier (or preamplifier) must incorporate the appropriate equalization for the individual inputs, apart from suitable impedance matching.

DNL (Dynamic Noise Limiter)

All practical methods of sound recording, transmission and playback inherently add noise to the recorded signals. This is one basic reason why tapes have for so long been regarded as inferior to discs for hi-fi reproductions, since the Signal-to-Noise ratio is inherently limited by the granular nature of the tape surface itself. Apart from refinements in tape surface, the only other direct method of offsetting this inherent limitation is by increasing the tape area involved, either by increased track width, or increased tape speed. Thus fundamentally the conventional tape with a standard speed of $3\frac{3}{4}$ inches/sec (9.5 cm/sec) is superior on area consideration to cassette tape with a speed of $1\frac{1}{8}$ inches/sec (4.725 cm/sec). However the difference is not necessarily all that great. To produce a 10 dB improvement in Signal-to-Noise ratio a tenfold increase in tape area is required.

SET UP YOUR OWN HI-FI

There are a number of indirect ways in which noise reduction can be accomplished. In fact as far as the human ear is concerned, one noise is often readily concealed by another, particularly if the unwanted noise is steady. Thus tape 'hiss' is readily masked by music and could pass undetected, except in periods of quiet. Masking can also be produced electronically, but here such a system needs to be discriminating, modifying the signal levels in a frequency-dependent way during non-masking passages to raise them above the noise, and restoring original levels at playback.

This is the principle employed in the Dolby system (also known as DNL or dynamic noise limitation, although there are other dynamic systems employed in audio engineering). It can be explained simply by reference to the series of designs in Figs. 9 and 10. The first (Fig. 9) shows at A an original passage of sound, indicated by vertical lines, the height of which is proportional to the loudness of the individual sounds making up that particular passage. The second diagram (B) shows the noise level inherent in the apparatus being used to record that passage, e.g. a tape recorder, with a characteristic level of 'hiss'. Diagram

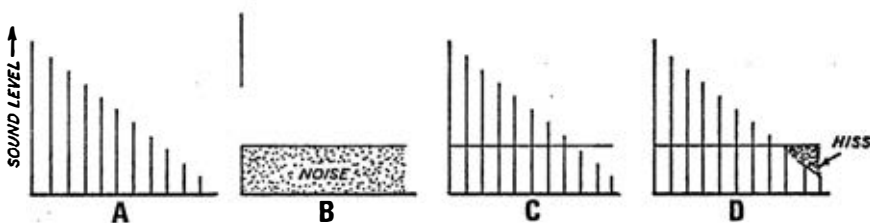

Fig. 9 THIS SEQUENCE OF DIAGRAMS SHOWS THE OBTRUSIVE EFFECT OF INHERENT NOISE ON TAPE RECORDING PLAYBACK

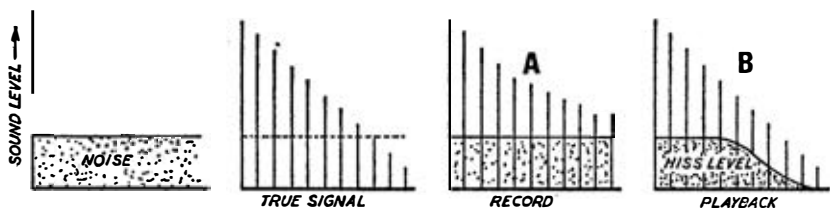

Fig. 10 A DOLBYIZED RECORDING BOOSTS SOUND LEVELS ABOVE THE NOISE LEVEL AND THEN RE-CONVERTS TO THE ORIGINAL SOUND LEVELS WITH REDUCTION OF HISS ON PLAYBACK

DEFINING HI-FI

(C) shows the effect of recording the sound passage over this hiss. On playback (D), in certain parts of the passage the sound will be at a lower level than the hiss, and this 'hiss' will obtrude on the sound heard. At higher levels the sound itself will mask the hiss.

The Dolby system incorporates a special circuit to pre-listen to the sounds being recorded, and the information obtained is decoded in the form of a boost to the levels of the quieter passages during actual recording. In other words, the recorded sound levels are now all above the likely 'hiss' level so that each level of sound will stand out above the 'hiss'—Fig. 10 (A). This will be evident on playback—Fig. 10 (B). All the sounds are at a high enough level to mask the hiss.

However, the individual sound levels will no longer be a faithful reproduction of the original. Some will be boosted to a higher level. To complete the cycle of dynamic noise level control a Dolby circuit is also required in the playback circuit, working in the opposite way to the record. That is, the artificial 'boost' is deleted immediately prior to playing, restoring the true signal level. This, as shown in Fig. 10 (B), will also have the effect of reducing the 'hiss' at those restored levels.

In practice Dolbyized recordings can be played back on either a standard or Dolby system deck. In the former case the playback will not be true hi-fi, but the absence of 'hiss' (masked by all the sounds) may make it sound better and clearer. Some adjustment of the controls, particularly the tone control, can improve the fidelity as far as the critical ear is concerned, as it is the treble which is most likely to be obtrusive. Also certain side-effects may be apparent—but again only to the trained ear. Thus, for example, flutter may be exaggerated, particularly on piano music. It should be noted that even without a Dolby recording, cutting back the treble (via the tone control) is a standard method of reducing 'hiss'—but obviously in this case with even greater loss of fidelity.

The Dolby recording, with Dolby circuit operative on playback, is certainly the most practical method yet produced for rendering cassette tapes with true hi-fi quality. In particular it is largely responsible for the exceptional hi-fi qualities which can now be achieved with cassettes. An essential requirement, however, is that the Dolby circuit in a deck must be properly aligned for optimum performance. This is not always as satisfactory as it could be in proprietary decks incorporating Dolby noise reduction circuitry. Also the ultimate results achieved will still depend on the quality of the tape used.

SET UP YOUR OWN HI-FI

Even more sophisticated Dolby circuits are used in professional audio systems, e.g. the Dolby A System, and many Dolbyized recordings may be made on such a system. This is fully compatible with the Dolby B System used on generally available decks.

The Dolby system is also applicable to FM radio reception and can be incorporated in such units. The advantages of FM, low background noise and relative immunity to interference, are compromised considerably by stereo multiplex broadcasting. Because stereo increases FM background noise by more than 20 dB, compared to a monophonic broadcast from the same transmitter, listeners who could receive monophonic programmes are now often unable to obtain satisfactory stereo reception from the same stations. In addition, stereo is more susceptible to interference due to signal reflections which cause multipath reception, and to 'chirping' produced when background music is transmitted by a station simultaneously transmitting FM stereo. Although many tuners are still able to provide satisfactory reception, even the best now require a signal strength of at least 1,000 microvolts—far above their 'rated' sensitivity figure—to achieve minimum noise levels. Many listeners are too far from their preferred stations to obtain a signal of this strength.

The Dolby system restores the high standard of performance listeners expect of FM. Dolby noise reduction can increase the area of station coverage by making listening satisfactory in areas where the signal is now too weak. In areas where signal strength is adequate, use of the Dolby system allows the best tuners to achieve noise levels so low that they could only be matched by a direct cable from the studio to the listener's home. However, no BBC FM transmissions are Dolbyized.

The now well-known Dolby B system is being increasingly adopted for cassettes, both for the preparation of pre-recorded cassettes (generally referred to as 'Dolbyized') and for cassette decks. Quite a number of master tapes for 'Dolbyized' cassettes were, however, recorded before the advent of the professional A-type Dolby System and some tape hiss may be audible from such masters.

Although unique in its way, there are other DNL systems in use, notably the Philips DNL. Philips DNL is a dynamic noise limiting circuit used only in the playback mode and is applicable to any cassette. In other words all the 'noise elimination' is provided by the deck circuit regardless of the type of cassette used. As such it is more versatile than the Dolby system but rather more limited as regards fidelity characteristics.

DEFINING HI-FI

DIN 45 500 HI-FI STANDARDS (*Minimum requirements*)

Record Player Requirements

| | |
|--------------------------|-----------------------------|
| Speed tolerance | + 1.5 per cent — 1 per cent |
| Wow and flutter (peak) | ± 0.2 per cent |
| Rumble | — 35 dB (unweighted) |
| (ref 1 kHz at 10 cm/sec) | — 55 dB (weighted) |

PICKUP

| | |
|------------------------------|---|
| Frequency response | 40–12,500 Hz ± 5 dB 63.5–8,000 Hz ± 2 dB |
| Channel Balance | within 2 dB |
| Intermodulation distortion | 1 per cent |
| Crosstalk at 1,000 Hz | — 20 dB |
| at 500–6,300 Hz | — 15 dB |
| Max. playing weight | 5 g. |
| Compliance | at least 4×10^{-6} cm/dyne |
| Stylus tip radius— spherical | 0.6 ± 0.1 thou |
| elliptical | 0.78 × 0.24 thou |
| Stylus tip mass | 2 mg. |
| Vertical tracking angle | 15° ± 15° |
| Sensitivity— crystal/ceramic | 0.5–1.5 V, 470 k ohms |
| magnetic | 8–20, V, 47 k ohms. |

VHF Tuner Requirements

| | |
|----------------------------------|---|
| Frequency response | 40–12,500 Hz ± 3 dB 50–6,300 Hz ± 1.5 dB |
| Channel balance | within 3 dB 250–6,300 Hz |
| Harmonic distortion | 2 per cent for 40 kHz deviation |
| Crosstalk 250–6,300 Hz | 26 dB |
| 6,300–12,500 Hz | 15 dB |
| Signal-to-noise ratio | 54 dB |
| Pilot tone suppression at 19 kHz | 20 dB |
| at 38 kHz | 30 dB |
| Audio output | 0.5 to 2 Volts into 470 K. |

SET UP YOUR OWN HI-FI

Amplifier Requirements

| | |
|-----------------------------------|--|
| Frequency response—'flat' inputs | 40–16,000 Hz \pm 1.5 dB |
| equalized inputs | 40–16,000 Hz \pm 2 dB |
| Channel balance | within 3 dB |
| Harmonic distortion—pre-amplifier | 1 per cent from 40–4,000 Hz |
| power amplifier | 1 per cent from 40–12,500 Hz and down to – 20 dB. |
| Intermodulation distortion | 3 per cent |
| Crosstalk (interchannel) | |
| at 1,000 Hz | – 50 dB |
| from 250–10,000 Hz | – 30 dB |
| Crosstalk (between inputs) | |
| at 1,000 Hz | – 50 dB |
| from 250–10,000 Hz | – 40 dB |
| Signal-to-Noise ratio | 50 dB |
| Output power—mono amplifier | 10 Watts |
| stereo amplifier | 2 \times 6 Watts. |
| Inputs— linear | 500 mV at 470 K |
| magnetic pickup | 5mV at 47K |
| Outputs— pre-amplifier | 1 Volt at 47K |
| to tape recorder | 0.1 to 2mV for each 1,000 ohms |
| speaker impedance | 2, 4, 8, 16, 32, 50, 100, 400 or 800 ohms. |
| damping factor | at least 3 |

Tape Recorder Requirements

| | |
|--------------------------------|----------------------------------|
| Speed stability | \pm 1 per cent over 30 seconds |
| Wow and flutter (peak) | \pm 0.2 per cent |
| Frequency response | 40–12,500 Hz |
| Distortion for full modulation | |
| at 333 Hz | 5 per cent |
| Signal-to-Noise ratio | 45 dB (unweighted) |
| | 50 dB (weighted) |
| Crosstalk (at 1,000 Hz)— mono | – 60 dB |
| stereo | – 25 dB |
| Erasure | – 60 dB |

DEFINING HI-FI

Loudspeaker Requirements

| | |
|--|--|
| Frequency response (axis) | 50-12,500 Hz |
| Matching of stereo pairs | within 3 dB 250-8,000 Hz |
| Polar response | within 4 dB at 15° from axis up to 8,000 Hz |
| Sound pressure— at 1 metre | 12 microbars |
| at 3 metres | 4 microbars |
| Distortion factor—250 to 1,000 Hz | 3 per cent |
| 1,000 to 2,000 Hz | falling from 3 per cent to 1 per cent |
| above 2,000 Hz | 1 per cent |
| Transient performance | Slope not to exceed 12 dB/octave in range 50-250 Hz. |
| Impedance variation (over frequency range) | within 20 per cent of nominal |
| Power handling capacity | 10 Watts |
| Nominal impedance | 4, 8 or 16 ohms |

Requirements for Integrated Systems

RECORD PLAYER/AMPLIFIER

| | |
|------------------------|----------------------------|
| Frequency response | 40-12,500 Hz \pm 6.5 dB |
| | 63.5-8,000 Hz \pm 3.4 dB |
| Channel Balance | within 5 dB |
| Crosstalk— at 1,000 Hz | - 19 dB |
| from 500-6,300 Hz | - 14 dB |

TAPE RECORDER/AMPLIFIER

| | |
|--------------------------------|---------|
| Crosstalk (stereo) at 1,000 Hz | - 24 dB |
| from 250-10,000 Hz | - 21 dB |
| Signal-to-Noise ratio | 41 dB |

SET UP YOUR OWN HI-FI

VHF TUNER/AMPLIFIER

| | |
|--|--|
| Frequency response | 40-12,500 Hz \pm 4.5 dB 50-6,300 Hz \pm 3 dB within 6 dB |
| Channel balance (250-5,300 Hz) | |
| Harmonic distortion (40 kHz deviation) | 2.5 per cent |
| Crosstalk at 1,000 Hz | - 24 dB |
| from 250-6,300 Hz | - 18 dB |
| from 6,300-10,000 Hz | - 14 dB |
| Signal-to-Noise ratio | 50 dB |
| Pilot tone suppression at 19 kHz | - 19 dB |
| at 38 kHz | - 29 dB |

CHAPTER 3

COMPLETE SYSTEMS

A COMPLETE system embraces basically, a *source* of programme signal, rendered at Audio Frequency (AF), the strength of which is then boosted by an *amplifier* to develop enough power to drive a *loudspeaker*. The source can be a radio frequency *tuner* (which besides picking up the radio frequency signal to which it is tuned converts this into an AF output), a *gramophone record player*, a reel-to-reel *tape deck*, a *cassette deck* or a *cartridge deck*—Fig. 11. In the latter cases, the player or

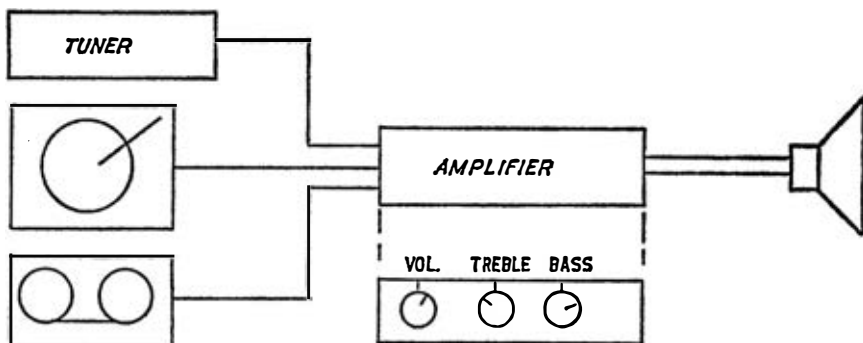

Fig. 11 MONOPHONIC SYSTEM COMPONENTS SHOWN IN DIAGRAMMATIC FORM

deck generates the AF signal directly from pre-recorded information on the record or tape, respectively.

Virtually all hi-fi equipment is now designed to accommodate two-channel information, or stereo. Exactly the same basic set-up applies except that the amplifier unit effectively embraces two separate amplifiers, one to deal with each channel—Fig. 12. The basic amplifier controls are usually commoned (e.g. volume, base and treble 'tone' controls), or the tone controls may be duplicated. An additional 'balance' control is also introduced to allow the signal outputs to the

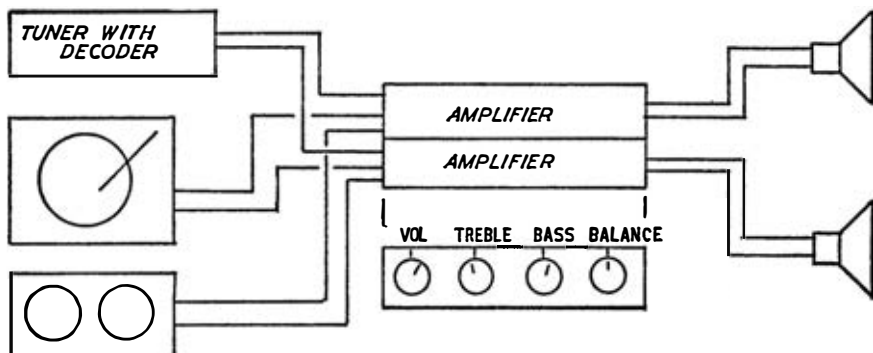

Fig. 12 STEREOPHONIC SYSTEM ELEMENTS

separate speakers to be adjusted differentially for optimum effect. The modern trend is towards the use of integrated rather than electronically separated amplifier units.

Gramophone records (discs) and tapes can provide 'stereo' information direct, i.e. can provide two-channel input to the amplifier. In the case of stereo radio transmissions, the tuner has to have an additional stereo decoder section incorporated to extract these stereo signals as two separate outputs.

Ordinary monophonic signals can still be played on stereo equipment, e.g. an ordinary radio broadcast or a 'mono' record or tape recording. To accommodate 'mono' satisfactorily a 'mono' switch can be incorporated to feed the same (single-channel) signal to both speakers. This would be a normal feature of a mono-stereo tuner and used to be a feature on amplifiers for use with tape decks. Mono equipment will accommodate stereo input directly—simply mixing the two signals together to feed the loudspeaker. This will normally result in quite acceptable single-channel sound, although the spatial effect of stereo recording will, of course, be lost.

Quadrophonic sound is basically restricted to tape recordings (as being the most practical way of recording more than two separate channels of information). Four-channel output is then fed directly to a quadruple amplifier, each section of which feeds its own loudspeaker—Fig. 13. There is also the possibility of a two-channel deck being converted to a 'quad' system by interposing a decoder to transform the

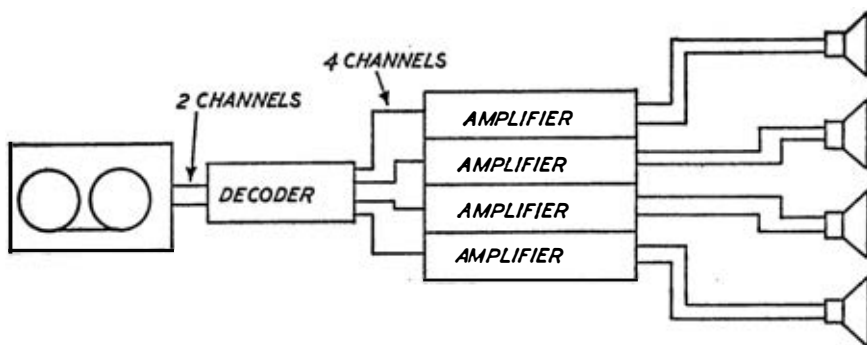

Fig. 13 SYSTEM ELEMENTS FOR QUADROPHONIC SOUND. The normal source of input is a tape recorder

information into the required four-channel output to feed a quad amplifier in a similar manner to the stereo decoder incorporated in a radio tuner.

Source, i.e. record or tape player, plus amplifier and loudspeaker(s) can be incorporated in a single cabinet or in one 'package', for convenience. From the point of view of optimum ultimate performance, however, this has a number of undesirable features. For instance, it is better for the source unit, amplifier and speakers to be physically separated to minimize or eliminate mechanical and electrical inter-reactions. It is also essential for good stereo effect for the speakers to be separated by a much greater distance than can be accommodated in a practical size of cabinet.

A separate source is generally described as a deck, e.g. record deck, tape deck, cassette deck, cartridge deck. The amplifier is then a separate unit, mounted in its own cabinet, and matched to the output of the deck. The amplifier may well, however, incorporate a radio tuner to provide dual facilities, i.e. radio reproduction, or deck reproduction, through the same system. This particular form of combination will not materially affect the performance of the hi-fi system, provided all the essential requirements of a high quality tuner and high-quality amplifier are maintained. Both are exacting.

The amplifier is the heart of the system and largely responsible for the ultimate performance potential achieved. Besides the basic necessity of boosting the input signals required by up to 1,000 times, it must

SET UP YOUR OWN HI-FI

handle these signals with high fidelity and also at the same time, if possible, remove any spurious signals present—the latter facility can be provided by special filter circuits in the amplifier. The modern amplifier may also provide a number of other functions, notably equalization and other controls, as well as smoothed and regulated power supplies for tuners and preamplifiers. Certain duties, notably control facilities and filtering, may be separated when an amplifier is used in conjunction with a preamplifier.

The amplifier must also be correctly matched, both as regards output and input. Output matching is via the load offered by the loudspeakers, expressed as their effective 'resistance' or impedance in ohms—see Chapter 7. Input is also matched by impedance and sensitivity. This can be quite different for different types of inputs, requiring facilities for accurate switching to adjust to alternate inputs. In the case of magnetic pick-up cartridges, a matching amplifier input is usually of the order of 50 K ohms, with a sensitivity of about 3 to 9 millivolts. With ceramic and crystal cartridges, the matching impedance is very much higher, e.g. of the order of 1 M ohms or more, with a sensitivity of 50–750 millivolts. Another basic difference between these two types of pick-ups is that frequency equalization is also required (switching in an additional circuit) with a magnetic pick-up, but equalization circuits are not required with ceramic and crystal cartridges. Load impedances are different again with tape decks, e.g. typically 100 K ohm or 500 K ohm with a sensitivity of 3 millivolts or 100 or 120 millivolts, respectively.

For the average hi-fi enthusiast all items making up the complete system should be purchased as finished commercial units—'ready-to-go'. The competent electronics enthusiast, however, may find greater satisfaction and greater scope—with considerable saving in cost—in constructing tuner and amplifier units from published designs, or kits—but here it must be stressed that a considerable degree of skill and practical experience is necessary to produce results competitive with high-quality professional units. Some cost savings may also be possible by home-construction of specific enclosures from published designs matched to particular loudspeakers, but again the same qualification applies. There is no 'do-it-yourself' substitute for the commercial deck—whether disc or tape.

The following notes are intended as a guide to the selection of suitable

commercial amplifiers, tuners and decks, which can be studied in conjunction with related subjects, e.g. Chapter 7 on loudspeakers and the general descriptions of Hi-fi features in (Chapters 1 and 2). The more technical aspects of amplifiers and tuners and related circuitry are also described in separate chapters later.

Amplifier Selection Characteristics

Amplifier selection can be based on *power*, *basic performance* (as an amplifier), and *additional functions* provided. Amplifier output power is expressed in watts, being a measure of the maximum power that it can deliver to the loudspeaker(s). Unfortunately two different forms of power measurement are used, one referring to 'continuous' or RMS (root mean square) power generated on steady tones, and the other to IHFM (Institute of High Fidelity Manufacturers) rating which gives a numerical value some 25–50 per cent higher for the same actual power. This is also known as *music power rating*.

For the average domestic installation an output power of 15 watts RMS per channel will usually be more than adequate (except possibly for 'pop' enthusiasts); and a very much lower power may still be quite satisfactory. Unless there are other special considerations, a 10 W or 15 W amplifier would be a normal choice, or even a 5 W amplifier for smaller rooms (a 5 W amplifier is the maximum required for in-car installations, for example).

Basic performance factors are concerned with frequency response, noise and distortion. Extreme requirements for *frequency response* are a range of 20 Hz to 20 KHz. Response to any lower frequency is certainly undesirable as, although below the audible spectrum, it can produce intermodulation and spurious signals resulting from resonance with turntable or microphone rumble. The question of the optimum high frequency cut-off point is more debatable, as too low a cut-off can cause marked changes in phase response or phase shift in the region of the cut-off frequency, or even instability. Thus if a relatively low cut-off frequency is adopted, particular attention must be given in the circuit design to stability requirements. This can also apply even when the cut-off frequency adopted is well beyond the upper limit of the audible range.

DIN recommendations for hi-fi amplifiers specify a frequency response of 40 Hz to 16 KHz \pm 1.5 dB. This is somewhat lower than the

SET UP YOUR OWN HI-FI

performance specification figures for most commercial hi-fi amplifiers and can thus be regarded as a minimum requirement for hi-fi.

The DIN recommendation for Signal-to-Noise ratio is 50 dB below 100 MW for amplifiers of less than 20 W output, which again is below the specification figures for most high-quality commercial amplifiers, but the actual figures achieved will be dependent on power level.

The distortion figure quoted by the DIN recommendation is not greater than 1 per cent from full power down to -2 dB over a frequency range of 40 Hz to 12.5 KHz.

Separate inputs must be provided for the amplifier to accommodate magnetic or crystal pick-ups, or tape decks, or corresponding input load adjustments provided by an input selector switch. Such input circuits should also incorporate equalization to within ± 1.5 dB of the standards involved, where appropriate.

Separate outputs are normally provided for loudspeaker(s) with a specified impedance; stereo headphones with a specified impedance; and tape recorder (typically 250 K ohm impedance).

In addition to volume and on-off control(s), separate controls are also provided for bass and treble. The latter are normally designed to give from ± 10 dB to ± 15 dB increase (or 'lift') and decrease (or 'cut') at around 50 Hz and 10-15 KHz, respectively.

Ideally the mid-range adjustment should be flat and well defined and special circuits are incorporated, rather than a simple variable potentiometer control, to avoid excessive emphasis of either bass or treble approaching extreme control positions.

Stereo amplifiers require that the two circuits, whether separate or integrated, be accurately matched as regards frequency response, phase and gain, the overall gain being matched to 2 dB or better for optimum results. A fine control is also provided for adjusting the relative gain of the two channels, this being the balance control.

Amplifiers may also be specified as Class A, Class B or Class AB, referring to the characteristics of the push-pull output stage. With a Class A amplifier, the two circuits in the push-pull output each handle the complete signal waveform, joining as a single output across the speaker load. With Class B, the two circuits each handle one half of the waveform only which, when formed, do not always fit together exactly, resulting in what is called *crossover distortion*—Fig. 14. Thus Class A is potentially superior to Class B, but Class B has the advantage that the circuit

COMPLETE SYSTEMS

load is halved, enabling higher power amplifiers to be built without using large power transistors and heat sinks. Class B amplifiers are, therefore, basically more attractive for transistor circuits than Class A (but *see also* Chapter 9).

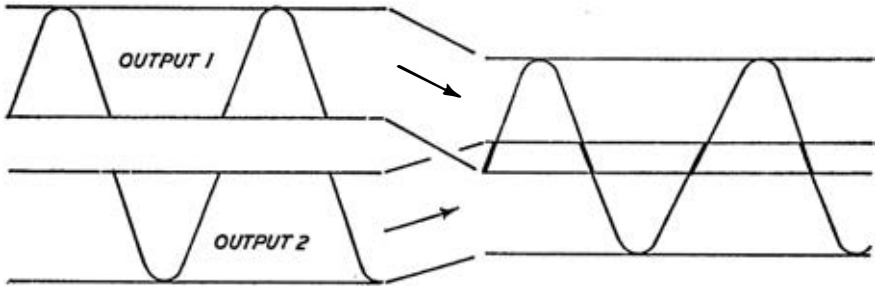

Fig. 14 CLASS B AMPLIFIER HANDLES HALF WAVE FORM OF SIGNAL IN EACH OUTPUT. When joined this can cause cross over distortion

Crossover distortion in a Class B amplifier can be reduced, or even eliminated, by special circuitry, so that the performance of the two types can be directly comparable. Class B is also more efficient since the power input is proportional to the audio output, not constant as with Class A. But Class A more or less guarantees freedom from crossover distortion, if there is any doubt as to the quality of the circuit design of a Class B unit.

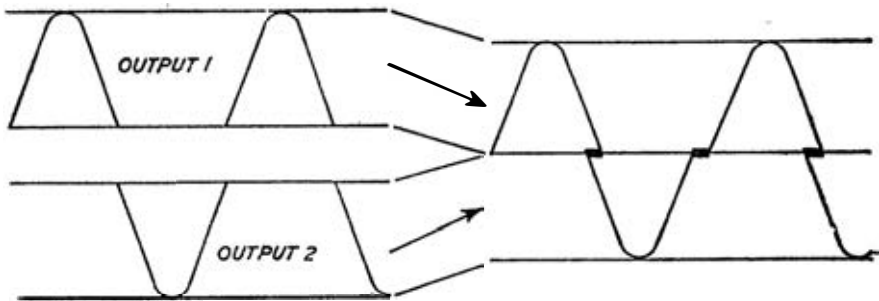

Fig. 15 CLASS AB AMPLIFIERS OVERLAP THE TWO HALF-WAVE FORM OUTPUTS WHEN JOINED TO REDUCE CROSSOVER DISTORTION

There is also a compromise design, known as Class AB which, in effect, is a Class B amplifier designed so that each circuit takes more than 50 per cent of the waveform, so that when joined likelihood of crossover distortion is reduced, and more readily compensated by biasing—Fig. 15.

Tuners

Any good quality domestic VHF/FM radio receiver is potentially capable of providing hi-fi reproduction via its own speaker—preferably an external speaker. It may also incorporate a relatively simple decoder circuit—or may have provision for connecting a separate decoder—for deriving a two-channel output to two speakers for the reception of stereophonic sound broadcasts.

There are, however, three inherent limitations which can seriously degrade the actual performance achieved. The first is the relatively limited range of FM broadcast transmissions, and their susceptibility to screening effects by intervening masses. For optimum FM reception, therefore, a good aerial system is important, and essential for more distant reception with the line-of-sight range of VHF. Requirements are complicated by the fact that VHF/FM broadcasts are *polarized*, or radiated in either a longitudinal or vertical plane and the aerial should be similarly arranged for optimum results, i.e. longitudinally to receive a longitudinal polarized signal and vertically to receive a vertical polarized signal. Horizontal polarization is almost universal, however, calling for the use of a horizontal aerial. The problem is then complicated by the fact that VHF/FM radiations are directional and hence for optimum reception the horizontal aerial should be aligned with the transmitting station.

A good aerial configuration is even more essential in the case of stereo broadcast reception, since stereo demands an extra strong aerial signal if background noise is not going to be too obtrusive.

For maximum selectivity and response the aerial should also be *resonant* with the broadcast signal frequency. The simplest type of resonant aerial would be a single longitudinal wire of resonant length, i.e. half the wavelength of the signal. This is known as a half-wave aerial or *dipole*, when the specific resonant length can be calculated from the simple formula:

COMPLETE SYSTEMS

$$\begin{aligned}\text{length} &= \frac{492}{f} \text{ feet (theoretical)} \\ &= \frac{474}{f} \text{ feet (corrected for end effect)} \\ &= \frac{144.5}{f} \text{ metres}\end{aligned}$$

where f = frequency of signal in MHz.

The practical half-wave dipole takes the form of two rods, with a matched impedance co-axial or shielded twin feed, as shown in Fig. 16.

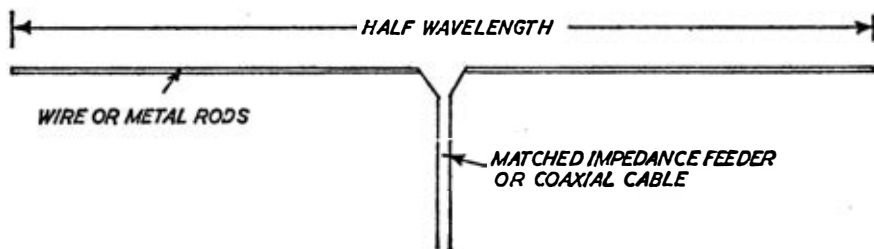

Fig. 16 BASIC DIPOLE AERIAL

The FM band II extends from 87.5 to 100 MHz and so a good compromise length to cover this band would be a dipole length of 5 feet. This is capable of giving excellent results in areas of medium to high signal strength, with optimum alignment determined by trial-and-error. For other areas, a folded dipole or some similar form of aerial may be necessary, incorporating directors and a reflector. The advice of a specialist in the subject should be sought, if a simple dipole does not give adequate results. Consistently good hi-fi reception is unlikely in areas of weak signal strength, even with quite elaborate equipment.

A second factor involved is that VHF signals are very susceptible to local interference, which may result from local spurious signals or are self-generated by the equipment. Shielded or screened connections may be needed on all interconnecting leads, etc., to eliminate the latter effectively.

The third—and usually the most significant—factor is that the domestic-type radio receiver which may provide multi-band coverage lacks

SET UP YOUR OWN HI-FI

many of the essential requirements of optimum VHF/FM reception, due to necessary design compromises. It would probably give better results, for instance, if the output is tapped at some earlier stage than the design output and fed to a separate high-quality amplifier. Thus, basically, for the best quality reception of FM a VHF/FM *tuner* is to be preferred, designed as a unit and coupled to a matching high-quality amplifier (either as a combined unit, or as separate entities). The tuner can then incorporate additional features specifically desirable, such as adequate limiting action, muting or squelch reduction, tuning filters of adequate bandwidth, stabilizing circuits and a suitably designed discriminator circuit. The latter is virtually essential to produce an undistorted audio signal from the FM signal.

Another feature of FM transmissions which requires attention is 'pre-emphasis'. This is the 'rising' characteristic given to the signal to improve the Signal-to-Noise ratio. This needs *de-emphasis* in the receiver by the application of equalization, normally expressed in terms of the time constant of the equalizing components. This is standardized at 50 microseconds for European FM transmission (75 microseconds in North America).

Stereo FM Tuners

The standard method of stereo FM broadcast is by sub-carrier from a single transmitter—also known as the *pilot-tone* system. The two original stereo channels L and R are encoded or *multi-plexed* to give a sum frequency ($L + R$) which is used to modulate the RF carrier; and a difference frequency ($L - R$) transmitted by a sub-carrier in addition to a *pilot tone* of 19 KHz.

For stereo reception the FM tuner (or radio receiver) incorporates (or is connected to) a *decoder* which extracts the two original stereo signals L and R separately, for stereo outputs through separate amplifiers and also removes the pilot-tone frequency. Although above the audible range, the pilot tone and its harmonic present in the output could cause interference with subsequent bias frequencies (e.g. in tape recorders). Thus at least 30 dB suppression of the pilot tone is usually specified.

The stereo decoder should also provide phase compensation if necessary and give adequate channel separation (cross-talk suppression). In general the best results which can be achieved in this respect are

COMPLETE SYSTEMS

superior to stereo channel separation provided by gramophone pickups, but inferior to the best which can be achieved by stereo tapes.

A stereo decoder is normally fitted with a switching facility for 'mono' and 'stereo', the latter mode being indicated by an illuminated indicator. In the 'mono' mode the response to stereo input will be a $L + R$ monophonic output. Since stereo transmissions are arranged to be compatible with monophonic reproduction, the audible result usually is difficult to distinguish from true monophonic transmission. Equally, the average monophonic FM receiver will provide the $L + R$ signal at the discriminator output, with similar overall results.

It can be connected to stereo reception by the addition of a decoder after the discriminator, provided the original circuit has sufficient bandwidth to accommodate the pilot tone and the sub-carrier in the multiplexed stereo signal.

CHAPTER 4

UNIT AND CIRCUIT CONSIDERATIONS

PROBABLY the most important requirement of a satisfactory hi-fi set-up is that all the units should be of comparable quality. The quality of the programme input cannot be better than the performance of the FM radio, gramophone deck or tape deck selected, and performance limitations of any of these units may even be exaggerated by a higher quality amplifier and speakers. For example, 'rumble' may well be apparent from a medium-performance turntable, followed by a high quality amplifier and speakers which have a good bass response.

Logically, therefore, all units in the chain should be of comparable hi-fi quality, and the best that can be afforded. Top quality equipment is expensive—and can be prohibitively expensive to many—but fortunately cost and ultimate performance is not the complete answer. The final assessment of performance is still subjective. To the average enthusiast moderately priced units may well provide quality above the limits of *appreciation* of the listener, when the superior performance characteristics of considerably more expensive equipment would probably be wasted.

On the other hand there is a very considerable difference between 'ordinary' and 'true' hi-fi equipment, even though the former may be quite costly. This difference will show up by a study of the specification performance characteristics, as explained in Chapters 1 and 2. No unit of less than hi-fi performance should be used in the chain, otherwise it will *degrade* the performance potential of all the other units.

Certain troubles which may appear, however, can be curable. Thus mains hum can be a fault of the installation or interconnection, rather than inherent in the design of a unit (it should not be present in a true hi-fi unit, anyway). 'Rumble', mentioned above, can be eliminated by introducing a rumble filter (although again this would probably already be included in a hi-fi amplifier or preamplifier). Thus these general failings are more likely to appear when using home-constructed tuner or amplifier units, either built from published circuits or kits. Provided the faults which show up are not inherent in the original circuit design, in

UNIT AND CIRCUIT CONSIDERATIONS

the quality of the components and circuit assembly, or due to unsatisfactory alignment, they may well be curable by additional circuitry, or attention to circuit layout.

Mains Hum

Mains cables and all components carrying mains current tend to radiate an alternating magnetic field which, if induced into adjacent wiring, can cause a low frequency hum. The most vulnerable parts are those carrying low signal currents which are subsequently amplified (when the hum will also be amplified), i.e. at the pick-up on a gramophone deck, or on any other input circuit to the amplifier.

Hum can be eliminated by screening all input leads over their whole length, with terminations interconnected as necessary to provide continuity of the screen (earthed) connections. As far as possible, all such leads should take a path distant from mains-carrying leads or components.

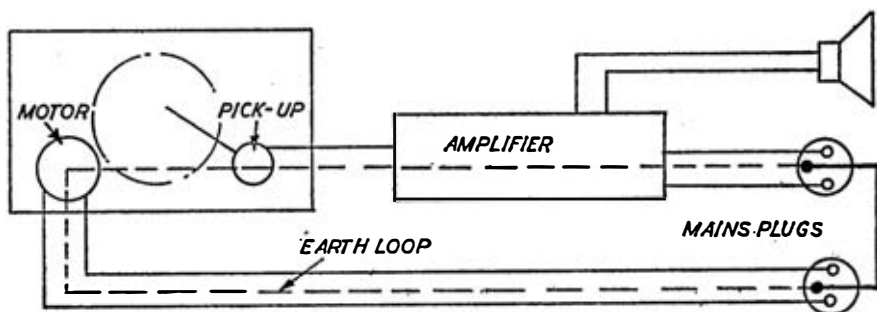

Fig. 17 A TYPICAL EARTH LOOP FORMED BY DECK, MOTOR, PICK-UP AND AMPLIFIER WITH RETURN VIA MAINS EARTH

Even with screening, earth-loop currents can still be generated if the various earth connections in a system form a continuous loop, e.g. *see* Fig. 17. Such a complete earth loop is susceptible to picking up induced alternating magnetic fields. In this case a cure can usually be effected by breaking the loop, e.g. omitting one (or more) 'commoning' screen connections; or omitting the screen to plug connection on one (or more) of the units. Trial-and-error will show which unit should be 'isolated' to provide most effective breaking of the earth loop.

As a general guide, a 50 Hz hum is likely to be caused by poor screening

SET UP YOUR OWN HI-FI

or the presence of an earth-loop. A 100 Hz hum has its origin in the power supply and is usually due to poor decoupling, or incorrect earthing. A 150 Hz hum originates in the magnetic field of the mains transformer, and will be aggravated by an earth-loop on the input side to a pre-amplifier or amplifier. Good screening of the mains transformer is also essential. Also the transformer should be as remote as possible from the input.

Thus the relative positions of input, output and power supply are equally important to earthing and screening. In other words, circuit layout is as important as good circuit design. In particular, output must be kept separate and adequately screened from the input.

A stereo system is more complicated than a mono system in this respect since a single power supply with common earth for two input signals makes it even more difficult to avoid earth-loops. However a suitable arrangement should be as shown in Fig. 18, with separate connections to the earth point from power supply, amplifiers and outputs.

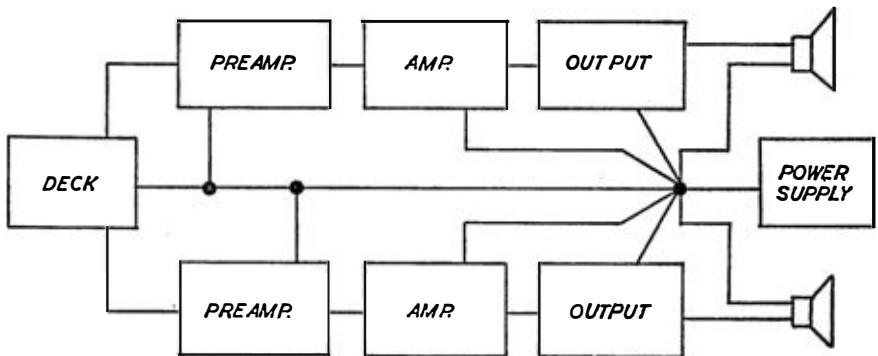

Fig. 18 A GENERALLY SATISFACTORY EARTHING ARRANGEMENT FOR STEREO SYSTEMS

Earth-loop currents can also be formed when mains powered equipment is physically connected to a circuit, e.g. a piece of test equipment for signal injection, or even an electric soldering iron. In the case of test equipment, this should be earthed chassis-to-chassis with the circuit under test, to avoid the possibility of generating induced earth-loop currents of high enough value to be damaging to transistors. In the case of a soldering iron, unless the iron is connected to earth (i.e. via the normal three-wire connections), the power supply to the soldering iron should always be switched off when making contact between the iron

UNIT AND CIRCUIT CONSIDERATIONS

and circuit. If the soldering iron is not earthed (i.e. has a two-wire connection), the iron should be disconnected after heating up, and the solder joint made with the iron in this state.

Component Noise

High quality components only must be used throughout circuits in hi-fi installations, specially selected if necessary for inherent low noise levels. This applies particularly in the case of transistors, although it is not so commonly realized that resistors, also, tend to be inherently noisy due to thermal effects. This noise is usually directly proportional to the voltage across them, i.e. the actual current flow, responsible for heating. Carbon-film rather than carbon composition resistors are, therefore, generally recommended for hi-fi circuits; or metal oxide resistors for load, bias and feedback resistors of input stages.

Rumble Filters

'Rumble' is low frequency noise, introduced by turn-table motors or

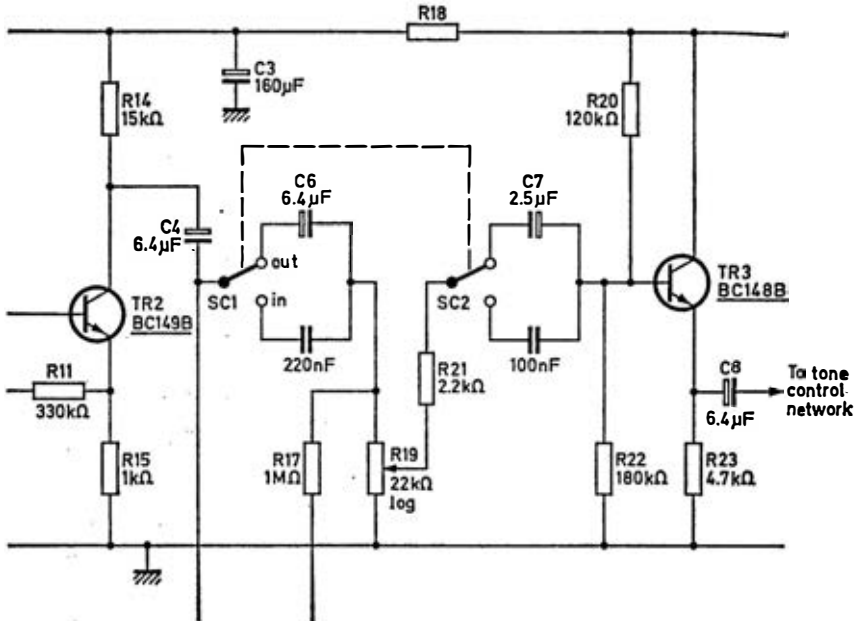

Fig. 19 RUMBLE FILTER CIRCUIT (MULLARD)

SET UP YOUR OWN HI-FI

deck motors which, although basically mechanical in origin, can also induce spurious low frequency signals into adjacent electronic circuits. To overcome this a rumble filter network can be inserted in an appropriate part of the circuit, usually in the pre-amplifier or amplifier immediately preceding the tone control network.

A typical high quality rumble filter network is shown in Fig. 19, the component values being selected to provide a rapid fall in relative response at frequencies below about 100 Hz, i.e. marked 'filtering' of the low frequencies responsible for 'rumble', or 'bass cut'.

A rumble filter may be combined with a noise filter in a common

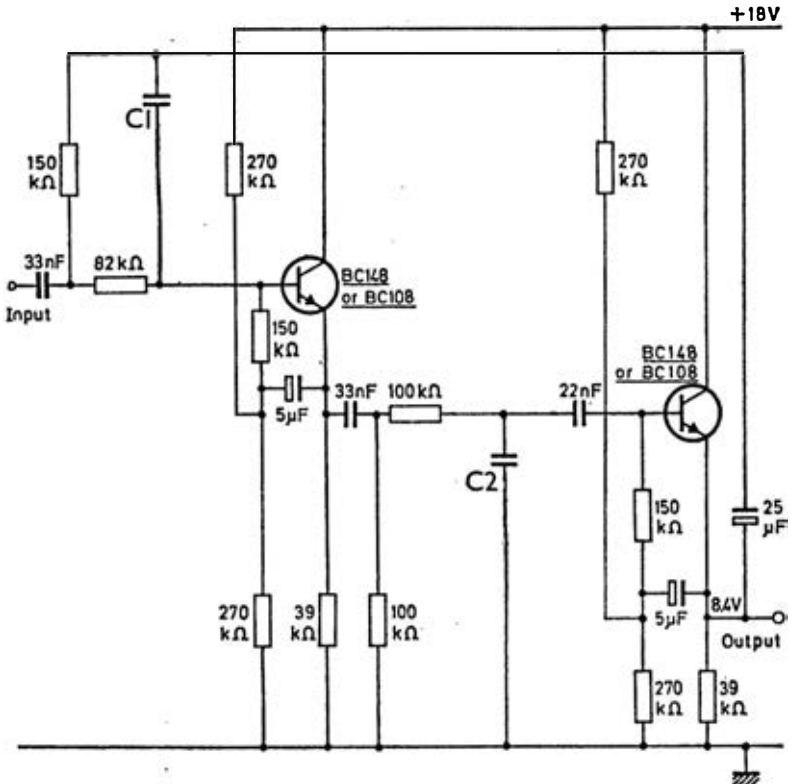

Fig. 20 NOISE AND RUMBLE FILTER CIRCUIT (MULLARD). Capacitor C determines switch-in frequency. Typical values—120 to 240 pF

UNIT AND CIRCUIT CONSIDERATIONS

network. An example of this type of circuit is shown in Fig. 20 where the rumble filter is designed with a frequency limit of circa 45 Hz, and thus effectively passes all higher frequencies. The noise filter operates at the higher end of the frequency range, its 'switch-in' point being determined by the value of capacitor. Alternatively two or more capacitors can be used in place of each of capacitors C₁ and C₂, selected in turn by a ganged switch so that different 'switch in' frequencies can be selected for noise filtering, e.g. a higher switch-in frequency can then be selected if it is desirable that the relative response of the circuit to the high frequency content of the true signal is to be maintained

All filters normally incorporate a network of resistors and capacitors, i.e. an RC network. The performance of a filter over its operating range can be defined specifically by the downward slope of the response curve (reduction in relative response against frequency). This is normally quoted as so many decibels per octave.

Apart from basic performance as filter networks, the main requirement of any such network is that total distortion induced is kept to an absolute minimum for hi-fi working.

Scratch Filters

Scratch filter circuits are generally designed to provide strong blocking of high frequency 'noise' and again usually have selective switching-in points for hi-fi working, e.g. 5 KHz, 7.5 KHz, 10 KHz, etc. The sharp downward bending of the relative response at the design 'switch in' point is generally known as 'roll-off', again quoted as so many decibels per octave.

Scratch filter networks invariably induce a phase-changing effect, with a slight peaking effect on the response curve immediately before roll-off starts. A damping resistor is therefore added to the filter network, which may be connected in parallel or series. A parallel resistor provides a sharper roll-off than a series resistor, although the distortion is increased. A high quality scratch filter circuit is shown in Fig. 21.

Tone Controls

The elementary form of tone control employed on simple radio receivers usually comprises a variable resistor in series with a capacitor connected across the primary terminals of the output transformer—Fig. 22. This, in effect, forms a tuned circuit, the resonant frequency of

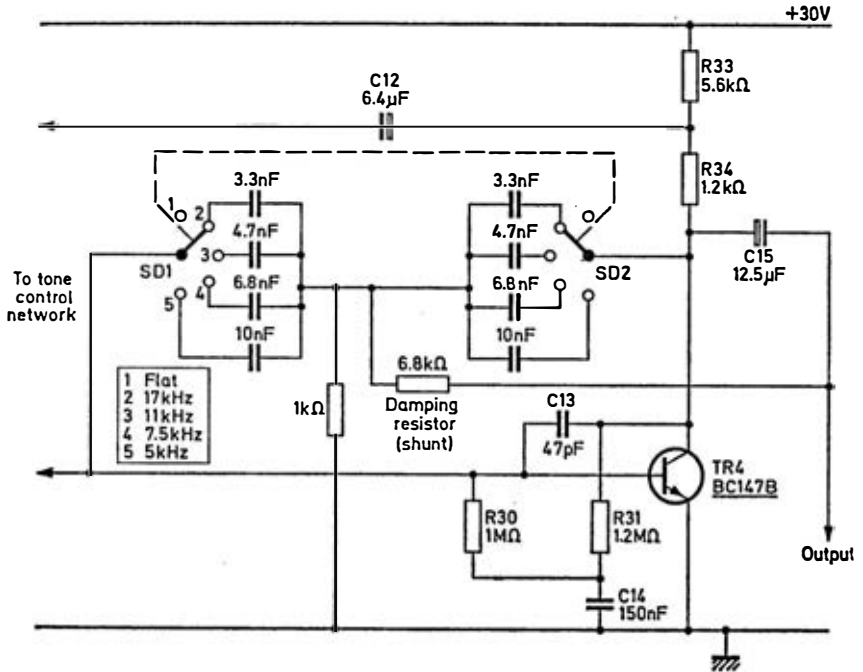

Fig. 21 SCRATCH FILTER CIRCUITS (MULLARD)

which can be adjusted by the setting of the potentiometer to 'favour' bass or treble by additional amplification.

This is quite unsuitable for quality reproduction which demands special type tone control circuit with a frequency-dependent feedback network to yield the response characteristics shown in general form in Fig. 23 together with low distortion. Amongst the best known are the Baxandall 'passive' circuits which are commonly used between two stages of a pre-amplifier and provide a well defined flat central portion of the response curve.

An alternative is the 'active' type of tone control circuit, an example of which is shown in Fig. 24. An 'active' filter differs from a 'passive' filter in working as a tuned circuit responding to a particular frequency by resonating. In practice an RC (resistance-capacitor) network is combined with an amplifier or 'active' element to give the combined effect of an inductance which is resonated with a capacitor.

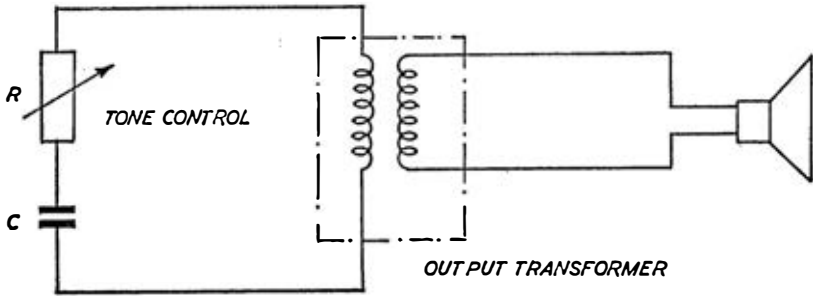

Fig. 22 ELEMENTARY TONE CONTROL CIRCUIT as used in inexpensive radios and players with transformer output. Typical values are $R = 10$ k ohms. Capacitor 0.1 microfarad

Balance Controls

The balance control is used to vary the voltage gain in either (or both) channels of a stereo system and thereby adjust the relative loudspeaker volumes for optimum listening results. Again although the basic form of control needed could be provided by a simple potentiometer circuit working as a voltage divider, a more elaborate circuit is required to

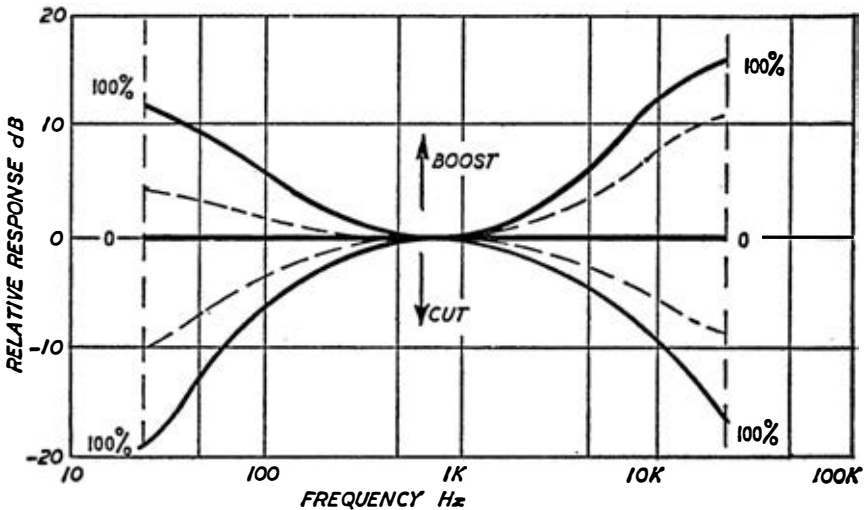

Fig. 23 CHARACTERISTICS OF TYPICAL ACTIVE TONE CONTROL CIRCUIT

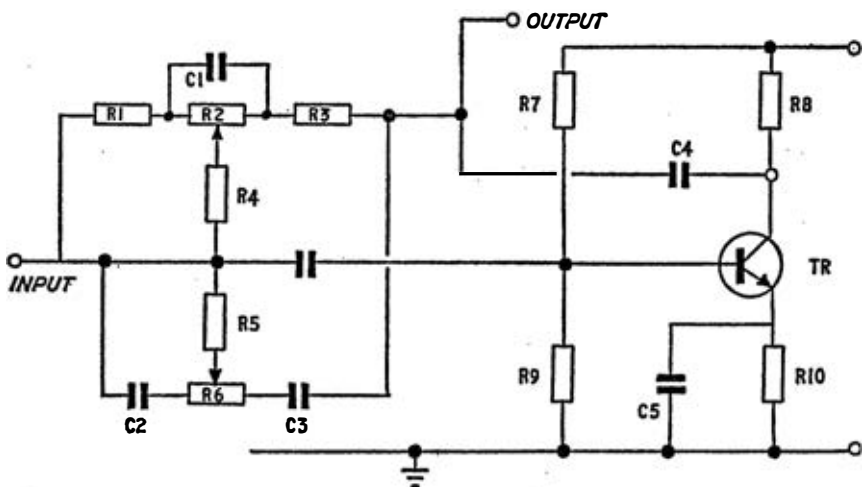

Fig. 24 ACTIVE TONE CONTROL CIRCUIT (MULLARD)

| | | | | | |
|----------------|---|------------|-----------------|---|--------------------------|
| R ₁ | — | 4·7 k ohms | R ₉ | — | 33 k ohms |
| R ₂ | — | 100 k ohms | R ₁₀ | — | 1 k ohm |
| R ₃ | — | 4·7 k ohms | C ₁ | — | 47 pF |
| R ₄ | — | 39 k ohms | C ₂ | — | 2·2 pF |
| R ₅ | — | 5·6 k ohms | C ₃ | — | 2·2 pF |
| R ₆ | — | 100 k ohms | C ₄ | — | 50 μF |
| R ₇ | — | 180 k ohms | C ₅ | — | 50 μF |
| R ₈ | — | 3·9 k ohms | TR | — | Mullard BC 148 or BC 108 |

maintain good quality of reproduction, so a network incorporating feedback is normally used. Such a circuit is shown in Fig. 25 providing for a variation in voltage gain of 6 dB in each channel, whilst holding distortion to a very low level (less than 0·20 per cent at circa 12·5 Hz with minimum gain; and less than 0·25 per cent at maximum gain).

The setting of the balance control is normally done 'by ear', but it is readily possible to incorporate a meter circuit which can indicate balance directly. This only requires a centre zero meter, typically with a 1 milliamp movement, connected between the two speakers as shown in Fig. 26, with current flow to the meter controlled by diodes. The series resistor adjusts the amplifier output to the rating of the meter and would normally be of the order of 10 K ohms. The two capacitors in the circuit serve to damp the meter movement.

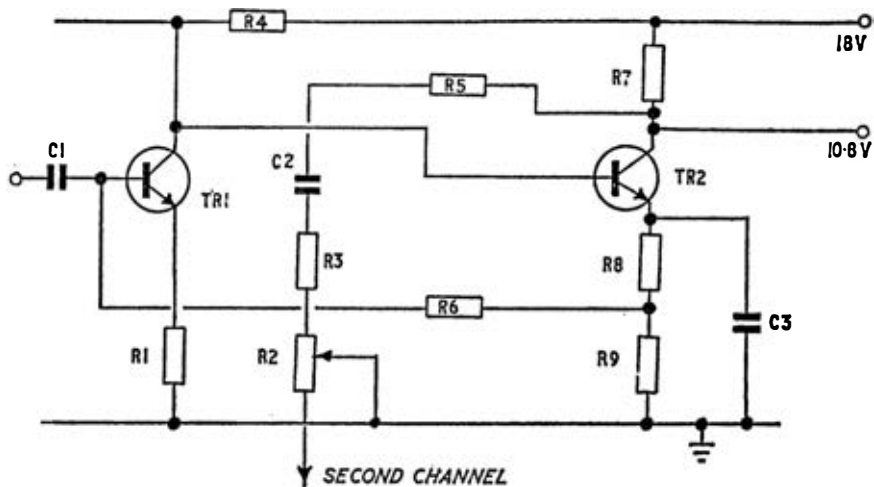

Fig. 25 BALANCE CONTROL CIRCUIT

- | | |
|-----------------|--------------------------------|
| R1 — 4.7 k ohms | R8 — 470 ohms |
| R2 — 1 k ohm | R9 — 1.2 k ohms |
| R3 — 560 ohms | C1 — 220 pF |
| R4 — 120 k ohms | C2 — 100 μ F |
| R5 — 12 k ohms | C3 — 250 μ F |
| R6 — 150 k ohms | TR1 — Mullard BC 148 or BC 108 |
| R7 — 1.8 k ohms | TR2 — Mullard BC 148 or BC 108 |

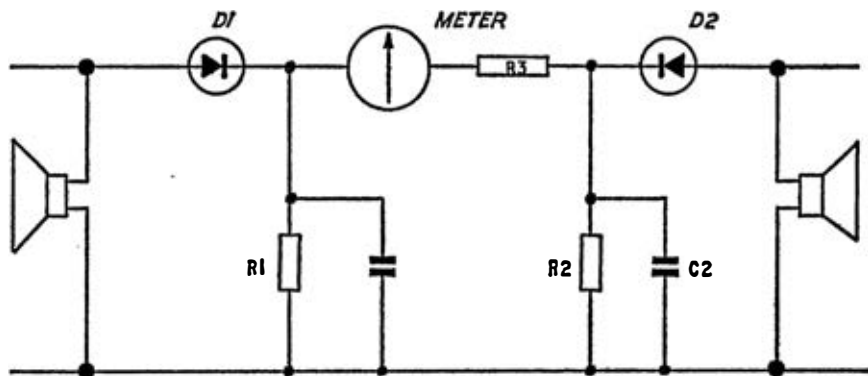

Fig. 26 CIRCUIT FOR BALANCE USING A CENTRE ZERO METER

- | | |
|--|------------------|
| R1 — 4.7 k ohm | C1 — 100 μ F |
| R2 — 4.7 k ohm | C2 — 100 μ F |
| D1 and D2—Mullard AA 119 diodes (or equivalent) | |
| Resistor R3 to match meter current rating (typically 10 k ohms). | |

CHAPTER 5

DISCS, DECKS AND PICK-UPS

THE modern gramophone master record is cut with a 90 degree angle microgroove 0.0075 inches (1.9 mm) wide and 0.0013 inches (0.3 mm) deep, with high dimensional accuracy and surface finish. The groove is, of course, continuous, and spaced at 250 grooves per inch, (100 grooves per cm), giving an LP playing time of approximately 15 minutes at $33\frac{1}{3}$ rpm. The recorded information is reproduced by the cutter in the form of complex waveforms on the groove surface, the amplitude of which may range from a few millionths of an inch up to 0.00075 inches (0.02 mm) or up to 0.002 inches (0.05 mm) when automatic groove widening is used during recording. The requirements for accurate cutting are particularly exacting and may also incorporate a carefully calculated amount of 'correction' found necessary for optimum results— as well, of course, as having to vary the wavelength from the outside to the inside groove. Thus the recorded wavelength at 10,000 Hz would be 0.003 inches (0.075 mm) at the outside of the disc reducing to 0.0015 inches (0.038 mm) at the end of the disc to compensate for the difference in circumference at different diameters, with constant speed of rotation. Pressings from the master disc reproduce the groove pattern and finish faithfully.

For playing, the primary requirement is that the pick-up stylus should follow the groove modulations accurately so that its vibrations can be converted into an electrical signal having the same waveform as the original impression. Certain deviations are fundamental, and due to inevitable tracing distortion, which may be partially, if not completely eliminated by compensation both in recording and playback. Others are due to inadequacies in the pick-up system, or deterioration, wear, damage, etc., which may occur on records and stylus during use.

The stylus tip may be spherical or elliptical, the latter now generally being preferred as minimizing tracing distortion. However, many discs are produced with pre-distorted grooves to provide automatic compen-

DISCS, DECKS AND PICK-UPS

sation to the tracing distortion inherent with a spherical tip. Other reproduction systems may incorporate additional correction for elasticity of the disc material, stylus pressure, stylus mass, etc., presenting further problems in deciding the optimum stylus form.

The hemispherical tip has been standardized for a long time, and most 'corrected' recordings are made to accommodate this tip form. Standard tip radii are:

0.001 inches (0.029 mm) for mono LP (33 $\frac{1}{3}$ or 45 rpm)

0.005 inches (0.175 mm) for stereo (33 $\frac{1}{3}$ or 45 rpm)

0.007 inches (0.175 mm) for a 'compatible' tip, i.e. one which can be used both on mono and stereo records.

The modern elliptical tip has minor and major radii of 0.0007 inches (0.0175 mm) and 0.003 inches (0.075 mm), respectively, the major radius being aligned across the groove so that the stylus sits at an optimum depth, whilst the minor radius gives improved reproduction of the minute high frequency waveforms. Again this is a 'compatible' tip.

The question of optimum stylus tip materials is much more easily answered. Diamond is definitely best, although the most expensive, and with low pick-up pressure should have an indefinite life and produce little record wear. The fact that a pick-up is diamond does not automatically guarantee top performance, however, since unless meticulously ground to precise dimensions, and highly polished, it can give inferior results and promote rapid wear on the records. Sapphire or ruby are alternative tip materials, both much softer than diamond. Again with light pick-up pressure, life can be hundreds of record playings for general use, but for the meticulous a sapphire tip will commonly need replacing after possibly as little as 40-50 LP sides.

Hardness of Jewel Tips

| <i>Type</i> | <i>Moh Hardness (Relative Hardness)</i> | <i>Actual Hardness (Knoop Scale)</i> |
|------------------|---|--|
| diamond | 10 | 6200-6500 |
| sapphire or ruby | 9 | 1650-2000 |

Pick-up Requirements

Mono recordings are formed by lateral excursions of the groove cutter. This results in a narrowing and widening of the groove, the narrowing tending to produce a 'pinch' effect. The tracking weight or down pressure on the pick-up must be light to avoid excessive forces (and wear) on the groove walls, whilst the transducer itself must avoid responding to any vertical movement as this will only yield a spurious signal resulting in noise or distortion.

With stereo recordings, separate information for the left and right channels are cut on each groove wall. The resulting motion traversed by the pick-up involves lateral movement when the two channels are in phase, and vertical movement when in anti-phase. The in-phase signals usually predominate but the pick-up must be capable of following and responding to both planes of motion. Basically, this requires a high compliance pick-up with lower tip mass than for a mono pick-up, as well as two independent sensing systems. Thus the two systems are not really compatible, despite the availability of 'compatible' tips.

Pick-up cartridges can be either electromagnetic or piezoelectric (crystal or ceramic) type. The former type are generally preferred for hi-fi and have the advantage that they can be operated with lower tracking weight (e.g. 1 to 3 grams). Piezoelectric cartridges generate a higher signal output but need to operate at higher tracking weights (e.g. 5 to 6 grams). This will increase record wear, although the higher tracking weight sets less stringent demands on the design of the tracking arm. Piezoelectric pick-ups are thus usually less expensive than electromagnetic types.

Pick-up connections are standardized, the following colour code for wiring being in general use for stereo units:

| | | | |
|-------|---|----------------------|----------------------------|
| Red | — | Right channel | |
| White | — | Left channel | |
| Green | — | Right channel sensor | } may be common connection |
| Blue | — | Left channel sensor | |

See also Fig. 27 for DIN standard pin/plug connections

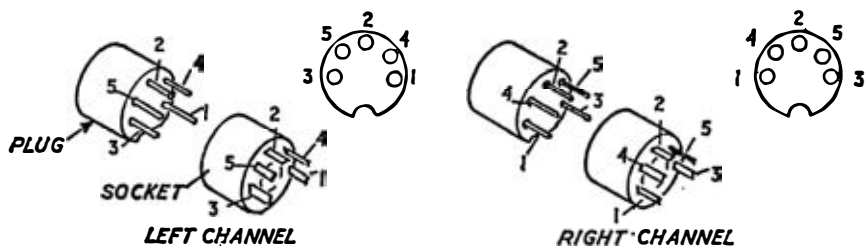

Fig. 27 DIN PLUG AND SOCKET CONNECTIONS

The Pick-up Arm

The requirements of the tone arm are exacting. Since this swings about a vertical pivot outside the disc the geometry of movement will inherently tend to provide an angular error in tracking. This can be minimized by cranking or offsetting the cartridge at a suitable *offset angle*. This is usually between 15 and 30 degrees depending on the length of the arm—see Fig. 28. The object is to reduce the actual angular

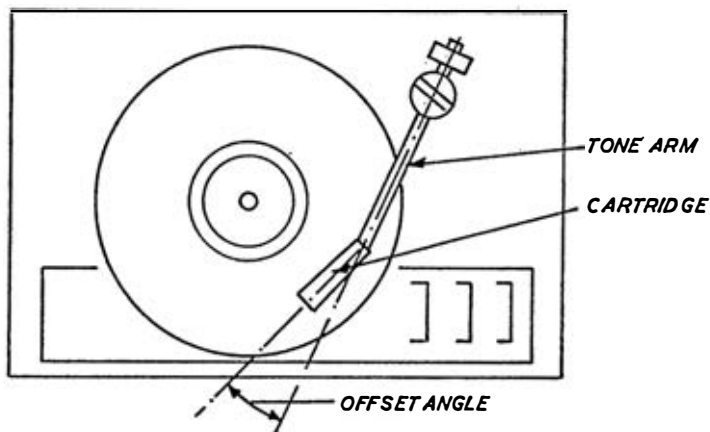

Fig. 28 OFFSET ANGLE

tracking error to less than 5 degrees, when distortion will be negligible. The cartridge or pick-up stylus should also be set at an angle to the vertical, to correspond to the 15 degree vertical angle of the cutter producing the original groove. In practice, distortion is not

SET UP YOUR OWN HI-FI

likely to be apparent if the vertical stylus angle lies between 5 and 25 degrees.

The pick-up offset angle has the effect of introducing a side load on the tip, and thus a tendency to climb out of the groove, particularly at low tracking weights. On top-quality units side-thrust correction is usually fitted, provided by springs, magnetic bias or a cord and weight system.

Incorrect tracking can also arise from a number of other factors, such as:

- (i) warped records
- (ii) turntable not level
- (iii) excessive pivot friction
- (iv) poor pick-up design
- (v) unsatisfactory pick-up arm offset angle; or more likely on high quality equipment, incorrect side thrust adjustment.

The Turntable

Again the design and construction of the turntable is critical where high-fidelity performance is required. Factors of particular importance are constancy of speed, absence of mechanical noise and vibration, and isolation from external mechanical shocks, mains transformers, etc. High-quality turntables meeting hi-fi requirements are generally known as *transcription turntables*, or transcription decks.

Turtables can also be generally classified as single (record) players or auto-changers. The dedicated hi-fi enthusiast will dismiss auto-changers on three counts:

- (i) for the possibility of damage caused to records as one drops on to another during the change cycle;
- (ii) for the intermission of mechanical 'clicks' during the changeover period; and
- (iii) the fact that for a combined programme the sequence is invariably side one followed by side two on a record, demanding manual manipulation—hence a single-player best meets this requirement.

In practice, both single-players and auto-changers of transcription quality are suitable for hi-fi.

DISCS, DECKS AND PICK-UPS

In use it is also important that the turntable be accurately bushed. Any departure from the horizontal when the record is rotating will induce side thrusts on the pick-up which can distort the signal.

Record Care

Unfortunately the vinyl material from which all modern records are pressed has the undesirable characteristic of readily attracting an electrostatic charge, which will attract dust, etc., which will cling to the record—and extreme cleanliness of the record when played is essential for hi-fi reproduction. A *minimum* requirement, therefore, is that records should always be kept in their sleeves when not in actual use, and surface dust removed each time before playing by means of a synthetic velvet cloth or proprietary dust-off device. During manipulation the record should be handled only by the extreme edge, or by velvet 'handling pads'. Certainly records should never be 'fingerprinted', or blown on to clear off dust.

There are various proprietary record cleaning devices and machines; also some quite elaborate groove cleaning units. None can be recommended as a 'complete' answer. There are also proprietary anti-static fluids which can prove beneficial in inhibiting dust-collection, although many record manufacturers state that liquids should not be used to clean their records. In practice, cleaning fluids or anti-static fluids based on *distilled* and *demineralized* water as a solvent are generally satisfactory. Ordinary water (even a damp cloth) and other fluids should *never* be used—nor should records be rubbed or polished other than with materials specifically produced for the job.

Record 'Faults'

Contaminants collected in the grooves are the most common fault with records, causing noise and poor reproduction. Abrasive contaminants (e.g. some dust particles) can cause permanent damage by widening the grooves under the pressure of the stylus, leaving a pock-mark if subsequently cleaned away, sufficient to produce an audible 'click' when played.

New records may also have faults when pressed, which should be evident on first playing. A less obvious fault is where the central hole is not concentric with the grooves (or perhaps excessively oversized so that the record is not concentric with the turntable). This can cause

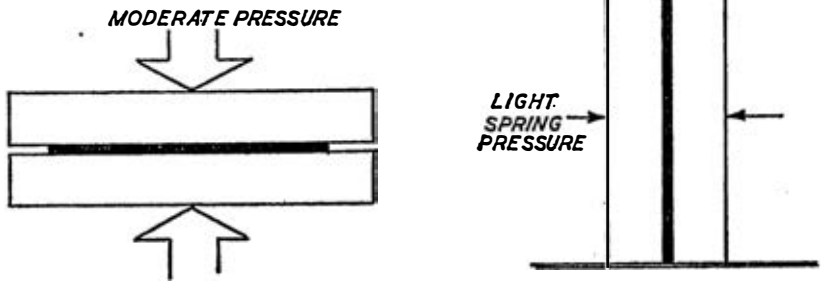

Fig. 29 CORRECTING A WARPED RECORD

distortion of sound by virtue of the sideways swinging motion generated on the pick-up arm. This can be detected by a swing detector.

It should be noted that many records may generate an appreciable amount of 'swing' although its effect may not always be apparent. A swing detector is useful to re-position the record on the turntable to give the least amount of swing for most faithful reproduction.

A record which has warped will introduce distortion in the sound played because of the cyclic stretching of the groove and consequent deformation of the groove geometry. The cyclic deformation will provide 'wow', and the groove deformation distortion. Unfortunately there is no real cure for a warped record as it is virtually impossible to render it perfectly flat again. Much of the warp can be reduced, however, by clamping between two perfectly flat and rigid surfaces under moderate

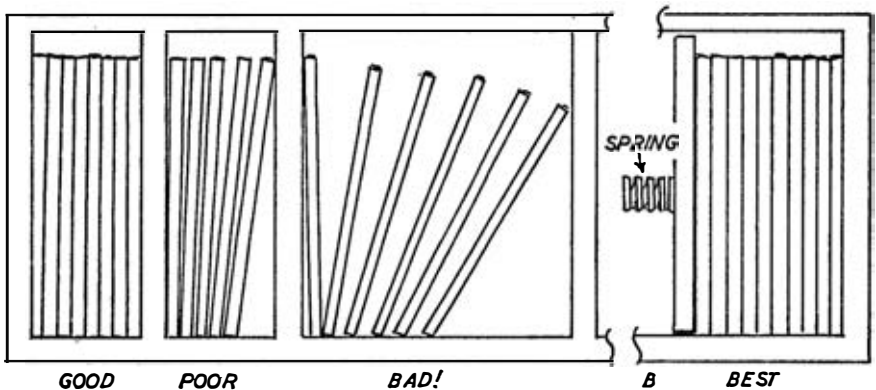

Fig. 30 VERTICAL RECORD STORAGE

DISCS, DECKS AND PICK-UPS

pressure and then leaving it stored in a vertical position for a considerable time—Fig. 29.

Vertical storage under very light spring pressure is also the best way to keep records—Fig. 30. Loosely spaced vertical storage, or separated vertical storage in racks, is *not* recommended and can induce warping. Horizontal storage in a stack is not satisfactory, since it will not ensure freedom from warping.

CHAPTER 6

TAPES AND TAPE MACHINES

TAPES are produced in two standard widths— $\frac{1}{4}$ in. (6.35 mm) nominal (0.244–0.248 inches or 6.2–6.3 mm) for reel to reel machines and cartridges: and approximately half this width (0.15 inches) for compact cassettes. Similar materials are employed for both the basic tape (usually PVC or polyester) and the magnetic coatings, but there can be considerable variations in the application of these materials.

One basic variation is in tape thickness. The thinner the tape the greater the length of tape which can be accommodated on a reel or spool, and hence the longer the playing time. At the same time the thinner the tape the more important it is that tape strength should be adequate. Tape strength is also an important factor where tapes are used on machines with rapid rewind.

Conventional $\frac{1}{4}$ in. (6.35 mm) tapes are categorized by 'playing time', or more specifically tape thickness, viz.:

| | |
|----------------|---|
| Standard play | 0.002 to 0.0018 inches thick (0.05–0.046 mm) |
| Long play | 0.0016 to 0.0013 inches thick (0.04–0.033 mm) |
| Double play | 0.0011 inches thick (0.028 mm) |
| Triple play | 0.0007 inches thick (0.0175 mm) |
| Quadruple play | 0.0006 inches thick (0.015 mm) |

Playing times for different lengths of tape are summarized in Table 1 (see p. 70).

Cassette tapes are similarly categorized by 'playing time', e.g.

| | | |
|-------|---|---|
| C 60 | — | standard or 30 minutes each side (60 minutes total) |
| C 90 | — | 45 minutes each side (90 minutes total) |
| C 120 | — | 60 minutes each side (120 minutes total) |

Length in this case is determined by the size of spool which is necessarily fixed to fit inside a standard cassette; but playing time is extended

TAPES AND TAPE MACHINES

by standardizing the tape speed at one half that of reel-to-reel tapes (or cartridges) i.e. $1\frac{1}{2}$ inches/sec (4.75 cm/sec) as against standard $3\frac{3}{4}$ inches/sec. (9.5 cm/sec). This has its effect on quality of recording.

At a standard tape speed of $3\frac{3}{4}$ inches/sec the recorded wavelength of 1000 Hz is 0.0036 inches (0.09 mm)—or roughly twice that of the recorded wavelength of the same tone on the outer groove of a quadrophonic record—*see* Chapter 6). On this basis the cassette tape with its recorded wavelength of 0.0018 (0.0457 mm) inches for 1,000 Hz should be directly comparable to disc quality, but other factors are involved. In fact, for superior reproduction there are advantages in increasing the tape speed above standard, e.g. to $7\frac{1}{2}$ inches/sec (19 cm/sec) or even 15 inches/sec (39 cm/sec) for superior hi-fi systems. This is only practical on reel-to-reel machines with variable speed controls.

Quality is also directly related to the magnetic and mechanical characteristics of the oxide coating used. Ferric oxide is the standard coating, the performance of which has been considerably improved by refinements of the crystal formation and density of coating, followed by grinding and polishing of the coated surface, contributing substantially to the reduction of 'hiss' of modern tapes. The frequency response of tapes has been further enhanced by the introduction of chromium dioxide (CrO₂) coatings instead of iron dioxide. It must be remembered, however, that the two types of tapes are not compatible and require different balance and equalization circuits for optimum results. Thus the modern tape machine is normally provided with a changeover switch to accommodate either standard (iron oxide) or CrO₂ tapes.

Although the final properties of tape are controlled by manufacture, quite obviously there will be considerable differences in performance between tapes of different quality. This can appreciably modify equipment test readings, or specified performance. In other words, to realize the full potential of high-specification equipment, the tape must be capable of comparable performance. Limitations in this respect may be inherent in the manufacture of the tape, or accidentally introduced during use.

For example, the Signal-to-Noise ratio may initially be better than 50 dB, but could be degraded by accidental magnetization of the tape, noise induced by modulation, or limited erasure on re-recording, etc. On cheaper types of tapes, too, the noise may vary appreciably over its length, due to coating differences during manufacture.

SET UP YOUR OWN HI-FI

Other tape characteristics, or faults, which can cause degradation of performance are summarized briefly:

Print-through—or the tendency for weak signals to be ‘printed’ from one layer on to the next. The possibility of ‘print-through’ is increased by the presence of stray AC magnetic fields, high temperatures and tight spooling. Also the thinner the tape, the more likely the possibility of print-through. It follows that to eliminate print-through as far as possible, tapes should always be kept clear of alternating magnetic fields (e.g. mains operated units, TV sets, etc.), and stored in a place where they cannot get too warm (e.g. clear of radiators, or direct exposure to sunlight). Also for hi-fi recordings, the use of thicker tapes is usually preferred.

If print-through is apparent, then re-spooling or a forward-reverse wind will usually reduce the amount of ‘echo’ heard to negligible proportions. Remember that loudspeakers incorporate powerful permanent magnets, so tapes should never be placed in close proximity to speaker cabinets (the worst thing of all being to store tapes on top of a loudspeaker unit!).

Drop-outs are momentary gaps in the signal, caused by a coating fault in the original manufacture, or developed due to wear, etc., affecting the coating thickness or adhesion locally. Accumulations of dust or dirt on the tape can also cause ‘drop-out’.

Blocking is localized sticking which may be caused by overall gumminess developing on the tape surface, or attraction of an electrostatic charge built up on the tape. This can cause ‘wow’; or in bad cases of localized sticking, even squeals.

Cupping is the tendency of some tapes to develop a curl across their width. This can be caused by exposure to high temperatures.

Bias is a waviness developing on the edge or edges of a tape, again due to differential expansion or stretching effects. In bad cases, or mis-use, tape edges may actually fray with particles of coating breaking off.

Tape stretch is not normally significant, provided the machine transport system is correct. Modern tapes are more prone to stretching than their earlier acetate counterparts and so excessive tension should not be applied to them. The recommended figure is that tension should not exceed about 5 to 6 ounces on standard width tapes during either recording or playback, and a lower tension is desirable in the case of thinner tapes. Tapes will normally stretch in an ‘elastic’ manner, recov-

TAPES AND TAPE MACHINES

ering to their original length when the tension is removed. However, recovery is not exact, and if subject to excessive tension, some permanent stretch can be induced, with consequent effect on quality of performance.

Loss of quality of reproduction and/or recording on a hitherto satisfactory tape is almost always due to dirt on the tape heads. The head is an extremely critical component and consists, basically, of electrical windings on a ring core of non-metal, or Permalloy or permite with a small gap across which the tape passes (one gap for each track). The tape is normally held in rubbing contact with the head by pressure pads. Professional tape recorders may have three separate heads—one for erasing, one for recording and one for playback. Most commercial recorders use a combined record/replay head and a separate erase head.

Since the tape is in rubbing contact with the head, small particles of oxide dust are invariably rubbed off and can accumulate on the head(s) and pressure pads and other parts traversed by the tape. The initial effect of dust on the heads will be loss of upper frequency response, later followed by 'rippling' of the sounds and increased noise, with these conditions getting progressively worse. The performance of the erasure head will also gradually deteriorate, leaving faint 'ghost' images remaining of previous recordings.

Regular cleaning of the heads—also pressure pads, guide pillars, and capstan—is thus essential to maintain top quality performance. This can conveniently be done by using a *cleaning tape* (comprising a special 'plain' tape impregnated with a silicone cleaning agent), although the cleaning action of such tapes is seldom complete. Direct cleaning of the head is more effective, using a cotton wool pad on a small stick or dowel, dipped in medicinal alcohol, methylated spirit or special head cleaning fluid. This is gently manipulated over the head until the original mirror-bright surface is restored. No other solution, or any abrasive, should ever be used for head cleaning.

Direct access to the head for cleaning is usually straightforward in reel-to-reel machines and most cassette players. On cartridge players there is usually adequate access through the 'letterbox' slot. Cleaning should also be applied to the capstan and roller or powerwheel assembly as a build-up of dust here can affect the performance of the transport system and cause speed variations and 'wow'. Again cleaning tapes generally do only a limited job in this respect.

SET UP YOUR OWN HI-FI

Frequency of cleaning depends mainly on the quality of tapes used—some tapes shedding oxide more readily than others—and the operator's ability to detect the first signs of loss of top response. The dedicated hi-fi enthusiast may clean the heads (if not the rest of the transport system) before each playing session. A more normal requirement would be after every twenty or thirty tapes have been played, or once a week or fortnight depending on frequency of use.

Defluxing

Strictly speaking, cleaning on its own is not sufficient to guarantee continued high quality performance. Periodically tape heads, and other metal parts in the path of the tape, may require demagnetizing, or defluxing or degaussing, as it is usually termed. Defluxers can be purchased for this purpose, but used inexpertly, or improperly, can often do more harm than good. The specific instructions supplied with a defluxer must be followed implicitly, taking particular care never to switch a defluxer on or off when in close proximity to the tape unit.

The majority of defluxers available are designed for use on reel-to-reel decks, but are generally easy enough to use on cassette decks where there is ready access to the heads. A special type of demagnetizer is usually required to deflux 8-track cartridge decks.

Reel-to-reel Machines

The reel-to-reel machine may be a deck, or be combined with its own amplifier. Separate speaker(s) would be used for hi-fi working and the equipment selected accordingly. A synchronous motor drives the capstan flywheel via a rubber tyred wheel at the required speed for recording and playback. Where alternative speeds are provided $1\frac{7}{8}$ inches/sec ($4\cdot75$ cm/sec) is for speech, $3\frac{3}{4}$ inches per second ($9\cdot5$ cm/sec) for music and $7\frac{1}{2}$ inches/sec (19 cm/sec) for 'high quality' record/playback. The take-up spool (and footage carrier) are driven from the flywheel by a rubber band 'belt'. A slipping clutch arrangement is included to maintain the required tape tension.

For reversal of tape motion a reverse-idle is engaged or a larger diameter of the stepped rotor pulley so that the tape is transported at a much faster speed. A similar arrangement is usually provided for fast forward wind.

The important features are the accuracy and stability of the transport

TAPES AND TAPE MACHINES

system, and the absence of any electrical and mechanical 'noise' which could cause imperfection with recording/playback. The top class machine may employ three separate motors—one for the tape transport and one for each spool. In this case the transport motor would be of synchronous type for constancy of speed, and the spool motors either induction or hysteresis type motors. Most commercial machines however use a single motor drive with 'slipping clutch' power take-off to the spools.

Standard tape can readily accommodate four separate channels of recorded information, in four separate tracks, dispersed as shown in Fig. 31. Two tracks are then available simultaneously for working in any

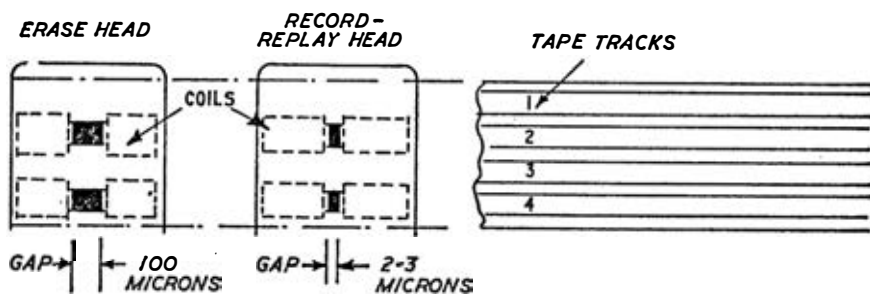

Fig. 31 TAPE HEADS AND TRACKS. Erase head has more powerful coils and wider gap than record/replay head

direction, e.g. 2 and 4. Reversal of the spools then makes the second pair of tracks operative, e.g. 1 and 3. All four tracks can be used independently for mono; or pairs of tracks, (2 and 4) and (1 and 3), for stereo working.

8-track Stereo Cartridge

The 8-track stereo cartridge utilizes standard width tape, in endless loop fashion, wound on a single spool. The loop 'feeds' from the centre of the spool and is carried around a guide and pinch roller back to the cartridge of the spool—Fig. 32. When the cartridge is inserted into a cartridge player the tape is sandwiched between a drive roller and the pinch roller and the mechanism is automatically switched on to drive the tape, driving it past the head in the player. Transport will continue indefinitely until the cartridge is disengaged, either manually or automatically.

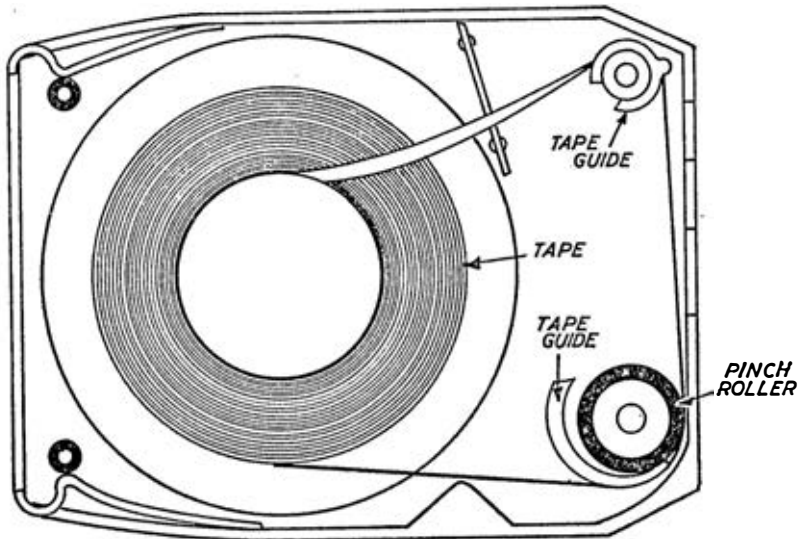

Fig. 32 CASSETTE CARTRIDGE EMPLOYS ENDLESS LOOP OF TAPE WITH CONTINUOUS RECIRCULATION

The standard cartridge tape carries eight channels of information—8 tracks, divided into four pairs. Each pair represents a left hand and right hand stereo programme. The playback head scans a pair of tracks. At the completion of one complete programme the playback head moves automatically to scan the next pair of tracks; a process which continues through the third and fourth pair, then back to the first pair again and so on. The system is thus well suited to the requirements of continuous playing of background music although it lacks the programme selectivity of reel-to-reel or cassette machines. Play is possible only in one direction, and there is no selective facility other than to switch from programme 1 to 2 to 3 to 4 to 1, etc., in sequence. 'Hi-fi' quality, on the other hand, can be almost as good as that of reel-to-reel recorders. Also, of course, the 8-track cartridge is readily usable for quadrophonic recording/playback, although at the expense of halving the playing time.

Compact Cassettes

Compact cassettes have only recently qualified as true hi-fi equipment with the introduction of dynamic noise limiting circuits for record or

TAPES AND TAPE MACHINES

playback, and the introduction of CrO_2 tapes. These have largely overcome the inherent limitations of the tape hiss, and the frequency deficiencies of lower tape speed. Further improvements have been realized with the adoption of hysteresis motors or true synchronous motor drives, as opposed to mechanically governed or electronic motor speed controls, although all these refinements have raised the price of the hi-fi quality cassette deck to the level of the reel-to-reel machines.

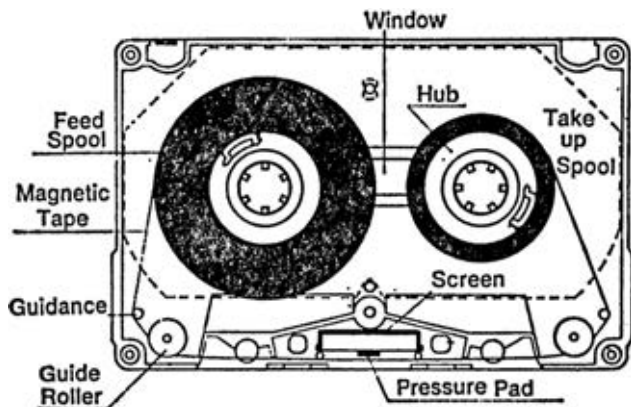

Fig. 33 PHILIPS COMPACT CASSETTE

The layout of a compact cassette is shown in Fig. 33. It does, in effect, provide reel-to-reel (or rather spool-to-spool) facilities in a closed and compact container. The tape can accommodate four tracks, but unlike standard width tape, pairs of channels for stereo working are located adjacent to each other, rather than alternately. This has the singular advantage of providing 'mono' compatibility. Thus when a stereo recording is played on a 'mono' head, the head scans half the tape width, or two different stereo channels, picking up both to reproduce as complete 'mono' sound. With a stereo head, each of the tracks is scanned separately to provide two separate (stereo) outputs. Reversal of the tape, with the cartridge the other way up, provides the same possibilities on the second pair of stereo channels.

Cassette cases may be either of welded or bolted-together assembly. The latter is considered preferable for it allows the cassette to be disassembled for tape editing, or for dealing with a damaged or misplaced

SET UP YOUR OWN HI-FI

tape. Editing a cassette tape, however, is a tricky business and virtually demands the use of a special tape editing kit and extreme patience and care. Apart from the narrow width, with its ready tendency to twist into tight curls when free, the coated side is on the outside, thereby preventing one from making editing marks with a wax pencil in the conventional manner. Also the slow speed associated with cassette tapes makes accurate 'timing' of cued-in editing difficult. Spliced joints must be *exact* as regards width, otherwise the tape will jam in the cassette. If the splice is too thick, this will also cause jamming. For most people, therefore, the cassette system is not one to choose for edited recordings. A reel-to-reel machine offers far more scope in this respect, and much easier work is involved.

Pre-recorded cassettes ('Musicassettes') have a built-in safety factor to prevent accidental erasure. A standard 'clean' cassette has two small openings in the back of the case blanked off—Fig. 34. These are open

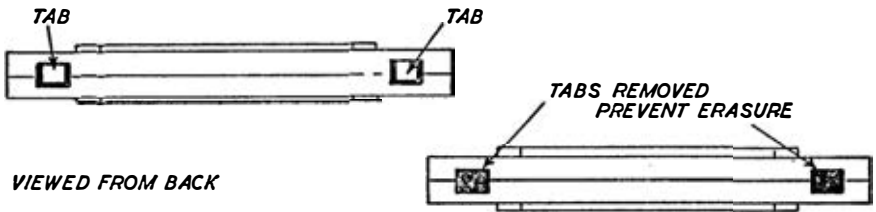

Fig. 34 POSITION OF TABS ON BACK OF COMPACT CASSETTE

on a pre-recorded cassette, permitting a certain travel on the switching mechanism of the player when the cassette is inserted to lock the 'record' facility off. A 'clean' cassette, which has subsequently been recorded on, can be rendered erasure proof by removing these two tabs. Equally, a pre-recorded cassette which it is desired to erase and use for a later recording can be rendered 'usable' for this purpose by blanking off the open holes. Special tabs can be purchased for clipping into the openings.

Cassette Care

Although compact cassettes are precision-made units the miniature sizes involved make them more prone to trouble than reel-to-reel tapes. Also, being sealed in a case, dealing with such troubles as may develop can be difficult.

TAPES AND TAPE MACHINES

As a general rule, a cassette should never be opened to look for, or attempt a cure of some trouble, unless this becomes absolutely essential. Treatment should first be tackled 'from the outside'.

Jamming can be a common trouble, generally brought about by misuse resulting in the tape winding on a spool unevenly. The treatment is to slap the cassette sharply on a flat surface, side down, several times to try to knock the spooling into line again. If this is not successful, and the cassette has bolted-together assembly, slight slackening of the screws followed by slapping is likely to prove effective.

Spillout is another trouble which can develop, when a loop of the tape is pulled out of the cassette, often jamming up the player. Extreme care must be taken in removing the cassette to free the tape without damage. The cassette can be removed first, allowing extra tape to spool off as necessary, to tackle the job of unravelling the original spillout. Provided the tape is recovered undamaged it can then be wound back into the cassette by inserting a pencil or sharpened dowel into one of the spool centres and rotating gently. Wind back well past the original spillout point and then slap the cassette several times to bed down the manual spooling.

Cassette tapes can also become twisted—usually as a result of a fast stop causing the tape to jump into a slack loop which turns over when tension is next taken up. The fact that the tape has twisted may not be noticed until played again, when sound will cease at the twist.

The cassette must be removed from the player and the spools turned manually by a pencil until the point of twist is found. A little slack should then be pulled out very carefully and the twist corrected by gentle manipulation. In practice, it may be necessary to 'carry' the twist right to one end of the tape, before it can be rectified.

Jamming and twisting can also result from slack spooling, due to repeated fast forward and return windings with sudden stops, and especially sudden reversals of fast winding direction. For a valuable recording it is good practice to avoid fast winding modes on cassette machines.

SET UP YOUR OWN HI-FI

Table 1 Reel-to-Reel Tape Playing Times

Playing Time per Track

| <i>Type</i> | <i>Diameter of reel (inches)</i> | <i>Tape length (feet)</i> | <i>1$\frac{7}{8}$ in./sec.</i> | | <i>3$\frac{3}{4}$ in./sec.</i> | | <i>7$\frac{1}{2}$ in./sec.</i> | |
|----------------|----------------------------------|---------------------------|---|--------------|---|--------------|---|--------------|
| | | | <i>(h.</i> | <i>min.)</i> | <i>(h.</i> | <i>min.)</i> | <i>(h.</i> | <i>min.)</i> |
| Standard Play | 5 | 600 | 1 | 4 | | 32 | | 16 |
| | 5 $\frac{1}{2}$ | 900 | 1 | 36 | | 48 | | 24 |
| | 7 | 1200 | 2 | 8 | 1 | 4 | | 32 |
| Long Play | 3 $\frac{1}{2}$ | 300 | | 32 | | 16 | | 8 |
| | 5 | 900 | 1 | 36 | | 48 | | 24 |
| | 5 $\frac{1}{2}$ | 1200 | 2 | 8 | 1 | 4 | | 32 |
| | 7 | 1800 | 3 | 12 | 1 | 36 | | 48 |
| Double Play | 3 $\frac{1}{2}$ | 400 | | 42 | | 21 | | 10 |
| | 4 | 600 | 1 | 4 | | 32 | | 16 |
| | 5 | 1200 | 2 | 8 | 1 | 4 | | 32 |
| | 5 $\frac{1}{2}$ | 1650 | 2 | 54 | 1 | 27 | | 44 |
| | 7 | 2400 | 4 | 16 | 2 | 8 | 1 | 4 |
| Triple Play | 3 | 450 | | 48 | | 24 | | 12 |
| | 3 $\frac{1}{2}$ | 600 | 1 | 4 | | 32 | | 16 |
| | 4 | 900 | 1 | 36 | | 48 | | 24 |
| | 5 | 1800 | 3 | 12 | 1 | 36 | | 48 |
| | 5 $\frac{1}{2}$ | 2400 | 4 | 16 | 2 | 8 | 1 | 4 |
| | 7 | 3600 | 6 | 24 | 3 | 12 | | 36 |
| Quadruple Play | 3 | 500 | 1 | 4 | | 32 | | 16 |
| | 3 $\frac{1}{2}$ | 800 | 1 | 24 | | 42 | | 21 |
| | 4 | 1200 | 2 | 8 | 1 | 4 | | 32 |

Table 2 Compact Cassette Tapes

| <i>Type or Designation</i> | <i>Running time (double track)</i> | <i>Tape length</i> | <i>Tape thickness</i> |
|----------------------------|------------------------------------|--------------------|-----------------------|
| C-30 | 30 min. | 150 ft | 0.7 mil. (0.015 mm.) |
| C-40 | 40 min. | 200 ft | 0.7 mil. (0.018 mm.) |
| C-60 | 60 min. | 300 ft | 0.7 mil. (0.018 mm.) |
| C-90 | 90 min. | 450 ft | 0.5 mil. (0.013 mm.) |
| C-120 | 120 min. | 600 ft | 0.35 mil. (0.009 mm.) |

Note. 1 mil. = 1/1000 inch.

TAPES AND TAPE MACHINES

Table 3. Tape Lengths for Correct Speeds over 30 Seconds Play

| SPEED <i>inches/sec</i> (<i>cm/sec.</i>) | <i>Tape Length*</i> | | | | |
|--|---------------------|-----------------|-------------------|---------------|---------------|
| | <i>ft</i> | <i>in.</i> | (<i>metres</i>) | <i>inches</i> | (<i>cm</i>) |
| 1 $\frac{1}{2}$ (4.75) | 4 | 8 $\frac{1}{2}$ | (1.429) | 1.43 | (3.63) |
| 3 $\frac{1}{2}$ (9.5) | 9 | 4 $\frac{1}{2}$ | (2.858) | 2.86 | (7.26) |
| 7 $\frac{1}{2}$ (19) | 18 | 9 | (5.715) | 5.71 | (14.50) |
| 15 (38) | 37 | 6 | (11.93) | 11.42 | (29.00) |

* Should be within ± 0.5 per cent for good fidelity of reproduction.

CHAPTER 7

LOUDSPEAKERS

ULTIMATELY the quality of sound from any reproduction system depends on the loudspeaker unit(s) and their location. The cost of such units can range from less than £1 up to several hundred pounds and price alone is not necessarily a reliable guide to the results likely to be achieved. For high-fidelity reproduction much depends on the position of the speaker(s) and the acoustic properties of the room itself, as well as the specific performance of the speaker units—and finally the subjective assessment of ‘sound quality’ by the listener.

The basic factors involved are *matching* and *performance*. Matching is the easiest to understand since this is applicable to all speakers, regardless of other design features and specific performance. The two factors involved in matching are *power rating* and *impedance*.

Power Rating

Power rating is simply a figure showing the design maximum power for the speaker, expressed in watts (W). In other words, a 5 W speaker is designed to operate at power loads up to 5 watts. Amplifier output will also have a specific power rating and the speaker should be selected to accommodate this full power if necessary, e.g. a 10 W speaker is required to match a 10 W amplifier. No harm will be done in using a speaker with a higher power rating than the amplifier, but if the speaker power rating is *less* than that of the amplifier, it can be overpowered during loud passages of music, and very likely permanently damaged. In any case, reproduction will suffer.

Impedance

The impedance is the effective ‘resistance’ offered by the speaker to the amplifier output circuit which is designed to supply output into a specific load. If the two do not match, the power level in the circuit will be changed. Thus too high a specific impedance will reduce the output power; and too low an impedance will increase the output power. The

LOUDSPEAKERS

former may not be significant, but an increase in power can result in overloading and damage to the amplifier circuit (particularly transistor circuits).

Most amplifiers are designed for matching output load impedances of either 4, 8 or 16 ohms, e.g. for use with 4-ohm, 8-ohm or 16-ohm impedance speakers, respectively. These are nominal values quoted as the lowest measured value of impedance above the resonant frequency of the speaker. In practice, the actual impedance of a speaker will vary with frequency, and so a perfect or constant match is impossible to achieve.

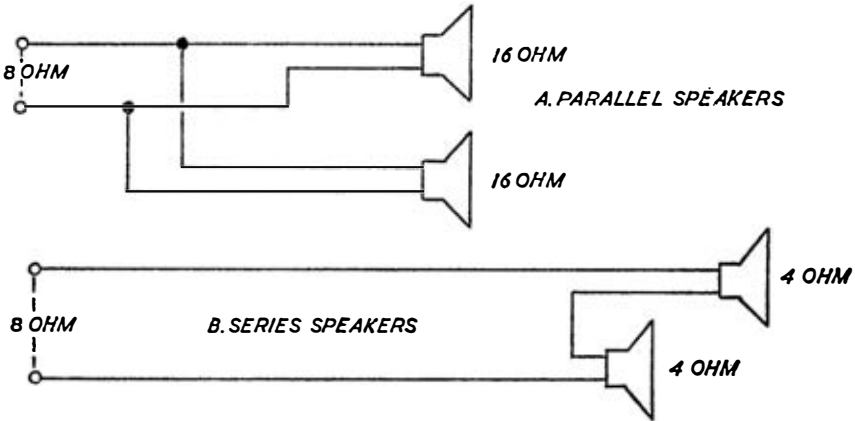

Fig. 35 PARALLEL AND SERIES CONNECTIONS FOR MAIN AND EXTENSION SPEAKERS OPERATING ON MONOPHONIC SYSTEM

Basically, it is sufficient that the nominal match is correct, but additional thought or selection is necessary if more than one speaker is operated off a single channel (e.g. for simultaneous reproduction in two rooms). If the speaker connections are made in *parallel*, then the speaker impedance required is *twice* that of the specified load impedance. If the speakers are connected in *series*, then the speaker impedance is *one half* that of the specific load impedance. This is illustrated in Fig. 35 for an 8-ohm specified load impedance for the amplifier. Parallel connection would be more usual, but series connection can provide economy of wiring.

If 'twinned' speakers are not required to provide simultaneous operation then the simple parallel circuit of Fig. 36A would appear

SET UP YOUR OWN HI-FI

obvious, with each speaker of nominal match to the amplifier impedance. However, should both speakers be switched on together the total impedance will be halved (i.e. to 4 ohms), which could overload the

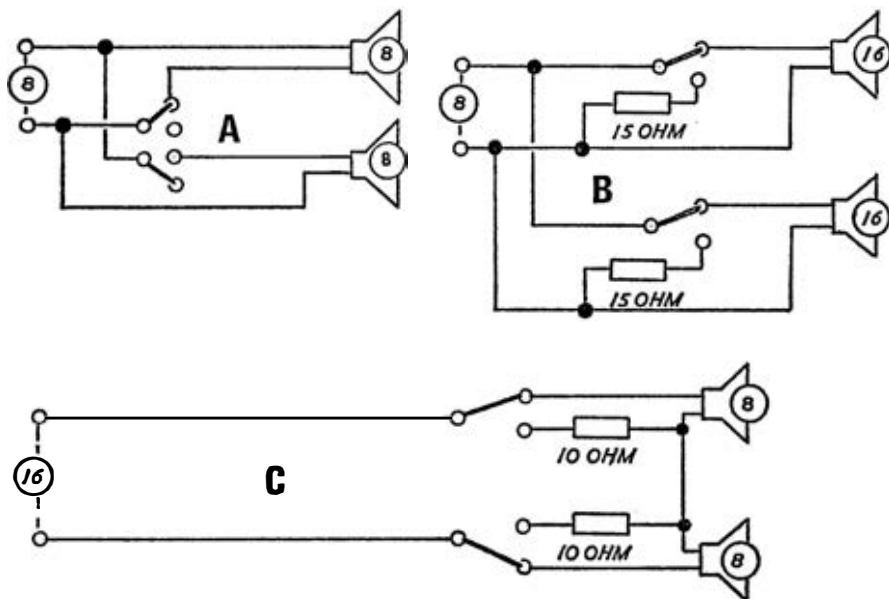

Fig. 36 (A) PARALLEL SPEAKER CONNECTIONS WITH SELECTIVE SWITCHING
 (B) PARALLEL SPEAKER SYSTEM WITH BUILT-IN PROTECTION
 (C) SERIES SPEAKER CONNECTIONS WITH SELECTIVE SWITCHING

amplifier output circuit. A better arrangement, therefore, is to arrange that when a speaker is switched off a resistor is automatically switched into the circuit to maintain an 'equivalent' load (or nearly so), as in Fig. 36B. With series connection such a resistor would be essential, both to maintain the total load value and prevent the circuit being broken completely—see Fig. 36C.

One basic difference between valve amplifiers and transistor amplifiers should also be noted here. Valve amplifiers are best never left 'working' against an open circuit and so any switching in the loudspeaker circuit should ensure that there is always a matching load in the circuit with the amplifier operating. For the same reason a valve amplifier

LOUDSPEAKERS

should not be left on with the speaker(s) disconnected for any reason. In the case of transistor amplifiers, damage is likely if the output is short circuited, even momentarily, unless a special current limiting or short-circuit protection circuit is incorporated in the amplifier.

Similar considerations apply in selecting matching headphones—their impedances should agree with that of the specified output load (impedance) of the amplifier. The normal arrangement with jack connection of headphones is that usually the jack automatically disconnects the speaker circuit(s), this change-over action also incorporates 'safe' switching according to the type of amplifier.

Performance Factors

The majority of loudspeakers are of moving-coil type—similar in working principle to the original speakers which first appeared some fifty years ago, but considerably improved in detail, design and performance. The basic constructional elements involved are shown in simplified diagrammatic form in Fig. 37.

Heart of the unit is a speech coil suspended in the gap of a powerful magnet by means of a spider. To the other end of the speech coil is attached a cone, the outer extremities of which are also supported in the frame by a convoluted or flexible cone surround permitting relatively free movement of the cone and attached speech coil. The complete wiring system is made as light and rigid as possible, so that the drive initiated by the interaction between the AF signal current flowing through the speech coil and the constant magnetic flux in the radial magnetic gap is as efficient as necessary.

Such a moving system has certain inherent limitations which can affect the fidelity or reproduction (i.e. transformation of AF signal into audible sound waves via speaker coil and cone movement).

The more important of these are:

- (i) *Non-linearity* due to the fact that the relationship between the force on the cone and cone displacement is not truly linear. Thus distortion is introduced with increasing cone displacement, e.g. overloading will produce distortion.
- (ii) *Intermodular Distortion* brought about if the speaker is producing sounds of different frequency at the same time. These can react to produce further unwanted sounds.

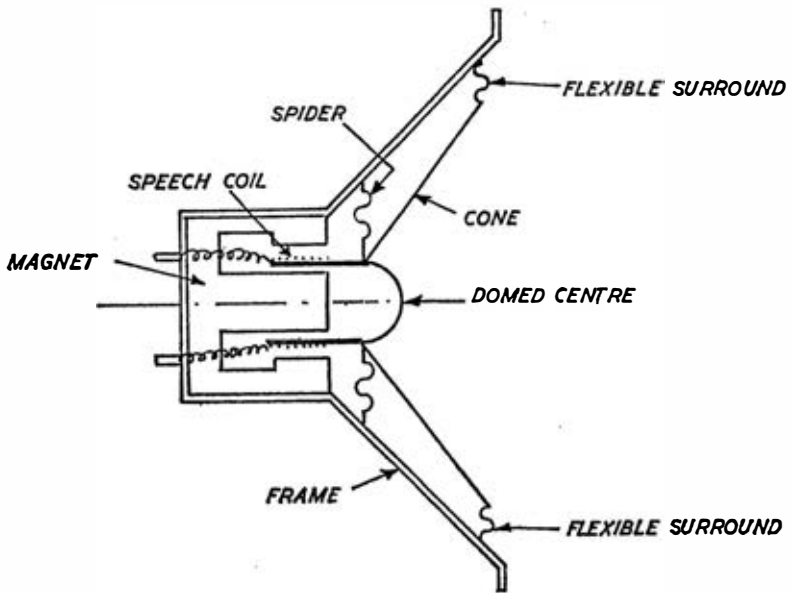

Fig. 37 SIMPLE DIAGRAM SHOWING BASIC ELEMENTS OF A MOVING COIL LOUDSPEAKER

- (iii) *Interaction*, where once more unwanted frequencies are produced, this time by sound waves generated which are smaller than the depth of the cone and can thus strike the cone again after being launched.
- (iv) *Doppler distortion* due to the fact that in responding to one frequency the cone may already be moving inwards or outwards under the influence of another frequency. This will have the effect of modifying the pitch of the second frequency.

Many of these unwanted effects can be eliminated or at least reduced to an acceptable level, by careful attention to mechanical design and optimum choice of materials for speaker construction. However, 'optimizing' performance in this respect can only be effective over a limited frequency range. Basically for 'optimized' lower frequency (bass) performance the cone wants to be as large as possible, with a high mass. For 'optimized' high frequency (treble) performance a small speaker diameter is required (and the cone may even be omitted) with the moving system having a low mass.

LOUDSPEAKERS

One method of overcoming these conflicting requirements is to fit the speech coil with a smaller lightweight cone concentric with the main cone to handle the treble separately (on the basis that at higher frequencies the speech coil is the only part which may be moving). The more usual approach for high-fidelity reproduction is to employ separate speakers for bass and treble, known respectively as a 'woofer' and 'tweeter'. This may be carried one stage further by introducing a third speaker to handle the mid-frequencies, known as a 'squawker'—the mechanical design of each speaker being 'optimized' for the frequency range it is intended to handle. To prevent individual speakers being fed with signals it is not required to handle (and which would produce intermodular distortion, etc.) a *crossover network* is then introduced in the system to divide the complete frequency range between the two (or three) speakers.

A basic crossover network for two speakers is shown in Fig. 38. It

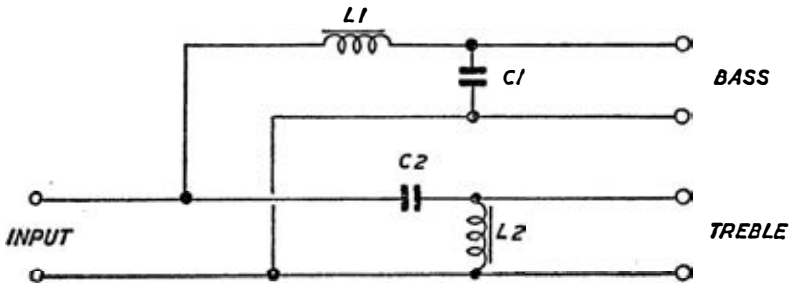

Fig. 38 CROSSOVER NETWORK FOR TWO-SPEAKER SYSTEM

comprises a low-pass filter in series with the bass speaker to 'pass' low frequencies but stop high frequencies; and a high-pass filter in series with the treble speaker, with the opposite action. Each filter comprises one inductance L and a capacitor C , the values of which can readily be calculated, viz.

$$L = \frac{\sqrt{2}}{2\pi} \times \frac{R}{f} = 0.215 \times \frac{R}{f}$$

$$C = \frac{\sqrt{2}}{4\pi} \times \frac{1}{Rf} = \frac{0.113}{Rf}$$

where R is the inductance of the speaker and f is the crossover frequency.

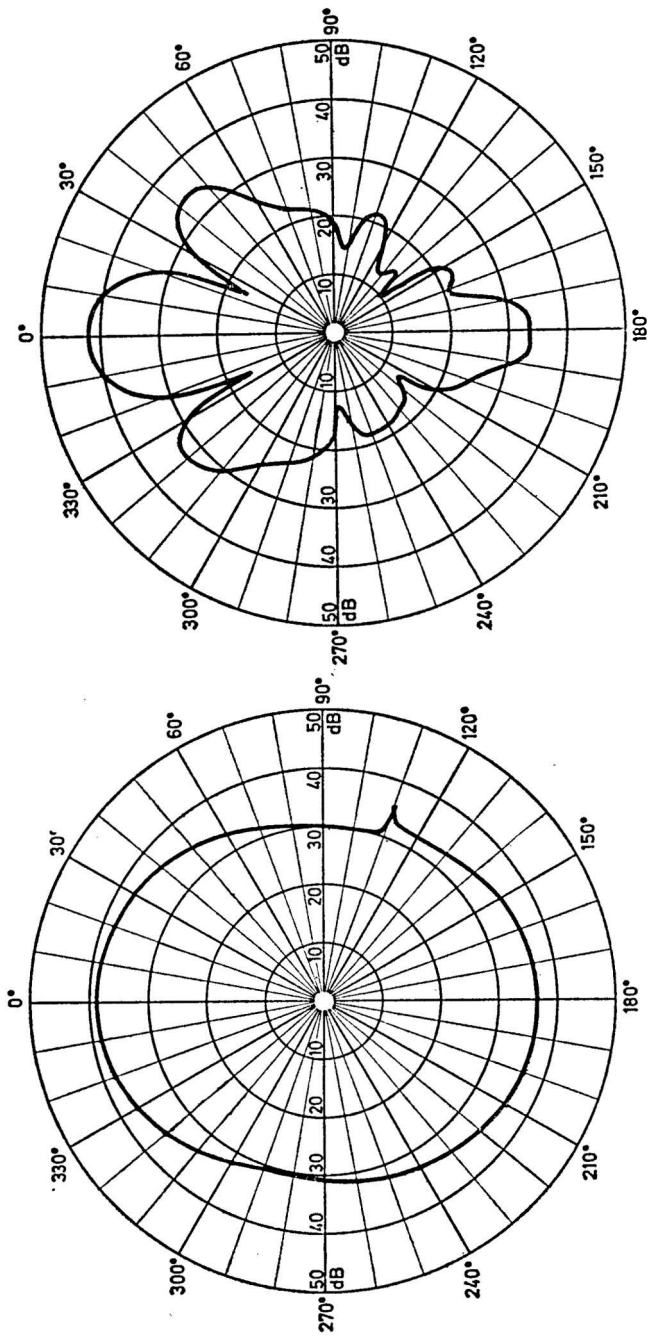

Fig. 39 DIRECTIONAL CHARACTERISTICS (REPRESENTED BY POLAR DIAGRAMS) OF TYPICAL WIDE RANGE SPEAKERS. *Left.* At a signal frequency of 2 kHz. *Right.* At a signal frequency of 5 kHz

LOUDSPEAKERS

Directional Characteristics

The directional characteristics of a speaker are also important. In general terms, lower frequencies will tend to be radiated omni-directionally in a free field (or anechoic room), as shown by the first diagram in Fig. 39. At some higher frequency when the depth of the speaker corresponds to one half of the wavelength of the sound produced, acoustic 'short circuiting' will occur, with the sound pattern or *polar diagram* in the 'figure of eight' form with greatly reduced sound at 90 and 270 degrees to the speaker axis (Fig. 40). At higher frequencies the sound

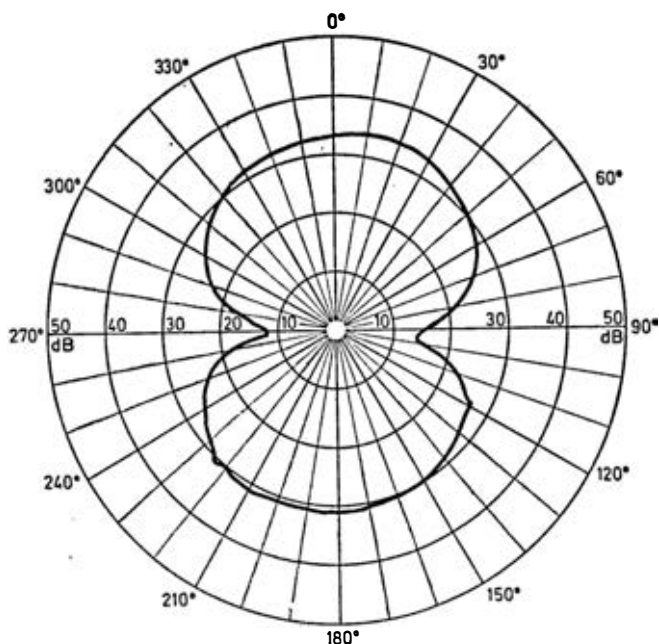

Fig. 40 ACOUSTIC SHORT-CIRCUITING WITH 'FIGURE-OF-EIGHT' POLAR RESPONSE

distribution or polar response will develop even more lobes, so that the sound distribution becomes even more directional.

Thus 'tweeters', and to a lesser extent 'squawkers', will inherently tend to be *directional* speakers, as far as their distribution of sound is concerned, with signal strength likely to be considerably reduced if

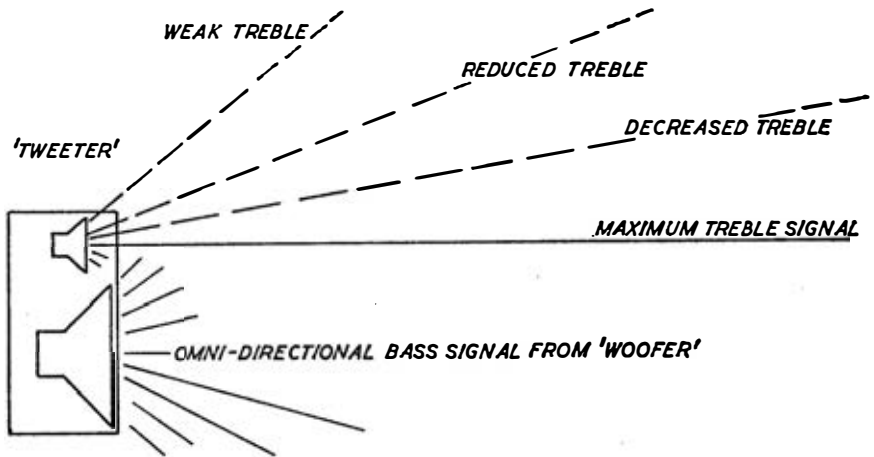

Fig. 41 MAXIMUM TREBLE SIGNAL IS HEARD IN LINE WITH 'TWEETER'. 'WOOFER' IS NORMALLY OMNI-DIRECTIONAL

listened to at a position offset from the axis of the speaker—Fig. 41. The location of a treble speaker, therefore, can be important in obtaining the right effect. In practice, however, actual listening results are modified by the acoustic properties of the room, as well as the design of speaker enclosures—both of which factors can be more significant than the actual 'free field' characteristics of the speaker(s) involved.

Speaker Resonant Frequency

Every speaker will have an inherent resonant frequency which will almost inevitably lie within the audible frequency range. Every time the speaker is driven at this particular frequency it will vibrate excessively, producing an overload sound. Good speaker design aims at making this resonant frequency as low as possible, so that it will not distort normal bass response. Ideally it should be lower than the lowest frequency required to be heard so that the speaker is never driven through resonance. However resonant frequency is not necessarily a critical factor in hi-fi reproduction, for much can be done in the design of a speaker enclosure to provide damping at resonance, should it occur.

Enclosures

Enclosures for speakers are a specialized subject on their own. Basically mounting on a baffle rather than in an enclosure can be as

LOUDSPEAKERS

effective as anything since a baffle or panel which isolates the two sides of the cone can eliminate acoustic 'short circuiting' and also improve the low frequency response. However to be properly effective in this respect the size of the baffle required is usually prohibitive, e.g. the shortest dimension of the baffle required must be at least as long as half the wavelength of the sound, to avoid interaction. This would call for a baffle with a side dimension of at least 14 feet to accommodate frequencies down to 40 Hz.

The baffle principle is employed in *reflex enclosures* where the baffle is folded into the form of a box or cabinet housing the speaker. For optimum performance the enclosure is 'tuned' to the speaker. The simplest way to do this is to cut a hole or port in the box when the enclosure will act as a resonating system because of the enclosure of air at these ports, the resonant frequency depending on the volume of air in the enclosure and the dimensions of the port. There are a number of other rather more elaborate ways of providing a tuned, ported system or ported reflex enclosures, incorporating necessary damping, and both proportions and construction can be quite critical.

The modern trend is towards the use of a sealed enclosure with no port. Again the volume of air in the enclosure is critical as governing the loading of the speaker, but no special matching by a tuned port is required and the whole geometry is simplified. The cabinet size can be reduced and the properties of the cabinet are not important, as long as the required air volume is present. The bass response of sealed enclosures is, however, generally inferior to that of well-designed ported reflex enclosures. This places a premium on speaker and cabinet design for hi-fi application.

Apart from geometric considerations, it is also important that the enclosure structure should be rigid and well damped. Rigidity is necessary to avoid unwanted resonances. Damping is necessary to prevent internal reflection of sound waves and the formation of 'standing waves', either of which could introduce spurious frequencies or *coloration* as it is called.

Two or more speakers can be mounted in the same cabinet. The 'woofer' being the larger and heavier unit, it is usually mounted at the bottom. 'Tweeter(s)' and 'squawker' (if used) must be contained in separate sealed enclosures within the cabinet—ranged vertically, for preference, for any interaction of sound is then confined to the vertical

SET UP YOUR OWN HI-FI

plane which is less likely to be noticed. Where two 'tweeters' are used then these should be well separated longitudinally.

Speaker Qualities

As a rough guide, speakers can be classified by 'quality', viz.

- (i) *Low cost speakers* primarily designed for use with portable radios and players, built into the set or in separate small enclosures (e.g. for use in car systems). These range in size from about 2 inches to 5 inches in diameter or 6×4 inches elliptical. Efficiency is usually high in order to reduce the input power required, but sound quality is very limited, particularly at the lower and upper ends—frequency range is typically 200 Hz to 10 Hz (or perhaps less). Resonant frequency of speakers of this class will usually be between 100 and 300 Hz. They are quite unsuitable for hi-fi reproduction.
- (ii) *Standard Quality*—typical of the speakers designed for use in better quality domestic radios, radiograms and recorders—usually integrally mounted in the same cabinet. They are generally single wide-range speakers with a frequency range which may cover 60 Hz to 10–15 Hz, but the enclosure may also incorporate a 'tweeter'. Diameter sizes lie between 5 inches and 10 inches and the resonant frequency of speakers of this class is usually of the order of 80 to 100 Hz. They have limited suitability for hi-fi reproduction.
- (iii) *High-quality speakers*—much more expensive and also invariably mounted in separate cabinets or enclosures, specially designed to match. A 'woofer' of from 5 to 12 inches diameter is used with one (or two) 'tweeters' of 1 to 2 inches diameter. A 'squawker' (typically of 5 inches diameter) may also be incorporated in the unit. These are true hi-fi speakers, although their actual performance is dependent on design and construction. Typical overall frequency range is 30 Hz to 20,000 Hz. Resonant frequencies—
 - woofer 25 to 50 Hz ✓
 - squeaker 250 Hz
 - tweeter(s) 800 to 1000 Hz.

Other Speaker Types

Alternatives to the moving coil design have appeared offering considerable possibilities for hi-fi working. These include the *electrostatic*

LOUDSPEAKERS

speaker, *ionophone* and ribbon speaker (basically restricted to 'squawkers').

The *electrostatic speaker* is a modern wide-range type which dispenses with the need for baffles or enclosure and comprises, in essence, a large flexible diaphragm mounted between perforated electrodes. The diaphragm is polarized by a high voltage supply applied through a resistance and 'driven' directly by the electrodes, resulting in wide response characteristics with absence of resonant effects. Bass and middle frequency response can be exceptionally good, the only limitation with the higher frequencies being a tendency to focusing. This can be eliminated by a cross-over network restricting the area of high frequency radiations.

Electrostatic speakers have bi-directional (figure of eight lobed) characteristics.

The still more recent *ionophonic* speaker employs no mechanical moving parts at all, vibration of an air column being induced directly from a quartz cell placed at the throat of a horn. Linear response characteristics are limited only by the properties of the horn. Again this is a wide-range speaker type, offering particularly favourable characteristics with increasing frequencies.

Apart from higher cost, a disadvantage of the electrostatic speaker is that it requires a high tension supply of several kilowatts for polarization of the diaphragm, and thus a special power supply. Also it can present additional matching problems to the amplifier since it represents a capacitive rather than a resistive (impedance) type of load.

Speaker Connections

A loudspeaker has two terminals and for a single-speaker system it does not matter which way round these are connected to the amplifier output, nor is the length of connecting lead employed necessarily significant. Strictly speaking, since the connecting lead must have resistance, it will modify the impedance of the speaker (quoted as that of the speech coil) and thus the output impedance load. In practice it is only necessary to employ reasonably low resistance flex for connection, e.g. 14/0076 stranded twin flex is satisfactory for extension leads up to about 40 feet. Thicker multi-stranded wire is recommended for larger runs.

In the case of stereo systems the speaker connections are marked +

SET UP YOUR OWN HI-FI

and —. Again the speakers will work whichever way round they are connected, but for correct stereo reproduction polarity *is* important in order to preserve the correct channel phasing. A reversed speaker connection will put the channels out of phase which can degrade the performance and particularly the stereo effect.

A simple check is to operate both speakers on a mono signal and adjust the tone control for plenty of bass; taking each speaker in turn, change over the speaker connections to find which gives the strongest bass and the most clearly defined central image.

Individual Volume Controls

In particular installations, e.g. with extension speaker(s), it may be desirable to have a separate volume control associated with the speaker point. This can be provided quite simply by wiring in a potentiometer at or near the speaker point, as shown in Fig. 42. The value of the potentiometer

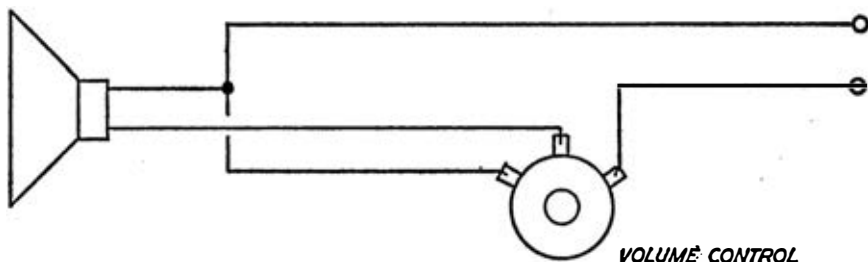

Fig. 42 SIMPLE VOLUME CONTROL FOR INDIVIDUAL SPEAKER

meter used should be approximately the same as the impedance of the speaker, e.g. a 10-ohm potentiometer for a volume control for an 8-ohm speaker; or a 25-ohm potentiometer for a 16-ohm speaker.

A good quality linear potentiometer should be used for an individual volume control as otherwise the performance of the speaker may be degraded.

Speaker Location

In the end, the all-important factor is the acoustic properties of the room, as these finally govern the quality of the sounds heard. The listener's ears will receive sounds direct from the speaker(s), and also

LOUDSPEAKERS

sound waves reflected from the walls, ceiling and furniture. The *size* of the room can also affect lower frequency quality.

A measure of the acoustic properties of a room is the *reverberation* time, or the time taken for a sound to decay to one millionth of its original level. A large reverberation time will produce prolonged 'echoing' effects. Zero reverberation time—where all the sound is absorbed at the room surfaces instead of being reflected, as in an anechoic room, will produce a 'dead' sound—unnatural because there are no reflections.

Reverberation time can be calculated from the formula:

$$\text{Reverberation time (seconds)} = \frac{0.049 V}{S \times \alpha}$$

where V = room volume in cubic feet

S = surface area of room in sq. feet.

$$= \frac{0.161 V}{S \times \alpha}$$

When V is in cubic metres S is in square metres.

The quantity α is the *absorption coefficient* of the room surfaces, or simply a measure of the amount of sound energy they reflect. For a typical average room the value of α is likely to be about 0.15, giving a reverberation time of something like $\frac{1}{2}$ second for a 12 ft. \times 10 ft room 8 ft. high. The absorption coefficient is increased, and the reverberation time reduced, by large areas of curtains or drapes which are effective in absorbing sound; and also by the presence of 'absorbent' furniture. It is reduced, and the reverberation time increased, by the presence of plain, highly reflective surfaces.

A reverberation time of between a quarter and one half of a second produces a 'natural' effect in most rooms. Anything less may appear 'dead'; anything very much higher too 'echoing'. This, however, is largely a subjective factor which can vary from individual to individual, and also with the type of programme being listened to.

The best position for speakers can only be found by trial-and-error. Generally speaking a corner position is usually adopted, but this is not always the best. Corner location with stereo, particularly, can lead to a 'hole in the middle' effect. There is also a natural tendency with corner location to mount the speakers too high.

As a general rule speakers should be mounted about ear level, or the

SET UP YOUR OWN HI-FI

'tweeters' slightly above ear level to clear furniture which might absorb higher frequencies readily, bearing in mind also the directional characteristics of many 'tweeters'. When 'woofer' and 'tweeter' are mounted in the same cabinet it does not matter whether the cabinet is upright or sideways, or inverted.

All large surfaces near a speaker, particularly reflective surfaces like plain walls, will tend to act as baffles to enhance bass response. This may or may not be desirable. Again trial-and-error will show the best result, moving the speakers away or close to a wall, or angling with respect to the wall to modify the reflection characteristics.

In the case of stereo reproduction, symmetrical disposition of the speakers should be used, relative to the usual listening point, but taking care to avoid a 'hole in the middle'. Usually best results are achieved with the speakers between 6 and 12 feet apart, and their angling 'optimized' by trial-and-error.

Finally there is the significance of room size. Resonance will occur if any one room dimension is equal to one half of the wavelength of any sound being produced. This can result in the formation of standing waves modifying the sound levels in different parts of the room, as well as the quality of the sounds. If such effects are present, they can usually be reduced or overcome by altering the position of the speaker(s) or furniture, or using drapes to cover large reflecting surfaces.

What cannot be so simply treated is the inherent *cut-off* frequency of the room, which is determined by the length of the room *diagonal* from floor to ceiling. This dimension represents half the wavelength of the *lowest frequency* which can be sustained by the room—in other words no frequencies with a greater wavelength will be reproduced properly. Thus a smaller room with a diagonal measurement of about 11 feet will *cut off* all frequencies below 50 Hz. (See also frequency and wavelength table in appendix.)

CHAPTER 8

TUNER DESIGN

DEMANDS are exacting for a high-quality FM tuner. The frequency range to be covered is Band II (88MHz to 108MHz). High-quality reception demands that the tuner has outstanding signal-handling ability, coupled with low noise, rendering both the design and construction of the circuits critical, especially for working in areas of low signal strength. The reception of stereo broadcasts also requires the addition of a stereo decoder.

Typical stages involved are shown in simplified diagrammatic form in Fig. 43. The RF stages involve the tuned circuit and RF amplifier,

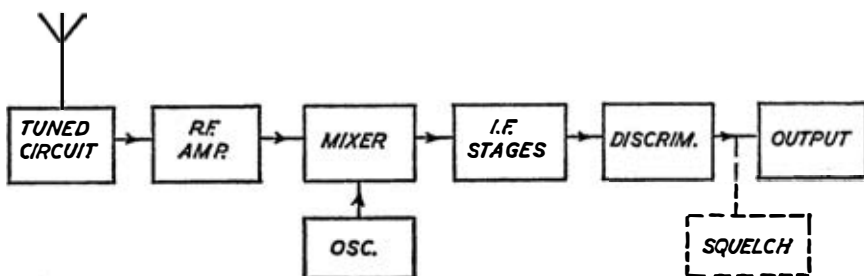

Fig. 43 BLOCK DIAGRAM OF TUNER CIRCUIT

local oscillator and mixer, with tuning by ganged capacitors. The IF stages may or may not include band-pass filters as well as IF amplification; and are followed by the detector or discriminator. The decoder (when required for stereo) is switched on to the output of the discriminator, subsequently feeding into separate audio amplifiers.

Numerous sub-circuits may also be involved for filtering, etc. Thus refinements in the tuner design may also include 'squelch' circuits to provide an input gating effect with the object of introducing a limit below which the receiver has no response to the input signal. This has

SET UP YOUR OWN HI-FI

the effect of inter-signal quieting, or the considerable reduction in noise normally inherent on FM when tuning between stations.

Because of the complexity involved, and the difficulties associated with alignment without considerable experience and access to specialized equipment, home-built tuners may prove quite disappointing, or even not work at all, even when built to good original designs. Nevertheless, this is a field which is particularly attractive to the amateur constructor with some previous experience of the requirements involved.

As a general guide to specification figures, the following are typical values required:

Sensitivity: 2 microvolts

Audio response: flat within plus or minus 1 dB.

Image rejection: 50 dB or better (this may vary with tuning frequency and also be influenced by aerial configuration employed)

IF rejection: 65 dB or better (again this will vary with tuning frequency and is usually best at the lower RF frequencies)

Noise factor: 5 dB or lower

Repeat-spot suppression: 70 dB or better at worst RF tuning

Double-beat suppression: better than 60 dB

Continuous-beat suppression: better than 65 dB

Stereo channel separation: better than 30 dB at 50 per cent input/pilot signal voltage ratio; or at 1 kHz signal.

Silicon planar transistors are commonly chosen for tuners because of their good signal-handling capabilities and a relatively straightforward circuit of this type, embracing RF, mixer and oscillator stages is shown in Fig. 44. Here the tuned circuit is matched to the RF transistor by a fixed inductance, allowing the transistor to be matched for optimum noise performance. For the BF200 transistor specified, the optimum load is a parallel combination of a 125-ohm resistor and 500-ohm inductance, yielding a typical noise factor of the order of 2 dB. However the emitter resistor, inductance L_2 and capacitor C_6 also contribute noise, resulting in an overall noise factor of under 5dB. The mixer stage contributes very little noise. Harmonics are eliminated in this stage by keeping the oscillator signal to the base of the transistor as low as possible, whilst R_7 in series with the collector, prevents parasitic oscillation. The mixer gain is a little under 20 dB.

The oscillator transistor operates in the common base configuration

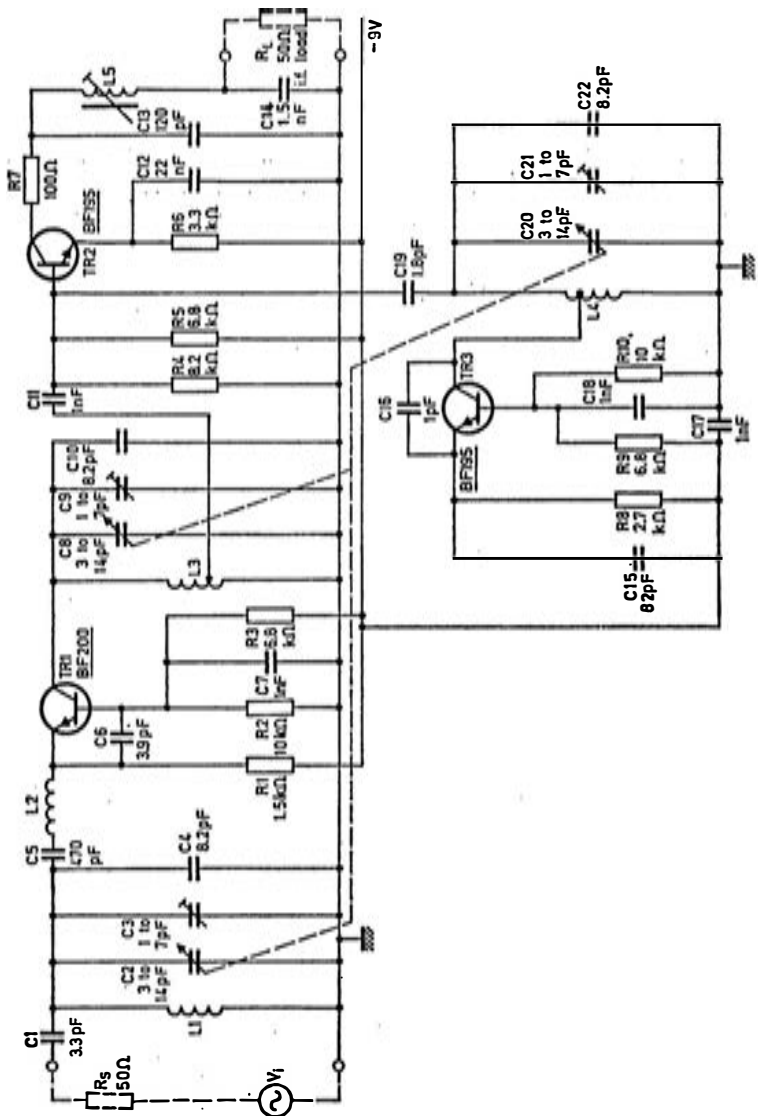

Fig. 44 SILICON PLANAR TRANSISTOR FM TUNER, Embracing RF stage, mixer stage and local oscillator (Mullard)

SET UP YOUR OWN HI-FI

with the coupling capacitor (C₁₉) value chosen to ensure that large aerial signals have no effect on the oscillator circuit.

Tuning is by ganged variable capacitors.

Although basically a simple circuit to construct, component placement can be critical. In particular capacitor C₆, which prevents parasitic oscillation at very high frequencies, must be mounted between and as close as possible to the base and emitter leads of TRI.

Field effect transistors (fet's) are also widely favoured for the RF stage in FM tuners and many modern designs employ these. In this case the aerial input circuit is usually transformer-coupled to the transistor. Similar considerations apply in providing an optimum source impedance for minimum noise factor, using the secondary of the input transformer as the inductance in parallel with a suitable resistor.

Field effect transistors need higher supply voltages with higher currents in the RF stage, placing a premium on transistor selection. The power gain (transducer gain) of the RF stage is usually substantially less than that achieved with a silicon planar transistor.

The IF stages normally comprise one or more stages of amplification, with selective filters as necessary. Crystal filters are particularly effective, ground to be resonant at the IF and used as a selective coupler between IF stages. Besides providing a higher Q than transformer coupling, crystal filters provide good discrimination against adjacent signals and also reduce noise. A single crystal is suitable for single-signal reception, but two or more crystals are required for bandpass filtering.

The detector required for FM is different from an AM detector in that it must be capable of converting frequency variations into amplitude variations. This is conveniently done by a *discriminator* circuit which combines FM to AM conversion with rectification to give an AF output from the AM signal input.

A basic circuit of this type is shown in Fig. 45, where FM to AM conversion is done by the transformer operating at the IF of the tuner. The voltage induced in the transformer secondary is 90 degrees out of phase with the primary current. The primary voltage is introduced at the centre tap of the secondary via a capacitor and combines with the secondary voltages on either side of the centre tap. The resultant voltage on one side of the secondary thus leads the primary voltage, and that on the other side of the secondary lags the primary voltage by the same phase angle. When rectified by the diodes, these voltages are equal and

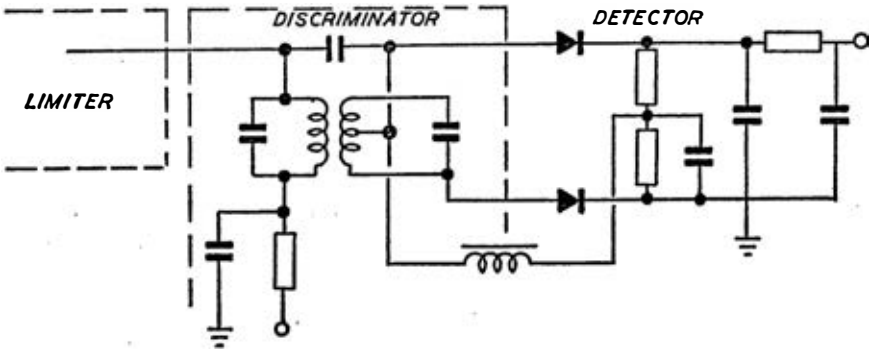

Fig. 45 BASIC DISCRIMINATOR CIRCUIT

opposite when the circuits are resonant to a particular unmodulated carrier frequency. When the frequency changes there is a shift in phase angle, resulting in an increase in output amplitude on one side and a decrease on the other side. Thus the difference between these voltages, when rectified, is the AF output derived from the modulated RF.

For practical working it is necessary to precede this type of discriminator by an amplitude limiter, for unless this form of control is present a high noise level may be generated because of the dependency of the AF output amplitude on the amplitude of the input signal.

An alternative form of FM detector is the *ratio detector*, as shown in Fig. 46. This does not need to be preceded by a limiter since AM components are suppressed by a capacitor across the diode loads. The

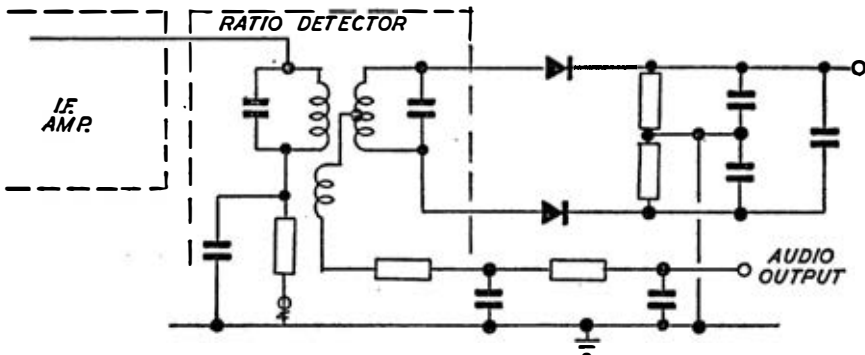

Fig. 46 BASIC RATIO DETECTOR CIRCUIT

SET UP YOUR OWN HI-FI

diodes are also reversed and the AF is extracted from a tertiary winding on the transformer, tightly coupled to the primary. The sensitivity of a ratio detector is only about one half that of a discriminator, but by suitable transformer design the actual performance achieved in practice may be almost directly comparable.

A further type which has particular attractions for hi-fi working is the pulse-counting or *digital detector*, based on integrated circuits. This has the advantage of requiring no tuned circuits and provides linear characteristics over a wide frequency range. A typical circuit train is shown in Fig. 47. The first three ICs are the input stages which amplify, limit and convert the FM signal into a pulse train of constant amplitude and

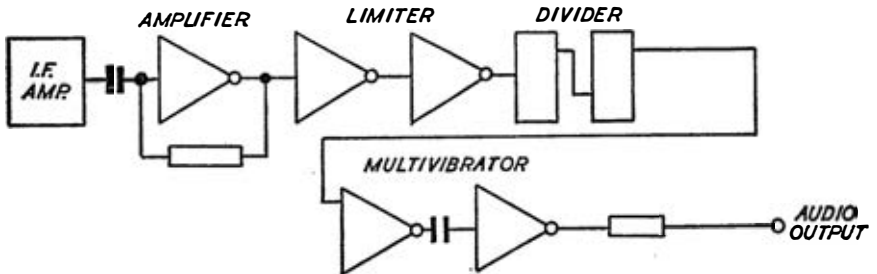

Fig. 47 PULSE COUNTING OR DIGITAL DETECTOR CIRCUIT BASED ON INTEGRATED CIRCUITS

width, with a repetition rate varying in proportion to the signal frequency. The pulse signal is then fed to a two-stage flip-flop counter which divides the signal frequency by four to enable the following monostable vibrator to be triggered. The period of the multivibrator is set at less than half the period of the FM signal, and as a consequence the multivibrator output consists of pulses of variable repetition rate with on-off times proportional to the frequency variation of the incoming signal. This pulse signal is fed to an RC de-emphasis network which converts the pulse train into an AF signal the amplitude of which is varying in proportion to the change in ratio of on-off times, and consequently proportional to the original AM.

Stereo Decoders

Again there are numerous variations in circuit design, although the

TUNER DESIGN

basic requirement is to separate the Left- and Right-hand signals and totally suppress the sub-carrier.

A typical circuitry is shown in Figs 48 and 49. The pilot tone is extracted from the multiplex input by the resonant (19 kHz) circuit immediately following the discriminator output. This tone is then amplified by TR₁ and applied to the base of TR₂, biased to operate in Class B so that only positive half-cycles of tone are amplified. The resultant waveform is rich in second harmonic content, this being extracted by a tuned circuit (38 kHz), with peak-to-peak amplitude limited to twice the supply voltage. Thus signal amplitude is constant, regardless of input level, once a certain value has been exceeded.

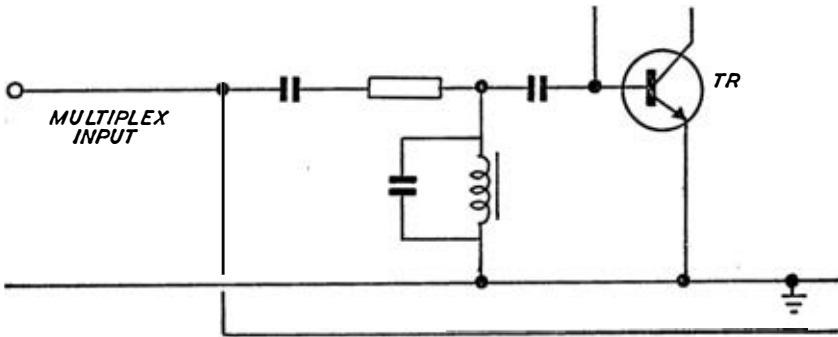

Fig. 48 'FRONT END' OF STEREO DECODER

Antiphase switching signals are applied to the emitters of the two transistors via the centre tapped secondary winding, with the multiplex signal applied to the bases. This results in synchronous detection to obtain the 'difference' signal, together with matrixing of the 'sum' and 'difference' signals, with the appearance of separated Left- and Right-hand signals, one at the collector of each transistor.

In point of fact, only a limited amount of separation is achieved; also there is a considerable second harmonic (38 kHz) content remaining in the output, although de-emphasis can be provided in the collector circuits. Such deficiencies can be removed by additional circuitry.

Fig. 49, for example, shows the same initial circuits extended to provide satisfactory performance as a practical decoder. The degree of crosstalk present after TR₁ and TR₂ is controlled and rendered in anti-phase to the inherent crosstalk, with a cancelling-out effect. Conven-

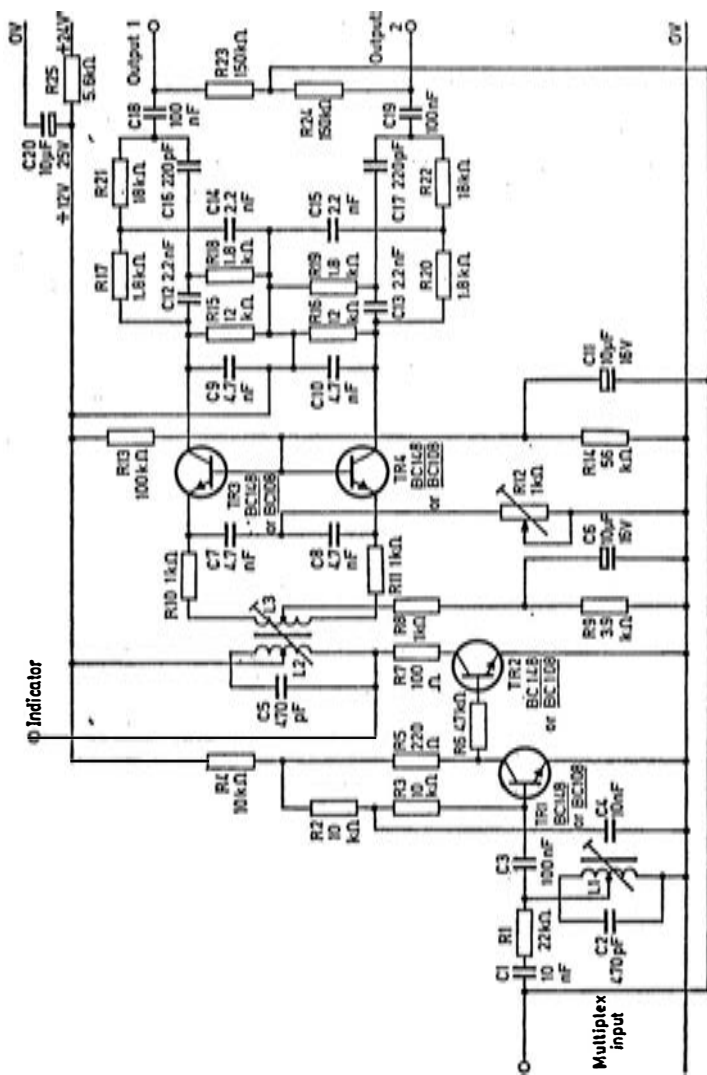

Fig. 49 COMPLETE STEREO DECODER CIRCUIT (MULLARD)

TUNER DESIGN

tional de-emphasis is incorporated in the two collector circuits, but a parallel-T filter is also included in each circuit to remove the 38 kHz content. In this condition the two transistors are biased to Class A operation and thus any signal applied to their bases is reproduced at output at their collectors, i.e. the circuit is compatible and requires no switching from mono to stereo.

CHAPTER 9

AMPLIFIER CIRCUITS

THE simplest type of amplifier is a single transistor circuit, as shown in Fig. 50. This may be used as an AF amplifier in small, portable equipment where size is important, the output load being the primary of the loudspeaker transformer. Such an amplifier is invariably operated as Class A, where the values of the signal and bias voltages applied to the transistor ensure that the collector current always flows. Bias is provided

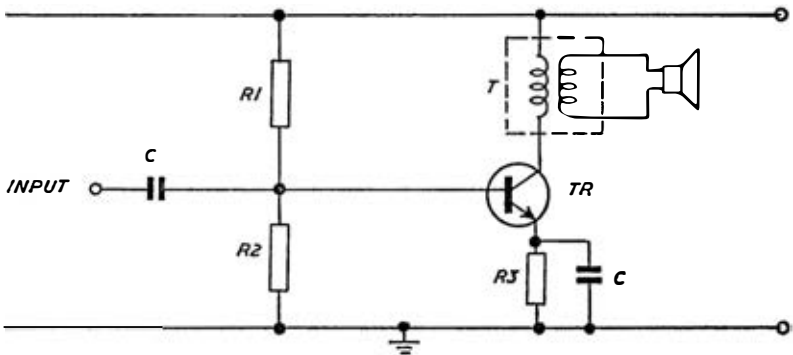

Fig. 50 TYPICAL CLASS A OUTPUT STAGE CIRCUIT

by resistors R_1 and R_2 , whilst resistor R_3 provides thermal stabilization. This is a generally efficient form of amplifier, and also subject to distortion. The same type of circuit may, however, be used in the earlier stages of multi-stages amplifiers, where current levels are comparatively low and the limitations of the circuit are less apparent, i.e. distortion of class A amplifier is lower than class B or AB at low signal levels.

Push-pull amplifiers are normally preferred for output stages since as well as eliminating the need for an output transformer the output power is more than doubled and distortion is decreased. Push-pull amplifiers

AMPLIFIER CIRCUITS

may also be used in the driver stages of multi-stage amplifiers (again eliminating the need for a driver transformer). They normally operate as Class B or Class AB.

A basic push-pull output amplifier circuit is shown in Fig. 51, employing a complementary pair of transistors (TR_2 and TR_3). The two transistors are biased to nearly cut-off so that only a small quiescent current flows under zero-signal conditions. The signal is applied through

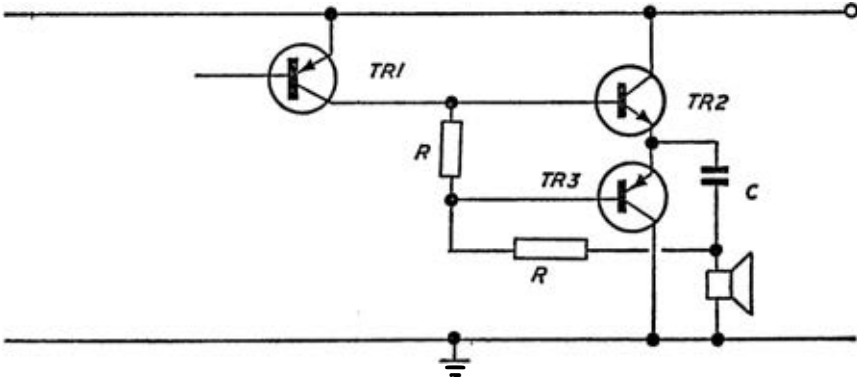

Fig. 51 COMPLEMENTARY-PAIR OUTPUT STAGE CIRCUIT

a phase-splitter to each transistor in antiphase, so that when one transistor is conducting the other is cut off. In practice bias is arranged so that slight forward bias is always present on each transistor in the cut-off condition to avoid crossover distortion (which will occur if each transistor is biased exactly to cut-off). There is an optimum bias at which crossover distortion will be at a minimum.

An inherent limitation with this type of circuit is that the operating limits for the transistors are clearly defined by the resistive load, but with an inductive load transient currents or voltages may be generated of damaging proportions. Thus either transistors with high breakdown voltages must be used, or some form of compensating circuitry added to transform any inductance present into what is effectively resistive load. An example of this type of circuitry is the Zobel network, comprising a capacitor and resistor in series, forming a parallel circuit with the loudspeaker—Fig. 52. The values of the Zobel network components required are derived as:

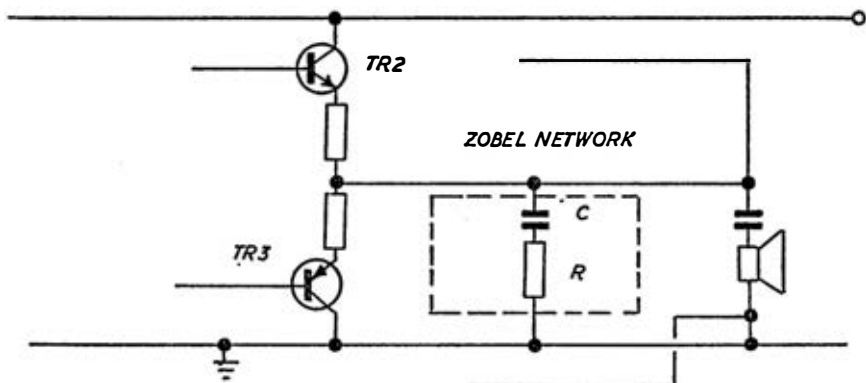

Fig. 52 COMPLEMENTARY-PAIR PUSH-PULL OUTPUT CIRCUIT WITH ZOBEL NETWORK

R_z = series resistance of loudspeaker

$$C_z = \frac{\text{series inductance of loudspeaker}}{(\text{series resistance of loudspeaker})^2}$$

The 'series resistance' and 'series inductance' values referred to are the resistance and inductance which, connected in series, would equal the *impedance* of the loudspeaker. These can only be a close approximation rather than exact values.

Circuits may thus be designed to accommodate normal overload conditions or, where this is not practical in higher power amplifiers, an additional circuit may be incorporated to provide protection. This can take the form of a current-limiting circuit or a current-trip circuit. Such a circuit can also provide automatic protection against accidental short circuiting of the output and may be incorporated for this primary purpose.

Protective circuits of this type are generally described as either current-limiting or current-tripping, although their action is basically the same. They effectively disconnect the driver stage from the output stage in the event of the output current exceeding a given value.

Where high power outputs are required it may be preferable to use two similar NPN transistors rather than a complementary pair in push-pull, since high power NPN transistors are more readily available than corresponding PNP types. In this case the two NPN transistors can be driven in push-pull configuration by a complementary-pair push-pull circuit, as shown in Fig. 53.

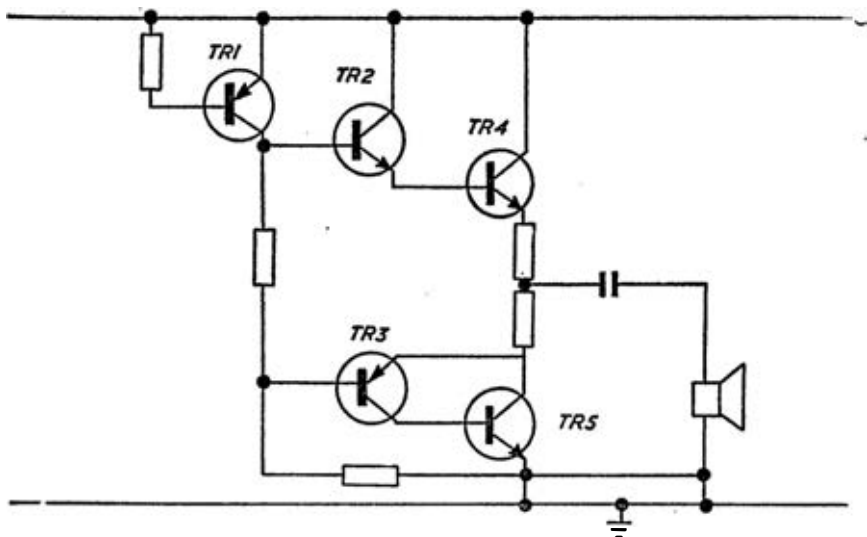

Fig. 53 PUSH-PULL OUTPUT CIRCUIT USING TWO SIMILAR NPN TRANSISTORS. This transistor pair is driven by a complementary push-pull circuit

Modes of Operation

In class B operation the two transistors in a push-pull stage are biased to nearly cut-off, as previously described. With Class AB operation the values of bias and signal currents are arranged so that collector current flows for appreciably more than one half of the cycle of signal voltage. This can offer certain advantages in reducing crossover distortion. It can also be carried a stage further to the point where the total current remains constant with drive. Increasing the level of drive then causes the transistors to change first from Class A to Class AB and then to Class B. This is generally referred to as a Class AB amplifier operating in the pi-mode (π -mode).

The advantage is low distortion at low power levels (Class A operation), with the advantages of AB and B operation at increasing power levels. Also the current drain is constant, thus regulation of the power supply is not important—and only simple filtering is required. Actual power output available from π -mode operation, however, is relatively low, calling for additional stages to be used and thus a greater number of components.

Amplifiers can also be designed to operate as Class D where the transistors are worked as switches in a single-ended push-pull configura-

SET UP YOUR OWN HI-FI

tion. The input signal takes the form of a square wave with pulse width modulation and the switching times corresponding to the mark-space ratio of the input. This has considerable potential advantages for high quality work but is, as yet, relatively undeveloped for general use.

Examples of Amplifier Designs

A basic AF amplifier circuit is shown in Fig. 54, characterized by high input impedance and low output impedance. Using Mullard BC148 or

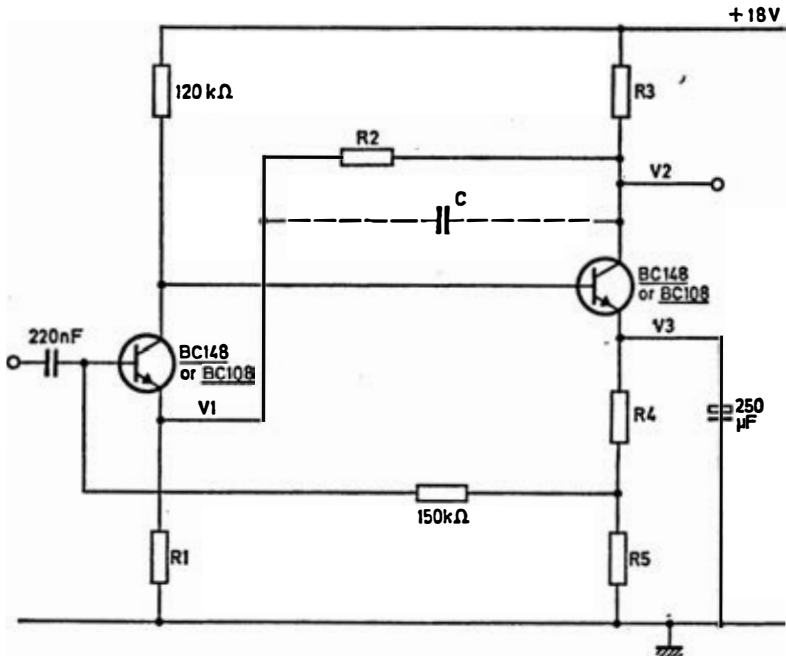

Fig. 54 BASIC AUDIO AMPLIFIER CIRCUIT (MULLARD)

VOLTAGE GAIN

| <i>Component</i> | <i>10 dB</i> | <i>20 dB</i> | <i>30 dB</i> | <i>40 dB</i> |
|------------------|--------------|--------------|--------------|--------------|
| R1 | 4.7 kΩ | 1.5 kΩ | 1.5 kΩ | 1 kΩ |
| R2 | 12 kΩ | 15 kΩ | 56 kΩ | 180 kΩ |
| R3 | 1.8 kΩ | 2.2 kΩ | 2.2 kΩ | 2.2 kΩ |
| R4 | 470 Ω | 560 Ω | 330 Ω | 680 Ω |
| R5 | 1.2 kΩ | 470 Ω | 270 Ω | 220 Ω |
| Capacitor C — | 10 pF | | | |

AMPLIFIER CIRCUITS

BC108 transistors, voltage gains of 10 dB, 20 dB, 30 dB or 40 dB can be provided by selecting the resistor values accordingly. Corresponding impedance values are as follow:

| <i>gain</i> | <i>input impedance</i> | <i>output impedance</i> |
|-------------|------------------------|-------------------------|
| 10 dB | 145 k ohm | 63 ohm |
| 20 dB | 140 k ohm | 140 ohm |
| 30 dB | 135 k ohm | 260 ohm |
| 40 dB | 110 k ohm | 700 ohm |

Maximum total distortion and noise voltages of the four amplifiers are summarized in the table at the foot of the previous page.

This is the type of simple high-performance audio amplifier design particularly suitable for an auxiliary AF amplifier, and easy to construct. The circuit is temperature stabilized by two DC feedback loops, one from the emitter of the second transistor to the base of the first transistor; and one from the collector of the second transistor to the emitter of the first transistor. Frequency response on all four circuits is from 20 Hz to 20 kHz.

Fig. 55 shows an example of a Class B amplifier circuit with an output power of 10 W and a distortion level of less than 0.1 per cent, achieved by excellent symmetry. This is a purely conventional circuit, with the exception of TR₃, included to stabilize the the quiescent current of the complementary-pair of output transistors.

Another feature of this circuit is direct coupling which is now finding increasing favour for hi-fi amplifiers and tuners, eliminating the damping effect of coupling capacitors, or the distortion, noise and efficiency loss inherent in coupling transformers.

A rather more elaborate circuit is shown in Fig. 56 which can provide a 15 W output into an 8 ohm load with Class A operation. The same circuit connected to a 4-ohm load will provide 20 W output, operating in Class AB. Total distortion, again, is less than 0.1 per cent at full output.

Buffer Amplifiers

A buffer amplifier may be used to connect two RC filter networks in series. This is normally designed with a high impedance input and low impedance output and a voltage gain of unity. The main requirements

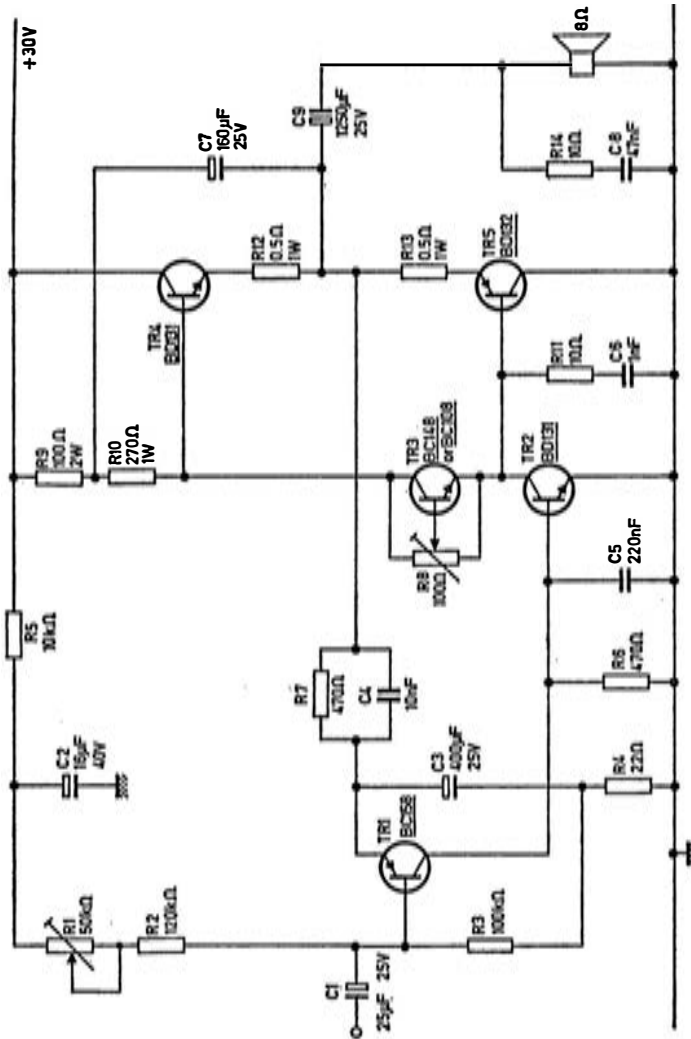

Fig. 55 10 W AUDIO AMPLIFIER DESIGN (MULLARD). Component values shown on drawing

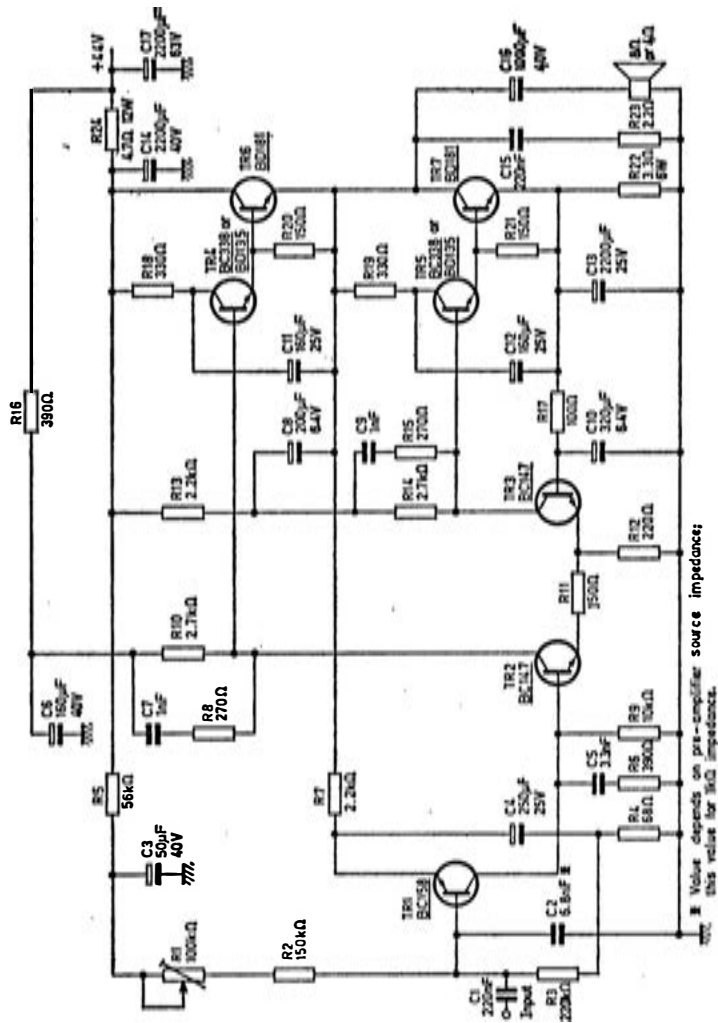

Fig. 56 15/20 W AUDIO AMPLIFIER DESIGN (MULLARD). Component values shown on drawing

SET UP YOUR OWN HI-FI

are full frequency response with lowest possible noise and distortion. Its primary function is isolation rather than power gain.

An example of a buffer amplifier circuit is shown in Fig. 57.

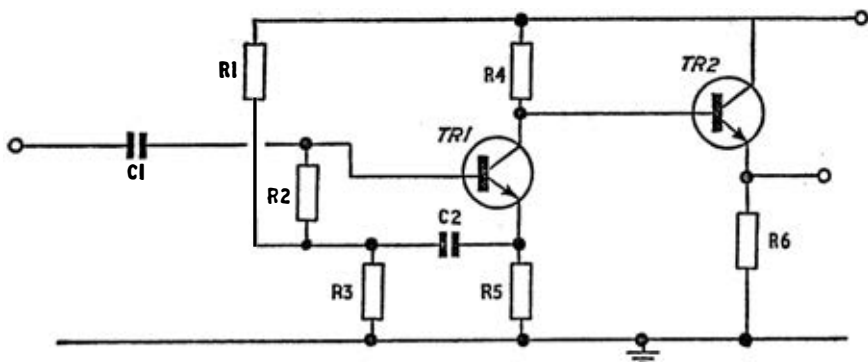

Fig. 57 TYPICAL BUFFER AMPLIFIER CIRCUIT

| | | | |
|----------------|--------------|-----------------|----------------------------|
| R ₁ | — 470 k ohms | R ₆ | — 27 k ohms |
| R ₂ | — 150 k ohms | C ₁ | — 47 pf |
| R ₃ | — 180 k ohms | C ₂ | — 5 f |
| R ₄ | — 22 k ohms | TR ₁ | — Mullard BC 148 or BC 108 |
| R ₅ | — 22 k ohms | TR ₂ | — Mullard BC 148 or BC 108 |

Pre-Amplifiers

A pre-amplifier is, basically, a separate amplifier unit or amplifier stage, introduced to improve the sensitivity or response to, a particular input. In addition to working as an amplifier it may also incorporate filter circuits, tone controls, decoder for stereo, equalization and compensating networks, etc. In other words it can become the main link in the chain, with controlled performance, leaving the AF amplifier unit to be just that—a power amplifier for boosting the output power to the required level.

In the absence of a pre-amplifier/controller in a simpler set-up of signal source (radio or deck)—amplifier-loudspeakers, the amplifier unit itself must incorporate the necessary controls and filter and compensating networks. In other words, the amplifier unit performs all the amplification required (e.g. any necessary pre-amplification followed by power amplification), and incorporates all the necessary controls and auxiliary circuits.

A radio tuner may also have a pre-amplifier, either incorporated as a

AMPLIFIER CIRCUITS

stage or as a separate unit. In this case, however, the pre-amplifier is specifically concerned with RF amplification in the tuned circuit, to improve the sensitivity.

Pre-amplifiers are a favourite subject for the experienced home constructor to tackle, with numerous published designs available. Because of the critical function of such units constructional requirements are usually specific, particularly as regards component layout, screening, etc.

The main requirements are that the inputs available meet all the requirements as regards type of input, and suitable sensitivity to each input, adequate frequency response, high Signal-to-Noise ratio, low distortion level and satisfactory hi-fi performance throughout the working range—plus all the control facilities required.

Typical input requirements are:

| <i>input</i> | <i>sensitivity</i> <i>mV at 1 kHz</i> | <i>input impedance</i> <i>k ohms at 1 kHz</i> |
|---------------------|--|--|
| magnetic pick-up | 4 | 47 |
| crystal pick-up | 300 | 1000 |
| radio (tuner) | 150 | 500 |
| tape deck | 300 | 500 |
| magnetic microphone | 3·5 | 22 |

Frequency response available is usually wider range than audio requirements, e.g. from 10 Hz to 30–40 kHz or better.

Output signal level from a pre-amplifier only needs to be quite low, e.g. 100–400 millivolts; it only being necessary that the following power amplifier has a similar input sensitivity.

A circuit design of a 'universal' pre-amplifier meeting the above performance requirements is shown in Fig. 58. This employs two input transistors of low noise type, the first two stages being directly coupled with DC feedback for stabilization. Five inputs are provided, compensated as necessary, for different types of pick-ups, tape, tuner and microphone. The circuit is suitable for mono or stereo, the Left-hand channel output only being shown. The circuit includes volume, bass and treble and balance controls, but no filter circuits. A rumble filter network could be incorporated between TR₂ and TR₃; and a scratch filter circuit between the tone control network and TR₄.

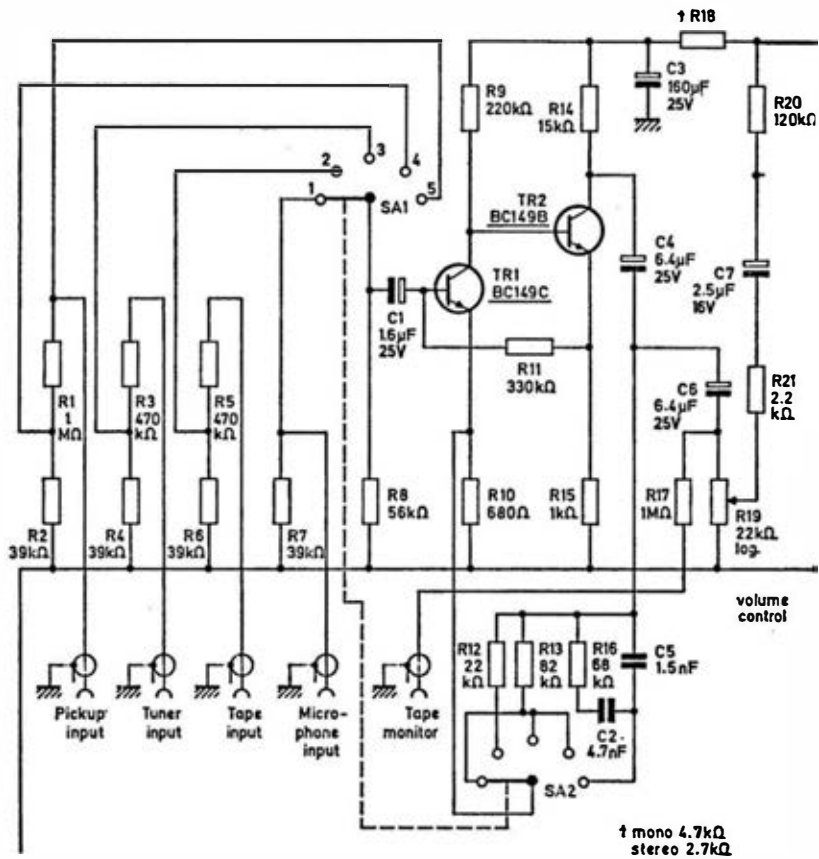
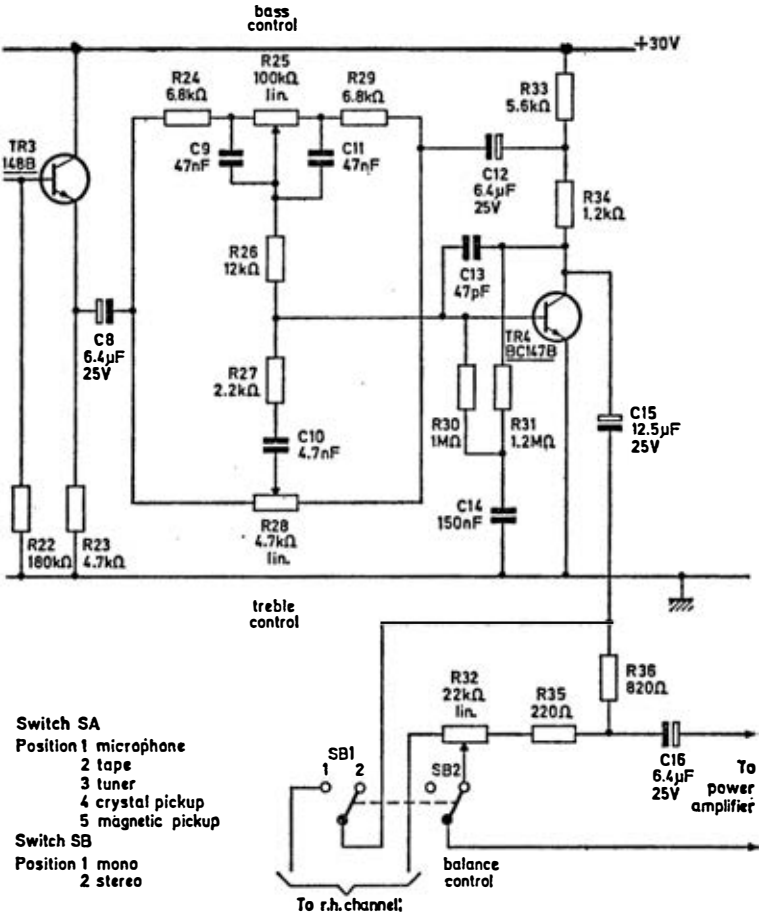

Fig. 58 PRE-AMPLIFIER CIRCUIT DESIGN (MULLARD).



Left-channel stereo output only shown

CHAPTER 10

MICROPHONES

THE classic carbon granule microphone—still a standard for telephones—is largely ruled out for high-fidelity work because of its non-linear distortion and unfavourable noise characteristics. Piezo-electric microphones (with crystal or ceramic transducers) are generally preferred, although alternative types are *condenser* (electrostatic or capacitor) and *moving coil* or *ribbon* (dynamic) microphones. All have linear characteristics, but certain other limitations specific to each type. Moving coil microphones, for example, tend to have a poor response at low frequencies, but have good omni-directional characteristics. Ribbon microphones can provide high quality of speech and music with

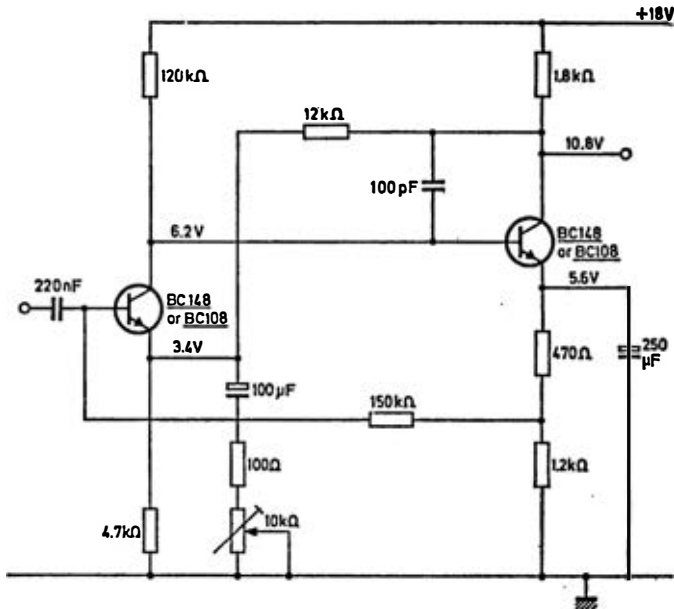

Fig. 59 MICROPHONE AMPLIFIER CIRCUIT (MULLARD)

MICROPHONES

polar characteristics which substantially reduce, or eliminate, unwanted background noise, but are sensitive to air turbulence (i.e. are generally unsuitable for use outdoors). Condenser microphones are more prone to self-noise than other types.

There is thus no such thing as an 'ideal' microphone type, although the individual characteristics of a well-designed microphone can be tailored to suit specific applications, e.g. close-up or distant recording, directional or non-directional pick-up, and other special characteristics.

It is also a general characteristic of all these microphone types that the signal level generated (output level) is low, requiring amplification. The necessary amplifier may or may not be built into the microphone unit itself. The basic requirement of such a circuit is that it has low noise and correct matching in order to obtain the best possible Signal-to-Noise ratio.

An example of a microphone amplifier circuit is shown in Fig. 59, in

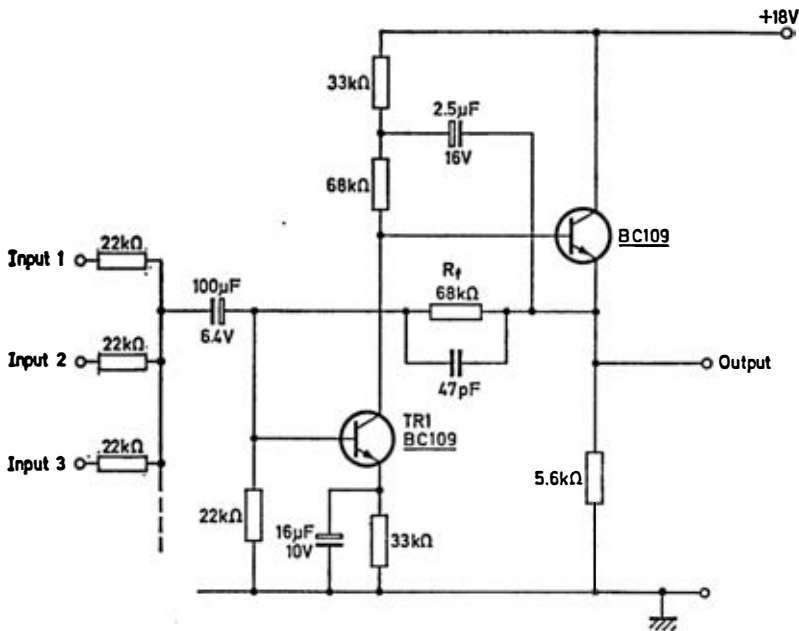

Fig. 60 MIXER AMPLIFIER CIRCUIT FOR MORE THAN ONE INPUT (MULLARD) R_f is feedback resistor

SET UP YOUR OWN HI-FI

which provision is made to adjust the voltage gain between 13 dB and 40 dB by varying the feedback. Total distortion is less than 0.1 per cent at 1 kHz (0.15 per cent at 12.5 kHz) for a gain of 13 dB; and 0.7 per cent at 1 kHz (0.75 per cent at 12.5 kHz) for a gain of 40 dB. Frequency response is from 20 Hz to 20 kHz (or better). Input impedance is 145 k ohm at 13 dB voltage gain, with output impedance 47 ohms. At 40 dB voltage gain, input and output impedances are 120 k ohm and 120 ohm, respectively.

This is a Mullard circuit design, based on BC148 or BC108 transistors, and is particularly attractive for home construction.

In the case of stereo (or where several microphones are used), a 'mixer' unit is required, which can be combined with a microphone amplifier. Again there are numerous published designs suitable for home construction, a typical example being shown in Fig. 60. This, in fact allows up to five input to be used without degradation of performance.

A special feature of this circuit is the very low impedance at the mixer 'summing' point, resulting in negligible crosstalk. The feedback action results in only very low a.c. voltages at the base of the first transistor which is thus virtually at earth potential. For this reason, this type of circuit is referred to as a 'virtual earth' mixer-amplifier.

Signal-to-Noise ratio is as good as likely to be required in any hi-fi system — 85 dB with a nominal output level of 350 mV (RMS). The voltage gain is the ratio of the feedback resistor to the input impedance.

Microphone Impedance and Matching

Microphone impedances are characteristically low or high. Dynamic microphones (moving coil and ribbon) are low impedance transducers. Piezo-electric and condenser microphones are high impedance transducers. Recorders and pre-amplifiers may have alternative inputs, e.g. low impedance and high impedance—to accommodate alternative types, or be restricted to a specific type of microphone—usually a high impedance type. In that case, to use a low impedance microphone connection to the input would have to be made through an impedance matching (microphone) transformer.

In point of fact the input circuits themselves may already incorporate a transformer to provide an optimum match to a transistor input stage. Thus a low impedance input may be through a step-up transformer; and a high impedance input through a step-down transformer. External

MICROPHONES

impedance-matching units may also be applicable to a single input to match the characteristics of individual microphones. In the case of valve amplifiers, different conditions apply since a high impedance input match is required.

General purpose microphones are usually omni-directional with a generally flat response for all sound sources more than about three feet away. They have certain limitations for close-up speech reproduction. A directional microphone has the potential advantage of excluding unwanted background noise by its polar characteristics when aligned in an optimum direction. Response is generally flat at a distance, but low frequency response tends to rise fairly rapidly as the source approaches near to the microphone. This can be compensated by introducing an attenuating circuit for close-up working.

Stereo sets pose particular problems as the basic requirement is that the two microphones should be spaced apart sufficiently to provide differentiation of the inputs. This, in turn, can lead to a time difference being introduced into the two input channels, although this is normally not likely to be significant. The normal choice is crossed directional microphones for optimum stereo effect, although the actual results achieved will be influenced by reflections and reverberations, contributing to background effects. Coloration may be desirable in many recordings to provide a natural rather than a 'flat' effect; this also applying to mono as well as stereo recordings. The main requirement is to record the two channels at substantially the same level, although even this can be adjusted on playback by the balance control. Other recording deficiencies can be adjusted, to a certain extent, by the availability of separate treble and bass controls on each channel on playback.

The ultimate effects achieved by microphone recordings—assuming the use of suitable high-quality microphones(s)—is, in fact, largely bound up in the studio technique applied (or lack of such technique). This, in itself, is a complete subject worthy of separate study by the serious enthusiast. The majority of home hi-fi recordings, however, are normally disc-to-tape or tape-to-tape, so the average enthusiast has little call to study microphone recording technique in detail.

SET UP YOUR OWN HI-FI
Basic Microphone Types and Characteristics

| <i>Type</i> | <i>Response</i> | <i>Sensitivity</i> | <i>Selectivity</i> | <i>Impedance</i> | <i>Remarks</i> |
|----------------------------|-------------------------------------|--------------------|--------------------|------------------|--|
| PIEZO-ELECTRIC: | | | | | |
| Rochelle Salt | } linear | extremely good | fair | } high | susceptible to damp. Damaged by high temperatures very rugged |
| Quartz | | very good | very good | | |
| ADP | | very good | very good | | |
| Barium titanate (ceramic) | | fair to good | good | | |
| Lead zirconate (ceramic) | | good | very good | | |
| DYNAMIC: | | | | | |
| Moving Coil | falling at low and high frequencies | good | very good | low | tends to have poor low frequency response very sensitive to air turbulence |
| Ribbon | rising at low frequencies | very good | good | low | |
| CONDENSER: | | | | | |
| Electrostatic or capacitor | linear | good | excellent | high | prone to self-noise |
| CARBON: | | | | | |
| | Non-linear | very good | poor | high | used for telephony only |

Appendix I

BBC TEST-TONE TRANSMISSIONS

BBC test-tone transmissions are a considerable help in setting up stereophonic equipment. Tones are transmitted on WEDNESDAYS and SATURDAYS at the times shown below. On other days a 250 Hz tone is transmitted on the left channel only from about four minutes after the end of the last programme on Radio 3 for a duration of about twenty minutes. This tone may be interrupted from time to time. The main purpose of this tone is to facilitate channel identification and adjustment of channel cross-talk.

BBC Test-tone Transmissions

| <i>Test No.</i> | <i>Time</i> | <i>Left Channel (A)</i> | <i>Right Channel (B)</i> |
|-----------------|-------------|---|---|
| 1 | T* | 250 Hz at zero level | 440 Hz at zero level |
| 2 | T + 2' | 900 Hz at + 7 dB | 900 Hz at + 7 dB, antiphase to left channel |
| 3 | T + 6' | 900 Hz at + 7 dB | 900 Hz at + 7 dB in phase with left channel |
| 4 | T + 7' | 900 Hz at + 7 dB | No modulation |
| 5 | T + 8' | No modulation | 900 Hz at + 7 dB |
| 6 | T + 9' 2" | Tone sequence at—4 dB 60 Hz 900 Hz 5 kHz 10 kHz | No modulation |
| | | This sequence is repeated | |
| 7 | T + 10' 20" | No modulation | Tone sequence as for left channel on Test 6 |
| 8 | T + 11' 20" | No modulation | No modulation |
| | T + 13' | Reversion to monophonic transmission | |

* T is approximately 4 minutes after the end of Radio 3 programmes.

Notes on Adjustment

Balance is best carried out by listening to announcements during a stereophonic transmission since these are always made from a centre stage position.

SET UP YOUR OWN HI-FI

Cross-talk adjustment is made on Tests 4 and 5 on receivers where the adjustment is by means of sub-carrier phase.

Alignment where the receiver has separate controls for cross-talk (separation) and sub-carrier phase is carried out by first adjusting the sub-carrier phase to produce maximum output from either channel A or channel B during Test 2; and then adjusting the cross-talk on Tests 4 and 5 for minimum cross-talk between channels.

Appendix II

BBC VHF RADIO TRANSMISSIONS

THE following VHF Radio Transmitting Stations are operative in Great Britain at the time of writing (1974). Stations transmitting stereo programmes are noted by the letter S. The number of stations—particularly local stations—and those transmitting stereo can be expected to increase considerably.

ENGLAND—Radio 2, Radio 3, Radio 4

| | <i>Frequencies (MHz)</i> | | |
|------------------------------|--------------------------|----------------------|----------------------|
| | <i>R₂</i> | <i>R₃</i> | <i>R₄</i> |
| <hr/> | | | |
| <i>London and South-East</i> | | | |
| Oxford | 89·5 | 91·7 ^S | 93·9 |
| Swingate | 90·0 | 92·4 ^S | 94·4 |
| Wrotham | 89·1 | 91·3 ^S | 93·5 |
| <hr/> | | | |
| <i>Midlands</i> | | | |
| Sutton Coldfield | 88·3 | 90·5 ^S | 92·7 |
| Churchdown Hill | 89·0 | 91·2 | 93·4 |
| Hereford | 89·7 | 91·9 | 94·1 |
| Northampton | 88·9 | 91·1 ^S | 93·3 |
| <hr/> | | | |
| <i>East Anglia</i> | | | |
| Peterborough | 90·1 | 92·3 | 94·5 |
| Cambridge | 88·9 | 91·1 | 93·3 |
| Tacolneston | 89·7 | 91·9 | 94·1 |
| <hr/> | | | |
| <i>South</i> | | | |
| Rowridge | 88·5 | 90·7 ^S | 92·9 |
| Brighton | 90·1 | 92·3 ^S | 94·5 |
| Ventnor | 89·4 | 91·6 | 93·8 |
| <hr/> | | | |

SET UP YOUR OWN HI-FI

| | <i>Frequencies (MHz)</i> | | |
|-------------------|--------------------------|----------------------|----------------------|
| | <i>R₂</i> | <i>R₃</i> | <i>R₄</i> |
| <i>West</i> | | | |
| Wenvoe | 89.95 | 96.8 | 92.125 |
| Barnstable | 88.5 | 90.7 | 92.9 |
| Bath | 88.8 | 91.0 | 93.2 |
| Oxford | 89.5 | 91.7 ^B | 93.9 |
| <i>South West</i> | | | |
| Les Platons | 91.1 | 94.75 | 97.1 |
| North Hessary Tor | 88.1 | 90.3 | 92.5 |
| Okehampton | 88.7 | 90.9 | 93.1 |
| Redruth | 89.7 | 91.9 | 94.1 |
| Isles of Scilly | 88.8 | 91.0 | 93.2 |
| <i>North</i> | | | |
| Belmont | 88.8 | 90.9 | 93.1 |
| Holme Moss | 89.3 | 91.5 ^B | 93.7 |
| Scarborough | 89.9 | 92.1 ^B | 94.3 |
| Sheffield | 89.9 | 92.1 ^B | 94.3 |
| Wensleydale | 88.3 | 90.5 | 92.7 |
| <i>North West</i> | | | |
| Holme Moss | 89.3 | 91.5 ^B | 93.7 |
| Douglas | 88.4 | 90.6 | 92.8 |
| Kendal | 88.7 | 90.9 ^B | 93.1 |
| Morecambe Bay | 90.0 | 92.2 ^B | 94.4 |
| Windermere | 88.6 | 90.8 | 93.0 |
| <i>North East</i> | | | |
| Pontop Pike | 88.5 | 90.7 | 92.9 |
| Weardale | 89.7 | 91.1 | 94.1 |
| Whitby | 89.6 | 91.8 | 94.0 |
| Sandale | 88.1 | 90.3 | 94.7 |

APPENDIX II
ENGLAND—Local Radio
Frequency MHz

| | |
|------------------------------|-------|
| <i>London and South East</i> | |
| London | 95·3 |
| Medway | 97·0 |
| Oxford | 95·0 |
| <i>Midlands</i> | |
| Birmingham | 95·6 |
| Derby | 96·5 |
| Leicester | 95·2 |
| Nottingham | 94·8 |
| Stoke-on-Trent | 94·6 |
| <i>East Anglia</i> | |
| — | — |
| <i>South</i> | |
| Brighton | 95·8 |
| Solent | 96·1 |
| <i>West</i> | |
| Bristol | 95·4 |
| <i>South West</i> | |
| — | — |
| <i>North</i> | |
| Humberside | 95·3 |
| Leeds | 94·6 |
| Sheffield | 88·6 |
| (Rotherham) | 95·05 |
| <i>North West</i> | |
| Blackburn | 96·4 |
| Manchester | 95·1 |
| Merseyside | 95·8 |
| <i>North East</i> | |
| Durham | 94·5 |
| Newcastle | 95·4 |
| Teesside | 96·6 |

SET UP YOUR OWN HI-FI
WALES, SCOTLAND AND NORTHERN IRELAND—
Radio 2, Radio 3, Radio 4

| | <i>Frequencies (MHz)</i> | | |
|-------------------|--------------------------|-----------|-----------|
| | <i>R2</i> | <i>R3</i> | <i>R4</i> |
| <hr/> | | | |
| Wales | | | |
| Blaenplwyf | 88·7 | 90·9 | 93·1 |
| Dolgellau | 90·1 | 92·3 | 94·5 |
| Ffestiniog | 88·1 | 90·3 | 92·5 |
| Machynlleth | 89·4 | 91·6 | 93·8 |
| Haverfordwest | 89·3 | 91·5 | 93·7 |
| Llanddona | 89·6 | 91·8 | 94·0 |
| Betws-y-Coed | 88·2 | 90·4 | 92·6 |
| Llangollen | 88·85 | 91·05 | 93·25 |
| Wenvoe | 89·95 | 96·8 | 94·3 |
| Brecon | 88·9 | 91·1 | 93·3 |
| Carmarthen | 88·5 | 90·7 | 92·9 |
| Llandrindod Wells | 89·1 | 91·3 | 93·5 |
| Llanidloes | 88·1 | 90·3 | 92·5 |
| <hr/> | | | |
| Scotland | | | |
| Kirk o'Shotts | 89·9 | 92·1 | 94·3 |
| Ashkirk | 89·1 | 91·3 | 93·5 |
| Campbeltown | 88·2 | 90·4 | 92·6 |
| Forfar | 88·3 | 90·5 | 92·7 |
| Longilpheed | 88·3 | 90·5 | 92·7 |
| Perth | 89·3 | 91·5 | 93·7 |
| Pitlochry | 89·2 | 91·4 | 93·6 |
| Toward | 88·5 | 90·7 | 92·9 |
| Meldrum | 88·7 | 90·9 | 93·1 |
| Bressay | 88·3 | 90·5 | 92·7 |
| <hr/> | | | |
| Grantown | 89·8 | 92·0 | 94·2 |
| Kingussie | 89·1 | 91·3 | 93·5 |
| Orkney | 89·3 | 91·5 | 93·7 |
| Thrumster | 90·1 | 92·3 | 94·5 |
| Rosemarkie | 89·6 | 91·8 | 94·0 |
| Ballachulish | 88·1 | 90·3 | 92·5 |
| Fort William | 89·3 | 91·5 | 93·7 |
| Kinlochleven | 89·7 | 91·9 | 94·1 |
| Melvaig | 89·1 | 91·3 | 93·5 |
| Oban | 88·9 | 91·1 | 93·3 |
| Penifiler | 89·5 | 91·7 | 93·9 |
| Skriaig | 88·5 | 90·7 | 92·9 |
| Sandale | 88·1 | 90·3 | 92·5 |
| <hr/> | | | |

APPENDIX II

| | <i>Frequencies (MHz)</i> | | |
|-------------------------|--------------------------|----------------------|----------------------|
| | <i>R₂</i> | <i>R₃</i> | <i>R₄</i> |
| Northern Ireland | | | |
| Divis | 90.1 | 92.3 | 94.5 |
| Ballycastle | 89.0 | 91.2 | 93.4 |
| Brougher Mountain | 88.8 | 91.0 | 93.2 |
| Kilkeel | 88.8 | 91.0 | 93.2 |
| Larne | 89.1 | 91.3 | 93.5 |
| Londonderry | 88.3 | 90.55 | 92.7 |
| Maddybenny More | 88.7 | 90.9 | 93.1 |
| Newry | 88.6 | 90.8 | 93.0 |

Appendix III

RADIO FREQUENCY WAVELENGTHS*

| <i>Frequency MHz</i> | <i>Wavelength</i> | |
|--------------------------|-------------------|---------------|
| | <i>Feet</i> | <i>Metres</i> |
| 1 | 984 | 300 |
| 2 | 344 | 150 |
| 3 | 328 | 100 |
| 4 | 246 | 75 |
| 5 | 197 | 60 |
| 6 | 164 | 50 |
| 7 | 140 | 42.8 |
| 8 | 123 | 37.5 |
| 9 | 109 | 33.3 |
| 10 | 98.4 | 30 |
| 20 | 49.2 | 15 |
| 30 | 32.8 | 10 |
| 40 | 24.6 | 7.5 |
| 50 | 19.7 | 6 |
| 60 | 16.4 | 5 |
| 70 | 14.1 | 4.3 |
| 80 | 12.7 | 3.8 |
| 90 | 10.8 | 3.3 |
| 100 | 9.84 | 3 |

* Note: wavelength of radio waves (ft) = $\frac{984}{\text{frequency in MHz}}$

wavelength of radio waves (metres) = $\frac{300}{\text{frequency in MHz}}$

Appendix IV

WAVELENGTH OF SOUND WAVES*

| Frequency Hz | Wavelength | | Frequency KHz | Wavelength | |
|-----------------|------------|--------|------------------|------------|--------|
| | Feet | Metres | | Feet | Metres |
| 10 | 111.7 | 34 | 1 | 1.12 | .34 |
| 20 | 55.9 | 17 | 2 | .56 | .17 |
| 30 | 37.2 | 11.3 | 3 | .37 | .11 |
| 40 | 27.9 | 8.5 | 4 | .28 | .085 |
| 50 | 22.4 | 6.8 | 5 | .22 | .067 |
| 60 | 18.6 | 5.7 | 6 | .19 | .058 |
| 70 | 16.0 | 4.9 | 7 | .16 | .049 |
| 80 | 14.0 | 4.3 | 8 | .14 | .043 |
| 90 | 12.4 | 3.8 | 9 | .12 | .037 |
| 100 | 11.2 | 3.4 | 10 | .112 | .034 |
| 200 | 5.6 | 1.7 | 11 | .102 | .031 |
| 300 | 3.7 | 1.1 | 12 | .093 | .029 |
| 400 | 2.8 | .85 | 13 | .086 | .026 |
| 500 | 2.5 | .68 | 14 | .080 | .024 |
| 600 | 1.93 | .57 | 15 | .074 | .023 |
| 700 | 1.6 | .49 | 16 | .070 | .021 |
| 800 | 1.4 | .43 | 17 | .066 | .020 |
| 900 | 1.24 | .38 | 18 | .062 | .019 |
| 1000 | 1.12 | .34 | 19 | .059 | .018 |
| | | | 20 | .056 | .017 |

* Note: Wavelength of sound waves (ft) = $\frac{1117}{\text{frequency (Hz)}}$

Wavelength of sound waves (metres) = $\frac{340}{\text{frequency (Hz)}}$

Appendix V

CUT-OFF FREQUENCIES

| <i>Cut-off Frequency (Hz)</i> | <i>Length of Room feet</i> | <i>Diagonal* metres</i> |
|-----------------------------------|--------------------------------|-----------------------------|
| 60 | 9.25 | 2.83 |
| 50 | 11.2 | 3.4 |
| 45 | 12.4 | 3.78 |
| 40 | 14.0 | 4.25 |
| 35 | 15.9 | 4.85 |
| 30 | 18.5 | 5.66 |
| 25 | 22.4 | 6.8 |
| 20 | 28.0 | 8.5 |

* Length of room/ = $\sqrt{L^2 + W^2 + H^2}$

where L = length of room

W = width of room

H = height of room

Example: find the cut-off frequency for a room size 11 ft long by 10 ft wide by 8 ft high.

$$\begin{aligned}\text{Length of Room Diagonal} &= \sqrt{(11 \times 11) + (10 \times 10) + (8 \times 8)} \\ &= \sqrt{285} \\ &= 16.9 \text{ ft}\end{aligned}$$

Therefore cut-off frequency will be between 30 Hz (18.5 ft) and 35 Hz (15.9 ft)—say about 33 Hz.

Appendix VI

PLUG AND SOCKET CONNECTIONS

THE majority of hi-fi equipment now uses DIN sockets to which connection is made by matching DIN plugs (see Fig. 27). Connections to DIN plugs are not standardized, but the following is the usual method adopted by most manufacturers.

Radio and Radiograms

- pin 1 Left output to tape recorder
- 4 Right output to tape recorder
- 2 Screen
- 5 Right Playback from tape recorder
- 3 Left Playback from tape recorder

Tuner

- pin 1 *Right input
 - 4 blank
 - 2 screen
 - 5 *Right input
 - 3 Left input
- * usually commoned connection

Pick-up Cartridge

- pin 1 blank
- 4 blank
- 2 screen
- 5 Right input
- 3 Left input

Microphone

- pin 1 Left input
- 4 Right input
- 2 screen
- 5 blank
- 3 blank

SET UP YOUR OWN HI-FI

Headphones

pin 1 *screen
4 Left input
2 *screen
5 Right input
3 *screen

* usually interconnected

Note: Stereo headphones may also be connected via a jack plug when the following connections are usual:

plug tip — Right channel
ring — Left channel
shank — screen

Tape Recorders

Diode—as Radio (above)

Radio Input—pin 1 blank
4 blank
2 screen
5 Right input
3 Left input

Outputs—pin 1 Right channel
4 blank
2 screen
5 blank
3 Left channel

Universal Socket (where fitted) may be used for connection of a pick-up, tape recorder or tuner. The usual connections are:

pin 1 Left input. High sensitivity
4 Right input. High sensitivity
2 screen
5 Right input. Low sensitivity
3 Left input. Low sensitivity

INDEX

- Absorption coefficient, 85
- Active filters, 48
- Active tone controls, 48, 50
- Aerial lengths, 38, 39
- Alignment, 114
- Amplifier, 33, 34
 - circuits, 95 *et seq*
 - designs, 100 *et seq*
 - functions, 35
 - modes of operation, 99
 - power requirements, 35
 - requirements, 28
 - selection, 35
- Amplitude, 21
 - limiter, 91
- Anechoic room, 85
- Antiphase switching, 93
- Audio frequency (AF), 31
 - spectrum, 15
- Audible sound range, 13
- Auto-changers, 56
- Automatic protection, 98

- Background noise, 19
- Baffles, 80
- Balance adjustment, 113
 - control circuit, 51
 - controls, 49
- Bandpass filters, 90
- Bass cut, 46
- Bass speaker, 77
- BBC Test-tone transmissions, 113
- BBC VHF radio transmissions, 115
- Bias, 62
- Blocking, 62
- Breakthrough, 19
- Buffer amplifiers, 101

- Capacitor microphones, 108
- Carbon microphone, 108
- Cartridge deck, 31
 - system, 9
 - tape, 66
- Cartridges, 8, 65
- Cassette assembly, 67
 - care, 68
 - cartridge, 66
 - deck, 31
 - jamming, 69
 - protection, 68
 - tapes, 60
- Cassettes, 8
- Centre zero meter, 51
- Ceramic cartridges, 54
- Checking speaker polarity, 84
- Chirping, 26
- Chromium dioxide, 8, 61
- CLA average, 21
- Class A amplifiers, 36
 - AB amplifiers, 36, 97, 99
 - B amplifiers, 36, 97, 99
 - D amplifiers, 99
- Cleaning tapes, 63
- Close-up working, 111
- Coloration, 111
- Compact cassette tape playing times, 70
 - cassettes, 8, 66
- Compatible tips, 53
- Component noise, 45
- Condenser microphones, 108
- Crossover distortion, 36
 - frequencies, 77
 - network, 77
- Crosstalk, 93, 110
 - adjustment, 114
- Crystal cartridges, 54
 - filters, 90
- Cupping, 62
- Current-limiting, 98
- Current-tapping, 98
- Cut-off frequency, 86

- Damping, loudspeakers, 81
- Damping resistor, 47
- DC International system, 9
- 'Dead' sound, 85
- Decibel, 15
- Deck, 33
- Decoder, 40
- De-emphasis, 40, 95
- Defluxing, 64
- Degaussing, 64

SET UP YOUR OWN HI-FI

- Demagnetizer, 64
- Detector, 90
 - discriminator circuit, 90
- Diamond stylus, 53
- Digital detector, 92
- DIN amplitude, 21
 - 4 5 500 hi-fi standards, 27
 - specification for hi-fi, 13
 - standard pin and plug connections, 54, 55
 - standard plugs and sockets, 123
- Dipole, 38
- Directional characteristics of speakers, 78, 79
 - sound, 10
 - speakers, 79
- Distortion, 18, 36, 75
- DNL, 23
- Dolby A, 26
 - B, 26
 - system, 24
 - system decks, 25
- Dolbyized recordings, 25
- Doppler distortion, 76
- Double play tapes, 60
- Drop-outs, 62
- Dynamic microphones, 108
 - noise limiter, 23
 - range, 16
- Earth-loop, 43, 44
- Echo, 85
- Eight-track stereo, 65
- Electromagnetic cartridges, 54
- Electronic noise, 19
- Electrostatic microphones, 108
 - speaker, 82
- Enclosures, Loudspeakers, 80
- Equal loudness curves, 17
 - curves, 23
- Erase ratio, 16
- Erasure, 61, 63
- Ferric oxide, 8
- Field effect transistors, 90
- Filters, 46, 47, 77
- Flutter, 19
- FM, 7
 - bands, 39
 - radio, 42
 - tuner, 87
 - tuner requirements, 88
- 'Free field', 80
- Frequency, 13
 - range of human voice, 14
 - range of typical instruments, 14
 - response, 13, 35, 105
- Garrard, 9
- Gramophone groove, 52
 - master record, 52
 - record, 7
 - record player, 31
 - record speeds, 52
- Groove geometry, 52
- modulation, 52
- Grundig, 9
- Harmonic distortion, 20
- Headphone connections, 124
- Headphones, 12
- Hi-fi, defined, 13
 - DIN specification, 13
 - equipment, 31, 42
 - frequency response, 15
 - radio reception, 26
- High-pass filter, 77
- High-quality speakers, 82
- Hiss, 19, 61
- 'Hole in the middle', 86
- IF stages, 90
- Incorrect tracking, 56
- Input gating, 87
- Integrated circuit (IC), 92
- Interaction, 76
- Intermodular distortion, 75
- Ionophone, 83
- Jewel tips, 53
- Lear-Jet, 9
- Local oscillator, 87
 - radio stations, 117 *et seq*
- Long play tapes, 60
- Loudspeaker cabinet design, 81
 - damping, 81
 - impedance, 72
 - matching, 72
 - power rating, 72
 - requirements, 29
- Loudspeakers, 72
 - performance factors, 75
- Low cost speakers, 82
- Magnetic wire recorders, 7
- Main and extension speaker connections, 73, 74
- Mains hum, 19, 43
- Microgroove, 52
- Microphone amplifiers, 109
 - connections, 123
 - impedance, 110
 - matching, 110
 - technique, 111
 - types and characteristics, 112

INDEX

- Microphones, 108
 - close up, 111
- Mixer, 87, 110
- Mono recordings, 54
- Moving coil loudspeaker, 76
 - coil microphones, 108
- Multi-band radios, 39
- Multi-plexed, 40
- Musicassettes, 68

- Natural sound, 85
- New record faults, 57
- Non-linearity, 75

- Offset angle, 55
- Optimum stylus tip, 53
- Orchestral music, 13
- Output amplifiers, 96
 - load impedance, 73
 - stage, 96, 97, 98, 99
- Overtones, 14

- 'Passive' filters, 48
- Performance factors for loudspeakers, 75
- Permalloy, 63
- Permite, 63
- Philips compact cassette, 8
- Philips DNL system, 26
- Pick-up arm, 55
- Pick-up cartridge connections, 123
- Pick-up cartridges, 54
- Pick-up connections, 54
- Pick-up requirements, 54
- Pick-up stylus, 52
- Piezoelectric cartridges, 54
 - microphones, 108
- Pilot tone, 40, 93
- Pi-mode, 99
- Pitch control, 22
- Plastic tapes, 7
- Playing times for tapes, 60
- Plug and socket connections, 123
- Polar diagram, 79
- Polyester tapes, 8
- Ported reflex enclosures, 81
 - systems, 81
- Pre-amplifier requirements, 105
- Pre-amplifiers, 104
- Pre-recorded cassettes, 68
- Pressure pads, 63
- Print-through, 62
- Protective circuits, 98
- Pulse counting circuit, 92
 - signals, 92
- Push-pull amplifiers, 96
- PVC tapes, 8

- Quad sound, 11, 32, 33
- Quadrophonic system elements, 33
- Quadruple play tapes, 60

- Radio and radiogram connections, 123
- Radio 4, 115
- Radio frequency wavelengths, 120
- Radio 3, 115
- Radio tuner, 104
- Radio 2, 115
- Ratio detector, 91
- R C filter, 101
 - network, 47, 48
- Record care, 57
 - cleaning, 57
 - faults, 56, 57
 - player/amplifier requirements, 29
 - player requirements, 27
 - speeds, 22
 - storage, 58
- Reel-to-reel machines, 64
- Reel-to-reel systems, 8, 9
- Reel-to-reel tape deck, 31
- Reference level, 18
 - levels, 16
 - standards, 20
- Reflex enclosures, 81
- Relative loudness, 15
- Requirements for integrated systems, 29
- Resonant frequency, speakers, 80
- Reverberation time, 85
- RF amplifier, 87
 - transistors, 88
- Ribbon microphones, 108
 - recorders, 7
 - speaker, 83
- RMS, 20
- Roll-off, 47
- Room acoustics, 85
 - echo, 85
 - resonance, 86
 - size, 86
- Ruby stylus, 53
- Rumble, 19, 42
 - filters, 45

- Sapphire stylus, 53
- Scratch filter, 47
- Screening, 43
- Sealed enclosures, 81
- Separation, 93
- Shellac disc, 7
- Signal-to-noise, 109
- Signal-to-noise ratio, 16, 36, 61, 105, 110
- Silicon planar transistors, 88

SET UP YOUR OWN HI-FI

- Sound absorption, 85
 - contours, 17
 - pressure level, 16
 - waves, wavelengths, 121
 - reflection, 85
- Speaker connections, 83, 84
 - enclosures, 80
 - location, 84, 85
 - positioning, 80
 - qualities, 82
 - resonant frequency, 80
 - volume controls, 84
- Speech coil, 75
- Spillover, 69
- Squawker, 77, 81
- Squelch, 87
- Standard play tapes, 60
 - quality speakers, 82
 - tapes, 61
- Step-down transformer, 110
- Step-up transformer, 110
- Stereo, 9
 - amplifiers, 36
 - broadcasts, 115 *et seq*
 - decoders, 92
 - FM tuners, 40
 - headphones, 12
 - microphones, 111
 - reception, 40, 41
 - recording, 10, 54
 - speaker polarity, 84
 - speaker positioning, 85
 - systems, 44
 - system speakers, 83
- Stereophonic system elements, 32
- Stylus tip, 52
 - types, 52, 53
- Swing, 58
- Switch-in frequencies, 47
- Synchronous motor, 64
 - speeds, 20
- Tape cleaning, 64
 - heads, 63
 - lengths for correct speed, 7
 - playing times, 70
 - recorder/amplifier requirements, 29
 - recorder connections, 124
 - recorder requirements, 28
 - recorder speeds, 64
 - recorders, 7
 - sizes, 60
 - speeds, 61
 - stretch, 62
 - tracks, 65
 - widths, 60
- Tapes, 60
- Tapes, playing time, 60
- Telefunken, 9
- Threshold of hearing, 15
- Tone control circuit, 50
 - controls, 47
- Tracing distortion, 52
- Tracking error, 55
- Transcription deck, 56
 - turntable, 56
- Treble speaker, 77
- Triple play tapes, 60
- Tuned circuit, 87
- Tuner connections, 123
 - design, 87
- Tuners, 38
- Turntable, 56
- Tweeter, 77, 81, 86
- Twisted tape, 69
- Universal pre-amplifier, 105, 106, 107
- VHF, 7
 - aerials, 38
 - Tuner/amplifier requirements, 30
 - Tuner requirements, 27
- Virtual earth, 110
- Volume controls, speakers, 84
 - level, 20
- VU, 20
- Warped records, 58
- Wavelength of sound waves, 121
- Weighting, 17
 - curves, 18
- Woofers, 77, 86
- Wow, 19, 63
- Zobel network, 97

Other books by R.H. Warring

MAKING TRANSISTOR RADIOS: A BEGINNER'S GUIDE

This book covers just about every type of transistor radio receiver which the amateur can tackle, and develops these from the basic crystal set to the advanced superhet model. Each stage has been carefully illustrated with the author's own line drawings.

BEGINNER'S GUIDE TO RADIO CONTROL

Ideal for the model builder who wishes to understand the elements of radio control operation; how to install it, how to make the most practical use of it, and how it works. The book has been extensively revised to take into account the latest multi-channel proportional equipment for use in model ships and aircraft.

HAM RADIO: A BEGINNER'S GUIDE

An introduction for the enthusiast, covering the whole field of equipment, maintenance, receiving, transmission, the 'language of the air' and licensing arrangements.

BEGINNER'S WORKSHOP MANUAL

Detailed advice on how to set up an efficient workshop. Power tools and their attachments are discussed and the author surveys wood-working in detail and includes hints on making joints, finishing techniques, wood carving and turning. Other important chapters cover working with plastics and metals.

BEGINNER'S GUIDE TO PRACTICAL ELECTRONICS

R. H. Warring introduces the reader to meanings of the technical terms and symbols used in electronics and gives an easy-to-follow survey of basic circuitry. Among the projects covered are automatic flashing lights, burglar alarms, sun-powered radios, electronic organs, amplifiers, hearing aids, oscillators and radio control transmitters.

LUTTERWORTH PRESS