

JOURNAL OF THE American Institute of Electrical Engineers



PUBLISHED BY THE INSTITUTE
33 WEST 39TH ST • NEW YORK CITY

American Institute of Electrical Engineers

COMING MEETINGS

Pacific Coast Convention, Del Monte, Calif., October 2-5

Midwinter Convention, Philadelphia, Pa., February 4-8

MEETINGS OF OTHER SOCIETIES

American Electric Railway Association, Atlantic City, N. J., October 8-13

Association of Electragists International, Washington, D. C., October 8-13

Society of Naval Architects and Marine Engineers, New York, N. Y., November 8-9

Telephone Pioneers of America, Atlantic City, N. J., October 19-20

JOURNAL

OF THE

American Institute of Electrical Engineers

PUBLISHED MONTHLY BY THE AMERICAN INSTITUTE OF ELECTRICAL ENGINEERS
33 West 39th Street, New York

Subscription. \$10.00 per year to United States, Mexico, Cuba, Porto Rico, Hawaii and the Philippines; \$10.50 to Canada and \$11.00 to all other Countries. Single copies \$1.00.

Entered as matter of the second class at the Post Office, New York, N. Y., May 10, 1905, under the Act of Congress, March 3, 1879. Acceptance for mailing at special rate of postage provided for in Section 1103, Act of October 3, 1917, authorized on August 3, 1918. Printed in U. S. A.

Vol. XLII

OCTOBER, 1923

Number 10

TABLE OF CONTENTS

Papers, Discussions, Reports, Etc.

The Axially Controlled Magnetron, by Albert W. Hull.....	1013	General Considerations in Grounding the Neutral of Power Systems (Dewey); The Neutral Grounding Reactor (Lewis); Operating Performance of a Petersen Earth Coil (Oliver and Eberhardt); Present Day Practice in Grounding Transmission Systems (Committee Report); Systems Transmitting at Generated Voltage (Woodruff) and Systems Transmitting at Higher than Generated Voltage (Stone).....	1082
Hongkong Heat Makes Fans Sell Well.....	1018	Selective Relay System of the 66,000-Volt Ring of the Duquesne Light Company (Sleeper); Ground Selector for Ungrounded Three-Phase Distribution Systems (Ackerman); The Distance Relay for Automatically Sectionalizing Electrical Networks (Crichton).....	1087
Pellet Type of Oxide Film Lightning Arrester, by N. A. Lougee.....	1019	Mechanical Computation of Root Mean Square Values, by L. A. Umansky.....	1093
A Simplified Method of Analyzing Short-Circuit Problems, by R. E. Doherty.....	1021	Japanese-American Radio Circuit, by C. W. Latimer.....	1095
Much Water-Fuel in New Zealand.....	1028	Big Water Power Project in India.....	1096
Floating Neutral <i>n</i> -Phase Systems, by Leonard A. Doggett.....	1029	The Production of Porcelain for Electrical Insulation-VII, by Frank H. Riddle.....	1097
Specifications for Electrical Instruments.....	1032	Facts about Priest Rapids, by Henry J. Pierce..	1102
A Miniature A-C. Transmission System, by O. R. Schurig.....	1033	Illuminations Items	
Adjustment of Automobile Headlights.....	1040	Illumination-Production Tests in the Industries.....	1104
A Continuous-Current Generator for High Voltage, by S. R. Bergman.....	1041	New Parabolic Lens for Motion Picture Projection.....	1105
Two Photographic Methods of Studying High-Voltage Discharges, by Karl B. McEachron.....	1045	Remote Control of Multiple Street Lighting.....	1106
Telephone Transmission over Long Distances, by H. S. Osborne.....	1051		
Magneto-Mechanical Loads on Bus Supports, by Lloyd N. Robinson.....	1063		
Specifications for Cylindrical Dry Cells.....	1067		
Discussion at Midwinter Convention			
Qualitative Analysis of Transmission Lines (Goodwin).....	1068		
Transient Conditions in Electric Machinery (Lyon).....	1076		
Discussion at Spring Convention			
Frequency Conversion by Third Class Conductor and Mechanism of the Arcing Ground and other Cumulative Surges (Steinmetz); Voltages Induced by Arcing Ground (Slepian and Peters).....	1078		

Institute and Related Activities

Institute's Publication Policy Amended.....	1107	Engineering Societies Library	
Future A. I. E. E. Meetings.....	1107	Book Notices.....	1109
Report of Publication Committee.....	1107	Past Section Meetings.....	1110
Future Section Meeting.....	1108	Personal Mention.....	1110
Dinner in Honor of L. A. Ferguson.....	1108	Addresses Wanted.....	1111
Meeting of Institute of Radio Engineers.....	1108	Employment Service	
Power Exposition Grows in Scope.....	1108	Men Available.....	1112
Third Annual Convention of West Virginia-Kentucky Association of Mine, Mechanical and Electrical Engineers.....	1109	Membership.....	1113
American Engineering Council		Officers, A. I. E. E.....	1113
Power Conference Pushed by U. S.....	1109	Local Honorary Secretaries.....	1115
Executive Board of F. A. E. S. to Meet in Rochester.....	1109	A. I. E. E. Committees.....	1115
		Digest of Current Industrial News.....	1116

Copyright 1923. By A. I. E. E.

Permission is given to reprint any article after its date of publication, provided proper credit is given.

Current Electrical Articles Published by Other Societies

Association of Iron and Steel Electrical Engineers, September

Motor Operated Centrifugal Pumps in Steel Plants, by B. A. Cornwell

Electrical Transportation, by F. O. Schnure

Standardization of Engine Stops, by Walter Greenwood

The Complete Electrification of the Foundry Industry, by Leonard W. Egan

Ore Bridge Control, by P. R. Canney

Single Bucket Blast Furnace Skip Hoist Characteristics, by A. C. Cummins
and A. R. Leavitt

Electrical Development Committee Report for 1923, by Walter C. Kennedy

Systematizing the Work of an Electrical Engineering Division, by P. T.
Vanderwaart

Electric Furnace Phenomena, by Edward T. Moore

Transactions of the Illuminating Engineering Society, September

Lighting the Silk Industry with Incandescent Lamps, by H. W. Desaix

The Axially Controlled Magnetron

A New Type of Magnetron, Controlled by Current Through the Filament

BY ALBERT W. HULL

General Electric Company

Review of the Subject.—In vacuum tubes with straight filaments of large diameter, it is found that the magnetic field of the heating current exercises a restraining effect on the escape of electrons, equivalent to the action of the grid in the plotron, or the impressed magnetic field in the magnetron. This new valve principle may be utilized to control the output of the tube for practical purposes, such as changing high-voltage direct current into alternating

current; and leads to a very simple and efficient type of tube.

CONTENTS.

Review of the Subject. (85 w.)
 Introduction. (120 w.)
 Theory. (450 w.)
 Table I.—Critical Voltages for Tungsten Filaments at 2500° K. (225 w.)
 Experimental Tests. (1650 w.)
 Applications. (750 w.)

INTRODUCTION

IN a former number of this journal¹ a simple two-electrode tube was described in which the electron current between a straight cathode and a concentric cylindrical anode can be controlled by a magnetic field parallel to the axis of the tube. Such tubes are very easy to construct in comparison with three-electrode tubes; but the advantage so gained is partly offset by the requirement of an externally wound magnetic field coil.

The purpose of this paper is to show that in the case of large magnetrons such as are of interest for engineering applications, the magnetic field of the heating current which flows through the filament is sufficient for controlling the electron flow, so that the external magnetic field coil is unnecessary.

THEORY

Fig. 1 show a typical magnetron, consisting of a straight filament in the axis of a concentric cylindrical anode. The lines of magnetic force produced by the heating current are circles about the filament. Electrons passing from cathode to anode across these lines of force are deflected at right angles to the lines, as illustrated in Fig. 1B. The deflection is greater the larger the filament current, and with a sufficiently large filament current the electrons miss the anode entirely and return to the cathode (Fig. 1C).

Calculation shows that, with a given potential difference, E , between cathode and anode, the electrons should all reach the anode or fail to reach it, according as the current I through the cathode is greater or less than a critical value, given by the equation

$$E = 0.01882 I^2 \left(\log_{10} \frac{D}{d} \right)^2 \quad (1)$$

D, d = diameters of anode and cathode respectively.

I = current through cathode in amperes.

E = critical potential difference between anode and cathode, in volts.

The current I in Eq. 2 may be expressed in terms of the diameter of the cathode, for any given temperature.²

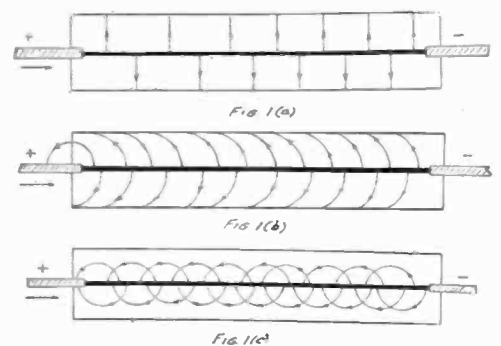
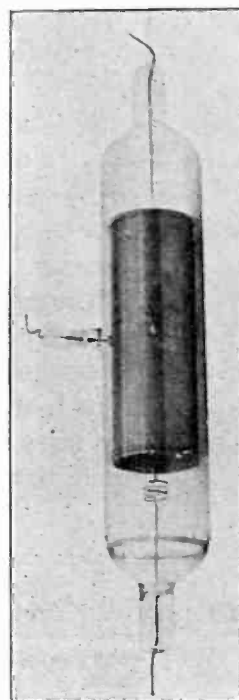

FIG. 1—SMALL MAGNETRON IN GLASS

- (a) Longitudinal cross-section through the filament showing paths of electrons with no filament current.
 (b) The same for weak filament current.
 (c) The same for strong filament current

Thus for tungsten cathodes at 2500 deg. K. Eq. (2) becomes:

$$E = 0.000716 d^3_{mils} \left(\log_{10} \frac{D}{d} \right)^2 \quad \text{(tungsten cathode of dia. } d \text{ at 2500 deg. K. in axis of cyl. of dia. } D)$$

or

$$E = 44100 d^3_{cm} \left(\log_{10} \frac{D}{d} \right)^2 \quad (2)$$

For the general case of a tungsten cathode at any temperature near 2500 degrees absolute, the critical

2. Characteristics of tungsten filaments, Langmuir, *Phys. Rev.*, 7, 302-30, 1916; *G. E. Rev.*, Mar., 1916.

1. JOURNAL of the A. I. E. E., Sept. 1921, pp. 715-23; also *Phys. Rev.*, 18, 31-57, 1921.

Presented at the Annual Convention of the A. I. E. E., Swampscott, Mass., June 26-29, 1923.

voltage may be expressed with sufficient approximation by the eq.:

$$E_{volts} = 44100 d^3_{cm} \left[\log_{10} \frac{D}{d} \right]^2 \left[1 + 0.00143 (T-2500) \right] \tag{3}$$

Eq. 3 shows that the critical voltage, that is, the voltage below which the magnetic field of the heating current is able to hold back the electrons, increases as the cube of the filament diameter, for the same temperature and relative size of electrodes. For example, in the "peanut" pliotron, UV-199, which has a filament of 0.0006 inches diameter, surrounded by a grid of approximately 0.06 in. diameter, operating at 1900 deg. K., the critical voltage is 0.0003 volts. For a 0.0085 in. filament, such as is used in the 50 watt pliotron UV-203A, the critical voltage (assuming the same ratio of

anode to cathode diameter) is $\left(\frac{85}{6}\right)^3$ or 2800 times

as great, viz. 0.84 volts³. Increasing the filament diameter to 0.085 inches would again increase the critical voltage 1000 fold, to 840 volts. Another ten fold increase of cathode diameter, with the same ratio of anode to cathode diameter (100 to 1), is impractical because of the size of the anode; but taking a ten to one ratio of anode to cathode diameter, a 0.85 inch diameter filament operating at 2500 deg. K. would have a critical voltage of 440,000.

The critical voltage increases less rapidly than the cube of the cathode diameter when the anode diameter is kept constant, instead of the ratio of anode to cathode diameter. A few examples, tabulated in Table I, will give an idea of the cut-off voltages for different sizes of filament heated by direct current, in a two-inch diameter anode.

TABLE I
CRITICAL VOLTAGES FOR TUNGSTEN FILAMENTS AT 2500° K

Diameter of Anode cm.	Diameter of Filament cm.	Critical Voltage volts
5.00	0.0025	0.0075
5.00	0.025	3.6
5.00	0.100	127.
5.00	0.250	1140.
5.00	1.00	21,600.
5.00	2.50	62,300.

It is seen that for all cathodes used in standard tubes at the present time, the effect of the magnetic field of the heating current is entirely negligible. For large cathodes, on the other hand, such as are needed for power tubes, the magnetic field of the heating current is able, even at the highest voltages used in engineering, to inhibit entirely the electron current between cathode and anode; *i. e.*, to give the tube infinite resistance. It

3. Both of these values of critical voltage are meaningless, as they are scarcely larger than the average initial velocity of the electrons, and much smaller than the voltage drop in the filament.

is thus a factor that must be considered in the construction and operation of large tubes, both as a possible limitation and as a means of useful control, performing the function of the grid of the pliotron. Experimental tests of this method of controlling electron current, and possible applications of it, are described in the following pages.

EXPERIMENTAL TESTS

According to the theory outlined above, the electron current from a straight filament to a concentric cylindrical anode should be zero for all voltages below the critical value, given by Eq. 1; while for all voltages above this critical value the magnetic field should have no effect, *i. e.*, the electron current should be limited only by the temperature of the filament or the mutual

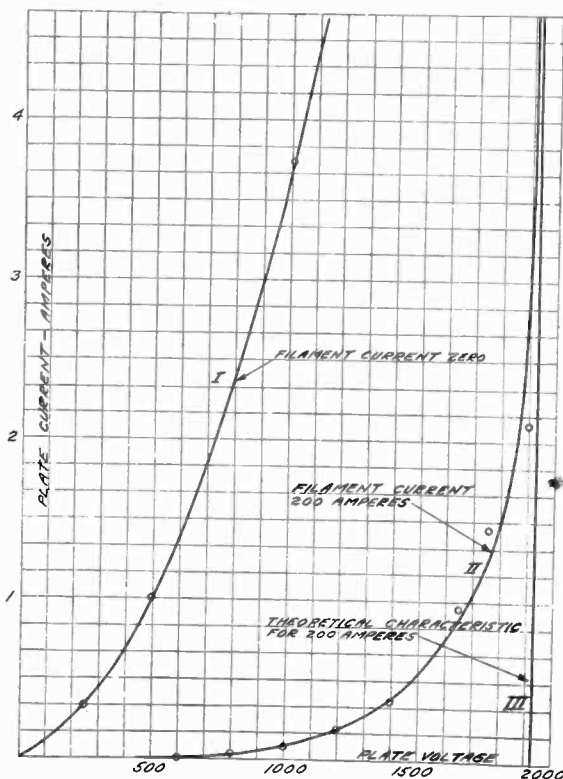

FIG. 2—VOLT-AMPERE CHARACTERISTIC OF TUBE SHOWN IN FIG. 1

Filament diameter 100 mils, anode diameter 4 in.

repulsion of the electrons in the space (space charge limitation.)

Fig. 2 shows the currents observed, as a function of voltage, in a tube containing a 100 mil (0.25 cm.) diam. filament in the axis of a cylindrical anode 4 inches (10 cm.) in diam. by 12 inches long. Curve 1 shows the ordinary space-charge characteristic observed in the absence of magnetostriction. These values were obtained by opening the filament switch, and observing the plate current before the filament had time to cool. Immediately upon opening the filament switch the plate current rises to the value set by space-charge, remains constant for an instant, then falls rapidly as the filament cools to the point of temperature limitation. Curve 2 shows the currents observed when the heating current of 200 amperes was flowing through the fila-

ment. The characteristic predicted by theory is represented by the vertical straight line at 1930 volts (Curve 3).

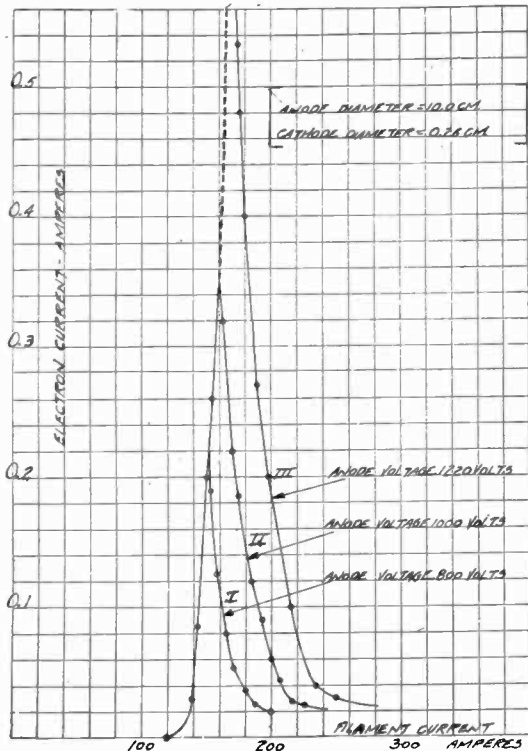

FIG. 3—VARIATION OF PLATE CURRENT WITH FILAMENT CURRENT AT CONSTANT ANODE VOLTAGE

It is seen that the magnetic field of the filament current has a profound effect on the characteristic, reducing the plate current to essentially zero at all plate voltages

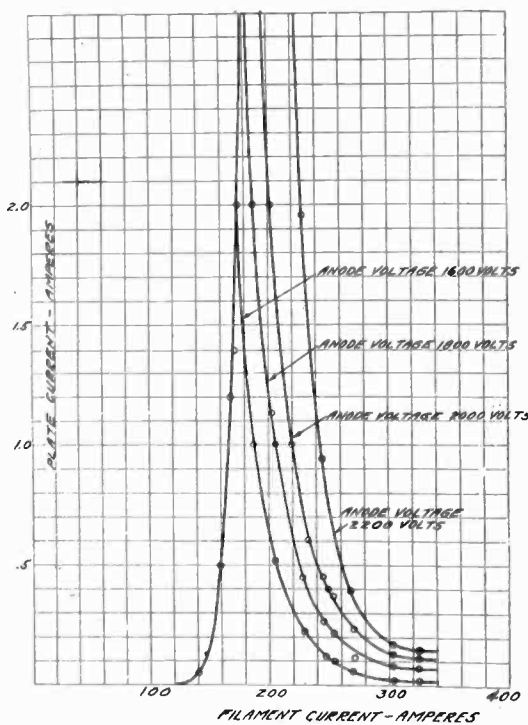

FIG. 4—VARIATION OF PLATE CURRENT WITH FILAMENT CURRENT AT CONSTANT ANODE VOLTAGE Higher Voltage than in Fig 3.

ness of the filament, which was bowed about an inch out of center at its middle point; and partly by deflection of a small fraction of the electrons by collision with gas molecules. All the characteristics obtained show slight transition currents of this kind, but their magnitude is always small compared with the current under control.

Fig. 3 shows the variation of plate current with filament current at constant anode voltage for the same tube (filament 100 mils diameter, anode 4 inches diameter by twelve inches long. Curve 1 was taken with 800 volts on the anode, curve 2 with 1000 volts, and curve 3 with 1220 volts. The left hand, ascending branch is the same for all voltages, and depends only

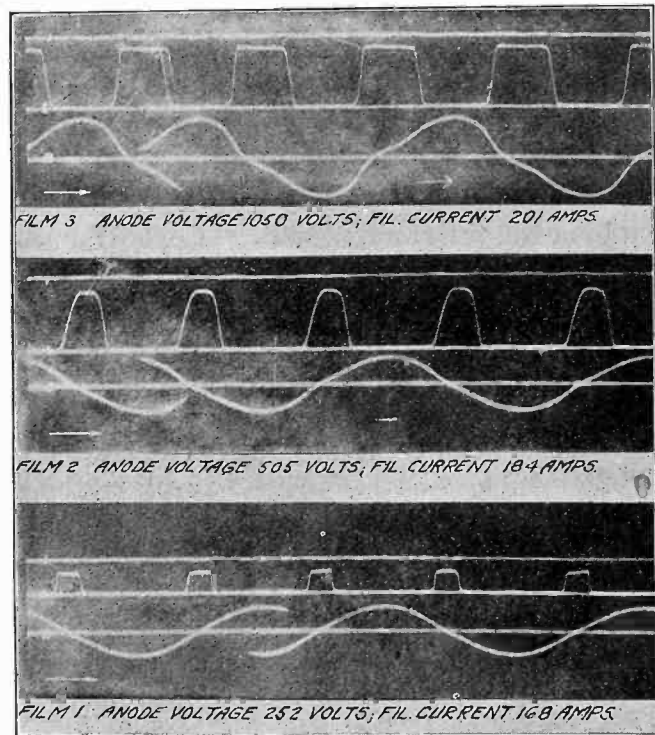

FIG. 5—THREE FILMS SHOWING THE CONTROL OF PLATE CURRENT BY 60-CYCLE FILAMENT CURRENT IN A SMALL MAGNETRON, WITH CONSTANT ANODE VOLTAGES OF 250, 505, AND 1050 VOLTS DIRECT CURRENT

Record A — Plate current of rectangular form with the zero value at A. Record A to 1 — Deflection, for calibration, given by a plate current of 1.4 amp. in film 1; 4.0 amp. film 2; and 6 amp. film 3.

Record B — 60-cycle filament current.

Note that the plate current flows only when the filament current is below a definite value.

on the temperature. It represents the temperature-limited saturation emission from the filament, and is given accurately by the equation.⁴

$$i = 60.2 T e^2 - \frac{52600}{T} \frac{\text{amperes}}{\text{cm}^2}$$

The right hand descending branches are due to magnetostriction. It is seen that for each constant anode voltage the electron current begins at a definite heating current (minimum temperature for emission) and increases rapidly with heating current up to a

4. Dushman, *G. E. Review*, 16, 153-60, Mar. 1923 and *Phys. Rev.*, Apr. 1923.

below about 1400 volts. The fact that the transition from zero current to full space charge current is not abrupt, may be partly accounted for by the crooked-

critical point. This critical point is the "critical filament current" given by Eq. 1. When the heating current is raised above this critical value, the electron emission falls rapidly to essentially zero because of the magnetic effect of the heating current.

Fig. 4 shows a similar series of characteristics with higher plate voltages and larger currents. At the highest filament current, 325 amperes, the filament is at 3300 deg. K., and is capable of emitting approximately 2000 amperes of electrons. The actual emission at 1600 volts is only 20 milliamperes.

Fig. 5 shows an oscillographic record of the plate current in the same tube when 60-cycle alternating current is used to heat the filament. In this case the filament temperature remains constant while the instantaneous value of the heating current changes, so that the full space-charge current flows during that part of each cycle in which the heating current is below the critical value, and no current during the part when the field is above the critical value.

The lower film (film 1) was taken with a constant potential of 250 volts on the anode. During the greater part of each cycle the filament current is above the critical value for 250 volts, and the plate current is zero, as it should be. When the filament current falls to the value 73 amperes, plate current begins and increases rapidly to the maximum value allowed by space charge. As soon as the filament current again reaches the same value of 73 amperes in the opposite direction, the plate current begins to fall, and drops rapidly to zero. The

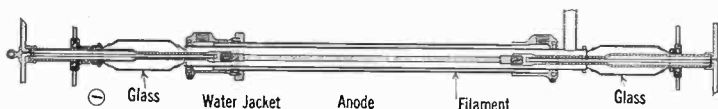

FIG. 6—CONSTRUCTION OF HIGH-POWER MAGNETRON

plate current is thus interrupted twice each cycle, since both directions of filament current are alike in their magnetostrictive effect.

The second film was taken with 505 volts on the plate. The space current is larger and flows for a longer part of each cycle, beginning and ending when the filament current reaches the value 101 amperes. The critical value given by Eq. 2 is 102 amperes. The filament current in this test (184 amperes) was larger than that used for the first film, and the curve shows a slight distortion due to saturation in the filament transformer.

For the upper film (film III.) a plate voltage of 1050 was used, and a larger filament current (201 amperes). The filament current curve shows bad saturation distortion, so that the distance from the point where it crosses the axis to the point where it reaches its critical value is very different above and below the axis. In spite of this, the plate current begins and ends accurately at the critical filament current of 157 amperes, which agrees with the theoretical value of 149 amperes within the error of measurement.

The observed plate currents in each of these oscillographic tests are about 3 times as large as the value to be expected from the space charge law. The increase is due to reduction of space charge by gas ionization. It is notable that an amount of ionization sufficient to neutralize space charge to this extent does not noticeably affect the magnetic cut-off, showing that the magnetron is slightly less susceptible than the plotron to the presence of gas.

3. A series of tests with much larger filaments has been carried out by Mr. J. H. Payne. Exact measurements are more difficult in this case, because of the inability of ordinary generating systems to deliver

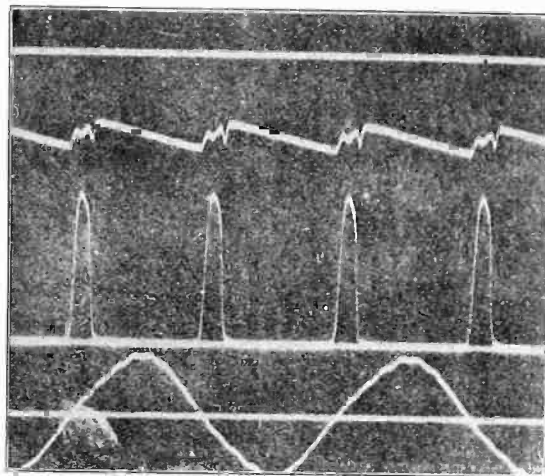

FIG. 7—CONTROL OF PLATE CURRENT BY 60-CYCLE FILAMENT CURRENT IN A HIGH-POWER MAGNETRON. FILAMENT DIA. = 1 CM. ANODE DIA. = 4.6 CM.

Record A — Voltage between filament and anode (deflection downward)
Record B — Current from filament to concentric anode.

Record C — 60-cycle current in the filament.

Note that the current between filament and anode is zero except when the filament current is below a critical value.

intermittently the large amounts of power required, and the difficulty of getting rid of this power when delivered. For low voltages, up to 2000 volts, the tests are very satisfactory (oscillograms, Figs. 7 and 8). Electron currents up to 50 amperes are seen to be under perfect control by the magnetic field of the filament current; and the critical values of voltage and filament current agree well with those predicted by theory. At higher voltages only the low-current portion of the curves could be obtained with the generating system available (30 kv., 20 kv-a. transformer, with kenotron rectifiers and condensers). These oscillograms (Fig. 9) show suppression of the plate current when the magnetic field of the filament current is above the critical value, but give no idea of the magnitude of the plate current that would normally flow when the magnetic field is below the critical value.

The tube used for these tests is shown in Fig. 6. The anode is a copper tube $1 \frac{13}{16}$ inches (4.60 cm.) in diameter by 30 in. (76 cm.) long, surrounded by a water jacket. The cathode is a tungsten rod 0.400 inches (1 cm.) in diameter, 22 inches (56 cm.) long. Upon each end of the cathode is tightly swaged a short bar of

molybdenum, which is threaded so that it can be screwed into the copper lead. A short section of glass at each end insulates the filament from the anode.

The results of these tests are shown in Figs. 7, 8 and 9. Fig. 7 shows a test at 1700 volts anode potential. This potential was furnished by a 20-kw., 3000-volt d-c. generator, with 50 μ f. across its terminals to stabilize the voltage during the sudden starting and stopping of

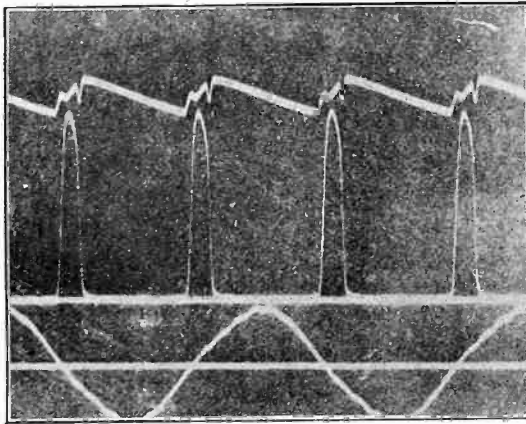

FIG. 8—SAME CONDITION AS FIG. 7 EXCEPT THE VOLTAGE AND CURRENT BETWEEN FILAMENT AND ANODE ARE LARGER

the current. In spite of this, the voltage dropped 25 per cent during each current pulse, and then rose gradually during the remainder of the cycle, as shown in curve A. Curve B shows the electron current that flowed from cathode to anode and thence in the plate circuit. It is seen that this current is completely suppressed except during the short fraction of each

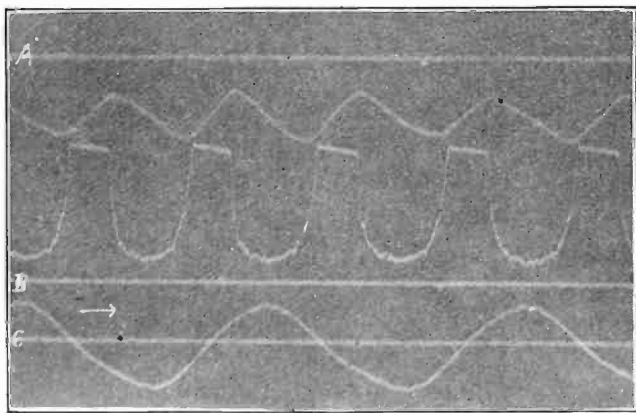

FIG. 9—CONTROL OF PLATE CURRENT BY 60-CYCLE FILAMENT CURRENT IN HIGH-POWER MAGNETRON. FILAMENT DIA. = 0.87 CM., ANODE DIA. = 7.5 CM.

Record A — Plate voltage (deflection downward).
Record B — Plate current (deflection upward).
Record C — 60-cycle filament current.

cycle when the filament current is below a critical value. During these short periods, twice each cycle, it rises to 36 amperes, and then falls abruptly to zero as the filament current again reaches the critical value. The filament voltage, which is nearly in phase with the filament current, is shown in curve C.

Fig. 8 shows a similar test at 2100 volts. The anode current in this case rises to 45 amperes.

Fig. 9 shows a test at 8000 volts. The electron current (curve B) is limited by filament temperature to 1.7 amperes, and even with this small current the anode voltage (curve A) falls from 8000 to 3000 volts during the short fraction of each cycle when power is being drawn. The small residual current of $\frac{1}{4}$ ampere, due to gas and end leakage, shows prominently on the large scale of the oscillogram. It is entirely negligible however, compared with the normal useful current of 50 amperes which the tube can control. In this test the cathode was smaller, viz., 0.350 inches diameter, and the anode 3 inches diameter.

Preparations are being made for tests at higher voltage with larger amounts of power. A few tests already made at 20,000 and 30,000 volts, show that the magnetic control is effective at these voltages, but the currents available were too small for satisfactory oscillograms.

APPLICATIONS

The magnetron, like all high vacuum thermionic tubes, is a high resistance device, so that its use is limited to either small power or high voltage. The type of magnetron here described suffers the further re-

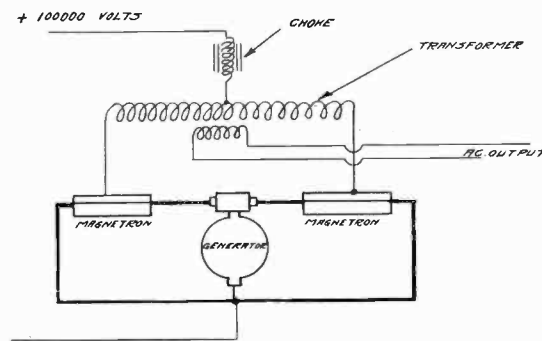

FIG. 10—CIRCUIT FOR CONVERSION OF DIRECT-CURRENT TO SINGLE-PHASE ALTERNATING CURRENT BY MEANS OF MAGNETRONS

striction that it is operable only with large diameter filaments, and hence is adapted only to high power applications. For these applications, however, it appears to be the simplest and most efficient tube that has yet been studied.

A single example will serve to illustrate the method of operation and the efficiency to be expected. The problem chosen is the conversion of high-voltage direct current into alternating current. Let the direct-current voltage be 100,000 and the alternating-current voltage anything that is desired. A tube is chosen similar to that shown in Fig. 5, having a cathode of 2.0 cm. (0.79 in.) in diameter by 1 meter long, and an anode 8.0 cm. (3.1 in.) in diameter. A current of 4400 amperes heats the filament to 2500 deg. K., at which temperature its electron emission is 170 amperes; and the magnetic field of this heating current is capable of making the magnetron a non-conductor at 200,000 volts.

For conversion to single-phase alternating current two of these tubes may be connected as shown in Fig. 10. Current passes from the positive d-c. terminals, through

a choke coil, to the middle point of the high-voltage winding of a transformer, whose terminals are connected to the anodes of the two magnetrons. The cathodes are connected to the negative d-c. terminal, and are heated by square-wave current of the frequency of the desired alternating current. This square-wave current may be obtained in a variety of ways. For example, it may be derived from a d-c. generator and commutator, giving the wave form shown in Fig. 11A; or from a quarter-phase alternator of proper design, giving the wave form shown in Fig. 11B; or it may be derived

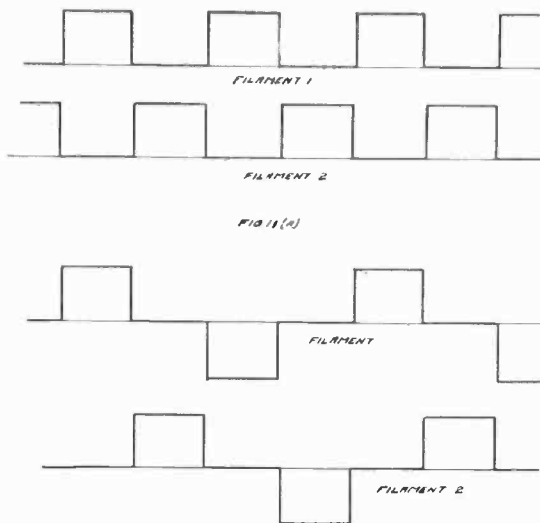

FIG. 11A— WAVE-SHAPE AND PHASE OF FILAMENT CURRENTS WHEN D-C. GENERATOR IS USED

FIG. 11B— WAVE-SHAPE AND PHASE OF FILAMENT CURRENTS WHEN ALTERNATOR IS USED

partly from a d-c. generator and partly, by suitable coupling, from the alternating-current output, provided the output circuit contains a frequency-determining element, or is tied to a system of fixed frequency.

The operation is as follows: Current from the d-c. line flows through the choke and the transformer winding to the magnetron anodes, and then through one of the magnetrons—the one whose filament current is zero—to the negative d-c. terminal. If the load is adjusted for 100 amperes in the d-c. line, a voltage of 3000 volts will be required to carry this current through the tube, the remaining 97,000 volts being supported by the reactive drop in the transformer.

Just before the magnetron that has been carrying current becomes a non-conductor by the establishment of filament current through it, the filament current in the other tube becomes zero and the load is transferred to it. The slight disturbance incident to this transfer is absorbed by the choke coil.

The total power converted by this pair of tubes is 10,000 kw. (100 amperes \times 100,000 volts); and the efficiency, exclusive of transformer losses, is 96 per cent (150 kw. per tube dissipated at anode, 50 kw. in filament). The power used for control is that which heats the filament, and the total amount of power needed for this purpose, in case it is furnished by a separate generator, is 100 kw., or 1 per cent of the output. The calculated life of the filament, which is taken arbitrarily as the time necessary to reduce its diam. by 5 per cent by

evaporation, is 60,000 hours, or approximately 7 years of continuous operation. The life will be shorter than this if there is appreciable disintegration of the filament due to bombardment with gas ions. The amount of this disintegration cannot be predicted from data at present available.

The simple single-phase conversion system just described gives square alternating-current waves. This is an advantage, if the alternating current, after being stepped down to the desired voltage, is to be again rectified and used as direct current. Sine waves of any required degree of purity may be obtained by the use of an appropriate number of these single-phase units, connected according to well known multiphase circuits. A system containing 6 single-phase units (12 tubes) would give an output of 60,000 kw. of fairly good wave-form, with an efficiency of 96 per cent.

It is seen that the power capacity of these tubes is ample for conversion purposes, and their efficiency, so far as can be predicted at present, compares favorably with that of other types of conversion apparatus. Unquestionably many problems remain yet to be solved before high-voltage operation of these tubes is practical; but there is no known obstacle or limitation in sight. It is hoped that actual conversion tests, as well as static characteristics, at high voltages, will soon be available.

I wish to acknowledge the very able assistance of Mr. F. R. Elder and Mr. E. F. Hennelly in carrying out these tests.

HONGKONG HEAT MAKES FANS SELL WELL

Hongkong and vicinity are important markets for electric fans, on account of the long hot summers which make this appliance practically a necessary part of both house and office equipment, says Consul Larcey Webber in a report to the Department of Commerce.

Annual sales in South China are estimated at about 7000 oscillating fans and 1000 ceiling fans, all of which were imported and sold through Hongkong. The United States supplies approximately 70 per cent of the imports, followed by Great Britain with 20 per cent and the balance from Italy, Germany, and other European countries.

Users and retail dealers generally make their purchases from the Hongkong branch houses of foreign firms, which as a rule, carry ample stocks. Sales are usually made on the basis of cash with 30 days.

Hongkong being a free port, no duty is charged on this class of goods. However, there is a 5 per cent ad valorem on all goods entering the Republic of China.

The sale of foreign fans is on the increase. Dealers report that quotations received from foreign manufacturers vary from 20 to 60 per cent below those of American makes, and that this difference will be an important consideration in the future sales of American fans in this market.

Pellet Type of Oxide Film Lightning Arrester

BY N. A. LOUGEE

Associate A. I. E. E.
Stone and Webster, Inc., Boston, Mass.
Formerly with General Electric Co., Schenectady, N. Y.

Review of the Subject.—Practise has confirmed the theory that a valve type of lightning arrester is the best; that is, one which has a very large resistance or impedance at rated voltage, but which has a resistance of only a comparatively few ohms at say double rated voltage. The aluminum arrester was the first of this type and its success is well known. Somewhat later the oxide film (OF) arrester was developed to overcome the disadvantage of charging, and this type too has had remarkable success.

A modification of this "OF" type is now announced. Briefly, pills or pellets of lead peroxide, the chemical powder used in the present "OF" type, are made and coated with an insulating film of powder. They are about the size of the familiar sugar coated pills. These are simply poured in an insulating tube,

terminals put on each end in contact with the pellets, a series gap added, and the arrester unit is complete.

In action, each pellet is a miniature "OF" cell, so the arrester tube contains a number of them in series and parallel. The over-voltage surge discharges through the pellets, which have a low resistance after the powder film is punctured, and sealing occurs at the contact of the various pellets. No dynamic or normal frequency current passes.

The characteristics are similar to those of the present "OF" arrester, giving it the fundamental characteristics a successful arrester must have. The pellet construction permits of a simple, flexible and comparatively cheap design.

THE theory and principle of the oxide film lightning arrester have been pretty thoroughly taken up in previous papers¹ and its successful operation in thousands of installations has proved the results obtained in the laboratory. From the first, efforts have been directed toward applying this principle to a form of construction other than the present one, so that a less expensive unit



FIG. 1—LEAD PEROXIDE PELLETS BEFORE BEING COATED WITH AN INSULATING POWDER

could be made. For small capacity of power apparatus, there is a limit to the money which can be expended for protective apparatus, and it is for such conditions that the type of arrester to be described, was developed.

The main difference between this new pellet type of oxide film (OF) lightning arrester and the present "OF" cell is based upon a relation explained by colloidal chemistry.

A small part of the subject of colloids deals with grains, and states that a small grain will adhere to a larger one and cover it. As a familiar example, sugar adheres and coats blueberries, when the two are shaken together. Also in the extreme, it is for the same reason that lead pencils write on paper, and chalk on boards, that is, the plane surface in these cases is the larger grain.

This principle has been made use of in applying the basic principle of the oxide film arrester to this new pellet type. If lead peroxide (PbO_2), the filler of the "OF" cell, be made into a round pill or pellet, and

shaken up with a fine powder, the pellet will become coated with this powder. This then is what is done: Lead peroxide pellets are shaken up with an insulating powder and thoroughly coated. Fig. 1 shows the pellets before being coated and Fig. 2 after being coated. Each pellet is now a miniature "OF" cell, consisting of an outside film, which is the insulating powder, and the active internal filler, which is the original pellet. To make a lightning arrester these covered pellets are placed in an insulating tube, of say porcelain, and bare electrodes attached to each end of the tube in contact with the pellets. The electrodes act both as terminals and covers for the container. Between the terminals of the container, there are hundreds of these miniature "OF" cells in series and parallel. The over all length of the container depends upon the voltage rating of the arrester desired, and the chosen diameter of the tube is related, (to a certain extent), upon protective value and life of the arrester.

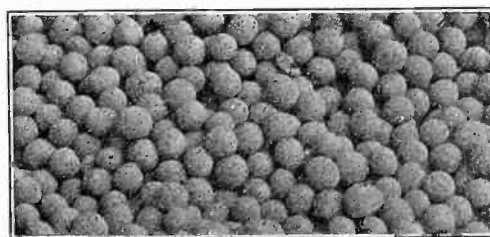

FIG. 2—LEAD PEROXIDE PELLETS AFTER BEING COATED WITH AN INSULATING POWDER AND BEFORE BEING USED IN A LIGHTNING ARRESTER

The film of insulating powder apparently acts as a porous spacer and not as a solid insulation. This is shown in Fig. 3, in a way, by the microphotograph of a covered pellet magnified to 25 diameters. In the photograph, due to the high magnification, only the center of the pellet is in focus. The insulating film, acting as a spacer and not as a solid, eliminates the objectionable time lag of establishing a spark, that solids have. This fact is borne out in tests—the equivalent sphere gap (E. S. G.) being low. A high-voltage impulse discharge goes through this pellet arrester in a number of

1. TRANSACTIONS, A. I. E. E., 1918, Vol. XXXVII, page 871.

TRANSACTIONS, A. I. E. E., 1920, Vol. XXXIX, page 1981.

Presented at the Annual Convention of the A. I. E. E., Swampscott, Mass., June 26-29, 1923.

parallel paths and sealing or recovery occurs at the contact surfaces of all pellets effected by the discharge in the path of the discharge current.

While the basic principle of this pellet arrester is the same as the present used "OF" unit, the difference in construction of the pellet type causes some modification in the film action. The leakage current is very much less in the pellet type. It is less than one milliamperere when new, and contrary to expectations, continued

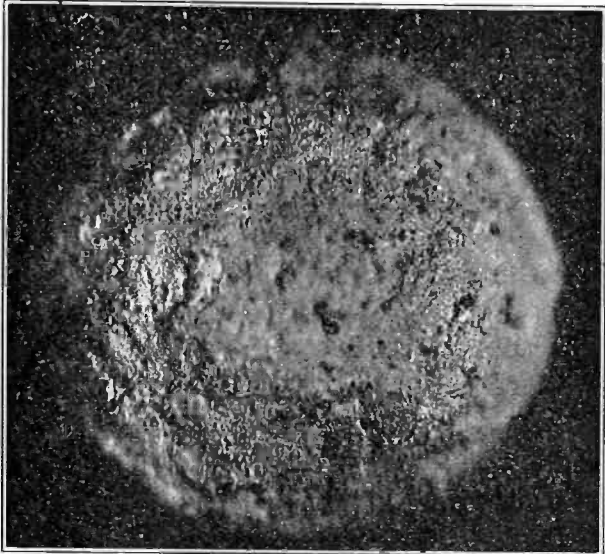

FIG. 3—A LEAD PEROXIDE PELLET AFTER BEING COATED WITH AN INSULATING POWDER
Magnification is 25 diameters. Only a central ring is in focus.

service does not increase it. It seems that sealing or recovery is more complete between peroxide surfaces than between a lead peroxide and a metal surface, — the condition which exists in the present "OF" cell. This fact is of course beneficial. The pellets become a bit irregular due to continued use and the sealing surfaces can be easily seen on each one. Fig. 4 shows a picture of a lot of pellets taken from a 2300-volt arrester which had been given repeated discharges from a lightning generator² while also connected to a 2300-

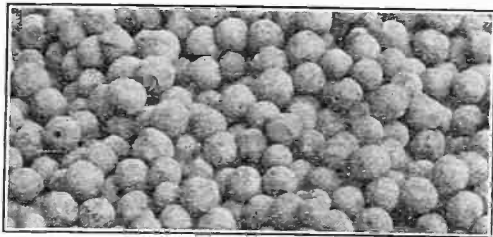

FIG. 4—LEAD PEROXIDE PELLETS AFTER BEING COATED WITH AN INSULATING POWDER AND AFTER EXTENSIVE USE IN A LIGHTNING ARRESTER

volt 60-cycle circuit of high kw. capacity. The worn condition of the pellets can be readily seen.

It might be expected that such small contact surfaces would be quickly worn away, but such does not seem to be the case. A contact surface once punctured by the discharge, and sealing having occurred, is still available for further use; that is, the life of the contact surface between pellets is great. The pellets do become a

2. *General Electric Review*, 1921, Vol. 24, page 946.

bit irregular in shape from service, but they are amply strong to carry a heavy impulse discharge. Although dynamic does not follow the impulse, over voltage dynamic tests show the pellets also to have ample strength to carry a heavy dynamic discharge. Life tests show hardly any deterioration although an excess of the insulating covering of the pellets becomes blown or shaken off. The necessary amount of covering seems to adhere regardless of service. This fact, however, is beneficial rather than harmful as it improves the protective value.

The construction and size of the pellets for both successful and best operation is of course important. A successful arrester must (1) discharge the surge freely at some definite voltage above normal; (2) the free discharge must be sufficient to relieve the voltage strain;

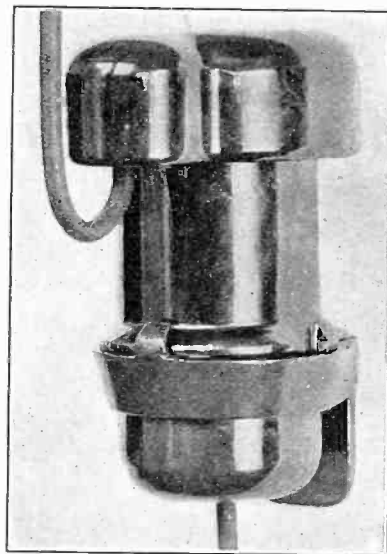

FIG. 5—PELLET TYPE OXIDE FILM LIGHTNING ARRESTER FOR 2300-VOLT SERVICE

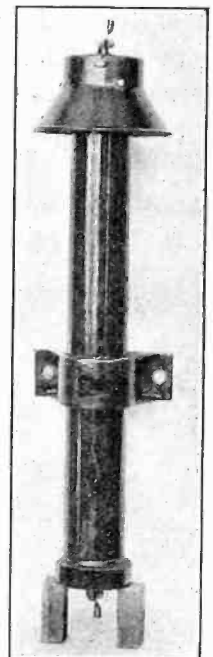

FIG. 6—PELLET TYPE OXIDE FILM LIGHTNING ARRESTER FOR 15,000-VOLT SERVICE

(3) the insulating film on the pellets must reseal, that is, prevent the dynamic from following the abnormal surge and (4) it must have endurance and life. All of these factors are related to the size of pellet, and the best size has been determined by extensive laboratory tests. Pellets, as now used, are about one eighth of an inch in diameter.

The electrical characteristics of this pellet arrester are very similar to those of the present "OF" arrester, therefore oscillograms of representative tests are not shown, as they would simply be duplicates of those published heretofore in the papers already referred to.

The future of this type of lightning arrester appears to be very bright—it has all the characteristics demanded by the basic theory of lightning arresters, and the mechanical form of pellets lends itself to a convenient, flexible and relatively cheap construction. Fig. 5 shows a 2300-volt arrester and Fig. 6 a 15,000-volt arrester.

A Simplified Method of Analyzing Short-Circuit Problems

BY R. E. DOHERTY

Associate, A. I. E. E.
Consulting Engineering Dept.
General Electric Company, Schenectady, N. Y.

CONTENTS

Review of the Subject.—This paper presents the theoretical basis for a theorem by which the practical analysis and visualization of short-circuit phenomena can be greatly simplified. The theorem follows from the approximation of neglecting resistance in the application of Kirchhoff's Law to closed circuits. Thus in any problem of short circuits in which the effect of resistance is negligible in the initial moment, and this includes many of them, the theorem applies. It is: If the resistance of a closed circuit is zero, then the algebraic sum of the magnetic linkages of the circuit must remain constant.

Illustrative examples are given, including the transformer, the single-phase and polyphase alternator, and the induction motor.

Review of the Subject.	(115 w.)
Introductory.	(65 w.)
Scope.	(175 w.)
Theoretical Basis.	(40 w.)
Simple Case.	(225 w.)
General Case.	(800 w.)
Illustrative Examples	
Transformer.	(2000 w.)
Single Phase Alternator.	(750 w.)
Polyphase Alternator.	(400 w.)
Induction Motor or Generator.	(650 w.)
Summary.	(165 w.)

THE practical analysis and visualization of many short-circuit problems may be greatly simplified by the theorem of constant flux linkages. This theorem has been mentioned in an incidental way on two previous occasions,¹ but its importance appears to warrant further emphasis. Attention was drawn to its possible greater usefulness, by the mathematics and some of the conclusions in a recent Institute paper on *Electromagnetic Forces*.²

SCOPE

The purpose of this paper, therefore, is to present the theoretical basis for the theorem, and illustrate its use by a few practical examples.

It is based on Kirchhoff's law of voltages, and follows from the approximation of neglecting the resistance in the circuits. It is stated as follows: *If the resistance of a closed circuit is zero, then the algebraic sum of the magnetic linkages of the circuit must remain constant.*

The theorem thus applies in any case in which the effect of resistance can be neglected. This includes most practical problems, because the effect of resistance in determining the initial rush of current is usually negligible. Its effect in determining the transient, or decay of current is, of course, decisive; but usually the problem is to determine the initial current rush. That is, the result of first importance is the initial condition, immediately following sudden short circuit; and this is, of course, practically the condition which would exist if there were no transient—in other words, the condition which would exist if the resistance in the circuits were zero. The application to practical problems, therefore, is very broad.

1. Reactance of Synchronous Machines by Doherty and Shirley, TRANS. A. I. E. E. 1918, Vol. 37, Part 2, p. 1209.

Short-Circuit Current of Induction Motors and Generators, by Doherty and Williamson, TRANS. A. I. E. E., 1921, Vol. 40, p. 509.

2. By Carl Hering, JOURNAL A. I. E. E., Feb. 1923, p. 139.

Presented at the Annual Convention of the A. I. E. E., Swampscott, Mass., June 26-29, 1923.

THEORETICAL BASIS

In most short-circuit problems, Kirchhoff's two laws are dealt with. The second law states that the sum of all e. m. fs. around a closed circuit must equal zero. That is,

$$\sum e = 0 \quad (1)$$

Simple Case. It follows that in a simple circuit³ as shown in Fig. 1,

$$r i + \frac{d}{dt} (L i) = 0 \quad (2)$$

where

$$\begin{aligned} r &= \text{resistance (ohms)} \\ L &= \text{inductance (henries)} \\ i &= \text{current (amperes)} \end{aligned}$$

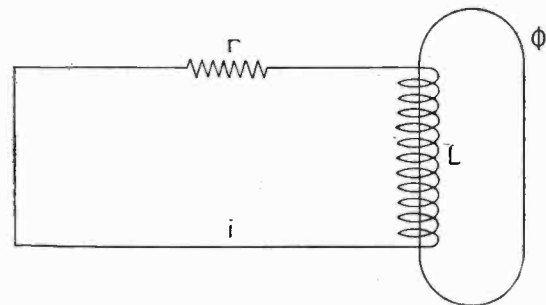

FIG. 1

Referring to equation (2), if

$$r = 0$$

then

$$\frac{d}{dt} (L i) = 0 \quad (3)$$

That is, the product $L i$ is constant. But what does the product $L i$ represent? The inductance L is equal to the "flux-turns," or "linkages" per ampere. That is,

$$L = \frac{\phi N}{i \times 10^8}$$

3. Neglecting capacitance which is practically never a significant factor in short-circuit problems.

Thus the product $L i$ represents ϕN , which is the magnetic linkages of the circuit. Therefore, the magnetic flux⁴ linked with a closed circuit of zero resistance cannot change.

It will be shown that this is true not only for the simple circuit shown in Fig. 1, but in general, even for a circuit which is part of a network and which may, in addition, be in mutual inductive relation to other circuits. The only conditions are, that the circuit shall be closed and shall contain no resistance.

General Case. The validity of the theorem for the general case will now be established.

Consider the circuits shown in Fig. 2, which are assumed to be in relative motion.⁵

Applying equation (1) to the closed circuit A,

$$i r + \frac{d}{dt} (L i) + \frac{d}{dt} (M_1 i_1 + M_2 i_2 + M_3 i_3 + \dots) = 0 \quad (4)$$

or in general

$$i r + \frac{d}{dt} (L i + \sum M i_s) = 0 \quad (5)$$

where i_s = current in secondary or inductively related circuits. Neglecting resistance,

$$\frac{d}{dt} (L i + \sum M i_s) = 0 \quad (6)$$

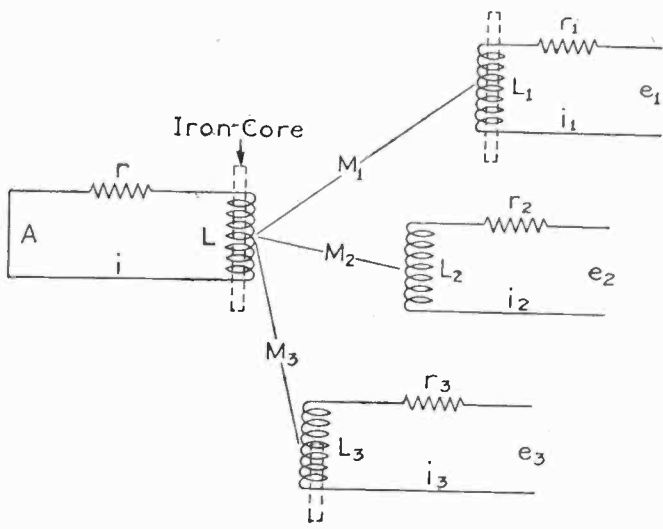

FIG. 2

or

$$L i + \sum M i_s = \text{constant} \quad (7)$$

But the expression

$$L i + \sum M i_s$$

represents the magnetic linkages of the closed circuit

4. More accurately, the magnetic linkages. For instance, two lines linking half the turns would obviously represent one total linkage. Thus on account of partial linkages, it is not quite accurate to say the "magnetic flux" is constant, but only the flux representing complete linkages is constant.

5. And therefore both the M 's and L 's are variable: M 's variable by relative motion; L 's may be variable either by saturation or by proximity to moving iron of secondary circuits.

A. Hence, the theorem applies to a detached closed circuit as shown in Fig. 2, in mutual inductive relation to any number of secondary circuits.

It remains to be proved that it holds also for the perfectly general case, as illustrated in Fig. 3, in which, as in Fig. 2, the circuits are assumed to be in relative motion and in addition the closed circuit A is made up of branches of a network.

Thus consider any closed circuit, as A in Fig. 3.

(a) in relative motion to, and inductive relation with, any number of secondary circuits.

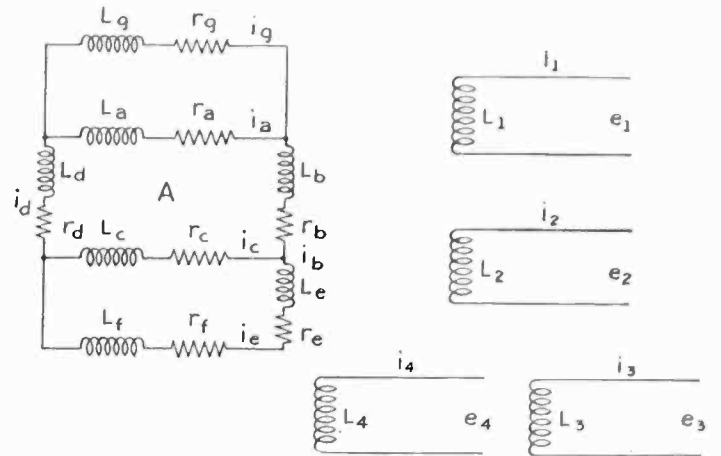

FIG. 3

(b) in multiple connection with other circuits.

Let

$i_a, i_b, i_c,$ etc. be the currents in the several individual branches of the closed circuit.

$L_a, L_b, L_c,$ etc. be respectively the inductances of these branches.

$r_a, r_b, r_c,$ etc. be the corresponding resistances.

$M_1, M_2, M_3,$ etc. be the mutual inductances between the closed circuit and the secondary circuits.

$i_1, i_2, i_3,$ etc. be the currents in the secondary circuits.

All the quantities are considered as variables. The units are: i 's in amperes; r 's in ohms; L 's and M 's in henries. By Kirchoff's Law

$$\sum e = 0$$

Thus, summing the voltages around the circuit A,

$$(i_a r_a + i_b r_b + i_c r_c + i_d r_d) + \frac{d}{dt} (L_a i_a + L_b i_b + L_c i_c + L_d i_d + M_d i_d + M_e i_e + M_f i_f + M_1 i_1 + M_2 i_2 + M_3 i_3 + \dots) = 0 \quad (8)$$

That is,

$$i r + \frac{d}{dt} (\sum L i + \sum M i_s) = 0 \quad (9)$$

Neglecting resistance this becomes

$$\frac{d}{dt} (\sum L i + \sum M i_s) = 0 \quad (10)$$

But, as before, the quantity in the parenthesis repre-

sents the number of magnetic linkages of the circuit. The equation states that the rate of change of the number of linkages is zero; hence the number is constant. Therefore the theorem is general.

Thus to repeat: *If the resistance of a closed circuit is zero, then the algebraic sum of the magnetic linkages of the circuit must remain constant.*

It is well at this point to interpret the physical meaning of this statement. Magnetic linkages are expressed numerically by the product of the magnetic flux and the number of turns with which the flux is linked,⁶ or, in general, by the product of the inductance L or M by the current. Therefore in a closed circuit without resistance if the inductance, either self or mutual, changes for any reason, or if the current changes in any mutually related circuit, then there must be a compensating change in current in the closed circuit to maintain constant its magnetic linkages. Do not misunderstand. The distribution of linkages among the different branches or component, series elements of the closed circuit need not remain the same, but the algebraic sum of all linkages must remain constant.

However, in special cases of symmetrical branches such as the star-connected polyphase machine, with sine wave flux distribution on open circuit, it can be shown⁷ that the flux linkages in each branch or phase remains constant when the terminals are short-circuited.

ILLUSTRATIVE EXAMPLES

Transformer. Consider a few simple illustrations to visualize what this means. In Fig. 4A, a transformer

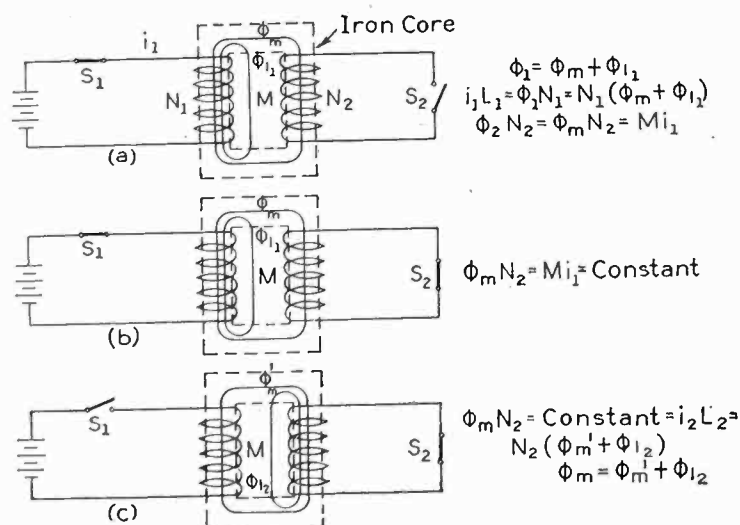

FIG. 4

primary is connected to a battery,⁸ the secondary being open. Of the total flux ϕ , established by and linking with the primary, part of it ϕ_m links the secondary, and the remainder ϕ_{l1} passes between the windings, that is, as leakage flux. Now close switch s_2 (Fig. 4B),

6. Keeping in mind the statement previously made regarding partial linkages.

7. *Short-Circuit Current of Induction Motors and Generators*, Doherty and Williamson, TRAN. A. I. E. E., Vol. 40, p. 537.

and assume zero resistance in the secondary. Obviously no electrical change will follow. Open switch s_1 (Fig. 4C). What happens? We know that the secondary linkages

$$\phi_m N_2 = i_1 M$$

cannot change, and hence a secondary current i_2 must appear such as to satisfy the condition

$$i_2 L_2 = i_1 M = \text{constant} \tag{11}$$

It is interesting to follow this further. Suppose the secondary winding is now taken completely out of the transformer, that is, away from any iron as indicated in Fig. 5A. The theorem still applies. The inductance

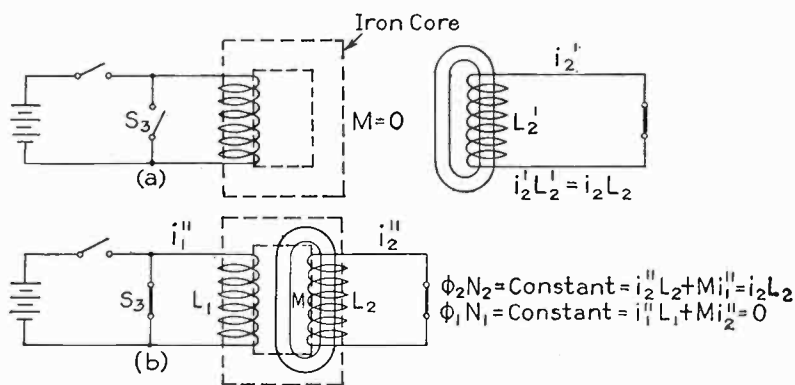

FIG. 5

L_2' is very much less, perhaps 0.005 of its former value, L_2 . It does not matter. The linkages must remain constant. Hence the current i_2 must correspondingly increase so that

$$i_2 L_2 = i_2' L_2' \tag{12}$$

Thus the current would increase 200 fold. In other words, regardless of what else happens, the magnetic linkages cannot change as long as the circuit is closed and the resistance is zero.⁸

A step further: How much work would be required to pull the coil away from the iron core, assuming infinitely thin saw cuts in the core that would permit removal of the coil. This work must be equal to the increase in stored energy. The stored energy is

$$1/2 L_2 i_2^2 \text{ before}$$

and

$$1/2 L_2' i_2'^2 \text{ after}$$

$$\text{Work is } W = 1/2 (L_2' i_2'^2 - L_2 i_2^2) \tag{13}$$

But by (12),

$$L_2 i_2 = L_2' i_2'$$

Solving for i_2' and substituting in (13),

$$W = 1/2 L_2 i_2^2 (L_2/L_2' - 1) \tag{14}$$

If L_2 is large compared with L_2' , as here, (14) becomes,

$$W \approx 1/2 L_2 i_2^2 (L_2/L_2')$$

That is, the work is approximately equal to the initial stored energy multiplied by the ratio

$$L_2/L_2' = 200$$

$$\text{or } W = 200 (1/2 L_2 i_2^2)$$

8. If the circuit contains some resistance, as of course it must, the linkages must decrease at a rate just sufficient to generate the $i r$ drop.

Next consider what happens when the same secondary coil, now shown in Fig. 5A is again placed in the transformer as before, except that before this is done, the switch s_3 is closed as in Fig. 5B. The primary is thus closed under the condition of zero magnetic linkages, and must therefore remain in that condition. Thus the number of magnetic linkages of primary is

$$i_1'' L_1 + M i_2'' = \text{constant} = 0$$

and of the secondary

$$i_2'' L_2 + M i_1'' = \text{constant} = i_2 L_2 \tag{16}$$

From which

$$i_1'' = -i_2 \frac{M L_2}{L_1 L_2 - M^2} = -i_2 \frac{M}{L_1} \frac{1}{1 - K^2} \tag{17}$$

and

$$i_2'' = i_2 \frac{L_1 L_2}{L_1 L_2 - M^2} = i_2 \frac{1}{1 - K^2} \tag{18}$$

where

$$K = \sqrt{\frac{M^2}{L_1 L_2}} \tag{19}$$

K is called the "coefficient of magnetic coupling."

From the case of Fig. 5B, it is clear that the effect of the closed primary in maintaining zero flux⁹ is to force the flux, which is linked with the secondary, out of the main magnetic path into the leakage paths. Thus the current i_2'' is as much greater than i_2 (which corresponds to Fig. 4c) as the reluctance of the leakage paths is greater than the reluctance of the main magnetic path. This is the ratio of the short-circuit current to the magnetizing current, and is given by equation (18), thus

$$i_2''/i_2 = \frac{1}{1 - K^2}$$

The foregoing examples involving direct current have

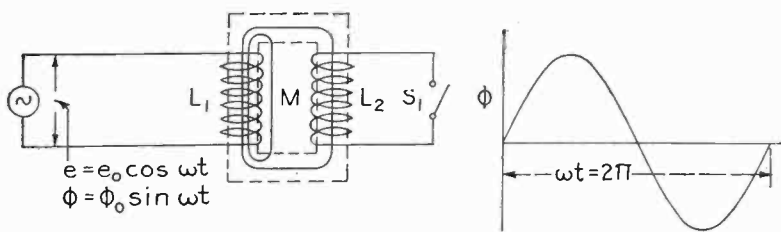

FIG. 6

been given for the purposes of illustrating with emphasis what would happen if the resistance were zero. Although actually with direct current the magnetic flux and the current in such cases as illustrated would gradually die out or decay, nevertheless for sudden changes or for many alternating-current conditions in which the change, or tendency to change, is rapid, the results are very closely those which would exist if the resistance were zero.

9. Or linkages, to be accurate

Consider now the transformer as shown in Fig. 6. Assume that the primary is connected to an infinite alternating current system, that is, that the alternating voltage holds up after the switch s_1 is closed. Before short circuit, the number of magnetic linkages of the primary was

$$\Omega_1 = L_1 i_0 \sin \omega t \tag{20}$$

and of the secondary

$$\Omega_2 = M i_0 \sin \omega t \tag{21}$$

where

- i_0 = magnetizing current
- $\omega = 2 \pi f$
- f = electrical frequency
- t = time

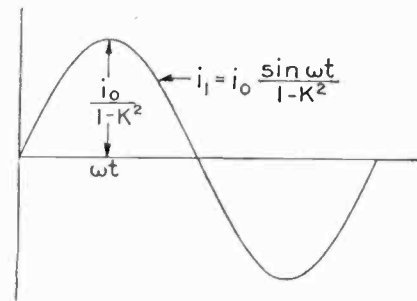

FIG. 7

After short circuit Ω_1 is still given by (20), since the voltage and therefore the alternating flux must hold up. But Ω_2 is the value of magnetic linkages existing at the moment t_1 when the secondary is short-circuited by closing switch s_1 . It is,

$$\Omega_2 = M i_0 \sin \omega t_1 \tag{22}$$

and must remain constant

Thus,

$$\Omega_1 = L_1 i_0 \sin \omega t = i_1 L_1 + M i_2 \tag{23}$$

$$\Omega_2 = M i_0 \sin \omega t_1 = i_2 L_2 + M i_1 \tag{24}$$

From these equations¹⁰

$$i_1 = i_0 \frac{\sin \omega t - K^2 \sin \omega t_1}{1 - K^2} \tag{25}$$

and

$$i_2 = -i_0 \frac{M}{L_2} \frac{\sin \omega t - \sin \omega t_1}{1 - K^2} \tag{26}$$

Now if s_1 is closed at $t_1 = 0$, (25) becomes

$$i_1 = i_0 \frac{\sin \omega t}{1 - K^2} \tag{27}$$

and (26) becomes

$$i_2 = -i_0 \frac{M}{L_2} \frac{\sin \omega t}{1 - K^2} = -M/L_2 i_1 \tag{28}$$

Equation (27) is plotted in Fig. 7.

The similarity of (27) and (18) is at once apparent,

10. Assuming L_1 , L_2 and M constant. If they are not constant, the expressions for i_1 and i_2 will be more complicated.

the only difference being that now the current is alternating. That is, the relation between the current before and after short circuit is the same in either case, namely,

$$\frac{1}{1 - K^2}$$

Assume now that s_1 is closed at the instant $\omega t_1 = \pi/2$, that is, when the secondary encloses, or is linked with, maximum flux. The fact that the secondary linkages thus "caught" by the short circuit must

$$i_2 = -i_0 M/L_2 \frac{\sin \omega t - 1}{1 - K^2} \tag{30}$$

also for values of $t > t_1$.

It will be observed that (29) and (30) each involve a constant or "direct" component of current in addition to the "alternating" component. In (29), for instance, the direct component is

$$i_1' = -i_0 \frac{K^2}{1 - K^2} \tag{31}$$

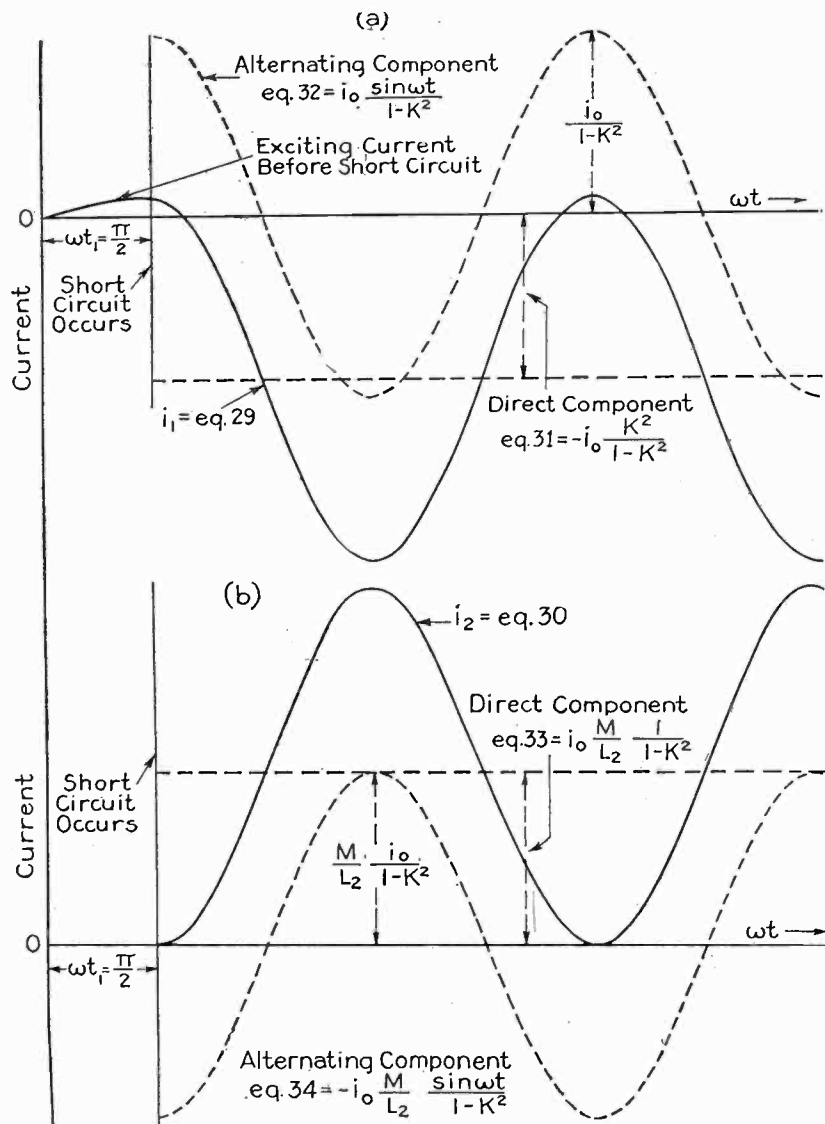

FIG. 8

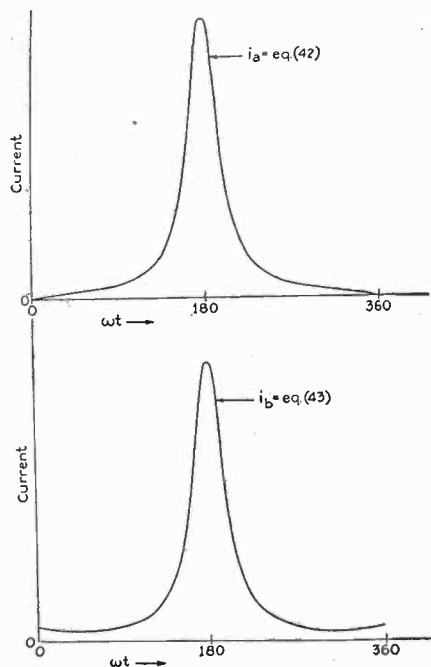
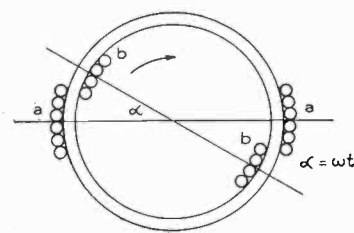

FIG. 10

remain constant, gives interesting consequences. Consider these consequences first in the light of the equations, and then from the physical point of view. By equation (25), for

$$\omega t_1 = \pi/2$$

$$i_1 = i_0 \frac{\sin \omega t - K^2}{1 - K^2} \tag{29}$$

for values of $t > t_1$, since the equations obviously hold only for conditions after the short circuit. And by (26)

and the alternating component is

$$i_1'' = i_0 \frac{\sin \omega t}{1 - K^2} \tag{32}$$

In (30), the direct component is

$$i_2' = i_0 M/L_2 \frac{1}{1 - K^2} \tag{33}$$

and the alternating component is

$$i_2'' = -i_0 M/L_2 \frac{\sin \omega t}{1 - K^2} \tag{34}$$

Equations (29) and (30) are plotted in Fig. 8, showing graphically the relation between the alternating and direct components.

Now examine the physics of the problem. Consider the case in which the switch s_1 , Fig. 6, is closed when the secondary is linked with maximum flux, that is, when $\omega t = \pi/2$. This flux, or linkages rather, must remain constant. But obviously one-half cycle later, the flux in the primary is full value in the opposite direction, since the impressed voltage is maintained. That is, the primary is trying to force flux through the closed secondary, which must not only prevent this opposite flux from entering, but also must maintain constant the flux with which it is linked. This instant corresponds to the maximum current in Fig. 8. Since the reversed primary flux cannot enter the secondary, and the secondary flux cannot enter the primary, it follows that both fluxes must pass through the leakage paths between the windings. It thus requires twice¹¹ as much maximum current as the case in which the switch s_1 was closed when the secondary enclosed zero flux.

Thus the actual current in both the primary and the secondary comprises a direct and an alternating component of about equal maximum values. In the secondary the direct, or constant flux, with which it is linked, requires a direct current to maintain it, and an alternating current is required to prevent the alternating flux of the primary from linking the secondary. And similarly the primary requires a direct current to prevent the direct flux of the secondary from linking it (since the primary flux must at all times correspond to the impressed voltage), and also requires an alternating component to force the alternating flux through the leakage paths. Thus the total current in either of these windings comprises the two components as shown in Fig. 8.

The transformer problem thus illustrates in fundamental respects the facility of calculation and of visualization made possible by the "theorem of constant magnetic linkages." Other illustrations will now be given in a much briefer way.

Single-Phase Alternator. In Fig. 9, aa represents the armature winding, bb the field winding. Assume that the field winding is excited by the current i_0 ; that the field winding, having zero resistance, is short-circuited at the collector rings.¹² Thus as long as the permeance of the magnetic circuit is not changed, i_0 would continue to flow, by the condition that the field linkages must remain constant. But whatever happens, the field linkages cannot change. Remove the rotor from the machine. The field current will increase

11. Actually $(1 + K^2)$ times as great. K^2 is of the order of 0.99 in a transformer.

12. The exciter voltage, of course, supplies only the $i r$ drop, and therefore corresponds to the initial rate at which the flux would actually die down if the collector rings were short-circuited on the given machine. Without resistance, it would not die down.

because the inductance has decreased. Replace it, and the current is once more i_0 .

When running with open armature circuit, the number of field linkages is

$$\Omega_b = i_0 L_b \quad (35)$$

and the armature linkages,

$$\Omega_a = i_0 M \quad (36)$$

where,

$$M = M_0 \cos \omega t \quad (37)$$

M_0 = mutual inductance between armature and field windings in position $\alpha = 0$, Fig. 9.

ω = electrical angular velocity.

Assume that a short circuit occurs at the time t_1 . Then by (36) and (37) the number of armature linkages at this instant is,

$$\Omega_a = i_0 M_1 = i_0 M_0 \cos \omega t_1 \quad (38)$$

and the field linkages

$$\Omega_b = i_0 L_b \quad (39)$$

Thus, after short circuit, Ω_a and Ω_b must remain constant, and

$$\Omega_a = i_0 M_1 = i_a L_a + M i_b \quad (40)$$

and

$$\Omega_b = i_0 L_b = i_b L_b + M i_a \quad (41)$$

Substituting (37) and (38), and solving simultaneously,

$$i_a = -i_0 M_0 / L_a \frac{\cos \omega t - \cos \omega t_1}{1 - K^2 \cos^2 \omega t} \quad (42)$$

and

$$i_b = i_0 \frac{1 - K^2 \cos \omega t_1 \cos \omega t}{1 - K^2 \cos^2 \omega t} \quad (43)$$

where,

$$K = \sqrt{\frac{M_0^2}{L_a L_b}}$$

Equations (42) and (43) are plotted in Fig. 10 for $\omega t_1 = 0$.

How does the magnetic energy storage vary during rotation, and what is the torque? Neglecting saturation, the magnetic energy storage in the field is¹³

$$W_b = 1/2 \Omega_b i_b 10^{-8} \text{ joules} \quad (44)$$

and in the armature,

$$W_a = 1/2 \Omega_a i_a 10^{-8} \text{ joules} \quad (45)$$

But Ω_a and Ω_b are constant. Therefore the energy of each circuit varies directly with the current. The total energy is

$$W = W_a + W_b = 10^{-8}/2 (\Omega_a i_a + \Omega_b i_b) \quad (46)$$

Since the electrical power supply is cut off, the change in energy must be supplied mechanically. That is, the energy supplied to the magnetic field during rotation through the angle $d\alpha$ is equal to the mechanical work done: Torque \times angle. Hence,

$$dW = T d\alpha$$

13. Stored energy = $W = 1/2 L i^2 10^{-8} = 1/2 (L i) i 10^{-8}$ joules. But, $L i = \Omega$ Hence, $W = 1/2 \Omega i \times 10^{-8}$ joules.

That is, the torque is

$$T = \frac{dW}{d\alpha} \quad (47)$$

where $\alpha = \omega t$.

Differentiating (46),

$$T = \frac{dW}{d\alpha} = 10^{-8}/2 \left(\Omega_a \frac{di_a}{d\alpha} + \Omega_b \frac{di_b}{d\alpha} \right) \quad (48)$$

Thus the electromagnetic torque during short circuit is determined by the slope of the current curves.

Polyphase Alternator. At any moment the total flux from each field pole is linked with the coils of some phase or phases. If, for example, one phase encloses zero flux, then all of the flux must be enclosed by the other phases. Hence regardless of the point of the cycle at which a polyphase short circuit occurs, the full flux from each pole is "caught" by the armature coils. Therefore, after the short circuit, there must be a series of armature poles, of full flux, disposed around the periphery, the center lines of these poles corresponding to the center lines of the field poles at the instant of short circuit—thus, somewhat as if the field poles of the rotor had at the instant of short circuit, stamped their replica upon the stator, and then moved on.

Now imagine the rotor to be removed from the stator. Since the flux of the armature, as well as the flux of the field, must persist, it follows that, although removed from each other, each of these members must retain its own set of poles as shown in Fig. 11. If this picture is kept in mind, there will be little difficulty in visualizing polyphase short circuits. These two separate sets of magnetic poles—the armature and the field—both of about equal flux per pole, must persist, regardless of what happens, so long as the circuits are closed, and the resistance is zero. Thus if the rotor is again put into place and rotated, these two sets of poles, one rotating, the other stationary, pass over each other, and the currents adjust themselves so as to maintain constant flux linkages. When the poles are in the same relative position as that when the short circuit occurred, the currents will be of the value existing the instant before short circuit, namely, zero in the armature, and no load exciting current in the field. One

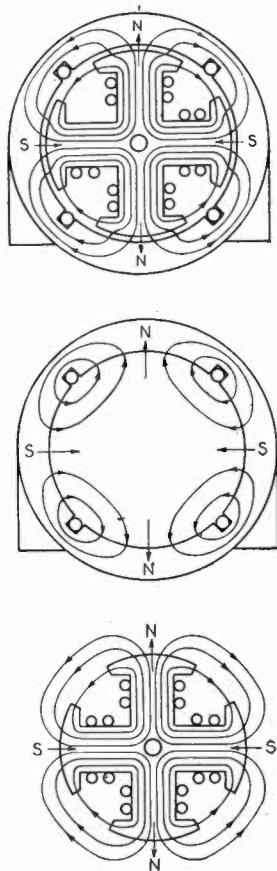

FIG. 11

pole pitch, *i. e.*, one half cycle, later, when the poles are opposing each other, thus forcing double flux through the leakage paths, the currents are maximum. Thus in the alternator, as in the transformer, if the armature, or secondary, "catches" any flux when the short circuit occurs, there must be a direct component of current, and also the maximum value of the total current occurs one half cycle after the moment of short circuit. Fig. 12 is an oscillogram of a three-phase

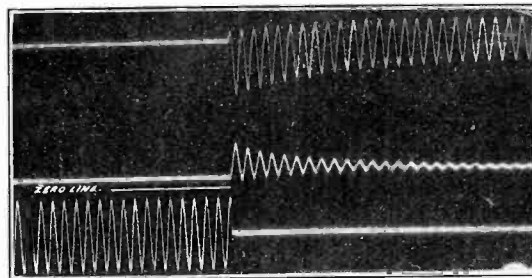

FIG. 12—THREE-PHASE SHORT CIRCUIT OF A 10,000 KV-A., 6600-VOLT, 63-CYCLE GENERATOR

Upper curve—current in phase a.
Middle curve—field current.
Lower curve—armature volts.

short circuit of an alternator, showing the current of one phase, the field current and the line voltage. The large direct component of current which produces nearly complete offset of the armature current wave, shows that at the instant of short circuit the particular armature phase had "caught" nearly full flux.

Induction Motor or Generator. At the moment the terminals are short-circuited, the rotating magnetic field, which is linked with the closed secondary, has a definite position on the face of the stator. Like the case of the polyphase alternator, this field is linked with the coils of some phase or phases of the short-circuited stator winding, and must remain stationary, and at full value. But the flux linked with the rotor must also remain at full value and stationary *with respect to the rotor winding*. That is, it must continue to rotate in space. In other words, the two sets of poles exist, just as in the case of the alternator, and with the same results.¹⁴ Of course in the actual case, there is resistance in the circuits and the currents would die down to zero. But initially the phenomena of short circuit in an alternator and in an induction motor are practically identical.

As a further illustration of this method of analysis it can be shown that the initial current rush to an induction motor¹⁵ is the same when the line switch is closed upon the motor at standstill, as when the motor is running at synchronous speed.¹⁶ In either case, the number of flux linkages in the closed secondary, or

14. For further discussion of this, see "Short Circuit of Induction Motors and Generators" by Doherty and Williamson, TRANS. A. I. E. E., Vol. XL, 1921, p. 509.

15. If the motor is of sufficient size so that the resistance is practically negligible in the first moment after short circuit.

16. To the Author's knowledge, no tests have been made to confirm this, but it follows from the theorem.

rotor, circuits is zero, and must remain so after the line switch of the primary circuit is closed. The primary circuits are open and of course contain zero linkages before the switch is closed. But consider the closed circuits formed by the switch, namely those each of which is made up of a motor phase and the corresponding alternator phase in series. In each of these circuits, each electrically disconnected from the other, a definite value of flux existed, or was linked with the circuit, at the moment the switch was closed, the value of flux linkages in each circuit depending, of course, upon the alternator pole position at that moment. The value of flux thus caught in each circuit must remain constant. But since, assuming constant line voltage, the flux in the alternator phase must continue to vary, through fixed values, and thus (by assumption of no leakage) can not hold the constant component of flux which must continue to exist somewhere in the circuit, it follows that it must exist in the primary phases of the induction machine. In other words there must be a direct, or stationary magnetic field around the periphery of the induction motor, just as in the previous illustrations. Also since the voltage is held up at the terminals of the motor there must also be a rotating field. That is, there exists a stationary, and a rotating set of poles around the stator periphery; and none of this flux can link with the rotor. Therefore, at standstill, the secondary must contain direct current to prevent the stationary primary flux from entering; and must contain alternating current to prevent the rotating flux from entering. And these components of current must be of the same magnitude since the fields they oppose are of the same value. On the other hand, the primary winding must contain direct current to sustain the constant or stationary component of flux in the linkage paths, and an alternating component to sustain the rotating field—both of same magnitude. Thus the total current in either the primary or secondary windings must contain a direct and an alternating component of current of the same magnitude.

If the rotor is driven by external means at synchronous speed when the switch is closed, then, since neither the rotating nor the stationary field of the stator (both, the same as in the foregoing case) can enter the rotor, all conditions will be the same as before, excepting the rotation. Now the stationary field of the stator of course requires direct current in the stator windings, but it produces due to rotation of the rotor, alternating current in the closed rotor circuits; also the rotating field of the stator requires alternating currents in the stator windings, but being stationary with respect to the rotor, produces therein a direct current. And all currents are of about the same maximum values, and hence the same as at stand-still.

SUMMARY.

Summarizing briefly the points brought out in the paper, it follows from Kirchhoff's Law of Voltage,

that if the resistance of a closed circuit is zero, then the algebraic sum of the magnetic linkages of the circuit must remain constant. Thus if the reluctance of the magnetic path linking the closed circuit is increased, the current in the circuit must increase, and vice versa, to maintain constant the magnetic linkages. Or if a separate magnetomotive force is impressed on the magnetic circuit linking the closed circuit, tending to change the linkages of the closed circuit, then the current in the latter must adjust itself to balance the new m. m. f. and thus maintain constant linkages. The application of the foregoing theorem to the problems of short circuits of electrical apparatus accomplishes two important results: In the first place it tremendously simplifies the mathematics and calculation of the short-circuit current and related problems; also it makes it possible to visualize easily the phenomena—which, of course, is always highly desirable in any analysis.

MUCH WATER-FUEL IN NEW ZEALAND POTENTIAL HYDRAULIC HORSE POWER ESTIMATED AT OVER FOUR MILLION, MAINLY IN SOUTH ISLAND

Estimates of the amount of available water power in New Zealand, forwarded to the Department of Commerce by Vice Consul J. C. Hudson, show a total of 4,076,700 horse power, of which 759,700 horse power is in the North and 4,317,000 in the South Island. In the distribution of power resources, the South Island is in an advantageous position as the bulk of its potential supply is located near the deep water sounds of the west coast, where there are many sites suitable for electrochemical and electrometallurgical industries.

A program for water power development has been laid out in which the important sites of the North Island will be utilized. These include Lake Waikaremoana, which has sufficient storage capacity to run the proposed generating plant for 21 months without rainfall, and the Waikato River project which tops Lake Taupo. The first installment will involve an estimate expenditure of £15,000,000 for the headworks, plant and transmission line to Auckland, and will develop 50,000 of the 138,000 horse power, which it is estimated can be ultimately obtained.

State commitments up to the end of 1923 for the Lake Waikaremoana project amount to £110,000. By the end of 1924 it is planned to spend £1,075,000 when it is expected that 24,000 horse power will be available from this source. The method of financing hydroelectric development in New Zealand is chiefly through State aid, no projects of importance being promoted by private organization. Southland province with some assistance from the State is carrying on its development through a local body, the Southland Power Board.

Floating Neutral n-Phase Systems

BY LEONARD A. DOGGETT

Member, A. I. E. E.

Prof. of Engineering, U. S. Naval Academy, Annapolis, Md.

Review of the Subject.—Although this paper treats of the general case of floating neutral polyphase systems, one of its prime objects is to find the very simplest method of solving three-phase unbalanced star circuits. The method presented below is considered much simpler than the one in which the star circuit is replaced by an equivalent delta circuit; also simpler than the method of replacing one unbalanced circuit by two balanced circuits, one being subjected to direct phase rotation and the other to opposite phase rotation. Although these methods are fairly useful for the three-phase case, they become very unwieldy for a number of phases greater than three. Not only is this method more simple than any so far proposed, but it is a direct method, based on a straight forward application of Kirchhoff's Laws. A final and very important advantage of the method is that all the results are perfectly general, applying

equally as well to a single-phase system as to any polyphase star system.

CONTENTS:

Review of the Subject.	(165 w.)
Introduction.	(185 w.)
(I) Description of Types of Circuits.	(100 w.)
(II) Notation.	(220 w.)
(III) General Expression for Current in any Branch.	(225 w.)
(IV) General Expression for Voltage in Neutral for Any Branch.	(60 w.)
(V) General Expression for Voltage Between Geometrical Neutral and True Neutral.	(175 w.)
(VI) Discussion of Effect of Phase Rotation and Tabulation of Operators to Assist in Calculations. Sample Calculations.	(1000 w.)
(VII) Resonance.	(325 w.)
Bibliography.	(200 w.)

INTRODUCTION

WHEN an a-c. receiving circuit is operated without grounding the neutral, the potential of the neutral in respect to the supply lines may take on a very wide range of values depending on the constants of the various branches or phases and on which way the source alternator may be rotating. Some use of this last fact has been made in determining what is called Direction of Phase Rotation.¹

It is proposed in this paper to investigate such floating neutral systems, under the following sub-headings:

- I. Description of Types of Circuits.
- II. Notation.
- III. General Expression for Current in any branch of an n -phase system.
- IV. Voltage to neutral for any branch.
- V. Voltage between geometrical and true neutral.
- VI. Discussion of Effect of Phase Rotation and Tabulation of operators to assist in calculations. Sample Calculation.
- VII. Discussion of Resonance. Some Test Results.
- VIII. Bibliography.

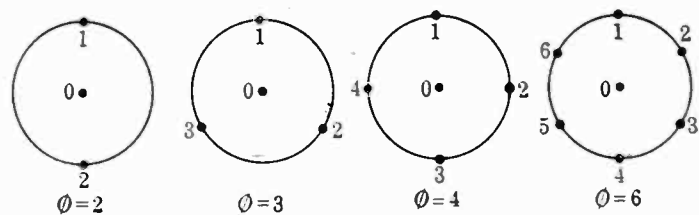

FIG. 1

I. Description of Types of Circuits. Referring to

1. W. V. Lyon, Determining Phase Rotation, See Bibliography No. 9.

T. W. Varley, Determining Phase Rotation, See Bibliography No. 8.

Presented at the Annual Convention of the A. I. E. E., Swampscott, Mass., June 25-29, 1923.

Fig. 1, ϕ stands for the number of branches or phases between lines and neutral, 0.

For example, for $\phi = 3$, there are three branches to neutral. Between 0 and 1 is located one branch which may contain resistance, inductance and capacity in any desired combination. Similarly the branches 02 and 03 may include any desired constants. In the general case there are ϕ branches all tied together at 0.

Fig. 2 shows the alternating-current sources corresponding to Fig. 1. In both Fig. 1 and Fig. 2 the

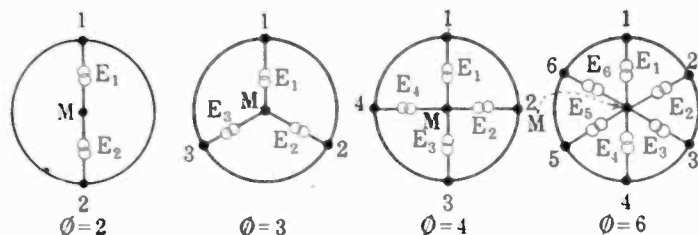

FIG. 2

branches are numbered in clockwise sequence around the circle.

II. Notation. The voltage from M to 1 will in all cases be taken as standard phase.

As the large majority of voltages, currents, impedances and admittances in this paper are complex numbers, ordinary type will be used for them. Script letters will be used for ordinary numbers.

Let $\alpha = \cos \frac{2\pi}{\phi} + j \sin \frac{2\pi}{\phi}$ for counter clockwise rotation.³

2. Defined in Part (V).

3. This definition takes the point of view of the vector diagram of the voltages. If the sequence in which 01, 02, 03, etc. receive the impulse of voltage is considered, then the terms counter clockwise and clockwise must be interchanged. It is worth noting that the A. I. E. E. has no standard definition for Phase Rotation.

$$\alpha = \cos \frac{2\pi}{\phi} - j \sin \frac{2\pi}{\phi} \text{ for clockwise rotation}^3$$

where ϕ = number of phases or branches.

- $E_1 = E \alpha^0$ = Voltage between M and 1.
- $E_2 = E \alpha^1$ = " " M and 2.
- $E_3 = E \alpha^2$ = " " M and 3.
- $E_n = E \alpha^{n-1}$ = " " M and n .

where E = numerical value of impressed voltage to geometrical neutral.²

- Z_1 = Impedance between 0 and 1.
- Z_2 = " " 0 and 2.
- Z_n = " " 0 and n .
- Y_1 = Admittance between 0 and 1.
- Y_2 = " " 0 and 2.
- Y_n = " " 0 and n .

- I_1 = Complex quantity expression for current in $\overline{01}$.
- I_2 = " " " " " $\overline{02}$.
- I_n = " " " " " $\overline{0n}$.
- E_{on} = " " " " voltage between true and geometrical neutral.

III. General Expression for Current in any Branch.

Fig. 3 represents three receiver branches and three corresponding source branches of the general case

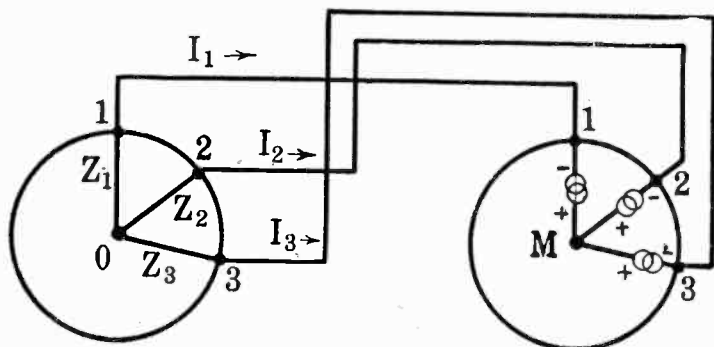

FIG. 3

where it is assumed that there are any number of branches up to n in number.

Applying Kirchhoff's Laws to this general case.

$$\begin{aligned} I_1 + I_2 + I_3 + \dots + I_n &= 0 \\ -I_1 Z_1 + E_1 - E_1 \alpha + I_2 Z_2 &= 0 \\ -I_1 Z_1 + E_1 - E_1 \alpha^2 + I_3 Z_3 &= 0 \\ \text{etc.} \\ -I_1 Z_1 + E_1 - E_1 \alpha^{n-1} + I_n Z_n &= 0 \end{aligned}$$

Solving the above equations,

$$\begin{aligned} I_1 (1 + Z_1/Z_2 + Z_1/Z_3 + \dots + Z_1/Z_n) \\ = E_1 \left(\frac{1 - \alpha}{Z_2} + \frac{1 - \alpha^2}{Z_3} + \dots + \frac{1 - \alpha^{n-1}}{Z_n} \right) \end{aligned}$$

$I_1 =$

$$\frac{E \alpha^0 \left(\frac{1 - \alpha}{Z_2} + \frac{1 - \alpha^2}{Z_3} + \dots + \frac{1 - \alpha^{n-1}}{Z_n} \right)}{Z_1 (1/Z_1 + 1/Z_2 + 1/Z_3 \dots + 1/Z_n)}$$

In general then, for the p th current

$$I_p = \frac{E/Z_p \left[\alpha^{p-1} - \frac{\alpha^0/Z_1 + \alpha^1/Z_2 + \dots + \alpha^{n-1}/Z_n}{1/Z_1 + 1/Z_2 + \dots + 1/Z_n} \right]}{1/Z_1 + 1/Z_2 + \dots + 1/Z_n} \quad (1)$$

$$I_p = E Y_p \left[\alpha^{p-1} - \frac{Y_1 \alpha^0 + Y_2 \alpha^1 \dots + Y_n \alpha^{n-1}}{Y_1 + Y_2 + \dots + Y_n} \right] \quad (2)$$

The use of this formula is illustrated by the problem of Part VI.

IV. General Expression for Voltage to Neutral for any Branch. Equations (1) and (2) give this quantity at once as

$$I_p Z_p = E \left[\alpha^{p-1} - \frac{\alpha^0/Z_1 + \alpha^1/Z_2 + \dots + \alpha^{n-1}/Z_n}{1/Z_1 + 1/Z_2 + \dots + 1/Z_n} \right] \quad (3)$$

$$I_p Z_p = E \left[\alpha^{p-1} - \frac{Y_1 \alpha^0 + Y_2 \alpha^1 \dots + Y_n \alpha^{n-1}}{Y_1 + Y_2 + \dots + Y_n} \right] \quad (4)$$

V. General Expression for Voltage between Geometrical Neutral and True Neutral. The geometrical neutral is defined as the center of the circle located by the potentials of the various lines. Thus in Fig. 1, if point 1 is taken as zero potential and if points 2, 3, 4, etc. are located on a circle a properly graduated scale will read the potential difference between any two lines.

The true neutral is fixed by the intersection of the various $I_1 Z_1, I_2 Z_2, I_3 Z_3$, etc. vectors and coincides with the geometrical neutral only in the case of a balanced load.

Since $I_p Z_p$ is the voltage between the p th line and the true neutral and since $E \alpha^{p-1}$ is the voltage between the p th line and the geometrical neutral, their difference is the voltage between the true and geometrical neutral. Hence from (4),

$$E_{on} = E \alpha^{n-1} - E \left[\alpha^{n-1} - \frac{Y_1 \alpha^0 + Y_2 \alpha^1 \dots + Y_n \alpha^{n-1}}{Y_1 + Y_2 + \dots + Y_n} \right]$$

$$\begin{aligned} E_{on} &= E \frac{Y_1 \alpha^0 + Y_2 \alpha^1 + \dots + Y_n \alpha^{n-1}}{Y_1 + Y_2 + \dots + Y_n} \\ &= E \frac{\sum_1^n Y_n \alpha^{n-1}}{\sum_1^n Y_n} \quad (5) \end{aligned}$$

VI. Discussion of Effect of Phase Rotation and Tabulation of α -Operators to Assist in Calculations. Sample Calculations. With the purpose of giving some physical interpretation to the results above obtained, it is desirable to follow the wanderings of the true neutral in these floating neutral polyphase systems. The travels of this neutral are almost unlimited. It can take up any position from infinite distance from the geometrical neutral at resonance down to zero distance

from geometrical neutral for a balanced load. If the alternator supplying the system is stopped and brought up to speed in the opposite direction, then this E_{on} vector might in some particular case move from a 10:30 o'clock vector to a 6:30 o'clock vector of less than half its original magnitude. The locus of this true neutral when constant voltage but varying frequency is maintained on a given circuit will in some cases be a circle, in others a cusp, in others an ellipse. It has been only in recent years that attention has been called to the fact that phase rotation has such a pronounced effect on this E_{on} vector.⁴

To illustrate and to aid in the use of the formulas, the following example is solved:

Find the voltage between the true neutral and the geometrical neutral for a system where the line voltages

$$I_1 = 57.7 \times 1.0 \left[\begin{aligned} & 1 \\ & \frac{1.0 + (1.0 - j1.0)(-0.5 - j0.866) + (0.5 + j1.0)(-0.5 + j0.866)}{1.0 + (1.0 - j1.0) + (0.5 + j1.0)} \end{aligned} \right]$$

$$= 57.7 (1 + 0.5928 + j0.1732)$$

$$= 92.1 + j10.0 = 92.6 \text{ amperes}$$

$$I_2 = 57.7 \times (1.0 - j1.0) [(-0.5 - j0.866) + 0.5928 + j0.1732] = -34.65 - j45.3$$

$$= 57.2 \text{ amperes}$$

$$I_3 = 57.7 \times (0.5 + j1.0) [(-0.5 + j0.866) + 0.5928 + j0.1732] = -57.35 + j35.3$$

$$= 67.6 \text{ amperes}$$

TABLE I.
CLOCKWISE OPERATORS

ϕ	α^{-5}	α^{-4}	α^{-3}	α^{-2}	α^{-1}	α^0	α^1	α^2	α^3	α^4	α^5
2	-1 + j0	1	-1 + j0
3	-0.5 - j.866	-0.5 + j.866	1	-0.5 - j.866	-0.5 + j.866
4	0 - j1.0	-1.0 + j0	0 + j1.0	1	1.0 + j0	-1.0 + j0	0 + j1.0
5309 - j.9511	-.809 - j.5878	.809 + j.5878	.309 + j.9511	1	.309 - j.9511	-.809 - j.5878	-.809 + j.5878	.309 + j.9511
6	+0.5 - j.866	-0.5 - j.866	-1 + j0	-0.5 + j.866	0.5 + j.866	1	0.5 - j.866	-0.5 - j.866	-1 + j0	-0.5 + j.866	+0.5 + j.866

COUNTER CLOCKWISE OPERATORS

2	-1 + j0	1	-1 + j0
3	-0.5 + j.866	-0.5 - j.866	1	-0.5 + j.866	-0.5 - j.866
4	0 + j1.0	-1 + j0	0 - j1.0	1	0 + j1.0	-1.0 + j0	0 - j1.0
5309 + j.9511	-.809 + j.5878	-.809 - j.5878	.309 - j.9511	1	.309 + j.9511	-.809 + j.5878	-.809 - j.5878	.309 - j.9511
6	+0.5 + j.866	-0.5 + j.866	-1 + j0	-0.5 - j.866	+0.5 - j.866	1	0.5 + j.866	-0.5 + j.866	-1 + j0	-0.5 - j.866	+0.5 - j.866

are 100 and where the constants of the three branches are, $Y_1 = 1.0$; $Y_2 = 1.0 - j1.0$; $Y_3 = 1/2 + j1.0$; (a) when phase rotation is clockwise and (b) when phase rotation is counter clockwise.⁵

Using equation (5) and Table I:

(cw) $E_{on} =$

$$57.7 \frac{1.0 + (1.0 - j1.0)(-0.5 - j0.866) + (0.5 + j1.0)(-0.5 + j0.866)}{1.0 + (1.0 - j1.0) + (0.5 + j1.0)}$$

(ccw) $E_{on} =$

$$57.7 \frac{1.0 + (1.0 - j1.0)(-0.5 + j0.866) + (0.5 + j1.0)(-0.5 - j0.866)}{1.0 + (1.0 - j1.0) + (0.5 + j1.0)}$$

$$E_{on} = -34.25 - j10 \text{ cw.}^6$$

$$E_{on} = 45.8 - j10 \text{ ccw.}^7$$

To further illustrate the use of the method of this paper, the currents are calculated.

The clockwise currents are, using equation (2).

The counter clockwise currents are, using equation (2),

$$I_1 = 57.7 \times 1.0 \left[\begin{aligned} & 1 \\ & \frac{1.0 + (1.0 - j1.0)(-0.5 + j0.866) + (0.5 + j1.0)(-0.5 - j0.866)}{1.0 + (1.0 - j1.0) + (0.5 + j1.0)} \end{aligned} \right]$$

$$= 57.7 (1 - 0.7928 - j0.1732) = 11.93 - j10.0$$

$$= 15.6 \text{ amperes}$$

$$I_2 = 57.7 \times (1.0 - j1.0) [(-0.5 + j0.866) - 0.7928 - j0.1732] = -34.65 + j114.6$$

$$= 118.5 \text{ amperes}$$

$$I_3 = 57.7 \times (0.5 + j1.0) [(-0.5 - j0.866) - 0.7928 - j0.1732] = 22.7 - j104.8$$

$$= 107 \text{ amperes.}$$

A quicker way to solve problems of this type is to lay off to scale a triangle of the three line voltages and on this graph locate the true neutral from the calculated value of E_{on} . All phase voltages may then be scaled off as the distance from the true neutral to the corners of the triangle. A phase voltage times the phase admittance equals phase current.

VII. Resonance. Resonance in an n -phase circuit may be defined as the condition under which

$$Y_1 + Y_2 + Y_3 + \dots + Y_n = 0 \tag{6}$$

4. See Numbers 8, 9, 14 of Bibliography.
 5. This problem is taken from page 377 of the 1917 Edition of Alternating Currents and Alternating-Current Machinery, by D. C. & J. P. Jackson.
 6. The solution given in D. C. & J. P. Jackson's Textbook.
 7. This solution is not mentioned in the above textbook.

With conditions approaching this, large currents will flow.

For the single-phase case, $\phi = 2$, resonance occurs when $Z_1 = -Z_2$. For the three-phase case, $\phi = 3$,

it occurs when $Z_1 = -\frac{Z_2 Z_3}{Z_2 + Z_3}$. For $\phi = 4$, it occurs when

$$Z_1 = -\frac{Z_2 Z_3 Z_4}{Z_3 Z_4 + Z_4 Z_2 + Z_2 Z_3}$$

As a resonant circuit will best illustrate the possibilities of a floating neutral system, the following test was carried out. A three-phase, star-connected circuit was prepared with the following constants: Number one branch an air-cored inductance of 0.1745 henry and 4.6 ohms d-c. resistance, number two branch a capacity of 106.2 microfarads, and number three branch a capacity of 105.6 microfarads. In each branch an ammeter was placed. A voltmeter was arranged to

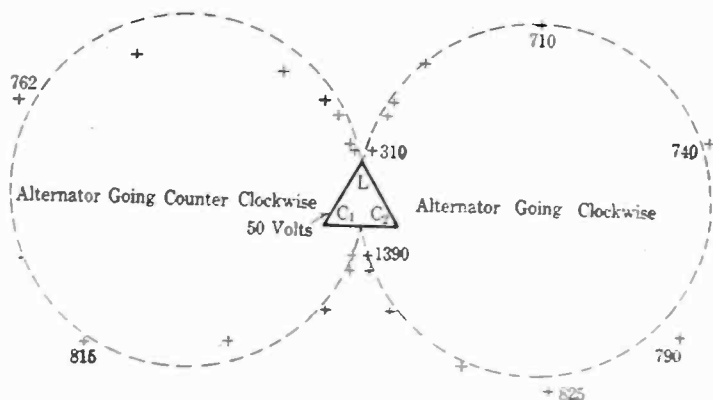

FIG. 4

read the three-line voltages and the three-phase voltages. Line voltages were maintained equal by adjusting the currents taken by an auxiliary three-phase load from the same alternator.

Speeds were varied from 300 to 1400 rev. per min. and readings of currents and voltages were taken for each speed. The results were then reduced to a standard line voltage of fifty, as represented by the triangle of Fig. 4. On Fig. 4 is plotted the true neutral as found by swinging from the appropriate corners arcs equal to the phase voltages. The neutrals so found are shown by crosses with the corresponding alternator speeds close by. By using formula (5) and the constants above the locus of the true neutral was found to be two circles somewhat larger than the two circles indicated by the test data. The explanation of this is that the resistance during the tests, *i. e.*, with alternating current, was slightly greater than that given by a d-c. measurement. It is interesting to note that if the resistance could be reduced to zero the locus for both directions of alternator rotation would be a straight line upward from the top vertex of the triangle and downward from the center of the base of the triangle.

VIII. BIBLIOGRAPHY

1. A. E. Kennelly, Determination of Current in 3-Pointed Star Systems, *Elec. World*, Vol. 34, 1899, p. 268.
2. A. E. Kennelly, Equivalence of Deltas and 3-Pointed Stars, *Elec. World*, Vol. 34, 1899, p. 413.
3. A. Burt, Three-Phase Power Factor, *TRANS. A. I. E. E.*, XXVII, 1908, p. 801.
4. H. P. Wood, Application of Symbolic Functions, *Elec. World*, June 16, 1910, p. 1597.
5. C. H. Johnson, Solution of Problems in Star-Connected Unbalanced 3-Phase Circuits, *Elec. World*, Dec. 15, 1910.
6. L. G. Stovkis, Analysis of Unbalanced 3-Phase Systems, *Elec. World*, May 1, 1915, p. 1111.
7. Gilman and Fortescue, Single-Phase Power Service from Central Stations, *TRANS. A. I. E. E.*, XXXV, 1916, p. 1329.
8. T. W. Varley, Determining Phase Rotation, *Elec. World*, Mar. 10, 1917, p. 466.
9. W. V. Lyon, Determining Phase Rotation, *Elec. World*, May 19, 1917, p. 968.
10. C. J. Feehheimer, Phase Rotation, *The Electric Journal*, 1917, p. 111.
11. V. Karapetoff, Harmonics in M-Phase Systems, *Elec. World*, Mar 30, 1918, p. 660.
12. C. L. Fortescue, Method of Symmetrical Coordinates, *TRANS. A. I. E. E.*, Vol. 37, 1918, p. 1027.
13. L. A. Doggett, Study of Unbalanced 3-Phase Loads, *Elec. World*, Sept. 6, 1919, p. 512.
14. W. V. Lyon, Unbalanced 3-Phase Circuits, *Elec. World*, June 5, 1920, p. 1304.
15. D. C. & J. P. Jackson, Alternating Current and Alternating-Current Machinery, The Macmillan Co., 1917, Ch. VIII.
16. Magnusson, Alternating Currents, McGraw-Hill Book Co., 1921, Ch. XXV.
17. Lawrence, Principles of Alternating Currents, McGraw-Hill Book Co., 1922, Ch. XII.

SPECIFICATIONS FOR ELECTRICAL INSTRUMENTS

Realizing the benefits which would result from national specifications for electrical measuring instruments in the United States, the Bureau of Standards has been striving to get consideration for the subject in this country. It has translated the French and German specifications and sent copies of them together with the British specifications to American makers and large users of electrical instruments.

In cooperation with the Instruments and Measurements Committee of the American Institute of Electrical Engineers, a personal canvass of the instrument makers of America has been made. The results of this canvass show that a majority of the makers are in favor of standard specifications and indicate the desirability of having tentative specifications prepared to serve as the basis for further discussion. Such a tentative specification was prepared and presented as an appendix to a technical paper on the standardization of electrical measuring instruments given before the convention of the American Institute of Electrical Engineers at Swampscott, Mass., last June. Further progress in the development of American standard specification will be based on the comments and suggestions which will be received from instrument makers and users.

A Miniature A-C. Transmission System

For the Practical Solution of Network and Transmission-System Problems

BY O. R. SCHURIG

Member, A. I. E. E.

General Electric Company, Schenectady, N. Y.

Review of the Subject.—The use of so-called "artificial lines" — i. e. miniature models of electric circuits — for experimental laboratory studies of transmission-line phenomena is well known. The miniature models are commonly made so as to represent, in true proportion, the electrical constants of a real line. Thus there are artificial telephone lines, artificial submarine cables, artificial long-distance power-transmission lines, etc. A miniature line is a true model of a real line to the extent that the miniature circuit has, for any desired degree of approximation, the same electrical behavior as the full-size circuit. Such laboratory models frequently permit — far more conveniently than the full-size circuit — the study of actual circuit phenomena in a practical and efficient manner. When their limitations are properly understood, miniature circuits may be of great value to transmission-line and operating engineers.

Miniature electric circuits may for the present purpose be divided into two general classes:

(1) Miniature circuits intended for the study of problems on long lines, such as lines having continuously distributed circuit constants.

(2) Miniature circuits for the solution of problems involving complete system networks, inclusive of generating-station and substation apparatus.

The following paper deals with a three-phase miniature a-c. system of the network type. The circuit includes synchronous machines, transformers, adjustable resistors, reactors, and condensers, for complete representation of generating stations, substations, lines and loads. The circuit connections are variable, so that any system having not more than the available number of circuit elements may be represented for the correct experimental solution of low-frequency problems.

This miniature system has so far given about three years of service in the experimental analysis of transmission system behavior, for existing systems and for systems to be constructed. The problems solved have been within the realms of both the designing and the operating engineers, and have been applied to power systems in this country as well as abroad.

One of the by-products of the miniature system is the confirmation and extension of the theory of transmission-line phenomena. Several prominent engineers have expressed the belief, and made the prediction, that after a few years of proper use of the miniature system, the theory and calculation of the present transmission problems will have been so well established that experimental solutions will no longer be necessary.

In this paper are given (1) a brief discussion of some of the present problems calling for solutions by the miniature experimental method, (2) a full description of the miniature equipment, (3) an outline of the operating procedure in the solution of problems, and (4) an example illustrating the application of the miniature equipment.

CONTENTS

Review of the Subject.	(440 w.)
Introduction.	(500 w.)
Object.	(45 w.)
General Discussion of Problems.	(70 w.)
Determination of Current Division Due to Normal Loads.	(325 w.)
Determination of Currents During Single-Phase Short Circuits, for the Protection of Circuits, and Associated Problems.	(500 w.)
Other Short-Circuit Problems.	(300 w.)
Problems of Stability of Machines.	(175 w.)
The Miniature A-C. System with Adjustable Circuit Constants.	(500 w.)
Operation of Miniature System and Measurements.	(700 w.)
Example	(100 w.)
Determination of Load-Current Flow in a System Network.	(1500 w.)
Conclusion.	(400 w.)

INTRODUCTION

A TYPE of miniature electric circuit which has been found to be of great practical value is one designed primarily for the experimental solution of problems arising in transmission networks. One of the problems is the determination of current division in a system network, both under normal load and during short circuit. Furthermore, the proper use of relays often requires definite knowledge as to both magnitudes and relative phases of currents and voltages at numerous points of a system under short-circuit conditions. The solution of these problems involves not only the line characteristics and the transmission network connections, but also the type and connections of transformers, the characteristics of synchronous apparatus and their location with respect to the transmission network. Likewise, the stability of rotating machinery, under changing loads or for different methods of system operation, is a highly important practical problem in connection with transmission system design and operation.

Presented at the Annual Convention of the A. I. E. E., Swampscott, Mass., June 26-29, 1923.

While a number of the problems of the type mentioned in the preceding paragraph can be and have been solved theoretically by calculation, experimental solutions are often desirable—not only as a means of verifying the calculations and thus establishing the practical value of, and the fullest confidence in, the theoretical solution, when the latter is possible,—but also as the only available practical procedure for problems not readily subject to theoretical solution.

The requirements of problems of the above type, suggest a laboratory miniature electric system embodying the following features:

Two or more generators capable of representing separate generating stations.

Two or more banks of transformers permitting a variety of connections in accordance with central-station practise.

Adjustable resistor, reactor and capacity units, for polyphase (three-phase) circuits.

A sufficient number of the line units to permit representation of interconnected networks (or at least of portions thereof).

Switching arrangements for facilitating the practical procedure of interconnecting the various elements of the miniature system in any manner desired.

Provision for inserting measuring instruments, actual relays, current transformers, etc. at any point of the system.

A sufficiently high rating of the miniature apparatus such as to render inappreciable the errors introduced by the connection of practical measuring apparatus to the system.

A miniature system designed to meet these requirements has been installed and experimented with in the General Engineering Laboratory at Schenectady. The conception of the plan is due to Mr. H. H. Dewey, and a considerable amount of preliminary work preparatory to the construction of the miniature system was done by Mr. W. W. Lewis. Acknowledgements are also due to Messrs. D. P. Savant and A. R. Miller for their work in connection with the design and installation of the miniature system. The miniature system was built in 1919 and has since then been applied to the solution of a variety of electric-circuit problems.

OBJECT

It is the object of this paper (1) to review and discuss the nature of some of the practical problems to which this miniature system is applicable, (2) to describe its essential parts, and (3) to illustrate by an example its application to practical problems.

General Discussion of Problems

Under this heading will be shown the practical nature, and the importance to transmission system design and operation, of some of the problems which called for the construction of the miniature transmission system. The results of the experiments made will not be presented here. In some cases these results were applicable to one central-station system only, in others they have been of a fundamental character and therefore applicable more generally. A number of problems of each kind considered below have been solved with the aid of the miniature system.

DETERMINATION OF CURRENT DIVISION DUE TO NORMAL LOADS

This problem, already referred to, is one of vital importance to the economical layout and efficient operation of a transmission system. For a purely radial system of transmission from generating station to substations, without interconnecting feeders between substations, calculations of current flow in the feeders are relatively simple. Experimental solution is then of no particular advantage. For complex networks, however, having numerous interconnecting tie lines, thus offering a multiplicity of paths of current flow from the generating stations (one or more), the calculations are quite lengthy and often impractical. The complications of calculations are due not only to the circuit

connections but also to the use of reactors—frequently causing dissimilar impedance angles in the various conducting elements of a network—and to dissimilar power factors of the loads on the system. Consideration has been given to the possible merit of approximating the solution of load-current problems by a d-c. experimental circuit, with the result that this sort of approximation cannot in general be expected to give reliable results, on account of the last-mentioned factors.¹ The experimental solution thus calls for an a-c. miniature system. With the proper equipment it is possible to determine, by the closing or opening of a switch, in the laboratory, the effect of adding to or withdrawing from the system a feeder or a tie line.

To summarize: The predetermination of normal current flow in the branches of networks is frequently desirable for the best design of new transmission systems as well as for the practical study of system additions or changes. The experimental solution of these problems calls for a miniature a-c. system.

DETERMINATION OF CURRENTS DURING SINGLE-PHASE SHORT CIRCUITS, FOR THE PROTECTION OF CIRCUITS AND ASSOCIATED PROBLEMS

When all three phases of a three-phase system are simultaneously short-circuited, the sustained short-circuit currents are balanced three-phase currents in all the circuit elements affected by the short circuit, regardless of the number of generating stations, the transformer connections or the circuit connections. For all other types of short circuits, an unbalanced current flow results. Such short circuits are

Short circuit between two phases,

One-phase-to-ground short circuit on grounded-neutral circuit,

Simultaneous ground short circuits occurring on two phases of a grounded-neutral circuit.

While there are a great many cases where consideration of three-phase short-circuit currents, as obtained by the short-circuit calculating table, is sufficient for the determination of relay settings, circuit-breaker ratings, electromagnetic stresses, etc., detailed studies of single-phase short circuits are often necessary, when it is considered that a large number of short circuits are of the single-phase variety.—According to L. C. Nicholson,² the short circuits due to lightning on an aerial system were observed to be proportioned as follows: 60 per cent two-wire short circuits, 10 per cent three-phase short circuits, and 30 per cent single-wire-to-ground flashovers.—During short circuits, causing an unbalanced current division among the phases, the voltages between the lines generally become distorted from their normal balanced condition (represented by an equilateral triangle of voltage vectors). This distortion

1. See discussions of the paper on "Experimental Determination of Short-circuit Currents in Electric-Power Networks," A. I. E. E. Midwinter Convention, New York, 1923.

2. Discussion, A. I. E. E. TRANSACTIONS 1911, part 1, p. 359

may be very pronounced at the points at which relay operation is desired. The distortions of the voltage triangle are due to the tendency for the voltage between the points short-circuited to approach zero. If, for example, a short circuit occurs between phases *A* and *B* on a three-phase circuit, the phases of which are *A*, *B*, and *C*, the voltage V_{AB} will approach zero at the point of short circuit, while the voltages V_{BC} and V_{CA} at the point of short circuit will tend to become equal, each being less than its normal magnitude before the short circuit. Moreover, the relative phases of currents and voltages throughout the system will be far different from those applying to normal load conditions or to three-phase short circuits. Calculation of power-directional relay torques (their magnitude and direction) for the types of short circuits under discussion is often extremely laborious in view of the above considerations. Miniature tests in the laboratory on a suitable a-c. miniature system enable practical data on the performance of power-directional relays to be obtained under short circuits simulating those in actual service. Furthermore, miniature studies of this kind permit the factors affecting voltage and current relations during short circuits and their bearings on relay performance to be analyzed. Consequently a miniature laboratory transmission system serves not only in the solution of protection problems for the selected systems tested in miniature, but should aid, above all, in the advancement of knowledge towards a fuller understanding of short-circuit phenomena.

OTHER SHORT-CIRCUIT PROBLEMS

If a station with *Y*-connected generators has one generator neutral grounded, the other neutrals being ungrounded, the current contributed by each of the ungrounded generators to a line-to-ground short circuit will differ from that obtained when all the generator neutrals are grounded. This problem lends itself to laboratory solution by a miniature transmission system. A similar problem is due to the use of multiple *Y*-connected transformers when only one transformer neutral is grounded.

For short-circuit current determinations the reactance values, under short-circuit conditions, of generators and transformers must be known, as well as the paths traversed by the short-circuit current components.

Other problems within this class are the determination of transient³ and sustained reactances, of an alternator when short-circuited between terminals or from one or more terminals to neutral in the various possible ways.

Since relay operation commonly takes place during the short-circuit transient, the rates of short-circuit current decrement are of importance in the adjustment and behavior of relays, and in circuit-breaker application. The difficulties of short-circuit current deter-

mination increase when several generating units of dissimilar rates of current decrement feed current into a short circuit. Their combined effects on the short-circuit current transient, on relay behavior throughout a system, and on circuit-breaker requirements may be studied experimentally in miniature. To vary the time-constants of alternator windings, inductances and resistances external to the miniature alternators may be employed. Fundamental data on this kind of problem may be gathered by miniature tests with the aid of oscillograph records of current and voltage, and may be confirmed, in some cases, by direct connection of relays to the miniature circuit.

PROBLEMS ON STABILITY OF SYNCHRONOUS AND INDUCTION MACHINES

Both synchronous machines and induction motors will perform their normal functions and run in a stable manner only if operated within certain limits of load and circuit conditions, but will become unstable⁴ under other operating conditions. One of the problems of growing importance, within this class, is that of the stability of operation of induction motors and synchronous motors at the receiver end of long high-voltage aerial transmission lines. For this kind of circuit the voltage, current and power conditions for stable motor operation may be materially different from those pertaining to motors operating on constant-voltage mains. Various problems of stability of both synchronous and induction machines lend themselves to solution by calculations, without tests, provided the machine characteristics and the circuit constants are known. Nevertheless, our understanding of instability problems of this type can hardly be said to have been advanced to the stage at which experimental solutions for the verification of calculations are no longer required.

The Miniature A-C. System with Adjustable Circuit Constants

The miniature system consists of the following equipment (see Fig. 1):

Generators: two type *A H I*, 3-phase, 4-pole, 3.75 kv-a., 1800-rev. per min., 110-volt, 60-cycle alternators, each coupled to a 10-h. p., 1700-rev. per min., 230-volt, d-c. motor. These generators are arranged for delta and star connections, and are of the revolving-field type. Each alternator may be operated as a synchronous motor driving its d-c. machine as a generator. A three-kw., motor-driven exciter set is provided.

Transformers: six type *M*, air-cooled, single-phase, 2 kv-a. 110/220-440-volt transformers. They may be connected to form two three-phase banks, thus per-

3. The "transient" reactance is the reactance determining the r. m. s. a-c. component of initial short-circuit current.

4. The word "unstable" is used here in the following sense: A synchronous motor becomes unstable when the relations of power supplied to the motor and power demanded by the motor are such as to cause it to drop out of synchronism and come to a dead stop; similarly, in induction-motor operation instability occurs at the breakdown point.

mitting the various customary transformer connections, including auto-transformer schemes.

Reactors: twenty-four reactors, single-phase, air-cooled, iron-core type with fixed air-gap. Each reactor

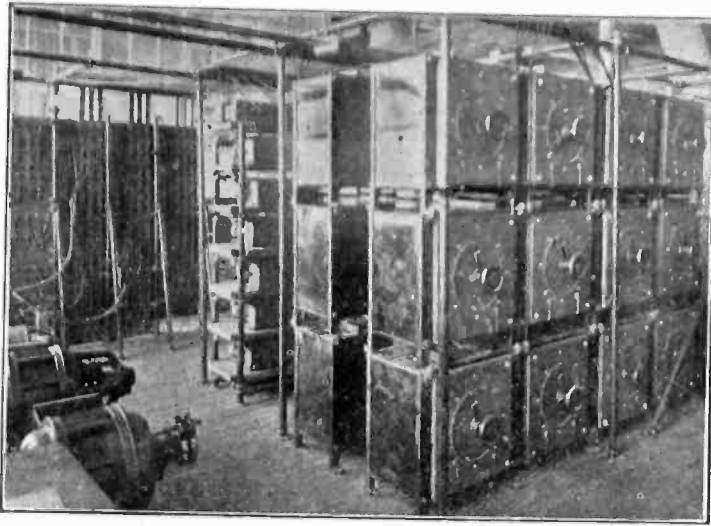

FIG. 1—MINIATURE ELECTRIC-POWER TRANSMISSION SYSTEM, VIEW OF RESISTANCE AND REACTANCE UNITS, OF SWITCHBOARD WIRING, OF ALTERNATORS AND OF EXCITER

Total floor space 18 ft. by 20 ft., including space for operator and instrument table.

has 15 taps brought to a terminal board. In this way, 128 reactance values are available, ranging from 0.2 to 30 ohms at 60 cycles. The sustained current-carrying capacity is 10 amperes. The reactance values are constant for current values up to 20 amperes. The

than 2 per cent of their resistance, and hence negligible. Their sustained current-carrying capacity is 10 amperes.

Condensers: The condensers are of the oil-immersed, flat, paper type. Enough units of approximately 2 and 5 microfarads are available to permit three-phase representation of lines several hundred miles long. The condenser units are not adjustable. The capacity values desired for any problem are obtained by series and parallel connections of the fixed units available. In Fig. 1 the condensers are not shown. Provision is made for connecting them to the back of the switchboard.

Switchboard: A slate switchboard for interconnecting generators, transformers and line units is shown in Fig. 1 (rear view). The permanent circuit connections are shown in Fig. 2. Jumpers with copper terminals to fit the studs and wing nuts on the front of the switchboard are provided for making the particular system connections required for any problem. Brass short-circuiting strips are used for bridging across the front terminals not needed for series-connected instruments or other series equipment.

OPERATION OF MINIATURE SYSTEM AND MEASUREMENTS

The resistor, reactor and condenser units may be used to represent either one phase (to neutral) of a three-phase balanced system under conditions of balanced current flow, or a full three-phase system for problems involving unequal current division among the

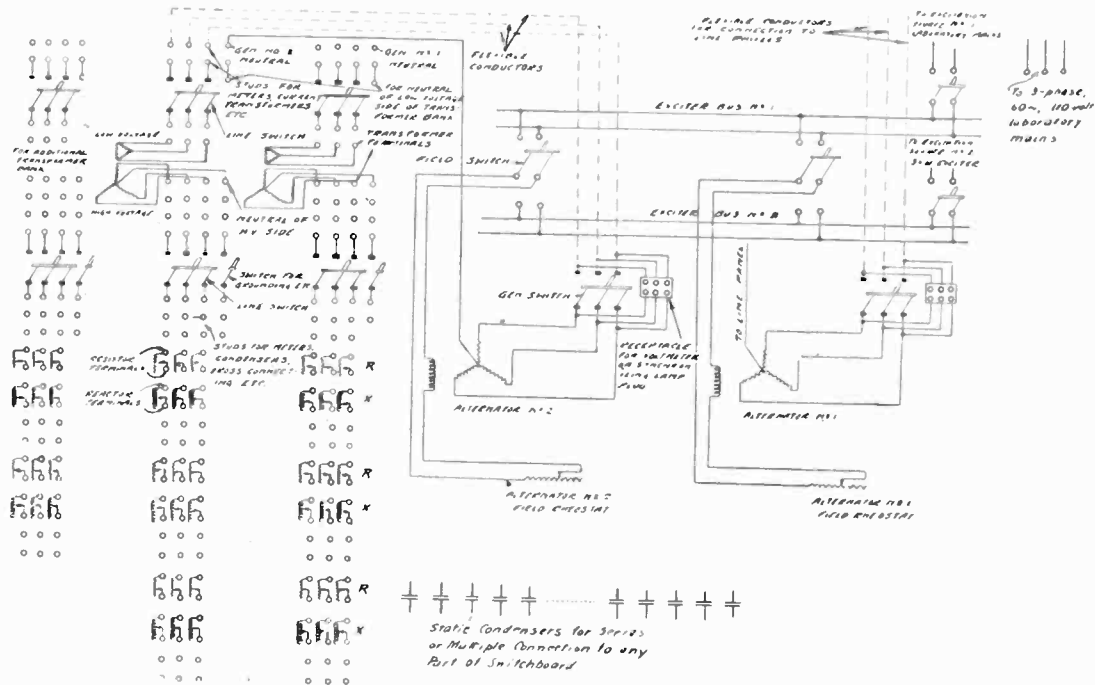

FIG. 2—WIRING DIAGRAM AND PANEL LAYOUT FOR MINIATURE TRANSMISSION SYSTEM

effective resistance of these reactors is negligible for all but the smallest values of reactance.

Resistors: twenty-four single-phase resistors, of "German silver" wire, wound on asbestos tubes; resistance range from 0.2 to 30 ohms, in 74 steps. The reactance, at 60 cycles per sec., of these units is less

phases and distorted line voltages. In the former arrangement (single phase to neutral) 24 independently adjustable circuit units may be represented, while in the latter arrangement 8 three-phase separately adjustable circuit elements of a network may be reproduced in miniature. The two three-phase alternators,

together with the 60-cycle laboratory mains, permit representation of three separate generating stations of a three-phase system. For problems involving loads, one or both alternators may be operated as synchronous motors to simulate separate loads, or any number of the available resistor and reactor units may be connected to represent single-phase or three-phase load impedances.

For the study of problems involving generating stations with step-up transformers and a transmission network, one method of operation is as follows (other methods are often desirable and may be employed within the range of conditions permitted by the equipment):

TABLE I

	Volts terminal voltage	Amperes full-load line current	Full-load kv-a.
Generators.....	110	19.7	3.75
High-tension line conditions for delta-delta transformer connections, ratio 1:4.....	440	4.9	3.75

Under these or similar conditions, the circuit will accommodate a variety of relays, also current transformers. Frequently, the reduction factors from actual system values to miniature system values of voltage, current and impedance may be chosen such that the insertion of these devices introduces but negligible changes of circuit conditions. In other cases, proper allowance is made in the circuit constants for the impedance of the series devices inserted.

Under the circuit conditions of Table I, the constants of the apparatus of the miniature system are those shown in Table II.

TABLE II
CIRCUIT DATA FOR MINIATURE SYSTEM

Generators (When Delta-connected)		
Three-phase rating.....	3.75 kv-a.	
Current.....	19.7 amperes	
Voltage.....	110 volts	
Resistance per coil.....	0.17 ohms	1.8%
"Transient" reactance.....	0.48 ohms	5 %
Synchronous reactance.....	4.4 ohms	45. %
Transformers (Delta-delta connection)		
Total equivalent resistance.....	1.1%	
Total equivalent reactance.....	1.6%	
Total equivalent impedance.....	1.9%	
Resistors*.....	0.4% to 58%	
Reactors*.....	0.4% to 58%	

*Based on three-phase rating of 3.75 kv-a. at 440 volts.

It is often convenient to observe sustained short-circuit conditions with the aid of indicating instruments. Such observations are permitted in view of (1) the overload capacity of the principal equipment and (2) the wide range of the circuit constants.

Oscillograph measurements may be made for the determination of short-circuit transients (limited, of course, to those at fundamental frequency). The miniature system is not applicable to the solution of high-frequency problems, such as arise in connection

with lightning disturbances, arcing grounds, switching, etc. Experimental data on such problems may be obtained from tests of actual systems or, in some cases, from laboratory tests of "smooth" miniature circuits (*i. e.* circuits with continuously distributed, rather than lumped, circuit constants).

The lumped circuit units of resistance, reactance and capacity in the miniature system under consideration do, however, permit correct representation of the steady-state behavior of long transmission lines at any one desired value of (low) frequency—such as 60 cycles per sec.

Example

A simple example is given below to illustrate the method of procedure in a miniature test, the magnitude of the circuit values employed, and the accuracy of the results obtained. Thus the items to be dealt with are the following:

- (1) the derivation of the miniature-system circuit data employed in the tests, from the full-size data,
- (2) the results of the miniature tests,
- (3) the conversion of these results into full-size system values,
- (4) the determination, by means of calculations, of the accuracy of the results,
- (5) a comparison of the results obtained by miniature tests with those measured on the full-size system.

DETERMINATION OF LOAD-CURRENT FLOW IN A SYSTEM NETWORK

The circuit to be considered is that of Fig. 3A, which was reduced to that of Fig. 3B for purposes of simplification. It is desired to determine the normal current

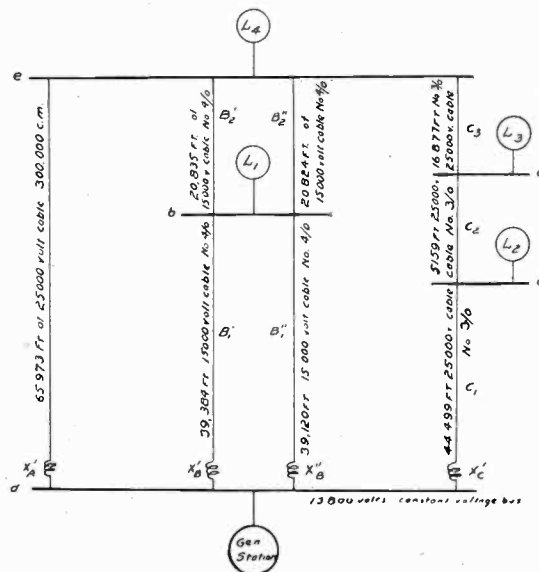

FIG. 3A—ONE-LINE CIRCUIT DIAGRAM FOR THREE-PHASE, 60-CYCLE NETWORK WITH BALANCED LOADS

flow throughout the network when the following data are given: Four loads, the impedance values of the network branches and the generator bus voltage. The data appear in column 2, Table III. The problem is one of the simplest which has been encountered and

can, of course, be solved by calculation. Its value should, therefore, not be judged on the basis of complexity. On the other hand, its merit lies in the fact that full-size system tests could be made for comparison with the miniature tests. Furthermore, the procedure in a more complex test differs in no essential respects from that outlined in this case.

three-phase) system is made, the three-phase miniature system value of kv-a. equivalent to the full-size value of 11,820 kv-a. is:

$$\frac{3 \times 440 \times 18}{1000} = 23.7 \text{ kv-a.}$$

This gives a kv-a. reduction factor of $\frac{11,820}{23.7} = 498$, or approximately 500, which latter value will be used.

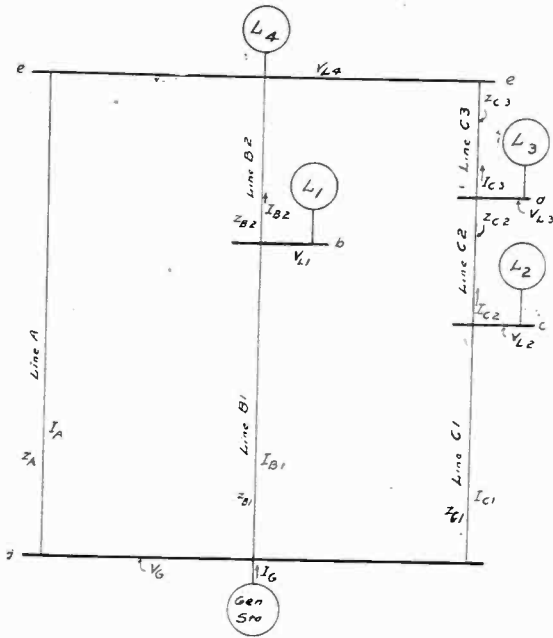

FIG. 3B—THE SIMPLIFIED DIAGRAM OF CIRCUIT 3A AS EMPLOYED IN MINIATURE TESTS

One of the most essential steps in the procedure is the choice of suitable conversion factors to be applied to the full-size data. Each problem to be solved generally calls for different reduction factors. Separate factors apply, in any one case, to the values of current, voltage, power, and impedance. A number of items which determine the reduction factors are: current, voltage, and kv-a. rating of full-size circuit; the range of the miniature-system circuit constants; the type of problem, that is, whether short-circuit problem or normal-current problem; the method of measurement to be employed, *i. e.* whether oscillograph or indicating-meter method; the accuracy of the results desired.

For the problem under consideration, the miniature series impedances representing the lines should be as large as possible, on account of accuracy, and the current values should likewise be sufficiently high to give reasonably precise readings on the available indicating ammeters and wattmeters of low series impedance. A current value between 5 and 10 amperes, say 6 amperes, is a convenient one for the average of the currents in the principal lines A, B₁, and C₁ (in Fig. 3B). Thus a total generator current I_g of approximately 18 amperes is obtained, representing a full-size-system total generator output of 10,400 kw., or 11,820 kv-a. at a power factor of 0.88 (see bottom of column 2, Table III.) If, then, 440 volts are used — this value being the rated voltage of the high-voltage miniature equipment — and a line-to-neutral, single-phase representation of the (balanced

TABLE III
FULL-SIZE SYSTEM DATA AND CORRESPONDING
MINIATURE TEST VALUES

1	2	3	4	
Symbols refer to Figs. 3A & 3B	Full-size Data for balanced 3-φ system	Data Reduced to Miniature scale by conversion factors*	Miniature system data employed in test	
Line A reactor X _A '	0 + j 1.20 ohms			
Line A cable Z _A ''	2.42 + j 2.40 ohms			
Total Line A, Z _A	2.42 + j 3.60 ohms	3.70 + j 5.50	3.70 + j 5.54	
Reactors X _B ' = X _B ''	0 + j 3.65 ohms			
Impedances of Cables B ₁ ' & B ₁ ''	2.04 + j 1.39 ohms			
Total line B ₁ , Z _{B1}	1.02 + j 2.52 ohms	1.56 + j 3.85	1.51 + j 3.87	
Impedances of Cables B ₂ ' & B ₂ ''	1.25 + j 0.855 ohms			
Total line B ₂ , Z _{B2}	0.625 + j 0.427 ohms	0.95 + j 0.65	1.00 + j 0.68	
Reactor X _C '	0 + j 5.12 ohms			
Cable C 1	2.92 + j 1.76 ohms			
Total line C 1, Z _{C1}	2.92 + j 6.88 ohms	4.46 + j 10.50	4.68 + j 10.46	
Total line C 2, Z _{C2}	0.34 + j 0.204 ohms	0.52 + j 0.31	0.25 + j 0.40	
Total line C 3, Z _{C3}	1.105 + j 0.668 ohms	1.68 + j 1.02	1.61 + j 1.08	
			Single-phase kw.	Single-phase p. f.
	kw., 3-φ	p. f.		
Load L 1	1862	0.82	1.24	0.84
Load L 2	1060	0.695	0.707	0.670
Load L 3	200	0.50	0.133	0.129
Load L 4	not given		4.18	0.94
Total generator load	10,400	0.88	6.93	0.86
Line voltage bus a	13,800 volts		440 volts to neutral	440 volts to neutral

*The full-size-to-miniature reduction factors are as follow: For computing miniature system values, divide the full-size values by these quantities:

- 500 for power or kv-a.
- 18.1 for voltage
- 27.6 for current
- 0.655 for resistance, reactance, or impedance

From the figures already given, the voltage reduction factor is $\frac{13,800}{440\sqrt{3}} = 18.1$. Consequently, the current

reduction factor is $\frac{500}{18.1} = 27.6$, and the impedance

reduction factor is $\frac{18.1}{27.6} = 0.655$; that is, the minia-

ture-system resistance and reactance values are numerically larger than those of the full-size system.

With these ratios, the desired miniature-circuit values of Table III, column 3, were obtained. Capacity charging currents, being practically negligible for the purpose of these tests, were left out of consideration. The effect of measuring instruments on the circuit impedances will be illustrated for the case of line B_1 . From Table III, column 3, the desired miniature value of Z_{B1} is $1.56 + j 3.85$ ohms. A 10-ampere ammeter and a 10-ampere current-coil of a wattmeter (both of type P3) introduce additional series impedances of $0.044 + j 0.019$ ohms and $0.030 + j 0.014$ ohms, respectively, representing a total combined impedance of $0.074 + j 0.033$ ohms due to the instruments. For line B_1 the

resulting errors are then $\frac{0.074}{1.56} \times 100 = 5$ per cent

for the resistance component, $\frac{0.033}{3.85} \times 100 = 1$ per

cent for reactance component, and, likewise, 2 per cent for impedance magnitude. The impedance error is negligible. In other cases, the resistance and reactance box settings were reduced in accordance with the instrument impedances, if the latter were more appreciable.

The loads L_1, L_2, L_3 and L_4 were represented as constant impedances by adjustable resistance and reactance units. It is quite feasible, when desired, to employ one or both of the 3.75 kv-a. alternators as motors in place of constant-impedance loads, as already indicated.

In column 4 of Table III, are shown the miniature-system data employed in the tests. These values differ slightly from those of column 3, *i. e.* from the desired miniature values, on account of the steps of the variable resistors and reactors. The differences in question, however, do not exceed 6 per cent for the values which determine the accuracy of the results.

From the four load values and the circuit impedances given in Table III, the experimental miniature results and the corresponding full-size results shown in Table IV were obtained. The results comprise the currents throughout the network and the voltages at the substation busses, for balanced generator voltages and balanced loads. A sufficient number of phase angles were determined, with the aid of indicating wattmeters, to establish definitely the phases of all currents throughout the system.

Vector calculations for the accuracy of the miniature results were made, as indicated in Fig. 4. The vector voltage drops over each of the three paths from bus a to bus e (see Fig. 3b) were obtained by complex algebra, by multiplication of test current values (converted to full scale, from Table IV last column) with actual-system impedances (from Table III, column 2). The maximum per cent mutual disagreement between the voltage drops so found is 7.5 per cent, while their per cent deviation from the average of the voltage drops is of the order of 4 per cent or less. It may, therefore,

be concluded that the errors of the current values are of a similar order of magnitude. The errors include, of course, those due to current and impedance magnitudes and phases. In view of the small errors of voltage

TABLE IV
RESULT OF MINIATURE TESTS FOR CIRCUIT DATA OF
TABLE III AND FIG. 3

	Miniature Test Values		Data converted to full-size scale by conversion factors
	Amperes		Amperes
Current I_A	5.88	27.5° lag*	162
" I_{B1}	8.25	33.1° lag*	228
" I_{B2}	4.74		131
" I_{C1}	3.27	37.6° lag*	90.2
" I_{C2}	1.07		29.5
" I_{C3}	0.80		22.1
" I_{L1}	3.51		97.0
" I_{L2}	2.39		66.0
" I_{L3}	0.645		17.8
" I_{L4}	11.1		306
" I_G	17.4		480
	Volts to neutral		Volts line-to-line
Voltage V_G	440		13,800
" V_{L1}	407		12,770
" V_{L2}	404		12,680
" V_{L3}	403		12,640
" V_{L4}	402.5		12,620

*Lag angles referred to voltage V_G to neutral.

drops, the errors of the bus voltages obtained by miniature test should be so small as to be hardly noticeable.

Finally, a comparison between actual-system tests and miniature-system tests will be made. While the load-

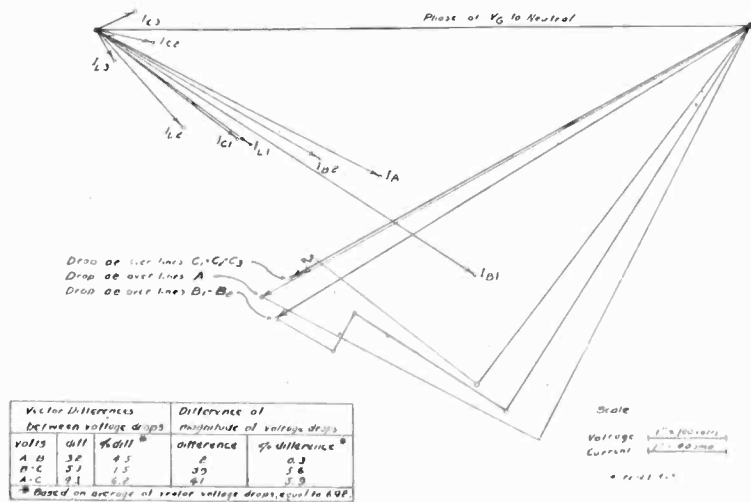

FIG. 4—VECTOR DIAGRAMS OF VOLTAGE DROPS OVER THE LINES OF FIG. 3b FOR TEST CONDITIONS OF TABLE IV

These voltages were obtained by multiplying test values of full-size currents by actual-system line impedances. Disagreement between vector voltage drops is due to test errors.

kw. and power-factor values for these tests were the same as those previously employed (Table III, column 2), the line reactors X_{11}' , X_{11}'' and X_{c1}' were omitted, all other impedance data being those of Table III. In the miniature tests, the load values (in kilowatts) were adjusted, as before, to approach reasonably closely to

the values obtained in the actual-system tests, according to the lower part of Table III. Comparative results of both tests, shown in Table V, indicate discrepancies of less than 5 per cent. with the exception of the values of power for line A, which differ by 10 per cent. In the consideration of these differences, the complications involved in the actual-system measurements—made at mutually remote points under varying loads, with

system not only to solve practical problems for transmission and operating engineers, but also to confirm, in several instances, the theory underlying calculations of circuit phenomena. The experimental laboratory solution has been compared, and found to be in good agreement, with the results of tests made in the field on commercially operating circuits and with the results of calculations.

TABLE V.
COMPARISON OF MINIATURE-CIRCUIT AND ACTUAL-SYSTEM TESTS

	Results of Miniature Tests				Results of Actual system tests		% discrepancy between miniature & full-size results; % based on full-size values
	Small-scale values		Equivalent full-scale values		Amperes	Power factor	
	Amperes	Power factor	Amperes	Amperes corrected for voltage*			
Current I_A	4.00	0.68	111	106	105	0.77	For current
" I_{B1}	9.77	0.92					0.9%
" B_1'	4.88	0.92	134	128	130	0.88	1.5%
" B_1''	4.89	0.92	135	129	135	0.92	4.5%
" I_{C1}	4.18	0.89	115	110	108	0.91	1.7%
	Single - phase kw.		3 - phase kw.		3 - phase kw.		for kilowatts
Kilowatts line A...	1.20		1800		2000		10%
" " B_1 ...	3.94						
" " B_1' ...	1.97		2950		2850		3.5%
" " B_1'' ...	1.97		2950		3100		4.8%
" " C_1 ...	1.64		2460		2450		0.4%
	Line-to-neutral volts		Line Voltage		Line voltage		
				corrected†			
Voltage V_G	440		13,800	14,400	14,400		

*Corrected by factor 138/144 due to difference of generator voltages in miniature and full-size tests.

†Correction factor 144/138 applied.

switchboard instruments,—should be taken into account. It may, therefore, be concluded that the miniature-test data are a good equivalent of the actual-system behavior. Moreover, the preceding comparisons established a relatively good accuracy of the actual-system tests.

Conclusion

The miniature a-c. electric power transmission system described permits the experimental solution, in the laboratory, of operating and design problems for actual transmission systems. Generating stations, transformers, substations, the transmission network and loads for systems may be correctly represented in the laboratory. Conditions of normal operation as well as short-circuit conditions may be reproduced. High-frequency transients, such as traveling waves, cannot be experimented with on this type of miniature system, on account of its lumped circuit elements, but the low-frequency transients, such as those of alternating-current generators, are correctly shown in the miniature circuit. Adjustable circuit constants, and quickly variable circuit connections, are used to permit miniature representation of the majority of the customary circuit conditions and system connections.

It has been possible with the aid of this miniature

ADJUSTMENT OF AUTOMOBILE HEADLIGHTS

Satisfactory specifications for the testing of headlight lenses are available as the result of careful work by the Illuminating Engineering Society. For regulatory purposes, these specifications have been approved by the Society of Automotive Engineers. Based on these specifications 11 states have prepared a list of 27 lenses which, when properly adjusted, comply with the Illuminating Engineering Society's specifications as to intensity and distribution of light. Notwithstanding this fact that adequate specifications are available and are now being used for the approval of types of lenses, the situation in general is not satisfactory because a large majority of headlights are not properly adjusted. To secure information covering this point, the Bureau of Standards conducted tests on headlights of over 400 cars operated in the District of Columbia and voluntarily submitted for test. Although 72 per cent of these cars were equipped with lenses of the type included in the approved uniform list, only 5½ per cent of these headlights were in good condition. For the past month the Bureau has been engaged in an active campaign to secure better adjustment of headlights and has given most of its attention to the conditions existing in Washington.

A Continuous-Current Generator for High Voltage

BY S. R. BERGMAN

Associate A. I. E. E.
Consulting Engineer, General Electric Company

Review of the Subject.—Of all electro-dynamic machines, the direct-current machine probably is the best understood. It was the first machine to be commercially utilized and it is an interesting matter from an engineering standpoint to follow the evolution which this type of machine has passed through. The first great improvement to be incorporated in this type of machine was the application of commutating poles. As is the case in any radical development, engineering opinion was much divided as to the usefulness of such a construction. At first it was held that commutating poles were only useful where the service was severe, as, for example, in adjustable speed motors covering a large speed range. Today, however, it is well realized that commutating poles are advantageous in all kinds of direct-current machines, except in very small machines of fractional horse power output.

It is well understood in the art that commutating poles alone do not offer a perfect solution of the direct-current problem, since there exists in such machines troublesome flux distortions. Many attempts have been made to overcome this by aid of distributed windings, and in this paper is described a form of such windings, which

have given excellent results both from an operating and an economical standpoint. This distributed winding consists of two parts, one of which may be considered a counterpart of the armature, and is called a compensating winding. This winding opposes the armature reaction in every point around the circumference and effectively prevents any distortion of the flux. There is also a second winding for supplying the excitation and as is described in the paper, this winding is also distributed.

By aid of such field windings, it is possible to meet very extreme conditions of service, for example, as is met with in high-voltage machines. In the machine that is described, the voltage between bars runs up to about 100 volts, or nearly four times the conventional value; nevertheless, the commutation is perfect. Machines rated 15 kw. have been built successfully up to 15,000 volts.

One of the mechanical difficulties in building high-voltage, direct-current machines lies in the building of the commutator. A novel type of commutator is described in the paper. This commutator construction provides simple means for holding the segments together, and at the same time secures high insulation qualities.

A PROBLEM of long standing in electrical engineering, which offers many difficulties both from an electrical and from a mechanical standpoint, is that of producing continuous-current machines for very high voltages. The application of high-voltage continuous current to power transmission has been seriously considered, and to a small extent carried out abroad by Thury. The Thury system consists of a number of series-excited generators coupled in series, each generator being designed for a moderate voltage of a few thousand volts. While this system has been actually carried out in a few instances abroad, it has not had any application in this country, and since the generators are only of moderate voltage, their structural features, viewed from the standpoint of high voltage, do not appear to be of any great interest since the voltage that we are considering ranges as high as from 12,000 to 20,000 volts per generator.

In the early development of arc lighting, machines for high voltage were produced to give unidirectional, but pulsating current. The voltage ran as high as 10,000 volts per circuit. Examples of this type are the well-known Thomson-Houston arc generator and the Brush arc machine. These machines cannot, however, be considered continuous-current machines since they produce a pulsating current. They are of the open coil type and come nearer to that type of apparatus known as rectifiers. A very marked arcing occurs on the rectifying segments, and since the current is pulsating, this type of machine cannot be used for any purpose requiring a non-pulsating voltage.

Lately, a demand has been created for continuous current machines of high and steady voltage for wire-

less work. By means of vacuum tubes, the direct current is converted into high-frequency alternating current. This system has proved to be successful and possesses a great many advantages. The purpose of this article is not to discuss the system as a whole, but to describe the design and construction of continuous-current generators built for wireless applications and ranging in voltage from 12,000 to 20,000 volts. It is believed that this type of machine possesses a number of novel features of general interest.

Early experiments with high-voltage, continuous-current machines for wireless work have shown that under certain conditions, difficulties arose due to pulsations in the current wave. At first, it was thought that this was due to the fluctuations inherent in any commutator machine, since the resultant voltage in such machines is, in reality, a rectification of a large number of coils. However, these fluctuations often became much larger than the theoretical value, and an investigation disclosed that these fluctuations were mainly due to faulty commutation. If the current is not properly commutated, it is a well-known fact that the extra currents react magnetically upon both the exciting and commutating circuits, resulting in changes in the induced voltage. It is, therefore, essential that the commutation should be absolutely perfect.

Another difficulty that is met with due to the characteristics of the tubes, is the possibility of dead short circuits. The machine must, therefore, be built to withstand short circuits without flashing, since flashing at this high voltage may seriously damage the commutator and brush rigging.

Another difficulty in designs of this nature lies in the mechanical limitation of the number of segments in the commutator. It is generally considered that in con-

Presented at the Annual Convention of the A. I. E. E., Swampscott, Mass., June 26-29, 1923.

tinuous-current machines, the average voltage between bars should not exceed 25 volts. In order to limit this voltage, two armature windings are employed, each winding connected to a commutator at each end of the armature. An investigation of the mechanical dimensions of a 15-kw. generator showed that by employing the largest number of segments that were practical per commutator, the average volts per bar become about 90 volts, or nearly four times the conventional value.

One of the serious questions is, therefore, whether it is possible to build a continuous-current machine having 90 volts per bar which will withstand instantaneous short circuit without flashing.

It is well understood that where commutation conditions are severe, as in motors which must operate over a wide range of speed, or in machines which have to endure heavy and sudden fluctuations in load, the operation of direct-current machines can be greatly improved by employing a compensating winding for neutralizing the armature reaction. A well-known form of a compensated machine consists of a concentrated form of exciting winding with definite poles and a compensating winding laid into the pole faces. Experiments have shown that a still better operation can be obtained if both the exciting and the compensating windings are distributed. Windings of this type were, I believe, first proposed by Deri, but, as far as I am aware, this type of winding has not been

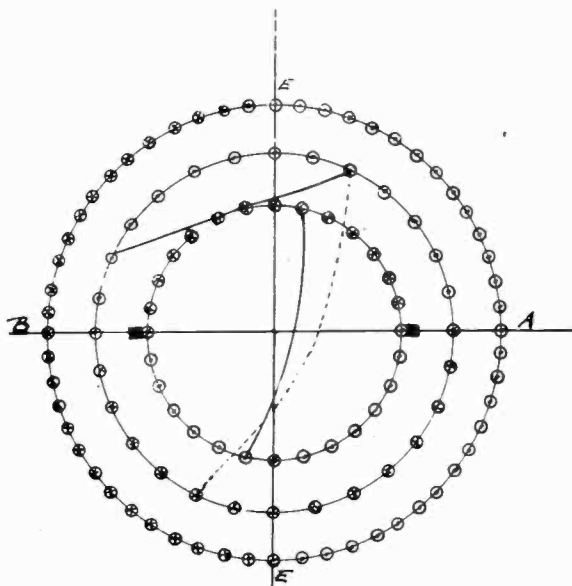

FIG. 1

employed to any large extent in the industry due to the additional expense of such windings, both due to material and labor. The writer has, however, found that by distributing the compensating and the exciting windings in a certain way, it is possible to obtain results which are electrically perfect, mechanically simple and economical with respect to material.

In order to explain the arrangements proposed by the writer, reference is made to Fig. 1, representing a two-

pole machine. The inner circle represents the conductors of the armature winding, the middle circle represents the conductors of the compensating winding, and the outer circle represents the conductors of the exciting winding. The current distribution in the conductors is shown by means of the usual convention in which crosses and dots applied to the conductors indicate respectively that the current is flowing away from or toward the reader. The direction of the armature reaction is obviously indicated by the line *A B*. The

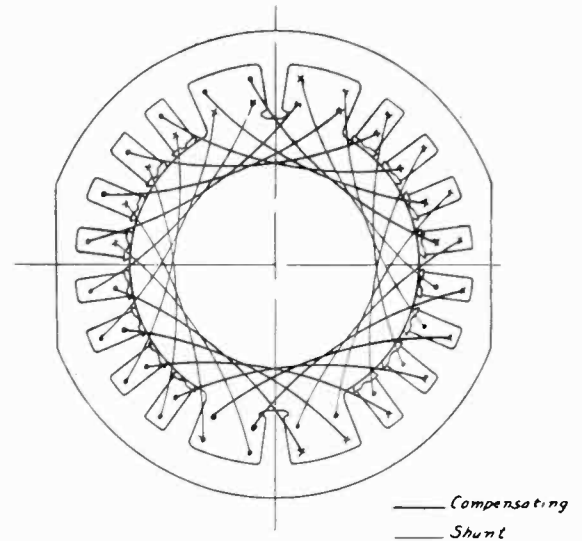

FIG. 2—FIELD WINDING FOR 12,000-VOLT, D-C. GENERATOR

compensating winding is so arranged that the current in each conductor is flowing in the opposite direction to the current in the opposite conductor in the armature. The compensating winding accordingly produces a resultant magnetomotive force in the direction *B A*, opposite to the armature reaction. The exciting winding should be so arranged that its magnetic polarization is along the line *E E*, *i. e.*, displaced 90 electrical degrees in space from the line *A B*.

Referring again to Fig. 1, it is indicated that the armature winding is a full-pitch winding. The compensating and the exciting windings would, most naturally, also be laid out as full-pitch windings in which case the end connections would be represented by the dotted line in Fig. 1, in such case the compensating winding would be a counterpart of the armature winding mechanically as well as electrically. The writer, has, however, found that exactly the same distribution of the field winding can be obtained by the use of a 50 per cent pitch winding, one single coil being indicated by the full drawn line in Fig. 1. In Fig. 2 all of the coils are shown, and it will be observed that in each slot there is a compensating as well as an exciting coil, and that all of the coils together form a mechanically single winding similar to lap windings as they are often used in the field of induction motors. It is interesting to note that the armature reaction of a full-pitch armature winding is neutralized by a completely distributed winding of a half pitch. It is

obvious that by the use of a half pitch winding in the field, a large economy is obtained as compared with a full-pitch winding, because both windings exert exactly the same amount of magnetomotive force by the use of the same number of turns, but the length of the turns of the half pitch windings is far shorter than in the full pitch winding. From Fig. 2 may be seen that the teeth of the field are evenly distributed except that one tooth on each side of the commutating tooth is left out, thereby creating a wide neutral zone.

An examination of Fig. 2 reveals the fact that the construction provides for two commutating teeth. The compensating winding is made slightly stronger than the armature reaction and the difference in ampere turns sets up a commutating flux through the commutating teeth.

Experiments have shown that the fully distributed exciting winding has the advantage of producing a nearly sine wave flux distribution, resulting in a gradual building up of the voltage gradient on the commutator.

The slots as shown in Fig. 2 are open, making it possible to wind and insulate the coils outside of this machine. After the coils have been assembled, steel wedges are inserted closing the slot openings. The wide slots on each side of the commutating pole do not contain steel wedges since that would be undesirable as it would cause the commutating flux to leak sideways instead of penetrating the armature.

The most important feature of this new machine is illustrated in Fig. 2 and the advantage of this construction may be summarized as follows:

First: A mechanically simple single-coil winding is used, which winding is economical with respect to material, due to the use of a 50 per cent pitch.

Second: A single compensating winding is used both for the purpose of neutralizing the armature reaction and producing a commutating field.

Third: The exciting winding is fully distributed giving the advantage of being placed close to the armature, thus securing a minimum of leakage, and also giving a nearly sine wave flux distribution.

Fourth: Wide neutrals are provided so as to remove the exciting flux from the coils undergoing commutation.

The armature, as has already been stated, carries two independent windings, each being connected to a commutator. As the bottom winding naturally has more self induction than the top winding, it was found that if the compensating winding was adjusted to give black commutation for the top winding, the brushes on the commutator belonging to the bottom winding would spark. Vice versa, if the compensating winding were adjusted properly for the bottom winding, the top winding would spark. It is obvious that the bottom winding, which possesses the larger self induction, reverses more slowly than the top winding and it was found that this difficulty could be overcome by the use of thicker brushes for the bottom winding than for the

top winding. The brushes on the commutator connected to the bottom winding were about one-third thicker than the brushes belonging to the top winding.

In order to further illustrate the field winding, in Fig. 3 are shown the field coils developed in a plane. In Fig. 4 is shown the connection diagram of the machine, and as may be seen, a separate exciter is used in preference to self excitation. The reason for using a separate exciter is two-fold:

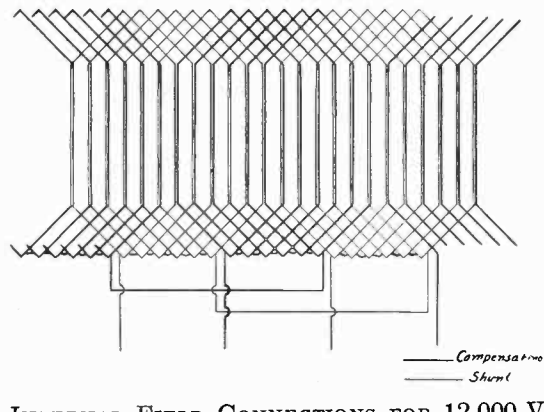

FIG. 3—INTERNAL FIELD CONNECTIONS FOR 12,000-VOLT, D-C. GENERATOR

First: It would be difficult to wind and insulate a shunt field for 6000 volts and above, which is the voltage on one commutator.

Second: At a sudden variation of the load, the tremendous induction of the shunt field would cause a discharge through the armature setting up disturbances and possibly making the machine flash over.

Tests have proved that this machine possesses ex-

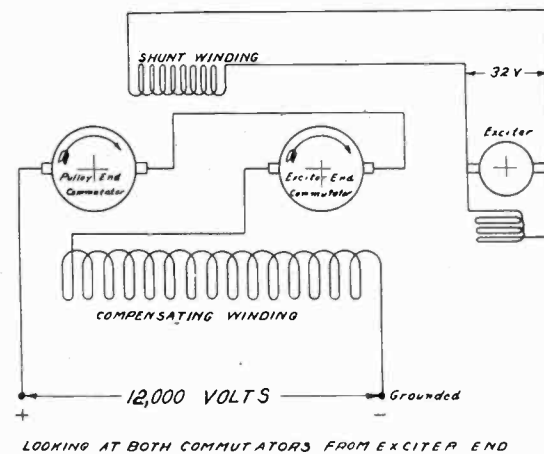

FIG. 4—CONNECTION DIAGRAM FOR 12,000-VOLT, D-C. GENERATOR

cellent operating qualities. The commutation is perfect up to five times load, which load can be thrown on and off without causing any sparking or the slightest amount of flashing. The excitation can be thrown on and off without any resistance being inserted in the exciting winding. Instantaneous short circuits through the tubes, which have repeatedly occurred, do not disturb the machine in the least.

During the construction of the first sample machine, serious difficulties arose in the building of the commutators. The first commutators were constructed in accordance with standard practise, the commutator bars being clamped in place by mica cones, the cones being moulded from what is known as pasted mica. It was found that these mica cones would not withstand the required testing voltage, which was set as high as 40,000 volts.

This difficulty was finally overcome by a new method of building commutators, the construction of which is shown in Figs. 5 and 6. The idea originated from the construction of a special gear made by the General

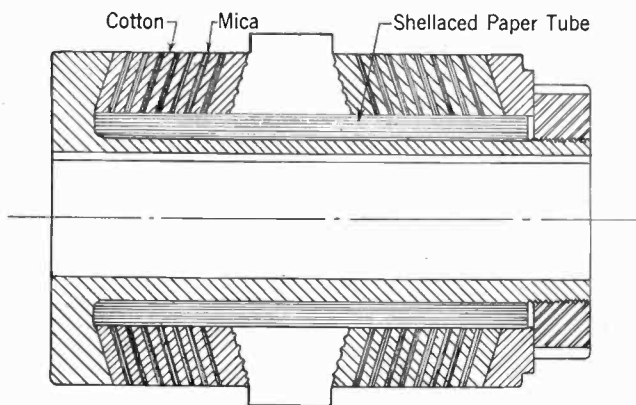

FIG. 5—FABROIL COMMUTATOR FOR 12,000 VOLTS

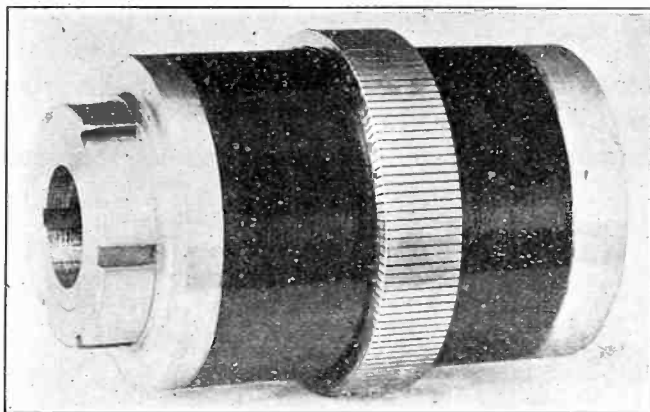

FIG. 6—FABROIL COMMUTATOR FOR 10,000-VOLT, D-C. GENERATOR

Electric Co., called "the fabroil gear." The commutator segments are held together under heavy pressure between washers of cotton batting and in order to obtain high dielectric strength, washers of mica are interspersed between these cotton washers. The commutator is put up under a very heavy pressure, about 5 tons per square inch, amounting to a total pressure on the particular commutator under consideration of 120 tons. As cotton possesses the characteristic of resiliency under heavy pressure, the pressure is maintained at all times and the commutator, therefore, is tight under all conditions. Therefore, there need be no provisions made for tightening the commutator after it is once completed. This construction gives a three-fold advantage:

First: We obtain a large and clean creeping distance to ground.

Second: The multiplicity of mica washers provides an excellent insulation since these washers are placed in series with the voltage, a factor which is not obtainable by constructions heretofore employed in commutators.

Third: The commutator, being under a continuous

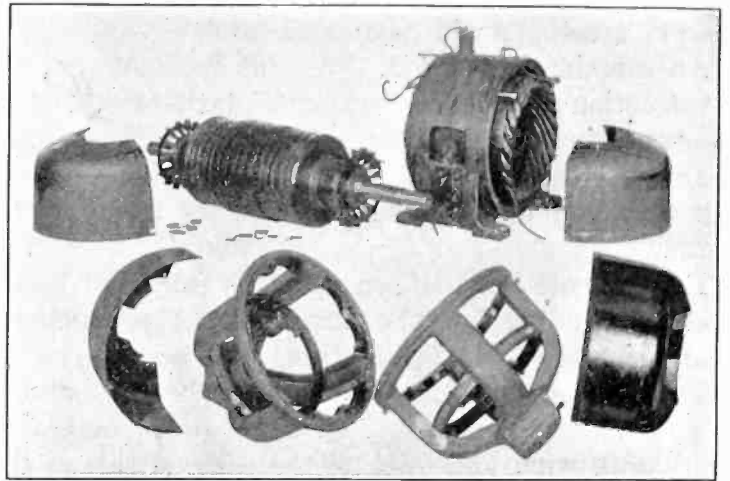

FIG. 7—TYPE C Y-70-15 KW., 12,000-VOLT, 1800 REV. PER MIN. GENERATOR

pressure, due to the resiliency of the cotton, needs no provisions for tightening after completion.

In order to give an understanding of the appearance of a finished machine, photographs of the disassembled parts, as well as the assembled machine, are shown in Figs. 7 and 8. This machine is rated 15 kw., 12,000 volts, 1750 rev. per min.

From the results obtained from tests, some interest-

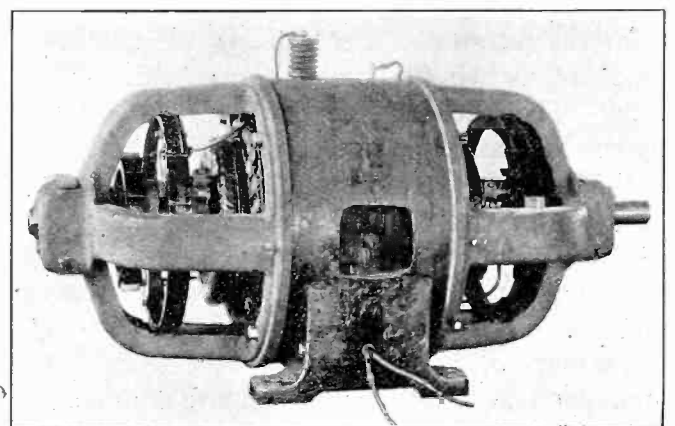

FIG. 8—TYPE C Y-70-15 KW., 12,000-VOLT, 1800 REV. PER MIN. GENERATOR

ing observations may be made. The very fact that the volts between bars run as high as 90 volts, shows that the individual armature coils contain an unusually large number of turns, which means that the reactance voltage is considerable. Nevertheless, the commutation is perfect. As has already been stated, when conditions of operation are serious, a distributed compensating winding should be used, which statement is

fully vindicated by the results obtained in this machine. In machines with commutating poles in which no compensating winding is employed, the stability is imperfect due to the fact that the armature reaction is only compensated for along one single line. In machines with fully distributed compensating windings, the armature reaction is neutralized in every point and no disturbances occur due to shifting of the flux. Because of the completely distributed exciting winding, the leakage of this winding is limited to a much smaller

amount than in machines where the exciting winding is massed together, and furthermore, the distribution of the voltage around the commutator is much better since this distribution of the winding gives a favorable distribution of the flux securing the particular advantage of a wide and stable neutral zone.

Since great successes have been obtained with generators of this type for wireless work, it is thought that this will open up new avenues for progress and it is for that purpose that this description has been given.

Two Photographic Methods of Studying High-Voltage Discharges

BY KARL B. McEACHRON

Member, A. I. E. E.

Lightning Arrester Eng. Dept., General Electric Co., Pittsfield, Mass.
Formerly Research Assoc., Purdue University.

Review of the Subject.—This paper presents some of the results of two methods of drawing out the alternating-current corona discharge along a time axis.

The first method consists in photographing, with the usual camera, the discharge from a needle point revolved by the alternator which is the source of supply for the high-voltage transformer. The needle is revolved inside a porcelain tube whose outside surface is made conducting and grounded.

The second method makes use of a special camera using mirrors revolved synchronously by the alternator itself. This camera is equipped with a shutter so arranged that photographs of sparks may be taken using one sweep of one of the mirrors.

Photographs have been taken showing the discharge between needles, both with and without a solid dielectric placed midway between the points.

When drawn out along the time axis certain characteristics of corona discharges may be seen, even when the discharge is extremely

weak for the exposure may be continued for any length of time with a reoccurring phenomenon.

A few photographs giving some conception of the different discharges under varying conditions are given.

CONTENTS

Review of Subject.	(230 w.)
Introduction.	(230 w.)
PART I—Using the Revolving Electrode—Apparatus Employed.	(450 w.)
Results.	(200 w.)
PART II—Using the Corona Camera.	(50 w.)
The Camera.	(550 w.)
Results.	(550 w.)
Effect of Electrode Shape.	(185 w.)
Tests with Air Dielectric Only.	(95 w.)
Photographs of Sparks.	(150 w.)
Special Tests.	(300 w.)
Summary.	(125 w.)
Conclusion.	(125 w.)
References.	(90 w.)

INTRODUCTION

FOR several years the Engineering Experiment Station at Purdue University¹ has been investigating the problem of the fixation of atmospheric nitrogen using various forms of discharge at high voltage.² During the progress of this investigation, the need for further knowledge concerning the mechanism of these discharges became increasingly apparent.

It has been shown that the chemical effects produced by these discharges are erratic,³ this being particularly so when using the corona or so-called "silent discharge." The nature of the gas and even the solid dielectric in the electric field seems to play an important part in determining the nature of the discharge. As a rule, engineers have been more interested in the prevention of corona than in its production, which involves a viewpoint somewhat different from that of the author.

Presented at the Annual Convention of the A. I. E. E. Swampscott, Mass., June 26-29, 1923

Many investigators have been concerned with the discharge from the static machine or the induction coil, through gases under varying conditions.⁴ Farwell⁵ used a number of direct-current generators in series and studied the characteristics of the corona using different diameters of wires inside concentric tubes. Much important work has been done in recent years in connection with the alternating-current corona discharge by Peek, Whitehead, Ryan, and others.

The present investigation of electric discharges in air deals with two methods which are somewhat different from any other known to the author. These two methods will be described separately.

PART I

Method Using the Revolving Electrode

APPARATUS EMPLOYED

If a needle point is revolved synchronously with the particular alternator which produces the potential for corona discharge, the successive discharges of each

alternation of the potential will appear to the eye as stationary in space and discharges which are scarcely visible to the eye may be photographed if the exposure is made sufficiently long.

The apparatus for producing the corona is shown in Fig. 1. The wooden shaft shown at the left of the photograph is connected to an extension of the shaft of an 8-pole, surface wound, alternator rated at 10-kv-a., 110/1100 volts, 133 cycles. This alternator at frequencies below 60 cycles produced a voltage wave which departed considerably from the true sine wave. The unfortunate effect of this irregular form of wave was to render the photographs of discharges somewhat difficult to analyze. This machine was, however, the only one available. The alternator was connected to a 50-kv-a., air-cooled transformer capable of producing 100 kv. from line to ground or 200 kv. between lines.

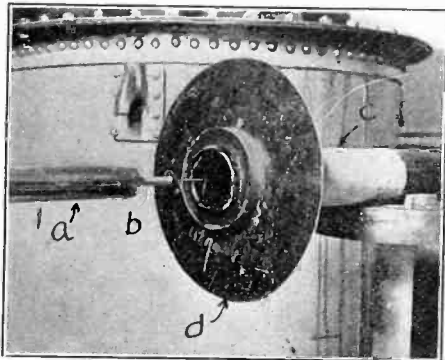

FIG. 1—REVOLVING ELECTRODES (SLIGHTLY WITHDRAWN) AND PORCELAIN TUBE USED IN MAKING PHOTOGRAPHS OF CORONA

- a.—Wooden shaft extension of alternator
- b.—Chuck and discharging needle point
- c.—Grounded tinfoil covering of porcelain tube
- d.—Insulating disk to prevent arc over the end of the porcelain tube.

The wooden shaft extension of the main shaft of the alternator carries at its outer end an adjustable chuck in which is fastened a No. 14 iron wire bent at right angles to the shaft in the form shown in Fig. 1. The end of the wire was carefully pointed and polished. When revolved, the needle point traces a circle 1.78 inches (4.52 cm.) in diameter. The plane of this revolving point was made to coincide with the plane of the end of a porcelain tube which was 3 inches (7.62 cm.) inside diameter and 4 inches (10.15 cm.) outside diameter and several feet in length. Part of the outside of this porcelain tube was covered with tinfoil which was grounded. The nearest approach of this foil to the plane of the revolving needle was one inch (2.54 cm.). Precautions were taken to limit the form of discharge to either glow or spark. To prevent a discharge from taking place directly from the needle point to the tinfoil, a pressboard collar was sealed over the edge of the tinfoil in the manner shown in the photograph (Fig. 1). Sealing wax was used to close the space between the disk and tube.

A connection was made from the high-voltage ter-

minial of the transformer to the revolving needle by the use of a wire looped loosely around the chuck which held the needle.

When the voltage was raised sufficiently high, eight discharges on the circumference of the circle traced by the needle point could be plainly seen. These corresponded to the eight poles on the alternator, being alternately positive and negative. All of the photographs shown in the paper were taken from the rear of the tube. By shortening the porcelain tube to about 12 in. (30.5 cm.) in length, it was possible to take the pictures full size.

The photographs were all taken in a dark room, the exposure being 60 minutes. Standard plates made by the Eastman Company were used for the photographs.

The frequency was varied by changing the speed of the driving motor, and in most cases its value was determined from the alternator speed.

A preliminary test to determine the polarity of the discharge was made in a very simple manner. With full field excitation, the generator shaft was revolved slowly by hand while note was made of the position of the shaft that gave positive and negative deflection on a 750-volt permanent-magnet type of voltmeter which was connected between the needle point and the ground.

RESULTS OF TESTS

Successive photographs were taken at four frequencies: 15, 30, 60 and 120 cycles. At each frequency three successive voltages were applied:

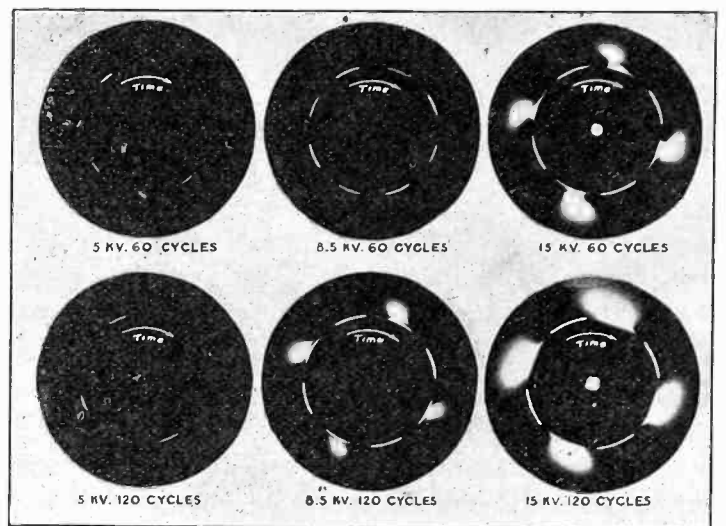

FIG. 2

5, 8.5 and 15 kv. However, only photographs of discharges at 60 and 120 cycles are shown here (Fig. 2).

The voltage impressed on the needle point by the transformer was determined by the readings of a tertiary coil which had been previously calibrated against a standard 25-cm. sphere gap. A calibration curve was taken for 30, 60 and 120 cycles and the results for the three were found to be identical.

The difference between the positive and negative

discharge was recorded on the photographs. When the needle was positive it showed more or less brush discharge in a radial direction. When the needle point was negative the tiny glow at its point traced on the photographic plate the arc of a circle. With the aid of a stroboscope, Peek⁶ has obtained photographs of the positive and negative discharges which show the general characteristic observed here, namely the positive brush discharge and the negative point discharge.

When the needle was positive a dark space between the brush and the point discharge in the radial direction on the photograph could be plainly seen in Fig. 2 at 8.5 kv., 120 cycles. Similar dark spaces were found at the lower frequencies.

At 15 kv. the discharge at 15 cycles (not reproduced here) was about as strong as that at 120 cycles, but the 30-cycle discharge showed no brush at all. At 8 kv. and 60 cycles there was no brush discharge recorded. The reason for this anomaly was not apparent.

It is interesting to note that in Fig. 2 the positive brush apparently forms in the air before the needle point itself shows any glow. This effect is due, partially at least, to the natural spreading out of the brush in a cylindrical form and also, perhaps, to the motion of the needle.

PART II

Method Using the Revolving Mirror

The preliminary study using the revolving point showed clearly some of the interesting characteristics

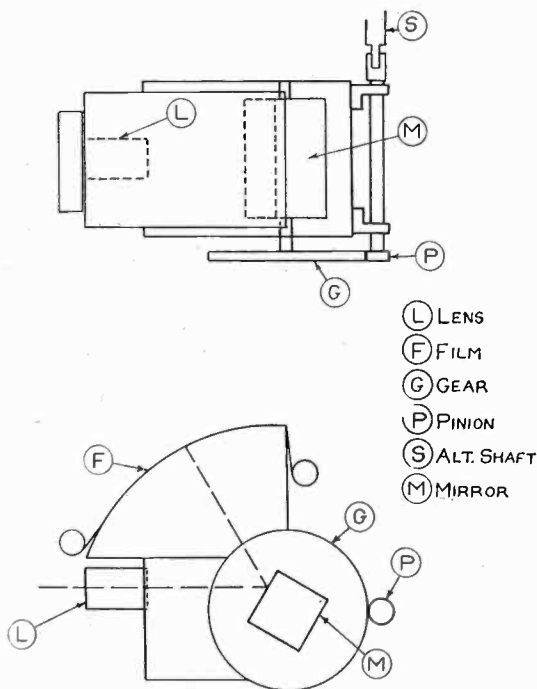

FIG. 3—SKETCH OF CORONA CAMERA

of the corona discharge, but a method of observation in which the needle point did not move would be advantageous in some ways. As a substitute for the revolving electrode the attention naturally turned to the use of a camera employing revolving mirrors driven synchronously.

*The Camera and Revolving Mirrors.** The essential parts of the camera are shown in the diagrammatical sketch (Fig. 3).

Four "first-surface" mirrors are mounted as indicated at *M* and driven by the gear *G* mounted on the same shaft as the mirrors. Gear *G* is driven by pinion *P*, the ratio being 8 to 1. The light from the discharge to be photographed passes through the glass lens *L* and is reflected from the mirror surface *M* to the surface *F* on which a sensitized film has been placed. The surface *F* was constructed of heavy celluloid, supported on wooden side pieces shaped to such a curvature that a sharp image is obtained with any angle of the shaft carrying the four mirrors.

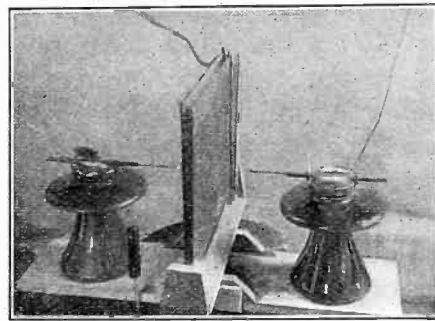

FIG. 4—WATER-COOLED GLASS DIELECTRIC SET PERPENDICULAR TO THE ELECTRIC FIELD

The camera was mounted on a stout tripod with braced legs to prevent vibration, and a considerable weight was hung underneath to increase its stability. One end of the pinion shaft was provided with a universal joint coupling, thus, not only allowing a positive drive, but also preventing the mechanical vibration of the alternator from being communicated to the camera. The camera was provided with magazines for the film, and spring clamps for holding the film taut and in position.

In order to obtain photographs of sparks where only one exposure of the film was desired, use was made of a shutter operated by a contact arrangement mounted on the mirror shaft.

On one of the curved wooden surfaces supporting the film, a pin was placed in such a manner that the position of the film could always be determined, since the pin passed through a hole previously punched through the edge of the film.

All photographs were made either at night, or in a light-tight room which was later found desirable to build around the apparatus. To prevent the possibility of fogging the film, the duplex paper provided by the film manufacturers was kept over the film. In addition to this, the camera was always covered with a black cloth when in use.

The water-cooled glass dielectric which was used for most of the tests is shown in Fig. 4. Two plates of

*The success of this camera is largely due to the skillful work of Messrs. George, Pugh, and Maupin, all of Purdue University.

double weight window glass approximately 0.118 in. (3 mm.) in thickness were sealed to wooden spacing pieces with a special insulating compound. The total thickness of the dielectric was 0.695 in. (1.765 cm.) including the space occupied by the cooling medium. Cooling water from the city supply was circulated at a rather slow rate,—a glass tube 5 ft. (1.5 m.) in length and 0.39 in. (1 cm.) in diameter being used to convey the water to the dielectric. The level of the water was kept constant by means of the overflow pipe which discharged the water in a discontinuous stream. This arrangement, in effect, grounded the water between the two glass plates through a high resistance.

The needles used were made of steel rod 0.127 in. (0.323 cm.) in diameter, and were adjustable. They were carefully pointed and polished. Considerable care was taken to get the points accurately in line and perpendicular to the dielectric surfaces.

The secondary terminals of the high-tension transformer whose primary was excited by the 8-pole alternator, were connected by the use of bus bars directly to the needle points. No resistance of any kind was placed between the points and the transformer. The resistance of the transformer secondary was 33,390 ohms, and the inductance by short-circuit test was 1920 henries. The middle of the high-tension winding was grounded as were also the alternator and the metal parts of the camera.

RESULTS OF TESTS

It was found by trial that a film exposure of 45 minutes was necessary to secure a satisfactory image of the corona discharge at low potentials, and this length of exposure was therefore used with all of the corona

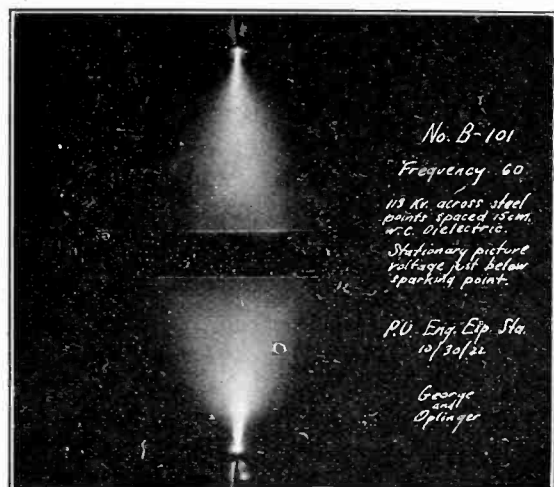

FIG. 5—DISCHARGE BETWEEN POINTS AS IT APPEARS TO THE EYE
Taken with the camera mirrors stationary. The potential is 113 kv. at 60 cycles. (The edges of the glass dielectric are plainly outlined by the parallel reflections appearing as bright lines.)

photographs regardless of the intensity of the discharge.

Data on the following points were obtained: Effect of changing the potential, frequency, spacing of electrodes, dielectric material and electrode shape.

For many of the corona photographs the voltage was raised to a point so near the sparking potential that occasionally a spark would pass. From the appearance of such sparks on the developed film, it was concluded to make some investigation of sparks. On account of the high resistance and reactance of the transformer, such tests could be easily made without the possibility of an arc following.

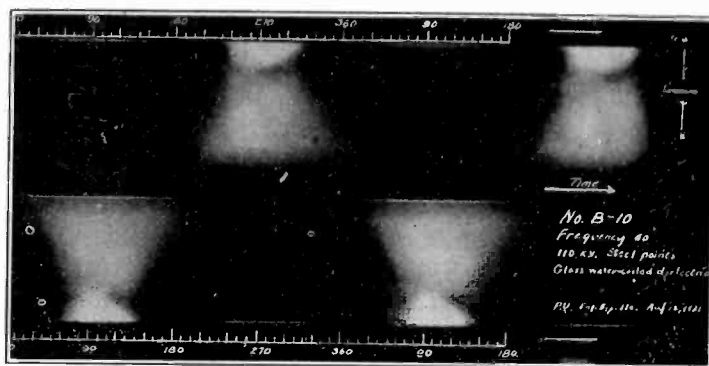

FIG. 6—CORONA DISCHARGE AT 11 kv., 60 CYCLES, DRAWN OUT ALONG A TIME AXIS BY THE USE OF THE SYNCHRONOUSLY DRIVEN ROTATING MIRROR CAMERA. 16 CM. SPACING

In Fig. 5 may be seen the discharge as it appears to the eye. This was taken with the pinion driving the mirror shaft disconnected from the alternator, the mirrors thus being stationary. The discharge seems to consist of two parts, the neck or stem and the brush which extends to the glass dielectric. This characteristic form has been noted by others, and some very good photographs were obtained by Peek,⁷ whose only dielectric was air. Thus to the eye the discharge appears essentially the same whether the solid dielectric is present or not.

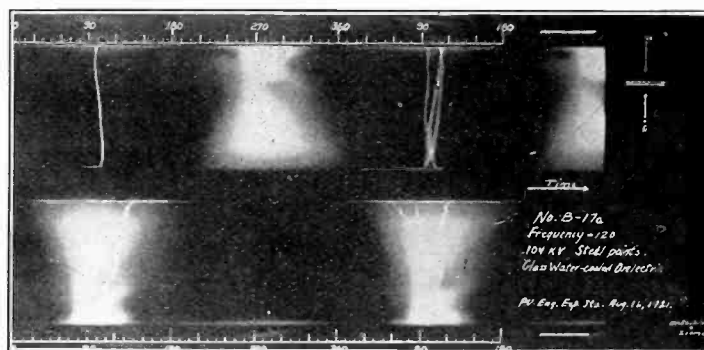

FIG. 7—CORONA DISCHARGE AT 104 kv., 120 CYCLES. 15 CM. SPACING

When these discharges are drawn out along a time axis at right angles some additional features can be seen. The stroboscopic method, as used by Peek showed plainly the difference between the positive and the negative discharges, but did not show how they vary with time. Fig. 6 shows the discharge at 60 cycles and Fig. 7 at 120 cycles, the voltage in each being kept as high as possible without sparking.

As in the photographs showing the discharge with the revolving point, the negative appears as a line,

which is the trace of a concentrated glow on the needle point, while the positive discharge is accompanied by the characteristic brush extending from the needle points to the surface of the glass dielectric (Figs. 6 and 7). At all frequencies studied, the negative discharge seems to take place throughout the entire 180 degrees. This condition was made use of in determining the location of the position of the degree scale, for it was possible, on the film, to erect a perpendicular at the end of the negative on one needle to the beginning of the negative on the other. The degree marking was drawn on a separate film, and by the use of the punch marks, which determined the location of the film on the camera, the degree marks could be located in the same position for each frequency.

The positive discharge shows a distinct dark space between the end of the neck and the brush. The shape is somewhat different at the different frequencies, the change being most marked at 120 cycles (Fig. 7) where there is evidence of a double dark space. On both films there is a point discharge from the needle point before the neck forms and the brush appears. With each frequency this point discharge continues a short time after the neck has disappeared. Oscillograms of the current flow between a wire and a concentric cylinder taken by Bennett⁸ show the presence of a slight flow of current previous to the point of "copious ionization." It should also be noticed that the discharge is not symmetrical with respect to the mid-points—90 and 270 degrees.

The negative discharge is much the same for each frequency and shows in each case a stronger discharge during the time that the positive neck exists.

In studying these photographs, it is important to remember that there is considerable overlapping of the brush discharge since it has appreciable width.

EFFECT OF ELECTRODE SHAPE

With a brass sphere 24 mm. in diameter substituted

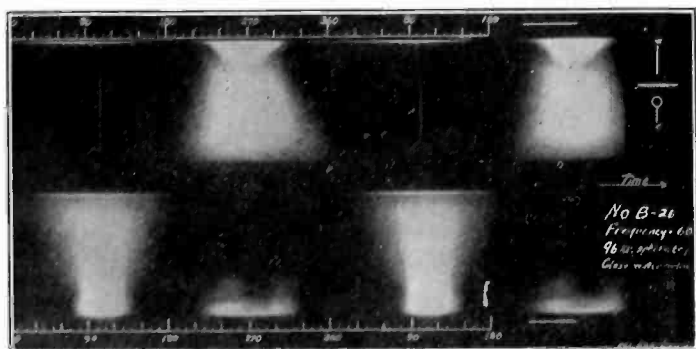

FIG. 8—SHOWING THE DISCHARGE BETWEEN A NEEDLE (UPPER) AND A SMALL SPHERE (LOWER ELECTRODE) AT 96 KV. AND 60 CYCLES. 15 CM. SPACING

for the lower needle, and with a spacing of 15 cm., photographs were taken showing the discharge at different frequencies. The discharge from the needle point is not appreciably changed by the substitution of the sphere for the lower point. The discharge from

the sphere itself seen in the lower half of Fig. 8 is interesting. The negative is no longer a point discharge but extends out some distance. A brush appears at the beginning and at the end of each negative discharge from the sphere, the first brush with a dark space and the second without one. This effect is very plain on the film but may be lost in reproduction. The positive has no dark space and shows no point discharge. The neck forms abruptly and ceases in the same manner. Both the positive and the negative discharge are shorter in degrees than with needle points.

It should be mentioned in connection with these tests with the sphere and needle that the discharge from the sphere looks very different from that of the needle, consisting of much coarser streamers and tending more toward the condition of sparks than is the case with needles.

TESTS WITH AIR DIELECTRIC ONLY

With the glass dielectric removed it was only with difficulty that photographs of corona could be obtained, for the spark point is close to the corona point with this spacing. Photographs were taken at 30, 60 and 120 cycles. Fig. 9 shows the discharge at 120 cycles. The positive brush has extended clear across to the negative. The positive dark space is plainly seen in this photograph. The positive brush starts at the same time the glow begins on the positive point. The brush extending to the negative does not form until the 90 degree point has been reached.

PHOTOGRAPHS OF SPARKS

Quite a large number of photographs of sparks were taken. The characteristics seen in Fig. 10, which represents only one sweep of one mirror, are observed at all of the different frequencies studied. When using the glass or a bakelite dielectric, the sparks from the positive needle point are straight for a short distance out from the point and then become quite crooked,

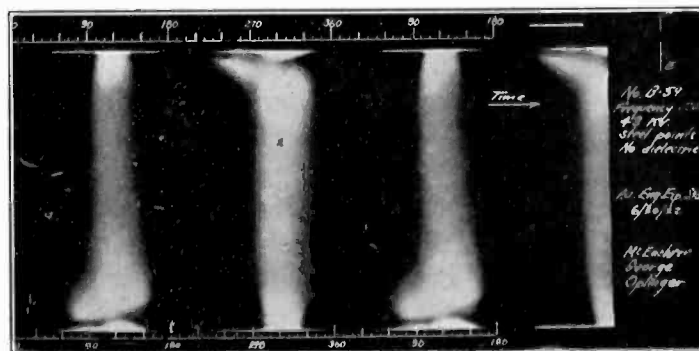

FIG. 9—DISCHARGE WITH AIR DIELECTRIC ONLY. 43 KV., 120 CYCLES. 15 CM. SPACING

deviating considerably from a straight line connecting the needle points. On the other hand, the negative in many cases passes in a straight bold path to a point close to the dielectric, where it jumps to one side before reaching the dielectric.

It should be noticed that the negative spark widens out at the same average distance from the needle point that the positive begins to deviate from a straight line. This distance at 60 cycles is about 17 mm.

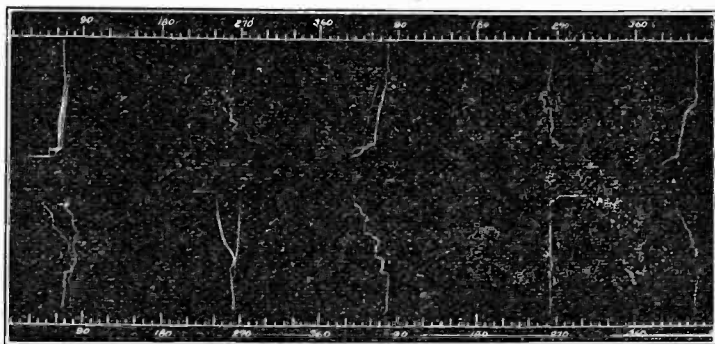

FIG. 10—PHOTOGRAPH OF SPARKS: STEEL POINTS, 15 CM. SPACING GLASS DIELECTRIC, SINGLE EXPOSURE, 116 KV., 60 CYCLES

Sparks from a small sphere (2.4 cm. dia.) are nearly as straight when the sphere is positive as when it is negative.

SPECIAL TESTS

Placing an air condenser in series with one of the needle points allowed a much larger discharge without the formation of sparks. The dark spaces, although present, are considerably modified in appearance.

A photograph was taken without a solid dielectric with one of the needles turned through 90 degrees about the point as a center. Sparks from the end of this needle follow the direction of its axis for a short distance.

When a grounded plate was placed in the cooling water, it was found that it was not possible to produce any appreciable corona discharge without the formation of sparks, (15 cm. spacing). This calls attention to the fact that with a dielectric between two needles, the dielectric will not be at ground potential if a discharge is taking place, but will have a potential closer to the positive than to the negative point. This effect is quite appreciable for with grounded cooling water, only 68 kv. is required to produce sparks, while 115 kv. is necessary when the ground plate is removed. This has an important bearing in several applications; for instance, in an ozonizer, the maximum discharge will be obtained when the dielectric is not in contact with either electrode.

When a bakelite dielectric was substituted for the glass, the general form of the discharge was unchanged, but differences in detail were noted particularly in connection with the shape of the dark space.

A peculiar discharge when the needle is negative is found to have occurred with many of the photographs taken with the corona camera. A luminous point formed back along the needle a distance of about 1 cm. from the point. This point discharge moves in toward the point as the cycle progresses, the total movement being three or four mm. The clearness of the image on the films shows that this movement occurs synchronously when the needle is negative. This has

occurred with both needles even after having been re-polished. When photographing a wire, Whitehead⁹ found a spiraling effect which may be of the same nature.

SUMMARY

Two methods which show the variation of the discharge with time have been developed. In the first method, the discharging point is moved synchronously with the alternating current.

The second method, by the use of synchronously revolved mirrors, draws out the discharge along a straight time axis.

It has been found by the use of these two methods that a region exists, between the positive brush and the brilliant discharge from the end of the needle, which does not affect the photographic plate.

It has also been found that the appearance of the positive discharge is considerably modified by changes in circuit conditions.

Sparks from needle points to a solid dielectric are found to possess definite characteristics depending on whether the needle point is positive or negative.

CONCLUSION

A large number of photographs under many different conditions have been taken, using the methods described in this paper. It is hoped that these may soon be published in a Bulletin of the Engineering Experiment Station.

Much additional information should be obtained using quartz lenses and studying the discharge with different gases and at varying pressures. This work is being continued at Purdue University with the idea of learning more about the mechanism of this discharge.

The author wishes to express his appreciation to his associates in conducting this work, especially to R. H. George, Research Assistant, and E. Pugh, Instructor; both of Purdue University. To Dr. Anderegg, and to Prof. C. F. Harding under whose general direction the work was done, thanks are due.

REFERENCES

1. C. F. Harding and K. B. McEachron, *TRANS. A. I. E. E.*, Vol. XXXIX, 1920, p. 761.
2. Bulletin No. 9, *Eng. Exp. Sta.*, Purdue Univ., 1922.
3. *Loc. Cit.* (2) p. 55.
4. See J. J. Thomson "Conduction of Electricity through Gases." Also J. S. Townsend, "Electricity in Gases."
5. S. P. Farwell, *TRANS. A. I. E. E.*, Vol. XXXIII, 1914, p. 1692.
6. F. W. Peek, Jr., *TRANS. A. I. E. E.*, Vol. XXXI, 1912, p. 1088.
7. F. W. Peek, *Loc. Cit.*, (6).
8. Edward Bennett, *TRANS. A. I. E. E.*, XXXII, 1913, p. 1800.
9. J. B. Whitehead, *TRANS. A. I. E. E.*, Vol. XXXI, 1912, p. 1105.

Telephone Transmission Over Long Distances

BY H. S. OSBORNE

Fellow, A. I. E. E.

Transmission Engineer, American Telephone and Telegraph Company

Review of the Subject.—In this paper are pointed out some of the similarities and contrasts of power transmission and telephone transmission over long distances. The problems of telephone transmission on open-wire lines are illustrated by a discussion of the methods by which the over-all efficiency of the transcontinental telephone circuit has been greatly improved. A brief discussion is given of recent important developments in telephone transmission

through cables over long distances. An outline is given of the results obtained in the commercial application of carrier telephone and telegraph systems. Finally, a demonstration talk between Havana, Cuba, and Avalon on Catalina Island off the Pacific coast, is described as an illustration of what can be done with the commercial telephone system in its present stage of development.

* * * * *

At a convention where the main topic of discussion is the transmission of power over long distances, it would appear interesting to review some of the problems involved in the transmission of telephone currents over long distances. This review does not contribute very much which could be used directly in solving the power problems but serves to point out some interesting similarities and some very important differences between these two branches of electrical art.

In essence, both consist in the transmission of alternating currents over very long electrical circuits and in both, therefore, the problem of reducing the losses of electric power in transmission is very important. In the case of power transmission, however, the commodity delivered is the power itself and, therefore, for commercial success a large percentage of the power transmitted into the line must be delivered at the output. In the telephone problem, on the other hand, the commodity delivered is communication and the delivery of electrical power is only a means to this end. The efficiencies of the telephone transmitter and of the telephone receiver are such that under many conditions satisfactory communication can be given when only a small fraction of 1 per cent of the transmitter output is delivered to the receiver at the distant end of the line, the rest being absorbed largely in line losses. Furthermore, in many cases the power delivered does not come directly from the transmitting end but comes only from the nearest repeater station on the line.

The power engineers are free to choose, with a view to transmission efficiency and other features of economy, the frequency of alternating current to be used. As a result, a relatively low frequency is always chosen. In telephone transmission, on the other hand, the frequency of transmission is necessarily high, for it cannot be lower than the important harmonic components of the complex waves which constitute speech. How complicated these waves are is illustrated by Figs. 1 and 2. Fig. 1 shows oscillograms of telephone currents corresponding to the vowels "o" and "e". The most prominent oscillation in the vowel "o" is, roughly, 800 cycles a second and the most prominent

oscillation in the vowel "e" is about 1900 cycles. Fig. 2 is an oscillogram of the word "Pacific." The pronunciation of this word occupies less than a second, but the oscillations are so complicated that it has been necessary to crowd them together very closely in order to get the whole word in one figure. These two figures are illustrations of the fact that the important harmonic components of telephone currents cover a frequency range from 200 cycles to well over 2000 cycles and that components as high as 3000 or 4000 cycles in frequency contribute somewhat to the intelligibility of speech. By using the speech currents to modulate a carrier current the frequencies transmitted over the

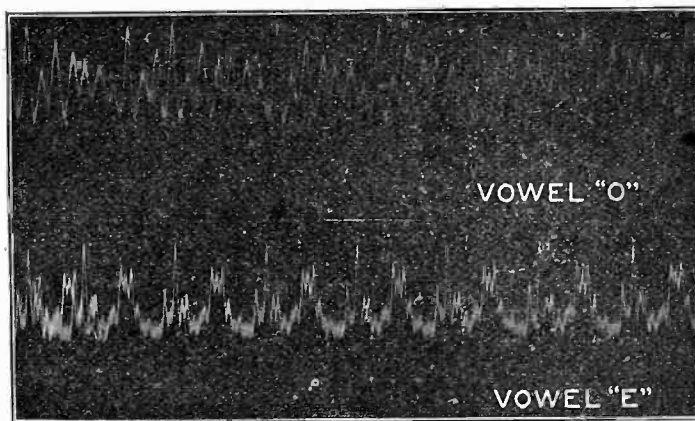

FIG. 1—OSCILLOGRAPH RECORDS SHOWING THE FLUCTUATIONS IN THE ELECTRICAL CURRENT WHEN THE VOWELS "O" AND "E" ARE SPOKEN INTO THE TELEPHONE TRANSMITTER, THE SPEED OF THE FILM WAS ABOUT 10 FEET PER SECOND.

line can be raised as may be desired, but no feasible method has been suggested for lowering them materially.

This difference in frequency between power and telephone currents is an important difference from the standpoint of transmission, because the losses per unit length go up rapidly with the frequency. Furthermore, the wave lengths are shorter for higher frequencies, so that long telephone lines may be many wave lengths in length.

Another fundamental difference between the power and telephone transmission systems arises from the difference in type of service which they perform. In

To be presented at the Pacific Coast Convention of the A. I. E. E., Del Monte, Cal., October 2-5, 1923.

the case of the power system all customers can be served from the same circuit and the tendency is, therefore, towards interconnection and toward the development of large systems consisting of a relatively small number of very large units. In the telephone system, on the other hand, an independent channel of communication must be given to each pair of talkers. This necessity has led to great efforts to find ways to make a moderate amount of copper provide a large number of circuits either by the use of small conductors or by the superposition of a number of independent channels of communication on one pair of wires.

In the telephone system also the amount of power is necessarily small. When talking in an ordinary tone of voice the power delivered to the telephone transmitter in the form of acoustic waves by the talker is in the order of millionths of a watt. The telephone transmitter amplifies this power by a large ratio, so that the power delivered to the telephone lines has peak values of the order of 0.001 to 0.01 watt.

throughout and was provided with six repeater points between New York and San Francisco.

Loading¹ is the means by which in telephone practise the electrical efficiency of the line is increased by using lower currents and higher voltages to transmit a given amount of power. In a power circuit the voltage can be raised by simply changing the ratio of terminal transformers. In a long telephone circuit the voltage cannot be raised in that way. The ratio of voltage to current at the transmitting station depends not on the impedance of the receiving station, but as the telephone line is electrically long, it depends upon the characteristics of the line itself. Therefore, to raise the impedance, the characteristics of the line itself must be changed.

There are several ways in which this can be done. For the transmission of a single frequency, it can be done very effectively by connecting inductive loads across the circuit at regular intervals. For telephone transmission, however, where a uniform efficiency of

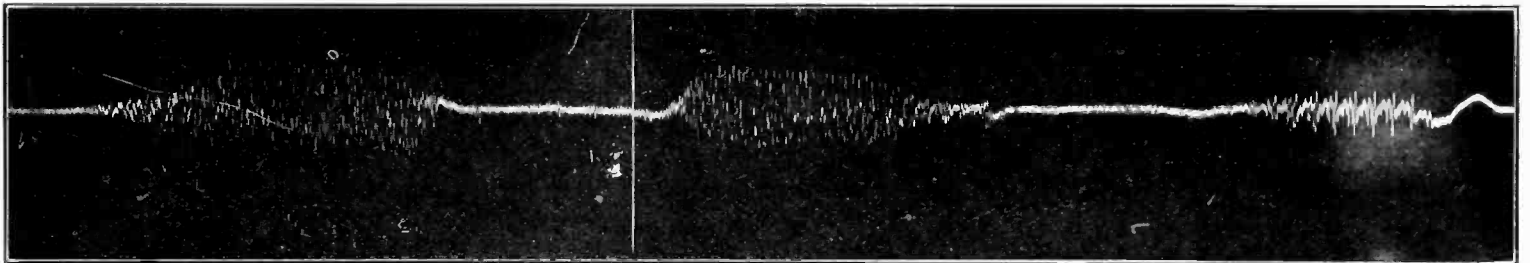

FIG. 2

Both power and telephone transmission systems have important insulation difficulties. In the telephone system, however, the difficulty is of course, not in the strength of the insulation to withstand voltage stresses but is to prevent, as far as practicable, the absorption of power in or over the surface of the insulation at the relatively high frequencies of the alternating currents transmitted.

TRANSCONTINENTAL TELEPHONY

As a result of the different fundamental requirements and different technical conditions, the development of the two industries has led to the transmission of telephone currents over considerably greater distances than power currents. A conspicuous example of long distance telephone transmission is the much used service between the Atlantic and Pacific Coasts. The circuit between New York and San Francisco is about 3400 miles (5500 kilometers) long, largely in open-wire construction of copper weighing 435 pounds to the wire mile. (600 kg. per km.). Recent improvements in this circuit have very greatly increased its over-all transmission efficiency, and it is believed that a brief discussion of these improvements will be of interest as illustrating the technical problems involved in telephone transmission over very long open-wire lines.

As originally constructed, this line was loaded

transmission over a wide range of frequencies is necessary, the result is accomplished by the use of series inductance loads, designed for very low energy losses and located regularly at eight-mile intervals throughout the line.

The extent to which the efficiency can be improved is rather narrowly limited in open wire by the insulation losses in the line which are, of course, increased as the voltage is raised and in part offset the decrease in series resistance losses due to decreased current. By means of loading, however, it is possible on a circuit such as the transcontinental telephone line to raise the voltage by about 80 per cent. and reduce the losses per unit length by a factor of about 2.2 in dry weather.

The benefits from the use of loading are insufficient to make transcontinental telephony commercially practicable without the use also of telephone repeaters² which receive the attenuated telephone currents after transmission over a few hundred miles of line and deliver to the adjacent section of line greatly amplified

1. For detailed information regarding the loading of telephone circuits, see paper entitled: "Commercial Loading of Telephone Circuits in the Bell System," by B. Gherardi, TRANSACTIONS, American Institute of Electrical Engineers, 1911.

2. For discussion of the design and action of telephone repeaters see paper entitled: "Telephone Repeaters," by B. Gherardi and F. B. Jewett, TRANSACTIONS, 1919, Vol. XXXVIII.

currents of the same wave shape. The results obtained on the transcontinental circuit by the combination of loading and repeaters are shown in the upper part of Fig. 3 which is drawn to represent the amount of energy at different points of the circuit when 1000 microwatts are delivered to the circuit at the San Francisco end. The power rapidly decreases along the circuit, due to line loss, at Winnemucca is amplified to 700 microwatts, falls off again rapidly, and so by successive stages of attenuation and amplification 10 microwatts are at last delivered to the local telephone circuits at New York.

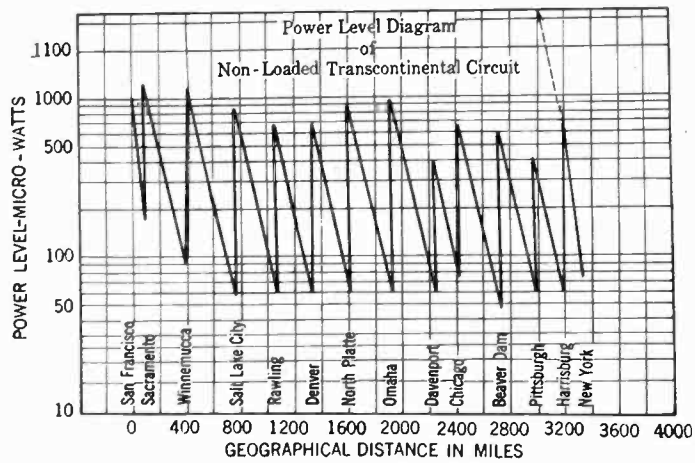
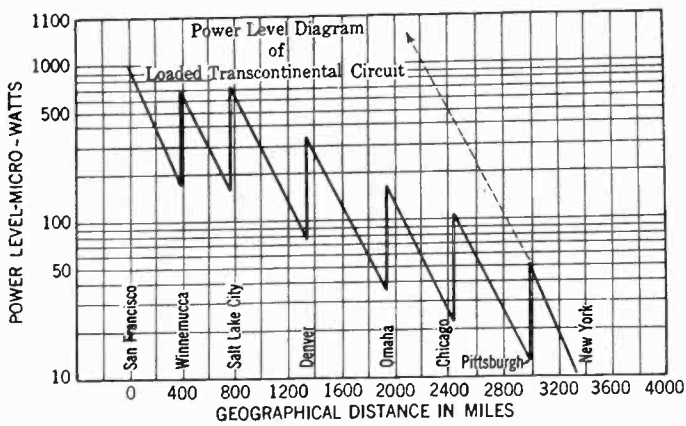

FIG. 3

The improvements in the transcontinental line mentioned above have been brought about by removing the loading from the circuit and modifying the characteristics of the repeaters. Also, in view of the much larger line losses to be made up by the repeaters and in order to stay within economical upper and lower limits of power output and input of the repeaters, the number of repeaters was doubled. This change, however, was not essential and would not have brought about the improvements in transmission without the other changes. The energy level at different points in the circuit under the improved conditions is indicated in the lower part of Fig. 3, and it will be seen that now instead of 10 microwatts, 70 microwatts are delivered at New York when 1000 are transmitted into the San Francisco end of the line.

In view of the benefits which can be obtained by

loading, it may seem surprising that improvements in the efficiency of this circuit were obtained by removing the loading. The explanation of this result requires the discussion of some very interesting transient phenomena which are important in very long distance transmission.

When a train of oscillations is launched upon a long electrical circuit, it travels along the circuit attenuating in magnitude but without reflection so long as the impedance characteristics of the circuit are uniform. When a non-uniformity in line impedance is reached a part of the wave is reflected and the reflected wave travels back towards the transmitting end, being of course attenuated in the process. By this process of successive reflection the steady state of transmission is produced, although in the process there are of course other transient components of the currents which do not concern us here. In open-wire telephone circuits a few hundred miles in length, or less, the steady state is established very rapidly and the reflected currents are not noticeable. In very long circuits, however, which are made of high over-all efficiency by the use of repeaters or otherwise, the reflected current may have sufficient volume and time lag to be noticeable and even to be heard as distinct echoes. Hence they have been named "Echo Currents."

Echo currents, of course, may be heard by the listener

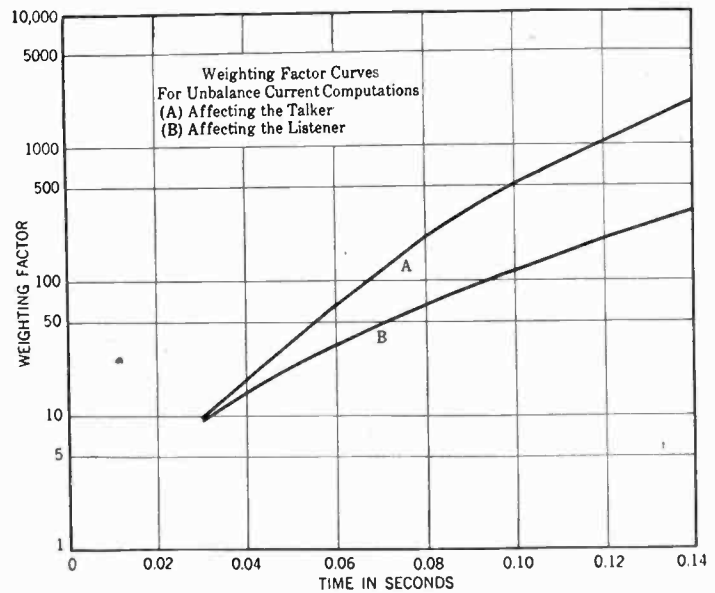

FIG. 4

as well as by the talker, for the reflected current, striking a second irregularity, is reflected again towards the listener.

In order that the transmission may be satisfactory the conditions of the circuits should be such that this echo current is not noticeable, having either a very short time interval or a small magnitude. It has been found that there is a definite relation between the time lag of an echo and the maximum amount of echo current which can be permitted without appreciable effect on the clearness of speech. This is indicated in Fig. 4 in

the form of relative weighting factors for echo currents of different time lags, showing for both talker and listener and for different time lags the reciprocal of the relative maximum amount of power in the echo for no material interference with conversations.³

In the transcontinental line, which is chosen as our example, the most important echoes heard by the talker come from the irregularities at the distant end of the line where there is a marked change in the characteristics of the line due to the change from toll line to local construction. With the loaded circuit the velocity of propagation is about 55,000 miles (88,000 km.) per second, and the time lag of this echo is about 0.11 second. On the non-loaded circuit, however, the velocity of propagation is much faster, being about 180,000 miles (290,000 km.) per second, and the time lag of the echo from the distant end is only about 0.04 second. The corresponding weighting factors are 670 and 15, which means that on the non-loaded line this echo could be about 44 times as loud as on the loaded circuit for the same effect of the terminal irregularities on transmission.

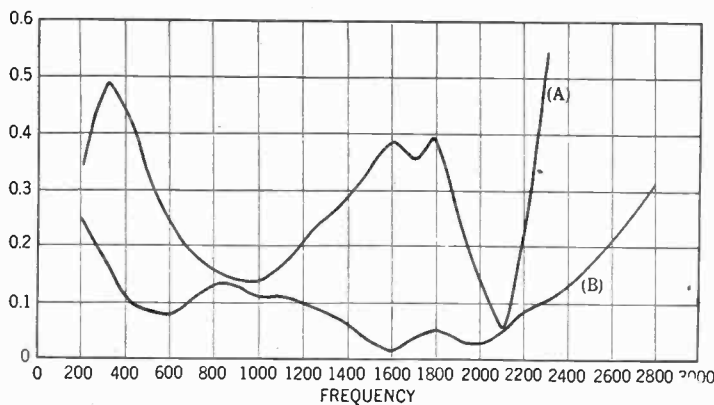

FIG. 5—DIFFERENCE BETWEEN LINE AND REPEATER IMPEDANCE EXPRESSED AS A FRACTION OF THE SUM OF THESE IMPEDANCES.

- (A) THE LOADED TRANSCONTINENTAL CIRCUIT
- (B) THE NON-LOADED TRANSCONTINENTAL CIRCUIT

The magnitude of the echo for a given irregularity depends upon the over-all transmission efficiency of the circuit, and the increase in permissible volume of echo current, therefore, means that the over-all efficiency of the circuit may be increased without interference from the echo currents.

So far we have been discussing the effect of reflected currents due to terminal irregularities. This, however, is not the whole story. On a line provided with repeaters there are irregularities not only at the terminals but also at the repeater points, due to the impracticability of making the impedance of the repeaters identical with that of the lines at all frequencies. In making the line non-loaded, it was found possible by modifying the telephone repeaters to improve the

3. For further discussion of echo currents, see Mr. A. B. Clark's paper on "Telephone Transmission on Long Cable Circuits," JOURNAL A. I. E. E., January, 1923.

similarity of impedance of the repeaters and the line, thus reducing the amount of reflected current at these points. The extent to which this was practicable is indicated in Fig. 5 which shows the ratio of difference to sum of line and repeater impedance over a range of frequencies for the loaded circuit condition and for the non-loaded circuit condition.

The result of these two improvements, namely, increasing the velocity of transmission over the line and decreasing the amount of the irregularities is

TABLE I
LOADED TRANSCONTINENTAL CIRCUIT OVER-ALL TRANSMISSION EFFICIENCY 1 PER CENT
Unbalances Affecting Talker

	No. of paths	Length in miles	Time in seconds	Weighting factor (a)	Energy ratio (b)	Weighted index (a × b)
Worst Path.....	1	6000	0.107	670	0.0001	0.067
Total-All Paths.....	6	Varying for Different Paths				0.248

Worst Path includes all repeaters, *i. e.* is the over-all path.

Unbalances Affecting Listener

	No. of paths	Length in miles	Time in seconds	Weighting factor (a)	Energy ratio (b)	Weighted index (a × b)
Worst Path.....	1	1040	0.0187	4.35	0.0035	0.015
Total-All Paths.....	21	Varying for Different Paths				0.160

Worst Path includes end repeater and next adjacent repeater.

TABLE II
NON-LOADED TRANSCONTINENTAL CIRCUIT OVER-ALL TRANSMISSION EFFICIENCY 7 PER CENT
Unbalances Affecting Talker

	No. of paths	Length in miles	Time in seconds	Weighting factor (a)	Energy ratio (b)	Weighted index (a × b)
Worst Path.....	1	6500	0.037	15.3	0.0019	0.029
Total-All Paths.....	12	Varying for Different Paths				0.191

Worst Path includes all repeaters, *i. e.* is the over-all path.

Unbalances Affecting Listener

	No. of paths	Length in miles	Time in seconds	Weighting factor (a)	Energy ratio (b)	Weighted index (a × b)
Worst Path.....	1	6200	0.035	11.3	0.00072	0.0085
Total-All Paths.....	78	Varying for Different Paths				0.199

Worst Path includes all repeaters, *i. e.* is the over-all path.

indicated in Tables I and II. Table I summarizes the effect of echo currents on the loaded circuit. This table shows for the worst current path the percentage of transmitted and received energy appearing as echo current, the time lag in seconds, the corresponding weighting from Fig. 4 and the product of energy and weighting.

This detail is shown only for the worst echo current but has been computed for all the echo current paths,

and the sum of the products of energy ratios and weighting factors is given in the table. This total gives a good means for comparing the echo-current effect in different circuits.

Table II shows the corresponding figures for the non-loaded transcontinental circuit after improvement of the repeaters and establishment of the higher over-all efficiency. It will be noted that in spite of the facts that the amount of energy represented by the worst echo current paths is greatly increased and that the number of echo paths is also increased, the much shorter time lag due to the higher velocity of propagation results in a total weighted echo current of about the same magnitude as the total for the loaded circuit at a very much lower efficiency.

TABLE III
LOADED TRANSCONTINENTAL CIRCUIT OVER-ALL TRANSMISSION EFFICIENCY 7 PER CENT
Unbalances Affecting Talker

	No. of paths	Length in miles	Time in seconds	Weighting factor (a)	Energy ratio (b)	Weighted index (a × b)
Worst Path.....	1	6000	0.107	670	0.0055	3.68
Total-All Paths.....	6	Varying for Different Paths				5.24

Worst Path includes all repeaters, i. e. is the over-all path.

Unbalances Affecting Listener

	No. of paths	Length in miles	Time in seconds	Weighting factor (a)	Energy ratio (b)	Weighted index (a × b)
Worst Path.....	1	5200	0.093	97	0.0054	0.52
Total-All Paths.....	21	Varying for Different Paths				1.58

Worst Path includes all repeaters, i. e. is the over-all path.

For comparison, Table III is made up for the loaded circuit, assuming it to be operated at the same over-all efficiency as the non-loaded circuit, i.e., 7 per cent. This table shows how much greater the effect of the echo currents would be at that equivalent.

In addition to the improvements discussed above, the changes in the transcontinental line made it practicable to improve the quality of telephone transmission by increasing the degree of uniformity of transmission of the different frequencies within the important telephone range. For long stretches of line the non-loaded open-wire transmits current with much more uniform efficiency than the loaded open wire. This is illustrated in Fig. 6 which shows the percentage of output to input power at different frequencies in the telephone range for a 281 mile (452 km.) section of non-loaded open wire 0.165 inches in diameter (435 pounds per wire mile) and a 563 mile (907 km.) section of loaded open wire of the same size. The distances chosen are in each case an average repeater section.

Furthermore, in modifying the telephone repeaters, changes were made to improve the uniformity of amplification given by the repeaters over a wide range

of frequencies. Fig. 7 shows the amplification frequency characteristic of these repeaters before and after their modification.

These improvements in the transmission characteristics of the line and repeaters made it possible to get a very good over-all transmission frequency characteristic in spite of the very great length of this line.

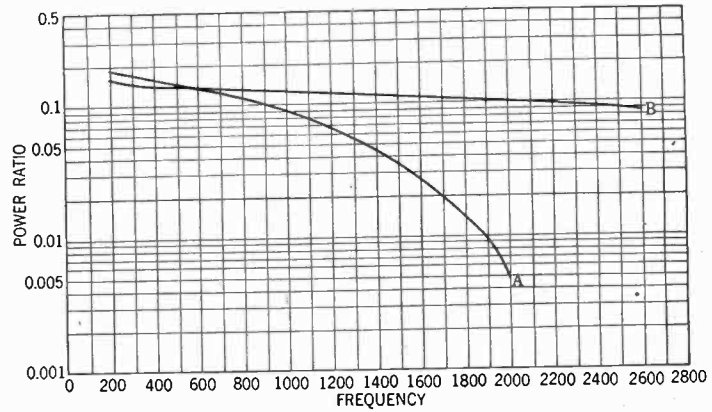

FIG. 6—POWER RATIO—FREQUENCY CHARACTERISTICS OF AVERAGE REPEATER SECTIONS ON TRANSCONTINENTAL CIRCUIT (A) LOADED TRANSCONTINENTAL CIRCUIT (B) NON-LOADED TRANSCONTINENTAL CIRCUIT

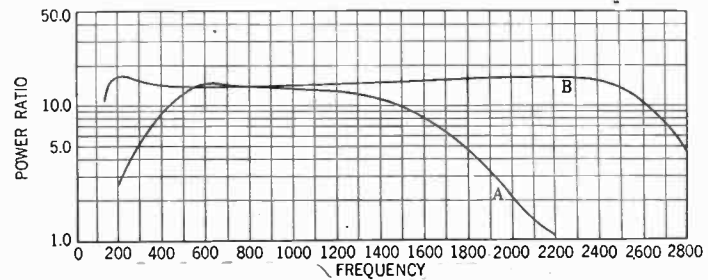

FIG. 7—POWER RATIO—FREQUENCY CHARACTERISTICS OF TELEPHONE REPEATER USED ON TRANSCONTINENTAL CIRCUITS (A) LOADED TRANSCONTINENTAL CIRCUIT (B) NON-LOADED TRANSCONTINENTAL CIRCUIT

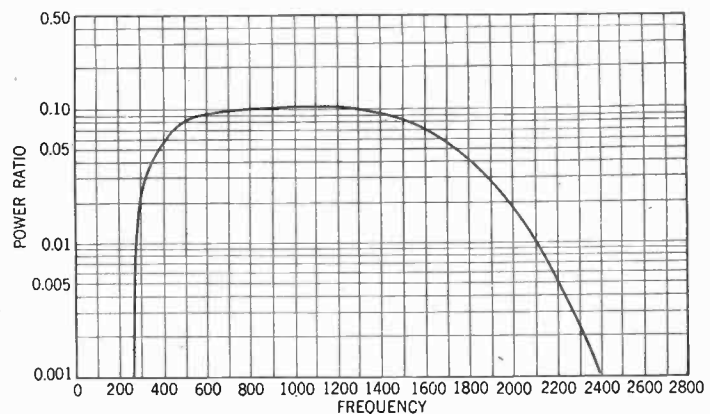

FIG. 8—POWER RATIO—FREQUENCY CHARACTERISTICS OF COMPLETE NON-LOADED TRANSCONTINENTAL CIRCUIT

The result expressed in terms of net over-all efficiency is indicated in Fig. 8.

An incidental advantage of the change from loaded to non-loaded construction is greater independence of weather conditions. The loaded circuit being a higher voltage circuit, varies much more in efficiency between

wet and dry weather conditions than the non-loaded circuit. On the other hand, the non-loaded circuit involves twice as many telephone repeaters and the over-all efficiency of the circuit depends on a very exact maintenance of the amplification of each of these repeaters. This requires very carefully planned and faithfully executed maintenance routines. It should be said that the results which have been obtained over this circuit have been exceedingly satisfactory.

TOLL CABLES⁴

The transmission of telephone currents through cables has always been difficult in comparison with the transmission over open-wire lines. One factor of difficulty is the much greater loss in the cable circuits per unit of length. This is due in part to the close proximity of the two sides of the circuit and in part to the fact that economical construction in cable requires relatively small conductors. The telephone repeater has been developed to a point where a practically unlimited number of them can be used in tandem in a

this type of construction is illustrated by Fig. 9 which indicates important toll cable routes in the Northeastern part of the country. In this section, because of the congestion of population and business, the toll cable development has been most pronounced, and as you will note, the cable which was completed some years ago up and down the Atlantic Coast, between Boston and Washington, has been supplemented by cable stretching westward now as far as Cleveland. This cable will be extended as far as Chicago as rapidly as the work can be carried out and will provide high grade telephone circuits entirely in cable between Chicago and the Atlantic seaboard cities.

An outstanding advantage of the cable type of construction is the ability thereby to concentrate very large numbers of circuits along a single route. Typical aerial toll cable construction is shown in Fig. 10 which shows a section of the cable between Pittsburgh and Cleveland, carrying about 260 circuits. In open-wire construction 6 or 7 very heavy pole lines would be required to provide this number of circuits. In many

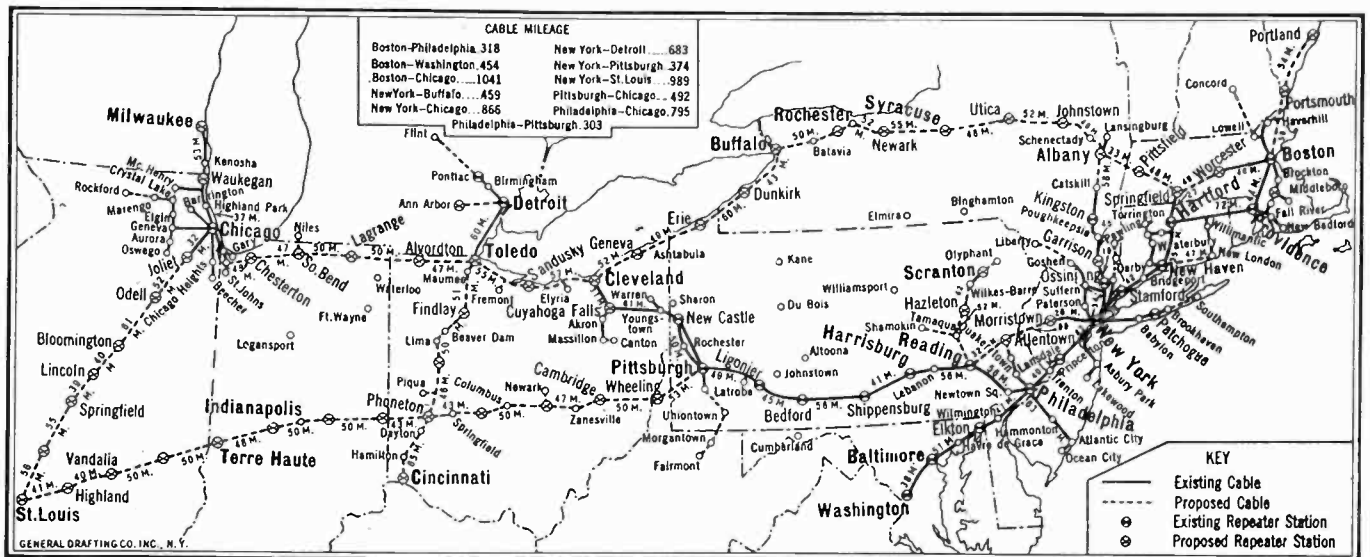

FIG. 9—LONG TOLL CABLES, EXISTING, PROPOSED AND IMPORTANT BRANCHES

circuit without distortion of the telephone currents. This has, therefore, removed the limitations which were set by high attenuation losses in the cable conductors. Although there are other important limitations and there have been large difficulties to overcome, cable transmission has been made practicable up to distances of at least 1000 miles (1600 km.).

As a result, the development of toll cables has become an exceedingly important phase of long distance telephone development and during the next few years it is expected that toll cables will be built in the Bell System at the rate of more than 500 miles (800 km.) a year. The extent of present and prospective use of

4. For a more detailed discussion of modern toll cable developments, see paper entitled: "Philadelphia-Pittsburgh Section of the New York-Chicago Cable" by J. J. Pilliod, JOURNAL A. I. E. E., August, 1922, and "Telephone Transmission on Long Cable Circuits" by A. B. Clark, JOURNAL A. I. E. E., January, 1923.

places where cable construction is now being used the available highway routes for pole lines are largely occupied and purchase of numbers of rights-of-way would be exceedingly expensive, so that in many cases the toll cable development furnishes almost the only practicable method of providing for the large numbers of circuits which the great development of toll business is requiring.

Another advantage of cable construction is the fact that where underground sections are necessary in passing through cities no irregularity is caused in the constants of the circuit as is the case with open-wire construction. With the general use of repeaters in connection with long toll circuits these irregularities in type of construction are important factors in limiting the efficiency.

Another important advantage of cable construction is its relative immunity from the effect of weather and

particularly from the effect of sleet. The damage which can be done by sleet storms is illustrated in Figs. 11 and 12. The cable construction can be made very substantial and capable of withstanding severe conditions of sleet.

The large number of circuits provided by one cable are obtained by the use of very small conductors, the gages in common use being 19 B. & S. (20 lb. to the wire

ferent frequencies. By loading, this variation is reduced with a corresponding improvement of the quality of transmitted speech and at the same time the efficiency of transmission is raised. This is illustrated in Fig. 13 which shows the transmission efficiency at different frequencies of 1 mile (1.6 km.) of 19-gage toll cable circuit non-loaded and when provided with the type of loading most used for toll cables. With the

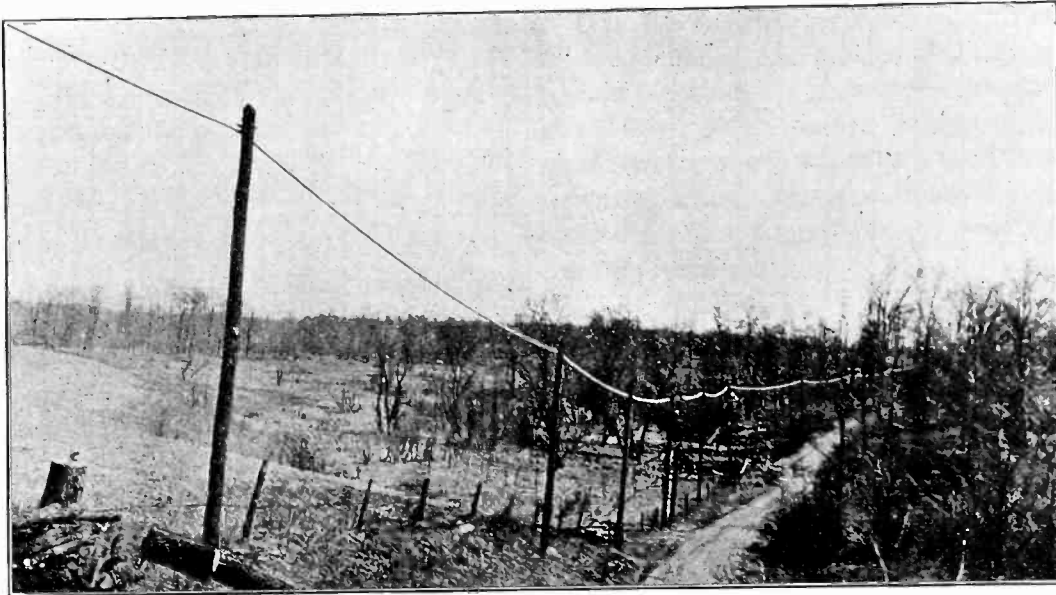

FIG. 10

mile) and 16 B. & S. (40 lb. to the wire mile). In the longest circuits two 19-gage circuits are required, each carrying the transmission in one direction only. Nevertheless, the amount of copper required is only 80 pounds to the mile as contrasted with 870 pounds per mile for the open-wire circuits which these circuits replace.

type of loading shown in the figure, the voltage for 1000-cycle transmission is increased by loading by 70 per cent and the losses per unit length are reduced by a factor of about 3.6.⁵

In the loaded cable circuit, as in the loaded open-wire circuit, the velocity of transmission is relatively low, being about 10,000 miles (16,000 km.) per second for the type of loading mentioned above, as compared with 180,000 miles (290,000 km.) per second on non-loaded open-wire lines. Therefore, for circuits more

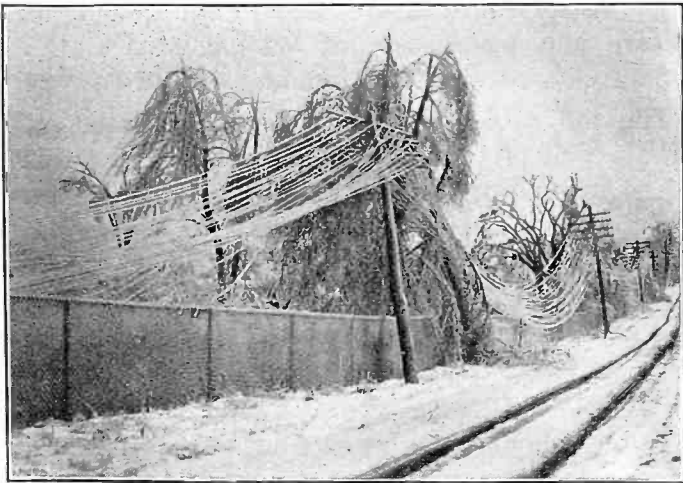

FIG. 11

In contrast to the recent developments on open-wire lines discussed above, toll cable circuits are always loaded. A non-loaded cable circuit consists largely of resistance and capacity, and as a result there are very wide differences in efficiencies of transmission at dif-



FIG. 12

than a few hundred miles long, care must be taken to avoid excessive echo currents. On the very long toll cable circuits, say over 500 miles (800 km.), a lighter weight of loading is used, whereby, because of the

5. In part, this improvement is due to improvement in power factor, in addition to the improvement caused by higher impedance.

lesser inductance per mile inserted in the cable, the velocity of propagation is as high as 20,000 miles (32,000 km.) per second. In addition to the echo currents, care must be taken in the design of the cables to avoid interference with speech by the transients produced by the periodic structure of the loaded cable circuit.

One of the interesting problems involved in the

cable, and manufacturing methods have been carefully worked out to give the greatest possible degree of symmetry in the construction of the two insulated conductors which are twisted together to form a pair and of the two pairs which are twisted together to form a quad. The construction of the various pairs and quads, also, is such as to properly coordinate all of the circuits which will be near each other in the cable.

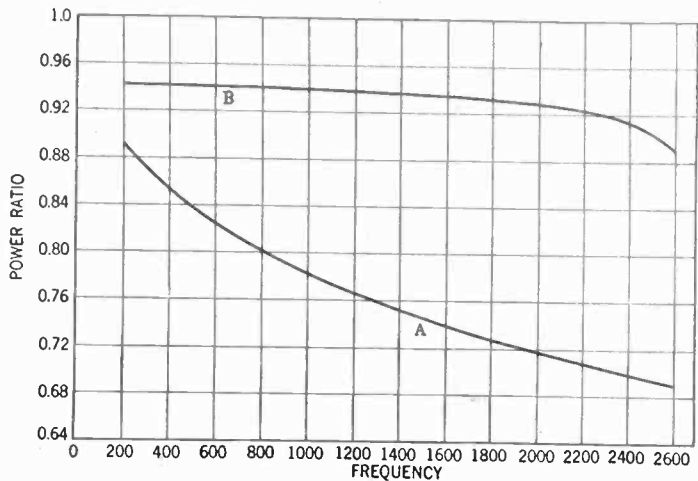

FIG. 13—POWER RATIO—FREQUENCY CHARACTERISTICS FOR No. 19 GAGE SIDE CIRCUITS
(A) WITHOUT LOADING
(B) WITH MEDIUM HEAVY HIGH CUT-OFF LOADING

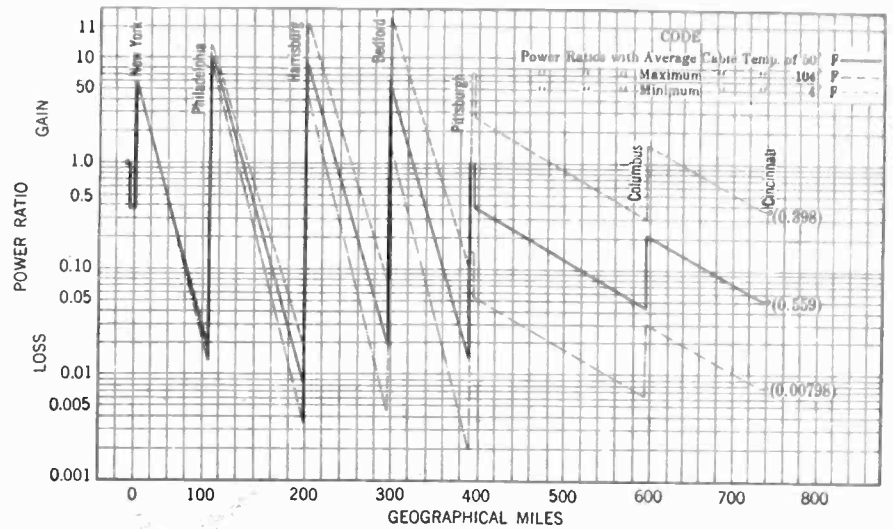

FIG. 15—TRANSMISSION ON LEVEL DIAGRAM OF NEW YORK—CINCINNATI, No. 1

design of long toll cables is the prevention of excessive crosstalk, that is, of excessive transfer of electrical energy from one circuit to another. The difficulty of avoiding this with a very large number of circuits crowded within a 2 5/8-in. sheath, is increased in the long circuits by the very long distances throughout which these circuits parallel each other and the frequent

These manufacturing precautions are supplemented by very careful tests made when the cables are installed, and by splicing procedure by means of which, based on the results of the tests, the induction between circuits is still further greatly reduced. As a precaution against slight series unbalances, all joints are soldered. Further precautions include the segregation into different parts of the cable of groups of circuits which would be particularly likely to interfere with each other.

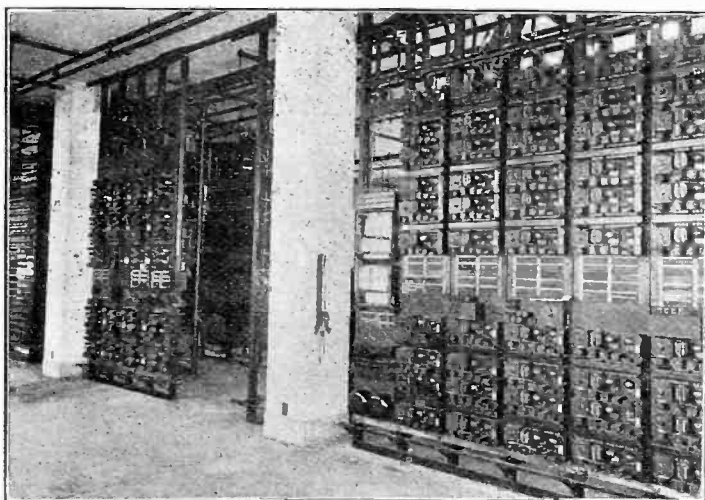

FIG. 14

Similar precautions are used in the design, manufacture and installation of loading coils and other apparatus used with the circuits.

large amplifications of both transmitted current and crosstalk at repeater stations along the line. An adequate discussion of this problem would require a paper in itself. In this paper we must be content to note merely a few of the more important methods which have been developed.

The toll cables require telephone repeaters at intervals of 50 or 100 miles (80 or 160 km.), and this has led to much work in the development of economical repeaters and auxiliary equipment for use with cable circuits.⁶ Fig. 14 shows a considerable group of telephone repeaters in the repeater station at Bedford, Pa., and illustrates the degree of condensation which has been worked out in the present types of apparatus developed for this service.

The telephone cable benefits not only traffic between points along its route, but at important points connects to open-wire lines along other routes. This use of the toll cable is well illustrated by Fig. 15, which shows the relative power levels at different points of a typical circuit now in use in the New York-Chicago cable

The problem starts with the construction of the

6. Refer to paper by Mr. Pilliod noted above and to paper entitled: "Telephone Equipment for Long Cable Circuits," by C. S. Demarest, A. I. E. E. Convention, Swampscott, June, 1923.

route. This circuit is in cable between New York and Pittsburgh and takes open-wire between Pittsburgh and Cincinnati, forming a New York-Cincinnati circuit. This figure has been drawn to represent the ratio of power at any point in the circuit to power transmitted to the circuit at New York and shows the variations in the amount of power transmitted due to variations in the resistance of the cable with temperature. It is to be noted that these resistance variations would introduce a variation of more than 7:1 in the amount of received power, which would be sufficient to prevent a satisfactory use of the circuit. These variations are automatically compensated for by the use of the automatic transmission regulators described in Mr. Clark's paper.

CARRIER-CURRENT SYSTEMS

It has already been mentioned that the necessity for providing large numbers of mutually non-interfering telephone circuits has led to great efforts to find ways of making a moderate amount of copper provide a large number of independent telephone and telegraph channels. One way in which this is done is by the use of very small conductors in toll cables which have just

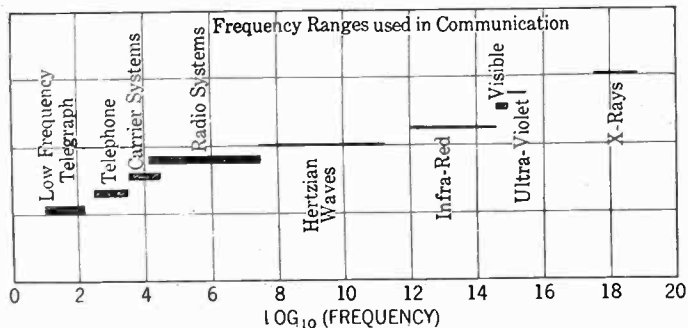

FIG. 16

been discussed. This is in general economical only where the traffic is heavy.

Another way of obtaining the same result is by requiring each pair of conductors to transmit a wider range of frequencies and using different portions of this range for independent channels of communication. A telephone conversation occupies the range between 300 cycles and something over 2000 cycles. It has long been the custom to use the range below 300 for telegraph and signaling purposes. The range above two or three thousand, however, was not commercially useful until the development of carrier-current systems.⁷

In the carrier-current telephone system the voice frequency telephone currents are made to modulate a higher frequency current. The frequencies of the modulated currents used in the carrier system represent the same width of band arithmetically as the original telephone frequencies, but all are shifted in magnitude by the frequency of the carrier current. That is, a

7. Refer to paper entitled: "Carrier-Current Telephony and Telegraphy," by E. H. Colpitts and O. B. Blackwell, A. I. E. E. TRANSACTIONS, Vol. XL, 1921.

telephone band of 300 to 2000 cycles, when used to modulate a 15,000-cycle carrier current, produces a band of frequencies ranging between 15,300 and 17,000 cycles in addition to other bands which are not used in existing systems and which need not be considered in this discussion. The principle of modulation is the same as is employed in radio telephony, but in the carrier system the modulated waves are carried along wire circuits, rather than radiated into space.

This development considerably increases the range of frequencies which can be used commercially for communication. The present situation is indicated in Fig. 16 which shows the ranges of frequency of electromagnetic waves which are used in different ways for communication, together with the frequencies which at the present time have no practical application to communication.

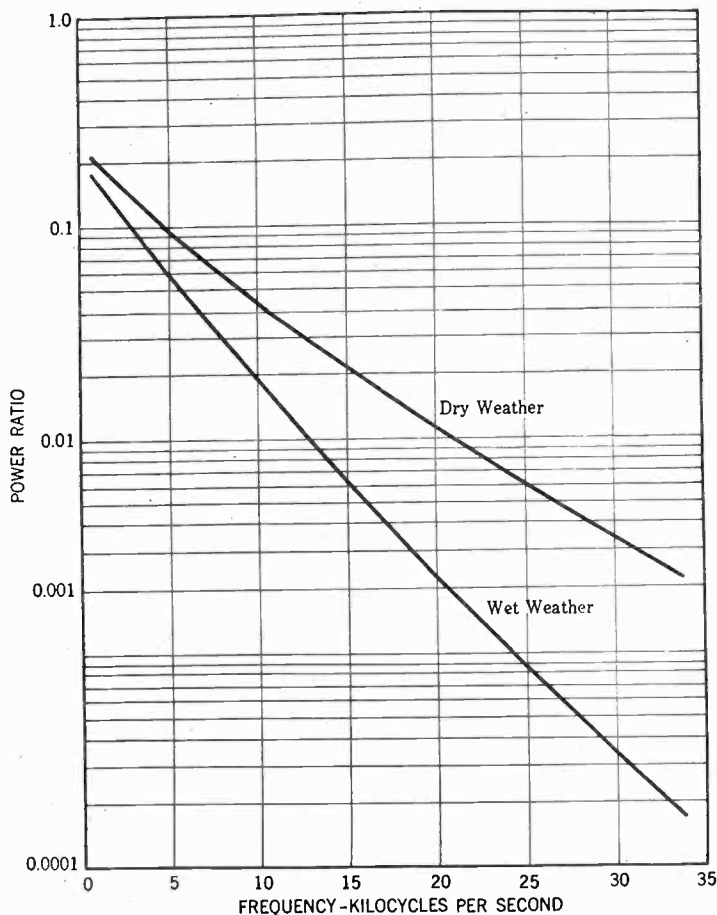

FIG. 17—TYPICAL POWER RATIO-FREQUENCY CHARACTERISTICS OF 165-IN. DIAMETER COPPER OPEN WIRE, 200 MILES LONG

The question may naturally arise why the lower frequencies have been chosen for the wire carrier systems developed for commercial use. A very important argument for using the lower frequencies in commercial telephone practice is that a number of carrier systems covering the same frequency ranges are used on different pairs carried on the same pole line. The crosstalk between the pairs is prevented by specially designed systems of transpositions in the circuits. The difficulty of preventing interference between the

two circuits, however, goes up more rapidly than the frequency of the currents, so that at frequencies very much higher than those now used it would probably be impracticable with present forms of construction to avoid excessive interaction between the circuits.

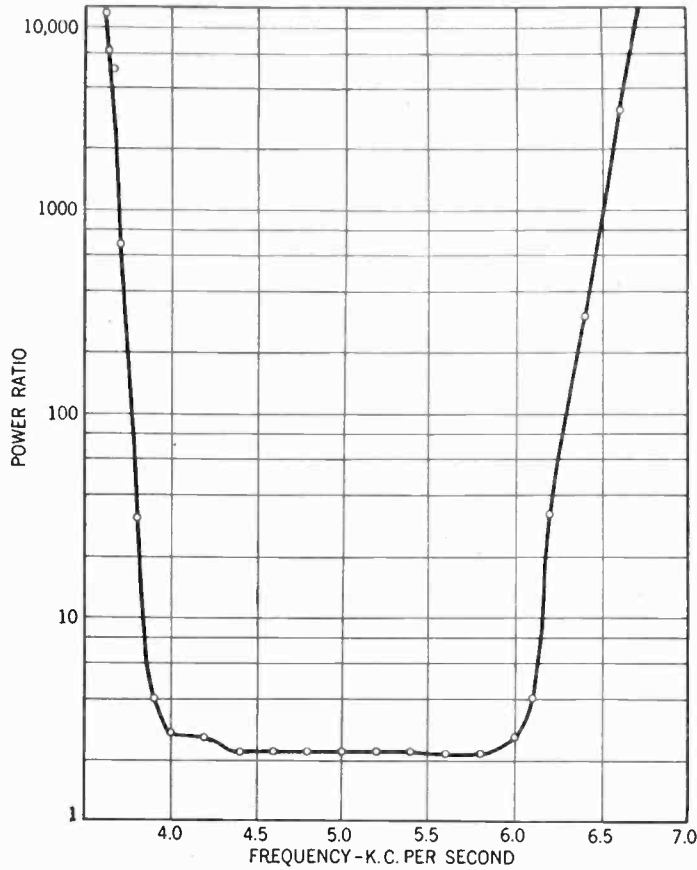

FIG. 18—ATTENUATION OF THE 4-6 K. C. BAND FILTER

The types of loading which were designed for voice frequency currents do not transmit currents of more than 3000 cycles frequency and for the carrier frequencies used in commercial telephony special loading with a very close spacing of loading coils has been developed.

Another way in which the lower frequency is advantageous is indicated in Fig. 17 which shows the ratio of output to input power at different frequencies under typical wet and dry weather conditions, for 200 miles (320 km.) of metallic circuit composed of copper wire 0.165 inches in diameter (435 pounds per wire mile). It will be noted that this loss increases rapidly with increasing frequency and furthermore that the variation of the loss between the wet and dry weather conditions also increases with frequency.

One of the problems involved in using low-frequency carrier currents for telephony arises from the fact that the width of the band of frequencies is appreciable compared with the frequency of the carrier current. For example, the carrier band of lowest frequency used in present Bell System practise is the band between 4000 and 6000 cycles. It is necessary to transmit all frequencies within that range with approximately uniform efficiency and to sharply cut off frequencies outside the range. A sharply tuned circuit would obviously be of no use, as it would very greatly distort the speech. This problem is beautifully solved by the invention of the electrical filter which provides a path for transmitting with almost uniform efficiency any selected band of frequencies and excluding all others.

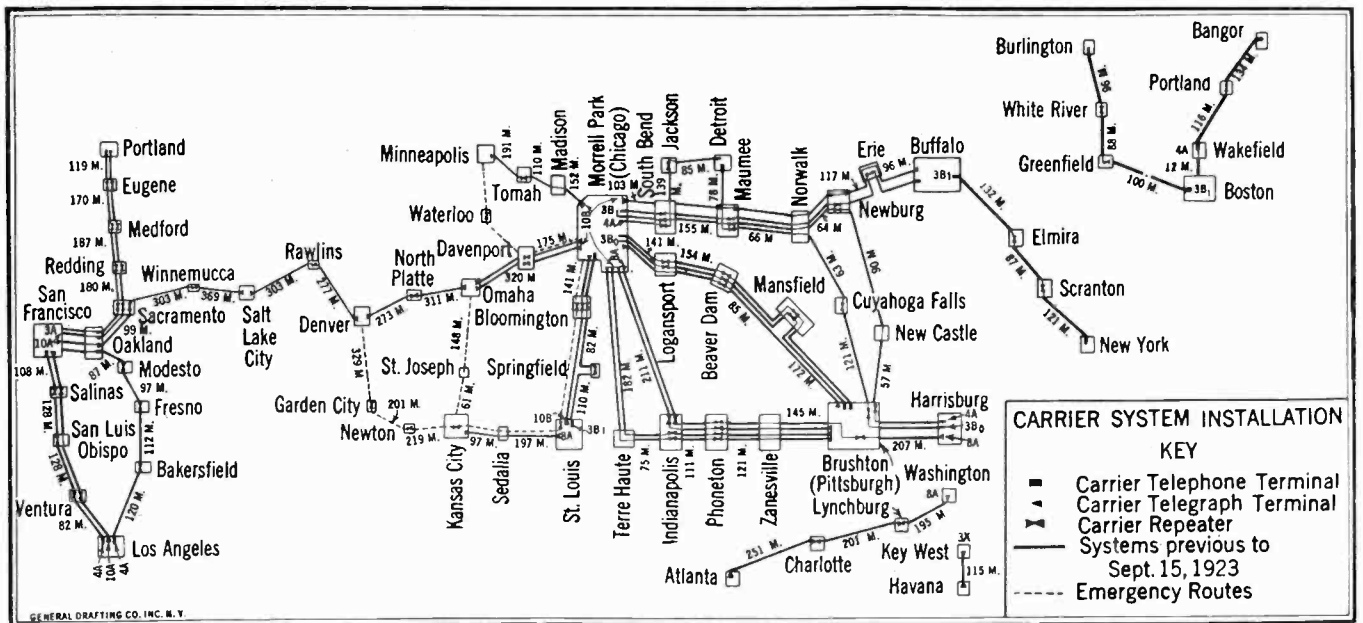

FIG. 19

Another important reason for using the lower carrier frequencies is the relatively great effect on high-frequency currents of short sections of cable inserted in the open-wire line. These effects can be reduced to a considerable extent by loading but the difficulties of loading efficiently increase rapidly with the frequency.

The action of an electrical filter is illustrated in Fig. 18 which shows the measured transmission characteristics of one of the filters in use in a carrier-current system.

The use of carrier systems saves the installation of additional copper conductors, but to offset this requires

the use of relatively expensive terminal apparatus and of repeaters at frequent intervals. The expense of terminal apparatus is such that carrier telephone systems are economical under present conditions only on the longer circuits, or in cases where their installation makes possible the deferment of a large expense such, for example, as a new toll cable. The extent of use of carrier systems in the Bell System is indicated in Fig. 19. Each line in this figure represents a system, that is, in the case of carrier telephone, three or four telephone circuits, and in the case of carrier telegraph, usually ten telegraph circuits. The total carrier circuit mileage now in use is about 20,000 miles (32,000 km.) of carrier telephone and 88,000 miles (140,000 km.) of carrier telegraph. The considerable number of carrier systems between Chicago and eastern points are

up the central transcontinental route as to make desirable the establishment of a southern route from Los Angeles across Arizona and New Mexico. This route is now under construction and will be in service by the end of the year. With the completion of this line there will be at least two independent routes all the way from the Atlantic to the Pacific Coast, whereas at the present time through traffic is dependent upon a single route in the section between Denver and Salt Lake City. Further development of traffic will no doubt require later a route to the Pacific Coast across the northern part of the country and that, with a connecting line across the State of Texas, will provide a very complete gridiron of high-grade routes over the western part of the country, as now over the eastern part.



FIG. 20

required largely to take care of growth on congested routes pending the completion of the New York-Chicago toll cable. The terminal apparatus can then be shifted to provide carrier circuits from Chicago to St. Louis, Omaha and other points not reached by the cable system.

CONCLUSION

The developments which are briefly discussed above have made it possible to realize in a large measure the goal of a universal telephone service throughout the country, making use of a network of very long telephone circuits covering the country. A number of the more important routes are indicated in Fig. 20. It is of interest to note that the growth in traffic has so loaded

By means of the trunk lines indicated in Fig. 20 and a much more extensive network of shorter lines, it is possible to carry on satisfactory telephone conversations between any two cities of moderate size in the country and to a large extent even small places can communicate with each other, irrespective of their relative location. A demonstration which was given in connection with the formal inauguration of service between the United States and Cuba in April, 1921, is a striking illustration of what can be done.

The service to Cuba was established by means of the extension of the wire lines to Key West along the viaduct of the Florida East Coast Railroad and the installation of long submarine telephone cables between Key West and Havana. The construction of the cables

involved a considerable number of very interesting problems.⁸ The demonstration referred to was a conversation between Havana and Catalina Island. This circuit was about 5500 miles (8800 km.) long, included the submarine cables lying at the bottom of the Florida Straits, open-wire lines extending up the Atlantic Coast to New York, across the continent to San Francisco and down the Pacific Coast to Los Angeles, and finally the unique circuit from Los Angeles to Catalina Island which at that time included a wireless telephone link between Long Beach and the Island.

A feature of interest in connection with this demonstration is to note that the telephone circuits involved carry regularly in commercial service not only the voice frequency channel used for the demonstration but many other channels of communication. This is indicated in Fig. 21, which shows the number of

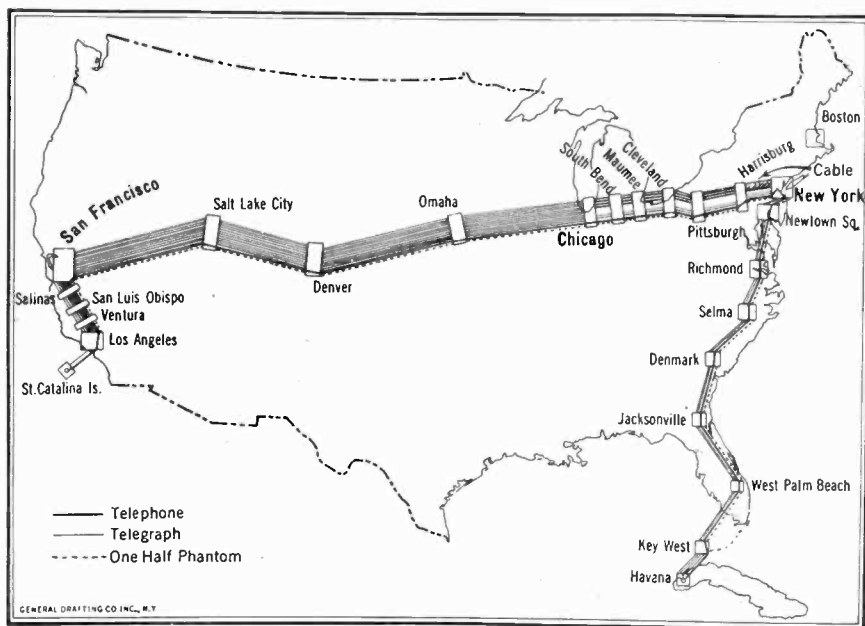

FIG. 21

independent channels of communication provided in the different sections by the single pair of conductors used. The heavy line represents a telephone conversation and the dotted heavy line indicates that the wires used form one of two pairs which together provide a phantom circuit. The heavy lines between Harrisburg and Chicago and between San Francisco and Los Angeles represent additional channels obtained by carrier telephone systems. The light lines indicate telegraph circuits, two circuits being obtained over the pair of wires throughout by direct-current composite telegraph system and 10 additional telegraph circuits being obtained between San Francisco and Chicago by carrier telegraph systems.

It is interesting to note that the sound is transmitted over this 5500-mile circuit in less than one tenth of a

second. This emphasizes the necessity for using electrical means for the transmission of speech over great distances. If the means were acoustic and transmission was through the air, it would take seven hours for the sound to be transmitted from one end of the circuit to the other.

The essential part which amplifiers at intermediate points play in giving service over these very long circuits is evident. The Havana-Catalina circuit passed through 25 amplifying stations. The impossibility of getting equivalent results by amplification of the terminals is perhaps best illustrated by an example. In talking from San Francisco to Havana, for example, with the transmitter delivering 1000 microwatts at San Francisco, the power delivered at Havana is about 25 microwatts. If there were no intermediate amplifiers, and assuming for the moment that the circuit could carry unlimited power without burning up, it would be necessary in order to deliver 25 microwatts at Havana that power sufficient to light an incandescent lamp would be flowing in the circuit at some point in North Carolina, and at Philadelphia the power would amount to five kilowatts. It is estimated that the total mechanical and electrical power generated in the world is equivalent to that required for about 20 billion electric lamps, and this power would have to be flowing in the circuit a little east of Denver. This power is, however, only about 1/200,000 of the power which is received by the earth from the sun, but all of this power would be required to be flowing in the circuit at Sacramento.

As pointed out at the beginning of this paper, the practical requirements of telephone transmission and of power transmission over long distances are very different. However, to solve the telephone transmission problems it has been necessary to work out the electrical transmission theory both for steady and for transient states⁹ for circuit conditions which are more extreme than any which are likely to be met with in power transmission, and it may be that the solution of these purely electrical parts of the problem will contribute to some extent to the power transmission problem in cases where very long distances are involved.

The writer gratefully acknowledges the assistance of Mr. O. B. Jacobs and of many others of his associates in the Departments of Development and Research and of Operation and Engineering in the American Telephone and Telegraph Company in the collection of data used in this paper.

8. Refer to paper entitled: "Key West-Havana Submarine Telephone Cable System," by Messrs. Martin, Anderegg and Kendall, A. I. E. E. TRANSACTIONS, Vol. XLI, 1922.

9. Refer to paper entitled: "Theory of Transient Solutions of Electrical Networks and Transmission Systems," by John R. Carson, A. I. E. E. TRANSACTIONS, Vol. XXXVIII, 1919.

Magneto-Mechanical Loads on Bus Supports

BY LLOYD N. ROBINSON

Associate, A. I. E. E.
Stone & Webster, Inc., Seattle, Wash.

Review of the Subject.—Current progress in electrical development and the increasing capacity of power systems has brought into prominence many factors of mechanical strength that were previously negligible in the design of electric stations and circuits. Heavy currents, that may develop during short circuits in stations that are connected to large generating systems, make it essential that bus and cable supports be strong mechanically as well as adequately insulated. Formulas are given for estimating the forces that may be developed under various conditions with different arrangements of conductors and supports.

The mechanical strength of bus and cable supports should be guaranteed by manufacturers and tested as well as the insulating qualities. In order to facilitate the selection of bus and cable supports, it is desirable that uniform terms for expressing the various kinds of loads, standard methods of conducting tests and a minimum factor of safety for mechanical strength be adopted.

THE successive improvements in the insulation and control of high-voltage circuits are the means of ever increasing the scope and capacity of electric power systems. This progress demands the solution of innumerable problems and naturally most of the factors entering these problems are of an electrical nature. However, one outstanding feature of the electrical development of the past decade or so, has been the increasing prominence of mechanical factors that were previously negligible in electrical station and circuit design.

Special attention is now given to the matter of anchoring and bracing generator and transformer windings. Safety catches are now a necessity on most disconnecting switches. And the oil circuit breaker is finally rated on the basis of its capacity to perform its originally intended function, namely to interrupt current. Numerous other cases might be cited but the above indicate the growing importance of mechanical features in the design of electrical apparatus and circuits.

In small stations, and especially in those that are blessed with double busses, the failure of a bus support may not involve a serious interruption of service nor a considerable expense for repairs. But in large stations, where every interruption of service is serious and the breakdown of a bus is practically certain to entail costly repairs, it is doubly essential that busses be strong mechanically as well as adequately insulated.

As a rule bus supports must be spaced at such frequent intervals in order to prevent sagging of the conductors and the usual types appear so rugged compared to the weight of the conductor supported that, to a casual observer, there seems little reason to question their adequacy as mechanical structures. However,

To be presented at the Pacific Coast Convention of the A. I. E. E., Del Monte, Cal., October 2-5, 1923.

CONTENTS

Text. (1500 w.)	Space
Appendix A.	
D-C. Conductors. (110 w.)	
A-C. Conductors. (110 w.)	
Short-Circuit Reactance. (200 w.)	
A-C. Short-Circuit Current. (250 w.)	
Single-Phase Circuit. (210 w.)	
Three-Phase Circuit. (100 w.)	
(1) Short-Circuit of Two Adjacent Conductors. (140 w.)	
(2) Short-Circuit of Three Conductors. (160 w.)	
A	
(a) Three Conductors in Equilateral Triangle B C Short-Circuit occurring at Instant of Zero Voltage in Phase A—Between Conductors by Pairs. (210 w.)—On Each Conductor. (520 w.)	
(b) Three Conductors in Plane C B A or A B C—Short-Circuit occurring at Instant of Zero Voltage in Phase A—Between Conductors by Pairs. (210 w.)—On Each Conductor. (110 w.)	

a brief computation of the magneto-mechanical forces, that may develop between parallel conductors in medium sized and large stations especially during short circuits, shows that these forces are far from negligible.

This has been recognized for some time and formulas and curves for estimating the forces involved have been published¹ so it does not seem necessary to present a complete discussion of the fundamental principles at this time, but merely to give some convenient formulas for the more common cases. The present purpose is rather to emphasize the fact that it is becoming more and more important to ascertain the mechanical strength of bus and cable supports for inside station wiring and to point out that there is room for standardization in this respect.

The magneto-mechanical phenomenon produced by electric currents in parallel conductors is fundamentally the same as the basic reaction in an electric motor. It can be thought of as the attraction, or repulsion as the case may be, between the current in one conductor and the magnetic field set up by the current in the other conductor or, perhaps more conveniently, as the force between the magnetic fields set up by the two currents.

In the design of motors and similar machines involving alternating currents the chief interest lies in the average force developed. But, in dealing with the mechanical requirements of bus supports, we are interested primarily in the maximum instantaneous force that may be developed.

The instantaneous force, corresponding to instantaneous currents, i_1 and i_2 in parallel conductors, is

$$S = \frac{5.40 i_1 i_2}{10^7 D} \text{ lb. per ft. of parallel}$$

¹C. P. Steinmetz, TRANS. A. I. E. E., 1911, p. 367.

H. B. Dwight, *Electrical World*, Sept. 1917, p. 522.

S. G. Leonard and C. R. Riker, *Electric Journal*, Dec. 1917, p. 491.

where D is the interaxial distance in inches between the conductors. This is the general formula for the determination of the magneto-mechanical force exerted upon a conductor of electric current due to the proximity of another parallel current. In parallel conductors, currents flowing in the same direction attract each other, tending to draw the conductors together, and currents flowing in opposite directions repel each other, tending to force the conductors apart.

The derivation of the formulas that apply for certain arrangements and various conditions on direct-current and alternating-current busses are given in the Appendix in sufficient detail so that formulas may be derived readily for special arrangements of conductors or groups of busses and for other than single-phase and three-phase circuits.

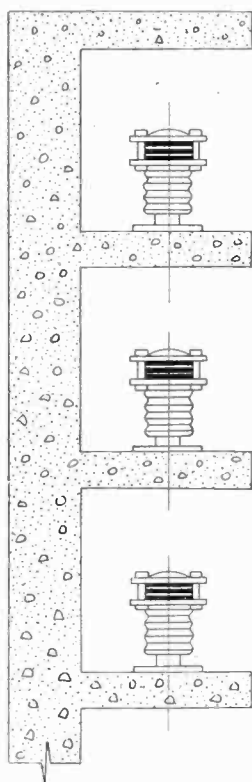

FIG. 1—TYPICAL CROSS-SECTION OF THREE-PHASE BUS

It is seen from the formulas in the Appendix that, for one three-phase bus having its conductors arranged in a plane, the maximum stress on a conductor will be developed when two adjacent conductors are short-circuited. Then

$$S = \frac{2.62 I_3^2}{10^6 D} \text{ lb. per ft. of parallel (repulsion).}$$

For example, in a station where the symmetrical three-phase, short-circuit current for a short circuit on the main bus is 30,000 amperes, and the conductors are arranged in a plane 18 inches apart on centers, the force of repulsion between two adjacent conductors when they are short-circuited may become

$$\begin{aligned} S &= \frac{2.62 (30,000)^2}{18 \times 10^6} \\ &= \frac{2.62 \times 900}{18} \\ &= 131 \text{ lb. per ft. of parallel.} \end{aligned}$$

If the bus supports along each conductor are spaced

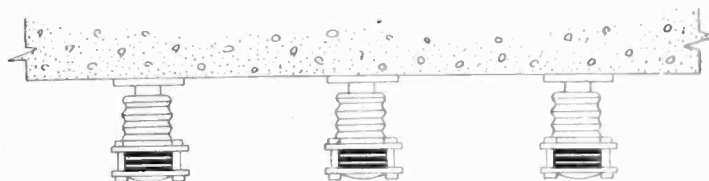

FIG. 2—TYPICAL CROSS-SECTION OF THREE-PHASE BUS

27.5 inches apart, the corresponding force on each support will be

$$\begin{aligned} F &= \frac{27.5 \times 131}{12} \\ &= 300 \text{ lb.} \end{aligned}$$

If the conductors of the three-phase bus in the above example are arranged as in Fig. 1 and two adjacent conductors are short-circuited, the repulsion between these two conductors will result in a tensile force of 300 lb. on each bus support of the upper one, and a compressive force of 300 lb. on each bus support of the

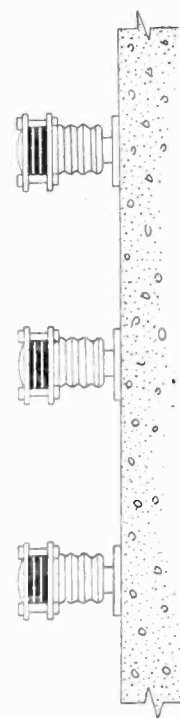

FIG. 3—TYPICAL CROSS-SECTION OF THREE-PHASE BUS

lower one; and the bus supports should have ultimate tensile and compressive strengths of not less than 1200 lb. if the factor of safety is 4.

On the other hand, if the conductors in the above example are arranged as in Fig. 2 or Fig. 3 and two adjacent conductors are short-circuited, the repulsion between these two conductors will result in a load of

300 lb. on each bus support as a cantilever beam. If the height of the bus support is such that the distance from the bottom of the base to the axis of the conductor is, say, 7.5 inches, the cantilever load will be

$$7.5 \times 300 = 22,500 \text{ pound-inches.}$$

And, if the factor of safety is 4, the ultimate strength of the bus support as a cantilever beam should be not less than 90,000 pound-inches.

After determining the magnitudes and character of the loads involved and the ultimate strengths required, the next step is to select bus supports of adequate mechanical strength. In this, reliance must be placed upon the experience of the manufacturers with their various types and sizes of supports. But it is clear that mechanical strength, as well as insulating qualities, should be guaranteed; and, in view of the inevitable variations from time to time among porcelains, it is only fair that at least a reasonable percentage of the supports covered by the order should be tested under specified types of mechanical loads up to the guaranteed ultimate strength.

In order to facilitate testing and to put the matter on a uniform basis for the benefit of the manufacturers as well as for the convenience of purchasers, it seems highly desirable that the field be canvassed and standards adopted because there now are considerable divergencies among manufacturers as to the meanings of terms and methods of test.

For instance, some manufacturers test the complete bus support and some test only the porcelains. It is clear that the complete support should be tested because metallic bases and clamps have been known to fail earlier than the porcelains, also because the method of clamping or cementing the metallic parts to the porcelain sometimes determines the breaking point of the porcelain especially under a cantilever load.

Tensile and compressive strength should mean strength in carrying loads applied along the line joining the centers of the base and bus clamp, and not refer to tension or compression along the axis of the bus.

At present, some manufacturers express the ultimate mechanical strength as a cantilever beam in pound-inches and others express it in pounds without giving the length of the lever arm or radius. It is clear that the former is the preferable way because the strength of the bus support should be independent of the dimensions of the bus except in so far as the latter affects the size of the clamp.

Whether the factor of safety should be 4, based on the ultimate strength of the support, is somewhat a matter of opinion and judgment. But, as in machine and structural design, it is desirable to have a standard minimum factor of safety. In view of the metallic parts used and the variations in the quality of porcelain, it does not seem wise to use a factor of safety much less than 4.

There are undoubtedly other phases of the subject

that might be standardized but only a thorough canvass of the field can bring out all of them.

Appendix

D-C. CONDUCTORS

In a direct-current bus, consisting of two conductors carrying equal currents, I , in opposite directions, the stress exerted by each conductor upon the other is

$$S = \frac{5.40 I^2}{10^7 D} \text{ lb. per ft. of parallel (repulsion)}$$

where D is the perpendicular distance in inches between the axes of the conductors.

The value of the current, I , that will develop in the case of a short circuit on a direct-current bus, will be determined by the generating capacity connected to the system and the equivalent resistance of all the paths feeding into the short circuit combined.

A-C. CONDUCTORS

In the case of an alternating current, having a root-mean-square value of I , the maximum instantaneous value of current is $\sqrt{2} I$. Consequently, in a single-phase bus, carrying a normal root-mean-square current, I , the instantaneous magneto-mechanical stress exerted between the busses pulsates between zero and the maximum value,

$$\begin{aligned} S &= \frac{5.40 (\sqrt{2} I) (\sqrt{2} I)}{10^7 D} \\ &= \frac{1.08 I^2}{10^6 D} \text{ lb. per ft. of parallel (repulsion).} \end{aligned}$$

SHORT-CIRCUIT REACTANCE

The current, that will develop at a short circuit, depends on the rated kv-a. of the synchronous equipment connected to the circuit and upon the impedance of the combined circuits feeding into it.

Obviously, it is tedious to determine the combined impedance of the numerous groups of series and multiple circuits that make up a generating and distribution system. However, it is usually true that the reactances involved are large compared to the respective resistances so that the impedance is only slightly greater than the reactance numerically. Consequently, to simplify the calculations it is usually sufficiently accurate to neglect the resistances and to use the reactances in place of the impedances.

This approximation is customary in dealing with short-circuit problems and the term "reactance" is used in this sense hereinafter. It gives values of short-circuit current slightly larger than actually obtain and consequently the results are on the safe side. Of course, in cases where the resistances are large compared to the respective reactances or economies may be effected that will warrant the extra labor of the more precise determination, the total impedances, including resistances, should be used.

A-C. SHORT-CIRCUIT CURRENT

The maximum instantaneous value of current, that will be produced when a synchronous generator is short-circuited, depends upon the instantaneous value of the voltage when the short circuit takes place.

If the short circuit occurs at the instant of maximum voltage, the short-circuit current wave will be symmetrical about the time axis. And the effective value of the short-circuit current will be that corresponding to the rated kv-a. of synchronous equipment, that is connected to the circuit, divided by the transient reactance expressed as a decimal (that is, the per cent reactance divided by 100).

But, if the short circuit occurs at an instant when the voltage is not at its maximum, the current wave will be symmetrical not about the time-axis, but about an exponentially decaying curve which finally becomes tangent to the time-axis. Under the worst condition, namely, short circuit occurring at the instant of zero voltage, the axis of symmetry of the current may be so high as to produce a maximum instantaneous value of current approximately 1.8 times that which arises in case of a symmetrical short circuit.

In the case of a three-phase synchronous generator, if a short circuit of all three phases occurs at the instant of zero voltage in phase *A*, the factor of asymmetry for phase *A* is approximately 1.8, and that for phases *B* and *C* is approximately 1.35.

Since we are most often concerned with the maximum currents that may arise during a short circuit, these factors 1.8 and 1.35 are usually included in the formulas pertaining to short circuits of alternating-current conductors.

SINGLE-PHASE CIRCUIT

The symmetrical short-circuit current of a single-phase circuit is

$$I_s = \frac{100 I}{X}$$

where *I* is the total rated current of all the synchronous machines connected to the circuit reduced to terms of the circuit voltage; and *X* is the per cent reactance of the circuits (including equipment), that feed into the short circuit, based on the total rated generating capacity of the synchronous machines.

The maximum peak value of current, in case of a short circuit occurring at the instant of zero voltage, then is

$$1.8 \sqrt{2} I_s.$$

And the stress on each of the two parallel conductors, spaced *D* inches apart and carrying this current, is

$$S = \frac{5.40 \times 1.8 \sqrt{2} I_s \times 1.8 \sqrt{2} I_s \cos 180^\circ}{10^7 D}$$

$$= \frac{-3.50 I_s^2}{10^6 D} \text{ lb. per ft. of parallel (repulsion).}$$

THREE-PHASE CIRCUIT

The symmetrical three-phase short-circuit current of a three-phase circuit is

$$I_3 = \frac{100 I}{X}$$

where *I* is the total rated three-phase current of all the synchronous machines connected to the circuit reduced to terms of the circuit voltage; and *X* is the per cent reactance of the circuits (including equipment), that feed into the short circuit, based on the total rated kv-a. capacity of the synchronous machines.

(1) SHORT CIRCUIT OF TWO ADJACENT CONDUCTORS

The maximum peak value of current, in case of a short circuit occurring between two adjacent conductors of a three-phase circuit at the instant of zero voltage, is

$$1.8 \sqrt{2} \left(\frac{\sqrt{3}}{2} \right) I_3.$$

And the stress on each of these two conductors (if parallel and spaced *D* inches apart) then is

$$S = \frac{5.40 \times 1.8 \sqrt{2} (\sqrt{3}/2) I_3 \times 1.8 \sqrt{2} (\sqrt{3}/2) I_3 \cos 180^\circ}{10^7 D}$$

$$= \frac{-2.62 I_3^2}{10^6 D} \text{ lb. per ft. of parallel (repulsion).}$$

(2) SHORT CIRCUIT OF THREE CONDUCTORS

In calculating the currents that develop during the short circuit of all three conductors of a three-phase circuit, it is of course necessary to take into account the time-phase of the three currents. Assume the current in phase *A* is *I*₃, that in phase *B* is *I*₃ /120° and that in phase *C* is *I*₃ /240°. The total magneto-mechanical force exerted on each conductor is a resultant of the forces exerted by each of the other conductors. It is necessary to solve first for the forces exerted between conductors by pairs and then obtain the resultants by combining these individual forces, taking into account the angles between their directions.

The forces depend on the distances between the conductors and consequently upon their relative positions. The two most common configurations of three-phase conductors are: (a) at the corners of an equilateral triangle, and (b) in a plane. Formulas are given below for these two common types of arrangement. Equations corresponding to other configurations can readily be derived.

(a) Three Conductors in Equilateral Triangle

A
B C

Short-circuit occurring at instant of zero voltage in phase *a*.

Between Conductors by Pairs:

$$S_{AB} = \frac{5.40 \times 1.8 \sqrt{2} I_3^2 \times 1.35 \sqrt{2} \cos 120^\circ}{10^7 D}$$

$$= \frac{-13.1 I_3^2}{10^7 D} \text{ lb. per ft. (Repulsion)}$$

$$S_{BC} =$$

$$\frac{5.40 \times 1.35 \sqrt{2} I_3 \cos 120^\circ \times 1.35 \sqrt{2} I_3 \cos 240^\circ}{10^7 D}$$

$$= \frac{+4.92 I_3^2}{10^7 D} \text{ lb. per ft. (Attraction)}$$

$$S_{CA} = \frac{5.40 \times 1.35 \sqrt{2} I_3 \cos 240^\circ \times 1.8 \sqrt{2} I_3}{10^7 D}$$

$$= \frac{-13.1 I_3^2}{10^7 D} \text{ lb. per ft. (Repulsion)}$$

On each Conductor:

$$S_A = \frac{(13.1 + 13.1) I_3^2 \cos 30^\circ}{10^7 D}$$

$$= \frac{22.7 I_3^2}{10^7 D} \text{ lb. per ft. (Upward)}$$

$$S_B = S_{B'} + j S_{B''}$$

$$S_{B'} = \frac{(-13.1 \sin 30^\circ + 4.92) I_3^2}{10^7 D}$$

$$= \frac{-1.63 I_3^2}{10^7 D} \text{ lb. per ft. (Toward Left)}$$

$$S_{B''} = \frac{-j 13.1 I_3^2 \cos 30^\circ}{10^7 D}$$

$$= \frac{-j 11.35 I_3^2}{10^7 D} \text{ lb. per ft. (Downward)}$$

$$S_B = \frac{I_3^2}{10^7 D} \sqrt{1.63^2 + 11.35^2}$$

$$= \frac{11.47 I_3^2}{10^7 D} \text{ lb. per ft. (Resultant)}$$

$$S_C = S_{C'} + j S_{C''}$$

$$S_{C'} = \frac{(13.1 \sin 30^\circ - 4.92) I_3^2}{10^7 D}$$

$$= \frac{1.63 I_3^2}{10^7 D} \text{ lb. per ft. (Toward Right)}$$

$$S_{C''} = \frac{-j 13.1 I_3^2 \cos 30^\circ}{10^7 D}$$

$$= \frac{-j 11.35 I_3^2}{10^7 D} \text{ lb. per ft. (Downward)}$$

$$S_C = \frac{I_3^2}{10^7 D} \times \sqrt{1.63^2 + 11.35^2}$$

$$= \frac{11.47 I_3^2}{10^7 D} \text{ lb. per ft. (Resultant)}$$

(b) Three Conductors in Plane

C B A or A B C

Short-circuit occurring at instant of zero voltage in phase *a*.

Between Conductors by Pairs:

$$S_{AB} = \frac{5.40 \times 1.8 \sqrt{2} I_3 \times 1.35 \sqrt{2} I_3 \cos 120^\circ}{10^7 D}$$

$$= \frac{-13.1 I_3^2}{10^7 D} \text{ lb. per ft. (Repulsion)}$$

$$S_{BC} =$$

$$\frac{5.40 \times 1.35 \sqrt{2} I_3 \cos 120^\circ \times 1.35 \sqrt{2} I_3 \cos 240^\circ}{10^7 D}$$

$$= \frac{4.92 I_3^2}{10^7 D} \text{ lb. per ft. (Attraction)}$$

$$S_{CA} = \frac{5.40 \times 1.35 \sqrt{2} I_3 \cos 240^\circ \times 1.8 \sqrt{2} I_3}{2 \times 10^7 D}$$

$$= \frac{-6.55 I_3^2}{10^7 D} \text{ lb. per ft. (Repulsion)}$$

On each conductor:

$$S_A = \frac{(13.1 + 6.55) I_3^2}{10^7 D}$$

$$= \frac{19.65 I_3^2}{10^7 D} \text{ lb. per ft. (Toward A)}$$

$$S_B = \frac{(-13.1 - 4.92) I_3^2}{10^7 D}$$

$$= \frac{-18.02 I_3^2}{10^7 D} \text{ lb. per ft. (Toward C)}$$

$$S_C = \frac{(-6.55 + 4.92) I_3^2}{10^7 D}$$

$$= \frac{-1.63 I_3^2}{10^7 D} \text{ lb. per ft. (Toward C)}$$

SPECIFICATIONS FOR CYLINDRICAL DRY CELLS

Specifications for dry cells of the cylindrical form have recently been adopted by letter ballot of the Signal Section of the American Railway Association. These specifications are in agreement with those recently adopted for dry cells by the Federal Specifications Board and issued as Bureau of Standards Circular No. 139. The Bureau assisted in the preparation of the specifications for the Signal Section, which have now been finally adopted. The above-mentioned Circular entitled "United States Government Specifications for Dry Cells" is also designated as Standard Specifications No. 58 of the Federal Specifications Board, and can be obtained from the Superintendent of Documents, Government Printing Office, Washington, D. C., at 5 cents a copy.

Discussion at Midwinter Convention

QUALITATIVE ANALYSIS OF TRANSMISSION LINES* (GOODWIN), NEW YORK, N. Y., FEBRUARY 14, 1923

R. D. Evans: In discussing Mr. Goodwin's paper, we wish to comment on three points, as follows: 1. The conditions for the most efficient transmission of power; 2. Stable operating conditions for long transmission lines; 3. The desirability of the circle diagram for calculating performance of transmission lines.

The first statement given under the caption of "Summary," suggests that the transmission of the critical load will be most efficient at unity power factor at the receiver. We wish to point out, however, that the most efficient transmission of power for a given transmission line and receiver voltage occurs at a slightly lagging power factor. This condition can best be explained by means of the circle diagram.

In Fig. 1, is shown a circle diagram for a transmission line, 125 miles in length. In this diagram, the receiver load is plotted in kw. along the X axis and in reactive kv-a. along the Y axis. The circle with solid line, with radius C_R is a graph of the different receiver load conditions which satisfy certain definite voltage conditions at the supply and receiver ends of the transmission line. The dotted circle represents a similar graph for a

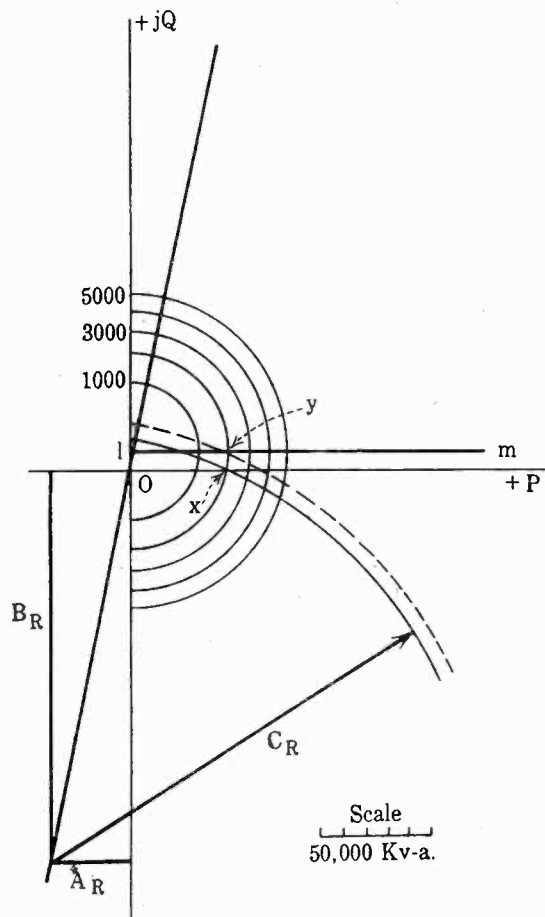

FIG. 1

different supply voltage condition. The transmission losses for a definite transmission line and with constant receiver voltage may be represented by a series of concentric circles, only segments of which are plotted. It will be noted from the loss circles, that the line lm represents the receiver load and supply voltage conditions for minimum transmission loss or maximum transmission efficiency for the particular amount of power to be transmitted. The critical load for the transmission line, is indicated graphically as a load at the point x . It will be observed, that lower transmission line losses will occur if the critical load is operated at a

slightly lagging power factor and at a slightly higher generator voltage. As indicated by the condition for the point y , most transmission line loads are of lagging power factor and synchronous condensers are required to improve the power factor and thus, regulate the system voltage. Hence, operation of a transmission line at the critical load, as indicated by the point x of Fig. 1, will occasion greater transmission losses, higher condenser losses and require greater condenser capacity than would occur under the more favorable operating condition indicated by the point y .

The second point we wish to discuss is in reference to stable

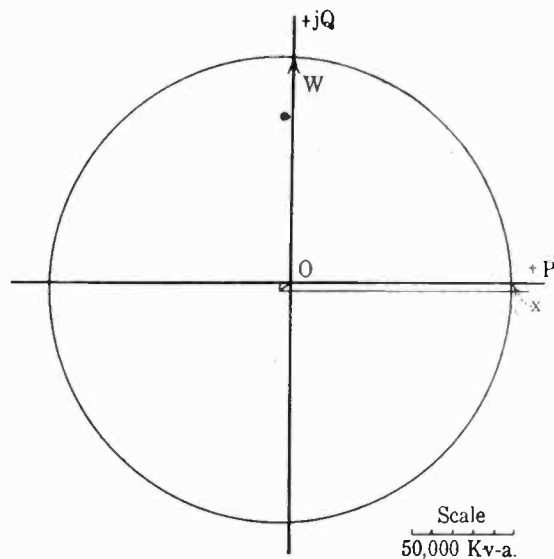

FIG. 2

operating conditions of transmission lines. In Mr. Goodwin's paper, there is included under the heading of "Practical Examples of Transmission Lines Operating at Critical Load," a list of existing lines with their critical loads; also some data as to very long transmission lines. By inference, it might be supposed that it is practicable to transmit over 100,000 kw. at 60 cycles over a distance of 775 miles. The circle diagram for this very long transmission line, given in Table No. 4 of Mr. Goodwin's paper, will appear as indicated in Fig. 2. The critical load occurs at the point x and it will be noted that the transmission system will not deliver any appreciable load in excess of the critical load. If this line supplied synchronous machinery at the receiver, the operation would be unstable and difficulty would be experienced in maintaining synchronism. Furthermore, with the actual, transformers would be required which would further limit the amount of power that might be transmitted with satisfactory operating conditions. The circle diagram also shows that, in order to maintain the same voltage at no load as at full load, the reactive kv-a. required would be very nearly equal to the maximum kv-a. that might be transmitted over the transmission line. With a 60-cycle line of 775 miles in length, there would be a very real problem in limiting transmission line voltages, in case the load were dropped for any reason and the problem of making the generators non-self-exciting would be extremely difficult. Mr. Goodwin has pointed out that there would be difficulties incident to the operation of these very long transmission lines at light loads, but the speaker wishes to emphasize that the full-load operating condition would also be unsatisfactory. On such long transmission lines in order to insure stable operating conditions, loaded transmission lines with intermediate synchronous condenser stations should be employed.

The speaker feels that there is danger in the idea which has been advanced in some quarters that it is possible with unloaded transmission lines to transmit very large amounts of power per

*A. I. E. E. JOURNAL, 1923, Vol. XLII, January, p. 48.

circuit to almost unlimited distances and that all that is necessary is to build a 220-kv. line and close the switches and the system will operate satisfactorily. The problem, however, is not as simple as that although it may be solved readily enough. There are factors such as unstable operating conditions that must be given consideration because of the large amount of power which may be involved and which may require loading of the transmission lines.

In connection with studies of transmission line performance, it seems desirable to emphasize the advantages resulting from the use of the circle diagram method of solution. This method was rather fully discussed in articles by H. K. Sels and the speaker, published in the *Electric Journal*, during 1921-1922. The advantages of this method arise from the graphical presentation of the different voltage, load, and transmission loss conditions. This method readily shows the conditions for maximum efficiency on the transmission system for different conditions of supply and receiver voltages. The diagram also gives directly, information as to the probable stable operation of the transmission system. It is to be emphasized that a mathematical solution of a transmission line may not be a stable operating condition.

Summarizing, the maximum efficiency of a transmission line does not occur for the critical load at unity power factor, but at a slightly lagging power factor. Second, critical load conditions on very long transmission lines will have unstable operating characteristics, which may be avoided in a practical way, only by the use of loaded transmission lines with intermediate condenser stations. Third, the circle diagram method of calculating transmission lines has many desirable characteristics, including a graphical presentation of the various conditions with regard to variation in generator and receiver voltages, maximum transmission efficiency, and stable operating characteristics.

V. Karapetoff: I should like to discuss the first page of Mr. Goodwin's paper, particularly the statements regarding the properties of the critical load. Mr. Goodwin refers to Mr. Percy H. Thomas's paper of 1909, and so I looked up that paper for a confirmation or a proof, of the statement made here, but I found none. I looked up Mr. Thomas' companion paper, his mathematical discussion of the same date, but there also I could find no proof, and so I tried to check these statements mathematically. They do not seem to check, and I feel that Mr. Goodwin owes us an appendix to the paper, proving the statements made on the first page.

The general equations of a transmission line are quoted on p. 135 of my paper on the "Heavisidion," and I shall only refer to them without repeating them here. Mr. Goodwin's critical load is one for which $E_2 = Z_s I_2$, so that the second term in my eqs. (1) and (2) is equal to zero. Thus, the critical load is characterized not only by the voltage and the current, but also by a definite phase angle which depends on the line constants.

In the light of this theory, I should like to quote some of Mr. Goodwin's statements: "The critical load when placed on a transmission line at unity power factor will be transmitted at unity power factor." While I realize that the phase angle of the surge impedance may be small, nevertheless, I feel that in a statement of this kind, it should be explained that this only is so provided that the resistance and the leakage are neglected. I am afraid that the above statement may later be used and quoted as a reference, and the fact that it is only approximate may not be noted.

The second part of the statement reads: "The current will be constant throughout the line." This is not quite true, because both the current and the voltage have a decremental factor, αS . Again, neglecting the resistance and the leakage, the foregoing statement is true, but this limitation must be definitely stated.

The second statement is as follows: "If the kv-a. load is greater than the critical load, the power factor at the sending end of the line will be *always* more lagging than the power factor at the receiving end of the line." We cannot compare the critical

load with any other load unless we take into account the power factor. Such a general statement does not seem to be true without further qualifications. Moreover, the power factor varies from leading to lagging and back, as you proceed along the line. If you start with a receiver condition, you can assume the generator end to be anywhere you please, one mile, seven hundred miles, or fifteen hundred miles, from the receiver end. There is no definite generating end in that sense, and as you proceed from the receiver end, you will meet line conditions of both leading and lagging power factor; thus, the above statement, as you may see, depends on where you take the generating end.

For all these reasons, I feel that Mr. Goodwin owes us much more explanation and proof than he has given us.

C. P. Steinmetz: A transmission line has four constants, two representing the energy dissipation, and two the energy storage, as depending on current and on voltage respectively.

1. The *resistance* r , calculated in the usual manner from material and size of wire, represents the *energy dissipation* depending on the line *current*: $r i^2$.

2. The *shunting conductance* g , representing the *energy dissipation* depending on the line *voltage*, such as by leakage through insulation, corona, dielectric hysteresis, etc. in transmission lines. This usually is so small as to be neglected.

3. The *inductance* L , representing the *energy storage* depending on the *current*, in the *magnetic field* surrounding the line, and giving rise to the *inductance voltage* or counter e. m. f. of self inductance.

4. The *capacity* C , representing the *energy storage* depending on the *voltage*, in the *electrostatic field* surrounding the line, and giving rise to the *capacity current* or charging current of the line.

The inductance, per unit length of line conductor, is given by:

$$L_0 = 2 \log L/R \times 10^{-9} h \tag{1}$$

or, in common logarithms:

$$L_0 = 4.6 \log L/R \times 10^{-9} h \tag{2}$$

where R = radius of line conductor, and L = distance from return conductor.

The line capacity, per unit length of line conductor, is given by:

$$C_0 = \frac{1}{c^2 L_0} \tag{3}$$

where:

$$c = 3 \times 10^{10} \text{ cm. is the velocity of light}$$

Instead of the inductance L and the capacity C of the line the surge frequency f_0 and the surge resistance r_0 may be used as line constants, and in some respect give a better physical insight into the behavior of the transmission line.

Any change of circuit conditions, such as current or voltage of a transmission line, means a change of the energy stored by inductance and by capacity, and thus a readjustment of the stored energy. This occurs usually by an oscillation, that is, electro-magnetic energy of current in the inductance changes to electro-static energy of voltage in capacity and back. It thus follows, that the rate of change, that is, the frequency of the oscillation, and the ratio of the voltage to current must be determined by the inductance and the capacity. The ratio of voltage to current is of the nature of a resistance or impedance, and therefore called the *surge resistance*, or *surge impedance*, or *natural impedance* of the line, and denoted by r_0 or z_0 , while the frequency is called the *surge frequency* or *natural frequency* f_0 of the line.

It is:²

$$f_0 = \frac{1}{4 \sqrt{L C}} \tag{4}$$

$$r_0 = \sqrt{L/C} \tag{5}$$

1. This does not include the magnetic field inside of the conductor.

2. Due to the effect of the resistance (and shunted conductance) f_0 and r_0 are slightly changed, so that the above strictly are only approximations.

Substituting (1) and (3) into (4) and (5), gives the surge frequency:

$$f_0 = \frac{l}{4c} \tag{6}$$

where l = length of line, and c = velocity of light or, the wave length:

$$\begin{aligned} l_0 &= f_0 c \\ &= 4l \end{aligned} \tag{7}$$

that is, the wave length is 4 times the length of the line.

$$\begin{aligned} \text{and } r_0 &= 2c \log L/R \times 10^{-9} \\ &= 4.6c \log L/R \times 10^{-9} \end{aligned} \tag{8}$$

or, substituting for c :

$$r_0 = 138 \log L/R \tag{9}$$

It is interesting to note that:

The surge frequency of a transmission line does not depend on size and distance of conductors or line construction, but depends only on the length of the line.

The surge resistance of a transmission line does not depend on the length of the line, but only on its construction, and is proportional to the logarithm of the ratio of the radius of the conductor into the distance of the return conductor.

f_0 and r_0 therefore segregate the energy storage line characteristics into two constants of which the former depends only on the length, the latter only on the construction of the line.

All the infinite variety of transients which may occur in a circuit, such as traveling waves, stationary waves, discharges, etc., therefore must always occur at a definite frequency, the surge frequency or its multiples, and in every component wave or impulse, the ratio of voltage to current must always be the same, the surge resistance r_0 .

The natural frequency of the line is familiar, but the meaning of the surge resistance r_0 is relatively little understood, though this constant probably is more important than the frequency, since it determines or limits the current which a transient voltage wave or impulse can give, and inversely.

As r_0 is the ratio of voltage to current, at which the readjustment of energy storage by inductance and capacity occurs, it follows that at this ratio r_0 , capacity and inductance balance, thus no shift or change of phase occurs along the line, and no reflection. In other words, if a transmission line is closed by a resistance r_0 , any transient passes into this resistance without reflection, while at any higher or lower resistance or impedance, at open circuit or short circuit, a voltage or current reflection must occur.

In lightning protection, the surge resistance r_0 is of fundamental importance, since it gives the discharge current, which the protective device must be able to pass, with a given lightning voltage, to keep the voltage at the protective device down to safe value.

For instance, if $r_0 = 180$ ohms is the total surge resistance, if the line flashes over at an instantaneous voltage $e_0 = 200$ kv. and this therefore is the limiting lightning voltage which may occur on the line, the maximum lightning discharge which as traveling wave may reach the protective device, is $e_0/r_0 = 1100$ amperes, and the discharge rate of the protective device thus must be sufficiently high so that when discharging 1100 amperes, the voltage across the impedance of the arrester does not back up to a value endangering the apparatus.

Inversely, with a given and known discharge rate and discharge voltage of a lightning arrester, and the known maximum instantaneous value of voltage, to which the protective apparatus can be safely exposed, we can calculate the maximum discharge current and therefrom the lightning potentials, up to which protection may be expected.

For instance, with a lightning arrester containing a series resistance of 200 ohms, and a maximum permissible (momentary)

voltage of 25,000 on the protected transformers, 125 amperes would be the maximum discharge, which the arrester could take, and at a surge resistance of 360 ohms, this would give a lightning voltage of 45,000; therefore, if the voltage induced by lightning rises higher than this (which it often does), the arrester will probably fail to protect.

This ratio r_0 between current and voltage however applies only to a single component wave or impulse, such as a traveling wave running along the line, or the discharge of the bound charge induced by a thundercloud on a distribution circuit. If reflection occurs, the main wave and the reflected wave superimpose, and in the resultant wave the voltage is the sum and the current the difference of the component waves (or inversely), and for the resultant waves, this simple relation between voltage and current does not hold any more. That is, in the study of circuit protection, the effect of reflection (and refraction) and the voltage rise possible thereby, must be separately studied.

An interesting application of the conception of the surge impedance r_0 is given in the paper.

The standard equations of the transmission line consist of two components; each of the current components equals the corresponding voltage component divided by r_0 , and in each of the components the voltage current ratio thus is constant and the phase relation between current and voltage constant, that is, the power factor constant. However, in the voltage the two components are added, in the current subtracted (or inversely), so that in the resultant wave phase relation, power factor and voltage current ratio along the line change. The first component decreases, the second one increases with increasing distance from the power supply. The latter therefore is the reflected wave. If then in the load at the receiving end the current is chosen so that r_0 is the voltage current ratio, then the second component wave vanishes, there being no reflection at the end of the line, as discussed above. This is the "critical load" referred to in Mr. Goodwin's paper.

Thus, the "critical load" of Mr. Goodwin's paper is given by: Volts divided by amperes equals surge resistance, where the surge resistance is given by equation (9).

A table of surge resistances for different sizes of transmission conductors are given in the following, for different distances between the conductor and the return conductor, and for different resistances between the conductor and the ground. The latter is the surge resistance which comes into consideration in discharges to ground, such as lightning. These latter values are approximate only, as they depend on the conductivity of the ground. The assumption has been made that the neutral plane lies 15 feet below the ground surface.

As seen, with very wide variations of conductor sizes and distance of the return conductor, the surge resistance varies relatively little, within the range of commercial transmission line proportions, so that for approximate estimate of discharge rates, etc., we may assume 360 ohms as the surge impedance of a line conductor against another line conductor, and 500 ohms as the surge impedance of a line conductor against ground.

TABLE OF SURGE IMPEDANCE

$r_0 = 138.15 L/R$ ohms per conductor

Size of Wire No.	R	Distance of Return Conductor, L, = Distance above Ground ¹							
		0.30 1'	0.60 2'	1.20 4'	2.40 8'	4.80 16'	4.50 15'	9 30'	18 m. 60'
3	0.115	278	320	362	403	446	524	549	579
1	0.145	264	306	348	389	430	510	535	565
00	0.183	251	292	333	376	416	496	521	552
Cable	0000	0.250	232	273	315	357	397	477	502
	350000	0.325	212	256	297	339	381	462	486
	500000	0.390	206	247	289	330	372	451	476

~ 360 ohms. ~ 506 ohms

1. Assuming neutral plane 15 ft. below ground.

C. L. Fortescue: Mr. Goodwin's paper suggests to my mind old thoughts expressed in a new way. In this world we seldom get something for nothing, and this applies with particular truth to power transmission. In fact, a transmission line, like all electro-magnetic apparatus, requires for successful operation reactive power. As a matter of fact, reactive power on a transmission line is something like taxes—you cannot get away from it.

An engineer may elect to supply this reactive power entirely from the generator end, but his object is to transmit power from a locality where it is cheap to one where it is dear and to do this as expeditiously as possible.

To deliver real power requires a prime mover in addition to a generator, but reactive power does not require a prime mover, but it may be done by that wonderful machine called the synchronous condenser, which we may conveniently call a wattless power generator.

To transmit this wattless power is an expensive process, and we have to pay for it not only in the wattless power which we transmit to the point where it is required, but we have to produce more wattless power in order to transmit that amount. So that it is a very expensive process to transmit that power over a whole transmission line to the point where it is required. However, we can elect to transmit our wattless power or supply it at any point in the line where we please.

Suppose we have a transmission line of a certain length; our first idea is to transmit our power and supply also the wattless power required from the generator. To supply the real power, of course, we must have a prime mover, but the wattless power does not require a prime mover. We can use a synchronous condenser.

We may divide the line into sections and supply the wattless power to these sections by means of a synchronous condenser. They have to transmit the wattless power for the section in which they are placed a short distance only. This arrangement is absolutely necessary, so that we can supply the necessary wattless current at the least possible cost, and in so doing we do not gum up our power transmission, by transmitting this wattless current over the line. Therefore, the supplying of this wattless energy at the point where it is needed, not only gives us a better operating system, and a more stable transmission line, but gives us more economical power transmission for the same amount of wattless generating apparatus; in other words, with the proper use of synchronous condensers, we can transmit more power over a given distance.

Mr. Goodwin has treated the only case where the wattless power is applied at each point just as it is needed, through the medium of the distributed capacitance of the line that is the critical load condition, but for a practical operating line, we have to supply the necessary wattless power under all conditions of load, and the synchronous condenser enables us to do that because it can supply either condensive energy or inductive energy, according to the excitation.

As an actual fact, the total amount of condenser capacity required for a line so supplied with its wattless energy is much less for a given amount of power transmitted than one supplied at one end only. The economical spacing of the condenser depends on the cost of condensers, on the cost of substations, maintenance, etc. The idea that power can be transmitted without supplying the necessary magnetic energy which seems to be rather prevalent among some engineers does not hold.

There is another point which I wish to emphasize which Mr. Evans has brought out, and that is that the mathematical solution of the transmission line is not necessarily a practical solution. The peculiarities of the apparatus used for regulating the line, have to be considered as for instance, not only the synchronous condenser, but also the voltage regulators. Under certain conditions of load the system becomes unstable and is no longer operable.

F. G. Baum: I am glad to see engineers take up the matter of the constant potential transmission line. This type of transmission must finally come to be our standard for large power transmission because we must have (1) a safe and stable transmission, (2) a reversible transmission, and these can be had only with (3) a constant potential transmission system. But with a constant potential transmission the calculations become extremely simple because the charging current per unit length of line is constant and therefore the charging current can be expressed as a simple linear equation in terms of the length of the line. This makes the solution very simple. See diagram and explanation, Fig. 3.

If we are to have all points of the line at one voltage, then the resultant line pressure for all loads fall on the arc of a circle. (See Figs. 2 and 3).^{*} Fixing this condition then makes the calculations merely the solution graphically or analytically of the

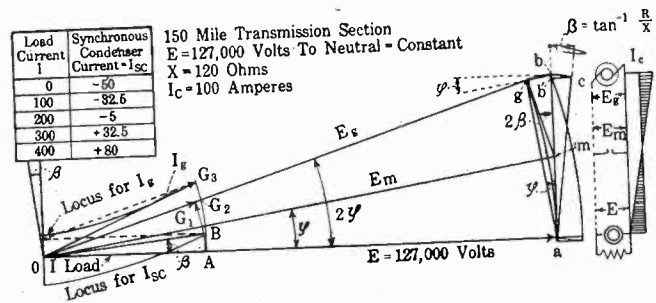

FIG. 3—CONSTANT POTENTIAL TRANSMISSION SYSTEM

CASE 1: ($R = 0, I$ in Phase with E).

For $E = \text{Constant}$, the resultant line pressure must be tangent to circular arc ag drawn with radius $oa = E$ with o as center. This means that the current must be kept in phase with E at all points of the line. From similar circular sectors we have (since $ag = IX$, practically):

$$I_c/I = \frac{IX}{E} \text{ or } I_c = \frac{I^2 X}{E} \tag{1}$$

(or capacity current varies as the square of I). Draw $ab = IX$ at $Rt. \perp s$ to oa at a . Bisect ab at m , making $am = mb = \frac{IX}{2}$. Draw arc bg with mb as a radius. Now arc bg , the voltage compensation, is $\left(\frac{IX}{2}\right)^2 \div 2E$. But $2E = IX$ or $\frac{IX}{2E}$.

Therefore: Arc $bg = \frac{I^2 X^2}{2E}$ or combined with (1),

$$bg = \frac{I^2 X}{E} (X/2) = \frac{I_c X}{2} \tag{2}$$

From (1) we also get

$$I = \sqrt{\frac{I_c E}{X}} = \sqrt{\frac{E^2 C \omega}{X}} = E \sqrt{\frac{L}{C}}$$

(Where $C = \text{Capacitance}$ and $L = \text{Inductance}$). Hence it is seen that I is proportional to voltage but independent of the length of the line. Also

from (1) $I = \sqrt{\frac{C \omega}{X}} = E/400$ (Practically), or kv-a. per phase (E in Kilovolts) = $\frac{1000 E^2}{400} = 2.5 E^2$ (3)

For $E = 127,000$ this is kv-a. 3 phase = 121,000. This may be called natural capacity of the transmission system. In equation (1) I Load current = 325 amprs. or about 80 per cent of full load.

CASE 2: ($R = 15$ ohms, I in phase with E).

Draw ac making angle $\beta = \tan^{-1} \frac{R}{X}$ with ab . Project bc at $Rt. \perp s$ to a . Project c to b' at $Rt. \perp s$ to a . ($bc = IR$). To compensate for this drop in voltage we must have concentrated capacity at load end so that line ac will be rotated to ab , then the distributed capacity as per (2) will rotate point b to g . Now $b'c = bc$ (practically) and bc must be compensated for by $I_{sc} X$ where I_{sc} is the leading current or synchronous condenser current at the load end of the line. Therefore

$$IR = I_{sc} X \tag{4}$$

^{*}TRANS. A. I. E. E., 1921, Vol. XL, p. 1017.

To compensate for both $I R$ drop and reactance drop we must have, combining equations (2) and (4):

$$I_{sc} X + \frac{I_c X}{2} = I R + \frac{I^2 X^2}{2 E} \quad (5)$$

$$I_{sc} = I R/X + 1/2 \left(\frac{I^2 X}{E} - I_c \right) \quad (6)$$

For power factors below unity we must of course balance the lagging kv-a. by leading kv-a. of the synchronous condenser. For angle of lag θ draw line making angle θ with ac and project c at $R I$. ¹⁵ to this line. The distance c to the line gives the kv-a. The diagram shows visually the results and effect of varying the different factors.

In the current diagram correction for $I R$ drop results in generator current changing from OG to OG_3 . The length $G_2 G_3$ is practically equal to AB , so that we have the same current and voltage relations (except that current has increased to make up line losses) as we had at the beginning of the line. Therefore we may add any number of such line sections to form a transmission line of any length. Condensers placed every 150 miles will thus control the potential for all load conditions and give (1) a stable line, (2) a constant potential line, (3) a reversible line. Only by such a line can the big power problems of the U. S. A. be solved.

simple trigonometric functions of the circle. The calculations for a 150-mile line section have been carried out on the following page on a small sheet and yet the calculations are as accurate as the constants of the line are known and as accurate as the measurements could be made on the completed line. By placing synchronous condensers say every 150 miles we get a line that is practically independent of the generators for voltage regulation and the charging current and no load voltage conditions are under control. I don't see any other way of operating a long transmission system, and we must have such a large capacity transmission system to solve the power problems of the country today.

For the ordinary transmission system we purchase generators for say 0.8 power factor and 125 per cent normal voltage. This means extra capacity of 125 per cent \times 125 per cent or 156 per cent of the actual available capacity. This same extra capacity is required in transformers, and as the transformation is repeated several times (we have two to four or more transformations) the burden of extra plant capacity becomes very great. Also the transmission and distributing line capacities must be increased for the low power factors = 100/power factor or for 0.8 power factor the increase is 25 per cent. A tremendous burden is therefore being carried by the power systems due to the low power factors of the systems, and it is inevitable that the burden must be relieved. There are two means of relief, (1) install more synchronous motors instead of induction motors, (2) install synchronous condensers to correct the power factors; the burden of the cost of the synchronous condensers would fall on the class of customers having low power factors. But if we can reduce the total burden of the power installation as shown above by the power factor correction, the cost of the system per unit delivered will be less than the cost when carrying the burden, then it is good business to modernize our method of power transmission. See the paper on voltage regulation, etc. referred previously.

The solution of the Pit River power and transmission problem and the reasons therefore, as described in the *Electrical World* for January 27th, 1923, may be of interest.

J. R. Dunbar: Mr. Goodwin has presented some very interesting qualitative facts regarding the operation of transmission lines under certain conditions of load, but his formulas are not based on the hyperbolic theory. In this discussion, the formulas based on the hyperbolic theory are derived, and it is shown that those in the paper are approximations for the rigid formulas. To engineers familiar with the hyperbolic theory, this discussion may help to clarify some obscure points in the paper.

In the paper, a load called the "critical load" is used, and it is defined as a non-inductive load having an equivalent resistance equal to $\sqrt{L/C}$. In the derivation of this expression, certain assumptions were made which are strictly true only for an infinitesimal line, or for a line with resistance and leakance both absent. For short aerial transmission lines, where the resistance

is small compared to the inductance and the leakance may be assumed zero, the assumptions are approximately true, and the formulas are sufficiently accurate to form the basis of engineering computations.

In the transmission line shown in Table IV of Mr. Goodwin's paper, it is stated that the conditions at the receiving end have been chosen to give constant power factor throughout the line. In order to do this, a load equal in kv-a. to the "critical load" and having an indeterminate proportion of reactive kv-a. has been taken. No data are given in the paper to indicate how the amount of reactive kv-a. required has been determined, so it was probably determined by a trial and error process. In this way Mr. Goodwin has determined approximately the load for uniform power factor along the line. The exact formulas for this load will now be developed using the hyperbolic theory.

Let:

E_A, I_A, P_A = the voltage, current and volt-amperes, respectively, at the point A , the sending end of the line, expressed in vector form. Similarly for any point on the line, P , and for the receiving end, B .

z_0 = the "surge impedance" of the line.

$\alpha = \alpha + j \alpha^2$ = the "hyperbolic angle" per mile of line.

r, l, g, c = the resistance, inductance, leakance, and capacitance, respectively, per mile of line.

x = the distance from A to the point P .

The formulas for z_0 and α are as follows:

$$z_0 = \sqrt{\frac{r + j l \omega}{g + j c \omega}}$$

$$\alpha = \sqrt{(r + j l \omega)(g + j c \omega)}$$

If we consider a load having an equivalent impedance equal to the surge impedance of the line, connected at the receiving end, we have what Dr. Kennelly has named the virtually infinite line.³ That is to say, the line behaves as if it were infinite in extent. Dr. Kennelly has considered this line, and the formulas for this case are as follows:

$$E_P = E_A e^{-\alpha x} = E_A e^{-\alpha' x - j \alpha'' x}$$

where e is the base of natural logarithms.

$$I_P = I_A e^{-\alpha x} = I_A e^{-\alpha' x - j \alpha'' x}$$

$$P_P = P_A e^{-2\alpha x}$$

From these formulas, it is seen that the magnitudes of the voltage and of the current fall off from A toward B according to a simple exponential law. Also the angle between the voltages at any two points varies directly as the distance between them. The same holds true with respect to the currents. Furthermore, the volt-amperes fall off at double the rate of the current and the voltage, but still in accordance with an exponential law, and the power factor is constant over the whole line. It is apparently this load that Mr. Goodwin was searching for and he has hit upon a close approximation for ordinary commercial transmission lines. In fact, when $r = 0$ and $g = 0$, z_0 becomes equal to $\sqrt{L/C}$.

The formulas for the virtually infinite line are very readily adaptable for use with ordinary logarithmic tables. As already pointed out, the change in angle is directly proportional to the change in distance. The length corresponding to an angle of 360 deg. is the wave length of the line and is equal to

$$\frac{2 \pi}{\alpha_2} \quad \text{The angle corresponding to any other length is found by}$$

direct proportion from this value. For the transmission line given in Table IV, the wave length is 3043.9 miles (4898.5 km.). The wave length of a line containing resistance depends not only on the frequency but also on the relative values of resistance, inductance and capacitance.

In order to determine the magnitude of the voltage at any

3. "Artificial Electric Lines: Their Theory, Mode of Construction, and Uses"—A. E. Kennelly, A. M., Sc. D., pages 43 to 46.

point, the formula is $E_P = E_A e^{-\alpha x}$. This may be trans- and from (4)
formed as follows:

$$\log_e E_P = \log_e E_A - \alpha_1 x$$

$$\log_{10} E_P = \log_{10} E_A - 0.43429 \alpha_1 x.$$

In the last formula, all the quantities may be determined from ordinary logarithmic tables, so that the calculation of the voltage distribution on any transmission line for one particular load by means of the rigid hyperbolic theory is a very simple matter, and is well within the capabilities of any electrical engineer. The current at any point is directly proportional to the voltage, and the volt-amperes is equal to the product of the current and the voltage. The power factor is uniform.

In order to illustrate the application of these formulas, the transmission line in Table IV has been calculated for a receiving end voltage of 115,500 and for a load having an impedance equal to the surge impedance. The computation is shown in Table A. In Table B, the results are tabulated in such a manner that they may be compared with the results given in Table IV. It should be noted that the points used in Tables IV and B are not quarter wave length points.

A comparison of the results in Tables IV and B show some discrepancies, but the differences are not beyond reason. It is therefore not unreasonable to believe that Mr. Goodwin's general conclusions respecting the qualitative operation of transmission lines, loaded with the "critical load" as used in the paper, will apply when the load having an impedance equal to the surge impedance of the line is used as the basis of the argument, to the same extent as they apply to the conditions considered by Mr. Goodwin. The quantitative relations will, of course, be different.

The load mentioned in this discussion may be obtained from formulas which are obtained from formulas (3) and (4) of the paper by substituting the expression

$$\sqrt{\frac{r + j l \omega}{g + j c \omega}}$$

for the expression $\sqrt{L/C}$. Thus, from formula (3) we obtain

$$(kv-a.)_p = \frac{1000 e^2}{\sqrt{\frac{r + j l \omega}{g + j c \omega}}}$$

$$kv-a. = \frac{1000 E^2}{\sqrt{\frac{r + j l \omega}{g + j c \omega}}}$$

In the particular case when $r = 0$ and $g = 0$, these reduce to (3) and (4). Thus in the present overhead transmission lines, the load as given by formulas (3) and (4) may be taken as an approximate value of the load as considered in this discussion. For cable systems, the approximation does not hold.

TABLE A
OPERATING CHARACTERISTICS OF VERY LONG TRANSMISSION LINE AT UNIFORM POWER FACTOR

$r = 0.0558$ ohms	Length = 3100 miles
$\omega l = 0.791$ ohms	$E_B = 115,500$ volts to neutral.
$\omega c = 5.38 \times 10^{-6}$ mhos	
$g = 0$	
$z = r + j \omega l = 0.0558 + j 0.791 = 0.79297 / 85.965^\circ$	
$y = j 5.38 \times 10^{-6} = 5.38 \times 10^{-6} / 90^\circ$	
$z_0 = \sqrt{z/y} = 383.92 / 2.0175^\circ$	
$\alpha = \sqrt{z y} = .0020655 / 87.983^\circ$	
	$= .0000721104 + j .0020642$
Wave length = $\frac{2 \pi}{.0020642} = 3043.9$ miles	

Power factor = 99.9375 per cent leading
 $\alpha_1 x$ for 1 wave length (3043.9 miles) = 0.21949

Distance from A	Wave Lengths	0.43429 $\alpha_1 x$	$\log_{10} E_P$	E_P	Angle with E_A	I_P	Kv-a.	Kw.
0	0	0	5.15967	144,430	0°	376.2	54,340	54,300
380.5	0.125	0.01192	5.14775	140,520	45°	366.0	51,440	51,400
761.0	0.25	0.02383	5.13583	136,720	90°	356.1	48,690	48,660
775	0.2546	0.02427	5.13539	136,580	91° .66	355.8	48,590	48,560
1141.5	0.375	0.03575	5.12392	133,020	135°	346.5	46,090	46,060
1521.9	0.5	0.04766	5.11199	129,420	180°	337.1	43,630	43,600
1550	0.5092	0.04854	5.11112	129,169	183° .32	336.4	43,450	43,420
1902.4	0.625	0.05958	5.10009	125,920	225°	328.0	41,300	41,270
2282.9	0.75	0.07149	5.08817	122,510	270°	319.1	39,090	39,070
2325	0.7638	0.07281	5.08685	122,140	274° .98	318.1	38,860	38,830
2663.4	0.875	0.08341	5.07616	119,170	315°	310.4	36,990	36,970
3043.9	1	0.09533	5.06434	115,970	360°	302.1	35,030	35,010
3100	1.0184	0.09708	5.06258	115,500	366° .64	300.9	34,750	34,730

TABLE B

Item	Point 1 Receiving End	Section 1-2	Point 2	Section 2-3	Point 3	Section 3-4	Point 4	Section 4-5	Point 5 Sending End
Section Length (miles)		775		775		775		775	
Total Length (miles)		775		1,550		2,325		3,100	
" " (wave lengths)		0.2546		0.5092		0.7638		1.0184	
Volts (delta)	200,000		211,500		223,700		236,600		250,200
Volts (Y)	115,500		122,140		129,160		136,580		144,430
Angle with potential at Point 1 (degrees leading)	0		91° .66		183° .32		274° .98		366° .64
Load kv-a. (total)	104,250		116,580		130,350		145,770		163,020
" kw. (total)	104,190		116,490		130,260		145,680		162,900
" kv-a. (per phase)	34,750		38,860		43,450		48,590		54,340
" kw. (per phase)	34,730		38,830		43,420		48,560		54,300
Current (amperes)	300.9		318.1		336.4		355.8		376.2
Power factor (leading)	0.9994		0.9994		0.9994		0.9994		0.9994
Angle (degrees leading)	2.0175		2.0175		2.0175		2.0175		2.0175
Line loss (kv. total)		12,300		13,770		15,420		17,220	
" " (kw. per phase)		4,100		4,590		5,140		5,740	
Line drop (volts delta)		11,500		12,200		12,900		13,600	
" " (volts star)		6,640		7,020		7,420		7,850	
Per cent line loss (section)		11.8		11.8		11.8		11.8	
" " " (total)		11.8		25.0		39.9		56.3	
" " " drop (section)		5.76		5.76		5.76		5.76	
" " " " (total)		5.76		11.85		18.3		25.1	

C. F. Wagner: On the first page of his paper, the author attributes certain properties to transmission lines operating at their critical load. The fifth property states, "If the load is the critical kv-a. but at a lagging power factor, the power factor at the sending end will still be lagging but nearer unity." Since there is no discontinuity at the critical load, one could increase the kv-a. load by such a small amount that the above condition still exists, *viz.*, that the power factor at the sending end will still be lagging but nearer unity. However, as soon as the load is increased ever so slightly above the critical load, the second property becomes applicable *viz.*, "If the kv-a. load is greater than the critical load, the power factor at the sending end of the line will be always more lagging than the power factor at the receiving end of the line." In this case, the two properties are contradictory. Attention is therefore called to the desirability of adding the limitations to each respective property as affected by length of line, power factor, per cent of critical load, resistance of line, etc.

Percy H. Thomas: No one who has not attempted to decide on the best conditions for which to lay out an important transmission line would appreciate what a great help an understanding of the principle discussed by Mr. Goodwin, namely, the inherent relation between voltage and best load, will be in arriving at the desired result. While it is seldom that a line will work out practically to exactly meet the best condition layed down by his equation $kv-a. = E^2/0.4$, deviations can be made in the way of slightly lower power factor or higher power factor, higher load or lower load, as may be called for by the particular case in hand and these variations can be intelligently made in such a way as to proceed directly to the results sought.

It is very surprising that resistance, even if numerically but a small fraction of the reactance of the line, still plays a dominating part in the performance of a line operating at approximately the most efficient load. Mr. Goodwin has shown the fundamental nature of these relations by extending his calculations to lines thousands of miles long and find that the results were very much the same order as with shorter lines.

From the point of view of full-load line losses the possibility of operating under substantially d-c. conditions is most favorable but there are certain other characteristics of such a line which are not altogether favorable and call for careful consideration. For example, while no great harm results from under-loading such line, provided the voltages are maintained substantially constant at both ends, it is still utterly incapable of taking any immaterial overload. Even with the far end of the line dead-short-circuited, the current flow will not, in a long line increase greatly over the full-load current appropriate to the load given by Mr. Goodwin's formula. This characteristic is most marked in those lines having a resistance low in comparison with the reactance.

One of the practical questions to be considered in applying this principle for securing the most economical transmission is the fact that a power factor approaching unity is highly desirable. In most transmission systems securing such a high-load power factor will be a more or less expensive process, since synchronous condensers of large capacity will usually have to be provided. This condition is, however, already well recognized.

The curve shown in Fig. 8 of the paper under heading "Leading Power Factor," showing the variation of phase angle plus and minus along the transmission, is an interesting and curious freak of these lines.

Taking it all in all, the design and layout of what we may call superpower lines turns out to be quite a different thing from the usual transmission line problem as known for the last twenty years and requires quite a different handling especially with regard to the terminal connections and terminal apparatus and the various provisions for automatic regulation. I believe this subject should still receive further study in the near future.

H. Goodwin, Jr.: It is the pleasure of the author to take most of the discussion as amplifying the paper and confirming the good of and need for "Qualitative Analysis." The confirmation of the *need for Qualitative Analysis* is of two kinds: Direct expression of such opinion; and, incomplete or misstatements by those contributing to the discussion. The latter will be dealt with in detail.

It is a particular pleasure to draw attention to the discussion by Dr. C. P. Steinmetz which develops many points in a most interesting and helpful manner.

In general reply to some criticism in the discussion, the author frankly acknowledges the sketchiness of some sections of the paper. He felt, however, that to develop all the interesting phases of the subject would make the paper long and burdensome—almost require a book; also that this would entail further delay in making this most helpful method generally available to the profession.

Mr. Evans first takes exception to the first statement under the caption "Summary" which is in regard to the most economical transmission of power over a long distance line.

First it should be noted that this is *quoted* from Mr. Thomas's paper and is not a direct statement by the author. It has only been inserted to complete better the picture which Mr. Thomas paints. "Qualitative Analysis" deals with the qualitative operating characteristics of transmission lines and carefully avoids quantitative statements. The author hopes to present something in a future paper on the subject of efficiency of transmission which will develop the subject fully, logically and in a new light. But since Mr. Evans has gone to such length on this point it may be well here to discuss the matter further that others be not misled. Notice first that Mr. Thomas's statement is in regard to "a long-distance line," while Mr. Evans' example is concerned only with a short line 125 miles long.

Measuring from Mr. Evans's Fig. 1, it would appear that his claim is that the transmission would be more economical with the current at the receiving end lagging behind the voltage at an angle of 10 deg., which corresponds to a power factor of 0.9848. This means an increase in current at the receiver end of 1.6 per cent and a total increase in losses of about 3 per cent. His statement that the generator voltage would be higher under his conditions is correct, according to the rules of "Qualitative Analysis." It would therefore appear that Mr. Thomas's statement is more accurate than Mr. Evans's deduction from his diagram.

The circle diagram for long transmission lines has often been called into question and various efforts have been made to correct its deficiencies. It is based on assumptions. In an exposition of the circle diagram in the *Electric Journal* for December, 1921 by Mr. R. D. Evans and another author, there is given on page 533 a derivation of the "loss circle diagram." One of the bases is the statement: "the losses *neglected*—are *practically constant*" (italics by present author). In general, the derivation is so incomplete and involved as to make checking most difficult. But in opening this article on the circle diagram, the authors state: "The primary object of an approximate graphical solution is not one of accuracy—the rigid mathematical solution may be applied to the particular case with any further degree of accuracy that may be desired." It is but natural to suggest that Mr. Evans apply a rigid mathematical solution to his assumed load and line and prove thereby that the lagging power factor condition is more efficient than the unity power factor condition suggested by Mr. Thomas from the simple, fundamental, physical conception. When he has thus demonstrated to his own satisfaction that Mr. Thomas is correct, he might try a few degrees leading (about half the small angle of the impedance triangle of his assumed short line). Mr. Evans has not given sufficient data on his assumed line to allow others to do this.

Mr. Evans then calls upon his circle diagram as given in his Fig. 2 to prove the "instability" of some of the long lines given

examples by the author to show some of the characteristics of long lines operating at fixed critical loads. The author's calculations were made by the rigid mathematical formulas on which Mr. Evans' circle diagram is supposed to be founded. Is it but reasonable to suggest that Mr. Evans again follow his own advice and check the conditions which he proposes and the conditions which the author has suggested by the rigid mathematical formula. Fortunately Mr. J. R. Dunbar has in later discussion shown the results of repeated calculations on one of the lines calculated by the author which for the present purposes check with very fair accuracy, particularly in regard to the question of power factor.

But this aside. Acknowledge that starting with certain receiver conditions it is possible to figure the conditions at a supply point 100 miles or several hundred miles distant; again make this point and load the receiver conditions for another length of line; repeat this as often as desired. What is there then to question in the result if each step has been made accurately? How can a "diagram," based on very short lines and modified by approximation for longer lines, be called upon to over-throw the result with one stroke of the compasses?

Enough has probably already been said to counter Mr. Evans' third point of "the desirability of the circle diagram," etc. His discussion rather proves the desirability and necessity for the use of "Quantitative Analysis" based on simple, physical conceptions by all transmission engineers, even though they may be expert with various methods of "Qualitative Analysis."

Just one more point—a warning is necessary in this connection: The greatest care must be used in the application of any formulas, which have any assumptions whatsoever, to lines operating at the critical load near unity power factor.

Dr. Karapetoff called upon the author for proof of the statements on the first page and suggested the possibility of proving them by making many calculations on his "Heavisidion." If the section of the paper headed "Vector interpretation of critical load transmission" is studied sympathetically and thoroughly the bases of the rules given on the first page will readily be understood. As for the matter of checking by actual calculation, the author has checked these rules by numerous calculations and by comparing with the results of accurate calculations by others, and complete agreement has always been found.

As for the derivation of the rules from the hyperbolic formula, Mr. J. R. Dunbar has very kindly contributed in discussion such a derivation. Mr. Dunbar notes that the rules in the paper are approximations for the rigid formula. This is readily agreed. The rules are given in a simple form and are stated as applicable to "transmission lines of *present commercial lengths*."

The last of Mr. Karapetoff's discussion is fully covered by noting again that the rules are given to apply only to "transmission lines of present commercial length."

In regard to Dr. Steinmetz's discussion, the author has little to say except to thank him for his confirmation of the author's work and his fuller explanation of many of the interesting points. However, in his last paragraph he states "we may assume 360 ohms as the surge impedance of a line conductor against another line conductor." In view of the values given in Table I of the paper for various high-voltage transmission lines, it would appear that while 400 may be a very little above the average there are no lines which have a value so low as 360. Therefore, the factor 0.4 in the approximate formula for the critical load would seem to be entirely satisfactory.

Mr. Fortescue's discussion, as does a section of Mr. Evans's, dealing with distributing synchronous condensers along the line really goes by the whole point of the paper and shows again the necessity for "Qualitative Analysis" and understanding the reversal of conditions which take place when the load on a line passes the critical load.

In Mr. Fortescue's seventh paragraph he says "but for a practical operating line," etc. The author maintains that the information which he has set forth in this paper is much more practical and useful than any discussion on the use of synchronous condensers distributed at different points on a long transmission line. We have with us now hundreds of transmission lines showing the characteristics expounded in this paper, but we have not as yet one transmission line with synchronous condensers scattered along it at various points for the delivery of reactive power.

The author fully appreciates the application that may be made of synchronous condensers in this manner and has considered them in certain definite applications but he maintains that their use will be much better appreciated and their application made more logically if the principles of "Qualitative Analysis" are thoroughly understood and applied before detailed figures are started on the use of synchronous condensers.

In Mr. Fortescue's last paragraph, he amplifies some of Mr. Evans' criticisms and says finally "under certain conditions of load the system becomes unstable and is no longer operable." If there is any question about instability and impossibility of operation of very long lines, it will not be at the critical load. The instability and difficulties of operation will come at other loads and the one stable condition which the line will naturally and easily maintain itself is the condition of critical load.

Mr. Baum's discussion is very interesting, as is the work which he has done on constant potential transmission. However, the author would like to suggest to any one following Mr. Baum's work that he thoroughly familiarize himself first with "Qualitative Analysis" which will greatly aid him in understanding the exact qualitative figures given by Mr. Baum.

Mr. Dunbar's discussion is greatly appreciated. The angle of lead in Table 4 which he questions is half the small angle of the impedance triangle. It was obtained by trial and error, if you will, but it took but one trial to determine it originally, it being apparent from the physical consideration set forth in the paper that this should be the correct angle. Many calculations made since the original assumptions have checked its accuracy.

Attention of others who have discussed this paper is drawn particularly to Mr. Dunbar's sixth paragraph in which he particularly confirms the points disputed by Mr. Evans.

The author has no contention with Mr. Dunbar on the wave length of the lines given. 3100 miles is generally considered by practical engineers as a wave length at 60-cycles. According to Mr. Dunbar's figures, this is long by less than 2 per cent. The wave lengths for the aluminum line and the copper line are different, and the only way to put them on an easily comparable basis is to assume the distances the same. Appreciation of the fact that 3100 miles is not the exact wave length is shown by the angles given and by the vectors in Fig. 8 of the paper.

Mr. C. F. Wagner questions the rules given on the first page of the paper under conditions when "the load is increased ever so slightly." Mr. Wagner's attention is drawn to the sentence introducing the rules in which these rules are set forth for commercial transmission lines. The increases which he speaks of are far beyond the accuracy of any commercial instruments and beyond the accuracy of commercial engineering. He can see that the author appreciates them by following through the latter part of the paper and studying the calculations for extra long lines. It is hoped that Mr. Dunbar's discussion may also assist him. None of this, however, changes the general application of the rules given.

In closing, the author again wishes to draw attention from this discussion to the great need for the general application of the practical and useful principles involved in "Qualitative Analysis of Transmission Lines."

C. F. Wagner: On the first page of his paper, the author attributes certain properties to transmission lines operating at their critical load. The fifth property states, "If the load is the critical kv-a. but at a lagging power factor, the power factor at the sending end will still be lagging but nearer unity." Since there is no discontinuity at the critical load, one could increase the kv-a. load by such a small amount that the above condition still exists, *viz.*, that the power factor at the sending end will still be lagging but nearer unity. However, as soon as the load is increased ever so slightly above the critical load, the second property becomes applicable *viz.*, "If the kv-a. load is greater than the critical load, the power factor at the sending end of the line will be always more lagging than the power factor at the receiving end of the line." In this case, the two properties are contradictory. Attention is therefore called to the desirability of adding the limitations to each respective property as affected by length of line, power factor, per cent of critical load, resistance of line, etc.

Percy H. Thomas: No one who has not attempted to decide on the best conditions for which to lay out an important transmission line would appreciate what a great help an understanding of the principle discussed by Mr. Goodwin, namely, the inherent relation between voltage and best load, will be in arriving at the desired result. While it is seldom that a line will work out practically to exactly meet the best condition layed down by his equation $kv-a. = E^2/0.4$, deviations can be made in the way of slightly lower power factor or higher power factor, higher load or lower load, as may be called for by the particular case in hand and these variations can be intelligently made in such a way as to proceed directly to the results sought.

It is very surprising that resistance, even if numerically but a small fraction of the reactance of the line, still plays a dominating part in the performance of a line operating at approximately the most efficient load. Mr. Goodwin has shown the fundamental nature of these relations by extending his calculations to lines thousands of miles long and find that the results were very much the same order as with shorter lines.

From the point of view of full-load line losses the possibility of operating under substantially d-c. conditions is most favorable but there are certain other characteristics of such a line which are not altogether favorable and call for careful consideration. For example, while no great harm results from under-loading such line, provided the voltages are maintained substantially constant at both ends, it is still utterly incapable of taking any immaterial overload. Even with the far end of the line dead-short-circuited, the current flow will not, in a long line increase greatly over the full-load current appropriate to the load given by Mr. Goodwin's formula. This characteristic is most marked in those lines having a resistance low in comparison with the reactance.

One of the practical questions to be considered in applying this principle for securing the most economical transmission is the fact that a power factor approaching unity is highly desirable. In most transmission systems securing such a high-load power factor will be a more or less expensive process, since synchronous condensers of large capacity will usually have to be provided. This condition is, however, already well recognized.

The curve shown in Fig. 8 of the paper under heading "Leading Power Factor," showing the variation of phase angle plus and minus along the transmission, is an interesting and curious freak of these lines.

Taking it all in all, the design and layout of what we may call superpower lines turns out to be quite a different thing from the usual transmission line problem as known for the last twenty years and requires quite a different handling especially with regard to the terminal connections and terminal apparatus and the various provisions for automatic regulation. I believe this subject should still receive further study in the near future.

H. Goodwin, Jr.: It is the pleasure of the author to take most of the discussion as amplifying the paper and confirming the good of and need for "Qualitative Analysis." The confirmation of the need for Qualitative Analysis is of two kinds: Direct expression of such opinion; and, incomplete or misstatements by those contributing to the discussion. The latter will be dealt with in detail.

It is a particular pleasure to draw attention to the discussion by Dr. C. P. Steinmetz which develops many points in a most interesting and helpful manner.

In general reply to some criticism in the discussion, the author frankly acknowledges the sketchiness of some sections of the paper. He felt, however, that to develop all the interesting phases of the subject would make the paper long and burdensome—almost require a book; also that this would entail further delay in making this most helpful method generally available to the profession.

Mr. Evans first takes exception to the first statement under the caption "Summary" which is in regard to the most economical transmission of power over a long distance line.

First it should be noted that this is *quoted* from Mr. Thomas's paper and is not a direct statement by the author. It has only been inserted to complete better the picture which Mr. Thomas paints. "Qualitative Analysis" deals with the qualitative operating characteristics of transmission lines and carefully avoids quantitative statements. The author hopes to present something in a future paper on the subject of efficiency of transmission which will develop the subject fully, logically and in a new light. But since Mr. Evans has gone to such length on this point it may be well here to discuss the matter further that others be not misled. Notice first that Mr. Thomas's statement is in regard to "a long-distance line," while Mr. Evans' example is concerned only with a short line 125 miles long.

Measuring from Mr. Evans's Fig. 1, it would appear that his claim is that the transmission would be more economical with the current at the receiving end lagging behind the voltage at an angle of 10 deg., which corresponds to a power factor of 0.9848. This means an increase in current at the receiver end of 1.6 per cent and a total increase in losses of about 3 per cent. His statement that the generator voltage would be higher under his conditions is correct, according to the rules of "Qualitative Analysis." It would therefore appear that Mr. Thomas's statement is more accurate than Mr. Evans's deduction from his diagram.

The circle diagram for long transmission lines has often been called into question and various efforts have been made to correct its deficiencies. It is based on assumptions. In an exposition of the circle diagram in the *Electric Journal* for December, 1921 by Mr. R. D. Evans and another author, there is given on page 533 a derivation of the "loss circle diagram." One of the bases is the statement: "the losses *neglected*—are *practically constant*" (italics by present author). In general, the derivation is so incomplete and involved as to make checking most difficult. But in opening this article on the circle diagram, the authors state: "The primary object of an approximate graphical solution is not one of accuracy—the rigid mathematical solution may be applied to the particular case with any further degree of accuracy that may be desired." It is but natural to suggest that Mr. Evans apply a rigid mathematical solution to his assumed load and line and prove thereby that the lagging power factor condition is more efficient than the unity power factor condition suggested by Mr. Thomas from the simple, fundamental, physical conception. When he has thus demonstrated to his own satisfaction that Mr. Thomas is correct, he might try a few degrees leading (about half the small angle of the impedance triangle of his assumed short line). Mr. Evans has not given sufficient data on his assumed line to allow others to do this.

Mr. Evans then calls upon his circle diagram as given in his Fig. 2 to prove the "instability" of some of the long lines given

examples by the author to show some of the characteristics of long lines operating at fixed critical loads. The author's calculations were made by the rigid mathematical formulas on which Mr. Evans' circle diagram is supposed to be founded. Is it but reasonable to suggest that Mr. Evans again follow his own advice and check the conditions which he proposes and the conditions which the author has suggested by the rigid mathematical formula. Fortunately Mr. J. R. Dunbar has in later discussion shown the results of repeated calculations on one of the lines calculated by the author which for the present purposes check with very fair accuracy, particularly in regard to the question of power factor.

But this aside. Acknowledge that starting with certain receiver conditions it is possible to figure the conditions at a supply point 100 miles or several hundred miles distant; again make this point and load the receiver conditions for another length of line; repeat this as often as desired. What is there then to question in the result if each step has been made accurately? How can a "diagram" based on very short lines and modified by approximation for longer lines, be called upon to re-throw the result with one stroke of the compasses?

Enough has probably already been said to counter Mr. Evans' third point of "the desirability of the circle diagram," etc. His discussion rather proves the desirability and necessity for the use of "Quantitative Analysis" based on simple, physical conceptions by all transmission engineers, even though they may be expert with various methods of "Qualitative Analysis."

Just one more point—a warning is necessary in this connection: the greatest care must be used in the application of any formulas, which have any assumptions whatsoever, to lines operating at the critical load near unity power factor.

Dr. Karapetoff called upon the author for proof of the statements on the first page and suggested the possibility of proving them by making many calculations on his "Heavisidion." The section of the paper headed "Vector interpretation of critical load transmission" is studied sympathetically and thoroughly the bases of the rules given on the first page will readily be understood. As for the matter of checking by actual calculation, the author has checked these rules by numerous calculations and by comparing with the results of accurate calculations by others, and complete agreement has always been found.

As for the derivation of the rules from the hyperbolic formula, Mr. J. R. Dunbar has very kindly contributed in discussion such derivation. Mr. Dunbar notes that the rules in the paper are approximations for the rigid formula. This is readily agreed. The rules are given in a simple form and are stated as applicable to "transmission lines of present commercial lengths."

The last of Mr. Karapetoff's discussion is fully covered by noting again that the rules are given to apply only to "transmission lines of present commercial length."

In regard to Dr. Steinmetz's discussion, the author has little to say except to thank him for his confirmation of the author's work and his fuller explanation of many of the interesting points. However, in his last paragraph he states "we may assume 360 ohms as the surge impedance of a line conductor against another line conductor." In view of the values given in Table I of the paper for various high-voltage transmission lines, it would appear that while 400 may be a very little above the average there are no lines which have a value so low as 360. Therefore, the factor 0.4 in the approximate formula for the critical load would seem to be entirely satisfactory.

Mr. Fortescue's discussion, as does a section of Mr. Evans's, dealing with distributing synchronous condensers along the line really goes by the whole point of the paper and shows again the necessity for "Qualitative Analysis" and understanding the reversal of conditions which take place when the load on a line passes the critical load.

In Mr. Fortescue's seventh paragraph he says "but for a practical operating line," etc. The author maintains that the information which he has set forth in this paper is much more practical and useful than any discussion on the use of synchronous condensers distributed at different points on a long transmission line. We have with us now hundreds of transmission lines showing the characteristics expounded in this paper, but we have not as yet one transmission line with synchronous condensers scattered along it at various points for the delivery of reactive power.

The author fully appreciates the application that may be made of synchronous condensers in this manner and has considered them in certain definite applications but he maintains that their use will be much better appreciated and their application made more logically if the principles of "Qualitative Analysis" are thoroughly understood and applied before detailed figures are started on the use of synchronous condensers.

In Mr. Fortescue's last paragraph, he amplifies some of Mr. Evans' criticisms and says finally "under certain conditions of load the system becomes unstable and is no longer operable." If there is any question about instability and impossibility of operation of very long lines, it will not be at the critical load. The instability and difficulties of operation will come at other loads and the one stable condition which the line will naturally and easily maintain itself is the condition of critical load.

Mr. Baum's discussion is very interesting, as is the work which he has done on constant potential transmission. However, the author would like to suggest to any one following Mr. Baum's work that he thoroughly familiarize himself first with "Qualitative Analysis" which will greatly aid him in understanding the exact qualitative figures given by Mr. Baum.

Mr. Dunbar's discussion is greatly appreciated. The angle of lead in Table 4 which he questions is half the small angle of the impedance triangle. It was obtained by trial and error, if you will, but it took but one trial to determine it originally, it being apparent from the physical consideration set forth in the paper that this should be the correct angle. Many calculations made since the original assumptions have checked its accuracy.

Attention of others who have discussed this paper is drawn particularly to Mr. Dunbar's sixth paragraph in which he particularly confirms the points disputed by Mr. Evans.

The author has no contention with Mr. Dunbar on the wave length of the lines given. 3100 miles is generally considered by practical engineers as a wave length at 60-cycles. According to Mr. Dunbar's figures, this is long by less than 2 per cent. The wave lengths for the aluminum line and the copper line are different, and the only way to put them on an easily comparable basis is to assume the distances the same. Appreciation of the fact that 3100 miles is not the exact wave length is shown by the angles given and by the vectors in Fig. 8 of the paper.

Mr. C. F. Wagner questions the rules given on the first page of the paper under conditions when "the load is increased ever so slightly." Mr. Wagner's attention is drawn to the sentence introducing the rules in which these rules are set forth for commercial transmission lines. The increases which he speaks of are far beyond the accuracy of any commercial instruments and beyond the accuracy of commercial engineering. He can see that the author appreciates them by following through the latter part of the paper and studying the calculations for extra long lines. It is hoped that Mr. Dunbar's discussion may also assist him. None of this, however, changes the general application of the rules given.

In closing, the author again wishes to draw attention from this discussion to the great need for the general application of the practical and useful principles involved in "Qualitative Analysis of Transmission Lines."

DISCUSSION ON "TRANSIENT CONDITIONS IN ELECTRIC MACHINERY"

(LYON) New York, N. Y., Feb. 15, 1923

D. W. Roper: Professor Lyon talks about transients in electrical machinery and develops equations for their analysis. It would be interesting if he would apply the same type of analysis to the transients which we have in our large transmission and distribution systems as well as in the machines.

The Commonwealth Edison Company is shortly going to develop and propagate some transients artificially by means of tests, and if Professor Lyon can develop equations which will give him some clue to the transients which occur in a transmission or distribution system, we will be glad to offer him the facilities of the Commonwealth Edison for checking his conclusions. We hope by cooperating in this way with the scientists and the manufacturing companies, to become more familiar with transients such as lightning discharges and the transients which follow short circuits on the system. We would like to have those transients named and classified.

R. F. Franklin: Professor Lyon demonstrates how the transient current of electrical apparatus may be calculated by the use of the *Generalized Angular Velocity Method*. I believe that the solution of a number of transient electrical problems could be simplified by this method.

The author makes the interesting suggestion that core loss might be taken into account by representing it by a component $-jL_2$ of the inductance; thus the inductance would be, $L = (L_1 - jL_2)$. In the calculation of transformers, induction motors, etc., the core loss is usually represented by an effective resistance. The chief merit in the proposed scheme of using an inductance $-jL_2$ instead of an effective resistance lies in the fact that the watts consumed in this inductance is, like the core loss, a function of the frequency. While of course, the core loss does not vary directly with the frequency as is assumed in this scheme, nevertheless, it is a closer approximation than the use of a resistance which is independent of the frequency. As stated by the author, the core loss can usually be neglected in the calculation of short-circuit currents.

In calculating the short-circuit current of electrical apparatus the question of the best method of determining the inductances and resistances arises. The most accurate method is to determine them from the currents measured under actual short-circuit conditions, the inductances being determined by the magnitudes of the currents and the resistances by the rate of decay of the currents. However, this method is not always possible. The inaccuracy in the determination of these constants by any other method lies in the difficulty of reproducing the flux densities and distribution that actually exist under short-circuit conditions.

In a polyphase short circuit the flux distribution in an induction motor is as follows: normal flux (*i. e.* flux corresponding to the impressed voltage) in the stator core behind the teeth; approximately normal flux in the rotor core behind the teeth; the sum of these, *i. e.*, approximately two times normal flux, in the leakage paths at one instant during the cycle, the instantaneous value varying from practically zero to nearly two times normal flux in the leakage paths. This condition of flux distribution can be approximated in the following manner.

With the rotor and stator in the position of maximum flux enclosure and the rotor circuit open, a voltage is impressed on the stator. The voltage that appears at the rotor rings is that induced by the mutual flux. If now a voltage equal in magnitude and in phase with the voltage appearing across the rings is impressed on the rings zero current will flow in the rotor, just as when two alternators of equal voltage and in phase are connected together. The stator current will obviously be the same as before, *viz.* merely, the exciting current. If now the rotor and stator voltages are maintained constant

and the rotor turned through one cycle then the currents in the rotor and stator at different points of the cycle will be those that would exist at the same points of the cycle under sudden short-circuit condition, provided there is no transient. The reason for this is that the flux distribution is the same, assuming no transient, as would exist during the cycle under the short-circuit condition.

The ordinary static impedance test affords another, but less accurate means of determining the motor constants. In this case the flux distribution is as follows: full flux (*i. e.* corresponding to the impressed voltage) in the stator core behind the teeth; zero flux¹ in the rotor core behind the teeth; and full flux in the leakage paths. In other words the stator flux returns entirely through the leakage paths. For reasons already discussed the effect of saturation in this case causes error.

For synchronous machines which involve a single-phase secondary or field winding, or in induction machines with one single-phase member the leakage impedance can be approximately determined by a static impedance test by short-circuiting the single-phase winding, that is the field winding, and impressing a voltage on a primary phase which is lined up in space position with the field winding. This method approximates in accuracy that of the static impedance test of the induction motor discussed above.

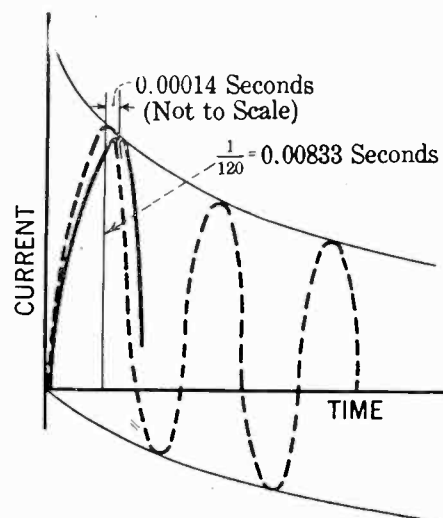

FIG. 1

An interesting point of investigation is the determination of the effect of the large short-circuit torque of a rotating machine on the magnitude of the short-circuit current. The maximum short-circuit current occurs one-half cycle from the instant of short circuit, as stated by the author. This is based on the assumption that during the short circuit the rotor maintains constant speed and does not drop back in space position. Actually, the large short-circuit torque causes it to drop back and thus the maximum short-circuit current occurs at a later time. Thus, in Fig. 1, if the rotor had maintained constant speed and space position the short-circuit current would be represented by the dotted curve with the maximum at one-half cycle or $1/120$ second for 60-cycle current. However due to the slowing up or falling back in space position of the rotor the short-circuit current will actually follow the full line, with the maximum value at a later time. Therefore, due to the transient the peak for the actual condition is less than that for the constant speed rotor. However, consideration of the following calculation will show that the difference in magnitudes is not appreciable.

If the power supply of an average induction motor is cut off, then normal torque applied to the shaft will bring it to rest from full speed in from one to two seconds. Taking the lower limit of one second, the deceleration under constant torque is 100

1. Or more strictly magnetic interlinkages, and further assuming zero resistance.

per cent speed change per second, and the total speed change in 1/120 second is $1/120 \times 100$ per cent = 0.833 per cent. This calculation assumes constant normal torque. Actually, the maximum value of the short-circuit torque is, say, six times normal. Assuming sine wave of torque the average value is $2/\pi \times 6 = 3.82$ times normal torque. Due to this increased torque the total speed change in 1/120 second is 3.82×0.833 per cent = 3.18 per cent. Thus in 1/120 second the rotor speed would have decreased 100 per cent to 96.82 per cent. The average speed during this interval would be 98.41 per cent, and in order to move the rotor one-half pole pitch at this reduced speed it would require $1/120 \times 100/98.41 = 0.00847$ second instead of 1/120 or 0.00833 second. Thus a difference of only 0.00014 second. Obviously, the difference in magnitude of the peaks, due to the transient, in this small interval of time is not appreciable.

J. O'R. Coleman: A method of attack so useful and widespread in its application as that presented by Professor Lyon in his paper on "Transient Conditions in Electrical Machinery" is of vital interest from both a theoretical and practical viewpoint. Whenever a new method is introduced, doubt arises in the minds of many as to its application to practical cases. A limited amount of experimental work has been done along these lines, and has so far produced very favorable results.

These tests were performed on a General Electric 75-h. p., 900-rev. per min., 220-volt (full-load 180 amperes, no-load 60 amperes) three-phase induction motor operated as a generator.

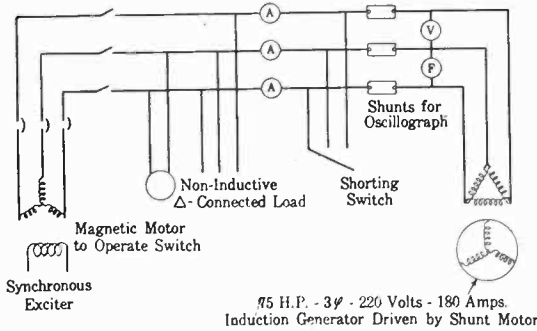

FIG. 2—DIAGRAM OF CONNECTIONS FOR SHORT-CIRCUIT TEST ON AN INDUCTION GENERATOR

This machine was driven by a shunt motor of like size. The excitation for the induction generator was supplied by a 30-kw. synchronous generator. Although the circuit breakers would not remove this machine until late in the transient, the impedance of the path through the oscillograph shunts and the induction generator was so large compared with that of the short-circuiting switch that the disturbance of the synchronous exciter would not alter appreciably the record of the oscillograph. The diagrammatic arrangement of the units is shown in Fig. 2.

The vector diagram for a sudden short circuit occurring at no-load is shown in Fig. 3. The vectors I_{1B} , I_{1C} and I_{1A} represent the current in the three phases just before the short circuit occurs. The short begins at the moment just before the current in phase B reaches its positive maximum. At this moment I_{1B} , for example, breaks up into two components I_{1B}' and I_{1B}'' , whose vector sum is equal to the initial vector. After short circuit the terminus of the vector I_{1B}' travels along the logarithmic spiral shown at a velocity of 360 circular radians per second and is damped at the rate of 96 hyperbolic radians per second. The terminus of the vector I_{1B}'' travels in a like manner along a logarithmic spiral as shown at a velocity of 17 circular radians per second and is damped at the rate of 60 hyperbolic radians per second. The value of the transient current at any instant is the projection of the vector sum of the two vectors on the time axis. The first maximum occurs about 0.008 of a second after the short circuit. The positions of the vectors at

this instant and the projection of their vector sum is shown in the diagram. The figure at the right of the diagram shows the resultant current obtained in this manner plotted in rectangular coordinates.

An oscillogram of the transient current during short circuit taken when operating at no load is shown in Fig. 4. It will be

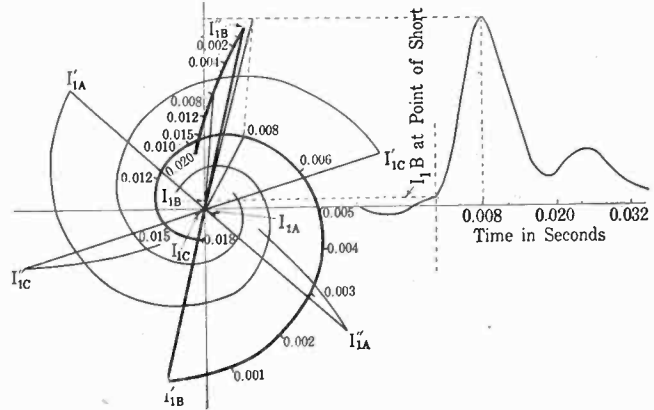

FIG. 3—VECTOR DIAGRAMS FOR THE SUDDEN SHORT CIRCUIT OF A 3-PHASE INDUCTION MOTOR

$$R_{1ohm} = 0.0172 \quad R_{2ohm} = 0.0455 \quad L_{1c} = 0.00569$$

$$L_2 = 0.00996 \quad S = 0.0483$$

Taking into consideration the effective resistance

$$m_1' = 96 + j360 \quad m_1'' = 60.4 + j17.5$$

$$I_{1B}' = 90.5 \sin 85^\circ$$

$$i_{1B}' = I_{1B}' e^{-96t} \sin(360t + 258^\circ)$$

$$i_{1B}'' = I_{1B}'' e^{-60.4t} \sin(17.5t + 78.3^\circ)$$

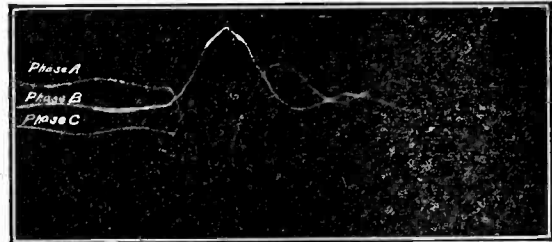

FIG. 4

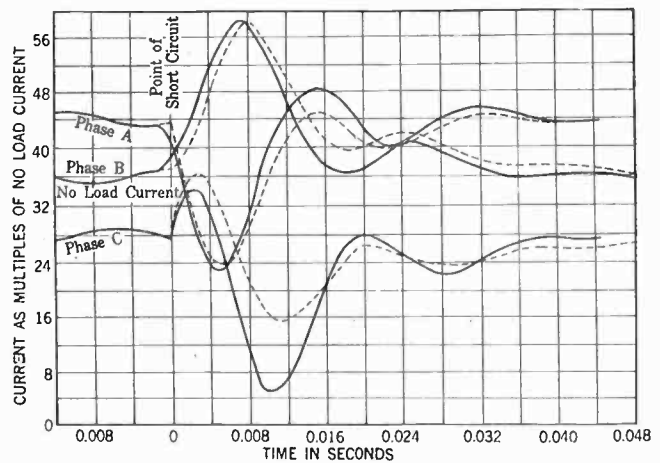

FIG. 5—CURVES OF SUDDEN SHORT-CIRCUIT OF A 75-H. P., 3-PHASE, 60-CYCLE, 900-REV. PER MIN., 220-VOLT INDUCTION MOTOR OPERATING AS A GENERATOR AT NO-LOAD.

----- CALCULATED CURVE
 ———— OSCILLOGRAM

noticed that the short circuit occurred in phases A and B nearly 0.001 of a second before that in phase C. Due to a very decided change in the slope of the transient curves of phases A and B when short circuit occurred on phase C, the latter point was taken as the point of short circuit in the calculations.

Fig. 5 shows a reproduction of the actual oscillogram compared

with the calculated values as obtained from the vector diagram described above. For phases *A* and *B* the agreement is very satisfactory for both magnitude and phase position. Phase *C* while agreeing as to phase position does not agree very well as to its magnitude. Due to the position of phase *C* at the time of short circuit, a very slight change in the point of short circuit taken for the calculations will make a large difference in the magnitude of the calculated curve. Although the difference in the time of short circuit is very small it is doubtless one of the reasons why the oscillogram and calculated curve do not agree so well for Phase *C*.²

W. V. Lyon: The author is much interested in Mr. Roper's statement. The cooperation of which he speaks when carried out with a teacher brings the important engineering problems

2. This discussion submitted in partial fulfillment of the requirements for the degree of Master of Science from M. I. T. carried out under the the direction of Professor Lyon, and with the assistance and cooperation of Mr. W. Ferguson.

of the day to the attention of those young men who will soon be responsible for our progress. From direct contact with the problem the teacher can speak authoritatively. Aside from the technical knowledge that the student absorbs the mental stimulus he receives of thus being brought into contact with a vital problem may be of inestimable importance.

The author wishes to express his appreciation for the suggestions that Mr. Franklin makes in regard to the measurement of the constants that should be used in determining the transient currents. Mr. Franklin's estimate of the probable error involved by assuming that the speed is constant during the time of the first current rush is also interesting. It bears out the feeling that the author had that the error would probably be very small.

Other students who have continued Mr. Coleman's investigations have been able, by reason of his experience, to check the observed and computed transient currents with surprising accuracy.

Discussion at Spring Convention

FREQUENCY CONVERSION BY THIRD CLASS CONDUCTOR AND MECHANISM OF THE ARCING GROUND AND OTHER CUMULATIVE SURGES¹ (STEINMETZ), and VOLTAGES INDUCED BY ARCING GROUNDS² (SLEPIAN AND PETERS)

PITTSBURGH, PA., APRIL 24, 1923

H. R. Woodrow: In both papers, the maximum surge potentials have been given neglecting the absorption of our systems, and I believe experience would show that the actual potential rise is less than that given in either one of the two papers particularly on underground systems. This factor has been brought out in connection with some tests which have recently been conducted and which I hope someone will discuss later.

Our surges are not all due to arcing grounds, but some of them are due to switching operations, and on some tests which have recently been made on the Brooklyn Edison system, it appears that these surges may be as high as two and a half times normal voltage.

I have felt in a good many of our cases we say our trouble is due to arcing grounds and surges, and in many cases our deductions are simply the result of our inability to connect the trouble to anything else.

A particular case of this type has come to my attention recently and has caused a great deal of worry and annoyance as to the source of the trouble. We did find some surges of small magnitude and short duration, but none of them seemed to properly account for the trouble. However, after two or three months' study, and the loss of several 5000 kv-a. transformers, we found it due to nothing more than a little piece of iron placed in the wrong position and without ventilation.

J. Slepian: It is brought out very clearly in the first part of Dr. Steinmetz's paper that the generation of the high frequency is due to the properties of arcs. Some peculiar properties are necessary in arcs in order to produce high frequency. One would expect in a mathematical treatment, that somewhere in the treatment a definite statement would be made as to what is assumed about the arc. An equation or some definite statement should be made as to what is assumed as to the nature of the arc so that from it the currents and voltages can be calculated. However, you look in vain for any such statements in the mathematical work. You have to go through it carefully and look for points here and there. Sometimes it is a definite

statement, and sometimes in a rather concealed way a property of the arc is assumed.

Now, of course, I was helped considerably going through the mathematical work by the previous discussion. The previous discussion gives some idea of the simplified characteristic that Dr. Steinmetz takes for the arc.

Taking on page 273, the first equation given, he assumes that the arc has a straight line characteristic, as given by the equation $e = E_1 - r_1 i$.

The equation given there would give a straight line as shown in accompanying Fig. 1, the slope r_1 , being the negative resistance. This applies only for the low frequency. When it comes to the high frequency, he brings in the idea of time lag between current and volts. That is, the high-frequency volts and high-frequency amperes are not in phase. This is expressed in the equations at the bottom of the same column on page 273.

These equations plotted with volts and amperes as coordinates

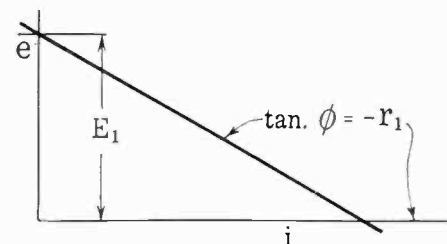

FIG. 1

give an ellipse as shown in accompanying Fig. 2, so we guess that probably the characteristic that Dr. Steinmetz makes use of in his mathematic work is something of that nature.

Now, to find where he brings in quantitatively the magnitude of the negative resistance and axes of the ellipse, and so on, we have to hunt carefully. The first assumption we find is in equation 16 on page 276, which says, Let $r_1 = E_1/I_1 =$ effective resistance of the third class conductor.

In this section, however, he is dealing only with the low-frequency terms. In calling this resistance r_1 , he makes the assumption that volts and amperes of the low frequency are in the same ratio as for the high frequency. This means that the low-frequency volt-ampere curve is a straight line which has the same positive slope as the negative resistance with which he is going to work. As the low-frequency volts and amperes rise and fall, the high-frequency volts and amperes go round ellipses, and these ellipses come in and out, swell and retract, so that you

1. A. I. E. E. JOURNAL, 1923, Vol. XLII, March, p. 272.

2. A. I. E. E. JOURNAL, 1923, Vol. XLII, August, p. 781.

get a curve of volts and current similar to that given on page 275 Fig. 4.

The high-frequency volts and amperes rise and fall with the low frequency but for some reason he has chosen to take the two in equal ratio. There is no reason why that should be the case.

The next assumption he makes as to the magnitudes in the arc is rather hard to illustrate in the mathematical work, so I will go to the first numerical case on pages 278 and 279. By assuming that delta equals sixty degrees as the time lag between high-frequency current and volts, an arbitrary assumption is made as to the shape of the ellipse. However, I don't quarrel with that. Some assumption must be made and that seems to be reasonable.

We next come to the assumption whereby a numerical value is given to the negative resistance, r_1 . Near the top of page 279,

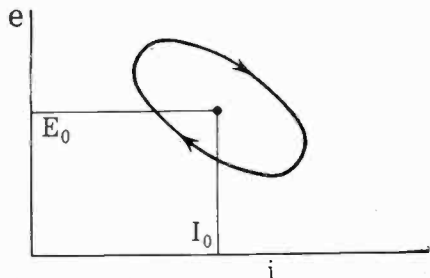

FIG. 2

taking the high-frequency resistance of the oscillating circuit as $r = 60$ ohms, Dr. Steinmetz says, "and assuming stationary conditions reached by the transient negative resistance of the spark discharge having dropped to equality with the ohmic resistance, that is:

$$r_1 \cos \delta = 60, \text{ and } r_1 = 120 \text{ ohms,}" \text{ etc.}$$

Thus, from the resistance of the oscillating circuit he has calculated the negative resistance of the arc.

Now, this is not always a correct procedure and may as in this example lead to absurd results. In the text of the paper itself, it is explained very clearly that we may not calculate the negative resistance in this way. In the last paragraph of Section III on page 273 we find, "Thus the final result of a condenser discharge through a third class conductor of sufficiently high effective negative resistance is an alternating current of a frequency determined by the circuit constants."

I have italicized the words *sufficiently high* because they indicate that there are two possibilities as to the steady state. If the negative resistance is *sufficiently high* there will be sustained oscillations with the negative resistance reduced to equality with the ohmic resistance of the oscillating circuit. But if the negative resistance is not *sufficiently high*, the steady state will be one with no oscillation and the negative resistance of the arc will not be equal to the ohmic resistance of the oscillating circuit.

Now, in applying these ideas to a practical case, we must not forget that there are these two possibilities for the steady state. Dr. Steinmetz assumes that the first possibility holds, namely, that the negative resistance is *sufficiently high*, so that oscillations will build up until there is equality between the negative resistance and the ohmic resistance. Thus he is able to calculate the negative resistance from the resistance of the transformer coil, and using the other assumptions, he calculates the various other currents and voltages of the circuit. But this does not prove that there will be oscillations, but only that if there are sustained oscillations, and if the other assumptions are valid, the arc must have a negative resistance $r_1 = 120$ ohms, as indicated on page 279. The thing to do now is to consider whether it is reasonable to expect the arc to have so large a negative resistance. If it is unreasonable, then we must conclude that the other possibility holds, namely, that the negative resistance is not *sufficiently great*, and that oscillations will not be built up.

I have taken the currents and voltages of the arc as calculated by Dr. Steinmetz, on page 279,

$$e_1 = 47,000 \sin \phi \{1 + \sin (837 \phi - 60.)\}$$

$$i_1 = 392 \sin \phi \{1 - \sin 837 \phi\}$$

and plotted them as a volt-ampere diagram. (Fig. 3). The ellipse shown is for ϕ in the neighborhood of $\frac{\pi}{2}$. Now, this

is a most extraordinary characteristic for an arc. For definiteness consider the point marked in Fig. 3. Here with 500 amperes flowing through it, the arc must have a voltage of 78,000 volts. There never was such an arc!

An actual arc characteristic plotted on the same scale would look as in accompanying Fig. 4, full line. When the current exceeds a few amperes, the voltage falls to well under a kilovolt. If we wish to approximate to the dynamic characteristic by means of an ellipse, we must make the axis of the ellipse nearly horizontal, dotted curve, Fig. 4. That is, the negative resistance of such a heavy current arc is extremely small, and could not sustain alternating current in a 60-ohm oscillating circuit.

We can assure ourselves that heavy current arcs do not have high voltages and large negative resistance by considering the Poulsen arc generator of radio frequency currents. Here it is desirable to make the negative resistance as large as possible, but using all the means known to us, we cannot make a fifty or one hundred kilowatt arc consume more than a few hundred volts, or have a negative resistance greater than ten ohms or so.

The conclusions which Dr. Steinmetz arrives at in the numerical example also show that the arc required by the mathematics is not such a one as really exists. Thus he finds that the magnitude of the low-frequency current is considerably, affected by the

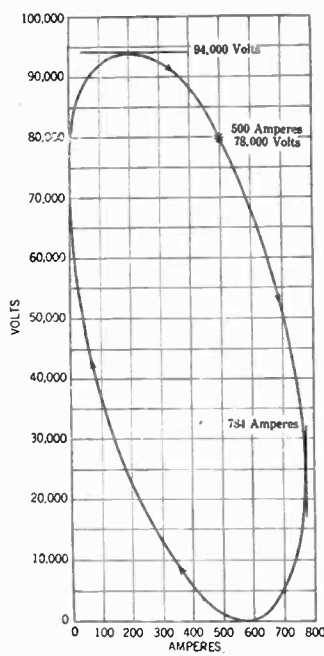

FIG. 3

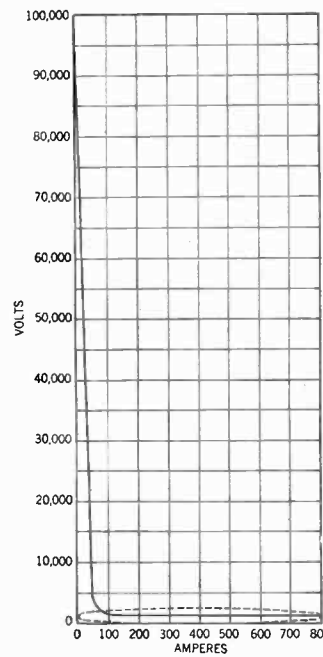

FIG. 4

arc, whereas the common expectation which is probably based on experience, is that an arc-over of a transformer is practically a short circuit of the 60-cycle current.

In closing my discussion I would like to repeat that what criticisms I have felt it necessary to make apply only to part B, Mathematical Calculation. Part A, Physical explanation, is a masterly work. I maintain, however, that the description of the phenomena in an arc given in Part A does not supply sufficient data for the calculations carried out in Part B, and that in Part B tacit assumptions are made which lead to erroneous conclusions.

E. P. Peck: The arcing ground on an isolated system is a definite occurrence, and quite often a very prominent one. I do not doubt that every old operating man who has dealt with large isolated systems has had as much trouble and as serious trouble from arcing grounds as from any other one thing.

The papers this morning brought out some of the early arguments and discussions on the relative merits of the isolated delta and the grounded neutral systems. It happens that down in the Georgia Company we were going through the argument among ourselves a number of years ago, and we could not reach in practise the conclusions that some of the highly theoretical engineers reached. We found that we had to establish grounded neutrals on our systems in order to keep the long transmission lines in service. There was one particular 22,000-volt line 63 miles long that developed voltages which we knew were higher than 180,000 volts. A large series of troubles which had extended over several months was cured entirely by putting a grounded neutral on the line. The value of the grounded neutral had been proved previous to that time on other lines.

Rather recently, on the Utica system, we had some troubles which started locally and spread to other points in which the secondary troubles were much more serious than the originating troubles. These troubles were also cured, and apparently permanently, since we have had no recurrence of them, by establishing a solid ground on the neutral, which, in this case, is on the generator.

Going back into the old history, it is very interesting indeed to see that the consensus of opinion has now come to agree with what we found the requirements to be a number of years ago. It is true, as one of the speakers said to-night, we are quite likely to blame a good many troubles on arcing grounds simply because they are mysterious. However, a great many of the troubles that occur are so evidently tied up with and follow so closely an arcing ground that there is no question as to the cause of them.

L. C. Nicholson: I was interested in Dr. Slepian's remark that an arc may be 780 in. long. I do not think that 780 in. is longer than an arc can be. I have definite evidence of an arc drawing out for approximately 400 feet. This was a short circuit of a 60,000-volt transmission system. The arc carried about 3000 amperes, 25-cycle current. It started by flashover of a pin type insulator, and a strong wind blew one end of it out along the conductor and the other end down the tower leg. The total length of the arc was about 400 feet. Its passage along the conductor could easily be traced by burns on the power wire.

A side-light on the conductivity of arcs is the length of time necessary for an arc to cool sufficiently to prevent its reforming. Exhaustive study of this subject shows that a 25-cycle arc of several hundred or several thousand amperes, will re-form, that is, strike again, if it is not interrupted for say one-fifth second. This minimum time seems to be dependent to some extent upon the length of the arc. This being the case, it appears that a power arc is a good conductor when thought of in half-cycle intervals, and that the resistance of the arc is low throughout the cycle. Otherwise, suppression of the voltage at the arc for so long a time as indicated would not be required to stop it.

Arcing grounds on ungrounded systems certainly cause disastrous voltages. It has been my experience that if the neutral of a star-connected system is grounded through a resistance low enough to carry, say fifty amperes, the surges which are produced on delta or ungrounded systems do not occur to any dangerous degree. Accidental grounds produce no dangerously high-voltage effects on the ungrounded phases throughout the system, as indicated by the absence of lightning arrester discharges at various connected stations. For this reason, I do not consider that a high-resistance neutral is objectionable from the voltage standpoint; on the other hand, it is very desirable, from a current standpoint, since the flow of ground current is limited to a moderate amount.

Herman Halperin: Mr. Woodrow made some remarks about surges on underground cables, and I thought he was referring to some tests concerning which I was telling his committee which had taken place the last month in Chicago. I will show in brief, Fig. 5, what we did and what was found on some of these surge tests.

A kenotron set with one side grounded was used and the d-c. voltage charged a factory condenser. After that condenser was charged up in a few seconds or so, it went over the sphere gap into some three-phase paper-insulated lead-covered cables. In these three-phase cables we usually discharged into one conductor and the other two conductors were grounded; and at the end of the lines, the one conductor was grounded solidly or through a resistance. Then at various points we measured the voltages to ground by means of sphere gaps. In one case the first length was 350 feet and the remaining cable was about 15,000 feet long or more. These traveling waves that were put in at the sphere gap had a steep front and a gradually decreasing tail. The length of the main portion of the wave would be of the order of twenty micro seconds in time, which is a wave of very high frequency. In these tests we found that the voltage was decreased to somewhere around two-thirds of its initial value after it had gone through 350 feet of cable, and that it went down to a fifth or so at the end of the line, depending upon the cable and connections. Plotting the voltages against feet from the station the waves of this nature decreased in voltage rapidly at first and gradually towards the end. Of course when resorting to waves corresponding to very high frequency, the voltage decrease was very rapid at the beginning. The wave after it got down to the end of the cable was considerably flattened out.

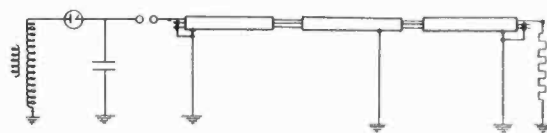

FIG. 5

It just indicates that traveling waves such as are shown in this second paper on page 791 will be considerably reduced in voltage after traveling a very short distance in underground cables, due to the damping qualities of the cable.

W. A. Hillebrand: Some of the largest of the high-power radio stations in the world utilize the negative temperature coefficient of the arc in order to transform the energy from a d-c. generator into the energy of a high-frequency oscillation. This is known as the Poulsen arc.

Dr. Steinmetz, in Fig. 3 sets up the circuits of the Poulsen arc and the equations thereof naturally follow. The identity between the fundamental relations that he derives and the Poulsen arc is rather striking.

With respect to some of the discussion on this subject, I would say that in order to generate oscillations by means of an arc, the magnetic field is not necessary, neither is it necessary to have a field of hydrogen. The magnetic field is used in the field with the Poulsen arc to get uniform arc conditions, so the conditions will repeat with a fair degree of uniformity. The hydrogen is used because of the high mobility of the hydrogen, and because of the high amount of radiation that is obtained. It is equivalent to a very large increase in the quantity minus R_1 that Dr. Steinmetz uses. In my opinion, in this discussion of the arcing ground, the matter of voltage is not of fundamental importance. One of the most important factors, it seems to me, has been overlooked and that is the matter of frequency. The moment you puncture the dielectric, you will get a streamer that will travel practically indefinite distance due to the high current that results from high frequency, and the high conductivity of the resulting arc. The relations between the strike distance of such an arc, once the dielectric is punctured, and those of, for instance,

the normal 60-cycle variety, or rather, I would say the two bear no relation to one another whatsoever.

On one of the large high-voltage systems of the country, for example, one of the operating men told me he has actually observed in time of trouble streamers emanating from the conductor of a familiar type, such as you get from oscillators and such as you can only get under conditions of high frequency.

There is one form of arcing that can occur under one set of conditions, not referred to by Dr. Steinmetz in his paper, namely, between contacts of switch plane and clip where an imperfect contact is made.

That is of either an air break or oil type switch. I believe it is possible under such conditions for disturbances to be set up of the type that Dr. Steinmetz describes although obviously not of the same intensity.

C. L. Fortescue: There is evidently no doubt that arcing grounds do give trouble. We have had ample evidence from operating men today, that they do have trouble at times very high voltages are obtained by this cause on their systems.

Dr. Steinmetz has given a mathematical explanation and some figures showing that with certain assumptions the voltages that can be obtained reach very high values. Now, I think that Dr. Steinmetz' idea of the negative resistance might be carried out so as to give possibly more plausible values for the voltages reached.

I think that the principal thing these studies show is that our knowledge of these phenomena is very limited and that there is need for much further study.

Now, one of the difficulties of the study of these problems is that it is impossible to study them on a large scale because of the danger of causing damage. They have to be studied in the laboratory and in studying them in the laboratory we are so apt to get conditions that we do not get outside; it is so difficult to approximate conditions in the laboratory to those in actual service and theoretical analysis without corroborative experimental work is not very convincing when the problem is so complicated as in this case.

Charles P. Steinmetz: It is regrettable that Mr. J. Slepian rather misunderstood the bearing of my paper, as this led him to guess at assumptions made in the paper, and as I did not make these assumptions, his discussion, being based on these assumptions, becomes non-pertinent to the paper. For instance, I never made the assumption of a linear arc characteristic, which Mr. Slepian imputes by a misinterpretation of the equation on page 273, and his discussion based on this assumption does not apply. The purpose of the paper is not to prove that an arc produces high-frequency oscillations. It has been well known for years, that an arc may produce undamped and cumulative high-frequency oscillations, or continual oscillations, or isolated damped wave trains—such as once more described in Messrs. Peters' and Slepian's present paper—depending on circuit conditions. For instance, in my book on "Theory and Calculation of Electric Circuits" which was published in 1917, an entire chapter of 40 pages is given to this subject. There for a number of different arcs, the stationary characteristics are given and the transient characteristics—called "dynamic characteristics" by Mr. Slepian—as derived by oscillogram, and discussion of the arc characteristics giving the various types of arc oscillations and their limitations, and oscillograms of undamped high-frequency waves produced by the arc. All this being well known, its rehash obviously has no proper place in the paper, especially as it has no direct bearing on it.

The purpose of my paper, as indicated by the title, is to show the mechanism by which a third class conductor—which may or may not be an arc—can act as frequency converter. None of the assumptions, which Mr. Slepian tries to find in the paper, are made, nor are they necessary, but the only assumption is that the circuit, Fig. 3, contains a third class conductor, as defined in the paper, that is, a conductor in which, over a certain range of

current, the voltage decreases with increase of current. The argument of the mathematical part of the paper then is: Whatever may be the particular characteristic of the third class conductor, as univalent functions of time, current and voltage can be represented by a Fourier series with constant coefficients, equation (7). Integration of the differential equation then shows that only two terms can exist in this Fourier series, a low-frequency term, of the supply frequency, and a high-frequency term, the coefficients of current and voltage are found of the same sign, and their ratio r_1 therefore is positive, representing power consumption. In the high-frequency term, the coefficients of current and voltage are found of opposite signs, and their ratio (approximately r , the load resistance) therefore is negative, representing power production. The mechanism of frequency conversion consists in the low-frequency component acting as motor circuit, due to the positive r_1 , and the high-frequency component as generator circuit, due to the negative $-r$, as seen in the equations (35). To make oscillation possible, the power of the fundamental or motor component r_1 must be equal or greater than that of the high-frequency or generator component r . As r_1 is a function of the amplitude, the amplitude of the oscillation adjusts itself at that value of r_1 , where the motor and generator components are equal.

Here Mr. Slepian seems to have been badly mixed up, and to mistake for assumptions the mathematical conclusions derived from the equations. There is no assumption whatever involved in the term r_1 , but r_1 is merely defined as the constant ratio of the two constant coefficients of the fundamental terms of the Fourier series of current and voltage respectively, equation (7). Being of the dimension of resistance it is called "effective resistance." As conclusion from the equations and not as assumption as Mr. Slepian seems to think, the relation between the load resistance r of the high-frequency component, and the effective resistance r_1 of the low-frequency term is derived.

As regards to the numerical values, and the probability of high power oscillating arcs in industrial circuits, I may best quote from my book of 1917.

"In transmission lines, usually the resistance is too high to produce a cumulative oscillation; in underground cables, usually the inductance is too low and thus no cumulative oscillation results,—in the high-potential windings of the large high-voltage power transformers, however, as circuits of distributed capacity, inductance and resistance, the resistance commonly is below the value through which a cumulative oscillation can be produced and maintained, and in high-potential transformers, destruction by high voltages resulting from the cumulative oscillation of some arc in the system, and building up to high stationary waves, have frequently been observed."

J. F. Peters: With reference to Mr. Woodrow's and Mr. Halperin's remarks, there is no doubt but what considerable absorption of surges occur, preventing the full value of possible surges neglecting absorption. This is particularly true for cable systems.

It is very interesting to note the large degree of absorption obtained by tests described by Mr. Halperin. Since energy varies with voltage squared after the surges have traveled 350 feet, the energy was reduced to less than one-half of its original value.

With reference to Mr. Hildebrand's discussion concerning an arc as generator of high frequency, he states that a gas is not necessary but is used on account of the large amount of radiation that it produces. The increased cooling of the arc is the big factor in making an arc generate high frequency. This is shown clearly by the difference in characteristics of an arc in air and in gas, as shown in Figs. 8A and 8B. With reference to the streamer following puncture of dielectric, mentioned by Mr. Hildebrand, I assume he means the gaseous vapors produced by the large current resulting from shorting the electrolytic charge.

This, of course, may reach a considerable distance. High-frequency voltage of short duration, such as accompany surges, will not jump any further and when solid insulation is involved will not jump as far as low-frequency voltage.

GENERAL CONSIDERATIONS IN GROUNDING THE NEUTRAL OF POWER SYSTEMS¹ (DEWEY); THE NEUTRAL GROUNDING REACTOR² (LEWIS) OPERATING PERFORMANCE OF A PETERSEN EARTH COIL³ (OLIVER AND EBERHARDT); PRESENT DAY PRACTISE IN GROUNDING TRANSMISSION SYSTEMS⁴ (COMMITTEE REPORTS; (a) SYSTEMS TRANSMITTING AT GENERATED VOLTAGE, (WOODRUFF): (b) SYSTEMS TRANSMITTING AT HIGHER THAN GENERATED VOLTAGE (STONE),

PITTSBURGH, PA., April 24, 1923.

R. W. Atkinson: I want to say a word with regard to the comparison between the condition of a cable system and an overhead open-wire system with regard to the grounding of the neutral. There is a large and important difference for two reasons. The most important reason is the relative cost of insulation of the cable system as compared with the overhead cable for high voltage. The insulation is a very important part of the transmission system, whereas it is a relatively minor part in the overhead system. You can afford in the overhead system to put on insulation to take care of the voltage rise due to abnormal conditions, and you can afford to put on the insulation to take care of service conditions; whereas the same difference in service conditions costs you a whole lot more in insulation of cable systems. Another difference from the standpoint of operation, is the very much greater electrostatic capacity for the cable system.

Another thing that we have often overlooked, not only the operating people but some of engineers connected with the manufacturers, is that when you have the same thickness of insulation between conductor and sheath in a cable, as you have between conductors, you really haven't the same voltage strength.

The best reason perhaps is the fact that the ratio between the maximum stress and the average stress is much higher where you have the stress concentrated only on one side, as you do from the conductor to the sheath, as compared with where you have it concentrated in two places, and your stress subdivided. Your belt insulation is probably not equal in its voltage resisting strength to the insulation on the conductor, and as a general proposition a cable with equal insulation between copper and sheath as between conductor and conductor; has very much less actual strength from copper to sheath than from copper to copper. Therefore, if we only got the same amount of voltage disturbance or the same potential between copper and lead, as between copper and copper, we would be expecting more trouble.

As a matter of fact, with the underground system, it has been shown to proceed to higher ground as in cases of arcing grounds. Coming to the other side of the case, the neutral grounded through resistance; there we have removed the most serious source of possible disturbance, but we still have the condition that any conductor of the system may be subjected suddenly to a potential, exceeding line potential. In view of the less apparent strength of the insulation from conductor to sheath, we want to have more insulation there than we would have applied otherwise.

Another point to consider in comparing systems is the matter of the size of the system. A very few cable systems oper-

ate without grounded neutrals at voltages above 90 kv. and a few have operated with resistance in the neutral. I believe all of those systems above 20 kw. which have not operated with solidly grounded neutral are very small or the actual part of the system itself is small. That is, if we have a bus at the generator voltage and a step-up transformer to the cable, and then through the cable to another transformer, without going to a bus, then only the one cable is involved. That system is radically different in its operating condition from the other system, whereby the voltage is stepped up before you get to the bus, and you have a bus voltage above generator voltage. Now, in that case, all of the cable on the system is subjected to the abnormal condition resulting from a single voltage failure, which means that we have the difference between the large and small system.

The large transmission system may have a number of small units each having the same characteristic, as far as the effect on grounding neutral is concerned, as a small transmission system, and the effect is this.

A system, of course, without grounded neutral acts just exactly like one with the grounded neutral as long as nothing happens. As soon as something happens, you put strains on the system, and one thing causes something else, and that causes something else again, and troubles will be multiplied in proportion to the square of the amount of cable involved, perhaps, if they are troubles due to incomplete grounding.

There is another thirty-three thousand volt cable in operation in this country, (it is a very small amount in addition to the one which is mentioned here) in Los Angeles, and that is operating with a solidly grounded neutral system, and has been for nearly two years.

F. C. Harker: Mr. Dewey has given us a very comprehensive review of the problems involved in grounding the neutral of transmission and distribution systems. I do not believe that too much emphasis can be placed on the advantages of operating a system with the neutral stabilizer. The principal argument for the free neutral, that it permits continuity of supply even when one phase is grounded, is misleading in that it is a dangerous practise as well. The possibility of arcing grounds with their resultant recurring oscillations are so likely to cause extremely high voltages as to be dangerous. It is far better policy to remove a circuit that has failed from service rather than risk more general and widespread breakdowns due to high-voltage disturbances.

While it is true that the smaller systems can generally operate successfully with the neutral free, it is also true that is a limit to the growth of a system. One of the systems referred to by Mr. Dewey, the Montana Power Co., was initially a delta system operating with the neutral free. As the system grew the effect of failures became more serious and widespread with the result that the engineers practically reached the conclusion that there was a definite limit to the size of a transmission system that could be operated successfully. The solution of the problem was in the stabilization of the neutral. This has proved so successful that, based on the experience of several years operation, the present conclusion is that there is no limit to the size of a transmission system.

The strongest advocates of the stabilized neutral are the Pacific Coast systems. In 1898 a transmission system operating at 60,000 volts was planned by the Standard Elec. Company. They adopted the 60-cycle, grounded system and the same plan was adopted later by the Bay Counties Power Company. The grounded system has been generally used on the Pacific Coast from the beginning and engineers, prominent on the coast have expressed the opinion that their success is largely due to the fact that the neutral was fixed.

An analysis of the relative magnitude of possible surge voltages on the free neutral and grounded neutral systems will show to the advantage of the grounded system. Advantages

¹ A. I. E. E. JOURNAL, 1923, Vol. XLII, June, p. 589.
² A. I. E. E. JOURNAL, 1923, Vol. XLII, May, p. 467.
³ A. I. E. E. JOURNAL, 1923, Vol. XLII, Sept. p. 904.
⁴ A. I. E. E. JOURNAL, 1923, Vol. XLII, Sept. p. 928.

of this feature can be considered in two ways, first by retaining the greater factor of safety, in insulation strength and second, by grading the insulation. On lower potentials up to 110,000 volts the advantage in cost is not great and it may be desirable to retain the higher factor of safety. On higher voltage systems the saving is appreciable and we are justified in taking advantage of the reduction. Very appreciable savings have resulted in apparatus purchased for operation on 220 kv. and have been accepted by operating engineers after careful comparative analysis of various factors affecting the conditions.

J. B. Taylor: A few years ago there would have been little difficulty in securing a number of papers on this general topic in which perhaps the majority would have favored working without grounded neutral. The absence of any paper today in which the author definitely advocates running in the old method is quite obvious; it is not necessary to comment on it. The practise is fairly well crystallized and those who haven't swung into line, as far as I can discover, are holding back either for reasons of expense or because their systems may be in such good shape that their troubles with the free neutral are not serious.

Of course, if there were no causes of trouble, there would be no point in deciding whether to work one way or the other, and the whole question could be left open. Consequently, it isn't possible for me at any rate to dispute much of what is said here, and a discussion is necessarily limited to commenting and questioning a few of the points which boil down really to comparatively minor differences in practise.

We might emphasize this best by calling your attention to the fact that Mr. Dewey in his conclusions advocates grounding heavily so that voltage rises will be kept down at the expense of currents. Mr. Lewis, in his conclusions, says the Petersen coil is a good thing where it is desirable to keep down the rises in current at the expense of voltage. In the report of the committee, I think you will find on one page a statement that the tendency is to cut out the resistance and elsewhere a statement that the tendency is to increase the resistance.

Now, this state of affairs is not disturbing; all systems are not alike. They operate at different voltages, have different lengths of line; the cables are from different makers and loaded to different extents. The ducts are laid differently, so that there are plenty of good reasons why the prevailing kind of trouble which one system has is different from the prevailing kind of trouble which another system has.

One thing to which the engineers who have presented the papers, at any rate, agree and probably a great many more, is that grounding in some form is desirable.

Now, the particular form seems to come down to a matter of accumulated experience on the particular system and engineering judgment on how to meet that particular condition.

I am inclined to think that if you can clear your faulty cable without a big rush of current, even though your apparatus will stand that rush, there is particular virtue in doing it that way. Consequently, continued experience in designing selective relays and these various differential arrangements will perhaps be the tendency.

I am also inclined to make a general comment on some of the statements in the committee reports. It seems to me there is a little confusion in spots between presenting the present practise and stating the trend.

Now, a census does not always show the trend of things at all. It may show the amount of previous mistakes compiled, so we must discover the trend in more subtle ways instead of counting up what you already have on your hands. I would draw a line through the word trend, because it appears to have been put in where they should have said the practise is thus and so.

There is only one more point. In the committee's reports where there is a discussion of what determines the value of

resistance in the neutral, where resistance is used, on the third page, the middle of the first column. My comment is that the most important controlling factor in determining this resistance is included under the several other features not mentioned. The current-carrying capacities of the cable determines the setting of the oil switch, very often set on triple, double and normal load.

The neutral resistance, to work properly, must take into account the setting of the switches. I believe that this has been the controlling factor in determining the value of this resistance.

L. P. Ferris: In presenting these remarks I want to emphasize that I do not wish to suggest that the features which I will mention are necessarily to be considered controlling. All I wish to do is to call attention to some of the effects which manifest themselves and that these effects should be given their due consideration and nothing more.

On the third page of his paper Mr. Dewey states as a conclusion, that no serious telephone interference under normal operating conditions need be anticipated even though the neutral is grounded at many points. I believe that operating experience does not justify such a generalization, although there are doubtless instances where this conclusion holds. There is just this difference, under normal operating conditions, between the grounded neutral system and the isolated neutral system: In the former you give opportunity for triple harmonic voltages to be impressed upon the line with respect to the ground, and thereby affect the neighboring communication circuits, whereas in the isolated systems these triple harmonic voltages and currents cannot get out on the line. There are certain minor exceptions to that which we won't go into.

Sometimes this effect is emphasized by multiple grounding of the neutral although you can create a disturbance with only a single ground. The capacity of the system to ground presents a path for any triple harmonic current, the circuit being completed via the neutral. Such current would in general be negligible from the standpoint of the operation of the power system, however, there are cases where it is important in its effect on neighboring circuits.

I am glad to note on page 5 of Mr. Dewey's paper his conclusion that the use of Y-Y transformers is very limited in view of the interference which they tend to cause in the neighboring communication lines.

Obviously from the standpoint of telephone interference it is an advantage to limit the short-circuit current to ground which if not limited may give severe acoustic shocks to operators listening on parallel circuits. Mr. Dewey, evidently inadvertently, stated the contrary at the bottom of his fifth page.

Will Mr. Dewey please explain what is meant by a semblance of arcing ground effects.

At the midwinter convention of a year ago, I called attention to some of the properties of the Petersen coil from the standpoint of its effects on induction into neighboring circuits. It is very gratifying to note from the paper by Messrs Oliver and Eberhardt that operating experience with this device shows that its use reduces the interruptions due to flashovers from lightning by some 83 per cent. Without that device, it is fair to conclude that in those cases in which the coil cleared the fault there would otherwise, in general, have been a direct short circuit to ground on the system, and had there been a telephone line from Lock 12 extending toward Vida, it is reasonable to expect that in a good many of those cases there would have been induced in the telephone circuits high voltages, some producing acoustic shock. In such a situation the use of this coil would have saved about 83 per cent of the disturbances in the neighboring circuits.

This installation uses in combination with the Petersen coil a short-circuiting switch which solidly grounds the system in those cases where the Petersen cannot be expected to clear the line. In this instance there is no particular reason why a

This, of course, may reach a considerable distance. High-frequency voltage of short duration, such as accompany surges, will not jump any further and when solid insulation is involved will not jump as far as low-frequency voltage.

**GENERAL CONSIDERATIONS IN GROUNDING THE NEUTRAL OF POWER SYSTEMS¹ (DEWEY);
THE NEUTRAL GROUNDING REACTOR² (LEWIS)
OPERATING PERFORMANCE OF A PETERSEN EARTH COIL³ (OLIVER AND EBERHARDT);
PRESENT DAY PRACTISE IN GROUNDING TRANSMISSION SYSTEMS⁴ (COMMITTEE REPORTS; (a) SYSTEMS TRANSMITTING AT GENERATED VOLTAGE, (WOODRUFF); (b) SYSTEMS TRANSMITTING AT HIGHER THAN GENERATED VOLTAGE (STONE),**

PITTSBURGH, PA., April 24, 1923.

R. W. Atkinson: I want to say a word with regard to the comparison between the condition of a cable system and an overhead open-wire system with regard to the grounding of the neutral. There is a large and important difference for two reasons. The most important reason is the relative cost of insulation of the cable system as compared with the overhead cable for high voltage. The insulation is a very important part of the transmission system, whereas it is a relatively minor part in the overhead system. You can afford in the overhead system to put on insulation to take care of the voltage rise due to abnormal conditions, and you can afford to put on the insulation to take care of service conditions; whereas the same difference in service conditions costs you a whole lot more in insulation of cable systems. Another difference from the standpoint of operation, is the very much greater electrostatic capacity for the cable system.

Another thing that we have often overlooked, not only the operating people but some of engineers connected with the manufacturers, is that when you have the same thickness of insulation between conductor and sheath in a cable, as you have between conductors, you really haven't the same voltage strength.

The best reason perhaps is the fact that the ratio between the maximum stress and the average stress is much higher where you have the stress concentrated only on one side, as you do from the conductor to the sheath, as compared with where you have it concentrated in two places, and your stress subdivided. Your belt insulation is probably not equal in its voltage resisting strength to the insulation on the conductor, and as a general proposition a cable with equal insulation between copper and sheath as between conductor and conductor; has very much less actual strength from copper to sheath than from copper to copper. Therefore, if we only got the same amount of voltage disturbance or the same potential between copper and lead, as between copper and copper, we would be expecting more trouble.

As a matter of fact, with the underground system, it has been shown to proceed to higher ground as in cases of arcing grounds. Coming to the other side of the case, the neutral grounded through resistance; there we have removed the most serious source of possible disturbance, but we still have the condition that any conductor of the system may be subjected suddenly to a potential, exceeding line potential. In view of the less apparent strength of the insulation from conductor to sheath, we want to have more insulation there than we would have applied otherwise.

Another point to consider in comparing systems is the matter of the size of the system. A very few cable systems oper-

ate without grounded neutrals at voltages above 90 kv. and a few have operated with resistance in the neutral. I believe all of those systems above 20 kw. which have not operated with solidly grounded neutral are very small or the actual part of the system itself is small. That is, if we have a bus at the generator voltage and a step-up transformer to the cable, and then through the cable to another transformer, without going to a bus, then only the one cable is involved. That system is radically different in its operating condition from the other system, whereby the voltage is stepped up before you get to the bus, and you have a bus voltage above generator voltage. Now, in that case, all of the cable on the system is subjected to the abnormal condition resulting from a single voltage failure, which means that we have the difference between the large and small system.

The large transmission system may have a number of small units each having the same characteristic, as far as the effect on grounding neutral is concerned, as a small transmission system, and the effect is this.

A system, of course, without grounded neutral acts just exactly like one with the grounded neutral as long as nothing happens. As soon as something happens, you put strains on the system, and one thing causes something else, and that causes something else again, and troubles will be multiplied in proportion to the square of the amount of cable involved, perhaps, if they are troubles due to incomplete grounding.

There is another thirty-three thousand volt cable in operation in this country, (it is a very small amount in addition to the one which is mentioned here) in Los Angeles, and that is operating with a solidly grounded neutral system, and has been for nearly two years.

F. C. Hanker: Mr. Dewey has given us a very comprehensive review of the problems involved in grounding the neutral of transmission and distribution systems. I do not believe that too much emphasis can be placed on the advantages of operating a system with the neutral stabilizer. The principal argument for the free neutral, that it permits continuity of supply even when one phase is grounded, is misleading in that it is a dangerous practise as well. The possibility of arcing grounds with their resultant recurring oscillations are so likely to cause extremely high voltages as to be dangerous. It is far better policy to remove a circuit that has failed from service rather than risk more general and widespread breakdowns due to high-voltage disturbances.

While it is true that the smaller systems can generally operate successfully with the neutral free, it is also true that is a limit to the growth of a system. One of the systems referred to by Mr. Dewey, the Montana Power Co., was initially a delta system operating with the neutral free. As the system grew the effect of failures became more serious and widespread with the result that the engineers practically reached the conclusion that there was a definite limit to the size of a transmission system that could be operated successfully. The solution of the problem was in the stabilization of the neutral. This has proved so successful that, based on the experience of several years operation, the present conclusion is that there is no limit to the size of a transmission system.

The strongest advocates of the stabilized neutral are the Pacific Coast systems. In 1898 a transmission system operating at 60,000 volts was planned by the Standard Elec. Company. They adopted the 60-cycle, grounded system and the same plan was adopted later by the Bay Counties Power Company. The grounded system has been generally used on the Pacific Coast from the beginning and engineers, prominent on the coast have expressed the opinion that their success is largely due to the fact that the neutral was fixed.

An analysis of the relative magnitude of possible surge voltages on the free neutral and grounded neutral systems will show to the advantage of the grounded system. Advantages

*1. A. I. E. E. JOURNAL, 1923, Vol. XLII, June, p. 589.

2. A. I. E. E. JOURNAL, 1923, Vol. XLII, May, p. 467.

3. A. I. E. E. JOURNAL, 1923, Vol. XLII, Sept. p. 904.

4. A. I. E. E. JOURNAL, 1923, Vol. XLII, Sept. p. 928.

of this feature can be considered in two ways, first by retaining the greater factor of safety, in insulation strength and second, by grading the insulation. On lower potentials up to 110,000 volts the advantage in cost is not great and it may be desirable to retain the higher factor of safety. On higher voltage systems the saving is appreciable and we are justified in taking advantage of the reduction. Very appreciable savings have resulted in apparatus purchased for operation on 220 kv. and have been accepted by operating engineers after careful comparative analysis of various factors affecting the conditions.

J. B. Taylor: A few years ago there would have been little difficulty in securing a number of papers on this general topic in which perhaps the majority would have favored working without grounded neutral. The absence of any paper today in which the author definitely advocates running in the old method is quite obvious; it is not necessary to comment on it. The practise is fairly well crystallized and those who haven't swung into line, as far as I can discover, are holding back either for reasons of expense or because their systems may be in such good shape that their troubles with the free neutral are not serious.

Of course, if there were no causes of trouble, there would be no point in deciding whether to work one way or the other, and the whole question could be left open. Consequently, it isn't possible for me at any rate to dispute much of what is said here, and a discussion is necessarily limited to commenting and questioning a few of the points which boil down really to comparatively minor differences in practise.

We might emphasize this best by calling your attention to the fact that Mr. Dewey in his conclusions advocates grounding heavily so that voltage rises will be kept down at the expense of currents. Mr. Lewis, in his conclusions, says the Petersen coil is a good thing where it is desirable to keep down the rises in current at the expense of voltage. In the report of the committee, I think you will find on one page a statement that the tendency is to cut out the resistance and elsewhere a statement that the tendency is to increase the resistance.

Now, this state of affairs is not disturbing; all systems are not alike. They operate at different voltages, have different lengths of line; the cables are from different makers and loaded to different extents. The ducts are laid differently, so that there are plenty of good reasons why the prevailing kind of trouble which one system has is different from the prevailing kind of trouble which another system has.

One thing to which the engineers who have presented the papers, at any rate, agree and probably a great many more, is that grounding in some form is desirable.

Now, the particular form seems to come down to a matter of accumulated experience on the particular system and engineering judgment on how to meet that particular condition.

I am inclined to think that if you can clear your faulty cable without a big rush of current, even though your apparatus will stand that rush, there is particular virtue in doing it that way. Consequently, continued experience in designing selective relays and these various differential arrangements will perhaps be the tendency.

I am also inclined to make a general comment on some of the statements in the committee reports. It seems to me there is a little confusion in spots between presenting the present practise and stating the trend.

Now, a census does not always show the trend of things at all. It may show the amount of previous mistakes compiled, so we must discover the trend in more subtle ways instead of counting up what you already have on your hands. I would draw a line through the word trend, because it appears to have been put in where they should have said the practise is thus and so.

There is only one more point. In the committee's reports where there is a discussion of what determines the value of

resistance in the neutral, where resistance is used, on the third page, the middle of the first column. My comment is that the most important controlling factor in determining this resistance is included under the several other features not mentioned. The current-carrying capacities of the cable determines the setting of the oil switch, very often set on triple, double and normal load.

The neutral resistance, to work properly, must take into account the setting of the switches. I believe that this has been the controlling factor in determining the value of this resistance.

L. P. Ferris: In presenting these remarks I want to emphasize that I do not wish to suggest that the features which I will mention are necessarily to be considered controlling. All I wish to do is to call attention to some of the effects which manifest themselves and that these effects should be given their due consideration and nothing more.

On the third page of his paper Mr. Dewey states as a conclusion, that no serious telephone interference under normal operating conditions need be anticipated even though the neutral is grounded at many points. I believe that operating experience does not justify such a generalization, although there are doubtless instances where this conclusion holds. There is just this difference, under normal operating conditions, between the grounded neutral system and the isolated neutral system: In the former you give opportunity for triple harmonic voltages to be impressed upon the line with respect to the ground, and thereby affect the neighboring communication circuits, whereas in the isolated systems these triple harmonic voltages and currents cannot get out on the line. There are certain minor exceptions to that which we won't go into.

Sometimes this effect is emphasized by multiple grounding of the neutral although you can create a disturbance with only a single ground. The capacity of the system to ground presents a path for any triple harmonic current, the circuit being completed via the neutral. Such current would in general be negligible from the standpoint of the operation of the power system, however, there are cases where it is important in its effect on neighboring circuits.

I am glad to note on page 5 of Mr. Dewey's paper his conclusion that the use of Y-Y transformers is very limited in view of the interference which they tend to cause in the neighboring communication lines.

Obviously from the standpoint of telephone interference it is an advantage to limit the short-circuit current to ground which if not limited may give severe acoustic shocks to operators listening on parallel circuits. Mr. Dewey, evidently inadvertently, stated the contrary at the bottom of his fifth page.

Will Mr. Dewey please explain what is meant by a semblance of arcing ground effects.

At the midwinter convention of a year ago, I called attention to some of the properties of the Petersen coil from the standpoint of its effects on induction into neighboring circuits. It is very gratifying to note from the paper by Messrs Oliver and Eberhardt that operating experience with this device shows that its use reduces the interruptions due to flashovers from lightning by some 83 per cent. Without that device, it is fair to conclude that in those cases in which the coil cleared the fault there would otherwise, in general, have been a direct short circuit to ground on the system, and had there been a telephone line from Lock 12 extending toward Vida, it is reasonable to expect that in a good many of those cases there would have been induced in the telephone circuits high voltages, some producing acoustic shock. In such a situation the use of this coil would have saved about 83 per cent of the disturbances in the neighboring circuits.

This installation uses in combination with the Petersen coil a short-circuiting switch which solidly grounds the system in those cases where the Petersen cannot be expected to clear the line. In this instance there is no particular reason why a

resistance would offer advantages over the direct grounding of the system. However, had there been a telephone system exposed to this power line, in those cases where it was necessary to resort to other means than the Petersen coil to clear the line, if instead of grounding the neutral solidly the switch had connected the neutral to ground through a moderate resistance of such value as to permit reliable operation of a ground relay you could have accomplished the desired result and at the same time prevented a condition which might give rise to a disturbance in the telephone system. The combination of this coil and a moderate resistance, may, therefore, offer advantages in situations where we have disturbances in telephone lines to contend with.

In closing, I would make one suggestion for the consideration of the authors of the Petersen coil papers. The network of the Alabama Power Company with which the coil is associated is in the form of a Y, and Mr. Lewis presents curves which show that at resonance the current in the neutral reaches a maximum as we should expect, amounting in this case to about six amperes. That is due, of course, to the unbalanced voltages of the system produced by the unbalanced line capacitances acting in the series resonant circuit. There is an unusual opportunity at the junction point of this Y to connect conductors of high, low and medium capacitance to ground, one from each branch of the Y, and so to improve the balance of the system without the expense of transpositions. Of course, if the branches of the Y are very different in length, this scheme would not work so well, unless the excess lengths of two branches over the third were transposed. At any rate, a considerable improvement would seem to be practicable at slight expense. Improved balance would, of course, enable the coil to be operated closer to the resonance adjustment without excess current under normal conditions.

H. W. Smith: In regard to the question of grounding the neutral of power systems, it should be pointed out that the engineers of the Westinghouse Company have consistently advocated this from the early days of power transmission.

For instance, P. M. Lincoln read a paper in 1907 on "The Grounded Neutral With and Without Series Resistance in High-Tension Systems," which he followed in 1909 with a paper on "Protection of Electrical Equipment" in which he stated "It is my opinion that so far as protection to apparatus is concerned, the advantages of grounding the neutral very much outweigh the disadvantages and if protection to apparatus alone were to be considered I would have no hesitation in recommending a solidly grounded neutral system."

The experience of transmission companies is recorded in the files of A. I. E. E. in such papers as: 1914—The Experience of the Pacific Gas & Electric Company with Grounded neutral by Messrs. Jollyman, Downing & Baum; 1916—Report of the Transmission Committee; 1919—Grounding The Neutral of Generating and Transmission Systems by H. R. Woodrow; Grounded Neutral Transmission Lines by W. E. Richards. They have led towards a general adoption of the grounded neutral.

I believe the operating companies, as regards this question of grounded neutral, should be divided into three classes: 1. Large metropolitan companies transmitting at generator voltage mostly through underground cables. 2. Medium voltage systems transmitting at 22, 33 or 44 kv. These systems often do not involve a large kw. capacity, but there is a large mileage of lines covering large districts. These systems often distribute at these voltages, rather than transmit; 3. High-voltage systems 66 kv., 88 kv., 110 kv., 132 kv., 154 kv., 165 kv., and 220 kv.

The general practise in class 1, is to ground the neutral. This was done quite early in the art, for example on the Manhattan Railway in New York about 1904.

A severe cause of trouble which was theoretically investigated by Dr. Steinmetz in his paper "High Power Surges in Electric Distribution Systems of Great Magnitude" (TRANS. 1905), led

to the grounding of the neutral through a 6-ohm resistance (1000 amperes for two minutes).

As mentioned by Mr. Dewey, these systems can be:

(1) Grounded solidly; (2) Grounded through low resistance to pass currents in case of ground of such magnitude to operate relays set for short current protection; (3) Grounded through higher resistance to limit the current and prevent excessive burning of cable in case of ground.

This latter system involves a special system of ground relays the expense of which many companies have not seen fit to incur.

Satisfactory systems of ground relays have been developed for this use and are available for those companies which desire to use them.

Exact data showing the proportion of cable faults which are grounds and those which start as short circuits would be a welcome contribution to our information and help us to decide whether such ground relays should be used.

As pointed out, if it is desired to apply differential protection to generators to disconnect them in case of a ground on winding, it is necessary to ground the neutral of one or more generators.

In regard to the design of grounding resistors I believe it is safe to work up to a maximum temperature of 600 deg. cent. It should be pointed out that working through this range there is a considerable increase in the value of the resistance probably around 50 per cent, so that a resistor which was 5 ohms when cold would be around 7½ ohms at the end of the time interval for which it was designed.

In regard to the time for which the grounding resistor should be designed there are a number of points to be considered. If there are a number of feeders in parallel feeding a substation, in the case of a ground occurring in that substation or beyond, the ground current will divide up so that the relays will probably not trip out the lines carrying the ground current and the total ground current through the resistor may burn it out. The resistor, therefore, in a case like this should have a long time element or should be protected by thermal relays which will either short-circuit or open-circuit the resistor when it reaches a dangerous temperature.

In regard to systems of the second class. In many cases the neutral is grounded at several points through a resistance. There is no doubt that as these systems grow they will reach a point where it is essential to ground the neutral. There are however a number of systems with single-loop transmission lines having customers tapped at intervals which hesitate to ground the neutral on account of interruption of service. In many cases these systems are not properly equipped with relays and oil circuit breakers. All extensions to such systems should be made so that adequate relay and circuit breaker protection are installed with duplicate lines to important load centers so that a grounded neutral system can be installed as soon as possible.

In regard to considerations fixing the size of resistance. If no resistance or a low resistance is used to ground the neutral, then any ground will seriously distort the voltage triangle, and affect synchronous apparatus on the system.

Tests have been made which show that the factor to be considered is the positive phase sequence component of the voltage at the terminals of the apparatus considered. If this voltage is less than 70 per cent of normal voltage it is probable that no trouble will be experienced from apparatus dropping out of step provided they are not overloaded and have full excitation. Tests have shown that the value of ground resistance to give this drop in voltage is approximately a resistance which allows double full-load current to flow to ground, that is

$$\frac{\text{phase voltage}}{R} = 2 \times \text{F.L. current, so that if the ground current}$$

does not exceed twice full-load current, synchronous apparatus should generally stay in step.

H. M. Trueblood: I have merely a brief suggestion to offer with regard to the three cases of doubtful operation of the Petersen coil which are mentioned in the paper by Messrs. Oliver and Eberhardt. They are referred to on page 907 of that paper and further in Table I, under the dates of July 7 and August 25, 1922, and February 23, 1923. It is rather interesting, I think, that in each of these three cases what was observed was a flashover on the 44-kv. bus, and, connected with that disturbance in some way, was an operation of line switch 206 between the line and the bus.

In the diagram, the Fig. 1, 1, 2, and 3 represent the three poles of a switch and the condensers C_{10} , C_{20} and C_{30} represent the direct capacities of the three phases to ground. X is the Petersen coil. Let us suppose that one of the three switch contacts, *e. g.*, No. 3 opens up while the other two remain closed, as might occur, for instance, if, through some defect in the switch mechanism, the three poles are not operated simultaneously. In this case the capacity in what has sometimes been called the "series resonant circuit", consists of C_{10} and C_{20} in parallel, plus an additional capacity equivalent to the direct capacities of phases 1 and 2 to phase 3 in parallel, in series with C_{30} . Now, if the reactance in X is larger than is correct for resonance with all three poles of the switch closed, a condition of resonance with pole No. 3 open may be approached. This will tend to produce high voltages across the inductance and

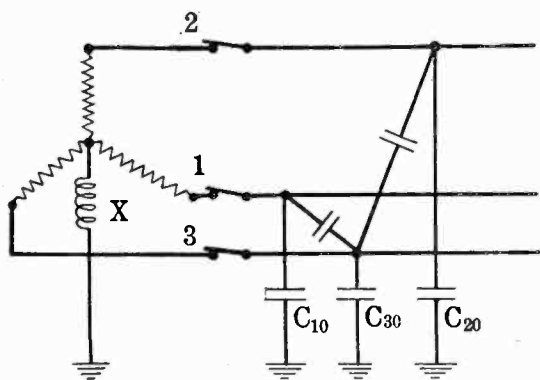

FIG. 1

also across the capacity of the series circuit. If the reactance of the Petersen coil exceeds the correct value for resonance under normal conditions by the appropriate amount, it will, of course, resonate exactly with the capacity of the system to ground with one pole of the switch open. In this case there will be nothing to limit the rise of voltage except the system losses.

In comparing the data in the table on page 906 of the Oliver-Eberhardt paper with Figs. 21 and 22 of Mr. Lewis' paper, I have been led to the conclusion that the system described has been operated with a reactance on the Petersen coil in excess of the proper value for resonance under normal conditions. *E. g.*, the curves of Fig. 22 of Mr. Lewis' paper indicate that for exact resonance about 980 ohms is required in the reactor. From the table in the other paper, however, it appears that the reactance actually used for the system arrangement referred to is 1207 ohms. The excess reactance is thus about 23 per cent in this case. The same condition may be traced from a comparison of Fig. 21 of Mr. Lewis' paper with the data in the Oliver and Eberhardt paper. The figure shows that about 1410 ohms in the reactor would be correct for lines 1, 2 and 4. The value used, however, is apparently 1735 ohms. The excess is again about 23 per cent.

If I am correct in inferring from these data that the system has been operated with excess reactance of this magnitude in the Petersen coil, I think that the explanation of the excessive voltages that have been observed may be as I have indicated.

The condition could, of course, be corrected by decreasing the reactance used.

R. D. Evans: Mr. Oliver and Mr. Eberhardt have presented the results of the operating experience with the Petersen coil installed on the Alabama Power Company's system. In comparison with the previous year's operation as a solidly grounded neutral system, the Petersen coil installation resulted in decreased interruptions due to line insulator flashovers caused by lightning, and increased interruptions in the remainder of the system, apparently due to excess voltages causing bus flashover and transformer trouble. Both of these results might have been anticipated, as previous discussions have pointed out their probability. That excess voltages may occur with the Petersen coil is borne out by the flashovers on the 44-kv. bus at Lock 12, which followed the opening of a circuit breaker between the coil and the transmission line. These flashovers may have been due to the non-simultaneous opening of the 3 poles of the circuit breaker, which condition is one that may produce excessive voltages with the Petersen coil system.

The operating record shows that in a number of cases an insulator flashover produced an arc lasting for two seconds, when the neutral was grounded by the circuit breaker. All of these conditions were not produced by dead grounds, as in some cases the line could be closed back in service o.k. The operating log for these cases is marked "Correct Operation" though the Petersen coil did not suppress the arc, and it is doubtful if it would after the arc had persisted for two seconds. In the arcing test made by Mr. Lewis, it is to be noted that the arc was maintained for 14 cycles for a reactor setting of 80 per cent normal, and that the arc resembled "a power arc". The arcing test and the maintenance of an arc for two seconds under service conditions indicates that the limits for the satisfactory operation of the Petersen coil are being approached for a system as extensive as this section of the Alabama Power Company's 44-kv. system.

On account of the high voltages produced by switching operations, which led to interruptions, Mr. Oliver and Mr. Eberhardt have concluded that all switching operations should be performed with the neutral solidly grounded. In view of this fact, and because of the number of conditions where the arc was not suppressed by the Petersen coil, it appears very desirable to supplement the Petersen coil with equipment to solidly ground the neutral.

Mr. Lewis is of the opinion that the field of the Petersen coil will probably be limited mainly to isolated neutral systems, whose operation is not satisfactory, but on which for some reason it is not wished to solid-ground the neutral. In view of the reasons given above for supplementing the Petersen coil with grounding equipment, it would appear that a change-over from a free neutral system would require that the system be designed for solidly grounded neutral operation, including the installation of relays and circuit breakers, in addition to the Petersen coil, auxiliary grounding circuit breakers and relay. It is to be noted that Mr. Lewis concludes that for the present, at least, the Petersen coil is not of general application, but limited to comparatively low-voltage lines of relatively short length.

C. L. Fortescue: In 1914 I presented a paper (Proc. May 1914 p. 771) grounding of the neutrals of systems, above 44,000 volts. At that time the General Electric made an announcement of their new policy with respect to grounding neutrals of high-voltage systems. It is interesting to see that about a decade later we are investigating the results of this agreement in the engineering policy of the two large electric manufacturing companies and the results are quite gratifying.

Mr. Dewey seems to imply that at that time there was a certain amount of uncertainty in the minds of engineers as to whether to ground or not to ground. However, my impressions at that time were that the evidence in favor of ground-

ing was quite convincing. The basis of the evidence on which this conclusion was based was well borne out by the experimental work of Mr. Faccioli. The theory on which most of us worked at that time was that an ungrounded system was free to oscillate at its natural period with very little damping, and therefore in extensive systems surges set up would be reflected, superimposed, etc., causing high-voltage disturbances. At the present time with the very extensive high-voltage systems that are in contemplation, there are additional very weighty reasons for grounding, and also for grounding at many points.

For example, let us consider a 750-mile transmission line of 440-kv. I have taken this length because it is not outside future possibilities, and happens to be about one-quarter wave length of 60 cycles. If such a line were ungrounded a ground near the generating station would be equivalent to a potential of 127,000 volts impressed on an open line 750 miles long, and having exceedingly low loss. The result would be, to quote from a recent paper by Mr. Peck, "Instability will be noticed at distances considerably less than this. At no load and very low generator voltages, the power of such a line would be limited, in fact, only by the losses." Therefore, if a high-voltage line of the kind in contemplation were not grounded, we would have in the case of ground on one line exceedingly high-voltages at the further end.

A transmission system grounded at many points is on the other hand equivalent to a number of short-circuited transmission lines, and the surge potentials that can be obtained due to disturbance at immediate points are very limited in value.

In regard to the effect on telephone systems, these will best be taken care of by keeping as far away from such high-voltage transmission lines as possible. Quick operating relays may afford a measure of relief, but the power companies and the telephone will have to depend much on co-ordination.

The Petersen coil seems to have found the place which was predicted for it. Personally the writer believes that the use of grounding resistance, of value below the critical value, will be found more satisfactory.

As to how to ground, high-voltage systems above 110,000 should be solidly grounded. In general this should apply for still lower voltages, say, down to 66,000 volts. On very high-voltage systems, all distributing points and the substation at the end of all feeders of high voltage should be grounded.

Of course, no system can actually be solidly grounded, but as far as the transformers are concerned if their neutral points are solidly connected to ground, the potential stresses they will be subjected to will be a minimum. This will also permit graded insulation which in the case of very high-voltage transformers makes a very substantial reduction in cost.

J. A. Johnson: There are two or three points in connection with this matter of grounding which I feel should be perhaps brought out a little more in detail than have been mentioned.

In the first place, systems differ very greatly in characteristics, and I very much doubt whether any one system of grounding will ever be found satisfactory for all systems; systems which have large exposure to communication systems may always require high-resistance grounding for the limitation of interference. In that connection engineers I think, as well as other people, are prone to follow the line of least resistance and when they run against a problem which requires an immediate solution, they usually jump to something that looks pretty obvious and if it works, why, they stick to it until something else comes up that causes them to change, and possibly some situation of that sort may be responsible for some of the systems using high-resistance grounding.

Now, in connection with systems, more particularly those operating at generator voltage: I think that we sometimes lose sight of how the tools which we have to work with influence our practise, and in that connection I want to bring to

your notice the connection between the characteristics of our modern relays, referring especially to the so-called induction type, having the inverse-time characteristic, and the question of grounding.

In using these relays for short-circuit protection, on account of the fact that short-circuit currents usually exceed normal currents by so great an amount as they do, it is very difficult to apply these relays in such a way as to take advantage of their inverse-time-current characteristic, and they become in most cases simply current relays, operating at their minimum time, so that for selective action, we have to depend mostly on the time adjustment rather than on the current adjustment.

Now, when we come to the question of grounding, one of the objects of grounding, or at least one of the advantages that we get from grounding, is the ability to isolate a circuit that is in trouble with a minimum of interference with the operation of the system. The fact that a system will stand short circuits, so far as the apparatus goes, is to my mind, no excuse for subjecting it to unnecessary short-circuit currents because large currents are bound to interfere more or less with operation, even though they do not injure the apparatus.

Now, suppose you have a simple radial system, consisting of some sort of a center of distribution, with various generating sources feeding into it, and various lines feeding out of it. And let us suppose that we get a ground on a feeder. If we ground our neutrals at all of these generating sources through moderately high resistances, we will then get a moderate ground current going over each of these circuits, but all concentrating into the feeder that is in trouble, and if we use a ground relay separate from our overload protection; we can choose that relay of such a capacity or we can choose our resistances of such a value as to produce a ground current which comes within the normal range of the relay and take advantage not only of the current characteristic but also of the time characteristic of the relay. We can thereby trip out the faulted circuits without danger to the rest of the system better than we can if we depend solely on the over-current relays for tripping out ground faults.

L. F. Blume: The excellent performance of the Petersen earth coil, as recorded in the two papers presented today is a gratifying confirmation of the sound theory upon which it is based. Although it was clear theoretically that such a coil should function to reduce the current flowing in a line fault to ground, it nevertheless could not be foretold that it would prove so effective in disposing of the line fault and thereby materially lessen interruptions in service.

The flashover which resulted in the breakdown of the busses is probably very excellently explained by Mr. Trueblood and shows the effect of extreme dissymmetry in the lines, dissymmetry of the three lines being very extreme due to the breaking of the line at the point of the operation of the switch.

It is perfectly feasible by having fifty per cent untuning, combined with this combination of circumstances, to get serious resonance of this voltage to ground, and at normal frequency. Of course, under those conditions very excessive voltage will be obtained. The remedy for that however is very simple. All that one need do is to be sure that this coil is untuned on the other side of resonance, by making the resistance a little less than for the normal resonating conditions. The voltages which you will get under this particular condition of operation will be only moderate, so if that is the explanation of the flashovers from the busses, I think that a simple adjustment of the coil will take care of the trouble.

It seems to me that the records given in the two papers show that the operation of the coil could be improved by introducing more resistance. The coil as designed has very little resistance, because it was designed to operate continuously with a fork on the line.

Now, if it is to be operated for intermittent duty only, it is perfectly feasible to introduce considerable inherent resistance

in the coil which will be very effective in preventing danger due to serious over-voltage, resonance, dissymmetry. It will reduce the residual current under such conditions as shown by the oscillograms considerably.

H. L. Wallau: We have been operating for about eighteen years a moderate voltage system with a grounded neutral and the results of our experience, confirms Mr. Johnson's statements to a very wide degree. I wanted to comment in that connection on a statement made by Mr. Smith: If I understood him rightly he said that the thermal capacity of the resistance might be a considerable factor where a ground took place beyond a substation bus, which bus was fed by a number of lines in parallel, because the ground current would be divided between these lines. It seems to me that would only be the case if the breaker in the outgoing line was set so high that it could not trip at a reasonable speed with the total ground current that must flow through it, due to the current flowing into the fault beyond the substation bus.

You might have but a few hundred amperes in the individual supply lines, but the total current would flow in the final line on which the ground developed, and if the time of tripping is reduced to a minimum, you need not have such a large thermal capacity.

Another point brought up by Mr. Atkinson was that the cables with equal thickness of insulations, conductor insulation equal to belt insulation were not quite as effective as cables would be designed with a greater belt thickness. It has been our experience that since we changed over from a six by six thirty-seconds insulation on 11-kv. cables to eight by two, thereby increasing the insulation between phases and decreasing from phase to ground, we have had considerably less cable trouble, and I believe although I am not positive, less trouble from phase to ground.

W. I. Slichter: There is a practical condition in connection with the tuning and detuning of the circuit which seems to me has been overlooked, namely that the step-down transformers at the receiving end of the transmission line will probably remain in circuit and they afford a circuit between phases which it would seem would prevent the detuning. I wish to ask whether this is not the case in practical operation.

W. W. Lewis: The discussion has brought out a number of constructive suggestions. Mr. Ferris suggests transposing the three banks of the Y at Vida; Mr. Trueblood gives an explanation of the possible cause of the three cases of over-voltage which resulted in bus flashover and suggests a reduction in the reactor ohms to remedy the situation; Mr. Blume suggests increasing the resistance of the coil to reduce the residual current and increase the damping effect. All of these suggestions will probably be acted upon within the present year and will no doubt be reflected in an improved operating record.

As to Mr. Evans' statement that the use of the coil resulted in increased interruptions in the remainder of the system, apparently due to excess voltages causing bus flashover and transformer trouble: I would call attention to the fact that the 343 minutes outage due to transformer trouble in January was the result of a burned out transformer coil. This transformer had been subjected to repeated short circuits during the progress of switch tests in November and December 1921 and January 1922, which finally broke down the transformer winding. The Petersen coil was not in circuit during the switch tests but the neutral of the transformer bank was dead grounded. The Petersen coil can only be charged with the three insulator flashovers which caused a total outage of 229 minutes.

W. W. Eberhardt: Mr. Evans has obviously made a misinterpretation of Tables III and IV of our paper in stating that "The Petersen coil installation increased interruptions in the remainder of the system apparently due to excess voltage causing bus flashover and transformer trouble." As pointed out in the explanation of the 1922 interruptions, the 343 minute interrup-

tion charged to transformers occurred during a short-circuit test when the Petersen coil was out of service; the interruptions charged to conductors were caused by trees falling on the line; and the interruptions charged to oil switches were caused by mechanical trouble in the switches. These interruptions were obviously, therefore, not caused by any action of the Petersen coil. The only interruptions strictly chargeable to the Petersen coil are the bus insulator flashovers of 79 and 62 minutes in Table IV. Eliminating the cases of trouble not chargeable to the Petersen coil, the total for 1922 would be 9 cases of trouble with a total outage of 155 minutes compared with 45 interruptions in 1921 with a total outage of 304 minutes.

In order to make the comparison between Tables III and IV complete, we wish to present the following tabulation of lightning storms occurring over the Lock 12-Vida line in the years 1921 and 1922.

	1921	1922
January.....	0	3
February.....	7	7
March.....	8	12
April.....	2	8
May.....	6	17
June.....	11	16
July.....	18	16
August.....	19	10
September.....	11	8
Total.....	82	97

From this tabulation it is seen that during the period when the Petersen coil was in service the lightning storms were more numerous than before the installation, thereby making the comparison even more favorable for the Petersen coil.

Mr. Trueblood in his discussion has pointed out that the Petersen coil has been operated with approximately 23 per cent excess reactance. The object in operating above the resonant point is to avoid the continuous flow of the neutral current of 6 amperes at the point of resonance. As pointed out by Mr. Trueblood, the same results could be obtained by operating below the resonant point, with the added advantage of perhaps eliminating the excessive voltages obtained in the past. Experiments will probably be carried out along this line.

Mr. Blume's suggestion of improving the operation of the Petersen coil by the introduction of more resistance, thereby, preventing danger due to serious overvoltage and resonance is well taken. As pointed out in our paper, our experiments with the Petersen coil will be continued along the lines suggested, the results of which we hope to have available at some future date.

SELECTIVE RELAY SYSTEM OF THE 66,000-VOLT RING OF THE DUQUESNE LIGHT COMPANY¹

(SLEEPER);

GROUND SELECTOR FOR UNGROUNDED THREE-PHASE DISTRIBUTION SYSTEMS²

(ACKERMAN);

THE DISTANCE RELAY FOR AUTOMATICALLY SECTIONALIZING ELECTRICAL NET WORKS³

(CRICHTON);

PITTSBURGH, PA., APRIL 25, 1923.

R. N. Conwell: Mr. Sleeper's paper gives an example of one of the methods of determining whether relays are correctly set for selective operation. There is another method, that of keeping accurate records of relay operations in service, which will give equally good results but these are not obtained as promptly as by applying actual short-circuit tests. The ex-

1. A. I. E. E. JOURNAL, 1923, Vol. XLII, July, p. 723.
 2. A. I. E. E. JOURNAL, 1923, Vol. XLII, April, p. 211.
 3. A. I. E. E. JOURNAL, 1923, Vol. XLII, August, p. 793.

pense, however, is much less and it is the only method applicable to those systems in which the transmission cannot be taken out of service for tests. Both methods must be preceded and followed by the same careful analytical study which Mr. Sleeper has given to his problem.

I regret that Mr. Ackerman has brought into the subject of relay protection the item of interference to signal systems. The two are separate and distinct problems and I feel sure that any system of relay protection installed on a power supply line as a remedial measure in a case of inductive interference will be an entirely different relay system from that installed solely to isolate defective apparatus or transmission lines. The scale of fundamental limiting factors of time, current and voltage in the two problems are in the ratio of 10 or 100 to 1. Furthermore, Mr. Ackerman's paper brings up the old question of grounded versus ungrounded systems from both the system protection and interference points of view. From a purely power system point of view, I believe there is little doubt as to the desirability or even necessity of grounding. Inasmuch as Mr. Ackerman's device may be considered as a Creighton arc suppressor with the high-tension phases crossed, the reduction in interference claimed for the device is not apparent, for the occurrence of a single-phase fault to ground in an ungrounded system results in the device operating to ground another phase and permitting the current required to operate the relays to flow through the ground between the fault and the ground established by the device. The condition therefore, is not unlike that found in a grounded neutral system when considered from the interference point of view.

The relay which Mr. Creighton has shown will fill a long felt need. The continual increase in the number of substations to be supplied from a transmission network has forced the use of long time settings, if arrangements could not be made for parallel line protection. The troubles and hazards incident to the use of long time settings in such cases will now be obviated by the use of the "Distance Relay."

P. Ackerman: I have been interested to hear the paper by Mr. Crichton, chiefly because I have been working on a similar principle, such scheme being in operation on one of the Shawinigan Water & Power Co's. systems for about three years. My scheme has been described in a paper read before the Engineering Institute of Canada and published in the *Journal* of the E. I. C. in the December 1922 issue.

The only thing common to the distance relay of Mr. Crichton and the one used on the Shawinigan System is the underlying idea of using the potential for restraining the tripping tendency of the current unless the voltage is very low. With respect to the detail consideration of obtaining selective action of switches located in series to each other the two schemes are widely divergent. This is apparently due to the fact that the two schemes were developed with entirely different ends in view, probably because of the difference of the systems.

Mr. Crichton gave primary consideration to the desire of obtaining a relay which was not limited in its active distance range, so as to obtain a standby protection for switches located in series to each other. He thus conceived of the distance-time relay wherein the tripping time was an approximate function of the distance to the short-circuit point. He obtained this feature by cleverly combining the voltage restraining element with a time-limit overload relay.

I, on my part, was anxious to obtain primarily instantaneous protection over the largest possible portion of a line so as to reduce the damage to the line and the disturbance to the system, the latter consisting largely of synchronous motor load. I was also desirous of obtaining a protection which could be successfully applied to the generators. In view of the above, I found it desirable to keep the functions of the a-c. relay and the selective time-limit feature separate.

As shown in Fig. 1 I used a balanced beam with a current

solenoid at one end and a potential solenoid at the other end. The balance between current and potential solenoids can be adjusted for any desired active distance range. Thus a relay can be adjusted to be effective to the end of a line, but not beyond. Such relay will not have to be selective with any other switch and in consequence can be made instantaneous. A second set of relays is adjusted to have an active distance range beyond the substation, thus obtaining a protection for substation shorts. If this latter set of relays was made instantaneous it would become non-selective with the protection of the feeder ahead. In order to assure time selective action, therefore, this latter set of relays is arranged to trip the oil switch through a definite time relay instead of directly.

Fig. 2 illustrates the difference in time curves obtained by the two types of protection. (a) represents the time curve of Mr. Crichton's relay and (b) the time curve for the principle used on the Shawinigan system.

A distinct drawback of Mr. Crichton's relay is the fact that it cannot be applied to any case where the voltage difference between switches, located in series to each other, is less than 5 per cent. It therefore cannot be used for generator protection to act selectively with feeder switches emanating from the generator bus bar since the voltage condition of the two relays will be the same. In the principle used on the Shawinigan system such a case is taken care of by time selective difference of the two switches, as shown in Fig. 2.

A further drawback of Mr. Crichton's relay is the fact that the relay is not a strictly distance time relay but the time is also

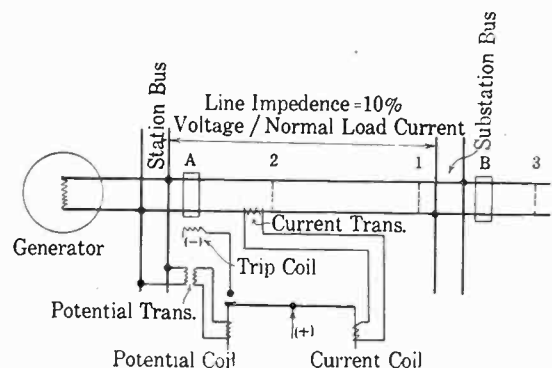

Condition	Relative Magnetic Pull on Solenoids		Action of Relay
	Potential Coil	Current Coil	
Light Load		■	Potential Coil Overpowers Current Coil and Keeps Trip Circuit Blocked
Full Load			Potential Coil Overpowers Current Coil and Keeps Trip Circuit Blocked
Short at end of Line at Point. 1			Potential and Current Coils just keeping balance. Relay adjusted for this balance.
Short near Power House at Point. 2.	■		Current Coil Overpowers Potential Coil and Trips Switch.
Short beyond Line at point. 3.			Potential Coil Overpowers Current Coil and keeps Trip Circuit Blocked.

FIG. 1—SCHEMATIC DIAGRAM OF CURRENT POTENTIAL OVER-BALANCE PRINCIPLE FOR A SINGLE-PHASE CIRCUIT WITH TABLE SHOWING FUNCTIONING UNDER DIFFERENT CONDITIONS.

partly dependent on the actual current magnitude as will be seen from the curves in Fig. 7 of Mr. Crichton's paper. In consequence its adjustment is dependent on the connected generator capacity and it is essential that extreme operating conditions be taken into account when determining the setting.

This feature will necessitate an increase in time settings in order to assure proper time selective action for all possible operating conditions. In the principle used on the Shawinigan system the time feature is absolutely independent of operating conditions.

Another condition which will increase the time setting on Mr. Crichton's relay is the one of two substations of different distances being located in series to each other as is illustrated in Fig. 3. Substation (C) is assumed closer to (B) than substation (B) to (A). Assume (b) being the time curve for switch (B) for short circuits along the line (B-C). Curve (a) represents the time curve for switch (A) which is necessary

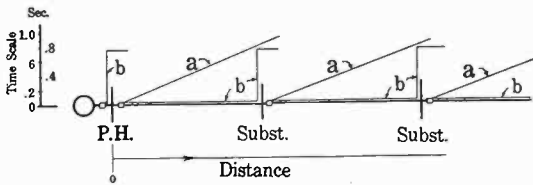

FIG. 2

to assure time selective action with switch (B) for short circuits beyond (B) but close to (B). The time difference (X) is considered the minimum necessary time distance for selective action. For short circuits at the end of line (B-C) the time curve (a) is not time selective with curve (b). In order to make it time selective for all conditions the time curve for switch (A) must be raised to time curve (a₁) which means an undesirable increase of the tripping time.

These few points mentioned must not be considered as a criticism of Mr. Crichton's relay. His scheme forms an advance in the art of relay protection in the right direction, but it has its distinct limitations as any type of relay has. As a result it can only be applied intelligently if its characteristics are fully taken into consideration. The points discussed were made to bring out more distinctly some of those limiting features which must be known in the practical application of the relay.

The fact remains that an effective protection cannot be de-

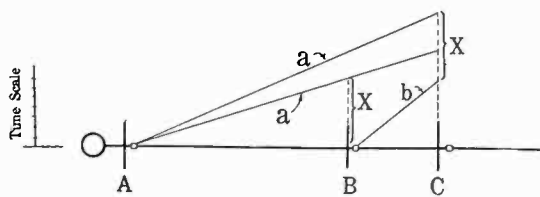

FIG. 3

veloped without full knowledge of the system and its general operating conditions, as well as the full knowledge of the intricate characteristics of the relays to be used. Only a proper harmonizing of operating needs and relay characteristics can bring the desired results.

W. V. Lovell: On the first page of Mr. Ackerman's paper appears the statement that the general opinion is overwhelmingly in favor of the grounded neutral, and there is little hope or desire to controvert that after hearing the papers presented on grounding at this session, but in his table, under Item 13 he states that short circuits with ground return will create heavy electromagnetic interference to telephone lines. The deduction is that the sentiment is overwhelmingly in favor of heavy interference. I don't think that is a conclusion that anyone would draw who has followed the efforts of the operating engineers to reach a

solution of the problem, and surely it is not the sentiment of the Bell engineers.

I think the chief difficulty is with the broad claim in Item 13 which was probably made without very thorough analysis. I do not find in the paper data to substantiate that and similar conclusions as expressed in references No. 14 and 15. In Item 15 the question as to whether or not all of the current in the case of shorts between the two phases of the grounded system and ground will pass back through the ground and neutral, does not appear to be developed fully. There is something more to investigate on that point, particularly in view of the fact that the conclusion is drawn that the advantageous scheme is the system using the ground selector. In the case of simultaneous shorts to ground, the neutralizing action would only be secured in case both breakdowns occurred at the same point.

I would not necessarily accept the conclusions as outlined here—that the ground selector system is a most advantageous one from the standpoint of inductive coordination—without having the theory developed and supported by something in the way of operating data.

E. A. Hester: Mr. Sleeper says that in order to get credit for effective relay operation it is necessary to get it when the relays are installed and before they are called upon to operate. That is to say, in effect, that the relays thereafter are usually blamed for any failure of lines or apparatus to clear, or for faulty sequence of operation. Unfortunately, that is true in a great many companies even at the present time, although there is a tendency toward a more thorough investigation of trouble, which in a great many cases absolves the relays from blame and attaches it to faulty application, or to the failure of other apparatus. In any case, it is the duty of the protection or relay engineer to draw the attention of his organization to successful relay operations. Attention is automatically drawn to unsuccessful operations, which quite often gives executives and others not so closely in touch with the actual operation a wrong impression. It is very interesting to note that a great many companies are establishing a bureau which takes care of protection alone. This is a very encouraging sign and it is to be hoped that these bureaus, by making careful analysis of relay operations and of interruption reports, will give the protective relays a reputation, which is rightfully theirs, of apparatus, which when correctly applied, is almost unequaled in precision of operation.

In this connection it may also be mentioned that the American Institute of Electrical Engineers and the National Electric Light Association both have Relay Subcommittees engaged in the preparation of a relay handbook. This should also do its share in preventing wrong applications with resultant faulty operation.

I should like to bring out one point with reference to Mr. Crichton's paper and Mr. Ackerman's discussion, *i.e.*, that this principle of "voltage restraint," as it was once called, has been successfully used by an operating company before the apparatus described in this paper and discussion was produced. Several years ago the West Penn Power Company tried out a scheme in which they locked the circuit breaker mechanism for voltages above a predetermined percentage. I believe Mr. Crichton was somewhat interested in this application. The scheme worked out very well for a while on this system, which had very long lines and relatively few stations scattered over a large territory. The scheme and its operation have been described in other papers presented before the Institute, both at Lake Placid, New York, in 1919 and in Niagara Falls, Ontario, in 1922.

H. A. P. Langstaff: Mr. Hester has referred to the voltage restraining relay on the West Penn System. This installation was made several years ago when the West Penn System was comprised mostly of radial feeders, and under this condition, operation was quite reliable. As the system grew and additional loops as well as generating stations were added, it was found

advisable to install a more up-to-date type of relay, and as this installation was being made on part of the system, operation seemed to drift toward other sections of the system where the voltage restraining relay was still in service.

This feature brought out a very important point, which was brought quite forcibly to our attention, in connection with all switch operation analyses; *i.e.*, the re-equipping of a system as large as the West Penn with new relays. The work should be complete as soon as possible. In our particular case we found that the new relays, we might say, dammed up the operations in the new relayed section and diverted them to the remainder of the system.

In connection with the new impedance relay, we are wondering whether or not Mr. Crichton is going to allow us a royalty on the original idea.

We found that the time element of the West Penn voltage restraining relay was entirely too speedy, and we found that the addition of a time delay relay materially improved the selective operation. Twelve stations were equipped with this time element relay within one month's time, thereby enabling us to materially rearrange the operating scheme of dividing the system into three parts previous to storms, and remaining in parallel, which greatly reduced the number of interruptions.

There is one point which I would like to mention in connection with balance protection, which needs to be guarded against, and that is when one tie-line is out of service for repairs or in case of trouble, the remaining lines should have a sufficiently high setting to prevent an incorrect operation due to trouble on some foreign section. It is quite possible that a radial feeder out of a substation might have a considerably higher setting than the tie-line which is left in service.

Another point which has not been mentioned is that wherever more than one type of relay is used to control the one breaker, some form of indicator should be installed to show which relay was the cause of the switch operation. I believe this feature should be made standard equipment with all relays. This has a very important bearing on the setting of the relays, especially ground relays, which are more or less difficult to figure unless it is possible to carry out a schedule of experiments similar to those mentioned in Mr. Sleeper's paper. The writer has developed, and we now have in operation, about 25 indicators which give an audible as well as a visual alarm, and also has a Voeder counter which actually automatically records the total number of relay operations. This acts as a guide to the station attendant, and gives him a check on his switching equipment.

There is also another point which has not been mentioned in any of the papers or discussions, and that is the advisability of testing all relays in the laboratory. This question has been under consideration by us for some time, and we have not yet found this to be advisable. In the last two years we have installed approximately 600 relays and not more than 10 of these have been in our laboratory. All shipments are made direct from the factory to the job, installed on panels and given more or less of a laboratory test, and the settings made directly with the relays in position. Our percentage of failures has been exceptionally low.

Before starting on our relay program, the question of source of tripping current was very thoroughly investigated, and it was finally decided to use 12-volt storage batteries and vibrating rectifiers, adjusted to give a continuous trickling charge. We now have 15 of these installations in operation. Of course, all breakers are equipped with 12-volt, 5-ampere trip coils and the plunger in this is set approximately one-half its distance up in the coil in such a way that the coil will actually operate on six volts.

During the last two years I know of no failure which can be attributed to this low-voltage service. We have had one case of

complete failure, due to the blowing of a main line d-c fuse, making all switches in this one station non-automatic, but this condition would have applied, regardless of the d-c voltage.

Chas. McL. Moss: The difficulty of any system of balance relay protection is inherently the number of cross connections required between the current transformers of the two lines. I think you probably have not used them. Even in the diagrams we have had shown us, the connections are somewhat complicated and Mr. Sleeper admits that he left out some of them. The complications are further increased if there are more than two lines.

He has pointed out the necessity of operating lines in pairs, but has neglected to state that the Duquesne Light Company ran into some difficulties at some points where they had four lines, and if you try to pair four lines, and use all possible combinations the necessary complications cause it to fall down by its own weight, so they wisely abandoned it.

The meat of Mr. Crichton's paper was in his first few words, in which he stated that the distance relay was essentially a "self-setting" relay. We all know that we can set up any predetermined line conditions and can pack relays on that line and give the proper time setting, directional settings, current settings, to take care of any difficult conditions we can impose. Somebody comes along and puts on additional stations, involving more time settings. Instead of having normally multiple lines, we have single line operation and then in order to maintain our full protection we must reset the relays or limp along on a partially automatic protective scheme.

Mr. Ackerman, in pointing out the disadvantages of the grounded systems, brings out in a great many places in his tabulation the disadvantages of a grounded system due to transient grounds always interrupting the service. It appears to me that that difficulty should not be given so much importance because in any large system of today supplying any important service, we practically always maintain that over duplicate feeds because outside of normal maintenance we may get other faults besides grounds. With a grounded system with adequate relaying, we can clear a fault immediately, maintaining the service over the other lines. He also brings up in his tabulation the difficulty of grounded neutral system, due to the requirement of star-star transformers throughout, thus requiring tertiary windings. In a large number of systems where we have both the high and low-tension grounded, that is very simply and economically avoided by proper combinations of Y-delta transformers, making the tertiary unnecessary.

O. C. Traver: Mr. Sleeper makes a specification that single line operation must be possible, preferably without additional relays over the number required for parallel line operation. That is very laudable, but at the same time, there is one difficulty, in that without additional relays, it would take the same time to clear a short whether you have parallel line operation or single line operation. The single line must have enough time to allow others to clear. Therefore, the 1.2 seconds time mentioned by the author would be necessary to clear a fault in any case.

You have noticed in the moving pictures just shown that the arc developed first very small, and very rapidly swung across the screen out of the range of the picture. That is the sort of thing that makes trouble many times. It is the sort of thing I believe it is wise to steer clear of. Accordingly I think two sets of relays in most cases are more than justified, if you can prevent an arc from swinging into a phase-to-phase or three-phase fault. To secure the desired result you would use relays of the same general type as Mr. Sleeper has described, but two sets of them, the first set would be as nearly instantaneous as possible; the second coming into play automatically only after one line has gone. There is no material complication and the scheme works out very nicely.

I have seen a test similar to the one shown here on the screen, an arc started by a fuse, across a 110,000-volt circuit, with the full power of a large system back of it, and I was very much disappointed and greatly surprised because I expected to see some real honest-to-goodness fireworks and didn't get them. There was a ball of fire about the middle of the fuse and that ball never moved out of its tracks simply because the breaker was protected by an instantaneous relay. Although the wind was blowing at a good rate the arc had no time to move over and involve the other phases. For that reason, I am very much in favor of using as quick a time as can be had for parallel operation, and then automatically introducing a longer time for the remaining single-line operation. You usually secure an additional advantage through time grading making it possible to care for more than one line out of service at the same moment. It may not happen very often that you need to care for a condition like that, but it does happen sometimes, and this arrangement will give you entire control under all conditions.

Passing now to Mr. Ackerman's paper: He states at the start that his particular circumstances were such that grounding, either by changing to star-connected transformers or by providing an artificial grounding scheme, was not readily possible. He, therefore, hit upon a very clever scheme of taking care of the situation which was apparently troublesome. He put on something and that something worked. I cannot quite agree, however, with his conclusions as applied to the general case.

Mr. Crichton has demonstrated a mighty interesting relay. The pioneer work of the West Penn Company and Mr. Ackerman's installation have already been referred to. The earliest reference to this principle, of which I am aware, is contained in a German patent issued about 16 years ago. Since this time the difficulty, as it appeared to some of us, has been that potential connections are required, and a double set at that, to care for both phase-to-phase faults and faults to ground. The usefulness of the scheme when properly applied cannot be doubted although any universal use is seriously questioned.

Some time ago the General Electric Company developed what was called an "overload-undervoltage relay" but due to the above mentioned difficulties the time was not considered ripe for exploitation. The characteristics are about the same as for the relay described by Mr. Crichton though the method of securing them was very different. This relay also consisted of two elements but instead of a direct mechanical connection, the two elements worked independently. One of these was a voltage element and the other was an induction over-current relay of standard construction. The net action of the combination was that the voltage element automatically varied the time setting of the over-current relay.

L. P. Ferris: Mr. Ackerman has referred in several places to the matter of inductive interference, as have also two of the previous speakers in discussing his paper. In a comparison of the grounded neutral system, and the isolated system, it is well to differentiate sharply between the situation under steady state or normal operating conditions and the situation under abnormal conditions as of short circuit.

In Mr. Ackerman's Table 1, reference No. 4, operating conditions normal, he brings out a recognized difference between the grounded neutral system and the system operated without ground connection. In the first we have a source of residual current and voltage which is not present in the isolated system, so I believe he is correct in stating that the isolated system has the advantage from that standpoint.

In reference 13, condition of a ground on one wire, Mr. Ackerman draws no conclusions as to which system is the more advantageous. He states in reference to the ungrounded system that the short-circuit will have the same serious effect as in the case of the grounded system. That, I think, should be qualified

because with Mr. Ackerman's scheme he grounds a phase which is not normally grounded, producing a phase-to-phase short circuit through the ground. Now, if the two grounded points and line between them embrace the parallel, you have a phase-to-phase short circuit completed through the ground which may give a more severe condition than the grounded neutral system, but that will depend to some extent upon the amount of resistance which Mr. Ackerman uses. If that resistance is small I should expect the grounded neutral system to have the advantage.

In reference No. 14 I believe Mr. Ackerman's conclusion is that the two systems stand on a par, and this is substantially correct.

In reference No. 15, I think the statement that the ungrounded system gives a metallic short circuit and neutralizes interference should be made conditional on the grounds on the two phases occurring on the same side of the parallel. If the grounds are on opposite sides of the parallel, you will have the condition of a phase-to-phase short circuit embracing the parallel and, of course, you will get induced voltages.

In reference No. 19: Mr. Ackerman claims as an advantage of the ungrounded system, greater current to actuate his relays. That same greater current would, of course, give greater induction.

Mr. Ackerman points out that with his system on the 12,000-volt network, there is a certain percentage of cases of temporary surges which clear without a short circuit, and, of course, this is an advantage to the extent to which it can be accomplished because otherwise those conditions would produce a short circuit on a grounded neutral system. Apparently, this holds for the moderate or low-voltage systems where the arcing ground is not a serious factor. Of course, where you have an arcing ground on the power system, that is a factor which is disadvantageous from the interference standpoint as well as from the power standpoint.

E. P. Peck: Mr. Ackerman evidently had a particular problem which was quite serious, and he met that problem with an excellent solution for the particular conditions. However, if we examine carefully the tables on pages 314 and 315, the application of his solution to his problem leads to conclusions which do not apply equally well to other systems and to other problems. In comparing the *B*'s and the *A*'s, we found a number of *B*'s which indicate his system is best, one clear *A* and a few *A*'s "apparently." Looking over the table in the light of experience on other systems, and re-marking it, I found a good many question marks under the *B*'s, a good many "apparently's" scratched out under the *A*'s, and a good many *A*'s filling in the blank spaces. In other words, the conclusions in the paper should be taken as applying to the particular set of conditions encountered, and not to systems in general.

One remark on the next page rather makes me think there is something special in that particular system. "Regarding the danger of high-frequency surges created by an arcing ground at the point of fault, it may be pointed out that in the writer's opinion the existence of the arcing ground should be extremely rare." This is true. Arcing grounds should be extremely rare, but they do occur on isolated systems, and when they occur the results are often quite serious, and frequently secondary troubles are produced at quite a distance from the original arcing grounds.

F. M. Billhimer: Mr. Sleeper's description of the selective relay system on the Duquesne Light Company was very interesting and instructive. I say this because of the fact that he not only described the relay system of the Duquesne Light Company, but in addition, he told us why they used this system, how they went about it to test the system after it was installed, and the results of the tests after everything had been put in working order.

advisable to install a more up-to-date type of relay, and as this installation was being made on part of the system, operation seemed to drift toward other sections of the system where the voltage restraining relay was still in service.

This feature brought out a very important point, which was brought quite forcibly to our attention, in connection with all switch operation analyses; i.e., the re-equipping of a system as large as the West Penn with new relays. The work should be complete as soon as possible. In our particular case we found that the new relays, we might say, dammed up the operations in the new relayed section and diverted them to the remainder of the system.

In connection with the new impedance relay, we are wondering whether or not Mr. Crichton is going to allow us a royalty on the original idea.

We found that the time element of the West Penn voltage restraining relay was entirely too speedy, and we found that the addition of a time delay relay materially improved the selective operation. Twelve stations were equipped with this time element relay within one month's time, thereby enabling us to materially rearrange the operating scheme of dividing the system into three parts previous to storms, and remaining in parallel, which greatly reduced the number of interruptions.

There is one point which I would like to mention in connection with balance protection, which needs to be guarded against, and that is when one tie-line is out of service for repairs or in case of trouble, the remaining lines should have a sufficiently high setting to prevent an incorrect operation due to trouble on some foreign section. It is quite possible that a radial feeder out of a substation might have a considerably higher setting than the tie-line which is left in service.

Another point which has not been mentioned is that wherever more than one type of relay is used to control the one breaker, some form of indicator should be installed to show which relay was the cause of the switch operation. I believe this feature should be made standard equipment with all relays. This has a very important bearing on the setting of the relays, especially ground relays, which are more or less difficult to figure unless it is possible to carry out a schedule of experiments similar to those mentioned in Mr. Sleeper's paper. The writer has developed, and we now have in operation, about 25 indicators which give an audible as well as a visual alarm, and also has a Veeder counter which actually automatically records the total number of relay operations. This acts as a guide to the station attendant, and gives him a check on his switching equipment.

There is also another point which has not been mentioned in any of the papers or discussions, and that is the advisability of testing all relays in the laboratory. This question has been under consideration by us for some time, and we have not yet found this to be advisable. In the last two years we have installed approximately 600 relays and not more than 10 of these have been in our laboratory. All shipments are made direct from the factory to the job, installed on panels and given more or less of a laboratory test, and the settings made directly with the relays in position. Our percentage of failures has been exceptionally low.

Before starting on our relay program, the question of source of tripping current was very thoroughly investigated, and it was finally decided to use 12-volt storage batteries and vibrating rectifiers, adjusted to give a continuous trickling charge. We now have 15 of these installations in operation. Of course, all breakers are equipped with 12-volt, 5-ampere trip coils and the plunger in this is set approximately one-half its distance up in the coil in such a way that the coil will actually operate on six volts.

During the last two years I know of no failure which can be attributed to this low-voltage service. We have had one case of

complete failure, due to the blowing of a main line d-c. fuse, making all switches in this one station non-automatic, but this condition would have applied, regardless of the d-c. voltage.

Chas. McL. Moss: The difficulty of any system of balance relay protection is inherently the number of cross connections required between the current transformers of the two lines. I think you probably have not used them. Even in the diagrams we have had shown us, the connections are somewhat complicated and Mr. Sleeper admits that he left out some of them. The complications are further increased if there are more than two lines.

He has pointed out the necessity of operating lines in pairs, but has neglected to state that the Duquesne Light Company ran into some difficulties at some points where they had four lines, and if you try to pair four lines, and use all possible combinations the necessary complications cause it to fall down by its own weight, so they wisely abandoned it.

The meat of Mr. Crichton's paper was in his first few words, in which he stated that the distance relay was essentially a "self-setting" relay. We all know that we can set up any predetermined line conditions and can pack relays on that line and give the proper time setting, directional settings, current settings, to take care of any difficult conditions we can impose. Somebody comes along and puts on additional stations, involving more time settings. Instead of having normally multiple lines, we have single line operation and then in order to maintain our full protection we must reset the relays or limp along on a partially automatic protective scheme.

Mr. Ackerman, in pointing out the disadvantages of the grounded systems, brings out in a great many places in his tabulation the disadvantages of a grounded system due to transient grounds always interrupting the service. It appears to me that that difficulty should not be given so much importance because in any large system of today supplying any important service, we practically always maintain that over duplicate feeds because outside of normal maintenance we may get other faults besides grounds. With a grounded system with adequate relaying, we can clear a fault immediately, maintaining the service over the other lines. He also brings up in his tabulation the difficulty of grounded neutral system, due to the requirement of star-star transformers throughout, thus requiring tertiary windings. In a large number of systems where we have both the high and low-tension grounded, that is very simply and economically avoided by proper combinations of Y-delta transformers, making the tertiary unnecessary.

O. C. Traver: Mr. Sleeper makes a specification that single line operation must be possible, preferably without additional relays over the number required for parallel line operation. That is very laudable, but at the same time, there is one difficulty, in that without additional relays, it would take the same time to clear a short whether you have parallel line operation or single line operation. The single line must have enough time to allow others to clear. Therefore, the 1.2 seconds time mentioned by the author would be necessary to clear a fault in any case.

You have noticed in the moving pictures just shown that the arc developed first very small, and very rapidly swung across the screen out of the range of the picture. That is the sort of thing that makes trouble many times. It is the sort of thing I believe it is wise to steer clear of. Accordingly I think two sets of relays in most cases are more than justified, if you can prevent an arc from swinging into a phase-to-phase or three-phase fault. To secure the desired result you would use relays of the same general type as Mr. Sleeper has described, but two sets of them, the first set would be as nearly instantaneous as possible; the second coming into play automatically only after one line has gone. There is no material complication and the scheme works out very nicely.

I have seen a test similar to the one shown here on the screen, in arc started by a fuse, across a 110,000-volt circuit, with the full power of a large system back of it, and I was very much disappointed and greatly surprised because I expected to see some real honest-to-goodness fireworks and didn't get them. There was a ball of fire about the middle of the fuse and that ball never moved out of its tracks simply because the breaker was protected by an instantaneous relay. Although the wind was blowing at a good rate the arc had no time to move over and involve the other phases. For that reason, I am very much in favor of using as quick a time as can be had for parallel operation, and then automatically introducing a longer time for the remaining single-line operation. You usually secure an additional advantage through time grading making it possible to care for more than one line out of service at the same moment. It may not happen very often that you need to care for a condition like that, but it does happen sometimes, and this arrangement will give you entire control under all conditions.

Passing now to Mr. Ackerman's paper: He states at the start that his particular circumstances were such that grounding, either by changing to star-connected transformers or by providing an artificial grounding scheme, was not readily possible. He, therefore, hit upon a very clever scheme of taking care of the situation which was apparently troublesome. He put on something and that something worked. I cannot quite agree, however, with his conclusions as applied to the general case.

Mr. Crichton has demonstrated a mighty interesting relay. The pioneer work of the West Penn Company and Mr. Ackerman's installation have already been referred to. The earliest reference to this principle, of which I am aware, is contained in a German patent issued about 16 years ago. Since this time the difficulty, as it appeared to some of us, has been that potential connections are required, and a double set at that, to care for both phase-to-phase faults and faults to ground. The usefulness of the scheme when properly applied cannot be doubted although any universal use is seriously questioned.

Some time ago the General Electric Company developed what was called an "overload-undervoltage relay" but due to the above mentioned difficulties the time was not considered ripe for exploitation. The characteristics are about the same as for the relay described by Mr. Crichton though the method of securing them was very different. This relay also consisted of two elements but instead of a direct mechanical connection, the two elements worked independently. One of these was a voltage element and the other was an induction over-current relay of standard construction. The net action of the combination was that the voltage element automatically varied the time setting of the over-current relay.

L. P. Ferris: Mr. Ackerman has referred in several places to the matter of inductive interference, as have also two of the previous speakers in discussing his paper. In a comparison of the grounded neutral system, and the isolated system, it is well to differentiate sharply between the situation under steady state or normal operating conditions and the situation under abnormal conditions as of short circuit.

In Mr. Ackerman's Table 1, reference No. 4, operating conditions normal, he brings out a recognized difference between the grounded neutral system and the system operated without ground connection. In the first we have a source of residual current and voltage which is not present in the isolated system, so I believe he is correct in stating that the isolated system has the advantage from that standpoint.

In reference 13, condition of a ground on one wire, Mr. Ackerman draws no conclusions as to which system is the more advantageous. He states in reference to the ungrounded system that the short-circuit will have the same serious effect as in the case of the grounded system. That, I think, should be qualified

because with Mr. Ackerman's scheme he grounds a phase which is not normally grounded, producing a phase-to-phase short circuit through the ground. Now, if the two grounded points and line between them embrace the parallel, you have a phase-to-phase short circuit completed through the ground which may give a more severe condition than the grounded neutral system, but that will depend to some extent upon the amount of resistance which Mr. Ackerman uses. If that resistance is small I should expect the grounded neutral system to have the advantage.

In reference No. 14 I believe Mr. Ackerman's conclusion is that the two systems stand on a par, and this is substantially correct.

In reference No. 15, I think the statement that the ungrounded system gives a metallic short circuit and neutralizes interference should be made conditional on the grounds on the two phases occurring on the same side of the parallel. If the grounds are on opposite sides of the parallel, you will have the condition of a phase-to-phase short circuit embracing the parallel and, of course, you will get induced voltages.

In reference No. 19: Mr. Ackerman claims as an advantage of the ungrounded system, greater current to actuate his relays. That same greater current would, of course, give greater induction.

Mr. Ackerman points out that with his system on the 12,000-volt network, there is a certain percentage of cases of temporary surges which clear without a short circuit, and, of course, this is an advantage to the extent to which it can be accomplished because otherwise those conditions would produce a short circuit on a grounded neutral system. Apparently, this holds for the moderate or low-voltage systems where the arcing ground is not a serious factor. Of course, where you have an arcing ground on the power system, that is a factor which is disadvantageous from the interference standpoint as well as from the power standpoint.

E. P. Peck: Mr. Ackerman evidently had a particular problem which was quite serious, and he met that problem with an excellent solution for the particular conditions. However, if we examine carefully the tables on pages 314 and 315, the application of his solution to his problem leads to conclusions which do not apply equally well to other systems and to other problems. In comparing the *B*'s and the *A*'s, we found a number of *B*'s which indicate his system is best, one clear *A* and a few *A*'s "apparently." Looking over the table in the light of experience on other systems, and re-marking it, I found a good many question marks under the *B*'s, a good many "apparently's" scratched out under the *A*'s, and a good many *A*'s filling in the blank spaces. In other words, the conclusions in the paper should be taken as applying to the particular set of conditions encountered, and not to systems in general.

One remark on the next page rather makes me think there is something special in that particular system. "Regarding the danger of high-frequency surges created by an arcing ground at the point of fault, it may be pointed out that in the writer's opinion the existence of the arcing ground should be extremely rare." This is true. Arcing grounds should be extremely rare, but they do occur on isolated systems, and when they occur the results are often quite serious, and frequently secondary troubles are produced at quite a distance from the original arcing grounds.

F. M. Billhimer: Mr. Sleeper's description of the selective relay system on the Duquesne Light Company was very interesting and instructive. I say this because of the fact that he not only described the relay system of the Duquesne Light Company, but in addition, he told us why they used this system, how they went about it to test the system after it was installed, and the results of the tests after everything had been put in working order.

It was my privilege to be present at this series of tests, and the results were quite gratifying. With grounds on the 66,000-volt system, the proper breakers opened up the faulty section of the system, isolating that fault without dropping any load.

Oscillograph records obtained from this system during the test were obtained from the secondaries of 60,000 to 100,000-volt potential transformers, thereby getting the voltage direct. These oscillograms showed that the voltage unbalance due to the current of 900 amperes flowing over that insulator was not more than about ten per cent. You can readily see that synchronous apparatus will continue to operate satisfactorily under those conditions.

Yesterday, everybody seemed to agree that a resistance in the neutral was advisable, but we were not quite decided as to whether it should be high or low. After a few more carefully planned relay systems have been put into operation, equipped with ground relays, which will protect the system and service by opening the faulty section before a short circuit has occurred, we believe that the ohmic value required of neutral grounding resistors will be fairly well established. Although all systems do not present the same problems as those of the Duquesne Light Company system, I believe that you will all agree that a careful study of the conditions to be met, whether it is parallel operation of lines or some other condition, followed by working out and testing of the scheme after installation will insure excellent system protection and reliability of power service which the public utility is required to give.

H. P. Sleeper: Replying to Mr. R. N. Conwell, I would state that the primary reason for making service tests on our system was the fact that the ground relays which we are using are an entirely new development which had never had service; and in addition, we were very desirous of determining the value of ground currents which would be available on ground faults. Both of these points were completely investigated by the tests made.

Mr. Hester's point is well taken that relay performance on the system should be thoroughly investigated and broadcasted, especially the successful operations which frequently in service are overwhelmed by the undue prominence given a few incorrect operations. We will all agree, however, that it is comforting to know that important relays have operated successfully under service conditions.

In regard to the use of back-up relays for single-line operation on our balanced system, I would state that we have recognized the desirability of this additional protection and that we are at this time taking steps to install it at various points.

Mr. Moss brings out the point that any scheme of balanced relay protection is complicated. As far as this point is concerned, no system of relaying multiple lines can be said to be extremely simple. The complications of a relay system, however, can hardly be considered a serious limitation if its correct performance can be assured.

Mr. Traver's description of the 110,000-volt arc tests are very interesting, particularly relative to the small amount of destruction resulting from the instantaneous operation of the relays. The pictures which you have seen would apparently compare unfavorably with the operations which Mr. Traver has described, but I would point out the fact that on all but one of the arcs which we made, the relay action was delayed far beyond normal. This delay was caused by the fact that the ground relays were not allowed to operate and that the short-circuit relays only were in circuit, thus resulting in a long time operation and the arc achieved considerable magnitude as you have seen. However, in the one operation where the ground relays were in circuit, we were much pleased to note that the arc barely got well established before the breakers opened and the resulting damage was negligible.

As a result of the tests which we made we do not wish to give the impression that we recommend this procedure as a method of periodically testing relays. However, as a method of exhausting possibilities of new equipment, we believe that such a procedure is well justified and we feel amply repaid for the results obtained.

P. Ackerman: The criticism offered to my paper on the ground selector is not unexpected. General opinion has, in the past few years, expressed in favor of the grounded system for well known reasons. It is quite natural, therefore, that any scheme of such a radical departure such as the ground selector, claiming the same advantages as the grounded neutral system, should find its critics. Yet, I do not see the need of retracting any of my statements made in the Table I, and the General Conclusions of my paper.

One of the chief criticisms seems to center in the inductive interference problem, as expressed in items (4), (13), (14), and (15), of Table I.

As a whole there should be little difference in the inductive interference problem between the two systems except for the benefit derived from the ungrounded system as expressed in items (4) and (15).

Regarding item (15) it is to be clearly understood that this item meant to cover the case of the two phases short-circuiting through ground at the same point of the line, such as is frequently the case with lightning flashovers. Any cross short circuit of one phase at one point to another phase at another point of the system is identical with the case covered in item (13).

Regarding the fear of harm being done by arcing grounds as expressed by Mr. Peck and Mr. Ferris, I believe that the operating results are sufficient proof that no such fear need be entertained.

We do not need to argue as to whether the secondary breakdown on ungrounded systems is caused by the dynamic over-voltage breaking down depreciated insulation or by the high-frequency surges set up by the arcing ground. The fact remains that the ground selector relieves such an abnormal condition within such a brief period that no harm is done to the rest of the system. The best proof of this can be found in the operating record of the 12,000-volt Toronto distribution, which system is under my observation for the past ten years, of which period the system was operating for five years without and for five years with ground selector. There has not been a single case of a permanent secondary breakdown since the installation of the ground selector whereas previous to that secondary breakdowns were a common occurrence.

The chief advantage of the ground selector, doubtlessly, lies in its application to medium capacity and medium voltage systems with large overhead distribution. Such systems are largely exposed to temporary grounds by birds, etc., due to the small height of the insulators. With a limited capacity current of the system the chance of self-extinction of the arc, after the grounding object has fallen off, is quite pronounced. In any such case a partial interruption to the load is avoided. This advantage is plainly noticeable from Table III.

On large underground systems where most of the troubles are of a permanent nature, or where the capacity current is of such magnitude that it loses its self-extinguishing property the benefit of saving the interruption is lost, and as a result the ungrounded system combined with ground selector may be considered on par compared with the grounded system as far as selective clearance of faulty lines is concerned. Other factors will govern in such case the advisability of using one or the other system.

In closing I once more wish to emphasize my firm belief in the general opinions expressed in the conclusions of my paper.

Mechanical Computation of Root Mean Square Values

BY L. A. UMANSKY

Associate. A. I. E. E.

Power and Mining Engineering Department, General Electric Company, Schenectady, N. Y.

Review of the Subject.—Varying values of electric current with time are practically the ever-present condition in applications of electricity. There are two main divisions: First, varying loads, producing such data as are given, for example, by the current record of a curve-drawing ammeter; the time is recorded in hours, minutes or seconds. Second, the condition of varying currents in the alternating-current waves themselves or in electrical transient phenomena, as given by a photographic record of an oscillograph (a galvanometer capable of recording instantaneous values of current). The time is here recorded in thousandths of a second.

In both cases the energy is proportional neither to the instanta-

neous nor average value of the current, but to the square of the instantaneous current, as expressed in the familiar equation ($i^2 R$). The process of squaring successive instantaneous values, averaging the square, and extracting the square root, is quite tedious and laborious.

After reviewing some prominent labor-saving methods the writer points out that the root-mean-square (RMS) value can be quickly calculated mechanically by a device, invented some sixty-five years ago and widely used for other purposes. Fig. 3 shows the picture of this device, called *Amsler's Mechanical Integrator*.

* * * * *

THE electrical engineers have quite frequently to determine the mean effective value of a performance cycle of various electrical apparatus. It may be, for instance, a calculated duty cycle of a rolling mill motor or of an electric locomotive; or it may be a chart drawn by a recording graphic ammeter inserted in some existing electric circuit with fluctuating load; again, it may be an oscillogram representing, for instance, a short-circuit phenomena. Whenever the capacity of the electric apparatus is to be determined by the heating during the period, represented by the chart, oscillogram or plotted duty cycle curve, it is essential to calculate the average heating, which is represented by the root-mean-square (RMS) value of the performance cycle.

It will be assumed in the following that the curve is plotted in rectangular coordinates. This is the simplest and most illustrative way in which all calculated duty cycles are naturally plotted; the oscillograph records also belong to this class. The up-to-date

a motor from the line changes with the course of time. In order to calculate the average heating for the period of T seconds it is necessary to sum up the square values of the instantaneous ordinates and then to take the average of these values. Mathematically it is expressed that

$$RMS = \sqrt{\frac{1}{T} \int_0^T i^2 dt} \quad (1)$$

Whenever the performance curve $i = f(t)$ has an

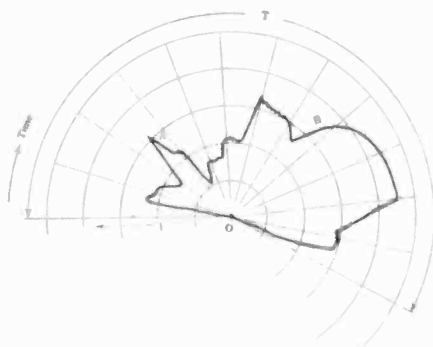

FIG. 2—DUTY CYCLE SAME AS REPRESENTED BY FIG. 1 BUT PLOTTED IN POLAR COORDINATES. THE AVERAGE RADIUS-VECTOR OF THIS CURVE IS THE ROOT-MEAN-SQUARE VALUE OF THE DUTY CYCLE

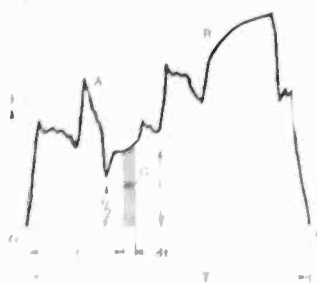

FIG. 1—A DUTY CYCLE CURVE THE ROOT-MEAN-SQUARE VALUE OF WHICH IS TO BE DETERMINED; i IS THE INSTANTANEOUS VALUE OF THE CURRENT AFTER t SECONDS; G IS THE CENTER OF GRAVITY OF THE ELEMENTARY (SHADED) AREA

graphic meters, too, draw their records on rectangular charts.

For instance, Fig. 1 shows how the current drawn by

J. C. O. Mailloux "Méthode de Détermination du Courant Constant produisant le même échauffement qu'un courant variable." (Paper presented before the International Electrical Congress, Turin, 1911.)

irregular shape, as on Fig. 1, these calculations become tedious and time-consuming. One who tried to determine, for instance, the r. m. s.-value of the current input to the reversing mill motor readily understands what amount of work this involves.

Various methods have been suggested to eliminate the necessity of squaring the numerous ordinates and of performing the further calculations. In the best known method, suggested by C. O. Mailloux¹, the chart is first re-plotted in polar coordinates. For instance, Fig. 2 represents the replotted original record, Fig. 1. Inasmuch as the area of a sector of a given angle is proportional to the square of the radius it is obvious that the area $OABC$ (Fig. 2) represents in certain scale the amount of heat produced by the electric

current during that period of time. In other words the area $O A B C$ represents the value

$$\int_0^T i^2 dt \tag{2}$$

Ingenious as this method is, in its published form it requires the replotting of the original record which work takes appreciable time for any curve of irregular and complicated shape.

There is a need for a device that will compute

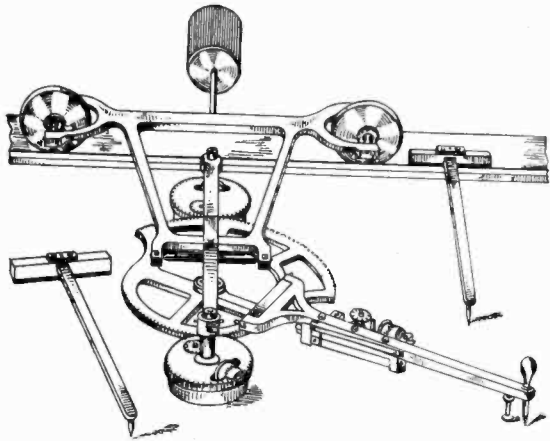

FIG. 3—GENERAL VIEW OF AMSLER'S INTEGRATOR WHICH MAY BE USED FOR MECHANICAL COMPUTATION OF THE ROOT-MEAN-SQUARE VALUES

mechanically the r. m. s.-value in the same simple way as the average value is computed by means of a planimeter, *i. e.*, without making any changes whatsoever on the original curve sheet.

The writer believes that the electrical engineers have overlooked the possibilities which gives them in this respect an existing device, invented and developed some 65 years ago by Prof. Amsler, the inventor of the better known planimeter. This device, known as a mechanical integrator, is used to quite considerable

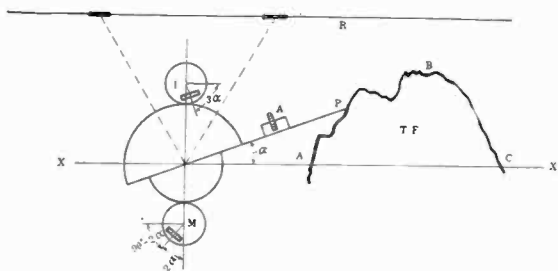

FIG. 4 ELEMENTARY DIAGRAM OF THE AMSLER'S INTEGRATOR

extent by civil engineers and naval architects. The Fig. 3 gives the general view of the integrator, and its elementary diagram is shown on Fig. 4.

The theory of the integrator is well covered in several books² and it will suffice here to state that this device has three integrating disks (A, M, I), the readings on which are taken in the same manner as on an ordinary planimeter, *i. e.* before and after the point P has covered the whole curve $A B C A$.

2. See for instance pp. 250-252 of "Graphical & Mechanical Computations," by Joseph Lipka, N. Y., 1918.

The readings on the dial "A" give, in certain scale, the area of the figure F , these on the dial "M", the moment of the figure F about the axis XX , whereas the combination of readings on dials A and I gives the moment of inertia of F about the same axis XX .

Now assume that we use the integrator for determining the moment of area $O A B C$ (Fig. 1) about the line $O C$. The moment of whole area is the sum of moments of elementary portions, like the shaded part of the Fig. 1.

The moment of any area about an axis equals (area) \times (distance from axis to center of gravity) Thus, the moment of the shaded portion, Fig. 1, is

$$i \times dt \times \frac{i}{2} = \frac{i^2}{2} \times dt \tag{3}$$

and therefore the total moment, which will be determined by the integrator:

$$M = \frac{1}{2} \int_0^T i^2 dt \tag{4}$$

The comparison of expressions (1) and (4) clearly shows that the

$$R M S = \sqrt{\frac{2 M}{T}} \tag{5}$$

The relation thus established between the root-mean-

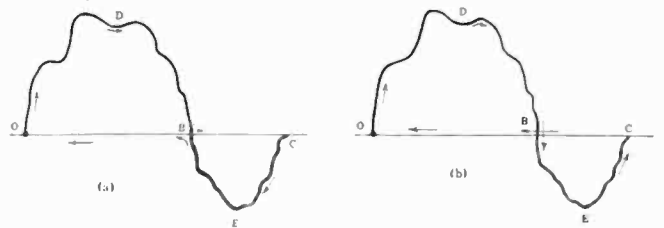

FIG. 5—DUTY CYCLE CURVE WITH POSITIVE AND NEGATIVE VALUES. ARROWS (A) SHOW HOW THE INTEGRATOR POINTER SHOULD TRACE THE CURVE FOR DETERMINING THE MOMENT ABOUT AXIS OC ; ARROWS (B) INDICATE THE WAY OF USING THE INTEGRATOR FOR ROOT-MEAN-SQUARE CALCULATIONS

square of the duty cycle curve and the moment of the figure encircled by that curve, about the line of abscissas, gives us the answer to our problem.

It is obvious that all that is necessary is to lay the record chart on a flat table or drawing board, set the guide rail R , (Fig. 4 and 3) by means of the trams (T), parallel to the line of abscissas, then to follow the performance curve with the pointer P of the integrator, taking the initial and final readings on the dial M .

The range of the commercial type instrument as illustrated is 13 inches, *i. e.*, $6\frac{1}{2}$ inches each way from the line of abscissas, and the longitudinal range is limited only by the length of the rail. A 5-ft. rail is quite common; in case of extra long charts the record can be subdivided in sections, the moment of each about the line of time to be determined separately, and then added together. Their sum is the value M , to be inserted in expression (5).

Let us assume now that the load of the electrical

device under consideration changes its sign, *i. e.* the parts of the duty cycle curve lie above as well as below the zero line OC (Fig. 5). For instance, an electrical machine may work part time as a motor and part time as a generator. How should the integrator be used in this case?

The moment of the combined area $ODBECO$ is the difference of moment of ODB minus the moment of BEC . The integrator will automatically make the subtraction if we follow its pointer along the curve in the same direction *i. e.* clockwise (shown by arrows on Fig. 5A) or counter-clockwise. For example, if the moment of ODB equals in value the moment of BEC the total moment is zero and the dial M of the integrator will return to its initial positions.

On the other hand, it is obvious that the heating of the motor is not lessened by the fact that part of the time it is carrying a negative load, *i. e.* it acts as a generator. It is necessary therefore to add (instead of subtracting) the moments of ODB and of BEC .

In order to do this the point P of the integrator should follow the curve as shown on Fig. 5B, and not as on Fig. 5A. It will be readily seen that in this case the positive part of the duty cycle curve is followed in clockwise direction, but the negative part in counter-clockwise direction (or vice versa). Thus the separate moments are added, which is exactly what is necessary.

Hence, the simple and general rule, applicable to any duty cycle curve:

Follow the curve with the integrator pointer in the same order as the graphic meter would have drawn it; then return to the starting point following the line of abscissas.

The operation of the integrator is as simple and as self-evident as that of the ordinary planimeter. Its application for root-mean-square calculations is apt to make these quite simple and done in only a fraction of the time previously required. Another good point of this method is that it involves the use of already existing, highly developed and well-known devices.

Japanese-American Radio Circuit

BY C. W. LATIMER

Associate, A. I. E. E.

The radio telegraph circuit between the United States and Japan is operated continuously carrying a large portion of the transpacific telegraph traffic.

When the recent disastrous earthquake devastated Tokio and Yokohama the radio service was not interrupted. The first news of the disaster came to the United States over this radio circuit

THE Iwaki Radio system owned and operated by the Japanese Government, Department of Communications, comprises a transmitting station at Haranomachi and a receiving station at Tomioka. These two towns are on the east coast of the main island, Hondo, of the Empire of Japan in Tuckushima prefecture. Tomioka is 155 miles by rail to the north-east of Tokio and Haranomachi is some 23 miles still farther north.

The general location of these stations was determined by the comparative freedom of the district from seismic disturbances.

The transmitting antenna at Haranomachi is of the umbrella type, supported by a self-supporting central tower and an outer ring of 18 spliced, guyed wooden masts at a radius of 1300 feet. The central tower is a reinforced concrete tube 660 feet high, 57 feet in outside diameter at the base and 14 feet outside diameter at the top. The walls are 33 inches thick at the base and 14 inches thick at the top. An iron ladder is mounted inside the tube giving access to the top. The reinforcing steel is not electrically bonded or grounded.

The wooden masts in the outer ring are 250 feet

and for several days thereafter the most complete despatches describing the extent of the losses and damage came by radio.

The writer recently returned from Japan where he was engaged as a representative of the Radio Corporation of America in cooperative work with Japanese engineers at the Iwaki station.

The following is a description of the Japanese stations working with America as they exist at the present time.

high and consist of three sections. The bottom section contains two poles in the form of a narrow inverted V. A system of counterweights at each mast maintains proper tension on all antenna wire tail ropes.

The umbrella wires, 54 in all, are No. 7/15 S. w. g. silicon bronze, each 1000 feet long. Thus, each wooden mast supports three antenna wires, a simple triatic system being employed to secure uniform spacing of the antenna wires. The antenna capacity is 0.031 μ f.

There are two downleads each consisting of 18 No. 7/15 S. w. g. wires in a plane, varying from 10 to 30 feet in width. They are supported at the top of the tower from either end of a steel crossarm structure. Stays attached to the downleads at about the 300-foot level serve to swing them well out from the tower. This is done to reduce to a minimum their capacity to the reinforcing steel of the tower. The umbrella is split into fully insulated halves, each half being served by one downlead. The downleads are tied together at the entry to the power house. The tuning coils are located inside the power house.

The ground system centers just outside the power house about 350 feet away from the base of the concrete tower. It is in two sections. One consists of 50 sets,

each of 8 copper plates 1 by 1½ in., buried on edge in an 8-foot diameter circle at a radius of 100 feet. The other section consists of 200 wires, No. 7/15 S. w. g. copper, buried in pairs in trenches two to four feet deep. They enter the ground, four together, at a radius of 100 feet from the center. Most of the wires are about 900 feet long over all, but on the side towards the tower the length was increased to a maximum of 1280 feet to bring the edge of the ground system there under the rim of the umbrella. In the opposite direction the ground wires extend some 300 feet beyond the rim of the umbrella.

The power house was originally all frame construction but later, because of a fire, the end containing the high-frequency apparatus was reconstructed with concrete walls and slow-burning floor and roof. The powerhouse centers about 350 feet away from the base of the concrete tower.

The high-frequency generators are two arcs rated 500 kw. each, one being a spare. The normal input is about 350 kw., 270 amperes at 1300 volts. Induction motor generator sets, rated 400 kw., 267 amperes at 1500 volts d-c., convert 3500-volt 60-cycle three-phase a-c. power supply into d-c. for arc supply.

The arc is keyed by a form of magnetic amplifier shunting a small inductance coupled with the aerial tuning coil. The arrangement, as applied, is somewhat wasteful of power as its losses are considerable, but improvements are in progress.

The antenna current averages about 165 amperes. The effective height has been measured as 108 meters. The antenna resistance, total, exclusive of the keying system effective resistance, is 1.08 ohms at 14360 meters.

The construction of the station was commenced during the war when steel was scarce and expensive. The estimated cost of a central steel tower was so high that re-inforced concrete construction was resorted to as a matter of economy. Mr. Wakamatsu is the Chief Engineer, in charge.

The receiving building at Tomioka is a long frame structure in three sections. The west section contains batteries, motor generator set and switchboard; the center section, offices, storeroom and workshop; the east section, test room, radio room and telegraph rooms.

Prior to December 1922 the antenna system used for commercial reception from the RCA station, KGI, at Kahuku, Hawaii, was a large two-turn rectangular loop 1200 feet long and about 200 feet high suspended about 100 feet above ground at either end from a guyed, spliced, wooden mast. A similar single-turn loop was used for reception of a small amount of government business from the U. S. Naval station, NPM, at Pearl Harbor, Hawaii. A large inverted L antenna was sometimes used in winter when conditions were favorable, but the combination of this antenna and the loop to give the cardioid diagram of reception had not been used. Self-heterodyne receivers of Japanese design were used. They were unshielded.

During the Summer of 1922 a Rice-Beverage wave

antenna 10 miles long and directed on Kahuku was constructed by the Japanese Department of communications according to RCA specifications. In conjunction with one of the RCA long-wave, high-power receivers the wave antenna was placed in commercial service in December 1922, by the writer, with highly gratifying results.

There are four wire lines between Tomioka and Haranomachi for control of the arc transmitter and for communications. Two wire lines connect Tomioka with Tokio and carry the entire transpacific radio traffic. One of these wires is normally extended from Tokio to Yokohama some twenty miles south, allowing Yokohama traffic to be handled direct with Tomioka. The other wire terminates at Tokio. Traffic for all other cities in Japan and Korea is relayed at Tokio.

Two wires from Tokio to Sendai, a city about seventy-five miles north of Tomioka, pass through the Tomioka station and are available in case of emergency. Sendai is an important repeater location—all domestic traffic between Tokio including points south and east of Tokio and the north end of Hondo and the island of Hokkaido, pass through it. The trunk lines between Sendai and Tokio pass well inland from Tomioka along the main line of the railway.

The normal operating staff of Tomioka consists of Mr. K. Yonemura, the Superintendent, one receiving engineer, nine radio operators, one machinist, one clerk and a number of laborers and servants. Nine cottages are available for the married men and two large houses for the unmarried men. All are constructed in Japanese style.

BIG WATER POWER PROJECT IN INDIA

An application has recently been made to the Government of Madras for the sole right to develop electric energy from the Pykara river in the Nilgiri Hills of South India. It is proposed, according to advices to the Department of Commerce, to construct a dam 150 feet high across the river forming a lake which will have a storage capacity of 6,000 million cubic feet with a catchment area of 38 square miles. The water from the lake will be conveyed by an aqueduct one mile in length, on the right bank of the river, to a forebay and from there through a pipe line to the power house situated at the bottom of the gorge. The project is so outlined that the tail water, after use, will be allowed to flow into the Moyer river. As the Moyer river flows through a deep gorge, the establishing of another power house is contemplated at a suitable point to generate electricity by the further fall of the river from the deep gorge.

A total of 50,000 horse power which is expected to be generated under the present scheme together with its future possibilities. The power obtained is to be utilized for electrochemical industries and electrical reduction of ores.

The Production of Porcelain for Electrical Insulation—VII

BY FRANK H. RIDDLE

Associate, A. I. E. E.

Champion Porcelain Company, Jeffrey-Dewitt Insulator Company

Review of the Subject.—Plant control check tests are of importance primarily to the manufacturers of a product. These tests are, however, of considerable importance to the consumer. The lower a manufacturer's losses are, the cheaper his production costs will be. As high losses are caused by defects in the product it is evident that the fewer pieces there are with noticeable defects in them, the fewer pieces there will be that have minor defects in them that will escape detection even with the most careful inspection. Tests that will pick out the pieces that have these minor defects are of great importance to the consumer.

Porcelain should be non-porous and tests which will make it possible to cull porous pieces are of paramount importance. If the fuchsine dye penetration method is to be used for this porosity test the selection of the test specimens must be made in a definite and dependable manner. If the firing of the porcelain is not done in a uniform manner so that the location of the pieces most likely to be porous are definitely known the test of any one piece would be of no value and it would obviously be impossible to test every piece.

Where a continuous car tunnel kiln is used and the cross sectional area is relatively small the selection of the proper test specimen is not only possible but has been used successfully for several years.

A recent development for testing disk insulators comprises a mechanism for subjecting each of the insulators under test to a pull test of 5000 pounds for two minutes, and simultaneously subjecting the pieces to the high-frequency oscillator test. This eliminates

any doubt as to whether the porcelain would resist the two tests when applied at once.

A petrographic study of thin sections of various porcelains is of great interest, in fact it is essential if the manufacturer or consumer desires to know something of the structure of the product, the extent to which the pyrochemical reactions have progressed and what the variations are from time to time.

Several photomicrographs of various types of porcelain are illustrated. These are selected from a wide variety of wares in order to show the various steps in the development of different qualities of porcelain.

The unlike thermal expansion and contraction of various porcelain ingredients is undoubtedly the cause of some of the deterioration of aged porcelain. It is evident that if some of the particles in the porcelain are under stress due to their tendency to contract more than the surrounding glassy matrix during cooling, after firing, there will be a tendency for these particles to rupture and break down in order to relieve this local strain. One of the illustrations shows this very well.

Overfiring causes the development of gases in the body at a stage when the glassy matrix is in a molten condition. Continued firing causes expansion of the gases and results in the development of a vesicular structure. The degree of overfiring governs the size of the vesicles and the extent to which they have become interconnected. Too glassy a structure also develops brittleness and is to be avoided. Overfiring is well illustrated in Fig. 50.

CERAMIC TESTS ON FINISHED PRODUCT

IN the manufacture of porcelain, if the quality of the product is to be maintained, it is absolutely necessary that control tests be made at every step in the manufacturing process and that the tests on the finished product be reliable. If tests are to be reliable the selection of the specimen for test is of paramount importance.

Tests of this character, particularly the plant control tests, are of interest chiefly to the manufacturers themselves. The consumers' greatest interest is in the tests of the finished product. If tests on manufacturing processes are made in such a way that the plant manager can analyze the reasons for various losses, they should also be of interest to the consumer as he knows they tend toward lower cost of manufacture and also lessen the chances for defective pieces passing through the final inspection. The higher the losses are in the factory the more pieces there are going through production with minor defects which tend to lower the percentage of perfect pieces, and the greater are the number of pieces which appear perfect and yet have minor defects.

It is not the intention of the writer to deal with any of the tests of finished insulators as regards their electrical characteristics. There are several important tests, however, of a ceramic nature which are essential to the successful manufacture of vitreous porcelain.

Porcelain of this character must be free from me-

chanical strains, absolutely vitreous and non-absorbent and must have a high physical strength and as uniform a texture as possible.

Since it is possible to fire porcelain so rapidly that the outside is vitreous and non-absorbent and still have it porous in the heart it is necessary to devise tests to determine this condition in a positive manner. If the firing is erratic so that it is impossible to pick out the most porous pieces for test, it is evident the test is of no value unless each piece is tested. This is obviously impossible. The only thing to do under the circumstances is to see to it that the firing is right. It is the writer's opinion that this is impossible with periodic kilns, excepting in very rare cases. It is possible, however, with properly constructed and fired tunnel kilns. Reasons for these statements have been previously given.¹

Fig. 38 shows the method of unloading a Dressler kiln car of fired insulators and placing them in crates for inspection. It has been shown that because of the small cross sectional area and the method of firing a tunnel kiln the lowest temperature and consequently the greatest chance for underfiring occurs in the bottom of the center bung of ware on the car. It is obvious that if a piece of ware that has been fired in this location is non-porous, every other piece of ware on the car is also non-porous. In using the method of unloading

1. See Part VI.—"The Production of Porcelain for Electrical Insulation" under the caption "Uniformity of Heat Treatment".

that is illustrated, the crate used is of such a cross sectional area that one horizontal layer of insulators taken from the car will nicely fill the cross-sectional area of the crate. A layer of insulators is removed from the car and laid flat in the crate and in the same relative position to the other insulators in the same layer as it was on the car. This layer is covered with a stiff piece of beaver board. Then the second layer is unloaded from the car and placed on top of the first layer in the crate in the same manner and this is repeated until the car is completely unloaded and the center insulator from the bottom row of ware on the car is placed in the center and on top of the ware loaded in the crate.

This insulator, which is obviously the lowest fired insulator of any on the car is selected by the inspector as the piece to test for porosity. There are several methods of accomplishing this test. In the writer's opinion the fuchsine dye penetration test is the most satisfactory. This consists of breaking the specimen

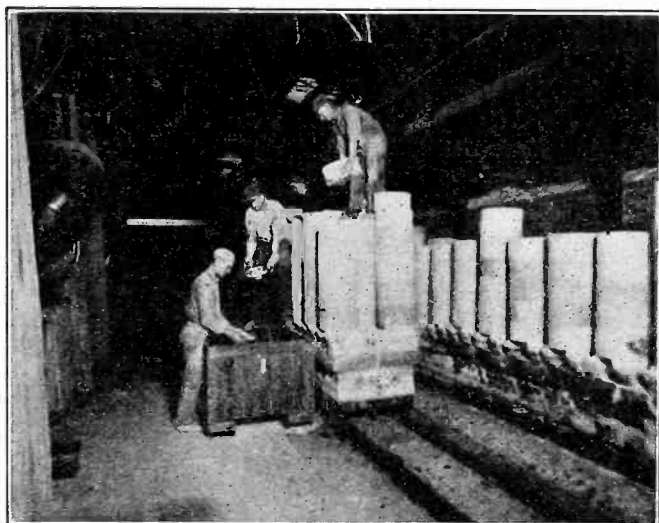

FIG. 38

Illustrating the method of unloading a kiln car of fired insulators layer by layer and placing them in proper order in crates so that those insulators from the bottom of the car which are the first to show underfiring, if there be any, are on the top layer in the crate where they can be easily located for the porosity test.

into pieces and selecting those pieces for test that are the nearest the center or heart of the piece. Obviously this part of the insulator would show underfiring if any part would.

Fig. 39 illustrates the fuchsine dye penetration equipment as regularly used at one of the insulators plants. This consists of a cast steel pot of suitable size, so arranged that when the broken porcelain test pieces are placed in it and the cover is clamped on, a solution of fuchsine dye in alcohol can be pumped in and a pressure of 200 lb. per square inch maintained over a period of two hours. The pot is large enough to hold the test samples from one day's run. Each piece is properly marked before it is tested. Alcohol is capable of absorbing air so that the colored alcohol easily displaces any air entrapped in the porous part of

the porcelain if there be any. When the specimens are removed from the pot after testing, they are placed in a dryer and all alcohol thoroughly dried out, thus preventing it from running over the surface when the pieces are broken to see if there has been penetration. The slightest sign of penetration can readily be seen as the porous parts are stained red. Fig. 40 shows a

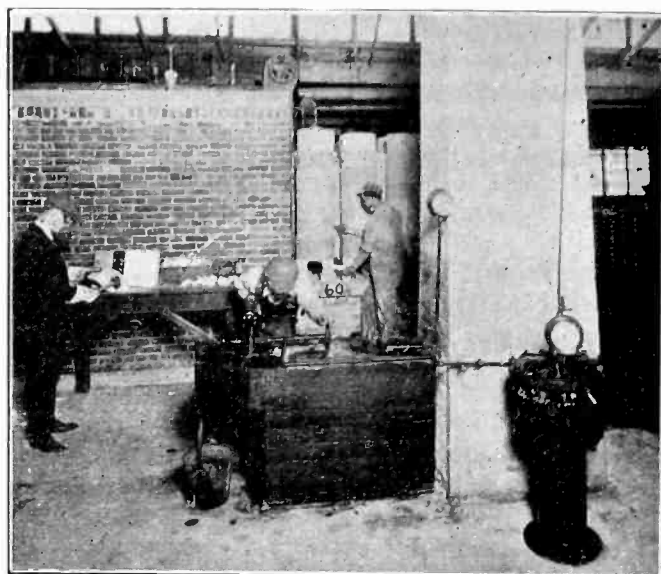

FIG. 39

Fuchsine dye penetration pressure pot in which the broken insulator test specimens are tested for porosity. No car of ware drawn from the kiln is released for final inspection and assembly unless it has successfully passed this test.

broken specimen of porcelain that failed in this test with a second sample that did not fail. As the porcelain is white and the dye red the contrast is much greater than the illustration indicates.

If there should be any penetration on any of the test blocks the car from which the piece was selected is 'stopped,' the remainder of the cars being sent on for

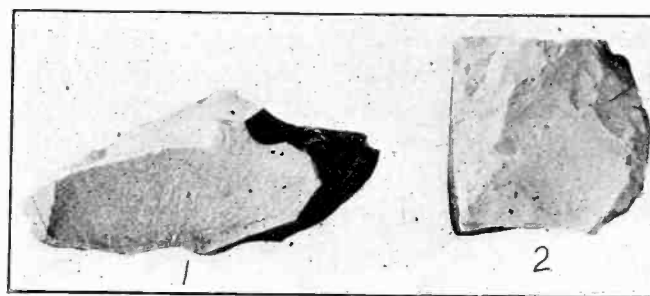

FIG. 40

Two broken porcelain test specimens after having received the penetration test. No. 1 has failed as shown by the penetration while No. 2 has not failed.

visual inspection. All of this first row of insulators are rejected. A second test insulator is taken from the car on which the first failed or showed penetration. This second test piece is the one from the center bung of ware and in the row directly above the first test piece and it is the piece most likely to be underfired of all those in the second row. If the test specimen from

the second row is free from penetration the balance of the car of ware is passed for final inspection and assembly. If, however, it shows penetration, this row is also rejected and a third test made. If the third test is a failure, the entire car of eight rows is rejected.

The outside edges of the top saggars on each bung are exposed to the greatest heat, hence the skirts of the top insulators are the first ware to show overfire. Overfire naturally occurs in the most exposed and thinnest part of the insulator first and can be detected by small blisters on that part of the ware. These blisters can be seen much more easily when clear transparent glazes are used than they can when opaque glazes are used. The blisters are a surface indication.

cases will find an outlet to the surface. Fig. 50 shows the formation.

The fuchsine dye penetration test is not dependable for detecting overfire unless the voids have become interconnected as the walls of the voids are vitreous and gas tight. Overfiring in itself is not so serious as underfiring; however, it should be avoided, particularly if bad, as it indicates that the pyrochemical reactions have been carried too far and the porcelain is likely to be too glasslike and brittle as compared to properly fired porcelain.

A COMBINED MECHANICAL AND ELECTRICAL TEST

Although it is not the purpose in this article to

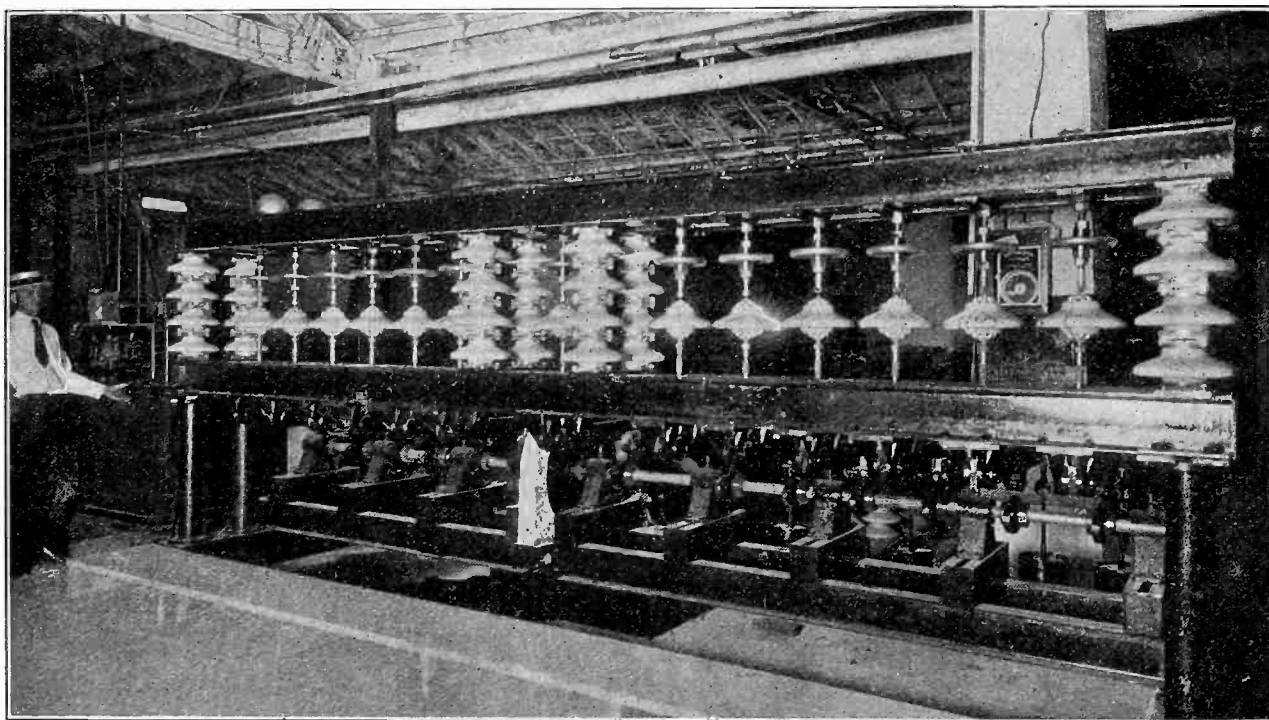

FIG. 41

A combined mechanical and electrical testing rack where assembled insulators receive their final test before being arranged into strings and crated.

When an overfired piece is broken open it will show many voids usually along places horizontal to the surface. The depth these voids go into the body of the porcelain depends entirely upon the degree of overfiring. When a piece of porcelain overfires it causes an evolution of gas from some of the particles comprising the porcelain. As these gases are trapped in the vitreous glasslike mass, they cause bubbles, the size of the bubbles depending on the viscosity of the mass and the pressure of the gas. The pressure of gas increases of course, as the temperature rises after the gases have been generated, due to the expansion of the gas. The bubbles are naturally larger near the surface, particularly where glazed, as the glaze tends to soften the surface of the body somewhat and make it less viscous. If overfiring continues, several small voids eventually form one large void and in some

discuss any electrical tests, it is of interest to mention a recent development in testing apparatus.

Fig. 41 illustrates a combined mechanical and electrical test of 5000 pounds and flashover voltage from the high-frequency oscillator for a duration of two minutes.

THE USE OF THE MICROSCOPE AS AN AID IN THE STUDY OF THE QUALITY AND STRUCTURE OF PORCELAIN

As grain size, degree of solution of the more nearly insoluble particles, the degree of development and character of sillimanite and freeness from foreign matter and voids all have an effect upon the finished porcelain, it is evident that an examination of these qualities should be made by all parties interested. This can be best done by use of the petrographic microscope either by examining the powdered porcelain,

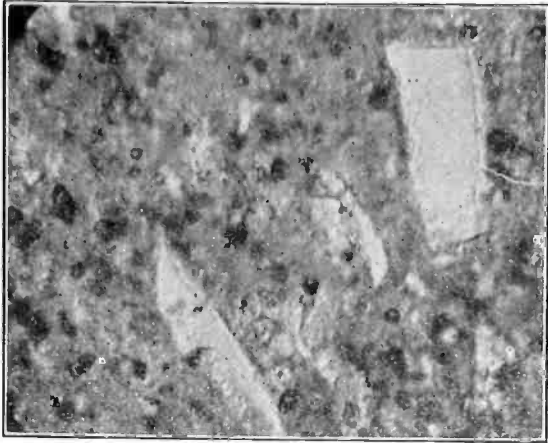

FIG. 42

Magnified 50X. Photomicrograph of a commercial high-tension insulator of rather poor quality burned at cone 10. The large angular grey areas are quartz grains. The balance of the field is made up of more particles of quartz not so easily distinguished as well as clay partially dissolved in the feldspathic glassy matrix.

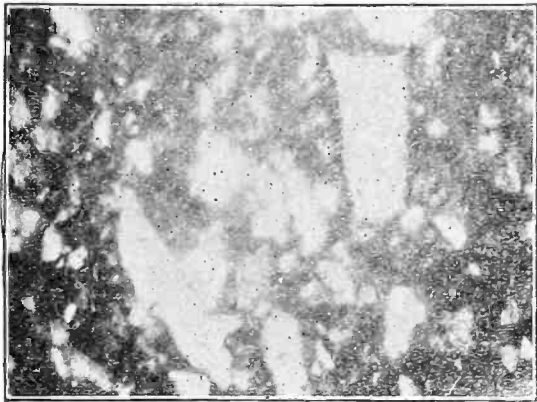

FIG. 43

The same slide photographed with crossed nicols (Mag. 150X) the quartz is not extinguished under cross nicols and can thus easily be distinguished as compared to grains of other material that are extinguished. Note how much more quartz can be seen here than in the previous photograph of the same area.

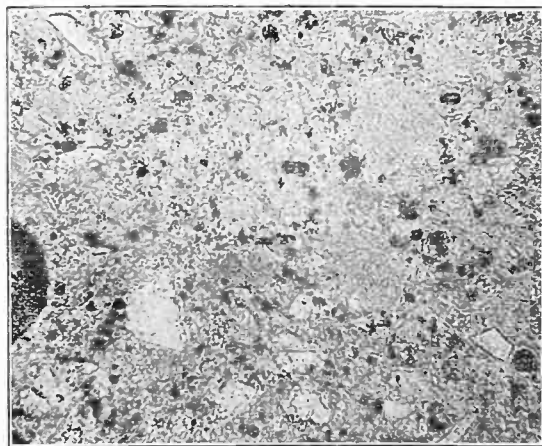

FIG. 44

Mag. 150X. Photomicrograph of a commercial high-tension insulator of a high standard of quality and fired at cone 12 down. A few angular quartz grains are noticeable but they are much smaller altho not any more rounded or dissolved in the glassy matrix than are those shown in figures 42 and 43. Also note the uniform dark grey fields. These are large, fairly uniform fields of amorphous and crystalline sillimanite. The proper development of sillimanite in a body is to be sought as it is an indication of high mechanical strength and is the result of proper firing at fairly high temperature. The character of the glassy matrix and the temperature of firing both have a marked effect upon the growth and character of the sillimanite.

or preferably by examining thin sections cut from the porcelain. These sections are usually 0.001 inch in thickness.

The accompanying series of photomicrographs has been selected with a view of illustrating several different types of porcelain from a poor quality insulator porcelain to a high grade spark plug porcelain.

Figs. 42 and 43 are photomicrographs of a coarse-grained high-tension insulator porcelain. The average porcelain is better than these but they are shown to

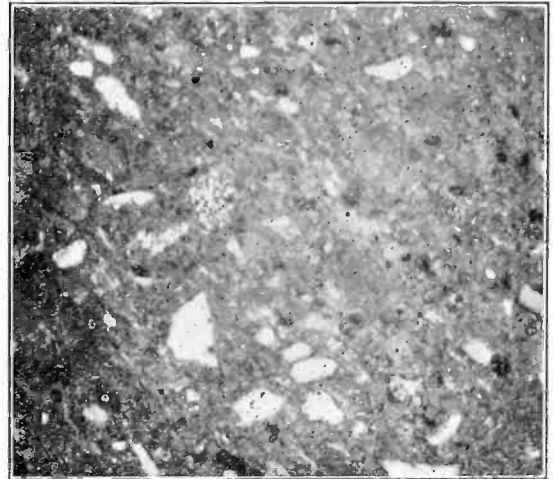

FIG. 45

The same as Fig. 43 but under crossed nicols. Note how clearly the quartz grains are distinguishable. Also note the large uniform areas of amorphous and crystalline sillimanite.

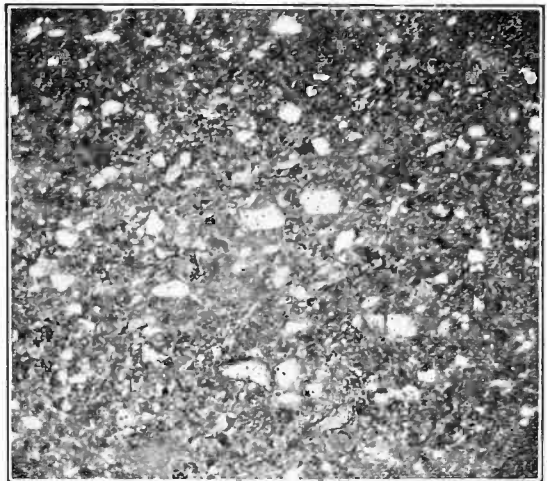

FIG. 46

Photomicrograph (Mag. 150X) of an extremely fine ground triaxial or flint, feldspar, clay porcelain fired at cone 12 down. This is one of the first improvements made in porcelain for spark plugs and it is of finer quality than any porcelains used at the present time for high-tension insulators. This is taken under crossed nicols as the quartz is shown more easily than under plain polarized light.

illustrate what will result if the fineness of grain of the raw materials is not checked where the body is prepared from coarse materials by blunging or disintegrating in water rather than by grinding.

Figs. 44 and 45 illustrate a porcelain rather above the average, particularly in its sillimanite development.

Figs. 46, 47 and 48 illustrate what can be accomplished

by the use of more active fluxes than feldspar, proper grinding and increased temperature.

The development of sillimanite and solution of the components of the porcelain takes place only very slightly at cone 9 to 10 even under the best of conditions. There is a definite increase in this development that starts at cone 12 down and continues rapidly as the

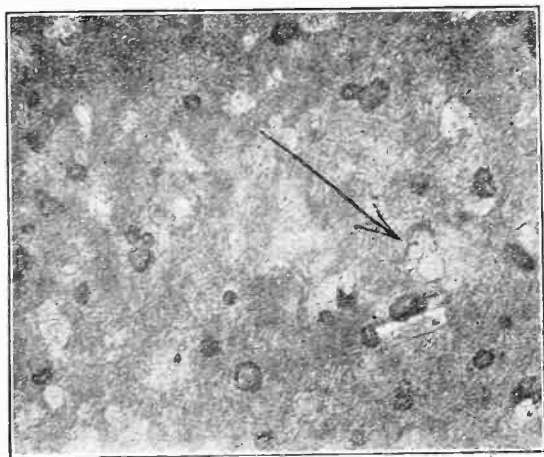

FIG. 47

Photomicrograph (250X) of a cone 13 porcelain containing not only feldspar or alkali fluxes but also alkaline earth fluxes, talc and whiting. It also has a low content of flint or quartz. Note, however, that not only on account of the quality of the flux but also the temperature of firing and the degree of grinding the quartz is practically all dissolved in the glassy matrix. Only one piece of quartz can be found and it, as indicated by the arrow, is well rounded off showing considerable solution. Needles of sillimanite are easily distinguishable throughout the field. The magnification of this photograph 250 diameters is much greater than the previous ones (150 diameters) and yet it appears much more uniform in quality.

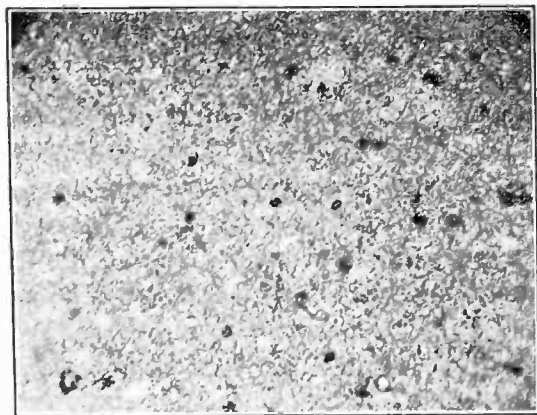

FIG. 48

Photomicrograph (Magnified 150X) of a fine ground cone 17 spark plug porcelain made up of a mixture of clay, natural sillimanite and alkaline earth flux. This is a mass of sillimanite in a glassy matrix. The slide from which this photograph was taken was only two thirds as thick as those from which the other photographs were taken and yet it is very much less transparent. The reason for this is the extremely fine network of interlaced crystals. The black specks are particles of grinding powder which have lodged in the porcelain during the preparation of the thin section. This porcelain has more than twice the mechanical strength of the ordinary porcelain.

temperature increases. At cone 17 to 18 the development is remarkable. There is a noticeable difference in insulators fired from cone 9 to 10 and those fired at cone 12 D.

The mechanical strength of a porcelain depends more upon the temperature to which it is burned than

any other one thing. The higher temperatures produce the stronger bodies. It is evident from this that the tendency among the manufacturers is going to be to increase their burning temperatures and increase the fineness of grinding of the body ingredients. This

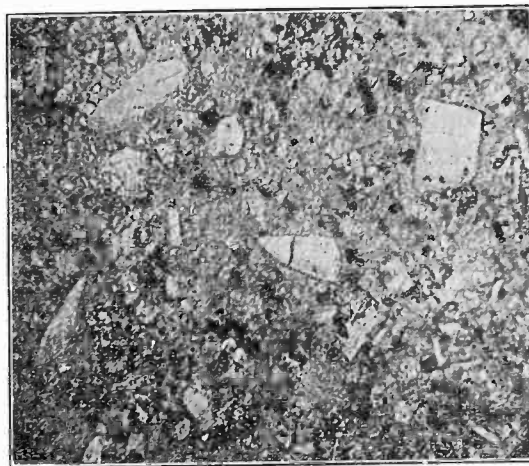

FIG. 49

Photomicrograph (Magnified 150X) of a high-tension insulator porcelain in which a grain of quartz has cracked due to the great contraction of quartz in cooling as compared to the surrounding mass. This tendency of quartz to be under constant strain in porcelain no doubt accounts for some of the deterioration of aged porcelain.

will mean a greater cost but the quality of the ware will still warrant the increase.

Fig. 49 is of particular interest. Note the triangular-shaped quartz grain in the center of the field. This piece is cracked into two pieces. This is not an uncommon occurrence and it is to be attributed to the

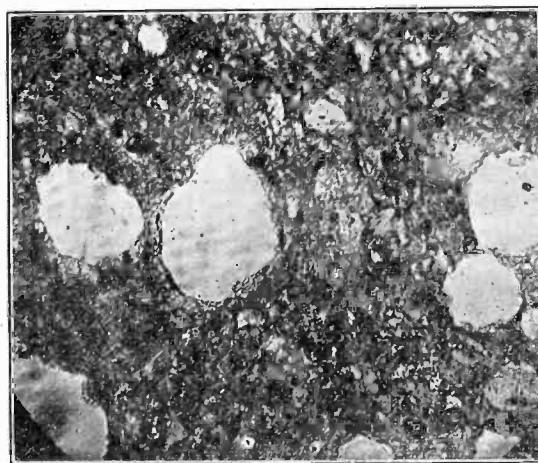

FIG. 50

Microphotograph (Magnified 150X) of a piece of overfired high-tension insulator porcelain. Note the gas voids. Continued overfiring results in these voids joining to form channels or ducts that eventually lead to the surface of the porcelain thus making moisture penetration possible.

fact that the porcelain is under constant strain due to uneven expansion of various parts of the aggregate. As was illustrated in a previous chapter quartz has a very definite and pronounced volume change at 575 deg. cent. which is reversible on cooling. This volume change is much greater than the volume change due to the thermal expansion of the

porcelain mass as a whole. When the porcelain is fired and still at its maturing temperature the mass as a whole must be fairly free from strains as the fluxes are mobile and will adapt themselves to the volume changes of the other particles. As the porcelain cools, however, the flux freezes and as the cooling continues, if there be any difference in contraction between the various parts, strains are bound to result. When 575 deg. cent. is reached the quartz grains contract materially while the surrounding mass does not. The result is obvious. In some cases the grains actually rupture. In other cases there are many fine relief cracks around the grains. These are only noticeable under high magnification. It is to be expected that this constant strain will bring about a certain de-

terioration as the porcelain ages and it is quite likely that deterioration due to ageing can be at least partially explained by this condition.

Fig. 49 is an excellent illustration of how overfiring produces gas voids in the porcelain. As this overfiring continues the increase in voids and their interconnection occurs more and more rapidly until finally some voids will run from deep down into the body of the porcelain to the surface. Severe overfiring is bound to result in failure.

The writer wishes to express his thanks to Dr. Joseph A. Jeffery for his cooperation and criticism in preparing these articles, also to Mr. A. V. Bleininger for his suggestion and criticism, and to Prof. Albert Peck for preparing the photomicrographs.

Facts About Priest Rapids

The Largest Possible Hydroelectric Development in the United States West of Niagara Falls

BY HENRY J. PIERCE

President, Washington Irrigation and Development Co., Seattle, Wash.

THE Priest Rapids of the Columbia River are located a little south of almost the exact center of the State of Washington. The four principal cities of the far northwest—Portland, Seattle, Tacoma and Spokane—having an aggregate population of about 800,000, are each "as the crow flies" about 150 miles distant from Priest Rapids. The main lines of the Chicago, Milwaukee and St. Paul R. R. crosses the Columbia at Beverly, 14 miles above the foot of the Rapids. The Great Northern R. R. crosses the river at Trinidad, 40 miles north, and the Northern Pacific, the Union Pacific System and the Spokane, Portland & Seattle R. R. cross the river at Pasco, 60 miles south. A branch of the Milwaukee is now in operation along the River from Beverly, past Priest Rapids to Hanford, a distance of 40 miles. An extension of this line is projected north to Trinidad and south to Pasco which will give Priest Rapids the service of four of the great transcontinental railroads: The Great Northern, the Chicago, Milwaukee and St. Paul, the Northern Pacific and the Union Pacific System.

The Columbia is the twelfth largest river in the world, and second largest in the United States, and carries a greater annual volume of water than the Mississippi at Memphis. Its drainage area above Priest Rapids is estimated at 95,000 square miles. The river is navigable from the Pacific Ocean to the foot of Priest Rapids, a distance of 400 miles. With the installation of locks and a dam at Priest Rapids navigation will be extended for a further distance of 130 miles into the interior of the State of Washington, to within 110 miles of the Canadian Border. The Columbia is now navigable for ocean going vessels for 120 miles from its

mouth, and for 1000-ton river steamers and barges from that point to Priest Rapids. Therefore, with one change of bulk, water transportation can be had to and from Priest Rapids and any port of the world.

The Columbia falls 90 feet in 9 miles at Priest Rapids, and the installation of the dam and power plant, which it is proposed to build at foot of the rapids, will develop 400,000 primary, all the year round—horse power—and during the high water stage of the river, from the middle of March to the middle of October an additional amount of 300,000 secondary power may be produced. The flow of the river during the low water period averages 50,000 second feet, and during the summer months it reaches over 400,000 second feet. The average flow of the Niagara River is but 250,000 second feet. The dam will be 90 feet high and two miles long—the longest in the world; longer than the Assouan dam in Egypt.

The valley of the Columbia from Wenatchee to Pasco, a distance of about 100 miles, with Priest Rapids lying about midway, is for the most part a desert silent land. The rainfall is but 4 inches per annum. The soil is a rich volcanic ash which, given water, will produce every crop which can be grown in the temperate zone. At an experimental ranch at Priest Rapids, the Egyptian long fibre cotton as well as the ordinary grade of southern cotton has come to full fruition by the middle of September—sugar beets, tobacco, peanuts, soy beans, sweet potatoes, every kind of vegetable, flax, barley, rye, wheat and corn have given wonderfully abundant crops. Alfalfa has yielded four cuttings to the season. There are 300 days in the year of sunshine. The summer days in that northern locality are long; while the nights are pleasantly cool, the days are hot—a dry, not

unpleasant heat, but it makes corn grow nine feet high. There in that silent valley lie hundreds of thousands of acres of parched thirsty land only awaiting water to become one of the richest agricultural districts in the world. And washing the shores of that land flows the mighty Columbia, and the rushing rapids of the river contain the power necessary to raise the water to the land. It is providential that the river is at its flood during the irrigation season. For, without calling upon or diminishing the primary power, it furnishes during the growing season an abundance of cheap secondary power, and water for agricultural purposes. One horse power is required to pump water sufficient for two acres.

The low water period west of the Cascade Mountains occurs in the summer which is the high water period at Priest Rapids. Therefore, it is proposed to build a transmission line 110 miles long from Priest Rapids to connect with the already interconnected lines of the power plants located west of the Cascades which supply electric energy to Seattle, Tacoma and the western portion of the State, and to transmit one hundred thousand Priest Rapids secondary power to make up the summer shortage which is now supplied by steam plants which lie idle for the remaining eight months of the year, and in the winter which is low water period at Priest Rapids and high water west of the Cascades, sufficient power can be transmitted to Priest Rapids from west of the cascades if made necessary by any unusually low water stage, whereby to stabilize and always keep uniform Priest Rapids 400,000 primary power. Thus two uses are provided, agricultural and transmission, which will absorb 300,000 secondary horse power to be developed at Priest Rapids. It is most remarkable that this region should itself furnish use for this immense output of secondary power, while not requiring at the outset the primary power.

It is the ambition of those who are to undertake the development of this power project to induce the building of an industrial and commercial city at Priest Rapids—to make it the Niagara Falls of the west. No large city exists at present between Seattle and Spokane, a distance of over 300 miles. Priest Rapids, almost exactly half way between and in the center of the great Columbia valley, is the logical location for a large town. The irrigation of vast tracts of nearby rich farming lands will make it the center of a great agricultural community, and its jobbing business should be very considerable. But the development of 400,000 cheap primary horse power dependable for every day in the year should make Priest Rapids the great manufacturing city of the northwest. It would have the railroad service of four transcontinental railroads, and cheap water transportation via the Columbia to the Pacific Ocean and thence to the Atlantic Seaboard via the Panama Canal, and to all parts of the world. Ever increasing freight rates are bound to localize manufacturing. The cost of transportation across the continent furnishes a differential which would mean

protection from eastern competition, and profit to the manufacturer. The present population of the far western states as given by the census of 1920 is as follows:

Arizona.....	333,903
California.....	3,426,861
Idaho.....	431,866
Montana.....	548,889
Nevada.....	77,407
New Mexico.....	360,350
Oregon.....	783,389
Utah.....	449,396
Washington.....	1,356,621
Total.....	7,768,682

Not a great population to be sure when compared with that of the older eastern portion of the country, but the growth of these nine Pacific Coast States is bound to be relatively the fastest growing part of the United States from now on. The public domain consisting of 768,000,000 acres, an area larger than all the United States east of the Mississippi River, is contained within these states. They contain also 70 per cent of the water power resources of the Country. The manufacturers who locate at Priest Rapids will have for their export market half the population of the world which faces us across the Pacific. Practically none of the great staples are now manufactured on the Pacific coast. Not a ton of pig iron is made there though 1,200,000 tons of finished iron and steel products were consumed there last year. A report has been made by a well known expert as to the practicability of establishing an iron and steel industry at Priest Rapids which shows that pig iron and steel can be produced there to compete successfully with eastern products delivered in this field. As is well known half a horse power per ton is required in turning pig iron into completely finished products. Here, therefore, is apparently a use for a large amount of the primary power to be produced at Priest Rapids. It is proposed to coke the coal used by industries at Priest Rapids in by-product ovens. This will mean a Semet-Solvay plant. It will also provide the gas for heat in production of glass and pottery, none of which is now made on the Pacific Coast. All the ingredients for glass making exist in quantity within a few miles of Priest Rapids. The projectors of the power project own a limestone deposit, of which it is estimated ten million tons are in sight, and 300 samples taken from different parts of the property average 98½ per cent pure carbonate of lime—there are also large deposits of soda, sodium sulphate and soda carbonate in Grant County in which Priest Rapids is located. This material is used in making glass and pottery. It is estimated that the consumption of glass in Washington and Oregon alone, exclusive of window and plate glass, is 2000 carloads annually, all of which is shipped from the east.

It is the desire of those who have the Priest Rapids project in hand to see a diversified use of the power—

a diversity of manufacture, whether much or little power is used.

The following are among the metallic and non-metallic substances which exist in the far northwestern states and in British Columbia, and within 500 miles of Priest Rapids:

Antimony	Nickel	Alunite	Clay, vitrifying
Chromium	Platinum	Arsenic	" cement
Cobalt	Quicksilver	Clay, common	Coal
Copper	Silver	" china	Diatomaceous Earth
Lead	Tungsten	" fire	Feldspar
Manganese	Vanadium	" pottery	Fluorspar
Molybdenum	Zinc	" porcelain	Fullers Earth
Garnet	Limestone	Quartz	Sandstone
Graphite	Marble	Soda	Sulphur
Gypsum	Mica	Silica	Talc
Infusorial Earth	Phosphate Rock	Soda Carbonate	Timber products
Kaolin	Pyrites	Sodium Sulphate	

It is hoped that Priest Rapids power will be used for many electrochemical and electrometallurgical purposes; for the manufacture of abrasives and ferro-alloys; the refining of steel, the treatment of zinc, lead and other minerals electrolytically; the manufacture of wood pulp and paper from the vast stands of wood pulp timber existing within 135 miles of Priest Rapids; cement, calcium carbide; flour from the wheat of the wheat fields of eastern Washington. Ninety per cent of the 3,000,000,000 tons of high grade phosphate rock estimated to exist in the United States is contained within the states of Idaho, Montana and Wyoming. It is thought that quantities of ammonia phosphate may be produced at Priest Rapids, principally for export. Over 100,000 tons of crude phosphate rock was shipped to Japan during 1920.

All necessary rights and permits for development of the Priest Rapids water power have been secured from the State and Federal Governments. The power site and the 7000 acres of land, which will be overflowed by the installation of the dam, have been purchased. The company also owns ten thousand acres of land extending along both sides of the lake which will be created by the building of the dam, and including three miles of river frontage below the dam. This affords ample area for location of factories, railroad yards and docks, and for the building of the industrial city of Priest Rapids.

Extensive exploration of the bed of the river under the dam site is now being made through diamond drilling to a depth of 400 feet, and with the work about one-half completed (Feb. 1, 1922) the results are entirely satisfactory, showing solid rock foundations. The Priest Rapids water power project is the largest in the United States with the exception of the power possibilities of the Niagara and St. Louis rivers. Hydroelectric power can be produced at Priest Rapids as cheaply as at any point upon the American continent. Cheap power in great quantity, combined with water transportation to any port in the world, affords an almost unequalled opportunity for industrial use, largely in connection with the electric furnace where the cost of power is a principal factor.

ILLUMINATION ITEMS

By the Lighting and Illumination Committee

ILLUMINATION—PRODUCTION TESTS IN THE INDUSTRIES

Recently conducted illumination-production tests covering a wide diversity of operations in various industrial plants demonstrated in a larger field than ever before the value of higher intensities of illumination and more uniform distribution of light. Among the tests shown in Table I, special interest is attached to the result of the investigation recently made in the United States Post Office Department. In that investigation conducted by the Office of Industrial Hygiene of the United States Public Health Service, it was definitely ascertained that when 8 foot-candles of illumination replaced the 3.6 foot-candle level, there resulted an average increase of 4.4 per cent in the work of the letter-separators.

Average figures can serve to give only a very general indication of the results that may be obtained by providing higher levels of illumination in industrial plants. Averaging the results of these nine tests, however, shows that raising the initial illumination from about 2 foot-candles to a value of 11 results in an increase in production of over 15 per cent, and this result is produced at the low additional cost of about 2 per cent of the payroll.

To the definite and tangible production value which can be expressed in terms of dollars and cents, modernizing a lighting system adds value to the plant by preventing accidents, lessening eye strain, raising shop morale, and bettering conditions generally. The plant in which the workmen are handicapped by poor lighting is carrying an extra burden in meeting the competition of other plants which are equipped with lighting systems supplying abundant, properly distributed, well diffused light.

Shop	Average foot-candles with old system	Average foot-candles with new system	Increase in production with new system	Additional lighting cost in per cent of payroll
(a) Pulley Finishing.....	0.2	4.8	35%	5%
(b) Soft Metal Bearing...	4.6	12.7	15%	1.2%
(c) Heavy Steel Machine...	3	11.5	10%	1.2%
(d) Carbureter Assembly...	2.1	12.3	12%	0.9%
(e) Jute Spinning.....	1.5	9.0	17%	No data
(f) Plant Mfg. Elec. Gas.. and Sad Irons.....	0.7	13.5	12.2%	2.5%
(4.0 at tool point)				
(g) Semi-Automatic Buffing Brass Shell Sockets.....	3.8	11.4	8.5%	1.8%
(h) Mfg. Piston Rings....	1.2	18.0	25.8%	2%
(i) Letter Separating....	3.6	8.0	4.4%	0.6%
Average.....	2.3	11.2	15.5%	1.9%

Table I—Production Increases due to Modernized Lighting in various Industries. The tests were conducted at: (a) Pyott Foundry Company; (b) Foote Bros; (c) Lee Loader & Body Co; (d) Stromberg Carbureter; (e) Dolphin Jute Mills; (f) Dover Mfg. Co.; (g) General Electric Co.; (h) Detroit Piston Ring Co.; (i) U. S. Post Office Dept.

NEW PARABOLIC LENS FOR MOTION PICTURE PROJECTION

New Development Broadens Application of Incandescent Lamp Projection in Moving Picture Theaters

For many years condenser lenses have been made in either of two ways: Molded as is the prismatic lens used in motion picture projection and in railway signal lamps, or ground with plane or spherical surfaces as are the plano-convex lenses, regularly used with arc lamp projectors. For some time it has been known that accurately ground surfaces of other than plane or spherical contour (aspheric surfaces) would permit much better control of the light, but early lenses of this design were so costly that they were not practicable for motion picture condensers.

Intensive development to produce more efficient and less expensive lenses has resulted in the commercial production of the new aspheric condensing lens for use with incandescent lamps (Fig. 1). Not only is better control of the light obtained because of the special parabolic curvatures, but the second element has been made larger than that placed next to the lamp, and utilizes light which is entirely lost with two-element lenses of the same diameter, in which latter case the second lens does not intercept all of the light transmitted by the first.

From 20 to 60 per cent more screen illumination is obtainable with the new lens than with the prismatic-type condenser, the increase depending on the focal length of the projection objective employed. Thus the new lens provides materially increased amounts of

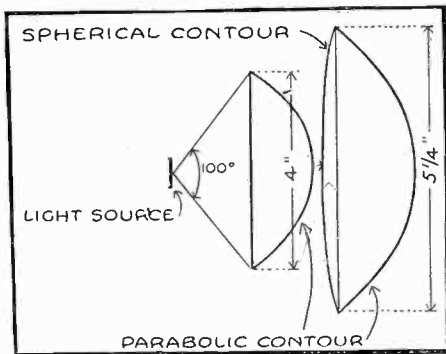

FIG. 1—NEW TWO-ELEMENT PARABOLIC CONDENSING LENS FOR USE WITH INCANDESCENT LAMP PROJECTORS.

light for objectives of any focus, and therefore for any given projection distance and picture size.

With the new type condensers it is possible to produce, for substantially larger picture sizes at greater throws, intensities of screen illumination which have been employed with excellent results on shorter throws with the prismatic condensers. Allowing for the usual larger areas of pictures which are projected longer distances, the new condenser produces, at about 125 feet, the same intensity of screen illumination obtained

at 100 feet with the prismatic condenser. Thus the new lens will find a wide application with the longer projection distances and larger picture sizes where additional light is most needed. These are, in general, throws from 100 to 125 feet or more and picture sizes of from 15 to 18 feet and larger, depending on the amount of light from the auditorium and orchestra luminaires reaching the screen, type of screen employed and angle of projection.

The new development effects a material improvement

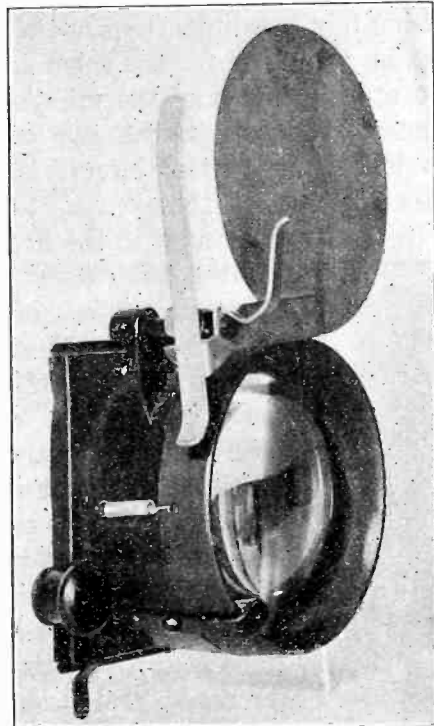

FIG. 2—NEW CONDENSER MOUNTED IN SPECIAL HOLDER FOR ATTACHMENT TO LAMP HOUSING.

in projection efficiency, and is a distinct step forward in the art of motion picture projection with incandescent lamps.

To save the eyes of youth, the American Engineering Standards Committee has appointed the American Institute of Architects and the Illuminating Engineering Society to be joint sponsors for a code governing school lighting that bids fair to correct conditions partially responsible for the defective vision of ten to twenty per cent of American children.

The First Recorded Street Lighting Ordinance dates from London, in 1414, when all citizens having houses on certain streets were ordered to hang lamps before their doors at dark. Penalties were enforced for allowing lamps to go out, the fines being collected by the night watchmen. In Paris, municipal street lighting began in 1558 when pitch in stone urns was lighted at dark.

REMOTE CONTROL OF MULTIPLE STREET LIGHTING

W. T. DEMPSEY
New York Edison Co.

Adoption of the multiple system for street lighting circuits in many cities has prompted the design of various types of devices for remote control of these circuits. One type of switching device offering many advantages is illustrated in Fig. 1.

The branched glass tube contains mercury, which is connected by the two inner leads to the load circuit. The longer central branch of the tube contains a plunger of approximately the dimensions of the center tube, which acts as an armature for the solenoid shown surrounding the upper portion of the middle tube. The solenoid is energized through the two outside leads. When the solenoid or control circuit is closed, the armature lifts up out of the central tube and the mercury in the horizontal part of the tube flows into it, thus breaking the load circuit.

Opening the control switch drops the armature forcing the mercury out of the central tube and completing the circuit between the two outer tubes. All circuits are made and broken in the mercury stream flow; pitting of contact points is eliminated. The additional advantage is apparent that the circuit is made and broken within a sealed chamber. Movable flexible leads, primary and secondary contacts, etc., are eliminated, the rise and fall of the solenoid armature controls the entire switch.

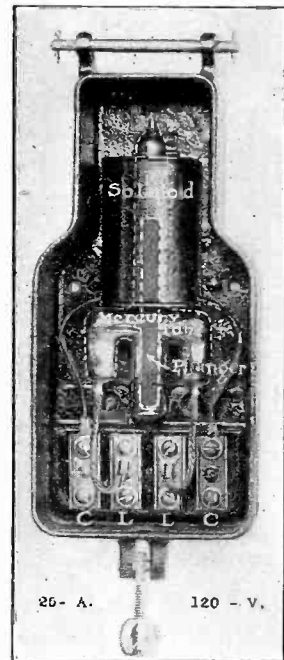

FIG. 1

This device can be used for low-tension multiple street lighting systems where the source of supply is either a-c. or d-c. When the load is d-c. either one or two wires may be run from the switch to the controlling station, but when the load is a-c. two wires must be used, as the device operates on direct current.

The diagram Fig. 2 illustrates the method of wiring. To provide against the remote possibility that the control wire be made alive accidentally, the signal bell shown at Station B is installed. When a section of the street lights is cut out, the signal bell rings and the operator is automatically notified. If the control wire is cut accidentally between stations, thus cutting off a section of wire from Station A's control, this dead section could be controlled from Station B by throwing the single-pole double-throw switch. This would energize the control wire between Station B and the point of break.

Thus in the daytime, the switch control circuits are energized, and all street lamp circuits are open. In the event that the control circuits are broken in the ducts, the street lights would be turned on automatically and any necessary repairs could be made without sacrifice of street illumination. This feature circumvents the usual serious consequences of dark streets when switching circuits are disturbed.

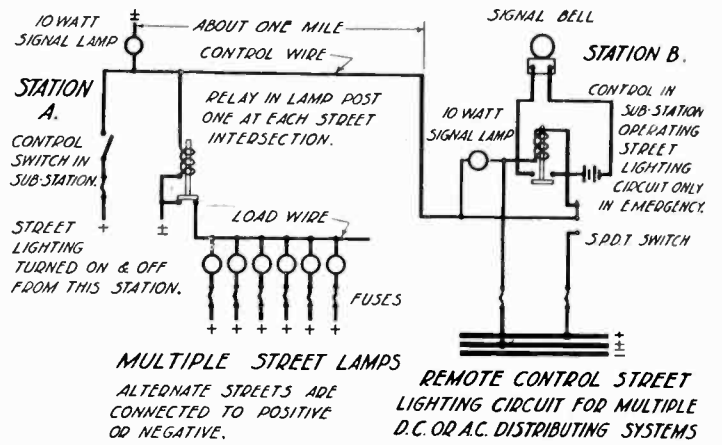
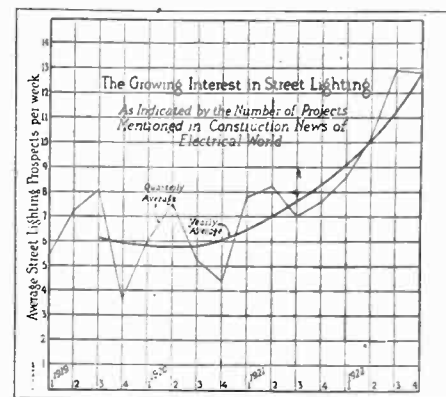

FIG. 2

This system of remote control has been in successful operation for more than five years on a street lighting installation of some 8000 lamps.

GROWING INTEREST IN STREET LIGHTING

In each issue of *Electrical World* under the heading "Construction News" is published a list of electrical projects, plans, bids, and contracts, contemplated or actually under way. This list, compiled from reports



from every section of the country furnishes a bird's eye perspective of activity from coast to coast. An analysis of these listings for 1919, '20, '21, and '22 clearly shows the remarkable and consistent growth of interest in street lighting. The average number of street lighting projects mentioned per issue is plotted by quarters in the light weight line of the accompanying chart. The heavy line, averaged from the same data, shows the yearly trend.

JOURNAL OF THE American Institute of Electrical Engineers

PUBLISHED MONTHLY BY THE A. I. E. E.
33 West 39th Street, New York
Under the Direction of the Publication Committee

HARRIS J. RYAN, *President*
GEORGE A. HAMILTON, *Treasurer* F. L. HUTCHINSON, *Secretary*

PUBLICATION COMMITTEE

DONALD McNICOL, *Chairman*
L. W. W. MORROW E. B. MEYER
F. L. HUTCHINSON L. F. MOREHOUSE

GEORGE R. METCALFE, *Editor*

Subscription. \$10.00 per year to United States, Mexico, Cuba, Porto Rico, Hawaii and the Phillipines; \$10.50 to Canada and \$11.00 to all other countries. Single copies \$1.00. Volumes begin with the January issue.

Changes of advertising copy should reach this office by the 15th of the month for the issue of the following month.

The Institute is not responsible for the statements and opinions given in the papers and discussions published herein. These are the views of individuals to whom they are credited and are not binding on the membership as a whole.

Institute's Publication Policy Amended

Elsewhere in this issue is printed the report of the Publication Committee which inaugurates several definite changes from the policy heretofore followed in the publication of the JOURNAL and the TRANSACTIONS. It has been apparent for several years that the constant growth of Institute activities and the increasing number of papers presented at our conventions would result in an accumulation of material for publication too great for the space limitations of a monthly JOURNAL of reasonable size. This condition has been reached during the present year. With only two more monthly numbers available this year, there remain several hundred pages of convention papers and discussions yet unpublished, as well as a large number of acceptable contributions to the JOURNAL. It therefore became imperative for the Publication Committee to take some action to relieve the situation, and at its first meeting this year it promulgated the policy and rules outlined in its Report, on this page.

In formulating these rules, the committee was guided by a certain fundamental requirement, *viz.*, every paper published by the Institute is to be available in full without cost to every member who wants it. With this consideration in mind it is confidently expected that the changes inaugurated will meet with the hearty approval of the membership, inasmuch as the new policy offers everything in the line of publications to which the members have been accustomed and in addition creates space in the JOURNAL for much diverse and valuable material for which there has long been an insistent demand.

Future A. I. E. E. Meetings

PACIFIC COAST CONVENTION

When this issue of the JOURNAL reaches many of the members the Pacific Coast Convention will be in progress in Del Monte, Calif. It is expected that a large attendance will be attracted to Del Monte by the various aspects of transmission and hydroelectric power offered in the program, as well as by the generous time allotted for enjoying sports and the unusual beauty of scenery afforded by that part of the country.

MIDWINTER CONVENTION

Philadelphia has been chosen for holding the Midwinter Convention, which will take place February 4-8. The subject of railroad electrification will be emphasized, and it is planned that two sessions will be devoted to reviewing the present status of electrification, and prospective plans for electrification as outlined by some of the foremost railroad men in the country.

A feature promising special interest will be a celebration of the 40th anniversary of the A. I. E. E. at which talks by some of the founder members of the Institute on historical reminiscences of the early days of the A. I. E. E. will be given.

SPRING CONVENTION

Plans are being made to hold the Spring Convention in Birmingham, Ala., during the week of April 7th. Hydroelectric development, steel mill and mining applications of electricity will be subjects under discussion.

ANNUAL CONVENTION

Evanston, Ill. has been recommended as the meeting place for the Annual Convention, which will be held during the last week in June. Details of program and entertainment features have not yet been worked out.

Report of Publication Committee

To the Executive Committee of the A. I. E. E.

A meeting of the Publication Committee was held at Institute headquarters, New York on the afternoon of August 30, at which various matters relating to Institute publications and related topics were discussed. It developed that, as one result of the present policy of holding four general conventions each year in addition to the several hundred meetings under the auspices of Sections, there are now more papers accepted for presentation than can be published in full in the JOURNAL, unless the number of pages and the consequent cost are considerably increased. There are already available for publication more 1923 convention papers and discussions than can be printed in full in the remaining issues of the JOURNAL for the present calendar year unless the usual appropriation is materially increased. Some of these very valuable papers are so long that in one respect they are unsuitable for publication in full in the JOURNAL because such publication would restrict the contents of the issues in which they appear to a few subjects, and would crowd out other material that would otherwise provide the diversity of interest that is essential to satisfy the demands of the membership.

A large proportion of the contents of the JOURNAL consists of highly theoretical and mathematical papers, which, while extremely valuable contributions, nevertheless are of interest to a very limited portion of the membership, whereas more than 20,000 copies of each issue of the JOURNAL are now published, and for several years past there has been a constantly increasing demand voiced by the membership through individual letters, committee and Section meetings, and otherwise, for the publication of a larger proportion of engineering papers and material of a different nature.

The Directors had also referred to this Committee the action taken at the Swampscott Convention, June 1923, by the Section Delegates who voted to approve a suggested plan whereby highly theoretical and mathematical papers shall be interpreted in abstract form in the JOURNAL, published in full in pamphlet form for distribution to members who indicate their desire for them, and also in full in the annual TRANSACTIONS, thus bringing about a wider reading of such papers by interesting a greater number of members by means of the interpretative story, and at the same time making available more space in the monthly JOURNAL for other engineering material of more general interest.

The following recommendations are made by our Committee, the vote being unanimous in each case:

Journal, Transactions and Pamphlets

1. That all papers presented at Institute conventions be published in full in pamphlet form for use at the conventions and for distribution to members on request.

2. That papers exceeding about eight pages in length, or almost wholly mathematical, shall not be published in full in the JOURNAL, but that an abridged version to be furnished by the author, not exceeding about 4000 words, be published in the JOURNAL with a statement that the complete paper will be furnished without charge in pamphlet form to any member upon request.

3. That mathematical papers be written in two parts: (1) a readable and complete explanatory version of the subject without mathematics, which may be published in the JOURNAL, and (2) a mathematical appendix which will not necessarily be published in the JOURNAL.

4. That the contents of the TRANSACTIONS be selected from the convention and other papers of the year, and that the papers which were abstracted in the JOURNAL be printed in full in the TRANSACTIONS, articles omitted from the TRANSACTIONS to be referred to in the index.

It is our belief that the adoption of the procedure outlined above will enable this Committee to carry out much more completely and definitely the policies recommended by the Development Committee and the Editing Committee in 1919, and which were definitely approved by the Directors at that time and announced in the first issue of the JOURNAL in its present form in January 1920.

The present By-laws of the Institute provide that the Publication Committee shall have supervision of the publications of the Institute "including decisions regarding the publication of papers, discussions and of other matter available for publication and the formulation and carrying out of plans for bringing into practise the policies regarding publications that may be determined from time to time by the Board of Directors."

While this Committee therefore has authority under the By-laws to make changes in procedure, nevertheless inasmuch as, to the greater portion of the membership, the Institute publications undoubtedly constitute the principal benefit of membership, the Committee hereby reports its views and recommendations to you and requests your approval of the procedure as outlined herein to take effect immediately in order that the work under the supervision of this Committee may be kept within the bounds of the usual appropriations.

Respectfully submitted,

PUBLICATION COMMITTEE

F. L. HUTCHINSON

E. B. MEYER

L. F. MOREHOUSE

L. W. W. MORROW

DONALD McNICOL, Chairman.

The Executive Committee of the Institute has approved the above report and adopted all the recommendations embodied therein. The procedure outlined is therefore now in effect.

Future Section Meetings

Vancouver.—October 19, 1923. Dinner meeting to receive report of Pacific Coast Convention of the A. I. E. E.

November 9, 1923. Speakers: Messrs. Youill and Moo.

December 7th. Plans yet to be made.

Dinner in Honor of L. A. Ferguson

Louis A. Ferguson, vice-president in charge of operation of the Commonwealth Edison Company, has been in the service of that and predecessor companies thirty-five years. At the Drake Hotel, Chicago, on the evening of September 12, 1923, three hundred Edison men who have been associated with him upwards of ten years commemorated the event with a dinner in his honor. A memento presented at the time was a book of morocco and vellum containing the signatures of a thousand men and women who have served with him for a decade or more. Another remembrance of the anniversary and presented to him at the dinner was an eight-piece silver service, the gift of the signers of the book.

During the thirty-five years that Mr. Ferguson has been either in direct or general charge of the company's operating work he has made many valuable contributions to the development of the business. To him belongs the credit of being the first central station engineer in this country to recommend the present system of generating three-phase alternating current with transmission lines to substations containing rotaries converting the current from alternating to direct for general distribution. That system has proved a great economy in the operation of the business, one that has made possible the great electric power developments in the large cities of this country.

Likewise, Mr. Ferguson is responsible for the adoption of the system of differential light and power rates now largely employed in this country, known as the Wright Demand System. This system is universally admitted to be the most equitable method of charging for electric light and power service.

In the early years of his career, Mr. Ferguson was especially successful in the negotiation of long term contracts for light and power with some of Chicago's largest mercantile establishments. Some of these are in force today.

Mr. Ferguson was one of the pioneers of the electric vehicle industry, early recognizing the importance of building up the "valley" of the power station load by charging electric vehicles at night. He was one of the founders of the predecessor company to the present Walker Vehicle Company.

Incidentally, Mr. Ferguson is one of the two men who has been president of three national engineering societies. He served two terms as president of the Association of Edison Illuminating Companies, one with the National Electric Light Association, and one with the American Institute of Electrical Engineers. He is a lecturer on the staff of engineering schools, notably Purdue, the University of Wisconsin and his alma mater, Massachusetts Institute of Technology.

Meeting of the Institute of Radio Engineers

The next meeting of The Institute of Radio Engineers will be held on the evening of Wednesday, October 10th, 1923, at 8:15 p. m., at the Engineering Societies Building, 29 West 39th Street, New York City.

A paper on "New Applications of the Sodian Detector" will be presented by Mr. H. P. Donle of the Connecticut Telephone and Electric Company.

Power Exposition Grows in Scope

The Power Exposition to be held December 3-8, 1923, at the Grand Central Palace, New York City, is expected to be even a greater success than the one held in 1922. Up to the middle of August, 90 per cent of those exhibiting in the 1922 show had engaged space for this year.

An advisory committee to conduct the supervision of the exposition is headed by I. E. Moulthrop, of the Edison Illuminating Company of Boston, who will be assisted by a committee of fourteen men prominent in various aspects of the power industry.

Third Annual Convention of West Virginia-Kentucky Association of Mine Mechanical and Electrical Engineers

On October 19-20, 1923 the West Virginia-Kentucky Association of Mine, Mechanical and Electrical Engineers will hold their third annual convention at the Frederick Hotel, Huntington, W. Va. Technical sessions will be held in the morning and afternoon of October 19th, and in the morning of October 20th. There will be a luncheon and inspection trip in the afternoon of October 20th.

AMERICAN ENGINEERING COUNCIL

POWER CONFERENCE PUSHED BY U. S.

O. C. Merrill, General Chairman of the American Section of the World Power Conference, reported, upon his return from Europe, that the plans for the conference were being matured, as a result of the very satisfactory arrangements which he and Mr. Challies, Chairman of the Canadian Committee, had made. It has been decided to hold the conference, beginning July 1,

next, and continue for 7 to 10 days, according to the development of the program.

A tentative program was adopted at a meeting of national chairmen in England, after which Mr. Merrill and Mr. Challies went to Paris to secure French cooperation.

The general program will cover power resources, production, distribution, utilization and a general discussion. The first division is considered to be of interest to the whole conference and will cover a general survey of national power resources, available and utilized power resources and their administration, as well as the consideration of the electric power market from the standpoint of the central station, industry, chemistry, transportation, etc.

EXECUTIVE BOARD OF THE F. A. E. S. TO MEET IN ROCHESTER

According to instruction of the Executive Board, the next meeting will be called in Rochester on October 12 and 13. The Rochester Chamber of Commerce assisted in making the plans, and engineering organizations in the city will be invited to a public meeting which will be held Friday noon, October 12, at which time a member of the Board will address the meeting.

Among other important reports to be received at this meeting will be those from the Reforestation Committee, a report on the progress of Storage of Coal study and a report on recommendations for re-districting of the United States so as to secure equitable representation by regional directors on the Executive Board.

Engineering Societies Library

The library is a cooperative activity of the American Institute of Electrical Engineers, the American Society of Civil Engineers, the American Institute of Mining and Metallurgical Engineers and the American Society of Mechanical Engineers. It is administered for these Founder Societies by the United Engineering Society, as a public reference library of engineering and the allied sciences. It contains 150,000 volumes and pamphlets and receives currently most of the important periodicals in its field. It is housed in the Engineering Societies Building, 29 West Thirtieth St., New York.

In order to place the resources of the Library at the disposal of those unable to visit it in person, the Library is prepared to furnish lists of references to engineering subjects, copies or translations of articles, and similar assistance. Charges sufficient to cover the cost of this work are made.

The Director of the Library will gladly give information concerning charges for the various kinds of service to those interested. In asking for information, letters should be made as definite as possible, so that the investigator may understand clearly what is desired.

The library is open from 9 a. m. to 10 p. m. on all week days except holidays throughout the year except during July and August when the hours are 9 a. m. to 6 p. m.

BOOK NOTICES, (AUGUST 1-31, 1923)

Unless otherwise specified, books in this list have been presented by the publishers. The Society does not assume responsibility for any statements made; these are taken from the preface or the text of the book.

All the books listed may be consulted in the Engineering Societies Library.

LE CORRENTI ALTERNATE INDUSTRIALI.

By T. Jervis. Torino-Genova, S. Lattes & Co., 1923. 261 pp., 10 x 6 in., paper.

A textbook for students of electrical engineering dealing with the more common problems of the transmission and utilization of alternating currents, in which the underlying scientific principles are presented concisely and the simplest, most rapid methods of calculation are explained.

FOREST RESOURCES OF THE WORLD.

By Raphael Zon and William N. Sparhawk. 1st edition. N. Y. & Lond., McGraw-Hill Book Co., 1923. 2 v., maps, tables, 9 x 6 in., cloth, \$12.00.

An inventory of forest resources in all countries. In order to make it possible to compare different countries, an attempt has been made in every case to show the forest area, annual growth and annual cut, and to make deductions from these factors as to

the forest resources of the different countries. The topics discussed for each land are: Forest area; character and distribution of forest; character of ownership; annual growth; annual cut; exports and imports; domestic consumption; progress in forest conservation; and the probable future. A mass of useful information, hitherto widely scattered, is brought together and conveniently summarized. References to sources of information are included.

MINING ELECTRICIAN'S HANDBOOK.

By Lionel Fokes. Wigan, Eng., Thomas Wall & Sons, 1923. 414 pp., illus. diags., 8 x 5 in., cloth. 10s 6d.

The author of this book has had several years' experience in the installation of electrical equipment in the South Wales coal field and in coal mining. His book is intended to provide mine electricians, managers and engineers with a practical treatise on electricity, setting forth simply the fundamental principles that underly the operation of electrical apparatus, and giving hints on its maintenance under mining conditions.

PETROLEUM RESOURCES OF THE WORLD.

By Valentin R. Garfias. N. Y., John Wiley & Sons; Lond., Chapman & Hall, 1923. 243 pp. maps, tables, 8 x 5 in., fabrikoid. \$3.00.

This volume of convenient pocket size records the salient facts about the producing and prospective oil fields of the world and

about the countries in which the fields occur. The laws relating to petroleum are also set forth.

Sketch maps show the location of the fields and the refining qualities of typical crude oils from all producing fields are tabulated. Tables of measures, etc. are also given. The book will be useful work of handy reference for persons interested in petroleum.

TOWNS AND TOWN-PLANNING, ANCIENT AND MODERN.

By T. Harold Hughes & E. A. G. Lamborn. Oxford, Clarendon Press, 1923. 156 pp., illus. plans, 10 x 8 in., boards. \$5.00. (Gift of Oxford University Press, American Branch).

The authors present an interesting, readable account of the development of town planning from antiquity to modern times, with some discussion of the future. Special attention is given to the development of the British town and village. The book is profusely illustrated with attractive sketches and photographs.

PAST SECTION MEETINGS

Atlanta.—August 30, 1923. Election of officers for the ensuing year, as follows: C. L. Emerson, Chairman; F. B. Davenport, Vice-Chairman; H. N. Pye, Secretary-Treasurer; H. E. Bussey and G. K. Selden, Members of the Board of Directors. Attendance 25.

Chicago.—September 10, 1923. Subject: "Some Aspects of Railway Electrification." Speaker: E. Marshall, Electrical Engineer of the Great Northern Railway Company, St. Paul, Minn. Attendance 215.

Denver.—September 4, 1923. Special meeting in honor of Dr. Chas. P. Steinmetz. A dinner at the Metropole Hotel was attended by 110 members and guests. The meeting was held in the Municipal Auditorium, which had been equipped for the occasion with a public address system for amplifying the speaker's voice, and about 4000 people were present. Dr. Steinmetz gave an address on "The Electrical Power Industry."

Seattle.—May 23, 1923. Election of the following officers: Chas. A. Lund, Chairman; Joseph Hellenthal, Secretary. Clifford E. Mong, Transmission Engineer, Pacific Telephone & Telegraph Company, spoke on "Typical Installation of a Long Distance Telephone Cable." Attendance 58.

Vancouver.—September 15, 1923. Excursion to Stave Falls for inspection of the plant of the B. C. Electric Company.

PERSONAL MENTION

G. H. WIRTH has accepted a position as Electrical Engineer with the Right and Left Tool Holder Company, in Philadelphia, Pa.

GLENN L. ENGLAND is now Distribution Engineer with the Madison County Division of the Illinois Power & Light Corp., in St. Louis, Mo.

R. K. ELLIOTT left, during the summer, for Japan for a three years' stay, where he will work for the International General Electric Company.

E. J. SPENCER has become Vice-President and General Manager of the Brown & Hall Supply Company, 1504 Pine St., St. Louis, Mo.

M. SANDOVAL VALLARTA has accepted a position as Research Associate in mathematical and theoretical Physics at Mass. Inst. of Technology.

G. E. STRINGFELLOW has accepted the position of General Sales Manager of the Edison Storage Battery Company and is now located at Orange, N. J.

E. B. LAMB is now employed by the Illinois Traction System in Peoria, Ill. His previous connection was with the Inland Steel Co., Indiana Harbor, Ind.

L. W. HAYWARD severed his connection with the General Electric Company, to accept the position as Field Engineer for the Benjamin Engineering Company, Cleveland, O.

L. M. DELLINGER has recently been employed by the Otsego Tire and Repair Company, Otsego, Mich. Formerly he was with the Bell Telephone Company of Pennsylvania.

MINTON CRONKHITE, who was formerly Export Manager of Smith, Hogg & Co., New York City, is now President of the Liberty Electric Corporation, of Port Chester, N. Y.

L. R. JONES, formerly Research Assistant at Mass. Inst. of Technology, accepted a position in the Transmission Department of the Public Service Company of Northern Illinois in Chicago, Illinois.

FREDERICK W. CARLSON, who until recently has been with the Westinghouse Electric & Mfg. Co., is now connected with the Skagit River development in the Pacific northwest, as Electrical Engineer.

CARL H. HERMANCE, who was formerly with the United Electric Light & Power Company of New York, N. Y., is now with the Southern California Edison Company, of Los Angeles, California.

CLIFFORD R. BEARDSLEY is now Superintendent of Electrical Construction of the Brooklyn Edison Company. He was formerly Electrical Engineer with Fred L. Ley & Co. of Springfield, Mass.

MATTHIAS J. MAIRES, who was until recently Asst. Switchboard Engineer with the Milwaukee Electric Ry. & Light Co., has become Instructor in Chicago Central Station Institute, Chicago, Ill.

W. E. DOUGLASS severed his connection with the Westinghouse E. & M. Co., Pittsburgh, Pa. on September 1 1923. to enter the employ of the Wisconsin Valley Electric Company, Wausau, Wis.

W. H. CAHOON, has recently formed a connection with McClellan & Junkersfeld, of New York City, as Asst. Electrical Engineer. He was previously associated with C. M. Read of Lansing, Mich.

BERNARD DIBNER has become Designer for the Electric Bond & Share Company, New York City. He was previously connected with the Adirondack Light & Power Company, Schenectady N. Y.

BENJAMIN ROBINSON has resigned his position as Chief Electrician at the plant of the Bristol Brass Corporation, of Bristol, Conn., in order to give his entire time to private research. He is located in Albany, N. Y.

WARD H. SNOOK, has entered the firm of Snook-Hillhouse Company, Consulting Engineers, Columbus, Ohio, as President of that firm. He was previously Inspector of Power Wires, Public Utilities Comm. of Ohio.

ROBERT L. ELTRINGHAM has become Manager of the California Electrical Co-Operative Campaign, San Francisco, Cal. His

previous connection was with the Industrial Accident Committee of California, also in San Francisco.

EDWARD J. GIBBONS, who has been associated with the General Electric Company in its Pittsburgh office for several years, has accepted a position as Chief Electrician with the Halcomb Steel Company, of Syracuse, N. Y.

EUGENE HERZOG has resigned from the employ of the United Electric Light & Power Company of New York City and has accepted a position with the Thomas Research Laboratory, General Electric Company, Lynn, Mass.

ROBERT B. GEORGE, who has been recently connected with the Mississippi Agricultural and Mechanical College, has accepted the position of Professor of Electrical Engineering at Oklahoma A. & M. College, Stillwater, Okla.

ERWIN FLEMING has accepted a position in the Switchboard Engineering Dept. of the General Electric Company of Schenectady, N. Y., having recently resigned from the employ of the Electric Products Company, Cleveland, Ohio.

W. J. WOOLDRIDGE, who until recently was connected with the Whitaker-Glassner Company of Portsmouth, O., has become Manager of the Electrical Sheet Department in the Mansfield Sheet & Tin Plate Company, Mansfield, Ohio.

E. W. OESTERREICH has severed his connection with Wm. G. Woolfolk, Consulting Engineer of Chicago, Ill., to accept a position with the Duquesne Light Company of Pittsburgh, as Superintendent of the Underground Cable Division.

H. L. MOODY has severed his connection with the Westinghouse Elec. & Mfg. Co. of Philadelphia, Pa., where he was Manager of the Central Station Division, to become associated with the U. G. I. Contracting Company, Philadelphia, Pa.

CARL WHITMORE has recently accepted the position of Division Superintendent of Installation, of the Western Electric Company, San Francisco, Cal. His previous work was with the Pacific Telephone & Telegraph Company at Portland, Ore.

N. H. COIT has resigned his position as Superintendent of the Auburn Plant of the Western Public Service Company, Auburn, Nebraska, to take up the duties as Assistant to H. G. Harvey, Commercial Manager of the Pennsylvania Edison Company, Easton, Pa.

CARL J. SITTINGER, who for the past twelve years has been associated with John A. Stevens, Consulting Engineer, of Lowell, Mass., has accepted the position as Senior Engineer in the Division of Engineering and Construction, with Stone & Webster, Inc., in Boston.

SORAB B. DAMANIA, who was formerly Construction Engineer, Andhra Valley Hydro-Electric Power Supply Co., Ltd., Bombay, India, has changed his position to Engineer-in-Charge of the Bombay Electrical Supply and Tramway Company's power house, at Bombay, India.

EUGENE BETTS was recently advanced to Assistant Consulting Engineer, Southern Pacific Company, 165 Broadway, New York City. Mr. Betts was formerly associated with the activities of J. G. White & Co., Ltd. in railway and utilities projects in Central and South America.

RALPH E. DODSON has severed his connection with the Louis A. Robey Company, Consulting Engineers of Cincinnati, O., with which company he has been for three years, and has accepted a position as Electrical Engineer with the Westinghouse Elec. & Mfg. Co. at Cincinnati, O.

ROBERT B. MORTON, recently associated with Tolz, King & Day, Engineers, St. Paul, Minn., as Electrical Engineer in connection with the design and construction of a large steam power plant, has severed his connection with that firm, to accept the position of Project Engineer with Gibbs & Hill, of New York.

W. A. DANIELSON, Major, U. S. A., who has been on duty in the Office of the Quartermaster General in Washington, in charge of maintenance of buildings, roads, maintenance of and operation of utilities at all Army posts and depots, has been transferred to Fort Sam Houston, where he will act in the capacity of Corps Area Utilities Officer for the Eighth Corps Area.

W. E. DOUGLASS resigned from the employ of the Westinghouse Electric & Mfg. Co. Aug. 25, 1923, to accept a position with the Wisconsin Valley Electric Company in the capacity of Electrical Engineer in charge of generating stations and transmission. Mr. Douglass had been with the Westinghouse E. & M. Co. for ten years.

A. B. CAMPBELL is a recent addition to the forces of the National Electric Light Association, in New York City, where his work has to do with the activities in formulation of safety rules with the various state commissions and other regulating bodies. For more than three years he was connected with the Iowa Railroad Commission.

FRANK H. RIDDLE, of the Champion Porcelain Co. and Jeffrey-Dewitt Insulator Company, expects to visit several European countries to inspect ceramic manufacturing plants. While abroad he will attend the International Conference on High-Tension Transmission Lines, which will be held in Paris, Oct. 8, and he will read a paper on the "Relation between the Composition, the Microstructure and the Physical Properties of Porcelain." Mr. Riddle will also visit the newly completed plant of the Compagnie Generale d'Electro Ceramique. This plant was constructed especially for the manufacture of high-tension insulators under the Jeffrey-Dewitt patents.

Addresses Wanted

A list of members whose mail has been returned by the Postal Authorities is given below, together with the addresses as they now appear on the Institute records. Any member knowing the present address of any of these members is requested to communicate with the Secretary at 33 West 39th Street, New York, N. Y. All members are urged to notify Institute headquarters promptly of any change in mailing or business address, thus relieving the member of needless annoyance and also assuring the prompt delivery of Institute mail, the accuracy of our mailing records, and the elimination of unnecessary expense for postage and clerical work.

- 1.—M. G. Bindler, 2 Margaret St., Derby, England.
- 2.—George G. Chow, c/o S. K. Lau, 351a Weihaiwei Road, Shanghai, China.
- 3.—Thomas R. Cummins, Autorite Products Co., Ontario, Calif.
- 4.—Chas. T. Minnich, 2nd & Boylston St., Los Angeles, Calif.
- 5.—Cyrus A. Perkins, 139 Dundas St., E., Toronto, Ont., Can.
- 6.—Richard T. Quaas, 2154 Crotona Ave., New York, N. Y.
- 7.—Oscar A. Schlesinger, 64 Fairfax Ave., Piedmont, Calif.
- 8.—E. D. Simpson, 4104 Agua Vista St., Oakland, Calif.
- 9.—E. Slager, 4149-51 East 79th St., Cleveland, Ohio.
- 10.—V. K. Srinivasaiyengar, No. 554-6 Malleswaram, Bangalore, India.

Employment Service

The Engineering Societies Employment Service is conducted by the national societies of Civil, Mining, Mechanical, and Electrical Engineers as a cooperative bureau available to their membership, and maintained by the joint contributions of the societies and their individual members who are directly benefited.

MEN AVAILABLE.—Under this heading brief announcements will be published without charge to the members. These announcements will not be repeated, except upon request received after an interval of three months, during which period names and records will remain in the active files of the bureau. Notice for the JOURNAL should be addressed to **EMPLOYMENT SERVICE, 33 West 39th Street, New York City.** Such notices will not be acknowledged by personal letter, but if received prior to the 16th of the month will usually appear in the issue of the following month.

OPPORTUNITIES.—A bulletin of engineering positions available will be published and will be available to members of the societies concerned at a subscription rate of \$3 per quarter, or \$10 per annum, payable in advance.

VOLUNTARY CONTRIBUTIONS.—Members obtaining positions through the medium of this service are invited to cooperate with the societies in the financing of the work by nominal contributions. It is believed that a successful service can be developed if these contributions average \$10 for all positions paying a salary of \$2000 or less per annum; \$10 plus one per cent of all amounts in excess of \$2000 per annum; temporary positions (of one month or less), three per cent of total salary received. The income contributed by the members, together with the finances appropriated by the four societies named above, will, it is hoped, be sufficient to increase and extend the service.

REPLIES TO ANNOUNCEMENTS.—Replies to announcements published herein or in the Bulletin, should be addressed to the key number indicated in each case, and forwarded to the Employment Service as above. Replies received by the bureau after the positions to which they refer have been filled, will not be forwarded.

MEN AVAILABLE

ESTABLISHED RADIO MANUFACTURER, ENGINEER, seeks partner, preferably active, or with the view of becoming active, with small capital. References exchanged. Business open to thorough investigation. E-4468.

A YOUNG MAN of 23, single, an Enrolled Student of the A. I. E. E., and a Mason, desires a job with some firm where he will have a chance for advancement. Would like to get in the sales department, but would consider other class of work. Have had one year schooling and two years experience in electricity inside work also assembling fixtures. Am at present employed, but will come at any time. E-4469.

ELECTRICAL ENGINEER, technical graduate, age 27, single. G. E. test experience, army officer during world war, 4 years transformer design. At present employed. Desires position with middle western public utility as transformer expert. Familiar with all of the latest developments in transformers. Would also consider a position with a mid-western college offering a chance for graduate study or sales work in the middle west with a responsible concern. E-4470.

ELECTRICAL ENGINEER. Experienced in overhead construction, estimating costs, electrical distribution, electric meters, inside wiring, power plant efficiency work, steam heading, and combustion. Desires position in the nature of superintendent of public utility, age 36. E-4471.

SALES ENGINEER, JR. EXECUTIVE, ASSISTANT, age 27, desires a position with a good reliable concern, E. E. graduate. Have five years of varied technical experience, and also sales experience. Graduate of business administration course. Initial salary secondary, desires a position with a fighting chance. E-4472.

MANAGING EXECUTIVE, age 44, married. Technical education, electrical engineering, 20 years experience managing public utilities, serving light, power and street railways. Knowledge, capacity and ability in operation and construction of these properties. Tactful, good organizer and successful in public relations. E-4473.

GRADUATE ELECTRICAL ENGINEER, 25 years of age and married, having 3½ years experience in test engineering and power factor correction work. Desires position with growing organization. At present connected with public utility. Accustomed to assuming responsibility and handling men. E-4474.

TRANSMISSION LINE ENGINEER. University graduate in electrical engineering. One year's experience in electrical testing; 7 years in transmission line design and estimating in connection therewith. In responsible charge of work. This experience has been mostly in connection with the structural and mechanical

feature involved. Also experience in connection with the formulation and application of safety rules. Would prefer position in Eastern U. S. E-4475.

ELECTRICAL ENGINEER, Age 36, married. Nine years varied experience. Power house operation and construction also cable testing in factory and N. C. Meter testing. During last eight years experience with gasoline-driven isolated electric lighting plants in capacity of electrical engineer and manager of electrical department. Assoc. A. I. E. E. E-4476.

ASSISTANT ELECTRICAL ENGINEER, 5 years practical experience in design and engineering of substations, transmission, switch gear and protective apparatus. Capable of taking care of design with little or no supervision. Age 27, married. Location immaterial. E-4477.

YOUNG MAN, 28, desires permanent position as assistant to an executive. Good technical education along electrical engineering lines. At present employed by large public utility in the maintenance department. Also 3 years experience in the auditing department of steamship company. Available on short notice. E-4478.

ELECTRICAL ENGINEER, age 30, married. Twelve years experience, holds New York State license. Has specialized in the various phases of public utility accounting requiring engineering knowledge such as valuation, budget systems, job order systems, fixed capital records, financial reports, classification and interpretation of accounts. Considerable power plant construction and operation experience. E-4479.

YOUNG MAN, at present employed as construction foreman and engineer with a concern doing electrical and mechanical contracting desires to make a connection with an engineering firm as engineer. Experience and technical education along lines of electrical and mechanical nature including industrial plant layouts. E-4480.

ELECTRICAL ENGINEER. Experienced in design, construction and maintenance of power plants, substations etc. Desires position with consulting engineers. Penn. State license. E-4481.

ELECTRICAL ENGINEER. Age 34, graduate 1915. Seven years experience along lines of design and construction of light and power distribution systems, high and low-tension transmission lines and stations. E-4482.

RESEARCH ENGINEER, age 30, degree of Sc. D. 10 years' experience in radio and general research with American-European companies. A. M. I. E. E. and M. S. R. E. Would consider connection with respectable concern or as Associate Professor. First class references at hand. Managerial ability. At present head of a commercial laboratory abroad, contract expiring

in October. Understands several foreign languages. E-4483.

TECHNICAL GRADUATE. Having B. Sc. in mechanical engineering, single, and having had several years' experience in drafting and general shop practise, one year assisting in electric laboratory. Desires position with reliable organization or private company, with chance for advancement. Preferably Chicago or immediate vicinity, other locations considered. Junior Member W. S. E. and Enrolled Student, A. I. E. E. Available at once. E-4484.

ELECTRICAL ENGINEER M. S. from M. I. T., in 1922 desires foreign experience in hydroelectric or transmission line design. Has had G. E. test and one year of distribution and transmission line design. Age 25, married. Assoc. A. I. E. E. E-4485.

ENGINEER desires position as assistant to executive. Five years' experience in electrical and mechanical engineering. Five years experience in chemical engineering. Has developed several chemical processes. Technical graduate, M. E. E. 1914, age 33, married. Location preferred, New York City and vicinity. E-4486.

ELECTRICAL ENGINEER is seeking connection with engineering organization as representative in China. Cornell graduate, 2 years G. E. test, and 3½ years office engineering. At present is employed as designing engineer with a prominent concern. E-4487.

SALES ENGINEER. University graduate over eleven years' experience in engineering and business. desires to make connection with representative manufacturers covering Philadelphia, Baltimore and Washington territory. E-4488.

COAL MINING ELECTRICAL ENGINEER. Technical graduate, age 32, married. Experienced in mining and the preparation of anthracite. Familiar with details incident to application of electrical machinery to all kinds of mining. Power plants, substations, transmission lines, hoists, pumps, both types of locomotives and general breaker machinery. Experienced in steel mill maintenance and drafting and general field work. Also experienced in commercial work as power engineer of public utility. Student, Alexander Hamilton Institute. At present employed. Location immaterial. E-4489.

GRADUATE ELECTRICAL ENGINEER: Will go anywhere; ten years' experience in construction, operation and maintenance of steam generating stations, efficiency production of power, meter and installation work. Knowledge of Spanish. Married, age 35. E-4490.

ELECTRICAL AND MECHANICAL ENGINEER. Technical graduate, age 33, with extensive experience in electrification, both design and construction, also operation and

construction of power plants, automatic substations, maintenance of rolling stock, desires position with electric road, power system or consulting engineer. Available immediately. E-4491.

PRODUCTION ENGINEER. Young man competent to assume a position of responsibility in the planning and production control departments of concern manufacturing electrical equipment. Thoroughly versed in modern methods and able to handle men. Assoc. A. I. E. E. and the Soc. Industrial Engineers. E-4492.

YOUNG MAN. Age 23; B. S. and C. E. degrees; 4 years E. E.; was for two years teacher of mathematics, physics and chemistry (evenings) and for three years employed in engineering construction, would like to work evenings for engineer without compensation. E-4493.

ELECTRICAL ENGINEER. Age 30, single. Technical graduate. 7 years' experience G. E. test, investigations and reports on power and transmission problems, relay protection, estimates, rates, etc. Can qualify for responsible position with public utility management corporation, consulting engineering firm or public commission. E-4494.

GRADUATE ELECTRICAL ENGINEER. 1923, B. S. degree in electrical engineering from a Texas A & M. College; 21 years of age and single. Has had no practical experience in electrical engineering but theoretical knowledge. Prefers being with big company owning a chain of plants, receive training and be ultimately in charge of one of these plants. Ambitious, good personality, and good health. Now employed with gas company. Can furnish references as to character and personality. Location, middle west or western states preferred. E-4495.

ELECTRICAL ENGINEER. Age 34, experienced in operating, commercial and executive utility and professional engineering positions. Can handle situations with public and regulatory bodies. Clear record, good references, commercial and mechanical graduate. Married. Health excellent. American. Desires connection with independent utility company or engineering firm in middle or far west. Available at once. E-4496.

MECHANICAL ENGINEER. 1917 graduate. High-tension electrical experience. Transformer manufacture. Bakelite moulding. Acetylene welding. Broad experimental experience. Location New York. E-4497.

EXPERIMENTAL RESEARCH AND DEVELOPMENT ENGINEER E. E. M. E. Ten years varied experience in responsible positions. Especially qualified to organize and direct original research, scientific or commercial. Residence, New York. Location immaterial. E-4498.

BUYER, technical graduate, age 27, desires position in purchasing department of manufacturing concern as buyer of electrical and mechanical equipment. Location preferably New England. Available on 30 days notice. E-4499.

ELECTRICAL ENGINEER. Age 38, with 17 year's experience in design, construction and operation of power and substations, transmission systems, light and power layouts, reports, specifications, contracts, handling economical problems in connection with industrial and chemical plant operations, desires position with a reliable concern.

Fellow and Member of Engineering and scientific societies. E-4500.

ELECTRICAL ENGINEER. Member, A. I. E. E. Licensed engineer, N. Y. State, have 25 years' in office, shop, power stations and high-tension lines, design, construction and operation. Last 7 years engineer for large industrial, three plants-electric furnaces 25,000 kv-a. Previous with hydroelectric stations positions up to 6 years as superintendent 80,000 h. p. rotary stations 45,000 kv-a. Will accept agency for equipment in Western N. Y. E-4501.

GRADUATE ELECTRICAL ENGINEER. With eight years' transmission and distribution engineering experience with power and light utilities desires work with utility company which will develop into executive or managing position. E-4502.

GRADUATE ELECTRICAL AND MECHANICAL ENGINEER. Desires position requiring executive and technical ability. 3 years' industrial and 9 years' public utility experience. Principal work power plants, substations and transmission lines. Well qualified to head a department or fill position of assistant chief engineer of a large public utility 1,200,000 kw. or larger. E-4503.

LICENSED PROFESSIONAL ENGINEER with electrical engineering as his specialty, versatile in allied branches (mechanical, structural, concrete etc.) available for engagement. Successful experience in power station work, design and development of various new machines (electrical and mechanical), research aided by theory and mathematics. Resourceful, reliable, productive in office and field. E-4504.

GRADUATE ELECTRICAL AND MECHANICAL ENGINEER, registered professional engineer and land surveyor, of Pennsylvania. Four years as electrical engineer for public utility holding company, 11 years' diversified engineering and executive work. Desires responsible position in connection with generation and distribution of power or operation of public utility. E-4505.

ELECTRICAL ENGINEER, technical graduate, Assoc. A. I. E. E., has had 18 months telephone inspection work, 6 months power system protection work and 3 months as inspector of station construction, post-graduate study both theoretical and practical, desires a position affording chance for advancement. E-4506.

ELECTRICAL ENGINEER, technical graduate, with six years' experience, three of which have been in industry and three in teaching, desires position with concern manufacturing electrical equipment or appliances. Intensely interested in development work. Location not of first importance. Salary to start \$225. E-4507.

ELECTRICAL ENGINEER, Technical graduate with additional training in railroad work. Eight years' experience on electrical design and supervision of construction on large industrial layouts and power plants. Desires opportunity for permanent position with an electric railway, public utility or consulting engineer. E-4508.

ELECTRICAL ENGINEER Member A. I. E. E., age 31, with seven years' experience as assistant to executives of large public utility company in addition to construction and engineering experience. Graduate B. S. in E. E.,

desires position as local manager of electric utility company in a good town. E-4509.

RECENT GRADUATE A. B. and B. S. in E. E., with some experience in steam electric power plant and ice plant testing, desires employment in central station work. Age 34, married. Present position temporary and permanent opportunity sought. E-4510.

ELECTRICAL ENGINEER Technical graduate, 1912, two years' test and nine years' electric utility experience, commercial engineering construction and maintenance of power houses, substations and transmission lines. Desires responsible position with possibility of ultimate interest in engineering or operating company, immediate partnership with successful engineer considered. References given. E-4511.

METER MAN, six years public utility practise, four year course in middle western state University, age 35, single. E-4512.

ELECTRICAL ENGINEER, 1922 graduate, with experience in indoor and outdoor substations layout, design of transmission powers, switching structures, etc. Desires position in similar or allied work in New York City or vicinity. At present employed. E-4513.

PROTECTION ENGINEER, Technical graduate, age 28, with experience in large public utility dealing with operating problems in General Manager's office and later investigating breakdowns, testing equipment such as fuses, lightning arresters, circuit breakers etc., in engineering department. Desires position with utility as protection engineer or assistant electrical engineer. Salary \$3000. E-4514.

CONSTRUCTION ENGINEER B. S. in E. E., age 25, with three years' experience in construction and maintenance of electrical transmission systems, in power wiring and in cost estimating. Desires position in Chicago with manufacturing or consulting organization. Available November 1st. E-4515.

DEVELOPMENT ENGINEER, experienced designer of electrical and mechanical equipment, with ability as an inventor. Can take complete charge of a proposition from the inception of the rough idea, to putting it into quantity production. In charge of development, research, and material test laboratories. Ten years' experience with motors and generators, equipment similar to signal apparatus, magnetic tests of iron and steel, and other material tests. E-4516.

GRADUATE ELECTRICAL ENGINEER, age 27, married. 2 years' experience in motor sales. Familiar with central station operation. Desires position of responsibility and future opportunities. Prefer location in middle west. E-4517.

GRADUATE MECHANICAL ENGINEER, having five years' experience as an engineering draftsman on special and automatic machinery, structural steel and building work. Desires position where industry and loyalty will be recognized by advancement. Age 26, single, willing to travel. E-4518.

ELECTRICAL ENGINEER, 20 years' experience with large central station company, desires to change location. Experienced in layouts, design and construction of power stations, substations, transmission and distribution systems etc.; also the handling of engineering forces. References from present employers if desired. E-4519.

MEMBERSHIP — Applications, Elections, Transfers, Etc.

ASSOCIATES ELECTED SEPTEMBER 21, 1923

*ALBERTSON, DAN EARL, Asst. Distribution Engineer, East Penn Electric Co., Pottsville, Pa.; for mail, Gloucester City, N. J.
ARIAS, BERNARDO ESTEBAN, Telegraph Line Construction, 3a, Tabasco No. 81, Mexico, D. F., Mex.

BAIN, JAMES WILLIAM, Testing Dept., Canadian Westinghouse Ltd., Hamilton, Ont., Can.

BASFORD, CHARLES REGINALD, Asst. to Chief of Electrical Dept., Underwriters Association, 316 Walnut St., Philadelphia, Pa.

BOULASSIER, RENE PIERRE, Engineer, Pignolet Instrument Co., 76 Greenwich St., New York, N. Y.

*BOURKE, LIONEL JOSEPH, Engineering, Washington Coast Utilities, 618 New York Block, Seattle, Wash.

BURNETT, WILLIAM, Jr., Division Electrician, Peabody Coal Co., Marion, Ill.

- COLBY, JOHN BURNS, Division Traffic Engineer, Western Union Telegraph Co., 1747 Champa St., Denver; res., Wheatridge, Colo.
- CONLEY, DAVID LEE, Switchboard Operator, Alabama Power Co., Muscle Shoals, Ala.
- CORCORAN, THOMAS F., Appraisal Engineer & Public Utility Consultant, 1050 Amsterdam Ave., New York, N. Y.
- CRANDELL, EDWIN DAVIS, Engg. Assistant, Public Service Production Co., Public Service Terminal, Newark, N. J.
- CRESSMAN, CHARLES STREEPER, Asst. to Electrical Engineer, Philadelphia & Reading Coal & Iron Co., Pottsville, Pa.
- CROSS, HARRY, Supervising Engineer, International Western Electric Co., Inc., Wellesley St. P. O., Auckland, N. Z.
- CUNNINGHAM, JOHN OLIVER, Second Engineer, Hawera County Electric Co., Ltd., Power House, Normanby, Taranaki, N. Z.
- DALEY, JOHN JOSEPH, Electrical Draftsman, Electric Bond & Share Co., 71 Broadway, New York, N. Y.
- DAVIS, GREGORY, Chief Electrician, Kentucky Light & Power Co., Fulton, Ky.
- DREYER, HARRY WILLIAM, 2021 Dorchester Road, Brooklyn, N. Y.
- EBERLY, J. CLYDE, Central Station Operator, Firestone Tire & Rubber Co., Akron, Ohio.
- *EITEL, HENRY CHESTER, Inspector, Public Service Co. of Northern Illinois, 911 Church St., Evanston, Ill.
- ENGLISH, WILLIAM COLLINS, Asst. Superintendent, Erie Lighting Co., 129 W. 11th St., Erie, Pa.
- FOLAN, HARRISON G., Dist. Superintendent, New York & Queens Electric Light & Power Co., 2227 Flushing Ave., Maspeth; res., Brooklyn, N. Y.
- FOSTER, ROSS W., Maintenance Supervisor, Western Union Telegraph Co., 433 Worcester Bldg., Portland, Ore.
- FOWLER, WARREN HENRY, Installer, Rochester Telephone Corp., 72 Fitzhugh St., Rochester, N. Y.
- GREER, R. C. L., Resident Engineer, East Penn Electric Co., 2nd & Market Sts., Pottsville; res., Schuylkill Haven, Pa.
- *GREVE, LYMAN F., Engineer, Commonwealth Edison Co., 72 W. Adams St., Chicago, Ill.
- GRIFFITH, GEORGE MILTON, Underground Engineer, Dallas Power & Light Co., Interurban Bldg., Dallas, Texas.
- HAGIS, CARLETON DEANE, Research Physicist, Victor Talking Machine Co., Camden, N. J.
- HALL, FREDERICK LEARD, Foreman-Electrician, Beech Bottom Power Co., Power, W. Va.
- HANSEN, A. FRED, Machinist, Southern Pacific Railroad Co., Dunsmuir, Siskiyou Co., Calif.
- HAWKER, CHARLES, Electrical Draftsman, Metropolitan Board of Water Supply & Sewerage, Sydney, N. S. W., Australia.
- HAYES, WINSTON, Radio Electrician, Camp Alfred Vail, N. J.; for mail, Marietta, Ga.
- HELD, CARL A., Electrical Engineer, Porcupine Davidson Gold Mines, Ltd., South Porcupine, Ont., Can.
- HOFFMAN, SAMUEL O., Industrial Scientific Research, 145 Hyde St., San Francisco, Calif.
- HOGAN, ANDREW ALBERT, Draftsman, Pacific Gas & Electric Co., 17th & Clay Sts., Oakland; res., Berkeley, Calif.
- ILLING, I. L., Illuminating Engineer, The Milwaukee Electric Railway & Light Co., 380 Public Service Bldg., Milwaukee, Wis.
- JERABEK, EMANUEL H., Electrical Engineer, 312 E. 79th St., New York, N. Y.
- KASNICK, CHARLES FRANK, Engineer, Public Service Co., 911 Church St., Evanston, Ill.
- *KENWORTHY, JOSEPH WARDMAN, Salesman, Wagner Electric Corp., 1632 Sanson St., Philadelphia; res., West Philadelphia, Pa.
- KIRBY, FRANK MARTINDALE, Superintendent and Estimator, Edwards Electric Construction Co., 70 E. 45th St., New York; res., White Plains, N. Y.
- KIRKWOOD, ARTHUR CARTER, Student, 1531 Wood Ave., Colorado Springs, Colo.
- LARRALDE, HERNAN, Electrical Engineer, National Power Commission, Isabel la Catolica 28, Mexico City, Mex.
- *LITTLE, EDWIN G., Asst. Electrical Engineer, Industrial Controller Co., 866 Greenbush St., Milwaukee, Wis.
- MENKE, CARL HOBSON, Switchboard Operator, Mississippi River Power Co., Keokuk, Iowa.
- *NORDLING, WILLIAM GUNNAR, Engineer, J. Livingston & Co., Inc., Grand Central Terminal, New York, N. Y.; res., Newark, N. J.
- *NYERGES, WILLIAM STEVENS, Electrical Engineer, National Lamp Works, Nela Park, Cleveland, Ohio.
- OKA, YUICHIRO, Electric & Power Station Engineer, South Manchuria Railway Co., Fushun Colliery, South Manchuria, China.
- PAGE, KENDALL LESLIE, Junior Power Engineer, New York & Queens Electric Light & Power Co., Electric Bldg., Bridge Plaza, Long Island City; for mail, Rockaway Park, N. Y.
- PAMPLONA, RENATO L., Commercial Engineer, General Electric Co., Schenectady, N. Y.
- PATTISON, GEORGE EDWARD, 1st Operator, Pacific Gas & Electric Co., Cassel, Shasta Co., Calif.
- RAY, CHESTER HAROLD, Engineer, Dept. of Operation & Engineering, American Tel. & Tel. Co., 205 Broadway, New York, N. Y.
- RAYMOND, CHESTER BLAINE, Operator, Portland Railway, Light & Power Co., Station E, Portland, Ore.
- *RERUCHA, ERNEST A., Brainard, Nebr.
- RIENSTRA, PETRUS JAN, Electrical Engineer, Knox Associates, 101 Park Ave., New York, N. Y.
- RILEY, CURTIS C., Inspector, Submarine Signal Co., 68 Broad St., New York; res., Brooklyn, N. Y.
- SAMPSON, ELMER B., Electrical Contractor-Dealer, Main St., Chatham, Mass.
- SHEA, TIMOTHY EDWARD, Engineer, Western Electric Co., Inc., 463 West St., New York, N. Y.
- SHUTE, JAMES MADISON, Illuminating Engineer, Hodenpyl Hardy Co.; Central Illinois Light Co., Peoria, Ill.
- SIROTKIN, GEORGE, Electrical Engineering Dept., Allis-Chalmers Mfg. Co., Milwaukee, Wis.
- *SMITH, WILLIAM MINOR, Inspector, South-Eastern Underwriters Association, Atlanta, Ga.
- STILLMAN, CLARENCE BRITTAN, Tester, Crocker-Wheeler Co., Ampere; res., East Orange, N. J.
- STOCKLAND, ROBERT INGERSOLL, Chief of Methods Engineers, Installation Dept., Correspondence School, Western Electric Co., Inc., 430 S. Green St., Chicago, Ill.
- THOMAS, RICHARD NORMAN, Asst. Electrician, Tramway Car Shops, Moorhouse Ave., Christchurch, N. Z.
- TILLY, CHARLES STILON, Electrician, Public Works Dept., Government of Burma, Secretariat Bldgs., Rangoon, Burma, India.
- TOPALIAN, ASADOUR, Electrical Engineer, Brighton, Mass.
- TREE, FRANCIS GEORGE WILLIAM, Engineer, Electricity Dept., Glasgow Corp., 75 Waterloo St., Glasgow, Scotland.
- UHALT, ALFRED HUNT, Foreman Electrician, Trillillo Railroad Co., Point Castillo, Honduras C., A.
- UPHOUSE, WILLIAM F., Transmission Engineer, Southwestern Bell Telephone Co., Boatman's Bank Bldg., St. Louis, Mo.
- VILLARES, GUILHERME DUMONT, Sales Manager, Rio de Janeiro Tramways, Lt. & Pr. Co., Ltd.; Sao Paulo Tramways Lt. & Pr. Co., Ltd., Praca Antonio Prado, Sao Paulo, Brazil, S. A.
- WARFIELD, STERLING O., President, M. O. & W. Engineering Corp., Norton, Va.
- WEBSTER, GEORGE ALBERT, Sales Engineer, National Carbon Co., Inc., Cleveland Ohio; res., Auburndale, Mass.
- WERNER, FREDERICK, Foreman, Construction Dept., General Electric Co., 120 Broadway, New York, N. Y.
- WHITNEY, LAURENCE HAINES, Engineer, General Electric Co., Pittsfield, Mass.
- WOLLABER, ARTHUR B., District Manager, California Edison Co., 44 N. Raymond Ave., Pasadena, Calif.
- WORDAL, OSCAR JOHN, 581 Van Buren St., Milwaukee, Wis.
- WYLIE, LAURENCE, Asst. Engineer, Electrification Dept., Chicago, Milwaukee & St. Paul Railway Co., Passenger Station, Seattle, Wash.
- YONEKURA, JUMPEI, Electrical Engineer, Takata & Co., 50 Church St., New York, N. Y.

Total 76.

*Formerly Enrolled Students.

ASSOCIATE REFLECTED**SEPTEMBER 21, 1923**

ADENDORFF, GERALD VICTOR, Consulting Electrical & Mechanical Engineer, Hilliard's Chambers, Church Square, Cape Town, South Africa.

MEMBERS ELECTED SEPTEMBER 21, 1923

CARPENTER, EDWARD EMERY, Consulting Engineer, British Columbia Railway Co., Ltd., Vancouver, B. C., Can.

COLLIER, CHARLES ALLEN, General Sales Manager, Georgia Railway & Power Co., Electric & Gas Bldg., Atlanta, Ga.

CRAIGLOW, HARRY H., Asst. Superintendent, The Buckeye Steel Castings Co., Columbus, Ohio.

TENNANT, FRANCIS ADELBERT, General Superintendent, Erie Lighting Co., 129 W. 11th St., Erie, Pa.

TOWNE, R. E., Electrical Engineer, Municipal Light Dept., City Hall, Tacoma, Wash.

TRANSFERRED TO GRADE OF MEMBER**SEPTEMBER 21, 1923**

HOUSTON, ROBERT, Resident Electrical Engineer, Water Conservation & Irrigation Commission, Leeton, N. S. W., Australia.

MARTINI, UMBERTO E., Administrateur Delege & Directeur General, Societa Generale Italiano Imprese Elettriche, Rome, Italy.

RECOMMENDED FOR TRANSFER

The Board of Examiners, at its meeting held September 17, 1923, recommended the following members of the Institute for transfer to the grades of membership indicated. Any objection to these transfers should be filed at once with the Secretary.

To Grade of Fellow

BUCK, A. MORRIS, Associate Editor, *Electric Railway Journal*, McGraw-Hill Company, 10th Avenue and 36th Street, New York, N. Y.

GRAHAM, WILLIAM P., Vice-Chancellor, Syracuse University, Syracuse, N. Y.

PARKS, CHARLES WELLMAN, Rear Admiral (C. E. C.) U. S. Navy, Retired.

To Grade of Member

HARTLEY, R. V. L., Telephone Engineer, Western Electric Company, 463 West Street, New York, N. Y.

APPLICATIONS FOR ELECTION

Applications have been received by the Secretary from the following candidates for election to membership in the Institute. Unless otherwise indicated, the applicant has applied for admission as an Associate. If the applicant has applied for direct admission to a higher grade than Associate, the grade follows immediately after the name. Any member objecting to the election of any of these candidates should so inform the Secretary before October 31, 1923.

- Andren, A., res., 177 Park Place, Brooklyn, N. Y.
- Anderson, J. W., General Electric Co., Erie, Pa.
- Bennett, D. E., Gray & Davis, Inc., Cambridge, Mass.
- Boddy, L., General Electric Co., Erie, Pa.
- Berry, E. W., Electric Specialty Co., Stamford, Conn.
- Bunker, F. C., General Electric Co., Schenectady, N. Y.
- Coffin, H. W., Bangor Railway & Electric Co., Bangor, Me.
- Collier, H., with T. E. Murray, Inc., New York, N. Y.
- Conover, O. E., General Electric Co., Schenectady, N. Y.
- Corriveaux, F. M., General Electric Co., Schenectady, N. Y.
- Cornejo, A., Public Water Supply Works, Mexico, D. F., Mex.
- Cotter, J. S., So. California Edison Co., Los Angeles, Calif.
- Crotte, J. V., Mexican Light & Power Co., Mexico City, Mexico
- De Niro, F. J., Erie Lighting Co., Erie, Pa.
- DeVitis, R. M. S., Electric Bond & Share Co., New York, N. Y.
- Dieringer, H. C., Allis-Chalmers Mfg. Co., Milwaukee, Wis.
- Dixon, J. B., United Y. M. C. A. Schools, New York, N. Y.
- Downing, R. E., University of Maine, Orono, Maine.
- Elson, H. H., Faultless Rubber Co., Ashland, Ohio.
- Erdman, E. A., Western Electric Co., Chicago, Ill.
- Eskelsen, R. M., Brigham Municipal Corp., Brigham City, Utah
- Fallen, A. E. J., Kaministiquia Power Co., Ltd., Ft. William, Ont.
- Flir, D., Adlanco Industrial Products Corp., New York, N. Y.
- Fromuth, H. H., Cutler-Hammer Mfg. Co., New York, N. Y.
- Gebhard, L. A., U. S. Naval Experimental & Research Lab., Bellevue, D. C.
- Gilliam, M. W., W. Virginia Engineering Co., Williamson, W. Va.
- Giraud, E. J. A., Sargent & Lundy, Chicago, Ill.
- Givens, R. C., Ridgway Dynamo & Engine Co., Ridgway, Pa.
- Goiri, F. R., Mexican Light & Power Co., Mexico, D. F., Mexico
- Gosney, G., West Penn Power Co., Charleroi, Pa.

- Graner, L. P., Electric Specialty Co., Stamford, Conn.
- Gunther, E. O., Kennywood Park Corp., Pittsburgh, Pa.
- Hanford, R. B., General Electric Co., Schenectady, N. Y.
- Henry, L., Potomac Public Service Co., Hagerstown, Md.
- Heyd, J. T., Bell Tel. Co. of Pa., Philadelphia, Pa.
- Huntsberger, J. D., Bell Telephone Co. of Pa., Philadelphia, Pa.
- Hutchinson, C., Peoples Tel. & Tel. Co., Knoxville, Tenn.
- Klaas, G. P., Electric Bond & Share Co., New York, N. Y.
- Kraus, P. T., Bell Telephone Co. of Pa., Philadelphia, Pa.
- Lehman, C. H., Westinghouse Elec. & Mfg. Co., St. Louis, Mo.
- Lies, A. N., Commonwealth Edison Co., Chicago, Ill.
- Lintott, H. T., Pacific Coast Steel Co., South San Francisco, Calif.
- Maillard, A. L., (Member) Fuller & Maitland Kansas City, Mo.
- McCarthy, J. E., Westchester Lighting Co., New Rochelle, N. Y.
- McGowan, J. A., Bell Telephone Co. of Pa., Philadelphia, Pa.
- Menschik, L., Dubilier Radio Corp., New York, N. Y.
- Mills, S. A., Brooklyn Edison Co., Brooklyn, N. Y.
- Musselman, J. A., Leeds & Northrup Co., Philadelphia, Pa.
- Nash, R. L., Potomac Electric Power Co., Washington, D. C.
- Oakley, R. N., Philadelphia Electric Co., Philadelphia, Pa.
- Ostroff, L., with T. E. Murray, Inc., New York, N. Y.
- Panalyzer, A. L., Ohio Salt Co., Rittman, Ohio
- Patterson, C. A., Western Colorado Power Co., Durango, Colo.
- Pedrazzi, J., Mexican Light & Power Co., Mexico, D. F., Mexico.
- Ray, J. A., Portland Ry. Lt. & Pr. Co., Portland, Ore.
- Reeves, F. M., Western Electric Co., Inc., Chicago, Ill.
- Ross, M. D., Westinghouse Elec. & Mfg. Co., E. Pittsburgh, Pa.
- Russell, L. S., Pittsburgh Railways Co., Pittsburgh, Pa.
- Saki, T., Utah Copper Co., Garfield, Utah
- Salzmann, O. M., Canadian General Electric Co., Toronto, Ont., Canada.
- Specht, H. C., (Member), Westinghouse Elec. & Mfg. Co., E. Pittsburgh, Pa.
- Strickler, W. M., with Albert Kahn, Detroit, Mich.
- Suttle, F. L., New York Telephone Co., New York, N. Y.
- Suydam, C. H., Federal Telegraph Co., Palo Alto, Calif.
- Taverner, H. B., Commonwealth Edison Co., Chicago, Ill.

- Thackeray, R. M., General Electric Co., Schenectady, N. Y.
- Tigerstedt, E. M. C., (Member), Electrical Engineer, New York, N. Y.
- Vondercrone, J. W., Bell Tel. Co. of Pa., Philadelphia, Pa.
- West, W. B., Alabama Power Co., Birmingham, Ala.
- Wheeler, W. C., General Electric Co., Schenectady, N. Y.
- Winje, S. W., Indiana Service Corp., Fort Wayne, Ind.

- Total 71
- Foreign**
- Chester, F. H. E., Canterbury Frozen Meat Co., Belfast, Ireland
 - Cintra, J., Paulista Railway, Junidahy, Sao Paulo, Brazil
 - Damant, E. L., (Member) University of the Witwatersrand, Johannesburg, South Africa.
 - Faulks, J. R. B., Newcastle City Council, Newcastle, N. S. W., Aus.
 - MacLean, G. F., National Electrical & Engg. Co., Ltd., Auckland, N. Z.
 - Smouloff, A., (Fellow) Electrotechnical Institute, Petrograd, Russia.
 - Turner, G. E., National Electrical & Engineering Co., Dunedin, N. Z.
 - Waddington, E. L., Hubert Davies & Co., Ltd., Cape Town, S. Africa
 - Wood, T. A., Cerro de Pasco Copper Corp., Oroya, Peru, S. A.
- Total 9

STUDENTS ENROLLED SEPTEMBER 21, 1923

- 17364 Dyke, Curtis T., Drexel Institute
 - 17365 Bainbridge, Kenneth T., Mass. Institute of Technology.
 - 17366 Theodore M. Burkholder, Mass. Institute of Technology
 - 17367 Garrison, Frederic G., Mass. Institute of Tech.
 - 17368 Sovitsky, Walter, School of Engineering of Milwaukee
 - 17369 Donnelly, Austin J., School of Engineering of Milwaukee
 - 17370 Ruth, Edward L., School of Engineering of Milwaukee
 - 17371 McNally, James O., Mass Institute of Technology
 - 17372 Haller, Cyrus W., Mass. Institute of Technology
 - 17373 Samuel, Arthur L., Mass Institute of Tech.
 - 17374 Helfman, Samuel J., Mass. Institute of Technology
 - 17375 Manuele, Joseph, Jr., Mass. Institute of Technology
 - 17376 Page, J. Edw., Syracuse University
 - 17377 Lindquist, Kurt E., Mass. Institute of Technology
 - 17378 Weaver, Burr S., Mass. Institute of Tech
 - 17379 Wang, Tsung-Cheng, Mass Institute of Technology
 - 17380 Hackett, James D., Northeastern University
- Total 17

OFFICERS OF A. I. E. E. 1923-1924

- | | |
|---|---|
| <p>President
HARRIS J. RYAN</p> <p>Junior Past-Presidents
FRANK B. JEWETT</p> <p>Vice-Presidents
W. I. SLICHTER
R. F. SCHUCHARDT
H. T. PLUMB
G. FACCIOLI
H. W. EALES</p> <p>Managers
HAROLD B. SMITH
JAMES F. LINCOLN
E. B. CRAFT
R. B. WILLIAMSON
A. G. PIERCE
HARLAN A. PRATT</p> <p>Treasurer
GEORGE A. HAMILTON</p> <p>Honorary Secretary
RALPH W. POPE</p> | <p>WILLIAM MCCLELLAN</p> <p>J. E. MACDONALD
HERBERT S. SANDS
S. E. M. HENDERSON
H. E. BUSSEY
WILLIAM F. JAMES</p> <p>H. M. HOBART
ERNEST LUNN
G. L. KNIGHT
WILLIAM MCCONAHEY
W. K. VANDERPOEL
H. P. CHARLESWORTH</p> <p>Secretary
F. L. HUTCHINSON</p> |
|---|---|

LOCAL HONORARY SECRETARIES

- Carroll M. Mauseau, Caixa Postal No. 571, Rio de Janeiro, Brazil.
- Charles le Maistre, 28 Victoria St., London, S. W., England.
- A. S. Garfield, 45 Bd. Beausejour, Paris 16 E, France.
- H. P. Gibbs, Tata Sons, Ltd., Navsari Building, Fort Bombay, India.
- Guido Semenza, 39 Via Monte Napoleone, Milan, Italy.
- Lawrence Birks, Public Works Department, Wellington, New Zealand.
- Axel F. Enstrom, 24 A Grefuregatan, Stockholm, Sweden.
- W. Elsdon-Dew, P. O. Box 4563, Johannesburg, Transvaal, Africa.

A. I. E. E. COMMITTEES

(A list of the personnel of Institute committees may be found in the September issue of the JOURNAL).

A. I. E. E. SECTIONS AND BRANCHES

A complete list of the Sections and Branches of the Institute, with the names of the chairmen and secretaries may be found in the September issue of the JOURNAL.

DIGEST OF CURRENT INDUSTRIAL NEWS

NEW CATALOGUES AND OTHER PUBLICATIONS

Mailed to interested readers by issuing companies.

Motors.—Bulletin 1118-B, 12 pp. Describes "AR" squirrel cage induction motors from ½ h. p. to 200 h. p., together with control apparatus. Allis-Chalmers Manufacturing Company, Milwaukee, Wis.

Theatre Lighting.—Pamphlet. Stage and auditorium lighting from its origin to the present day. Ward Leonard Electric Company, Mount Vernon, N. Y.

Battery Charging Equipment.—Bulletin 60, 16 pp. Motor generators and switchboards for all classes of industrial battery recharging service. The Electric Products Company, Clarkstone Road, Cleveland, Ohio.

Conduit Fittings.—Catalog, 206 pp. Describes "Unilets" and other conduit fittings for every requirement. Appleton Electric Company, Chicago, Ill.

Transformers.—Bulletin 2020, 24 pp. Contains 54 photographic reproductions of transformer installations on lines of public utilities, steel mills, coal mines, and industrial companies. Pittsburgh Transformer Company, Pittsburgh, Penn.

Motor Protective Device.—Bulletin, 12 pp. Describes the "Minibreaker," for starting and protecting small motors against overload, short circuit, stalling and single phasing, without blowing fuses. Miniature Breaker Company, Inc., 200 Fourteenth Street, Long Island City, N. Y.

CO₂ Recorder.—Bulletin 116-A, 8 pp. Describes three devices for completely eliminating soot, moisture and sulphur from the CO₂ equipment and the tubing which conveys the gas sample to the instrument. Uehling Instrument Company, Paterson, N. J.

Controller Valve.—Bulletin 319, 16 pp. Describes the new Bristol-Fuller Controller Valve used with automatic temperature control apparatus to regulate the flow of air and gas, air and oil, steam and oil; also for air, gas, steam, oil and other liquids. The Bristol Company, Waterbury, Conn.

Non-Magnetic Cast Iron.—Bulletins Fa75 and Fa76, 4 pp. each, describing "Nomag," a non-magnetic cast iron for use in electrical machinery. An increased electrical resistance and more complete freedom from hysteresis and eddy currents than any other material is claimed for this metal. Ferranti, Ltd., Hollinwood, Lancashire, England.

Motors.—Bulletin 1014, 24 pp. Describes type "AS" direct-current motors. This type is designed to run at any speed and to develop a constant horse power output over any range up to 1 to 10. No electric controller is required for producing the speed changes, which are obtained by means of an armature shifting arrangement. Reliance Electric & Engineering Company, 1088 Ivanhoe Road, Cleveland, Ohio.

Powdered Coal Systems.—Catalog L-1, 12 pp. Outlines the theory and mechanical features of "Lopulco Pulverized Coal Systems," which within the past year have been installed in connection with some of the notable boiler plant projects in this country. Combustion Engineering Corporation, Broad Street, New York.

Line Material.—Catalog, 200 pp., covering line material and porcelain insulators. This catalog is supplementary to the company's large supply catalog and has been issued for the convenience of purchasers of these two allied lines of materials. Westinghouse Electric & Manufacturing Company, East Pittsburgh, Penn.

NOTES OF THE INDUSTRY

The Electric Furnace Construction Company has removed its offices to the New Jefferson Building, 1015 Chestnut Street, Philadelphia, Penn.

The Acme Wire Company, New Haven, Conn., has closed its Cleveland Office and opened an office at Detroit in the Krosge Building, in charge of J. T. Crippen.

Western Electric Company.—The general sales office of the supply department has been removed to the Pershing Square Building, 42nd Street, New York. This change is due to the physical separation of the supply department from the telephone manufacturing end of the business.

Packard Electric Company, Warren, Ohio.—The construction of a \$350,000 addition to this company's plant has begun. The new building will be devoted exclusively to the manufacture of transformers, with sufficient capacity to triple the present output. The existing buildings will be altered and turned over to the manufacture of automotive cables.

The International Western Electric Company has received a cable reporting satisfactory progress of wrecking operations on several buildings of its associated company, the Nippon Electric of Tokyo, which were destroyed during the earthquake. The cable says that manufacturing will probably be resumed in three months. Despite the extent of the disaster, the Nippon Company is actually transacting business. Philip K. Condit of New York, Vice President of the International Western Electric Company, who was in Japan at the time of the disaster, is remaining on the scene during the critical restoration period, or about six weeks.

Portable Oscillograph.—A portable oscillograph that is extremely compact, but yet will cover a broader field of work and is more easily operated than the earlier more bulky instruments, has been developed by the Westinghouse Electric & Manufacturing Company, East Pittsburgh, Penn.

The new oscillograph is complete in one unit except for the motor and film holder. The main unit is 11 inches wide, 11½ inches high and 25 inches long and includes the entire optical system, special incandescent lamp illuminant, a highly sensitive three-element galvanometer, complete control equipment for vibrator elements (including 30,000 ohms of non-inductive resistors) and a transformer (for operating the lamp and motor) for 110 or 220 volts supply at any frequency from 25 to 70 cycles.

A special lamp control switch and automatic lamp extinguishing switch enable the operator to apply a greatly abnormal voltage to the incandescent lamp to obtain results equal to those formerly secured only with the intense light of an electric arc. With this automatic control the same lamp can be used for hundreds or even thousands of oscillograms, since the lamp is at greatly abnormal voltage only for a small fraction of a second during the exposure.

The galvanometer is of the latest construction and is equipped with supermagnets of a newly developed permanent type which make the vibrators more sensitive than with any previous electro-magnets. This new construction does away with the necessity for a field-rheostat, ammeter, control switches, storage battery and rectifier.

The outfit also includes a special film holder that can be loaded and unloaded without going into a dark room. It takes standard kodak films which can also be developed without a dark room in a tank developing outfit. The main unit weighs but eighty pounds complete and the whole outfit together weighs hardly more than one hundred pounds.

William Henry Merrill.—Word has been received of the death, on September 17, of Mr. Merrill, founder and president of the Underwriters' Laboratories, Chicago.



KERITE

in a half-century of
continuous production,
 has spun out a record
 of performance
 that is
unequaled in the
 history of insulated
 wires and cables



KERITE INSULATED WIRE & CABLE COMPANY
 NEW YORK CHICAGO

Littbridge 80-535

Please mention the JOURNAL of the A. I. E. E. when writing to advertisers.

Every small motor

*can have an armature
with no weak spot in its armor*

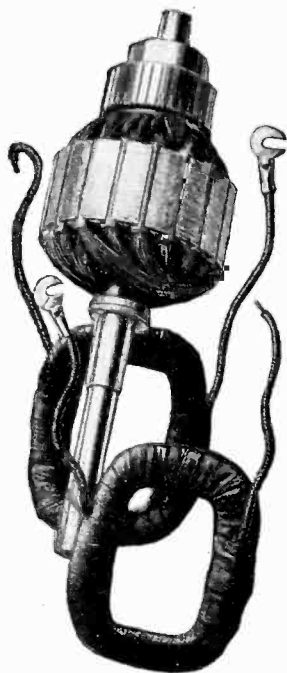

WHEN a motor goes dead the customer blames you. It may have been carefully designed and constructed. The workmanship may have been of the best. Yet you may have built into that motor a hidden source of trouble.

It is the wire with which the armature and field coil are wound. That wire is the heart of the motor. Hundreds of feet of it—so much opportunity for one little imperfection to creep in, and such serious results if it does.

Every day, manufacturers are more and more using Acme Wire—the wire that *goes in the space*.

Acme Wire is even, uniform, perfectly sized, and free from all lumps and imperfections. It is covered with a smooth, unvarying coat of insulation of high dielectric strength. There is no necessity of hammering or forcing Acme Wire into place. It goes in the space easily, with the required number of turns.

Acme Wire is made to meet actual winding conditions. We know these conditions thoroughly, because in our own plant we wind hundreds of thousands of coils. For years this company has specialized in the aim of making the best wire that can be made for one particular purpose—winding coils. The result is a product you will be proud to use in your motors.

THE ACME WIRE CO., New Haven, Conn.
NEW YORK CLEVELAND CHICAGO



Some Users of Acme Magnet Wire

Atwater Kent Mfg. Co.
Azor Motor Mfg. Co.
Century Electric Co.
Dayton Engineering Laboratories Co.
Delco-Light Co.
Diehl Mfg. Co.
Domestic Electric Co.
Eisemann Magneto Corporation
Electric Auto-Lite Corp.
Electric Specialty Co.
Electrical Products Mfg. Co.
Eureka Vacuum Cleaner Co.
Ford Motor Co.
Gray & Davis, Inc.
Hamilton Beach Mfg. Co.
Holtzer-Cabot Electric Co.
Hoover Suction Sweeper Co.
Klaxon Co.
Robbins & Myers Co.
Sangamo Electric Co.
Sunlight Elec. Mfg. Co.
U. S. Auto Supply Co.
Wagner Electric Corporation
Western Cartridge Co.
Westinghouse Elec. & Mfg. Co.

Acme Wire Products

"Enamelite," plain enameled Magnet Wire; "Cottonite," Cotton-covered Enamelite; "Silkenite," Silk-covered Enamelite; Single and Double Cotton Magnet Wire; Single and Double Silk Magnet Wire. We also have a complete organization for the winding of coils in large production quantities.

Acme Varnished Insulations

Varnished Cambrics, Silks and Papers. Varnished Tapes in rolls; straight or bias. Varnished Tubing (Spaghetti).

Acme Radio Specialties

Audio Transformer windings.
Radio Frequency windings.
Magnet windings for Head Sets.
Enameled wire—especially the finest sizes, 40-44 B & S gauge.
Silk and cotton-covered magnet wire.
Enameled Aerial wire—single wire and stranded.

Illustrated Catalog on request to Engineers, Purchasing Agents, Executives and Operators.

AcmeWire

"It goes in the space"

Please mention the JOURNAL of the A. I. E. E. when writing to advertisers.

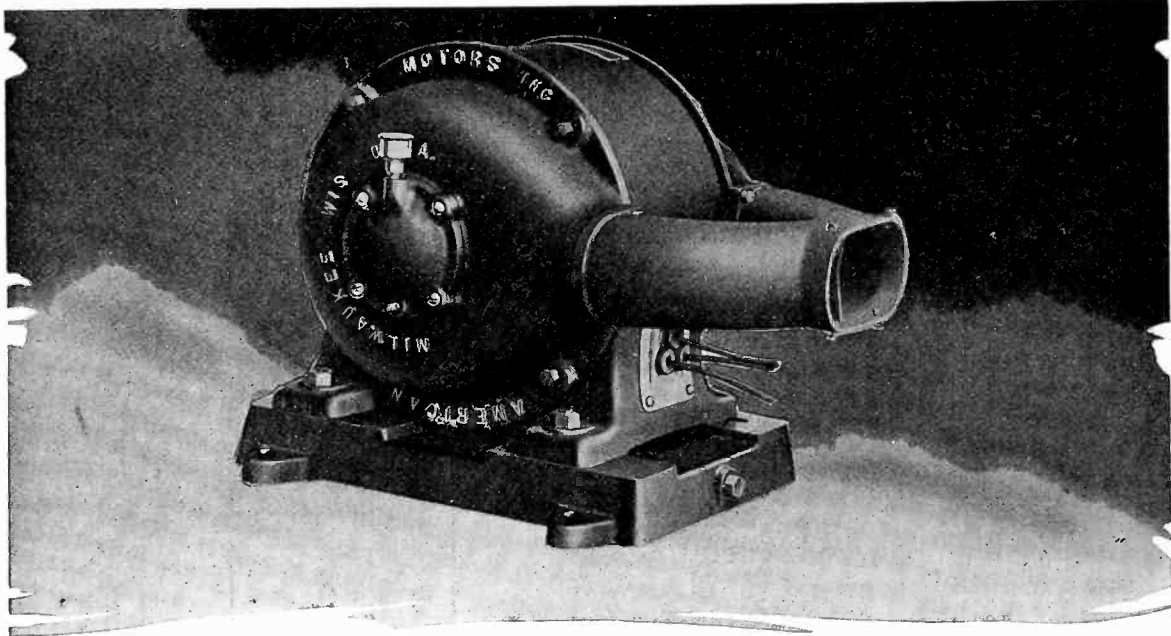

No Dust Nor Grit Can Enter Ball Bearing Housings on Electric Motors

IF PLAIN bearings are used on motors designed for use in foundries, wood-working plants and flour, grist and grain mills, it is practically impossible to prevent dust and grit from finding their way into the bearings causing them to run hot and wear. Then, too, bearings of this type are likely to leak oil which, when combined with dust or shavings, forms a highly inflammable mixture.

On this totally inclosed, self-ventilated motor designed for use in dusty locations,

both problems are solved by supporting the armature on Skayef self-aligning ball bearings. This type of bearing operates in sealed housings which effectively prevent the entrance of dust and grit and which keep the lubricant from leaking out.

Because they reduce friction to a minimum and maintain the necessary clearance without need of adjustment, ball bearings have the enthusiastic endorsement of experienced users. May our engineers submit recommendations?

THE SKAYEF BALL BEARING COMPANY

Supervised by **SKF** INDUSTRIES, INC., 165 Broadway, New York City

1022



Normal View

Deflected View

BALL BEARINGS
The Highest Expression of the Bearing Principle

Please mention the JOURNAL of the A. I. E. E. when writing to advertisers.

Advances in the

The Muffler

When a circuit breaker equipped with mufflers opens a heavy short circuit, the air in the top chamber is forced out through the muffler in advance of the arc gases rising through the oil; this eliminates the possibility of a violent explosion in the breaker structure due to the mixture of oxygen and arc gases. The rupturing capacity and the severity of the duty cycle which a given breaker structure will handle are thereby greatly increased.

Segregated Phase Arrangements of Oil Circuit Breakers

Many of the new high powered generating stations have adopted segregated phase switching. The O line of breakers is readily adopted to either vertical or horizontal phase segregation.

The Westinghouse CO and O oil circuit breakers are available in interrupting capacities suitable for all modern stations of voltages up to 25 kv. The CO-11 and CO-22 breakers can be used where space is the limiting factor. The OE-6, O-11, O-22, O-33 and O-4 breakers can be arranged for mounting either as a three-pole unit or for segregated phase service.

For complete information, consult our nearest district office.

Westinghouse Electric & Manufacturing Company

East Pittsburgh

Pennsylvania

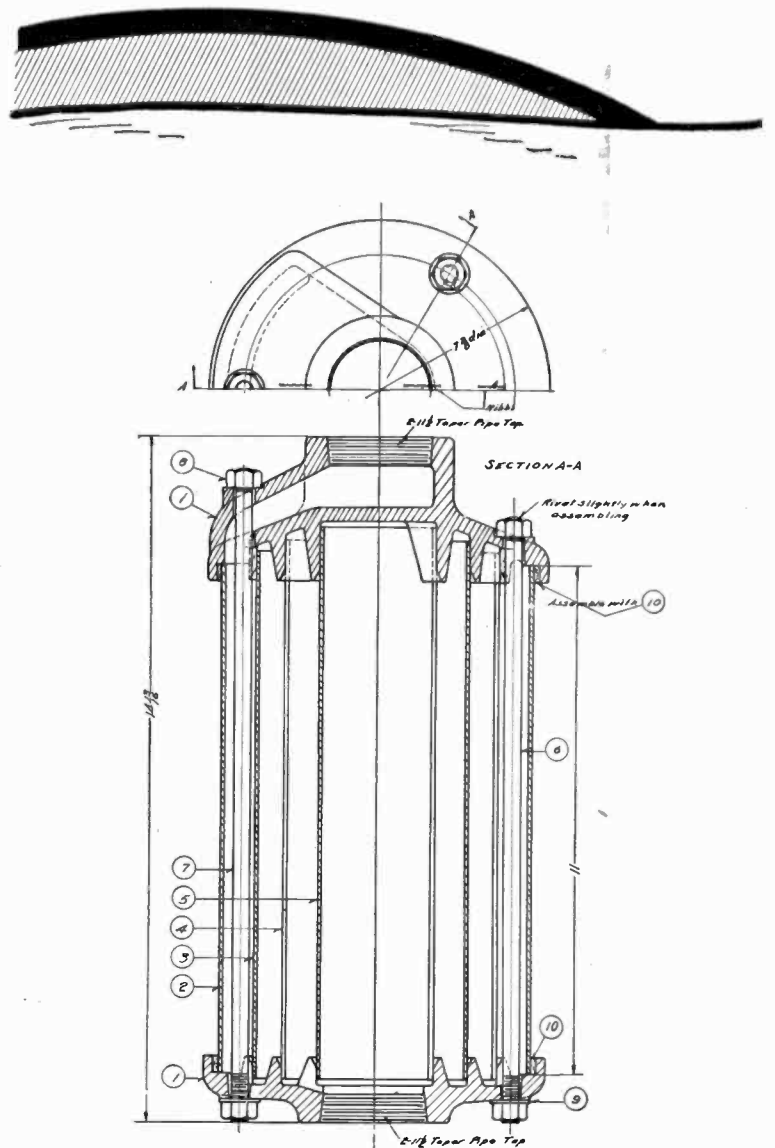

Sectional view of Muffer used with Westinghouse Oil Circuit Breakers.

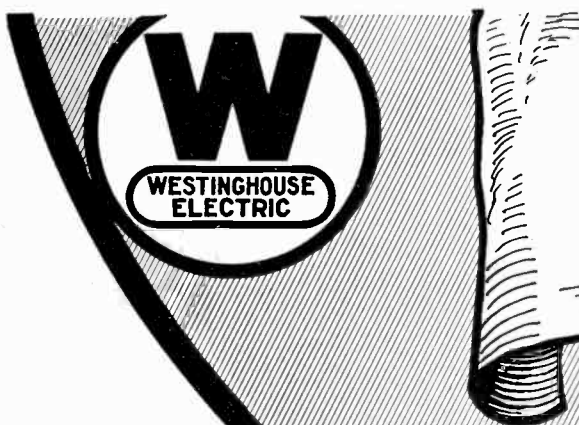

Westinghouse

Please mention the JOURNAL of the A. I. E. E. when writing to advertisers.

Oil Circuit Breaker Art

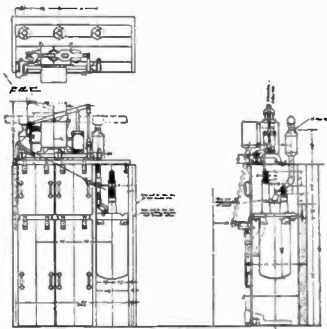

Type OE-6 oil circuit breaker, 15,000 volt, 3 P. S. T. cell mounting.

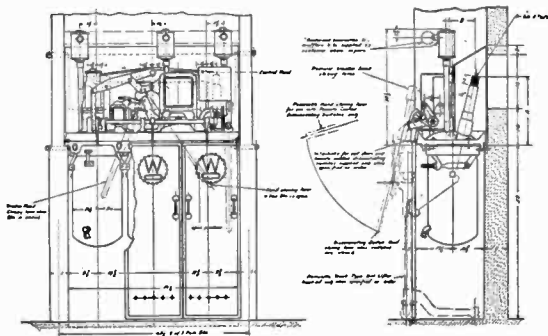

Type CO-11 oil circuit breaker, 25,000 volt, 3 P. S. T., cell mounting.

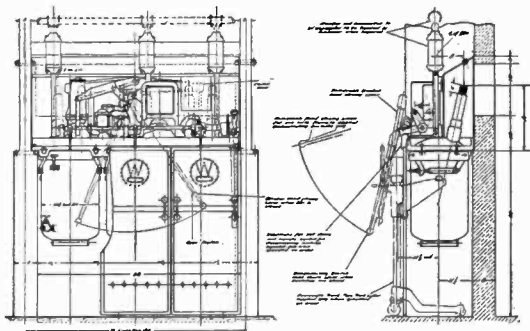

Type CO-22 oil circuit breaker, 25,000 volt, 3 P. S. T., cell mounting.



Westinghouse

Please mention the JOURNAL of the A. I. E. E. when writing to advertisers.

Segregated Phase Arrangements

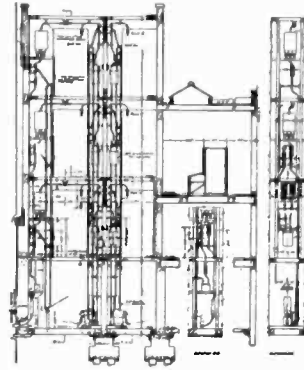
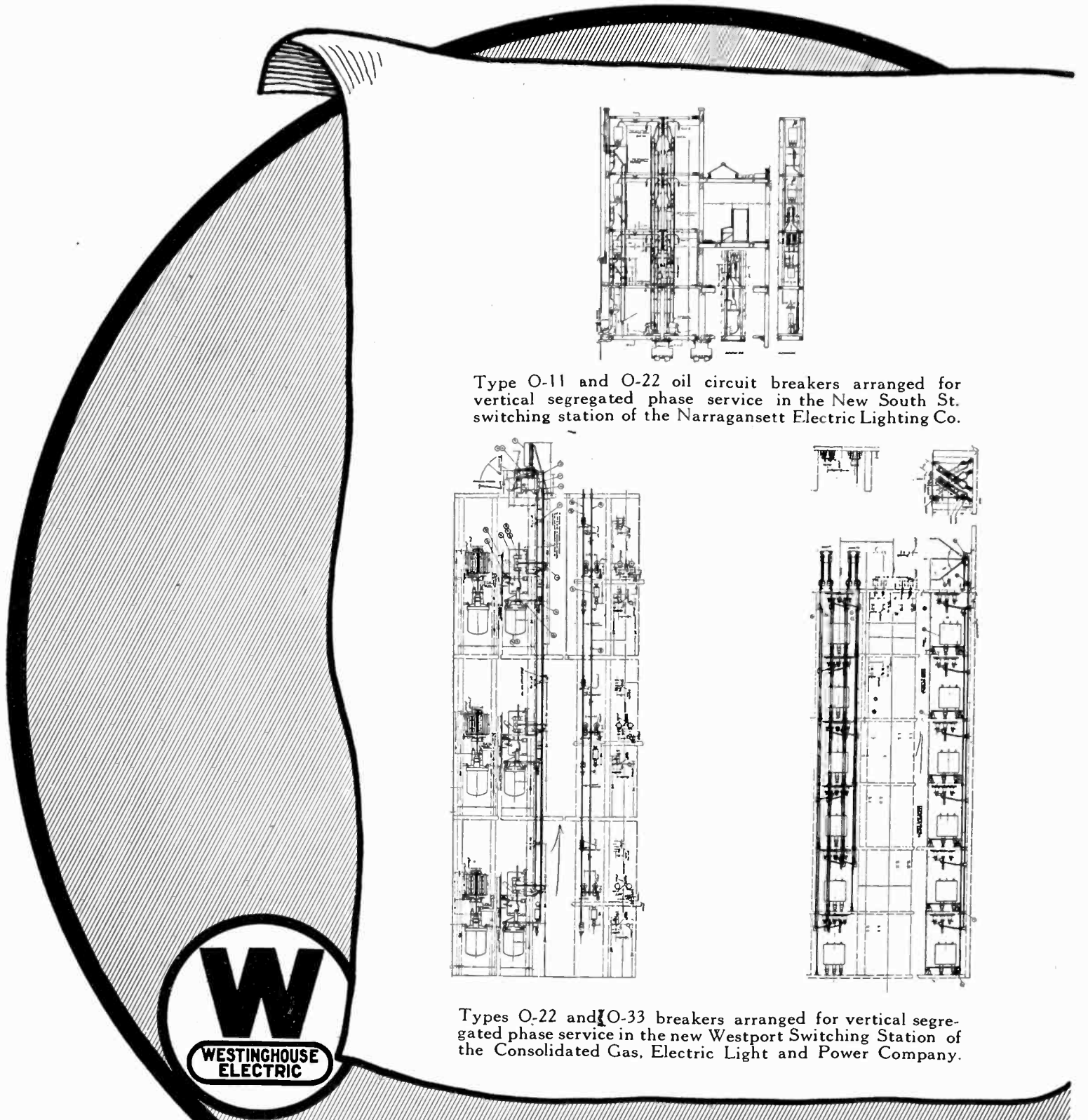

Type O-11 and O-22 oil circuit breakers arranged for vertical segregated phase service in the New South St. switching station of the Narragansett Electric Lighting Co.

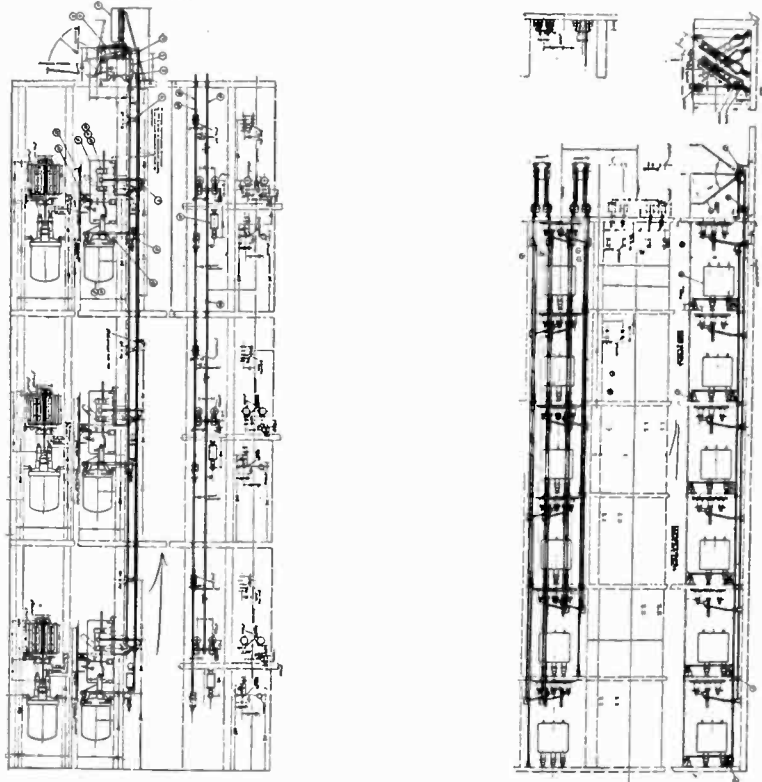

Types O-22 and O-33 breakers arranged for vertical segregated phase service in the new Westport Switching Station of the Consolidated Gas, Electric Light and Power Company.

Westinghouse

Please mention the JOURNAL of the A. I. E. E. when writing to advertisers.

of Oil Circuit Breakers

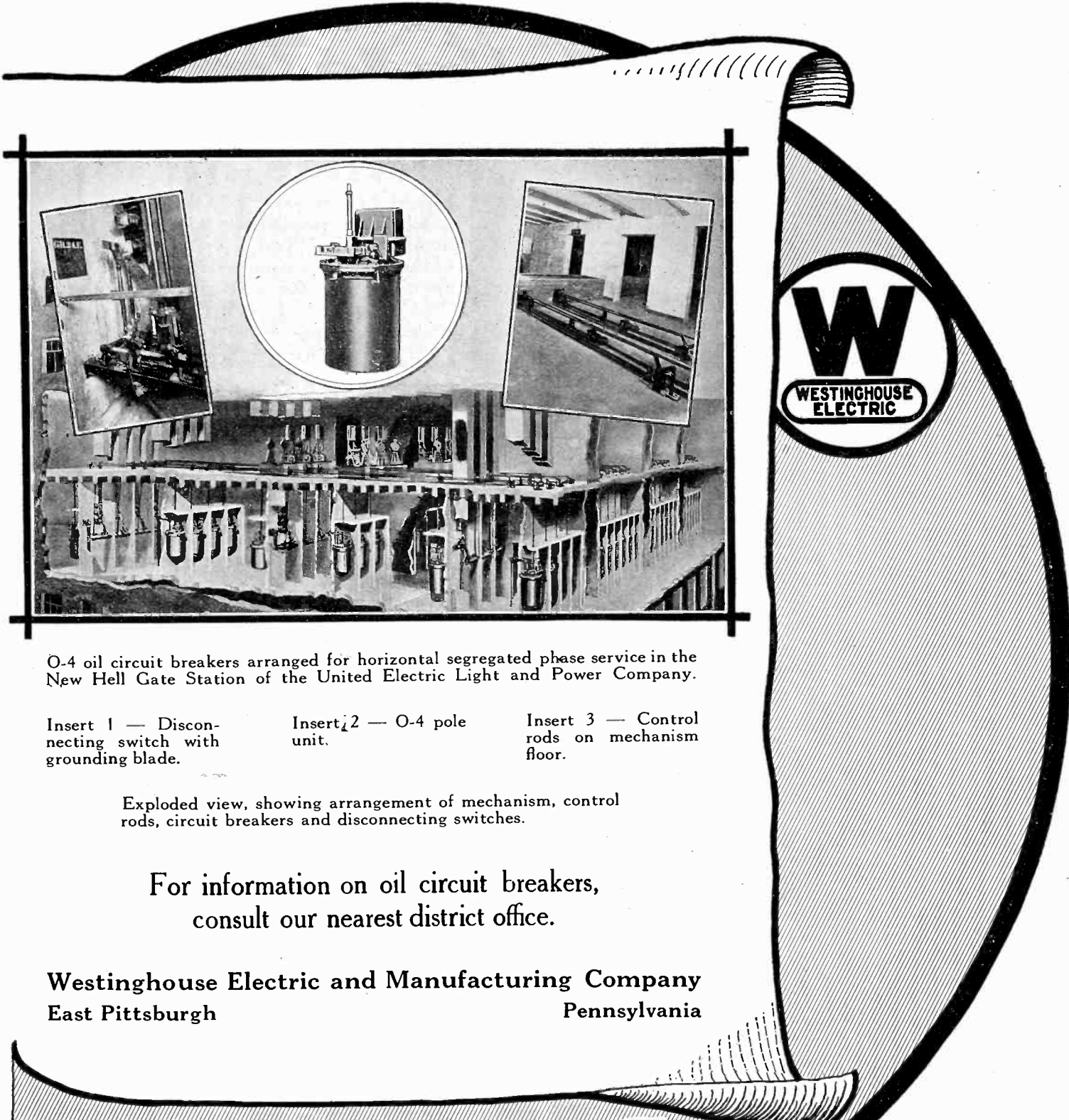

O-4 oil circuit breakers arranged for horizontal segregated phase service in the New Hell Gate Station of the United Electric Light and Power Company.

Insert 1 — Disconnecting switch with grounding blade.

Insert 2 — O-4 pole unit.

Insert 3 — Control rods on mechanism floor.

Exploded view, showing arrangement of mechanism, control rods, circuit breakers and disconnecting switches.

For information on oil circuit breakers, consult our nearest district office.

Westinghouse Electric and Manufacturing Company
East Pittsburgh Pennsylvania

Westinghouse

Please mention the JOURNAL of the A. I. E. E. when writing to advertisers.

Vast Space?

Vast Space?

Never! In fact, very, very little space is all that is needed for this type of breaker. But—if you had all the space of the ocean, you couldn't find a better circuit breaker, for its rated duty, than the Condit, truck type, F-11.

Husky, dependable—adaptable to individual requirements—and installed at a relatively low cost.

Condit truck type F-11's afford better service—use them and make the most of your space.

CONDIT ELECTRICAL MFG. CO.

Manufacturers of Electrical Protective Devices

South Boston, Mass.

Northern Electric Company
LIMITED

Sole Distributor for the Dominion of Canada

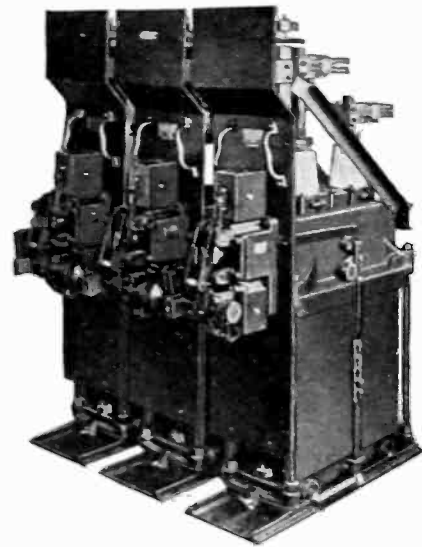

F-11

Specifications: Single, two, three or four pole: 1200 amperes or less, 15,000 volts; 1600 amperes, 7500 volts; 2000 amperes, 4500 volts. Manually or electrically-operated. Interrupting capacity: 10,000 amperes at 15,000 volts.

4752

CONDIT

Please mention the JOURNAL of the A. I. E. E. when writing to advertisers.

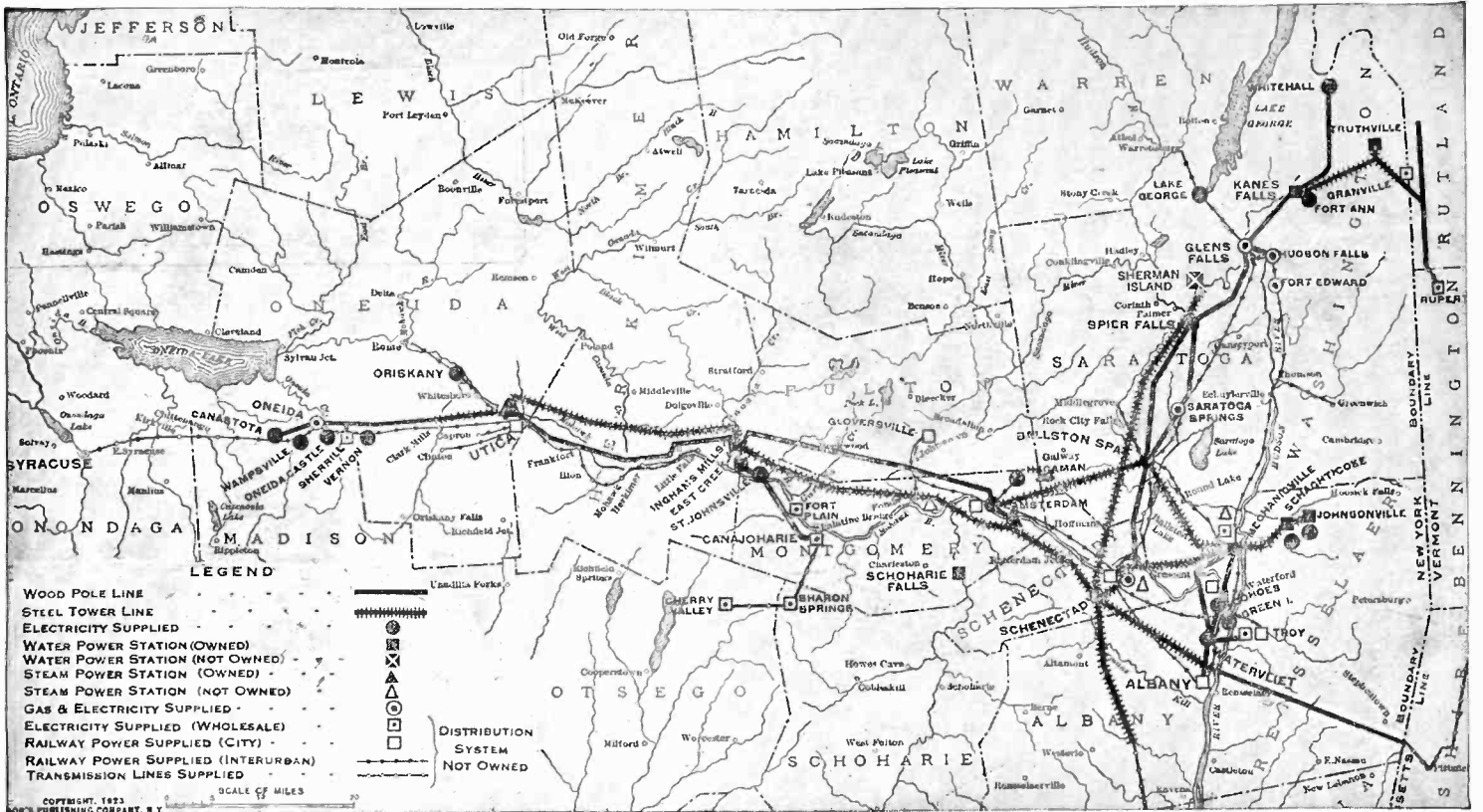

System of the Adirondack Power & Light Corporation and subsidiary companies, New York. This company supplies more than 325 million kilowatt-hours a year to an estimated population of 700,000, operating 350 miles of primary transmission and 4,225 miles of secondary distribution lines. In addition, it supplies energy to 10 other electrical companies and all the electric railway systems from Syracuse east to Albany and north to Lake George.

Systems like this must have Adequate Relay Protection

AS the interconnection of existing systems increases, networks necessarily become more intricate, but service reliability must be maintained.

The relay's function is to maintain maximum continuity of service under all conditions. It does this by:

- (1) keeping "hot" all parts of the system except where a fault has developed;
- (2) "killing" the faulty line as soon as possible, and re-establishing service quickly.

The assistance that the General Electric Company can render you in this connection is engineering advice on the proper relaying of your whole system. And when your needs have been determined a G-E relay can be supplied for every requirement.



General Electric Company
Schenectady, N. Y.
Sales Offices in all Large Cities

GENERAL ELECTRIC



Typical Control Relay



Typical A-C. Reverse Power Relay

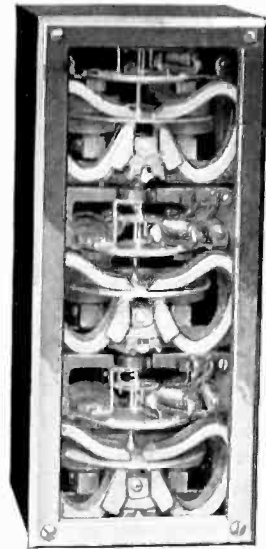

Typical Induction Differential Relay

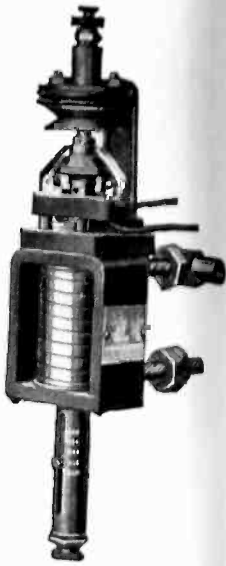

Typical Series Overload Relay

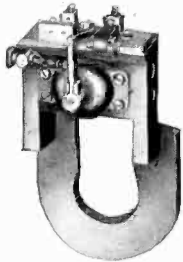

Typical D-C. Reverse Power Relay

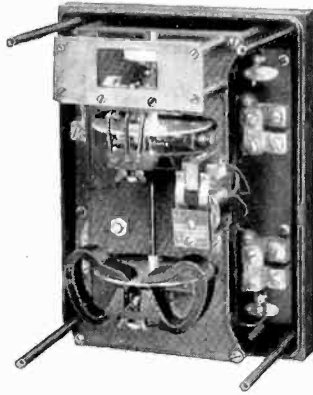

Typical Induction Power Relay

G-E Relays Protect:

—lines against excessive or unbalanced current and reversal of normal power flow and against phase-to-phase or phase-to-ground faults in single lines, parallel lines, tie lines or lines connected in loop.

—constant-current lines against the high potential of open circuit and machines against loss of field excitation.

—machines and apparatus against excessive voltage drop or total failure of potential.

—machine bearings against overheating.

—three-phase machines, "Edison System Generators" or balancer sets against excessive current and unbalanced load.

—alternators and transformers against internal troubles.

—motor generators and synchronous converters against over-speeding on loss of a-c. supply.



Typical D-C. Differential Relay



Typical Auxiliary Relay
—Hinged Armature type



Typical Plunger type Overload Relay

SWITCHBOARD DEPT. RELAYS
GENERAL ELECTRIC COMPANY
Schenectady, New York.

CURRENT

OVER UNDER DIRECTIONAL DIFFERENTIAL OVER

GENERAL

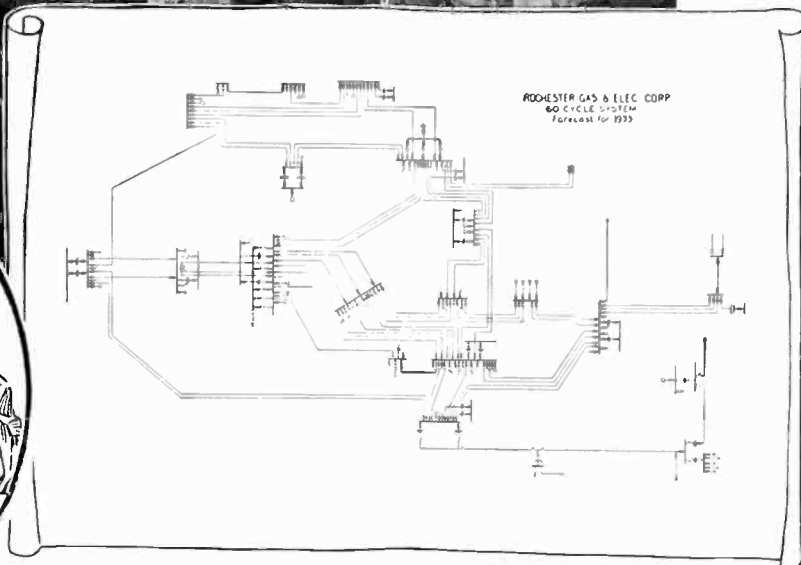
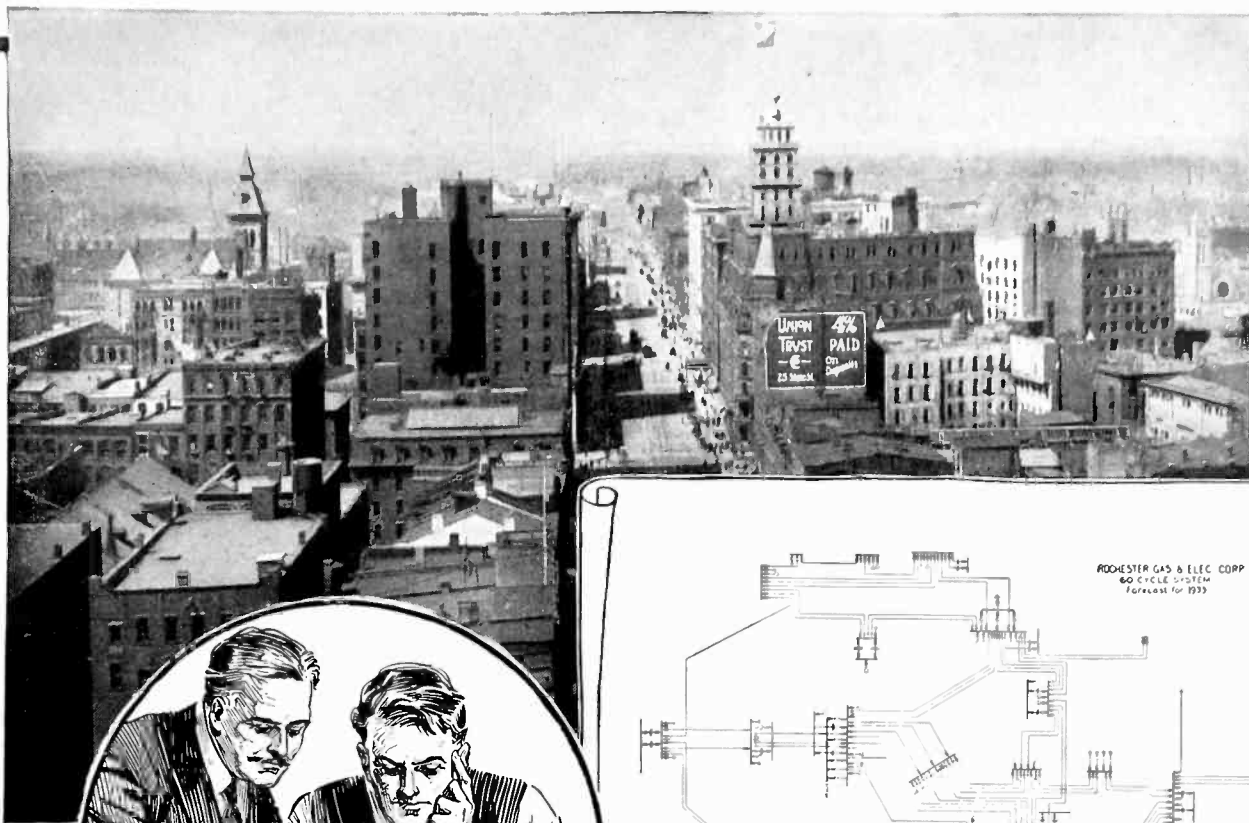

The Rochester Gas & Electric System is one instance where the engineers of the operating company and G-E Relay Specialists have co-operated to secure adequate relay protection.

A Problem that Requires Engineering Analysis

Extensions to distribution systems and inter-connection with other systems materially change the characteristics of the whole. The present insignificant feeder may later become the connecting link of an important loop.

Maximum continuity of service can be maintained only by giving particular attention to the protective relays whenever a change in the system is made. Sometimes a change in setting of the present relays is all that is necessary; in other cases it is highly advantageous to adopt another type.

The General Electric Company maintains a staff of relay engineers whose duty it is to study transmission systems and prescribe relays and relay settings *which will keep the lines "hot."*

These specialists on relay problems are assisting many power companies in selecting relays for *adequate* protection. The nearest G-E office will put you in touch with them.



General Electric Company
Schenectady, N. Y.

GENERAL ELECTRIC

What's in your telephone

This picture, taken "behind the scenes", gives some idea of the complexity of your telephone. In the 201 parts which make up this instrument are materials brought from every corner of the earth.

To select these materials and refine them, to produce from them the finely-wrought coils and contacts and diaphragms, to assemble the many parts into a smooth-working and long-lasting telephone—all this calls for a manufacturing skill of high order.

Western Electric telephones are the product of fifty-four years' manufacturing experience.

Western Electric

Since 1869 Makers of Electrical Equipment

No. 4 of a series on raw materials.



In linen paper in transmitter button.

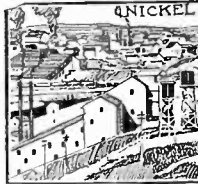

Contact springs. Also for nickel plating transmitter parts.

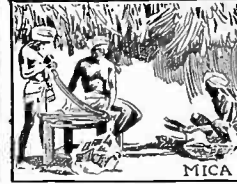

Transmitter button.

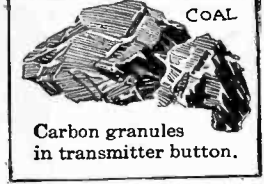

Used in mouthpiece composition.

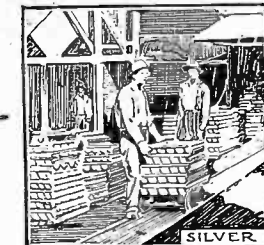
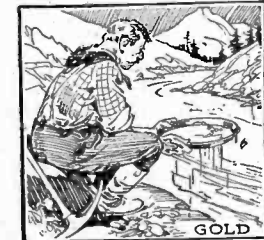
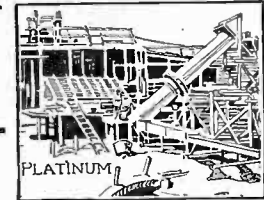

Contact metal for contact points in springs.



In covering on cord.

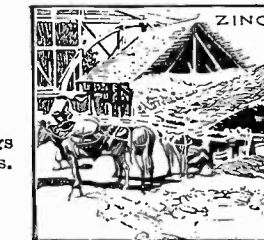

In contact springs and all brass parts.

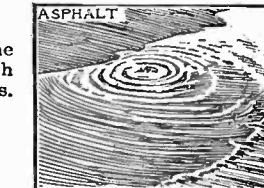

One of the outside finish constituents.

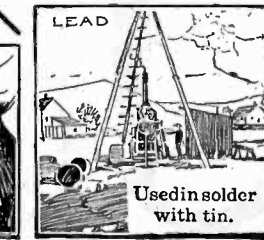

In all soldered joints.

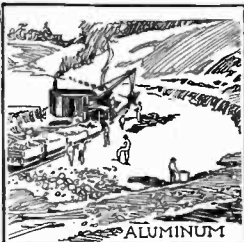

Transmitter diaphragm

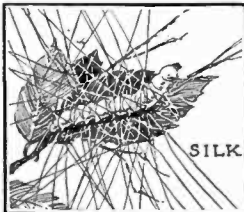

In covering on receiver and extension cords.

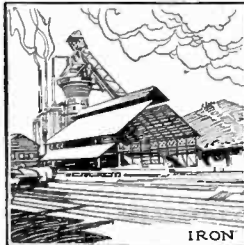

Magnet structure. Terminal and base plate, clamp and screws.

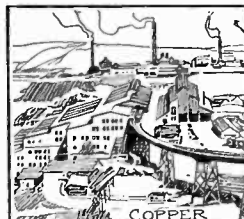

Coil windings. (As brass) receiver terminals, screws, handle.

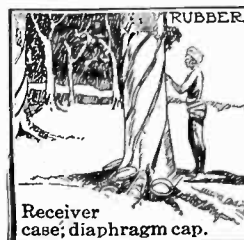

Please mention the JOURNAL of the A. I. E. E. when writing to advertisers.



“You can’t create a molding department overnight that can compete with “J-P” —said the Consulting Industrial Engineer

“YOU people pay me my retainer to tell you what to do and how to do it—but there are times when I can save you more money by telling you what not to do. Don’t figure on starting a molding department and think you can save money and get the production and quality you need. You may get away with it but the chances are you won’t. Making molded products

is a highly specialized business. You might in time get an organization together for handling the work. But it would take you years to develop a molding department that could give you the service you can get now from the Johns-Pratt Company. And by the time you had reached that point, the Johns-Pratt people would still be way ahead of you.”

Johns-Pratt

Please mention the JOURNAL of the A. I. E. E. when writing to advertisers.

IMPARTIAL investigation of all sides of the question will conclusively demonstrate that it is most economical and otherwise advantageous for large users of molded products to rely on Johns-Pratt Molding Service to supply all such material. Molding is a highly specialized business. It requires costly machinery, highly skilled labor and long experience.

The designing of the molds, their construction, handling and use—each of these is an art in itself.

Whether your needs call for molded parts in Bakelite, Condensite, Redmanol or special compositions—for electrical, chemical or mechanical

purposes—in any shape or size from the most simple to the most intricate—in any quantity, large or small—Johns-Pratt Molding Service is organized and equipped to handle the work to your best advantage.

We have been makers of molded products since 1884 and are today one of the largest concerns operating in this field.

You are especially invited to utilize the service of our engineers and our special facilities for the development of new molded products.

Send us the data outlining any molding proposition in which you may now be interested.

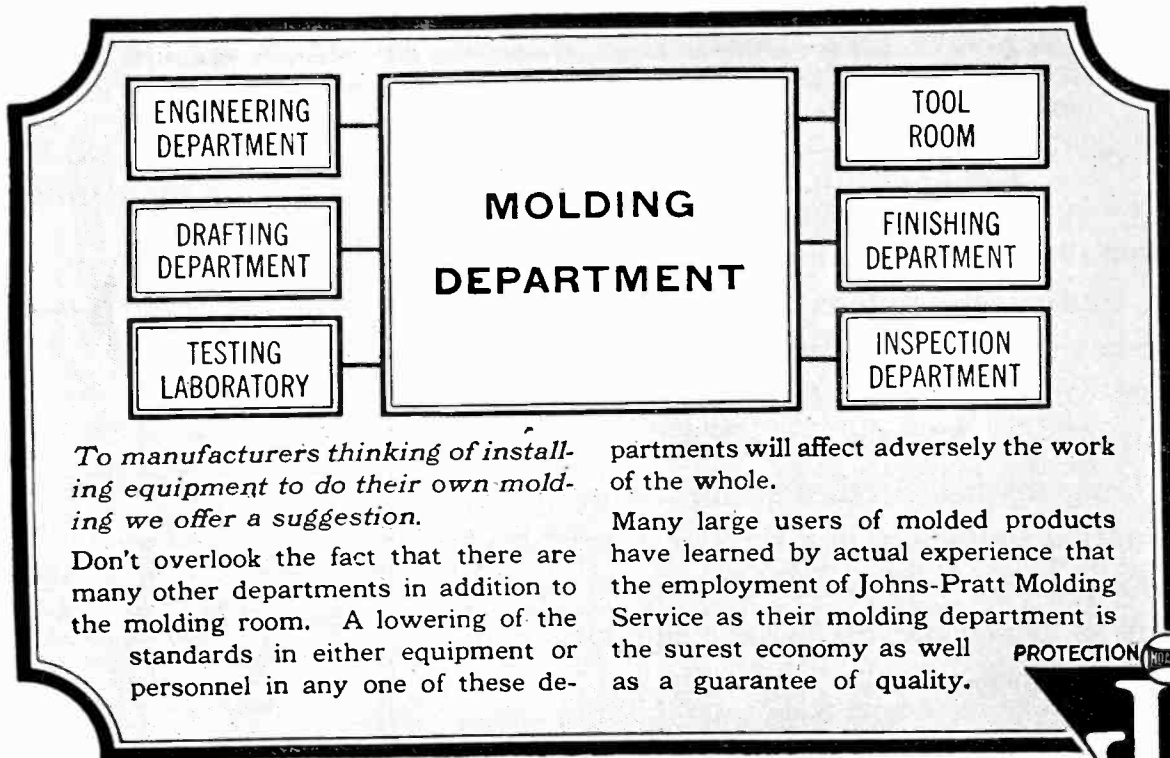

To manufacturers thinking of installing equipment to do their own molding we offer a suggestion.

Don't overlook the fact that there are many other departments in addition to the molding room. A lowering of the standards in either equipment or personnel in any one of these de-

partments will affect adversely the work of the whole.

Many large users of molded products have learned by actual experience that the employment of Johns-Pratt Molding Service as their molding department is the surest economy as well as a guarantee of quality.

PROTECTION SERVICE



The **JOHNS-PRATT COMPANY**, Hartford, Conn.

BOSTON (9)
161 Summer St.
PHILADELPHIA
22 So. 15th St.

CHICAGO
35 So. Desplaines St.
PITTSBURGH
104 Sixth St.

CLEVELAND
1365 Ontario St.
ST. LOUIS
314 N. Broadway

NEW YORK
41 East 42nd St.
SAN FRANCISCO
74 New Montgomery St.

EXPORT DEPARTMENT, 30 Church Street, New York, N. Y., U. S. A.

Molding Service

*Bakelite
Condensite
Redmanol
Molded Mica
Vulcabeston
"201" Stock*

Please mention the JOURNAL of the A. I. E. E. when writing to advertisers.

Allis-Chalmers

Steam Turbo-Generators

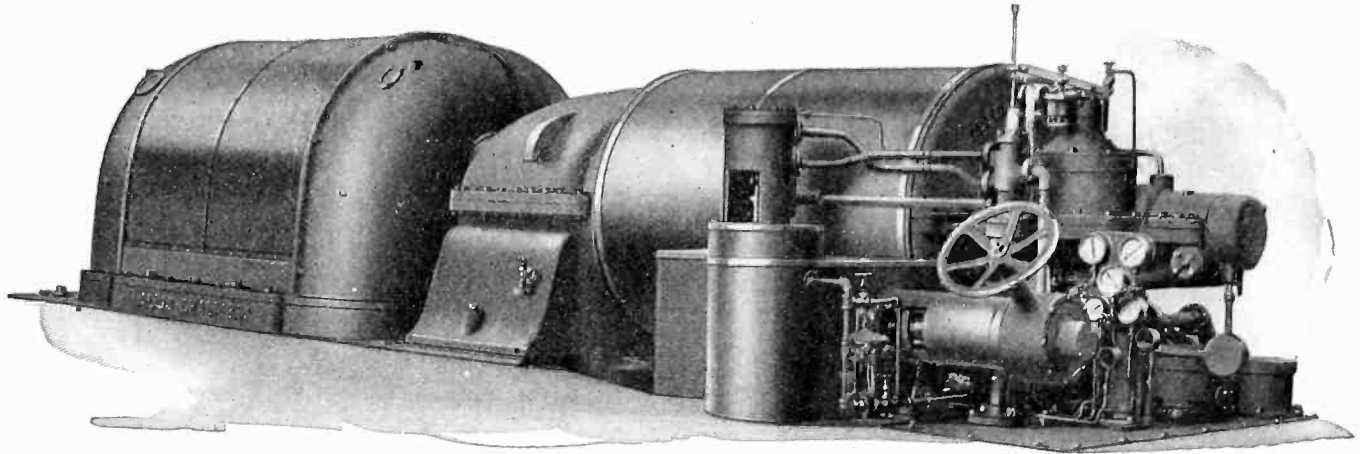

The above cut shows an Allis-Chalmers 5000 K. W. steam turbine and generator unit of the most modern design built for the Municipal Power Plant of the City of Ashtabula, Ohio. The Municipal Power Plant Station of the City of Cleveland, Ohio and the Lake Union Power Station of the City of Seattle, Washington, are the largest Municipal Power Plants in the United States and are equipped exclusively with Allis-Chalmers steam turbines and generators.

The exacting requirements of Municipal Power Plant service embodying perfect regulation, continuous uninterrupted operation, highest economy and freedom from repairs or adjustments can only be met by the highest type of prime mover. The Allis-Chalmers Manufacturing Company has installed steam turbine power generating equipment in a very large number of Municipal Power Plants in the United States many of which are exclusively equipped with Allis machines.

The fact that Allis-Chalmers turbines meet the requirements of service mentioned above makes these machines ideal for all manufacturing establishments and especially for those where the processes of manufacture require continuous operation.



PRODUCTS

Steam Turbines
 Electrical Machinery
 Steam Engines
 Condensers
 Oil Engines
 Gas Engines
 Hydraulic Turbines
 Pumping Engines
 Centrifugal Pumps
 Mining Machinery
 Metallurgical Machinery
 Crushing Machinery
 Cement Machinery
 Flour Mill Machinery
 Saw Mill Machinery
 Air Compressors
 Air Brakes
 Steam and Electric Hoists
 Farm Tractors
 Power Transmission Machinery

ALLIS-CHALMERS

MILWAUKEE, WIS. U. S. A.

Please mention the JOURNAL of the A. I. E. E. when writing to advertisers.

Do you know ?

“The Rule of 3”

of Turbine Lubrication

?

It's given on page 32 of “The Lubrication of the Steam Turbine”
Published by The Texas Company.

THIS 36 page book has received high praise from operators
and builders of turbines. It is not loaded with propaganda
for Texaco Turbine Oils.

This book discusses LUBRICATION. In logical sequence these
important items are taken up: oiling systems—lubricating methods
—effect of heat, water and deposits—cleaning—starting—oil
coolers—reduction gears.

NOT a theoretical treatise for students only; but for men in-
terested in turbines and the use of oil. It contains no pretty
pictures or long “History of the Turbine” going back to the
ancient Greek who discovered its principle. The text pages are
all “meat.”

“LUBRICATION OF THE STEAM TURBINE” was written
by and checked up by men who have observed lubricants at work
on all types of turbines.

Interesting enough to read at a sitting

Important enough to become part of your technical library.
Get a copy at once. Use Coupon below—NOW, before some
more immediate claim on your time causes you to forget.

Use This Coupon



THE TEXAS COMPANY, U. S. A.

TEXACO Petroleum Products

Dept. EE, 17 Battery Place, New York City

Offices in Principal Cities



Kindly send me free copy of your book “Lubrication of the Steam Turbine.”

Name..... Street.....

City..... State.....

10-23

Please mention the JOURNAL of the A. I. E. E. when writing to advertisers.

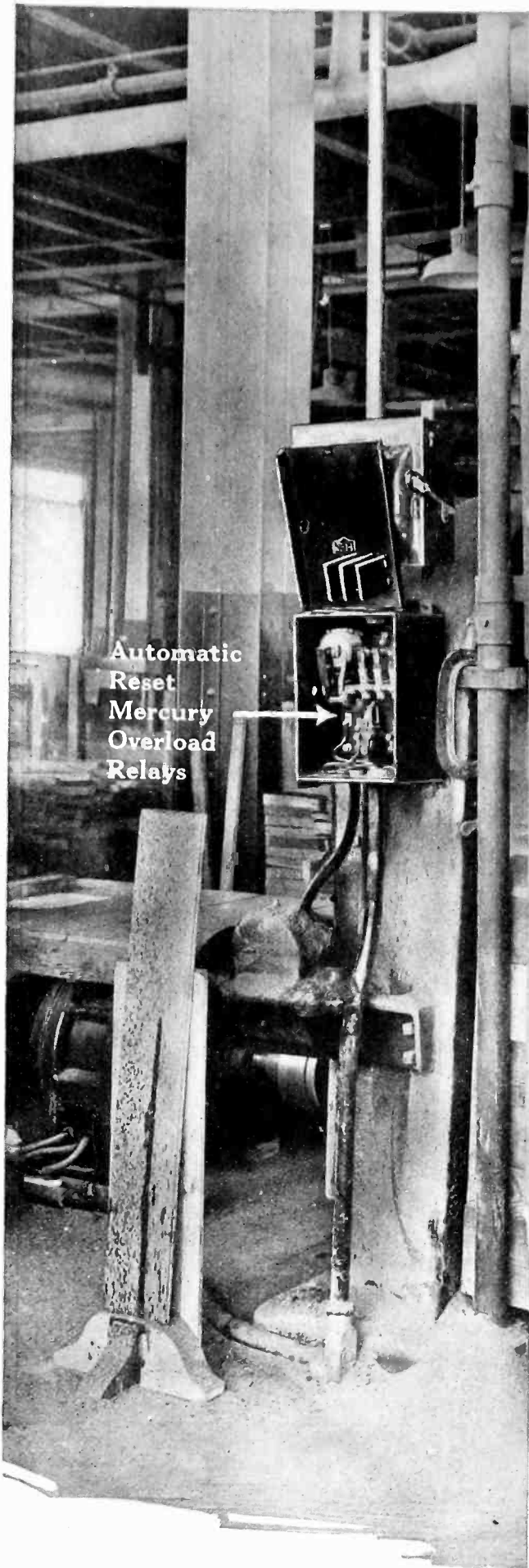

Automatic
Reset
Mercury
Overload
Relays

Reducing Fuse Expense on A. C. Motor Installations

The automatic reset Mercury Type Overload Relays used in C-H 9604 Automatic Starters give protection to squirrel cage motors during the starting *and* the running periods.

They provide this marked advantage: They allow the motor a sufficiently large current to provide good starting torque without tripping—because they function on the thermal principle.

The Overload Relays operate on heat rise rather than current rise—and since the larger current used in starting is only for a short period there is practically no overheating. But should this be lengthened due to excessive load on motor—or should one phase fail—the Relays open before the heating becomes dangerous.

Thus the expense of unnecessary fuse replacement is eliminated and protection provided against burning out of the motor windings.

The C-H 9604 Starter is enclosed and may be located where desired with push button “start” and “stop” stations placed where most convenient to the workman operating the machine.

Sales engineers in any of the C-H offices will be glad to give you detailed information on automatic starters or consult with you on any problem of motor control.

THE CUTLER-HAMMER MFG. CO.

Motor Control Department

Works: MILWAUKEE and NEW YORK

Offices and Agents in Principal Cities

Northern Electric Co., Ltd., Canada



AUTOMATIC STARTERS

ENCLOSED TYPE FOR SMALL A. C. SQUIRREL CAGE MOTORS

Please mention the JOURNAL of the A. I. E. E. when writing to advertisers.

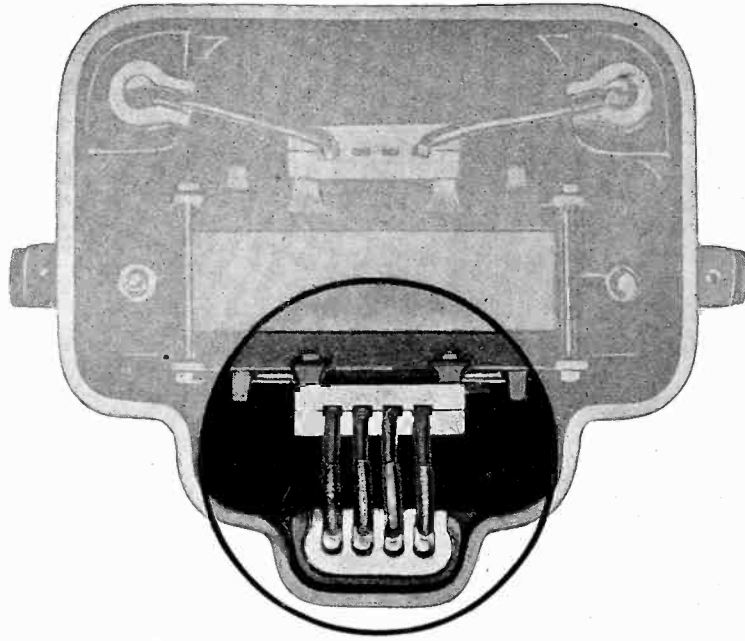

Notice

this neat porcelain terminal board

The back of a properly constructed switchboard is just as well built as the front. Every wire is run neatly and in perfect order.

So it should be in the arrangement provided for bringing out the high voltage leads of a transformer. Orderly, effective, without extravagance.

That is a good description of the high voltage terminal arrangements of WAGNER Distribution Transformers. The high voltage leads are brought up through a

neat porcelain board of such dimensions and shape as to insure proper electrical characteristics and rigid though simple mechanical construction.

Men who know transformers appreciate the importance of proper and safe terminal support. The superiority of WAGNER Transformers in this respect is a significant instance of WAGNER attention to every detail of transformer design and construction.

Write for Bulletin 1286.

WAGNER ELECTRIC CORPORATION SAINT LOUIS

Wagner, Quality

40° MOTORS AND "BLUEBLOOD" TRANSFORMERS

61-5320-4

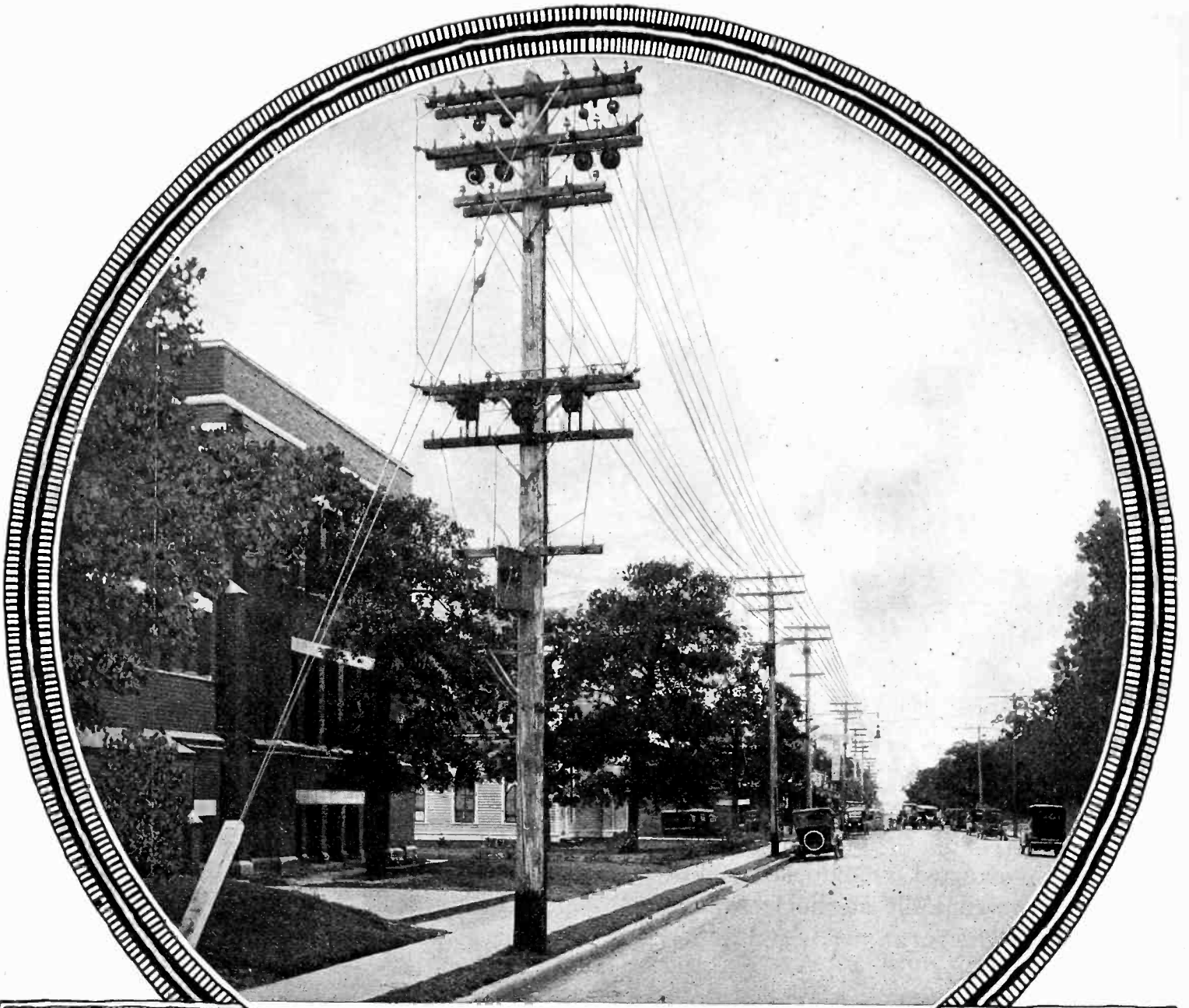

"P & H Process" Poles in lines of Dallas Power & Light Company, Dallas, Texas

"P & H Process"
1/2 inch Guaranteed Penetration
Saves you money

The longer life of "P & H Process" Poles assures a minimum of replacements and consequently lower maintenance costs. Investigate, find out for yourself why others prefer "P & H Process" Poles. Prompt shipment on all Cedar Pole needs, Butt-Treated or untreated.

"Still in the Lead"

PAGE AND HILL CO.
MINNEAPOLIS, MINN.

New York, N. Y. 50 Church St.
 Chicago, Ill. 19 So. LaSalle St.

Kansas City, Mo. 717 Bryant Bldg.
 Omaha, Neb. 513 Electric Bldg.

Dayton, Ohio, Reibold Bldg.
 Dallas, Texas, Central Bank Bldg.

Please mention the JOURNAL of the A. I. E. E. when writing to advertisers.

HOW MUCH DOES IT COST YOU TO CHANGE A FEEDER?

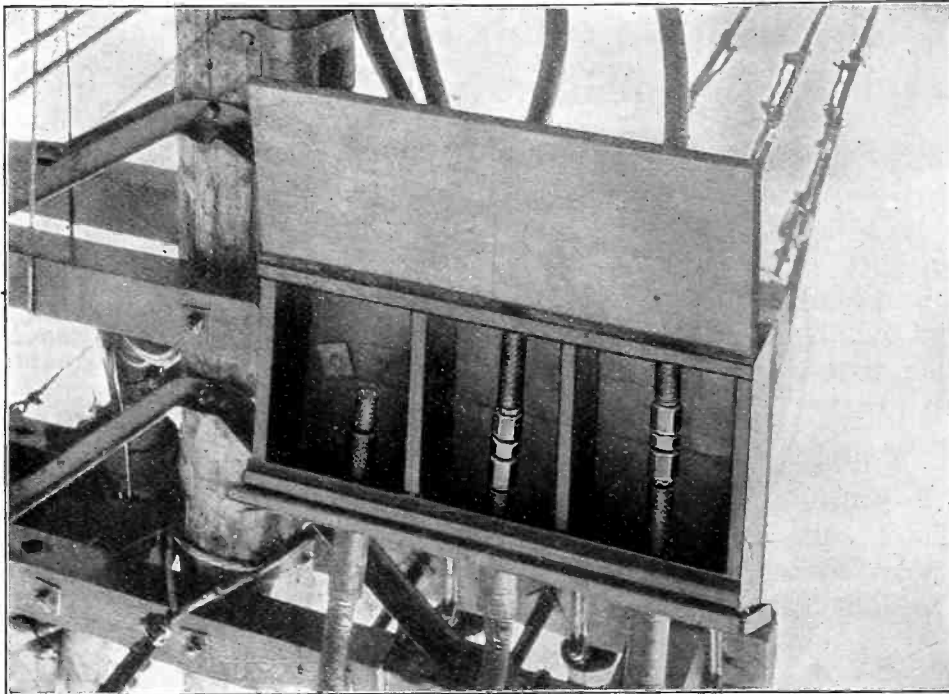

The above cut shows the method of using 1,000,000 C. M. (circular mils) straight 2-way Dossert connectors connecting underground return system to the overhead system.

In case of trouble or test work, the negatives can be opened in very little time. This is a very big labor-saving factor over the old method of making and soldering the joints and a big saving over switches.

Tests which have been made from time to time show that Dossert connectors run at as low temperature as enabled by the conductors connected to them.

A FEW OF THE BIG CENTRAL STATION USERS OF DOSSERT CONNECTORS

*Adirondack Power & Light Co.
Brooklyn Edison Co.
Cleveland Electric Illuminating Co.
Coast Counties Gas & Electric Co.
Connecticut Power Co.
Consolidated Gas, Electric Lt. & Power Co., Baltimore
Consumers Power Co.
Edison Electric Illuminating Co., Boston
General Electric Co.
Metropolitan Edison Co.
Mountain States Power Co.
New York Edison Co.
New York & Queens Elec. Lt. & Power Co.
Ohio Power Co.*

*Pacific Gas & Electric Co.
Pennsylvania Power & Light Co.
Public Service Electric Company of N. J.
Public Service Co. of Northern Illinois
San Joaquin Light & Power Co.
Southern California Edison Co.
Stamford Gas & Electric Co.
Toledo Edison Co.
United Electric Light & Power Co.
Union Gas & Electric Co., Cincinnati
United Gas & Elec. Engineering Corp.
United Illuminating Co.
Westinghouse Elec. & Mfg. Co.
York Haven Water & Power Co.*

SEND FOR CATALOG 15

DOSSERT & COMPANY

H. B. LOGAN, *President.*

242 W. 41st Street, New York

Learn for Yourself the Reasons for J-D Surpassing Qualities



No cement to crack or crumble under vibration or mechanical impact.

Power transmission engineers wishing to study J-D insulators and the methods by which they are made, assembled and tested are cordially invited to visit our factory.

Every step of assembly and test from kiln car to freight car can be watched without undue consumption of time. There will be no long delay for cement to set. The J-D product is cementless.

The assembly of J-D insulators is accomplished quickly as the metal spiders are anchored with J-D alloy which has a very low co-efficient of expansion. Tensile tests can be made, therefore, a few minutes after assembly.

Whether the tests be for mechanical strength, porosity or flashover value you will be interested in observing their complete thoroughness and the effective methods employed. Without doubt they are the severest known to the industry and several of them are applied by means of exclusive devices designed by our own engineers.

These tests are of the greatest importance because, combined with the principles of J-D manufacture and assembly, they guarantee a product that for high flashover value and permanency cannot be equalled on the market today.

Jeffery-Dewitt Insulator Company
Kenova, W. Va.

Executive Sales Offices: 50 Church Street, New York City



Please mention the JOURNAL of the A. I. E. E. when writing to advertisers.

California Leads the World in High Voltage Transmission—

Locke supplies California with high voltage insulators—

The eyes of the engineering world are turned toward California where one company, the Southern California Edison Co., has already commenced operation on its 240 miles Big Creek Line at the newest and highest practicable transmission voltage ever known, 220 k. v., while the Pacific Gas & Electric Co. will shortly put its 202-mile Pit River Line into operation at the same voltage.

As pioneer in the manufacture of high-voltage insulators—it is fitting that Locke Insulators have been supplied to both of these pioneer companies of high-voltage transmission.

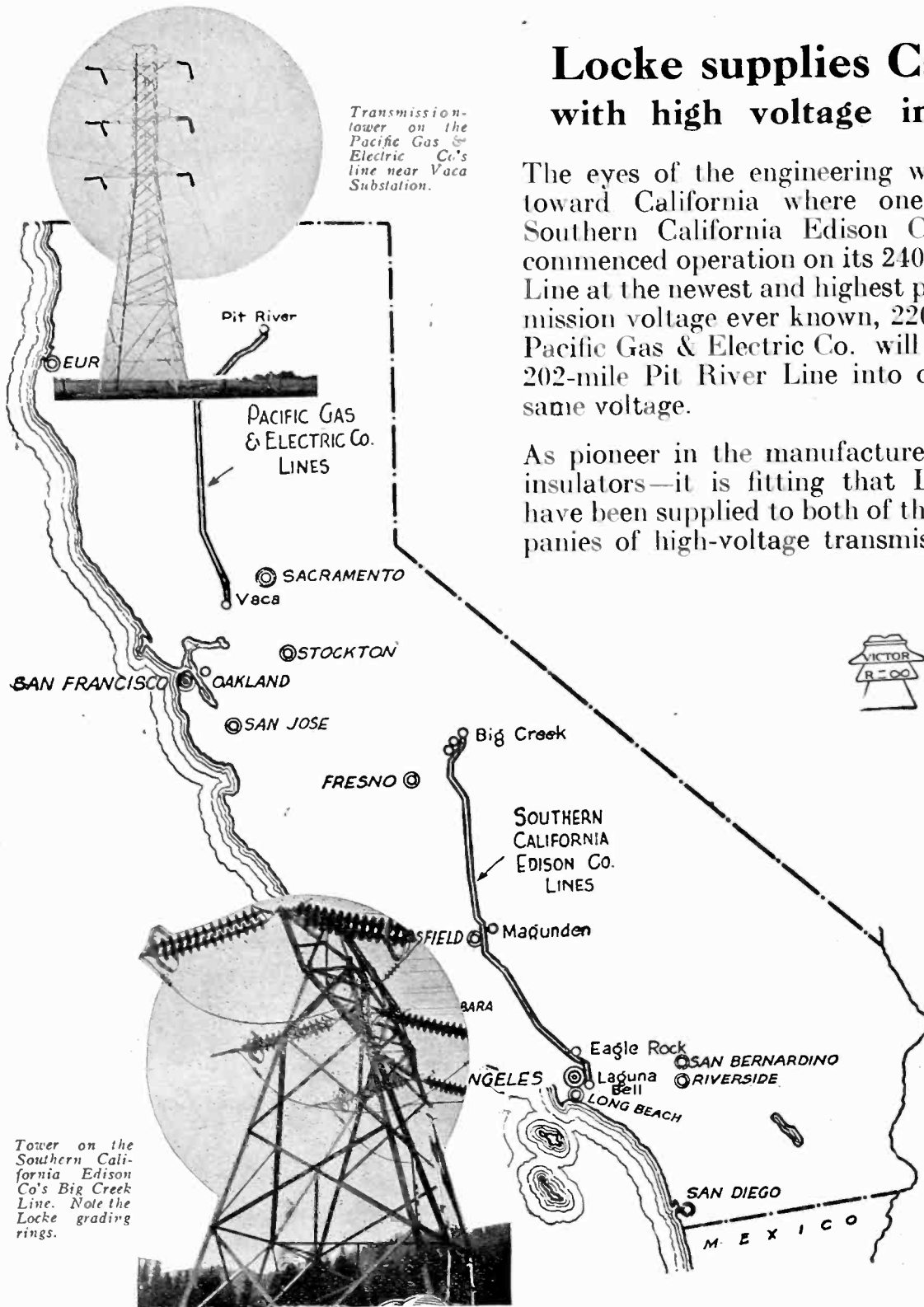

Transmission-tower on the Pacific Gas & Electric Co.'s line near Vaca Substation.

Tower on the Southern California Edison Co.'s Big Creek Line. Note the Locke grading rings.

LOCKE INSULATOR CORPORATION Victor, N. Y.

Over a quarter of a century manufacturer of electrical porcelain for high tension electrical power transmission

Factories: Victor, N. Y., and Baltimore, Md.

The Best
by
Line Test



An American
Standard
Since 1873

Thomas Quality Insulators and Transmission Line Fittings

The R. Thomas and Sons Co.
East Liverpool, Ohio.
U. S. A.

SALES OFFICES
New York - Boston - Chicago - London
Western Electric Co. Inc. on Pacific Coast
Northern Electric Co. Ltd. in Canada

The Line that R. and I. E. Co. Builds!

This is the  Base-Unit Channel

That supports the  H. & I. E. Interchangeable Insulator Units with Forged Steel Pins and Pressed Steel Caps. No design, no errors.

That carries the  Clamp Terminals, Brass Post Supports and Arcing Horns.

That holds the  Glass Cartridge Fuse. Protects Fuse Wire and makes Re-fusing easy.

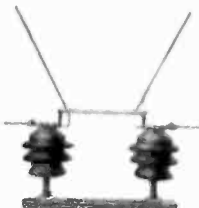
That makes up the  Interchangeable Unit Fuse Holder. Standard and parts completely designed and carefully made. Insure interchangeability.

Interchangeable Unit Fuse Holder and Fuse that R. and I. E. Co. Builds

R. & I. E. Interchangeable Insulator Unit Equipment for outdoor service includes Bar Supports, Disconnecting Switches, Air Break Horn Gap Switches, Choke Coils, Fuse Holders, Lightning Arresters, Substation Combinations and Outdoor Steel Substations.

Manufactured by
Railway and Industrial Engineering Co.
Greensburg, Penna.

Sales Offices in New York Boston Pittsburgh Chicago Cincinnati

6

The Problem

"High-tension line failures"

It has been found that breakdown of Insulation is prevalent more particularly in the Cable Joint.

By the exclusion of air, moisture, dirt and gas, a Joint stronger in every way than the Cable itself is possible.

The Joint must be correctly designed. It must be properly filled.

MINERALLAC INSULATING COMPOUND No. 78

is a very important specification in this connection. It thoroughly fills the Joint, pervading all voids and crevices and driving out undesirable matter.

The care used in preparing, filling and closing the Joint, decides whether it will or will not "stand up."

No. 78 will Insulate

We will be glad to send you Bulletin.

MINERALLAC ELECTRIC COMPANY

1045 Washington Blvd. Chicago, Ill.



Lapp Insulators do not fail

LAPP INSULATOR CO., Inc.

LE ROY, N. Y.

Sales Representatives

SAN FRANCISCO, S. H. Lanyon, 509 New Call Bldg.
DENVER, O. H. Davidson Equipmt. Co., 1633 Tremont St.
ST. LOUIS, Commercial Electrical Supply Co., Broad & Spruce Sts.
MINNEAPOLIS, J. E. Sumpter Co., 222 Security Bldg.
DETROIT, F. R. Jennings Co., 805 Ford Bldg.
INDIANAPOLIS, W. D. Hamer Co., 518 Trac. Terminal Bldg.
PITTSBURGH, Union Electric Co., 933 Liberty Ave.
BUFFALO, Robertson-Cataract Electric Co.
CHARLOTTE, N. C., J. W. Fraser Co.
PHILADELPHIA, Rumsey Electric Co., 1007 Arch St.
NEW YORK CITY, Shield Electric Co., 149 Broadway
BOSTON, Wetmore-Savage Co., 76 Pearl St.
WELLINGTON, New Zealand, Jas. J. Niven & Co.

Please mention the JOURNAL of the A. I. E. E. when writing to advertisers.

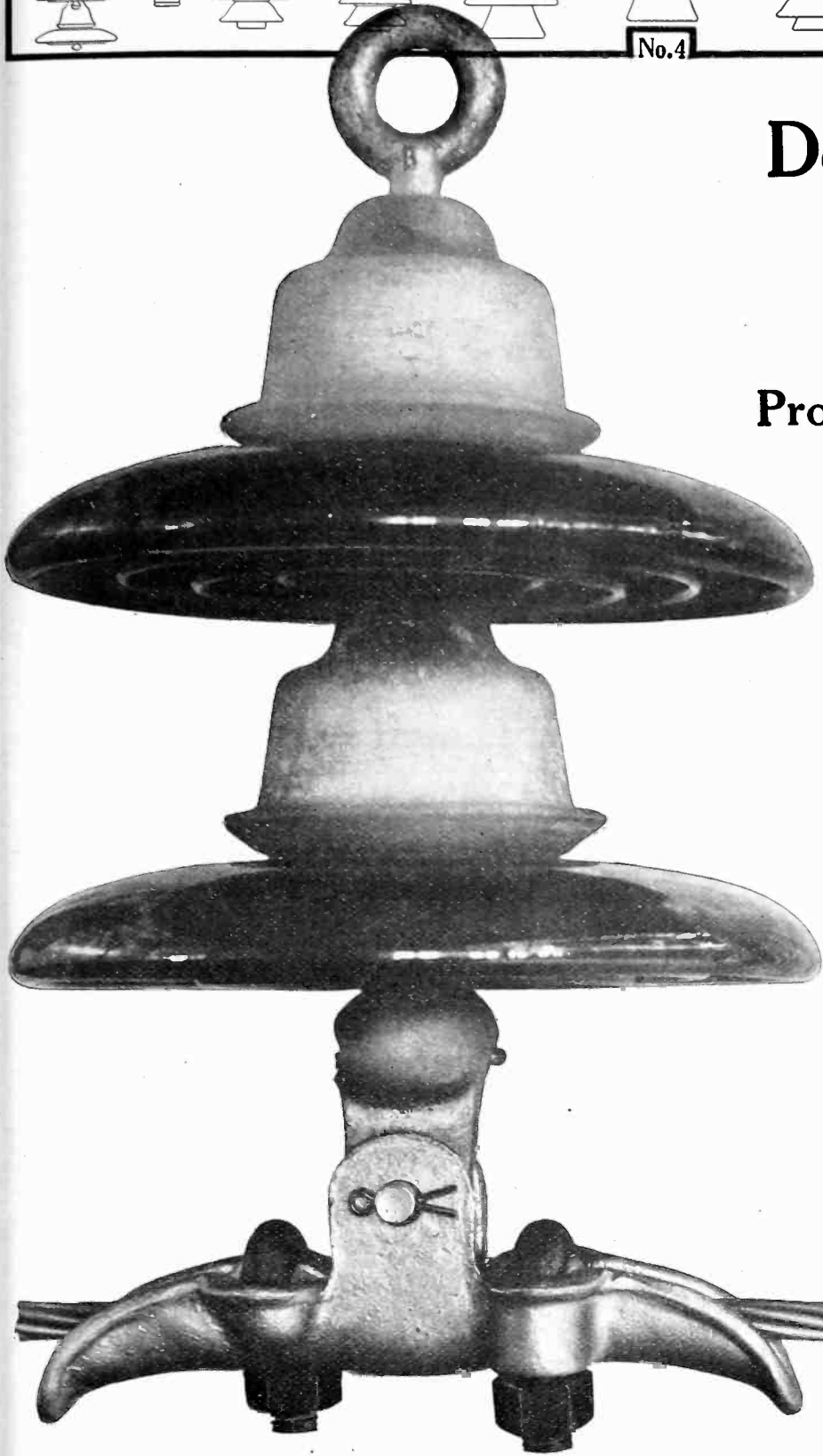
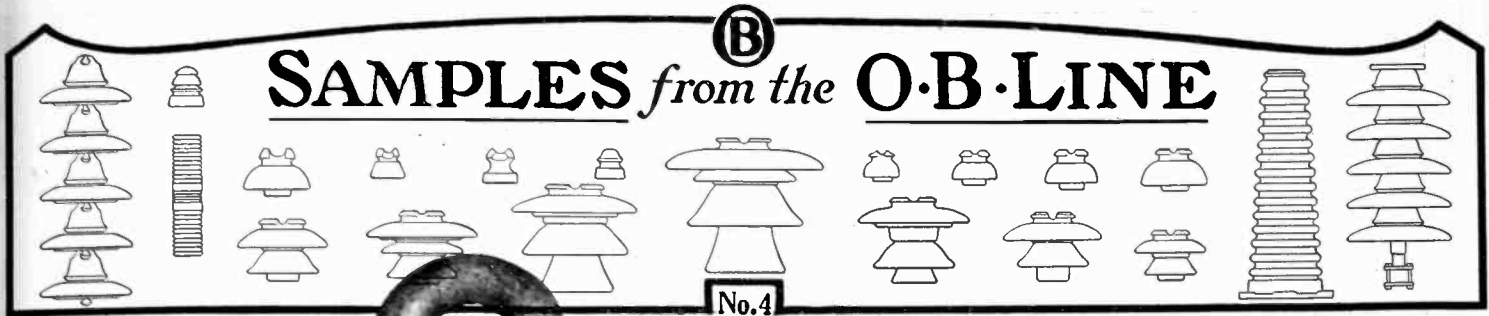

Dependable Suspension Insulators

Proved by years of service

YEARS ago, a large installation of O-B Suspension Insulators very similar in design to those illustrated here, was put into service. The design was radically different from any of the others suggested for the installation mentioned, but quickly proved its merit, and has since been extensively imitated.

Various refinements and valuable improvements have been added, but the original design has persisted, almost without change, and has made a truly remarkable record for reliability and long life.

Field service records of some of the largest operating companies indicate that O-B Insulators of this design have only their own field performance records to break.

115

The **Ohio**  **Brass** Co.
Mansfield, Ohio, U.S.A.

New York Philadelphia Pittsburgh Charleston, W. Va. Chicago Los Angeles San Francisco Paris, France
Products: Trolley Material, Rail Bonds, Electric Railway Car Equipment, High Tension Porcelain Insulators, Third Rail Insulators

Please mention the JOURNAL of the A. I. E. E. when writing to advertisers.

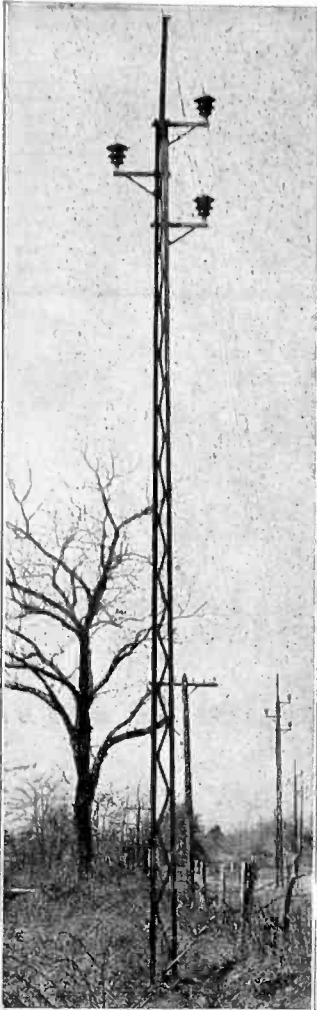

Bates Steel Poles

"Pole Value"

Every buyer of poles is concerned primarily with securing the most obvious "pole value" for the minimum investment.

By "pole value" we mean, ample strength to insure uninterrupted service, assurance of long life, adaptability for the service contemplated, moderate maintenance costs and initial costs that are not prohibitive.

Bates engineers will gladly co-operate with you in your planning.

Bates Expanded Steel Truss Co.
 Illinois Merchants Bank Bldg.,
 Chicago, Ill.

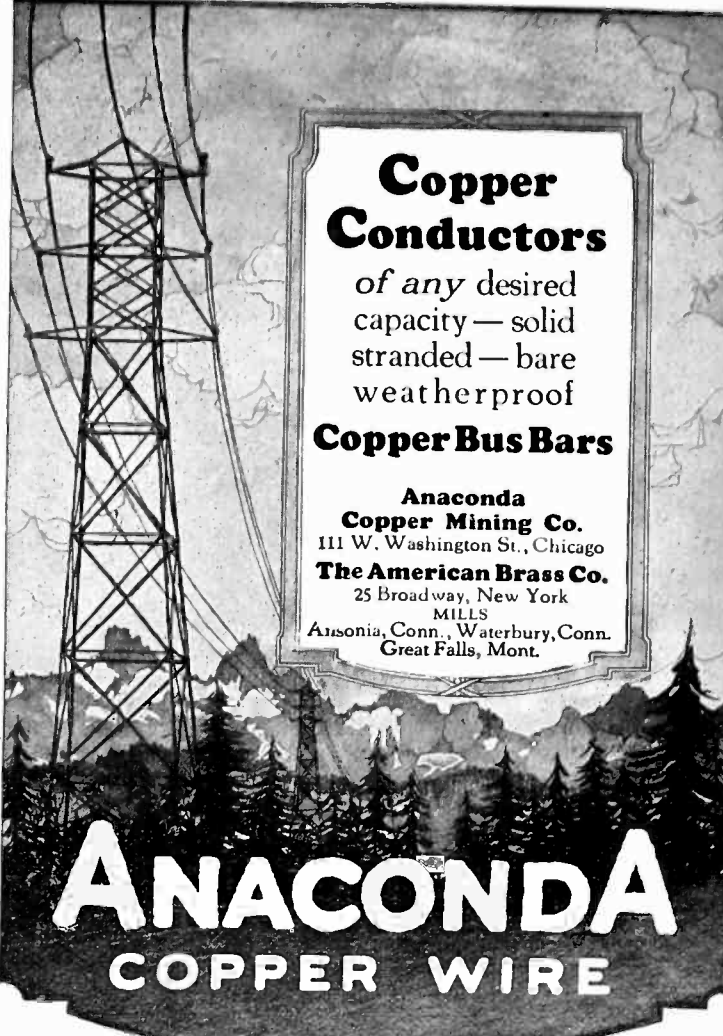

Copper Conductors

of any desired capacity — solid stranded — bare weatherproof

Copper Bus Bars

Anaconda Copper Mining Co.
 111 W. Washington St., Chicago
The American Brass Co.
 25 Broadway, New York
MILLS
 Ansonia, Conn., Waterbury, Conn.
 Great Falls, Mont.

ANACONDA

COPPER WIRE

HEMINGRAY

GLASS INSULATORS

The transparency of Hemingray Glass Insulators makes line inspection very simple. The lineman can tell at a glance whether the insulator is intact or not. Hemingray insulators are mechanically and dielectrically dependable, non-porous and uniform in structure. They defy moisture and age.

Send for Bulletin No. 1.

HEMINGRAY GLASS COMPANY
 Muncie, Indiana



BENNETT

SURGE ARRESTERS

*Ideal Protection
 Ruggedness
 Simplicity*

*Write for
 Bulletins and
 Questionnaire*

Electro **SERVICE** Company
 MARIETTA, GA.

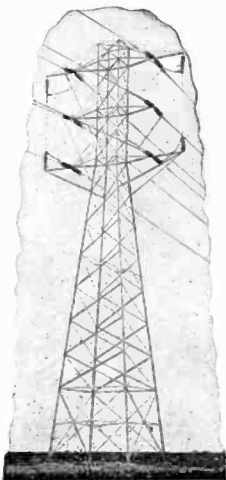

Transmission Line Structures

Built of High Elastic Limit Steel
 Refined — Rolled — Fabricated —
 Galvanized in Our Own Plants

PACIFIC COAST STEEL COMPANY

MANUFACTURERS OF
OPEN HEARTH STEEL
 STRUCTURAL SHAPES MERCHANT AND REINFORCING BARS
 TRANSMISSION TOWERS AND STRUCTURES

Gen'l Office: Rialto Bldg., San Francisco Plants: San Francisco, Portland, Seattle

Please mention the JOURNAL of the A. I. E. E. when writing to advertisers.

STANDARD

Copper Wire — High Strength Bronze Wire — Copper Clad Steel Wire

For trolley and transmission service

Meet every service requirement, however exacting

They are rolled and drawn in our own rod and wire mills from the highest grade copper wire bars, and their superior and uniform quality is assured by a system of careful inspections and tests at different stages of manufacture. Their dependability has been demonstrated by many years of service under all sorts of operating conditions.

We have unexcelled manufacturing and shipping facilities at our several factories and, in addition, carry considerable stocks of standard materials at convenient shipping points.

Write our nearest office about your requirements.

STANDARD UNDERGROUND CABLE CO.

NEW YORK	WASHINGTON	PITTSBURGH	DETROIT	SAN FRANCISCO	SEATTLE
BOSTON	PHILADELPHIA	ATLANTA	CHICAGO	ST. LOUIS	LOS ANGELES
KANSAS CITY					

Factories: PERTH AMBOY, N. J.; PITTSBURGH, PA.; ST. LOUIS, MO.; OAKLAND, CALIF.
FOR CANADA: STANDARD UNDERGROUND CABLE CO. OF CANADA, LIMITED, HAMILTON, ONT.



CABLE TERMINAL DEVICES

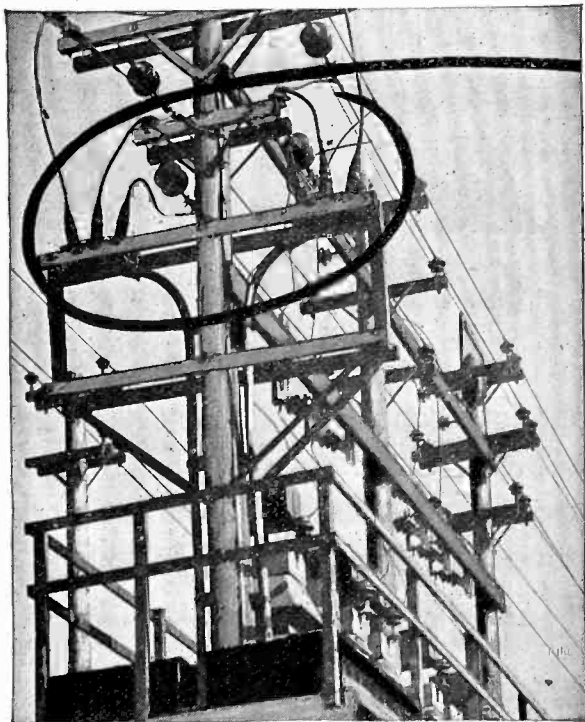

POTHEADS, DISTRIBUTION BOXES

Better Overhead Construction

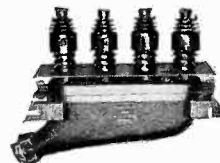

Better Protection for Linemen

Note how these potheads are situated. Doesn't this overhead construction recommend itself to your work? Did you ever see a neater and simpler way of providing a completely serviceable, simple and flexible distribution system?

There are hundreds of places where it pays to use G and W Potheads and other specialties. Tell us your conditions and send today for catalogs, blue prints, prices and suggestions applicable to your conditions.

G & W ELECTRIC SPECIALTY CO.

Chicago Illinois

Representatives in All Principal Cities

G & W ELECTRIC SPECIALTY CO.

page 53

page 54

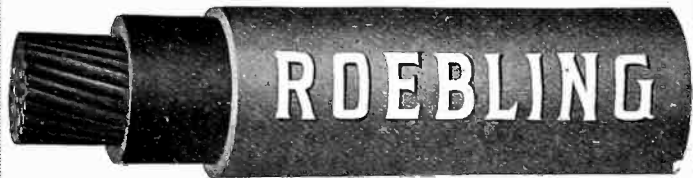

ELECTRICAL WIRES

AND CABLES
WIRE ROPE WIRE STRAND
WELDING WIRE

John A. Roebling's Sons Co.
Trenton, New Jersey

WIRE PRODUCTS For Varied Applications

We manufacture many types of wires, cords and cables for specific uses. Among them are:

Rubber Covered Wire—Solid Conductor, Stranded Conductor, Flexible Conductor, Extra Flexible Conductor. Lamp Cords, Reinforced Cords, Heater Cord, Brewery Cord, Canvasite Cord, Packinghouse Cord, Deck Cable, Stage Cable, Border Light Cable, Flexible Armored Cable, Elevator Lighting Cable, Elevator Operating Cable, Elevator Annunciator Cable. Switchboard Cables, Telephone Wire, Flameproof Wires and Cables, Railway Signal Wires, High Voltage Wires and Cables. Automobile Ignition Cables, Automobile Lighting Cables, Automobile Starting Cables, Automobile Charging Cables. Moving Picture Machine Cable.

Boston Insulated Wire & Cable Co.
Main Office and Factory:
Dorchester District Boston, Mass.
Canadian Branch, Office and Factory, Hamilton, Ont.

CEDAR POLES

NORTHERN WHITE CEDAR
WESTERN RED CEDAR

PLAIN OR TREATED BUTTS.

Prompt shipments guaranteed.

Ask for our delivered prices.

T. M. PARTRIDGE LUMBER CO.
729 - 32 Lumber Exchange,
MINNEAPOLIS, MINN.

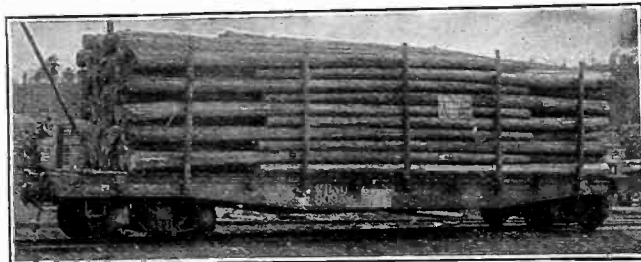

CEDAR POLES NORTHERN WHITE
WESTERN RED
PLAIN OR BUTT-TREATED

Satisfaction Guaranteed

THE MAC GILLIS & GIBBS COMPANY
Milwaukee, Wis.

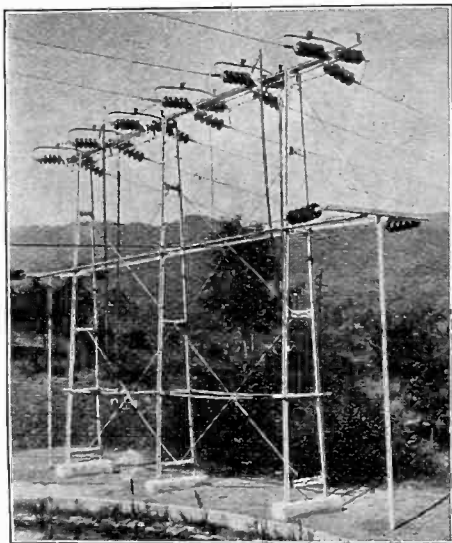

**Simpler—
Stronger—
Better—**

Installation K-P-F
60 KV. Switches,
San Joaquin Lt. &
Pwr. Corp., Calif.

K-P-F POLE TOP SWITCHES consist of fewer parts, are more rugged and require less labor and material for installation than any other.

Each pole becomes a self-contained unit. Switches are shipped ready to bolt on to cross-arm in place of line insulator.

One crossarm supports it. Contacts are far removed from insulators and a unique device prevents sticking or freezing.

Send for bulletin K105 containing full details.

K-P-F ELECTRIC CO.
855-859 Howard St. San Francisco

"COPPERWELD"

OVERHEAD GROUND WIRE

DOES NOT RUST AWAY

Most objections to overhead ground lines have arisen from troubles following rusting of the wires.

A life at least equal to the power conductors is now recognized as the foremost requirement in the selection of an overhead ground wire.

Copperweld wire does not rust.

COPPER CLAD STEEL COMPANY

36 Church St., New York, N. Y.
Braddock P. O., Rankin, Pa.
129 S. Jefferson St., Chicago, Ill.
403 Rialto Bldg., San Francisco, Cal.

COPPERWELD IS MADE BY THE MOLTEN WELDING PROCESS
Fill out the coupon and mail to our nearest office

Please mail me Engineering Data on Copperweld Overhead Ground Wire, and Sag and Tension Charts for my personal files.

Name.....

Company.....

Address.....

Tantalum metal forms an electrolytic valve when used in a cell with another electrode. Tantalum is not attacked by acids or alkali solutions.

Fansteel Products Company manufactures tantalum in sheets, wires and rods. Other metals manufactured by the same company which may help solve electrical difficulties are molybdenum in sheets, wires and special shapes or tungsten contact points.

Fansteel tungsten contact points have been standard of quality for eight years.

FANSTEEL PRODUCTS COMPANY, INC.
North Chicago Illinois

MOLONEY TRANSFORMERS

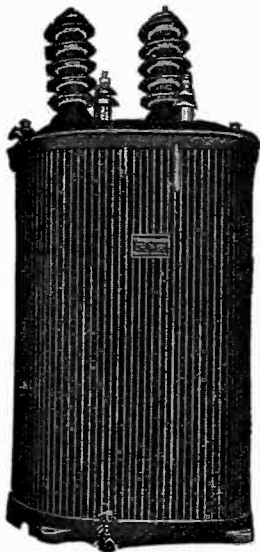

WE have been manufacturing transformers now for over a quarter of a century—a long time in an industry so young.

Moloney Engineering Experience has dealt with the transformer in every phase of its development.

From the first, Moloney Engineers have been animated by a two-fold purpose: to build the highest attainable quality, and to build it economically.

Moloney Transformers are recognized by all transformer users as the highest standard—a fact which demonstrates the success which has crowned the efforts of Moloney Engineers.

Moloney Electric Co.
Manufacturers of Transformers Exclusively

FACTORY AND MAIN OFFICE

St. Louis, Mo.

Offices in All Principal Cities

TIREX RUBBER ARMORED CABLES

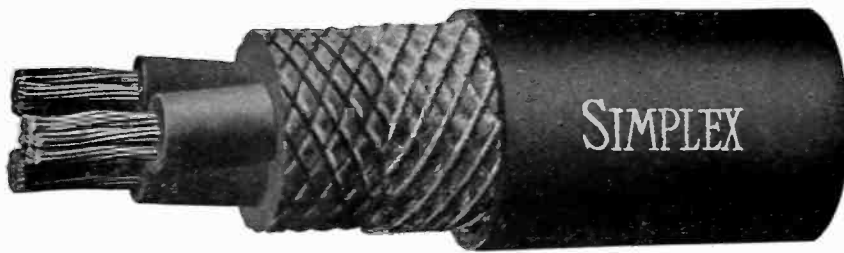

The main distinguishing feature of TIREX Cables - like TIREX Portable Cord and TIREX Lamp Cord - is the rubber sheath which envelops the insulated conductors and protects them from injury. This sheath is of high-grade tire-tread stock containing 60% of Para rubber and specially compounded and cured to insure maximum wearing qualities and toughness.

Additional detailed information including terms and prices, upon application.

SIMPLEX WIRE & CABLE CO

MANUFACTURERS

201 DEVONSHIRE ST., BOSTON 9
CHICAGO SAN FRANCISCO NEW YORK

Irvington Varnish & Insulator Co.

Has obtained the Sole Selling Agency of the products of

THE HARVEY WIRE COMPANY

Newark, N. J.

We offer the Electrical Trade a full line of

ENAMELED, SILK COVERED AND COTTON COVERED WIRE

The production of enameled and insulated wires is basically an insulation problem, and every co-operative effort will be made by the Technical and Manufacturing staffs of both Companies to maintain the standards of quality which are characteristic of IRVINGTON products.

IRVINGTON VARNISH & INSULATOR CO.

Irvington, New Jersey.

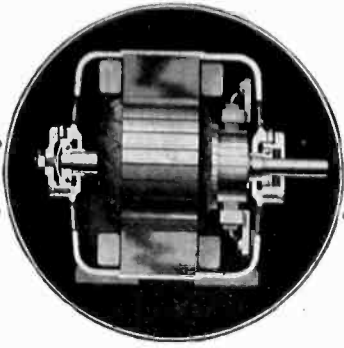

Do Your Motors Need Frequent Servicing?

A motor is a good motor—from the buyer's and user's standpoint—only when it runs right. When he has to send for the service man, troubles begin—and multiply.

"NORMA" PRECISION BALL BEARINGS

In fractional hp. motors minimize the necessity for servicing—most of which (experience proves) comes from neglect of proper oiling. Magazine lubrication in the "NORMA" mounting keeps the motor running smooth and free, for long periods, without renewal, without attention. This means maximum motor life, minimum servicing expense.

*Let us send you the booklet on
making good motors better*

THE NORMA COMPANY OF AMERICA

Anable Avenue
Long Island City New York
BALL, ROLLER AND THRUST BEARINGS

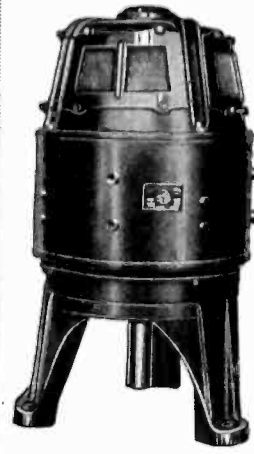
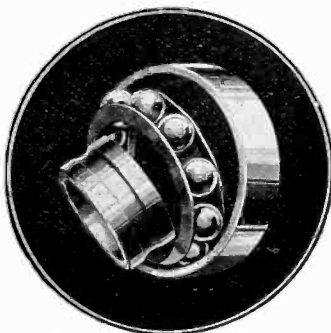

STAR Ball Bearing Motors For All Purposes

Horizontal-Vertical

- D. C. Interpole Motors
for hard usage—1 to 40 hp.
Sparkless commutation at
all times.
- A. C. Polyphase Motors
squirrel cage induction and
slipping—all cycles, 1 to
40 hp., 110 to 550 volts.
- A. C. and D. C. Generators and
Motor-Generator Sets
Write for Bulletins.

Star Electric Motor Co.

Miller St. and N. J. R. R. Ave., Newark, N. J.

"AK" Variable Speed Motor for Printing Machinery

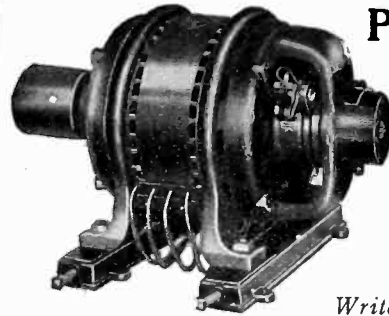

Highest efficiency under
variable load. Wound
for 25% overload.
Push button control.
For A. C. any cycles.
In sizes 1/20 to 5 H. P.

Modern, safe equipment
for job or cylinder press.

Write for complete information.

NORTHWESTERN ELECTRIC COMPANY

Also Mfrs. of the new "Martin" Rotary Converter.
409 So. Hoyne Avenue, Chicago, Ill.
Minneapolis—8 N. Sixth St. Kansas City, Mo.—1924 Grand Ave.
Toronto, Can.—308 Tyrrel Bldg., 95 King St., E.

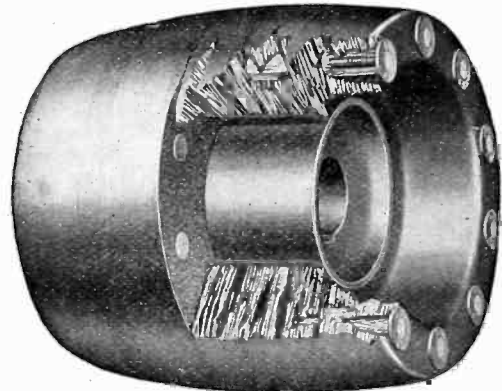

[Section removed to show construction]

ROCKWOOD PAPER PULLEYS

1. Reduce slippage
2. Decrease belt tension
3. Transmit more power
4. Lower total cost of drive,
due to narrower belts.

Whenever you buy a pulley for a motor, get a Rockwood Paper Pulley, the pulley that most every motor is equipped with when it leaves the factory. Rockwood is more than a pulley—it is pulley service! Order from your electrical dealer or direct from us.

THE ROCKWOOD MFG. COMPANY
194 English Avenue INDIANAPOLIS, U.S.A.

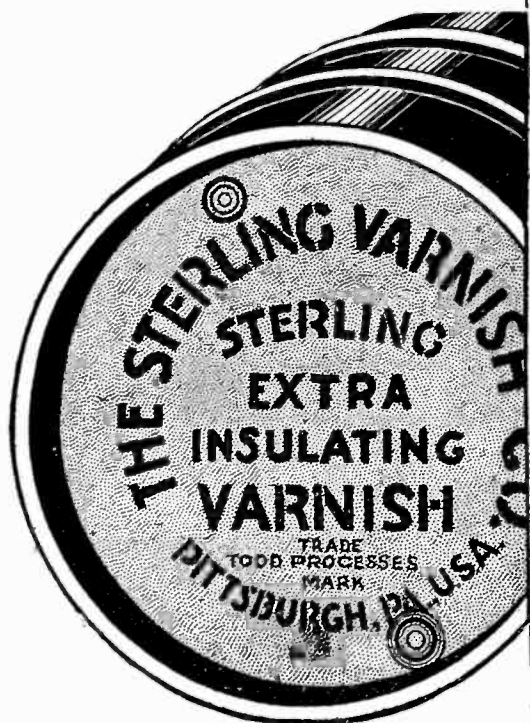

"A course in Good Motor Practice"

That is what a maintenance engineer called this handbook

—for the foundation of good motor service is the proper winding and insulating of motors.

Your problem—insulating motors—coils, fields, armatures—will be made easier by reading this book.

It gives the best practice and enables you to pick just the varnish, enamel or japan you need for a given job.

Catalog No. 20 is a real text book on insulation. It is too valuable not to have on your desk. Especially when a request from you will bring it promptly. Write today for Catalog No. 20.

STERLING VARNISH
THE STERLING VARNISH COMPANY, PITTSBURGH, PA.

New Departure Ball Bearings

Electrical Engineers Should Have This Book

Portable tools especially need ball bearings, because of the necessary compactness of the installation. The fact also that these tools are handled at all angles renders the oil retention features of ball bearings most imperative.

The Ball Bearing Reference Book illustrated is issued by the Engineering Department in loose leaf form, and new data is added monthly to the 3,000 engineers and designers on our mailing list. Please use your Company letterhead in requesting.

The New Departure Manufacturing Company
Chicago Bristol, Conn. Detroit

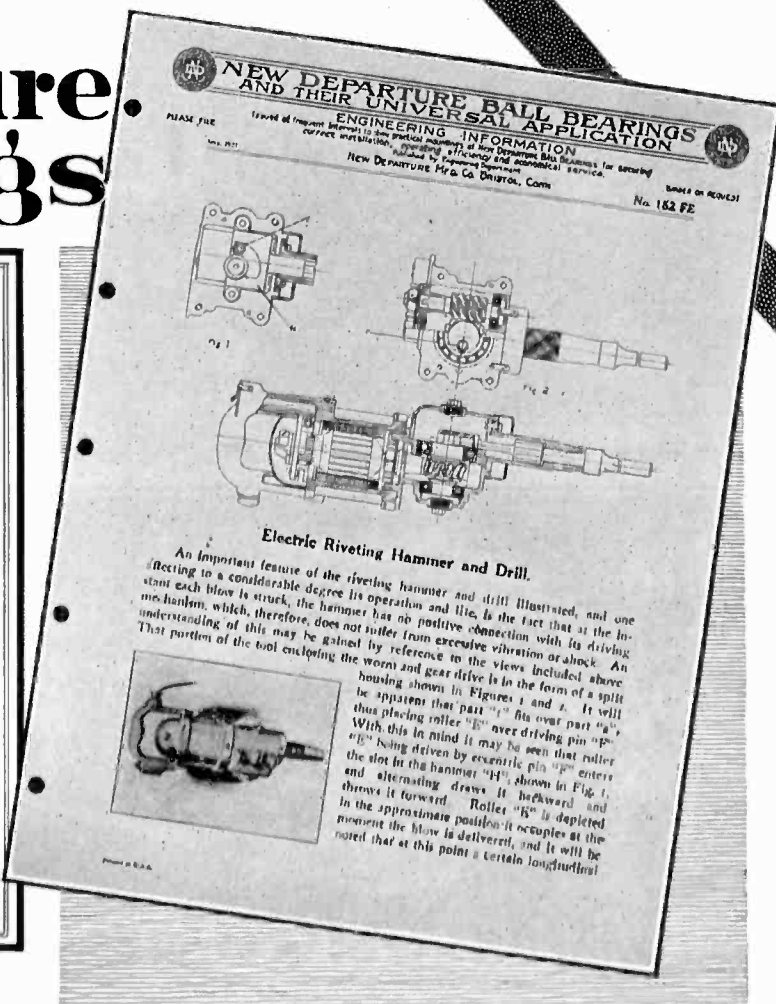

Please mention the JOURNAL of the A. I. E. E. when writing to advertisers.

TRANSFORMER DELIVERIES

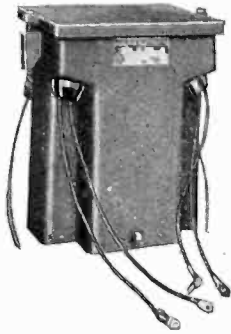

Distribution Sizes
from stock

Power and
Transmission Types
promptly

Since
1893

Get our stock list of

KUHLMAN TRANSFORMERS

Kuhlman Electric Company
Bay City, Michigan

Every Central Station Manager
Has Complaints to Settle



Bristol's Recording Ammeter

With just a glance at our Ammeter chart, you can tell every fluctuation and quantity of current, together with the length of time.

TRADE MARK
BRISTOL'S
REG. U. S. PAT. OFFICE.
Recording Ammeters

will keep you posted as to the exact conditions in the Central Station and on the distributing lines. They are unequalled for settling complaints.

Ask for Catalog BC-1501.

THE BRISTOL COMPANY
Waterbury, Conn.

Branch Offices:
Boston New York Philadelphia Detroit Pittsburgh
Chicago St. Louis San Francisco

Pittsburgh Transformer Company

Largest Manufacturers of Transformers exclusively
in the United States

Pittsburgh, Pennsylvania

THE
WORLD
CAN
DEPEND
ON



THE ELECTRO DYNAMIC MOTOR

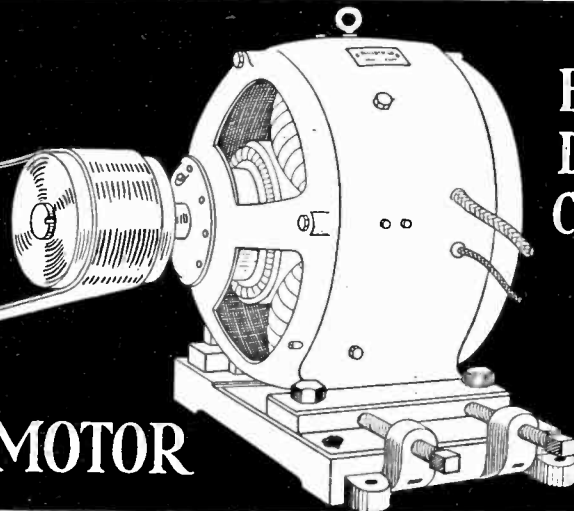

ELECTRO DYNAMIC COMPANY

BAYONNE,
N. J.

Sales offices
in
Principal cities

Air Washers!

for turbo-generators

SPRACO "Vertical" Air Washing and Cooling Equipment for the new enclosed system of ventilation possesses three important advantages:

- (1) Increases reliability of generator unit, eliminating shutdowns.
- (2) Secures long period of contact between hot air and cool water through VERTICAL discharge of Spray.
- (3) Automatic control for air inlet and discharge dampers insures absolute safety under emergency conditions.

For full particulars
write Dept. A W-69

Spray Engineering Co.
60 High Street Boston, Mass.

Manufacturers of Air Washing Equipment, Spray Cooling Equipment, Paint Spraying Equipment, Flow Meters, Park Sprinklers, Self Cleaning Strainers.

Engineers for Spray Cooling Systems, Irrigation Systems, Aerating Reservoirs, Air Conditioning, Gas Washing.

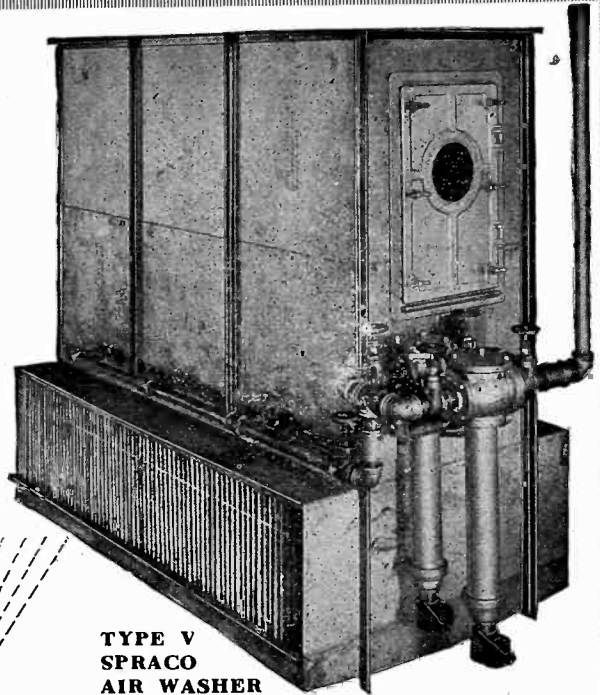

**TYPE V
SPRACO
AIR WASHER**

Uses same air over—rewashing and recooling.
Enables generator to run indefinitely without cleaning.



TRADE MARK

SPRACO

BOSTON

DOES THIS
INTEREST YOU?

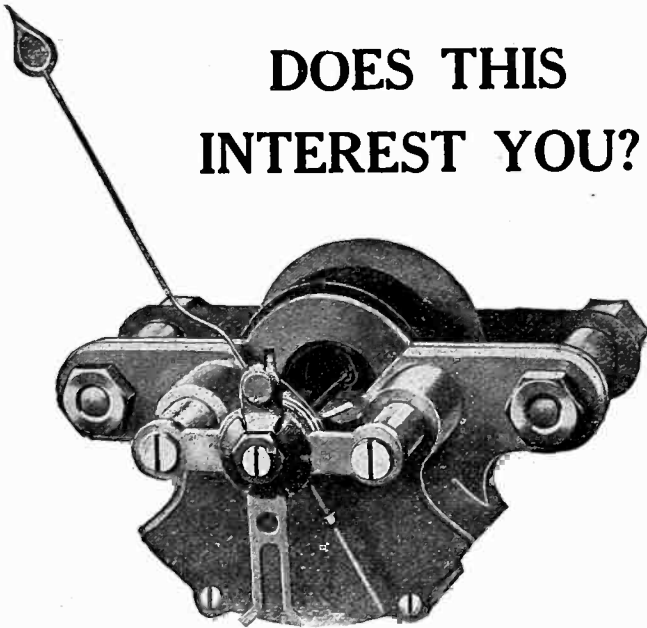

If it does, send for *new* Bulletin No. AE-450 and you will find a lot of other interesting things concerning a most comprehensive line of alternating current switchboard instruments.

ROLLER-SMITH COMPANY
Electrical Instruments Meters and Circuit Breakers

MAIN OFFICE
12 Park Place, NEW YORK

WORKS:
Bethlehem, Penna.

Offices in Principal Cities in U. S. and Canada

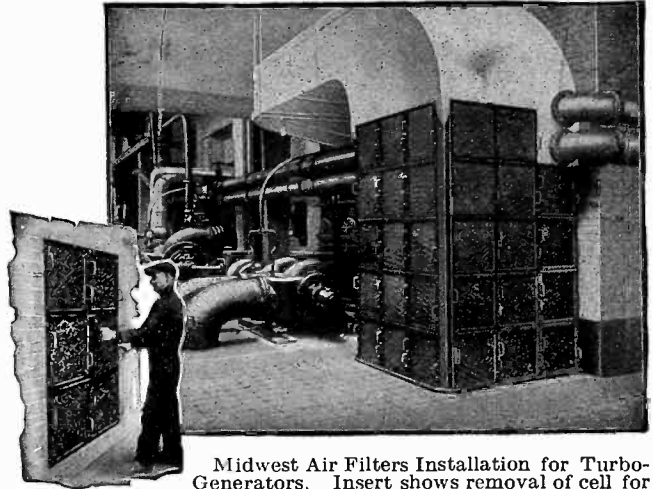

Midwest Air Filters Installation for Turbo-Generators. Insert shows removal of cell for cleaning.

Don't Let Dust Do Damage!

Dust *can* ruin your turbo-generators, air blast transformers, motors, etc. Dust *does* cut down the capacity of this equipment by making it operate at higher temperatures. Dust is in the air of *your* plant in dangerous quantities, even if you cannot see it.

MIDWEST AIR FILTERS

Supply clean cooling air without the use of any moving parts, sprays, pumps, or anything to get out of order. If you want a reliable source of clean air there is only one way—Midwest Air Filters.

Send for our new catalog. Write Dept. F-1.

MIDWEST AIR FILTERS

MIDWEST CANADA LIMITED MONTREAL CANADA	INCORPORATED 100 EAST 45TH STREET NEW YORK CITY	MIDWEST AIR FILTERS PACIFIC, INC. 933 MONAGHOCK BUILDING SAN FRANCISCO, CAL.
---	---	--

OFFICES IN PRINCIPAL CITIES

Please mention the JOURNAL of the A. I. E. E. when writing to advertisers.

THE ROWAN A.C. STARTING SWITCH

PUSH BUTTON OPERATED
OIL IMMERSED



FOR
STARTING AND STOPPING SMALL SQUIRREL CAGE
MOTORS THAT CAN BE THROWN ACROSS
THE LINE

ROWAN CONTROL
THE ROWAN CONTROLLER CO., BALTIMORE, MD.

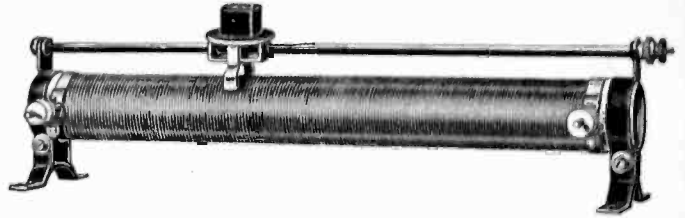

JAGABI RHEOSTATS

are provided with sliding contacts which permit very small and gradual variations from zero to full rating.

Tube Rheostats are made in three different sizes, with lengths of 8", 16" and 20" respectively; and are supplied in "single", "vertical", "double", "universal" and "Dodge" types. Stone Rheostats are 8" long, and are available in "single", "double" and "universal" types.

For Single Tube Rheostats the resistance values may be as high as 14,000 ohms, with current capacity of 0.2 ampere; or as low as 0.34 ohm with current capacity of 25 amperes.

Jagabi Rheostats meet a very definite need in Research, Educational and Industrial work; especially as they combine a high degree of reliability with moderate prices.

Write for bulletin J-980.

JAMES G. BIDDLE
ELECTRICAL INSTRUMENTS
1211-13 ARCH ST., PHILADELPHIA

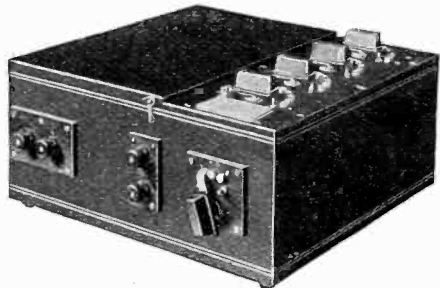

TYPE 216

CAPACITY BRIDGE

Do you ever have occasion to make capacitance measurements of but a few micromicrofarads?

Do you ever need to make dielectric loss measurements?

If you do, you will appreciate the simplicity of the Type 216 Capacity Bridge. It is designed for precision measurement work.

— PRICE \$160 —

Send for BULLETIN 406E describing this bridge.

GENERAL RADIO CO.
Manufacturers of
ELECTRICAL AND RADIO LABORATORY APPARATUS
Massachusetts Avenue and Windsor Street
CAMBRIDGE MASSACHUSETTS

A cheap
Circuit-Breaker,
wrapped up
in tin, is not
a

U-RE-LITE

CUTTER *The* **COMPANY**
ESTABLISHED 1888  PHILADELPHIA

1829 Hamilton Street

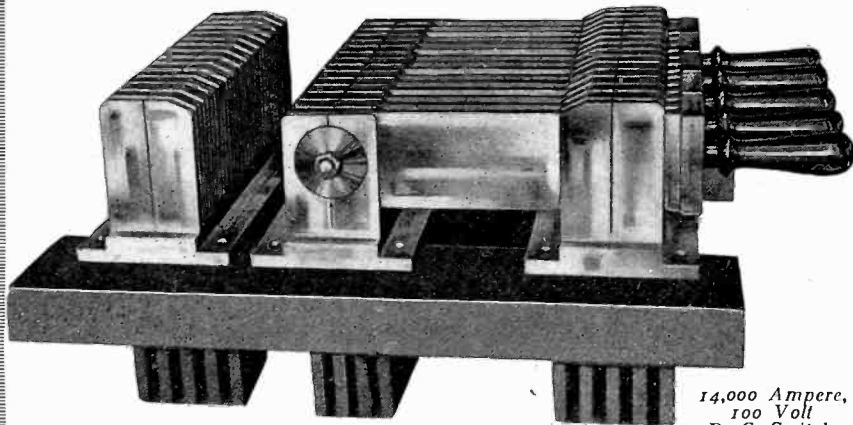

14,000 Ampere,
100 Volt
D. C. Switch

Heavy Duty Switches

This is one of the switches built for the Chile Exploration Company and in use near Lake Titicaca, Chile. The construction is necessarily massive, yet its action is most precise.

We specialize in the design and construction of heavy duty switches and have built such types for numerous large central stations and industrial power plants. Similarly, our disconnecting switches and switchlocks are in use on many of the greatest power systems.

Write us on any high or low tension switch problem. We shall be glad to submit sketches and costs, without obligation on your part.

Thoner & Martens

463 Commercial Street, BOSTON, MASS.

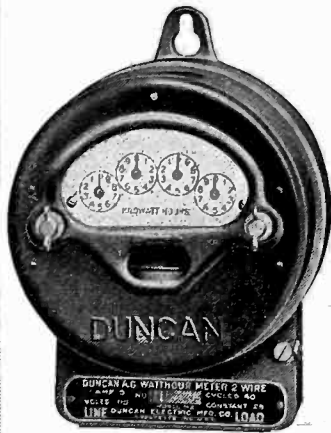

DUNCAN MODEL M2.

An A. C. Watthour meter that for accuracy, efficiency and low cost up-keep is without a peer. Its design represents perfection in every detail and central stations are loud in their praises concerning its dependability.

DUNCAN ELECTRIC MFG. CO.

Lafayette, Ind.

METER TESTING

APPARATUS

THE STATES
COMPANY

44 Francis Ave., Hartford, Conn.

For Central Stations

Science Abstracts

All electrical engineers actively engaged in the practice of their profession should subscribe to "Science Abstracts."

Published monthly by the Institution of Electrical Engineers, London, in association with the Physical Society of London, and with the cooperation of the American Institute of Electrical Engineers, the American Physical Society and the American Electrochemical Society, they constitute an invaluable reference library.

Through "Science Abstracts" engineers are enabled to keep in touch with engineering progress throughout the world, as one hundred and sixty publications, in various languages, are regularly searched and abstracted. "Science Abstracts" are published in two sections, as follows:

"A"—PHYSICS—deals with electricity, magnetism, light, heat, sound, astronomy, chemical physics.

"B"—ELECTRICAL ENGINEERING—deals with electrical plant, power transmission, traction, lighting, telegraphy, telephony, wireless telegraphy, prime movers, engineering materials, electrochemistry.

Through special arrangement, members of the A. I. E. E. may subscribe to "Science Abstracts" at the reduced rate of \$5.00 for each section, and \$10 for both. Rates to non-members are \$7.50 for each section and \$12.50 for both.

Subscriptions should start with the January issue. The first volume was issued in 1898. Back numbers are available, and further information regarding these can be obtained upon application to Institute headquarters.



American Institute of Electrical Engineers

33 West 39th Street, New York

Please mention the JOURNAL of the A. I. E. E. when writing to advertisers.

INSULATION

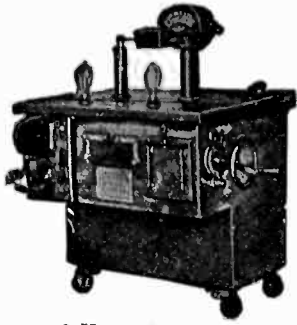

2 Kv-a., 60 Cycle,
50,000 Volts

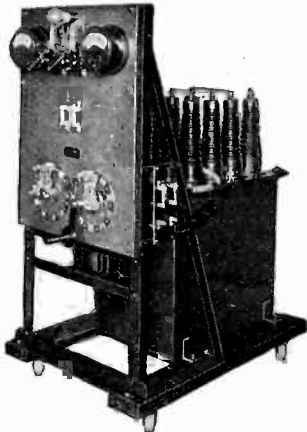

10 Kv-a., 60 Cycle,
220-25,000/50,000/100,000 Volts

Two of many types of American Transformer Testing Sets.



For Difficult Transformer Problems

THE problem of insulation is one of the greatest confronting the electrical industry today. A thorough understanding of the complex properties of insulating materials will constitute a notable advance in the science of electricity.

Insulation tests are simplified with American Transformer testing sets. Such sets, either portable or stationary, provide a flexible and a most accurate means of securing a gradual rise in voltage and are designed for any desired capacity. They can be used for determining the dielectric strength of any insulating material or electrical apparatus—oil, varnish, mica, cloth, paper, rubber, porcelain, cables, generators, etc.

We shall be glad to have you submit your testing problems to us, sending as complete data as possible. We specialize in the design of equipment in which transformers form an integral part.

The American Transformer Company
176 Emmet Street, Newark, N. J.

For Radio Fans and Engineers.—The AmerTran has far greater amplifying power (30-40) and less distortion than any similar device now on the market. Send for Bulletin 1005, containing an unusual chart of audibility amplification of the transformer, and musical scale. The AmerTran is moderately priced and is distributed through jobbers and dealers.

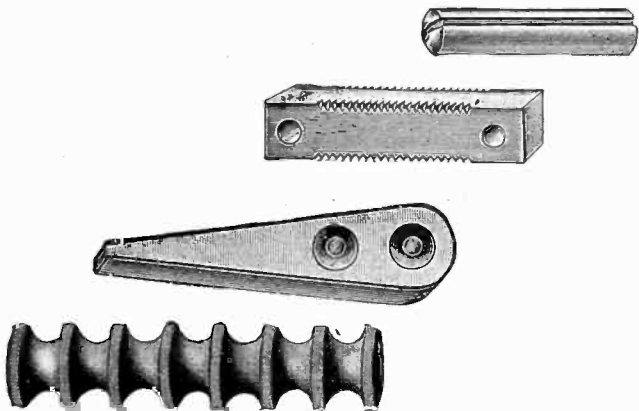

INSULATORS made of LAVA are specified by electrical engineers and designers because they meet the exacting requirements demanded in the manufacture of electric appliances.

LAVA possesses retained mechanical and dielectric strength, under high temperature.

AMERICAN LAVA CORPORATION
27-67 Williamson Street
CHATTANOOGA, TENNESSEE
Manufacturers of Heat Resistant Insulators

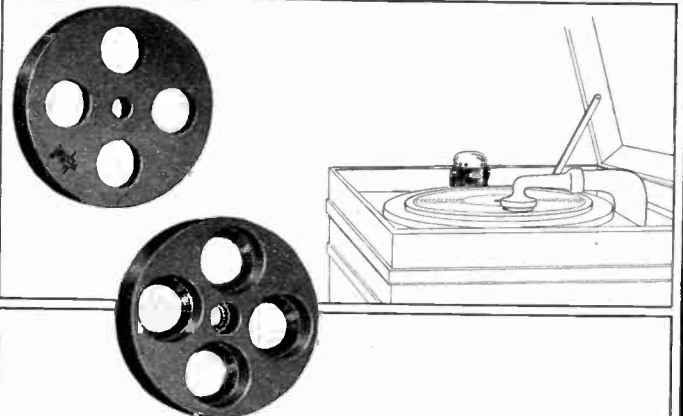

Extreme accuracy is demanded — for all parts of a motor as small as this one—a motor just a few inches over-all.

A Bakelite molded part was selected for the switch base of this Shelton Phonograph Motor, because it could be depended upon to retain its exact dimensions and its insulating properties.

Manufacturers are finding that phenol resin molded parts, sold only under the trade-marks Bakelite—Condensite—Redmanol, combine to an unequalled degree those properties essential to permanently successful electrical insulation.

We welcome inquiries.



are the registered Trade Marks for the Phenol Resin Products manufactured under patents owned by BAKELITE CORPORATION

BAKELITE CORPORATION
Address the Divisions
General Bakelite Company,
8 W. 40th St., New York City.
Condensite Company of America,
Bloomfield, New Jersey.
Redmanol Chemical Products Co.,
636 West 22nd St., Chicago, Ill.

THE MATERIAL OF A THOUSAND USES

The Hammer Blow Makes a Permanent Fastening - -

which is one of the reasons that this remarkable invention—Hardened Metallic Drive Screws—has made possible enormous savings in attaching name plates to steel, cast iron, brass and aluminum castings, bakelite, etc., and in making assemblies where a permanent fastening is required.

They Eliminate Tapping!

Tapping—always a costly operation when machine screws are used—is entirely eliminated when Hardened Metallic Drive Screws take their place. The breakage of taps and the upkeep of tapping machinery is also done away with—because the fastening is made under the blow of a hammer.

And, remember, they are easier to use and you get a better fastening with

Parker-Kalon Hardened Metallic Drive Screws

(Patented)

because they cut their own thread as they are being driven and anchor in the material. They cannot become loose like machine screws or escutcheon pins.

More than 2000 manufacturers are using them.

You too, may find that these Screws will help to reduce your manufacturing cost, speed up production and improve your product. Write for samples to

PARKER-KALON CORPORATION

358 West 18th Street, New York

Agents for the British Isles: Charles Churchill & Co., Ltd., Finsbury, London, E. C. 2, England

No Tapping Necessary!

Parker - Kalon Hardened Metallic Drive Screws cut their own thread in steel, cast iron, bakelite, etc., under the blow of a hammer. The expensive tapping operation is eliminated.

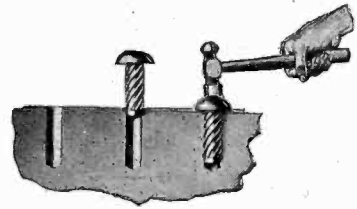

Their Use Involves But 3 Simple Operations

1. Drill a hole.
2. Insert the tip of Screw.
3. Drive in with a hammer.

As easy as driving a nail—anyone can do the job.

MARINE RULES



Recommended Practise for Electrical Installations on Shipboard

THE Marine Rules have been drawn up to serve as a guide for the equipment of merchant ships with electrical apparatus for lighting, signaling, communication and power, but not including propulsion. They indicate what is considered the best engineering practise with reference to safety of the personnel and of the ship itself, as well as reliability and durability of the apparatus. These rules are intended to supplement the STANDARDS of the A. I. E. E., which should be followed wherever applicable.

Linen covered, 97 pp., price, \$1.00 per copy, with discount of 25% to members of the A. I. E. E., dealers, and purchasers of ten or more copies.

AMERICAN INSTITUTE OF ELECTRICAL ENGINEERS

33 West 39th Street, New York

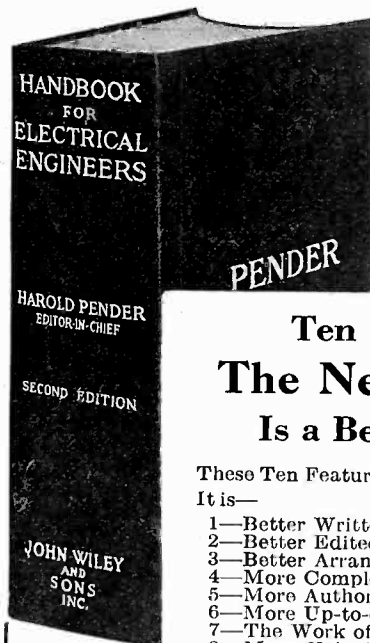

The New PENDER

in
Genuine Leather
\$7.00

Ten Reasons Why The New 'PENDER' Is a Better Handbook

These Ten Features make a Direct Appeal to YOU It is—

- 1—Better Written
 - 2—Better Edited
 - 3—Better Arranged
 - 4—More Complete
 - 5—More Authoritative
 - 6—More Up-to-date
 - 7—The Work of 44 Experts
 - 8—More Valuable than ever before because it Contains the very Latest A. I. E. E. Standards and Rules
 - 9—Written to Cover every Last Detail of Electrical Engineering
 - 10—Now Bound in Genuine Leather
- 2263 pages. 4 1/4 by 7. Illustrated.

Examine a Copy Now!

WILEY FREE EXAMINATION COUPON

John Wiley & Sons, Inc., 432 Fourth Avenue, New York City. Gentlemen: Kindly send me the *New Pender* (Real Leather, \$7.00; "Atholeather," \$6.00—check binding desired.) I agree to remit the price of the edition ordered within 10 days after its receipt.

Name

Address

I am a member of

(State what society) A.I.E.E. 10-23

Please mention the JOURNAL of the A. I. E. E. when writing to advertisers.

PROFESSIONAL ENGINEERING DIRECTORY

For Consultants In the Fields of Engineering, and Related Arts and Sciences

Established 1857
ALEXANDER & DOWELL
 Attorneys at Law
 PATENT, TRADEMARK AND
 COPYRIGHT CASES
 902 F Street, N. W. Washington, D. C.

WALTER G. CLARK
 Consulting Engineer
 Electrical, Mining and Industrial
 Reports
 Supervision of Organization and Arrange-
 ments for Financing
 8 WEST 40th STREET NEW YORK

Edward F. Croker Ex-Chief N. Y. Fire Dept.
 Chas. W. Mitchell Electrical Engineer
FIRE PROTECTION ENGINEERS
 Fire Alarm Engineers & Contractors
 Fire Drills, Fire Appliances and Equipment
 22 W. 30th St. New York, N. Y.

AMBURSEN DAMS
 Hydroelectric Developments
 Water Supply and Irrigation Dams
 DAMS ON DIFFICULT FOUNDATIONS
 AMBURSEN CONSTRUCTION CO.
 Incorporated
 Grand Central Terminal, New York
 Kansas City, Mo. Atlanta, Ga.

EDWARD E. CLEMENT
 Fellow A. I. E. E.
 Attorney and Expert
 in Patent Causes.
 Soliciting, Consultation, Reports,
 Opinions.
 McLachlen Bldg., Washington, D. C.
 700 10th St., N. W.

FORD, BACON & DAVIS
 Incorporated
ENGINEERS
 115 Broadway, New York
 Philadelphia Chicago San Francisco

THE AMERICAN APPRAISAL CO.
 Valuations and Reports
 of
 Public utility, industrial
 and all other properties
 Rate Cases Reorganizations
 Condemnation Suits Liquidations
 NEW YORK MILWAUKEE
 1896 And Principal Cities 1922

DAY & ZIMMERMANN, Inc.
 Engineers
 Power Plants, Sub-Stations,
 Transmission Lines, Industrial Plants,
 Examinations and Reports, Valuations,
 Management of Public Utilities.
 1600 WALNUT ST., PHILADELPHIA
 New York Chicago

FRANK F. FOWLE & CO.
 Electrical and Mechanical
 Engineers
 MONADNOCK BUILDING CHICAGO

THE ARNOLD COMPANY
 Engineers
 Constructors
 Electrical - - Civil - - Mechanical
 CHICAGO
 105 So. La Salle St.

ROBERT E. DENIKE, Inc.
 Electrical Engineers
 and Constructors
 NEW YORK CITY

FREYN, BRASSERT & COMPANY
 Chicago Philadelphia
 Consulting and Constructing
 Engineers
 Gas, Steam and Hydro-Electric Power Plants
 Electrification of Rolling Mills
 Fuel, Oil, Tar, Gas Combustion Engineering
 Design and Construction of
 Electric Furnace Installations

ROBERT BAHAMON
 Mechanical and Electrical Engineer
 Assoc., A. I. E. E.
 Consulting, Contracts, Construction
 and Agencies
 BOGOTA, COLOMBIA, S. A.

Fellow A. I. E. E. Member A. S. M. E.
W. N. DICKINSON
 Consulting Analyst
 BUSINESS AND ENGINEERING
 PROJECTS ANALYZED
 Aeolian Hall, 33 W. 42d St., New York City
 Telephones:
 Longacre 8196 Longacre 8645

**FULLER ENGINEERING
 COMPANY**
 Engineers and Constructors
 Designs Estimates
 PULVERIZED COAL PLANTS
 and burning equipment for Steam Boilers,
 Locomotive Boilers and Industrial Furnaces
 FULLERTON, PA.
 50 Church Street New York

W. S. BARSTOW & CO.
 Incorporated
 Consulting and
 Construction Engineers
 Public Service Properties
 Financed and Managed
 50 Pine St, New York.

CHARLES C. EGBERT
 Engineer
 Hydroelectric Power Development
 Reports, Construction, Supervision
 NIAGARA FALLS, N. Y.

WILLIAM S. HIGBIE
 Electrical Engineer
 ENGINEERING AND PURCHASING
 SERVICE
 Design—Manufacture—Construction
 Own Shops
 Own Yard for Handling
 114 LIBERTY ST. NEW YORK CITY

BATTEY & KIPP
 Incorporated
ENGINEERS
 Complete Industrial Plants
 Power Plants & Electrical Installations
 Engineering Reports, Analyses & Appraisals
 128 W. Madison Street CHICAGO

DAVID V. FENNESSY
 Consulting Power Engineer
 MILLS BUILDING EL PASO, TEXAS

Dugald C. Jackson
 Edward L. Moreland
JACKSON & MORELAND
 CONSULTING ENGINEERS
 387 Washington St. Boston, Mass.

A. R. CHEYNEY, Engineer
 Examinations—Reports
 Design—Construction—Management
 Industrial and Public Service
 Power Plants
 Mechanical—Electrical Systems
 Auto Transportation
 WASHINGTON, D. C. MILLS BLDG.

MONTAGUE FERRY
 ELECTRICAL and MECHANICAL
 ENGINEERING
 38 South Dearborn Street Chicago
 50 Church Street New York

J. KAPPEYNE
 Consulting Engineer
 Valuations, Examinations and Reports.
 Operating and Rate Investigations
 909 Comstock Ave., SYRACUSE, N. Y.

PROFESSIONAL ENGINEERING DIRECTORY

For Consultants in the Fields of Engineering, and Related Arts and Sciences

E. S. LINCOLN, INC.

Consulting Electrical Engineers

Designs Investigations Reports
Electrical Research Laboratory

534 Congress St. PORTLAND, MAINE

I. S. PRENNER

of the Philadelphia Bar
Mem. A. I. E. E., S. A. M. E.

Technical Patent Expert

404 Penfield Bldg.
1328 Chestnut St. PHILADELPHIA

FREDERICK G. SIMPSON

Electrical Engineer

Reports, Designs, Specifications.
Electric Power

and
Industrial Developments.

RADIO COMMUNICATION SYSTEMS,
Telegraph and Telephone.

3301 L. C. Smith Bldg. Seattle, Wash.

J. N. MAHONEY

Consulting Engineer

Fellow A. I. E. E. Mem. Am. Soc. M. E.
Design, Supervision, Specifications, Reports
Specialist in Electrical Power Switching and
Protective Equipment, Industrial and
Railway Control and Brake
Equipment

615-77th STREET BROOKLYN, N. Y.

PUBLIC SERVICE PRODUCTION COMPANY

Engineers and Constructors

Design and Construction of Power Plants,
Substations and Industrial Plants.
Examinations and Reports, Valuation and
Management of Public Utilities.

80 PARK PLACE NEWARK, N. J.

SPRAY ENGINEERING CO.

Engineers and Manufacturers

Spray Cooling Systems - Irrigation Systems
Aerating Reservoirs - Air Conditioning
Gas Washing Pneumatic Paint Spraying
Spray Problems of All Kinds

Consulting Laboratory

60 HIGH STREET BOSTON

McCLELLAN & JUNKERSFELD

Incorporated

Engineering and Construction

NEW YORK

45 WILLIAM ST.

CHICAGO PHILADELPHIA

DWIGHT P. ROBINSON & COMPANY

Incorporated

Design and Construction of
Power Developments, Electric
Railways, Industrial Plants

125 East 46th Street, New York
Chicago Youngstown Philadelphia
Los Angeles Montreal Rio de Janiero

JOHN A. STEVENS, Engineer

Power Plants

Transmission Lines - Sub-stations
Hydro-electric Stations

Consultation - Analysis - Design
Supervision of Construction

Purchased Power Contracts Negotiated

LOWELL, MASSACHUSETTS

W. E. MOORE & CO.

Engineers

Plans and Specifications for
Hydroelectric and Steam Power Plants
Industrial Plants and Electric Furnaces

Union Bank Building Pittsburgh, Pa.

SANDERSON & PORTER

Engineers

Reports Designs
Construction Management

Hydro-electric Developments

Railway, Light and Power Properties

Chicago New York San Francisco

William M. Stockbridge Victor D. Borst

STOCKBRIDGE & BORST

Patent Lawyers

41 PARK ROW NEW YORK CITY

N. J. NEALL

Consulting Engineer

for

Electrical and Industrial Properties

12 PEARL STREET BOSTON, MASS.

SARGENT & LUNDY

Incorporated

Mechanical and Electrical
Engineers

1412 Edison Bldg., 72 West Adams Street
CHICAGO, ILLINOIS

STONE & WEBSTER

Incorporated

Examinations Reports Appraisals

on
Industrial and Public Service
Properties

NEW YORK BOSTON CHICAGO

NEILER, RICH & CO.

Electrical and Mechanical
Engineers

Consulting, Designing and
Supervising

Manhattan Building - - - Chicago

ADOLF P. C. SCHRAMM, E.E.

Mem. S. A. E. Assoc. A. I. E. E.

Consulting Engineer

Fractional Horse Power Motors
Designs
Manufacturing Methods and Processes
Labor Saving Devices

ADRIAN, MICHIGAN

PERCY H. THOMAS

Consulting Engineer

ELECTRIC POWER

Generation - Transmission
Applications

120 BROADWAY NEW YORK

OPHULS & HILL, Inc.

Formerly Ophuls, Hill & McCreery, Inc.

CONSULTING ENGINEERS

112-114 WEST 42d ST., NEW YORK CITY

Ice Making and Refrigeration

Investigations and Reports

SESSIONS ENGINEERING COMPANY

Engineers on

Power Plant Design & Industrial

Betterments

Electrification

140 SO. DEARBORN ST. CHICAGO

UNITED GAS & ELECTRIC ENGINEERING CORPORATION

Engineers Management
Construction Appraisals

Reports, Estimates and Specifications

Now supervising the Engineering

and Operation of 32 Public Utility

Properties located in 12 states

61 BROADWAY NEW YORK CITY

A CARD in the Engineering Directory will keep your name, and the specialized service you are prepared to render, constantly before your prospective clients throughout the year for \$40.00. Circulation 21,000 copies monthly.

PROFESSIONAL ENGINEERING DIRECTORY

For Consultants in the Fields of Engineering, and Related Arts and Sciences

VIELE, BLACKWELL & BUCK

Engineers

Designs and Construction
Hydroelectric and Steam Power Plants
Transmission Systems Industrial Plants
Reports Appraisals
49 WALL STREET NEW YORK

GARDNER S. WILLIAMS

Mem. Am. Inst. Cons. Eng. Mem. Am. S. C. E.

Consulting Engineer

Hydroelectric Developments
Investigations and Reports

Cornwell Bldg. ANN ARBOR, MICH.

EUGENE C. WOODRUFF, Ph.D

Member A.I.E.E. and A.E.R.A.
Fellow A.A.A.S.

Electric Railway Engineering
Automobile Engineering

STATE COLLEGE PENNSYLVANIA

THE J. G. WHITE

ENGINEERING CORPORATION

Engineers—Constructors

Industrial Plants, Buildings, Steam Power
Plants, Water Powers, Gas Plants, Steam &
Electric Railroads, Transmission Systems.
43 EXCHANGE PLACE NEW YORK

*To be printed in the following
issue, copy for cards must be
received by the 15th of the month.*

J. G. WRAY & CO.

Engineers

J. G. Wray, Fellow A.I.E.E. Cyrus G. Hill

Utilities and Industrial Properties

Appraisals Construction Rate Surveys
Plans Organization Estimates
Financial Investigations Management

1217 First National Bank Bldg., Chicago

ELECTRICAL

TESTING LABORATORIES

80th Street and East End Ave.
NEW YORK

Inspections — Tests — Research

Tests may be used by the purchaser for the following purposes:

- (1) To determine the quality of competing samples. This enables the purchase of the best quality for the money.
- (2) To make sure that shipments comply with specifications. This makes possible the assurance to the customer that shipments match buying samples.
- (3) To furnish an impartial decision in case of disputes between purchaser and manufacturer.

Testing place the whole buying problem on a sound basis.

A Great Engineering Library

THE Engineering Societies Library, 33 West 39th St., New York, is a reference library for engineers, directed by the national engineering societies. It contains 150,000 volumes and receives 1500 periodicals relating to civil, mining, mechanical and electrical engineering, metallurgy and industrial chemistry.

A staff of experienced investigators is available to make searches upon engineering subjects, prepare lists of references and translate engineering publications from foreign languages.

The Library can also supply photoprint copies of any articles appearing in engineering journals, old or recent. Prices for any services will be quoted on application.

At Your Service



Is your
name on our
mailing list for
bulletins and
catalog?

Morganite Brushes

Morganite
Brush Co., Inc.
519 W. 38th St.
New York

Please mention the JOURNAL of the A. I. E. E. when writing to advertisers.

STANDARDS

OF THE A. I. E. E.

1922 Edition

THE Standards give definitions of electrical terms, technical data, standard performance, specifications for tests of electrical machinery, standard voltages and frequencies, and general recommendations, as adopted by the Standards Committee and approved by the Board of Directors of the A. I. E. E.

A number of changes and additions have been made in the 1922 edition, the most important of which are mentioned below.

A new chapter is included presenting standards for Storage Batteries.

In Chapter I an additional class of insulating materials has been provided.

Definitions have been given in Chapter III of "power factor," distinguishing between "momentary" and "average" power factor, and of the "normal voltage of a system." The term "Oersted" has been adopted for the unit of magnetic inductance, and the term "electrical tension" has been adopted for use as an alternative to "voltage" in cases where the electric potential is not expressed in volts.

In Chapter VI a distinction is made between "full capacity taps" and "reduced capacity taps" of transformers.

To Chapter VII there have been added a considerable number of definitions of different types of power control relays and of the qualifying terms applied to them. A slight modification has been made in the temperature limits for circuits breakers, relays and switches.

In Chapter VIII the Corona voltmeter is recognized as a satisfactory form of crest voltmeter

To Chapter XII have been added a number of definitions, for the most part referring to machine switching telephone apparatus.

The Rules for Electrical Machinery of the International Electrotechnical Commission, adopted October 1919, are given in an appendix.

Flexible fabrikoid leather cover, 192 pp. Indexed. Price \$2.00 per copy, with 25% discount to members of the A. I. E. E., and to dealers and purchasers of ten or more copies.

American Institute of Electrical Engineers
33 West 39th St., New York

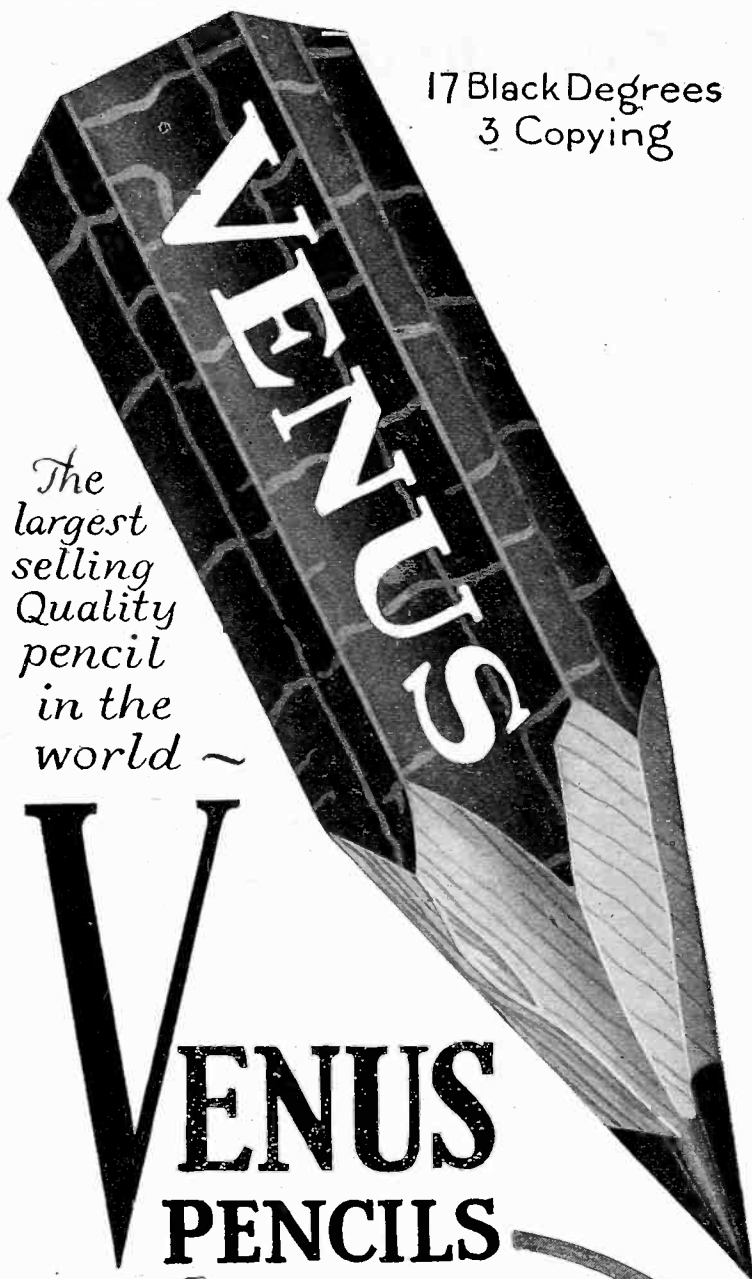

17 Black Degrees
3 Copying

The largest selling Quality pencil in the world

VENUS PENCILS

THE superb VENUS, for every drawing and writing purpose, is and for years has been the favorite in drafting rooms, throughout this and all countries.

17 Black Degrees
6B Softest to 9H Hardest
also 3 Copying

Plain Ends,— per doz. . . . \$1.00
Rubber Ends,—per doz. . . . 1.20

At stationers, drafting supply dealers and stores throughout the world

American Lead Pencil Co.
204 Fifth Ave., New York
and London, Eng.



VENUS ERASERS are perfect.

Made in 12 sizes.

MAIL COUPON FOR FREE SAMPLE
Send samples VENUS degrees checked—and a VENUS ERASER.
For bold, heavy lines 6B-5B, 4B-3B
For general writing and sketching 2B, B, HB, F, H
For clean, fine lines and F or delicate, thin lines 2H, 3H, 4H, 5H, 6H 7H-8H, 9H
Name _____
Address _____
Profession _____

Classified Advertiser's Index for Buyers

Manufacturers and agents for machinery and supplies used in the electrical and allied industries.

Note: For reference to the advertisements see the Alphabetical List of Advertisers on page 50.

- AIR COMPRESSORS**
Allis-Chalmers Mfg. Co., Milwaukee, Wis.
General Electric Co., Schenectady, N. Y.
Western Electric Co., All Principal Cities
- AIR COMPRESSOR FILTERS**
Midwest Air Filters, Inc., New York
- AIR FILTERS, CLEANERS, CONDITIONERS**
Midwest Air Filters, Inc., New York
- AIR WASHERS**
Spray Engineering Co., Boston.
- AMMETERS, VOLTMETERS**
(See INSTRUMENTS, ELECTRICAL)
- BATTERY CHARGING APPARATUS**
Cutler-Hammer Mfg. Co., Milwaukee
General Electric Co., Schenectady, N. Y.
Western Electric Co., All Principal Cities
Westinghouse Elec. & Mfg. Co., E. Pitts-
burgh
- BEADS, INSULATING**
Martindale Electric Co., The, Cleveland
- BEARINGS, BALL**
New Departure Mfg. Co., The, Bristol, Conn.
Norma Co. of America, L. I. City, N. Y.
S K F Industries, New York
- BOOKS, TECHNICAL**
Wiley & Sons, Inc., John, New York
- BOXES, FUSE**
General Electric Co., Schenectady, N. Y.
Metropolitan Device Corp., Brooklyn, N. Y.
Western Electric Co., All Principal Cities
Westinghouse Elec. & Mfg. Co., E. Pitts-
burgh
- BOXES, JUNCTION**
G & W Elec. Specialty Co., Chicago
Metropolitan Device Corp., Brooklyn, N. Y.
Standard Underground Cable Co., Pittsburgh
- BRAKES CAR**
Allis-Chalmers Mfg. Co., Milwaukee, Wis.
General Electric Co., Schenectady, N. Y.
- BRUSHES, COMMUTATOR**
Carbon
Morganite Brush Co. Inc., New York
Westinghouse Elec. & Mfg. Co., E. Pitts-
burgh
Copper Graphite
Morganite Brush Co. Inc., New York
Westinghouse Elec. & Mfg. Co., E. Pitts-
burgh
- BUS BAR FITTINGS**
General Electric Co., Schenectady, N. Y.
Westinghouse Elec. & Mfg. Co., E. Pitts-
burgh,
- CABLE ACCESSORIES**
Dossert & Co., New York
G & W Electric Specialty Co., Chicago, Ill.
General Electric Co., Schenectady, N. Y.
Minerallac Electric Co., Chicago
Standard Underground Cable Co., Pittsburgh
Western Electric Co., All Principal Cities
- CABLES**
(See WIRES AND CABLES)
- CABLEWAYS**
Roebbing's Sons Co., John A., Trenton, N. J.
- CAMBRIC, VARNISHED**
Irvington Varnish & Ins. Co., Irvington, N. J.
- CARBON BRUSHES**
(See BRUSHES COMMUTATOR)
- CHAINS, POWER TRANSMISSION**
Morse Chain Co., Ithaca, N. Y.
- CIRCUIT BREAKERS**
Condit Electrical Mfg. Co., So. Boston, Mass.
Cutter Company, The, Philadelphia
General Electric Co., Schenectady, N. Y.
Roller-Smith Co., New York
Western Electric Co., All Principal Cities
Westinghouse Elec. & Mfg. Co., E. Pitts-
burgh
- CLUTCHES-MAGNETIC**
Cutler-Hammer Mfg. Co., Milwaukee
- COILS, MAGNET**
Acme Wire Co., New Haven, Conn.
Belden Mfg. Co., Chicago, Ill.
Dudlo Mfg. Co., Ft. Wayne, Ind.
General Electric Co., Schenectady, N. Y.
Westinghouse Elec. & Mfg. Co., E. Pitts-
burgh
- CONDENSATION PRODUCTS**
Bakelite Corporation, New York
Condensite Co. of America, Bloomfield, N. J.
General Bakelite Co., New York
Redmanol Chemical Products Co., Chicago
- CONDENSERS**
Allis-Chalmers Mfg. Co., Milwaukee
General Electric Co., Schenectady, N. Y.
Westinghouse Elec. & Mfg. Co., E. Pitts-
burgh
- CONDUIT, UNDERGROUND FIBRE**
Western Electric Co., All Principal Cities
- CONNECTORS, SOLDERLESS**
Dossert & Co., New York, N. Y.
Western Electric Co., All Principal Cities
Westinghouse Elec. & Mfg. Co., E. Pitts-
burgh
- CONNECTORS AND TERMINALS**
Dossert & Co., New York
G & W Electric Specialty Co., Chicago, Ill.
Western Electric Co., All Principal Cities
Westinghouse Elec. & Mfg. Co., E. Pitts-
burgh
- CONTACTS TUNGSTEN**
Fansteel Products Co., Inc., North Chicago, Ill.
General Electric Co., Schenectady, N. Y.
- CONTROLLERS**
Cutler-Hammer Mfg. Co., Milwaukee
General Electric Co., Schenectady, N. Y.
Rowan Controller Co., Baltimore
Western Electric Co., All Principal Cities
Westinghouse Elec. & Mfg. Co., E. Pitts-
burgh
- CONVERTERS**
Allis-Chalmers Mfg. Co., Milwaukee
Northwestern Electric Co., Chicago
Westinghouse Elec. & Mfg. Co., E. Pitts-
burgh
- COOLING AIR FILTERS**
Midwest Air Filters, Inc., New York
- COOLING PONDS**
Spray Engineering Co., Boston
- COPPER CLAD WIRE**
Copper Clad Steel Co., Rankin, Pa.
Standard Underground Cable Co., Pittsburgh
Western Electric Co., All Principal Cities
- CUT-OUTS**
Condit Electrical Mfg. Co., S. Boston, Mass.
General Electric Co., Schenectady, N. Y.
G & W Elec. Spec. Co., Chicago
Johns-Pratt Co., Hartford, Conn.
Metropolitan Device Corp., Brooklyn, N. Y.
Thoner & Martens, Boston
Western Electric Co., All Principal Cities
Westinghouse Elec. & Mfg. Co., E. Pitts-
burgh
- DRAWING MATERIALS**
Keuffel & Esser Company, Hoboken, N. J.
- DYNAMOS**
(See GENERATORS AND MOTORS)
- ELECTRIFICATION SUPPLIES, STEAM ROAD**
General Electric Co., Schenectady, N. Y.
Ohio Brass Co., Mansfield, Ohio
Westinghouse Elec. & Mfg. Co., E. Pitts-
burgh
- ENGINEERS, CONSULTING AND CON-TRACTING**
Stone & Webster, Inc., Boston
(See also PROFESSIONAL ENGINEERING DIRECTORY)
- ENGINES**
Gas & Gasoline
Allis-Chalmers Mfg. Co., Milwaukee
Oil
Allis-Chalmers Mfg. Co., Milwaukee
Steam
Allis-Chalmers Mfg. Co., Milwaukee
- FANS, MOTOR**
Century Electric Co., St. Louis
General Electric Co., Schenectady, N. Y.
Star Electric Motor Co., Newark, N. J.
Western Electric Co., All Principal Cities
Westinghouse Elec. & Mfg. Co., E. Pitts-
burgh
- FARM LIGHTING GENERATORS**
Western Electric Co., All Principal Cities
Westinghouse Elec. & Mfg. Co., E. Pitts-
burgh
- FIBRE**
Diamond State Fibre Co., Bridgeport, Pa.
- FILTERS, AIR**
(See Air Filters)
- FURNACES, ELECTRIC**
General Electric Co., Schenectady, N. Y.
Westinghouse Elec. & Mfg. Co., E. Pitts-
burgh
- FUSES**
Enclosed Refillable
General Electric Co., Schenectady, N. Y.
Johns-Pratt Co., Hartford, Conn.
Western Electric Co., All Principal Cities
Westinghouse Elec. & Mfg. Co., E. Pitts-
burgh
Enclosed Non-Refillable
General Electric Co., Schenectady, N. Y.
Johns-Pratt Co., Hartford, Conn.
Western Electric Co., All Principal Cities
Open Link
General Electric Co., Schenectady, N. Y.
Metropolitan Device Corp., Brooklyn, N. Y.
Western Electric Co., All Principal Cities
High Tension
Metropolitan Device Corp., Brooklyn, N. Y.
Railway & Industrial Engg. Co., Greens-
burg, Pa.
Western Electric Co., All Principal Cities
- GEARS, FIBRE**
Diamond State Fibre Co., Bridgeport, Conn.
General Electric Co., Schenectady, N. Y.
- GENERATORS AND MOTORS**
Allis-Chalmers Mfg. Co., Milwaukee, Wis.
Century Electric Co., St. Louis, Mo.
Electro-Dynamic Co., Bayonne, N. J.
General Electric Co., Schenectady, N. Y.
Northwestern Electric Co., Chicago
Star Electric Motor Co., Newark, N. J.
Wagner Electric Corp., St. Louis
Western Electric Co., All Principal Cities
Westinghouse Elec. & Mfg. Co., E. Pitts-
burgh
- GENERATING STATION EQUIPMENT**
Allis-Chalmers Mfg. Co., Milwaukee
General Electric Co., Schenectady, N. Y.
Western Electric Co., All Principal Cities
Westinghouse Elec. & Mfg. Co., E. Pitts-
burgh
- GRINDERS, COMMUTATOR**
Martindale Electric Co., The, Cleveland
- GROUND RODS**
Copper Clad Steel Co., Rankin, Pa.
Western Electric Co., All Principal Cities
- HEADLIGHTS**
Ohio Brass Co., Mansfield, O.
- HEATERS, INDUSTRIAL**
Cutler-Hammer Mfg. Co., Milwaukee
General Electric Co., Schenectady, N. Y.
Western Electric Co., All Principal Cities
Westinghouse Elec. & Mfg. Co., E. Pitts-
burgh
- HEATING & VENTILATING EQUIPMENT**
Midwest Air Filters, Inc., New York
- INDICATORS, SPEED**
Biddle, James G., Philadelphia
Roller-Smith Co., New York
- INSTRUMENTS, ELECTRICAL**
Graphic
Biddle, James G., Philadelphia
Bristol Co., The, Waterbury, Conn.
Ferranti, Ltd., London, Eng.
General Electric Co., Schenectady, N. Y.
Westinghouse Elec. & Mfg. Co., E. Pitts-
burgh
Indicating
Ferranti, Ltd., London, Eng.
General Electric Co., Schenectady, N. Y.
Roller-Smith Co., New York
Westinghouse Elec. & Mfg. Co., E. Pitts-
burgh
Integrating
Biddle, James G., Philadelphia
Duncan Elec. Mfg. Co., Lafayette, Ind.
Ferranti, Ltd., London, Eng.
General Electric Co., Schenectady, N. Y.
Roller-Smith Co., New York
Sangamo Elec. Co., Springfield, Ill.
States Co., The, Hartford, Conn.
Western Electric Co., All Principal Cities
Westinghouse Elec. & Mfg. Co., E. Pitts-
burgh
Repairing and Testing
Electrical Testing Laboratories, New York
Scientific, Laboratory, Testing
Biddle, James G., Philadelphia
Foote-Pierson & Co., Inc., New York
General Electric Co., Schenectady, N. Y.
Leeds & Northrup Co., Philadelphia
Metropolitan Device Corp., Brooklyn, N. Y.
Roller-Smith Co., New York
States Co., The, Hartford, Conn.
Western Electric Co., All Principal Cities
Westinghouse Elec. & Mfg. Co., E. Pitts-
burgh
Telegraph
Foote, Pierson & Co., Inc., New York
Western Electric Co., All Principal Cities
Wireless
Acme Apparatus Co., Cambridge, Mass.
General Radio Co., Cambridge, Mass.
- INSULATING MATERIALS**
Cloth
Irvington Varnish & Ins. Co., Irvington, N. J.
Minerallac Electric Co., Chicago
Westinghouse Elec. & Mfg. Co., E. Pitts-
burgh
Composition
Bakelite Corporation, New York
Belden Mfg. Co., Chicago
Condensite Co. of America, Bloomfield, N. J.
Cutler-Hammer Mfg. Co., Milwaukee
General Bakelite Co., New York
Hopewell Ins. & Mfg. Co., Hopwell, Va.
Redmanol Chemical Products Co., Chicago
Westinghouse Elec. & Mfg. Co., E. Pitts-
burgh
Compounds
Minerallac Electric Co., Chicago
Standard Underground Cable Co., Pittsburgh
Sterling Varnish Co., Pittsburgh
Western Electric Co., All Principal Cities
Fibre
Diamond State Fibre Co., Bridgeport, Pa.
Lava
American Lava Co., Chattanooga, Tenn.

Please mention the JOURNAL of the A. I. E. E. when writing to advertisers.

I. P. Morris Hydraulic Turbines

The Wm. Cramp & Sons Ship & Engine Building Co.
Richmond and Norris Streets, Philadelphia

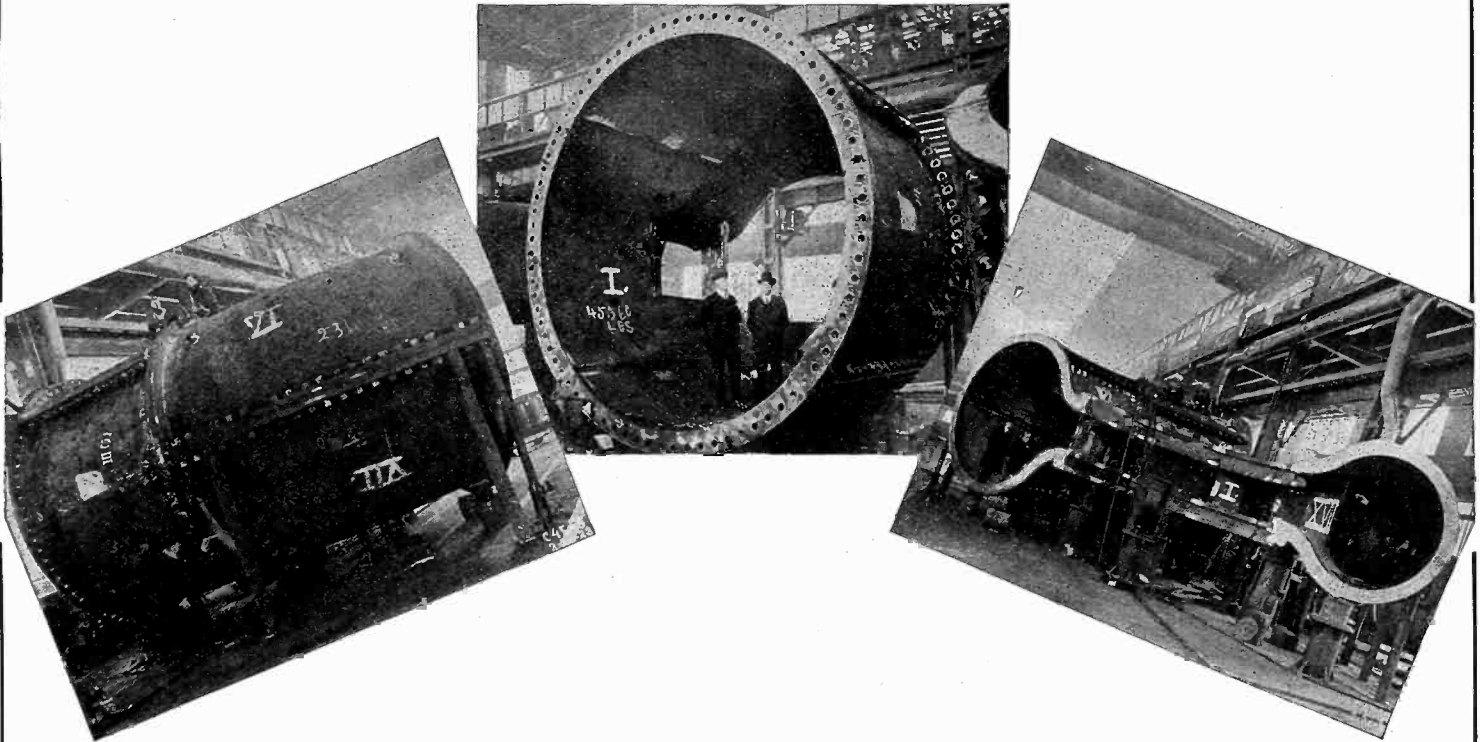

Cast Steel Casing Sections for Two 70,000 H. P. Turbines—"Most Powerful in the World"
are now under construction for installation in Plant No. 3-C of

THE NIAGARA FALLS POWER CO.

HEAD 213.5 FEET

SPEED 107 R. P. M.

Special Features included in design of these units:—

Pneumatic Lubricating System
Moody Spreading Draft Tube
Automatic Governor Control
Offset Operating Gear

Taylor Sectionalized Cast-Steel Casing
Adjustable Lignum vitae Guide Bearing
Labyrinth Runner Seals
Disk Guide Vanes

Double Floating Lever Governors

Thirteen 10,000 H. P. turbines, two 1,000 H. P. turbines and two 37,500 H. P. turbines have previously been installed in the above Power Company's Plant. The first of these units was installed in 1907, and the service rendered by this plant is demonstrative of the dependability of I. P. MORRIS HYDRAULIC TURBINE MACHINERY.

Three Johnson Hydraulic Penstock Valves—"Largest in the World"

are also under construction for the above development

Designers and Builders of the Johnson Hydraulic Valve

Associated Companies

THE PELTON WATER WHEEL COMPANY, San Francisco and New York
DOMINION ENGINEERING WORKS, LTD., Montreal, Canadian Licensees
M. HILPERT & CO., Rio de Janeiro, Brazilian Licensees

Please mention the JOURNAL of the A. I. E. E. when writing to advertisers.

Classified Advertiser's Index for Buyers—Continued.

INSULATING MATERIALS—Continued

- Paper*
Irvington Varnish & Ins. Co., Irvington, N. J.
- Silk*
Irvington Varnish & Ins. Co., Irvington, N. J.
- Slate*
Structural Slate Co., The, Pen Argyl, Pa.
- Tape*
Belden Mfg. Co., Chicago
Minerallac Electric Co., Chicago
Okonite Co., The, New York
Western Electric Co., All Principal Cities
Westinghouse Elec. & Mfg. Co., E. Pittsburgh
- Varnishes*
General Electric Co., Schenectady, N. Y.
Irvington Varnish & Ins. Co., Irvington, N. J.
Minerallac Electric Co., Chicago
Sterling Varnish Co., Pittsburgh
- INSULATORS, HIGH TENSION**
- Composition*
General Electric Co., Schenectady, N. Y.
Hopewell Ins. & Mfg. Co., Hopewell, Va.
- Glass*
Hemingray Glass Co., Muncie, Ind.
- Porcelain*
General Electric Co., Schenectady, N. Y.
Jeffery-Dewitt Insulator Co., Kenova, W. Va.
Lapp Insulator Co., Inc., LeRoy, N. Y.
Locke Insulator Mfg. Co., Victor, N. Y.
Ohio Brass Co., Mansfield, O.
Thomas & Sons Co., R., East Liverpool, O.
Western Electric Co., All Principal Cities
Westinghouse Elec. & Mfg. Co., E. Pittsburgh
- INSULATORS, TELEPHONE & TELEGRAPH**
Hemingray Glass Co., Muncie, Ind.
Western Electric Co., All Principal Cities
- LAMP GUARDS**
Western Electric Co., All Principal Cities
- LAVA**
American Lava Corp., Chattanooga, Tenn.
- LIGHTNING ARRESTERS**
Electro Service Co., Marietta, Ga.
General Electric Co., Schenectady, N. Y.
Railway & Industrial Engg. Co., Greensburg, Pa.
Western Electric Co., All Principal Cities
Westinghouse Elec. & Mfg. Co., E. Pittsburgh
- LOCOMOTIVES, ELECTRIC**
General Electric Co., Schenectady, N. Y.
Westinghouse Elec. & Mfg. Co., E. Pittsburgh
- LUBRICANTS**
Texas Co., The, New York
- MAGNET WIRE**
Acme Wire Co., New Haven, Conn.
Belden Mfg. Co., Chicago
Dudlo Mfg. Co., Ft. Wayne, Ind.
Roebing's Sons Co., J. A., Trenton, N. J.
Western Electric Co., All Principal Cities
- METERS, ELECTRICAL**
(See INSTRUMENTS, ELECTRICAL)
- METER TESTERS**
Johns-Pratt Co., Hartford, Conn.
States Co., The, Hartford, Conn.
- MOLDED INSULATION**
Bakelite Corporation, New York
Belden Mfg. Co., Chicago
Condensite Co. of America, Bloomfield, N. J.
Cutler-Hammer Mfg. Co., Milwaukee
General Bakelite Co., New York
Hopewell Ins. & Mfg. Co., Hopewell, Va.
Johns-Pratt Co., Hartford, Conn.
Redmanol Chemical Products Co., Chicago
Westinghouse Elec. & Mfg. Co., E. Pittsburgh
- MOLYBDENUM**
Fansteel Products Co., Inc., North Chicago, Ill.
- MOTORS**
(See GENERATORS AND MOTORS)
- PANEL BOARDS**
(See SWITCHBOARDS)
- PATENT ATTORNEYS**
(See PROFESSIONAL ENGINEERING DIRECTORY)
- PHASE MODIFYING APPARATUS**
States Co., The, Hartford, Conn.
- PLUGS**
Cutler-Hammer Mfg. Co., Milwaukee
General Electric Co., Schenectady, N. Y.
Western Electric Co., All Principal Cities
Westinghouse Elec. & Mfg. Co., E. Pittsburgh

POLES, STEEL

- Bates Expanded Steel Truss Co., Chicago
Pacific Coast Steel Co., San Francisco, Calif.
Western Electric Co., All Principal Cities
- POLES—TIES, WOOD**
MacGillis & Gibbs Co., Milwaukee, Wis.
Page & Hill Co., Minneapolis, Minn.
Partridge Lumber Co., T. M., Minneapolis
Western Electric Co., All Principal Cities
- POTHEADS**
G & W Electric Specialty Co., Chicago
Standard Underground Cable Co., Pittsburgh
Thoner & Martens, Boston
Western Electric Co., All Principal Cities
- PROTECTIVE DEVICES**
Metropolitan Device Corp., Brooklyn, N. Y.
Western Electric Co., All Principal Cities
- PULLEYS, PAPER**
Rockwood Mfg. Co., The, Indianapolis
- PUMPS**
Allis-Chalmers Mfg. Co., Milwaukee
Goulds Mfg. Co., Seneca Falls, N. Y.
- PUMPS, SPIRAL**
Cramp & Sons Ship & Engine Bldg. Co., The Wm., Philadelphia
- PYROMETERS**
Leeds & Northrup Co., Philadelphia
- RADIO APPARATUS**
General Electric Co., Schenectady, N. Y.
General Radio Co., Cambridge, Mass.
Johns-Pratt Co., Hartford, Conn.
Westinghouse Elec. & Mfg. Co., E. Pittsburgh
- RADIO INSULATING PARTS**
Hopewell Ins. & Mfg. Co., Hopewell, Va.
- RADIO LABORATORY APPARATUS**
Acme Apparatus Co., Cambridge, Mass.
General Radio Co., Cambridge, Mass.
Westinghouse Elec. & Mfg. Co., E. Pittsburgh
- RAILWAY SUPPLIES, ELECTRIC**
General Electric Co., Schenectady, N. Y.
Ohio Brass Co., Mansfield, O.
Western Electric Co., All Principal Cities
Westinghouse Elec. & Mfg. Co., E. Pittsburgh
- REACTANCE COILS**
Metropolitan Device Corp., Brooklyn, N. Y.
- RECTIFIERS**
General Electric Co., Schenectady, N. Y.
Wagner Electric Corp., St. Louis
Western Electric Co., All Principal Cities
Westinghouse Elec. & Mfg. Co., E. Pittsburgh
- REGULATORS, VOLTAGE**
General Electric Co., Schenectady, N. Y.
States Co., The, Hartford, Conn.
Western Electric Co., All Principal Cities
Westinghouse Elec. & Mfg. Co., E. Pittsburgh
- RESISTANCE ELEMENTS**
Cutler-Hammer Mfg. Co., Milwaukee
General Electric Co., Schenectady, N. Y.
- RHEOSTATS**
Biddle, James G., Philadelphia, Pa.
Cutler-Hammer Mfg. Co., Milwaukee
General Electric Co., Schenectady, N. Y.
Western Electric Co., All Principal Cities
Westinghouse Elec. & Mfg. Co., E. Pittsburgh
- ROPE, WIRE**
Roebing's Sons Co., John A., Trenton, N. J.
- SCREWS**
Drive Hardened
Parker-Kalon Corporation, New York
Self-Tapping, Hardened
Parker-Kalon Corporation, New York
- SEARCHLIGHTS**
General Electric Co., Schenectady, N. Y.
Westinghouse Elec. & Mfg. Co., E. Pittsburgh
- SLATE**
Structural Slate Co., The, Pen Argyl, Pa.
- SLOTING EQUIPMENT, COMMUTATOR**
Hand and Motor Driven
Martindale Electric Co., The, Cleveland
- SOCKETS AND RECEPTACLES**
Cutler-Hammer Mfg. Co., Milwaukee
General Electric Co., Schenectady, N. Y.
Western Electric Co., All Principal Cities
Westinghouse Elec. & Mfg. Co., E. Pittsburgh
- SOLENOIDS**
Acme Wire Co., New Haven, Conn.
Belden Mfg. Co., Chicago
Cutler-Hammer Mfg. Co., Milwaukee
Dudlo Mfg. Co., Ft. Wayne, Ind.
General Electric Co., Schenectady, N. Y.
Westinghouse Elec. & Mfg. Co., E. Pittsburgh
- STOKERS, MECHANICAL**
Westinghouse Elec. & Mfg. Co., E. Pittsburgh
- STONES, COMMUTATOR**
Martindale Electric Co., The, Cleveland

SUB-STATIONS

- Electro Service Co., Marietta, Ga.
General Electric Co., Schenectady, N. Y.
Railway & Industrial Engg. Co., Greensburg, Pa.
Westinghouse Elec. & Mfg. Co., E. Pittsburgh
- SWITCHBOARDS**
Allis-Chalmers Mfg. Co., Milwaukee, Wis.
Condit Electrical Mfg. Co., So. Boston, Mass.
General Electric Co., Schenectady, N. Y.
Metropolitan Device Corp., Brooklyn, N. Y.
Western Electric Co., All Principal Cities
Westinghouse Elec. & Mfg. Co., E. Pittsburgh
- SWITCHES**
- Automatic Time*
Ferranti, Ltd., London, Eng.
General Electric Co., Schenectady, N. Y.
Minerallac Electric Co., Chicago
Westinghouse Elec. & Mfg. Co., E. Pittsburgh
- Disconnecting*
Condit Electrical Mfg. Co., So. Boston
General Electric Co., Schenectady, N. Y.
K-P-F Electric Co., San Francisco
Pacific Electric Mfg. Co., San Francisco
Railway & Ind. Engg. Co., Greensburg, Pa.
Thoner & Martens, Boston
- Fuse*
General Electric Co., Schenectady, N. Y.
Metropolitan Device Corp., Brooklyn, N. Y.
Thoner & Martens, Boston
- Knife*
Condit Electrical Mfg. Co., So. Boston
Cutter Company, The, Philadelphia
General Electric Co., Schenectady, N. Y.
Western Electric Co., All Principal Cities
Westinghouse Elec. & Mfg. Co., E. Pittsburgh
- Oil*
Condit Electrical Mfg. Co., So. Boston
General Electric Co., Schenectady, N. Y.
Western Electric Co., All Principal Cities
Westinghouse Elec. & Mfg. Co., E. Pittsburgh
- Remote Control*
Condit Electrical Mfg. Co., So. Boston
Cutler-Hammer Mfg. Co., Milwaukee
General Electric Co., Schenectady, N. Y.
Railway & Ind. Engg. Co., Greensburg, Pa.
Rowan Controller Co., Baltimore
Western Electric Co., All Principal Cities
Westinghouse Elec. & Mfg. Co., E. Pittsburgh
- Safety Enclosed*
Johns-Pratt Co., Hartford, Conn.
- TACHOMETERS**
Biddle, James G., Philadelphia
- TANTALUM**
Fansteel Products Co., Inc., North Chicago, Ill.
- TELEGRAPH APPARATUS**
Western Electric Co., All Principal Cities
- TELEPHONE EQUIPMENT**
Western Electric Co., All Principal Cities
- TESTING LABORATORIES**
Electrical Testing Labs., New York
- TOWERS, TRANSMISSION**
Bates Expanded Steel Truss Co., Chicago
Pacific Coast Steel Co., San Francisco, Calif.
Western Electric Co., All Principal Cities
- TRANSFORMERS**
Acme Apparatus Co., Cambridge, Mass.
Allis-Chalmers Mfg. Co., Milwaukee, Wis.
American Transformer Co., Newark, N. J.
Duncan Elec. Mfg. Co., Lafayette, Ind.
Ferranti, Ltd., London, Eng.
General Electric Co., Schenectady, N. Y.
Kuhlman Electric Co., Bay City, Mich.
Moloney Electric Co., St. Louis
Pittsburgh Transformer Co., Pittsburgh
Wagner Electric Corp., St. Louis
Western Electric Co., All Principal Cities
Westinghouse Elec. & Mfg. Co., E. Pittsburgh
- Factory*
American Transformer Co., Newark, N. J.
Kuhlman Electric Co., Bay City, Mich.
Moloney Electric Co., St. Louis, Mo.
Pittsburgh Transformer Co., Pittsburgh
Wagner Electric Corp., St. Louis
Western Electric Co., All Principal Cities
- Furnace*
Allis-Chalmers Mfg. Co., Milwaukee
American Transformer Co., Newark, N. J.
Moloney Electric Co., St. Louis
Pittsburgh Transformer Co., Pittsburgh
- Metering*
American Transformer Co., Newark, N. J.
Ferranti, Ltd., London, Eng.
Pittsburgh Transformer Co., Pittsburgh, Pa.
- Mill Type*
Pittsburgh Transformer Co., Pittsburgh
- Radio*
Acme Apparatus Co., Cambridge, Mass.
American Transformer Co., Newark, N. J.
- Street Lighting*
Kuhlman Electric Co., Bay City, Mich.
Western Electric Co., All Principal Cities

Please mention the JOURNAL of the A. I. E. E. when writing to advertisers.



PUBLICATIONS

JOURNAL. Published monthly.

An engineering periodical containing technical papers and discussions thereon presented before meetings of the Institute and its Sections and Branches; descriptions of new developments characterized by notable advances, and items relating to the activities of the Institute.

Subscription price: \$10.00 per year. Agents, publishers and dealers are allowed 20 per cent discount; a special discount of 50 per cent is allowed on single subscriptions received directly from college or public libraries.

Postage to Canada on annual subscription \$0.50 additional, and to foreign countries, \$1.00. (Postage should not be included when computing discounts.)

TRANSACTIONS. Published annually.

Contains such of the technical papers and reports published by the Institute in the JOURNAL and elsewhere as are selected and authorized by the Publication Committee; also the discussions on the technical papers. The TRANSACTIONS form a permanent record of the progress of electrical engineering.

Volumes for years 1921 and 1922 may be purchased by non-members at \$10.00 per year in either paper or cloth binding. Volumes covering the years 1902 to 1920 inclusive, may be obtained at reduced prices which will be quoted upon request. The 1919 edition of the TRANSACTIONS is out of print, as are a number of the volumes for the years previous to 1902; a price list of those available will be furnished upon application.

Members of the Institute may purchase the TRANSACTIONS for 1921 and 1922 in cloth binding,, at prices of \$3.00 and \$2.00 respectively. Available back volumes published prior to 1921 may be obtained by members at a cost of \$1.50 per book.

College and public libraries are allowed a discount of 50% from non-member prices upon direct subscription to Institute headquarters; publishers and subscription agents, 20% from non-member prices.

SEPARATE PAPERS AND DISCUSSIONS.

Most of the recent papers and discussions contained in the TRANSACTIONS can be furnished separately at the following prices: Single copies of any paper, usually with discussion, \$0.50. Five or more copies of any paper, each \$0.40.

Discount of 20 per cent allowed to publishers and subscription agents; 50 per cent is allowed from the above prices to Institute members and college and public libraries.

STANDARDS. 1922 Edition.

Gives definitions of electrical terms, technical data, standard performance, specifications for tests of electrical machinery, standard voltages and frequencies, and general recommendations as adopted by the Standards Committee and approved by the Board of Directors of the A. I. E. E. It also contains, as an appendix, the rules for electrical machinery of the International Electro-technical Commission, adopted in October 1919. Price per copy, flexible cover, \$2.00.

Discount of 25 per cent allowed to members, libraries, publishers, subscription agents, and purchasers of ten or more copies.

MARINE RULES. 1921 Edition.

Recommended practise for electrical installations on shipboard. Drawn up to serve as a guide for the equipment of merchant ships with electrical apparatus for lighting, signalling, communication and power, but not including propulsion. The rules indicate what is considered the best engineering practise with reference to safety of the personnel and of the ship itself, as well as reliability and durability of the apparatus. The Marine Rules are intended to supplement the Standards of the A. I. E. E., which should be followed wherever applicable. Price per copy, flexible linen cover, \$1.00.

Discount of 25 per cent allowed to members, libraries, publishers, subscription agents, and purchasers of ten or more copies.

YEAR BOOK. 1923 Edition.

A directory, published annually in March, of the membership of the A. I. E. E. Gives in alphabetical order, the names, occupations and addresses of all members. The membership is also listed in geographical order. The Year Book contains general information regarding the scope and activities of the Institute, including the Constitution and By-Laws, lists of Sections and Branches, the various committees, governing body, etc. Price per copy, linen cover, \$2.00.

Discount of 20 per cent to publishers and subscription agents; 50 per cent to college and public libraries. Single copies will be supplied to members without charge upon application.

American Institute of Electrical Engineers

33 West Thirty-ninth Street, New York, N. Y.

TRANSFORMER SPECIALISTS

We are pleased to quote prices and delivery on transformers singly or in quantity

Acme Apparatus Co.

198 Massachusetts Ave.
Cambridge, 39, Mass.

Transformer Engineers and Manufacturers



Use Diamond Fibre

Wherever the job in hand demands a tough, service-giving material of great strength, light weight and high dielectric qualities, use Diamond Fibre. We produce this remarkable raw material in easy-to-handle

SHEETS - RODS - TUBES

ready for all machining processes or fully machined to your own specifications. Write for samples and full information.

Diamond State Fibre Company

Bridgeport (near Philadelphia), Pa.

In Canada: Diamond State Fibre Company of Canada, Limited,
245 Carlaw Ave., Toronto, Ont.



THE SILSBEE CURRENT TRANSFORMER TESTING SET

is a compact *portable* set for making precision tests of current transformers in position. Checks ratio and phase angle.

Described in Bulletin 715F.

LEEDS & NORTHRUP CO.

4901 Stanton Ave., Philadelphia



— WANTED —

Copies of the following back numbers of the JOURNAL (1923) are urgently required:

January, February, March

Twenty-five cents will be paid for each copy returned directly to headquarters.

AMERICAN INSTITUTE OF ELECTRICAL ENGINEERS
33 West 39th Street, New York

Classified Advertiser's Index for Buyers—Continued.

TROLLEY LINE MATERIALS

General Electric Co., Schenectady, N. Y.
Ohio Brass Co., Mansfield, O.
Western Electric Co., All Principal Cities
Westinghouse Elec. & Mfg. Co., E. Pittsburgh

TURBINES, HYDRAULIC

Allis-Chalmers Mfg. Co., Milwaukee
Cramp & Sons Ship & Engine Bldg. Co.,
The Wm., Philadelphia.

TURBINES, STEAM

Allis-Chalmers Mfg. Co., Milwaukee, Wis.
General Electric Co., Schenectady, N. Y.
Western Electric Co., All Principal Cities
Westinghouse Elec. & Mfg. Co., E. Pittsburgh

TURBO-GENERATORS

Allis-Chalmers Mfg. Co., Milwaukee, Wis.
Westinghouse Elec. & Mfg. Co., E. Pittsburgh

VALVES

Johnson Hydraulic
Cramp & Sons Ship & Engine Bldg. Co.,
The Wm., Philadelphia

VARNISHES, INSULATING

General Electric Co., Schenectady, N. Y.
Irvington Varnish & Ins. Co., Irvington, N. J.
Minerallac Electric Co., Chicago
Sterling Varnish Co., Pittsburgh
Westinghouse Elec. & Mfg. Co., E. Pittsburgh, Pa.

WELDING EQUIPMENT, ELECTRICAL

General Electric Co., Schenectady, N. Y.
Ohio Brass Co., Mansfield, O.
Westinghouse Elec. & Mfg. Co., E. Pittsburgh

WIRELESS APPARATUS

Acme Apparatus Co., Cambridge, Mass.
General Radio Co., Cambridge, Mass.
Westinghouse Elec. & Mfg. Co., E. Pittsburgh

WIRES AND CABLES

Armored Cable
Belden Mfg. Co., Chicago
Boston Ins. Wire & Cable Co., Boston

General Electric Co., Schenectady, N. Y.
Kerite Ins. Wire & Cable Co., New York
Okonite Company, The, Passaic, N. J.
Roebling's Sons Co., John A., Trenton, N. J.
Standard Underground Cable Co., Pittsburgh
Western Electric Co., All Principal Cities

Asbestos Covered

Belden Mfg. Co., Chicago
General Electric Co., Schenectady, N. Y.
Rockbestos Products Corp., New Haven, Conn.

Auto

Belden Mfg. Co., Chicago
Boston Ins. Wire & Cable Co., Boston
General Electric Co., Schenectady, N. Y.
Kerite Ins. Wire & Cable Co., New York
Roebling's Sons Co., John A., Trenton, N. J.
Standard Underground Cable Co., Pittsburgh
Western Electric Co., All Principal Cities

Bare Copper

American Ins. Wire & Cable Co., Chicago
Anaconda Copper Mining Co., Chicago
Belden Mfg. Co., Chicago
Copper Clad Steel Co., Rankin, Pa.
Roebling's Sons Co., John A., Trenton, N. J.
Standard Underground Cable Co., Pittsburgh
Western Electric Co., All Principal Cities

Copper Clad

Copper Clad Steel Co., Rankin, Pa.
Standard Underground Cable Co., Pittsburgh
Western Electric Co., All Principal Cities

Flexible Cord

Belden Mfg. Co., Chicago
Boston Ins. Wire & Cable Co., Boston
General Electric Co., Schenectady, N. Y.
Okonite Company, The, Passaic, N. J.
Roebling's Sons Co., John A., Trenton, N. J.
Standard Underground Cable Co., Pittsburgh
Western Electric Co., All Principal Cities

Fuse

General Electric Co., Schenectady, N. Y.
Roebling's Sons Co., John A., Trenton, N. J.
Western Electric Co., All Principal Cities

Lead Covered (Paper and varnished cambric insulated)

Atlantic Ins. Wire & Cable Co., Stamford Conn.
General Electric Co., Schenectady, N. Y.
Kerite Ins. Wire & Cable Co., New York
Okonite Company, The, Passaic, N. J.
Roebling's Sons Co., John A., Trenton, N. J.
Simplex Wire & Cable Co., Boston
Standard Underground Cable Co., Pittsburgh
Western Electric Co., All Principal Cities

Magnet

Acme Wire Co., New Haven, Conn.
Belden Mfg. Co., Chicago
Dudlo Mfg. Co., Fort Wayne, Ind.
General Electric Co., Schenectady, N. Y.
Rockbestos Products Corp., New Haven, Conn.
Roebling's Sons Co., John A., Trenton, N. J.
Standard Underground Cable Co., Pittsburgh
Western Electric Co., All Principal Cities

Rubber Insulated

Atlantic Ins. Wire & Cable Co., Stamford, Conn.
Belden Mfg. Co., Chicago
Boston Ins. Wire & Cable Co., Boston
General Electric Co., Schenectady, N. Y.
Kerite Ins. Wire & Cable Co., New York
Okonite Company, The, Passaic, N. J.
Roebling's Sons Co., John A., Trenton, N. J.
Simplex Wire & Cable Co., Boston
Standard Underground Cable Co., Pittsburgh
Western Electric Co., All Principal Cities

Trolley

Anaconda Copper Mining Co., Chicago
Copper Clad Steel Co., Rankin, Pa.
Roebling's Sons Co., John A., Trenton, N. J.
Standard Underground Cable Co., Pittsburgh
Western Electric Co., All Principal Cities

Weatherproof

American Ins. Wire & Cable Co., Chicago
Copper Clad Steel Co., Rankin, Pa.
General Electric Co., Schenectady, N. Y.
Kerite Ins. Wire & Cable Co., New York
Okonite Company, The, Passaic, N. J.
Roebling's Sons Co., John A., Trenton, N. J.
Simplex Wire & Cable Co., Boston, Mass.
Standard Underground Cable Co., Pittsburgh
Western Electric Co., All Principal Cities

Please mention the JOURNAL of the A. I. E. E. when writing to advertisers.

Avoid electrical hazards—

QUOTING no lesser authority than the "National Electrical Safety Code," which says

"The use of measuring tapes and ropes having metal threads woven into the strand is dangerous and may be entirely avoided."

We recommend the

"SAMSON"

(Non-Metallic)

Woven Measuring Tape

which, while of great strength, has no metal strands in its line that might form a conductor. Its triple waterproof coating protects it from moisture.

Furnished in lengths of 25, 50, 75 and 100 ft. Greater lengths to order.

Send for literature and prices.

KEUFFEL & ESSER CO.

NEW YORK, 127 Fulton Street. General Office and Factories, HOBOKEN, N. J.

CHICAGO 616-20 S. Dearborn St. ST. LOUIS 817 Locust St. SAN FRANCISCO 30-34 Second St. MONTREAL 5 Notre Dame St. W.

Drawing Materials, Mathematical and Surveying Instruments, Measuring Tapes

MORSE SILENT CHAIN DRIVES

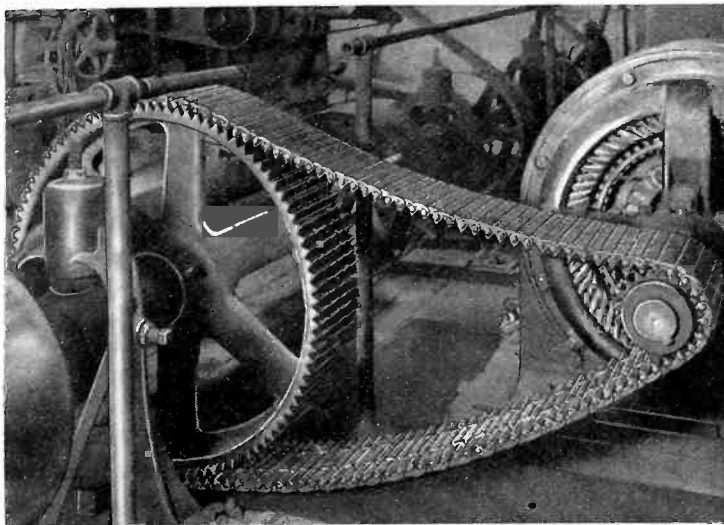

Get the Maximum Service and results from your motors

BELTS slip, resulting in an inevitable loss of power and reduced machine speed, slowing up production and piling up costs.

Gears have no flexibility, transmit the entire shock of load changes to the motor, reducing materially its usefulness and life.

Morse Silent Chain Drives, combine the flexibility of a belt, with the positive action of a gear. Transmit 98.6% of the power developed, permitting the use of short centers, a significant item in conserving valuable space and making convenient arrangement possible. Run cool, quiet, and clean. Require practically little attention other than timely lubrication, and will, with ordinary care, work efficiently for many years.

MORSE CHAIN CO., ITHACA, N. Y.

There is a Morse Engineer near you

ATLANTA, GA.	DENVER, COLO.	PHILADELPHIA, PA.
BALTIMORE, MD.	DETROIT, MICH.	PITTSBURGH, PA.
BOSTON, MASS.	KANSAS CITY, MO.	SAN FRANCISCO, CAL.
CHARLOTTE, N. C.	NEW YORK CITY	ST. LOUIS, MO.
CHICAGO, ILL.	MINNEAPOLIS, MINN.	TORONTO, Ont., Can.
CLEVELAND, OHIO	MONTREAL, Que., Can.	WINNIPEG, Man., Can.

PENNSYLVANIA ELECTRICAL SLATE

for

Switchboards, Panelboards, Fuse Blocks, Bus Bar Supports, etc.



THE STRUCTURAL SLATE CO.

118 Robinson Avenue, Pen Argyl, Penna.

Comprehensive Data on Electrical, Chemical and Physical Properties of Pennsylvania Slate sent on request

PUMPS

INDUSTRIAL-AGRICULTURAL-MUNICIPAL-RESIDENTIAL

A TYPE FOR EVERY SERVICE

Bulletins on Request

THE GOULDS MANUFACTURING COMPANY

Seneca Falls, N. Y.

Agencies in all principal cities

GOULDS

Please mention the JOURNAL of the A. I. E. E. when writing to advertisers.

Century

FRACTIONAL HORSEPOWER Repulsion Start Induction Single Phase Motors



1/8 H. P. and larger

These motors (1/8 to 3/4 H. P.) were designed to meet the demand for a small motor of rugged construction and high starting torque (325% full load) as required by carbonators, house pumps, etc. yet with a low starting current (260% full load current) so as not to cause the usual annoying voltage fluctuations.

Temperature Rise not over 40° C.

CENTURY ELECTRIC COMPANY

ST. LOUIS, MO., U. S. A.

Sales Offices and Stocks in Principal Cities

ALPHABETICAL LIST OF ADVERTISERS

	PAGE		PAGE		PAGE
Acme Apparatus Company	48	Ford, Bacon & Davis, Inc.	40	Parker-Kalon Corporation	39
Acme Wire Company, The	2	Fowle & Company, Frank F.	40	Partridge Lumber Company, T. M.	29
Alexander & Dowell	40	Frey, Brassert & Company	40	Pittsburgh Transformer Company	34
Allis-Chalmers Manufacturing Co.	16	Fuller Engineering Company	40	Prenner, I. S.	41
Ambursen Construction Company, Inc.	40	G & W Electric Specialty Company	27	Public Service Production Company	41
American Appraisal Company, The	40	General Bakelite Company	38	Publications A. I. E. E.	47
American Insulated Wire & Cable Co.	28	General Electric Company	Insert	Railway & Industrial Engineering Co.	24
American Lava Corporation	38	General Radio Company	36	Redmanol Chemical Products Company	38
American Lead Pencil Company	43	Goulds Manufacturing Company, The	49	Robinson & Company, Inc., Dwight P.	41
American Transformer Company	38	Hemingray Glass Company	26	Rockbestos Products Corporation	28
Anaconda Copper Mining Company	26	Higbie, William S.	40	Rockwood Manufacturing Company, The	32
Arnold Company, The	40	Irvington Varnish & Insulator Company	31	Roebbling's Sons Company, John A.	29
Atlantic Insulated Wire & Cable Co.	28	Jackson & Moreland	40	Roller-Smith Company	36
Bahamon, Robert	40	Jeffery-DeWitt Insulator Company	22	Rowan Controller Company, The	36
Bakelite Corporation	38	Johns-Pratt Company, The	14, 15	Sanderson & Porter	41
Barstow & Company, W. S.	40	Journals Wanted	48	Sangamo Electric Company	51
Bates Expanded Steel Truss Company	26	Kappeyne, J.	40	Sargent & Lundy, Inc.	41
Batthey & Kipp, Inc.	40	Kerite Insulated Wire & Cable Co.	1	Schramm, Adolph P. C.	41
Belden Manufacturing Company	28	Keuffel & Esser Company	49	Science-Abstracts	37
Biddle, James G.	36	K-P-F Electric Company	29	Sessions Engineering Company	41
Boston Insulated Wire & Cable Co.	29	Kuhlman Electric Company	34	Simplex Wire & Cable Company	31
Bristol Company, The	34	Lapp Insulator Company, Inc.	24	Simpson, Frederick G.	41
Century Electric Company	50	Leeds & Northrup Company	48	S K F Industries, Inc.	3
Cheyney, A. R.	40	Lincoln, Inc., E. S.	41	Spray Engineering Company	35, 41
Clark, Walter G.	40	Locke Insulator Corporation	23	Standard Underground Cable Company	27
Clement, Edward E.	40	MacGillis & Gibbs Company, The	29	Standards of A. I. E. E.	43
Condensite Company of America	38	Mahoney, J. N.	41	Star Electric Motor Company	32
Condit Electrical Manufacturing Co.	8	Marine Rules A. I. E. E.	39	States Company, The	37
Copper Clad Steel Company	29	McClellan & Junkersfeld, Inc.	41	Sterling Varnish Company, The	33
Cramp & Sons Ship & Engine Bldg. Co.	45	Metropolitan Device Corporation	52	Stevens, John A.	41
Cutler-Hammer Manufacturing Company	18	Midwest Air Filters, Inc.	35	Stockbridge & Rorst	41
Cutter Company, The	36	Minerallac Electric Company	24	Stone & Webster, Inc.	41
Day & Zimmerman, Inc.	40	Moloney Electric Company	30	Structural Slate Company, The	49
Denike, Inc., Robert E.	40	Moore & Company, W. E.	41	Texas Company, The	17
Diamond State Fibre Company	48	Morganite Brush Company, Inc.	42	Thomas, Percy H.	41
Dickinson, W. N.	40	Morse Chain Company	49	Thomas & Sons Company, The R.	24
Dossert & Company	21	Neill, N. J.	41	Thoner & Martens	37
Dudlo Manufacturing Company	28	Neiler, Rich & Company	41	U. E. S. Library	42
Duncan Electric Manufacturing Co.	37	New Departure Manufacturing Co., The	33	United Gas & Electric Engineering Corp.	41
Egbert, Charles C.	40	Norma Company of America, The	32	Viele, Blackwell & Buck	42
Electrical Testing Laboratories	42	Northwestern Electric Company	32	Wagner Electric Corporation	19
Electro Dynamic Company	34	Ohio Brass Company, The	25	Western Electric Company	13
Electro Service Company	26	Okonite Company, The	Inside Back Cover	Westinghouse Electric & Mfg. Co.	4, 5, 6, 7
Engineering Directory	40, 41, 42	Ophuls & Hills, Inc.	41	Wiley & Sons, Inc. John	39
Fansteel Products Company, Inc.	30	Pacific Coast Steel Company	26	White Engineering Corp., The J. G.	42
Fennessy, David V.	40	Page & Hill Company	20	Williams, Gardner S.	42
Ferranti, Ltd.	Outside Back Cover			Woodruff, Eugene C.	42
Ferry, Montague	40			Wray & Co., J. G.	42
Fire Protection Engineers	40				

(For classified list of Advertisers see Pages 44, 46 and 48)

Please mention the JOURNAL of the A. I. E. E. when writing to advertisers.

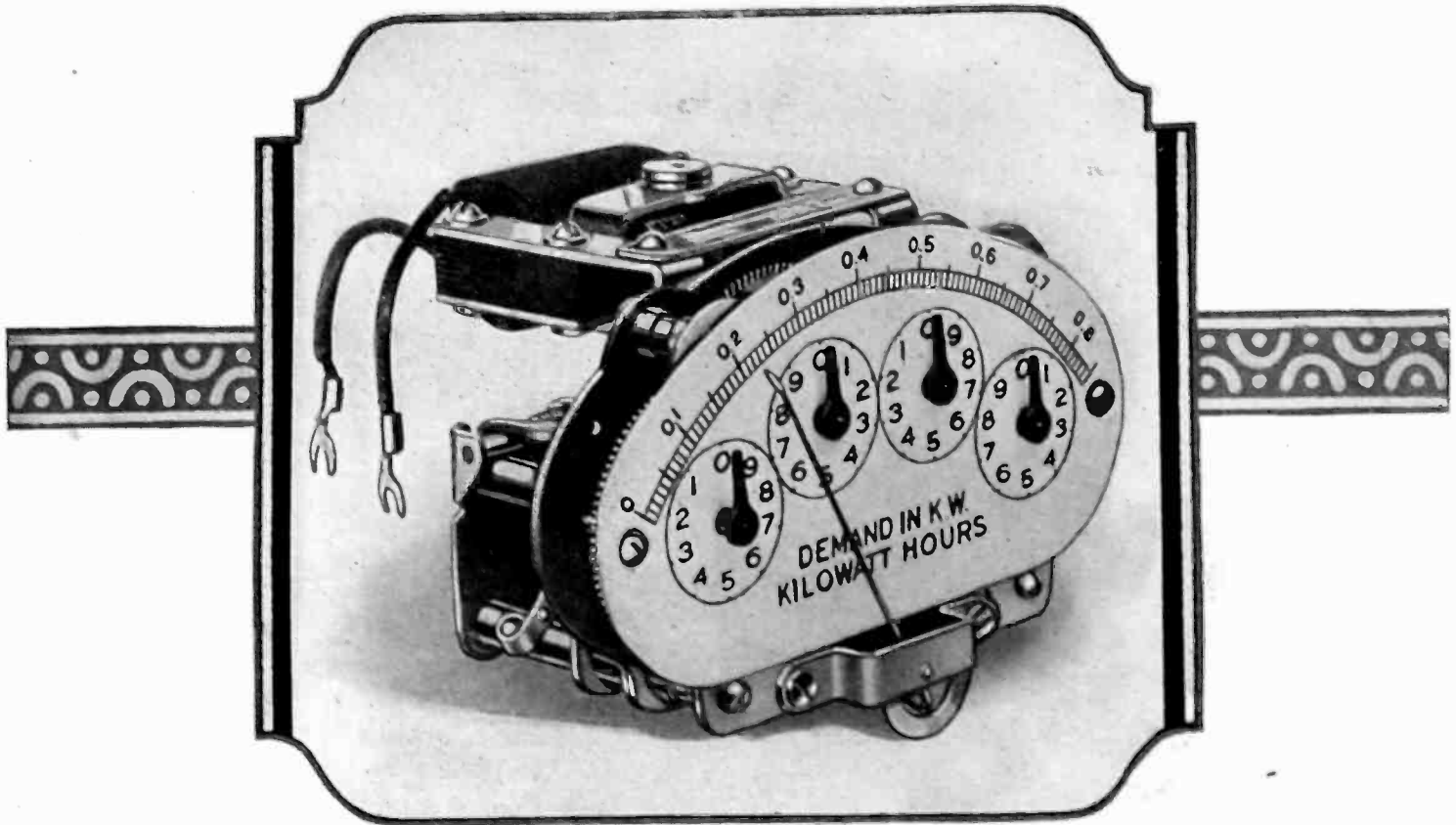

Sangamo Maximum Demand Register -the first commercially successful register with a synchronous motor

IN ALL present-day maximum demand registers the watthour meter mechanism, in addition to recording the energy, actuates a pusher which, at the beginning of a predetermined period of time, advances the maximum demand indicator hand over the scale. This advance proceeds at a rate continuously proportionate to the instantaneous rate of speed at which the meter disk is rotating.

At the end of the predetermined interval of time the forward motion of the pusher ceases and it is instantly withdrawn to the point from which its travel started. The indicator hand is left at the point on the demand scale to which it was carried by the pusher, at which point it will remain until it is either advanced by a further travel of the pusher, during a later operative period, or is manually set back by the meter inspector.

The extreme position to which the maximum demand indicator is advanced will thus at all times correctly indicate the maximum demand which has occurred since the last time the meter was read and the indicator adjusted—providing the time intervals during which the pusher is moving forward are constant.

Therefore, it is vitally important that the

means provided for driving the timing device shall operate under all conditions at a speed as nearly constant as possible.

That is why the use of a special SYNCHRONOUS Motor drive for operating the timing of the Sangamo Maximum Demand Register is a feature of outstanding interest to every electric light and power company attempting to include actual maximum demand as a factor in making its rates!

Equipped with SYNCHRONOUS timing motors the timing accuracy of SANGAMO Maximum Demand Registers CANNOT be affected by voltage variations, nor friction variations. Moreover, so extremely high is the torque of the specially-designed Sangamo SYNCHRONOUS Motor that the friction-torque can never approach the pull-out torque. Therefore the accuracy and dependable performance of the Sangamo Maximum Demand Register cannot be affected by friction variations.

The use of SYNCHRONOUS motors in connection with demand registers is a SANGAMO development.

Write for details covering this and other features of Sangamo Maximum Demand Registers—easily applied to any Sangamo Type-H Watthour meter.

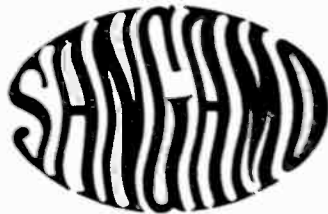

Sangamo Electric Company

Springfield, Illinois

NEW YORK

CHICAGO

ST. LOUIS

SAN FRANCISCO

LOS ANGELES

SPECIALISTS IN METERS FOR EVERY ELECTRICAL NEED

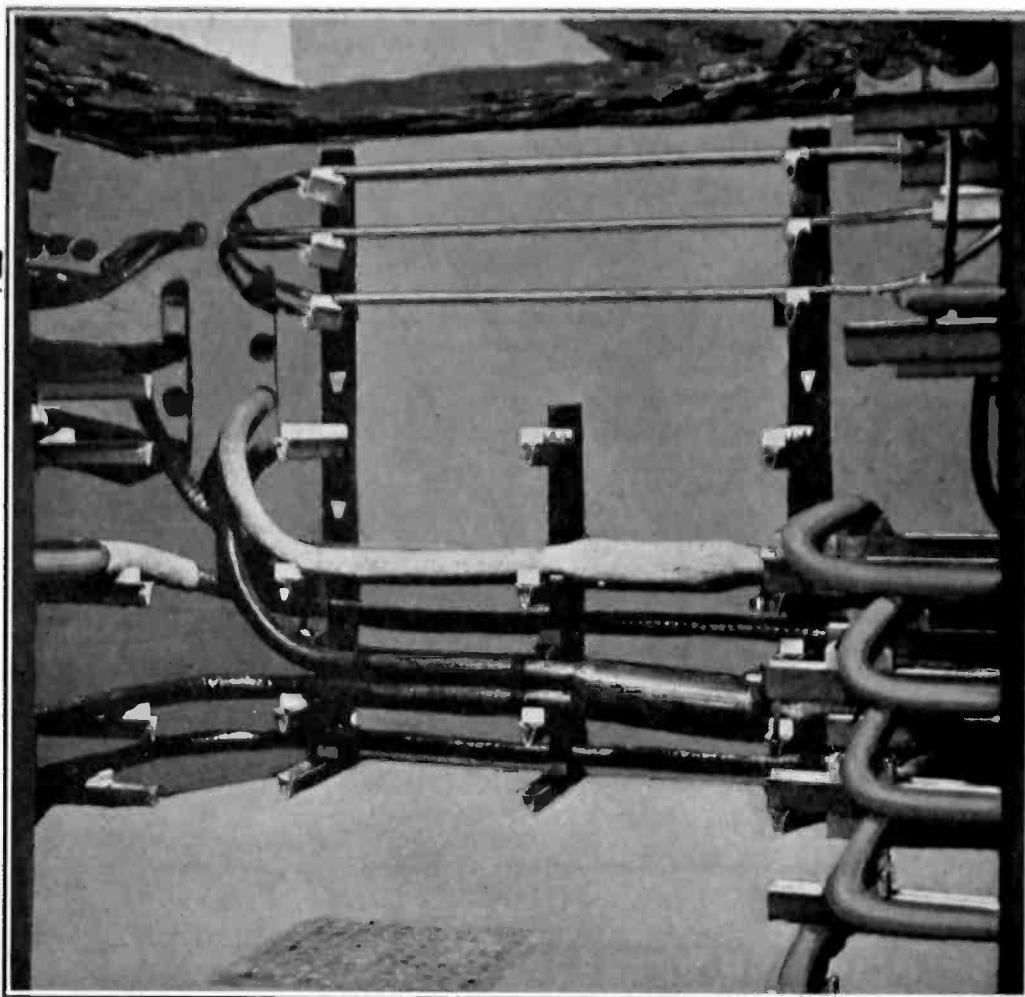

Metropolitan Subway Cable Racks

Specified by the distribution engineers who look to the future.

And WHY? This is the only hanger in use which insulates the cable from the manhole proper. No chance for electrolysis. The porcelain insulator used in this device entirely prevents trouble from this source and makes it highly desirable for all power and signal cable requirements.

The grooved hanger permits the porcelain insulator to be moved to any position of the cable. This is very important because of constant alterations due to extensions and improvements.

SEND FOR FULL DETAILS. Metropolitan Subway Cable racks merit your consideration when planning your next distribution schedule.

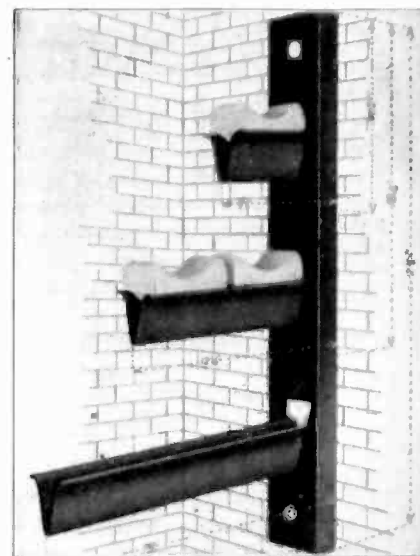

Metropolitan Subway Cable Rack with Porcelain Insulators

Other Metropolitan Safety Devices

- Network Protectors
- High and Low Tension Fuses
- Junction Boxes
- Standardized Switches
- High Tension Cable Joints
- Primary Cutouts
- Subway Sectionalizing Units
- D.C. Cable Testing Ammeters
- Cable Racks

METROPOLITAN DEVICE CORPORATION

1250 Atlantic Avenue, Brooklyn, N. Y.

Gentlemen:—Please send data and full information on Subway Cable Racks.

Name..... Company.....

Address..... Title.....

And kindly check any of the items at the left on which you desire information.

Please mention the JOURNAL of the A. I. E. E. when writing to advertisers.

NARRAGANSETT ELECTRIC LIGHTING CO.

Main Generating Station

PROVIDENCE. R. I.

Ninety-five per cent of the cables running out of this Station are OKONITE, furnishing light and power to the city of Providence and surrounding territory. OKONITE FIRST INSTALLED - 1899

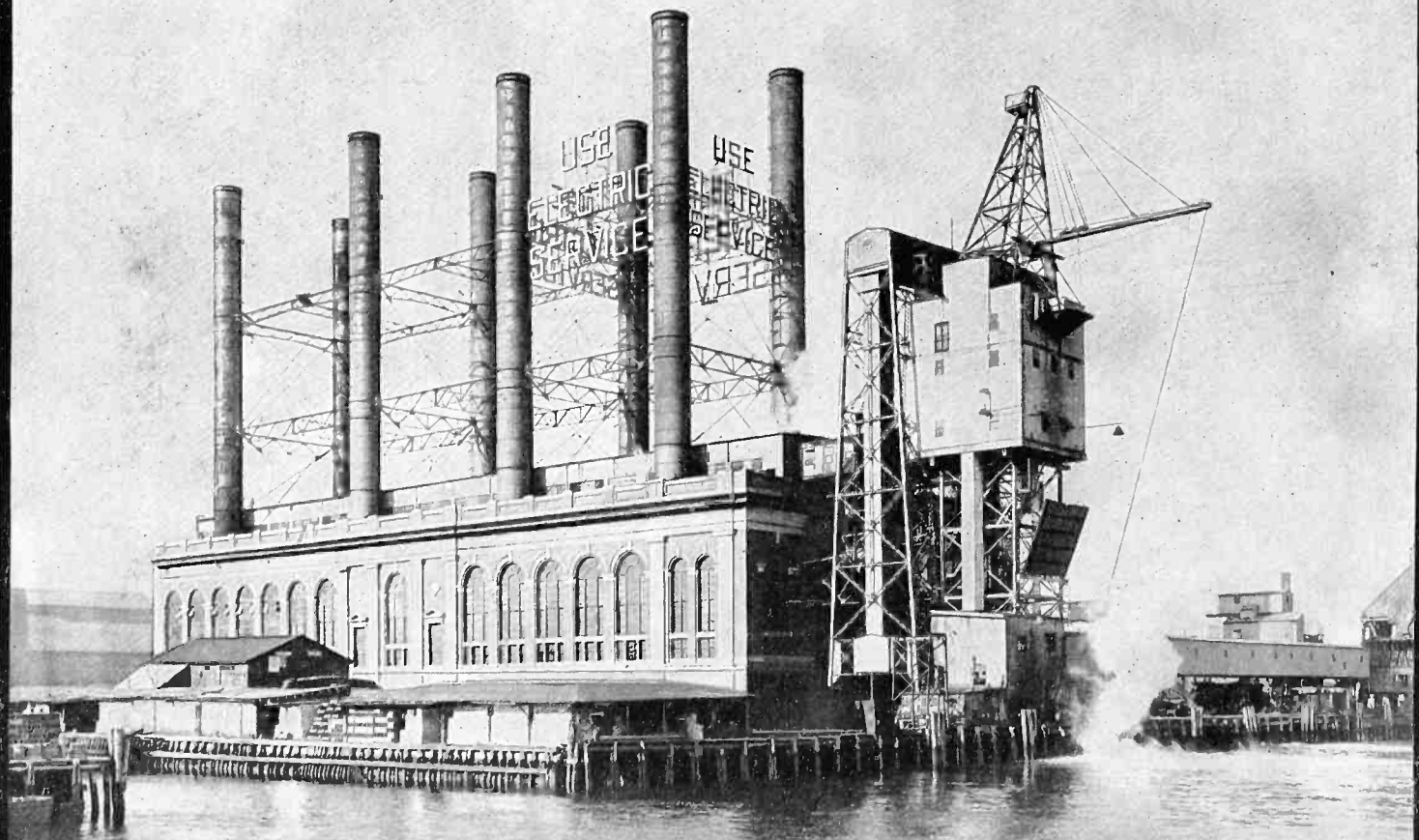

THE OKONITE COMPANY, Passaic, N. J.

INCORPORATED 1884

Sales Offices: New York Atlanta San Francisco

Central Electric Company, Chicago, Ill., General Western Agents

F. D. Lawrence Electric Co., Cincinnati, O. Novelty Electric Co., Philadelphia, Pa.

Pettingell-Andrews Co., Boston, Mass.



NOMAG

NON-MAGNETIC CAST IRON

Dawson-Ferranti Patent Aplⁿ. 33290-20

*A METAL WHICH CAN
BE DESCRIBED IN
FIGURES* →

	Magnetic Permeability	Specific Resistance
	Maximum	Micro-ohms per cm. cube
Ordinary Cast-iron	330.00	95.0
NoMag	1.03	140.0
Brass	1.00	7.5

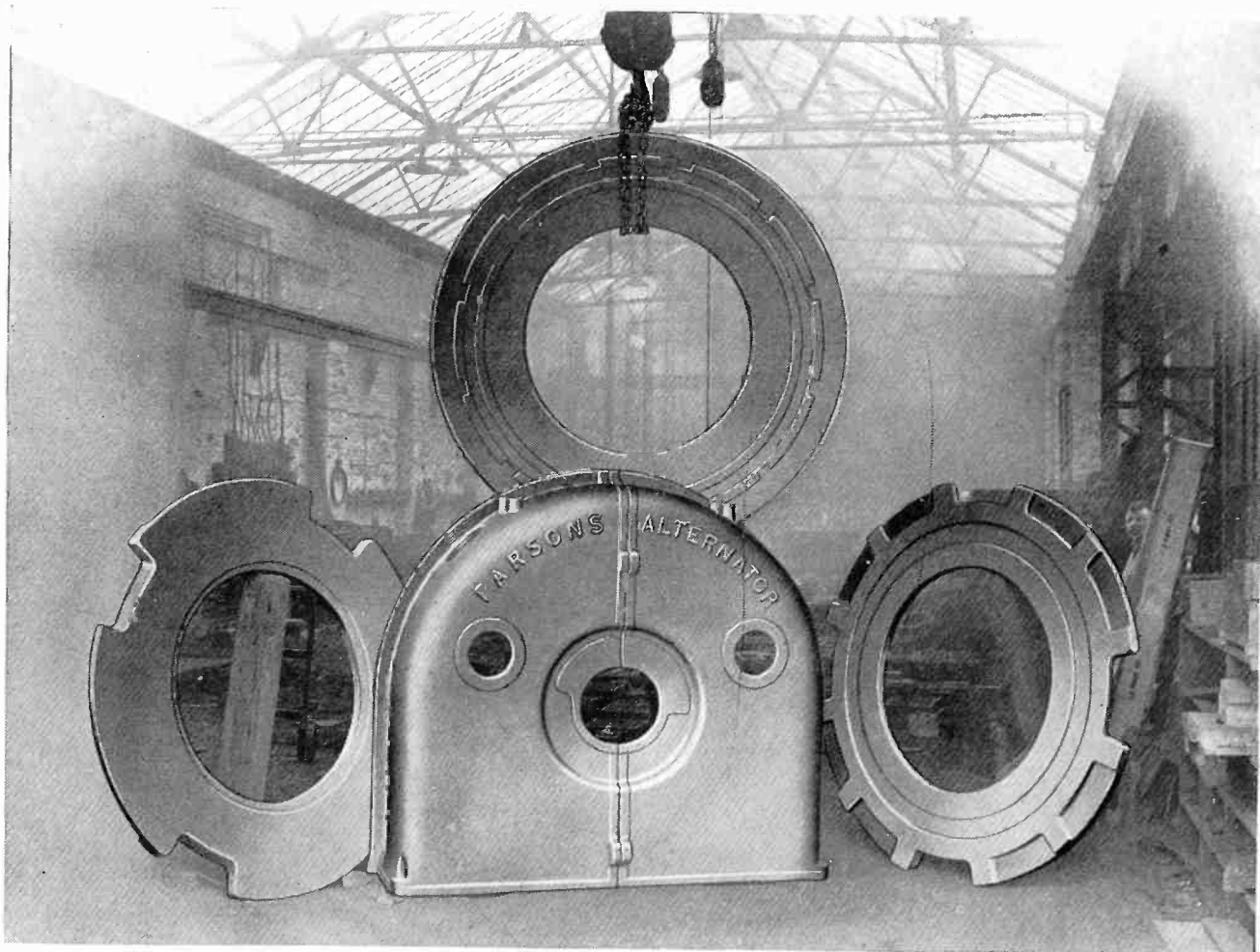

NOMAG has electrical resistance higher than iron, and permeability as low as brass.

It is less subject to hysteresis and eddy currents than any other metal yet discovered.

The use of NOMAG for end plates and other parts of generators and motors affords the maximum freedom from stray field losses.

FERRANTI LTD.
HOLLINWOOD
LANCASHIRE
ENGLAND