

INNOVATION

New cameras Electronic changes function	16
Listen to the airband Eavesdrop on the airport	24
Non-flat batteries New from Dunlop	47
Philips PM 3320 Resolving the difference	95
CSS The complete stats pak	125

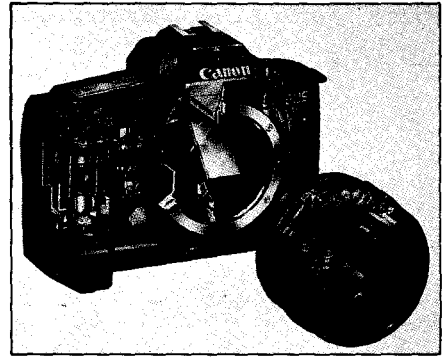

Page 16

TECHNOLOGY

The waking giant The next superpower shapes up	10
Video formats Patterns of change	28
Airships The latest blimps	42



Page 20

SOUND INSIGHTS

News	2
Perreau 200w amp	8
Roland surround sound	14
Industry news	21
CD reviews	23

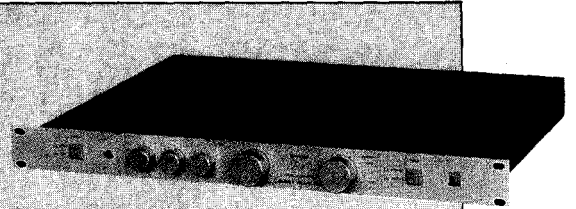

S / Page 8

ELECTRONICS

ETI-1429: Noise gate	100
ETI-1411: Headphone distribution box	106
ETI-1620: Printer buffer — Part 1	108
ETI-616: Midi interfaces — Part 2	114



Page 42

DEPARTMENTS

Editorial	5
News	6
Politics	20
Communications news	22
Comment — Bruce Middleton	38
Videotex news	53
Kilohertz comment	56
Product news	83
Semi conductor watch	92
Coming events	129
Dregs	130

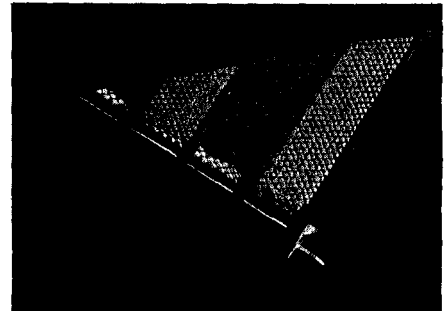

Page 47

TAKE YOUR PERSONAL COMPUTER OUT INTO THE BIG WIDE WORLD. WITH TELECOM VIATEL.

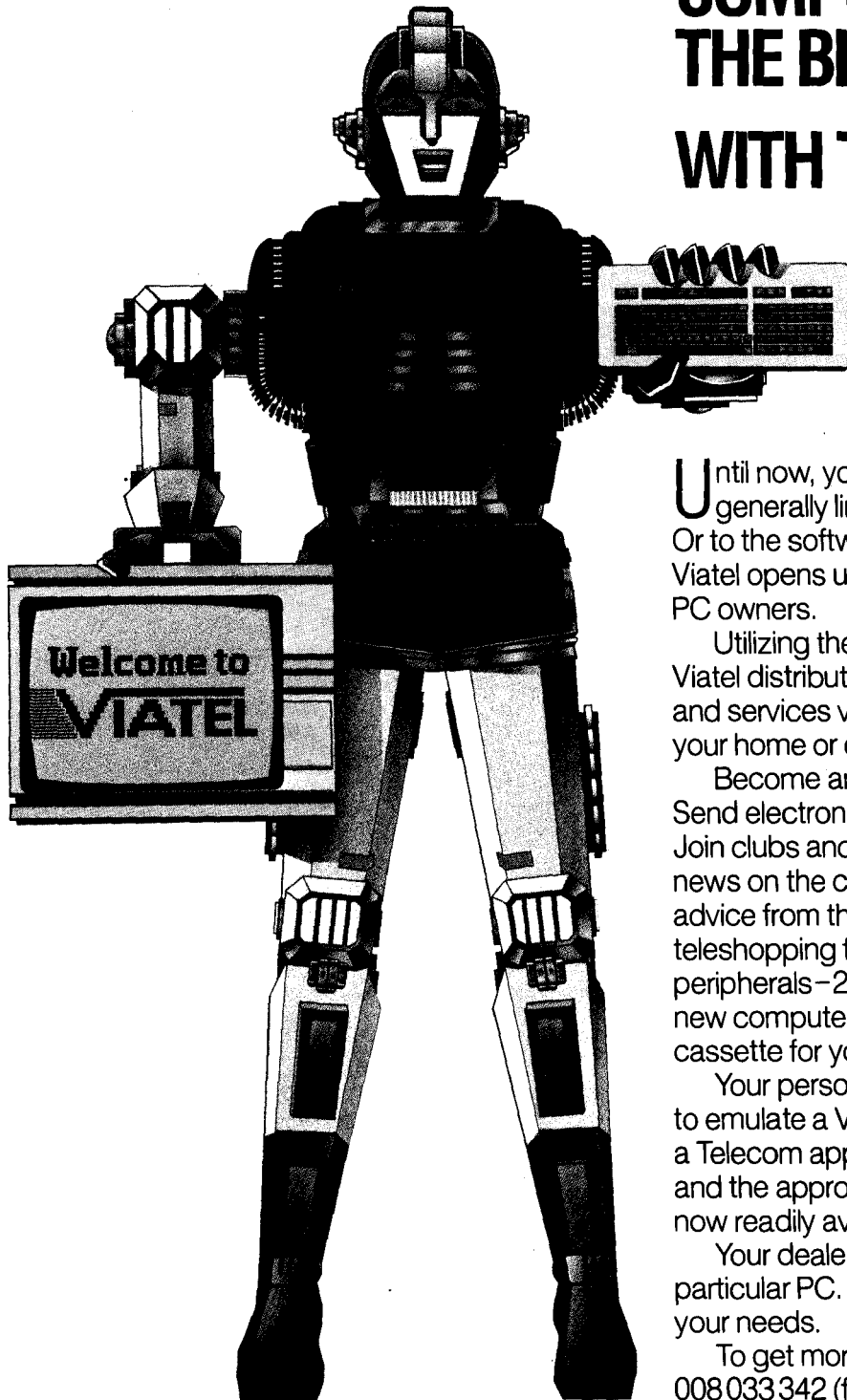

Until now, your personal computer was generally limited to your information input. Or to the software available. Now Telecom Viatel opens up a whole new world for PC owners.

Utilizing the existing telephone network, Viatel distributes a wide range of information and services via a central computer. Direct to your home or office.

Become an identity on the bulletin boards. Send electronic mail clear across Australia. Join clubs and user groups. Get the latest news on the computer industry, as well as advice from the experts. There's teleshopping for hardware, software and peripherals—24 hours a day. Even download new computer programs onto disk or cassette for your own use.

Your personal computer can be adapted to emulate a Viatel terminal. All you need are a Telecom approved 1200/75 baud modem and the appropriate software. These are now readily available for most PC's.

Your dealer will know what is best for your particular PC. Talk to him first about your needs.

To get more information on Viatel phone 008 033 342 (for the cost of a local call).

Telecom

VIATEL®

AUSTRALIA'S NATIONAL VIDEOTEX SERVICE

TM844



Telecom Australia
Better for Business

READER INFO No. 9

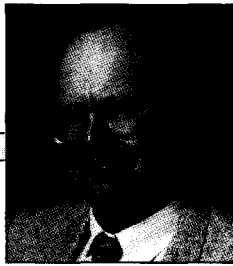

JON FAIRALL

TV — the media barons and the price we pay

A November decision by the minister of communications, Mr Ralph Willis, to bury a proposal on pay TV for the duration by sending it back to his department is symptomatic of the price Australia is paying for the close relationship the current Labor government has forged with the media barons.

That the media, both written and electronic, is too highly concentrated for the political health of the country is widely understood. Less well understood is the price we pay, and will continue to pay, in terms of arrested progress.

In the last ten years, the technology of TV reticulation has exploded. Satellite, microwaves and optical fibre have all matured to the point that they can be used as practical components in a broadcasting system. This has changed the economics of the operation out of all recognition.

When our broadcasting system was set up, it was planned around a studio and a single transmitter. It was all the technology allowed. Thus, each TV operator had to be able to generate sufficient revenue (viewers) within the range of that single transmitter. The rules were set up appropriately. In the capital cities it meant that two, sometimes three, commercial stations could compete with the ABC. In the provincial centres it meant at the most one commercial operator, and of course, over much of the countryside, it meant no TV at all.

With the arrival of Aussat, this changed somewhat. While direct reception at the viewer's home proved too complex and expensive given the power constraints of the satellite, cheap reticulation from studio to studio became an option. Of course, coaxial links had existed since the 1960s, but only at a price. The government moved with the speed of a stunned snail to allow some extremely

'The government moved with the speed of a stunned snail to allow limited forms of networking'

limited forms of networking, and the amalgamation of some viewing areas. It did so in the face of enormous resistance from the owners.

Last year saw a huge ownership shake out, and the creation of a small number of media barons, all closely connected to the government. Revelations before the Broadcasting Tribunal in Sydney have revealed just exactly how close that connection has become.

More importantly perhaps, during the last two years, the launch of powerful satellites in Europe and the US, plus the availability, at long last, of cheap and small downstation equipment, has made direct satellite reception possible.

Overseas, the result has been an explosion in the number of TV services supplied to households. Many are supplied direct from satellites, others on cable systems themselves supplied by satellite. Either way, what is happening is that intercontinental distances are becoming irrelevant in the broadcasting game. From a studio in Sydney, you can reach down the road, or Perth, just as cheaply.

This fact has the potential to radically alter broadcasting in Australia. A market of 16 million viewers will easily support twenty or thirty channels, based on US experience. That's 30 channels into every house in the country, not just the ones in the big cities. This many channels would undoubtedly change what we expect from TV. Broadcasting would be replaced by 'narrowcasting'; channels for sport, documentary, music, old movies, new movies and education would compete with the existing networks for viewers.

The only people to suffer would be, of course, the cosy cabal of owners. Their assets could not possibly sustain the current value they put on them. In the normal course of events, of course, one would not expect the government to make policy for the benefit of just a few individuals. But these are not just any individuals. They have the power to bring down the government, or keep it there. It will be a brave politician who will challenge them. Certainly it will not be the tired administration of Mr Bob Hawke. One would be more optimistic if the federal opposition contained any knights in shining armour. It doesn't.

EDITOR

Jon Fairall B.A.

PRODUCTION EDITOR

Anne Lawton

EDITORIAL STAFF

Terry Kee B.Sc. (Hons.), M. Phil.

DRAUGHTING

Kerry Benyon

DESIGNER

Clive Davis

ART STAFF

Ray Eirth

PRODUCTION

Mal Burgess

NATIONAL ADVERTISING MANAGER

Mark Lewis

ADVERTISING PRODUCTION

Brett Baker

SECRETARY

Nina Stevens

ACOUSTICAL CONSULTANTS

Louis Challis and Associates

PUBLISHER

Michael Hannan

MANAGING EDITOR

Brad Boxall

HEAD OFFICE

180 Bourke Road,
PO Box 227, Waterloo, NSW 2017
Alexandria, NSW 2015.
Phone: (02) 693-6666.
Federal Facsimile: (02) 693 9935

ADVERTISING

New South Wales: Kim Bucknole, The Federal Publishing Company, 180 Bourke Road, Alexandria, NSW 2015. Phone: (02) 693 6666. Facsimile: (02) 693 9997.
Victoria and Tasmania: Valerie Newton, The Federal Publishing Company, 221a Bay Street, Port Melbourne, Vic 3207. Phone: (03) 646 3111. Facsimile: (03) 646 5494.

Queensland: John Saunders, The Federal Publishing Company, 26 Chermiside Street, Newstead, Qld. Ph: (07) 854 1119. Facsimile: (07) 252 3692.

South Australia and Northern Territory: Michael Mullins, C/- Federal Publishing, 98 Jervois Street, Torrensville, SA 5031. Ph: (08) 352 7937.

Western Australia: Des McDonald, 48 Clevedon Street, North Perth 6006 WA. Phone: (09) 444 4426.

New Zealand: Rugby Press, 3rd Floor, Communications House, 12 Heather Street, Parnell, Auckland. Phone: 796-648. Telex: NZ63112, "Sportby".

Britain: Peter Holloway, C/- John Fairfax & Sons, 12 Norwich Street, London EC4A 1BH. Phone: 353 9321.

ELECTRONICS TODAY INTERNATIONAL

is published and distributed monthly by The Federal Publishing Company Pty Limited, 180 Bourke Road, Alexandria, NSW 2015, under licence from Double Bay Newspapers Pty Limited, General Newspapers Pty Limited and Fairfax Community Newspapers Pty Limited. Printed by Hannanprint, Sydney. Distributed by Newsagents Direct Distribution, Alexandria, NSW 2015. *Maximum and recommended Australian retail price only. Registered by Australian Post. Publication No. NBP0407. ISSN No. 0013-5216. COPYRIGHT © 1985, Double Bay Newspapers Pty Limited, General Newspapers Pty Limited and Fairfax Community Newspapers Pty Limited (trading as "Eastern Suburbs Newspapers").



Industry News

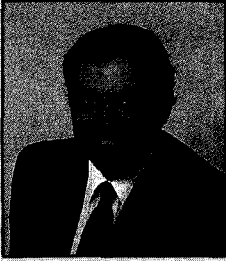

Bob Crabbe

Bob Crabbe has been appointed managing director of the George Brown Group. He was previously the Group marketing director.

Stephen Costello of BIS banking systems has been appointed regional manager for Asia, the Pacific and Australia. The move follows the merger of the Asian and Australasian branches of the London headquartered company. He entered BIS with the acquisition of JBA in 1987, and formerly worked as a management consultant.



Edna McKelvey

Edna McKelvey has been appointed marketing manager of Apscore International, the Sydney company that developed Cue-Bic software for Pick based systems. She was formerly with Wang and Attache Software in Canada.

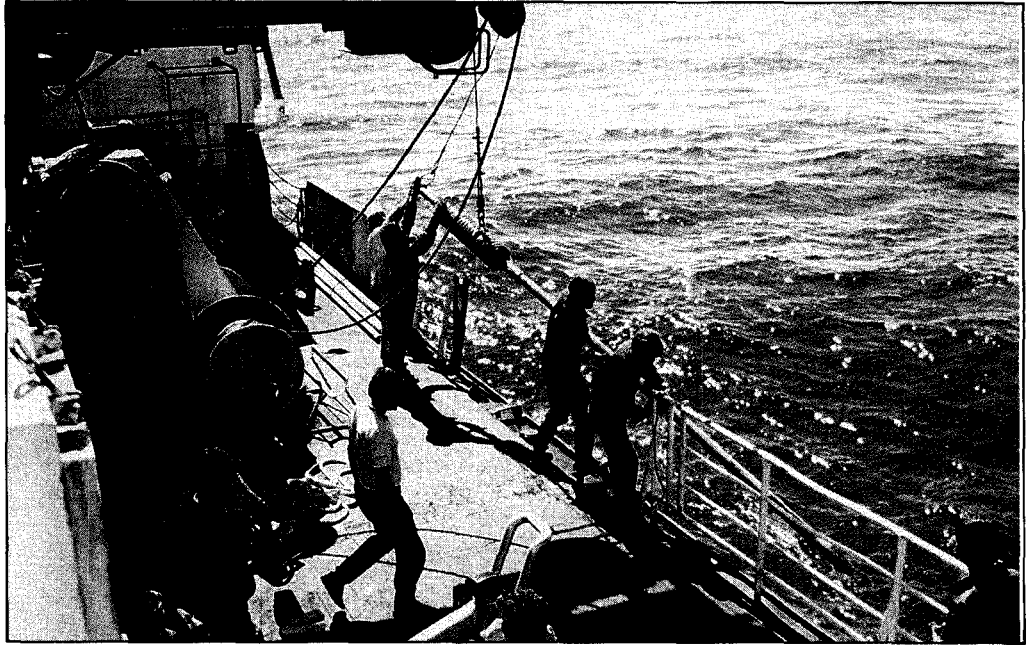

Surveying the route aboard RV Rapuhia.

Tasman 2 moves on

Australia and New Zealand moved closer to the establishment of high capacity telecommunications links between the two countries with the signing of an agreement in Sydney recently, to construct the \$160m optical fibre Tasman 2 cable. This formalises an earlier memorandum of understanding.

The submarine cable will use the world's most advanced technologies in optical fibres and lasers to vastly increase the communications capacities between the countries.

Laying of the cable from Sydney will begin in April, 1991, and it is expected to reach its New Zealand landfall, Auckland, in May. It is scheduled to begin service the following December. Under the agreement, OTC and ICNZ have decided to build three fibre pairs into the cable between the countries. Only two of the pairs will be used initially.

Tasman 2 is the first stage of the world's largest submarine optical fibre cable network. The first stage, which will be between Australia and Auckland, will be followed by an extension to

Honolulu. Another cable will be laid between Australia and the Western Pacific Rim countries. The network, known as PacRim, will cost more than \$1000m and is due to be completed in 1995.

Balloons over Alice

Two NASA heavy-lift balloons are scheduled to be launched from Australia this month to continue scientific studies of Supernova 1987A, marking the fifth Supernova campaign conducted in the past 2 years.

A 28.4 million cubic foot balloon is scheduled to carry a scientific experiment to measure gamma-ray and hard X-ray emissions. Another balloon is scheduled to carry a scientific experiment that will measure gamma-ray emissions, but over a different energy band.

NASA has completed 15 scientific balloon flights from Australia since the exploding star was first discovered in February 1987. These investigations were conducted in four campaigns from Alice Springs and were part of a three-tiered effort by NASA to study the Supernova.

Other efforts included six sounding rockets launched in two campaigns from the Woomera Range in South Australia and a NASA aircraft research effort from New Zealand.

Atari grows up

Atari recently demonstrated the ATW, a powerful low cost workstation based on the Inmos T800-20 RISC processor. It's designed to produce high resolution graphics, lots of memory and fast storage. The ATW represents an order of magnitude jump in price performance over other systems on the market.

Atari Computers' managing director, Nigel Shepherd, said that the ATW represents the completion of two years of intensive research and development by Atari UK and Perihellion Hardware. The ATW, in its entry level configuration, outperforms an 80287 equipped IBM AT by a factor of 13. With the addition of four Transputer Farm cards, a further 16 T-800-20 processors can be added to the computer. These processors can be interconnected allowing the processing speed to be increased by a factor of 16.

The ATW has been designed to accept an unlimited number of T-800 processors. An external farm of 48 processors is available enabling a single workstation to address 65 T-800 processors for a total performance of some 650 MIPS.

Helios has been chosen as the operating system for the ATW. Designed as a multi-user, multi-tasking operating system for parallel processing systems, Helios has a low-level user interface familiar to users and programmers who have worked with UNIX.

Since last June software developers in Europe and North America have been working on ATW development systems. Already a number of applications are close to completion. Atari plans to produce several hundred pre-production units for the additional seeding of

developers and corporate users. Full scale production is expected to begin this month, with an Australian retail price in its base configuration of between \$7500 to \$10,000.

The development of the ATW signals strengthening interest within Atari in the business end of computing.

The current market leader in video games, Atari's managing director, Nigel Shepherd, is confident that next year will see Atari recognised as a major force in the personal and business computer markets.

Already the company has made a major penetration into the consumer market with the Atari ST computer and has secured a number of education contracts with this same machine.

Currently, they are the company's flagship line and represent over 70% of Australian revenues. The ST's are 32-bit computers powered by the Motorola 68000 micro-processor.

Atari is also active in the desktop marketplace with the

Atari MEGA Computers. Employing the same operating system as the Atari ST there is a 2MB RAM (MEGA 2) and 4MB RAM (MEGA 4) version of this product. These units are ideal for Desktop Publishing, CAD, Animation, and Music applications. Already the MEGA, which has a built-in MIDI port, is the most popular computer in the Australian electronic music market.

"There is a strategy and natural progression to everything that we do," says Shepherd. "From video games to personal computers to workstations to transputers has been a natural evolution in technology for Atari. As our products have evolved so have the strategies we employ to support these products in the marketplace," said Shepherd.

"We are very serious about our future in Australia. It has only taken the new Atari four years to reach Fortune 500 status (500 largest corporations in the United States) and 1989 will be the year when Atari will become established as one of the major forces in the Australian computer industry," added Shepherd.

The Atari MEGA desktop computer.

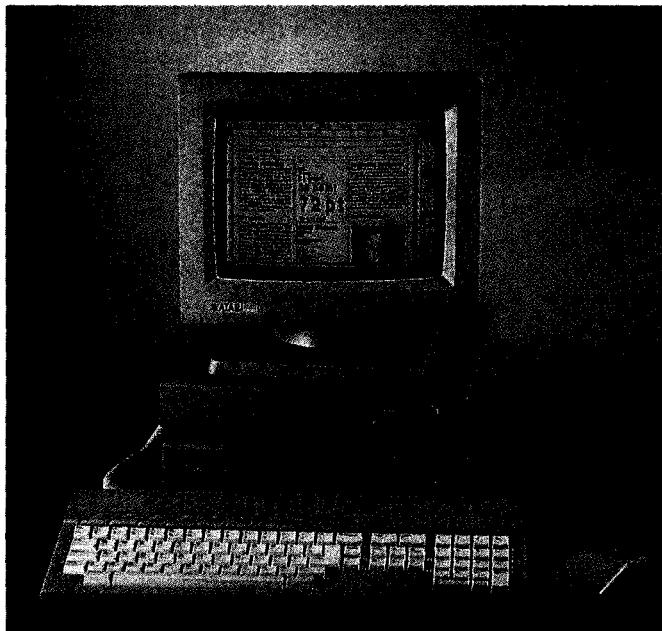

Industry News

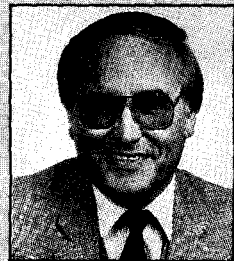

Baxter Henderson

Baxter Henderson, national service manager at CPE Australia, has been appointed resident of the Melbourne chapter of the Association of Field Service Managers.

NEC information systems has appointed Bill Woolridge as ACT branch manager. He was formerly with Cullnet software, Honeywell and Digital. Meanwhile, David Steinbeck has been appointed personnel manager.



Phil Carnaffin

Trace Technology has announced the opening of a branch in Brisbane to service broadcasting and communications clients in the North. Phil Carnaffin is the new state manager. He was previously sales manager of Cunningham Consolidated in Queensland. He has previously worked for Canon, Rank, Sony and John Perry.

Industry News

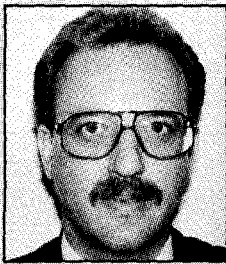

Peter Della Tolla

Peter Della Tolla has been appointed national sales manager for Trace Technology. He was previously with Consolidated Electronics where he was national product manager for data communications.

Greg Boot has been appointed managing director of Rod Irving Electronics and Ritronics Wholesalers. Rod Irving has left the company to concentrate on his real estate interests. Boot was formerly manager of the Melbourne store as well as managing director of Software Express.

SGS Thomson microelectronics has posted a third quarter profit of \$4.5m. The news marks the consolidation of the French Italian conglomerate's position as one of the world's leading semiconductor manufacturers.

Aussat's annual report shows strong growth during 1987, with revenue up 40% to \$104m. This still represents a loss, however, of \$5.3m. Use of the satellites increased by 28%, so that 70% of the existing space capacity is now committed.

Voca Communications has moved its Canberra office. New address is 24 Marcus Clarke St, Civic ACT 2601. Phone contact on (062) 572 628.

Fibre optics cable system for army

AWA has developed a battlefield fibre optic communications system (FOCS) for the Australian Army. It is currently undergoing final testing prior to manufacture of prototypes.

AWA's FOCS has been designed to handle communications tasks within the Army's Parakeet system. Parakeet consists of a network of mobile communications centres - known as 'nodes' - which link the frontline soldiers using Raven portable radio equipment, manufactured by Plessey, to Australia's fixed communications network, codenamed Discon.

Each node of Parakeet will typically consist of a group of communications vehicles which must be capable of being rapidly deployed. Normally these vehicles would be spread out a kilometre or two apart and FOCS will form the link between them.

The hardware for FOCS consists of a three module terminal set, and rugged fibre-optic cable

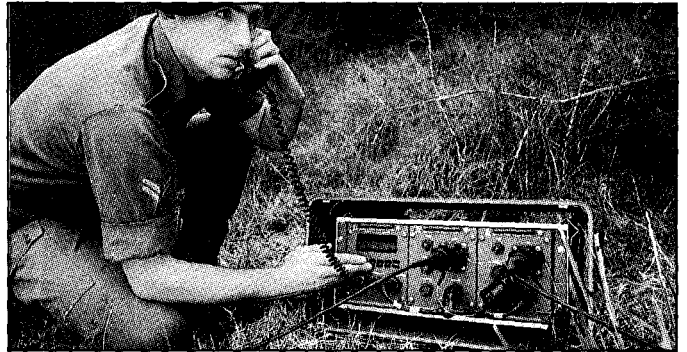

FOCS has been designed for communications tasks within the Army's Parakeet system.

linked by connectors for link lengths up to 7km without the need for repeaters.

Up to now coaxial cable has been used for this sort of short-haul work, but fibre optic cable is much lighter, more rugged, and can carry far more information. In fact a single soldier can handle one kilometre of fibre-optic cable, as opposed to just 250 metres of the heavier coaxial cable. The fibre-optic cable used

in FOCS can carry 120 voice channels - or nearly 200 if the auxiliary channel is used - which compares to just 24 voice channels for equivalent coaxial cable. FOCS cable can carry facsimile or other digital data and is so rugged that trucks can be driven over it, or even over the connectors between cable lengths, without causing damage. It can also be laid from drums mounted in trucks or

New dispersion technology

CSIRO, in collaboration with Auspharm International, is seeking interest in a novel method of dispersing powders in air and gases, in vacuum, and through insulating liquids.

'Whilst our interest is primarily in pharmaceutical applications, we believe the technology has enormous potential in many other areas,' said Auspharm's technical director Dr David Buckley. 'It could lead to the development of new X-ray sources, dry paper-making, coal-fired diesel engines, new medical technology and developments in powder metallurgy.'

The basis of the new technology is a phenomenon called 'electro-suspension' (ES), an electrokinetic effect generated by applying intense electromagnetic fields to powders. CSIRO'S Dr Steve Szirmai of the Coal Technology Division discovered the ES effect in 1974. 'When the effect is produced in a closed insulating vessel, the suspended cloud of dust reaches

equilibrium with the powder bed, rather like a vapour over a liquid in a closed space,' explained Dr Szirmai. 'The concentration of the suspended cloud may be varied by purely electrical means,' he added.

In association with Professor DH Morton of the University of NSW and with Unisearch, Dr Szirmai has already developed a technique for vapour-coating powders using ES in vacuum. He found that when the vapour of a high-melting metal is allowed to diffuse through the dispersed cloud, coating occurs by condensation of the metal onto the surfaces of the suspended particles. This vacuum technique is applicable to the low-volume production of certain exotic materials.

As a result of this early work, a novel X-ray source is under development with Unisearch, based on X-ray emissions from vacuum-dispersed metal dust. These sources are easy to construct and do not rely on a



Dr Steve Szirmai

fragile, life-limiting filament for their operation. Therefore they are rugged, long-lasting and potentially very cheap compared with conventional X-ray sources.

More recently, CSIRO's work with Auspharm has resulted in an electro-suspension coating process that will operate at atmospheric pressure. This new process will therefore be suited to continuous high-volume industrial production and will have particular application in the formulation and coating of pharmaceuticals and in powder

Superconducting oxides

helicopters for even greater mobility and speed.

The terminal equipment modules are themselves light and portable, and fit into three aluminium pods designed to be rack-mounted in two-tonne type vehicles, such as the Army's new Landrover 100s. There is a fibre optic modem to provide optical and electrical interfaces for the main 2M bit/s channel and the auxiliary 1M bit/s channel; a supergroup multiplexer module; and a control module for the system with a user-friendly menu-style mode of operation and a liquid crystal display. The control module has a built-in supervisory facility which automatically self-tests the system.

Austral Standard Cables of Melbourne designed the cable, using a slotted core technique in which the fibre optic filaments - each the thickness of a human hair - run through channels wide enough to withstand a good deal of compression.

Metal Manufacturers Ltd (MML) and the School of Materials, Science & Engineering at the University of New South Wales, are working on a joint program on the industrial applications of high temperature superconducting oxides.

Superconducting wires have already been produced in Australia, utilising superconducting oxides prepared by the School of Materials, University of NSW and fabricated by Metal Manufacturers using proprietary techniques. The CSIRO Division of Applied Physics has fulfilled a key role in characterisation of the superconducting properties of these oxide materials.

Until March 1987, most work on superconductivity was confined to niobium based compounds held at temperatures below 20K. At these temperatures, involving the use of expensive liquid helium, commercial applications of superconductivity have been extremely limited.

However, the annual meeting of the American Physical Society in March 1987 marked a dramatic change in outlook. Reports were received from a number of laboratories of superconducting transitions in oxide ceramics containing yttrium oxide, barium oxide and copper oxide at temperatures above the liquid nitrogen temperature of 77K.

One of the technological and economic advantages in the use of superconducting compounds is the absence of energy losses. For example, approximately 20 per cent of energy transmitted through high tension lines is lost in the form of heat. Heat generation is also a major problem in the design of computers.

The establishment of superconducting ceramics with a transition temperature above the liquid nitrogen barrier raises new opportunities in power transmission. One possibility would be a superconducting ring around the Central Business District and superconducting riser mains in major high rise buildings. This would alleviate many of the

problems encountered in high voltage, high current density electrical reticulation in urban areas.

Similar situations exist in other high voltage applications such as transmission from power stations to the initial switching yards.

The discovery of materials which are superconductive at liquid nitrogen temperatures has greatly reduced the complexity of cryogenic systems needed for superconductors, hence reducing their cost. This will stimulate the existing interest in superconductive cables and rapid developments are expected to take place in heavily urbanised and industrialised countries.

Depending on the properties developed in the family of oxide ceramic materials which has been identified to date, it is conceivable that commercial systems may be operational within five years.

Industry News



Jim Torrosian

Jim Torrosian has been appointed R and D manager at Hypertek. He was formerly Hypertek's senior hardware engineer.

Compucare has signed a contract to distribute Datasat's new Allegro 24.24SA modem, as well as future product releases from Datasat. Compucare is offering a 24-month warranty on the new device, twice the industry standard.

metallurgy.

An additional prospect is the electro-suspension of fibres in dry paper-making which would avoid the current costly technique of dispersing them in water. The use of ES in coal combustion and medical device technology is also being explored.

Several of the applications of the new powder-dispersion technology are already covered by international patents. CSIRO and Auspharm would welcome ideas for other applications and are looking for expressions of interest in a joint venture which is being formed to develop this exciting new technology. Richard Cartmer, Auspharm's Project Search and Development Manager is co-ordinating the commercial development of the venture.

For more information, contact Dr Stephen Szirmai, CSIRO Division of Coal Technology, PO Box 136, North Ryde, NSW 2113, ☎ (02) 887 8666.

MAXIM

LARGEST A.D. SECOND - SOURCE

AD 2700/01/10	AD 7581
AD 3554	AD 7520/4/8
AD 565/6	AD 536
AD 578	AD 574
AD 580/1/4/9	MAX 7624
AD 7224/5/6	+ + PLUS + +
AD 7520/1/3	improved versions
AD 7524/6/8	MAX 130 family
AD 7530/1/3	MAX 150 family
AD 7541/2/3	MAX 160 family
AD 7545/8	MAX 170 family
AD 7572/4/6	MAX 670 family

**MAXIM QUALITY - SUPERB
VELTEK PRICING - SUPERB**

Sydney:
(02) 599 1900

VELTEK

Melbourne:
(03) 288 7511

VEL 2

READER INFO No. 39



ANNA GRUTZNER

Anna Grutzner reports on the growth of India's Defence Forces. Does the largest navy in the Indian Ocean threaten Australia?

Aparochial eye, ever-watchful of the Indonesian military to the immediate north, Australia has taken but a passing interest in a massive military build-up a little further afield.

The defence forces of India have undergone, in recent years, the most dramatic modernisation and expansion ever witnessed in the Asian region.

India's decision to lease a nuclear-powered submarine from the Soviet union last year unleashed a flood of speculation about her intentions, though in reality, the

build-up has far broader manifestations.

It is a phenomena worth examining, as it undermines previous Western assumptions about the essentially defensive role of India's military capability. While Australia has nothing itself to fear from a stronger India, it is certainly affected by any shift in the strategic balance of power in the Indian Ocean. The expansion, especially in naval forces, signals a long-term aim to protect India's military capability well beyond her own shores.

The obsolescence of traditional concepts of spheres of military influence is driven home

INDIA, THE WAKING GIANT

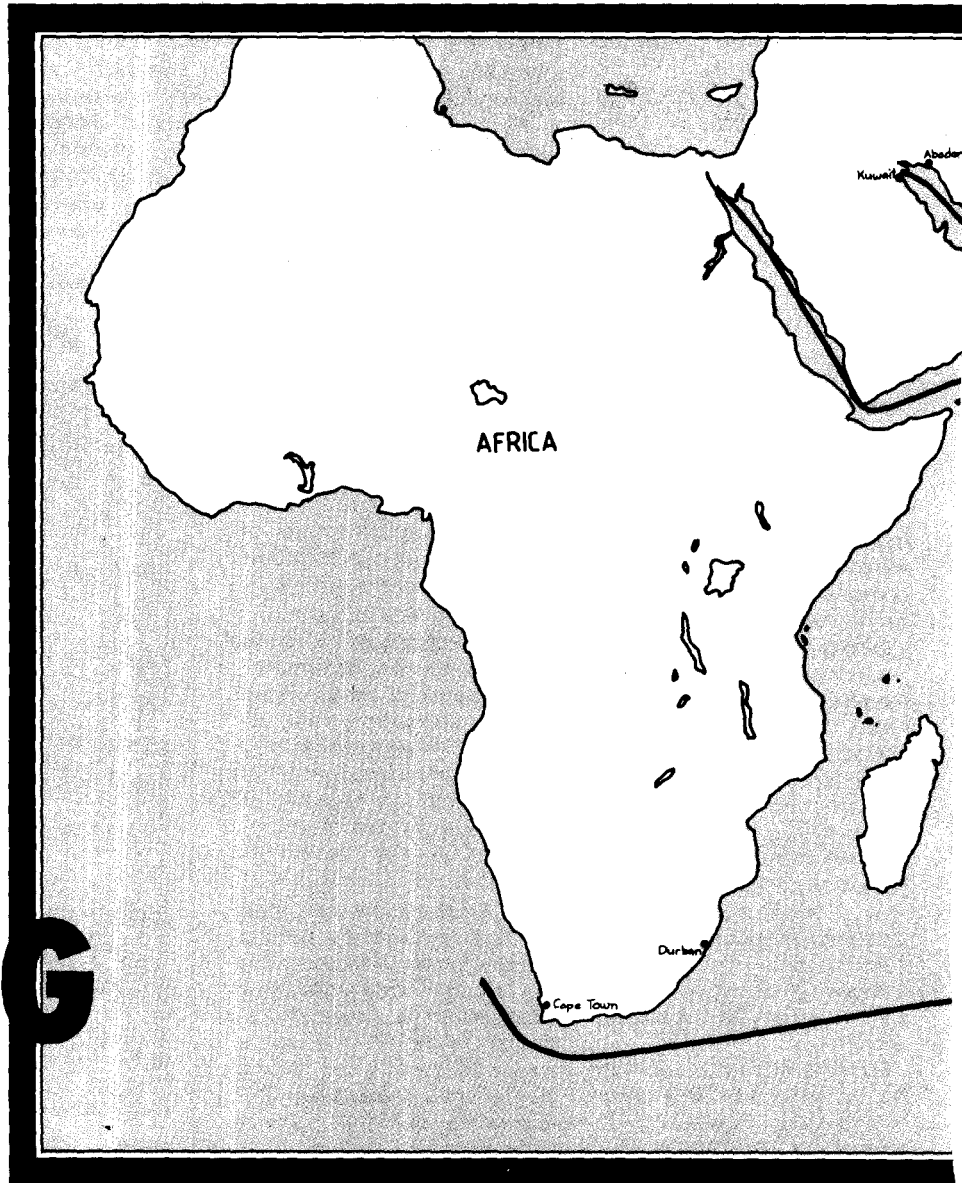

by the Indian build-up. Modern technology, in the form of long-range missiles and reconnaissance aircraft, over-the-horizon radar, and nuclear-powered submarines, has made our region a smaller place. India and Australia now are effectively neighbours.

The stability formerly provided by Britain has long gone, although renewed British interest in the Five-Power defence argument with Malaysia, Singapore, Australia and New Zealand, suggests it is reappraising its commitments in Asia. The United States's presence, besides an irritant to India in the form of military aid to Pakistan (\$1.5b in the next six years), is confined to a surveillance installation on Diego Garcia.

India wants to be the predominant force in the Indian Ocean, both in regional and superpower terms. An impressive navy with nuclear-power capability would give it the

muscle to ensure its interests are recognised and respected by the superpowers as well as its less-than-friendly neighbours. Patriotism and prestige are as much behind the moves to embark on a domestic program of defence production as is the urge to become self-sufficient.

'India wants to be the predominant force in the Indian Ocean.'

The official 1987-88 defence budget of a record 125 billion rupees, or \$17.4b, cited by New Delhi, bears out the theory that India has put defence high on its list of national priorities. At more than 15% of GDP and 43% up on the previous year's spending, defence is the biggest single budget item.

In the six previous years, the Indian defence forces spent another \$17.4b modernising jet fighter forces, missiles, tanks and field guns. Not even domestic criticism that this poorest of nations is buying weapons when it cannot feed its own people, has quelled sizeable middle-class support for the goal of security through military might.

The potential for India's military drive to destabilise its relationship with its neighbours is one of the most disconcerting aspects of the build-up. Pakistan, chilled by the memory of three bloody wars with India, did not hide its displeasure at the submarine acquisition. It firmly believes India will try to dominate the region, if not by war, then by invincible military strength. Despite India not having exploded a nuclear device since 1974, Pakistan is also concerned by signs that it will revive its nuclear research program. Such a move

New equipment in the Indian Navy will allow it to dominate the Indian Ocean when and if required. It's not an insignificant fact for Australia.

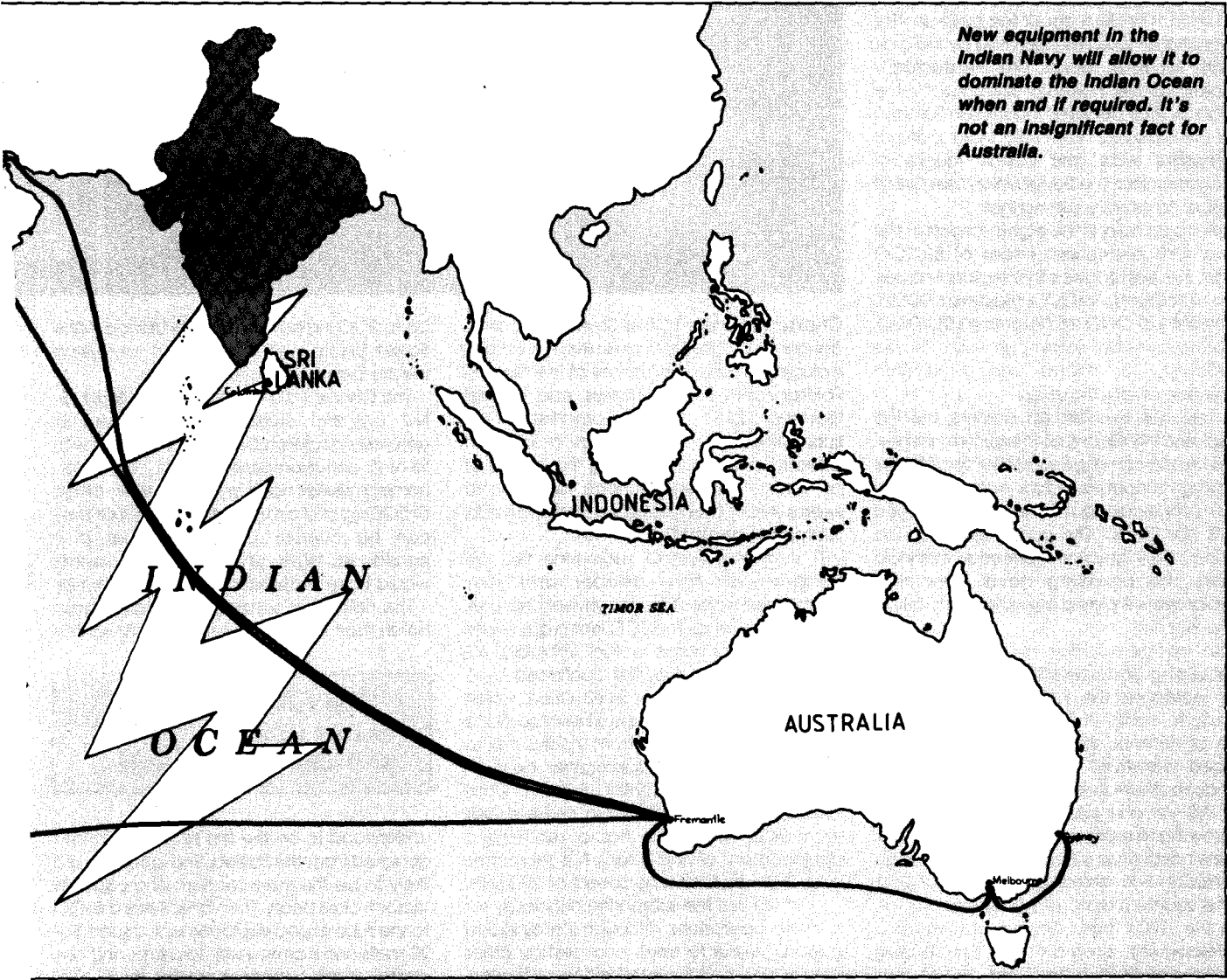

Indian defence

could trigger a nuclear arms race between the rival Hindi and Islamic nations.

China, India's greatest threat, does not fit easily into the emerging picture of its motives for the military build-up. Why is the Navy the centre-piece of the expansion when China is a land threat? According to the deputy head of the Centre for Strategic and Defence Studies at the Australian National University, Dr Ross Babbage, Indian nuclear-powered submarines would be the only vessels capable of threatening China's seaboard in the event of tensions between the two nations once again erupting into open warfare.

The People's Republic navy, of 44 major surface vessels and three nuclear powered submarines, has made India nervous recently by visiting three of its ambivalent neighbours: Pakistan; Sri Lanka and Bangladesh. China is, moreover, India's main rival as an economic power in Asia. It is a major exporter of military hardware, including its Silkworm anti-shiping missile, which dominated the Gulf war.

Even Indonesia, which shares a sea border with India, is anxious about the build-up. The naval and air facilities operated by India on Great Nicobar Island are strategically situated at the northern entrance to the Malacca Strait between Indonesian Sumatra and the Malaysian Peninsula. India scoffs at Indonesia's fears and openly laughs at speculation that the Soviet Union uses Great Nicobar to service submarines.

The Indian navy is the eighth largest in the world, with permanent forces of 52,000 sailors. It overshadows other regional navies, such as Pakistan's 10,000, Malaysia's 9000, Indonesia's 37,000 and Australia's 20,000. The navy owns five Soviet-built Kashin II-class destroyers, 23 frigates and a sizeable collection of landing ships.

It also has two aircraft carriers, the INS Viraat and INS Vikrant, both ex-British Hermes-class vessels carrying Sea Harrier aircraft and Sea King helicopters. India is planning to build a third carrier along the lines of an enlarged "HMS Ark Royal". The priority given to the carriers' anti-submarine role reveals that India shares the prevailing naval view that submarines will play a key role in any future naval conflict.

The modernisation of both India's shipbuilding and operational base facilities has facilitated the naval expansion. The Mazagon docks in Bombay have been a hive of defence activity. The Soviet Union helped construct a new ship yard at Vishakapatnam in eastern India; where the big INS Virbahu submarine base and INS Satyavahana submarine school are situated. A new naval base is being built out of range of Pakistani F-16 aircraft at Karwar, near Goa, in the southern state of Karnataka.

In the 1970s Indira Ghandi authorised a development program for locally-built nuclear-powered submarines, but it was finally abandoned in 1984. The leasing of INS

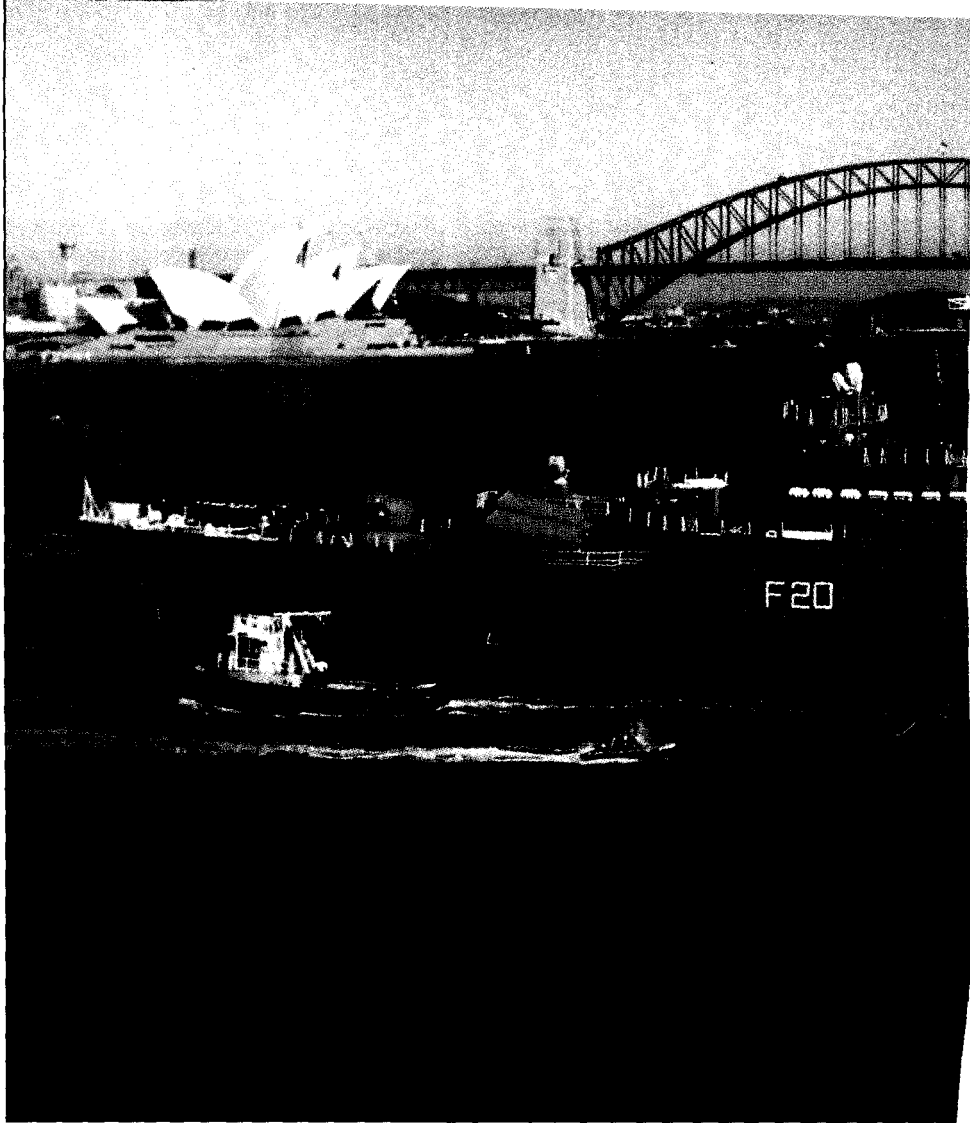

Chakra, a Charlie 1 Class Soviet submarine, enhances an already-impressive naval fleet, including 13 other submarines of the Kilo and Foxtrot (both Soviet) classes, and a West German "209" Class submarine. While submarines are regarded as a low-cost effective means of offsetting the impact of an enemy's superior surface forces, India seems intent on building up both powerful submarine and surface forces.

A nuclear-powered submarine like INS Chakra can dive deeper and stay submerged longer than a conventional one, and can travel up to 1000 kms a day - well beyond India's home waters. Ironically, INS Chakra's identity was first confirmed by a Royal Australian Air Force P3 Orion, which shadowed the attack submarine through the Malacca Strait *en route* from Vladivostok to the Vishakapatnam submarine base in January last year (1988). Built in Gorki between 1967 and 1972 as a cruise-missile submarine, the vessel has a submerged displacement of 4800 tons. It is 94 metres long and has a cruising speed of 23 knots.

India will use the submarine principally for anti-ship operations, although it may prove a useful vessel to track and destroy other submarines, and for intelligence-gathering, as it can stay submerged for months on end.

Up to 200 Indian submariners trained in the Soviet Union over a period of four years before bringing the vessel home.

The Charlie 1-Class is armed with eight SS-N-7 anti-ship cruise missiles, housed in upwardly-angled tubes in the bow, and with SS-N-15 anti-submarine rockets. The radar-homing missiles have an explosive warhead of 500 kg and a range of 64 kms. While they can be nuclear or conventional, it is considered highly unlikely that the Soviets would have supplied India with the former.

This noisy and outdated submarine does not in itself warrant great concern. But it is

'The Charlie-1 class is armed with light SS-N-7 anti-ship cruise missiles.'

understood to be the first of six submarines acquired from the Soviets. The latter five are likely to be the more modern and capable Victor III-class boats. The Victor III has a 6300 tonne submerged displacement, a speed of 29 knots and is armed with torpedos and two classes of anti-submarine missiles, the SS-N-15 and the SS-N-16. Such a submarine capability

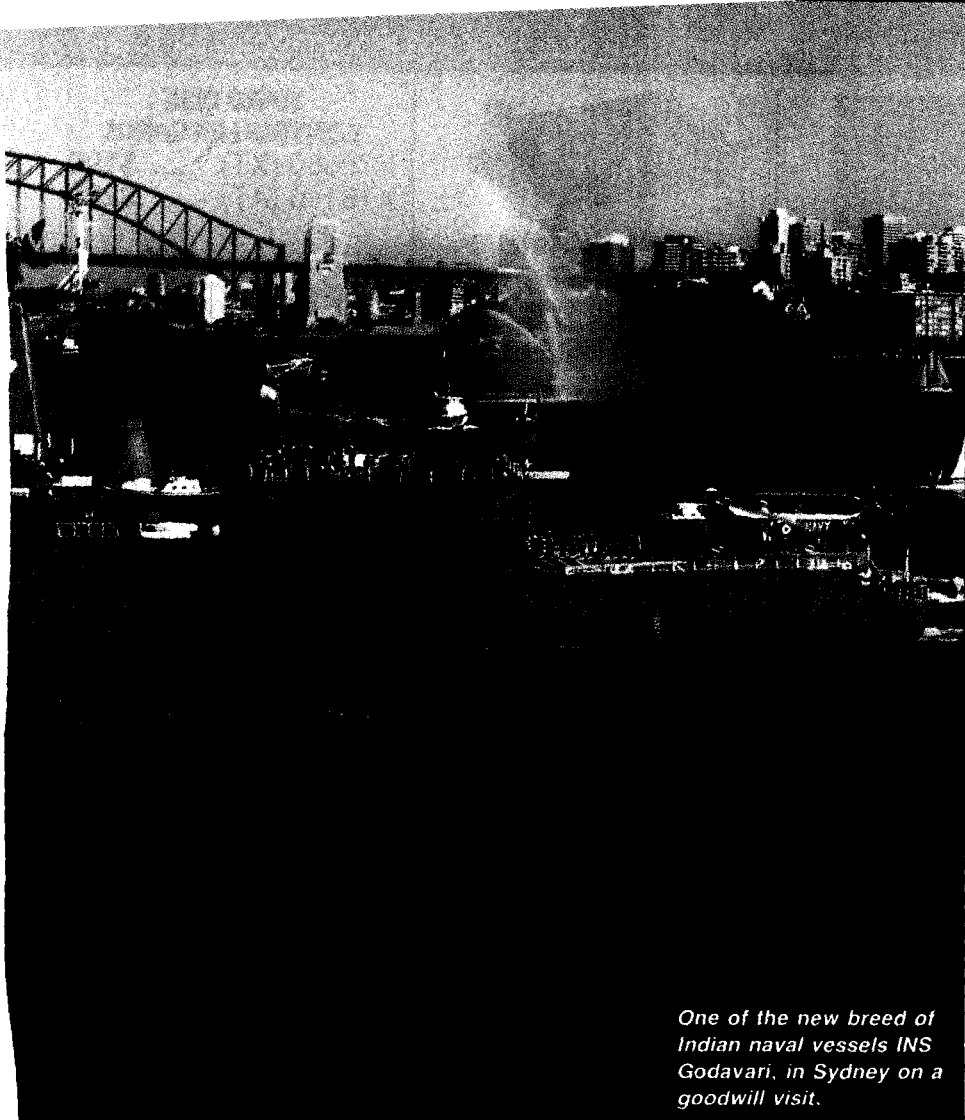

One of the new breed of Indian naval vessels INS Godavari, in Sydney on a goodwill visit.

would force potential aggressors to think twice before encroaching on India's territorial waters.

Many defence analysts argue the submarine deal is another step towards India becoming reliant on the Soviet Union, and away from its traditional non-aligned stance. While *Jane's Fighting Ships* suggests the Soviet Union may impose some operational constraints on India's use of the Chakra, it remains an important contributor to the country's naval expansion.

In the immediate future, Soviet involvement is likely to extend beyond the submarine hull lease, as the colossal expense of establishing and training personnel to manage a nuclear-power capability is beyond the Indians' budget. Soviet spare parts and expertise will also be needed to maintain the submarine. It is rumoured that the Soviet Union was reluctant to conclude the marine deal, doing so only after India agreed to take two outdated enriched-uranium nuclear reactors off its hands.

But on a more positive note, Prime Minister, Rajiv Ghandi has been more even-handed in his defence relations than his mother, spreading weapons-procurement orders evenly to the USA and Europe as well as the Soviet Union.

Indian naval expansion is all the more serious because it is not explicable in historic terms. However, it is worth looking briefly at trends in land and air power underway within India's other armed services.

For instance, India has acquired the Tupalov TU 142 reconnaissance aircraft. Bigger than a Boeing 747 jumbo and with a range of 10,000 kms-plus, the TU-142 can fly at a pinch to Australia or South Africa and back without refuelling. The four-turbo prop Bear has a proven track record of service in the Soviet airforce for 33 years.

Its role will be similar to that performed by the P3 Orion for the RAAF, though its size would easily permit accommodation of the largest air-to-surface missiles and radar carried by any aircraft. The TU-142 complements the IAF's 175 Soviet MiG combat aircraft, 85 British Jaguar strike aircraft, and 40 French Mirages.

The Indian army is the fourth largest in the world, with 1.2 million troops. It has received more than 1000 new combat tanks (Soviet T-55 and T-72), thousands of surface-to-air missiles, and, from Sweden, a controversial \$1b of Bofors' howitzer field guns, production of which will be continued in India.

The revelation that India has developed a long-range missile, the Prithvi, raises further

questions about the regional strategic balance. Armed with a conventional warhead, it is an inaccurate weapon capable of little damage. It would become a dangerous weapon with a nuclear warhead however.

Not coincidentally, the submarine acquisition has come at a time of renewed debate in government circles about developing a nuclear industry. The risks associated with a Third World country like India possessing nuclear power, and therefore the capability to produce nuclear weapons, is a source of serious concern. In a country hamstrung by inefficiency and bureaucracy, the spectre of nuclear accident looms a little larger.

Australia's Minister for Defence, Mr Kim Beazley, has reacted coolly to developments on the Indian sub-continent. He argues that Australia has its own surface and subsurface maritime strike capability, and should not be unduly worried by a regional nation building up theirs. Moreover, India's tensions with its neighbours, and in the Gulf, are a perfectly valid explanation for India's heightened defence awareness.

The 1986 Dibb report on Australia's future defence capability recognised the growing importance of the Indian Ocean region. The ocean is a vital shipping route for oil from the Gulf. About 20% of Australia's supplies are shipped through the Indian Ocean, as well as 50% of its other trade tonnage. Free passage through the region is also crucial for Australia's friends and allies, such as Japan, and is therefore of indirect interest.

The re-location of part of the RAN to Western Australia will give the country a two-ocean navy, though its strength is the important factor. The proposed Cockburn Sound naval base, a patrol boat base elsewhere in the north-west, and HMAS Stirling, the future home of four of the navy's six Kockums Type 471 conventional submarines, will enhance the naval presence on the Indian Ocean seaboard.

However, an issue which continues to provoke much heated debate within local defence circles is whether Australia should also acquire nuclear-powered submarines, matching the nuclear-power capability of our neighbours. It is not, however, a realistic option for a government beholden to an anti-nuclear left-wing.

The Federal Opposition has said it would pursue the nuclear-power option if in government, and even the Chief of the Defence Forces, General Peter Gration, has indicated a preference for nuclear-powered submarines for the generation to replace the Kockums Type-471. In the meantime, India will not be seriously challenged in its bid to become the predominant naval force on Australia's Western seaboard.

Anna Grutzner is the Canberra-based defence correspondent of The Australian.

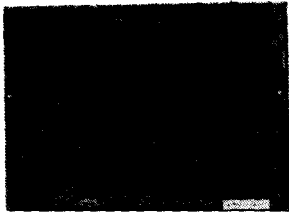

XT* TURBO MOTHERBOARD

- 8MHz
- 8088 Processor
- Expandable to 640K on board.
- Provisions for up to 6 x 2732 EPROMs on board
- Keyboard connector
- 8 Expansion slots

X18030 (excl. RAM) **\$135**
 X18031 (incl. 640K RAM) **\$699**



10 MHz XT* TURBO MOTHERBOARD

Increase the performance of your sluggish XT* approximately four times with this super fast motherboard.

- 8088-2 running at 10 MHz, no wait state
- Turbo/Normal selectable
- 640K fitted
- 8 Expansion slots
- 4 Channel DMA
- Keyboard port

Excluding RAM . **\$199**
 Including RAM) . **\$749**

BABY AT* MOTHERBOARD (WITHOUT MEMORY)

- 6/10 MHz system clock with zero wait state. 12 MHz, 1 wait state.
- 80286-10 Microprocessor
- Hardware and software switchable
- Socket for 80287 numeric data co-processor
- 64K ROM
- Phoenix BIOS
- 8 Expansion slots

X18200 (excl. RAM) **\$689**
 X18201 (incl. 2MB RAM) **\$1,649**

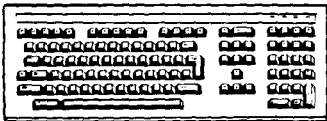

IBM* COMPATIBLE EXTENDED KEYBOARD (101 KEYS)

These new keyboards are both XT* and AT* compatible!

- 20 Dedicated function keys
- Enlarged "Return" and "Shift" key
- Positive feel keys
- Low Profile Design, DIN standard
- Separate Numeric and Cursor control keypads
- Additional Functions: Key-in-Lock, Audio Beep, Previous Word, Next Work, Fast Repeat, Line Feed, Pause, Reset, Clear Screen.

Cat.X12022. only **\$109**

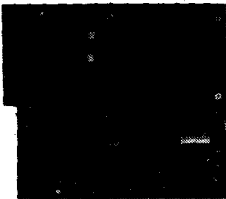

6/10 MHz AT* MAIN BOARD

- 6/10 MHz system clock with zero wait state
- Hardware and software switches for alternative system clock.
- Rechargeable battery backup for CMOS configuration table and real time clock.
- 80286-10 microprocessor
- Socket for 80287 numeric data co-processor
- 256KB, 512KB, 640KB, or 1,024KB RAM
- 64KB ROM, expandable to 128KB
- 8 Input/Output slots
- Hardware reset jumper
- Power and turbo LED connector
- Phoenix BIOS

X18100 (Excl. RAM) **\$689**

386 MAIN BOARD

- Intel 80386 CPU (16MHz)
- Socket for 80387 Math co-processor
- 32 bit BUS system, 1 M/Byte or 640K on board memory
- Built-in speaker attachment
- Battery backup for CMOS configuration table and real time clock.
- Keyboard controller and attachment
- 7 Channel DMA
- 16 Level interrupts
- 3 Programmable timers
- 8 System expansion I/O slots: 5 with a 36 pin and a 62 pin expansion slot 2 with only the 62 pin expansion slots 1 with two 62 pin expansion slots (32 bit BUS)

X18101 without RAM **\$2,390**
 X18103 1 M/Byte RAM **\$2,960**
 X18105 2 M/Byte RAM **\$3,500**

EMS EXPANDED/EXTENDED 3-5 M/BYTE CARD

● AT* compatible only
 X18056 Without RAM . **\$299**

512K RAM CARD (SHORT SLOT)

● User selectable from 64K to 512K
 ● DIP switches to start address
 X18013 Without RAM **\$99**
 X18014 With RAM **\$459**

3 M/BYTE RAM CARD

Plugs straight into BUS ports on motherboard. AT* compatible. RAM not included.
 (Excluding RAM) **\$239**



MULTI I/O & DISK CONTROLLER CARD

This card will control 2 x double sided, double density drives, and features a serial port, a parallel port, and a joystick port or games port. It also has a clock/calendar generator with battery backup.

Cat. X18040 **\$145**



FLOPPY DISK DRIVE CONTROLLER CARD

These cards will control up to 2 or 4 double sided 360K IBM* compatible disk drives.
 X18005 (2 Drives)...**\$52**

FLOPPY DISK DRIVE CONTROLLER CARD

● Supports 1-44MB, 1-2MB, 720K, 360K
 ● PC*/XT*/AT* compatible
 ● 5 1/4" and 3 1/2" drives
 X18009 **\$139**

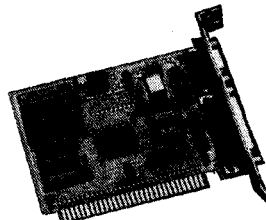

GRAPHICS CARD

- Hercules compatible
- Interface to TTL monochrome monitor
- One Centronics parallel printer port
- 2K-Static RAM, 64K Dynamic RAM
- Display Mode: 720 dots x 348 lines

Cat. X18003 **\$139**

COLOUR GRAPHICS CARD

This card plugs straight into I/O slot and gives RGB or composite video in monochrome to a monitor.
 Colour graphics: 320 dots x 200 lines.
 Mono graphics: 640 dots x 200 lines.
 Cat. X18002 **\$99**

ENHANCED GRAPHICS ADAPTOR CARD

● Auto switch CGA, EGA, & Hercules*
 ● Full 256K video RAM
 ● Flicker free scrolling
 ● Standards: 320 x 200, 640 x 200, 640 x 348, and 720 x 348.
 ● Short slot
 ● XT* & AT* compatible
 X18070 **\$330**

PRINTER CARD

This card features a parallel interface for Centronics printers. Included is printer data port, printer control port, and printer status port.
 Cat. X18017 **\$29**

EPROM PROGRAMMER CARD

● Programs 2716, 2732, 2732A, 2764, 2764A, 27128, 27128A, 27256, 27256A, 27512, 27512A, 27C64, 27C128, 27C256, 27C512
 ● Software set program voltage: 12-5, 21, 25
 ● Software: Write, read, verify, blank, check, copy, files, process.
 ● Intelligent programming method:
 2716 6 sec. 2732 12 sec.
 2764 24 sec. 27128 48 sec.
 27256 96 sec. 27512 300 sec.
 X18022 **\$245**

HARD DISK CONTROLLER CARDS
 X18060 (XT) **\$190**
 X18140 (AT) **\$290**

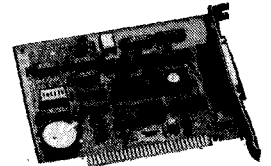

RS232 & CLOCK CARD (WITHOUT CABLE)

This RS232 card supports 2 asynchronous communication ports. Programmable baud rate generator allows operation from 50 baud to 9600 baud. Fully buffered. Clock includes battery back-up and software.
 Cat. X18028 **\$65**

RS232 (SERIAL) CARD (WITHOUT CABLE)

This RS232 card supports 2 asynchronous communication ports. Programmable baud rate generator allows operation from 50 baud to 9600 baud. Fully buffered. First serial port is configured as Comm.1 Second serial port is optional and configured as Comm.2.
 Cat. X18026 **\$49**

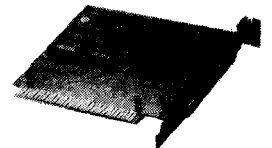

GAMES I/O CARD

Features two joystick ports. (DB15).
 Cat. X18019 **\$29**

CLOCK CARD

Complete clock card including battery back-up and software.
 Cat. X18024 **\$55**

I/O PLUS CARD

Provides a serial port, a parallel port and a joystick port, and even a clock/calendar with battery backup!
 Cat. X18045 **\$119**



"IBM* XT* TYPE* KEYBOARD

● 100% IBM* PC*, XT* compatible,
 ● 84 keys, including function keys, and a numeric keypad
 ● low profile keyboard design,
 ● proper placement of shift keys with large key tops to suit professional typists
 ● 3 step height/angle adjustment.
 ● Curl lead plugs straight into IBM* PC/XT
 ● Status displays, Power, Cap Lock and Numeric Lock
 Just like the "real McCoy" only at a fraction of the price! Why pay more?
 Cat. X12020 **\$89**

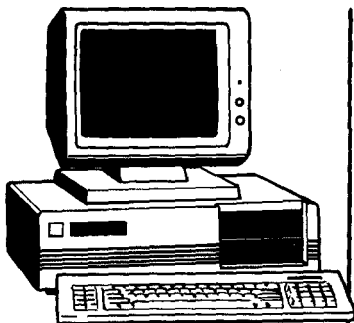

IBM* XT* COMPATIBLE COMPUTERS FROM \$895

Check these features and our prices. They're exceptional value for money!

- Final assembling and testing in Australia!
- Fast TURBO Motherboard
- AT* style keyboard
- Tested by us for 24 hours prior to delivery!
- 8 Slot motherboard
- 12 months warranty!
- 150W power supply

*** \$895 WORKSTATION COMPATIBLE COMPUTER**
256K RAM Single Drive, Graphics and Disk Controller Card. \$895

640K RAM TURBO COMPATIBLE COMPUTER
2 x 360K Disk Drives, Multifunction Card, Colour Graphics, Disk Controller, 1 Serial, Parallel Port. (Includes Timer Disk). \$1,095

WITH 20 M/BYTE HARD DISK:
& single 360K Floppy Disk Drive... \$1,395
& dual 360K Floppy Disk Drives... \$1,595

WITH 40 M/BYTE HARD DISK:
& single 360K Floppy Disk Drive... \$1,595
& dual 360K Floppy Disk Drives... \$1,795

WITH 80 M/BYTE HARD DISK:
& single 360K Floppy Disk Drive . CALL
& dual 360K Floppy Disk Drives .. CALL



IBM* XT* COMPATIBLE CASE
XT* size and styling. Features security key switch, 8 slots, and mounting accessories. Size: 490(W) x 390(D) x 140(H)
Cat. X11090 \$69

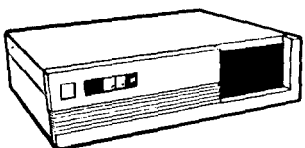

IBM* XT* COMPATIBLE CASE AT* STYLING
Now you can have the latest AT* styling in a XT* size case. Features security key switch, 8 slots, and mounting accessories. Size: 490(W) x 145(H) x 400(D)
Cat. X11091 \$99

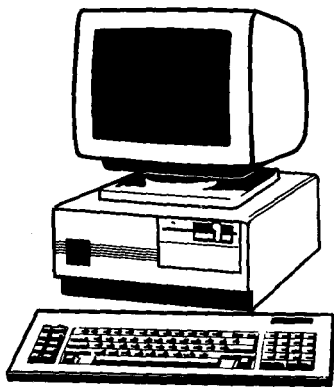

BABY AT* COMPATIBLE COMPUTER!

2 M/B RAM \$2,595

- Final assembling and testing in Australia!
- 4 M/Byte Main Board, 2 M/Byte fitted
- Switchable 8/10/12 MHz
- 1.2 M/Byte Floppy Disk Drive
- 80286 CPU
- Colour Graphics Display Card
- 8 Slots
- Floppy & Hard Disk Controller
- Printer Card and RS232
- Keyboard
- 200W Power Supply
- Manual
- 6 Months Warranty
- Size: 360(W) x 175(H) x 405(D)mm

WITH 20 M/BYTE HARD DISK . \$2,595
WITH 40 M/BYTE HARD DISK . \$2,795
WITH 80 M/BYTE HARD DISK . CALL

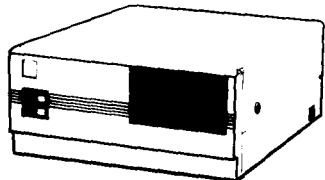

BABY AT* STYLE COMPUTER CASING

Our latest computer casing, featuring security key switch, 8 slots, and mounting accessories etc.
Size: 360(W) x 175(H) x 405(D)
Cat.X11093 ONLY \$99

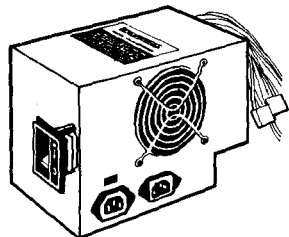

200W SWITCH MODE POWER SUPPLY FOR IBM* AT* & COMPATIBLE
DC OUTPUT: +5/16A, -5V/0.5A +12V/5A -12V/0.5A
Cat. X11097 \$199

180W SWITCH MODE POWER SUPPLY FOR BABY AT* COMPATIBLES
Cat. X11098 \$199

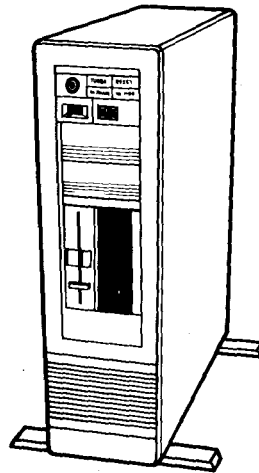

386 TOWER PC

The 386 Tower PC is a high performance system that's IBM*AT* compatible. However, the 386 Tower PC gives you 2-5 times the performance.

FEATURES:

- Intel 80386-16MHz microprocessor
- Switchable 16/20 MHz
- 2 M/Byte fitted. Total memory expandable up to 16 M/Bytes.
- Up to 2 M/Byte or 8 M/Byte RAM modules on system board or on RAM card
- Option for 80287 & 80387 co-processor socket
- Operates in page mode with interleave memory subsystem
- Shadow RAM supported to allow system BIOS to be executed on system memory instead of slower EPROM
- Four 16-bit I/O slot. Three 8-bit I/O slot, and one 32-bit memory slot.
- 8042 keyboard controller interface for AT* compatible keyboard
- Seven direct memory access (DMA) channels
- Chips and Technology chip set
- AMI 386 BIOS / Phoenix 386 BIOS / AWARD 386 BIOS (AMI fitted)
- 50 M/Byte Miniscribe hard disk. Fast access. Formatted to 42 M/Byte.
- EGA card

\$5,995

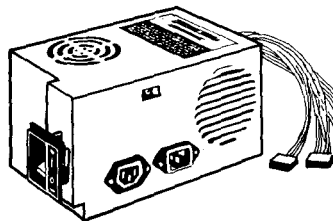

150W SWITCH MODE POWER SUPPLY FOR IBM* PC*/XT* & COMPATIBLE
DC OUTPUT: +5/13A, -5V/0.5A +12V/4.5A -12V/0.5A
Cat. X11096 \$129

SERIAL/PARALLEL/GAMES CARD

- PC*/XT*/AT* compatible
- 1 Parallel port three port addresses selectable (378, 278, 3BC) and disable.
- Serial port: 2 serial ports available, both can be set to address comm 1, 2, 3, or 4
- Game adaptor: 2 joysticks can be connected. Paddles must be 0 - 100K range.

X18151 \$115



8087 CHIPS

GENUINE INTEL CHIPS WITH MANUAL AND DATA SHEETS PACKED IN BOXES

8087-3 (4.77MHz)	\$245
8087-2 (8MHz)	\$350
8087-1 (10MHz)	\$475
80287-6 (6MHz)	\$375
80287-8 (8MHz)	\$555
80287-10 (10MHz)	\$690
80387-16 (16MHz)	\$995
80387-20 (20MHz)	\$1460
80387-25 (25MHz)	\$1860



ROD IRVING ELECTRONICS

MELBOURNE: 48 A'Beckett St.

Phone (03) 663 6151

NORTHCOTE: 425 High St.

Phone (03) 489 8866

SYDNEY: 74 Parramatta Rd, Stanmore

Phone (02) 519 3134

Fax (02) 519 3868

CLAYTON: 56 Renver Rd.

Phone (03) 543 7877

MAIL ORDER & CORRESPONDENCE:

P.O. Box 620, CLAYTON 3168

Mail Order Hotline:

STD Orders: 008 33 5757 Orders only

Local Orders: 543 7877

Inquiries: (03) 543 7877

Telex: AA 151938

Fax: (03) 543 2648



MAIL ORDER HOTLINE 008 335757

(TOLL FREE, STRICTLY ORDERS ONLY)

LOCAL ORDERS & INQUIRIES (03) 543 7877

POSTAGE RATES:

\$1 - \$9.99	\$2.00
\$10 - \$24.99	\$3.00
\$25 - \$49.99	\$4.00
\$50 - \$99.99	\$5.00
\$100 plus	\$7.50

The above postage rates are for basic postage only. Road Freight, bulky and fragile items will be charged at different rates.

All Wholesale and Sales Tax Exempt inquiries to:

RITRONICS WHOLESALE,

56 Renver Road, Clayton.

Phone: (03) 543 2166 (4 lines)

Fax: (03) 543 2648

Errors and omissions excepted.

Prices and specifications subject to change

IBM*, PC*, XT*, AT* are registered trademarks of International Business Machines. Apple is a registered trademark.

*Denotes registered trademarks of their respective owners.



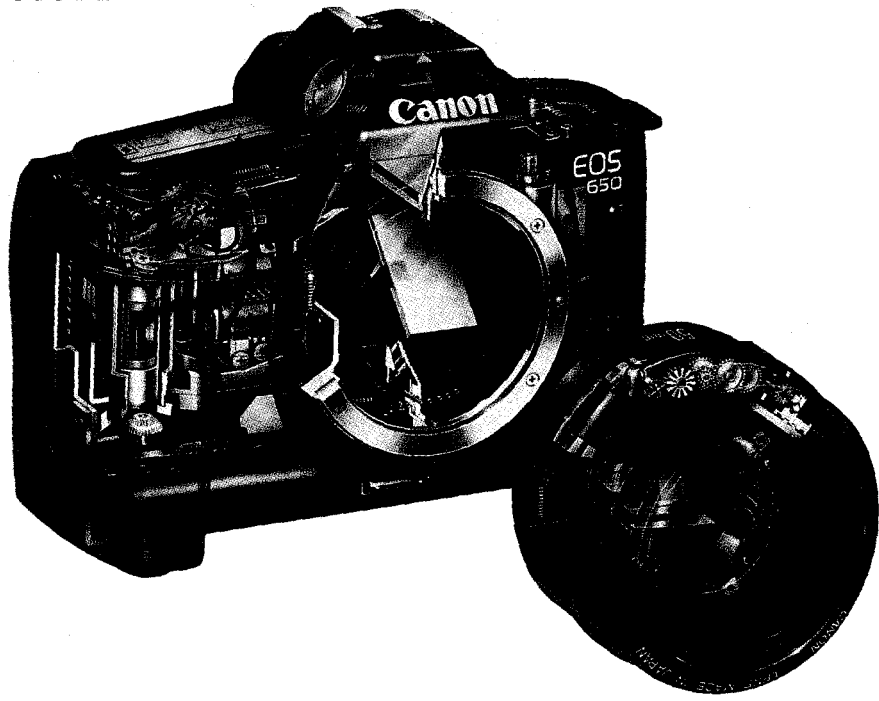

Canon EOS 650 incorporates 'Factor-Six Light Analysis' — fancy name for exposure determination using segmented matrix of luminance: total of two metering patterns and six exposure modes.

PRESSING THE BUTTON

Or pushing the limits?

Revolutionary advances in SLR camera design will ensure its continued use in the art of picture making. Barrie Smith reviews some new releases.

Having eagerly fallen upon photography as a youngster, I stoutly persisted in spite of fuzzy, burnt out images sadly despoiled by a pinhole in the bellows. These days, I experience continued delight as I reliably get stunning, flare-free, well-exposed and focused results with my state of the art 35 SLR.

Old-time, technologically primitive cameras may be fun in a collection — but they can be hell as picture-takers.

As we approach the 1990s the art of committing an image to a light sensitive emulsion is taking unexpected directions. We encounter cameras that give endless choices of the 'right' exposure, disbar us from unsharp pictures and put flash quality into our visuals that David Bailey would envy.

These days, a \$10 disposable 'film with a lens' can shoot family snapshots indistinguishable from those made with a quality \$1,000 SLR.

Despite this, electronics, computer science and advanced physics are all being enlisted in a desperate effort to keep the SLR in the forefront of picture making, and prevent the hobby/art/industry of photography from the economically disastrous (for the camera industry) return to simple compact AF and fixed focus cameras that produce surprisingly good pictures with no fuss and little cost.

Nikon F4

Released last September, Nikon's F4 is an important camera, not only to commercial pros and press photographers, but as an example of how advances in electronics and computer assistance have finally become accepted as reliable, and near-essential, features on a professional camera.

Its ergonomically contoured body, designed by Giugiaro of Saab 9000 fame, manages to envelop a myriad of complexities — 1,750 separate parts — within its copper siumin aluminium carcass.

Three metering systems, five exposure modes, manual and auto focussing, 1/8000 sec top shutter speed, 1/250 flash sync, interactive flash system, multiple exposure capability, exposure bracketing, low vibration shutter balancer and quadruple mode film advance are all included.

The camera is built in three specialised plants across Japan, with final assembly at the Nikon Mito plant near Tokyo. Test procedures are stringent: each shutter is fired 1,000 times; environmental conditions are simulated which subject samples to +70°C and -40°C temperatures for over 20 hours, and 90% humidity at 40°C, plus constant vibration tests for an hour in both vertical and horizontal positions.

Nikkor AF lenses are driven by body integral

autofocus motors. The lenses feature built-in microcomputers, and integrated electrical contacts. Almost all commands and information are relayed through these contacts.

Manual focus is possible, with status verification indicated via finder LEDs.

Single Servo Autofocus permits shutter release only when the subject is in focus. Continuous Servo Focus continues focussing as long as the shutter release is pressed.

Focus detection is available in light as low as EV minus 1 (f1.4 at 4 seconds). The autofocus module has 200 high sensitivity CCD sensors, linked into an 8-bit microcomputer controlling a coreless drive motor in the camera body; another micro in the body and one in the lens itself process and act upon the focus information. Thirty% of incoming light is diverted to the CCD line sensor package.

Focus tracking enables follow focus of moving objects. Focus is detected at least twice before exposure. The camera measures first and second focus points of a moving subject, computes its speed, then predicts its next, third position, driving the lens to this mark. Coupled with a 5.7 frames per second motor drive the mode is a useful one for sports photographers.

Freeze focus will fire the shutter when the subject arrives at a manually pre-determined focus point; with shutter depressed and correctly framed the shutter will only trigger when the subject arrives 'on the spot'.

Die hard pros using separate meters are a thinning breed. With the F4's three metering systems the ranks will slim even further.

Sixty/forty centre weighted was chosen as a useful averaging ratio for general photography; spot metering monitors only 2.5% of the scene's area, giving precise control; matrix metering is considered the most appropriate choice for quick changing light conditions, remote control work and fill-flash operation.

Matrix metering in particular will see a revolution in in-camera exposure determination. In this mode the camera's meter provides correct exposure in any lighting situation, without the need for exposure compensation.

Two SPD sensors sit on each side of the eyepiece lens; these divide the scene into five segments. In five-segment reading, the three element SPD cells on the left sensor read two corners of the frame plus a portion of the centre; the cells on the right read the opposing two corners and the centre portion (again).

A computer divides the scene into 25 matrix boxes, each of which has one or more algorithms. By analysing scene patterns - high key, low key, central (or off-centred) dark or light main subject - an exposure value is computed and transmitted to the lens/shutter.

Should the camera be held vertically a sensor is activated by a mercury switch, allowing the F4 and its sweating algorithms to breathe easy when they detect a bright

blue sky at the side of frame.

Five exposure options operate in chain with the metering systems: manual, high and normal speed program, shutter and aperture priority.

Program is interesting because of its dependence on the CPU built into each of the AF Nikkors, and Nikkor's superb 500 mm f4 P lens. EVs from -5 to +21 are within its grasp - in terms of stops and secs that's a range of f1.4 at 30 secs, to f16 at 1/8000 sec.

Bracketing is, and always has been, the difference between the men and the boys. But, these days, the frailty of client relations, their expectations and the frightening prospect of the latter having to face a choice of only one or two trannies of a given subject has led to most pros being forced into delivering a carefully graded range of exposures. Clipping on a multi-control back (one of which can hold 250 frames) allows you automatic access to 19 continuously fired, variably exposed frames. I make it out as a range of -3 to + stops at 1/3d stop increments. Now, with that gear, the boys are the men!

The camera incorporates four coreless motors: film advance at up to 5.7fps, shutter charging up to 1/8000 sec, autofocus drive of lenses up to 300 mm focal length, and rewind.

The latter motor serves a dual purpose, as it also changes a pair of filters in the autofocus module; these block erroneous IR light in normal shooting, and transmit in low-light focus detection where the camera emits a shaft of IR as a measuring beacon.

Nikon's approach to flash photography is just as all-encompassing. Called cybernetic flash the system promises to produce correctly exposed frames whatever exposure mode chosen. For example, the

matrix balanced fill-flash setting relies on a microcomputer to determine luminance values of the scene, and contrast range to deliver properly exposed foreground subject matter, whatever ambient light is present.

The company claims the computer system is the largest ever built into an SLR.

The body has nine ICs, including one 4-bit microcomputer, and two 8-bit micros: the latter pair consist of a 16K-byte ROM and 256-byte RAM for focus control, and an 8K-byte ROM and 384-byte for sequence and exposure control.

The viewfinder has four ICs and an 8-bit micro with 4K-byte ROM and 192-byte RAM processing the matrix metering algorithms. Focus detection relies on a 200 sensor CCD, exposure on a cluster of light sensitive elements in the finder, the optical path, and reflection from the film itself.

All of these elegances would be enough to impress the most sceptical, but the hardy Nikon reputation is further enhanced by a close inspection of its new shutter. Using two vertically traveling shutter curtains, made from four special carbon-fibred epoxy plates and four in aluminium alloy, the designer has produced a mechanism that is both lighter and stronger than previous types. Top exposure: 1/8000 second.

The company's lower-priced F-801 embodies much of the F4's advanced technology, with surprisingly few feature deletions.

Minolta Dynax

Minolta, which surprised the world with its interchangeable lens Maxxum 7000 in 1984, open the whole SLR autofocus can of worms - so to speak.

Now, it continues the bloodline with the Dynax 7000i, and 3000i. Letter 'i' is for intelligent: computer-controlled multi-sensor AF module, AF-integrated multi-pattern

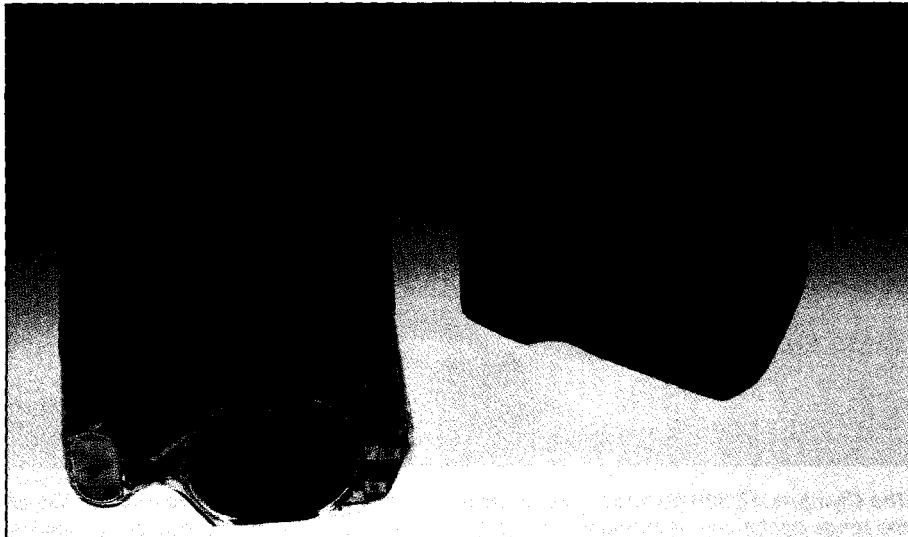

The Yashica Samurai is a new concept in camera design forged on a solid base of integrated silicon. It has an f/3.5 lens that zooms from an equivalent 35-105 mm. It has an electronically controlled autofocus, a centre weighted light metering system that can automatically adjust for backlight conditions, and an automatic shutter that can be varied from 1/500 sec to 2 secs. It also has an automatic film transport mechanism.

SLR cameras

metering, auto multi-program choice, auto film advance and a flash 'command' system.

Going one better than Nikon the Dynax boasts three CCD sensors, arranged vertically and laterally to cope with a wider range of subject matter. The total area of CCDs is said to be twelve times larger than compact AF cameras, and being larger they can cope more efficiently with moving subjects.

Auto focussing of low-light subjects is accomplished by emitting a narrow red LED beam able to reflect from a subject nine metres away.

Intelligent exposure relies on a six segment SPC (silicon PE cell) set into the pentaprism. In a fashion similar to Nikon's method, it compares luminance levels in portions of the frame to determine whether the subject is evenly lit, backlit or spotlight. When the subject is correctly focussed, its position in the frame is determined by the AF sensors. Image magnification is then computed by comparing focus distance and focal length data from the lens ROM IC. The shape of the meter sensitivity pattern is adjusted to give primary emphasis to the subject area. 'Real time' operation allows adjustment immediately before exposure if the subject should move or focus be changed.

The camera is powered by a 6 volt lithium battery, estimated to be sufficient for exposure and rewind of 65 rolls of film.

The Minolta's unique selling proposition is its use of creative expansion cards. Each tiny card contains a memory circuit connected to a microprocessor. When the postage stamp-sized silver is inserted into the camera the microprocessor interfaces with the camera's main computer and uses data in the memory circuit to control the camera's autofocus, exposure, and film advance systems.

Five feature cards control, in turn, exposure bracketing, highlight/shadow accent,

**'It's completely circular,
and drives the lens
directly'**

program shift, fantasy effect, and data memory.

For example the exposure bracketing card allows you to take 3, 5 or 7 successive frames with 1/3, 1/2 or 1 stop changes in exposure.

The quaintly-named 'fantasy effect' drives the focus motor during exposure, producing a soft, dreamy effect similar to the effect produced by a soft-focus lens.

Four special application cards instruct the camera to concentrate all its resources in specific ways for portrait, sports, close ups and auto depth requirements. For example, with the close up card installed small apertures are given, and auto focus is limited

to a small, central area for precise attention to small details.

Canon EOS

Canon's EOS range consists, at this point in time, of five cameras. EOS 620 is placed as the 'top of the line' model, mainly for the near-professional market.

It is a fact of life that all AF cameras use lens motors for lens focus drive and aperture control. Other makers, by installing the drive motor within the camera body, are obliged to supply one motor capable of handling the differing torque requirements of the entire lens range - from, say a 24 mm wide angle to a 300 mm tele.

But Canon decided to place two high-precision motors within the lens itself. The EOS method thus allows a precisely powered and geared unit to cope with the short travel of a wide, or long stretch of a long focus optic.

Further, the camera employs a new lens mount, EF, for electro-focus, which appears to be the first totally electronic mount on a 35 mm SLR. The only mechanical linkage is a tiny button which switches on the camera's AF and exposure circuits when the lens is attached. The camera sends signals to the lens, controlling these latter two functions.

EOS lenses may carry a motor, but you would never be aware of it, with no suspicious bulge to give away its presence. Labelled AFD for arc form drive, and USM for ultra sonic motor, these two motors were created for the differing requirements of two different lens types in the EF range.

The majority of EOS lenses utilise the arc form drive motor. Basically a modified, brushless, Hall effect unit, it is arranged in a partial arc around the lens mount. Extremely complex circuitry inside the lens barrel minimises mechanical linkages, and permits future expansion of electronic interfaces.

But the ultra sonic unit is the one which has received the most industry acclaim.

It is completely circular, and drives the lens directly. It relies on the piezo-electric effect for its operation: when certain crystals, e.g. quartz, are compressed an electrical discharge is produced. Gas lighters and dynamic audio pickups are examples.

In the USM the reverse is utilised: controlled ultra sonic signals from the camera and polarity are introduced into the piezo-electric material. What would otherwise be the conventional stator is, in the USM, a ring holding the piezo-electric elements. Phase shifts of 90° in the signal cause a travelling wave to develop along the elastic body of the stator, and this drives the rotor. Thus, the focussing movement is driven.

Currently, the USM motor is used in the large aperture, and high cost, 50 mm f1.0L, 300 mm f2.8L tele, and 28-80 mm f2.8L zoom optics.

In another department the EOS boasts exclusive depth of field automation. This



The Olympus AZ-300 features a list of facilities that were once reserved only for top of the range equipment. It autoloads the film, adjusts for the film speed, sets the exposure and aperture and even triggers the flash, just when required. Focusing is accomplished by a highly sophisticated sensor circuit based on an IC. It receives visual information on a photo diode array which is then compared electronically. The output is used to drive the autofocus motor. The result: the optical compromises necessary in a fixed focus lens are avoided, while preserving the ease of use. About the only thing left to do is set the zoom and press the trigger.

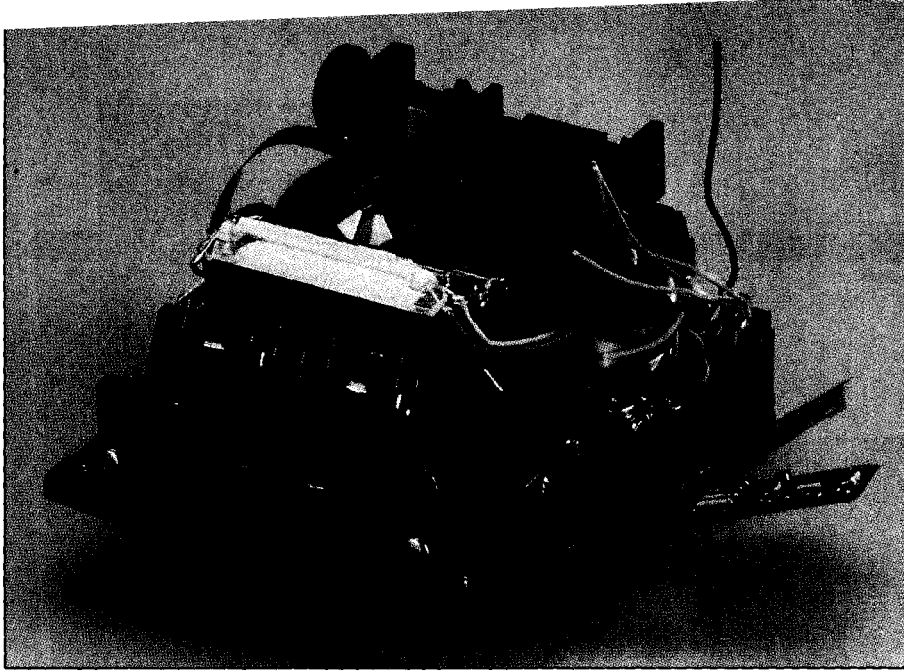

Nikon's multi-meter viewfinder houses four ICs and an 8-bit microcomputer to monitor three metering systems and five exposure modes.

mode combines focus and exposure information to automatically determine the nearest and farthest points the photographer wants in focus, then sets the necessary aperture/shutter speed/focus that will deliver this depth range.

Leica R6 Reflex

But, way across the other side of the globe,

the Leica company has had other thoughts.

To begin with there is a less than widely-known legal action boiling away between Leitz and certain USA and Japanese interests over the creation of the auto-focus methods now so widely employed. It seems the Germans came up with an auto-focussing system - Correfot - in the 60s, and although the first unit was roughly about the size of a

table it bore a remarkably similar operating principle to the early Honeywell system used in the first AF camera - the Konica C35AF.

Anyway, Leitz is still playing with Correfot - we may see it one day. However, in the mean time, it's worth a peek at the Leica range of precision 35 cameras to see what electronics or computerisation the company has installed.

For a start, the Leica philosophy is: 'Highest optical performance ... mechanical precision for reliable and durability ... concentration on essentials ...' Which leaves precision little room for 8-bit micros, cybernetic flash and arc form drive motors.

The Leica R6 Reflex offers two metering modes: spot or averaging. A flashing light will indicate over- or under-exposure, necessitating action by the photographer to alter aperture or shutter, or add flash. Focussing is by hand - manual, I believe it is called.

The M6 range finder unit has 'selective metering' - a lens-equipped photo-diode monitors the shutter curtain and responds to a 12mm diameter area on its surface. Focussing is by courtesy of those familiar digits.

Which could be a hint to any computer chip salesman reading this piece - keep up the Japanese lessons, and prepare to give up the sauerkraut.

Shh... "Killer" is at work.

You would call it a Merlin Gerin UPS.
YI call it "Killer" because it kills off the Power Bugs which would love to get into my data.
 From 150 V.A to 4800 kV.A, Merlin Gerin protects all computers against "infested" power, brown-outs and black-outs.
 Talk to Merlin Gerin first.
 It will be
 the last you suffer from bugs in your data.

PHONE TOLL-FREE
008-02-3173.
 MERLIN GERIN

READER INFO NO. 4

ETI FEBRUARY '89

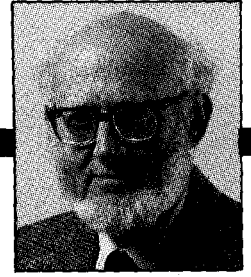

JOHN COULTER

ADDRESSING THE GREENHOUSE PROBLEM

Breaking down the barriers

Technologies are already available which can reduce future greenhouse effect. The reasons these technologies are not being implemented, says John Coulter, are mainly institutional, not technical.

Although Arrhenius described the greenhouse phenomenon last century and occasional scientists have sounded warnings ever since, it is only in the last few years that governments and the community at large have shown any concern. Such is the nature of exponential processes that perception and response are often overtaken by events.

Remember the pond with the water lily which doubles its area every minute and covers the whole pond in 60 minutes. The pond is only half covered at 59 minutes.

A number of gases blocking long wave length radiation from the Earth are increasing in the atmosphere exponentially. This has the effect of trapping this

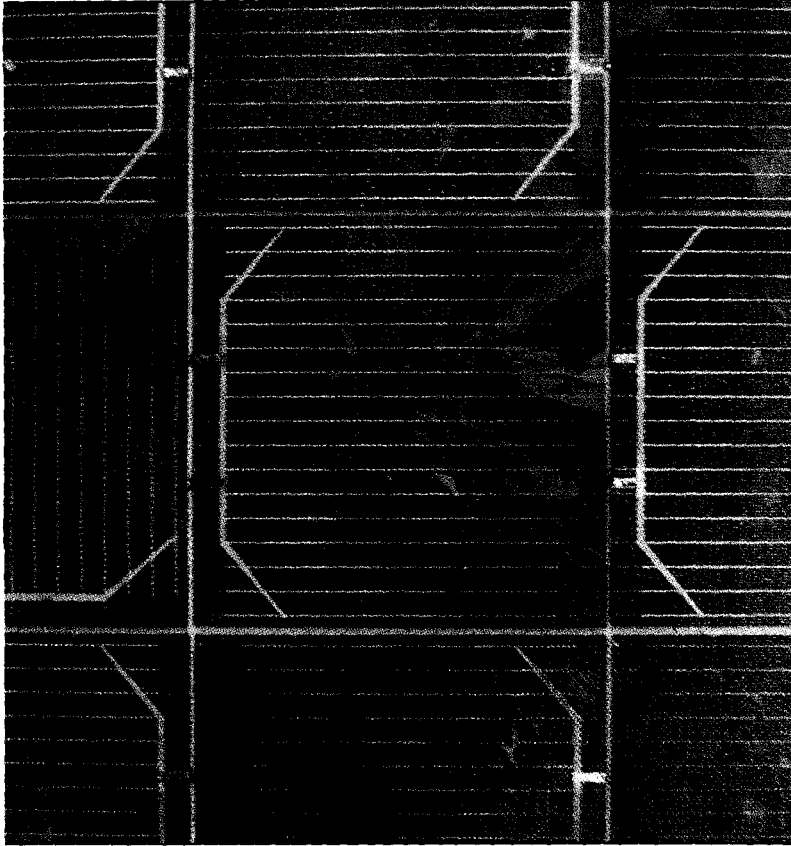

Commercial polycrystalline silicon solar cells.



World's largest photovoltaic installation (6.5 megawatt) at Carrisa Plains, California.

radiation leading to an increase in surface temperature. Ice-core samples of gas obtained from Greenland and the Antarctic have revealed that the carbon dioxide concentration of the atmosphere has fluctuated between about 190 ppm and 270 ppm over the last 200,000 years, being low during periods of glaciation and high during interglacials. The level is now about 350 ppm and rising at approximately 1/2% per year.

The ice-core analysis also shows that a number of other gases are well above their pre-industrial levels and concentrations are increasing even faster than carbon dioxide. Nitrous oxide from fossil fuel burning, nitrogenous fertiliser use and cutting of tropical rain forest is increasing at 0.6% per annum. Methane, from natural gas, (but principally from marsh gas in rice paddies and ruminant animals) at 1.1% per annum, and chlorofluorocarbons 11 and 12 at 5 and 7% respectively. These other gases will contribute together as much greenhouse warming as CO₂ over the next 40-50 years by which time the effective concentration of greenhouse gases will have doubled compared with pre-industrial times. Unless concerted action is taken before then, the rate of increase will be then much steeper and the next doubling time much shorter; such is the nature of exponential change. It has often been remarked that we are conducting a massive experiment on a global scale with no clear idea of what the result may be.

How might the problem be addressed? Two factors characterising industrial civilisation must be kept clearly in mind.

1. The economic model adopted is judged by how well it can maintain exponential growth. GDP is a measure of resource flow through the economy. Pursuing economic growth means attempting to increase the dollar value (in constant dollars) of resources used up year on year, including those resources contributing to greenhouse warming and

those used in combating it. It follows that the signals indicate a growing, and by implication, a healthy economy may also be indicating further deterioration in the environment, including greenhouse warming.

2. For most of this century, but particularly since the 1950s, there has been a tendency to see all problems as technical with technical solutions. Many problems are essentially social, political or institutional. Attempting to interpret these problems as technical and to find technical solutions often compounds the problem and makes its solution more intractable.

Complexities

Many of the difficulties besetting an attack on greenhouse are of

'We're conducting a massive experiment on a global scale'

a complex nature requiring both institutional and technical changes. Many helpful technologies are already available; institutional barriers slow or block their adoption. In South Australia 40% of electricity is used in the home and some 40% of this is used to heat water. Solar water heaters are already well developed. The reason they are not used is that, while the capital cost of generating equipment made necessary by the purchase of an electric hot water

facility is borne by the Electricity Trust (that is, other consumers), the whole capital cost is borne by the purchaser of a solar facility. This could and should be addressed by instituting a two part tariff, one part based on maximum demand (Kw) in any one rating period, the other the amount used (Kwh). Metering would involve a relatively cheap piece of electronics.

Similar efficiency gains and greenhouse emission reductions could be achieved in cooking. Over 50% of domestic stoves in South Australia are electric rather than gas. Most readers will understand the relative thermodynamic efficiency of the two ways of cooking taking into account that most electricity in South Australia is generated from gas.

Similar efficiency improvements could be made in other electricity applications and in all states in Australia. The reason the changes are not made are institutional not technical. State Electricity authorities have an installed overcapacity; they seek to increase electricity consumption and resist the changes suggested which would deliver appropriate price signals to consumers leading to reduced consumption (but with no decline in end use service). Note also that increasing consumption of electricity is counted as an addition to GDP.

A wide range of energy efficiency improvements using known and established technology and equipment could be made leading to very significant

reductions in most greenhouse emissions. We could probably reduce effective greenhouse emissions by 50-60% with no impairment of end use service. In all cases the reasons for non adoption are institutional, supported by easily challenged economics.

Efficiency improvements

The first, technically the easiest and certainly the most cost effective, attack on greenhouse must be efficiency improvements. Beyond that a number of exciting technologies are emerging. While nuclear is slipping economically further behind (the latest USA nuclear station cost \$8.6/watt to build) direct solar-electric conversion is becoming cheaper. The latest thin film solar cells developed through the joint efforts of the Solar Energy Research Institute of the US Department of Energy and Arco Solar Incorporated using a copper-indium-diselenide/cadmium sulphide bilayer have achieved 11.2% efficiency at a cost of only \$100 per square metre. This corresponds to a capital cost of approximately \$3 per watt on a 24 hour basis.

The technology of transport changes beyond readily achievable efficiency improvements are more difficult to envisage. We have an enormous investment in an urban environment built around the private car. That will take some time to modify.

ETI

GREENPEACE ANTARCTIC WORLD PARK BASE 1990/91 OVERWINTER VOLUNTEERS

The international environmental organization, Greenpeace, is looking for volunteers for the position outlined below for the 1990/91 Overwintering Team at the Greenpeace World Park Base in Antarctica.

RADIO TECHNICIAN

Familiar with maintenance and repair of HF and VHF communications systems. Knowledge and experience with digital computer communications, HF antenna theory, and satellite installation and maintenance is essential. Possession of an amateur radio licence a definite advantage. Some knowledge of alternative energy systems, such as wind and solar energy, is useful. Will also be responsible for base electrical systems.

For general information about the expedition/campaign please contact Lyn or Michael at Greenpeace Australia, ph (02) 211 0500.



ETI FEBRUARY '89

READER INFO NO. 3



STUART CORNER

TELECOM'S TELINC TROUBLES

Suppliers not offering support

Telecom had high hopes for its proposed inter PABX signalling protocol, Telinc. But many major PABX suppliers have resolved not to implement it. Stuart Corner reports.

Telecom's plans for an inter PABX signalling protocol for the ISDN network appear to have suffered a setback. Most of the major PABX suppliers are refusing to implement the protocol, Telinc, on their systems.

It's possible to interconnect modern PABX systems in several locations by leased lines so that the network appears to users as a single PABX. This is achieved by signalling between the PABX over the leased lines. Each manufacturer uses a proprietary signalling system, so all PABX in the network must be from the same manufacturer, and often the same or similar models.

With the Integrated Services Digital Network (ISDN), due to come into service next year, it will be possible to establish virtual private networks of PABX systems where the link is set up through the ISDN only at call time. But for the network to function like a private network of similar PABX systems connected by leased lines, there must be an ISDN-compatible signalling protocol and each PABX in the network must support that protocol.

Unfortunately, work in international standard bodies to develop such a protocol has not progressed very rapidly. In the absence of any emerging international standard, Telecom invested over \$1m to develop its

own protocol, Telinc.

Telecom hoped that major PABX suppliers in Australia would implement Telinc on their system. But these hopes may have been dashed with the issue in October of a statement by the Australian Electronics Industries Association on behalf of several members; AWA/Nortel; IBM (which manufactures the Rolm PABX); NEC; Philips; GEC Plessey; Siemens; Alcatel-STC and Teletrade Services (Mitel).

Unanimous resolve

The statement said that these companies had "unanimously resolved not to implement Telinc on their products until such time as an agreement was reached with Telecom as to the content of Telinc."

The statement claimed that Telinc "omits certain significant portions of the standards developed by CCITT and other European standards bodies (eg ECMA)," and that "it cannot be considered an open protocol, due to its Australian-specific nature."

The only two major suppliers not party to the statement were Ericsson and Fujitsu. Ericsson is believed to have been in general agreement with the statement but not the precise wording.

Rod Maddock, general manager, advanced

communications systems in Telecom's corporate customer division, suggested that the statement was largely political and that the two suppliers with significant market share, Ericsson and NEC, would eventually offer support for Telinc.

Fujitsu has a joint venture with Telecom, Information Switching Technologies, for the development and manufacture of communications equipment including PABX systems. It has confirmed its intention to implement Telinc and expects to be able to support Telinc next year on the 9600 series of PABX which will be sold exclusively by Telecom. Already, ten have been sold, which is almost the maximum permitted by regulations in the first year of sale

Telecom invested over \$1m in its protocol, Telinc'

for a new PABX.

A Fujitsu spokesman said the company was enthusiastic about Telinc and even expected to find a market for it overseas. This approach contrasted with the views of other suppliers who felt that the prospects for an international standard had improved considerably since Telecom embarked on Telinc, reducing the viability of the private protocol.

No market

One supplier, who did not wish to be quoted, estimated that it would take two years elapsed time to implement Telinc, and said it was likely that a useful international standard would emerge within a year. He did not see that there would be any market for Telinc outside Australia and doubted that parent companies of the multinationals operating in

Australia would authorise the expenditure on development of Telinc support for a market the size of Australia.

In March this year, at a Telecom ISDN seminar, Trevor Jordan, supervising engineer, technical support PABX engineering, justified Telecom's decision to develop Telinc on the basis that nothing was forthcoming from international standards bodies.

One sceptical commentator from a PABX supplier suggested that, rather than develop an open protocol which all suppliers would implement, Telecom was hoping to use Telinc to secure market share for its chosen PABX system. It was also suggested that other vendors were forming a caucus to support the British Telecom developed DPNSS1 signalling protocol as an alternative. This had been operational in the UK for several years, and those manufacturers active in the UK market should be able to support it without much difficulty.

DPNSS1 seems to have been very successful in the UK, according to BT. In a paper presented to Telecom '87 in Geneva last October, Ted Rook of BT said that DPNSS1 had allowed BT to secure a significant number of new network sales and had been "the most successful high value upgrade offered to our PABX customers. Many have been persuaded to order a new network or to upgrade their old because they have seen the feature in operation."

However, a less enthusiastic response to DPNSS1 was made by David Hamer from BP in the UK. Speaking at an Australian seminar in 1987, Hamer said that support for the 17 supplementary services offered by DPNSS1 was optional and it was common for PABX from different manufacturers to support

different subsets of these services with only minimal overlap.

And elsewhere . . .

Australia to broadcast to SE Asia

A Hong Kong based company, Television Asia Ltd, is planning to broadcast educational and entertainment television programs to South East Asia from Australia via the Indonesian Palapa satellite. Television Asia is a division of Satellite Education Systems, a Hong Kong based company with a majority Australian shareholding.

The company's studios will be located in Darwin which is within the footprint of Palapa. Programs will be beamed up to the satellite from a nine-metre dish in Darwin. The transmission will be receivable throughout Indonesia, Thailand, Papua New Guinea, The Philippines, Singapore, Hong Kong and Burma. According to the company there are already 20,000 dishes in Thailand and Indonesia alone which can receive the service. Dishes will cost less than \$1000.

All the countries in the region are signatories to Intelsat, the international satellite organisation. This means that the use of any other satellite for international communications is subject to co-ordination with Intelsat. At the time of going to press co-ordination had only been established with Indonesia. But a company spokesman said he anticipated other countries in the region which permitted public ownership of TV receive - only antennas would follow suit. Singapore, because of tight censorship laws, is unlikely to participate.

Because only OTC is authorised to provide Australia's international communications service, the Darwin earth station will be sold to OTC once completed. It will then be leased back to Television Asia and operated by the company's staff in accordance with OTC practice, the spokesman said.

The company plans to

broadcast educational programs during the day and entertainment in the evenings. There will be facilities for interaction between a course tutor in the studio and students through a return telephone link. The transmission will carry two-channel audio, one channel in English and a parallel channel in a local language. All broadcasts will be encrypted and reception will be available through subscription. The company will sell corporate sponsorship of programs, but there will be no on-air advertising. Transmissions were scheduled to start on January 1.

Satellite Education Systems says that the educational content of its transmissions will be determined by authorities in the recipient countries; ministries of education; leading academics and business leaders. The company will then liaise with educational institutions in Australia, the USA and Europe which can provide suitable course material.

As well as being a more cost effective method of education than sending students overseas to study, the company's literature suggests education via satellite will also reduce the problem of 'acculturation' - students adopting other cultures and subsequently settling overseas.

Use of the facilities will cost course providers \$US6000 per hour. The company will also broadcast material on commission as a percentage of student enrolment fees.

To provide entertainment facilities, Satellite Education Systems will have links into the ABC, SBS, the Golden West Network, QSTV and TSN11. It will also be prepared to relay services from other satellite or terrestrial carriers. All broadcasts will be in the 625 line PAL (B) format.

New Australian Intelsat signatory

The Minister for Communications, Senator Gary Punch, has suggested that the Overseas Telecommunications Commission (OTC) may be relieved of its role as Australia's signatory to Intelsat, the international satellite organisation. Speaking at a seminar on global communications organised by the Australian Telecommunications Users Group in November, Punch said, "There will be an increasing need for governments to become involved in organisations like Intelsat. Previously many countries have been content to leave it to their international carriers to represent national interests. This may no longer be appropriate where carriers are expected to be increasingly commercial, and to face competition."

OTC, which was due to become a corporation on January 1, 1988, has been given greater freedom to operate competitive, commercial

services and already there are alternative international communications to New Zealand. Satellite Education Systems is using the Indonesian Palapa satellite to beam signals from Australia to South East Asia.

Under the terms of Intelsat membership, member states are not permitted to allow any private or domestic national satellite system to provide international communications services where there is danger of "significant economic harm" to Intelsat. For example, OTC had to seek permission for Australia to use the Aussat satellite to provide TV coverage of the Pacific Heads of Government meeting in Tonga in September.

Punch said that in Australia "We wish to see Intelsat's global system continue to grow and develop. But," he said, "we may expect to also see the development of separate international systems alongside (Intelsat). The parties and signatories to Intelsat now face decisions about how to respond to competition."

The most likely body to take over the signatory role from OTC would be the new Australian Telecommunications Authority Austel, the body being set up to regulate domestic telecommunications independent of Telecom.

Stuart Corner is a former editor of C in C News, and a regular writer on computers and communications.



Philips consolidates communications and data systems

Pictured at the opening of the new Australian headquarters of Philips Telecommunications and Data Systems Division (TDS) in North Ryde (Sydney) are Willem

Maclaine Pont, chairman and managing director of Philips Australia (left), Yvonne van Rooy, Netherlands Minister for Foreign Trade and Mr Chris Saines, general manager of TDS division. The division is responsible for Philips PABX products, radio communications system, optical storage, banking and financial terminal products and office dictation systems. The new facility consolidates operations from a number of premises around Sydney. It also houses the NSW headquarters of the division.



INNOVATION

Do good things really come in small packages? When the opportunity came to review the latest in handheld air band radios, I jumped at the opportunity to find out.

The unit was an Icom IC-A20, kindly offered to me by Brian Beamish, manager of Brisbane radio equipment store, Emtronics, and what better time to review it than while en-route to the biennial air show at Richmond RAAF base in NSW?

Having worked for some time in the radio field, and being aware of the Icom pedigree, I was prepared for the quality and presentation of the A20. What I wasn't prepared for was the number of features the Icom engineers have crammed into such a little box!

Some of the features, in addition to those of the usual Icom handheld range included:

- VOR (VHF omnirange) direction finding and position fixing.
- Digital CDI (course deviation indicator).
- ILS (instrument landing system) coordination.
- Instant access to the international emergency frequency.

In spite of the number of features, the unit remained simple to operate due to the inclusion of a clearly written manual.

Description

The physical appearance of the A20 is almost identical to that of the Icom IC-O2A and O4A series radios. On the front panel there is the LCD function display, a 16-key numeric pad, output for the built-in speaker and, of course, input for the microphone. The top of the unit holds the volume and squelch controls, antenna jack (BNC), automatic noiser limiter (ANL) switch, high/low power switch and the jacks for external speaker, microphone and power. On the side of the unit is the push-to-talk (PTT) switch, light switch (for the function display) and a second function switch.

Operation of the A20 as a straight transceiver is as simple as with any radio. Dial up the frequency you require (key the frequency in via the keypad), check that nobody is already communicating then hold down the PTT switch to make your call.

If there are several frequencies that you regularly use, or know you will use, in the course of a flight, enter them into any of the 16 memory channels available, and they can be recalled at the touch of a button. Similarly,

if you are required to monitor more than one frequency, the A20 has a built-in scanning ability that allows the user to scan any combination of memory channels. When a transmission is heard on any selected frequency, the A20 will pause for the duration of the transmission. The scanning can also be set-up to scan right from the start of the band through to the end. This enables you to pick up any transmissions that may not have been sent on an "established" frequency. To solve the problem of the A20 stopping and locking onto a continuous transmission (ie: a VOR station), the user also has the ability to "lock-out" frequencies.

The A20 has the ability to operate in a duplex mode, that is, on two frequencies at

'I wasn't prepared for the number of features crammed into such a little box!'

once. For example, you can monitor a VOR navigation aid on 113.70 Mhz, but when you press the PTT switch the set will actually transmit on a different pre-set coms frequency of your choice. This ability is of dubious advantage because it is essential that you monitor your coms frequency for any reply to your transmission. This ability is not available. As soon as you release the PTT switch, you drop back to your original frequency.

The piece de resistance of the A20 is undoubtedly the way in which the set can be used as a navigational aid. For navigation purposes, at various points around the country, radio beacons, called VOR's, have been set-up. In conjunction with a radio and visual indicator in an aircraft cockpit, a pilot is able to use these aids to find the way by tracking towards them.

Cross referencing between two VOR's will determine the exact position. Icom has included this ability in the A20. When you key in a VOR frequency, the A20 will receive the beacon's signal (assuming you are in range) and display the appropriate heading you need to fly to reach that beacon. Also the A20 will display your direction from any respective beacon. This allows the pilot to take a "resection". That is, if his direction from

Lance Farrell looks at the new Icom IC-A20 radio. It's designed for operation in the aviation frequencies.

LISTEN TO THE AIR BAND

ETI FEBRUARY '89

On Heard Island, Antarctica, the Australian Antarctic Division lost one of their IC-M12 portable two-way radios.

Then, with the onset of winter, the base had to be abandoned. And so was all hope of finding the radio.

But the following year, it was found. And though it had seen 12 months of exposure

So Australian Antarctic bases and exploration parties use IC-M700 HF transceivers to communicate to and from remote destinations up to 1,000 kilometres inland.

Helicopters as well as search and rescue boats use IC-M80s, often via a pilot's headset.

And ground parties and other personnel carry the IC-M12s because they combine

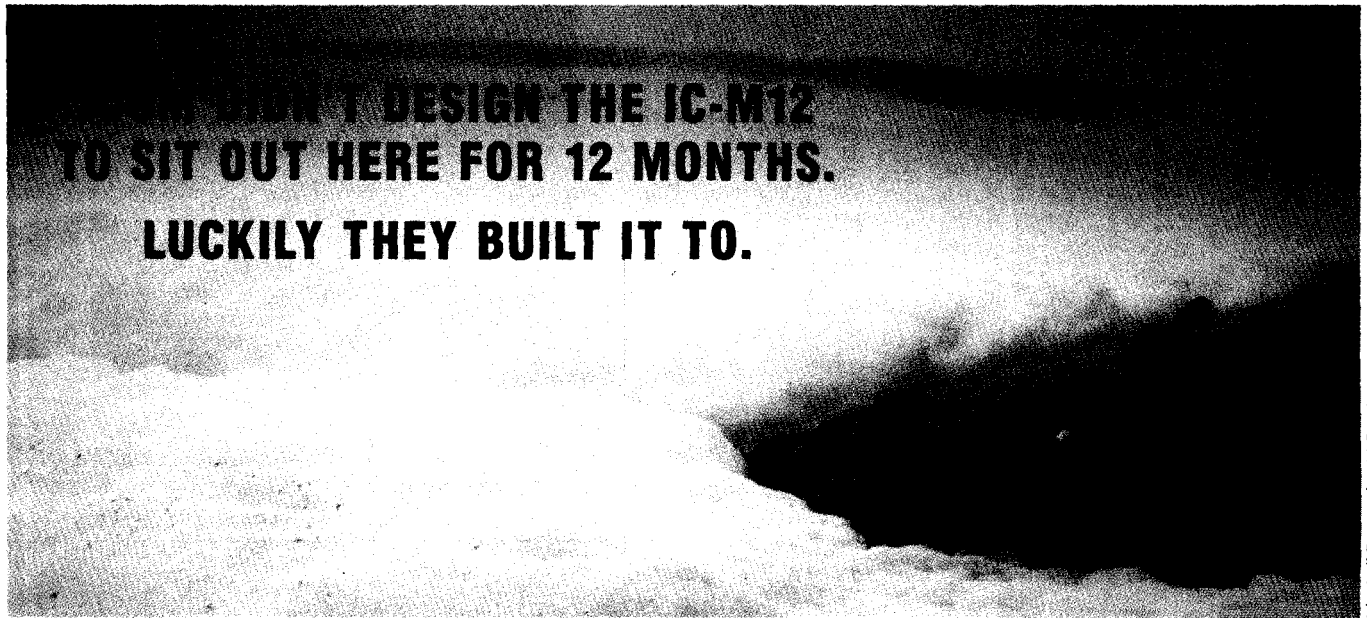

to rain, snow, sleet and seaspray, the scientist who found it decided to put in a fresh battery and see what happened.

Amazingly, it worked like new. And so did another unfortunate IC-M12 that a member of the Division dropped from a tower to the ground 70 feet below.

In fact, it was experiences like those that led to the replacement of more expensive 'military standard' radios with the more reliable ICOM range.

practical, easy to use functions with proven toughness and reliability.

Of course, ICOM's wide range of radio equipment is designed for thousands of commercial and marine applications.

And if they can survive the Antarctic, they can handle what you have in mind.

Because at ICOM, we know we can't design our radios specifically for each and every potential use. So we build them to take anything.

ICOM

Air radio



METENPOL AIRCRAFT
 DESIGNED 1978
 SPAN 30 FT
 WING AREA 50 SQ
 EMPTY WT 430 LBS
 CRUISE 80KTS
 ENDURANCE 4.5 HR
 ENGINE 100 HP
 1ST FLOWN 1984
 BUILDER G. ALLEN
 NOOSA Q.

The new ICOM IC-A20 air radio should interest ultralight pilots and gliding clubs.

Specifications

General

- Frequency coverage :Receive: 108.000 – 135.975Mhz
Nav. band 108.000 – 117.975Mhz
Com. band 118.000 – 135.975Mhz
Transmit: 118.000 – 135.975Mhz
- Mode :A3E 6K00
- Channel spacing :25Khz
- Memory channels :16
- Antenna impedance :50 Ohms
- Power supply requirement :13.2V DC +/-15%
- Current drain :Receive Squelched 55mA
Max. Audio output 220mA
Transmit HIGH 900mA
LOW 600mA
- Usable temperature range :-10c - +50c
- Frequency stability : +/-0.002%

- Dimensions :65(W) x 198(H) x 35(D)mm
(Projections not included)

- Weight :675g

Transmitter

- Output power :HIGH 5.0W PEP
(1.5W carrier power)
LOW 1.6W PEP
(0.5W carrier power)

- Modulation system :Low level modulation

Receiver

- Receive system :Double-conversion superheterodyne
- Sensitivity :Nav. band 2.0uV for 6dB S/N with
1Khz 30% modulation
Com. band 1.0uV for 6dB S/N with
1Khz 30% modulation
- Audio output power :500mW at 10% distortion with an 8
Ohm load

one VOR is 275°, the pilot draws a line on the map in this direction from the respective VOR. The pilot then selects another VOR and reads his direction from it, draws a line appropriately and where the two lines intersect, is the position of the aircraft!

The A20 also has a digital course deviation indicator (CDI). If you are flying towards a VOR and the A20 is telling you the heading fly is 140°, pressing the CDI button will give you a graphic display representing course deviation needles. That is, if you are off course by 4° to the right, it will show two

*'ILS co-ordination
is really a token
gesture'*

arrows to the left, indicating your need to turn left to get back on the track. If you are off course to the left, the arrows will tell you to turn right. Each arrow represents 2° up to 5 will be displayed before an overflow indicator is shown. When you are on course, no arrows appear.

In my opinion the ILS (instrument landing system) coordination is really a token gesture. On picking up the localiser signal the A20 will simply display "LOC" with no additional information. I really can't imagine many pilots having the time for this on a true ILS approach.

Other features include the ability to lock the keypad to prevent inadvertent entries and also a "beep" function to indicate when a key has been pressed.

Performance

For a handheld radio, the performance of the Icom IC-A20 is exceptional. In direct comparison to aircraft radio sets however, it tends to pale somewhat. For example, whilst on track from Archerfield to the Point Lookout VOR, the A20 failed to lock onto the VOR until we were within 8 nautical miles. This may not sound too bad, but if you are in an aircraft this is a very small distance. Let's take a look at this in context:

- The radio was handheld, with a small antenna and was inside an all metal aeroplane.
- Connected to an external antenna there would be a dramatic improvement.
- We were able to receive the West Maitland VOR (higher power) at 58 nautical miles (twice the range).
- On our return flight at night we were able to receive Pt Lookout at 52 nautical miles.

Taking these factors into consideration, I felt the A20 performed quite well. Remember, whilst some factors work against it, it still has all the advantages of any

handheld; flexibility and portability. We found the A20 immensely helpful for copying the airport terminal information service (ATIS) during flight planning stages before reaching the aircraft, and for scanning other frequencies whilst the aircraft's comms radios were in use.

Ultralight pilots should be very interested in this radio with the proposed changes to the air navigation orders (ANOs) covering operations to these aircraft. Gliding clubs should also be interested from the portability point of view. Their ground crew can carry the unit on the airfield and in the retrieve vehicle, clubs can move the radio from aircraft to aircraft etc.

Unfortunately, I can't see that great a demand for the A20 in the general aviation sector. ANOs specify that all aircraft must carry a radio (except agricultural and some others) so, therefore, these aircraft will already have a radio unit. For the safety-conscious pilot the A20 would make an excellent back-up unit. Another problem which I experienced was - inability to transmit with the hand-held once we were under way. The background noise of the engine was just too much.

The noise problem could be overcome by purchasing the HS-20SB, a manual switch unit and adapter for aircraft-style headsets. This would enable the pilot to use his normal headset in conjunction with the unit.

Options

Icom has an impressive range of options available for the IC-A20. The range includes:

- headsets
- speaker/microphone
- high speed battery charger unit
- larger batteries
- mobile mounting bracket
- shoulder strap
- DC-DC converter (Aircraft 24V to 12volt)
- cigarette lighter power adapter

Battery life naturally depends on the amount of transmitting carried out. There would be no problem on average flights of 3-4 hours. If you do a lot of transmitting on long flights a dc-dc converter can be purchased allowing you to make use of your aircraft's 24 volt electrical system.

For further information contact: ICOM, 7 Duke Street, Windsor, VIC 3181. ☎ (03) 529 7852 or: Emtronics, 416 Logan Road, Stones Corner, QLD 4120. ☎ (07) 394 2555.

Lance Farrell was trained by the RAAF as a radio technician, is currently employed as a computer engineer and also holds a pilot's licence and gliding certificate.

ETI FEBRUARY '89

27

YOU DON'T HAVE TO GO TO THE ANTARCTIC TO SEE THE ICOM RANGE.

VICTORIA:

Melbourne. Associated Calibration Lab. (03) 842 8822. **Bairnsdale.** Bairnsdale Communications. (051) 52 4622. **Bendigo.** Bendigo Communications (054) 47 8647. **Warrnambool.** Ansonic Electronics. (055) 62 9688. **Wendouree.** Wecam Communication. (053) 39 2808.

NEW SOUTH WALES:

Sydney. Argent Pty. Limited. (02) 671 3333. **Captain Communications.** (02) 633 3545. **Master Communications.** (02) 682 5044. **Raymond Terrace.** Alback Communications (049) 87 3419. **West Gosford.** Pacer Communications. (043) 24 7844. **Wollongong.** Macelec. (042) 29 1455.

SOUTH AUSTRALIA:

Adelaide. Jensen Communications. (08) 269 4744. **Transceiver Services.** (08) 42 6666.

QUEENSLAND:

Brisbane. Delsound. (07) 839 6155. **Mobile Communications (Qld).** (07) 277 4311. **Mackay.** D.S. Marine. (079) 51 1635. **Mackay Communications.** (079) 51 3544. **Cairns.** Integrated Tech. Services. (070) 51 8400. **Gladstone.** Jones Communications. (079) 72 1116. **Townsville.** Tradewinds Sailing School. (077) 72 4021.

WESTERN AUSTRALIA:

South Fremantle. McCorkills Coastal. (09) 335 5875. **Perth.** Communication Systems Aust. (09) 445 1333. **Boulder.** Hock Communications. (090) 93 1700.

TASMANIA:

Launceston. Marcom Watson. (005) 31 2711. **Hobart.** Marcom Watson. (002) 34 4500.

NORTHERN TERRITORY:

Darwin. Integrated Technical Services. (089) 81 5411. **Alice Springs.** Farmer Electronics. (089) 52 2388.

ICOM AUSTRALIA HEAD OFFICE:

7 Duke Street, Windsor, Victoria. 3181. Phone: (03) 529 7582.



READER INFO No. 6

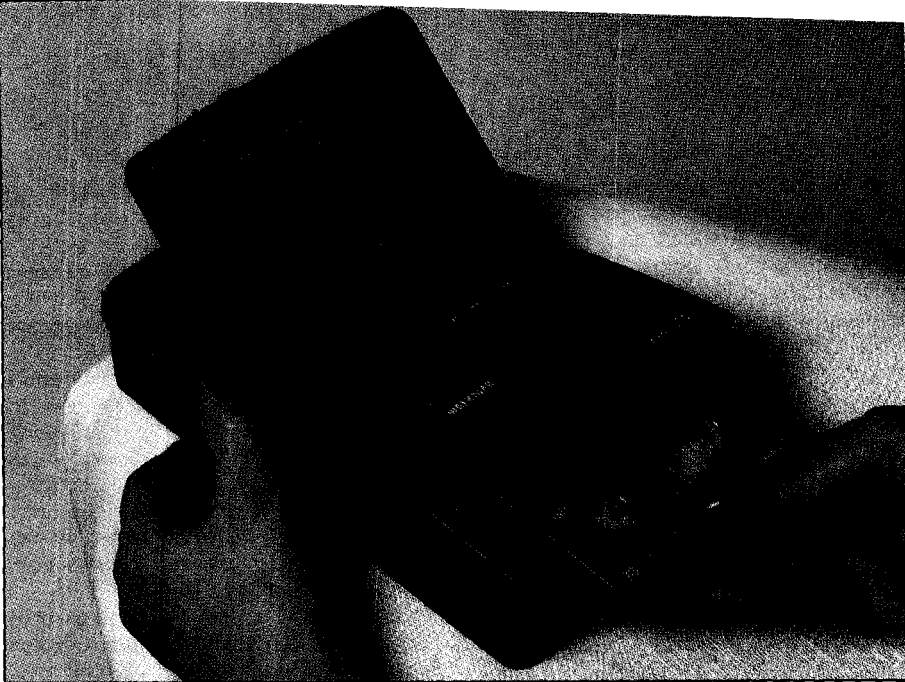
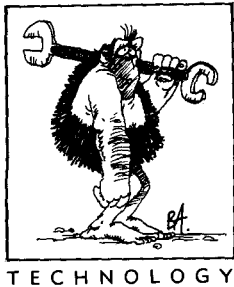

Figure 1: a new Sony video walkman. It will be available in March, and indicates the size that can be achieved with 8mm technology and colour LCD screens.

VIDEO FORMATS COMPARED

Sorting out the maze

Derek J Powell looks at the evolution of video formats from prehistory to the present day.

Just when you think the smoke is clearing from the video format war, along comes another round in the manufacturers' battle for the home video dollar. To help in understanding the battlefield, this guide to the video formats will trace the technological evolution of the home VCR and indicate the possible paths ahead.

There are currently around 20 (!) different formats in use for recording PAL video signals. This includes broadcast standard equipment, but not equipment designed for specialised medical or scientific purposes. As we would quickly lose our way among such a forest of whirling video heads this review will only take in those standards designed for the domestic market.

Fundamental problem

The fundamental problem in recording video signals, compared with audio signals, is the huge frequency range (bandwidth) which must be accommodated. The audio bandwidth is around 20 kHz while colour video recording demands up to 6MHz.

In any magnetic recording system, ultimately the bandwidth will be determined

by the speed of the tape across the record/reply head. While it is something of a simplification, as video has a bandwidth of about 300 times the audio spectrum, the tape in a video recorder should run at about 300 times the speed of tape in an audio recorder.

The very first experimental video recorders (in the early 1950s) somewhat resembled turbo-charged audio recorders. They used 1/4 inch tape and operated at phenomenal tape speeds, around 50 kph in fact.

While these machines certainly worked, there were substantial limitations. Even with a huge reel of tape the recording time was only a few minutes. Getting the tape up to speed and decelerating at the end of the reel further decreased the recording time and complicated the tape transport.

The answer to this dilemma was to draw the tape slowly past a swiftly rotating head. The mechanism was arranged so that the head traced a series of narrow tracks at an angle across the tape. All practical video tape recorders use a variation on this system.

The first commercial video tape recorder, the Ampex VR-1000, used a head drum rotating at right angles to the direction of

tape travel. Four heads mounted on the drum traced a series of short tracks, each containing 16 lines of the television picture, across a tape 50 mm wide.

This system, called quadruplex recording, was very successful and endured for over 20 years as the standard for television broadcasting. However, there were inherent difficulties in reconstructing a complete picture from a series of 16 line segments. Also no still frame, fast or slow motion effects were possible with the quadruplex system.

Slowing achieved

In 1959, after four years development, JVC released what was claimed to be the world's first helical scan video recorder. In the helical scan system, the tape is wrapped at a slight angle around a drum that rotates in the same direction as the tape travel. Two heads set into the drum trace much longer tracks at a shallow angle across the tape. Each track records one complete television field. It is this characteristic which allows still frames and slow motion effects to be achieved.

Development continued throughout the 1960s with a variety of open reel monochrome and colour recorders. The next big development, as far as our story is concerned, occurred in October 1971 with the announcement of 3/4 inch U-Format, the first colour videocassette system.

The U-Format was the first real VCR standard, adopted jointly by JVC, Matsushita (National Panasonic) and Sony. The U/Matic system (to give it its Sony trade name) used a fairly bulky cartridge wound with 3/4 inch tape.

The tape speed adopted three 3/4 inches per second (NTSX), gave good audio quality on the two linear sound tracks but limited the total recording time to one hour.

Manufacturers quickly realised that for the domestic market, a different system was needed. The first issue was compactness. The equipment had to be brought down to the size range of familiar stereo audio components. This meant a smaller diameter rotating head drum and narrower tape. Secondly, surveys revealed strong consumer interest in sporting events and movies so a two hour minimum recording length was set as a goal.

With these criteria plus other factors (ease of use, compatibility, reasonable price) the major consumer electronics manufacturers set about developing a domestic system. Hardware and software compatibility was seen as essential to the success of any format and extensive consultations were held between manufacturers.

Whatever happened to U/Matic?

Far from fading away, U/Matic was enthusiastically adopted by educational and industrial users and is still in widespread use today. Phases in the U/Matic development closely parallel what later happened in the

VHS and Beta stories.

The U/Matic cassette was too large to allow a practical portable recorder so a smaller shell was developed containing just 20 minutes of tape. This cassette was fully compatible with bench top machines but allowed the introduction of the first field recorders in 1976. The introduction of the compact VHS format in 1982 was a very

'It would be very attractive to have one type of transport and medium for data storage'

similar answer to the problem of size.

The U/Matic format was brought up to broadcast specification with the development of HiBand recording, paving the way for the adoption of 3/4 inch as the standard ENG format for television. Later, in 1986, an improved tape formulation saw the introduction of HiBand SP with improved video and audio quality. Ironically, it is the development of high band systems in VHS, Beta and 9 mm which may yet see the demise of the U/Matic system.

V2000

The V2000 system was introduced in the early 1980s by Philips/Grundig. A 1/2 inch tape cassette, similar in size to VHS, was employed but the tape was two sided with only 1/4 inch used on each pass. The video heads were mounted on piezo actuators which allowed them to swing up and down to very precisely follow the video tracks. This same system (called dynamic tracking) is now used in top end broadcast machines and allows superb quality still frames and slow motion effects. In short, the V2000 was technically a tremendously advanced system. However, by the time it was launched, the VHS-Beta was in full swing and consumer resistance to yet another

incompatible system over-rode the technical superiority. V2000 sank without trace and Philips now sells VHS machines.

Beta

When Japanese manufacturers started the race to develop a consumer system, several things quickly became clear. Half inch tape would be the standard with a helical scan recording system. To allow the tape to wrap around the head, it would have to be drawn out of the cassette and threaded around the capstan, video head drum and the audio heads. This is where the systems started to diverge however. Sony had patented both the U-loading system (used in U/Matic VCRs) and the M-load (subsequently used under licence by all the VHS manufacturers). The U-Load seemed to have several advantages: it was tried and tested, tape was handled more gently and rapid functions like cue and review were much easier to implement.

So the Beta camp, led by Sony, adopted U-Loading while VHS took on the M-Load. Once this decision was taken, all hope of a compatible standard was lost. Sony released its first Beta VCR in 1975 and followed that with a series of developments which were to be matched point for point by the VHS camp. The U-Load arrangement and a relatively large head drum (20% bigger than VHS) gave Beta a number of technical advantages. Firstly, the writing speed (of the video head across the tape) was better by one metre per second than VHS. This meant potentially a better luminance and chrominance bandwidth and improved signal-to-noise ratio. Tape guidance was more accurate, giving improved software interchangeability.

At the same time the cassette shell was smaller which had very important advantages for portable systems. Indeed the next major development for Beta was the release in 1983 of the Betamovie home camcorder. Billed as the world's first consumer colour video camera with

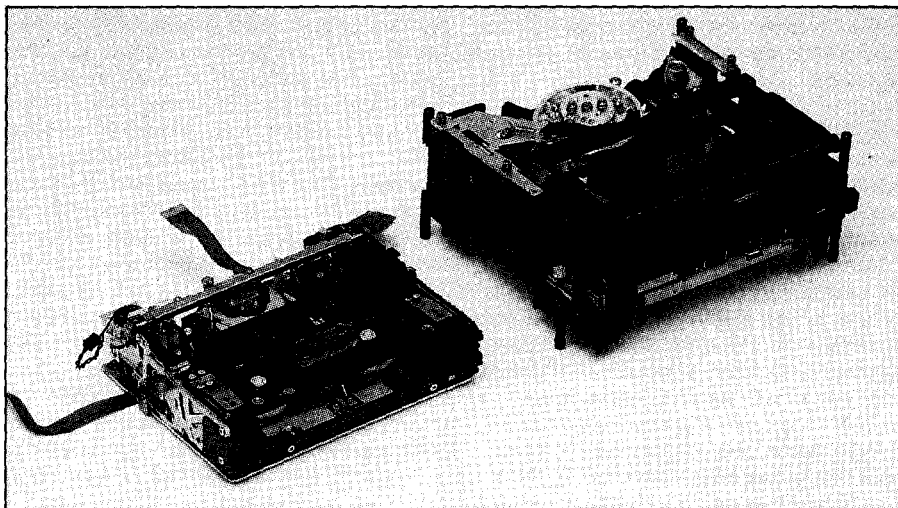

Figure 2: the early 8mm tape transports (right) were small, but the latest, as used in the new 8mm camera's are even smaller.

Video formats compared

recording capability, the Betamovie used standard Beta tapes.

It achieved its compact dimensions by using a smaller head drum, retaining compatibility by wrapping the tape further around the drum (the Omega wrap). However, the Betamovie had no replay facility. The optical viewfinder gave little indication of the quality of the video signal being recorded and there was no way to check it back on the spot.

These were fatal flaws which the competing VHS Camcorders, released at about the same time, fully capitalised on. Sony could perhaps take comfort in the fact that the Betacam broadcast camcorder, released the previous year, took off like a rocket, completely over-whelming its then competition. The Betacam system used Beta cassettes running at six times normal speed and kept the luminance and chrominance component recording systems entirely separate. (ED Beta and Super VHS use some of the same ideas).

Also in 1983 hi-fi stereo sound was introduced to Betamax. A stereo audio signal was frequency modulated onto a carrier frequency between the luminance and chrominance signals to be recorded by the rotating heads. By this stage, Beta was seriously losing ground world-wide to VHS. However there were still some innovations to come. 1985 saw the introduction of Super Beta.

This development gave a sharper and more detailed picture by improving the emphasis characteristics of video signals in recording and improved noise cancelling in playback. This was followed by a third operating mode; Super Beta PRO. Super Beta PRO is a high band system which shifts the FM carrier frequency of the luminance signal upwards by 500 kHz. This allows a wider luminance bandwidth giving increased sharpness. At the same time the luma/chroma interference is reduced giving better chrominance signal-to-noise ratios. A special tape must be used to record in Super Beta PRO.

So, if you are still with me after Beta, Super Beta and Super Beta PRO, allow me to introduce Extended Definition Beta, brought onto the market by Sony just two months after the announcement of HS.

This is an Ultra HiBand system in which the FM luminance frequency is shifted up by a massive 3.7 MHz and the frequency deviation is more than doubled. The specification promises a resolution of more than 500 lines and enhanced signal-to-noise ratios. To maintain the gains made by reducing the chroma/luma interference, separate Y/C input and output circuits are used. To handle such high frequencies, a specially developed metal tape has been prepared for the new system with better coercivity and higher

magnetic density. ED Beta tapes can't be used with conventional players but standard tapes can be recorded and played using a mode selector on the ED Beta VCR.

The picture quality of ED Beta is reported as "stunning" and certainly the specifications exceed any other consumer format. A camcorder, an edit recorder and a consumer machine are available in NTSC. However, with the Sony people pushing Video 8 so strongly, no-one is yet promising that this format will be released in Australia.

VHS

The VHS story has been one of conspicuous market success, built on an apparent technical handicap. VHS was first released in 1976, the year after Beta. The tape-to-head velocity was lower, the M-loading system more difficult and the cassette was physically larger. However, these barriers were overcome one after another and the pace setters, JVC and Matsushita (National Panasonic) quickly started to outstrip the Beta camp in both the number of features and the diversity of specialised models.

In 1979, VHS gained a long-play mode by

'The fundamental problem in recording video signals is the huge frequency range'

adding a second pair of heads to the drum. The two independent pairs of heads are located at 90 degrees to each other, one pair for SP mode, the other handling LP. When high quality still framing came along, yet another head was added with a different azimuth angle to allow noiseless still frame reproduction.

The introduction of hi-fi sound in 1983 demanded yet another pair of heads, for the system used is quite different from Sony's Beta hi-fi. In the depth-multiplex recording system, the audio signal is still frequency modulated but it is laid down on the video track by a separate pair of heads mounted 120° ahead of the video heads. The construction of the heads results in the audio being laid down at a deeper level of the magnetic coating with the vision recorded shallowly directly above. A different azimuth angle (30° vs 6°) and different recording allow different signals to be effectively drawn out of the same section of tape with very little interaction.

The year 1983 also saw JVC tackle the awkward problem of cassette size head on. The result was VHS "C" and it made possible a generation of truly lightweight and portable camcorders.

Echoing the portable U/Matic cassette of some seven years earlier, JVC developed a

½ inch cassette that was only one third the size of a standard VHS. This cassette could be played (albeit with a somewhat awkward adaptor cradle) on any standard VHS machine.

Like Betamovie, a smaller head drum with increased wrap (270° vs 180°) was employed. By spinning the head at 37.5 rps instead of the standard 25 rps, full compatibility with the VHS standard was maintained. Unlike Betamovie, VHS C machines had electronic viewfinders and could replay on the spot.

The HQ (high quality) enhancement arrived in 1985. HQ used three innovations, all completely compatible with standard VHS to improve picture quality. This white clip level was raised by 20% resulting in much sharper black/white transitions, which in turn gave clearer and sharper edges and profiles. A detail enhancer improved fine detail and a recursive filter circuit reduced chroma noise. The next year, control track coding (CTC) appeared which allowed users to quickly access a number of segments recorded on one tape. And so to 1987 and 88, which saw the release of, first the NTSC, and then the PAL versions of Super VHS.

Like Super Beta PRO and ED Beta, it attacks the twin problems of poor resolution and chroma/luma interference by shifting the frequency of the luminance FM carrier upwards from VHS standard. This defines S-VHS as a high band system.

The frequency deviation of the luma carrier is increased from 1 MHz to 1.6 MHz which gives the system its better than 400 line resolution. At the same time, moving the luminance signal away from the recorded chroma sub carrier reduces interference for a much cleaner picture. Best results are achieved by keeping the luminance and chrominance signals completely separate, so dedicated Y and C input and output sockets are provided to mate with similarly equipped monitors and camera. As in the other HiBand systems, the inevitable result of expanding the recorded bandwidth is that a special tape formulation is required. In the case of Super-VHS the highest frequencies exceed 7 MHz and a new cobalt doped ferric oxide tape has been employed. This is quite an advantage, as, if metal tapes had been chosen, a degree of compatibility with existing systems would have been lost.

Compatibility is a factor though, for while a Super-VHS machine can record or play standard VHS, a standard machine cannot replay an S-VHS recording. A minor plus for the new Super-VHS Euro System, as it is called, is that it actually removes one degree of incompatibility between PAL and SECAM. Super-VHS tapes recorded in either PAL countries (Australia, Britain and much of Europe or SECAM nations France, USSR) will now be exactly the same and can be replayed on either system provided that Y/C component inputs are used on the monitor.

Video 8

In 1982, Sony, JVC, Matsushita, Philips and Hitachi began working together on a new video format. A year later at The First 8 mm Video Conference, agreement on the new standard was announced between 122 companies from around the world. This was truly an outstanding achievement and perhaps reflected a desire on the part of many companies not to have their fingers burnt again with format incompatibilities.

The 8 mm video started out with all the advantages of both major systems. Interestingly, U-Loading was adopted as the standard and an FM mono soundtrack included instead of a stationary head. Sound was not to be the poor cousin, however, as a PCM digital stereo track was optional. In a decision with major implications for serious video editing, this PCM track was so arranged that it could be edited and dubbed independent of the video. This is a major advantage over both the Beta and VHS hi-fi soundtracks which have to be edited along with the vision.

What's more, the system could be used as an audio-only recording medium by using space allotted to the vision for five additional 90 minute digital stereo tracks!

Two speeds would be standard with a three-hour maximum recording length. Writing speed is a relatively slow 3.12 m/sec so the tape used from the start was a metal type, either metal powder or the more esoteric metal evaporated kind.

The small head drum (40 mm) and tiny cassette meant that it was a natural format for development of camcorders. This is by far the major sales area for 8 mm systems with many traditional photographic manufacturers like Kodak and Cannon producing camcorder equipment. Console machines for home use are also available but lack of pre-recorded software and the cost of tapes have limited sales to date. However in the years since the finalisation of the standard, things have changed somewhat. The emphasis on video quality with S-VHS and ED Beta had left Video 8's 250 line video resolution specification looking a bit tatty. So the conferences were recalled and in March 1988 ten manufacturers jointly announced an 8 mm HiBand specification. By now you should be able to guess that:

- (i) the luminance FM carrier frequency was shifted upwards and the deviation increased (shifted up by 2.3 MHz with deviation up from 1.2 to 2.0 MHz) and
- (ii) Y/C component inputs and outputs were added.

And yes, a new tape would be called for, either an improved MP tape or an ME tape. Details on 8 mm HiBand specifications are still sketchy with the first product only just due to have been released but with ME tape it is expected that 430 lines of resolution will be realised.

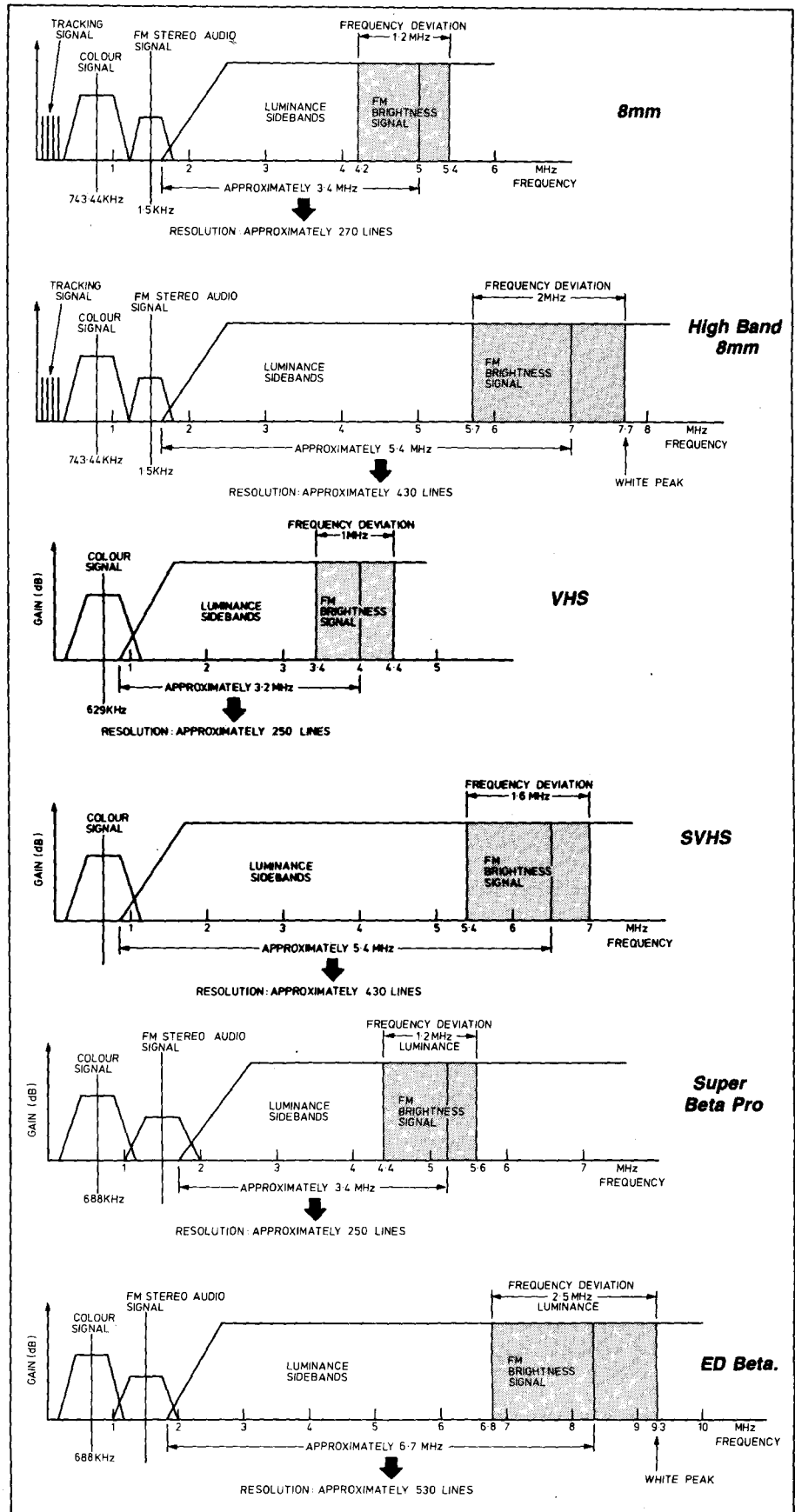

Figure 3: frequency distribution of signal components.

Video formats compared

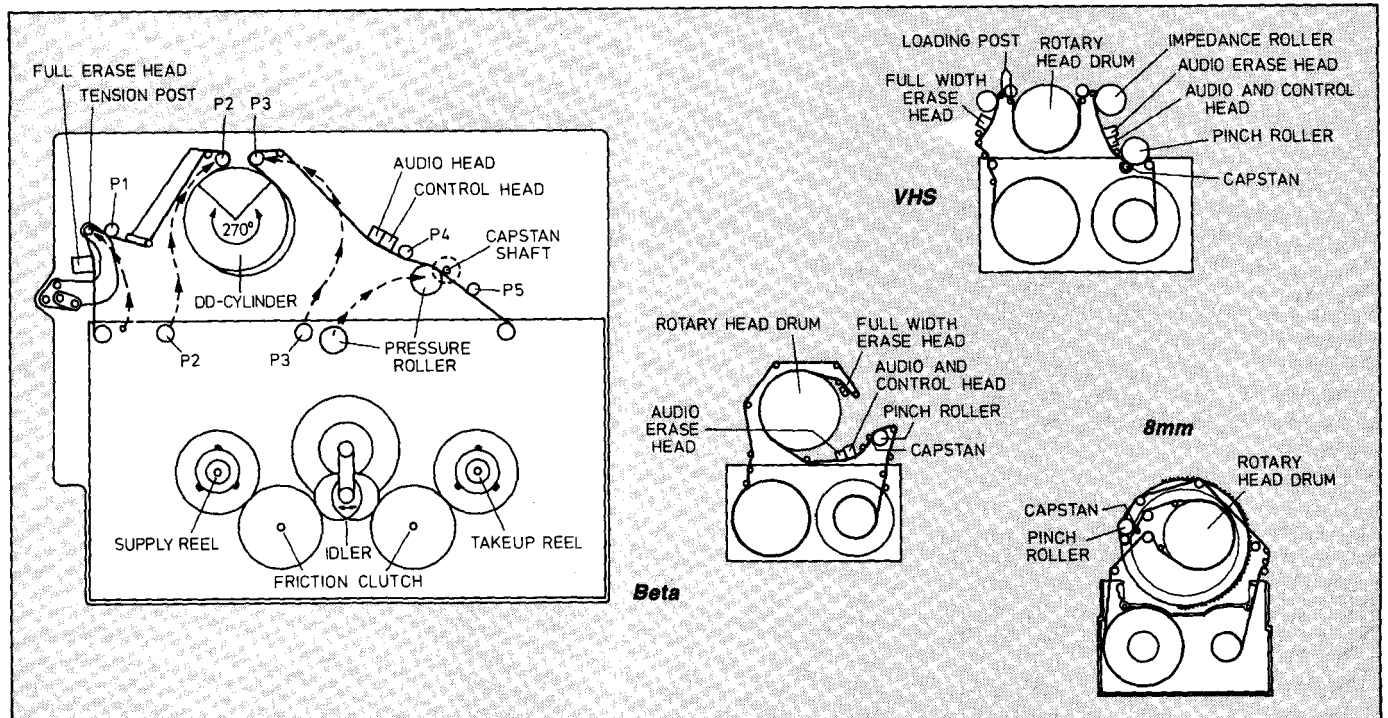

Figure 4: comparison of cassette loading paths.

The future

Will the format war continue as recorders and their tapes become ever more specialised? Or will things start to converge to a single, universal standard? Such a coherent utopia seems a long way off yet, although there are several strands which it will be interesting to follow over the coming decade.

One of the strongest marketing points of the VHS format has been its compatibility. As JVC is fond of pointing out, even the latest Super VHS machine can faithfully reproduce the very first VHS cassettes recorded. It seems that VHS still has plenty of development left, so, what's next? There seems little reason that the next step shouldn't be to record digital vision on a VHS format cassette. A faster drum speed and narrower tracks would probably be demanded, but given improvements in tape

and head technology it would not seem impossible.

The D2 broadcast cassette format has already achieved digital recording using a 19 mm cassette so domestic machines may not be too far away. There seems no technical reason why a digital VHS machine shouldn't be switchable to also reproduce the S-VHS and standard VHS recordings as well, thus preserving the massive investments in software for the VHS system. Another area worthy of careful attention is optical disc. The announcement by Tandy and others of an erasable laser disc may well signal a whole new phase of development for this versatile medium. The advantages of laser disc are great:

- easy duplication
 - virtually wear free
 - versatility of use
 - high information density
- It would be very attractive to have just one

type of transport and medium for data storage, audio reproduction, video replay and a variety of other interactive or random access applications.

Finally, it has been seen for many years that the ultimate video recorder (or audio recorder for that matter) would have no moving or wearing parts at all. Instead of dropping in a tape cassette, one would simply plug in a RAM or ROM chip to access the images and sounds stored in digital memory. No wear, instant access to any point, simultaneous record and replay, perfect dubbing and editing, perfect still framing and slow motion – the advantages go on and on.

If you think that this particular version of utopia is pie in the sky, then think again! Enter the Questech SSVR (solid state video recorder). The Questech does all this and more, with only one tiny limitation – with its 12 GigaBytes of RAM it can only store 78 seconds of video.

While this is more than enough for many video production applications (commercials, sports instant replay) it is clear that we are still some way from having *Gone With The Wind* on a 16 pin DIL package. Still, one only has to compare the UNIVAC of 40 years ago with the latest laptop pcs to see the feasibility of such a reduction in storage size.

In the meantime, I'm still wondering whether to dub my venerable Super 8 films to VHS or Beta or Super VHS or HiBand Video 8 or hard disc or...

Derek J Powell is at Gaytone Studios in Brisbane.

Developing high density recording

During the past 30 years, a succession of video formats has resulted as manufacturers have refined the helical scan system. Each succeeding type packed ever narrowing tracks closer together on progressively skinnier tape. In fact, the history of VCR formats could fairly be said to be the history of improvements in high density recording techniques. As video recording heads and video tape developed, the surface area of tape needed to record each minute of

video has decreased dramatically. Improvements in videotape formulations have contributed greatly to this progress. Metal powder (MP) tape, because of its high magnetic density (Br) and magnetic resistance (Hc) characteristics has replaced alpha ferric oxide in the highest density applications (such as Video 8). Now, further improvements are expected from metal evaporated (ME) tape.

Something in the air . . .
Coming soon:

*An up-to-date, comprehensive guide to Australian Astronomy.
Find out about the people, the technology
and the theories that fuel the exciting
resurgence in sky watching.*

*Practical information on
buying a telescope and
finding your way around
the heavens.*

*If you're into
sky watching,
watch our for*

ON SALE IN MARCH

TREES! THE OZONE LAYER AND ETI

Magazine proprietors love subscriptions. Tree lovers get all sweaty pained at the thought. Even the occasional editor has been known to spend an idle minute ruminating on the thought.

Why? Well, give a thought to how this magazine reaches you. To give you the best opportunity to buy the magazine, we must get copies into every newsagent in the country. This is, in itself, a considerable organisational task that costs a lot of money. But even worse, with a special interest title which can't even aspire to multi-million circulation figures, the number of people who are going to buy the magazine in any given newsagent is actually quite small, perhaps only one or two.

The implication is that, to keep our presence up, it might be necessary for us to supply four or five copies to a given newsagent, in the hope that we will sell one or two. Averaging across the country, publishers like ours work on the assumption that 1.7 magazines need to be supplied for every one sold. That's a lot of magazines wasted in the course of a year.

The publisher doesn't like it because it costs him money. The forests don't like it because it costs trees. Greenies don't like it because it decreases the amount of oxygen in the air. I don't like it because I hate to think of all the work that goes into this magazine being shredded. You don't like it because guess who pays in the long run?

When you become a subscriber we only have to produce one copy to supply your one copy. Ruminating on such things, we've decided rather than provide a competition and a special gift as part of your subscription we are going to begin a series of subscription drives that reflect more accurately the economics of our operation.

You can now subscribe for 12 months for only \$28, that's a huge 37½% saving on the normal subscription rate, or better still, subscribe for 24 months for only \$52 and save 40% on the normal subscription rate.

This is the inexpensive, efficient and easy way to ensure you get your magazine every month.

Protect the forests, protect the ozone layer and protect your subscription against price rises.

Regards,

JON FAIRALL

SAVE 40% ON TECHNOLOGY

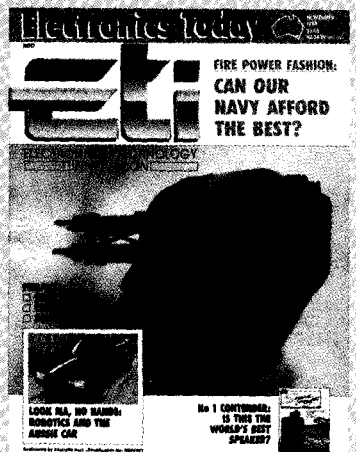
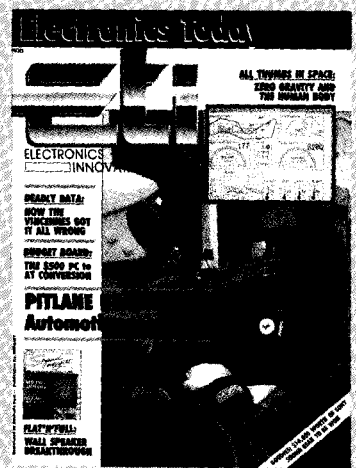
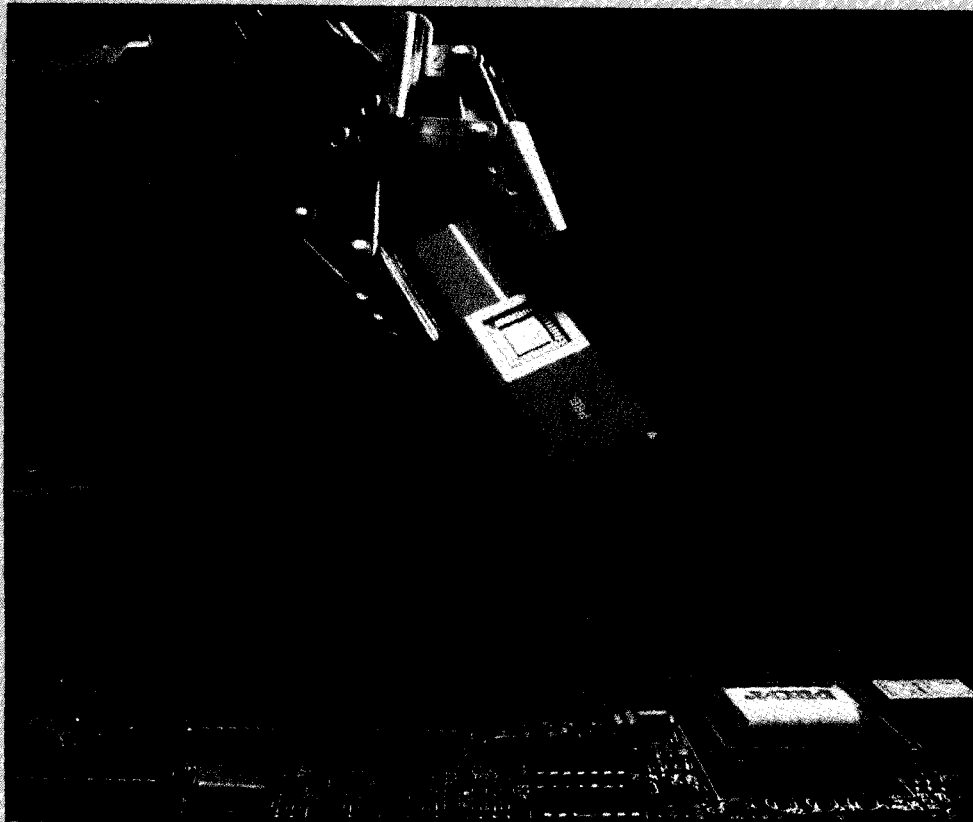

THE ETI ON RATE

SAVE 40% ON INNOVATION

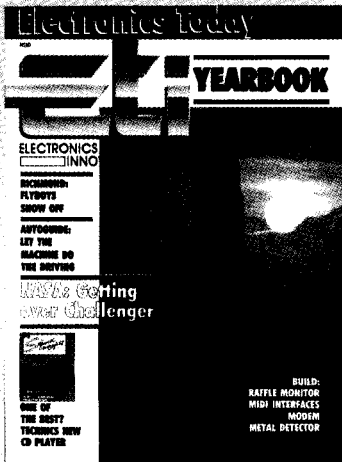
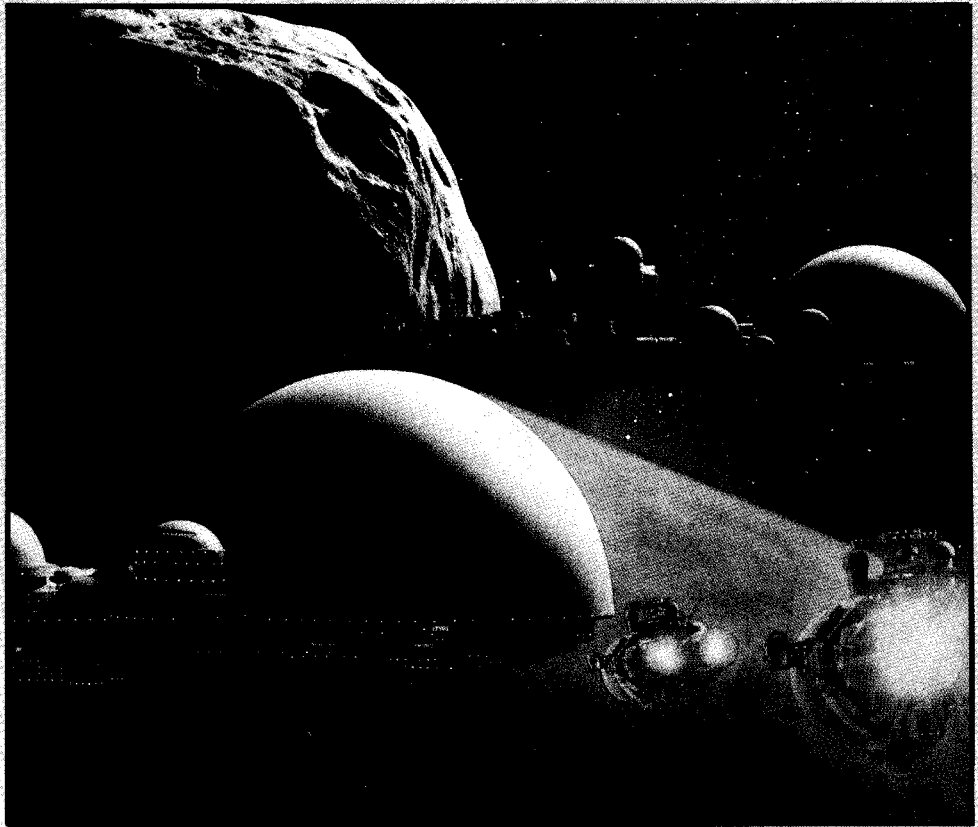

SAVE 40% ON ELECTRONICS





© 1997 Ian Edgar



Good marketing will not work wonders if a product has been badly designed. Ian Edgar writes on the importance of design in today's increasingly competitive product market.

Above: the Tara telephone, shaped by the author, Ian Edgar.

Right: the author in action. If your product's a dog, turn it into an egg.



PROFIT BY DESIGN

Teaching an old dog new tricks

Good marketing will not sell a bad product – at least, not for long, and not without making a large dent in a company's credibility. But companies confronted with dwindling sales persist in looking to increased marketing and promotional efforts as the only solution – even when everyone from the chairperson knows that the product is a dog. It may have been a lovely little creature once, charming the market and earning a tidy little return. Or it may have always been a dog, a 'me too' copy of what everyone else was trying to sell. Whichever the case, potential buyers seem increasingly aware they are being sold a pup.

What really hurts is that the competition is still selling, and their product uses roughly the same materials, construction and production processes. So what's their competitive edge? Let's say the dog has been analysed and it can't be made more cheaply. Its quality is

OK – at least, it seems no worse than the competition. Distribution is not the problem.

What can the company do? Give up? Abandon that market segment? (What if it's the major segment?) Is offshore production the solution?

When all the quick-fix avenues have finally been exhausted, perhaps its time to look at the design of the product.

Design for success

Design is the component all too often overlooked in product analysis, even though it is a key part of what makes a product a masterpiece or a mongrel (just ask the designers of British Leyland's P76!).

Design is not a new technique, nor a single skill. It involves form, function, fashion, aesthetics, engineering and production processes. Combined, these establish the intrinsic character, quality and appeal of a product.

Design has enjoyed a chequered career in industry. In the old days, when a craftsman created a product, design and production were intimately intertwined. The Industrial Revolution divorced design from production and engineering became all-important. A resurgence of interest in design in the 1930s was swamped, first by the ascendancy of the finance managers and then, more recently, the marketers. In the 1980s, design is being rediscovered as a vital component which can make the difference between the mundane and the magnificent money-spinner, particularly when linked with electronics and modern communications technology.

Design for the times

Solid state and VLSI circuitry, linked with phenomenal developments in micro-computers and memory capacity have freed the designer to approach the product without the constraints of cumbersome internal workings that previously took up so much space and dictated external shape. The form of the product can now respond simply to the needs of the user and the creativity of the designer.

In the past, minimum size technology has sometimes given rise to the ridiculous – e.g. calculators incorporated in wrist watches, requiring the user to have 20/20 vision and extra digits to operate them. Many products that have succumbed to the 'small is beautiful' dictum are now returning to a more human scale. Easily operated knobs and buttons are reappearing; unnecessarily complex controls are being scrapped. Enthusiastic bands of industrial designers are pushing this trend, creating free form designs that are both user friendly and highly competitive.

Production technology has become more complicated, and for that reason the multi-disciplinary approach is becoming the norm in product design, from the minute some-

one's idea gets the nod. It is no longer acceptable to do all the engineering and then call in the designer to provide form and colour. Design, engineering, production, marketing, management, labour, after sales service and even advertising need to contribute from the very beginning. The product can then not only be tailored to the end user, but also be easy to manufacture and service.

The time is now

Top design is a must in the international marketplace and, with a storehouse of world class designers to call on, Australia is well-placed to meet and beat the competition. However, management must take a conscious decision to allow designers the freedom to come up with new ideas. While local companies are still struggling with this concept, many talented Australians are currently working for overseas clients either on-shore as staff or off-shore as consultants.

There is no doubt that investment in design can pay handsomely, and that returns of 200-500% can be achieved. Our neighbours in Asia have been quick to recognise this, and the commitment of countries like Japan is ending the reign of the Europeans as design supremos. The classic example is the automobile. Most people would agree that the quality of Japanese cars is world class, and that their design now offers a real challenge to the European classics.

Japan is far from being alone in its commitment to effective design. In the past decade, Taiwan has moved away from manufacturing cheap imitations and developed its own, distinctive products. In Singapore the government offers manufacturers sizeable monetary incentives to lift their design game. The notion of design as the competitive edge is firmly established in Europe and Japan, and is now rapidly spreading in the USA. Can we in Australia afford to ignore it?

Design or perish

We cannot. Southeast Asia, one of the world's fastest developing markets, is just milliseconds away from us. The time difference between us is usually one to two hours. But unless we, too, seize the initiative in design that difference will expand to light years as our products fail to compete at home or offshore.

'Design or perish' could have been the motto of European pioneers in Australia. They came up with the stump-jump plough, the Coolgardie safe (and the Kelpie) to enable them to cope with their new environment.

We would do well to adopt the same motto if we are to survive as a force in today's world marketplace. If we don't, we can well and truly expect to go to the dogs.

Ian Edgar is managing director of CiDA (Corporate Industrial Design Australia) in Melbourne.



BRUCE MIDDLETON

AUSTRALIA'S SPACE PROGRAM

Launching us into the future

Most industrial and many developing countries are committing millions, sometimes billions, of dollars to space. Australia should not be left behind. Bruce Middleton writes on this important issue.

At the risk of preaching to the converted, I want to open my remarks by addressing the question of why Australia has, or should have, a space program. Is not space the playground of glamorous and expensive national and international programs undertaken in the main by very rich countries? Why should Australia aspire to join this club, especially in tough times when government dollars are an increasingly scarce resource?

The answers are multiple, all positive and important. First, we are already involved with space. We have a domestic communications satellite system representing large and continuing major expenditures. We are a major shareholder in, and user of, international satellite-based search-and-rescue services. We are a skilful user of remote sensing satellites, for meteorology, minerals exploration, resource management and other purposes. We have 30 years experience in space tracking and host major tracking facilities for two of the world's four largest space programs. And we have comparative advantages which are capable of being translated into benefits industrial, economic and social.

But perhaps the most

persuasive reason is revealed by addressing the consequence of not being involved. Virtually all the industrial countries with whom we like to compare ourselves, and a substantial

*'Their
commitment is an
act of vision'*

number of developing countries, are now committed to major investments in space. I am not speaking of a few million dollars, but sums ranging from tens of millions to billions.

There are many reasons why this is so, including reasons of national security and national prestige. But the overriding reason is that, without exception, the governments of these countries are persuaded that it will be important for their prospects in the next century that they should be significant participants in space. Their commitment is an act of vision as much as, if not more than, an expression of short-term national objectives. For Australia not to build a significant space program of its own would represent a decision - one would hope an

informed and conscious decision - that we do not share that vision and that we see a future for our children which has different (and lesser) aspirations than have all these other countries. I do not believe this is the Australia to which we aspire.

Following the Madigan report in 1985, the Australian Space Board was formed in 1986. The Australian Space Office was formed in September, 1987, within the Department of Industry, Technology and Commerce (DITAC) to be the focus of national space policy and activities. Its responsibilities include managing, under the supervision of the Australian Space Board, the National Space Program; responsibility for matters relating to space science, and the operation of tracking stations for NASA. Under this new arrangement both the Australian Space Office and the CSIRO Office for Space Science and Applications are located in the one portfolio.

The government's space policy is designed to achieve specific objectives. It seeks to encourage greater involvement by Australian industry in commercial space activities and in space research and development. To this end it seeks industry involvement at an early stage in publicly funded space activities, and as much as practical of the research and development undertaken by or in conjunction with industry.

Within this framework and the industry development objectives of DITAC, the office has developed an initial strategy whose central objectives include the development of commercially viable industries and activities which are export oriented and internationally competitive, based on space technologies. It also seeks to generate an environment supportive of innovation through

greater involvement of local industry in space research and development activities.

Much of this is well known to this audience. What, perhaps, you really want to know is, what directions are we heading in, and what is the plan? I shall try to give you a feel for our thinking.

Let me first say that our development of a strategy is a dynamic process which is still at a relatively early stage. We see the strategy producing selected R & D, manufacturing and service capability in space-related goods and services.

There are of course generally available measures in place which are designed to assist technology based industries such as the space industry. These include the 150% tax concession for industrial R & D, the Grants for Industry Research and Development, the Offsets scheme, and under AUSTRADE, the Export Market Development Grants scheme.

One of our major levers is the Offsets policy, and we have been closely involved in both local content and offsets aspects of the Aussat B procurement. No doubt we will continue to have an involvement at least to the extent of monitoring the discharge of the relevant obligations as the contract is fulfilled. Looking to the future, we would wish, on the occasion of Aussat's next RFT, to have done our homework better and perhaps be in a position to indicate, in a pro-active mode, to tenderers what we seek by way of industrial (and perhaps scientific) benefits and where they might find them.

However, our major policy instrument is of course the National Space Program.

The 1988-89 Budget has provided the National Space Program with a long term funding allocation. The government has, for the first time, endorsed

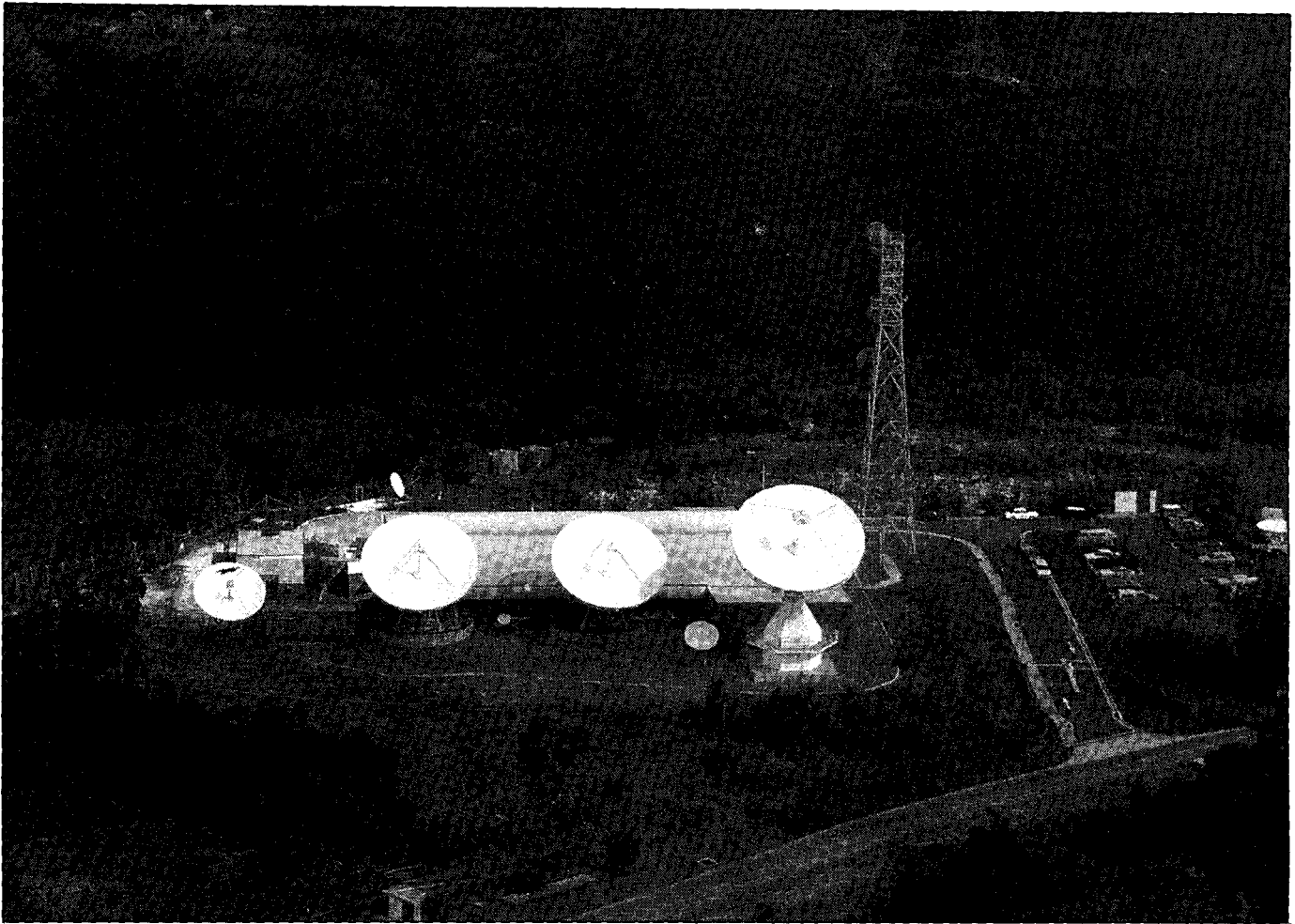

Australia's investment in space technology is large, and growing daily. This is Aussat's Belrose Earth Station. Most of it comes from overseas.

ongoing funding for the program, thereby providing a basis for strategic planning. The \$5.4m funding provided for 1988-89 will, however, not be sufficient to enable the immediate support of major new space projects.

One major task which we are undertaking in the immediate future is the development of a Space Industry Development Strategy. This will be both a refinement and development of the initial strategy and the framework in which future activities will be planned and executed. It will also provide the basis for future discussions with the government.

As part of the effort to develop this strategy, the board has identified a set of priority areas:

- remote sensing of the earth;
- satellite-based communications;

- ground support for foreign space programs;
- an Australian commercial space launching facility;
- scientific research supporting industry development, especially in the above areas.

Each of the first three is the subject of a concurrent specific study through a working party and, in several cases, the use of consultants. The launch facility priority focuses on Cape York and I shall speak more on this later. The fifth, space science, is the subject of a study by the Academy of Science which we have commissioned, the interim results of which will be discussed at a conference in Melbourne just before Christmas. We intend that the results of our study on remote sensing be discussed at the same conference.

We do not, however, intend to

sit on our hands (in the project sense) until this planning is complete. Rather we have advertised nationally for expressions of interest in conducting feasibility studies of possible industrial opportunities in the priority areas. Studies will be selected which are consistent with, and support, the overall strategy and its priorities.

However, any future proposal arising out of these studies which is put to the government for funding will have to be firmly based on facilitating achievable and realistic industrial opportunities. It is the Space Board's view that, until the funds available to the space program are adequate for a balanced set of activities, program funds will be restricted to supporting projects where there is likely to be a practical outcome and net

economic benefit, preferably in the near future.

The industrial benefits which the strategy is expected to generate are based on proposals which focus on Australian comparative advantages, or the opportunity to develop such advantages.

The strategy is also aimed at combining a need in government for new technology with industry's need for world class products. It is an approach which has served other countries well. Canada, for example, has fused meeting national needs with space industry development. That is, they have largely spent their money on products which Canada needed and which also lead to the kind of industrial benefits they have in mind.

Obviously it is our intention to ensure the maximum possible

Comment

Australian industry participation in systems, equipment and components involved in both space and ground segments. To this end we are encouraging the formation of strategic alliances with overseas companies and organisations, both in the early stages of space programs and in their later commercialisation.

International linkages are particularly important, we believe, to our success in this most international of industries. For this reason the Space Office is working to open up opportunities through strengthening existing linkages, such as those with NASA and ESA, and with our friends in Canada and Japan. At the same time we are opening up new relationships of potential value, for example with Sweden, the USSR, China and the European community. Shortly we hope to open dialogue with one or two other countries. In this connection I draw attention to the report of the recent mission to the USSR under the Australian-

USSR Space Research Co-operation Agreement, which I had the pleasure to lead. The report, which is available from my Office, lists around twenty opportunities for research co-operation with the Soviets.

At this point, I want to outline one of the projects managed by the Space Office as an illustration of the comprehensive nature of the program. This concerns the European ERS-1 Mission: Australian participation in the ERS-1 program is probably the best example of the changes that have occurred in our participation in space R & D.

One of the instruments on ERS-1, the Along Track Scanning Radiometer (ATSR) has been developed with very substantial contributions from Australia. The spacecraft's Digital Electronics Unit, which provides control and timing to the ATSR, was designed and manufactured in Australia and was recently delivered to the UK for integration into the ATSR instrument package.

The satellite ground station at Alice Springs is being modified so that we have access to the advanced imagery to come from ERS-1, and develop our own applications. Mission-specific data processing equipment for the upgrade is being developed by Australian industry. The major part of this is the development of a high speed image processing computer which will reduce the time taken to process

'What directions are we heading in, and what is the plan?'

synthetic aperture radar data by ninety per cent; it will take ten minutes to process one minute of data instead of one hundred minutes as required by current state-of-the art equipment. The commercial prospects of this product are, we understand, considerable and the FDP is a good example of combining the national need with the development of high technology products.

In addition, we are negotiating an access agreement with ESA; we hope that it will allow access to data for both the ACRES site at Alice Springs and for the facility being built at Hobart.

Finally, some 23 Australian proposals have been accepted by ESA under the research program of ERS-1.

Australia's geographic location and characteristics have advantages for tracking, scientific ballooning and sounding rocket campaigns. Our experience in these areas over a number of years enhances our attractiveness as a location for such experiments.

We have already made some progress in seeking to create commercial opportunities from our space science program. The European Space Agency has invited Australia (as well as Japan and the US) to make a proposal to provide at our cost a second ground station for the 1993 Infrared Space observatory mission, in exchange for scientific participation in the mission. The invitation is very welcome. It suits

our thinking on trying to develop an Australian tracking industry, and has a price tag which is, we believe, within our capacity. For the scientists, it offers an appropriate, low cost entry into a succession of exciting space science missions. We have made a positive response to ESA, and are working with the science and industry communities to define details of our proposal, with commitments from all three parties (including my Office).

Speaking of commercial opportunities, it is perhaps appropriate to record one or two of the achievements of Australia's investment to date. Perhaps best known are achievements from the ground, for example, making advanced use of meteorological satellite data for long range weather forecasting. More spectacularly, the use of remote sensing imagery for major mineral discoveries needs to be highlighted.

In the space sector our achievements are more recent. As a result of National Space Program Investments, several of our companies now have the skills and facilities to design and build hardware to the very exacting standards required for space flight. When Aussat purchased its first three satellites, the Australian content was of the order of \$1 million, in wiring harness. The current order, for two spacecraft, will produce \$32 million of Australian content, and we believe there are prospects for follow-on orders for the components involved.

Cape York

The proposal to establish a spaceport on Cape York in north east Australia is one of our most exciting possibilities for the future. It reflects the new Australian awareness of the opportunities and potential of space. The development would provide a major technical and scientific stimulus for Australia and would also create substantial commercial opportunities for Australian industry.

A spaceport on Cape York offers a number of natural advantages over most existing and proposed operational sites in the world:

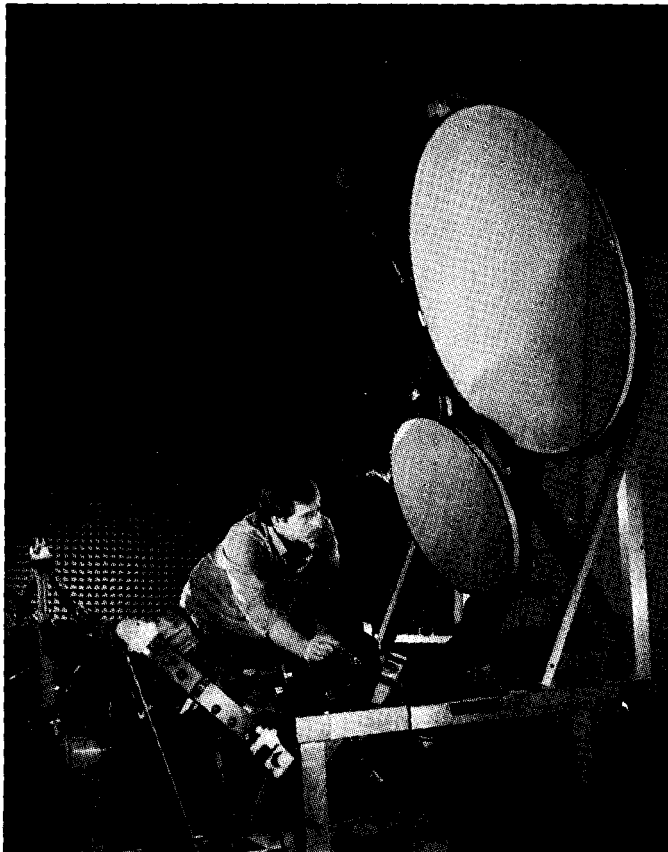

The Aussat satellites were built by Hughes in California. More work will come to Australian industry for the second generation.

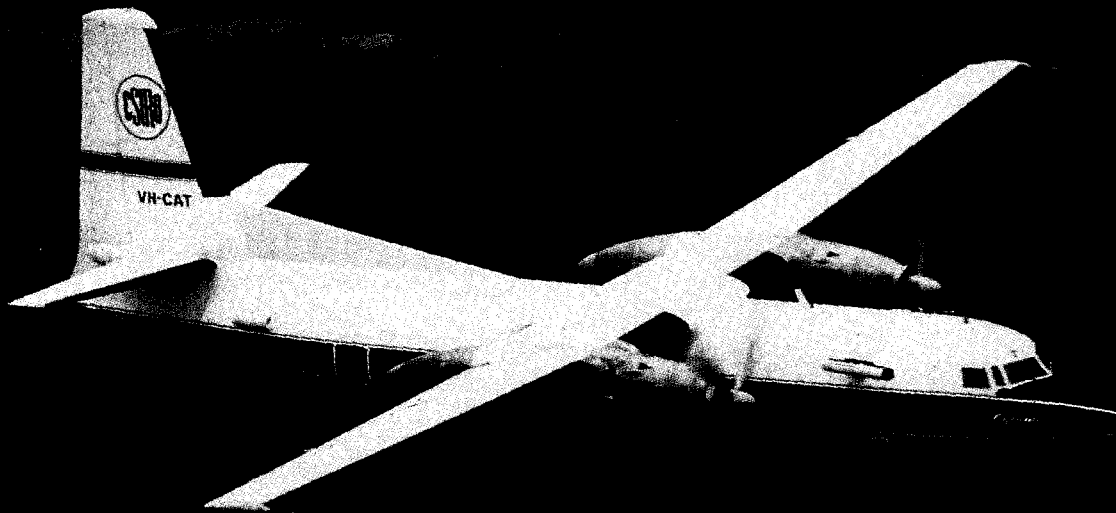

A lot of Australian remote sensing technology is born in COSSA's F27 aircraft, here shown flying with an equivalent NASA aircraft.

- Cape York's proximity to the equator (only 12° south) allows equatorial launches into geostationary orbit to be achieved with heavier payloads for a given booster size; and

- Australia is politically stable and provides a very suitable technical, industrial and commercial environment.

The Australian government supports the concept of a commercial spaceport on Cape York and has developed a co-ordinated approach to the project with the Queensland State Government and with interested consortia.

Currently, two consortia (Cape York Space Agency Pty Ltd and the Australian Spaceport Group) are undertaking feasibility studies and the Australian and Queensland governments are

assisting the consortia to address and resolve the major issues so that the viability of the spaceport can be determined as early as possible.

These studies have reached an interesting and promising point. Both have now resulted in Phase 1 reports which, I am pleased to report, were furnished to the two governments within the last few days. While the concepts pursued by the two consortia are different, their initial conclusions are in both cases based on thorough professional examination of technical aspects, an innovative approach to design (especially in cost reduction), and initial consultations with potential users. Perhaps the most encouraging outcome is that both consortia are themselves sufficiently encouraged to be prepared to make further

investments in progressing their studies through to the next, more detailed, stage.

This program fits very well with the objectives of Australia's space program - that is, to develop space related industries based on our natural or competitive advantages.

Conclusion

Australia's space program is modest by the standards of the major space nations. However, it benefits from the defined national goals set out in the government's space policy and from the strategy being developed. These will focus the activities conducted under the program so that its effectiveness is maximised, and ensure that we are utilising our natural and competitive advantages.

The Australian space program has already substantially improved our ability to participate in space projects. In looking to the 1990s, we will be building on:

- achievements to date;
- our comparative advantages; and
- international collaboration to develop selectively a carefully balanced, well-targeted program. Both the Space Board and my office look forward to working with Australian companies and our space science community in developing our national potential in this important field - a field in which many countries are investing heavily in the future.

Dr Bruce Middleton is executive director of the Australian Space Office.



INNOVATION

A balloon floats because it's lighter than air. It almost seems a paradox that the Skyship 600 and its maximum payload weigh nearly seven tonnes with the envelope deflated. However, aided by 7,000 cubic metres of helium gas, it can be trimmed easily by adjusting ballast to a point of neutral buoyancy, when it just floats in the breeze.

The Skyship 600 is descended from the Skyship 500, the first commercially viable airship operated by Airship Industries in the UK, and one of the first of a new breed of airships that is raising interest in the oldest form of manned flight.

At one stage, just after World War 1, airships were much more successful than fixed wing aeroplanes in carrying large payloads over

long distances. A series of disasters struck during the 1920s and 30s, however, and severely dented the public image of the craft. Even without this, the first generation of airships was doomed, rapidly overtaken by advancing aeroplane technology.

However, the 1980s has seen a resurgence of interest in airships, as the potential of new fabric technologies, plus better methods of controlling helium have become apparent.

Airship Industries, which began as a private venture in the UK, but is today owned by Perth based Bond Corporation, is probably the flagship company of the new movement. It has certainly sold the most balloons. Today, several 500 series craft, plus a number of the 600 series, are operating in the USA and

Airship departing Bankstown Airport on tourist flight.

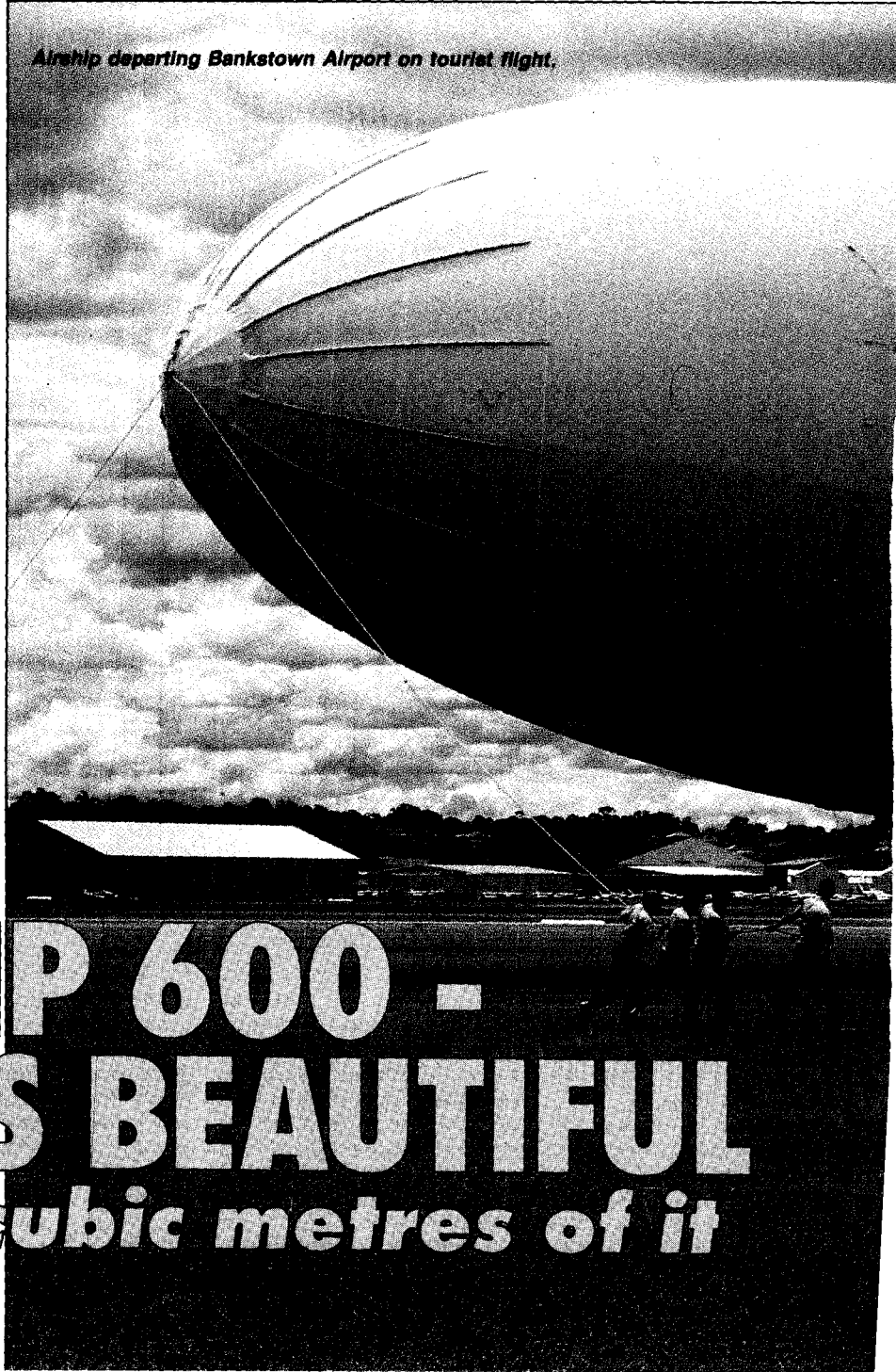

The Skyship 600 is one of a growing breed of very real and practical aircraft. Dave Jeanes went out to Bankstown airport in Sydney recently and gained some 'hands on' experience of this remarkable machine.

**SKYSHIP 600 -
SLOW IS BEAUTIFUL
7,000 cubic metres of it**

Japan. By the end of 1986, Airship Industries 500 and 600 series airships had flown over 11,000 accident free hours. The latest craft brought to Australia, initially for the America's Cup races, has since been used for passenger flights over Sydney and Melbourne as well as spending 6 months this year operating over Expo 88.

The old R-100 and R-101 airship hangars at Cardington in the UK are now the home of Airship Industries. Because of poor flying weather in the UK, most training is carried out at Weeksville in North Carolina, USA. This is the site of the old wartime blimp hangars, and is also only a few miles from Kittyhawk, of Wright Brothers fame.

Airships Pacific Pty. Ltd., the Australian company, hopes to attract training to this

country, with Schofields, west of Sydney, as the likely base.

Skyships

The Skyship 600 is a non-rigid, twin engined airship. The term non-rigid means the envelope does not have a rigid framework to maintain its shape. Almost the whole interior of the envelope is filled with helium, an inert and non-inflammable gas. One cubic metre of pure helium will lift 1.024 kg (in standard conditions at sea level). The helium is maintained at a pressure just slightly greater than atmospheric pressure (i.e.: about 27 mm of water), allowing the envelope to maintain its correct aerodynamic shape.

The pilot must continually make adjust-

ments to maintain correct gas pressure. This is achieved by filling or venting two air bags, called ballonets, located inside the fore and aft sections of the envelope. The ballonets, when filled with air under slight pressure, take up 28% of the envelope space.

As the airship climbs after takeoff, atmospheric pressure decreases, causing the helium to expand inside the envelope. The pilot can provide for this gas expansion by venting air from the ballonets. The maximum safe altitude is reached when the helium expansion has taken up the whole internal space (28%) previously occupied by the air in the ballonets. Further ascent and expansion of the helium may cause distortion or damage to the envelope. Maximum safe altitude varies with conditions, but is



Airship 600

VR-HAN
GENCO

ilot at controls during flight
in Schoonbeek to Bantown
vicinity of



commonly around 3,000 to 4,000ft above sea level.

A second vital role of the ballonets is in adjusting fore and aft trim. Venting air from the forward ballonet increases forward buoyancy and causes a nose up attitude. Venting the rear ballonet provides a tail up, nose down trim. The ballonets are filled by air ducted from the propeller wash, or by electric fans when the engines are operating at low power.

Description

The envelope is constructed of single ply polyester fabric, coated externally with polyurethane which is heavily loaded with titanium dioxide. This coating reflects heat from the sun and limited damage from UV rays. An internal layer of gas-impervious plastic retains the 6,666 cubic metres and \$85,000 worth of helium.

The gondola (cabin) is constructed of lightweight Kevlar, and is attached to the upper parts of the envelope interior by Kevlar cables secured at 13 mounting points. The cruciform tail fins, which carry the flight control surfaces, are laced to the envelope at their roots and supported by guy cables.

The nose cone, strengthened by battens, provides a strong attachment to the mooring mast. With the twin-tyred undercarriage leg free to castor, the airship can withstand winds of up to 80 knots whilst moored. Electrical ground power is fed to the ship via a connection at the masthead.

The trailing edges of the tail fins contain moveable control surfaces, horizontal elevators and vertical rudders. These are operated by the pilots' control wheels which are rotated left and right to turn the airship, and moved fore and aft to descend or ascend. There are no foot operated rudder pedals. Elevator control comes into play at about 23 knots airspeed, and rudder control at about 10 knots.

Aerodynamic lift from the envelope shape becomes apparent at about 20 knots.

The gondola

The two pilot crew sits at the forward end of the gondola, with panoramic views. In front of them is the flight instrument panel and control pedestal. Overhead are electrical switching and circuit breaker panels, plus sets of large levers for controlling air to the ballonets and for helium venting, etc.

The main cabin is spacious with seating for up to 12 passengers, plus a toilet compartment aft. Large picture windows allow breathtaking views outwards and below. The transparent window panels are removed in cruise flight to provide for perfect photography.

Lockers within and under the cabin carry ballast in the form of canvas bags, each bag holding 10 kg of lead shot. These are



Gondola showing entry door, cockpit, engine nacelle and castoring undercarriage wheel.

removed or added during passenger loading to provide a suitable negative buoyancy of about 150 to 200 kg. Additional water ballast (up to 450 kg) is carried in a tank at the rear of the gondola, and this can be jettisoned rapidly to gain extra lift in an emergency.

Also fitted in the rear of the gondola is the fuel tank, which can carry up to 680 litres of petrol, sufficient for more than 10 hours of flight at full cruise power with a fuel burn rate of 40 kg (almost 40 litres) per hour.

Engines

The airship is powered by two Porsche 930 engines. These are six cylinder, horizontally opposed air cooled and turbo charged units, with fuel injection and electronic ignition. Maximum takeoff power for each engine is 255 HP at 5,200 rpm.

Each engine drives a ducted propeller through a composite drive shaft and a 90° gearbox derived from a Westland Lynx helicopter tailrotor assembly. The five-bladed propellers have pitch adjustment from coarse pitch through fine, to reverse pitch.

The large ducting assembly surrounding each propeller improves thrust efficiency and protects ground personnel. The whole propeller/duct arrangement can be swivelled (vectored) around a horizontal axis, from +85° upwards to -110° downwards, to provide the pilot with an effective means of controlling the forward ascent and descent motion of the airship.

The engine ignition is a breakerless capacitor discharge ignition (CDI) system operating from the 28 Vdc supply, and incorporating a Bosch coil and distributor with vacuum advance.

Engine cooling is by way of an axial fan driven by a single V-belt from a crankshaft pulley. Engine lubrication is a dry sump system with oil supplied from a remote tank. A high pressure pump forces oil through the engine reciprocating components, into the sump where a low pressure scavenge pump returns the oil to the external tank via a filter and oil cooler.

Fuel is supplied to the engine by a Bosch K-Jetronic continuous injection system, which is mechanically operated. As the pilot adjusts the throttle lever position, the mixture control unit senses a change in air flow into the

induction tract, and meters an appropriate amount of fuel to the injectors.

Electrical system

Each engine is fitted with an alternator, belt driven from the crankshaft. Rated output of each is 100 amps at 28.5 volts. The output of both alternators can comfortably handle the in-flight loads, and the 43 amp/hour spillproof lead-acid battery merely floats in the line. A regulator, over-voltage sensor, and alternator-fail sensor protect each alternator.

Routine engine starting is accomplished using an external power unit plugged in near the rear of the gondola. During this sequence the alternator fields are isolated. When the engines are running each alternator field is switched in and the output checked on the ammeter and digital voltmeter. Total service load is restricted with the engines running at low speed.

A flexible multi-busbar system distributes 28 volt power to the various services, via main circuit breaker disconnects. The busbars are labelled *Flight, Essential, Aft1, Aft3, General services* and *Emergency*. The arrangement allows the pilot to rapidly shed the electrical load according to a priority system.

Individual component protection and selection is provided by circuit breakers, fuses and toggle switches located in the cockpit's overhead panels. Normal external power for ground operation is supplied through the masthead socket, and this must be available 24 hours a day whilst the airship is moored. A watchkeeper is always in attendance to monitor helium gas pressure.

Avionics

The control panels for the avionics (aviation electronics) equipment are located in a forward console between the pilots. The top unit is the KWX-56 colour weather radar screen, with the actual radar antenna and transceiver fitted inside the top section of the gondola, above the cockpit.

The radar scanner sweeps left and right through the 90 degree forward arc ahead of the aircraft. Return echoes are painted in three colours relating to signal strength - red for strong echoes, then yellow and green for weak echoes.

As the radar is primarily for weather

Airship 600

avoidance, its operating frequency (9.950 GHz) has been selected to give best echo returns from raindrops. Areas of excessive air turbulence are generally associated with heavy rain, and the radar assists in pinpointing these. A secondary role for the radar is for terrain mapping. The radar range scales vary from 0-10 nautical miles through to a maximum of 0-160 nautical miles.

Communication is provided by two VHF transceivers, each with quarter wave ground plane antennas secured to the underside of the envelope just ahead of the cockpit.

Frequency selection is in 25 kHz steps from 118 to 139 MHz and power output is 16 watts (AM).

Two VHF navigation receivers combine with a systems black box to provide VOR (VHF omni range), DME (distance measuring equipment), and ILS (instrument landing system) facilities. A micro-processor in the black box can provide up to 15 waypoints, permitting virtual chart type navigation to be instantly displayed to the pilot as simple 'course to steer' and distance readout information.

A single ADF (automatic direction finder) set is fitted, with a small combination electronic loop and sense antenna almost flush mounted under the gondola. ADF works in the LF/MF band, providing bearings to

aero beacons known as NDBs (Non directional beacons).

An ATC transponder is also fitted, providing a form of 'secondary radar'. The transponder is interrogated by the air traffic control (ATC) ground radar pulses, and it responds by transmitting its own discretely coded reply. Various codes can be selected by the pilot, as directed by ATC. This is called 'squawking', a process which enables the air traffic controller to identify the particular aircraft echo on his screen.

For cross country flights, such as Sydney to Perth, where the airship would be beyond VHF range, an HF/SSB transceiver is fitted. A longwire loop antenna is secured to the underside of the airship and tuned by an automatic antenna tuner.

The future

The Airship 600 is a representative sample of the configuration of a modern airship. But it by no means represents the ambitions of the new generation of airship designers.

Construction is well underway at Weeksville in the US of the huge 5000 series Sentinel model, being produced under a US navy contract. This airship will be 128 metres (423ft) long, have a gross takeoff weight of over 64 tonnes, carry a crew of 10, be powered by two 1625 HP diesel engines, with a 1750 HP

turbo-prop 'Sprint' engine as backup.

The gondola will be double decked, with sleeping, cooking and eating areas. Inside the huge envelope will be housed a variety of radar scanners and communications antennas.

Advantages

The ability of an airship to stay aloft for several days gives it considerable advantages over fixed wing aircraft, even long duration types such as those being considered for AWACs type operation (See ETI, December 1988). Their ability to carry the radar to a reasonable altitude gives them considerable advantage over surface based radars as well.

The only problem for airships in a military role is their vulnerability. Fundamental laws of physics dictate that airships will always be big and slow. However, electronic countermeasures, flares and stealth radar technology may all have a part to play in keeping a military blimp aloft.

Civilian versions are also planned. One proposal on the drawing boards is for a civilian version of the Sentinel. It should be capable of extended flights of several days, while carrying over 100 passengers. One day they may be common sights over such beauty spots as the Great Barrier Reef. **ETI**

DIAMOND

Fibre Optic Connectors in Australia

Swiss excellence, combined with simplicity of design, has enabled DIAMOND to rapidly become one of the World's leading manufacturers of Fibre Optic Connectors. STC-CANNON is proud of providing connectors of the future to the Australian market. A full range of Singlemode and Multimode connectors is available. For further details, contact your nearest Sales Office.

ALCATEL
STC-CANNON

248 Wickham Road Moorabbin, Vic. 3189
☎ (03) 555 1566 Fax: (613) 553 3801 Telex: 30877
Sydney (02) 663 2283 Adelaide (08) 363 0055 Brisbane (07) 832 5511

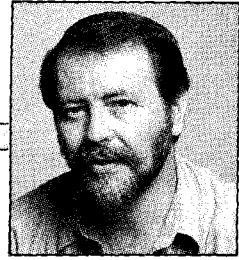

BRIAN WOODWARD

A Melbourne company has come up with a car battery that won't go flat. Brian Woodward reports on the Switch.

The year was 1780. In the culinary capital of Northern Italy, a professor of medicine was lecturing his students while his wife skinned frogs in the kitchen. The frogs weren't supper, but examples used by the professor in his lectures.

Suddenly, Signora Galvani let out a shriek. She had been dismembering the frogs on a zinc plate, and dropped the scalpel. As the circuit of steel scalpel, zinc plate and frog's leg was completed the leg twitched violently. Luigi Galvani repeated his wife's mistake several times to confirm his belief and rushed in to his students shouting, "I have made a great discovery—animal electricity, the primary source of life!"

Of course he was wrong. What he had watched was a potential generated by dissimilar metals causing a current to flow, which in turn caused involuntary convulsion in the frog's muscles. Such was the attraction

of the idea of animal electricity, the 'life force', that he clung to it for the rest of his life.

But experimenting with 'Galvanism' became immensely popular in laboratories across Europe. In fact, Galvani gave his name to many words we use today such as galvanising and galvanometer. We even say that someone was, "galvanised into action"

'I have made a great discovery — animal electricity!'

when they leap as if given an electric shock.

In 1800, another Italian professor, Alessandro Volta discovered that a pile of silver and zinc plates separated by blotting paper soaked in brine would form a battery. In 1801, he swapped expensive silver for cheaper copper, and was immediately summoned to a meeting with Napoleon, who was looking for a military application for this new-fangled electricity.

His Voltaic Pile was subjected to much research, and soon afterwards Sir Humphry Davey displayed an arc lamp when he caused a discharge between two carbon conductors connected to a Voltaic battery. But Volta's batteries soon went flat, and even when George Leclanche moved progress forward to the stage where he developed what we still know as the dry cell, or carbon battery, one problem remained. Chemicals could be arranged to create a battery, but they always went flat. It was one-way electricity.

A different battery

In 1860 Gaston Plante rolled together two strips of lead separated by rubber and

A single unit, or pair, from a Pulsar battery. To increase current capacity, a number of the units can be added in parallel.

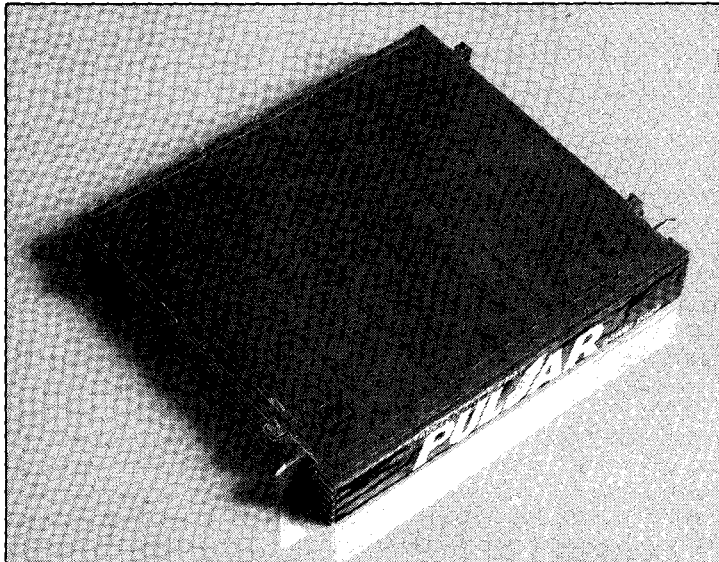

THE NON-FLAT BATTERY

ETI FEBRUARY '89

Non-flat battery

immersed them in sulphuric acid. He not only created a different type of battery, but one which could be recharged. Each cell was found to develop around two volts, and when the motor car came stuttering and smoking into view around the turn of the century, it was natural to use combinations of these two volt cells to store electricity for the starting motor and ignition.

For many years, cost forced the average vehicle to use a battery made from three of the cells, for a six volt system. Reduced costs and greater demands for cranking larger engines finally brought about the six cell, 12 volt, battery. Two problems have remained since the lead acid battery first found application in the motor car.

Firstly, in the nature of the case, if a more powerful battery is needed then larger cells are needed. The voltage output remains the same, but the number of amps which can be discharged in an hour is determined by the size of the cell. The standard unit of the capacity of a lead acid battery is ampere/hours. This means that a battery manufacturer has to have many different sized cells, grids and cases to cover a wide range of needs. Naturally, this has cost implications. Secondly, if the battery went flat, then the car's engine couldn't be started to recharge the battery. Catch 22 of the car battery world.

Gaston Plante's battery remained virtually unchanged, in principle, for 110 years, until Bill McDowall, of Dunlop Batteries in Melbourne, decided to design a car battery from scratch. He decided to cast aside all the old rules and constraints which had been in place since Plante's cells were first developed. After 10 years of research a new battery was ready for the market. It still used the lead/acid reaction for storage, but all other similarities with the Plante cell had gone.

Injection moulded plastic

The Pulsar battery is made from injection moulded plastic frames. The sections of these frames are filled with the active materials, and are separated by high molecular weight polyethylene separators. Each frame consists of three positive and three negative charged sections. Place two frames together with a polyethylene separator between them and you have a low amp/hour 12 volt cell. This cell is called a "pair" by McDowall and to increase the capacity of a battery the number of pairs in parallel is increased. Although the construction materials used in the new Pulsar battery are more expensive than the conventional Plante cell battery, the cost of making a wide range of batteries for different applications is far lower. Need a battery for a motorcycle? Simple. Two pairs should do. Need a big battery for a Kenworth? Easy, slap another 13 pairs onto the bike battery for a huge, gutsy truck battery.

But the word 'huge' is important here, because the Pulsar battery is around 50% of the size of a Plante lead/acid battery of the same capacity. This also means 50% lighter and, in an automotive world where weight is the enemy, any weight saving is valuable. In the field of motor sport, Pulsar batteries, which have a capacity just large enough to start the race engine on the grid if it stalls, have gained popularity faster than anyone would have thought possible.

Also, the Pulsar design is sealed. The electrolyte is added to the battery at manufacture by being injected through tiny holes in the top. These holes are then sealed with a special ptfе (Teflon or polytetrafluoroethylene) film which permits the free flow of air (or hydrogen during charging). One of the active ingredients of the battery is a calcium alloy lead mesh which greatly reduces gassing during recharge. Yet the porous nature of the film is such that the liquid electrolyte will not pass through even if the battery is inverted.

Three tests

There are many academic and laboratory methods for determining the capacity and storage ability of a battery. Three such tests are the three-minute test, the 20 hour test

'A test which could be understood clearly by motorists'

and the reserve capacity test. All three test the amount of energy available over a period of time rather than the practical application of a battery to its duties. When fitted to a car the most important moment is the first second when the first piston is pulled up and over its compression cycle. The next five seconds are also critical as the engine overcomes inertia and starts to spin, but still needs enough power to light up the ignition system.

Typically, a massive 400 amps may be required by a car being started in winter, during the first five seconds. The Pulsar exceeds similar sized competitors in five second tests.

But the real test came outside the laboratory when Dunlop decided to create its own test - one which could be understood clearly by motorists. A Pulsar 10 pair battery (similar to a 60 amp/hour conventional battery) was connected in series to no less than six cars. All six were started simultaneously! The best the 60 amp/hour conventional battery could manage was three cars. Similarly, a seven pair Pulsar battery was able to start four cars simultaneously while a 45 amp/hour conventional battery managed only two.

One of the reasons for this immense

current capacity from the new Pulsar design, is that the current path per cell in a conventional battery is around 150mm while the Pulsar design reduces this to 30mm, greatly reducing internal power losses.

Other laboratory tests were carried out on the Pulsar design; tests such as reserve capacity, life cycle (constant charge/discharge cycling) and charge acceptance. In all cases the Pulsar battery showed improvements over the conventional battery. But the eye opener came with the vibration resistance test. In Pulsar's design it is not possible for the paste to fall down between the grids. As a result the Pulsar's ability to survive immense punishment is unequalled.

The test involved a 10G vibration being applied to the battery at a rate of 50Hz. Under these conditions a conventional battery typically survives less than 30 minutes. The Pulsar remains unaffected even after 40 hours.

Sales failed

But the best news was yet to come. Sales of the Pulsar battery failed to set the world on fire - mainly because it is a premium priced battery. Also, the Pulsar battery can still go flat if a car is parked with the lights on. However, the major benefit of the Pulsar battery - its ability to have capacity increased just by jamming a few extra pairs on the end - was the benefit which led to the Pulsar Switch. This is the battery which won't run flat.

Attached to one end of the conventional Pulsar is a few extra pairs that are isolated from the main battery by diodes. This permits the main battery and the supplementary pairs to be charged by the car's charging system in the normal way. But if the lights are left on, then the supplementary pairs are isolated from the discharge. The main battery discharges but the supplementary pairs don't.

When a driver comes back to a car and finds that turning the ignition key causes nothing but an ill-tempered "Grrrr" from the starter motor, despair is the normal reaction. With the Pulsar Switch the driver merely lifts the bonnet and throws a switch on the side of the battery. The supplementary pairs have enough current to start the car several times. When the engine starts, the car is driven for 20 minutes or so to recharge the main battery (and the supplementary pairs) and then the switch returned to its "safety" position. It is ready to be abused again.

With considerable wisdom, Dunlop Pacific has decided to market the premium priced Pulsar Switch battery at the 4WD and more luxurious end of the Australian market, and to anyone in the USA or the UK who has had a winter flat battery (and that's almost everyone!).

It isn't often that a new product is so new. The Pulsar battery is new.

ETI

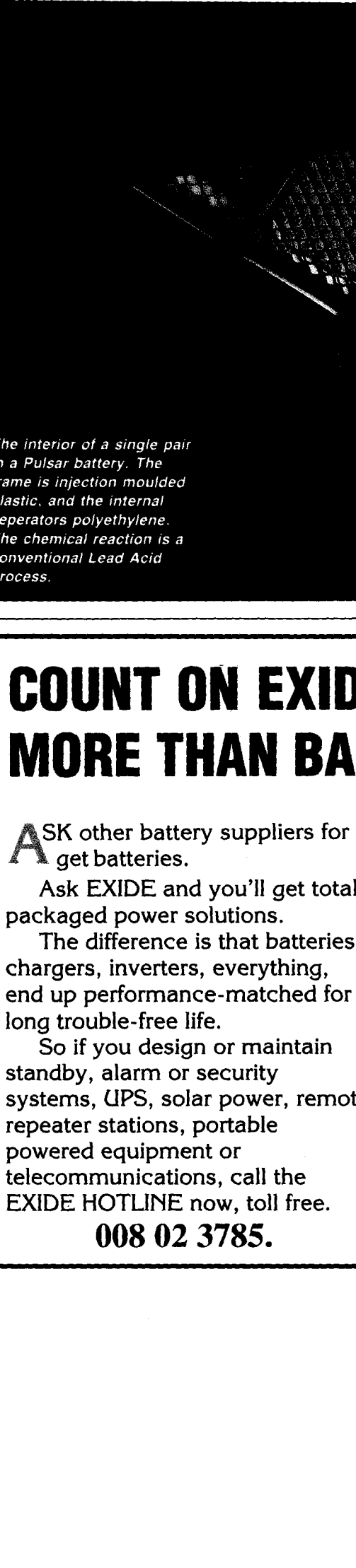

The interior of a single pair in a Pulsar battery. The frame is injection moulded plastic, and the internal separators polyethylene. The chemical reaction is a conventional Lead Acid process.

COUNT ON EXIDE FOR MORE THAN BATTERIES

ASK other battery suppliers for batteries and you'll get batteries.

Ask EXIDE and you'll get total packaged power solutions.

The difference is that batteries, chargers, inverters, everything, end up performance-matched for a long trouble-free life.

So if you design or maintain standby, alarm or security systems, UPS, solar power, remote repeater stations, portable powered equipment or telecommunications, call the EXIDE HOTLINE now, toll free.

008 02 3785.



PACIFIC DUNLOP BATTERIES

Industrial Division

Home of Exide packaged power.

MONITORING THE FLOW

A Sydney company has built a new system to monitor and control large networks of any type. Peter Hayes reports.

In Sydney's Alexandria, Leeds and Northrup has developed, designed and currently manufacture a SCADA (Supervisory Control And Data Acquisition) system which has enjoyed sales of \$40 million outside of Australia. The LN-2068 consists of any number of computers or data loggers on a high speed network, with each station performing part or parts of the SCADA responsibilities. Together, the whole system works to provide control of a network as well as get information from it.

SCADA systems are typically used in large, distributed networks, such as electrical generation and distribution, gas and oil distribution, mining, water distribution, nuclear reactors, and so on. To use an exotic example, on a 1,400 kilometre gas pipeline from the Amadeus Basin to Darwin, the temperature, the flow and the pressure of the gas are monitored using a number of solar powered remote stations. The information is relayed to an operator via a Telecom microwave link where action may be taken to correct most faults or simply

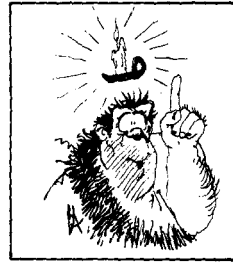

INNOVATION

Above: the LN-2068 circuit board.





A board is tested using automatic test equipment.

optimise performance.

The LN-2068 uses distributed architecture, which has long been popular in industrial control systems, but has been adapted to a SCADA system for the first time. Previously, a SCADA system has a central large computer, and a back-up mechanism. The larger the system, the more complex and unreliable it became. The LN-2068 system has a master station that uses a high speed

data highway on a local area network to remote sensing stations.

The master station includes five sections.

- A communications station which manages all data transmission from remote stations, checking the status of each one at regular intervals, usually from one to 60 seconds.
- An operator station which interfaces the operator to the system. It includes operator panels and CRT displays. It gets dynamic data via requests to the data highway.
- A logging station which provides long and short term data storage and retrieval.
- A local input/output station which adds local analogue and digital inputs and outputs for system wall diagrams or local plant supervision.
- A host computer interface which provides a convenient interface to one or more computers.

The host computers gather and affect data from remote stations. The most modern of Leeds and Northrup remote stations uses the familiar Motorola 68000 processor and a multi-processing bus. The LN-2608 system uses time division multiplexing over voice frequency circuits to acquire data from and to carry out control functions at these remote stations.

Leeds and Northrup is currently developing software, and manufacturing six interconnected LN-2068 systems, for the Snowy Mountains Hydro Electric Authority. Apart from the fact that the existing equipment in the Snowy Mountains is at the final phase of its operational life, the new system is expected to achieve savings to the

order of one million dollars per year through more effective utilisation of water. The contract includes supply of two DEC VAX8500 computers. This system is specified to be able to handle 100,000 data points, to be able to make a scan every second and be at least 99.7% reliable under continuous operation.

While some aspects of the LN-2068 design are innovative, the general emphasis is on international standards. The highway is based on an IEEE standard 802.4 local area network. Each station consists of a VME file of Eurocard format boards. The PC boards are plated through whole and multilayered.

'The host computers gather data from remote stations.'

Quality control at all stages includes use of an automatic PC board test system, the bench-top Marconi Checkmate. The Checkmate holds the board to be tested to its pinface by partial vacuum. Each type of board has a test routine computer program which can be created readily by a technician. Practically any type of digital or analogue test from in-circuit to logic and waveform analysis can be performed. The Checkmate is also used to check incoming goods.

The LN-2068 has created world-wide interest. Twenty five systems are already in use outside Australia. Independent LN-2068 users' groups meet to discuss applications, and exchange ideas in the USA (where the system is known as the LN-700), New Zealand and China. **eti**



Left: an LN-2068 is used by the State Electricity Commission of Victoria.

ROD IRVING ELECTRONICS



**RITRON
VGA COLOUR MONITOR**
Quality monitors without the exorbitant price tag!
Display Tube: 14 inch 90° deflection P22 Non-glare, tint. 0.31mm Dot pitch,
Active Display Area: 245 x 185mm
Resolution: 800 dots(H) x 600 lines(V)
Display Colour: TTL input
TTL input: 8/16/64 colours
Analog input: unlimited colours
..... only \$945

PRINTER LEAD
• Suits IBM® PC/XT, compatibles
• 25 pin "D" plug (computer end) to Centronics 36 pin plug
P19029 (1.8 metres) \$14.95
P19030 (3 metres) ... \$19.95
P19032 (9.5 metres) . \$39.95



ROD IRVING ELECTRONICS

SYDNEY: 74 Parramatta Rd. Stanmore, 2048.
Phone (02) 519 3134
Fax (02) 519 3868

MELBOURNE: 48 A Beckett St.
Phone (03) 663 6151

NORTHCOTE: 425 High St.
Phone (03) 489 8866

CLAYTON: 56 Renver Rd.
Phone (03) 543 7877

MAIL ORDER & CORRESPONDENCE:
P.O. Box 620, CLAYTON 3168
Order Hotline: 008 335757
(Toll free, strictly orders only)
Inquiries: (03) 543 7877
Telex: AA 151938
Fax: (03) 543 2648



**ORDER HOTLINE
008 335757
(TOLL FREE)**

STRICTLY ORDERS ONLY

LOCAL ORDERS & INQUIRIES
(03) 543 7877

POSTAGE RATES:
\$1 - \$9.99 \$2.00
\$10 - \$24.99 \$3.00
\$25 - \$49.99 \$4.00
\$50 - \$99.99 \$5.00
\$100 plus \$7.50

The above postage rates are for basic postage only. Road Freight, bulky and fragile items will be charged at different rates.

All sales tax exempt orders and wholesale inquiries to:
RITRONICS WHOLESALE,
56 Renver Road, Clayton.
Phone: (03) 543 2166 (3 lines)
Fax: (03) 543 2648

Errors and omissions excepted. Prices and specifications subject to change.

IBM®, PC®, XT®, AT® are registered trademarks of International Business Machines. Apple is a registered trademark. Denotes registered trademarks of their respective owners.

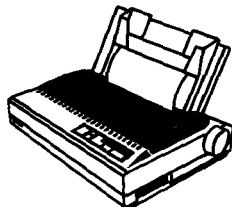

STAR NX1000 PRINTER
• 144 c.p.s. high speed draft printing
• 36 c.p.s. NLQ printing
• 8 built-in NLQ fonts
• Proportional printing available in all font styles
• Convenient push button control panel
• Paper parking mechanism
• Tractor and friction feeds standard
• Standard parallel interface
• Two emulation modes:
IBM Proprinter II, EPSON ESC/P
C22049 \$495



20 M/BYTE HARD DISK
Drive with controller card. IBM® compatible. 12 month warranty.
X20010 ONLY \$449

42 M/BYTE HARD DISK
IBM® compatible. 50 M/Byte unformatted. 12 month warranty.
Without controller .. \$595
With controller \$695

80 M/BYTE HARD DISK
IBM® compatible. 12 month warranty
X20030 Please call

50 M/BYTE VOICE COIL HARD DISK
Capacity: 50.5 M/Byte unformatted
Access Time:
Track to track: 6 ms
Average 28 ms
Full span 52 ms
Size: 146(W) x 41(H) x 203(D)
C20008 \$1,100

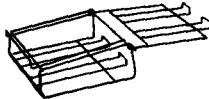

PRINTER STANDS
• Restores order to your work area.
• Conveniently stacks paper printout in document tray automatically
• Made of black plastic coated steel
• Suitable for most printers
• Excellent value at this price!
C21056 \$29.95

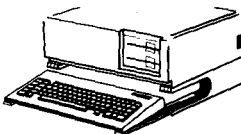

KEYBOARD SLIDE-AWAY
Slide your keyboard neatly away when not in use. Gives you more desk space. Securely holds any keyboard, wide or narrow.
C21083 Only \$64.95



KEYBOARD STORAGE DRAWER
Stores keyboard under the PC or monitor conveniently out of the way. Fits PC/AT keyboard or 234"(H) x 22 1/4"(W) x 9 1/2"(D)
C21081 (YU-E21B) \$84.95

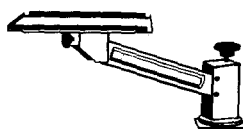

MONITOR MOVER ARM
Position your monitor exactly where you want it! Place your monitor in an ideal working position, or out of your way when you're not using it. Maximise desk space!
• Solid steel structure
• Height adjustment by knob (3cm - 27cm)
• Span 33cm
• Tray 30cm (tilting + -15°)
• Desk clamp range 3cm - 7.5cm
• Maximum load 50kg
C21079 \$159



DATALIFE DL-600 DATA CARTRIDGE
C12614 \$99.95

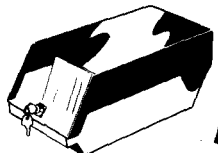

5 1/4" DISK STORAGE (DD100-L)
Efficient and practical. Protect your disks from being damaged or lost!
Features...
• 100 x 5 1/4" disk capacity
• Smoked plastic hinged lid
• Lockable (2 keys supplied)
• High impact ABS plastic base.
• Contemporary design
C16020 only \$15.95



3 1/2" DISK STORAGE (DD80-L)
• Holds up to 80 x 3 1/2" diskettes.
• Smoked plastic hinged lid
• Lockable (2 keys supplied)
• High impact plastic base
• Contemporary design
C16038 only \$19.95

3 1/2" DISK STORAGE
• Holds up to 40 x 3 1/2" diskettes.
• Lockable (2 keys supplied)
• High impact plastic lid and base
C16035 only \$14.95

KEYBOARD EXTENSION LEAD
P19038 \$6.95

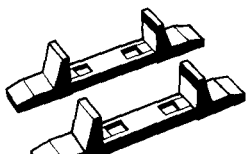

2 PIECE, VERTICAL COMPUTER STAND
SAVE VALUABLE DESK SPACE BY PLACING YOUR PC ON ITS SIDE ON THE GROUND!
• Adjustable width from 119-225mm
• Accommodates IBM® PC/XT/AT and most compatibles
• Stable 2-piece design
C21077 \$24.95

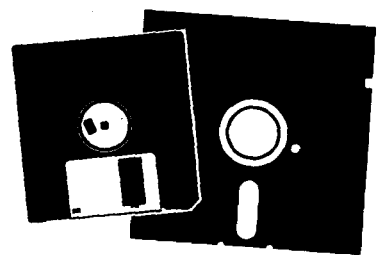

"NO BRAND" DISKS!

Now you can buy absolute top quality disks that are also the cheapest in Australia! They even come with a lifetime warranty, which indicates the quality of these disks. So why pay 2-3 times the price for the same quality?

Packs of 10, D/S D/D without boxes, or brand name, just their white paper jacket, and index labels. (5 1/4" disks includes write protects).

5 1/4" 2S/2D "NO BRAND" DISKS
10+ DISKS \$6.95^{ea}
100+ DISKS \$6.75^{ea}
1,000+ DISKS \$6.50^{ea}
(ALL PRICES PER 10 DISKS)

5 1/4" HIGH DENSITY DISKS (DOUBLE SIDED)
10+ DISKS \$21^{ea}
100+ DISKS \$20^{ea}
1,000+ DISKS \$19^{ea}
(ALL PRICES PER 10 DISKS)

3 1/2" 2S/2D "NO BRAND" DISKS
Suitable for IBM, PS/2, Macintosh, Atari, etc.
\$21
(ALL PRICES PER 10 DISKS)

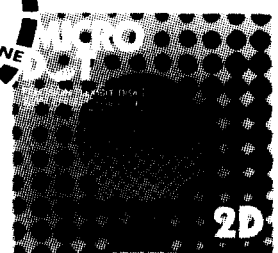

MICRODOT DISKS!

DESCRIPTION	1-9 BOXES	10+ BOXES
3 1/2" 2S/2D	\$23.95	\$22.95
5 1/4" 2S/2D	\$11.95	\$10.95
5 1/4" 2S/HD	\$21.00	\$20.00

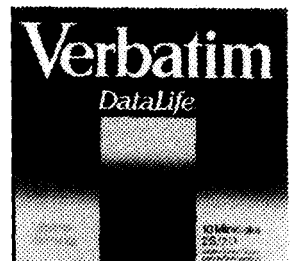

VERBATIM DISKS!

(ALL PRICES PER BOX OF 10 DISKS)

DESCRIPTION	1-9 BOXES	10+ BOXES
3 1/2" 1S/2D	\$39.95	\$37.95
3 1/2" 2S/2D	\$46.95	\$43.95
3 1/2" 2S/HD	\$99.00	\$89.00
5 1/4" 1S/2D	\$22.00	\$21.00
5 1/4" 2S/2D	\$26.00	\$24.00
5 1/4" 2S/4D	\$75.00	\$70.00
5 1/4" 2S/HD	\$41.00	\$39.00



PAUL BUDDÉ

SEA RESCUES AT ALICE SPRINGS

Government's \$1.4m to those in peril

Victims endangered at sea will soon have a better chance of rescue with Australia's participation in the Global Maritime Distress Safety System. Paul Budde reports.

The system GMDSS, was ratified by an international conference on Safety of Life at Sea (SOLAS) held in London in November. It will come into force on February 1, 1992. There will be a transition period of seven years during which time all ships over 300 gross tons will be fitted with equipment to use the new service.

GMDSS will replace the present monitoring of international distress frequencies by coastal radio stations with a network of polar orbiting COPAS/SARSAT communications satellites able to relay positional and other

information about ships in distress to ground stations on shore. This information will then be immediately relayed to the appropriate search and rescue facility.

The Federal Government has committed \$1.4m to the installation of a local user terminal (LUT) over the next 12 months. Located in Alice Springs, it will pick up signals sent from emergency position indicating radio beacons (EPIRB) via satellite. This information will then be relayed to regional rescue centres via the Federal Sea Safety Centre in Canberra.

EPIRBs are carried on small vessels and are required by law to be fitted to life rafts. They are also fitted to aircraft so the aircraft can be located if it crash lands.

The present EPIRB monitoring system relies on commercial aircraft on scheduled flights to make the initial detection. A search aircraft must then overfly the area to precisely locate the beacon.

According to the Department of Transport and Communications, the LUT will need an estimated \$3.5m annually in search costs alone. It will also lead to a higher recovery rate for missing mariners.

Around the world

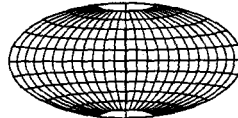

Turbo-Comms expands

A Sydney based computer dealer, ABC Computers, is hoping to break into international markets with its own PC

communications software Turbo-Comms.

Turbo-Comms is a memory resident, multitasking communications software designed for file transfer and remote support of PCs. The company is currently in negotiation with Olivetti and Toshiba and hopes that one or both of these companies will market Turbo-Comms overseas, by bundling Turbo-Comms with their respective PCs as part of their offsets obligations. This could generate many millions of dollars in export earnings, according to ABC Computers.

The product provides terminal emulation for DEC VT100 and VT220 terminals and other emulations are under development. Turbo-Comms uses a proprietary error correcting protocol. It can be activated with a single key stroke and can operate in background to other PC applications.

The product originated to provide remote support for PC software developed by ABC computers for an associated company, Yellow Express couriers. Since then, the company has successfully sold Turbo-Comms to a number of large organisations for remote support of personal computers. Users include the NSW Education Department, BHP, CSR and the NSW State Rail Authority. The State Bank of NSW recently purchased 100 copies to support in-house developed PC software in its branches throughout the state.

ABC Computers recently launched Turbo-Comms as a standalone communications package on the Australian market. It will sell for \$384 retail, including tax.



Life at sea will be just a little safer due to GMDSS.

Paul Budde specialises in the marketing and management of electronic services and communication networks.



TECHNOLOGY

It seems an extraordinary fact that possibly Australia's greatest genius is a person few people have heard of. He lived and died in Victoria inventing such things as an ornithopter, the Gram dynamo, a telephone, a storage battery, a pump used by the Edison Company and a crude form of television. Yet he died in 1912, intestate, and is today largely unknown.

His father had the brilliant idea of manufacturing a concertina made out of leather and wood, which he played on the goldfields at Ballarat. He never struck gold, but the concertina caught on, and the demand in Ballarat for musical instruments

grew. Richard Henry Sutton became prosperous in his music warehouse on the Main Road.

In fact, he shipped in drayloads of musical instruments and made his fortune. His company was still in business a hundred years later.

His son, Henry, was born on 3rd September 1856. He was shy and modest, but possessed a remarkable genius which was soon apparent. By the age of 11 he had left school because he had exhausted all its possibilities. He did a postgraduate's course in the library of the Mechanic's Institute in Ballarat.

His inventive streak began to show. At age 14, he invented an ornithopter. This heavier-than-air craft levitated and flew in a circle with flapping wings powered by a clockwork motor. News of it reached the Royal Aeronautical Society in England, and he was asked to write a paper for them on the subject. It was 70 pages in length – a remarkable feat for a 14 year old boy.

Valuable lessons

This was almost fifty years before Kittyhawk, and twenty years before Hargrave was experimenting with gliders in New South

THE BALLARAT TELEVISION

The booming gold town of Ballarat played host to more than brawling miners in the last century. Journalist Angie Testa uncovered evidence of genius as well.

The inventive genius of Henry Sutton

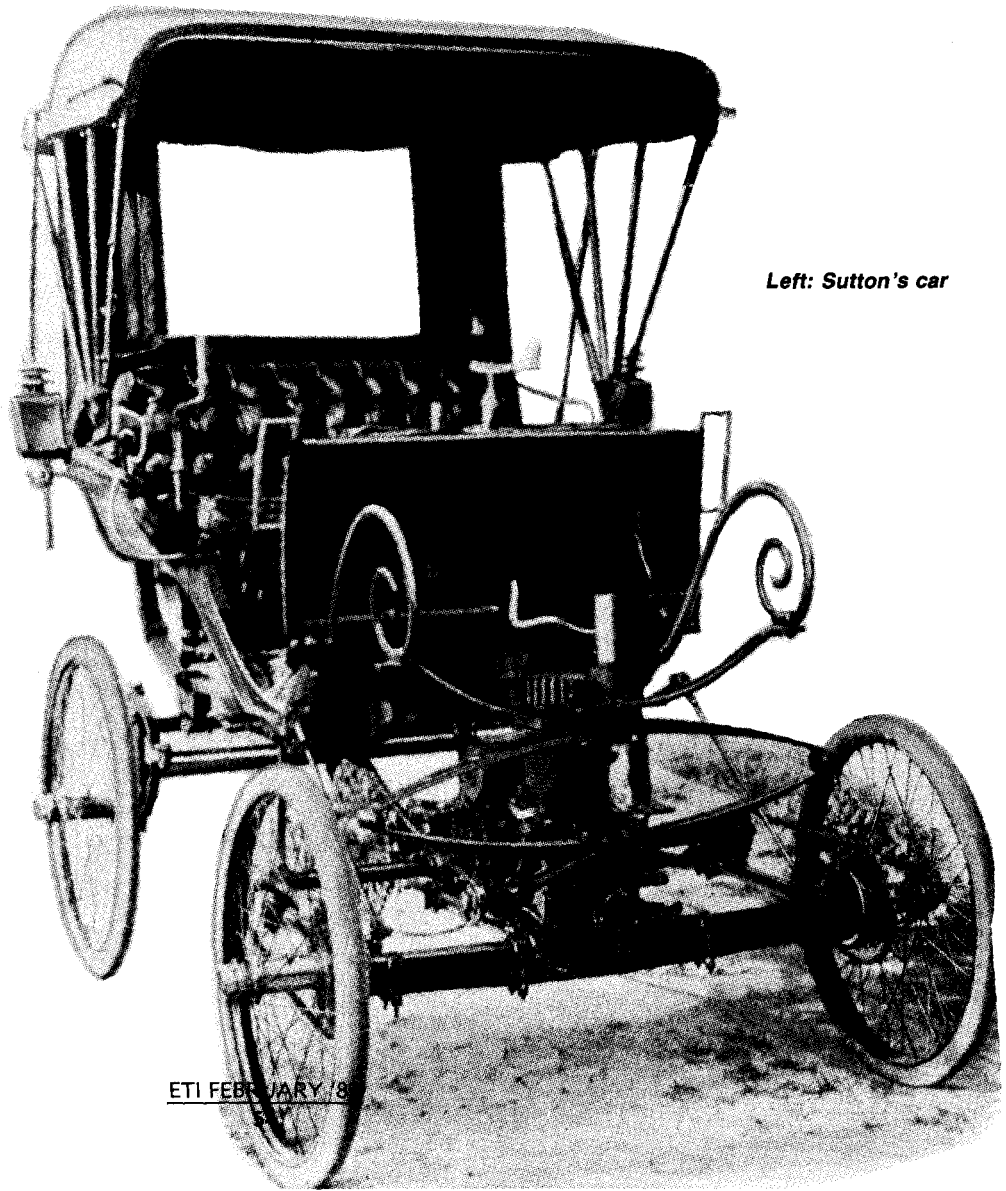

Left: Sutton's car

ETI FEBRUARY '88

Wales. Although the ornithopter was a dead end, it taught inventors some valuable lessons about how not to create a flying machine.

Within the year he had jumped from aeronautics to electronics. He was 19 when he first learned of Bell's invention of the telephone, and promptly set about building one. In fact, within a year he had built 24 telephones, all operating on different principles. He didn't see any point in reinventing anything. But he wasn't totally impractical. He linked the Sutton's Music Warehouse with the main store by telephone, so becoming the first owner of a commercial communications system.

However, his practicality didn't extend to his science. Like many of his contemporaries, he strongly believed in the freedom of knowledge. He did not trouble with taking out patents on his inventions, preferring rather to benefit science with his gift. Later, sixteen of his telephones were patented by other people.

According to his friend, W.B. Withers, Henry Sutton designed an electric continuous current dynamo with a practical armature as early as 1870.

The Italian, Pacinatti, had invented a dynamo in 1860, as a means of converting rotating mechanical energy into electrical energy. Improvements to the basic design were not long in coming. The Belgian E.T. Gramme is generally credited with the first moves leading to the modern dynamo. Coincidentally, perhaps, his design was exactly the same as Sutton's.

From there, it was but a short step to the electric light. Shortly after Thomas Edison's carbon lamp was announced on 21st December 1879, Sutton had one almost identical. It would have been impossible for him to copy the Edison lamp in the isolation of Ballarat.

Perhaps his only flop was a torpedo. It only went 25 yards before it ran out of power. Inspired by this lack of success, he focused his energy on storage batteries. In 1880, he invented a lead storage battery based on copper sulphate, which changed colour when charged.

It was his philosophy that 'eight hours' work won't lift a man in this world' so he invariably worked right through the night. Always by invitation, Sutton contributed papers to learned societies in Australia and overseas on such topics as electricity, colour photography and the process of engraving by the aid of photography. He wrote a paper on his electric storage battery which received acclaim when read before the Royal Society of London in 1881.

Explosion engines

He only ever took out two patents in Victoria. In 1886, he took out one for 'improvement in electric circuits for telephonic purposes' and in the following year for 'An improved process of converting a photographic image

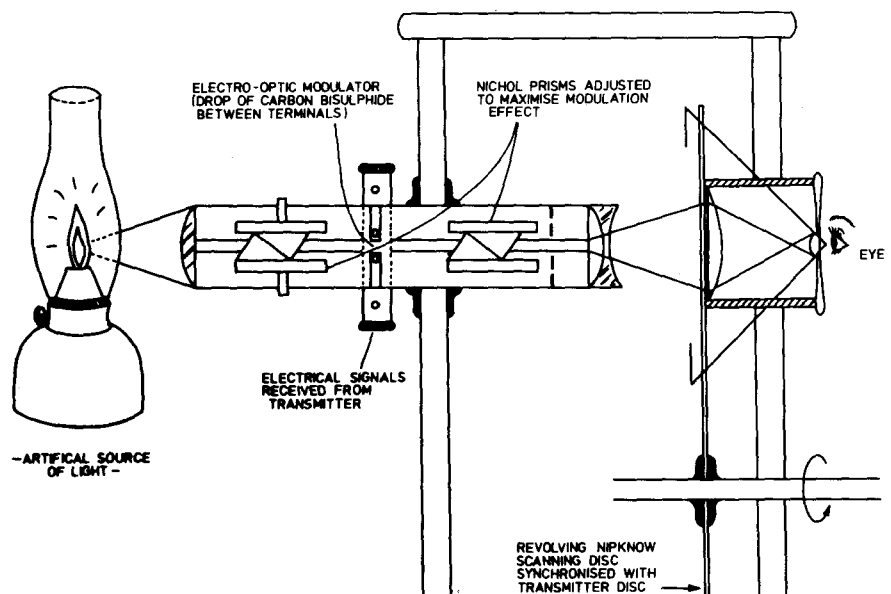

Above: Schematic diagram of the earliest TV. The light source at left shines through the prism onto an electro-optic modulator which receives signals from the transmitter. The modulated light shines on the second prism, through a revolving disc out to the observer. The disc spins in sync with the transmitter. The prisms enhance the modulation effect of the electro-optic modulator — effectively a drop of carbon bisulphate between two terminals. Apparently it worked, but it's hardly broadcast quality.

on a gelatine surface into a relief or intaglio printing surface...' In New South Wales the records also reveal two patents for explosion engines and 'Intaglio... photo printing'.

In July 1882, his mercury air pump was recommended for the manufacture of lamp bulbs, and a vacuum pump worked by a water jet was presented to the Ballarat School of Mines for use in chemistry classes.

In 1885 he invented what was to be in many ways his 'piece de resistance' — a television set. It wasn't quite the kind that we are used to in the 1980s but remarkable for its time. It was invented with the purpose of allowing the people of Ballarat to see the Melbourne Cup. It operated using a Kerr cell. A Kerr cell is a method of controlling light by means of

'His father made a concertina out of leather and wood'

an electric field. Liquid in a Kerr cell will rotate the plane of polarisation of polarised light according to the electric field across the liquid.

Sutton arranged things so that he could scan an image with a contraption called a Nipkon disc. Light would fall onto a selenium cell, where it would modulate a current. This was used to drive the receiver, or more accurately, the Kerr cell. Using polarised light, the Kerr cell could be used to increase or decrease the strength of a light beam. In this way, an image could be built up.

Of course, it was hardly an image as we would understand it. Nevertheless, it was the first step on the way, and the citizens got to see the race.

He invented a printing process for making photographic blocks and in the early part of the 1900s built a portable radio with a range of 50 yards.

Automotive enthusiast

He was also, predictably, one of the first automotive enthusiasts. He made Australia's first car. He began the RACV at a meeting of 55 motorists held at the Port Phillip Club Hotel, Melbourne, on 9th December 1903. A motion was moved to form the Automobile Club of Victoria by Henry Sutton and seconded by Thomas Rand. He also made Australia's first lift. His mother had become slightly invalid and had to go up three floors to the 'grand house' at the top of Sutton's music store.

Of his private life we know little. Among his other activities he found time to give lectures at the Ballarat School of Mines where he taught electricity and applied magnetism from 1883 to 1887.

At the age of 25 he married Elizabeth Wyatt at Ballarat. At the age of 46 he married Annie May Patti at Malvern. On 28th July 1912, he died of heart failure and chronic nephritis and was buried at Brighton cemetery. He was survived by his second wife and their two sons and two of the three sons of his first marriage.

Amazingly, he died intestate although he left property worth £9984. Today he is acknowledged as one of Australia's greatest geniuses, perhaps even the greatest, although his name is not as well known as that of Edison, Bell and his other contemporaries. However, he might not have enjoyed fame. He was a shy, retiring person. His aim was always to 'benefit fellow workers in science'. He certainly achieved this much.



ARTHUR CUSHEN

ENGLISH LESSONS FOR CHINA

Radio Canada using Japan's facilities

A 40-week English course produced by Radio Canada International will reach a potential 100 million Chinese.

Recently, Radio Canada began using Radio Japan's facilities to relay their broadcasts into China on shortwave. It has extended this project by the use of mediumwave stations inside China which gives a potential audience of many millions of listeners.

Radio stations in Beijing, Shanghai, Guangzhou and Xian will broadcast 'Everyday English', a 40-week course produced by Radio Canada International at its headquarters in Montreal.

Radio Canada International, the shortwave service of the Canadian Broadcasting

Corporation, is not the first international broadcaster to offer English lessons by radio. However, it is the first to design a course for listeners in a specific country.

BBC, Voice of America and Radio Australia have put together general courses aimed at people anywhere in the world. The Canadian course is significantly different because it is tailor-made for the People's Republic of China. Another major difference is that it will be carried by local radio stations, rather than broadcast by shortwave. The Beijing, Shanghai, Guangzhou and Xian stations have a

combined audience of 100 million people.

The lessons are based on a tour of Canada of three Chinese teachers and throughout the series, subsequent lessons follow as they cross the country, learning about Canada's geography, resources, industries, political and social systems and culture. There will be a total of 120 lessons; three will be broadcast per week, with each lesson repeated four times.

Radio Canada, in its service to the South Pacific, is depending on secondary coverage and there are several transmissions which are well received. English 2200-2300UTC is on 9760, 11945kHz, while through Radio Japan the broadcast is 1200UTC on 15385 and 17710kHz.

There is a news broadcast Monday to Friday, in French and English, carried from the Radio Canada transmitters at Sackville and relayed by the BBC, Daventry 0600-0700UTC. The program includes 15 minutes of news in French at 0600 and 0630 and 15 minutes of English at 0615 and 0645. The frequencies include 6145, 9760, 11840 and 15235kHz, which provide the best reception in the South Pacific of the channels carrying the broadcast.

The session is called 'Shortwave Listeners Digest' and is broadcast on Saturday at 2205UTC, while the earlier transmission to Africa is heard at 2135UTC on 11880, 15150 and 17820kHz.

VOA expansion

The worldwide expansion of Voice of America's shortwave facilities continues, though it will be 1996 before the complete program is operational. The Washington studios are also undergoing major renovations with 19 new studios being fitted for broadcasting.

According to Dr Robert Freeth,

director of engineering & technical operations, the results of the modernisations will take about two years to be observed by the listeners.

The main object is to get the stations closer to the audiences and agreements with several governments have been signed, while effective aerial systems are being installed so that a more controlled signal to the audience will eventuate. There has also been a reduction in the cost of power due to the installation of modern, efficient transmitters.

Some of the projects which have been completed include a mediumwave station in Costa Rica and a mediumwave station with two transmitters in Belize.

An order has been placed with the Marconi Corporation for giant 500kW transmitters for stations which have expanded in Thailand, Morocco, Sri Lanka and Botswana. Progress at these four sites varies: in Morocco the groundwork has been completed; in Botswana the power has been fed to the remote site; in Sri Lanka and Thailand the area has been fenced off. Each construction will cost about \$200m.

Thailand and Antigua will both open in 1993, Botswana in 1995 and Sri Lanka in 1996. A mediumwave station at Grenada will also be opened.

As mediumwave is more popular in the Central American and Caribbean areas, these stations will operate in this band, with broadcasts in English and Spanish.

This item was contributed by Arthur Cushen, 212 Earn St, Invercargill, New Zealand. He would be pleased to supply additional information on medium and shortwave listening. All times are quoted in UTC (GMT) which is 11 hours behind Australian Eastern Daylight Time.



The Radio Canada International transmitting plant, Sackville, New Brunswick.

Sounded insights

NEW PERREAUX AMPLIFIER



ROLAND SURROUND MAGIC

THE MULTI DOCKING SYSTEM



Tuning into FM

Canadian hi-fi products, FM-101 and FM-11 tuners from Magnum Dynalab, are unusual in two respects; Firstly they are FM only tuners and secondly they use analogue technology in this digital era.

Features included on both these tuners, are: a keyed automatic gain control to reduce interference from signals; a noise activated muting system with manual defeat; and an automatic stereo separation circuit sensitive to the strength of the signal. The tuners use a MOSFET front end to provide three stages of amplification followed by a 'group-delay'

ceramic filtering.

The more expensive FT-101 has a switchable wide/narrow IF bandwidth, for greater selectivity in signal-congested areas, and multipath detection circuit. Both

models are available as 19" rack mount units in black or silver.

The FM tuner might have a limited market at present in Australia while the airwaves are brimming with popular AM

broadcasts, but there is a long term intention to shift many of these signals to FM. The tuners are, however, for the purists: they retail at \$1850 for the FT-101 and \$1400 for the FT-11.

READER INFO No. 175



Mini headphones

Arista Electronics has released the ESP-200 mini headphones. They are suitable for use with all digital equipment including CD and DAT, and, of course, analogue equipment.

Features include a samarium cobalt magnetic transducer and 1.25 m high quality shielded cable with a gold right angled plug to make a solid connection.

The individual left and right earpieces of the headphones are, according to Arista, suitable for joggers, aerobic gymnasts, and generally active people.

The headphones fit into a dispenser type protective black carry case which fits neatly into a purse or pocket. RRP is \$39.99. Contact: Arista. ☎ (02) 648 4010.

READER INFO No. 177

Car audio operation easier

Keep your eyes on the road. That's Philips' message with the release of its DC774 car tuner/cassette with remote control and large, easily found, single control for volume, bass, treble, balance and fader functions.

The so-called SOFAC knob permits volume settings to be preset and gradually works up to that volume when the unit is switched on. The remote control, which can be operated from the

back seat, controls mode selection (cassette or radio), programming, volume and autostore.

The unit also, interestingly, is capable of receiving radio data system signals such as station identifications and traffic information that is piggybacked on signals in Europe but has not been introduced in Australia (see E T I, July 1988 SI p6). The DC 774 sells for \$949 RRP.

READER INFO No. 176

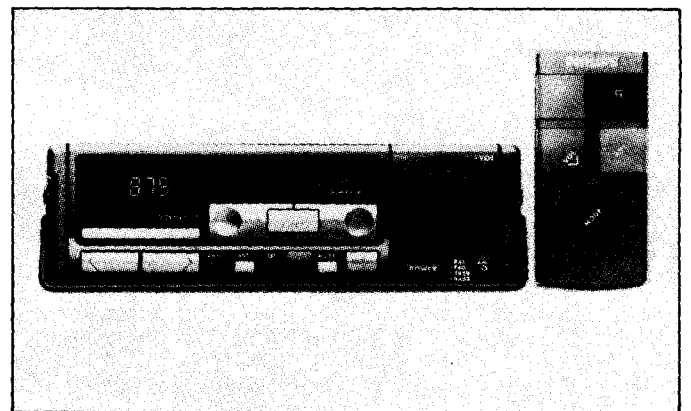

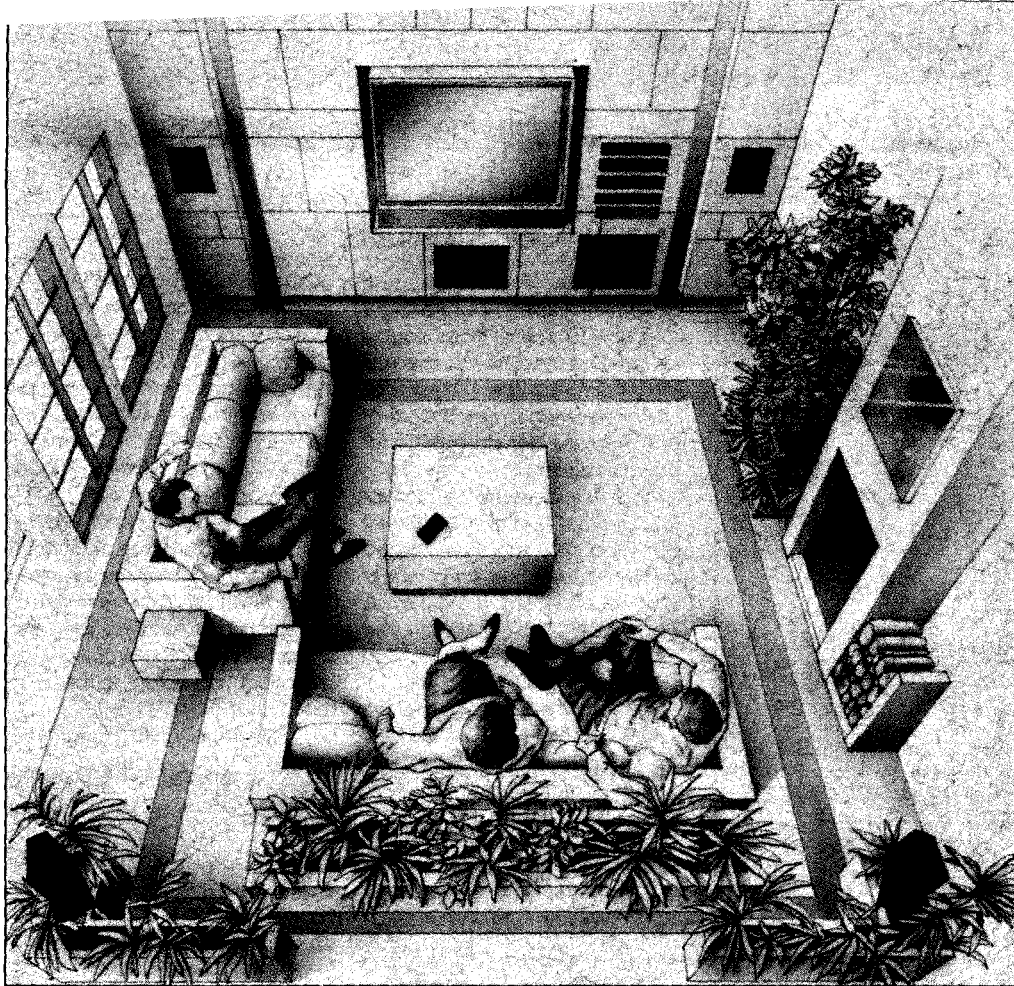

Home theatre

The Shure HTS Reference System aims to recreate the sound of a picture theatre equipped with Dolby Stereo in your own lounge room.

A typical Shure HTS Home Theatre comprises the following components: a Dolby stereo source (eg, a Dolby Stereo video tape and a stereo video tape player); an HTS5300 acra-vector logic decoder (to recover the original four recorded channels with a high degree of separation between channels and to allow adjustable delay time for tailoring to various sized rooms); three,

HTS50SPA signal processing stereo power amplifiers; an HTS50CF centre front loudspeaker; four HTS50 LRS loudspeakers; an HTS50SW subwoofer loudspeaker; and a video display monitor.

Someone wanting to establish a home theatre system might need to purchase all or only some of these items, but almost certainly the logic decoder to recover Dolby Stereo Theatre sound.

The synthesis of this sound involves various stages. One part of the process includes recording

films with three channels (left, centre, right) and one rear (or surround) channel. The Dolby Stereo Theatre encoding/decoding process uses a code to combine the four audio tracks into two stereo tracks, then back into the four original tracks (known as the 4-2-4 process). When Dolby Stereo films are transferred to the video format, the encoded sound tracks are preserved, and are then called Dolby Surround. Australian agent: Audio Engineers. ☎ (02) 29 6731.

READER INFO No. 178

Sun shining, speakers blaring

With summer weather in full swing, it's the time for barbecues and outdoor hi-fi. An American company, Parasound, has produced a range of "all weather speakers" designed for permanent installation outside.

The range consists of three models which feature a carbon fibre reinforced woofer cone, and a weatherproofed tweeter. The weatherproof quality comes,

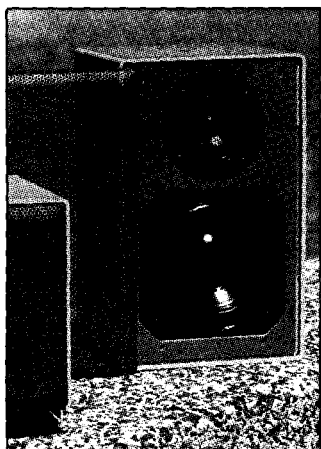

according to distributors NZ Marketing, from a high density inner enclosure encased in a weatherproof outer shell made from ABS resin.

The speakers are designed for mounting on walls, under eaves or even under seats and come with mounting bolts or brackets. RRP starts at \$450 per pair.

READER INFO No. 179

Addendum to "Tuning into FM2"

For professional users, Audio Q in Melbourne is offering a couple of modifications it will make on instructions from Dynalab. The first is provision of an alarm to indicate if an FM transmission fails; the second is an adjustment for a balanced output.

READER INFO No. 180

Speakers from Melbourne

Melbourne-based loudspeaker company GNP Acoustics has released a range of speakers. The tall, heavy Models 90 and 100 both have a 200 mm Neoflex twin voice coil, bass/mid-range driver and a focal magnet dome tweeter. Crossovers include thermal circuit breakers. These Model 90 and Model 100 speakers are \$1300 and \$1500 a pair respectively.

Models 150 and 200 are bookshelf-sized speakers. The 150 has two 125 mm focal drive units for base and mid-range and a 25 mm focal inverted dome tweeter for treble. On model 200 a 175 mm Edgewound voice coil replaces one of the 125 mm drivers. These speakers are \$2000 and \$2500 respectively.

Of GNP's Reference series, the Grange has increased emphasis on cabinet construction, including lead lining on the base enclosures. The four drivers use a 200 mm Edgewound bass, 175 mm Neoflex Edgewound mid-range, a 25 mm Kevlar dome tweeter and a Ribbon super tweeter. They retail at \$4000 a pair.

The other Reference model, Connoisseur, has similar construction but has six speakers, four-way combined for \$6000 a pair.

GNP also has a range of sub-woofers which complement their speakers, priced from \$1000 to \$2800 and able to handle up to 500 watts. Contact: GNP Acoustics. ☎ (03) 470 3171.

READER INFO No. 181

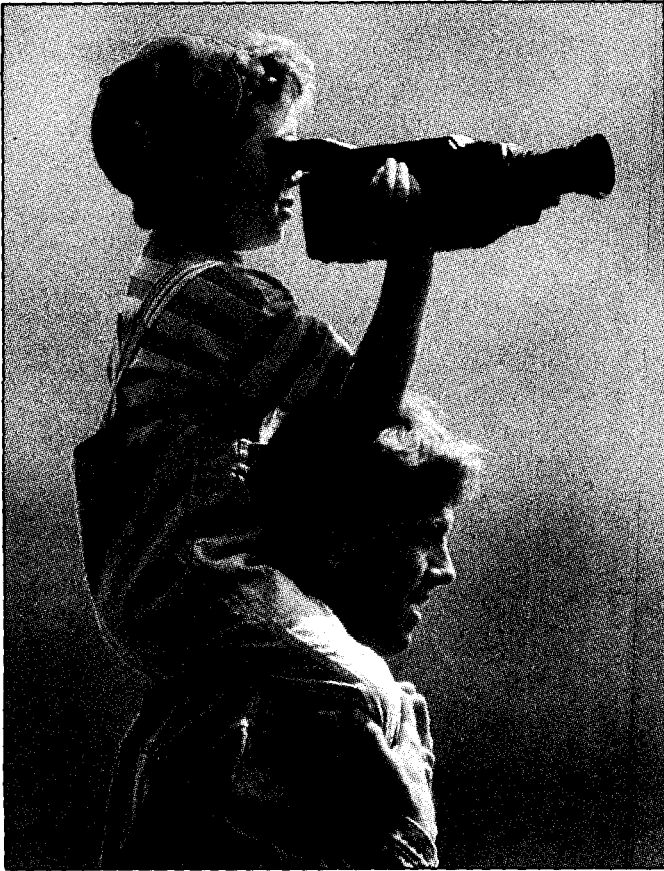

All there on video

Sanyo has a new 8mm video camera/recorder, VM-D5P. The camera has CCD image sensor and variable electronic shutter speed up to 1/4000th second.

Titles, messages, etc. can be superimposed onto video picture. With carry-case and accessories RRP is \$3299.

READER INFO No. 182

New Oz speakers

Homemade Australian hi-fi products are increasingly available, and that goes doubly for speakers. Australian speaker manufacturers are burgeoning while receiving a good deal of attention and commendation for their product.

From Adelaide (homebase for the famous Duntech speakers) comes a new range produced by Krix Speaker Systems. Four of its speaker systems are the small, compact Brix model, the K100MP bookshelf model, and the Monitor 250 model.

The latest in the range is the K150MB. This 520 x 220 x

300 mm large bookshelf model is a 2-way speaker system, with stated frequency range of 42 Hz to 20 kHz, 150 Wrms power handling, and 89 dB for 1 watt at 1 metre. The bass driver – or, rather, the two bass drivers in parallel – are 165 mm doped polypropylene drivers with 100 mm magnet and 33 mm voice coil diameter. Resonant frequency is 30 Hz. The tweeter is made with a 25 mm soft dome diaphragm. It features the new Hexatech voice coil with ferrofluid damping. Crossover point is at 2 kHz.

READER INFO No. 183

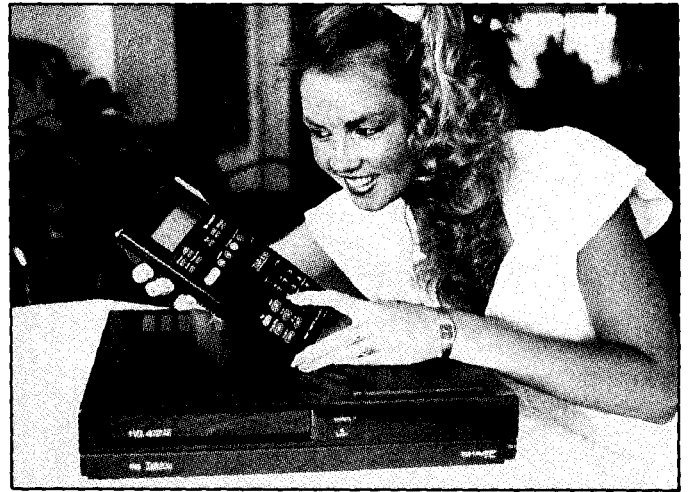

Watch me, I'm talking

"Ouch! Get off me!" Those words might very nearly come from your remote control – because Sharp has released a video player that comes with a remote control that talks.

The "Chatterbox" remote control speaks in a feminine voice with a Japanese accent, and works in conjunction with its latest four-head long play video player. The combination, known as the VCT510X, has been devised to give oral instructions to anyone who needs guidance using their remote control. For example, it tells the user how to set the timer for recording, or to set the clock and alarm clock. Other features of the video player are a variable speed slow motion, still frame and frame

advance and a 365 day/8 program timer. The search facility covers the counter, index and interval.

This long play video format has been remarkably successful, according to Sharp, with its sale of four-head long play units having risen by 222 per cent in the first eight months of last year. Average industry figures for 1987, it says, were 1,500 per month which rose to 1165 per month for the first four months of 1988. Since then sales have been more erratic: 2981 for May 1988, 2849 for June, 4552 for July and 2475 for August. Sharp attributes the increase to interest in the Olympic Games among other things. The VCT510X has a \$900 RRP. READER INFO No. 185

Second generation sound processor

In building the Yamaha DSP-1 sound processor, Yamaha researchers visited scores of auditoria and concert halls in Europe and Japan, measuring and recording impulse responses at different positions within the chamber. The company has now released the improved second generation DSP-100.

The DSP-100 offers 21 user programs (five more than the DSP-1) imitating such sound venues as the Roxy Theatre Rock Concert Hall, Village Gate Jazz clubs, Tokyo discos, concert halls, churches and orchestra chambers. The DSP works by super-

READER INFO No. 184

imposing the reverberation and delay characteristics of these venues over your chosen input (CD, tape, record, etc). These "venue" programs can be adjusted to the user's taste.

The DSP-100 also has four movie theatre options and Dolby surround.

Unlike the original DSP-1, the DSP-100 has a master volume control to enable volume setting of both the main and effect amplifiers from one point and from the remote control. A display on the front panel shows the mode and parameter levels. RRP of the DSP-100 is \$999.

SOUND INSIGHTS, FEB. '89

IN BRIEF

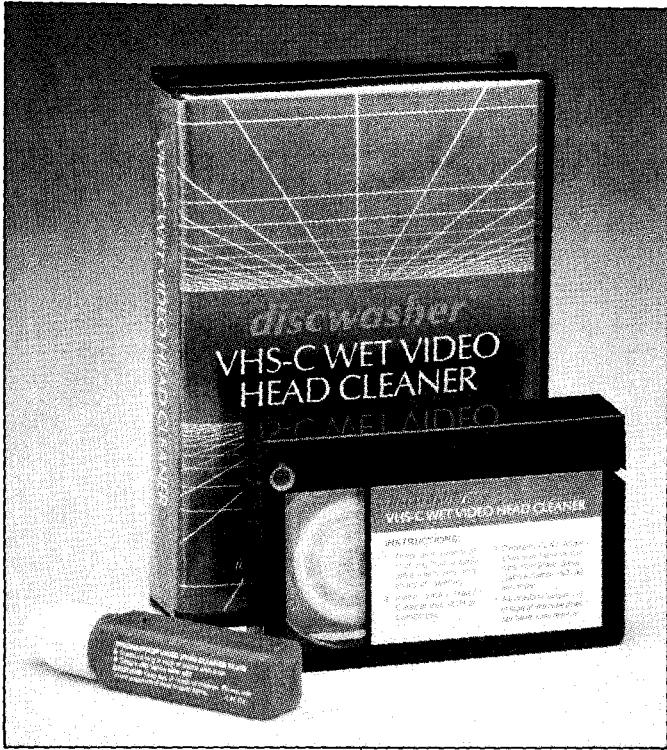

Head cleaner ▲

A special VHS-C format head cleaner has been released by Discwasher using a non-abrasive

cleaning tape for removing dust and tape oxides from VCR heads. RRP is \$24.95.
READER INFO No. 186

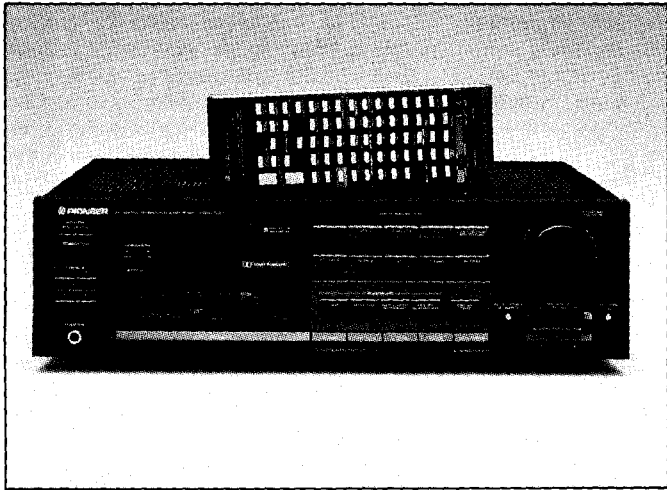

A/V surround sound amplifier ▲

The most characteristic modern sound product is the audio/video amplifier. Capitalising on a trend for homes to have many sound sources (CD players, hi-fi TVs and VTRs are some new ones) and many sets of speakers, they provide a method for

accommodating this. Pioneer has released its VSA-700 A/V digital surround sound amplifier. This integrated amp includes a surround sound processor for Dolby, Stadium, and Simulated Surround Sound.

READER INFO No. 187

Home recordists

For home recordists who feel they could be getting more out of their efforts than they do, TDK has available a small booklet, "The TDK Guide to Better Recording". It advises on such

things as taking care of cassettes, good recording techniques, and some technical specifications. Local dealers should have supplies of the booklet.

READER INFO No. 188

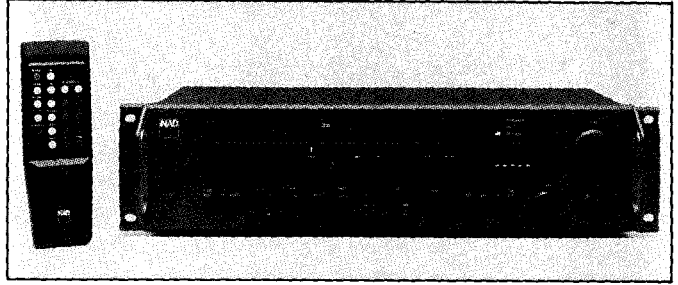

Preamp/tuner in one ▲

The NAD 1700 preamplifier/tuner has been released in Australia. This unusual combination of functions allows free choice of power amplifier. It can be used alone with earphones, with

powered loudspeakers, with a single power amplifier, or with an electronic crossover in a bi-amplified or multi-amplified system.

READER INFO No. 189

Tweet sound

The latest speaker from Monitor Audio is R300MD which uses a metal dome tweeter similar to the R852MD. With a real timber

veneer finish, a pair of the new speakers will set you back about \$950.

READER INFO No. 190

Travel for video addicts

A USA airline company flying the route between Detroit and Tokyo has installed a personal video system mounted on the back of airline seats for a trial period of

120 days. The system offers a choice of six video channels and was developed by Philips and Warner Bros.

READER INFO No. 191



Cover shot: this month's cover shows the Technics SPL 770 CD player reviewed last month.

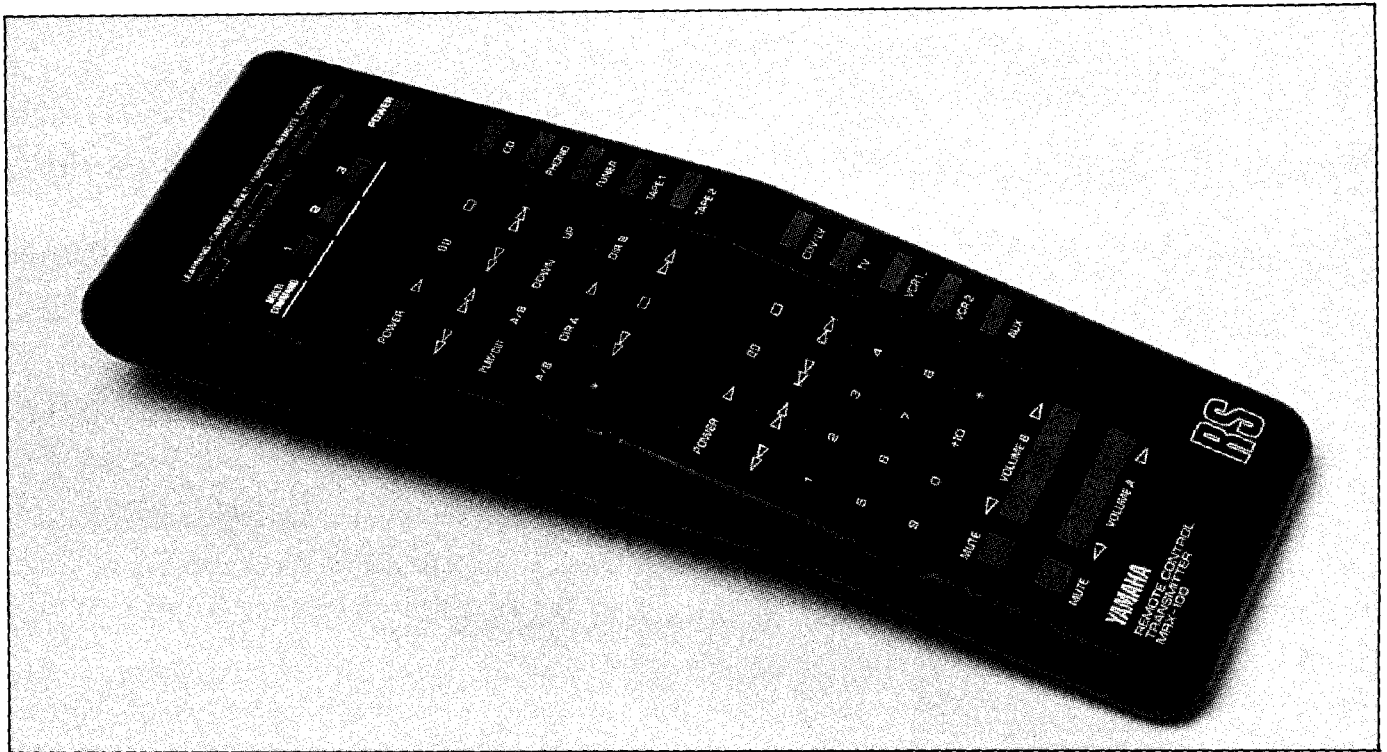

The Yamaha MRX-100.

Armchair button pushing has become the most common form of physical exercise when watching TV or listening to music on the hi-fi. Flexing finger muscles on a panel of buttons has become so popular that it is now virtually impossible to buy a VTR without a remote control facility. Because of this trend towards remote controlled A-V equipment there is every chance that the gear already resides in your lounge room and that the problem of aiming the wrong remote controller at the wrong bits of gear has arisen more than once. The solution to this tedium is to use a universal remote controller to memorise the functions of other controllers so that only one controller needs to be used. This does not mean, however, that the other controllers can be

binning, as they will be needed for reprogramming.

All three models to be described work on the infra-red principle, and have the ability to receive control codes in the learning mode, as well as transmit codes in the normal mode. These programmable remotes are programmed by facing the transmitting heads of both controllers together, separated by a small distance and programming the corresponding keys. Proprietary codes are pre-programmed in the Pioneer and Marantz model.

Pioneer CU-AV 100

The function keys are divided into three groups which are switchable via a 3-way selector switch: audio (CD player, tape deck,

DAT machine etc.); video (VTR1 or 2, TV, CDV etc.) and Aux which is the position to program the keys through the learning process. The controller is pre-programmed with factory presets to operate all products compatible with Pioneer's common system remote control units marked with the symbol SR.

The 1-12 numerical keys, TV power, VCR/VDP/TV input selector, volume up/down keys operate in both the audio and video mode. The bottom section of the remote locates the keys dedicated for surround amplifier functions which are active in all modes.

Programming

A total of 154 functions can be programmed. In the audio or video position the learning mode operates on all the keys other than the surround amplifier function keys. In the Aux mode the learning function applies to all the keys. Pioneer control codes are stored internally and can be restored after other codes have been memorised. Any operation that requires two keys to be pressed simultaneously is programmed by pressing the two keys at the same time whilst in the learning mode. When programming, both remotes should be placed on a level surface and separated by a distance of about 2 to 5 cm.

The CU-AV 100 cannot memorise multiple function codes such as single key operation to operate an array of functions simultaneously or programming functions where several codes are transmitted simultaneously (timer programming etc.). If

UNIVERSAL REMOTE CONTROLLERS

Upgrade your audio-visual equipment with the latest breed of remote controller. Terry Kee looks at three models.

SOUND INSIGHTS, FEB. '89

the function names differ from those on the keys then the names can be written on a template and placed on the panel. Two templates are supplied with the unit.

RRP for the CU-AV 100 is \$199.

Yamaha MRX-100

The plastic case supports a flip-top panel that is hinged in the middle so that two layout options of re-naming keys are possible. The layout of the keys gives a nice uncluttered appearance with a column of keys on the extreme right hand side of the panel dedicated for device selection. The hinged panel breaks the function keys into two sections. The natural step to program the MRX-100 would be to allocate each section to a specific device and to use the hinged flip-top to rename the functions on the other side. Volume and mute keys for two audio components are situated at the bottom of the panel.

Programming

The MRX-100 allows one to copy 95 different keystrokes. Two functions can be assigned to each of the 40 centre buttons by flipping over the flip-top. The interesting feature of this remote is the ability to memorise multi-commands (series programming) where several different keys can be operated in series by pressing one key. A single multi-command key can store up to 15 commands. Three multi-command keys (1, 2, 3) are located at the top of the unit for this purpose. When programming these keys, it is important to get the sequence of events correct. For example, the VTR cannot be set into playback mode before the unit is powered up! The norm-learn switch is located at the side of the case and optimum separation between the remotes is about 5 to 10 cm.

Internal memory is extended automatically when a long code is received and blinks the

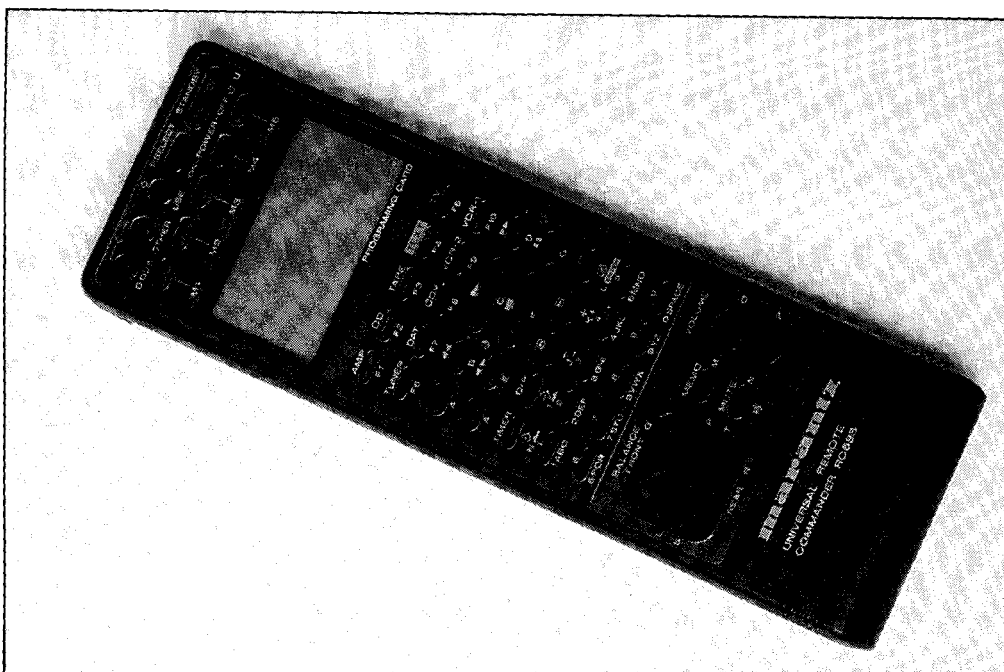

The Marantz RC583.

error/battery indicator twice to show this state; the code then needs to be re-transmitted. The keys can be renamed using one of the four adhesive labels that is supplied with the unit.

RRP for the MRX-100 is \$169.

Marantz RC583

This remote features an LCD display to relay information of the functions selected and other messages for programming. A contrast control is included to adjust the contrast of the display for viewing at different angles. Power is automatically shut down when no entry is made for approximately 30 seconds to extend battery life and pressing any key

will turn it on again. The panel is clearly laid out with the function keys used for device selection taking up two rows of keys immediately below the display. The balance, volume, mute etc. keys for a surround amplifier are situated at the bottom of the panel.

Programming

This remote control has 10 function keys assigned to control 10 components of A-V equipment. For Marantz equipment owners, the 10 function keys are programmed with the codes assigned to Marantz audio-visual equipment called DBUS codes stored in an internal memory. To reassign DBUS codes to different keys, rewrite new codes, or to rename function keys, the programming template and DBUS code chart needs to be used (both are supplied with the RC 583). Initial impressions of programming DBUS codes are a little confusing but it became clearer with some practice.

Programming the RC 583 via other remote controllers is done by separating the transmitting section of both remotes by about 2 to 5 cm and pressing the Other key of the programmable remote to put it into the learning mode. The LCD displays the instructions when to press and release the corresponding keys. The 10 function keys can be renamed in the display to suit the user. The function select key which is located at the top of the panel needs to be pressed to transmit control signals programmed in the function keys.

RRP for the RC 583 is \$199.

The idea of the universal remote controller is very good, however the extra number of keys can make it quite complex to use and some time needs to be spent getting used to it.

eti

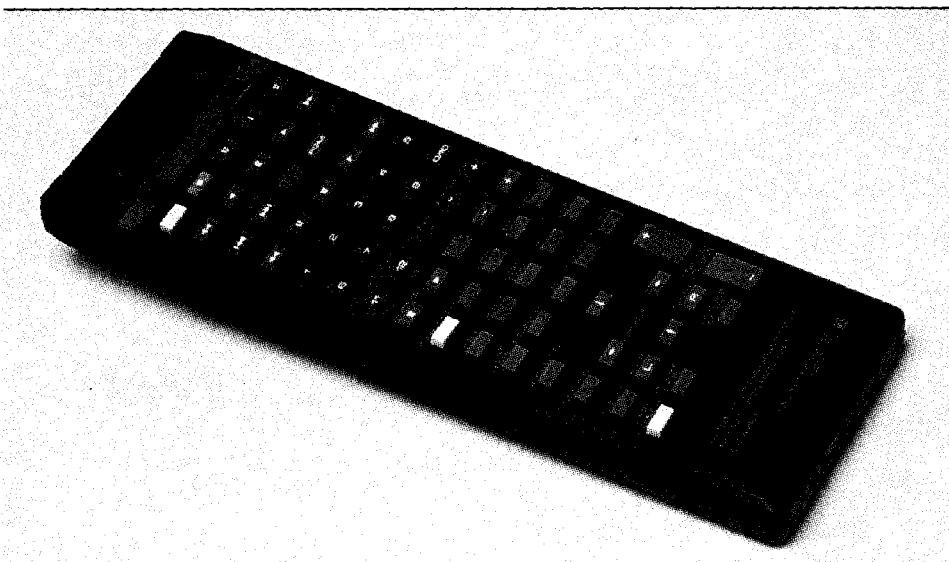

The Pioneer CU-AV100.

Louis Challis reviews the Perreux PMF 2350 200 watt amplifier and places it near the top of the class.

In the fourteen years since Peter Perreux started building amplifiers as a hobby, he has had a meteoric rise to one of the premier positions in the Australian and New Zealand electronic manufacturing scene. Not only have his products managed to create an enviable reputation in both countries, his penetration of the American market is something of a record.

The basis of the Perreux design is the use of power Mosfet transistors in the output stages. These provide sonic characteristics which are very similar to, if not better than, those of the best valve amplifiers. The story goes that Perreux was very unhappy with his early experimentation with transistors, primarily because they tended to produce discordant audible characteristics which were totally unlike the warm, mellow sounds of a valve amplifier to which he was accustomed. What Perreux found was that the Mosfet power transistor is capable of providing all the sonic attributes of a valve, matched by the practical convenience of a transistor.

The basis of Perreux marketing philosophy is that the product will be hand crafted, ruggedly constructed, electro-acoustically efficient, and with performance that has to be, to use Perreux' words, 'second to none'. And there were plenty of buyers. His most popular amplifier is the 200 watt stereo unit, and his factory has just kept on growing to fill the demand.

The latest version of the Perreux 200 watt amplifier, the Perreux PMF 2350 has a number of refinements over the previous generation, which it now replaces. The first of these relates to the use of much heavier internal wiring to lower the impedance of the internal circuitry. The second improvement is the use of a double thickness of copper laminate on the printed circuit boards. The third improvement is to add more effective heat sinks on both sides of the amplifier casing, to provide more effective heat dissipation. The last improvement is to upgrade the electrolytic capacitors to enhance the filtering of the power supply circuit.

When I opened the cabinet, I found that the power supply now utilises a fully tropicalised power transformer. It also utilises the largest air cored chokes that I have ever seen in an amplifier. They are typical of the size I would expect to find in an AM broadcast band radio frequency transmitter.

The front panel of the amplifier is simple yet bold, with a raised ridge extending right across the front of the panel. The name Perreux is engraved deeply in the ridge. A power switch is located at one end, with a dummy switch at the other to match the depressed (activated) power switch when the unit is switched on. A small blue LED is adjacent to the power switch, and apart from the silk screened PMF 2350 and Perreux logo, there are no other controls on the front panel. The rear panel of the unit is almost as bare, with a pair of gold plated, colour coded input sockets and two pairs of universal output terminals for connecting one

'His products would be hand crafted and second to none'

pair of speakers. Apart from a panel mounted fuse holder and IEC mains socket there are no other controls on the back panel.

Deeply ribbed heat sinks extend along both sides of the amplifier, which I discovered are a potential source of danger because of their sharp corners.

The inside of the amplifier is well constructed, although I was amazed how few components are required in a modern 200 watt stereo amplifier. One of the claimed features for this amplifier is that it does not incorporate output protection circuitry, which I found rather strange. Whilst Mosfets protect themselves far better than ordinary bi-polar transistors, one good short on the output could still wreak havoc.

The Perreux agent sent us an SA 33 high-fi preamplifier with the PMF 2350 and so, although I wasn't asked to test both, I

PERREUX PACKS A PUNCH

Latest Mosfet power amplifier

SOUND INSIGHTS, FEB. '89

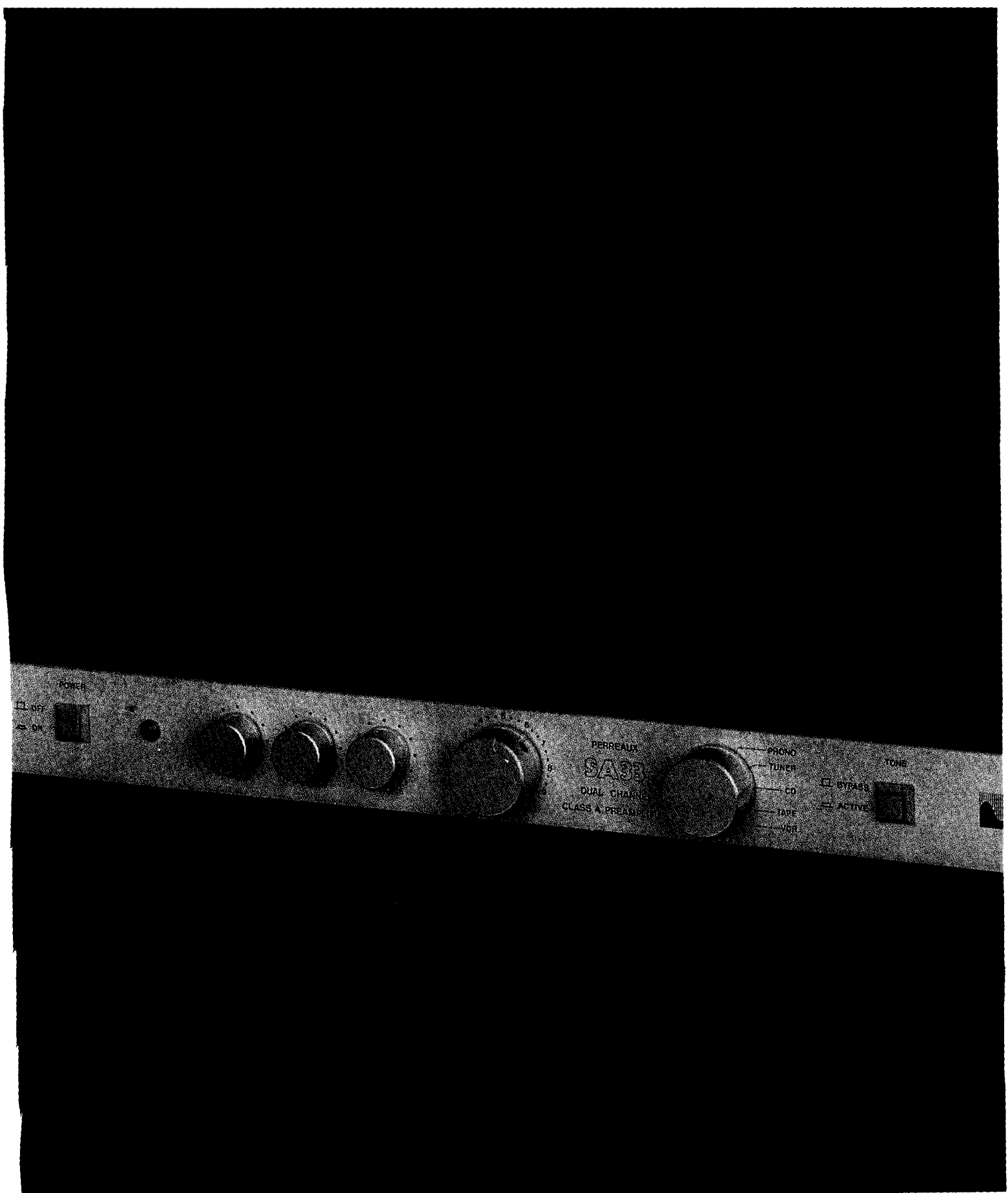

BOSE

The Bose 601 Series III Direct/Reflecting Loudspeaker System

Bose engineers have devoted more than 25 years of company research to the one goal: creating the illusion of a live performance. The next best thing to hearing music live is hearing it through a Bose Direct/Reflecting speaker. Creating the illusion of a live performance, especially with a speaker that sits on the floor, is the last best thing you can do for your sound.

The research: three dimensional sound.

Sound is a three dimensional phenomenon. It is not just a pressure wave that bounces off walls and reflects off surfaces. It is a complex phenomenon and especially sound that is live. It is not just a simple matter of concentrating energy on output. As with any complex phenomenon, the speaker must be designed, built, and proportioned.

We designed our speakers based on the natural combination of direct and reflected sound. The difference between listening to a conventional speaker and Bose Direct/Reflecting speakers is like the difference between seeing a movie on a screen versus experiencing it in a theatre.

The 601 system creates a three dimensional sensation of music—giving the sound depth, height and width. It gives you the same thrill in a live performance. The clarity of sound reaches your ears after being directed off the walls, floor and ceiling. With conventional speakers you simply hear the direct sound. Bose Direct/Reflecting speakers give the music a richness to which you cannot attain with a conventional speaker. The result is a more natural sound that fills the room. The result is a more natural sound that is precisely the same as live.

The performance: ideal for audio, video and digital.

The Bose 601 system is designed to be used with any stereo system. It is also ideal for use with digital audio systems. It is designed to provide clear results with all video formats including VHS and Video CD.



It fills the room—even when you sit directly in front of one of the speakers.

The 601 system is the best corner speaker in a room. It fills the room with the full spectrum of your sound system. It is also the best speaker for your stereo and digital systems. The Bose 601 system is designed to provide clear results with all video formats including VHS and Video CD.

The Bose 601 system is designed to be used with any stereo system. It is also ideal for use with digital audio systems. It is designed to provide clear results with all video formats including VHS and Video CD.

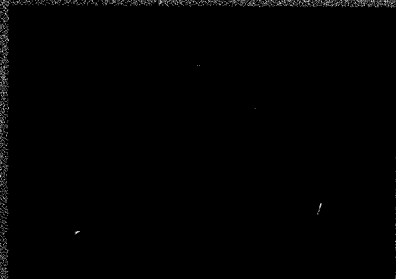

Best of Direct/Reflecting® system.



Conventional speaker system.

Bose Australia (02) 211 1111, Mural Acoustic Systems, NSW 2116, Telopea (02) 894 1022, 050 1001

Bose Distributors:

NSW and VIC: Bose Australia (Reverse charge) (02) 894 1022; QLD: Stereo Supplies (07) 225 7630
WA: Prosound (08) 325 1166; SA: Backwood Sound (08) 274 1061; TAS: Chessman Distributors
(03) 26 4622

READER INFO No. 10

1000

Perreaux amplifier

separately evaluated them before embarking on my subjective evaluation.

The pre-amplifier displayed exemplary performance as the level recordings reveal. The noise figures for both the low input and high level phono circuits in particular proved to be excellent. The frequency response was exceptionally flat being within ± 0.5 dB from 5 Hz to 80 kHz. The pre-amplifier band width was slightly wider than that of the power amplifier, which is 10 Hz to 50kHz ± 0.5 dB or 3 Hz to 200 kHz ± 3 dB. Whilst a frequency response as wide as this may be considered desirable by some, I am from the old school which believes that a reduced response at low frequencies is often better for your speakers, especially when playing records. I am not convinced as to the merits of a 200 kHz upper 3 dB point, especially when my speakers only really produce useful output to about 25 kHz.

The output impedance of the amplifier is 13 milliohms at 1 kHz which is extremely low and shows what fat wiring and parallel Mosfets in the output stage can achieve. The measured hum & noise figures relative to 1 watt output were particularly good at 79 dB unweighted or 88 dBV (A) weighted. At 200 watts output this noise level corresponds to -111 dB(A) which is extremely good

'Rhiannon brought my wife and son into the room'

performance. The total harmonic distortion of the amplifier at 1 watt is also extremely low being 0.0025% at 6.3 kHz. With the power output increased to 200 watts into 8 ohms, these figures increase somewhat to 0.015% at 100 Hz, 0.0091% at 1 kHz and 0.013% at 6.3 kHz, which are still very good for an amplifier with only modest levels of

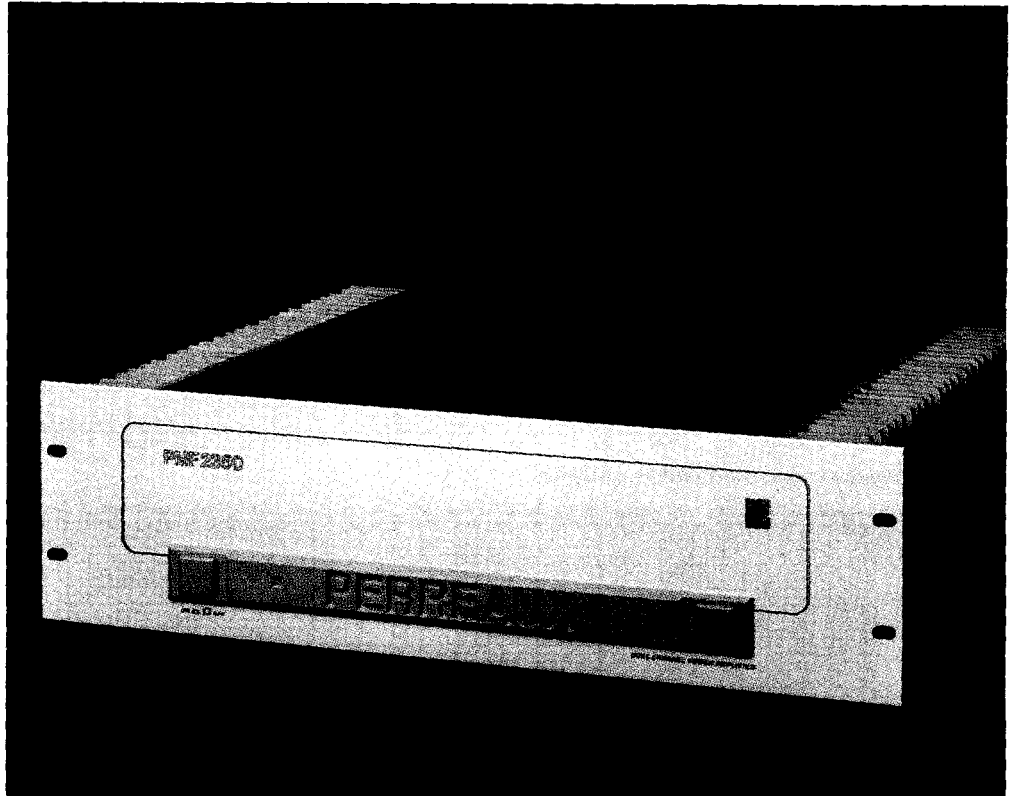

feedback. These THD figures are matched by extremely low IEC, high frequency, total difference frequency distortion figures.

These were 0.0022% at rated power only 0.00058% at 1 watt power output level, which are excellent performance figures. The amplifier still has heaps in reserve at rated output as the dynamic head room at 200 watts output is 2.45 dB, whilst with 330 watts of output into 4 ohms the dynamic head room is still a healthy 2.3 dB (this corresponds to 561 watts peak into the 4 ohm). This is obviously an amplifier that can take a lot of punishment, and with that sort of power

output capability, can most probably deliver quite a bit of punishment. The channel separation and cross talk are exemplary, being better than 90 dB at 1 kHz and still only rising to -70 dB at 20 kHz.

The performance of the SA 33 pre-amplifier

DIMENSIONS

Width	483 mm
Depth	413 mm
Height	148 mm
Weight	15 kg
RRP	\$2,795

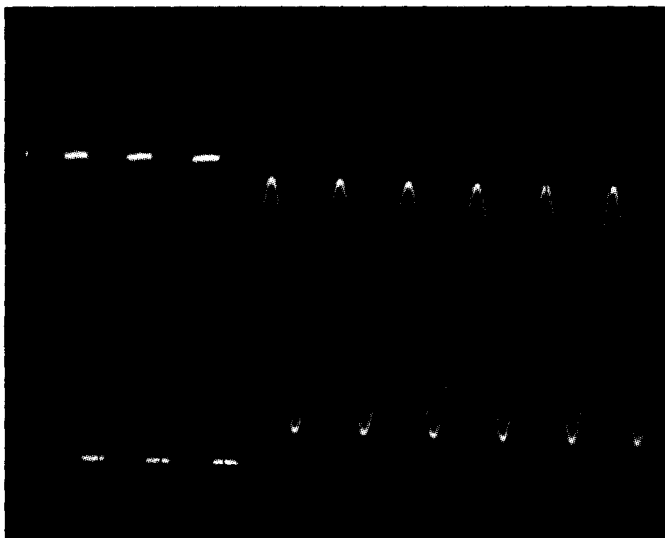

1 mS/Div.

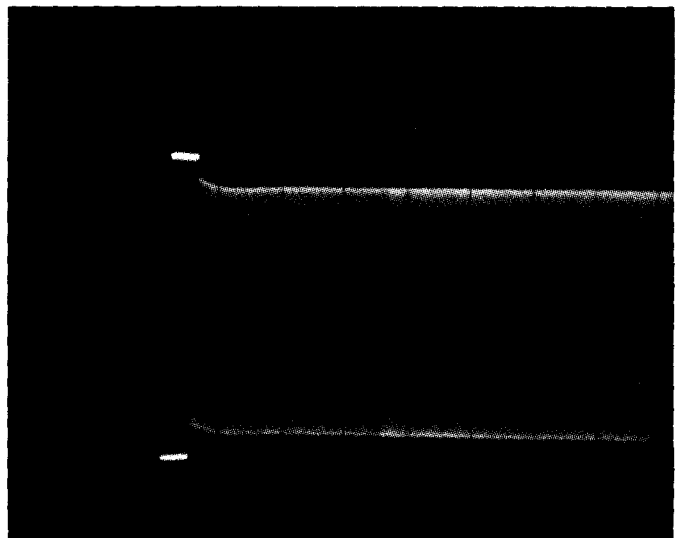

50 mS/Div.

Transient overload recovery.

SOUND INSIGHTS, FEB. '89

Perreaux amplifier

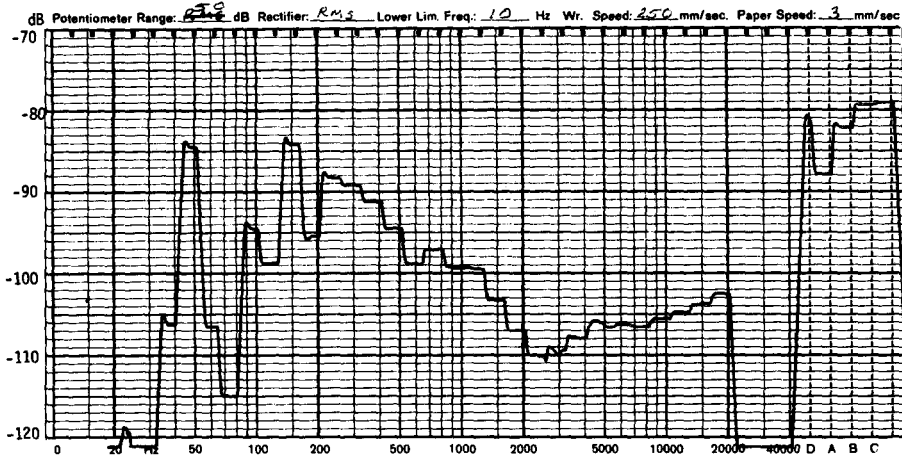

Crosstalk: one third octave analysis.

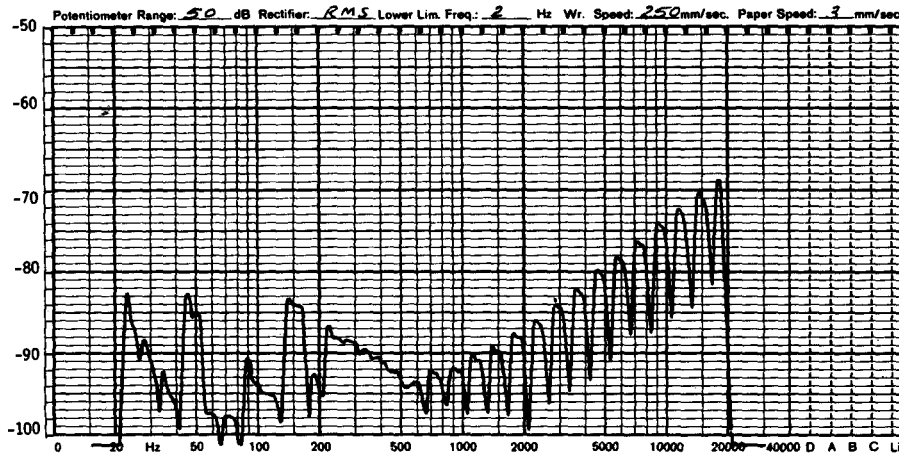

Hum and noise: one third octave analysis.

was also impressive and its total distortion figures as well as its hum and noise figures were every bit as good as the power amplifier. I plugged the two units together and connected them up to a pair of B & W 801 speakers to evaluate their performance with some of the latest classical and pop music recorded on both CD and records.

I was immediately impressed by the power output of the amplifier. It was more than I

really needed to drive a single set of speakers to their clipping point (where the protection circuit is activated with peak input of 300 watts input or thereabouts). I connected a second set of speakers in parallel to provide sound level pressures in excess of 120 dB in my living room. With my family starting to complain, I reset the controls to a more reasonable listening level of around 100 dB and under those

conditions the amplifier was almost idling.

The first disc I played was a brand new Australian CBS disc by Daryl Braithwaite, "Edge" (CBS 4626252), the first disc manufactured by Discronics in Melbourne that I have heard. Although I wouldn't have gone out of my way to audition this disc with this amplifier, I must admit I was very impressed by the music, the quality of the recording and production and most particularly by the amplifier. When I did my research I discovered that Daryl Braithwaite used to be the front man for Sherbet and although away from the music scene for quite a while (following his lead role in Macbeth at the Victorian Arts Centre in 1985) he has returned to take his rightful place as one of Australia's most outstanding vocalists.

The second disc I played featured an absolutely outstanding vocalist. Basia Trzetrzewska. Her new album "Time and Tide" from CBS is one of the most refreshing pieces of funk Latin music I've heard in ages. I played the number five times and each replay sounded better than the last. The extract I heard from "Time and Tide" was on CBS CDSAMP191.

I played a selection from "Fleetwood Mac's Greatest Hits" (Warner Brother 9258382) and most particularly Track No. 1, Rhiannon, which brought my wife and son into the room. Even the dog was wagging his tail to the music.

The Perreaux PMF 2350 is an exciting amplifier which, supported by good software and good speakers, can produce brilliant sound. Its major attributes are its low harmonic distortion, extremely low inter-modulation and low total difference frequency, high frequency distortion and a quality of sound that is on par with the best valve amplifiers that I have heard. The only liability with this amplifier is its price tag which puts it above the reach of far too many prospective buyers. This is one amplifier, however, that is really designed for the fastidious listener and it delivers power and sonic performance that place it close to the 'top of the class'.

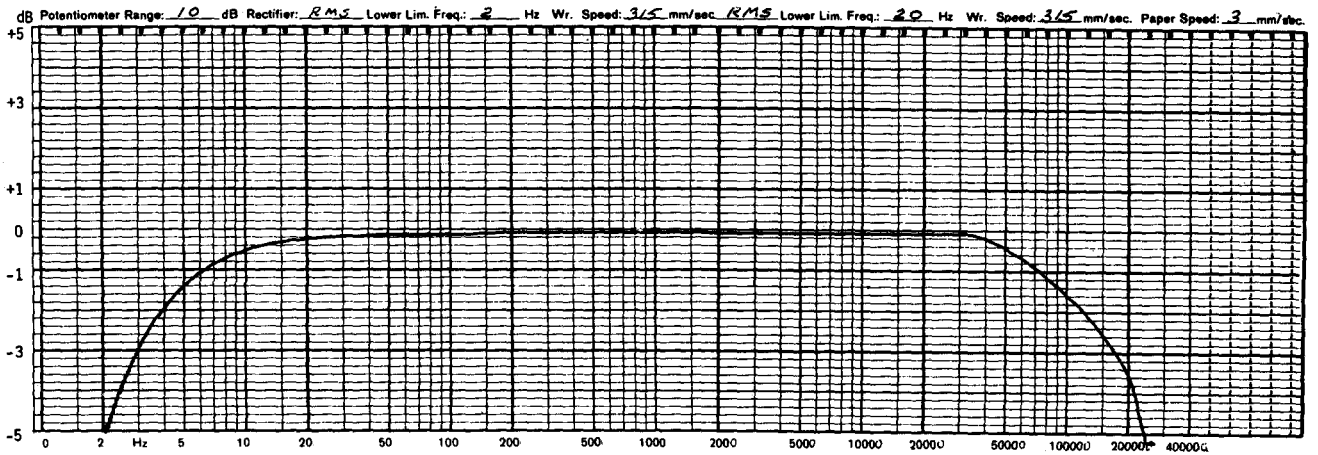

Frequency response: 110mV Input and 1 watt output into a 8R. 2Hz - 200kHz.

MEASURED PERFORMANCE OF PERREAU PMF 2350 AMPLIFIER

SERIAL NO P20702

FREQUENCY RESPONSE

(-3dB re 1 Watt, 0.3V Input to Aux.)
(see curve 2Hz to 200kHz)

Left	2.9 Hz	to	200kHz
Right	3.0 Hz	to	200kHz

SENSITIVITY

(for 1 watt in 8 Ohms)

	Left	Right
Auxiliary	110mV	109mV

INPUT IMPEDANCE (@ 1kHz)

	Left	Right
Auxiliary	48 k ohms	48 k ohms

OUTPUT IMPEDANCE (@ 1kHz)

= 13 milliohms (@ 1kHz)

NOISE & HUM LEVELS (re 1 watt in 8 ohms)

(re 1 Watt into 8 ohms)
(with volume control set for 1 watt output with, 110mV input (Aux.))

Main input	79dB(Lin)	88dB(A)
------------	-----------	---------

HARMONIC DISTORTION

(A) (At rated power of 200 Watts into 8 ohms = 40 Volts)

	100Hz	1kHz	6.3kHz	
2nd	-97.9	-100.2	-96.5	dB
3rd	-82.5	-82.7	-83.9	dB
4th	-112.0	-115.9	-110.3	dB
5th	-96.5	-95.9	-	dB
THD	0.015	0.0091	0.013	%

(B) (At 1 Watt into 8 ohms)

	100Hz	1kHz	6.3kHz	
2nd	-104.8	-114.6	-107.0	dB
3rd	-102.1	-117.7	-101.2	dB
4th	-104.2	-	-105.0	dB
5th	-	-116.0	-	dB
THD	0.0025	0.0006	0.0023	%

MAXIMUM OUTPUT POWER AT CLIPPING POINT

(IHF-A-202)

(20mS burst repeated at 500mS intervals)

8 ohms	4 ohms
130 VP-P	134 VP-P
= 392 Watts	= 361 Watts

... Dynamic Headroom = 2.45dB (re 200 W) 2.3 dB (re 330 W)

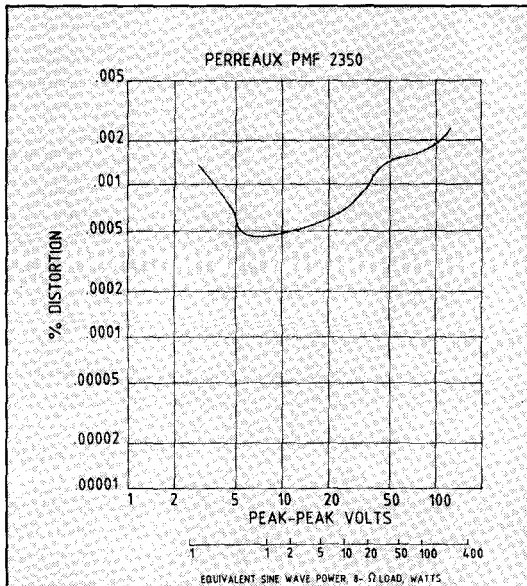

IEC high frequency total difference frequency distortion.

THE ONLY WIRELESS THAT TAKES COMPLETE ADVANTAGE OF SHURE MICROPHONES



Sounds like a mic with a cable

Superb audio because advanced microphone technology is precisely matched with unique electronics. Truly a major step beyond conventional wireless systems. Genuine Shure microphone for unvarying uniformity and accuracy of sound reproduction. Plus—legendary Shure reliability and durability throughout.

Overcomes problems

Exclusive Diversi-phase™ dual-antenna system eliminates dropout. Provides strongest possible signal. Corrects reflected or direct signals that are out of phase—won't cancel each other. Rejects TV and radio signals.



Many options

Diversi-phase or single-antenna receiver. Compact, reliable transmitter. Can be used with specially-designed WL83 or WL84 Electret condenser microphones, or a variety of other Shure microphones.



Computer selected frequency

Finds frequency best suited to the area, or a special frequency for touring needs. Tuned linear phase filters screen out unwanted signals, without distortion.



SHURE WIRELESS SYSTEM

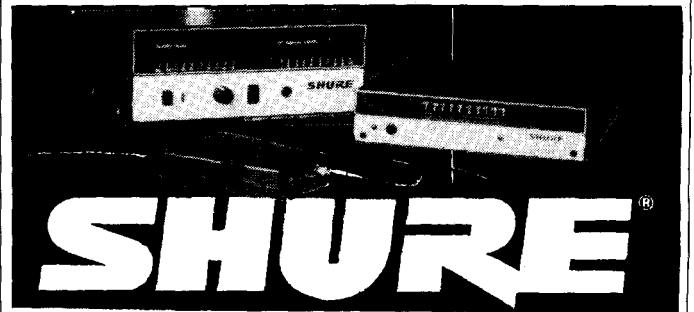

AUDIO ENGINEERS PTY. LTD.
342 Kent St, Sydney, NSW. 2000
Ph: (02) 29-6731

MARKETEC PTY. LTD.
51 Scarborough Beach Rd,
North Perth, WA. 6000
Ph: (09) 242-1119

AUDIO ENGINEERS (VIC)
Ph: (03) 879-0320

AE16

Roland's DSP-2000 makes Les Cardilini think about the new wave of digital sound processors. Are they really worth it?

Someone should have told us that sound systems are really a big confidence trick.

Or have we known that all along?

I refer, of course, to the fact that for a sound system to be convincing it has to fool our super-smart and observant hearing system.

Yet, just as we are convinced that what we are listening to on our hi-fi system is the real thing and feel that it is safe to open our eyes, what do we see? Instead of an orchestra or some other exciting spectacle, we are confronted by a few stiff speaker cones vibrating in wooden boxes - what a let down!

Changing from mono to stereo is a practical example of stepping up towards realism. However faithfully a mono system reproduces the electrical signals, it still manages to squeeze a full orchestra and its associated reverberation into a point in the acoustic centre of the speaker system. Please do not misunderstand; the sound of

several musicians can still be mellow and sweet coming from a single speaker but it is hardly realistic if we get the feeling that the artists are all crowded into a single point in the room. Mono hi-fi was nonetheless revered by true audiophiles for many years and doubtless some still have happy memories of their early mono systems.

Stereo, the next step, at least gives the sound some dimension from left to right and reproduces a sound stage within which the different instruments and voices are each assigned a unique location on the stage. The notion of depth, the third dimension in a stereo sound stage, is conveyed by the balance of direct and reverberant sounds recorded for each voice or instrument.

But, three-dimensional as a conventional stereo system might be, it still tends to keep all of the sound up-front. At a concert or in the theatre, on the other hand, the sound heard arrives not only from the front but from the sides and rear as well, after being reflected from walls, ceilings and other features of the venue. Surround sound systems in cinemas exploit this feature of live sound, to give the audience a sense of realism and participation in some of the visual action they see on the screen.

What we hear in any live situation, then, is not only the sound of the source but also the indirect sound determined by the character of the surroundings. Organ music is enhanced by reverberation contributed by the expanse and hard reflecting interior of a cathedral. Even electronic versions of the organ take into account this characteristic in the sound of that instrument.

In fact, every sound we hear is accompanied by clues which convey the impression of distance, direction and possible surroundings. For example, it is not difficult to guess correctly whether a recorded voice was produced in a tunnel or out in the open. The main clue in this instance would be the echo-like reverberation which we have learned accompanies a voice in a tunnel.

That example, of course, was quite straightforward. The clues might not always be as simple and obvious; they could be complex and subtle and, typically, we are not likely to be especially aware of them unless they conflict with our expectations or understanding of what is taking place. For instance, it would be disconcerting to hear the evening news presented with a cathedral-like sound on TV while the screen shows the newsreader in a small sound-proofed booth; the aural clues conflict with the visual scene to which they relate.

Most sounds reaching our ears are likely to have three main components which can be likened to the ripples which form on the smooth surface of the water when a stone is dropped into a swimming pool.

The first part is that initial ripple or wave which emanates from the point where the stone falls, and the similar waves that follow.

The second part is the set of reflected

CATHEDRAL SOUND AT HOME

Roland hi presence digital sound processor

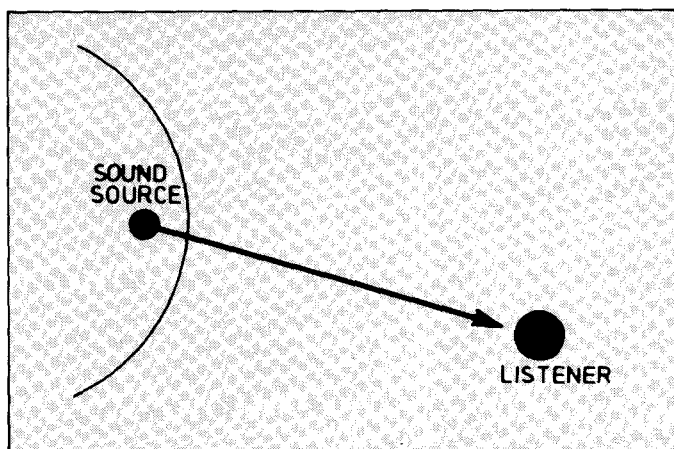

Figure 1: direct sounds.

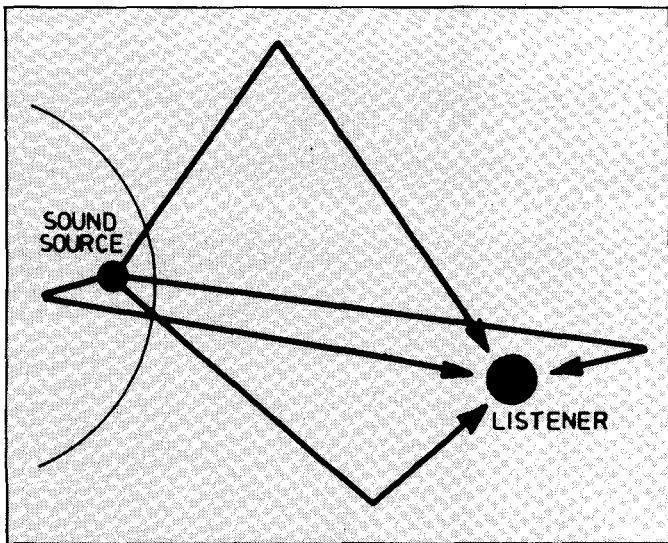

Figure 2: initial reflections.

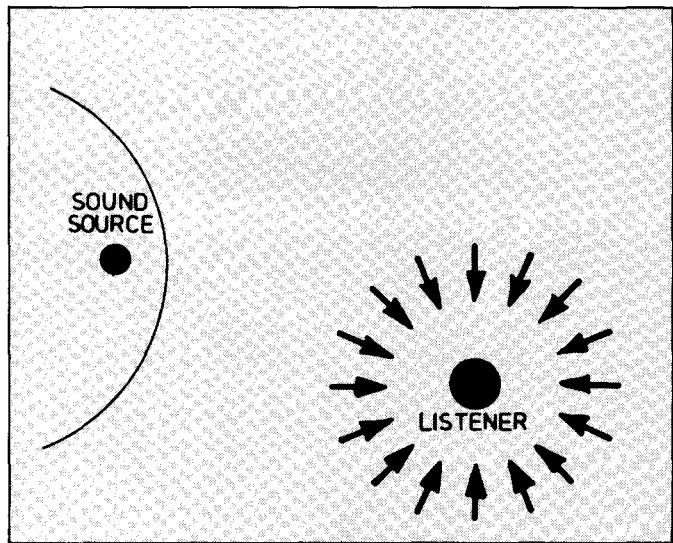

Figure 3: secondary reflections.

waves which are created when the initial wave reaches the edges of the pool closest to where the stone fell. These "early reflections" then follow behind the initial, or direct, wave as it travels towards the other end of the pool.

The third part begins when the direct wave and the early reflections reach the farther edges of the pool's perimeter where more reflections occur and travel back and forth in all directions across the pool until the waves die down and the water is again smooth.

A similar sequence or pattern occurs with soundwaves in air, following, say, a sharp handclap. In a soundwave the third stage is called reverberation.

In the example of the pool each part that goes to make up the final complex wave pattern travels relatively slowly and is readily identified visually. In a sound wave, however, time differences in the order of only thousandths of a second are involved. Following a sharp handclap in a small room at home, for example, the sequence of direct sound, early reflections and reverberation might be completed, and the room silent again, in considerably less than one second. In a cathedral the sound might linger for many seconds. Our hearing processes are nonetheless able to "measure" the minute time differences, to identify the sound and form opinions (often, subconsciously) about its likely surroundings.

The vital clues are in the timing. Soundwaves in air travel at 340 metres per second. That is about one metre in approximately three one-thousandths of a second (3 mS). Using this information we can see how a direct sound can be well on its way before the first reflections begin to occur from the floor and nearby walls, even in terms of milliseconds.

If our hearing process is capable of measuring differences in the order of less than one millisecond, then delays in the order

of 10 ms, 50 ms and 100 ms should be a piece of cake. These are the first clues to sensing the size of the room, in general terms. Longer delays between the direct sound and the first reflections an observer hears means the room boundaries must be further apart. Smaller rooms will have shorter time differences between these components in the sound wave.

Meanwhile, the direct sound and the first, or early, reflections continue to travel to the farther boundaries and reflect back into the room, by which time reflections are occurring from the whole perimeter of the room and slowly dying away. How quickly they fade in volume depends on the number of times they bounce off a reflecting surface and how much energy they give up each time they do. Sustained reverberation and echoes typify large rooms with hard reflective walls. In smaller, absorptive rooms and halls, reverberation time is very short and sound is inclined to appear clipped and thuddy. No reverberation at all would suggest that there are no boundaries or reflecting surfaces, outside, in the open air, for example.

So, here is where part of the electronic

confidence trick comes in. If our hearing process detects all of these components in a sound then it will assess the surroundings according to the delays between them, and the reverberation time, even if they are artificially generated.

The Roland Corporation's new digital sound processor, Model DSP-2000 exploits very well this phenomenon of hearing. In the DSP-2000, early reflections and reverberation are derived from a normal stereo program and then played back into the room with the "direct" sound from the regular stereo pair of speakers in the system. Apart from taking the direct signal from the system preamplifier, or, alternatively, from the tape output on an integrated amplifier, the DSP-2000 operates into a separate and otherwise typical, stereo amplifier and speakers, in what Roland calls the presence system. (The amplifier and speakers in the presence system are purchased separately from the DSP-2000.)

Within the DSP-2000 timing of the early reflections and reverberation can be controlled to provide indirect sound to simulate a wide variety of venue acoustics,

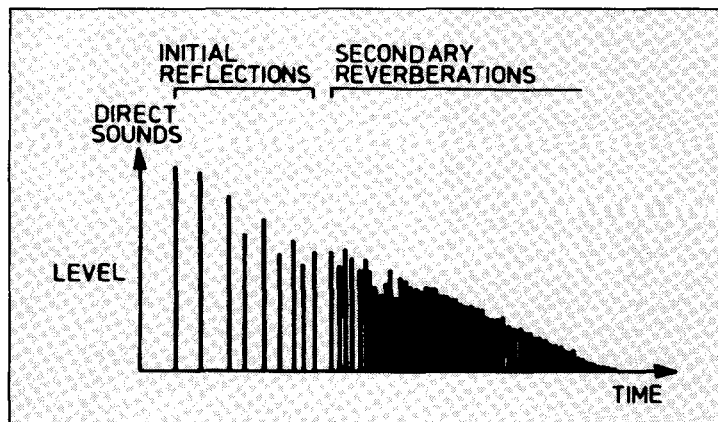

Figure 4: a time axis pattern of all sound waveform groups.

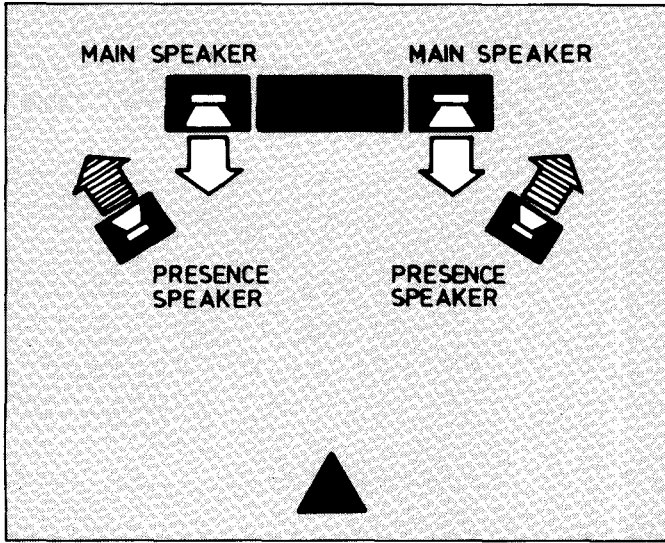

Figure 5: a basic HI Presence system.

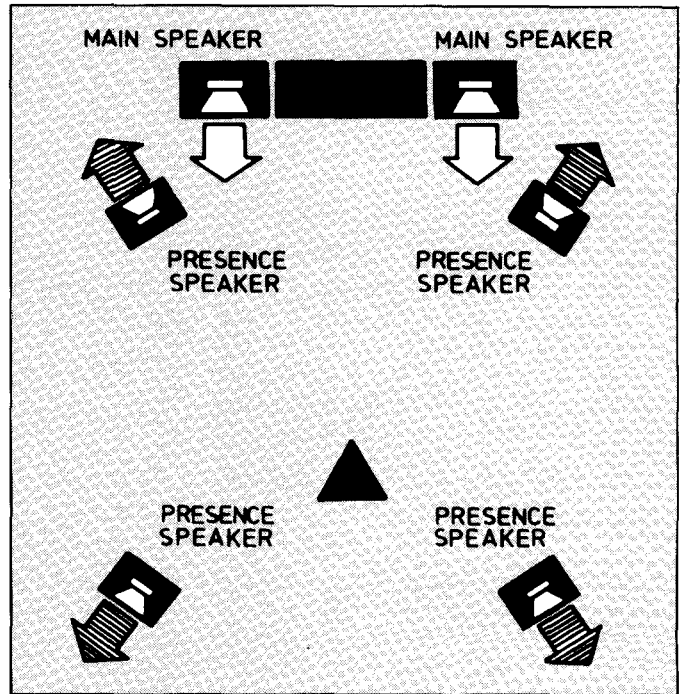

Figure 6: a higher level six-channel HI Presence system.

from small relatively dead lounge rooms to large cathedrals with reverberation times of up to 20 seconds. The acoustics program library in the DSP-2000 can hold up to 40 program presets. A combination of ten of these combinations used regularly can be transferred to the user memory and each program can be further adjusted independently in each channel, to suit the user's requirements.

Up to five delay times for initial reflections can be set and stored for each, left and right, channel in the DSP-2000. Another preset changes the intensity of reverberation while a third sets the reverberation time from 0 to 20 seconds through a number of finer steps. Yet another reverberation setting determines how long it should take for the reverberation to become audible, thereby adjusting the perceived distance to the room boundaries, in an aural perspective.

In real life the reverberation time of a room is not necessarily the same at all frequencies. Typically, high frequencies, or treble sounds, die away more rapidly than the lower mid-range and bass notes. A shorter reverberation time for higher frequencies is characteristic of softly furnished or heavily draped rooms. The DSP-2000's HLF preset, controls the reverberation at high frequencies within the range of 5 to 99 percent of the main reverberation preset. Accordingly, early reflections and normal reverberation in the presence system will cast an aural description of rooms or hall size overall, while the high frequency decay rate carries an impression of texture and furnishings within the hall or perhaps the number of people in a fictional audience.

Perhaps it should be pointed out that

opinions we form of sounds we hear are largely based on our experience of hearing the same kind of sound on many occasions. Accordingly, decisions about sounds we hear are more or less spontaneous and not likely to be based on lengthy deliberation over the "clues". An exception might be some sound that we had not heard previously, or an unfamiliar combination of direct and reflected sounds - strange sound effects, for example.

The 40-program library is comprised of three sets of ten kinds of halls from small to large within each set. The remaining ten presets, or special bank programs, are made up of individual sets of parameters to simulate the following venues: cathedral, arena, lobby, rock concert, theater, saloon, chapel, discotheque, live house and lounge. A memory protect switch can be used to prevent accidentally writing over stored parameters.

The DSP-2000 first converts the analogue audio into digital for processing. Sixteen-bit pulse code modulation (PCM) and 44.1kHz sampling, the same as that used in the compact disc digital audio system, are used in the analogue-digital digital-analogue interfaces in the processor. Processing with this digital resolution and sampling rate gives the presence system a dynamic range of 96dB, the same as the compact disc digital audio system. The claimed frequency response is within 3dB from just under 20Hz to 20kHz and about 7dB down at 10Hz.

Accordingly, the frequency response of the presence channel should not affect the integrity of the reverberation and HF damp settings, across the spectrum of audible frequencies. The analogue audio volume

control in the DSP-2000 can be turned manually at the set itself or motor-driven using the up-down buttons on the cordless remote control. The set can also be comprehensively preset and switched between its various functions and modes, including changing program parameters, using the remote control.

Positioning the two, left and right, presence speakers relative to the rest of the system would be a matter of choice. They can be turned away to reflect and disperse the presence sound from the walls behind the main, front stereo speakers or set up to face into the room.

It was interesting to follow the sound in a TV movie, in and out of its sequence of indoor and outdoor scenes, and, using the DSP-2000, to try and match the expected acoustics for each scene in the TV picture. It worked quite effectively. In the arena (open area) mode on the DSP-2000 the voices of the TV sports commentators seemed to join the spectators out in the open at the cricket and golf, realistically. Of course, the Roland processor is not confined to use with only TV and video sound and might be more at home in a stereo hi-fi system. Old recordings might even be given a new lease of life, by using the DSP-2000 to strike up the old band in new surroundings.

The DSP-2000 is slightly wider than the typical hi-fi amplifier and might need a shelf of its own outside the system cabinet if the existing amplifier just fits into the available width. The front panel is simply laid out and includes an illuminated display showing the selected mode or venue. The display also indicates parameters for editing or storing in the program memories. Illuminated bar-type

peak level indicators on the front panel are used for calibrating the input levels to the processor and can be switched off if desired.

Gold-plated RCA sockets are provided for the left and right channel inputs from the system pre-amplifier, or integrated amplifier in the main stereo system. Two direct output RCA connectors are also available on the rear panel. The presence signal outputs are at minus 14 to plus 6dBV, via two pairs of left and right RCA sockets also located on the rear panel of the DSP-2000. Explanations and diagrams showing how to connect the processor into a variety of existing and proposed stereo system configurations are given in the user manual which also lists preset parameters for the library memory and provides blank tables for user applications.

The Roland DSP-2000 hi-presence digital sound processor sells for around \$2200 recommended retail, which does not include the presence amplifier and speakers.

Further information: Roland Corporation, 38 Campbell Avenue, Dee Why West, NSW 2099.



Program memory composition

Listening Room Condition (library)

Memory Number	A 20 square metres (215 sq. ft.) or more	B Approx. 15 square metres (160 sq. ft.)	C 10 square metres (110 sq. ft.) or less	S Special	User Memory
1	large hall	large hall	large hall	cathedral	1
2	large hall	large hall	large hall	arena	2
3	large hall	large hall	large hall	lobby	3
4	medium-sized hall	medium-sized hall	medium-sized hall	rock concert	4
5	medium-sized hall	medium-sized hall	medium-sized hall	theater	5
6	medium-sized hall	medium-sized hall	medium-sized hall	saloon	6
7	medium-sized hall	medium-sized hall	medium-sized hall	chapel	7
8	small hall	small hall	small hall	live house	8
9	small hall	small hall	small hall	disco	9
10	small hall	small hall	small hall	lounge	10

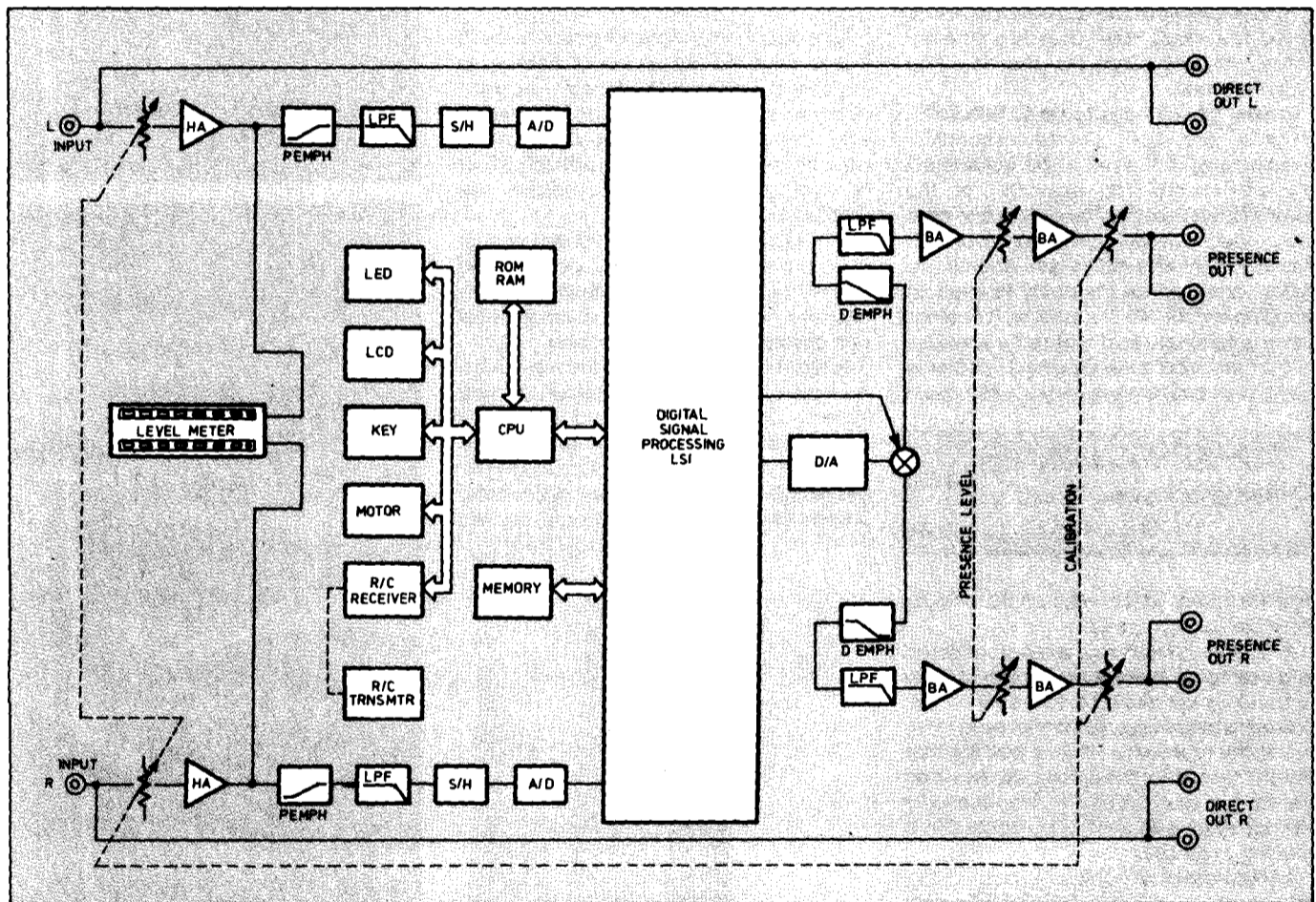

The DSP-2000 block diagram.

SATELLITE SPEAKERS

Pat Hayes looks at a set of novel speakers from Sweden.

In a perfect world, buying a new pair of speakers would be a simple task. Go to a few shops, listen to a few different types, compare prices. Buy the ones that sound the best.

So why does it have to be so difficult?

There are, of course, technical requirements that need to be considered. The power handling capacity of the speakers, and whether the system can drive them effectively without being driven into distortion on music peaks is one. Whether the system amplifier has the ability to keep on pumping current into the speakers is another. It's an unfortunate fact that some speakers sound brilliant, but have a built-in impedance dip, that, at certain frequencies, produces a

*'Unlike the family dog,
we can't send them out
of the room'*

thirst for power which would make a South American dictator appear wimpish.

All of these problems can be considered and overcome. However, as well as listening to speakers, we also have to live with them. Unlike the family dog, we cannot send them out of the room when visitors call. But that doesn't mean that the criteria we use when selecting a young dshlicker from the local lost dog's home should not be applied to a speaker purchase.

A St Bernard is not considered a good dog for a small flat and, unless fine music is your only, all-consuming passion, a monster pair

of speakers is likely to look just as out of place.

An elegant living room will cease to be so if it is inhabited by a pair of doberman pinschers, or a pair of electrostatic speakers as big as doors. And there are some rooms where virtually any speakers will block the view, trip people up, interfere with the decor or even, in yuppie circles, destroy the ambience.

Is it possible to get miniature poodle speakers that will still give good sound quality? It is. They are called satellite speakers and their design is based on sound physical and psycho-acoustical reasoning.

Satellite systems, like those just released in Australia by the Swedish MDS (Multi Docking System) company, consist of one large speaker to handle the bass notes, and two or more tiny speakers to produce the higher frequencies. In a traditional sub-woofer system, only, one bass speaker is required

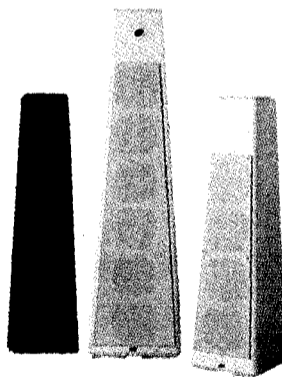

SOUND INSIGHTS, FEB. '89

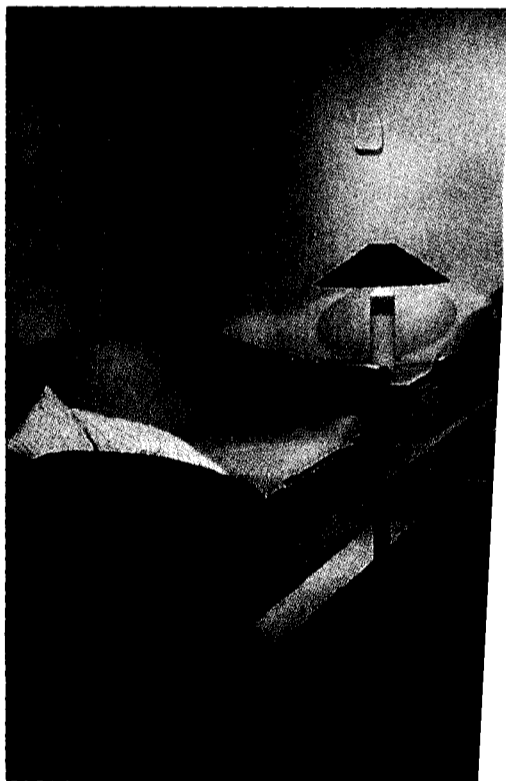
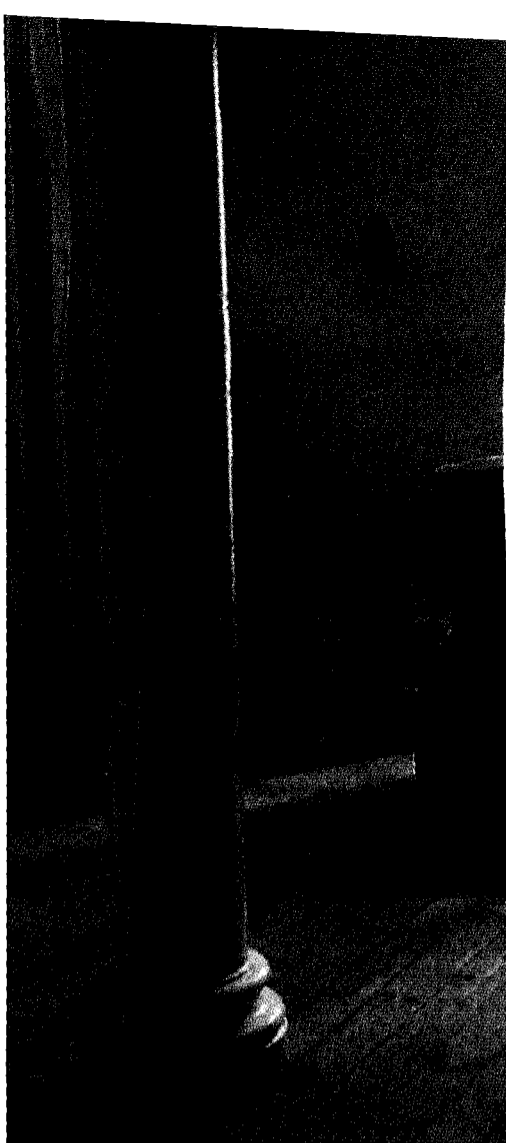

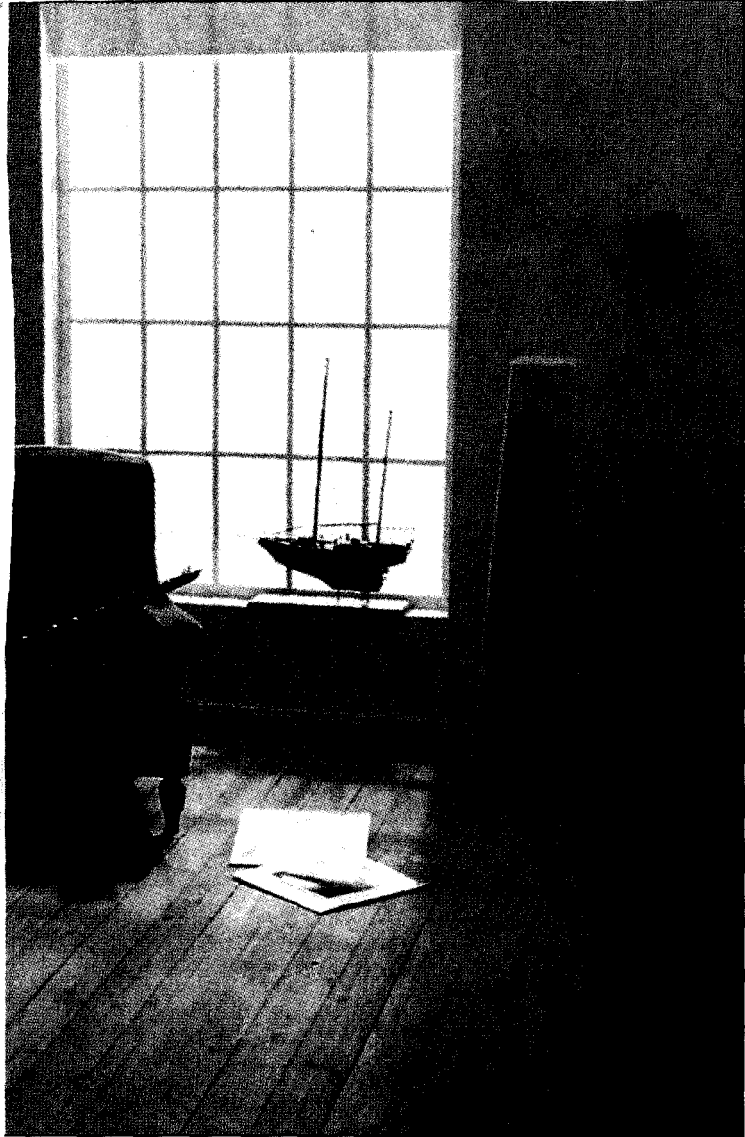

Surround is a term which crops up more and more often in circles concerned with qualified sound reproduction. It refers to a number of speakers working together to create an acoustic "room" around the listener. You can recreate the space of a large concert hall of church, the enclosed, intimate atmosphere of a small jazz club, or the spirit and closeness of a rock festival. If you have seen a recent, technically advanced film (e.g. one of Steven Spielberg's) you have probably experienced surround stereo.

The difference between ordinary stereo and surround stereo is enormous. Much greater than that between mono and stereo.

A number of hi-fi manufacturers already have surround decoders, either as separate units or built into amplifiers or receivers.

When you connect your MDS System 2000 (or System 1000 with additional lateral speakers) to one of these your record collection steps into the future.

System 1000 consists of three parts — two small, easily positioned speakers for mid-range and treble with optional (and interchangeable) attachments, and a woofer having four bass units and a built-in filter.

System 1000 is the complete hi-fi combination for those who have very high demands regarding sound quality. And it doesn't dominate the room, but blends easily into its surroundings.

System 2000 consists of five parts — four small, easily positioned speakers for mid-range and treble with optional (and interchangeable) attachments, and a woofer having six bass units and a built-in filter with level control.

System 2000 opens up new possibilities. The four lateral speakers, when correctly positioned, give you the feeling that you are right at the centre of where the music is created. You are completely surrounded by music. Better sound dispersion through the room, more power and dynamics. 14 speaker units, perfectly controlled by a precision filter, provide you with awesome power and realism.

P.O. Box 199, Turrumurra, N.S.W. 2074
Telephone: (02) 44 2155

READER INFO No. 40

SONICS MAGAZINE

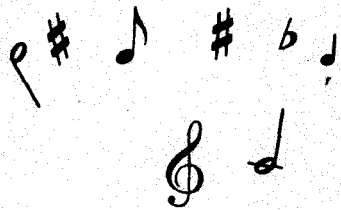

THE ALL AUSTRALIAN MUSIC MAKERS' MAGAZINE

OUT NOW

For: Musicians,
Road Crews,
Recording Engineers,
Lighting People,
Managers, Promoters
and anybody
interested in what
goes into
today's music-making.

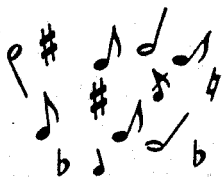

Available bi-monthly at
your newsagent or
subscribe now by phoning
(02) 693-9517 or 693-9515.

Satellite speakers

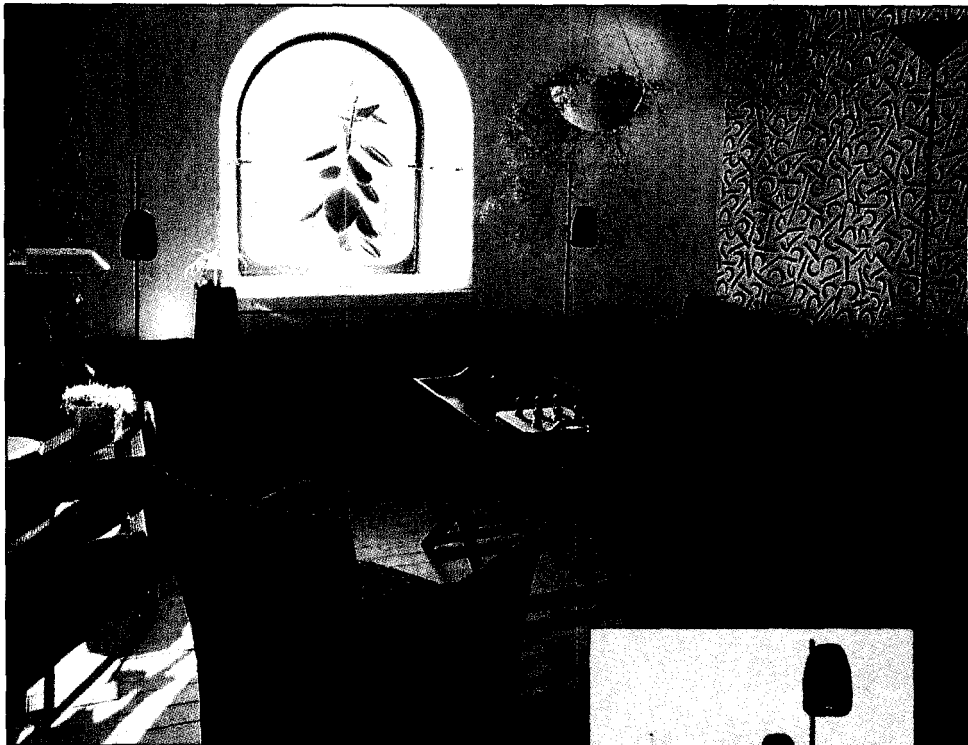

because our ears do not perceive low notes as coming from any particular direction. The stereo image is produced entirely by the higher notes.

However, the bass speaker in a satellite system is not a true subwoofer because it runs into frequencies that a normal speaker can reproduce. The two MDS system bass speakers run up to 120 Hertz and 125 Hertz. This means a satellite system does not leave you free to place the bass driver just anywhere. It does contain a certain amount of directional information, so it is better to place it somewhere between the high frequency speakers. You also need to place it near a wall to get the best possible effect.

The high frequency speakers can be quite tiny and still be able to reproduce music accurately. In fact, their small size can be an advantage as it enables them to radiate sound more effectively than speakers with a large, flat front surface.

The designers of the MDS speakers clearly have a good idea of why people buy satellite systems. They have come up with elegant shapes that would be at home in any decor or ambience.

The low frequency speakers are white or black columns with four drivers. The high frequency speakers are small, egg-shaped two-way speakers that can be hung on a wall, placed on a table or suspended on thin tubular stands. The amplifier is fed into the base of the bass speaker unit where the crossover network separates the high frequencies to be sent to the small speakers.

The MDS 1000 unit consists of the four-driver bass speaker and a pair of the high

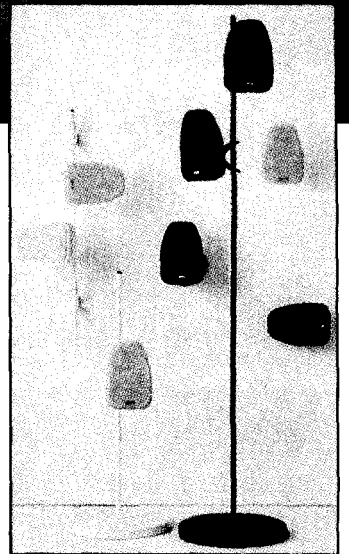

frequency speakers. Its recommended retail price is \$1599.

The MDS 2000 model has a bass speaker with six drivers and a level control that, strangely, is used to attenuate the high frequency speakers and four of the small high frequency speakers. Its recommended retail price is \$2800.

'The bass speaker in a satellite system is not a true sub-woofer'

The MDS 1000 bass unit is 830 mm high. The MDS 2000 stands 1120 mm high. The high frequency speakers are 160 mm wide, 155 mm high and 65 mm deep.

In Melbourne they can be seen at a new outlet, Audio Video Network, 338 Punt Road, South Yarra, ph (03) 267 5155.

SOUND INSIGHTS, FEB. '89



MARY RENNIE

NO OFFSET WITH TAPE LEVY

Copyright laws to change

Australia is moving swiftly in a bid to revise copyright legislation. Last year saw the passage from the House of Representatives to the Senate of the Copyright Amendment Bill. Mary Rennie writes.

The descent of digital audio tape into the well regulated western markets has prompted the revision of copyright laws. In the USA (where the future of digital audio tape technology seems still to hang on anti-copying legislation,) and in Europe, there has been much committee work. A paper recently published by the Commission of the European Communities has discussed the issues in detail, looking at the levy of a tax on blank tape as well as the introduction of anti-copying devices into DAT players. West Germany already charges such a levy on blank tapes.

Australia is moving more swiftly than the EC, however, and the final session of parliament last year saw the passage from the House of Reps to the Senate of the Copyright Amendment Bill with little opposition from either political side. The bill, among other things, seeks to address the copyright infringement problem of taping by "providing for a blank audio tape royalty to be paid to copyright owners in return for domestic copying of published sound recordings". The royalty, to be set by the Copyright Tribunal, will be "an amount per minute of normal playing time".

The actual amount, however, won't be divulged for some time yet, as the bill has still two readings to go; furthermore, the Tribunal's hearings on the audio tape levy are still to come. Given the interests of various parties, these are expected to be lengthy. Apart from looking at overseas experience, the Tribunal expects to hear from the Australian Recording Industry Association, blank tape manufacturers, and retailers or wholesalers who will possibly end up as the collectors.

According to the ARIA's David Watts, tape wholesalers and retail importers such as the

large chain stores are the preferred collectors of the levy, because as first sellers they are fewer and administrative costs are minimised.

So who are the beneficiaries? Broadly speaking, those who hold copyright – but exact proportions have yet to be worked out. The bill proposes the formation of a collecting society which Watts suggests will be a limited company with all copyright owners entitled to membership. Watts also suggested 15% of the levy would go to the Australian Contemporary Music Investment Company.

While this is good news for publishers and artists, to the consumer it only means a price

hike. There will be no corresponding drop in the price of records and CDs. ARIA describes the levy in moral terms as "some recompense for the infringement of copyright". Watts denies that there is any margin on records and CDs for income foregone from the pirating of tapes, so this levy represents an increase in profit – or income – for copyright holders.

If you bought your tape to record music you put together yourself, for computer programs, for recording lectures or interviews, or for any activities that do not infringe copyright, bad luck. The levy does have an exemption for you – if it's not too much trouble for you to present the collecting society with proof of the purchase and a statutory declaration that the tape will not be used to make copies of copyright sound recordings. The legislation has no mention of a refund for time and trouble expended in the effort. One of the curiosities of this bill is that it levies microcassettes, which are not capable of professional recordings, and lets off video tape.

However, the Copyright Tribunal's hearings on the levy on blank tape will be held in the following months. Any group or individual wishing to make representations about the issue has its opportunity there.



Tascam DA-50 is a professional DAT player. They are allowed into the country on sufferance.

SOUND INSIGHTS, FEB. '89

A BIT MORE OR A BIT LESS?

The bigger the better gets 'em in

J. Timmermans takes a close look at CD players and two factors which can present traps for the unwary buyer — sampling rate and word length.

When it comes down to the units, there's often not much between most of the leading hi-fi products. A certain standardisation due to technology, patents and quality control has become part of the industry. Yet the salesmen have still got to find a way to sell the goods, so they throw the figures at you — and hope the bigger the better will get you in.

The CD player is the classic case of this trend. Its performance is standardised, its parts protected by patent, and they almost never break down. Yet they still have to be sold. There are three factors on which buyers can be asked to select one model over another — price, sampling rate and word length. Price speaks for itself, but the other two present a few traps for the unwary.

The CD audio reproduction system can be seen as a cascading of three different building blocks, each of which can have different audio performance.

These building blocks are: the analogue to digital conversion (ADC) system at the recording side; the disc itself (storing the audio data); and the digital to analogue conversion system (DAC) in the CD player. To have the full benefit of the total system, each of the three building blocks must have the full channel capacity of perfect 16-bit amplitude resolution at the 44.1kHz sampling frequency.

The performance of the total system can never exceed the performance of the weakest of the building blocks.

The disc is a really perfect 16-bit, 44.1kHz system, but the ADC and DAC systems may only approach this performance level.

Assuming the ADC system is ideal, the total system audio quality is determined by the CD player's DAC. However the total result can never exceed the equivalent 16 bits at 44.1kHz. Practically, the DAC will be the boundary in the total system.

From this point of view it makes sense to raise the DAC's performance, but it doesn't make sense to raise it well above the equivalent 16 bits at 44.1kHz — a chain can never be stronger than its weakest link.

For instance, using a real 18-bit DAC converter at 44.1kHz does not give any



Information on the disc is the fundamental limit in a CD system

improvement compared with a real 16-bit DAC at 44.1kHz. Of course, using a 14-bit DAC at 44.1kHz decreases the performance, because it is now the weakest link in the chain.

However, it doesn't follow that all claims to multi bit performance are spurious. There can be two reasons why some manufacturers use 18-bit converters.

The first reason is that the perfect DAC doesn't exist. A typical more-bit DAC is better than a typical less-bit DAC. So normally a 10-bit converter will be better than an eight-bit converter. Therefore, some advantages might accrue by going to 18 bits if this

masked inaccuracies in your 16-bit DAC technology.

By and large, however, this does not apply to modern state of the art products. The converter's accuracy is not improved, as it once was, by simply adding bits. In fact, accuracy is now dependant on the technology locked up inside ULSI devices.

This means that an 18-bit DAC will not have better accuracy than a state-of-the-art 16-bit converter. Current technology is limiting accuracy until a certain level, a level that has nothing to do with the number of bits in a converter.

The second reason is not related to technology at all, but rather to advertising. For a typical outsider, the more bits used in a system, the better the total system is bound to be, even if the total system is restricted on another point in the system.

This is why some brands even compose two or more standard 16-bit DACs in some ways, to obtain a so-called '18-bit' system. The performance of these composed systems, however, is always worse than if only one of the 16-bit DACs had been used straightforwardly.

Oversampling

Oversampling is a different item. Basically, the higher the digital oversampling rate, the easier and simpler the analogue post-filter can be.

In other words, the more effort put in to the digital filter, the less effort is needed in the analogue post-filter.

But there are some caveats. The first is that the absolute gain obtained by raising the sampling frequency becomes less and less as the over-sampling rate increases.

The gain when going from the standard sampling rate to twofold oversampling is much more than going from twofold to fourfold oversampling.

The gain when going from fourfold to eightfold oversampling is still less. Of course, the step when going from fourfold to 16-fold oversampling is worth doing.

Unfortunately, there is a drawback when increasing the sampling rate of the DACs. When the sampling rate (or operating frequency) of a DAC system increases, its absolute performance decreases. This is because the DAC system has less time to settle properly.

With current state-of-the-art technology in consumer electronics, an 18-bit converter does not perform as well at eightfold oversampling, as at fourfold oversampling.

So, here too, more is not necessarily better. One must be careful when believing that eight-times oversampling is better than four-times oversampling. 

J. Timmermans is with the Product Innovation department at Philips.



ANTHONY O'GRADY

CD Reviews



Tracey and Melissa of Voice of the Beehive.

VOICE OF THE BEEHIVE

LET IT BEE

(London)

Cat. No. 828100.2

It would be all too easy to pigeon hole American singers Melissa Brooke and Tracey Bryn of Voice of the Beehive as under-graduates from the same school

at which The Bangles gained a PhD.

That's all too easy. Voice of the Beehive has a talent for turning tacky clichés into quirky beat, and, on my CD list at least, that makes them a major buzz.

A gym teacher told me she slipped Beehive's *The Beat Of Love* between Michael Jackson and John Farnham, only to have the class complain the beat was too hard to sweat to! It's not. It's

a direct descendant of David Bowie's *Gene Genie*, and if Reeboks can't get jiving to that, it's time to take up origami.

Still, in the hands of Beehive rhythm section (bassist Martin Brett and drummer Daniel Woodgate, ex-Madness) the beat does sound viciously staccato and brand new – the perfect backdrop to Melissa Brooke's emphatic vocals. "The beat of love is a nasty one/it's a flame from the devil's fire/cause nothing is stronger than boys and their eyes/and it's worse when you know he's a liar..."

As the song develops, the innuendos become more explicit. Writer Tracey Bryn never resorts to repeating a verse, and in modern songwriting, where the general rule is to repeat the first verse almost as often as the chorus, that's amazing.

Another surprise about *Let It Bee* is the fact that every song is different. These girls can sing it fragile and sweet, rock raucous, leather-lung tough, or with a heavy metaloid screech.

Suffice to say there are 11 tracks on *Let It Bee* and not one of them ever threatens to duplicate another's structure. The continuing links in this album are the basic timbre of the girls' voices and the quality of the song-writing. Long may the Beehive thrive.

DEEP PURPLE

NOBODY'S PERFECT

(Polydor)

Cat. No. 835-897-2

Deep Purple, like Yes, achieved enormous popularity in the 70s. Unlike Yes, who tried a reformation tour a few years back with minimal reaction, Purple can

pack out arenas and headline rock festivals on the strength of their past reputation and greatest hits.

Nobody's Perfect packs a double live album's worth of live recordings onto a single CD, and proves how little has changed in nearly 20 years of heavy rock. Or needs to change. Whether they're revamping classic Purple like *Black Night* or *Highway Star*, or flexing guitar solos on newer material like *Perfect Strangers*, the formula remains the same.

Drummer Ian Paice and bassist Roger Glover stamp out the beat like two synchronised, heavy duty pneumatic hammers, keyboard player Jon Lord occasionally emerges from the mix to finger a few quasi-classical motifs, vocalist Ian Gillan is living proof old lungs can still scream almost like new, while everyone takes care not to impede against Ritchie Blackmore in his quest for at least one lengthy solo – every song.

With Purple, there's little middle ground, you either appreciate them on an almost purely muscular twitch level, or passionately oppose them, and their genre, for any number of reasons, including the rampant sexism of the songs and their assumption of machismo for no other reason except volume overload.

Either way, there's no denying this lineup out-powers most of the younger heavy rockers around today. Nowadays, Ian Gillan may have to coast through the dementedly high pitched screams that are the feature point of *Child In Time*, but otherwise his vocals are in fine shape. Meanwhile, Ritchie Blackmore, long regarded as one of the most tedious guitar heroes in rock, seems to have re-

discovered some of the dexterity and sparkle that caused him to be so well regarded in the 70s.

VAN MORRISON AND THE CHIEFTAINS

IRISH HEARTBEAT

(Mercury)

Cat. No. 834-496-2

Irish Heartbeat links two national heritage forces to Irish music. For Van Morrison it's very possibly a welcome respite from the tortures of his demanding muse. For the Chieftains it's yet another chance to propagate traditional folk to the modern world.

Both aims are fulfilled satisfactorily. The Chieftains' multi-textured music is a fitting backdrop for Van Morrison to keen and wail on such standards as Raglan Road and Carrickfergus, though his most heartfelt vocals come on his two originals, Irish Heartbeat and Celtic Ray.

Overall, though sometimes the mood veers towards cosiness on the likes of Marie's Wedding, Irish Heartbeat espouses the complex heartbeat behind the deceptive simplicity of Celtic folk.

ELVIS PRESLEY

THE NUMBER ONE HITS

(RCA)

Cat. No. 6382-2-R

Surprisingly, Elvis Presley does not make an appearance on any Australian Top Hits list. But then, the first recognised Top 40 chart did not appear in this country till March 1958, by which time Elvis had already dominated world charts for nearly three years.

This collection of Number One Hits is based on the American Billboard charts and contains 18 hits, starting with Heartbreak Hotel in 1956 and ending with Suspicious Minds in 1969.

As such, it's very much a compilation of styles. Early Elvis was a rockabilly rebel, a wild, beautiful voice strung over the impeccable rhythms of class players like guitarist Scotty Moore and bassist James Black.

To many, this period, featuring songs such as All Shook Up and Heartbreak Hotel will always be the definitive Presley. But the secret of his longevity was his ability to adapt his voice to all styles; a syrupy ballad like Love Me Tender could be followed by the pap pop of Teddy Bear, and then the semi-operatic It's Now Or Never.

By the 60s, with Presley almost totally buried in formula films, the happy coincidence of his vocal ability meeting a quality song was a rare event. The late 60s did bring a renaissance of sorts, with the spectacular Suspicious Minds being his last US No 1 in late 1969.

Presley has not been served well by re-issues and repackages. Even this CD (which has the virtue of being official history) has been compiled with a bare minimum of information and no liner notes whatsoever.

CRASH POLITICS

MOTHERS INVENTION

(Rooart)

Cat. No. 836 123-2

SECRET SOCIETY

DISQUE

(Aural Sect Records)

Cat. No. A5 001

These two very different sounding albums are reviewed together (a) because both bands are Australian independents and, (b) even though they come from different ends of the sound spectrum, they have something in common - they both sound incredibly old-fashioned.

Crash Politics has a strong following around Sydney. At their best on stage, they raise a sweat and send the punters home happy. On record though, they sound as if they're having as much fun as a visit to the dentist.

A song with the promising title of Great Smell Of Freedom is delivered with all the *elan* of reading a grocery list. The music has the feeling of been constructed in fragments; get the

rhythm section on a groove, add guitar and keyboards, lay the vocals on top. This is a time honoured, relatively failsafe system of songwriting. The downside is a plethora of carefully constructed music that lacks dynamics.

Crash Politics' greatest problem is, by the time they've made their music bed, they've also determined exactly how they're going to lie in it. Their vocal melodies are so predestined that after you've heard the first few lines of any of their songs, you know how the remainder must flow.

Secret Society hails from Nimbin, the last stand for Australia's hippie population. In 1986, they made it onto Countdown with a homemade video of their first single, Brave New Way. They have been determinedly slogging it alone ever since.

Their spirit is commendable, but, given their background, it's somewhat surprising when the opening track, Vision Of A Promised Land, emanates from the speakders sounding uncannily like Duran Duran, circa 1981.

In the late 80s, when the biggest business band in the world is the reformed Pink Floyd, why aren't four boys from Nimbin hauling out psychedelic power chords and wearing flowers in their hair?

According to voluble manager, Phil Tripp, the band loathes psychedelia. Nevertheless, they are eclectic; disco pop, acoustic ballads, power pop and refined metal all make appearances on Disque. And Secret Society do have strengths - their rhythms are perky, the melodies full. Their lyrics are about love, the misery of urban and bureaucratic sprawls, and the horror of nuclear politics.

While Crash Politics and Secret Society are independent bands by virtue of not being signed direct to a major distributor, both are distributed by PolyGram Records.

Secret Society, though, had more "hands on" involvement with their CD. They not only organised and supervised the manufacture, they printed the cover inserts on their home computer and assembled the finished product.

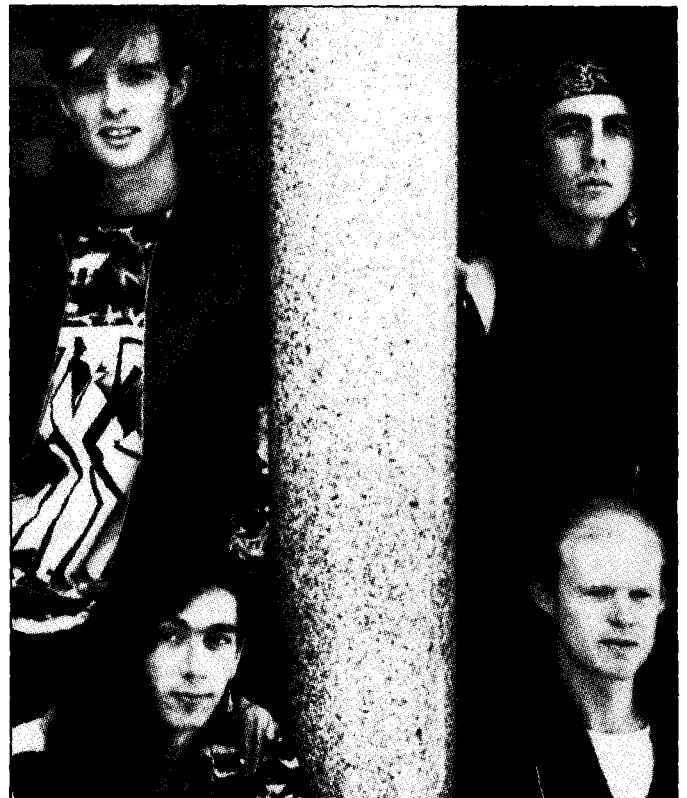

Secret Society.

THE TECHNICS HI-FI CHALLENGE:

When you're in the market for a Hi-Fi system, it's easy to become confused by the myriad of brands and styles available. It's often difficult to choose between systems — what features are really important? And which are merely for show?

At Technics we make this choice easy. We use the latest technology and fine craftsmanship to create features that expand your musical experience. Such as Major Function infra-red remote control, which allows you to operate your unit from anywhere in the room.

Normally, this function is only available on expensive top-of-the-range models. But at Technics we thoughtfully provide you with full remote control on every one of our Midi Hi-Fi systems.

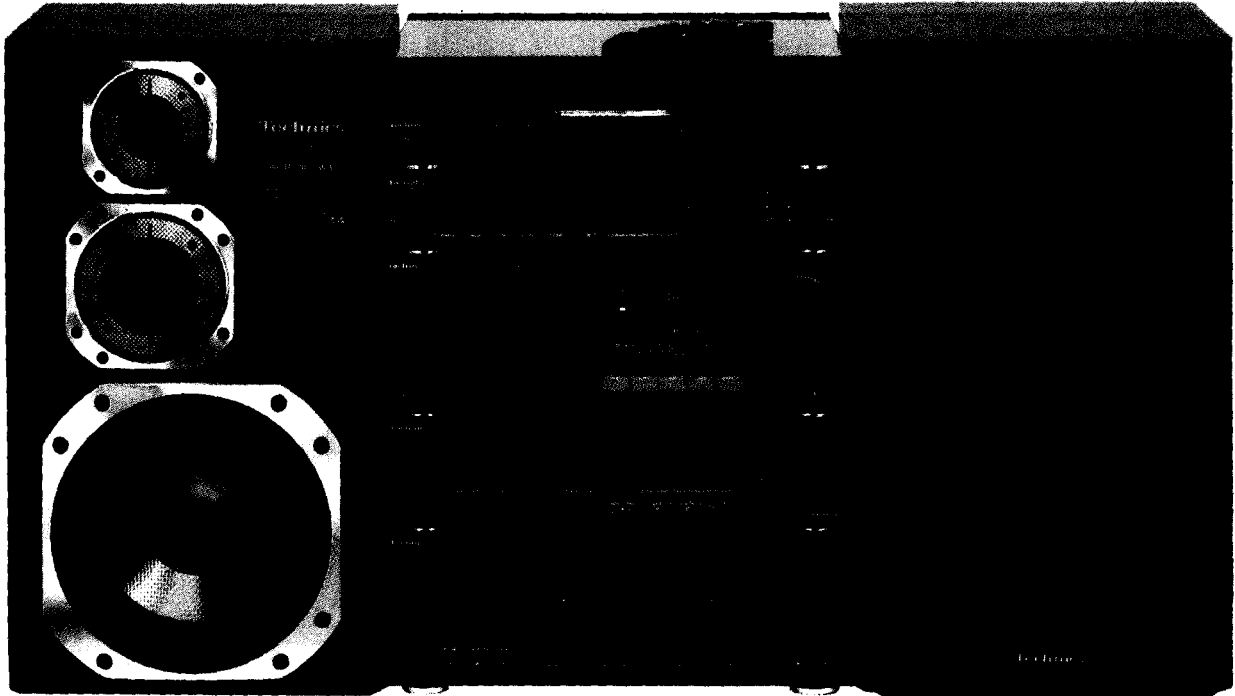

Nothing comes remotely close.

We also give you other important features. Like Class AA amplifier circuitry, which reduces noise while purifying and concentrating your sound power; double, auto reverse tape decks; fully programmable *CD players; Digital Response speakers, and sophisticated Quartz Digital tuners.

It all adds up to superior sound quality at an affordable price.

So don't waste your hard-earned dollars on another possibly obsolete sound system.

Take up the Technics Challenge — on features, quality, service and reliability. We know you'll be glad you did.

*CD player optional.



National, Panasonic, Technics are from National Panasonic (Australia) Pty Limited.

READER INFO NO. 11

Technics

HI-FI

YAMAHA'S NEW CDX 1110 CD PLAYER OWES ITS BRILLIANCE TO A PIECE OF TWO-BIT TECHNOLOGY.

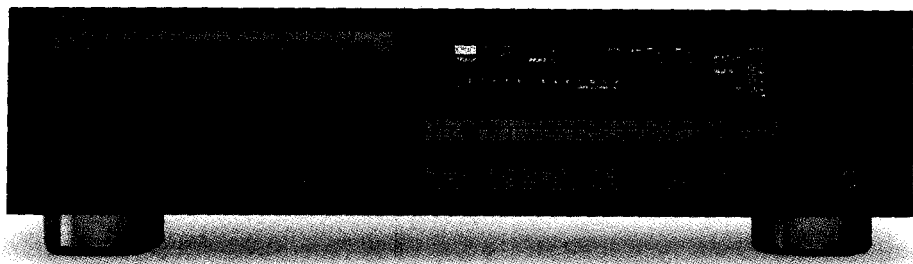

Until now, CD players were limited to 44.1 kHz and 16 bit technology. Now Yamaha has, as Audio Magazine states, "found a way to improve on perfection". Introducing the world's finest CD player that features 18 shifting bits and 8 times oversampling digital filters. A technological progression that quadruples both sampling frequency and density to produce exquisite wave-form resolution.

The result is unsurpassed sound quality. We could mention its 44 key wireless remote control, its new 3 beam laser pick-up, its 24 track direct access and random access programmable playback. Or we could compare it to our previous model, the CDX 1100. Of which Audio Magazine said "As to how a CD player is ideally supposed to sound, we do not hesitate to say that it should sound like the

CDX 1100". All of which proves that the new CDX 1110 won't sound one bit better than any other CD player. It'll sound two-bits better. Starting at \$399, our entire CD player range is there for the picking in your local Yamaha Hi-Fi store.

Y M H

5 YEAR WARRANTY.

PERREAUX

BY
PERREAUX

UNIT 10, 21-29 CHESTER STREET, CAMPERDOWN, SYDNEY, NSW. TELEPHONE: (02) 519 3977

READER INFO No. 32

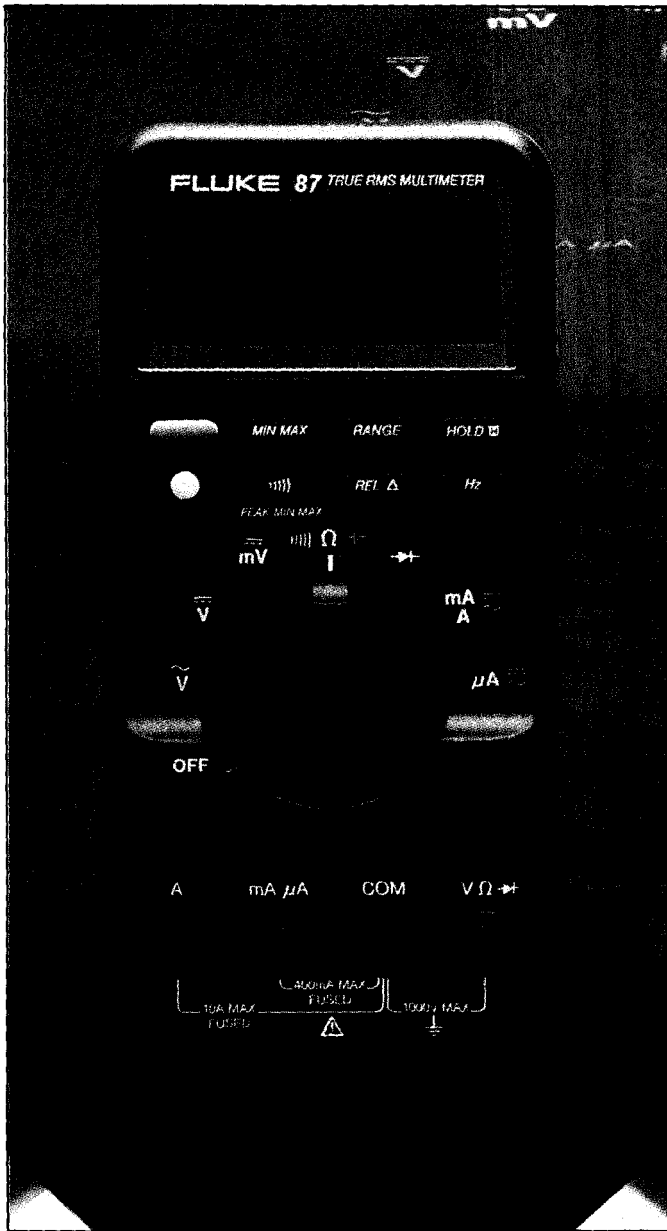

New from Fluke ▲

The 80 series is a new three-model family of low-cost, high-performance 3½ digit sealed handheld multimeters from Fluke. The Fluke 83, the higher accuracy Fluke 85 and the top-of-the-line Fluke 87 offer true RMS, including frequency, duty cycle, capacitance, simultaneous minimum-maximum-average recording, Min-Max alert and input alert.

The Fluke 80 series incorporates the features of the existing 70 series with higher accuracy and more ranges. The

Min-Max average recording mode also makes the 80 series well suited for finding intermittent failures and interference. The audible Max-Min alert pinpoints intermittent failures by signalling the user with a short beep only when a new minimum or maximum value has been recorded.

For more information, contact: Phillips ☎ (02) 929 4784.

READER INFO No. 150

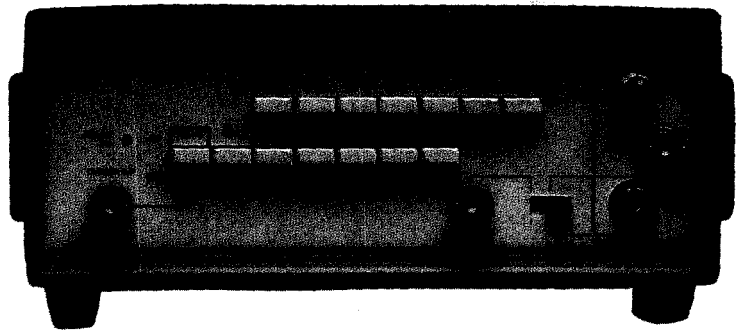

Colour pattern generator ▲

A low cost, mains operated bench instrument, the Orion TV and video PAL pattern generator has been manufactured and developed in the UK for TVs, VCRs, and monitors.

Features include separate rf and composite video outputs with level control, turntable rf carrier, internal or external sound modulation, switchable sound

carriers and positive or negative video modulation. A front panel source of frame and line sync pulses is provided for scope triggering. It is compatible with PAL systems B, D, G, H, I, K.

For more information, contact: Atest Electronics ☎ (03) 233 5889.

READER INFO No. 151

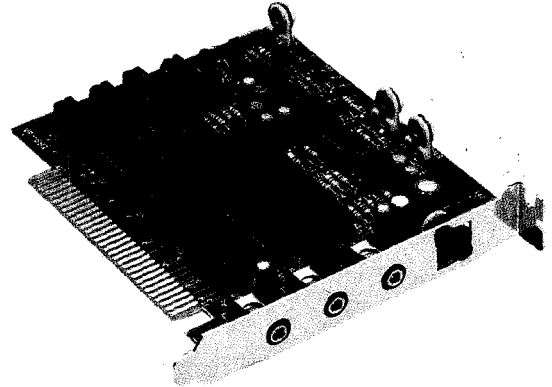

Solidstate cassette ▲

The Eltech VP870 voice card is a general purpose sound/music recording, storage and playback device with excellent sound reproducing fidelity. It is a plug in card for a PC. To meet various system requirements, a manual is provided with detailed information about the hardware, block diagram, I/O ports definition and accessible sub-routines for personal software entries.

The basic performance of the VP870 is similar to a cassette recorder. The operations of record, play, stop, forward rewinding, rewind and position indicator of a normal cassette recorder are also available in the

VP870.

Software version 3.01A has a buffer of 64K which is used for temporary storage of the current recording before transfer to the hard disc. This arrangement enables a 20Megabyte hard disc to store and record up to 1.3 hours at 32K bps sampling rate, or more than two hours when the sampling speed is 20K bps.

To meet the speed requirement, version 3.01A must operate with a hard disc and with system speed no less than 10MHz at the maximum sampling rate of 40K bps.

For further information contact: Zenology, ☎ (03) 232 0599.

READER INFO No. 152

Arraycorder ▶

The new WR3600 Mark 10 is capable of recording eight 40 mm wide channels of dc to 10 kHz data. There are three modes of operation – direct, transient, and logging, selectable by a single key stroke. 32K of memory per channel is provided. The recorder prints a timing and amplitude grid simultaneously with the data, and a selection of six grid formats is available. Full control of channel width and trace expansion – to 80 mm or 160 mm is by front panel input.

The Mark 10 offers 44 pre-set chart speeds ranging from 0.01 mm per minute to 200 mm per second. There are 15 sample rates, ranging from 2K through 100K samples per second, selectable from the front panel.

For more information contact: AWA Distribution ☎ (02) 888 9000.

READER INFO No. 153

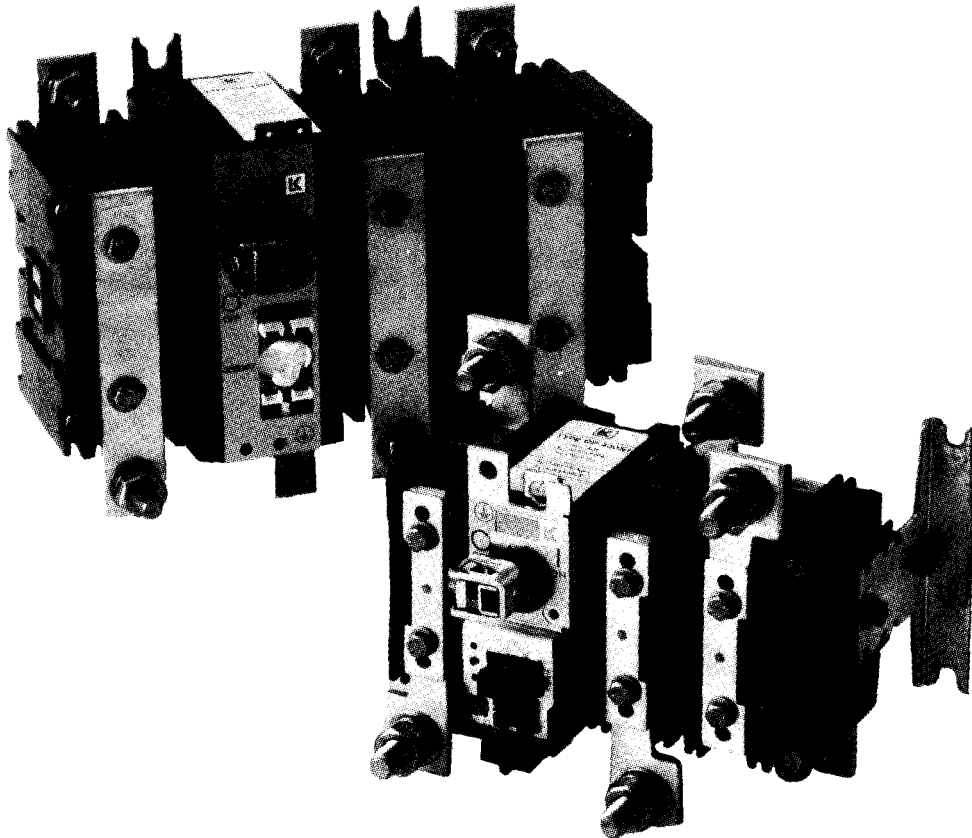
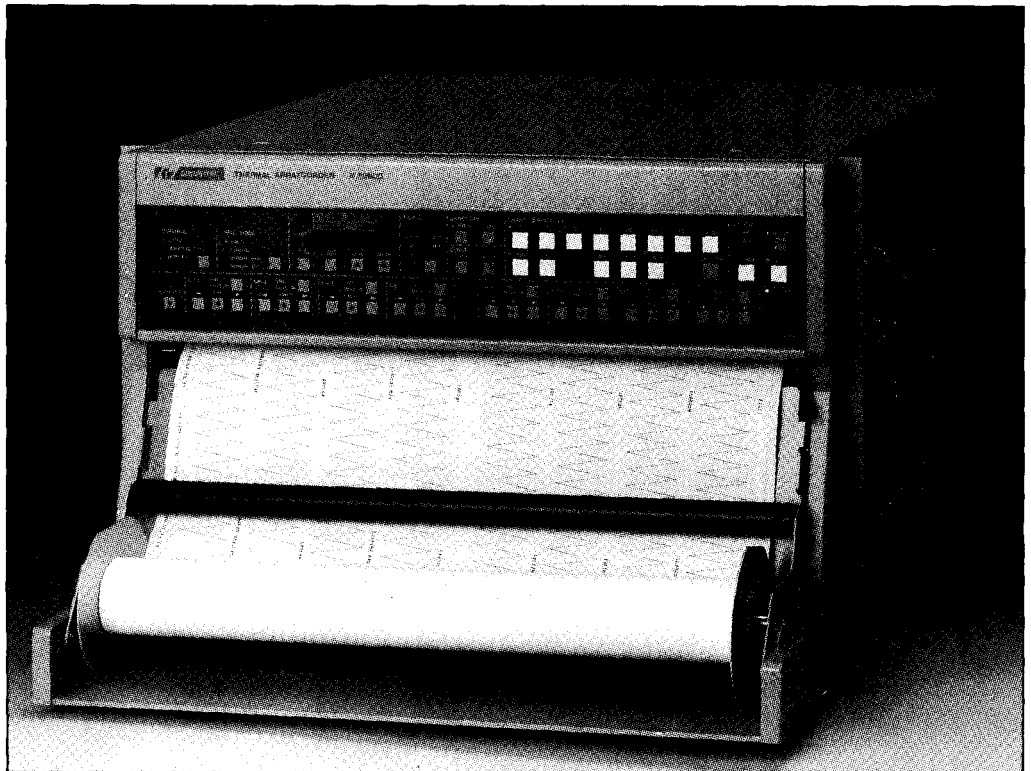

Loadbreaker ◀

The LK loadbreak switches are split into two types. First of all, the very high switching performance QA motor switches and the very high, short time rated QP general purpose switches. Both are specified for 400A applications.

Obviously, there must be a reason for two switches to do the one job and that is basically size, economy and ratings. The first of the new switches is the QP 400N1 which is in the frame size 1 module size. This switch has fused short circuit ratings up to 50kA and has a short time rating of 8kA for one second on its own.

The second switch is the QP 400N which is in the frame size 2 module size. It can be packed up by a 630 amp fuse to a fault level of 100kA and has a short time rating on its own of 25kA for one second.

As usual, with the LK switches, both these loadbreak switches are rated for 400 amp full load current when totally enclosed.

For more information, contact: NHP Electrical Engineering ☎ (03) 429 2999.

READER INFO No. 154

IEEE-Z

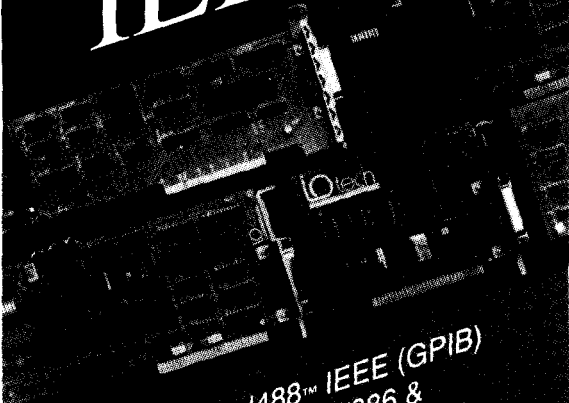

Our Personal488™ IEEE (GPIB) interfaces for PC/AT/386 & PS/2s are packed with these **easy-to-use** features:

- DOS device driver loads at power-on
- Hewlett-Packard style commands
- Automatic error indication
- BASIC ON SRQ GOSUB capability
- DMA transfers over 300K bytes/s
- Up to four IEEE boards/computer
- NEC-7210 compatible software
- Serial/Parallel/IEEE port redirection
- DMA and interrupt channel sharing
- Compatible with popular languages (no extras to buy), including BASIC, GWBASIC, Quick BASIC, Compiled BASIC, Turbo BASIC, True BASIC, TBASIC, Turbo Pascal, Microsoft Pascal, Turbo C, Microsoft C, Aztec C, Lattice C, Microsoft Fortran, Lotus 1-2-3/Symphony/Measure, ASYST, DADISP, Test Windows, AutoCAD, and many more.

LOtech



SCIENTIFIC DEVICES AUSTRALIA PTY. LTD.

Melbourne (03) 579 3622
 Fax (03) 579 0971
 Sydney (02) 958 8064
 Fax (02) 958 8890
 Adelaide (08) 281 3788
 Fax (08) 281 4194

READER INFO No. 13

OrCAD

Systems Corporation

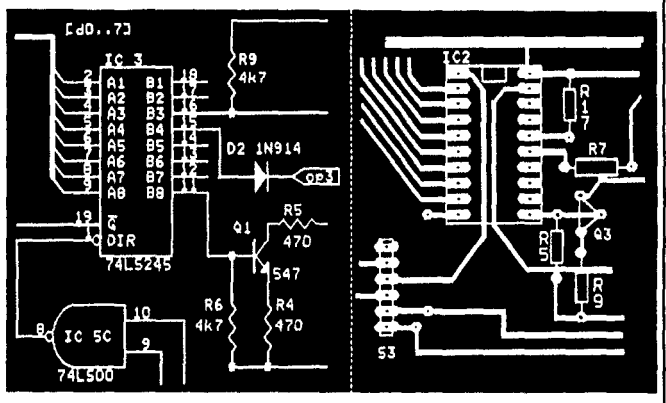
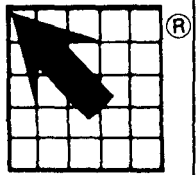

Power and Speed at an affordable price, on your IBM PC.

OrCAD the powerful and easy to use Electronic Design Software now provides complete End to End Design.

First design your circuit using the Schematic Design Tools (SDT).

OrCAD/SDT Features:

- Over 3700 unique library parts and graphic parts editor
- Unlimited levels of hierarchy
- Standard macros supplied and user entry of keyboard macros
- Netlisting to 22 other packages plus other post processing utilities
- Variable size worksheets, text and output

Simulate your design with Verification/Simulation Tools (VST).

OrCAD/VST Features:

- 14,000 gate capacity from up to 50 channels input
- 10,000 events per second (8MHz AT)
- 10 breakpoints, 16 AND/OR signals per breakpoint
- Logic analyser format simplifies data analysis
- Selectable minimum or maximum delays and model library source

Finally produce your design using Printed Circuit Board (PCB).

OrCAD/PCB Features:

- Auto routing up to 32" x 32" with 16 copper layers maximum
- Selectable track, via and isolation from 0.001" to 0.255"
- Square, rectangular, round, oval and SMD pads
- Grid bases of 100, 50, 25, 10, 5 mils. Off grid to 1 mil.
- Ratsnest, force vector for placement optimization

All OrCAD products are fully compatible and include **12 months free updates and support.**

CUT OUT AND MAIL TODAY.

We will send you a FREE Demo and Literature.

Name _____
 Title _____
 Company _____
 Address _____
 Telephone _____ Fax _____

Prometheus Software Developments Pty Ltd
 260 high Street Kew. Vic. 3101.
 Telephone: (03) 862 3666.
 Fax: (03) 862 2092.

READER INFO No. 14

New copier ▶

Toshiba's new BD-8510 plain copier is designed to meet a wide variety of user requirements from professional quality documents to sales reports, overhead transparencies, copying on letterhead stationery and other special materials. It can output 999 copies in a single run at a speed of 40 copies per minute, ensuring a substantial productivity increase for any office. It has a recirculating automatic document feeder (RADF) as standard, so that "hands off" copying is available.

For further information, please contact: Toshiba ☎ (02) 887 6054.

READER INFO No. 162

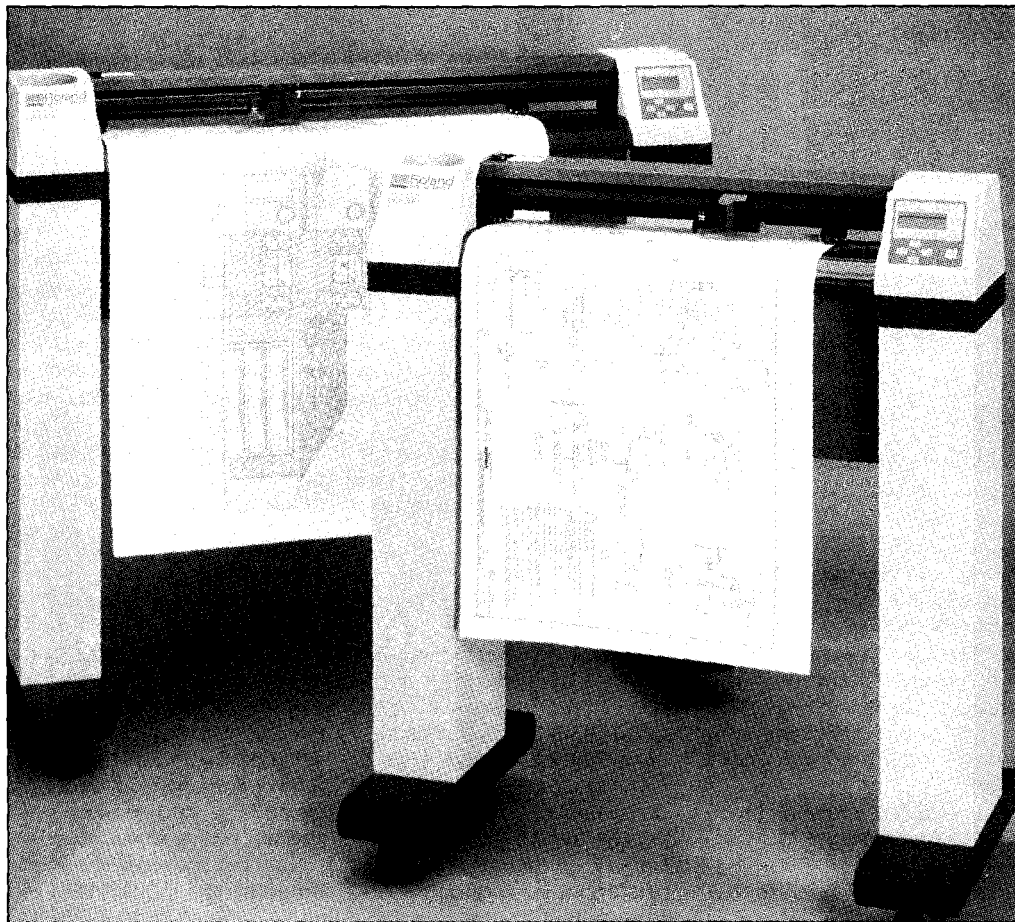
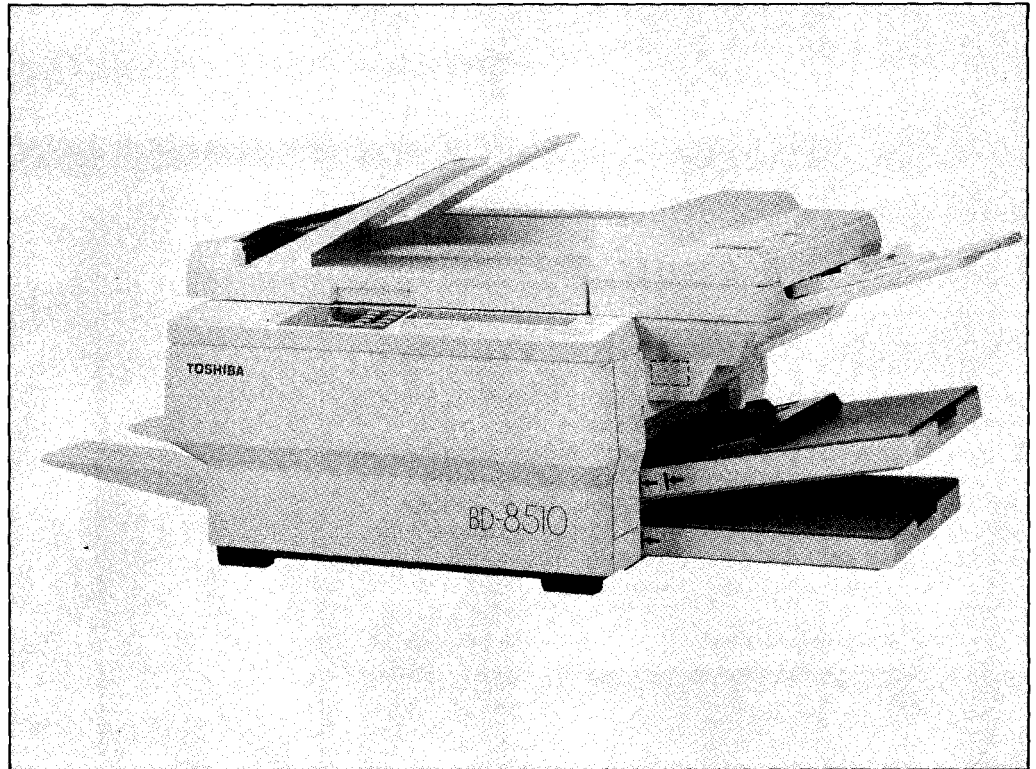

1Mb RAM Plotter

Roland DG Australia's newly released GRX 300 and 400 series plotters have been upgraded to incorporate 1Mb memory as standard.

The plotters can operate as stand-alone units, carrying out plots and re-plots and freeing the host computer for further design work.

The GRX-400 AO plotter operates at speeds of 600 mm/sec with an acceleration of 3g, while resolution of 1.56 microns (0.00156 mm).

This accuracy is much finer than the tip of a pen, and allows drafting of plans to be used with greater accuracy in the field.

Price of the GRX 300 unit ex tax is \$9490, and the GRX 400 (ex tax) \$12,956.

For further information contact: Adrian Stephens, Roland, ☎ (03) 241 1254.

READER INFO No. 163



Multigate connects for Webster

Webster's Multigate was publicly exhibited recently for the first time at Darling Harbour in Sydney.

It is a multi-functional product that provides a gateway for Macintoshes to communicate with each other and with other computer systems running TCP/IP.

Only one Multigate is needed

to connect up to four LocalTalk networks. At the same time, if required, Multigate can be used as a gateway between four LocalTalks and an Ethernet.

For further details contact: Webster Computer, 1270 Ferntree Gully Road, Scoresby, Vic, 3179. ☎ (03)7641100.

READER INFO No. 164

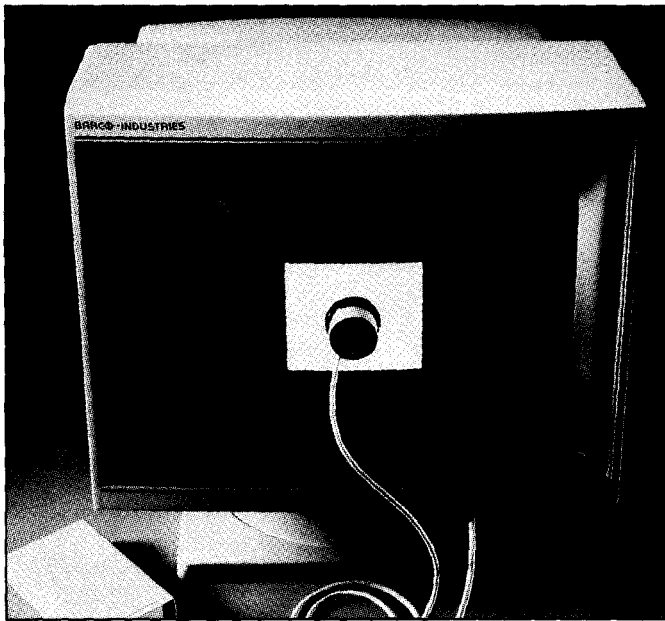

The calibrator

A self-calibrating colour monitor is now available in Australia through Trace Technology.

The Calibrator, from Barco Industries, is described as the first intelligent high resolution colour graphics display.

Barco claims it's a completely new concept in display technology. It is equipped with a microprocessor, memory and RS-232 communications. It reports its colour settings to a host computer, accepts commands

for new settings from the host and, with the help of a colorimeter from Barco, calibrates itself in about 2 minutes. All setup parameters - colour drive, parabola, trapezium, sweep size, linearity, phase and frequency - are under the microprocessor's control.

For more information contact: Trace Technology ☎ (03) 646 5833.

READER INFO No. 165

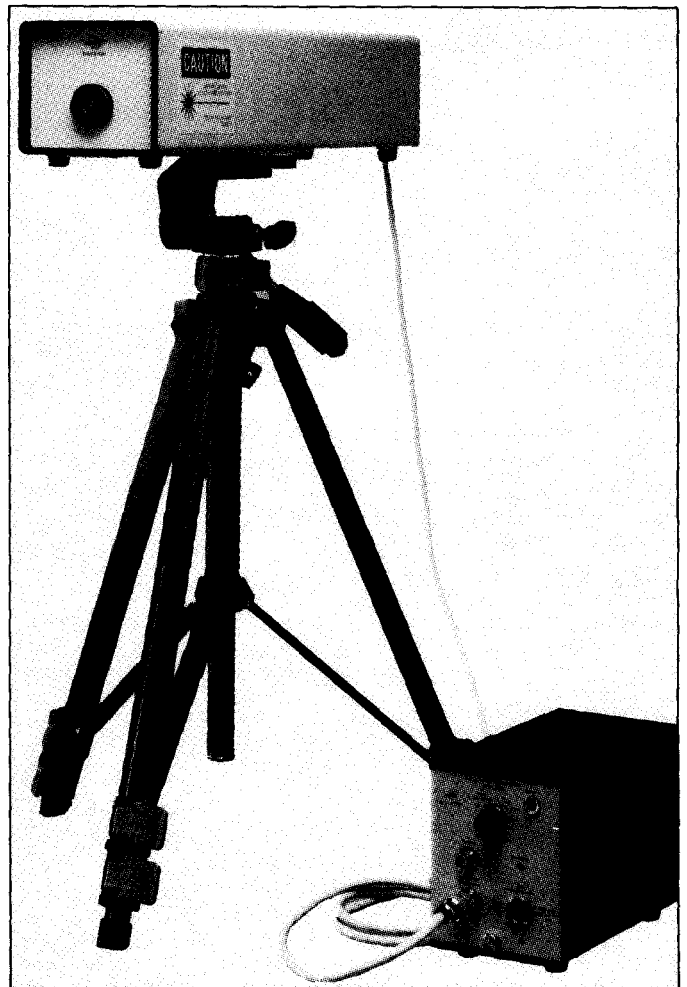

Vibration measurement

With the introduction of the laser velocity transducer, Brüel & Kjær advances into the world of non-contact vibration measurement. It uses a laser to measure vibration amplitude.

The Type 3544 is designed for applications where an accelerometer cannot be used or mounted.

The Type 3544 is fully portable, battery-driven and safe. It complies with the requirement for Safety Class 2 of ANSI Z136.1 and BS4803: radiation safety of laser products and systems.

Further information is available from any Brüel & Kjær local office. ☎ (03) 370 7666.

READER INFO No. 167

Measure data acquisition

Elmeasco Instruments has released an enhanced version of the Lotus Measure data acquisition and instrument control software system. It runs on IBM PC/XT/AT personal computers, and several IEEE-488 boards for these machines. It comes with multifunction analogue, digital, and input/output boards.

Measure is a software system for scientific applications that require data acquisition and instrument control. It consists of a set of data acquisition drivers for 1-2-3 or Symphony for acquiring, formatting, and storing data directly into a spreadsheet.

For more information contact: Elmeasco ☎ (02) 736 2888.

READER INFO No. 168

SPEED, FIDELITY and... ...UNPRECEDENTED TRIGGERING

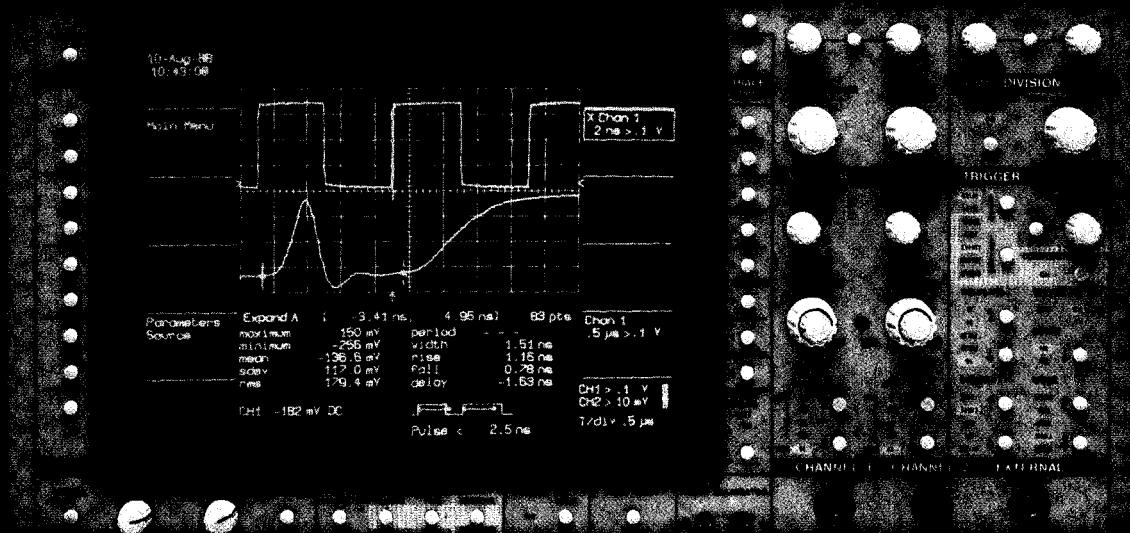

FASTGLITCH trigger mode is used to trigger on a glitch 1.51 nsec wide which occurs before the leading edge of a 500 kHz clock signal (top trace, see trigger arrow at the bottom of the graticule). Fast sampling rates, automatic pulse parameters and horizontal expansion by 250 times (lower trace) all combine to reveal the signal details.

- * 350 MHz Bandwidth, 400 Ms/s ADCs
- * 50K Non-volatile Memory per Channel
- * Glitch, Interval and Logic Trigger Modes
- * Automatic Waveform Parameters

Until now, recording very high-frequency signals with digital oscilloscopes often meant giving up measurement fidelity, due to short acquisition memories, inadequate vertical resolution, or sometimes even both. **NOT ANY MORE!!**

With LeCroy's new 9450 you get it all, 350 MHz bandwidth, 400 megasample/sec digitizing rates, 8-bit vertical resolution (12-bit with averaging), 50,000 words of acquisition memory per channel and... a uniquely powerful trigger system.

Glitches, drop-outs, logic patterns and states are all triggered on easily with LeCroy's new and innovative FASTGLITCH, INTERVAL and LOGIC trigger modes.

The 9450's massive memories show more pre- and post-trigger information so you can examine the cause and effect of any signal perturbation. Waveform expansion (up to 1000 times) reveals **ALL** the signal details you are looking for, and fast parameter calculations deliver the answers you need in a fraction of a second.

And... you already know how to use it. A familiar front panel, together with a push-button **AUTO SETUP** facility, lets you rapidly learn to operate this new member of the LeCroy oscilloscope family.

ETPOXFORD

LeCroy Corporation, 20000 LeCroy Drive, Hickory Creek, PA 19037

Innovators in Instrumentation



Optical head ▲

Tektronix' S-42 optical sampling head is the first off-the shelf instrument designed to work integrally with an oscilloscope to convert optical signals with bandwidths from dc to 6.4GHz. A fully calibrated instrument, the

S-42 can be used with any Tektronix 7000 series oscilloscope equipped with a 7S12 or 7S11 sampling plug-in.

For more information, contact: Tektronix ☎ (02) 888 7066.

READER INFO No. 171

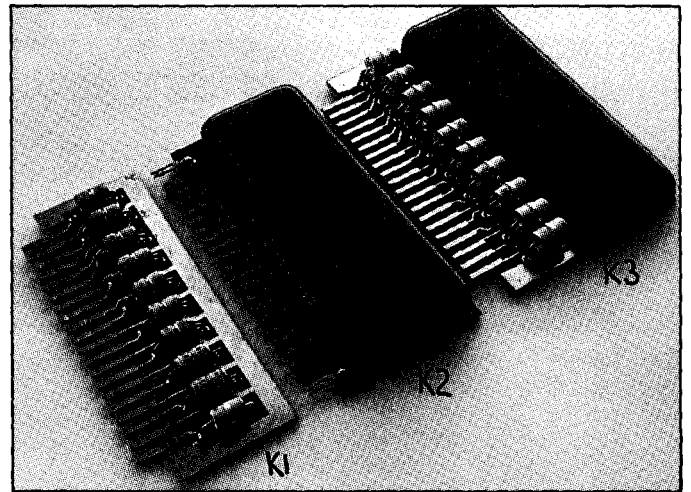
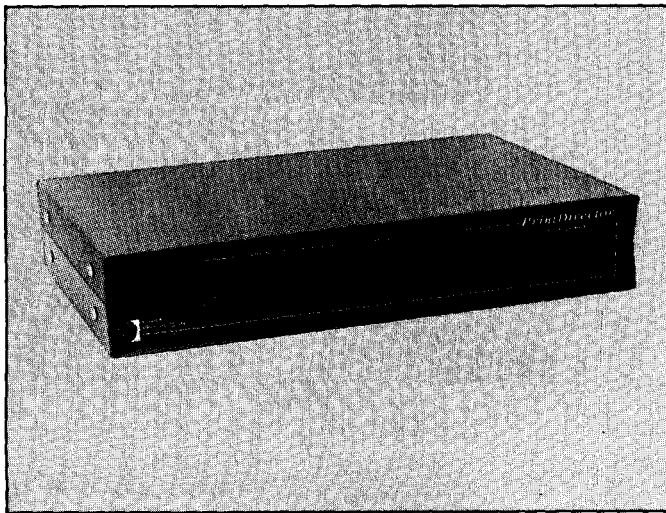

Lightning protector ▲

Lightning is a major cause of damage to electronic PABX and telephone systems. The SLPIO series of protector units limits overvoltage. They are transparent to voice signals, and do not affect dial impulses or shunt ring current. Under lightning surge

conditions they act to limit overvoltage. Transient impulses of 6kV, 5kA are bypassed and equipment voltages are typically limited to less than 80 volts on 50 volt systems.

For more information contact: Fax (002) 73 1871.

READER INFO No. 172

25MHz clone

Email Electronics, the Australian distributor for Intel Corporation, has just released the Microsystem SYP302 PC-compatible.

Running at 25MHz, the Intel 80386 based System 302 offers OEM's state of the art performance in a PC-AT compatible design. A 64K byte cache provides effective O wait state execution, without the high cost of fast access memory. Memory

capacity is extensive, beginning at 2MBytes or 4MBytes on board, expandable to 24MBytes via two 32 bit expansion slots. Additionally the System 302 is designed to pass FCC B and VDE B levels of EMI/RFI regulations, a significant test at 25MHz.

Units are now available. Contact: Email Electronics ☎ (03) 544 8244.

READER INFO No. 173

Print director ▲

A new multi-port system released by Data Bridge Communications enables multiple PC users to share common peripherals such as printers, modems and facsimile machines.

The product, called Print Director, was developed by Digital Products. It is available in a series of configurations, from six ports to a mixture of 32 serial, parallel and RS422 ports.

Print Director enables any type of printer - laser, dot matrix, letter quality - or plotter or facsimile to be accessed by any other PC or

other host terminal that is connected. It is completely transparent to both computer and peripheral.

An in-built buffer acts as a print spooler, freeing up the PC even if the chosen printer is in use.

The base unit Print Director retails at \$1900, while a six-port version, the Print Director Junior with 250K-bytes of memory is available as an introductory offer for \$999 (inc. tax).

For further information: Data Bridge ☎ (03) 578 0814.

READER INFO No. 174

THE ELECTRONIC COMPONENTS SHOP

289 Latrobe Street,
MELBOURNE

PHONE: (03) 602 3499 FAX: 670 6006

METRIX MULTIMETERS



MX41 \$298.80
MX43 \$342.00
MX45 \$534.00
MX47 \$594.00

EUROPE'S LARGEST SELLING
MULTIMETER.

IF YOU WANT A MULTIMETER
THAT'S GUARANTEED TO WORK.

- Measuring rate 2.5/s
- Autoranging or Manual Range Switching.
- 'MEM' function to hold measured value.
- 'MAX' function to hold maximum value.
- True RMS measurement (MX47).
- Temperature measurement with K-Type thermocouple probe (MX47).

IC MEMORY

*Been having trouble sourcing memory?
We have the following ex-stock (as of 1-12-88)*

DRAM	SRAM	EPROM	CMOS EPROM
4116.....\$ 2.50	2114.....\$ 3.00	2708.....\$10.00	27C32.....\$ 8.50
4164.....\$ 6.00	6116.....\$ 7.00	2716.....\$ 8.00	27C64.....\$ 8.00
41256.....\$20.00	6264.....\$18.00	2732.....\$ 7.50	27C128.....\$10.00
411000.....\$60.00	62256.....\$25.00	2764.....\$ 6.50	27C256.....\$12.50
4464.....\$20.00		27128.....\$ 9.50	27C512.....\$22.00
		27256.....\$12.00	
		27512.....\$20.00	

* Due to worldwide shortage on IC Memory, prices shown are valid as of 1-12-88 and may vary at the time of publication.

ALL PRICES INCLUDE SALES TAX. TAX EXEMPT AND OEM P.O.A.

Freight: The prices quoted are ex Store, cost of delivery and the risk of loss in transit fall upon the purchaser. For the convenience of customers, delivery can be arranged through the supplier at the schedule of rates set out below.

Minimum Charge Only

1. Local Cost \$2.50
2. Interstate Post \$3.50
3. Carrier: Melbourne & Metropolitan — \$5 up to 3kg
4. Carrier: Interstate — \$8 up to 3kg

only SMALL ITEMS will be sent by post.



SEMICONDUCTOR WATCH

ETI engineer Terry Kee takes a look at the latest available in semiconductors

18-bit audio DAC

Analogue Devices has introduced an 18-bit audio DAC (digital-to-analogue converter) that requires no external components. The AD 1860 is a proprietary monolithic DAC designed specifically for compact disc players, digital audio tape (DAT) players and recorders, synthesizers, digital audio amplifiers and keyboards. Fabricated on a single BiMOS chip and housed in a spacesaving 16-pin DIP, this DAC

includes a voltage reference, voltage-output amplifier, switching circuitry, laser-trimmed thin-film resistors and digital logic interface. The integration of these features eliminates the need for as many as twenty-four external components.

The converter provides audio designers with the simplest available upgrade path from 16- to 18-bit resolution. The AD 1860 is pin-for-pin compatible with popular 16-bit audio DACs, allowing designers to improve total harmonic distortion and noise (THD+N) with no major circuit changes. The AD 1860 is

capable of 2X, 4X and 8X oversampling and accepts serial data directly from second-generation digital filtering chips at rates up to 12.7 MHz. It supplies a ± 3 V (peak) or ± 1 mA (peak) output with a dynamic range of 108dB. Phone (02) 888 8777.

READER INFO No. 156

Two A/Ds with internal buffer

Datel's ADC-520 and ADC-521 are two new 12-bit, 800 nanosecond analogue-to-digital converters with an internal buffer amplifier. Both models are identical except for the analogue input voltage range. The ADC-520 includes voltage ranges of ± 10 V, 0 to +10 V, 0 to +20 V, and 0 to -20 V. The ADC-521 includes voltage ranges of ± 2.5 V and 0 to +5 V. Their

performance is based on utilising a proprietary custom chip and unique laser trimming schemes. Features include extremely low initial errors of ± 3 LSB's maximum for offset and gain errors, CMOS/TTL compatibility, three-state outputs, and a maximum power dissipation of 1.9 Watts. Output coding for both models can be in straight binary/offset binary, complementary binary/complementary offset binary, or two's complement, and complementary two's complement by using the COMP BIN and MSB pins. Both parts are tightly specified over the full operating ambient temperature range and power supply range. Power requirements for both models are ± 15 Vdc and ± 5 Vdc. Typical applications include spectrum, transient, vibration, and waveform analysis.

For additional information Phone (02) 736 2888

READER INFO No. 155

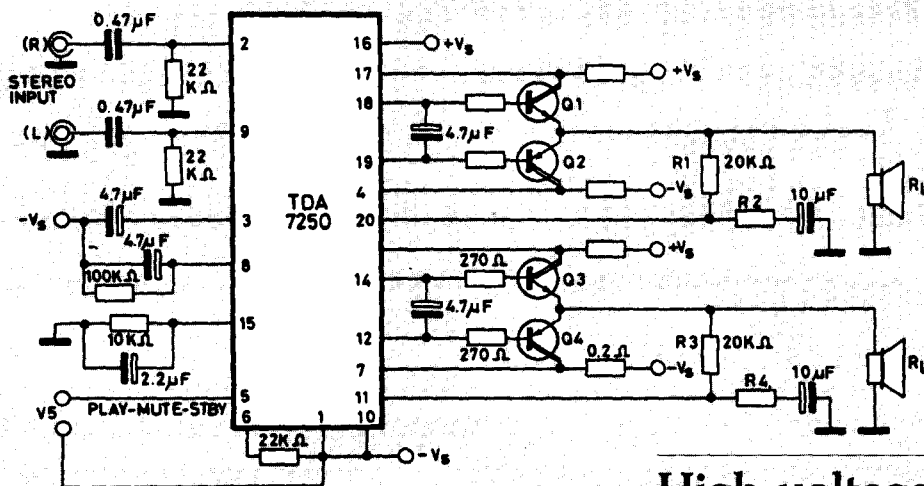

High voltage stereo driver

A high voltage bipolar IC, the SGS-Thomson TDA7250 drives two discrete transistor output

stages in hi-fi stereo amplifiers delivering 2 x 15 W to 2 x 100 W. Because it can operate on supplies up to 90 V the TDA7250 reduces the size and cost of the mains transformer, replacing the cumbersome discrete circuits used previously for high voltage drivers.

The TDA7250 has other benefits, too. It includes an automatic control circuit for the output stage quiescent current so no trimming is needed in production and thermal stability is guaranteed without temperature sense elements.

Moreover, it protects the output transistors against current overload and includes input bias control circuitry to eliminate spurious noises when the audio is muted.

For further information contact: Promark Electronics. Phone (02) 439 6477 READER INFO No. 157

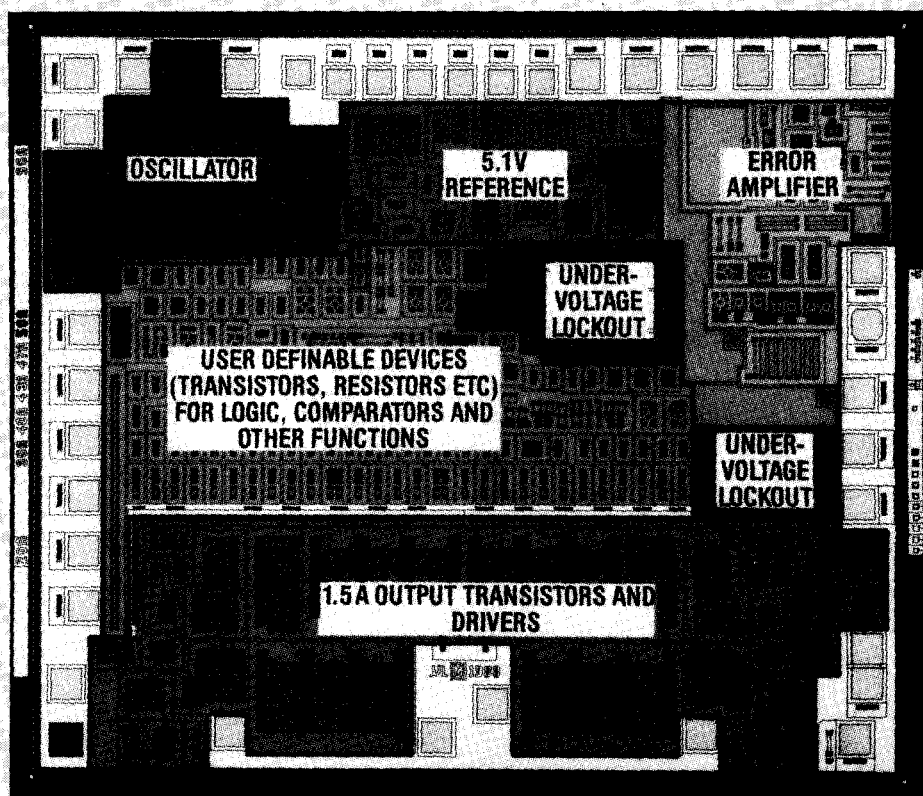

New class of analogue semicustom platform

Micro Linear Corporation has announced an analogue array employing a system-level core technology - the first linear semicustom platform targeted at a specific class of applications. Emulating the migration of digital ASICs from horizontal, non-specific arrays to more complex LSI and VLSI market-specific ICs, Micro Linear's FB3480 is the first vertical market analog array.

Implemented on a 36 volt,

bipolar process, the core of the FB 3480 array consists of a core group of specially designed cells interconnected to form a high-performance pulse width modulator (PWM) controller for switching power supply designs requiring up to 1MHz operation. All of the most commonly used switch mode power supply functions are contained in the core of the FB3480, including an oscillator, precision voltage

reference, error amplifier, and two totem pole high-current output stages specifically optimised for high performance at high frequency.

To simplify design and specification of the array, Micro Linear has a menu of pre-simulated "soft macro cells" such as gates, latches, comparators, error amps, and various analog functional blocks. Unique controller topologies and

features can be implemented through the interconnection of these additional components by modifying the double-layer metal masks of the array which eliminates the need for external discrete devices. Integrating the modifications on-chip allows compact PC board layout and minimises induced RFI/EMI.

For further information contact: Repechnic. Phone (02) 426 3422

READER INFO No. 158

8-bit Flash video A/D converter

Brooktree Corporation has introduced the Bt208, an 8-bit flash, video analogue-to-digital converter. The Bt208 is designed specifically for image capture equipment such as picture transmission systems, broadcast video, scanners, capture boards and medical imaging devices. To meet the needs of this equipment, the Bt208 integrates many special imaging features, substantially reducing the

number of external components and PC board area required to implement image digitisation circuitry.

It utilises flash converter topology to achieve 20 million sample per second (MSPS) speeds. This high sampling rate allows up to four times oversampling of NTSC, PAL and SECAM video signals, giving the engineer flexibility and a margin for worst case situations.

Designed specifically to fit the specifications of image capture applications, the Bt208 requires no additional video amplifier to meet input level requirements. It features an analogue input range of 0.714 V to 1.2 V, which covers the NTSC, PAL, SECAM and RS-343A video standards.

External zero and clamp control allows ac coupled video signals to be dc restored during each horizontal blanking interval.

This eliminates the need for additional circuitry to perform DC restoration.

Brooktree's Bt208 is constructed in +5 V monolithic CMOS, and requires a standard +5 V power supply. It features $\pm 1/4$ LSB differential non-linearity, $\pm 1/2$ LSB integral non-linearity. Two versions are available, 24-pin 0.3" plastic DIP or a 28-pin PLCC package. Phone (07) 376 2955

READER INFO No. 159

Something New in Specialist Audio retailing.

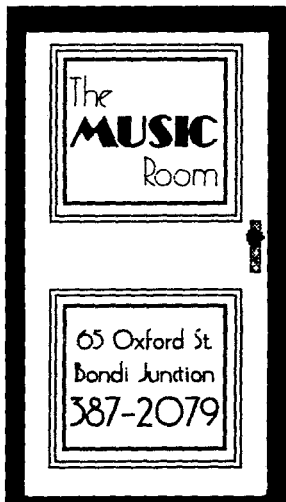

Audio Technica
Amber
Craft
Dynavector
Lambert Audio
Onix
Orpheus
Proton
Rega
Richter
Thorens
Space & Time

Specialising in Australian & New Zealand Audio Products

READER INFO No. 16

ROCKBY ELECTRONICS

244A Huntingdale Road
HUNTINGDALE

P.O. Box 189
HUNTINGDALE 3166

Phone (03) 562 8559
FAX: (03) 562 8772

**CATALOGUES ARE
NOW
AVAILABLE**

FOR YOUR COPY OF OUR FREE ILLUSTRATED
CATALOGUE JUST SEND YOUR BUSINESS CARD
TO THE ABOVE ADDRESS.

READER INFO No. 17

INTRODUCING: THE ULTIMATE COMMUNICATIONS INTERFACE CARD

For IBM® PC, XT & AT & COMPATIBLES

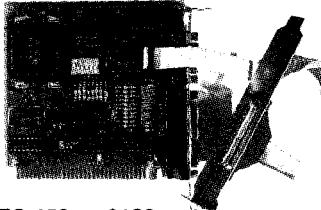

THE EC-452 — \$129 + tax
KIT EC-452-SK — \$99 + tax

**SUPPORT YOUR MOUSE,
MODEM AND PRINTER
ON ONE CARD!**

Ideal for applications requiring Multiple Printers.
Highly Reliable. Fully Socketed.
As featured in Electronics Australia May 88.

ORDER YOUR FIRST CARD TODAY

Suitable for Machines Running
up to 16 MHZ.

25 Pin SERIAL PORT
9 Pin SERIAL PORT
25 Pin PARALLEL PORT
All Mounting Hardware
Comprehensive User Manual

KEN CURRY
Managing Director



26 Boron Street,
Sumner Park, Brisbane
Qld, Australia, 4074
Fax: (07) 376 3286

BRISBANE —
(07) 376 2955
WELLINGTON — N.Z.
(04) 85 8742

**energy
CONTROL**

READER INFO No. 38

UV PROCESSING EQUIPMENT

KALEX LIGHT BOX

- Autoreset Timer
- 2 Level Exposure
- Timing Light
- Instant Light Up
- Safety Micro Switch
- Exposure to 22in x 11in

\$650.00

PCB PROCESSING KALEX ETCH TANK

- Two Compartment
- Heater
- Recirculation
(by Magnetic Pump)
- Two Level Rack • Lid

\$650.00

3M Scotchal Photosensitive Riston 3400 PCB Material

All prices plus sales tax if applicable

KALEX 40 Wallis Ave
East Ivanhoe 3079
(03) 497 3422
497 3034
Fax (03) 314 7400

ELECTRONIC COMPONENTS & ACCESSORIES
• SPECIALIST SCHOOL SUPPLIERS

READER INFO No. 19

Software and Hardware for controllers professionally made to your specification

We specialise in converting fixed
logic designs to 8039, 8749 and
6805 single chip microprocessor
systems with enhanced capabilities
at economical prices.

**Enquire about our PC based 4800
and 6805 series cross-assemblers
that will assemble a 20K source
file in 10 seconds.**

VANDATA

Suite 8, Midway Arcade
145 Maroonah Highway
Ringwood 3134
(03) 870 6078

V262/AME

READER INFO No. 20

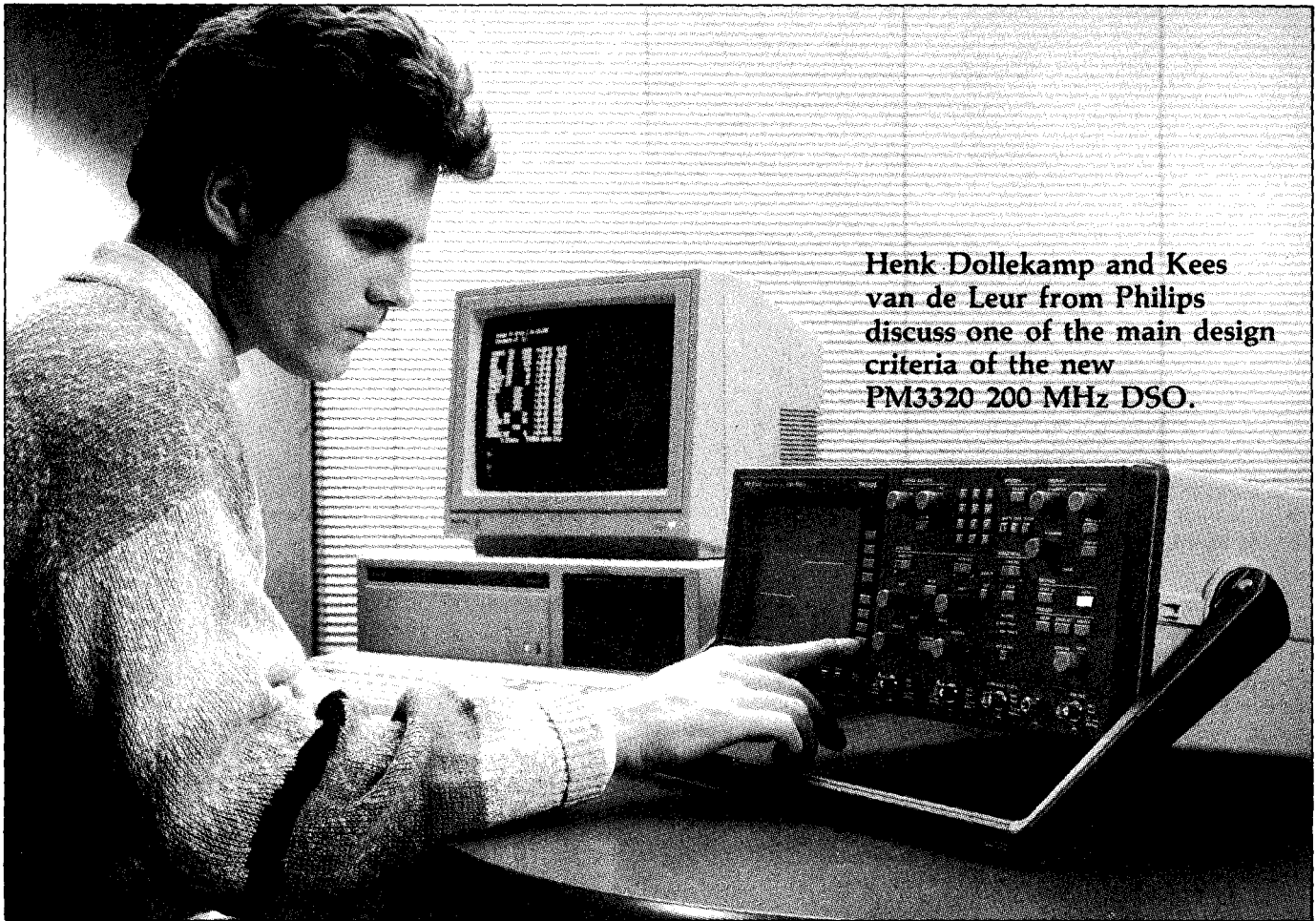
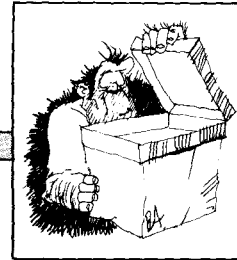

Henk Dollekamp and Kees van de Leur from Philips discuss one of the main design criteria of the new PM3320 200 MHz DSO.

Philips believes that due to the excellence of its design, the PM 3320A's effective resolution — taken together with its very wide 200 MHz bandwidth — provides the other DSO manufacturers with some strong competition.

RESOLUTION IN DIGITAL OSCILLOSCOPES

Last month, ETI published a review of the LeCroy 9450, which focused on that product's long memory length. The argument put forward was that memory length is one of the most significant factors in the design of a digital storage oscilloscope (DSO). This view is not uncontroversial. One of the guiding principles behind the design of the latest in the Philips' range of DSOs is that the effective resolution of an oscilloscope is its most important feature: no

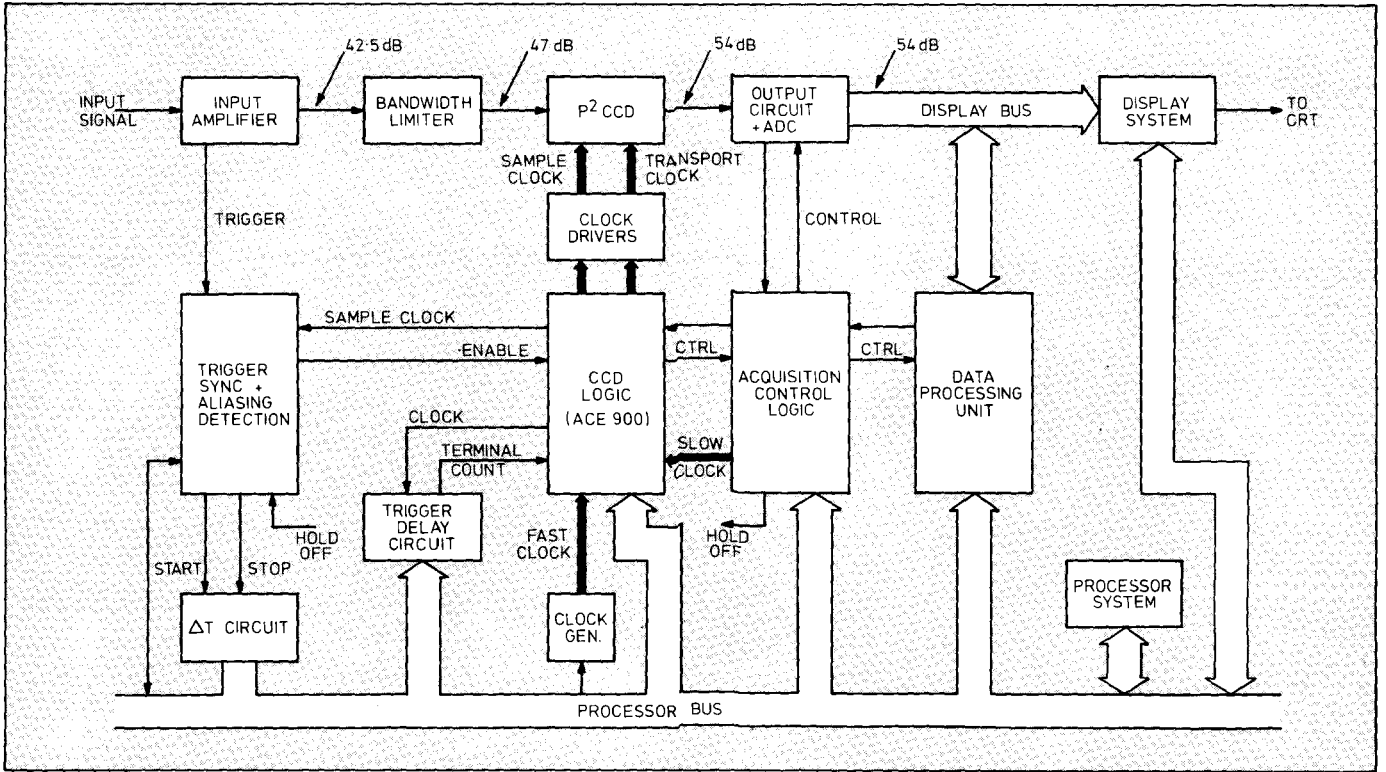

The input amplifier, the P²CCD sampling mechanism and the P² CCD output circuitry are the main sources of noise in the PM 3320A. In fact, as the noise figures show, their noise contribution is relatively small.

measurement has any value without this key piece of information. But the question of how to quantify the effective resolution of a digital storage oscilloscope (DSO) in the laboratory is much less simple than it looks. Engineers at Philips' laboratories at Enschede, the

Netherlands, have carried out an in-depth program of tests that clearly shows that DSO users should look closely at both resolution and bandwidth specifications for single-shot signals before choosing a particular instrument.

Moreover, their results also show that another performance criterion – equivalent noise resistance – is equally important.

But first, we should review the mathematics of DSO performance. Aside from the design resolution of the ADC, the effective resolution of a DSO is limited by three factors: system noise produced by the front end of the instrument, non-linear distortion and aperture uncertainty. In fact, because noise varies in proportion to the square root of the bandwidth, the larger the bandwidth offered by a particular DSO the larger the noise factor becomes.

The basic definition of effective resolution measured in bits is:

$$N_b = \log_2 \left(\frac{\text{RMS}(\text{actual})}{\text{RMS}(\text{ideal})} \right)$$

Where N_b is the resolution of the analogue-to-digital converter measured in bits, RMS (actual) is the RMS value of the deviation from the ideal analogue signal and RMS (ideal) is the RMS value of the ideal analogue signal.

Continuous averaging is twice as effective as real averaging. This screen demonstrates how the technique – here using an averaging constant of 64 – can clean up a very noisy signal.

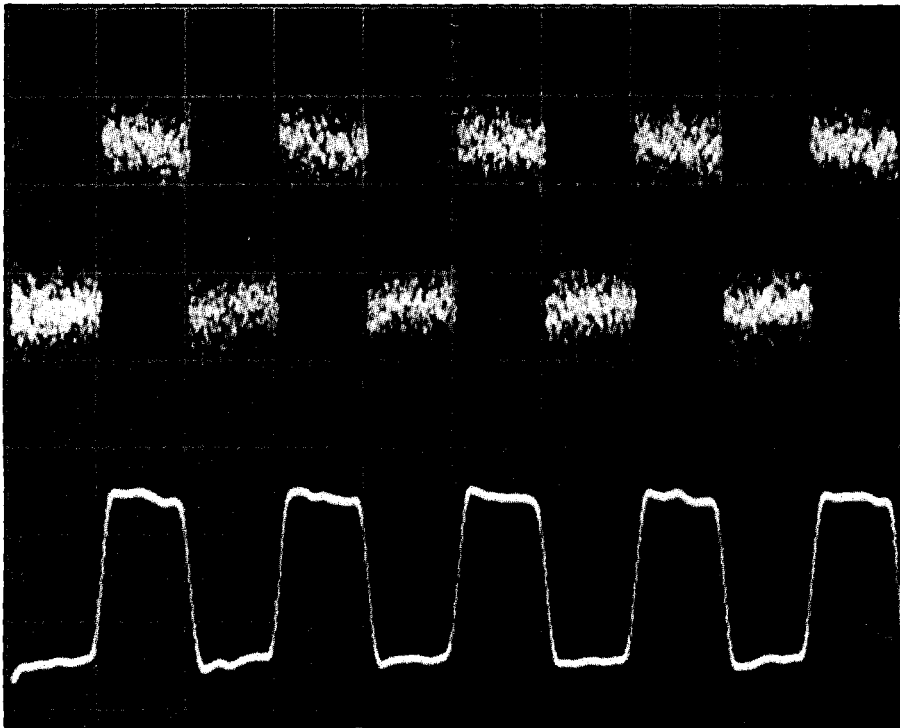

to-noise ratio (in dBs) as

$$\text{Effective resolution} = \frac{\text{SNR} - 1.8}{6}$$

Averaging is often used to improve the effective performance of DSOs when working with repetitive signals. Continuous averaging, however, provides twice the resolution of real averaging techniques.

In averaging, if the time between records is long enough for the noise to be uncorrelated, the traces can be added as a square.

In continuous averaging, each new sampled trace is subtracted from the record in memory and a fraction of the difference is then added to the original signal. The resulting improved trace replaces the original record in memory.

The average factor C can be chosen independently. If C is equal to 64, therefore, the noise reduction is very nearly the same as can be achieved with conventional averaging 128 times. In the case of the PM 3320A, the instrument displays the initial captured signal and then modifies it progressively to create a high resolution, very low-noise trace. For any scope, however, averaging techniques can only provide an improvement if there is a significant amount of noise to start with: the initial noise divided

'DSO users should look closely at resolution and bandwidth'

by the averaging factor must be greater than the value of the least significant bit.

Aperture uncertainty

The effective resolution also depends on aperture uncertainty – the accuracy of the timing with which each sample made by the ADC is taken. In normal use the timing accuracy of the PM 3320A becomes significant only rarely: in fact the effective resolution falls to 8 bits only at very high frequencies (figure 4).

Other deviations from the ideal signal – thermal noise, for example – have an effect on effective resolution across the whole of

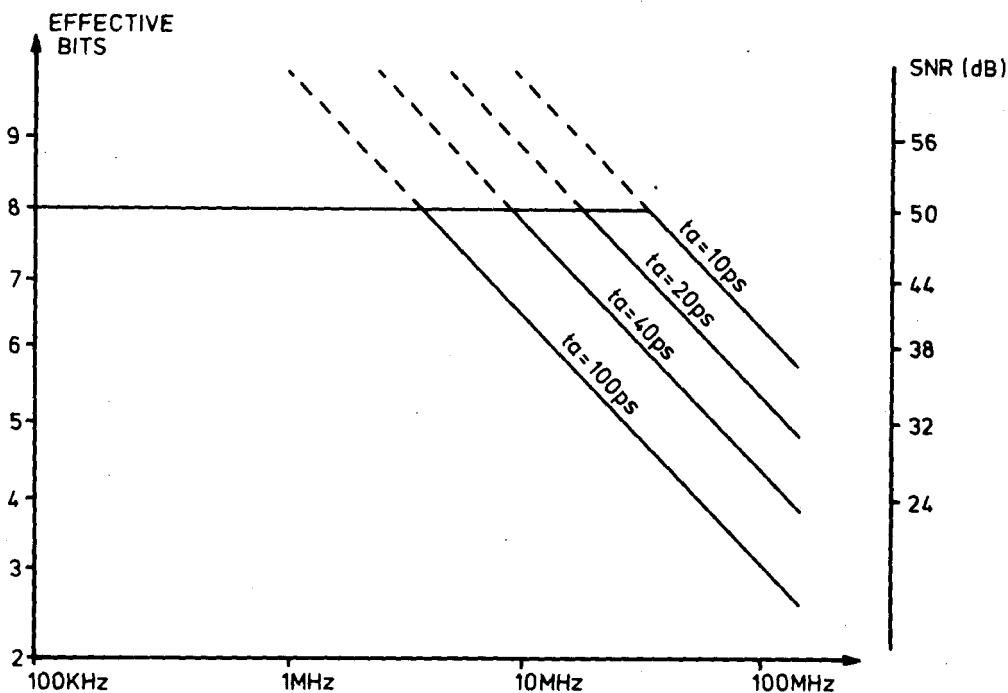

the frequency range. However, if it can be kept below 49.8 dB, an effective resolution of 8 bits can be achieved.

For single-shot signals the maximum useful is normally assumed to be one tenth of the sampling frequency. The PM 3320A, for example, has a sampling rate of 250 megasamples per second and – as far as single-shot work is concerned – the instrument is most likely to be used with signals containing important harmonics up to 25 MHz. Given that the aperture uncertainty is specified as less than 20 ps, it is clear that – at least as far as sample timing is concerned – the instrument can easily achieve 8 bits within this frequency range.

Random sampling

For repetitive signals, random sampling can be an extremely useful technique. Random sampling offers the advantage of pre-triggering, which allows us to sample the signal before the trigger-point ie; it allows the user to see the waveform before, as well as after, the trigger point so that pulse preshoot or ringing can be observed. As the trigger pulse lies somewhere between the

Figure 4. This graph shows how aperture uncertainty limits effective resolution in a typical digital storage oscilloscope. In this hypothetical case other factors such as thermal noise limit the overall resolution to eight bits.

measured samples, the timing uncertainty is equivalent to one sample distance, which for the PM 3320A is 100 ps at 5 ns per division.

Using this formula we can show that while the instrument has an effective resolution of 6 bits at 100 MHz in real time, with random sampling the resolution falls to just 3.7 bits. At 50 MHz in real time the resolution falls from 7 bits to 4.7 bits.

However, by using the PM 3320A's continuous averaging feature and an averaging factor of 64 it is possible to increase effective resolution in the random sampling mode by 3.5 bits. By using the averaging feature, therefore, users can achieve effective resolutions as high as 7 bits at 100 MHz.

Services:

- ★ Layout
- ★ Editing
- ★ Pen plots
- ★ Checkplots
- ★ Netlists
- ★ N/C drill output
- ★ P.C.B. assembly

P.O. Box 2316 Brighton North 3186
Phone: (03) 698 0264

Professional P.C.B. layout

- ★ Single sided boards
- ★ Double sided boards
- ★ Multi-layer boards
- ★ Surface mounted devices

Specialists in:
Fast – Accurate – Quality Service

*Played strong,
done fine*

**NOW
ON
VIDEO!**

**ONLY
\$39.95**

*Plus \$4.00 packing
and postage*

**THE
JACK GIBSON
COLLECTION**

RING NOW TO ORDER!

Toll free 008-251592 24 hrs a day – 7 days a week

OR SIMPLY FILL IN THE ATTACHED COUPON

If the envelope/coupon has already been used, list the video you require with its price. Include your name, address, telephone, plus cheque, money order or credit card details (card type, card number, expiry date and signature) include \$4 for postage and handling.

SEND ALL THE INFORMATION TO: Federal Publishing Video Offer, Freepost No.4, P.O. Box 227, Waterloo, NSW 2017. NO STAMP REQUIRED!!

And don't forget to sign all orders.

**LIMITED
OFFER**

*For a limited period
only you can have a
personally signed copy
by Jack ... but you'll
have to phone NOW!*

THERE'S A LITTLE BIT OF ALL OF US IN THIS MAGNIFICENT ADVENTURE.

YOUR LAST CHANCE TO OBTAIN THESE MAGNIFICENT VIDEOS

"And all I ask is a tall ship and a star to steer her by"

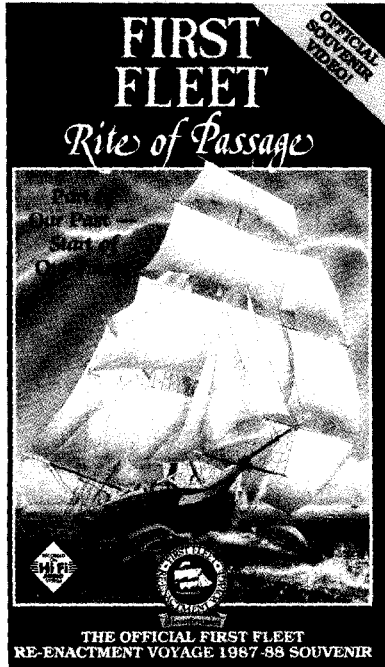

WINNER OF FIVE MAJOR AWARDS AT THE 1988 BICENTENNIAL WORLD BROADCASTING AWARDS

OVER THREE HOURS OF EXTRAORDINARY ADVENTURE. This is one of the most unique videotapes ever produced. Filmed entirely live, it captures all the triumphs, the headaches, the heartaches, the incredible human stories that abound in this mammoth achievement compelling viewing from the very first minute right up to the spectacular Australia Day finale on Sydney Harbour, January, 26th 1988. Winner of no fewer than 5 Awards in the Australasian Academy of Broadcast Arts and Sciences Awards, 1988, from over 470 entries from 22 different countries.

\$29.95 VHS = ZV-B0A-030-V
RRP BETA = ZV-B0A-030-B

YOUR RECORD OF THE GREATEST BICENTENNIAL EVENT!

THE GREATEST DAY IN AUSTRALIA'S HISTORY. The celebration of Australia Day, 1988, was a day like no other in Australia's history. Two million people turned out for the party, a crowd never seen before in Australia. People still tell the story of that day with reverence, recalling special moments that have become a part of this nation's rich folklore. Here, in stunning reality, is the triumphant First Fleet entry into Sydney Harbour, the Tall Ships Parade, the fireworks display, the people and the pageantry. Tape also contains 20 minutes from the Award winning "Rite of Passage" video.

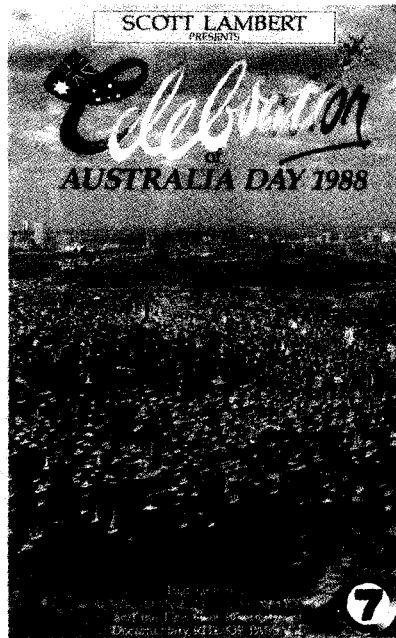

\$29.95 VHS = ZV-B0A-031-V
RRP BETA = ZV-B0A-031-B

BUY BOTH VIDEOS AND RECEIVE THE FIRST FLEET POSTER ABSOLUTELY FREE! (NORMALLY \$19.95)

To order simply fill in the attached coupon. If the envelope/coupon has already been used, list the videos you require with their prices. Include your name, address, telephone number, plus cheque, money order or credit card details (card type, card number, expiry date and signature) include \$3 per video for postage and handling. Send all the information to: Federal Publishing First Fleet Video offer, Freepost No. 4, P.O. Box 227, Waterloo, NSW 2017. No stamp required!! And don't forget to sign all orders.

SEE PAGES 66 & 67 FOR YOUR REPLY-PAID ENVELOPE & ORDER FORM



ELECTRONICS
ETI - 1429

ETI's Terry Kee
shows how to get rid
of crackle, pop and hum
with this noise gate.

HUM AND HISS NO MORE Eliminate annoying audio noises

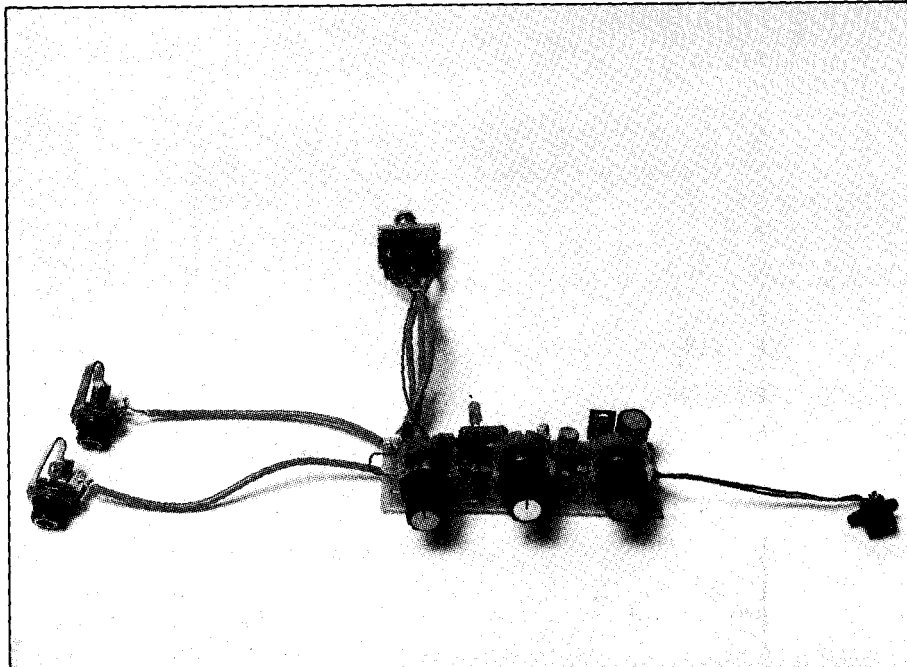

Typical audio noises, such as hum and hiss, are most apparent and most annoying when there are pauses in the music. When music is present, the noise is masked by the music signal and is not as discernable to the listener, even though it is still there.

Ideally, noise problems in audio equipment should be located and rectified, but sometimes this is not practical. In situations like this, a noise gate is a must. The principle is quite simple. Any noise signal will generally be at a lower level than the average value of the signal, hence if the noise gate can be set to allow signals at high levels through but shut down at lower levels then the dynamics of the signal will largely be retained, but the hum will be reduced. When signal is not present the noise is effectively gated out.

The applications of the noise gate can be used to good effect in many situations. Musical instruments that use magnetic pickups are prone to pick up hum, particularly if they are located close to a magnetic field like a power supply in an amplifier, which is quite likely to occur in a live situation. The noise gate can also improve the quality of live recordings where audience noise, or sounds from instruments, spill over into adjacent microphones. Connecting a noise gate in each of the mic channels cleans up the sound by gating out the spill-over. Another use of the noise gate, common in recording studios, is to reduce the reverberation times of instruments, notably drum sounds, which already have added reverberation. In this context the noise gate acts as an envelope generator which shapes the envelope of the signal. The ETI-1429 can produce some envelope shaping by varying the threshold where the gating starts, so that lower signal levels are attenuated more

sharply than the higher levels. The result is a shorter and punchier drum sound.

Internal workings

The ETI-1429 noise gate is configured around a compressor with low level mistracking and an expander based on the 572 companding chip. The signal is compressed in the compressor with a 2:1 ratio. This means that input signal level in dBs above a threshold level of -18 dBm are reduced by 2:1 and levels below the threshold are increased by 2:1 (refer to the graph plotted in table 1). If the threshold level is referenced at 0 dB then an input level of -20 dB is increased to

*'Another use is to reduce
the reverberation times of
instruments'*

-10 dB and a 12 dB input level is reduced to 6 dBs.

The output of the compressor is fed into an expander circuit which provides a complementary action to the compressor. It expands signal levels above and reduces signals below the threshold with a 1:2 ratio. The result is a unity gain signal i.e. a 1:1 ratio. A graph of the companding system levels of the 572 is shown in Table 1. The noise gate action is introduced at the compressor by mistracking the compression ratio at low levels. This means that at high levels the signal undergoes a 2:1 compression whereas low levels tends towards a 1:1 ratio.

At the output of the expander the applied signal undergoes the nominal 1:2 expansion, which reconstructs the top half of the signal so that it follows the input signal. But due to

the low level mistracking of the compressor the bottom half signal is expanded down by a factor of 2.

The threshold where low level mistracking of the compressor occurs is made variable. The graph plotted in Table 2 shows the effect of varying the threshold. The response of the noise gate has to be compared to the 1:1 graph where the input equals the output. With the threshold set to minimum, signal levels below about -50 dBm start to detract from the nominal 1:1 curve. When the threshold is set to maximum it is raised to around 5 dBm. The thresholds of -40 dB, -30 dB and -20 dB are also shown in table 2.

NE 572 companding chip

The 572 is a dual channel gain control circuit where one channel is configured as the compressor and the other as the expander. Each channel has a full-wave rectifier that detects the average value of the applied signal, a variable gain cell and a time constant buffer. This buffer allows separate control of the attack and recovery time constants. This feature reduces the low frequency ripple that controls the gain cell and reduces the distortion at these frequencies. The attack time of the noise gate is set fairly fast to 3.3 ms via C12 and C16 and the release time by C11 and C15 to 47 ms (see the circuit diagram). These time constants work well with sharp percussive drum sounds and guitar. Note that C12 must equal C16 in value (ditto for C11 and C15) if you want to experiment with different time constants. Reducing the release time will increase the low frequency ripple and thus worsen the low frequency distortion.

Performance

With the values shown in the circuit a THD of

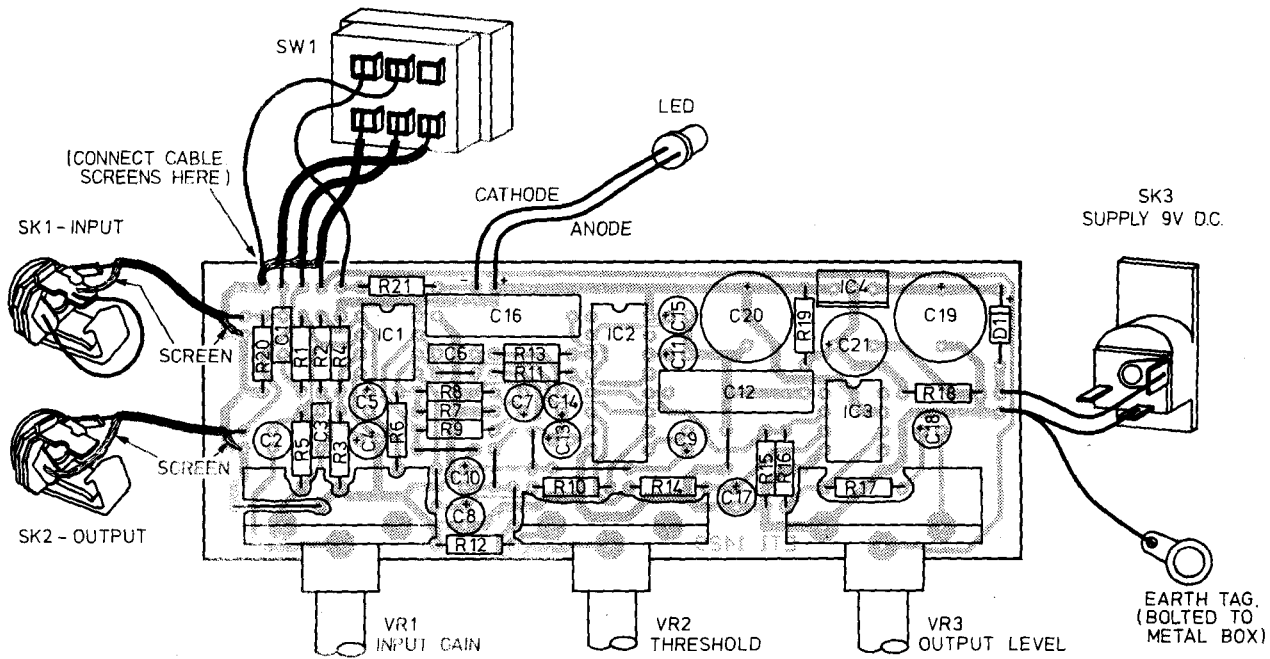
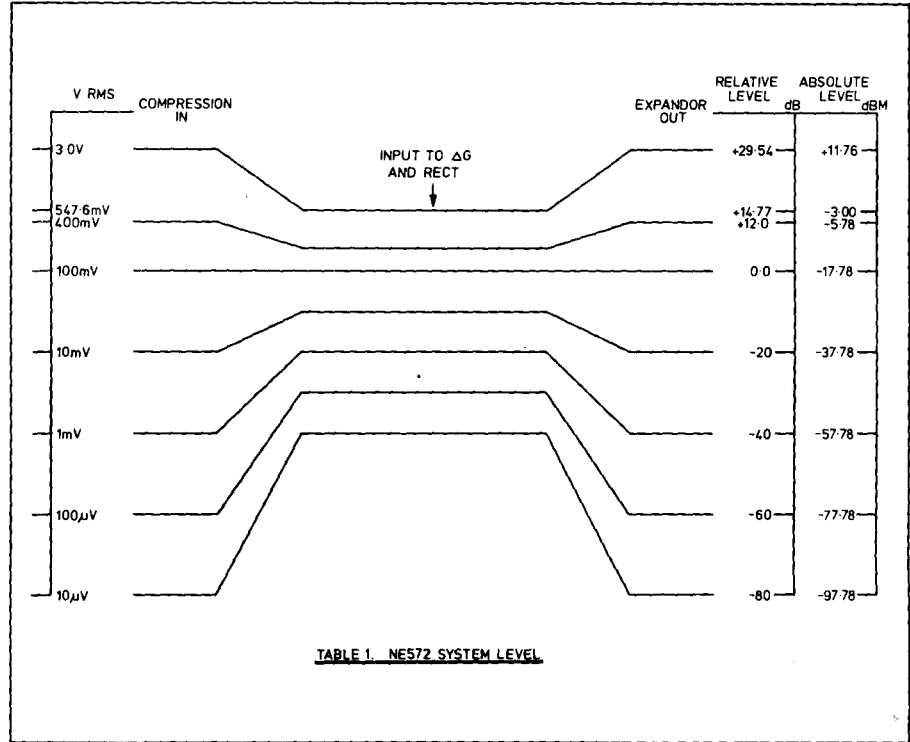
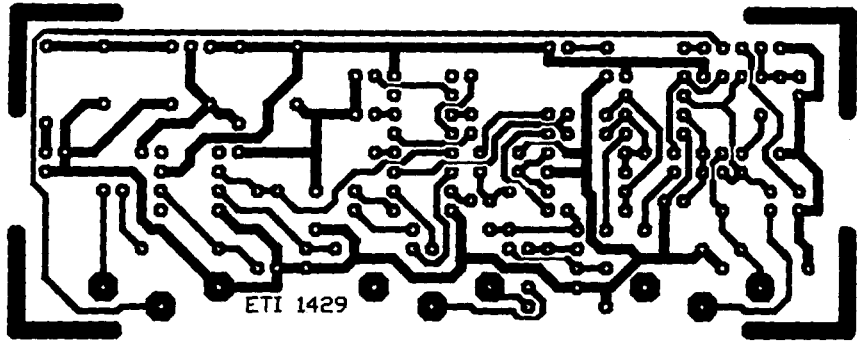

ETI FEBRUARY '89

RENT ELECTRONIC INSTRUMENTS

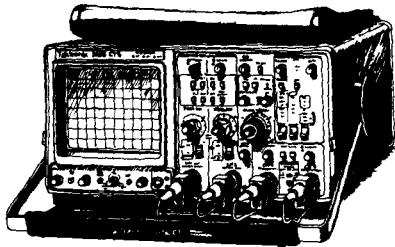

- Oscilloscopes
- Digital Multimeters
- Power Supplies
- Calibrators
- Signal Generators
- Spectrum Analysers
- Communications Testers
- Logic & Data Analysers
- Prom. Programmers
- TV Test Equipment
- AC Power Analysers
- Component Testers
- Cable Fault Locators
- Computers & Peripherals

**For your free
72-page
'89 Catalogue call**

TR TECH RENTALS

MELBOURNE (03) 879 2266
 SYDNEY (02) 736 2066
 BRISBANE (07) 875 1077
 ADELAIDE (08) 344 6999
 PERTH (09) 470 3644
 CANBERRA (062) 57 4983
 AUCKLAND (9) 504 759
 WELLINGTON (4) 379 196

READER INFO No. 21

Price & Payne 1951

Noise gate

0.6% at 100Hz and 0.08% at 1kHz was measured at a 0 dBm level. The noise floor of the unit sits at about -84 dBm with the input shorted to ground and signals starts to clip at about 8 dBm (1.9 V rms). The bandwidth (-3 dB points) occurs between 8 Hz to 40 kHz.

Signal levels

Due to the companding process, the operation of the noise gate is dependent on the applied signal level, threshold level setting and input gain. Optimum signal levels are between -10 dBm (245 mV rms) and 0 dBm (775 mV rms) which are typical line levels so a good place to insert the unit would be between the pre-amp and the power amp or at the effects send and return of a mixing stage. The noise gate also

incorporates an input amplifier that boosts signals over a variable 0 to 18 dB range to give some control on the input levels. The output level control can then be used to attenuate the output to compensate for the additional gain set at the input amplifier. In practice this is done by switching over the bypass switch and adjusting the output control until the levels are equal.

Construction

The construction is fairly straightforward as all the electronic components, except for the sockets and switch, are contained on the pc board with dimensions 110mm x 40mm. The pc board is designed to accept pc mount pots which simplifies the wiring and the board can be mounted directly to the panel of the box with the pot nuts bolting the pc board down. The choice of box is left to the reader so no enclosure details are given here. However a metal one is preferred for screening purposes. If the noise gate is to be floor mounted then a diecast box is recommended. The unit will have to endure quite a bit of foot bashing, so a heavy duty footswitch should be used for the bypass switch. Otherwise a standard DPDT toggle switch should suffice.

Start by inspecting the pc board for any unetched or broken tracks as some are quite thin and run close together. A finely tipped soldering iron will make life easier. Mount and solder in the links (use some hook-up wire), resistors and capacitors. Take note of the polarity of the electrolytics. Refer to the component overlay.

Next, insert and solder the pc mount pots making sure they sit parallel to the board. Solder in the op-amps, 572, D1 and the 5V regulator, taking careful note of their correct orientation. The pc board soldering is now finished and all that remains to be done is to wire in the switch, LED and sockets.

Drop the board inside the box and measure and drill out the holes for the 3 pots, sockets, switch and LED. Refer to the overlay and commence with the wiring. It would be easier to mount all the hardware into the box so that the length of the wires can be measured out accurately. Use screened audio cable for the input, output and switch connections and hook-up wire for the dc socket and LED connections. Note that the ground screen is cut off at the switch (SW1) end but joined together and soldered to ground at the pc board. The metal chassis of the box has to be connected to ground and this can be done by bolting a tag to the chassis and soldering a ground connection to the tag. Insulate any exposed contacts if there is any possibility of shorting.

Testing

Before you apply power, sit back and carefully check the pc board for solder splashes across tracks and bad solder joints.

Parts List — ETI-1429

Resistors: — all 1/4 W, 5% unless stated otherwise.

R1, R2100k
R3, R4100k 1%
R54M7
R6, R1218k
R722k
R8, R910k
R10, R141k
R11, R213k3
R132k2
R1515k
R1612k
R1782R
R18150R
R19220R
R202M7
VR1, VR21M log pc mount pot, 24mm diameter
VR35k log pc mount pot, 24mm diameter

Capacitors

C182n greencap
C210 u/25V bipolar electro
C3100p ceramic
C4, C7, C13, C1410 u/25V electro
C5, C8, C9, C10
C17, C182u2/25V electro
C11, C154u7/25V electro
C6390p ceramic
C12, C16330n greencap
C191000u/25V electro
C20100u/25V electro
C2133u/25V electro

Semiconductors

IC1TL072 dual op-amp
IC2NE 572 companding ic.
IC3TL071 op-amp
IC47805 5V regulator
D11N4004
LEDany 5 mm led will suffice

Miscellaneous

SK1, SK26.5 mm Jack socket (contacts open when plug is inserted).
SK3dc plug pack socket
SW1DPDT switch (can be toggle or footswitch type). ETI-1429 pc board, 9V dc plugpack at 200mA, suitable metal box, 3 off knobs to fit ports.

ETI FEBRUARY '89

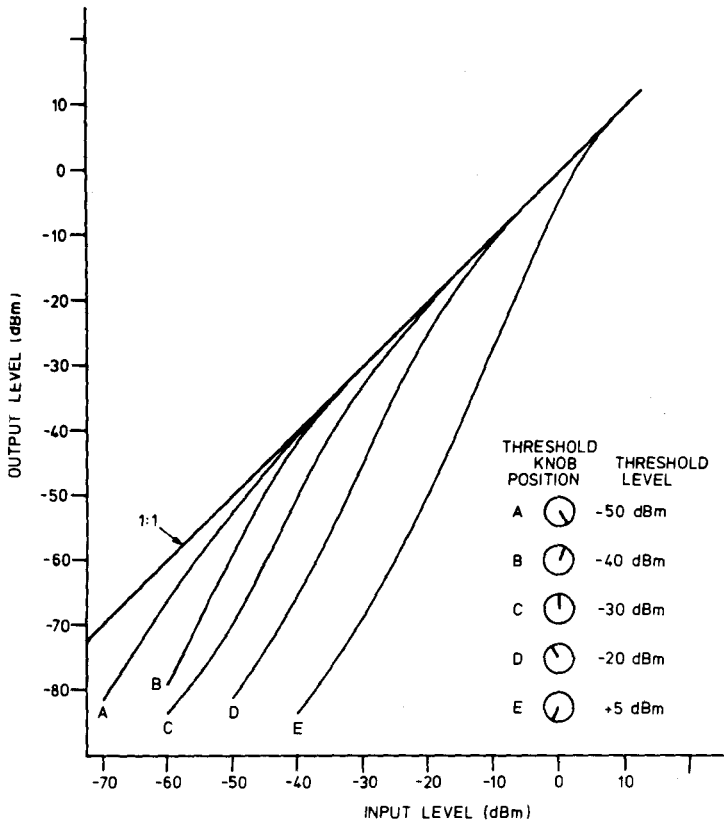
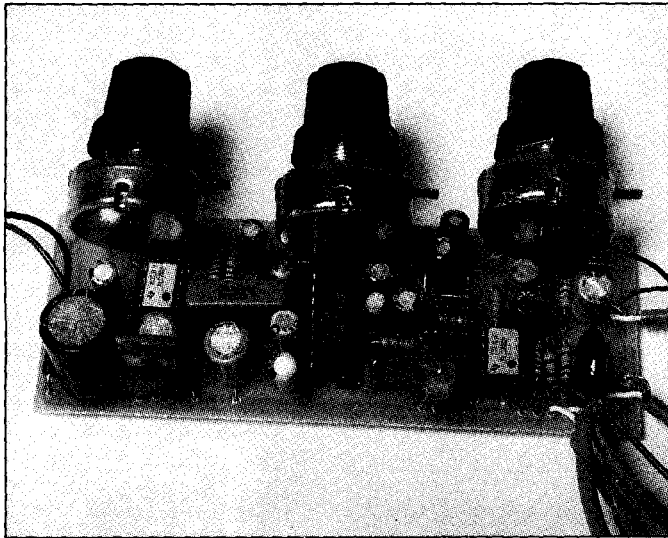

TABLE 2. RESPONSE WITH VARYING THRESHOLDS

Check the wiring as well. Once you are satisfied with your handywork connect in the 9Vdc plugpack and check that 9Vdc is present on the power rails with a multimeter. If not then disconnect the power and check that the polarity of the plugpack plug corresponds to the socket. Once the 9V has been established check that it appears on pin 8 of IC1, pin 16 of IC2 and pin 7 of IC3.



DATAGUARD U.P.S.

ELIMINATE

- Blackout
- Brownouts
- Surges
- Spikes
- Electrical Noise

Dataguard true no break U.P.S. utilizes state of the art technology attractively designed to blend into modern office and laboratory environments.

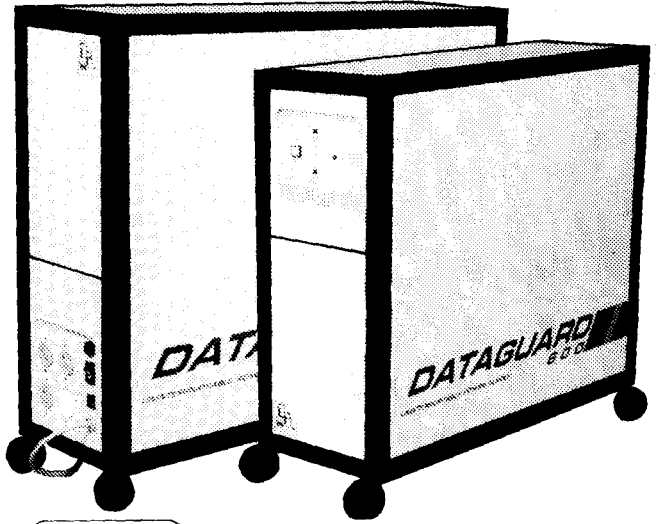

COMPONENT RESOURCES PTY LTD

QLD (07) 391 8222 ACT (062) 51 5467
 NSW (02) 688 4528 VIC (03) 555 6777
 VIC (03) 419 4477 SA (08) 371 1002
 WA (09) 293 2000 NT (089) 41 0322

(002) 73 0066

Switch over the bypass switch and the LED should light up in one position. If not, then the legs of the LED are possibly reversed. If the circuit is tested outside the box, connect the metal case of the input control pot and the footswitch to ground, to avoid inducing hum into the audio circuits.

Setting up

The performance of the unit depends on the level of the applied input signal and the settings of the input gain, threshold and output level controls. Because the three controls interact with one another it would be best to follow a sequence to set it up. Start the procedure with the input gain control turned fully anti-clockwise (i.e. unity gain), the threshold turned fully clockwise (i.e. maximum threshold) and the output level

control set fully clockwise (i.e. maximum volume). Use this setting as the starting reference point because the output of the noise gate closely follows the input except at input levels below about -50 dBm. The response follows curve A in the graph plotted in table 2. Apply a signal to the input and connect the output to an amplifier. Activate the bypass switch and the levels should be similar; incidentally the LED lights up when the output of the noise gate is selected.

The threshold level should be reduced by rotating the knob slowly anti-clockwise until the hum or hiss is gated out. Test that the main signal is still present and adjust the input and output controls for equal level if it is required. The unit is designed to operate at levels higher than about -10 dBm (245 mV rms) so connect the noise gate at the output

of a pre-amplifier or at the end of a chain of effect pedals if the input level is insufficient.

Increasing the input gain should be complemented by reducing the output level control, because the signal including the hum and hiss is boosted by the input amplifier. Be careful with the gain control set to boost input signals and switching between input and output as there can be heaps of gain difference between them; certainly enough to give one's ears quite a fright not to mention overloading power amps and speakers! Avoid just twiddling the knobs and hoping for the best. Always start from the reference setting and work from there. For envelope shaping the threshold level needs to be set fairly high to produce maximum attenuation and thus the most noticeable effect. Happy gating.

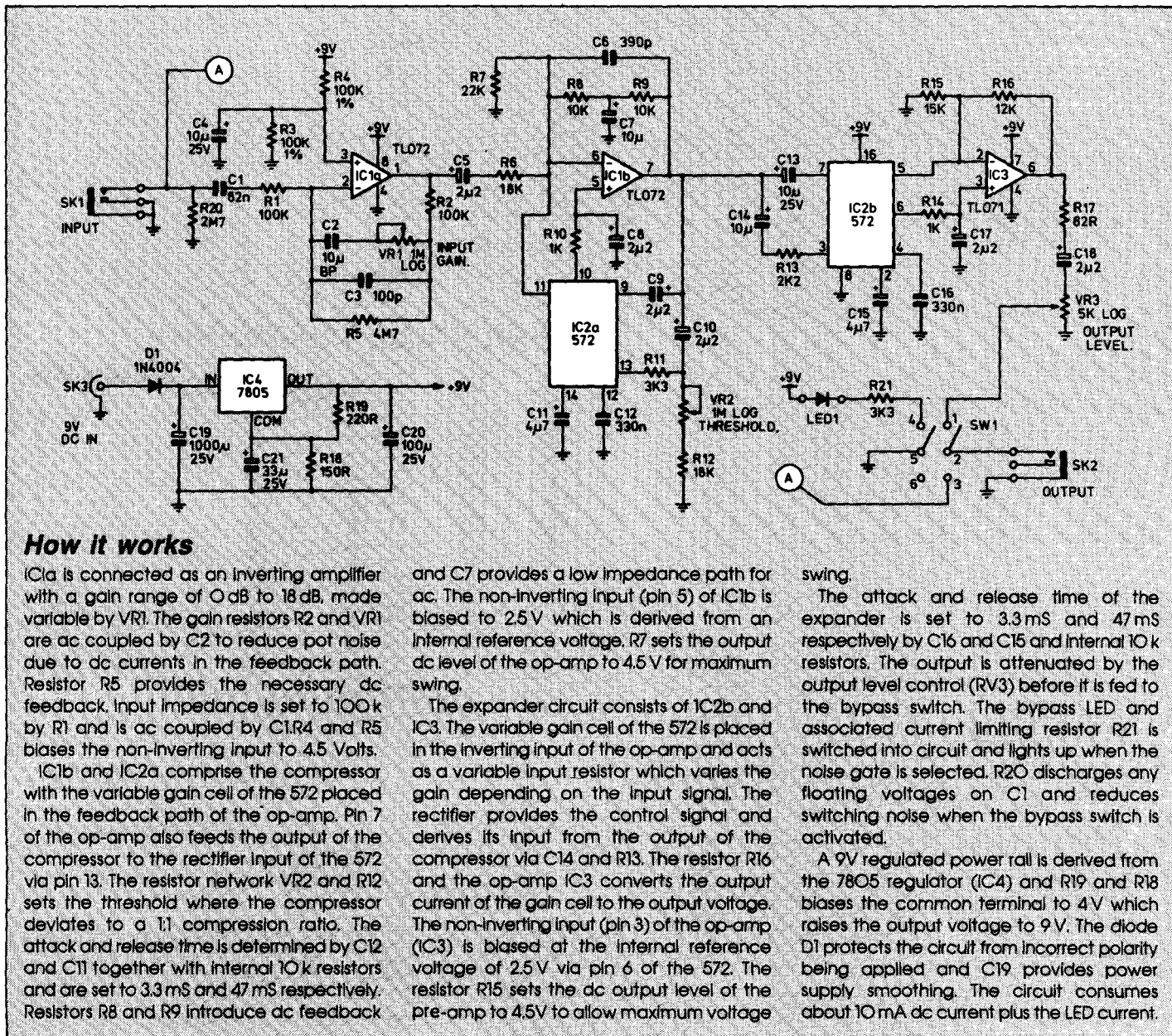

How it works

IC1a is connected as an inverting amplifier with a gain range of 0dB to 18dB, made variable by VR1. The gain resistors R2 and VR1 are ac coupled by C2 to reduce pot noise due to dc currents in the feedback path. Resistor R5 provides the necessary dc feedback. Input impedance is set to 100k by R1 and is ac coupled by C1. R4 and R5 biases the non-inverting input to 4.5 Volts.

IC1b and IC2a comprise the compressor with the variable gain cell of the 572 placed in the feedback path of the op-amp. Pin 7 of the op-amp also feeds the output of the compressor to the rectifier input of the 572 via pin 13. The resistor network VR2 and R12 sets the threshold where the compressor deviates to a 1:1 compression ratio. The attack and release time is determined by C12 and C11 together with internal 10k resistors and are set to 3.3mS and 47mS respectively. Resistors R8 and R9 introduce ac feedback

and C7 provides a low impedance path for ac. The non-inverting input (pin 5) of IC1b is biased to 2.5V which is derived from an internal reference voltage. R7 sets the output dc level of the op-amp to 4.5V for maximum swing.

The expander circuit consists of IC2b and IC3. The variable gain cell of the 572 is placed in the inverting input of the op-amp and acts as a variable input resistor which varies the gain depending on the input signal. The rectifier provides the control signal and derives its input from the output of the compressor via C14 and R13. The resistor R16 and the op-amp IC3 converts the output current of the gain cell to the output voltage. The non-inverting input (pin 3) of the op-amp (IC3) is biased at the internal reference voltage of 2.5V via pin 6 of the 572. The resistor R15 sets the dc output level of the pre-amp to 4.5V to allow maximum voltage

swing. The attack and release time of the expander is set to 3.3mS and 47mS respectively by C16 and C15 and internal 10k resistors. The output is attenuated by the output level control (VR3) before it is fed to the bypass switch. The bypass LED and associated current limiting resistor R21 is switched into circuit and lights up when the noise gate is selected. R20 discharges any floating voltages on C1 and reduces switching noise when the bypass switch is activated.

A 9V regulated power rail is derived from the 7805 regulator (IC4) and R19 and R18 biases the common terminal to 4V which raises the output voltage to 9V. The diode D1 protects the circuit from incorrect polarity being applied and C19 provides power supply smoothing. The circuit consumes about 10mA dc current plus the LED current.



ELECTRONICS
ETI - 1411

Professional studios use
headphone distribution
boxes — you can
make one to suit your
home studio needs.
Greg Simmons tells how.

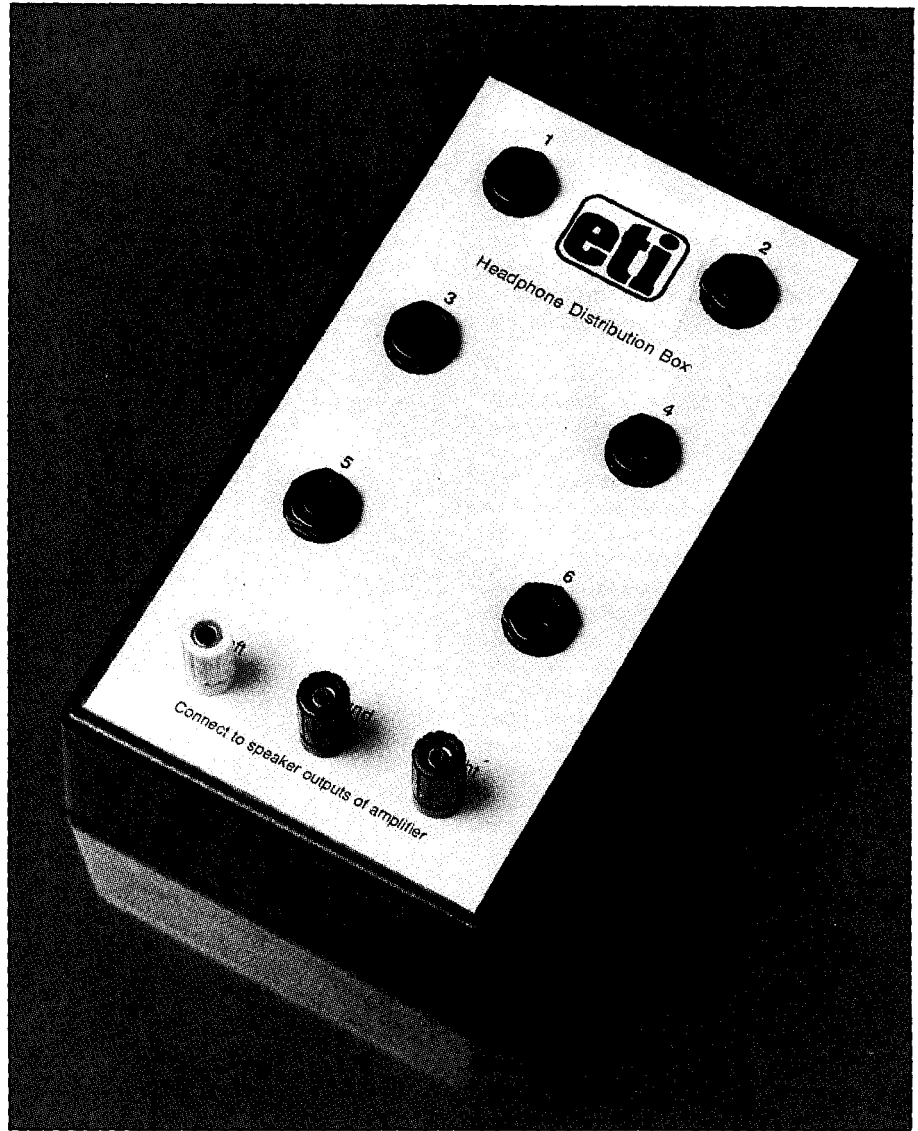

There comes a time in the career of every ambitious home recordist when the need for more than one pair of headphones arises. Many home studios use domestic hi-fi amplifiers for driving the monitor speakers, which, typically, allows two pairs of headphones (one pair connected to

the mixer headphone output, and another pair connected to the headphone socket of the amplifier). Anyone with an electronics background will be able to wire more headphones into the system using a combination of series and parallel wiring. Unfortunately, this is often messy, time

HEADPHONE DISTRIBUTION BOX

A project for the home recordist

ETI FEBRUARY '89

105

Headphone distribution box

consuming and generally not very satisfactory.

Professional studios use headphone distribution boxes which allow up to, say, six pairs of headphones to be connected to the speaker output of an amplifier. If the headphones used are all the same, each pair will receive the same level. If more than six pairs of headphones are needed, another distribution box can be connected to the amplifier.

Many studios use professional 50 to 100 watt amplifiers to drive the headphones(!). The average pair of headphones requires less than 1 watt for high listening levels, so you may wonder why studios use such high powered amps. The reasons for this are similar to the reasons why 20 to 30 watt reference monitors (Auratones, NS10s, etc.) are connected to high powered amplifiers.

Firstly, the headphone amplifier, like the monitor speaker amplifiers, is usually turned on at the start of the day's work and remains on until the studio is shut down for the night (or early morning!) Obviously, the amplifier must be able to withstand this long workload. A 50 watt amplifier delivering a few watts of power to headphones is not going to be working very hard, and there is less risk of it overheating and malfunctioning. In addition to this, there is little risk of amplifier clipping, since the amplifier is running well within its capabilities. Amplifier clipping is possibly the biggest cause of tweeter and headphone voice coil burn-out. It also makes things sound BAD.

Most home studios don't demand this much from their amplifiers, nor can they afford to buy a 50 or 100 watt amplifier for the headphone system.

The Sonics headphone distribution box allows six pairs of high impedance headphones (40 to 600 ohms) to be driven by a 20 to 40 watt amplifier, such as most domestic hi-fi amplifiers. It can be assembled in a few hours using parts that are readily available from electronic component suppliers including Jaycar, Dick Smith Electronics, David Reid Electronics, Tandy, etc. There is no printed circuit board needed, and the whole thing costs approximately \$35.00.

Circuit details

The circuit diagram is shown in Figure 1. The circuit is designed to drive up to six pairs of stereo headphones with impedances of 40 ohms or more. For best results use headphones of the same or similar impedance, ideally the same models.

The resistors labelled Rh form voltage dividers with the headphones, and protect the amplifier from being damaged. Even if all six headphones go short circuit, the amplifier never has to drive a load lower than 3 ohms per channel.

The resistors labelled RL ensure that with

no headphones plugged in, the amplifier is still connected to a load. Many amplifiers do not appreciate being turned on without a load connected to their outputs - I believe this can sometimes lead to amplifier damage, but I don't intend to prove it.

The circuit diagram shows the stereo

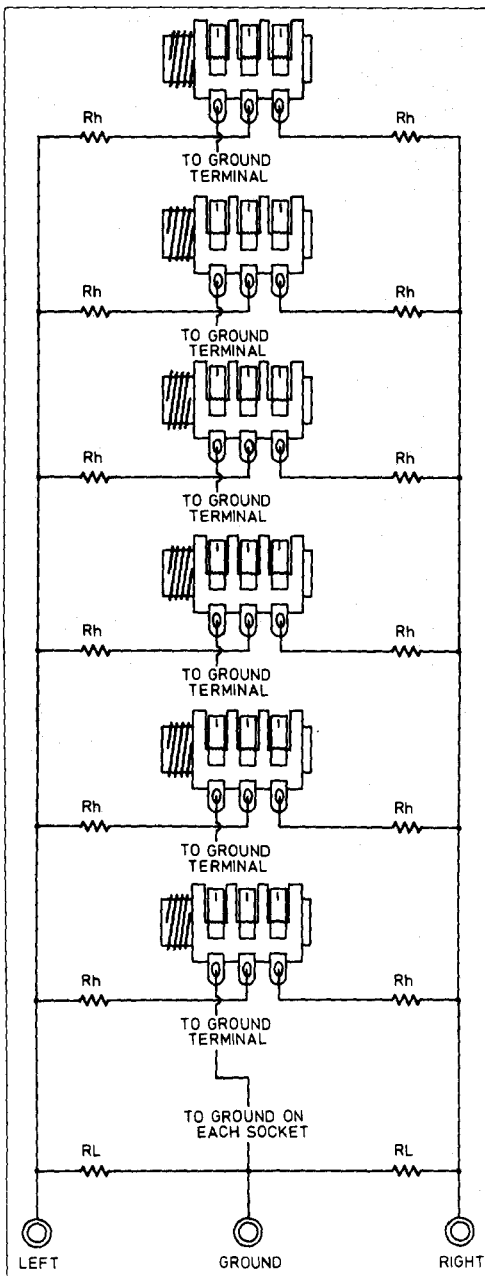

Figure 1: circuit diagram.

sockets as they appear in real life, simplifying the construction and (hopefully) ensuring that everything gets soldered in the right place.

Construction

The unit is housed in a plastic 'zippy' box approximately 11 cm x 20 cm x 6 cm. Since a headphone distribution box spends most of its time on the floor, you may want to build

it into a tougher metal or diecast box. If so, make sure the sockets, terminals and wiring are electrically insulated from the box, or else you may create a short circuit and damage the amplifier.

All sockets and terminals in the prototype were mounted on the bottom of the box, as this is much more rigid than the lid. Start by marking out and drilling all the holes. The template provided in this article will make the job easier, and also serves as a front panel. Just photocopy it, cut it out and fix it to the box with a thin smear of glue (I used a 'UHU' glue stick). Make sure the entire template is glued down, not just the edges, or else the holes will not be accurate. Drill small pilot holes first, and don't push the drill too hard or else it will damage the edges of the holes when it comes through the other side, and may also tear the template (you did use a photocopy, didn't you?) After the holes are drilled, clean up the edges and put a layer of clear self-adhesive contact onto the front panel. This will protect the template and provide a durable finish. Use a scalpel or blade to cut the appropriate holes in the contact for the sockets and terminals to go through.

The prototype uses stereo 6.35 mm sockets, available from Jaycar. They are made from black or coloured plastic, with three metal strips across them that serve as contacts. These particular sockets make it easy to see what contact connects to which part of the headphone plug. Being plastic, they can also be used in metal boxes with no insulation problems.

Figure 2 shows the bottom of one of these connectors. Underneath, you will find six terminals, a row of three on each side. Make sure you use the row that connects to the long strips across the top of the connectors. (The terminals that connect to the short strips are used for switching only, and do not connect to anything when the plug is in the socket.) If you use a different type of stereo 6.35 mm socket, you may have to use a multimeter to find out which terminals connect to the left, right and ground connections of the plug. Sometimes you can work this out by carefully studying the construction of the socket.

The next step is to solder the components onto the connectors. The easiest way to do this is to mount the stereo sockets upside down, so that the sockets are on the outside of the box. You can now solder all the components in place with relative ease (don't make any connections to the three 'speaker' terminals yet). Solder the components to the contacts on the stereo sockets exactly as shown in the circuit diagram.

Once everything is soldered in place, unscrew the 6.35 mm sockets and carefully mount the completed circuit inside the box.

The prototype uses three 4 mm 'banana'

terminals for the connections from the amplifier, each one a different colour – white for left, black for ground and red for right. Put the three terminals in place and make the final three connections to them. (You may want to use a 3-pin XLR connector, or a stereo 6.35mm socket instead.) Double-check your workmanship, screw the lid on, and you're ready to test it.

Testing

Connect the headphone distribution box to a 20 to 40 watt amplifier with a length of 3-core power lead, or two lengths of 2-core speaker wire (avoid using shielded signal cable). Make sure the amplifier is turned off while doing this.

Most amplifiers have four terminals for speaker connections. Two of these will be for ground, or negative, usually marked with a '-' symbol. To connect the distribution box, you must link the two ground terminals together on the back of the amplifier, as shown in Figure 3. These terminals are often linked together inside the amplifier. There are four terminals because each speaker has its own speaker lead, and each lead must have a ground connection.

With headphones, there is only one lead from the amplifier, and since the ground is common to both channels, only three connections are used. (Some amplifiers have

totally separate power supplies for each channel, and linking the grounds may degrade performance a little. Fortunately, these amplifiers are generally high powered and unlikely to find themselves being used for headphone amplifiers in home studios. If you're uncertain, consult the owner's manual or a service centre.)

With the connections made, turn the amplifier volume down to minimum and switch it on. Plug some headphones into the box, apply a stereo signal to the amplifier, and slowly bring up the volume until you get a decent monitoring level with no signs of distortion and a good stereo balance. If not, you may have to check the wiring. If anything starts to smoke you have certainly made a wrong connection somewhere! You have my sympathy.

If you cannot get enough level, and all the wiring and soldering proves to be correct, you are probably using very low impedance headphones, less than 40 ohms. Although the distribution box is not designed for this, using a higher powered amplifier might solve the problem. Be careful when you first try it out, though...

In use

For best performance use headphones of similar impedance. The circuit is designed so

PARTS LIST — ETI-1411

- 12 x 18 ohm, 5 watt resistors (Rh)
- 2 x 100 ohm, 5 watt resistors (RL)
- 6 x stereo 6.35mm sockets (see text)
- 3 x 4mm 'banana' sockets (see text)
- 1 x 'Zippy' box – 11cm x 20cm x 6cm
- 1 x 20cm length white hookup wire
- 1 x 20cm length black hookup wire
- 1 x 20cm length red hookup wire
- 1 x 3m length 3-core power lead

that plugging in an additional set of headphones should not noticeably affect the level of those already connected. Using different impedance headphones may result in different levels, and it will be necessary to find a compromise amplifier volume setting. Try giving the louder headphones to the drummer and bass player – that should keep everyone happy.

Most home studio mixers provide a mono foldback/headphone signal. If so, be sure to connect the appropriate mixer output to both left and right inputs of the amplifier, otherwise you will only have signal in one side of the headphones. Alternatively, if the amplifier has a mono switch, use this instead. Hopefully, all has gone well and you are now the proud owner of a sonics headphone distribution box. Happy headphone monitoring!

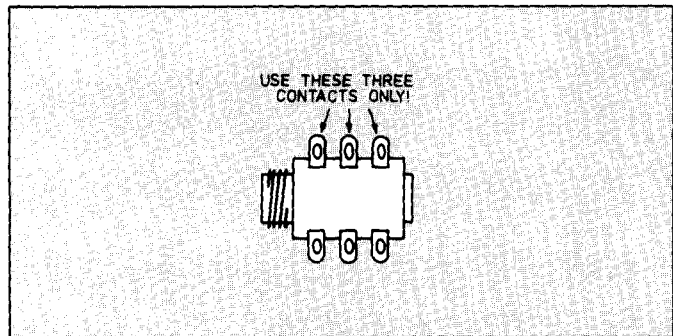

Figure 2: view of stereo socket from underneath.

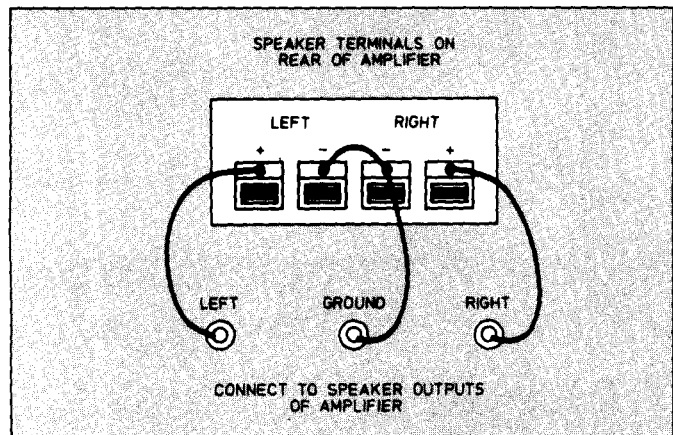

Figure 3: connections from stereo amplifier to headphone box. (Note the link between the negative terminals of the amplifier).

THE DESIGN GROUP THAT PREFERS ATTRACTIVE SOLUTIONS TO PRETTY PICTURES.

If your organisation believes its future lies in a marketing-driven assault on world markets, we have already established considerable common ground.

For us, the conventional view of industrial design is archaic. Our place is beside your marketing specialists, adding consumer attraction and profit to every facet of a product's presentation.



The shape of things to come

(03) 560 6777 Ian Edgar

FAX (03) 560 6782

*Award Winning International Designer
Managing Director*

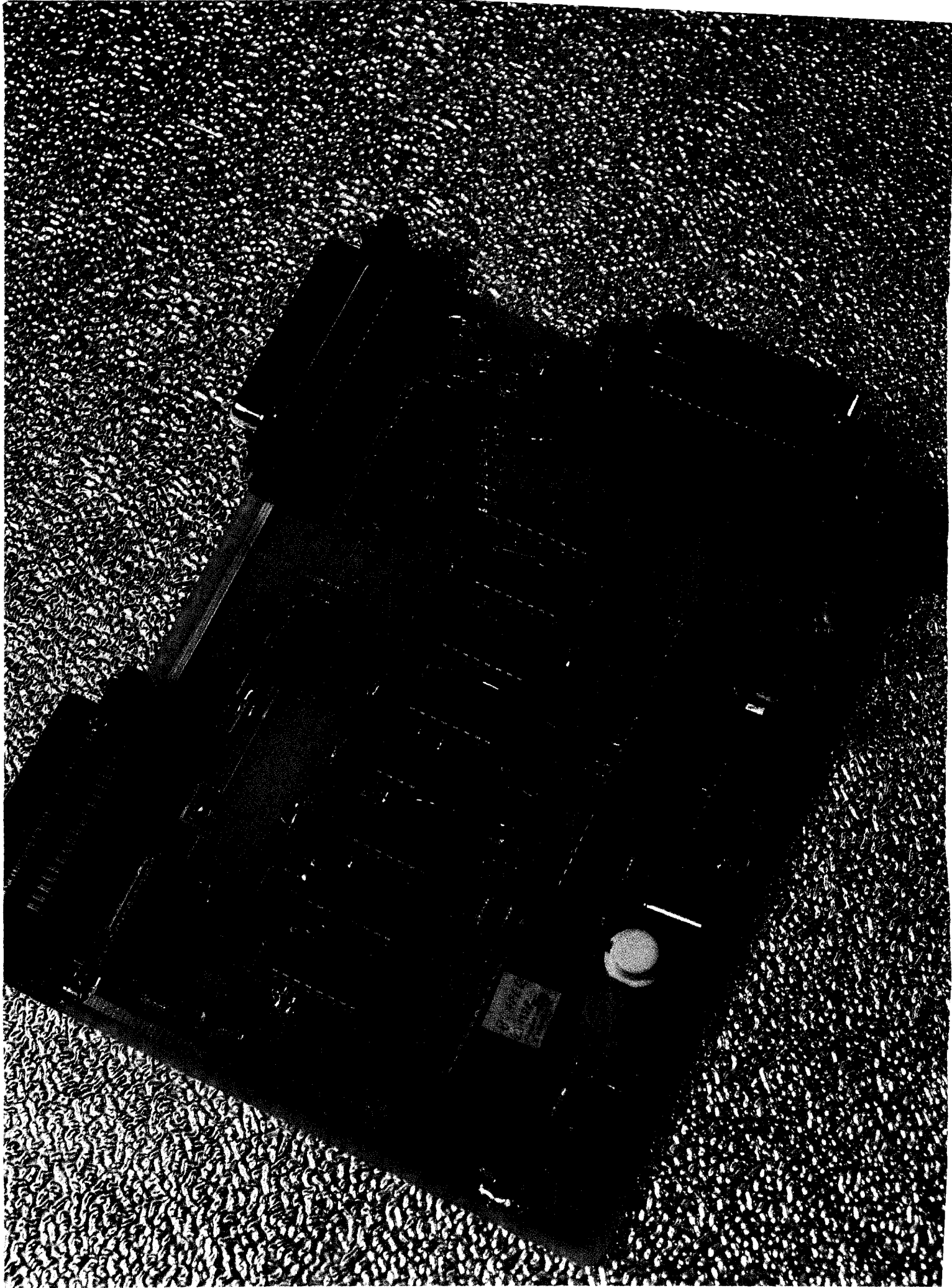



ELECTRONICS
ETI - 1620

This external printer buffer will allow two computers to share one printer without the bother of swapping cables. The first of a two-part series by Andrew Conway.

Sick of waiting for your printer? Sick of swapping cables? Build a printer buffer and solve both problems.

Most computers can send out data to their printer at a much greater rate than the printer can print it. Usually, this means that the computer is tied up, waiting for the printer to finish, before it can do anything else.

Printers usually have a small internal buffer (typically between 0.1k and 8k), which allows the printer to accept data from the computer before it is ready to print it. This data is then just stored until it is needed. This means that the computer can go on and do something else while the printer is printing the data in the buffer. This arrangement is very useful for short one-page letters, but almost useless for large printouts.

An external printer buffer operates in a similar way. It receives data from the computer at a high speed, and then sends it out to the printer slowly, as it is needed.

This project is an external printer buffer with a large 256K storage. That is about fifty full pages (66 lines of 80 characters each) or about a hundred normal pages. It also allows two computers to share one printer without the bother of swapping cables.

Note that this has been designed for Centronics parallel interfaces; it is not designed for and will not work with serial interfaces.

How to use it

There are typically three Centronics sockets on the printer buffer: two inputs (typically from computers) and one output (typically to a printer).

As far as the computers are concerned, the buffer is just a fast printer, while, as far as the printer is concerned, the buffer is just a patient computer. This means that you can hook up anything that expects to be talking to a printer to an input, and you can connect the output to anything that acts like a printer. For instance, I have my computer connected to one input, and an ETI-747 (which takes RTTY in and produces Centronics out) connected to the other input.

There is a little green light beside each of the two input ports, indicating which one is currently active. The port whose LED is glowing is selected, and data can be received by it. Press the green SWAP button to enable the other port. The buffer will only accept data from one port at a time (otherwise you could get a horrible mess with the two data streams being merged). If you want to change to the other computer, press the SWAP button. This will cause future data to come from the other parallel port.

When the buffer is empty, a green (empty) LED is lit up. When the buffer is full (a rare occurrence), a red (full) LED is lit up.

There are two more red LEDs, one for each input port. When they are on, they indicate that there is data ready at that input port. If that port is inactive, it will stay on until the SWAP button is pressed. If the port is the

'The buffer acts just like a fast printer'

active one, and the buffer is not full, this data will be dealt with in a few microseconds, causing the LED to go off. If a continuous stream of data is coming in that port, the LED will flash on and off thousands of times a second. This will just appear as a dull glow, and indicates that data is entering the buffer from that port.

This is all the buffer need do. However, being intelligent (see design section), the buffer can do more. At any stage, the information in the buffer can be cleared if you decide not to print it, by pressing the red CLEAR button. Pressing the yellow REDO button will re-print everything printed since the buffer was turned on or last cleared. If more than 262144 characters have been printed, the buffer signals an error condition (as old data would have been written over by new data) by lighting both the full LED and

PRINTER BUFFER

Large 256K storage

ETI FEBRUARY '89

Printer buffer

How it works

There are five main sections of this circuit – the single chip microcomputer and its support circuitry, the port selection section, the input data buffering, the dynamic RAM memory, and the power supply. These sections shall be treated separately. The ICs in brackets after the headings are the main ones used in that section.

Single chip microcomputer (IC1 and IC7)

The single chip microcomputer, IC1, acts as a central arbitrator.

The clock signal is provided by an external oscillator comprised of a schmitt trigger inverter (IC7), a 4MHz crystal, and two resistors and capacitors. It produces a 4MHz square wave. IC1 contains an on-chip oscillator, but it isn't used in this circuit as the clock is also needed in the memory system. Pin 5 is normally used in the on-chip oscillator. When an external clock is used (as in this case), it is grounded.

Pin 1 of IC1 is ground, and pin 3 is Vcc and connected accordingly. Pins 6 and 7 are used for programming and the timer. In this circuit they are connected to Vcc (inactive).

Pin 28 of IC1 is reset, an active low signal. Reset on power up is provided by C1, which is charged by an on-chip pull up resistor in IC1. S1 shorts out C1, causing a reset.

LEDs 5 and 6 are driven directly by active low outputs from IC1.

Switches S2 and S3 each pull low a line on IC1 which is otherwise held high by a pull resistor. These pins are polled by software inside IC1.

The output strobe circuit is provided directly by pin 16 of IC1. The output port busy signal

(which is an input to the buffer) is first passed through S4, then on to pin 2 of IC1, where it is polled by software. If S4 disconnects the BUSY line, IC1 sees a high signal on pin 2, causing it to think that the output port is busy, preventing any data from being sent out.

Port selection

The 687O5P3 outputs a select signal on pin 12, which is low when port A is active and high when port B is active. The task of the port selector is to direct IC1's commands to the appropriate port, and send the appropriate port's status back to IC1. This selection is done with IC3, a quad two input multiplexor. The select signal from IC1 is connected to its select pin, so an output Yx (x = a,b,c or d) is equal to an input signal Ixa if port A is active, and Ixb if port B is active.

Each port requires an active low enable signal to say that it is the current port. For port A, this is just the unmodified select signal. Port B requires the select signal inverted. This inversion is performed by the first multiplexor in IC3.

Each port produces an active high data ready signal. The appropriate one is selected by the second multiplexor, and the result is sent to IC1 pin 11, where it is polled by software.

The last function of the port selection is to take the active high acknowledge signal from IC1 pin 15, and send it to the active port. This is done by the last two multiplexors.

Input port buffering (IC4,IC5,IC6, 1/2 IC2)

The input port buffering consists of two identical sections, one for each input port.

I shall therefore only describe the port A section.

The eight input data bits from the input port are latched on the rising edge of the STROBE signal from that port in a 74LS374 latch. The output enable for this latch is taken from the active low enable signal from the port selection section. The output lines of the enable signals is active at any time, this means that the dynamic RAMs always have the current data from the active port on their data in pins.

The other job of the enable sign is to directly drive a LED to indicate which port is active.

There is also a one bit D latch (IC6) in the input buffering stage. This latch is cleared (indicating data is ready) by STROBE from the input port being low, and is set (indicating data is not ready) by the start of the acknowledge signal from the port selection section, or by a reset signal. Thus the inverted output provides the active high data ready signal to the port selection section, and also the wait signal to be returned to the input port. The uninverted output directly drives the data ready LED.

Lastly, the acknowledge signal. The signal from IC1 is active high (purposefully, so that the data acknowledge latch is triggered at the leading, not trailing edge). It has to be inverted to go to the input port, which requires an active low signal. A NOR gate (from IC2) with the inputs tied together is used as the inverter.

RAM interface (ICB-15, IC16, 1/2 IC2)

Software inside IC1 does almost all of the

the empty LED. The clear button must then be pressed to continue.

The buffer will go into BOTH mode if the SWAP button is pressed and held down while the REDO button is pushed and released, and then the SWAP button is released. This is easier to do than say. In this mode, the buffer will try both ports until one of them presents some data. The buffer will then stay on that port until no more data has been received for about five seconds, after which the buffer will once again try both ports for data. The buffer will stay in BOTH mode until the CLEAR key is pressed.

Finally, there is a black slide switch which prevents any data from being sent to the printer when it is slid towards the green SWAP switch. This is similar to turning the printer off-line, except that it doesn't affect any data already in the printer's internal buffer.

Design approach

A simple off-the-shelf parts design was ruled

out due to the large number of components needed, so I used a single chip microcomputer to do the main arbitration. This little marvel is a 28-pin integrated circuit that contains, on the chip, an entire microcomputer – RAM, EPROM, CPU, and I/O ports. Almost all the pins are general purpose inputs or outputs, which the program inside can use for whatever it wants.

The particular chip I chose was the Motorola MC687O5P3S (687O5P3 for short), the same one as used in ETI 747 (though with different software). An overview of single chip microcomputer technology is given in ETI September 1986.

This chip then, when programmed with the appropriate software, can be considered to be a dedicated printer buffer controller chip as far as hardware design is concerned. A description of the pin functions in this application is given in a table elsewhere.

Unfortunately, it does not contain enough RAM to be useful by itself as a buffer – it only

contains 112 bytes. Thus, it desperately needs external memory. Now, this external memory must be addressed by the I/O pins, and, as there are a limited number of I/O pins, the fewer pins used the better. Dynamic RAMs satisfy this job beautifully – they already have multiplexed address lines. They also have the advantages of being small and relatively cheap (even despite the recent price explosion).

The DRAMs used were HM5O256 or compatible. They are 256KX1 (so eight are required for the 256K bytes).

The speed of the DRAMs is largely irrelevant. They need to have an access time of 250 nS or less. This is easily satisfied, as the most common are 150 nS. DRAMs are currently relatively expensive, but you only need slow ones, and they are much cheaper. One possible source is from a friend who is replacing RAMs in a memory card with faster ones.

Now, a brief discussion on DRAM refreshing.

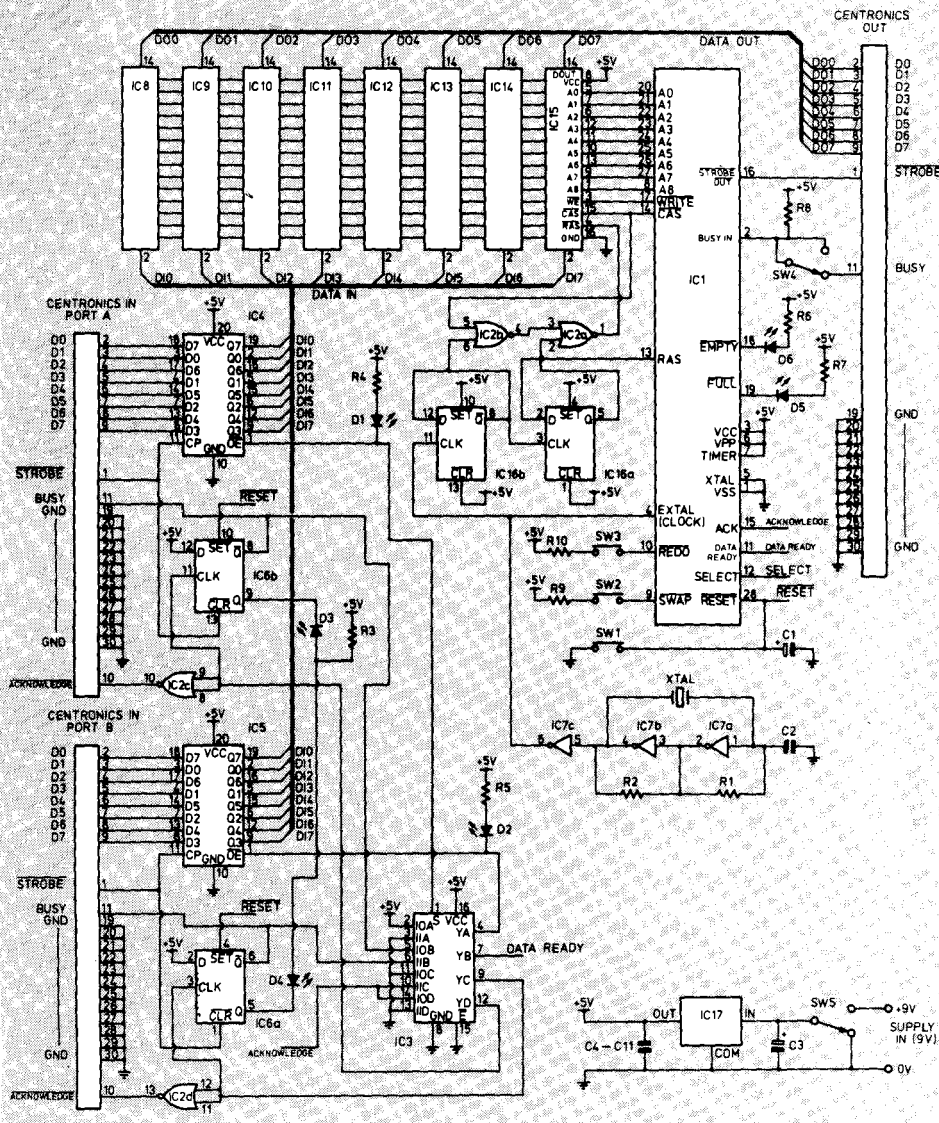

work here. Address lines for the dynamic RAMs are connected directly to outputs on IC1, as are CAS and WE.

RAS is slightly more complicated. In order to refresh the DRAMs, using CAS before RAS refresh, CAS must be held low, and RAS must be toggled. This toggling action must be provided by an oscillator. Now, the 4MHz system oscillator is faster than needed (and would cause 120 nS DRAMs to be required). IC16 is a dual D flip flop. The first half of this is set up as a divide by two counter, to generate a 2MHz signal. The other half is used to synchronise the RAS signal coming out of the 68705P3 with the 2MHz clock to avoid glitches.

Whenever IC1 outputs a low on both pins 13 and 14, the oscillator is gated into the CAS circuit, to provide the RAS pulses necessary for the CAS before RAS refresh. In a normal RAM access, pin 13 goes high (causing RAS to go low) before pin 14 (CAS) goes low, avoiding unwanted toggling of RAS.

Finally, the data out pins of the DRAMs go directly to the output port. Note that the data in and data out pins are NOT connected to each other. This avoids the need for extra logic to switch the input buffers off when a read is being performed.

Power supply (IC17)

Raw power is provided by a 9V plugback which is then filtered by capacitor C3. The 9V is then regulated to the required 5V by a 7805. Various 0.1 uF decoupling capacitors are placed around the board to absorb spikes due to high speed switching.

Dynamic memories have a problem: they are dynamic. This is due to their construction as a huge array of leaky capacitors. These capacitors will discharge unless they are regularly topped up. In fact, this topping up (technical buzz word: "refreshing") must be done, on each cell, hundreds of times a second.

Naturally, this is a headache for designers working with DRAMs. Fortunately, when you refresh one cell, you also refresh many others on that row. However, in order to preserve data integrity, it is necessary to access each of 256 rows at least once in every four millisecond interval. This usually involves an address counter to count the row being refreshed, and multiplexors to put this on the address buss, on top of all the arbitration logic ... a real mess.

Then someone got the brilliant idea of putting the counter on the RAM chip itself. This means that in order to perform a refresh, all that is needed is to assert CAS before RAS

(in normal use, RAS is asserted before CAS.) The RAM chip itself then looks after the addressing. This is the method used in the project, and is called CAS before RAS refresh.

Most 256K DRAMs have the capability to perform this type of refresh, but not all do. If they do, it will probably say in their datasheets under the heading "features". The following dynamic RAMs are supposed to have this facility, according to their specifications (Note that this list is not exhaustive by any means):

- Texas Instruments: TMS4256, TMS4257**
- Oki semiconductor: MSM41256A, MSM41257A (but not MSM41256)**
- Mitsubishi: M5M4256 (P,S or L), M5M4257(P,S or L)**
- NEC electronics: uPD41257 (but not necessarily uPD41256)**
- Hitachi: HM50256**
- Motorola: MCM6256, MCM6257**

Many of the above came from preliminary

data sheets, so the specifications may have changed. I have some NEC uPD41256 chips, which, according to my 1985 data book, do not have CAS before RAS refresh. Indeed, those with a date of '85 on them didn't work...but those dated '86 worked perfectly!

If you already have some memory chips, and are not sure if they have CAS before RAS refresh, try them - if they work, they must have the CAS before RAS refresh.

An interesting design point is that the actual data being buffered never goes anywhere near the 68705P3. The data path is from the input port to the DRAM data-in pins, and then from their data-out pins directly to the output port.

The software core of the 68705P3 allows for many special functions. The REDO function and the BOTH mode are both easy to implement in software, but would need many extra circuits if a single chip microcomputer were not used. The operation of the software is invisible to

68705P3 PINOUT

The 68705P3 is a general purpose chip, and so I have had to make up my own pin names for this application. The following chart gives a list of the pins, the "official" names, my names, whether it is an input (I) or an output (O) and a brief explanation of their purpose.

Pin	Name	My Name	I/O	Description
1	Vss	Vss		ground
2	INT	busyin	I	high indicates that the output port is not ready to receive more data
3	Vcc	Vcc		positive power
4	XTAL	clock	I	4MHz clock input
5	XTAL		I	not used; grounded
6	Vpp		I	not used; tied to Vcc
7	TIMER		I	not used; tied to Vcc
8	PCO	A8	O	dynamic RAM address 8
9	PC1	swap	I	active low signal connected to SWAP pushbutton. Debouncing is done by software internally
10	PC2	redo	I	active low signal connected to REDO pushbutton. Debouncing is done by software internally
11	PC3	dataready	I	active high signal indicates there is data ready at the active input port
12	PBO	select	O	indicates which port is active
13	PB1	ras	O	active high signal which goes to the RAS pins on the dynamic RAMs after being inverted, and made to oscillate if it and pin 14 are both low
14	PB2	cas	O	active low CAS signal for the dynamic RAMs
15	PB3	acknowledge	O	active high signal providing the acknowledge signal for the active input port
16	PB4	strobeout	O	active low signal directly provides strobe signal for the output port
17	PB5	write	O	active low signal directly provides WE signal for dynamic RAMs
18	PB6	empty	O	active low signal directly drives empty LED
19	PB7	full	O	active low signal directly drives full LED
20	PA0	A0	O	dynamic RAM address 0
21	PA1	A1	O	dynamic RAM address 1
22	PA2	A2	O	dynamic RAM address 2
23	PA3	A3	O	dynamic RAM address 3
24	PA4	A4	O	dynamic RAM address 4
25	PA5	A5	O	dynamic RAM address 5
26	PA6	A6	O	dynamic RAM address 6
27	PA7	A7	O	dynamic RAM address 7
28	RESET	reset	I	active low signal causes a reset

the constructor, but the following brief description of the algorithm in pseudo code may be of some interest:

```

initialise counters, status, IO pins, etc;
exercise dynamic memories (They need 8
cycles to "warm up");
repeat;
if dataready signal active then
  set delaycount = max
if not full then
  increment in address
if in address equals out address then
  set full flag and LED
  clear empty flag and LED
  perform write to dynamic memory (using
in address)
  send acknowledge pulse
if output port not busy and not empty then
  increment out address
if in address equals out address then
  set empty flag and LED
  clear full flag and LED
  start read from dynamic memory (using
out address)
  send strobe pulse
  end read from dynamic memory
if swap key held down then
  delay for rebounding
if redo key held down then
  set BOTH flag
  set delaycount = min
  invert select signal
  wait until swap key released
  delay for rebounding
if redo key held down then
  delay for rebounding
  wait until key released
  delay for rebounding
if LONG flag not set then
  in address = 0
else
  set both full and empty LEDs
  stop
decrement delaycount
if delaycount equals zero and OSC flag set
then
  invert select flag
  set delaycount = min
forever

```

Obtaining 68705P3

I will send you a programmed, verified, and tested MC68705P3 for \$40 including air mail, postage and secure packing. This price is for Australia only.

I reserve the right to change this price, as the price of the unprogrammed MC68705P3s is beyond my control, so if you are making this project more than three months after publication, please contact me first.

Send a cheque or money order to:
 Conway Electronics
 10 Gilmore Road
 Doncaster Victoria 3108

The software is copyright 1988 by Andrew Conway.

FEATURE COMPARISON CHART

■: Present □: Absent O: Optional L: Limited

FEATURE	CSS	SPSS/PC+
Data Handling		
Conditional case selection	■	■
Computed variables	■	■
Free field data formatting	■	■
Joins data files	■	■
Lag variables	■	■
Merges data files	■	■
Missing values	■	■
Reads/Writes Ascii files	■	■
Reads/Writes Lotus/dBase files	■	■
Sorts cases/variables	■	■
Split data files	■	■
Spreadsheet data editor	■	■
Transformations	■	■
Transpose data	■	■
Variable labels	■	■
Batch Facility	■	■
Macro Facility	■	■
Contingency Tables		
Multway tables	■	■
Chi-square tests	■	■
Other tests	■	■
Nonparametric Tests		
Fisher's exact test	■	■
Friedman Anova-by-ranks	■	■
Mann-Whitney U	■	■
Kendall's Tau	■	■
Kolmogorov-Smirnov	■	■
Wilcoxon	■	■
T-Tests		
Independent	■	■
Matched pairs	■	■
Correlation		
Fisher's r to z transformation	■	■
Partial correlations	■	■
Pearson correlations	■	■
Spearman rank-order	■	■
Reliability/Test Item Analysis		
Regression		
Standard multiple	■	■
Logistic	■	■
Nonlinear	■	■
Residuals Analysis	■	■
Simultaneous ridge	■	■
Stepwise	■	■
Analysis of variance (Anova)		
Analysis of covariance (Ancova)	■	■
Latin-square design	■	■
Multway factorial	■	■
Nested designs	■	■
Planned comparisons	■	■
Post-hoc comparisons	■	■
Repeated measures	■	■
Split-plot designs	■	■
Unbalanced designs	■	■
Log linear models	■	■
Survival analysis	■	■
Multivariate Analysis		
Analysis of covariance (Mancova)	■	■
Analysis of variance (Manova)	■	■
Factorial Manovas	■	■
Canonical correlation	■	■
Discriminant analysis	■	■
Multivariate Analysis		
Analysis of covariance (Mancova)	■	■
Analysis of variance (Manova)	■	■
Factorial Manovas	■	■
Canonical correlation	■	■
Discriminant analysis	■	■
Factor analysis	■	■
Hotelling's T-squared	■	■
Multivariate classification	■	■
Planned multivariate comparisons	■	■
Post-hoc multivariate comparisons	■	■
Principal component analysis	■	■
Repeated measures Manovas	■	■
Cluster Analysis		
Multi dimensional Scaling		
Quality control		
Time Series Analysis		
Auto correlation	■	■
Partial auto correlation	■	■
Cross correlation	■	■
Fast Fourier transform	■	■
Auto spectral analysis	■	■
Cross spectral analysis	■	■
Data tapering/smoothing	■	■
Box Jenkins ARIMA models	■	■
Graphics/Graph types		
Box and whisker plots	■	■
Casement plots	■	■
Chernoff faces	■	■
Contour (density) plots	■	■
Histograms/frequencies	■	■
3-D histograms	■	■
Line graphs	■	■
Logarithmic/semilogarithmic plots	■	■
Pie charts	■	■
Probability/cumulative probability plots	■	■
Scatter plots	■	■
Stem and leaf plots	■	■
X-Y-Z plots	■	■
Graph features		
Overlaid plots	■	■
Error bars	■	■
Multiple text fonts	■	■
Free form text positioning/orientation	■	■
Flexible chart sizing	■	■
Colour graphics support	■	■
Plotter support	■	■
Mouse support	■	■
Can use maths co-processor	■	■

INCIDENCE OF STRESS IN DIFFERENT AREAS. PERCENTAGES SHOWN ARE OF HIGHER THAN EXPECTED AVERAGE

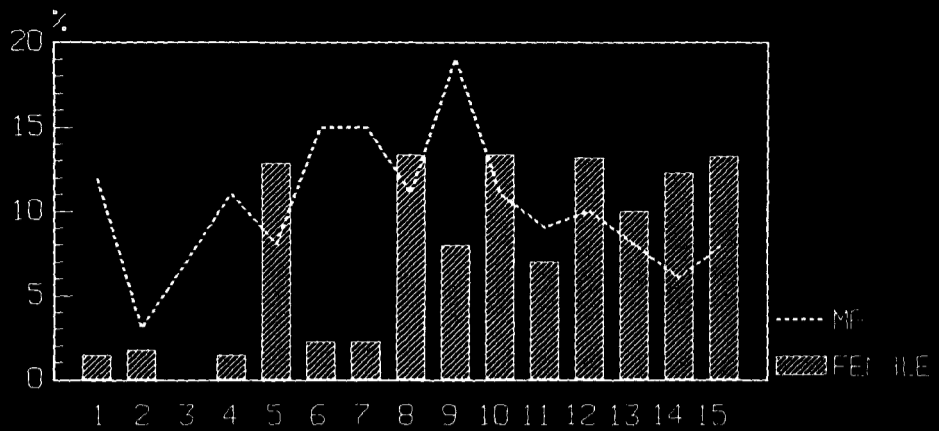

COMPLETE STATISTICAL SYSTEM

CSS (Complete Statistical System) is a high performance, integrated statistical data processing, database management, and graphics system for science, business, and engineering applications, for your PC! The comprehensiveness and speed of CSS make it a realistic and attractive alternative to mainframe statistical packages. CSS is incomparably faster and more flexible than mainframe programs and at the same time offers an equal or better selection of analytical methods.

CSS is capable of Basic and Descriptive Statistics, Multiway Frequency Tables, Nonparametric Statistics, Exploratory Data Analysis with Analytical Graphs, Multiple Regression Methods, Time Series Analysis with Modeling and Forecasting, General Anova/Ancova/Manova, Contrast Analysis, Discriminant Function Analysis, Factor Analysis/Principal Components, Multi-dimensional Scaling.

\$900

If you would like more information and a free demonstration disk on CSS, simply send us a copy of this advertisement with your business card attached.

SOFTWARE EXPRESS

WE ONLY DO SOFTWARE

SYDNEY: 74 PARRAMATTA RD, STANMORE. 2048.
PHONE (02) 519 3249 FAX (02) 519 3868

MELBOURNE: 48 A'BECKETT ST, MELBOURNE 3000
PHONE (03) 663 6580 FAX (03) 663 6117

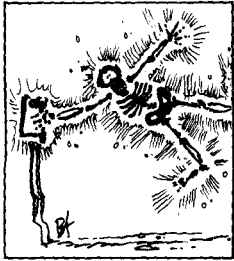

ELECTRONICS
E T I - 6 1 6

The third interface uses a simpler type of computer, but a more complex form of MIDI interface. The added complexity is only minor, so all readers with a Commodore 64 or a 6502 based micro (or Z80 for that matter) who are currently trembling can rest easy. The complexity is of concern to us when programming, rather than the few extra components needed in the hardware. I have included some data you will need if you are planning to program the thing yourself.

The speed of most 6502 type of computer may seem very fast, but they are quite slow compared to the other two computers, the Amiga and the Macintosh. So the interface

design will have to include a through/out function to be of any practical use.

Another problem is baud rate. I have yet to come across a 6502 computer that has a serial port to cope with MIDI's 31,250 baud rate.

To get the system up and working we need a MIDI interface that will grab hold of data that comes out of a parallel port (ie, eight bits ... a whole word at a time) and transfer them in a serial fashion at the correct baud rate.

At the heart of the interface is a universal asynchronous receive and transmitting device (UART). The UART that was designed for the 6502 and similar microprocessors is

Switch Function	1	2	3	4	5	6	7	8
	IRQ	NMI	IO1	IO2	+5V	A3	R/W	A1

Figure 1.

6850 Registers	Control	Status	Tx	Rx	Interrupt
Sequential	\$DE00	\$DE02	\$DE01	\$DE03	IRQ \$95
Passport	\$DE08	\$DE08	\$DE09	\$DE09	IRQ \$95
Syntech	\$DE08	\$DE08	\$DE09	\$DE09	IRQ \$95
NameSoft	\$DE00	\$DE02	\$DE01	\$DE03	NMI \$95

Figure 2.

THE MANY FACES OF MIDI

Doh, re, me on a pcb

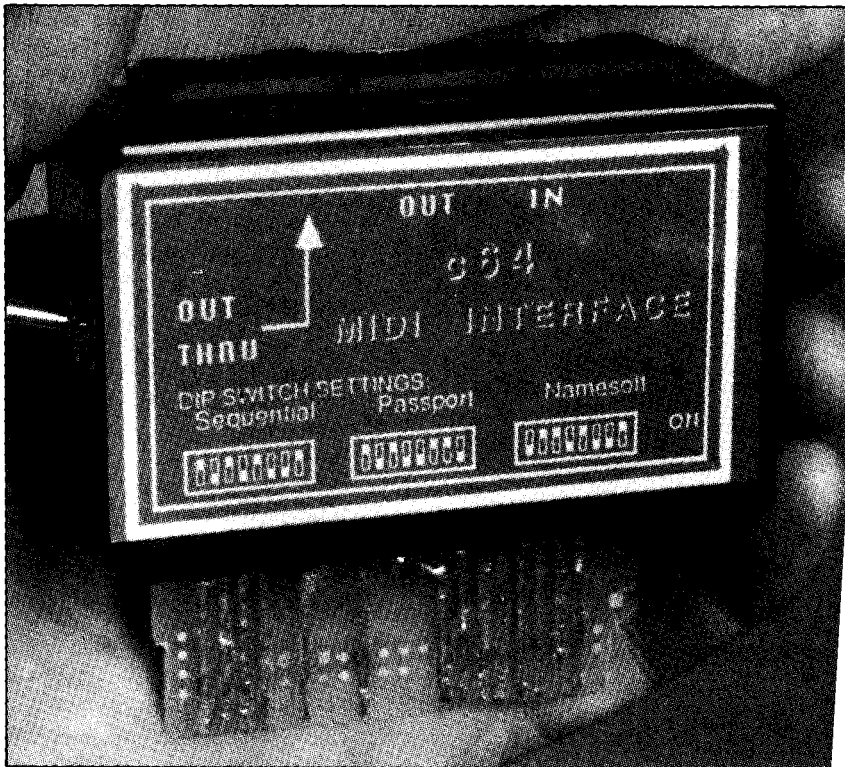

This month, in the second part of our two-part MIDI series, Royce Craven takes a look at the Commodore 64.

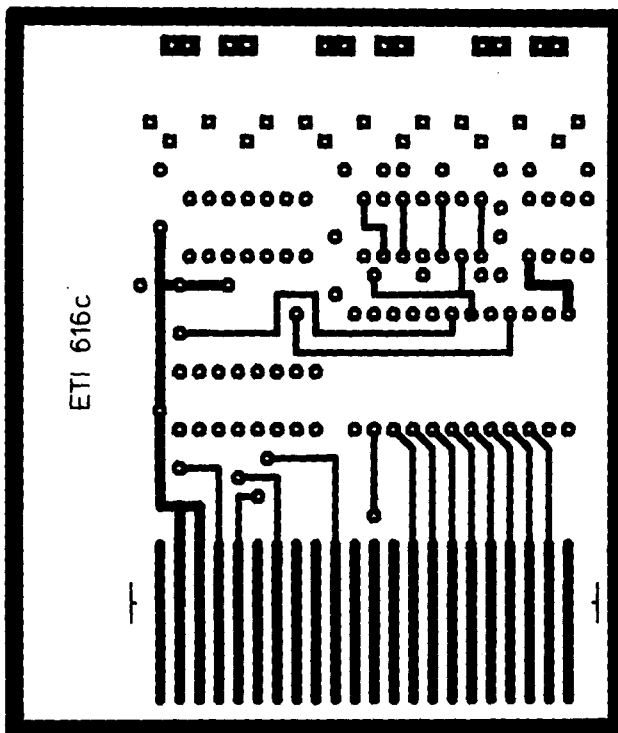
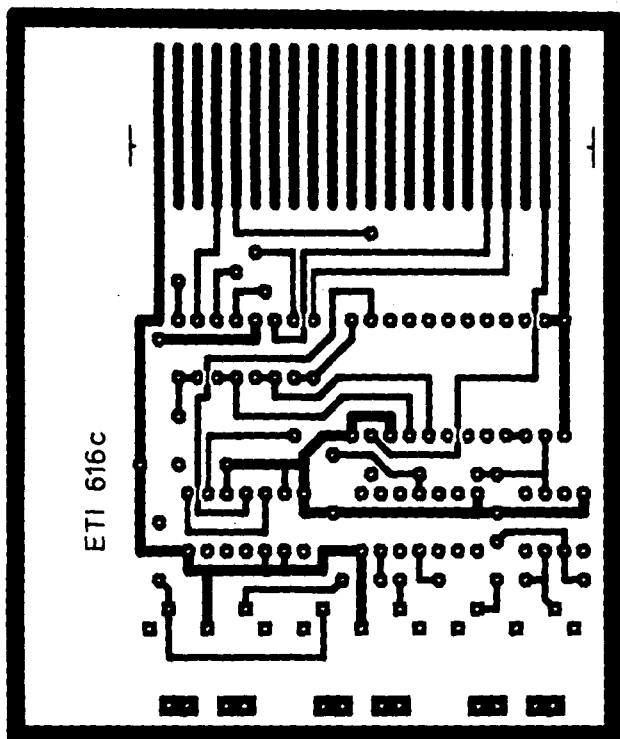

the 6850. This device has independent receive and transmit clocks, so with a bit of cleaning up of the processor clock this can be used to drive the UART at MIDI speed. Both the connection to the computer and the connection to the outside world are 0/+ volts, so interfacing to MIDI is much simpler.

The 6850 can divide the receive and transmit clocks by 16 or by 64. The C64 clock is around 1MHz and as 1,000,000 needs to be divided by 32 to get to the 31,250 MIDI speed, we're in trouble, and we need some extra components. Setting up a 74LS74 as a divide by two device reduces the clock to 500,000Hz and the UART can divide this by 16. Another benefit of the 6850 is that its logic states are TTL, i.e. 0 and +5 volts. We can use a common TTL buffer 74LS04 to connect us to the MIDI world and we don't have to worry about the strange voltage levels of a normal RS232 serial port.

The C64 has an edge connector for its cartridge/parallel port. This makes a double-sided printed circuit board necessary. These boards are quite hard to make and best left to the experts if you can afford the added expense. When the interface is completed it fits snugly behind the computer with only its small zippy box case showing.

Multi standard

One of the main features of this interface is its ability to be set up in several of the more popular configurations, allowing it to work with a wide range of software. The configurations are sequential circuits, passport/syntect and NameSoft.

The one called NameSoft is the preferred

6850 control register

Bit	Write	Read
0	CD1	Receive buffer full
1	CD2	Transmit buffer empty
2	WS1	Data carrier detect (DTC)
3	WS2	Clear to send (CTS)
4	WS3	Framing error
5	Tx Cntrl 1	Receiver overrun
6	Tx Cntrl 2	Parity error
7	Receive interrupt enable	Interrupt request

CD = Clock divide

CD2	CD1	Divide clock by . . .
0	0	/1
0	1	/16
1	0	/64
1	1	Master reset

WS = Serial Word type

WS3	WS2	WS1	Word
0	0	0	7 bits/even parity/2 stop bits
0	0	1	7 bits/odd parity/2 stop bits
0	1	0	7 bits/even parity/1 stop bit
0	1	1	7 bits/odd parity/1 stop bit
1	0	0	8 bits/2 stop bits
1	0	1	8 bits/1 stop bit
1	1	0	8 bits/even parity/1 stop bit
1	1	1	8 bits/odd parity/1 stop bit

6850 protocol

This section is mainly for the musician/programmer.

Inside the 6850 UART there are two POKeable and PEEKable registers. The first is called the control/status port, the second is the DATA port. Writing (POKEing) to the control register will set the protocol (how the

device is to send and receive the data), reading (PEEKing) will show what state the device is in. (i.e. if it is clear to send another byte or if it has received a byte).

The DATA port is obviously where the data is read from, or written to.

The Midi connection

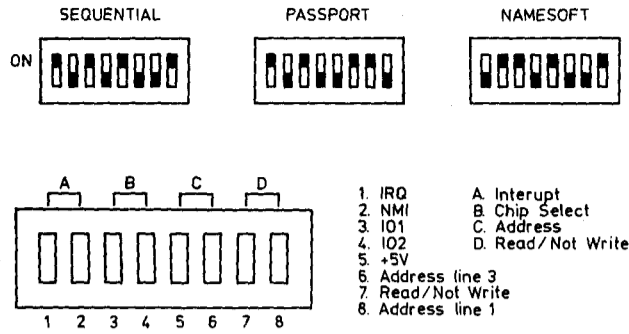

Figure 3. The MIDI connection.

PARTS LIST — ETI-616c	
IC1	74LS74
IC2	6850
IC3	74LS04
IC4	6N138
R1, 2, 3, 4, 5, 6	220R
D1	1N4001
SW1	DIP8
SW2	5PST

setting for the programmer, Ken Stephenson, as it takes advantage of the non-maskable interrupt (NMI). Ken has written a lot of music software for the C64 and this interface. If you're interested write to him at PO Box 2053, Richmond South, 3121, Victoria.

Commercial interfaces can only work in one configuration which sometimes limits the software that can be run. This interface uses an 8-way DIL switch for the different configurations.

The switch settings are shown in Figure 3. Resetting the switches requires you to turn the computer off and remove the interface and its case. This is to safeguard the computer as the switches should really be single pole double throw types, but for ease of construction and cost the 8-way DIL was used.

Looking at the DIL switch as it sits in the C64 expansion port, the switches are as shown in Figure 1.

These switches work in pairs. Either IRQ or NMI may be selected, but *not both*. Either IO1 or IO2 may be selected, but *not both*, and so on.

Switches 1 and 2 select the interrupt line. The 6850 can be made to pull an interrupt line down when a byte has been received. This is great for receiving bulk data from synths. When large amounts of data are transmitted from a synth the normal house-keeping routines, such as updating the clock, must be turned off or some of the data will not be picked up and processing in time. The quickest way to do this is to turn off the maskable interrupt using the assembler command SEI. The NMI can't be turned off, so an interrupt routine for the NMI can be written just to deal with the data coming in so none will be lost.

Switches 3 and 4 select the paging location (IO1 selects \$DE00 and IO2 selects \$DFO0).

Switches 5 and 6 and 7 and 8 are the specific lines used by the commercial interfaces.

Configuration addresses are as shown in Figure 2

Construction

The construction is fairly straightforward, remembering that some of the components have to be soldered to the foil on the top

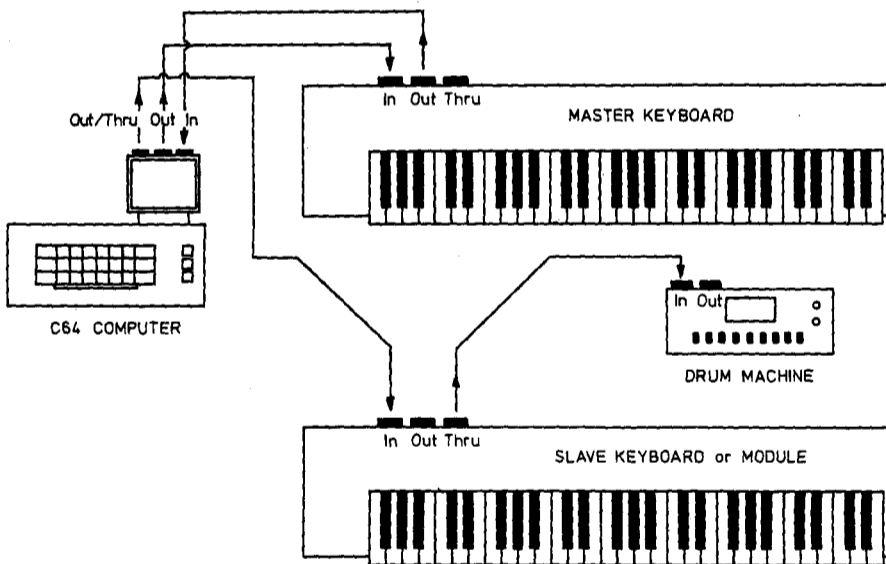
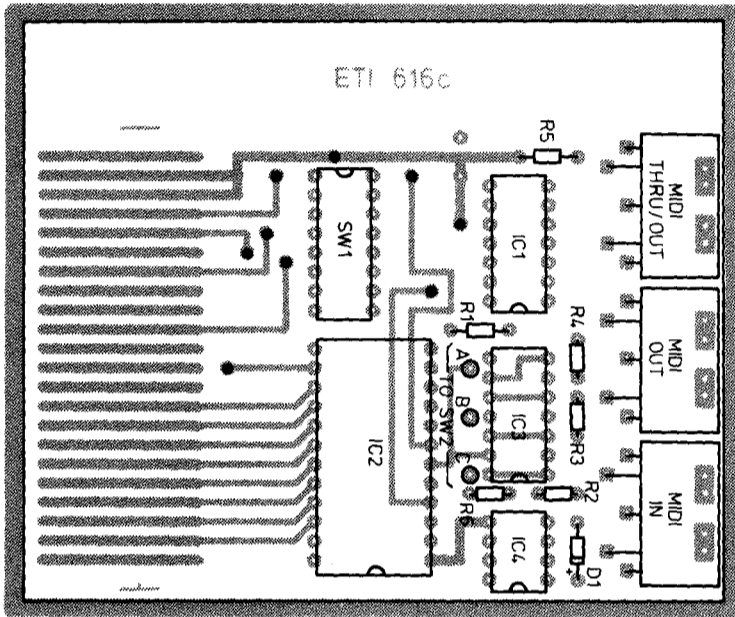

Figure 4. The MIDI system.

of the printed circuit board. There are a few places where a piece of wire is soldered to join the top and the bottom of the board. The OUT/THRU switch is corrected by three strands of ribbon wire. Don't make this too long as there isn't all that much room in the case.

Setting up

Follow Figure 3 and set up the switches for the sequential interface.

On the C64 you must be careful when you insert and remove the interface as damage may occur to both the computer and the interface if the power is turned on to the computer.

With the power turned off, push the

interface into the expansion/cartridge port. You can keep the case off at this point. Turn the computer on and in a second or two the normal Commodore screen should appear. This is quite scary for someone like me who isn't used to the long boot up time of the C64. I had visions of buying Ken Stephenson a new C64 for the privilege of letting me become the proud owner of a broken C64.

If you don't see the screen in a few seconds (don't wait too long!) or if anything starts to heat up on the interface or the screen has unreadable characters, TURN OFF THE COMPUTER. Check for correct component orientation, for solder bridges and the switch settings.

Assuming all is AOK, plug in a MIDI cable

from MIDI OUT on the controlling keyboard to the IN on the interface, and the MIDI In on the master keyboard into the OUT on the interface.

The switchable THRU/OUT socket should be connected to another MIDI module. When you are using a sequencer program on the computer, flicking the switch to the THRU position will let you control the module from the master keyboard (great for setting up the module sound or rehearsing the part you want to record). After recording a part on the sequencer, flick the switch to the OUT position. Now you can play back the sequence without having to repatch the MIDI cables from the computer to the module (see Figure 4).

How it works

The data input/output from the C64 is fed into a 6850 UART IC2 which converts it to a serial bit stream.

The clock for the 6850 is produced by the computer system clock which has been divided by two down to 500 k by a 74LS74 IC1.

The clock is divided internally by 16 to provide the 31.25 k baud required by MIDI. The raw system clock is connected to the enable pin on the 6850 to provide synchronisation of the data bus.

The 6850 provides an interrupt when a byte is in the receive buffer. This can be switched to the NMI or the IRQ of the C64 (the interrupt enable must be selected by software).

The switch bank SW1 is used to give the registers of the 6850 different computer addresses and so make it compatible with the various standards.

A byte of information is sent from the computer to the 6850, where it is converted to a stream of bits moving at 31,250 bits per second. This serial output of the 6850 is sent to two TTL inverters, IC3d and 3a, which drive the MIDI OUT. It is also sent to one side of the MIDI OUT/THRU switch SW2. R1 is used to keep the input of the first inverter IC3c high. This prevents rubbish being sent down the MIDI OUT/THRU port when the switch is thrown. The MIDI OUT/THRU port has two TTL inverters identical to the OUT port. The resistors R3,4 are current-limiting resistors.

The MIDI IN signal is fed into a current-limiting and reverse voltage protection circuit before being isolated to prevent ground loops which might cause 50 Hz noise in the audio. R2 is a pull-up resistor required by the opto-isolator ISO1. This signal is then fed to the other side of the MIDI OUT/THRU switch and into the 6850 where it is converted to a byte of data (and flags an interrupt if enabled) ready to be picked up by the computer.

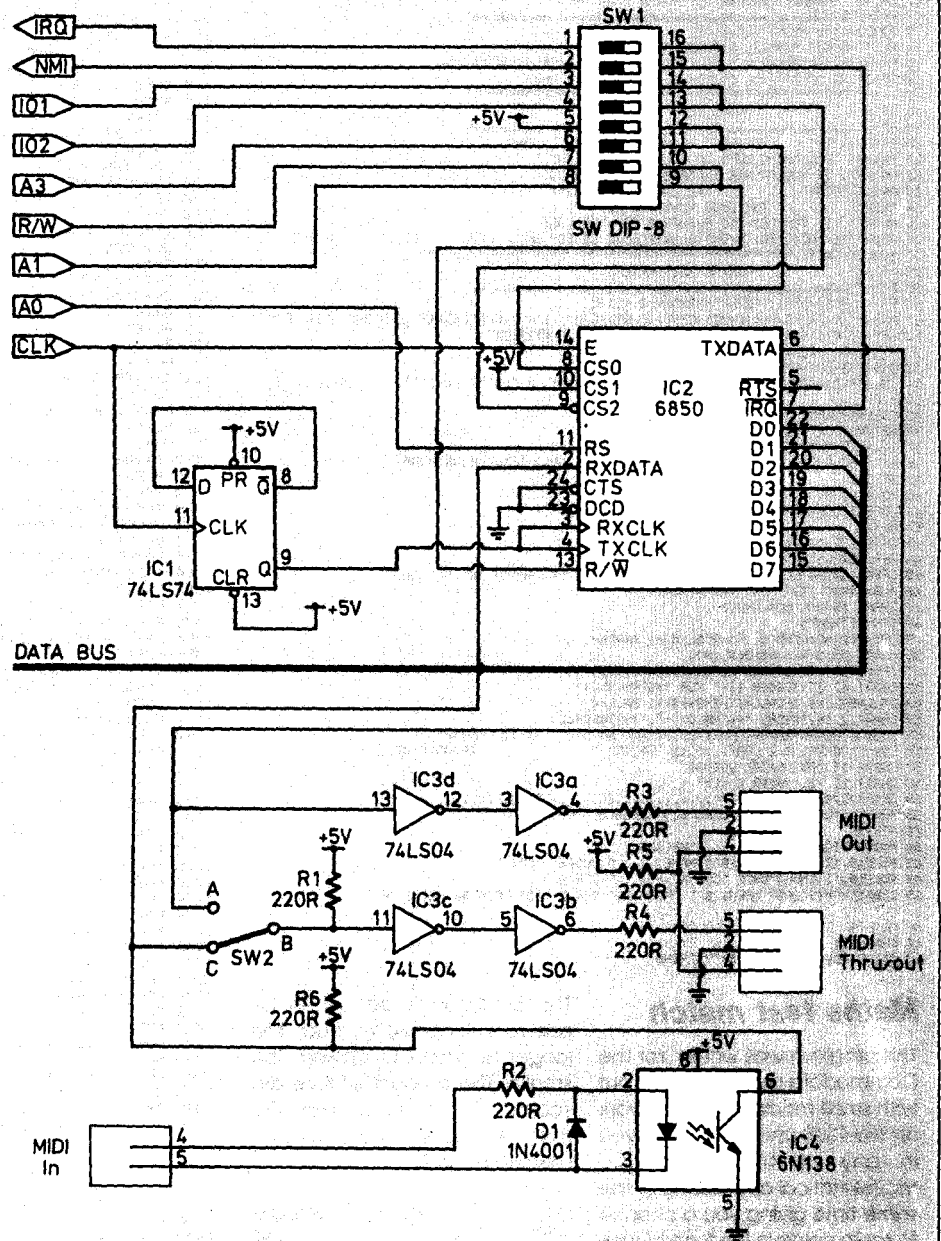



Programs

VZ 200/300

```

1 REM *****
2 REM * MATHS TEST MATCH *
3 REM * DARREN YATES *
4 REM *****
5 DIM B*(11),B*(9,11) N=1
6 SCHCLR OPEN:OPEN:1:8:0:"HISCORE"
7 FORZZ=1TO9
8 INPUT#1,HS*(ZZ):IFHS*(ZZ) THEN10
9 INPUT#1,HS*(ZZ):INPUT#1,DT*(ZZ):NEXTZZ
10 CLOSE1:PRINT
11 PRINT " HIGHEST SCORES ON 'MATHS TEST MATCH'"
12 PRINT"-----"
13 FORZZ=1TO9:PRINT " LEVEL"ZZ
14 PRINTHS*(ZZ),HS*(ZZ),DT*(ZZ):NEXTZZ
15 PRINT:PRINT"PRESS KEY TO CONTINUE.....":PRINT:GETKEYWH#
16 COLOR1,2:COLOR0,7,0:COLOR4,3,2:GRAPHIC0,1:N=1
17 PRINT"-----"
18 PRINT " MATHS TEST MATCH"
19 PRINT"-----"
20 PRINT:PRINT " YOU HAVE TO ANSWER CORRECTLY THE"
21 PRINT " FOLLOWING SUMS TO COLLECT YOUR RUNS."
22 PRINT " IF YOU ANSWER INCORRECTLY, YOU'RE OUT"
23 PRINT:PRINT " THE LONGER YOU WAIT"
24 PRINT " THE LESS RUNS YOU GET"
25 PRINT " IF YOU FAIL TO ANSWER A SUM, YOU LOSE ONE RUN"
26 PRINT"(C/DN)(C/DN)(C/RT)(C/RT)(C/RT)(C/RT)(C/RT)(C/RT):INPUTSL
27 SCHCLR:PRINT"-----"
28 PRINT " MATHS TEST MATCH"
29 PRINT"-----"
30 PRINT:FORZZ=1TO11:PRINT"BATSMAN"Z:NEXTZ
31 PRINT"(C/DN)(C/DN)(C/RT)(C/RT)(C/RT)(C/RT)(C/RT)(C/RT)(C/RT)(C/RT)
(C/RT)(C/RT)(C/RT)(C/RT)(C/RT)(C/RT)(C/RT)(C/RT)SCORE:"
32 N1=RND(0)*SL*10:N2=RND(0)*SL*10
33 AN=STR(N1)+STR(N2):R=7,0
34 COLOR1,6,4:CHAR1,13,19,*(RVON)+STR(N1)+* X *STR(N2)+*...+*(RVOF)*:CO
LOR1,2
35 FORL=1TOLEN(AN)-1
36 GETX(L):IFX(L)>" " THENNEXTL
37 IFL=LEN(AN) THEN40
38 R=R-.05:CHAR1,17,21,"RUNS LEFT:"+STR(INT(R)):IFINT(R)=0 THEN49
39 GOTO36
40 POKE239,0
41 FORZ=1TOLEN(AN):C=C+X*(Z):X*(Z)=""
42 NEXTZ
43 CHAR1,25,19,C#
44 REM CORRECTNESS
45 IFVAL(C#)=VAL(AN) THENCHAR1,24,19,AN#
46 QU=STR(N1)+* X *STR(N2)
47 CHAR1,16,3+H,QU:N=H+1
48 IFN=1 THEN58
49 IFINT(R)=0 THENB*(SL,N)=B*(SL,N)-1:RN=RN-1
50 CHAR1,35,3+H,STR(B*(SL,N))
51 IFVAL(C#)=VAL(AN) THENCHAR1,24,19,AN#
52 CHAR1,27,17,STR(N-1)+* FOR *STR(RN)+* "
53 BALL=BALL+1:IFBALL=6 THENOV=OV+1:BALL=0
54 CHAR1,2,16,"OVERS:"+STR(OV)+*,"+STR(BALL)
55 IFOV THENRR=RN:OV:CHAR1,2,17,"RUN RATE:"+STR(INT(RR))+* "
56 C#="" :COLOR1,3,2:CHAR1,13,19,*(RVON):COLOR1,2
57 FORZZ=1TO5:00:NEXTZZ:GOTO32
58 CHAR1,11,23,"PRESS A KEY"
59 GETKEYZZ#:SCHCLR:PRINT".....SKILL LEVEL"SL"....."
60 FORXX=1TO11:IFB*(SL,XX) THENH*(SL)=B*(SL,XX)
61 NEXTXX
62 PRINT"HIGHEST SCORE....."HS*(SL)
63 POKE19,12:INPUT"SCORER'S NAME.....":HS*(SL):PRINT
64 POKE19,12:INPUT"DATE (DD.MM.YY)...":DT*(SL)
65 SCRATCH"HISCORE":OPEN1,8,1,"HISCORE":FORZZ=1TO9:PRINT#1,HS*(ZZ):PRINT#1,HS*(ZZ)
)
66 PRINT#1,DT*(ZZ):NEXTZZ:CLOSE1
67 CHAR1,11,23,"PLAY AGAIN? (Y/N)"
68 GETKEYZZ#:PRINT:IFZZ#="" THEN6
    
```

Maths test match

This program was written for the Commodore plus 4 and C16 but with small mods, it will also work on the C128 and C64. It drills you in any of the four basic mathematical operations, at the same time giving you a chance to score points in the form of runs.

The batsman is out when he answers incorrectly and the longer he takes to answer, the smaller the amount of runs are scored. The screen takes the form of a scoreboard, which is self-explanatory.

**D Yates
Frenchs Forest
NSW**

Commodore

```

1 GOTO1800
3 REM!!
4 LOAD"
5 REM!!
6 BLOAD"
10 REM!!
20 RUN"
30 REM!!
40 BRUN"
50 REM!!
60 ERA" :RUN
90 REM
91 *****
92 * DOS "HELLO" PROGRAM *
93 * VZ300/200 *
94 * WRITTEN BY G.TUNNY *
95 * (C)OPYRIGHT 1988 *
96 * NOVEMBER *
97 *****
100 T=PEEK(30884)+256*PEEK(30885)
120 REM
130 T=T+1
135 IF T>32767 THEN T=65536
140 P=PEEK(T)
150 IF P=33 AND PEEK(T+1)=33 THEN 200
160 IF P=94 AND PEEK(T+1)=94 THEN RETURN
170 GOTO130
200 T=T+1
210 IF PEEK(T)=34 THEN 230
220 GOTO200
230 T=T+1
240 FOR I=1 TO LEN(F#)
250 C#=MID*(F#,I,1)
260 C=ASC(C#)
270 POKET,C
280 T=T+1
290 NEXT I
300 IFL=7 THEN160
310 FOR I=L TO L
320 POKET,32:T=T+1
330 NEXT I
340 GOTO160
1000 T=28672:C=65:A=1
1005 P=PEEK(T):F(A)=P
1010 POKET,C:POKET+1,93
1020 T=T+32:C=C+1:A=A+1
1030 P=PEEK(T):IF P=96 THEN1050
1040 GOTO1005
1050 DIM F*(20):DIM N F*(20)
1060 T=28673:C=C+1:F=F+1
1065 F*(C)="
1070 FOR J=1 TO 8:IF PEEK(T+J)=96 THEN NEXT J:GOTO1100
1075 P=PEEK(T+J):IF P>95 THEN P=P-64
1080 F*(C)=F*(C)+CHR*(P)
1090 NEXT J
1100 C=C+1:T=T+32:FN=FN+1
1110 IF PEEK(T)=96 THEN1150
1120 GOTO1065
1150 GOSUB2100
1200 FOR I=1 TO LEN(B#):A#=#INKEY*:I#=#INKEY*
1210 PRINT@448,MID*(B#,I,30)
1220 X=USR(X)
1230 IF A#="" THEN NEXT I:GOTO1200
1235 IF A#="1" THEN L D=1:GOSUB1900
1237 IF A#="2" THEN L D=2:GOSUB2000
1240 A=ASC(A#):IFA<65 OR A>90 THEN1200
1250 A=A-64
1255 IFA>FN THEN SOUND31,1:GOTO1200
1260 F#=#F*(A)
1270 IF F(A)=68,CLS:PRINT TAB(6);"CANNOT LOAD DATA FILE!":GOTO1500
1280 GOSUB100
1283 IFLD=1 AND F(A)=84 THEN 3
1285 IFLD=1 AND F(A)=66 THEN 5
1287 IFLD=2 THEN 60
1290 IF F(A)=84 THEN 10
1300 IF F(A)=84 THEN 30
1310 CLS:PRINT" IDENTIFICATION ERROR!!"
1320 STOP
1500 FOR I=1 TO 3: SOUND31,1:24,2:117,4:NEXT I
1510 RUN
1800 CLEAR1500:F#=#FILENAME"+POKE30862,80+POKE30863,52
1810 CLS:DIR:DIM F*(20)
1820 B#=""
1830 B#=#"+LOAD...2-ERASE...WRITTEN BY G.TUNNY (C)OPYRIGHT "
1835 B#=#"+1988....."
1840 GOTO1000
1900 IF INKEY<>" " THEN1900
1910 PRINT@800," TYPE LETTER TO LOAD "
1920 IF INKEY="" THEN1920
1930 RETURN
2000 IF INKEY<>" " THEN2000
    
```

ETI FEBRUARY '89

```

2010 PRINT@480," TYPE LETTER TO ERASE *";
2020 IF INKEY$="" THEN 2020
2030 RETURN
2100 K=FN:FOR I=1 TO FN
2110 L$=LEFT$(F$(I),1)
2120 L=ASC(L$)
2130 IFL=42 THEN NEXT I:GOTO 2200
2140 Z=Z+1:IF$(Z)=F$(I):F(Z)=F(I)
2150 X=USR(X)
2160 NEXT I:GOTO 2200
2200 SC=2:Y=1:FN=Z
2210 PRINT@SC, FN$(Y); " "
2220 IF Y=FN THEN 2250
2230 Y=Y+1:SC=SC+32
2240 GOTO 2210
2250 FOR I=1 TO FN
2260 F$(I)=FN$(I)
2270 NEXT I
2280 FOR I=FN TO 14
2290 PRINT@I*32,"
2300 NEXT I:RETURN

```

Hello program

This hello program loads the directory onto the screen and conveniently allows the user to load, run or erase programs without typing lengthy filenames. If there are any filenames that you don't want to come up in the

hello program, rename the filenames to have an asterisk at the front. e.g. a file - 'picture' becomes (*Picture).

**G Tunny
Gorokan
NSW**

```

00640 S=S+1:IFS=A:S=0:GOTO 670
00650 FOR D=S+1 TO A:IF P1(D)<=P1(S):NEXT D:GOTO 640
00660 GOSUB 710:GOTO 640
00670 S=S+1:IFS=A:RETURN
00680 FOR D=S+1 TO A:IF P1(D)>P1(S):NEXT D:GOTO 670
00690 IF P1(D)>=P1(S) THEN 670
00700 GOSUB 710:GOTO 670
00710 N1$(0)=N1$(D):N1$(D)=N1$(S):N1$(S)=N1$(0)
00720 P(0)=P(D):P(D)=P(S):P(S)=P(0)
00730 W(0)=W(D):W(D)=W(S):W(S)=W(0)
00740 L(0)=L(D):L(D)=L(S):L(S)=L(0)
00750 P1(0)=P1(D):P1(D)=P1(S):P1(S)=P1(0)
00760 RETURN

```

Oops, I goof'd

My 8-Ball Percentages program published in the October edition has a minor flaw. The program as submitted will run. However, the sorts as described will not work fully due to my omission of NEXTD in lines 650 and 680. An upgrading of the routine has also

been performed and the lines 640 to 760 should be amended. I humbly apologise for any inconvenience caused by my oversight and promise that all care will be taken in future.

**Gary R Laming
Mile End
SA**

VZ 200/300

```

40 REM UISISORT
50 REM FOR VZ200/300
60 REM BY P.J.SHEPPARD
80 CLS
100 PRINT@200,"-< UISISORT >-";
105 ' INITIALISE VARIABLES, ETC
110 CLEAR 500:DIMS(20,2),A$(13),S$(13):X1=400:X2=25:Q=CHR$(34)
120 PP=36:N1=154:N2=250:N3=186:N6=411:A1=30:A2=36:A3=36
130 SOUND=9
140 CLS
150 PRINT:PRINT " * U I S I S O R T * "

```

```

160 PRINT "-----":PRINT
170 PRINT (1)..STANDARD BUBBLE SORT
180 PRINT (2)..BUBBLE SORT WITH SINKER
190 PRINT (3)..SUPER BUBBLE SORT
200 PRINT (4)..EXCHANGE SORT
210 PRINT (5)..DELAYED REPLACEMENT SORT
220 PRINT (6)..SHELL SORT
230 PRINT (7)..SHELL - METZNER SORT
240 PRINT (8)..QUICK - SORT
250 PRINT (9)..EXIT PROGRAM
260 PRINT@451,"SELECT SORT ROUTINE ...";
265 D=INKEY$
270 FOR J=0 TO 8:CH=INKEY$:J=(CHR$(J+1)OR CH)>"9":NEXT
280 CH=VAL(CH):IF CH=9 THEN 230 ELSE PRINT CH: SOUND 30,7;0,2
290 CLS
300 GOSUB 430
310 FOR K=0 TO 9: A$(K)=S$(K):PRINT@32*K+32,A$(K);:NEXT
320 NE=0:NC=0:NO=0:NI=186
330 IF NS>9 THEN NI=184
335 ' SORT STATUS
340 PRINT@76,"NO OF ITEMS .. "USING"##";NS+1
350 PRINT@106,"-----";
360 PRINT@140,"COMPARISONS .. 0";
370 PRINT@172,"EXCHANGES ... 0";
380 PRINT@204,"-----";
390 PRINT@236,"TOTAL ACTIONS 0";
400 PRINT@268,"-----";
405 ' SORT ROUTINES
410 IF CH=1 GOSUB 210 ELSE IF CH=2 GOSUB 140 ELSE IF CH=3 GOSUB 130
414 IF CH=4 GOSUB 150 ELSE IF CH=5 GOSUB 100 ELSE IF CH=6 GOSUB 180
418 IF CH=7 GOSUB 190 ELSE IF CH=8 GOSUB 210
420 GOSUB 800
430 PRINT@300,"*****";
440 PRINT@332,"% SORT COMPLETE %";
450 PRINT@364,"*****";
460 PRINT@423,"RESORT ORIGINAL";
470 PRINT@461,"LIST.....(Y/N)";
475 D=INKEY$
480 FOR J=0 TO 8:RF=INKEY$:J=(CHR$(J+1)AND(RF<"N")):NEXT:GOTO 140
485 SOUND 30,1
490 IFRF="Y" THEN 750
495 ' SORT DATA
500 FF=0:NS="";
510 PRINT"HOW MANY ITEMS TO SORT";
520 PRINT"SELECT BETWEEN 1 AND 14 -- ";
525 D=INKEY$:SS="";
530 SS=INKEY$:SOUND 0,1
535 IF SS=" " THEN 525 ELSE SOUND 30,1
540 IF SS="1" AND NS<"1" THEN NS=NS+SS:FF=1:PRINT SS;:GOTO 530
550 IF FF=1 AND (SS<"0" OR SS<"4") OR FF=0 AND (SS<"4" OR SS<"9"),530
560 PRINT SS: NS=NS+SS: NS=VAL(NS)+1
570 PRINT:PRINT"SUPPLIED BY COMPUTER OR USER ?";
580 PRINT"PRESS "Q"C"Q" OR "Q"U"Q"...";
585 D=INKEY$:RI=INKEY$
590 IF RI="U" THEN 0 ELSE IF RI="C" THEN PRINT"COMPUTER" ELSE 55
595 ' COMPUTER DATA
600 PRINT:PRINT"NUMBERS OR LETTERS?";
610 PRINT"PRESS "Q"N"Q" OR "Q"L"Q"...";
615 D=INKEY$
620 FOR J=0 TO 8:R=INKEY$:J=(CHR$(J+1)AND(R<"N")):NEXT
630 IFR="N" THEN PRINT"NUMBERS" ELSE IFR="L" THEN PRINT"LETTERS"
635 SOUND 0,1
640 FOR K=0 TO 9
650 IFR="L" THEN S$(K)=CHR$(RND(26)+64) ELSE S$(K)=STR$(RND(82)+10)
660 NEXT K
670 GOTO 250
675 ' USERS DATA
680 CLS
690 PRINT"ONE CHARACTER PER LINE MAXIMUM";
700 PRINT"LETTERS OR NUMBERS ONLY";
710 FOR K=0 TO 9
720 PRINT"ITEM #K=";
725 D=INKEY$:FOR J=0 TO 8:S$(K)=INKEY$
730 J=(S$(K)<"0")OR("Z"<S$(K))OR("9"<S$(K))AND(S$(K)<"A")
735 NEXT J
740 PRINT S$(K):SOUND 20,1:NEXT K
750 R$="N"
760 CLS
770 RETURN
780 PRINT@336,"PRESS (RETURN) TO";
790 PRINT@428,"START THE SORT...";
795 D=INKEY$
800 KI=INKEY$:IF KI<" " OR CHR$(13) THEN 800
810 GOSUB 800
815 ' SORT SPEED
820 PRINT@390,"SPEED SET AT 1-"SOR(X1/25);

```

JOIN THE WIRELESS INSTITUTE OF AUSTRALIA

The Wireless Institute of Australia (W.I.A) represents radio amateurs in local and international matters and provides assistance, education and many other services. As a member you will receive:

- AMATEUR RADIO the monthly magazine of the WIA.
- News of DX, propagation, clubs, satellites, etc.

OTHER SERVICES INCLUDE:

- A world-wide QSL service
- Weekly news and information broadcasts
- Books and publications sales
- Classes for students for the Novice, Limited and Full Call Certificates
- Lessons by correspondence
- Participation in contests, seminars and field days
- Sole representation for amateurs at government level

Learn more about the W.I.A. and AMATEUR RADIO

Forward this coupon, or write to:

**W.I.A.
P.O. BOX 300
CAULFIELD SOUTH
VICTORIA 3162**

Registered Address: 3/105 Hawthorn Road, Caulfield North

Please send a WIA membership form to:

NAME

Address

Postcode

BKP68/129A

READER INFO No. 23

```

930 PRINT@428,"O - B ALTERS SPEED";
940 PRINT@460,Q*,"Q*" STOPS PROGRAM";
950 RETURN
960 FORSC=1 TO 7:PRINT@268+SC**92,"
";NEXT
965 RETURN
970 ' POINTER ROUTINE
980 NCH=1:PRINT@N1,USING"###";NC
990 NCH=NE:PRINT@N2,USING"###";ND
995 PRINT@32X+PP,"";
910 PRINT@32Y+PP,"";
920 FORI=1 TO X1:NEXT
930 PRINT@32X+PP," ";
940 PRINT@32Y+PP," ";
950 D=INKEY:J=INKEY
960 IF#D<>" THENX1=VAL(CWJ)*2*25:Y2=SQRLX1:
PRINT@N6,VAL(WJ)
970 IF#D=" THENGOSUB860:PRINT@333,"SORT
TERMINATED":GOTO460
980 RETURN
990 ' SWITCHER ROUTINE
1000 FORK=0 TO 4
1010 PRINT@32*I+K*92," #A@CJ";
1020 PRINT@32*J+K*91," #A@CJ";
1030 NEXTK
1040 PRINT@32*I+K*92," #A@CJ";
1050 FORJ=1
1060 FORK=1 TO DF
1070 PRINT@32*I+K*92," #A@CJ";
1080 PRINT@32*J+K*91," #A@CJ";
1090 FORI=1 TO X1:NEXT
1100 PRINT@32*J+K*91," #A@CJ";
1110 PRINT@32*I+K*92," #A@CJ";
1120 NEXTK
1130 FORK=4 TO 0:STEP-1
1140 PRINT@32*J+K*91," #A@CJ";
1150 PRINT@32*I+K*92," #A@CJ";
1160 NEXTK
1170 NCH=NE
1180 PRINT@N6,USING"###";NE;
1190 TE=#A@CJ:#A@CJ:#A@CJ:#A@CJ:#TE
1200 RETURN
1210 PRINT@2,"***** BUBBLE SORT *****
1220 GOSUB780
1230 FL=0
1240 FORI=0 TONS-1
1250 X=I:Y=I+1:Y#J:GOSUB880
1260 IF#A@CJ<#A@CJ THENI280
1270 FL=1
1280 GOSUB1000
1290 NEXTI
1300 IFFL=1 THENI290
1310 GOSUB420
1320 RETURN
1330 PRINT@2,"***** SUPER BUBBLESORT *****
1340 GOSUB780
1350 FORI=0 TONS-1
1360 X=I:Y=I+1:Y#J:GOSUB880
1370 IF#A@CJ<#A@CJ THENI460
1380 GOSUB1000
1390 I=I+1
1400 IFI=0 THENI450
1410 J=I+1:Y=I+1:Y#J:GOSUB880
1420 IF#A@CJ<#A@CJ THENI460
1430 GOSUB1000
1440 GOTO400
1450 I=I+1
1460 NEXTI
1470 RETURN
1480 PRINT@2,"***** BUBBLE SORT WITH SINKER *****
1490 GOSUB780
1500 FL=0:IS=0:J=1
1510 FORI=0 TO 58
1520 X=I:Y=I+1:Y#J:GOSUB880
1530 IF#A@CJ<#A@CJ THENI550
1540 FL=1:GOSUB1000
1550 NEXTI
1560 IFFL=1 THENI500
1570 GOSUB420
1580 RETURN
1590 PRINT@2,"***** EXCHANGE SORT *****";
1600 GOSUB780
1610 FORI=0 TONS-1
1620 FORJ=I+1 TONS
1630 X=I:Y=J:GOSUB880
1640 IF#A@CJ<#A@CJ THENI660
1650 GOSUB1000
1660 NEXTJ,I
1670 GOSUB420
1680 RETURN
1690 PRINT@2,"***** DELAYED REPLACEMENT SORT *****
1700 GOSUB780
1710 J=0:R=0:I=-1
1720 I=I+1
1730 IFI=NSTHENI870
1740 J=I:R=J+1
1750 X=J:Y=R:GOSUB880
1760 IF#A@CJ<#A@CJ THENI780
1770 J=R
1780 R=R+1:IFR<NSTHENI750
1790 IFI=I THENI720
1800 GOSUB1000
1810 GOTO1720
1820 GOSUB420
1830 RETURN
1840 PRINT@2,"***** SHELL SORT *****
1850 GOSUB780
1860 M=NS
1870 M=INT(M/2):IFM=0 THENI950
1880 H=M
1890 I=H:FL=0:J=I+M:X=I:Y=J:GOSUB880
1900 IF#A@CJ<#A@CJ THENI920
1910 GOSUB1000
1920 FL=1
1930 H=H+1:IFJ<NSTHENI890
1940 IFFL=1 ANDM=1 THENI800 ELSEI870
1950 GOSUB420
1960 RETURN
1970 PRINT@2,"***** SHELL - METZNER SORT *****
1980 GOSUB780
1990 M=NS
2000 M=INT(M/2):IFM=0 THENI2100
2010 F=NS-1
2020 H=0
2030 I=H
2040 J=I+M:X=I:Y=J:GOSUB880
2050 IF#A@CJ<#A@CJ THENI2080
2060 GOSUB1000
2070 I=I-M:IFI=0 THENI2040
2080 H=H+1
2090 IFH/PTHENI2000 ELSEI2030
2100 GOSUB420
2110 RETURN
2120 PRINT@2,"***** QUICK SORT *****
2130 GOSUB780
2140 I=0:J1=NS:IP=0
2150 PRINT@300,"STACK COUNTER... USING"###";P
2160 I=I+1
2170 PRINT@332,"SUPER-RECORD... #A@CJ";
2180 J=J1+5=-1
2190 X=I:Y=J:GOSUB980
2200 IF#A@CJ<#A@CJ THENI2230
2210 GOSUB1000
2220 S=I
2230 IF#S=1 THENI+1 ELSEJ=J-1
2240 IFI<J THENI2190
2250 IFI+2>J THENI2270
2260 P=P+1:SSCP,1)=I+1:SSCP,2)=J1
2270 J1=I-1
2280 IFI<J1 THENI2150
2290 IFP=0 THENI420
2300 I1=SSCP,1):J1=SSCP,2):P=P-1
2310 GOTO2150
2320 ' EXIT
2325 CLEAR50:CLS:END

```

Visisort

This program implements eight sort techniques at selectable speeds of which O is the fastest. Sort data can be either letters or numbers which can be chosen by the computer or the user. The program is approximately 5.6 k

long and runs on the VZ 200/300, but not on the unexpanded VZ 200. Instructions to use it are contained in the program.

**PJ Sheppard
Christchurch
New Zealand**

Letters

PC — Turbo Board

In relation to ETI 1614 (ETI, November 1988), the PC-Turbo board is not much use when OS/2 comes out as OS/2 needs a 80286 microprocessor. A replacement mother board would be a good idea.

**Lucas James,
Munno Par
SA 5115**

Educated editorial

Great! At last someone with some sense about education (Editorial, October 1988). This is the idea of any useful teacher in the high school system.

**L. McIntosh,
Murwillumbah
NSW 2484**

The customer's always right

I have been a subscriber to ETI for a year now. I enjoy the reading and I really enjoy creating some of the projects. ETI is such a great magazine, and I am pleased to

say that I have recently subscribed for another year. Give yourself a pat on the back Ed.

**Joshua Wales,
Young
NSW 2594**

Mapping the Shelf

Re 'The Tides of Change' (ETI, December 1988), some comment could have been made about the work the Federal Government's ship 'MV Cape Pillar' is doing in the field of hydrographic surveys around Australia and the Pacific Islands. They use Doppler sounding gear and satellite tracking gear to map the Continental Shelf.

**Steve Fleming,
Kingslake
VIC 3763**

Simply solar?

Very good articles. Interesting projects but could you please have a simple project (e.g. that can be soldered onto a veroboard etc.) published in the magazine. An ideal one would

be a FM or AM transmitter/receiver type project, or a project using solar cells as the power source. It would be much appreciated.

**Peter Soumanis Jnr,
Noranda
WA 6062**

Computer circuits

I feel Electronics Today could be improved 100% if there was more emphasis on computer-related circuits. Nov 88 was a superb issue and I feel I must congratulate you on your PC Turbo Board which was a real surprise package! Congratulations from a loyal supporter.

**Derek Jenkins,
Lambton
NSW 2299**

Confessions of a fan

What a pleasure to read the new ETI. The improved quality and variety of articles, the new design and the increased size, colour content and even paper quality make it the most interesting technical magazine around. I thought "Confessions of a field

service technician" (Dregs, October 1988) hilarious. Who wrote it?

**Peter Hayes,
Vaucluse
NSW 2030**

AT last

Thanks for the article on Radioastron (ETI, November 1988) - and I thought AT was a computer!

**Andrew Bromage,
Mooroolbark
VIC 3138**

Cheap, please!

It's good to see coming events back. You need more small single issue projects that student hobbyists can build in their price range e.g. \$0-\$20.

**Stephen Wilkey,
Normanhurst
NSW 2076**

Dramatic plea

Pretty good magazine. I think it has improved considerably over the last 10 months. I feel the target level of reader is more my level now. I am very impressed with the IBM AT motherboard project! (ETI, November 1988).

Applix 1616 update

1988 has seen a consolidation of the Applix 1616's hardware and software base. The HI-Tech "C" Compiler, SSFORTH, MINIX, CP/M, 1616OS/3, SCSI hard disc, sound digitiser, high performance graphics card and the "mini-1616" are just some of the developments.

The Applix 1616 has a flexible and open design which makes customisation of both hardware and software possible and enjoyable. New developments range from the sort of software which is available for many machines to highly specific hardware add-ons.

The 1616's software takes advantage of its operating system environment. For example, the full screen editor is available to all programs via a simple system call; the system's sophisticated line editor is available to any program which requires keyboard input.

The Australian HI-Tech "C" Compiler, has been available on the 1616 for over a year. Unix-like utilities such as Make, Grep and More and more recently the SCSI hard disc add to the programming environment.

SSFORTH, written by Peter Fletcher, is well integrated into the 1616 operating system, enabling easy access to the 1616's graphics, sound and general I/O. Full Forth source is also available.

The 1616 operating system (as described in ETI April 1987) underwent changes in July; new features include sophisticated memory management, hierarchical file systems, code relocation for multiple program loading and improved command history recording. Last 10 line command recall and ever-present powerful line-editor are very handy for non-perfect typists.

A new development is the porting to the 1616 of the Unix-like operating system Minix by Colin McCormack, of Tangled Web Software. This O/S was originally developed for the teaching of

operating system design. It provides an effective multiprocessing environment for the 1616. Full source code for the O/S and its utilities will be made available for study or further development.

An 8Mhz version of CP/M now runs on the 1616 disc coprocessor card enabling access to WordStar, Dbase II, Turbo Pascal and other popular application programs. The SCSI hard disc driver software, developed by Mark Harvey, supports all known SCSI discs and it is also possible to run PC style hard drives via an adapter card.

Another 1616 user, Greyham Stoney, has written a suite of programs which download into the 280 disc coprocessor card. Functions include disc block caching and reading/writing of alien disc formats.

The Hutchison brothers have developed a high quality audio digitiser, complete with sound effects and graphic display software. This board utilises an external serial analogue to digital converter to obtain higher sampling rates than is available from the on board converter.

Applix also has a high performance graphics board based on the Texas Instruments 34010 graphics processor chip. It is capable of resolutions up to 1024 x 512 with a choice of 16 colours from a palette of 1/4 million colours and a selection from 256 colours at lower resolutions. 1616/OS has been ported to another 68000 board. Smaller than the 1616, it has 256K of static RAM, two serial ports, a parallel port, and facility for an alphanumeric LED display.

Widely dispersed though they are, communication between 1616 users is very good. The Peripheral Newsletter, edited and produced by Eric Lindsay, has recently been averaging about ten pages per month; interested ETI readers are invited to contact Applix. Dave Wilson in New Zealand writes a regular newsletter for the Kiwi users.

Also, I am very interested in theatre - maybe some projects? Please?!

**J. Ellemar,
Aspley
QLD 4034**

Chardonnay ETI

Good magazine. Keep up the good work as like a wine you have improved with age.

**Simon Clowes,
Parramatta
NSW 2150**

V2300-Atari

Great magazine. How about having a project to allow the V2300 to support Atari-type joysticks.

**Mark Tearle,
Busselton
WA 6280**

Absurd sayings

People who should know better all too often say absurd things such as "rms power", or even ignore physics, as in your interesting article about Dexterity in Zero G-Force (September).

Therein we read about the "absence" of gravity, which has been "eliminated" for orbiting astronauts. They are constantly falling due to gravity, although their altitude remains constant.

There are many of us who would very much like to know how to eliminate gravity, since such a patent would be the key to the vault.

**George Lindley,
Redfern
NSW 2016**

Send them in

I think your magazine should have programs for IBM compatibles. I have 2 IBM compatible Wang computers and my son wants to learn programming, but he can only find programs for Microbee and Commodore. Please publish some.

**Gherhard Seegers,
Newport
NSW 2106**

Well, what about it readers? Send us your IBM programs and we will publish them - Ed.

Good news?

Good to see an unbiased account of the shooting down of the Iran Airbus (ETI, September 1988). Pity the television news hasn't mastered this reporting style.

**M.P. Atkinson,
Wantima
VIC 3152**

More complete

The all-new ETI is great - far more interesting. I'm concerned that the projects are becoming too expensive for the average hobbyist (eg: expandable mixing console). I would prefer smaller, cheaper projects.

New articles and their variety make ETI a more complex magazine. Even better value!

**Brett Smith,
Lobethal
SA 5241**

Robots

I would like to see more detailed reviews of new products such as Phillips Imaging Module, or a series of articles on the transmissions and protocols of fax machines, which can be very interesting. Perhaps a review of the latest design in industrial robotic arms, etc.

**A.J. McConnell
Nth Balwyn
VIC 3104**

Winners

The following readers were winners in the Psion Organiser contest run in ETI September 1988:

P O'Brien, 4/28 Beaconsfield St, Bexley NSW 2207,
B Sloss, 57 Alexandra Ave, Canterbury Vic 3126,
M MacDonald, 1/35 Moore St, Hillston NSW 2675,
S Gloor, 30 Larsen St, Leichardt Qld 4305.

Congratulations. The winners should have been contacted directly by the distributor, Eastern Micro Electronics, 45-47 Tope St, South Melbourne Vic 3205.

DO YOU WANT TO SALVAGE SOME CASH?

TURN YOUR SURPLUS STOCK INTO CASH!!!

Jaycar will purchase your surplus stocks of components and equipment. We are continually on the lookout for sources of prime quality merchandise.

Jaycar ELECTRONICS

115 Parramatta Road
Concord 2137
or phone
(02) 747 2022
ask for Bruce Routley
or Mark Harris

Circuits

Low current siren

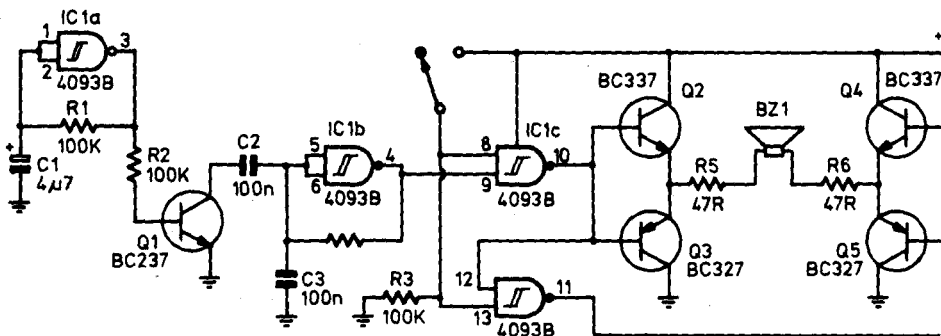

This efficient circuit provides an output of 10 V RMS (approximately 103 dB at 1 m) at a current consumption of only 30 mA.

Low frequency oscillator IC1a varies the frequency of audio oscillator IC1b by switching in and out C2. The rapidly varying audio signal is gated by IC1c to output

amplifier stage Q2,3 and an inverted signal is passed to Q4,5. The piezo transducer is connected between the stages with 20 V peak-to-peak across it.

Resistors R5 and R6 serve to limit the current and stabilise the output stages.

Eight-way stereo selector

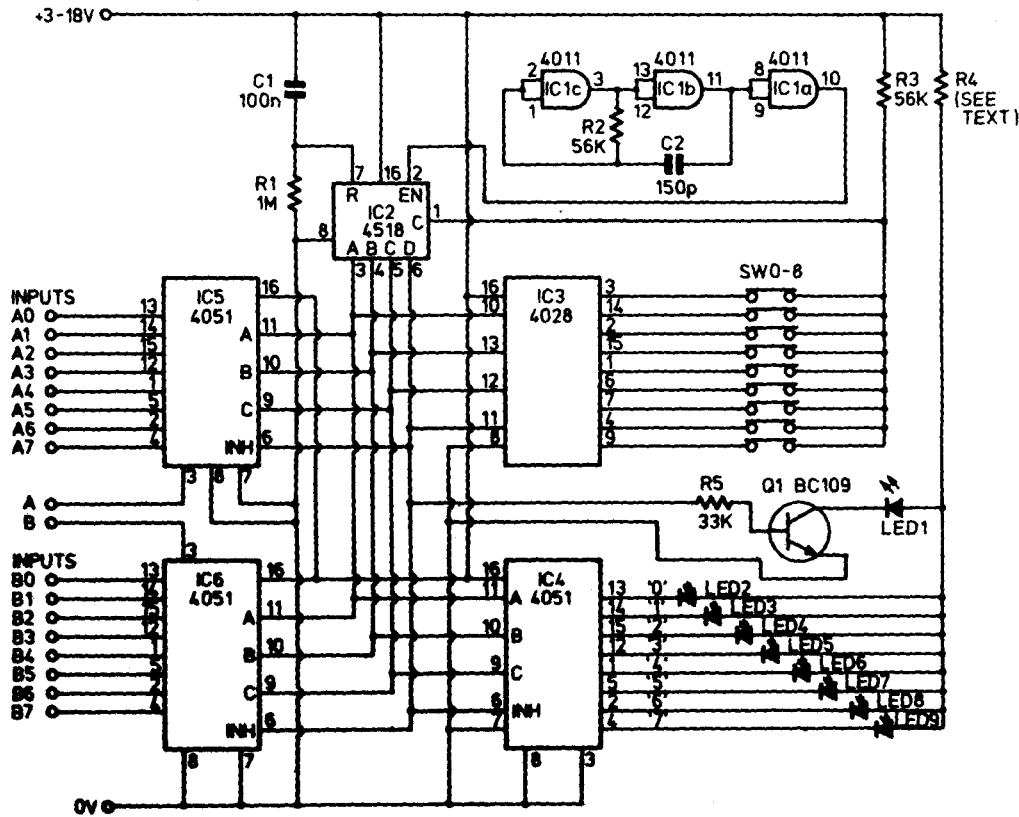

This circuit provides noiseless remote selection and routing of eight audio signals, either stereo or balanced pair mono, using simple non-locking push-switches.

The BCD counter IC2 is disabled from counting IC1's 1 MHz clock rate by the high on pin 1. A momentary closure of SW2, say, enables the counter and the switching action is effectively debounced. The code 0010 is now present on all the ICs so that LED 2 on IC4 is now lit and inputs A2 and B2 are connected to the outputs of IC5 and IC6.

SW8 selects BCD 1000, inhibiting the 4051s and providing an 'off' facility. ICs 5 and 6 may, of course, be remote from the selection and indication circuitry - advantageously sited with respect to the audio signal paths.

The power requirement is only about 1/2mA above that required by the LEDs. Select R3 to suit the supply voltage assuming 25 mA for the LED (so 140R for 6V, 260R for 9V, 380R for 12V, 500R for 15V and so on).

Guitar preshaper

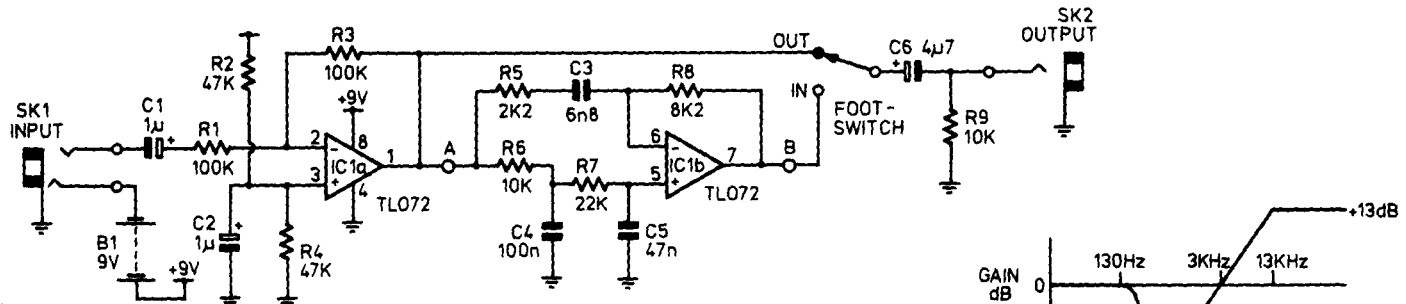

Some upmarket bass and guitar amps are fitted with a present tone circuit to give an instant clean modern sound without the tedious EQ setting. In this circuit IC1b filters high and low frequencies then recombines them to produce a frequency

response approximately as shown. This produces a clean, bright sound for either 6-string guitar or bass.

The circuit can be built as a footpedal powered from a PP3 (no power LED is included to extend battery life). If fitted in

your amplifier between preamp and power amp then the buffering and level shifting circuitry can be omitted leaving just the components between A and B.

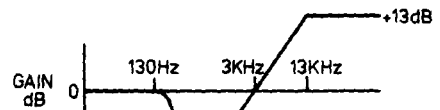

The MAESTRO 2400XR

Here's a fully-featured, Hayes compatible 1200 & 2400 bps full duplex modem for just

\$369 (incl. tax).

This modem uses the LATEST in DSP chip Set Technology and microprocessor control, bringing you the future Today.



Super price on a super V.22/V.22 bis Modem!

The MAESTRO 2400 ZXR

4 Speed Version **\$399 (incl. tax).**

Don't Wait! RING NOW (043) 68 2277 or 68 2278

Maestro Distributors

Calool St. South Kincumber, NSW 2256

READER INFO No. 25

Envelope generator

This envelope generator was designed to boost the performance of an ancient monophonic synthesiser which came equipped with only one. This way one can control either the VCA or VCF with each generator and it's small and cheap.

C1 charges at a rate set by the attack pot when the gate goes high (at the start of a note). At a certain voltage (set by RV2), the flip flop of IC1a,b resets and C1 discharges at a rate set by the decay pot. When the gate is removed (note off) C1 discharges through the release pot.

RV1 sets the maximum sustain level which should be set to match the voltage controlled device. IC4 buffers the voltage across C1 for the output.

Using this circuit with a Moog Rogue produced excellent results.

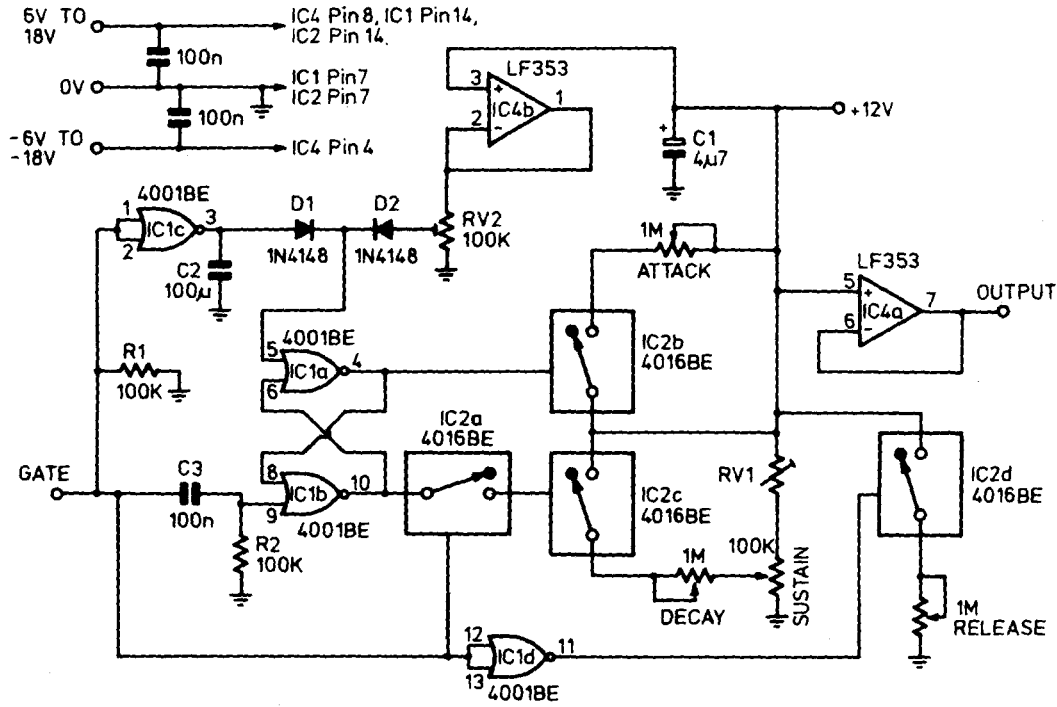

Feed Forward needs your minds. If you have ideas for circuits that you would like to enter in our idea of the month contest, programs for the computing columns or just want a word with the editor, send your thoughts to:

Feed Forward
ETI, Federal Publishing,
PO Box 227,
Waterloo, NSW 2017

Contributors can look forward to \$20 for each published idea/program which should be submitted with the declaration coupon below.

Programs MUST be in the form of a listing from a printer. You should indicate which computer the program is for. Letters should be typewritten or from a printer, preferably with lines double spaced. Circuits can be drawn roughly, because we have a draughtsman who redraws them anyway, but make sure they are clear enough for us to understand.

'Idea of the month' contest

Scope Laboratories, which manufactures and distributes soldering irons and accessory tools, is sponsoring this contest with a prize given away every month for the best item submitted for publication in the 'Ideas for Experimenters' column — one of the most consistently popular features in ETI Magazine. Each month, we will be giving away a Scope Soldering Station (model ETC60L) worth approximately \$191.

Selections will be made at the sole discretion of the editorial staff of ETI Magazine.



RULES

The winning entry will be judged by the Editor of ETI Magazine, whose decision will be final. No correspondence can be entered into regarding the decision.

The winner will be advised by telegram. The name of the winner, together with the winning idea, will be published in the next possible issue of ETI Magazine.

Contestants must enter their names and addresses where indicated on each coupon. Photostats or clearly written copies will be accepted. You may send as many entries as your wish.

This contest is invalid in states where local laws prohibit entries. Entrants must sign the declaration on the coupon that they have read the above rules and agree to abide by their conditions.

COUPON

Cut and send to: **Scope-ETI 'Idea of the Month' Contest/ Computing Column, ETI Magazine, PO Box 227, Waterloo NSW 2017.**

"I agree to the above terms and grant *Electronics Today International* all rights to publish my idea/program in ETI Magazine or other publications produced by it. I declare that the attached idea/program is my own original material, that it has not previously been published and that its publication does not violate any other copyright."
* Breach of copyright is now a criminal offence.

Title of idea/program

Signature Date

Name

Address

..... Postcode



INNOVATION

Generally, *complete* is a subjective term, but CSS is a comprehensive and impressive package. It is offered as a pc alternative to mainframe statistical packages, and although costing over \$900 is much cheaper than similar mainframe programs.

CSS uses a modular design, with each module accessible either from the main menu or direct from the operating system prompt. The exception to this is graphics module INTERGRAPH, which is available from all other modules.

It is fortunate that StatSoft has used the modular approach, as otherwise the program would have been completely unwieldy. My review copy came with two massive manuals weighing in at more than two kilograms and containing seventeen discettes. Each module is generally on a single discette, and you need only load the ones you want onto your hard disc. Statsoft hasn't yet caught up with 90 mm discettes and provided only 135 mm. I copied the first seven discettes onto two 1.44 MB discettes which I then transferred onto my hard disc. These files occupy nearly 2 MB. Last year, StatSoft abandoned copy protection so you simply copy the discettes. The instructions with CSS cover the possibility that you will use the program from floppies, but you'd be punishing yourself and I wouldn't recommend it.

What types of statistical analysis can you carry out with CSS? Perhaps the easiest way to do this is to list the contents of each discette:

- ☆ startup and utilities
- ☆ data management

- ☆ basic statistics
- ☆ multi-way tables
- ☆ analytic graphs
- ☆ multiple regression methods
- ☆ time series analysis and forecasting
- ☆ quick anova/ancova
- ☆ general manova/contrast A/discriminant function A (two discs)
- ☆ nonparametric statistics
- ☆ factor analysis, principal components analysis
- ☆ multidimensional scaling
- ☆ cluster analysis techniques
- ☆ log/linear analysis
- ☆ nonlinear estimation, logit/probit analysis
- ☆ Pascal (programming language)
- ☆ canonical correlation analysis
- ☆ quality control analysis
- ☆ survival/failure time analysis
- ☆ development environment

Quite a list, isn't it? If you've been paying

'In the middle of making a choice, Help doesn't always work'

close attention you will have noticed that whereas I said the package contained 17 discs the list contains 22. In fact, the manuals include only up to multidimensional scaling with the next four relegated to an appendix. The last five discs are not included - much to my disappointment, as I was looking forward to trying out the quality control analysis or survival/failure time analysis on some of the computer equipment I work with. That's one of the advantages of the modular approach I guess; you can put out an incomplete version of a complete program. Presumably the last five programs will follow sometime.

Automatic configuration

CSS claims that it configures itself

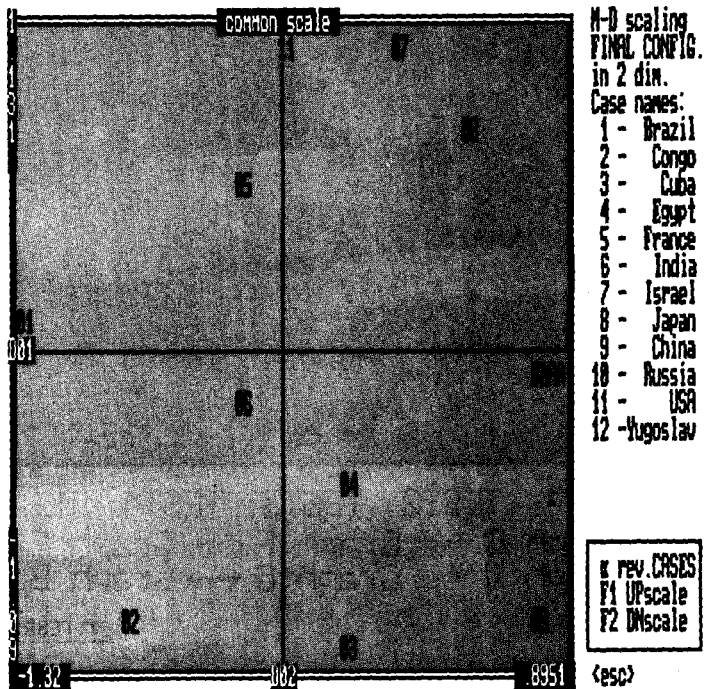

STATISTICS MADE EASY The complete computation system

StatSoft has released a software package that will solve all your computational problems. John Nicholls reports.

Statistics made easy

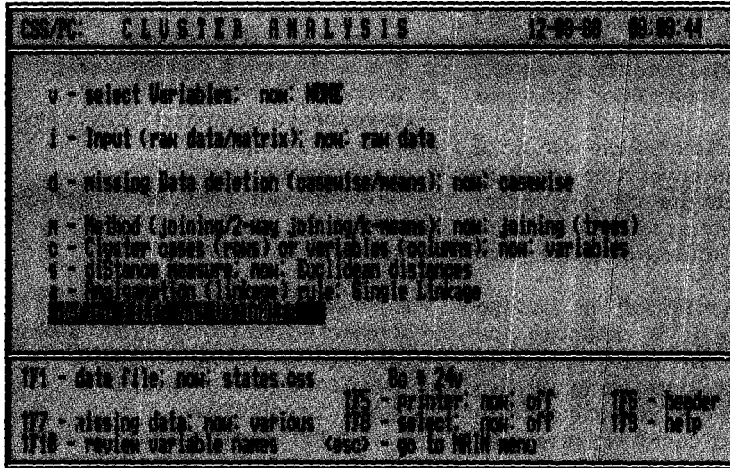

header of RAW DATA file: states.css
Eight demographic indicators of movement for 24 selected states

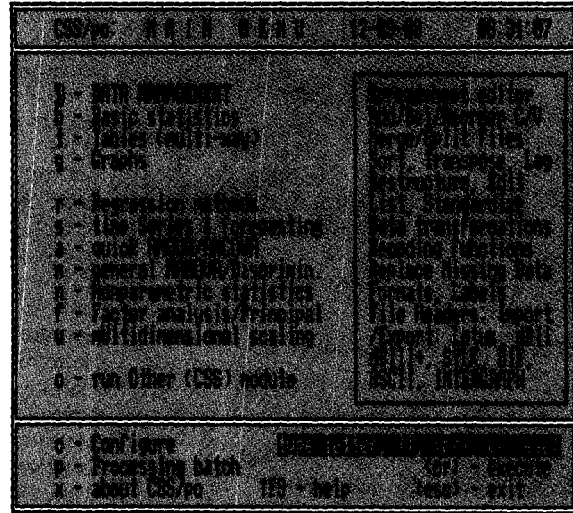

automatically to your hardware. The only module you need to configure is INTERGRAPH, where you need to specify your printer and plotter. This is quite simple, and the program provides for practically every printer and plotter ever made. The Hewlett Packard 7475 is selected as default plotter. There is also a selection for screen, which appears to default to IBM CGA. Just to make sure, I selected IBM VGA to match the Compaq VGA I use.

The program loads quickly, displaying the main menu, which shows the choices available plus a box going into more detail

about what is contained in each menu choice. There is a slight pause after you select a menu choice while the program module is loaded. Then you get a further list of choices, for which Help is available by pressing Shift-F9. Someone should tell StatSoft (and WordPerfect) that everybody uses H for Help. If you are in the middle of making a choice, Help doesn't always work, even when Shift-F9 is displayed on the list of choices.

I had some trouble at first getting the program to produce a directory listing, at one stage locking up the computer on a blank screen, and found that the Help

choices are confined to details of statistical methods and options, so some of the computer operations are obscure. However the statistical details are admirably clear, with choices following logical sequences. CSS claims to have used some artificial intelligence features in its user interface, but everyone says that these days.

You enter data into a spreadsheet, a process made easy by the intelligent use of cursor keys to move quickly about the spreadsheet. Editing is just as simple. You select the operations you want to perform on your data from a series of straightforward menus that proceed in a logical order. Once you have made the selection and start the calculations a message appears which continually updates the screen to show you what stage the calculations have reached. Without making direct comparisons with other programs it is difficult to judge its speed, but it appeared perfectly adequate on the 16 MHz Compaq 386S I use. A 4.77 MHz 8088 would appear slow (as it does on every program once you've got used to a faster machine). To provide speed the program bypasses DOS and writes directly to the video memory.

Precision retained

When the calculations are finished they are displayed in a summary form with a limited degree of precision so that more data can be displayed on the screen. However the full degree of precision is retained, and can be displayed by narrowing down the range you want displayed. CSS describes this as having multiple layers, hidden beneath the surface layer, which is a good description. You review these layers by pressing the function keys listed on the bottom of the screen. In its sample correlation matrix, the top layer, 'compressed mode', displays only two digits. One keystroke increases this to 4 digits, a higher precision is possible by looking at single cells.

INTERGRAPH is a presentation que

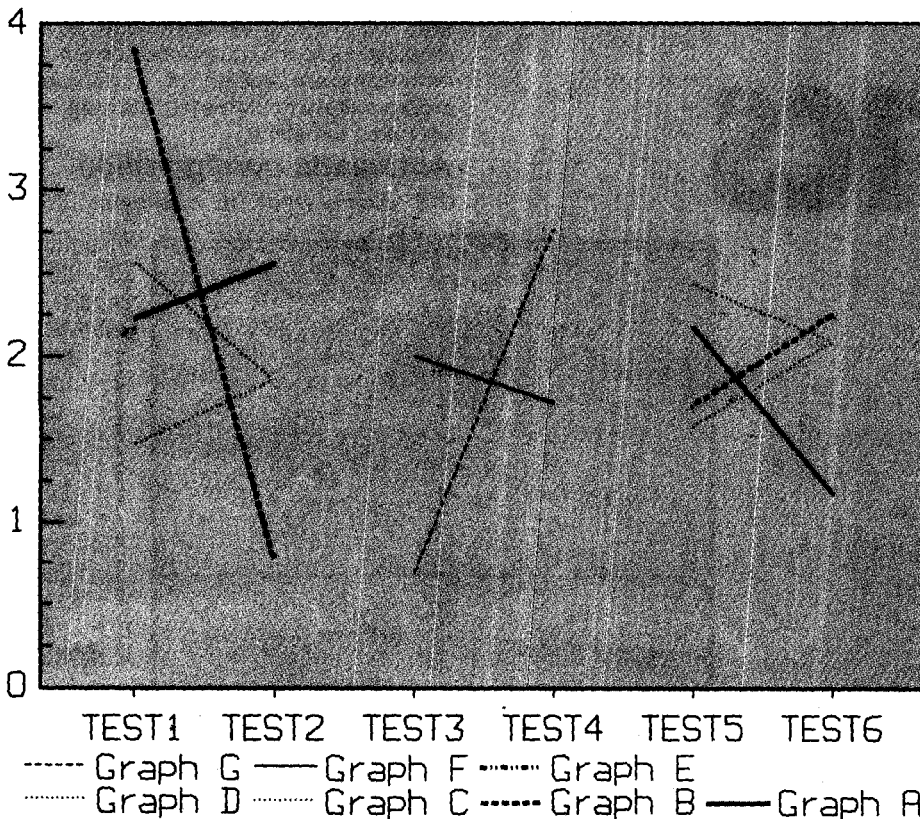

graphics program which produces a number (11) of the most common types of graphs, plus combinations of different chart types. It can be loaded into memory at the same time as the main CSS program (it takes 128 K). It is then available from within every other module.

You have a lot of options in INTERGRAPH, and the excellent user interface makes it fun to use. On a VGA screen you can set 8 foreground and 8 background colours, although not all of the 64 combinations are usable. The Epson LQ-1000 was the only printer I had readily available, and its graphics print quality is not the best, but the illustrations show examples of the small, medium and large printout. The small and medium graphs are printed horizontally, but when you select large, the program automatically switches it to a vertical printout. It seems a shame to dismiss INTERGRAPH in a couple of paragraphs, because it is a package with plenty of features but also easy to use.

Graphics

Two other graphics packages are included in CSS. The first is (logically) called GRAPHS, and is a statistical/analytical graphics module with built-in statistics for exploratory data analysis. The second graphics option is specialised graphics subprograms built into

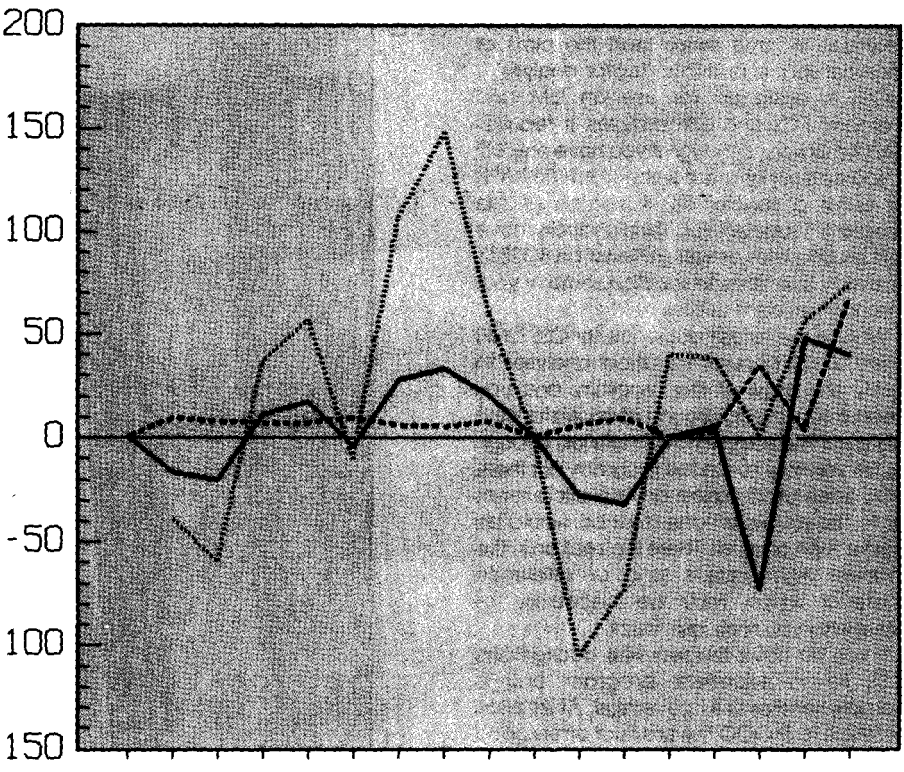

..... Graph C Graph B — Graph A

ELECTRONICS TODAY

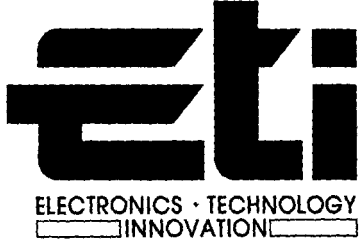

Reader Information Card

On the reverse of this page you will find the Reader Information Card. This is a service ETI provides free to readers who want more information about products advertised or otherwise mentioned in the magazine. At the bottom of the article or advert you will find a RI number. Just circle that number on the card and send the card to us. We will pass on your

address to our contacts, either the advertiser or our source for the story, who will then inundate you with literature on the product of your choice. Another feature: to the right, there is a blank space. Why not use it to drop us a line, and let us know what you think of the magazine. We are particularly interested in ideas from readers on how we can improve things.

Note to the Editor:

Name:

Address:

.....

Postcode:

Statistics made easy

other modules, such as a dynamic graphics interface in 'time series' and the plots of factorial space built into 'factor analysis'.

CSS is designed for use on IBM and Compac PCs and compatibles. It requires 640 K memory, although if you have only 512 K you can either use it without INTERGRAPH or order a special 512 K version of the program. I suggest you should ideally have a fast computer as well (at least an 80286). You may also have to sacrifice some of your memory resident utilities.

What is the target audience for CSS? You need to do enough statistical analyses to justify the price of the program, and you need a sound background of understanding statistics. The samples in CSS are just enough to tell you how to run the program, but there is no attempt to explain any statistical terms or to tell you when one method would be better than another. There is a section in the manual eight pages long of reference material which may be necessary as otherwise you may get stuck.

If you do have the requisite background CSS is an excellent program and is comprehensive in its coverage. At its price of \$900 to \$1,000 the product offers good value.

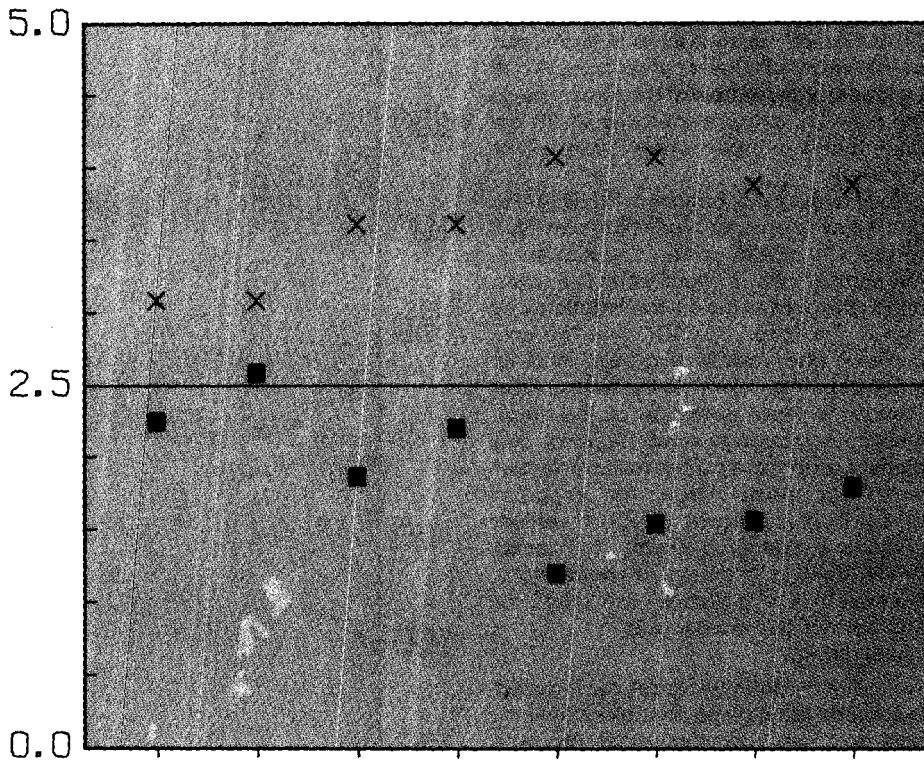

■ Graph B x Graph A

John Nicholls is an accountant and regular contributor to many computer magazines.



READER INFORMATION SERVICE COUPON



READER INFORMATION SERVICE

To find out more about the products and services in this issue, note the Reader Service Number from the advertisement or article, and circle the corresponding number in this coupon. Enclose it in an envelope and send to:

FREE POST No. 4
The Federal Publishing Company
P.O. Box 227, Waterloo, N.S.W 2017

No stamp required if posted in Australia.

- A. Engineer/Designer
- B. Technical Officer
- C. Technician
- D. Programmer/Analyst
- E. Manager
- F. Teacher/Lecturer
- G. Student
- H. Interested Consumer
- I. Other (please state).....

Please ✓ the box that best fits you.

Name

Address

..... P/C.....

1	26	51	76	101	126	151	176	201	226	251	276	301	326
2	27	52	77	102	127	152	177	202	227	252	277	302	327
3	28	53	78	103	128	153	178	203	228	253	278	303	328
4	29	54	79	104	129	154	179	204	229	254	279	304	329
5	30	55	80	105	130	155	180	205	230	255	280	305	330
6	31	56	81	106	131	156	181	206	231	256	281	306	331
7	32	57	82	107	132	157	182	207	232	257	282	307	332
8	33	58	83	108	133	158	183	208	233	258	283	308	333
9	34	59	84	109	134	159	184	209	234	259	284	309	334
10	35	60	85	110	135	160	185	210	235	260	285	310	335
11	36	61	86	111	136	161	186	211	236	261	286	311	336
12	37	62	87	112	137	162	187	212	237	262	287	312	337
13	38	63	88	113	138	163	188	213	238	263	288	313	338
14	39	64	89	114	139	164	189	214	239	264	289	314	339
15	40	65	90	115	140	165	190	215	240	265	290	315	340
16	41	66	91	116	141	166	191	216	241	266	291	316	341
17	42	67	92	117	142	167	192	217	242	267	292	317	342
18	43	68	93	118	143	168	193	218	243	268	293	318	343
19	44	69	94	119	144	169	194	219	244	269	294	319	344
20	45	70	95	120	145	170	195	220	245	270	295	320	345
21	46	71	96	121	146	171	196	221	246	271	296	321	346
22	47	72	97	122	147	172	197	222	247	272	297	322	347
23	48	73	98	123	148	173	198	223	248	273	298	323	348
24	49	74	99	124	149	174	199	224	249	274	299	324	348
25	50	75	100	125	150	175	200	225	250	275	300	325	350

ETI FEB '89

For a prompt reply

POST TODAY

POST TODAY

POST TODAY



FEBRUARY

4-17: Beyond 2000 Spectrum Exhibition. Royal Melbourne Exhibition Building, Melbourne. Information from Spectrum Exhibitions. ☎ (02) 281-2555.

13-17: The World Conference on Engineering Education for Advancing Technology will be held at the University of Sydney. Contact the Conference Manager, Institution of Engineers, 11 National Circuit, Barton. ACT 2600.

20-25: Asia Telecom 89 in association with the ITU and Telecom Singapore. ☎ +65 730 3935.

MARCH

14-17 biannual: PC89 The 12th Australian Personal Computer Show at Darling Harbour, Sydney. Contact (03) 267-4500.

14-17: Elenex Australia the Australian International Electrical and Electronic Industries Exhibition at The Sydney Convention and Exhibition Centre, Darling Harbour, Sydney. Contact: Australian Exhibition Services Pty Ltd, 424 St Kilda Road, Melbourne, VIC 3004. ☎ (03) 267-4500.

APRIL

10-14: National Engineering Conference, Perth. More information from the Institutions of

Remote Sensing Short Courses—1989

The University of New South Wales has provided the following list of dates and topics for short courses to be conducted by its Centre for Remote Sensing.

- 13-15 February** Advanced topics in image classification (to be held in Melbourne)
- 20-22 February** Introduction to remote sensing and image processing for remote sensing (to be held at Northern Rivers CAE, Lismore, NSW)
- 23-24 February** Image enhancement and
- 13-17 March**

- 3-5 April** classification Introduction to remote sensing and image processing for remote sensing (to be held in Mildura, Vic.)
- 6-7 April** Synthetic aperture radar
- 31 July-4 August** Digital mapping with SPOT and TM data
- 25-29 September** Advanced topics in image classification
- 2-4 October** Remote sensing for planning and urban studies
- 6-10 November**

- Engineers Telex AA62758.
- 17-19: Australian Symposium on Signal Processing and Applications (ASSPA)** at the University of Adelaide. The exhibition will run concurrently. ☎ (08) 267-1755.
- 27:** The Institution of Engineers, Australia, has called for papers for a conference on **New Business Applications of Information Technology**, to be held in Melbourne. ☎ (062) 70-6549.

27-29: The Computer '89 computer show will be held at the Perth Entertainment Centre. Contact Swan Exhibitions ☎ (09) 443-3400.

MAY

10-12: There's been a call for papers for the **Fourth Australian Software Engineering Conference, ASWEC 89**, to be held in Canberra. ☎ (062) 70-6549.

REGULAR MEETINGS

- Vic branch of the **Australian Datatex Users Group** meets the second Wednesday of each month at Bird Cameron, 316 Queen Street, Melbourne, at 6 pm. ☎ (052) 21-1300 or (03) 670-9212.
- The **NSW Datatex Users Group** meets the third Tuesday of each month at the offices of Touche Ross, Level 40, MLC Centre, Sydney at 5.30 pm. Contact Gary Reid. ☎ (02) 816-5866.
- The **Sydney Open Access User Group** meets the second Tuesday of each month at the Fujitsu Education Centre, 475 Victoria Avenue, Chatswood. Contact Judy Jeffrey. ☎ (02) 439-5982.
- The **Sydney Apple User Group** meets the first and second Monday of every month at the Stephen Roberts Theatre at Sydney University. Contact Graham Clarke. ☎ (02) 58-2709.
- Mac** meets the second Wednesday of each month in Lecture Theatre 5, Carslaw Building, Sydney Uni at 6.30 pm. Contact Ian Hinder. ☎ (02) 660-5530.

- ARCAD/GDS User Group** meetings are held in Sydney the first Tuesday of every month. For information contact Klaus Bartosch. ☎ (02) 958-2388.
- The **Apricot-Victor Users' Group** meets the last Wednesday of every month at 6.15 pm at Prince Henry's Hospital, Melbourne. Contact Elizabeth Lyons. ☎ (03) 611-2873.
- The **C Language Users' and Enthusiasts' Society (CLUES)** meets at Frenchs Forest in Sydney on the first Tuesday of the month. Contact Jim Sharples. ☎ (02) 958-4705.
- The **Australasian Lotus Users' Group** meets on the first Tuesday of each month at 5.45 pm. Contact Barry Roberts. ☎ (03) 267-4844.
- The NSW branch of the **Office Automation Association** meets the last Wednesday of each month at the Commercial Travellers Club in Sydney from 6 pm-8 pm. Contact Pat Reid. ☎ (02) 371-5132.
- Western Australia Unix Systems Group** meets on the third Wednesday of each month. Contact Sam Pascoe ☎ (09) 470-3077.

- Special Interest Groups of PC users:** CONSIG meets on the first Wednesday of each month in Sydney; ☎ (02) 290-2655. The DTP Graphics SIG (Desk-top) meets on the second Tuesday of the month in Sydney; ☎ Mark Richards (02) 929-5855. PCWEST meets on the first Monday of the month in Sydney; ☎ Bill McEwen (02) 627-2488. ACS Expert Systems SIG meets third Monday of each month in Melbourne; Phone Tony Davidzik (03) 873-1664.
- The **NEC Users' Group of NSW** meets at St Leonards, Sydney, on the second Tuesday of each month. Contact Ian Cowell. ☎ (02) 489-1156.
- The **CAT-dBase Users Group** meets every third Tuesday of the month at 6.30 pm at Expert Technology Training, 185 Elizabeth Street, Sydney. Contact Hans Schneider. ☎ (02) 309-2961.
- The **South Australian Apple Users' Club** meets the first and third Fridays of the month at the Prospect Town Hall at 7.30 pm. Contact Ian Bagust. ☎ (08) 293-7183.



BUFFOONERY

A REAL BOMB FOR THE USA

Long list of problems with the B2 bomber

The long-awaited unveiling of the USA's so-called stealth bomber has given rise to much speculation about its capabilities.

At long last, last November the US military unveiled the B2, the so-called stealth bomber (See ETI August 1987), designed to fly to the Soviet Union at high altitude and drop its bombs on various targets which may or may not be civilian.

It has been constructed of materials that absorb radio signals, and together with a shape that minimises reflections, the generals claim its radar signature is reduced to the

equivalent of a large bird. Its turbines have been hidden underneath extensive cowlings, so that heat seeking missiles will find it difficult to lock onto its exhaust, and radar waves will not be reflected by the turbine blades.

The result: an aircraft that will be able to penetrate deep into the Soviet Union, and survive in an environment where everybody is interested in shooting it down. At least, that's what the Pentagon wants people to believe.

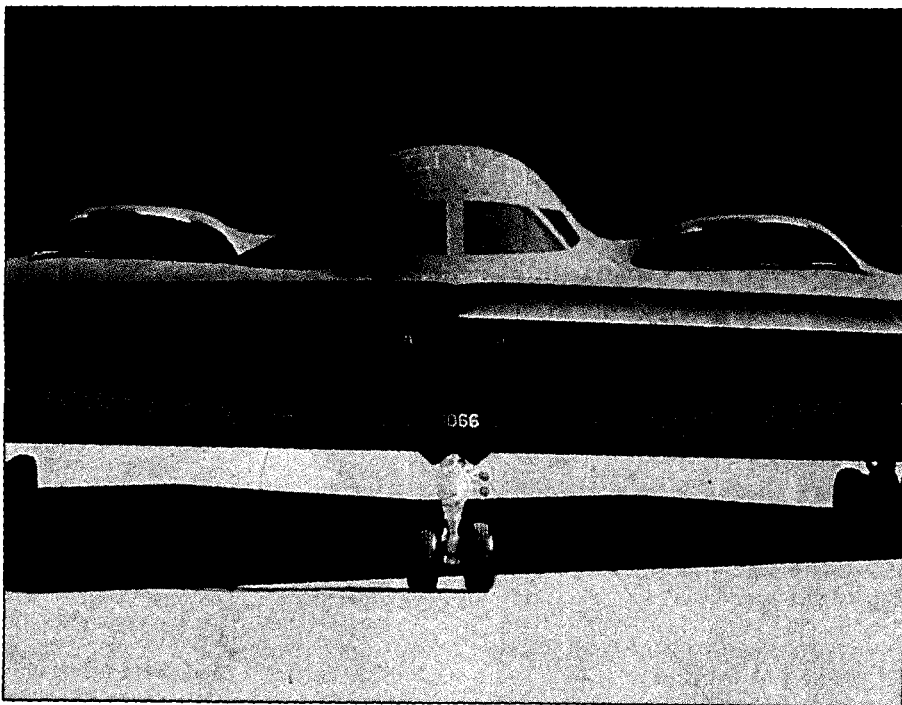

The B2: airborne buffoonery.

The list of problems with the B2 is long and grows every day. It starts with its mission. The USA has well over 1000 guided missiles, each with multiple warheads, mounted in silos in the US, on mobile rocket launchers in Europe, and on submarines at sea. The very best that one can say about the B2 is that it's unnecessary.

But worse follows. The B2 is slow. Because of the need to hide its intakes and exhausts the B2 can't take advantage of any of the advances in aerodynamic theory that have occurred since the second world war. As a result, it will be forced to spend many unnecessary hours over Russian territory about twice as much, in fact, as the 1950's vintage Hustler, or 1960's F1-11.

And even worse: just as the B2 gets going the electronics of detection is getting better and better. New Digital Signal Processing (DSP) techniques and Spread Spectrum Technology will allow the creation of radars with phenomenally improved reception capability within the next few years. What's more, DSP techniques will allow the extraction of a great deal of information from the returning echo. For instance, it is suggested by people working in the field that the returns may actually be analysed to interpret the shape of the object making the return. If so, the stealth bomber will not only that its cover is gone, but that it is broadcasting its own unique signature to the entire Soviet Union. What's more, the cost of implementing such techniques will be trivial next to the cost of the B2.

If it can't get any worse, you say? Oh, but it does. Stealth aircraft are the result of exotic manufacturing processes. In some cases, the materials being used are classified so that the workers themselves don't know what they are handling. Now, several are saying they have contracted cancers, skin diseases and lung problems because of exposure to toxic chemicals. Several have already died.

Whether the B2 is dangerous to the Russians is a moot point. It seems there is little doubt it is dangerous to Americans.

And the price, you say? Well, for a chancing bit of machinery, the US people have forked out \$7b. enough to re-build the schools in the USA, set up a colony on the moon, or fund an entire fusion program. Enough in fact, to make the USA a world power again.